

APRIL

N.S.E.

25 CENTS

POPULAR MECHANICS MAGAZINE

WRITTEN SO YOU CAN UNDERSTAND IT

REG'D. TRADE MARK. GREAT BRITAIN. No. 410426

REG. U. S. PAT. OFF.

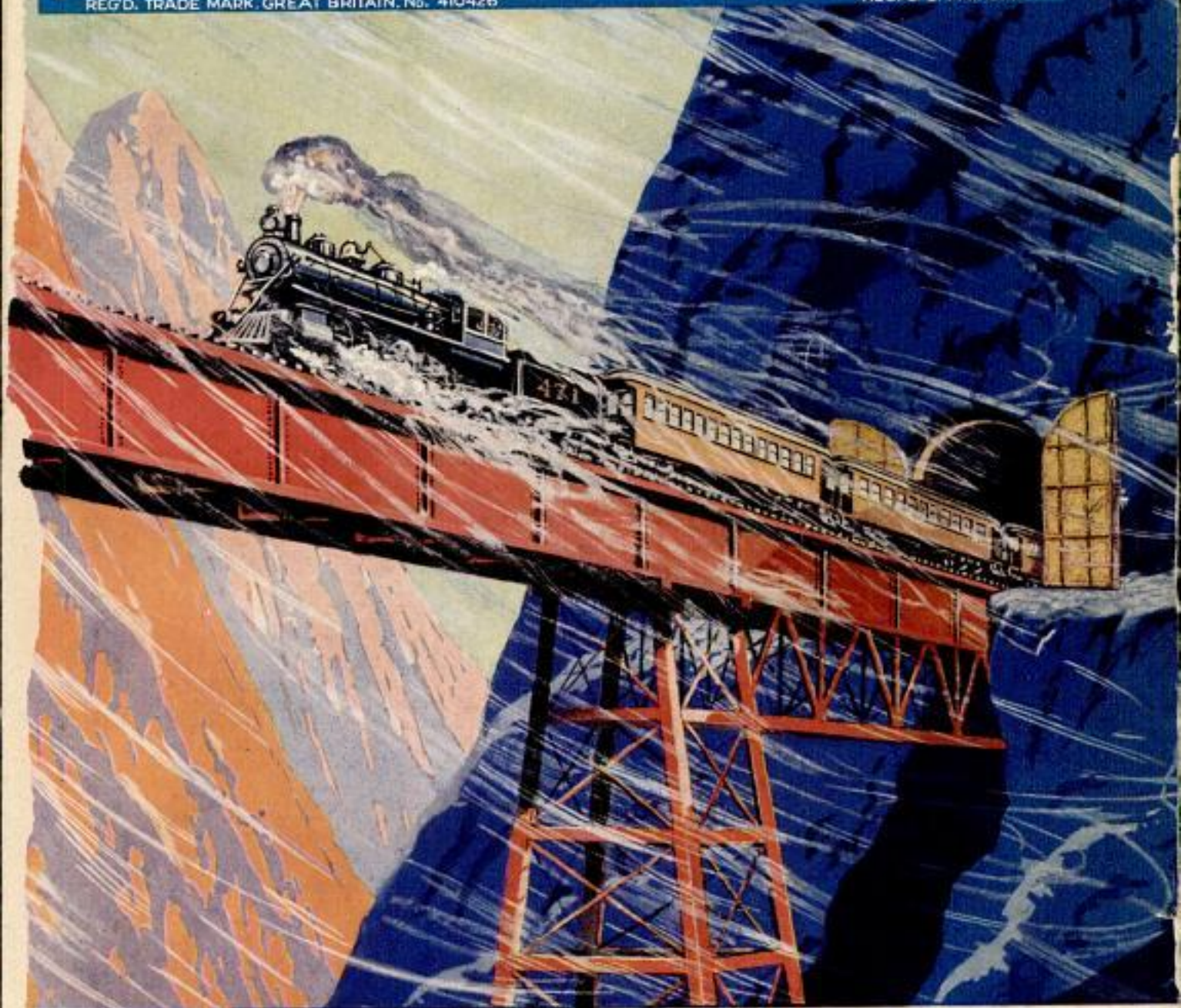

Prosperity Ahead For Farmers—Senator Capper

PAGE 525

Copyrighted material

Be an Auto and Electrical Expert

**McSweeney Trained Men in Demand
at \$40 to \$150 a Week**



Here's one instance of the success McSweeney Training has brought thousands of men:

George W. Smith, West Alexandria, O., has earned over \$800 a month ever since he finished his training. He now owns his own garage and auto agency. When Smith came to me he knew nothing about autos. In eight weeks my methods made a big-money man out of him. And there's no reason why any boy can't do just as well.

**I'll Pay Your Railroad Fare to Cincinnati
and Board You for My Full 8 Weeks Term**



I get calls every day from garages, battery stations, auto factories and so on, for McSweeney-trained men. Albert Boyer, of Alexandria, Ky., is only 19 years old, but has been making a big success in his own business. He says my training made him win out. To fill the calls on me for trained experts, I'm making this wonderful offer for a short time. I'll pay your railroad fare to Cincinnati, and board you for the full eight weeks.

**In 50 Days You're Ready
to Command a Big Pay Job**



13,000,000 Autos and 1,000,000 Tractors must be kept running. Spend 50 days in my great shops and no job will be too hard for you. Big wages and steady work certain. "McSweeney training made me Chief Mechanic of a big plant in three months," writes Fred Pendley, Blowing Rock, N. C.

Electrical Course Included

Every one of my students receives a complete course in practical electricity. He learns ignition, starting, lighting, power plant and generator wiring—all by the same work-shop job-methods which teach him all about carburetors, transmissions, vulcanizing, battery construction and repair. He learns in 50 days to tackle any machine, in any condition, and "put it on its feet".

**"Mac" Trains Men With Tools - Not Textbooks
You Learn Under Experts in a Wonderful Shop**



"The Great McSweeney School"

I have successfully managed more auto and tractor schools than any man in the world. Now I am in complete control of the former Rahe Auto & Tractor School, of Cincinnati, Ohio. Now I can put into complete operation many ideas and plans which, I sincerely believe, will make this the greatest Auto, Tractor and Electrical training institution in existence. Write me and I'll tell you what this splendid school can mean to YOU, to your pay envelope and to your future.

**Write Today for Free Catalog & Special Reduced
Tuition Offer for McSweeney Life Scholarship.**

MCSWEENEY
Auto, Tractor & Electrical
NINTH & WALNUT STS. **SCHOOL** CINCINNATI OHIO
Successors to Rahe Auto & Tractor School

McSweeney Auto, Tractor & Electrical School
Dept. 143, Ninth & Walnut, Cincinnati, Ohio

Send me your Big Free Book on auto and tractor business, and send me information on special reduced tuition offer, in effect for a short time only.

Name

Street or R. R.

City or Town..... State.....

(No facilities for colored students)

There's a Radiola

for every purse

New and Revolutionary
Radio Achievements
in the new Radiolas



Radiola III, an improved two tube receiver of antenna type, sensitive and selective. Complete with two WD-11 Radiotrons and headphones (everything except batteries and antenna) . . . \$35.

Radiola III-a, which is Radiola III and its balanced amplifier complete in one cabinet; including four WD-11 Radiotrons, headphones, and Radiola Loudspeaker (either type FH or UZ 1320.) Everything except antenna and batteries . . . \$100

Radiola X—selective and non-radiating. Remarkable for distance reception. Built-in type loudspeaker. Complete with four WD-11 Radiotrons—everything except batteries and antenna.

\$245.



This symbol of quality is your protection.

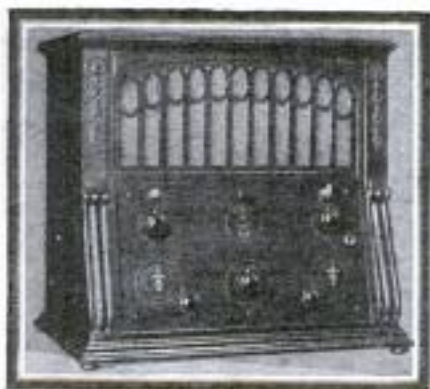

Radiola Super-VIII—an improved Super-Heterodyne. Selective and non-radiating. With no antenna, and no ground connection, it receives far distant stations, even while local ones are operating. Loudspeaker built in. Complete with six UV-199 Radiotrons—everything except batteries . . . \$425.

Radiola Super-Heterodyne, same as Super VIII but semi-portable in mahogany finished cabinet, with Radiola Loudspeaker. With six UV-199 Radiotrons, but without batteries . . . \$286. Same as above, but without Radiotrons or Loudspeaker . . . \$220.

Radiola Regenoflex, a modified Radiola X. With four WD-11 Radiotrons and Radiola Loudspeaker but less batteries and antenna . \$206. Same as above, but without Radiotrons and Loudspeaker \$150

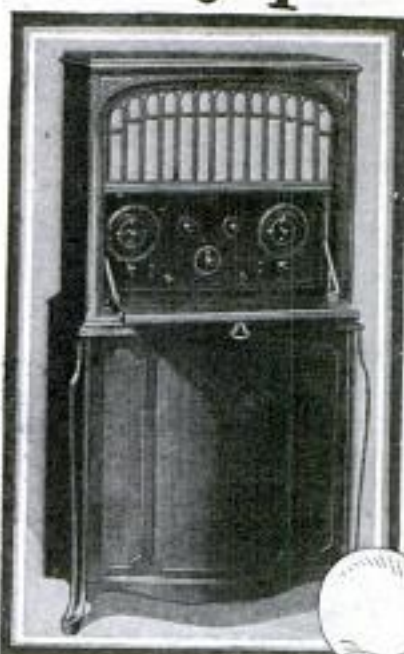

Radio Corporation of America

Sales Offices

233 Broadway
New York

10 So. LaSalle Street
Chicago, Illinois

433 California Street
San Francisco, California

RADIO CORPORATION OF AMERICA
Dept. 514 (Address office nearest you.)
Please send me your free Radio Booklet.

Name _____

Street Address _____

City _____

State _____

Radiola

REG. U.S. PAT. OFF.

An Important Statement about Cypress
 "The Wood Eternal":



ALMOST everybody knows the unequalled investment value of "Tidewater" Cypress, historically described as "The Wood Eternal."

People who know very little about "lumber" know all about Cypress. It is "the nation's most respected wood."

But—knowing what you want, and why you want it, is not always quite enough.

How are you to know that you get it?

In trying to buy *non-rot* lumber you must take account of the fact that the true "Wood Eternal" *kind* of Cypress grows only within about 200 miles of the coast line.

*It is, therefore, necessary to specify
 "TIDEWATER CYPRESS,"*

and then to *identify the genuine* by insisting on seeing the registered Cypress Arrow Trade-mark, thus:



on every board, and on every bundle of small pieces. Do not let yourself be deceived. The difference in permanent value to you is too important to trifle with. Responsible lumber dealers will gladly aid you.

Respectfully submitted:

SOUTHERN CYPRESS MANUFACTURERS ASSOCIATION
 1219 Poydras Bldg., New Orleans, La., or 1219 Graham Bldg., Jacksonville, Fla



Popular Mechanics Magazine

200 E. Ontario Street, Chicago, U. S. A.

H. H. WINDSOR, Editor

London: Hachette & Co.,
16-17 King William Street, Charing Cross, W. C. 2

Paris: Hachette & Co.,
111 Rue Reaumur

Melbourne, Australia
The Australasian News Co.

ISSUED MONTHLY

SUBSCRIPTION:

SINGLE COPY, 25 CENTS

In United States and its possessions, also Canada, Cuba, and Mexico, per year, postpaid - \$3.00

To all other countries in the Postal Union 3.50

All subscriptions are discontinued at expiration. Please examine the date printed on your wrapper.

Entered as Second Class Matter Sept. 15, 1905, at the Post Office at Chicago, Illinois, under Act of March 3rd, 1879.

Entered as Second Class Matter at the Post Office Department, Canada.

Published monthly by POPULAR MECHANICS CO.

Copyright, 1924, by H. H. Windsor.

Copyright in Australia. Copyright in France

Vol. 41

Contents for April, 1924

No. 4

Adding Machine, Story of	458	Expander Tells Lung Power	574
Advertisers Aided by Booklet Attached to Letter	535	Farmer Has Prosperous Outlook	525
Aeroplane-Snowshoes for Mountain Flights	492	Faucet is Drinking Fountain and Bottle Washer	523
Antelope Given Large Tract of Land	527	Fenders of Sealskin Protect Boat	496
Archer's Bow Folds	570	Film Makes Electric Charge Visible	495
Auto Brake Extension	555	Fish Kept Fresh for Year by Freezing Method	587
Auto, Bullet-Proof for Pursuing Thieves	492	Forms, Woodworking Machine Aids in Making	646
Auto Cottage Gives Tourists Home Comforts	496	Fountain Pen on Chain for Public Desks	599
Auto Death in U. S. Every Thirty-Five Minutes	500	Fruit Cutter Like Pliers	511
Auto Drivers Warned by Death Meter	590	Fruits Preserved by New Methods	558
Auto Is Skid-Proof	557	Galoshes without Buckles	585
Auto-Paddle on Gas-Gauge Works Dial	585	Gas Burner Has Spark Lighter	590
Auto Raised from Water by Tackle on Barges	524	Gas Mask for Almost Every Purpose	576
Auto Rims Measured by Dial Wheel	600	Gas Stove for Campers, Pocket Size	505
Auto Steering Wheel Like Ship's	585	Gasoline Mixed With Red Dye to Stop Accidents	586
Auto's Weight Taken Off Tires by Clamp	591	Gauge Wear, Steel Balls Compensate for	645
Baby Buggy Tied on Cane	517	Glass Furnace Gives Control of Heat	527
Balking Poachers in the Frozen Arctic	571	Glycerin and Water New Quenching Medium	647
Balls Carved from Wood	527	Goldsmith's Art Unchanged in Century	569
Barrel Loader Aids in Filling Freight Cars	537	Golf "Green" for Playing Indoors	592
Beards Removed with Mud	586	Grand Canyon Surveyed by Government	562
Benzol as Engine Fuel	645	Guide for Tourists on Signpost	583
Birds, Cone Famine Sends from North Woods	511	Hacksaw Blades Sharpened by Special Machine	646
Birds Treated for Ills by Woman Surgeon	500	Hair Waver for Use in Home	544
Blind Persons Build Electrical Appliances	577	Hammer and Drill Combined	648
Boat Travels Mile-a-Minute	521	Highways in U. S. Would Circle Earth	495
Boxing Gloves on Lever Saves Heads of Workers	551	Horse Racing Revolutionized by Science	489
Brick, Fireproof, Made of Sawdust	543	Hospital in Sidewalk Booth for Street Accidents	591
Bridge Planned for the Golden Gate	548	Ink Is Acid-Proof	560
Bridging the Countless Chasms of Asia	570	Insect War Planned on Hessian Flies	545
Building Built on Steel "Stilts"	530	Inventors Shun Pitfalls	580
Building Materials Testing	512	Ironing Board Folds on Wall	537
Cabinet Bars Dust and Prevents Moths	577	Lamp Is Lighted by Wireless	535
Cable Links Europe with Inland Cities of U. S.	583	Lens Accuracy Proved by Light Rays	570
Camera for Photographing Meters	523	Lifter Reaches High Shelves	542
Camera Made Water-Tight for Undersea Photos	596	Lighthouse Lamp Throws Rays Ninety-Five Miles	553
Cancer Serum Tested by Doctors	497	Locomotive Driven by Air to Pass through Floods	570
Candle Extinguisher Does Not Drip	495	Locomotives Transported on Ship's Deck	529
Can Opener Leaves Smooth Edges	529	Lumberjacks' Homes Float to Timber	551
Carpet, Floral, Has Beauty of Tapestry	532	Lumber Lift for Saw Saves Time and Labor	544
Cast Iron Tied in Knots by Heating	585	Magic Carpet's Flight, Engineering the	547
Chest Under Bed Saves Space	588	Match Scratcher for Auto	542
Cigarette Holder for Mah-Jongg Players	584	Meals Cooked without Fire in Volcano Fields	517
Clip Has Forked Knife for Opening Letters	574	Milk Bottle Dial Gives Day's Order	535
Clock Has Wicker-Work Case	554	Money, Counterfeit, Public Warned of	561
Comment and Review	533	Motion Pictures Given Voice by "Speaking Flame"	490
Concrete, Ready-Mixed, Stops Street Blocking	586	Motion Pictures, Two Shows Simultaneously on One	555
Coppersmiths Achieve Beautiful Effects	501	Screen	570
Coupling, Flexible, Adapts Itself to Load	647	Motor Bus Like Pullman Car	570
Crankshafts, Fixture Tests	647	Music Is Turned into Glowing Color	515
Crucifix in Throat Ten Days	500	Navy to Chart North Pole Route	521
Deer Increasing in Numbers	591	Needle Threader Folds Like Pocket Knife	559
Diphtheria, Electric Pump Aids Victims	512	Oiler for Pulleys Adjusts Itself	588
Dog Kennel Outside Window	500	Oranges' History Traced to Twenty Trees	554
Doors, Ventilators in, Do Away with Transoms	518	Organ Has Six Thousand Throats	490
Drill and Hammer Combined	648	Oxygen Used for Blasting	523
Drill, Electric, Is Stud and Screwdriver	645	Packing, Plastic Metallic, Fits Any Box	648
Drip Pan with Alarm Warns of Overflow	522	Padlock Designed for Rough Treatment	522
Dyes, Supremacy in, Predicted for America	553	Paint Won't Turn from White to Yellow	522
"Ear," Electric, Catches Sounds of Insects	551	Panama Canal Kept Open by Ceaseless Vigil	530
Editor's Mail Bag	650	Parachute Invented by Japanese	497
Elevator, Floating, Handles Cargoes Quickly	519	Patent Office Gives Women Special Department	493
Engine Front Painted White to Prevent Accidents	545	Payroll Card System Prevents Mistakes	504
Events of Twenty Years Ago from Popular Mechanics	555	Pearl Hunting in Inland Waters	550

[Continued on Page 4]



QB93-W6K-CGHS

Ventilators, Revolving chute for RR Car windows 583

[Contents—Continued]

People of Arctic Take Up Farming 596

Photographs Turned Out by the Million 593

Photos Reveal Mystery Ray 494

Pipe Cleaned While Lighted 576

Planer Made Surface Grinder by Attachment 648

Plant Breeding to Increase World's Food Supply 517

Prize Offers and Announcements 649

Pump, Electric, Aids Diphtheria Victims 512

Punctures Stopped by Dimpled Tube in Tire 544

Rabbits Are Slain by Plague Every Seven Years 584

Radio—Bus Equipped with 602

Radio—Calibrating Stations Chosen 601

Radio—Chart Tells Time All Over World 603

Radio—Compact Units Aid Assembly 604

Radio—Deal Taught by 601

Radio—Foreign Broadcasting Stations 608

Radio—Ground Clamp Bites into Clean Metal 608

Radio—Hiker's Ideal Set 601

Radio—His Voice Wins Prison Pardon 607

Radio—Miners Carry Small Receiving Sets 602

Radio—Music Lessons by 607

Radio—Mystery of Arctic Barrier Baffles Experts 604

Radio—Naval Service Makes Money 607

Radio—New York Plans Great Broadcasting Station 601

Radio—One-Wire Antennae for Merchant Ships 604

Radio—Sea Shell Used as Loud Speaker 607

Radio—Six Phones Used in One Plug 603

Radio—Smallest Set 602

Radio—Switch Aids Tapping of Inductances 608

Radio—Two Simple Regenerative Receivers 605

Radio—Used to Balk Stock Swindlers 532

Radio—Vernier Dial Operated by Finger Touch 603

Rail-Coaches Ventilated by Disk in Windows 583

Railroading in the Andes 539

Railway's Needs Vital to the Nation 506

Razor Hone Fits Any Blade 523

Road and Air Resistance of Auto Gs Measured 551

Road Sprayer Is Steam Heated 595

Roads' Pavement Tested by Boring Holes 599

"Roller Skates" Fit on Skid for All-Year Conster 513

Sand Is Forged through Pipe on River Bed 584

Sander, Electric, Does Day's Work in Hour 551

School, Floating, Biscuits and Radio in Course 503

Screws, Fiber Plug Holds in Stone or Iron 503

Sealer, Electric, Has Stamp and Heater for Wax 543

Shade Holder Alarm Barks Intruders 530

Ship's Finder Gives Distances of Objects at Sea 557

Ships Run by Motors Oust Steamers 537

Ships Unloaded through Tunnels in Hold 504

Shovel, Electric, Takes Eight Cartloads at Once 518

Skeleton of Giant Sloth Found in Brazil 513

Spark Plugs, Shield over Points Keeps Out Oil 511

Sparrows Defy Gas "Attack" 536

Statues Restored to Beauty by Steam 528

Steam Generator, Baby, Two Hundred Horsepower 513

Street Announcer in Cars 535

Streets Shown on Bronze Tablet 561

Sugar Aids Soap in Cleaning 529

Suitcase Carries Slight or Bulky Loads 519

Tank Weighing Eight Tons Carried on Two Trucks 577

Telephone Bracket Is Adjustable to Height of User 512

Telephones Found to Be Busiest in Morning 505

Tickets with Numbers Prevent Jams at Bus Stops 522

Time-Study Board Aids Production 645

Tool for Woman's Workshop in Home 556

Tow Line with String Eases Strain on Cars 537

Toy Industry Grows Under Traffic Embargo 583

Tractor Has Crane, Hoist and Shovel 600

Trees Grow Faster in Cut-Over Areas 550

Trees Planted by Machinery Faster Than by Hand 577

Trouser Creaser 524

Truck Body Rises and Tilts 532

Trucks Used by Railway for Short Hauls 574

Tunnel Crew Fed Underground by Diner 591

Umbrella Stuck at Angle Holds Top Level 511

Vanity Case Worn on Wrist 597

Water Piped in Paper 524

Water Plant, One-Man, Supplies City 497

Weatherstrip in Roll Stops Rattles and Drafts 569

Weather Vane Resembles Spanish Gal'oon 592

Weight Lost While Sleeping Recorded 597

Whale Is Killed After Seven-Hour Battle 536

Wheel Chain, Double-Strand, Aids Auto Traction 517

Wheels of Aluminum Tested in England 648

White-Plague Victims Given Medicine in Lungs 493

Wild Animals Cured of Ills 598

Wind Harnessed to Pumps Waters Farm 543

Wood Cut to Mine Coal Taxes Forests 554

Wrench Jaws Fit Any Nut 597

X-Ray Tube to Aid Cancer War 551

SHOP NOTES

Bell Pattern, Turning to Size 611

Chute, Cold-Air Check for 613

Clock, Watchman's 620

Collars, Stamping Graduated 623

Draftsmen, Two Kinks for 624

Drawers, Backless, Aid in Office 625

Drift-Bolt Holes, Gauge for 618

Drill Press Clamp Bolts 613

Drills, Base Chuck for Round Shank 624

Dust Caps, Removing from Hubs 624

Fire Extinguisher Mounted on Truck 626

Gate, Self-Closing Rail 626

Gib-Head Key Guard 610

Hammer Used as Reamer Wrench 625

Ladle, Improving 623

Measuring Without Yardstick 618

Mechanical Powers 614

Micrometer Holder Keeps Oil from Spindle 610

Oil-Hole Covers 620

Orchard, Increasing Yield of 610

Orchard Land, Homemade Drag for Leveling 612

Paper Cutter, Draftsman's 619

Pen Cleaner, Efficient 617

Pipe, Measuring with Taps 623

Power Plant for Farm, Portable 621

Pump, Counterweight for 620

Pump, Improved Torch Air 625

Sandblast, New Use for 611

Saws, Filing Crosscut 623

Steam Traps, Preventing Damage to 619

Tap Breakage, Preventing 613

Template, Attachment for Locating 618

Tractor Belt, Tightening 619

Tractor, Hitching Wagon Train to 611

Turnbuckle, Novel 626

Valve Has No Packing 618

Vise Jaws, Cast Copper 610

Washers, Cutting in Lathe 612

Watchman's Clock, Recording Gauge Used as 620

Wood-Sawing Rig Made from Old Auto 609

Wrench, Reamer, Hammer Used as 625

AMATEUR MECHANICS

Auto, Starting a Cold 634

Automobile, Electric, Making a Small 631

Batteries, Filling Storage 644

Calendar, Reference 636

Candlesticks, Wiring Mantel 638

Canoe Paddles, Lightening 643

Cypress, Novel Method of Finishing 640

Drain Tile, Screen for 629

Drinking Cup, Making a Paper 635

Fence Posts, Bracing 634

Film Struck by Light, Saving 633

Filter, Efficient Sky 643

Fish Lines, Preserving 641

Furnace Heat, Preventing Loss of 642

Insect Killer, Electric 639

Jars, Opening Screw Top 628

Keys, Keeping in Door Locks 635

Kitchen, Ventilating the 642

Ladder Rack 634

Lamp for Dash, Double-Purpose 630

Laundry Yard, Ornamental 644

Linoleum, Cutting 636

Maps, Preventing from Curling 636

Milk, Simple Device Stirs While Cooling 635

Newspapers, Tags Aid in Distributing 642

Pedals for Individual Drivers 641

Photos of Buildings, Correcting 630

Pipe, Rethreading Well 637

Radiator-Leak Compounds, Using 638

Rowboats, Small Wheel on Keel 629

Shooting at Night, Enamel Streak Aids 642

Skid for the Farm 630

Sled, "Limousine" for Small Children 641

Stove Lighter, Electric 628

Tennis Balls, Keeping "Lively" 637

Toy, "Lame Duck" 627

Trees, Pruning Apple 629

Tube, Alcohol Used in Patching 628

Wheatstone Bridge, 1,000-Ohm 637

Wheel, Removing Ford Rear 637

Window Frames, Removing Putty from 644

Windows, Kink for Washers 638

Wire Stretcher, Homemade 628

Wristpins, Lubricating 635

DRAKE'S PRACTICAL MECHANICAL BOOKS

THEY WILL RAISE YOUR PAY—

ORDER ON 5-DAY TRIAL

The books listed below will perfect you in your chosen trade—pave the way to the big positions. Written in non-technical language—easy to read and understand. **Every book covers its subject completely. An entire course of instruction condensed into one volume.** Your choice sent postpaid—you benefit 5 days—money refunded in full if not entirely satisfactory. Order direct from this page.



1924
Edition

Automobile Books

Automobile Starting, Lighting and Ignition, by Manly. [Pub. Jan. 1924.] 700 pp.	Leatherette	\$3.00
Brookes' Automobile Handbook, 1924 Edition.	Leatherette	\$2.00
Ford Motor Car, Truck and Tractor, by Manly.	Cloth	\$1.50
Starting and Lighting Troubles, Remedies and Repairs, by Manly.	Leatherette	\$3.00
Automobile Battery, Care and Repair, by Manly.	Leatherette	\$2.00
Automobile Catechism and Repair Manual.	Leatherette	\$1.50
Tires and Vulcanizing, by Tuford.	Cloth	\$2.00
Gas and Oil Engine Handbook.	Cloth	\$1.50
Automobile Upkeep and Care, by Manly.	Cloth	\$1.50
Motorcycle Handbook, by Manly.	Cloth	\$1.50

Shop Practice Books

Sheet Metal Workers' Manual.	Leatherette	\$2.00
Oxy-Acetylene Welding and Cutting.	Cloth	\$1.25
Slide Rule and Logarithmic Tables.	Leatherette	\$2.00
Handbook for Millwrights.	Cloth	\$2.00
Modern Blacksmithing.	Cloth	\$1.25
Machine Shop Practice.	Cloth	\$2.00

ORDER DIRECT FROM THIS PAGE—ON OUR MONEY-BACK PLAN

The books listed above are only a few of the many in our catalogue, which you will receive promptly after filling out and mailing us the attached coupon. For quick action order direct from this page—cross name of each book wanted and send in with price quoted. We prepay postage and send the books on our money-back plan.

FREDERICK J. DRAKE & CO.

PUBLISHERS

1008 Michigan Ave., Chicago

Drake Books Are For Sale at All Book Stores

Mail Coupon For Free Catalogue
Your Guide to Home Study

Mechanical Drawing and Machine Design.	Cloth	\$2.00
Pattern Making.	Cloth	\$1.50

Carpentry Books

Cloth Binding

Modern Carpentry, 2 vols.	\$3.00
The Steel Square, 2 vols.	\$3.00
Wooden Boat and Shipbuilding.	\$1.50
Modern Estimator.	\$1.50
Timber Framing.	\$2.00
Builder's Architectural Drawing.	\$2.00
Concrete.	\$1.50
Practical Bungalows.	\$1.00
Low Cost Homes.	\$1.00
Roof Framing, by Van Gasbeek.	\$1.50
Stair Building and Hand Railing.	\$1.50

Electrical Books

Telephony, Including Automatic Switching, by Smith. [Pub. Jan. 1924.] 500 pp.	Leatherette	\$2.50
Practical Applied Electricity.	\$2.00	
Alternating Current.	\$1.50	
Electric Motor Control Systems.	\$1.50	
Wiring Diagrams and Descriptions.	\$1.50	
Electrical Tables and Data.	\$1.50	
Armature and Magnet Winding.	\$1.50	
Modern Electrical Construction.	\$1.50	
Modern Electric Illumination.	\$1.50	
Electricians' Operating and Testing.	\$1.50	
Motion Picture Operation.	\$1.50	
Drake's Electrical Dictionary.	\$1.50	
Electric Motors, D. & A.	\$1.50	
Electrical Measurements and Meter Testing.	\$1.50	
Drake's Telephone Handbook.	\$1.50	
Easy Experiments.	Cloth	\$1.25
Wireless Telegraph and Telephone Handbook.	Cloth	\$1.25
Telegraphy Self-Taught.	Cloth	\$1.25

Steam Engineering

Swingle's Handbook for Steam Engineers and Electricians.	Leatherette	\$4.00
Examination Questions and Answers for Marine and Stationary Engineers.	Leatherette	\$2.00
Steam Boilers.	Leatherette	\$2.00
Swingle's Catechism of Steam, Gas and Electrical Engineering.	Leatherette	\$1.50

Painting Books

Scene Painting and Bulletin Art.	Cloth	\$4.00
A Show at Show Cards.	Cloth	\$4.00
Sign Painting.	Cloth	\$4.00
Strong's Book of Designs.	Leatherette	\$4.00
Strong's Art of Show Card Writing.	Cloth	\$4.00
Signist's Alphabets.	Cloth	\$2.50
Modern Painter's Cyclopedia.	Cloth	\$2.00
Automobile Painting.	Cloth	\$1.50
Estimates, Costs and Profits, Printing and Decorating.	Cloth	\$1.50
New Hardwood Finishing.	Cloth	\$1.50
The Amateur Artist.	Cloth	\$1.50
New Stencils.	Cloth	\$1.25
Chalk Talk and Crayon Presentation.	Cloth	\$1.25

Farm Books

Farm Mechanics.	Cloth	\$1.25
Farm Buildings.	Cloth	\$1.25
Farm Engines.	Cloth	\$1.25
Traction Farming.	Cloth	\$1.50

Business and Reference Books

Better Business Letters.	Cloth	\$1.00
Better Business English.	Cloth	\$1.00
Better Advertising.	Cloth	\$1.00
Finger Prints Simplified.	Cloth	\$1.25
Practical Bricklaying.	Cloth	\$1.25
Practical Instruction for Detectives.	Cloth	\$1.00
Practical Plumbing.	Cloth	\$1.50
Hot Water Heating.	Cloth	\$1.50
Elementary Chemistry.	Cloth	\$1.50
Courses in Civil Service.	Cloth	\$1.50
Cyclopedia of Recipes.	Cloth	\$1.50
American Star Speaker.	Cloth	\$1.50

Modern Languages

By Prof. P. S. Allen, U. of Chicago

French without a Teacher.	Cloth	\$1.25
Spanish without a Teacher.	Cloth	\$1.25
German without a Teacher.	Cloth	\$1.25
Everyday French.	Cloth	\$1.25
Everyday Spanish.	Cloth	\$1.25

FREDERICK J. DRAKE & CO.
1008 Michigan Avenue
Chicago, Ill.

GENTLEMEN:—Please send me free, postage paid, your illustrated catalogue which lists and describes over 100 Practical Mechanical Books for Home Study.

My name is

and my address



"I'm Going to Make More Money!"

"I'm tired working for a small salary. I know I have just as good a head on me as Fred Moore and Bob Roberts, for we used to work side by side. But they've gone far ahead of me.

"Why? Because they saw the value of special training, and I didn't.

"But I know better now. If the International Correspondence Schools can raise the salaries of men like Fred Moore and Bob Roberts, they can raise mine, too!

"If they have helped others to advance, they can help me. Today—right now—I'm going to send in this coupon and at least find out what the I. C. S. can do for me."

INTERNATIONAL CORRESPONDENCE SCHOOLS Box 5395-D, Scranton, Penna.

Without cost or obligation, please tell me how I can qualify for the position or in the subject before which I have marked an X:

BUSINESS TRAINING COURSES

- | | |
|------------------------------------------------------------------|---------------------------------------------------------------------------|
| <input type="checkbox"/> Business Management | <input type="checkbox"/> Salesmanship |
| <input type="checkbox"/> Industrial Management | <input type="checkbox"/> Advertising |
| <input type="checkbox"/> Personnel Organization | <input type="checkbox"/> Better Letters |
| <input type="checkbox"/> Traffic Management | <input type="checkbox"/> Show Card Lettering |
| <input type="checkbox"/> Business Law | <input type="checkbox"/> Stenography and Typing |
| <input type="checkbox"/> Banking and Banking Law | <input type="checkbox"/> Business English |
| <input type="checkbox"/> Accountancy (including C.P.A.) | <input type="checkbox"/> Civil Service |
| <input type="checkbox"/> Nicholson Cost Accounting | <input type="checkbox"/> Railway Mail Clerk |
| <input type="checkbox"/> Bookkeeping | <input type="checkbox"/> Commercial School Subjects |
| <input type="checkbox"/> Private Secretary | <input type="checkbox"/> High School Subjects |
| <input type="checkbox"/> Spanish <input type="checkbox"/> French | <input type="checkbox"/> Illustrating <input type="checkbox"/> Cartooning |

TECHNICAL AND INDUSTRIAL COURSES

- | | |
|-------------------------------------------------|----------------------------------------------------------------------|
| <input type="checkbox"/> Electrical Engineering | <input type="checkbox"/> Architect |
| <input type="checkbox"/> Electric Lighting | <input type="checkbox"/> Blue Print Reading |
| <input type="checkbox"/> Mechanical Engineer | <input type="checkbox"/> Contractor and Builder |
| <input type="checkbox"/> Mechanical Draftsman | <input type="checkbox"/> Architectural Draftsman |
| <input type="checkbox"/> Machine Shop Practice | <input type="checkbox"/> Concrete Builder |
| <input type="checkbox"/> Railroad Positions | <input type="checkbox"/> Structural Engineer |
| <input type="checkbox"/> Gas Engine Operation | <input type="checkbox"/> Chemistry <input type="checkbox"/> Pharmacy |
| <input type="checkbox"/> Civil Engineer | <input type="checkbox"/> Automobile Work |
| <input type="checkbox"/> Surveying and Mapping | <input type="checkbox"/> Airplane Engines |
| <input type="checkbox"/> Metallurgy | <input type="checkbox"/> Navigation |
| <input type="checkbox"/> Steam Engineering | <input type="checkbox"/> Agriculture and Poultry |
| <input type="checkbox"/> Radio | <input type="checkbox"/> Mathematics |

Name.....
Street.....
Address..... 11-21-23

City..... State.....

Occupation.....
Persons residing in Canada should send this coupon to the International Correspondence Schools Canadian, Limited, Montreal, Canada.

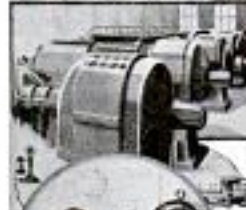

LEARN BY DOING

Every phase of all branches of

ELECTRICITY

taught by
Actual Practice

In America's foremost
and oldest institution
for trade training

No Books Used

Individual Instruction
Start Any Day

Write for FREE 64-page catalog

**THE NEW YORK
ELECTRICAL SCHOOL**
44 West 17th St., New York City

LAW

STUDY AT HOME
Become a lawyer. Legally trained men win high positions and big success in business and public life. Greater opportunities now than ever before. Lawyers earn \$3,000 to \$10,000 Annually. We guide you step by step. You can train at home during spare time. Let us send you records and letters from LaSalle students admitted to the bar in various states. Degree of LL.B. conferred. Thousands of successful students enrolled. Low cost, easy terms. We furnish all text material, including fourteen-volume Law Library. Get our valuable 120-page "Law Guide" and "Evidence" books FREE. Send for them—NOW.
LaSalle Extension University, Dept. 664-L, Chicago, Ill.

Does Your English Help or Hurt You?

Wonderful new way to learn English. No rules to learn. No hard study. Grammar, spelling, punctuation and expression, taught in 15 minutes a day—at home. Self Correcting feature makes it fascinating as a game. Write today for Free Book "How to Speak and Write Masterly English." Address



SHERWIN CODY SCHOOL OF ENGLISH
54 Searle Building ROCHESTER, N. Y.

ART SUPPLIES

Send for Our Illustrated Catalogue giving prices on all kinds of practical ART SUPPLIES.
PENCRAFT SUPPLY SERVICE, Dept. P, 849 Broadway, NEW YORK CITY

FREE

\$20 Fine Tone Musical Instruments

We have a wonderful new copyrighted system of teaching note music by mail. To first pupils in each locality we will give free a \$20 superb Violin, Tenor Banjo, Ukulele, Hawaiian-Guitar, Banjo, Mandolin, Banjo-Ukulele, Banjo-Mandolin, Cornet or Banjo-Guitar absolutely free. Also teach Piano and Organ. Very small charge for lessons only. Four lessons will teach you several pieces. Over 150,000 successful players. We guarantee success or no charge. Complete outfit free. Write today, Dept. 148. No obligation.
SLINGERLAND SCHOOL OF MUSIC, 1815 Orchard Street, CHICAGO, ILLINOIS

CARPENTERS

GUIDES THAT SOLVE PROBLEMS

A Complete Course in Practical Carpentry and Building Work

POCKET SIZE—
FLEXIBLE
COVERS—
3100 ILLUS-
TRATIONS
— 1500
PAGES

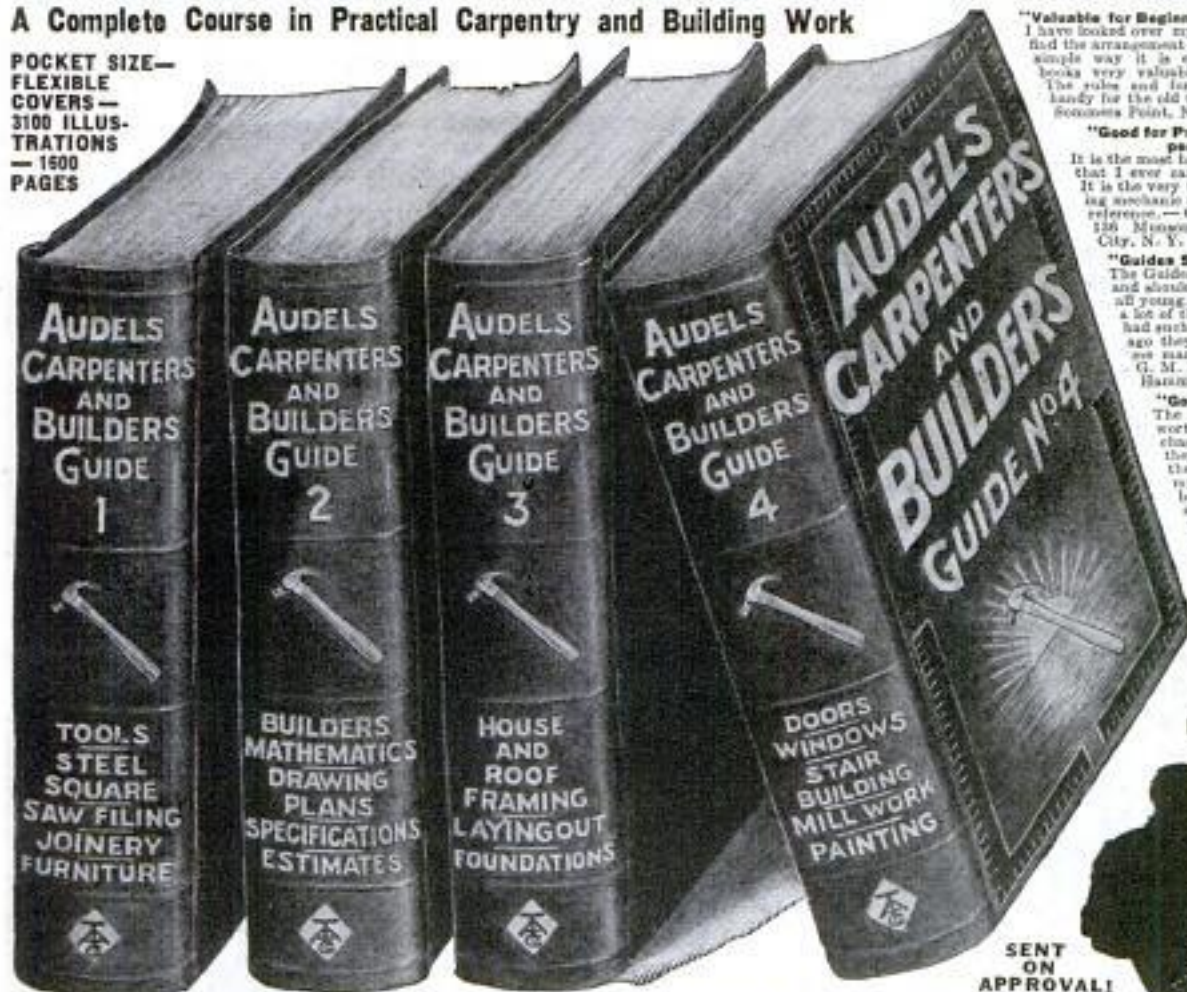

"Valuable for Beginners or Old Timers"
I have looked over my Audel Guides and find the arrangement of subjects and the simple way it is explained makes the books very valuable for the beginner. The rules and formulas are mighty handy for the old timers.—Ross Smith, Secaucus Point, N. J.

"Good for Professional Carpenters"

It is the most handy reference work that I ever came in contact with. It is the very thing that the building mechanic needs every day for reference.—George H. Watson, 126 Monaca St., Long Island City, N. Y.

"Guides Save Hard Knocks"

The Guides are truly wonderful and should be in the hands of all young carpenters as well as a lot of the older heads. If I had such information 20 years ago they would have saved me many a hard knock.—G. M. McJohnston, E. H. I., Hammond, Ind.

"Good for Amateurs"

The books are surely worth more than the purchase price, especially as they serve as a guide to the nonprofessional like myself who is trying to build himself a home at the least expense.—Otis F. Schulze, P. O. Box 163, Westmont, Ill.

\$1

PER MONTH



SENT ON APPROVAL!

NEW IDEAS—MODERN METHODS—SHORT CUTS

This course, "Audel's Guides for Carpenters and Builders," consists of 4 handy volumes of over 1500 pages with thoroughly illustrated charts, diagrams, graphs, pictures with calculations for every job from making the excavation to constructing the entire building. You will find these new Guides most complete and comprehensive in addition to being both timely and practical. There are 3700 actual examples of efficient construction work with new methods, ideas, solutions, plans, systems, short

cuts, time and labor saving suggestions, new ways that cover the entire theory and practice of the subject illustrated by sketches and forms all specific and practical. Audel's Guides give you the short cut, professional information you want. No need to guess or take chances. Every day you have before you in this set the exact, practical, useful information that will help you with every job that comes up in your daily work.

HOW To Handle the Job That Puzzles YOU

There are thousands of examples of modern construction and building work—new methods, new ideas, proved efficiency plans, short cuts, time saving suggestions, new ways that cover the entire theory and practice of modern carpentry. Every point is easy to read and understand and clearly illustrated with sketches and forms. Inside Trade Informa-

tion for Carpenters, Builders, Joiners, Building Mechanics and all Woodworkers on—Care and Use of Tools—How to Use the Steel Square—File Saws—Make All Kinds of Joints—Draw and Read Plans—Write Specifications—Make Estimates—How to Frame Roofs and Houses—Lay Out Work—Put in Foundations—Full Instruction on In and Outside Building Work—Stair Building—Saw Mill Work—Practical Painting—Thousands of Short-Cuts that save time and money—Information usually obtained only by hard experience.

NO MONEY!
MERELY SEND
COUPON AND
LOOK THE
SET OVER
AT
AUDEL'S
RISK

FREE

EXAMINATION

Not a cent to pay until you see the books. No obligation to buy unless you are satisfied. Fill in coupon in pencil. Send now—today—get this great help library for carpenters and builders.

THEO. AUDEL & CO., 72 5th Avenue, NEW YORK CITY
Send me for free examination AUDEL'S CARPENTERS AND BUILDERS GUIDES, 4 numbers. If satisfactory I will send you \$1 within 6 days and mail \$1 monthly until \$5 in paid.

Name.....
Address.....
Occupation.....
Employed by.....
Reference.....
P. M. Apr. 24

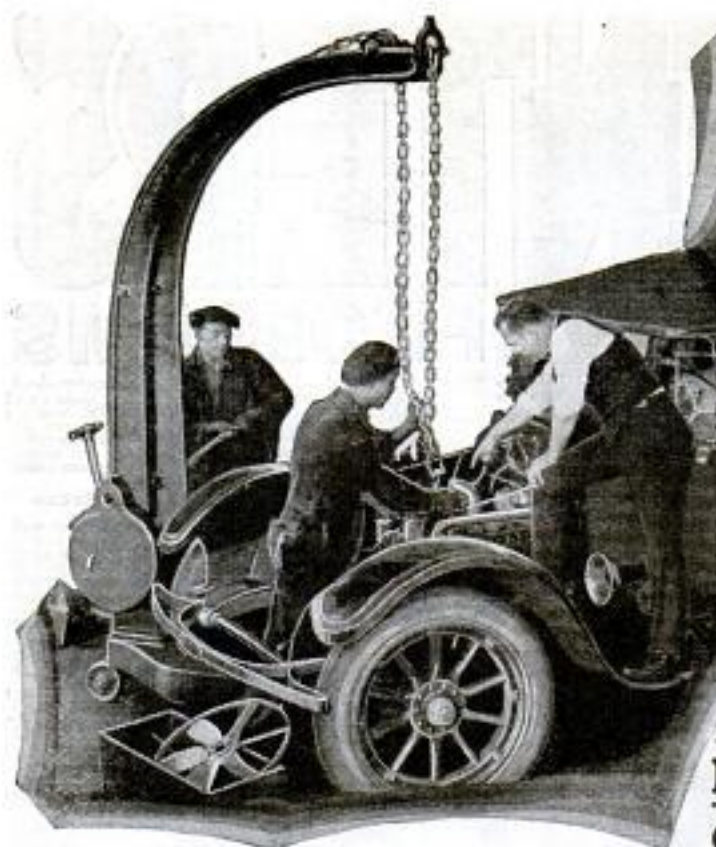

Be An **AUTO EXPERT**
Make \$75 to \$200
A WEEK

Let Me
Train You
At Home
to **BOSS**
the **JOB!**



B. W. Cooke, Directing Engineer

CHICAGO AUTO SHOPS

I WILL make you a successful **AUTO EXPERT**, prepare you to go into business for yourself, train you for positions paying \$3,000 to \$10,000 a year. Keep your job, stay home—just loan me a part of your spare time. As Directing Engineer of the big **CHICAGO AUTO SHOPS**, I know what training you need and I give it to you. I train you the "JOB-WAY"—not with books. Go into the best-paying business on earth—get your share of the thousand million dollars spent every year to keep Autos, Trucks and Tractors running!

I TRAIN YOU

AT HOME!

My home-training makes Auto **EXPERTS!** I prepare you to **BOSS THE JOB!** My "JOB-WAY" instruction makes you **MASTER** of every branch of Automobile work—Mechanical, Electrical, Battery, Ignition, Farm Power plants, Welding, Brazing, Vulcanizing, Garage Management, Salesmanship, etc. I guarantee satisfaction or to refund every penny of your money.

AUTO BOOK FREE!

Start Now! I'll help you *start* and help you *succeed!*

Inducements you cannot resist *right now* to ambitious men. Easy terms, within reach of everybody. Special Offer Now. Coupon

brings your *greatest* opportunity—mail it to me right away!

B. W. Cooke, CHICAGO AUTO SHOPS
Directing Engineer
Dept. 416, 1553 W. Madison St., CHICAGO

B. W. COOKE, Directing Engineer
Dept. 416, 1553 W. Madison Street, CHICAGO

Please send me Free Book and complete information about your "Job-Way" training at home. Tell me about the opportunities today for Auto Experts. I am mailing this promptly to secure **FREE REPAIR OUTFIT** and the reduced prices and special terms you offer, now.

.....NAME

.....ADDRESS

.....CITY.....STATE

.....AGE.....OCCUPATION

MAIL COUPON TO-DAY!

Experts Wanted!
\$3,000 to \$10,000 a year!

The "best-paying business on earth" is hungry for **EXPERTS!** Where else can you find such opportunities as in the **AUTO** business? 15 million Autos, Trucks and Tractors to keep going. 50 million tires to repair, 15 million starting, lighting and electric systems to maintain, 15 million batteries to service and replace. *Man alive!* Wake up to this rich money-making opportunity!

GO INTO BUSINESS!

Make \$5,000 to \$15,000 a year!

There are thousands of opportunities to go into business for yourself, with small capital. Auto Experts run big service stations, make up to \$15,000 a year! The same wonderful opportunity is *waiting for you*. My "Job-Way" instruction prepares you for it.

My "Job-Way" training makes successful high-priced AUTO EXPERTS

FREE Outfit

Big repair and testing outfit free to my students! Mail coupon for my remarkable offer. Use it to do my **JOBS**, use it to make money, use it to make this training pay for itself!

FREE JOBS

My big Employment Department helps my graduates get big pay jobs without one penny of cost.



“I Was At The End of My Rope”

“WE lived in a fairly comfortable home, but it was a terrific struggle to make both ends meet. I couldn't save a cent and I was deeper in debt than I dared confess to my wife.

“I hadn't had a decent raise in years, and there were nights—too many of them now—when I lay awake for hours wondering what we would do if I ever lost my position.

“For other men were getting ahead of me and I knew that I couldn't stand still. I either had to go up or down. And I was afraid it was going to be down!

“Then suddenly one night it came to me like a flash that the reason I wasn't getting anywhere was mainly because I had never made any definite effort to make myself more valuable to the firm.

“I knew my own little routine job, but that was all. I was just one of the force to my employers. There was really no reason why they should think of me when a better position was open.

“That night I made my decision. ‘If the I. C. S. can raise the salaries of other men,’ I said to myself, ‘it can raise mine. If it can help other men to win promotion and have happier, more prosperous homes, it can help me, too. To-night, right now, I'm going to send in that coupon and find out what the I. C. S. can do for me.’

“It was the best move I ever made. My employers heard about my studying and started to take an interest in me. Six months after I enrolled with the I. C. S. I received my first increase in salary. Within two years I was head of my department. And I'm going still higher.”

An International Correspondence Schools course will help you just as it helped this man whose letter is reproduced here. It will help you to have the happy home—the bigger salary—the comforts that you want for your wife and your family.

For spare-time study is that vital something which makes one man succeed where one hundred fail—that lifts a man out of the rut and makes him a trained worker instead of just a “hand.”

One hour a day, spent with the I. C. S. in the quiet of your own home, will prepare you for the position you want in the work you like best. Put it up to us to prove it!

MAIL THE COUPON TO-DAY

INTERNATIONAL CORRESPONDENCE SCHOOLS
Box 5594-D, Scranton, Penna.

Without cost or obligation, please tell me how I can qualify for the position or in the subject before which I have marked an X:

BUSINESS TRAINING COURSES

- | | |
|------------------------------------------------------------------|---------------------------------------------------------------------------|
| <input type="checkbox"/> Business Management | <input type="checkbox"/> Salesmanship |
| <input type="checkbox"/> Industrial Management | <input type="checkbox"/> Advertising |
| <input type="checkbox"/> Personnel Organization | <input type="checkbox"/> Better Letters |
| <input type="checkbox"/> Traffic Management | <input type="checkbox"/> Show Card Lettering |
| <input type="checkbox"/> Business Law | <input type="checkbox"/> Stenography and Typing |
| <input type="checkbox"/> Banking and Banking Law | <input type="checkbox"/> Business English |
| <input type="checkbox"/> Accountancy (including C.P.A.) | <input type="checkbox"/> Civil Service |
| <input type="checkbox"/> Nicholson Cost Accounting | <input type="checkbox"/> Railway Mail Clerk |
| <input type="checkbox"/> Bookkeeping | <input type="checkbox"/> Common School Subjects |
| <input type="checkbox"/> Private Secretary | <input type="checkbox"/> High School Subjects |
| <input type="checkbox"/> Spanish <input type="checkbox"/> French | <input type="checkbox"/> Illustrating <input type="checkbox"/> Cartooning |

TECHNICAL AND INDUSTRIAL COURSES

- | | |
|-------------------------------------------------|----------------------------------------------------------------------|
| <input type="checkbox"/> Electrical Engineering | <input type="checkbox"/> Architect |
| <input type="checkbox"/> Electric Lighting | <input type="checkbox"/> Blue Print Reading |
| <input type="checkbox"/> Mechanical Engineer | <input type="checkbox"/> Contractor and Builder |
| <input type="checkbox"/> Mechanical Draftsman | <input type="checkbox"/> Architectural Draftsman |
| <input type="checkbox"/> Machine Shop Practice | <input type="checkbox"/> Concrete Builder |
| <input type="checkbox"/> Railroad Positions | <input type="checkbox"/> Structural Engineer |
| <input type="checkbox"/> Gas Engine Operating | <input type="checkbox"/> Chemistry <input type="checkbox"/> Pharmacy |
| <input type="checkbox"/> Civil Engineer | <input type="checkbox"/> Automobile Work |
| <input type="checkbox"/> Surveying and Mapping | <input type="checkbox"/> Airplane Engines |
| <input type="checkbox"/> Metallurgy | <input type="checkbox"/> Navigation |
| <input type="checkbox"/> Steam Engineering | <input type="checkbox"/> Agriculture and Poultry |
| <input type="checkbox"/> Radio | <input type="checkbox"/> Mathematics |

Name.....
Street.....
Address.....

11-21-22

City..... State.....

Occupation.....

Persons residing in Canada should send this coupon to the International Correspondence Schools Canadian, Limited, Montreal, Canada.

\$90 Drafting Course FREE

There is such an urgent demand for practical, trained Draftsmen that I am making this special offer in order to enable deserving, ambitious and bright men to get into this line of work. You get your course FREE for getting two additional students. I will teach you to become a Draftsman and Designer until you are **Drawing a salary of \$250.00 a month.** You need not pay me for my personal instruction or for the complete set of instruments. **But you must take advantage of this special offer at once.**

\$300 a Month Salary— \$450 on the Side at Home!



Chief Draftsman Dobe

That's the kind of money my drafting students make. Read what this one says:

"As a beginner I am doing fine. Am earning a salary of \$300 per month, besides I made over \$450 at home the last two months, drawing plans for private parties. The practical drafting training you gave me by mail put me where I am in less than six month's study. Thank you for all your personal interest and help you gave me so far."

(Signed) J. B.

(Name and address upon request)

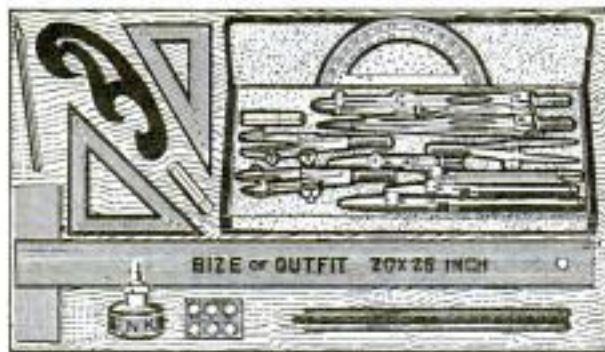

This Outfit FREE

And more—I give you a whole set of drafting tools the minute you become my student. You get every tool you need. A magnificent set of instruments which will build your success in draftsmanship.

Chief Draftsman, Engineers Equipment Co.
1951 Lawrence Ave. Div. 13-54 Chicago, Ill.

Without any obligation whatsoever, please mail your book, "Successful Draftsmanship," and full particulars of your liberal "Personal Instruction" offer to few students.

Name..... Age.....

Address.....

Post Office..... State.....

I Guarantee

To Train You Until You Are
Placed in a Position Paying
up to \$250 and \$300 a Month

Write and I'll tell you how I make you a first-class, big-money-earning draftsman in a very few months! I do this by a method no other man nor institution can imitate. I give you personal training at home by mail until you are actually placed in a position paying up to \$250 and \$300 a month. Six thousand draftsmen are wanted every month.

Free Book

Send Coupon Today

No matter what plans you have for the future. Get this great book—"Successful Draftsmanship." Find out about the simply marvelous opportunities ahead now. How the world needs draftsmen, engineers, architects and builders. What great salaries and possibilities there are! Send coupon for free book today.

Chief Draftsman, Engineers Equipment Co.
1951 Lawrence Ave. Div. 13-54 Chicago, Ill.

We Will Make You An Electrical Expert In 3½ Months At Coyne



Students Doing Actual Work On
Power Transmission Apparatus



Students Working on Massive
A. C. Control Equipment



Students Practicing House-wiring
In Skeleton Houses

Send For Free Book

Send for the Big Free Book which shows the Great School of Coyne and a great part of our massive electrical equipment. You will be convinced that the only place to get a practical electrical training is in the Great School of Coyne.

COYNE

Electrical School
Endorsed by Electrical Industry

1300-1310 W. Harrison St., Dept. 13-54, Chicago

Earn \$65 to \$200 a Week! Or Go In Business for Yourself and Make \$3500 to \$15,000 a Year!

Yes, 3½ months at the **Great School of Coyne**, located in Chicago, The Electrical Center of the World, will make you an **Electrical Expert** capable of commanding big pay. The whole world of electricity is open to the practical man—the man who has had actual experience with electrical apparatus. Coyne gives you a practical training on a stupendous outlay of electrical apparatus, everything from door bells to power plants.

Not a Correspondence School

We don't make you a mere "paper" electrician. We train you by practice on our mammoth outlay of actual equipment. We train you in house-wiring by having you do it exactly as it is done outside—not just by reading about it. The same applies to armature winding, power plant operating, motor installations, automotive work and hundreds of other electrical jobs. That's why we can train you to become a **Master Electrical Expert**.

No Books—No Lessons—You Do Actual Work

The Coyne practical course includes no books, printed lessons or useless theory. We train you to work with your head and hands on the same kind of electrical apparatus as you will find "out in the field." Coyne gives you Free a Life Scholarship which enables you to stay as long as you want without extra charge or return later for more practice, and assists you to a position after graduation. We also include Free a course in radio.

Age, Lack of Experience or Education Is No Hindrance

Our students range from 16 to 60 years of age. No previous training necessary. You don't even have to be a grammar school graduate.

Earn While You Learn!

We help students to secure jobs to earn a good part of their living expenses while studying.

Coyne Electrical School, Dept. 13-54
1300-1310 W. Harrison St., Chicago

Dear Sir: Please send me free your big catalog and full particulars of your special offer.

Name

Address

ENGINEERING

Self taught

Here in these handy pocket size books is a modern, progressive, illustrated course covering the entire field of Modern Engineering and Mechanical Practice. The field is broad and big. **To earn more—learn more.**



AUDEL'S ENGINEERS & MECHANICS GUIDES

In Audel's Master Set for Engineers and Mechanics is found a practical course for study and reference work. Valuable to all Engineers, Electricians, Mechanics and students. Eight

progressive numbers; 8754 trade illustrations; 4750 pages. Flexible binding, gilt edge, pocket size. Free examination. No obligation to buy unless satisfied.

AUDEL'S GUIDES INCREASE PAY

Practical Sets for Practical Men

Audel's Engineers and Mechanics Guides contain a course of all the more important subjects together with the latest modern additions. They are presented in a way most practical for a practical man. L. M. Cowan, Sandwich, Ill.

Helps to Higher Position

I started in as a locomotive fireman but with the help of Audel's Engineers and Mechanics Guides I soon expect to be able to fill a higher position and intend to apply for a higher class license.

T. A. Pellissier,
Marion, Wash.

Combines Theory with Practice

I have several volumes on power plant practice, but I am more pleased with Audel's than with any other treatise on this subject. This set is just what I have been looking for, because it thoroughly combines theory and practice.

Nell N. Cox,
Chicago, Ill.

Four Weeks Study Did It

I studied your Engineers and Mechanics Guides only four weeks and passed an examination with a high percentage. Any man, no matter how little mechanical knowledge he may have, can be successful after studying your course.

James Scott,
Bellevue, O.

Worth \$50 a Vol.

I know that in order to know the value of your books one must own them. I would not sell my books for \$50 apiece, if I could not buy another.

S. C. Pissell,
Tennant, Cal.

TURN SPARE TIME INTO CASH!!

Fifteen minutes study a day will increase your pay. Spare time reading brings cash returns.

Use
Coupon

QUESTION AND ANSWER METHOD EASY TO LEARN

Study This Brief Table of Contents: Theory, Practice and Operation of ALL Steam Engines, Valve Motions—VALVE SETTING: complete information on all engines and pumps—CORLISS ENGINES and the Theory, Construction and Operation of all Steam Engines, including UNIFLOW and POPPET VALVE ENGINES, and LOCOMOBILES—Locomotive-Marine Engines; Turbines; Rotary Engines—the Indicator—Lubrications—PRACTICAL MANAGEMENT. How to use Indicator—GAS, GASOLINE, OIL, SEMI- and FULL DIESEL ENGINES—Aeroplanes and Aviation—HOW TO SELECT AN ENGINE, working instructions, drawings on STEAM ENGINE DESIGN, including rules and formulae. Theory and Construction of ALL Steam Boilers; Heat-Combustion; Fuel and Flue Gas Analysis—

CO₂ recorders—Characteristics of Boilers—Materials—Construction of all types of Boilers. (THE LATEST PRACTICE.)—Boiler Construction—Mechanical Stokers—Oil Burners—Setting—Chimneys—Mechanical Draught—HOW TO SELECT A BOILER—Complete instructions and drawings on BOILER DESIGN based on A. S. M. E. BOILER CODE—OPERATION, including installation, FIRING; care and repair of Steam Boilers—Pipes, Fittings and Pipe Fitting—Heating and Ventilation—Refrigeration—Cooling Towers—Condensers—Distilling Apparatus—Elevators—Cranes and Hoisting Machinery—Ropes and Cables—Splicing—electric wiring in ALL branches; compendium of practical electrical engineering as an aid for engineers and electricians in obtaining a license—57 chapters—ready reference index, covering entire field of Modern Electricity.

FREE EXAMINATION

Not a cent to pay until you see the books. No obligation to pay unless you are satisfied. Send coupon now—today and get this new master set for engineers.

PAY ONLY \$1 A MONTH

THEO. AUDEL & CO., 72 Fifth Ave., New York City

Please submit me for free examination, AUDEL'S MASTER SET FOR ENGINEERS AND MECHANICS. Ship at once prepaid, the 8 numbers, total cost \$12.00. If satisfactory, I agree to send you \$1 within seven days and to further mail you \$1 each month until paid.

Name.....
Occupation.....
Employed by.....
Home Address.....
Reference.....

PM Apr. 24



Tighten Your Grip on a Trade

Be An Electrical Expert At \$75 to \$200 a Week

Every up-to-date fellow knows what a future there is in electricity.

Big pay—fascinating work on land or sea—rapid advancement in a field where jobs are ten times more numerous than trained men to fill them, where \$75.00 a week is just a fair starter, where top notchers pull down ten thousand dollars or more a year—in a field, where any man if he wishes, can easily have a business of his own, have men working for him, be his own boss!

But what the average young man does NOT know, is what a simple, easy, A-B-C sort of a job it is to get started.

You Can Start Right Now!

Yes, you. You don't need a thing you don't already have! You can read. You can write. You can figure. You can think. And in your breast is the fire of ambition—the desire to get ahead! All right, that's all you need—we can help you just as you are—just as we have helped scores, yes, thousands of other two-fisted young fellows determined to get out of the rut and into the electric field—into work that will be pleasant—easy—and all in your home, during spare time.

Fascinating Home Study As You Hold Your Old Job

With the help we will give you, you can slip right into one of these big pay—be-man jobs and never lose a day's work. After a few weeks' start, you can earn enough in installation and electric repair jobs alone to more than pay for the Course and lay a foundation for an Electrical Contracting or Repair Shop Business of your own. When the proper time comes, we will tell you the easy way to go about doing it.

The Most Practical, Thorough and Condensed Electrical Course Ever Written

This is the only home study electrical course that gives you the combined practical and theoretical training you most have before you can be a successful electrician without which you cannot succeed—with which you cannot fail.

Written not by ONE man, with the narrow one-man viewpoint, but by 22 of the brainiest, most successful, electrical experts ever drawn from the field of practice and theory. Gives you the complete mastery of the subject—qualifies you as electrical expert to boss jobs—fits you right into the kind of a job you want—and does it in shortest time—at lowest cost—with the

Most Binding Guarantee of Results Ever Offered!

Satisfaction guaranteed or no sale! We not only SAY we can make you an electrical expert, we Guarantee it! If you are not absolutely satisfied when you have finished our Practical Electrical Course, we will refund every nickel you sent us.

FREE! Experimental Outfit Worth \$30 Find out all about our offer. Find out about the thousands who have taken this course in preference to all others and MADE GOOD. Find out about the Electric Library—four elegant volumes—worth \$25, but free. About the free Drafting Course worth another \$30. The free Experimental and Demonstration Outfit, including a real, not a make-shift Electric Motor, Wheatstone Bridge, etc.—the most scientific, high-grade and complete Experimental Outfit ever supplied with a Course in Electricity. Get all the facts without obligation, without expense! Just send the coupon!

American School

Dept. E-474

Drexel Ave. and 58th Street, Chicago

FREE Electrical Coupon

American School,
Dept. E-474, Chicago

Please rush all information relative to your Course in Electricity. This obligates me in no way whatever.

Name.....

Address.....



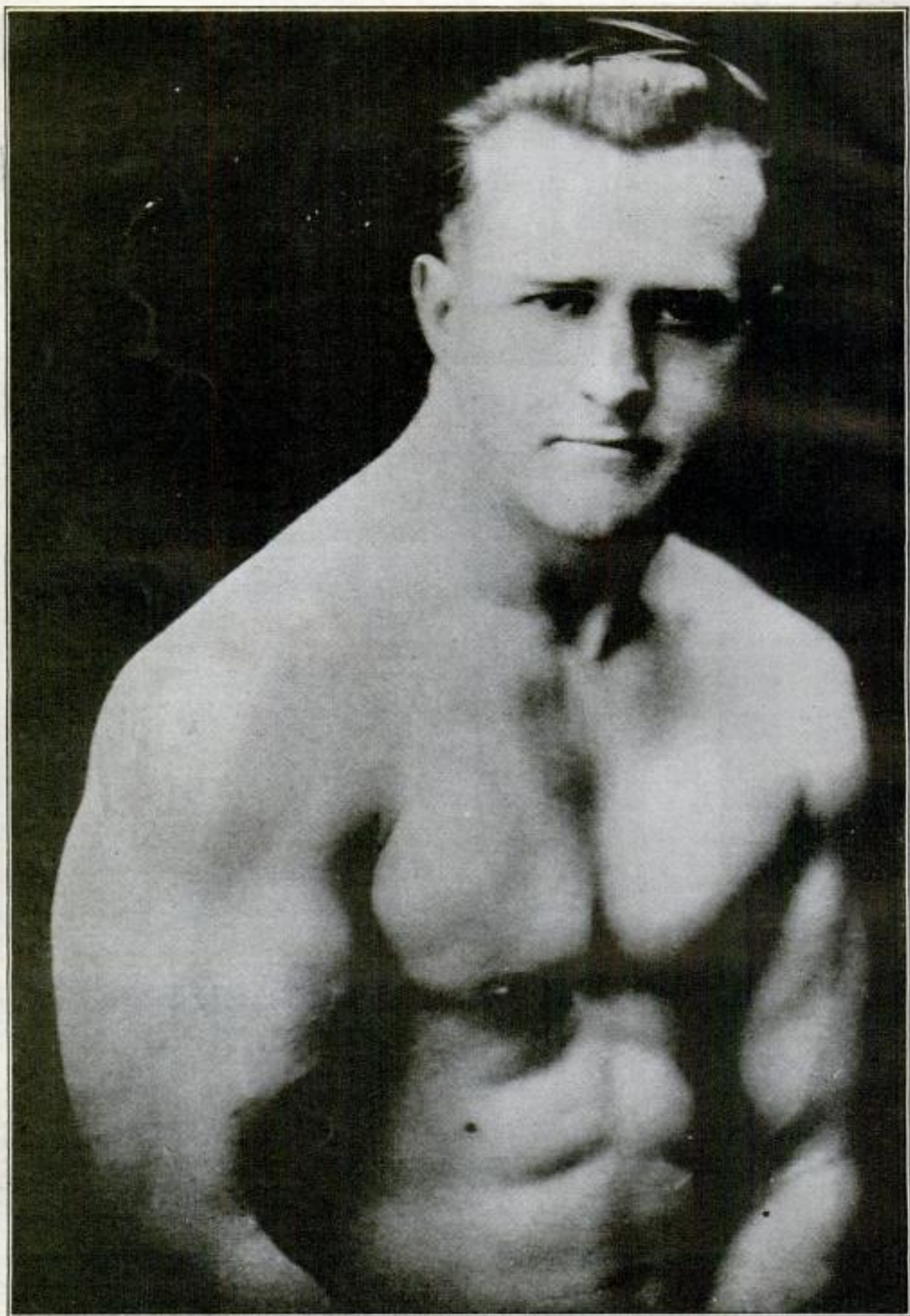

EARLE E. LIEDERMAN, *America's Leading Director of Physical Education*

Do You Need a Bust in the Nose

before you start to fight? Do you need this kind of treatment to bring you to your senses? If you are that kind of a fellow, the chances are strong that you are going to get it.

Be Ready I don't recommend that you be a rowdy who goes around looking for a fight. But I do believe you should be alert and, when the time comes, be prepared to beat the other fellow to the punch.

The Wise Man

Some men never pay any attention to the condition of their house till it begins to fall on their head. Others watch for the first sign of a crack and immediately have it put in condition. How about the house you live in—your body? Are you going to let it clog up and waste away until you suddenly realize you have tuberculosis or some other dreadful, incurable disease? Get wise! Check up on yourself! Put your body in shape and keep it so.

The More You Use 'Em The Bigger They Get

An apple is no good unless you eat it. Let it lie, and it will rot away. Let your muscles lie idle and they will waste away, but use your muscles and you have more muscle to use.

"The Muscle Builder"

That's what they call me. I don't claim to cure disease. But I do absolutely guarantee to make a strong, husky man out of anyone who will give me a chance. If you wait until some disease gets you, the doctor is the only one who can save you—but come to me now and the doctor will starve to death waiting for you to take sick. I'll put one inch of solid muscle on your arm in just 30 days and two inches on your chest in the same length of time. But that's only a starter. Then comes the real works. I'll put an armor plate of muscle over your entire body and build up the walls in and around every vital organ. I'll shoot a quiver up your spine that will make you glow all over. You will have a spring to your step and a flash to your eye that will radiate life and vitality wherever you go. And what I say doesn't just mean maybe. I absolutely guarantee these things. Do you doubt me? Then make me prove it. That's what I like. Are you with me? Come on then. Let's go.

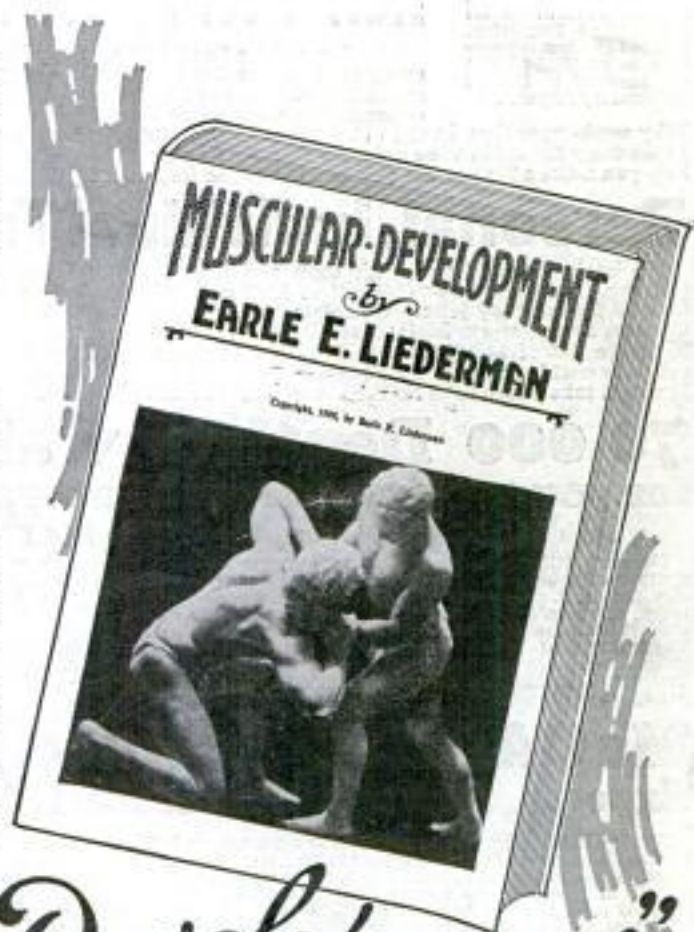

Send For My New
64 Page Book—

"Muscular Development"
IT IS FREE

It contains forty-three full page photographs of myself and some of the many prize-winning pupils I have trained. Many of these are leaders in their business professions today. I have not only given them a body to be proud of, but made them better doctors, lawyers, merchants, etc. Some of these came to me as pitiful weaklings, imploring me to help them. Look them over now and you will marvel at their present physiques. All I ask is 10 cents to cover cost of wrapping and mailing. For the sake of your future happiness, send for your copy today—right now—before you forget it!

EARLE E. LIEDERMAN
Dept. 2004, 305 Broadway, New York City

EARLE E. LIEDERMAN

Dept. 2004, 305 Broadway, New York City

Dear Sir:—I enclose herewith 10 cents, for which you are to send me, without any obligation on my part whatever, a copy of your latest book, "Muscular Development." (Please write or print plainly.)

Name.....

Street.....

City..... State.....



I will make you a Dental Laboratory EXPERT

H. A. McCarrie

H. A. McCarrie is recognized as one of the great authorities on Mechanical Dentistry. But his greatest reputation is as TRACHER of successful Dental Laboratory Experts.

NEW BIG PAY Profession

The demand for Dental Laboratory Experts is getting bigger every day! Right this minute there are THOUSANDS of big-salaried positions open to you. HUNDREDS of wonderful opportunities for running Dental Laboratories waiting for you. Laboratory Expert in a few quick months, help you to a fine position or to go into business, help you make a big success, just as I have done for hundreds of McCarrie graduates.

Why waste your time in the old, worn-out overcrowded trades? I will make you a Dental Laboratory Expert in a few quick months, help you to a fine position or to go into business, help you make a big success, just as I have done for hundreds of McCarrie graduates.

Personal, Individual Training!

No books here. Learn with tools and instruments. I personally supervise your training. Positively no "classes" at McCarrie School. You learn by doing actual Dental Laboratory jobs! Complete training, every branch included: Rubber plates, Crowns, Bridge work, Metal Base Dentures, fixed and removable bridge work, etc. A complete list of subjects would fill this entire page. Yet my rapid-fire, short-cut methods enable you to get it all in a few months, and get it **thoroughly and perfectly!** It would take years to cover the same ground as an apprentice.



70,000 Dentists waiting for you to open your own Laboratory!

Ask Your Own Dentist About This Big Field

Dentists will encourage you to take my training, to prepare to open a Laboratory of your own. Because they must have quicker, better service than they can get now. Comparatively few Laboratories now. They work day and night, and can't turn out the work as fast as it comes in. Dentists have awakened to the advantages of sending their mechanical work to Laboratories. They are glad to pay \$3 an hour for Dental Laboratory work, because their own time is worth \$6 to \$15 an hour working on the patient's mouth. There will be 250,000 Dentists in the U.S. in a few years—so get ready now!

McCARRIE-Trained Experts Always Successful!

This is what I guarantee to give you as my student: 1. Free R. R. fare to Chicago or to my new school in Detroit. 2. \$50 outfit of instruments and supplies Free providing you mail coupon right away. 3. Employment service helps day students find outside evening jobs, helps night students find day-time jobs—all the help you need to take advantage of this wonderful training. 4. Employment service helps graduates find big-pay positions, or helps you find a good location for your own Laboratory. 5. Life consultation service and many other valuable features. I don't merely promise you success—I GUARANTEE TO TRAIN YOU UNTIL YOU ARE SUCCESSFUL!

RUSH COUPON TODAY!

- \$50 Outfit Free
 R. R. Fare to Chicago or Detroit Free

H. A. McCarrie, Director
 McCarrie School of Mechanical Dentistry,
 Dept. 701, 34 and 36 W. Lake St., Chicago

Please send me your special offers and facts about the great new profession of Dental Laboratory work

Name

Address

City.....State.....

FREE!

RR. Fare to Chicago
 or Detroit

FREE!

\$50
 Outfit

\$20



No other work or business is growing as rapidly as Dental Laboratory work.

a Day for Dental "Lab" Experts!

Easiest, pleasantest, most interesting work in the world. Be your own Boss, be successful, make money from the very start. Many start their own Laboratory on a "shoe-string" when they are McCarrie-trained. \$3 an hour the average Laboratory charge.

Coupon Brings Full Information!

The enormous demand for McCarrie-trained Dental Laboratory Experts has compelled me to open a new branch school at Detroit. Special prices, easy terms and many extra features right now. Coupon brings complete information and new big catalog—all free. Mail it to me personally—today!

H. A. McCARRIE, Director
McCarrie School of Mechanical Dentistry
 Dept. 701, 34 and 36 W. Lake St., CHICAGO



Blame Yourself

If This Message Doesn't Bring You A Big Salary Increase

LET'S be specific. What do you want in life? You want more money than you're getting. You want your own home, car, membership in a good club, you want to wear good clothes, educate your children and put away enough money to make you independent. If you are like other men, you want to be your own boss. You want to travel and meet the wide-awake people who are doing things.

All right. I'll tell you a quick, easy way to accomplish all this. If you don't take it you are the only loser. You are the only one who will have to face the accusing finger of the man you might have been. If you do take it you'll thank me the rest of your life for putting this information in your hands. For now it is possible for you to quickly enjoy bigger earnings, and have all the joys in life that your bigger self demands. If this was a guess I couldn't print it. I know it to be a certainty. It is proved by the cases of thousands of other men who have done exactly the same thing. Listen.

What It Brought These Men

For instance, Ellis Summer Cook, 20 E. Jackson Blvd., Chicago, left a \$25 a week job and last year made \$9,000! H. D. Miller, another Chicago boy, was making \$100 a month as a stenographer in July, 1922. In September, 3 months later, he was making \$100 a week as a salesman. W. P. Clenny of Kansas City, Mo., stepped from a \$150 a month clerkship into a selling job at \$500 a month. He is making \$850 a month now. M. V. Stephens of Albany, Ky., was making \$25 a week. He took up this training and now makes 5 times that much. J. H. Cash of Atlanta, Ga., exchanged his \$75 a month job for one which pays him \$500 a month. O. H. Malfroot of Boston, Mass., stepped into a \$10,000 position as a SALES MANAGER—so thorough is this training. All these successes are due to this easy, fascinating and rapid way to master certain invincible secrets of selling. But why continue here when I can send you hundreds of similar stories of success?

The Secret Is Yours

What you want to know is how it's done. I'll tell you. Although none of these men had ever sold a thing in their lives, we took them without experience or training of any kind, and in a short period of time made Master Salesmen of them. Then our Employment Department helped them to select the right position and they were off with a boom to the success they had dreamed of.

The National Salesmen's Training Association can do exactly this for you. If this big organization of Master Salesmen and

Take any ten average men who are in blind alley jobs at low pay. Analyze each case without prejudice. You'll find that every one of them is solely and entirely to blame for his poor earning power. Every one of them has had a golden opportunity. They either have failed to recognize it, or, recognizing it, lacked the courage to follow it up. But now comes your chance. If this page doesn't bring you a big increase in salary—quick—you have no one to blame but yourself. **By J. E. Greenslade**

Sales Managers had raised the salaries of only a few men, then you might call it luck. But we've been doing it for sixteen years, day in and day out. Today we're so accustomed to the amazing increases in salary our members receive that we take them as a matter of course.

There is only one thing I ask of you in return for this offer. Don't let the idea of a big salary, the thought of traveling all around the country and meeting worth-while people, make you think that the job is beyond you. Keep an open, unprejudiced mind on this subject—at least until you have read the remarkable book that I want to send you without charge.

diced mind on this subject—at least until you have read the remarkable book that I want to send you without charge.

Read This Free Book

This book, "Modern Salesmanship," explains why thousands have quickly succeeded in the selling field—how it is easy to make big money once you are in possession of the Secrets of Selling and how you can quickly get these fundamental secrets. It will also explain the National Demonstration Method which shows you how to overcome nearly every sales problem you will meet in a lifetime in the selling field. This is the book I will send you, absolutely free. Read it—then decide for yourself.

National Salesmen's Training Association
Dept. 12-D, Chicago, Ill.

National Salesmen's Training Association,
Dept. 12-D, Chicago, Ill.

I am willing to investigate the opportunity you offer without cost to myself. Please mail me Free Proof that I can become a Master Salesman and qualify for a good sales position. Also send your illustrated book, "Modern Salesmanship," and particulars of membership in your Association and its Free Employment service.

Name

Address

City.....State.....

Age.....Occupation.....

LEARN Modern Barbering

NEW EASY WAY

Earn \$50 to \$150 EACH WEEK



NO matter what you are now doing, no matter how much you earn, our amazing new system of training for the barbering profession enables you to step into this clean, pleasant, profitable business in a few short weeks. Start right in earning \$50 to \$150 a week.

J. E. McGregor, of New Orleans, writes: "I have never been out of a job since you sent me to the one from the Post Graduate department a year ago. I have saved up a nice bank account. I am glad I learned Modern Barbering with you."

F. Erbat, of Chicago, writes: "I own my own home! I have my own automobile! I am independent! Have made it all since graduating from your school five years ago."

What Moler System Means to You

Our national advertising educates the public to the safety, comfort and economy of Moler post graduate work. It makes you the sought-after barber in your locality. It keeps your chairs filled and turns profits into your pocket. You as graduate are a part of a national institution which assures steady, profitable business. Through no other method can you get this.

We Equip Your Shop on Easy Terms

If you own your own shop your success is assured. If you are a worker you are assured of steady employment.

Send for This
Free Book
Today

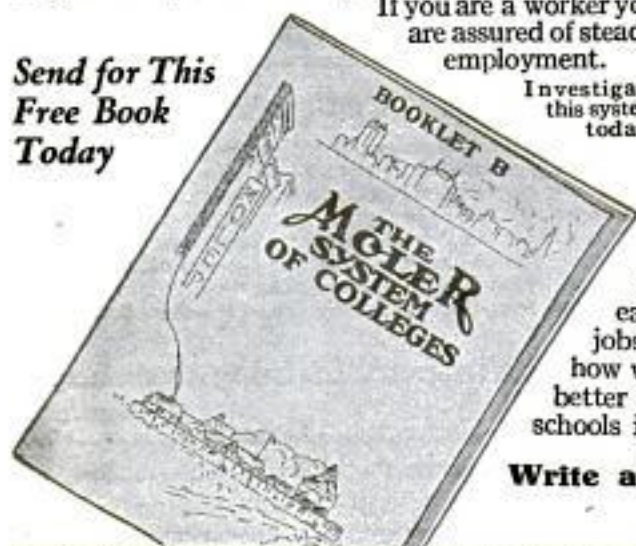

Investigate
this system
today.

We Train You to Be An Expert IN A FEW WEEKS

You want to get ahead—you want to make more money—big money. Our short, practical course gives you a complete training in modern barbering, including the electric hair cutter, the mechanical massage and scientific treatments. It also affords a study, if one desires, on hair and skin—it makes you an expert and expert barbers are always in demand.

Easy Work Always Busy BIG PAY

A trade that enables you to travel and see the world—one that pays in tips and commissions in addition to salaries. Moler System graduates are in great demand and have no trouble in securing good jobs.

Write for Free Book

Our catalog that we mail free tells how we enable you to earn while learning, how we put you into the best city jobs, how we equip your shop on easy payments. In fact, how we take you just as you are, make your life's work easier, better paying and more independent. We have 33 branch schools in leading cities. We have one near you.

Write anyone of the following addresses for our booklet B. Do it today.

MOLER SYSTEM OF COLLEGES

Address Nearest Branch →

Please send me without obligation on my part your Booklet B.

Name.....

Address.....

City..... State.....

The Moler System of Colleges

157 Third Ave. New York, N. Y.	215 Huron Rd. Cleveland, Ohio	23 N. Forsyth St. Atlanta, Ga.
105 S. Wells St. Chicago, Ill.	1045 Cass Ave. Detroit, Mich.	80 N. 2nd St. Memphis, Tenn.
810 N. 6th St. St. Louis, Mo.	1229 17th St. Denver, Colo.	910 Main St. Dallas, Texas
544 Main St. Kansas City, Mo.	110 S. 14th St. Omaha, Nebr.	712 Franklin Ave. Houston, Texas
206 E. 4th St. Cincinnati, Ohio	513 E. Water St. Milwaukee, Wis.	430 W. Houston St., San Antonio, Texas
	1005 Canal St. New Orleans, La.	

FREE Trial Lesson



This lesson in Drafting is sent free upon request. Learn from it how well qualified you are for this profession. See also how Chicago Tech. gives expert training by mail. Chicago Tech. does not require enrollment and payment of fees in advance but sends this lesson first. Just mail the coupon.



DRAFTING Train at Home in Spare Time

Make hours that you now have idle count in training that will double your income. By utilizing a little of your spare time under the direction of the Chicago Tech. experts, you can become a master Draftsman—you can command a high salary and hold an important position. No need to stay in a "blind alley" job, no need to wait years for real success when you can so easily acquire a profession which will put you among the men for whom great opportunities are always open.

You Can Double Your Earnings

There are not enough really able Draftsmen to supply the demand. Great industries everywhere are searching for men who have the training to handle the important problems which must be worked out practically and accurately—and the men who can do this work can name their own salaries. Don't put off a day—start now to get this Chicago Tech. training which gives you the short cut to a larger income.

FREE Drawing Outfit

Enrolled in the Chicago Tech. Home Study Drafting Course you get this complete Drawing Outfit (retail price \$25.00), without extra cost or you are given a credit on fees if you have an outfit.



Send the Coupon

Mail the coupon and get the Free Trial Lesson—also catalogs and full information about the Chicago Tech. Method of teaching Drafting by mail. Find out about the opportunities that Drafting offers to ambitious men. No cost to you—no obligation. Sign and mail the coupon today.

Salary increased 75% since taking the course.

T. E. Anderson

Income 300% greater than before I enrolled.

R. L. Cary

Successful in own business as result of Chicago Tech. Training.

O. L. Roala

Get Practical Men Back of You

Chicago Tech. experts teach you the practical methods which enable you to take a job knowing just what to do and how to do it. No time put in on mere theories. Every lesson deals with actual problems and you have the direct, personal instruction of these experts at every step. All this you get by mail in your spare time.

Chicago Tech. Men in Demand

Everywhere you find Chicago Tech. men in important positions, because they have the practical knowledge which makes them worth money to railroads, manufacturers, engineers, architects, contractors, electrical works and other great industries. This training given by mail or in the day and evening classes at the College in Chicago.

To Employers:

Chicago Tech. men are practical. Write to us when you need Draftsmen.

CHICAGO TECHNICAL COLLEGE
430 Chicago Tech. Bldg., 118 E. 26th St., CHICAGO

Chicago Technical College,
Dept. 430, Chicago Tech. Bldg., 118 East 26th St., Chicago, Ill.

Without cost or obligation on me please send instructive matter about opportunities in line I have marked with "X."

Drafting. (The Big Salary Course.) No experience necessary. Free Lesson sent now.

Building Trade Course. For men in the building lines.

Name.....

Address.....

Post Office.....State.....

Learn Cartooning



BRANNER

WINNIE WINKLE
When I consider the small investment I made in taking your course and the enormous profits I am making now I feel like a proffeer.
M. M. Branner.



GENE BYRNES

REG'LAR FELLERS
I attribute my success to the thorough and highly competent course I received from you.
Gene Byrnes.



FRECKLES

Mere words cannot express my appreciation of the course of lessons I received from the Landon School.
Merrill Blosser.



"CAP" STUBBS

No one could take your course and regret it — your instructions made it possible for me to do the work.
Edwina Dumms.

At Home in Your Spare Time by the World Famous Landon Picture Chart Method

YOU can learn to make original drawings with the aid of this remarkable method, just as easily as you learned to write. A series of big picture charts with each lesson of this great course, explains step by step, just how to proceed in making original drawings of your own. Every detail of cartoon drawing is fully covered throughout this complete course. Instructions on originating cartoon ideas are also included. A complete criticism service gives you the full benefit of the experience of one of America's foremost newspaper artists.

Newspapers want more cartoonists and comic artists trained to do snappy original work. That's why they are constantly employing Landon-trained cartoonists, who are now earning from \$50 to \$200 and more a week.

RESULTS TELL THE STORY

Here are four of the famous characters created by Landon students who have attained national reputations as Comic Strip Cartoonists. Hundreds of former students of this School are producing cartoons on political and national affairs, sports, comic strips, etc., for leading newspapers and syndicates all over the United States and Canada. Many newspapers now employ from two to five students of this School; one big newspaper employs nine. Many successful students who prefer to work at home are selling their drawings by mail. The record of results produced by this School is evidenced in the increasing demand by Newspaper Editors for Landon graduates.

Send NOW for complete information and sample Picture Chart to test your ability. Please state your age.

The Landon School
1238 National Bldg., CLEVELAND, O.

Learn to Write

I Teach by Mail

I can make a good penman of you at your home during spare time, no matter where you live or how poorly you now write. My simplified system has shown thousands the way to good penmanship during the past twenty-five years — it CAN and WILL do the same for YOU.

My beautifully illustrated 32-page Book

"How to Become a Good Penman" FREE!!

It contains many beautiful specimens of penmanship showing what others have accomplished by the Tamblin System, with testimonials and general information about our courses. (Your name elegantly written on a card if you enclose stamp for postage.) Ladies taughting successfully as men. Write Today. Address

F. W. TAMBLIN
419 Ridge Bldg. Kansas City, Mo., U. S. A.

HOW TO BECOME A PROFESSIONAL PHOTOGRAPHER EARNING \$35 TO \$125 A WEEK



Three to six months' course. Motion Picture, Commercial, Portraiture. Practical instruction. Modern equipment. Ask for Catalog No. 49.

N. Y. INSTITUTE OF PHOTOGRAPHY
NEW YORK CHICAGO BROOKLYN
141 W. 36th St. 630 So. Wabash Ave. 505 State St.

Learn to Mount Birds



Learn at home by mail, to mount birds, animals, game heads; tax fur, make rugs and robes. Complete lessons. Easily and quickly learned by men, boys and women.

FREE Write today for Free Taxidermy Book. Tells all about it. Every Sportsman, Hunter, Trooper and Nature lover should know this wonderful fascinating art. Save your trophies. Big profits. Success guaranteed. Our school is 20 years old — 75,000 graduates. Investigate today. Write for Free Book.

Northwestern School of Taxidermy 1774 Elwood Bldg., Omaha, Neb.

Learn Watchwork, Jewelrywork and Engraving.

A fine trade commanding a good salary, and your services are always in demand. Address **Horeological**, Dept. P; Bradley Institute, PEORIA, ILL., for our latest catalog.

STAMMER

If you stammer attend no stammering school till you get my large FREE book entitled "STAMMERING, Its Origin and the Advanced Natural Method of Cure," bound to cloth and stamped in pure gold. Ask for special tuition rate and a FREE copy of "The Natural Speech Magazine." Largest, best equipped and most successful school in the world for the cure of stammering; stuttering, etc. No sing-song or time beat. Write today. The North-Western School, 2317 Grand Ave., Milwaukee, Wis.

FREE BOOK LEARN PIANO

This interesting free book shows how you can become a skilled player of piano or organ at quarter usual cost. It shows why one lesson with an expert is worth a dozen other lessons. Dr. Quinn's famous Written Method includes all of the many important modern improvements in teaching music. Brings right to your home the great advantages of conservatory study. For the beginner or experienced player. Endorsed by great artists. Successful graduates everywhere. Scientific yet easy to understand. Fully illustrated. All music free. Diplomas granted. Write today for free book. Quinn Conservatory, Studio PM04 590 Columbia Road, Boston 25, Mass.

ELECTRICITY

THE BIG PAY TRADE

In Electricity there is a wide range of opportunity for the **trained** man—the man that knows the business **thoroughly**. In Hawkins Electrical Guides you find complete information and instruction, from the Basic Principles to Modern Methods and Short Cuts.

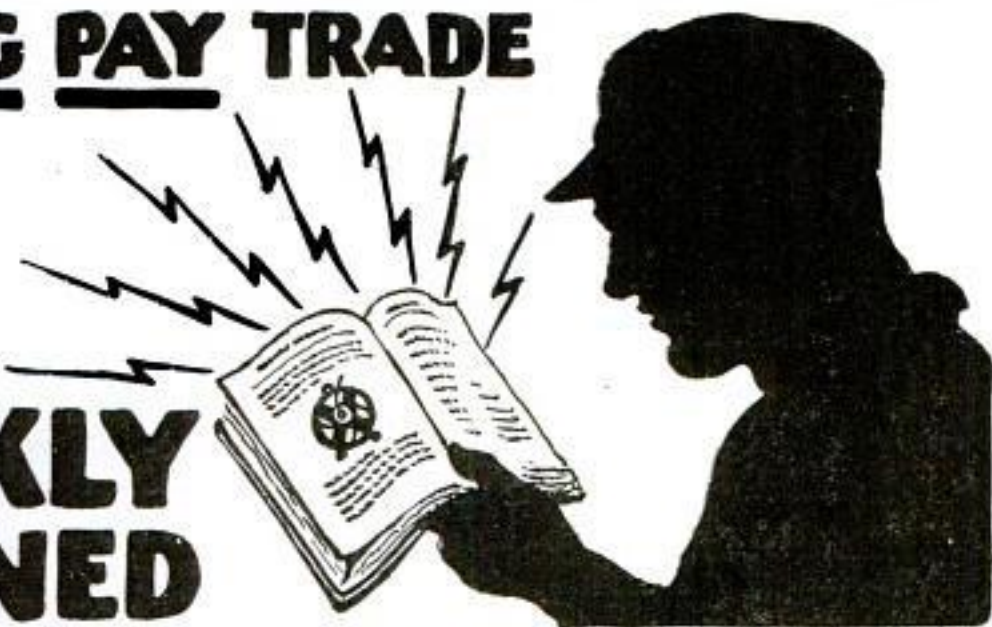

QUICKLY LEARNED BY EASY SPARE-TIME READING

No need to worry about getting a job or holding a job if you have a practical working knowledge of electricity. **Electricity** is the most Important Factor today. This is the Age of Electricity. Electrical Workers that really know electricity are in demand! The way to keep in close touch with the progress made in electrical work is to consult these Guides daily for study, reference and review. **Hawkins Guides** will protect you from mistakes, check leaks, waste and increase your earning power.

Free Examination Coupon Below!



HAWKINS ELECTRICAL GUIDES

3500 PAGES—4700 PICTURES—\$1 A VOLUME—\$1 A MONTH—10 VOLUMES

Know the facts in Electricity. They mean more money and better position for you. Hawkins Guides tell you all you need to know about Electricity. Every important electrical subject covered so you can understand it. Easy to study and apply. A complete, practical working course, in 10 volumes. Books are pocket size; flexible covers. Order a set today to look over.

LEARN ALL ABOUT THESE IMPORTANT POINTS

Magnetism—Induction—Experiments—Dynamamos—Electric Machinery—Motors—Armatures—Armature Windings—Installing of Dynamamos—Electrical Instrument Testing—Practical Management of Dynamamos and Motors—Distribution Systems—Wiring—Wiring Diagrams—Sign Flashers—Storage Batteries—Principles of Alternating Currents and Alternators—Alternating Current Motors—Transformers—Converters—Rectifiers—Alternating Current Systems—Circuit Breakers—Measuring Instruments—Switchboards—Wiring—Power Stations—Installing—Telephone—Telegraph—Wireless—Bells—Lighting—Railways. Also many Modern Practical Applications of Electricity and Ready Reference Index of the ten numbers.

FREE Not a cent to pay until you see the books. No obligation to buy unless you are satisfied. Send Coupon now—today—and get this great help library and see if it is not worth \$100 to you—you pay \$1 a month for ten months or return it

THEO. AUDEL & CO., 72 Fifth Ave., New York City

Please submit me for free examination, HAWKINS ELECTRICAL GUIDE, (Price \$1 a number). Ship at once prepaid, the 10 numbers. If satisfactory, I agree to send you \$1 within seven days and to further mail you \$1.00 each month until paid.

Name.....

Occupation.....

Employed by.....

Home Address.....

Reference.....

PM Apr. 24





American Machinists' Library

THE day of the trained machinist is here! On every hand employers are calling for him—bidding for him! They are looking for men who really know machine shop practice—men who are capable of handling all kinds of machine shop work equally well.

The all-round knowledge that is in demand today is the kind of knowledge you get in the new American Machinists' Library.

The latest and most practical books in the machine shop field

THIS library—just off the press—is without a doubt the most complete—the most thorough—the most practical set of books ever published in its field.

The authors are all recognized authorities in the machine shop world, and they have packed their books to the covers with sound advice and helpful data on every phase of machine shop work. The set should be in the hands of every man who wants to make himself a master of modern machine shop practice.

American Machinists' Library 6 VOLUMES

2000 pages—
2500 illustrations

- Vol. 1—Machine Tools and Their Operation—Part I
- Vol. 2—Machine Tools and Their Operation—Part II
- Vol. 3—Punches and Dies
- Vol. 4—Jigs and Fixtures
- Vol. 5—Tool and Gage Work
- Vol. 6—Working of Steel

Machine shop work as experts know it

Within these six volumes will be found everything that the machinist and toolmaker wants to know about modern machine shop work. All the latest methods—all the latest machines—all the finer points of machine shop work—are described and pictured for you in clear, interesting text and illustrations.

With these books a man can know machine shop practice as experts know it and fit himself to earn an expert's pay.

Free Examination—Only \$1.00 in 10 days and \$2.00 a month for 7 months

Fill in the coupon below and we will send you a set of these books for 10 days' Free Examination. No expense—no obligation. We pay carrying charges both ways. If you find the books to be what you want, send us \$1.00 in ten days and the balance in monthly installments of \$2.00 until the special price of \$15.00 has been paid.

FREE EXAMINATION COUPON

McGRAW-HILL BOOK CO., Inc.
370 Seventh Avenue, NEW YORK

Send me for ten days free examination your American Machinists' Library, all charges prepaid. If satisfactory, I will send \$1.00 in 10 days and \$2.00 a month until I have paid your special price of \$15.00 for the set. If they are not what I want, I will write for return shipping instructions.

Signature.....

Res. Address.....

City and State.....

Your Employer.....

Your Occupation.....

PM-4-24

We Teach COMMERCIAL ART

Meyer Both Company, the largest Commercial Art Organization in the World

offers you an unusual opportunity for practical training, based upon twenty-three years of success. This nationally known organization each year produces and sells to advertisers over 15,000 commercial drawings. Meyer Both instruction is the difference between successful fact and experimental theory. This well paid profession equally open to men and women. Home study instruction.

Get Facts Before You Enroll in Any School

Ask the Advertising Manager of the leading newspapers in your city, anywhere in the United States, Canada, England or Australia about the Meyer Both Company—let them tell you about us. Write for our illustrated book telling about the success of our students—for one-half the cost of mailing—four cents in stamps.

MEYER BOTH COMPANY Department of Art Instruction

Michigan Ave. at 20th St., Dept. 16 CHICAGO, ILL.

Note—To Art and Engraving Firms: Secure practical artists among our graduates. Write us.

MUSIC LESSONS FREE

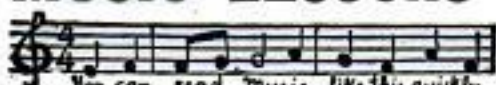

You can read Music like this quickly

IN YOUR
OWN
HOME

Piano, Organ, Violin, Mandolin, Guitar, Banjo, etc. Beginners or advanced players. One lesson weekly. Illustrations make everything plain. Only expense about 2c per day to cover cost of postage and music used. Write for FREE booklet which explains everything in full.

AMERICAN SCHOOL OF MUSIC, 51 Lakeside Building, CHICAGO

"STAMMERING

Its Cause and Cure"

You can be quickly cured if you stammer. Send 10 cents, coin or stamps, for 288 page cloth bound book on Stammering and Stuttering. It tells how I cured myself after Stammering and Stuttering for 20 years. BENJAMIN N. BOGUE
6908 Bogue Building, 1147 N. Ill. St. Indianapolis

LEARN WATCH REPAIRING

Be a watchmaker—you can learn this profitable trade by correspondence in a few weeks in your own home by the DeSelms Chart System. After you complete the course you will know a watch from A to Z. You will know just what the matter is and how to repair one. When you graduate you will be a practical watchmaker and repairer and competent to fill any position. Positions for our graduates. Ask for our Free Book. It explains our system and terms.

THE DeSELMS WATCH SCHOOL
23 Perry Street ATTICA, INDIANA



Learn Photography at HOME

Make \$75.00 a Week on the Side

Establish yourself as a Photographic Expert quickly—during your spare time—under a leading photographer. I'll show you how to start your own business—or command a large salary. Send for your free offer—It's a real opportunity. Ask at once. A postal will do. H. R. VANT.
INTERNATIONAL STUDIOS, Inc.
Dept. 1124, 2601 Michigan Ave., Chicago, U.S.A.



"I Found a New Way to Become Popular—Quickly"

"They used to avoid me when I asked for a dance. Some said they were tired, others had previous engagements. Even the poorest dancers preferred to sit against the wall rather than dance with me. But I didn't 'wake up' until a partner left me standing alone in the middle of the floor.

"That night I went home feeling pretty lonesome and mighty blue. As a social success I was a first-class failure. Then I saw your advertisement in a well-known magazine. At first I wouldn't believe that you could teach by mail because I always had the idea that one must go to a dancing class to learn. But I figured I could risk 10c—especially since you guaranteed to teach me.

How Dancing Made Me Popular

"Being a good dancer has made me popular and sought after. I am invited everywhere. No more dull evenings—no bitter disappointments! My whole life is brighter and happier. And I owe it all to Arthur Murray!

"I was astonished to see how quickly one learns all the latest steps through your diagrams and simple instructions. I mastered your course in a few evenings and, believe me, I surely did give the folks around here a big surprise when I got on the floor with the best dancer and went through the dance letter perfect. Now that I have the Murray foundation to my dancing I can lead and follow perfectly, and can master any new dance after I have seen a few of the steps.

"My sister's family have all learned to dance from the course I bought from you, and it would do your heart good to see how fine her little kiddies dance together after quickly learning from your new method of teaching dancing at home without music or partner."

Learn Any Dance in a Few Hours

Whether you want to learn the Fox Trot, One Step, Waltz, or any of the new dances, you won't have any trouble in doing it through Arthur Murray's new Method. More than 120,000 people have learned to dance by mail and you can learn just as easily.

Arthur Murray is America's foremost authority on social dancing. Through his new improved method of teaching dancing by mail, he will give you the same high-class instruction in your own home that he would give you if you took private lessons in his studio and paid his regular fee of \$10 per lesson.



Posed by
Hope Hampton,
Movie
Star, and Ar-
thur Murray.

Five Dancing Lessons Free

So sure is Arthur Murray that you will be delighted with his amazingly simple methods of teaching that he has consented, for a limited time only to send FIVE FREE LESSONS to all who sign and return the coupon.

These five free lessons are yours to keep—you need not return them. They are merely to prove that you can learn to dance without music or partner in your own home.

Write for the five lessons today—they are free. Just enclose 10c (stamps or coin) to pay cost of postage, printing, etc., and the lessons will be sent to you. You will receive: (1) The Secret of Leading. (2) How to Follow Successfully. (3) How to Gain Confidence. (4) A Fascinating Fox Trot Step. (5) A Lesson in Waltzing. Don't hesitate. You do not place yourself under any obligation by sending for the free lessons. Write today.

ARTHUR MURRAY

Studio 132, 801 Madison Ave., New York

Arthur Murray, Studio 132
801 Madison Ave., New York City

To prove that I can learn to dance at home in one evening you may send the FIVE FREE LESSONS. I enclose 10c (stamps or coin) to pay for the postage, printing, etc.

Name.....

Address.....

City.....State.....

(Also at 150 Southampton Row, London, England)

The AUTOMOBILE BUSINESS is THE Business to Get Into

Fifteen Million
Automobiles
Need Service

Fifteen Million Cars, seventy million tires, millions of batteries and electrical systems to over-haul, repair and replace to keep in running order. Get that picture well fixed in your mind, then you can begin to appreciate WHY the AUTOMOBILE Business is THE Business to get into.

Think of the opportunities in the repair and resale end of the business alone! There are only about 50,000 garages and service stations in the United States. Thousands of additional garages, thousands of battery repair shops, tire shops and welding shops, are needed to help care for these millions of cars.

Try to picture in your mind what FIFTEEN MILLION AUTOMOBILES mean—a line that would reach one and one-half times around the world! Think what that means as

a business opportunity!! Can you think of a better field for ambitious, wide-awake men who have been specially trained for that kind of work?

Remember, this branch of the business continues regardless of whether or not the factories turn out another car. But they are making four million new ones a year. These millions of cars must have service the whole year 'round—a fact which means much for the success of Trained Men.

Earn \$2,000 to \$10,000 Yearly



Both the manufacture and repair of all these machines require skilled men—trained men—men who KNOW! The automobile industry employs millions of men, and additional men are needed all the time. Factories, garages and service stations are continually asking us for "Michigan State" Trained Men who can fill responsible jobs with good pay. The "Michigan State" Trained Man doesn't have to worry—and wonder. He KNOWS—and that means SUCCESS!

What We Teach—and Why

The Automobile Industry must have Trained Men. The average mechanic or "handy man" won't do. Automobiles are too expensive to let an untrained man experiment with them. Even though sturdily built, an automobile engine is a delicate piece of machinery. They must be accurately adjusted in every particular—pistons, connecting rods, crank shaft, valves, timing gears, etc. Then the starting, lighting and ignition system, and the power transmission through gears, etc. All these points and many others, must be thoroughly understood to successfully solve the many problems connected with automobile construction and operation. Our Course covers every one of these subjects completely. When you have finished our Course you will be able to handle any problem connected with the construction, upkeep, repair and operation of autos, trucks, tractors, gas engines and farm lighting plants. That is why "Michigan State" Graduates are always in demand. They are thoroughly trained—they KNOW!

Read What the Manufacturers Say

These letters written by Factory Executives speak for themselves. The "Michigan State" is endorsed by automobile manufacturers many of whom helped us outline our Courses because they appreciated the work we were doing and were glad to co-operate with us. Do you think it pays to get the benefit of experience such as these men offer? It certainly does!

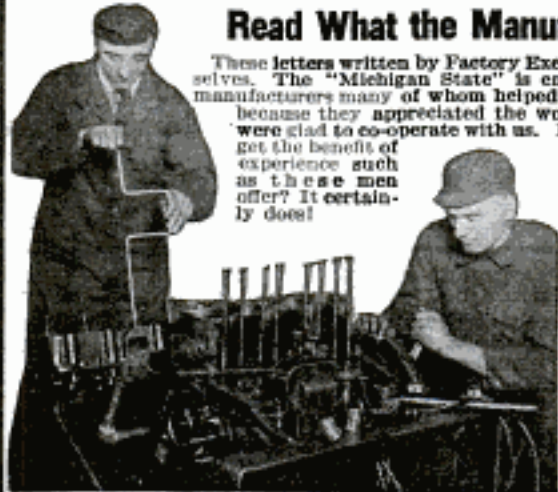

Endorsed by Big Factories
Read These Letters

DODGE BROTHERS
INCORPORATED
DETROIT, U. S. A.

"We believe the Michigan State Automobile School of this city to be an exceptionally high class school, and no doubt a diploma from this school would assist materially in obtaining employment with high class automobile dealers."



BUICK MOTOR COMPANY

"We believe the MICHIGAN STATE AUTO SCHOOL, Detroit, would best meet your requirements, as its course of technical training is most thorough and complete in every detail."

THE STUDERBAKER CORPORATION
OF AMERICA

"We do not know of a better automobile school than the MICHIGAN STATE."

Learn in Detroit—
It's a Big Advantage

When you think of automobiles you think of Detroit, the Auto Center, and it is only natural to think of the "Michigan State" in the Auto Center when you think of Automobile training. This is the Heart of the Auto Industry—the Automobile Center of the World. Practically 79% of the automobiles are made in the Detroit district. This is a big advantage for "Michigan State" Students. They get the benefit of hearty co-operation from the big factories. They meet the factory executives and service men; they learn factory methods first handed; they listen to lectures and talks by factory men; they learn about cars in a manner impossible away from the factories. That is why "Michigan State" Trained Men are in demand with big factories and service stations.

Michigan State
304 Auto Bldg. Detroit, Mich.

This Man Made \$8,000. Last Year



in a little
shop of
his own

If you are one of those fellows who wonders if there are any opportunities left, read what this man Epps has to say in his letter quoted on this page. And when you read it, remember this one fact: Epps was not an exceptional fellow, neither has his experience been exceptional. He is just an average man—only one of thousands of "Michigan State" Graduates who have "Made Good" because they were THOROUGHLY TRAINED!

The real secret of Epps' success was that he wanted to "get somewhere" and had the gumption to START! He knew that all the good jobs were not held by the "white collar" boys and he started out to prove it. His letter tells a pretty complete story—and we have lots more like it in our files — wonderful letters which tell how boys from 17 to 65 have been helped upward and onward toward Success by "Michigan State" Training.



Endorsed by Graduates

Read Mr. Epps' Letter

SQUARE DEAL GARAGE

E. H. EPPS & SON
YARNA, ONTARIO

FORD SERVICE STATION

M. S. A. S.
Detroit, Michigan.

Dear Friends:

Just a line to let you know how I am getting along since I graduated in 1917 and started in business. Last year our net profits ran about \$8,000 on used cars, repairing, and tire repairing. I have one of the largest Tire Repair depots in Western Ontario. I returned to the M. S. A. S. for advanced electricity, battery, and radiator work, all of which I am now adding to my business.

Speaking of recommendations, last summer I had a party stop at the garage and ask for Mr. Epps. When I went to see him he told me that a friend of his in Denver, Colo., had told him if he was in Western Ontario to be sure and go to Epps' Square Deal Garage to get his work done. Wishing you all success,

Your graduate,

LOWRE K. EPPS.

The Kind of Men Who Make Good

A lot of folks get the idea that a man must be a "natural mechanic" to make good in the automobile business. Maybe he does have to "like machinery" but he doesn't need to be a mechanic. One of the best graduates we ever turned out was a \$13.50 per week "pencil pusher" who hardly knew what a wheel base was. We changed him into a \$42.50 per week automobile electrician, and he is still climbing.

Another man quit an office job to take our Course—and pushed himself into a \$10,000 per year garage business. Another came here as a High School graduate at 17, and about a year after finishing our Course was making nearly \$5,000 per year in a business of his own. Another real fellow who through hard luck was unable to support his family, borrowed the money to take our Course, and today has a successful business in Minnesota.

All these fellows had Gumption—they had Ambition—they wanted to Get Somewhere!—and they were willing to do the necessary plugging to get there. Mere wishing won't do it—neither will waiting. You must get Action! If you are willing to do that, Our Course will help you Get There!



**Good Positions
Await Our Graduates**

Factories, garages and service stations continually call for "Michigan State" trained men. These positions pay good salaries and offer excellent opportunity for advancement or to build a business of your own. There are more opportunities for trained men in Detroit and elsewhere than we can fill. Let the "Michigan State" fit you for the wonderful future of the Automobile business. —A. G. Zeller, Pres.

READ THIS GUARANTEE

We guarantee that a graduate of our Automobile and Tractor Course will be qualified to fill a position as assembler, demonstrator, tester, repair man, auto electrician, chauffeur, tractor operator or farm lighting expert, or we will refund his tuition fee.



This Is Your Opportunity

Don't say you never had a chance. A Big One faces you right now! Get Busy! Don't wait for some one to push you along. Send for our free literature. Learn what other fellows have done, then show the World what YOU can do. Be a Winner. Get Started! Fill out and mail the Coupon NOW—TODAY!

SEND THIS COUPON TODAY!

Michigan State Automobile School
304 Auto Building, Detroit, Michigan

Send me FREE and without obligation your 100-page catalog and Auto School News, giving complete information about Detroit-training to make the most money.

Name.....

Street or R. F. D.....

City..... State.....

Do you prefer to start your training at home

or at our School in Detroit?.....

Automobile School
3729 Woodward Ave., Detroit, Mich.



Thousands Can Draw CARTOONS Who Have Never Even Tried

Cartoonists earn from \$60 to far over \$300 a week. Why tie yourself to work that is drudgery when through a remarkable new method you can easily learn at home in spare time to draw cartoons that **SELL**?

MANY are earning pitifully small salaries who could make wonderful salaries in cartooning. Briggs, Fox, Fisher, Goldberg and other leading cartoonists earn more than the President. Yet a few years ago many of our most successful cartoonists never dreamed they could draw a good cartoon!

The World's Easiest, Pleasantest and Best Paying Profession

Just watch a cartoonist work. A few little lines—a couple of simple curves—a splash of black here and there—and then you see a splendid cartoon before you. With a few strokes of his pen, he has taken some little incident of his day's experience—some humorous or sad scene he has witnessed—and produced a wonderful cartoon.

New Easy Way to Learn Cartooning

This fascinating ability to draw cartoons can now easily be yours—this ability which can mean so much real pleasure and profit to you. Through a wonderful new method you receive right at home through the mail a complete training in Cartoon Making, and personal corrections on all of your work from one of America's most prominent cartoonists!

With his help, you can, in an amazingly short time, learn to draw the comic strip, humorous, political and animated cartoons which are in such big demand.

Learn More About Cartooning— Send for FREE BOOK

Never have cartoons been so popular. Millions of dollars were spent last year on cartoons of all kinds—and every week newspapers increase the amount of cartoons used. Get full details on the amazing opportunities in this fast growing field of Cartooning and full information on this remarkable home study method. Mail coupon for FREE BOOKLET today.

WASHINGTON SCHOOL OF CARTOONING
Room 304, 1113-15th St., N. W. WASHINGTON, D. C.

WASHINGTON SCHOOL OF CARTOONING
Room 304, 1113-15th St., N. W., Washington, D. C.

Please send me without obligation your illustrated FREE BOOKLET on Cartooning and details of Free Offer.

Name
(Write name plainly. State Mr., Mrs. or Miss)

Address

City State

If under 16 years, please state age

Electrical men with training are in demand. For more than thirty years, this school has been training men of ambition and limited time for the electrical industries. Condensed course in **Engineering** enables graduates to secure good positions and promotions. Theoretical and Practical Electricity, Mathematics, Steam and Gas Engines and Mechanical Drawing. Students construct dynamos, install wiring and test electrical machinery. **In One Year** Course with diploma complete



Over 4,000 men trained. Thoroughly equipped fire-proof dormitories, dining hall, laboratories, shops. Free catalog. 32nd year begins Sept. 24, 1924.

BLISS ELECTRICAL SCHOOL
104 Takoma Ave. WASHINGTON, D. C.

BE A JAZZ MUSIC MASTER



PLAY PIANO BY EAR

Play popular song hits perfectly. Hum the tune, play it by ear. Self-instruction—no teacher required. No tedious ding-dong daily practice—just twenty brief, entertaining lessons which you master

At Home in Your Spare Time

Send for FREE BOOK. Learn many styles of bass and syncopation—trick endings, fill-ins, etc.

Niagara School of Music
Dept. 647 Niagara Falls, N. Y.

Send for this Free Book

A FILE

NOT A FILE

Stop Forgetting

Make Your Mind an index from which you select facts, figures, dates, faces. Develop concentration, self-control; overcome brain-sluggishness, forgetfulness.

Write today for FREE memory and concentration test and illustrated booklet, "How to Remember."

PROF. HENRY DICKSON
Dept. 7054 Evanston, Ill.

Anyone CAN LEARN

No talent or experience necessary. Fascinating work. Pays big money. Complete instruction book tells about: Automobiles, Colors, How to Mix Paints, Show Cards, Window Boards and Wall Signs. Ready made letters, Gilding, Tricks of the Trade, also gives 100 Alphabets and Designs. Book bound in flexible art. leather-gold edges, and four half-bearing Show Cards. Sent postpaid \$3.00. (C. O. D. 10c ex.)
Opaline Pub. Co., 57 East St., Dept. 50, N. Y. City

**EARN MONEY IMMEDIATELY—
WE FURNISH EQUIPMENT TO START!!**

Ride A Ranger

The finest bicycle ever built. 44 Styles, colors, sizes; made in our new factory. SAVE \$10 to \$25 by direct from the factory purchase.

Delivered free on approval, express prepaid, for 30 Days' Free Trial. 12 MONTHS TO PAY, if desired.

Tires best quality at factory prices, express paid. Lamps, wheels, horns, equipment and repairs at unusually low prices. Send No Money, do business direct with makers.

Mead Cycle Company
Dept 1-100 Chicago

Write today for free Ranger Catalog, factory prices and marvelous easy payment terms.



WANTED — Railway Mail Clerks

Travel—See Your country
\$1600-\$2300 Year
Mens — Boys
18 Up
Mail Coupon Immediately

FRANKLIN INSTITUTE
Dept. H178, Rochester, N. Y.

Write: I want to travel. Send me, without charge, (1) specimen Railway Mail Clerk Examination question; (2) list of government jobs now obtainable; (3) tell me how to get a government job.

Name

Address

Repair Any Auto ^{OR} Auto Truck

Examine These NEW AUTO BOOKS FREE

Be an expert auto repair man. You can have the skill that makes every complicated trouble as easy to fix as taking out a spark plug. Learn every detail of all makes of cars and trucks. Know exactly how to find what's wrong and how to make all repairs quickly. These great new Auto Books show you how.

Make Money Repairing Autos

Over 9 million cars are in operation and thousands of men are needed to keep them in good going condition. There are more jobs open than there are good men to fill them. Never before have expert auto repair men been in such great demand and made so much money. Now is your great money-earning opportunity in the auto repair business. Every mechanic, every chauffeur, every car owner needs this great New Library of Automobile Engineering.

Tells About
Explosion Motors, Welding, Motor Construction and Repair, Carburetors and Settings, Valves, Cooling, Lubrication, Fly-Wheels, Clutch Transmission, Final Drive, Steering Frames, Tires, Vulcanizing, Ignition, Starting and Lighting Systems, Shop Kinks, Public Garage Design, Equipment and Operation, Electrics, Storage Batteries—Care and Repair, Steam Cars, Motorcycles, Commercial Trucks, Glossary. More than 100 blue prints Wir'g Diagrams.

75c a Week If You Decide to Buy

Let us send you the complete six-volume set of Automobile Engineering for one week's examination. Read the simple directions for repairing every automobile trouble. Six thick volumes 5½x 8¾ inches, flexibly bound and stamped in gold, 2,650 pages, 2,100 illustrations, wiring diagrams, etc. Everything in plain, every-day language simple to understand. If you decide to keep them, send only \$2.80 in seven days, and \$3 a month thereafter until the special introductory price of \$21.80 has been paid. The regular price is \$45.00, so you save \$23.20 by acting at once.

Send No Money

Don't send a penny! Your name and address in the coupon brings the six books to you at once for seven days' trial.

Mail Coupon NOW

American Technical Society
Dept. A-419 Chicago, U. S. A.

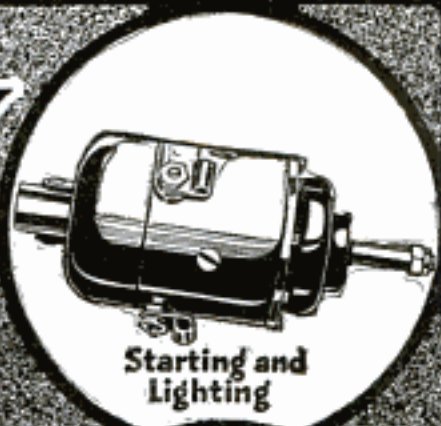

Starting and Lighting



Welding

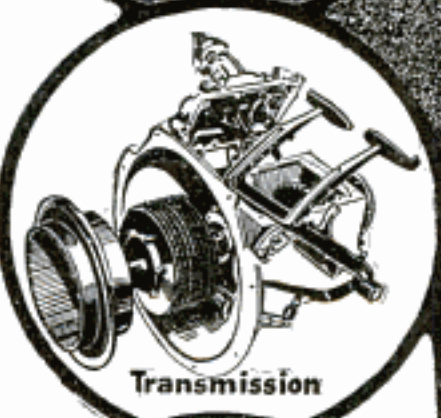

Transmission

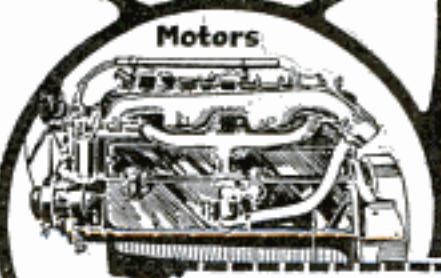

Motors

AMERICAN TECHNICAL SOCIETY

Dept. A-419, Chicago, U. S. A.

Please send me the six-volume set of Automobile Engineering for seven days' examination, shipping charges collect. If I decide to buy, I will send \$2.80 within seven days and balance at \$3.00 a month until \$21.80 has been paid. Then you will send me a receipt showing that the set of books are mine and fully paid for. If I think I can get along without the books, I will return them, after 7 days, at your expense.

To insure prompt shipment fill out all lines.

Name.....

Address.....

Employed by.....





This Man Earns \$3500 to \$5000 a Year

—WORKING WITH A DENTIST—
THREE MONTHS' TRAINING
QUALIFIED HIM TO DO IT

There are thousands of these positions awaiting trained men in this profitable profession. After just a few months of specialized training hundreds of men will have become full-fledged members of the dignified profession of

MECHANICAL DENTISTRY

They will have the technical knowledge and skill to enable them to earn several thousand per year. You can be among them. 2500 more Dental Mechanics are needed right now and the Dental Profession is constantly calling for graduates of the four great schools of this institution; salaries from \$35 to \$45 a week to start, with advancement up to \$125 a week.

FREE PARTIAL SCHOLARSHIPS

In order to meet this urgent demand for the men we train, we are offering for a limited time Free Partial Scholarships. You will want to get in on this exceptional offer—so don't delay. NOW is the time!

JUST COMPARE

Compare the unusual opportunities this profitable professional trade offers with what you are now doing—the earnings, the pleasant, dignified occupation. Compare also our ability to train you and put you in touch with the right opportunity—our large, well-equipped schools, over 30 years of experience in this one line, our wide acquaintance with the Dental Profession throughout the nation!

SEND FOR CATALOG AND SCHOLARSHIP OFFER

Describes the field and why the demand. Shows how students "Learn by Doing" actual work through practical, individual instruction, day or evening sessions. Shows how you can "Earn while Learning."

BODEE DENTAL INSTITUTE

136 West 52d Street, NEW YORK

PHILADELPHIA BUFFALO BROOKLYN
1305 No. Broad St. 1226 Main St. 15 Flatbush Ave.

BODEE DENTAL INSTITUTE: Without obligation to me send me a Free Copy of your catalog and complete details of the Free Partial Scholarship Plan No. 2.

Name

Address



Here is the ideal mandolin for the beginner who does not wish to make a large investment. A real musical instrument with Stradivarius arching and other patented Gibson features, which assure perfect scale, powerful tone, permanent construction and make it easier to play. A mandolin you can tune accurately. You can master a Gibson quickly and and soon be playing the day's popular music. Write now for FREE BOOK and details of EASY PAYMENT plan on any Gibson, including Mandolin, Mandola, Mando-Cello, Guitar, Harp-Guitar, Mando-Bass and the NEW Gibson Mastertone Banjos.

GIBSON, Inc.
411 Parsons Street Kalamazoo, Mich.

HOME STUDY

Become More Efficient

through courses in Chemistry, History, Mathematics, English, Psychology, Education, Business and 35 other subjects which the University gives by mail. They command credit toward a Bachelor degree and may be begun at any time.

The University of Chicago 15 Ellis Hall
Chicago, Ill.

LEARN ENGINEERING

Great Demand for Practical-Technical Men. Big Salaries. Wonderful Opportunities. Beautiful New Building. Extensive Laboratory and Shop Equipment. Not a trade school but a Practical-Technical College. Faculty of Trained Experts. 3 months courses in Practical Electricity and Steam. 1, 2 and 3 year courses in Mechanical and Electrical Engineering. Architectural, Structural, Mechanical Drafting. Day and night. Degrees awarded. 22nd year. Write for catalog D.

FINLAY ENGINEERING COLLEGE, Kansas City, Mo.



Wrestling Book FREE

You can learn to be an expert wrestler at home—during your spare time. The book tells you how. The world's marvelous undefeated champion and his trainer Frank Gotch and Farmer Burns will now teach you. Learn wrestling, self-defense and jai-alai easily at home by mail. Know all the science and tricks. First chance to learn from world champions. Men and boys, here is your great opportunity. Send for free book today stating age. Burns Sch. of Wrestling 977 1/2 Railway Bldg., Omaha, Neb.



"BECOME A LIGHTNING TRICK CARTOONIST"

MAKE MONEY CHECK TALKING. SEND \$1.00 FOR SAMPLE PROGRAM OF TRICK DRAWINGS WITH INSTRUCTIONS BY A PROFESSIONAL CARTOONIST. SATISFACTION GUARANTEED. CIRCULAR FREE. BALDA ART SERVICE, Q1 OSHKOSH, WIS.

WHY NOT spend Spring, Summer and Fall gathering butterflies, insects? I buy hundreds of kinds for collections. Some worth \$1 to \$7 each. Simple outdoor work with my instructions, pictures, price-list. Send 10c (not stamp) for my Illustrated Prospectus before sending butterflies.

MR. SINCLAIR, Dealer in Insects, Dept. 8, CEAN PARK, CALIF.



LEARN WATCH REPAIRING



You can learn by our modern and original system of instruction every part of the Watch Repairing Trade at home as good or better than at a shop. You can earn money while learning and secure a well paying position or start in business after completing our course of instruction. Good watch repairers are always in demand and earn from \$30 to \$70 per week. For particulars apply to the Wisconsin School of Watch Repairing 106 Mason St., MILWAUKEE, WIS.

YOU CAN PLAY THE HAWAIIAN GUITAR

Just Like the Hawaiians!

Because Our Native Hawaiian Instructors Will Show You How!

Be the Most Popular Member of Your Set, Play "When You Walked Out," "Ten Ten Tennessee," "Stella," "Louisville Lou." All the Late Song and Dance Hits. You can play First Selection in Half an Hour and Harmonious Chords AT ONCE.

Here is your chance to get in the swim—to learn to play the most fascinating of all instruments, the Hawaiian Guitar, just as the Hawaiians do, and in an amazingly short time. Our method is so simple, plain and easy that you begin a piece your first lesson. In half an hour you can play it! Thousands of successful students prove this to be true. It is quite astonishing to find the ease with which you can master the Hawaiian Guitar—no matter how little your knowledge of music may be you can positively learn to play by our plain and easy method.

Expert Hawaiians Teach You to Quickly Master Their Secrets of This Fascinating Music

The instructions you receive from such world famous experts as Lawrence Kalaluki, Walter Kolomoku, Frank Ferrer, Carl Seville and others are invaluable. No other Conservatory can even begin to give you the expert teaching and knowledge you gain through us. And remember, while it is conceded that the Hawaiian Guitar produces the sweetest music, yet its mastery by you will be simple and quick, since there are

ONLY 4 EASY MOTIONS

to learn to be able to play any music—popular, dance, classical, native Hawaiian airs, or old time melodies and hymns. Just think of it! You need never have read a musical note in your life! For that matter, even though you haven't the slightest knowledge of any musical instrument we guarantee to teach you how to play just like the Hawaiians!

A Complete Conservatory Course!

Never before has such a complete and easily understood Conservatory Course in Hawaiian Guitar been offered. We are able to grant you this opportunity of quickly learning how to play the Hawaiian Guitar through acquiring the services of real Hawaiians to teach you.

How well this has been accomplished is proved by the fact that this is the only Conservatory teaching Hawaiian Guitar exactly as played by the Hawaiians. It is your good fortune as well as ours, that these Native Masters of Hawaiian Guitar came to this Conservatory to teach—and best of all

We Furnish Everything

When you enroll as a student in this Conservatory you receive FREE a handsome, sweet toned Genuine Hawaiian Guitar—valued at \$15.00—52 especially arranged lessons and 52 carefully selected pieces of music, as well as all necessary picks, Steel Playing Bar, etc. There is nothing extra to buy, everything is furnished.

SEND FOR TODAY

of this remarkable course—simply fill in the coupon, mail to us and we'll gladly send you full details of our complete Conservatory Course and FREE Hawaiian Guitar Offer! We know you will not let another day go by without enrolling as a student in this Conservatory, once you learn how quickly and easily you can master this most popular of all instruments—the Hawaiian Guitar—So mail the Coupon NOW.

First Hawaiian Conservatory of Music, Inc.
Dept. 48, 233 Broadway (Woolworth Bldg.) N. Y.

Special Courses Under Famous Teachers: TENOR-BANJO
VIOLIN, BANJO-UKULELE and UKULELE



FREE

This Genuine
HAWAIIAN
Guitar—

A Real
\$15.00
Value



MAIL THIS COUPON NOW!

First Hawaiian Conservatory of Music, Inc.
Dept. 48 233 Broadway, (Woolworth Bldg.), New York

Please mail at once full details of your 52 easy lessons and FREE Hawaiian Guitar offer. This, of course, does not obligate me in the least.

Name _____

Address _____

City _____ State _____

(Please PRINT name and address clearly)



Follow this Man

Secret Service Operator 38 is on the job

FOLLOW him through all the excitement of his chase of the counterfeit gang. See how a crafty operator works. Telltale finger prints on the lamp stand in the murdered girl's room! The operator's cigarette case is handled by the unsuspecting gangster, and a great mystery is solved. Better than fiction. It's true, every word of it. No obligation. Just send the coupon and get—

FREE!

The Confidential Reports No. 38 Made to His Chief

And the best part of it all is this. It may open your eyes to the great future for YOU as a highly paid Finger Print Expert. More men are needed right now. This school has taken men just like you and trained them for high official positions. This is the kind of work you would like. Days full of excitement. Big salaries. Rewards.

Can you meet this test?

Can you read and write? Are you ambitious? Would you give 30 minutes a day of your spare time preparing yourself for this profession? Would you like a life of excitement, thrilling adventures and high pay? Answer "yes" and I'll show you how to attain all this.

Send the coupon and I'll send the Free Reports—also a wonderful illustrated book telling of the future awaiting you as a Finger Print Expert.

T. G. COOKE, Pres.

UNIVERSITY OF APPLIED SCIENCE
1920 Sunnyside Ave., Dept. 13-54 Chicago, Ill.

University of Applied Science
1920 Sunnyside Ave., Dept. 13-54. Chicago, Ill.

Gentlemen:—Without any obligation whatever, send me the Reports of Operator No. 38, also your illustrated Free Book on Finger Prints and your offer of a FREE course in Secret Service Intelligence and the Free Professional Finger Print Outfit.

Name

Address

Age



WANTED MEN AND WOMEN TO LEARN PHOTOGRAPHY!

Photographers and Photo-Engravers earn \$200 to \$500 a month. The field is uncrowded. Learn these profitable and fascinating professions. Taught by largest and best college of its kind in the world. Established over 30 years. Demand for our graduates far exceeds supply. Good positions secured. Tuition and living expenses low.

Get this FREE Book! Write today for free beautifully illustrated book describing wonderful opportunities in this field. Illinois College of Photography, Box 444, Effingham, Ill.

Learn Music

Make More Money

Never before such a demand for musicians as now. Not enough trained people to supply the positions open at theaters, clubs, hotels, amusement parks, orchestras and private entertainments everywhere. Big salaries waiting for those who can qualify. Learn to play an instrument and double or triple your earning power. Many musicians make as high as \$200 weekly.

Learn at Home—In Spare Time!

By the University Extension method, you can quickly and easily master any instrument. Experts will teach you by mail in your spare time. No special talent or previous study required. Thousands successful through this training. Write and mention instrument preferred. Postcard brings information.

UNIVERSITY EXTENSION CONSERVATORY
702 East 41st Street, Dept. 929 Chicago, Illinois

BE AN ARTIST

WE CAN TEACH YOU DRAWING in your own home during your spare time. Twenty-five years of successful teaching proves our ability. Artists receive large salaries.

Write today for Art Year Book.

SCHOOL OF APPLIED ART
Room No. 2 BATTLE CREEK MICH.



Wonderful, new device, guides your hand; corrects your writing in few days. Big improvement in three hours. No failures. **Complete outline FREE.** Write C. J. Ozment, D-34, St. Louis, Mo.

STAMMER NO MORE

Kill the fear of stammering. Re-education the key. The widely famed Hatfield Method fully outlined in an accurate, dependable, worthwhile book—"HOW TO STOP STAMMERING." It has helped thousands. Free copy today.

THE HATFIELD INSTITUTE, 109 N. Dearborn, Chicago, Ill.

LEARN WATCHMAKING

and become independent. Good-paying positions secured. Easy to learn. Send for FREE CATALOG.

ST. LOUIS WATCHMAKING SCHOOL, Dept. 5, ST. LOUIS, MO.



Eliminate the Electrician Everybody's Electrical Handbook

(New edition) tells how to safely do wiring for bells and lighting, also repair electrical appliances. 30 per cent of trouble in appliances can be fixed in a few minutes, yet you pay dollars to have it done. This is the most complete book on everything electrical in the home.

Send No Money Just your name and address, pay postman \$1.00 plus a few cents postage, or send a dollar bill with order. Money back if not satisfied. Circular Free. **HOME BOOK CO., 388 E. Arcade Bldg., Cleveland, Ohio**

You! can be a \$5000 Auto Expert!



Garage Owner or Manager



Automotive Expert



Automotive Electrician



Salesman, Demonstrator

"What Big-Pay Work Can I Learn Quickest?"



J. R. Bayston, M.S.A.E., Pres.
CHICAGO AUTOMOTIVE
INSTITUTE

Originator of the "Job-Way" System of Training
I give you this Tool Kit FREE
and train you to use it



18 Piece Master Mechanics' Tool Kit FREE!

This Complete \$15.00 outfit doesn't cost you one penny! Full size, everything you need to do the "Jobs." 75 lessons, 150 Jobs, 12 lectures and many Free features in the C. A. I. course. And "Clear-ette Money" pays for it!

"THE C. A. I. JOB-WAY TO BIGGER PAY!"

LOAN me an hour of your spare time a day! I'll guarantee to put you in the \$100.00 a week class quicker than you can learn any other big-pay work! **Don't quit your job! Stay home!** Thousands of men **no better than you** are making big salaries, holding down important jobs, earning enormous profits in their own business. I know how you can do the same, and I'll tell you how!

Learn Auto Repairing! Learn Automotive Electricity! Learn Vulcanizing, Welding, Battery!

My copyrighted "Job-Way" system teaches you in an hour what ordinarily takes a month to learn! The speed with which C. A. I. students get ALL the work of the complete course has astonished educators everywhere! So simple a school-boy can understand it. Think of it! 13,000,000 autos to repair each year—13,000,000 batteries to service—13,000,000 ignition systems to keep going—65,000,000 tires to sell and repair—3,000,000 trucks to overhaul. Do you realize how hungry employers are for competent men? Do you know what they're willing to pay for Automotive Experts? Can you imagine the opportunities today to make big money in a business of your own?

Coupon Brings FREE BOOK and FREE LESSON!

I don't ask you to risk a penny. I know you can learn to earn \$3,000 to \$8,000 a year as an Automotive Expert. So I guarantee in writing to return every cent of your money if you don't think it's the most profitable investment you ever made. I want you to send for my free book, read the free lesson, find out about my wonderful "Job-Way" method. See why I offer this complete Automotive course for the least money, and on easiest payments. Mail Coupon or postal today!

MEN WANTED!

Thousands of big-pay jobs open right now, all over the U. S. Our Employment Service FREE to both students and graduates, reaches employers in every part of the Country. Look at this:

Master Mechanics	\$3,000 to \$8,000
Electrical Experts	\$3,600 up
Garage Manager	3,800 up
Battery Expert	2,400 up
Expert Welder	2,400 up
Salesman	3,000 up
Tractor Engineer	2,400 up

My graduates earn money fast enough to go into business. Own your own Garage, Battery Station, Ignition Service, Repair or Welding plant.



Mail Coupon for
FREE BOOK!

Bigger-Pay Coupon!

J. R. Bayston, M.S.A.E., Pres.
Chicago Automotive Institute
Dept. 1774, 536 So. Clark St., Chicago

Without a penny of expense or the slightest obligation, please send me Free Book about your rapid course in Automotive Master Mechanics, and Free Tool Kit offer. Explain your money back guarantee. I want to see a Free Lesson, too.

Name.....

Address.....

CHICAGO AUTOMOTIVE INSTITUTE

J. R. Bayston, Pres., Dept. 1774, 536 So. Clark St., CHICAGO

LEARN AT HOME THE C.A.I. JOB-WAY

Get a Job Like These

Earn \$3500 to \$10,000 a Year

in the Big Pay Field of

ELECTRICITY



20 Years Old— Makes Almost \$500 a Month

Harold Hastings of Somers, Conn., says: "The profit on my electrical business amounts to \$470 a month. My success is due entirely to your instruction. You make your men just what you say—Electrical Experts. No man will ever make a mistake enrolling for your course."



Dickerson Gets \$7,500 a Year

"I earned \$30 a week when I started with you—\$50 a week when half through your course. Now I clean up at the rate of \$7,500 a year. Thank you a thousand times for what you did for me. Electricity pays big on the farm." Herbert M. Dickerson, Warrentown, Virginia.



\$20.00 a Day for Schreck

"Use my name as a reference and depend on me as a booster. The biggest thing I ever did was answer your advertisement. I am averaging better than \$500 a month from my own business now. I need to make \$15.00 a week."

A. Schreck,
Phoenix, Ariz.



Pence Earns \$9,000 a Year

W. E. Pence, Choballs, Wash., says: "Your course put me where I am today. Mr. Cooke—making \$750 a month doing automobile electrical work—think of it—\$9,000 a year. Besides that I am my own boss. My wife joins me in thanking you for what you did for us."



\$30 to \$50 a Day for J. R. Morgan

"When I started on your course I was a carpenter's helper, earning around \$5.00 a day. Now I make from \$30 to \$50 a day and am busy all the time. Use this letter if you want to—I stand behind it."

J. R. Morgan,
Delaware, Ohio.

It's your own fault if you don't earn more. Blame yourself if you stick to your small pay job when I have made it so easy for you to earn \$3500 to \$10,000 a year as an electrical expert. **Electrical Experts** are badly needed. Thousands of men must be trained at once. One billion dollars a year is being spent for electrical expansion and everything is ready but the men. Will you answer the call of this big pay field? Will you get ready now for the big job I will help you get? The biggest money of your life is waiting for you.

I Will Train You at Home

I will train you just like I trained the five men whose pictures you see here. Just like I have trained thousands of other men—ordinary, everyday sort of fellows—pulling them out of the depths of starvation wages into jobs that pay \$12.00 to \$30.00 a day. Electricity offers you more opportunities—bigger opportunities—than any other line and with my easily learned, spare time course, I can fit you for one of the biggest jobs in a few short months' time.

Quick and Easy to Learn

Don't let any doubt about your being able to do what these other men have done rob you of your just success. Pence and Morgan and these other fellows didn't have a thing on you when they started. You can easily duplicate their success. Age, lack of experience or lack of education makes no difference. Start just as you are and I will guarantee the result with a signed money back guarantee bond. If you are not 100% satisfied with my course it won't cost you a cent.

FREE—Electrical Working Outfit and Tools

In addition to giving my students free employment service and free consultation service, I give them also a complete working outfit. This includes tools, measuring instruments, material and a real electric motor—the finest beginners' outfit ever gotten together. You do practical work right from the start. After the first few lessons it enables you to make extra money every week doing odd electrical jobs in your spare time. Some students make as high as \$25 to \$35 a week in spare time work while learning. This outfit is all FREE.

Mail Coupon for FREE BOOK

—the Vital Facts of the Electrical Industry

The coupon below will bring you my big free electrical book—over 100 interesting pictures. The real dope about your opportunities in electricity—positive proof that you, too, can earn \$3500 to \$10,000 a year. Send for it now. Along with the book I will send you a sample lesson, a credit check allowing you a \$45.00 reduction, my guarantee bond and particulars of the most wonderful pay-raising course in the world. Send the coupon now—this very second may be the turning point in your life. Send it while the desire for a better job and more money is upon you, to

L. L. COOKE, Chief Engineer

Chicago Engineering Works

Dept. 14 2150 Lawrence Ave., Chicago

The Cooke
Trained Man
is the Big
Pay Man

L. L. COOKE, Chief Engineer, Chicago Engineering Works,
Dept. 14, 2150 Lawrence Ave., Chicago, Ill.

Without obligating me in any way send me the "Vital Facts," your Free Book, Sample Lessons and particulars of your Free Outfit Offer, Free Employment Service, and proof that you can fit me for a big-pay electrical job.

Name

Address

Occupation..... Age

Classified Advertisements

WORLD'S BEST WANT AD MEDIUM

Advertisements in this section, 25 cents per word, each insertion, minimum 10 words, payable in advance. To be inserted under proper classification in May issue, copy should be in our office March 18th.

ADVERTISING AGENCIES

TO secure agents or salesmen or for selling farms and reaching investors, use classified (want) ads in largest newspapers and magazines. Price list No. 30 sent free. Ankrum Advertising Agency, 20 W. Jackson Blvd., Chicago, Ill. The largest classified advertising agency in the U. S.

25 WORDS—355 Rural Weeklies \$14.20. Ad-Meyer Agency, 4112-M Hartford, St. Louis.

FOR ADVERTISERS

AGENT'S names and addresses on gummed stickers ready to attach. \$1.00 per 100; \$5.00 per 1,000. Taken from original inquiries. Havana Treat Cigar Co., Utica, N. Y.

20 WORDS 40c; 4 times \$1.00. Quick, paying results. North West News, 2343 Milwaukee Ave., Chicago.

INTERNATIONALIZE Your Business! Sell—Trade!—Buy! Everything!—Everywhere! Advertisements: \$1.00 Inch; 1c word. Circulation worldwide! Subscriptions: Six Months (trial only), 25c; Copy 10c. International - Opportunity, Brookings, S. Dakota.

70 MAGAZINES—Twice—6c Word. Copy 10c. Arthur Machemer, Sinking-Spring, Penna.

INCH Display 100 Magazines, Thrice, \$8. Beck, 5406 Alaska, St. Louis.

INCH Display—65 magazines \$2.00. Thrice \$3.00. Literature 10c. Klesse Service, East 89th, New York.

ADVERTISE in 24 Big Sunday Newspapers, 24 words \$15.00. Catalog listing 1,000 leading Dailies, Weeklies, Magazines, 4c stamps. Union Advertising, Baltimore Bldg., Chicago.

ADVERTISE, hundred magazines, three issues, 10c word. Pennell-Company, Covington, Ky.

SALES PROMOTION

\$5000 ANNUAL Sales Increased to \$100,000 annually within two years after adopting my direct mail plans, copy and counsel. \$50 to \$50,000 daily sales developed for clients. Submit details of sales problems for free diagnosis. Ten years Sales Promotion Manager Larkin Co. James C. Johnson, 118A Woodbridge Ave., Buffalo.

400 FORCEFUL, Effective, Business-getting Letters, prepared in typewritten form. Covers practically every kind of business; \$5.00 prepaid. Particulars free. J. Rodgers Hoggard, Windsor, N. C.

ONE letter \$5. Three \$10. Twenty Years' Experience. Cash and data with order. Hudson, Station H-2, Buffalo.

AUTOMOBILE SUPPLIES

AIR Compressors, Automatic, Twin Cylinder, Guaranteed. Easy payments. Free Air service increases business and profits. Particulars free. Hobartson, Troy, Ohio.

FOR Sale—Glass for automobile bodies or windshields. Get our low prices. Pulver, Glass Dealer, Hudson, N. Y.

AUTHORIZED Rayfield Carburetor Service. Carburetors repaired and rebuilt. Guaranteed one year. C. D. Loftus, 3941 Washington Blvd., Chicago, Ill.

MICROMETER (New Type) as accurate as \$50.00 set. Easier to read. Endorsed by all leading mechanical and scientific magazines. Measures 2 1/2 to 5 inches. Price, \$1.00. Robert L. Schaap, 354 Cumberland Street, Brooklyn, N. Y.

SAVE \$25 on your next Top Recovering. See Page 146.

AUTOMOBILE gears, shafts, bearings and springs, in new parts at very low prices. Differential and transmission gears, fiber timing gears, axle shafts, drive shafts, Timken, Hyatt, New Departure, connecting rod and crankshaft bearings for most all makes and models of cars. Prices quoted on request. Auto Tire & Parts Co., 501 Broadway, Cape Girardeau, Mo.

AUTO Camp Carrier. Booklet Free. W. Kierman Co., Whitewater, Wis.

BATTERY recharging pays \$100 to \$100 monthly with new Eight Hour Charging System. Easy monthly terms let outfit pay for itself. Thirty day's trial, money back guarantee. Particulars free. Hobartson, Troy, Ohio.

AUTO and Truck Parts. Save 25-80%. New and used motors, gears, axles, bearings, springs, generators, \$10 up. New Zenith, Johnson, Rayfield, Stromberg carburetors, \$7.50 up; new waterproof Stumms and Berling magneto, \$15; Ford retopping, \$4-\$6; other cars, \$12 up. Brightman Auto Exchange, 321 Windsor Ave., Hartford, Conn.

AUTOMOBILE Parts—Used parts for most any car at half factory list prices. Allen, Briscoe, Buick, Cadillac, Chalmers, Chevrolet, Dodge, Ford, Grant, Hudson, Hupp, Oakland, Overland, Oldsmobile, Reo, Studebaker and many others. Send list of parts wanted. Maxwell Bros., 4106 Olive St., St. Louis, Mo.

RAJO Head \$32.50. Philbrin, Duplex Ignition \$24.00. Miller Carburetor, \$10.00. Ralph Foley, Durango, Colo.

ATTENTION Auto Owner! What about the finish on your car? Preserve finish on your new car. Save old car and cost of repainting. Remove checks and scratches. Saves time and expense of washing. Results absolutely guaranteed. Not a wax. Po-Lax Laboratories, 1514 E. Jefferson, Detroit, Mich.

REPAIRING Ford Cars, Trucks and Tractors in the most proper and efficient way is explained in a new 229-page book by the former director of the Ford Motor Co. Service School. This information is otherwise unavailable outside of the Ford Plant. Written more especially for the mechanic and repairman. Price \$2 postpaid. Popular Mechanics Book Dept., 206 E. Ontario St., Chicago.

BARGAINS—Guaranteed Radiators—Dodge \$19.95, Maxwell, \$21.50, Chevrolet 4-90 \$16.95, and many others. State make and model required. Sport Bodies built to order; send sketch. Independent Radiator Co., 1119 Wabash Ave., Chicago, Ill.

WE'VE Got Everything in New and Used Auto Parts, Accessories and Supplies, for all makes and models of cars. Engines, Transmissions, Clutches, Axles, Wheels, Rims, Tires, Radiators, Gears, Axle Shafts, Bearings, Magnets, Starters, Generators, Coils, Batteries, Etc., Etc. Ours is the largest stock of its kind in the world. Our Motto is "Service, Quality, and Low Price." Write for catalog and bargain lists. Warshausky & Company, Inc., World's Largest Car Wreckers and Replacement Parts House, Phone Calumet 7315, 1915-35 S. State St., Chicago, Ill. No Branches.

AUTOMOBILE parts for all cars. Lowest prices. Save money; get our wholesale catalogue. State make of car, model and parts wanted. Parts shipped immediately from stock. We refund your money if not satisfied. Mechanics Gear Co., 3706 No. Halsted St., Chicago.

REMANUFACTURE Fords—most profitable business on earth—\$14,355.00 Made on 300 complete jobs, \$450.00 completely equip shop with tools recommended by Ford Motor Company. Circular. K. B. Wilson, Buffalo, N. Y.

AUTOMOBILES

BUILD a Real Automobile—Weight 150 pounds. Handy men or boys build at small cost. Complete Book Easy-To-Follow Plans 25c. Also sold complete. Famous 2 1/2 H. P. Shaw Motor supplies power. Stamp brings descriptive circular. Shaw Manufacturing Company, Dept. P. M. 2, Galesburg, Kans.

PATENTS Procured. Send sketch or model today for examination, prompt report and advice. No charge for preliminary advice. Write for free Booklet and blank form on which to disclose your idea. Highest references. Promptness assured. Clarence A. O'Brien, Registered Patent Lawyer, 581 Security Bank Building, Directly across the street from Patent office, Washington, D. C.

PATENTS—M. P. Laughlin—Engineer-Attorney, 48 East 41st St., New York.

\$1 WILL buy a positive Headlight Telescope. Handy Dental Specialty Co., Somerville, Mass.

RACING Bodies for Fords and Chevrollets 490. Send for free particulars. Our book "How to Build a Ford Racer" sent on receipt of 25c. Central Auto Supply Company, Dept. 129-C, Louisville, Ky.

DYKE'S Automobile Encyclopedia, 13th edition, new, greater than ever, entirely rewritten and rearranged. Contains greatest array of automobile facts ever published in one volume. Separate books containing same information cost \$21. Over 1200 pages and 4100 illustrations. Cloth \$9. Flex. Amer. Morocco \$7.50 postpaid. Popular Mechanics Book Dept., 206 E. Ontario St., Chicago.

PATENTS—Write for our Guide Books and "Record of Invention Blank" before disclosing inventions. Send model, or sketch and description of your invention for our free opinion of its patentable nature. Highest references. Reasonable terms. See advertisement on pages 170 and 171. Victor J. Egan & Co., 185 Ninth, Washington, D. C.

A REAL trouble shooter motor book. Shows the car owner how to make adjustments and minor repairs in every case where the services of an expert repairman are not actually required. \$1 postpaid. Popular Mechanics Book Dept., 206 E. Ontario St., Chicago, Ill.

FOR FORD OWNERS

FORD Repair Book Free: A very complete and well illustrated book explaining how to make repairs on most every part of your Ford. We offer this book free with a nine months' subscription to Ford Owner and Dealer Magazine—at only \$1.00. Everyone interested in the Ford car should read this big magazine of about 200 pages monthly. It clearly explains the things you want to know about cutting down the cost of operation, the engine, ignition, transmission, carburetor, etc. Send Today and get the valuable Repair Book Free. Ford Owner and Dealer Magazine, 540 Montgomery Bldg., Milwaukee, Wis.

FREE Photos, Descriptive Circular. Classified Coupe-Speedster ever designed. Complete plans. Pacific Body Designers, 137 E. 46th St., Los Angeles, Calif.

UNDERSLING your Ford with Fordspeed Underslung Fixtures. Fordspeed Sport Bodies produce wonderful sport cars. See ad, page 139.

THATCHER Rear View Mirror with universal bracket, fits any car. Best Mirror made. \$2.50 Post-Free. Agents Wanted. Weatherby Company, Box 102, Medina, Ohio.

NEW, 16 valve head, carburetor, plugs, wires, pumps; cost \$150, sell \$75; send \$10, balance C. O. D. E. Rush, Gay St., Phoenixville, Pa.

FORD Owners, Fill your gasoline tank without lifting cushion! Have a gasoline gauge always in sight! Kirstin F11-O-Meter is a gauge and filler combined; \$5.00 Retail. Salesmen wanted. Write today. A. J. Kirstin Co., 19 Kirstin Bldg., Escanaba, Mich.

UNDERSLING with "RKO" Swing Lo Irons. See "Red-I-Kut" ad page 130.

MOTORCYCLES, BICYCLES & SUPPLIES

SEND for our Bargain Bulletin and Money Saving Message. It will save you money on Motorcycles, Side Cars, Motor wheels, Repair Parts and Accessories. Some used parts at less than half. Cleveland and Ace Motorcycles our specialty. See our ad on page 148. American Motor Cycle Co., 2043-5-7 W. Chicago Ave., Chicago.

50% OFF. Used parts in stock for Thor, Excelsior, Henderson, Reading, Harley, Rogers Side Cars, Eclipse clutches, cylinder grinding. Central Motorcycle, 913 Washington, Chicago.

MOTORCYCLE Riders make big money Demonstrating and Selling Internationally Famous Fixible Sidecars and other products in open territories. Special Discount on Demonstrating car and Liberal Commissions on Sales. Fixible Co., 328 Water Street, Loudonville, Ohio.

SEND for Bargain Bulletin. All makes of rebuilt motorcycles at lowest prices. Used parts half-price. Ash Motor Corporation, Rochester, N. Y.

BARGAINS in used Harley-Davidsons and used parts. Vic. Ross, Omaha, Nebr.

NEW and used parts for Motorcycles and Bicycles. Get our prices on parts needed. Kingshighway Motor Co., 1166 N. Kingshighway, St. Louis, Mo.

INDIAN, run 1000 miles—\$90.00; sell Engine \$20.00. Natanns, 104 Colvin, Baltimore, Md.

SEND 10c now for big catalogue Excelsior or Henderson parts. Parts for all makes. Lowest prices. Nebraska Motorcycle & Bicycle Co., Motorcycle Bldg., Omaha, Nebr.

1922 HARLEY-DAVIDSONS, \$135; 1921, \$115; 1920, \$85; 1919, \$65; 1917, \$50; 1916, \$45; 1915, \$40; 1914, \$35. Guaranteed. Money refunded if not satisfied. Circular free. Wisconsin Cycle Sales Co., 726 National Ave., Milwaukee, Wis.

MOTORCYCLE Sidecars—Bargain Prices on Experimental and Discontinued Models. Write Flexible Co., 328 Water Street, Loudonville, Ohio.

USED parts for all motorcycles, cheap. State wants. Schuck Cycle Co., 1922 Westlake, Seattle, Wash.

DONT buy a Bicycle Motor Attachment until you get our new catalogue and prices. Also runs washers, pumps, and shop machinery. Shaw Mfg. Co., Dept. 27, Galzburg, Kans.

SEND for big list of slightly used motorcycles on the easy payment plan. Howard Cycle Co., Trenton, N. J.

AVIATION

"LEARN to Fly." Ten Twenty Minute Lessons, \$100. Curtiss Training Plane. Start Right now! Plans for Sportplane Builders: Monoplane \$1, Biplane \$2.50, Knockdown Plane \$100, up. Used Sportplane with motor, \$300. Aviation Engineering Co., Lawrence, Kans.

TEN lessons in the air, of twenty minutes each will make you a pilot, by our advanced method of training. This together with our five-week shop course at \$100.00 makes America's oldest aircraft factory, the most popular flying school. Work after class hours guaranteed. Heath Airplane Co., Inc., Chicago, Ill.

AEROPLANE Models; all types with parts and supplies listed in our 48 pp. catalogue. 5c postpaid. Ideal Aeroplane Co., 165½ Spring St., New York.

80-H. P. AIRPLANE Motor, Brand new, \$95. Complete; Cost U. S. Government \$3,900. Airplane Model, scientific, flies 200 feet under own power, \$1.35 prepaid. Air Transport Co., L. I. City, N. Y.

SEND 10c for our latest aeronautical catalogue, listing a complete line of airplane goods at reduced prices. Ford or Motorcycle motored airplane catalog 4c each. Heath Airplane Co., Chicago, Ill.

LEARN To Fly with Varney Aircraft Co., Peoria, Ill. Lowest tuition compatible with Safety, Thoroughness, and Efficiency.

GET a Chamblee sling shot Aeroplane. Flies over 500 ft. and stunts. Postpaid 20c. Chamblee Aeroplane Company, 1845 East 18th St., Cleveland, Ohio.

SEND one dollar for beautiful pair of sterling silver wings mounted on stick or bar pin with safety catch. Wear one to boost aviation. Money refunded if not absolutely satisfactory. Wallace Aero Company, Dayton, Iowa.

THREE foot model aeroplane. Small cost. Circulars free. Aero Shop, 3050 Huribout Ave., Detroit, Mich.

HEATH propellers represent the most efficient method of aerial drive. Each propeller individually designed for the particular work to be done, as laid out by America's oldest aeronautical engineers. Propeller catalog 4c. 8x12 blue prints \$2.00. Jersey aviator helmets 95c; resistal goggles \$2.90. Heath Airplane Co., Chicago, Ill.

PATENTS Procured. Send sketch or model today for examination, prompt report and advice. No charge for preliminary advice. Write for free Booklet and blank form on which to disclose your idea. Highest references. Promptness assured. Clarence A. O'Brien, Registered Patent Lawyer, 581 Security Bank Building, Directly across the street from Patent Office, Washington, D. C.

AIRPLANES, \$350 to \$1,500. Motors, 28 to 200 H. P. Propellers, \$3 up. Leather coats, \$19 to \$15. Smith Machinery Co., Houston, Texas.

THE American School of Aviation announces a new correspondence course in Mechanics of Aviation. A thorough training in Practical Aeronautics. American School of Aviation, Dept. 1868, 3601 Michigan Ave., Chicago, Ill.

WELDING

WELDING Encyclopedia—New Third Edition. Complete training course for operators in all welding processes; oxyacetylene, electric arc, electric resistance and thermit. Welding of all weldable metals fully discussed. 437 pp., 600 Ills. The accumulated experience of the welding brains of America is yours for \$5. Money back if not satisfied. Popular Mechanics Book Dept., 206 E. Ontario St., Chicago.

BOOKS AND PERIODICALS

ELECTRICIANS—aid to examination for license; Illustrations, diagrams, tables, etc.; price \$1.25. Marine and Stationary Engineers—latest answers to questions asked at examinations; profusely illustrated. Price \$2.50. Steam Boilers—construction, care and operation; 170 illustrations; complete and valuable information; price \$2.50. Catechism of Steam, Gas and Electric Engineering, over 1,000 questions and answers; price \$2. All books written in simple, concise English by expert authorities. Reade Pub. Co., 296 Broadway, New York.

BASHFULNESS, fear and timidity banished, self-reliance achieved in ten nights of subconscious reconstruction; in ten days of directed activity or your money promptly refunded. Address Harry Lawrence Juhnke, Box 854-A, Sacramento, Calif.

FREE—Our Rare, Instructive and Entertaining Book Catalog. Wright & Son, 601 S. Ind. Ave., Peoria, Ill.

INTERNATIONAL - OPPORTUNITY (Brookings, S. Dak.), a free, progressive, inspirational magazine especially published for amateur inventors, authors, artists, business men and women and all other coming leaders of the world. Copy, 5c. Year, 35c.

BOOKS on love, human nature, dreams, letter writing, poetry, hypnotism, spiritualism, health, etc. Two intensely interesting books 25c with catalogue free. E. Smetana Company, Orono, Mich.

"MASTER KEY" \$2.75. "Power of Will" \$2.75, 610 pages each. "Successful Salesmanship" \$1.35, all \$6.00 (new). Phipps, 1014 Belmont, Chicago.

FREE—Send for my Newthought, Self-culture, Occult, Mystic and Scientific book literature. Martens Publisher, Burlington, Iowa.

LEFAX—"Facts on Leaves." You make your own handbook, loose-leaf. From our complete list of Lefax data sheets you select only those that you actually need, then fill in your own notes or diagrams on extra blank sheets which come in 100 different styles. These in loose-leaf binder make up a book covering your individual needs. Send for complete information and price list to Popular Mechanics Book Dept., 206 E. Ontario St., Chicago.

COPIES of 25 entirely different small mailorder magazines and papers, amateur publications, etc.—only 25c each. Carl Hansen, Brookings, S. Dak.

"BOOKS of the Month"—Interesting illustrated pocket magazine. Briefly describes new books. Sample 10c. Are you interested in art publications also? Dunbar, Boston 24, Mass.

USED Books? Extra Bargains. Lists Monthly. Higgen's, A2441 Post, San Francisco.

SUGGESTION. Scientific Spanish methods. Produces sound, curative sleep quickly in self or others. Guaranteed instructions \$1.10. Prof. Deprado, PM-257 Oak, Chicago.

HYPNOTISM, astounds, controls, gratifies wants and ambitions. 25 easy lessons \$1.10. "Mindreading" (any distance), wonderful. \$2.00. Popular Institute, M-1014, Belmont, Chicago.

FICTION Writers' Question Book helps you write stories that sell. \$2 postpaid (money order). Brattle Book Co., Cambridge 38, Mass.

HINDU Psychology, Secret Sciences. Illustrated Catalogue, lesson 25c. Adaros, 116 South Michigan, Chicago.

"LIGHTS, Colors, Tones and Nature's Finer Forces," covering Vibrations; Odic-Auras; Cold-lights; Radio; Inventions; 270 pages. Satisfaction guaranteed; \$2.00. Circulars Free. M. Stevens, Publisher, 242 Powell, San Francisco.

WRITERS Study at home. Thirty textbooks, and criticism and advice regarding markets for manuscripts. Catalogue. Correspondence invited. James Knapp Reeve, Editor, Franklin, Ohio.

INDUSTRIAL Alcohol. Wright's book everybody wants. Full directions for making with drawings of necessary apparatus. \$2.50 postpaid. Spon & Chamberlain, 129 P. M. Liberty Street, New York, N. Y.

OUR valuable catalog of over 500 practical books arranged for easy reference under 80 different subject headings will be sent free on request. Popular Mechanics Book Dept., 206 E. Ontario St., Chicago.

PICTURES AND POSTCARDS

JOIN Live Postcard Club. Membership lists, including catalog, 10c. Harvey Teeple, Decatur, Ind.

50 POSTCARDS. Beautiful girls; fascinating poses; 27c (coin). 200 assorted \$1.00. Smith's Novelty, M9145, Bishop, Chicago.

JOIN the Old Reliable Card Club. Membership, 10c. Riverside Club, Frederick, Md.

EXCHANGE Postcards, Fascinating Magazine information, 5c. "Universalist," 1034P West Eighteenth St., Chicago, Ill.

SOUVENIR postcards of Asheville (In the land of the sky), 25c per dozen. Box 821, Asheville, N. C.

NOVELTIES, CURIOS, ETC.

ARMADILLO Baskets, Unique novelty; samples parcel post paid, plain baskets, \$2.50; silk trimmed, \$3.50 each; satisfaction guaranteed or money back. Address Charles Apelt, Comfort, Texas.

MAGIC at home—The rising cards. Full instructions, 50c. Coast Novelty Co., 3737 E. 5th St., Los Angeles, Cal.

GAMES, ENTERTAINMENTS AND PLAYS

LEARN To Swim—Complete instructions 50c. Mercatus Co., Box 1422, Indianapolis.

MAH-JONG: The talk of the country. 144 tiles, 4 winds, 8 red counters, value 500; 32 yellow counters, value 10; 36 green counters, value 100; 40 blue counters, value 2; one complete instruction book. Two dice and 8 racks scored. Complete set \$1.00 postpaid. This special offer to introduce our free catalogue. F. & P. Sales Co., Madison, Wis.

VENTRILLOQUISM taught almost anyone at home. Small cost. Send 2c stamp today for particulars and proof. George W. Smith, Room M-816, 125 N. Jefferson Ave., Peoria, Ill.

200 KINDS Iron, wood and wire puzzle. Leader and Illustrated list 10c. Western Puzzle Works, St. Paul, Minn.

PLAYS, musical comedies and revues, minstrel music, blackface skits, vaudeville acts, monologs, dialog, recitations, entertainments, musical readings, stage handbooks make-up goods. Big catalog free. T. S. Denison & Co., 623 So. Wabash, Dept. 11, Chicago.

MAGIC TRICKS, BOOKS, AND JOKERS' NOVELTIES

250 MAGIC Tricks 10 cents. Lowe, Box 287, Spokane, Wash.

TRICKS, puzzles, jokes, magical apparatus, plays, stage supplies, mind-reading, sensational escapes, large illustrated professional catalog, 10c. Oaks Magical Co., Dept. 548, Oshkosh, Wis.

CUT Woman In Half. Seventh world wonder revealed. Price \$1. Also, amazing mind-reading trick. Price \$1.5. Mystify, astound your friends. Both easily performed. Both tricks \$1.50. Box 198, Oshkosh, Wis.

MAGIC goods, cards, books, novelties, tricks. Catalog free. C. Fenner, 2401 Jefferson, Louisville, Ky.

NEW and Original Magic. Massey, 205 pages, 28 page plates. \$3.15 postpaid. Spon & Chamberlain, 122 P. M. Liberty Street, New York.

FREE—our puzzle, trick, game, joke Novelty Catalog. Wright & Son, 601-G Ind. Ave., Peoria, Ill.

FUN for every occasion. Magic Mechanical Misc. Blackie and Whittie. World's Greatest funmakers. 25c. Gerstenfeld, 126 Adkins Avenue, Brooklyn, N. Y.

10 AMAZING Card Tricks and catalogue 10c. "Norelec," 68 Houghton, Worcester, Mass.

BOOKS, Novelties, Illustrated catalog, 10c. R. F. Bronz, Saylorsburg, Pa.

25 MAILORDER Magazines and Papers 25c. Hansen Company, One, Brookings, S. Dak.

MAGIC—Tricks, Books and Supplies. For Amateurs as well as the great professionals. Anyone can learn through our instructions. Feature Acts in Mind Reading, Spiritualism, Rope Ties, etc. Large Illustrated Professional Catalog, 20c. Chicago Magic Co., 140 S. Dearborn St., Dent, B. Chicago, Ill.

MAGICIAN'S Nickeloed Pistol \$1.00. Seven tricks and four catalogs 25c. Gilmagico, Morgan Park, Chicago.

STAMP COLLECTING

START a Stamp Collection—70 different stamps from 70 different foreign countries, including Africa, Asia, Australia, Europe, West Indies, etc. Our pamphlet which tells "How to make a collection properly," and price list of albums, packets and sets all for only 16 cents. Queen City Stamp Co., Room 35, 604 Race St., Cincinnati, O.

FREE—100 different Stamps with each application for my 1c and 2c approvals. A. Sziklas, 137 Peterboro St., Boston, Mass.

BOYS! Big \$\$\$ outfit for 12c. 2 Airplane, 2 special Delivery, 2 Pictures 2 Map, 5 Newspaper, 3 parcel post, 2 Red Cross, 2 Animal, 5 French Colonies, 7 Russian Starvation (Hades, Starvation Children, etc.) and fine packet from Cyprus, Sudan, Nicaragua, etc. All for 12c to Approval Applicants sending postage. Specialist in Mexican Stamps. World Wide Stamp Co., Phoenix, Ariz.

SET German Air Post. Eight different China Ships, and 50 different unused Hungary, cataloging over \$1.50. Millimeter scale, ruler, and perforation gauge. To those requesting our new Sudden Service approvals—2c. Fennell Stamp Co., Dept. P2, Fullerton Bldg., St. Louis.

ZAMBESIA, Zanzibar, Abyssinia, Herzegovina, Allenstein stamps, menagerie collection, album, 10c. Liberty, 3974 Arsenal, St. Louis, Mo.

BEST one-cent approvals in America. F. P. Hand, 1117 So. 60th St., Philadelphia, Pa.

U. S. STAMPS on approval. Willow Stamp Company, 26 Willow Court, Dorchester, Mass.

MYSTIC'S "Mysterious" Packet! Contains stamps from the lands of cannibals, heathens, sun worshippers, and wild savages. Included are Travancore, Malay, Dutch Indies, Liberia, Siam, Africa, Abyssinia, North Borneo, Nyassa, Congo, etc. This wonderful packet containing 110 all different (mostly unused) for only 8 cents to approval applicants. Mystic Stamp Co., Dept. 8, Camden, New York.

50c EACH—All different—200 Austria, 90 South America, 500 World. Fred Onken, 630 79th Street, Brooklyn.

STAMPS sent on approval at 70% discount. Reference required. Emory Renoll, Hanover, Pa.

STAMPS on approval, 1/4 cent up. Free Premium. Herbert Kelgwin, Middletown, N. Y.

1,000 DIFFERENT stamps \$1.25; 500 British Colonies, \$5.00. Luther Matheson, Newton, N. C.

105 DIFFERENT with approvals 5c. Robinson, 41 First St., Fulton, N. Y.

500 DIFFERENT stamps, wonderful quality, only 30c to applicants for approvals. Nickles, 122 Florida, Washington, D. C.

FREE stamps given to approval applicants sending two cents postage. G. B. G. Stamp Co., 21 Madison Ave., Morristown, N. J.

PACKAGE of Novelties Sent Free. Cornish Company, Schenectady, N. Y.

100 DIFFERENT stamps free to applicants for our Popular Approvals. Postage 2 cents. Christensen, Syracuse Bldg., Milwaukee, Wis.

IMPERFORATE Harding to approval applicants sending references. Majestic Stamp Co., Grimsby, Ontario.

1,000 MIXED Foreign Stamps 20 cents. Nielsen, 3244 Whipple St., Chicago.

UNUSED 1,000,000,000 mark German stamp free to applicants for 50% approvals. Frank Varley, Manitoa, Manitoba.

PACKET of 23 stamps, no two countries alike. Packet hinges. Set of \$1 and \$2 U. S. Rev., all for 5c. Mention paper, P. M. Miami Stamp Co., Toledo, Ohio.

20 UNUSED stamps free. All different. Postage, 2c. P. M. Fisk Stamps, Toledo, Ohio.

FREE, Dollar Stamp Free to applicants for my 60% approvals. Norman Shultz, Colorado Springs, Colo.

FUME, 50 different 50c. F. Buffham, Lake Ave., Racine, Wis.

FOUR unused sets including "Paderevski." 55 different, hinges, premium, 15c. Deering, Newton St., Marlborough, Mass.

25 VARIETIES to approval applicants 2c. A. Doktor, 132 Esther St., Toledo, Ohio.

ESTHONIA Triangular Airplane stamp; also 200 different stamps for 20c. Jacob Fischer, 4230 Crystal St., Chicago.

UNIVERSAL Packet, 100 varieties, all over the world, 10 cents. Corvert Stamp, 39 State, Rochester, N. Y.

APPROVALS for Senior Collectors. Discount to 80%. Reference. International, 2117 Regent Place, Brooklyn, N. Y.

FINEST one-cent approvals. Boehm, 401 W. 149th St., New York.

BAVARIA, 50 var., 10c. Germany, 50 var., 7c. George, 285 Seventh St., Milwaukee, Wis.

ANCHER'S \$\$\$ Outfit—Only 12c! Fine triangle stamp; set German stamps with (pre-war) value forty million dollars (interesting!); perforation gauge, mm. scale; small album; 2 approval sheets; airmail set; scarce stamp from smallest republic on earth; newspaper set; packet good stamps from Travancore, Johore, Dutch Indies, etc. Entire outfit for 12c to approval applicants! (Extra premium this month only! Nice pocket stock book, value 25c, with every order!) Ancher Stamp Co., 9 1/2 Monticello Ave., Jersey City, N. J.

SOUTH BEND'S "Savage" Packet contains stamps from some of the wildest and most obscure countries in the world! Included are Kenya and Uganda, Congo (head of warrior) San Marino, Johore, Dutch Indies, Cape of Good Hope, Malay, South Africa, etc.—over 100 stamps in all, mostly unused! This excellent packet only 8c to approval applicants! South Bend Stamp Co., South Bend, Indiana.

20 DIFF. Turkey 8c. Approvals. Fryrear, 1411 4th Ave., Cedar Rapids, Iowa.

1000 MIXED Foreign Postage Stamps 20 cents. Nielsen, 3244 Whipple St., Chicago.

100 RARE Stamps, all different; Bargain Hsts. Stamp Magazine, everything 7c. Stanton, Niantic, Conn.

PATHE Special Bargain, 100 new Europe, est. over \$2.00, for only 6 cents to approval applicants. Perforation gauge, mm. scale, price list and one Premium Certificate Free. Send reference, please, and try our approval service. Pathe Stamp Co., 521 Woodward Ave., Atlanta, Ga.

WE want your Duplicate Stamps in Exchange; will give you good trade. Finest Approvals 50% and lower. 1,000 American Hinges and Premium Set 10c. Albums, Packets, Sets and Accessories, cheap. Big List free. Reference required. Supreme Stamp Co., 2 Bradford, Pa.

30 DIFFERENT Newrops, German Air Mail Set. Free to applicants for my 1, 2, and 3c net approvals; also my high-priced stamps at 50% discount. Chas. W. Schmidt, 3227 Benner St., Wissinoming, Philadelphia, Pa.

"RITE-RITE" pencil free to every new customer sending 10c for our 100 varieties New Europe, including Danzig, Poland, Lithuania, etc., and asking for selection of Fenway net approvals. Best on the market. Fenway Stamp Co., Fenway Station, Boston, Mass.

2,000 DIFFERENT stamps \$5.35; 1,000, \$1.45; 500, 45c; 300, 25c. Micheal, 5353 Calumet, Chicago.

STAMPS, 100 all different. Postage 2c. Lists free. P. M. Quaker Stamp Co., Toledo, O.

\$1.00 FOR 12c! 100 different Newrops, Catalogued \$2.00 Red Cross set, Airplane set, Perforation gauge, Millimeter scale, Fine wallet, 5 approval sheets, 250 hinges scarce packet from Nyassa, Abyssinia, etc., price list and approvals—all for 12c to approval applicants. Atlanta Stamp Co., Box 532, Atlanta, Ga.

FREE, unused German set. Pre-war value; millions of dollars sent to approval applicants at 60% discount. Reference required. J. de Jong, 516 West 162nd St., New York, N. Y.

FREE—25 different U. S. Stamps with 60% approvals to reliable parties. 75 different U. S. Stamps 25c. C. Seidenberg, Marton, Wis.

300 FOREIGN 25c; 25 stamps free, including stamp and coin list. A. McCreery, Chatham, Ontario.

25 DIFFERENT Poland 10c; 50 different U. S. 10c; 30 different Sweden 10c; 1,000 different stamps \$1.50. R. H. Carlton, 360 W. So. Temple, Salt Lake City, Utah.

FREE—35 Diff. Ireland, Barbadoes, Bermuda, Dominican, Malay, etc., gauge premium, for 2c postage, 100 Diff. U. S. 22c—25 Bulgaria 9c. Hawkeye Stamp Co., Cedar Rapids, Ia.

FREE—"Leader" Pkt. to approval applicants sending 2c stamp. Earl Stamp Co., 1811 26th Ave. North, Minneapolis, Minn.

FREE—50 varieties to approval applicants sending 2c. Richard P. Lamprecht, Valparaiso, Ind.

NYASSA Giraffes and packet of 52 different scarce stamps. Fume Triangle, large \$1.00 U. S. Rev., millimeter scale, perforation gauge and ruler for only 9c. To introduce our Sudden Service approvals. Fennell Stamp Company, Dept. P, Fullerton Bldg., St. Louis, Mo.

DANZIG Free—Nice Set Danzig Stamps with Biggest Lists issued, 2c postage. Midland Stamp Co., Station E2, Toronto, Canada.

FRENCH Colonies Free—Pretty Picture Set, Native Chiefs, Tigers, 2c Postage. Empire Stamp Company, 342 Lippincott, Toronto, Canada.

BIG Variety Packet Foreign Stamps Free for 2c postage. Gray Stamp Company, Station E10, Toronto, Canada.

500 DIFFERENT Stamps 32c. 1,000, \$1.25, to approval applicants. Stadler, 437 Beach Ave., Bronx, N. Y.

PACKET of 23 stamps, no two countries alike. Packet hinges. Set of \$1 and \$2 U. S. Rev., all for 5c. Mention paper. Miami Stamp Co., Toledo, Ohio.

158 GENUINE Foreign Stamps. Mexico War Issues, Venezuela, Salvador and India Service, Guatemala, China, etc., only 10c. Finest approval sheets 50 to 60%. Agents Wanted. Big 72-p. Lists Free. We Buy Stamps. Estab. 20 years. Hussman Stamp Co., Dept. 54, St. Louis, Mo.

FREE—Two sets Nyassa, 20 Diff. British Colonies Barbados and Jamaica pictorials and a packet of hinges—all for a request for my 1, 2 and 3c net approvals, none better. Chas. T. Egner, 4821 Frankford Ave., Frankford, Phila., Pa.

24 VARIETIES Cuban stamps, 10 cents. List of 6,000 low-priced stamps free. Address Chambers Stamp Co., 111P, Nassau St., New York City, N. Y.

STAMPS, 50 varieties, Africa, Brazil, Peru, Cuba, Mexico, etc., 10c. 50 different U. S., 25c; 1,400 mixed, 40c; 1,000 hinges, 10c. List free. C. Stegman, 5948 Cote Brillante, St. Louis, Mo.

105 CHINA, etc., stamp dictionary, list, 2c. Album (500 illustrations), 3c. Bullard, Sta. A. Boston.

RARE COINS

POLITICAL Cent, Jackson cent or "Hard Times" Token, issued in 1834 to 1842. Highly interesting, some with jacks, turtle, etc. Get one now with my large 50-page illustrated Coin Catalog for only 20 cents. This is just a special "get-acquainted offer." B. Max Mehl, Numismatist, Mehl Bldg., Dept. P, Fort Worth, Texas. Largest Rare Coin Establishment in the United States.

50,000 COINS, medals, paper money, daggers, Indian relics, curios, antiques. Catalogue free. Nagy, 33P South 18th, Philadelphia.

CALIFORNIA gold, 3/4 size, 27c; 3/8 size, 53c; three-cent-piece and catalogue, 10c. Norman Shultz, Colorado Springs, Colo.

\$2 TO \$50 each paid for hundreds of Old Coins. Keep all Old or Old Money. It may be very valuable. Send 10c for New Illustrated Coin Value Book, 4x6. Get posted. We pay cash. Address Clarke Coin Co., Ave. 2, Le Roy, N. Y.

OLD Coins. Large Spring selling catalogue of coins for sale, free. Catalogue quoting prices paid for coins, 10c. William Heasler, 101 A Tremont St., Boston, Mass.

OLD Money Wanted. Have you an odd or old coin or bill? It may be worth several dollars. Get posted. Send 4c for Coin Circular. May mean much profit to you. Send now. Numismatic Bank, Dept. H, Fort Worth, Texas.

1,000,000,000 GERMAN Marks for \$1.00, or 2,500,000,000 for \$2.00. Send Money Order to Public State Bank, Dept. 102-A, Chicago, Ill.

RARE Coins, Medals, Paper Money, United States, Foreign and Ancient. Villa Coin and New Catalog 10c. Alexis Mengelle, Box 387, Colorado Springs, Colo.

RARE United States Coins for sale. Everette Granville, Numismatist, West Fitchburg, Mass.

TURKEY and Austria coins 15c. Durso, 25 Mulberry, N. Y. City.

40 OLD Coins, all different \$1.00, 20 Large U. S. Cents, all different dates, \$1.25, 25 different Confederate Bills \$2.25, 200 Different German City Bills \$1.00. Claud Denny, Box 315, Dallas, Texas.

100 MIXED foreign copper coins from Holland, France, Russia, Finland, German East Africa, Norway, Denmark, Sweden, Switzerland; all bright new condition; post-paid, 50 cents. Nagy, 33P South 18th Street, Philadelphia.

BEAUTIFUL New Mexican Bills, 5 and 10c each. California Gold \$, 27c; 1/2, 53c. Magic Bill Book, 3 Bills and Price Lists, 25c. AL E. Bonsall, Richmond, Ind.

HIGHEST Cash price for old United States Coins. Catalogue stating prices paid 10 cents. Ambrose Brown, Box 293, Marblehead, Mass.

FOR BOYS

MOUTH-ORGAN Instructor, 25c. Learn in one hour. 150 Song Parodies, 10c. Secret Conversation Cards, 10c. Secret Writing System, 10c. 250 Magic Tricks, 10c. G. Elsea, Bowling Green, Ohio.

BOOKS — "Ventriloquism," "Toymaker Book," "Boy Electrician," 10c each, all for 25c. G. Elsea, Bowling Green, Ohio.

CAMERAS AND PHOTO SUPPLIES

PHOTOGRAPHIC equipments and accessories of every description are listed and illustrated in our 178-page catalogue. It will pay you to secure a copy which is issued free, as our prices are low. We also deal in used goods which are sold under the same guarantee as new goods. Ask for our Bargain Book. Central Camera Co., Dept. E-80, 124 S. Wabash Ave., Chicago, Ill.

8x10 ENLARGEMENT from your film colored and framed for 98c plus 2c for insurance. Cash with order. Send for circular. Albes Photo Service, Braintree, Mass.

COLOR Photographs! Make big money. Fascinating, steady work. My book teaches entire profession. \$1.00 postpaid. Abenir LeHeart, 302 Douglas Bldg., Los Angeles.

DO you Like to Paint? Any one with a little talent for coloring can paint beautiful pictures with the aid of our Canvasographs. We make a photographic enlargement of any kodak picture or photo direct on canvas. Giving you a clear copy to work on. Send \$1.00 and 10c postage with picture for 11x14 Canvasograph. Canvasograph Company, 6215 Wentworth Ave., Chicago.

COLOR Photographs with Inexpensive Developer. Investigate! Greenhalgh, B-278, Indianapolis, Ind.

FILMS developed, prints made. Write for Price List today. Z. Koscielnak, 17214 Lamont, Detroit, Mich.

SPECIAL! Beautiful "Old Master" Enlargement, 8x10, 11x14 or 14x17. "Sepia or Oil" from negative or photo, \$1.00. Finest equipped plant in America! Film Artists Productions, Box 417, Los Angeles, Cal.

SUPERIOR Enlargements from your choice negatives. Retouched. Embossed with one inch borders, double weight stock. Unsurpassed quality and workmanship. Money with orders. 5x7 50c, 6x5 60c, 8x10 75c. Linn Photo Co., Dept. E, Lansing, Mich.

HAVE You a Camera? Write for Free sample of our big magazine, showing how to make better pictures and earn money. American Photography, 116 Camera House, Boston, 17, Mass.

SUPERIOR quality finishing and enlarging. Trial offer: Any size 6 exposure roll developed and printed, 25 cents. 8x10 enlargement unmounted, 30 cents. Carckuff Photo Finishing Co., 2129 W. Van Buren St., Chicago, Ill.

BIG Money Saved on Photographic Lenses and Apparatus—goods exchanged; repairing done. Ralph J. Golsen, 1128 Arzyle St., Chicago, Dept. P.

MODERN Photography in all its branches now taught by mail. New Successful Method. Students earning \$300.00 while learning. Big Opportunity. Write for particulars and unusual offer open for short time. Dept. 3431, International Studios, Inc., 3661 Michigan Ave., Chicago.

KODAK Films—Special trial offer: your next kodak film developed, 5c—prints, 2c each. Messer & Son, 1917 St. James Ave., Cincinnati.

FILMS Developed. Special Trial Offer. Any Size Kodak film developed 5c, prints 3c each. Trial 6x10 Enlargement in handsome folder 40c. Overnight Service. Roanoke Photo Finishing Co., 269 Bell Ave., Roanoke, Va.

MOTION PICTURES

ELECTRICITY 10c per hour. Motoco Auto Generator operates on any automobile or truck. Produces electricity for moving picture machines, theatres, tents, schools, churches, etc. Mazda equipment and globes for all professional and suitcase machines. Details free. Monarch Theatre Supply Co., Dept. S. T., 724 So. Wabash Avenue, Chicago.

\$35.00 PROFIT nightly. Small capital starts you. No experience needed. Our machines are used and endorsed by government institutions. Catalog free. Atlas Moving Picture Company, 482 Morton Bldg., Chicago.

MOVIE Films for toy and professional machines. complete stories with best movie stars. comedies, westerns and dramas. in 1, 2 and 5 reels. Special 1000 foot reels only \$5.00. Mutt and Jeff cartoons per reel \$8.00. Illinois Film Sales Company, Dept. 83, 724 So. Wabash Avenue, Chicago.

O BOY! The Bass "Bargaingram" for this month will astonish you. Think of a complete Professional Motion Picture Camera, Tripod, Film, ready to start in a news weekly studio or commercial motion-picture film for only \$74.50. Dozens of other items just as good. Write for your copy at once. Hundreds of Bass' customers have become financially independent making motion pictures. The 575-page "Cinema Handbook" for only \$3.00 postpaid. The 52-page "Bass Catalogue" is free! Write or wire at once! Bass Camera Company, 195 North Dearborn St., Chicago, Ill.

AMERICA'S Greatest Fortunes made in the Motion Picture business. We furnish complete theatre equipment on easy payments. Openings everywhere. Catalog free. Monarch Theatre Supply Co., Dept. A, 724 So. Wabash Av., Chicago, Ill.

REMARKABLE light weight New Model Motion Picture Projector, standard film, electric high power, low voltage illumination. Hand Drive, complete, at \$65.00. Motor drive, \$90.00. Weight, twelve pounds. Satisfaction absolutely guaranteed. Catalogue upon request. DeFranne Importers, 109 N. Dearborn St., Chicago, Ill.

WONDERFUL Opportunities for Making Fortunes in this Business. No Experience needed. Complete Theatre Outfits sold on Easy Terms. Free Catalog. Monarch Theatre Supply Co., Dept. P. Memphis, Tenn.

MOVING Picture Film one cent foot. Candee, 551 South Salina St., Syracuse, N. Y.

MOVIE Films for Home, School, Church and Theatres. Comedy, Drama, Cartoon, Cowboy, Indian, Jungle, Religious, Historical, Fairy, Travel, Vodevil and Educational subjects. \$5.00 per reel up. Complete List. Monarch Theatre Supply Co., Dept. G, Memphis, Tenn.

HENRI DEFRANNE announcing that he has purchased 500,000 feet of film consisting of one-reel comedies, educational, news weekly subjects and two-reel comedies, also five-reel features. The greatest offer—1,000 feet of single reels at \$5.00. Two-reelers at \$10.00 to \$15.00 and five-reelers from \$25.00 to \$100.00. A marvelous opportunity! Write or wire your needs, all films in perfect condition. DeFranne Importers, 109 North Dearborn St., Chicago, Ill.

MOVIE Projector, largest reels \$25.00. Motor driven Projector \$50.00. New \$250 suit case Motor Projector \$75.00. Films, 100 feet \$1.00 postpaid, 800 feet \$3.00; Comedies \$5.00. Films rented. Pocket Movie Camera with tripod \$70.00. 200 foot Camera \$85.00. 400 foot Professional Movie Camera \$100.00. Ray, 324 5th Ave., New York.

MOVIE Films for home and theatrical use; largest stock, lowest prices; comedies, complete subjects, \$3.50 reel up; features \$20 up. Write for list. Independent Film Exchange, Dept. B, 363 West Commerce St., San Antonio, Texas.

MAKE money writing photoplays; details free to beginners. No correspondence course. Producers League, 239 Walnut, St. Louis.

BIG Money Nightly—Good assortment. Complete Outfits, installment plan. Splendid Home Outfit, \$25.00. Ralph J. Golsen, Dept. M, 1128 Arzyle St., Chicago.

SCENERY TO RENT

SETTINGS for Opera, Plays, Minstrels. Plush drops. Address Amelia Grain, Philadelphia.

EDUCATIONAL AND INSTRUCTION

PAINTERS, Decorators, Printers, Artists: Mix 3,000 Beautiful colors. Example: Sepia brown is 20 parts orange, 1 black. Book giving proportions \$1.00 postpaid (money refunded), information free. Fine Arts Publishers, 2033-35 College Ave., Indianapolis, Ind.

PIANO Jazz: Teaches Negro Harmony. Player Piano Style, Blues, Vamping, Close Harmonizing, Ear Playing, etc. Booklet Free; Write "Piano Bill," 211 Ossington Ave., Toronto, Canada.

HOMESTUDY, Law, Shorthand, Real Estate. Secretary, 1552 Broadway, Grand Rapids, Mich.

BE a Laboratory Expert. Earn \$300.00 to \$500.00 a month. Study Microbiology, Bacteriology, Laboratory Technology, Sanitation. Interesting Extension and Residential Courses. Diplomas and Degrees granted. 71-piece Urinalysis Outfit Free to students. Write for Free 48-page Prospectus Today. Int'l Physicians and Surgeons College of Microbiology, Room 955, 550 Garfield Ave., Chicago, Ill.

LEARN Penmanship; Instructions 25c (Silver). Prince, 130 W. 104, New York.

MATHEMATICS and Drafting taught by mail. Courses in Arithmetic, Algebra, Geometry, Mensuration, Trigonometry, Logarithms, Mechanics, Mechanical Drafting, and Tool Designing. Harding School, Box H, Highland Park, Mich.

CARTOONISTS—Improve your style by following the work of the greatest cartoonists found in the bound volumes of Cartoons Magazine. Three volumes, each covering six months, Jan-June 1919 to Jan-June, 1920, inclusive. 1200 cartoons, 800 pages to a volume, 7 by 9 1/2 in., 3 in. thick. New books, durable and attractive binding. Sold separately at \$2 per vol. postpaid. Supply limited. Send at once. Popular Mechanics Book Dept., 206 E. Ontario St., Chicago.

BARGAINS in educational books on all subjects; details free. Wilson Argo Co., Dept. 15, St. Louis, Mo.

JOURNALISM—Photoplays—Short Stories. Plot Chart and Copyright Book free to those wishing to enter above professions or to dispose of manuscripts on Commission. (The Service offered is given by Professional Authors and Editors of high standing.) Harvard Company, 431, San Francisco, Calif.

SHORTHAND, Automatic Vowel System. Write today. C. K. Mathews, 115 Common St., Shreveport, La.

SHOW-CARD writing a pleasant, profitable profession easily and quickly learned by our new, simple, graphic block system. Artistic ability not necessary. We teach you how. Distance no object. Full particulars and booklet free. Wilson Methods, Limited, Dept. 53 C, East Richmond, Toronto, Canada.

USED educational matter, books, etc., sold, rented and exchanged. Big list free. Lee Mountain, Pisgah, Ala.

ROPP'S Calculator and Short-Cut Arithmetic shows the answer as quickly as a watch shows the time to all problems likely to occur in office, store, shop, bank, farm or factory. Price, pocket size, paper 35 cents; cloth 50 cents; leatherette \$1. Desk size, cloth, \$1.50 postpaid. Popular Mechanics Book Dept., 206 E. Ontario St., Chicago.

WORLD-ROMIC System, Masterkey to All Languages. Primers, \$1.94 each language: Cantonese, English, French, German, Italian, Portuguese, Russian, Spanish, Swedish. Pronunciation-Tables, 50c each language. Dictionaries, grammars, 4,000 languages, of 1,700,000,000 people: Afro-Asiatic, Amerindic, Eurindic, Indo-Pacific, Siberic, Sinitic. Languages Publishing Company, 8 West 40th Street, New York.

WRITE articles, stories, news, in spare time for newspapers and magazines. Big pay. Copyright book free. Press Syndicate, 552, St. Louis, Mo.

YOU can have a business profession of your own and earn big income in service fees. A new system of foot correction; readily learned by anyone at home in a few weeks. Easy terms for training; openings everywhere with all the trade you can attend to. No capital required or goods to buy, no agency or soliciting. Address Stephenson Laboratory, 1 Back Bay, Boston, Mass.

DOUBLE Entry Bookkeeping mastered in 60 hours with 8 keys; guaranteed; diplomas. Our graduates lead in bookkeeping, auditing, accountants, balance sheets, and financial statements. International Bookkeeping Institute, Dept. 8, Springfield, Mo.

USED books and educational matter bought, sold, exchanged. List 1,000 items free. Students' Exchange, 47-A West Forty-second Street, New York, N. Y.

ARTIFICIAL Marble, sanitary flooring instructions, ornamental casting, concrete plaster, papier-mache decorations, garden furniture, statuary, Rubber-moulds, Electrometallurgy, particulars and 200 illustrations free. Chris Mahler, Box 122, Huntington, N. Y.

BOOKKEEPING in a Week, \$1 Postpaid. Dukes, 1857 Walton Ave., New York.

VEST-POCKET Bookkeeper—Complete instructions for the correct keeping of books of accounts. Shows an entire set of books based upon actual transactions. 160 pp. Leatherette. \$1 postpaid. Popular Mechanics Book Dept., 206 E. Ontario St., Chicago.

"WHAT to Invent for Profit" free. Patent News-N, Washington, D. C.

SHOW Card Writing, a pleasant, profitable profession. Quickly and easily learned through our new, simple method. No canvassing or soliciting. We show you how, no matter where you live. Full particulars and booklet free. American Show Card System Limited, 203 Adams Building, Toronto, Canada.

RADIO OUTFITS AND SUPPLIES

AUTOPLEX Circuit; One tube set works loud speaker, no aerial or ground; complete parts with diagram, instructions, etc. \$18.50 tube free with every order. List of other bargains on request. Royal Mfg. Co., Dept. 501, 296 Broadway, New York.

ATOMITE, World's Premier Crystal Loud Everywhere. Tune in Any Place. Long Distance Reception. Choice for Reflex; 50c Postpaid. Non Fixed Detectors, \$1.00. Guaranteed Loud. Jobbers and Dealers discounts. Keystone Products Co., Royal Oak, Mich.

BEAUTIFULLY made, sharp tuning, long distance Crystal Receiving Set, set loud headphones, antenna and ground wire, complete for \$7.75. Shipped C.O.D. on receipt of deposit. Greatest value. Bass Camera Company, Atwater Kent Agents, 109 N. Dearborn St., Chicago.

DICTIONARY of Radio words and terms, electrical symbols, wiring diagrams, radio diagrams and complete electrical dictionary, new, up-to-the minute, just published. 188 pages, cloth cover, vest-pocket size. 35c postpaid. Popular Mechanics Book Dept., 206 E. Ontario St., Chicago.

COMPLETE Radio Crystal Set, with Phones, Aerial and Insulators, Postpaid \$4.25. Guaranteed. Get our prices on your Radio Parts. Radio Sales Co., 1166 N. Kings-Highway, St. Louis, Mo.

BIG profits recharging radio batteries. Outfit on easy payments. Write Hobart Radio, Troy, Ohio.

CRYSTAL Radio Receiving Set. Guaranteed to work. 50c postpaid. Dealers Wanted. Tru-Blu Supply Co., 104 Lake, Rochester, N. Y.

RENEWING Dry Batteries, 3 Guaranteed Processes, 25c. "Universal," 4047-D, North Whipple, Chicago.

RADIO Map of the U. S.—Government Radio Stations, Broadcasting Stations, Commercial Stations, Call Letters, Wave Lengths, etc., 35c postpaid. Popular Mechanics Book Dept., 206 E. Ontario St., Chicago.

2,650 MILES Distance with one tube. Any novice understands our Simplified Instructions, including Panel Layout and Photo 25c. Vesco Radio Shop, Box PM-117, Oakland, Calif.

COMPLETE Radio set for receiving broadcasting, postpaid \$3. Includes receiver, headphones, aerial, and insulators. Specialty Sales Bureau, 1429B Milton St., Grand Rapids, Mich.

RADIO Generators, 500 Volt, 100 Watt, \$28.50 each. Battery Chargers \$12.50. High Speed Motors, Motor-Generator Sets, all sizes. Motor Specialties Co., Crafton, Pa.

LOUD Speaking Crystal Set. Broadcastings heard throughout house. Easily constructed. Instructions complete 25c. Catalog free. Stelmets Wireless Mfg. Co., Eastend, Pittsburgh, Pa.

TELEGRAPHY

TELEGRAPHY—Both Morse and Wireless—taught thoroughly and quickly. Tremendous demand. Big salaries. Wonderful opportunities. Expenses low; chance to earn part. School established fifty years. Catalog free. Dodge's Institute, 11 St., Valparaiso, Ind.

TRADE SCHOOLS

FREE Railroad Fare to Chicago. Enroll in the Greatest School of its kind in the United States, and get a training in a few weeks that other tradesmen have spent years to learn. Our instructors are experts in their lines and impart their years of experience to you in such a short time that it seems almost impossible. Complete practical courses in Sign, Scenic and Pictorial Painting—Interior Decorating—House Painting—Auto Painting—Paperhanging—Graining and Marbling and Show Card Writing. New Catalogue just out and free. Chicago Painting School, 148 W. Austin Ave., Chicago.

BE a Bricklayer: Good Pay, Interesting Out Door Work. Tuition \$25.00 per month. Five Days per week, Eight Hours per day. Course three to six months according to student's ability. Send for Circular. Associated Building Employers of Michigan, 112 A. B. E., Grand Rapids, Mich.

PAINT Automobiles, Trim Automobiles. Become a Certified Electrician, Auto Battery Builder, Ignition Expert on Starting and Lighting, Metal Finisher, and a complete course in Auto-Repairing, Bricklaying and Plastering. We fit you for a big money job. Make you an expert able to step right into a position paying \$45 to \$100 per week. You are paid while learning. Come to Detroit, the Automobile hub; the world's wonder City. Write today. Standard Trades School, 416 Woodward, Detroit, Mich.

LEARN Piano Tuning at home. Chicago School Piano Tuning, River Forest, Ill.

BUSINESS OPPORTUNITIES

ROOF Paint Salesmen: Get into business for yourself—build for the future, selling your own private brand Roof Coatings and Cements. Don't work through Sales or District Managers; make double profit yourself. New Plan. Write—Craftsman Paint Works, 303 Kerper Street, Reading, Pa.

GET Out of the rat, \$100 sufficient learn privilege trading. Dept. M, Paul Kaye, 149 Broadway, New York.

LEARN Candy Making. Make big profits at home or in shop. Big demand for good candy. Easily, quickly learned through our correspondence course. Write today for booklet 1-4. The Candy Institute, Sixty West Fifth Street, New York.

THERE is a real business opportunity waiting for you in your own town or city. Start a "Buy and Sell Bureau," a positive success and money maker that works the year round, and ten dollars will start you. Complete working plan \$3 postpaid. Buy and Sell Bureau, Rexburg, Idaho.

PATENTS Procured. Send sketch or model today for examination, prompt report and advice. No charge for preliminary advice. Write for free Booklet and blank form on which to disclose your idea. Highest references. Promptness assured. Clarence A. O'Brien, Registered Patent Lawyer, 581 Security Bank Building, Directly across the street from Patent office, Washington, D. C.

MANUFACTURE Your own Products. Get State Rights on my valuable Automobile and Metal Polish. Complete instructions for manufacturing and bottling. B. G. Earl, 56 E. Randolph, Chicago.

FORMULAS, Processes, Trade Secrets—Different, dependable, profitable. Catalog free. B. Thaxly Co., Washington, D. C.

INTERNATIONAL OPPORTUNITY (Brookings, S. Dak.), especially published for amateur business men. Year, 40c. Copy, 8c.

START a pressing, cleaning and dyeing shop; excellent field, splendid profits. We tell you how. Write for booklet, Ben-Vende System, Dept. C, Charlotte, N. C.

THE 20th Century Business Encyclopedia, containing 128 pages of valuable knowledge, \$1.00 postpaid. Johnson's Variety Store, New Suffolk, N. Y.

START a Real Estate Office of your own. Earn from \$3,500 upwards. Our course of 21 lessons tells you how. Booklet M, on application. Frederick Jenkins, Corbaer Heights, Schenectady, N. Y.

AGENTS Wanted—Something New—Fire fighter sells easily. Makes a spectacular demonstration; car owners, homes, factories, stores, practically buy on sight. Our men make \$10.00 to \$50.00 a day; exclusive territory. If you wish to establish a business of your own with unlimited possibilities for making big money, write us today. Fyr-Fyter Co., 103 Fyr-Fyter Bldg., Dayton, Ohio.

COST \$5.00, Your profits \$4.75, transferring monograms on autos, trunks, bags, etc. No skill required. Samples and information free. World Monogram Co., Dept. 16, Newark, N. J.

MAKE toys and novelties at home. Big profits, instructions and 200 illustrations, 25c. Astrolite Company, Sharnsburg, Pa.

MANUFACTURE your own Beauty Clay. Send 25c for original \$50.00 formula. Valley Laboratories, Wilmerding, Penna.

PROFITABLE home work for carpenters or anyone handy with tools—making newly invented combination article, needed in every home. Drawings 50 cents. Home Equipment Co., Drawer 923, Butler, Penna.

PATENTBOOK, 139 mechanical movements and illustrations, sent free. Labinere, 3 Parkrow, New York.

I MADE \$30 a Week Home. French Breadmaking, 15 years' experience; Free Booklet tells. Ashbrook 67, Marengo, O.

AGENTS—\$150 to \$575 monthly easy—Introducing New Style Guaranteed Hosiery. Must wear or replaced free. We deliver and collect. You simply show samples furnished you and take orders. Promotions to General Agency made from Active workers. Steady repeat business. Cotton, lisle, silk, heather, hose for all the family. Spare time satisfactory. No experience required. No capital needed for stock. Your pay daily. Mac-O-Chee Hosiery Company, Room 2584, Cincinnati, Ohio.

"GET into the Specialty Manufacturing Business" or "Why Work for Others?" may sound good to you, but you won't succeed in that business unless you possess Formulas that are absolutely reliable, the same required by leading manufacturers supplying the Best. Don't be bunked into buying a Collection of cheap "Formulas" and expect to succeed. Send today for my valuable literature and Formula Lists and Real Money-Makers in the Specialty Manufacturing Business. 26 years supplying the Best. Miller, Chemist, 805 De Leon St., Tampa, Fla.

"HOW to Sell Patents" free. Patent News-H, Washington, D. C.

OPERATE your own business. Small capital. Big results. Repeat. Po-Lax Laboratories, 1514 E. Jefferson, Detroit, Mich.

GREATEST Fortunes in Motion Picture Business, Small Capital Starts you with Complete Outfit. Details Free. Monarch Theatre Supply Co., Dept. F, Memphis, Tenn.

INSTEAD of working for someone else, why not make something work for you? If you have not less than \$500 in cash you can build a business of your own right in your own back yard and make \$2,000 to \$5,000 yearly. If you are ambitious and really serious about becoming independent, write at once to Windswept Farms, 912 Windswept Building, Henderson, N. Y.

GET the money. Make and sell Wall Paper Cleaner. Inexpensive and easy to make. Save expense of cans, freight and packing. I tell you where to buy all materials; Furnish Formula and complete directions for \$1.00. Your success guaranteed. H. Sech, 855 S. Grote, Oak Park, Ill.

NICKEL plate automobile accessories, hardware, electrical parts. Big profits. Requires no capital. Simple battery process. Write today. Webster Engineering Co., Webster Groves, Mo.

SERIES of Letters and Instructions for Starting Collection Agency, \$1.00. Commercial Agency, Box 383, Helena, Mont.

MONEY in Cash Grocery. Our Copyright Course tells all about it. \$5.00 postpaid. MacDonald, Box 15, Detroit, Mich.

HAMILTON Beach carpet washer; start a business. Solter, 1407 1 Ave. So., Minneapolis, Minn.

FOR territory and machine to manufacture 20,000 Eclipse Rubber Wrapping Bands per hour of inner tubes, address C. B. Martin, 1129 6th, N. W. Canton, Ohio. Small investment required.

WINDOW Cleaning. New system. Big profits. Particulars, 10c. Alfred Hansen, 122 W. 30th St., Los Angeles, Calif.

FORTY Famous Business Plans \$2.00. Processes for manufacturing many fast-selling necessities; selling plans; where to buy materials. Gilmer's, 4450 W. End, Chicago.

GET into the Window Screen business. We furnish parts. All metal construction and fly-tight fit. No experience nor special tools required. \$75.00 to \$250.00 per week net profit. Foster, 141 Ogden St., Newark, N. J.

120 MONEY-MAKING Plans Free! Welterine Bureau, Bl, Muskegon, Mich.

PATENTS Procured; Trade Marks Registered—A comprehensive, experienced, prompt service for the protection and development of your ideas. Preliminary advice gladly furnished without charge. Booklet of information and form for disclosing idea free on request. Richard B. Oren, 30 Owen Bldg., Washington, D. C., or 2276-R Woolworth Bldg., New York.

FREE Book—Start little mail order business anywhere; home employment evenings; beginner's working outfit furnished; 500 circulars, samples, things to sell; you deal direct with manufacturers; no stock to carry; instructive booklet free. Pier, 753 Cortland St., New York.

MAKE money. Start mail business. 29 Gilt-Edged Plans Free. Star Bureau, 1918 North St., Philadelphia, Pa.

25 MAILORDER Magazines and Pa... 25c. Hansen Company, Brookings, S. Dak.

START and Operate Your Own Business. Our System proprietary specialty manufacturing offers wonderful opportunity to make \$100 to \$500 weekly. Openings everywhere. Either men or women. We furnish everything and show you how. Big explanatory book, "The Open Door to Fortune" free. Write for it now. National Scientific Laboratories, 208 Monroe, Richmond, Va.

BE a Laboratory Expert. Earn \$200.00 to \$500.00 a month. Study Microbiology, Bacteriology, Laboratory Technology, Sanitation, Interesting Extension and Residential Courses. Diplomas and Degrees granted. 71-piece Urinalysis Outfit Free to students. Write for Free 48-page Prospectus Today. Int'l Physicians and Surgeons College of Microbiology, Room 971, 550 Garfield Ave., Chicago, Ill.

GO into the Crispette business. Everybody likes Crispettes. You can make a lot of money. We start you. Write for facts. Long Eakins, 1959 High St., Springfield, Ohio.

PATENTS—Write for our Guide Book and "Record of Invention Blank" before disclosing inventions. Send model or sketch and description of invention for examination and instructions. No charge for the above information. See advertisement on pages 179 and 171. Victor J. Evans & Co., 192 Ninth, Washington, D. C.

SIGNS, Banners and Cards easily painted with Letter Patterns. Samples for Stamp, John F. Bahn, A2433 Greenleaf Ave., Chicago.

ATTENTION!! You can have a business of your own. Establish and operate New System Real Estate Business, brokerage and insurance agency in your community. Office at home. Earn \$5,000 year. Representatives wanted everywhere. Send stamp for free booklet. Hayes Realty Association, Cincinnati, Ohio.

NEW Way, make money, home, spare time, no canvassing, mixing, manufacturing. Plan costs \$2. Clean, sure, quick, steady income, \$18-\$30 weekly. Circular free. E. M. Barrell, 3614 California, St. Louis.

THE Mail Order Review—Leading Mail Order Journal published. 24 pages of money-making ideas, plans, schemes, formulas. Year \$1.00; sample 10c coin. A. Oswald Pfaff, Baltimore, Md.

53 BUSINESS Opportunities. Each a good Practical Plan. Particulars 2c stamp. Pioneer Sales Co., Marietta, Ohio.

RAISE Capital for your business or patent by syndicating among investment bankers. Details free. Guardian Co., Knickerbocker Bldg., New York.

BIG Paying Business: Manufacture automobile supplies. Refinish Old Cars like new—we teach you how at home. Modern approved methods. Autorenuco, Sheboygan, Wis.

THE Great Wheat Secret. Market swings not caused by manipulation, but by a Great Natural Force dominating this grain. Up-swings and declines easily forecasted. Secret of immense value to Traders, Millers, Brokers, anyone interested in cash wheat or futures. Eye-opening folder free. Write today. Market Forecaster Co., Dept. M, Topeka, Kans.

MAKE \$5.00 hourly. Electric Lawn Mower Sharpening, 415 South Lawndale Ave., Kansas City, Mo.

CEMENT Masons, Plasterers, Contractors. Build successful business, succeeding old and new buildings with Everlastone Indestructible Stucco; also installing Corkstone Floors over worn-out flooring. Write immediately for agency proposition. Everlastone Corporation, 119 N. Collington Avenue, Baltimore, Md.

FIFTY "Money-makers" for Mail Dealers. 500% profit. K. Home, 1957 Warren, Chicago.

INVENTORS—Write for our Guide Book, "How to Get Your Patent" and Evidence of Invention Blank. Send model or sketch of your invention for our prompt opinion of its patentable nature. Randolph & Co., Dept. 435, Washington, D. C.

MAKE Money at Home—making toys. We show you how. Send \$1 for complete working drawings and instructions. DeKalb Designing Co., Decatur, Ga.

I MADE Big Money Spare Time Evenings. Mail Order business, booklet for stamp tells how. Sample and plan, 25c. Free 32 articles worth \$3. Alpmo Scott, Cohoes, N. Y.

LEARN destroying superfluous hair permanently without scar. Complete Instructions \$1. Henri Zilka, Fairview, Mass.

OPEN a rental bureau in your city under unique "Personal Inspection" plan. No capital required. Ask for details. Washington Service Bureau, District National Bank Bldg., Washington, D. C.

INCH Display Advertisement 166 Magazines. Thrice \$15. Year \$30. Page \$100. Wood's Popular Services, Atlantic City, N. J.

SILVERING Mirrors! My exclusive French Tartaric method opens enormously profitable business. Booklet free. H. Barstow, 514 21d Street, Oakland, Calif.

MAIL Order Business is your opportunity. Brenner's Famous Handbooks teach how to start small, grow big. Sell merchandise, service, ideas; enormous profits. Spare time to begin. Get complete set, 11 books, \$3.00, and be posted. Brenner, 335 Walnut, Philadelphia. Descriptive Catalog and big batch interesting mail order information, 25c. None free.

BIG money writing photoplays, stories, poems, songs. Send for free copy America's greatest magazine for writers. Tells you how to write and sell. Writer's Digest, 603 Butler Bldg., Cincinnati, Ohio.

EXCEPTIONAL Opportunity for Sales Manager capable of handling state distribution. Marvelous new Adding Machine. Retail \$15. Work equals \$350 machine. Tremendous possibilities. Unlimited profits. Write quick for details. Lightning Calculator Co., Dept. B, Grand Rapids, Mich.

WE Start You in Business, furnishing everything; men and women, \$30.00 to \$100.00 weekly operating our "New System Specialty Candy Factories" anywhere. Opportunity lifetime; booklet free. W. Hillver Ragsdale, Drawer 4, East Orange, N. J.

ENTER a new business. Earn \$3,000 to \$6,000 yearly in professional fees making and fitting a foot specialty, openings everywhere, with all the trade you can attend to; easily learned by anyone at home in a few weeks, at small expense; no further capital required, no goods to buy, job hunting, soliciting or agency. Address Stephen Laboratory, (1) Back Bay, Boston, Mass.

GOOD money easily earned at home spare time silvering mirrors; no capital. Free instructive book tells how. Patterson & Co., Brooksville, Ky.

RAISE guinea pigs. Pay better than poultry or rabbits; easy to raise; little space required. We guarantee market. Particulars and booklet how to raise free. Cavies Distributing Co., 3102 Grand Ave., Kansas City, Mo.

DOLLARS Yearly in your Backyard No mushroom dope. Particulars free. Metz, 313 East 89th, New York.

"SCHEMER Magazine." Alliance, Ohio, prints big profit schemes; one subscriber making \$25,000 from three; another \$10,000 from one. Try your luck. Year, only \$1.00; three months, 25c.

MARBLE mixing instructions, covering wood or cement flooring 1/2 inch thick, fire-proof, waterproof, low cost, sanitary, all colors. Particulars, 200 illustrations free. Chris Mahler, Box 122, Huntington, N. Y.

EARN \$10 daily silvering mirrors, plating and refinishing metalware, autos, chandeliers, bedsteads, headlights. Outfits furnished. E. Decio Laboratories, 1133 Broadway, New York.

STOP Plodding! Be Successful. Operate a Tire Repair Shop. Make big profits in any locality. We teach you and furnish complete equipments \$190.00 up. Book of Opportunity free. Haywood's, 1305 South Oakley Avenue, Chicago.

LEARN the collection business. Good income, quick results. Interesting booklet, "Skillful Collecting" free. National Collectors Assn., Long St., Newark, O.

\$3,000 TO \$6,000 Yearly. Want it? Others are making it. Send check or money order today for our invaluable books "How to Sell Real Estate," \$3.00—and "How to Conduct Real Estate and Insurance Business," \$1.50. Absolute satisfaction guaranteed. Free catalogs. Realty Book Co., Dept. 52, Cleveland, Ohio.

CHEMICAL Expert furnishes manufacturing formulas with complete working directions, resulting products possessing distinct individuality and merit. Processes perfected. All lines. No lists of worthless stock formulas but reliable individual service. Charges reasonable, correspondence invited. Dr. Arthur VanHeeden, 508 South Oakley Boulevard, Chicago.

MANUFACTURE Ready-Made Gold Window Sign Letters. Unlimited Profits! We furnish complete instructions, accurate patterns. Absolutely no experience required. Wonderful Business Opportunity! Particulars, Wiltberding, 3161 Abbott Court, Chicago.

"WHAT to Invent for Profit" free. Patent News-C, Washington, D. C.

CHEMISTRY

CHEMICAL and Bacteriological examinations guaranteed accurate. Research Work, Formulas, Processes, Trade-Secrets, All Lines. Work Guaranteed. List Free. J. F. Mazur, M. E., 237 W. 20th St., Lorain, Ohio.

CHEMICAL Analysis of Steel-works and Foundry materials undertaken. Work guaranteed. Wm Chemical Society, 2056 East 197th St., Cleveland, Ohio.

TRY our laboratory service, write for reasonable rates. Doris Chemical Laboratories, East Cleveland, Box 59, Cleveland, Ohio.

PRODUCTS formulated, duplicated, improved, cheapened. Universal alcohol substitute, \$3.50; Waterless Hot Water Bag, \$25.00. Circular. Hurry-Harding, L. B. 1029, Chicago.

CHEMICAL Processes, Analysis, Research, Technical Information. Consulting Chemist, Madison, Maine.

STUDY Bacteriology, etc. Big demand. 70 Piece Urinalysis Outfit Free to Students. Write for Free Prospectus today. International Physicians and Surgeons College, Room 954, 550 Garfield Ave., Chicago.

EXPERIMENTERS—Complete supplies for the chemical laboratory. Catalog 5c. National Scientific Supply Co., 241 Pa. Ave., Washington, D. C.

YOUR chemical problem solved and working process furnished Five Dollars. Write me. W. Stedman Richards, Consulting Chemist, address, Box 2102, Boston, Mass.

CHEMICAL Service. Formulas, analysis, methods, experiments. Jacob Sluyter, Chemist, 2525 East St., Davenport, Iowa.

FORMULAS AND TRADE SECRETS

LEMON Cream, Beauty Clay, guaranteed formula, instructions postpaid \$1.00. Ernest Mayon, No. 309 West 52nd Street, New York City.

500 FORMULAS: Resilvering Mirrors, Mechanics Soap (powdered). Valuable collection, 25c. Catalog free. Bestoval Laboratories, 4017-B4, North Whipple, Chicago.

500 VALUABLE Formulas 25c. Literature free. Harvey Teeple, Decatur, Ind.

FORMULA—Salve for Chapped hands, 10c. Herbert Ciesch, Garber, Iowa.

10,000 SELECTED chemical, technological and practical recipes and processes, including hundreds of so-called trade secrets for every business, alphabetically arranged in one large volume of 800 pages. Price \$4 postpaid. Popular Mechanics Book Dept., 205 E. Ontario St., Chicago.

1,000,000 FORMULAS—1,016 Pages, \$2. "Universal," 4017-M, North Whipple, Chicago.

FORMULAS—Best that Chemical Science can devise. Not "Better Sort" Formulas, but Guaranteed Reliable processes in all lines. Stamp brings Valuable Literature and Latest Summer Sellers from an Analytical Chemist. Miller, Chemist, 807 De Leon, Tampa, Fla.

5,000 RECIPES, \$1.25. Best formulas and processes for every business, trade or occupation are in "Youman's Guide." Many never before published. Worth \$1.25 each, 530 pages. Paper cover \$1.25. Cloth \$2.00, postpaid. Book catalog free. Wells and Edwards, Department X, 852 George, Chicago.

MONEY-MAKING Formulas, Books, Plans. Big Catalog Free. "Universal," 4017-B North Whipple, Chicago.

FORMULAS Free. Get my proposition. Leighton, Ph. G., Phenix, R. I.

BIG, Interesting formula catalog free. National Scientific Laboratories, 208 Monroe Street, Richmond, Va.

AGENTS WANTED

WRITE for Proof of Profits and New Sales Plan—Free—\$5 to \$15 daily easy—Year pay in advance demonstrating and writing orders for New Style Guaranteed Hosiery—Special Premium offer to new customers make quick easy sales—Put in all your time selling—We deliver and collect—Sample outfit furnished—All colors—grades including full fashioned silks. Mac-O-Chee Company, Room 2564, Cincinnati, Ohio.

WHY Work for others? Start and operate your own business. Our system proprietary specialty business offers wonderful opportunities to make \$100 to \$500 weekly. Openings everywhere. We furnish everything and show you how. Booklet free. National Scientific Laboratories, 208 Monroe, Richmond, Va.

FREE Copy—Agent's and Mail order Magazine. Harvey Teeple, Decatur, Ind.

\$10.00 DAILY easily made selling Needle Cases; retails 25c. Send 10c for sample. Mail Order House, Wilmerding, Penna.

START your own business as our sole agent. Selling 100 famous home products. All or spare time. Dr. Blair Laboratories, Dept. 524, Lynchburg, Va.

\$3.50 AUTOMATIC Adding Machine. Quick, profitable seller. Guaranteed accurate as highest priced machines. Exclusive territory granted. 75,000 already sold. Can be sold anywhere to anyone having adding of any kind to do. Act quick. Bassett Co., 1438-G, Hollywood Avenue, Chicago.

MAKE \$75.00 a week and up selling our fine made-to-measure, all-wool suits at \$31.50 retail, direct to wearer. Biggest values—positively sell on sight. Biggest commissions, paid in advance. We attend to delivery and collections. 6x9 swatch samples furnished free. W. Z. Gibson, Inc., Dept. D-8, 161 W. Harrison St., Chicago.

MORE Money. Anybody can get it. Free booklet shows how. Pitts, 561 W. Washington St., Chicago.

BIG Demand among Homes, Stores, Garages, etc., for Electric Burglar Alarms. Sell \$7.50. Comm. \$2.00. Write for territory. Warro Alarm, Box 684, Chicago.

DISTRICT Managers, Agents, 15 Hosiery numbers. Guaranteed silks, 18 guaranteed Neckwear Patterns, 10% Bonus to Managers. Largest commission, Single Sales. We deliver. Write for Free Samples. Dept. 1162, S. Q. 8, Lexington, Ky.

BIG money and fast sales—every owner buys gold initials for his auto. You charge \$1.50, make \$1.44, 10 orders daily easy. Samples and information free. World Monogram Co., Dept. 73, Newark, N. J.

WONDERFUL invention eliminates all needles for Phonographs. New, different, lasts for years. Presser's records, 12,000,000 prospects. \$15 to \$30 daily easy. Carry day's supply in pocket. Everplay, Desk 7-D, McClurg Bldg., Chicago.

AGENTS Coining Money applying Monograms on automobiles; you charge \$1.50, profit \$1.40; \$15 daily easy; experience unnecessary; free samples. Worcester Monogram Co., Worcester, Mass.

MY patented telephone pencil holder sells fast. Big profits. Sample 15c. Harry Mathews, 222 East Durham St., Philadelphia, Pa.

\$200 WEEKLY. Agents, State distributors. Wonderful new patented Ford accessory. Mosedale, 25 North Dearborn, Chicago.

ATTENTION—Agents! Big Money-Making proposition. Mozart Felt Bag, guaranteed, made of entirely new felt. Rapid seller. 100% Profit. Sample prepaid \$1.75. Write today for full particulars. Malsley-Payne Mfg. Co., 20-D, Sudbury St., Boston, Mass.

GET into the Big Money Class. Make \$15 to \$25 daily selling the famous guaranteed Hamilton Hosiery from Mill to Wearer. Selling outfit free. G. M. Hamilton Corporation, 11 Barrow St., New York.

EARN \$50 to \$75 weekly selling our beautiful umbrellas. Splendid value makes rapid sales. Every sale nets 1% commission. Write for particulars. A. E. Erasmus Specialty Co., 305 Broadway, New York.

MAKE \$31.00 Profit—Cost you \$1.50. Complete Gold Monogramming Outfit. Transferred Instantly on Automobiles, Trunks, Bags, Windows. Experience Unnecessary. Free Samples. NuLife Monogram, Hartford, Conn.

EXCLUSIVE Territory Genuine Army and Navy goods purchased from United States Government. Sells Farmers, Mechanics, Miners, Lumbermen, Hunters, etc. Free catalogue. Army and Navy Corp., 70 Church Street, New Britain, Conn.

AGENTS—Big Money \$8 to \$10 a day. Aluminum handle cutlery set. Brand new. You display and take orders. We deliver and collect. Pay you daily. Sample free. Try it out. Jennings Mfg. Co., Desk N-11, Dayton, Ohio.

ANY man handy with paint-brush or light tools can start new mechanical business on nearly nothing; needed everywhere; nearly all profit; experience not required. John Braconland, 1457 So. Ninth, Philadelphia, Pa.

AGENTS, make big commissions selling guaranteed hosiery direct to consumer. Wescott Hosiery Co., 1123 Broadway, New York City.

EARN \$25 to \$50 weekly selling silk hosiery at \$1 per pair. Send \$2 for samples and full particulars. Betty B. Hosiery Company, P. O. Box 968, City Hall Station, New York City.

AGENTS—New household necessity. Sample 10c. Leon Church, Herkimer, N. Y.

IF you're in selling to make money and you want to make the greatest amount of it, and you want to do it in a clean, legitimate, dignified business that is permanent where every sale means a satisfied customer and a repeat order, as well as an immediate profit, get in touch with us at once. We've got the proposition for you and we're prepared to prove it to you with facts. This is addressed particularly to you men who are tired of selling catch-penny jimcracks, novelty and luxury articles, as well as you new men who are just starting and want to get started right. It will cost you nothing to investigate, and remember, we're prepared to show you facts, and write at once. Your name and address on a card will do. Address Dept. 865, Goodwear Chicago, Inc., 814 West Adams, Chicago.

SEND For Proof of Profits—Free—New Sales Plan and detailed explanation how to go into business for yourself without capital or experience—\$5 to \$15 daily easy—spare time or full time—No delivering or collecting. Mac-O-Chee Company, Room 5864, Cincinnati, Ohio.

WHY Work for others? Start and operate your own business. Our system proprietary specialty business offers wonderful opportunities to make \$100 to \$500 weekly. Openings everywhere. We furnish everything and show you how. Booklet free. National Scientific Laboratories, 208 Monroe, Richmond, Va.

A SALE in Every Home: The Barn's Guaranteed Bread Knife. Cuts warm bread or cold bread—cuts it without leaving a crumb. All you have to do is to let people try the knife. They will buy. We guarantee the sale and a good profit. Write now. Don't delay. Someone is going to sell this knife in your community. J. M. Pitkin & Co., 617 Commercial, Newark, N. Y.

WE deliver the goods. Agents to take orders for a patented household necessity. Tested and approved by Good Housekeeping. Modern Priscilla, New York Tribune Institute. Dundee Mfg. Co., Inc., 17 Edinboro St., Boston, Mass.

CABBAGE Cutter, slices 20 different vegetables; all metal, never dulls or rusts, 5 knives. Cincinnati 25,000 users. Endorsed by Good Housekeeping. Sample 50c. Meyer Cutter Co., Orland Ave., Cincinnati, Ohio.

\$100.00 WEEKLY writing orders for sensational \$12.50 English Topcoats; complete 26-piece set of Rogers Silverware free to customer makes sales easy. Jackson Co., 1145, Blue Island, Chicago.

AGENTS—Send for free sample "Fretnot"—washday wonder. You can clear at least \$20 to \$100 weekly, according to spare or whole time. You don't have to talk; if she doesn't buy at sight, leave sample; she will be looking for you long before you are able to make the rounds again. Samples furnished free. Premiums for your customers. Exclusive territory. Credit given. Empire Specialties Co., 1549 N. Wells, Dept. 101, Chicago.

MANUFACTURERS' agents and specialty salesmen want articles of merit for the Pacific Coast States, Oregon, Washington and California. C. H. Farr & Co., P. O. Box 355, Portland, Ore.

\$100 WEEKLY easy selling Oriental Perfumes and Cosmetics. Highest profit. Sample Case and Illustrated catalogue absolutely free. Bonola Parfumerie Inc., 6546 Cottage Grove Ave., Chicago.

HANDY Men!—Permanent, profitable business; needed everywhere. Calhan, 52 Levant, San Francisco, Calif.

MARVELOUS Ink, Rust, Stain, Spot remover. 25c tubes, 150% profit. Largest house in America for agents. Jet Pharmaceutical Co., Allentown, Pa.

AGENTS—Mosco Corn and Callous remover will build you a steady repeat business. Send today for pocket size trial outfit. The Moss Company, 182 Searle Bldg., Rochester, N. Y.

NEW novelties from Japan, Germany and France. \$20 a day easy. Write for selling plans. Spore Co., Lesueur Center, Minn.

AGENTS: Sell Artkraft felt rugs, ever new. Our low price assures fast sales. Size 28x38, \$14.00 per dozen. Sample \$1.50 prepaid. For full particulars address E. P. Condon, 77 Bedford St., Boston, Mass.

AGENTS—Fall in Line! Others making \$60 to \$100 weekly selling our Everdry Rubber Household Necessities. Big demand everywhere. Act now. Write American Rubber Products Company, Dept. 308, Pittsburgh, Pa.

AGENTS—Mah Jong is the World's Latest Craze and is taking the country by storm. Retail one dollar. 100 sales daily easy, your profit \$60; get started to-day. Oriental Importing Company, 110 West 40th, New York.

SALES Agents, Man or Woman; \$200 a month. Year round position. No lay-off. Take orders for Jennings New Style Hosiery. Written guarantee of satisfaction or new hose free. Write for outfits. Jennings Mfg. Co., Dept. 298, Daxton, Ohio.

AMERICAN Woolen Mills Co., Dept. 2075, Chicago, are making a free suit for one agent in each community to introduce their fine tailored to order suits at \$18 and up. Write them today for their offer.

UNEXCELLED hundred per cent Propulsion. "Opie Lift and Force Pump" Best constructed. Best seller. "Beware of infringement on my Patent" with an inferior pump before being Distributor for any Pump Co. Write John N. Opie, 3108 North Calvert St., Baltimore, Md.

BIG Profits. Something entirely New; a real money maker. Twenty to sixty Dollars weekly easily made. Dept. 538, B. & G. Rubber Co., Pittsburgh, Pa.

FIRE Extinguishers 35c each. No catch to this. Guaranteed to do what any others do and more than some. Cepco Co., 1637 W. Market St., Indianapolis, Ind.

EVERY house a sale; Fast sellers; Particulars. Helmers Company, Hoboken, N. J.

AGENTS: 100% profit—\$100.00 weekly selling famous Aceto Products. Big repeaters. Get our free goods trial offer. Talmage Mfg. Co., 1302 Washington Blvd., Chicago.

AGENTS—Get our big sample assortment free offer. Tea, coffee, extracts, spices, food products, things people eat. 240 fast sellers. Big profits. Harley Co., 332 Harley Bldg., Dayton, Ohio.

AGENTS: \$75.00—\$100.00 weekly taking orders for popular price-smashing raincoats. \$3.98. Largest commission advanced. Prompt shipment. We collect. Free coats. Eagle Raincoat Co., 626 Mid City Bank Building, Chicago.

AGENTS: Take orders guaranteed raincoats \$3.95 to customer. Also full line. Pay advanced. We deliver. Free coats. Hydro Raincoat Co., 3510 Polk, Dept. 430, Chicago.

AGENTS make 500% profit handling Auto Monograms, New Pictures, Window Letters, Transfer Flags; Novelty Signs. Catalog Free. Write Hinton Co., 1153 No. Wells, Chicago.

AGENTS: Write for catalog of Live Sellers—Copyrighted Selling Plan insures success. Every product unconditionally guaranteed. Fifteen years successful experience. Convincing details free. Write quick. Togstad Co., Dept. E, 29 S. Clinton, Chicago.

YOU can easily make \$60 weekly selling new, popular Perflex Fibre Broom. Outlasts four ordinary brooms. 100% profit. Get agent's Special Introductory Offer. Perflex Products Co., 145-C New Jersey Ave., Brooklyn, N. Y.

CUSHION Tube dealers repeating harvest; no experience necessary; no competition. Ask for free sample. Service Tube Mfg. Co., 4010 E. 15th, Kansas City, Mo.

MONEY! Silvering Autolights, Radiators, Mirrors, tableware, stoves. Outfits. Methods free. Clarence Sprinkle, Dept. 28, Marion, Ind.

MEN to sell highest-grade Advertising Booster Plate in the world. Clamps free with plates. Good commissions. Roche and Moore, Cochranton, Pa.

MEN Wanted in every county to place our salesboards with merchants; collect weekly big profits; protected territory. Send 60c stamps for \$1.20 sample and our proposition. Arvon Products Co., Box 192-A, San Antonio, Texas.

E-Z-SEALER. Big Profits. Just out. Practical. Useful office necessity. Sells at sight for \$1.00. Have men and women making \$15 daily. Write for our Free introductory offer. Marienhoff Sales Co., Minot, N. Dak.

NEWLY discovered chemical glass cleaner—big profits—repeater—bottle free agents. Rusticide Co., Frankfort, Cleveland, Ohio.

SOAP agents; biggest profits 200 articles; free samples. Paris "Z" Laboratories, St. Louis.

AGENTS make big money selling silk knitted neck ties. Direct delivery. Pennsylvania Hosiery Mills, 1705 Ludlow St., Philadelphia, Pa.

GET Free Sample Outfit! Earn \$3,000 to \$5,000 a year selling the most complete line guaranteed Hosiery and Underwear in America. No experience needed. You can become District Manager and have others working for you—if you act quick! Write today. Malloch Knitting Mills, 544 Grant St., Grand Rapids, Mich.

FREE Sample. "Rain Shield Wiper." Retail \$1.00—Costs (25c). Sold, Clear and Rainy Days. No Cloth—No Paste—No Attachment. (1) Rub keeps Windshield Clear (48) Hours. Experience unnecessary. NatLife Corporation, Hartford, Conn.

MOST Wonderful Seller. 96c profit every dollar. No stock to carry. License unnecessary. Sample free. Mission Factory P.M. 519 No. Halsted, Chicago, Ill.

GENUINE Gold Leaf Letters anyone can put on store windows. Guaranteed to never tarnish. Large profits. Enormous demand. Free samples. Write today. Metallic Letter Co., 438-A North Clark, Chicago.

112 DAILY easy. Introducing Ladies' and Men's sweaters in silk, wool and artificial silk—23 colors—Latest novelties. Going like wildfire. You simply show samples we furnish—take orders—we deliver and collect. Your pay daily. Mac-O-Chee Sweater Company, Form 1104, Cincinnati, Ohio.

WHY Work for others? Start and operate your own business. Our system proprietary specialty business offers wonderful opportunities to make \$100 to \$500 weekly. Openings everywhere. We furnish everything and show you how. Booklet free. National Scientific Laboratories, 208 Monroe, Richmond, Va.

AGENTS: Largest line of metal household specialties. Quick, easy. Big Profit Sellers. Write now. General Products Co., 7 Oliver St., Newark, N. J.

\$8.00 TO \$20.00 per day. A wonderful seller. Any man, woman, boy or girl can make big wages Selling Crimp Grip Clothes Line Fasteners. It is a perfect rope holder and can be used for many purposes. Crimp Grips are a simple, time-saving device. They last a life time and will not rust; it holds the line tight, and saves time on wash days. Every borer is a booster. Send 5c for Mounted Sample and one pair of Crimp Grip Clothes Line Fasteners. Write for particulars. Crimp Grip Company, Belvidere, Ill.

INSTEAD of working for someone else, why not make something work for you? If have not less than \$500 cash you can build a business of your own right in your own back yard and make \$2,000 to \$5,000 yearly. If you are ambitious and really serious about becoming independent, write at once to Wind-swept Farms, 812 Windswept Building, Henderson, N. Y.

AGENTS, \$50 a week. Take orders for New line Cresco Guaranteed Raincoats for men and women. Also full line of top coats. All made in our own factory. You take orders. We deliver and collect. Pay you daily. No experience necessary. Full or spare time. Outfit and sample coat furnished. Improved Mfg. Co., Coat 478, Ashland, Ohio.

300% PROFIT: Whirlwind Seller. Tremendous repeater. "Kleanrite." Marvellous Discovery. Washes clothes without rubbing. Premiums for customers. Sells 25c. You make 18c. Free samples make easy sales. Write quick. Bestever Products Co., 1941-K4 Irving Park, Chicago.

AGENTS: New Portable Talking Machine. Does more than machines costing five times its price. Carry it with you anywhere. Built in just like a suitcase. Biggest seller ever put on the market. Low priced. Write for sample and territory. Perry-Ludlow Co., Class 1862, Dayton, Ohio.

DISTRICT Salesmen wanted to establish sub-agents for handling our complete line—212 articles—food flavors in tubes, toilet preparations, pudding powders, stain removers, etc. Goods well-known. Big demand, large commissions. C. H. Stuart & Co., 5267 Broadway, Newark, New York.

AGENTS—Make \$7 to \$14 a day. Brand new Aluminum handle Cutlery Set. You take orders, we deliver and collect. Pay you daily. Full or spare time. No experience necessary. No Capital. We need 1,500 Sales agents, men or women, to cover every county in the U. S. Demand enormous. Write quick. Jennings Mfg. Co., Dept. 1868, Dayton, Ohio.

\$30.00 DAILY taking orders for \$3.98 Union made raincoats. Factory prices. Fast sellers. Pay daily. We deliver. American Eagle Raincoat Mfg. Co., 155 No. Union, Dept. 702, Chicago.

AGENTS: Sell combination purses \$1 each. Purse folded 7x5. Unfolded, roomy shopping bag 18x14. Costs \$5.50 dozen. Sample 5c. Write for free catalog. Economy Sales Co., Dept. 417, Boston, Mass.

CLARKE made \$18 an hour selling vest-pocket windshield cleaner needed by every autoist, motorman, engineer; one rub keeps glass clear 24 hours; 90,000 sold; amazing proposition free. Security Mfg. Co., Dept. 735, Toledo, Ohio.

THESE Advertisements of mine have appeared in Popular Mechanics for sixteen years. Hundreds of Successful Manufacturers today owe their success to my formulas and valuable information. Majority started with practically nothing. You can do the same—write today for my valuable literature relative to my Guaranteed Manufacturer's Formulas for making Non-Thermic Ice-Saving Cloths, Delicious Beverages for Home, Bottlers and Fountain sale. Pure Food Products, Non-Alcoholic Flavors, Launderite Washing Marvel, Zebest, greatest stain remover, Sta-Combed, Marcel Hair Curler, and latest Toilet specialties, Mexican Yucca Soap, Laundry Soaps, Flynox, Samsol, and all latest disinfectants. Amazon Tire Repair, Toy Rubber Balloons and all latest selling goods in all lines. Don't compare these with "junk" commonly offered. Analytical work carefully done. Highest references. Miller, Chemist, Tampa, Fla.

PORTRAITS, photo pillow tops, frames, sheet pictures, medallions, merchant's signs, water-proof and tea aprons, guaranteed hose, toilet requisites, luminous crucifixes. Catalog 50 specialties free. 30 days' credit. Jas. C. Baller Co., Desk A-4, Chicago.

AGENTS: \$60 a week selling guaranteed hosiery for men, women and children. Must wear 12 months or replaced free. All styles and colors, including finest line of silk hose. Mrs. McClure makes over \$2,000 a year. Mrs. Schurman averages \$60 a month working spare time. Gos. Noble made \$35 in one day. Write for sample outfit. Thomas Mfg. Co., Class 562, Dayton, Ohio.

AGENTS—Snappiest household line on earth. Red hot sellers, steady repeaters—100% profit. 350 light weight, fast selling, popular priced necessities. Selling outfit free. Get busy quick. Write today; postal will do. American Products Co., 1794 American Bldg., Cincinnati, O.

EXCLUSIVE territory. Wonderful opportunity. No competition. Automobile Show Sensation. Write immediately. Emmons Manufacturing Company, Brant Bldg., Canton, Ohio.

AGENTS—\$25 daily taking orders for Ford Clutch Control. Something Henry forgot. Big profits. Advanced commissions. We deliver, collect. Peramid Co., 6018 State, Chicago.

AGENTS—Buy finest quality ladies' silk hosiery direct from importers. Surprisingly low prices. Your profits tremendous. Particulars free. Arthur B. Bennett & Co., 467 Broadway, New York City.

AGENTS, Salesmen, Demonstrators, you will have the devil's own time trying to find a better seller than "Zippo." If there was such a thing we'd have it. Splendid profit on 50c "Go Getter" repeat article that sells on ten second demonstration. Works while You Watch It. Demonstrates value, while others waste time making claims. New Discovery! Greatest Scientific Triumph of the age. It's the berries. Haven't room to tell our story here. Write immediately. Karam-Smith Co., 604 Bozart St., Ft. Wayne, Ind.

AGENTS—\$15 a day—Easy, quick sales—Free Auto—Big weekly Bonus—\$1.50 premium Free to every customer. Simply show our Beautiful 7-piece Solid Aluminum Handle Cutlery Set. Appeals instantly. We deliver and collect. Pay daily. New Era Mfg. Co., 803 Madison St., Dept. 21-Y, Chicago.

AGENTS, make over \$100 every week selling Nu-Way Mending Fluid. 150% profit—a sale every two minutes. Mends hosiery and all fabrics quicker and better. Every housewife buys. Write for outfit quick. Nu-Way Laboratories, Inc., Dept. T-2, Mt. Healthy, Cincinnati, Ohio.

AGENTS—\$7 to \$10 a day. Take orders for our line of household specialties, food flavors, toilet preparations, etc. 30 years of successful business. Known from coast to coast. Easy to take orders. Big repeaters. Must satisfy or money back. Big money for your spare time. Write for sample and free Outfit offer. C. H. Stuart & Co., 5667 Broadway, Newark, New York.

HOSIERY Agents, make \$50 to \$75 weekly selling complete line—silk, chiffon, novelties, woolen hosiery. Silk knitted ties and scarfs. We deliver direct. Full or part time. Pennsylvania Hosiery Mills, 1765 Ludlow St., Phila., Pa.

EARN \$10 to \$25 a Day. Sell beautiful, durable "Novo" Hosiery. Knitted Neckwear and Pull-out Shirts. Complete family line. Silks, Sport Styles, Seasonable Colors. Kid-dies' Socks, etc. Customer-satisfaction defies competition. All or spare time. Investigate. Novo-Tex Co., Dept. E., 3rd & Sedgley, Philadelphia.

AGENTS sell made to measure gabardines, whipcords. \$14.50; reversible raincoats; \$75-100 weekly. Outfit free. Standard Raincoat, Dept. 5, 129 W. 17 St., New York.

50 SUCCESSFUL Money Making Enterprises. Write Stearline Company, Waltham, Mass.

SPECIALTIES, fast sellers, big profits. Jones, 2035C, Austin St., Oakland, Calif.

AGENTS—Men and Women. Establish a permanent business. 34c money order or check brings sample of a wonderful Gravy and Stew Improver. Try it yourself and be convinced. Every home a prospect. Every sale will bring repeat orders. A new article with a big future. Exclusive territory to live agents. Smith & Gray, Guinda, Calif.

STAMPING names on emblem key checks. Sample 20c. Key check outfits, steel dies, key cases, etc. Service Sales Corporation, Shelby, Ohio.

YOUR Pay in Advance. \$15.00 daily taking orders Donde Brand Superfine Hosiery direct to wearer. Full fashioned Silks, Chiffons, Lace Clox, Glove Silk Panties and novelties of the Season. Also Pure Silk, four pair \$5.50. State and District Manager wanted. Donde Hosiery Co., 19 So. Wells, Dept. 427, Chicago.

AGENTS: You can coin money selling our new Fabric Table Covers, require no laundering. Size 56x50, prepaid \$1.50. 13-piece Luncheon set included Free. Write for sample and special offer. P. Condon, 77 Bedford St., Boston, Mass.

AGENTS: Big money Monogramming by Transfer Method. Catalog Showing Over 50 Styles and Particulars Free. Motorists' Accessories Co., Mansfield, Ohio.

AGENTS—Men's Moccasin Work Shoes. Your commission \$1.00 pair. We carry stock. Direct to wearer. Exclusive territory open in various counties. Big repeat business. Write now. Charles Kellert Co., 116 Bedford St., (Dept. 501), Boston, Mass.

SEND Me to the Darn E-Z Laboratories, Dayton, Ohio, and I will show you how their representatives are making big money selling Darn E-Z Universal Fabric Cement, either full or spare time.

AGENTS making thousands of dollars selling our line of rugs. Easy to sell. 50 to 100% profit. Constant demand. Protected territory allotted. Not a flimsy fly-by-night proposition, but a real substantial one that will assure a good healthy income. Eastern Mills, Everett, Mass.

A REAL HIT. Everyone needs the patented, reversible, refillable Two-in-One Twinko Broom. Saves money—sweeps easier. Used and approved by thousands. Ready seller. Write quickly. Dept. E, Twinko Mfg. Co., Monrovia, Cal.

AGENTS—New field. 600,000,000 prospects. 1000% profit. Write for details. Warner, 148 West Ocean, Long Beach, Calif., Dept. G.

SELF-THREADING Needles. Needle Books, Machine needles, find sales in every home. Fine side lines, easily carried, big profits, sample and catalogue free. Prentice Lee, 145 East 23rd St., New York.

AMERICAN Woolen Mills Co., Dept 3035, Chicago, are making a free suit for one agent in each community to introduce their fine tailored to order suits at \$18 and up. Write them today for their offer.

YOU can sell every merchant in town our changeable signs. Large profits; easy sales. Write for territory now. Changeable Sign Co., 581 East 162nd, Cleveland.

AGENTS—New Interlock guaranteed hosiery for men, women, children. All styles, colors. Full line. Guaranteed to satisfy or replaced free. 12 months demand—make \$5 to \$12 a day. Full or spare time. Samples to start you. Parker Mfg Co., Sample 678, Dayton, Ohio.

WANTED—Men and Women sell direct to wearer special constructed shoe. Low price. Extra-long wear. Mooney Shoe Co., 453 Washington St., Boston, Mass.

ANGLE-IRON Rear Fender Braces makes Ford Fenders Rigid. No more broken fenders. Stops rattle. Considerably over 100% profit. The Albine Company, 6523 Euclid Ave., Cleveland, Ohio.

MAN in each town to plate auto parts, reflectors, bathroom fixtures, refinish beds, mirrors, chandeliers; by new method. No capital or experience required. Simple plan of manufacturing at home starts you in big money-making business. Outfit furnished. Free particulars and proofs. Gun Metal Co., Ave. H, Decatur, Ill.

MAN Wanted. Handle County Business. Experience unnecessary. Largest concern of its kind in the world. Our men now getting \$200 weekly. Lowest prices. Red Seal Coal Co., 200 Coal Exchange Bldg., Armour Station, Chicago.

FREE Gold Tooth, This Month! Stay home, have your False Teeth fixed by mail. Save 75%. We make and repair Rubber or Gold Plates. Home Dental Specialists, Cincinnati, O.

AGENTS, 100% profit, men and women; sell our fast cutting sharpening stones. Complete line, 20c to \$1.50. Easy to demonstrate; fast sellers; everyone a prospect. A. Goodrich, Mfr., 1500 Madison St., Chicago.

AGENTS, Men and Women: Sell Photo-Pillow-Tops, the old reliable money maker for live agents. \$1.50 for sample roll starts you in business for yourself. Sales waiting for you everywhere. Write today. Canvasing Company, 6215 Wentworth Ave., Chicago.

AMERICAN Scientist discovers marvelous Shaving Soap. Toughest beards shave without pull. This is the greatest aid to pleasant shaving ever discovered. Send 25c in check or stamps for enough in metal container for 100 perfect shaves, or \$1.00 for 500 shaves. Everet Safety Razor Company, Sault Ste. Marie, Mich.

OUR 5c Vest Pocket Razor Blade Sharpening Outfit makes any make of blade good for 50 shaves. Agent's Sample 25c. Climax Co., 1619 Broadway, Brooklyn, N. Y.

AGENTS, Big money-making opportunity, selling Pure Silk guaranteed hosiery. Permanent business proposition. Mayville Textile Mills, Mayville, N. Y.

THE Agent's Guide—Tells where to buy almost everything. Copy, 30c. Wilson, The Guide, 1400 Broadway, New York.

\$75.00 weekly taking orders for combination top-coat or Raincoat \$3.95. Sample free. Commission advanced. \$1.00 gift free. Garfield Raincoat Co., 1147 Blue Island, Chicago.

AGENTS—150% profit, \$50.00—\$75.00 weekly. Everybody buys on sight. All year round seller. Big season on. Surety Mfg. Co., 26 W. Washington, Chicago.

ONCE a Customer Always a Customer. Every man likes Pitkin's "2 in 1" Velvet Shaving Cream. No other cream like it. Softens the beard quickly without rubbing. No After Shaving Lotion needed. Sold direct to consumer through our factory representatives. Never sold in stores. \$80 a week clear profit easily made. Muland sold 500 tubes in one week. Write today for territory and proposition. J. M. Pitkin & Co., 631 Commercial Bldg., Newark, New York.

NEW Winners—No Dust Brooms, No Dust Brushes, New Automobile Washers; Live Sellers. Liberal profits. Get agency now. Hanson Mfg. Co., 3945 Lake St., Chicago.

AGENTS—Earn real money, selling new Kismet Combination Lamp. Exclusive territory. Free Offer. Write today. Kismet, 126 Atkins Avenue, Brooklyn, N. Y.

GOLD Mine—Selling LeBernhardt pearl necklaces; opalescent, indestructible; 30 inches long; Sterling silver clasp; handsome case; engraved guarantee marked 225; sample, \$2. Money back if not satisfied. United Sales System, 309 Sheffield Ave., Brooklyn, N. Y.

IMPORTED liquid light pocket lamp. No matches; sensational, beautiful. Enormous demand. Particulars and sample 25c. Box 1181, Washington, D. C.

DeWILDE Earned \$480.00 Selling Puller-on Kuff Buttons; Sample pair \$1.00. Fifty other meritorious Jewelry Specialties at wholesale prices. Master Jewelers, Sheboygan, Wis.

BIG, Quick Money. Earn \$2-\$3 hour with Luxcel Hosiery; free folder tells how; steady permanent cash business. Hopkins Hosiery Co., 453 Washington St., Boston.

GET posted—Good prices paid for butterflies, insects. See Sinclair display advertisement, page 28.

MEN to Introduce the Finest Combination Kitchen Cutlery Set—Housewife's Friend. Sells on sight. Every house and office a prospect. Wonderful seller—new plan. \$1.25 premium with each set. Can sell separate pieces also. Samples free. Mac-O-Chee Cutlery Company, Stand 1164, Cincinnati, Ohio.

AGENTS: Big profit. Genuine Gold Leaf Window Letters, anyone can put up. Scripts and 57 varieties. Consolidated Sign Letter Co., 612 South Dearborn St., Chicago.

FORMULAS, Processes, Trade Secrets—Different, dependable, profitable. Catalog free. B. Thaxly Co., Washington, D. C.

DISTRIBUTORS and Agents: Make 100 to 200% profit selling our complete line Automobile Polishes and Gas-O-Pep Tablets. They keep the new car from getting old; make the old car look and run like new. Gas-O-Pep Tablets guaranteed to increase mileage, prevent and eliminate carbon at practically no cost. Build a permanent business for yourself; customers sure repeaters. Exclusive territory available. Write us to-day. Taylor Products and Mfg. Co., 26 West Natchez, Columbus, Ohio.

AGENTS—Make Big Money Quick. \$4.00 to \$8.00 profit on each order paid in advance, taking orders for our fine tailoring from friends and neighbors. Finest all-wool samples, fashions, stationery, etc. Entirely new and different style outfit. Pulls Orders On Sight. Sent Free. Write at once. Washington Tailoring Co., Dept. D-342, Chicago.

EVERY-DAY necessities for every-one. Unlimited demand. Every article guaranteed. Sales Dept., Elms College, Newark, New York.

AGENTS Wanted: New Invention, Electric Iron Pilotlight, tremendous money maker. No competition, exclusive territory. Agent's sample, \$1.00. Special reduction for quantity orders. P. D. Yankoff, Ft. Smith, Ark.

PATENTS Procured. Send sketch or model today for examination, prompt report and advice. No charge for preliminary advice. Write for free Booklet and blank form on which to disclose your idea. Highest references. Promptness assured. Clarence A. O'Brien, Registered Patent Lawyer, 381 Security Bank Building, Directly across the street from Patent office, Washington, D. C.

LODGE Member Agents for Fielding's Steel Engraved Charts, Masons, Oddfellows, Knights Pythias. Stanley, Cornhill, Boston, Mass.

AGENTS—Grab this quick. New pocket device for Photographs; whirlwind seller. Tremendous profits—easily \$10 to \$20 daily. Exclusive territory. Write at once. Van-Sands, Suite 28, P. E. Bldg., Long Beach, Calif.

\$100 WEEKLY selling One-Minute Tire Changer to car owners, garages, bus lines, etc. Simple—sure—speedy—sells on sight. Big sales records. Makes wonderful demonstration. Exclusive. We help you start. Write R-M Mfg. Co., 14 Riegel Ave., Dayton, Ohio.

NEW Patented Household Article; 300% profit; sold on Money Back Guarantee; everybody buys; wonderful money maker. Specialty Mfg. Co., 745 Lincoln Bldg., Detroit.

AUTO owner tire agent wanted each locality to use and take orders for handmade Mellinger fabric and cord tires; guarantee bond 8,000 and 12,000 miles (no seconds); shipped prepaid on approval; get your tires free; no capital or experience required; make \$100 to \$300 weekly. Write for wholesale prices and sample kit. Address, Mellinger Tire Co., Dept. 200, Kansas City, Mo.

WONDERFUL! Startling! Amazing! Our Ex-Cel Luminous Crucifix and Magical (Luminous) Necklace shine brilliantly in the dark. Sell on first demonstration. Big profits to you. Write for further particulars, or better still, send for sample and territory protection immediately. Crucifix \$1.50. Necklace \$1.00. postpaid. W. G. Hannan Co., Dept. B, 57 E. 18th St., Chicago.

SELLS Like Blazes! New, Instant Stain Remover. Fine Premium every sale. Big Profits. Outfit free. Write quick. Christy, 15 Union, Newark, New York.

\$75 WEEKLY Selling Nustile Guaranteed Hosiery. Your pay daily. All styles and colors; also Pure Silk, 4 pairs, \$5.50. Special monthly bonus. Sample outfit furnished. Nustile Hosiery Mills, Dept. 175, Philadelphia, Pa.

GOLD Mine for Salesmen. New invention, a complete outfit. Washes and dries windows, sweeps, scrubs, mops, etc. Costs less than brooms. Over 100% profit. Greatest year 'round seller. Write Harper Brush Works, 132 2nd St., Fairfield, Iowa.

EVERYBODY uses extracts. Sell Duo Double Strength Extracts. Complete line household necessities. Big repeaters. Write today. Duo Co., Dept. EI, Attica, N. Y.

SELL Madison "Better Made" Shirts direct from our factory to wearer. No capital or experience required. Easily sold. Big profits. Write for free samples. Madison Mills, 503 Broadway, New York.

AGENTS—Sell "Instant Shine" Metal Polishing Cloths, 25c; costs 7½c. Sample free. Instant Shine Polish Company, Utica, N. Y.

GOLD Leaf Sign Letters; make and sell; profits exceed 1,000%; immense demand; particulars free. Johnston Co., Quincy, Ill.

RHEUMATISM Conquered by wonderful new discovery, after doctors failed. No stomach dosing. Quickly relieves sprains, strains, sore muscles. Sold on money back guarantee. Agents wanted—big commission and \$5.00 bonus on every dozen. Nu-Rhu Co., Box 345, Cincinnati, Ohio.

NEW Auto Accessory. Costs 6c. Retail \$1.50. "Free Sample." Box 494-M, Hartford, Conn.

IF you want good live agents—follows who can get the business—ask me how others are doing it. I'll gladly render the necessary assistance. Geo. F. Baker, Mgr. Classified Advertising, Popular Mechanics Magazine, Chicago.

AGENTS, both sexes, we manufacture and control new household article. Fast seller. Big profits. Exclusive territory. Write now. Connolly, 123 Liberty St., New York.

AGENTS—Sell "Karrzone" Wonderful new specialty. Sensational Wildfire Seller. Auto Owners buy on sight. Guaranteed. 100% profit. Sure repeater. Demonstrating Sample. Instructions, terms, territory, all 10c Postage. Myers & Co., 22 Baird, Cambridge, Ohio.

BUILD a lasting business, in your own community, with the Waterlizer. Big profits—cumulative—clean cut. James B. Lund, Manufacturer, 19 S. La Salle, Chicago.

HANDKERCHIEFS, "Quality" line. Factory prices to agent-canvasers. Write for the plan of this dependable business. Turnover Company, 18A East 17th St., New York.

AGENTS: A sale in every home for our beautiful dress goods, silks and general yard goods. Quick sales! Big profits. Large book of nearly 1,000 handsome fabric samples furnished to agents. Write today. National Importing & Mfg. Co., Dept. 6X, 578 Broadway, New York, N. Y.

YOU can be your own boss with our Key-Check outfit. Good for \$5 a day stamping names on pocket key checks, fobs, etc. Sample check with your name and address, 20 cents. Pease Die Works, Dept M, Winchester, N. H.

SELL Komik Display Cards, airbrushed window cards, price tickets, card holders, etc. Big demand. Komik Advertising Co., Cambridge, Ohio.

SELL Rubber Rugs, duplicating rug rugs in appearance. Every home a prospect. Small samples free. Trump Bros. Rubber Co., Akron, Ohio.

FORMULAS—Dependable manufacturing formulas with complete working directions. Charges reasonable. Write me. S. Vignins, Chemist, 135 Meadow St., Pittsburgh, Pa.

AGENTS to sell men's hats direct from factory. Guerin Hat Co., South Orange, N. J.

CASH In on this quick seller. Wingo cleared \$1,000 with Never Fail Razor Sharpener in six weeks; Purdy, \$40.50 first day. Applewhite, also inexperienced, six orders in thirty minutes. No end to ready buyers. Exclusive territory for quick workers. Be first. Address Never Fail Company, 159 Allen Bldg., Toledo, Ohio.

AGENTS—Make \$10 to \$20 daily selling the famous Nerv-Ease Foot Comforts. Big demand. Over 100% profit. Write today. Manhattan Products Co., 2520D Bailey Ave., New York.

ASTOUNDING invention starts Fords instantly, coldest weather, doubles mileage. Big profit. Super, 1306 Fondulac, Milwaukee, Wis.

MAGIC Polishing Cloth—great seller—big profit. Get our proposition. Newton Co., 61 Main St., Newark, New York.

MEN'S Shirts Easy to Sell. Big demand everywhere. Make \$15.00 daily. Undersell stores. Complete line. Exclusive patterns. Free Samples. Chicago Shirt Manufacturers, 241 W. VanBuren, Factory 211, Chicago.

YOU can make \$75.00 to \$100.00 a week selling our big line of 150 articles, used constantly in every home. Write us, we will send you our handsome \$15.00 Sample Case Outfit on trust. Federal Pure Food Co., Dept. PP, Chicago.

SHEEP Wool Moccasins, Polishers, Dust-ers, Box 26, East Boston, Mass.

ABSOLUTELY free, box Bassett's Native Herbs sent to introduce. For constipation, indigestion, rheumatism, headache. Big money selling all or part time. Established 1879. Bassett, Dept. 1, Columbus, Ohio.

AGENTS: Big Money Selling Great Household Necessities. Sample 25c. Webster Co., 2545 N. Clark St., Chicago, Ill.

AGENTS! Make money selling Men's Rubber Belts with fancy buckles—black, cordovan and gray, plain, stitched and walrus grain. \$12.00 per gross. Sample 15c. Star Belt Company, Akron, Ohio.

TAILORING Agents. Make \$50 to \$100 a week selling all wool 2 piece suits at \$21.50. Also our famous virgin wool suits at \$21.50—none higher. Commissions daily. Beautiful assortment of 6x9 swatches free. No experience needed. Can use spare time workers—If hustlers. Write J. B. Simpson, Inc., Dept. 759, 843 West Adams St., Chicago.

TO secure agents or salesmen or for selling farms and reaching investors, use classified (want) ads in largest newspapers and magazines. Price list No. 80 sent free. Ankrum Advertising Agency, 20 W. Jackson Blvd., Chicago, Ill. The largest classified advertising agency in the U. S.

AGENTS—If you have formerly sold felt rugs, write for our new proposition concerning new goods. It's a winner. Newark Felt Rug Company, 27-C 16th Ave., Newark, N. J.

BIG Money and Fast Sales. Every owner buys Gold Initials for his auto. You charge \$1.50; make \$1.35. Ten orders a day easy. Write for particulars and free samples. American Monogram Co., Dept. 40, East Orange, N. J.

EXCLUSIVE agents \$225 weekly. Genuine gold letters for store windows. Free samples; selling instructions. Chicago Window Sign System, 6225-A Kimbark Avenue, Chicago.

LIVE Agents make \$10 a day selling Eureka Strainer and Splash Preventer for every water faucet. Takes on sight. Widely advertised and known. Get details today. A. H. Seed Filter Company, 73 Franklin, New York.

WONDERFUL Scientific Discovery: "Blue-White Sapphires" rival finest diamonds, \$3 carat. "Rainbow Sapphires," changes color, greenish purple to ruby red, \$3 ct. "Meteor Sapphires" like golden diamonds, \$2 ct. Pearls, Watches, Diamonds, solid gold mountings; new sales ideas; wholesale prices; be our agent. Pauer (Importer), 152 Dewitt, Buffalo, N. Y.

AGENTS Wanted—Something New—Fire Fighter sells easily. Makes a spectacular demonstration; car owners, homes, factories, stores, practically buy on sight. Our men make \$10.00 to \$50.00 a day; exclusive territory. If you wish to establish a business of your own with unlimited possibilities for making big money, write us today. Fyr-Fyter Co., 103 Fyr-Fyter Bldg., Dayton, Ohio.

AGENTS—Stamping names on Pocket Key Protectors; sample Check with your name and address, 25c. Stamping Outfits, Emblem Checks, Check Fobs, Name Plates, Hart Mfg. Co., Desk 2, 303 Degraw St., Brooklyn, N. Y.

AGENTS—Our soap and toilet article plan is a wonder; get our free sample case offer. Ho-Ho-Co., 2725 Dodder, St. Louis.

MAKE money silvering mirrors, all kinds plating, knives, spoons, auto headlights. Outfits furnished. Free booklet. International Laboratories, Dept. 25, 311 Fifth Ave., New York.

INSTANT Weld. Repairs largest punctures without cement or heat. Lemm's profit one day, \$56. Write quick. Free sample; territory going fast. Tourists' Pride Mfg. Co., Desk T, Minneapolis, Minn.

AGENTS: Where to buy 12,000 articles. Wholesale. Actually worth \$50. Enclose stamp. Wholesale Supply Co., Valdosta, Ga.

PORTRAIT and Medalion Agents—Our Goods Will Make You Big Profits; delivery guaranteed; prompt shipments; low prices; send for latest catalog. Adam J. Kroll & Co., 602 Blue Island Ave., Chicago.

AT Last—World's Greatest Adding Machine. Almost human. Retail \$15; work equals \$300 machine. \$500 monthly easily made, demonstrating to stores, offices, garages, factories. Simple, easy; adds, subtracts, multiplies, divides automatically. Speedy, accurate, durable, handsome. Five year guarantee. Tremendous demand, amazing profits. Liberal trial offer. Protected territory. Write quick. Lightning Calculator Corp., Dept. F, Grand Rapids, Mich.

POLMET—The Wonderful Polishing Cloth that cleans all metals without liquid, paste or powder. Approved by "Good Housekeeping" and "Modern Priscilla"—sells fast at 25c. Sample free. Gale & Co., Inc., 15 Edinboro St., Boston.

We start You Without a Dollar. Soaps, Extracts, Perfumes, Toilet Goods. Experience unnecessary. Carnation Co., Dept. 291, St. Louis.

"HOW to Sell Patents" free. Patent News-O. Washington, D. C.

MAIL-ORDER houses and distributors; we seek big profit beauty creams, face powders, perfumes, toilet preparations with your label. Chemist, 944A No. Clark, Chicago.

AGENTS—Steady Income. Large manufacturer of handkerchiefs and dress goods, etc., wishes representative in each locality. Factory to consumer. Big profits, honest goods. Credit given. Send for particulars. Prospect Mfg. Co., 59 Main St., Brooklyn, N. Y.

WHY Work for others? Start and operate your own business. Our system proprietary specialty business offers wonderful opportunities to make \$100 to \$500 weekly. Openings everywhere. We furnish everything and show you how. Booklet free. National Scientific Laboratories, 208 Monroe, Richmond, Va.

DUSTLESS Sponge Cloth. New Invention. Retail \$1.50—costs 16c. (1) Rub Cleans, Polishes Automobiles, Planos, Furniture. NuLife Sponge, Hartford, Conn.

CALIFORNIA Rosebuds selling like hot cakes. Agents coming money; new stuff. Big profits. Catalog free. Mission Factory P.M. 519 No. Halsted, Chicago, Ill.

AGENTS—Best seller: Jem Rubber Repair for tires and tubes; supersedes vulcanization at saving of over 800 per cent; put it on cold, vulcanizes itself in two minutes, and is guaranteed to last the life of the tire or tube. Sells to every auto owner and accessory dealer. For particulars how to make big money and free sample, address Amazon Rubber Co., Amazon Bldg., Philadelphia, Pa., Dept. 505.

AGENTS clear \$50.00 weekly selling Opaline Portraits. Expense money advanced. Credit given. Big line now ready. Samples and Catalog free. Consolidated Portrait Co., Desk 2, Chicago.

PATENTED Cigar Lighters with Glass Advertising Front. Also Electric Cigar Moisteners. Wonderful Sellers. No Competition. Big Steady Profits. Proof, Cuts, Sales Plan Free. Drake Mfg. Co., Dept. M, Milwaukee, Wis.

WE have the finest needle case. \$50.00 to \$200.00 weekly. Send 10c for sample; sells 25c. Empire Specialties Co., 1549 N. Wells, Dept. 301, Chicago.

AGENTS get Kiosquik the newly invented door spring. Whirlwind seller. Retail for 50c. You make 100% or more. Sell 50 to 80 a day easy. Write for 4c sample and easy starting offer. Kiosquik Mfg. Co., Dept. A, 17 West 42nd St., New York.

AGENTS: Can start you in Mail Order Business immediately. Keen at it 17 years. Small capital needed. Particulars stamp. Home Business Expert, Valdosta, Ga.

\$80-\$200 A WEEK. Genuine Gold Letters for store windows. Easily applied. Free samples. Liberal offer to general agents. Metallic Letter Co., 47-D, North Clark, Chicago.

WE Pay \$50 a Week and expenses and give a Ford Auto to men to introduce poultry and stock compounds. Impafat Co., D-23, Parsons, Kan.

AGENTS—Good salary and commission selling "Ratskill," new rat and mouse exterminator; ready for use; no bait required; non-poisonous; rodents die outside premises; no odor. Empire Specialties Co., 1549 N. Wells, Dept. 301, Chicago, Ill.

AGENTS sell Wolverine Laundry Soap. Wonderful repeater and good profit maker. Free auto to hustlers. Wolverine Soap Co., Dept. P37, Grand Rapids, Mich.

GET Our Free Sample Case—Toilet articles, perfumes and specialties. Wonderfully profitable. La Derna Co., Dept. A, St. Louis, Mo.

AGENTS—Clever Invention! Inkspoon makes every pen a fountain pen. Fast office seller; big profit, demand increasing everywhere. Exclusive territory offered. Sample free. H. Murul Company, Tribune Bldg., New York, N. Y.

AGENTS: Big returns, fast office sellers; particulars and samples free. One Dip Pen Co., 2 Daily Record, Baltimore, Md.

AGENTS: \$60.00 weekly selling newest sensation; Leather Link Belts going over big. Easy, quick sellers. Big profits. Write quick. Victory Belt Co., 1772 Wilson, Chicago.

AGENTS—Silk fibre knitted neckties sells the whole year round; send \$36.00 for a gross, 100% clear profit; dozen \$3.25; if you can't sell them we will refund your money. Raymond Mfg. Co., 132nd St. and Madison Ave., New York.

MAKE \$17 daily—Finest Extracts, Food Products, Toilet Preparations, Household Necessities. Credit: Sample Case Free. Write for amazing offer. Perkins Products, B-6, Hastings, Nebr.

AGENTS: Big profits. Best and cheapest window letters made. Easily applied. Dine brings five samples. Particulars free. Stalbritte Co., 1115 Second Ave., New York.

AGENTS. Make \$10 to \$20 daily, selling small kitchen necessity. Over 200% profit. Sells rapidly everywhere to nine out of ten women. New plan make sales easy. Premier Mfg. Company, Dept. 813, Detroit, Mich.

MAKE \$8 a day selling Imported Bamboo Fountain Pen. Whirlwind seller. Free sample. Mohler, Dept. 5, 416 S. Dearborn, Chicago.

EARN \$10 daily silvering mirrors, plating and refinishing metalware, autos, chandeliers, bedsteads, headlights. Outfits furnished. E. Decle Laboratories, 1133 Broadway, New York.

WANT Distributing Agents everywhere for Hanslick, the new original powdered handsoap. Removes grease, grime, ink, paint, and most anything from the hands without injury to the skin. Every mechanic and auto-owner, everybody who gets his hands dirty will be a customer. A great opportunity for a hustler to get in business for himself. Full information free. Send 10 cents, coin or stamps, for liberal sample can. Solar Products Company, 122 West Lake Street, Chicago.

MAKE \$25 to \$50 Week, representing Clows' Famous Philadelphia Hosiery, direct from mill—for men, women, children. Every pair guaranteed. Prices that win. Free book "How to Start" tells the story. George Clows Company, Desk 31, Philadelphia, Pa.

AGENTS Everywhere! Women's and children's guaranteed shoes direct to wearer. We deliver. A. P. Condon, Sales Manager, The Allen Shoe Co., 110 Sumner St., Boston, Mass.

EARN big money fast applying gold initials to autos. Every owner buys—\$1.35 profit on \$1.50 sale—particulars and samples free. Write quick. Lithogram Co., Dept. 17, East Orange, N. J.

EASY, pleasant work for Mechanics, Shop Men, Clerks, during spare hours; will add many dollars to their salaries. Also want persons who can give full time. Big wages assured. Novelty Cutlery Co., 67 Bar St., Canton, Ohio.

SELL Necessities. Everybody needs and buys the "Business Guide." Bryant cleared \$800.00 in July. Send for sample. It's free. Nichols Co., Box 4-B, Naperville, Ill.

HIGH-GRADE SALESMEN WANTED

AGENTS Wanted—Something New—Fire fighter sells easily. Makes a spectacular demonstration; car owners, homes, factories, stores, practically buy on sight. Our men make \$10.00 to \$50.00 a day; exclusive territory. If you wish to establish a business of your own with unlimited possibilities for making big money, write us today. Fyr-Fyter Co., 103 Fyr-Fyter Bldg., Dayton, Ohio.

BEATS Owning a Store. "This new way of selling beats owning a store. Any earnest worker can easily make \$4,000 to \$5,000 a year net without investment or financial risk," says William Garden, former merchant who started with us two years ago. Other former merchants now happy and prosperous with us are De Longe, Paek, Carter, Bogen, Lee, and Peck. They earn as much or more than ever; have no investment or financial worries and are building a constantly growing business. We are now making the best suit that we ever produced retailing at \$31.50. Our values are remarkable. Our fit and style so good that you can sell the best trade. Every fabric is virgin wool. Every garment tailored to order. Our all wool summer suits retail for \$21.50. Both the \$31.50 and \$21.50 lines are red-hot sellers. We have openings for men who are looking for a permanent connection and have the courage to depend solely on their own industry for success. Such men will find a wonderful opportunity with us. Write for full information, Dept. 800, J. B. Simpson, Inc., 831 Adams St., Chicago.

RAINCOAT Salesmen—We have a nifty raincoat and weatherproof coat line for men, women and children that can be put in the pocket and used as a very profitable side line no matter what you are selling. Prices low, commissions big. It will be sent you free if you tell up what you are now selling. Address—Raincoat Dept., Interstate Tailors, 403 Fourth Street West, Cincinnati, Ohio.

EIGHT Quick-Selling Auto Accessories! Windshield Cleaners, Side-wings, Grease Retainers, etc. Low prices. Big profits. No investment. Salesmen write quick to Jubilee Company, 53 Sta. C, Omaha, Neb.

TAILORING Agents make \$10 every sale; wonderful line all-wool fabrics retail three prices, \$29.50—\$34.50—\$46.50. New way selling gives you big profit. Write for full information. Kahn Bros., Dept. A449, 500 S. Throop St., Chicago.

A WONDERFUL Seller! Any man, woman, boy or girl can make big wages. Some agents make from \$8.00 to \$20.00 per day. Crimp Grip Clothes Line Fasteners are a simple, time-saving device for holding a rope—also used for many other purposes. It pays for itself quickly in time saved on wash days. No knots—it fastens and releases quickly. Every home a prospect. Every housewife who uses Crimp Grips—and there are thousands of them—is a booster. There is but one Crimp Grip. Write for particulars, or send 50c for one pair and a mounted sample, with full particulars to agents. Crimp Grip Company, Belvidere, Ill.

SAFETY-INK: Indelible on paper. Washes from clothing. Send 25c for quart. Acidproof Ink Co., Nicetown, Philadelphia, Pa.

OVER 250% Profit. Salesmen—Crew Managers—Agents; Large Profits, Easy Sales. Satisfied Customers, are prime factors in selling. Midwest Household Necessities embrace these factors. Particulars free. Midwest Drug Co., 185 E. Naghten St., Columbus, Ohio.

SALESMEN—Sell "Amens" Radioux Shirts, guaranteed to wear a year. Very liberal commissions. Get our proposition first. Menzies Shirt Co., 481M East Tremont Avenue, New York.

SALESMEN—You can make \$120 per month in your spare time selling only one policy a day! Five policies a day pays you \$720 monthly! Policy pays \$5,000 death and \$25 weekly benefit for sickness or injury. Total cost \$10 yearly. You get amazing results using our Direct-by-Mail Selling Plan. Address Underwriters, Dept. RL, Bannell Bldg., Newark, N. J.

SALESMEN, Sell New Road Maps to advertisers everywhere. Easy to sell. Liberal commission. Pocket samples. Standard Map Company, 125 West Ohio St., Chicago, Ill.

SALESMEN—Exclusive territory for new product needed by most every business, manufacturer and retailer. Finest proposition in America. General Manager, 2728 Lisbon Avenue, Milwaukee, Wis.

SELL coal in carload lots. Side or main line. Experience unnecessary. Earn Week's Pay in an Hour. See our ad on page 175 this issue. Washington Coal Company, 708 Coal Exchange Building, Armour Station, Chicago.

DISTRICT Managers Wanted; Appoint Local Agents for us in your locality. No canvassing or delivering. \$100 weekly easily made. Commissions advanced. Bob Russell, A2399 Archer, Chicago, Ill.

SALESMEN appreciating quality make \$200 to \$500 monthly selling Northcraft steel engraved personal and commercial greetings direct or resale. Handsome, reasonably priced; neat samples free; liberal commissions. Our quality assures success and future. Northcraft Studios, Minneapolis.

SELL Advertising Specialties. They move fast. Good men easily make \$100 weekly. Write today for full particulars. S. G. Silver Chamberlin Company, Clayton, N. J.

DISTRIBUTORS for high grade Automotive Merchandise. Rodefeld Mfg. Co., Richmond, Ind.

SALESMAN: If you think in terms of \$6,000 this year write me. Strong retail store line. Advertised nationally. Established Company. Liberal weekly advance to producer. The Continental Co., 1920 Euclid Ave., Cleveland, Ohio, Dept. 200.

SALESMEN—Hustlers wanted; \$20 daily calling on merchants. Ford car furnished. Daily necessity in attractive "self-selling" counter displays; over 100% profit each for merchants and salesmen; enormous repeat business; permanent employment or side line. Elcor Corporation, 421 Maryland Building, Washington, D. C.

AGENTS—\$50 week selling boy's suits. Our prices half retail stores. Real \$18 values—\$11.95. Agents make 20%. Profits in advance. We deliver and collect. Selling outfit free. Write for full information. Wright & Co., Dept. A-449, Congress, Throop and Harrison Sts., Chicago.

SALESMEN wanted for the best automobile cleaner-polish on earth. Distinctly different. Liberal commission. Presso Products Co., 319 West Fortieth, Savannah, Ga.

ARE You on the Right Track to Bigger Earnings in 1924? If not, check up on yourself and find out the reason. Perhaps your present line doesn't interest you as it should—or perhaps you are not earning as much money as you feel you are worth. In either case you will find the solution of your problem in the Alexander Film proposition. Our Motion Picture Publicity Service covers more than fifty different lines of business, offering a variety not to be found in any other business in the world. A dignified profession—interesting and profitable. A proposition you will be proud to present to your prospects. Our Salesmen earn \$5,000.00 to \$20,000.00 per year in commissions. We know of no other similar organization which pays its salesmen so liberally. These facts are before you—make up your mind to get out of the rut—and Do It. Before you turn this page write us a letter for particulars. Alexander Film Co., 3389 So. Broadway, Denver, Colo.

SALESMEN: If you are accustomed to earnings of \$75 to \$100 or more per week, and seek a permanent connection, with exclusive territory which you may develop as your own, and insure to yourself the increased business which you build up from year to year, write us. We are manufacturers of Harvest Hats and Caps. Our line is large, complete and includes a wide range of distinctive styles and values. Well known and wanted by the best general stores throughout the country. Liberal commission basis. Must have auto, a clean record, and furnish three good business references. Address Commonwealth Harvest Hat Co., Dept. 8, 22nd and Washington Av., St. Louis, Mo.

WANTED—Tailoring Salesmen, make \$60 to \$125 per week. Biggest merchants in many towns have started with our line. We are the largest made-to-measure tailoring house in the country, furnishing elaborate sample equipments, including 500 all-wool fabrics. You make your own profits from \$8.00 to \$15.00 on each order. Guaranteed absolute satisfaction, perfect fit, best workmanship, or no sale. Write for line and all accessories to be sent free. Tell us all about yourself. Address N. O. Perry, Sales Manager, Box 482, Chicago, Ill.

SALESMEN—Crew Managers. You will have the devil's own time trying to find a better seller than "Zippe." If there was such a thing we'd have it. Splendid profit on 50c "Go Getter" repeat article that sells on ten second demonstration. Works While You Watch It. Demonstrates value while others waste time making claims. New Discovery! Greatest scientific triumph of the age. It's the berries. Haven't room to tell our story here. Write immediately. Karam-Smith Co., 6091 Bozart St., Ft. Wayne, Ind.

EVERYONE Buys Every Day some part of our line. You can take orders for complete line of groceries, paints, roofing, motor oils, tires and radio sets, from institutions, boarding houses and private families. We deliver and collect. Our goods are nationally known and guaranteed quality; just show samples and secure large orders. No capital or selling experience necessary. Heavy orders make a steady profitable business. Address Hitchcock-Hill Company, Dept. 226, Chicago. Reference: any bank or express company.

MAKE \$120 Weekly in Spare Time. Sell what the public wants—long distance radio receiving sets. Two sales weekly pays \$120 profit. No big investment, no canvassing. Sharpe of Colorado made \$955 in one month. Representatives wanted at once. This plan is sweeping the country—write today before your county is gone. Ozarka, 862 Washington Blvd., Chicago.

DISTRIBUTORS, Salesmen, Agents wanted everywhere to handle the Murey Rim Tool; quick, easy sales; big profits; chance to earn \$300-\$500 monthly; trade and consumer boy on sight; monopoly rights to those who mean business. Get opportunity folder today. Murey Rim Tool Co., Blissfield, Mich.

TAILORING Salesmen wanted to take orders for our all-wool, made-to-measure suits and overcoats direct to customer; easy to learn and highest commissions paid when order is taken; we deliver and collect; iron-clad guarantee; spring line now ready. Send three business references. Act quick before territory is all gone. Interstate Tailors, 403 Fourth Street West, Cincinnati, Ohio.

ANNOUNCEMENT—We are now prepared to consider additional applications from salesmen and distributors for wonderful new Victory Income Tax Record (copyrighted). Write for details of greatest specialty proposition in United States today. Victory Corporation, Marquette Mich.

SELL gummed tape. Rapidly replacing twine—\$50.00 to \$150.00 weekly. Sager Company, Manufacturers, Dept. 8 104, 1637 Roosevelt Road, Chicago.

SALESMAN wanted. Experienced tool salesman to sell to the retail trade. Must be a first-class man, preferably one known to the Eastern and Middle Western trade, to sell high-grade new patented tools. Write the Simon & Skidmore Mfg. Co., 110 East Sixth St., Santa Ana, Calif.

SALESMEN: Write your name and address on a card and mail it to us. By return mail we'll show you sure earnings of \$20.00 a day. Will you risk one minute and a one-cent stamp against \$20.00? Mind you, we say we'll show you. Address Dept. 866, Goodwear Chicago, Inc., 844 West Adams Street, Chicago.

TAILORING Salesmen: Take orders for \$45.00 All Wool Suits at \$29.50. Union made to order by oldest established wholesale tailors on earth. Satisfaction guaranteed. Biggest commission paid in advance. Also Liberal Bonus. Exclusive territory. Outfit and free advertising furnished. Experience unnecessary. Wilson Tailoring Co., 905 W. Jackson, Chicago.

DISTRICT Managers wanted every city and county in U. S. to manage branch offices. No experience required; we teach you how to earn \$100-\$200 weekly. Must appoint sub-agents, salesmen. Fireite sells to every home, store, factory, office, garage, hotel, public building, etc. Lifetime opportunity for men with few dollars capital. Your territory open. Write Fireite Co., Maestown, Pa.

GIVE customer \$100 value for \$10.00. Your profit \$0.50. Excellent side-line. Get details. Box 1007, New Orleans, La.

MEN'S Shoes—Factory distributor wants agents to sell direct to wearer. Every pair guaranteed. Easy to sell. No capital required. Write Colt Shoe Co., 729 Atlantic Ave., Boston, Mass.

TAILORING Agents—\$6 to \$9 profit every sale. Virgin wool suits \$25.50. Greatest line in America. Write for full information. Fred Kauffman, Dept. A449, 1390 W. Harrison St., Chicago.

SALESMEN sell sales and order books, auto, reg. rolls and bill ledgers. Large demand. Liberal commission. Wirth Sales Book Co., Chicago.

DEPENDABLE Goods: \$5.00 "Peerless" Income Tax Record; \$7.50 "Zim's Peerless Collector." Creditors' Association, E-312 McKnight Bldg., Minneapolis, Minn.

\$700 MONTH for Salesmen—Am rounding out 1924 sales force. Proposition is right. No competition. Virgin territory to assign. My men averaged \$5,000.00 to \$8,000.00 for past year. Buffalo representative averaged \$700.00 month. I offer unusual opportunity to salesmen who qualify. Write at once. Address C. R. Coppock, Salesmanager, National Advertising Service, Inc., P. O. Box 62, LaGrange, Ind.

WHY Work for others? Start and operate your own business. Our system proprietary specialty business offers wonderful opportunities to make \$100 to \$300 weekly. Openings everywhere. We furnish everything and show you how. Booklet free. National Scientific Laboratories, 208 Monroe, Richmond, Va.

BEST Seller: Jem Rubber Repair for tires and tubes; supersede vulcanization at saving of over 80%; put it on cold, vulcanizes itself in two minutes, guaranteed to last life of tire or tube; sells to every auto owner and accessory dealer. Get particulars how to make big money and free sample. Amazon Rubber Co., Philadelphia, Pa., Dept. 510.

FOUR \$7.50 sales to merchants net you \$20.00 daily. Savers Systems, 2803 Sheffield Ave., Chicago, Ill.

\$1.00 PROFIT on Every \$5.00 sale. "Free Sample"—New Specialty. (Money Getter.) Every Storekeeper, Doctor, buys quickly. Experience unnecessary. Territories open. Box 590, Hartford, Conn.

TRAVELING Salesmen calling on retail stores wanted by large manufacturer to sell unique line of business-boosting articles. Year round, fast selling, main or side line. If not earning \$150 weekly, address Elsasor Works, 222 Charles St., Boonville, N. Y.

\$80-\$200 A WEEK. Genuine Gold Letters for store windows. Easily applied. Free samples. Liberal offer to general agents. Metallic Letter Co., 438-B North Clark, Chicago.

CALIFORNIA Rosebuds selling like hot cakes. Agents coining money. Absolutely new. Big profits. Catalog free. Mission Factory SP, 519 No. Halsted, Chicago, Ill.

SALESMEN Can make \$5.00 a day selling our Calendars, Pencils, Signs, Advertising Novelties, Yardsticks, Whistles, etc. Liberal terms. Sells entire year. Fine side line. Local and traveling agents. Model Calendar Co., Dept. 226, South Bend, Ind.

TAILORING Salesmen—Fastest selling line, suits, overcoats, made to measure—\$32.50—one price, all wool. Profits in advance. Biggest old reliable house, W. D. Smith & Co., Dept. 66, established 1895, Chicago.

SALESMEN—Sideline pays five to ten dollars a day taking orders for Specialty printed gummed advertising and Match Box stickers. Write for proposition, samples, etc., today. Beardley's Printery, Rock Island, Ill.

HELP WANTED

AGENTS—Just write orders for Mac-O-Chee New Style Guaranteed Hosiery—Make \$5 to \$15 Daily Easy—No delivering—No collecting—Not a dollar needed for stock. No experience required—We teach you—We pay big commission daily in advance. Special premiums offered purchasers make sales easy—Repeat orders double your income—Big outfit furnished—All colors—grades including full fashioned silks. Mac-O-Chee Company, Room 2604, Cincinnati, Ohio.

STEADY work. No strikes. No layoffs. Commence \$133 month. Raise to \$192 monthly. Become U. S. Government Railway Postal Clerks. Pleasant work. Traveling constantly. See your country on Government time. Vacation with pay. Common education sufficient. List positions free. Men—boys, 18 up, write immediately, Franklin Institute, Dept. H-3, Rochester, N. Y.

FIREMEN, Brakemen, Baggage men, Sleeping car, train porters (colored). \$140-\$209. Experience unnecessary. 810 Railway Bureau, East St. Louis, Ill.

SALESMEN—Needle Books \$5.50 and \$6.50 per gross. Self-Threading Needles—\$2.75 per 1,000 needles (100 envelopes). 50% profit on every sale and wonderful value. Catalog Free. Needle Book Specialty Co., 661 Broadway, New York.

GET posted—Good prices paid for butterflies, insects. See Sinclair display advertisement, page 28.

\$35.00 WEEK. Men 15 up. Become Automobile experts. Earn while learning. Write Franklin Institute, Dept. H-20, Rochester, N. Y.

MONEY! Silvering Autolights, Radiators, Mirrors, tableware, stores. Outfits. Methods free. Clarence Sprinkle, Dept. 28, Marion, Ind.

SALESMEN—We pay larger commissions than any other Brush House in the Country to men selling our line of Sanitary twisted-in wire Brushes. Sanitary Wire Grip Brush Co., 15 Mercer St., New York.

CLERKS for Government Postal and other good positions \$1400-\$2300 yearly. Experience unnecessary. Full particulars free by writing G. W. Robbins, Civil Service Expert, 411 Burchell Bldg., Washington, D. C.

RAILWAY Postal Clerks—Start \$133 month. Railroad pass; expenses paid; questions free. Columbus Institute, E-2, Columbus, Ohio.

STORIES, poems, plays, etc., are wanted for publication. Good ideas bring big money. Submit manuscripts or write Literary Bureau, 522, Hannibal, Mo.

\$50-\$200 A WEEK. Genuine Gold Letters for store windows. Easily applied. Free samples. Liberal offer to general agents. Metallic Letter Co., 438-C, North Clark, Chicago.

FINGER Print Experts—Excellent paying positions; particulars free. Finger Print Headquarters, 188 East 79th, New York.

WANTED, Railway Mail Clerks, \$1600 year. Particulars free. Write immediately, Franklin Institute, Dept. H-20, Rochester, N. Y.

SALESMEN—Become Independent. Own your business; experience unnecessary; selling our \$7,500 Accidental Death, \$50 Accident, \$25 Sick Weekly Benefits; \$12.50 yearly; other amounts proportionate. Guaranteed steady income from renewals. \$250,000 deposited Insurance Department. Registration Dept. A, Newark, N. J.

MEN wanting Forest Ranger, Railway Mail Clerk and other good positions, write for particulars. McKane, B12, Denver, Colo.

MAKE money writing Photo-plays; details free to beginners. No correspondence course. Producers' League, 230 Wainwright, St. Louis.

MEN—Women 18 up, wanted. Government Jobs. \$1140-\$3000 year. List positions free. Write immediately, Franklin Institute, Dept. H-20, Rochester, N. Y.

WHY work for others? Start and operate your own business. Our system proprietary specialty business offers wonderful opportunities to make \$100 to \$500 weekly. Openings everywhere. We furnish everything and show you how. Booklet free. National Scientific Laboratories, 208 Monroe, Richmond, Va.

SEND for Proof of Profits—Free—New Sales Plan and detailed explanation how to go into business for yourself without capital or experience—\$5 to \$15 daily easy—spare time or full time—No delivering or collecting. Mac-O-Chee Company, Room 4724, Cincinnati, Ohio.

LOCOMOTIVE Firemen for railroads nearest their homes—everywhere; beginners \$290, later as Locomotive Engineers, \$300-\$350 monthly. Best paying positions in Railroad Service. Railway Association, Desk M-1, Brooklyn, N. Y.

U. S. GOVERNMENT wants Railway Mail Clerks—Mail Carriers, \$1400-\$2300 year. Steady. Men 18 up. Examination schedules free. Write immediately, Franklin Institute, Dept. H-20, Rochester, N. Y.

EARN \$10 daily silvering mirrors, plating and refinishing metalware, autos, chandeliers, bedsteads, headlights. Outfits furnished, E. Decle Laboratories, 1133 Broadway New York.

MEN—Age 18-40, wanting Railway Station-Office positions, \$115-\$250 month, free transportation, experience unnecessary. Write Baker, Supt., 74 Wainwright, St. Louis.

ALL men, women, boys, girls, 17 to 65, willing to accept Government Positions, \$117-\$250 traveling or stationary. Write Mr. Osmont, 161 St. Louis, Mo., immediately.

WANTED: Railway Mail Clerks—\$1,600 to \$2,300. Exams everywhere. Write today for full information. Patterson, Civil Service Expert, Box 4025, Rochester, N. Y.

WRITE articles, stories, news, in spare time for newspapers and magazines. Big pay. Copyrighted book free Press Syndicate, 533, St. Louis, Mo.

\$1600-\$2300 YEAR. Railway Mail Clerks Wanted. Schedule examination places—free. Write immediately, Franklin Institute, Dept. H-20, Rochester, N. Y.

INVENTORS desiring to secure patents should write for our book "How to Get Your Patent," tells our terms and methods. Send sketch for our opinion of its patentable nature. Randolph & Co., Patent Attorneys, 629 F, Washington, D. C.

OUR genuine gold window sign letters are an excellent money-making proposition for handy men. Slann Sign System, Bethune Ave. E., Detroit, Mich.

SILVERING Mirrors, French plate. Easily learned; immense profits. Plans free. Address, Wear Mirror Works, Excelsior Springs, Mo.

INFORMATION

HOW? How Much? What? Where? Why? When? Who? Have you a question of any kind which needs answering? Some of us can probably answer it no matter what it is. Send us One Dollar. You will get your Dollar back or a satisfactory answer promptly. Technical Associates, Dept. C, P. O. Box 1478, Boston, Mass.

GUARANTEED information, any subject \$1.00. Doris Chemical Laboratories, East Cleveland, Box 59, Cleveland, Ohio.

AUTHORITATIVE. Any subject. Dunbar, Boston 24, Mass.

COMPLETE, accurate, information on any subject \$1. National Information Bureau, 1429X Milton St., S. E. Grand Rapids, Mich.

BUSINESS SERVICE

DELAWARE Incorporator. Charters; Fees Small; forms. Chas. G. Guyer, 901 Orange St., Wilmington, Del.

TYPEWRITERS AND SUPPLIES

TYPEWRITERS All Makes. Save one-half. Thoroughly rebuilt in our factory by the famous "Young Process." Fully guaranteed. Free trial. We handle all standard makes. Cash or sold on easy terms. Write for Catalog. Young Typewriter Co., Dept. 5924, Chicago, Ill.

UNDERWOOD Typewriters—only \$3.00 down. Easy monthly payments. Low prices at less than manufacturers. 10 days' free trial. Rebuilt, all worn parts replaced. Just like a new machine. 5-year guarantee. Write for big free catalogue 1514. Shipman-Ward Mfg. Co., 1514 Shipman Bldg., Chicago, Ill.

TYPEWRITERS, all standard makes, \$10 up. Fully guaranteed. Free trial. Write for complete illustrated lists. Northwestern Typewriter Exchange, 320 West Goethe Street, Chicago.

ALL Makes, rebuilt, refinished and guaranteed ten years, shipped privilege 30 days' trial. Olivers, Remingtons, Underwoods, others, \$15.00 up. Get our prices and agents' proposition. Typewriter Exchange, 2316 University Ave., New York City.

TYPEWRITER Papers—Second sheets; Samples free. Richard Elliott, 305 South Third, St. Louis.

ADDING MACHINES

FREE Trial. Marvelous new Adding Machine. Adds, Subtracts, Multiplies, Divides, automatically. Work equals \$350.00 machine. Price only \$15.00. Speedy, durable, handsome. Five-year guarantee. Used by largest corporations. Write today for catalogue and free trial offer. Lightning Calculator Co., Dept. E, Grand Rapids, Mich.

NEW \$3.50 Automatic Adding Machine. Makes adding easy for anyone. Guaranteed accurate as highest priced machines. 75,000 pleased owners already. Capacity \$999,999.99. Postpaid \$3.50. Bassett Co., 1458-F Hollywood Avenue, Chicago.

DUPLICATORS AND DEVICES

YOU can make 50 to 100 copies of a letter, notice, etc., at a cost of three cents on a Hoyer Quality Duplicator. Write for free trial offer. The Hoyer Duplicator Co., 14 S. Wells St., Chicago, Ill.

"MODERN" Duplicators save Time, Labor, and Money. Gets business. Reproduces Typewritten or Panned Letters, Drawings, Lessons, Music, Menus, Bids, Notices, Specifications, Maps or anything in one or more colors. Prints Two per minute. Special Sale On 30 Days' Free Trial. \$2.25 up. Booklet Free. J. E. Durkin-Roeves Co., Pittsburgh, Pa.

PRINTING, ENGRAVING AND MULTIGRAPHING

1,000 "NEARGRAVURE" Letterheads—beautiful—\$3.50 postpaid. Samples. Soliday's, Knox, Ind.

ART Ad Slips—3 1/4 x 5 1/2, 150 words. Attractive paper—1,000. \$1.99; 5,000, \$3.50, prepaid; 25,000, \$18.00; 50,000, \$27.50 collect. Good's Printery, Harrisonburg, Va.

1,000 **HAMMERMILL** letterheads, envelopes, \$3.25; 250, \$1.25. Samples Free. Trob Press, 28 Providence, Worcester, Mass.

COMMERCIAL Printing! Write requirements. Franklin Press, B-32, Milford, N. H.

AUTOMATIC Cardpresses—prints 100 cards minute. Information free. Habben, 3127 Locust, St. Louis.

200 PRINTED 8 1/2 x 11 Hammermill Letter-heads, Envelopes, Billheads or business Cards \$1.00. Postpaid. Race Printery, Hudson, N. Y.

ENVELOPES or Shipping Tags at sensible prices. Richard Elliott, 305 South Third, St. Louis.

1000 20-LB. Bond Letter Heads, name and address, \$2.75 postpaid. E. Fowler, 365 State Street, New Haven, Conn.

PERSONAL Stationery. 200 Sheets, 100 Envelopes, printed (3 lines) \$1.00 prepaid. Blue ink. Craftsmen, Keene, N. H.

PERSONAL Stationery—your name and address or any other four lines, printed on 200 sheets and 100 envelopes for \$1.00, postage prepaid. Sheets size 5 1/2 x 7 and envelopes 3 1/2 x 5 1/2; both white lines finish Hammermill Bond. Money must accompany order. Sweeney Printing Company, Fort Branch, Ind.

1000 BUSINESS Cards \$2.75. No Junk. Geo. Allen, 326 So. State, Chicago, Ill.

100 ENVELOPES and 100 Two-color Note-heads, beautiful design in orange, type in blue. Not over four lines. \$1.25 postpaid. Sanor Press, Box 421-A, Kankakee, Ill.

CATALOGUE and Job Printing. Get our estimate on your printing needs. Smith-Roberts, Watseka, Ill.

500 GUMMED Labels, Name and address, 25c. Leon Church, Herkimer, N. Y.

GILT lettered Advertising-Pencils for you. Buy direct; save entire middleman's profit. Samples free (no agents). Address S. Masial & Co., 10-12 Lincoln St., Yonkers, N. Y.

150 EACH Letterheads; Envelopes, C. O. D. \$2. Jacobus Service, Irvington, N. J.

500 BOND letterheads or envelopes, \$2.50, prepaid. Send money order with copy. Free samples. Letterhead Shop, Aetna Bldg., Indianapolis.

250 BOND Letterheads or Envelopes \$1.50. Geyer Printery, Box 850A, Dayton, Ohio.

ALL Printing Prices Smashed. 5,000 Letterheads or envelopes \$13.87. Samples. Quality Printshop, Marietta, Ohio.

500 TWO-COLOR Letterheads \$2.75. Sample free. "Superior", 1825 Roosevelt, Indianapolis.

225 BOND letterheads, envelopes, billheads, cards, \$1.25 each. Combination, \$4.00. Economic Press, Leonia, N. J.

QUALITY Printing! Reasonable Prices! Tell us your wants and let us quote our Money-Saving prices. Best Work. We print anything. Ernest Fausus, 525 South Dearborn Street, Chicago.

PRINTING Outfits—Presses, type supplies, type novelties. Send stamp for catalogue. Medal Press, York, Penna.

PRE-USED Printing Presses, Type and supplies. List for stamp. Popular Bargains, Richland, Pa.

WE print everything. Stationery, Booklets, Catalogs, Circulars, Samples. Commercial Press, Batavia, Ohio.

250 LETTERHEADS, 250 white envelopes, printed and mailed, \$3.00. Samples printing free. Sunco, Mohawk, N. Y.

1,000 LETTERHEADS or Envelopes, \$1.00. Sent Prepaid. Samples Free. Monitor Press, Morrisville, Pa.

FOR MEN

BUY Direct from manufacturer. Save 50%. Genuine imports. English Broadcloth Shirts—\$2.29 or 3 for \$5.95. Agents Wanted. All orders sent: Parcel Post, C. O. D. Consumers Mfg. Co., 621 Broadway, New York.

ARE you old at forty? See our advertisement on page 155 of this issue. The Electro Thermal Company, 2132 Main St., Steubenville, Ohio.

FOR SMOKERS

HONEYDEW Tobacco: Mild, Satisfying, worldwide reputation, guaranteed. Smoking, 5 lbs. \$1.00; 12 lbs. \$2.00; Handpicked chewing, 5 lbs. \$1.50; 12 lbs. \$3.00. Sample 25 cents. Paul Newton, Gilbertsville, Ky.

BOATS AND LAUNCHES

16-FOOT Rowboat—easily made. Construction blueprint 30c. Weesha-Uco, West Market, Detroit, Mich.

BOATS that always go are propelled by Ford engines. Send for Ford Boat Book. Harry Rider, 206 Commercial Bldg., Norwalk, Conn.

"HOW to make your boat leakproof." Send for booklet. L. W. Ferdinand & Co., 152 Kneeland St., Boston, Mass.

MAKE rowboats sail, \$5.00. Graham Centerboard Mfg., Harbor Springs, Mich.

RAZORS AND BLADES

BLADES resharpened, 3c any make; guaranteed service. Standard Safety Razor Corp., Pittsburgh.

BLADES, resharpened, one edge 2c; double 3c. New York Edge Co., Glen Cove, N. Y.

FURS

YOUR raw furs tanned and made into beautiful garments. Enormous savings. Catalog Free. Arthur Felber Fur Co., 25 N. Dearborn St., Dept. P. M. 5, Chicago, Ill.

DIAMONDS, WATCHES AND JEWELRY

21-JEWEL Watch \$4.99. All makes about half regular price. Agents wanted. List free. Rex Co., Andover, Ohio.

WATCHMAKERS: Earn highest wages. Understand adjusting thoroughly. Circular free. Write Walter Kleinlein, Publisher, Waltham, Mass.

OPTICAL GOODS

GENUINE Hensoldt Pocket Microscopes, very powerful, 25X to 225X, described June Popular Mechanics, reveals nature's wonders, serves many useful purposes. Regular \$30—sent C.O.D. \$17.50; number limited. H. Rieger, 2250 Grand Concourse, New York City.

FOR Quick Sale! One Carl Zeiss Prism Telescope 12, 24 and 42 Power, Complete with Heavy Leather Carrying Case and Especially Adapted Panoramic Tripod, \$137.50, One Bausch and Lomb Student Microscope Complete, \$27.50. Send for Photograph. DeFranne, Importers, 109 N. Dearborn St., Chicago, Ill.

FOR THE HOME

CONCRETE Handbook, for the Amateur. We have just published a book describing 173 ways of using concrete in the home, shop and on the farm, with full directions for doing these things yourself with ordinary tools. 138 illustrations. It is "written so you can understand it." Price \$5.00 cents, postpaid. Popular Mechanics Book Dept., 206 E. Ontario St., Chicago.

LOOMS—Only \$9.90—Big money in weaving rugs, carpets, portieres, etc., at home, from rags and waste material. Weavers are rushed with orders. Send for free loom book. It tells all about the weaving business and our wonderful \$9.90 and other looms. Union Loom Works, 480 Factory St., Rosenville, N. Y.

KENNEDY Moth Proof Garment Bags protect your out-of-season garments against dirt and moth damage. Sold by Drug, Notion, Variety and Syndicate stores. Made by the Kennedy Car Liner & Bag Co., Shelbyville, Indiana.

ANTIQUES, WAR, RELICS AND INDIAN GOODS

COLLECTED from Europe's Battlefields, Firearms, Medals, Helmets, etc. Illustrated catalogue with sample War Photographs, 25c. Lieut. Welsh, 2117 Regent Pl., Brooklyn, N. Y.

PHONOGRAPHS AND RECORDS

PERFECTION phonograph motors, tone-arms, amplifiers, cabinets, hardware. Highest quality, very low prices. Catalog free. Federal Supply Co., Indianapolis, Ind.

SUPERIOR equipment at lowest prices for building fine phonographs. Superior Phonographs Co., Erie, Pa.

BUILD your own Phonograph. We furnish everything. Write for catalog and free Blueprint offer. American Phonograph Co., 3515 North Crawford, Chicago.

BUILD Your Phonograph. Quality phonographs. Quality Serenado motor and motors of other types. Electric Motors, tone-arms, reproducers, amplifiers, case materials, accessories. Free blueprints and building instructions. Big saving. Wonderful results. Prompt delivery. Catalog mailed for ten cents. Hoosier Manufacturing & Supply Co., 313 Baldwin Block, Indianapolis, Ind.

BUILD your own phonographs. We can supply you with motors, tone arms and all accessories at wholesale prices. Write for catalogue AX. Pleasing Sound Phonograph Co., 204 East 113th St., New York, N. Y.

MUSIC AND MUSICAL INSTRUMENTS

CORNETISTS—Trumpeters—Saxophonists—Clarinetists. Get "Free Pointers." Name instrument. Virtuoso School, Concord, Mass.

MUSIC! Music! Music! Great song hit entitled "A Smile Will Go a Long, Long Way," for treat copy by mail 30c; phonograph record 75c; player piano roll \$1.25. Levi Bryant, 4808 Champlain Ave., Chicago, Ill.

VIOLIN Tuning simplified for beginners. Details free. Olneyville, Box 59, Providence, R. I.

FOR Sale—Violins (2), beginner's and advanced student's. Emil Weisik, Guttenberg, N. J.

COMPLETE, easy self-instructors—Saxophone, Violin, Piano, Drums, Accordion, Mouth-organ, 25c each. G. Elisea, Bowling Green, Ohio.

WRITE Songs. Big money and reputation. Write for information. J. Gordon Pub. Co., 201 N. Hoyne Ave., Chicago.

"MUSIC Composed" to words. Bauer Bros., (formerly of Sousa's Band), Oshkosh, Wis.

VIOLINS. Deep, Mellow, Soulful—on credit. Easy terms for wonderful instrument. Get details today. Gustaf F. Henning, 2424 Gaylord St., Denver, Colo.

PATENT ATTORNEYS

PATENT Procured. Prompt service. Personal, careful and efficient service. Highest references. Moderate fees. Send sketch or model for actual search and advice. George P. Klamm, Master of Patent Law, 51-D Loan and Trust Bldg., Washington, D. C.

5% OF Inventors lose their commercial rights through faulty applications and non-protective patents. Investigate before you apply for patent. See "Bulletin 5A"—free. American Patents Corporation, Barrister Building, Washington, D. C.

PATENTS Secured. Design Patents \$30. Before proceeding, write for Record of Invention Form and Free Book. Highest references. Jacobi & Jacobi, 201 Ouray Bldg., Washington, D. C.

PATENT SENSE—"The book the inventor keeps." Free. See Lacey ad, page 172.

PATENTS Procured; Trade Marks Registered—A comprehensive, experienced, prompt service for the protection and development of your ideas. Preliminary advice gladly furnished without charge. Booklet of information and form for disclosing idea free on request. Richard B. Owen, 30 Owen Bldg., Washington, D. C., or 2276-R Woolworth Bldg., New York.

INVENTORS should write us for our book, "How to Obtain a Patent," which clearly sets forth what may be patented and the necessary steps to protect an invention; it describes the procedure in patent office and tells about assignments, licenses and trade marks, and gives many useful facts about patents which every inventor should know; many persons well versed in patent matters have pronounced the book the best of its kind they have ever read; it is written so you can understand it; copy free upon request. Talbert & Talbert, Patent Lawyers, 481 McGill Bldg., Washington, D. C.

INVENTORS! Write for new plan telling how and where to sell commercially acceptable inventions—whether Patented or Unpatented. Results assured. W. T. Greene, 806 Jenifer Bldg., Washington, D. C.

HORACE L. WOODWARD—Efficient, conscientious service. Send sketch for preliminary advice. Established 1906. 701 Ninth, Washington, D. C.

PATENTS Procured. Send sketch or model today for examination, prompt report and advice. No charge for preliminary advice. Write for free Booklet and blank form on which to disclose your idea. Highest references. Promptness assured. Clarence A. O'Brien, Registered Patent Lawyer, 581 Security Bank Building, directly across the street from Patent office, Washington, D. C.

MONROE MILLER, Ouray Bldg., Washington, D. C. Patent Attorney; Mechanical, Electrical Expert. Free Blue Book gives candid advice.

MILLIONS spent annually for ideas! Hundreds now wanted! Patent yours and profit! Write today for free books—tell how to protect yourself, how to invent, ideas wanted, how we help you sell, etc. American Industries, Inc., 500 Kresge Bldg., Washington, D. C.

PATENTS, Trade-Marks, Copyrights, and Patent Litigation. Write for advice and instructions how to proceed, costs, etc. Hand Book with illustrations of 100 Mechanical Movements sent free on request. Albert E. Dieterich, Patent Lawyer and Solicitor, 621-B Ouray Bldg., Washington, D. C.

H. F. LOWENSTEIN, Registered Patent Attorney, Technical expert. McLachlen Building, Washington, D. C.

PATENTS—M. P. Laughlin—Engineer-Attorney. 48 East 41st St., New York.

PATENTS: Personal attention and investigation given to patent matters for reasonable charge. Albert Robinson, McLachlen Bldg., Washington, D. C. Formerly an Assistant Examiner of Patents.

PATENTS—Let me assist you in obtaining your valid Patent rights. Personal service. Promptness assured. George Van Den Berg, Barrister Bldg., Washington, D. C.

EDWARD C. SANNETT, 510 McGill Building, Washington, D. C., formerly a Principal Examiner in the United States Patent Office.

PATENTS and Trade-marks obtained. Prompt service. Write for our new book on patents. Established in 1889. D. Swift & Co., 269 7th St., Washington, D. C.

INVENTORS—Send for form "Evidence of Conception" to be signed and witnessed. Form, fee schedule, information free. Lancaster and Allwine, 221 Ouray Bldg., Washington, D. C.

THE PATENTOME is free. A liberal education in patents. Anderson & Son, attorneys, estab. 1865, 635 F St., N. W., Washington, D. C.

PATENTS—Write for our Guide Books and "Record of Invention Blank" before disclosing inventions. Send model or sketch of your invention for Examination and Instructions. No charge for the above information. See advertisement on pages 170 and 171. Victor J. Evans & Co., 934 Ninth, Washington, D. C.

TRADEMARKS \$35; Design patents \$35; Copyrights \$5; Booklet Free; 20 years experience. Sanders, Registered Patent Attorney, 7 Rand-McNally Building, Chicago.

PATENTS. My fees in installments. Advice book free. Frank Fuller, Washington, D. C.

"INVENTOR'S Adviser," the valuable Patent book with 129 mechanical movements and illustrations, sent free upon request. M.M. Labiner, Patent Attorney, 3 Parkrow, New York.

PERCY S. WEBSTER, Savings and Loan Building, Stockton, California. Long established organization. Send for free book on Patents.

COMMERCIALIZE your ideas according to My Cooperative Plan before patenting. Booklet Free. Ralph Burch, Patent Lawyer, Jenifer Building, Washington, D. C.

PATENTS. Booklet free. Highest references. Best results. Promptness assured. Send model or drawing for preliminary examination. Watson E. Coleman, Patent Lawyer, 644 G Street, Washington, D. C.

INVENTORS—Write for our Guide Book, "How to Get Your Patent" and Evidence of Invention Blank. Send model or sketch of your invention for our prompt opinion of its patentable nature. Randolph & Co., Dept. 420, Washington, D. C.

INVENTORS: Send sketch or model of invention for opinion concerning patentable nature and exact cost of patent. Book "How to Obtain a Patent," sent free. Tell what every inventor should know. Established twenty-eight years. Highest references. Prompt service. Reasonable charges. Address Chandice & Chandice, 436 Seventh, Washington, D. C.

HERBERT JENNER, patent attorney and mechanical expert, 606 F Street, Washington, D. C. I report if patent obtainable and exact cost. Send for circular.

"**INVENTORS' Guide**" free on request; gives valuable information and advice for all who have original ideas or improvements. Frank Ledermann, Registered Attorney and Engineer, 13-P Park Row, New York.

PATENTS. Trade marks, copyrights. Prompt, personal, reliable service. Over 36 years' active practice. Write for terms. Book free. Address E. G. Siggers, N. U. Bldg., 918 F St., Washington, D. C.

FOR INVENTORS

PATENTS. If you have an invention which you wish to patent you can write fully and freely to Munn & Co. for advice in regard to the best way of obtaining protection. Please send sketches, or a model of your invention and a description of the device, explaining its operation. All communications are strictly confidential. Our vast practice, extending over a period of seventy-eight years, enables us in many cases to advise in regard to patentability without expense to the client. Our Hand-Book on Patents is sent free on request. This explains our methods, terms, etc. in regard to Patents, Trade Marks, Foreign Patents, etc. "Scientific American" contains Patent Office Notes, Decisions of interest to inventors and particulars of recently patented inventions. Munn & Co., Solicitors of Patents, 623 Woolworth Bldg., New York; Scientific American Bldg., Washington, D. C.; 801A Tower Bldg., Chicago, Ill.; Hobart Bldg., San Francisco, Calif.

LARGE well financed manufacturing concern specializing in sheet metal work, but also fully equipped with stamping, die making, machining, brass founding, pattern making and nickel plating departments, wants to take on the manufacture and sale of additional line, either on purchase or royalty basis. What have you? Write with full description and all details to Fenne, c/o Popular Mechanics, 209 East Ontario Street, Chicago, Ill.

"PATENTS and their Sale." Inventor's invaluable guide. Synopsis free. Snodgrass & Co., Law Publishers, 105 W. Monroe St., Chicago.

INVENTORS of improvements to Steam Engines, Boilers, Valve Gears, etc. We build working models and do experimental work. Estimates promptly. Model engineering catalogue, 20c. Bathe Manufacturing Co., Dept. D, 5214 Woodland Ave., Philadelphia.

INVENTORS' Educator; 900 Mechanical Movements, 50 Perpetual Motions. How to procure and sell patents. Mechanical Movements greatly assist inventors, suggest new ideas. Explains how to select an attorney and avoid Patent Sharks. Price \$1.50. Postage Free. Albert E. Diesterich, 621 Ouray Building, Washington, D. C.

INVENTORS: We develop your invention to practical use; make necessary drawings, models; expert engineering counsel; before or after patent; also help market your invention. Investigate. (No attorneys or brokers.) Custon-Guay Engineers, Washington, D. C.

INVENTORS—Write for our Guide Books and "Record of Invention Blank" before disclosing inventions. Send model or sketch of your invention for our free opinion of its patentable nature. See advertisement on pages 170 and 171. Victor J. Evans & Co., 157 Ninth, Washington, D. C.

PATENTS Procured; Trade Marks Registered—A comprehensive experienced, prompt service for the protection and development of your ideas. Preliminary advice gladly furnished without charge. Booklet of information and form for disclosing idea free on request. Richard B. Owen, 30 Owen Bldg., Washington, D. C., or 2274-B Woolworth Bldg., New York.

LACEY Patent Sense. See page 172.

PATENTS Procured. Send sketch or model today for examination, prompt report and advice. No charge for preliminary advice. Write for free Booklet and blank form on which to disclose your idea. Highest references. Promptness assured. Clarence A. O'Brien, Registered Patent Lawyer, 581 Security Bank Building, Directly across the street from Patent office, Washington, D. C.

INTERNATIONAL - OPPORTUNITY (Brookings, S. Dak.), especially published for amateur inventors. Year, 50c. Copy, 12c.

MONROE MILLER, Ouray Bldg., Washington, D. C. Patent Attorney; Mechanical, Electrical Expert. Before proceeding, read free Blue Book.

CASHING In—If you have a practical, useful invention to sell, write us promptly. American Patents Corporation, Barrister Building, Washington, D. C.

53% OF inventors lose their commercial rights through faulty applications and non-protective patents. Investigate before you apply for patent. See "Bulletin 5"—free. American Patents Corporation, Barrister Building, Washington, D. C.

SPECIALIZED service for inventors. You furnish the idea, we'll work it out. Expert machine designing. Drafting. Opinions given on practicability of ideas. Confidential dealings. Your ideas fully protected. Write for full particulars. Otis Engineering Co., Desk C D, Omaha, Neb.

PATENT Application (simple invention) prepared, prosecuted—total fee, \$25. Easy payments. A. M. Benner, Olympia, Wash.

UNPATENTED Ideas can be sold. I tell you how and help you make the sale. Particulars free. Write W. T. Greene, 807 Jenifer Bldg., Washington, D. C.

MODEL Making and experimental work. Modern shop; expert workmen. Manufacturing. Lawson Electrical & Mfg. Co., 625 W. Jackson, Chicago.

TO sell your Patent. Write me; experienced handling, immediate action. Address Arthur S. Billings, Suite 401 Dekum Bldg., Portland, Ore.

PATENTS—Send for Booklet. Contains valuable information for inventors. Our charge for search of Patent Office records \$3.00. Prompt service, twenty years' experience. Talbert & Talbert, 540 McGill Building, Washington, D. C.

I SELL Patents. Established in 1900. The Service you have looked for, but I doubt if you have ever found. Charles A. Scott, 773 PM Garson Avenue, Rochester, N. Y.

INVENTORS. Sell your patented or unpatented ideas direct to reliable manufacturers and dealers. Send descriptions and \$1.00 for names and addresses. M. H. Heinicke, 305 Richmond Ave., Port Richmond, New York City.

PATENTS sold for cash or royalty; quick action. Blanchet & Co., 347 5th Ave., New York.

HAVE You an invention? If so, write for our free book, "How to Get Your Patent" tells our terms and method. Send model or sketch for our opinion of its patentable nature. Randolph & Co., Dept. 114, Washington, D. C.

GET your own patents. Application blanks, complete instructions \$1. Cutting Sons, Campbell, Cal.

PATENT Application Blanks free to inventors. Patent News-D, Washington, D. C.

WE Develop your ideas into commercial shape for presentation to purchasers, making working models, drawings, experiments or tests. Courtesy, efficiency, secrecy and ample equipment; 30 years' experience. Ducommun-Rich Engineering Co., 504 Pacific Mutual Bldg., Los Angeles, Calif.

PATENTS FOR SALE

THE Automatic Train Control, patented in 1922, consists of one second track, formed in two as follows: leave one track and go in the other in succession. The current is obtained from the locomotive forming a circuit by the aid of a brush. If there should be anything near this locomotive either in front, behind or on either side, the train will stop immediately. The companies that are interested in this apparatus are cordially invited to examine it and see the benefit it can bring. In order to understand fully the effect, write to Thorn Engineering Co., New York City, who analyzed my invention, therefore give you a more satisfactory explanation. If you wish any particular information, write to 1612 S. 11th St., Philadelphia, Pa. Orazio Bonocorso, the inventor.

WILL sell my patent on Triumph Concrete Conveyor. Has new and remarkable features. W. L. Jones, Decker, Mich.

SAFETY device for Bliveting Hammer. Will accept any reasonable offer. F. E. Johnson, 1927 11th Ave., Altoona, Pa.

MUSIC Turner, works by foot power, adjustable to any size sheet; turns music forward or backward; no machined parts. Thos. Marshall, 2285 24th Ave. N., Nashville, Tenn.

FOR Sale—Patent on a Cable Tie Hanger. The simplest and most practical device of its kind. May be bought either outright or on royalty basis. For terms, etc., address J. H. Jessop, 129 Ellsworth Ave., Salem, Ohio.

OUTRIGHT or royalty: Toy Torpedo, Patent pending. Charles Squire, Deans, N. J.

PATENT for Sale—outright or half interest. Photographic flash apparatus, both gun and cabinet, to be used both for amateur and professional use. Covered in U. S. and Canada. Box 499, Patchogue, N. Y.

NEWLY patented invention embodying radical improvements in construction of chain books. To apply for Canadian Patent also. Outright or royalty. Write for particulars. Geo. Poppo, 238 Center St., Massena, N. Y.

FOR Sale—Patents on one-boy Merry-Go-Round. Cash or royalty. Thousands can be sold; money maker. For full particulars address Box 440, Claude K. Armstrong, Princeton, W. Va.

BEST Automatic Lock for "Milk Boxes or other Receptacles" ever invented. Cheaply manufactured. Outright or Royalty. Leo O. Miller, 9341 Pontiac St., Detroit, Mich.

PATENT Applied For. For Sale—Improved gas valve with removable handle. Absolutely safe where gas is used. Will sell outright or contract on a royalty manufacturing basis. Drawing or valve sent on request. Write N. M. Savatovic, 2816 B Street, Omaha, Neb.

IMPROVED trench digging machine. Outright or royalty. A. F. Figures, Gilberton, Ala.

SELF-CLEANING Lawn Rake, Patented in three countries. Sales Unlimited. \$5000 cash. Will consider royalty or trade. Stanley Scarvie, Deoruch, Iowa.

PATENT on pencil Holder attachment; great convenience for clerical work; cheaply manufactured. Write for particulars. Bernard J. Blaskie, 340 Lincoln Way West, Mishawaka, Ind.

PATENT For Sale—"The Auto Cooker." C. M. Daly, 538 West 29th St., New York—See Page 810 of the December 1923 issue of Popular Mechanics Magazine. You will find an illustrated description of the "Auto Cooker," patented July 31st, 1923, U. S. 1,463,576; Canadian Nov. 1923.

FOR Sale or Royalty, Seven U. S. Patents on Electric Hammer. European Patents sold. George L. Killok, 1024 Columbia Street, Seattle, Wash.

FOR Sale Outright—pedal lock for automobiles. A new and most practical device. Recently patented. Best offer takes it. E. Graham, 1229 Birch St., Los Angeles, Calif.

MANUFACTURERS of Dredging Machinery. For sale: United States and Canadian Patents for an Automatic Clam Shell operated on one Cable. One hundred per cent efficient. Saves time and labor. If interested, apply, Edward Woolley, 332 Atlas Ave., Toronto, Ont., Canada.

FOR Sale—Patent on improved construction of automobile steering wheel. P. Jourdan, 2911 E. Virginia, Evansville, Ind.

FOR Sale—United States Patent on Automatic Delivering Cigarette Case. Priced right. W. P. J. Hagarty, Avon, S. D.

WILL sell all or part of newly patented self-wrapping attachment for all mop handles. William Fortner, 708 Avon St., Freeport, Ill.

PATENTED 1909, right-hand and left-hand plow; connected team goes from end to end on cable; works well as swim plow, sulky or riding plow. Every good Blacksmith can make it. Karl Stauffer, Pewee Valley, Ky.

OUTRIGHT or Royalty. Device preventing spoilage from contact with air of top ensilage in silos. Lasts long as silo. Each time installed saves more than cost. F. Bright, 208 West 139th Street, New York City.

PATENT on combination nailset and holder; worth investigating. Ralph Long, 3363 Pacific Ave., San Diego, Calif.

PATENT for Sale for Adjustable Rubber-Plane. John Szako, Inventor, 302 West 42nd Street, New York City.

ATTENTION, Mfgs: I have an automatic Fountain Comb for sale. U. S. Patent. P. D. Yankoff, Ft. Smith, Ark.

MUST Sell Patent Pending No. 559,681, for Carrying and Protecting Automobile Curtains when not in use. Manufacturing cost less than 50c. A. P. Kyle, Glenmora, La.

PATENTS For Sale: To sell, buy or obtain patents, write Patent News-P, Washington, D. C.

YOU have a worth-while patent, haven't you. Why don't you tell our two million readers about it? Most of them are specially interested in patents and new inventions. Ask me to tell you how other inventors successfully sold their patents. Geo. F. Baker, Manager, Classified Advertising, Popular Mechanics Magazine, Chicago, Ill.

SURVEYING INSTRUMENTS

NEW and used surveying instruments direct from factory. Satisfaction guaranteed or money refunded. Wissler, 619 Broadway, St. Louis.

MODELS AND MODEL SUPPLIES

SEND sketch and get lowest prices on Model and Experimental work. Ideal Company, 165 1/2 Spring St., New York.

DIES, Tools and General Manufacturing. Models and Manufacturing of new inventions our specialty. Logan Machine Co., 222 S. Clinton St., Chicago, Ill.

MODELS and Tools made to order. Schmidt, 394 Canal St., New York.

INVENTORS—Write for our Guide Books and "Record of Invention Blank." Send model or sketch of inventions for our free opinion of patentable nature. See advertisement on pages 170 and 171. Victor J. Evans & Co., 165 Ninth, Washington, D. C.

BEFORE you buy model engines, boilers, send stamp for our new illustrated list of machined castings, parts for boilers, boat fittings. Model Machine Shop Co., 417 East 71st St., New York City.

PATENTS Procured. Send sketch or model today for examination, prompt report and advice. No charge for preliminary advice. Write for free Booklet and blank form on which to disclose your idea. Highest references. Promptness assured. Clarence A. O'Brien, Registered Patent Lawyer, 581 Security Bank Building, Directly across the street from Patent office, Washington, D. C.

WE make working models for inventors and do experimental work and carry a complete stock of brass gears and model supplies. Send for catalogue. The Pierce Model Works, Tinley Park, Ill.

SPECIAL machine builders, tool and die makers, inventors' models, production work of all kinds. Let our factory be your factory and save money. Quality Hardware & Machine Co., E. Ravenswood and Thorndale Aves., Chicago, Ill.

MODEL Making and experimental work; Modern Shop, expert workmen. Manufacturing. Lamson Electrical and Mfg. Co., 625 W. Jackson, Chicago.

MANUFACTURING

LET us manufacture it for you. Can quote low prices and can furnish a product you would be proud of. Ideas worked out and simplified. Models made. Metal parts made to drawings or sample. Simplex Tool Co., Woonsocket, R. I.

BOLTS, nuts, rivets. O. L. Dickey, 48 Truck, Bayonne, N. J.

OUR factory will make your models, manufacture your articles as well as build your tools, dies and fixtures. Standard Die & Specialty Co., 317 W. Washington Blvd., Chicago, Ill.

WIRE goods made to order. Cooley Mfg. Co., 524 N. Western Ave., Chicago.

EXPERIMENTS developed, dies, models and manufacturing machine designing. Estimates and information promptly given. Address Schroer Bros. Machine Works, 512 East 25th Street, Kansas City, Mo.

PATENTED Articles, Models, Brass Work, Machine Construction; Dies Made. Baum's Metal Specialties, Kansas City, Mo.

LONG established manufacturer of auto accessories which are daily sold by practically all wholesale and retail accessory houses will consider manufacturing and distributing new automobile products, capable of equally wide sale through same channels. Patented articles preferred. Address Auto Accessory Manufacturer, 1512 North American Bldg., Chicago, Ill.

SCREWS, nuts, screw machine products, all metals. Autocrew Works, 355 West Broadway, New York City.

IRON, Brass, Aluminum Castings, Models, Patterns, Light Manufacturing. Welch Brothers Co., North Chicago, Ill.

WE can design and manufacture special machinery of every description, automatic or semi-automatic. Jigs, fixtures, punches, dies, and special production tools of all kinds. The John Steptoe Company, Stock Yards Station, Cincinnati, Ohio.

PATTERNS, wood and metal. Models, tools and dies. Brass, bronze, aluminum and iron castings. Screw machine work, production work of all kinds. Write Modern Machine & Pattern Co., Terre Haute, Ind.

MACHINERY, TOOLS AND SUPPLIES

ONE Steam Vulcanizer, in good shape. Henry Miller, Downs, Kans.

MICROMETER for one dollar—measures five inches inclusive. See advertisement under "Automobile Supplies."

ONE 18"x38" Pratt and Whitney metal planer \$175. One 24"x12" Reed engine lathe \$300. One 15" Hendy shaper \$225. One 20" drill press \$65.00. Complete line machinery and supplies. Cincinnati Machinery Supply Co., 218 E. Pearl Street, Cincinnati, O.

LATHES—We must sell our stock of 137 bench lathes. Swing 7 in. Between centers 18 in. Ideal for the experimenter or inventor. Not a toy. Special price \$42.50. Write for details. Mechanical Equipment Co., P. O. Box 723, Chicago, Ill.

SPECIAL labor saving machinery designed and built. Punches and Dies and other special tools furnished for manufacturing work. Simplex Tool Company, Woonsocket, R. I.

ENGINES, MOTORS AND DYNAMOS

ENGINES: Steam; Gas; Gasoline; 1/2 H.P. up. Castings; Blue Prints; Model Makers' Supplies. Cat. No. 22, 20c. Cat. No. 24, 20c. Postpaid. Modern Engine & Supply Co., 53 W. Jackson Blvd., Chicago, Ill.

BIJUR Generators, brand new, 6 volts, maximum output 22 amperes at 2000 r. p. m. Government paid \$45.00 each, our price \$10.00. General Sales Company, 1919 S. Michigan Avenue, Chicago, Ill.

MOTORS—G. E. 1/2 hp. \$15.00—3/4 hp. \$22.50—1 hp. \$29.50. Generators 5v. 10 amp. \$15—32 v. 500 watt \$30. Other sizes low prices. Motor Specialties Co., Crafton, Pa.

FOR MECHANICS

MAKE accurate micrometer callipers to 2.4 inches; complete instructions one dollar. Edwin Kilburn, Spring Valley, Minn.

PATENTS—Write for our Guide Books and "Record of Invention Blank" before disclosing inventions. Send model or sketch of your invention for examination and instructions. No charge for the above information. See advertisement on pages 170 and 171. Victor J. Evans & Co., 184 Ninth, Washington, D. C.

ELECTRICAL

TATTOOING Outfits \$1 up. Roberts Company, 635 West Ave., Buffalo, N. Y.

BLACKSMITHS

SENSATION of the season: the new Hoesfeld Wrenchless Universal Bender; bends Eye bolts, U's, Angles, etc. Bends 1 1/4 in. standard Pipe cold. Also rolls perfect Automobile Spring Eyes. Machine can be instantly set for any kind or size of work without the use of a wrench. Simple, Powerful, Inexpensive. Send for circular. Universal Iron Bender Co., Inc., Winona, Minn. Representatives Wanted.

BLACKSMITHS, Listen! Make more money doing hard jobs easy with Toy's Modern Methods of Master Machine Blacksmithing, Forging and Solid Welding, Tool Dressing and Tempering to a standard with colored tempering charts. All for One Dollar. Samples Free. W. M. Toy, Sidney, Ohio.

FOR SALE—MISCELLANEOUS

FOR Sale—600 ft. of new galvanized steel pipe, 2 1/2 in.; threaded both ends; one coupling on each section. Never used. Bought a carload for water system, have this left. Price \$225. P. O. B. boat or car. Camden, Maine. Address H. H. W., 200 East Ontario St., Chicago.

ADDRESSOGRAPHS, Letter Folders, Multigraphs, Envelope Sealers, Duplicators, less than half price. Guaranteed. Pruitt Co., 170 N. Wells, Chicago.

LET'S Swam! Buy! Sell! What's ya got? What's ya want? Four months, dime. International Opportunity, Brookings, S. Dak.

MITER boxes, for ordinary hand saws, \$2. M.A.M. Mfg. Co., Box 56, Newport, Kentucky.

100 MILLIONS German Mark Banknotes \$5.00. Rivers Hicks, Knoxville, Nora Scotia.

SALE F. P. Light Plants; Picture Machine Films; Jazz Swing, Cheapest Ride. Harry Smith, Gratz, Pa.

BUY—Exchange—Sell! Many of our readers have for sale or exchange the article you are looking for—and lots of them are looking for the very items you want to turn into cash. Get together! Let our two million readers know your wishes—they'll help you! Send your ad today to Geo. F. Baker, Manager Classified Advertising, Popular Mechanics Magazine, Chicago.

WANTED—MISCELLANEOUS

WE pay 2c each plus transportation charges for old discarded spark plugs in lots of not less than 100 at a time. Kelly Lamp Works, Oak Park, Ill.

WANTED—Automatic Card Printing Press, State condition and price. Irvin Depoy, Muncie, Ind.

OLD sparkplugs bought. Send postal for information. General Products, 898 8th Ave., New York City.

MAIL us your discarded Jewelry, Gold, Crowns and Bridges, Watches, Diamonds, Silver, Platinum, and old False Teeth. Money promptly mailed. Goods returned if offer refused. United States Smelting Works, (The Old Bellable), Dept. 71, Chicago.

CASH Via Wire Within One Hour. Simply Mail Jewelry, Diamonds, Old Gold, Platinum Points, Unused U. S. Canadian, Postage, Thrift, Stamps, Bonds, Silver, Teeth, Job-Lots, Anything Valuable. Valuables Held Returnable Ten Days if Price Unsatisfactory. L. Simon, Reliable Refiner, 315 Hippodrome Bldg., Cleveland, Ohio.

REAL ESTATE, FARM AND ORCHARD LANDS

BUY these bargains by mail; \$73 for 12 acres choice lake frontage, \$75 for 25 acres, trout stream accessible, \$97 for 50 acres, beautifully wooded—shooting, \$105 for 50 acres, hunting camp site, \$49 for small acreage, Georgian Bay, \$125 for good acreage, big game district, \$215 for large acreage, hunting camp site, \$285 for mining claim, may be worth a million. Also beautifully situated hunting camps and fishing lodges, where there is real hunting and fishing. Summer cottage sites, islands of all sizes, heavily wooded acreages all situated in Muskoka, Georgian Bay District, with its ten thousand islands. Algonquin Park with its 300 lakes, Highlands of Ontario, Lake of Bays, and the famous Muskoka Lake region. All offered at 10 cents on the dollar of their value, and on easy monthly payments of \$5.00 and upwards. Send for illustrated list of the above and one hundred other properties seized and sold for taxes. If you are interested in the forthcoming boom in Canadian Gold and Silver mines, and would like a mine all your own for two or three hundred dollars send for list 241A. Every property is fully described and offered at a stated price. Send no money. Send for list today, so you will have first chance. If you wish you may make the payments to your local trust company. Tax Sale Service, 72 Queen Street, West, District 15, Toronto, Ontario, Canada.

FLORIDA Orange Grove for \$1650. An association of orange growers and nurserymen, not land men, but residents wishing to rapidly develop this beautiful section, will sell you ten acres of fine, young orange or grapefruit grove for only \$1650, or \$165 per acre, about one-fourth cost elsewhere. Terms, \$750 cash and \$10 a month. Fine trees and fine land in Florida's great highland lake region. No swamps, palmetto or malaria. Save all agent's or middlemen's profits; buy from owners. No time for curiosity seekers or tourists, but if you want a grove, write for free book of actual facts and photos. Lake County Land Owners' Association, 93 Nursery Avenue, Fruitland Park, Fla.

70-ACRE Farm Near Village; 3 cows, Poultry, Tools, Crops, Hog, etc., included; close village, 40 acres tillage, orchard; 6-room house, barn, poultry house. All only \$1500 to settle affairs. See page 63 Illus. Catalog. Copy free. Strout Farm Agency, 150P Nassau St., New York City.

WANT to hear from owner having farm for sale; give particulars and lowest price. John J. Black, Chippewa Falls, Wis.

20 ACRES or more of our best land in Michigan; close to town of 3,000 people. Only \$10 down, balance long time. Send postal for 52-page book Free. Swigart Land Company, P-1258 First Nat'l Bank Bldg., Chicago.

ATTENTION—"Get acquainted." Cash for your property, Farms, Hotel or Retail Store, no matter where located; confidential service. Hayes' Business Agency, Cincinnati, Ohio.

ONE Acre, ten Pecan and forty Orange trees \$120. \$10 monthly. Guaranteed care. Ultimate production \$1,000 yearly. Suburban Orchards Co., Dept. M, Biloxi, Miss.

SELL your property quickly for cash, no matter where located. Don't pay big commission. Particulars free. Real Estate Salesmen Co., Desk B., Lincoln, Neb.

\$5.00 DOWN, \$5.00 monthly; 10 acres unimproved poultry, fruit, stock, woodland; \$100; Ozarks. Fishing, hunting, trapping. Alfred Zimmerman, 1800 N. Fifth, Kansas City, Kan.

DOGS AND PETS

BEAUTIFUL White Collie Puppies. Fully pedigreed and eligible for registration. All puppies shipped satisfaction guaranteed. Runners' Rest Collie Kennels, Flora, Ill.

SILVERBLACK Foxes \$300.00. Airedales, Time Payments. Arthur Schumacher, Lockland, Ohio.

FOR Sale, high class German Police Pups. Imported Stock, \$30.00 and up. Riverside Police Dog Kennels, Cooperstown, N. Dak.

BEAUTIFUL registered bull pups cheap. Bulldogs, 501 Rockwood, Dallas, Texas.

POULTRY

BLACK Langshan, Chicago Coliseum Winners. Eggs \$1.95, 15 prepaid. Roy Ridenhower, Vienna, Ill.

ALUMINUM Chick Feeder for Feed, Grit, Milk or Water. Simple, safe and sanitary. Chicks cannot get feet into contents. Send 30c, cash or stamps, for one postpaid. Money back if not satisfied. American Poultry Journal, 418-523 Plymouth Ct., Chicago.

PLANS for Poultry Houses. All styles, 150 illustrations; secret of getting winter eggs, and copy of "The Full Egg Basket." Send 25 cents. Inland Poultry Journal, Dept. 74, Indianapolis, Ind.

SEEDS, PLANTS, TREES, ETC.

KUDZU: World's Best Hay and Pasture. C. E. Pleas, Chipler, Fla.

PERSONAL

SUCCEED! Stellar Numerology demonstrates. Particulars, Stamp, Box 1646, Denver, Colo.

LUCKY Charms, Secrets, Lodestones, Occult Books. Catalog 4 cents. Box 55, Station 1, New York.

YOUR Horoscope — Business, Character Changes, Friends, Enemies. Send birth date and ten cents (stamps) for remarkable test reading. Zanya, 200-C. W., 70th St., New York City.

ANALYZE Yourself.—S. Gargilis, who has astounded astrologers of national repute by his marvelous abilities in interpreting the horoscope, offers to demonstrate these possibilities to you—free of charge. Just send your birth date, year, and a specimen of your handwriting, with ten cents to cover postage, and test its personal value for yourself. Three pages. Gargilis Studio, P. O. Box 2771-D, Boston, Mass.

ARE You Old at Forty? See our advertisement on page 155 of this issue. The Electro-Thermal Company, 2132 Main Street, Steubenville, Ohio.

ASTROLOGY—Stars tell Life's Story! Send birthdate and dime for trial reading. Eddy, 1985 B, Suite One, Kansas City, Mo.

UNUSUAL Horoscope—Six pages, consisting of extensive four-page Special Horoscope, Astro-Analysis, and two-page valuable guide giving daily and monthly advice covering entire year. Send 50c and birth date. Money returned if dissatisfied. Prof. Bolles, Box 5, Fordham Station, New York, N. Y.

TOBACCO kills manly Vigor. Quit easily. Cigarettes, chewing, smoking, snuff conquered or no charge. Small sum if satisfactory. Stops craving; harmless. Full treatment on trial. Perkins Co., 34-A, Hastings, Neb.

TOBACCO or Snuff Habit cured or no pay. \$1.00 if cured. Remedy sent on trial. Superba Co., TP, Baltimore, Md.

FREE—Information of a scientific nature that has brought happiness through perfect health to thousands. No charge; no obligation. Enclose stamp for reply. C. O. Wood & Co., Colorado Springs, Colo.

FREE—Stop using tobacco. We will give free information how to conquer habit easily and permanently. Results guaranteed. Anti-Tobacco League, Box K, Omaha, Neb.

MISCELLANEOUS

LIVE County Distributors. Greatest Necessity. Automobile Show's Sensation. Opportunity Now Ripe. No Competition. Exclusive Best Seller. Emmons Manufacturing Co., Canton, Ohio.

ARE You Old at Forty? See our advertisement on page 155 of this issue. The Electro-Thermal Company, 2132 Main Street, Steubenville, Ohio.

COMBINATION outfits for "resharpening hair clippers." "Making paper flower decorations, samples." "Automobile liquid windshield rain shedder." Two dollars. Free—"100 shaves per blade." Roseto Honery, Roseto, Pa.

CUTS anybody can make. Simple, cheap process. \$1. Specimens, particulars, 2c stamp. M. Day, Windfall, Ind.

CREAMY Fudge Secret—Not Sugary—Easy—Sure—Guaranteed—10c. Donnell, Box 70, Ann Arbor, Mich.

LOCKSMITHING, complete 500 tricks of the trade, new edition, many added features. \$1.50, money back if dissatisfied. H. Houtson, 5406 Andover St., Oakland, Calif.

TATTOOS Removed in one week. Safe, sure and contented. Mail dollar for complete instructions. W. E. Peck, 57 So. Bannock, Denver, Colo.

ALCOHOL—The Alchometer enables anyone to find quickly the alcoholic content of any liquid. Now giving good satisfaction in police work. Box 22, Carlisle, Pa.

GET posted—Good prices paid for butterflies, insects. See Sinclair display advertisement, page 28.

LOCKSMITHS: Send \$1.00 for valuable chart for cutting tumbler padlock keys. Globe System, 278 Washington St., Newark, N. J.

ROCKS and Minerals for sale—hundreds of varieties—price list free. Peter Zedac, 157 Wells St., Peekskill, N. Y.

MONEY in Minerals. Many common minerals have market value. List 10c. Minerals tested. Mineralogist, Joplin, Mo.

UNDRILLED South Sea Island Pearls. Eight Inch Round Sample 50c. MacKenzie, Box 9, Long Beach, Calif.

LEARN Secret of Knife-throwing. \$1.00. S. W. Lewis, East Point, Ga.

MAMMOTH Papershell Pecan nuts \$1.40. Music rubber stamps, rubber type. W. Karstaedt, Dayton, Ohio.

ARTIFICIAL Eyes, \$3. Booklet free. Denver Optic, 559 Barclay, Denver, Colo.

HOMEOPATHIC and Biochemic preparations sent postpaid to all parts of the world. Manual and booklets free. Halsey Bros. Co., 111 N. Washburn Ave., Chicago, Ill. Established 1855.



BECOME A RAILWAY MAIL CLERK

No strikes. No lockouts. When everybody else is worrying about his job or looking for work, the U. S. Civil Service Employee is earning good, steady pay in a pleasant occupation of his own selection. **Earn \$1600 to \$2300.** Let me train you to pass the U. S. Civil Service Examination with **high rating** so you can

get a position **quickest** at \$1600 to \$2300 a year as a Railway Mail Clerk or in Customs, Internal Revenue, Departmental, Immigration, Postmaster, Post Office and Rural Branches. I have trained thousands to successfully pass the examination. Money refunded if unsuccessful in securing a position. Write today. **Mail coupon for catalog.**

PATTERSON CIVIL SERVICE SCHOOL
Dept. 84 ROCHESTER, N. Y.

Patterson
Civil Service School,
Dept. 84, Rochester, N. Y.

See: Send me without charge your
catalog, describing this and other U. S.
Government Positions.

Name.....

Address.....

POSITIONS OPEN IN HOTELS

PAYING UP TO \$400 AND \$500 PER MO.

You can easily qualify for one of many good hotel positions open by preparing in spare time at home. Hotels looking to us for *trained* men and women—many positions open. Opportunities without comparison as to salaries paid, rapid advancement, luxurious surroundings. You can prepare without previous experience in few weeks' time. Training endorsed by leading hotel executives.



Let Us Train You

Send for full particulars as to *big future* for you in hotels, successful graduates, easily-mastered training. Cost moderate; pay as you learn. *We help you secure a position.* Send coupon today for free booklet No. H-166.

Standard Business Training Inst.
Carlton Court, Buffalo, N. Y.

Send Free Booklet No. H-166.

Name.....

Street.....

City.....

Be a B. W. COOKE-TRAINED AUTO EXPERT



I will train you AT HOME!

The world's biggest, most fascinating business needs you! Why slave away at small pay when there are unlimited opportunities as a *Cooke-trained* Auto Expert waiting for you? Mail coupon and I will tell you how I train you **at home** in your spare time for **AUTO EXPERTS** big-pay position.

Earn \$75 to \$200 a Week!

When you read that there are now 15 MILLION autos, trucks and tractors — that car owners are paying out SIX THOUSAND MILLION DOLLARS A YEAR for *up-keep* you will realize here is the business to get into! Enormous demand for *Cooke-trained* Auto Experts. My training includes Garage management, automobile salesmanship and advertising—how to go into business for yourself and make a success of it.

Earn While You Learn!

Get my big Auto Book—it's **FREE**—see what others have done after only a few months of my **JOB-WAY** training. In this book I prove to you under a written Money Back Guarantee that you will find your success as a *Cooke-trained* Auto Expert. Almost at the start I train you to do actual jobs and make extra money doing it. 92 out of every 100 of my students report that they are doing practical work, many of them are already making more money than the entire cost of "JOB-WAY" training!

Big Auto Book FREE!

I don't care how old or young you are, how much or little education you have. **Mail Coupon!** this training will make you a successful Auto Expert. Special inducements and many **EXTRA** features *right now*. Easy terms and low cost. Coupon brings free book and complete information. *Mail it today!*

B. W. COOKE, Directing Engineer
CHICAGO AUTO SHOPS, Dept. 416A
1553 W. Madison Street Chicago, Illinois

No Other Training Like Mine!

As Directing Engineer of the great Chicago AutoShops I know what training you need to make big money, and I GIVE YOU THAT TRAINING! Right in your own home, I make you **MASTER** of every branch of Auto, truck, and tractor work. I train you with **JOB** — not books. I give you complete and practical instruction in every detail of Mechanical and Electrical work, Battery, Ignition, Farm Power Plants, Welding, Brazing, Vulcanizing, etc.

Go into Business—make \$3,000 to \$15,000 a year!

Mighty little capital needed. The big thing is **COOKE JOB-WAY TRAINING**. Rich prizes, big profits await every man who has been trained to give car-owners **EXPERT** service. I give you this training, and I also train you how to start, and run a business of your own.

FREE!
Big
Repair
Outfit

Costly training and repair outfit free to every student for a limited time. Coupon brings special offer.

FREE! AutoBook

B. W. COOKE, Directing Engineer, CHICAGO AUTO SHOPS
Dept. 416A, 1553 W. Madison St., CHICAGO
Send me **FREE** Auto Book and proof that I can become an Auto Expert at home in spare time. Also send your special offers of **FREE** outfit, reduced price and easy terms.

Name.....

Address.....

City..... State.....

Occupation..... Age.....

"I wouldn't sell my course for ten times what I paid for it, if I couldn't get another."
Norman Tompeett,
Tidiante, Pa.



WAS
\$5.00

BOXING
now \$1.67

Also Jiu-Jitsu and Wrestling

THINK of it—over 80 complete lessons in Boxing, Jiu-Jitsu and Wrestling—6 big books printed on fine paper and over 200 photographic illustrations—all for \$1.67! You can have it on 10-day trial. Send no money.

The greatest secrets of the ring, the best blows and guards used by Jack Dempsey, Benny Leonard, Kid McCoy, Jim Corbett, etc. The fine points of feinting, ducking, clinching, breaking ground, judging distance and timing. Instructions on how to train. And a history of the world's greatest boxers right up to the minute with such famous fights as the Dempsey-Firpo, Firpo-Willard, Dempsey-Gibbons fights, with ring-side views.

Marshall Stillman cuts the time of learning in half. His system is based on the methods used by famous Professor Mike Donovan, former boxing instructor at the New York Athletic Club. So quickly do pupils learn that many outbox bigger and stronger opponents after only a few weeks' training.

SHADOW BOXING—To prepare you for your first test, Marshall Stillman also puts you through three fast rounds of shadow boxing—great exercise for producing speed, wind and confidence.

JIU-JITSU AND WRESTLING—How to subdue an armed opponent, how to throw an opponent who grabs you from behind, the Gotch Toe-Hold, the Stecher Scissors Hold, the Head-lock, etc. And to build you up physically, you're given a complete set of muscle-building and breathing exercises.

SEND NO MONEY—Simply fill in and mail the coupon. When you have the course in your hands, deposit \$1.67 (plus the actual postage) with the postman. Use the course for 10 days—try it out thoroughly. If for any reason, you are not entirely satisfied, return the course, and get your money back at once. Mail the coupon now to

Marshall Stillman Association
Dept. 1224-D, 50 E. 42d, New York

10-DAY TRIAL

Marshall Stillman Association
Dept. 1224-D, 50 E. 42d, New York

Send me on approval the Marshall Stillman Course. When I have the course in my hands, I will deposit \$1.67 (plus the actual postage) with the postman, with the understanding that if, after 10 days, I wish to return the course I may do so and my deposit will be instantly refunded. If I keep the course, there is to be nothing further to pay.

Name.....

Address.....

Canadian and foreign orders must be accompanied by cash (\$1.67 U.S. funds) subject to money back guarantee if not entirely satisfactory.

**I Can Train You For A
\$3500 Hotel Job
in 20 weeks**



The Hotel Business offers wonderful opportunities to the trained man or woman! Now fourth largest industry in America. Hundreds of high-salaried executive positions now standing open—waiting for the trained worker. You can easily qualify for one of these big-paying jobs—in your spare time at home. No previous experience necessary.

I Guarantee to Teach You

in my 50-lesson home-study course on hotel work, all that the leading hotel experts know about the business—men making from \$5,000 to \$50,000 a year! My students are eagerly sought by the biggest and best hotels in the country. You won't have to look for a job. Big pay, fine living, free meals and apartment, fascinating work—these are only a few of the many advantages of hotel work.

Send for FREE Book

20 Years' Experience in 20 Weeks is what this wonderfully complete course gives you. Course prepared by Clifford Lewis, a hotel expert of national reputation. Endorsed by managers of such hotels as Biltmore, Waldorf-Astoria, Copley-Plaza, Commodore, etc. Interesting free book explains all. Send for it today.

LEWIS HOTEL TRAINING SCHOOLS

Founded 1916, The Original Hotel Training School
CLIFFORD LEWIS, President
Room K-330 Washington, D. C.
The National Institute for Hotel, Restaurant and Tea Room Training

MUSIC LESSONS FREE

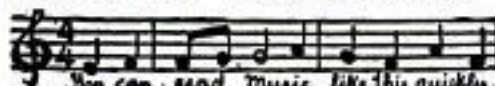

IN YOUR OWN HOME

You can read Music like this quickly.
Piano; Organ, Violin, Mandolin, Guitar, Banjo, etc. Beginners or advanced players. One lesson weekly. Illustrations make everything plain. Only expense about 2c per day to cover cost of postage and music used. Write for FREE booklet which explains everything in full.
AMERICAN SCHOOL OF MUSIC, 50 Lakeside Building, CHICAGO

AVIATION INFORMATION FREE

Send us your name and address for full information regarding the Aviation and Airplane business. Find out about the many great opportunities now open and how we prepare you at home, during spare time, to quality. Our new book "Opportunities in the Airplane Industry" also sent free if you answer at once.

AMERICAN SCHOOL OF AVIATION
Dept. 1194 3601 Michigan Ave. CHICAGO

Be an Expert Repairman on Motors and Generators

Repair men are in big demand—particularly men expert in armature winding. Get into this well paid line.

Learn in 3 Months

—to master this work and insure yourself a permanent income and bigger opportunities—here at this Great Electrical School. In this short time you learn the theory and actually wind all types of D. C. and A. C. armatures under expert instructors.

Write for FREE Booklet

—giving full particulars of this 3 Month's Armature Winding Course. Write today—you will not be obligated. Address—

SCHOOL of ENGINEERING of Milwaukee

P. M. B.-424, 415 Marshall St. Milwaukee, Wis.





Is Your Time Worth \$50 an Hour?

FIFTY DOLLARS AN HOUR would be a mighty satisfactory price to receive for your time, wouldn't it? Yet, as a matter of fact, it may easily be within your power to invest a certain portion of your time in a way that, provided you are sincere and conscientious, will surely bring you that return—very possibly even more.

Sometime ago, an analysis of the relation of education to earning power—made by one of the largest philanthropic organizations in the country—demonstrated the fact that the average adult gets back in increased earnings the sum of thirty dollars for every hour spent in well directed study.

That certainly throws a new light on study habits, doesn't it? But read what follows.

This university trains men in their spare hours at home for specialized activities in the higher fields of business. Its resources of over seven and a half million dollars make possible the maintenance of staffs comprising many of the leading business specialists in the country.

It conducts its training by the LaSalle Problem Method—distinctive with this university—whereby the student gains not "book learning" but actual practice and experience, at every stage of his progress. He learns to do by *doing*. To all intents, from the moment he begins he is actually performing the work of the position he is training to fill.

Naturally you would expect the rewards to be higher for the man who trains this way than for the man who follows a less intensive—a less practical method.

The facts show that the gains *are* greater.

It is a matter of record—established by the facts in our files—files built out of the experience of the four hundred thousand men who have enrolled with LaSalle—that the time invested in the study of any highly specialized LaSalle course by the average member who *completes* that training, returns him in increased earnings not less than \$50 an hour.

Indeed, we have many reports showing that spare hours spent at home with LaSalle training have resulted in increased earnings which—when apportioned over the ordinary period of a

man's business activity—would show a return in excess of \$100 an hour.

Such reports are by no means unusual.

But it is safe for *any* man to expect—and with every prospect of realization—that with diligence and sincerity he can make the time he devotes to acquiring LaSalle training yield him returns at the rate of \$50 for each hour so invested.

LaSalle has no magic formula—no marvelous cure-all. All that it does—as witnessed by the progress-records of 400,000 men—is

to provide an effective way to help men help themselves.—Which is all the right man *needs*.

But that, as we see it, is a mighty big, a vitally important task, and we feel and realize the full necessity of living up to the tremendous obligation it carries—because it is our job as it is our privilege to serve one of the most sacred things in human life—ambition.

To the man who "doesn't care," LaSalle means nothing. But to the man who is looking for "the way," this institution has a message.

J. J. Henkle
President
LaSalle Extension University

LaSalle Extension University

The Largest Business Training Institution in the World
Dept. 464-R Chicago, Illinois

Upon request, the book "Ten Years' Promotion in One," and material completely descriptive of the course and service that interests you, will gladly be sent without cost or obligation. Indicate your choice by checking, and write below your name and address.

- | | |
|-----------------------------------------------------------|----------------------------------------------------------------------|
| <input type="checkbox"/> Business Management | <input type="checkbox"/> Modern Business Correspondence and Practice |
| <input type="checkbox"/> Modern Salesmanship | <input type="checkbox"/> Modern Foremanship and Production Methods |
| <input type="checkbox"/> Higher Accountancy | <input type="checkbox"/> Personnel and Employment Management |
| <input type="checkbox"/> Law: Degree of LL. B. | <input type="checkbox"/> Expert Bookkeeping |
| <input type="checkbox"/> Traffic Management | <input type="checkbox"/> Business English |
| <input type="checkbox"/> Railway Station Management | <input type="checkbox"/> Commercial Spanish |
| <input type="checkbox"/> Commercial Law | <input type="checkbox"/> Effective Speaking |
| <input type="checkbox"/> Industrial Management Efficiency | <input type="checkbox"/> C. P. A. Coaching |
| <input type="checkbox"/> Banking and Finance | |

Name

Present Position

Address

HOME-STUDY

By the LaSalle Problem Method

MAKES THE EXPERIENCE OF SUCCESSFUL MEN YOURS



After **47** Days Every Step into a Big Pay Job **So Can You!**



Will you take a look at this picture? These are men who a short time ago were struggling along in small pay jobs or no jobs at all. Nothing to look forward to. Wanting to be their own boss but not a chance in sight. Then they read my advertisement, just like you are doing now. And they acted. They spent a two-cent stamp for my book that cost me a dollar and I proved to them that they, too, could be big money men, and have their own business. And now in 47 days—just like 60,000 other men I've successfully trained—they'll be stepping into success. And I want to tell you that this is exactly what you can do—send for my FREE book right now and I'll show you how you can get started.

MEN WANTED

Of course, I've never seen you. But I say I can train you in 47 days for one of these jobs in the automobile and tractor business, and aviation and radio, with pay ranging from \$150 to \$600 a month and up. If there were not 20,000 of these men now proud owners of their own profitable garages, vulcanizing, repair and tire shops, etc., I wouldn't be so quick to say you can do the same. For I do believe in stating facts only, and know I couldn't have stayed here in Kansas City 15 years, and been so successful if I'd ever let myself indulge in wild claims I couldn't make good on. But these men had no fine education. They had little capital to speak of. But they were Sweeney trained and made good. And when you remember that this is the fastest growing business in the world, that thousands of men are needed right now, then you can know that this is your big opportunity.

What Job Do You Want?

Demonstrator and Salesman	\$150 to \$600
Garage Manager	\$150 to \$400
Tractor Engineer	\$10 a day
Auto Electrician	\$225
Auto Mechanic	\$6 to \$10 a day
Chauffeurs	\$90 to \$150
Truck Drivers	\$125
Tire Vulcanizers	\$100 to \$200
Welders	\$140 to \$200
Battery Men	\$150 to \$200

**FREE
RADIO
COURSE**



LEARN A
Sweeney
SCHOOL OF AUTO
37-D SWEENEY BLDG.



One of these Men Will or His Own Business!

TOOLS NOT BOOKS

Every one of these 60,000 successful men I have trained is living proof that I know exactly what you need to fit you for success, too. Their records speak lots louder than mere words. I've been successful because I use tools—not books. I give you the real practice, the actual training right here with my superior equipment that cost me more than \$200,000 to install. That's why I can train you in only 47 days. And when I say 47 days I don't want you to get me wrong. I don't mean that you've got to go at the end of that time. Not at all. You can stay as long as you want, a year if you wish, and I'll guarantee to give you the very best attention possible. But in 47 days you can be through and ready to step into this success I've trained you for.

LET EXPERTS TRAIN YOU RIGHT!

Naturally, I'm proud of my school. And I'm proud of my instructors—every man nationally recognized as an expert. These men answer to me for your training step by step. Every one takes a personal interest in you. They are master craftsmen. And with these instructors here in my school where you have the finest companionships, and bathing pools, gymnasium, athletics, social life, you can't help but forge ahead fast like all these other men have done.

TRADE
me
TRACTOR-AVIATION
KANSAS CITY, MO

*I'll pay Your
Railroad Fare!*

To help my students get started right I pay your railroad fare to Kansas City from any point in the United States. So don't worry about the distance. Write for my book and you'll learn that here is an opportunity that won't cost you a lot of money—you'll be amazed at the small cost. But the very first step towards this success is to write for my

FREE BOOK! AND SPECIAL OFFER ■

This beautifully illustrated 64-page book will tell you everything. Send for it now—don't say, "I'll write to that man Sweeney tomorrow and learn all about that wonderful training." No! Do it now. Spend that stamp this minute—take this one first step on the big road to a successful career. No colored students accepted.



Mail
This
Now

FOR BIG OFFER AND FREE BOOK
EMORY J. SWEENEY, Pres., Dept. 37-D, Sweeney Bldg., Kansas City, Mo.

Please send me free, without any obligation to me, your book telling me all about your system, and the opportunities there are for me in the Auto and Tractor Business.

Name

Address

P. O.

State



High School Course in Two Years!

You Want to Earn Big Money!

And you will not be satisfied unless you earn steady promotion. But are you prepared for the job ahead of you? Do you measure up to the standard that insures success? For a more responsible position a fairly good education is necessary. To write a sensible business letter, to prepare estimates, to figure cost and to compute interest, you must have a certain amount of preparation. All this you must be able to do before you will earn promotion. Many business houses hire no men whose general knowledge is not equal to a high school course. Why? Because big business refuses to burden itself with men who are barred from promotion by the lack of elementary education.

Can You Qualify for a Better Position

We have a plan whereby you can. We can give you a complete but simplified high school course in two years, giving you all the essentials that form the foundation of practical business. It will prepare you to hold your own where competition is keen and exacting. Do not doubt your ability, but make up your mind to it and you will soon have the requirements that will bring you success and big money. YOU CAN DO IT.

Let us show you how to get on the road to success. It will not cost you a single working hour. Write today. It costs you nothing but a stamp.

American School

Dept. H474, Drexel Ave. and 58th St., Chicago

American School

Dept. H474, Drexel Ave. and 58th St., Chicago

Send me full information on the subject checked and how you will help me win success.

- | | |
|-----------------------------|---------------------------|
|Architect |Lawyer |
|Building Contractor |Machine Shop Practice |
|Automobile Engineer |Photoplay Writer |
|Automobile Repairman |Mechanical Engineer |
|Civil Engineer |Shop Superintendent |
|Structural Engineer |Employment Manager |
|Business Manager |Steam Engineer |
|Cert. Public Accountant |Foremanship |
|Accountant and Auditor |Sanitary Engineer |
|Bookkeeper |Surveyor (& Mapping) |
|Draftsman and Designer |Telephone Engineer |
|Electrical Engineer |Telegraph Engineer |
|Electric Light & Power |High School Graduate |
|General Education |Fire Insurance Expert |
|Vocational Guidance |Wireless Radio |
|Business Law |Undecided |

Name.....

Address.....

PLAY TEN-TEN-TENNESSEE!

THE TENOR BANJO JAZZ

No Previous Musical Knowledge Necessary--Quick--Easy--Positive Prof. Barker's method is so simple and easy that you quickly play any and all of the popular dance hits just as you have heard them played in Gance or orchestra, on the stage--everywhere. **JAZZ NEW ORCHESTRA STYLE NEW EASY WAY--FUN GALORE**

Just Mail a Post Card for Details of our remarkable **FREE Tenor Banjo Offer**--simply write "I am interested"--**BUT DO IT TODAY.**

First Hawaiian Conservatory of Music, Inc.
Desk 60
233 Broadway
(Woolworth Bldg.)
New York City

Special courses under famous teachers: Egyptian Guitar Violin - Ukulele Instrument Eyes

FREE A Beautiful Tenor Banjo

How to Box 40c

By Terry McGovern, James J. Corbett, J. Gardner Smith, M.D., Arthur P. Keeley and Gus. E. Keeley.

How to Box to Win, How to Build Muscle, How to Punch the Bag and How to Stand, Walk or Run.

This interesting book written by experts is known also as "The Book of Health and Strength." It will greatly assist everyone in keeping fit, in putting them in condition to master a strenuous undertaking either physical or mental.

68 Illustrations. Size 4 1/2 x 7 1/2 in. Paper cover, 135 pages

SHREWSBURY PUBLISHING CO.
5311 West Lake Street, CHICAGO, ILL.

LEARN PIANO TUNING

MAKING TRIALS OF TRUE TONE

By TUNE-A-PHONE

We furnish our accurate teaching device with tools, action model and lessons. Diploma given graduates. 25th year teaching this art by correspondence. Write today for free booklet and guarantee plan.

NILES BRYANT SCHOOL 30 BRYANT BLDG. AUGUSTA, MICH.

BE AN ARTIST

Comics, Cartoons, Contemporary, Newspaper and Magazine Illustrating, Pastel, Crayon Portraits and Fashions. Our simple method quickly develops your talent in spare time. By Mail or Local Classes. Write for terms and list of successful students.

ASSOCIATED ART STUDIOS 67-B Flatiron Building, NEW YORK

Rider Agents Wanted

Select from the 44 Styles, colors and sizes of **Ranger Bicycles**. Ride and exhibit sample Ranger and make money. **Delivered free, express prepaid, on Approval. Factory-to-Rider prices save \$10 to \$25.**

12 Months to Pay on any Ranger if desired. Boys and girls easily save the small monthly payments. Parents often advance first payment.

Tires best quality, at factory prices, **express prepaid.** Lamps, wheels and equipment, low prices. **Send No Money, do business direct with makers.**

Write today for free Ranger Catalog, factory prices and favorable easy payment terms

Mead Cycle Company
Dept. L Chicago 100



What Would You Do?

If obstacles of every kind seemed to be placed in your path?

If you were forced into doing the very thing which you did not want to do?

If your most cherished plans were continually thwarted?

If progress seemed to be almost impossible?

If your every action seemed to be anticipated?

If you were continually embarrassed and humiliated by events which seemed to be beyond your control?

Write and let me send you a Key with which thousands are converting loss into gain, lack into plenty, fear into joy, and hope into fruition.

It Will Cost You Nothing!

**Mail this
COUPON
At Once**

COUPON
CHARLES F. HAANEL
214 Howard Bldg., St. Louis, Mo.

I will be glad to have you send a Master Key without cost or obligation of any kind.

Name

Address

City

State



An Easy Way to Learn PHARMACY AT HOME

Graduate pharmacists are always in demand. The work is interesting and pleasant and salaries are good. Many young men open drug stores of their own and become independent.

There's an easy way to learn pharmacy right in your own home in spare time, without losing a day or a dollar from your present work.

The International Correspondence Schools course in Pharmacy supplies the knowledge which it will be necessary for you to have in order that you may pass your State Board Examination.

Just mark and mail the coupon printed below to the International Correspondence Schools, Box 5599-D, Scranton, Pa., and full particulars about the Pharmacy Course or any other work of your choice will come speeding to you by return mail.

INTERNATIONAL CORRESPONDENCE SCHOOLS Box 5599, D, Scranton, Penna.

Without cost or obligation, please send me full information about the subject before which I have marked an X in the list below:

TECHNICAL AND INDUSTRIAL COURSES

- | | |
|--------------------------------------------------|-----------------------------------------------------------------------------|
| <input type="checkbox"/> PHARMACY | <input type="checkbox"/> Civil Engineer |
| <input type="checkbox"/> Chemistry | <input type="checkbox"/> Surveying and Mapping |
| <input type="checkbox"/> Automobile Work | <input type="checkbox"/> Mine Foreman or Engineer |
| <input type="checkbox"/> Navigation | <input type="checkbox"/> Steam Engineer |
| <input type="checkbox"/> Agriculture and Poultry | <input type="checkbox"/> Gas Engine Operating |
| <input type="checkbox"/> Mathematics | <input type="checkbox"/> Wireless <input type="checkbox"/> Airplane Engines |
| <input type="checkbox"/> Electrical Engineering | <input type="checkbox"/> Architect |
| <input type="checkbox"/> Electrician | <input type="checkbox"/> Contractor and Builder |
| <input type="checkbox"/> Mechanical Engineer | <input type="checkbox"/> Architectural Draftsman |
| <input type="checkbox"/> Mechanical Draftsman | <input type="checkbox"/> Concrete Builder |
| <input type="checkbox"/> Machine Shop Practice | <input type="checkbox"/> Structural Engineer |
| <input type="checkbox"/> Railroad Positions | <input type="checkbox"/> Plumbing and Heating |

BUSINESS TRAINING COURSES

- | | |
|---------------------------------------------------------------------------|---------------------------------------------------------------------------|
| <input type="checkbox"/> Business Management | <input type="checkbox"/> Salesmanship |
| <input type="checkbox"/> Industrial Management | <input type="checkbox"/> Advertising |
| <input type="checkbox"/> Personnel Organization | <input type="checkbox"/> Better Letters |
| <input type="checkbox"/> Traffic Management | <input type="checkbox"/> Foreign Trade |
| <input type="checkbox"/> Business Law | <input type="checkbox"/> Stenography and Typing |
| <input type="checkbox"/> Banking and Banking Law | <input type="checkbox"/> Business English |
| <input type="checkbox"/> Accountancy (including C.P.A.) | <input type="checkbox"/> Civil Service |
| <input type="checkbox"/> Nicholson Cost Accounting | <input type="checkbox"/> Railway Mail Clerk |
| <input type="checkbox"/> Bookkeeping | <input type="checkbox"/> Common School Subjects |
| <input type="checkbox"/> Private Secretary | <input type="checkbox"/> High School Subjects |
| <input type="checkbox"/> Business Spanish <input type="checkbox"/> French | <input type="checkbox"/> Illustrating <input type="checkbox"/> Cartooning |

Name.....
Street.....
Address.....

City..... State.....

Occupation.....

Persons residing in Canada should send this coupon to the International Correspondence Schools Canadian, Limited, Montreal, Canada

Radio Experts Earn Thousands

\$2,500 to \$15,000 yearly for fascinating, easy work; wonderful future in Radio. Thousands of new, big paying positions.



Easy to Learn at Home

You can easily and quickly become a "certified" radio expert through startling new method of National Radio Institute, one of the largest and oldest schools of radio in world. Instruction radio instruments free for practical work at home. Employment service free to graduates.

Send for FREE BOOK

"Rich Rewards in Radio"

Get full details of wonderful opportunities in Radio, of thousands of our successful graduates, and of remarkable, easy method of learning Radio at home to qualify for high paid positions in this tremendous new field. Mail postcard now for 32-page Free Book and Special Tuition Offer to those who enroll now. State age.

NATIONAL RADIO INSTITUTE

Established 1914

Dept. 15DA, Washington, D. C.



LEARN TO DRAW

AT HOME—IN YOUR SPARE TIME

From the school that has trained hundreds of successful cartoonists and illustrators—now earning from \$50 to \$200 and more a week. The Landon Picture Chart Method of teaching makes original drawing easy to learn. Send 6c in stamps for full information and chart to test your ability. Also state your age and what kind of drawing you like to do.



THE LANDON SCHOOL 1438 Nat'l Bldg.
CLEVELAND, O.

GOV'T. HELP NEEDED

All men, women, boys, girls, 17 to 65, willing to accept Government Positions, \$117-\$250, stationary, at or near home, or traveling, write Mr. Ozment, 111 St. Louis, Mo., immediately.



MEN WANTED

Prepare as Firemen, Brakemen, Electric Motormen, and colored Train Porters. Hundreds put to work. No experience necessary. 400 more wanted. Name position you want.

RAILWAY INSTITUTE Dept. 35 Indianapolis, Ind.

SONGS

Clean, catchy hits that everybody likes. Ballads, comic songs, novelty songs, coon songs; full sheet music with beautiful colored covers. Ideal for public entertainment or home diversion. Hundreds of plays and entertainment books. Big catalogs free.

T. S. DENISON & CO., 623 So. Wabash Ave., Dept. 200, Chicago

Learn to PAINT SIGNS and SHOW CARDS

Big field—unlimited possibilities—increasing demand for men with creative ideas. Our course develops ability and originality. Work is intensely interesting.

EARN \$25 TO \$75 WEEKLY

You can do it if ambitious. Successful graduates everywhere. Our course thoroughly covers every phase of work. Our graduates command big salaries. Write for catalog, samples, guarantee and Free Offer. Detroit School of Lettering, 624 D. S. L. Bldg., Detroit, Mich.



ELECTRICITY

in
**20
Weeks!**



Free Proof For You

That You Can Equip for the Biggest Jobs - *at home*

Just think of being able to have this wonderful book free—the book that is bringing thousands big money in electricity. There is no field in the world that offers such great money-making possibilities to trained men as Electricity. Thousands are qualifying the new way by actual S. & H. Shop Type Training. A few weeks during spare time in your own home, then you are equipped to step right into jobs paying from \$50 to \$150 per week. Get this wonderful book, which tells you just how you can do this. Sent free.

Train for \$3,000 to \$10,000 Jobs

Don't stand back on account of education, experience, age, or location. No matter where you live, or what you are now doing, through my course you have the chance to become in a very short time a big pay "electrical expert."

Shop Methods In Your Own Home

For I have devised a wonderful new system that gives you the benefit of actual shop experience in your own home. Never before has this been possible. But now, after finishing my training you will be at home in the biggest electrical plant, in a sub-station, in a battery station, or with expert maintenance men, or on automobile and tractor starting, lighting and ignition work, because you will have had actual experience.

Backed by Lincoln Inst. of Technology

This new system of teaching Electricity has proved so successful that it has been highly recommended and endorsed by the great Lincoln Institute of Technology. When you enroll you

know you are backed by a great institution. You receive free employment service and expert advisory service as long as you live.

Free Outfit—Mail Coupon

There is such a call for men now that we are giving free an electrical outfit for experimental and practical home use if you enroll now. Think what it will mean to leave forever the low pay rut to become a trained, efficient electrical technician, capable of managing and supervising ten or five hundred men on the biggest jobs; to travel, to be a man of influence—to have a salary of \$5000 to \$10,000 per year. You cannot afford to delay a day. Send right now for this wonderful free book that is pointing the way for thousands to big money in electricity. The coupon brings you this book entirely free, without obligation. Fill it out.

ENGINEERING COMPANY
S & H

Affiliated with

Lincoln Institute of Technology

Dept. D-1, 1422 W. Monroe Street, Chicago, Ill.

S & H Engineering Co.

Dept. D-1, 1422 W. Monroe St., Chicago, Ill.

Please send me at once your big book "How to get the Better Jobs in Electricity," and full particulars of your course in practical Electricity, your Free Outfit and your Free Employment Service Offer. I am not obligated in any way.

Name.....
Address.....
City..... State.....
Give age if under 16.....



Are You Earning Big \$100 a Week?

J O B S O p e n

Would you like to be a star salesman? Men who have mastered salesmanship—who are really proficient—name their own salaries. \$5,000 to \$10,000 a year and better not uncommon. Big money and opportunities in business always open to men who can SELL. Success in selling field leads to highest executive positions. Demand enormous. Old theory about "born salesman" exploded. Any man of average intelligence can now learn to sell thru scientific coaching. Training, the secret. Write today for free book, "MODERN SALESMANSHIP." It tells how you can quickly get into the selling game and win your way to the big-pay jobs. Learn in spare hours at home principles and methods of ablest sales organizations in America. Successful salesmen report sales doubled and trebled thru scientific study of salesmanship under LaSalle Problem Method. Low tuition fee—easy terms. Write now for information.

LASALLE EXTENSION UNIVERSITY
The Largest Business Training Institution in the World
Dept. 464-SR Chicago, Illinois

Gentlemen: Send without obligation to me information regarding course indicated below:

Modern Salesmanship
LaSalle is the largest business training institution in the world. It offers training for every important business need. If more interested in any of these courses, check here:

- | | |
|------------------------------------------------------------------|----------------------------------------------------------------------|
| <input type="checkbox"/> Business Management | <input type="checkbox"/> Modern Business Correspondence and Practice |
| <input type="checkbox"/> Higher Accountancy | <input type="checkbox"/> Modern Foremanship and Production Methods |
| <input type="checkbox"/> Traffic Management—Foreign and Domestic | <input type="checkbox"/> Personnel and Employment Management |
| <input type="checkbox"/> Railway Station Management | <input type="checkbox"/> Expert Bookkeeping |
| <input type="checkbox"/> Law, Degree of LL. B. | <input type="checkbox"/> Business English |
| <input type="checkbox"/> Commercial Law | <input type="checkbox"/> Commercial Spanish |
| <input type="checkbox"/> Industrial Management Efficiency | <input type="checkbox"/> Effective Speaking |
| <input type="checkbox"/> Banking and Finance | <input type="checkbox"/> C. P. A. Coaching |

Name.....
Present Position.....
Address.....

WANTED

RAILWAY MAIL CLERKS

\$1600 to \$2300 Year

MEN — BOYS 18 UP.

MAIL COUPON IMMEDIATELY

Steady work. No layoffs. Paid Vacations

Common education sufficient:

TRAVEL—SEE YOUR COUNTRY

\$50-\$300 a Week



Paint Cars in Auto Plants



Repaint Cars For Dealers



Own Your Own Shop



Be Head of Big Business

BIG PAY

made painting autos. You can do it. Highest paid work in whole motor car industry. You can step right into a job that starts you on road to success.

Most fascinating of all work. You can do the work as well as anyone else. Big pay right from start—every opportunity for advancement. You can make more money

PAINTING AUTOS

Work in big auto and body plants or for auto dealers. Jobs open all over country. Demand for men greater than supply. Work year round and always under most pleasing conditions. Also unlimited opportunity if you start auto painting shop of your own. Easily make

\$3 000—\$15,000 Year

We positively can teach you auto painting—exactly as done by master auto painters. You can go right from here to position. Pay big right from start. In few weeks we qualify you.

COME or WRITE Come to Detroit; visit our school; see for yourself. Lastest, finest

equipped school of its kind in world. Only place where you can be taught by the "Wall System"—the system which teaches you everything and the right way from the start, in quickest possible time. School has highest endorsements and recommendations. Students from all parts of the country. Graduates holding best of positions everywhere—many own their own business. Or, write for facts. Send letter today. Ask quickly.

ADDRESS
Detroit Auto Painting School
1420 Van Dyke Ave.
Detroit, Mich.

WE FIT YOU FOR BIG PAY IN FEW WEEKS

BE AN ARTIST

ARTISTS EARN BIG MONEY

Turn your talent into money. We can teach you drawing in your home during spare time. Well-trained artists earn from \$40 to \$200 a week. Thousands of publishers and advertisers need the work of good artists. The MODERN METHOD is an easy way to learn to draw original pictures. Write today for full particulars showing opportunities for you. State your age.

MODERN INSTITUTE OF ART
Dept. 104 7 East 42nd Street, New York City

EARN \$35 TO \$100 A WEEK

AS A MECHANICAL DRAFTSMAN. Write today for Free Book telling how we train you in spare time, at home, and help you secure a position. Fine set of professional Drafting Instruments furnished Free. Write today.

COLUMBIA SCHOOL OF DRAFTING
Dept. D-14, 14th & T Sts., N. W., Washington, D. C.

LEARN TO PITCH



Lessons by "MATTY" WALSH, WHITE, JOHNSON, RUCKER, WOOD — PITCH THE FADE-A-WAY, SPITTER, KNUCKLER, SMOKE BALL, etc., clearly described and illustrated by 56 Pictures. Entire COURSE OF LESSONS sent p. p. for 25c. J. C. DORN, 721 S. Dearborn St., Dept. 65, Chicago, Ill.



FRANKLIN INSTITUTE, Dept. H177, Rochester, N. Y.

Sirs: Send me without charge, (1) Sample Railway Mail Clerk Examination questions; (2) Send List of U. S. government jobs now obtainable; (3) Send free illustrated book, "How to Get Government Jobs."

Name.....
Address.....

MEN WANTED

FOR AUTO BUSINESS

We have hundreds of jobs open for ambitious men who want to learn to make \$50 to \$125 per week in the **AUTOMOBILE BUSINESS**. Many employers have asked us to supply men for these high paid jobs. With our training we **GUARANTEE** that you will be one of the chosen men. And we **GUARANTEE** a **JOB** to help you while you train. Get this proposition firmly in mind!

JOBS GUARANTEED

If you are in need of assistance while training, we **GUARANTEE** for a limited time to get you an "earn-while-you-learn" job paying from \$20 to \$30 per week or more *from the start*. You make only a partial payment down on your instruction, and pay balance from your earnings.

While you earn you learn the Automobile Business in every detail. When you graduate we **GUARANTEE** to place you in a well paid automotive position. Opportunities like this are few. Accept this one **NOW**, while it is before you!

We Pay Your Railroad Fare to Chicago

This special offering is made to fill the many jobs we now have open. Within ten blocks of our new seven story building, which is filled with training shops from top to bottom, there are at least 40 large Automobile Sales Agencies. Throughout the city are approximately 5,000 Garages and Repair Shops. Here is the place to train and to secure high paid employment. In Chicago the opportunities for trained men are unlimited. Mail the coupon *at once* for **FREE** Book "How to Succeed in the Automobile Business," and let us give you **ALL** the information about getting you a job and finding you a home.

Greer Automotive Training Shops
2054 S. Wabash Ave., Chicago, Ill.

**Mail this
COUPON
At Once**

ERWIN GREER, Superintendent
2054 S. Wabash Ave., Chicago, Ill.

Please send me **FREE** Book, "How to Succeed in the Automobile Business," and full information about your "earn-while-you-learn" proposition.

NAME _____

ADDRESS _____



The only man who could talk to the Superintendent

"SOON after I began studying," a student wrote to us the other day, "we had a change in management at our plant. I certainly was glad then that I had decided to study in my spare time. For, thanks to my I. C. S. course, I was the only man in the organization who could talk to the Superintendent in his own language. As a result, I was promoted over men who had been here from ten to twenty years. My salary has been increased 90% in the last ten months."

THAT'S a true story of what just one I. C. S. student has done. There are thousands of others. Every mail brings letters from men and women telling of promotions and increases in salary due directly to spare-time study.

One hour a day, spent with the I. C. S. in the quiet of your own home, will prepare you for success in the work you like best. *Yes, it will!* Put it up to us to prove it. Mail this coupon to-day.

INTERNATIONAL CORRESPONDENCE SCHOOLS Box 5598-D, Scranton, Penna.

Without cost or obligation, please tell me how I can qualify for the position or in the subject before which I have marked an X:

BUSINESS TRAINING COURSES

- | | |
|------------------------------------------------------------------|---------------------------------------------------------------------------|
| <input type="checkbox"/> Business Management | <input type="checkbox"/> Salesmanship |
| <input type="checkbox"/> Industrial Management | <input type="checkbox"/> Advertising |
| <input type="checkbox"/> Personnel Organization | <input type="checkbox"/> Better Letters |
| <input type="checkbox"/> Traffic Management | <input type="checkbox"/> Show Card Lettering |
| <input type="checkbox"/> Business Law | <input type="checkbox"/> Stenography and Typing |
| <input type="checkbox"/> Banking and Banking Law | <input type="checkbox"/> Business English |
| <input type="checkbox"/> Accountancy (including C.P.A.) | <input type="checkbox"/> Civil Service |
| <input type="checkbox"/> Nicholson Cost Accounting | <input type="checkbox"/> Railway Mail Clerk |
| <input type="checkbox"/> Bookkeeping | <input type="checkbox"/> Common School Subjects |
| <input type="checkbox"/> Private Secretary | <input type="checkbox"/> High School Subjects |
| <input type="checkbox"/> Spanish <input type="checkbox"/> French | <input type="checkbox"/> Illustrating <input type="checkbox"/> Cartooning |

TECHNICAL AND INDUSTRIAL COURSES

- | | |
|-------------------------------------------------|----------------------------------------------------------------------|
| <input type="checkbox"/> Electrical Engineering | <input type="checkbox"/> Architect |
| <input type="checkbox"/> Electric Lighting | <input type="checkbox"/> Blue Print Reading |
| <input type="checkbox"/> Mechanical Engineer | <input type="checkbox"/> Contractor and Builder |
| <input type="checkbox"/> Mechanical Draftsman | <input type="checkbox"/> Architectural Draftsman |
| <input type="checkbox"/> Machine Shop Practice | <input type="checkbox"/> Concrete Builder |
| <input type="checkbox"/> Railroad Positions | <input type="checkbox"/> Structural Engineer |
| <input type="checkbox"/> Gas Engine Operating | <input type="checkbox"/> Chemistry <input type="checkbox"/> Pharmacy |
| <input type="checkbox"/> Civil Engineer | <input type="checkbox"/> Automobile Work |
| <input type="checkbox"/> Surveying and Mapping | <input type="checkbox"/> Airplane Engines |
| <input type="checkbox"/> Metallurgy | <input type="checkbox"/> Navigation |
| <input type="checkbox"/> Steam Engineering | <input type="checkbox"/> Agriculture and Poultry |
| <input type="checkbox"/> Radio | <input type="checkbox"/> Mathematics |

Name.....
Street..... 11-21-23
Address.....
City..... State.....

Occupation.....

Persons residing in Canada should send this coupon to the International Correspondence Schools Canadian, Limited, Montreal, Canada.

Learn How to WRESTLE

In Your Own Home
By Mail

Yes, learn to become an expert wrestler right in your own home, by mail, from the greatest wrestlers the world has ever known. Be an athlete, be strong, be healthy. Learn how to throw and handle big men with ease. Learn to defend yourself. All taught in our course of lessons, and illustrated with hundreds of charts and actual photographs by

Farmer Burns and Frank Gotch

Farmer Burns, "the grand old man of the mat," taught Frank Gotch, the World's Champion, all he knew about wrestling, so Gotch said. He will now teach you Scientific Wrestling—Physical Culture—Jiu-Jitsu—Self Defense. Every man and boy in America, no difference what age, needs this wonderful course of lessons. Write today—your name, age and address on a postcard or letter brings you our free book absolutely free—no obligation of any kind. A splendid book on wrestling and physical culture. Write today stating your age.

Farmer Burns School of Wrestling 1774 Railway Bldg., Omaha

This Wrestling Book FREE



How to Dance 50c and What to Dance POSTPAID

This is the latest book published and will teach you the latest jazz, the one-step, the waltz, with the best variations of the fox-trot, all of which when danced properly are graceful and pretty. In addition it also contains some of the older and well known dances. The steps are so simply explained that these can be learned very easily, and for 50c you can become a modern and expert dancer. The information given in this book will make it unnecessary to take expensive lessons. Bound in Kraft paper covers. Size 4 3/4 x 7 1/4". Pages 128. Postpd. 50c.

SHREWSBURY PUBLISHING CO.
5311 West Lake Street, Chicago, Ill.

ARTIST'S OUTFIT FREE

Write quick for our remarkable offer. Learn NOW at home, in spare time, by our new instruction method. Commercial Art, Cartooning, Illustrating, Designing. Delightful, fascinating work in big demand. \$50.00 paid for one drawing. Hand-some book free explains everything. SEND FOR IT TODAY.

WASHINGTON SCHOOL OF ART, Inc.
Rm. 304, 1115-15th St. N.W., Washington, D.C.

Do You Want Money?

Could you use from \$25.00 to \$50.00 a week more than you are now making?

If so, write us at once and we'll show you a way to make it, sure, steady and at the most interesting work you have ever undertaken. We have nothing to sell you. This is an honest, straightforward offer from an old established house of the highest standard and rating. Write us at once for the full facts about our truly remarkable proposition. Address Dept. 867.

GOODWEAR Chicago, Inc.
West Adams St. at Peoria CHICAGO

PIMPLY SKIN made WELL

When a few applications of this wonder-working lotion has cleared faces of pimples, blackheads, acne eruptions on the face or body, barbers itch, eczema, enlarged pores, oily or shiny skin, you can realize why CLEAR-TONE has been tested and approved in over 100,000 Test Cases. The simplicity of the treatment, and The Story of How I Cured Myself are all explained in my free booklet, "A Clear-Tone Skin." Write for your copy today and learn of the results gotten by thousands of men and women.

FREE BOOK Clear-Tone

E. S. GIVENS, 128 Chemical Bldg., Kansas City, Mo.

California Needs Auto Men

Jobs Open
\$40 to
\$125
week

10% of all Autos
in U.S. are in
California

FREE
84 Page
Illustrated
Auto Catalog
Mail Coupon

Be an Auto Expert!

Learn Autos at National Automotive-Los Angeles

IN that wonderful State of California there are big opportunities in the auto business for you. Of the thirteen million autos in the entire United States, 10% of them are in California. Think of it!—one automobile to every four persons.

Crowded with Autos

And because of the thousands of miles of paved highways through beautiful scenic country from the mountains to the sea, because of twelve months of delightful spring-time weather, the auto traffic in California is heavy the year round. City streets, state highways, and country boulevards are crowded with cars.

Prosperity in California

All this means prosperity in the auto industry in California. It means that thousands of auto men are making big money. It means that you, too, can earn big pay, build a business and win success as an auto expert.

Learn Auto Trades Now Jobs Open—\$40 to \$125 Week

Right now there's a tremendous shortage of trained auto men in California. Garages and service stations are needed. Hundreds of jobs are open at big pay—\$40 to \$125 week. **AND MEN CAN'T BE TRAINED FAST ENOUGH TO SUPPLY THE DEMAND.**

Learn auto trades now, and make big money! YOU can be an auto expert. Short-time, special training course at National Automotive will qualify you in auto mechanics and construction, electrical work, trouble shooting, lathe

and milling machine operation, vulcanizing, etc.—everything there is to learn about automobiles you learn at National, and learn it right.

National's system of training has been tested for 20 years. It gives you the practical knowledge and actual experience that enables you to earn big money as an auto expert, run your own business, or make a large salary and commission demonstrating and selling autos.

Thousands of Successful Graduates

Men from every State in the Union and from foreign countries, are now earning big money as a result of National training. They write of 100, 200 and 300 percent increases in earnings. Many own their own business and earn from \$4,000 to \$10,000 a year. With National training, you can duplicate their success. It's the training that counts. And it's National training that gives you a "head start" over other men.

Earn While You Learn

We furnish spare-time jobs that pay living expenses while learning. Your only cost is small tuition fee for life scholarship. No extras; no tools to buy. Ideal living conditions; and remember, it costs less to live in California.

Make up your mind now that you'll be an auto expert. Decide now to be a National trained man—and be sure of success.

Send for Big FREE Auto Catalog

Mail coupon for big, free auto catalog. It explains everything. 84 pages of auto facts. Scores of photo illustrations of auto construction. Tells why and how any man of any age can learn at National. Send for this wonderful and interesting auto catalog today. Read the letters from men who have won success through National training. How National places hundreds of men in big-pay jobs. How National will find your job for you when you finish training. Mail the coupon now.

"Training
Headquarters
for Auto
Experts"



National Automotive

LOS ANGELES

ESTABLISHED 1903

Free
Catalog

NATIONAL AUTOMOTIVE SCHOOL,
Dept. 59, 4804 So. Figueroa, Los Angeles, Cal.
Please send me, absolutely FREE, your big, 84-page
illustrated catalog, postage prepaid.

Name.....

Address.....

City..... State.....

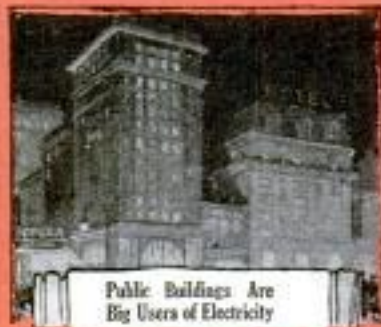

Public Buildings Are
Big Users of Electricity



Electrical Construction
Needs Trained Experts



Electrified Railways
Offer a Big Field

ELECTRICITY

Electrical Experts Earn

Be a **COOKE** Trained Electrical Expert

The Men in the Picture

Below is a picture of L. L. Cooke, Chief Engineer, and his Engineering Staff, engaged in Students' Consultation Work. Through this Free and unlimited consultation service, nine trained and competent engineers help the students of this school with the problems that come up in their work—not only while they are studying but for years afterward—just as long as they care to use it. Think what this means to you—having a group of engineers advising and helping you—without costing you one penny.

This is only one of the features of the unbeatable "Cooke" Service that backs up "Cooke" Training.

Now you earn \$20 or \$30 or \$40 a week. In the same six days as an Electrical Expert you can make \$70 to \$200 and make it easier—not work half so hard. Why, then, remain in the small-pay game, in a line of work that offers no chance, no big promotion, no big income? Fit yourself for a "bossing" job—Be a Cooke Trained Electrical Expert.

Today even ordinary Electricians—the "screw driver" kind—are making money—big money. But it's the trained man—the man who knows the whys and wherefores of Electricity—the "Electrical Expert,"—who is picked to "boss" the ordinary Electricians—to boss the Big Jobs—the jobs that pay \$3500 to \$10,000 a year.



The "COOKE" Trained Man



Hydro-Electric Plants
Being Built Everywhere

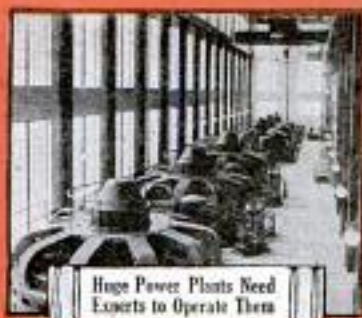

Huge Power Plants Need
Experts to Operate Them



Automotive Electrical
Men Are Needed

for BIG PAY

\$3500 to \$10,000 a Year

Get in line for one of these "Big-Pay Jobs" by enrolling now for my easily learned, quickly-grasped, right-up-to-the-minute, Spare-Time Home-Study Course in Practical Electricity.

Age or Lack of Experience No Draw-Back

You don't have to be a High School graduate—it isn't even necessary that you should have finished the grades. As Chief Engineer of the Chicago Engineering Works, I know exactly the kind of training you need, and I will give you that training. My course in Electricity is so simple, thorough, successful and practical that it offers every man, regardless of age, education, or previous experience, the chance to become in a few short months, an "Electrical Expert," able to make from \$70 to \$200 a week.

Earn While You Learn

With me you do practical work—at once. In my first few lessons I show you how to make money doing Electrical work in your spare time. (Over half of my students are paying for their course in this way.) I show you also, how to get started in business for yourself, and then help you to get started.

FREE—Electrical Working Outfit—FREE

To do spare time work you'll need tools, etc. These I give you,—Free—a whole kit including measuring instruments, a real electric motor (no toy), and other things—the greatest value ever given.

Your Satisfaction Guaranteed by a Million Dollar Institution

I absolutely guarantee to return every penny paid me in tuition if, when you have finished my Course, you are not satisfied in every way with my instruction. And back of me, in my guarantee, stands the Chicago Engineering Works, a million dollar institution.

Nothing Like "Cooke" Training Anywhere

"Cooke" training is different because it is thoroughly practical and has proven successful, and is backed up by the greatest Service to students ever known. It's this Service, plus "Cooke" training, that makes the "Cooke" trained man the "Big Pay" man everywhere. Become a "Cooke" Trained Man yourself, and earn \$12 to \$30 a day—\$70 to \$200 a week—\$3500 to \$10,000 a year.

Investigate! Mail Coupon

Get the Vital Facts. Let me send you free my big new book on The Future of Electricity. Let me tell you more about the big demand for "Cooke" trained Electrical experts. Sign and send me Coupon below.

L. L. COOKE, Chief Engineer
Chicago Engineering Works, Inc.

2150 Lawrence Ave.

Dept. 514

CHICAGO, ILL.

SOME FEATURES OF COOKE TRAINING THAT MAKE SUCCESS CERTAIN

1. Practical Money-Making Instruction—no useless, high-sounding theory.
2. Free Electrical Outfit.—Finest outfit ever sent out for home experiment and practical use.
3. Free Unlimited Employment Service. (Helps you get a good job.)
4. Free Unlimited Consulting Service. (No chance to get stuck on anything, while studying or afterward.)
5. Free Subscription to Monthly Engineering Magazine.
6. Free use of my Big Electrical Laboratory.
7. Extra Courses Free—Radio—Electrical Drafting — Business — Automobile Electricity—Mine Electricity and Special Lessons on Health and Thrift.
8. Spare Time Work—Special earn-while-you-learn lessons.
9. Reduced prices on all Electrical Supplies.
10. Cash Refund Guarantee Bond.

These Features are all explained in my big Free Book —the "Vital Facts."



L. L. COOKE,
Chief Engineer,
Chicago Engineering Works,
Dept. 514,
2150 Lawrence Ave.,
Chicago, Ill.

Dear Sir—Send at once the "Vital Facts" containing Sample Lessons, your Big Book, and full particulars of your Free Outfit and Home Study Course—all fully prepaid, without obligation on my part.

Name.....

Address.....

City and State.....

Occupation.....Age.....

is the "BIG PAY" Man

Are You the Boss? —or Are You Riley?

THE BOSS gives the orders—Riley takes them and does what he is told. Both started the same, had equal ability to begin with. Riley works harder than the BOSS and gets less money. What is the answer?

Training did it. Your brain is an engine that needs fuel. Study and training supply the fuel that makes it go. And when you mix brains with your work you **SIMPLY CANNOT HELP BUT GET AHEAD.**

Be a Contractor or Builder

Fit yourself for a big job in the Contracting or Building business. Train for it right at home. The Course is easy to learn, is simple but thorough, is taught by experts who have made it their life study. We teach you Estimating, Blue Print Reading, Building Regulation, Use of Steel Square, Water Supply and Drainage, Heating and Ventilating, etc.

The cost is low, terms easy, results quick and sure. Our money-back guarantee insures satisfaction. Thousands are earning **BIG MONEY** in this business today. Get ready to get yours. Fill out the coupon now. Check the Course you are interested in. It costs you nothing but a 2c stamp for full information. It will mean much for your future.



American School

Dept. G-474
Drexel Ave. & 58th St.
CHICAGO

© A. S.
1923

"Riley—Take up These Bricks" "All Right Boss"

AMERICAN SCHOOL,
Dept. G-474 Drexel Ave. & 58th St., Chicago
Send me full information on the subject checked.

- | | |
|-------------------------------------|--------------------------|
| .. Architect | .. Business Law |
| .. Building Contractor or Carpenter | .. Lawyer |
| .. Automobile Engineer | .. Machine Shop Practice |
| .. Automobile Repairman | .. Photoplay Writer |
| .. Civil Engineer | .. Mechanical Engineer |
| .. Advertising Manager | .. Shop Superintendent |
| .. Business Manager | .. Employment Manager |
| .. Financial Manager | .. Steam Engineer |
| .. Sales Manager | .. Foremanship |
| .. Cert. Pub. Accountant | .. Sanitary Engineer |
| .. Accountant & Auditor | .. Surveyor (& Mapping) |
| .. Bookkeeper | .. Telephone Engineer |
| .. Draftsman & Designer | .. Telegraph Engineer |
| .. Electrical Engineer | .. High School |
| .. General Education | .. Fire Insurance Expert |
| .. Personal Analysis | .. Wireless-Radio |
| | .. Undecided |

Name

Address.....

Occupation.....



THIRTY-FIVE EASY LESSONS IN RADIO 50c

A systematic course of elementary principles written in a simple and concise lesson course, easily understood. Thousands have taken up Radio for entertainment and are operating their own amateur sets.

This book embodies all the principles and application of everyday radio for the home and in business. Paper cover.

Price postpaid 50c

SHREWSBURY PUBLISHING COMPANY
5311 West Lake Street CHICAGO, ILL.



We have a wonderful new copyrighted system of teaching note music by mail! To first pupils in each locality we will give free a \$20 superb Violin, Tenor Banjo, Ukulele, Hawaiian-Guitar, Banjo, Mandolin, Banjo-Ukulele, Banjo-Mandolin, Cornet or Banjo-Guitar absolutely free. Also teach Piano and Organ. Very small charge for lessons only. Four lessons will teach you several pieces. Over 100,000 successful players. We guarantee success or no charge. Complete outfit free. Write today, Dept. 167. No obligation. **SLINGERLAND SCHOOL OF MUSIC, 1815 Orchard Street, CHICAGO, ILLINOIS**

Learn Expert Auto Painting



There is **Big Money** in auto painting and refinishing. Our Home Study Course in **Practical Auto Painting** will enable you to do the finest work and earn big wages. Wonderful opportunity for new money-making business of your own.

FREE circular tells all about this big new business. Be first. Write quick.

CHICAGO COLLEGE OF AUTO PAINTING
Dept. 44, 140 S. Dearborn St., CHICAGO, U.S.A.

FREE Finger Print Outfit

Everything you need to gain practical experience in finger print work while you are training to become a great Finger Print Expert. The Big Money Finger Print Experts and secret service men are ones who know the finger print branch of this profession. Easy to learn in spare time at home. **Write now for Free Offer.**

U.S. SCHOOL OF FINGER PRINT, Dept. 13-54, 7003 N. Clark St., CHICAGO, ILL.

WRITE JOKES

EARN FROM \$50 TO \$150 PER WEEK

writing jokes, epigrams and humorous stories for publications. Tremendous demand for material. Our short course in Humor Writing teaches you to write humorous material that sells. Learn in your spare time—earn in your spare time. Complete marketing plan and markets furnished.

Write for full particulars

AMERICAN INSTITUTE OF HUMOR
Office J, 414 Park Bldg., Cleveland, Ohio



LEARN WATCHMAKING AND ENGRAVING



Earn while learning. Most practical watch school. Individual instructions. Graduates in great demand. Book free. Chicago School of Watchmaking, Dept. 20, 4840 Lincoln Ave., Chicago

PIANO JAZZ

By Note or Ear. With or without music. Short Course. Adult beginners taught by mail. No teacher required. Self-instruction Course for Advanced Pianists. Learn 67 styles of Bass, 180 Syncopated Effects, Blue Harmony, Oriental, Chime, Movie and Cafe Jazz, Trick Endings, Clever Breaks, Space Fillers, Sax Sturs, Triple Bass, Wicked Harmony, Blue Obligato, and 247 other Subjects, including Ear Playing and Musical Invention. 110 pages of REAL Jazz, 25,000 words. A Postal brings our **FREE Special Offer.**

Waterman Piano School, 258 South Main St., Los Angeles, Cal.

PLAY A SAW

You can produce wonderful, soft, sweet music from a common carpenter's saw with a violin bow or soft hammer, if you know how. No musical ability required—you need not know one note from another.

Easy to Learn in Three Weeks
We absolutely guarantee to teach you to play popular and classical music within three weeks. We give you the secret of my 10 years' success as a saw musician, secrets we guarded carefully until we introduced "The Musical Saw." Successfully instructed thousands. No charge if we fail.

FREE—a special tempered Musical Saw, Saw Bow, Soft Hammer free with Course of Instruction. This Course is short, simple and easy. Only three lessons, one each week—no months of tedious practice.

MAKE BIG MONEY and amaze your friends playing for dances, Lodge and Church Entertainments. Write today for information "How to Play a Saw"—sent Free.

MUSSEHL & WESTPHAL, 211 Second Street, Ft. Atkinson, Wis.



MASTER ELECTRICAL AT HOME

HOW TO SELECT THE RIGHT SCHOOL

- 1st—Make as complete a list as possible of schools teaching electricity by mail.
- 2nd—Do not let the size of an advertisement influence you, but get a catalog from each school.
- 3rd—Study it carefully and take your time about it. Note the claims made and finally select the school you believe is best fitted to fulfill these claims.

Then Take your Burgess Catalog, read it carefully and note among other things the exclusive feature. "Start any time, stop any time, and pay for just what you get."

BURGESS ELECTRICAL SCHOOL
YORKE BURGESS, Superintendent
Dept. 4, 744 East 42nd Street, CHICAGO, ILLINOIS
Canadian Branch: 201A Crawford St., Toronto

WHAT ABOUT THAT BEAUTIFUL BODY OF YOURS

YOUNG MEN can now become perfect human Masterpieces with Tremendous Muscles—Old Men can have Perfect Health—Unlimited Vitality and a Perfect Body. You may now banish the fear of approaching years without the use of Medicine, Drugs, Stimulants, or any artificial aid. **ANALYZE YOURSELF** and you will be shocked at the poison in your System. **PEOPLE DIE TOO YOUNG** because they do not give nature a chance externally, or internally. **DOCTORS CANNOT CURE YOU** unless nature assists them. **CONSTIPATION** often causes High Blood Pressure and some of our most fatal diseases.

KILL CONSTIPATION

or it will surely kill you. If you have that Tired Feeling—Poor Memory—Can't Sleep—Nervous Indigestion—Headache—Constipation—Weak Back—Thinness—Flat Chest—Round Shoulders—Short Windedness—Endurance—or a Drug Addict. Write us for our latest scientific improved way of treating by nature at home without Drugs. **THERE ARE FIVE HUNDRED MUSCLES** in your body. Give them a Chance. We can Increase the Muscle in your Arm one inch, and your chest two inches within Thirty Days—Then Watch them Grow. **WE CAN PUT MUSCLES ON YOU** that will be the envy of all your friends and make you afraid of no man. You will then pity the poor weakling and **WAKE UP FULL OF PEP**—With Eyes Sparkling—Brain Clear, and **EAT LIKE A KID**. It is a crime not to be Physically Fit—Why be Just Average when you can Be Admired By Everyone? **NOW BLAME YOURSELF** if this message does not bring you Strength, Health and Happiness.

FREE Send name and address for Proof and Free Copy of "Strength, Health and Happiness," sent absolutely Free in Plain Cover.

UNITED STRENGTH INSTITUTE
214 Dinan Building DETROIT, MICHIGAN



This Tenor Banjo FREE

WORTH \$18



This handsome, full size, professional tenor banjo is yours. I want to make one thousand new friends this month. I want to present one of these wonderful, delightful instruments as a gift to each of one thousand readers of this magazine—and here's why.

Before becoming a professor, and a lover of music, particularly the tenor banjo, I yearned and yearned for the possession of a genuine, professional instrument, the same kind used by the big, successful professionals of the world. Now that I have succeeded, I want to help every music-lover that I can, attain success, and this gift offer is made to pave the way for you, and no previous musical knowledge is necessary. I have another surprise for you! Not only do I start you on the way to popularity, success and fame by supplying you with an instrument that you can compare to any used or displayed in your town, but under my personal supervision you will be given, by mail, the benefit of my twenty-two years as head Professor of Music (my name is Harry S. Six) at the New York University. I don't just send you a lot of printed words and instructions and trust to luck that you will catch on. My method is different and has proven to be the simplest devised by man—that is why I claim you'll be able to play in thirty minutes. Put me to the test.

Not only do I start you on the way to popularity, success and fame by supplying you with an instrument that you can compare to any used or displayed in your town, but under my personal supervision you will be given, by mail, the benefit of my twenty-two years as head Professor of Music (my name is Harry S. Six) at the New York University. I don't just send you a lot of printed words and instructions and trust to luck that you will catch on. My method is different and has proven to be the simplest devised by man—that is why I claim you'll be able to play in thirty minutes. Put me to the test.

Learn in 30 Minutes With My Picture Method

Arthur Brisbane, the highest paid journalist in the world, once said that "a single picture is worth a thousand words." He was right, for it stands to reason, when you take your instrument in hand along with the actual photographs of myself in action as your guide, it is easy to imitate and do the right thing. But that is not all. I also furnish, as an additional guide, phonographic records of my own playing of the piece you are learning, along with my thorough, printed and illustrated, easy-to-read course.

Phonographic Records Free

Don't Send a Single Cent

Investigate my offer today. Don't put off until tomorrow, because you might forget and miss this wonderful opportunity. It might be the turning point in your career. Don't send me a single cent. Just drop me a line—use coupon or a postal card will do—telling me you are interested in receiving full particulars about my course and to reserve one of my regular eighteen dollar, full size professional tenor banjos for you, which I have offered as a gift.

Act quickly, because there may not be enough gift banjos to go around for the million or more readers of POPULAR MECHANICS. This does not obligate you in any way. Therefore, do not hesitate—put in your reservation now, this very minute. You will soon join my happy army of enthusiastic finished tenor banjo musicians.

EARN BIG MONEY

Hundreds have already started orchestras in their towns and are making money.

FREE BANJO COUPON

New York Academy of Music
Desk 1-A, 212 Fifth Avenue, NEW YORK

Please rush all information relative to Prof. Harry S. Six's Tenor Banjo Course and reserve a gift banjo for me. This obligates me in no way whatever.

Name

Address

City.....State.....

STRONGFORTIZE AND YOU CAN NAME YOUR OWN SALARY



STRONGFORT
The Perfect Man

You can't get on the right side of Success without first getting Health, Energy and Stamina on your side. Heads of great business and industrial enterprises write me that the weak, the incompetent and impotent have no chance with them.

GO GET IT!

Don't be a piker. Be a "big boss" in this man's world. Stand in with real people by standing out as a fine, fit, fearless fellow who asks no odds of anyone. **Dominate** in your work, in social life, in the regard of your employers and in the love and devotion of "the one woman" who holds your happiness in the palm of her hand.

BE NATURAL!

STRONGFORTISM raises men to the heights of physical and mental supremacy by attuning all their forces to the perfect plan of Nature. It makes lithe, clean-limbed, straight-thinking champions of society and business. It confers mastery by making a man completely master of himself and of his vital powers.

My friend, cast off the shackles of your weakness. Unlock the treasure chest of vigor with the master-key of STRONGFORTISM. Look your ailments in the face and overwhelm them with the indomitable truths of natural science taught by me with amazing results for over a quarter of a century.

READ MY GIFT-BOOK

If you want to read the most frankly startling book ever printed on the subject of human regeneration, send at once for your private copy of my life-story, "Promotion and Conservation of Health, Strength and Mental Energy." It relates how Health, Strength and Masculinity returned to thousands of broken and despairing victims of sickness and neglect. Beautifully illustrated and packed with vital facts for you. Fill out the Free (confidential) Consultation Coupon and send to me today with 10c (one dime) to cover mailing costs.

LIONEL STRONGFORT Physical and Health Specialist for 25 Yrs.
Department 1393 Newark, New Jersey

.....CONSULTATION COUPON.....
Absolutely Confidential

LIONEL STRONGFORT, Department 1393, Newark, N. J.

Please send me your big 54-page book. I enclose ten cents (one dime) for postage. Send me special information on subjects marked (x) below, without obligation.

..... Colds Skin Disorders
..... Catarrh Debility
..... Too Fat Torpid Liver
..... Too Thin Vitality Restored
..... Stomach Trouble Muscular Development
..... Flat Chest Great Strength
..... Bad Blood Rupture
..... Nervousness Lumbago
..... Constipation Neuralgia
..... Dependency	

Name.....

Age..... Occupation.....

Address.....

(For Immediate Enrollment Check Below)

ENROLLMENT FORM

I hereby enroll for a Complete Personal Course in STRONGFORTISM, for which I enclose:

- \$15 Payment in Full for Complete Course, Including Resistance-Increasing Dumb-Bells.
- \$ 5 Partial Payment, Agreeing to Pay Balance in Two Monthly Payments of \$5 each, plus \$3.75 extra for Dumb-Bells.

Commercial Engineer

IN ONE YEAR
Big Paying Jobs Awaiting
FOR TRAINED MEN
EARN WHILE
YOU LEARN
IF YOU LIKE

One-half day instruction and one-half day employment in leading concerns. This new profession demands young men with combined technical and commercial training. We take personal interest in every student. Individual instruction. Radio Broadcasting WIAD every day. Other courses offered:

Automotive Electricity, 3 months.
A. C. and D. C. Armature Winding, 3 months.
Practical Electricity, 6 months.
Electrotechnics, 12 to 18 months.
Commercial Electrical Engineering, 1 year.
Electrical Engineering, B. S. Degree in 3 years.

19th year opens April 1, 1924. Write NOW for Big Free Illustrated book just off the press. State age, education and course interested in.

SCHOOL of ENGINEERING PMB-424, 415 Marshall St.
of Milwaukee Milwaukee, Wis.



SHOW CARD LETTERING

A pleasant, profitable profession, quickly and easily learned by our new, simple method. No canvassing or soliciting. We show you how, no matter where you live. Full Particulars and Booklet Free.

DETROIT SHOW CARD STUDIOS, 214 Dinan Bldg., Detroit, Mich.

THE OUTLINE OF SCIENCE

Edited by Professor J. Arthur Thomson

This epoch-making work is being read by tens of thousands. Send for Free Illustrated Booklet.

G. P. PUTNAM'S SONS, Dept. 213, 2 W. 45th St., NEW YORK CITY

MECHANICS FOR YOUNG AMERICA

Plain and complete directions for building boats, water motors, wind mills, searchlight, burglar alarm, ice boat, water bicycle, cabins, camps, hites, etc. 6x9 in. Illustrated. 25c, postpaid. Popular Mechanics Book Dept., 200 E. Ontario St., Chicago.

What About Radio in 1925?

Can You Keep Pace with Its Progress?

While RADIO is now a very big institution, it is true, nevertheless, that there will be many new developments, some new parts, and many new "hook-ups" before RADIO attains its final state of perfection. Can you keep track of all these changes—to-day, to-morrow, in 1924, and in 1925?

LEFAX RADIO HANDBOOK PERPETUALLY UP-TO-DATE!



LEFAX RADIO HANDBOOK always keeps pace with new developments in Radio—the book is loose-leaf, and every month to every purchaser of the book is sent additional pages that keep the book up-to-date. No extra charge for this service for one year. Written by the two chiefs of the RADIO dept. U. S. Bureau of Standards. Fine imitation morocco leather cover.

Price \$5 postpaid, complete with year's service
POPULAR MECHANICS BOOK DEPT.
200 E. Ontario St., CHICAGO

"SOME SUMMER SELLER"



Says Slade of N. J.
Have made \$13,500
in 3 months. Some
summer seller.

Every Woman Wants It Low Price—Big Profit

Representatives, salesmen, spare time workers are literally cleaning up fortunes with an amazing new invention—the Oliver Oil-Gas Burner that makes any range just like a city gas stove. No more sweltering summer kitchens, coal, soot or ashes.

Amazing Invention Ends Summer Coal Fires

Right in her own range, the housewife can cook and bake quicker and better than ever before. She turns a valve—just as with city gas—and her own oven regulates to any temperature. Then, the instant she is through the heat is turned off, the kitchen is cool and clean the rest of the day. Saves 65% of all household work. No lifting or carrying dirty coal, wood, ashes—no wicks, no experimenting. Absolutely safe. Last a lifetime.

\$100 a Week—Spare Time—Easy

You can see how Slade, N. J., made \$13,500 in 3 months. Why Russell makes \$660 a month, J. Carney makes \$1,000 a month, how hundreds of others make \$100 a week and more just in spare time. Here is an opportunity to make a Summer's work yield more than you ever made in a whole year. You don't need to be a super-salesman. The Oliver—sells itself. You take the **OLIVER GIVES** money. Write at once for full details about our Free Sample Case and Big **FORDS AWAY** Exclusive Territory Offer. Oliver gives Fords away—no contests. Write quick for Big Summer Profits.

OLIVER OIL-GAS BURNER & MACHINE CO.
457 Oil Building St. Louis, Mo.
Canadian Office, 457 Webster Building, Toronto

Electrical Course

Here is the quickest, easiest, cheapest way to learn electricity. Think of it! A complete electrical course in book form. No tiresome lessons with a lot of mathematics. Just plain everyday electrical facts—the very things and the only things you need know to hold down a good paying job. Written and simplified by 27 of the biggest men in the electrical field. 8 big books—4100 pages and 3200 pictures.

Electricity Means Success

—Good Pay and a Good Job. You can succeed in electricity. It's one of the best paying fields open to young men who know.

You do not have to give up your present position, just a few pleasant hours spent in the evenings on this subject, and success is yours.

FREE TRIAL!

Just mail the coupon—don't send a cent. We send books for a week's free use. Look them over yourself, and see how thoroughly and completely everything about electricity is explained in them.

American Technical Society
58th St. & Drexel Ave. Dept. E-419

American Technical Society, Dept. E-419 Chicago

Send me your 8-volume set of Electrical Books for a week's free use. I will either return the books in 7 days or remit \$2.50 and pay you \$3.00 each month until a total of \$25.00 is paid.

Name.....

Address.....

Employed by.....

Copy this coupon on larger sheet if more convenient

EARN UP TO \$250 Per Month EXPENSES PAID

In This Uncrowded Profession



BE A RAILWAY TRAFFIC INSPECTOR

Hundreds of Successful Inspectors



Read what Mr. Dewey Burcham writes: "The chances of advancement in this line of work are unlimited. I find the work very interesting and I like it better than anything I ever did."

J. A. Smallick states: "After one year's work in the capacity of Traffic Inspector, I find myself in a position which pays \$180 a month plus expenses. Due to the completeness and easily understandable language of your course, what would in other channels take years to learn can be learned in a few short months."

Unlimited Opportunities



Glen O. Trego writes: "I find railway traffic inspection to be the most interesting position with unlimited opportunities that any man could look for. I find that being a railway traffic inspector does not only enable a man to receive higher positions in railways, but it also verses one so he is more capable of conducting any kind of business which may be chosen for the future."

Ralph E. Becker states: "Finished my course five months ago and ten days after receiving my diploma I was given a position with a large railway company in the East."

(Addresses of these men will be furnished upon request.)

POSITION GUARANTEED OR MONEY REFUNDED

You prepare for this fascinating profession, in your spare time at home, with absolute assurance that if, upon graduation, you do not receive a position paying at least \$110 a month and expenses, your money will be refunded.

You take no risk. You have many opportunities to travel as Railway Traffic Inspector. Places you in contact with high railway officials. Pleasant, healthful, outdoor work; short hours; steady employment. Advancement rapid with experience. Prepare in three months' spare time. Any average man can qualify. Railroads need more trained men—we must supply them.

DON'T DELAY—ACT NOW

Mail coupon for full information contained in free Booklet No. D-63. Standard Business Training Institute Buffalo, N. Y.

**STANDARD BUSINESS TRAINING INSTITUTE
BUFFALO, N. Y.**

Send me, entirely free, Booklet No. D-63, giving full particulars about course in Railway Traffic Inspection.

Name

Street

City.....

What Kind of a Man Are You?

Look Yourself in the Mirror



CHARLES ATLAS

"The World's Most Perfect Man"

Winner of two \$1000.00 FIRST PRIZES and a DIPLOMA for Physical Perfection. No other living man can claim this title.

"SECRETS OF MUSCULAR POWER AND BEAUTY"

It's the greatest muscle building book ever printed. Yes, and it's just chock full of large page photos of my pupils and myself. You'll be thrilled at the marvelous collection of strong muscular giants you'll see in this book. There's nothing else like it in the physical culture world. And it's printed in beautiful colors, too—and bigger and better than anything of its kind. In addition to the scores of pictures, you are plainly told the secrets for developing Huge, Powerful, Rippling muscles on the outside and have Inner Health and Energy on the inside. The edition is limited. I have only a few thousand copies left, so clip the coupon and send for Your copy Right Now. It will mark the beginning of a new and better life for you.

FREE! Everyone who writes me will have an opportunity of securing six large photographs of myself absolutely FREE. Also write at once for full particulars about the big cash prizes, expensive trophies and beautiful Diplomas I am giving away to pupils free this year.

CHARLES ATLAS

"The World's Most Perfect Man"
Dept. 416, 96 Fifth Ave., New York City

***** MAIL THIS NOW! *****

CHARLES ATLAS
96 Fifth Avenue, Dept. 416, New York City

Dear Sir: Please send me your big free book: "SECRETS OF MUSCULAR POWER AND BEAUTY." I enclose 10c to cover wrapping and mailing charges. This places me under no obligation.

Name.....

Address.....

City..... State.....

(Please write or print PLAINLY)

SUMMER is coming and bathing suits will soon be in style—a man's figure is exposed to the stares of everyone. What will your friends think of YOURS? Every woman admires a well developed, powerful body. "Skinnies" and "fatties" will be out of luck. But cheer up; YOU needn't be one of those they scorn and poke fun at! Through my instructions you can take off or put on weight wherever you desire. Muscles that are powerful—yet beautiful and symmetrical—will make you the ADMIRER instead of pitied. By July you can be a PERFECT MAN—strong, healthy, athletic—with a development the whole world will envy.

BE A MAN Not a Manikin!

Quit wishing and wanting and waiting for Health, Strength and a Perfect Physique. Hook up with me and I'll carve out of your body a mighty, powerful Herculean development with far more energy and strength than you ever dreamed possible. All I require is about 30 minutes' snappy, play-time exercise a day till summer. Thousands of others, just like you are benefiting by my Course. In fact, many of my pupils are more perfectly developed than some of the physical instructors are. If you have any vigor and vim and vision lose no more time, but get started immediately and develop the Giant within you, so that YOU, too, can be a POWER among men and an inspiration to others.



**MAKE
MONEY
WHERE
YOU ARE**

**EARN
BIG
INCOME**
\$50.00 TO
\$100.00
WEEKLY

Stay right where you are or locate anywhere. Earn big money! Learn SHOW CARD AND SIGN WRITING, most in demand, easiest learned, most profitable trade known. Our method is easily mastered—We teach you in SIXTY DAYS! We establish you in paying SHOW CARD AND SIGN SHOP, pay, first month's rent, supply all material with a mail plan to secure orders which should net \$60.00 weekly up, or paying JOB awaits you. You'll get lots of orders and money. Merchants buy your work at sight. We guarantee you can learn, or money back on demand. Thirty years successful record and ample capital back of this guarantee. Write for beautiful illustrated matter, price, terms. FREE.

Empire P. M. Institute of Lettering, 1476 Broadway, New York



WANTED! RAILWAY MAIL CLERKS

**UNCLE SAM - MEN and BOYS 17 to 45
WANTS - YEARS**

\$1600 to \$2600 A YEAR

Travel—See the Country—NO LAYOFFS—LIFE-TIME JOB. Holidays with pay. Write today for FREE BOOKLET and Sample Examination Questions.

UNITED BUSINESS TRAINING INST., 214 Dana Bldg., DETROIT, MICH.

LAW IN YOUR SPARE TIME

Learn law with only institution giving same course by correspondence as was given for years at resident classes of this college. **DEGREE OF LL. B. CONFERRED.** One year business law course prepares you for success in business. Law trained business men in demand. Three year university course covers preparation for bar examination. Money back guarantee if not satisfied. Low fee, easy terms, includes complete 1921 thirteen volume library, text material and all expenses. Write for **FREE BOOK.**

Hamilton College of Law
431 South Dearborn St.
Dept. 64 Chicago



**\$50,000.00
REWARD**

Be a Finger Print Expert. Learn SCOTLAND YARD METHODS, Big Pay, Enormous Rewards. We teach you How and arrange a connection for you as soon as you have finished our course. Send today for Free Booklet telling about SCOTLAND YARD, and how to become a Finger Print Expert.

UNITED DETECTIVE TR. INST.
214 Dinan Bldg. Detroit, Mich.

Mathematics Made Easy by ROPP'S CALCULATOR AND SHORT-CUT ARITHMETIC

Shows the Answer as Quickly as a Watch shows the Time to all Problems likely to occur in the Office, Store, Shop, Bank, Farm, or Factory. **Over 2,000,000 Sold**



Explains and simplifies every principle in Arithmetic, Mechanics, and Mensuration.

PRICES POSTPAID
Desk Size...\$1.50
Leatherette, Pocket Size...\$1.00
Pocket Size, Cloth...\$0.50
Pocket Size, Paper...\$0.35

PopularMechanics Book Dept., 208 E. Ontario St., Chicago



"I guarantee that the new method which penetrates to the starved root cells will produce a new, healthy growth of hair in 30 days or your money will be immediately refunded. And furthermore, I want you as the user to be the sole judge. My special free book, now ready, explains the method in detail and tells you precisely why I am able to make this unusual free proof guarantee."

ALOIS MERKE.

New Hair in 30 Days -or Costs You Nothing!

Alois Merke discovers a new, simple method guaranteed to grow thick, beautiful, luxuriant hair, or money instantly refunded. Gives new life and health to hair that is thin, falling, lifeless.

At the famous Merke Institute, Fifth Avenue, New York, letters are pouring in from all over the country requesting information concerning this new method for growing hair. So successful is it that it has been guaranteed to grow new hair in 30 days or cost nothing!

To women this method is particularly interesting as it often transforms thin, falling hair into rich, luxuriant beauty in an unbelievably short time. It is unlike anything ever known in this country. It penetrates to the starved root cells, revitalizes and nourishes them—and the hair grows thick, lustrous, beautiful.

There is no massaging, no sinping, no unnecessary fuss or bother of any kind connected with this new method. It is simple, pleasant. Already hundreds of women who had thin, falling hair, hundreds of men who were "thin on top," have acquired new luxuriant growths of hair. Often the results are almost unbelievable.

Thin, Falling Hair Given Glorious, New Health

Is your hair thin, lifeless? Does it fall out, break? Is it dull and without lustre?

All these conditions are nature's signs of starved or atrophied hair roots: Ordinary methods cannot revitalize the roots, cannot reach them—no more than rubbing "growing fluid" on the bark of a tree can make the tree grow. You must get right at the roots and stimulate them. This remarkable new method provides at last an efficient way of invigorating the roots themselves. The hair becomes brighter, fluffier. New growths make their appearance within 30 days—if they don't there is no cost to you.

Some of the Amazing Results

The proof-guarantee is made possible only through splendid results that have already been achieved—as these few excerpts from letters testify. The letters are on file at the Merke Institutes and anyone may see them by coming to the office.

"I have been bothered with dandruff for 20 years and had lost nearly all of my hair. I have used your treatment 30 days now and have a good growth of hair coming in.

"Am glad to say I can see such great change in my hair. It is growing longer and my head is full of young hair that has made its way through since I have been using Merke Treatment."

"I must frankly state I was skeptical as to your claim, but a faithful use of Merke Treatment for a month

has removed all doubt and three of us are obtaining unbelievable results both in looks and growth.

Free Booklet Explains the Method

We have prepared a special free booklet called "New Way to Make Hair Grow" which tells you everything you want to know about the remarkable new method for growing hair. This booklet explains the method in detail, gives you many interesting facts and proofs concerning this new method. We know you would like a copy, and we will be glad to send it to you absolutely without obligation.

Among other things, this free booklet will tell you how this method penetrates to the hair roots—without any massaging, rubbing or other tiresome methods. And it tells how the dormant root cells beneath the skin's surface are awakened, giving new life, new strength.

Mail this coupon for your copy of the special free book today. Remember there is no obligation whatever. The Allied Merke Institutes, Inc., Dept. 164, 512 Fifth Avenue, New York City.

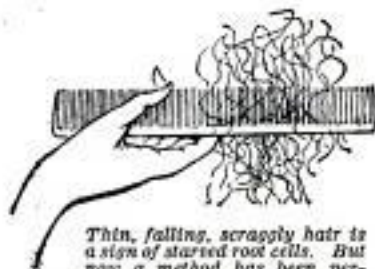

Thin, falling, scraggly hair is a sign of starved root cells. But now a method has been perfected which penetrates to these cells and stimulates them into new activity.

The Allied Merke Institutes, Inc. Dept. 164
512 Fifth Avenue, New York City

Please send me, without cost or obligation on my part, a copy of the new special booklet "New Way to Make Hair Grow," explaining in detail the remarkable method for growing glorious healthy hair.

Name.....
(State whether Mr., Miss or Mrs.)

Address.....

City.....State.....



"Good-bye, Boys!"

"Today I dropped in for a last word with the boys at the office. And as I saw Tom and Dave there at the same old desk it came to me suddenly that they had been there just so the day I came with the firm four years ago.

"When I started here I was put at a desk and given certain routine things to do. But after a few months I began to realize that I was nothing but a human machine—doing things that any one could do.

"So I wrote to Scranton and arranged for a spare-time study course that would give me special training for our work. Why, do you know, it gave me a whole new interest in our business? In a few months I was given more responsibility and more money. Since then I've had three increases. Six months ago I was put in charge of my department, and now my big chance has come—I'm to be manager of our Western branch at \$5,000 a year! It just shows what spare-time training will do."

If you want to make more money, show your employer you are trying to be worth more money. If you want a bigger job, show him you are willing to prepare for it.

There's a simple, easy way to do it. For 32 years the International Correspondence Schools have been training men and women right in their own homes whenever they had a little time to spare. More than 150,000 are studying now. Ten thousand are starting every month.

Can you afford to let another priceless hour pass without finding out what the I. C. S. can do for you? Here is all we ask—without cost, without obligating yourself in any way, mark and mail this coupon.

INTERNATIONAL CORRESPONDENCE SCHOOLS Box 5597-D, Scranton, Penna.

Without cost or obligation, please tell me how I can qualify for the position or in the subject before which I have marked an X:

BUSINESS TRAINING COURSES

- | | |
|------------------------------------------------------------------|---------------------------------------------------------------------------|
| <input type="checkbox"/> Business Management | <input type="checkbox"/> Salesmanship |
| <input type="checkbox"/> Industrial Management | <input type="checkbox"/> Advertising |
| <input type="checkbox"/> Personnel Organization | <input type="checkbox"/> Better Letters |
| <input type="checkbox"/> Traffic Management | <input type="checkbox"/> Show Card Lettering |
| <input type="checkbox"/> Business Law | <input type="checkbox"/> Stenography and Typing |
| <input type="checkbox"/> Banking and Banking Law | <input type="checkbox"/> Business English |
| <input type="checkbox"/> Accountancy (including C.P.A.) | <input type="checkbox"/> Civil Service |
| <input type="checkbox"/> Nicholson Cost Accounting | <input type="checkbox"/> Railway Mail Clerk |
| <input type="checkbox"/> Bookkeeping | <input type="checkbox"/> Common School Subjects |
| <input type="checkbox"/> Private Secretary | <input type="checkbox"/> High School Subjects |
| <input type="checkbox"/> Spanish <input type="checkbox"/> French | <input type="checkbox"/> Illustrating <input type="checkbox"/> Cartooning |

TECHNICAL AND INDUSTRIAL COURSES

- | | |
|-------------------------------------------------|----------------------------------------------------------------------|
| <input type="checkbox"/> Electrical Engineering | <input type="checkbox"/> Architect |
| <input type="checkbox"/> Electric Lighting | <input type="checkbox"/> Blue Print Reading |
| <input type="checkbox"/> Mechanical Engineer | <input type="checkbox"/> Contractor and Builder |
| <input type="checkbox"/> Mechanical Draftsman | <input type="checkbox"/> Architectural Draftsman |
| <input type="checkbox"/> Machine Shop Practice | <input type="checkbox"/> Concrete Builder |
| <input type="checkbox"/> Railroad Positions | <input type="checkbox"/> Structural Engineer |
| <input type="checkbox"/> Gas Engine Operating | <input type="checkbox"/> Chemistry <input type="checkbox"/> Pharmacy |
| <input type="checkbox"/> Civil Engineer | <input type="checkbox"/> Automobile Work |
| <input type="checkbox"/> Surveying and Mapping | <input type="checkbox"/> Airplane Engines |
| <input type="checkbox"/> Metallurgy | <input type="checkbox"/> Navigation |
| <input type="checkbox"/> Steam Engineering | <input type="checkbox"/> Agriculture and Poultry |
| <input type="checkbox"/> Radio | <input type="checkbox"/> Mathematics |

Name.....
Street.....
Address..... 11-21-23

City..... State.....

Occupation.....

Persons residing in Canada should send this coupon to the International Correspondence Schools Canadian, Limited, Montreal, Canada.



Do Your Friends Marvel

at your physique as it stands today? Do they talk about you as the strongest man in the neighborhood? Most likely they do not, but if you had only excelled with me three months ago, you would now be the talk of your friends and relatives.

This popularity would be brought about by the harvest you would now be reaping of better health; an overflow of pep and endurance; strength that would make you a leader, even among real men; a physique that would make your friends worship you and your enemies respect you; joints and muscles that would be so supple your body would possess the greatest possible ability. And beside these you would have learned in those three short months more about your body and its needs; more about exercise and physical culture in general than you

ever have in any past six months or will in the same length of time in the future.

HOW WOULD A 15-INCH UPPER ARM LOOK

In place of that frail one you now possess? How would it look as good solid muscle instead of flabby fat? You can imagine how it would look, with other measurements in proportion, because you surely know that a 15-inch upper arm means arm. Yes, you can imagine how it would look, but you can never get it on there with imagination. So satisfy yourself that you must "make a break." "Take the step."—anything for a start. That is it—get started. But just as important as starting—is the matter of starting right.

YOU START RIGHT When You Send for My FREE Booklet and you end right when you finish my course. The title of my Booklet is "The Royal Road to Health and Strength. It was written for men which are given to many poses of myself and my pupils.

IMPORTANT
My New Booklet, "Your Muscles, Where They Are and What They Do," will be sent with my Book and it is also free. Every person contemplating physical culture should get this Booklet first. Then you will really know what you are doing. Get both of them by return mail.

It also gives a thorough explanation of my methods as well as of my muscle control tests, tumbling, hand-balancing and other valuable information. You receive all this FREE and never in the history of physical culture was there just one book set worth more to the eye, mind, and body. You need this Booklet.

CHARLES MACMAHON

2103 Oriana St., Philadelphia, Pa.
STUDIO D-3

LAW

Course in 2 Years

Be a lawyer. Law trained men earn big money and occupy top positions in social, business and public life.

\$5,000 to \$10,000 a year is what you can earn. Our improved system guides you step by step until you have passed the bar examination in any state. Low cost. Easiest terms. We furnish everything including complete Law Library—send for free catalog.

American School

Dept. L-474 Drexel Avenue and 58th St., Chicago

Learn Auto

and Tractor Business

EARN \$150 TO \$400 A MONTH

Greater opportunities than ever for Rahe Trained Motor Mechanics. Learn here in Six to Eight Weeks. WRITE TODAY for special low tuition rate. Free R. R. fare and board and room offer. No colored enrollments.

RAHE AUTO & TRACTOR SCHOOL

Dept. 1750, 11th & Locust Sts., KANSAS CITY, MO.
Dept. 1750, 916 Forbes Street, PITTSBURG, PENN.

MINSTRELS

Musical Comedies and Revues, with full instructions for staging. You can stage your own show with our books. Full line of plays, music, cross-fire, monologues, afterpieces, vaudeville acts and makeup. Catalogues free.

T. S. DENISON & CO., 623 So. Wabash, Dept. 19, CHICAGO

INSTRUCTION BOOKS, MUSIC

These books are illustrated and gotten up to make the method of self-teaching so simple that any one without any knowledge of music could learn to play any of the following:

SAXOPHONE - 25c	MANDOLIN - 25c
ACCORDEON - 25c	PIANO - 25c
BANJO - 25c	UKULELE - 25c
GUITAR - 25c	VIOLIN - 25c

The above prices are postpaid. Any above 5 titles, \$1.00, postpaid.
J. C. DORN, 725 So. Dearborn St., Dept. 17, CHICAGO, ILL.

21 JEWELS

Adjusted to the Second
Adjusted to Temperature
Adjusted to Isochronism
Adjusted to Positions
21 Ruby and Sapphire
Jewels
25 Year Gold
Strata Case
Your choice of Dials
(Including Montgomery
Railroad Dial)
New Ideas in Thin
Cases



The Burlington Bulldog ONLY \$1.00 DOWN



The watch of a nation. The "on-time-to-the-second" watch—even after hard work and rough usage. The watch for the worker—the outdoor man.

It stands up under bumps and jars and knocks. It is the kind of a watch you have been looking for. Strong, rugged, reliable, and yet right up to the last detail in everything a watch should have and be to keep time to the second. It has 21 jewels and is guaranteed for 25 years. You can have any dial you want and in almost any kind of a case. It is the watch that thousands of rugged Americans have been looking for. Now offered at a sensational price—only \$1.00 down. The Special Offer is on NOW!

Mail this Coupon Today!

Write for the Free Burlington Watch Book describing this sturdy Bulldog model which keeps on ticking off the seconds with absolute precision even when it is bumped and jarred by the hardest work that you can do. Remember, 21 genuine ruby and sapphire jewels, adjusted to temperature, position and isochronism. Send for the FREE Burlington Watch Book TODAY!

Burlington Watch Co., Dept 13-54, 19th St. & Marshall Blvd., Chicago
Canadian Address: 62 Albert Street, Winnipeg, Manitoba

Burlington Watch Co., Dept. 13-54
19th St. and Marshall Blvd., Chicago, Illinois
Canadian Address: 62 Albert St., Winnipeg, Man.
Please send me (without obligations and prepaid)
your free book on watches with full explanation
of your \$1 down offer on the Burlington Watch.
PRINT YOUR NAME AND ADDRESS PLAINLY

Name _____

Address _____

\$1.00 DELIVERS to Your Home



Complete Outfit

Violet Ray

ONLY \$1.00 brings this complete, scientific Violet Rays outfit to you. Treat yourself and family at home, save delay, costly doctors and medicines. Thousands use Violet Rays at home to relieve pain and sickness. The identical outfits doctors have bought from us for years and with which they successfully treat many ailments, including those listed below.

QUICK RESULTS—No Medicine

Violet Rays work quickly. It's scientific, goes after the cause. That's why results are quick, permanent. Dr. Duncan, Kewanee, Ill. writes, "Violet Rays is the finest thing I ever used . . . to relieve pain, treatments are so pleasant all my patients like it." Use it yourself at home, you save Doctor's bills.

BEAUTY AID

Brings natural, magnetic beauty of health, no dieting, exercise or drugs. FREE book tells in detail how high priced beauty specialists use it to improve scalp and skin.

EARN CASH

Men, women, without experience earn liberal profits in spare time showing Violet Rays to neighbors. Proves results first demonstration. Sells on sight. Get attractive offer and wholesale prices now.

SEND FOR FREE BOOK

Explains how Nikola Tesla discovered Violet Rays, how it works, why it heals. Tells what doctors and plain folks accomplish in conquering pain, disease and nervous trouble with Violet Rays.

Reveals Marvelous Scientific Discovery Shows charts of human body, explains where pains start, how to banish them. Offered FREE for a limited time only, to introduce Violet Rays. Send for FREE copy.

Check Your Ailment Below for Free Advice Here is a partial list of ailments successfully treated with Violet Ray:

Catarrh	Eye Diseases	Lumbago	Skin Diseases
Chilblains	Falling Hair	Nervousness	Sore Throat
Colds	Hay Fever	Neuritis	Sprains
Constipation	Headache	Paralysis	Tonsillitis
Earsaches	Goitre	Piles	Whooping Cough
Eczema	Insomnia	Rheumatism	Asthma

Mail Coupon—Send No Money

VI-REX COMPANY
211 S. Peoria St. Dept. 24, Chicago
Please send me without cost or obligation your free book describing your VI-REX Violet Ray outfits, and details of your \$1.00 offer.

Name _____
Address _____
City _____ State _____

LEARN Jewelry Making



Easy To Learn

a delightful accomplishment, a money-making profession. \$10 for 15 lesson course. You complete two pieces of jewelry in first lesson. Tools for every article in course included FREE.

Send for illustrated booklet.
N. Y. School of Jewelry Making,
110 E. 23rd St., New York

Make \$100 a Week

Here's the short cut to big pay. Positions \$2400.00 to \$6000.00 a year are open. Not enough trained men to fill them. Not only do we guarantee to get you a position (city or traveling) —but we also guarantee you can

BE A MASTER SALESMAN IN A FEW WEEKS' HOME STUDY

Fascinating work. Thoroughly practical course. Extremely low price and easy terms. Men under 25 years, earning less than \$50.00 a week, and men between 25 and 55, earning less than \$100 a week, should hurry and

WRITE FOR FREE BOOK

Explains details of course. Tells about guaranteed positions. Gives details of low price and easy terms. Read Money-Back Guarantee. Write today. Book is free. No charge. No obligation. CHICAGO SALESMAN'S TRAINING INSTITUTE Dept. 1774 2709 Bosworth Avenue, CHICAGO, ILL.

DETROIT

IS LOOKING FOR Standard Trained Men Pay \$8—\$18 Per Day

With a few weeks of intensified training, you can become a Standard Trained Man. Standard Training includes:

Auto Repairing	Auto Metal Finishing
Auto Painting	Auto Battery Building
Auto Trimming	Auto Electrician
Bricklaying	Plastering
Construction Electrician License Furnished	

We teach by actual practice in completely equipped shops, superintended by experts. Don't delay your training because you haven't the Money.

EARN WHILE YOU LEARN

We guarantee to teach you—sleeping accommodations provided. In Detroit, 3,500,000 automobiles will be built during the coming year, and the 1924 building program is the largest in the history of the city.

You supply the will and we supply the way.

Write Today Free Catalogue

STANDARD TRADE SCHOOL

416 Woodward Avenue, Detroit

Auto Repairing <input type="checkbox"/>	Auto Metal Finishing <input type="checkbox"/>
Auto Painting <input type="checkbox"/>	Auto Battery Building <input type="checkbox"/>
Auto Trimming <input type="checkbox"/>	Auto Electrician <input type="checkbox"/>
Bricklaying <input type="checkbox"/>	Plastering <input type="checkbox"/>
Construction Electrician <input type="checkbox"/>	

Name _____
Street _____ City _____

From Invalid to Hercules

Through "Milo" Methods

JUST READ THIS LETTER

December 22, 1922

The Milo Bar-Bell Company.

Gentlemen:

I bought a bar-bell from you several years ago. At that time I was in very poor health, and the specialist who attended me said I was on the way to become a consumptive. I was then 5 feet 10 inches tall, my chest was 29 inches around, and I weighed only 111 pounds. Naturally when I started at your course I had to adjust my apparatus to very light weights. I became so fascinated with the progressive schedule, and so well pleased with my progress, that ever since then I have stuck religiously to your system of exercise, and I am now a genuine bar-bell enthusiast.

The small picture I am sending you shows how I looked after I had been training for a year. By that time I had increased to 150 pounds and had gained a couple of inches in height. If I looked like that when I weighed 150, you can imagine what I looked like when I was at my worst, and weighed only 111 pounds.

The large picture shows me as I am today. I now weigh 199 pounds, and have a 42 inch normal chest, 16½ inch upper arm, and 25 inch thigh. Also, I have a wonderful power of expanding my chest.

I wish to gratefully acknowledge all the help and advice which you have given me.

Yours truly,

H. J. KNIERIEM, JR.

1160 Selter Ave., Bronx, New York.



Look at the man. He does not look much like a consumptive now. He has a wonderful pair of lungs. Mind you, he got his bar-bell as a last resort, to win back his failing health. Today he is more than "just healthy." He is tremendously vigorous, and just overflowing with pep. And though he trained simply for health, just see what he got along with it! A magnificently shapely body, and enormous strength!

WHAT HE DID—YOU CAN DO ALSO

Our specialty is getting results for young enthusiasts who have tried every other method, and failed to become as strong, shapely, and healthy as they knew they could be. We showed them how.

And we have been the positive salvation of a lot of middle-aged men who thought because they had passed the forty-year mark, they were doomed to be puny, weak and half-invalids the rest of their lives.

We do not care how weak, puny, and undeveloped you are at present, for we know we can show you how to get a perfect figure, enormous strength, and abounding health and vitality.

We Manufacture Bar-Bells of all Kinds, Sizes and Prices

and every bar-bell we make is of the adjustable variety, so that it can be instantly adjusted to suit the strength of any one muscle, or set of muscles—and also that the pupil may practice the progressive resistance method, which is the foundation principle of our system.

Every Pupil Gets Individual Instruction

and if you take our bar-bell course, our expert will prescribe the special exercises and the most suitable progressive schedule for your case, and those instructions will enable you to make the greatest possible gains in the shortest possible time.

We advise you to send at once for our booklets, and learn about the "near miracles" which our pupils have accomplished through training with bar-bells. You can read about them in our big booklet.

"Health, Strength and Development and How to Obtain Them" and the Special Pamphlet

"How Much Can I Improve At 20—At 30—At 40 Years?"

Both free on request—use the coupon

THE MILO BAR-BELL COMPANY

Diamond and Third Streets
PHILADELPHIA, PENNSYLVANIA

M-4-24

MILO BAR-BELL COMPANY
Diamond and Third Sts., Philadelphia, Pa.

Gentlemen: Please send me without obligation on my part your free booklet, "Health, Strength and Development and How to Obtain Them." Also your pamphlet entitled, "How Much Can I Improve at 20—at 30—at 40 Years?"

Name.....

Address.....

City.....

State.....

SENSATIONAL RADIO OFFER!

UNIVERSAL RECEIVER

10 CIRCUITS IN ONE

with Two Stages of Amplification including ALL PARTS (knocked down) IS YOURS WITHOUT A PENNY'S COST, if you will devote some of your spare time acting as representative of

POPULAR MECHANICS MAGAZINE

in taking subscriptions in your neighborhood. The 10 circuits include the

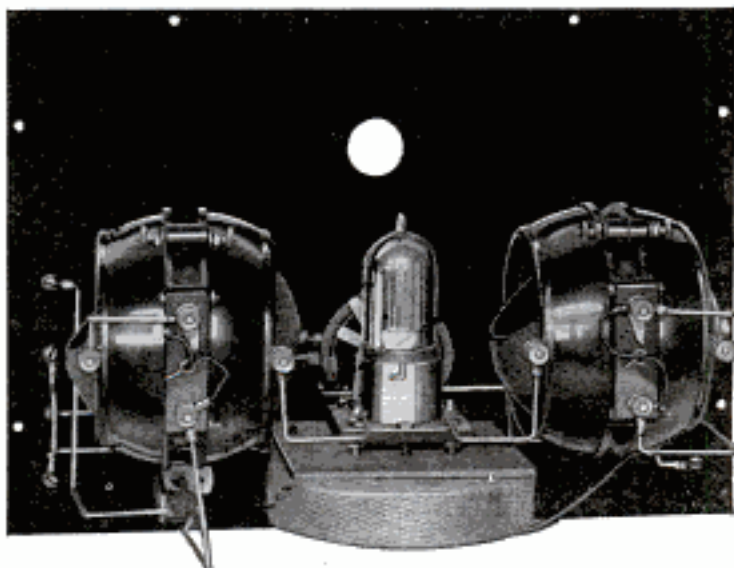

ULTRA-AUDION COCKADAY
FLEWELLING REINARTZ
SUPERDUC MILOPLEX

150-20,000 - METER
3-CIRCUIT TUNER

SINGLE CIRCUIT REGENERATIVE
3-CIRCUIT SHORT-WAVE TUNER
COLDYNE

A Complete Set of Diagrams of the 10 Circuits will be sent with ALL PARTS and SPECIAL DRILLED PANEL so that you can change from Any Circuit to Any of the Other Nine in Jigtime.

Popular Mechanics Magazine

also offers ALL PARTS (knocked down) for the AUTOPEX One-tube Circuit illustrated herewith, or with One Stage of Amplification, WITHOUT COST.

DO NOT DELAY Fill out and mail attached coupon immediately and FULL PARTICULARS about this SENSATIONAL RADIO OFFER, and your Agent's Outfit will be sent to you FREE. **Name two references.**

POPULAR MECHANICS MAGAZINE,
Room 408, 200 East Ontario Street, CHICAGO

Please send me full particulars about your SENSATIONAL RADIO OFFER and your Agent's Outfit.

Name

Street

City..... State.....

MY TWO REFERENCES ARE:

1 Name

Business Address.....

City..... State.....

2 Name

Business Address.....

City..... State.....

Popular Mechanics building is devoted exclusively to the production of this great magazine.



Your Chance to Make

\$3000⁰⁰

to

\$5000⁰⁰

a Year

after Training in New York

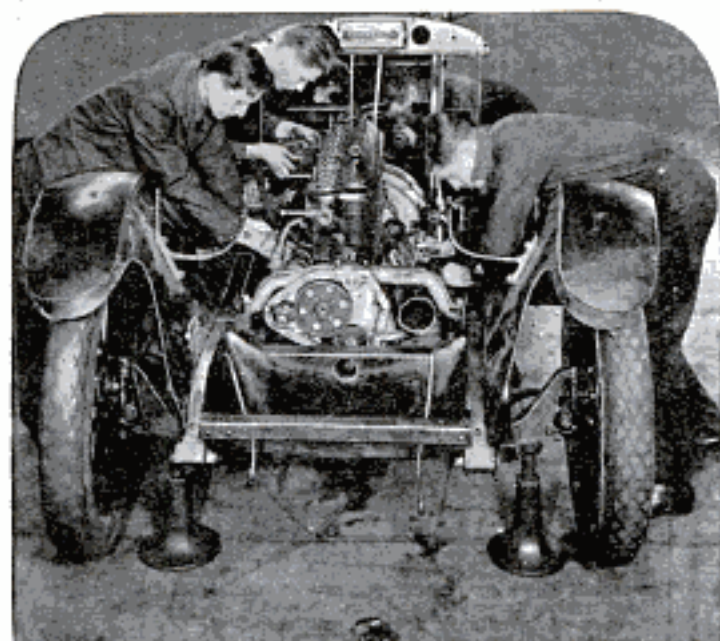

SUCCESS doesn't just happen. People are divided into two classes. Those who go ahead, "Take the bull by the horns" and do something, and those who sit and wonder why success doesn't come. The first are the successful men—the others are the failures.

Get Out of the Rut!

Now is the time and this is the opportunity for you to take a big step forward, to snap yourself out of the rut and to start on the road to success.

Remember that when proper training is backed up by determination nothing is impossible. Half of greatness is quick decision and action.

Decide NOW

If you are not earning at least \$50 to \$75 or more a week—with a business of your own in sight—this message is intended for you. It is now possible for any average man, regardless of education or experience, to be trained at the Stewart Auto School for a big pay job in a few weeks. There is a crying demand for good men right now—But you must act quickly.

You Can Now Learn the Auto Trade in Ten Weeks in New York

In the big, splendidly-equipped shops of the Stewart Automobile School you can master all kinds of repair work in only 10 weeks' time. Here you can lay the foundation for a successful career in the world's largest industry. You can learn how to be your own boss—and can step right into a big pay job soon after you graduate.

There is no mystery—it is not difficult in any way—as you will see in our catalogue. You can do it easily. The Stewart Automobile School has thousands of successful graduates.

The Stewart System Makes Learning Easy

Stewart Instructors—all hand picked men—have perfected the "personal instruction" policy of this school. Each beginner is studied—his individual characteristics noted—then he receives his instruction in the way that will be most valuable to him and easiest to grasp.

The course of training is thorough—no one is rushed and every point is driven home. The complete catalogue (which you will receive as soon as you send in the attached coupon) contains a guarantee that you can remain until you are entirely satisfied.

A Living While You Learn

Our Employment Department will find a job for you while you are taking the course. In this way you can pay for all

your living expenses and yet not have any interference with your training at the Stewart School.

We will also place you in a good paying position after you have finished the course. Think what this means! You need not worry about the future. We will take that responsibility.

NOW—Special Business Management Course—FREE

For a limited time only the Stewart Automobile School offers a business course—free. In this course you will learn how to sell your own services; how to manage a garage, service station or sales business of your own. It will teach you the fundamentals of bookkeeping and how to figure "overhead," how to systemize your work, finance yourself, how to keep cash and charge sales records. Find out immediately about this special course in Business Management. Write now before this offer closes.

FREE BOOK—Send for It

You can open up the way to newer and better things by a mere scratch of the pen or pencil. You can take advantage of the great opportunities in the rapidly expanding automobile business. Investigate now. It costs you nothing and does not obligate you to buy anything. But find out—investigate—take a new lease on life. Send the coupon for our new big FREE book which explains all details. Here is the coupon. Send it now!



STEWART AUTOMOBILE SCHOOL
225 W. 57th St., Dept. 1774, New York, N. Y.

Please send me your free book that describes your school and the opportunities in the Automobile Business. I am under no obligation.

Name.....

Address.....

City.....

State.....

WATCH YOUR NERVES

We are living in the age of nerve strain, the mile-a-minute life. Nearly everyone is troubled in some way by over-strained and deranged nerves. How about YOUR nerves?

Read NERVE FORCE

A 64-Page Book on Nerve Culture by Paul Von Boeckmann

This book explains in clear and simple language all about nerve strain, and how to remedy it. It teaches how to develop courage, ambition, power, and self-confidence. How to make your nerves immune to stock, worry, and all other modern nerve strains. Only 25 cents (coin or stamps). Send direct to the author—TODAY.

Paul Von Boeckmann, Studio 490, 110 W. 40th St., New York



PAUL VON BOECKMANN
Hygienist—Psychologist

Author of many books on Deep Breathing, Sexology, Neurasthenia and kindred subjects. Over 1,000,000 copies of his various books have been sold during the last 25 years.

THE JIMMY DeFOREST Physical Training System

DeForest trained or conditioned the late President Roosevelt, Elbert Hubbard, and Supreme Court Justice Mahoney, Jack Dempsey, besides hundreds of others. Send 10c for booklet on "Co-Ordination of Mind and Muscle".

JIMMY DeFOREST Dept. 6
347 Madison Ave., N. Y. C.

PRACTICAL ELECTRICAL EDUCATION

Learn by the thorough approved scientific methods which our seventeen years of specializing enable us to give you. A. C. and D. C. Armature Winding, Wiring and Testing, Practical Electricity, Drafting, Electrotechnics, Commercial Engineering, Electrical Engineering with B. S. Degree. "Earn While You Learn." Radio Broadcasting WIAO Every Day. Next term opens June 25th. Write for 72-Page Illustrated Catalog, 4c's Free. Mention Age, Education and Course interested in.



School of Engineering of Milwaukee, P.M.A-424, 415 Marshall St., Milwaukee, Wis.

Whatever Your Question;—be it the pronunciation of Fascista, the spelling of a puzzling word, the location of Esthonia the meaning of soviet, realtor, vitamin, etc., this Supreme Authority—

WEBSTER'S NEW INTERNATIONAL DICTIONARY

contains an accurate, final answer. 407,000 Words 2700 Pages. 6000 Illustrations.
Regular and India-Paper Editions. G. & C. MERRIAM CO., Springfield, Mass.
Write for specimen pages, prices, etc. and FREE Pocket Maps per POPULAR MECHANICS



Trained Men Make Big Money in the Auto Business



Six weeks at the Cleveland Auto School will give you a training that is second to none. More than 7,000 of our graduates are now earning big wages in all branches of the business. Many own their own garages and are prosperous and respected members of their communities. You can do the same. A new class starts soon. Write now for full information.

THE CLEVELAND AUTO SCHOOL, 1816 East 24th Street, CLEVELAND, OHIO

"THERE'S MONEY IN IT"

AT HOME

LEARN TELEGRAPHY

AT HOME

MORSE AND WIRELESS

TEACH YOURSELF

in half usual time, at trifling cost, with the wonderful Automatic Transmitter, THE OMNIGRAPH. Sends unlimited Morse or Continental messages, at any speed, just as an expert operator would. Adopted by U. S. Government, and leading Universities, Colleges and Telegraph Schools. 3 Styles. Catalog free. OMNIGRAPH MFG. CO., 16-22 Hudson St., NEW YORK

If you own a Radio Phone Set—and don't know the code—you are missing most of the fun.



WANTED! Get \$1600 to \$2300 Year

U. S. RAILWAY
MAIL
CLERKS

MEN—BOYS 18 OR OVER

MAIL COUPON IMMEDIATELY

Franklin Institute, Dept. H179, Rochester, N. Y.

Sirs: Send me, without charge, (1) sample Railway Mail Clerk Examination questions; (2) tell me how to get a U. S. Government job; (3) send list of places at which examinations will be held; (4) send copy of illustrated book, "How to Get Government Jobs."

Name.....

Address.....

Steady Work—No Layoffs—Paid Vacations
Travel—See Your Country
Common Education Sufficient — Send Coupon Today — SURE

Copyrighted material

Look Here!

**I WILL MAKE
YOU A
DRAFTING
EXPERT**



If you're earning less than \$65.00 a week GO INTO DRAFTING. I guarantee to train you AT HOME, the JOB-WAY, with actual Drafting Room jobs. Send for my free book, find out about the wonderful opportunities to earn big money in this easy, fascinating business. Drafting Experts are close to the Boss, are first in line for promotion to executive positions.

\$250 to \$400 a MONTH!

Common schooling all you need. I train you by my copyrighted "JOB-WAY" instruction. I train you thoroughly in Drafting by giving you actual Jobs to do. Most complete training, only instruction giving my original "Job-Way" training. No books or useless theory to waste your time. My graduates are SUCCESSFUL — employers ask for Coyne-trained Draftsmen. So I guarantee to satisfy you or to refund every penny of your money.

Learn at Home!

Thousands of big-salaried jobs, all over the country, looking for DRAFTING EXPERTS! Railroads, factories, builders, architects, ship-yards, auto plants, Cities, Countries, States, the U. S. Government—all hungry for Drafting Experts. Man alive, wake up to your biggest opportunity!

Experts' Outfit FREE!

"JOB-WAY" training makes you a DRAFTING EXPERT quick because you learn to do actual jobs with the same professional instruments you will use when employed at a big salary. To encourage you to START RIGHT NOW, I will give you with my course this costly outfit without one penny of cost! Coupon brings complete information.

DRAFTING BOOK FREE!

Mail Coupon Today!

**Address CHIEF DRAFTSMAN
COYNE SCHOOL OF
DRAFTING**

1-9 S. Ashland Ave., Dept. 419
CHICAGO, ILL.

**Chief Draftsman
COYNE SCHOOL OF DRAFTING
1-9 S. Ashland Ave., Dept. 419, Chicago, Ill.**

Without obligating me in any way, please send me your book, "Drafting, the Foundation of Industry" absolutely free. Also complete information of your rapid "Job-Way" home-study Drafting course, free instruments and special offer.

Name.....

St. No.....

City.....State.....



FREE! MAIL COUPON TO-DAY!

ONLY

\$1

POPULAR MECHANICS HANDBOOK *for* FARMERS

One of the
most remarkable
books ever published.
Contains over 861
discoveries to reduce
labor and increase
income.

POPULAR MECHANICS PRESS
CHICAGO

683 Illustrations

You Won't Let a Dollar Bill Block Your Way to Success!

The only thing that can stop you from ordering this book at once is that "put-it-off" feeling, the Devil's most effective device for keeping your nose on the grindstone.

The Discoveries of 417 Successful Farmers and Farmers' Wives

The Devil Didn't Get Me

with his "put-it-off" temptation, and here's my dollar. Send me Popular Mechanics Handbook for Farmers just as quick as you can. I want to put some of the 861 discoveries to work at once.

Name

Town.....State.....

Street or R. F. D.....

Fill out, clip, and mail with a dollar to Popular Mechanics Press, Room 504, Popular Mechanics Bldg., Chicago, Ill.

*"The most remarkable
Book ever
published
for Farmers"*

—says one
authority.

It is remarkable in the extreme practical nature of its contents, in the wide range of farm subjects covered, in the world of illustrations it contains, and in the extremely low price.

861 Discoveries

One discovery sometimes makes a fortune. Here are 861 of them, any one of which may be of many dollars value to you. These discoveries may be classified as follows:

- 138 for the farm shop
- 35 on fencing
- 98 on auto, truck, and tractor
- 61 on farm buildings
- 36 on field machines
- 48 on concrete work
- 22 on orchard work
- 23 on painting
- 15 on live stock
- 25 on electrical work
- 7 on greenhouse work
- 22 on farm tools
- 54 on garden work
- 34 on poultry
- 17 on the lawn
- 140 on household helps
- 70 on miscellaneous farm work
- 16 on hunting, fishing, and trapping

—and every plan has been tested and found to be a money-saver. Most of the articles are illustrated with photographs or drawings. The devices described are easy to make because of these pictures and clear descriptions.

Suppose You Could Live Your Life 417 Times

How you could forge ahead of other farmers in a way that would insure you liberal and steady profits! This book enables you to do the next best thing — you may have the experiences of 417 lives — experiences of successful farmers as told by themselves — briefly, clearly, completely. And many of these experiences are illustrated with accurate drawings! Just think of the value to you!

Never before have so many such discoveries pertaining to farming, gardening, poultry raising, and home making been collected into one book. The collecting of them has required several years, and now you may have the whole lot at your elbow for use whenever an emergency arises. The articles are all classified and indexed so that you may find all the plans on any one subject without delay. With so much valuable information collected into one book, it is hard to believe that it can be sold for the remarkably low price of \$1. But the large quantity published has made this possible.

\$1
ONLY

Popular Mechanics' Absolute GUARANTEE

Popular Mechanics Press absolutely guarantees this book to be all that is claimed for it. If, upon receipt of it, you believe that it has been misrepresented in any way, send it right back and your dollar will be returned the same day your book is received. Our only reason for offering this book to you is because we believe that it will be of untold value to everyone interested in farming, gardening, or poultry raising. If it is not going to be worth far more than you pay for it, we much prefer that you send it right back. Popular Mechanics Handbook for Farmers is absolutely guaranteed to be all that is claimed for it.

A New and Mystifying Happiness A Startling Discovery Unique Elucidations

PEOPLE everywhere are becoming actually excited over these marvelous elucidations. The subtle influence of these sensational elucidations has aroused and excited men and women to a degree hitherto unknown.

Never before have men and women been so stirred and electrified as by these unique elucidations. Thousands of men and women have been "fired" with a new and mysterious "life," zeal and buoyancy by the influence of these elucidations. These men and women have been filled with a vitalized "flame" of youth, ambition and power that is startling.

The influence of these unique elucidations is bringing human beings a new kind of pleasure, happiness, gratification, health, strength, confidence and success. These people, in every walk of life, have become uplifted, vivified and stimulated in a new and overwhelming degree.

Through the influence of these elucidations, men and women everywhere have obtained such marvelous energy of mind and body, and they are enjoying life so fully, that the old life to which they were accustomed appears totally inferior in every respect.

The influence of these elucidations gives a new idea of how truly alive, vital, joyful and happy a human being can be—how easily one can be overflowing with life, joy, bubbling vitality, and the "fire" of triumph. No wonder these elucidations have stirred the most eminent men and women of this and other countries!

Just think what it means to human beings to have a new power and source of life, pleasure, gratification, success and happiness to draw upon endlessly!

Just think what it means to these men and women to have unlimited freedom to enjoy life in the new way without exhaustion or without being penalized by Nature—without being worn out!

No wonder these men and women are excited over the subtle influence of these elucidations!

Through the influence of these mysterious elucidations, thousands of men and women are enjoying a life of most intense and endless happiness—a life of transcendental ecstasy and bliss. These men and women have become so fascinated, thrilled and startled and their lives have become so joyfully revolutionized by these elucidations that they are "reborn."

It is really amazing to see how men and women change from weakness, sluggishness and sadness to power, liveliness, happiness and joy. It is thrilling to see even the old become young again.

Thousands of men and women everywhere are secretly enjoying this new state of existence—this "Heaven on Earth."

These men and women are like a new race of human beings, yet they are here and everywhere. Every community now has them. They are represented in practically every prominent family—in the Vanderbilt, Rockefeller, Gould, Huntington, Iselin, Armour, Swift, Roosevelt, McAdoo, Hughes, Penrose, Dupont, Croker, Newbury, Simmons, Root, Morgan, Kahn, Strauss, Lewisohn, Stillman, Tiffany, Cutting, Delafield, Oelrich, Phipps, Vanderlip, Lippincott, Pierrepont, Hearst, Biddle, Westinghouse, Wanamaker and almost countless other families of prominence.

The influence of these mysterious elucidations is revolutionizing the lives of farmers, mechanics, laborers, clerks, teachers, lawyers, doctors, brokers, bankers, congressmen, senators, judges, governors, as well as society men and women—the lives of men and women of every grade have been revolutionized and transformed amazingly.

Just as the rays of the spring sun transform the dead soil into a "sea" of luxuriant vegetation, so is the influence of these marvelous elucidations joyfully transforming the lives of human beings. These elucidations are leading men and women everywhere to a beautiful, plentiful and brilliant existence.

Anyone, male or female above 18 years of age, who is interested in this new, unique and lasting pleasure, happiness, success, health and life may have these elucidations upon request.

These unique elucidations are gratis—there is no charge for them.



ALOIS P. SWOBODA,

2517 Berkeley Building, 21 West 44th Street,
NEW YORK CITY, N. Y.

Send me gratis—without charge, the unique elucidations.

Name

Street

City State

Mr. Claude L. Johnson, graduate of the Radio Institute of America, Radio Operator on Grace Line ships sailing to interesting South American ports.



Radio Means Opportunity

Travel—adventure—opportunity. And good pay right from the start. These are the things that have lead many men to study Radio. And today you will find men who began as operators holding the biggest positions in the radio field.

And Radio is growing! So fast that not enough trained men can be found to fill the jobs. Therefore the Radio Institute of America now offers its famous course for home study. This brings it to wherever you may live—teaches you code and modern radio practice—starting right from the beginning of electricity. A few months study prepares you for your government operator's license—and your first job.

The Radio Institute of America is under the auspices of the Radio Corporation of America, and its graduates are given preference for placement in positions, because of the thoroughness of their course. Write today to learn more about it!

Advanced Radio Course

Great popular demand by the advanced student, experienced amateur and wireless operator has led to the opening of an **ADVANCED HOME STUDY RADIO COURSE**, specializing in C. W., I. C. W., telephone and radio measurements. Investigate!

Radio Institute of America

(Formerly Marconi Institute)
Established 1909

326A Broadway, New York City

Indicate by a cross X the course you are interested in:

Radio Institute of America,
326A Broadway, New York.

Please send me full information about radio opportunities today, and your

COMPLETE RADIO COURSE
ADVANCED RADIO COURSE

Name

Address



Popular Mechanics NEW LATHE HANDBOOK

Contains the experiences of 106 successful lathe operators in the U. S. and in the principal foreign manufacturing countries. 83 articles tell how to make special lathe tools and attachments. 33 tell

how to make gauges and indicators. 23 describe special devices for holding work. 9 special lathe centers are explained. 29 articles tell how to do unusual jobs on the lathe. 28 tell how to do boring and drilling jobs. 11 are on thread cutting. And 32 describe special methods for miscellaneous lathe work.

212 Illustrations The pictures make it easy for a beginner to understand the descriptions which are essentially for those experienced in lathe work. Every article, however, is written so anyone can understand it, and every kink has been thoroughly tested.

377 Items Indexed No matter on what sort of lathe job you need help, you are almost sure to find it by referring to the index of Popular Mechanics New Lathe Handbook. Within the book itself, the articles are classified by the subjects that are of most concern to lathe users. For example, you will find the articles on special lathe tools grouped so that you have several ideas on tools before you at one time.

Remarkably Low Price Although this book includes some of the most valuable helps ever collected for lathe operators, the price is extremely low. It is the same as the price on all Popular Mechanics Handbooks—

50c

Send 50c today for Popular Mechanics New Lathe Handbook.

POPULAR MECHANICS PRESS
Room 503, Popular Mechanics Bldg., Chicago, Ill.



Play "JAZZ" on the Saxophone

Become a musician so quickly as to astound everyone. Learn by playing **real music**—instead of tiresome "exercises." You'll soon become the most popular person in your "set."

New Easy Method

is a revelation. Nothing else like it for thoroughness and rapidity. So simple that young and old find it easy to play with amazing skill. No "trick music"—but actual notes, learned quickly right in your own home.

FREE BOOK and Illustrated Folder

offers this wonderful musical opportunity. Send for them today before copies are exhausted. You'll be astounded, thrilled, fascinated, at this easy, rapid way to become a veritable **master** of your favorite instrument. Name below the instrument you are particularly interested in.

LEARN TO PLAY ANY INSTRUMENT

Piano	Mandolin
Organ	Drums and
Viola	Traps
Banjo	Harp and
Clarinet	Composition
Flute	Sight Singing
Harp	Ukulele
Cornet	Piccolo
Cello	Trombone
Guitar	Saxophone
Voice and Speech	Culture
Automatic Finger Control	

U. S. SCHOOL OF MUSIC, 74 Brunswick Building, NEW YORK CITY.
Send me your amazing free book "Music Lessons in Your Own Home." Also, Illustrated Folder. This does not put me under any obligation. (Please Write Plainly.)

NAME.....

ADDRESS.....

INSTRUMENT.....

C.J. Buckwalter, President, the man behind the remarkable instruction which has astonished the teaching profession and which offers wide-awake men a 50-day short-cut to big earnings.



1923 SEPTEMBER 1923						
1	2	3	4	5	6	7
8	9	10	11	12	13	14
15	16	17	18	19	20	21
22	23	24	25	26	27	28
29	30	31				

1923 OCTOBER 1923						
1	2	3	4	5	6	7
8	9	10	11	12	13	14
15	16	17	18	19	20	21
22	23	24	25	26	27	28
29	30	31				

50 days - then \$132 a week

In New Automotive Electrical Business

The shortest road to big earnings ever known. Scarcity of experts makes positions certain and pay high. A remarkable new system of training enables you to earn \$132 a week in less than two months. And we can prove it. Get my free book.

THINK of it! Only 50 days training puts you in a position to earn \$132.00 a week! All because there is an enormous demand for Automotive Electrical Experts and there are far from enough. Employers are ready to snap up our graduates at once. Our free employment service helps you to get the very "pick" of such positions. See facts and figures in my free book.

Experience Not Necessary

You don't need to know about Automobiles or Electricity at the start. Nor do you need any more education than the ability to read simple English. We give you all the knowledge you need—teach you completely—in 50 days. My book explains everything free.

Amazing New Way to Train

When the government needed Auto-Electrical Experts for the war there was no time to waste. Men had to be trained 100% right and sent out almost overnight. The man who invented the 50 day method was the man to whom Uncle Sam went for help. Results were amazing. Never before had such a thing been accomplished by anyone. A complete practical thorough training in 50 days. So remarkable that after the war and at a great cost it was made available to Ambu students only. Ambu has even improved on the original plan by not admitting more than 20 men to a class; the smaller the class the more you learn.

Get Out of the Grease

All my graduates are masters of their profession. And they are so enthusiastic over the way in which they've stepped from their former poor-pay jobs into this delightful, big-pay profession that I am glad to have you write them. I'll give you their names. They will tell you how fine it is to get out of the grease into big money.

Unusual Short Time Offer

I have a most remarkable offer to make for a short time to those who send for my free book at once. It will be a revelation to you. So be sure to mail the coupon at once, while this offer is in force. Write me personally.

C. J. BUCKWALTER, President

AMBU ENGINEERING INSTITUTE
Dept. 44 2632 Prairie Avenue, CHICAGO

BIG JOBS OPEN FOR AMBU MEN

78% of all auto troubles occur in the electrical system—battery timing, wiring, etc. And the ordinary automobile mechanics will fiddle around for 10 hours without discovering a trouble which an Ambu man will locate and repair in 15 minutes. No wonder Automotive Electrical Experts are in such big demand and the pay is so large.



Makes 4 Times His Former Salary
"I was making \$40 a week as Head Bookkeeper when I took up your training. Last week I made \$175, including overtime, and hardly a week passes in which I don't make about \$100. No hard work either—I locate the trouble and make the mechanics do the hard work."
Henry L. Ludlow, Ind."

Makes \$1,000 a Month
"I trained with you people 7 weeks, if you remember, then started right to work with big garage. Averaged about \$150 a week. After 3 weeks of this I opened a shop of my own. Sell a few batteries but make my big money on electrical repairs. Find it easy to get any price I charge. Clearing over \$1,000 a month."
M. J. Ellard, Can."



Come to Chicago or Stay At Home

For those who cannot come to Chicago I have prepared a home study course. Makes you as proficient as a resident course at Chicago. So easy a child can master. Learn in spare hours. Positively fascinating. Personal coaching given by mail by the instructor to whom we assign you. Hundreds of our graduates are "home study" men and they are just as expert and their earnings are as large as those who trained in Chicago.

FREE BOOK Explains all about this new field. Shows why there is such a big demand for Automotive Electricians and why the pay is so large. Tells what our graduates are making and reprints copies of their own grateful letters. Shows how you get paid for your head work rather than handwork. And how you can do the directing while others perform the labor, and handle the dirt and grease. Get this remarkable book at once.

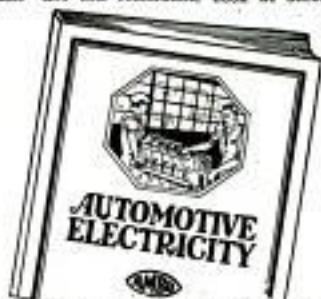

C. J. Buckwalter, Pres., Ambu Engineering Institute,
Dept. 44, 2632 Prairie Ave., Chicago, Illinois

Please send me FREE Book and complete information about the big-pay uncrowded field of Automotive Electricity. Explain also your remarkable short time offer. I am interested in

Home Study Course
 Resident Course at Chicago

Name.....

Address.....

City..... State.....



He Starts at \$5,200 a Year

One hundred dollars a week!—And only a few years ago his weekly wage was less than \$30. Didn't dream he could do it when he first took up the study of Higher Accounting under the LaSalle Problem Method; but he just couldn't help getting ahead—so he wrote—because he found it the most interesting thing he ever tackled.

Knew nothing about bookkeeping, but LaSalle quickly gave him the necessary foundation. Then, step by step, he was trained in the practical work of Cost Accounting, Auditing, Business Law, Organization, Management, Finance, Income Tax Procedure—not theoretically, mind you, but by the solving of actual problems lifted bodily from business life. As a result, he sits as Auditor at a big mahogany desk and commands a salary of \$5,200 a year.

His Chance is Yours!

Typical, this man's experience, of that of thousands of ambitious men who have found their path to success in the LaSalle Problem Method. During three months' time, 1,193 LaSalle members wrote to the University telling of the "raises" they got as a result of their training. *The average increase per man was 89 per cent.*

These men were not unusual; they had no "pull" or "luck;" they got their start by signing just such a little coupon as appears directly below this text. Mark that coupon, sign and mail today—and get the facts. Remember, the cost of LaSalle training is small and can be covered in easy monthly payments, if you so desire. The decision that you make this moment is important. Mail the coupon now.

LASALLE EXTENSION UNIVERSITY
The Largest Business Training Institution in the World
Dept 464-HR Chicago, Illinois

Please send me catalog and full information regarding the course and service I have marked with an X below. Also a copy of your book, "Ten Years' Promotion in One."

Higher Accountancy

Training for positions as Auditors, Comptrollers, Certified Public Accountants, Cost Accountants, etc.

Other LaSalle Training Courses

LaSalle is the largest business training institution in the world. It offers training for every important business need. If more interested in any of these courses, check here:

- | | |
|----------------------------------------------------------------------|--------------------------------------------------------------|
| <input type="checkbox"/> Business Management | <input type="checkbox"/> Banking and Finance |
| <input type="checkbox"/> Salesmanship | <input type="checkbox"/> Modern Foremanship |
| <input type="checkbox"/> Traffic Management | <input type="checkbox"/> and Production Methods |
| <input type="checkbox"/> Railway Station Management | <input type="checkbox"/> Personnel and Employment Management |
| <input type="checkbox"/> Law: Degree of LL. B. | <input type="checkbox"/> Expert Bookkeeping |
| <input type="checkbox"/> Commercial Law | <input type="checkbox"/> Business English |
| <input type="checkbox"/> Industrial Management | <input type="checkbox"/> Commercial Spanish |
| <input type="checkbox"/> Efficiency | <input type="checkbox"/> Effective Speaking |
| <input type="checkbox"/> Modern Business Correspondence and Practice | <input type="checkbox"/> C. P. A. Coaching |

Name

Present Position

Address

DRAW CARTOONS

Cartoonists Trained by W. L. EVANS



MAKE MONEY

SOME of the cleverest cartoonists in America today are former students. They studied during their spare time and are now making good money. Cartoonist Evans' system of teaching is so simple, easy and practical that it is not hard to learn to draw originals. The school has a long established reputation and is recommended by well-known cartoonists because they know the students are handled right.

If you like to draw, send us a sample of your work, either a copy or an original. You may have more ability than you think. We will send you a portfolio of cartoons and full details about the school.

The Course is NOT EXPENSIVE

THE W. L. EVANS SCHOOL OF CARTOONING

821 Leader Bldg. CLEVELAND, OHIO

LEARN Penmanship

I Teach Penmanship by Mail

Small Cost. Spare Time. Write for my Free Book, "How to Become an Expert Penman." It contains specimens and tells how others became expert writers by the Tevis Method. Your name written on card if you enclose stamp. Write Today.

T. M. TEVIS, Box 25K, CHILlicothe, MO.

Factory to Rider

Saves \$10 to \$25 on 12 Ranger Bicycle you select. You can have your choice of 44 Styles, colors and sizes. Delivered free on approval, express prepaid, for 30 DAYS' FREE TRIAL.

12 Months to Pay If desired. Possession and use at once on our liberal year to pay plan. Parents often advance first payment.

Tires best quality, at factory prices, express prepaid. Lamps, wheels and equipment, low prices. Send No Money, do business direct with makers.

Mead Cycle Company
Dept L103 Chicago

Write today for free Ranger Catalog, factory prices and marvelous easy payment terms.

MONEY IN POULTRY

HOW TO RAISE POULTRY FOR PROFIT

RAISE POULTRY for PROFIT

We teach you how. Easily learned at home. We have successful students in all parts of the world. Our proven methods make success certain—indorsed by leading Agricultural Colleges. Send today for Free Book, "How to Raise Poultry for Profit."

THE NATIONAL POULTRY INSTITUTE
Dept. 312-A
WASHINGTON, D. C.

Your Copy of this great book



FREE

Send for it TODAY

This handsome, profusely illustrated book will tell you of the astonishing growth of the great Electrical Industry, and of the thousands of big money jobs and opportunities waiting for trained men.

More important, it will tell you of the great Associated Electrical Engineers—chartered by the State of Illinois, as an institution for the advancement of every phase of Electrical Science. Not a mere school, but a great National organization of Electrical Experts and Specialists, who have developed a MOST REMARKABLE SYSTEM for HOME TRAINING IN ELECTRICITY.

**NOW—As
NEVER BEFORE**
your chance lies
in the high-pay
electrical field

You may think that there isn't as big an opportunity for you—in electricity—as we tell you there is.

But the bare facts—the cold statistics of the industry—show that there's a real and startling **SHORTAGE** of trained electrical workers. The facts show that this great industry is growing so fast that the shortage of men can't be overcome in five years, at least.

The chance is there for you now, as never before. Don't let anyone tell you it isn't. Don't let yourself be led to say "it can't be done" before you have gotten the actual facts.

The proof—in overwhelming measure—is in our book on Electrical Opportunities. Get it! Write for it now—if you want solid proof that electricity really *does* offer high-pay positions that you can train yourself to hold.

We Train You At Home in your spare time, quickly and surely, by our **EXCLUSIVE AND COPYRIGHTED METHOD** to qualify to **Earn \$75 to \$200 a Week** as an Electrical Expert or in business for yourself—and

We Help You "Cash In" through our Placement Department and our great **FREE BUSINESS COURSE**, which will show you how to get the big-money Electrical jobs and how to establish your own independent, profitable Electrical business.

Our Book Tells the Story Our **BIG 64-PAGE ILLUSTRATED BOOK** will tell you fully about every one of the 9 remarkable features of

Associated Electrical Engineers Service, and how they will be the stepping stones for you from futureless, low-paid jobs up into the limitless, big-money opportunities in Electricity.

Don't Let Lack of Education Stop You

If you have the **AMBITION** to succeed and make big money as an Electrical Expert, we will guarantee the rest.

Mail the Coupon NOW

Get this remarkable book. It is **FREE**. You will incur no obligation in asking for it. We want every ambitious man in America to have one and receive this great message. Your copy is ready. Send for it **TODAY**.

Here's Opportunity's Wide Open Door

Send this coupon to

**Associated Electrical Engineers of America
Dept. 144, 537 S. Dearborn St., Chicago, Ill.**

Without obligation, send me your 64-page illustrated book on Electricity, together with full details of your remarkable plan of home training and membership in the A. E. E.

Name

Address

City

Associated Electrical Engineers OF AMERICA



"I'm Going to Send It in To-night"

"I'VE been drifting too long. . . . Two years ago, when Tom Adams took up an I. C. S. course, I determined to study too. But I put it off—and off—and off—"

"Tom's manager of the department now and earning twice as much as I am. It isn't because he has more natural ability than I have, but because he's trained! That's it—he's trained!"

"Me? Why I'm just one of a score of routine workers. Tom gets the big salary because the firm knows he's trained himself to handle work that I can't do.

"I've wasted two years, but it's not too late. This time I'm really going to send in that I. C. S. coupon too. The sooner I send it in, the sooner I'll be promoted like Tom."

Mail the Coupon To-day!

INTERNATIONAL CORRESPONDENCE SCHOOLS Box 5598-D, Scranton, Penna.

Without cost or obligation, please tell me how I can qualify for the position or in the subject before which I have marked an X:

BUSINESS TRAINING COURSES

- | | |
|------------------------------------------------------------------|---------------------------------------------------------------------------|
| <input type="checkbox"/> Business Management | <input type="checkbox"/> Salesmanship |
| <input type="checkbox"/> Industrial Management | <input type="checkbox"/> Advertising |
| <input type="checkbox"/> Personnel Organization | <input type="checkbox"/> Better Letters |
| <input type="checkbox"/> Traffic Management | <input type="checkbox"/> Show Card Lettering |
| <input type="checkbox"/> Business Law | <input type="checkbox"/> Stenography and Typing |
| <input type="checkbox"/> Banking and Banking Law | <input type="checkbox"/> Business English |
| <input type="checkbox"/> Accountancy (including C.P.A.) | <input type="checkbox"/> Civil Service |
| <input type="checkbox"/> Nicholson Cost Accounting | <input type="checkbox"/> Railway Mail Clerk |
| <input type="checkbox"/> Bookkeeping | <input type="checkbox"/> Common School Subjects |
| <input type="checkbox"/> Private Secretary | <input type="checkbox"/> High School Subjects |
| <input type="checkbox"/> Spanish <input type="checkbox"/> French | <input type="checkbox"/> Illustrating <input type="checkbox"/> Cartooning |

TECHNICAL AND INDUSTRIAL COURSES

- | | |
|-------------------------------------------------|----------------------------------------------------------------------|
| <input type="checkbox"/> Electrical Engineering | <input type="checkbox"/> Architect |
| <input type="checkbox"/> Electric Lighting | <input type="checkbox"/> Blue Print Reading |
| <input type="checkbox"/> Mechanical Engineer | <input type="checkbox"/> Contractor and Builder |
| <input type="checkbox"/> Mechanical Draftsman | <input type="checkbox"/> Architectural Draftsman |
| <input type="checkbox"/> Machine Shop Practice | <input type="checkbox"/> Concrete Builder |
| <input type="checkbox"/> Railroad Positions | <input type="checkbox"/> Structural Engineer |
| <input type="checkbox"/> Gas Engine Operating | <input type="checkbox"/> Chemistry <input type="checkbox"/> Pharmacy |
| <input type="checkbox"/> Civil Engineer | <input type="checkbox"/> Automobile Work |
| <input type="checkbox"/> Surveying and Mapping | <input type="checkbox"/> Airplane Engines |
| <input type="checkbox"/> Metallurgy | <input type="checkbox"/> Navigation |
| <input type="checkbox"/> Steam Engineering | <input type="checkbox"/> Agriculture and Poultry |
| <input type="checkbox"/> Radio | <input type="checkbox"/> Mathematics |

Name.....
Street.....
Address..... 11-21-22

City..... State.....

Occupation.....

Persons residing in Canada should send this coupon to the International Correspondence Schools Canadian, Limited, Montreal, Canada.

Sworn Proof of Success in 8 Weeks IN AUTO BUSINESS

Here is the chance of your lifetime to learn the Auto, Tractor, Electrical and Aeroplane business—quality in a few weeks for one of the jobs always open to men we train as experts—then earn \$150 to \$400 per month, or start a garage and repair shop of your own and make \$2,000 to \$10,000 a year.

YOU GET MY COMPLETE COURSE

I have no extras—everything taught in this school you get for the one price. Learn all about autos and tractors—how to build, repair and run them; tire, radiator, repairing; battery repair, charging; farm lighting systems; airplane, marine, stationary engines; brazing, welding; garage, repair shop management.

YOU GET 72-PAGE CATALOG FREE

Read all about the success of other men who have learned by my practical method. Send for FREE Catalog of Sworn Proof of Success in 8 Weeks in Auto Business. Write today sure.

I TEACH WHITE STUDENTS ONLY

OHIO STATE PRACTICAL MOTORS SCHOOL
D10-4, CINCINNATI, OHIO

"I Earn \$50 to \$83 Weekly!"
At work nicer than Movies

\$5 to \$10 made daily while taking
Lowest-cost, Simple-to-learn, Fun-
giving, Personal Radio Instruction.
First 4 jobs pay instruction cost. Be
an expert by MARVELOUS NEW METHOD.
Pay by installment. Write for details

JAMES A. DOWIE, RE.
402 E. 14th, RADIO VA.

LEARN TO GET DOLLARS OUT OF WATCHES.
WATCH-REPAIRING, ENGRAVING, JEWELRY REPAIRING.

WRITE NOW.

ENICAR TRADE SCHOOL
530 W. MONUMENT SQUARE, RACINE, WIS.

Get this Wonderful Book without cost



PROF. TITUS
as he is today

It is written by the man who has trained many of the world's greatest strong men. It tells you how to develop
**Vitality, Energy, Endurance,
Nerve Strength, Muscular
Strength, Perfect Physique.**

My new 64 page book, "Building Better Bodies" is just off the press. It contains the kind of clearly written information you want, including 30 halftone illustrations of my pupils now among the professional ranks. It tells you, if you are weak and underdeveloped, how to grow strong; if strong, how to grow stronger. It explains how to develop the lungs and muscles—a strong heart and vigorous digestion—in short, how to improve health and strength internally as well as externally.

If you will send me 10c in coin or stamps to help pay postage and wrapping, I will mail you a copy at once. Send TODAY—NOW.

PROF. H. W. TITUS 105 E. 13th St., Dept. 57
NEW YORK CITY

Drawing Table Free!



Yes, this is exactly what I am doing. I am giving this drafting table free to you when you enroll as my student. I do this because I want you to have the right kind of Draftsman's Working Outfit — because I want to help ambitious men and boys get ahead. This is the kind you will use when you have completed my course and have become a regular draftsman.

Complete Drawing Outfit FREE

Besides the drafting table I also furnish free the set of regular working instruments shown here. You get both table and instruments free if you enroll at once. I will do everything possible to help you get ahead.

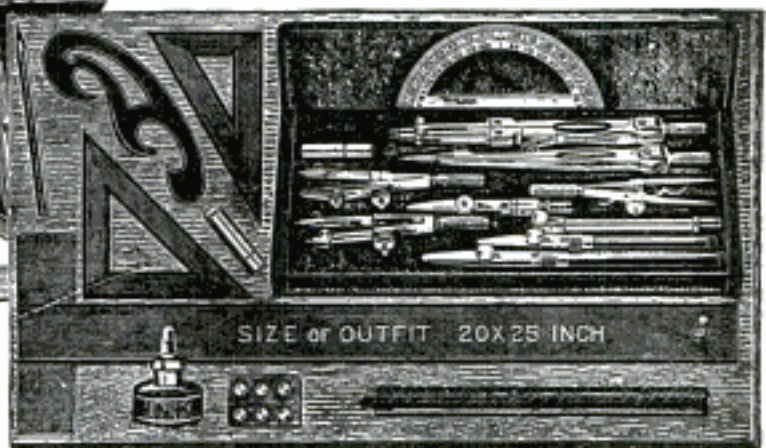

Also FREE \$90 Drafting Course

To my students enrolling now I give an opportunity of getting a \$90 drafting course absolutely without cost to them. This means you need not pay me for my personal instructions or for the complete working outfit.

Salaries up to \$250 and \$300 a Month

Positions paying up to \$250 and \$300 a month which ought to be filled by skilled draftsmen are vacant everywhere. There are in every part of the country ambitious men, who with practical training and personal assistance will be qualified to fill the positions. I can now take and train a limited number of students, guarantee to train them by mail UNTIL placed in a permanent position at a salary up to \$250 and \$300 a month.



Here is the Rule you get FREE

To each young man stating his age when sending a sketch as shown in box at right, I am going to mail FREE AND PREPAID the Draftsman's Ivory Pocket Rule shown here.

Mail Coupon

Mail coupon at once for full information how you can get the table and working instruments Free, also how you can get the \$90 drafting course Free. Even if you don't send in a copy of the sketch send for this information.

Chief Draftsman, Engineers' Equipment Co.
1951 Lawrence Ave., Div. 93-54 Chicago, Ill.

Extra!!

Copy this Sketch and Get Ivory Pocket Rule

To each young man sending a sketch I will mail free prepaid the Draftsman's Ivory Pocket Rule shown here. With it I will send you a 6 x 9 book on "Successful Draftsmanship." Just state your age.

There are no conditions requiring you to buy anything. You are under no obligations in sending in your sketch.



Chief Draftsman, Engineers' Equipment Co.

1951 Lawrence Ave., Div. 93-54, Chicago, Ill.
Without any obligation to me please mail your book "Successful Draftsmanship" and full particulars of your liberal "Personal Direction" offer to a few students. Also full information as to how I can get a \$90 Drafting Course Free.

Name

Address

Age

Be Master of a Job that Pays

\$75 to 200

A WEEK



\$25.00 Set of Books
At No Extra Cost
Valuable Library of Automobile Engi-
neering worth \$25, included with course.

Send This FREE Book Coupon Today

Automotive Division, American School
Dept. A-474 Drexel Ave. & 58th St., Chicago

Send me at once the FREE auto book and
all information about your automotive
course. This request obligates me in no
way whatever.

Name.....

Address.....



Quick Success! BIG PAY

If \$20—\$30 or \$40 a week is the limit of your ambition, stop reading this right now!—it isn't meant for you. But if you are sick and tired of your small pay, no future job, you're the man we're talking to.

Listen: We're ready to line you up for a **real job at real pay**—where the sky's the limit on opportunity for quick success, and big money—where \$75 a week is just a fair **starter**—where good men pull down \$5000 to \$10,000 or more a year, and where any man can easily have a business of his own, have men working for him, **be his own boss!** Sounds good?—then come on, we'll put you across to big success in the **AUTOMOTIVE BUSINESS!** **BE AN**

Auto Expert

Take your choice of a dozen fine jobs. **Boss the job** instead of being bossed. Draw big pay—**work short hours**. Enjoy your work—**own your own business**. Be independent—a success! You can do it!—Yes, and do it quickly and surely. It makes no difference whether you know a carburetor from a transmission, or whether you've even lifted the hood of a car, we can teach, train, prepare you, simply, quickly, and surely for a top-notch job at big pay.

Keep Your Job—Learn at Home

Don't quit your job—stay at home! Hold on to your salary while you prepare for the big job. Then when you're trained and ready, slip out of the old job into the new one without having lost a day or a dollar. We give you a real training—thorough and practical—the kind of training that qualifies you as a full-fledged **Automotive Expert**—ready and able to take on any job, make good—**make money.**

In All The World No Course Like This!

Investigate! Get the facts on this great course before you decide on any line of work. Here's a course prepared by many experts. Not just one man. A course backed by real service that insures your success, and backed by the strongest guarantee of results ever offered! Learn why thousands have taken this course in preference to any other, and **made good.**

Free Auto Book Tells of big opportunities open to you. Shows how easily and quickly you can get ready and how sure is your success. No obligation or expense. Send the coupon for your copy today!

Automotive Division

American School

A-474 Auto Div., Drexel Av. & 58th St., Chicago, Ill.

"THE AIR IS FULL OF THINGS YOU SHOULDN'T MISS"



Why Big Cells Count in Radio "B" Batteries

THIS handsome metal case Eveready "B" Battery No. 766 costs only two-thirds more than the smallest Eveready "B" Battery, but it contains seven times the electricity! This makes the No. 766 over four times as economical as its baby brother. That is why most people buy it.

Its fifteen large cells give 22½ volts of strong, steady energy day after day. Cells that pour out power the moment you turn on your tubes. Cells that rest well when idle, renewing their vigor for your next demands.

No cells have a bluer-blooded ancestry than these. They are the product of thirty years of dry battery research and development of the world's foremost electro-chemical laboratories. We think that No. 766 is the handsomest battery



Eveready "B" Battery No. 766
22½ volts. Six Fahnestock Spring Clip Terminals, giving variable voltage from 16½ to 22½ volts, in 1½-volt steps. Length, 6¾ in.; width, 4¾ in.; height, 3¾ in. Weight, 5 lbs.

ever made. But that is a matter of opinion. It is a matter of engineering record, however, that this great standard "B" Battery has proved itself as perfect in performance as we are convinced it is superfine in appearance.

The 45-volt Eveready No. 767 contains the same large powerful cells as the No. 766. For maximum "B" Battery economy, therefore,

buy the 22½-volt Eveready No. 766 or the 45-volt Eveready No. 767, as you prefer. Here is the "B" Battery at its best.

NATIONAL CARBON COMPANY, INC.
Headquarters for Radio Battery Information
New York San Francisco
Canadian National Carbon Company, Limited
Factory and Offices: Toronto, Ontario

If you have any radio battery problem, write to G. C. Furness, Manager, Radio Division, National Carbon Company, Inc., 207 Manley Street, Long Island City, N. Y. Informative and money-saving booklets on "A," "B" and "C" Batteries sent free on request.



EVEREADY

Radio Batteries

- they last longer



How Volcano of Flaming Gas from Leaking Street Main Was Conquered without Interrupting Service by "Plugging Off" a Section of the Pipe with Rubber Balloons—See Page 565.

4068

International Newsreel Corp
326 W. Madison, Chicago

Popular Mechanics Magazine

REGISTERED IN U. S. PATENT OFFICE

WRITTEN SO YOU CAN UNDERSTAND IT

Vol. 41

APRIL, 1924

No. 4



Science Revolutionizes "Sport of Kings"

Speed of Horses Almost Doubled by Improvements in Tracks, Sulkies, Hobbles, Shoes and Other Equipment

By DONALD M. EWING

(Copyright, 1924)

ALTHOUGH public interest in racing has been revived by the establishment of many new records, few persons realize how much science has contributed to the increase in speed of the horse.

Centuries ago, a pair of Arabian thoroughbreds were imported into England. They became the ancestors of virtually every speedster of today. Yet, their early descendants had a maximum rate of fifteen to twenty miles an hour, while now their progeny travel nearly forty miles an hour.

Science supplies the answer. Progress in mechanics, which brought the inanimate automobile and airplane into undreamed of speeds, has accomplished similar results with living things—horses. The most sensational progress has been with harness horses—trotters and pacers which carry their driver in a two-wheel sulky. As recently as eighty years ago, bets were freely made that no animal could trot or pace a mile in three minutes—twenty miles an hour. Today the record is 1:54½ held

by Dan Patch—more than 30 miles an hour. Running horses—with jockey in a saddle—travel at a rate of nearly forty miles an hour.

To bring about this speed, science has conquered the elements—wind, water and earth—and has devised numerous mechanical aids to speed and has even tended toward changing the nature and instincts of the animals. Take the harness horses, for there the change is greatest and most recent.

Some eighty years ago, the sulkies used for these racers were heavy contraptions with wheels nearly five feet in diameter and the driver perched high above and behind the horse. The wheels were straight edged. When three minutes for a mile was reached, many thought the maximum had been obtained, but men with a mechanical turn of mind thought otherwise. They found that the straight-edged wheels cut too deep in the turf, retarding the animal. Steel tires were substituted—and it was



easy to make a mile in three minutes. Gradually, more and more attention was turned to improving the sulkies, until in 1890 horsemen began to dream of a mile in two minutes.

First, the heavy axles of the sulkies were discarded. Inventions came which resulted in an axleless sulky. A light frame was run upward from one wheel, over and down to the other, with the driver's seat in the center. Mathematics enabled light steel trusses to give the exact strength needed without the heavy shaft. With these improvements, Sunol in 1891 made a mile in 2:08 $\frac{1}{4}$, the first time 2:10 was beaten. Nancy Hanks also broke 2:10, a year later.

There were still three drawbacks. The sulkies swerved on curves. The drivers, perched high, offered too much wind resistance. The animals sometimes became excited and broke into a gallop, instead of holding to trot or pace.

One single change overcame two of these faults. Low wheels—about two feet instead of five in diameter—with wire spokes and rubber tires were put in. Thus the driver was dropped down behind the horse and offered no obstruction to the

wind. The lower-to-the-ground sulky and the rubber tires gave better traction and stopped curve swerving. The result: Dan Patch, with a horse in front as a windbreaker, made a mile in 1:55 $\frac{1}{4}$

—more than thirty miles an hour against fifteen in the old days. In 1915, Directum I, in a race, won in 1:58 $\frac{1}{2}$, still the competitive record. Mechanics did it, for it cut the weight of the sulkies from sixty-five to thirty pounds besides making them better in many other ways.

Then hobbles were invented. They are rope-like contrivances, from leg to leg, which keep the horse from breaking out of trot or pace. They helped also in training. On this angle, horsemen also found, by experiments, that light shoes in front produced a pace and heavy shoes a trot.

Thus, even the horse's instincts were guided by science.

Running is a horse's natural gait. Running races started centuries ahead of the harness type. Thus, the improvements made there greatly antedate the harness type, but the progress has been about the same. First came the changes in starting. Once a drummer started the animals and they always got away slowly. Today, the starter presses a



Start of a British Racing Classic



button, a web-like barrier in front of the animals shoots outward and upward and they're off. The very quickness of the barrier seems to urge the horses on. Then there are the timing devices which authenticate the speed. In old days the timer used a "Big Ben." Then came the split-second stop watch and now electrical timers which run to the tenth of a second. Electric score boards give the spectators results almost as quickly as the judges gets them.

Plates—shoes—brought a big improvement in runners. Aluminum was substituted for steel because it was lighter. Thin half-inch wide aluminum plates are easily put on or taken off, and the horse does not carry the heavy steel shoe of olden days. Different types of plates are used for different track conditions. Stirrups are lightened through the use of aluminum, as are saddles and bits.

Many mechanical contrivances were produced only to be barred later. Electricity furnished the greatest. Years ago horses were given a bottle of wine before a race to pep them up. In the early '90's, Jockey Kuhn, riding for Louis Merriwether Clark, of Louisville, carried a small battery

inside his shirt. Wires ran down to the spurs. A jab of the spur gave the horse a sharp electric shock and he lunged forward for a quick start.

When these were barred, crooked owners had the jockeys carry the battery hidden in their hands, throwing it away after the start. Then came the electric whip—with a battery in it—and the saddle with an electrical contrivance concealed inside which operated when the jockey pressed a button. All are barred now.

But the greatest aids to speed—both in running and harness races—came through civil engineering—the construction of tracks. Old tracks were mere measured-off pastures. In 1884, railroad engineers built the first dead level track at Washington Park, Chicago. It was drained and the surface scientifically made. All modern tracks are engineer-built.

Experimenters soon found that the harder the surface the faster the speed. But they also found that runners would sprain their legs on hard tracks because of their big lunges. Trotters and pacers with short, quick strides did not suffer in this way.

Steel and leather ankle braces were designed for

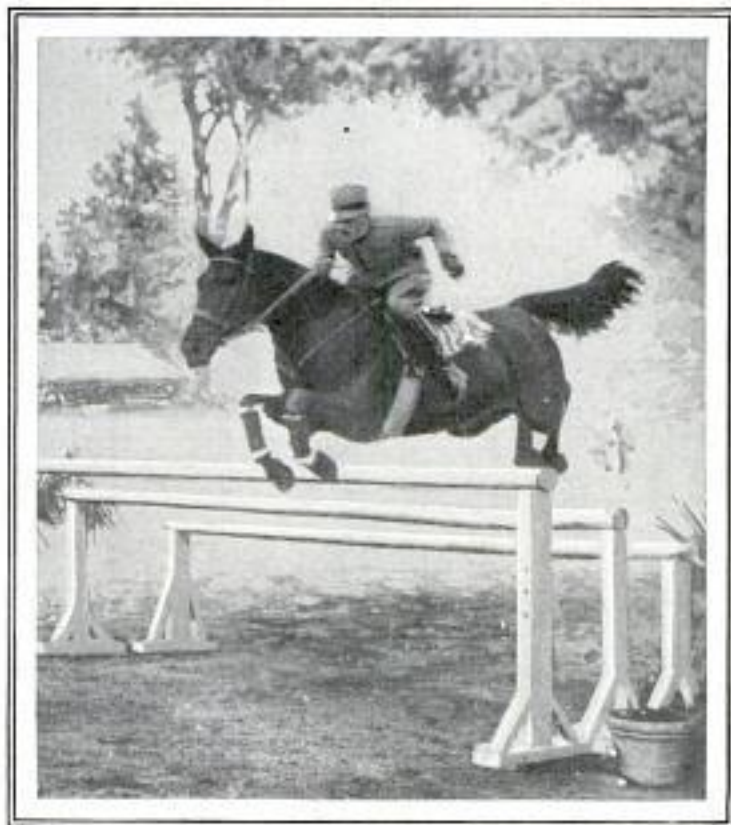

Copyright, Underwood & Underwood

Italian Cavalryman in Hurdle Race

runners. But they were not enough. So, special tracks were built for each type of horse—hard for harness animals, hard underneath but soft—yet firm—on top for runners. Experiments proved that an undulating or wavy surface was best for runners, for the downhill waves were placed at the right distance to catch the end of each stride and rest the animal. Harness horses, however, had to have a "dead-level" surface. So, the level and

transit were called on and the undulations put in—not perceptible to the eye.

So, in 1918, Roamer ran a mile at Saratoga in 1:34½. Yet Roamer's ancestors—the equine Adam and Eve—couldn't even approach that rate of nearly forty miles an hour. Horsemen will tell you that scientific breeding has done much to increase speed. True, of course, but science in the form of mechanical changes has done its part, too.



HALF WORLD'S ELECTRIC LIGHT USED IN UNITED STATES

Incandescent lights of the kind used today have about four times the efficiency of those of eighteen years ago, electrical experts have estimated. It is computed that there are 350,000,000 electric lamps in the United States, about equal to the number in all the other countries of the world combined. The increase is placed at approximately ten per cent each year.

make them capable of a mile-a-minute speed. Detectives assigned to ride in them carry high-powered rifles and shotguns.

SNOWSHOES ON MAIL PLANES AID IN MOUNTAIN FLIGHTS

Air mail planes flying over San Francisco bay and the high Sierras between the

FAST, BANDIT-CHASING AUTOS PROOF AGAINST BULLETS

Bandit-chasing automobiles have been put into service by the Philadelphia police in their campaign against crime. The cars are equipped with bullet-proof bodies and windshields, and the specially built motors



Armored Automobile with Specially Built Motor Used in Campaign against Crime



Air Mail Plane Equipped with Life Preservers and Snowshoes for Flight over Mountains

Pacific & Atlantic Golden Gate and Reno have been equipped with snowshoes and life preservers. The shoes are expected to be of assistance in case of forced landings in the snow-capped mountains. Although few accidents are reported, owing to the rigid inspection of the airplanes, the first consideration of the service is to safeguard the aviators.

ⓈAgriculturists fear that an insect pest, the Australian tomato weevil, recently discovered in the South, will become of great menace to crops unless suppressed.

The Engineer
12/28/23
189
107
Pacific & Atlantic Photos
25 Park Place,
New York.

Police

The Portal
Jan. 13, 1924

POPULAR MECHANICS

MORE FLOWERS GROWN YEARLY TO SUPPLY PERFUME

Acres of roses, violets, lilies and other flowers are raised each year in France and southern Italy, to supply the world's demand for perfume which is said to be increasing every year. To extract their fragrance, millions of freshly picked blossoms are placed upon sheets of glass covered with lard which absorbs the oils exuded by the flowers. Repeated layers of blossoms are required before the lard is fully saturated. When this process is complete, the concentrated extract is obtained by melting the lard and dissolving it in purified alcohol which leaves only the valuable, essential oil. This is further treated or mixed with other substances to give it the required quality and strength. In southern Italy, large distilleries have been erected recently for the extraction of valuable oils from the rind of the citrus fruit that yields essences used in the manufacture of perfumes.

MEDICINE IS FED INTO LUNGS OF WHITE-PLAGUE VICTIMS

For the treatment of pulmonary tuberculosis a medicine is being used that is inhaled directly into the patient's lungs through a tube and mouthpiece. It is composed of amorphous carbon and calcium salts which, it is declared, build up



Tuberculosis Patient Inhaling Medicine which Is Declared to Arrest Progress of the Disease

the fibrous tissues, arresting the progress of the disease. Good results are declared to have been obtained in experiments in the east.

Dr. Thomas H. Nolan,
60 W. 53rd St.,
New York City

Dr. W. Lee de Forest
1391 Sedgwick Ave.
New York City
493

"SPEAKING FLAME" GIVES VOICE TO TALKING MOVIES

Realistic reproduction of the tones of the human voice is given with a microphone that is known as a "speaking



Microphone that Converts Electrical Impulses into Sound Waves without a Diaphragm

flame." It is expected that this device will do away with the ordinary vibrating diaphragm, such as is used in the telephone, and that it will be of service in the movies. With it there is almost no distortion in converting electrical impulses into sound waves.

PATENT OFFICE GIVES WOMEN A SPECIAL DEPARTMENT

In the patent office at Washington there is a woman's department, with the specifications ranged in the order in which they were received. The first on the list is a patent taken out in 1809 by Mrs. Mary Kieser for a process of weaving straw hats with silk. One woman inventor, Hannah Lord Montague, is honored by a public memorial in Troy, N. Y., where she was born. As Mrs. Montague was doing the family washing on a hot summer day in 1825 it occurred to her that a shirt remained clean for a longer period than a collar, so when her husband's shirts were dry, she detached the collars from them. Later she started making detachable collars for sale to her neighbors, and the demand reached such proportions that before 1840 several factories of "string collars," as they were called in their infancy, were established in Troy.

Indianapolis News
Jan. 18, 1924
Copyrighted material

Mystery Ray Is Revealed By Photos

By *Prof.* WILLIAM D. HARKINS

University of Chicago

5437 *Ellis Ave., Chicago*

RAYS of a new type, called zeta rays, were discovered recently by Dr. R. W. Ryan and the writer. These rays have attracted much attention, presumably because they were first found by photographing them, or, more strictly speaking, by photographing the tracks they produce when they shoot through air. They are not light rays, but are electrons, or charges of negative electricity, thrown out by an atom.

All owners of radio outfits are familiar with the use of electrons shot out from a hot wire, since it is the stream of these particles of matter which is made to do various "stunts" in the different types of vacuum tubes. Such a stream of electrons is also shot out from the hot wire in every electric lamp, and may be collected on a metal



Luminous Paths of Incredibly Small Particles that Move at a Speed of Ten Thousand Miles a Second

plate if it is inserted inside the bulb.

While an atom is so small that it takes a hundred million in a straight line to reach an inch, electrons are very much smaller. Certainly one of the greatest discoveries of the twentieth century was made when C. T. R. Wilson, of Cambridge university, found a way to make the tracks of these exceedingly minute particles visible as dotted lines of light. The nucleus of a helium atom, or the central part of it, is supposed to be nearly as small as an electron, but carries two positive, instead of one negative charge. If this helium nucleus, usually called an alpha particle, is shot through air at high speed, it produces a track like that of the electron, except that the line of light is continuous and brighter. It may be explained that an atom is an exceedingly minute solar system, in which the central nucleus, which has practically all of the weight of the atom, plays the part of the sun. The tracks of electrons and of the atom are not self-luminous, but they are made bright by an ingenious device. Practically everyone knows that rain clouds consist of minute drops of water, and that these are produced by cooling moist air. Now these drops will not collect in dust-free air, except upon charged particles, that is, upon electrons,

Now these drops will not collect in dust-free air, except upon charged particles, that is, upon electrons,

Searching Movie Film for Traces of the Mysterious Zeta Ray

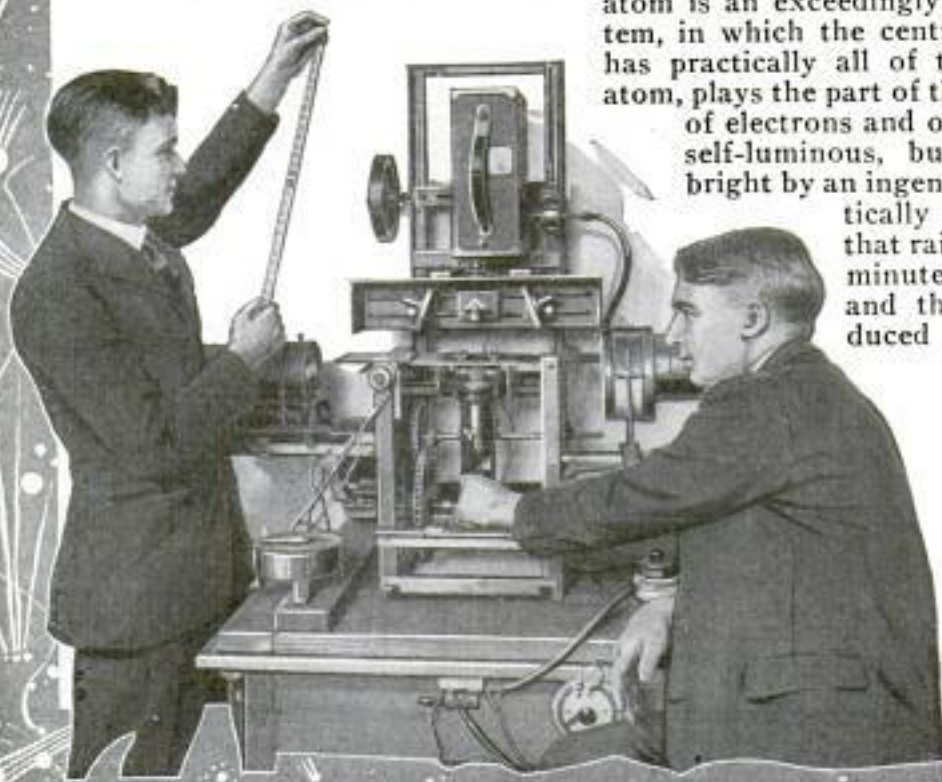

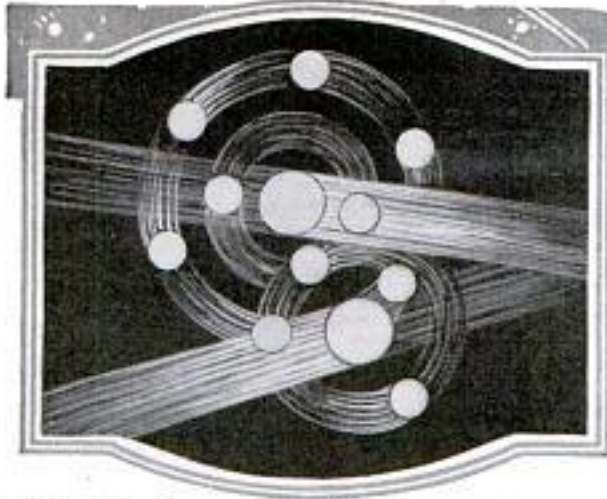

Minute Solar System Formed by Electrons Constantly Whirling About a Center Like the Planets

Electric Charge Made Visible By Film

electrons have been pulled, and these occur only in the line in which the fast alpha particle has moved. The brilliancy of these lines of minute water drops is due to the fact that two powerful searchlights are focused upon them.

The interest of the zeta rays results from the fact that they are exceedingly rare. Also there is no explanation of their peculiar form. They are about an eighth of an inch long and are highly curved. The discovery of these rays was partly accidental, though we were looking carefully for peculiar ways in which electrons may be ejected from atoms. The rays were found in photographs taken to show collisions between an alpha particle and the nucleus of an atom. Forty thousand such photographs were taken, and it is now planned to obtain two hundred and fifty thousand more.

or upon atoms which are charged with positive electricity and are known as positive ions. What is done is to put air or another gas into a glass cylinder provided with a flat top and with a piston for a bottom. The gas is kept moist by wet gelatin. On one of the walls of the cylinder a minute particle of a substance similar to radium is fastened. In these experiments thorium C, which is very much more powerful than radium, in that it shoots off alpha particles with twenty-six thousand times the velocity of the fastest rifle bullet, was used. When these high-speed particles shoot through a gas they travel so fast that they have no time to pass around the atoms, so they go straight through them. Very rarely the alpha particle hits the nucleus of the atom through which it is passing, and rebounds, so a very sharp change of direction results whenever such a collision occurs.

The operation of the apparatus consists in suddenly pulling down the piston, thus expanding and cooling the moist air. Water drops form immediately, but only upon the electrons pulled out of the atoms, or the positively charged atoms from which

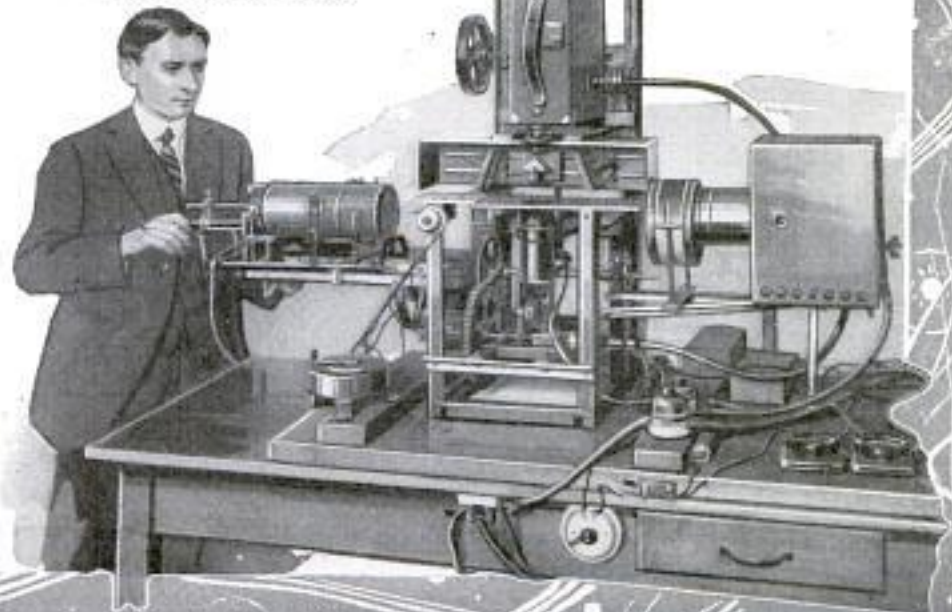

Producing Charged Particles in Cylinder to Reveal Paths

Owner - S. C. Young,
Cedar Rapids
Iowa.

496

POPULAR MECHANICS

COTTAGE BUILT ON AUTO GIVES TOURISTS HOME COMFORTS

50

Fitted upon the chassis of a small touring car, a miniature cottage supplies an Iowa contractor, his wife, and two chil-



Comfortable Cottage Touring Car that Sheltered Family of Four on Cross-Country Run

dren with luxurious quarters while on motor tours. Electric lighted throughout, the house provides ample protection from dust and rain, there is space for a cradle for the baby and other comforts of home. The front window in the roof gives the driver a full view of the road ahead and glass in the rear makes it possible to see behind. Entrance is provided by a side door and one at the rear. The radiator fills the screened-in "porch" which has one side on hinges so that the engine can be reached easily. The cottage weighs but little more than the inclosed body of standard type and proves an effective advertising device.

NO-DRIP CANDLE EXTINGUISHER HAS TAPER INSIDE TUBE

To prevent the soiling of altar linen, a non-drip adjustable candle extinguisher has been patented that also will extinguish the

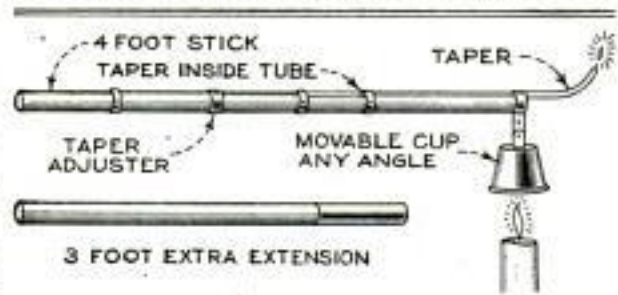

Candle Extinguisher with Taper Concealed Inside Tube to Prevent Dripping on Altar Linen

light without touching the wick. The taper is carried in a four-foot tube to which a three-foot extension may be attached. Because of the design, no grease can lodge in the extinguishing cup.

UNCLE SAM BUILDS HIGHWAYS ENOUGH TO CIRCLE EARTH

More than 8,000 miles of roads of all types were completed with federal aid during the year which ended June 30, 1923, according to a government report. This, added to the mileage completed previously, brought the total for finished projects up to 26,536 miles, or more than enough to circle the earth. The projects under construction at the close of the year amounted to 14,772 miles, and were estimated at 53 per cent complete.

Chicago Tribune 6/24

SEALSKIN FENDERS PROTECT 102 BOATS OF ESKIMOS

Skins of the leopard seal, also known as the sea leopard because of its spots, are put to a variety of uses in the frozen north. To the Eskimos, they are more valuable



Sea-Leopard Skins Blown Up for Bumpers to Protect Boats from Ice Cakes

than the pelts that produce the luxurious wraps so highly prized in warmer lands. Blown up like balloons, the skins are placed on the prows of hunters' boats to protect the sides of the fragile craft from the sharp, jagged edges of ice floes. Like fenders, these bumpers ward off the jabs of the ice cakes and on rocks and portages they act as rollers for the craft. Sacks also are made from them and they hold the family supply of blubber and oil. Their light weight makes them the favorite containers for freight that is to be handled by dog or reindeer teams.

*Cont. Mrs. L. P. Little page
Apr 10 2, The Abolitionist
Washington, D.C.*

*Anton Schroeder
2172 Carroll Ave. St. Paul
Minn.*

69 Cmt. Charles W. Isseiger,
Union League Club,

POPULAR MECHANICS

Post + Taylor San Francisco, Calif

497

ONE-MAN WATER PLANT SUPPLIES WHOLE CITY

Taking the muddy and contaminated waters of the Sacramento river, purifying them with alum and chlorine gas, and filtering them through sand until they sparkle like crystal and are free from germs, the vast filtration plant that supplies California's capital city with 48,000,000 gallons of pure water each day, rep-

had been expended on its construction. Housed in artistic buildings set in a tract of approximately 50 acres which is to be used for a municipal park, the elaborate apparatus of the plant is electrically driven throughout and may be controlled by one person from a single switchboard. Included in the works are an intake pier,

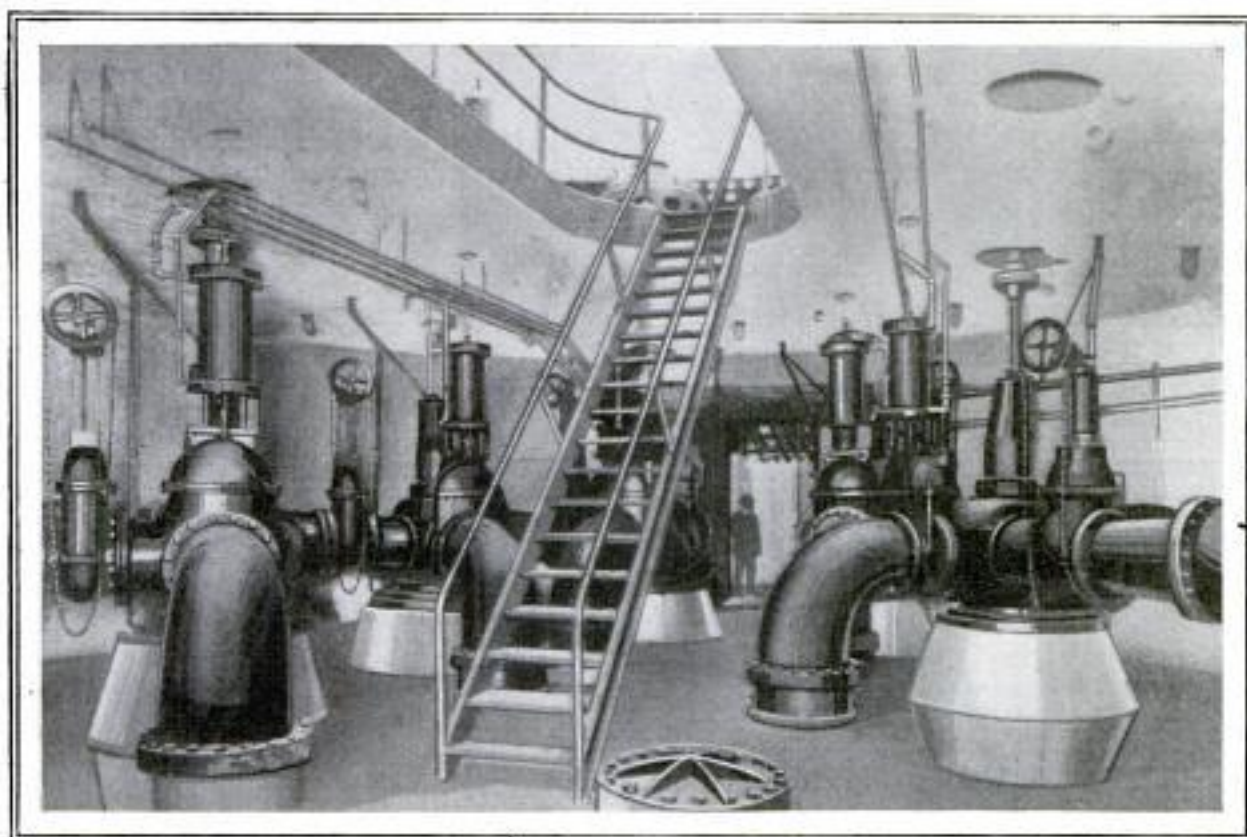

Interior of Pumping Station in Sacramento's New Water Plant: A Battery of Low-Lift Pumps for Starting the Supply on Its Way through the Filtering Process

resents a triumph in sanitary engineering. The plant was opened with the closing of a switch by a young woman stenographer on order by radio from President Coolidge, after several years and over \$3,000,000

pumping station, grit removal and storage basins, coagulating tanks, sedimentation basins, head house and filters, clear-water reservoir, force mains to the city and an alum manufacturing plant.

TOKYO CORRESPONDENT TELLS OF A "NOBLE INVENTION" 166

In report No. 176 from this magazine's Japanese correspondent, N. Sakata of Tokyo, the latter speaks of a new parachute for aviators just put in use by the Japanese army air service. It seems that details of construction have been withheld, but the following is the correspondent's statement:

"This idea caused one of investigator in the army air service field to invent the new wonderful device which was honored by the minister of army recently. His inven-

tion is to ignite the device electrically in very short minute and to cause open the parachute in full condition. Then you can save your life by hanging from it safe. When the airplane body is shown the symptom of some danger and lose its usual state, the electricity will flow up respectively, as I told above, and cause the small gas-contained bag to be ignited. This ignition will open the parachute in full. At this time the body will descend down with enormous speed, but the parachute is already in action. This noble invention of the army is strictly kept from announcement on account of army's usual way."

Invented by member of Japanese Army Air Service

Mr. Katayama, 605 7
Ali. Machi. Tokyo. Japan.
% American Engineering Co.
% Mr. Sakata of Tokyo, Japan.
Copyrighted material

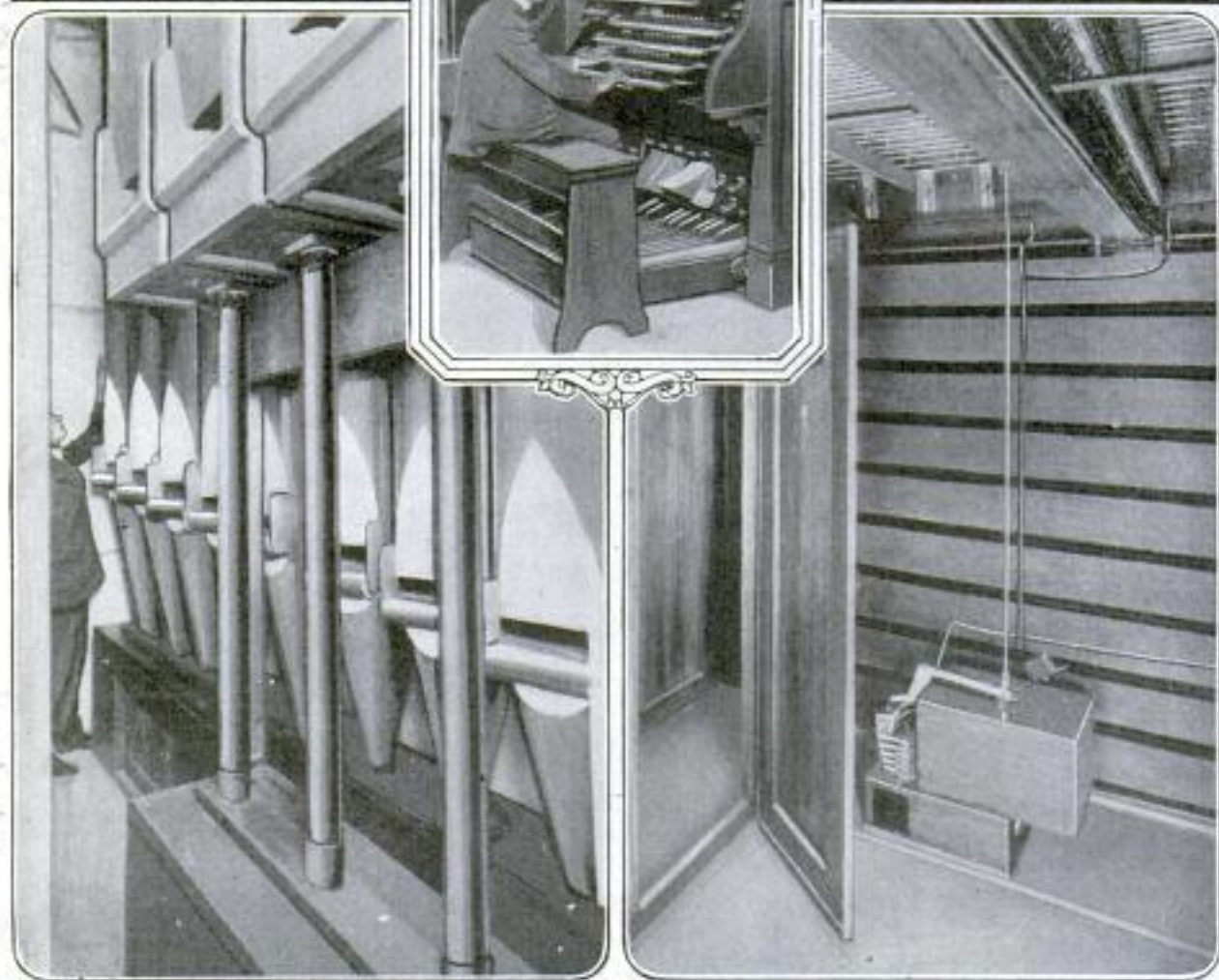
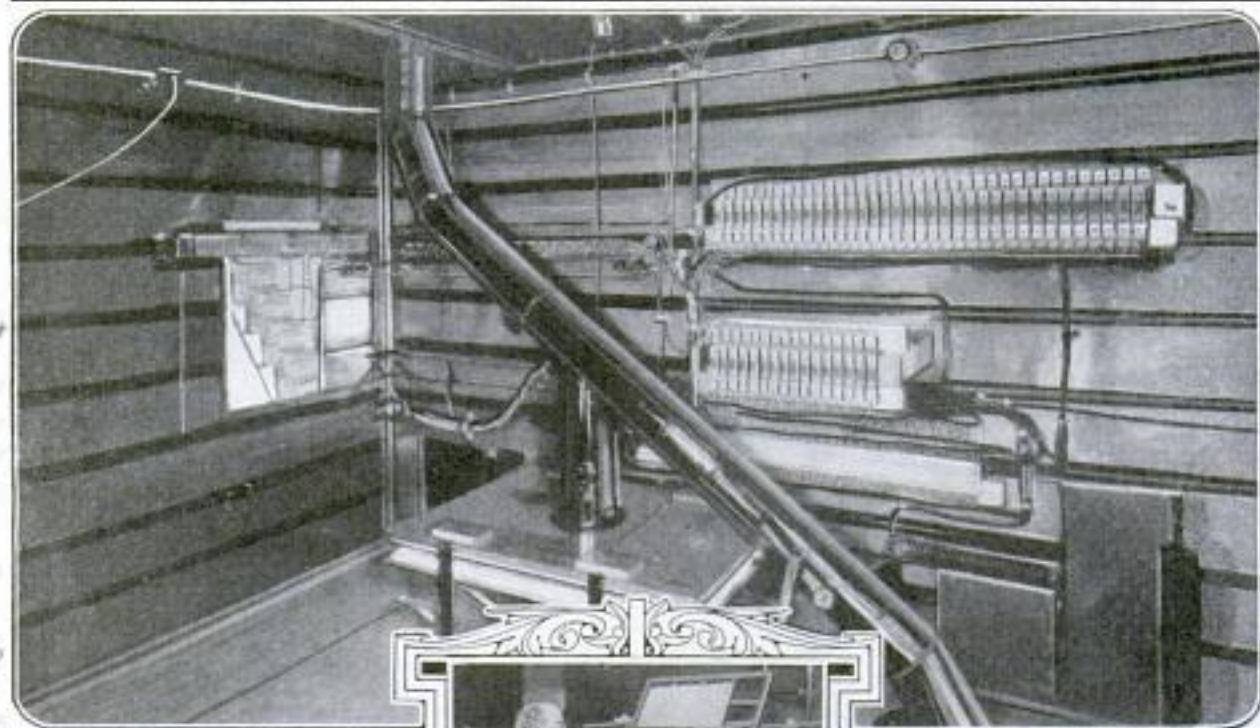

Electrical Control (Top); Organ Keyboard (Center); Mouth of Several of the Pipes (Left), and Wind Chest that May Be Entered During Concert (Right)

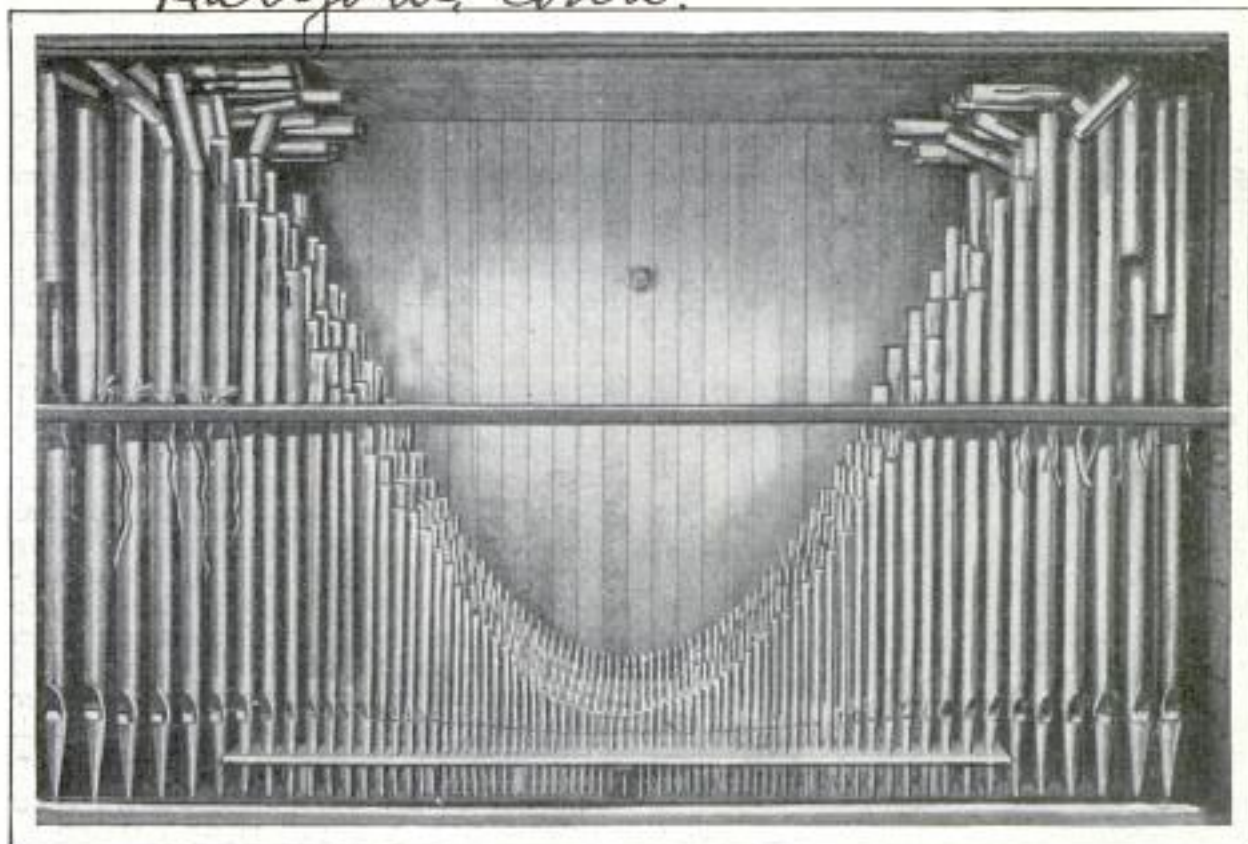

Floating String Organ Unit, Consisting of about Five Hundred Pipes; the Twisting and Doubling over of the Tubes Does Not Affect Their Tone

Huge Organ Has Six Thousand Throats

Thirty Thousand Miles of Wire Form Nerves of Instrument for Which Fifteen Electric Motors Supply Power

AS you listen to the majestic tones of a great pipe organ mere mechanical things seem far away, but behind that proscenium arch is an electrical and pneumatic system of intriguing complexity.

More than 30,000 miles of wire form the nerves which control the 6,000 throats of one of the largest organs in America which has just been completed at the University of Colorado in Boulder.

What looks like one organ, however, is really seven—the great, the choir, the solo, the pedal, the swell, the echo, and the floating string units—which, played as one, produce every tone possible to a symphony orchestra, except those of the percussion instruments, such as the drums.

Back of the stage is the successor of the small boy who used to pump the church organ—a huge turbine, driven by a thirty-horsepower electric motor, blowing air into the seven wind chests which supply each organ. But even this is not large enough and a ten-horsepower auxiliary motor and turbine automatically start to operate at

peak loads. Air-lock doors, something like those used in tunnel-construction work, permit a workman to enter the chambers without altering the air pressure. Thus the valve mechanism can be adjusted or repaired while a concert is in progress.

Electromagnets, controlled from the keyboard by the organist, move the thin strips of wood which operate the valves regulating the flow of air into the pipes which are made of silver, tin, zinc and lead.

Some pipes are doubled over. Others are turned in loops and circles like a cornet horn. Some taper; others have bell mouths. Many are stopped to produce a slightly softer tone. A few have a "beard" hanging over their mouths which slightly alters the tone.

Seven brick boxes with electrically operated steel shutters, enable the organist to control the volume of sound from a faint whisper to a crashing roar.

Fifteen electric motors furnish the power to operate the various units of the organ.

DOG KENNEL OUTSIDE WINDOW SOLVES A CITY PROBLEM

92 Keeping dogs in city apartments is simplified by a kennel placed outside the window. The inclosure is made of lath and



Copyright, Underwood & Underwood
 Window Kennel for Dog Is Easily Reached, Well Ventilated and Out of the Way

affords the dog a constant supply of fresh air. It is readily accessible through the window which opens and closes as the door to the pen.

Accident
AUTO DEATH IN U. S. EVERY THIRTY-FIVE MINUTES

178 Every time the clock recorded thirty-five minutes during the last year, a person was killed on the highways of the country, and each minute, approximately three persons were injured, delegates to the convention of the American road builders were told. In twelve months highway accidents claimed a total of 15,000 lives and caused 1,700,000 injuries, according to the figures given. Uniform traffic regulations, established by all states, strict enforcement of these laws, systematic maintenance of roads and safety education in schools were urged to curb the ever mounting number of fatalities. In Wisconsin, a survey of accidents during the past two years was said to have proved that most of them occurred on straight roads, largely due to attempts of drivers to pass one another. Railway grade crossings, however, were declared to be the most dangerous.

Chicago Evening Post 1/16/24

WOMAN BIRD SURGEON TREATS ILLS OF FEATHERED PETS

165 Acting as a surgeon for birds is the occupation of a New York woman who performs operations upon her feathered charges and cares for their various ills. Rheumatism, indigestion and fevers are some of the ailments she has treated. Surgical operations are performed in a completely equipped room on the third floor of the hospital she maintains. With several assistants, she is called upon to minister to the needs of more than 2,000 birds in the summer months when families leave for vacations and bring their pets to be "boarded"—in the wards of the hospital while they are gone. The birds like to be amused and show interesting characteristics, their keeper declares. Balls, beads and ribbons hung from the cages keep them from pulling out their plumage and music from a phonograph seems to cheer them when their own songs are silenced.

CRUCIFIX IN THROAT TEN DAYS REMOVED WITHOUT KNIFE

5 After lying for ten days, imbedded in the throat of a patient in a Boston hospital, a crucifix, two inches long, was extracted without surgery. X-rays located the obstruction and, although the victim was at the point of strangulation, no knife was used, despite the fact that the prongs had become lodged in the sides of the windpipe.

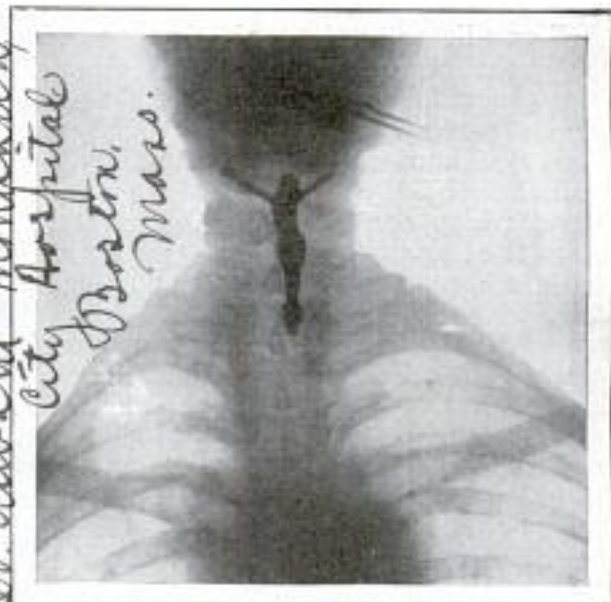

How the X-Ray Located a Two-Inch Crucifix Caught in Woman's Throat

Fastened in an upright position, the cross arms are believed to have prevented the piece from penetrating further.

United News pictures
 461-8th Ave. New York

Hues of Rainbow Rivalled in Copper

CROWNING one of the oldest crafts with new beauty made possible by modern knowledge of chemicals, Jean Durand, a French metal worker, has achieved unique and beautiful effects in hand-hammered copper and brass ware, samples of which were exhibited not long ago in Paris salons. Floral designs and other patterns are worked into the various articles in enamels by a secret process that is said to reproduce the natural shades of petals and leaves in their original brilliance and freshness. "Futurist" figures, also worked in colors, add a novel touch to the product of this artist's workshop—vases, bowls, gongs and pitchers that rival in symmetry and delicate form those



fashioned by workers centuries ago.

From a flat disk of metal, the object takes form under strokes of hundreds of wooden and metal hammers of various shapes and sizes. Each of these tools is used at some time during the hammering process on different pieces. The pounding is begun at the center of the disk and extended outward until the edges have been tapered off to the proper curve. Frequently as many as forty alterations are necessary before a vase is correctly modeled.

Finally hammered into shape, the article is ready for the heating process, a step taken to soften the metal for the engraving and enameling. Any pounding necessary after the metal is heated is done with steel



Filing and Chiseling the Finishing Touches on Ornamental Pieces for Hammered Bowls and Vases

Jean Durand, 5 Rue St. Paul, Paris, France

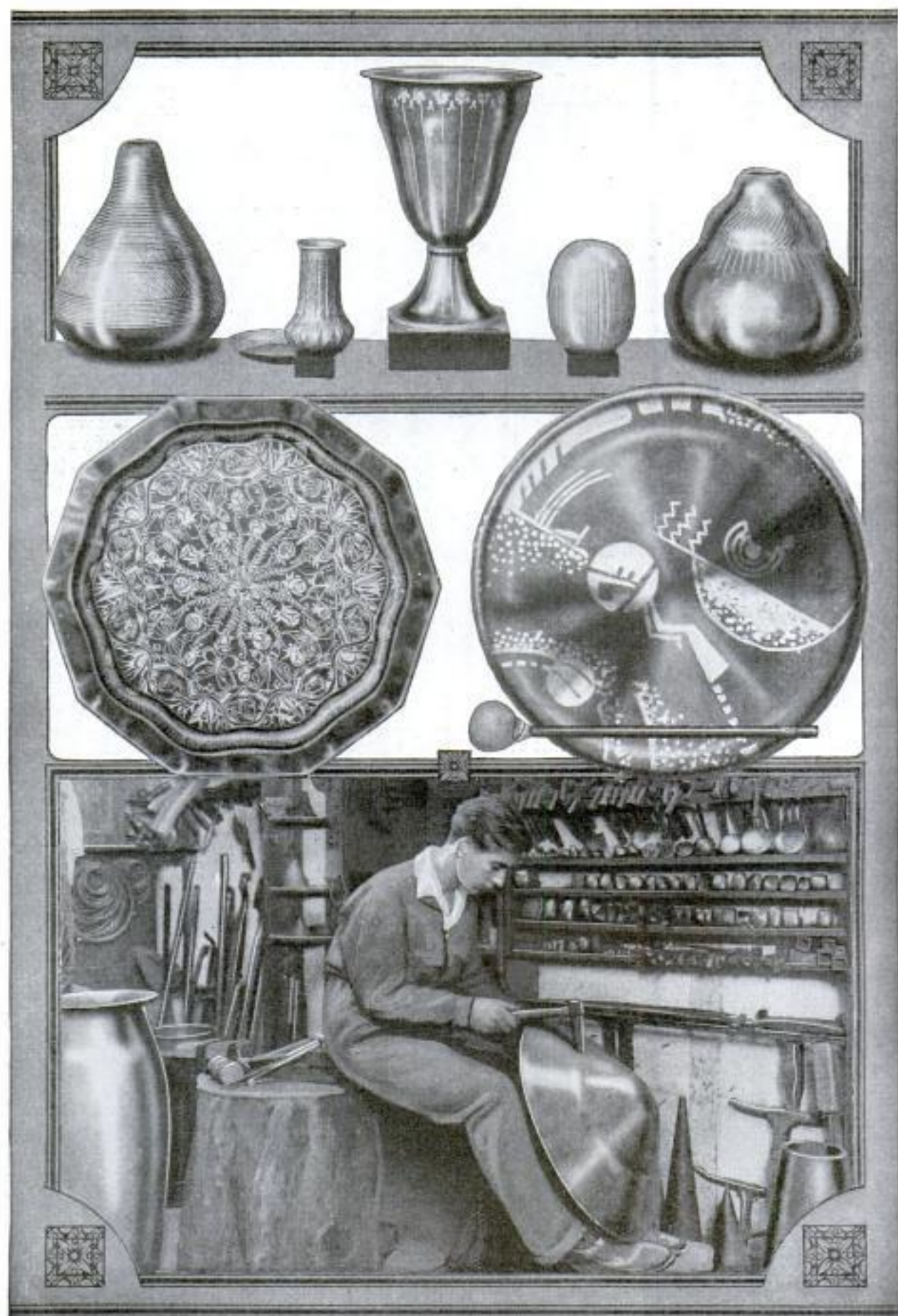

Shaping a Flat Disk; Above: Plates and Bowls, Samples of the Modern Coppersmith's Art, a Combination of the Antique with Up-to-Date Methods of Craftmanship

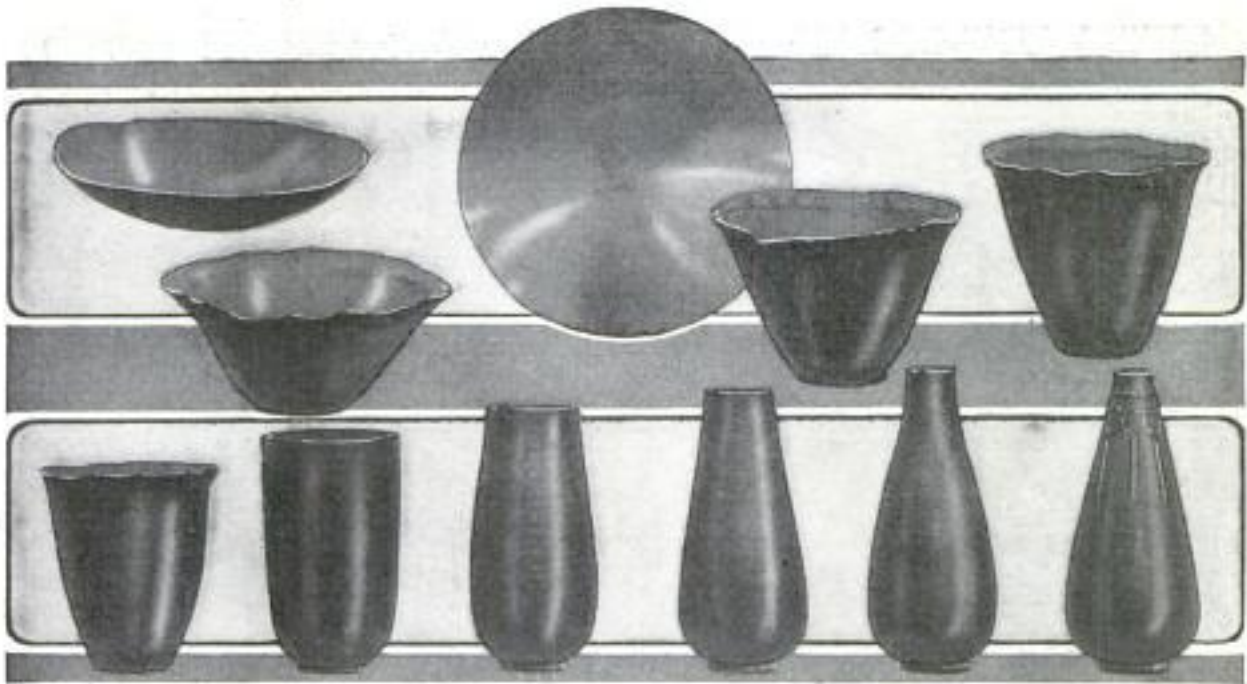

"Growth" of a Vase from a Flat Metal Disk Shown in Upper Center

hammers to give sharp outlines. Relief work is placed by tapping the surface with a sharp steel bar to raise small dents on the sides of the bowl or vase. This work requires great skill with the hammers, as too much force will spoil the outlines and make the indentations too deep. Engraving tools of various kinds, files, chisels and gauges are employed in the final stages, and after the color design has been completed, a finish, dull or polished, is placed upon the article.

Among the objects fashioned by this artist is a helmet designed for Marshal Foch, said to be one of the finest pieces of workmanship ever made by a coppersmith. Surmounting the headpiece, visor and wreath, worked in various metals employed in branches of the armies during the world war,

is the head of a cock with brilliant crest and with glittering feathers. The art of hammered metals, little practiced where machinery has supplanted hand tools, was known to the Assyrians and Egyptians several centuries B. C., and is still commonly practiced in Tunis and Algiers. In modern countries, it is little known except

where highly trained workmen, with patience, follow the exacting requirements of the craft.

Copper tools and utensils found in Egypt show that the metal was used before the pyramids. Some of the oldest objects were colored, an enamel background being applied over the entire surface before the designs were painted. A threatened shortage of the metal, experts believe, may be averted with the development of radio.



Heating the Metal with Torch Flame to Soften It

SHIPS UNLOADED THROUGH TUNNELS IN HOLD



Unloading Cargo of Crushed Stone with Automatic Rigging Installed in an Old Lake Freighter: The Belt Conveyor Placed the Material where It Could Be Reached Easily

Freighters on the Great Lakes are being equipped with a recently invented unloading device that is said to result in a saving of labor and time. Two open-sided tunnels are constructed on the cargo floor of the vessel. Through these operate large, bottomless drag scrapers supported by an overhead trolley. Digging in with a

steam-shovel action, the scrapers dump the material on a conveyor belt which discharges on deck. In a recent test 2,500 tons of crushed stone were unloaded in eight hours. Greater utilization of space, economy in operation and comparatively low cost are features claimed for the system as a result of recent tests.

PAYROLL CARD SYSTEM HELPS IN AVOIDING MISTAKES

Time, expense and mistakes in computing pay of employes of a large eastern company who work on an hourly basis are saved with the use of a system of cards

that indicate the length of time a man has worked and the exact amount due. When a task is started, a card, marked in fifteen-minute intervals from 7 o'clock in the morning until 6 o'clock in the evening, is punched to show the beginning hour. Another perforation is made on quitting. This card is placed upon a master card which shows the labor prices in progression from fifteen minutes up to and including eleven hours through the perforations. For the various kinds of work, seventy master cards are used in the factory. They are kept in a handy index so that they may be found immediately.

PART No.	DATE	JOB No
		RATE \$ PER
		No. HRS.
		COST LABOR \$
7	7 ³⁰ 7 ⁴⁵	8 8 ¹⁵
8 ⁴⁵	9 9 ¹⁵ 9 ³⁰	10 10 ¹⁵ 10 ³⁰ 10 ⁴⁵
11 11 ¹⁵ 11 ³⁰ 11 ⁴⁵	12 12 ¹⁵ 12 ³⁰ 12 ⁴⁵	1 1 ¹⁵ 1 ³⁰ 1 ⁴⁵
2 2 ¹⁵ 2 ³⁰ 2 ⁴⁵	3 3 ¹⁵ 3 ³⁰	3 ⁴⁵ 4 4 ¹⁵ 4 ³⁰ 4 ⁴⁵
5 5 ¹⁵ 5 ³⁰ 5 ⁴⁵	6	

Sample Payroll Card Marked with Forty-Two Hour Divisions for the Timekeeper's Punch

Popular Mechanics Magazine does not publish the name of maker or seiler of any device described in its pages, but this information is kept on file and will be furnished free by addressing our Bureau of Information.

Federal Products Corporation
 323 Harris Ave, Providence, R. I.

80

New York Times
12/24/23

POPULAR MECHANICS

Rawlings Bros. Ltd,
95 Gloucester Road,
505
South Kensington S.W. 7,
London, England

PHONES FOUND TO BE BUSIEST
DURING MORNING HOURS

4633
Rising and falling throughout the day, the distribution of telephone calls has been likened to the pulse of a city's activities. To show these fluctuations with accuracy, a chart has been made of the amount of business handled by the exchanges in New York City. Until five o'clock in the morning the number of calls is negligible, and may be considered as zero. A slight increase sets in a little after that hour, and by six o'clock the curve begins to sweep upward, reaching its highest peak for the day at 9:30. Then follows a slow decline until 11:30, when the curve suddenly takes a sharp downward turn and falls until 12:30, the lowest level of the business day. The highest point during the afternoon is at 1:30, after which there is a steady decrease.

POCKET-SIZE GAS STOVE COOKS
MEALS FOR CAMPER 4595

For the convenience of sportsmen and campers, a tiny stove that fits into the pocket and burns gas from a small, portable tank with a supply sufficient to cook twenty-five meals for four persons, has been invented. Connection is made through a leakproof rubber tube and the stove is lighted at the turn of a cock. Danger of forest fires is largely eliminated with this arrangement, smoke and sparks are avoided, a hot fire is assured, regard-

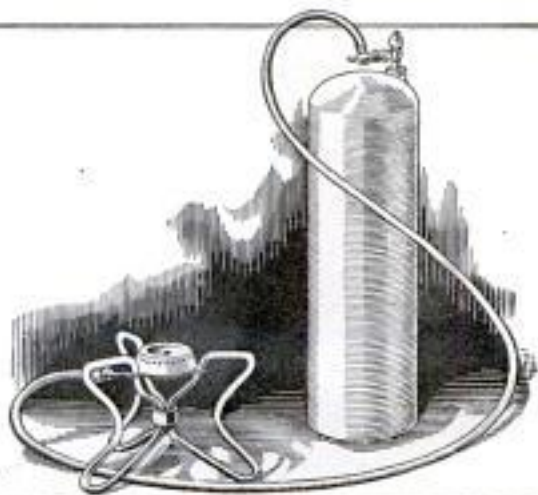

Pocket-Size Gas Stove Attached to Tank that Holds Supply for Several Meals

less of the weather, and there is no dependence on wood for fuel. At night, the gas provides a convenient light for reading, playing cards or for other purposes. The tank weighs only a few pounds. When empty, it is changed for a full one.

The Prest-O-Lite Co., Inc.
308 42nd St.
New York.

FIBER PLUG HOLDS SCREWS
SUNK IN STONE OR IRON
For holding screws firmly in stone, iron and similar materials affording no grip for the threads, a fiber plug is being manufac-



Fiber Plug to Hold Screws in Stone or Iron, and Illustration of Its Strength

tured by an English concern. Cylindrical in shape, it is inserted in a hole made by a drill and becomes a bed for the fastener, expanding against the sides of the opening as the screw enters, thus resisting any outward pull upon it. Used as an insulator in electrical work, it is said to serve in attaching wires to metal beams. It is claimed also that with it bathroom and light fixtures can be safely held in place in the most brittle compositions without danger of cracking the wall surfaces.

4641 — Unusual
BISCUITS AND RADIO IN COURSE
GIVEN ON FLOATING SCHOOL

Equipped as a model floating school, the power schooner Boxer has sailed for southeastern Alaska where the officers will undertake to teach the natives various trades, including wireless telegraphy and navigation. The voyage is being made under the direction of the United States bureau of education. One feature of the program will be instruction in modern cooking.

Christian Science
Monitor 12/24/23

Copyrighted material

U.S. Agent. The Rawlings Co. 66 W. Broadway, New York.

No price

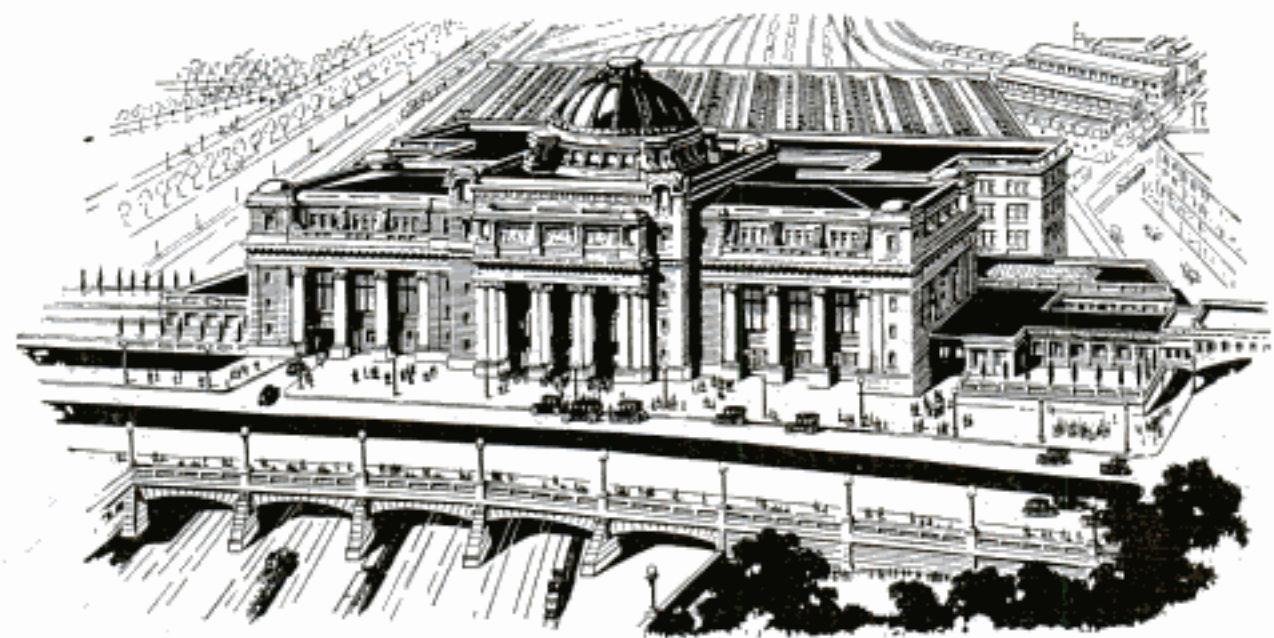

Proposed \$10,000,000 Main Passenger Station, an Important Link in the \$80,000,000 Chain of Illinois Central Railroad Improvements in Chicago

Railways' Needs Vital to the Nation

Opportunities for Young Men Declared to Be Great as Ever with Millions Being Spent for Improvements and Betterments

By C. H. MARKHAM
President, Illinois Central Railroad Company, *Chicago*
(Copyright, 1924)

IT has been well said, in effect if not in these exact words, that men do not in reality make laws; they merely discover them. To the extent that legislation is in accordance with the moral and economic principles that govern our relations one with another, such legislation is likely to be productive of good results. To the extent that legislation ignores and runs counter to these principles, it is likely to be destructive. Good laws are nothing more nor less than common sense solidified and made permanent.

The greatest need of the country in its consideration of the railway situation today is a close adherence to common sense. We hear more talk about "government ownership of railroads" than we do about the rights of private property, more about "watered stock" than about the danger in the excess of bonds over stock in present-day railway financing, more about "inflated valuation" than about the right of the railroads to earn a return upon their actual worth, more about "restrictive rates" than about the foolishness railway executives would display by advocating such rates, more about a "guaranty" than about the fact that the railroads would

have to be allowed some reasonable return under any kind of law.

Take the question of government ownership. The railroads are private property; they were conceived as private property; they grew to greatness as private property; they took their share of the country's business reverses as private property, and it is not fair, it is not common sense, that they should be denied the opportunity to get back on their feet and to serve the country as it should be served, still as private property.

If public service is to be the test of business that must be nationalized in any near-socialistic scheme of government, then the railroads undoubtedly would not be the only form of private property abolished. The railroads represent more than seven per cent of our national wealth. They are the life blood of and furnish the stimulus for agriculture and manufacturing, the value of which in 1920 was estimated as more than \$120,000,000,000. When this keystone of our industrial arch is taken into government ownership, what can be said for the future of the rest of the country's business—indeed, for the institution of private property itself?

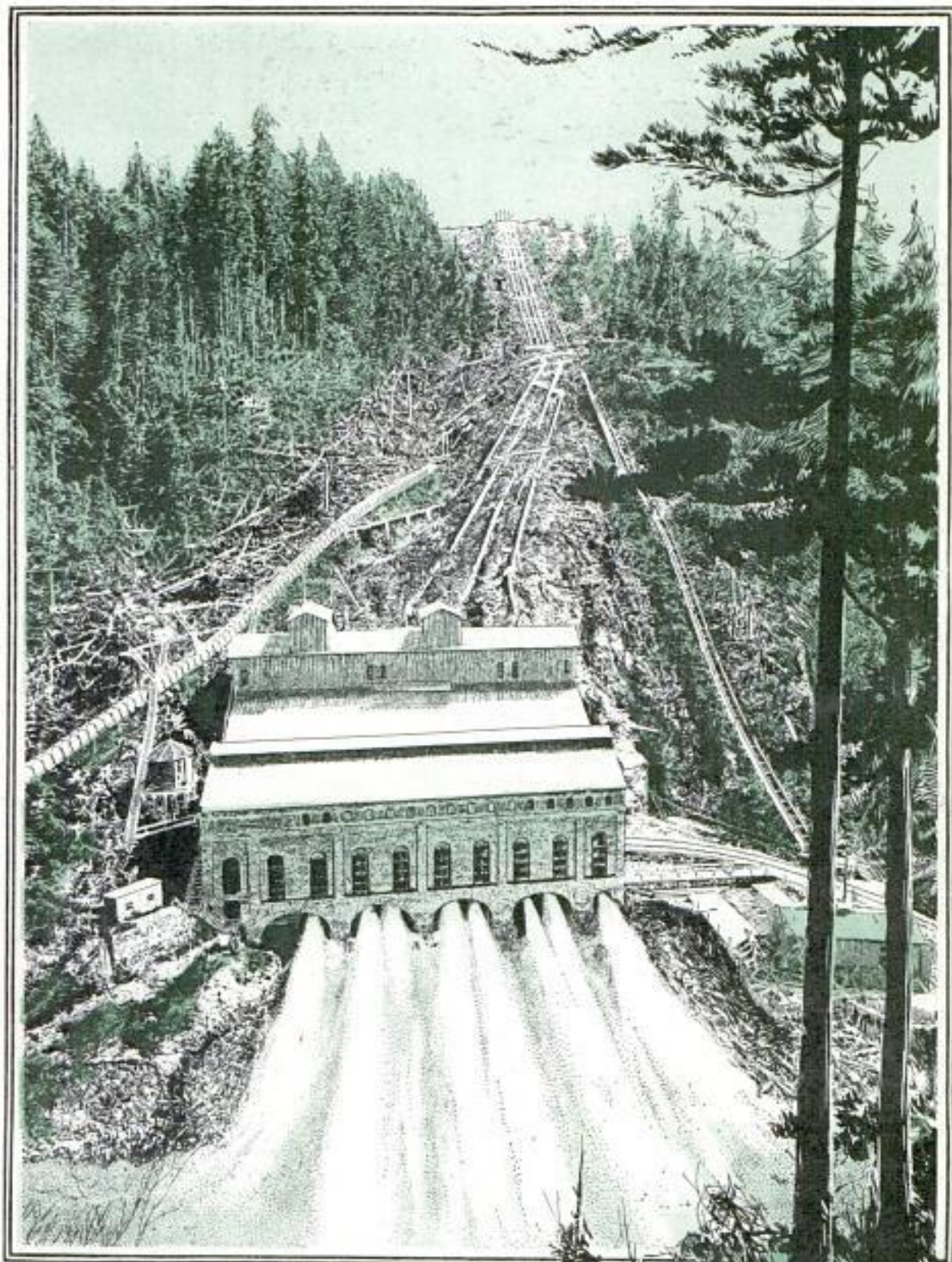

One of Many Great Hydroelectric Plants, Springing Up throughout the West, Where Melting Snows Are Harnessed to Light Cities and Turn the Wheels of Trains and of Factories; Scores of Sites like This among the Rockies Are Being Utilized as the Nation's Coal Supply Decreases

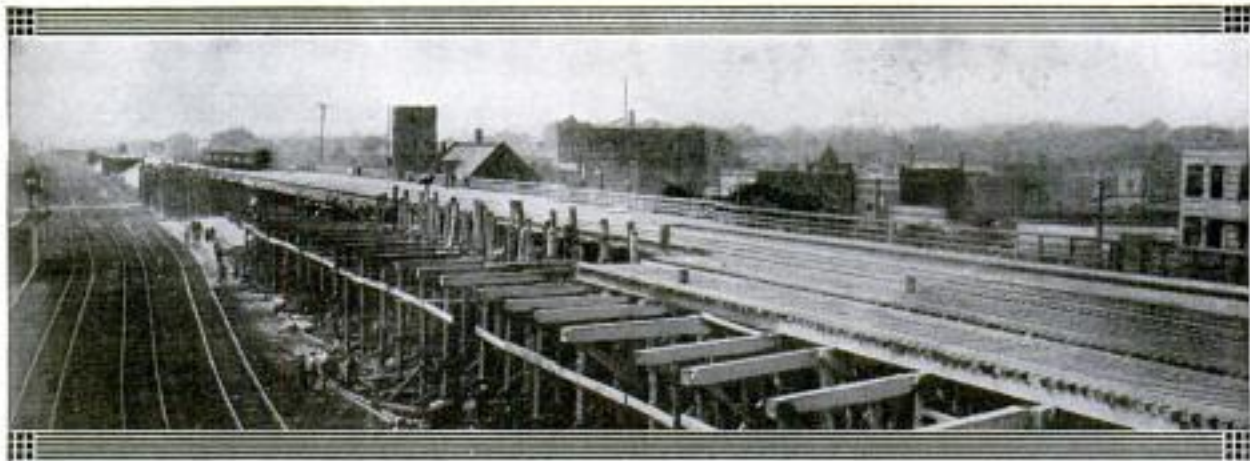

Track-Raising on Part of a Fifty-Mile Stretch to Eliminate Dangerous Grade Crossings and Insure Safety and Speedy Transportation for 300,000 Commuters Daily

In writing thus of government ownership, I advocate, strangely enough, the interest of the public as opposed to that of the present-day railway owners. Railway investors stand to lose nothing if the government takes over the railroads, since the bonds they would undoubtedly receive in return would draw a steady and a certain rate of interest, guaranteed by the credit of our nation; under government ownership, which certainly would not be accomplished by the confiscation of the value of their property, the present-day railway owners would be freed from the constant threat they now have of a reduction or disappearance of returns. Common sense tells us that the real sufferer from government ownership would be the public, not the present owners of the railroads; the rights of private property which would be invaded would be those, not of the railway owners, but of the public in general.

Common sense tells us that there is less to fear in the time-worn boggy of watered stock than there is in the fact that restricted railway earnings have made present-day railway financing almost altogether by bonds. In other words, instead of taking new partners in the business, the railway owners have been forced to mortgage their improvements as they have made them, until today more

than half of the railway investment is represented by bondholders and less than half by the holders of stock, who take the great risks of the business. This is an unhealthy condition, and the only way to remedy it is to assure adequate railway earnings in the future, which will restore railway credit and act as a magnet to draw new partners, as distinguished from new mortgagees, into the business.

But perhaps the greatest value of common sense in any discussion of the railway situation is to dispel the clouds that gather about the much-disputed matter of inflated valuation. Probably nine out of every ten persons who argue for a reduction in railway valuation by a half or a third do so in the belief that such action would promptly cut railway rates an equal proportion—that is to say, a half or a third. In 1922 about eighty-five per cent of the rates the railroads charged had to be collected by them so that they could pay their employes for their labor, the mines for their coal, their taxes, and so on. Actual

running expenses thus ate up eighty-five cents out of every dollar the railway patron paid. The fifteen cents left were sufficient to pay only a trifle more than a four per cent return upon the value of the properties, out of which interest on debts and the rentals of leased lines had

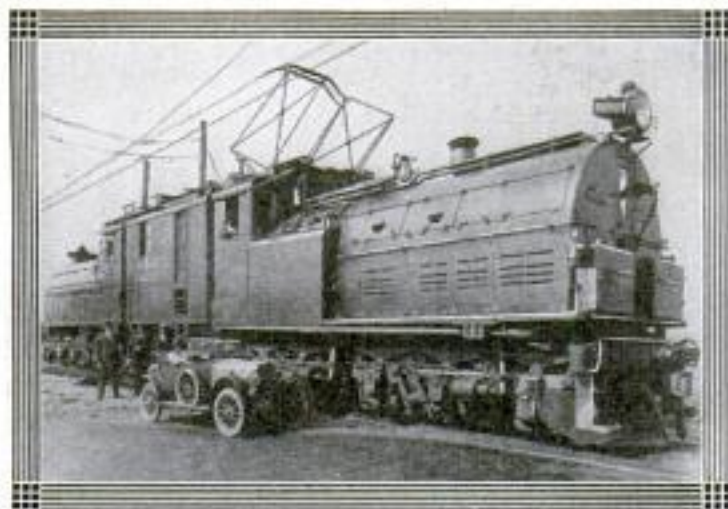

Contrasting Units of Modern Transportation: A Giant Electric Locomotive Beside a Touring Car

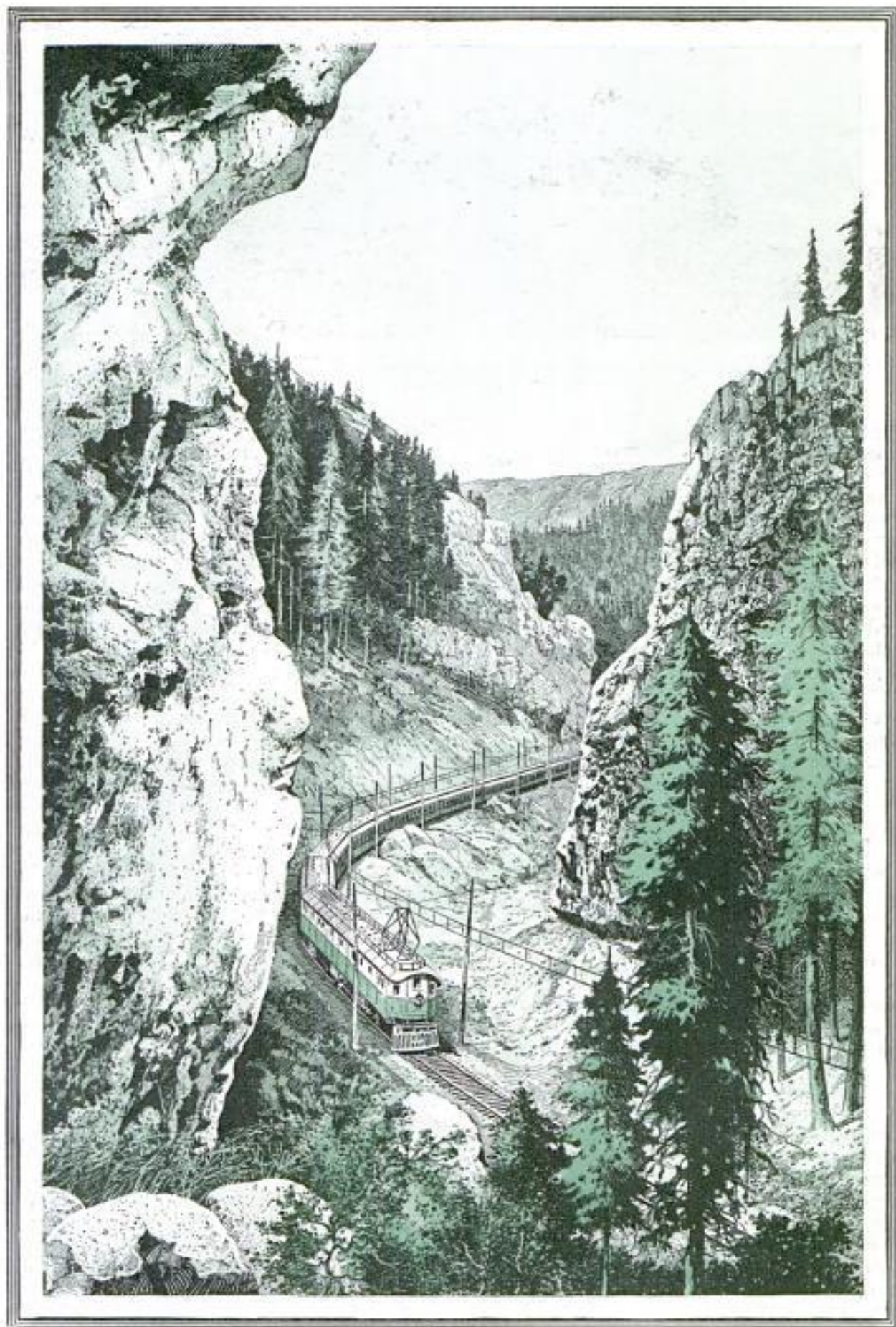

In the Towering Mountains of the West Where Huge Electric Engines Whisk Freight and Passenger Trains over 650 Continuous Miles, the Power Being Supplied Mostly by Waterfalls

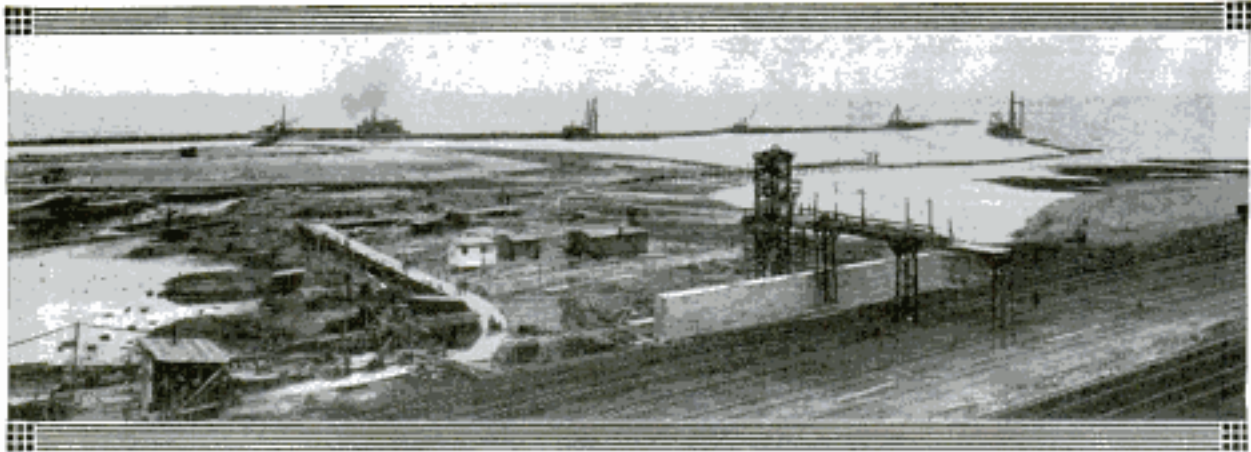

Dredging Sand from the Lake Bottom to Extend Shore Line; More than 1,500,000 Cubic Yards of Material Were Moved by the Illinois Central Railroad

to be paid before the stockholders got their share. Those fifteen cents of the dollar the railway patron paid were the only ones that could possibly have been affected by a change in valuation. If valuation had been cut a third, rates thus could have been cut one-third of fifteen cents, or five cents. This would have been a five per cent reduction, not the thirty-three and one-third per cent reduction which so many would have looked for who so mistakenly argued for reduction of a third in valuation.

Reviving railway credit made it possible for the railroads to put more than \$1,700,000,000 into their properties in 1922 and 1923. The railroad with which I am connected, in the last twelve years has expended \$225,000,000 in this kind of work, and this expenditure made it possible to carry our 1922 business for \$21,341,652 less than would have been needed if we had been limited in 1922 to the facilities of 1910. Common sense has shown us that it pays to spend money to save money, and the railway patron who fully realizes the value of an efficient transportation plant undoubtedly must see the matter the same way.

But no matter how fine a railway plant we have, it will be hampered greatly in its operation if poorly manned and officered. More attention must constantly be given, I believe, to cultivating the morale of the employes and to making the work attractive to the best of our coming young men. The higher railway positions must be allowed to pay well if we are to keep our capable railway officials in railroading and if we are to keep a continuing supply of new officer material coming up through the ranks. I, for one, do not believe that railroading is less attractive today than it was twenty, thirty or forty years ago.

The young man coming along today is concerned only with his future and with

what it is possible for him to do. Railway work, particularly in managerial matters, offers problems of diplomacy and of human relations which are peculiar to this age and which must be successfully solved if the progress of the railroads is to continue. I believe that our young men like difficult problems today as much as they ever did, and I believe that energy and talent will carry them as far in railroading as in any of the other lines of work open to them.

There are, of course, a great many capable men in railway management today—far too many, I believe, to allow the railroads to maintain rates that would stifle traffic. When the professional agitator of today talks about “restrictive rates” he is casting the worst kind of reflection upon the judgment of railway executives. Rates must be “just and reasonable,” as provided by law, but they must be just and reasonable to the railroads first of all, if we are to continue to have a railway plant. The minute a rate threatens to cut down traffic—and that is the real test of unreasonableness as far as the patron is concerned—you can be sure that the railway executives themselves will be the first to advocate a change in that rate.

A great deal of poor logic has been put forth as arguments about the so-called guaranty of railway earnings. A guaranty which cannot be enforced is not a guaranty. In three years under the Transportation act, which contains this so-called guaranty, the railroads of the country failed by more than a billion dollars to earn the fair return to which they are supposed to be entitled under this act. The railroads have no way to get this billion dollars from the government, and they have no expectation of asking for it—so where is the guaranty about this?

FAMINE OF CONES SENDS BIRDS FROM NORTHERN WOODS

How the season governs the action of furred and feathered creatures in constant search for food was illustrated by a shortage of pine cones, the principal fare of birds and squirrels in the sub-arctic regions, due to the extended drought, last year. Thousands appeared early much farther south than they do in normal seasons. In their wake traveled the goshawk, or Arctic owl, evidently driven to prey on the small birds because of a shortage of mice and rabbits, its normal food. Red-breasted nuthatches were observed starting from their northern haunts in August and red squirrels appeared in great numbers in Vermont, in search of the cones.

FRUIT CUTTER LIKE PLIERS STAMPS OUT DESIGNS

Scalloped edges are placed on grape fruit and orange halves for preparing

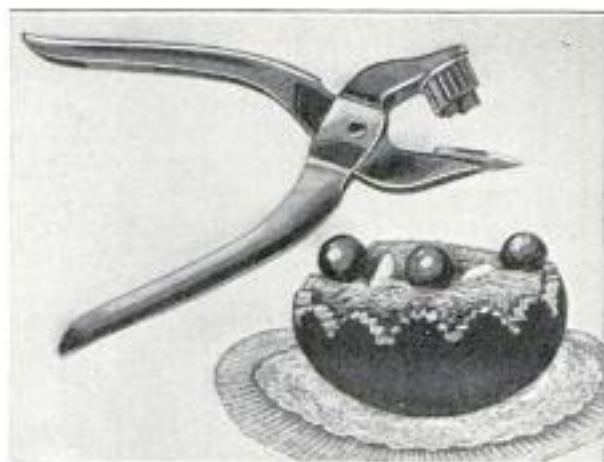

Fruit Cutter that Stamps Out Decorative Designs on Oranges and for Fancy Salads

"fancy" salads and other dishes with the aid of a pincer-shaped device. It has cutting blades shaped to stamp out a design with the precision of a die, and the leverage afforded by the spring handles makes the task easy. Fruit skins can be cut into basket handles and other fancy patterns that only a skilled person could achieve with an ordinary knife. It is made of durable metal, nickel plated, and the blades are strongly riveted to the handles.

Marshall Field & Co.

Nearly 700,000 spiders would be required to produce a pound of web, according to estimates of scientists who have experimented with the substance as a substitute for silk. A single spider has been known to spin a thread 34,800 yards long.

STICK OF UMBRELLA AT ANGLE HOLDS TOP LEVEL IN RAIN

So the top of an umbrella can be kept level when raised in rains, a French concern has designed one having the handle



Umbrella with Handle at Angle to Keep Top Straight and Protect Carrier's Back

at an angle with the frame. During downpours the canopy of the article can be held centered over the carrier's body, equally protecting all sides. When the stick is rested over the shoulder, the cover does not tilt up in front and allow water to drip on the user. The arrangement is also said to give greater protection to the back of the owner.

OIL KEPT FROM SPARK PLUGS BY SHIELD OVER POINTS

To prevent oil fouling spark plugs, a metal shield that fits about the porcelain jacket within the plug and bends under the center electrode has been devised. It is attached by shaping two "ears" at the top to fit the curve of the jacket, and has a slot which slips over the ground electrode.

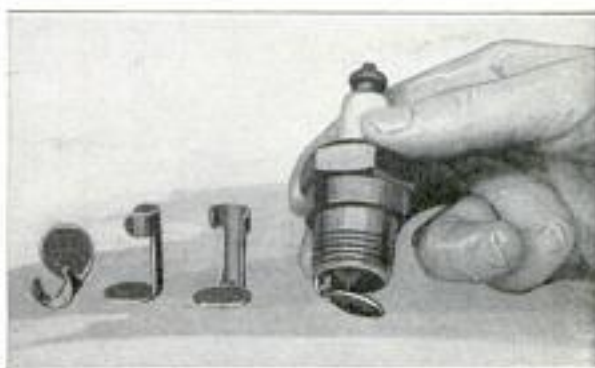

Spark Plug and Shield Designed to Prevent the Collection of Oil and Carbon

A broad extension bent up at the bottom acts as sort of an umbrella, to keep the oil spray from collecting.

*Red Eagle Products Co.,
Singer Bldg. New York*

Literary Digest 8/7/23

Used in Suction Room,
 Kingston Ave. Hospital,
 Brooklyn, N.Y.

512

POPULAR MECHANICS

4387 **ELECTRIC PUMP AIDS DIPHTHERIA VICTIMS**



Small Electric Pump for Cleaning Out the Throats of Those Afflicted with Diphtheria and which is Credited with Saving Many Lives as Well as Relieving Intense Pain

Persons stricken with diphtheria are being relieved of its resulting painfulness by means of a small electrically operated pump which draws from the patient's throat the false membrane produced by inflammation. The instrument is credited

with having saved many lives that otherwise would have succumbed to this contagious disease. The victim is stretched at full length on his back, while the operator manipulates the tiny device. It may also prevent poisons from entering the system.

4605 **TELEPHONE BRACKET ON SLIDE FITS HEIGHT OF USER**

To fit the height of anyone using the telephone, a bracket has been devised by a western inventor that slides in a slot fixed to the wall. The instrument can be moved to almost any distance from the floor so

that a person may stand or sit while talking. In case the receiver has to be set down before the call has been finished, it may be placed on a shelf that will lock in any of three different positions. When not needed, this ledge can be folded out of the way. The holder is said to eliminate much of the vibration and to give greater distinctness to the voice.

4673 **TESTS BY TIME AND FORCE AID SEARCH FOR BETTER HOMES**

In testing building materials for strength, durability, and resistance to wear, the government bureau of standards uses huge pressing machines to crush concrete columns and steel beams by applying tremendous force to their ends. To learn the ability of hollow tiles to prevent passage of heat and cold, sections of walls are constructed of the material between a room artificially chilled and a warm chamber. Soundproofing substances are submitted to a trial by filling an opening in a thick wall with a section made of the matter. Noises are directed at the spot

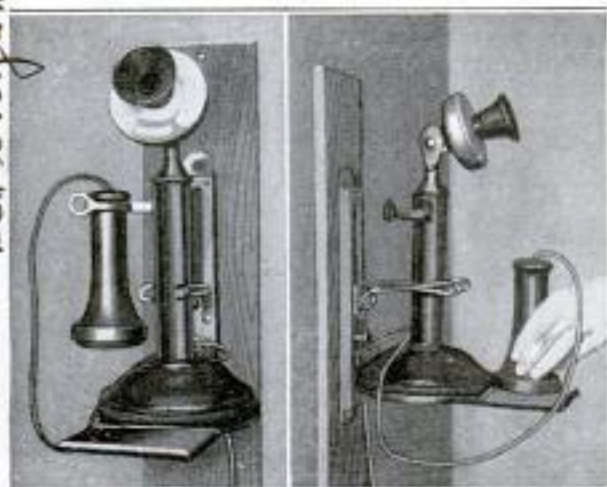

Sliding Telephone Bracket with Folding Shelf that Fits the Height of the User

Dr. J. J. Moss Chicago, Ill.
 3406 Leavitt St.

Business
 January 1924
 copyrighted material

POPULAR MECHANICS *513*

*Dr. L. P. Barlow
40 Brown Hoisting Machinery
4403 St. Clair Ave. Cleveland, O.*

and delicate instruments on the other side record any volume of sound that gets through. It has been found by the experimenters that a coating of aluminum or bronze paint applied to a surface will reduce the amount of heat radiating from it. In testing metal beams for structural work, a solid girder rolled from steel was proved to be equal to the ordinary article which is made up of several parts riveted together. Draperies, such as are employed for theater decorations, have been tried out for sound absorption, and interior linings for offices have been subjected to experiments to learn their worth in drowning the rattle of typewriters. More than seventy kinds of stucco are paneled on one long building, that is exposed to the weather over a period of years, to find which composition will successfully resist various climatic conditions.

4671

"ROLLER SKATES" FIT ON SLED FOR ALL-YEAR COASTER

Detachable rubber-tired wheels, like those on the latest type of roller skates, that can be fitted in a few moments into the runners of a "coaster," convert the sled into a smooth and silent running wagon for seasons when there is no snow. Steering is done by a convenient front rod which simultaneously turns the forward

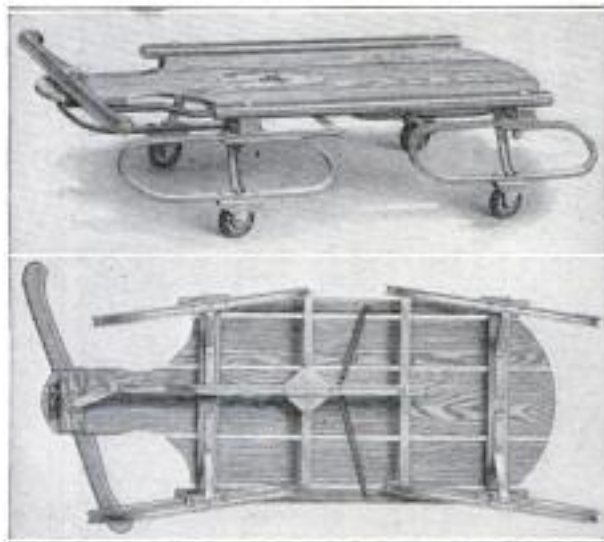

Side and Bottom Views of All-Year Coaster, Showing Rollers Attached and Steering Gear

and rear runners. Sharp corners can be managed in this way, the danger of "skidding" on steep hills is lessened and the sled is more easily controlled at high speeds. Springs and strong strips of steel are used in the gear and it is adjusted so that it cannot get "stuck." The sled weighs only fourteen pounds and is strongly built.

*Chicago Roller Skate Co.
4408 W. Lake, Chicago*

BABY STEAM GENERATOR GIVES TWO HUNDRED HORSEPOWER

4554 Although only five feet in height, a high-pressure steam generator has been built in Cleveland, Ohio, that is capable of

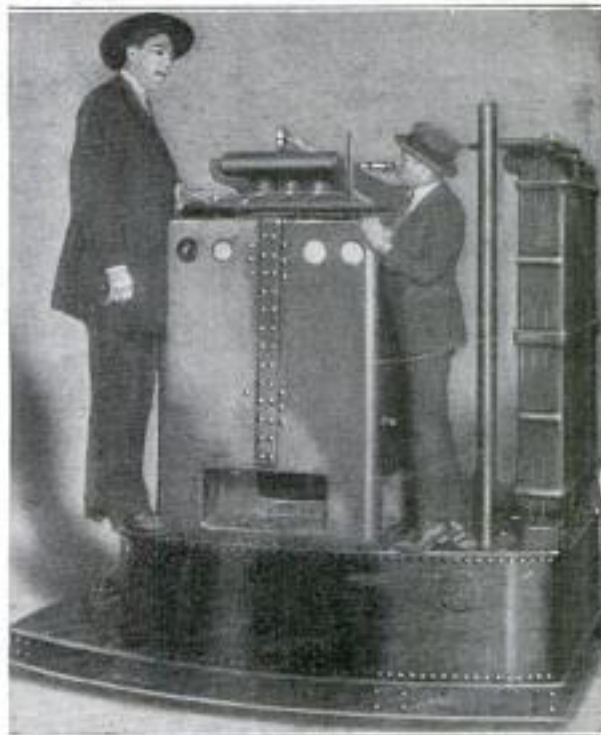

Midget, High-Pressure Steam Generator Beside Movie Giant, Who Is Eight Feet Nine Inches Tall

delivering 200 horsepower and of exerting 2,000 pounds pressure to the square inch. The military rights are controlled by the war department and a locomotive company using it is said to be making engines that are designed to run from New York to Chicago without a stop.

4630

SKELETON OF THE GIANT SLOTH FOUND IN WILDS OF BRAZIL

Petrified bones of the giant sloth, a creature now extinct, were found by Dr. Oliver C. Farrington, of the Field Museum of Natural History, after a 700-mile expedition into the interior of Brazil. The skull was discovered near a water hole, and other bones in a wall that the natives had erected to keep animals from the water. The precious fragments, for which continents had been scoured, had been fitted into the barricade in the belief that they were "just rocks." The skeleton is to be restored, the small bones, which could not be found, being molded of plaster. The sloth lived thousands of years ago. It was about ten feet long, six feet tall, and ate leaves from the lower branches of the trees by stretching out its long neck.

*Emb. Burk Williams, 50 Playhouse, Cleveland, Ohio.
New York Times 12/24/23*

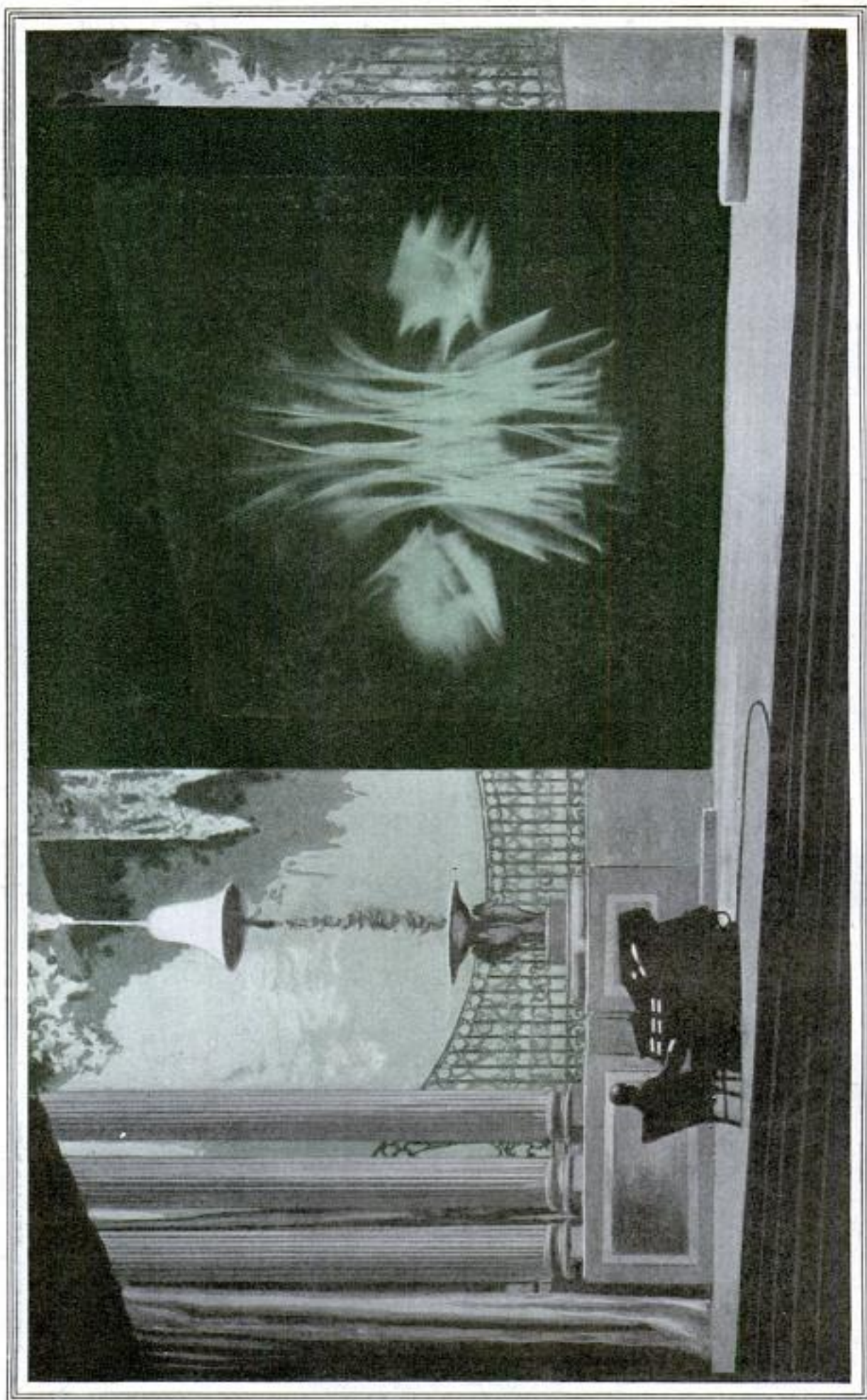

One of the Thousand or More Color Forms, Constantly Changing in Tone and in Hue, and the "Organ" with Which They Are Projected on Screen Before Audience at the Touch of an Artist upon Its Keys; the Result Has Been Hailed as the Creation of a New Art

Cont. W.C. Hardy, c/o Wide World.

Photos 128 N. Wells, Chicago

Music Is Turned Into Glowing Color

4451

Soundless Symphonies from Keys of "Organ" Projected on Screen Are Hailed as Birth of a New Art

THE audience sat in hushed and wondering expectancy within the darkened theater. Without accompaniment of sound, soft color suddenly glowed upon the screen. Slowly it moved into definite form, its modulation of figures evolving in majestic sweeps. Its hue deepened and then melted radiantly into iridescent crimson, and from the restless, ever-changing shapes a slow rhythm was born. It grew and blossomed, a symphony of light, plastic and mobile. The "clavilux," as Thomas Wilfred, the inventor, has named the organ, opens the door to a new art, the expression of moving color and form, which the artist-craftsman believes is destined to take a place as a sister of music and sculpture. It has long been the vision of dreamers; Mr. Wilfred has actualized the dream and provided the instrument that visualizes it.

The idea of the "art of light," according to the inventor, had its inception in the mystic rites of pre-historic man. The caveman, he notes, used to weave magic spells over his tribe by flourishing firebrands in weird combinations about a campfire. And in ancient China chemicals were used to make fires of striking colors at religious cer-

emonies. "Sound," he says, "was harnessed and placed at the command of a skilled player at a keyboard centuries ago.

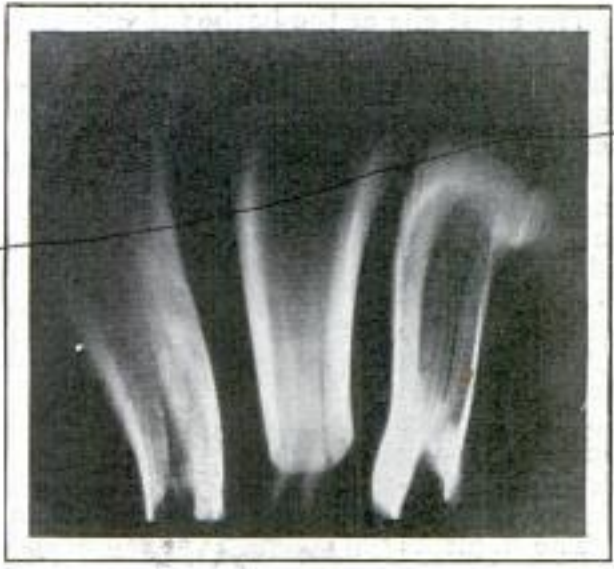

Huntington
E. C. New York

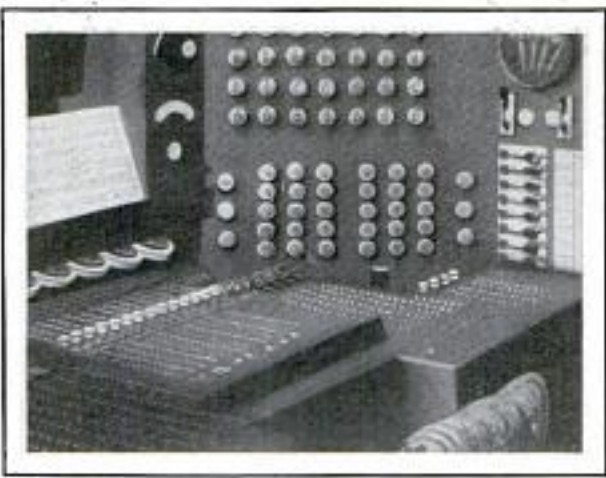

Light has had to wait for the electrical and optical developments of the last twenty years; but the young art of light has greater possibilities than any other art form, because its medium is the greatest power in the universe, the source of all life."

It was during his boyhood in Denmark that the inventor began experimenting with light, making rainbows on the walls with prisms pilfered from the chandelier. Later he learned to project light forms from a cigar box; and finally the finished product of his boyish experiments appeared in the steel instrument on which he now performs.

The clavilux has three manuals and a triple light chamber, corresponding respectively to the keyboard and wind chest of the pipe organ. Disk keys appear on the manual, moving to and from the operator and playing color and form almost as the pipe organ plays sound.

There are 100 positions for each key, making possible almost infinite combinations of color and form. The "music," or

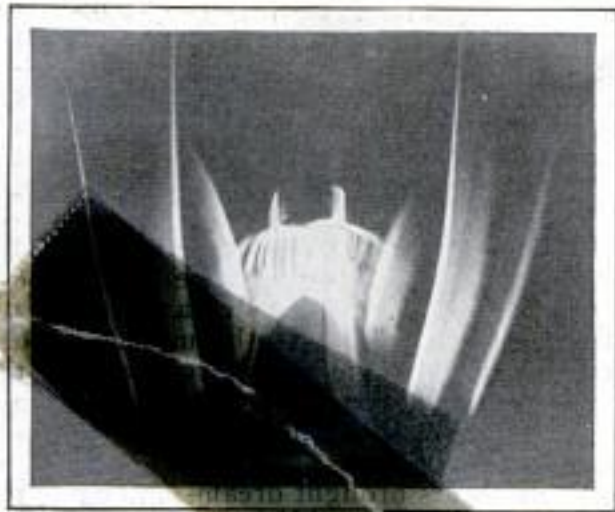

Color Combinations Produced with a "Clavilux" and a View of One Section of Its Keyboard

notation, is printed in figures upon a five-lined staff, three staves joined, as treble and bass clefs are joined for piano, to provide a "clef" for each of the three manuals. A color chord is represented by three figures; as, for example, "40-35-60"; and movement of the prescribed keys to the designated positions on the numbered scale of the keyboard produces the desired figure.

The artist sits at the keyboard with the notation book before him. He releases the light by means of switches. By playing upon the keys he projects it upon the screen, molds it into form, makes the form move and change in rhythm, introduces texture and depth, and finally injects color of perfect purity in any degree of intensity.

The light is concentrated into a beam which is projected through a form-producing device for depth and texture, then filtered through colored screens. And then in a darkened hall, through the three-dimensional projection of the "color organ," the light pours from lenses at the back of the instrument and the flat white screen "is made a window into space where fluid light-forms are built up in fantastic compositions. The result on seeing it for the first time is the same as if music had never existed and one were suddenly to hear the strains of a violin. What would the reaction be? The listener would say: 'Yes, this is nice, but of what use is it?' the inventor declared.

"Light music is as much an art as painting, sculpture or dancing. It can be used in the theater to intensify the emotions of the actors, or to supply what music does to the movies. Light, which is the source of all life, is a wonderful medium for artistic expression. In light compositions we aim at the abstract. We have no picture of a rose or a sunset; but, instead, the glory of the sunset, the spirit of the rose.

"I confidently predict that a few years will place 'light concerts' beside symphony concerts, the opera and the movies. And every home will have a color organ, as

every home now has a piano or a phonograph."

"The first screen of verdant jets, warming into waving sheaves, was suggestive of the coming of spring," says a critic in recording his reactions at a color recital; "and that was emphasized by the gorgeous colors of a tulip.

"The second composition took us into heaven with the imitation of an eagle's soaring, and pictured the beauties that could be viewed from its eerie height, — a fantasy in ethereal realism. The next composition was richer and more complex. The unique feature introduced here was the

the background either to light or to contrast with the form, and played upon it. It was the pomp and glory of the magnificent royal court.

"The colors bright dreams and distant visions with them, shifting and changing constantly as the artist touches the keys."



Inventor at Keyboard and a Color Symphony

**PLANT BREEDING TO INCREASE
4680 WORLD'S FOOD SUPPLY**

Selection and proper breeding of plants may increase the world's food supply more than 25 per cent, according to scientists. New kinds of growths that resist diseases of vegetation may be developed and others graded to suit various climates and conditions of the soil. Intense study and tests by actually raising and crossing the different types of crop plants, it is believed, may result in creating species heretofore undreamed of.

**DOUBLE-STRAND WHEEL CHAIN
ADDS TO AUTO TRACTION 4567**

Double strands across the tires in an automobile wheel chain of recent design are said to increase the traction and add to length of life and the strength of the device. When the wheels start to spin, one of the cross lengths is forced on top of the other, thus affording a better hold. Otherwise, they lie side by side and travel as smoothly as a single strand. The chains are attached with a safety hook on the side.

**MINNESOTA TIRE CHAIN CO.
640 W. W. Terminal Bldg.
MEALS COOKED WITHOUT FIRE
AMONG VOLCANO FIELDS 4535**

On the east shore of the Salton sea, in the Colorado desert, there is a vast field of natural mud volcanoes, spouting geysers

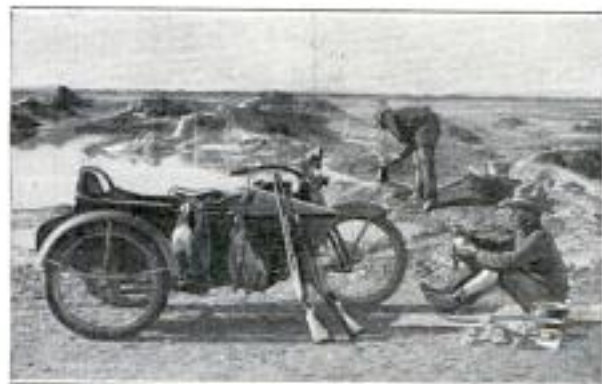

Duck Hunters Preparing a Meal in Their Camp Among the Volcano Fields near the Salton Sea

and holes in the ground, known as fumaroles, from which jets of live steam issue with terrific force. During the fall and winter months, the spot is the rendezvous of unnumbered thousands of migrant waterfowl, which makes it popular with hunters. Wood for camp fires and cooking purposes is almost totally lacking, but it is not needed as the live steam of the fumaroles supplies heat for all purposes.

Hogg's Road, 416 Union
League Bldg.
Los Angeles, Calif.

**TIES BABY BUGGY ON CANE
4642 TO REPLACE PUSH CART**

Fitted on the end of a walking stick, a small baby carriage has been invented by a father who got tired of using the ordi-



Baby Carriage Attached to End of Walking Stick that Folds Flat When Not in Use
This Agency, 152 Fleet St. E.
When not in use, the carriage folds up flat so that it can be carried readily. It runs on two wheels, the fabric being stretched over a collapsible frame.

**WATER SAVED FROM BURNT GAS
4664 IS BALLAST FOR AIRSHIP**

By condensing the exhaust gas from burning gasoline in airship engines and storing it as water in the ballast, loss in weight is prevented. This results in the saving of many thousands of dollars' worth of expensive helium gas that lifts the craft, and which otherwise would have to be released and wasted to keep the ship from rising to dangerous heights. A device for this purpose has been perfected and with its aid, the cruising radius of dirigibles is expected to be increased greatly. The weight of the water from the exhaust vapors more than equals that of the gasoline, which requires more than three times its weight in oxygen for proper combustion. More than one-third of this amount of the oxygen is formed into water to serve as ballast for the ship.

Minnesota, Minn.

London Eng.

developed by Government
Aerobautical and Scientific
Dept

Chicago

**EIGHT CARTLOADS AT ONE BITE
TAKEN BY ELECTRIC SHOVEL**

4583

Run by one man, an electric shovel has been made that will take eight dump cartloads at a bite every minute. In less than

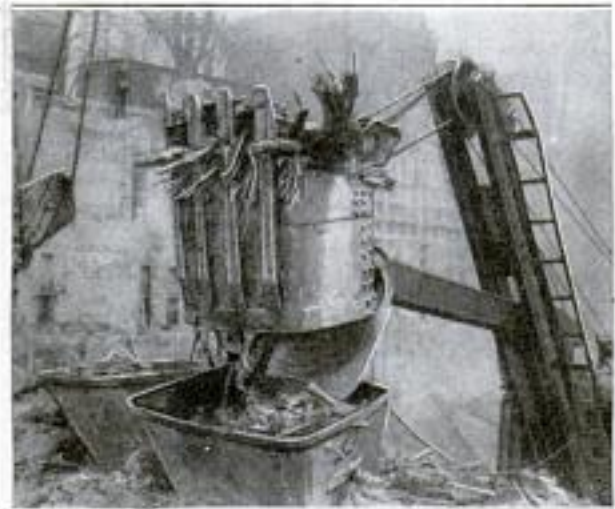

Powerful Electric Shovel that Was Victor in Struggle to Dislodge Stubborn Tree Roots

four working days it can handle material equal in cubic contents to the Washington monument. Because of the great boulders and hidden roots with which they have to contend, these shovels must be able to exert a tremendous force, and yet they are so easily controlled that an expert operator can break the crystal of a watch with the bucket without other injury to the time-piece. In deep excavations, strange objects often are uncovered. Fossils, bits of some previous civilization and even skeletons are sometimes found. Only a few months ago, a steam shovel disclosed a skeleton, presumably that of an Indian who was believed to have perished in the Fort Dearborn massacre more than a hundred years ago.

4665

**AUTOS CHANGE OSTRICH PLUME
STYLE IN WOMEN'S HATS**

Styles in women's hats are not wholly born of the whims and caprices of fashion, but often are due to the dictates of necessity, according to milliners. For instance, the single ostrich plume, it is said, is being discarded largely because women have found that its shape and beauty are damaged by the winds and storms encountered while riding in open automobiles. The large plume is, therefore, being replaced with smaller ones and with decorations woven from the feathers. In some cases, these are covered with a fine gauze-like material to prevent their being damaged. The in-

creasing number of closed cars also is said to favor the use of the smaller plumes, and several large millinery establishments report increasing sales of them. Most of the plumes are exported from South Africa, and reports from breeders there indicate that the industry, which was seriously damaged by the war, is recovering.

**GOLDEN GATE BRIDGE PLANNED
WITH TOWERS AND LIFTS**

Spanning a distance of over a mile and a half, a giant bridge planned to cross the Golden Gate at the entrance to San Francisco bay, will combine both the suspension and cantilever ideas. Steel towers rising from the rock shelves lying near shore will reach a height of 950 feet from the bottom. The roadway will be 200 feet above the water, thus permitting the passage of ocean craft having tall masts. The middle span will be almost a mile in length. It is said that the structure is to accommodate two trolley lines, an automobile passageway in each direction, and two sidewalks. Platforms are to be built at the tops of the towers for observation purposes and will be reached by elevators.

New York Times 12/30/23

**VENTILATORS IN STEEL DOORS
DO AWAY WITH TRANSOMS**

Steel doors with adjustable, built-in ventilators, to replace the usual transom,



have been designed for use in public buildings such as hotels and hospitals. The size of the opening at the top is regulated by a handle conveniently located on the inside. Drafts are avoided with this arrangement and greater privacy and safety are assured, as no entrance can be gained to the room over the top of the door. The movable

parts are tightly fitted to prevent rattling. The pressed steel surfaces are enameled, or grained to resemble wood. The invention simplifies carpenter work in building and saves the cost of glass.

The Ventilator Co.,
Bridgeport, Conn.

No information on maker

New York Times
Dec. 23, 1923

The Ventilator Co.

FLOATING ELEVATOR HANDLES CARGOES QUICKLY

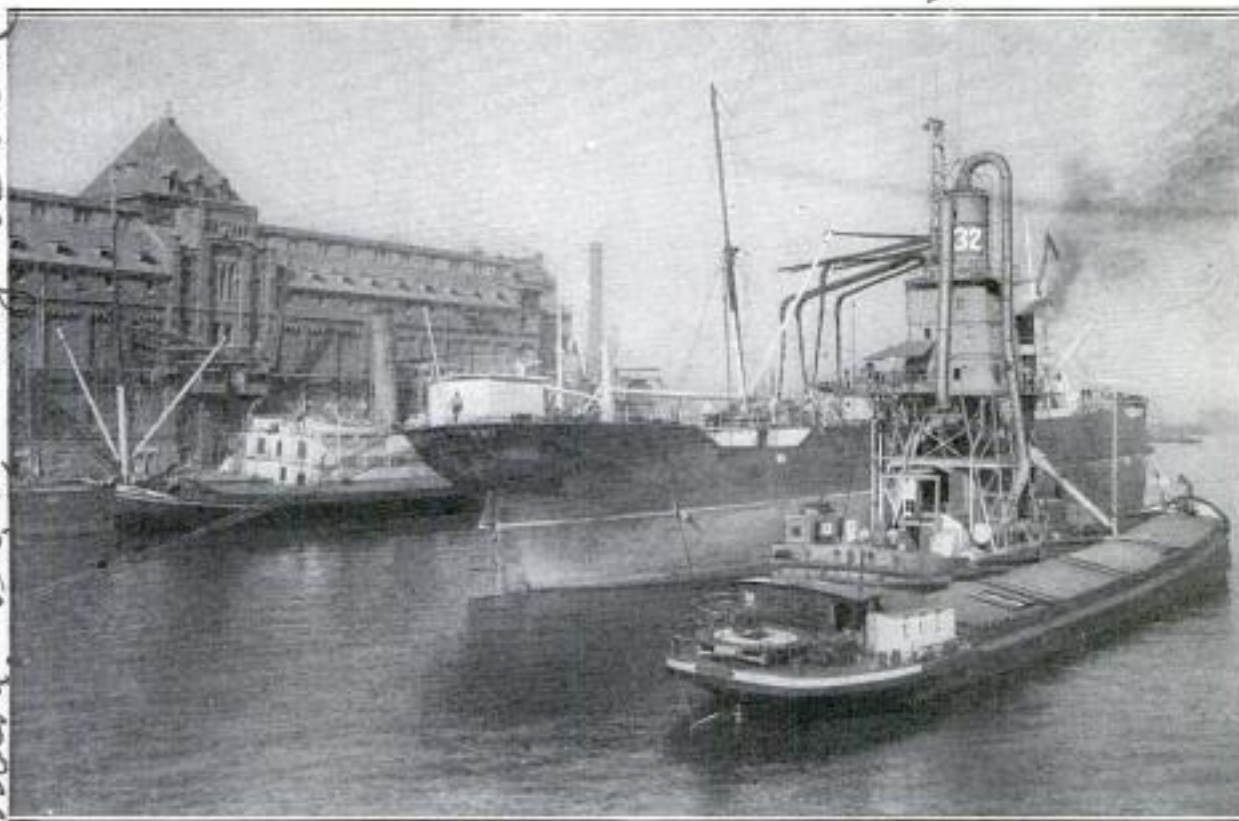

Floating Elevator for Handling the Grain Cargoes of Ships in Harbors too Shallow for Them to Approach the Docks; Suction Pumps Transfer the Wheat to Barges

To load and unload grain-carrying ships in shallow harbors of Holland, where the big boats can not approach the storage docks, seagoing elevators have been constructed that meet them in deep water to make transfers of the cargoes. Anchored alongside the steamer, the bargelike struc-

ture draws the material from the holds by means of pumps and chutes and deposits it in great bins. The operation is said to take no more time than is required by an ordinary land elevator, and the floating type can also be used for storage where necessity demands.

EXPANDING SUITCASE CARRIES SLIGHT OR BULKY LOADS

4566

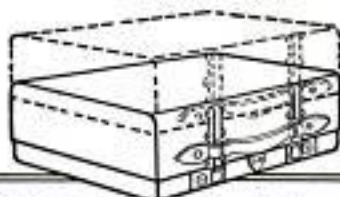

Expanding Suitcase in Enlarged and Normal Positions: Drawing Illustrates Extension Hinge Arrangement

Designed to hold loads of varying size and to eliminate the difficult task of closing the lids on tightly packed and bulging baggage, an adjustable suitcase has been put on the market by an English inventor. Its hinges are arranged so that a brass-rod extension on one is made to slip into the other as a holder. The top can be raised or lowered to fit loads of different bulk. It is locked securely when the top is pressed down firmly on the contents in the bottom. Also, it can be adapted for week-end, or longer visits, and frequently makes a trunk unnecessary.

Write our Bureau of Information, if you wish to know who makes or sells any article described in this magazine. Send no postage; the service is free.

The Revelation Expanding Suitcase Co, Ltd
 169 Piccadilly, London, W.1, Eng.

Exported by - Jiggers Ltd, Basishaw House, London, E.C.2, England
 Basinghall St.

No price

Copyrighted material

4325
520

The Isgreen Engine Co., Ltd.
166 Piccadilly, London W,
POPULAR MECHANICS
England

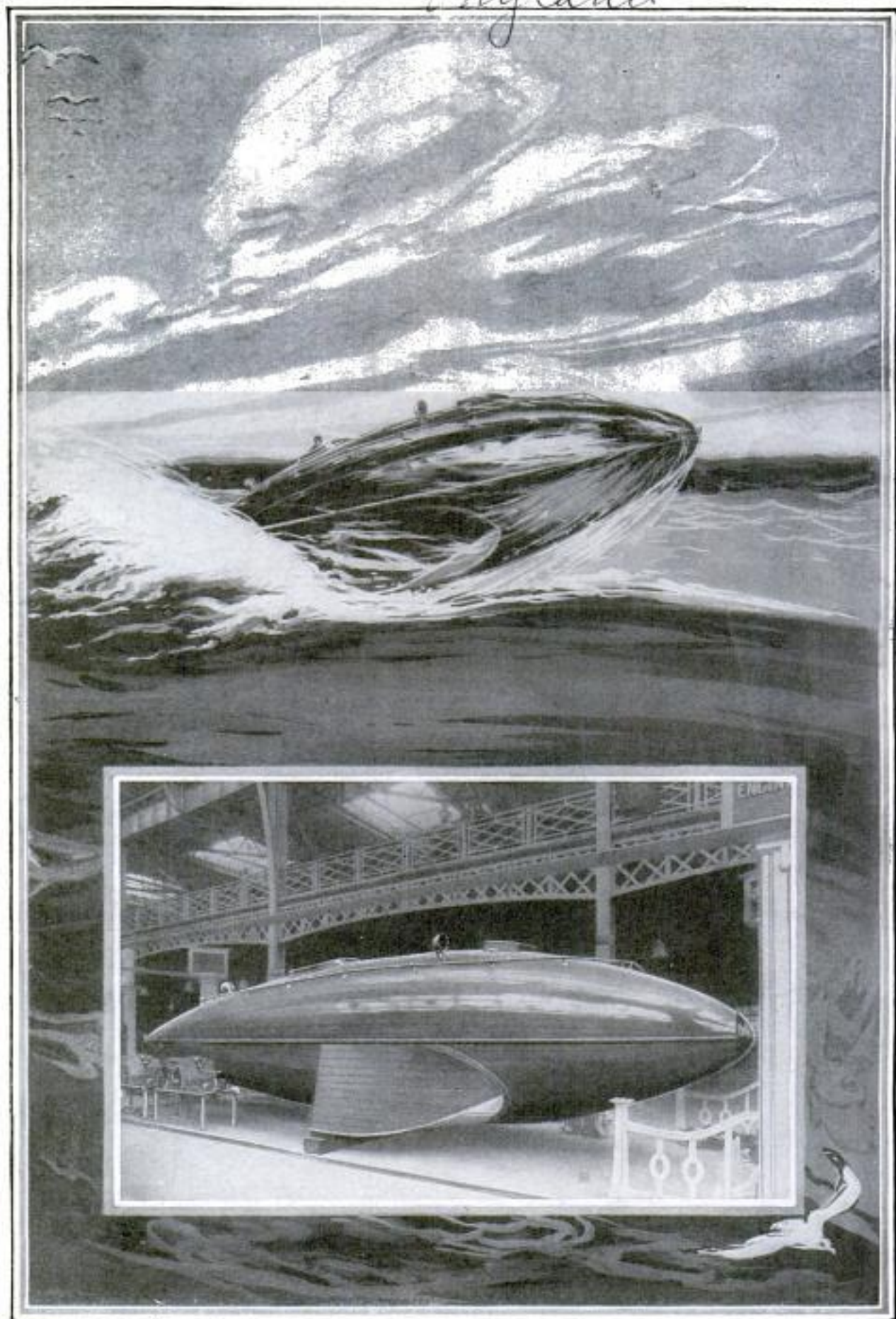

Mile-a-Minute Speed Boat that Is Built Like an Airship, the Hull Being Driven over the Waves by an Eighteen-Cylinder Gas Engine Developing over Four Hundred Horsepower

Worship

SPEED BOAT LIKE AIRSHIP TRAVELS MILE A MINUTE

To make over 60 miles an hour, a boat, shaped like the gas bag of a dirigible airship, has been patented in England. It is said that the model can be adapted to either a superspeed cruiser or a hydroplane. The hull consists of a mahogany "skin" two inches thick, built over circular steel ribs, any of which can be separately removed and renewed. When racing, the craft will be almost entirely out of the water. As its weight is less than one-third that of ordinary



View through the Hull of Speed Boat that is Built over Circular Steel Ribs and is Two Inches Thick

shells of similar sizes, the vessel can house an engine heavier and more powerful than ordinary types of power racing boats, thus making greater speed, with less resistance from the water. Energy is generated by a 450-horsepower gasoline motor of 18 cylinders. For extreme speeds detachable blades can be placed along the sides. These wings, resembling horizontal rudders, force the hull out of the water and assist it in skimming over the waves.

Personnel's work

NAVY FLIERS TO CHART FRIGID PATH TO THE NORTH POLE

Extensive preparations are being made by the United States navy for the air expedition which is to chart the north polar regions for an air route from Western Europe to Japan by way of Spitzbergen and Nome, Alaska. Two ships, six airplanes, and mooring masts for the Shenandoah, the giant dirigible, are included in the equipment. The flight is attempted, not for the purpose of making a dash to the pole, but to survey the entire arctic area, covering 1,000,000 square miles, a territory yet unexplored and, in extent, equal to nearly one-third of the United States. The expedition will go to Nome to establish a base, and to Spitzbergen, where preliminary surveys will be made. When preparations have been completed, the Shenandoah will follow, leaving Lakehurst, N. J., and sailing by stages, first to Fort Worth, Texas, thence to San Diego, California, Puget Sound, and to Nome by way of Seward and the west coast of Alaska. There the dirigible will be an-

chored to the mooring mast already erected by the vanguard of the expedition, and cruises will be made into the polar regions. The first summer's work, it is planned, will be devoted to reconnaissance and to the establishment of bases.

DEER INCREASING IN NUMBERS IN NATIONAL FORESTS

Stricter enforcement of the game laws, and better food supplies in the United States national forests, have proved so beneficial to herds of deer that it is estimated that 441,000 of the animals now make their homes within these protected boundaries. California alone has 185,000 of the animals in its national forests; Oregon is next with 57,000, Montana third with 41,000, and Idaho fourth with 39,000. In the Kaibab National Forest, of Arizona, is a herd of 20,000 deer and their numbers are annually increasing, as no hunting is allowed. Other game also has found sanctuary within the limits guarded by the rangers and wardens who keep vigilant patrols throughout the year.

Chicago Tribune 12/26/23

New York Times 12/24/23

Cont. Armstrong Perry,
 1513 O Street N.W.
 522
 Washington, D.C.
POPULAR MECHANICS
 NUMBERS ON TICKETS PREVENT
 4614 JAMS AT BUS STOPS

To keep waiting passengers in line according to the time of their arrival at automobile-bus stations in Paris during



"First-Come-First-Served" Ticket Stand on Street Rack that Prevents Motor-Bus Jams

rush-hour periods, every patron takes a numbered ticket from a rack attached to a pole. The cards are made up in pads and are perforated so they can be easily torn off. Each holder contains separate tabs for the different routes. Guards do not permit persons holding higher numbers than any one behind them to enter the coaches out of turn. This system of "first come, first served" is said to insure discipline among the crowds and to eliminate rushing for seats when the bus stops. Once aboard, the passenger discards the ticket.

NON-AGING PAINT WON'T TURN FROM WHITE TO YELLOW

Yellowing of white-enameled woodwork is expected to become a thing of the past as the result of experiments at Lehigh University in search of a process whereby paint may be made to retain its original color value for a much longer period than has heretofore been thought possible. The changes, it is stated, have been due to the pigments used. Under the new process linseed oil is bleached until it is nearly colorless before mixing it with the other ingredients. It was at first thought that the discolorations in white paint were due to

Brookhaven, Pa.

Refrigerator
 Pan Alarm Co.
 239 Eighth St. S. E.
 Washington, D.C.

the chemical changes, but the tests are said to have proved that the change resulted from the linseed oil gradually coming to the surface after the paint or enamel had dried. The bleaching process in no way works harm to the valuable properties of the oil, it is declared.

ALARM ON DRIP PAN TO KEEP WATER FROM OVERFLOWING

Damage and inconvenience caused by the overflow of drip pans underneath the refrigerator are avoided with the aid of an electric signal which fits on the side of the pan and rings automatically when the water is within an inch of the top. A float, resting on the surface and attached to the signal, is pressed upward as the basin fills from the melting ice. At a certain height, a connection is formed which starts the bell ringing to announce that the pan needs emptying. The alarm is simple to attach and does not interfere with the pan sliding under the refrigerator.



Price \$1.50

BOLT IN BARREL OF PADLOCK DEFIES ROUGH TREATMENT

Made of two solid pieces of steel, a padlock is secured with a patented bolt that slips into the casing of the lock. It is claimed that the hold is so positive that it cannot be picked or broken. By turning

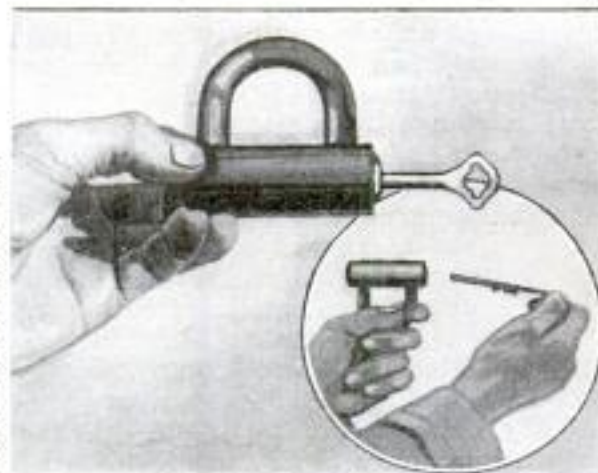

Padlock that is Locked with Bolt that is Inserted into its Solid Steel Casing

the shackle around and inserting the bolt through the end remaining in the casing, the padlock may be left open.

C. F. Asmoro Co.,
 219 W. 14th St.,
 New York City

New York Times
 1/6/24

68 C. F. Asmoro Co.

CAMERA FOR METERS TAKES PHOTO OF DIALS

Errors in reading gas, electric and water meters are largely eliminated with the use of a camera that makes photographic records of the dials from which the bills are computed, instead of the notations of readers.

tomer before them when making out monthly statements. The machine fits directly over the meter dials. Pressure on a lever exposes the film, opens and closes the shutter and turns on four electric lamps to fur-



Meter Camera Showing Shutter Lever

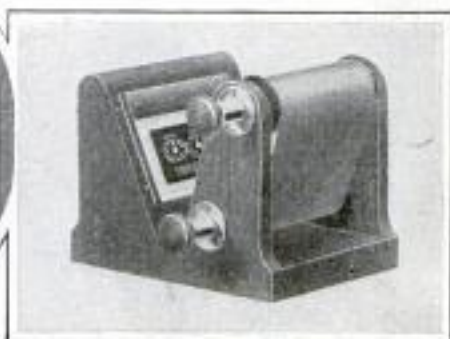

Film Spool: Left, Camera and Negative

The camera furnishes clerks with actual pictures so that they have, practically, the meter of each cus-

nish light for the picture. The current is supplied by dry batteries. Film for 225 readings can be carried.

Milwaukee
Luther Binder Co.,
235 S. Water St.

TEN-SECOND" RAZOR HONE FITS STRAIGHT OR SAFETY BLADES

Concave on one side to fit safety-razor blades and flat on the other for straight edges, a dry hone is being made to sharpen quickly and satisfactorily any kind of a razor. A gentle, sidewise movement of the blade on the surface of the sharpener, which is composed of a special abrasive material, will produce a shaving edge in ten seconds, it is said. The hone is made in convenient size and shape.



DRINKING FOUNTAIN ON FAUCET ALSO WASHES BOTTLES

Drinking from a washbowl faucet is possible with a convenient fountain attachment that slips on the ends of the hot and cold-water nozzles. It is fitted with a filter to strain the water and the bowl is so shaped that bottles are thoroughly cleansed and rinsed by inverting them over the stream that is shot from the top. Water is released into the bowl by open-

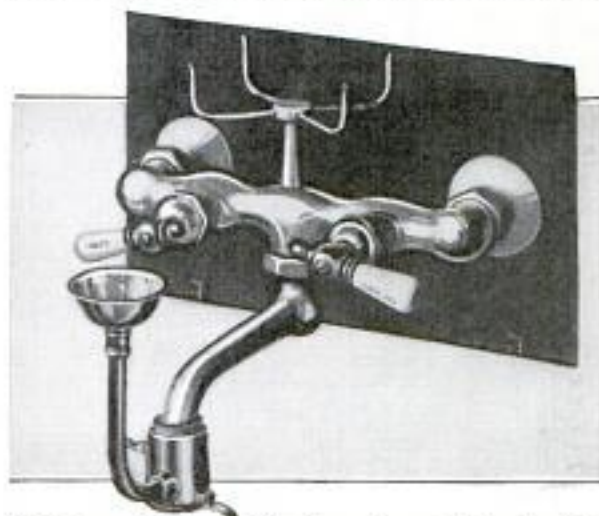

"Drinking Bubbler" Fitted on Faucet Nozzle: The Trap Release Is Seen at Bottom

LIQUID OXYGEN FOR BLASTING SUCCESSFUL IN TESTS

Cartridges of gas black and wood pulp soaked in liquid oxygen have been used successfully for blasting mine drifts, shattering a 200-ton cliff and for uprooting trees in Colorado. The tests were made by the department of the interior. The oxygen was shipped in an automobile in flasks built like thermos bottles. The cartridges were set off with instantaneous electric detonators or with cap and fuse, and no misfires occurred. Further experiments are being conducted.

ing a spring trap at the bottom of the "bubbler." The fitting is nickel-plated and adds to the attractiveness of the bathroom.

New York Times
1/6/24

Velguth Metal Parts Co.,
Milwaukee, Wis.

RAISE SUNKEN AUTO WITH TACKLE ON BARGES

28

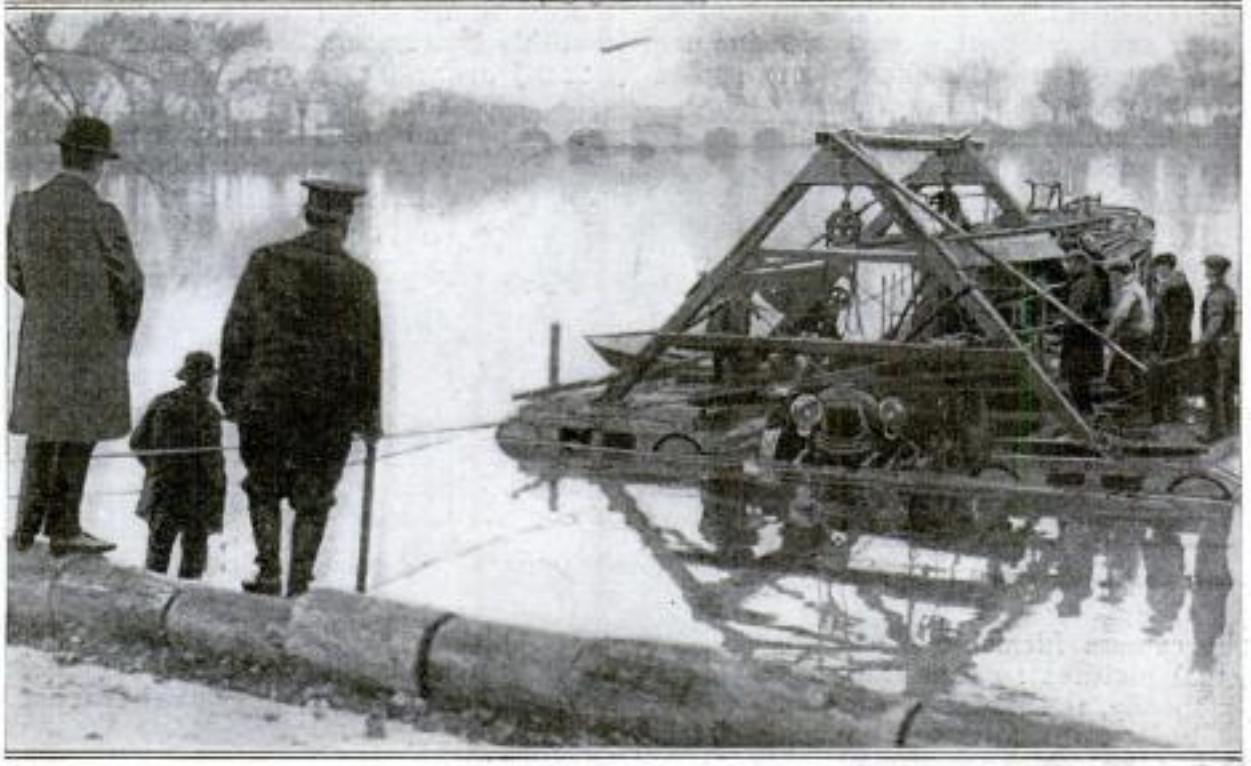

Revenue Agents Supervising the Raising of Sunken Automobile Which Was Thought to Contain Contraband Liquor; Right, Preparing to Float the Car Ashore on the Barge-Lifting Derrick

To raise an automobile which had plunged into the waters of the tidal basin in Washington, D. C., tackle was rigged to a triangular derrick anchored on two short barges. The apparatus was placed directly above the machine which was vis-

ible in the clear waters below. After chains had been attached to it with grappling hooks, the car was raised with little difficulty and was floated ashore. A small power boat was used to tow the car and the lifting machinery.

CREASER IN EACH TROUSER LEG ELIMINATES "BAGGY KNEES"

Sharp, straight creases are kept in trousers and "baggy knees" are eliminated by the use of a pair of collapsible stretchers

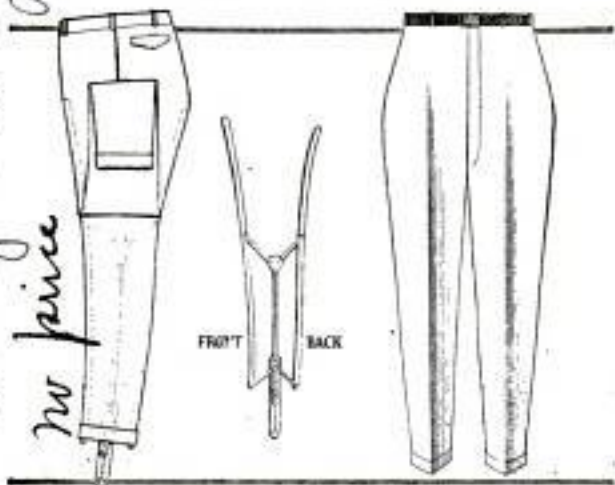

Collapsible Stretcher Fitted Inside Trousers Leg to Hold a Sharp, Smooth Crease

that fit inside each leg. The wires are shaped in front and back to fit the contour, and can be adjusted tightly or loosely as desired. They are about sixteen inches long when folded, occupy but little space in a suitcase or bag, and are adjusted in a moment's time.

PAPER USED IN PIPING WATER TO WITHSTAND PRESSURE

Paper piping for water under pressure has been designed by a French inventor who proposes to build it upon a commercial scale. The paper or light pasteboard is wound upon the shaft of a machine embodying a tank containing an adhesive substance. The last three layers are impregnated with tar, and, finally, the pipe is given a covering of bitumen. An enlarged diameter is provided at one end, into which is fitted the smaller end of the succeeding section, and the joint is wound with a strip of tarred fabric.

Joseph Hren, 211 W. Chestnut St.
 (Infr.) Kingston, N.Y.

Universal Trousers
 Creaser Co, 93 Nassau
 New York

M. Hainery



Prosperity Ahead for the Farmer

By **ARTHUR CAPPER**

United States Senator from Kansas

(Copyright, 1924)



I AM inclined to be optimistic over the future of American agriculture, despite the troubles which the business has encountered in the last four years. Conditions are improving, slowly but surely.

We are far enough along in the readjustment period so we can see the sunrise of economic hope faintly in the east. By this time next year the rays should be much brighter.

This improvement is being brought about by the operation of powerful forces which are slowly getting production in line with what the markets of the world demand. They are operating in several ways. For one thing, the number of producers is being reduced. About 650,000 folks left the farms in 1923, probably a half million in 1922, and it is believed that a half million or more will go in 1924. Please remember that there is a double action for every one who leaves; production is decreased by one unit, and one person is added to the consumer class.

Those who remain are going in more for types of production especially adapted to the locality in which they live. Especially has

there been a growth of diversified farming in the one-crop regions. Producers are getting away from the old plan of "putting all of their eggs in one basket." In the great wheat-growing regions of central Kansas, for example, I found last summer a most encouraging interest in dairying, poultry raising and livestock farming in general. In some sections, along the Arkansas river, for instance, farmers are turning their attention more and more to truck farming, which has been fairly profitable in many communities. All this is



an indication of the effort producers are making to bring their production in line with the requirements of the city trade.

Along with this is the same intelligent effort to adopt selling methods which are modern, and more satisfactory than the old "dumping" plans of the past. The growth of co-operative commodity marketing is one of the most encouraging items in the economic progress of American agriculture. Producers are working together to handle their products in a way they have never done before, especially in tobacco, cotton, wool and with California fruits. I think the effort which is now being made to organize the wheat farmers is a movement that has much promise of success, and that it will in time get the production of our great bread crop on a profitable basis.

I mention these things to show that the producers are trying to place their house in order. Other factors have helped, including Congress, which has passed some legislation, especially along rural credit and marketing lines, which will aid greatly in the fight toward prosperity. Another thing that will help



will be the growth of a powerful industrial life in America, which will increase the home demands for food. I am very optimistic over the future of the industrial life of this country. I believe it will continue to develop, aided by the intelligence and the ambition of the workingmen, and the extraordinary use of machinery, into a prosperity we have never before known. This is of vast importance to farmers, for the city workers who have money can always be depended on

to buy an ample supply of food of good quality.

The main thing for a man who is thinking of taking up agriculture as a vocation to consider is the long-range view of the business. He should enter it with a knowledge of the tendencies of the times, especially those of intelligent production, adapted to the section in which one lives, and co-operative commodity marketing. The man, or woman, who likes the life of the open fields, and who goes into the business of farming with his mind full of hope and a vision of what the coming days will bring is likely to succeed. And he probably will live a more satisfactory life, and raise happier children, than ever would be possible in an overcrowded city.

It seems to me that the opportunity for a better home life is one of the great advantages of the coun-



try. The surroundings of the rural home are more likely to be wholesome than those in the city. At least one has more of an opportunity to control them.

If a man has an ambition to live in the country a big thing to consider is the need for caution in locating. Take plenty of time, months if necessary, before deciding on either the community or the farm. Get out into the open fields, and work for some farmer who is above the average in financial success if possible. Absorb his viewpoint, and that of any of his friends you encounter.

A man who goes at the proposition slowly is likely to make the minimum number of mistakes, and to settle in a neighborhood in which he will do well financially, and live a more satisfactory life than the city can ever offer.



ELECTRIC FURNACE FOR GLASS GIVES CONTROL OF HEAT 188

Adapted to heating various metals to 1,300 degrees Centigrade, an electric furnace has been designed by a Swedish engineer. Because of an efficient system of temperature and current controls, it is said to be practical in the manufacture of uncolored window glass. The furnace was tested for six weeks in a large factory and the results are said to have been satisfactory. Gas has been used generally in the glass industry, as it develops a high temperature and is easily regulated.

BATTLE TO PREVENT ANTELOPE FROM BEING WIPED OUT 55

To prevent the threatened extinction of prong-horned antelope, a large tract of land in Oregon is to be used as a refuge. The necessity for this action is shown by recent statistics in which the number of these animals in the United States today is estimated at 22,000. In the pioneer days of the west, however, antelope were even more numerous than buffalo, numbering approximately seventy-five million.

*Chicago Tribune
2/26/23*

TWO BALLS CARVED OF WOOD INSIDE THIRD SPHERE 122

After months of effort, a wood carver has completed a ball, two and one-half inches in diameter, inside of which there is another sphere, one and seven-eighths inches wide. In the center of the latter there is a third ball. In another ball the

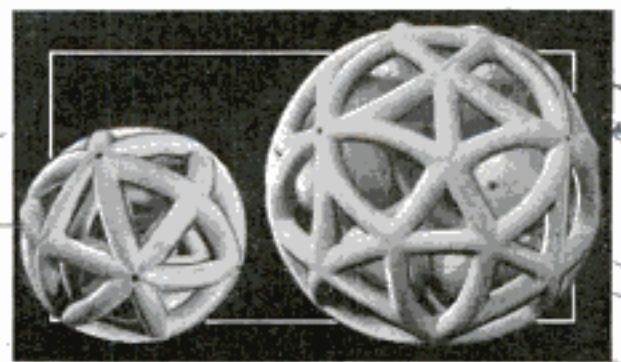

Balls Carved from Single Block of Wood with Other Spheres Inside of Them

same artist carved six smaller spheres, requiring four months to complete the task. Only a single block of wood was used in both cases.

*Samuel Karelevich
1450 71st St. New York.*



Cleaning Beautiful Statues
in Versailles Gardens
with Steam from
Hose



STEAM RESTORES BEAUTY TO FAMOUS STATUES

To clean the dirt of generations from the statues in the Gardens of Versailles, in France, and to enable experts to repair and restore them, a steam outfit, with hose and a flattened nozzle, has been employed. By this means encrusted deposits, almost as hard as the marble and bronze, were removed without injury to the surface below, bringing out, in clear relief, the beauty that

has been the pride of French rulers from the time of Louis XIII. From their pedestals, these statues have looked down on the historical events of modern times, for it was in these gardens that the storm of the revolution broke, and two treaties, one ending the Franco-Prussian War, and the other ushering in the armistice, were signed near by.

Ship's deck
**LOCOMOTIVES ARE SENT
 ACROSS SEA ON
 SHIP'S DECK** 4592

To save time and labor usually devoted to erecting new railroad engines at their destinations, a consignment of locomotives prepared for operation, were shipped by steamer from England to India recently. Huge hydraulic cranes lifted the iron monsters, intact, to the ship's deck, where they were covered for protection, and blocked against rolling by special tackle arrangements. Each was fitted with a sling designed so that it could be quickly taken from the boat. On being landed, the locomotives were put directly into service without the delay of passing through an erecting shop. This method, it is said, resulted in a great saving of material and labor that has been usually required to tear down and crate the engines and stow them in the hold.

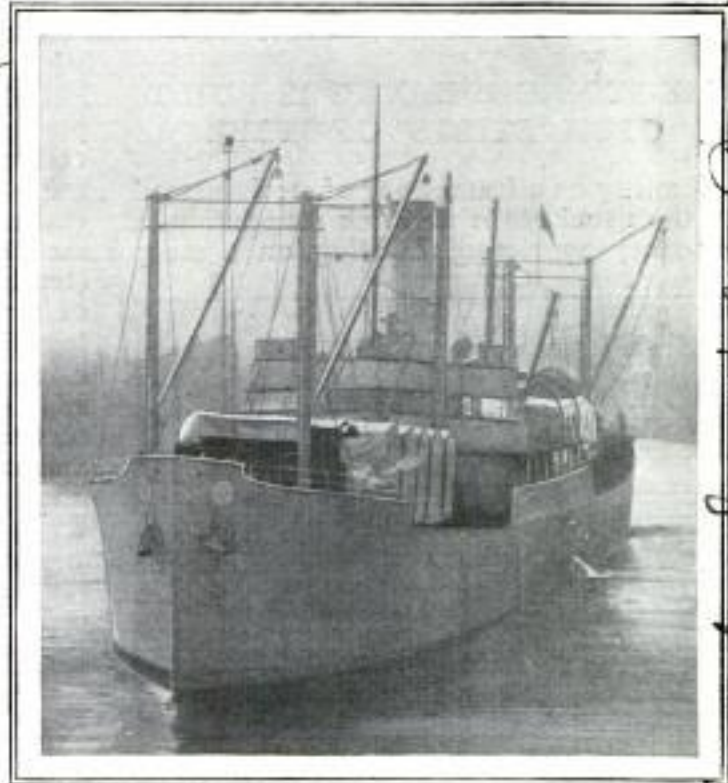

Locomotives Ready to Run, Loaded on the Deck of Steamship for Transportation Overseas

**ROLL CUTTER ON CAN OPENER
 LEAVES SMOOTH EDGES** 4667

Danger of cutting the hands in opening tin cans is eliminated by a safety opener that bends the rough edges downward as it cuts. It has a sharp, nail-like point on the end of a short steel bar that is punched through the center of the can top and is

curved to fit firmly under the tin. A grooved cutting wheel, that slides on the bar, fits over the rim of the can and slices the top as it is turned. The groove keeps the wheel from slipping off and strong leverage is easily exerted on the handle. The wheel may be reversed when the inside edge becomes dull. The cutter will fit cans of various sizes and may be used also for taking corks out of bottles.

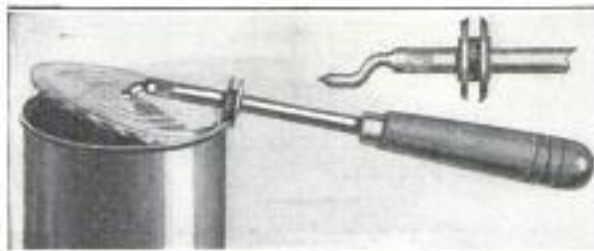

Can Opener that Eliminates All Danger of Cutting the Hands on Rough Edges

*Alaska Freezer Co,
 Winchendon Mass.*

SUGAR AIDS SOAP IN CLEANING 4483

Unusual cleansing qualities and less damage to fabrics, are claimed for a soap largely made of sugar. The manufacturer asserts that the alkali, commonly mixed with fatty oils and acids to obtain the lathering reaction, is injurious.

Serman patent

Copyrighted material

*Mechanically adapted by Sir W. G. & Co. Armbrong,
 Whitworth & Co. Ltd. London Eng.
 compressed air
 Dec. 1923*

530
4976

NEVER-ENDING PANAMA VIGIL KEEPS CANAL OPEN

Drills and dredges and numbers of workmen have been kept busy ever since the Panama Canal was opened to commercial navigation ten years ago, in removing tons of earth that occasionally slip into the passage in the steep cuts, and in widening the channel in places. To loosen the cliffs and break up the fallen material so that it can be handled easily, charges of dynamite are exploded and powerful machinery speeds the removal of debris, so that shipping will be tied up as short a

time as possible. In one slide not long ago, nearly 500,000 cubic yards of earth fell into the canal, and shortly after its completion, the passage was closed to traffic for several months until it could be safely cleared again. Dredges are kept ready for instant service, whenever the slides occur, and, while steamers ply through the channel, workers are still engaged in digging operations such as were employed in original excavations, to make the canal wider at various turns and sharp points.

SIX-STORY BUILDING IS BUILT UPON "STILTS" OF STEEL

455

Resting on a framework of steel, instead of the usual stone or brick foundation, a six-story apartment building on a steep

hillside in New York presents a unique appearance. Engineers calculated that the cost of brick or similar material, for high walls necessary on the incline would be exorbitant, and that they would be less secure than steel. Accordingly, the substructure was built on "skyscraper lines" of stout girders and cross-beams riveted together. Accustomed to seeing a tile or brick dressing over the steel skeletons that support many modern buildings, an observer gains the first impression that the apartment building's base is fragile, but it is capable of far greater strain than brick walls, engineers assert. Because of the airy space left under the lower floors, they are practically free from dampness.

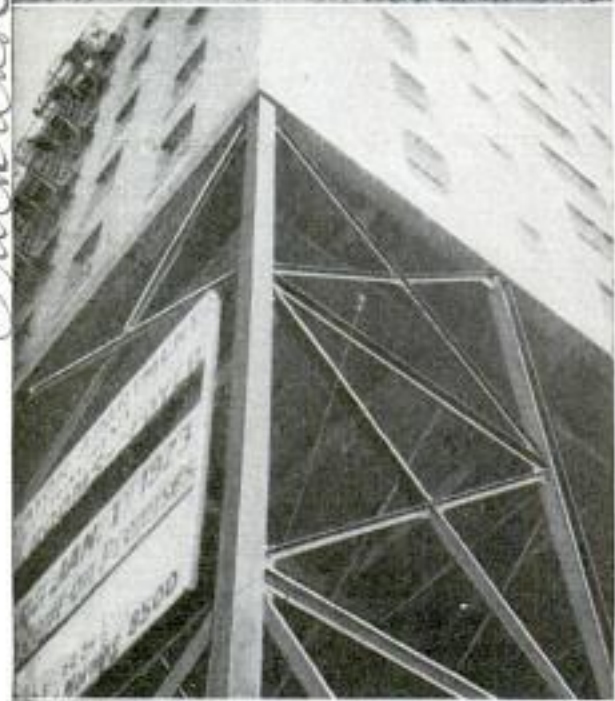

Apartment Building on Its Foundation of Braced and Riveted Strong Steel "Stilts"

SHADE HOLDER SOUNDS ALARM IF CURTAIN IS TOUCHED

4658

To keep intruders from entering windows, a bracket for shade rollers has been invented that sounds an alarm when the curtain is moved. Any disturbance causes an electric contact to be made in the mechanism of the holder which is wired to a bell. The device is said to defy efforts to prevent its action, as the slightest tampering will set it in operation. When desired, the apparatus can be put out of commission by throwing a switch.

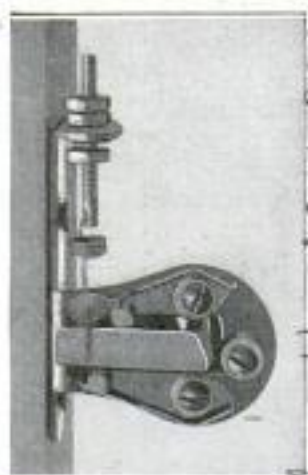

One engine per hour for thirty-one hours was the production record recently set by the Baldwin Locomotive Works.

Emb. Harold F. Blanchard,
Sucha-hoe net

W. S. ...
Harmon, 827 Maple
Bedford, Ohio.
John Hights,

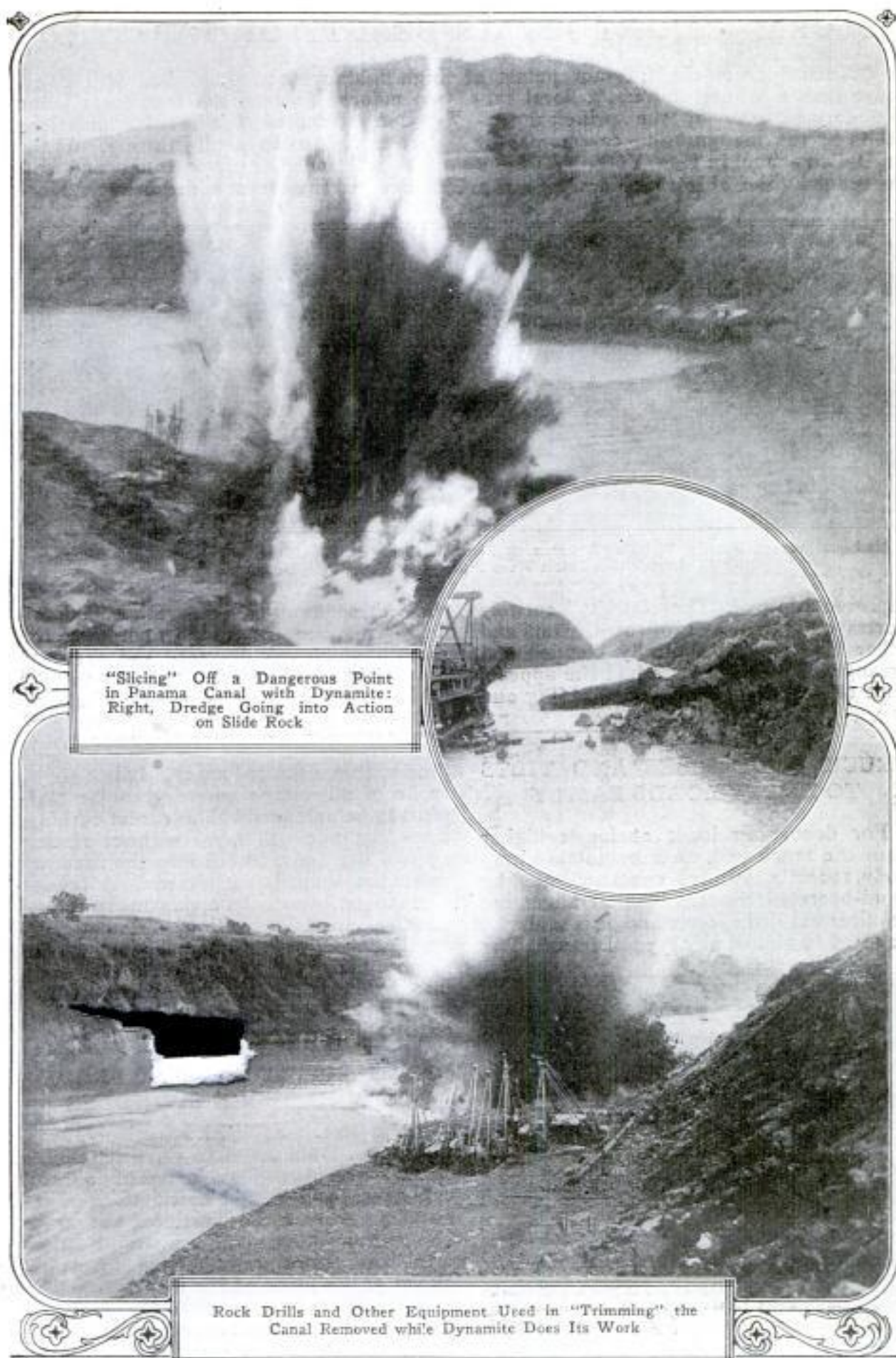

"Slicing" Off a Dangerous Point
in Panama Canal with Dynamite:
Right, Dredge Going into Action
on Slide Rock

Rock Drills and Other Equipment Used in "Trimming" the
Canal Removed while Dynamite Does Its Work

Made by *Michaele Falanga*
 223 *President St.*
 POPULAR MECHANICS
Brooklyn, NY

532

4639

FLORAL CARPET RIVAL'S BEAUTY OF TAPESTRY

"Woven" from the fragrant petals of more than a million flowers, a floral carpet formed one of the principal exhibits at the inauguration ceremonies of an Italian school in New York. Within a gorgeous border of intricate design, was a

high lights were accomplished with different colored flowers, the fragments being so deftly handled that facial expressions were as vivid as in an oil painting. As the "threads" faded, mellow tones and soft shades lent the carpet added beauty. More

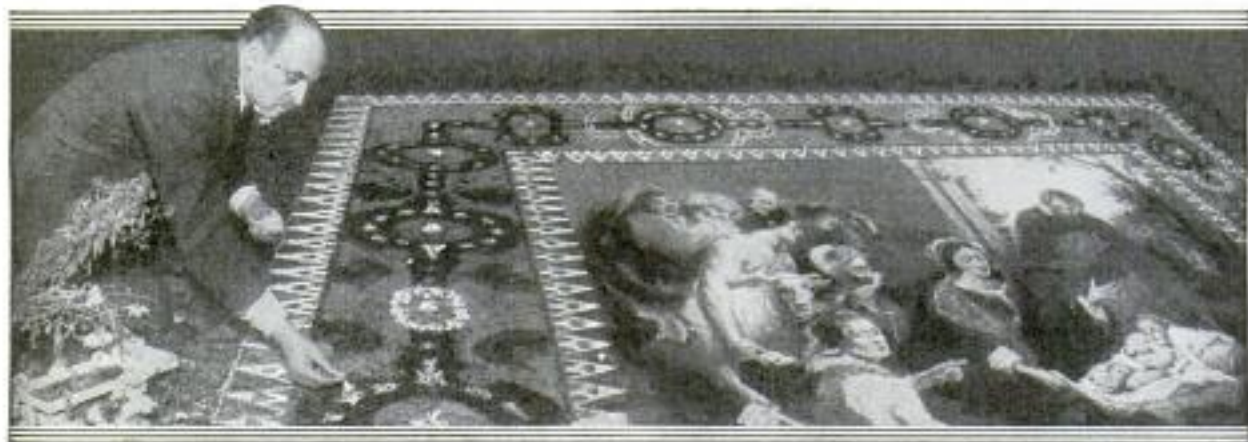

Michaele Falanga Putting Finishing Touches on Floral Carpet: At His Right Are Some of the Blossoms from Which Petals Were Picked to "Weave" the Design

representation of "The Nativity" entirely portrayed in the leaves of roses, asters and other blossoms so skillfully blended and arranged that the figures had the appearance of those on tapestries. Shading and

than three months' preparation and ten days' work were required to complete the pattern which was designed and executed by Michaele Falanga, known as the "Flower Wizard" for his artistic creations.

TRUCK BODY RISES AND TILTS TO EMPTY LOADS EASILY

For depositing loads at levels higher than the truck bed, an automobile dump body, recently invented, can be elevated by hand-operated gears. The arrangement requires but little power and, it is said, can be fitted to almost any type of frame. The

drop within a limited space. It is claimed to be of advantage where granular matter is to be unloaded behind street curbing, since the pile will form without resting against the body, to fall into the roadway when the truck is withdrawn. A release mechanism causes the apparatus to return to the normal position automatically. Sand, gravel, and similar substances can be poured directly from the elevated body into reservoirs of concrete mixers, eliminating the necessity of ~~the~~ materials in bins or heap.



Hand-Elevated Dump Hopper for Automobile Trucks that Deposits Loads on Raised Platforms

hopper may be made to extend beyond the rear of the car so that its contents will

RADIO BATTLE AGAINST FRAUDS TO END STOCK SWINDLES

Radio has been used effectively by a Cleveland, Ohio, bank to warn its clients against investments in ~~the~~ areas of doubtful value and to broadcast descriptions of securities known to be worthless and make known the methods of "fly-by-night" salesmen who fleece unsuspecting investors. Word of the plans of the men believed to be swindlers is conveyed to the company by advisors. A "talk" is prepared explaining the fraud and is concluded with the words, "Before you invest, investigate."

New York Times

12/20/23

Copyrighted material

Lee Trailer & Body Co Chicago 2343 S La Salle

COMMENT AND REVIEW

WHEN the automobile was passing the point where its possibilities for practical use first became apparent, the saturation point, beyond which few cars would be sold, was set very low. Each succeeding year the final limit of sales has been advanced until now the total number of registrations is in excess of 12,000,000 cars, which alone furnishes a permanent annual replacement market for 2,500,000 cars. These figures will, however, expand with the building of more permanent good roads, which are constantly enlarging the number who can use a car profitably. Then the natural increase in population year by year gives additional source of increased sales.

Increase in Automobiles

In another 20 years the population of the United States will probably be not far from 150,000,000, which at the present ratio would see nearly 30,000,000 cars in use, with a replacement of worn-out cars of about 6,000,000 per year. This figure will be not far from correct unless the entire country is covered with good roads by that time, or builders find a way to produce cars with a longer life than at present. When one recalls how many years elapsed before the umbrella, telegraph and telephone were adopted for general use it seems hardly possible that in only 20 years the yearly output should have grown from 21,000 to over 3,000,000 cars.

THE large harbors and navigable river mouths of this country are dotted with great ships lashed to docks or anchored singly or in groups.

The vessels which cost several billion dollars to construct are for the moment worthless for want of cargoes. No artificial means exists to restore value to these ships. They must wait the reviving influence of demand. This will be some years, during which, depreciation and improvements in construction and operation will cause irretrievable loss.

It is interesting to note the opinion of one of the world's greatest authorities on merchant marine, Sir Wescott Abell, who says: "It is all probability about 3,000,000 tons of war-built vessels, a million or more tons of normally obsolete ships, and a million tons which have become obsolete owing to recent developments, will have to be disposed of before the world's fleet is restored to efficiency."

Our own shipping board is offering steamships at ten cents on the dollar of cost. Occasionally they do manage to sell one.

World's Merchant Marine

ONCE producers are considering the question of an automatic device which will phonographically announce the words which are now flashed on the screen in printed letters. The idea is by no means new, but here and in Europe, several times during the past few years, announcement has been made of a "successful machine."

That such a device can be worked out scientific inventors admit, even though a perfect synchronism of picture and spoken text involves exact construction and operation. The effort would, naturally, increase cost of production considerably, though producers seem willing to assume this expense if it will improve their show or please their patrons.

But will it? All these years patrons have from the first been accustomed to have the necessary explanation presented in the form of printed words thrown on the screen. At present the entire action on the part of patrons is

The Speaking Screen

confined to a single sense—that of sight. To introduce spoken words means both eye and ear must be alert all the time. As the listener cannot know when the announcements are coming, he is under constant ear strain not to lose any essential explanation, lest the ear lose more or less of what is said. The printed text comes on the screen alone, the eye changing merely from picture to text. Moreover, if the reader misses part of the lines on first glance, he usually has time to reread before the message fades. Unless the spoken lines were repeated every time, and that is undesirable, he must catch all the words the first time or lose them. This constant watchfulness not to miss a word would produce a mental strain which would be fatiguing. Under these circumstances does there seem to be any real advantage in the spoken word?

DURING the previous presidential campaign, the insistence of party managers, and the natural desire of the people to look into the face and hear the voice of the two candidates, have almost compelled a candidate to tour the

*Campaigning
by
Radio*

land from ocean to ocean on a speaking trip, even when he was our President in office at the time. However satisfactory this has been to the voters, such an effort must be at great cost in health and vitality to the candidate, and in the case of one at the time occupying the highest office in our land, with a certain loss in dignity, coming

down, as it were, to the level of stump orators and candidates for ordinary town and county offices.

The radio, however, avoids this condition, and the utterance of a President from the White House carries dignity and weight, even though his utterance is really in furtherance of his own re-election. We predict that in years to come this method of appeal will be found acceptable to voters, campaign managers, and especially to the candidate himself. Besides, there is a strange, very forceful psychology, when a listener in a small remote hamlet realizes the words he hears are at the same instant being received at every other hamlet and city from the Atlantic to the Pacific, and from the Great Lakes to the Gulf, and even our possessions beyond the seas. It is a joy to be privileged to live in an age when mind and word are becoming so far reaching and universal, and which will very soon extend their utterances to the farthestmost point on our Earth.

LIKE dream fiction in a Jules Verne tale of a generation ago, the great dirigible "Dixmude" sailed away into the vast ocean of air, and, like so many mystery ships of the sea, disappeared and left little clue to the cause of its wreck. Built in greatest haste during the war by the

*"Dixmude,"
the Deadly
Dirigible*

Germans to bomb London, the craft had been pronounced by many engineers as unsafe in a gale. Investigation shows the ship went up for a short trial cruise with a small supply of gasoline aboard. Caught in a storm, which also wrecked ships at sea, it was driven this

way and that, the toy of the winds.

During the search, the fastest craft of several navies scoured the seas; while on land, airplanes, automobiles, and even camels were used in the hope of rescue. Shifting like a mirage, the airship was reported one day over the Mediterranean Sea, and the next high above the deserts of Northern Africa. But always elusive, and no message dropped to tell the weird tale of the prisoners wandering in the wilderness of space. It could neither be steered nor propelled. Even had the crew been able to descend on land the ship would have been totally wrecked, as not less than 200 experienced landing men were required to bring it safely to anchorage.

The few bodies recovered from the Mediterranean confirm the belief that it went down at sea, and some charred fragments indicate the immediate cause was due to explosion. An explosive gas was employed, but as the engines had

been idle probably for several days, the explosion might have been from a stroke of lightning. The fall was evidently from a great height, as all the limbs of the commander were broken when his body was found in the ocean. The officers and crew numbered some fifty men.

This magazine in the past has expressed its conviction that the dirigible is very limited in its uses; that by reason of its size it must always be uncontrollable in a high wind; it is costly and frail; as a vehicle of commerce it offers no promise of ever becoming a reliable, dependable medium of transportation. Nor can it ever be compared to a large ship at sea, one third of which is below the water line where a keel affords some hold. There is a dispute among sea captains as to whether the monster ocean ships are as safe in a storm as smaller vessels.

The "Dixmude" is the third dirigible accident within a short time in which great loss of life occurred.

The recent performance of the U. S. "Shenandoah," which fought a 60-mile-an-hour gale for nine hours, indicates a better performance due to better construction, partly, and probably, to a large degree, the splendid work of her officers and crew. We all, naturally, have reason to be very proud of our ship and men. The fact remains, however, that had the "Shenandoah" been sent on a highly important mission to a definite destination, which made it necessary to arrive there at a predetermined hour, she would have failed, had the destination been other than where the gale carried her. As it is, we are thankful and lucky to get the ship and her crew safely home to her hangar. The flight was an involuntary one, as the ship broke loose from her moorings at the top of a 167-foot mast. After the storm broke it was impossible to get her into the hangar.

WHEN President Coolidge recently broadcast his address on the proposed Harding Memorial, it was the first time in the world's history that the actual voice of the ruler of a vast nation was heard at the same instant by millions of his people in practically every part of its domain. The possibilities demonstrated and suggested on this occasion are almost limitless. Communities live in peace because they know each other. Our States continue in peaceful relationship for the same reason. Canada and the United States have lived side by side in perfect amity because we know each other; and, knowing, make understanding allowances.

*Talking
to
a Nation*

There are nations in Europe much smaller than many of our counties, where the people of one town cannot talk with those of another town only ten miles away. Their language is entirely different. Hence race hatreds, hundreds of years old, continue, and wars persist, chiefly for want of ability to speak with each other.

In proportion as these people become able to understand the speech of the others, they will grow to think in the same terms.

What a tremendous aid to mutual understanding, therefore, and in consequence, a mighty increase in confidence, when the President of the United States, in his office at the White House, can personally present his views on subjects of vital importance direct to millions of his own people. He has done so in the past, of course, through the daily papers, but the telephone has taught us how much more personal is the actual voice of one dear to us than a letter from the same person.

The possibilities, therefore, as the radio is improved and increased in numbers, are almost beyond comprehension at the present time.

H. H. WINDSOR

cont. Peter Esuldbrandsew, Porregade 2.
Vejele, Denmark.

536

POPULAR MECHANICS

4659

WHALE IS KILLED AFTER SEVEN-HOUR BATTLE

Surrounded by fishermen in a narrow inlet four miles from a large town in Denmark, a monster Greenland whale, which had invaded the shallow waters, fought its captors for seven hours before they finally killed it with rifle shots. Measuring fifty-five feet in length, the huge animal was

towed to shore and lifted with a powerful block and tackle. The presence of the creature was discovered when a fishing boat collided with it while putting to sea. Although pierced by many bullets, the whale put up a terrific battle, until weakened by exhaustion it died of the wounds.

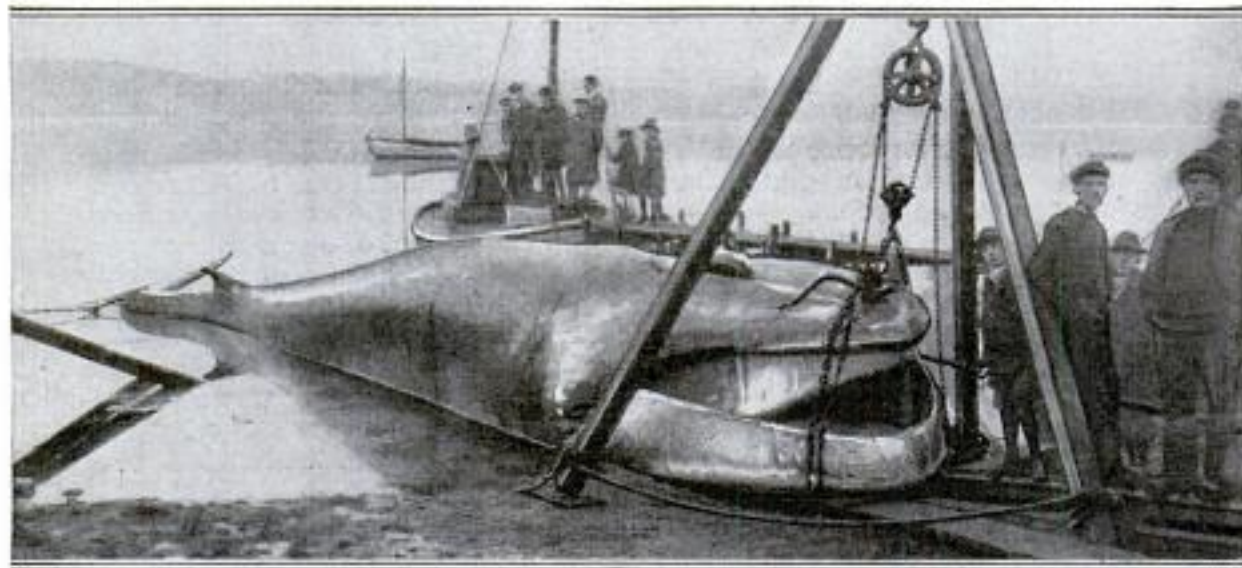

Monster Whale Killed by Fishermen after It Invaded a Narrow Inlet in Denmark

BOOKLET ATTACHED TO LETTER IS AID TO ADVERTISERS

To save postage and wrapping material and to insure attention from the person receiving it, a small three-page booklet has been designed at the lower corner of a letterhead. Space is provided for a cover

and two inside pages and, in case a larger volume is desired, more leaves can be inserted. The addition is placed so that it does not interfere with the body of a letter that can be written on the sheet. It is claimed that by its use costs are lowered, since little more labor is required to print both the top and bottom of the page.



Printed Booklet Made Part of Letter to Save Postage and Insure the Attention of the Reader

SPARROWS DEFY GAS "ATTACK" IN-WAR ON BIRD PESTS

Resisting the fumes of mustard gas, and other deadly chemicals in quantities that would have proved fatal to a human being, English sparrows and domestic pigeons survived gas "attacks" in recent tests conducted by the government to find a way to rid the country of various bird pests. The subjects were placed in tight compartments, so arranged that the observers could watch their actions. The gas was administered in varying quantities. Amounts that would have killed a soldier caused the specimens to evince little agitation, and they recovered when taken into fresh air. In all, six varieties of gas were tried but without the desired effect. The experiments emphasized the difficulties encountered in ridding the country of the English sparrow in particular.

Field Museum

Copyrighted material

Shinner + Kennedy Stationery Co.
416 N. Fourth St. St. Louis Mo.

12/17/23

**MOTOR SHIPS OUST STEAMERS
BECAUSE OF LOWER COST**

**PORTABLE BARREL LOADER AIDS
IN FILLING FREIGHT CARS**

Savings in running costs, due to decreased fuel consumption, especially on long voyages, and larger carrying capacity, because less space is required for storing oil, have caused wide adoption of motor ships in preference to steamers in new tonnage for British lines, according to an English journal. Engineers have figured that a motor ship of 9,000 tons dead weight, burns approximately twenty tons less oil per day than a steamer of the same size, thus enabling it to carry more cargo and allowing it a wider radius. The steamer's relative cargo-carrying capacity falls off rapidly on long voyages of 6,000 miles, or more, decreasing from sixteen to twenty per cent for that distance as compared to one of 1,000 miles, owing to the large storage space required for fuel. One English company sold its steamers not long ago and now owns twenty motor ships.

Saving both time and labor, a portable barrel loader has been built for filling the upper tiers of a freight car. Easily moved

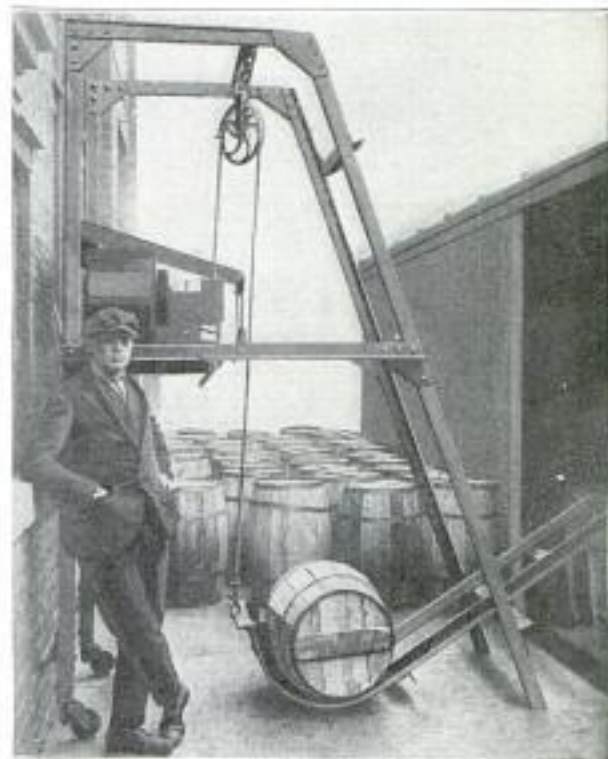

Electrically Operated Barrel Loader for More Easily Filling Upper Tiers of Freight Cars

**IRONING BOARD FOLDS ON WALL
OR BECOMES SMALL TABLE**

For use in households where space is an important consideration, and to save time, a folding ironing board that can be attached to a wall by a hinge has been patented. If its full length is needed, a pair of light wooden legs, furnished with the device, rest at an angle against the floor

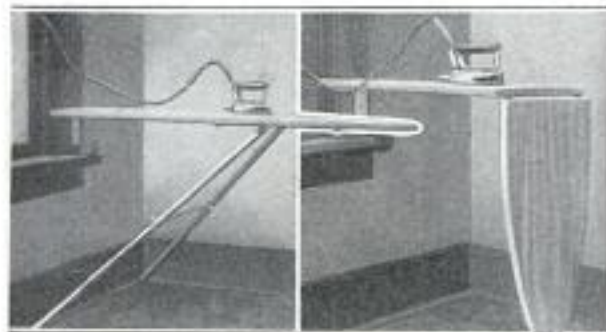

Wall Ironing Board with Folding Extension that May Be Easily Converted into a Table

at the bottom of the wall to support it. When only a small part of the board is necessary, half of its length can be dropped down, forming a table. It may be quickly detached from the hinge and placed out of the way when not in use, or it can be left to hang flat from the fastener and can be easily handled.

Approximately two-thirds of the world's inhabitants belong to the yellow, black, or brown races.

along a warehouse platform, it is operated by electricity, eliminating much of the heavy lifting usually required. Also, it is said to lessen the possibility of accidents due to the slipping of the heavy containers.

**SPRING IN AUTO TOW LINE
EASES STRAIN ON CARS**

Jerking and sudden strain are avoided in pulling automobiles by a patented tow line with a strong spring section which takes up the starting shock so that the force is applied to the car gradually. Danger of snapping the line is lowered, there is less wear on the cars and little likelihood of "killing" the engine in the forward car.



Tow Line with Spring Section that Acts as Shock Absorber When Attached to Cars

The line is easily attached by hooks on both ends to loop over the axles and it cannot slip off.

Safety Mfg. Co 1812 Walnut
St. Kansas City.
Copyrighted material
No. J

Used by Walworth Mfg. Co.
Cawnee, Ill.

4670

4653

Cawnee, Ill.



Railway Tunnel, High in the Andes, Where the Winds Are So Strong that Huge Wooden Doors Have Been Placed at the Entrance to Permit Ascending Trains to Make Headway



In Mountains of South America Where Man's Engineering Feats Have Conquered Nature's Perils

Feats of Railroading in the Andes

Marvels of Engineering Required to Span Mountains, Conquer Wilds at a Cost of \$100,000 a Mile

By PRESTON E. JAMES
University of Michigan

SOME one very aptly called the Andes a geographical tragedy. Rising to great elevations, they stretch in an unbroken barrier from the Caribbean to Cape Horn. In places their sides are drenched with tropical rains and dense vegetation clings to the precipitous slopes and clogs the narrow valleys. In places it is so dry that rain has never been known to fall and here there is no vegetation at all, only barren, wind-swept plateaus and slopes which do not support even a blade of grass or a speck of moss—such landscapes as the astronomers tell us exist in the mountains of

the moon. Amid such surroundings man is crushed by overpowering nature. His greatest feats of engineering crumble before the strength of the forces which oppose them. Against such odds it is no wonder that many of the countries in western South America have made slow progress, as their biggest problem is that of transportation. Before railroads were invented, three forms of transportation were in use. One was, and still is, the patient mule, carrying loads of from 200 to 300 pounds, and covering thirty to forty miles a day. Another is the native



Zigzagging between Towering Mountain Peaks

beast of burden, the llama, which carries only 100 pounds, and travels seldom more than ten miles a day. The third method is by Indian carriers, who can pack a load of fifty to one hundred pounds with ease and travel as much as twenty-five miles a day. But real development did not begin until the railroad made its appearance and today only those portions which are reached by steel highways show much prosperity.

The obstacles encountered by the engineers were discouraging to all but the most persevering. Many ambitious projects were begun, but only a few have been completed. At present only a single railroad actually crosses the Andes from one side to the other, and that one connects the big cities of middle Chile with the fertile pampa of Argentina. Here the mountains are not so broad as farther north, although the pass is at an elevation of 12,602 feet above sea level. Furthermore, in the south the Andes separate two prosperous nations, Argentina and Chile.

The trans-Andean railroad runs from Valparaiso, the chief seaport of Chile, to the beginning of the steeper part of the climb at Los Andes, on broad-gauge track. There the narrow-gauge begins. In the ascent several sections of rack and cog are

used, and the grade at places reaches eight per cent. On the Chilean side the snow is heavy in winter, and landslides very often block the track for months at a time. The highest point is reached at an elevation of 10,463 feet, where the train enters a tunnel and descends toward Argentina.

So strong are the winds on the western side, that large wooden doors are placed at the upper end of the tunnel, for otherwise the trains ascending from the east could scarcely make headway. Although this road still enjoys the distinction of being the only line to cross the mountains, it will not be long before several other trans-Andean railroads will be added to the list. One of these new lines will connect northern Argentina with Bolivia. A gap of 150 miles separates the two ends of the line, and construction is being actively carried on by an American company. This line will reach the highland cities of Bolivia, which are already connected by rail with ports on the Pacific coast. In addition, two other trans-Andean lines between Chile and Argentina are projected and construction on them has been started. One is in the north between the towns of Salta and Antofagasta on the Pacific; the other in the south where the mountain passes are much lower and construction much simpler.

Bolivia also is making great efforts to finance a line from Cochabamba in the

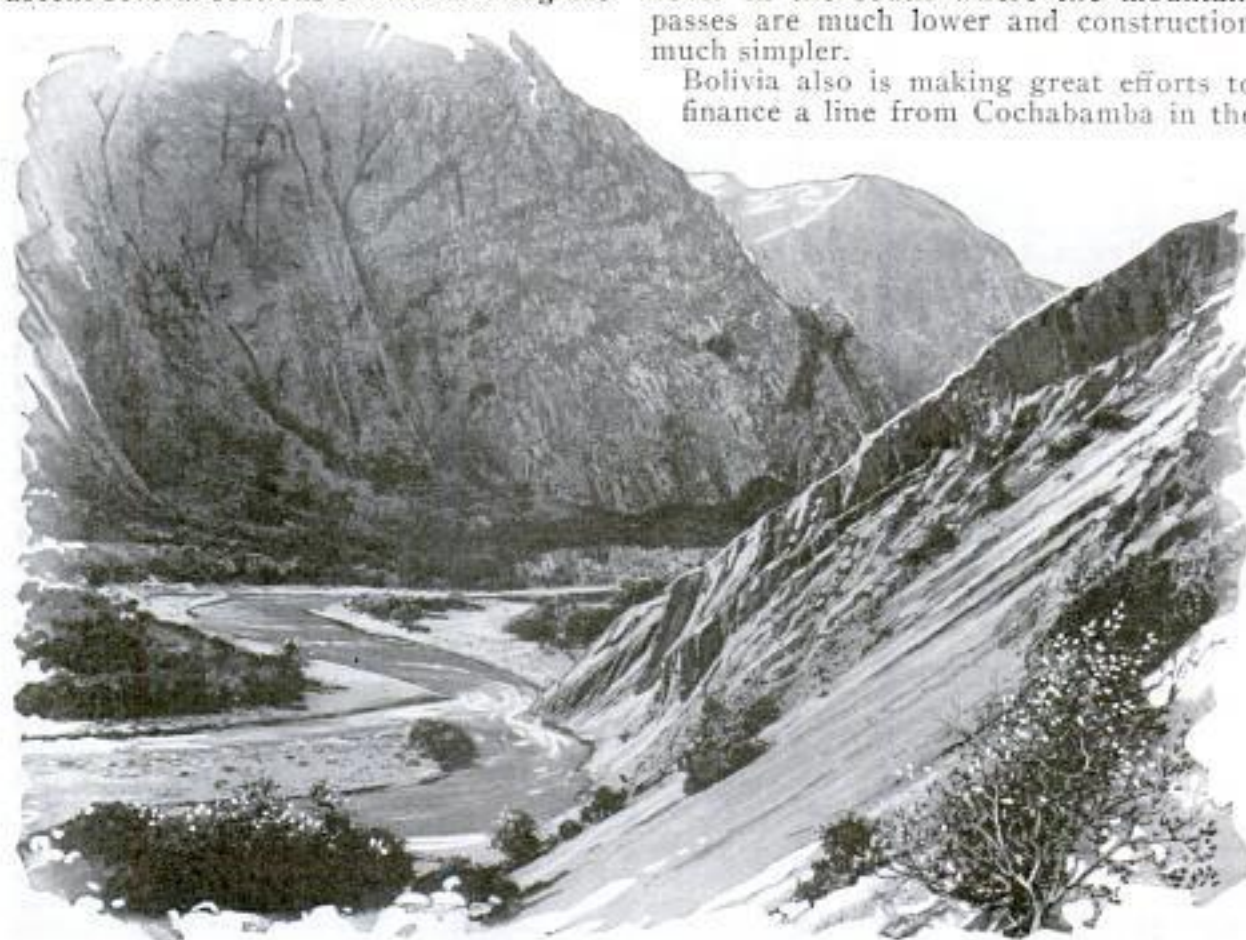

Where Only Poison Sprays Will Check Tropical Growths

mountains (already connected by rail to the Pacific) to Santa Cruz in the plains east of the mountains. A large part of the territory of Bolivia lies east of the Andes, but this section has never been settled, in spite of the fact that it is potentially very rich. The railroad will pass through a region where the rainfall is heavy. The valleys are narrow, V-shaped gorges with steep sides, and they wind about so much that to follow them would add many miles to the line. Moreover, there is always the danger of floods close to the rivers during the rainy, or to be more exact, the rainier season. There is no level ground between the streams, and therefore the tracks must be laid on the valley slopes where they are constantly exposed to avalanches.

To these difficulties must be added that of luxurious vegetation. Grasses and coarse weeds grow very rapidly and a roadway cleared of vegetation will be covered and completely blocked again within a few months. Poison sprays must be used constantly in order to keep back the rank growth. Ants and insects eat the ties, so that they must be replaced much more often than ties in this country. Metal parts rust very rapidly unless they are coated with paint.

Then, too, human beings suffer in such a climate, many diseases and fevers claiming the out-of-door workers in particular. On one such railroad it was necessary to recruit 3,000 laborers in order that 300 might be kept constantly on the job. It is small wonder that the line from Cochabamba to Santa Cruz is estimated to cost \$100,000 per mile.

Unquestionably the most remarkable engineering feat in mountain railroading is the famous Oroya railroad in Peru. This line has the distinction of reaching the greatest elevation of any standard-gauge road in the world, and that without use of rack or cable. The line climbs to a height of 15,665 feet in 106 miles. It takes about nine hours and thirty-eight minutes to mount to the summit, an average rise of

twenty-seven feet per minute. To make the grades possible, Henry Meiggs, who built the line, resorted to switch-backs. Just before entering, and just after leaving San Bartolome, the line passes through two short tunnels under the river, thus avoiding the danger of washouts. After sufficient elevation has been gained by backing, the train runs onto a level place, a switch is changed, and the train continues

its climb, now running forward up the valley. In this manner, swinging first back and then forward, the necessary elevation is gained, but at no place with a grade exceeding 4.08 per cent.

Not far above San Bartolome, the Rimac valley narrows to a gorge with almost perpendicular sides, and with towering mountain peaks rising to stupendous heights above it. The engineer who could have imagined a railroad through such a valley must have been touched by that

form of insanity which is called genius. The single track clings to the steep slopes on a bench cut from the solid rock walls, until a projecting spur requires a tunnel. Then the line dives into the mountainside and emerges beyond the spur where a new vista of unimagined heights is revealed.

Then there are side canyons which must be crossed. The train crawls out from a tunnel onto a bridge many feet above the valley floor, only to dive back into a tunnel beyond. The longest of these bridges is called the Verrugas. It is 575 feet in length and 252 feet above the valley. In climbing to the summit the train passes through sixty tunnels, over forty-one bridges, and thirteen zigzags.

At one point, near the station of Chicla, five lines of track are visible on the mountainside, one above the other, and the station, located in the valley, remains visible from the train for nearly an hour while the zigzags are being covered. During the climb the passenger passes successively through a number of different climates. The coast is tropical and its products are

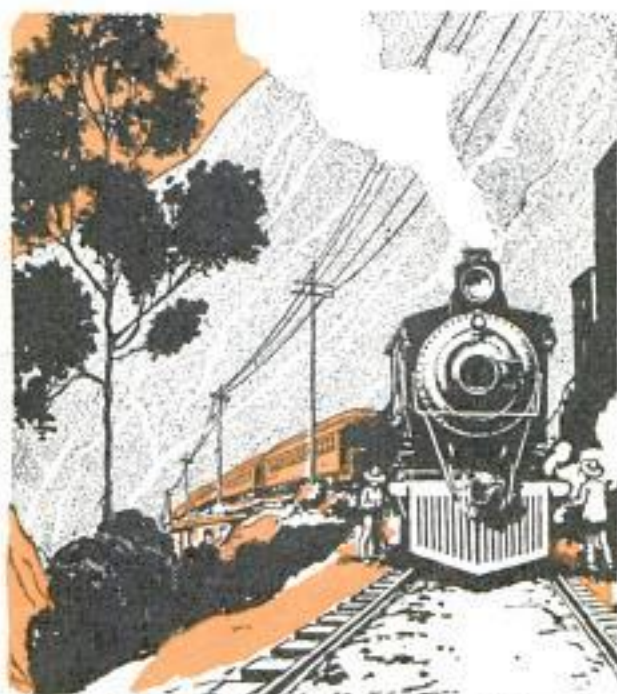

Tracks Laid on Mountainside at a Cost Estimated at Approximately \$100,000 a Mile

characteristic of warm countries. As one continues to rise, however, products of cooler climates are seen, first corn, then wheat and then barley. Finally the point is reached where nothing will grow but the small, bitter, Peruvian potato. Nowhere are there any trees, except those planted around the stations. The tall, graceful pine trees of the Rockies are entirely wanting, with the result that while the scenery is grander and more awe-inspiring, it is never as beautiful.

Another noteworthy thing in this rapid climb from sea level to over 15,000 feet, is the rare atmosphere. Because of the smaller amount of oxygen at the higher elevations, one must breathe in larger amounts of air to achieve the same results as at sea level. The slightest exertion leaves the passenger panting for breath. Persons with weak hearts often suffer from mountain sickness. Instead of feeling exhilarated, they are nauseated.

At one time an overzealous inventor constructed an airtight car for this line. The car was filled with air at the sea level pressure, and the passengers were shut up in it. Of course, the trip was made in perfect comfort, the scenery being enjoyed through the large glass windows. But the inventor might have foreseen the result of leaving the car at Oroya. Instead of making the change of air pressure in the space of nine hours required for the trip, the change was made in a fraction of a second, when the doors were unsealed, and the passengers stepped out. The strain was too great, they all became unconscious and were not revived until they were brought back to sea level and normal conditions.

MATCH SCRATCHER FOR AUTO CLAMPS ON WHEEL ARM

For the convenience of motorists, an inexpensive match scratcher has been patented which clamps about one of the arms

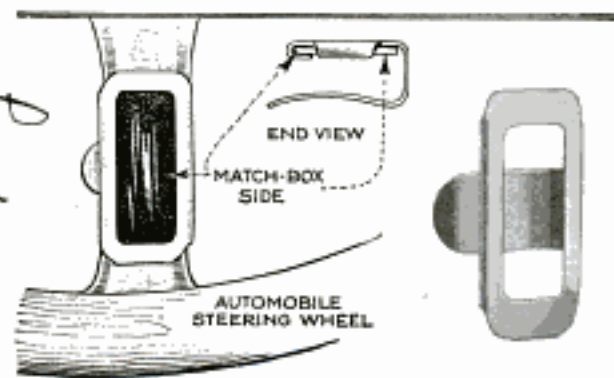

Match Scratchers that Fits on Arm of Automobile Steering Wheel without Obstructing the Hands

on the steering wheel. It is an aluminum shield under which a piece of emery board is slipped to provide a striking surface. It is within easy reach while offering no obstruction to the driver's hands in steering.

4635

LIFTER REACHES HIGH SHELVES WITHOUT A STEPLADDER

With an extension holder that has strong clasps or pincers at one end, boxes, bottles and other things can be picked up

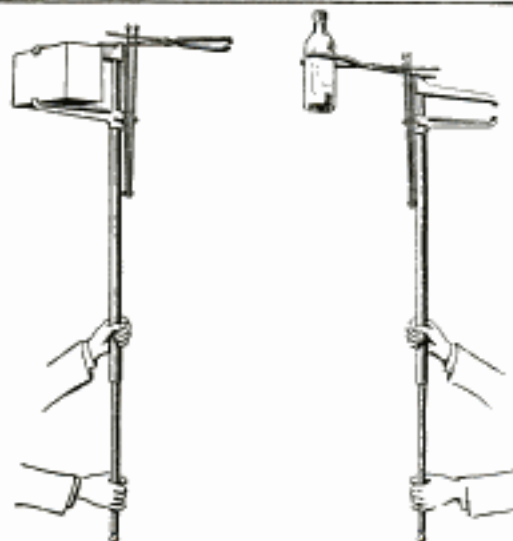

Lifter Adjusted for Package and Bottle; Jaws Tightened by Grip on Extension Handle

and placed on shelves without the aid of a stepladder. The invention, designed by a Frenchman, has two sections, one fitting into the other so that it can be adjusted to various lengths. When the upper part is pulled downward, the clasp is opened to take hold of the object. A reverse movement closes the jaws and holds the article while it is being lifted into place. A slight downward pull on the rod releases it. Two styles of clasps are made, one for round objects and the other for boxes or packages. The "gripper" weighs but little, and is simple to operate.

GASOLINE SAVED THROUGH TEST OF AUTO EXHAUST GAS

By proper adjustment of the carburetors on a fleet of government motor trucks, after analysis of the exhaust gases had been made, a saving of twenty-two per cent in gasoline was effected. Experiments by the bureau of mines also are said to have proved the feasibility of a portable indicator to show the kind of gases given off and to remove all guesswork in making proper adjustments of the carburetor.

Machinery

Jan 24, 1924

Dr. Michael Farone, 49 Water town, N.Y.

Copyrighted material

4163

Ans. H. L. Kuhlman, Box 605,
Garden City, Kans.
POPULAR MECHANICS

FARMS ARE WATERED BY WIND HARNESSSED TO PUMPS

Windmills, resembling those common to Holland, have been found practical for irrigation and power purposes in Kansas. Sufficient water may be pumped from a depth of 75 feet to irrigate a farm of 80 acres with one of the mills which operate two pumps simultaneously. The wing blades have an exposed surface of 144 square feet and are so arranged that in severe winds the sails open edgewise, allowing the blast to sweep through without damage. The wheel and scaffold are of simple construction and require little repairing.

Because of the extent of the wing surface, the mill is set in motion by only slight winds and a high tower is not necessary as with smaller wheels.

With the exception of the gears, practically all parts of the outfit can be made by hand with only a few tools. Thin strips

of sheet iron have been found suitable for the blades. They are easily adjusted into the frames fashioned from light iron or steel rods. Cross-arms are cut from strong wood and are braced with iron straps. This style of mill has proved so successful in the locality where it has been tried, that several others like it are being constructed. By setting the blades edgewise, the wheel can be thrown "out of gear" as it will not catch the wind. The short tower requires less wood than a

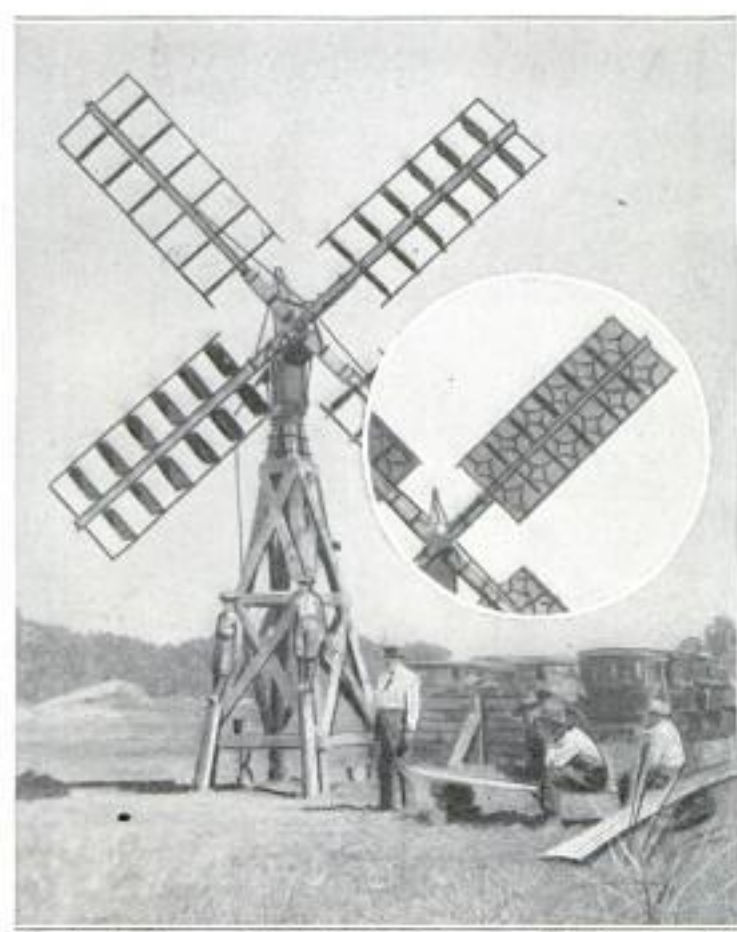

Handmade Kansas Windmill for Power and Irrigating with Swinging Wing Blades. Inset Shows Them Folded Flat

high structure and is considerably cheaper than one of steel.

FIREPROOF BRICK OF SAWDUST TREATED WITH CHEMICALS

Sawdust treated with chemicals, under a secret process discovered by a southern manufacturer, and subjected to heavy pressure, is said to have been used successfully in molding fireproof bricks for building purposes. They are said to be durable and easily handled, and have heat-resisting qualities superior to many other kinds. The dust is soaked in certain solutions and pressed in special molds. Tile is also manufactured from the material.

Antimonial Newerick

Barely visible to the naked eye, threads from melted quartz can be made so small that a bundle of a thousand of them is as small in diameter as a human hair.



Molding Fireproof Brick and Tile from Sawdust that Has Been Soaked in Chemical Solutions

*Hoyars Block Co. of Illinois
311 Chamber of Commerce Bldg
Chicago*

**RETORT FOR EXTRACTING OILS.
CONTROLS OWN HEAT** 38

Built in sections, each with its own furnace, a retort designed for extracting oils from wood, coal, tar, sands and similar substances has a control for automatically regulating the heat of the ovens. Any temperature desired can be maintained in the individual furnaces and, it is said, the arrangement prevents overheating or "cracking" of the products. The gases are drawn off in regular order, so that the most economical results may be obtained. The appliance may be run at almost any desired speed and is mechanically supplied with raw matter. If necessary, the machine can be made portable. The power required to operate it, it is claimed, is less than is ordinarily needed.

**ENGINE FRONT PAINTED WHITE,
TO AVOID ACCIDENTS** 4560

So that switchmen can readily see the locomotive fender in the darkness and so avoid accidents, a steel company in Mid-

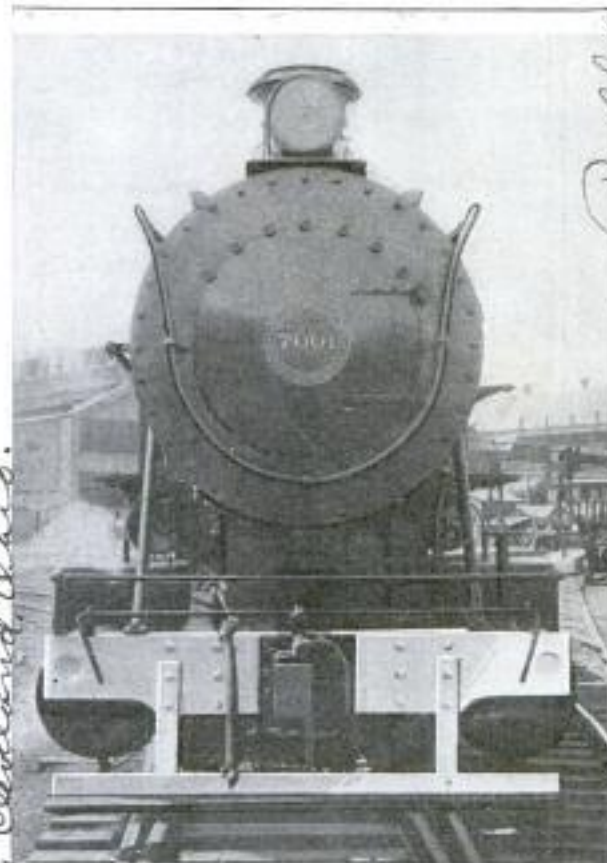

Running Board of Switch Engine Painted White So that It Can Be Seen Plainly in the Dark

**ELECTRIC SEALER HAS STAMP
AND HEATER FOR WAX** 4627

To save time and prevent injuries to fingers while holding sealing wax over bare flames, an electric iron is being made that has a heater for melting the composition and a stamp for impressions. It is claimed that the device quickly softens the wax without burning, thus causing it to form closer and more durable contact with the surfaces than is possible with the old method. Small round wafers of sealing material can be supplied for the machine and aid in making a neat and clearly defined disk. The apparatus is of sound construction, is light in weight and has no delicate parts that might become damaged.



the machine and aid in making a neat and clearly defined disk. The apparatus is of sound construction, is light in weight and has no delicate parts that might become damaged.

**ELECTRICAL IMMUNITY IS DUE
TO DRYNESS OF SKIN** 4482

Electricity will not pass through the bodies of all persons with equal ease, according to the assertions of experts. One prominent scientist has been known to resist a voltage that often has proved fatal, due, it is said, to the dryness of his skin.

*Compressed Air mag
Dec. 1923*

leton, Ohio, has painted the step white. In this way, considerable of the risk of missing the running board has been eliminated, and the number of deaths and injuries from this cause decreased.

**INSECT WAR PLANNED TO END
THE HESSIAN FLY PERIL** 4632

To exterminate the Hessian fly, one of wheat's greatest enemies, science is preparing to call to its aid a parasite, known as the platygaster himealis. A mere speck, when not viewed through the microscope, this foe of the fly is no match for it in open combat. Instead it stings the eggs, leaving behind infant parasites that eventually kill their host. When the last fly has been slain, the tiny insects will perish also, for they will have killed the species which alone can give them life. Reparations for the battle are being made by government experts at the Wichita, Kan., agricultural laboratory.

*new York Times
2/24/23*

*Used by the American Rolling Mill Co,
Middletown, Ohio.*

4373

546

POPULAR MECHANICS

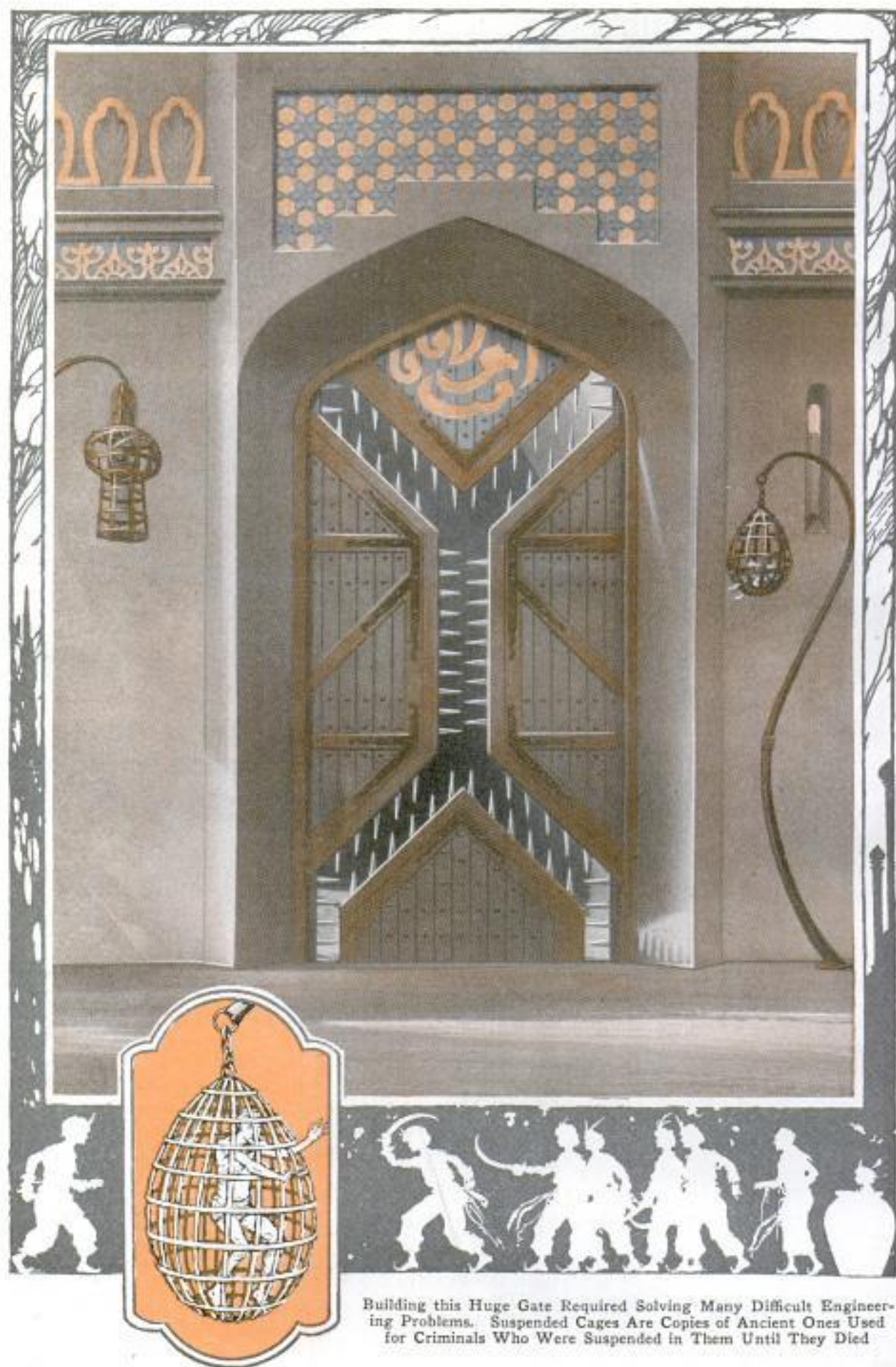

Building this Huge Gate Required Solving Many Difficult Engineering Problems. Suspended Cages Are Copies of Ancient Ones Used for Criminals Who Were Suspended in Them Until They Died

Mark Larkin, Publicity Director,
Douglas Fairbanks and Mary
Pickford, Hollywood, Calif.

Engineering the Magic Carpet's Flight

4373

Problems in Mechanics that Make the "Movie" Engineer's Profession Recall the Magician's Miracles

"BUILD me a magic carpet on which I can ride; a flying horse like Pegasus and arrange a set so that I can disappear in a whirlwind."

The "boss" of the moving-picture lot, without more ado, walked out of his chief engineer's office, leaving that hard-working individual the three problems which he mentally added to the score or more of similar commands he had executed since the actual "shooting" of the scenes in the huge spectacle had begun months ago. For the engineering staff of the larger moving-picture producers is used to facing and conquering problems that for sheer unusualness are perhaps unrivaled.

As the theater patron watches the unfolding of the silent drama and sees huge buildings flashed on the screen, great idols being worshiped or destroyed, hordes of actors engaged in furious warfare, castles being besieged, glimpses of seemingly ancient wagons hauling victims of the French revolutionaries' rage to the gaunt, terrifying gibbet—as he follows the thread of the story—but a passing thought is given to the astonishing accomplishments of the engineer.

A visit to the plants of the moving-picture industry leaves the spectator with at least one assurance—that few scenes in any of the so-called "super-spectacles" would be possible at all were it not for the services and skill of the engineer and other highly trained technical men. Every branch of mechanical knowledge is put

into action when the "boss" gets an idea. Walls must be made solidly of concrete, but constructed so that they can be removed with ease when they have served their purpose. To be sure, a great many of these seemingly huge buildings are but shells—perhaps just "fronts"—but even these must be made in such a way that

hundreds of persons may "act" upon them without fear of a fall or of the collapse of the structure. To create a whirlwind to accommodate an actor who wishes to disappear is not simple, yet the engineer who says, "I can't," quickly gets another position.

In the designing of a huge gateway to represent the childish whim of an ancient ruler of the Far East, one of the most perplexing problems of the engineering department of one big producer was solved. The gate had to part into four sections, one sinking into the ground, another being drawn upward and the two sides being pulled away from each other and into the castle wall. Since

the gate could not be square, the two sides traveled a shorter distance in being withdrawn than did the top and bottom pieces. A nice problem in mechanics was thus involved. Again, the door being of wood, it was difficult to build it sufficiently rigid to insure that the teeth, with which the edges of the four parts were armed, would come together accurately. Yet, although completed the gate weighed seven tons, its mechanism was so skillfully designed that one man could operate it by means of a

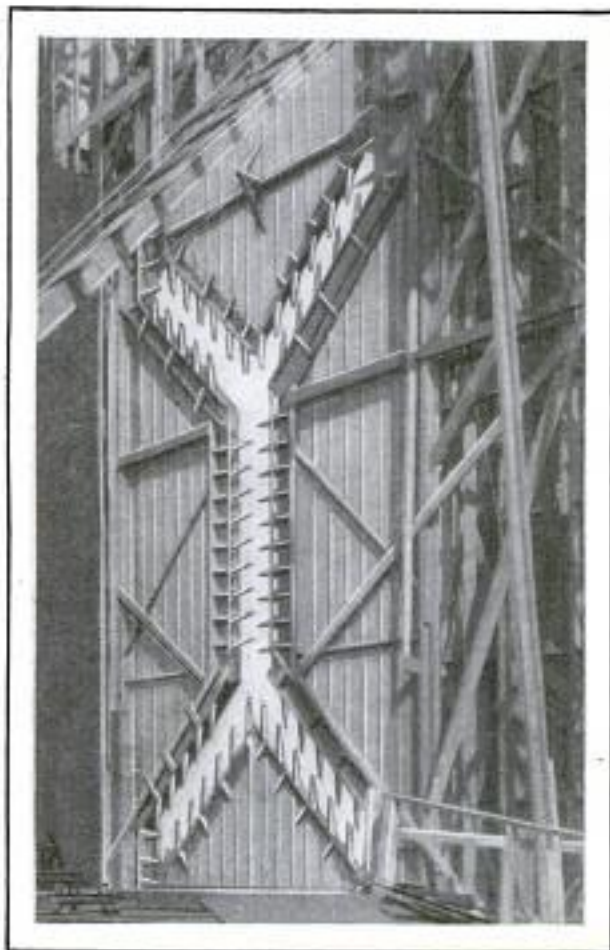

Back of Gate Weighing Seven Tons Yet Operated by One Man, So Accurately Was It Poised

series of pulleys and cables. Incidentally, it was conceived by one of the workmen and cost \$8,000.

Particularly difficult was the task confronting the engineers in a sensational drama where, because the story concerned a fairy tale, as few straight lines as possible were demanded. Stairways were crooked and in proportions only reasonable in a dream; windows were of odd outline; streets were "crazy" shaped; caverns and strange gods vied with intricately molded metal cages big enough to imprison full-grown men and hovels and palaces of the strangest aspect.

A scene was desired showing a cross-sectional view of a thieves' burrow beneath the surface of the ground, yet with many galleries and peep-holes from which the rascals could note the passing of a caravan of riches. Engineers devised such a structure supplied with a "cover" which, when fitted over the cave, restored the scene to an "above-ground" view. Huge rollers and pulleys were specially made to move this great bulk of material back and forth as the occasion demanded.

While a great deal of the responsibility for the making of copies of such "property" as submarines, steamships, airplanes, railroad coaches and so forth, rests on the carpenters and workers in other trades, yet the engineer finds himself called upon frequently to figure out stresses, leverages and other secrets of his profession for the use of the craftsmen. Being unable to secure the loan of real submarines from the government, one producer not long ago set about building one that was 100 feet long, with a beam of fifteen feet and a draft of four feet. The engi-

neer was told that the craft had to be of sufficient strength to withstand submergence to a depth of more than forty feet; would have to be provided with tanks, so that it could take on water to sink it to that depth, while compressed air must be furnished to blow out the water when it was necessary to raise the boat to the surface. The director also wanted torpedo tubes big enough for standard size missiles—and he wanted it all in a hurry. The "sub" was made of sheet iron, but it required six months of constant labor to build it.

In a recent war play, four giant siege guns were needed. The engineers finally produced wooden weapons which recoiled with full realism when the tiny charge of powder was exploded in their iron-lined barrels. And the variety of the engineer's tasks is limitless. It was desired that an actor in a comedy take hold of a live lion's tail and bite it. The engineer was finally called in and asked how mechanics could help save the actor from the lion's displeasure, for even a studio lion has emotions.

"Have both actor and lion perform on a moving platform," the engineer advised. "The lion won't turn around to strike the actor in that case." And so it proved.

For the purpose of another comedy the engineer was told to devise some means whereby a comedian could sail through the air hanging to an ostrich's tail-feathers. The engineer devised overhead strutwork attached to an automobile which followed the running bird and the actor suspended by an invisible wire from the overhead platform.

From the days when Thomas Edison

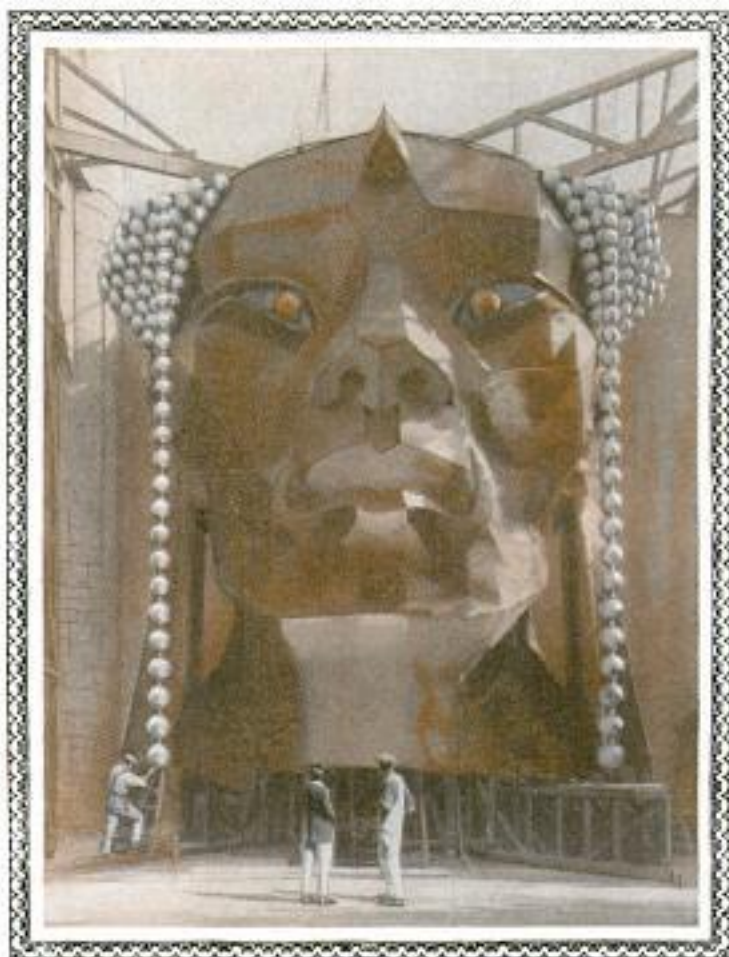

Great Idol Built with the Aid of Intricate Scaffolding; a Unique Bit of Engineering in "Movieland"

was experimenting with the "movies" and engineers were called in to build a studio on a turntable so that it would follow the sun during the day and thus permit of taking pictures indoors continuously, to the present when realism must be observed and minute details of mechanical construction followed faithfully, the engineer has been associated with the business. Not only is his science called in for replicas of modern inventions, but he must know how to build vehicles and machines of days long gone. It was he who designed and instructed the carpenters in building medieval wagons for a recent picture. The shafts, wheels and bodies were whittled out by hand to simulate the old-time carts.

The work of the engineer begins with the acceptance by the directors of the scenario. Following the adoption of an idea, the studio's research men—they may be college professors or other trained scientists—gather all imaginable data on the period and people of the time and countries involved. Artists then make free-hand drawings of how

they think the scenes should be made.

Once these are accepted, draftsmen redraw the artists' conceptions to absolute scale. From these blueprints, small models are made. Then comes in the engineer who, from his knowledge of mechanics, weeds out the impossible—if such a thing

exists in the mind of a movie engineer—and gives advice on the practicable.

The finished blueprints are then turned over to the carpenter and his crew, the plasterers, the masons, the bricklayers and—the engineer. The latter "bosses the job" until it is done. He is the man who finds a way to make Pegasus fly, to give the star a safe ride on a magic carpet, to wait the villain away in a cyclone and—to make it all seem real to the

man or woman who has paid to enjoy a couple of hours of thrills or laughter in the neighborhood movie.

To meet the demand for realism railways have been built on mountainsides on which trains have been wrecked, gaunt skeletons of ocean liners erected on dry land and deserts turned into populous cities.

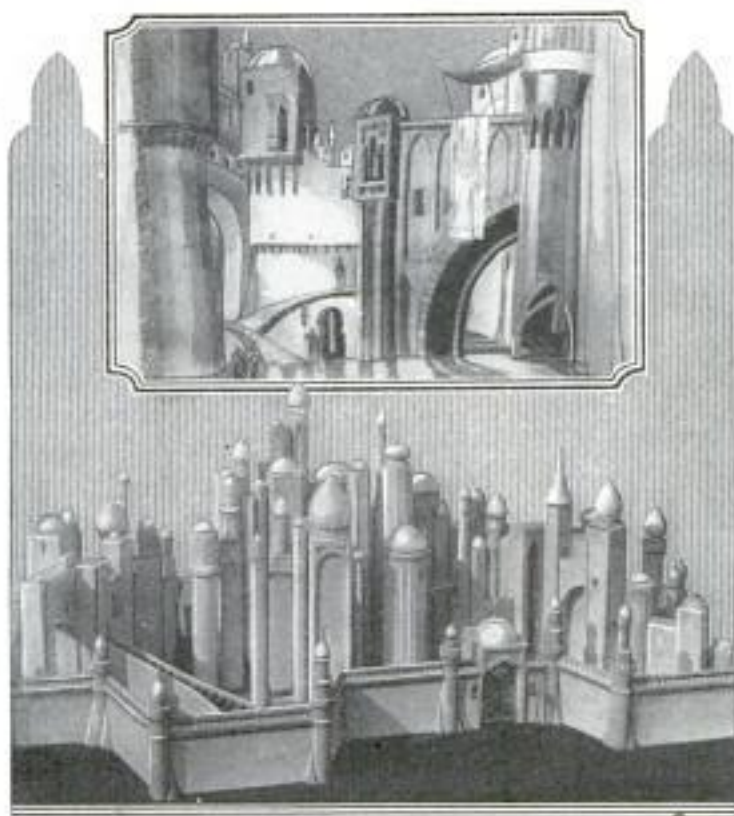

Above: Artist's Conception of Scene; Below, Working Model Constructed from Drawing and Used to Build "Life-Sized" Set

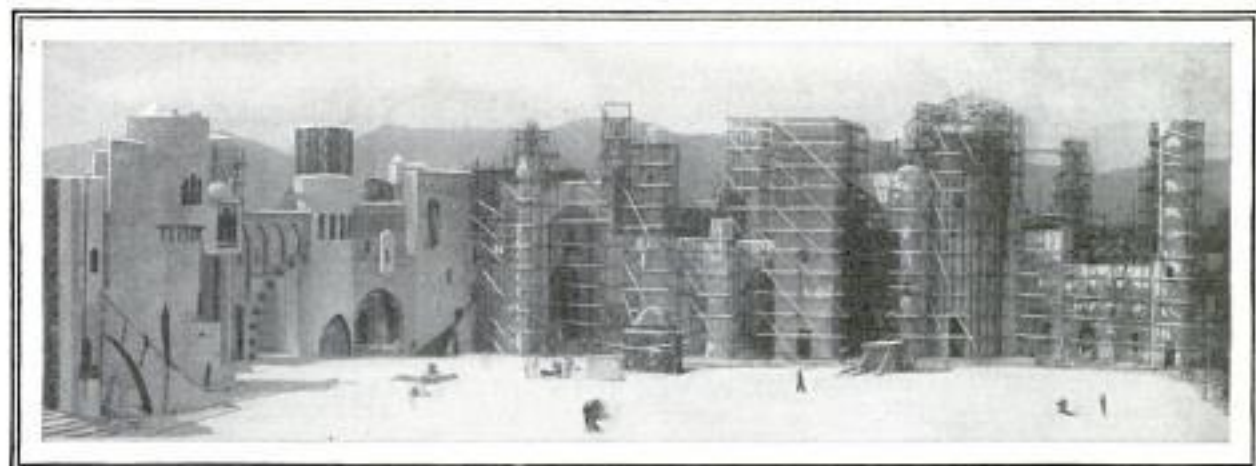

Set Being Built to Scale from Model of Artist's Drawing: More than Five Hundred Carpenters Worked Weeks to Erect this Eight Hundred Feet of "Background"

LURE OF PEARLS LEADS HUNT IN INLAND WATERS

3891
So valuable has the fresh-water pearl become, that fishermen have taken up the search for them wherever mussels are known to exist, for it is from the shells that the majority of the gems are taken. Rarely is a perfect specimen found, for it must be of a quality having the proper shape, color, and size to meet the requirement of the buyer. Out of about every thousand submitted, the experts find not

selected according to size and form. The purest ones, known as special high grade, are sometimes valued at more than \$3,000 each, depending on their weights. In dragging for the coveted jewels, the pearl hunter lowers a netlike arrangement of small grappling hooks over the side of his flat-bottomed boat. As it glides slowly over the bed of shells the points of the snares become fast in the opening of the mussels' homes and the valve is pulled



Fresh-Water Pearl Hunter Seeking Jewels among Mussel Shells, and the Type of Boat Used by Fishermen in Their Never-Ending Quest along Inland Streams

more than a hundred that are classed as prize articles. The remainder are used in the less expensive mountings. Pearls are picked from the mussel shells in almost every conceivable shape, and in many different colors. Pink, blue, cream-shaded, and even lavender ones are frequently found. The various hues are graded and

closed upon the prong by the wary occupant. Holding tightly to the grapple the mussel is drawn to the surface by the fisherman. The shells are pried open, the interior is cleaned out so the smallest pearl could not be missed, and the empty halves are thrown in a pile to be sold to factories, where they are cut into buttons.

GROWTH OF TREES IS FASTER IN CUT-OVER AREAS 26

Yellow pine trees grown from seeds left in cut-over lands grow much more rapidly and are less liable to die than those in virgin growths, according to experiments made by the Fort Valley Forest Experiment Station in Arizona. Out of thirty-three trees in a virgin forest near the station, eight had died after a period of twelve years, it was discovered, while out of thirty-four on the cut-over tract, only one had died. By boring out a section from the live trees with an instrument that

takes a core from the trunk about the size of a lead pencil and measuring the spaces between the rings, it was found that the mean annual growth during the last ten and twenty-five year periods for the trees on the cut-over area was almost twice as great as the growth of those in the virgin stand. Greater space to draw upon for plant food and for moisture caused the faster growth of the trees in the worked-over section, scientists believe.

☛ Chestnut trees have been cultivated since early times in the Mediterranean region, where they were first discovered.

New York Times
12/31/23

POPULAR MECHANICS

CITY OF LUMBERJACKS FLOATS TO TIMBER ON SEACOAST 14

Lumberjacks living in Simoon City on the British Columbia coast have their houses built to float on the water, so they can be towed along shore to timber tracts where the owners pitch logging camps. Owing to the impossibility of establishing large lumber towns near the woods, big concerns have ignored the heavy "stands" on the mountainous shores. Residents of the floating city took up the task and transport their entire homes to the scenes of action during the working seasons. Rowboats and motor craft are used to tow the "seagoing" dwellings. When the trees are felled and trimmed they are formed into rafts and hauled to near by sawmills. After operations have been completed, it is said, the scattered population cruises back to the permanent town site, where many amusements serve the inhabitants. A floating store is reported to be propelled up and down the coast to supply the needs of the workers and their families, while a postoffice aids in keeping them in touch with the outer world.

BOXING GLOVE ON LEVER SAVES HEADS OF WORKERS 456/

To prevent accidents to workers passing under a moving lever, the end was covered with an ordinary boxing glove by a Detroit

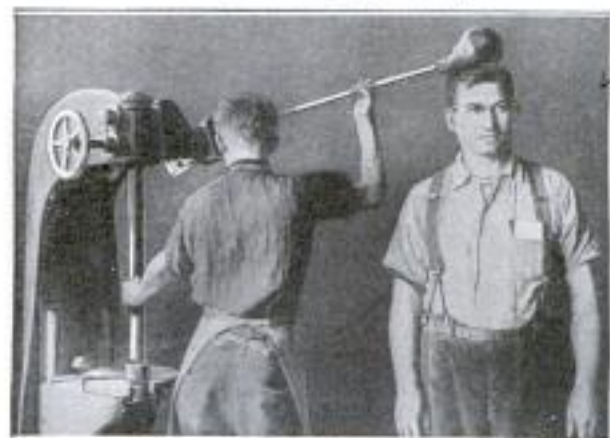

Boxing Glove Attached to Lever on Press So that Accidental Blow from It Would Not Injure Workers

motor-car manufacturer. This tended to deaden the blow and prevent serious injuries from accidental bumps on the head and shoulders of those passing the press.

Packard Motor Car Co.
Detroit Mich

Believed to be the oldest silver fork in existence, one bearing the date 1632 was discovered recently in England. Its owner is said to have been offered \$700 for it.

Dr. W. Clarence S. Bruce
Scientist, U. S. Bureau of

RESISTANCE OF ROAD AND AIR TO AUTO IS MEASURED 4663

Resistance of the road and air met with by moving automobiles can be measured by a meter invented by a government sci-



Copyright, Henry Miller News Picture Service, Inc. Meter that Accurately Measures the Resistance Air and Road Offer to Passage of Automobile

entist. By recording the two forces, an estimate of the power necessary to attain certain speeds with different types of cars can be reached, it is thought. The amount of gasoline being fed to the motor also is shown. It is believed that results of the tests may lead to changes in designs of automobiles and highways to save power.

SOUNDS MADE BY TINY INSECTS CAUGHT IN ELECTRIC "EAR" 4676

Sounds made by small insects generally believed to be absolutely mute, may be heard by a microphone reported to have been completed recently by scientists of an eastern electrical concern. Sounds heretofore too faint to be caught by the human ear, are said to be recorded by the device which registers the waves as they disturb a delicate current passing between contacts in an insulated ring. Experts claim that the apparatus may be of great advantage in the study of insect life.

MORE POWERFUL X-RAY TUBE TO AID WAR ON CANCER 34

To reduce the cost of treatment and increase its effectiveness, an X-ray tube has been invented which is said to radiate five or six times as many curative rays as ordinary tubes. Thus the time of exposure is cut down. Another process is being perfected to extend the use of the X-rays to internal cancer.

Dr. W. C. S. Urey, Research Engineer, Westinghouse Lamp Co., Pittsburgh, Pa.

Dr. W. C. S. Urey, Research Engineer, Westinghouse Lamp Co., Pittsburgh, Pa.

Chicago Evening Post 12/29/23

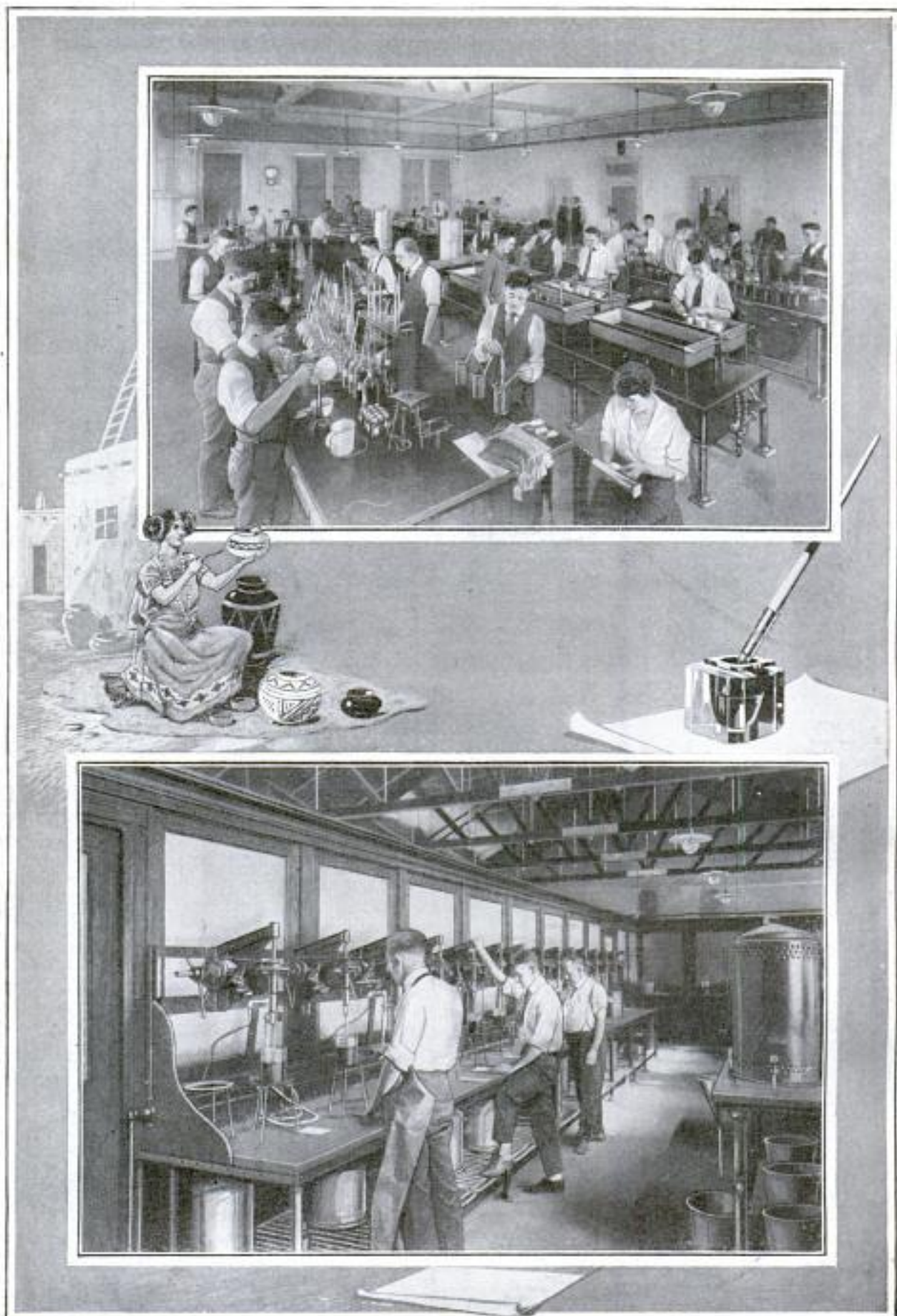

Laboratories for Testing Dyes (Top) and Paints and Ink (Bottom); Upon the Skill of the Workers Depends the Fastness and Beauty of the Colors in the Finished Product

AMERICA'S SUPREMACY IN DYES IS PREDICTED

Whenever you see any cloth, paper or leather with color upon it you may know that it has resulted from almost countless tests, as the making of dyes is a comparatively new industry in America, having been founded after the war cut off supplies from Europe. Chemists then became interested in the work, and the turning out of colors was started on a larger scale than had ever been possible before.

From 1918, various legislative devices kept out the foreign dyes until the passage of the tariff bill in 1922, which ensured a stability to the industry for some years to come. This has been regarded largely as a measure of national defense, for, theoretically, every chemical plant manufacturing dyes is a potential center for turning out munitions.

One of the largest manufacturers maintains a laboratory in New Jersey in which research work is handled. Here the company helps in working out coloring problems. When the consumer requires shades to be matched, the laboratory makes trial

tests on samples of his material run through a machine which is a model of his own factory equipment.

Then there is an experimental dye house fitted with all the machinery used in all classes of textile mills. These machines are not full size, but are practical working models. Calico printing machines make it possible to do extensive research work in textile-printing problems. Yarns are prepared, wound and weighed for dye-testing in another room.

America's supremacy in the industry is a matter of only a few years, declares Prof. J. H. James, of the Carnegie Institute of Technology. "This probability," he says, "is evidenced by the fact that the United States now produces about 93.5 per cent of the dyes it consumes."

According to his figures there were, in 1914, only seven American firms that manufactured a total of 6,619,729 pounds valued at \$2,470,096. In 1922, the sales of eighty-seven American firms totaled 69,107,105 pounds, valued at \$41,463,790.

Washington, D.C.

E. C. du Pont de Nemours & Co.

NEEDLE THREADER FOLDS UP LIKE A POCKET KNIFE



Needles of various sizes can be threaded quickly by a small device recently placed on the market. It has two thin steel blades with hook-like points, a large one from which the smaller extends, for use on darning or sewing machine needles.

After a blade is inserted in the eye, the thread is passed over the hook and pulled through as the point is withdrawn.

LIGHTHOUSE LAMP SHEDS RAYS NINETY-FIVE MILES

Shot from a revolving lantern with lenses so adjusted that the 1,167,000 candlepower beam will have a luminous range of 90 to 95 miles, rays from the lighthouse beacon on Eclipse Island, off the southwestern coast of Australia, will sweep their protecting banners across the heavens to guard shipping. Delicate clockwork mechanism, driven by a falling

weight, has been devised to turn the giant pedestal which holds the lights. The revolving part weighs approximately 7,720 pounds and "floats" on 386 pounds of mercury to decrease friction to a minimum.

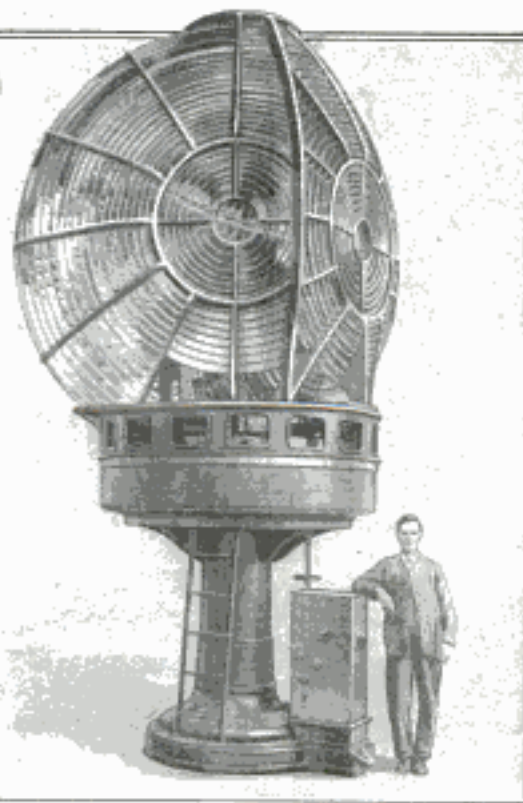

Giant Revolving Lighthouse Lamp: Part of Turning Apparatus Is in Box at Right

*4219
 proper size for all. Check
 5/16 2 1/2 in. all.*

4386
554

Exhibited at Basket Weavers Show in London.
POPULAR MECHANICS

Success



Wicker-Work Case for Grandfather's Clock that Required Nine Months of Basket-Weaver's Labor

WICKER-WORK CASE FOR CLOCK WOVEN IN NINE MONTHS

Done in basket work, of the finest and whitest willow reeds, a case for a grandfather's clock was shown at an exhibit recently held in England. The design is simple but attractive. Small towers rise beside the base, and ornamental weaving, that resembles hand embroidery, surrounds the face of the timepiece. This wicker cabinet is over seven feet high, and is said to be a remarkable specimen of the basket-weaver's art.

164 NAVEL-ORANGE CROP TRACED BACK TO TWENTY TREES

Started in 1870 from twenty trees brought to this country from Brazil for experimental purposes, the navel-orange crop in California now exceeds 8,000,000 boxes annually. The original planting was done under the department of agriculture. Two of the "pioneer trees" are said to be still alive, one in Washington, D. C., and the other in California.

Kansas City Star 1/13/24

84 CUTTING WOOD TO MINE COAL TAXES FORESTS

Supplying the hard coal mines in Pennsylvania and other sections with timbering, has so nearly exhausted the supply of near-by wood that material is being brought from the Pacific Coast for this

ther digging and to prevent cave-ins. Approximately 500,000,000 board feet of timber are required each year in the mines of Pennsylvania. So extensive has the cutting become in woods near the mining districts

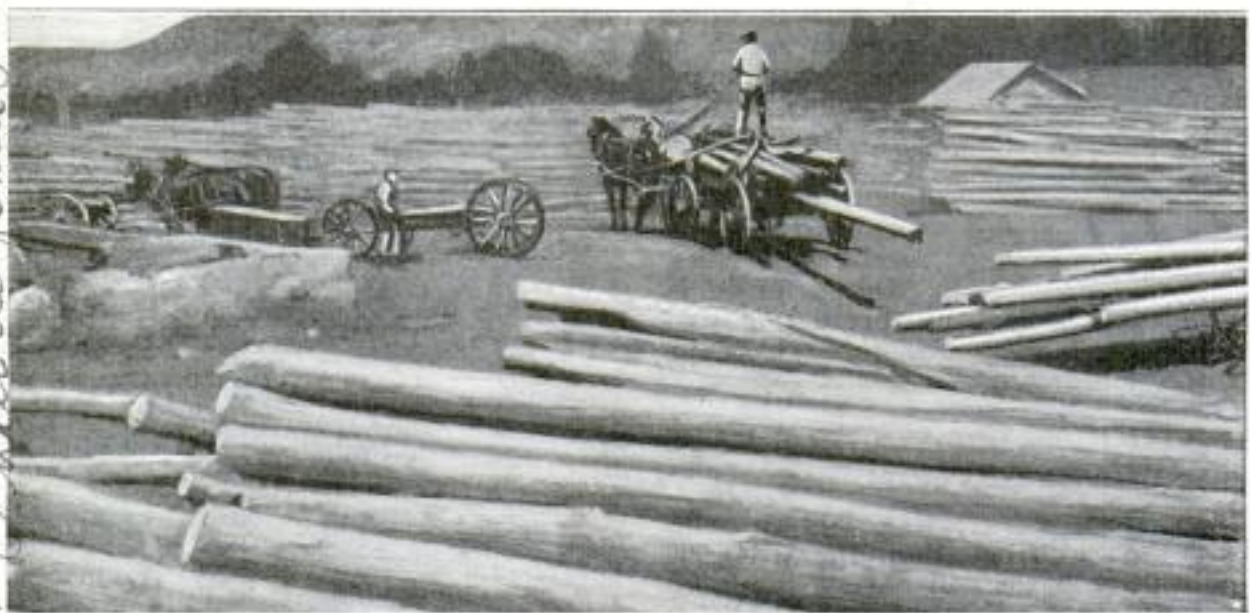

Hauling Timbering Props into Large Storage Yard near Anthracite Coal Mine where They Will Be Cut, Measured and Kept Until Needed for Protecting the Mine Shafts

purpose. It is estimated that for every ton of anthracite mined, seventy cents is spent for lumber to make the shafts safe for fur-

that the state forestry department has undertaken large cultivation and conservation projects.

Emb. Shows, H. Wittborn, 5733 Spring St. Philadelphia Pa.

At convention of American Association for Advancement of Science, Cincinnati

Electrical World.
Jan. 5, 1924

POPULAR MECHANICS

J. W. Carnochan, d. m.
101 University Ave.
Rochester, N.Y.

555

LAMP IS LIGHTED BY WIRELESS TRANSMISSION OF POWER 44

Just a glimpse of the future possibilities of the wireless transmission of power was given in the east recently, when an ordinary 110-volt incandescent lamp was lighted while being held a foot from a vacuum tube containing 2,000,000 cycles of alternating current. A loud speaker lacking a horn was also tested. It was a large disk, about three feet in diameter, and connected by wires and a vacuum tube with the mouth-piece. The device did away with the metallic noise, and proved it could reproduce the voice at almost any magnitude.

Willy R. Whitney, Director Research Laboratories, General
AUTO BRAKE EXTENSION PUTS LEVER WITHIN EASY REACH 3

Clamping over the top of the regular brake lever, an extension handle is being made that tends to end straining, reaching or groping. It works the ratchet automatically and almost without effort. When desired, it may be thrown back out of the way to permit easy and convenient entrance or egress from the driver's side of the car. It is made



The Toledo, Ohio
DIAL ON MILK-BOTTLE COVER GIVES DAY'S ORDER 22

To give orders to delivery men, a cover guard has been designed for milk bottles with a dial on which are printed various dairy products. A pointer is provided for each item and may be moved to indicate the quantity of the article desired. Placed on an empty container, the driver can transfer it to the fresh bottle after reading its instructions. Made of metal, it can be clamped on the rim of the jar to protect the contents. The face of the scale is guarded by a celluloid front, so that the printing can not be obliterated by rain.



Novelty Mfg. Co.
Green Bay, Wis.

STREET GUIDE IN CARS AIDS PASSENGERS AND CREW 10

Passengers in surface or elevated cars, subways or steam trains, are furnished a convenient guide and directory and are



Street-Car Announcer that Shows Approaching Intersections and Principal Buildings by Pushing Button

saved the results of errors and the trouble of asking questions by an electric street announcer. Worked by the motorman or conductor with a push button pressed as the car leaves each intersection, it shows on a printed card within a case, the next street or station. The device is placed at the head of the car or in any conspicuous position. When the button is pressed, a bell rings to attract attention. A legible sign slides into place and shows the principal stores, theaters or other buildings near by. The mechanism is operated from the lighting circuit, is quickly installed, and can be adjusted in a few moments for new routes. It is patented in the United States and in Canada.

TWO MOVIES SHOWN AT ONCE BY USING COLOR SCHEME 168

By means of colored glasses, the motion-picture patron will be given an opportunity to discriminate between two pictures shown simultaneously, according to the predictions of Prof. F. A. Osborne, of the University of Washington. Separate pictures in differing colors are to be shown on the same screen, it is said, and the glasses will serve to completely efface one while permitting the observer to view the picture he chooses of the performance.

Christian Science Monitor
1/2/24

Patent number unknown

Copyrighted material

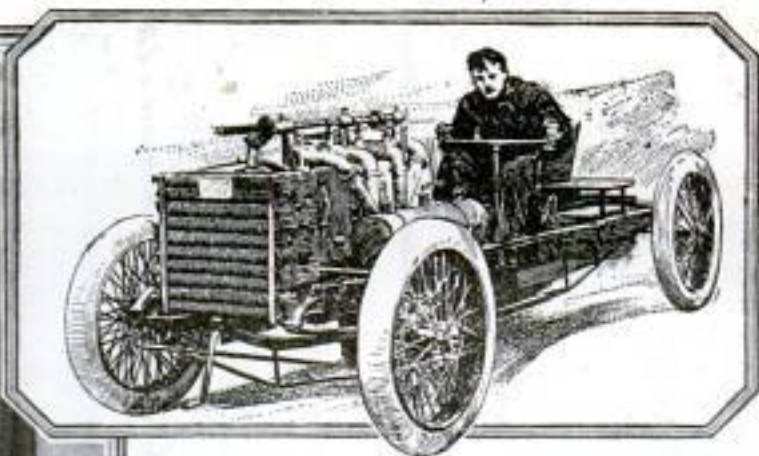

EVENTS OF TWENTY YEARS AGO FROM THE COLUMNS OF POPULAR MECHANICS

TWENTY years ago, the editor of this magazine found the record of events of the day one for astonishment, as indeed it was. Mme. and M. Curie's radium finds were beginning to be noised about in the workaday world, although they had been known for more than five years to scientists. The now familiar automatic magazine pistol had been on the market but a few weeks, and yet had earned the title of "the most deadly weapon known."

Santos Dumont, the aeronaut, had just found his first real competitors in the persons of the Labaudy brothers who flew over Paris in a "remarkable" new airship. A horseless street sweeper engaged the attention of doubtfully minded civic workers. The last spike in the Ogden-Lucien "cut-off," the huge permanent trestle across the mysterious Great Salt Lake, had just been driven by the executives of the Union Pacific railroad and Edward H. Harriman's "great sink hole" of millions in money had been proved worth while.

A writing-pad arrangement for attachment to telephones caused favorable comment. The first sleeping car on an electric railroad had been but recently put into service. A house built on a turntable so that it would always face the sun was eagerly endorsed in France. The Eiffel Tower, known all over the world, was condemned as unsafe—it had begun to lean to one side—and was to have been torn down "at once." It was, however, strengthened by engineers and saved to the world.

The pictures show a racing automobile, one of the first vacuum cleaners, a locomotive with an observation seat in front and the making of ping-pong balls.

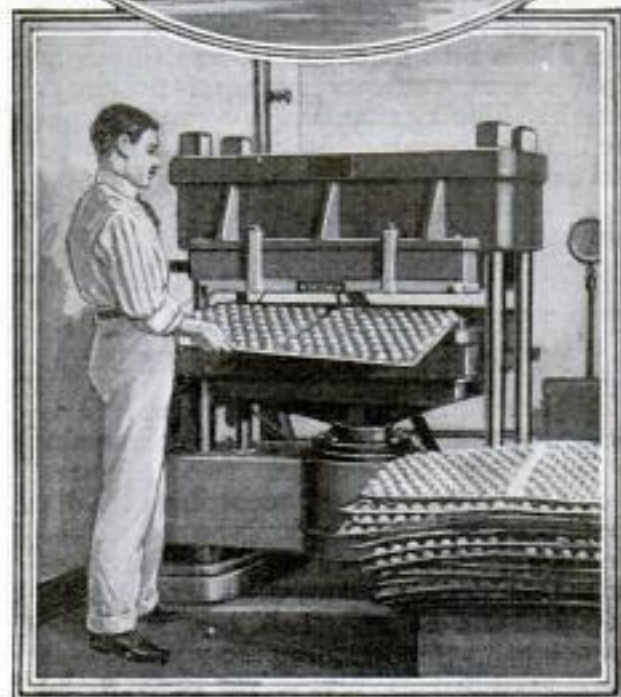
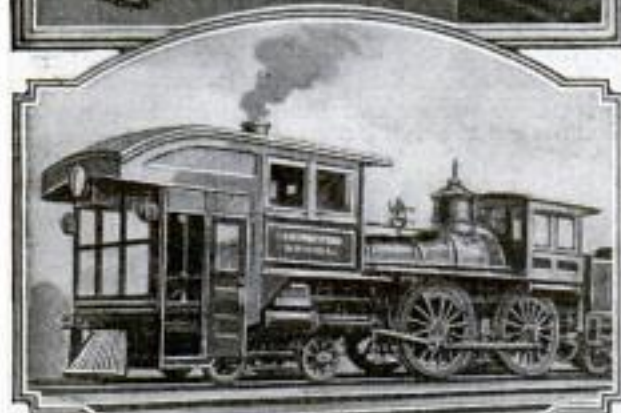

³³
NON-SKIDDING AUTO MOVES IN ANY DIRECTION

To prevent dangerous skidding, a four-wheel drive automobile has been designed in England. Behind the gear box is a unit called the distributor, containing a differential through which the power is transmitted through four shafts. Each wheel is

ten to twenty miles an hour. The springs took up all the shock and no skidding was noted, although the turf was damp and slippery. A demonstration also was given of the crab-steering effect. By shifting a lever, the front and rear wheels were made



Copyright, Underwood & Underwood
Automobile that Drives, Brakes and Steers from All Four Wheels and Is Able to Turn About in Its Own Length and Travel Sideways Like a Crab

connected to the frame by independent cantilever springs. In a test on a grassy slope on which the gradient was about one in four, the chassis was driven in a circle over the ruts and bumps at a speed of from

to move inward or outward together, instead of in opposite directions. This enabled the car to move bodily sideways. It was claimed that this ability would be of service in parking in congested traffic.

**SHIP'S FINDER GIVES DISTANCE
OF ANY OBJECT AT SEA 4651**

For the use of navigators in making quick and accurate estimates of distances, taking the ship's bearings and plotting the course, a device which combines the common purposes of a sextant and bearing finder has been perfected by a western inventor. It is a flat, figured board with adjustable rule arms and a measuring rod so arranged that when it is placed parallel to the ship's keel, the arms give readings in minutes or miles. It is said to be helpful to pilots on coastwise or lake vessels.

Electric lights suspended over the water in fish hatcheries have been found of aid in feeding the fish. Thousands of insects attracted by the brilliant rays, fall into the hatching tubs or are snapped out of the air by the hungry young fish.

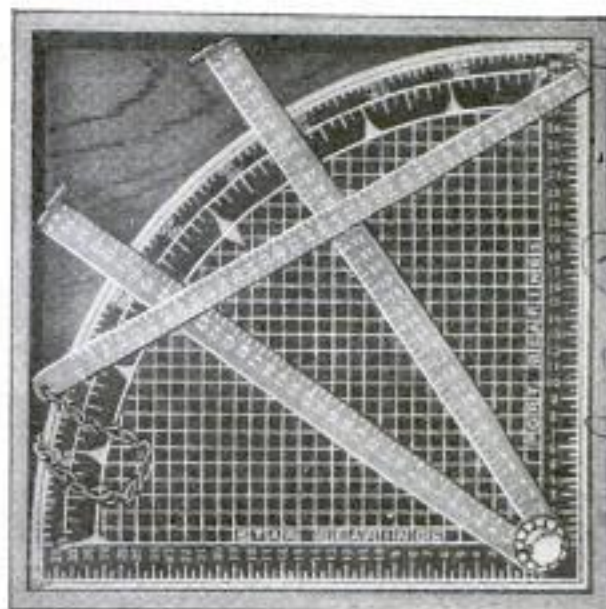

Navigator's Bearing Finder for Computing Sea Distances with Measuring Squares and Ruled Arms

*Edw. A. Adams, Chicago
1911*

4258
 Comb. H. H. Glenn, 2722
 Prince St., Berkeley Calif.
Fresh Fruits for Every Day of the Year

Discovery of Methods of Preserving Without Cooking and System of Drying to Save Growers Millions Yearly

RESIDENTS of London, Timbaktu or any other place in the world which can be reached by a pack train or an airplane, may now have grapes from the slopes of Vesuvius or the valleys of the San Joaquin; peaches from Mount Hy-mettus or the hills of New Jersey, or bananas from the Honduran jungles, just as fresh on the day they eat them as when plucked from the tree or the vine. These fruits, too, with the exception of the grapes, may be sent dried, so that when water is applied, they resume a shape and appearance very near to that they bore when first picked, with undiminished flavor.

This is the result of more than 1,000 experiments, conducted during the past five years, by the professors and pupils of the college of agriculture of the University of California, led by Professors F. T. Bioletti, A. W. Christie, E. L. Overholser, and W. V. Cruess, all of the faculty. Their discoveries are free to the world, and already are being used commercially.

With the students working under them these men have discovered that grapes may be packed and kept for sixty to ninety days and still be as fresh as when picked.

They have found a method whereby fruit may be packed without cooking, in airtight containers, and kept indefinitely at low temperature, so that when it is unpacked it will be in the same condition, have the same appearance, and retain the same flavor as when it was packed. They have discovered a system of drying fresh fruits and certain vegetables, whereby these products will resume very nearly their normal, fresh appearance and all their original flavor, when soaked in water. They have

originated a process by which fresh-fruit juices may be bottled, put away and forgotten until they are wanted, when they will be found to be exactly the same in consistency, condition and flavor as when they were expressed from the grape or the peach, the pear, the pineapple or any other fruit.

It is estimated that more than \$10,000,000 will be added to the value of the annual grape crop of California by the new method of packing and shipping fresh grapes and the making of juice which remains fresh, unadulterated and unfermented. White figs, probably the most perishable of all fruits, handled in the same manner as the grapes, have been laid down in New York, twenty days by sea from San Francisco, as finely flavored as when picked at Fresno, some 200 miles inland. The heaviest loss borne by growers of all kinds of fruits in all parts of the world is due to the time in shipment and the damage wrought during transit. By these discoveries in fruit preservation without cooking, this loss is reduced to a minimum, and the problem of the grower reduced to that of finding a market, regardless of time required in shipment. Like most discoveries, the methods

by which these results are accomplished are simple, require little equipment, and that is inexpensive, in fact, virtually all of it can be built at home. Grapes which have been kept packed seventy days before being opened, and probably could have been kept much longer—are packed in bunches, as they come from the vines, in airtight kegs. A small opening is left at one end of the keg for the escape of air, and through another opening is pumped sulphurous acid,



Sealing Cans of Fresh and Uncooked Fruit to Be Preserved by Keeping Them at Low Temperature

Burpee Can Sealer Co., 215 W. Huron, Chicago
 claim they make these machines

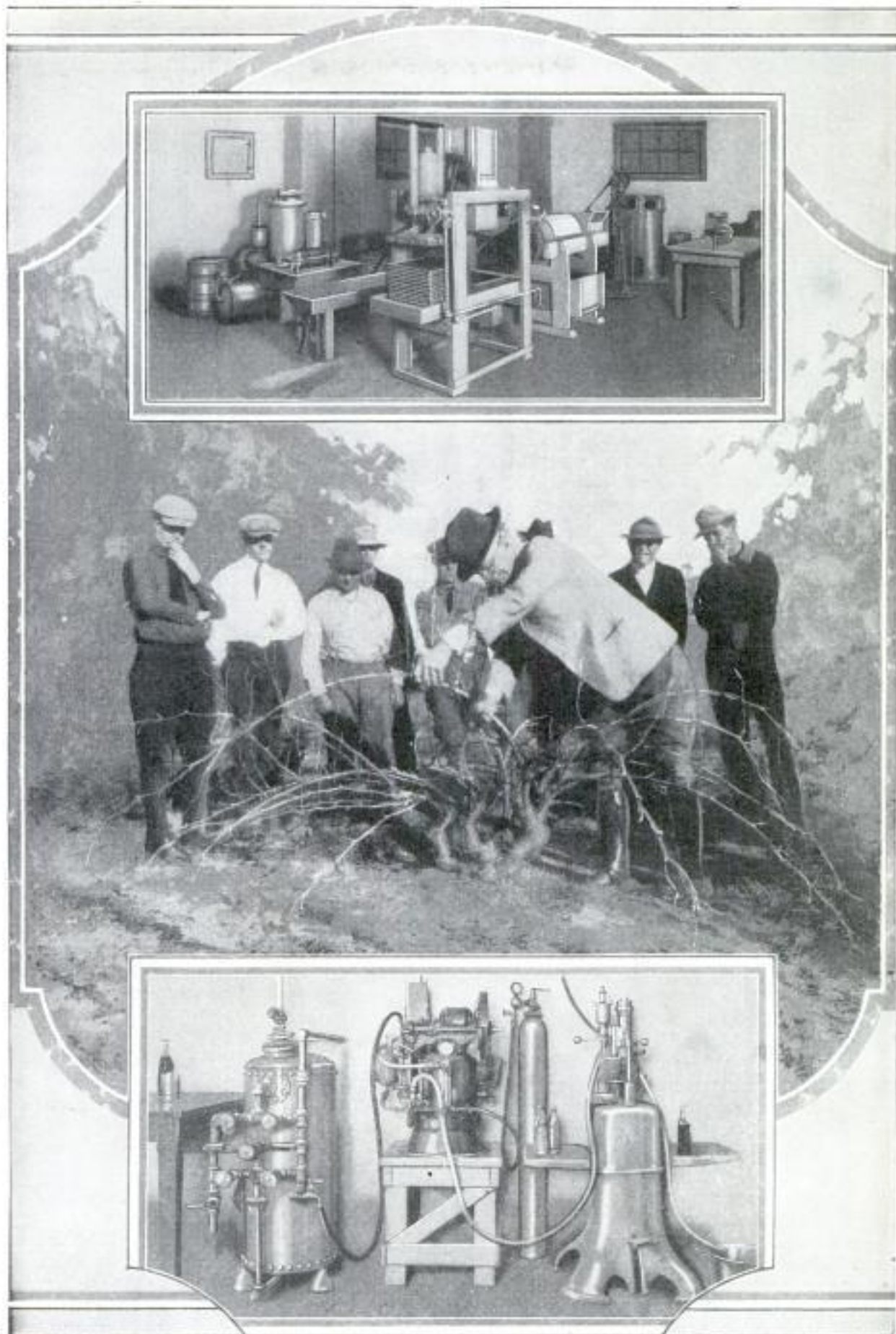

Heating Appliances Used in Search for Method of Preserving Fresh Fruits without Cooking (Top); Experiment in Grapevine Pruning, and (Bottom) Corner of University Laboratory

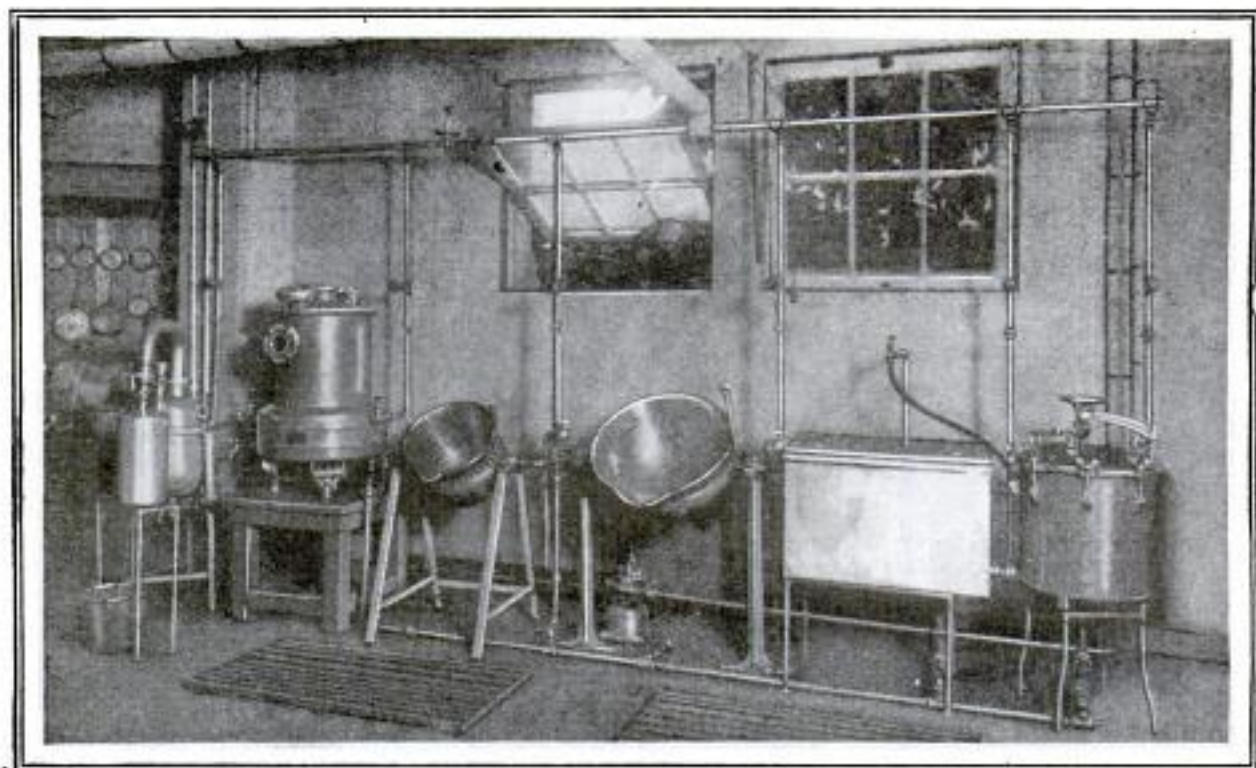

Apparatus Devised by the Faculty and Students of the College of Agriculture of the University of California in Their Discovery of Method of Preserving Fresh-Fruit Juices

which is a gas, until it has expelled all the air from the keg. The opening is then sealed hermetically, additional pressure put on the supply of sulphurous acid, and in a few seconds, the gas tube is withdrawn and that opening also sealed airtight.

No refrigeration of any kind is required and figs also have been shipped successfully in this manner, while experiments are now being conducted on perishable vegetables. The explanation of the grape-packing method is contained in the fact that the sulphurous acid keeps the skins of the grapes disinfected and free from the bacillus of decay, which cannot develop in the absence of oxygen.

The preservation of perishable fruits in airtight packages also has been accomplished this year in still another manner, of even greater value commercially. They are prepared and washed as if for immediate use, and packed into ordinary tin cans, a light sugar syrup is added, filling the cans to the exclusion of all air, and the cans hermetically sealed. These cans are then stored in a refrigerating plant or ice-box where the temperature is about twenty degrees Fahrenheit. This freezes the fruit. When thawed out, it retains its original flavor, freshness, size, shape and color for at least twenty-four hours.

Still another method of preserving for long-time shipment and distant use has been discovered in a new form of drying,

whereby all the water, and nothing but the water, is removed. This dehydrated fruit, if kept free from insect pests, will remain in good condition indefinitely. When wanted for use, water is added and in a few moments the fruit begins to swell and to take on something of the appearance it had when fresh. Naturally, this fruit is intended for cooking, and not for table use. The great value of this dehydration discovery lies in the fact that the fruit can be shipped, packed in insect-proof paper or wood packages without refrigeration.

The fourth and last of these discoveries in the preservation of fruits without cooking for long periods comes with the announcement from the same workers that fresh-fruit juices may be kept indefinitely by a new method of bottling. This is largely a commercial proposition, since the expense of the equipment necessary to successful bottling is rather too expensive for individual or even family use.

184
ACID-PROOF INK WON'T STAIN

Containing substances which combine with the paper to which it is applied to form an indelible compound, an ink is being made which will wash easily from the clothing or hands. It will work in fountain pens, as it does not clog and will not corrode steel or form sediment or "gum" in inkwells.

Acid proof ink Co.
3240
Philadelphia

2.13.11
3240

Mr. Gabriel

Barker & Co.,
~~25 S. Clinton~~
Chicago #61

POPULAR MECHANICS

WARN PUBLIC OF COUNTERFEIT
TEN-DOLLAR NOTES 202

Thousands of dollars' worth of counterfeit \$10 Federal Reserve Bank Notes were added to the account of spurious money recently. This last series, all purporting to be from the Chicago branch and bearing the numbers G-56637764A, G-56637746A, and G-56636744A, are so cleverly made as to mislead even experienced bank tellers. The notes bear the picture of Andrew Jackson and the number D-333 under the seal on the face of the note. On the reverse side they are off-color, having either a lighter or darker shade of green than the genuine bill. The threads of silk, as appearing in the genuine notes, are simulated in the counterfeit by printed lines. The lines cannot be seen when the counterfeit is held to the light.

ELECTRIC SANDER DOES DAY'S
WORK IN SINGLE HOUR 117

For finishing hardwoods or removing the varnish from old work, a portable, electric



Price - \$195.00.
642 W. Washington

Portable Sander that Also May Be Used on Floors by Attaching It to an Extension Handle

sander has been made which may be used either on the bench or on floors. The depth of the cut may be adjusted by a screw below the handle. Rollers guide the sand drum at the proper angle for the fastest and smoothest cutting. When used on floors it is attached to an extension handle. The motor is driven by current from any light socket. It is claimed that the device will do in an hour work that would ordinarily require a full day.

EVERY STOP OR START OF AUTO
IS RECORDED BY DIAL 186

Recording in miles and minutes the detailed operations of a motor car for a day of twenty-four hours, a small dial instrument, somewhat like a speedometer, has been put on the market by an English firm. A silver needle records on a sensitized chart by means of V-shaped and straight lines, the automobile's stops and journeys. The dial is turned by a clock-work mechanism and is marked into hours and fractions. It quickly tells the length of a halt and the time it took to go a certain distance. The instrument is securely locked in a waterproof case and is easily attached to the car. It is driven by a flexible shaft geared to the inside of the front wheel.

Wynburn Ave.
Sydney, Australia

Price W. N. Cary Ltd.
Speedometer Dial

New York
William Service
32 Union Square

EVERY STREET IN CITY SHOWN
ON BRONZE TABLET 126

Inscribed with a plan of the streets and principal highways of Berlin, a circular bronze tablet resting on a stone base in Potsdam Place, in the German capital, is an ever-ready guide to visitors. Points of the compass, important buildings and centers, and other information that will help strangers to find their way about, are



Bronze Tablet Inscribed with Plan of Berlin Streets Conveniently Located at Busy Corner

engraved on the durable surface of this accurate "information bureau."

For measuring the depth of water in wells, an Australian inventor has perfected an electrical device which can be carried in a coat pocket when not in use.



Surveying Depths of the Grand Canyon

**Roughest Three Hundred Miles of the Abyss Are Traversed
by Government Party to Obtain Mapping Data**

TO locate sites at which dams could be built to utilize the wasting waters for flood prevention, power development, and irrigation, the last stretch of the canyon of the Colorado that had not been surveyed in detail for accurate mapping, has been traversed by a government party in charge of C. H. Birdseye of the geological survey.

In four wooden boats, supplemented by a canvas canoe, the 300-mile journey was made through the roughest waters of the mighty chasm. These boats carried all the supplies of the party and also, except at portages, the men themselves. In addition to the usual instruments used by engineers and geologists, a radio-receiving outfit and complete photographic equipment were taken on the trip.

The start was made from Flagstaff, Ariz., the railroad station nearest to the point of departure, for Lee's Ferry, 140 miles away, with one boat on a motor truck and with all the provisions and instruments on another truck. "A part of the road to Lee's Ferry," said Colonel Birdseye, "was in a frightful condition—so bad that we had to stop every few miles and repair it before we could go along. This stretch of road includes the 'dugway,' a narrow road blasted out of the cliff, which at some places rises about 300 feet above the river, and the job of steering a heavy truck laden

with an 18-foot boat around the perilous turns lent lively interest to the journey."

About two weeks were spent under the stress and distress of a temperature that reached 110 degrees in the shade nearly every day, in making new topographic surveys. Starting down the canyon, the party camped at the head of Badger Creek rapids, seven and one-half miles below Lee's Ferry. Here the radio set was tried out, and in spite of adverse prophecies that a radio set could get nothing in the depths, Los Angeles was heard plainly, although the gorge here is 1,000 feet deep. From this point down the canyon the radio outfit was set up from place to place and received messages from Los Angeles, Salt Lake City, San Francisco, and on one occasion from Colorado Springs. Badger Creek rapids were run by the four wooden boats, the canvas canoe being portaged. These falls have a drop of thirteen feet in about a hundred yards, and they looked wild enough, although later experiences with rough water farther downstream made them seem in memory altogether tame. Even in this venture, however, the first boat through the rapids struck a rock with such force that a hole was knocked in its bottom.

Then the party portaged the boats and equipment past Soap Creek rapids, carry-



Downstream View of Upper Granite Gorge

ing and skidding them for about a hundred yards over the rocks into an eddy below the worst part of the stream. The boats were reloaded in this eddy and then run safely through the lower part of the rapids. These rapids have never been safely run by any other party. "It was man-killing work," said Colonel Birdseye, "to portage the heavy wooden boats here. Perhaps we might have got through safely without portage, as we ran worse rapids later, but it did not seem wise to take the chance so early in the trip.

"The next day," said Colonel Birdseye, "we reached a rapid that lay between vertical cliffs which rose directly from the water, so that there was no foothold for portage and no chance even to look the rapids over and form a plan to run them. We called them 'Sheer-wall rapids,' but we ran them safely, though everybody got wet. We put on life jackets and lay face down in the boats, clinging hard to the life lines that were stretched across the deck. The waves seemed mountainous, and to some of us our first ride of this kind was a genuine thriller, but we afterward became so used to riding rough water and getting soaked that we vied with one another to make the plunge with a lighted pipe or cigarette without losing the light."

Amid the excitement of running rapids and of the boatmen's dare-devil defiance of the swirling waters of the canyon, the scientific members of the party never for a moment forgot the main purposes of the expedition. At necessary places the surveying instruments were set up, photo-

graphs were taken, and calculations were made in furtherance of the larger ends in view. The canvas canoe was lost in an attempt to "line" it around Spring Cave rapids, that is, to drag it by means of lines attached to the bow and stern. The canoe might have run safely through the rapids, for the fall is only about five feet, but the waves were breaking high and were discouraging.

After several other rapids had been run, the boats passed Vasey's Paradise, thirty-one miles below Lee's Ferry, so named by Maj. J. W. Powell, the first explorer of the canyon, in honor of George Vasey, a botanist. Here a large stream of clear, cold water gushes from the cliff about seventy feet above the river. The party filled their canteens, explored a large cave, made surveys of a possible dam site, and camped on the limestone ledges, where radio messages were received. About forty-one miles below Lee's Ferry, some fine arches in the limestone wall of the so-called Marble canyon were passed. Here the walls, which rise sheer about 2,000 feet above the river, have been sculptured into wonderful forms by erosion and by the fall of great masses of rock.

The next day the boatmen ran the little fleet through Boulder rapids, and the rest of the party picked their way along the banks. Blake, one of the boatmen, was thrown out, turning a complete somersault and going out of sight, but he soon reappeared and caught his craft, which had not overturned, climbed in, and paddled on. One night the river rose three feet and

476 7

the party had to rouse themselves and hustle to pull up the boats. A voyager in the canyon always has reason to fear a rise in the river, particularly at night. A boat swamped or carried away means the loss of provisions and equipment, and even the lives of the men may be endangered if they are caught in a narrow box canyon where the walls are sheer and afford no foothold.

The dreaded Sockdologer rapids, seventeen miles below the Little Colorado, was the next big obstacle. The height of the

Grapevine rapids, which has a fall of seventeen feet in a few hundred yards and is full of rocks. At this place it is impossible to climb around the rapids, so the whole party shot through in the boats. The river had been rather high, and though the high water makes larger waves, eddies and whirlpools, it helps to keep the boats off the rocks and so perhaps makes the plunge safer. Between all these perilous plunges down dangerous cataracts the surveyors carried along their work.

When the boats plunged into Diamond Creek rapids, one of the party fell on the rocks and fractured a rib but insisted on continuing his survey. The fractured rib was painful, but bandages made it possible for him to carry on. From this point down the boats plunged through rapids



Geological Survey Boat Being Skidded over Rocks at the Head of Soap Creek Rapids

fall here has been immensely exaggerated in some accounts of trips through the canyon, one recording a drop of eighty feet in one-third of a mile. The fall really amounts to only nineteen feet, but most of it occurs in the first hundred yards. The waves have been described as thirty feet high, but they measured in fact only about twenty feet from trough to crest.

It is impossible to climb around these rapids, so all had to take the boats. Seen from above the rapids, the first boat and its passengers were glimpsed only at intervals; they were out of sight most of the time, but they finally appeared at the foot of the rapids right side up, and when the semaphore signals sent back O. K. to the rest of the party, everyone felt relieved. The next morning, the boats plunged into

after rapids, and as the sunshine did not get into the canyon until late in the morning, the first half of the day was chilly. The rapids have a fall of nearly twenty feet and look dangerous, and the sheer walls leave no chance to pass around them, so everyone had to ride in the boats. Three boatmen ran their crafts safely, but the deck loads made the boats top-heavy and caused them to dance about in the torrent like corks even after the cockpits were filled with water. The huge waves tossed one boat into the air, and when it came down, bottom side up, the passengers were thrown out and narrowly escaped being crushed by the rocks.

*J. H. Curtis, Peoples Gas Co
Chicago - furnished
for*

RUBBER BALLOONS IN GAS MAIN CONQUER FLAMING VOLCANO

When gas, escaping through a manhole in the street from a twenty-inch main, was ignited by the backfire from an automobile, the engineers of the Peoples' Gas Light and Coke company, of Chicago, faced a difficult problem. As the main fed a busy manufacturing district, it was necessary to conquer the flames without interrupting service. Fire engines were called to the spot and several streams of water were directed at the fronts of surrounding buildings, while workers at a safe distance dug down to the main at each side of the leak, which was caused by corrosion. Then four-inch holes were bored into the pipe and through these openings large rubber bags, attached to long tubes, were inserted. Air was pumped into the bags, effectively blocking further passage of the gas. After the flames had subsided, the break was repaired, the bags removed and the holes plugged without an instant's interruption of service.

GLARE SHIELD FOR AUTO FOLDS LIKE BLADES OF FAN

To guard the eyes of an automobile driver from glare, a protector that folds up like a fan is being made for fastening to the windshield. Simply turning a ring on

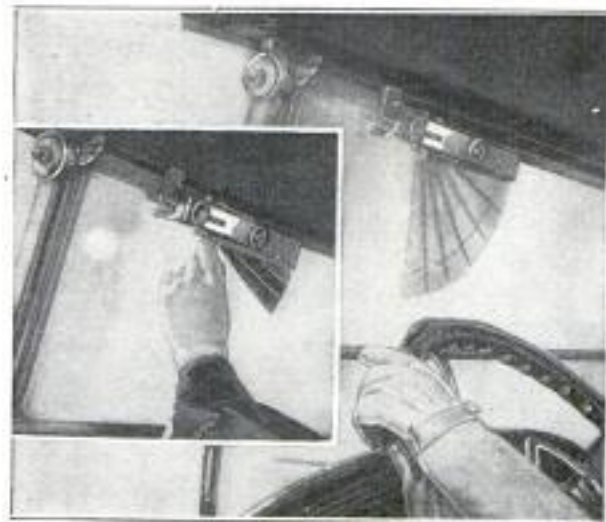

Fanlike Glare Shield which Is Easily Adjusted or May Be Folded Back in Case

the device causes it to spread a green curtain over a section of the glass, leaving space for the motorist clearly to see the side of the road. When not required, the mask can be closed into its metal case by another twist of the handle. Use of the glare shield is said to eliminate the need for heavy colored goggles during the day.

*Allen Glare Protector Co,
20 Ave. B, New York City*

AUTOMATIC FISH LANDING NET OPENS AT SINGLE TOUCH

Inclosed in a small round barrel, a landing net that opens at the touch of a button has been invented for the convenience of

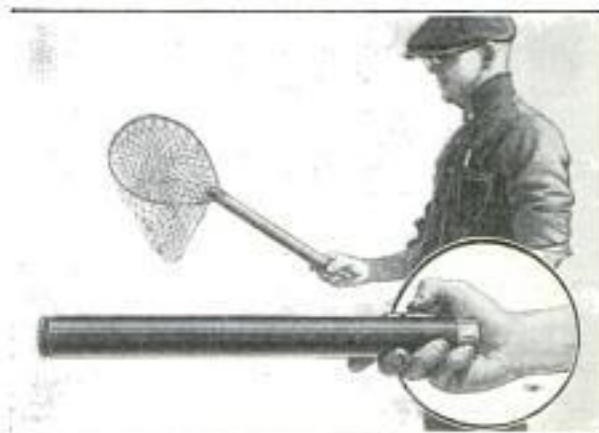

Landing Net and Carrying Case from which It Is Released by the Touch of a Button

sportsmen. It is entirely encased when not in use and can be carried in the belt or slipped into the pocket. A spring forces the bow on which the mesh is suspended out of the casing ready for action. When folded the holder is thirteen inches long. All metal parts are rustproof. The net saves space in the camping outfit and in the boat, and does not get torn or entangled with other things when not in use.

AIR HAMMER TAKES BENDS FROM OLD RAIL SPIKES

Old railroad spikes made worthless by being bent are reclaimed by an automatic straightening machine built by a western railway. The apparatus takes the crooks out after the nails have been heated in an oil furnace. As each piece is laid under a compressed air hammer, another is fed into the other side of the device. More than 2,000 spikes are treated in a day and, it is said, the operation has resulted in a great saving of materials.



road to be all + center

*Water
like the 7 by 6
of the 6 inch. W*

*Ent. Charles W. Leiger
Union League Club, 1st - 2nd
San Francisco, Calif
Jungles*

Time and Money-Saving Tools



1
Tester Which Quickly Tells Whether Egg Is Good or Bad by Light Shining through Shell on Mirror that Can Be Seen through Hole in Base



4
All the Thrills of a Toboggan and Swing Are Combined in This "Whizzer" Designed to Keep Children at Play in Their Own Yard



6
Pocket Comb that Is Made in Two Sections, One with Fine Teeth and the Other with Coarse; when Open, It Extends Six Inches; after Being Folded, It Occupies Only Half This Space



2
Turning Any Vase into an Attractive, Portable, Electric Light Is Possible with an Adapter that Carries the Socket for the Lamp on a Patented Grip inside of the Neck



5
Egg Beater for Making Mayonnaise Sauce with an Automatic Drip to Add the Oil as It Is Needed Without Touching with the Hands



3
Filter and Mixer that Regulates Temperature of Water and May Be Used to Clean Bottles (Left) or Wash Dishes (Right), and Is Attached to Faucets with Rubber Elbows

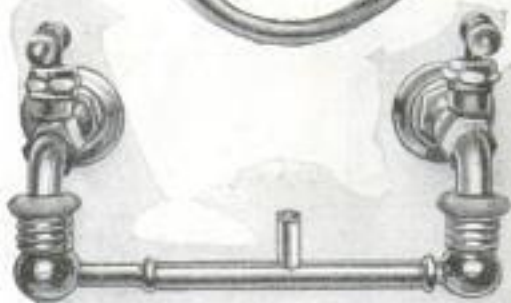

To Insure Pure Drinking Water, a Simple Filter and Siphon Have Been Combined, the Flow Being Started by Bulb Pressure

Anyone wishing further information on devices described in the editorial pages can

for Woman's Workshop in Home

9



Scissors with Detachable, Razor Steel Edged Blades Which, When Dull, May Be Replaced Quickly and Easily and at Trifling Cost

12



14



Can Opener Especially Designed for Campers and Boy Scouts, that Can Be Folded Flat and Carried on a Key Ring

10



13



15



16



Seat, Foot, Shower and Child's Bath Combined in One Tub that Requires Less Water and Yet Provides Ample Space When Standing or Sitting

Sharpener for Fiber Phonograph Needles that Operates Without Removing the Points from the Tone Arm and at the Touch of a Lever

Portable Electric Heater that Can Be Hung in Closets or Cupboards or Used to Dry Laundry Air

Mop Made of Swan Skin with the Down Still on It that Is of Service in Cleaning Statuary

Steak Grill Attached to Handle that Is of Service with Gas Stoves; the Edges Are Curved to Catch the Meat Juice

Fastener that Quickly Attaches Handle to Broom or Mop; This Permits the Use of Any Length of Stick So that Difficult Spots on the Walls or Ceiling May Be Reached; the Device Consists of Steel Jaws Operated by a Spring

obtain it by addressing Bureau of Information, Popular Mechanics Magazine, Chicago

4414

Making the Mechanical Mathematician

Watching the Ratchet Wheel on Planer Results in Invention That Is Now Sold in All Parts of the World

Inv. Dorr Eugene Felt.

JUST forty years ago a stocky young mechanic was toiling over his planer and filling an oily yard of heavy wrapping paper with figures and drawings during his spare time.

Fascinated by the busy little wheel which automatically adjusted the cutting edge of the tool, he became imbued with the idea that the ratchet could be turned into a counting machine. To do this, he figured, he need only number the notches on the wheel and then put more numbered wheels beside it. Then by making each wheel turn ten notches, or one complete revolution, in order to turn the next wheel a single notch, he would have solved the problem.

It was a long step from that ratchet to a machine which would actually calculate—an adventurous step that called for planning and figuring. Hence the yard of wrapping paper and the stub pencil used so industriously by Dorr Eugene Felt. But he clung to his one idea, and the shop hopelessly classified him as an inventive "nut" who lacked the redeeming feature of versatility. To him the idea of an adding machine was original—he knew nothing of the attempts, and failures, which had preceded his efforts. And he probably would not have cared, if he had.

Opposition and ridicule? He thrived on them. He would just grin and keep on figuring and experimenting. On rare occasions he would warm to the subject, and then he would say: "That little ratchet wheel can feed my planer tool,

can't it? And I've proved it can count, too, haven't I? Well; if it can count, it can add, and if it can add, it can figure—calculate. And I'm going to prove it, too!"

From the grocer he got an old macaroni box, from the butcher a dozen wooden meat skewers, and from the hardware store some staples. That store could furnish no springs that he could use, so he resorted to rubber bands as their substitute. So he went to work, a jackknife and a screwdriver being his principal tools.

This adding machine was no marvel. It worked, after a fashion, but not the way it would have to in order to be used as a demonstrator. Such a model must be made of metal—properly constructed. That meant money, and the young inventor had no money, but he obtained a loan from the proprietor of the shop.

Finally the finished model was ready for demonstration. It proved an unqualified success. The mechanical calculator was an accomplished fact. Capital was ready to back him now.

He accepted just enough to cover his barest needs, not enough to menace his control, put himself on a salary of \$20 a week, and figured to work fourteen hours a day.

That year the young mechanic-inventor turned out seven machines. Then he was made president of the firm which was organized to make and sell machines, and under his guidance this company has prospered until today its product is sold in every civilized country in the world.

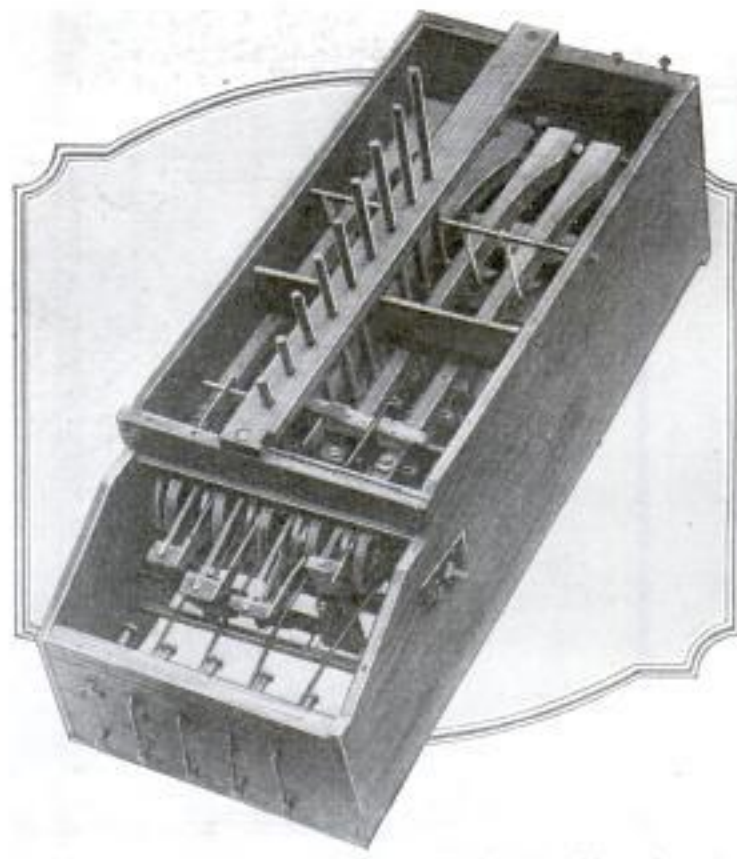

First Model of Mechanical Calculator Which Was Made Out of a Macaroni Box

Cont. Wm. Fleming French, 1348 Texas Ave. Chicago

ART OF GOLDSMITHS UNCHANGED IN CENTURY

Skilled goldsmiths, with the simple tools of their craft that were in use more than a century ago, demonstrated their cunning recently in preparing gold covering for the gates and railings in Buckingham Palace. Swinging hand mallets that weighed from 12 to 21 pounds, they pounded out practically pure gold into thin sheets of foil, so thin that an ounce



of the precious metal covered 200 square feet of surface. The hammers are swung with precision and have broad heads to avoid tearing and bruising the thin sheets. Starting with small blocks or bricks of gold molded from molten metal prepared in retorts, the workers pound with such skill that the finished sheets are often 1-282,000th of an inch thick.

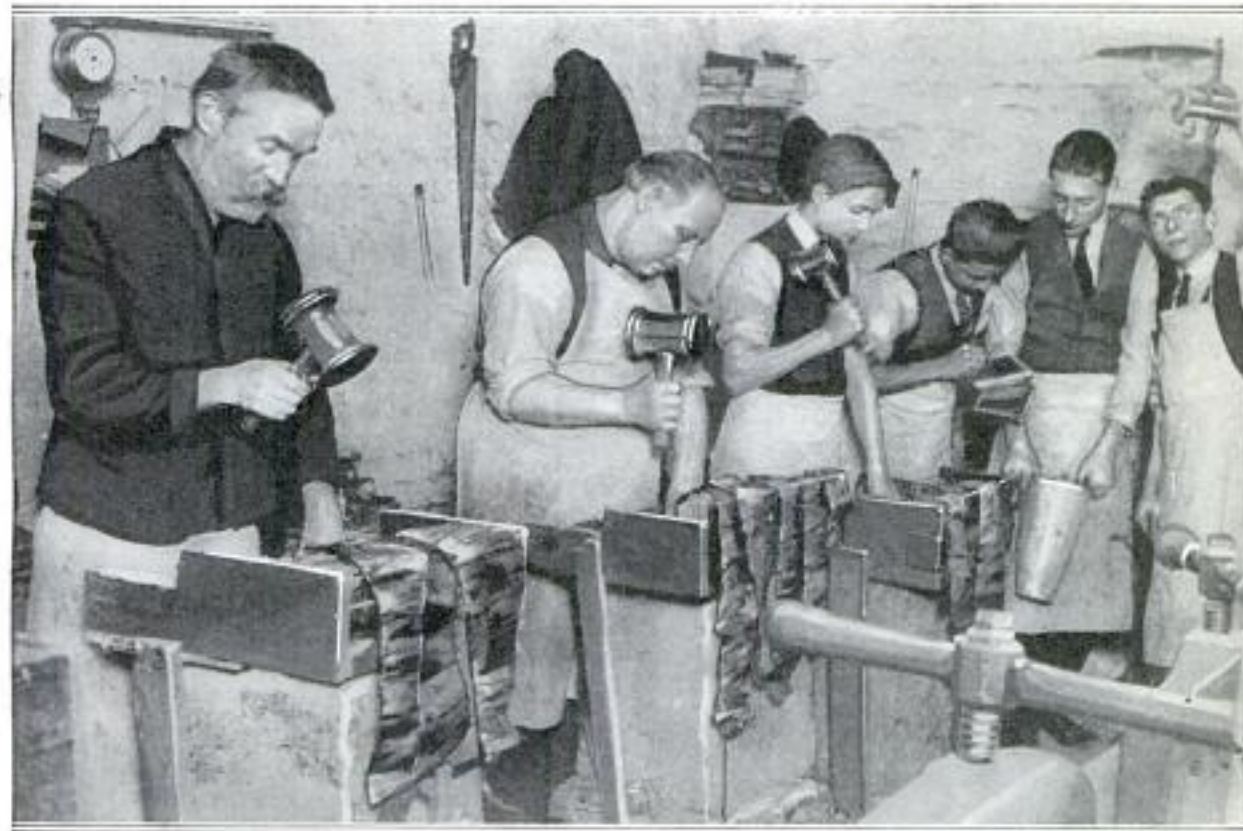

Copyright, Keystone View Co.

Beating Out Gold Foil Thinner than the Finest Tissue Paper Known: Above, Pouring Molten Metal from Retort into Mold to Form Gold Brick for the Pounders

WEATHERSTRIP IN ROLL STOPS
RATTLES AND DRAFTS 13

Loose, noisy windows and doors that let in wind and dust, are quickly silenced and made practically airtight with lengths of weatherstripping material composed of flexible, rubber-coated fabric that fits tightly

to the side of the frames and snugly about all cracks and openings. It is round, like rope, and cannot curl up around the edges and fold back, and comes in coils, the lengths being cut off as desired. On one side is a flap cut off as desired. It is especially adapted to fit tightly over irregular surfaces such as those of warped doors.

Mfr. E. J. Wurf,

*116 & 117th St.
St. Louis, Mo.*

**MOTOR BUS LIKE PULLMAN CAR
AIDS TOURIST TRAVEL**

4342

With parlor-car seats, card tables, and electric stand lights, luxurious motor busses have been put into service for the



Luxurious Automobile Bus of Type Used in Parts of Europe for Accommodation of Tourists

convenience of tourists in Europe. Vying with the comforts of railway travel, they afford better views of scenery and are scheduled to cover routes that often require six days to complete. The motor coaches also touch many isolated points of interest that cannot be reached by rail. This form of transportation has grown in favor, and the lines are crowded with visitors.

**FOLDING ARCHER'S BOW EASIER
TO AIM AND TO CARRY**

4542

So that it can be quickly taken apart for carrying, an archer's bow, patented by a Massachusetts inventor, joins at the middle in a handle, which is said to make it stronger than ordinary types. When the string is released for a shot, the arrangement is said to give it greater casting force

dim Almer E. Shephardson
Melrose, Mass.

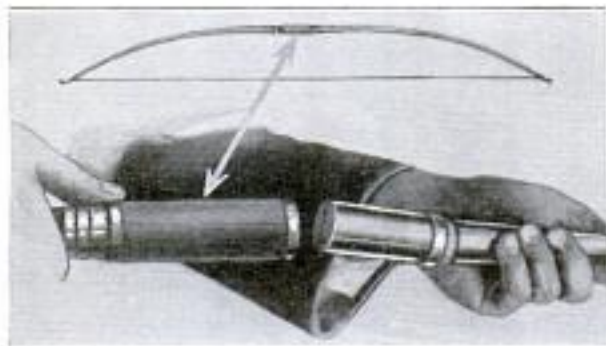

Folding Archer's Bow and Center Joint that Adds to Its Strength and Accuracy

and to eliminate "kick." A metal cylinder, it is claimed, prevents bending of the center and gives a smooth spring to the ar-

row as it takes flight, as well as furnishing a resting groove for the shaft. The grip is made to fit the hand of the archer comfortably, thus permitting steady aim. Either half of the device can be renewed.

**LOCOMOTIVE IS DRIVEN BY AIR
TO PASS THROUGH FLOODS**

12

So it can run safely over flooded tracks, a locomotive has been built in Italy that uses compressed air for power. Tests of the engine are reported to have shown that it can pass through water more than a yard and a half deep, while hauling a train. It is expected the apparatus will be of great advantage in rescue work and transportation of supplies in lowland regions frequently inundated by swollen rivers or storm-swept seas.

Keystone View Co. 41-9th New York

ACCURACY OF LENS IS PROVED

QUICKLY BY LIGHT RAYS

For testing lenses manufactured by a German optical concern, a beam of light is thrown from a tube upon a holder in which

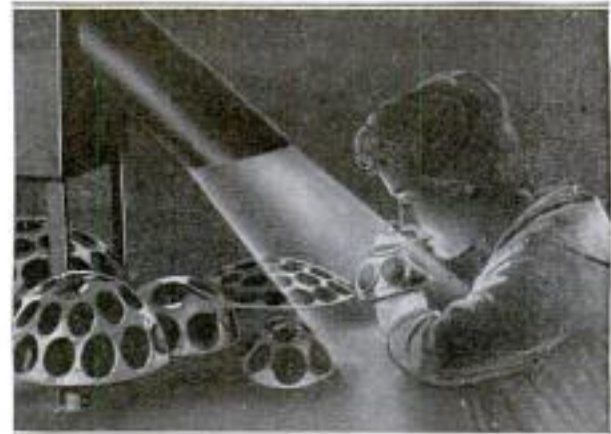

Inspecting Newly Ground Lenses with "Testing Glass" that Shows Imperfections as Colored Stripes

a number of the finished pieces are set. When a curved glass plate is placed over them, any imperfect surfaces can be seen, appearing as colored stripes under a magnifying glass. It is believed that this method will save much of the repeated inspections usually necessary to eliminate incorrectly ground lenses. Only a small part of each lot produced, it is said, are fit for installation, the remainder requiring remelting and recutting.

Carl Zeiss, Jena, Germany

(Nearly one-third of the entire available water power of the United States is located in the states of Washington, Oregon, and Idaho.

Berkeley, Calif.



Smashing through Arctic Ice-Pack

Balking Poachers in the Frozen Arctic

U. S. Coast-Guard Cutters Carry White Man's Law Past "Roaring Forties" to Protect Great Seal Herds

NORTH of Point Barrow and the "Roaring Forties" that seamen dread, the coast-guard cutter "Bear" plows into the vast Arctic ice pack. Three-quarters of the world falls away to the south, and all the solid land of which men have knowledge rolls over the shoulder of the globe astern. Each night the Aurora converts into day, and every day is barely long enough for the captain to make an observation.

Above, three masts spread vast wings of gray canvas, scarcely less dark than the smoke which pours from the single stack. In the crosstrees, a lookout signals a flag flying over Nigaluk, behind the barren isles. The bell to the engine room rings, the ship turns slowly toward the blue line which indicates the shore. A black spot develops into a boat, filled with rowers, coming out. The captain puts his glass on the flag. It is a man's coat and a woman's dress, flung to the wind from a high pole. "Storm ahead," he says; "somebody wants to get married."

When the gangway is dropped, a score of fur-clad figures, each one a Santa Claus without the bag of gifts, troop aboard. The leader makes guttural sounds, to which the captain replies. They smile and shake hands, and it develops that two of the figures are female. One of these and one of the men stand in front of the captain who reads a marriage service. They sign a

paper, with two white men in the uniforms of Uncle Sam's service as witnesses. Then the other woman and a man step forward. There is an exchange of more gutturals. Another paper is signed. The first man and the first woman cling together; the second pair draw apart.

"One tied and one untied," observes the captain, as he files the marriage papers and the divorce decree in the wall safe. Another man steps forward. His brother is sick. Where? In the boat below. A tackle is dropped and a bundle lifted out of the seagoing canoe. Laid on the table, the man reveals a broken leg. After it is set, splints are bound on, instructions given, bundle lowered back, the boat refills and shoves off.

Darkness thicker than the fog begins to spread over the waters north of 70, and the ship stands out to sea. It has been an easy day for the "Bear," now in her fortieth year spent in carrying the law and the government of the United States into the far north. Built of wood more than half a century ago, this three-masted cutter has won at least one fight each year with ice which annually crushes larger vessels, made of steel, in its world-warping grip. Each year she drags from the ice, crashing with her wooden bow a lane through the ice pack, ships which have delayed too long in leaving the frozen ocean, and patrols the coasts of Uncle Sam's domain from Queen

Charlotte Islands northward, around the Gulf of Alaska, along the steaming Aleutian chain, through Bering Sea, where she stops to hunt down poachers of the seal herds on the Pribilofs, and then on poleward again past towering Nunivak and long St. Lawrence Island.

Touching at Nome, she points northward again, the only white man's law north of the East Cape, with the exception of her sister coast-guard cutter, the "Algonquin." Through Bering Strait, past Point Hope and the Icy Cape, she steams to Point Barrow, the northernmost tip of America's domain in the new world, and sweeps abruptly eastward into the wet and silent desert of the Arctic ocean.

Signals greet her, here, there, everywhere. Here she heals the sick and buries the dead; there she picks up a stranded hunter or an explorer; somewhere else she puts down food to carry through the winter a starving group of white men or of Eskimos, for there is no bar of color or condition of race north of Nome. Her captain, Commander Cochrane, carries the power to grant marriages or divorces, to make arrests for any crime against the white man's law, to pass judgment when sitting with his officers in a court, and in flagrant cases, to carry out that judgment, even to the extent of summary execution, for which the swaying yardarm, half a hundred feet above the deck, furnishes the gallows tree.

To the "Bear" and her captain is due the fact that the salmon fishing fleets of Seattle and San Francisco, and the whalers of more northern ports come through their seasons year after year without loss of life, for the coast-guard cutters watch over these industries as they watch over the trading schooners, the freighters, the great sailing ships that bend their way by the northward route across the Pacific and into the Arctic every summer. From the time she leaves her winter moorings in San Francisco Bay, in April every year, until she returns late in October, hers is a constant watch. Night and day men search the sea from her decks seeking the good they may do.

Again, the wooden ship moves eastward until Herschel Island lies abeam. Suddenly a light flares out of the darkness, and then another. In what seems less than a moment, answering lights lift from the bridge of the "Bear." There is a short talk in silent flashes through the thickening air. The cutter works her way slowly inshore, as Captain Cochrane studies his charts. At the ultimate point he dares approach the shore in the night, he rings for the full stop. An anchor chain rattles through the hawsepipe, a final signal burns on the bridge, a riding light is swung from the masthead, and the frozen world drops off to sleep, forgetting the perils of the day.

When light lifts it reveals a steel tramp steamer caught in the pack ice, in the channel between the island and the mainland shore. Too much eagerness for trade with the Eskimo has caught her, held her too late, and, if she be not saved, she will be an empty hull, her crew dead from starvation, before the ice breaks in the spring. The "Bear" backs off, her captain studies his charts more closely.

Suddenly, in response to a signal from the bridge, the old wooden cutter leaps forward, smashing her nose through the pack ice.

But there are other and less pleasant tasks than performing marriages and rescuing ice-bound ships. In port in Alaska, the captain of the "Bear" receives word that poachers, crossing in schooners from the Asiatic mainland, are preparing to raid one of the fur-seal rookeries. With all sail set and her engines adding to her speed, she immediately starts for the threatened island. Lying below the horizon until night, she silently approaches the refuge of the seal herd. Rifles are distributed to the crew and belts filled with cartridges—for the poachers may fight, run, or submit. There have been many arrests, numberless flights and a few battles, fought up there on the silent sea, with only the barking of myriad seals to furnish background for the rattle of rifles. In every such incident, the "Bear" has been victorious, until today the poachers virtually have abandoned their efforts to loot the fur seals.



Executive Staff of the "Bear" Who Represent the United States Government North of Nome

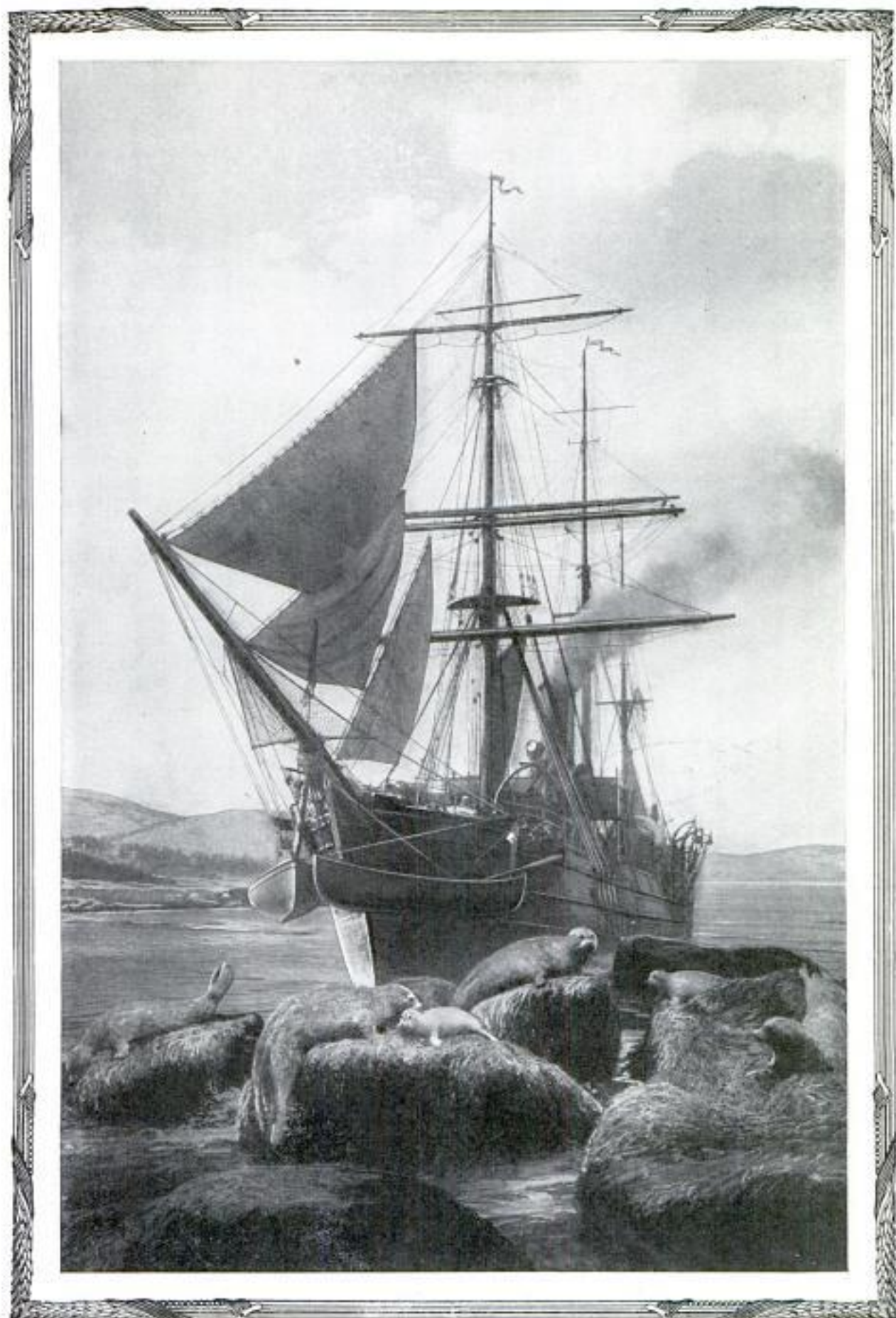

Coast-Guard Cutter Protecting Seal Herd in Far North, Preventing Poachers from Russia and Japan from Destroying the Great Rookeries Developed under International Treaties

The Psycho-Expander Co.,
 Dept. M, 1900 S. University Ave.
 Denver, Colo.

POPULAR MECHANICS
 4205

EXPANDER TELLS LUNG POWER AND ADDS TO STRENGTH 59

Chest expansion is measured accurately and the amount of air inhaled is shown in cubic inches on a flexible belt with legible



Chest Expander Adjusted: Measurements Are Registered in Opening of Ruled Section

indicator ruled in such a way that the readings are made easily. Slipped over the shoulders and fitted to the chest at normal position, it expands as air is taken into the lungs. The device has proved of special value in taking chest and breathing exercises. Resistance afforded by the spring tension of the belt urges the muscles to greater play and the user is afforded a constant incentive to deeper breathing in attempting to push the indicator to higher figures. Its use is said to result in rapid improvement in breathing and chest development.

RAILWAY RUNS MOTOR TRUCKS FOR SHORT-HAUL FREIGHT 60

To handle short-distance packages of less than carload lots of freight, the Pennsylvania railroad has put on a fleet of motor trucks between Wilmington, Del., and Philadelphia. This is regarded as a significant decision, as for years privately owned trucks have made inroads into the freight tonnage of the older carriers, but now the way has been opened to make them the allies instead of the competitors of the railways, according to traffic experts. Increasing use of trucks also will affect the highways, which already are overcrowded. On the more used routes, it is said, special roads will be necessary for trucks exclusively. Connecticut, for instance, is now paralleling the Boston post road with a highway for freight traffic only, and it is expected that this example will be followed shortly in other sections of the country.

"TRICK" FURNITURE SAVES RENT AND SPACE IN APARTMENTS

With the constantly increasing demand for economy of space because of the high rentals demanded for city apartments, the building of what is known as "trick" furniture has developed into an industry, and its design has challenged the ingenuity of inventors in all parts of the country. Beds that fit in doors, kitchenettes hidden in tables, ironers folded out of sight in attractive cabinets, radio outfits concealed in tea wagons, and many other useful devices have been constructed to save space with a consequent lowering of rents. Furnaces that are as decorative in appearance as a phonograph, and electric stoves that automatically shut off the current when the food is done, help to lighten the burdens of the modern housekeeper. As a result, three rooms may be made to meet the requirements which previously needed six.

OFFICE CLIP HAS FORKED KNIFE FOR OPENING ENVELOPES

For opening envelopes, an office clip is being made with a V-shaped notch in its end, both sides of which are sharpened to a cutting edge.



After inserting either of the jaws under the flap of the envelope, the paper is kept against the knife while slitting by a slight forward pressure. New correspondence can be stacked in separate piles and fastened together by the same clasp used to open it.

"HELLO" PASSING AS TELEPHONE GREETING TO SAVE TIME

After being in familiar use for years on the telephone, the conventional "hello" gradually is dying out in practice, according to an official of an eastern company. The reason for this is ascribed to economy of words and a desire to save time. The usual salutation now is, "Mr. So-and-So speaking." "Ahoy" was the word used by Alexander Graham Bell in his early experiments with the telephone, it is said, but this was discarded for the more easily pronounced "hello," which is believed to have originated in England when fox hunting was the favorite sport of the gentry.

Chicago Tribune
 Jan 6, 1924

Chicago Daily News
 Jan. 7, 1924

Barber Clark Co. H. H. Shaw St. Mo.

Psychological

New York

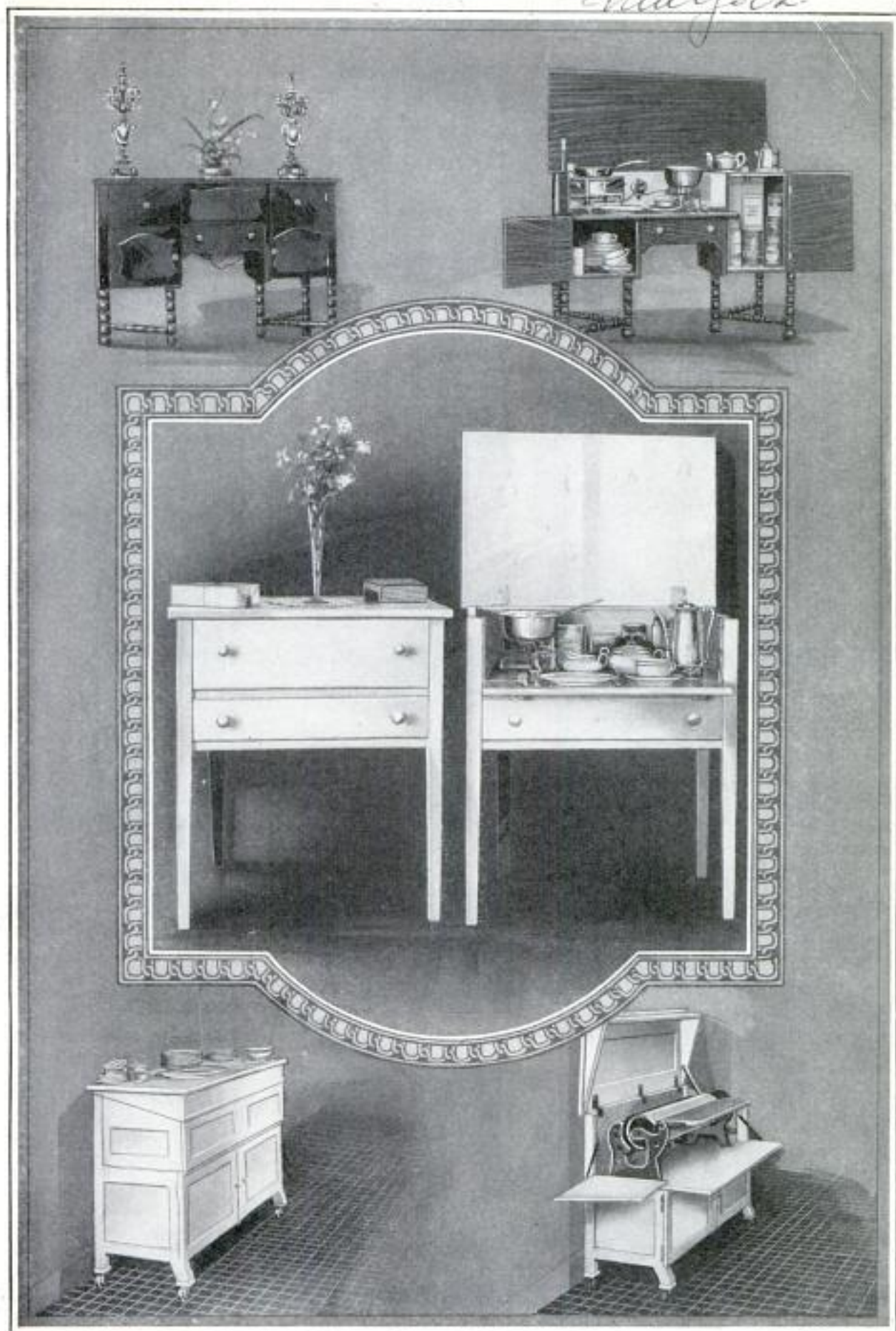

Space-Saving Furniture Designed to Meet Demands for Economy of Space; How Kitchenette May Be Hidden in Table (Top and Center), and an Ironer in Cabinet (Bottom)

United News pictures, Inc.
461- Eighth Ave.
New York City

576

POPULAR MECHANICS

ARMY HAS GAS MASKS FOR ALMOST EVERY PURPOSE

4



Various Types of Gas Masks Developed by the Army to Combat Deadly Fumes and Adapted to Many Peace-Time Uses, Including Mine-Rescue Work and Fire Fighting

Gas masks to suit almost every need for such articles have been developed by the chemical warfare service of the army. Since the days of wet cloths used to combat the first waves of deadly fumes early in the war, protectors have been made with devices at the mouthpieces to enable wearers to talk into telephones. Special ones

are designed for persons in submarines under the sea, while others have eyepieces which fit the ends of field glasses to guard those engaged in range work. Where fresh air can be had from another source, as in the case of workmen in oil or gas tanks, a mask with a long hose that can be run to the outside is provided.

PIPE CLEANED THROUGH SLOT IN BOWL WHILE ALIGHT

So that it can be cleaned thoroughly and easily while smoking and without removing the bit, a tobacco pipe with an

opening at the base of the bowl through which obstructions can be removed, has been designed. The cleaner is inserted at the mouthpiece and is easily pushed the whole length of the stem and through the slot at the end, as the openings are in line. A sliding cover, fitting tightly over the opening, keeps it closed when the pipe is lighted. Breakage and wear on the stem are avoided with this design, as the bit does not have to be removed and the "cake" in the bowl is not disturbed.



Cleaner Inserted: It Passes Out through Lower Slot without Disturbing Tobacco in Bowl

☛ Catnip, which is highly relished by domestic felines, is also enjoyed by mountain lions and bobcats. Government hunters use oil from the plant as a lure in trapping the animals.

J. Bachman Co.,
4020 N. Keeler Ave.,
Chicago, Ill.
460

**TREES PLANTED BY MACHINERY
— FASTER THAN BY HAND 17**

Seedling trees can be set out by a machine used by the government forestry service, at a rate ten times as fast as hand planting. The planter digs the furrow, places the young twigs and feeds water and fertilizer to the roots. It then pushes the soil around the growth and packs it firmly. Two attendants are required to keep the supply of seedlings constantly in the hopper. As each row is put in an attachment marks the position for the next line. It is said that about 15,000 trees can be planted in a day by the device, which is drawn by two horses.

**MOTOR TRUCKS, TWO ABREAST,
CARRY EIGHT-TON TANK 453 7**

To move a huge eight-ton oil tank three miles, a California company placed it on two motor trucks. The reservoir rested on loose blocks so that the vehicles could make turns in a space less than 100 feet wide. For loading the tank on the carriers, two other trucks were necessary. One dragged the immense cylinder along a platform by means of a cable looped around it, while the other car held the weight under control by keeping another rope attached to it stretched in the opposite direction.



Hauling Huge Tank on Team of Motor Trucks that Were Guided by Arm Signals

The drivers were guided in maintaining the proper distance apart by arm signals given by a man walking ahead, and by keeping a tight stretch on a wire that connected the front ends of the machines.

To promote the advance of aviation in the United States, a New York University has established courses in aeronautical engineering and industrial aviation. The plan has the financial support of the pioneers in the field of aviation.

University
Height
New York.

**STEEL CLOTHES CABINET BARS
DUST AND PREVENTS MOTHS**

Moths are barred from the interior of a steel clothes cabinet that is airtight and of sturdy design to resist intruders. It is said



Metal Cabinet for Clothes and Furs that Is Airtight to Keep Out Moths and Dust

that eggs of the destructive insects can not hatch, if by chance they should be carried within, owing to its construction. Garments infested with the pests can be cleared of them by placing the apparel in the locker with a fumigating solution. Furs and clothing, it is claimed, remain unsoiled by dust, even after long periods of storage in the vault. Chemicals that destroy insect life can be permanently kept in the cabinet, increasing its effectiveness.

**BLIND BUILD ELECTRIC-LIGHT
4609 SOCKETS AND CIRCUITS**

Inmates of a Chicago training institution for blind persons assembled more than 35,000 electric-lighting outfits for Christmas trees during the past year, it is reported. Cutting and scraping the wire, soldering and fitting the sockets, and testing the finished sets comprised the tasks of the workers. The completed material is tried out on a special machine equipped with a buzzer that sounds to indicate the perfect article. A contract involving 500,000 sockets was previously completed by the sightless toilers. About \$115,000 were earned in one year by ninety-eight graduates of the school's course and this total will be increased in the future, it is hoped.

Christian Science Monitor
12/21/20 Copyrighted material

Cont. Chap. Abbott Standard. Los Angeles
5626 Irvington Blvd

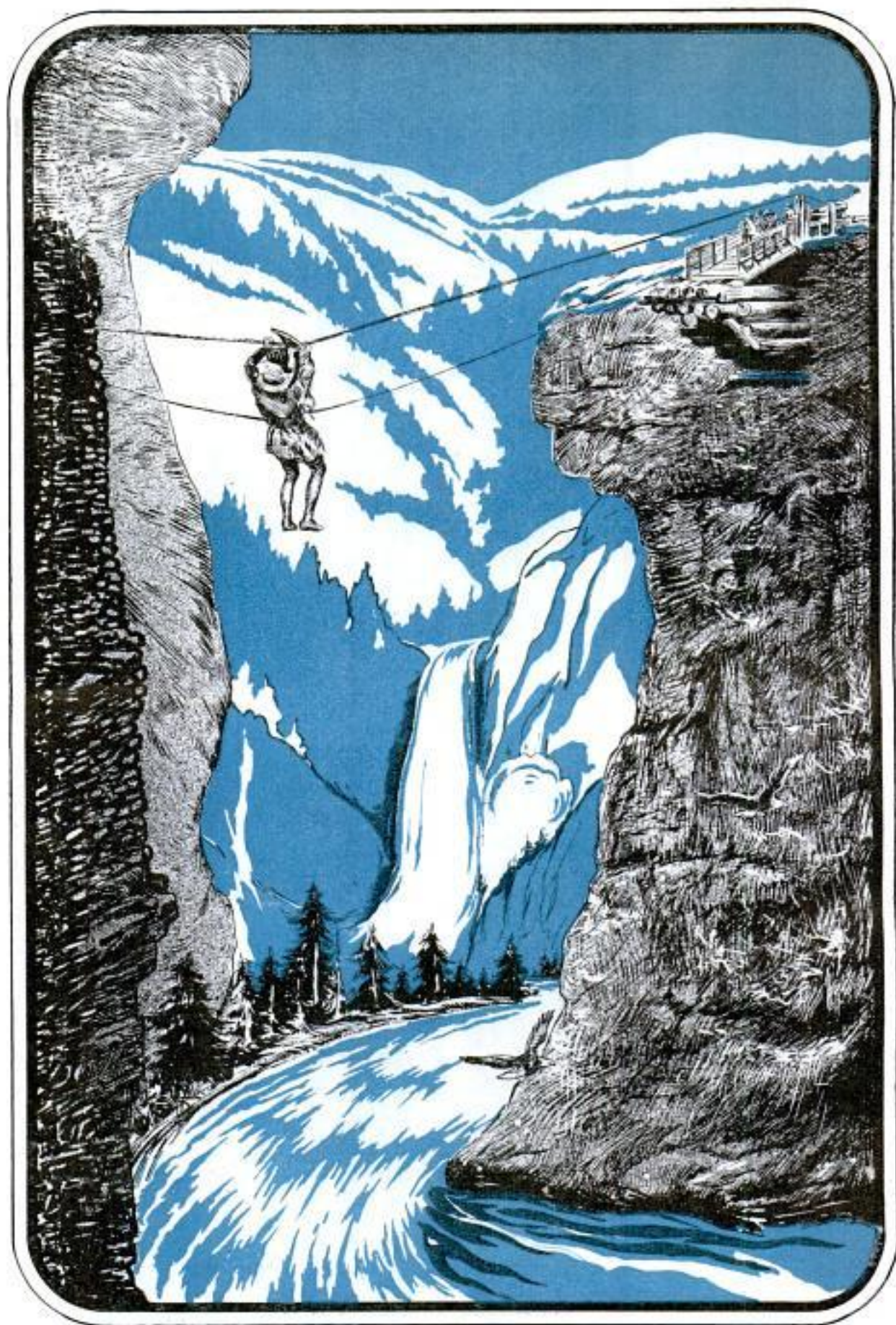

Explorer Crossing Deep Chasm on Rope Bridge in Depths of Asia Where a Fall Meant Certain Death in the Torrent Rushing from the Mountains toward the Sea



One of the Bridges in Srinagar, British India

Bridging the Countless Chasms of Asia

**Abysses Are Spanned with Steel, Stone, Chains, Ropes, Cables
High Above Torrents that Have Endured for Ages**

By SVEN ANDERS HEDIN

WHAT a hopeless task it is to attempt to describe in a few columns of a magazine the viaducts which, in the greatest continent of the earth, make it possible for individuals, caravans and railroads to cross rivers and abysses!

Nobody has ever attempted to count up the bridges of Asia, and nobody who would engage in such a hopeless task would ever succeed. From the imposing and substantial railroad bridges, which in their huge dimensions can emulate structures of their kind in Europe and America, down to the small, single ditch-planks, which in the Chinese and Mohammedan world are connecting one bank with another, we can number bridges by the hundred thousand over countless watercourses

of varying size—some as immense as the Amur river, some as insignificant as the canals of the irrigation system of Turkestan.

As I am now trying to arrange my memories, there seems to pass before my eyes a motley pageant of bridges, some of them a thousand years old and more, others quite young, and others again swept away by the high flood of every summer, and then newly built every fall. I recall bridges of stone, of tile, of iron and cement, of chains, ropes and cables, of wood, posts, planks and branches, and the natural rocks which in the course of time have broken asunder from a mountain and tumbled down into some wild ravine, where they now serve as spans for the natives.

Sven Anders Hedin, noted authority on those little-known lands, Tibet, Turkestan, Mongolia, and central Asia in general, has spent a great part of his life—he is now 58 years of age—in exploring these strange lands. These journeys, performed at times amid extraordinary hardships and always at the immediate risk of lingering and terrible death at the hands of savages or by starvation, have won for him high honors and a world-wide reputation and fame. Doctor Hedin is an honorary or active member of nearly every scientific society in the world; is the bearer of honorary degrees from most of the famous universities of the civilized world, and is now on his way to Asia for another journey through the wild interior where he has found strange buried cities and grotesque and terrible customs.—Editor's Note.

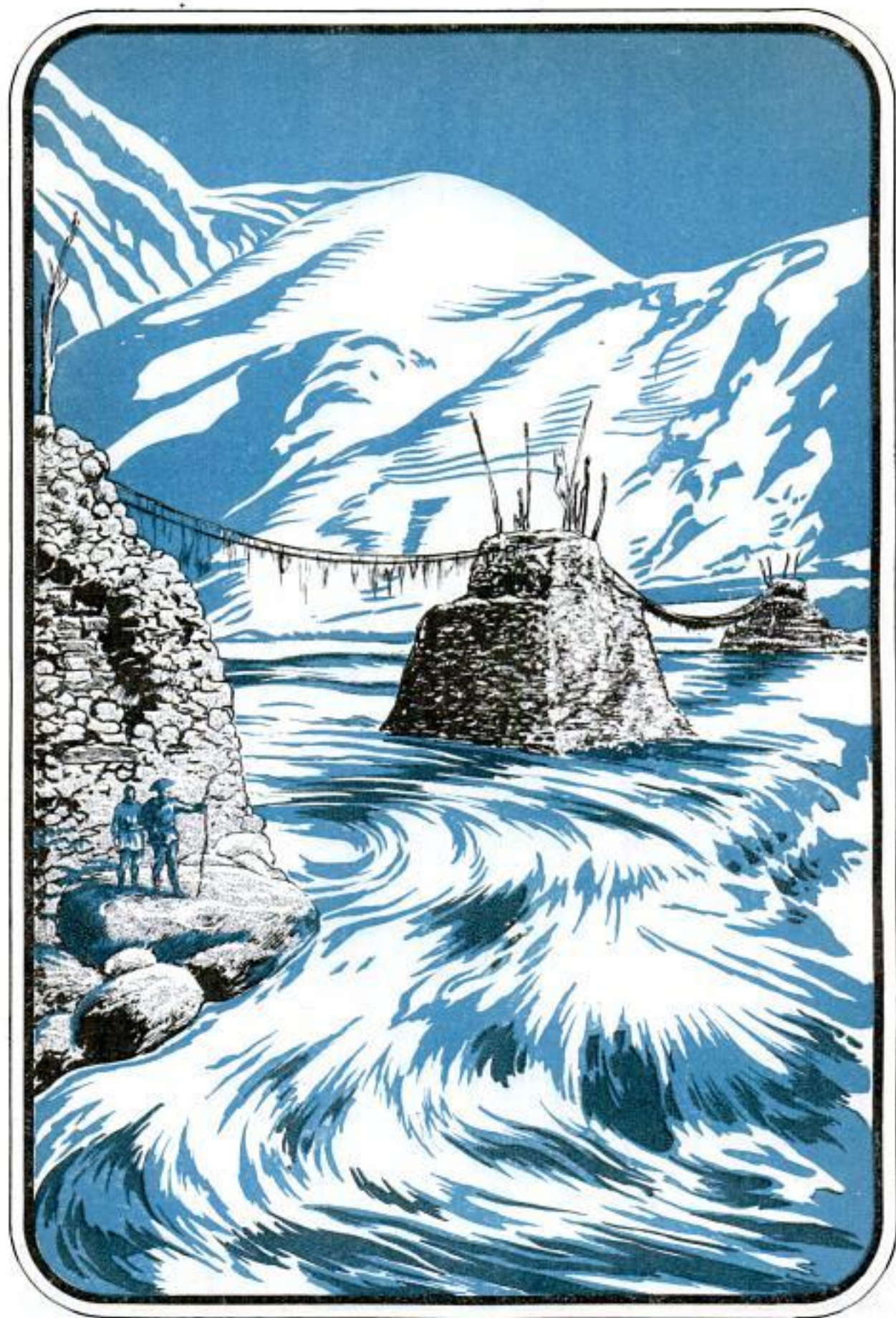

Primitive Bridge of Twisted Rope Used by the Natives of India in Place of the Substantial Spans Known to Civilization; Some of These Are Hundreds of Years Old

And I imagine I hear the rattling of heavily laden railroad trains, which on singing structures of iron are speeding forth over the gigantic rivers of Siberia and India. I hear the tinkling of bells, while caravans of camels are plodding over playful whirling eddies; the measured echo of clattering hoofs, as the horsemen are scampering over the tottering planks of a treacherous wooden bridge; the cheering call of herdsmen, as they are driving out their sheep on rocking structures over winding brooks. My ears are humming with the deafening roar of the waters which were rushing by, underneath my feet, while I was standing again on so many bridges in the remote corners of Asia and in the boundless wilderness that fills so much of the heart of the continent. What masses of water are streaming underneath all these in the course of years, of decades, of centuries! They never run dry, getting new nourishment steadily from their sources in the mountain tracts, and they never become tired of thronging toward the sea.

Asia is like the roof of a house, irregular in shape, falling off gently in the various directions. From its crown, rain water is pouring down in all directions. Near Erzerum in Armenia, I visited a place where, within an hour's time, a man can ride to the sources of three rivers flowing to different seas. No matter where the water-courses arise, they are still, as they sweep onward, crossed here and there and again by paths; in fact, these crossing points are almost innumerable, and countless likewise are the bridges which lead over the bright and gentle waves of some of these rivers as well as over the dark and eddying ones of the others.

In what follows we can leave entirely out of consideration the large bridges in the "edges" of the continent. Railroad spans are built everywhere on the same principles, and their aspect changes only

in form and dimensions. On that part of the Bagdad road which had been finished in 1916 when I traveled it, only one bridge of gigantic dimensions was to be noticed, namely, the one which leads over the Euphrates near Jerablus. This high iron structure, painted in red and resting on ballast beds, made a strange impression in the desolate Asiatic landscape with its lack of striking contrasts.

When Annenkoff's famous railroad was extended from Merv to Bokhara and Samarkand, the Russians, owing to their haste and to the expense, had to content themselves with a temporary wooden bridge over the Amu-daria near Charchui, an unprecedented structure as regards length, 4,592 feet, when considering the fact that it rested merely on posts driven down into the river bed.

Leaving now the subject of railroad bridges, and directing our attention to some larger rivers which are crossed by caravans, we naturally think first of Euphrates and

Tigris. In 1916 I rode on a Turkish ferry down the first-named river and covered in this way more than six hundred miles. I had had built a cabin of boards, in which I was living. It was in the middle of April and I had a table and a chair, so I could draw a map of the stream, with the aid of a compass and watch, and note the velocity of the current. As our ferry reached Deres-Sor, where the caravans pass over the Euphrates and an island divides the river into a larger eastern and a smaller western arm, we took the course in the latter direction. A wooden bridge leads from the main land to the island. The river was high and the current violent, so we drove quickly downstream against the bridge. Our situation looked threatening, because the horizontal bridge beams were not sufficiently high over the level of the stream to permit the cabin to pass underneath.

Had we driven with the full speed of the current against the bridge, either the cabin

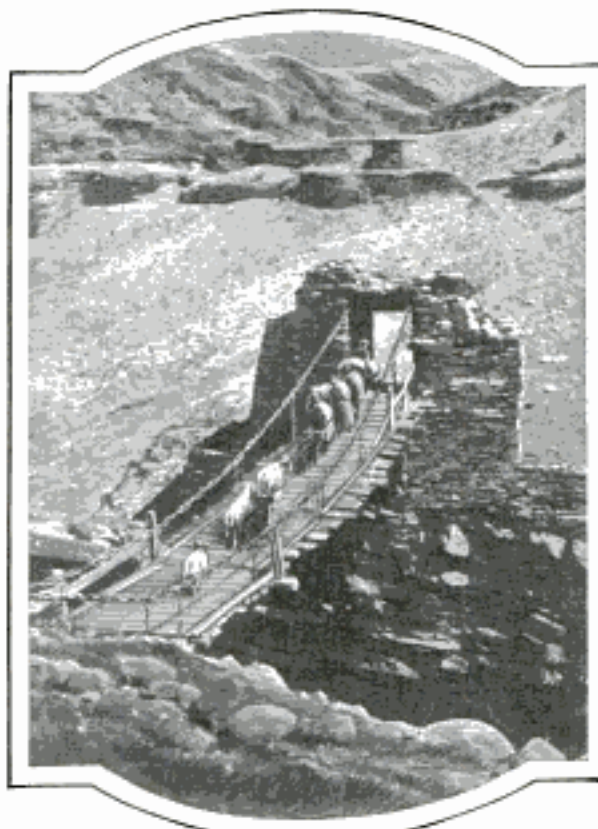

Plank Bridge for Beasts of Burden that Is Found in the Chinese and Mohammedan World

would have been shattered to pieces, or if its power of resistance had been strong enough, the ferry would have capsized, and been lost beneath the choppy waves. But luckily my ferrymen succeeded at the right moment in mooring the vessel just above the bridge, and there we had a carpenter saw off a foot from the height of the cabin so that we could pass under. The lost roof was then replaced by a canvas cover.

Near Mosul, directly opposite the ruins of Nineveh, an angular bridge of ludicrous appearance spans the Tigris. Half of it consists of stone and tile firmly imbedded in the ground, while the other half is upheld by pontoons. From the balconies of the Mosul cafes, which are in a long line skirting the right shore of the Tigris, and where the Turks and Arabs with their nargilehs or waterpipes are enjoying their "keif," that is to say, their truly Oriental idleness, a superb view can be had over the famous river and over the bridge with its lively traffic of camel and donkey caravans, horsemen, pedestrians and carts.

In Bagdad, the classical city of the Arabian Nights Tales, and one time the capital of the Abbaside caliphs, the two banks of the Tigris are connected by a pontoon bridge of this time-honored system. The pontoons are anchored at the bottom of the river, as well as it possibly can be done, and over them beams are laid to carry the cross planks. When I passed over this bridge for the first time, in 1886, I found it just as much worn out as when I traveled over it thirty years later. But probably its gray, shaggy and corroded paint had been renewed more than once in the meantime.

The Bagdad bridge, however, is inadequate for all the traffic between the two parts of Harun-al-Rashid's city. If the populace on the outskirts of Bagdad want to pass over to the other side, they do not choose the circuitous route over the bridge, but resort to their quaint, round, basket-shaped boats, the guffa, or else they swim across, on top of two air-filled goatskins.

From the ferry on the Euphrates I once noticed a man who came walking down to the shore of one of the wide water-arms of the stream. Without stopping for a moment, he took from his back an empty goatskin and blew into it with all the force of his lungs, so as to fill it with air, and twisted a cord around the opening. Stripping himself naked he rolled up his clothes, fastened the bundle on his head and threw himself into the river until the water was reaching up to his armpits and he had to make use of the goatskin, so as to reach the other side in swimming. When he arrived he let the air escape from the skin, dressed and continued his walk as if nothing had happened. He had thus made his way satisfactorily without any bridge.

In a similar, although more complicated, manner, the Tajik and Kirghiz natives are used to making their way across the waters of the Raskan-daria, one of the mighty sources of the Yarkand-daria in southern Pamir. With their help I once made my way over the river near Tong. Every once in a while merchants arrive there with horse caravans. The animals swim across, while the men take places on a small float whose under-rafters are borne up by air-filled goatskins.



Crude Boats Made of Skins Help in Crossing Unbridged Streams Often Found in Asia

Prof. William A. Sewall
 Berlin, Germany

Mr. Loeffelholz Co.,
 Milwaukee, Wis. 583

POPULAR MECHANICS

UNIVERSAL LANGUAGE OF COLOR
 "HAS NOTES" LIKE MUSIC

4645
 Color notes, by means of which others can produce tone harmonies they have never seen, have been devised by a noted chemist. It is predicted that this system will do away with the present elaborate outfits of color samples and substitute an exact and universal color language, by means of which contracts and orders can be executed without previous inspection of the goods. It is expected to be particularly valuable in the clothing and house furnishing industries.

4515

TOURIST GUIDE ON SIGN POST
 GIVES WAYSIDE DIRECTION

Information to aid the tourist is supplied at the roadside in a convenient waterproof, box arrangement, attached to a metal guide designed by an Illinois inventor. Cards printed with highway maps, facts about cities and towns and other helps to the traveler are fitted into frames on pivots in a case with a door, which automatically closes when the tourist has finished his examination of the leaves. When the box is opened, the cards are tilted for-

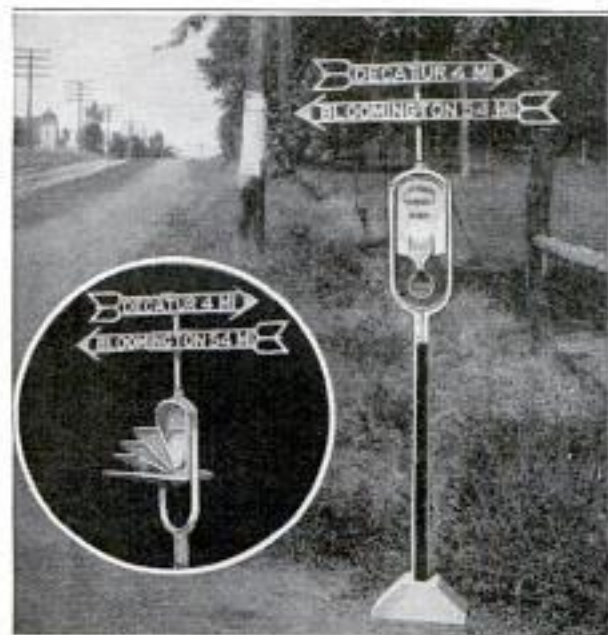

Roadside "Information Bureau" in Sign Post: Inset Illustrates how Leaves Open for Inspection

ward to a comfortable angle. A bar weight swings back and closes the frames when pressure is released and protects them from exposure.

Ducks are fond of honey bees and are able to swallow them without being stung.

DISK IN RAIL-COACH WINDOW
 HELPS TO VENTILATE CARS

4500
 Passengers are spared the annoyance of tugging at car windows to open them, and discomforts caused by drafts are avoided by



Rotating Ventilator Disk and Position It Occupies when Fitted into Window Pane

an easily regulated ventilator which fits into the lower part of the outside pane. It is a perforated metal disk with a sliding cover attached over a circular hole cut in the glass. When the lid is turned, an opening lets in a current of fresh air. Less dust and dirt gain access in this way than when the window is raised. The size of the opening may be increased or diminished to suit the wishes of the passenger. The disk does not obstruct the view, as it is placed low on the pane and occupies but little space.

36

DIRECT CABLE LINKS EUROPE
 WITH INLAND CITIES OF U. S.

Through the development of a repeater that automatically transmits signals from ocean telegraph cables to land wires, Chicago has been directly linked with the cities of Europe. Heretofore, all matter for points within the United States has been taken off the submarine wire and relayed from the coastal terminal points. With the new method, the time required for a message to make its way from a foreign station to destinations remote from the seaboard will be greatly reduced, it is said. An apparatus with a needlelike pen controlled from the sending office has been installed in Chicago. The device prints a code of dots and dashes on a running band of paper from which they are translated for delivery.

Chicago, North & West
 Milwaukee RR

Chicago Daily Tribune
 Herald, to America Jan. 4, 1924

Wm. Peter P. Sobberdel
 Lecatur, Ill.

*Cont. Mel Wharton
584 135 E. 12th St.
Portland Ore.*

*Designed by J. B. C.
Lokwood, Engineer
Port of Portland, Ore.
Spalding Bldg.*

POPULAR MECHANICS

SAND IS FORCED THROUGH PIPE ON BED OF RIVER

446 Sand for a dike being built on the Columbia River, in Washington, is drawn from the opposite side of the stream almost a mile away and carried by a pipe line to the scene of construction.

nel. Pumps mounted on a giant dredge force the material to its destination, as it is lifted by chain buckets. An average of 900 cubic yards an hour are sent through the hidden passageway. During one

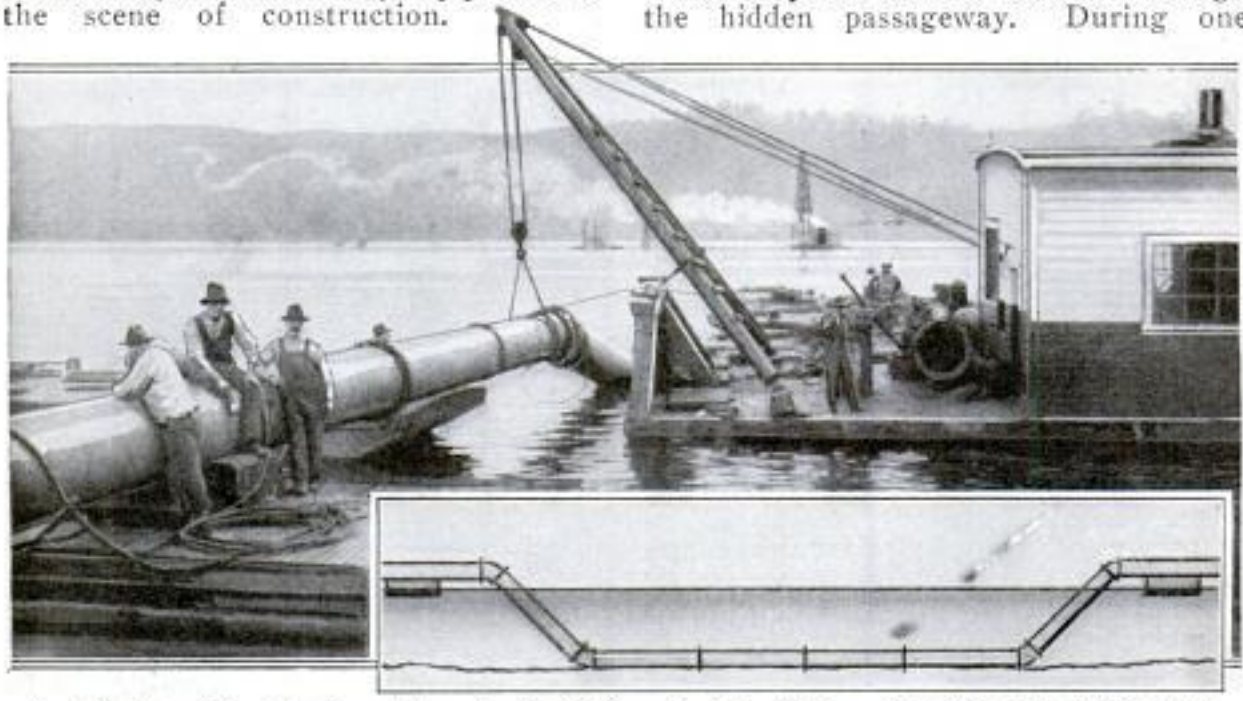

How Sand for a Dike Was Forced through a Pipe Laid on the Bed of a River, Out of the Way of Ships, from a Pit Almost a Mile from Scene of Construction

About a half mile of the tube rests on the river bottom in order to avoid interference with shipping passing through the chan-

nel. month, almost a million yards of sand were shot beneath the river to become part of the huge barrier, to be twelve miles long.

CANE AS CIGARETTE HOLDER AIDS MAH-JONGG PLAYERS

4619 Resembling a walking stick, a cigarette holder for use by players of Mah Jongg is being made with the socket at the bottom and the mouthpiece in the head. It is said to be of great convenience to those partici-

pating in the game, because it permits smoking without the annoyance of having constantly to lay the "smoke" aside while manipulating the pieces. It also keeps the raw fumes of the tobacco from the eyes. Ornamented with a brilliant tassel, it is strongly made, and the metal mountings are highly polished. The length of the "cane" is claimed to give an added coolness to the smoke.

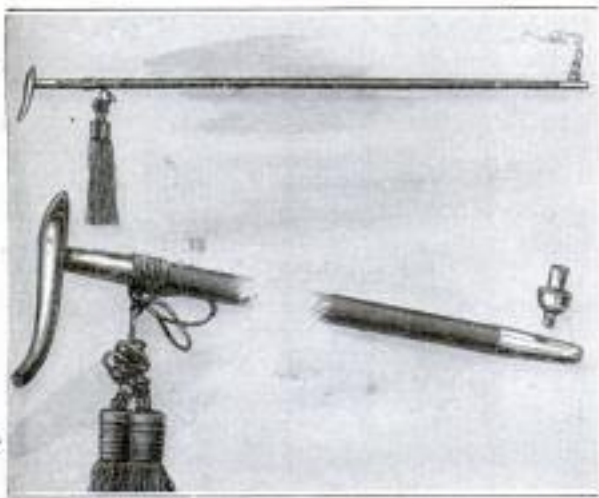

Decorative Cane that Serves as a Cigarette Holder for the Players of Mah Jongg

RABBITS ARE SLAIN BY PLAGUE AT SEVEN-YEAR PERIODS

54 Recurring every seven years, a disease which is fatal to wild rabbits depletes their numbers by thousands, according to scientists. Cottontails, northern hares and the "jack rabbit" common to the sagebrush plains of the west are said to be afflicted with the malady. When their numbers become scarce, coyotes, foxes, wolves and other animals that prey upon them are forced to seek better hunting grounds, and start to make ravages on the grouse and other game birds.

*Chicago Tribune
12/26/23*

Jays Shop, 230 N. Michigan Ave., Chicago

*Dr. W. Alexander K. Schaap, Brooklyn, N.Y.
274 St. John's Place*

POPULAR MECHANICS

585

20

**TYING CAST IRON INTO KNOTS
MADE EASY BY HEATING**

Transforming cast iron into a metal that virtually can be tied into knots is said to be the accomplishment of an eastern inventor. Everyone is familiar with the brittleness of most iron castings. Many are so hard that they are difficult to machine. By a special process of heating the metal, it has been found possible to render it pliable, easy to bend and almost springy. Previous attempts along this line are said to have weakened the castings, but the latest method is declared to add to their strength. The iron is raised to a temperature of about 1,600 degrees Fahrenheit, while protected in a muffle surrounded by a gas flame and open at the top. The conversion is accomplished in a little less than an hour.

**PADDLE ON GAS-GAUGE FLOAT
WORKS DIAL IN AUTO**

Equipped with a paddle fixed to a float, an automobile gasoline-tank gauge operates a dial on the instrument board when the car is in motion. As the liquid shifts about under the swinging of the machine, the rudderlike attachment is washed back and forth, causing the register hand to move smoothly on the scale. Even when the reservoir is being filled, the device is sufficiently affected by the ripples within to show the growing quantity on the dial. The arrangement is said to eliminate necessity for the driver to dismount to in-

**GALOSHES FASTENED WITH KEY
THAT LOCKS ROWS OF TEETH**

Galoshes are being made to fasten with two rows of metal teeth that lock together as a "key" is pulled across them. It is



Fastening Galoshes with a Pull on Key that Locks Row of Teeth

claimed that this method permits the overshoe to be adjusted in a few seconds and leaves a smooth surface with no buttons or buckles. When the footgear is to be removed, a downward stroke of the fastener separates the two edges. Closing tighter than the ordinary galoshes, cold and moisture are said to have little chance to penetrate to the inside. The key is concealed under the folding top of the boot.

**WOODEN-TOY INDUSTRY GROWS
UNDER TRAFFIC EMBARGO**

European competition having been almost killed by the traffic now in force, the wooden-toy industry is booming in America, several large centers of manufacture having sprung up. These factories are declared to be excellent outlets for the by-products of many working mills and go a long way toward making the lumber and coarse products' plants profitable. The largest center in the east is at Winchendon, Mass. Owing to the growing scarcity of wood and the cost of labor, wooden toys have increased in price in the last ten years about 100 per cent. Reforestation and scientific forest management, it is said, will tend to reduce current costs.

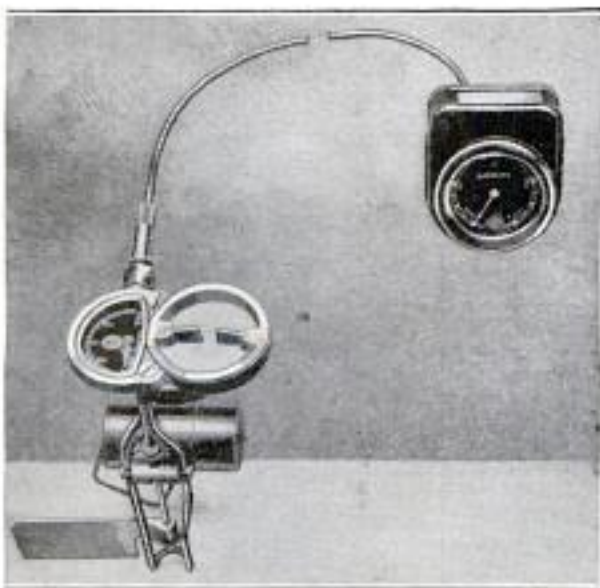

Dial for Auto Instrument Board and Float to Tell Exact Amount of "Gas" in the Tank

spect his fuel supply. It is also claimed that the paddle insures a more accurate record than ordinary types of indicators.

*Rochester Mfg Co, Inc.
Brighton, Rochester;
N.Y.*

*New York Times
Jan 13, 1924.*

B. F. Woodruch Co. Akron, Ohio

BEARD IS REMOVED WITH MUD AND USE OF X-RAYS

4640

Shaving beards from men's faces has been accomplished by a special mudlike paste that is undergoing experiments at



Man's Beard Being Removed with Mud (Bottom) and X-Ray Used for Facial Treatment

the hands of a New York doctor. After the mass has been applied, it hardens and is torn off. To finish the operation, X-rays are then directed against the skin. The originator of the method claims that it is beneficial and if used regularly will remove scars and similar marks of long standing. It is also said that the sticky treatment does not leave any ill effects on tender skins.

READY-MIXED CONCRETE STOPS BLOCKING OF STREETS

Concrete has become so widely used that a company in one city has found it profitable to supply large and small amounts of it in ready-mixed batches for the needs of individual consumers. Orders are taken by telephone, or by estimators who survey the "job," and the material is rushed to the buyer in motor-hauled tubs and dumped where it is needed. This saves the buyer the labor of mixing it himself and from having unsightly piles of sand, gravel and other material on his premises.

Smith Bros, Inc.
15th floor, American
National Exchange Bldg.
Harris, Pa.

Extensive contracts for street paving and other work have been undertaken in this way, and the plan is said to have been successful, especially in preventing the obstruction of the thoroughfares with large supplies of materials. At the mixer, skilled workmen see to it that the exact proportions of each ingredient are used. The motor haulers cover a wide radius in a short time.

4675

RED DYE MIXED IN GASOLINE TO PREVENT ACCIDENTS

Colored cans, plainly marked, have been used widely to hold gasoline so that disastrous mistakes might be avoided. Now it is proposed to color the gasoline itself with a brilliant red dye so that it can be distinguished instantly from water or kerosene. The suggestion is made by the bureau of mines as a further safeguard against accidents. Tests have shown that the dye found suitable for the purpose does not injure motors nor lower the fuel value of the gasoline. Enough of it to color 1,000 gallons can be purchased for seven cents and it mixes quickly as soon as it is poured in. During the war, army and navy regulations required that all gasoline of "fighting grade" be colored red to distinguish it from ordinary motor fuel. The plan proved successful in preventing mistakes.

Automobile Industry, 12/30/23

STEERING WHEEL LIKE SHIP'S IS HELP TO MOTORISTS

Adapting the principle of the mariner's helm to an automobile, an inventor has designed a steering wheel with six projecting handles to ease the task of guiding the car. By removing the strain necessary in gripping the wooden rim in the usual way and providing means for powerful leverage to aid in holding the car in mud or on slippery pavements, the handles enable the driver to lean comfortably back against the cushions, even on hilly or sandy roads. The wheel is made of polished aluminum and is eleven and one-half inches in diameter. The handles are brass tipped and are each four and one-fourth inches long. They do not interfere with the driver in the operation of other parts and enhance the appearance of the car.



W. E. Hancey
323 W. 11th St.
Waterloo, Iowa.

Mr. J. M. Marton, 347 1/2 1st Ave, New York City

J. G. Harris, 7437 Peachtree St, Chicago 624

ue, 1924. This, as you will note, is a description of

"Freezer house"



Packing
FISH ARE KEPT FRESH A YEAR
IN MAN-MADE ZERO
CLIMATE

Fish caught off the New England coasts are kept fresh for more than a year by being stored in "freezer" houses where temperatures of between 12 and 16 degrees below zero are maintained. After the catch has been washed, it is packed in pans of water that are then placed on shelves. The air in the storeroom is artificially chilled until the fish become imbedded in solid ice. The slabs are removed from the trays and stacked in tiers, much like cordwood. When needed for shipment, the ice cakes are broken up and the fish sorted in sizes before refreezing for transportation to distant points.



SAFETY PULLEY OILER ADJUSTS ITSELF AUTOMATICALLY

4602

Waste and danger in oiling pulleys and clutches while running, are largely elimi-

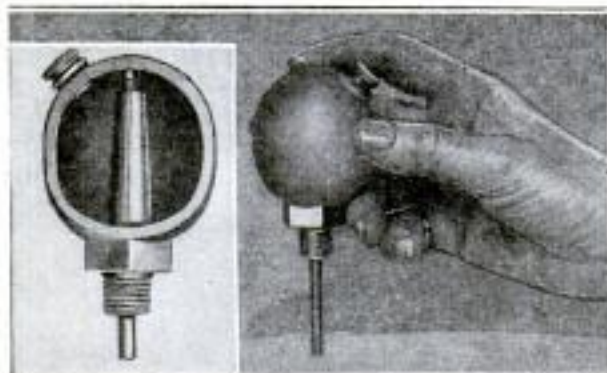

Interior and Exterior of Pulley Oiler, Illustrating Brass Feed Pipe and Spring Control

nated through the use of an automatic oiler permanently attached to furnish

continuous lubrication while the parts are in motion. It consists of a metal ball in which the oil is held, and has a brass pin at the bottom to feed the lubricant upon the shafts and inside the bearings. The pin rests against a spring inside the ball, and when the pulleys move compression is caused and releases oil. The device is constructed on the vacuum principle and retains the lubricant when the shafts stop. It may be regulated to suit the speed of the pulley, prevents accidents and wear on the machinery by insuring proper lubrication of the parts, and decreases the likelihood of fires frequently caused by friction or drippings from improperly oiled bearings.

¶ In 1922 there were more patent applications per 1,000 inhabitants filed from Connecticut than from any other state in the union, or any other country in the world.

SLIDING CHEST BENEATH BED SAVES STORAGE SPACE

37

Storage space for clothing, bedding and other articles is provided in a moth and dustproof chest fitted on brackets attached to the sides of the bed frame and made to slide on roller bearings, so that it does not take up extra room and is concealed from view. The bracket rails are furnished in various lengths to fit any size bed, and are clamped to the frame without the

aid of tools. The lid of the chest overlaps, making it dustproof and when pulled out an attachment on the rails prevents it from tipping downward. It is high enough above the floor so that a duster may be run underneath it, and slides so easily that it can be kicked back into place.

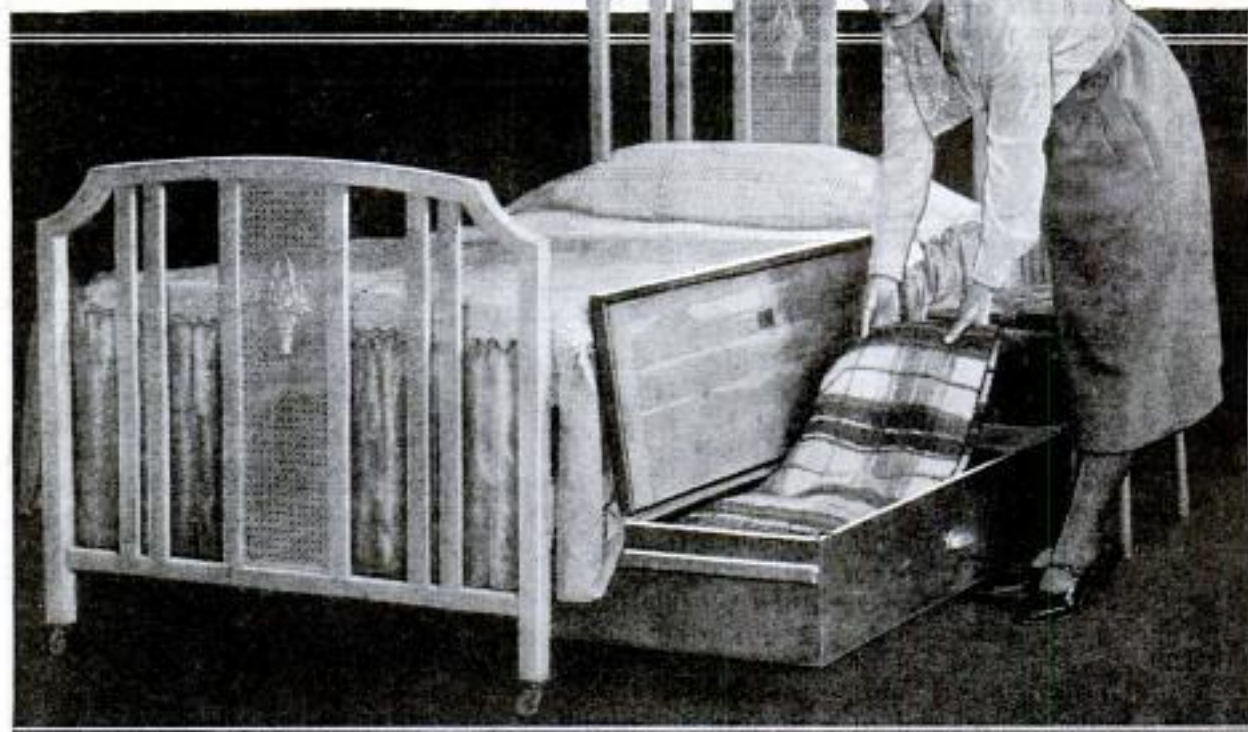

Putting Extra Blankets in Handy Sliding Drawer that Makes Storeroom of the Space Underneath Bed: Chest Is Entirely Concealed when Pushed Back on Sliding Rail

Federal Equipment Co., Pa.
Carlisle, Pa.

4361 *Capt. James Ryan Hayden*
of The Chicago Daily Journal
Pitfalls to be Shunned by Inventors
Chicago

Lack of Knowledge of Elemental Laws and of Other Efforts Along Same Lines Results in Wasted Time and Money

SIR John Dewrance, President of the Institution of Mechanical Engineers, London, recently declared that "more brain power is wasted by inventors than by any other class of people." He also said that "only one out of every 10,000 mechanical patents is worth doing anything with."

Since there are thousands of inventors in the United States who are devoting money and time to developing ideas, a survey of the situation was made in America which disclosed that the greatest waste of time is due to reinventions of things that have already been patented, tried out and discarded. For instance, a press was brought out recently to print large letters such as are used in window signs. It printed one letter at a time and used several colors. The work was excellent, but the inventor and promoter did not know that a somewhat similar machine had been tried out some fifteen years ago. The promoters at that time lost \$50,000 in the venture, for it is practically impossible to design a printing press using large letters that will work by hand and give enough service to be commercially useful on a large scale.

Just a few years ago there was an epidemic of car-coupler inventions. It would be a waste of brain power to work along this line now because the field has been thoroughly covered, say promoters. The rotary engine also has been a pitfall for numberless workers, although it is nearly always possible for a persistent man to pro-

duce a workable device from an original nonworkable one, experienced engineers say. Many such motors have been produced which will run, but which are not commercially practical. One promoter spent \$4,500 on an engine and was preparing to make another "that would work." When he was asked why he had not consulted a mechanical engineer, he replied that "the machinist who built it knew all about engines." When asked if he was going to consult an engineering expert before he tried again, he replied that he was not, because he knew why the first one would not work and he could now go ahead and manufacture the engines on a large

scale. Two years were wasted by a mechanical draftsman in developing a card-shuffling machine. Recalling his experience, he said: "The device worked perfectly. Repeated experiments disclosed that it never shuffled the same way twice. All the cards were thoroughly mixed and cheating was impossible. But when we tried to sell it we lost out. Gambling houses would not buy it because their patrons could shuffle the cards faster and with less

Inventive Genius of the Nation Guarded by Patent Office

THAT the value of inventive genius received early recognition in the United States is proved by the following excerpts from a circular issued in 1811 by Dr. William Thornton, first head of the patent office:

"Viewing with astonishment the inventions of my countrymen, I cannot contemplate them without being impressed with the idea that no nation on earth surpasses them in genius.

"The issuing of patents is grounded, not only on a desire to promote the progress of useful arts, but also to prevent loss of valuable secrets; for many have been buried with the inventors, previous to the organization of this system of protection.

"As it can be mathematically demonstrated that no human invention can produce a machine capable of undiminished power, or power regenerating itself, and forming what is called a perpetual motion—an operative model will be demanded for every such attempt."

trouble than the machine could. People who could not shuffle cards could not afford to buy the machine, which sold for \$250. I made a trip through the west and sold five machines. That is all the money anyone ever made out of it."

Many inventors waste brain power, it is said, in bringing forth worthless devices

because they do not know some of the simple laws of physics. An invention of this sort was a water propeller which revolved at high speed and got its propulsive reaction from imparting great velocity to a small quantity of water. This, however, constituted a greater waste than the ordinary loss with the present type of propeller. Had the inventor consulted a marine engineer familiar with the laws of hydromechanics he would have been saved a great deal of loss in time and money.

Some years ago a quarter of a million dollars were said to have been spent in perfecting a compressed-air starter for automobiles. All this money was lost because the promoters could not find a valve that would hold the compressed air without loss for any great length of time. A man having this starter on his car would drive into the garage at night and find in the

morning or a day or so later that all the air had leaked out of his compression chamber. This device violated the practical law of inventions that a successful invention must stand up under ordinary usage for a reasonable length of time.

Inventors waste most brain power, according to practical experts, in "solving" problems in mechanics, engineering, chemistry, physics and other fields of applied science, which already are well known, or in trying to do things that, by the simplest laws of mechanics, are utterly impossible. Unfortunately they do not know that this information generally is easily obtainable and freely given by people who have it. Inventors have great fear that in asking for information, they will reveal their idea and thus lose it by theft. He is a lucky inventor whose invention is good enough to be stolen, is an old saying.

"DEATH METER" URGES DRIVERS TO MAKE STREETS SAFE

As part of a safety campaign, a "speedometer," fifteen feet in diameter, on which were recorded the automobile fatalities for



Impressive Street Sign That Urges Safety by Recording Auto Fatalities and Accidents Daily

the day, week and year, was erected in plain view of motorists on one of the bus-

iest streets of Buffalo, N. Y. The figures and slogans, urging drivers to greater care, were visible for blocks, and the form of the warning sign vividly impressed the need for a decrease in reckless driving and for greater community pride and co-operation.

SPARK LIGHTER ON GAS BURNER AVOIDS DANGER OF MATCHES

Inconvenience and danger in lighting gas heaters with matches are eliminated in a spark fitted at the top of the burner. By turning a projecting key, a spring trigger arrangement shoots a large, hot spark into the ascending fumes of gas and ignition is quickly accomplished. The lighter does not mar the appearance of the heater, can be attached quickly and does not get out of order easily or misfire when turned.



More than twenty billion telephone conversations were held in the United States in 1922, according to recent figures.

LURE OF GLITTERING JEWELS COSTS MORE EVERY YEAR 140

In the course of the last fifty-five years, it is estimated, the people of the United States have spent substantially one billion dollars for diamonds. Statistics show that between 1867 and 1917, diamonds and other precious stones to the value of \$771,544,558 were imported, and of this total, \$750,000,000 represented the value of diamonds alone. When finally cut, set and disposed of to the ultimate consumer, these gems were worth at least twice their import value. In the five years following 1917, our imports of diamonds amounted to \$200,000,000, and in 1922 the imports totaled \$67,000,000.

CLAMP FOR IDLE AUTO WHEEL KEEPS WEIGHT OFF TIRE 4666

To keep the weight off the tires of automobiles standing idle for long periods, clamps have recently been invented by a New York man to replace the ordinary jacks. The appliance is equipped with strong jaws that work on springs and clutch the edge of the rim, supporting the car from a base on the ground. After they have been placed on the wheel just above the point where the tread touches the floor, the machine is moved so that they pass under the tire and raise



Clamps for Lifting Weight of Automobiles Off Tires When Cars Are Being Stored for Long Periods

the automobile. Strongly made, the holders can be attached or removed in a few minutes and their cost is but a fraction of that of larger types.

The Popular Mechanics' Bureau of Information offers its free service to all readers of our magazine. Names and addresses of manufacturers and dealers in articles described, and any other details in our possession, will be promptly furnished by addressing the Bureau.

Chapin
104 Harvard Place,
Syracuse, N.Y.

HOSPITAL IN SIDEWALK BOOTH AIDS VICTIMS OF TRAFFIC

To care for victims of traffic accidents, a booth containing first-aid equipment, a



Copyright, United Newspictures
Sidewalk Hospital for Victims of Traffic Accidents, Placed Near One of Berlin's Busiest "Corners"

folding hospital bed and a wheel chair, has been placed near one of the busiest spots in Berlin, Germany. In case of injury or sickness, the patient can receive preliminary treatment before going to a hospital. The instruments and material are easily reached and can be set up in a few minutes. Strongly built, the booth is inclosed by doors, and is decorated in large painted inscriptions announcing its purpose and giving instructions for the use of the contents in emergency cases.

TUNNEL CREW IS FED BY DINER \$2 IN UNDERGROUND SHAFT

To save time and tiresome journeys for workmen engaged in tunnel construction in California, midday meals are provided on dining-car trains which rush hot food to the diggers far below the earth's surface. Each train is made up of five cars, three equipped with tables and benches and the others for serving and storing the food. Containers like fireless cookers keep the dishes hot on the journey, waiters accompany each train and an extra locomotive is attached to speed the service.

Engineering News-Record
Dec 26, 1923

United Newspictures
New York City
Copyright 1924

Cont. S.A. Waters, c/o 416 S. Salina St.
Syracuse, N.Y.

INDOOR GOLF "GREEN" RETURNS BALL AFTER PUTT

21

To aid golf players to attain accuracy in putting, an indoor "green" that directs the pellet back to the starting point has been invented by a western man. The toy can also be used as a pastime for any number of persons, and may be set up on a lawn

or other flat, smooth surface. When the sphere is struck it passes up an inclined plane, and if it does not drop through the score hole, rolls back to the player. A channel at the side catches the ball, if it falls into the opening, and guides it out.



Practicing Putting on Indoor Golf "Green" with Regulation Sticks and Balls; the Sphere Is Returned Automatically to the Player after Every Stroke

GOLD-PLATED GALLEON'S SAILS SHOW WIND'S DIRECTION

Gold-plated metal sheets were riveted together, cut to resemble the outlines of a Spanish galleon, and swung inside a steel frame as a weather vane for the top of the

tower of the California building in San Diego. The completed figure weighed more than 500 pounds, and was put in place by two steeplejacks who risked their lives on a scaffold erected for the purpose. An earthquake shock added to the hazards of the task while the men were at work.

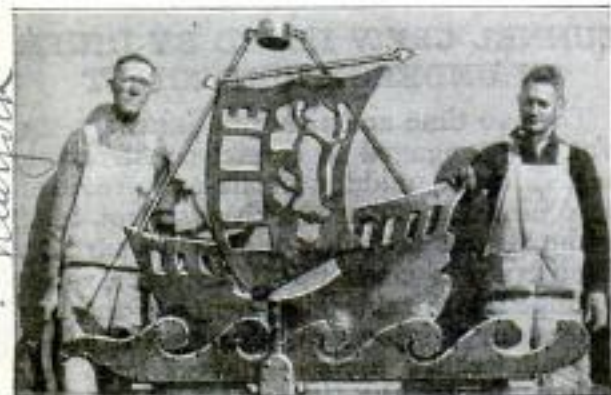

Gold-Plated Galleon Weather Vane Mounted in Steel-Frame Support, and Its Designers

BIRD SONGS LIKE HUMAN TALK ACCORDING TO NATURALIST

Study of the sounds made by birds is urged by a scientist who declares their utterances resemble human talk. He said that these songs or one-syllabled calls, have inflections of pitch and emphasis closely resembling the same phenomena in the speaking voice and that at times the whistles, chirps or twitters, resemble human words. The building up of a dictionary of bird sounds with reference to their pitch, intensity, speed, form, expression and timbre was urged.

Kansas City Times
 Jan. 12, 1924

*Pacific & Atlantic Photos
 2 Park Place
 New York*

4009

Peter J. Koch, Cary & Elster
 College Hill, Cincinnati
 POPULAR MECHANICS 593
 Ohio



Display Supplied Four Times a Year for Dealer's Windows

Turning Out Photographs by the Million

Mr. William Lachner Co.
 21 Pearl St. Cincinnati, Ohio

Great Plants in All Parts of the Country Are Developed to Supply Quick Service and Assistance for Army of Amateurs

DEVOTED exclusively to developing films and printing pictures for an army of amateur camera enthusiasts, great plants have been built up in all parts of the country. During the "busy" months of June, July, August and September, when the weather is best suited to taking pictures, the seven largest finishing plants in Chicago handle more than 114,000 pictures daily. Several have an output of 8,000 to 12,000 every twenty-four hours, and many print more than 5,000,000 as an annual average.

In Cincinnati, a single company serves almost a hundred drug stores, employing a fleet of automobiles to collect the film and deliver the pictures to the proprietors who have found that the "side line" in film service is a profitable advertisement and brings in potential customers. In one week, one of the collectors for this company brought in 20,000 spools of film and as many as 17,500 prints have been distributed in a single day.

However, the volume of the business is not the story of the photo-finishing trade. The marvel lies in its high standard of efficiency, its speed and accuracy. Keeping thousands of orders from getting

mixed up, maintaining a 24-hour or even shorter service, developing satisfactorily the work of untold thousands of untrained enthusiasts, including a few "cranks" who often know little of photography but are eager to get good pictures and extremely critical of the results, and how the larger companies with all the rush and confusion, find it possible to guide the struggling amateur with helpful suggestions from their experts hidden in vast dark rooms—all this represents a unique achievement in organization and service.

One company, for instance, printed over 500,000 pictures with just four errors, that is, wrong pictures or incomplete order. Co-operation on the part of all employes and an efficient system of checking as the films and prints pass through the thirty separate stages in the developing and handling processes made this record possible. A 24-hour service is maintained, but if rush work is wanted, it can be completed in less than three hours and give the delivery boy time to smoke a cigarette between the store and the shop, but this, the workers say, is not photography and the longer service insures the best results.

From the time the film leaves the cus-

The 7 ad stores, Wittenhofer Bldg, Cincinnati, Ohio.
Mr. William Lachner Co. President

4009

tomer's hand at the drug store or other place of delivery, until it is developed, the pictures printed and returned for the customer, it is guarded with hawk-like vigilance, at least seven checks being imposed for possible errors and a rigid system, tried and tested, followed to minimize errors.

Description of the order, that is, the number of rolls, size, number of prints desired, kind of paper wanted and other information, is placed on the envelope by the druggist's clerk.

At the finishing company's plant, this envelope is given

helpful suggestions tabulated on the envelope opposite numbers for each print. The anxious amateur will find tucked in with the prints, "No. X would make a fine enlargement." "Your camera leaks light." "Try a sharper focus." These pointers, and others coming from the recesses of the

big plant, strengthen the personal touch and kindle the mutual spark of enthusiasm for good pictures. The finishing companies are just as eager to see excellent work as is the photographer.

Due to the improvements in photographic appa-

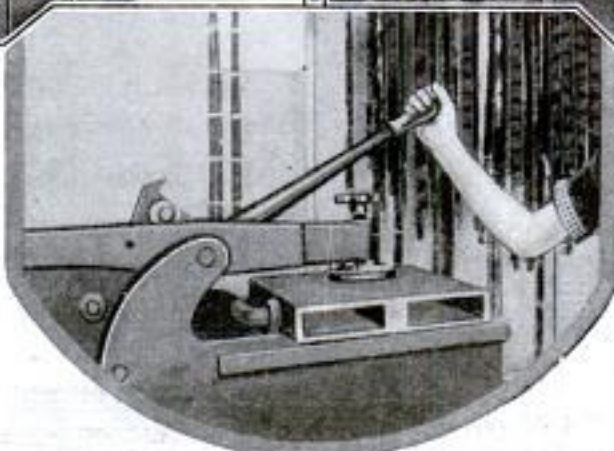
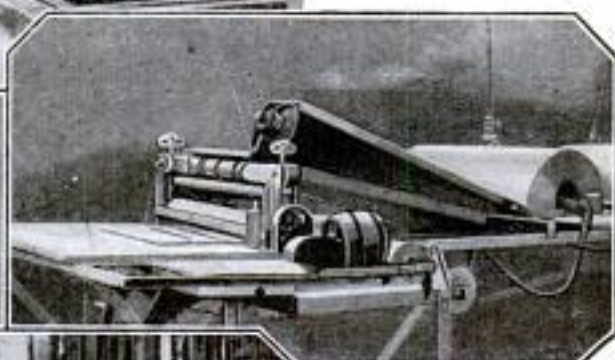
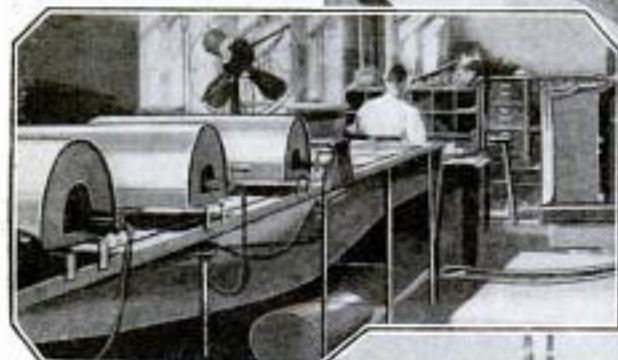
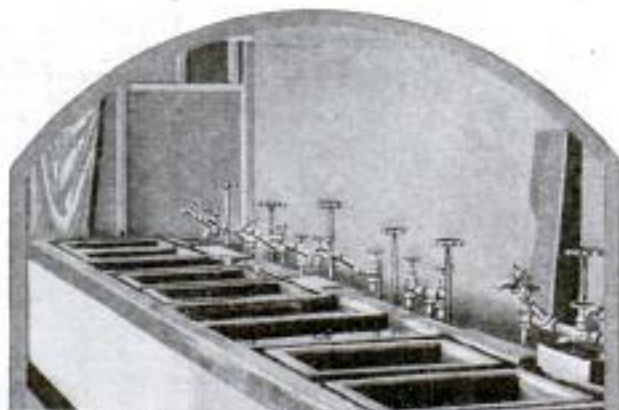

Four Views of "Daylight" Laboratory Where Negatives Are Developed, Printed, Finished and Sorted

a time and order-number stamp and other identification, and the film itself is marked with the order number given the envelope which travels throughout the shop with the film it contained. As each print is made, a pencil mark on the back identifies it with the roll to which it belongs.

Marginal marks are put on to assist in trimming the prints in lots of 200 or more. Rolls and prints are handled in "batches."

At the sorters' tables, at the printers' lamps and at the dopers' tanks where the prints are developed, and at every step in the process, the batches are kept separate. If errors do occur, they are quickly located within these small lots and no work is allowed to leave the inspector's desk until every envelope again contains the film, cut, developed and printed, according to the specifications it bears.

Some companies amplify the service with

ratus of all kinds, increased knowledge in the art and the co-operation of large organizations, amateur photography has developed to an astounding degree of excellence in the last ten years. "Some of the best photographers in the United States are the amateurs," says

H. C. Corning, vice-president of the Norman-Willeys Photo Supply Company, of Chicago. "Nowadays, less than two per cent of their work goes back as N. G.'s—the blank film or that which cannot be printed. Only ten years ago, at least twenty per cent was no good.

"Here is an illustration. Last summer, a party of eight girls returned from the Yellowstone National Park with 120 exposures. They had 111 good pictures out of that number and not one of the girls had taken pictures before to any extent. Three years ago, I remember a girl came



Wrapping Finished Prints for Delivery to Customers

in with a bunch of forty-eight exposures and she had just one good picture of the lot. She had been working the time indicator instead of the shutter release. There used to be lots of mistakes and a much lower standard in all the work done. Now it is mostly all what even an expert would call 'good' and much of it is excellent."

Chance is still an alluring factor in picture taking, but much of the needless worry of the amateur has been removed by the efficient organizations that serve him. If his camera is not at fault, if he has operated it properly, it is almost a certainty that he will get good pictures owing to the army of trained assistants that are ready to serve him at any hour of the day or night.

With the rapidly increasing num-

ber of amateur motion-picture cameras, several developing firms have devised special equipment for making positive films of twenty and 100-foot length of "movies" of vacation scenes and other views prized by the non-professional photographer. One company in Chicago handles more than 200 reels of this kind each week.

Developing wheels, an automatic timer that regulates the amount of light each exposure is given and other apparatus adapted to intensive work of this kind have been installed. Satisfactory enlargements may be made of any exposure in the reel.

Processes have also been devised for coloring the films so that the amateur will have a realistic and durable record of intimate family scenes and is saved considerable time and expense that a plant of his own would require.



Picture from Which Separate Print Was Made for Each Child

*Dr. Paul Bartsch
Head of the Division of Mollusks*

596
Smithsonian Institute
4586 Washington, D.C.
POPULAR MECHANICS
WATER-TIGHT CAMERA TAKES UNDERSEA PHOTOS

Intimate studies of the wonders under the waves are afforded through submarine motion pictures taken without elaborate apparatus or diving bells with the aid of a portable camera cover devised by the head of one of the departments of the Smithsonian Institute, in Washington, D. C. The mechanism and film are protected by the water-tight case and its portable construc-

tion enables the operator to film scenes and get "closeups" that could not be reached easily with a more complicated



Doctor Paul Bartsch of the Smithsonian Institute with His Submarine Motion-Picture Case



Examining a Length of Film: Camera Open and Shown without Its Water-Tight Submarine Case

outfit. To test the efficiency of the case, the inventor, protected by a diving helmet, descended into the clear waters off the Bahamas, not long ago, and made motion pictures of coral rainbows, blue angel fish, the butterfly fish and "spotted hinds" and "yellow tails" with the camera.

**STEAM-HEATED ROAD SPRAYER
DROPS AND SPREADS TAR**

For pouring and spreading melted tar, oil, or similar fluids on road surfaces, a machine has been built that applies the material and distributes it evenly by a series of brushes. The spray tube has a vibrating motion from side to side when in operation to scatter the liquid across its path. Its ends are fitted with collapsible

extensions so the length can be adjusted to the width of the highway. Steam heat, to prevent risk of fire, keeps the substances in a thin state. The brush drag is equipped with springs that force the brooms against the surface of the road. The discharging jets are controlled from the driver's position by a lever. Either horses or an automobile truck can be employed to haul the apparatus.



Road Sprayer with Moving Brushes for Spreading Tar or Other Liquids on Highways

**MYSTERY NOMADS OF ARCTIC
62 TAKING UP FARMING**

Sweden's Lapps, mysterious nomads of the north, are by no means a dying race, and after centuries of wandering are beginning to attach themselves to the soil, according to a government report. In fifty years they have increased in number about fifteen per cent, the official count now being, 8,128. About one-third still roam with their herds of reindeer over the Arctic hills and plateaus, but are declared to be showing an increasing desire to live in real houses instead of their "kaatas," or tepees.

*Chicago Daily News
June 1929*

*The Wheel Agency, Ltd., London
cont. 15271 lead St. E. C. 1*

PUPILS WARNED OF MISTAKES BY AN AUTOMATIC BELL

Spanish school children are aided in learning to write by an electric apparatus so adjusted that any mistake made in copying angles, loops and other designs traced on metal plates will be noted by the sharp ringing of a bell. The plates are connected by copper wires to the signal and any deviation from the true outline in copying, causes a circuit to be completed and the alarm sounded. The task is thus made sort of a "game" and the children are furnished an incentive to make their pictures exactly like those on the plates.

WEIGHT LOST DURING SLEEP IS RECORDED BY SCALES



Delicate scales, which show the constantly fluctuating weight of the human body, have been used at the Carnegie Institute to prove that persons lose weight while sleeping. Constant evaporation of moisture from the body while sleeping causes the loss during the night hours, it has been shown, and the deficiency is not balanced by food or water taken as it

is in the daytime. The amount of weight reduction while exercising and the changes from one hour to another also are registered by the nicely adjusted balances of the scales.

SERUM TO DISSOLVE CANCER TESTED BY DOCTORS

After ten years of study and experiments, two Vienna physicians have announced that they have found a substance which dissolves cancer cells. In healthy persons they found that the blood serum is able to carry away the growths. The vital fluid of the victims of the disease, however, lacks this power. After many tests, a culture was made that is said to dissolve the malignant cells. It is declared to be an organic acid, the formula of which is carbon, 42; hydrogen, 76; oxygen, 76.

Chicago Herald-Examiner
Jan. 7, 1924

VANITY CASE WORN ON WRIST OR LIKE A LOCKET

To be worn on a ribbon bracelet, or as a locket hung around the neck, a vanity case recently marketed is designed to carry



Vanity Case Like Wrist Watch that Also May Be Worn as a Locket

its contents conveniently without occupying space in purses or pockets needed for other articles. Used in this way as an adornment, it is always within easy reach and can be quickly opened. Powder, puff and a mirror are provided in the small interior. The outside of the container is finished in either gold or platinum effect. Clasps and ribbons are furnished with the cases so they may be worn as desired.

JAWS OF SLIDING-BAR WRENCH FIT ALMOST ANY SIZE NUT

To fit many sizes of nuts, a wrench has been recently patented that has a sliding beam that adjusts jaws at both ends of the tool. Gripped at the middle, the bar can be easily moved in either direction by turning a thumbscrew. Made of specially treated steel, it is said to resist wear and protect nuts from damage usually caused by pressure from ordinary devices. As an

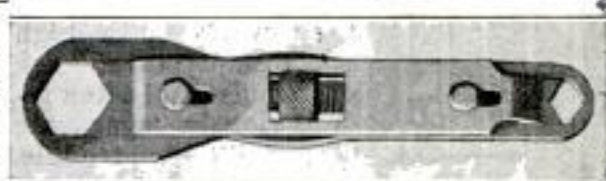

Two-Piece Wrench with Sliding Jaws at Both Ends that Are Adjusted by Thumbscrew

aid to automobile mechanics, the utensil is claimed to fit almost any square or cornered bolt or nut in a car's mechanism.

Garavan Co., 311 River St., Chicago

Mr. Ernst Freund -
Dr. Lina Kaminer -
Journal Weekly Medical Journal

Rosevelt Mfg. Co.
53 W. Jackson Blvd.
Chicago

Battling Wild Animals to Cure Their Ills

By GEORGE F. MORSE, Jr.
Director, Chicago Zoological Park

547 County Bldg, Chicago

ANIMALS in captivity, it has been found, suffer from most of the ills common to civilization. A fairly common trouble that keepers of lions and other members of the cat family have to contend with, is ingrown claws. This condition is caused by the lack of exercise and the absence of rough surfaces to wear them down, with the result that the points grow into the pads or bottom, of the foot.

In a case of this kind in a large zoological park, the animal was so active that it was found impossible to rope it, so the large exhibition cage was battened with blankets and several quarts of chloroform sprayed in before it could be handled. In another instance, a valuable lioness was deprived of food for forty-eight hours, so that when a raw bone, too large to pass between the bars of the cage, was put before her, she ravenously rushed for it and tried to pull it into the cage. In so doing she extended her paws through the bars and obtained a firm hold on the bone. While the animal was thus engaged, the keeper was able, with a pair of long-handled shears, to snip off, and pull out the offending claws.

It is readily apparent that arriving at a true diagnosis in wild animals is much more difficult than with domesticated species which usually docilely submit to examination, taking of temperatures and giving of medicine, whereas wild animals struggle fearfully and fight all handling, with the result that they work up a high temperature, quick pulse and often seriously aggravate their trouble. For ordinary

ills nature is the best healer, and by helping her out by providing plenty of fresh air, quietness and cleanliness, many troubles are overcome. If drugs must be given, it is necessary to concentrate and disguise them by putting in some tidbit to be eaten. Accidents, such as cuts and broken limbs, are very difficult to treat for

after the operation, the animal does not realize what has been done and pulls out stitches or removes bandages and splints, so slings and contrivances have to be made. For instance, a monkey insisted on removing splints from its broken arm and a wide wooden collar had to be put about its neck to keep it from getting its teeth at the bandage.

In another instance, a Himalayan black bear was found stretched out almost lifeless in its cage. The veterinary who was called said that it looked as if the animal had been poisoned, and held out little hope of recovery. The administration of spirits of ammonia was tried as a last resort. After hours of treatment, the creature began to show signs of life. Thereafter

it had to be coddled and was almost as helpless as a new-born infant. There was a paralytic condition of the muscles of the whole body that made it necessary for the keepers to stand over the patient and open the mouth to insert food and medicine. Then the throat had to be massaged downward. After a month the animal recovered its health.

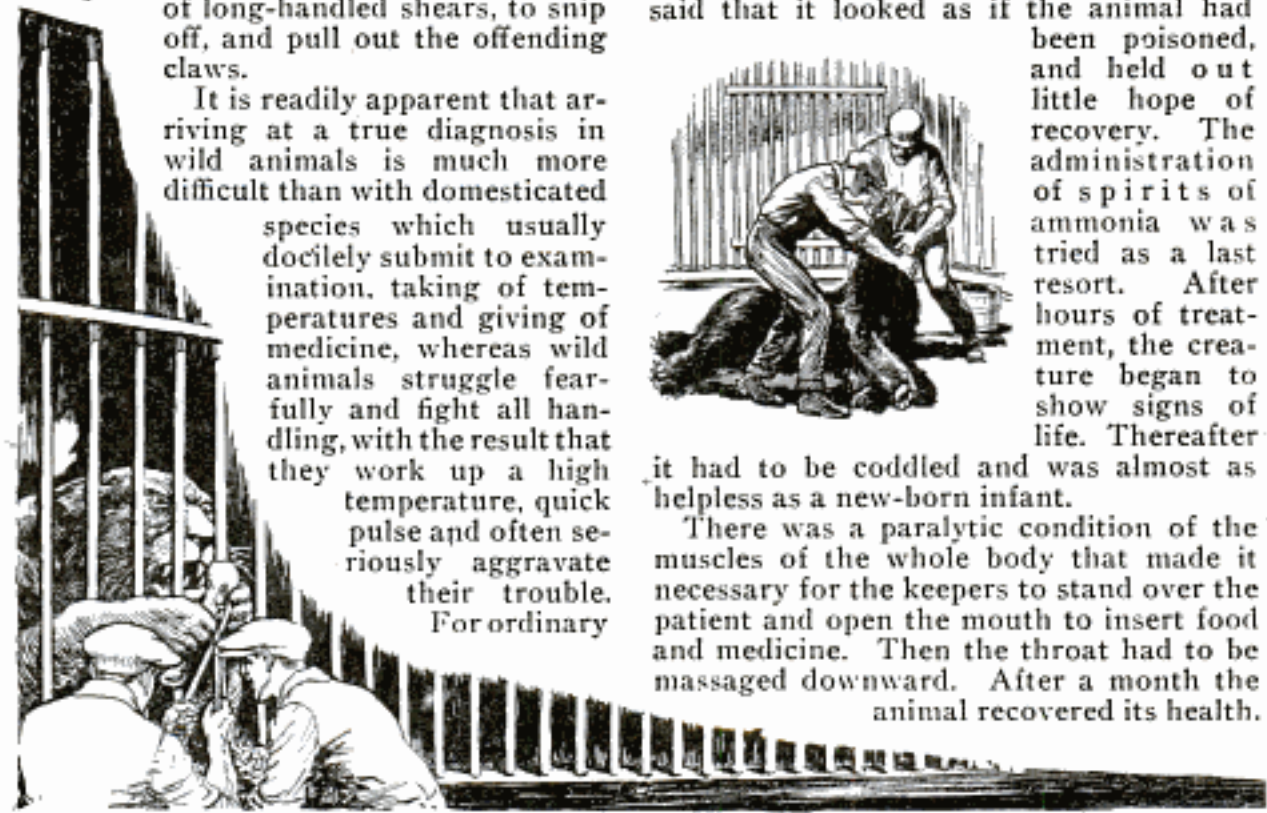

Kansas City, Mo.
BORING HOLES IN ROADS TO TEST PAVEMENT 85

While building and maintaining state highways has in many instances been more or less of a failure, in Illinois success has resulted from a system of testing which prevents the laying of pavement which does not come up to specifications and prevents the fraudulent contractor from cutting out the heart of the political

to loads, but one which not only is fairly firm, but is also elastic enough to recover from deformations. The continual movement of the pavement, due to temperature stresses, requires that the earth beneath follow it to some extent. After the roads are finished, a core drill is used to make observations. Concrete plugs are used in

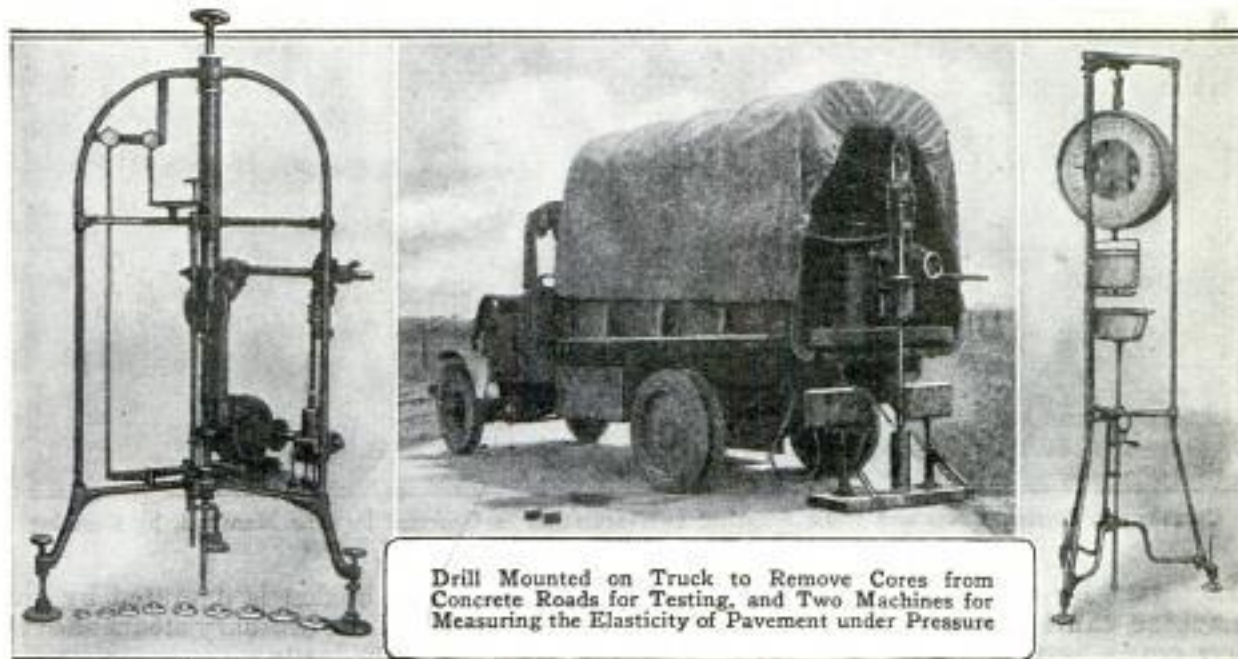

Drill Mounted on Truck to Remove Cores from Concrete Roads for Testing, and Two Machines for Measuring the Elasticity of Pavement under Pressure

melon. For this work several pieces of apparatus have been invented and developed. Three points which vitally affect the efficiency and lasting qualities of concrete pavement are considered in the tests: First, the bearing power of soil; second, the quality and thickness of the slab; and, third, the surface irregularities which would produce abnormal conditions of loading. To insure all of these factors, two machines have been constructed. One consists of a three-legged iron pipe frame, from which is suspended an automatic scale supporting a pail containing about thirty pounds of shot. Pressure is applied to the concrete and then released and the upward movement of the pavement measured on a dial. This has shown that, with a truck moving down the pavement toward a certain point, the soil beneath is subjected to an increasing pressure which reaches a maximum when the vehicle is directly over the spot. The other machine consists of an iron frame in which is mounted a spring for producing pressure that is exerted upon the soil through a plunger, the movements being recorded on a dial. Experiments are said to have proved that an ideal subgrade is not necessarily one which has the greatest resistance

filling up the holes made by the drill. When the cores are received in the laboratory they are carefully measured for diameter and tested for compressive strength.

FOUNTAIN PEN ON LONG CHAIN PULLS OUT OF DESK HOLDER

90 For use on desks and in public writing places, a fountain pen attached to a neat holder has been patented to replace un-



Fountain Pen and Attractive Holder to Replace Ink-wells in Public Writing Places

sightly inkwells. A chain that automatically adjusts itself to the desire of the user is fastened to one end of the pen. Finished in bronze, the stand makes an attractive ornament. The pen point is guaranteed and its use is said to result in economy in ink, pen points and holders.

Ex. also. Peter, 20
E. Jackson Blvd.
Chicago

Glasgow Engineering Co.
~~3720 N. Newstead Av.~~
 600
 POPULAR MECHANICS
In Louis, Mo. 4800 W. Pine Blvd.

CRANE, HOIST AND SHOVEL COMBINED ON TRACTOR

To help small contractors in making excavations or loading material, and for work in gravel pits and around industrial plants, a combined crane, hoist and shovel has been designed to be attached to gasoline

may be turned into a hoist. The rear wheels are filled with concrete to give greater stability. These may be replaced with weighted rubber tires where it is necessary to run over streets, or the floors of

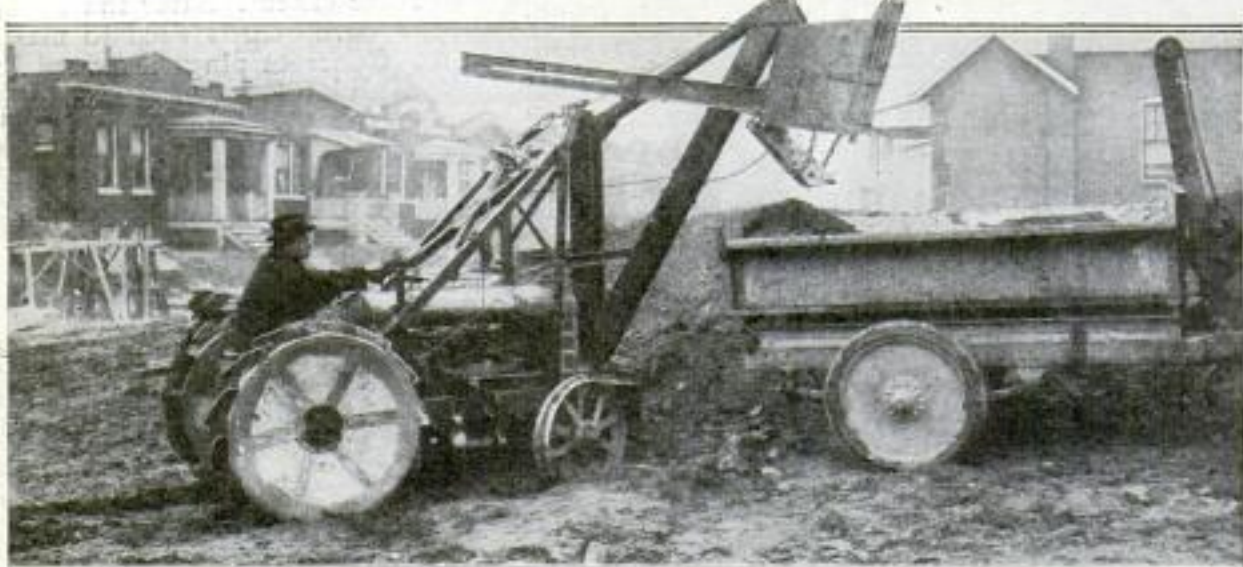

Combination Shovel, Crane and Hoist Attached to Tractor; It Is Operated by One Man and, by Covering the Wheels with Rubber, May Be Used on Factory Floors

tractors. By unlocking the bucket, the machine can be used as a small locomotive crane, and by unhooking the cable it

factories. The bucket is operated by one man, like that of the ordinary steam shovel, for handling light loads.

DIAL WHEEL MEASURES INSIDE OF AUTO RIMS AND TIRES

Inside circumferences of tires and rims can be measured with accuracy by an instrument being manufactured in Scotland. The ring is laid flat, and the device, which is weighted by its cast-iron base, is placed

around. The reading on the dial shows the distance traveled. Where wide tires are to be tested, two operations are necessary, one on each side of the rim. The results registered by the scale are then compared to insure equal dimensions.

ELECTRIC POWER TO TRIPLE IN NEXT TEN YEARS

Owing to the rapid advance in the adoption of electric energy as a source of light, heat and power, it is estimated that more than six billion dollars must be spent for new plants and equipment in the next ten years. During this period, according to a recent survey of the demands from the home, farm, mine and factory, it will be necessary to more than triple the present power output. At present it is estimated that there are almost 500,000 circuit-miles of transmission and distribution lines in the country, or sufficient to encircle the earth twenty times. By 1933 it is believed that this figure will be increased to 900,000 miles, a distance equivalent to almost four times the distance from the earth to the moon. The price of electricity is said to have increased only 5.1 per cent since 1914.

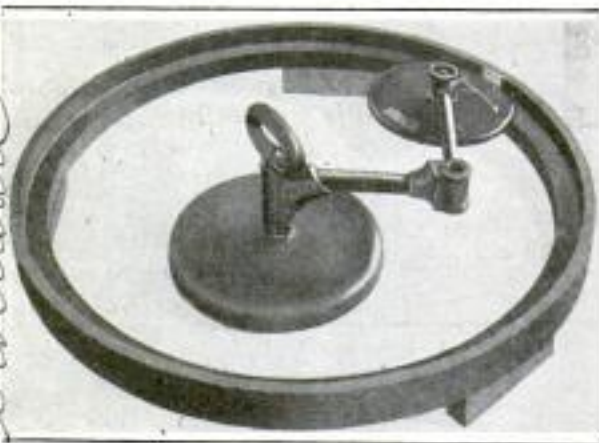

Dial Wheel on Arm that Measures the Inside Circumference of Tires and Rims

in the center. A swinging metal arm, holding a dial wheel that passes along the inner surface of the tread, is rotated once

*4-1
 End of business
 19/12 7/28
 no rise*

*Parr + Stroud, Ltd
 Anniesland, Glasgow,
 Scotland*

*Electrical World
 Jan. 5, 1924* Copyrighted material

RADIO

Calibrating Stations Chosen

Clipping 5.5 R
 Because of its power and location, which enables it to be heard on both the Atlantic and Pacific coasts consistently, station WLAG, the Twin City (Minneapolis and St. Paul) Radio Central, has been officially chosen by the United States bureau of standards as the central calibrating station for broadcasting signals of standard wave lengths all over the country, so that the 700 or more sending stations and the hundreds of thousands of receiving stations may tune their wave lengths accordingly. KDKA, at East Pittsburgh, has been selected as the eastern calibrating station. This station also broadcasts to the Pacific coast with the aid of its relay station KFKX, at Hastings, Neb. The government started this work in December.

Radio Teaches Deaf

43 R
 By means of powerful amplifiers, in connection with radio instruments, deaf-and-dumb children in the public schools of Cincinnati, Ohio, are hearing the human voice for the first time in their lives. It is the opinion of the supervisor of music in the schools, who is in charge of the undertaking, that the possibilities of this method of teaching the deaf are unlimited. Our photo shows a teacher, who came to Cincinnati from the California state school for the deaf, talking to a child who never before had heard the least sound.

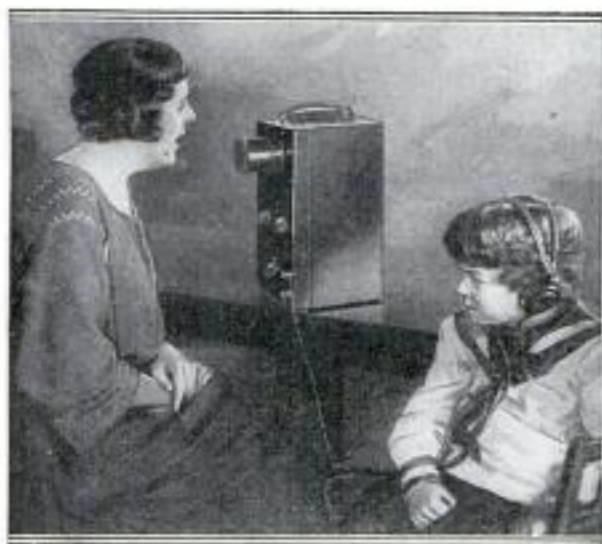

Teaching Deaf Children by Means of Radio Is Latest Educational Development.

The Ideal Radio Set for Hikers

26 R
 Henry Farkouh, a Brooklyn amateur, is the designer and builder of a novel radio *446-50th St.*



Complete Radio Set Attached to Canvas Belt, Strong Enough to Operate a Loud Speaker.

portable
 set that should prove ideal for the hiker. It is a three-tube receiver, operating on small batteries and is complete in all details. The instruments are fastened to a canvas-web belt, and each tube has its own rheostat; a potentiometer is also provided. The set has sufficient power to operate a loud speaker, and it is said that stations as far away as Chicago have been heard on it. The antenna consists of fine wire sewn between two canvas sheets so that it may be carried under the shirt, or in a pocket.

New York Plans Great Broadcasting Station

43 R
 Fifty thousand dollars have been appropriated for the erection of a great municipal broadcasting station in New York, and soon people all over the country will be able to hear the music the metropolis enjoys, and to listen to the great speakers and artists that visit the country's largest city.

*Atlantic Photos
 25 Park Place, New York*

Pacific

*Pacific & Atlantic Photos
 431 Michigan Ave
 Chicago*

*Crosley Radio
 Weekly*

Clipped

According to Commissioner Whalen, this means that at least 300,000 persons in the city can enjoy the band concerts in the park this summer, instead of only a few thousands around the bandstands, and that a million radio fans throughout the country can hear the famous bands and artists that delight New Yorkers.

32 R

The Smallest Radio Set?

What is claimed to be the smallest radio set in the world has been built by an amateur in Providence, R. I. Spurred on by accounts of what others had accom-

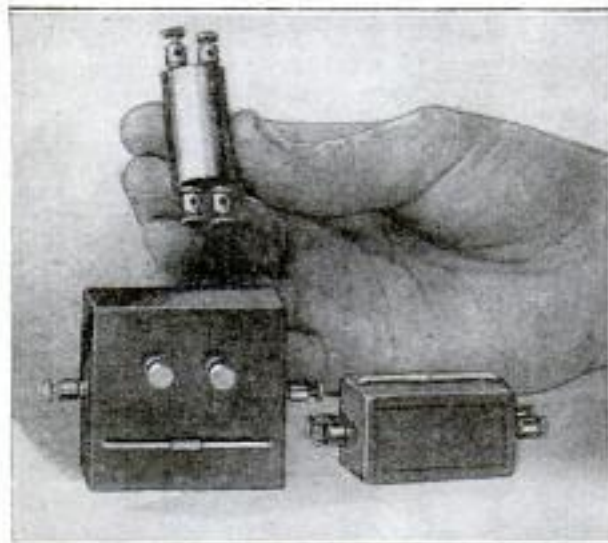

Interesting Examples of the Amateur's Skill: The Smallest Set Is but $\frac{3}{4}$ Inch in Diameter

plished in building small sets, he first built a set 2 in. long, 2 in. wide, and 1 in. high. This contained a fixed crystal, a phone condenser, and a single-slide bank-wound coil. His next attempt resulted in a set 2 in. long by 1 in. square, containing everything but the phone condenser, which was discarded as unnecessary. Slider bars on top of these sets permit tuning up to 500 meters.

Even the second was not small enough, so a third set was built, which can be covered completely with four postage stamps, one on each side. It is $\frac{5}{8}$ in. in diameter and $1\frac{1}{4}$ in. long. On this set concerts broadcast within a radius of 20 miles can be heard distinctly.

In Sweden plans have been made to erect a limited number of broadcasting stations, which are to be leased by the government to private operating concerns. The privilege of owning a receiving set will also be restricted to those obtaining a permit upon payment of a license fee.

Miners May Carry Small Receiving Sets

Experiments of far-reaching importance to miners, caisson workers, and divers were recently carried out in New York, when, in a dripping tunnel 90 ft. below the surface of the Hudson river, and 1,600 ft. from the nearest exit, a group of officials tuned in concerts broadcast from Pittsburgh and a number of nearer stations. The programs were heard distinctly, in spite of the 30 ft. of water, 60 ft. of earth, and several inches of reinforced concrete between the instruments and the outer air. This convinced the engineers in charge of the test that radio is quite practical for communication between the surface and entombed miners, or deep-sea divers.

M. M. Frolich, secretary of the New York state bridge and tunnel commission, said at the conclusion of the test: "Our divers, and caisson workers, whose lives are often imperiled or lost when the telephone lines they communicate with are swept away, may carry small portable transmitting and receiving sets that will make them independent of all other means of communication."

This is said to be the first successful test of underground radio reception, and was conducted with stock apparatus. A strange coincidence was that the first number heard was a lecture on "Safety First."

44 R

The Radio Bus Is Here

Passengers of bus lines in California are now being served with free music during

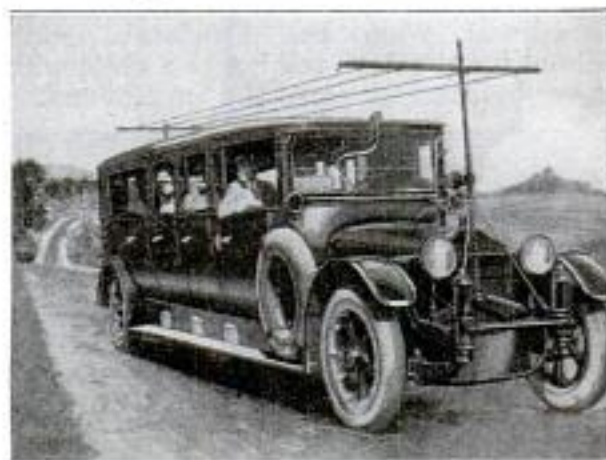

Busses on Sacramento Road in California Are Equipped with Radio Sets

their trips as a result of the enterprise of a motor-transit company.

On a run to Sacramento, the bus was able to pick up concerts broadcast from Oakland and San Francisco, using only a two-step amplifier and a short aerial.

Pacific & Atlantic Photos
431 N. Michigan Ave.
Chicago

Cont: H. E. Winelow, 353 Saunter Ave
 nber, East Providence, R. I.

Copyrighted material

Chart Tells Time All Over World

Station WGY, the General Electric broadcasting station at Schenectady, N. Y., puts out a very interesting world-time chart, a reproduction of which is shown in our illustration.

It consists of a central circular disk, graduated into day and night hours, mounted on a chart showing the time in various cities throughout the world. The manner in which it is used can best be described by an actual illustration: Supposing it is 7:00 p.m. in New York and it is desired to know what time it is in San Francisco. The black

portion of the line marked San Francisco will be found 3:45 in the white portion of the disk, so it is 3:45 p.m. in that city. Similarly 7:00 p.m. in Chicago is approximately 4:40 p.m. in San Francisco.

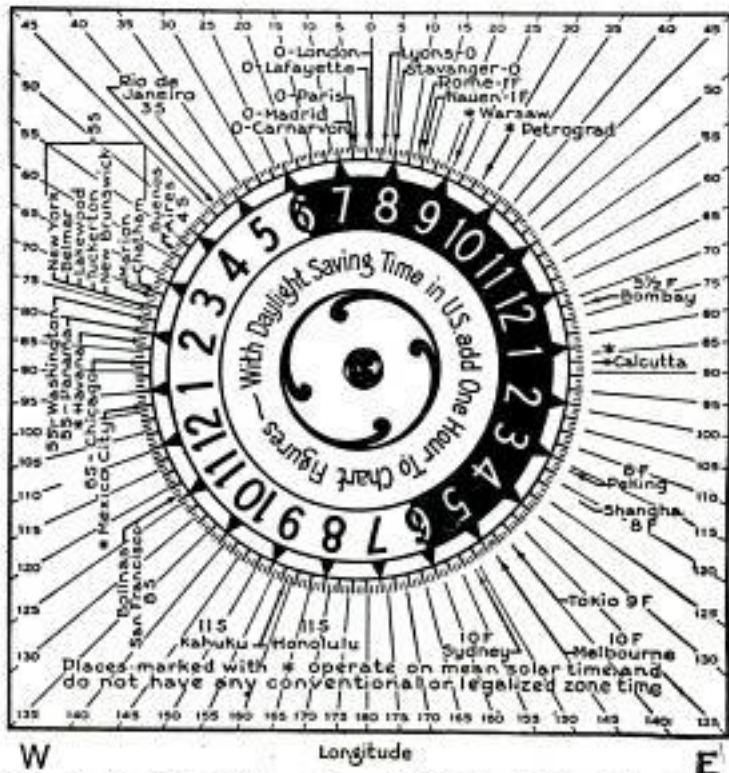

Our Readers Can Obtain a Copy of this Handy Time Chart from Station WGY, at Schenectady

Opposite various cities on the chart are found figures, followed by the letter F (Fast), or S (Slow). These indicate how many hours the clock time in any city is ahead or behind the clock time in London at any moment. Thus, New York, Marion, Chatham, etc., are marked 5 S; that is, 5 hours behind London time. Noon in London is 7 a.m. in New York.

disk represents night hours, so the disk is revolved until the 7 in the black space is opposite the line marked New York. Op-

Any of our readers can obtain a copy of this chart by writing to Station WGY, at Schenectady.

Finger Touch Operates Vernier Dial

Coarse adjustments, with a new vernier dial, are made with the hand on the knob in the usual manner. To obtain the vernier action all that is necessary is to drop the hand to the small knob and press it slightly upward; this engages a small pinion with a large gear on the back of the dial, and permits the minutest adjustment in either direction.



As the hand in making the fine adjustment is at a considerable distance from the device being tuned, capacity effects are reduced to a minimum. A further advantage is that the

fine adjustment may be made over the entire scale of the dial, enabling very sharply tuned stations to be "brought in."

Six Phones Used in One Plug

Any of our readers can obtain a copy of this chart by writing to Station WGY, design. The plug is made in three types:

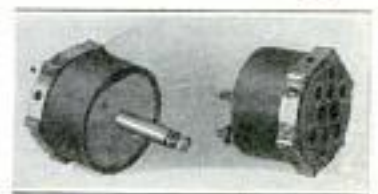

one for panel mounting, one for connecting to binding posts, and one with a standard plug stem for use in a jack. The heavy molded-insulation body contains six-terminal holes; one tip of the phone cord goes in a hole, the other is inserted under a spring-steel strip fastened around the outer edge of the plug, connecting the phones in parallel-series.

Bin. 4 in. \$1.25 \$1.65

Alden Mfg. Co. Mass. Springfield, Ohio.

New Amsterdam Electric Co. 91 Chambers St. New York.

de Witt - La France Co.

604

54 Washburn Ave

POPULAR MECHANICS

37 - Cambridge 40, Mass.

Compact Radio Units Aid Assembly

One-Wire Antennae for Merchant Ships

Builders of homemade radio sets will be interested in a remarkably compact and attractive radio unit now on the market. The units are built in two styles, for detector and amplifier. The detector unit consists of the tube socket and rheostat in one mounting, complete with knob and dial. The amplifier unit has also the tube socket and rheostat, and, in addition, the audio-frequency transformer mounted directly below the socket. The whole assembly is fastened to the panel with only two screws, thus saving a great amount of time in assembling. All metal parts are nickel-plated, and the units present an unusually neat appearance.



Exhaustive tests recently carried on with one-wire antennae on merchant vessels show that they are practicable for low-power transmission and for receiving purposes, although their efficiency is slightly less than that of the three and four-wire antennae generally used. But this slight loss of efficiency is compensated for by the reduced cost, space, and weight of the one-wire antenna, and this means much on cargo ships on which it is customary to lower the antenna during loading operations. The one-wire antenna can also be hoisted much higher than the three or four-wire antenna because it is lighter. The latter has been found the most satisfactory.

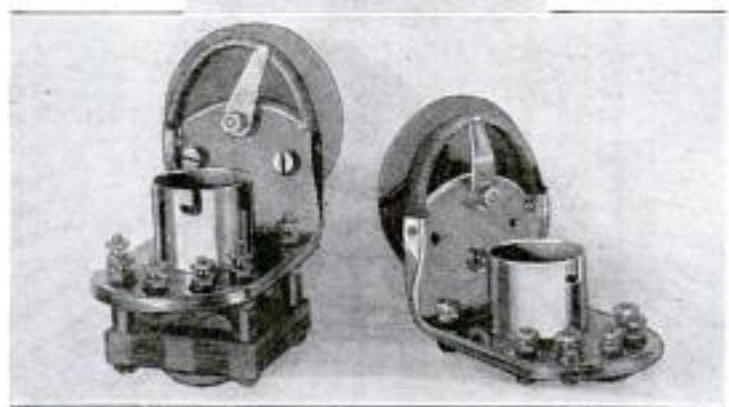

Rheostat and Tube Sockets of Compact and Neat Design, Attached to Panel by Only Two Screws

Mystery of Arctic Barrier Baffles Radio Experts

61 R

Since July, 1922, when the Maud, Amundsen's exploration ship, made its dash northward, and became frozen in the ice in latitude 78° north, longitude 165° west, the ship's radio has been sending out two messages a day. These messages have been received by nearly all stations in Europe, across the North Pole, but they have not been received in Alaska, the United States, or Canada.

MacMillan's ship, the Bowdoin, now frozen in at Refuge Harbor, latitude 78.30 north, longitude 72.30 west, has found that the only station with which it can communicate regularly is that of Jack Barnsley, station 9BP, of Prince Rupert, B. C., and since Sept. 7, 1923, all press stories from the Bowdoin and all messages to and from it have been handled through Barnsley. Other stations have heard WNP (the Bowdoin) but all report very unsatisfactory reception, and 9BP is the only one to get messages through to WNP.

Why is this? That is the question radio experts are asking. What mysterious, in-

visible barrier prevents these messages from reaching this country? Is it the influence of the aurora borealis or the magnetic pole that causes a "dead spot" surrounding the pole on this hemisphere? These questions the Aerial League of America has set itself to solve, and the cooperation of all radio amateurs is invited in the tests. Prizes will be offered by the league for the best reports of experiments by amateurs.

The object of the research work is, first, to ascertain the effect of daylight, twilight, and darkness; ice, water, snow, verdure, atmospheric conditions and geological formations on radio. Second, to ascertain and define the location and strength of natural disturbances and interferences acting upon receiving stations all over the world, under various conditions. Third, to locate and map the "dead areas" of the earth, and delve into the causes of the mysterious barriers to radio transmission. Fourth, to find out whether radio signals travel equally rapidly through earth, air, and water. The subject is an interesting one, and the results of the work should be very valuable.

de Witt - La France Co.,
 54 Washburn Ave
 Cambridge 40, Mass.
 Kansas City Star
 Dec. 9, 1923

14-00



TWO SIMPLE REGENERATIVE RECEIVERS

BY F. L. BRITTIN.



Part I—The Ultra-Audion

MANY radio enthusiasts who are now using crystal receivers would gladly substitute a tube for the detector, were it not for the expense and inconvenience of the storage battery. Of course, the 1½-volt tube has been available, but many people wanted something more nearly approaching the efficiency of the 6-volt tube. For the radio fan of this type there is now available a dry-cell tube—the Radiotron UV. 199 or Cunningham C. 299—the filament of which requires 3 volts, and is supplied by two dry cells. These tubes draw only .06 amp., so the drain on the cells is very light, and they are superior in performance to the 1½-volt tubes, approaching more nearly to the 6-volt tube. The two types of receiver described in this article are well adapted to these tubes, and give excellent results. The ultra-audion circuit, which is a little simpler to construct, and easier to tune, will be described first.

The panel layout is shown in Fig. 1. The panel may be of bakelite, radion, or formica, ¾ by 6½ by 10½ in. in dimensions, and is fastened to a ¾ by 6 by 10-in. baseboard by three ¾-in. round-head nickel-plated screws. The entire instrument may be mounted in a cabinet, if desired, in fact, this is recommended, as it keeps dust out of the various instruments in the set.

Drill all holes in the panel for mounting the instruments before screwing the panel to the baseboard, pricking off the location of the various screwholes with a scribe and marking each center with a center punch, so that the drill will not slip and mar the panel.

The variometer used in this circuit is of the ordinary type, but care should be taken to select a good make. This applies to all instruments used in a radio set, by the way; there are many cheap parts on the market, but the best will be found cheapest in the end. If cheapness is essential, a good wooden variometer should be selected, if not, use the best molded type available. The use of a variometer eliminates all taps and multi-point switches, and adds greatly to the simplicity of the circuit. The rheostat used is of the ordinary panel-mounting type, and should have a resistance of 40 ohms. The grid condenser is of .00025 mf. capacity, and the grid leak of 2 meg. resistance; these are a standard single-unit type. The socket may be of the ordinary type; this necessitates an adapter for use with the 3-volt tubes, but this is an advantage, as the builder may later wish to use a 6-volt tube, and if a standard socket is used at first, it will avoid the necessity of changing later, as the sockets for dry-cell tubes are smaller than the standard.

The phone jack is of the open-circuit type. The variable condenser is a standard 23-plate one with vernier, and the remarks previously made with reference to selecting the variometer apply to the condenser also.

The binding posts for the A and B-batteries are mounted on a small strip of bakelite ¾ by ¾ by 3¼ in. in size, raised from the baseboard on fiber collars or sleeves.

The negative lead of the A-battery is connected to the first post; the A-battery positive and B-battery negative leads go to the center post. It will be noted that

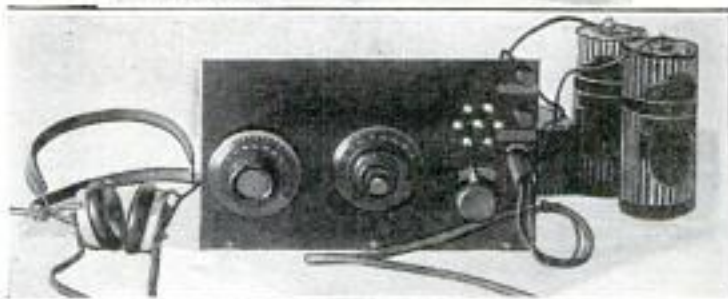
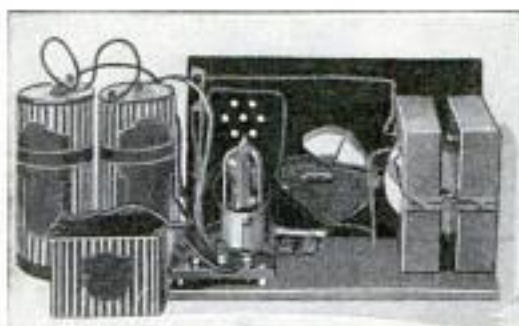

Photos of Front and Rear of Simple Receiver Incorporating the Ultra-Audion Circuit

the B-battery negative is shown connected to the A-battery lead; this is merely to save confusion on the drawing, and, in practice, both leads go to the binding post. The positive B-battery lead is connected to the remaining post; when the battery is new and fresh, the 18-volt tap will probably be found sufficient, but as the battery grows older, the 22½-volt tap should

acid flux for soldering connections on a radio circuit; rosin-flux paste or any of the good soldering solutions for this purpose on the market should be used. Always scrape the wire bright, use plenty of flux, and keep the copper clean and hot. Poorly soldered connections, usually due to imperfect cleaning of the wire, are the principal causes of poor results in homemade radio sets.

This instrument is very selective, and for performance and economy is hard to beat. The tuning is accomplished by means of the variometer and condenser and the wave-length range, with the ordinary aerial, is from 175 to 550 meters. Stations up

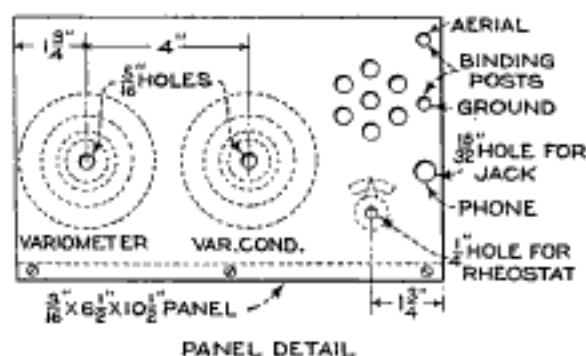

Fig. 1

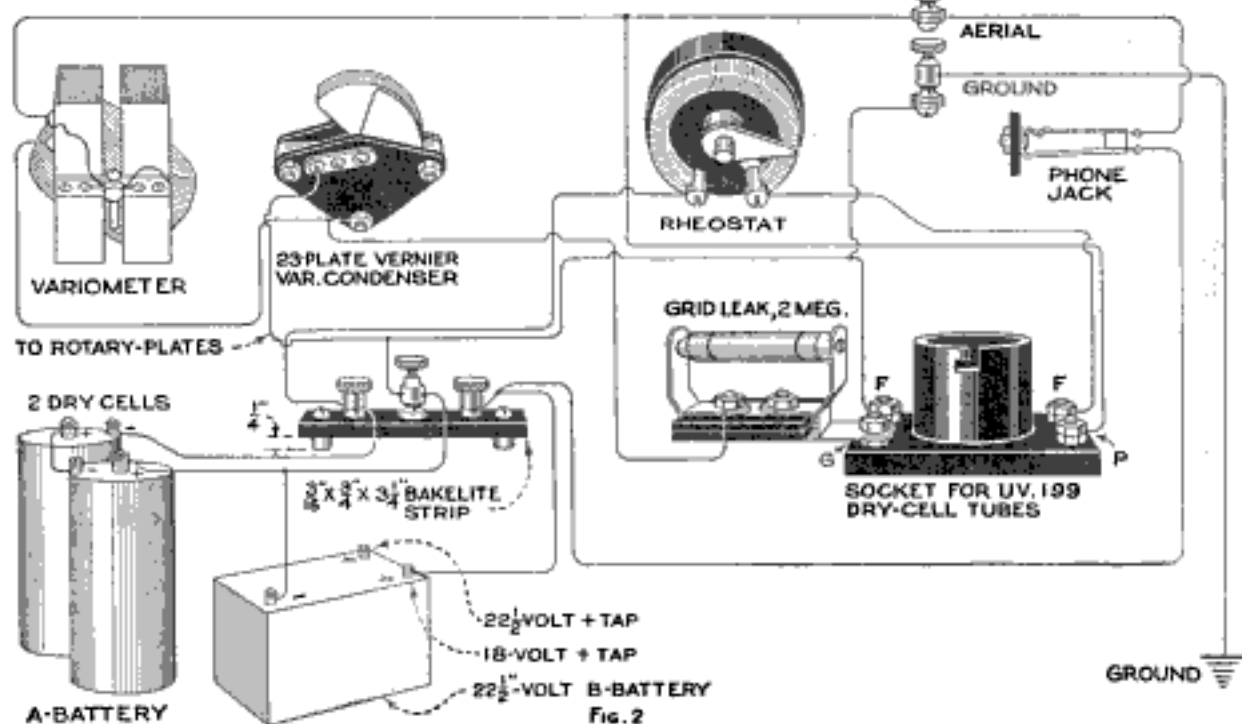

Fig. 1, Layout of Panel; Fig. 2, Simplified Wiring Diagram of Ultra-Audion Receiver Suitable for 3-Volt Dry-Cell Tubes. Variometer and Variable Vernier Condenser Are Used for Tuning

be used. The active life of a B-battery with this set is about 9 months, and, as the tubes draw little current, the life of the A-battery will be found long enough to make the dry cells quite economical. It will be noted that the dry cells are connected in series, to provide the necessary 3 volts. Use nothing but a good make of phones, of at least 2,000 ohms resistance.

Use No. 18 rubber insulated fixture wire for the circuit, and solder each connection carefully. Use a good non-corrosive flux and plain wire solder. In no case use an

to 1,000 miles have been received clearly on this set, with a good pair of phones.

A word of caution is necessary to those who have not built a set before: Check each wire carefully against the diagram before finally soldering it in place, and, before the tube is put in the socket, see that the rheostat is turned to the off position, then, after placing the tube, turn it up slowly until a slight "hiss" is heard in the phones. Turn the rheostat back until the hiss just disappears; this is the operating point of the tube.

The second part of the article, to be published in May, will describe the construc-

tion of a simple form of triple-coil receiver made of scrap material.

MATERIAL LIST
Ultra-Audion

- 1 3-16" by 6 1/4" by 10 1/2" bakelite panel.
- 1 3/8" by 6" by 10" baseboard.
- 1 3-16" by 3/4" by 3 1/4" bakelite strip.
- 1 open-circuit phone jack.
- 1 standard variometer.
- 1 23-plate variable vernier condenser.
- 1 standard socket.
- 1 adapter for UV. 199 or C. 299 tube.
- 1 .00025-mf. grid condenser with grid-leak mounting.
- 1 2-meg. grid leak, cartridge type.

- 1 dry-cell rheostat, 40 ohms resistance.
- 1 UV. 199 or C. 299 tube.
- 2 dry cells.
- 1 22 1/2-volt B-battery unit, small type.
- 5 binding posts.
- 1 lightning arrester.
- 1 ground clamp.
- 1 pair 2,000-ohm headphones.
- 20 ft. No. 18 rubber-covered fixture wire.
- 100 ft. aerial wire.
- 50 ft. lead-in. wire.

Naval Radio Makes Money

In spite of the fact that the naval radio service avoids competition with commercial companies, a recent report shows that the service earned nearly \$300,000 in 1922.

Wherever an emergency exists that the commercial companies cannot handle, or where it is possible to help business men extend American trade, the government is always ready to be of service. Many of the commercial messages handled are from business men trying to establish trade connections by radio in places not served by civilian companies.

Remarkable feats in quick transmission are accomplished by the naval service. On the occasion of a recent big sporting event in this country, extra newspapers containing the result were on the streets in Honolulu 50 minutes after the end of the game.

Had the entire business of the bureau, consisting of the transmission of 16,000,000 words, been based on commercial rates, over \$4,000,000 would have been earned.

Sea Shell Is Used as Loud Speaker

It is always refreshing to see a departure from the conventional, provided, of course, that the new arrangement works as efficiently as the ordinary one.



The sea-shell loud speaker shown in the photograph is not only attractive in appearance, but its acoustic properties are fully as good as those of the common type, which is in many cases, to say the least, an uninspiring object.

The base of the shell has been cut off square, and a type-C unit cemented in place, making a novel addition to the set.

Music Lessons by Radio

Pupils of Junior High School 61, in New York, recently had a treat when music broadcast from the Metropolitan Opera

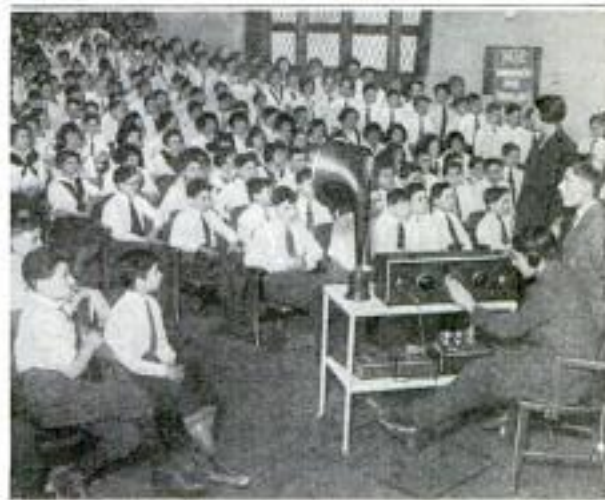

Class in New York High School Listening to Grand Opera Company

House was picked up on a receiver in the classroom, and made a part of their regular music lesson.

The experiment was very successful, and it is hoped to make this a regular feature of music work in the schools. The advantages of radio in educating the musical taste of students in this manner are apparent, as it permits thousands of school children to hear the best music, at a nominal expense.

His Voice over Radio Wins Pardon

Max Sasanof, a Russian tenor and painter, who was serving a 5-year sentence at the Atlanta federal penitentiary, recently won a pardon through radio. It became evident during one of WSB's prison concerts that he was an artist of no mean ability, and much interest was aroused in his case. Upon investigation it was found that Sasanof had been the victim of confederates in a counterfeiting plot, and he was immediately pardoned.

*Atlantic Photos New York
25 Park Place,
Pacific*

*Clipped
Pacific & Atlantic Photos, Inc.
25 Park Place
New York City*

59-2 Listen for These Foreign Broadcasting Stations

Below are given some of the foreign broadcasting stations that send out programs more or less regularly:

2 LO, London, Eng. 360 meters. Concerts, weekdays from 10:30 to 11:30 a.m., and from 12:00 noon to 5:30 p.m. Also 6:30 to 7:30 a.m. weekdays, and 10:00 a.m. Sundays.

5 WA, Cardiff, Wales. 353 meters. Same program hours as above, with the exception of the 6:30 to 7:30 weekday program, and the 10:00 a.m. Sunday one.

2 ZY, Manchester, Eng. 385 meters. Same hours as 5 WA.

5 NO, Newcastle, Eng. 400 meters. Same hours as 5 WA.

5 SC, Glasgow Scotland. 415 meters. Same as 5 WA.

5 IT, Birmingham, Eng. 420 meters. Same as 5 WA.

SPE, Rio de Janeiro, Brazil. 450 meters. Portuguese language. Exchange quotations, 12:00 noon and 4:00 p.m. Weather forecast, 2:00 and 7:00 p.m. Musical, 6:00 p.m.

Telegraph School of France. 450 meters. 2:30 p.m. Tuesdays and Thursdays, and 8:30 a.m. to 1:00 p.m. Saturdays. Announcements in French.

Station "Radiola Riviera," Nice, France. 460 meters. About 7:00 a.m., 12:00 noon, and 4:00 p.m. News and announcements in French.

HB1, Geneva, Switzerland. 900 meters. 12:00 noon to 2:30 p.m., daily, in French.

Station at Kbel, near Prague, Czecho-Slovakia. 1,000 meters. News, concert, and weather report daily at 1:20 p.m. In Czech and German.

PCKK, Velthuyzen station, the Hague, Holland. 1,050 meters. Concerts Fridays, 2:40 to 3:40 p.m. In Dutch.

PCUU, Huessen station, the Hague, Holland. 1,050 meters. Concerts Tuesdays, 1:45 to 4:00 p.m. Sundays, 3:40 to 4:40 p.m.

PCGG, the Hague, Holland. 1,050 meters. Con-

certs Sundays, 9:00 to 11:00 a.m. Mondays and Thursdays, 2:40 to 3:40 p.m.

PA5, Amsterdam, Holland. 1,050 meters. News and concerts Wednesdays, 2:10 to 3:10 p.m.

PCMM, Ijmuden, Holland. 1,050 meters. Concerts Saturdays, 2:40 to 3:40 p.m.

BAV, Brussels, Belgium. 1,100 meters. Concerts Tuesdays and Thursdays, 4:00 p.m. Sundays, 1:00 p.m. In Belgian.

OPO, Haren, Belgium. 1,300 meters. Weather report (in French), 7:00 a.m. and 11:00 a.m.

SFR, Paris, France. 1,780 meters. Concerts (in French) weekdays, 6:00 a.m., 11:15 a.m., 3:00 to 4:00 p.m. Sundays, 8:00 to 10:00 a.m. and 3:00 to 4:30 p.m.

As the majority of broadcast receivers in this country will not tune over 1,000 meters, this includes all they may expect to hear, but if any reader wants the remainder of the list it will gladly be supplied, on request.

The times given are Eastern standard time. (New York time.) For Central time (Chicago time), subtract one hour; for Mountain (Denver) time, two hours, and for Pacific (San Francisco) time, three hours. To find the time in Europe, add five hours to the figures, for England, France, Belgium, and Holland. The time in Czecho-Slovakia may be found by adding on six hours. Rio de Janeiro is about two hours ahead of New York; when it is 12:00 noon in New York, it is 2:00 p. m. in Rio.

The Echo Co., 111 W. Monroe, Chicago

35 Switch Aids Tapping of Inductances

Tapping and wiring of inductance coils is greatly facilitated by the use of a special switch recently placed on the market. Instead of drilling a hole on the panel for

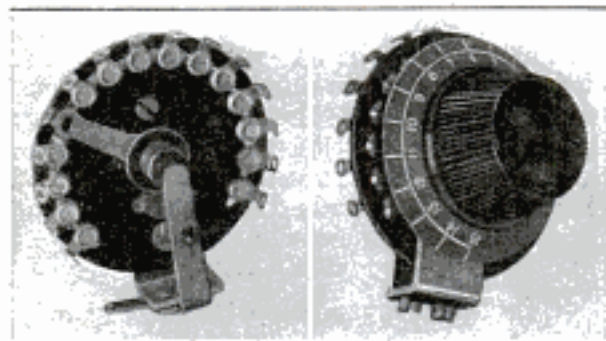

Left, Back of Inductance Switch, Showing Contact Points; Right, Graduated Dial and Knob

each switch point as is usually done, only three holes are drilled, one for the switch shaft, and two for the attaching screws. Contact to each point is made by a switch arm on the back of the unit; there are 15 contact points, and adjustable stops are provided so that any number of points may be used.

25 Ground Clamp Bites into Clean Metal

A novelty in ground clamps is one that makes it unnecessary to scrape several inches of paint from a pipe to secure good electrical contact. The fitting is made in the form of an ordinary C-clamp, but the end of the screw is hardened and pointed, so that it bites into clean metal with a slight pressure on the screw. The other end of the clamp frame has two small points that also aid in attaining a good contact. The ground wire from the radio set is fastened under a round-head screw in the center of the clamp frame.



⚠ Don't attempt to use the lighting circuit as an antenna without first finding out the principles of the idea. One fan did, with the result that his hands were badly burned, and the fire department was obliged to render first aid to both fan and house.

Carter Radio Co. St. Chicago 35
209 S. State



All Shop Notes published in 1923, in book form—from our Book Department.

Wood-Sawing Rig Made from Old Car

By L. B. ROBBINS

INSTEAD of spending from a hundred and fifty to two hundred dollars for a portable wood-sawing rig, a Cape Cod man made use of the power plant of an old car. It has been in use for several years, and will saw up the largest piece of cordwood with ease. The outfit, minus the saw and such parts, cost less than fifty dollars.

An old auto-truck frame with only the rear wheels left on was utilized for the portable foundation. The front cross member of the frame was sawed off, thus making a pair of shafts, into

rear cross timber, and the other to the cross member of the truck frame. The end of the shaft is threaded to take the flanges and retaining nut of an 18-in. circular saw. Spark, choke, and throttle rods are held under cleats on the timbers, and can be adjusted at will.

The saw table consists of a rectangular wooden frame, with deep notches cut in the top of the vertical members to take the sticks. The bottom is hinged to stakes which can be driven in the ground next to the saw, and the table is

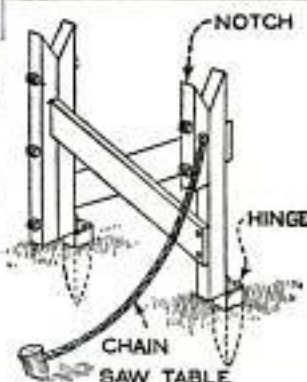
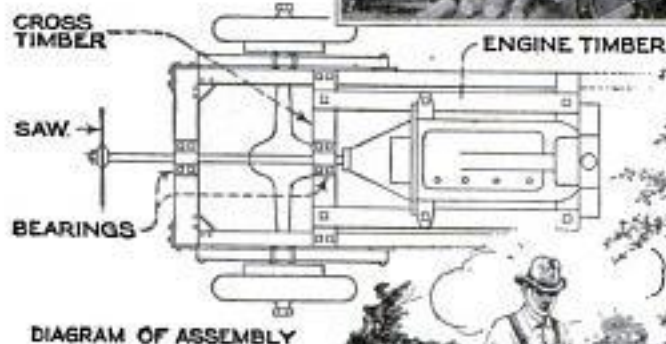
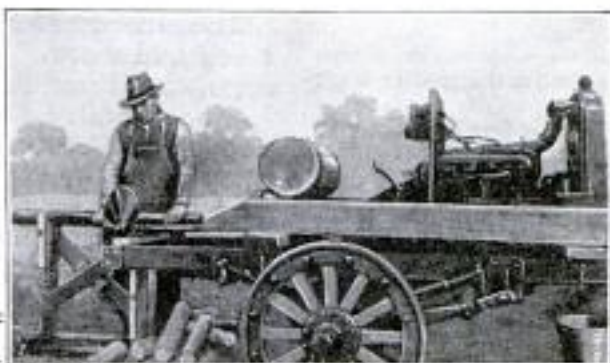

which could be hitched a horse for drawing the outfit around.

The engine, including radiator, transmission housing, dashboard, and gas tank, is mounted by means of bolts to heavy timbers attached to the chassis, as shown in the illustration. Low and reverse gears are removed, and the driving shaft run through two pillow-block bearings, one bolted to the



Details and Photo of Portable Wood-Sawing Rig Made from Old Automobile: Left, Plan of Assembly; Right, Details of Saw Table

ground on the side of the table away from the operator.

then ready for use. A chain keeps it from swinging back too far when a heavy stick is being sawed up, besides holding it in position ready for the sticks to be placed on it and pushed over against the saw. The chain is securely attached, by means of a staple, to a stake driven into the

Micrometer Holder Keeps Oil from Spindle

When a micrometer is required for measuring work produced on a machine where cutting oil is used, it is a good plan

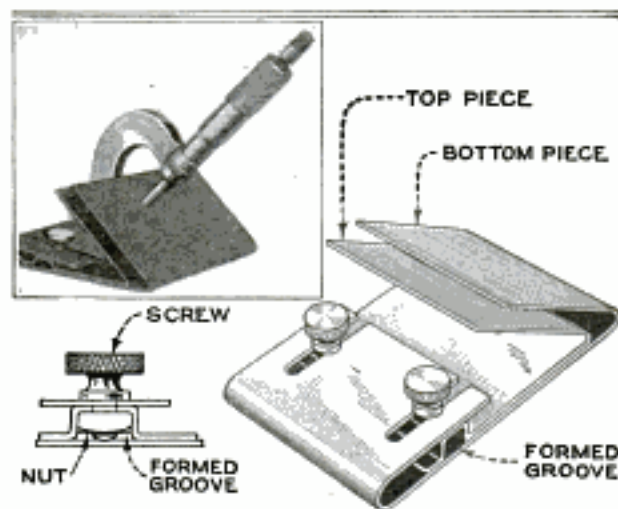

Simple Holder for Micrometer Used to Gauge Oily Work

to have some special device for holding it so that the oil will drain away from the spindle. As everything, including the operator's hands, is covered with oil, it is nearly impossible to keep the tool clean, but with a holder of the kind shown in the photo, the tool can be held in such a position that the oil will drain away from the thread, which would otherwise soon become inaccurate, due to the impurities that the oil contains.

The holder is made of two pieces of sheet metal, bent to the shape shown and held together with two thumbscrews, turning in nuts placed in a groove formed in the top piece. The bottom piece is slotted to make the holder adjustable, which is necessary to make the holder suitable for different settings of the micrometer on various jobs.

Increasing Orchard Yield

Farmers and orchardists in the United States are beginning to realize the necessity of restoring plant foods to the soil by applying concentrated fertilizers. Nitrogen is one of the foods that every plant needs and one that is soon exhausted from the soil, necessitating fertilizers, such as ammonium sulphate, sodium nitrate, and Chile saltpeter. Sodium nitrate is in such a form that it can readily be assimilated by the tree roots, while ammonium sulphate is slightly less soluble. When using these fertilizers in orchards the best results will be obtained if they are applied

to the soil in the spring, just when the season's growth begins. The amount of fertilizer applied to the soil under each tree varies, of course, with the condition of the soil, and with the kind, age and size of the trees. In recent experiments with apple trees on poor soil it was found necessary to apply $\frac{1}{4}$ lb. of fertilizer for each newly planted tree, and about 15 lb. for each mature tree that had been unproductive.

Cast Copper Vise Jaws

A large shop supplies its bench hands with copper vise-jaw pads to fit the different vises. They are cast from a metal pattern as shown in the illustration, and a good supply is always kept on hand so that a new set can be obtained when the old ones become badly battered and worn. The old ones are then returned to the foundry as scrap copper and recast. Any alloy metal, or even lead, may be used for this purpose, the lead being of special advantage for some classes of work. The pads are placed in the vise and the projecting ends are bent back over the jaws. Copper pads seem to stay in place much better than those made of sheet metal and they also last much longer.—H. L. Wheeler, Westwood, Mass.



Gib-Head Key Guard

An effective guard for gib-head keys of the kind shown in the illustration not only prevents a loose key from coming out, but it also eliminates the danger of having the projecting head of a revolving key catch

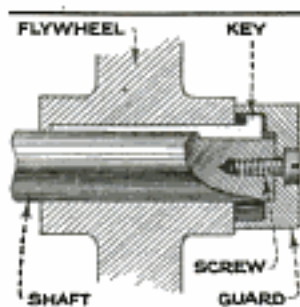

the workman's clothes, consequently causing injury. The guard consists of a cast-iron cap fastened on the end of the shaft so that it covers the head of the key. The cap is attached by means of a machine screw driven into a hole drilled and

tapped in the end of the shaft. The hole in the cap is counterbored to take the screw head.

Hitching Wagon Train to Tractor

Hauling grain, corn and other products of the farm with trucks is the most modern method, but it is questionable whether a train of wagons drawn by a tractor is not a still more efficient one. Although the time consumed in making the trip with a tractor is much longer than if the trip were made with a truck, a tractor can draw a number of loads at once while the truck must make a separate trip for each load. The only objectionable feature in the use of a tractor for such purposes is its clumsiness, which makes it difficult, and in some cases impossible, to pull the loaded wagons on the grain-elevator platform. Of course, much depends on the particular size and type of the tractor.

In the case shown in the photograph six wagons, loaded with shelled corn, having a total weight of 408 bushels, were drawn by the tractor. It was necessary to hitch the wagons as close as possible so that corners could be turned safely. To

do this the tongues were securely fastened to the front axle support of the wagon ahead, instead of the rear one as is customary. In order to avoid the necessity of

moving the wagons by hand the tractor was backed up in front of the first wagon, A, and its tongue was attached to the drawbar of the tractor, as indicated by the dotted lines of the detail. The first wagon was pulled up to a position directly in line with the second wagon, B, the tongue of which was cramped hard over. B was then backed until the tongue could be straightened, and A backed

so that the two could readily be hitched as described above. This operation was repeated for each wagon which could not be hitched before it was loaded. A team of horses drawing another wagon load was taken along with the train so that it could be used to pull the wagons on the elevator platform separately after they were unhitched; this could not be done by the tractor, owing to its size.

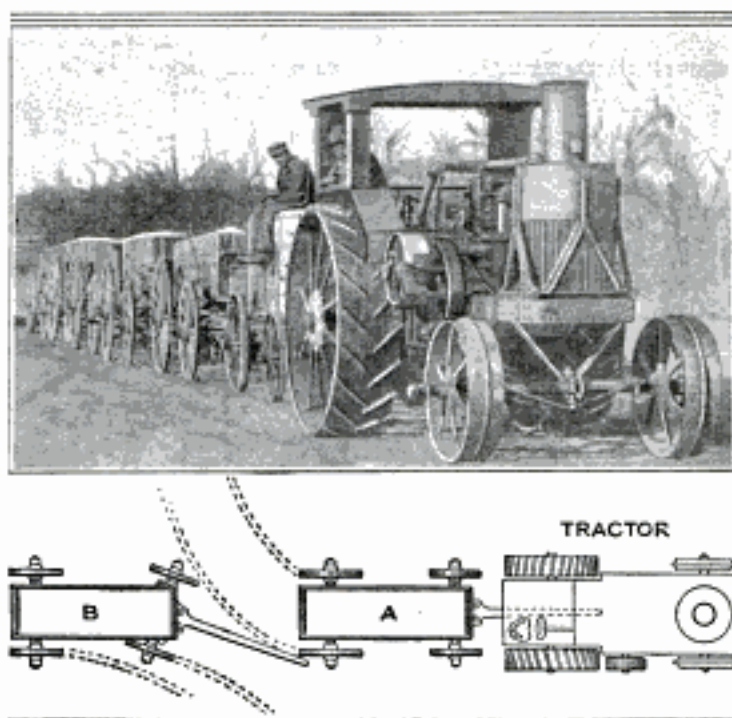

Above, Tractor Pulling 408 Bushels of Corn in Six Trailers; Below, Method of "Hooking Up"

Turning Bell Pattern to Size

In making a pattern for a large bell difficulty was encountered, after the inside was finished, in turning down the outside to the proper size, as no calipers that were large enough were available. The difficulty was overcome by drilling a number of holes through the pattern about 3 in. apart, and inserting plugs of a length equal to the desired thickness of the pattern at various points. The pattern was then mounted in the lathe

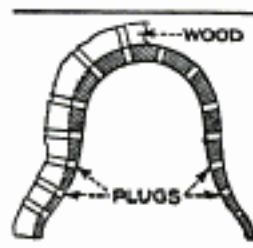

and the excess thickness turned down until the outer ends of the plugs were flush with the surface.—A. E. Holaday, Springfield, Massachusetts.

New Use for Sandblast

A novel application of the sandblast has been discovered by an English company—that of cleaning boiler tubes. It is claimed that the tubes of modern tubular boilers are rapidly cleaned of soot, etc., on the outside, and that the interior of each tube can be cleared of scale or other deposit thoroughly, and at a much greater speed than by any other existing method. This certainly has the merit of simplicity.

Homemade Drag for Leveling Orchard Land

After experimenting with several kinds of drags, the one shown in the illustration was found the most serviceable and convenient for leveling orchard land, which in this case, had been plowed the same way for several years with the result that the surface was formed in a series of ridges and furrows. Although a drag of this kind may not level the ground perfectly it will, nevertheless, help considerably. The work must, of course, be done when the soil is still loose from harrowing, before the winter rains pack it down.

The frame of the drag is made of two timbers of 2 by 8-in. pine or similar strong material, and four 2 by 4-in. crosspieces, two of which are bolted at each end, the upper one flat and the lower one on edge, as shown in the upper right-hand detail. The length of the drag, or rather the distance between the crosspieces at the ends, should be equal to the distance from center to center of the orchard ridges, and this depends, of course, on the distance between the rows of trees. About 3 ft. is the best width unless a tractor is used, and then the drag may be wider and

also much heavier. A 2 by 4-in. reinforcing block is bolted behind each lower crosspiece to prevent it from being torn off while dragging. Diagonal braces of 1 by 6-in. material or lengths of angle iron are

bolted across the frame to prevent distortion, but heavier timbers, say of 2 by 4-in. material, would be better, as there is a considerable strain on the drag when it is turned. A box is nailed at each end and filled with stones to give the drag the necessary weight. Steel plates, $\frac{1}{4}$ in. thick, or lengths of angle iron are bolted to the edge of the lower crosspieces, as shown, so that the drag will

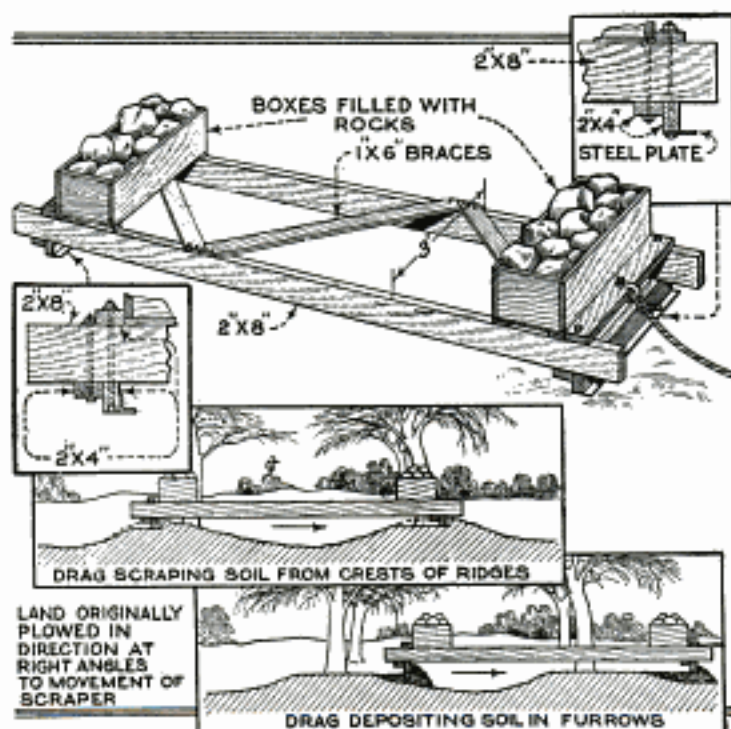

A Homemade Drag that Has Been Found Very Efficient for Leveling Orchard Lands

take a good "bite" when scraping the soil. One horse can readily pull a drag of this size. If a team or tractor is used more ballast may be added.

In use, the crosspieces scrape soil from the crests of the ridges and deposit it in the furrows. Some difficulty in the use of this drag is encountered in turning, but this can be eliminated by making the drag "double-ended" so that it can be pulled back without turning.—H. H. Parker, Los Gatos, Calif.

Cutting Washers in Lathe

There are all sizes of washers on the market, but it is often difficult to get one to fit snugly, because the shaft or spindle on which the washer is to be used is sometimes worn down a trifle below the nearest standard size of washers, or the particular size of the washer needed may not be available, making it necessary to cut an emergency one. An excellent method of cutting washers accurately to any desired size and without much trouble, is to do it on the lathe.

The material from which a washer is to be cut, whether felt, fiber, rubber, leather, etc., or even thin sheet metal, such as brass, copper and tin, is tacked to a wooden disk about $\frac{3}{4}$ in. thick, which is mounted on the screw faceplate of the lathe. The tail center is then moved forward to mark the center on the disk and a pair of dividers are used to mark the inside and outside diameters, which is done in the following way: The diameter of the shaft is measured with a slide caliper and the dividers set to slightly less than half of this distance, to insure a tight fit. Then with one

point of the dividers on the center mark just made on the disk a circle is carefully scribed on it, holding the dividers on the toolpost at an angle to the work, and revolving the faceplate slowly by pulling the belt. If the impression of the divider is not distinct enough, it can be brought out by running over it with a sharp-pointed pencil. The outside diameter is then scribed by setting the dividers to one half of this distance and proceeding in the same way. The lathe is set in operation and a sharp knife used to cut out the washer, the knife being steadied on the toolpost. It is obvious that the inner circle must be cut first. In cutting washers from soft materials such as felt, cork and rubber, which cannot readily be marked with the dividers and are not easy to cut, a stiff piece of cardboard is tacked over the surface and this surface used to mark on and cut through; the result will be that the material under it will be neatly cut to the same size. The size of the washers that can be cut in this way is limited only by the size of the lathe used to do the work. When cutting brass, copper and tin washers a regular metal-cutting tool must be used instead of a sharp knife.—J. E. Decker, Chicago, Ill.

Cold-Air Check for Chute

In a manufacturing plant where finished slabs are conveyed from the inside through a chute to the outside, a cold-air check was

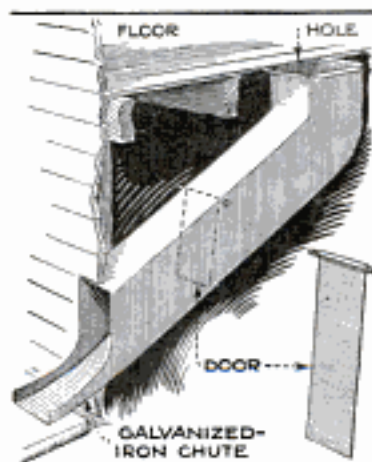

installed to prevent too great a loss of warm air in winter. The chute is made of galvanized iron and is nearly square in cross section. The check is also made of sheet iron and is slightly smaller across than the inside

width of the chute, but is about an inch longer. The upper edge is bent over to hinge on a wire that is run through the chute and is fastened on both sides. When the check is at rest, the lower or free edge is a little further out than the top; this prevents it from swinging inward and effectively keeps out all cold-air drafts. Still it does not interfere with the passage of the slabs in any way.

Preventing Tap Breakage

It often happens that a small tap suddenly breaks after it has been used constantly on the same kind of work. The

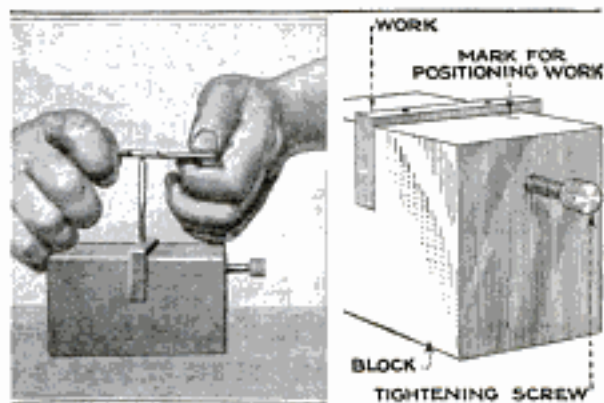

Left, Using Loose Block to Tap Small Work; Right, Details of Block

breakage is most likely due to too much torsional strain. Breakage of taps due to this cause can be eliminated by providing a loose block to hold the work; then if the tap binds in the work, the whole block will turn. The block is simply a piece of cast iron with a groove or slot cut in it to hold the work and a tightening screw to hold it securely. The block is placed on the bench plate and the friction between the block and the plate is sufficient to hold the former stationary while the tapping is being done. By moving the work so that the hole to be tapped is eccentric, the block can be adjusted to turn before the tap gets too great a strain. When this position is found a mark is scribed on the block so that the work can readily be placed in the correct position.

Drill-Press Clamp Bolts

Cheap and serviceable adjustable drill-press clamp bolts of the kind shown in the illustration can readily be made from suitable lengths of 1 by 1/2-in. iron. One end is cut down and threaded, while a series of holes to take a loose pin are drilled in line through the flat side as indicated. In use, the flat part is inserted into a slot of the drill-press table and the loose pin pushed through the hole that is nearest to the underside of the table. Then a nut is screwed in the threaded end to hold the work clamp.—John Harger, Honolulu, Hawaii.



MECHANICAL POWERS

By CARL W. MITMAN

Curator

DIVISIONS OF MINERAL AND
MECHANICAL TECHNOLOGY
UNITED STATES NATIONAL
MUSEUM



Copyrighted, H. H. Windsor

FOR many months the National Museum in Washington has been designing and building an unusual set of models of remarkable interest. These illustrate most simply and clearly the fundamental principles of the various Mechanical Powers. These models show at a glance, what textbooks have heretofore taken pages to describe. This is the second of a series of articles by Curator Mitman—who is himself an engineer of great ability—which not only explain in simple language what every mechanic and inventor who designs or builds a machine must know, but also tell how any one can exactly duplicate for himself the complete identical set of models in the National Museum. Mr. Mitman tells how to do this with ordinary tools and at practically no expense for materials.

For schools teaching physics or manual training, the opportunity is now presented for the first time of duplicating the set of these models in the National Museum. If one or more classes each year will build a few of the models, which should bear the nameplate of the class, in the course of two or three years the school will possess not only lasting monuments to the classes, but acquire, without cost, the full set for use of all future students, and which can be available to all local mechanics and inventors for all time.

If schools desiring to take advantage of this opportunity will communicate with us, we will be glad to furnish suitable nameplates, bearing the name of the class and year, free. Address Room 408, Popular Mechanics Bldg., 200 E. Ontario St., Chicago.

This series will run for many months to come; the third article will appear in the May issue, and, as this is the first time articles like this have ever been published, they should be preserved for future reference.

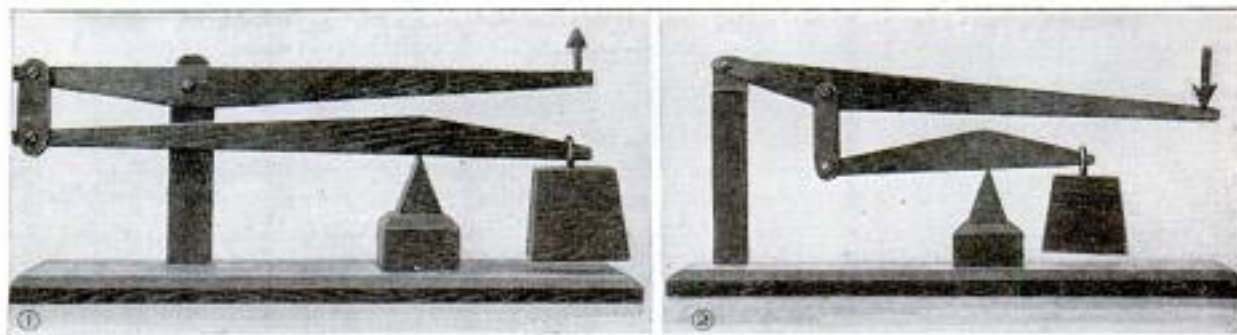

Photo No. 1, Completed Model of Compound Lever of the First Order; Photo No. 2, Model of Compound Lever Combining First and Second Orders

Part II—Moments and Compound Levers

A FORCE acting upon a lever tends to rotate it one way or another, depending first upon the magnitude of the force and second upon the perpendicular distance of the force from the fulcrum of the lever. These two factors taken together always determine the rotating or turning effect on the lever, and their product is called the moment of the force. In all questions involving levers and the work they are to do, the moments of the forces to be used must always be taken into consideration, and of greatest importance is the principle of moments. This states that when two or more forces act upon a lever and tend to rotate it about its fulcrum, then equilibrium will exist if the sum of the moments of the forces which tend to turn the lever in one direction equals the sum of the moments which tend to turn it in the opposite direction about the same axis. In other words, in the case of a first-order lever having two forces acting upon it on opposite sides of the fulcrum, as in Fig. 1, equilibrium will exist in the lever only when the moment of W (W times a) equals the moment of P (P times b). This is a very simple equation and is used to solve lever problems.

Should it be desirable, for instance, to know just how long a lever must be to accomplish a certain job or how much force must be applied to do that job with a lever of fixed length, the information is to be had by using the above equation. Fig. 2 illustrates just such a definite lever job, in that there is a force of 40

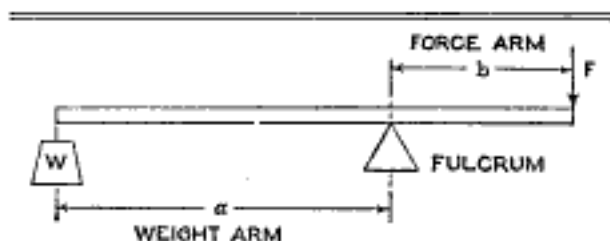

FIG. 1

Diagram Illustrating Principle of Moments

pounds available to bring into equilibrium three scattered forces acting on one arm of the lever and totaling 80 pounds pull. The question is, what length must the other arm of the lever be to permit the 40-pound pull to be effective. According to the principle of moments:

$$40 \text{ lb.} \times \text{length of lever arm} = 20 \text{ lb.} \times 40 \text{ in.} + 50 \text{ lb.} \times 30 \text{ in.} + 10 \text{ lb.} \times 25 \text{ in.}$$

$$\text{Length of lever arm} = \frac{800 + 1,500 + 250}{40} = \frac{2,550}{40}$$

$$\text{Length of lever arm} = 63\frac{3}{4} \text{ in.}$$

It will be noted that three calculations

have been combined into one in this example; that is, instead of figuring the moment of the weight arms separately, a short cut was taken.

The principle of moments is the underlying principle not only of levers, but of the whole subject of the action of forces in general. It is applied by the bridge designer in determining the type of structure necessary to support all loads and under all conditions; by the architect in the de-

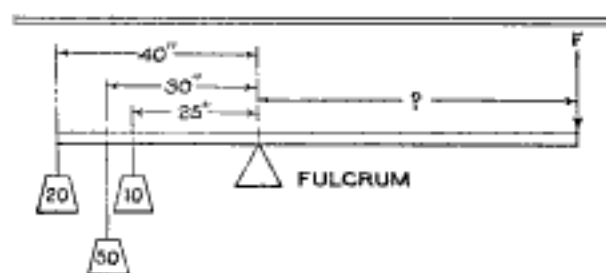

FIG. 2

Diagram Illustrating Problem in Design of Simple Lever

sign of buildings; and by the draftsman in the design of machines and machine parts.

When using levers to do work, and bearing in mind that the moments of the forces acting determine the effectiveness of the work done, it is quite easy to picture conditions in actual practice which would prevent the use of the simple order of lever, either due to the restricted space through which the applied force must act, the inconvenient location of the point of delivery of the power, or the prohibitive length of the lever arms. For such conditions combinations of the simple levers are used and these combinations are called compound levers. Of such mechanical powers there is an almost endless variety, beginning with combinations of two simple first-order levers; first and second-order combinations; first and third orders; two second orders; and so on. Then combinations of three, four and even five levers, some of which are first-order, others second and still others third-order. Thus the letter-printing action of one of the well-known typewriters is accomplished with a compound lever consisting of a second-order lever and two third-order levers. In the preceding chapter reference was made to that well-known saying, "What is gained in power is lost in speed." So, in the case of the typewriter action, speed is the object desired, but which must be produced with an available force of small magnitude (the fingers). The compound lever described above solves the problem.

Compound levers are sometimes rather difficult to recognize and even more difficult to devise for a specific piece of work

unless the individual parts of the combination can be distinguished. In this connection, therefore, attention is directed to Figs. 3 and 4, which illustrate two types of lever combinations, conventionalized for

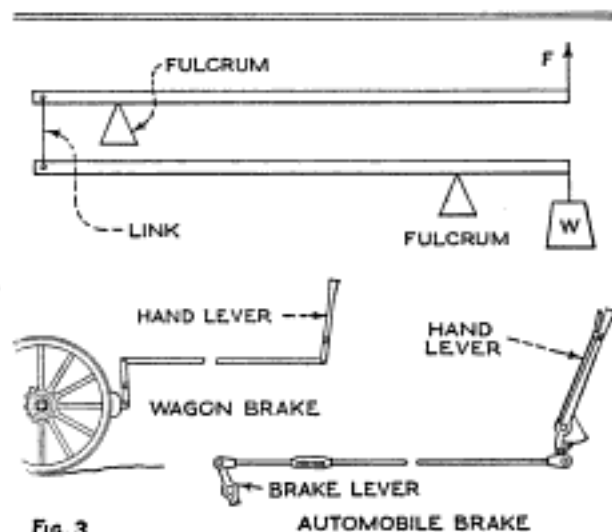

Fig. 3
Simplified Drawing of Compound Lever of First Order,
with Examples of Its Use

simplicity. Fig. 3 is a simplified drawing of a compound lever consisting of two first-order levers. That it is a combination of two first-order levers is recognized from the relative location of the applied force, the fulcrum, and the resisting force respectively, and it will be observed that the fulcrum in both the upper and lower levers lies between the two opposing forces, hence they are of the first-order, as brought out in the preceding article. The fulcrum in the upper lever in the model, Fig. 5, however, takes a different form from that of the lower. While this lever combination yields a mechanical advantage, it is gained at a loss of speed and distance through which the resisting force (weight) is moved. Even so, there are undoubtedly occasions in practice where this characteristic is the one desired. Probably the most extensive use of two first-order levers combined is in the hand brake of a wagon and the emergency brake of an automobile. Simply by substituting a longer link connecting the two levers, and a brake shoe or one end of a brake band for the weight, the diagram shown in Fig. 3 illustrates this mechanism. Again, the throttle control on certain American-type locomotives is gained by the aid of a compound lever consisting of two first-order levers.

Another type of compound lever is shown by the diagram in Fig. 4. This type is a combination of a second-order lever above and a first-order lever below. The combination is to be found in foot

brakes both on wagons and automobiles, the difference between this type and type shown in Fig. 3 being the reversal of the position of the fulcrum and connecting link of the upper lever. This permits the applied force to be moved through a lesser distance to obtain the same work, and also in the opposite direction. Another application of this lever combination is found in some types of children's vehicles, especially those propelled by the child sitting on a platform and operating a vertical handle backward and forward.

For the compound-lever model, the first order, the following materials are required:

- Base, 12-in. x 3-in. x $\frac{1}{2}$ -in.
- Fulcrum block, $1\frac{1}{2}$ in. square x $\frac{3}{8}$ in.
- Fulcrum, base $\frac{3}{8}$ -in. x $\frac{3}{8}$ -in., side 1-in. high.
- Two lever arms, 11-in. long, $\frac{1}{4}$ -in. wide, $\frac{1}{4}$ -in. at apex.
- Weight (resisting force), base $1\frac{1}{4}$ -in. square, top $1\frac{1}{4}$ -in. square, side $1\frac{1}{2}$ -in. high.
- Pillar, $4\frac{1}{2}$ -in. x $\frac{3}{8}$ -in. x $\frac{1}{2}$ -in.
- Arrow (applied force), $1\frac{1}{4}$ -in. long, $\frac{1}{4}$ -in. thick, $\frac{1}{2}$ -in. across barbs, $\frac{1}{4}$ -in. square shaft.

Square and face the base and block with a finish bevel on top of each. On the center line of the base, and 7 in. from the end, secure the block by gluing and bradding from beneath. On top of this glue and toenail the fulcrum with its longest dimension running parallel to the center line. $2\frac{3}{4}$ in. from the end of the base and 1 in. from its side, mortise a hole, $\frac{3}{8}$ in. x $\frac{1}{2}$ in., through the base. Connect the toe of one lever and the end of the other by the link, making the connection by drilling oversize holes in the ends of the levers and link, and inserting in these holes round-head brass screws. By a similar method pivot the

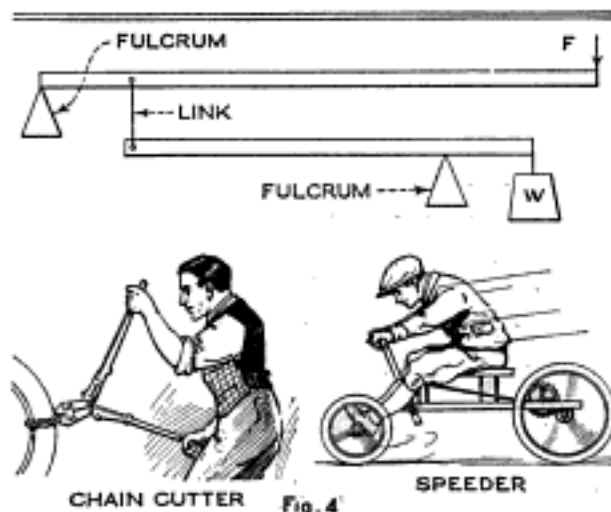

Fig. 4
Compound Lever of First and Second Orders, with
Examples of Everyday Compound Levers

lever on which the toe is linked to the pillar, by a hole drilled through the center of the lever at the apex, to accommodate a screw. Fasten the weight to the toe of the

lower lever by inserting the screw-eye, used as a handle, in a notch cut in the end of the lever. Attach the arrow to the end of the upper lever by inserting the point in a notch cut therein. Fasten this assembly to the base by inserting the pillar in the mortise, securing with glue, and pivoting the lower lever on the fulcrum below the apex, retaining it by an invisible brad. Finish as desired.

For the compound-lever model, 1st. and 2nd. orders, use the following materials:

- Base, 12-in. x 3-in. x $\frac{1}{2}$ -in.
- Fulcrum block, $1\frac{1}{2}$ -in. square x $\frac{7}{8}$ -in. high.
- Fulcrum, base $\frac{7}{8}$ -in. x $\frac{7}{8}$ -in., side 1-in. high.
- Upper lever arm, 11-in. x $\frac{1}{4}$ -in., $\frac{3}{8}$ -in. at apex.
- Lower lever arm, $6\frac{3}{4}$ -in. x $\frac{1}{4}$ -in., $\frac{3}{8}$ -in. at apex.
- Pillar, 5-in. x $\frac{5}{8}$ -in. x $\frac{1}{2}$ -in.
- Link, 2-in. x $\frac{3}{8}$ -in. x $\frac{1}{4}$ -in.
- Weight (resisting force), base $1\frac{3}{4}$ -in. square, top $1\frac{1}{4}$ -in. square, side $1\frac{1}{2}$ -in. high.
- Arrow (applied force), $1\frac{3}{4}$ -in. long, $\frac{1}{4}$ -in. thick, $\frac{1}{2}$ -in. across barbs, $\frac{1}{4}$ -in. square shaft.

Square and face the base and block with a finish bevel on top of each. On the center line of the base and 6 in. from the end secure the block by gluing and bradding from beneath. On top of this glue and toenail the fulcrum with its longest dimension running parallel to the center line; $\frac{3}{4}$ in. from the same end of base and $\frac{7}{8}$ in. from the side, chisel a mortise, $\frac{7}{8}$ in. by $\frac{1}{2}$ in. through the base. $\frac{3}{4}$ in. from one end of the pillar saw a cut across the

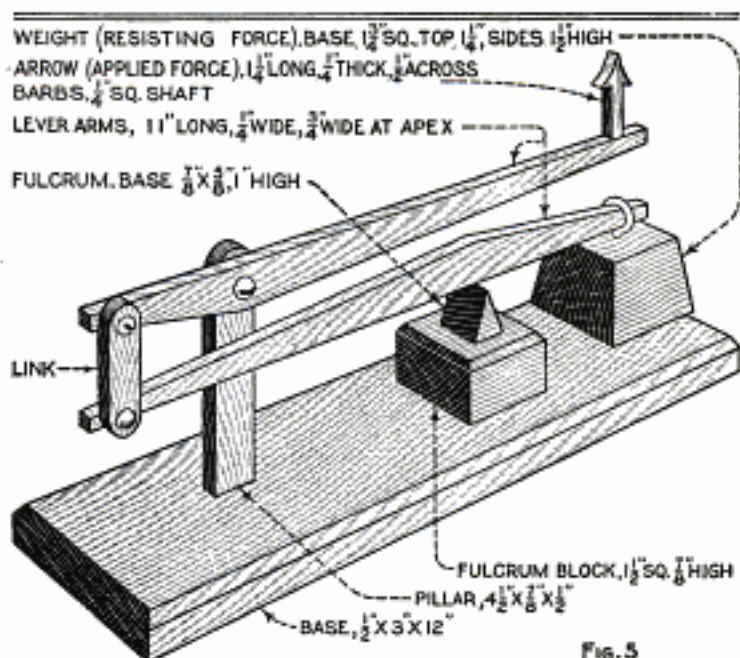

Dimensioned Drawing for Constructing Reproduction of Model of First-Order Compound Lever

width of the pillar $\frac{1}{4}$ in. deep, and remove the material from this cut to the nearest end. Insert the other end of the pillar into the mortise, gluing securely. Connect the apex of the upper lever and the end of the lower lever by the link, making the connection with screws inserted in holes bored in the ends of the link and the levers. Rest the screw-eye, used as a handle, in a notch cut in the toe of the lower lever. Fasten the arrow to the flat edge of the end of the upper lever by inserting the point in a notch cut therein. Fasten this lever assembly to the remainder of the model by pivoting the toe of the upper lever to the offset in the pillar with a screw and resting the lower lever on the fulcrum at a point under the apex, retaining it with an invisible brad. Finish as desired.

(Continued Next Month.)

An Efficient Pen Cleaner

Most draftsmen and others using ruling or writing pens have the careless habit of allowing the ink to dry on the points. This soon accumulates and becomes very hard to remove. A good method of cleaning these pens is to allow them to stand immersed in a small bottle of common red writing ink for a few minutes. Even pens covered with a hard and crusted cake will look like new in a few minutes after being immersed.

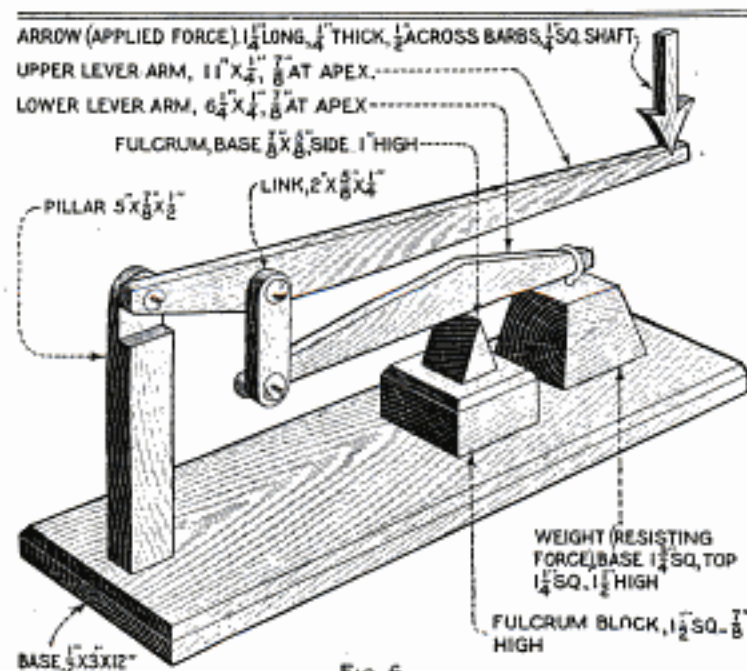
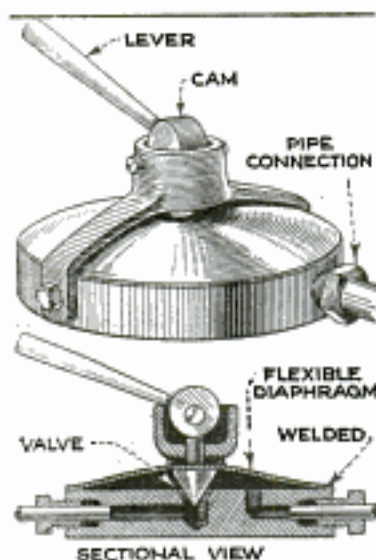

FIG. 6

Full Details of Model of Compound Lever Combining Levers of the First and Second Orders

Novel Valve Has No Packing

Users of compressed air will find the valve shown in the illustration of considerable utility. It was developed in a large machine shop, to eliminate the trouble due to gland leaks in the usual valves, and



found thoroughly practical. The valve body consists of a thick steel disk, drilled as indicated for the air passages, one of the passages being reamed to form a valve seat. A spring-steel diaphragm is dished and welded to the disk, and a conical valve welded to its center, as shown. A cast-iron yoke fits over the disk, and carries a cam fitted with a lever. The cam bears on the valve stem and forces it into its seat, and the spring of the diaphragm opens the valve again when the cam is released. This valve, of course, can be adapted to liquids as well as air.—G. A. Luers, Washington, D. C.

Attachment for Locating Template

Templates are usually the exact shape of the work they are used on and in many cases it is necessary to clamp them before marking off the job. If there are a number of pieces to be laid off, the locating and clamping of a template takes up considerable time. However, with the use of the clamp shown in the illustration the work can be greatly facilitated. Two studs, set on opposite sides, are riveted to the template as indicated and the heads are

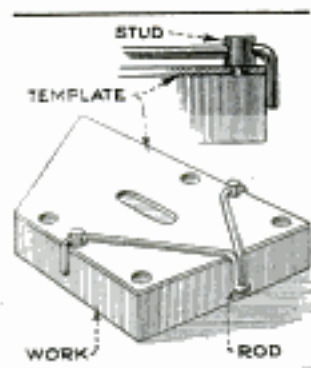

drilled to take a length of drill rod, which is doubled and bent to pass through the holes. In use, the template is placed on the work with the handle of the attachment in vertical position. The end of the template where the handle fits over should

be slightly out of line, that is, showing the work beneath, so that the ends of the handle locate the sides when the handle is pressed down and the double part, which is bent slightly outward, pulls the template along until it is flush with the end. Locating is thus effected very quickly and the attachment grips the work securely enough to prevent any movement while the marking off is being done.

be slightly out of line, that is, showing the work beneath, so that the ends of the handle locate the sides when the handle is pressed down and the double part, which is bent slightly outward, pulls the template along until it is flush with the end. Locating is thus effected very quickly and the attachment grips the work securely enough to prevent any movement while the marking off is being done.

Measuring without Yardstick

In hardware stores where wire, rope, screen, and various other materials are constantly measured with yardsticks, the method shown in the illustration, which has already been adopted by a number of dry-goods stores, will be found to save considerable time. The scale is laid off on the

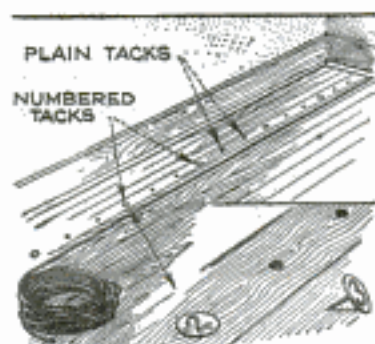

edge of the bench top, or on the floor, brass tacks being driven in at 1-ft. intervals. If several yards are laid off in this way, numbered tacks can be used to designate the yards and ordinary brass-headed tacks for the foot intervals. This method of measuring is as accurate as any other and has the advantage of being much more convenient.

Gauge for Drift-Bolt Holes

Often in ship and bridge work and other heavy wood construction drift bolts are used for fastening. These bolts are without nuts and depend on friction alone for their holding power. When they are used for fastening two or more members together, they should never reach the bottom of the hole, and this makes it necessary to measure both the bolt and the hole accurately. The illustration shows a simple and convenient gauge for doing this. It consists of a length of wire, about No. 10 or 12, with a ring formed at one end, and a cork pushed on as shown. In use, the

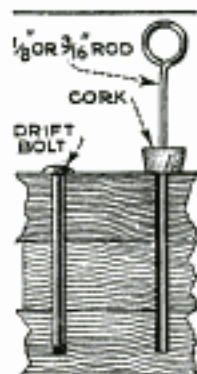

depth of the hole is measured by dropping

the wire down as far as it will go and then pushing the cork down until it touches the surface of the wood. The wire is then removed and a drift bolt selected that is a little shorter than the length indicated by the gauge.—J. A. Stevens, East Boothbay, Me.

Draftsman's Paper Cutter

Many T-squares and triangles are ruined by running a sharp knife or razor blade along the edge when cutting paper. This is a very careless practice and does not show good workmanship. It is much better to use a paper cutter of the kind shown in the photo.

This cutter was devised by a draftsman and found to facilitate the work considerably, without the danger of cutting into the T-square. It is made from two small pieces of sheet brass about $\frac{1}{16}$ in. thick, bent and soldered together as shown, with the lower edge of the vertical piece projecting about $\frac{1}{8}$ in. beyond the bottom piece to form a guide running on the edge of the T-square. The surplus solder is, of course, removed from the corner between the bottom piece and the projecting edge

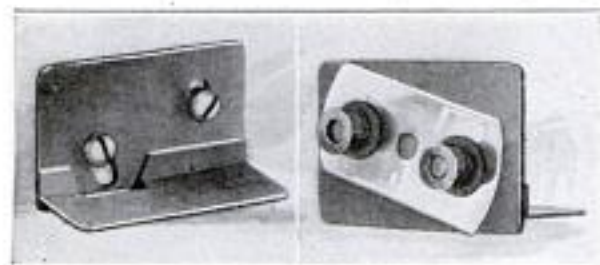

Simple Paper Cutter for Draftsmen that Protects the T-Square

of the vertical piece, by means of a triangular file and all the edges and corners of the device are also filed down smooth. Two $\frac{1}{8}$ -in. holes are drilled in the vertical piece at the points indicated, and are extended with a round file to form slots. The distance between these slots must be the same as the distance between the two holes in a safety-razor blade, which is then attached by means of small screws, $\frac{1}{2}$ in. long, fitted with thumbnuts. The blade can be adjusted to cut bristol board and drawing paper of various thicknesses, or even a number of layers of paper, and as it can be securely tightened to the holder, there is no danger of it breaking.

☛ To tin brass and copper, boil the article with tin filings in a solution of caustic alkali or cream of tartar.

Tightening Tractor Belt

When using light tractors to fill a silo, or to run a thresher or any other farm machine, trouble often arises from the belt slackening. A simple method of preventing this is shown in the photograph. An automobile jack is set securely against a stone, or a stake driven into the ground, and it is then jacked up against the front axle of the tractor.



If the tractor creeps, allowing the belt to slacken, it takes but a moment to jack it back enough to tighten the belt again.—J. C. Allen, West Lafayette, Indiana.

Preventing Damage to Steam Traps

In a heating system installed in a farm garage it was necessary to place a steam trap in a place where, at times, it was subject to frost, if neglected. This accident did occur a few times, and each time with the result that

the outer shell, which was made of cast iron, was broken, making the purchase of a new one necessary. To prevent recurrence of this trouble two holes were drilled in the side of the

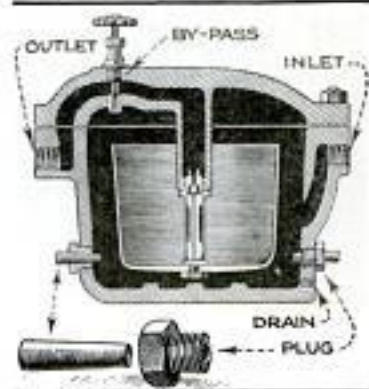

case as shown and tapped for $\frac{3}{4}$ -in. cast-iron pipe plugs. A $\frac{3}{8}$ -in. hole was drilled through each plug and a tapered steel pin driven in just tightly enough to withstand the ordinary pressure of the water inside. When the temperature became low the pins contracted more than the cast-iron plugs, and, if the water froze, the pins were pushed out without any damage to the case.—G. G. McVicker, North Bend, Nebraska.

Recording Gauge Used as Watchman's Clock

In order to assure himself that the watchman of a large office building visited the boiler room at stated intervals, the superintendent made use of a pressure-recording gauge installed on the boiler, instead of purchasing a time clock.

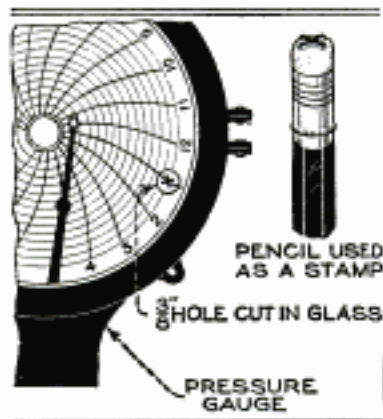

A $\frac{3}{8}$ -in. hole was drilled in the glass door of the gauge near its outer edge and on a line with the pen point. On each visit to the engine room the watchman inserts the inked rubber tip of

his pencil through the hole in the glass and stamps a mark on the chart, thus indicating his presence in the engine room at that time. As the chart revolves a separate and distinct mark results at each visit, when the inked pencil rubber touches the chart. This device is "fool-proof" and the record cannot be faked unless the lock is opened. An ordinary stamp pad fastened to the side of the gauge enables the watchman to ink the rubber tip of the pencil. Simple individual marks are easily cut in the rubber tips.—John H. Schalek, Pittsburgh, Pa.

Oil-Hole Covers

Insufficient lubrication is the root of many machine troubles and a frequent cause of this is the general custom of furnishing machines with oil holes that are simply plugged with short headless screws,

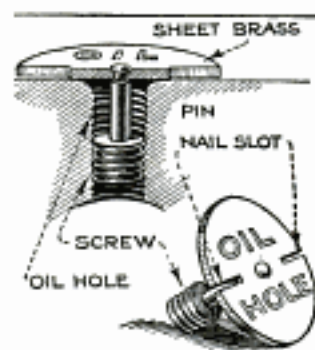

which often become entirely covered with dirt and grease so that they cannot be easily located. In order to make oil holes easily recognized, a pattern shop uses the covers shown in the illustration. Each consists of a circular piece of

sheet brass with two short slots cut in it as shown, and a pin driven tightly in the center, the other end of the pin carrying a short screw which also fits tightly. Space is left

between the cover and screw to allow it to be easily screwed down in the oil hole, which is tapped for this purpose. To place or remove the cover over the oil hole the finger nails are inserted in the slots. When stamped with plain letters, this cover is easily noticeable, even in out-of-the-way places, and, being very thin, it does not foul working parts.

Counterweight for Pump

When pumping water from a deep well with a single-cylinder pump, the type mostly used, the upward stroke is very heavy as the whole column of water has to be raised, and the downward stroke is light. This uneven load causes a great deal of strain on the pump jack and engine and therefore the counterweight, shown in the illustration, was adopted. The size of the weight needed was found by turning the pump-jack pulley by hand and adding weights until the load was

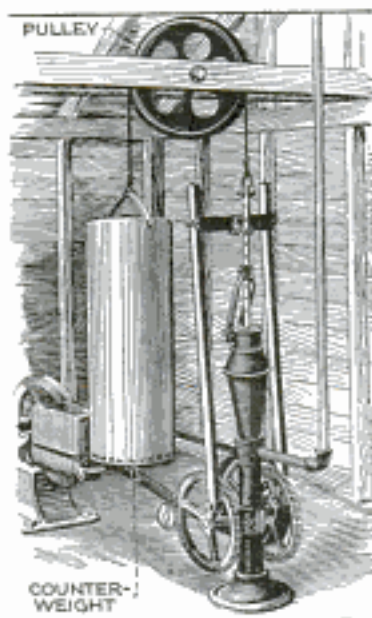

uniform, that is, when the downward stroke and upward stroke were equal. The counterweight used was an old hot-water tank, about 4 ft. long, partly filled with stones. It was suspended from a $\frac{1}{4}$ -in. steel cable, run over a 14-in. pulley and tied to the top end of the plunger rod of the pump. It was found that, due to this arrangement, an engine of less power could be used to do the same work.

However, as this engine was too small to do the work without a counterweight, a handle was attached to the latter, so that it could be made inoperative until enough water was raised in the well to counterbalance the weight. This is only necessary, of course, when an underpowered engine is used.—Jonas Byberg, Silverton, Ore.

☞ Two parts of tallow and one part of neat's-foot oil, melted together, make a good belt dressing. Apply once a month with a brush.

Isvernors { Victor Engineering Co., Allentown Pa.

Handy Isvernors Corp.
3021 *W. Wash Ave.*
Portable Power Plant for Farm

By J. V. ROMIG

Detroit, Mich.

Just as this article was being prepared for publication, we learned, with deep regret, of the death of Mr. Romig at his home in Allentown, Pa. Mr. Romig was one of our earliest and best contributors, and, through a long and friendly relationship, we had come to respect sincerely his ability as a mechanic, designer, and writer, so it is with a sense of real loss that we pen this brief tribute. His articles found many admirers among our readers, but for these friends of his and ours there is a measure of consolation, in that we have a number of his articles still unpublished; his constructive work will, therefore, not cease immediately.—Editor.

MANY old automobiles, the engines of which are in good and serviceable condition, are scrapped and broken up each year by junk dealers. Such an engine is good for many more years of stationary use, and would form the basis of an ideal portable power plant for the farm. Before purchasing any portable or stationary power plant, the prospective user should give the auto plant careful consideration.

The first cost is small, as these engines can be purchased as low as \$20, depending upon their condition. Any power, and any speed within their range can readily be secured, and governors can be fitted to them readily and cheaply, to hold them to any speed desired. These governors usually operate on the gasoline feed, controlling the opening and closing of the throttle in the intake manifold.

The best engine to select for a portable power plant is a four-cylinder water-cooled plant, of about 18 to 20 hp., with magneto ignition, and pump-operated water circulation. An engine with mechanical oilers should be shunned, as these are out of date, and a motor with a good constant-level splash lubrication is to be preferred, for this purpose, to one having a full force-feed system. If possible, the engine should be examined thoroughly before purchasing, to determine if the cylinders are scored or scratched; such a motor should not be bought, even though the cylinders can be reground, as regrinding is an expensive job. The water jacket should be examined for cracks and leaks, and, if any are found, the engine should be rejected. Loose pistons should also be a

cause for rejection, but if only the rings are worn, this is not important, as they can easily be renewed. Loose bearings can also be remedied easily, and, if the engine is good otherwise, may be overlooked.

Magneto ignition is very desirable, as it is a self-contained system. If the engine is of the magneto-ignition type, the starter and generator may be removed. If of the battery ignition type, discard the starting motor, but retain the generator.

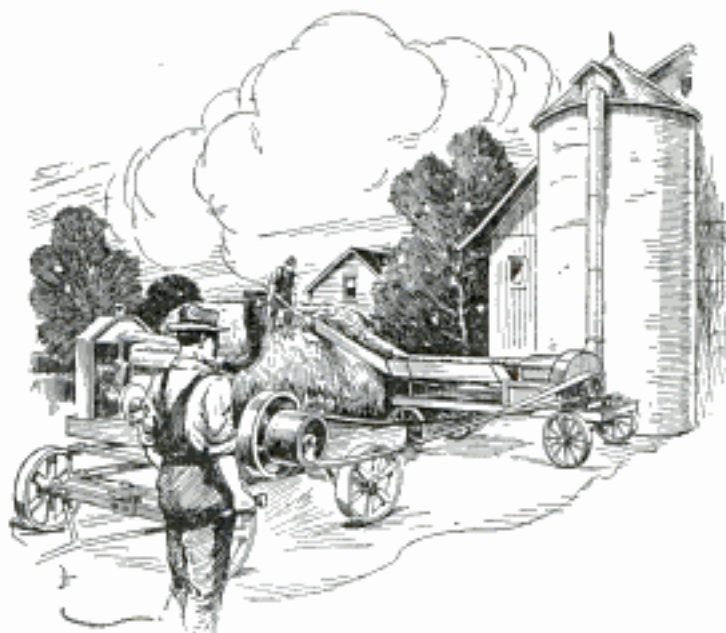

Driving the Silage Cutter and Elevator with the Portable Auto-Engine Power Plant

To be portable, the engine must be mounted on a truck of some sort, and, while a suitable truck can be bought comparatively cheap, the writer advises that only the wheels and axles be purchased, and that the frame of the truck be built up of 5-in. channel iron, as shown in the illustration. The mounting of the engine on the frame need not be a very hard job, if the builder has a few

hints to guide him in the construction.

Engines are supported in car frames in different ways, some having four supporting arms, like the unit shown, others but three, two at the rear, and a yoke or round journal at the front. In any event, a cross-mounted sub-frame will be found the best method of supporting the engine. This frame should be of 4-in. channel iron, and should project over the side of the truck, so that the radiator can be mounted in the same position as in the car. A crosspiece of the same material should tie the ends of the sub-frame, to support the cranking-handle bearing, and to stiffen the assembly. Cross-braces, made of $\frac{1}{2}$ by 6-in stock, should be used wherever necessary, and be fastened in place by capscrews. It is

recommended that the radiator used be one taken from a larger car than that from which the engine was obtained, or from a heavy truck, to provide the additional cooling capacity necessary for long runs under full load.

The drive pulley for general purposes can be built up of wood, bored out to fit over the clutch extension shaft, and fastened to the flywheel by means of long studs, screwed in place of the regular flywheel capscrews. This makes a strong and rigid driving pulley; for higher speeds,

the flywheel itself can be used as a pulley.

The gasoline tank should be a large one, of 15 to 20-gal. capacity, and should be mounted on flat-steel brackets high enough to provide a gravity feed to the carburetor. Care should be taken to obtain a tight tank, with well-soldered connections. A shut-off cock should be fitted between tank and carburetor.

The treatment of the exhaust is simple. A thin pipe section is bent and flattened, as shown in the drawing, then coupled to the end of the exhaust manifold by means of

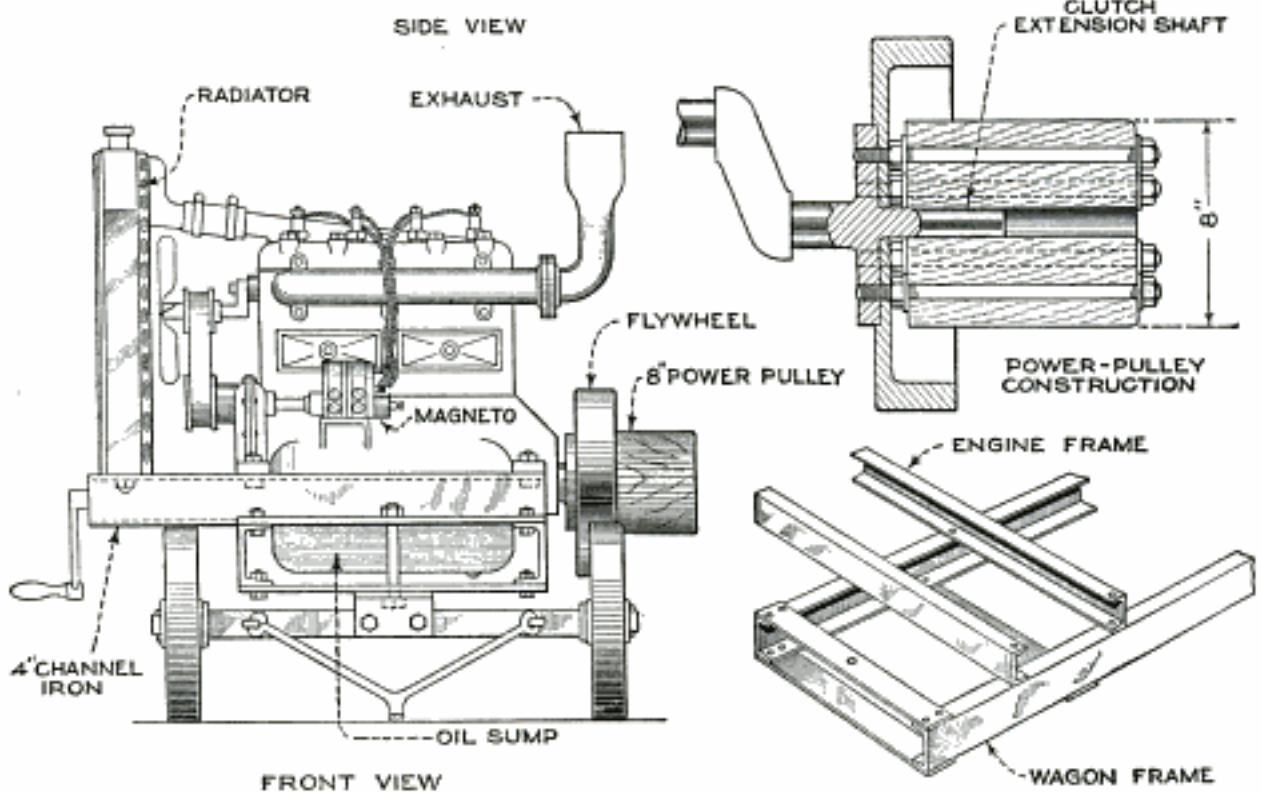
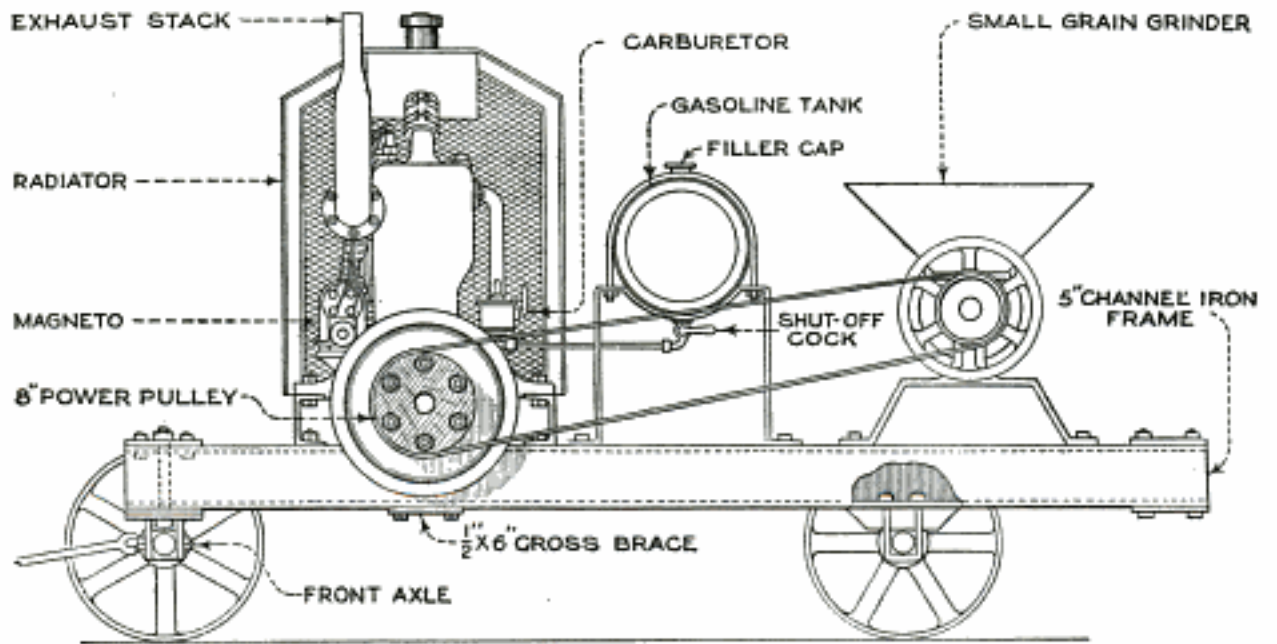

General Arrangement of Portable Gasoline-Engine Plant for the Farm, Showing Details of Frame, Sub-Frame, Drive Pulley, and Method of Mounting Engine

thin flanges, or a threaded coupling. The flat opening should be about $\frac{1}{4}$ in. wide; this will minimize the sound of the exhaust to some extent, while permitting free escape of the gases.

As large a fan as possible should be fitted, and the belt kept tight at all times. Use none but clean water in the radiator, and only the best grade of oil in the engine.

Besides driving the threshing machine, grain elevator, and other farm implements, the frame may be made to accommodate a

small machine, as suggested in the illustration. Such machines as a water pump, sprayer, or an air compressor may readily be mounted on the frame. The length of the frame will, of course, depend on the machine that is to be mounted on it.

A power plant of this type will prove of considerable value on any large farm, as instead of trying to connect the machine to a stationary engine by long pipes or belts, the portable plant may be driven right up to the job.

Stamping Graduated Collars

In a small shop having a number of graduated collars to stamp from 0 to 9, it was found that the usual method of stamping each number separately was too slow, and that a quicker method would have to be adopted to make the operation profitable. A fixture that was found to facilitate the work considerably is shown in the illustration. It consists of a steel ring that fits over the collars, having ten holes drilled through from the outside,

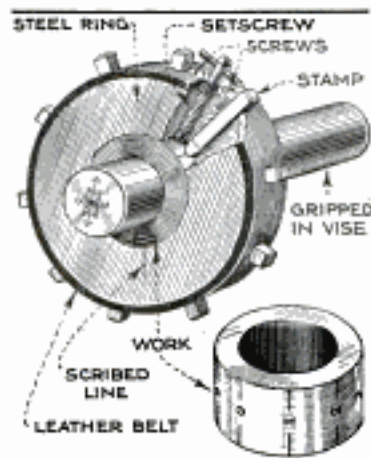

these being equal in diameter to the corner-to-corner dimensions of the stamps. To hold the stamps squarely in the holes and to prevent them from falling out, the ring is covered with a piece

of 1-in. belt, fastened with a couple of screws, and square holes are cut in the belt to fit tightly over the stamps. A hole is drilled and tapped for a tightening screw, with which the fixture is tightened on the collar. After the collar is slipped on a short length of steel rod, which is held in the vise, the ring is turned so that the numerals on the stamps are brought in line with a mark already scribed on the collar and they are then impressed by tapping lightly with a hammer.

Ⓢ A 30 by $3\frac{1}{2}$ -in. clincher rim sometimes causes the casing to pinch the tube. This can be prevented by cutting from a scrap tube a strip of rubber, $1\frac{1}{2}$ in. wide, and running this strip around the rim. One hole is cut at each end of the strip for the valve. An oversize tube should also be used.

Filing Crosscut Saws

Large crosscut saws used for sawing logs are, owing to their size, difficult to file when sharpening them without the aid of a vise.

Experienced woodsmen employ the slot-and-wedge method of holding the saw, as shown in the drawing. A deep slot is cut across a log or heavy timber and the saw is

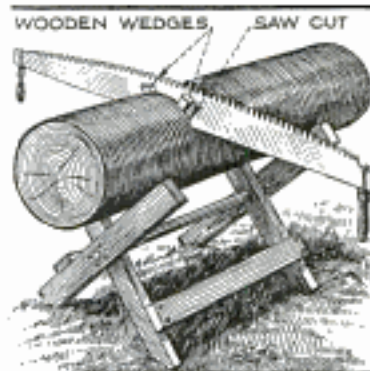

placed upside down in this cut. One or two small wooden wedges are then driven in the cut to hold the saw securely in position and it can then be filed readily. —G. E. Hendrickson, Argyle, Wis.

Improving the Ladle

When pouring a large number of small lead castings the writer was seriously handicapped by the necessity of frequently removing the dross from the surface of the molten lead, in order to obtain clean castings. After some experiments the method shown in the illustration was found to eliminate this trouble entirely. A short length of steel tubing was welded to the inside of the bowl of the ladle, from the center of the bottom to the lip, as indicated, so that the metal would be taken from the bottom where it was free from dross. It was then no longer necessary to skim the metal at all, and the work could be accomplished with much greater speed.

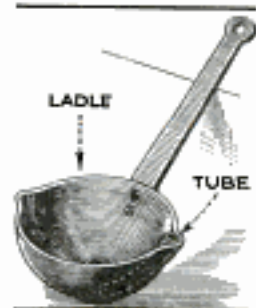

—R. H. Kasper, Philadelphia, Pa.

Removing Dust Caps from Hubs

Sometimes it is necessary to remove the dust cap from a front wheel of a Ford automobile, and this is usually done by

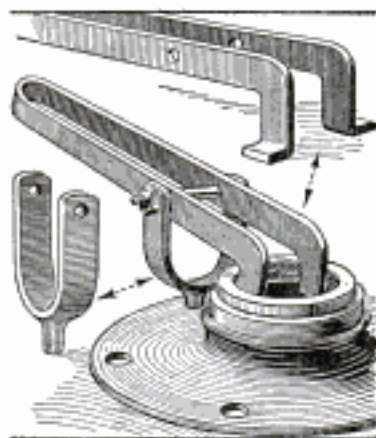

tapping the cap out of the hub with a hammer and punch. This method is objectionable, however, as it often results in damaging the cap. The tool shown in the illustration has been found very

practical for this job. It consists of a length of flat steel, 1 in. wide and $\frac{1}{4}$ in. thick, bent to the shape shown and pivoted on a yoke made of the same stock. A short length of round-steel rod is welded to the bottom of the yoke to fit in one of the bolt holes of the hub flange. In use the frame of the tool is pressed together to allow the ends to be inserted under the cap, and pressure is then applied on the doubled end; this draws the dust cap out without damage.—R. M. Thomas, Denver, Colorado.

Two Kinks for Draftsmen

In making record drawings from customers' patterns it is sometimes necessary to know the contour of a groove. Of course, a paper template can be made by the "cut-and-try" method, but a quicker way is to light a candle and let the drippings build up in the groove as shown in Fig. 1. This is removed and cut with a knife so as to form a section at right angles to the groove if it is straight, or radial if it is circular. The cut



Fig. 1

In a manganese-steel

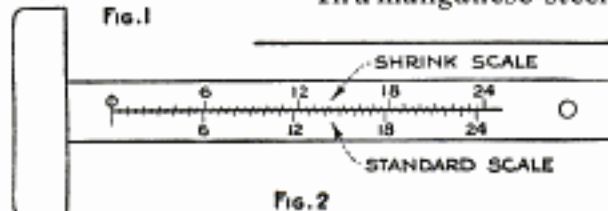

Fig. 2

Fig. 1: Accurate Method of Determining the Contour of a Groove. Fig. 2: A Standard Scale and a Shrink Scale Ruled on T-Square for Convenience

foundry drafting room where it is often necessary to obtain the actual length of a shrink-rule dimension, the T-squares are ruled as shown in Fig. 2 of the drawing. A centerline is first drawn and on one side a standard 2-ft. scale is laid off by eighths of an inch. On the other side of the centerline, a shrinkage scale is laid off. This makes a convenient reference in determining the actual lengths of pattern dimensions. For example, if it is desired to know the proper length of a soft-steel insert that is to be cast in the manganese steel for convenience in machining, the distance between the ends of the prints on the pattern is noted on the shrink scale and then the correct length to cut the soft-steel insert, so that it will fit in the mold snugly, may be obtained by reading the standard scale at the point noted.—D. A. Price, Chicago Heights, Ill.

Brace Chuck for Round-Shank Drills

When small bits are used in an ordinary brace they are frequently broken. The shanks, however, should not be thrown

away. Saw off the broken stem as shown in the illustration and slit it lengthwise with a hacksaw as shown, thereby dividing the shank into four pieces, save for a narrow strip at the small end. A small round-shank drill is inserted in the shank, which is then clamped tightly in the brace chuck. For larger sizes of round-shank drills,



it is, of course, necessary to enlarge the hole in the shank, which may be done by filing or chipping off the four inside corners, which grip the drill. Another way is to place two hacksaws side by side in the saw handle and split the shank with two saws instead of one, or for fairly large drills, to drill a hole in the shank before slitting.—James F. Hobart, Dunedin, Fla.

When painting a wire wheel it often happens that the valve stem is daubed, which makes it difficult to remove the valve nut after the paint is dry. To remove the valve nut, cut it with a chisel, or soak the stem in gasoline and light it to burn the paint off. It is usually necessary to repeat the latter operation a few times before the paint softens.

Raw Oil as Stain

While turning out a number of mahogany cabinets on a rush order the supply of mahogany stain became exhausted. As it would mean a considerable delay to have the order held up until more could be obtained, raw linseed oil was tried out as a substitute and the results obtained were highly satisfactory. It was rubbed into the wood until the desired shade was obtained and then rubbed down with a dry cloth. Coats of shellac were next applied and rubbed down, and the surface finished with a final rub-down of pumice and oil. —T. W. Bean, San Pedro, Calif.

Improving Torch Air Pump

Nearly every mechanic has experienced the annoyance caused by the leather washer on the air-pump plunger of a gasoline torch drying out, especially after the torch has not been used for a long time. A good

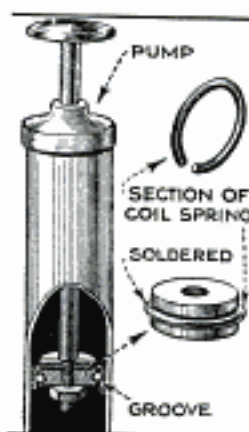

method of eliminating this trouble is shown in the illustration. A groove is turned in the side of the piston for a single turn of a coil spring to fit in, the groove being just deep enough to allow the springs to project about .01 in. above the surface. The coil spring, which must be of slightly smaller diameter than the piston,

will fit tightly in the groove, holding the leather skirt in place, and preventing any trouble even though the torch is not used for several months.

Measuring Pipe with Tape

Pipe workers will appreciate the spring shown in the illustration as it greatly facilitates measuring long lengths of pipe, when the work is done by one man.

A length of spring wire is bent to the shape shown, and is inserted in the end of the pipe so that the tape measure can be hooked onto it. The spring should be sufficiently strong to take care of pipe ranging from $\frac{1}{2}$ in. to 1 in. in size.

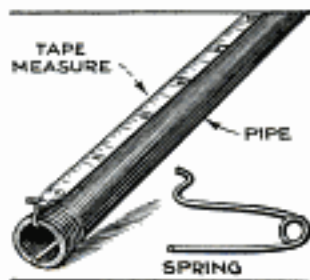

Backless Drawers Aid in Office

In a small establishment, where the office was located next to the shipping room, the drivers were in the habit of coming in constantly to get orders, and

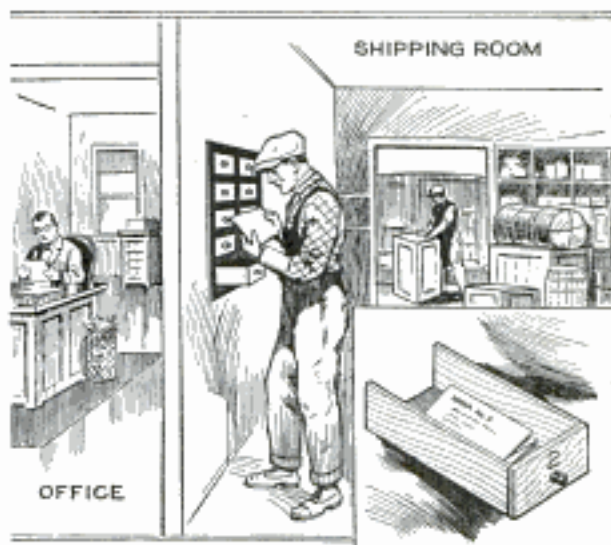

Drawers Installed in Partition Between Office and Shipping Room Found to Save Considerable Time

this was more or less disturbing to the office force. To prevent this annoyance, a number of small drawers were fitted in the partition between the office and shipping room, for the purpose of holding the orders in readiness for the drivers. The drawers were made of wood, and had no backs, so that the orders could be quickly inserted in them from the office side. A separate drawer was provided for each driver and this eliminated waste of time on the drivers' part in sorting the orders.

Hammer Used as Reamer Wrench

It is often possible to combine tools used constantly, to save time in handling them separately. The photo shows a combination tool consisting of a hammer and reamer. The hammer is an all-metal one with a hole drilled through the head for a reamer, which is driven in.

The shank of the reamer is ground flat so that a pin, driven in, holds it snugly and keeps it from turning. The tool was found to be a time saver, as it was first used to ream out holes for pins, which were then tapped in with the hammer.

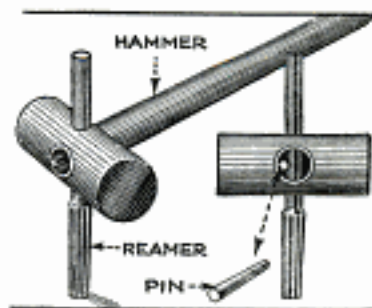

A Self-Closing Rail Gate

Part of the contents of a warehouse were considered dangerous enough to be railed off, and in constructing the rail a novel gate was built in the center of it. With

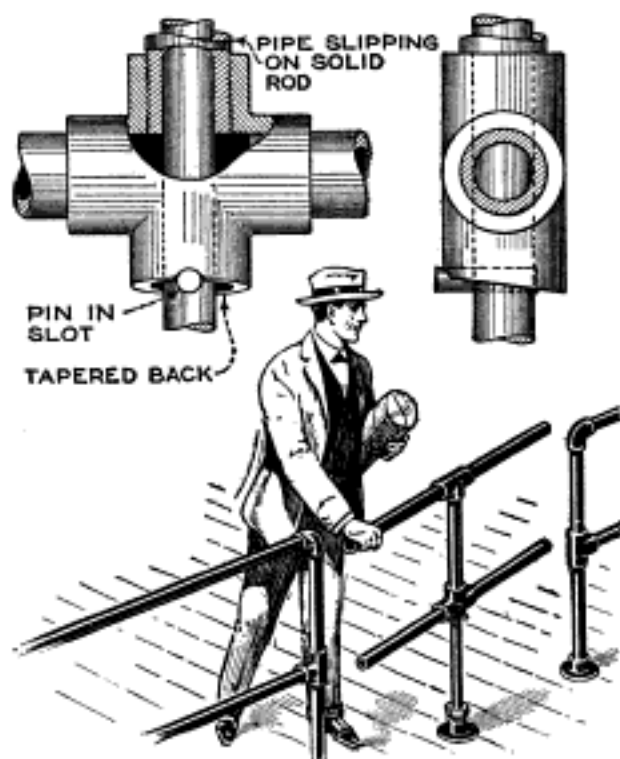

A Self-Closing Gate that Can Be Made from Lengths of Pipe and Fittings

the exception of one part, the gate is made up of iron pipe and fittings the same as the rail. In the center of the space left for the gate a piece of solid, round stock, with a pin driven in, is fixed vertically by screwing one end into a floor flange and screwing the latter to the floor. The gate proper is made from lengths of pipe, a cross and a tee. The vertical lengths of pipe between the fittings slide over the solid rod, as shown in the left-hand detail. A shallow slot is cut in the bottom of the cross to fit the pin driven through the rod. The edges of the slot are filed round, as shown in the detail, so that the gate can readily be pushed open without interference from the pin. The bottom edge of the cross is beveled toward the slot, as shown in the right-hand detail, so that the gate automatically turns to the closed position when released.

Screeching auto brakes are usually caused by particles of dirt and mud between the lining and the drum. Wash these out when washing the car, and the screeching will stop. The water also helps the lining.

Using Soap on Concrete Forms

Crude oil is usually applied to forms in concrete construction work to prevent the concrete from adhering to the wood. However, there is a disadvantage in using oil for this purpose if a finishing coat is to be applied later, as a thin film of oil will be left on the surface of the concrete and this prevents it from bonding properly with the finishing coat. Soap dissolved in water will serve the same purpose as the crude oil without the undesirable effect just mentioned. The soap solution should have the consistency of thin paste, and it can be applied hot by means of a whitewash brush or a broom. As soap is easily dissolved, even by cold water, the film can be washed away by means of a hose in a short time, leaving the concrete clean.

Fire-Extinguisher Mounted on Truck

A large automobile manufacturing concern doing a considerable amount of welding has provided a fire extinguisher on every truck carrying the welding equipment. A pair of heavy spring clips are attached to the crossbar of the truck near the handles to hold the extinguisher, which is of the hand-operated type, so that in case of fire it is within reach of the workmen.



A Novel Turnbuckle

Turnbuckles are usually tapped for a right and a left-hand screw, but a good one can easily be made that is tapped for two right-hand screws, having different-size threads. About three-fifths of the body of the turnbuckle is tapped with a U. S. S.-thread tap; the rest with a S. A. E.-thread tap. Due to the greater pitch of the U. S. S. thread, when the body of the turnbuckle is turned, the screw with this thread travels nearly twice as fast as the other screw.

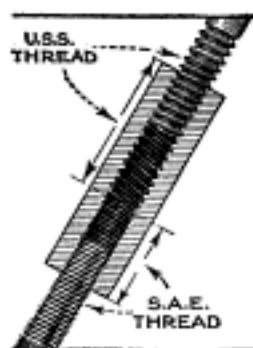



The "Lame Duck"

By LOWELL R. BUTCHER

THE "lame duck" is a toy that will delight the heart of any child. When pulled across the floor by the lead string, the duck will do a number of amusing things. It will wobble back and forth, sidewise, and will sometimes combine the two movements at the same time. By placing the four wheels that support the toy off center, a number of surprising actions are made possible.

The body of the toy is made of 2-in. material; 1-in. finished lumber may be used instead, but the 2-in. thickness will place the wheels farther apart, and there is less danger of upsetting the finished toy. Unless several of the toys are desired, in which case it is best to cut out a cardboard pattern, the body can be laid out directly on the board chosen for that purpose.

The toy shown in the photograph was made from a block of wood 5 in. wide, 9 in. long and approximately 2 in. thick. By marking the block off into 1-in. squares, as shown in the diagram, the shape of the duck can easily be sketched in by re-

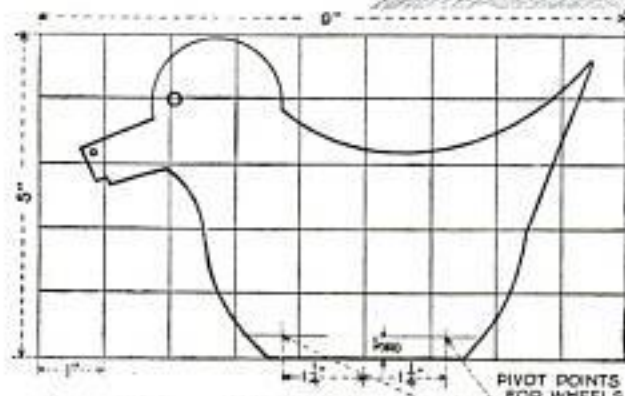

A Very Simple and Sturdy Toy that Will Provide the Growing Youngster with Endless Amusement

ferring to the illustration. A scroll or key-hole saw is best for sawing out the body shape.

Four wheels of $\frac{1}{2}$ -in. material are sawed



or turned to an outside diameter of $1\frac{1}{2}$ in. The holes for the wood screws that fasten the wheels to the body are drilled $\frac{1}{4}$ in. from the center of the wheels. The location of the pivot points of the wheels on the body is shown in the diagram. Naturally, the holes through the wheels should be

slightly larger in diameter than the screws to be used.

In assembling the toy, a thin washer should be placed between the body and each of the wheels. Likewise, a washer should be placed between the wheel and the screw head to prevent needless friction.

A very small hole drilled in the bill of the duck allows a lead string to be attached. If the toy is painted with some care, and the eyes, wings, tail feathers, etc., made darker than the remainder, the resemblance will be better. The completed toy is sturdy, with no complicated mechanism

to go wrong, and the "rollicking" action given by the eccentric wheels is amusing to the old as well as the young.

Electric Stove Lighter

Lighting the gas or oil stove with matches is the time-honored method, but the use of an electric spark to do this has

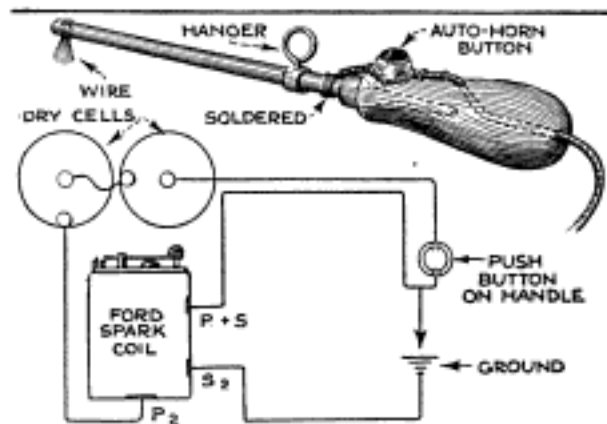

Simple Electric Gas-Stove Lighter Using an Induction Coil Can Be Made by Any Boy

been found much more convenient and economical. The device for producing the spark can be assembled by any boy who is interested in electricity. It consists of two or three dry cells, a Ford induction coil, and a wire brush made from an old fly swatter, fitted with a thick wooden handle. These parts are connected up as shown in the diagram, the high-tension side of the induction coil, indicated by S_2 , being securely grounded on the stove. A hanger is provided on the wall for the wire brush, which, when not in use, must be held away from the stove so that there can be no contact between the two. A small automobile push-button horn of the kind used on the steering column is mounted on the handle, as shown, to control the primary circuit. In use, the gas is first turned on, the push button pressed down, and the brush brought in contact with the gas plate. A series of hot sparks will jump from the brush to the plate and will ignite the gas immediately.—Ed. S. Allen, Troutdale, Ore.

Alcohol Used in Patching Tube

After immersing part of an inner tube in water to determine the exact spot of a puncture, it takes a long time before the tube is dry again and ready for the patch, it being absolutely essential to have the surface perfectly dry to secure a good adhesion. It has been found that the evap-

oration of the water can be hastened considerably by an application of alcohol on the punctured area with a small piece of cloth. The surface is then roughed with sandpaper or a scratcher in the customary way. Before applying the rubber cement a second application of alcohol is advisable, as it will clean and dry the surface immediately.—G. A. Luers, Washington, District of Columbia.

Opening Screw-Top Jars

When it is impossible to remove the screw cap of a jar by hand, the job can usually be accomplished very easily by inserting the cap between the edge of the door and the door jamb as shown in the illustration. This holds it tightly while force is applied to turn the jar. The foot is placed behind the door to press it against the jar. Too much pressure will, of course, break the jar or distort the cap.

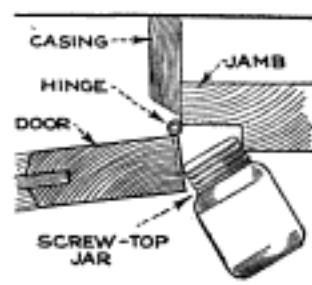

Homemade Barbed-Wire Stretcher

After trying various kinds of barbed-wire stretchers, none of which proved satisfactory, the stretcher shown in the illustration was constructed and gave excellent results. It was made from a piece of 2 by 4-in. material, about 3 ft. long. One end was slightly rounded to serve as a handle and a $\frac{5}{8}$ -in. hole was drilled about 4 in. from the other end. A $\frac{1}{4}$ -in. slot was then cut from the end to this hole to slip over the wire. After the wire is located in the hole, as shown, a round tapered wooden peg is pushed in to keep it there. Then, using the post as a fulcrum, the wire is pulled tight by drawing the stretcher up against one of the barbs. The peg should project far enough on each side of the hole so that it can readily be driven in or out with a slight tap of the hammer.—G. W. Adams, Haughton, La.

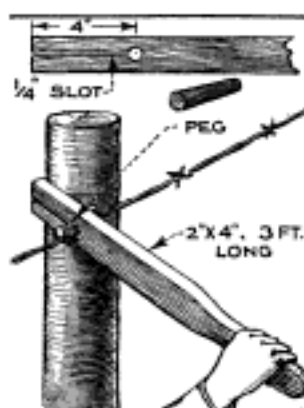

Pruning Apple Trees

For a number of years fruit growers have debated the comparative value of high and low heading of trees, and the heavy and light-pruning methods. In experiments conducted over a period of ten years by orchard horticulturists at the New York experimental station, with several standard varieties of apple trees, it has been found that with the trees all headed about 2 ft. above the ground when set out in the orchard very little pruning will produce a tree that will keep its shape and symmetry, and have greater bearing area than a tree that has been pruned considerably. The root systems of low-headed trees become more firmly established in the soil, and thus offer greater resistance to the wind than the high-headed trees.—E. R. Haan, Chicago, Ill.

Easily Made Screen for Drain Tile

After excavating more than 100 ft. of drainage tile to locate an obstruction that had clogged the entire system, and delayed plowing of an adjoining field, the cause of the trouble was found to be a

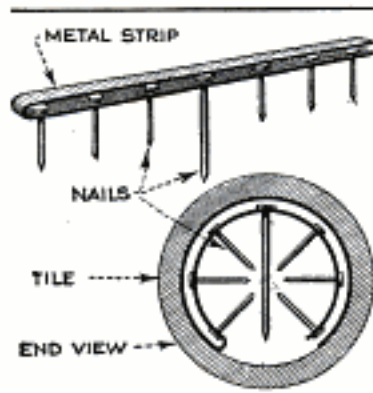

dead rabbit, which, according to appearances, had been wounded by hunters and had crept into the drain to die. Other cases are also known where dead rabbits, woodchucks, muskrats, and other animals

have caused the same trouble. A simple screen that will prevent this, and save the considerable expense of digging the drain open, is shown in the illustration. It consists merely of a few heavy nails or spikes and a 2-ft. length of steel barrel hoop. The strip of steel is perforated and the nails driven through as shown, then the strip is doubled over. The screen is bent to the shape of a horseshoe of smaller diameter than the diameter of the tile, and placed in the tile mouth. The spring of the steel strip will cause it to expand against the tile. Such a screen affords a good protection.

☛ Mothballs distributed in the runway of moles are effective in driving them away.

Facilitating Handling of Rowboats

Ordinarily it requires the efforts of two men to launch a rowboat, but one man can easily do the work if the rowboat is pro-



Small Bronze Roller Attached to Skag Keel on Rowboat Enables One Man to Launch It

vided with a small bronze roller as shown in the drawing. The detail shows how such a roller is attached; a wooden skag keel is fastened to the main keel at the stern by means of iron plates and lag-screws, and a recess is cut in the skag to accommodate the roller, which is held in place by means of two bronze side plates. The roller must, of course, turn freely between these plates. A steel or iron roller should not be used, as it soon rusts and then becomes useless. The roller should be kept well greased in order to obtain the best results.—J. E. Hoag, Los Angeles, California.

Powder Gun for Fuller's Earth

Fuller's earth is of great utility to the car owner for drying fan belts, clutches, brakes, etc., and for numerous other purposes around the house and garage. A convenient holder for this powder is a small insect gun, which can be purchased from almost any drug store for a few cents. With this gun the powder can be applied evenly and without wasting it, in places that cannot easily be reached otherwise. Talcum powder or mica dust, used when repairing inner tubes and tires, may also be applied in the same way.

Sturdy Skid for the Farm

One of the most useful things on a farm is a skid that can be used for hauling heavy loads. Such a skid, which is very durable, due to its sturdy construction, and is also convenient, as the things to be moved need not be lifted high when loading, is shown in the illustration.

The runners are 8 or 9 ft. in length and

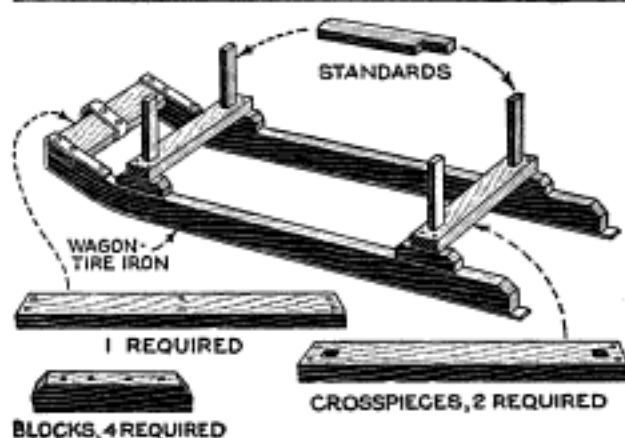

Easily Built and Sturdy Skid for Hauling Heavy Loads over Mud and Snow

are cut from logs that have a natural crook at one end. They must, of course, be of the same length and should preferably be of the same kind of wood. The edges are trimmed down with an ax to a uniform width and the top is also flattened where the crosspieces are to be attached. These are simply pieces of good strong plank, about 3 in. thick, 8 or 10 in. wide, and 4 ft. long. They are not fastened directly to the runners but to small 3 by 18-in. blocks, which are attached to both the runners and crosspieces by means of $\frac{5}{8}$ -in. bolts. The bolts are put in from the underside of both runners and blocks and in both cases the holes are countersunk to take the bolt heads. The rear crosspiece should be located about 20 in. from the rear end of the runners, and the front one just behind the crook. A third crosspiece is bolted to the front end of the runners as shown, a recess being cut in the runners so that the surface of the crosspiece comes flush, and it is made doubly secure, so that it will stand any strain in pulling, by running a length of wagon-tire iron over it as shown, and then running it along the underside of the entire length of the runner. Heavy flat-head wood screws are used to attach the iron strips to the runners, holes being drilled and countersunk for the screw heads.

It is advisable to provide short standards on the crosspieces to keep the load in place.

The ends of the standards are cut down to fit into square holes cut in the crosspieces. A clevis is also provided in the center of the front crosspiece.—J. R. Koontz, Bremen, Ind.

Correcting Distorted Building Photos

Unless provided with an adjustable front an ordinary camera cannot be used to photograph very high objects without tilting it to include the top of the object, and this produces a picture that is out of proportion, the walls appearing to converge near the top. To produce a normal picture from such a distorted photograph, print the negative through an enlarger, tilting the easel on which the printing paper is fastened at an angle to the negative. This will bring the object back to its normal proportions. This method has an advantage over the old of taking the picture with the camera level at a more distant location, which is not always desirable, as the whole object will then be much smaller. Tilting a camera is therefore entirely justifiable as a good method of photography, provided, of course, that the angle is reversed when printing through an enlarger.

Double-Purpose Dash Lamp

The dash light on an automobile is usually permanently mounted on the instrument board; the one shown in the illustration, however, can be quickly removed and attached to the dash, to provide light on the engine side, whenever necessary. The screw holes in the flange of the fixture are enlarged to clear the screw heads, and slotted as shown, to enable it to be detached by giving it part of a turn. The screws in the instrument board and dash are, of course, stationary. The cord used is long enough to permit the lamp to be shifted readily from one position to another.

This improvised engine light is handy very often, especially in the absence of a regular trouble light. By removing the small cap, a good light is obtained.

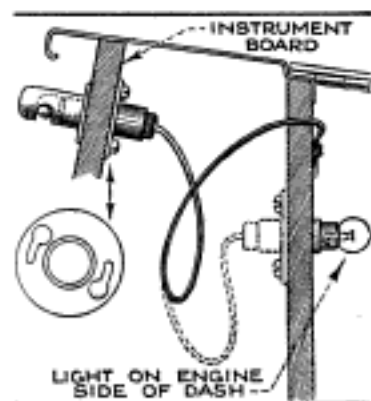

Parts from auto wreching shop and
electrical supply store.

MAKING A SMALL ELECTRIC AUTOMOBILE

By E. B. STACK

Monroe, N.C.

THE electric automobile described in this article is not merely a toy, but a real electric car. It was designed and made for children, but will carry a load of four hundred pounds with ease. Every part, while made as light as possible, is strong enough to stand any amount of rough usage. It is ideal for the youngster who is past the coaster-wagon stage, but not yet old enough to be allowed to run the "flivver."

The body is built of pop-

fitted with 1-in. rubber tires; these can be obtained from many supply houses, or taken from a coaster wagon. The two front wheels are ball-bearing, mounted in the same manner as in an automobile, as shown in Figs. 1 and 3, and in the detail drawings. The rear wheels are fastened tightly to the $\frac{5}{8}$ -in. rear axle by means of pins. The axle runs in three bearings, each bearing being made by bolting two $\frac{3}{4}$ by $\frac{3}{4}$ by 3-in. pieces of steel together, and



Wheeler

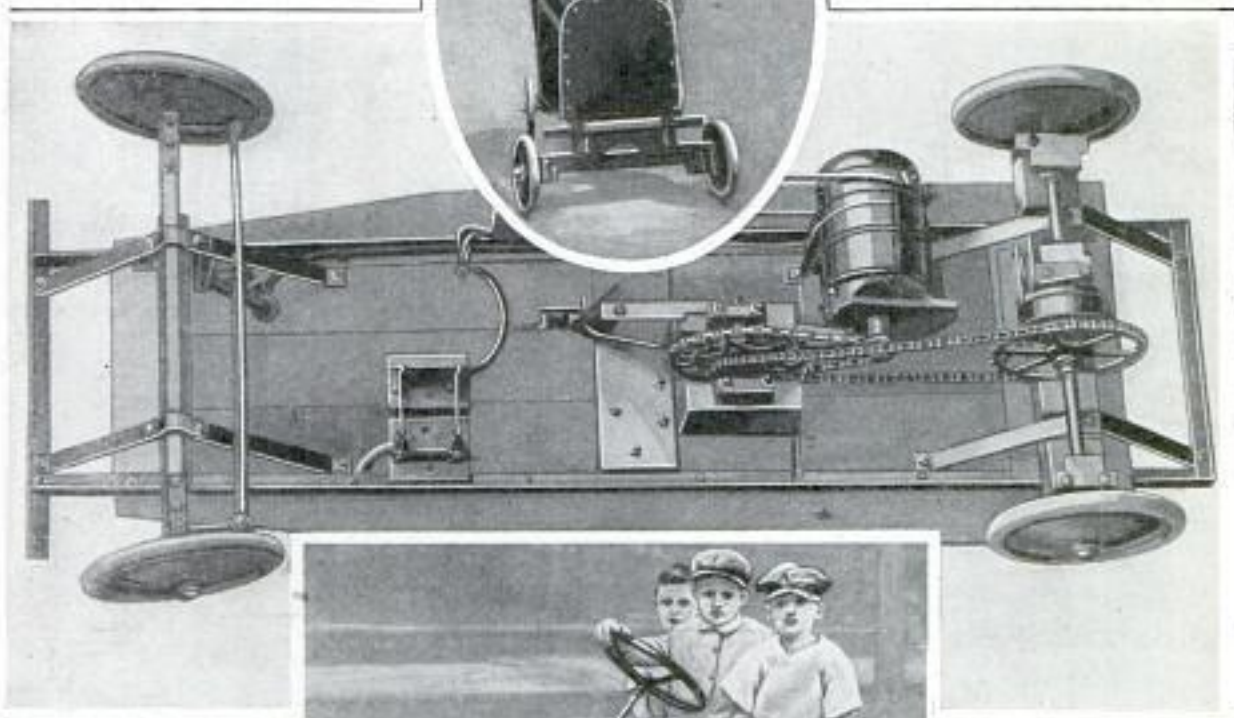

lar, with a streamline hood, and is supported by a steel chassis. The angles for the chassis were obtained from a discarded iron bed, and the bumpers were made of the same material. Steel disk wheels, about 10 in. in diameter are used,

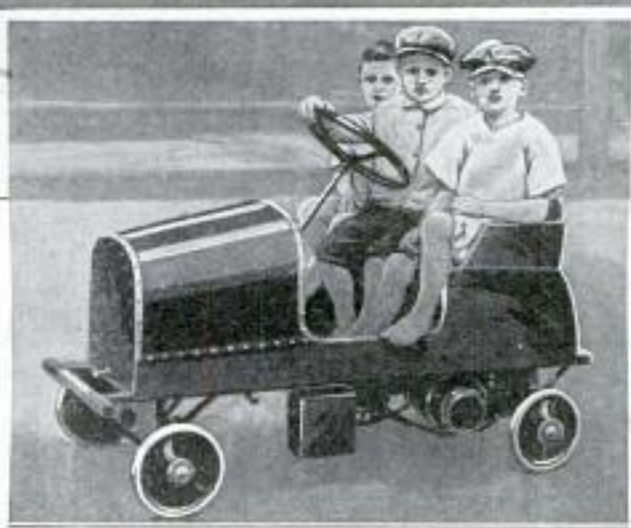

Above, Front View of Car; Center, View of Underside, Showing Transmission, Brake, Etc.; Below, Side of Car, Showing Location of Switch and Motor

drilling the bearing hole across the joint, thus leaving half of the bearing in each piece. The bearing bolts pass through a poplar crosspiece bolted to the chassis of the car. Tin covers are made and screwed over each of the bearings; these are

packed with oil-soaked waste, to lubricate the bearings. A small pulley, about 4 in. in diameter, is setscrewed to the center of the shaft, to act as a brake drum, and a thin piece of sheet steel, faced with regular brake lining, used as a brake. The method of mounting this and the connections to the brake pedal are clearly shown in the detail drawing.

Four bicycle sprockets and two chains form the transmission used to drive the car. Two of the sprockets are about 8 in. in diameter, and two 2½ in. One small and one large sprocket are pressed on a ⅝-in. steel shaft 6 in. long. The sprockets are made to fit the shaft by using bushings, which are turned in a lathe, and screwed or riveted to the sprockets; the sprockets

are then fastened to the shaft by drilling through bushings and shaft and driving in steel pins. The large sprocket on the rear axle is fastened in the same way; it is best to ream the holes with a taper reamer and drive in taper pins. A similar method of fastening is used for the rear wheels.

The steering mechanism is similar to that of the regular automobile, and a Ford steering wheel and rod are used. The drag link may be ⅜ or ½-in. steel rod, with the ends flattened and drilled for the bolts. The manner of connecting the links to the pivoted wheels, and the method of pivoting the wheels are clearly shown.

The hood of the car may be made of galvanized iron, or heavy stovepipe iron. The latter is perhaps preferable, as it holds the

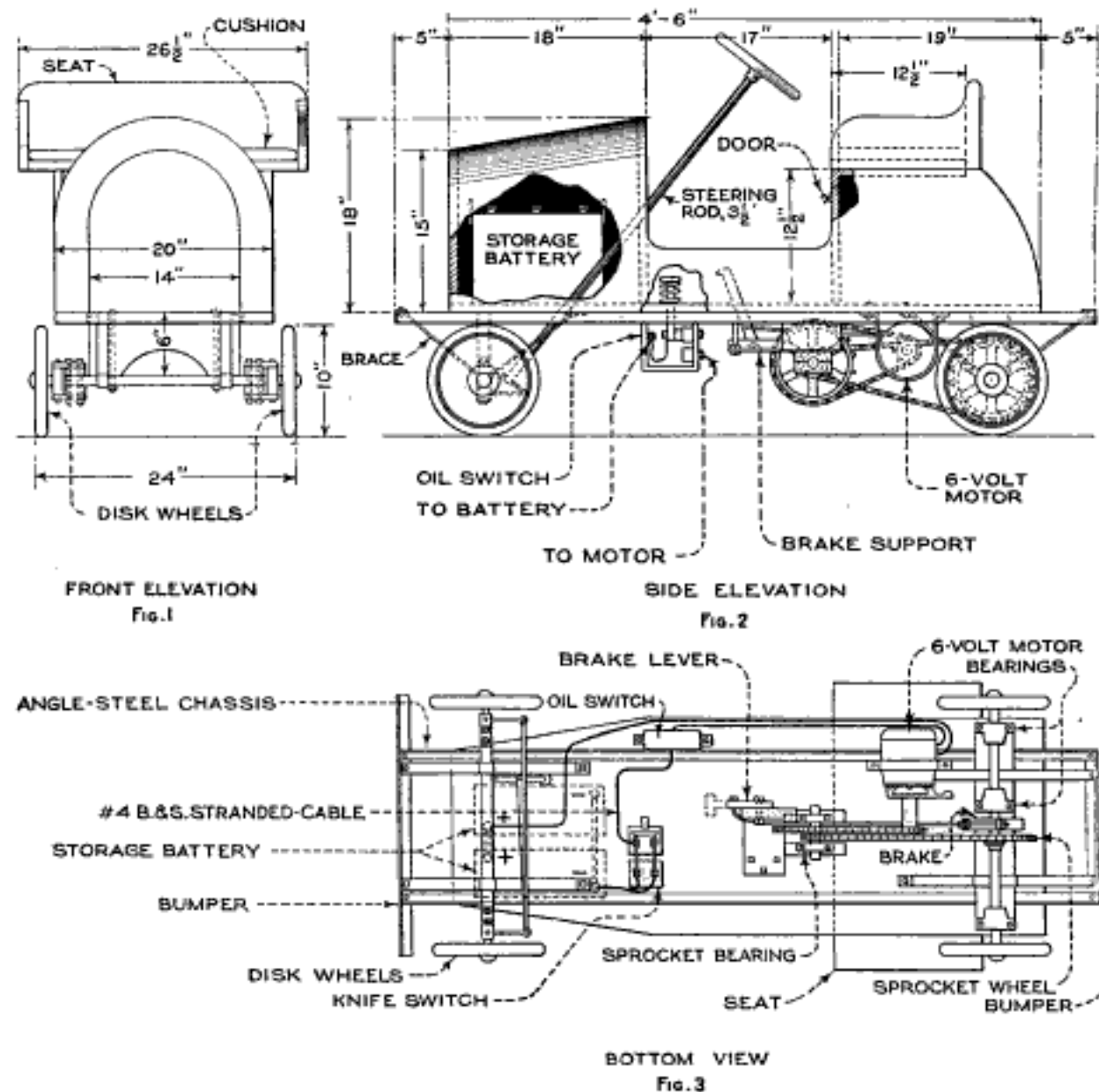

Detailed Drawings, Showing Dimensions and Location of Every Part of the Mechanism of the Small Electric Automobile; Also Wiring of Batteries, Switch, and Motor

paint better. The two 6-volt batteries that supply the current are carried under the hood; they are connected in parallel, thus increasing the capacity while keeping the voltage down to the 6 volts necessary for the motor.

The motor is a standard 6-volt automobile-starting motor, and the remaining 2½-in. sprocket is pressed on the end of the shaft and pinned. The motor is hung to the underside of the car by means of a heavy flat-steel strap.

The oil switch is made from a piece of slate ½ to ¾ in. thick, by 2 in. wide and 4 in. long; on this is mounted one dead, or "off" contact, and one that is connected to the motor. These are made of ½-in. square copper bar, 1 in. long, and are fastened to the slate panel ¼ in. apart. An iron rod, ½ in. in diameter, and 5 in. long, with a foot button on its upper end, passes through the

floorboards of the car, and on the lower end of this rod is a copper contact. A compression spring is slipped on the rod between the foot button and the floorboard, to keep the rod on the off contact. When the rod is pressed down, it makes contact with the motor connection, and the

car starts. Over this switch is placed a 2 by 3 by 4½-in. galvanized-iron box, with soldered seams. This is kept nearly full of transformer oil, to prevent sparking or arcking at the contacts. About 7 ft. of No. 2 starter cable is needed to wire the car, the connections being as shown in Fig. 3. A knife switch is mounted under the car, as shown, to break the circuit when the car is not in use.

The storage batteries may be recharged from any convenient 6-volt direct-current source, but a more convenient method is to mount a small rectifier under the seat of the car, and connect it permanently to the

battery. A receptacle is mounted flush on the dash, and during charging hours connection is made to this plug from a 110-volt a. c. supply. A small ammeter, also mounted on the dash, should be connected in the circuit to show the current flow-

ing to the batteries, to prevent reversal.

The car weighs about 150 lb. complete, and has a speed of about 10 miles per hour under full current. With two 80-amp.-hour batteries, fully charged, it will run about 5 miles. The car will climb steep grades with two or three passengers.

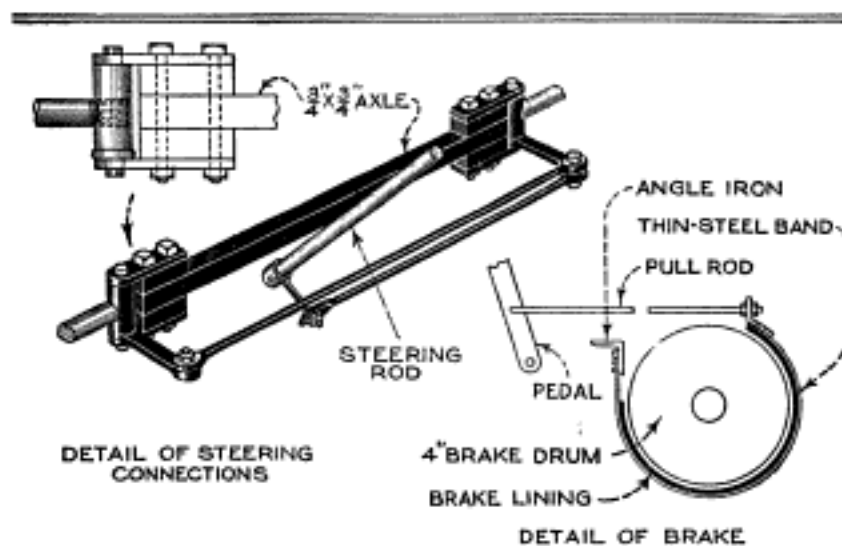

Details of Front Axle, and Steering Mechanism; Also Method of Mounting Brake and Its Connections to Brake Pedal

Saving Film Struck by Light

Every amateur photographer has some difficulty in always keeping his darkroom dark, as it often occurs that someone switches on a white light or opens a door just while a film is being developed. One day while developing a film that had been taken with great pains and under exceptional conditions, and could not be retaken, I turned off the red light during development to avoid any possibility of fogging, turning it on only at intervals to see how the image was coming up. In my excitement I turned on the white light by mistake instead of the red light, and exposed the film. However, injury was avoided by

instantly putting the film in the hypo solution, which prevented the exposure from developing out, and snapping out the light. —Edward H. Flaharty, Denver, Colo.

Oiling Steering Column

On a Ford automobile the steering column is provided with a short bearing at the dash, but no way is provided to oil this bearing except to let oil run down from the top of the column. The result is that this bearing becomes dry and causes the shaft to squeak and drag. If a small oil hole is drilled through the column, just above this bearing, it can be oiled with an oilcan whenever necessary.

A Ladder Rack

Those who have many ladders are sometimes perplexed just where to keep them so that they will be protected from the weather, and still be easy to get at when

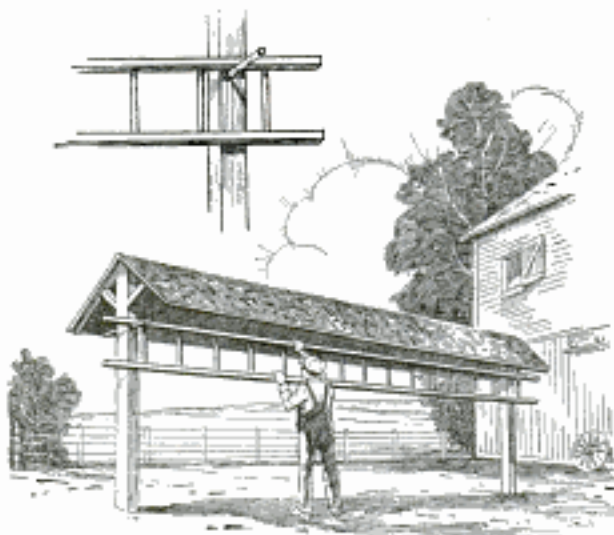

Easily Made Rack for Storing Ladders Where They Will Be Protected from the Weather

they are wanted. The drawing shows an ideal rack for this purpose. It is provided with a roof so that the ladders will be adequately protected from rain and snow, and as the sides and ends are open, the ladders are always accessible.

The rack consists of two 4 by 4-in. posts, 5 to 8 ft. high above the ground, supporting a small roof. Rafters of 2 by 4-in. material, laid flat, are nailed securely down on the posts as shown, and are braced with 2 by 4-in. crosspieces. The roof consists of 1-in. boards nailed on the rafters in the usual way and covered with roofing paper or shingles. A hole is drilled through each post near the top and a length of pipe driven through to serve as a ladder hook.—Robert Page Lincoln, Hopkins, Minn.

Starting a Cold Auto

Before starting the car on a cold morning raise the radiator hood and pinch the lower hose connection to feel whether or not the water is frozen. Even though one is using plenty of alcohol in the water for average winter temperature, an unexpected drop of temperature below the freezing point of the solution may cause it to freeze solidly. It is therefore better to be sure than sorry, by feeling the rubber-hose connection. Starting the motor during cold weather when the oil thickens between the pistons and cylinders is very

hard on the storage battery. To prevent excessive discharge due to this cause it is a good practice to turn the crankshaft over by hand a few times, with the ignition switch turned off, in order to break up the stiff film of oil.

Ordinary winter temperatures will not freeze the electrolyte of the storage battery very quickly unless it is almost entirely discharged. Therefore the battery should always be kept well charged.—A. G. Zeller, Detroit, Mich.

Enamel Streak Aids Night Shooting

Poultry raisers are often bothered by nocturnal prowlers, such as skunks, weasels, possums, etc., which have the habit of robbing the hen house of the choicest fowls. A shotgun is often used to shoot them, but due to the darkness one cannot aim well, and this results in poor shooting. It has been found that a strip of white enamel, $\frac{1}{8}$ in. wide, painted down the center line of the barrel helps considerably in sighting at night.

Bracing Fence Posts

Fence posts that must support more or less weight, as, for instance, a gate, should be securely anchored in the ground to prevent them from being pulled to one side. Large stones and boulders are frequently used to steady the post, but in some regions there are very few suitable stones, and therefore other methods must be used. Discarded harrow disks have been found excellent for this purpose. A disk is bolted to the bottom of the post, as shown in the illustration, and the post is then driven into place with the flat side at right angles to the direction of strain. The post with the disk attached can easily be driven in, as the disk offers very little resistance, due to its sharp edge, and the end of the post is sharpened to a point. Bracing fence posts in this way has been found very efficient and can be accomplished with a minimum of time. Corner posts can be braced in the same manner by driving the post with the disk at an angle of 45° to the wires.

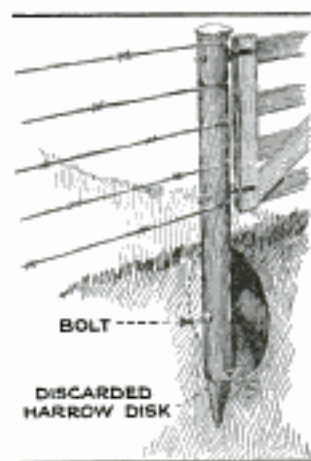

Electric Alarm for Bread Dough

An electric alarm to indicate when bread dough has risen sufficiently was installed in a bakery, and could just as well be used in the home. Nothing more is required than a pivoted lever with one end resting on the dough and the other end arranged to make contact and close a bell circuit when the dough has risen to the desired height.

Keeping Keys in Door Locks

Many door keys have a tendency to drop out of the locks frequently, which is very annoying, especially when the door is in constant use, and every slight jar causes the key to fall out. It is, however, a simple

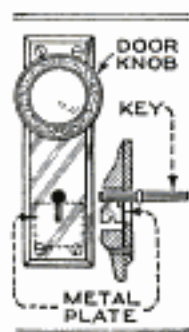

matter to prevent this trouble by inserting a small metal plate under the lock-plate as indicated in the drawing. The space that this plate should occupy is shown by the dotted lines; it should be as long as the width of the lockplate and wide enough to extend from the shank of the key, when inserted in the lock,

to the lower screws holding the lockplate in position. The object is to close the slot through which the key is inserted. Obviously, this device is an excellent burglar protection as the key cannot be pushed out of the lock from the other side.—J. E. Decker, Chicago, Ill.

Lubricating Wristpins

Wristpin bearings in automobile engines generally become loose mainly because the upper side is not properly lubricated. This trouble may be overcome by cutting a groove of saw-tooth form just below the lowest piston-ring groove and drilling a hole down through the upper part of each wristpin bearing as shown in the illustration. The oil scraped up by the groove will naturally drain through the holes and lubricate the top of the wristpin. The holes drilled through the piston will not cause any loss of compression.—Worth Alexander, Santa Ana, Calif.



Simple Device Stirs Milk While Cooling

Fresh milk is often stirred in order to cool it, and this is usually done by hand, which is a slow and tiresome task. A

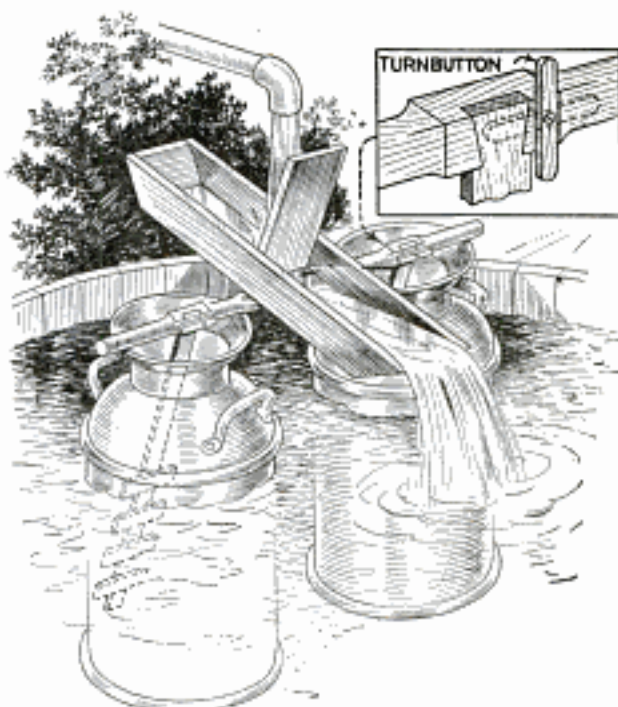

A Simple Rocking-Box for Stirring Fresh Milk Automatically by Water Flow

simple device for doing the work automatically by water flowing into a tank, as shown in the drawing, can be made by any farmer from materials that are available everywhere.

The device consists of a shallow box, made of 1-in. pine boards. The ends are sloping and the box is divided into two equal parts by a board extending vertically in the center about 8 or 10 in. above the sides. The box is mounted at its center on a wooden axle, and a stirring paddle is attached to each end as indicated. These paddles are made from laths, planed smooth, and having a number of short crosspieces nailed on. In use, the milk cans are placed in the water tank and the stirring device arranged as shown in the drawing, the rocking-box being located under a water pipe so that the water first flows into one side and then into the other side alternately. As soon as one side of the box is filled the weight of the water causes the box to tilt over, and the other side of the box is then filled.

☞ Kitchen knives can be sharpened by rubbing them on the edge of a stone crock. Use first a forward and downward-slanting movement, then pull back and down.

Making a Paper Drinking Cup

A simple method of making a paper drinking cup is shown in the illustration. The sheet of paper is regular business size; $8\frac{1}{2}$ by 11 in. The piece is first folded in

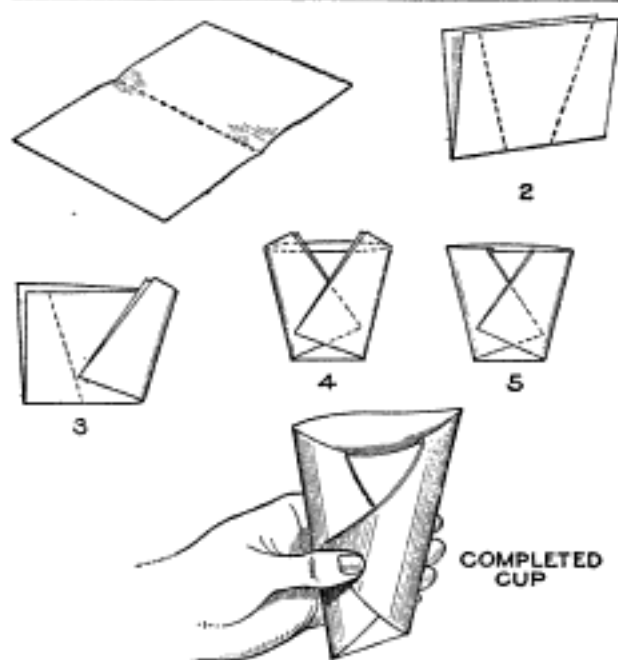

Simple Method of Making a Drinking Cup of Paper

half as shown in Fig. 1, then diagonally as shown in Fig. 2, and the projecting corners are turned over the edge of the cup, which completes it. The strength of the cup, of course, depends on the kind of paper used.

Cutting Linoleum

Large pieces of linoleum are usually cut a few inches too long so that when laid down, previous to tacking in place, one edge runs up against the wall as shown in the illustration. A strip must then

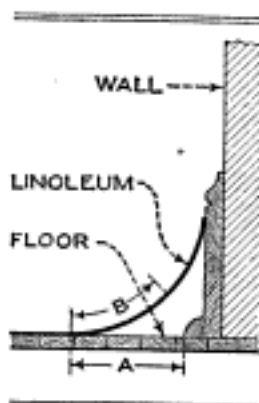

be cut off this edge so that the linoleum will fit snugly in the corner, and here is just where the difficulty comes. Naturally the width of the strip to be cut off should not be guessed at. A simple and accurate method of measuring the distance is to first make a mark on the linoleum at one end where it lies flat, say about 12 in. from the edge of the wall, as shown by arrow A. The same distance is

marked off on the linoleum as indicated by B and a corresponding mark made at the other end. A straightedge is then laid across the marks and the linoleum is cut off along this edge. It will now fit snugly against the edge of the wall.

A Reference Calendar

Almost everyone has occasion at one time or another to refer to some previous month on the calendar, and this cannot be done if the leaves are torn off, unless all the months are printed under the last leaf. Simply folding the leaves up does not look neat and the leaves will not stay in that position. An excellent method of folding back the leaves is shown in the photograph. A slit is cut over the calendar pad so that the leaves of previous months can be drawn through it when they are no longer needed. These leaves will then be out of sight, but are still always ready for reference.—Edwin G. Baker, Indianapolis, Indiana.



Preventing Maps from Curling

Usually after a large map book, such as is found in the offices of city engineers, has been used for some time, the edges of the leaves become cracked, torn, and have a tendency to curl up, which makes

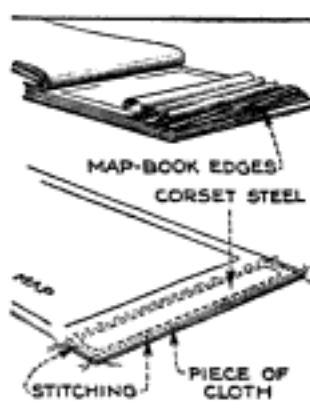

them difficult to read. One of the simplest methods of remedying the trouble, at a minimum of expense, is shown in the accompanying drawing. A strip of cloth, doubled over, is stitched along the edge of each leaf, on the underside, thus forming a seam about $\frac{1}{2}$ in. wide. A suitable length of corset or clock spring is then inserted, and the seam sewed shut to keep the spring in place. The edges of the leaves will then be kept down by the weight of the spring steel.

Removing Ford Rear Wheel

When it is necessary to remove the rear wheel of a Ford but no wheel puller is available the following method will prove effective: Remove the hub cap, cotter pin, and retaining nut. Inside of the hub place 3 or 4 washers with openings too small to slide over the end of the axle. Screw the hub cap in place as far as the threads allow and tap on the end when it turns tight. If the wheel is still tight repeat the operation until it is loose, adding a few more washers in the cap, but taking care not to strip the hub-cap threads.—Harold Pinkerton, Pawnee City, Neb.

Rethreading Well Pipe

Rethreading a damaged well pipe without removing it from the well can be accomplished by the tool shown in the illustration.

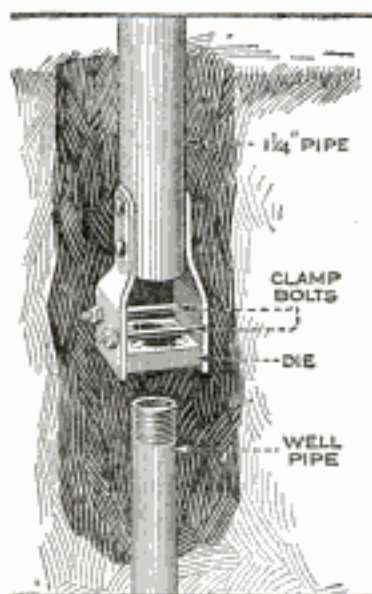

The tool consists of a length of $1\frac{1}{4}$ -in. pipe with two pieces of flat steel riveted on one end to hold a threading die. The die is held firmly between the pieces by two bolts as shown. In use, the threading fixture is lowered into the well and the die placed on the end of the pipe to be rethreaded. A small pipe wrench is used to turn the pipe that holds the die, or a hole drilled through the top to take a short bar.

A Simple 1,000-Ohm Wheatstone Bridge

An instrument much needed by the electrical student and experimenter, and seldom obtainable at reasonable cost, is a Wheatstone bridge for measuring unknown electrical resistances in telephone receivers, motor windings, and for similar purposes.

In the construction of the instrument described, it is unnecessary to wind any resistance coils; use three of the popular 10-ohm circular rheostats that can be obtained from almost any electrical-sup-

ply store. The rheostats are calibrated, as indicated in Fig. 1, by drawing an arc around the rheostat and marking it off

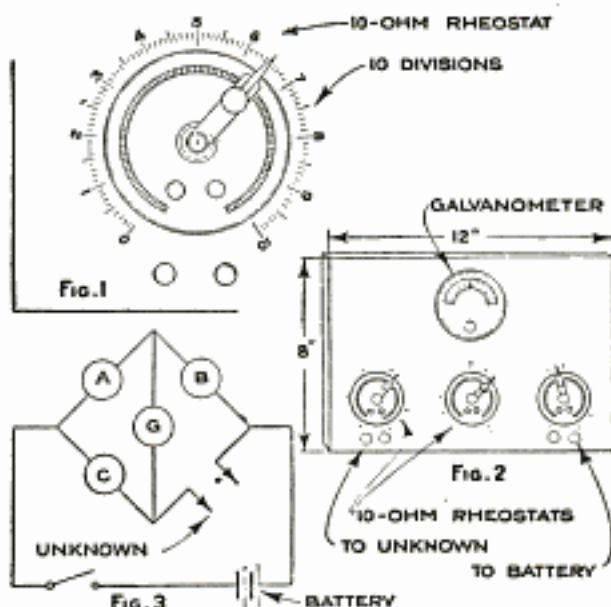

A Wheatstone Bridge for Finding the Unknown Resistance of the Windings of Electrical Instruments

ply store. The rheostats are calibrated, as indicated in Fig. 1, by drawing an arc around the rheostat and marking it off into 10 divisions of one ohm each, each subdivision indicating one-tenth ohm.

A small hardwood panel may be used for holding the rheostats, as in Fig. 2. The galvanometer, which is a standard instrument, is connected into the circuit, as shown in Fig. 3, binding posts being provided on the panel for connection to the battery and unknown resistance.

In use, connect a battery, of two or three cells, in series with a suitable switch, to the battery binding posts, the resistance to be measured being connected to the "unknown" posts. Turn on the current, and, due to the fact that the circuit is not balanced, current will flow through the galvanometer, which will register the flow one way or the other. Now, change the various resistances until the galvanometer needle shows no change when the current is turned on. The proper sequence of resistance changing is really quite complicated, but a little practice soon enables the user to get the right values quickly.—Philip A. Wall, Bedford, Massachusetts.

Keeping Tennis Balls "Lively"

Tennis balls tend to become less "lively" if kept over the winter months, due to the loss of air and the hardening of the rubber. If kept in a tightly sealed fruit jar they will retain their elasticity much longer than usual.—Charles D. Tenny, Gooding, Idaho.

Kink for Window Washers

When washing windows the surplus water has an annoying tendency to run down the handle of the cleaner and into



4" DISK CUT FROM INNER TUBE
Disk on Handle of Window-Cleaning Squeegee Keeps Worker Dry

the sleeves or onto the clothing of the worker. This trouble may be eliminated by placing a small rubber disk on the handle, about a foot from the end, as shown in the illustration. The water will then run down only to the disk and there it will drip off.

The disk should be about 4 in. in diameter and should be cut from soft rubber, such as a piece of inner tube. A hole slightly smaller than the thickness of the handle is cut in the center of the disk so that it will fit the handle snugly when slipped into place.—Denby Clark Stephenson, Augusta, Kan.

Using Radiator-Leak Compounds

Autoists who use commercial or home-made compounds for stopping small leaks in radiators often find that the cure is only temporary. This is generally due to a slimy scale that forms on the inside of the radiator after it has been used for awhile and prevents the non-leak compound from adhering. This scale must first be removed and the compound will then stick. A good method of removing the scale is to add about 10 oz. of concentrated lye to the water in the radiator, then allow the engine to run about 10 or 15 minutes with the spark retarded so that the water will be heated considerably. This solution is drained out and the radiator rinsed thor-

oughly, which can be done by means of an ordinary garden hose. Reversing the flow of the water in flushing also helps to dislodge some of the scale. Common washing soda added to the water in the proportion of 1 teacupful to 2 gal. of hot water, is also very effective for this purpose.

The solutions should not be made stronger than advised above as they are then liable to attack the rubber hose and the metal itself. They should under no circumstances be left in the radiator longer than an hour, and care should be taken not to spill them on painted or varnished surfaces. Lime deposits in kettles can be removed in the same way.

Wiring Mantel Candlesticks

The appearance of electrically lighted candlesticks on the mantelshelf of a fireplace is usually marred by the lamp cord that connects the candlesticks to a nearby socket or receptacle. This cord can be eliminated entirely by wiring the mantelshelf in a slightly different form than usual. This is done by providing a flush receptacle directly under the base of each candlestick and wiring the candlestick as shown in the illustration,

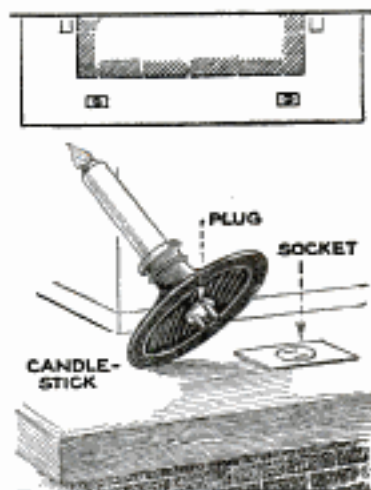

providing it with a cap to fit the receptacle. A hole is drilled in the center of the base to receive the cap, which is first wired and pulled up into position by drawing the wires through the candlestick, and the other ends are then connected to the socket terminals.—L. H. Georger, Buffalo, New York.

Tightening Eyeglass Lens

Loose eyeglass lens can be permanently tightened by putting a little shellac in the groove by means of a pointed match or toothpick and allowing it to dry until it is partly set. The lens is then replaced in the frame; if too tight it must be warmed up until the shellac softens. Perspiration or other dampness does not loosen it.—S. A. Asquith, Los Angeles, Calif.

An Electric Insect Killer

By C. FISKE

ALTHOUGH the 110-volt house-lighting current is ordinarily not fatal to the human body, it is very effective for electrocuting small animals and insects, because the resistance of these bodies is much less than that of the human body. This explains the effectiveness with which the electric insect killer, shown in the illustration, disposes of roaches, flies, spiders, and other insects. Once the apparatus is set up, it requires little or no attention, as it is automatic in its action, and there is no danger in having it connected continually.

The killer consists of a 10 by 12-in. slab of slate or marble with copper wire wound on it. The edges are nicked with a file to hold the wire in place securely. Care must be taken to get the nicks about $\frac{1}{8}$ in. apart so that the wires will run close to each other but will not actually touch. The wire used for this purpose is preferably No. 18, and it must, of course, be bare. Two separate lengths are wound side by side so that the alternate wires will be of opposite polarity when connected to the circuit. The ends of the wires are securely fastened to a pair of $\frac{1}{2}$ -in. brass screws at opposite corners of the slab to prevent the wires from unwinding. The heads of these screws project far enough below the slab to prevent the wires from touching the surface of the table upon

a lure, it touches two wires of opposite polarity, and this allows a sufficient amount of current to flow through its body to kill it instantly.

It is not advisable to connect the wires of the slab directly to the lighting circuit as a small piece of metal, accidentally dropped on the wires, will blow a fuse. A small circuit breaker should be provided to prevent this. The construction of a simple one is shown in the lower left-hand detail. It consists of a solenoid made by winding an ordinary thread spool full of No. 22 single cotton-covered copper

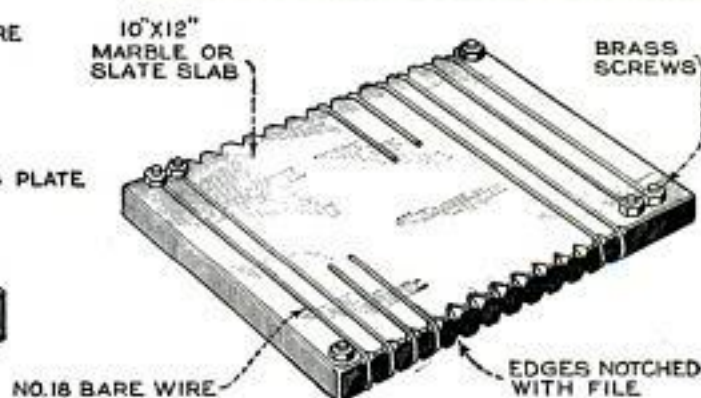
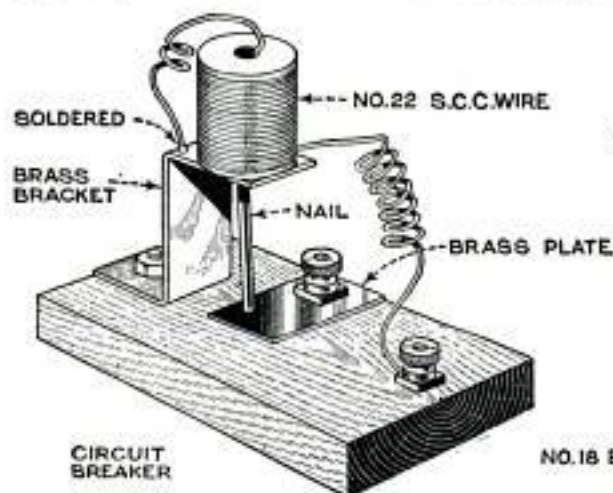
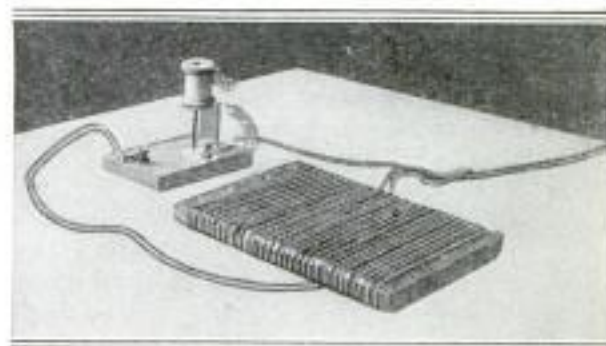
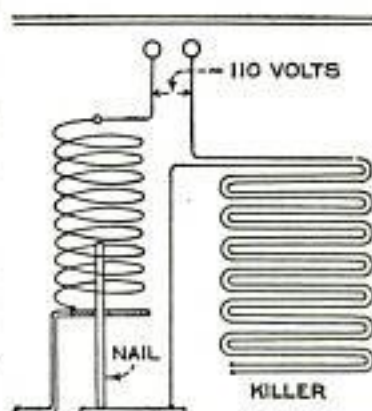

An Electric Insect Killer, Which Uses House-Lighting Current, and Has Been Found Very Effective. A Small Circuit Breaker Protects the Fuses in Case Too Much Current Flows

which it is laid, and single screws are provided on the other two corners so that the slab will rest solidly.

As soon as an insect crawls or alights on the wired surface of this slab, on which sugar or other attractive bait is spread as

wire, and using a small wire nail, with the head clipped off, as a plunger. The solenoid is mounted on a brass bracket, which is bent to the shape shown, and screwed to a wooden base. Through this bracket, directly under the hole in the spool, a hole

is drilled for the plunger. The spool is held on the bracket securely by small wood screws driven in from underneath. The height of the bracket should be a little less than the length of the plunger. A small brass plate is fastened to the base so that the plunger rests on it when in its normal position, and a thumbnut is provided on the screw that holds this plate in place. A second screw and thumbnut are provided as a separate terminal on the base, and to this terminal one end of the solenoid coil is connected, while the other end is soldered to the brass bracket. Connections are then made to the lighting circuit and to the killer, as shown in the diagram in the upper right-hand corner.

The action of the solenoid is as follows: Current passes through the solenoid and over the bare wires of the killer whenever any two wires of opposite polarity are brought into electrical contact with each other, either through the body of the insect or a piece of metal, shorting them.

As soon as the current becomes excessive, as it would naturally be in the latter case, the plunger is pulled up into the solenoid, and this breaks the circuit. Of course, the moment that the current is broken the solenoid is demagnetized and the plunger drops again to its normal position, but if the same current still flows the process is repeated continually, causing the plunger to vibrate rapidly. In operation the killer should, therefore, be set up on a slant so that every time an insect is killed it promptly falls off, preventing any long-continued operation of the circuit breaker.

It is surprising how many insects will be killed by this death trap if it is located in the proper place and baited with some sweet-smelling substance. The device can be left connected without any danger to the house wiring. If desired, a $\frac{1}{2}$ -amp. fuse can be inserted in the circuit so that in case the plunger sticks, the small fuse will be blown before the one in the lighting circuit.

Novel Method of Finishing Cypress

Although there are other woods more or less susceptible to the same or similar treatment, cypress, on account of the great difference between the carbonization point of the hard spring growth and the softer summer growth, is better adapted to the method of finishing described than any other. The difference between the hardness of the spring and summer growths is essential, as a flame is used to char the wood, and, in the case of cypress, a degree of heat that will char the softer parts will merely color the harder parts, and there is no pitch or resin to interfere with the treatment.

The driest possible lumber should be selected, and it should be sawed flat, showing but little edge grain. No attention need be paid to heart, sap, blue, or other stains, as the burning obliterates all defects in color. Checked and split boards should be avoided, however, as the defects will be aggravated by the burning, and the boards should be perfectly flat.

An ordinary gasoline blowtorch is used, and operated so as to get the hottest possible blue flame. This flame should be directed against the surface to be treated, and the burning should be merely sufficient to turn the surface black. Overburning should be avoided. The extreme heat of the torch will dry out the treated side and cause the board to cup toward the flame while it is being burned.

Immediately after burning, the work should be set aside without further treatment for at least 48 hours, in order to allow the moisture in the wood to balance itself. The warping is an unavoidable condition, which, however, remedies itself, if the pieces are set aside after charring, and if the boards were flat at the start. The straightening of a piece after it has been burned can be hastened by laying it on the ground, burned side down, and allowing the sun to shine on the back. The same thing can be done by using an open fire or radiator, turning the unburned surface to the heat.

The next operation consists in rubbing the charred surface with an ordinary steel-wire brush. Rub out all the charred portions, either with the grain or at right angles to it, although the former is perhaps preferable. Care should be used in the rubbing, to get as even a color as possible, as it is natural that the deeper a piece is rubbed the lighter the color will be. The final color effect depends entirely upon the rubbing, and not upon the burning, as might be supposed. One or two experiments on small pieces will teach all there is to know about the process. It is essential that each piece be cleaned of the dry brown powder that will accumulate in the grain; this can best be removed with an ordinary scrubbing brush.

Conf. A. C. Cole, Box 447, Chicago

The scrubbing brush imparts a beautiful finish when removing the brown powder. The work can be rubbed with rags or cotton waste, but the brush is better. As the finish at this stage is particularly beautiful, and has a soft brown color that is very pleasing, the work may be considered done. However, if a gloss finish is desired, ordinary floor wax, well rubbed in and polished, will give more brilliancy and contrast. An even better way to obtain an effect of color consists in thoroughly coating each piece with lead paint of the color desired, and immediately rubbing off all the paint that can be removed by wiping with rags. This will give a very pleasing effect, with the natural grain showing in relief. Varnishes should be avoided, as they cheapen the appearance of the work, and the results are not especially pleasing. Another effect can be obtained upon cypress treated in this manner by an application of muriatic acid, after the work has been burned and brushed out, but before wax or any other finish has been applied. The effect of the acid is to remove, to a large extent, the contrast of color, and to produce a pleasing gray tone.

Pedals for Individual Drivers

In many instances different members of a family or different employes of a firm drive the same car. The varying size of the drivers often makes the pedal position unsuitable for either the short or the tall drivers. A good method of compensating for these differences without altering the

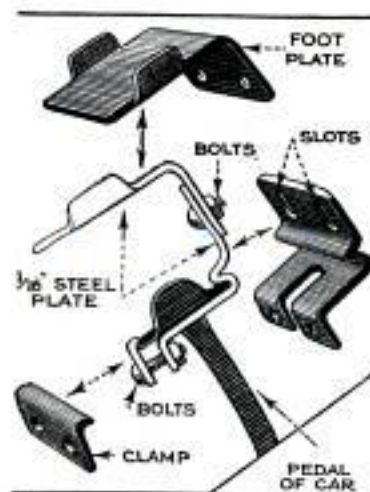

pedals is to provide an attachment of the kind shown in the illustration. This attachment is merely an extension on the pedal arranged so that either the pedal or the extension can be used by the driver. It consists of two parts made of $\frac{3}{8}$ -in. steel plate, bent to the shape indicated; one piece is clamped to the pedal and the other is bolted to the first, a slot in each permitting adjustment. The attachment can readily be made without resorting to forgings.

"Limousine" Sled for Small Children

Small children greatly appreciate the "limousine" sled shown in the photo, as it gives them the thrill of riding in their

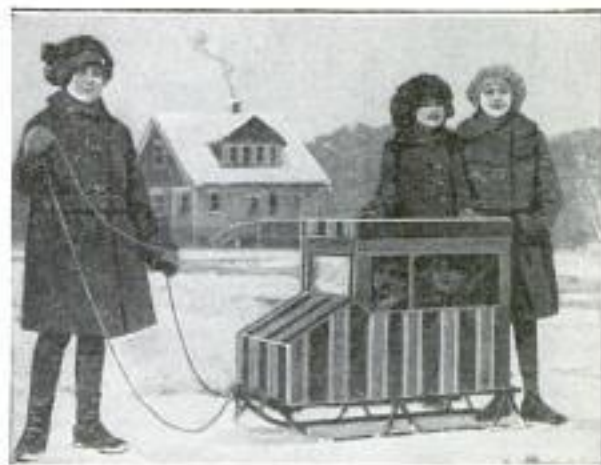

"Limousine" Which Keeps Small Children Warm While Sledding in the Snow

own sled, yet keeps them much warmer than an open one. The frame is made of smooth 1 by 2-in. wood, securely attached to the sled. The lower part of the frame, the floor of the sled, and the top are covered with heavy canvas, and panes of glass or heavy celluloid are fitted in the upper half of the frame as shown. The back serves as a door, being hinged on so that it can be opened or closed, and a screen-door hook provided to keep it closed. The door is made of 1-in. wood, covered on the outside with canvas to match the rest of the body.—Eugene Holland, Detroit, Mich.

Preserving Fish Lines

Silk casting lines are often allowed to lie around in the tackle box on a shelf and are thus exposed to all changes of temperature and humidity. The result of such exposure is that the lines become weakened and cannot be relied upon when needed to pull in a heavy fish, as they usually break just at a critical moment. The lines should therefore be protected against effects of temperature and humidity. A good method of doing this is to wind each line on a spool and keep the spools in a tightly corked bottle. Lines have been kept in good condition in this way for 3 years. Straight olive bottles, or similar ones with the neck and body of the same diameter, are excellent to use for this purpose. The bottle is first corked and the tin cap then screwed on, with a piece of waxed paper under it.—Robert Page Lincoln, Hopkins, Minn.

Tags Aid in Distributing Newspapers

The proprietor of a news stand has adopted the idea illustrated to familiarize newsboys with their routes. The names of

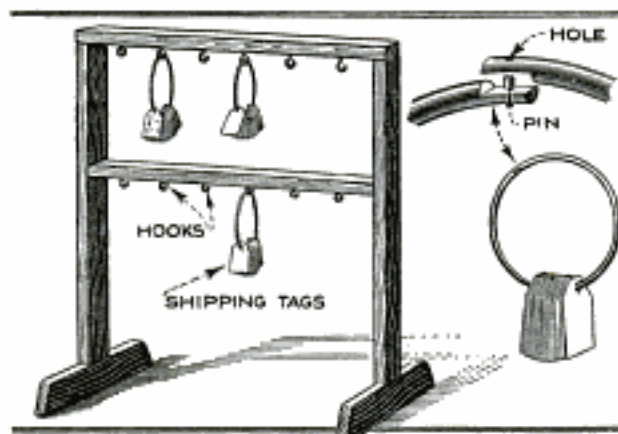

Tags with Customers' Names Make Newsboys Familiar with Routes

the customers, their addresses, and the paper to be delivered to each, is written on tags, and these are kept in the order that the customers' homes are found on each route. The tags, which are ordinary shipping tags, are strung on a steel ring about 10 in. in diameter, and are taken along by the newsboy until he becomes so familiar with the route that he does not need to refer to the tags. One ring of tags is kept for each route, and, when not in use, is hung on a small rack made for the purpose.—A. C. Cole, Chicago, Ill.

Preventing Loss of Furnace Heat

Although the installation of a hot-air furnace in homes of moderate size is considered one of the most healthful methods of heating, the loss of heat due to radiation from the furnace and hot-air ducts is an objectionable feature, and this, of course, means a proportionate waste of coal. A large area where heat is lost is the flat top of the furnace, if this is not properly covered with some nonconducting material.

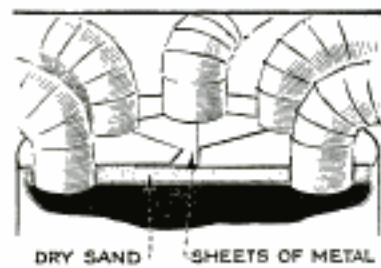

holes being cut in the pieces to fit around the hot-air ducts, and the results will truly be surprising. In making tests to determine

the effectiveness of this method, it was found that the temperature above the furnace top, with the thermometer not more than $\frac{1}{4}$ in. from the surface, was 95° without any covering, 75° with sand only, and 60° with sand and the tin cover. The hot-air ducts are usually covered with a singleply asbestos paper. The object of the asbestos is, of course, to retain the heat, but thorough tests at the University of Illinois have shown that approximately 30 per cent more heat is lost from ducts so covered than from ducts having no covering whatever.

Ventilating the Kitchen

In the construction of many houses the kitchen is built without much thought or consideration for the cook. The storm windows do not usually permit much ventilation and no pipe is provided to carry

away the smoke and fumes from the gas stove. A good method of providing proper ventilation is shown in the drawing. A wooden box incorporating the storm window is built around the window on the outside. This box is made about 5 in. longer than the storm window, which is allowed to rest on the lower edge of the box, thus leaving a 5-in.

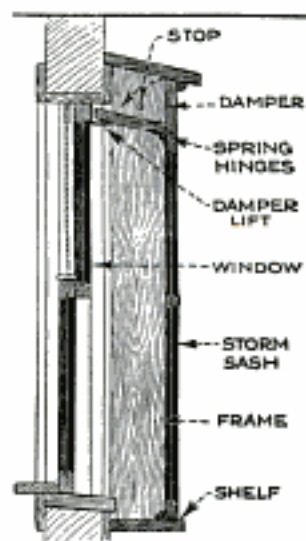

space at the top. A right-angled wooden damper is made to fill this space; it is hinged to the upper end of the storm sash, and long enough to rest on a length of angle iron screwed to the upper edge of the inside sash. Opening or closing the inside sash automatically opens or closes the damper. Whether the damper is open or closed the space between the two windows is practically tight all the time. The box itself can be used as an iceless refrigerator during the cold months, small shelves being built on the sides so as not to shut off any light, if the box is made wide enough for this purpose.—M. E. Dugan, Kenosha, Wis.

Leaky automobile tops can be permanently repaired by using ordinary inner-tube patches to cover the openings.

A Soldering Kink

It frequently happens that solder cannot be made to cover a large hole in a utensil. This difficulty can be prevented by holding a piece of cloth, folded to make a thick wad, under the hole, and unless the hole is entirely too large the solder can then be made to cover it. A very large hole can be closed by reaming it out, cutting a disk of tin to fit, and soldering this disk over the hole. The surface to be soldered should always be perfectly clean, and it is a good idea to use a file on it to roughen it slightly. Plenty of flux should be used to make the solder unite the parts firmly.—Louis Schneider, Clinton, Mo.

An Efficient Sky Filter

Most sky filters used in photography accomplish their purpose by using colored glass or celluloid over the lens, which screens out the blue and violet rays, rendering the sky a grayish shade instead of white as when no filter is used. When photographing buildings it often happens that halation makes the top of the building very light or over-exposed due to the brightness of the sky. This trouble is

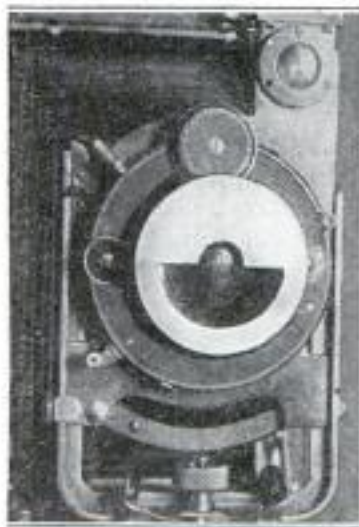

especially noticeable when photographing against the light, making the use of a sky filter necessary. A new kind of filter, shown in the photograph, permits an even exposure of the entire building and allows just enough exposure for the sky to make it come out white instead of gray. It can readily be made in a few moments from an empty paper pill box. The pill box should fit over the lens as snugly as possible. Two semicircular holes, one large and the other small, but both concentric, are cut in the bottom as indicated. The covered portion of the lens shuts out the excessive sky light, while the small semicircular hole allows just enough sky light through the center of the lens to expose the sky properly without any halation.—E. H. Flaharty, Denver, Colo.

Lightening Canoe Paddles

A canoe enthusiast who desired to make his paddles lighter without sacrificing strength, grooved the handles on each



Grooving the Handles of Canoe Paddles Reduces Their Weight without Sacrificing Any Strength

side, the grooves being cut in line with the edges of the blades. To make the handles perfectly round at the point where they are gripped when paddling, short pieces of wood were glued in the grooves, and trimmed down to the original contour of the handle. A few ounces saved in this way does not seem much, but on an all-day grind when the paddles are held constantly and swung thousands of times, a little less weight counts considerably.—Leroy William Hutchins, Bronxville, N. Y.

Getting Rid of Rodents

All food that is stored in the cellar or pantry should be kept in metal or glass containers if possible, as this will keep it out of reach of rats and mice. Large quantities of potatoes and other vegetables should be kept in wooden bins, lined with tin or galvanized sheet iron. If food is stored away from rodents they will not remain long but will go where more hospitality is extended. This method has been found much more effective than the usual methods of destroying and trapping the rats and mice.—Mable Chase Rundlett, North Adams, Mass.

An Ornamental Laundry Yard

By making the laundry "yard" ornamental as well as useful the appearance of the backyard and garden can be improved considerably. A neat way of building the laundry yard with a lawn seat integral with it, is shown in the photograph. The



Laundry Yard that Adds Beauty to Usefulness by Incorporating Trellis-Work and a Lawn Seat

yard is about 20 ft. long and 10 ft. wide. The posts are made of 4 by 4-in. material, are set in the ground about 2 ft., and extend about 8 or 10 ft. above it. Lengths of 2 by 4-in. stock connect the top of all four posts, the two 20-ft. lengths being laid with the narrow side up, and the 10-ft. lengths laid flat, resting on the caps of the posts. A narrow fence effect on the ends at the top is produced by nailing a 10-ft. crosspiece of 2 by 2-in. material about 18 in. below the top crosspiece, and nailing 18-in. lengths of 2 by 2-in. wood vertically between the two crosspieces. The curved braces are simply lengths of 1 by 2-in. wood, steamed and bent, and nailed in the positions indicated. The top of the structure is given an ornamental touch by adding trellis-work of 2 by 2-in. material with the ends cut off at an angle as shown. A double seat, back to back, extending between two end posts, affords a good rest for the laundry basket. The seat is made of 1-in. boards nailed to a 2 by 4-in. frame. The back consists of short lengths of 2 by 2-in. material, with a 2 by 2-in. stringer laid across the top and nailed on. The legs extend to the top of the arm rest, where they are notched and rounded to add to the ornamental effect. When completed, the whole is given two or three coats of white paint, which will set it off distinctively.

Windows to which one or more coats of waterproof varnish has been applied permit the light to enter, but cannot be seen through.

Removing Putty from Window Frames

Removing the pieces of a broken window pane is comparatively easy, but the putty along the edges is usually very hard and nearly impossible to remove without splintering the wood of the sash. However, it has been found that the putty will come off easily if softened with an application of hot lye, applied with an old paint brush. After allowing it to soak for half an hour, the putty peels off without any trouble, permitting a neat and clean job of reglazing to be done.—L. H. Georger, Buffalo, N. Y.

Curing Leaky Faucets

The rubber-ball valves in water faucets sometimes become so hardened that water is allowed to leak out continually, which is very annoying and, of course, also wasteful. A good method of repairing such a valve, when a new one is not available, is to remove it from the faucet and immerse it in a pan of gasoline for about an hour. This bath will soften the rubber considerably, and the valve can then be replaced in the faucet, when it will give good service for months.—G. E. Hendrickson, Argyle, Wis.

Filling Storage Batteries

Filling the cells of storage batteries with distilled water without spilling can be accomplished conveniently by the use of a small filling bucket of the kind shown in the illustration. The bucket is made from a hard-rubber jar of large size with a wooden handle attached to the top and a small hole drilled through the side near the bottom. A hard-rubber nipple is securely fastened in the hole with sealing compound, and a length of rubber tubing attached. Not a piece of metal is used in constructing this bucket—so that there will be no danger of rust getting into the electrolyte of the storage batteries. The free end of the rubber tubing is placed inside of the jar, as shown, to prevent the water from running out when the bucket is not in use. The bucket can easily be handled, can be set on any flat surface and can be used without a syringe or funnel.



118 m

\$125.00 - \$150.00

ELECTRIC DRILL IS STUD AND SCREWDRIVER

Designed not only to serve for the rapid starting and driving of nuts, studs, and screws, a new electric tool is also used on drilling and reaming operations. It is a real high-production tool. Wrenches, screwdriver, stud driver, or drill chuck can be changed instantly for the different operations.

The tool is built under a patent covering the operation of a friction clutch used in combination with a positive clutch, where the engagement or disengagement is caused by an axial movement in either direction. It thus permits a ready

engagement of the driving member with the part to be driven, and, after the seating of the driven member, allows an instant disengagement while the motor is running.

The motor is a universal one, specially designed, and the clutch is made so as to prevent any shocks from reaching the motor. The chuck is also a special one permitting the wrenches, drivers, or drill chucks to be changed at will, while the motor is at full speed.

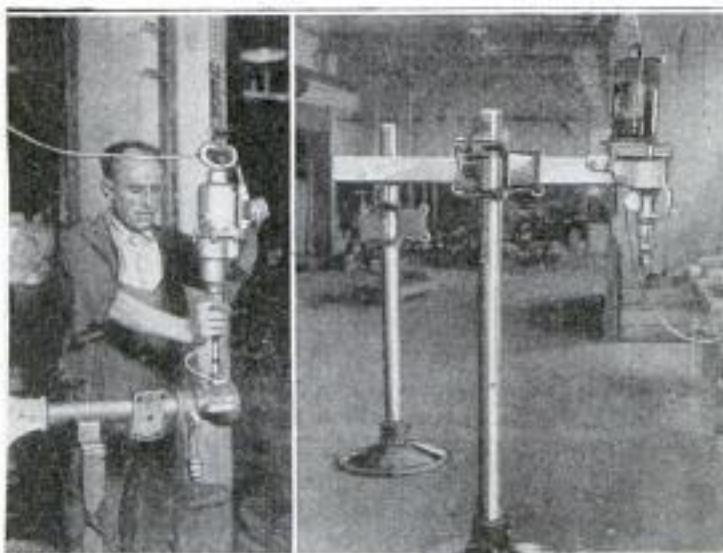

Left, Portable Tool in Operation; Right, Tool Mounted on Stand that Converts It into a Stationary Machine

A stand is furnished that makes the tool a stationary one, operating in a similar manner to a radial drill.

STEEL BALLS COMPENSATE FOR GAUGE WEAR

111 m

Made in a large variety of sizes, 1 in. and over, a new gauge for internal diameters is particularly useful for rapid inspection.

The stem of the gauge is cupped at both ends to hold a $\frac{3}{16}$ -in. steel ball, held in place by a threaded sleeve. The actual measuring contacts are thus furnished by the steel balls, and compensation for wear

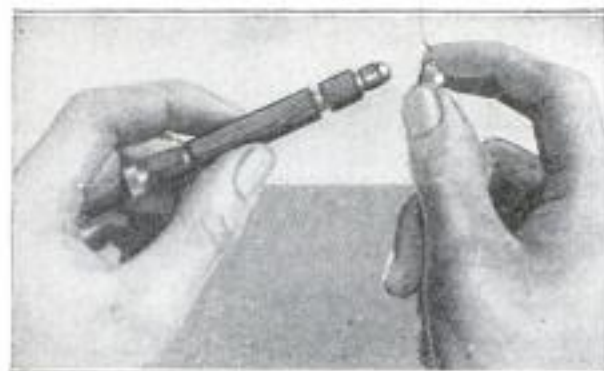

The Length of this Gauge Is Kept Accurate by Means of Steel Balls

may be attained by loosening the sleeves and turning the balls slightly to expose unused portions of their surfaces. In this way the accurate length of the tool may be retained for an indefinite period.

Central Tool Co., Auburn, A. S.

TIME-STUDY BOARD AIDS PRODUCTION

110 m

Time studies are conceded by all progressive manufacturers to be important factors in production, but not a great deal of attention has been paid to the equipment used for the work. This has been remedied by the marketing of a very useful time-study board and watch holder. The board provides a convenient writing surface for holding the record blanks, and holds the stop watch in a position in which it can easily be operated with the left hand while holding the board, leaving the right hand free for recording the figures. The board has also a filing recess or pocket in which all data relating to the job can be kept together.

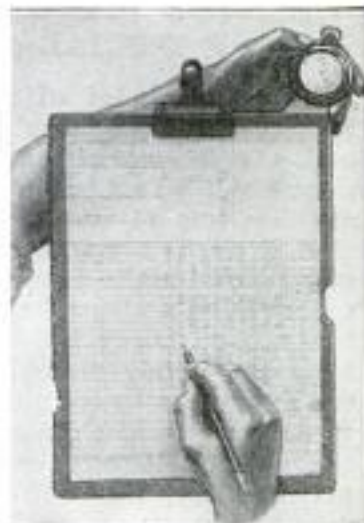

Stein & Ellbogen Co., 31 N. State, Chicago

WOODWORKING MACHINE AIDS IN MAKING FORMS

^{100 m} Making of forms for concrete and similar work is greatly simplified by the use of a machine now in course of production. The machine is a portable saw, and, by means of adjustable squares, on which the saw travels, the operator can cut the forms to exact length, with either square or beveled edges, in less time than it formerly took him to scribe a line to follow with the hand saw. By the use of a concave saw and a radius rod, the machine will also cut perfect circles for column caps, etc.

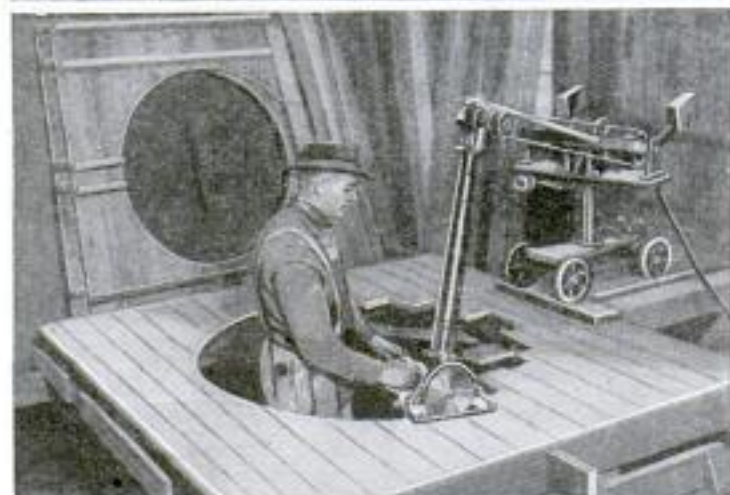
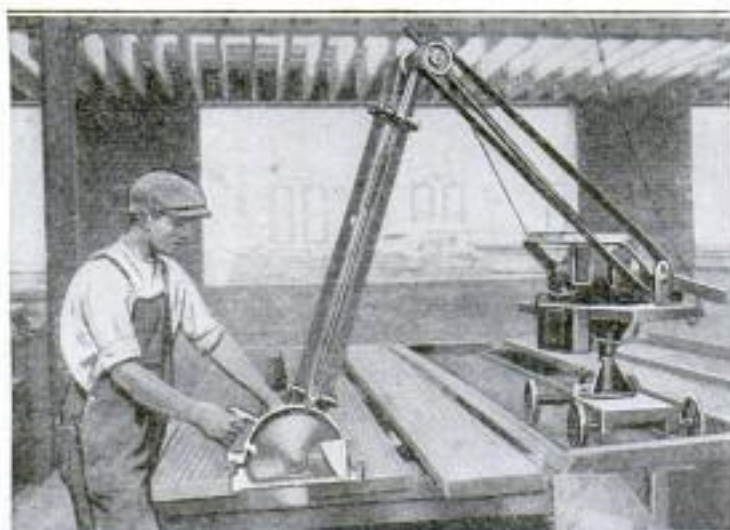

Above, Cutting Off Stock, with Machine on Special Runway; Below, Cutting Circular Holes in Concrete Forms

The machine is made in four sizes: The smallest will cut off 2-in. stock; the next size 4-in. material; the third 8-in., and the largest 10-in. stuff. The saving that can be realized by the use of a machine of this type, which can be taken to the job, instead of hauling the material to the machine, is apparent. It is useful not only to concrete contractors, but to woodworkers in every line of business. The smaller sizes should be particularly useful to building contractors for cutting off trim and other operations.

HACKSAW BLADES SHARPENED BY SPECIAL MACHINE ^{121 m}

Hacksaw blades of unusual design, a special sharpening machine for the blades, and a metal-sawing machine adapted to run at high speed under severe conditions, are features of new equipment recently placed on the market. The blades are made of high-speed steel, hardened throughout, and can be resharpened many times, even when the original teeth have been completely ground away, as a set of teeth of patented form extends below their root. It is said that the blades cut progressively faster after each sharpening, and are especially suited to hard materials, including high-speed steel.

The special sharpening machine grinds the blades to models or templates which have the correct tooth shape; these are located on each side of the grinding wheel, and, as the blade is fed in, its teeth are ground to the correct shape, on both faces.

The sawing machine is built in two sizes, one for stock up to 6-in. round or square, the other for 10-in. round, or sections up to 12 by 8 in. The machines may be run at 170 r.p.m., with a heavy blade pressure. The saw holder is fitted with an indicator to show when the blade has been strained sufficiently to prevent breakage, and the dash pot is provided with a device that enables a start to be made on a sharp corner of the work without danger of breaking the saw teeth, a very useful feature.

109- m

TEST BENZOL AS ENGINE FUEL

According to tests conducted by the department of the interior, at the Pittsburgh Experiment Station of the Bureau of Mines, motor benzol may serve as a satisfactory substitute for gasoline in the operation of internal-combustion engines, if refined by the use of gelatinous silica or sulphuric acid.

Machinery
Dec. 1902

Edward L. Herbert Ltd,
Chapel St., Levenshulme, Manchester, Eng.

Auto Industries
12/27/23

Falk Corporation
Milwaukee
Wis.

GLYCERIN AND WATER NEW QUENCHING MEDIUM *115 m*

Efforts were recently made, during the bureau of standards' investigation of steels for the manufacture of precision gauges, to find a quenching medium intermediate between water and oil, and quenching curves were taken of specimens cooled in solutions of glycerin in water. These seem to fill the gap effectively, so far as the cooling rates at high temperatures are concerned. On the other hand, the solutions cool much faster at lower temperatures than quenching oil, which is a desirable property. As a commercial quenching medium, glycerin or solutions of glycerin would not be unduly expensive, for, while the initial cost is high, the glycerin does not decompose upon heating as oils do. The composition of solutions may easily be maintained by hydrometer tests; they do not give off irritating fumes like the concentrated sulphuric acid sometimes used for this purpose, and thus are harmless to workers.

95 m

FIXTURE TESTS CRANKSHAFTS

Very few automotive mechanics give the crankshaft the attention it requires in an overhaul job. This is generally due, however, to lack of facilities for testing such work. A new machine, which is very simple to use and should

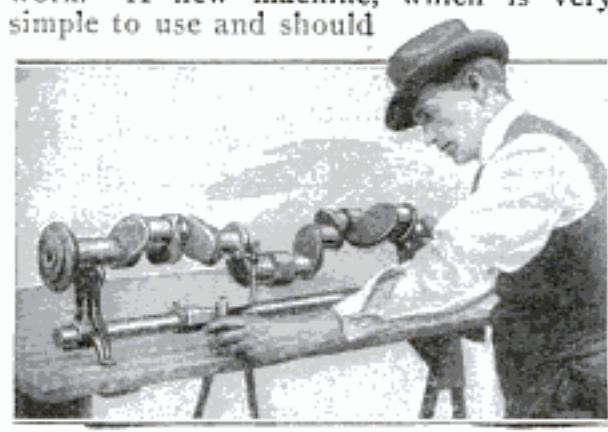

Testing Crankpin with Crankshaft and Piston-Testing Machine

prove of value to all service stations and repair shops, is specially adapted to such work.

The shaft revolves on accurately ground rollers, making centers unnecessary, and the indicator shows immediately if the shaft is bent, the bearings out of round, or the crankpins out of parallel with the main bearings. For the last test, an attachment is supplied that shows graphically what pins are out of parallel, and how much.

Pistons and camshafts may also be tested on this fixture.

*Utility Tool Works,
Norfolk, Nebr.*

FLEXIBLE COUPLING ADAPTS ITSELF TO LOAD *108 m*

That it will permit smooth running under exceptionally bad alignment conditions is the claim advanced for a new flexible coupling of ingenious design. The coupling consists of two flanged steel disks, one keyed to each shaft, two or more segments of a tempered-steel spring, forming a continuous grid,

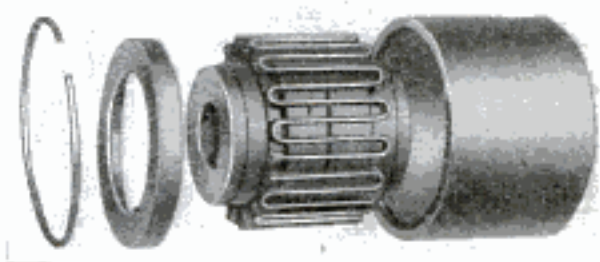
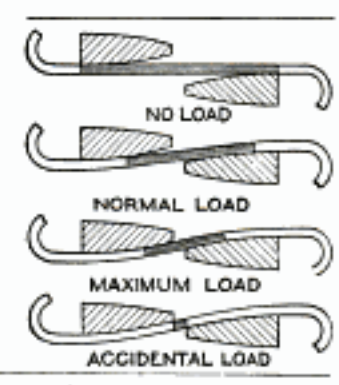

Flexible Coupling that Automatically Adapts Itself to All Loads: Above, Diagram Illustrating Operation

and a shell or cover. On the outside of the flanges are cut specially shaped grooves, in which the spring is placed. The spring is the flexible member, and its shape, together with that of the grooves, forms the characteristic feature of the coupling.

Under light and normal loads there is a long, free span of spring between the points of support on the flanges, allowing considerable flexibility, but under heavy overloads the springs are supported along the sides of the grooves, thereby automatically shortening without increasing the stress. Under very heavy overloads, the springs are in shear, and capable of resisting many times the load for which the coupling is designed.

At a recent demonstration, a centrifugal pump, mounted on a tank, was driven through one of the couplings by a 5-hp. motor. The motor was mounted so that it could be swung sidewise until the centerline of the motor shaft was 10° out of alignment with the pump shaft. When this was done, the set still ran smoothly and quietly, in spite of the tremendous misalignment.

On page 325 of our February issue, in the article on the vernier caliper, the readings should be 1-128 in. and 1/10 mm.

C. L. Hawes,
12 Adams St.

London General
Armubus Co.,
London, Eng

648 POPULAR MECHANICS
Ashtabula, Ohio
ATTACHMENT MAKES SURFACE
41-in GRINDER OF PLANER

Small shops will find a planer attachment now on the market a great convenience, as, with it, the planer may be

that will not score the spindle, but forms a fine surface in service. It will seal pumps perfectly tight even when the shafts have become scored and worn. It is not affected by heat under 550° F.; and is suitable for steam, air, brine or chemicals, and water.

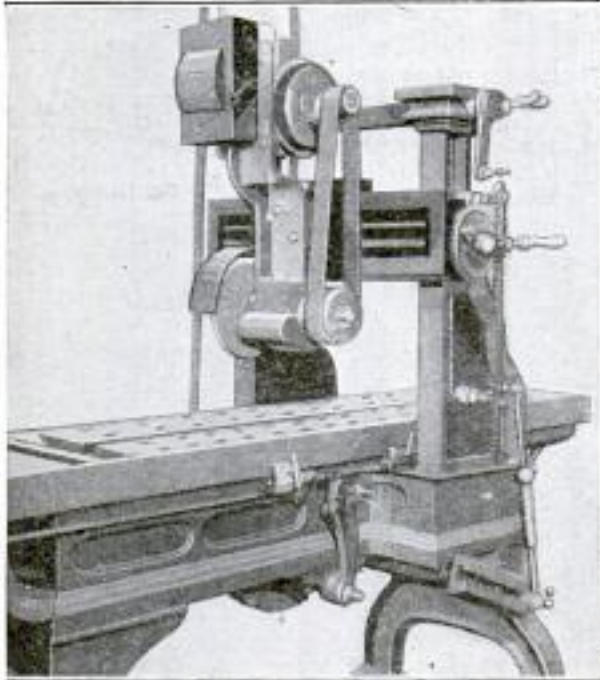

Attachment that Converts the Planer into an Efficient Surface Grinder

used as a surface grinder. The grinder attachment is fastened to the tool-head swivel, and is fed in the same manner as the regular head; the attachment is equipped with roller bearings, mounted in a dust-proof housing, and has an efficient oiling system, with a reservoir that need only be filled once a month. The motor may be adjusted to take up belt stretch. Emery wheels up to 12-in. diameter and 1½ in. wide may be used on the head.

120 in ALUMINUM 'BUS WHEELS
TESTED IN ENGLAND

Aluminum-alloy road wheels, which, although only half the weight of standard steel wheels, have given exceptionally satisfactory results, have been tested recently by a large English omnibus company.

A number of the wheels have been running for over 30,000 miles, and tests are being carried out on over 20 routes. The economical advantage possessed by the aluminum wheel is that the scrap value is very high—about two-thirds its original casting value. A further great advantage is the large reduction in unsprung weight, and in the minimizing of road destruction.

104-in COMBINED HAMMER AND DRILL

Apparently an ordinary electric drill, a tool recently invented by a Nebraska man, becomes a hammer merely by sliding a button. The blows are struck through the medium of a coil spring which is alternately compressed and released by a ratchet mechanism. The housing for the motor and gear train is aluminum, thus reducing weight to a minimum.

After eighteen months of semi-constant

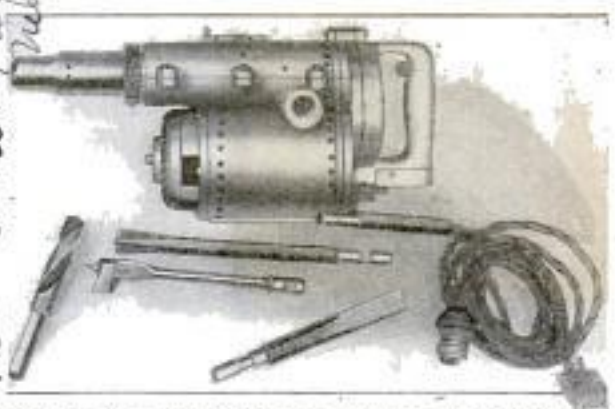

Electric Tool that Combines Hammer and Drill, with a Few of the Tools Used

service, it is said that the ratchets show but little sign of wear, and these are the only parts subject to heavy service.

Oxygen tanks should never be handled on the same platform with oil or grease, which might find their way into valves.

PLASTIC METALLIC PACKING
FITS ANY BOX 114 in

All users of stuffing-box packing, whether engineers, garage men, or automobile owners, will appreciate a packing recently developed. It is a semi-metallic composition, in a paste or putty-like form, which can easily be placed in a stuffing box of any size or shape; and, when the gland is set up firmly, makes a perfect fit on the shaft or rod. The material in the packing does not lose its life with long service, or become hard and brittle, but remains plastic and can be tightened with the gland at any time. It is well adapted for service on automobile water pumps and, it forms a practically frictionless metallic bearing

U. S. Payne, 224 E. 19th Ave. University Village

Price - \$165.00

Conneaut Packing Co. Ohio

\$1.65 per lb.
F. C. B. Conneaut

114.

Essay sent to Mrs. Fannie Fern
Andrews 405 Marlborough St.
Boston, Mass.

Prize Offers and Announcements

FIFTY-THOUSAND-DOLLAR ESSAY PRIZE FOR INTERNATIONAL PEACE

To stimulate interest in international peace among persons abroad, a \$50,000 essay contest, similar to the one recently conducted by Edward W. Bok, has been opened to English, French and Italian writers. The donor of the money is Edward A. Filene of Boston, Mass. The best practical plan for the general maintenance of peace is sought as the object of the contest. Any topic relative to the problem may be discussed; the League of Nations, reparations or any plan for international co-operation. Committees which will have charge of the essays submitted by writers in each of the three countries will select winning articles for the final choice.

ONE THOUSAND DOLLARS FOR ESSAYS ON ECONOMIC SUBJECTS

Two prizes, one \$650 and the other \$400, are offered through the American Economic Association by Roger W. Babson, to graduate or undergraduate students in any American or Canadian university or college, for the best essays on the subject, "Forecasting the Price of Wheat, of Cotton, or of Lumber." Any one of the commodities may be chosen for the discussion, and manuscripts are limited to 12,000 words. They must be sent to Ray B. Westerfield, secretary of the American Economic Association, Yale Station, New Haven, Conn., on or before Oct. 1, 1924.

FIVE THOUSAND DOLLARS IS OFFERED FOR BEST BATTERY LOCOMOTIVE

Charles Markham, of Chesterfield, England, has offered a prize of \$5,000 for the best electric storage-battery locomotive for use in underground coal mines. The competition will be supervised by the mines department of the British government and is open to manufacturers, or designers who have arranged for the manufacture of their designs. Competitors may be of any nationality. The donation of so attractive a prize, it is hoped, will stimulate the development and improvement of such important mining equipment. Coal mining and metal mining have many common needs, and it is thought that improvements in equipment that result from this prize will benefit the latter industry to a measurable extent.

TWENTY-FIVE-THOUSAND-DOLLAR AWARD FOR BEST PEACE PLAN

From an anonymous bequest of \$25,000, the World Federation of Education Association offers a prize of \$12,500 for the best plan for international peace accepted, and its author will receive an additional \$12,500 when his plan is inaugurated, according to announcements of the organization. Manuscripts should not exceed 2,500 words in length. They should be sent in a plain envelope and accompanied with one containing the author's name and address. Articles must be submitted before July 1, 1924, to Dr. Augustus O. Thomas, President, The World Federation of Education Associations, Augusta, Maine.

RADIO PRIZE OF TWENTY-FIVE DOLLARS WILL BE PAID EVERY MONTH

For short essays on Americanism that can be read over the radio in not more than twenty minutes, Station WLW offers a monthly prize of \$25. Manuscripts should be typewritten and accompanied by return postage. All rights for the winning "radio" will belong to the company. Contest closes the first of each month. Address articles to Radio Department, Crossley Manufacturing Company, Cincinnati, Ohio.

THREE PRIZES FOR PEACE ESSAYS OPEN TO TEACHERS AND STUDENTS

For the best essays on "Methods of Promoting World Friendship Through Education" and on "The Organization of the World for the Prevention of War," prizes of \$75, \$50 and \$25 will be given in a contest conducted by the American School Citizenship League. The first

subject is for students in normal schools and in teachers' colleges and to the second, seniors in secondary schools throughout the country are eligible. The awards, known as the Seabury prizes, will be made soon after June 1, 1924, when the contest closes. Essays should be submitted to Mrs. Fannie Fern Andrews, secretary, 405 Marlborough street, Boston 17, Massachusetts.

ONE THOUSAND DOLLARS PAID FOR STORY OR SCENARIO ABOUT JAILS

For the best play, motion-picture scenario or short story adaptable into a play or scenario on the American jail as a contributing force to the creation of criminals and to fostering crime, the Cosmopolis Press of New York will pay \$1,000. The first "next best" manuscript submitted will be sold if possible and the proceeds given to the author. The contest closes October 1, 1924. Matter should be sent to The Contest Department, Cosmopolis Press, 257 West 71st street, New York.

WRITERS TO WIN TWO THOUSAND DOLLARS IN ANNUAL ESSAY COMPETITION

Four prizes totaling \$2,000 for the best essays on economic subjects are offered by Hart, Schaffner & Marx, of Chicago in a contest closing June 1, 1924. Participants in the competition are divided into two classes, residents of the United States or Canada without restriction, to be known as Class A, and undergraduates of any American college to form Class B. In the first group, \$1,000 and \$500 are the prizes. Awards of \$300 and \$200 are open in the second. Among the subjects to be discussed are "A Survey of the World's Cotton Situation," "The Theory and Practice of Ship Subsidies," "The Sales Tax," "The Theory and Practice of Unemployment Insurance," "What Conditions Limit the Amount of Wages that Can Be Paid?" "A Comparison of Business Cycles in the United States, Great Britain and Canada." Papers should be sent to J. Laurence Laughlin, Esq., University of Chicago, Chicago, Illinois.

IMPROVEMENTS IN TEXTILE INDUSTRY ARE SOUGHT BY PRIZE OFFER

Believing that discussion of manufacturing processes in the various branches of the textile industry will materially assist in more economical and efficient production, the American Wool and Cotton Reporter, 530 Atlantic ave., Boston, Mass., has offered a total of \$2,000 in awards ranging from \$100 to \$5. There are 216 prizes in all. Arrangement of machinery, methods of routing material, suggestions for improving processes, defects that may have been discovered in present methods of accomplishing a given result and the suggestion for overcoming such defects or any other thoughts that may occur to the writer which he thinks would be of interest to someone else, are sought.

CONTESTS PREVIOUSLY ANNOUNCED

Advertising Prizes Offered: Awards amounting to \$8,500 and a gold medal for best individual advertisements and campaigns in advertising; announced March issue, 1924.

American Chemical Society Contest: Scholarships and \$10,000 in prizes for essays written by students in high and secondary schools to stimulate interest in chemical sciences; announced January issue, 1924.

Best Adventure Story for Novel: A \$2,000 prize for an adventure story not less than 60,000 words long, suitable for publication as a novel; announced March issue, 1924.

Two Hundred Dollars for Prize Joke: Monthly first prize of \$200 and smaller sums for other jokes in Gloom, a Los Angeles, Calif., publication; announced January issue, 1924.

Thrilling Experiences Paid For: Short narratives on personal "thrillers" receive prizes each month from Ace High Magazine; announced March issue, 1924.

Prize Poetry Award: Best sonnet about cities will win \$75; announced March issue, 1924.

FROM THE EDITOR'S MAIL BAG

In the past I have built several of the machines that you published instructions covering construction details of in Shop Notes Department. And I will say that the plans and instructions were very easily understood and carried out, and machines are very satisfactory. I have built the following articles: an external grinder; small power-driven bandsaw; riveting machine (described just a month ago); and I have the patterns now made for the castings for the Power Scroll Saw that was described last year. The mechanic that I showed the drawings to for this machine says that it is the slickest saw that has ever come to his notice.

I believe that you are the greatest help to the mechanic that there is today, as one gets more real help from Shop Notes for least money than from any source that I know. And your great willingness to serve through the Information Bureau is one of our greatest boons.—F. W. Schwartz, Aurora, Ind.

It is with pleasure that we respond to your request relative to the making of anything described in the pages of your fine magazine by any of your readers. My thanks are certainly due your publication for the many helpful suggestions which have been of much assistance to me in my work as general-all-around-mechanic associated with a summer-resort hotel, where the services of a plumber, carpenter, builder, designer, painter, etc., are in constant demand. In this multiple role, I have erected several rustic summer houses on the grounds whose designs were taken from Popular Mechanics. They have been much admired. A lovely Japanese pavilion graces the recreation dock built out into the lake at this place—a further suggestion from the same source. Also, a swimming pool made up of more than one description appearing in the pages of your popular magazine. We have an ornamental pergola entrance to the estate surrounding the Inn that is said to be one of the most "showy" between this place and New York City, and whose creation is largely due to designs appearing in former issues of Popular Mechanics.

There is scarcely a work of any degree of importance on the place now that I do not consult some copy of the magazine for hints and kinks. At this writing I am planning some rustic swings, furniture and ornamental arbors from designs which you have furnished.—H. Clay Rockwell, Ulster Park, N. Y.

I enclose herewith a list of things I have built from descriptions published in the magazine since June, 1922. I am pleased to say that I have had full success with all of them, everything being described and explained so clearly that one cannot make a mistake. Short-wave receiver; 2-step amplifier for above (June and July, 1922); simple receiver (Nov. 1922); dry-cell tube set with 2-step amplifier (June, 1923); storage B-battery (April, 1923); and spider-coil receiver with amplifier (March, 1923).—F. Thomas, Ste. Anne de Chenes, Man., Canada.



Japanese Pavilion on Recreation Dock Made by Mr. Rockwell from Popular Mechanics Designs

I have successfully built the jack described in the September issue, 1923, on page 467. In fact, I made a pair the same size. I find these very useful around the house for a great number of purposes. I am more than pleased to have found in your magazine what I have been wanting for a long time.—Frank Biondo, 257 La Grave Ave., S. E., Grand Rapids, Mich.

I made the "Walking Wampus" as described in your January issue. It was necessary to make one change, namely: I inserted a phonograph needle in the nose, so that it stuck out one-sixteenth inch, in order to keep it from sliding down the board, instead of walking down. Your articles are enjoyed very much.—F. C. Hartmann, 3212 Lyndale Ave., Minneapolis, Minn.

I wish to say that I have made the crystal receiver shown on page 157 of the January issue of Popular Mechanics. I have heard as far as KDKA at Pittsburgh, this station coming in very clearly. I consider this an exceptionally good crystal receiver.—Elvin Nelson, 107 So. Webster, Greenville, Mich.

It is an everyday occurrence for me to make something from your magazine. Besides making things I get such enthusiasm and inspiration from your book

that whenever a problem presents itself I always ask myself, "Now, how would Popular Mechanics do that?" then I go ahead and do it—funnels from bottles; bands for pipe covering; strap and stick for opening fruit jars; tire tape as repair for hose; poultry feeder; bird-house; garden tools; filing systems; pipe repairs; valve repairs; grinding compound; leather treatment that enables me to wear shoes from one to two years; rubber repairs; bicycle attachments; painting; staining; varnishing; medicine chest; grinder from sewing machine; water syphon—in fact, so many different things that I cannot mention them all. These are just

a few to show you how useful your magazine really is, and I hope you continue the good work.—J. P. Linden, Aurora, Ill.

I feel sorry sometimes, and sometimes I am glad, that I left my whole collection of your wonderful magazines to the "Engineers of Architecture Club" in Warsaw, Poland. Many of the members studied English just for the purpose of understanding the articles in Popular Mechanics. It is used now as a reference library.—E. M. Phillippe, 47 Yorkston St., Schenectady, New York.

As an amateur mechanic I have made and used many of the articles described in your magazine. My latest creation is a tool cabinet, and I am now working on a flat-top desk.—J. H. Shrieves, Leemont, Va.

In accordance with the editorial policy of this magazine never to accept compensation in any form for what appears in our reading pages, and also to avoid all appearance of doing so, we are obliged to omit the name of the maker or the seller of any article described. This information, however, is kept on file and will be furnished free, by addressing Bureau of Information, Popular Mechanics Magazine, Chicago. [Editor.]

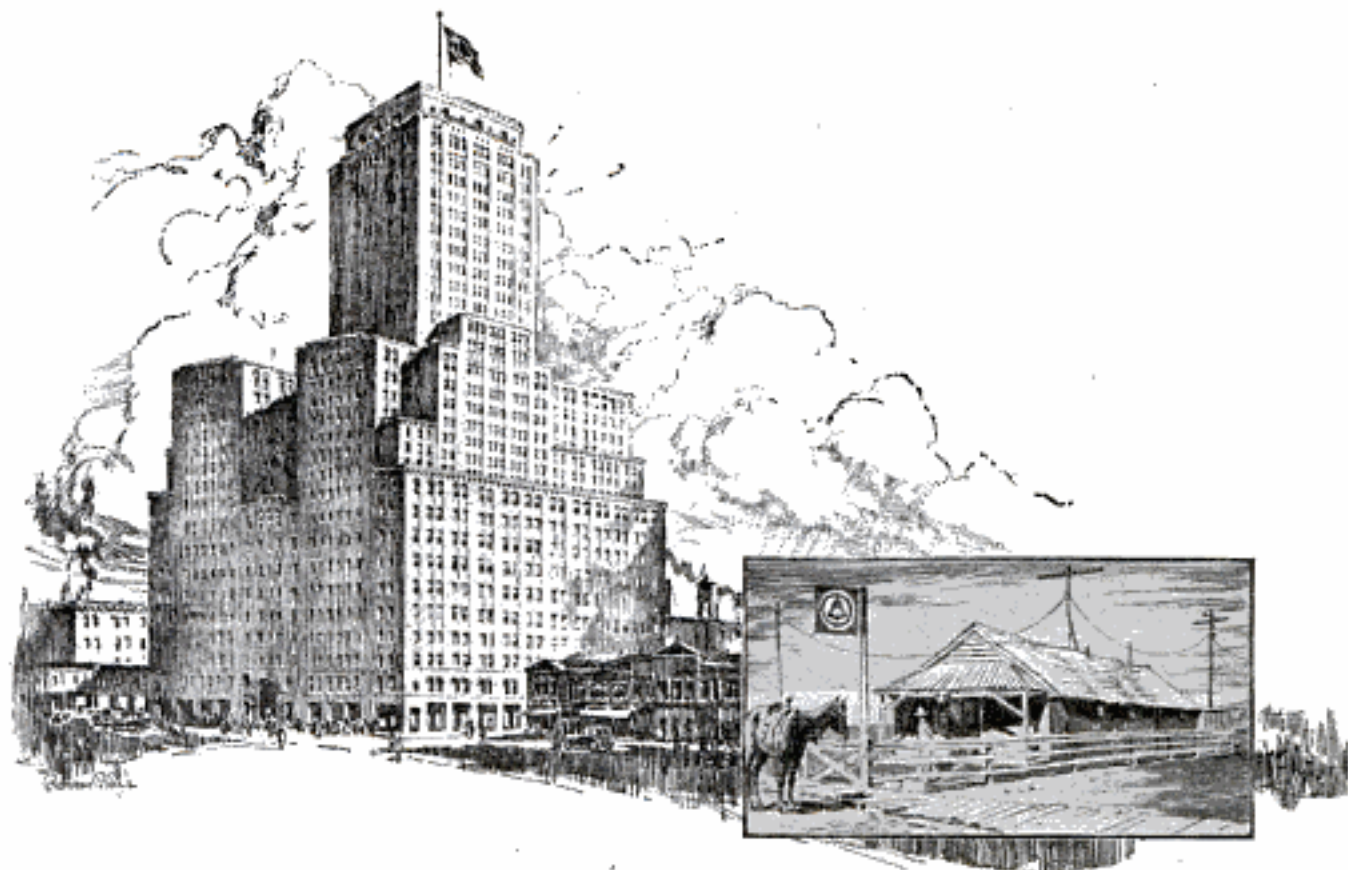

Each Serves Its Community

In Fraser, Colorado, a log cabin of three rooms shelters a telephone exchange that connects with the mountain homes of cowmen, miners, homesteaders and tie-cutters. In the heart of New York City a new building of twenty-nine stories is to become the home of several metropolitan central offices serving some 120,000 telephones. This building will contain, as well, offices for executives and for engineering, commercial, plant and accounting forces, providing space for over 7000 telephone workers.

Each of these buildings helps to render adequate and economical telephone service in its own community. They stand at the extremes in size, equipment and

personnel. Yet they both indicate the nation-wide need for adequate housing of the activities of the Bell System; and they illustrate the varied ways in which that need is being met. One of the largest single items of plant investment of the Bell System is real estate, comprising nearly 1700 buildings acquired, with their sites, at a cost of \$180,000,000.

It is continuously the aim of the Bell System to construct and so to situate each new building—whether executive office, central office, storehouse or garage—so that it shall serve its community with the utmost efficiency and economy, and remain a sound investment throughout its period of life.



AMERICAN TELEPHONE AND TELEGRAPH COMPANY
AND ASSOCIATED COMPANIES

BELL SYSTEM

One Policy, One System, Universal Service

"Old Town Canoes"



Push across to the bathing beach

DOWN by the wooded bank, a stone's throw from the cabin, an "Old Town Canoe" is moored. What a trim, graceful craft it is. What a picture it makes, resting lightly on the water, the sunlight dancing on its shining sides.

Shove off—light, easy strokes keep the "Old Town" flashing through the ripples. The bathing beach is a mile across the

lake, but you're there before you know it. Certainly, the "Old Town" is the easiest canoe you ever paddled.

"Old Town Canoes" owe their beauty of line to the Indians. Each "Old Town" model is patterned after a real Indian canoe. "Old Towns" are so light and steady. They are low-priced canoes too. \$64 up. From dealer or factory.

The new 1924 catalog is beautifully illustrated. It shows all models in full colors. Send for your free copy to-day.

OLD TOWN CANOE CO. 1464 Middle Street, Old Town, Maine, U. S. A.



**"YANKEE"
Automatic
Push Drill
No. 44**

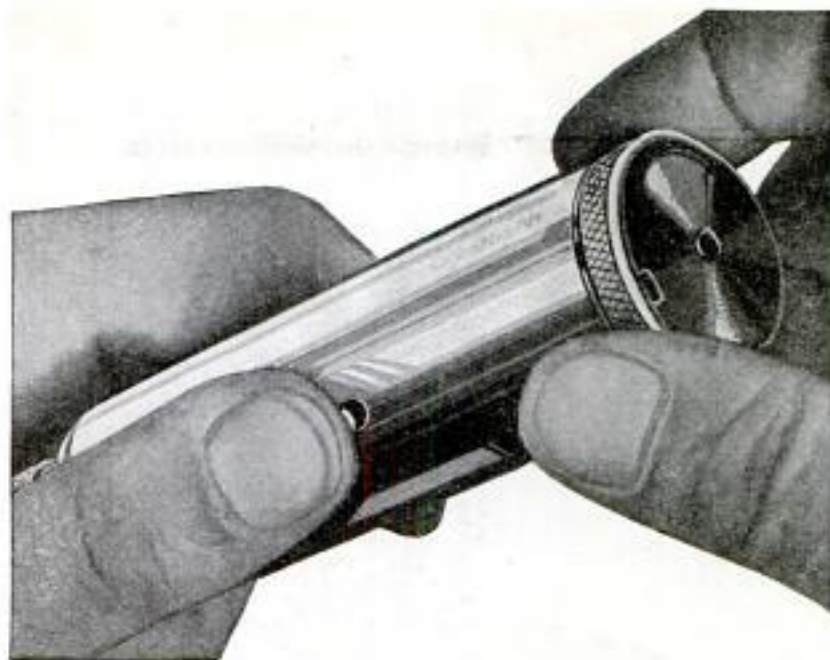

At the turn of the cap
**The right tension
for the work**

Just turn the cap on handle of "Yankee" Automatic Push Drill No. 44 to regulate tension. You get the right pressure for hard wood, soft wood, small drills, large drills. You do a better job and save drill points.

**"YANKEE"
Automatic
Push Drill
No. 44**

is the only drill with adjustable tension. It has seven different tensions. No other drill but this has a magazine handle that

opens up toward the chuck, exposing eight drill points, heads up, for easy selection.

"Yankee" Automatic Push Drill, No. 41. Without adjustable tension. This is the ideal drill for work where adjustable tension is not required. Eight drill points, $1/16$ — $11/64$, in plain sight when magazine is open.

Some other "Yankee" Tools

Ratchet Screw-drivers
Spiral Screw-drivers
Quick Return Spiral
Screw-drivers
Plain Screw-drivers
 $1\frac{1}{2}$ to 30 in. blades
Ratchet Breast Drills
Ratchet Hand Drills



FREE Tool Book
with illustrations
and descriptions
of all "Yankee"
Tools. Yours on
request.

Dealers everywhere sell "YANKEE" Tools

NORTH BROS. MFG. CO.

Philadelphia, U. S. A.

"YANKEE" TOOLS
Make Better mechanics

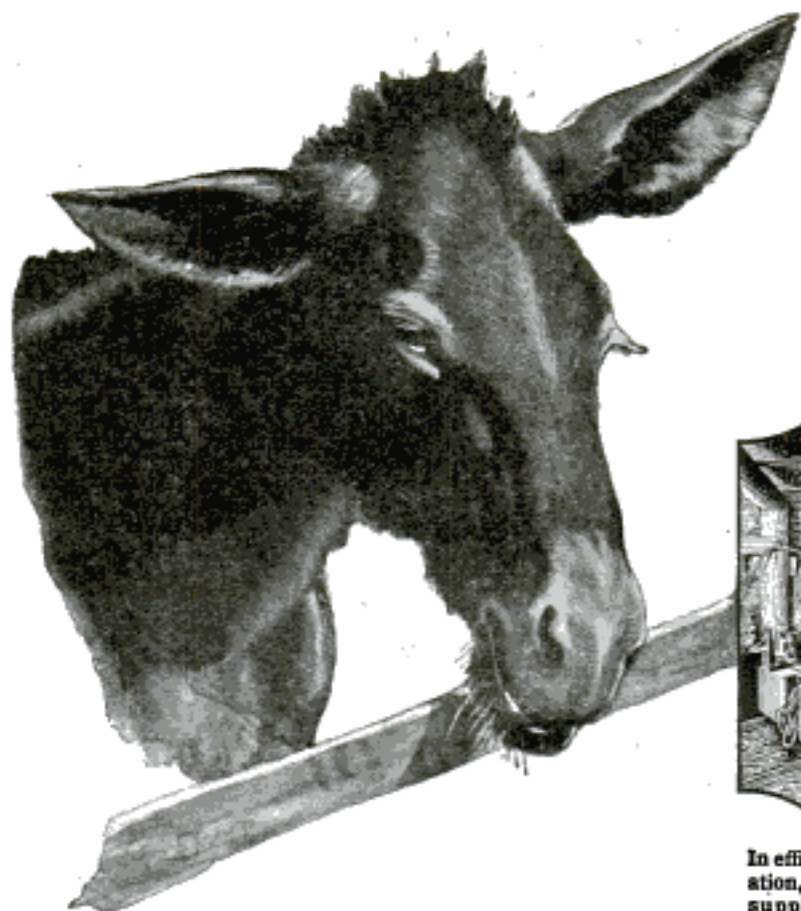

In efficient modern coal mine operation, G-E mine locomotives are supplanting the plodding mule

Good-bye, old mule



In 1892 a G-E locomotive was placed in a large mine in the middle west. It is still in service and has hauled more than four million tons of coal. Thousands of G-E locomotives are now serving mines and industrial plants.

A faithful old fellow, the coal mine mule; but expensive. He was slow, and required much attention; and his working life was short.

Today a durable G-E locomotive, with one operator, often hauls as much coal as three mules, with three drivers, used to haul.

GENERAL ELECTRIC



*Sargent Steel
Block Plane*

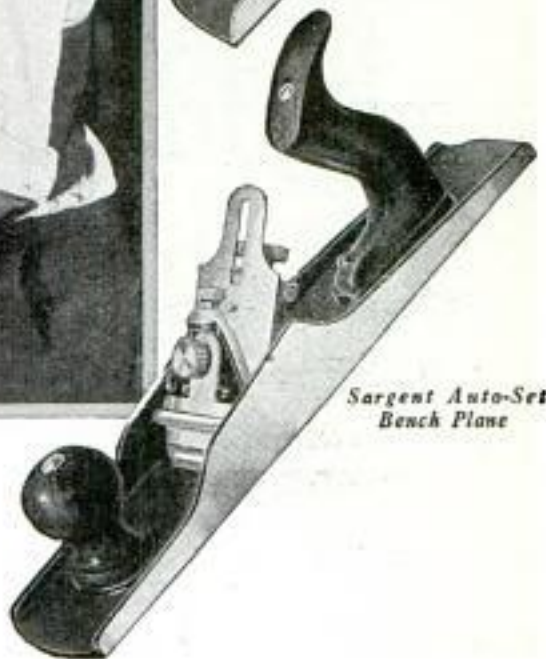

*Sargent Auto-Set
Bench Plane*

He'll have it planed in a jiffy!

IN THIS home workshop, radio is king. In fact, a goodly number of big and little sets, comparable to expensive commercial types, have gone from this bench into neighboring homes. This young man has a reputation for good workmanship. He takes particular pride in his ability to choose and use good tools.

Once you have used the handy little Sargent Steel Block Plane no other finishing plane will do. It is great for work in close quarters, for smoothing up panels, bureau drawers that have been sticking, and similar things. It is as true and clean cutting and as finely made as

the larger Auto-Set Bench Plane shown above.

The Auto-Set, of course, should be in every workshop for use on the bigger jobs. It is light in weight and remarkably easy to adjust or sharpen. The chromium steel cutter may be removed, honed and replaced without changing the original adjustment. Yet it is so firmly held in place that it never chatters even when cutting across the grain or over rough and knotty surfaces. You will find the Sargent Auto-Set Plane an aid to speed and accuracy.

See these Sargent Planes at your hardware dealer's and write us for interesting booklet.

SARGENT & COMPANY

Hardware Manufacturers

49 Water Street

New Haven, Conn.

SARGENT
Tools & Hardware



*Now I know why
the Boss has confidence in Jones*

When an especially particular job comes in, the Boss sends for Jones. Why? Because he knows that Perfection depends upon Accuracy, and for Accuracy he can depend upon Jones.

But without the finest and most accurate tools Jones could not be sure of his Accuracy. Jones knows this, and his choice every time is "Brown & Sharpe."

Brown & Sharpe Tools are "The Standard of the Mechanical World." When you use Brown & Sharpe Tools you have confidence that the results will be "right."

It pays to equip your kit with Brown & Sharpe Tools. Send for our Small Tool Catalog.

BROWN & SHARPE MFG. CO.

Providence, R. I., U. S. A.

BROWN & SHARPE TOOLS

"The Standard of the Mechanical World"



**5-YEAR
GUARANTEE**

No Money Down! FREE

NOT ONE CENT—you can have this genuine Underwood on **TEN DAYS' FREE TRIAL**. No obligation on your part. Rebuilt by the famous SHIPMAN-WARD process. Late models of the world's finest typewriter at prices that will astonish you. Mail the coupon today.

Ten Days' Free Trial

No obligation on your part. You can try this machine. Test it thoroughly and if at the end of ten days you are not satisfied, send it back. We have that confidence in our machine.

Standard Underwoods

Rebuilt by the famous SHIPMAN-WARD process. Easy action, perfect writing machine, equipped with all modern attachments, ready to use. All worn parts replaced with new rubber, new finish, new nickel, and you can not tell it from a new machine.

BIG PRICE CUT

Take advantage of our new prices. We can save you money. The finest quality typewriter for the money on the market today. Clip the coupon and save money.

Easy Monthly Payments

Our easy monthly payment plan makes it possible for YOU to own this splendid machine without having to pay out any big sum of money. You will hardly know you are paying for it. REMEMBER, you have the full use of this machine, just the same as though it was fully paid for.

"Big Book of Facts"

A trip through our factory explaining SHIPMAN-WARD'S wonderful system of rebuilding typewriters. We show you exactly how it is done. Now you are able to buy at a big saving. Complete and valuable information by the typewriter industry. Get this book today. Mail coupon below.

From Factory to You

These machines are shipped direct from our factory, rebuilt by the famous SHIPMAN-WARD process. Developed through 30 years in the typewriter business. By our money-saving methods of rebuilding and eliminating large expensive sales force we are able to make this money-saving offer to you. See for yourself and send for our free book of facts.

Free With Every Typewriter

Complete course in touch typewriting. You can learn to operate this machine in one day. Also, free water proof cover and all tools that come with a typewriter.



OUR FACTORY

All Shipments made direct to you from our modern factory—the largest typewriter rebuilding plant in the world.

SHIPMAN-WARD MFG. CO.,

2124 Shipman Bldg.,

Chicago, Ill.

FREE BOOK COUPON

SHIPMAN-WARD MFG. CO.,
2124 Shipman Bldg., Chicago, Ill.

Send by return mail your wonderful offer of Shipman-Ward Standard Rebuilt Underwoods, also your book of facts. (This is not an order and does not obligate me in any way.)

Name.....

Street.....

Post Office.....State.....

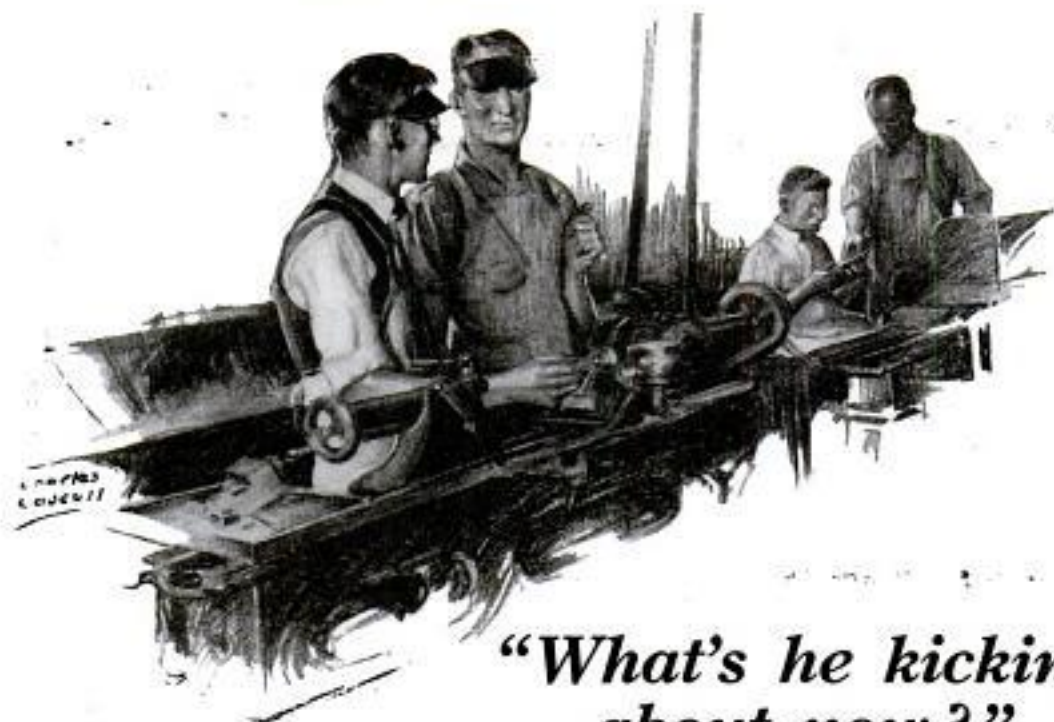

“What’s he kicking about now?”

“Same old thing. ‘Nother job came back on him and he’s grouching about the light again.”

“Funny he does n’t seem to learn by experience. If he’d use *Starrett* scales like everybody else in the shop he would n’t have any trouble getting accurate measurements — even if the light is poor.”

Put a glass over the graduations and you will see at once why Starrett Steel Rules are so much easier to read. Notice how clean cut the figures and division lines are. They are *cut deep* enough to be plain and distinct even after years of hard service. Starrett Steel Rules make it easier to do accurate work. A rule for every purpose — write for our free Catalog describing the many different Starrett Steel Rules, Straight Edges, etc. Ask for No. 22 “AP”

THE L. S. STARRETT CO.
The World’s Greatest Toolmakers
Manufacturers of Hacksaws Unexcelled
ATHOL, MASS.

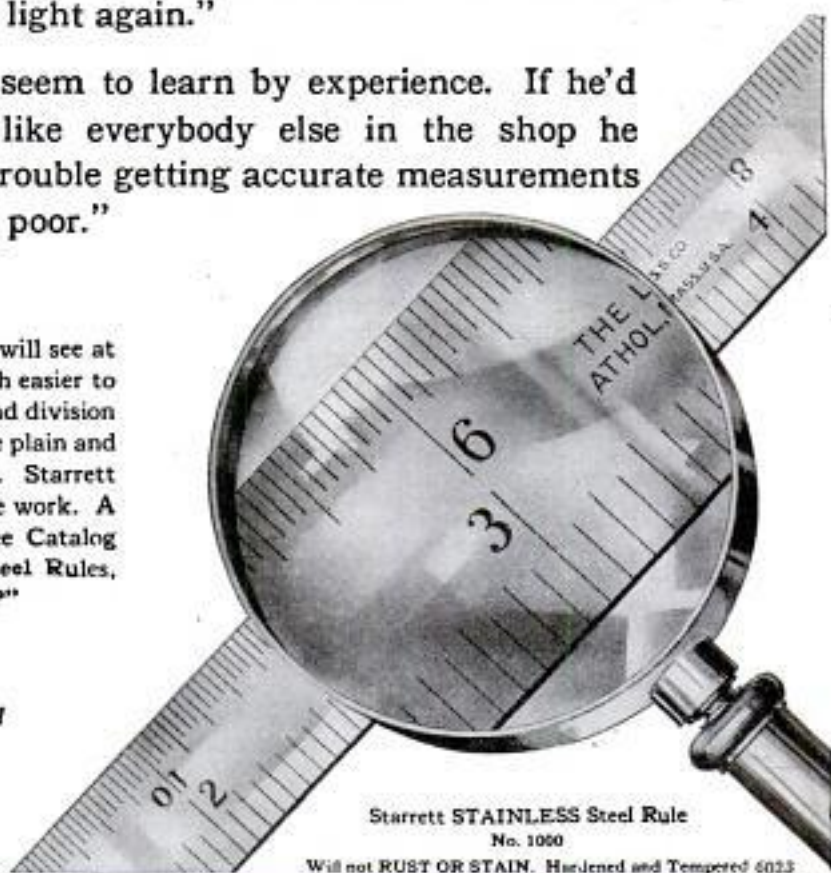

Starrett STAINLESS Steel Rule
No. 1050

Will not RUST OR STAIN. Hardened and Tempered 6023



Use Starrett Tools

21 Jewel Santa Fe Special

Sent
on

Approval

21 Perfect Jewels
Adjusted to Positions
Adjusted to Temperature
Adjusted to Isochronism
Adjusted to the Second
25 Year Gold Strata Case
Your choice of Dials (including
Montgomery R. R. Dial)
New Thin Models. All sizes.

WHILE other watch dealers are raising their prices, asking you for larger monthly payments, and making payment terms harder for you to meet, we are offering you our new model Santa Fe Special, no advance in price, no money down, easier terms and smaller monthly payments. We realize the war is over and in order to double our business we **MUST** give you pre-war inducements, better prices, easier terms, and smaller payments.

Send No Money Without one penny of advance payment let us place in your hands to see, to examine, to inspect, to admire, to approve a real masterpiece in watch creation. Our determination to this year double our sales of the world famous Santa Fe Special and Bunn Special Watches prompts this matchless offer.

Santa Fe's "New Elite"

This Artistic dependable Ladies' Wrist Watch, fitted with genuine Illinois Springheld movement. A perfect timepiece. Beautiful 14 Karat white or green solid gold case. Many designs—Ask for New Watch Book showing New Elite case designs in color. Watch sent on approval and sold on payments.

Page 12 of Our Watch Book Is of Special Interest to You!

Ask for our Watch Book free—then select the watch you would like to see, either the famous Santa Fe Special or the 6 position Bunn Special, and let us explain our easy payment plan and send the watch, express prepaid, for you to examine. No money down. **REMEMBER**—No money down—easy payments buys a master timepiece—a 21 Jewel guaranteed for a lifetime at about half the price you pay for a similar watch of other makes. No money down. A wonderful offer.

SANTA FE WATCH COMPANY

46 Thomas Building TOPEKA, KANSAS

"Home of the Great Santa Fe Railway"

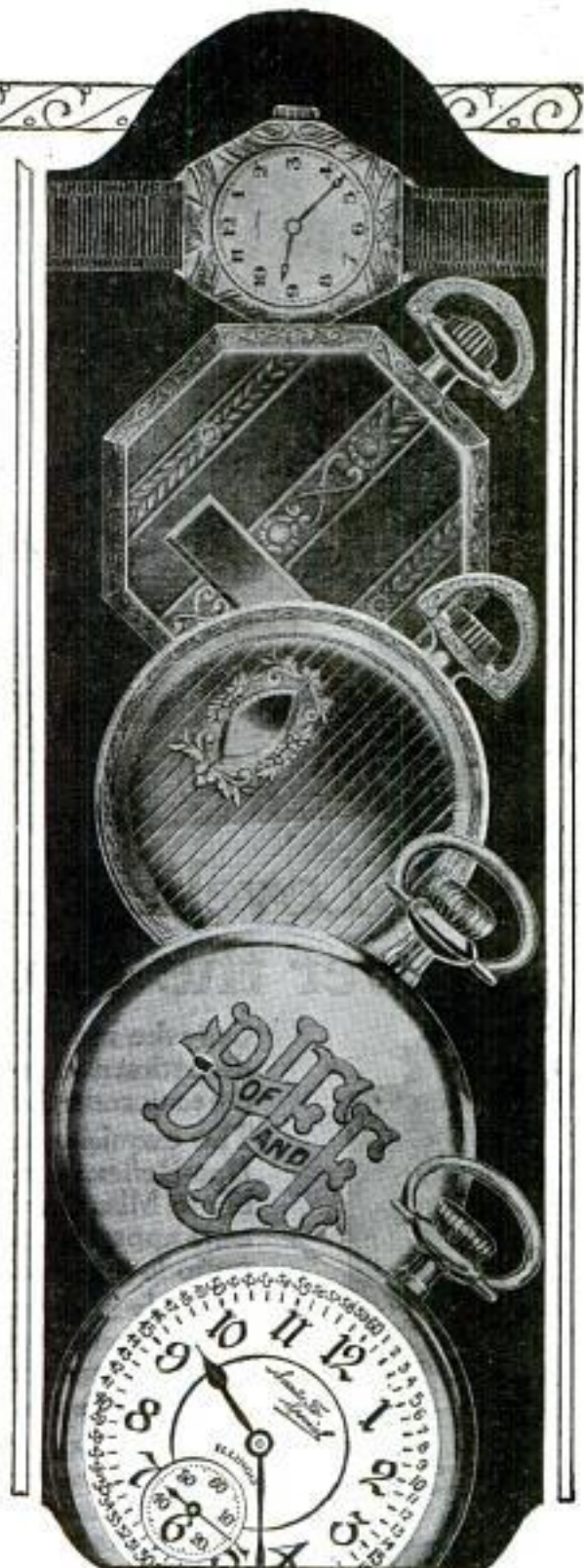

SANTA FE WATCH CO.

46 Thomas Bldg., Topeka, Kansas

Please send prepaid and without obligation your Watch Book free, explaining your "No Money Down" Offer on this Santa Fe Special Watch.

Name.....

Address.....

State.....



“The Loveliest Thing I’ve Ever Heard Over the Radio”—Mary Garden



Increased range and volume, as well as elimination of distortion, follow installation of Erla transformers. Reflex and Cascade types, \$5



Erla sockets embody every improvement, with nicked shell cast into Bakelite base, and tilted double contact springs. List \$1

Only the most flawless reproduction, free from distortion and parasitic noises, could earn a tribute so unreserved from America's queen of song. The exquisite tone quality and purity of Erla Duo-Reflex reception that appealed so irresistibly to Miss Garden is finding equally enthusiastic appreciation in the homes of super-critical radio lovers everywhere.

Not only in sheer tonal perfection, but in range and volume, have Erla Duo-Reflex receivers demonstrated decisive superiority. Tube for tube, they are the most powerful receivers known.

Complete Erla parts, including celebrated synchronizing radio and audio transformers that enable vacuum tubes to do triple duty, guarantee success to the amateur who “rolls his own.” Easily understood blue prints guide every step. Ask your dealer for free Erla Bulletin No. 20, giving latest Erla one, two and three-tube diagrams; or write direct, mentioning your dealer's name.

Electrical Research Laboratories, Dept. J, Chicago



Exclusive ability of Erla audio transformers to amplify three stages without distortion assures improvement in any receiving set. List \$5



Erla two-way phone plugs hold phone tips securely without use of tools or cutting or changing phone tips in any way. List, 75c

ERLA

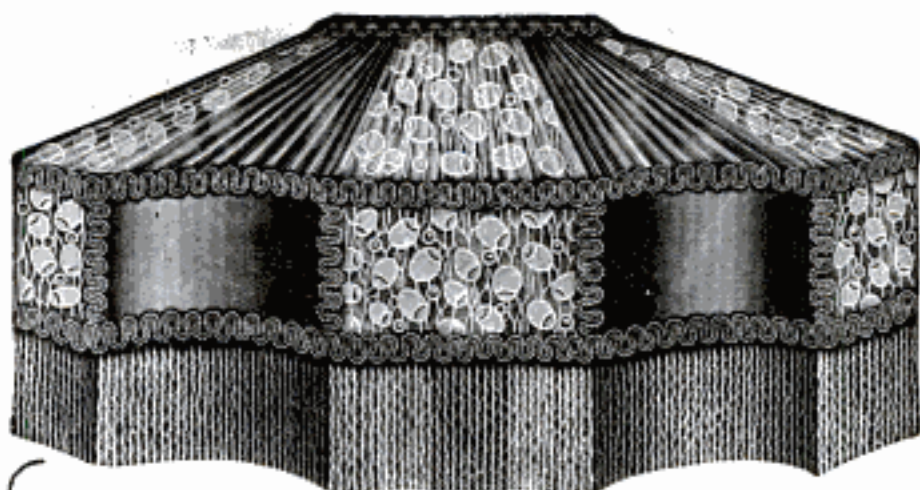

Gas or Electric The Lamp

Comes equipped for choice of gas or electricity. Has 2-light Benjamin socket for electricity only, with 8-ft. silk cord ready for use; or comes with 6-ft. rubber hose, burner, mantle and chimney for gas.

Mahogany Finish

Standard is 69 in. high, 3 in. in diameter. Highly polished French mahogany finish.

The Shade

Made in Fifth Avenue design, 24 in. in diameter, of delft blue silk, shirred top, alternating plain and fancy art silk panels. 12 panels in all, tinsel braid border with 4-in. Chenille fringe. American beauty shirred lining. The harmonious color scheme gives effect of red light shining through a blue haze—a rich warm light. Shipping weight, 27 pounds.

Marshall Silky Fringe Pull-Cords
Also pair of Marshall silky fringe cords with 3½ in. silky fringed tassels, giving an added luxurious effect.

For gas use, order by No. G6332NA.
For electricity, order by No. G6333NA.

Send only \$1 with the coupon, \$2 monthly. Total Bargain Price for lamp and shade, \$19.85.

Free Bargain Catalog

Shows thousands of bargains in home furnishings: furniture, jewelry, rugs, curtains, phonographs, stoves, dishes, aluminum ware, etc. All sold on easy terms. Catalog sent free with or without order. See the coupon.



\$1.00 Down Brings This

Floor Lamp With 5th Ave. Silk Shade

Here is something you have always wanted—a beautiful floor lamp with handsome and elegant Fifth Avenue silk shade—to add an extra tone of elegance and luxury to your home. On this generous offer you can see just how this floor lamp and silk shade will look in your home, without risking anything. Send only \$1.00 with the coupon below, and we will send it complete to your home on approval, equipped for use with either gas or electricity. We take all the risk.

30 Days Trial

When the lamp outfit comes, use it freely for 30 days. See how beautifully the colorings of the handsome silk shade blend and harmonize with everything in the home. How useful it is, too—so handy for reading, can be moved around with ease to furnish a beautiful light and rich warmth and coziness to any room in the house. If after 30 days trial you decide not to keep the lamp, just return it at our expense and we will refund your \$1.00 deposit, plus any freight or express you paid. You cannot lose a single penny.

\$2.00 a Month

If you discover that this lamp is a tremendous bargain at the price we ask and you decide to keep it, send only \$2.00 a month until you have paid the total bargain price of \$19.85. Yes, only \$19.85 for this luxurious lamp and silk shade complete. Compare this value with anything you could buy locally at anywhere near the same price—even for spot cash! Straus & Schram gives you this bargain price and almost a year to pay. We trust honest people anywhere in U. S. No discount for cash; nothing extra for credit. *No C. O. D.*

Price Slashed

Decide now to see this beautiful floor lamp and silk shade in your home on approval on this price smashing offer. Think how the nickels and dimes slip away for useless things; save them for something worth while that will give satisfaction for years. Send the coupon with only \$1.00 now! Satisfaction guaranteed.

Straus & Schram, Dept. 1774 Chicago

This bargain offer is limited. Send the coupon now while offer lasts.

Straus & Schram, Dept. 1774 Chicago, Ill.
 Enclosed find \$1.00. Ship special advertised Floor Lamp and Silk Shade as checked below. I am to have 30 days free trial. If I keep the lamp, I will send \$2.00 a month. If not satisfied, I am to return the lamp and shade within 30 days and you are to refund my \$1.00 plus any transportation charges I paid.
 Gas Floor Lamp No. G6332NA, \$19.85
 Electric Floor Lamp No. G6333NA, \$19.85
 Name.....
 Street, R. F. D. or Box No.....
 Shipping Point.....
 Post Office..... State.....
 If you want ONLY our free catalog of home furnishings, mark X here

"GET THE WORLD WITH N&K"

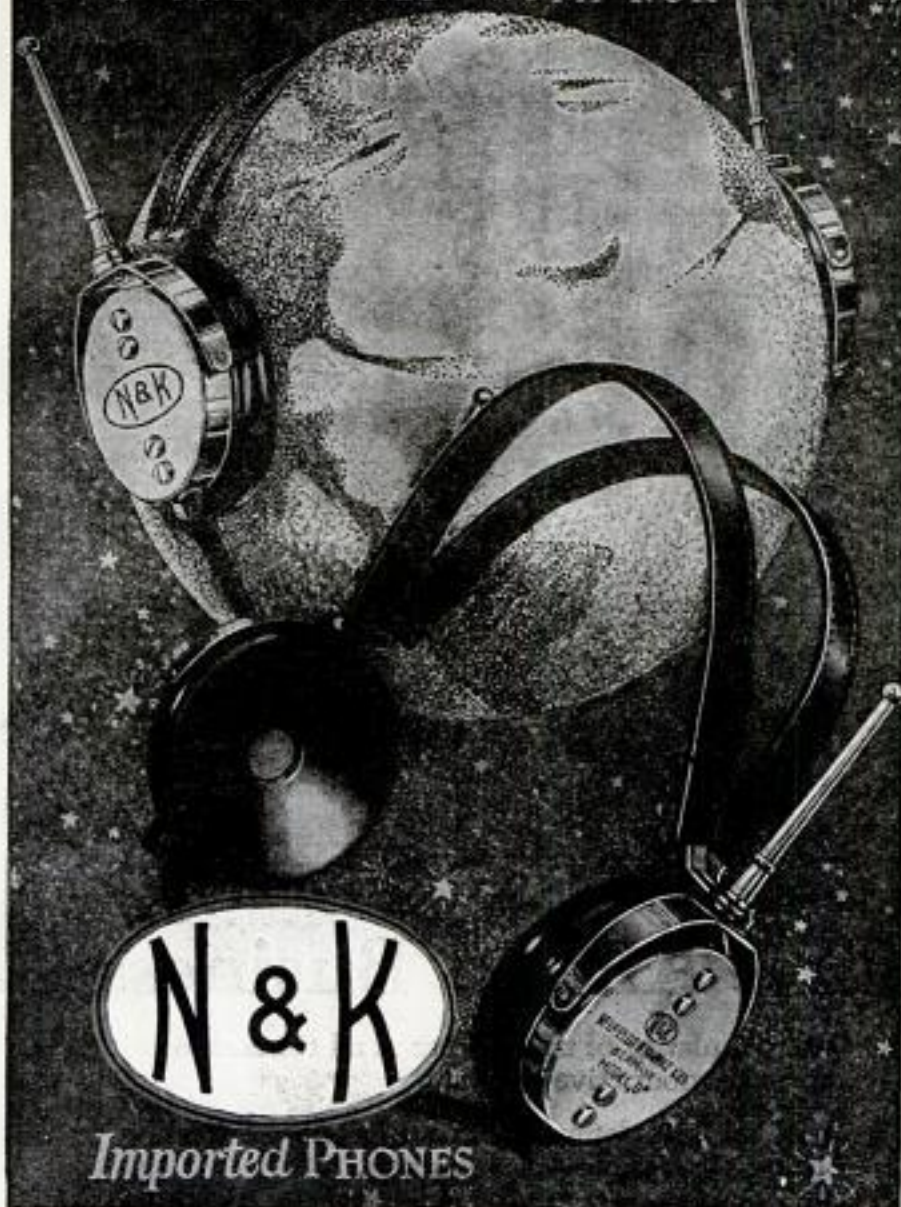

Imported PHONES

You shall be Sole Judge

A Most Unusual Offer

TEST N & K Phones on your radio set alongside *any other phones made*. If the N & K Phones do not reproduce both high and low tones more perfectly, if they do not give a clearer, more mellow tone, if they do not fit more comfortably on the head, send them back to the store within three days, and your money will be promptly refunded. No obligation whatsoever will be incurred. *You shall be the sole judge*. The N & K Head Set, Model D, 4000 ohms, is the imported head set that the radio "fans" are all talking about. Larger diaphragms. Nickered brass sound chamber. Leather covered bands. \$8.50 at leading stores. Ask for descriptive folder.

TH. GOLDSCHMIDT CORP., 15 WILLIAM STREET, DEPT. M4 NEW YORK

Any of the stores listed below or any other store displaying this advertisement will send you an N & K Head Set to make this trial.

- | | |
|--------------------|---------------------------|
| Athol, Mass. | M. Steinert & Sons Co. |
| Atlanta | M. Risk & Bros. Co. |
| Baltimore | Hochschild, Kohn & Co. |
| Bangor, Me. | Little Joe Winesfield Co. |
| Bloomfield, N. J. | Joel Goodman & Co. |
| Boston | Joann Electric Radio Co. |
| | M. Steinert & Sons Co. |
| | United Cigar Store |
| | Shepard Stores |
| | M. Steinert & Sons Co. |
| | A. P. Merriman Co. |
| | Iver Johnson Sporting |
| | Goods Co. |
| Budget | M. Steinert & Sons Co. |
| Booklin | Abraham & Stearns |
| | Frederick Loewer & Co. |
| | A. J. Norman & Son |
| | Royal Eastern Elec. |
| | Sup. Co. |
| | 25th Century Radio |
| | Corp. |
| | United Cigar Store |
| Chicago | Marshall Field & Co. |
| | Radio Instruments Co. |
| | of Chicago |
| Cleveland | The Max Company |
| | H. Lesser & Co. |
| Colorado Springs | Kaufmann & Co., Inc. |
| | Tyson Bros. |
| Dallas | The Anderson Piano Co. |
| Denver | Daniel & Fisher |
| | Stores Co. |
| Des Moines | Yountz Brothers |
| Des Moines | J. L. Hudson Co. |
| | Crowley, Miller Co. |
| | Detroit Electric Co. |
| East Orange, N. J. | United Cigar Store |
| Elmer | Barker, Rose & |
| | Clinson Co. |
| Fall River | M. Steinert & Sons Co. |
| Fitchburg | M. Steinert & Sons Co. |
| Harrisburg | Pomroy's |
| Hartford | Sage, Allen & Co. |
| Houston | W. C. Mann Co. |
| Indianapolis | Alamo Sales Corp. |
| Jamaica, L. I. | Bangert Electric Co. |
| | Royal Eastern Electric |
| | Supply Co. |
| Johnstown | United Cigar Store |
| Kansas City | Penn Traffic Co. |
| | The Schmeiser Co. |
| | Western Radio Corp. |
| | J. W. Jenkins Sons |
| | Music Co. |
| Long Island City | Royal Eastern Electric |
| | Supply Co. |
| Los Angeles | Hamburger's |
| Lowell | M. Steinert & Sons Co. |
| | Bon Marche D. G. Co. |
| | Bry-Bloch Mercantile Co. |
| Memphis | J. Goldsmith & Son |
| | Gimbel Brothers |
| Milwaukee | L. S. Donaldson Co. |
| Minneapolis | L. Bamberger & Co. |
| Newark, N. J. | Edward Malloy Co. |
| New Haven | M. Steinert & Sons Co. |
| | E. H. Higgins Co. |
| New Orleans | Davaga (11 stores) |
| New York City | Gimbel Brothers |
| | John Wamamaker |
| | Herbert & Haagen Co. |
| | United Cigar Store |
| | (10 stores) |
| | David Killock Co. |
| | Royal Eastern Elec. |
| | Supply Co. |
| | J. L. Lewis, Inc. |
| | Hanes-Zaner Co. |
| | Haynes-Giffin Radio |
| | Service, Inc. |
| Oklahoma City | J. W. Jenkins Sons |
| | Music Co. |
| Omaha | Oakford Music Co. |
| Patterson, N. J. | Richard M. Shles |
| Pawucket | Peterson Radio Co. |
| Puerto | M. Steinert & Sons Co. |
| Philadelphia | Block & Kohl Co. |
| | Gimbel Brothers |
| | John Wamamaker |
| | Lot Brothers |
| Pittsburgh | N. Swallenburg & Co. |
| | Boggs & Bohl |
| | Kaufmann & Barr Co. |
| | Ludwig Hommel & Co. |
| | Helden & Soner Co. |
| Pittsfield, Mass. | M. Steinert & Sons Co. |
| Portland, Me. | Meier & Frank Company |
| Providence | The Charles Co. |
| | M. Steinert & Sons Co. |
| | Kelman Electric Co. |
| Rochester | The Emporium |
| San Francisco | Leopold Adler |
| Savannah | Frederick & Nelson, Inc. |
| Seattle | Davidson Bros. Co. |
| Sioux City | Radio Exchange |
| Springfield, Mass. | M. Steinert & Sons Co. |
| St. Louis | Famous & Barr Co. |
| | Von-Arber Radio Co. |
| St. Paul | Pioneer Electric Co. |
| Springer | Alexander Grant's Sons |
| Tulsa | J. W. Jenkins Sons |
| | Music Co. |
| Washington | Woodward & Lothrop |
| Wheatburg | M. Steinert & Sons Co. |
| Worcester | M. Steinert & Sons Co. |

Dealers: We authorize you to refund the price of any N & K Head Set returned under the conditions named in this ad. We will exchange or replace any sets that come back to you.



for Economical Transportation



Superior
Utility Coupé

\$640

f. o. b. Flint, Mich.

First Aid to Business

The popularity of this car has at all times taxed our large productive capacity.

It meets completely the requirements of most business and professional workers.

The quality of this Chevrolet model is high and along strictly practical lines. The design, construction and finish of the body pleases discriminating motorists, and the economy of operation averages lowest for this type of car.

The mammoth rear compartment is of constant value to all who must carry luggage, equipment, samples, etc.

The best salesmen of this car are the people who use it daily. Ask any Chevrolet dealer, or talk to owners anywhere.

Prices f. o. b. Flint, Mich.

Superior Roadster . . .	\$490
Superior Touring . . .	495
Superior Utility Coupé . . .	640
Superior 4-Pass. Coupé . . .	725
Superior Sedan . . .	795
Superior Commercial Chassis	395
Superior Light Delivery . . .	495
Utility Express Truck Chassis	550

Fisher Bodies on closed models

Chevrolet Motor Company, Detroit, Michigan
Division of General Motors Corporation

In Canada—Chevrolet Motor Company of Canada, Limited, Oshawa, Ontario

Five United States manufacturing plants, seven assembly plants, and two Canadian plants give us the largest production capacity in the world for high-grade cars and make possible our low prices.

Chevrolet Dealers and Service Stations everywhere. Applications will be considered from high-grade dealers only, for territory not adequately covered.



\$50
buys this Corona
complete with
carrying case

*Easy terms arranged
if you desire*

You can own this splendid Corona typewriter

IT'S a beauty, as you can see—right up to the minute in every feature—just the kind of typewriter you have always longed to own!

With this machine you can type your own letters, orders, reports, or bills. You can write manuscripts of stories or articles for magazines.

The key to success

Successful people everywhere use Coronas because they have learned the value of time—and because they know that the *appearance* of their work may make all the difference between success and failure.

An hour spent with Corona each evening has put many a man on the road to bigger income.

Why Corona is the best all-round typewriter

Corona is the pioneer, portable typewriter with an 18 year record of Proved Durability.

Corona has automatic ribbon reverse, self spacing carriage return, two color ribbon, back spacer, wide 10 in. carriage, and many other improvements.

Corona writes VISIBLY—there is NOTHING between your eye and the paper.

Corona will make 12 to 14 good carbon copies.

Corona is one of the best stencil cutting typewriters made.

Corona fills in letters, fills out card records and addresses envelopes more accurately, quickly and neatly than the average "heavy typewriter."

Fine for office use

Business men are learning that Corona is not only more convenient than the heavy type of office typewriter—but *stands the strain of office work much better.*

One stenographer writes: "I use my Corona constantly for all kinds of office work and only twice in four years has it needed the slightest repair!"

You can have this Corona today!

You need not wait another minute. Just look up "Corona" in your phone book, telephone the Corona dealer and he will send this Corona to you for free examination. If you decide to keep it, pay only \$50 cash, or you can buy on easy monthly terms.

If Corona is not listed in your phone book, mail this coupon now while it is fresh in your mind. Don't delay. Success is built on decisive action.

MAIL THIS COUPON



CORONA TYPEWRITER COMPANY, INC.
108 MAIN ST., GROTON, N.Y.

Without any obligation, send me complete Corona literature and the address of the nearest Corona dealer.

NAME.....

ADDRESS.....



W. L. Douglas
 \$7.00 and \$8.00 SHOES
 Many at \$5 & \$6 - Boys' at \$4.50 & \$5

W. L. Douglas name and portrait is the best known shoe trade-mark in the world. It stands for a high standard of quality and dependable value. For economy and satisfactory service wear shoes that bear this trade-mark.

Stamping the retail price at the factory

W. L. Douglas
 PRESIDENT



W. L. Douglas CORFLEX
 for Women

Made of a fine grade of Brown Kid, also Black Kid, in Blucher Oxford pattern. A very neat model of the corrective type with splendid fitting qualities. The corset effect gives COMFORT and SUPPORT to the ARCH. Exceptional service at a low price. \$7.00.



Campus

A bright tan Russia Calf Oxford for Men on a wide brogue last. New, attractive pattern with black stitching and eyelets. Patent Leather Cork Welt and trimming around top; rolled heel. A smart, up-to-the-minute style for Spring and a wonderful value. \$8.00.

W. L. DOUGLAS name and the retail price are stamped on the soles of every pair at the factory. The value is guaranteed and the wearer protected against unreasonable prices.

W. L. DOUGLAS shoes are demanded by more people than any other shoes in this country. They are put into all of our 116 stores at factory cost. We do not make one cent of profit until the shoes are sold to you. It is worth dollars for you to know that when you buy shoes at our stores **You Pay Only One Profit.**

NEVER have you had the opportunity to buy such wonderful shoe values as you will find in W. L. Douglas \$7.00 and \$8.00 shoes in our retail stores in the principal cities and in good shoe stores everywhere. If you do not live near one of our stores, ask your shoe dealer for W. L. Douglas shoes. If he cannot supply you, write for catalog showing how to order shoes by mail, postage free.

W. L. DOUGLAS SHOE COMPANY

128 Spark Street, Brockton, Mass.



SAW FILING PAYS

Buy a Foley Saw Filer and Setter and establish an independent, profitable business. Prices and catalog on request. Territory open to interested parties.

FOLEY SAW TOOL CO.
 3613 Portland Ave., Minneapolis, Minn.



RANGER \$5 a Month

Finest bicycle built—44 styles, colors and sizes. Factory to Rider prices FREE delivery, express prepaid on 30 days Free Trial. Cash or easy pay 'ts.

TIRES lamps, wheels and equipment at half usual prices. Send no money. Write today for big catalog, special Factory Prices, free trial plan and marvelous offers.

MEAD CYCLE CO. Dept. CHICAGO
 L-108

ALL-WOOL

**3-Piece Fancy
Serge
Suit**

Brown
or
Blue



Only
\$100
DOWN
6 Months to Pay
Total Price \$22.50

This is a wonderful opportunity for you get in on one of greatest values ever offered.

These suits are thoroughly shrunk, hand tailored, cut and made under the best of supervision and carefully selected pattern and styles. You get not only the All-Wool Guarantee, but we also guarantee each suit to fit you perfectly. Worth more than we are asking on this Special Introductory Offer.

These suits are all wool Whitman worsted Business men's model — three piece—coat, pants and vest. The coat is cut in the most conservative and dignified three button style. Easy fitting, full lined, medium weight for all seasons. Vest has 5 buttons and no collar. Pants can be worn with or without belt. Sizes 34-46 breast; Trousers 29-46 inch waist.

Order by No. 5742.
We have this same suit in the young men's style — latest model and very snappy — as shown in upper left hand corner. A two button, narrow shoulder, form fitting coat, full lined. Pants made for belt only. Vest cut regular. Sizes 34-42 breast measure. Trousers 29-42 waist. **Order by No. 5743.** Both suits in navy blue or brown. We always send brown unless you state color wanted.

Pants may be had with or without cuffs
State size of suit if you know it—if not, be sure to give your weight, your chest measure, taken over vest for coat. Waist and in seam measure for Trousers.

Special Offer

Doubles Life of Your Suit!

With every order for a suit received from this advertisement, we will send an extra pair of pants like your suit **AT COST, only \$5.** This does not increase amount you pay per month.

Order Today!

You can't afford to miss this chance to get a high-grade, all-wool worsted suit, at this astounding bargain price. If you are not absolutely satisfied your money will be cheerfully refunded. If satisfied you have 6 months in which to pay. Fill out the coupon and mail it with just one dollar. **ORDER TODAY!**

Babson Bros., 19th St. and Marshall Blvd., Dept. 13-54 Chicago

Enclosed please find \$1.00. Send me the three piece Whitman worsted suit at advertised price. If I am not satisfied when I receive the suit I can return it and get my money back. If satisfied, I will pay the advertised rate of \$22.50, payments to be made \$4.00 monthly. I understand extra trousers will be \$5.

My weight is..... Extra Trousers (check) My measurements are:
Coat (chest over vest.....) Trousers (waist..... inseam.....)
Color desired (check) Navy blue Brown Trousers (check)
Order No. (check) 5742 5743 with cuffs without cuffs

Name.....

Address.....

City..... State.....

Age..... Occupation.....

STOP That Tire Thief with a **TEMCO Spare-Tire Lock**

You may think your "spare" is safe. It is until some thief comes along with a pair of heavy snips, and then—! But why court such loss? A **TEMCO Lock** will stop all worry by protecting your tire from theft. A specially designed malleable housing bolts to carrier lug and the heavy brass locking cap. Tumbler-Type lock makes it impossible to remove tire without the proper key. Temco Tire Lock can be used on Buick, Dort, Durant, Ford, Haynes, Maxwell, Nash, Oakland, Overland, Patterson, Willys Knight and many more.

PRICE \$3.00 ONLY

Get this tire protection **NOW!** Head today! Lock mailed parcel post on receipt of price and dealer's name.

Jobbers and Dealers! Help your customers protect their tires with Temco Tire Lock! Write for discounts; also complete information on Temco Portable Electric Drills, Grinders and Drilling Stands. Been making them since 1910.

**THE TEMCO
ELECTRIC MOTOR CO.**

1604 Sugar St., LEIPSIK
OHIO



RE-MANUFACTURE FORDS
Start a FORD Service Station
The **MOST PROFITABLE BUSINESS ON EARTH**

FORDS REMANUFACTURED BY THE FACTORY PROCESS

SQUARE DEAL GARAGE



\$14,355.00 Profit on 300 Jobs
Facts and figures from hundreds of KRW Equip Shop Records.

9,000,000 Fords Need Repairs

Are you getting your share of that business?

\$850 Completely equips your shop to RE-MANUFACTURE Fords

We can furnish entire equipment for cash or on easy payment plan. Ford Motor Co. recommend these tools. Catalog. **K. R. WILSON, 12 Lock St., Buffalo, N. Y.**

21 Jewel Burlington



Only \$1.00 Down

The 21-Jewel Burlington is sold to you at a very low price and on the very special terms of \$1.00 down—free examination—small monthly payments with acceptance. Send today for information.

Free Book Send for the most complete watch book ever produced. 100 designs and engravings beautifully illustrated in colors. Write for it today, it is free. A letter or a postcard will do.

Burlington Watch Company 19th St. and Marshall Blvd. Dept. 13-54 Chicago, Ill.

PAUL REVERE BICYCLE

A sturdy dependable Bicycle—all workmanship and parts absolutely guaranteed for five years. 7 models to choose from. 12 months to pay. Express charges prepaid. Beautiful catalogue free. Agents wanted.

MYEROW BROS.
15 Berkeley St., BOSTON, MASS.

DRESS UP \$3.85 YOUR CAR
AND UP CUSTOM MADE A seedy looking topspoils its appearance. Get a Liberty Custom Made Top. It's fun putting it on; simple directions furnished. Save a big labor bill. We are manufacturers of tops, side curtains and seat covers, for any make or model car. Amazing values. Special proposition for Fords, Chevrolets, Dodges and Maxwells. Write today for big money saving catalog.

Liberty Top & Tire Co., Dept. E-7, Cincinnati, Ohio

\$75.00 CASH WEEKLY also Guaranteed Salary

Sure income; pleasant, easy. Experience not essential; the demonstration makes the sale. Many buy on sight; sell our marvelous electrical device, brings health and beauty to all. Endorsed by leading doctors and plain folks. MEN and WOMEN earn big money, spare time or all time. We guarantee salary to experienced producers. Commissions very liberal paid in cash. We deliver and collect. Exclusive territory to workers. A push-over for quick money, steady income.

VI-REX CO. 211 S. PEORIA ST. CHICAGO
Dept. A-40

MAKE YOUR FORD INTO THIS SPORT CAR—SAVE \$50 to \$150 with Red-i-Kut Life-Size Pal! Patterns \$9.99

Famous **Red-i-Kut** Life-size patterns and picture instructions show you sure-fit how you can easily convert your Ford into this **Fast, Saucy, Sport Car** as thousands have done with easily obtained materials. No need to lay up the car. **LOOK AT WILFRED ENO'S PAL!** Eno says, "Total cost of car with steel and paint for my Pal only \$17.51. It took me just 5 Sundays to build it and I sure am proud to hear them say, 'He built that saucy sport car. I never cut any steel or did any woodwork before but one can't go wrong with Kuempel patterns.' Overland City, St. Louis, Mo."



"The red-headed young man who loves a car that will get up and go, a car low and rakish in line and snappy in appointments, picks the 'Pal'. With its easy rolling 38 inch seat and sweeping line it's a ten strike—bar none."

SPECIAL OFFER

Easy-to-Understand Instructions and Tail Delivered

on "All Weather Pal"—Life size patterns for each part of the "Pal" body as you can't go wrong. Picture instructions, conical disk wheel patterns and pressed Steel strapping rear; **GoSum Windshield** patterns with stormproof feature and Airway Control current board controlled Ventilator patterns with instructions; **Riffy Top** patterns with storm and fly curtain patterns—easily made—folds and slides into the body—makes your "Pal" warm and comfy. All complete and delivered for \$9.99 if you order at once. Think of it, with this outfit you can make your Ford into this "All Weather Pal" and be the talk of the community. "Pal" set of "R. K. O." steel for all sheet steel parts of the body and disks for the wheels—Good 22 gauge stuff—shipped from warehouse shop near you only \$9.51; extreme south and west \$11.99. "Pal" body patterns only with pressed metal tail delivered \$6.43.

Garagemen make big money converting Fords into classy Kuempel Sportsters Order now while we can make good delivery, and really enjoy the wonderful spring days in your "Pal". **Keen, Classy, Up-to-the-minute. You can build it. Over 11,000 in use. Don't hesitate.** "Swing Lo" Underling Irons, no frame cutting kind, only \$7.81. Send 5c coin for new manual of other distinctive sport body patterns from \$2.50 up—**RKO**—"Steel" Spring-Lo" Irons, "Quick-Get-Away Gear", "Riffy" Tops and "GoSum" Windshields. Order Now.

KUEMPEL COMPANY

Founded 1916 47 Kuempel Bldg., Guttenberg, Iowa

"Have finished the 'Pal'. It's a some jazz boat. I go where a goat can't or where others fail I go on. I can run thru mud on high where others can't go on low. Here by a picture. I am so proud. I am called the 'Ace' of Fords for I skip by them all, just like a rabbit." Cal Fettero, Colmbia, Ky.

SENSATIONAL SALE

GUARANTEED TYPEWRITERS



\$1 DOWN
Balance on
Easy Terms

This is the famous L. C. Smith typewriter which has set the world's standard for quality and service for over twenty years. Perfect machines, Standard size, Keyboard of Standard Universal arrangement, 42 Keys, writing 84 characters—universally used in teaching the touch system. The entire line of writing completely visible at all times; has the tabulator, the two color ribbon, with automatic reverse, the back spacer, ball bearing type bars, ball bearing carriage action, ball bearing shift action. This ball bearing construction makes it much easier to learn operating on the L. C. Smith than any other typewriter. Also it gives unlimited speed—beyond the limits of human possibilities. Every late style feature and modern operating convenience. Comes to you with everything complete: tools, cover, operating book and instructions—nothing extra to buy. You cannot imagine the perfection of this beautiful typewriter until you have seen it. We do the most perfect and highest class job of rebuilding known to the typewriter industry. We have sold thousands of these perfect late style machines at this bargain price and every one of these satisfied customers had this splendid, strictly up-to-date machine on five days' free trial before deciding to buy it. We will send it to you F. O. B. Chicago for five days' free trial. It will sell itself, but if you are not satisfied that this is the greatest typewriter you ever saw, you can return it at our expense. You won't want to return it after you try it, for you cannot equal this wonderful value anywhere.

FREE COURSE OF INSTRUCTION in the Touch System of typewriting given with every order. The best and quickest method of learning. Specially adapted to the L. C. Smith.

FREE BOOKLET giving description of this machine and other models, also Valuable Typewriter Information, sent on request.

Only \$1.00 down, then a few dollars a month and the machine is yours. This is absolutely the most generous typewriter offer we ever made. Why rent a machine when your rent money will buy one? Think of it—buying a perfect, late model highest grade \$102.50 Typewriter at a bargain price.

The Famous L.C. Smith Ball Bearing

Just send \$1.00 with the coupon and the machine will be shipped at once. Then after 5 days if you are convinced that it is the best typewriter you ever saw, keep it, send us \$4.15 and then send us \$4.00 a month until our bargain price of \$57.15 is paid. All cash, \$53.05, just a little more than half its original price.

FREE TRIAL
If you don't want it, return it and receive your \$1.00 back. We will pay the return express charges. This machine is guaranteed just as if you paid \$102.50 for it. It is standard. Over a half-million people own and use these typewriters and think them the best ever manufactured. The supply at this price is limited; the price will probably be raised when the next advertisement appears, so don't delay. Fill in the coupon today—the typewriter will be shipped promptly. There is no red tape. We employ no collectors—no chattel mortgage. It is simply understood that we retain title to the machine until full \$57.15 is paid. You cannot lose. It is the greatest typewriter opportunity we have ever offered. Get the coupon in the mails today—SURE.

SEND NOW—BEFORE THEY'RE GONE

SMITH TYPEWRITER SALES CO.
300-360 E. Grand Ave., Chicago, Ill.

Send This Free Trial Coupon NOW

SMITH TYPEWRITER SALES CO.,
300-360 E. Grand Ave., Chicago, Ill.

I enclose \$1.00 as evidence of my good faith. Ship me the L. C. Smith Model No. 5, F. O. B. Chicago. After five days' trial I will send you \$4.15 and then \$4.00 per month thereafter as rent until the \$52.00 balance of the Special \$57.15 sale price is paid. The title to remain in you until fully paid for. It is understood that I have five days in which to examine and try the typewriter. If I choose not to keep it, I will carefully repack it and ship it back to you and you will return my \$1.00 deposit. It is understood that you give the standard guarantee.

Name..... Street.....
City..... State..... Business or Employer.....
Two References.....

"What a whale of a difference
just a few cents make!"



— all the difference
between just an ordinary cigarette
and—FATIMA, the most skillful
blend in cigarette history.

POPULAR MECHANICS Shop Notes Book FOR 1924 IS READY

Send for your copy today. Like its predecessors, this volume is packed full of **Easy Ways to Do Hard Things** that are of daily use to every mechanic. The entire collection of 550 Shop Notes articles that appeared in Popular Mechanics Magazine during the past year is now offered to you in this one handy volume, conveniently indexed. **50c Postpaid**
Bigger and Better than Ever 248 Pages—455 1 Illustrations. If you have at hand for quick reference a set of Shop Notes consisting of 15 volumes previously issued, you will seldom, if ever, **GET STUCK ON A JOB.** You cannot afford to be without these helpful books any longer. The several thousand time and labor-saving kinks will save you the price of 50 cents a volume many times over. Make this a red-letter day of preparation for increased efficiency by mailing us your order for a set of the books.

POPULAR MECHANICS BOOK DEPARTMENT, 200 East Ontario Street, CHICAGO

500 PUNCTURES Yet Leaks No Air

We Want Agents

A new Puncture Proof inner tube has been invented by Mr. M. H. Milburn of the Milburn Puncture Proof Tube Company, Chicago. In actual test it was punctured with 500 nail holes without the LOSS OF AIR. This amazing new inner-tube increases mileage from 10,000 to 12,000 miles; eliminates changing tires and makes riding a real pleasure. Many users have run over 20,000 miles without removing a tire from the wheel.

These wonderful, no-trouble, puncture proof inner tubes cost no more than ordinary tubes and Mr. Milburn wants agents everywhere to help him introduce them.

CAR OWNERS WANTED

To sell and demonstrate this wonder tube. Interests everyone immediately. Automobile owners buy on sight. It makes no difference what car they drive or what tires they use. Our salesmen are coining money on our "DIRECT FROM FACTORY" scheme of selling. Absolutely no competition. We control all basic patents. No capital required to start. Previous selling experience not necessary.

EARN \$5,000 to \$10,000 A YEAR

Read What These Men Say

J. D. Cooper—"I have made 30,000 miles with my Milburn Puncture Proof Tubes and have not as yet removed a rim or casing and my casings are still in excellent condition."

J. C. Jerves—"I sold 50 Milburn Tubes in the first three days."

Chas. Cayton—"I sold twelve tubes yesterday in ten minutes."

L. S. Knapp—"My first few hours out I sold eight tubes, no trouble at all to sell them. The most wonderful tube on the market today, I think. I am hoping you will give me the agency for a big territory."

D. Edelere—"I have driven seventy-five miles in one of the 30x3 tubes and twenty were spike nails. It has gone above the test that you recommended to me it would do."

Earn \$5,000 to \$10,000 yearly or more. Get into business for yourself. Sell Milburn Puncture Proof Inner Tubes. Every car owner is a prospect. Your field is unlimited. Get in while it is good. Be independent. Find out all about it now and get started at once. Then you will be ready to make big money when the heavy spring selling season starts.

FREE TUBE SPECIAL FREE TUBE OFFER

Send coupon or write today for special free tube offer and further details. References, Industrial State Bank of Chicago, National Bank of the Republic, Chicago, Baker State Bank of Chicago. Don't hesitate. Fill out the coupon and send it in or write and send name and we will send you all details. This is your opportunity so don't delay. Address

M. H. MILBURN, Pres.

Milburn Puncture Proof Tube Co.

331 West 47th Street
CHICAGO, ILLINOIS

MILBURN PUNCTURE PROOF TUBE COMPANY
331 West 47th Street, Chicago, Illinois

I am interested in Puncture Proof Tubes. I can get a share of the profits without objection from the Milburn Puncture Proof Tube Company. I am interested in Puncture Proof Tubes. I can get a share of the profits without objection from the Milburn Puncture Proof Tube Company.

Name _____
Address _____
City _____
State _____



Look for the name
on the carton

Insist on Cunningham Radio Tubes
—there is no higher Quality

THE primary purpose of a trade name is to identify a product or firm in the mind of the buyer. Ask the next Radio enthusiast you meet to state one of the best known names identified with Radio and he will say: "Cunningham."

The presence of the word "Cunningham" on Radio Tubes tells the character and quality of this product — the ideals, engineering skill and service given to the Radio field since the year 1915 by E. T. Cunningham, Inc.

It is the radio tube that has made possible the broad and far reaching application of radio telephony, and that plays the most important part in the operation of your Radio Receiving Set.

Cunningham Radio Tubes, standard for all makes of receiving sets, built by one of the world's largest manufacturers with unlimited resources, are the product of years of manufacturing experience and the creative genius of the engineers of the great scientific organization, the Research Laboratory of the General Electric Co.

Patent Notices Cunningham tubes are covered by patents dated 2-18-08 and others issued and pending. Licensed for amateur, experimental and entertainment use in radio communication. Any other use will be an infringement.

The care and operation of each model of Receiving Tube is fully explained in our new 40-page "Radio Tube Data Book." Copies may be obtained by sending ten cents to our San Francisco office.

New Prices on Cunningham Tubes Now in Effect

C-301A—5 Volts 1-4 Ampere filament	\$5.00
C-299—3 Volts .06 amp. Dry Battery Det. and Amp.	\$5.00
C-300—5 Volts Gas Content Detector	\$5.00
C-11—1.1 Volts .25 amp. Dry Battery Det. and Amp. Special Base.	\$5.00
C-12—Similar to C-11 with standard base.	\$5.00

E. T. Cunningham Inc.

Home Office
182 Second St. 154 W. Lake St. 30 Church St.
SAN FRANCISCO CHICAGO NEW YORK

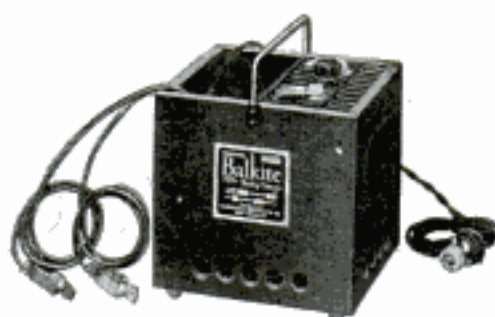

FANSTEEL
Balkite
PATENTS APPLIED FOR *Battery Charger*

Noiseless and Indestructible

A new battery charger for Radio "A" (6 volt) batteries. Entirely noiseless. Has no moving parts, requires no attention or adjustment, and cannot get out of order. No bulbs to break. Simple and unflinching in action. Can be used while the radio set is in operation. A positive economical charger for home use. Can also be used to charge automobile batteries. If your dealer can't supply you, sent direct on receipt of price. Money back guarantee.

Price \$18 (\$18.50 West of Rockies)

Dept. P7 Fansteel Products Co., Inc.
North Chicago, Illinois

CATALOG E19-100
PAGES
FREE

LATEST REFLEX AND NEUTRO DYNE CIRCUITS
One of the largest complete stocks in the world.

DEALERS ALLOVER THE U.S.

Making big profits handling our supplies. 24-hour service. Goods shipped same day order received.

AMERICAN RADIO MFG. CO.

WHOLESALE DISTRIBUTORS
Dept. O, 6 W. 14th St. KANSAS CITY, MO.

THE TRINITY LOUD SPEAKER

The only device of its kind in the radio field.

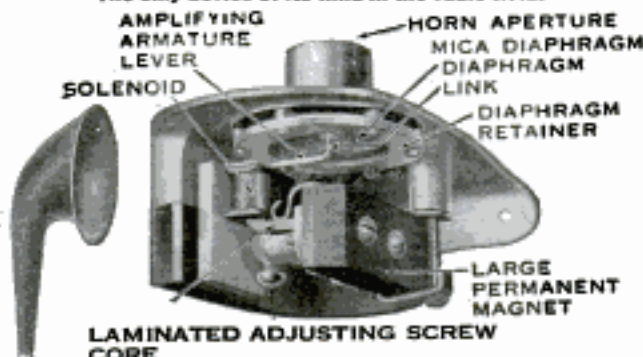

TYPE B \$12.50

Study the illustration carefully and you will understand why it produces full, clear natural tones with perfect reproduction of all vocal and instrumental music. May be used with phonograph or built into your set.

TRINITY RADIO CORPORATION
446 TREMONT ST., BOSTON, MASS.

FERBEND
Wave Trap

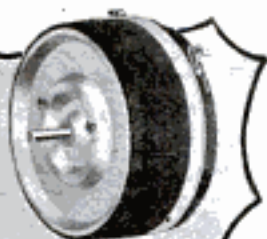

**An Entertaining Program
Brr-rr-rr? !
Another Station Spoiled Again!**

How many times have you been disappointed when listening to your favorite station or some especially good program because some other station interfered and drowned it out? Provoking, isn't it? It is no longer necessary to be bothered with this continual annoyance. The FERBEND WAVE TRAP tunes out any interfering station. It makes your set highly selective and allows you to hear stations that would otherwise be lost entirely.

Radio fans all over the country are taking to this easy inexpensive way of putting their fingers on the stations they want—the stations they enjoy. Hundreds of users report very gratifying results. We have hundreds of unsolicited testimonials. Equip your set with a FERBEND WAVE TRAP and stop being double-crossed by some innocent but offensive station. The FERBEND WAVE TRAP is mounted on formica panel in mahogany finished cabinet 6x5x6. Beware of imitations.

Order Direct

Just send your name and address, and pay Postman \$6.00 (plus postage) for the unmounted or \$8.50 (plus postage) for the mounted Wave Trap. If you prefer, send cash in full with order and we will ship postage prepaid. You take no risk, so order today.

Any Night is "Silent Night" with a FERBEND.

FERBEND ELECTRIC CO.
15 E. South Water Street, CHICAGO

FREE Radio Text Book and Catalog
A Post Card Brings It

**CONTAINS 75 VACUUM TUBE
HOOK-UPS
300 ILLUS. 500 RADIO ARTICLES**

All Armstrong Circuits: These important circuits are explained clearly, all values being given, leaving nothing to puzzle you.

Also 75 full, clear diagrams, explanations and instructions for all important vacuum tube circuits, from the simplest to the most advanced. How to make a wave-trap—how to increase wave length of set—serial data—tube data—battery data—reflex—regeneration—radio amplifiers—audio amplifiers—loud speakers—tables of component parts, and endless other radio subjects covered in simple, understandable way.

The 75 diagrams in book form alone would cost you \$3 to \$5. Get this all FREE. Send for it right away. Offer limited.

RADIO SPECIALTY COMPANY, 98 E. Park Place, N. Y. City



**FROST-RADIO
Catalog and
Instruction Book**

THIS new booklet on the care and operation of **FROST-FONES** and **FROST-RADIO** is now ready. Contains 36 pages of valuable information on radio apparatus. Your copy mailed free on request.

Address Dept. 14F62

Herbert H. Frost, Inc. FREE!
154 West Lake Street
CHICAGO, ILLINOIS



A post card from you will bring this 40-page catalog.



**Nature's Rogue
Gallery**

No. 1—The Crow

You can detect the criminals of nature by the tell-tale marks they leave. These are crow tracks—a destructive pest who pulls corn, and steals eggs and fruit. Keep this picture and use it in hunting birds and beasts of prey that destroy our crops and song birds.

**Stevens Junior—20-inch
barrel—military stock.
Shoots .22 short, long,
or long rifle. Only \$4.50.**



**A Stevens
will always
bring them down**

CROWS, squirrels, rabbits—doesn't make any difference—if you hold right you'll get them with a Stevens.

Just take the new **Stevens Junior** for example—a real honest-to-goodness rifle with a barrel that is rifled to less than a *thousandth of an inch* in accuracy—no wonder it shoots straight!

*And you can get this rifle
for \$4.50*

Whatever model you use—the old Favorite, the smooth working little **Visible Loader .22 Repeater**—you can always count on one sure thing—that if it's a Stevens it *does shoot straight*.

Ask some of the men or older boys around your neighborhood about Stevens—they know. You'll find men today who have been shooting the same Stevens for ten or twenty years and still swear by it for accuracy and hard hitting.

Drop in at your dealer's and take a look at these Stevens rifles—or write us today for interesting catalog. You won't find anything like them for accuracy, sturdiness and price.

J. STEVENS ARMS COMPANY

Dept. 559, Chicopee Falls, Mass.

Owned and Operated by the Savage Arms Corporation

Stevens

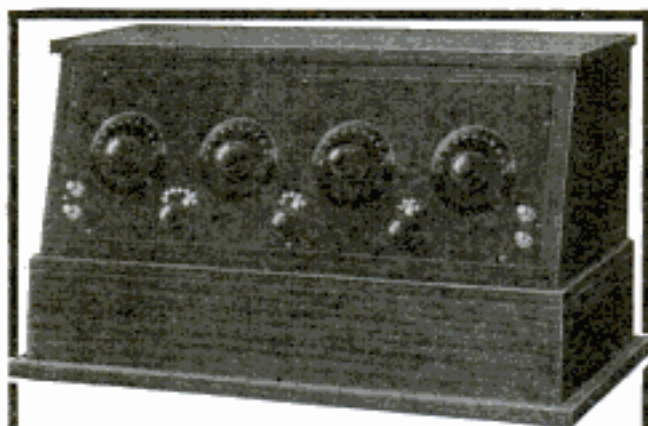

MAKE MONEY—SELL RADIO!

Radio offers the biggest money-making opportunity on earth today. And the Ozarka Plan opens the door to this big opportunity. Look at the picture of this beautiful Radio Receiver. This picture was made from an actual photograph. By the Ozarka Plan that Radio Instrument can be the product of your own making—easily, simply and surely. It will be yours to make, to sell and to reap a rich reward in cash profits.

No experience necessary. You need not have much cash. All you need is spare time, determination and action. If you're that kind of a chap, the Ozarka Plan will start you on a straight line toward a real money-making business of your own. It can be as big and as profitable as you are ambitious to make it. We want good men in every county. Exclusive territory is going fast. Be sure and give us the name of your county. Write today for the Ozarka Plan. A wonderfully interesting book, of facts, particulars and proofs. It is FREE. Act now.

OZARKA, INC.

851 Washington Blvd.

CHICAGO

AGENTS

Make \$10 to \$20 daily selling Premier Knife and Scissors Sharpeners.



200% PROFIT or more. 9 out of 10 women buy. Produces keen edge quickly. Sells for 50c.

PREMIER MFG. CO.
Dept. 29, DETROIT, MICH.

Your Radio Set needs SOLDERALL

a real metal solder in paste form

Ready for instant use



25¢

Solders All Joints
INSURES CLEAR RECEPTION
On Sale at All Dealers

The **SOLDERALL CO.**
NEWARK, N.J.

YOU DON'T NEED TUBES

to receive concerts from Distant Stations.
You can hear them on

YOUR CRYSTAL SET

If you fix it up the right way. You may already have everything you need and just have it connected up wrong. People using my methods hear programs clearly from stations

400 TO 1000 MILES AWAY

No Tubes, Batteries or Amplifying apparatus required. No Special Crystal Necessary. Changes often cost less than a dollar. Picture of my set and further information free. Write me today.

LEON LAMBERT, 539 So. Volusia St., WICHITA, KANSAS

Rings Bells Without Batteries

Avoid the annoyance of having bells out of order. At a nominal cost you can install this little device which will ring electric bells, buzzers, annunciators, electric heat regulators, door-openers, etc., from the same current that lights your home.

ONLY \$2.00
Canada \$3.00

Bell Ringer Transformer

Connects direct to lighting-current, and eliminates forever the use of troublesome dry batteries. Does not use enough current to register on meter. Buy it from any electrical dealer, or we will send it anywhere postpaid upon receipt of price. Your money back if you are not satisfied.

JOBBER, DEALERS, AGENTS—Write for selling proposition.

AIR-WAY ELECTRIC APPLIANCE CORPORATION
Toledo, Ohio

Save 1/2 Cost of New Tubes

VACUUM TUBES REPAIRED

Guaranteed equal to new. Send in your burned out or broken tubes by P. P. All repaired tubes returned P. P., C. O. D. We try to repair and return within 48 hours.

Harvard Radio Laboratories
200-204 Old Colony Ave., So. Boston, Mass.

Price Over \$29.50

MIRACO GETS 'EM FROM COAST TO COAST

At rock-bottom prices you get the efficiency of sets costing three times as much. Users tell us that Miraco Radio frequency receivers pick up stations from coast to coast. Operate either on dry cells or storage battery. Solid mahogany cabinets—finest workmanship throughout. Order direct or send for bulletin.

Two tube outfit . . . \$29.50
Four tube outfit . . . \$4.50

DEALERS—AGENTS—Write for proposition quickly—It's a winner

THE MIDWEST RADIO COMPANY
807 Main Street, Cincinnati, Ohio

Morrison



Loud Speaker MORRISON

is a name identified with all that is fine in a loud-speaking unit—for phonographs and horns. Everywhere, those who appreciate really good radio know they can depend on Morrison to bring out, consistently, the very best in radio reception.

These Are the Reasons:

Morrison Loud Speakers are manufactured by skilled radio workers in a laboratory ideally equipped. Quality is never sacrificed, either in material or workmanship. Every unit is triply tested before shipment. Thus Morrison Loud Speaker maintains its front rank in the field of radio.

Nickel Plated Model
\$10.00

Complete with a five-foot cord.

Send for an Illustrated Descriptive Catalog.

Distributors: There are several territories still available. We are interested in securing proper representation.

Jobbers—Dealers: Our plan of merchandising has been profitable to many jobbers and dealers—if you are interested, write or wire for details.

MORRISON LABORATORIES, Inc.
337 Jefferson Ave., E. DETROIT, MICH.



Branston D. L. Honeycomb Coils and Geared Back and Front Panel Mountings BEST for SELECTIVE TUNING

Superior construction and venier adjustment give better results in your set. Licensed under DeForest Patents. Send 2c for new Radio Manual with 5 Honeycomb Coil "Hook-ups."

CHAS. A. BRANSTON, Inc.
819 Main St. Buffalo, N. Y.
In Canada—Chas. A. Branston, Ltd., Toronto

SELL US A PRACTICAL IDEA

of some new and useful WAY to utilize Pressed Metal in place of other materials. The undersigned pays cash for every acceptable suggestion approved by our Engineering Advisory Board. Free book gives you the facts.

PRESSED METAL TRADE COUNCIL
27 QUINCY STREET, SUITE 1705, CHICAGO

\$14.95 Suit

Made to Order Now

SEND NO MONEY To introduce unbeatable values, classy style, perfect fit of PROGRESS tailoring we offer, for \$14.95 tailored to measure any style suit of your choice, delivered post-paid. We Guarantee Satisfaction or Money Back. Other wonderful values up to \$39.50.

AGENTS WANTED Earn \$9 to \$18 Daily spare time showing our samples to friends and neighbors, we explain how, no experience needed. Big Outfit, agent's wholesale prices, real wool pieces, fashion styles, tape measure, etc. Complete outfit and simple directions **FREE** **FREE** **SAMPLES**



The PROGRESS TAILORING CO. Dept. D-145 CHICAGO

\$14.24 DOWN



All Sizes: 2 to 25 H-P.

Puts the Famous WITTE Throttling ENGINE to Work for You

NOW the famous WITTE Throttling-Governor Engine, complete, Magneto-equipped, is within the reach of everyone—you can show a profit of \$500 to \$1,000 every year you have this rugged dependable engine at work. Known as the standard of cheap, dependable power for over 40 years, this WITTE Engine

Uses All Low- Priced Fuels BURNS KEROSENE, GASOLINE, DISTILLATE or GAS. No Special Attachments necessary. Most economical engine built but always delivers the big surplus of power needed for the hardest jobs. Simple to operate and trouble-proof. Guaranteed for a life-time of hard work. Equipped with the celebrated Wico Magneto—the best system of high-tension, jump-spark ignition known. Starts easily at 40 below zero—not affected by water or oil. Only one moving part—can't get out of order. Economical and far better than the old-style batteries.

SOLD DIRECT TO YOU

I sell the WITTE direct to you—no salesmen. Save 20 to 40 per cent and make your own terms on the easy payments.

WRITE TODAY FOR MY NEW ENGINE BOOK

Get my new free book that tells all about this remarkable engine and details of my **Ninety-Day Free Trial Offer**.

SEND COUPON— Wonderful illustrations, with state-
NO OBLIGATION ments from many of my 100,000 users, and full of engine information you should have.
—ED. H. WITTE, Pres.,

WITTE ENGINE WORKS

1748 Witte Building, Kansas City, Mo.
1748 Empire Building, Pittsburgh, Pa.

Ed. H. Witte, Pres., WITTE ENGINE WORKS,
1748 Witte Bldg., Kansas City, Mo.
1748 Empire Bldg., Pittsburgh, Pa.

Without obligating me in any way, please send me your new Engine Book and full details of your remarkable offer.

Name

Address

City.....State.....

Don't Send 1 Penny

USKIDE SOLE

SPRING-STEP
\$2.98
and \$3.48

Shoes Guaranteed to wear 6 months

Greatest Comfort—Men and Boys

We guarantee the shoe pictured above to wear six months, and will send you a new pair of shoes if they do not. The shoes are made on comfortable Munson last in army blucher style, with flexible, weather-proof leather upper, new double-wear Uskide soles and U. S. rubber heels. Solid leather innersole. Soft broad toe. These are the sturdiest shoes ever made. We are making this remarkable offer to introduce the shoe department of the Walter Field Co., and at the same time, to show you what wonderful wear Uskide soles will give.

COLORS—Brown or black. Wide widths.
No. 63—Boys' sizes, 1 to 5½. Price \$2.98.
No. 64—Men's sizes, 6 to 11. Price \$3.48.

Order Now—Delivery Free

Just send your name and address—no money. When the postman delivers the shoes at your door, pay him the price listed above. We have paid the delivery charges. If, for any reason whatsoever, the shoes are not better than you expected, return them at our expense and we will cheerfully refund your money. If, at any time within six months, these shoes wear out, we will send you a new pair free of charge.

WALTER FIELD CO., Dept. D1587, CHICAGO

LYON BODIES

Send For Our 1924 BOOK OF BARGAINS

Containing a full line of bodies and accessories at exceptionally low prices. Buy direct from the factory.

AUTO TIRE SALES CO.

Body Division Dept. P13
 1346 S. Michigan Ave., Chicago

\$27.50 AND UP

Murdock Radio Phones are built, not assembled

MURDOCKS are unsurpassed for efficiency. They are made in a single unit, of superior moulded insulation. The whole is moulded together—thus assuring firmness, strength, durability and maximum service. Other important features of Murdock Radio Phones are—powerful magnets and perfect diaphragm adjustment. This gives wonderful volume and clearness.

Get a Murdock today and test it out. They are fully guaranteed. Send for booklet. Wm. J. Murdock Co., 349 Washington Ave., Chelsea, Mass.

At your nearest dealer
MURDOCK PLUG JACKS

An excellent multiple plug that permits the use of one to four phones at the same time. Get one—and let the whole family listen-in.



Saves You 50%

2-Year Unconditional Guarantee

SILVER-S BATTERY

with genuine **AHLBELL NEVERLEAK** solid rubber case. Half price on this non-leakable Guaranteed Superior Quality Storage Battery. One-piece indestructible case can't leak, rot, spill or injure rugs or clothing. Read these prices.

5% Discount for Cash in Full with Order

AUTO PRICES		RADIO PRICES	
6-V, 11 Plate, .	\$13.00	6-V, 100 Amps. .	\$13.50
6-V, 13 Plate, .	15.00	6-V, 120 Amps. .	15.50
12-V, 7 Plate, .	18.00	6-V, 140 Amps. .	17.00

Read our 2 year unconditional Guarantee before you pay a cent. Battery shipped C. O. D. express subject to your approval. Send name and address and style wanted **TODAY**.

SILVER-S BATTERY CO., 201 E. Ontario St., Dept. 53 Chicago

PLANS for Poultry Houses

All styles, 150 illustrations, secret of getting winter eggs, and copy of "The Full Egg Basket." Send 25 cents. **INLAND POULTRY JOURNAL, Dept. 74 Indianapolis, Ind.**



Dhassi Will Tell You FREE

Do You Know Under which zodiac sign you were born? What significance it has in shaping your life?

Are You Lucky? IN LOVE MARRIAGE FRIENDS INHERITANCE SUCCESS

Send Birth Date

I have made Astrology my life's work and offer the most interesting astrological interpretations of the Zodiac sign under which you were born. Send exact name, address and

exact date of birth in own handwriting and receive your astrological interpretation in plain sealed envelope, post paid. A great surprise awaits you. Enclose 12c to cover cost of this notice and mailing. Address me personally **DHASSI**.

TARA STUDIO, 1133 Broadway, Desk 44-A, NEW YORK

LOFTIS
BROS. & CO. 1838

DIAMONDS WATCHES

Genuine Diamonds Guaranteed
CASH OR CREDIT



"Sylvia"
Diamond Ring
Blue white,
radiant,
perfect
cut Diamond.
The ring is 18-k
solid White Gold
\$100



Loftis
Carved
"PERFECTION"
Diamond Ring
Blue white,
perfect cut
Diamond
\$75



"No. 1
Special"
Diamond Ring
Brilliant Dia-
mond, blue white
and perfect cut.
Ring is 18-k Solid
White
Gold **\$50**

Terms: \$10 Down, \$2.50 a Week

Terms: \$5.00 Down, \$1.25 a Week

Loftis Carved "Perfection" Ring. Special at \$75. Terms: \$7.50 with order or on delivery, then \$1.75 a week. Also up to \$2,500.

SEND FOR CATALOG

Over 2,000 Illustrations of Diamond-set Jewelry, Watches, Wrist Watches, Pearls, Mesh Bags, Silverware, etc. Select as many articles as you wish and have all charged in one account. Sent prepaid for your Free Examination. Send for catalog.

High-grade Railroad Watches
Guaranteed to Pass Inspection

HAMILTON No. 992, 21 Jewels, Adjusted \$55
to 4 Positions, Gold Filled 25 Year Case

ILLINOIS "BUNN SPECIAL," 21 Jewels, \$50
Adjusted to 6 Pos. Gold Filled 25 Year Case

ELGIN'S LATEST RAYMOND, 21 Jewels, \$55
8 Adjustments. Runs 40 hours one winding

17-Jewel ELGIN

Rectangular Wrist Watch
18-k White Gold, 17 Jewels, \$29.75, 14-k, 15 Jewels, \$24.85.
Yours for \$3.00 down then \$1 a week until paid.

Money Back if not Satisfied

LOFTIS BROS. & CO.
National Jewelers
DEPT. M 894
108 N. State St., Chicago, Ill.
Stores in Leading Cities

No. 15—Green Gold, engraved, assorted patterns, guaranteed 25 years, \$32
12 Size, gilt dial
Terms: \$3.25 Down, then \$1.00 a Week.

No Money in Advance

This Marvelous CAMERA On Free Trial

Only 10,000 of these marvelous, instantaneous picture-taking and making cameras to be sent out absolutely on approval without a penny in advance just to prove that it is the most wonderful invention—the camera sensation of the age. So you must send for it quick! Just think of it—the new Mandel-ette

Takes and Makes Finished Pictures Instantly

You press the button, drop card in developer and in 1 minute take out a perfect, finished postcard photo 2½ x 3½ in. size. Camera, itself, is about 4½ x 5 x 7 in. Loads in daylight 16 to 50 postcards at one time.

No Films—No Plates—No Dark Room

Not a bit of the fuss and bother of the ordinary kodak or camera. It is instantaneous photography. Universal focus lens produces sharp pictures at all distances. Pictures develop and print automatically. Can't over-develop; results simply amazing.

We Trust You No difference who you are, where you live or what your age, we will send you the complete "Mandel-ette" outfit, including tripod, absolutely on approval and give you ten days to test it. If not satisfactory, return it. But when you see what elegant pictures it takes—so quick, so easy, with no trouble at all—if you wish to keep it you simply send us 50 cents a week until our special price of \$10.00 is paid.

Easy Payments—No References!

NO RED TAPE OF ANY KIND. Weekly payments so small you will not notice them. Lots of fun and big profits.

No Experience Required

Plain instructions and everything complete with outfit so you can begin taking pictures the moment it arrives. We guarantee that even a child can operate it. Mail the coupon RIGHT NOW. No risk or obligation to keep the camera.

The Chicago Ferrottype Co.
2309 W. Erie St., Desk 19, Chicago, Ill.

Send me at once one complete Mandel-ette Camera outfit including tripod, supply of post cards and instructions. I agree to examine and test it thoroughly and if satisfied keep it and pay you 50c a week until your special price of \$10.00 is paid. Otherwise I will return it at the end of 10 days.

Name.....

St. and No.....

Town.....City.....

COOK Without Coal

Amazing invention does away with coal or wood. The INSTANT GAS OIL Burner enables you to cook in a cool kitchen. Turned on or off instantly with each meal. Sets in firebox of any stove; burns 96% air and 4% kerosene. Gives better heat than coal and cheaper. Better cooking and baking. Installed in 5 minutes. No damage to stove. Sold on money back guarantee. Over 100,000 users.



Write today for special 30 DAY FREE TRIAL introductory offer and free book, "Scientific Oil Burning." AGENTS, we pay \$60 a week. Write for free sample offer.

INTERNATIONAL HEATING COMPANY
Dept. E., 117 South 14th St. St. Louis, Mo.

We Give To Boys

Choice of Base Ball Suit, with Cap and Belt, Bats, Balls, Catchers Mitts, Fielders Gloves, and 200 other Gifts, FREE for selling our Magic Healing Wavolene, at 25c box.

We Trust You!!

Order seven boxes today, on a postal. Sell quickly—it goes like wildfire—used in every home—return our money, choosing Premium you desire and are entitled to, according to the Plans in the Big Premium Catalogue.

Outfit A Whole Base Ball Team FREE! HURRY!!

WAVERLY CO.

318 Towner Bldg. Monongahela, Pa.



Don't forget
your pliers*



Start every work day—or play day with a pair of Bernards (No. 102) at your finger tips. You'll find a dozen uses for them. They grip like a vise because of the parallel jaws. The outside cutting blades bite cleanly through metal. They are great for bending or stretching wire. Insist upon

* BERNARD

Standard High-Power Cutting
PLIERS



No. 502 "Vulcan" Side
Cutting Pliers



No. 454 "Ideal" Long Nose
Cutting Pliers

Catalog "P" free on request from
WM. SCHOLLHORN CO., NEW HAVEN, CONN.

Drive This Beautiful Raceabout
Instead of Your OLD FORD



Choice of Four Colors; Flat or the Ballet Nose Radiator Shell. Send for 1924 Free Catalog of New Auto Accen', Bodies and

Speed Equipment. Direct from Factory.

AMERICAN TOP AND BODY CO., Park Ave. DELPHI, IND.

SEND
\$2
DOWN

PAY
\$6.70
PER
MONTH

Seven brilliant, blue white, perfectly cut diamonds are set in platinum. Looks like 2 ct. solitaire worth \$600. Fully guaranteed to stand any test.

TWO BLUE SAPPHIRES

are set in the shanks of this 18 kt. solid white gold engraved and pierced ring to add beauty and style.

FREE
TRIAL

NO
RED
TAPE

Send \$2.00 as a deposit and we'll send this handsome diamond ring. Then pay only \$6.70 a month for 10 months until bargain price of \$69.90 is paid. Former price \$100.00. All credit dealings strictly confidential. WRITE FOR CATALOG. It gives the exact weights and qualities of diamonds. Read valuable information on page 6.

STERLING DIAMOND & WATCH CO.
(Diamond Importers—\$1,000,000 Stock—Established 1879)
63 PARK ROW Dept. 1545 NEW YORK, N. Y.

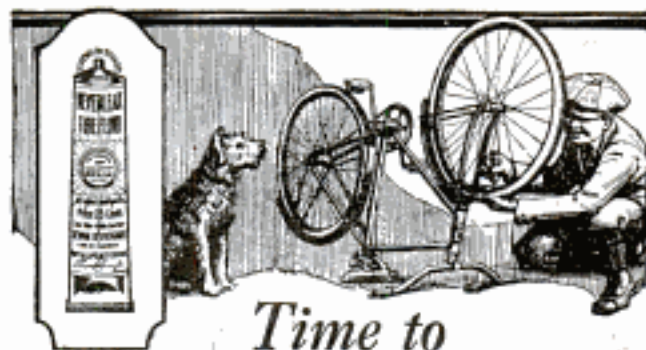

Time to Overhaul the Old Bike

The first warm days will be here before you know it. Better look the old bike over and get it in shape.

Make your tires puncture-proof and make them wear twice as long. How? By simply injecting a tube of Neverleak into each tire. You can then ride all summer without a single puncture.

Price 25c. at all bicycle and repair shops.
Buffalo Specialty Company, Buffalo, N. Y.

NEVERLEAK TIRE FLUID

"HEALS PUNCTURES ON THE RUN."

WRITE FOR FREE BOOKLETS describing and illustrating complete line of IVER JOHNSON Bicycles, Velocipedes, Revolvers and Shot Guns.
IVER JOHNSON'S ARMS & CYCLE WORKS
4 River Street FITCHBURG, MASS.

ADDING MACHINES

Your choice of Burroughs, Dalton, Wales and all standard makes often at less than one-third regular price! All sizes and styles. Every machine guaranteed A-1 condition. Rebuilt by experts.

1/3 PRICE
SOLD ON INSTALLMENTS

You can buy a regular \$300 machine for as low as \$5 down. Why pay big prices? Hundreds of well-known firms our customers. Write for FREE list of models and bargain prices that save you money. Do it NOW.

RELIABLE ADDING MACHINE CORPORATION
170 C W. Washington Street CHICAGO, ILL.

Change Angles Instantly

This square does the work of Trysquare, Mitre, Octagon, Bevel and Protractor equally well. Pressure on a button in the head of the handle releases the blade and you can change from one angle position to another instantly. Accurate always—fits the hand—the ideal tool.

Simore "Quick Change" Trysquare

With 4 1/2 or 6 inch blade..... \$3.75
With 7 1/2 inch blade..... 3.90

Sent postage prepaid on receipt of money order or your check.

Money refunded if not satisfactory. We invite dealers and others to write for information on Simore "Quick Change" tools.

The demand for these tools is increasing every day. Write today.

THE SIMON & SKIDMORE MFG. CO.
Dept. 4-4 SANTA ANA, CALIF.

\$3 DOWN BRINGS ANY MAKE TYPEWRITER FOR 10 DAYS TRIAL

DIRECT FROM OUR FACTORY TO YOU

L. C. Smith Silent Model 8

A good, practical, silent typewriter. The manufacturer's factory price of this typewriter is \$105.00. We will send it to you direct from our factory on easy payments for

Only \$55⁰⁰
Cash Price Only
\$49⁵⁰

Noiseless

The only Noiseless typewriter in the World today with standard improvements. Our supply is limited, only 50 left. The manufacturer's price of this typewriter is \$135.00. We will send it to you direct from our factory on easy monthly payments for

Only \$43⁰⁰
Cash Price Only
\$38⁷⁰

Only 15c Per Day Buys a Typewriter

Think of it! Securing any one of these latest model standard typewriters, fully guaranteed, for about one-half the original factory price. Simply send us \$3.00 with the coupon and we will send you your choice of any typewriter in this advertisement for ten days' trial without obligation to buy. After trial and when entirely satisfied send us only \$5.00 per month rental until our low direct-from-factory price has been paid and the machine is then yours.

5-Year Guarantee

We give you the same guarantee as if you paid the original factory price. You must be entirely satisfied in every way. So rush your order NOW!

Young Process

Re-Manufactured

The famous "Young Process" means a mechanically perfect operating typewriter, guaranteed like new. Every typewriter is completely torn down, cleaned thoroughly by our special process; hand-brush enameled, baked in our special ovens; highest quality nickel-plated; all worn weak or faulty parts replaced with new parts, entire machine completely assembled, adjusted and perfectly aligned by specialized typewriter experts. You cannot tell a "Young Process Re-Manufactured" typewriter from brand new in appearance, service and workmanship. You save about half the original manufacturer's price.

SEND COUPON TODAY

Save time and money. The supply of typewriters at these low prices is limited. This is your opportunity to secure a guaranteed standard typewriter at a big saving. Fill out and mail the coupon today sure.

Young Typewriter Co.
654 W. Randolph Street, Dept. 2104, Chicago

Remington Self Starter Model 10

With all latest improvements. A good typewriter at a real bargain price. The manufacturer's factory price of this typewriter is \$102.50. We will send it to you direct from our factory on easy payments for

Only \$53⁰⁰
Cash Price Only
\$47²⁰

Royal-10 The Master Model

This typewriter is preferred by thousands of people to all other makes because of its superior writing qualities. The manufacturer's factory price of this typewriter is \$102.50. We will send it direct from our factory on easy payments for

Only \$58⁰⁰
Cash Price Only
\$52²⁰

ORDER COUPON

YOUNG TYPEWRITER CO.

Dept. 2104, 654 W. Randolph St.
Chicago, Illinois

You may send me a typewriter on 10 days' trial, express collect. I enclose \$3.00 deposit and will pay \$5.00 monthly until your factory price in this advertisement is paid when the machine becomes mine. I may return the typewriter, at your expense, within the trial period and you will refund my deposit.

Name

Street Address

City State



LUMINOUS PAINT

Make Your Watches, Clocks, Etc., Visible by Night

The very latest discovery in the scientific world, Hittorio, practically unobtainable except at an exorbitant price, we have at last succeeded in producing this remarkable LUMINOUS PAINT, which, applied to the surface of any article, emits rays of white light, rendering it perfectly visible in the dark. **THE DARKER THE NIGHT, THE MORE BRILLIANT IT SHINES.** Quite simple to use. Anyone—you can do it. A little applied to the dial of your watch or clock will enable you to tell the time by night. You can read the push buttons or switch plates of your electric lights, match boxes, and innumerable other articles; make your own Luminous Crockery, Luminous Rattles, etc. Small bottle, price 25c. Larger sizes, 50c and \$1 postpaid.

Serpent's Eggs

Box contains 12 eggs. When lit with a match, each egg gradually hatches itself into a snake several feet long, which curls and twists about in a most life-like manner. Price per box, 10c postpaid, 3 for 25c.



Potmend

Mends Ironware, Agate-ware, kettles, pots, pans, boilers, etc. Made of copper, aluminum, tin, iron, pipes, crocks in brick-ovens, broken china, porcelain, tinware, brooms, blades, crockers, woodenware, marble, etc. Comes in powdered form. Just mix with water and apply. **HARDENS LIKE IRON.** Needs a big hole or a small crack. PRICE 15c, 3 for 40c, postpaid.

Midget Bible

GREAT CURIOSITY Smallest Bible in the World. Size of a postage stamp—200 Pages. Said to bring good luck to the owner. A genuine work of art. Must be seen to be appreciated. Make good money selling them to friends, church organizations, etc. PRICE 15c each, 3 for 40c, 12 for \$1.35, 100 for \$7.50.



STAGE MONEY

With a bunch of these bills, it is easy for each person of limited means to appear prosperous by flashing a roll of these bills at the proper time and peeling off a genuine bill or two from the outside of the roll, the effect created will be found to be all that can be desired. Prices, postpaid: 15 Bills 10c, 50 Bills 25c, 125 for 50c, or \$3.50 thousand.

Wonderful X-Ray Tube

A wonderful little instrument producing optical illusions both surprising and startling. With it you can see what is apparently the bones of your fingers, the lead in a lead pencil, the interior opening in a pipe stem, and many other similar visions. A mystery that no one has been able to satisfactorily explain. Price 10c, 3 for 25c, 1 dozen 75c. Johnson Smith & Co.



Good Luck Ring

Quaint and Novel Design

A VERY striking and uncommon ring. Silver finish, skull and crossbones design, with two brilliant, flashing gems sparkling out of the eyes. Said by many to bring Good Luck to the wearer, hence its name. **Good Luck Ring.** Very unique ring that you will take a pride in wearing. **ONLY 25 CENTS.**

Address orders for all goods on this page to

JOHNSON SMITH & CO.
Dept. 115 RACINE, WIS.

Our large catalog (356 Pages) of all the newest and best novelties, unobtainable elsewhere, free with every order.

The Dying Pig



The most laughable novelty yet produced. Made of rubber, and you have only to blow it up and stand the pig on his feet, when he begins to squeal as he slowly collapses and finally lies down and dies in the most natural manner. You can blow him up as often as desired, and each time he will go through the same performance to the great amusement and delight of your friends. Price, 15 cents; 3 for 40 cents; one dozen \$1.35, mailed.

Popular Watch Charms

15c
ONLY 3 for 40c; \$1.35 doz.

Very pretty little curiosities and decidedly novel. Filled with Magnifying Lenses that enlarge the reflection to a very surprising degree; in fact, it seems almost incredible that a clear picture could be possible in such a small compass, and how sharp and distinct they show up when you look through. Comes in assorted designs—Acropolis, views of Panama Canal, Lord's Prayer in type, etc.

Mystic Skeleton

A jointed figure of a skeleton 14 in. in height, will dance to music and perform various gyrations and movements while the operator may be some distance from it. **10c & pd.**

NEW BOOK ON ROPE SPLICING

Useful Knots, Hitches, Splices, etc.
A most practical handbook giving complete and simple directions for making all the most useful knots, hitches, splices, etc. Over 100 illustrations. All about wire rope attachments, lashing, blocks, tackles, etc. 27 Heraldic Knots Illustrated. Of great value to machinists, riggers, carpenters, boatmen. Price 20c postpaid.

MAGIC FLUTE

Wonderfully Sweet Toned and Musical

The Magic Flute, or Humastone, is a unique and novel musical instrument that is played with nose and mouth combined. There is just a little knack in playing it which, when once acquired after a little practice will enable you to produce very sweet music that somewhat resembles a flute. There is no fingering, and once you have mastered it you can play all kinds of music with facility and ease. When played as an accompaniment to a piano or any other musical instrument, the effect is as charming as it is surprising.



BLANK CARTRIDGE PISTOL

Protection against Burglars, Tramps & Dogs



Prices 50c \$1.00 Post-paid

Well made and effective; loaded on latest type of Revolver; appearance alike in enough to scare a burglar. When loaded it may be as effective as a real revolver without danger to life. It takes standard .22 Cal. Blank Cartridges obtainable everywhere. Price 50c, superior quality, \$1.00 post-paid. Blank Cartridges, by express, 50c per 100. Johnson Smith & Co., Dept. 115, Racine, Wis.

DANCING BEAUTIES

Get a Kinetograph and see the picture move. France's latest sensation. A great surprise. Is worth twice what they cost. Are made of solid brass, highly nickel-plated and very durable. Satisfactory of your money back. **50c** Price..... Johnson Smith & Co., Dept. 115, Racine, Wis.

BOYS! BOYS! BOYS!

THROW YOUR VOICE

Into a trunk, under the bed or anywhere. Lots of fun fooling the teacher, policeman or friends. **THE VENTRILO** a little instrument, fits in the mouth out of sight, used with above for Bird Calls, etc. Anyone can use it. Never Fails. A 32 page book on ventriloquism, the Ventrilo, ALL FOR 10 CENTS

1000 Silk Remnants

for patching Crazy Quilts, Sofa Cushions, Head Rests, Pin Pads etc. Large pieces, all colors and shades. Sure to delight you. For 10 Cents stamps, we send a large package and Book of quilt designs. 8 packages 25c. 1 pound makes a lovely large quilt. Price 15c postpaid. Our silk is the best. JOHNSON SMITH & CO., Dept. 115, RACINE, WIS.

LOOK 35c Look

Wonderful Instrument. Greatest thing yet. Nine separate articles in one. Everybody delighted with it. Odd, curious and interesting. Lots of pleasure as well as very useful. It is a double Microscope for examining the wonders of nature. It is also an Opera Glass, a Stereoscope, a Burning Lens, a Reading Glass, a Telescope, a Compass, a Pocket Mirror, and a Laryngoscope—for examining eye, ear, nose and throat. It is worth all the cost to locate even one painful cinder in the eye. Folds flat and fits the pocket. Something great—you need one. Don't miss it. Sent by mail, with 356 page Novelty Catalog. **Only 35c or 3 for \$1.00**

Resurrection Plant

One of the most wonderful plants known. Possesses the strange power of turning in a few minutes from an apparently lifeless, dry herb to a beautiful living fernlike plant of a dark green color. Simply place the plant in saucer of water, it will open up and start to grow in 30 minutes. When taken out it will dry up and go to sleep until placed in water again. Fine house plant—summer or winter. 10 cents each or 3 for 25c. **AGENTS WANTED** best paid. JOHNSON SMITH & CO., Dept. 115, RACINE, WIS.

\$1662⁰⁰ Earned IN ONE SEASON

A NEW BUSINESS—BIG BUSINESS

A Business to Enthuse Over—The "Ideal" Lawn Mower Sharpener

W. F. Kendt,
1476 Main St., Buffalo
writes:

I sharpened 994 lawnmowers last season, and the receipts were \$1662.00 which is not bad for a side line."

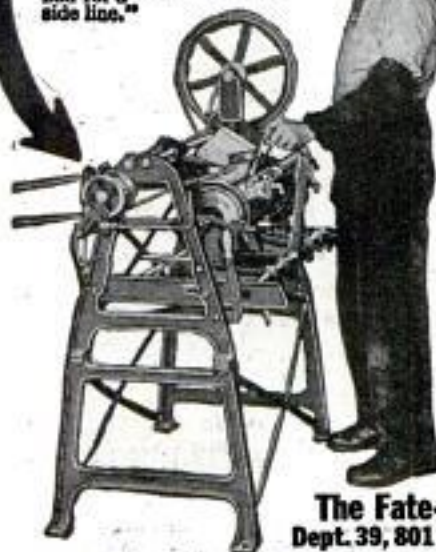

A wonderful invention that sharpens lawn mowers scientifically—quickly—perfectly; does the work as nothing else can.

Fred C. Milkert of Melrose Park, Ill., writes:

"The Ideal Lawnmower Grinder put me in business, starting in the basement of my home and forcing me now for the third time to move into bigger quarters. Today the dream of my life—a shop of my own—is realized. With a machine like yours and a little hustle any man can have a business of his own and be independent."

You Start Now No town too small. Lawn mowers are dull—owner doesn't know where to get them sharpened. Mowing the lawn dreaded because of dull or improperly sharpened mower. Lawn mowing healthful, invigorating and pleasant when Mower is "Ideally" sharpened. You do the work scientifically—you are in big demand.

Lawn Mowers Sharpened to Razor Edge—

People glad—owners delight in mowing lawn with mower sharpened on an "Ideal." Mower runs light—click-click-click and the grass is cut. Build permanent business for yourself. Start now!

Write Today Get our proposition

Free— We have detailed illustrated book to send you. Write today for our proposition.

The Fate-Root-Heath Company
Dept. 39, 801 Bell St., Plymouth, Ohio

USE THIS—Mail it Today

The Fate-Root-Heath Company
801 Bell Street, Dept. 39, Plymouth, Ohio

Please mail at once details of your complete proposition.

Name _____

Address _____

New 1/4 H. P. 110 volt A. C. Guaranteed Motors
60 cycle, complete with cord, plug and pulley



Gen. Elec. 1725 speed..... \$16.00
Gen. Elec. 1/4 H. P. Rep. Ind 39.00
Master 1/4 H. P. Rep. Ind.... 52.50
Master 1 H. P. Rep. Ind.... 60.00

Special values in rebuilt motors.

HYRE ELECTRIC CO.

615-T S. Dearborn St., Chicago, Ill.

PILLIOD

Tool Cases Excel

Machinists, Tool Makers and Carpenters find them most satisfactory in construction, appearance, service and price. Immediate shipment.

Booklet describing 20 styles on request.

THE PILLIOD LUMBER CO.
Dept. 1 Swanton, Ohio

Sebastian Lathes



The Standard of Medium Priced
Lathes for Thirty-eight Years
Any type. Write for catalog.

The Sebastian Lathe Company
107 Culvert St. Cincinnati, Ohio

The biggest little woodworker ever built!

You'll want this sensational Parks combination woodworker right away for your shop; includes 8-inch rip and cross-cut saw, 4-inch jointer, band-saw, borer, shaper, sander, and universal motor. Only \$210 complete! Lathe attachment only \$15 extra. First-class Parks angle-steel construction, all joints electric-welded. Steel table-top. The newest thing in small shop equipment. Guaranteed 10 years.

Send for Bulletin C-3, describing this machine in detail.

Parks "Cabinet Shop Special"

\$210.00

as illustrated with motor f.o.b. Cincinnati.

THE PARKS BALL-BEARING MACHINE CO.

1500-1540 Knowlton St.
CINCINNATI, OHIO

Canadian factory: 200 Notre Dame East, Montreal, Can.



PARKS

WOODWORKING MACHINES

ATKINS

METAL CUTTING

SAWS



Use
Atkins
"Non-Breakable"
Hack Saw
Blades

End Blade Breakage

WITH Atkins "Non-Breakable" Hack Saw Blades you can eliminate practically all losses due to blade breakage, and do your metal cutting faster and easier.

Made of selected steel, these blades are hardened and tempered by an exclusive gas and oil process which makes the cutting edge extremely hard and the body of the blade unusually tough and flexible. That's why they out-cut and out-last other blades. Prove it for yourself. Send us ten cents and tell us what metal you cut and we'll send a sample blade. You'll say it's the best you ever used.

Saws of All Kinds

When you need a hand saw, circular saw, band saw, pruning saw, or any saw for cutting wood or metal—there's an Atkins saw that will save time, money and labor. Write for our free booklets on any saws you want.



Send for This FREE Book

Here's a 32 page book that's full of practical suggestions on metal-cutting, and general shop information. Every man who buys or uses saws will find it helpful. Send for it NOW. Just write your name and address on the margin of this page and mail it to us.

E. C. ATKINS & CO., Inc.,
Dept. P, INDIANAPOLIS, IND.
Makers of "Silver Steel" Saws and Tools

Please Mention Popular Mechanics



A quick-grip chuck and a quick-action die-head make pipe-threading both fast and easy. The handy

OSTER

BULL-DOG DIE-STOCK

shown above threads eight different sizes, from 1/4 to 2" inclusive—other tools handle larger sizes.

Ask your supply house or write for Bull-Dog folder.

THE OSTER MANUFACTURING CO.
2100 E. 61st Place Cleveland, Ohio



It is the well known quality of CRESCENT machines that justifies you in selecting one of them each time you have need for wood working machinery. The CRESCENT line is better than ever and will always give you satisfaction in every particular. Ask today for catalog of hand saws, saw tables, jointers, shapers, planers, borers, planers and matchers, swing saws, disk grinder, cut off table, hollow chisel mortiser, variety wood worker. Universal wood workers.

THE CRESCENT MACHINE CO., 83 Columbia Street, Leontia, Ohio



LATHES

9 to 18-inch Swing

List price \$165 and up according to size. When ready to buy send for Lathe Catalog and prices.

W. F. & John Barnes Co.
100 Ruby Street, ROCKFORD, ILL.



5 SIZE TAP AND DIE SET, ONLY \$3.00 FOR THE HOME—THE FARM—THE WORKSHOP DIRECT FROM THE FACTORY TO YOU!

Our No. 12 Automobile Set furnished in our highly finished chestnut box contains 5 each tap and die (1-4, 5-16, 3-8, 7-16 and 1-2"), in the S. A. E. thread, 1 die stock, and one tap and reamer wrench.

Our No. 11 Set is the same as No. 12 except that the thread is U. S. S. instead of S. A. E. You are purchasing a splendid set at a very low figure.

Send us your order at once and be one of our many satisfied customers. Let us also send you one of our circulars illustrating our full line of Handy Tools. WORCESTER STEEL PRODUCTS CO. Dept. 24, 25 Union Street, Worcester, Mass., U. S. A.

Copyrighted material

Send No Money

Ladies' Solitaire Examination Free

This perfectly cut Diamond will be sent free of charge for your complete examination and approval. No money in advance. If satisfied, pay only \$2.00 on arrival and keep it. Price \$30.00.

10 MONTHS TO PAY

The balance you send in 10 small monthly payments—only \$2.00 a month. Take advantage of this amazing offer today.

FREE De Luxe Catalog in colors. Write for details of Great Diamond Offer and Book to Dept. 64J
Capital \$1,000,000



THE HOUSE OF QUALITY

AUTHORIZED CAPITAL \$1,000,000.

L.W. SWEET INC.

Dept. 64J 1660 BROADWAY, NEW YORK

MATHEMATICS

can be easily mastered with the Midget 5 in 1 Slide Rule. With this calculator you can instantly add, subtract, multiply and divide any combination of decimals, fractions, whole and mixed numbers. Also obtain all roots, powers, Logs, and Trig. Functions.

It is used at all colleges, 200 at Harvard, 300 at Cornell, etc. The Engine-Divided Scales are on white celluloid, mounted on aluminum and are grease and waterproof. Diameter 4 inches. Price with Instruction Book.....\$1.50 Leather Case 50c extra. Catalogue Free. Your money back if you are not satisfied. GILSON SLIDE RULE CO., Niles, Mich.



Mr. Shop Man!
Just what you want

GIT HAND PASTE

Cleans Hands CLEAN Quickly

10¢ at F. W. Woolworth Co. McCrory and other stores

1 1/2 OUNCES



GIT Hand Co. Westfield Mass



Gerstner TOOL CHESTS

are made so well, finished so neatly, and are such splendid values that Toolmakers and Machinists everywhere are more than pleased with them. Catalog free.

H. Gerstner & Sons

404 Columbia St., Dayton, Ohio

BURN YOUR NAME ON TOOLS WITH

ARKOGRAF

Protect your tools from theft. Write any name, engrave any design on metal with electricity like writing on paper with pen or pencil. Complete outfit \$3.50, prepaid anywhere. Interesting descriptive circular free. Write today. Agents Wanted. Arkograf Pen Company 481 East Couch St. Portland, Oregon



R6816. Scribing blade, useful in carpenter work, small pen blade and heavy sabre clip blade with lock back. Genuine stag handle.

Knives Worthy of the Up-and-Doing American

GOOD craftsmen were quick to sense the fact that Remington Knives are real tools.

Made up to the standards of what a man needs and expects in a knife.

Look at the Carpenter's and Mechanic's knife illustrated—a husky, sharp, lasting tool for the handy man.

Just one of many Remington Knives, made to suit the individual needs of different men. See them at your dealer's. See that the name Remington is stamped on the heel of the blade.

Write for circular on Remington Carpenter's and Mechanic's Knives.

Remington Arms Co., Inc., New York City
Established 1816

Remington

THE AUTHORITY IN FIRE ARMS, AMMUNITION AND CUTLERY

Also Makers of Remington Cash Registers

Please Mention Popular Mechanics

Copyrighted material

These FORDS ran

35 to 48 Miles

on Gallon of Gasoline

with Air Friction Carburetor

We guarantee any Ford 34 miles to the gallon of gasoline and 30% to 50% more power and "pep" on it or any other make of car. Guarantees of mileage on other cars given below. Guy Bickford, Newnan, N. Y., writes—"Put it on 1922 Ford—got about 35 miles per gal. and go up hills on high I hardly dared go up on low." Gust Zima, Grand Haven, Mich., writes—"I have been to Chicago, distance 183 miles on 4 1/2 gals. of gas—average better than 40 miles to the gal. on my 1922 Ford." Albert Wieseke, Chamberlain, S. D., writes—"Used my Air Friction Carburetor for two years on Ford and made as much as 40 miles on a gal. of gas." W. W. Parker, Mabank, Tex., writes—"Formerly got 17 miles to gal. of gas with my 1922 Ford—now get 40 with Air Friction Carburetor on." Wm. H. Tappen, 643 Ocean Avenue, Lakewood, N. J., writes—"I have used Air Friction Carburetor 13 years and get 38 miles out of Ford truck on one gal. of gasoline." Y. H. Gregory, Box 185, Morristown, N. J., writes—"Air Friction Carburetor gets 35 miles per gal. on my Ford car. Engine not in good condition, but think soon to go more miles than any other." What these men have done any other man can do. Don't take our word for it. Try it out on your own car—30 days' trial and money refunded if not satisfied.

SENT ON 30 DAYS TRIAL

We guarantee all other makes of cars to nearly double present mileage and power, flexibility and to make hills on high formerly difficult in low. Carburetors shipped same day order is received for any make or model of car, truck, tractor, marine or stationary engine with full guarantee of performance or money back. Makes old cars better than when new.

STARTS EASY AT ZERO

or colder without priming or heating—hundreds of letters to prove this from satisfied users. See our wonderful mileage guarantees or money back for other makes of cars:

Ford	34 mi.	Reo	24 mi.	Chevrolet	32 mi.
Buick 4	30 mi.	Chalmers	23 mi.	Maxwell (25)	30 mi.
Buick 6	24 mi.	Olds 6	23 mi.	Nash 6	23 mi.
Hudson	20 mi.	Paige 6	20 mi.	Lincoln 8	17 mi.
Hupp	25 mi.	Oakland 6	24 mi.	Stobkr. Lt. 6	23 mi.
Dodge	28 mi.	Overland 4	32 mi.	Cole 8	17 mi.

If your car is not mentioned here send us name and model number for particulars and our guarantee on it. Cadillacs and Lincolns report 18 to 20 miles on gal. You can drive any car in heaviest traffic without shifting gears. Starts off on high in any weather without priming or heating—no jerking or choking. No more foul spark plugs or carbon in cylinders. No leaking of gas into crank case. Try it 30 days on our guarantee of money back if not entirely satisfied. No strings to our guarantee. **YOU ARE THE JUDGE.** Anyone who can handle a wrench can attach it. No boring of new holes or changing of operating mechanism.

AGENTS WANTED

We want car owners, agents and dealers in every city and town. Special agent's introductory and demonstration discount given on first purchase for your own car. Many farmers make more money in winter selling Air Friction Carburetors to neighbors than they make on their farms in summer. Write today. No trouble to use your car all winter with Air Friction Carburetor on.

THE AIR FRICTION CARBURETOR CO.
257 Raymond Bldg. Dayton, Ohio, U. S. A.

Easy to Build this SHAW Cycle Car

Here's a Real Automobile with a Real Motor that any handy man or boy can build. The SHAW Speedster carries two passengers anywhere. Power supplied by famous 2 1/4 H. P. Shaw Motor. If you have a Shaw Motor get plans. If not, we supply everything. Write for FREE particulars or send 25c now for Easy-to-follow plans. Write today!

SHAW MFG. CO.

Dept. 37-S
Caleburg,
Kansas

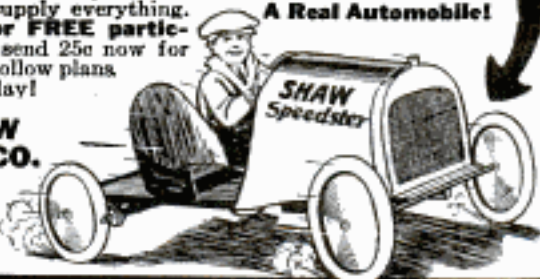

\$2⁵⁰ Then Small, Easy
Down Monthly Payments
for the
"Bicycle Supreme"

BABSON Motorbike Model

Yes! Only \$2.50 Down and small easy monthly payments for this king of bicycles—the last word in strength, durability, comfort, easy running and convenience!

30 Days FREE Trial

To prove to you that the wonderful Babson Motorbike is everything we claim, you may ride it for 30 days without the slightest obligation to buy, unless absolutely satisfied.

Write Today!

Get our wonderful offer before it is too late. Learn all about our other models for men, women, boys and girls. Learn how you can make a lot of money as a rider agent. Don't miss this chance! Write TODAY.

Babson Bros. Dept. 13-54 19th Street and California Avenue, Chicago, Ill.



Catch Fish, Eels, Mink, Muskrats and many other fur-bearing animals, in large numbers, with my New, Folding, Galvanized Wire Mesh Traps. They catch them like a fly-trap catches flies. Made in all sizes. Strong and durable. Write today for Price List, and my Special FREE Offer on best baits known for attracting fish and animals. **J. F. GREGORY, Dept. 102, Lebanon, Mo., U.S.A.**

Drive 100 Tacks and Save \$25

on your next Top or Seat re-covering. Fords \$5.20 to \$10. Chevrolats \$7.50 to \$15. All other cars \$5.95 to \$22. Our Plate Glass Lights enhance the value of your car. Side Curtains \$5.95 up. Seat Covers \$2.50 to \$32. Quality and fit the best. Our instructions make it easy to apply. Send for samples. Our prices include delivery at your door. Eastern orders shipped from Ohio. **Auto Equipment Co., 1117 So. Main St., Los Angeles, Calif.**



ENINGER WILL TRUST YOU

SEND 10c IN STAMPS FOR CATALOGUES
BIG MONEY SAVING FOR YOU

Used and rebuilt motorcycles \$25 to \$100, used bicycles \$9.50, tandems \$20. All machines fully guaranteed. New bicycles and motorcycles at factory prices, save dealers' profits. Motorcycles and automobile tires \$3. Complete line frames, engines, spindles.

ENINGER PRICE CUTTER, ROCHESTER, N. Y.

PAY AS YOU RIDE

MOTORCYCLES



RELIABLE STANDARD MAKES that you can **DEPEND** on. Enjoy the glorious experience of getting wherever you like—wherever you like. The price is within your means—31% to 50% less than others. These machines are strictly used, thoroughly overhauled or rebuilt. Read for catalogue.

MYCROW BROS.,
15 Berkeley St. Boston, Mass.



Secret Service



Choose! 50c or 75c for a can of this liquid or ten times that for auto radiator repair, with its inconvenient lay-up.

And get a better mending job with Radiator Neverleak. For it detects and seals *all* leaks—not just those apparent—and new ones as they occur.

Guaranteed—harmless as water itself—and to give entire satisfaction or money back. At auto supply and hardware stores. *Free booklet on request.*

RADIATOR NEVERLEAK

Buffalo Specialty Co. Buffalo, N. Y.

The **LIQUID VENEER** People

"Shines Cars Like Stars"

LIQUID VENEER AUTO POLISH

In Flask-Shaped Metal Cans
50" 80"
\$1.25



Fish Bite like hungry wolves, any season, if you bait with **Magic Fish Lure**.

Best Fish Bait ever discovered. Keeps you busy pulling them out. **\$1 Box Free** to introduce our fish and animal traps. Write today. Agts. Wtd. **Walton Supply Co., Dept. C-1, St. Louis, Mo.**

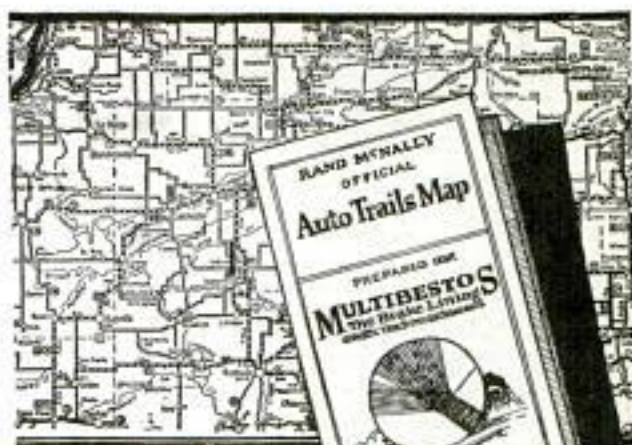

New Auto Map

only **10¢**

WE have made a special arrangement with Rand, McNally & Co., famous map makers, by which we can offer you, for a brief period, any of their official Auto Trail Maps for only 10c apiece. This series covers every state and gives all kinds of valuable information—Trail Signs; Best Hotels; Garages; Service Stations; etc. strictly up-to-date. Size 28½ x 34 inches, folded into strong covers, pocket size. Send 10c and address of the shop that usually relines your brakes, and we will send you a map of any state or section you ask for, together with complete list of all the maps. This offer is strictly limited, so order at once.

Multibestos Prepares You For Every Touring Emergency

The above offer is made frankly to acquaint you with Multibestos, the Brake Lining with the Interlocking Weave. This brake lining, which is specified as factory equipment by a majority of American car makers, is famous for the *long time it lasts*. Ask for Multibestos by name the next time your brakes need relining.

MULTIBESTOS COMPANY
Dept. P4 Walpole, Mass., U.S.A.

MULTIBESTOS

THE BRAKE LINING
with the Interlocking Weave





ONE-CAR SIZE
FRE-RENT GARAGE
\$106⁰⁰
COMPLETE

SAVE GARAGE RENT

All complete—doors, windows and even paint. All wood. Just bolt together the 10 sections and drive in your car. Easily portable. 11 sizes. Two-car size as pictured above only \$200.00. Write for booklet.

FRE-RENT GARAGE COMPANY
447 Walden Ave. Buffalo, N. Y.

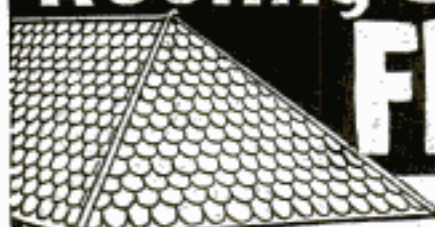
Roofing Book FREE



World's Best Roofing at Factory Price

Don't buy Roofing of any kind until you get our big Free Roofing Book, describing full line of Edwards Famous "Tightote" Galvanized Roofings, Sidings and Ceilings, and our lowest factory prices. Then see for yourself how much we save you by selling direct and saving you all in-between dealers' profits.

"REO" EDWARDS Metal Shingles

Absolutely rust proof. By our patented "Tightote" process, edges as well as sides of metal sheets are heavily coated with zinc—not a space the size of a pin point exposed to weather. Fire and lightning proof. Outlasts three ordinary roofs. Forever wind and weather proof. Need no repairs—and all roofing expense. Patent INTERLOCKING DEVICE makes water tight seams—all nail heads covered—no chance for rust or leaks.

EDWARDS Galvanizing Test

Edwards "Tightote" Galvanized Roofing can be bent, twisted or struck by lightning, and the galvanizing will not crack or flake. Bend it or hammer it—you can't loosen or scale the galvanizing. No other galvanized roofing can withstand this test.

Low Priced Garages

Wide variety of styles, all sizes of Portable Fireproof Metal Garages. Lowest prices ever made. Postal brings the Garage Catalog free.

Write Today for free samples and proof that we can save you a lot of money on any kind of roofing, siding or ceiling you may need. Ask for Roofing Book No. 106.

THE EDWARDS MFG. CO.,
400-450 Pike St., Cincinnati, O.



MOTORCYCLE BARGAINS

Save 25% to 65%

on Slightly used and Rebuilt Motorcycles, Side Cars, Johnson Motor Wheels, Evans Power Cycles, Bicycles. Send for Free Bargain Bulletin and Money Saving Newsletters. (With hundreds of Bargains in used, rebuilt and new machines, supplies, accessories, etc.)

AMERICAN MOTOR CYCLE CO.
Dept. 427, 2047 W. Chicago Avenue, CHICAGO



Your Tires Free and \$300 a month



Agent Users Wanted

SEE how easy it is with the MASTER SALESMAN KIT, which I send Free, to make \$10 to \$25 a day in your spare time showing MELLINGER TIRES at BIG SAVINGS to car owners. This powerful, hand-made, oversize, non-skid Cord is guaranteed by Bond for mileage half way around the world.

The Mellinger Plan starts you in business, all or part time; no capital or experience needed. Tires shipped prepaid on approval. Lowest wholesale prices in America. **FREE** If you will boost MELLINGER TIRES, I have a surprising offer that will give you a set of tires Free. Also the MASTER SALESMAN KIT with sample sections. Be first to get my free offer, amazing confidential wholesale prices and big free book. Simply send me your name today. E. L. MELLINGER, Pres.

MELLINGER TIRE & RUBBER CO.,
\$600,000 CAPITAL. 1724 Grand Ave., Kansas City, Mo.

This Book FREE

144 pages and valuable to those who want dependable household, automobile and shop repairs with big savings.

**SMOOTH-ON
REPAIR
BOOK**

SMOOTH-ON No. 1

On your car, stops leaks in radiator, bursted water jackets, tank, hose connections and at gaskets without taking down. Keeps bolts, nuts, grease cups and hub caps from dropping off.

In your home, stops leaks in water, gas and steam pipes, tanks and pots, roofs, etc.

In the shop, makes any kind of pressure joints, joins wood, metal, glass and concrete to each other and holds on any metal—iron, brass, lead, aluminum. Makes handles, screws and nuts lastingly tight.

Be your own "fixer" and save much money for better things.

To get perfect results, write to us for and use the Smooth-On Repair Book. Free if you mention this magazine.

Get Smooth-On No. 1 in 6-oz., 1 lb. or 5 lb. tins at any hardware store

SMOOTH-ON MFG. CO.
Dept. 37, 574 Communipaw Ave.
JERSEY CITY, N. J.



MOTORCYCLE BARGAINS

Save 25% to 65%

on Slightly used and Rebuilt Motorcycles, Side Cars, Johnson Motor Wheels, Evans Power Cycles, Bicycles. Send for Free Bargain Bulletin and Money Saving Newsletters. (With hundreds of Bargains in used, rebuilt and new machines, supplies, accessories, etc.)

AMERICAN MOTOR CYCLE CO.
Dept. 427, 2047 W. Chicago Avenue, CHICAGO



SPORT BODIES for FORD and CHEV. 490 at \$34.50

Life-size paper patterns—\$8

You can build your own body at small cost.



UP
UNDER
SLUNG
PARTS
Per Set
\$6.75

We are manufacturers and our quantity production enables us to quote exceptional low prices. Our unique shipping methods save you 73% in FREIGHT CHARGES. Send at once for free particulars on Central Bodies. Our Book "HOW TO BUILD A FORD RACER" sent anywhere on receipt of 25c in cash or stamps. **WRITE TODAY!**

Central Auto Supply Co. Dept. 125, Louisville, Ky.

DIAMONDS

FOR A FEW CENTS
A DAY



MONEY
BACK
GUARANTEE

\$1.50 a
Week
SEND NO MONEY
Looks like
\$350 Solitaire
NO. 61
only \$59.50
We Trust You

Million Dollar
Bargain Book

FREE

Don't send a single penny. Ten days' Free Trial. When the ring comes, examine it—if you are not convinced it is the Greatest Bargain in America, send it back at our expense. Only if pleased, send \$1.50 weekly—at the rate of a few cents a day. This Bargain Cluster Ring with 7 Blue-White Perfect Cut Diamonds can be yours. No Red Tape. No Risk.

Send for it today. It pictures thousands of Bargains. Address Dept. 1724

FREE



J.M. LYON & CO.
2-4 Maiden Lane N.Y.



FREE

140-page Book full of life-size ruled forms, each one completely filled in. The answer to problem and record keeping for any business or professional man.

Send for this Book today

John C. Moore Corporation
(Established 1839)
2124 Stone St., Rochester, N. Y.

MOORE'S LOOSE LEAF SYSTEMS
In Use In More Than
300,000 Offices

Beautiful HOUSES \$900 and BUNGALOWS

CAN BE BUILT FOR AND UP
This and many others in my new book, Building Plans for Modern Homes, will save you hundreds of dollars. One of the most complete and comprehensive books of plans ever published by any architect. New edition just off the press. Nearly 500 floor plans and photographs of bungalows, Colonial houses, etc., costing from \$200 up; gives sizes and cost to build.



FREDERICK H. GOWING
ARCHITECT
191 Tremont St., BOSTON, MASS.

Sent postpaid for \$2.00

SELF-FILLING INK PENCIL "INDEPENDENT"

Meets all requirements. Self-filling, non-leakable, safety cap. Attached clip. Smooth writing gold Style point.

Your Name in Gold—25 Cents Extra

AGENTS WANTED
J. C. ULLRICH & CO., 161 Washington St., New York

Guaranteed Improved Fountain Pen. Eliminates fatigue. Promotes efficiency. Writes uniform. A business necessity.

\$2 By Mail

AGENTS WE START YOU WITHOUT A DOLLAR

Famous Carnation Products—Creams, Soaps, Extracts, Perfumes, Toilet Goods, Household necessities. Widely known line; 200 items, 100% profit, repeat orders enormous. We give agents big concessions. Experience unnecessary. Write today, Carnation Co., 144 St. Louis, Mo.

FASTEN IT WITH AN AJAX EYELET FASTENER

Binds Paper, Cardboard, Leather, Cloth
It Saves Time by Punching the hole, feeding the eyelet and clinching it in one operation. Order from your Stationer

Machine Appliance Corp.
Dept. P. M., BROOKLYN, N. Y.



The Coleman Camp Stove

WHEREVER you go—camping, touring, hunting or fishing—you want good eats and you want 'em quick. Whether it's baked potatoes, ham and eggs, flap-jacks, savory fried trout or a batch of fluffy biscuits, the COLEMAN Camp Stove fills your order in right-now fashion. It fries,

bakes, broils; roasts, toasts, boils—cooks anything you want, any style, any time. The COLEMAN is the only camp stove with ALL these better features:

- Quick Hot-Blast Starter. Full cooking heat in less than 2 minutes.
- Built-in Fuel Tank. Swings outside when stove is in use. Folds inside for packing.
- Built-in Air Pump. Right in the end of the tank. Always there. No chance to lose it.
- Built-in Oven. Nests right into the lid when not in use.
- Built-in Wind-Baffle. Makes camp cooking easy and sure in any weather.
- Built-in Warming Cabinet. Keeps your biscuits and potatoes hot while you fry your fish.
- All Complete—No extras to buy.

THE QUICK-LITE LANTERN is another camping necessity. Lights up the whole camp. Always ready any night in any weather.

Brighter than 20 old-style oil lanterns. Has mica chimney—wind-proof, bug-proof, rain-proof.

Folds in soft-case style. Weighs only 18 1/2 Lbs.

Write us for Descriptive Literature and the names of dealers near you who sell the Coleman Camp Stove. Addr. Camping Dept. F. M. 12.

THE COLEMAN LAMP CO., Wichita, Kans.
Philadelphia Chicago Los Angeles
Canadian Factory: Toronto, Canada



This New Way To Iron Cuts Ironing Time In Half



New Invention Ends Forever Ironing Day Drudgery

Now, once and for all, you can do away with the hardest part of ironing day. No more need you keep a roaring hot fire to do your ironing. No more need you trot back and forth from ironing board to stove. No heavy back-breaking, hot-handled flat irons to carry. No tiring, tedious, drudgery in a sweltering, smothering kitchen, but instead, you can make ironing day delightfully easy, cool and comfortable with the new **Diamond Self-Heating Iron**. You can do your ironing—all of it with one iron—in any room—out on the porch—out-doors in the shade. No wonder housewives are delighted—amazed at its convenience, and pronounce the Diamond Self-Heating Iron the greatest labor-saving invention for housewives of the age.

Beats Electricity or Gas

Cheaper to Operate No home need be without the labor-saving advantage of the Diamond Iron. Gives all the conveniences of the electric or gas iron without the danger or annoyances. Has no hose attachments to break or leak—no cords, tubes nor wires to bother with or replace. Costs only one cent to do the average weekly ironing. Retains its heat—quickly regulated to right heat for any class of ironing. Ready in a minute—simply turn a valve. Absolutely dependable. Lasts a life-time. **Guaranteed.**

What Users Say:

"I am pleased with the Diamond Self-Heating Iron. It surely saves lots of steps, and it is much more pleasant to use."
Mrs. Freeman Crippen, Mich.

"I have used the Diamond Self-Heating Iron for the past eight months, and find it saving steps, does better work in half the time."
Mrs. P. H. Danaker, Conn.

"I bought a Diamond Iron and I will say every woman should have one. I would not sell mine for \$50.00 if I could not get another one."
Mrs. Wm. J. DeShazo, Mich.

FREE Trial

Special Advertising Offer

Try this Iron 30 Days FREE, use it for 4 weekly ironings without risk or obligation. See for yourself how easy ironing is done this new way. Send at once for Special Free Offer and descriptive circular—"A New Way To Iron"—tells all about this invention and how it works. Act now and you will be in time to receive special free trial advertising offer. Write today. Your name and address on a postcard will do.

THE AKRON LAMP COMPANY
34 Iron Street AKRON, OHIO, U. S. A.



AGENTS, \$1200 A Day

If you are making less than this, the position I have open in your town will interest you. Moyer, Pa., made \$164 in one week. Wonderful opportunity. New plan. Simply accept orders. Work is pleasant and dignified. No experience nor capital required. If you cannot work full time I will pay you well for your spare time. Outfit Free to workers. Exclusive territory. Address me personally—say, "Send Agent's Free Outfit Offer."
J. C. STEESE, President.

REMINGTON PORTABLE TYPEWRITER Dealers and Branches Everywhere

\$2.08 GUARANTEED
per gal.



FINEST QUALITY HOUSE PAINT A Real Bargain!

Crosby Ever-Wear Paint at our rock-bottom factory-to-you price. Not a cent paid out to middlemen. A flat saving to you of better than a dollar a gallon. On paint that has been the standby of thousands of customers for more than 20 years.

GENUINE HIGH QUALITY has not been sacrificed for the sake of price. Our paints are ready-mixed for immediate use; all fresh made; no stalling on dealers' shelves. And our iron-clad

MONEY BACK GUARANTEE goes with every gallon sold. This means your complete satisfaction or your money back—promptly and without argument. Test the quality yourself through our

FREE TRIAL OFFER Send your order. Try the paint. If you don't like it, return the balance at our expense and we'll refund your money.

Hand-Book FREE Send today for beautifully illustrated Painter's Hand-Book, showing colors and prices of every kind of indoor and outdoor paint, varnish, stain, enamel, etc. And practical lessons in home painting. Absolutely free on request. Without obligation. Write for it today.

Crosby-Frank Co., 314 Peoria St., Chicago, Ill.

CLEANS WINDOWS IN A JIFFY



The Lightning Cleaner

Cleans thoroughly with less effort. The chemicalized pad loosens the dirt, the rubber wiper dries and polishes. Saves hours of labor and does not muss or splash water. Ideal for homes, stores, shops, hotels, autos, etc. Sent postpaid for \$2. Satisfaction or money back. Agents, Dealers, write for prices.

International Specialties Co., P.O. Box 512, Seattle, Wash.



Build This Phonograph Yourself

TREMENDOUS SAVING IN COST Easy, fascinating work with our SIMPLIFIED PLANS. We furnish blue prints, diagrams, motor, cabinet pieces, ready-built horn, etc. You don't need to be a cabinet maker. A few hours assembling and you will have a fine instrument at one-quarter the regular retail price. **AGENTS MAKE MONEY** making and selling these instruments. Write today for full details and our FREE OFFER. Address

LUPERL PHONO PARTS CO.
2648 W. Chicago Ave. Dept. 12 CHICAGO, ILLINOIS

Get this Book of Factory Prices



Don't wish for a good range—write to Kalamazoo Manufacturers and own one. \$4 to \$15 down brings any range in our catalog on easy-payment plan. 200 styles and sizes. Porcelain enamel, cast iron, steel, malleable, etc. Furnaces, too. Special profit-sharing sale now on for limited time only—greatest money-saving event in years. Write today.

Kalamazoo Stove Co.
393 Rochester Avenue, Kalamazoo, Mich.

A Kalamazoo
Direct to You

Spencerian Personal Steel Pens

No. 1—
College,
fine point,
flexible
elastic.



No. 28—
Congressional;
speedy and
flexible.



No. 48—
Medium
point, all-
round
ability.



No. 42—
Gold and
some
pointed;
smooth
action.

Getting right down to the point—Spencerian Personal Steel Pens are fashioned from finest quality steel into the longest-lasting, smoothest-writing pens that you can buy. Made by seven hand processes! That's why they've been the standard for more than fifty years. And remember there is an exact style for your particular hand-writing.

SPENCERIAN
PEN CO.

349 Broadway, New York

A sample card of one dozen assorted pens for a dime and our hand-writing booklet, free.

State Distributors Wanted AMAZING NEW INVENTION

Patented Hand Envelope Sealer. Seals 60 envelopes per minute. Absolutely no competition; retails for \$4.00. Used and endorsed by largest corporations in America. Recent shipment made to U. S. Government. Tremendous demand! Repeat business enormous! Permanent connection. Sales organizers can make \$30,000.00 yearly. Write or wire for free particulars.

CONSOLIDATED CO., Dept. TT, 100 Boylston St., Boston, Mass.

Sell Shirts

Sell Madison "Better-Made" Shirts, Pajamas, and Nightshirts direct from our factory to wearer. Nationally advertised. Easy to sell. Exclusive patterns. Exceptional values. No experience or capital required. Large steady income assured. Entirely new proposition. WRITE FOR FREE SAMPLES. MADISON SHIRT CO., 503 B'way, N. Y. City

SOUSA

tells you the secret of Success in Music in this Free Book. Send for your copy and details of FREE TRIAL, EASY PAYMENTS on any Conn instrument for band or orchestra. Acclaimed best by world-famous artists.

C. G. Conn, Ltd.
431 Conn Building
Elkhart, Indiana



CONN
BAND
INSTRUMENTS

21 Jewel ~ Extra thin STUDEBAKER The Insured Watch

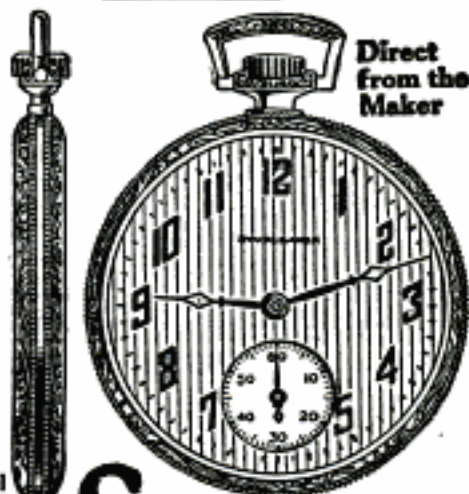

Direct
from the
Maker

New
Model
Extra
Thin

SENT FOR \$1.00 DOWN!

Only \$1.00! The balance in easy monthly payments. You get the famous Studebaker 21 Jewel Watch—Insured for a lifetime; a choice of 54 new Art Beauty Cases; 8 adjustments, including heat, cold, isochronism and 5 positions—direct from the maker at lowest prices ever named on equal quality. Write today for FREE BOOK of Advance Watch Styles.

Fine Chain FREE!

For a limited time we are offering FREE with every Studebaker Watch a beautiful pattern Studebaker Watch Chain. Write now while offer lasts.

Mail Coupon for FREE Book of Advance Watch Styles

Send at once and get a copy of this book—FREE! See the newest, beautiful, advance styles in Studebaker Art Beauty Cases and Dials. Read how you can buy a 21 Jewel Studebaker Insured Watch direct from the maker—save big money—and pay for it on easy monthly payments.

Write! for our free book. It will post you on watch styles and watch values. Send coupon at once. Get Free chain offer today while it lasts.
Studebaker Watch Co.
Dept. 224 South Bend, Ind.

LADIES' BRACELET WATCHES
Handsome new designs and shapes in 14-K white gold—excellent time-keepers. Write for special folder No. 1-W.

STUDEBAKER WATCH CO.
Dept. 224 South Bend, Indiana
Please send me your Free Book of Advance Watch Styles and particulars of your \$1.00 down offer.

Name

Address

City State



GET THIS WONDERFUL RING

IF YOU CAN TELL IT FROM A GENUINE DIAMOND SEND IT BACK
These Amazingly Beautiful CORODITE Gems match the scintillating beauty of GENUINE DIAMONDS in every way. They have the same gorgeous blazing flash and dazzling play of living rainbow fire. Standing the terrific Acid Test of direct comparison. Life time experts need all their experience to see any difference. Prove this yourself.

Wear a Genuine CORODITE and a Diamond side by side on the same finger. If you and your friends can tell the difference send it back, you won't be out a penny. That's fair enough. If you keep the ring, price printed here is all you pay. Remember CORODITE also have the same facet cutting as Genuine Stones.

Make this Test
No. 1 Ladies Solitaire 14K Gold Filled Ring - \$2.84
No. 2 Ladies Pierced Filigree 4 Post Ring, Platinum effect - \$4.19
No. 4 Ladies Hand Carved Basket Ring, Platinum effect - \$3.96
No. 5 Ladies Bridal Blossom Engraved Solitaire - \$4.28
No. 7 Mens Heavy Belcher 14K Gold Filled Ring - \$3.54
No. 8 Mens Massive Hand Carved Hexagon Gypsy - \$3.68

Carat Size Gems. Beautiful Hand Carved and Engraved. Mountings of most modern design, bearing an unqualified 20 year guarantee. Art Leather, Silk and Velvet Lined Gift Cases Free with each ring.
SEND NO MONEY Keep your money right at home. Just send name, address and number of ring wanted and size as shown by slip of paper fitting end to end around finger joint and your ring will come by return mail. Deposit amount shown above with postman. You do not risk a penny as our binding legal guarantee to refund your money in full is attached to every ring we sell. **SEND TODAY.**
E. RICHWINE CO., Dept. 30 19 West Jackson Blvd. CHICAGO, ILLINOIS
Sole Importers Genuine Corodite Gems

Different from all others—the NEW BENJAMIN

AIR RIFLE

Made on a different principle from all other Air-Rifles.

The Benjamin is really a strong air-pump used to compress the air in the air chamber to any degree of power desired. From one to six strokes of the pump give all the force necessary. Each additional stroke gives increased power. The Benjamin works on the same principle as all air-drills and air-hammers—with this difference:

You control the shooting force as you desire. Look at this block of hardwood. It shows how Benjamin power is regulated as you wish.

You can't have accidents with a Benjamin. It's safe, always, because you control the power. The Benjamin never loses shooting force, and has no springs to get out of order or shake your aim. Write us for an interesting folder about this wonderful air-gun.

If your dealer does not handle same, send direct to factory.

(PRICE \$5)
POSTPAID
BENJAMIN AIR-RIFLE & MFG. CO., 615 N. Broadway, St. Louis, Mo.

Ask your dealer for demonstration.

Pacific Coast Representatives
TRAYER & BOWER
Los Angeles, Calif., and San Francisco, Calif.

NO MORE COAL DUST OR WORRY HEAT YOUR HOUSE OR STORE with the **VICTOR** Furnace Oil Burner

WRITE TODAY
E. R. KNOTT MACHINE CO., 1 Ellery St., S. BOSTON, MASS.

MAH JONG SET

Complete with instructions, rules and illustrations, 144 characters, 152 counters, racks, dice and score card. Postpaid, in attractive box, on receipt of \$1.00. (Canada 25c extra.)
ORIENTAL IMPORTING CO., 110 W. 40th St., N. Y.
AGENTS WANTED

MOVIES In Your Home

Our marvellous, practical Movie Machines sell as low as \$5.00—and what's more, we have wonderful films at lowest prices—with a new film rental service. **DON'T MISS THIS!**

Write NOW for Free Catalogue
PARAMOUNT MFG. COMPANY
Box 1371, Dept. M2, Boston, Mass., U.S.A.

DEAFNESS IS MISERY

I know because I was Deaf and had **Head Noises** for over 30 years. My invisible Antiseptic Ear Drums restored my hearing and stopped Head Noises, and will do it for you. They are Tiny Megaphones. Cannot be seen when worn. Effective when Deafness is caused by Catarrh or by Perforated, Partially or Wholly Destroyed Natural Drums. Easy to put in, easy to take out. Are "Unseen comforts." Inexpensive. Write for Booklet and my sworn statement of how I recovered my hearing.

A. O. LEONARD, Suite 226, 70 5th Avenue, New York City

Men's Shirts

From factory to wearer. Easy to sell. Big demand everywhere. Make \$15 daily. Under-sell stores complete line. Exclusive patterns. No experience necessary. Free samples.

Chicago Shirt Manufacturers.
241 W. Van Buren St., Chicago, Factory 228

TAILORING SALESMEN

We Pay You Salary and Commissions

Greatest money-making line in America. Made to measure suits, overcoats, one price, \$33.65, express prepaid, all wool, all wool linings, hand tailored, finest workmanship. No extra charges for style or overize. Bigger advance commissions, weekly salary besides. Protected territory. Apply at once.

GREAT WESTERN TAILORING CO.
Dept. P, 837-841 W. Jackson Blvd. CHICAGO, ILL.

"If I hadn't been all through it myself, I wouldn't have the assurance to say to you 'cheer up.'"
ERICKSON.

The Beginning—1892

Those who wear them say:
ERICKSON LEGS are Wonderful
because they do not chafe, overheat or draw end of stump.



If you have had a recent amputation send for new booklet on TEST LEGS for beginners.
E. H. ERICKSON CO.
38-A Washington Av. N.
MINNEAPOLIS • MINN.

Deformities of the Back

Thousands of Remarkable Cases



An old lady, 72 years of age, who suffered for many years and was absolutely helpless, found relief. A man who was helpless, unable to rise from his chair, was riding horseback and playing tennis within a year. A little child, paralyzed, was playing about the house after wearing a Philo Burt Appliance three weeks. We have successfully

treated more than 50,000 cases in over 20 years.

30 Days' Trial Free

We will prove its value in your own case. There is no reason why you should not accept our offer. The photographs show how light, cool, elastic and easily adjusted the Philo Burt Appliance is—how different from the old torturous plaster, leather or steel jackets.

Every sufferer with a weakened or deformed spine owes it to himself to investigate thoroughly. Price within reach of all.

Send For Our Free Book.

If you will describe the case it will aid us in giving you definite information at once.

PHILO BURT MFG. CO.
53-15 66th Avenue
JAMESTOWN, N. Y.



GET RID OF THIS

with no effort at all!

Here is the easiest way in the world to rid yourself of that useless, joke-inviting, health-menacing paunch! Simply fasten on *Dr. Lawton's Automatic Waistline Reducer*—and the flabby flesh will vanish. Absolutely automatically! For men and women.

DR. LAWTON'S AUTOMATIC WAISTLINE REDUCER



Hour by hour, with every breath you take and every step you make, the *Waistline Reducer's* Vacuum Applicator massages away unwanted bulge. Made of soft, pliable, glove-like rubber. Fits snugly and comfortably to the figure. Weighs but few ounces. Flexible as a handkerchief.

SATISFACTION A SURETY

Dr. Lawton's Automatic Waistline Reducer is sold under a guarantee bond of absolute satisfaction.

Your money back if you do not like it when you get it. Write now—this minute—to Dr. Lawton for full description, convincing literature and low price. Mail the inquiry blank below now to

DR. THOMAS LAWTON

Dept. D-61, 19 W. 70th Street, New York City

Dr. Thomas Lawton, Dept. D-61, 19 W. 70th St., New York City

Dear Sir:—Send me complete description of *Dr. Lawton's Automatic Waistline Reducer*, convincing literature and illustrations, and tell me how low it is priced. This obligates me in no way.

NAME

STREET

TOWN STATE

Fibre-Lite Limbs

Easy Payments—Do Nature's Work. AGENTS WANTED who use Artificial Leg. GOOD PAY. FREE Fibre Sample. DESCRIBE STUMP TO WORMAN CO. 282-P HENNEPIN AVE. MINNEAPOLIS, MINN.

SAVE YOUR HAIR!

STOP HAIR AND SCALP TROUBLES NOW!

Prof. John H. Austin, over 40 years a bacteriologist, hair and scalp specialist, has discovered the best method known to science to stop

- Dandruff
- Itching Scalp
- Oily Hair
- Falling Hair
- Split Hair
- Dry, Brittle Hair

FREE HAIR REMEDY

Trial box to prove its worth, and Prof. Austin's own booklet, "Care and Treatment of the Hair and Scalp." Sent absolutely FREE. Write today.

Prof. JOHN H. AUSTIN
202 Hamburger Bldg. - LOS ANGELES, Calif.



Clear-Tone FOR DIMPLES

Your skin can be quickly cleared of Pimples, Blackheads, Acne Eruptions on the face or body, Enlarged Pores, Oily or Shiny Skin. \$1,000.00 Cold Cash says I can clear your skin of the above blemishes. WRITE TODAY for my FREE Booklet—"A Clear-Tone Skin"—telling how I cured myself after being afflicted for fifteen years.

E.S. GIVENS, 129 Chemical Bldg., Kansas City, Mo.

Wrestling Book FREE

Be an expert wrestler. Learn at home by mail. Wonderful lessons prepared by world's champions Farmer Burns and Frank Catch. Free book tells you how. Secret holds, blocks and tricks revealed. Don't delay. Be strong, healthy. Handle big men with ease. Write for free book. State your age.

Farmer Burns School, 5774 Railway Bldg., Omaha, Neb.

BURN Home Made GAS

In Your Old Wood or COAL STOVES

Change your coal or wood stove into a gas stove in 3 minutes. A Child can do it. Burn kerosene Vapor Gas—hotter than coal or wood and costs less. Safe and simple.

FREE TRIAL

Just turn a valve and get even heat instantly. No ashes, no dirt, no smoke, no wood to chop or carry. No fires to build and feed. No fuel wasted. Cooks and bakes better. No damage to stoves. Makes its own gas from common coal oil, cheapest, cleanest fuel. Guaranteed five years. Money back if not satisfied after 10 days' trial. Write for FREE folder with proof and SPECIAL OFFER.



AGENTS WANTED

410 Simplex Bldg. SIMPLEX UTILITIES MFG. CO. 1428 No. Wells St., Chicago



**Ford
Auto
FREE!**

We have a plan whereby our active workers can get a Ford without cost, in addition to their big cash earnings. Get the plan—quick!

"I have averaged \$7000

**Per Year for Three Years—Have Made
Over \$90 PROFIT in One Day"**

That is the statement of Frank DePries, one of our live-wire representatives. Keeton of Mississippi made \$252 on his first sale. Vickers of Alabama made \$118 in one week. Conant quit a \$6,000 job to come with us.



DePRIES

AGENTS WANTED

We need more men like these, because the demand for our Super Fly-Fyter is growing by leaps and bounds. Sells to garages, stores, factories, schools, homes, hotels, auto owners. Approved by the Underwriters. If you are willing to work and ambitious to make some real money, get our plan. You need no experience, as we train you without cost for the work. No great capital required. Good territory going fast. Better write us at once.

THE FYR-FYTER COMPANY

1730 Fyr-Fyter Bldg.,

Dayton, Ohio

AGENTS

Every woman wants this handy kitchen convenience

If a profit of 79¢ each on 10 to 30 sales a day appeals to you—line up with us. Tyler's Ideal Fibre Cutter is "the handiest tool in the kitchen" and our new Sales Manual gives you a selling plan that really works. *You are sure to succeed.*

House-to-House Salesmen
make from \$40 to \$100 Weekly

Write to

M. H. TYLER MFG. CO.
Dept. M-2 Muncie, Ind.



1,000,000,000 GERMAN MARKS for \$1.00

or 2,500,000,000 for \$2.00. Send Money Order to
PUBLIC STATE BANK, Dept. 102, Chicago, Ill.



**"Been on a
vacation
Bill?"**

"No, Jim — I've stopped smoking. Gained six pounds in a week. You know how I used to smoke—a package of cigarettes and a cigar or two a day—it sure had some hold on me. But I'm cured—

took a scientific home tobacco treatment—fixed me up in two weeks.

"Wasn't hard on me at all—noticed improvement the first day—I feel like a new man. It didn't interfere with my work—didn't leave any druggish after-effects—the money I saved in the last two weeks has paid for the treatment alone.

"Why don't you take it! It has cured men like you and me for over forty years—it is a doctor's individual prescription that sure fixes you up. Just send the coupon for full information NOW. No obligation. All correspondence is strictly confidential."



**"A Doctor's
Prescription"**

The Keeley Institute, Dwight, Ill.

Please send me, without any obligation on my part, your free booklet which will tell me how to rid myself of the tobacco habit.

Name.....

Town.....

Street..... State..... P. M.-4

30 DAY TRIAL SAVE BARBER BILLS!



CUTS
TRIMS
BOBS

**FAMILY
BARBER
OUTFIT**

High Grade Close Cutting Steel Clippers, Fine Barber Comb and Regulation Steel Barber Shears. A guaranteed full size, high grade, finely finished, durable, practical outfit. Fine for Cutting, Shaving, Trimming Hair or Neck. Sore and Ears. Money Barbering your family and friends. Mothers can save Time and Money Cutting or Shaving Children's Hair. Our Regular price \$4.00. Special price only \$1.95. Order today. When outfit arrives, per postman only \$1.95 and postage. Try outfit for 30 days. If dissatisfied, return in good condition and amount paid for outfit will be refunded. If you wish to save postage, send \$1.95 with order and try outfit under same guarantee. **STERLING CO. R-20 Baltimore, Md.**



CAMERAS

Over a Hundred Styles and Sizes
Send for new illustrated catalog showing latest reduced prices. It's Free.

10 days' trial given

SENECA CAMERA MFG. COMPANY
300 Central Avenue Rochester, N. Y.

\$3 Cash Buys Typewriter



Balance Only \$5 Monthly
Save 35 to 60% on all standard makes—Underwood, Royal, Remington, etc. Every machine thoroughly rebuilt and **GUARANTEED**. Try five days at our expense before you buy.

WRITE at once for Free Descriptive Circular and Special Low Prices.

**5
DAYS
FREE
TRIAL**

WYNN TYPEWRITER EXCHANGE 13 Reference Bldg. Kansas City, Mo.

\$1 Brings This Genuine DIAMOND

Easy for you to own this beautiful ring or give it as a present. Simply send \$1 to us today.

10 DAYS' FREE TRIAL

Wearing 10 days and if you don't agree it is an amazing bargain, return it and we will refund your money. If satisfied, pay \$1 a week until \$32.50 is paid.

FREE catalogue. Diamonds, Watches, Jewelry, \$10 to \$1000. All on long credit. Wonderful values. Est. 1890 Address Dept. 426

Blue white perfect cut genuine diamond, 18 kt. white gold hand engraved and pierced mounting. Rare beauty.
Only **\$32.50**

BAER BROS. Co.
6 MAIDEN LANE - NEW YORK

WINDOW SIGNS



AGENTS 500% PROFIT

Genuine Gold Leaf Letters

GUARANTEED TO NEVER TARNISH



For store fronts, office windows, Bank windows, Office Doors, Panels, Board Signs, Trucks, Automobiles and Glass Signs of all kinds. Anyone can put them on and make money right from the start without previous experience. All you have to do is to show your samples; the letters are very attractive and easy to sell. Letters costing 3½¢ sell for 25¢. One agent says: "Your Letters are the best thing I have seen in years: I have made \$125.00 the first week and still going strong." Paul Clark says: "Smallest day \$28.70." H. Gilder made \$835.00 in six weeks.

\$60 TO \$200 A WEEK

GENERAL AGENTS—It is easy to appoint sub-agents for this line. We pay you 20% cash commission on all orders we receive from local agents appointed by you anywhere. We allow you 50% discount on your own orders. You can sell to nearby trade or travel all over the country, as you please. Large demand for window lettering everywhere. Write today for free sample, full particulars and liberal offer to general agents.

Metallic Letter Co., 433-B N. Clark St., Chicago

What I Learned About Old Age

By Byron C. Kelley,
A.M., LL.D.



I recently had the most startling disclosure of my life on the subject of old age. I am approaching 40 years old myself. I had begun to wonder if I would soon begin to "break"—to lose my old-time pep and aggressiveness, my stamina and resistance against diseases, like most other men of this age. I wondered if I would soon be subject to the class of ailments which seem so prevalent among men past 40. Then, through a mutual friend, I made the acquaintance of a certain scientist, a member of the American Association for the Advancement of Science, who has recently brought to light most interesting facts about the peculiar conditions common to men past middle age.

65% Have Gland Trouble

I learned that 65% of all men past a certain middle age have a disorder of a little gland, called the Prostate. And prostate disorder not only is the direct cause of much distress, often necessitating operation, but it displays itself in many parts of the body.

Common Middle Age Ailments

Here is an important cause for many ailments which heretofore have been simply ascribed as "old age" symptoms—sciatica, aches in back, legs, and feet, frequently nightly risings, nervousness and irritability, often go along with it. And I learned how, by an astonishingly simple new method, that these disorders could be eliminated in a short time without drugs or operation—by an amazing new treatment that reaches this gland directly—yet is so convenient that anyone can apply it in their own home.

10,000 Men Find Relief

But most surprising of all, I found that 10,000 men have already found relief through this amazing discovery. Statesmen, bankers, lawyers, doctors in every section of the country are using and endorsing the method. And it is within the reach of every one. There are no drugs, no books, no electric rays.

Explained in FREE Book

If you are troubled with any of the disorders mentioned, if you have chronic constipation or Prostate trouble, you should learn the facts about this discovery at once. A vitally interesting book written by this scientist called "Why Many Men Are Old at 40," will be sent free if you request it at once. It describes this splendid treatment and shows how you may regain much of your youthful vigor and be free from certain disorders. No obligation. But write at once—the edition is limited. Simply mail request to **The Electro Thermal Company, 2132 Main Street, Steubenville, Ohio**, the concern that is distributing these books for the author.

Taxidermy Book FREE

Mount Birds



We teach you by mail to stuff and mount all kinds of Birds, Animals, Game Heads. Also to tan skins and make rugs. Be your own taxidermist. Decorate your home with your beautiful trophies or increase your income selling specimens and mounting for others. Easily, quickly learned in spare time by men and women. Highest endorsements by thousands of students. Write today for our great free book "How to Mount Birds and Animals" Free—write today. N. W. School of Taxidermy 9774 Elwood Bldg., Omaha, Neb.

WHY NOT IMPROVE YOUR PERSONAL APPEARANCE?



Send for booklet showing photos of Men with and without the PERFECT LEG FORMS for BOW LEGS and KNOCK-KNEES. Also BRACES for children for PERMANENT CURE

Perfect Sales Co., 140 N. Mayfield Ave., Dept. 5, Chicago, Ill.

AGENTS: \$6 PER DAY AND UP

Selling concentrated, non-alcoholic food flavors. Always fresh. Put up in collapsible tubes. Ten times the strength of bottled flavors. Guaranteed under U. S. pure food laws. All flavors. Sells in every home. Used every day. Not sold in stores. Big demand. Big repeater. 100% profit.

Men or Women can make big money. Haut sold over \$300 in one month. You will find this a big, easy seller and a sure repeater. Must satisfy customers or money back. Write for territory and sample outfit. Get a big line of customers. Get repeat orders every month and have steady income. Write quick.

AMERICAN PRODUCTS CO., 235 American Bldg., Cincinnati, Ohio



ACT QUICK WRITE TODAY

I PAY MEN \$75⁰⁰ a Week and up

I pay men \$75.00 a week and up by my plan which I want to send you at once. Be your own boss, work where and when you like. You can do fine even without previous experience. **Biggest values—positively sell on sight.**



Profits in Advance

My plan pays biggest profits and commissions in this line, paid in advance, we attend to delivering orders and collections.

Sell *fine* Tailoring



Astonishing values get orders easy when you show samples of our tailored to order, all wool, suits and overcoats, all one price \$31.50. Our advertising helps you take orders quick.

FREE

This big, fine sample outfit furnished free, contains 100 all wool big samples, all one price \$31.50, fine colored, fashions, stationery, supplies, tape, etc. All in classy fine carrying case. Also complete sales manual, we place you in Big Money class.

\$31⁵⁰ ONE PRICE
W.Z. Gibson

W. Z. GIBSON, Inc., CHICAGO, ILLINOIS
161 West Harrison Street, Dept. D-11

Please send me your plan for \$75 a week and up, also FREE outfit and sales manual.

Name _____

Address _____

City _____ State _____



MONEY in Printing

Printers' Wages are now so high you can make big money in spare time. No experience necessary. Our instruction book makes all easy. Presses \$12 up. Soon pay for themselves. Write for catalog presses, type, paper, cards. **THE PRESS CO., X-37 Meriden, Conn.**

Genuine
DIAMOND
Mounted in
1/2 Karat Setting \$2 down

**NO RED TAPE
—NO DELAY**
Simply send \$2.00 for this price - smashing diamond ring offer.
A perfectly cut, guaranteed blue-white, genuine diamond is set in a 3/4 Karat white gold cup. Latest design, hand engraved mounting of 18 K.

TEN MONTHS TO PAY
We take all chances—if you are not satisfied at the end of ten days, return the diamond ring to us and your deposit will be refunded. After trial pay balance \$4.75 a month for ten months. **Price only \$49.50.** A legal guarantee bond as to quality and value accompanies each ring. **ORDER NOW.**

FREE BOOK OF GEMS
Complete Jewelry Catalog sent FREE on request. **FULL YEAR TO PAY** on everything in our two million dollar stock. Address Dept. 1005. Established 1905

ROYAL DIAMOND & WATCH CO.
170 Broadway - New York

MONEY SILVERING MIRRORS

Plating and refinishing autolights, radiators, beds, chandeliers, stoves, tableware. Outfits. Methods free.
CLARENCE SPRINKLE, Dept. 25, Marion, Indiana

SEND NO MONEY
5 DAYS FREE TRIAL

"INVINCIBLE" Rebuilt GUARANTEED STANDARD No. 10 Self Starter Model REMINGTON

A real bargain. All late improvements—84 characters, standard type, back spacer, etc. As new in appearance and operation as modern methods and expert mechanics can produce. Many other standard makes. Time payments if desired. Shipments from nearest of our 29 stores. Order now or write for circular. Resident salesmen wanted.
American Writing Machine Co., Est. 1880
Factory, 452-R Central Ave., Newark, N. J.

Sells for \$1.25 — Agent's Sample 65c!



ITS THE POINT. HAS EIGHT GROOVES FOR INK TO FEED

Imported from Japan

"It makes Carbon Copies"

Guaranteed for One Year

Hustlers Make \$20 Daily! Money refunded if you don't think it the best pen you ever wrote with. Just Out! Up to 150 per cent Profit. Send for quantity price list and distributing plans.

F. SPORS & COMPANY

333 Main Street

Lesueur Center, Minnesota

New
**Self-Filling
Bamboo
Fountain Pen
with
Stylo Point**

5-Rooms ALADDIN 548

We Pay the Freight



You can buy all the materials for a complete home direct from the manufacturer and save four profits on the lumber, millwork, hardware and labor.

7-Rooms ALADDIN 1068

Large living room, dining room, kitchen, pantry, three bedrooms, clothes closets, bath. Semi-open staircase and rear porch. Four bedrooms plan with grade cellar entrance at same price.



12-Rooms ALADDIN 1932



Dutch Colonial for wide inside lots or narrow corner lots. Full ceiling heights entire second floor, sewing room, columned and inset front entrance.

Price includes all lumber cut to fit; highest grade interior woodwork, siding, flooring, windows, doors, glass, paints, hardware, nails, lath, roofing, with complete instructions and drawings. Freight paid to your station. Permanent Homes—NOT PORTABLE. Many styles to choose from. Write nearest mill today for FREE Money-Saving Aladdin Catalog No. 935.

The ALADDIN Co., BAY CITY, MICHIGAN

Wilmington, North Carolina; Portland, Ore.; Toronto, Ont.

A WALL FULL OF PHOTOS

Easily displayed. The transparent glass heads do not detract when you use

MOORE PUSH-PINS

Glass Heads—Steel Points

Harmonize with any color decoration

Moore Push-less Hangers

"The Hanger with the Twist"

10c pkts. Sold everywhere.

In Canada 10c

MOORE PUSH-PIN CO., Philadelphia, Pa.

Delivered to You Free

for 30 days trial on approval. You can have your choice of 44 Styles, colors and sizes of the famous RANGER Bicycles. Express prepaid. Factory-to-Rider Prices save you \$10 to \$25 on your bicycle.

12 Months to Pay if desired. Many boys and girls easily save the small monthly payments. Parents often advance first payment.

Tires best quality, at factory prices, express prepaid. Lamps, wheels and equipment, low prices. Send No Money, do business direct with makers.

Mead Cycle Company
Dept. 108 Chicago

Write today for free Ranger Catalog, factory prices and marvelous easy payment terms



This Wonderful Invention!

Converts any stove into a gas stove. OXO-GAS is made from kerosene and air (mostly air). Cheaper, cleaner and more efficient than coal. Eighteen different models for all purposes.

Responsible distributors wanted

GLORIA LIGHT COMPANY 137 N. May Street CHICAGO, ILL.

"I WAS AMAZED by the wonderful FARMING OPPORTUNITIES in Canada" —

Said the Editor of a Famous Farm Paper



\$20.00
Per Acre
Average
Price

"On my recent tour through Canada via the Canadian National Railways, with frequent stopovers and motor trips into the country, I was absolutely amazed by the farming opportunities I saw.

"Not only world-record grain production in quality and in bushels per acre, but prize-winning beef and dairy cattle, draft horses, sheep and poultry, huge potato crops, vegetables of all

kinds, as large and perfect as I have ever seen.

"I was surprised, too, at the towns and cities, schools, agricultural schools, universities, grain elevators, stock yards, the many thousands of miles of railroads with frequent branch lines and many shipping points, the many good dirt and gravel roads."

NEW and ATTRACTIVE TERMS LOW TAXES — INCREASING VALUES

To assist actual farmers purchasing land the Canadian National Railways have adopted a new policy of terms of payment which will make it easy to acquire title from the proceeds of the farm. The farmer need not fear adverse crop years. Our terms will protect him. You can buy land unsurpassed for fertility for an average of \$20 an acre. Our booklet shows the yield per acre. No tax at all on buildings, improvements, animals, machinery or personal property.

GET FREE BOOK TODAY

Our FREE illustrated book tells what others have gained by going to Canada. Read the book. You'll be convinced there is a better chance for you. Send your name and address for the book now—before it is too late. Let us help you—our advice is free and without obligation. Send now!

WHY DON'T YOU TAKE ADVANTAGE OF THIS PROSPERITY OPPORTUNITY?

There are still good farms and millions of acres of fertile land to be had at very reasonable prices and terms. Others have gone to Canada on just such farm lands and with the same opportunities you'll find. They have prospered and gone ahead. Any man who investigates as this famous Editor did is equally strong in praising Canada's farm opportunities. It's not too late for you to share in the prosperity to come. Canada's 1923 wheat crop broke all previous records. One-fifth of the world's wheat supply is produced by just a few thousand Canadian Farmers!

Special Excursion Rates

Reduced railway fares are in effect for landseekers and their effects to encourage inspection along the lines of the Canadian National Railways. Personally conducted excursions will also be arranged.

L. B. BOYD, Supt.

Land and Colonization Dept.
Canadian National Railways

Desk 434, 4th &
Jackson Sts.,
St. Paul,
Minn.

L. B. BOYD,
Supt., Land &
Colonization Dept.,
Canadian National Railways,
Desk 434, 4th &
Jackson Sts., St. Paul, Minn.
Dear Sir:—Please send me your free illustrated book on Canada.



Name.....
Address..... R.F.D.....
Town..... State.....

I want to Pay You
\$85 a week

Man or Woman
 Send for my proposition, I pay men and women \$85.00 weekly to as high as \$36.00 per day for either all or spare time help. No experience necessary.

Sell PRINCESS RADIUM LINGERIE
 Charming ladies lingerie and hosiery, pretty, low priced, sells on sight, actually. Miss Grace James averaged \$36 a day, spare time; R. G. Thompson earned \$53 in one day. You can do as well, we tell you how.

Profits in Advance
 Your profits in advance, we ship and collect. You show goods and mail us the orders. Nothing in any store compares in beauty and value to "Princess Radium" lingerie and hosiery.

High Grade—Steady
 Unusual opportunity for big cash quick, write for plan and exclusive territory, build a steady income for life. District managers wanted. Territorial rights going fast, don't delay, write now.

Free
 Handsome photos from actual models and samples of genuine "Princess Radium" silk, free.

ROBERTS-FRANK & CO
 1733 Irving Park Blvd
 DEPT 12523 CHICAGO

BATHROOM FLOORS

SANITARY AND ATTRACTIVE

You will always take pride in your Everlasbestos Floors. Always clean, good looking, no seams or edges to collect dirt. Costs less than other permanent floors.

Everlasbestos Flooring

for covering old floors or in new buildings. Laid one day, can be used the next. Superior ingredients and perfected directions for laying make satisfaction certain. Widely used in stores, offices, public buildings. Write for catalog and free sample.

Everlasbestos Flooring Co.
 Dept. P, 55 North St., Rochester, N. Y.



HANES For downright Underwear value

Hand Forged Razor Steel Blades, No. 57



A GENUINE \$2 KNIFE FOR \$1.18 POST PAID

Direct at Factory Prices

This \$2 KNIFE \$1.18 Postpaid
 Hand Forged Razor Steel Blades
 Handy shaped Blade makes this knife best for mechanics, sportsmen and farmers; light but strong; re-sharpened easily. Stag handle. German silver finish; blades file tested, hand forged from razor steel and warranted.

Sample \$1.18 3 for \$3.00 Postpaid.

Send for our 100-page List and "HOW TO USE A RAZOR" FREE

MAHER & GROSH CO., 106 A St., Toledo, Ohio

17c
 a Day
 Pays for
 this
 Beautiful
 Rocker

Tapestry or Velour

Over 1000 other bargains, Furniture, Rugs, Lamps, Silver, China, Blankets, Stoves, etc. **Save big money** at our **Factory-to-Family** prices. Pay as little as \$3 down; up to a year and a half to pay balance. Get all your Furnishings at once—pay as you use. Thousands buying this new way.

Big Catalog FREE
 New Spring "Larkin Book of Better Homes." Shows everything for parlor, porch, dining-room, bedroom, kitchen. **Bargain Prices** on famous Symphonola Phonographs. Also Symphonola Pianos, Player-Pianos in genuine Mahogany, Walnut, Fumed Oak. Free trial. Up to 4 years to pay. Satisfaction or money back. Check below article interested in.

Home Furnishings
 Pianos or Players
 Phonographs

Cut out this adv.—write TODAY for FREE Book.

Larkin Co Inc.
 Dept. 439 BUFFALO, N. Y.
 Peoria, Ill. Chicago, Ill.

FREE
 Fine Tone Musical Instruments
\$20

We have a wonderful new copyrighted system of teaching note music by mail! To first pupils in each locality we will give free a \$20 superb Violin, Tenor Banjo, Ukulele, Hawaiian-Guitar, Banjo, Mandolin, Banjo-Ukulele, Banjo-Mandolin, Cornet or Banjo-Guitar, absolutely free. Also teach Piano and Organ. Very small charge for lessons only. Free lessons will teach you several pieces. Over 100,000 successful players. We guarantee success or no charge. Complete outfit free. Write today, Dept. 377. No obligation.

SLINGERLAND SCHOOL OF MUSIC, 1815 Orchard Street, CHICAGO, ILLINOIS

\$25 A DAY
 Selling Suits

Fifth Ave. New York Custom Tailors

We want agents to sell advertised brand all wool tailored to measure suits and overcoats, direct to wearer. Lowest prices, sell on sight. No capital or experience required. Big line, swatch samples free. **Biggest commissions** paid daily. **Auto free to Agents.** Write **MONARCH TAILORING CO., 100 Fifth Ave., Dept. 1, NEW YORK**

MODELS 2.00 TO 10.00
Ingersoll
 RELIABLE WATCHES at LOW PRICES

Build Sportsman's Ideal Ford DeLuxe

With
Fordspeed
Body—
6 Models



Mount One on
your Ford
\$2900
Up

8-16
Overhead Valves
Selective Transmissions

Sport Fenders Underlung
Sport Fenders for
Standard Fords

Observe the beauty of this body and the wonderful change in the lines of a Ford. Fordspeed Bodies Offer Class—Quality—Variety—Reasonable Prices. Bodies are completely assembled and finished in most attractive sport colors—all ready to be set on chassis. Twelve complete sport cars on DISPLAY in our showroom, include DeLuxe Sport cars of extreme elegance and distinction, speedsters of marvelous snap and beauty, racers with full speed equipment for road track. Come and inspect the exhibit. If too far, write your New York friend to investigate for you, or get our free catalog with exact photographic reproductions of all models.

THIS MONTH'S SPECIALS

	Price	Now		Price	Now
Spinal Gear Magneto Drive	\$20	\$13.95	Speed & Power Camshaft	\$19.00	\$ 9.95
Underlung Fenders	15	9.50	Overhead Valves	\$7.75	44.75

Satisfaction or Money Back Guarantee. 50% with order, balance on delivery
H. J. FORD SPEED & POWER EQUIP. MFRS., 250 W. 54th St., New York, 2nd Floor

Safe in Rough Water!

NEVER mind the rough weather! Extra wide Tumble Home makes

Kennebec Canoes the safest to use. Sturdiest, lightest quality canoe. Low priced. Guaranteed 5 years.

SEND FOR FREE CATALOG with special prices and dealer's name.

Kennebec Boat & Canoe Co., Dept. M-21, Waterville, Me.



FREE
CATALOG

KENNEBEC

"Alpha" All Metal Circular Saw Bench



Small enough to be portable. Large enough to build a garage. With a 6" saw blade will cut off and rip 1 1/2" thick. Price \$40.00 f. o. b. New York. No expensive installation, just connect a 1/2 HP. motor to your electric light socket. Will carry an 8" dia. Saw Blade.

For full information and particulars write to

ALPHA FOUNDRY & ENGINEERING CO., Inc., 249 W. 34th St., New York N. Y.

SQUAB BOOK FREE!



Squabs are selling at highest prices ever known. Greatest market for 20 years. Make money breeding them. No mixing feed, no night labor, no young to attend. Start small, grow big. Start now. Read how our customers sell squabs for \$12 a dozen. We have been established for 23 years. Better look into this. Let us send you, at no cost to you, our big, illustrated free book telling how to make money breeding squabs. Address

Plymouth Rock Squab Co., 634 HSt., Melrose Highlands, Mass.

Why Burn Coal

or wood when you can burn gas in your stove or heater by installing a Uni-Hets Kerosene Burner (with exclusive 1524 features) in five minutes time. It gasifies common kerosene to the hottest and cheapest fuel known. Does away with dirt and high fuel cost. Heat regulated to any degree by valve. Increases stove efficiency 100%. Has brought joy and economy to thousands. FREE TRIAL. Save its cost in 30 days. Write quick for full particulars and introductory price.

Special Offer to Agents

Today's fuel prices make the Uni-Hets a big money maker for agents. We have made 20 heating devices for 23 years. Acorn Brass Mfg. Co., 457 Acorn Bldg., Chicago, Ill.

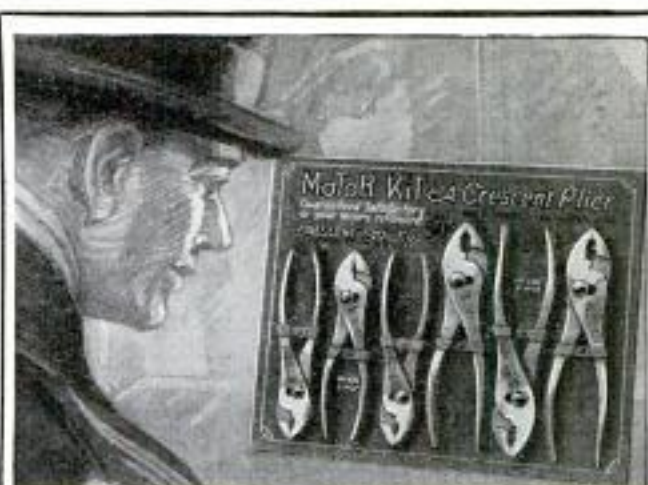

"Give me two Crescent MoToR KiT Pliers"

"One for the house and one for the car"

They are just as necessary to the house as they are to the garage. The housewife needs them, the children's toys can be repaired, the radio outfit adjusted, and countless other things come up that require the use of pliers. MoToR KiT Pliers are THE PLIERS for home use because of their sturdy construction, absolute dependability and wide range of usefulness. Five or six inch sizes at 50c each. Hardware or accessory stores.

Crescent Tool Company

210 Harrison St.
Jamestown
N. Y.

Originators
of the
Crescent
Wrench



CRESCENT
TOOL CO.,
Jamestown, N. Y.

Gentlemen:

Please send me
5-inch Motor Kit Pliers
and 6-inch Motor Kit
Pliers. You will find
\$ enclosed.

Name

Address

My dealer's name

Address

CRESCENT TOOLS

Floor Surfacing Pays Big Profits

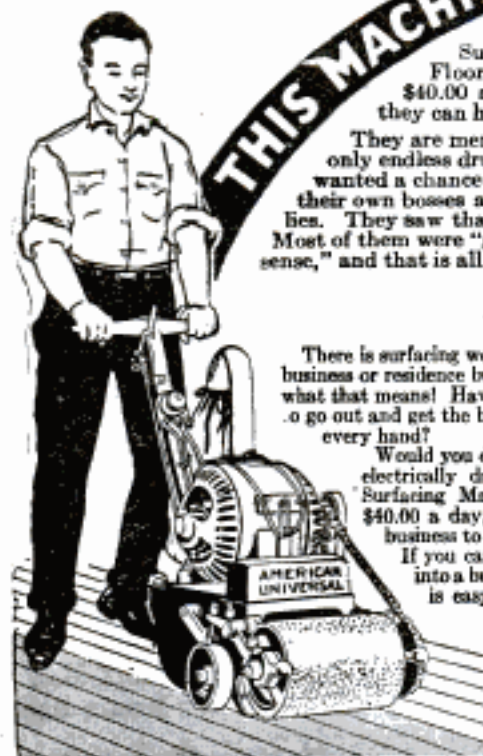

THIS MACHINE EARNS YOU

Young men, middle aged men, and older men whom we started in the Floor Surfacing business with American Universal Floor Surfacing Machines make from \$25.00 to \$40.00 and more per day and get all the business they can handle.

They are men from factory, store and office jobs who saw only endless drudgery ahead for them as wage earners. They wanted a chance to "get somewhere," to make real money, to be their own bosses and to build a future for themselves and their families. They saw that chance in the Floor Surfacing game and grabbed it. Most of them were "greenhorns" at this business, but they had ambition, energy and good sound "horse sense," and that is all any man needs to succeed as an American Universal Floor Surfacing contractor.

Every New Floor Must Be Surfaced Every Old Floor Needs Resurfacing

There is surfacing work to be done in every new and old business or residence building in your town. Think man, what that means! Have you energy and "get-up" enough to go out and get the business that is waiting for you on every hand?

Would you don a pair of overalls and guide an electrically driven American Universal Floor Surfacing Machine over a floor for \$25.00 to \$40.00 a day, until you can build up enough business to hire others to do the work for you?

If you can and will do so we can help you get into a business that is not overcrowded, that is easy to manage and operate, easy to build and enlarge; a business that

requires very little capital, almost no operating expense and one that can be made to pay big, handsome profits from the very first day you start. No town or community is too small. We can show you successful floor surfacing contractors in villages of 100 people.

No Experience Necessary

Any intelligent man can learn to operate the electrically driven American Universal Floor Surfacing Machine in half an hour, and with a few days' practice, can actually do the work of six men scraping by hand. And with the American Universal you can do better, smoother and more uniform and beautiful work than any man living could ever do by hand.

Write Now for Particulars. Send your name and address to us today with just a note saying, "Tell me how I can get into the floor surfacing business." We'll send you full information about the wonderful opportunity open to you. We'll tell you all about the American Universal Machine, what it does, how it works, what it costs, and give you letters, facts and figures that will cause you to do some tall thinking. Do it right now before you lay this book aside.

The American Floor Surfacing Machine Co. 823 So. St. Clair St., TOLEDO, OHIO

\$25⁰⁰
Per Day

Genuine Luxite DIAMOND
If you can tell it from a diamond send it back.
14 K. G.O.L.D.S.
\$3.49
FREE LUXITE DIAMOND SCARF PIN

Perfect 1 carat Blue White Luxite Diamond of dazzling brilliancy, set in a 14K. Gold S. Men's heavy belcher favorite ring. Only experts can tell that you haven't paid \$150. Guaranteed to keep brilliancy forever. Art leather case given with each ring. Half-price during this sale, **\$3.49**

FREE: Order quick and get 1 carat Blue White Perfect Luxite Diamond Solitaire Scarf Pin Free. Not even cost now. Pay postman for ring on arrival. Money back after inspection if not satisfied. Be sure and send paper strip for ring also.

GARFIELD IMPORTING CO. 3839 W. Roosevelt Rd., Dept. 279 CHICAGO

SEND for the INTERNATIONAL CATALOG
Our set price list. Full line of auto bodies and accessories for Ford at Wholesale Prices. Save big money on bodies by buying direct from factory.

Factory to Consumer direct—Pay only one cent.

INTERNATIONAL BODY WORKS, Dept. 7, 914 W. Ohio Street, CHICAGO, ILL.

NEW Laughing Frog FUN FOR ALL THE FAMILY Keeps you guessing when—where he will jump. Everybody's talking about this laughable toy—get yours today, 15 cents each, 2 for 25 cents. Do not send stamps. **FREE!** Boys—MAKE MONEY—sell 'em to your friends. FREE! our catalog of other specialties. Agents Wanted.

PITTS NOVELTY SALES CO., 561 W. Washington St., Chicago

SHAW MOTOR ATTACHMENT MAKES YOUR BIKE A MOTORCYCLE!
A high grade 2 1/2 H. P. motor attachment quickly clamped on any bike frame. Speed 4 to 40 miles an hour. 90 to 125 miles per gallon of gas. **Special Low Price Now!** Write today for Complete Description and Special Low Prices on SHAW Motor Attachments and the SHAW Complete Motorbicycle.

SHAW MANUFACTURING COMPANY
Dept. 37
Galesburg, Kansas

RAISE BELGIAN HARES
New Zealand Reds—Flemish Giants—American Blues
FOR US—BIG PROFITS—WE SUPPLY STOCK AND PAY \$2 TO \$8 EACH. Also other fur bearing animals; easily raised anywhere. Large Catalog and Contract **FREE!** Big Illustrated Rabbit Book, and copy of our large small stock magazine 10c.

OUTDOOR ENTERPRISE CO., 1015 G. E. Bldg., Kansas City, Mo.

'Saws Logs—Falls Trees—Buzzes Branches—Does Belt Work
10-Year Guarantee—Cash or Easy Terms.

One Man Saws 15 Cords a Day!

—Easy with the OTTAWA Log Saw! Wood selling for \$3 a cord brings owner \$45 a day. Use 4 H. P. Engine for other work. Wheel mounted—easy to move. Saws faster than 10 men. Shipped from factory or nearest of 10 Branch houses. Write for FREE Book—"Wood Encyclopedia"—today.

OTTAWA MANUFACTURING CO.
1741-T Wood Street, Ottawa, Kansas
Room 1741-T Magee Bldg., Pittsburgh, Pa.

\$50 a Week EASY AGENTS Free Sample Offer

You can start a big paying business at once. Don't wait. Get big money. We tell you how—selling the famous E-Z Self-Heating Sled Iron. No experience necessary. **Easy to sell.** Possibilities great. Every home a prospect. **Satisfaction guaranteed.** Absolutely safe. Thousands in use. Write today for proposition.

Enterprise Tool & Metal Works, Dept. 34, 2441-D N. Western Ave., Chicago



Pleasure and Profit With a "KING" Saxophone

IT'S so easy to learn to play the famous KING saxophone! A few weeks' practice and you can play popular music—then join a band or orchestra and make good money playing for dances and other entertainments.

"KING" Band Instruments and Saxophones are easiest to play because they are built acoustically correct. Scientific design, finest skilled workmanship, careful supervision at each phase of construction make "KINGS" the most perfect instruments in the world. The tone quality is impossible to duplicate. Leading bands and orchestras insist upon "KINGS." Let us send you one for 10 days' free trial.

Free Trial—Easy Payments

"KING" Band Instruments and Saxophones are fully described in beautifully illustrated circulars. Write today for complete information about our ten days' free trial and our easy payment plan on any instrument. Ask for bargains in rebuilt instruments; old ones taken in trade.

THE H. N. WHITE COMPANY
5211-50 Superior Avenue Cleveland, Ohio



How Did Your Garters Look This Morning?

Quite as important as anything you wear are your garters. Keep them fresh and lively. Ask always for Bostons for better quality. Sold everywhere.



GEORGE FROST COMPANY, BOSTON
MAKERS OF VELVET GRIP HOSE SUPPORTERS
FOR ALL THE FAMILY

THE SCREWDRIVER THAT HOLDS THE SCREW

As Good as a Third Hand in Assembling anything from a Watch to an Automobile



Appeals Especially to Radio amateurs and professionals. A wonderful (patented) Improvement.

Jobbers, Dealers and Agents. Favorable discounts
\$1.00 Postpaid **THE COBURN TOOL CO., 114 Bedford St., Boston**



"Lighting Fixtures"

READY TO HANG
(Direct from Manufacturers)

Completely wired, including glassware. New designs. Send for catalogue No. 24. Send for DEALERS' proposition.

ERIE FIXTURE SUPPLY CO.
STA. A ERIE, PA.

Be Independent!

Own a Grape Fruit and Orange grove—Truck or Poultry Farm. Increase your income. You can start a grove today under our new plan and have a Home and Income in Sunny Florida on the easiest terms imaginable. Any size Farm. Groves developed for Non-Residents. We raise our own guaranteed Citrus Trees in our own Nurseries. We have the Right Land—in the Right Location—at the Right Price, and on the easiest terms. Write for Book "The Call of the Southland"—It's Free.

NORTH TAMPA LAND CO., 404 Zack St., Dept. 4-24, Tampa, Fla.

30 Days' Free Trial

Select from 44 Styles, colors and sizes, famous Ranger bicycles. Delivered free on approval, express prepaid, at Factory Prices. You can easily save \$10 to \$25 on your bicycle.

12 Months to Pay on any Ranger if desired. Parents and girls can easily earn small monthly payments.

Tires best quality, at factory prices, express prepaid. Lamps, wheels and equipment, low prices, send No Money, do business direct with makers.

Mead Cycle Company
Dept. 100 Chicago



Write today for Free Ranger Catalog, factory prices and marvelous easy payment terms.

AMERICAN BOY SCROLL- SAW



Boys: This is what you need to cut your bakelite, fibre, wood, etc., for your radio

set, bird houses, aeroplanes, scooter and toys of every description. Saws wood up to 1" and soft metal up to 3/8" thick. Sturdy construction.

Parents: It's a character builder also. Send for particulars

Delta Specialty Co.
856 Third St., MILWAUKEE, WIS.

PEERBLOW ALCOHOL TORCH

The Heat of a Blast Furnace Under Control

Put This Torch to Work

If you are interested in electricity, mechanics, radio, or automotive work, you need this automatic blow torch. Absolutely safe and effective. On repair jobs it will save you money.

Mailed Parcel Post C. O. D.
PEERBLOW MFG. CO.
Leetsdale, Pa.

Price
\$2 Simplex
Type
\$3 Duplex
Type

AUTOMATIC SELF-BLOWING



AGENTS Big Winner \$90⁰⁰ A WEEK JUST OUT

NEW INVENTION, MARVELOUS QUICKEDGE SHARPENER

—a perfect, low priced Knife and Shear sharpener. Patented. Abolishes dull knives and shears forever from every home. Needed every day. Mechanical wonder. Works like magic. So simple a child can use it. Draws fine, keen, accurate edge on any kitchen knife, carving knife, paring knife, skinning knife, sticker, bread knife, or shears and scissors in 10 seconds. Just put knife in slot—turn crank—sharpens both sides at once—automatically. Always ready. Housewives demand it on sight. Will last for years. Absolutely guaranteed. The biggest, fastest seller invented in ten years. A necessity.

We Want Hustlers—Make \$15 a Day

An immediate cash opportunity for men and women who want to work fast and make money fast. Ten second demonstration gets orders at every home. No talking necessary. No competition. Sells at every house—in town, city, or country. Every woman wants one—Exclaims, "Just what I've always wanted." Sold on absolute money back guarantee.

No Experience Necessary

Profits start first day. Business furnishes capital. Gilbert, W. Va., sold 36 in eight hours. W. S. Swift, Montana, sold 9 in two hours. Herndon took 7 orders first hour. Soper, Wis., made \$55 in two afternoons. Lewis, of Kans., says, "I sold 100 sharpeners in four days." Kain, Ky., sold nine after supper. Hall, N. J., writes, "I think it's great. Sold six in half hour." Kerr, Md., says, "Women can hardly wait for them. You can make this money."

200% Profit—Start Now

Leave 50 on trial—pick up 50 orders at 200% Cash profit. Get busy at once. We take all the risk. No charge for territory. Your time is your own. No boss. High class, clean, money-making, unlimited opportunity. **Send No Money—** just write for complete particulars **FREE.** We'll hold your county for you. This means \$15 a day up to \$7500 a year to agent who gets your county. You can have it **FREE.**

Send your name and address. Give name of your county. Act at once. Address

QUICKEDGE SHARPENER COMPANY

104 Sharpener Building

JACKSON, MICHIGAN



Only
\$2
Selling
Price

Sharpens
Any Kitchen
Knife, Carving
Knife or Shears
in 10 Seconds

Accurate Measurements

Interlox MASTER SLIDE RULE

Inside or outside, made instantly. Rule slides in and out; no slow folding. Strong; brass trimmed. Any length, 2 to 8 feet, 20c per lineal foot. If not at dealer's, sent postpaid.

MASTER RULE MFG. CO., Inc., 341-43 East 138th Street, New York City



Dealers and Agents: request attractive proposition.

SAVE 40% ON GASOLINE

Autoists Amazed—Patented automatic testament starts motor instantly. Removes carbon while running. Improves combustion and increases mileage 20-50%—or More by Back "Wonderful Necessity for ALL engines—Marvelous on Fords, thousands of Glad Users Testify. Guaranteed Three Years. Big value for little investment. Put on in a Jiffy and Saves its cost ten times annually.

AGENTS, SALESMEN, DISTRIBUTORS

Wizard Vaporator Saves Money Three Ways: You can sell it on sight to all car and truck owners—earn \$100.00 weekly and better—fix yourself for life. Exclusive rights awarded. Spare or whole time. If you want a **Real Money Maker**, write quick for handsomely illustrated descriptive matter **FREE** Wizard Mfg. Company, 441-453 Central Ave., Rochester, N.Y.



Write today for illustrated folder



giving
complete
description
and
prices.

E. A. Pophal Mfg. Co. 1008 South 8th Ave. WAUSAU, WIS.

Save \$33⁵⁰

Regal Rebuilt Royal

A genuine, late model, visible Royal Typewriter, perfectly rebuilt and fully guaranteed, now yours at a fraction of the regular price! Try it for 10 days at our risk. If you like it, use it while you pay for it at only a few cents a day. Otherwise return it and you will owe nothing. We rebuild only the Regal—no other. That singular durability resulting from the firmness of its original construction is restored when rebuilt the Regal way. Equipped with two-color ribbon; four rows standard keyboard; back spacer; automatic ribbon reverse; tabulator, card holder, and 30 patented time-saving features. Send postcard or letter and save \$33.50, to REGAL TYPEWRITER CO., Dept. 44, 359 Broadway, NEW YORK

Only
\$69
In Easy
Payments



MAKE \$100 A DAY

Be a Jaffin Sales Specialist. Make the biggest money of your life. Others are doing it. So can you. No canvassing, peddling or ringing door-bells. You do business only with established retail merchants. No experience or capital required. We teach you the business and back you up with our co-operation. Send for free book containing positive proof of big money others are making and telling how you can double and triple your earnings.

JAFFIN ASSOCIATES, Suite N, 1129 Broadway, N. Y.

MAKE MORE MONEY TORIT ACETYLENE TORCH NO. 13

For soldering, heating, melting, tempering, auto radiator repairing, battery repair work, and for all kinds of small jobs requiring a hot flame instantly. Usually pays for itself in a single day.

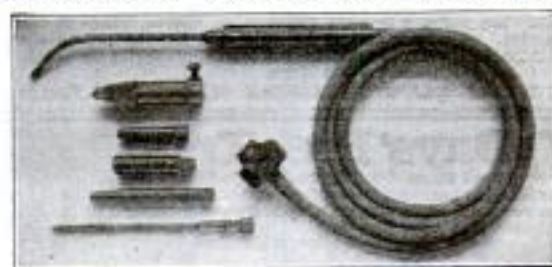

USES ACETYLENE GAS ONLY

Torch with 4 tips for different kinds of work, soldering copper, 5 ft. tubing and connection for auto-acetylene tank.....\$7.50

St. Paul Welding & Mfg. Co., 177 W. 3rd St., St. Paul, Minn.

The Best Seller in the Ford Field



Clamps into tank opening



Fills Tanks without removing cushion



Gas Gauge as seen from driver's seat

Dealers! Salesmen! Write or Wire Today!

Salesmen find Fil-O-Meter increases their earnings over 100%. Manguson made \$48.00 in one day; Laux, as a side line, cleared \$56.00. Already territory is completely closed in some states. Line up quick with this big money-maker.



Kirstin
FOR FORDS FITS ALL MODELS
Fil-O-Meter
A Gasoline Gauge and Filler Combined fills Ford gas tanks without raising cushion. Gas Gauge always within driver's sight. Basic patents prevent all competition. Weighs 2 pounds. Attaches to any Ford in ten minutes.

\$5 Retail—Big Profits

This handsome instrument retails at \$5.00 (open cars), \$6.00 closed models. (Add 50 cents in West.) You make a liberal commission and are given sales help such as local advertising, circularizing, printed matter, etc.

Territory Closing Fast

Now is the time to get lined up. Write today for complete plans, sales help, etc. On receipt of \$1.00 deposit, will ship sample C O D for balance of Distributor's Price.

A. J. KIRSTIN CO.

18 First Street, Escanaba, Mich.

SEND NO MONEY Big 3 foot Telescope in 5 Sections

See people and objects miles away just like they were close, see Moon and Stars as you never did before. Brass bound, useful and entertaining. "Could tell color of aeroplane 4 miles away"—Mrs. Yarbrough. "Watch my boy arrive at school 2 miles away"—Mrs. Horn. "Have been watching submarines 8 miles off the coast."—P. Ghost.

On arrival pay postman \$1.55 plus few cents postage. Satisfaction Guaranteed or money back.
FERRY & CO., 75 W. Van Buren, Dept. 5774, Chicago, Ill.

Write For Book About the Elto

3 H.P.—The Fastest "Light Twin"

Designed and built by Ole Evinrude
Weights less than 17 lbs. per H. P.

Gives half more power, much more speed, yet easy to carry. Instant starting without spinning. Safe rudder steering. Trouble-proof carburetor. Push button reverse, without danger of tipping boat. The ideal family motor. Fits carrying case without taking apart. Write for catalog.

ELTO OUTBOARD MOTOR COMPANY
Manufacturers' Home Bldg.,
Dept. AA, Milwaukee, Wis.

1/2
More Power—Much More Speed



YOUR NAME STAMPED FREE

BOTH
Inkograph
and
Leadograph
at
Combination
Price of **\$2.00**

Here's an opportunity for those seeking the joy of a perfect writing instrument. Secure both a pen and pencil with your own name on each for less than the usual price of a real fountain pen alone. We are making this unusual offer because we want 500 new Inkograph and Leadograph users this month. We know it pays to invest in new friends. Satisfied users make our best advertisement. Experience taught us that every pen sold makes new friends. There are over half a million now in use. Act quickly, for we reserve the right to withdraw this offer at any time.

INKOGRAPH IMPROVES WRITING 100 PER CENT.

Because of the ease that the ink flows, your writing will be improved 100 per cent. It cannot leak. Eliminates danger of soiling hands or clothing. The automatic feed works freely up and down within writing point.

14 KT. WHITE GOLD POINT AND FEED

A very beautifully polished pen of best grade hard rubber, has permanent lockable pocket clip giving it an appearance which compares with pens sold at double the price.

LEADOGRAPH SUPERIORITY

Rich in appearance, handsomely chased and highly polished, same as any high grade fountain pen. It is light in weight, will not cause writer's cramp and writes smoothly at all times. Works both ways (propels and retracts). Easily refilled with new Eversharp or any other standard make leads.

GUARANTEE

certificate and full directions with each order.

HOW TO ORDER

Print your name and address clearly on coupon below and enclose a two dollar bill. Your Inkograph and Leadograph with your name stamped on each will be sent by return prepaid mail. Or if you prefer, we will ship C. O. D. for \$2.25.

Agents Wanted

Inkograph Co., Inc.

Dept. 103 670 Sixth Ave., N.Y.

I accept your combination offer for the Inkograph and Leadograph with my name stamped free. Enclosed you will find \$2. In full payment. If you prefer C. O. D. shipment and want to pay the postman \$2.25 on arrival put "X" here

Name _____

Address _____

City _____ State _____

40 MONEY-MAKING BUSINESS PLANS \$2

Valuable processes for manufacturing many fast selling necessities, complete with selling plans and where to buy all materials.

Latest complete set \$2.00 prepaid.

GILMER SERVICE 4450 West End Avenue
CHICAGO, ILLINOIS

Orlando is Calling You

Do you want to get away
From the grind of every day—
From the drudgery of things you have to do?
Do you want to settle down
Near a lively, busy town,
Where the joy of living will appeal to you?

Do you want to scent the breeze
Coming through the orange trees?
Do you want to hear the birds call—loud
and clear?

Are you seeking perfect health
That's combined with certain wealth
And an income from an orange grove each
year?

Do you want a piece of land
That will grow to beat the band
All the different garden crops that you
enjoy?

Do you want to make a "Nest,"
And a permanent bequest
For the future welfare of each girl and boy?

Do you want a sunny clime
Where there's fishing all the time?
Where there's ducks and deer and quail
and other game?

Where the summer climate's cool,
And within each lake and pool,
You can swim in January—just the same?

Do you want to buy this land
On an easy-payment plan,
With about your monthly outlay for cigars?
Do you want to read a book
That will make you want to look
On the finest land that lies beneath the stars?

Send a letter right away;
Put it in the mail to-day,
We will send this Booklet absolutely FREE.
After you have read it through,
If a thought occurs to you—
Just address another letter here to me.

We will answer, straight and true,
Questions that occur to you.
We have nothing to evade or to conceal.
On an Orange County Farm
Life will take on added charm,
And you'll never lack a dollar—nor a meal.

Send for our Big, FREE Illustrated Book—
"TWENTY ACRES AND PLENTY." It
tells of almost unbelievable profits made
from trucking and fruit-growing in our part
of FLORIDA. Also about sick-and-out-of-
work Clauses, and other protective features
of our contract. Address Sylvester E.
Wilson, Dept. M-15, Orlando, Florida.

No Joke To Be Deaf



—Every Deaf Person Knows That

I make myself hear, after being deaf for 25 years,
with my Artificial Ear Drums. I wear them day
and night. They are perfectly comfortable. No
one sees them. They stop head-noises. Write me
and I will tell you a true story, how I became deaf
and how I make you hear. Address

GEO. P. WAY, Artificial Ear Drum Co. (Inc.)
80 Hoffman Bldg., 2339 Woodward Ave., Detroit, Mich.

\$12 to \$20 Daily for Ford Owners!

Demonstrate and sell GIDEWEL steering devices for Ford cars. A tried and proven invention. Entirely different. Nothing exactly like it. It's the device that sells itself. Does the talking. Whether you have ever sold goods or not you can sell the GIDEWEL. Just demonstrate GIDEWEL with your Ford for a quarter of mile and sale is made. A wonderful money-making proposition for full or part time. Exclusive territory given to workers. Millions of Fords swarming country. All need this wonderful device. Hundreds have been attached—not a single one has ever been removed.



There's Not a Ford Driver on Earth Who Wouldn't Gladly Pay \$10 for a GIDEWEL

Stops steering vibration. Takes the shock, jar, jerk and jiggle out of steering wheel. Eliminates front wheel wobble. Makes car track perfectly. Won't jump ruts. Rides bumps without swerving. Prevents locking on short turns. It's a MARVEL. Makes driving a pleasure. Adds safety to motoring in a Ford. Car responds to slightest touch on steering wheel. Can steer for miles over roughest roads without fatigue. GIDEWEL easily attached. May be installed without disturbing present construction of car. Is dirt-, dust-, and grit-proof. Practically no wear-out to it. Runs in oil. Can be transferred from one Ford to another. Hundreds in use. Once tried, Ford owners won't drive without GIDEWEL. Difference in steering amazing. Be first man in your territory to show and demonstrate GIDEWEL. Sells complete for \$10. You can take orders right and left. Every Ford owner live prospect. \$12 to \$20 day possible. Get our liberal proposition. Write or wire.

THE ROLLAWAY MOTOR CO.

421 Southard Ave.

TOLEDO, OHIO, U.S.A.

STOP USING A TRUSS

Do Away With Steel And Rubber Bands

FREE TRIAL



Inner surface is made adhesive to secure the PLAPAO-PAD firmly to the body, keeping the PLAPAO continually applied and the pad from slipping. No straps, buckles or springs attached. Soft as velvet—easy to apply.

It's the Non-Slip- ping, yet Non-Rigid Pad and What is Within It That Counts

FREE to 5,000 Truss Sufferers

To the extent of 5,000 sufferers who may apply I will send, ABSOLUTELY FREE, a sufficient quantity of the Plapao to positively convince them that this is the only logical, common-sense way of treating rupture. Plapao is a highly astringent medication placed within the Plapao-Pad and being absorbed through the skin, creates a wonderful feeling of relief and at the same time tends to strengthen the weakened muscles and thus permanently close the rupture opening. The process of recovery is natural, so you'll have no use for a truss—you can throw it away forever! Old and young have testified under oath that the Plapao-Pads cured their rupture—many of them long-standing, aggravated cases—without delay from work. Patent allowed in U. S. and foreign countries. Awarded Gold Medal at Rome and Grand Prix at Paris.

Send No Money—for a sufficient quantity of the Plapao is sent without charge to enable you to give it a thorough test; you pay nothing for this trial now or ever. Write for it and full information today. Address Plapao Laboratories, Block 1427 St. Louis, Mo.

**"I sold
six pairs
in 45 minutes
—made \$6.00
clear profit"**

"Yes, sir—that's how long it took me to take the shoe orders of these six girls. Just walked into the candy factory in my town, showed them my Style-Arch Shoe samples and got their orders and deposits. Since then I've been making no less than \$75.00 per week—and repeat business is increasing my profits constantly."—John W. Sommers.

You Can Earn This Money Too

This is YOUR chance! Hundreds of representatives are making \$65.00 a week and more with our exclusive direct-to-wearer Style-Arch shoes. Smartest styles, below-retail prices, and steel arch support features (usually found only in highest priced shoes) insure quick sales.



We Supply Complete Equipment

Every Style-Arch salesman equipped with sturdy, handsome carrying case and ACTUAL SHOE SAMPLES. No experience necessary to learn simplified method of selling shoes.

No matter what you are now selling, you can probably make MORE MONEY with our line. To get full particulars write at once.

STYLE-ARCH SHOE CO.
Dept. PM-4 Cincinnati, Ohio

Any Range A Real Gas Stove In 15 Minutes



NO more sweltering kitchens all Summer long—no more coal fires all day just to do a little cooking or baking—no more dirty coal, or wood, ashes, soot, or smoke. No more back-breaking lifting, carrying or chopping. No more smelly oil stoves.

The Oliver Oil-Gas Burner—that in fifteen minutes, makes your present coal or wood range into a real gas stove that turns on and off with a valve. Gives much or little heat—like city gas.

Wonderful Baking and Cooking

Bake right in your oven—better and quicker than ever before. Don't waste fuel and nurse a hot fire all day just for cooking and baking. With this wonderful invention you simply turn a valve, strike a match, and light your fire. In a jiffy the oven is at a fine even temperature—any degree you want. Put in your roast or baking—put on your stew or vegetables. Go

AGENTS!

Oliver representatives make big money—\$500 and more a month. Exclusive territories. Oliver gives Fords away to producers. Big season, just starting. Write at once—Free Sample Case Offer.

away and forget them. Come back when they are done, turn the valve—fire is out instantly—and you leave your kitchen cool and sweet all day long.

Mr. Oliver's wonderful invention fits any kind of cook stove or range without changes or drilling. You set it in your firebox. Presto! You have a gas stove. Absolutely safe, it lasts a lifetime.

FREE Book—Mail Coupon

Mail coupon at once for Free booklet "New Kind of Heat" which tells all about this wonderful device. By acting quick you will be entitled to the Special Introductory Price Offer being made. No obligation. But get the coupon in the very first mail.

Oliver Oil-Gas Burner Co. 456 Oliver Bldg. ST. LOUIS, MO.
Oldest and Largest Manufacturers of Oil-Gas Burners in the World.

OLIVER OIL-GAS BURNER CO.
456 Oliver Bldg., St. Louis, Mo.

Send me at once your Free Book, "New Kind of Heat." This does not obligate me. I am interested in a burner for
 Range Heater Furnace
(Specify whether Hot Air, Hot Water or Steam.)

Name.....

Address..... County.....

City..... State.....

A Pair of "Red Devil" Pliers

Handy for Quick Work

437 West Front St.,
Berwick, Pa.
November 12, 1923.

Smith & Hemenway Co., Inc.,
261 Broadway,
New York, N.Y.

Gentlemen:-

In my tool-box are many tools, probably fifty. In a pinch, twenty would fill the bill, but my favorite is a "Red Devil" Plier.

For quick and convenient use I carry my pair of "Red Devil" Pliers in my hip pocket. In a pinch, twenty would fill the bill, but my favorite is a "Red Devil" Plier.

I am a loomfixer and am frequently called upon to do repair jobs quickly. And in saving time and going back and forth to my tool-box, I use "Red Devil" Pliers wherever possible, as it is good for the operator and for me to do the work quickly.

I can tell of a great many other uses around the shop and home, where I am often called upon to do repair jobs.

Very truly yours,

Herbert C. Menck



"RED DEVIL" Slip Joint Pliers No. 1024—6½"—about as useful a tool as any mechanic can own. \$1.00 at dealers, or if not in stock, send dealer's name and order direct.

Send for "Red Devil" Mechanic's tool booklet.

Smith & Hemenway Company, Inc., Mfrs. of "Red Devil" Tools

260 Broadway,
New York, N. Y.

\$6.50

LITES-IT

AUTOMATIC POCKET LAMP

NO BATTERIES
Current is Generated by Movement of Lever

The most practical Electrical Pocket Lamp ever invented. Think of it—no batteries. A simple movement of the hand generates a current that throws a powerful light. Has beautiful aluminum case—nothing to wear out—lasts a lifetime. Ideal for Sportsmen, Motorists, Miners, Watchmen, Camping Parties and should be in every home.

ORDER NOW!

—while our supply is big—the enormous demand will soon be ahead of our large production facilities. Don't wait—send \$6.50 by Postal or Express money order. We ship postpaid. Price in Canada \$6.75. Dealers write us on your letterheads for attractive sales proposition.

Agents: Ask us to write you how to make big money selling the LITES-IT.

UP-TO-DATE MACHINE WORKS
2913-15 So. Wabash Ave. Dept. 418 Chicago, Ill.

Send
for this
Bulletin
it is FREE
POSTPAID



Prices of Bench Lathes

SIZE	Quick Change	Standard Change
9" x 3'	\$231.00	\$201.00
11" x 4'	278.00	238.00
13" x 5'	344.00	294.00



South Bend Lathe Works

555 E. Madison St.

South Bend, Ind.

ARMLESS Men and Women This Book is-FREE

—if you are interested in reading what armless men and women who are "carrying on," despite the loss of one or both arms, have to say. You will be surprised and inspired when you see the photographs of the many things that are easily accomplished by the wearers of the Carnes Artificial Arm.



The Most Lifelike Arm Ever Invented

This complete story is told in our Free 192-page catalog, which is really a record book of achievements of armless men and women. You will realize that the Carnes Artificial Arm is the most lifelike and useful substitute ever invented for the human arm—built on the most correct scientific principles; easy to wear.

Send for the Carnes catalog today

Carnes Artificial Limb Co.
66 Carnes Building
904 East 12th Street Kansas City, Mo.

Kill The Hair Root

My method is the only way to prevent the hair from growing again. Easy, painless, harmless. No scars. Booklet free. Write today enclosing 3 stamps. We teach beauty culture. D. J. Mahler, 874A Mahler Park, Providence, R. I.

DON'T WEAR A TRUSS

BE COMFORTABLE—

Wear the Brooks Appliance, the modern scientific invention which gives rupture sufferers immediate relief. It has no obnoxious springs or pads. Automatic Air Cushions bind and draw together the broken parts. No salves or plasters. Durable. Cheap. Sent on trial to prove its worth. Beware of imitations. Look for trade-mark bearing portrait and signature of C. E. Brooks which appears on every Appliance. None other genuine. Full information and booklet sent free in plain, sealed envelope.

BROOKS APPLIANCE CO., 215 State St., Marshall, Mich.



MR. C. E. BROOKS

NO MORE BALD HEADS



WHEN our VACUUM CAP is used a few minutes daily. We accept no pay until you have tried the Cap 60 days and are satisfied. The Vacuum Cap is an appliance that draws the blood to the Hair Roots and starts a new healthy crop of hair. It stops Dandruff, stops the hair from falling out.

Bought by Doctors and men who know that it is the only reasonable HAIR GROWER known to science. No Drugs Used. Write for application blank, testimonials, and booklet on "HAIR," sent sealed in plain envelope, FREE.

THE MODERN VACUUM CAP CO.
U 559 BARCLAY, DENVER, COLO.

Great *New* Invention for seekers of Health Power Beauty



Elco Health Generators at last are ready for you! If you want more health—greater power to enjoy the pleasures and delights about you, or if more beauty is your desire—write! Ask for the book on these inventions which has just been prepared. It will be sent to you without cost. It tells you how Elco Health Generators aid you in leaving the lethargy and hopelessness of bad health and weakness behind forever. Re-vitalize yourself. Bring back energy. Be wholly alive. Write today!

10 Days Free Trial—Write for FREE BOOK



These great new inventions generate *High Frequency Violet Ray, Mechanical Vibration, Medical Electricity and Ozone.* Combined or separate.

They operate on the electric light in your home or on their own motive power at less than 50 cents per year. Elco Health Generators are positively the only instruments which can give you in one outfit Electricity, Violet Ray—Vibration and Ozone—the four greatest curative agents. Send coupon below. Get the Free Book NOW!



For All These:

Rheumatism	Asthma
Cost	Hay Fever
Lumbago	Sore Throat
Neuralgia	Catarrh
Sciatica	Deafness
Headache	Insomnia
Neuritis	Pain
Nervousness	Development
Circulation	Skin Disease
Weakness	Pimples
Paralysis	Scalp Disorders
Eye Trouble	Obesity

MAIL the COUPON for FREE Book!

Do not put this paper down without sending the coupon. Don't go on as you are with pains and with almost no life and energy. You owe it to yourself to be a better man or woman. You were put here to enjoy life—not just to drag through it. So do not rest another day until you have put your name on the coupon here. That will bring the whole story of these great new inventions. Do it today—now.



Lindstrom & Company

442-448 North Wells Street, Dept. 13-54, Chicago, Ill.
Please send me your free book, "Health—Power—Beauty" and full information on your 10-day Free Trial Offer.

Name.....

Address.....

State your ailment and receive our expert advice
REPRESENTATIVES WANTED

PATENT TRADE MARKS PROTECT

ANY NEW article, machine, design or improvement thereof, or any combination of parts or improvements in any known article which increases its efficiency or usefulness, may be patented, if it involves invention.

IF YOU HAVE ANY NEW IDEAS

which you feel are useful, practical and novel, take prompt action to protect your rights. If you have invented any new machine, or new combination of parts or improvement, or any new design or process, SEND DRAWING, MODEL OR DESCRIPTION of it for information as to procedure to secure protection.



DRAFTING and SPECIFICATION ROOM of CLARENCE A. O'BRIEN, Registered Patent Attorney, Washington, D. C.

All Communications are held in strict confidence. My personal, careful and thorough attention is given to each case. I offer you efficient, reliable and prompt service—based upon practical experience. **Highest references.**

NO CHARGE FOR ABOVE INFORMATION

Clarence A. O'Brien

REGISTERED PATENT ATTORNEY

Member of { Court of Appeals, District of Columbia, United States Court of Claims;
Bar of { Supreme Court of United States, Supreme Court, District of Columbia

Practice Confined to Patents, Trade Marks and Copyrights

NTS

COPYRIGHTS YOUR IDEAS

WRITE TODAY FOR FREE BOOK,

"How to Obtain a Patent"

This book will give you valuable information, and it may save you much time and effort. Send for it, NOW. My practice is devoted exclusively to United States and Foreign Patents and Trade Marks. Write me freely, frankly and with full confidence; it is very probable that I can help you.



United States Patent Office as Viewed from My Office, Directly ACROSS THE STREET

WRITE TODAY FOR BLANK FORM "RECORD OF INVENTION"

USE THE COUPON attached, and immediately upon its receipt I shall send you this form to be returned to me with drawing, description or model of your idea; promptly upon receiving your idea I shall write you as to procedure and costs.

CLARENCE A. O'BRIEN, Patent Attorney, 701 Security Savings & Com'l Bank Bldg.
Directly Across Street from Patent Office WASHINGTON, D. C.

Please send me your free booklet, "How to Obtain a Patent," and blank form, "Record of Invention," without any obligation on my part.

**FREE
COUPON**

Name.....

Address.....

IMPORTANT! Write or print names clearly.



PATENTS

MAIN OFFICES OPPOSITE U.S. PATENT OFFICE

VICTOR J. EVANS & Co.

VICTOR BUILDING 956 9TH ST., N.W.



OUR OFFER:

No Charge for Examination and Instructions

HAVE YOU AN IDEA?

Your First Step Before disclosing an invention, the inventor should write for our blank form,

"RECORD OF INVENTION"

This should be signed and witnessed and returned to us together with model or sketch and description of the invention for examination and instruction. *No charge for the above information.*

VICTOR J. EVANS & CO.
PATENT ATTORNEYS

Main Offices: 956 9th St., N. W., WASHINGTON, D. C.

Opposite U. S. Patent Office

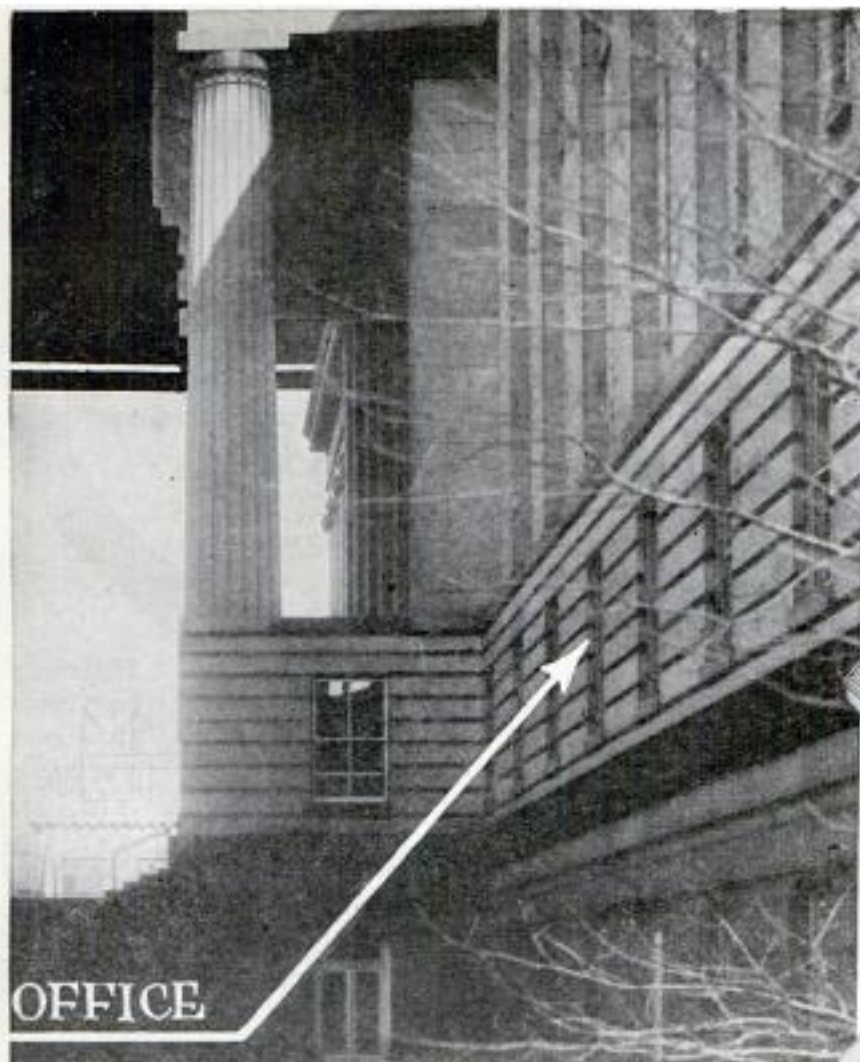

TRADE MARKS AND COPYRIGHTS



Our Three Books Mailed **FREE** to Inventors

Our illustrated Guide Book

HOW TO OBTAIN A PATENT

Contains full instructions regarding Patents. Our Methods, Terms, and 100 Mechanical Movements illustrated and described; Articles on Patent Practice and Procedure, and Law Points for Inventors.

Our Trade-Mark Book

Shows the value and necessity of trade-mark protection and gives information regarding Trade-Marks and unfair competition in trade.

Our Foreign Patent Book

We have direct agencies in all foreign countries and secure foreign patents in the shortest possible time and at the lowest cost.

FREE COUPON

VICTOR J. EVANS & CO. PATENT ATTORNEYS

NEW YORK OFFICES
1007 Woolworth Bldg.

CHICAGO OFFICES
1114 Tacoma Bldg.

PHILADELPHIA OFFICES
714-715 Liberty Bldg.

PITTSBURGH OFFICES
514 Empire Bldg.

SAN FRANCISCO OFFICES
Hobart Bldg.

MAIN OFFICES: 956 9th Street, N.W., WASHINGTON, D. C.

Gentlemen: Please send me *Free of Charge* your books as described above.

Name.....

Address.....

PATENTS

Seventy-eight Years of Practice

THE firm of Munn & Company filed its first application for a patent in 1846, and for seventy-eight years has endeavored to keep pace with the inventive genius of the United States.

An experience of many years is at your disposal. If you have an invention which you wish to patent, send your sketches or model together with a description of your device, explaining its operation, and you will receive prompt, courteous attention.

Write for our Handbook on PATENTS

A full and complete booklet on Patents, Designs, Trade-Marks, Foreign Patents, Copyrights, Labels and Patent Office Practice with an explanation about our methods, terms, etc.

All communications strictly confidential.

Keep in touch with the inventions of the world by reading

SCIENTIFIC AMERICAN

The MONTHLY MAGAZINE with a special appeal to every man of inventive genius. Recent rulings of the Patent Office, descriptions of the latest patented inventions, legislation and court decisions affecting patents, are noted in this authoritative publication.

MUNN & COMPANY

Patent Attorneys

672 Woolworth Building, New York City

Scientific American Building, Room 2
625 F Street, Washington, D. C.

Suite 801, Tower Building, Chicago, Ill.
601 Hobart Building, San Francisco, Cal.

Please Mention Popular Mechanics

Can You

think of a simple, practical idea that will fill one of the many requests we have on file for new inventions? It may mean a fortune for you. Thousands of things are needed **right now**. Your brains can help. Send today for our great new book—

"Inventions and Trade-Marks, Their Protection and Exploitation" and learn more about making money from ideas than you ever knew before. It tells many things that are wanted, too.

**A postal will do—
It is free**

We Help Our Clients

without charge, to get the dollars out of their ideas—having facilities none others possess. Advice free. Don't delay—get the book at once.

American Industries, Inc.
200 Patent Dept.
WASHINGTON, D. C.

**Patents
Advertised
For Sale Free**
in Invention and
Manufacturing Supplement

Published for the man with an idea. Send for free sample copy. One year's subscription, 50c.

PATENTS

C. L. PARKER
Formerly Member Examining
Corps, U. S. Patent Office
PATENT LAWYER
MCGILL BLDG.
WASHINGTON, D. C.

Patents, Trade Marks, Copyrights, Patent Litigation

Handbook for Inventors, "Protecting, Exploiting and Selling Inventions," sent free upon request.



PATENTS

Send us sketch or model for patentability opinion and exact cost of patent. Our book "How to Obtain a Patent." Sent Free on request. It tells how to apply for Patents, Trade Marks, Foreign Patents, Copyrights, etc.; gives information on Patent Procedure; tells what every inventor should know. Thousands of Inventors, who are our clients, are our references.

Chandlee & Chandlee, 25 Years' Experience.
455 7th St. Washington, D. C.

PATENTS

As one of the oldest patent firms in America we give inventors at lowest consistent charge, a service noted for results, evidenced by many well known Patents of extraordinary value. Book, Patent-Sense, free. Lacey & Lacey, 646 F St., Wash., D. C. Estab. 1869.

BLUE BOOK ON PATENTS

gives instructive information and candid advice.
MONROE E. MILLER, PATENT LAWYER
411-2 Ouray Building WASHINGTON, D. C.
ELECTRICAL AND MECHANICAL EXPERT

PATENTS

Trade-Marks, Copyrights and Patent Litigation

Write for advice and instructions how to proceed, costs, etc. Hand Book with illustrations of 100 Mechanical Movements sent free on request.

ALBERT E. DIETERICH

Patent Lawyer and Solicitor

Successor to Fred B. Dieterich & Co. 621A Ouray Bldg., Washington, D. C.

PATENTS

Booklet Free Highest References Promptness Assured Best Results
Send drawing or model for preliminary examination

ALL BUSINESS GIVEN PROMPT AND PROPER ATTENTION

WATSON E. COLEMAN, Patent Lawyer, 644 G St., Washington, D. C.

Have You An Invention?

If so the WORLD PROGRESS will show you how to
PROTECT AND PROFIT FROM YOUR IDEAS
Sample copy free. One year's subscription \$1.00.
Send for free book,

"WHAT TO INVENT"

containing SUGGESTIONS TO INVENTORS as to Inven-
tions Needed. We invite manufacturers to address us
regarding inventions they want.

WORLD PROGRESS PUB. CO., Inc.
Room 203 Victor Bldg. WASHINGTON, D. C.

PATENTS

Let me assist you in obtaining your
valid Patent rights. Personal ser-
vice. Promptness assured.

GEORGE VAN DEN BERG Barrister Bldg., Washington, D. C.



Buchstein's Fibre Limb

is soothing to your stump—strong, cool,
neat, light. Easy payments.
Braces for all deformities.
D. BUCHSTEIN CO.
610 3rd Ave., So., MINNEAPOLIS, MINN.

Send
for Catalog Today

WRITE TODAY for
Our 168-PAGE
FREE BOOK on

Deafness

and learn how Perfect Hearing is now being restored in every
condition of deafness or defective hearing. Our "Little Wire-
less Phones for the Ears" require no medicine, but effectively
replace what is lacking or defective in the natural ear drums.
They are simple devices, which the wearer easily fits into the
ears, where they are invisible. Soft, safe and comfortable.
WILSON EAR DRUM CO., Incorporated
887 Inter-Southern Bldg. LOUISVILLE, KY.

U.S. PATENTS



**SEND FOR
THIS FORM**

DON'T LOSE YOUR RIGHTS TO PATENT PROTECTION

Before disclosing your invention to anyone
send for blank form "EVIDENCE OF CON-
CEPTION" to be signed and witnessed. A
sample form together with printed instructions
will show you just how to work up your evi-
dence and establish the same before filing ap-
plication for patent. As registered patent at-
torneys we represent hundreds of inventors all
over the United States and Canada in the ad-
vancement of inventions. Our schedule of fees
will be found reasonable. The form "Evidence
of Conception," sample, instructions relating
to obtaining of patents and schedule of fees
sent upon request. Ask for them—a post card will do.

PATENTS AND TRADE MARKS



480 Ouray Bldg. Washington, D. C.
Originators of forms "Evidence of Conception."

INVENTORS PROTECT YOUR IDEAS

Send for our Guide Book, **HOW TO GET A PATENT**, and Evidence
of Invention Blank, sent Free on request. Tells our terms, methods, etc. Send
model or sketch and description of
your invention and we will give our
opinion as to its patentable nature.

RANDOLPH & CO.
600 F St., N. W., WASHINGTON, D. C.

NAME

STREET

CITY.....STATE.....

Diamonds

Here at 60% of Market Price

Never in three quarters of a century have we offered such amazing bargains. Hundred of money-saving opportunities in latest Diamond Bargain List, equalling those shown here.

Here's why we can offer such remarkable values: This 75 year old firm—rated at over \$1,000,000.00 capital—the largest and oldest diamond banking institution of its kind in the world has made loans on Diamonds, Watches, and other jewels in excess of \$25,000,000.00.

Why Pay Full Prices Costs Nothing to See

Thousands of unpaid loans. Most sell now. Diamonds, Jewels, Watches and other Gems of unusual qualities—at an entirely different price basis—via: loan values not market values. At our risk we send you any bargain you wish for absolutely free examination. No red tape. No obligation. Don't buy unless satisfied you can not match the bargain at 60 per cent more. Diamonds of desirable quality at \$25 per carat. Yes, some even lower priced—also, finest gems obtainable at higher per carat—but proportionately low bargain prices. Our bargains here guaranteed loan values also, unlimited exchange privilege at full price.

Latest List Diamond Loans

Send at once for latest list. Thousands of unpaid loans and other special advantage bargains described in full detail with exact weight, color, quality, etc. Get details of Free Examination offer. No obligation. List is free.

Mail Coupon Now



Jos. DeRoy & Sons,
1919 DeRoy Bldg., Pittsburgh, Pa.

Only Corsette Post Office
Without obligation, send me free, your latest Bargain List of Diamonds, Watches and other jewelry.

Name.....
Address.....
City..... State.....

\$47²⁵ Profit in 4 Hours

Doughnut Making business has wonderful possibilities. "Snow-Flake" Doughnuts have taken the country by storm. Enormous demand. \$25.00 to \$75.00 a day. Capacity 500 doz. a day. Makes plain, chocolate and coconut doughnuts. 200% profit. No experience needed. Put dough in hopper—turn crank—out drop sweet, savory, golden doughnuts.

AMAZING PROOF FREE

Money-making possibilities unlimited. Put this Automatic Doughnut Machine in display window. Attract crowds. Enticing odor whets appetite. You take in money fast. Pay for the machine the first week. Earnest & Wells Pa., say: "Sold 200 dozen first day." Others report earnings equal or better. Big money wholesaling.

WRITE NOW

Get in on the ground floor—act quickly before others start. These machines pay big anywhere—no town too small. Get full details of this new profitable business—costs nothing to investigate. Write today.

Delicious Potato Chips can be made with special attachment we supply.

BUTLER & BUTLER, Dept. 31, 5945 W. Chicago Ave., Chicago

PATENTS

To the Man with an Idea

I offer a comprehensive, experienced, efficient service for his prompt, legal protection and the development of his proposition.

Send sketch, or model and description, for advice as to cost, search through prior United States patents, etc. Preliminary advice gladly furnished without charge.

My experience and familiarity with various arts frequently enable me to accurately advise clients as to probable patentability before they go to any expense.

Booklet of valuable information and form for properly disclosing your idea free on request. Write today.

Richard B. Owen, Patent Lawyer
9-303 Owen Building, Washington, D. C.
2276-E Woolworth Bldg., New York City

PATENTS

REGISTERED PATENT ATTORNEY SINCE 1905
CHARLES W. LOVETT 810 1/2 BLDG. LYNN MASS.
(SEND FOR FREE BOOKLET)

Inventors!!

Who know your inventions would be practical commercially if simplified. We perfect inventions, make working models, and apply for patents. Send us description or model.

W. R. PIPER 3635 Michigan Boulevard, CHICAGO, ILL.

RACING BODIES for FORDS at \$34⁵⁰ Up

Send today for free particulars. Our book "HOW TO BUILD A FORD RACER" sent anywhere on receipt of 25 cents—cash or stamp.

CENTRAL AUTO SUPPLY CO., Dept. 120A, LOUISVILLE, KY.

As a mouthwash—Germ-destroying, cleansing and refreshing.
As a gargle—Soothes and relieves an irritated or sore throat.
With a dentifrice—Gets at crevice-hidden fermentation.
With a shampoo—Destroys dandruff germs; stimulates scalp.
After shaving—A delightful, first aid, antiseptic dilute lotion.

All druggists, \$1.25 or postpaid. Liberal trial bottle 10c., postpaid.

W. F. YOUNG, INC.
347 Lyman St. Springfield, Mass.

Absorbine, J

THE ANTISEPTIC LINIMENT

for Cuts, Bruises, Sprains, Strains, Chapped hands, Sore throat, Rheumatic aches

SELL COAL

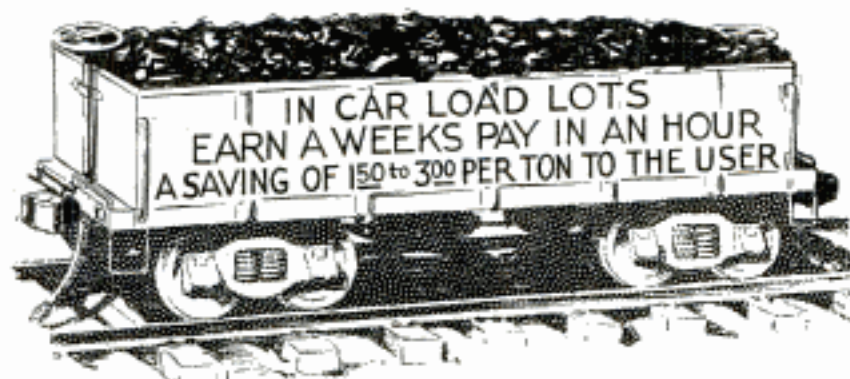

You May Handle This As a Sideline If You Desire

Conservatively you should make from \$2,000 to \$5,000 per year, depending entirely on the time you give the proposition and the determination and "Steam" you put back of your efforts. Our knowledge, gained through seventeen years in the coal business is constantly backing you up and helping you to make a success. We understand the salesman's problems and the co-operation he must have.

COAL IS A NECESSITY

Every garage, school, store, factory, hotel, bank, hospital, household, church and public institution use hundreds to thousands of dollars worth every year. Our salesmen are given courteous attention and find that sales can be quickly made. Figure out the money making possibilities of selling coal under our plan, sales are large, the commission per ton is liberal, we do not burden you with responsibilities. We do not require you to collect bills or take care of deliveries. You just take the orders. No sample case needed in this line, just our portfolio of COAL FACTS. You can make a very substantial income, as our new and better way of selling means volume business, lower prices to the consumer, quick sales and satisfactory commission to the salesmen.

WE ARE THE LARGEST firm in the United States exclusively delivering coal direct from car to consumer without use of any coal yards. Our sales are growing by leaps and bounds. As our volume of business increases each year, we are able to operate on a smaller margin of profit and can make even more attractive offers through our salesmen.

**You Need No Experience
You Need No Capital**

Liberal Drawing Account Arrangement

The 1924 selling season starts April 1st. In the spring and summer the carload buyers place their orders. Continuous customers are assured because the low price and high quality of our coal, coupled with prompt delivery and satisfactory service, means a steady, ever increasing income for you.

Write us today if you live in, or are now covering, any of the territory following: Michigan, Wisconsin, Illinois, Iowa, Minnesota, Eastern Dakotas, Eastern Nebraska, Indiana, Western Ohio, Missouri, Eastern Kansas, Kentucky, Tennessee, North and South Carolina, Georgia, Alabama, Mississippi, Arkansas, Louisiana. If you honestly want to tie up with a straightforward, money making proposition, where a man gets what he earns, we will send you full details by return mail.

WASHINGTON COAL COMPANY 717 Coal Exchange Building
Armour Sta., CHICAGO, ILL.

Summer Home in Maine

A gentleman's estate of 175 acres on the Maine coast, with frontage on a lake 9 miles long; master's house; large bungalow; caretaker's house; large garage; barns; private electric light and inexhaustible water works, and every modern improvement. Forty acres very large trees. Golf and yacht clubs only a few minutes away; good markets in the town.

The scenery of mountains, lake and ocean is pronounced one of the best five in New England. House and bungalow both completely furnished; steam heat.

Place will be sold at a great bargain as owner can no longer use it.

Address **OWNER**

206 East Ontario Street CHICAGO, ILL.

Do You Want \$200 a Week?

Right now—today—I'm offering you a chance to control a business of your own without investing a penny. You can be your own boss—work when and where you please—and make \$200 a week. You can do as well as Vance Polen of Indiana, who made \$12 in ten minutes; or Fred Roberts of Ohio, who made \$58 in a day; or R. A. Prentiss of Mass., who cleaned up \$945.00 in a single month. And you can start to enjoy such big earnings your very first week.



R. A. Prentiss

Splendid Earnings I want men and women everywhere to take orders for Comer All-Weather Coats. That's all you will have to do. We collect and deliver the coats. You simply take orders. And for doing this easy, pleasant work you will get a splendid commission—and you will get it at once.

You can work in your spare hours and make \$625 in a month as A. B. Spencer of Penn. did. You can devote all of your time and make \$1200 in thirty days as E. A. Sweet of Michigan did. And still more, you will have a chance to get a Buick Touring Car FREE. Fill in the coupon now and I will show you how you can make \$200 a week without experience or training, and have that \$200 in cash when the week is up. Mail the coupon at once for the facts.



The Comer Mfg. Company
Dept. 58-523 Dayton, Ohio

Mail This NOW

The Comer Mfg. Co., Dept. 58-523 Dayton, Ohio
Please send me, without obligation, details how I can make \$200 a week and get a Buick Touring Car FREE.

Name

Address

WURLITZER

TRADE MARK THE WORLD'S LARGEST MUSIC HOUSE



200 Years Ago in the little town of Saxony lived Hans Adam Wurlitzer, Master Violin Maker. His shop was a gathering place for musicians of the time, for he was a true craftsman.

When he died his shop passed into the hands of his eldest son, and for seven generations, down to the present day, the descendants of Hans Adam Wurlitzer have carried on his work.

Today in every Wurlitzer instrument you will find a quality, a character, that could not come from mere excellence of manufacture. It is the heritage of those seven generations of music craftsmanship.



Try
any Wurlitzer Instrument
in your
Own Home

YOU may now have any Wurlitzer instrument for a week's free trial in your own home. Examine the instrument, show it to your friends, play it as much as you wish. No obligation to buy—no expense for the trial. We make this liberal offer because we want you to try for yourself these wonderful instruments, the result of 200 years' experience in musical instrument building.

Easy payments are arranged to suit your convenience. This is your opportunity to try a famous Wurlitzer instrument in your own home.

Send for
New Catalog

The greatest musical catalog ever published! Over 3,000 articles—every known instrument described and illustrated; many of them shown in full colors. Gives you lowest prices and all details of Free Trial, Easy Payment plan. All sent FREE—no obligation

Send this Coupon



THE RUDOLPH WURLITZER CO., Dept. 1774

120 W. 42nd St., New York 117 E. 4th St., Cincinnati

329 S. Wabash Ave., Chicago 250 Stockton St., San Francisco

Send me, absolutely free, your new illustrated catalog, with prices and description of every known musical instrument. Also tell me how I may try any instrument in my own home and pay for it in small monthly sums. No obligation.

Name.....

Address.....

City..... State.....

Instrument..... (State instrument in which you are interested)

Copyright, 1924, The Rudolph Wurlitzer Co.

RIDE 30-Days FREE



On the dandy new model wheel all the boys are talking about! A bike that will make you the envy of all the other fellows. It's a real, racy speedster with exclusive features and electrically equipped. Of course it's a

BLACK-BEAUTY BICYCLE

The easiest riding, most substantial and finest looking wheel made. Shipped express prepaid, direct from the factory—at wholesale price. Guaranteed 5 years. 6 months' insurance against accident. 30 days' trial. Large selection of models and colors.

Supplies Tires, Lamps, Horns, etc. Everything for the bike at wholesale prices.

Send for a Free Black Beauty Bicycle Book
HAVERFORD CYCLE CO. of PA.

Established 28 years
Dept. 374 PHILADELPHIA, PA.
Be a Black Beauty Rider Agent



PATTERN-MAKING

for Those Who Should Know



Compiled by G. H. WILLARD, a pattern maker of many years' experience, for those who wish to increase their pay—or those who wish to enter this well-paying occupation. Filled to the covers with helpful shop-kinks and actual working information. Practical instructions written in plain language, which anyone can easily read and understand. Learn at home—in your spare time. Bound in cloth, 224 pages, 312 illustrations, diagrams and working drawings, etc.

Tells About Pattern making as a trade—The Tools—Wooden Joists—4 chapters on Turning—2 chapters on the Circular Saw—2 chapters on Machine Tools—3 chapters on Simple Tools—Crooked Patterns—2 chapters on Large Pattern Work—Cross-Head Guide patterns—Sweep work—Pipe work—Stove pattern work—Holding—Machine Work—Molding Pattern Work.

CORE MAKING AND MOLDING

Part II explains the simple and complicated problems in core making and molding which every good pattern maker should know. **Tells about**—Core making, simple and complex—principles in Molding—Loam Patterns—Loam Molds.

Everyone following this trade or intending to enter it should have this remarkable book. The price is so low that anyone can afford to buy it. Those who have it, wouldn't be without it.

Price Prepaid \$1 This book will be sent postpaid to any address upon receipt of purchase price. Send today. Take advantage of this remarkable offer NOW—before it is too late.

POPULAR MECHANICS BOOK DEPT.
200 E. Ontario St., CHICAGO

"Here's that treasure
of a dictionary
**WEBSTER'S
COLLEGIATE**"



Based on the
NEW INTER-
NATIONAL
the "Supreme
Authority"

One might write a
book on the excel-
lences of this *best*
abridgment. An
eminent educator
says: "Certainly a

gold mine about words, places, people. Only a little
less valuable than the New International." It has
a wonderful vocabulary—over 106,000 words—com-
plete definitions, adequate etymologies, and uses
the familiar Webster's disacritical marks. 1256 Pages,
1700 Illustrations.

The Thin-Paper Edition is so light, so handy, so
well printed that it is a real pleasure to use it.

Art Canvas, \$5 Fabrikoid, \$6 Leather, \$7.50

Guaranteed or money returned. Order from your
bookseller or write to the Publishers. Free Spec-
imen Pages if you name Popular Mechanics.

G. & C. MERRIAM CO., Springfield, Mass.

Every Welder
Should Have
**The Welding
Encyclopedia**

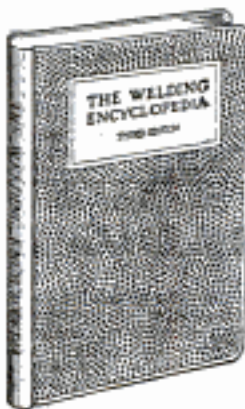

It is America's most com-
plete and authoritative re-
ference and instruction book
on welding. It gives you a
vast fund of expert knowl-
edge on all forms of weld-
ing, conveniently arranged,
fully illustrated by drawings and photographs and
written in language you can understand. It has the
approval of the leading manufacturers in the trade.
You need this book in your shop.

437 Pages — 600 Illustrations — Flexible Leather

Edited and Compiled by the Editors of the Welding Engineer
with the help of many experts in the welding trade

CONTENTS—Illustrated encyclopedia covering all words, terms
and trade names used in welding—Oxy-acetylene
Welding—Aluminum, Steel, Cast Iron, Copper, Brass, Bronze, Full
instructions for welding each of these metals.—Electric Arc Welding
—Electric Resistance Welding. Includes But, Line, Percussion and
Spot Welding.—Throat Welding.—Use and Misuse of Oxy-acetylene
Equipment.—Butter Welding.—Heat Treatment of Steels.—Sales and
Regulations.—Charts and Tables, including temperature color chart—
Condensed Catalogs and Buyers' Index.

**New Third Edition has a complete
training course for operators.**

Yours for \$5 Absolute Refund Guarantee:
—If, after having ordered and
examined this book, you are not satisfied with same,
return it to us and your money will be refunded.

POPULAR MECHANICS BOOK DEPT.
200 E. Ontario St., CHICAGO

Canada's
**1923 Crops
Beat All Records**
Share in Canada's Opportunities

In 1923 the wheat crop of Canada exceeded the 1922
crop by almost 100,000,000 bushels. In Alberta, the
average yield was 26.5 bushels per acre and there were
many individual cases where yields of 50, 60, 75 and 80
bushels were returned. Other crops showed a corre-
sponding increase over previous years with equally high
yields. These enormous yields on moderate priced land
even at average prices for farm products have placed
many farmers on the road to success.

Amazing New Farm Offer
Leaves You a Surplus for Comfortable Living

The Canadian Pacific Railway now offers you a Farm
Home in Western Canada on a New Long-Term Plan
of Easy Payments that is Extraordinary. The plan
makes it possible to own a farm home without taking all
profits to meet land payments and leaves a surplus for
the comforts and enjoyments of life.

Payments Extended Over 35 Years

FIRST YEAR Under this plan all the settler pays
down is 7% of the purchase price—
FREE One year's free use of the land without
any interest chargeable whatsoever.
USE OF LAND The balance of principal and interest
will be amortized on an easy payment
plan of 34 equal annual payments
which makes the second payment fall due two years after
the purchase of the land, which is figured on the basis of 7%
(including principal and interest) of the balance of the cost
of the land. For example, on a purchase of 160 acres costing
say, \$3,000, the down payment will be \$210 and the annual
payments, commencing at the end of the second year, will
be \$195.30. After 35 years the settler will get clear title to
the land—unless, of course, he wishes to pay sooner, which
is his privilege.

NO TAXES ON IMPROVEMENTS

Taxes are moderate and there are no taxes on livestock,
buildings, improvements, implements or personal effects.
Good markets, modern schools, roads, churches, amusements
make farm life in Western Canada desirable and attractive.

IRRIGATED FARM LANDS

In sunny Alberta—a district that is especially adapted to
mixed farming and where irrigation has been proved beneficial
—a vast irrigation system with an unfailing supply of water
administered under the direction of the Government, has
been constructed.

Irrigation in Southern Alberta—insures you a crop every
year—increases your crops each year—makes you inde-
pendent of weather conditions—produces great quantities of
course grains, pastures, alfalfa, roots, etc., thus developing
the livestock industry which is safer and ultimately more
profitable than wheat farming—tends toward closer develop-
ment, well-cultivated farms, good neighbors.

These lands are also for sale upon the same amortization
terms as our other farm lands. Full details on application.

YOU CANNOT BUY UNTIL YOU INVESTIGATE

You must inspect the land before buying in order to judge
of its fertility. Special inspection trips from points Calgary
and West will leave on the first and third Tuesdays each
month. Single fare plus \$2.00 for the round trip. Let us
arrange details. Send this coupon now. It will give you
without obligation complete information on the new and
amazing plan. These terms are so easy that you can own
your own farm home—instead of renting.

M. E. THORNTON, Supt. of Colonization,
Room 434, Canadian Pacific Ry. Depot, Winnipeg, Man.

M. E. THORNTON, Supt. of Colonization, Room 434,
Canadian Pacific Railway Depot, Winnipeg, Man., Can.

I am interested in learning more about
Prairie Provinces of Canada.
Irrigation Farming in Sunny Alberta.
Business and Industrial Opportunities in Western Canada
Lloydminster and Battleford Districts.

My Name.....

Address.....

Town..... State.....

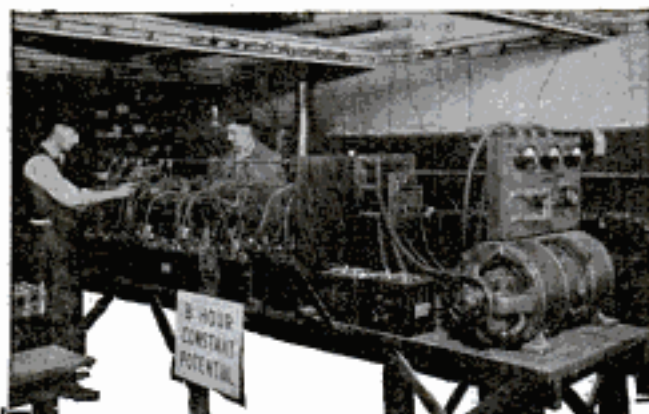

Big Profits Charging Batteries

Make \$1500 to \$3000 Profit Yearly

Start your own money-making battery charging business. Let us help you add \$150 to \$300 every month to your income. No experience needed to start this big business. HB Outfit comes complete, ready to set up and operate. Quickly pays for itself. Charges batteries perfectly in 6 to 8 hours, while old methods take 2 or 3 days. Costs less to operate, builds trade, beats competition, makes your shop the battery service headquarters.

Only \$20 Monthly Pays for Your HB 8-Hour Battery Charger

Small Cash payment puts an HB 8 Hour Battery Charger in your shop on 30 days' trial. Easy \$20 monthly payments let your outfit pay for itself out of your monthly profits, with nice surplus besides. Every HB is built complete in our shops. Big production and direct selling save you \$35 to \$115 on purchase price alone on an HB over other outfits. Exclusive patented features make HB the best outfit on the market.

30 DAYS' FREE TRIAL on Money-Back Guarantee

*More
HB 8 Hour
Battery Chargers
are in use than
any other
Make*

Order your HB outfit on trial and use it 30 days. If it does not fulfill every claim we make—cut charging costs, being new business, make big profits, and give more complete satisfaction than any other equipment—you return it, and we will refund every cent you have paid us. Our positive guarantee of satisfaction-or-money-back gives you complete protection. Send this coupon with your letterhead or your name and address for full information. Right now is the time to start making big battery charging profits.

HOBART BROS. CO., Box M 4, TROY, OHIO

HOBART BROS. CO.
Box M 4,
TROY, OHIO

Send me Bulletin 427
on Battery Charging
Profits.

Name.....

Address.....

*Mail
this coupon*

World's Greatest BATTERY BARGAIN

FREE

Written 2-Year Guarantee
Your Proof of Performance

Save 50%

Thousands of Popular Mechanics Readers will profit by this amazing offer. They will buy the famous 2-year guaranteed World Battery at the lowest price ever quoted. They will get their choice of a hydrometer and a "B" Battery or a nicked Auto Spotlight FREE. And they get the best battery built, with 2-year ironclad guarantee.

Compare These Prices

Automobile Prices		Radio Prices	
6 Volt, 11 Plate	\$12.25	Special 2 Volt Storage Battery	\$9.00
Ford, Chev., Mitchell, Hup.,		For W. D. 11 and W. D. 12 Tubes.	
Grant, Elgin, Vette, Daxon.		Will run 200 hours on one charge.	
6 Volt, 13 Plate	\$14.00	Rechargeable, Special 4 Volt	
Overland, Buick, Res. Paige,		Storage Battery	\$8.00
Hudson, Nash, Stude., Dort.		For U. V. 129 Tubes. Same	
12 Volt, 7 Plate	\$17.00	features as 2 Volt.	
Maxwell, Dodge, Regal, Frank.,		6 Volt, 40 Amps.	\$8.50
Hriscoe and Crow-Ellkhart.		6 Volt, 50 Amps.	10.00
Give year and model of car.		6 Volt, 100 Amps.	12.50
		6 Volt, 120 Amps.	14.50
		6 Volt, 140 Amps.	16.00

SEND NO MONEY and you need not send a penny. Just clip this ad and mail with your name and address. The battery you specify will be shipped to you the day your order is received. When the battery arrives, inspect it—read our 2-year guarantee before you pay one penny. Convince yourself you are protected from every angle—that the World Battery saves you 50 per cent. Get the "B" Battery and hydrometer, or Auto-Spotlight FREE. Clip the ad, and send your order today.

WORLD BATTERY CO.

Dept. 6, 1219 So. Wabash Ave., Chicago, Ill.



Build a SUPER HETERODYNE With BRANSTON Parts



Easy to hook up and operate. Log all stations and select at will. Get prices on transformers and necessary parts. Also our book on Super Heterodyne theory and construction. Immediate Delivery. At your dealer's or write for information.

CHAS. A. BRANSTON, Inc., 814 Main St., Buffalo, N. Y.
In Canada: Chas. A. Branston, Ltd., Toronto, Ont.

Our BUREAU OF INFORMATION will answer all questions regarding articles in this magazine. Address Popular Mechanics Magazine, Chicago.

The Best Hookup Book Ever Printed RADIO AGE ANNUAL For 1924

Detailed instructions for building every standard receiver, from a \$6 crystal set to neutrodyne and Super-Heterodyne. Wave traps, amplifiers, battery charger, etc. Forty-five complete articles—150 picture diagrams and illustrations. Scores of helpful hints. Broadcasting station list. Send your name, address and \$1.00 for your copy to

RADIO AGE, Inc., 500 N. Dearborn St., CHICAGO, ILL.



RADIO FANS! SPECIAL OFFER: Diagram-circular on Power Amplification with All-American Book of 22 Tested Radio Hook-ups mailed for 4c in stamps.
RAULAND MFG. CO., 2650 Coyne Street, CHICAGO

\$25 for \$10

THE FAMOUS BEL-CANTO Acoustical LOUD SPEAKER

**DIRECT FROM
MANUFACTURER
TO YOU**

You cannot buy the Bel-Canto Loud Speaker from any dealer, only direct from us. If we sold the Bel-Canto through the dealer you would have to pay \$25.00. Why? List price \$25.00.

Jobber's discount 50 and 10% off. \$11.25—cost to jobber.
Dealer's discount 33 1/3% off. \$16.67—cost to dealer.
**YOU SAVE ALL THEIR PROFITS.
WE ELIMINATE ALL POSSIBLE FINANCIAL RISK.**

You get one year guarantee from date of purchase besides. The Bel-Canto Loud Speaker was developed by one of the most famous acoustical engineers of the country. Its perfection is the result of three years of extensive research work. Buy one and when you receive it compare it with any \$25.00 loud speaker on the market, and you will be convinced of its unusual value.

Delivered C. O. D. to your door. Telephone Vanderbilt 8050.

**BEL-CANTO MFG. CO.
BENSEL-BONIS CO., INC.
GENERAL OFFICE & FACTORY DEPT. P. M.
417-419-421 East 34th Street, NEW YORK CITY**

7 Points of Bel-Canto Superiority

1. Our own Fiber horn. Crystalline finish.
2. Our own adjustable loud speaking unit, giving a wide range of tone quality and volume without distortion.
3. The base of cast iron, weighing four pounds, eliminating top heaviness.
4. All other metal parts are of heavy cast aluminum, highly polished.
5. Complete instrument stands 24 inches high, 10-inch bell.
6. Guaranteed for one year from date of purchase against mechanical defects of any kind.
7. No auxiliary batteries required. Just plug in on second stage.

GUARANTEE

Money back any time within ten days if dissatisfied. We further guarantee to the publication carrying this advertisement that each and every speaker sold will be exactly as advertised in this issue.

Price

\$10



RADIO SET GIVEN

Wonderful Receiving Set!

Complete, including head phones, aerial, ground wire, insulators, etc. Just hook up and listen in on Concerts, Sport Returns, Lectures, etc. No batteries needed.

ABSOLUTELY GIVEN

Rush name and address for Free Radio Plan

RELIABLE SALES CORPORATION
434 Broadway, N. Y. C. Dept. 7

READY TO LISTEN IN

COMPLETE WITH HEAD PHONES ETC.

**FINEST STEEL
PLIERS**

CUTTING SURFACES

For all electrical, automobile and mechanical work. Carefully tested and guaranteed to be absolutely current proof to 5,000 volts. Powerful leverage: clean, sharp cutting surfaces. Electricians, Garagemen, Mechanics, Radio Workers, etc., all need these pliers. Order now.

STANDARD RADIO CORP.
227 West Madison Street, Chicago, Ill.

TESTED TO 5000 VOLTS

RUBBER INSULATED HANDLES

SPECIAL SALE 69¢

6 inch size 88c for 7 in. size \$1.29 for 8 in. size

A Wonderful Value

CROSLEY

for the Radio World

New Two Tube Set at **\$18.50**

REGENERATIVE

THE most astounding value ever offered in radio—a new two tube receiver, Crosley Model 51, consisting of Armstrong regenerative detector and one stage of audio frequency Amplification. Licensed under Armstrong U. S. Patent Number 1,113,149.

Be sure to see this receiver.

For Sale by Good Dealers Everywhere
Free Catalog Sent on Request.

THE CROSLEY RADIO CORPORATION
POWEL CROSLEY, Jr., President

Formerly
The Precision Equipment Company & Crosley Manufacturing Company
415 Alfred Street CINCINNATI, OHIO
The Largest Manufacturer of Radio Receivers in the World



AMPLION
Junior
DeLuxe

\$26

So human it is
almost "uncanny!"

You doubt your ears when you first hear The Amplion. It is so distinct and natural in its reproductions of voice and music, that it is often described as "almost uncanny."

The reason is that The Amplion, instead of being a head receiver fitted with a horn, is the adaptation for radio of an electro-magnetic and acoustic instrument which for thirty years has been the standard loud-speaking device of the world's leading navies. Requires no power amplifier, no battery. Attaches to regular phone connections.

Rubber bushings insulate the non-vibrating wooden horn and the reproducer from the metal sound conduit.

The special alloy diaphragm is adjustable to meet all conditions of receiving sets.

The Amplion comes in a variety of models, including portables and phonograph units.

In all the world there is nothing to equal The Amplion—*The World's Standard Loud Speaker.*



Ask your dealer for a demonstration.

Patentees: ALFRED GRAHAM & CO.

SIGNAL ELECTRIC MFG. COMPANY

Sole United States Distributors Menominee, Michigan

BURNDEPT OF CANADA, LTD.

Canadian Distributors—172 King Street W., Toronto

ARLINGTON Receiving Set

COMPLETE
NOTHING ELSE
TO BUY \$750

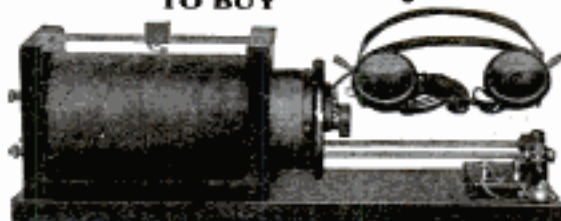

For all wave lengths up to 4000 meters. This is beyond doubt the best crystal set in the market. Ideal for local broadcasting and yet can pick up code on mostly used wave lengths. Everything complete including head-set, antenna and insulators, nothing else to buy.

*Begin with this set, learn radio
—there is a big future for you.*

HECCO ELECTRIC COMPANY
911 Sheridan Road Menominee, Michigan

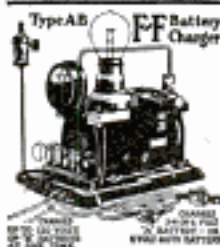

The Triple Duty Charger

Charges radio 2, 4 or 6 volt "A" battery, radio "B" battery up to 120 volts and auto batteries from lamp socket. Average cost per charge about a nickel. Solidly built—will not get out of order. Fool-proof and simple. The first successful charger—introduced over ten years ago. Type A, B, price \$20; West of Rockies, \$22. Type G for 6 volt "A" or auto batteries, price \$15; West of Rockies, \$16. "B" battery charging attachment, \$2.50 extra. Write for literature and name of dealer who will supply you with the genuine FF charger.

FRANCE MFG. CO.

10424 Berra Road CLEVELAND, OHIO

Tunall The Universal Tuner

Price
\$8

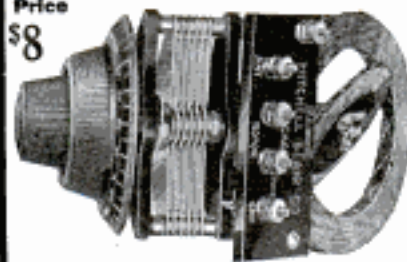

is 80% of an efficient receiving set and can be used with any popular Radio or Audio Frequency Circuit. Sturdy Design. Entire wave length controlled with dial. Receives on any wave length from 250 to 600 and permits sharp tuning. Long distance reception, good volume, excellent selectivity. Practically no resistance or capacity feed back loss.

MITCHELL BLAIR CO., 3942 Federal St., CHICAGO, ILL.
If your dealer cannot supply, write us.

Works Like Magic

Handy men need this tool. Serves many purposes. No skill required.

TURNER BLOTORCH

Safe as a Candle
Intense flame. Use gasoline or kerosene. Leakproof tank. Preferred by experts. 11 exclusive features. Only safe torch in the world. No home, workshop or garage complete without it. At hardware stores or direct **\$8.25** Postpaid

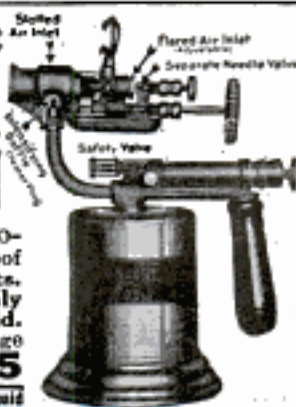

THE TURNER BRASS WORKS
Industry Ave., SYCAMORE, ILL.
The World's Largest Exclusive Manufacturers of Blow Torches, Fire Pots and Brazers

NO. 1 **NO. 2**
\$2.63 \$3.25

NO. 3 **NO. 4**
\$5.90 \$4.98

WEAR SEVEN DAYS FREE

OUR MARVELOUS MEXICAN DIAMONDS

have delighted thousands of customers for 18 years. They positively match genuine diamonds. Same perfect cut, same dazzling play of rainbow fire. Stand intense acid test of side by side comparison with genuine. Noted experts positively need their experience to detect any difference whatsoever. Perhaps the gems you admire on your closest friends are MEXICAN DIAMONDS and you never knew it. Test a MEXICAN DIAMOND FREE; you risk nothing. Wear it seven days side by side with a genuine diamond. If you see any difference, send it back; it won't cost you a cent.

HALF PRICE TO INTRODUCE

To introduce to new customers, we quote these prices which are all you pay and just half our catalog prices.

No. 1—Ladies 1 ct. Solitaire, fine 18k gold f. \$2.63
No. 2—Gents Heavy Tooth Belcher, 1 ct. gem, 14k gold f. 3.25
No. 3—Ladies 3 stone Duchess ring, fine platinum finish, two 1/2 ct. first water Mex. diamonds, one blue sapphire, 1.90
No. 4—Gents Ex. Heavy Gypsy Ring, platinum finish, black ink on sides; 1 1/8 ct. first water Mex. Diamond. 4.98

SEND NO MONEY Just send name, address and slip of paper that meets around ring finger to show size. Say which ring you want. We ship promptly. On arrival, deposit price with postman. If you decide not to keep it, return in 7 days and we'll refund your money. Write TODAY. Agents wanted.

MEXICAN DIAMOND IMPORTING CO.
Dept. ET LAS CRUCES, N. MEX.
Exclusive Controllers of Mexican Diamonds for 18 years.



Ford Owner Stop that rattle on your car. MAKE THIS TEST—take out rear floor if you notice play at the ball joint, you need Breder's Ball Shim. Price \$1.25. Ask your Dealer or send money order. We will ship prepaid.

NIJ BREDER'S SON MFG. CO., Rock Island, Ill.

Glareless Headlight at Last!

Puts light on road—not in eyes. For all cars—easily, quickly installed. Send \$1.00 and name of car for sample set. Regular \$2.00. Representatives wanted—exclusive territory.

MOTOR CITY SYNDICATE, Dept. 4490, Cass Ave., Detroit, Mich.

Tailoring Agents \$5⁰⁰ to \$25⁰⁰ Daily And FREE SUIT



To quickly obtain some good agents in territory where we are not represented, we offer one man in each community the chance to obtain our finest all wool \$30.00 suit free and \$5 to \$25 daily in spare time introducing our guaranteed made to order suits, \$18 and up. Special offer expires not later than January 1st, 1925 so if interested write at once for full details. Just your name and address on a postcard brings prompt reply.

AMERICAN WOOLEN MILLS CO.
Established 1858 Dept. 3045, Chicago

Clip this Ad

Ukulele Free!

Genuine Koa Wood finish Hawaiian Ukulele. Sweet ringing tone. Given free with Short-Cut Ukulele Instruction Course.

Play in 1 Hour by our new copy-right course. No months of practice—just one hour. Mrs. O. Brown writes: "It's all amazingly easy." Thousands pleased.

Send No Money!

for Instruction Course and full size Ukulele outfit. On arrival deposit with postman only \$2.98 plus a few pennies postage. Complete satisfaction guaranteed or money refunded. Send NOW!

FERRY & CO., 75 W. Van Buren, Dept. 1774 Chicago, Ill.

"The New Method is amazingly easy." Mrs. O. Brown.
"Ukulele is a Wonderful Value." C. C. Jacinto.

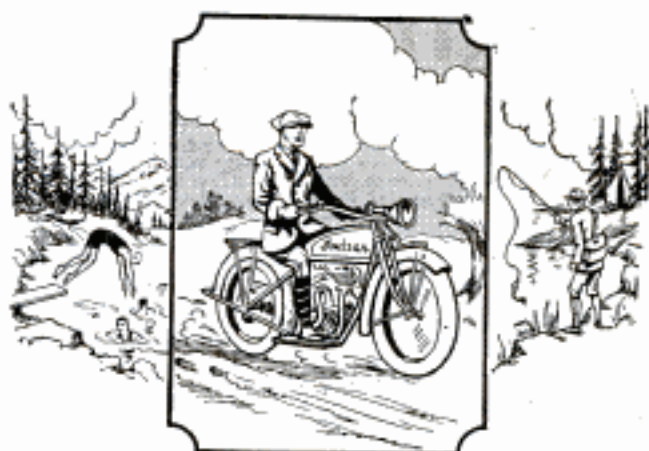

Answer the Call of the Wild

Venture out! Know the thrills of the great outdoors—where the free, crisp air is charged with romance and action—where the vast expanse of open country casts a bewitching spell over you. Let the pine scented forest enfold you in its mystic cloak of blissful enchantment and bring you forth happy, refreshed, inspired!

Life Is Wonderful With the New Indian Scout

The new Indian Scout will bring you more fun and greater health than you've ever enjoyed before. Takes you anywhere—any time—quickly, cheaply, comfortably. Light, powerful and perfectly balanced. Strong enough for a motor cop—safe enough for even a girl. Goes 60 miles to a gallon. Tires good for 10,000 to 15,000 miles! One hundred pounds lighter than average motorcycles. The favorite among motor police and red-blooded fellows everywhere!

Ask your local Indian dealer about the remarkable new Indian Scout—or write us for free descriptive literature and name of our nearest Indian dealer.

INDIAN MOTORCYCLE COMPANY

Dept. P-4, Springfield, Mass.

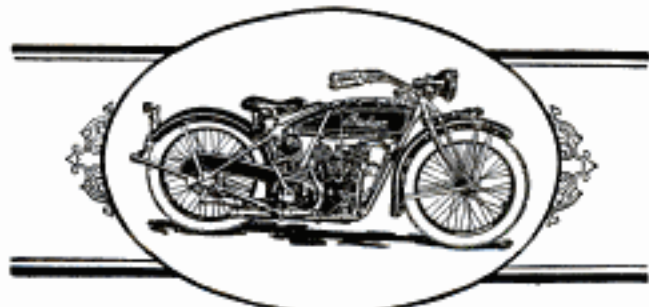

\$100 to \$200 Per Week

We Teach You How to Make It

Money—big money—is waiting for you to come and get it. No matter where you live nor what your experience, we teach you how to make money. *Special Proposition Open Now*

Fireite Sells on Sight

TRADE MARK

Fireite amazes everyone who sees it used. A single demonstration often makes a dozen sales. It has saved many thousands of dollars of property damage. Men, women and children are astounded and fascinated by the ease with which it puts out an alarming fire. It is no exaggeration to state that Fireite is one of the easiest to demonstrate and **fastest sellers ever made**. Why? Because it is so simple a child can use it with one hand. **It always works**—(wonderful secret composition). No pump nor mechanism. Beautiful and long lasting. The low price is within the means of everyone—50% less than most others. Sold to every home, school, garage, factory, office, store, hotel, etc., wherever shown.

AGENTS AND MANAGERS WANTED
In All Territory Not Taken

You can make big money using all or part of your time. We supply everything for your success. This is an **unusual opportunity** for a sound, substantial, permanent income. Write for our agent's—or manager's—special proposition today before it withdraws.

FIREITE CO., Dept. 2, Masontown, Pa.



Beat 'em all with Auto-Wheel

You can beat 'em all, race or no race, if you are "driving" an Auto-Wheel—the speediest boys' coaster. Winning is dead easy. Only another Auto-Wheel can give you any competition. It's the self-contained, friction-reducing roller bearings which make an Auto-Wheel Coaster go so easily that it seems to be running itself. But roller bearings are only one of the many superior features in the

Auto-Wheel Coasters and Auto-Carts

Write for catalog of all models of the Auto-Wheel and the Auto-Cart (for little brother or sister). If you send names and addresses of three coaster wagon dealers in your town, telling which sell Auto-Wheel, we give you a year's subscription FREE to the "Auto-Wheel Spokes-man," our magazine.

AUTO-WHEEL COASTER CO., Inc.
NORTH TONAWANDA, N. Y.



Harris Homes Beautiful PERMANENT BUILT

Your Home Is Within YOUR Reach
When You Buy From Us!

A mighty organization of thirty great departments ready to serve you. Managed by expert material buyers, designers and practical builders. We have vast stocks bought at huge quantities, price savings which are now at your command. Our sole aim and purpose is—

To help you get a home that will prove entirely satisfactory at a price that will mean a substantial saving in actual dollars of your money.

The combined efforts of these great departments in experimenting and testing materials and methods of construction have produced for you a GUARANTEED home, expert machine cut, bundled and marked—the last word in building economy.

Not One Penny in Advance

So sure are we of the super-excellence of our material and our GUARANTEED Ready-Cut Homes that we will ship you any HARRIS HOME without the payment of one cent down. Our Plan Book explains our liberal terms fully.

FREE Plan Book

for you, contains our FREE PLAN OFFER and photographic reproductions, with floor plans and specifications of 100 beautiful homes. Write for full particulars now!

Our Specialties: Houses, Plumbing, Heating, Lumber, Mill Work, "Fresto-Up" Bolt-Together Houses, Paints, Roofing, etc., etc., and Building Material of all kinds.

HARRIS BROTHERS CO.
Dept. PE-7, 1349 W. 35th St., Chicago

**RADIO
WITH**

Howard
Radio Co. Inc. Chicago, U.S.A.

PARTS

Sold by Dealers Everywhere. Ask your dealer to show you our rheostats, potentiometers, switch levers, binding posts, condensers, etc. Every piece is sold with a guarantee. Send 2c stamp for folder.

Howard Radio Co., 4244 N. Western Ave., Chicago, Ill.

WHOLESALE PRICES

SEND FOR OUR BIG FREE BARGAIN BOOK of the best Auto Supplies made! You'd be surprised if you knew our sources and names of manufacturers.

EVERYTHING

Special made Bodies—Tires—Tubes—Batteries—Spotlights—Bumpers—Tools, etc. This book exactly illustrates in colors thousands of bargains—whatever you need or want in Equipment. Every article backed by our Legal Binding Guarantee of absolute satisfaction. Thousands of pleased customers everywhere. Get on the inside of this Price-Saving business. Postal card or letter brings this book—FREE! Be sure to ask for Book Special P.

NEW YORK AUTO & RADIO SUPPLY CO.
Washington at Peoria Street

**BODIES
\$20.95 AND UP**

Chicago, Illinois

AUTO SUPPLIES

"DETROIT" Wire Hook Staggered Grip BELT LACING

The strongest, most flexible, longest lasting, most economical and easiest to apply. Saves time, Belts, power, money and annoyance. Used by International Harvester Company, Advance Rumely Company and thousands of others. Assorted lacing \$1.50 per box.

Free Trial—Whether you have one belt or a hundred we want you to try Detroit Lacing. Large lacing machine \$25.00, Vise Tool \$3.50. Write for Bulletin 26 "What Does It Cost to Lace a Belt."



Detroit Belt Lacer Co., Detroit, Mich.

Big Money IN AUTO SUPPLIES

Represent us in your territory. No experience required. Make \$100 to \$300 weekly. Write for wholesale prices and sample kit.

AUTO TIRE SALES CO.

1346 S. Michigan Ave.

Chicago, Ill.

**1/8 H. P. Gasoline Engine \$25.00
COMPLETE**

Castings \$7.50. 40 other styles and sizes. Gen. Cat. No. 22, 20c, Eng. Cat. No. 23, 20c. Both postpaid for 40c stamps (4 dimes preferred). Refunded first order.

MODERN ENGINE & SUPPLY CO.
334 Monadnock Bldg. CHICAGO, ILL.

Genuine Aluminum Level NOW ONLY \$3.95 DIRECT FROM FACTORY

Special limited offer introducing new genuine Aluminum Level. Highest quality. Non-adjustable, always accurate. Light weight. Fine for over-head work. Wire bubble markers. Easily read in poor light.

Two Year Guarantee
Spirit tubes protected by glass lens on sides. Broken glass replaced within 1 year.
Glass contains org. remover
able.

Just send your name and address. Pay postman on delivery. Use it and try it 10 days. Send it back if you can purchase a better level for less or you are not entirely satisfied. 18", 4 glass, \$3.95. 24", 6 glass, \$4.45. 26", 6 glass, \$4.95. 28", 6 glass, \$5.45. 30", 6 glass, \$5.95. Send Now.

MASTER LEVEL & TOOL COMPANY
5926-C Seminary Ave. DETROIT, MICHIGAN

10 Shaves FREE See Coupon



Don't Buy Yet

First prove our claims—

Make this ten-shave test

By V. K. Cassady, Chief Chemist

GENTLEMEN:

We never ask men to buy. All we urge or offer is a ten-shave test at our cost.

It is better than we expected

Palmolive Shaving Cream surprised us as much as it will you. We learned what men wanted in a Shaving Cream. We worked 18 months to meet those desires to the limit. We made up and tested 130 formulas before we satisfied ourselves.

Men were amazed

This Shaving Cream, when perfected, became an instant sensation. Millions flocked to this Cream when they tried it.

They told others about it. They wrote us letters—tens of thousands—to thank us for making it.

Now we ask you to make this test.

HOW IT EXCELS

- 1—Multiplies itself in lather 250 times.
- 2—Softens the beard in one minute.
- 3—Maintains its creamy fullness for ten minutes on the face.
- 4—Extra-strong bubbles support the hairs for cutting.
- 5—The palm and olive oil blend brings fine after effects.

To add the final touch to shaving luxury, we have created Palmolive After Shaving Tale—especially for men. Doesn't show. Leaves the skin smooth and fresh, and gives that well-groomed look. Try the sample we are sending free with the tube of Shaving Cream.

There are new delights here for every man who shaves. Please let us prove them to you. Clip coupon now.

**PALMOLIVE
SHAVING CREAM**



10 SHAVES FREE

and a Can of Palmolive After Shaving Tale.
Simply insert your name and address
and mail to

THE PALMOLIVE COMPANY
Dept. B-693, 360 N. Michigan Avenue, Chicago, Ill.



Are You Reaching for the Truth?

I will tell you
FREE

Under which Zodiac Sign were you born? What are your opportunities in life, your future prospects, happiness in marriage, friends, enemies, success in all undertakings and many other vital questions as indicated by ASTROLOGY, the most ancient and interesting science of history?

Were you born under a lucky star? I will tell you free, the most interesting astrological interpretation of the Zodiac Sign you were born under.

Simply send me the exact date of your birth in your own handwriting. To cover cost of this notice and postage, **enclose twelve cents** in any form and your exact name and address. Your astrological interpretation will be written in plain language and sent to you securely sealed and postpaid. A great surprise awaits you!

**Do not fail to send Birthdate and to enclose 12c.
Print name and address to avoid delay in mailing.**

Write now — TODAY — to the

ASTA STUDIO, 309 Fifth Ave., Dept. 138, New York

SELL

MEN'S WORK and DRESS SHOES

From Factory to Wearer
Surprising Opportunity

MASON SHOE MFG. CO.
Chippewa Falls, Wisconsin

Try This on Your Hair 15 Days



Then let your mirror prove results. Write Today for **FREE Trial Offer**. Your hair need not thin out, nor need you become bald, for there is a way to destroy the microbe that destroys the hair. This different method will stop thinning out of the hair, lifeless hair, remove dandruff, itching, darken gray hair and threatened or increasing baldness, by strengthening and prolonging life of the hair for men and women. Send your name now before it is too late for the 15 days' free trial offer.

AYMES CO., 3932 N. Robey St., M-390, Chicago

Earn \$50 a day

Selling
our well
known



Goodyear Raincoats

\$1.90 each, in dozen or gross lots. Sample sent upon receipt of \$2.15. Agents wanted.

(Write for our Money Making Catalogue.)

GOODYEAR RUBBER M'FG CO.
Dept. A. 34 East 9th Street, New York City

SHOP ENGINES

**\$33
UP**

Saved \$21 ordering direct from your factory says W. Price, Ind. You will save on our reliable engines. Built to do hard, heavy work. Kerosene, Gasoline, Easy to start — no cranking. Size 1-4 to 22 H.P. 3 Months' Trial, Cash, Easy Terms! 10-Year Guarantee. Free Book — "How to Know Better Engines." Write today.

THE OTTAWA MFG. CO.

531-A King Street,
Desk 531-A, Magee Bldg.,

OTTAWA, KANSAS
PITTSBURGH, PA.

PAPER MAGIC

A new book by Houdini in which are described not only a large number of tricks with paper, but also the amusing and puzzling articles which may be made of folded paper and tearing of paper. Paper Puzzles are also included. 206 pages, illus. Price \$2.50, postpaid.

Popular Mechanics Book Dept., 200 E. Ontario St., Chicago

It's Easy to Build Things

When your ripping, grooving, mitering, rabbetting, sanding, drilling, grinding and many other operations are done on



Boice Pony Bench Saw

Sold with
or without
motor

Boice-Built Bench Machines

Saws, Drills, Jointers, Band Saws, Lathes

The Boice Pony Bench Saw shown here is a compact, low-cost precision machine of all metal construction. Saws 1½" stock. Dados ¾" x ¾". Easily driven by ¼ or ½ h. p. motor. Top 10" x 12". Attaches to any light socket. Sold on guarantee of satisfaction or money refunded. Write today for descriptive literature on this and other Boice-Built Bench Machines and Motors.

W. & J. BOICE, Dept. P. M. 4, 1730-32 Norwood Ave., TOLEDO, OHIO

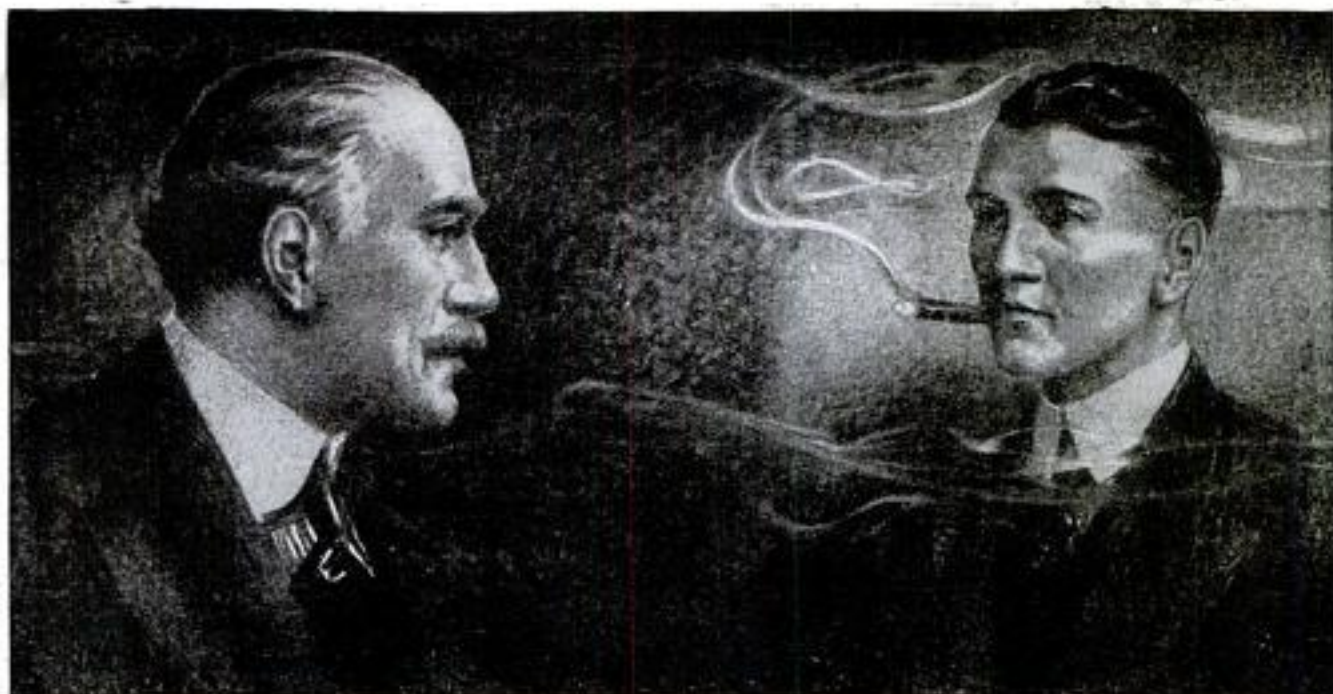

Tobacco Is Hurting You

Look at the facts square in the face, Mr. Tobacco User. You may think tobacco is not hurting you.

That is because you haven't as yet, perhaps, felt the effects of the nicotine poison in YOUR system. For you know that nicotine, as absorbed into the system through smoking and chewing tobacco, is a slow working poison. Slow, yes—but sure.

Tobacco is lowering your efficiency. It slows a man down. Makes it harder for you to concentrate your mind on your work. You haven't near the amount of "pep" and energy you would have if you stopped using it. There's many a man twice as old as you in years who's twice as young in energy, simply because he lets tobacco alone.

Some day you will realize to what an alarming extent tobacco has undermined your system.

When your hands begin to tremble—
and your appetite begins to fail—
and your heart seems to "skip a beat" now and then—
and slight exertion makes you short of breath—
then you have a right to suspect that
TOBACCO is getting the upper hand.

Any well-informed doctor will tell you that these are only a few of many symptoms of tobacco poisoning.

And YOU know that the use of tobacco in any form is an expensive, utterly useless habit. You know you ought to quit.

Tobacco Habit Banished Let Us Help You

It doesn't make a particle of difference whether you've been a user of tobacco for a single month or 50 years, or how much you use, or in what form you use it—whether you smoke cigars, cigarettes, pipe, chew plug or fine cut or use snuff—**Tobacco Redeemer** will positively remove all craving for tobacco in any form in a very few days. Not the slightest shock to the nervous system. Your tobacco craving will usually begin to decrease after the very first dose—there's no long waiting for results.

Tobacco Redeemer contains no habit-forming drugs of any kind and is marvelously quick, scientific and thoroughly reliable.

It is in no sense a substitute for tobacco. After finishing the treatment you have absolutely no desire to use tobacco again or to continue the use of the remedy. It helps to quiet the nerves and make you feel better in every way.

Results Guaranteed A single trial will convince you. Our legal-binding, money-back guarantee goes with each full treatment. We will refund every cent you pay for the treatment if after taking it according to the easy-to-follow directions, it should fail to banish the tobacco habit completely.

SEND Coupon for Free Proof Let us send you our free booklet on the deadly effects of tobacco, together with testimonial letters from men all over the country telling how they have been absolutely freed from the tobacco habit by this simple home treatment. You could not ask for stronger proof that **Tobacco Redeemer** will free you from the habit than the evidence we will gladly send on request. Just mail the coupon—or a postal will do.

NEWELL PHARMACAL CO.

Dept. 300

St. Louis, Mo.



Free Book Coupon

NEWELL PHARMACAL CO.

Dept 300

St. Louis, Mo.

Please send, without obligating me in any way, your free booklet regarding the tobacco habit and proof that **Tobacco Redeemer** will positively free me from the tobacco habit or my money will be refunded.

Name

Street and No.

Town..... State.....

BUNN SPECIAL

21 JEWEL ILLINOIS RR. WATCH

SEND **\$2.00** DOWN
 PAY ONLY **\$5.50** FOR TEN MOS.



FREE TRIAL

NO RED TAPE—NO DELAY

Just send \$2.00 deposit and we'll send the watch. If satisfied pay only \$5.50 a month for ten months until total price of \$57.50 is paid. Choose either dial illustrated above or the Montgomery dial.

TEN DAYS' FREE TRIAL

You can test this watch in your own pocket for 10 days with the distinct understanding that if you return the watch, we will refund every penny you paid. Order it now or write for additional information desired. Ask most any railroad man.

ADJUSTED TO SIX POSITIONS



Despite the fact that railroad regulations call for adjustment to only five positions, the famous BUNN SPECIAL is adjusted to six positions, making it superior to five-position watches now on the market. It's guaranteed to pass inspection on every railroad in the United States. Guarantee bond free.

GUARANTEED 25 YEARS

The famous Bunn Special 21-jewel movement is put in a 25-year gold filled case that will wear like solid gold for more than 25 years. We guarantee it against any defect in material or workmanship. These movements are built to give a lifetime of satisfactory service. Famous for accuracy and long service.

WRITE FOR NEW CATALOG

Our new catalog is ready now. Sent FREE on request. It brings our large jewelry store right into your home. Exact weights and quality of diamonds given, enabling you to buy like an expert. Many other bargains in watches and jewelry. Write for it today.

STERLING DIAMOND & WATCH CO.

Diamond Importers—\$1,000,000 Stock—Established in 1879
 63 Park Row Dept. 1571 NEW YORK

STERLING DIAMOND & WATCH CO.
 63 Park Row, Dept. 1571, New York.

Gentlemen: Please send the famous BUNN SPECIAL, 21 jeweled Illinois Watch, as described above, to me on 10 days' free trial. I enclose \$2.00 deposit to show my good faith. If I am not satisfied and return the watch within 10 days, you will return my money. If I keep the watch I will pay you \$5.50 every month for ten months until the total price of \$57.50 is paid. Title to this watch remains with you until I have paid you in full. It is understood that you fully guarantee this watch to be as described. Please send your catalog.

YOUR NAME _____

LOCAL ADDRESS _____

CITY & STATE _____

MOTOR BARGAINS

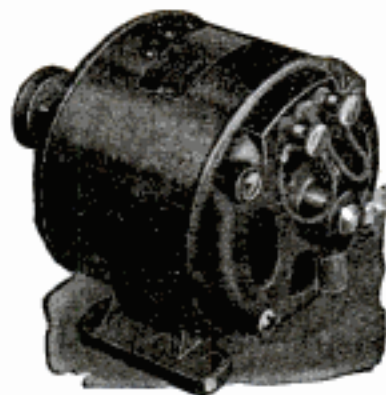

REBUILT and NEW

Every Motor Guaranteed

\$10.50
 1/4 H. P.

110 Volts—60 Cycles

Every motor guaranteed O. K. If not satisfactory, you can return and your money (less return charges) will be refunded.

	Rebuilt	New
A. C. 110 Volt 60 Cycles	\$10.50	\$13.00
D. C. 110 Volt	12.50	16.00

Radio Fans! New Motor-Generator Set for charging "A" battery 110 volt—60 cycles **\$35.00**

NORTHWESTERN ELECTRIC CO.
 408 South Hoyne Avenue CHICAGO

Agents \$200 a Week



That's the record of H. T. Gratz of Kentucky. Ted Gnaur averaged \$37 a day for four months. Arthur Yost of New York averaged \$660 for twelve months, almost \$8,000 a year. Profits and records like these are made right along by our Special Representatives who sell Serenolas, the world's greatest musical invention. Something new and different. Something you can sell easily and quickly—carry it with you anywhere—built in, just like a suitcase. Does as much as machines costing five times its price. Play any record.

New Plan Gives You Free Demonstrator

As soon as we receive your letter or postal, we will send you full details about the Serenola—our sales plan—and also tell you how you can get a Serenola for demonstrating purposes without investing any money. Get into this profitable business at once. Gratz left a \$30 a week job and is now making \$200 every week. Can you do it? Try it, **PERRY LUDLOW CO., S. 3048, Dayton, Ohio**

"The Biggest Little Lathe Built"



The MONARCH Junior
 9" Engine Lathe 2 1/2 ft. bed.

\$270

Here is a sturdy, small engine lathe built with the same quality construction that has made MONARCH Lathes standard the world over. Guaranteed to do any small work any other lathe will do and do it with 1-1000 of an inch accuracy. It will fit in any shop or home workroom. Just the lathe for inventors, experimenters, designers, auto repairmen. Easy to learn to operate.

WRITE for Free catalogue of MONARCH Lathes which are built up to 30" swing.

THE MONARCH MACHINE TOOL CO.
 400 Oak Street SIDNEY, OHIO



A LITTLE MONEY STARTS YOU IN THIS PROFITABLE BUSINESS!

HOW well off will you be financially when you're 65? Will you be among the 82% of men who at this age are dependent upon friends or relatives for support? Or will you be among the other 18% who are men that are in business for themselves, getting *profits* every day, not mere wages?

If you have a little money to spare, we can show how you can enter the chosen circle of the 18%. You can easily get into a good, clean, attractive, big-paying independent business of your own—a business with a big future.

Crispettes in Big Demand

Here's the way. You know the American public spends about \$1,220,000,000 yearly for candy and confections. Get in on the selling end of this enormous field. Operate a simple machine of your own that makes the famous Crispettes, the delicious and popular popcorn confection.

Easy to Make Money

Right now all over America are

men operating these machines, selling Crispettes, and making big money. You can do the same. You need no experience. The very day you get your machine you can operate it immediately, turn out batches of fresh, attractive Crispettes, and sell them at big profits. Here are examples of profits other men, no different than you, are making: Ben Levy cleared \$70 the first day he opened. George Alexander, Pennsylvania, made \$3,000 in four months. Mrs. Lane, Pittsburgh, says: "Sold 8000 packages in one day."

Big Income— Be Independent

Men answer a Crispette advertisement like this one. They order a machine. They open up, and the first day they make more money than they ever made before in one day in their whole lives! And their business keeps on growing week after week. They are not going to be among the 82% of men that at 65 are dependent on someone else for support! The Crispette Business has pulled many a man out of the

weekly-wage rut, and started him toward an independent income.

Small Amount Down— Pay Rest out of Profits!

Think for a moment—what other business is there that is as clean and attractive and as full of money-making possibilities as the Crispette Business, and that you can enter with a small investment, and pay the balance out of the profits from the business? To get into other businesses that promise such good returns you would have to invest thousands of dollars.

Write for FREE BOOK

Our valuable, illustrated *BOOK OF FACTS* tells how people in small towns and big cities are making great successes in the Crispette Business. Shows how and where to start. Full of valuable data. Sent free of charge. Write for it today.

USE COUPON BELOW

LONG EAKINS CO.
Springfield, O.
Please send me your Crispette Book of Facts. It is understood this places me under no obligation.

Name.....
Street.....
City and State.....

LONG EAKINS COMPANY
428 East High Street, SPRINGFIELD, OHIO

Makes the Deaf Hear



Here is good news for the Deaf or people who are hard of hearing. Science has at last triumphed over deafness. Unless your Auditory Nerve is entirely destroyed, the Acousticon will enable you to hear as perfectly as anyone whose hearing is normal. Thousands who have been Deaf for years report most gratifying results—many say they can hear the slightest whisper and that their natural hearing has been greatly improved. We have testimonials from Governors, Bankers, Ministers, Lawyers and thousands of others. So great is our confidence that we invite every sufferer to

Try It 10 Days FREE

You are not asked to purchase this remarkable invention until you have tried it 10 days FREE, until you have proved to your entire satisfaction that it is what you need and want—until you are absolutely certain that it will enable you to hear all sounds clearly. Then, if you wish, you may keep and pay for it, otherwise return it and there will be no charge.

Send No Money

We ask for no deposit. We do not ship C. O. D. We send you this latest scientific invention entirely at our own risk and expense for 10 days FREE TRIAL. We don't ask you to pay first and then refund your money if you are not satisfied. We send you the Acousticon without cost or obligation. It must prove its own merits to your entire satisfaction. Unless you are amazed and delighted with it, you are not asked to purchase. When we say FREE TRIAL, we mean FREE TRIAL, so send name and address at once for descriptive literature, testimonials and FREE TRIAL request blank.

Dictograph Products Corporation
1307 Candler Bldg. 220 W. 42nd St. New York

FORD OWNERS WANTED!

to use and introduce attachment that makes Fords run on 94% air. Thermostat on exhaust automatically turns down needle valve as engine warms exactly as Ford Manual says do by hand.

BLANCHE AUTO THERMO

An Automatic Carburetor Control

Makes Fords start easier winter or summer—saves half gas and oil—cuts repair bills one-half—reduces carbon formation one-half. Sells on sight to every Ford owner as easily as giving him a \$100.00 bill, because it saves \$100.00 every 10,000 miles. CADILLAC NOW USES AS STANDARD EQUIPMENT THERMOSTATIC CARBURETOR CONTROL UNDER BLANCHE LICENSE. You can make Big Money selling this wonderful proven device. Experience not necessary. Sample plan will start you without capital in a business of your own that makes you from \$250 to \$2500 a month profit. Write for free circulars Now!

A. G. BLANCHE & CO. Dept. 10, 602 W. Lake Street
CHICAGO, ILLINOIS



\$104 PROFIT IN 3 1/2 HOURS



FREE
NEW BOOK
"CANDY SUCCESS"

G. A. Barton, Indiana, made that amount—making and selling Candy Floss. Others send in amazing reports: Small, Chicago, says—“Did \$125 business on Sunday.” Wendel, Kansas, writes, “Averaged \$128 a day for 3 weeks.” Gardner reports, “2,437 sacks of candy sold from 11 a. m. to 10:15 p. m. Big Money in Candy Floss! Rees says: “Cleaned up \$225 in 4 nights in Greenville, Ohio.” Candy Floss is a delicious, novelty confection—fluffy, soft as cotton, white as snow, or any color or flavor. Can be made anywhere—in store window, in parks, on street corners, at picnics, summer resorts, base ball games, or wherever crowds gather. Machine easy to operate. Raw materials plentiful and cheap. Send name and address for free illustrated book of facts. Drop postal. Act now! Address

A. T. DIETZ
44 Sayre Bldg. Toledo, Ohio



\$2409 BUNGALOW \$16.06

\$489
5-ROOM HOUSE



FREE CATALOG
with many other beautiful homes at \$489 to \$4,797—all at big savings. Garages \$73 and up.

FREE
C.A.A.
LOG

ALL materials complete for only \$489! See specifications below. For double walls and floors add \$62.

You receive all lumber cut-to-fit (highest grade only), windows, doors, flooring, shingles, lath, glass, paint, varnish, putty, hardware, nails, molding, cupboards—everything plainly marked and easily assembled according to drawings and directions we furnish. \$1,606 Bungalow includes double walls and floors.

Buying Direct Saves 1/3

LET us ship you direct from our mill all the materials complete for a Sterling cut-to-fit Home (not portable) and save you four big profits on lumber, hardware, millwork and labor, besides a 20% saving in waste. Sterling Homes are substantially built and lasting. Many thousand satisfied Sterling Home owners. Satisfaction Guaranteed or money back promptly.

International Mill & Timber Co.
1973 South Wenona Ave.
Bay City, Mich.

I Made \$100,000

in less than five years as a

REAL ESTATE SPECIALIST

Started during my spare time, with no experience, and less than \$5 capital. If you want to learn the secret of my success and follow my money-making method, send your name and address at once to American Business Builders, Dept. 29, 1133 Broadway, New York. They send full information free, telling you how you can build up an independent, profitable business of your own by using my amazingly successful system.



GOVERNORS FOR AUTO ENGINES

When used for power purposes. Gives perfect control.
CANDEE-SMITH GOVERNOR CO.
SPRINGVILLE, N. Y., or 1015 South Los Angeles Street, LOS ANGELES

DISTRICT MANAGERS WANTED

Appoint Local Agents for us in your locality. No canvassing or delivering. \$100 weekly easily made. Commissions advanced.

BOB RUSSELL, B2309 Archer, CHICAGO, ILL.

\$2.49 Everybody is Playing Saxonette

Most Beautiful Weird Music

Sounds just like the Saxophone. Will play any tune. So simple a child can learn quickly. Amusement and fun every evening. (Value \$5.) While they last—Only \$2.49. 15 Popular Songs given absolutely FREE.

Send No Money Just your name and address. On arrival pay postage \$2.49 and a few cents postage. If not delighted return and we will gladly refund your money.

FREE CATALOG—Write for one today. It contains Everything Musical.

FREE 15 POPULAR SONGS

Saxophone

C. W. TAYLOR & CO.
218 S. Wabash Ave.
Dept. 54 Chicago, Ill.

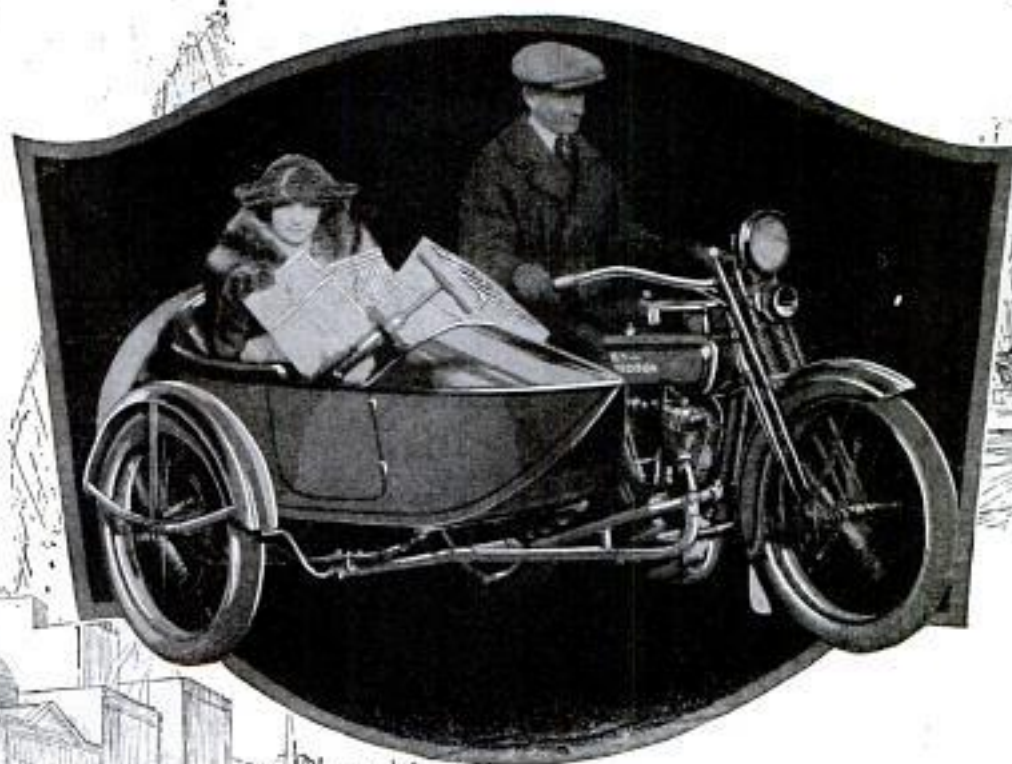

Save Money Every Mile

SHOPPING downtown—a happy vacation at the lake—a week's tour—or just a cool, bracing spin in the evening—you'll find a Harley-Davidson saves you money every day, every mile.

But the real pleasure of riding a Harley-Davidson is not its remarkable economy (50 miles for a dollar—gas, oil, tires and all). It's your ability to go to places you can't reach conveniently with any other kind of transportation. Seldom-fished streams, out-of-the-way camping spots, unexplored trails—where the fun hasn't been spoiled by the crowds!

Ask any Harley-Davidson rider. He can afford an automobile, but he gets more fun, more thrills, more economy from a Harley-Davidson.

HARLEY-DAVIDSON MOTOR CO.
Dept. P, MILWAUKEE, WIS.

Mail
this 

Ask your local dealer for a free demonstration ride on a '24. Note the lightweight-alloy pistons; Alemite lubrication; full-floating, easy riding sidecar; handsome olive green finish, maroon striped. Ask about your dealer's Pay-as-You-Ride plan. And send us the coupon below.

Harley-Davidson

The Motorcycle

Money-making sales opportunities in open territories. Write for particulars.

Harley-Davidson
Motor Co., Dept. P
Milwaukee, Wis.
Send me free, postpaid, new catalog showing 1924
models in actual colors.

Name _____

Address _____

KERMATH

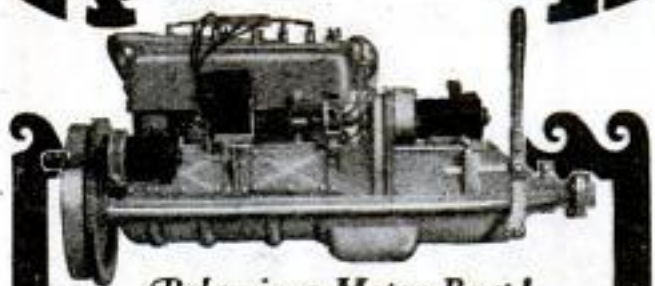

Relax in a Motor Boat!

Get off the crowded roads, forget the detours and dust, graduate from a motor car to a motor boat and know the joy of real recreation!

Whatever type or size of boat you want—for ocean, river or lake—there is a dependable Kermath motor for it. Ask our Courtesy Department about boats and motors. We'll be glad to help you—no obligation, of course.

You will see this famous motor at every watering place and on the finest boats. Kermath motors are used as standard equipment by 80% of the good boat builders and are specified by owners because they "always run," are economical, trouble-proof, simple to handle and because they are made in quantities, are very attractive in price. Kermaths are made in sizes from

3 to 50 H. P., from \$135 to \$1050

KERMATH MANUFACTURING COMPANY
5887 Commonwealth Ave. Detroit, Mich.

A Kermath Always Runs



Steady Work

in a fast growing business with Vanderpool Latest Improved Vulcanizer. Made in America.

Ask for Catalog

Vanderpool Co., Dept. 4P, Springfield, Ohio

F. H. DIBB, Agent for British Isles
26 Fairfield Rd. Winchester, England

Turn Your Ideas Into Profits

On Whether you are interested in light manufacturing, repairing or experimental work; whether you are a mechanic, engineer, amateur or student; whether you work in wood or metal, your ideas can be turned into profits with accuracy, speed and economy on

The Baby Grand Lathe

A sturdy, simple lathe of high quality at low price. Operation same as large lathes. Made of selected materials by skilled machinists who specialize on lathe building. Quantity production explains the low price. Not a toy but a practical machine for all small work. Sold direct from factory to you on positive money-back guarantee.

Write today for illustrated folder giving complete description and prices.



The Watson Mfg. Co.
104 Watson Bldg., Toledo, Ohio, U. S. A.



Clean-cut tones

No, more "wolf" notes

At Last! Band Instruments true to pitch

MAKE LEARNING EASY!

Now you can easily have the place in the band you've longed for! In 30 days you can be playing! For the world's foremost music house now offers you instruments with continuous conical bore—a revolutionary improvement.

No more waste of time learning to "favor" certain tones as in old-style horns! No more "wolf notes" to overcome!



**Continuous Conical Bore
(Conturier)
Band Instruments**

are built according to Nature's law that "a sound wave expands as it travels." All you need do with a Lyon & Healy instrument, is to learn to play the notes naturally, without forcing. Every note comes "true to pitch as a master's violin."

Learn now what this means to you—how you can be a band player in 30 days! Send for FREE Catalog with the whole amazing story! (Mention whether you want Band Instruments or Saxophones.) WRITE TODAY!

LYON & HEALY 65-73 Jackson Blvd.
Inc. CHICAGO

Dealers—Some choice territory still available

A New Book on Concrete For the Home, Farm and Factory

Describing 173 Ways of Using Concrete. Full directions for doing these things yourself with ordinary tools—138 Illustrations.

POPULAR MECHANICS'

CONCRETE

HANDBOOK NUMBER ONE

At the very outset it should be understood that while this book contains much that is of interest to the professional concrete worker, the clear directions and great variety of work covered make it especially suited to the needs of the amateur.

Shows you how to make such things as

Concrete Fence Posts on the Farm	Concrete Garden Furniture (5 articles)
Cheap Concrete Mixer	Concrete Tile
Concrete Forge	Concrete Sidewalk Flagger
Concrete Boat Landings and Decks	Horse Stalls of Concrete
Garden Seats of Concrete	Concrete Black Milk House
Molds for Making Concrete Biks.	Sanitary Drinking Fountain
Watering-Troughs in Concrete	Concrete Cuffs and Gutters
Furnes for Concrete Gate Posts	Faultless Concrete Sidewalks
Rural Mail Box Post	

And practically any other requirement in concrete.

PRICE FIFTY CENTS POSTPAID

Popular Mechanics Book Dept.
200 East Ontario Street, CHICAGO

WHERE CAN I GET ONE?

THIS IS THE REMARK THAT EVERY ONE MAKES WHEN SEEING FOR THE FIRST TIME THE MARVELOUS

BUILT **Security** CHECK-PROTECTOR FOUNTAIN PEN FOR SERVICE

"This wonderful combination of a perfect, smooth-writing, non-leakable fountain pen with a unique and practical check protector enables the writer to write and protect his checks any time—any place. Just think! \$53,000,000 was lost in one year through alterations of checks and other negotiable papers.

The Security Check Protecting Fountain Pen is designed to give protection of EVERY KIND, EVERYWHERE, against EVERY sort of check-manipulating crookedness. Its knife-edged steel rotating, cutting wheel scores the paper and fills the scoring with an in-eradicable acid-proof ink, which can not be removed. This protection is given to the amount, payee's name, check number, date and memoranda. It affords equal protection to names, amounts, signature and important clauses on deeds, wills, contracts, etc.

The Fountain Pen itself is the result of 17 years' experiment. It flows so easily, writes so smoothly and is so durable that on these merits alone, it should cause most fountain pen users to discard their present pen in its favor.



\$3,000
TO

\$10,000

A YEAR AND MORE
FOR AGENTS

Selling SECURITY Pens

AMBITIOUS MEN AND WOMEN

If you are anxious to get into a clean business, with the exclusive selling rights in your respective territory, if you are ambitious and hard-working, full of pep and stick-to-it-iveness, then write today. We have a very interesting proposition to offer you.

DISTRICT MANAGERS

Experienced salesmen who have the ability of organizing a direct to consumer sales force and can finance themselves to the extent of from \$300 to \$1,000 can easily earn \$5,000 to \$10,000 a year. Write us a letter giving a brief history of yourself, past experience, references and territory wanted.

WONDERFUL SIDE-LINE

You can make real money every day, not only in your spare hours but even when calling on your regular trade. Every business man in your territory is a potential prospect for a SECURITY. Every sale cements a lasting friendship with your buyer. The SECURITY needs only to be demonstrated to eliminate sales resistance. A few pens sold in a city or town will develop an ever increasing business in your territory. Five distinctive features mean quick sales. The check protector alone will close the sale in three minutes.

UNLIMITED SALES POSSIBILITIES

When you stop to consider that five hundred thousand pens were sold in the United States in 1900 and that the sales last year amounted to more than eighteen million pens, you can readily visualize the splendid and unlimited sales possibilities of the SECURITY compared with the ordinary fountain pens.

Remember that there is only one SECURITY on the market, fully protected by six patents, and that we furnish a five year written guarantee with each pen.

PRICES

No. 300 \$3.50 No. 600 \$5.00
No. 400 4.00 *No. 800 7.00
Long and Short Models

*No. 800 Security made in a beautiful red and black (mottled) finish with an extra gold band, has an exceptionally large ink capacity.



ORDER A
SECURITY TODAY

SECURITY PEN CORPORATION, DEPT. P. M. 10, 900-910 W. Jackson Blvd., Chicago, Ill.

Gentlemen: I am interested in your proposition from the standpoint of District Manager agent. I wish to devote full time part time. In the following territory. Explain in full.

Enclosed find.....check.....money order, \$..... Send me one Security Pen
No. Long Short Medium Fine Stub Coarse in flexible or Stiff action.
Also Demonstrating Outfit Free with pen. With the understanding that if I am not thoroughly satisfied with the pen you will return my money in full. Write name plainly.

NAME.....

ADDRESS.....

CITY.....

STATE.....

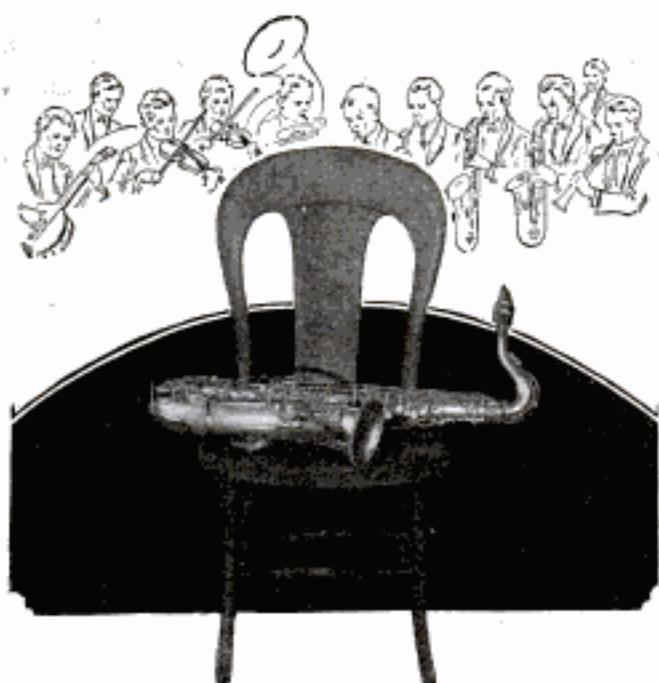

You Can Take Your Place In a Band or Orchestra in 90 Days

The Saxophone is the easiest of all instruments to play. Within an hour after you get your Buescher True-Tone Saxophone you can play the scale, in a few weeks play popular tunes and in 90 days take your place in band or orchestra.

Easy to Play - Easy to Pay

Although the Buescher is the favorite of the great record artists and famous orchestra leaders, such as Paul Whiteman, Paul Specht, Bennie Krueger, Clyde Doerr, Jascha Gurewich and others, it is priced within easy reach of all. Besides you may order any

BUESCHER

TRUE-TONE SAXOPHONE

Cornet, Trumpet, Trombone or other Band or Orchestra Instrument without paying a cent in advance and try it six days in your own home. If perfectly satisfied, you can pay for it on any of our terms to suit your convenience.

FREE SAXOPHONE BOOK tells all about this wonderful instrument, how Sax invented it and Buescher perfected it. Why Buescher Saxophones are so superior in tone—why they make you a better player. Get the facts. Send for this Free Book today.

Buescher Band Instrument Co.

Everything in Band and Orchestra Instruments
2548 Buescher Block Elkhart, Indiana

Buescher Band Instrument Co.
2548 Buescher Block, Elkhart, Ind.

Gentlemen: I am interested in the instrument checked below:
Saxophone..... Cornet..... Trombone..... Trumpet.....
(Mention any other instrument interested in.)

Name

Street Address

Town..... State.....

ALL LEATHER HERCULES WORK SHOE

AT WHOLESALE
MADE on the famous
Army Munson last,
of heavy pliable leather,
double tanned to resist
soil acids and to stand
hardest wear. Double
leather soles. Soft
too. Mahogany brown,
in sizes 6 to 11.
Wide Widths.
No. 01171.



Money Back
If Not Delighted
WEPAYPOSTAGE.

if money or check ac-
companies order. Or you can
PAY POSTMAN on delivery plus postage. Mention No.
01171, size and width, or all numbers in shoe you wear.
SEND TODAY FOR FREE CATALOG
with wonderful values in men's, women's
and children's shoes at 99c and up.

FREE
CAT-
ALOG

ANDERSON SHOE CO., Inc., Dept. 5 C-D
102 Hopkins Place Baltimore, Md.

Man Wanted Handle County Business. Expe-
rience unnecessary. Largest con-
cern of its kind in the world.
Our men are now getting \$200 weekly. Lowest Prices.
RED SEAL COAL CO., 202 Coal Exchange Bldg., Armour Sta., Chicago

**ALL BAND INSTRUMENTS AT
MAKES BAND 1/3 to 1/2 PRICE!**

All famous American and imported instruments for
band, orchestra or solo offered at astonishingly low
prices. Hundreds of bargains in new list. **New Guar-
antee. 5 Days' Free Trial and money back guaranteed.**

CONN
Buescher and all other
famous makes in rebuilt
new condition SAXO-
PHONES, offered with
case, reeds, strap, pearl
keys. Completely rebuilt
and replated—get our bar-
gain list for descriptions and
prices as low
as..... \$89.75

CONN
Buescher, Boston Silver plated
gold bell Cornet, in case, pearl
keys. Slightly used, completely
rebuilt, guaranteed new con-
dition, perfect. \$90
list. Our price.... \$17.95

DEAGAN
XYLOPHONE
\$15 list, 2 1/2 oc-
taves, slightly used,
re built guaranteed
like new. Our \$8.55
price..... \$8.55

SPECIAL!
Brand new Brass Cornet made
by most famous factory in U. S.
Low pitch, pearl keys. List \$35.
\$12.25

BARGAIN LIST FREE

WRITE TODAY! Don't
waste time and money. Dixie known for
23 years as bargain headquarters. Send for latest bargain list TODAY!
Dixie Music House, Dept. 331, 320 S. Wabash Ave., Chicago

Make Big Money

Tailoring Agents

Our wonderful outfit pulls orders quick, on
sight. Clever, new, different from all others.
Bigger profits, paid in advance, taking or-
ders for our fine made-to-measure clothes.
We deliver and collect for you.

\$65.00 a Week AND UP
Entirely NEW Plan

Just think, you get \$4.00 to \$8.00 profits on
every order. Cash in big on this winning NEW
WAY, no delay, no waiting. Get FREE classy
samples and booklet, explains everything clear, simple.

Big Sample Outfit FREE

You can't fail to make good. You will be de-
lighted with this wonderful outfit, cloth sam-
ples 3x2 1/2, handsome fashions and everything
needed to make success certain. All in classy
Backram cover with snap fastener. A knock-out
for Big Money. Limited supply left. WRITE TODAY.

Washington Tailoring Co., Dept. D-345 Chicago Send No Money



Complete RADIO Outfit

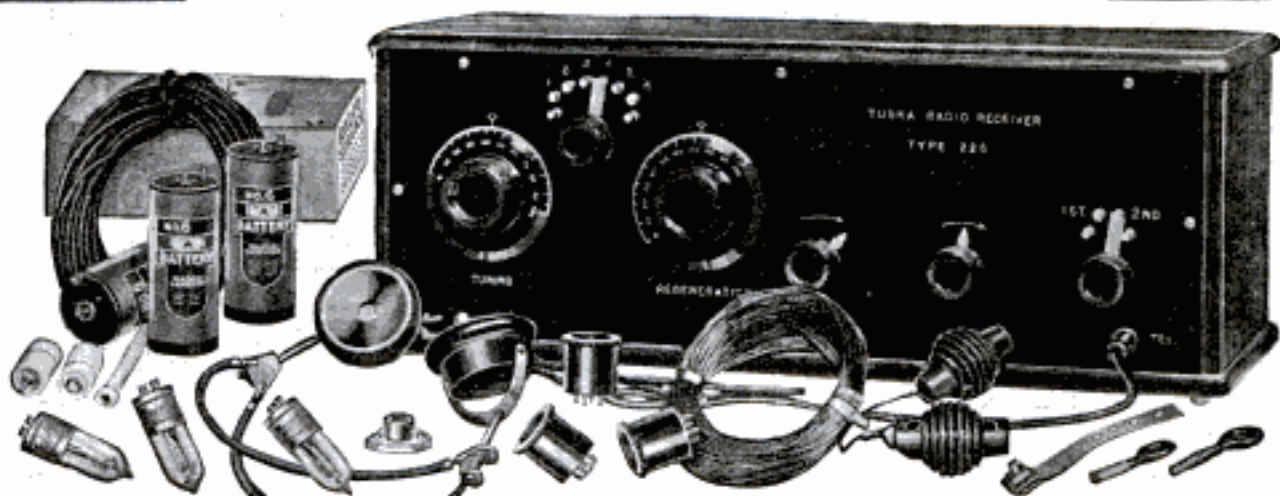

\$5

Down Puts This Famous **TUSKA**

**Armstrong Regenerative 3-Tube Outfit
in Your Home
Balance in Easy Monthly Payments**

NOW everyone can have the finest radio receiver and amplifier that is made. No need to put up with inferior equipment. For here we are offering you the set designed and built complete by Mr. C. D. Tuska, the famous Radio Engineer. It comes to you complete with all the accessories you need, for just a five-dollar payment. Take advantage of this new way of selling radio. Get an outfit that will give you permanent satisfaction. Send the coupon below for our Great Special Offer, made for a limited time only.

The Perfected Radio At Last!

So simple to tune that it is just the thing for the beginner. Yet so perfect that it will delight the most hardened "radio fan" who has long been searching for the ideal circuit. Its long range will bring in stations never heard before, so loud and clear that a loud speaker will delight the whole family. Wonderfully selective. With it interference, internal noises and annoying body capacity are forgotten.

Send Coupon for Great Special Offer

Just mail this coupon. Get all the details without any obligation. Don't think of buying a radio set without finding all about this new and better way. Very easy terms. Free Trial. The highest quality of radio equipment possible to own. Send coupon NOW.

MARSHALL RADIO PRODUCTS, Inc.
2843 West 19th Street, Dept. 13-54 Chicago, Ill.

No Accessories to Buy

The radio outfits we sell are absolutely complete. Most others make an offer on the bare set and leave you to buy all the extras like tubes, phones, etc. in addition. The outfit we offer you now includes, the Regenerative Receiver and 2 step Amplifier all enclosed in a solid mahogany case. Also the batteries, head-phones, tubes, aerial, lightning arrester, and full wiring installation equipment. You start operating without investing another single penny. Your \$5 payment brings it all.

UV 199 Tubes and Dry Cells Reduce Upkeep to Almost Nothing

Equipped with 3 of the latest type of dry battery tubes, which use only .06 ampere current. Most perfect tube, both for detecting and amplifying. Battery expense reduced to the absolute minimum.

MARSHALL RADIO PRODUCTS, Inc.
2843 West 19th Street, Dept. 13-54 Chicago, Ill.

Please send me your special offer on a Complete Tuska Radio Outfit on terms of \$5 down and monthly payments.

Name _____

Address _____

Make A Gas Range out of Your Old Stove in Five Minutes



FOR HEATING STOVES

The Standard Oil Burner fits any heating stove. Heats your living rooms in a few minutes on the coldest day. Think of keeping your home at an even, healthful temperature all day, without constant filling, shaking and poking.



IDEAL FOR FURNACE

The Standard Oil Burner can be installed in any hot air, pipeless, steam or hot water furnace. So simple and safe a child can light and regulate it. Clean, even heat all over the house, all the time.

BURN OIL

Think of it! Your old coal or wood stove can be made into a regular gas range in less time than it takes to tell you about it. You don't have to alter your stove one bit. Just set a marvelous new kind of burner in your fire box, attach it to a tank of coal oil, turn a valve, strike a match, and instantly you have a heating flame as steady, reliable and easy to adjust as city gas, at one-third the cost.

WHY HOME-MADE GAS IS CHEAP

The burner mentioned above is the Standard Oil Burner, a wonderful device that mixes 96% air and 4% kerosene (common coal oil) to form a gas whose heat is two or three times as great as that from coal or wood, and as convenient and easily controlled as city gas. Instant heat at the turn of a valve. No waste of fuel or time in starting a fire. Light it only when you need it—no need to "keep the stove going" to save building a new fire with coal and wood. No need to sweat and slave in a hot kitchen all summer.

SAVES HOURS OF DRUDGERY

The Standard Oil Burner saves you all the exhausting, disagreeable work of carrying heavy buckets of coal, splitting firewood and hauling dirty ashes. Burning gas does away with smoke, soot and dirt—makes your housework easy and lessens your weekly wash. Your meals are prepared quicker. With the Standard, you don't have to stay in the kitchen constantly while food cooks. A turn of valve regulates the heat. Once installed, you'll wonder how you ever did without a Standard.

SPECIAL PRICE AND 30 DAYS' TRIAL

to the first user of a Standard Oil Burner in your community. Act quickly and get the benefit of this generous offer. Make this trial on our absolute Money-Back Guarantee.

FREE BOOKLET. Use Coupon to get our attractive Booklet, HOME HEATING.

STANDARD OIL BURNER CO. DEPT. 16-A

103 North Main St.

St. Louis, Mo.

STANDARD OIL BURNER CO., Dept. 16-A
103 N. Main St., ST. LOUIS, MO.

Send Free Booklet on Home Heating and details of 30-days' trial offer with Money-Back Guarantee. I am checking the burner I am interested in:

Furnace Heating Stove Kitchen-Stove or Range Industrial Burner

I may want to take the Agency for Standard Oil Burners. Send details

Name.....Address.....

City.....State.....

Agent Made \$200 in One Day

The Standard sells like hot cakes. A demonstration means a sale nearly every time, because the Standard fills a long felt need. Everybody wants one. In a single day I made \$200.

W.M. J. FINLAY, Agent
Webster Groves, Mo.

AGENTS WANTED

Big money is being made by our agents selling Standard Oil Burners. Start Now. Sells easier in Spring than any other season. Part time or full time work. Exclusive territory. We give you every help in selling. Write today for money-making proposition.

ONE USER WRITES

I find the use of coal oil in the Standard 51% cheaper than coal, and 64% cheaper than gas. In convenience, cleanliness and comfort coal does not compare with it.

FREE TABLE SCARF

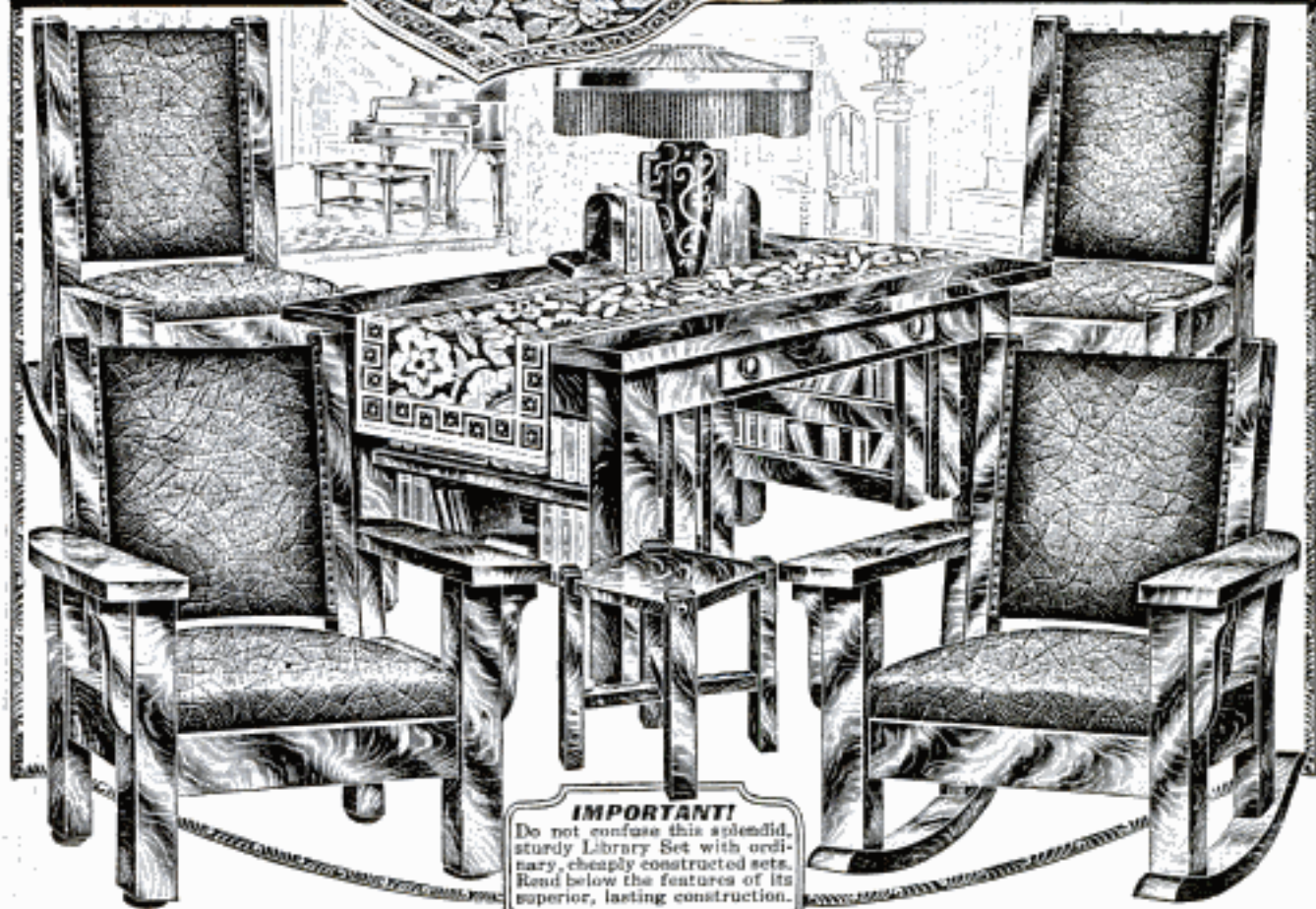

IMPORTANT!

Do not confuse this splendid, sturdy Library Set with ordinary, cheaply constructed sets. Read below the features of its superior, lasting construction.

NO MONEY DOWN!

No C. O. D.—Nothing to Pay for Library Set on Arrival

Just mail the coupon and Hartman, the Largest Home Furnishing Concern in the World, will send you this 7-Piece set of handsome Library Furniture, and with it, absolutely FREE, the beautiful Tapestry Table Scarf pictured above. Nothing

to pay for goods on arrival. No C. O. D. 30 days' Free Trial. If not satisfied, send everything back and we pay transportation charges both ways. If you keep them, pay only for the library set—a little every month. The Scarf is FREE.

7-Piece Quarter-Sawned and Solid Oak, Fumed Finish, Library Set

Seven splendid pieces—42 in. x 26 in. Table, Arm Chair, Arm Rocker, Straight Chair, Sewing Rocker, Tabourette and Book Ends. All full size and of seasoned solid oak in popular fumed finish, Mission style. Table top veneered with genuine quarter-sawned oak; arms of rocker and arm chair also genuine quartered oak. Chairs and table have domes of silence. Seats and backs

upholstered in heavy, imitation Spanish brown leather. Seats are auto type with hand-tied coil springs, resting on steel bands—cannot sag. A wonderful set of furniture at an unparalleled bargain price.

TAKE NEARLY A YEAR TO PAY!



FREE No Money Down Bargain Catalog

Over 200 pages, with 64 in actual colors, of the world's greatest bargains in home furnishings; silverware, etc.; also farm implements, etc. No Money Down, 30 days' free trial and nearly a year to pay. Ask for Catalog No. E 6403

Free Gifts

Book explains how you get glassware, jewelry, table linens, etc., FREE with purchases. Send a postal today for Free Catalog. "Let Hartman Feather YOUR Nest"

FREE HANDSOME TAPESTRY TABLE SCARF

Scarf sent FREE with order for library set. Made of rich colored tapestry, size 50 x 14 inches. Has a finished edge all around of mercerized cotton.

Don't miss this amazing bargain. Furnish your home with this elegant library set. Take nearly a year to pay—and get the Tapestry Scarf FREE.

HARTMAN FURNITURE & CARPET CO. Dept. 6403, Chicago, Ill.

Send the 7-Piece Library Set No. 112FMA10, Price \$49.95, as described, and with it the Tapestry Table Scarf, absolutely FREE. I am to pay nothing for the goods on arrival—only the freight charges. I am to have 30 days' free trial. If satisfied, I will send you \$4.50 monthly until full price of Library Set, \$49.95, is paid. Will pay nothing at any time for the Table Scarf. Title remains with you until paid in full. If not satisfied after 30 days' free trial, I will ship all goods back and you will pay transportation charges both ways.

Name.....

R. F. D., Box No.
or Street and No.

Town..... State.....

Occupation of
Head of Household.....

Order No. 112FMA10. Price of 7-Piece Library Set, \$49.95. No Money Down. \$4.50 Monthly. Table Scarf FREE.

HARTMAN Furniture & Carpet Co.
Dept. 6403, Chicago, Ill.
Copyright, 1934, by Hartman's, Chicago.
Largest Home Furnishing Concern in the World

This No-Money-Down Offer is Special to Readers of Popular Mechanics—This Issue Only

LIGHTING FIXTURES

FROM FACTORY TO YOU AT WHOLESALE PRICES



8 Room Complete Set \$13.95

This sturdy set is made of solid Brass, Satin or Flemish Finish. Highly polished Alabaster White Glassware—Completely wired with all the necessary attachments ready for installation—no extras necessary.

Val. \$30

The above fixtures can be purchased individually—When ordering mention fixtures of \$13.95 set

Hall	Dining Room	Bed Room	Parlor	Kitchen	Big Bed Room	Porch	Bath Room
\$1.50	\$3.75	\$1.50	\$4.75	\$1.25	\$2.50	\$1.00	\$1.25

This Set Is Worth Double the Money

Our National Leader

Complete Set for 8 Room House

This Popular Set Has Taken the Country by Storm

\$24.50
Val. \$50

This magnificent set of 8 massive fixtures comes to you completely wired, ready to be hung. No extras needed. Made of the finest Brass Metal in all finishes. White embossed fancy imported glassware—dustproof attachments—key sockets—a set you will be proud to own.



Guaranteed to last a lifetime. The above fixtures can be purchased individually—When ordering mention the \$24.50 set.

Kitchen	Big Bed Room	Porch	Bath	Dining Room	Hall	Parlor	Bed Room
\$1.75	\$3.50	\$1.25	\$1.50	\$8.50	\$2.25	\$7.50	\$1.75

OUR SPECIAL "DE LUXE" SET

For 8 Room House

SPECIALY PRICED \$39.50

This is really a de luxe set. Must be seen to be appreciated.

Modernized colonial design applies effective illumination. Made of solid spun brass and finely chased brass arms, fitted with satin finish white glass. Wired complete with key sockets. Finished in Roman, Velvet Brown or Jap. Gold. This is a dustproof set.



Fixtures of this set can be purchased individually—When ordering mention \$39.50 set

Big Bed Room	Bath	Bed Room	Hall	Parlor	Dining Room	Porch	Kitchen
\$6.50	\$2.50	\$2.50	\$3.50	\$10.00	\$12.50	\$1.50	\$2.50

WE PAY FREIGHT CHARGES

if you send cash, check or money order with your order. We also ship C. O. D. express collect. Satisfaction Guaranteed or Money Refunded.

WRITE FOR FREE CATALOGUE

All our fixtures are guaranteed to meet with the approval of the National Board of Fire Underwriters. Fixtures are equipped with key sockets. If you desire Pull Chain sockets instead, add 15c for each Pull Chain socket.

UNITED LIGHTING FIXTURE CO., Inc., 280 Bowery, New York City, Dept. P.

J. R. Bayston,
M.S.A.E., Pres.
CHICAGO
AUTO MOTIVE
INSTITUTE
Originator
of the
Job-Way System
of Training



Listen!

What's the sense of working for slave wages?
Why not make \$100 a week? Here's the way!
For just a few weeks—loan me an hour a day of
your spare time. I want to put you in the \$100 a
week class—as an **Auto Expert**—quicker than you can
learn any other big pay work.

Be a \$100 a Week Auto Expert Get into Business for Yourself

Learn: Auto Repairing—Auto Electricity—Vulcanizing—Welding—Battery

Your
Choice
of These
Big Pay Jobs

Automotive Expert
\$3,000 to \$8,000



Automotive Electrician
\$3,600 to \$10,000



Manager or Owner
\$3,000 to \$12,000



Thousan-'s of fellows *just like you* are earning big money—as auto experts. You can do the same. I'll show you how. My copyrighted "Job-Way" system teaches you in an *hour* what ordinarily takes a *month* to learn. Fascinating and interesting work. Intensely practical. Makes **you a specialist** in every branch of automotive work.

Learn at Home the Quick Way to Big Pay Work

Big opportunities in the city and on the farm. 15,000,000 autos to repair, 15,000,000 batteries to service, 15,000,000 ignition systems to keep going, 65,000,000 tires to sell and repair, 3,000,000 trucks to overhaul. Employers need auto experts and pay \$100 a week or more to get them. Also, endless opportunities to make big money in a business of your own. No long waiting, either. The first few of the C. A. I. "Job-Way" lessons will show you how to pick up a lot of money on the side. Earn while learning.

Write— for FREE BOOK and FREE LESSON

Learn how you can make \$3,000 to \$8,000 a year as an **Automotive Expert**. Read our "Money back guarantee." Send for free book. Read the **Free Lesson**. Find out about my **practical "Job-Way" Method**. Special low price and easy terms, too. Write today. Book is free. No obligation. Mail coupon or send a postal to

Chicago Automotive Institute
Dept. 9774, 536 S. Clark St. Chicago, Ill.

MEN WANTED!

Thousands of big-pay jobs open right now, all over the U. S. Our Employment Service **FREE** to both students and graduates, reaches employers in every part of the Country. Look at this:

Master Mechanics	-\$3,900-\$8,000
Electrical Experts	\$3,600 up
Garage Manager	3,000 up
Battery Expert	2,400 up
Expert Welder	2,400 up
Salesman	3,000 up
Tractor Engineer	2,400 up

My graduates earn money fast enough to go into business. Own your own Garage, Battery, Station, Ignition Service, Repair or Welding Plant. **Send now for Free Book and Free Lesson. Mail coupon.**

Free Tools

You get a set of fine tools—worth \$20.00 **FREE**. We show you how to make quick money with them. **Hurry and get details of our offer. Mail coupon.**

THE \$5,000 COUPON
USE IT NOW

J. R. Bayston, M. S. A. E., Pres.
Chicago Automotive Institute
Dept. 9774, 536 S. Clark St., Chicago, Ill.

Without a penny of expense or the slightest obligation, please send me **Free Book** about your rapid course in Automotive Master Mechanics, and **Free Tool Kit offer**. Explain your money-back guarantee. I want to see a **Free Lesson**, too.

Name.....

Address.....

FREE--Book on Wood Finishing

OUR book gives complete instructions for finishing all wood—hard or soft—old or new. Tells how inexpensive soft woods such as pine and cypress may be finished so they are as beautiful and artistic as hard wood. Explains just what materials to use and how to apply them. This book is the work of experts—beautifully illustrated in many colors—gives covering capacities—includes color charts, etc.

We will gladly send you a copy of this authoritative book on Wood Finishing, without cost or obligation. Just fill out and mail the coupon below.

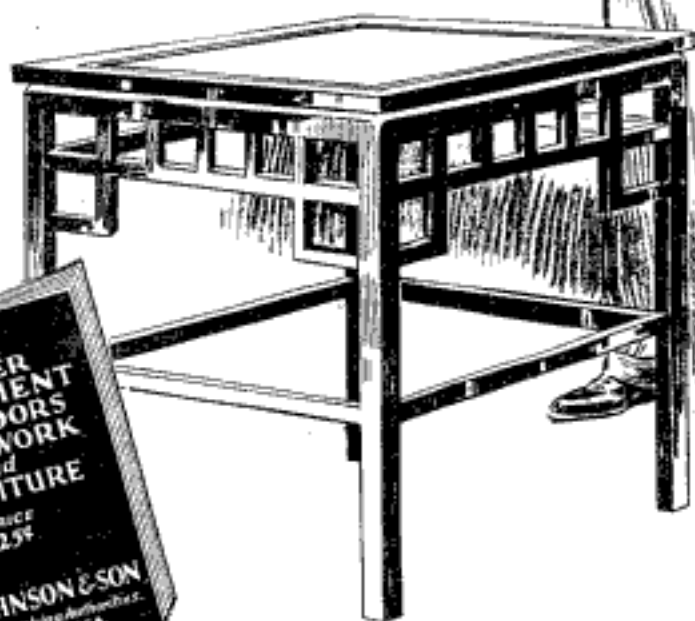

JOHNSON'S WOOD DYE

Johnson's Wood Dye is very easy to apply—it dries in four hours and will not rub off or smudge—penetrates deeply, bringing out the beauty of the grain. Made in fifteen popular shades all of which may be easily lightened, darkened or intermixed. Full directions on every label.

S. C. JOHNSON & SON, Dept. P. A. 4, Racine, Wis.
 "The Wood Finishing Authorities"
 (Canadian Factory—Brantford)

Please send me free and postpaid, your Instruction Book on Wood Finishing and Home Beautifying.

MY DEALER IS.....

My Name.....

Address.....

City & State.....

Johnson's Wood Dye has many uses, for both the artisan and amateur. *Architects* and *contractors* specify it for coloring *woodwork* and *flooring* in new buildings. *Painters* and *decorators* use it with equal satisfaction on new and old *woodwork* of all kinds. *Housewives* delight in it for doing over old *furniture* and for coloring *reed* and *wicker baskets*, etc. *Manual training teachers* and *pupils* use it for finishing their models. *Upholsterers*, *furniture repairers* and *cabinet makers* find it "just the thing" for their work—old and new.

S. C. JOHNSON & SON, Racine, Wis.
 "The Wood Finishing Authorities"

THE WOOD THAT
ALL ITS USERS PRIZE,
THE WISE
INVESTOR
SAFELY BUYS."

"BUILD OF CYPRESS
the "Wood Eternal"
AND YOU BUILD
BUT ONCE."

HERE'S MY OPINION OF
Tide Water
Cypress
"The Wood Eternal"

The following are excerpts from the U. S. Govt. Report on Cypress—Bulletin 95, Dept. of Agriculture, Forest Service. (You know the conservatism of Government Reports.)

"As siding it practically wears out before it decays."

"When made into porch columns it retains its shape, holds paint, and has sufficient strength to sustain necessary loads."

"Cypress is put to almost every use as an interior trim for houses. It may be finished in natural color or stained. The wood contains little resin and thus affords a good basis for paint, which it holds well."

"It is a popular wood for kitchens, where it is subjected to dampness and heat. It shrinks, swells or warps but little, and is used for drainage boards, sinks, kitchen and pantry tables, cupboards and kitchen cabinets."

"The farmer puts this wood to many uses, in all of which it gives good service," etc.

Cypress is in truth "the wood eternal." If you are putting up a PALACE, a PASTURE-FENCE or doing a "LITTLE JOB OF BACK-STEPS"—remember—"WITH CYPRESS YOU BUILD BUT ONCE."

SOUTHERN CYPRESS MFRS' ASSN.



1219 Poydras Building, New Orleans, Louisiana or 1219 Graham Building, Jacksonville, Florida



Radiotron

REG. U. S. PAT. OFF.



Radiola IV

In high quality receiving sets, vacuum tubes — the heart of their fine performance — carry the name **Radiotron** and the **RCA** mark. Be sure to look for this identification when you replace your tubes.



This symbol of quality is your protection



Radiola Grand

Radiotron WD-11 Radiotron WD-12
 Radiotron UV-199 Radiotron UV-200
 Radiotron UV-201-A

Radio Corporation of America

Sales Offices:

233 Broadway, New York

10 So. La Salle Street, Chicago, Ill.

433 California Street, San Francisco, Cal.

Radiola

REG. U. S. PAT. OFF.

Send for the free booklet that describes all Radiotrons and Radiolas.

RADIO CORPORATION OF AMERICA
 Dept. 512 (Address office nearest you.)
 Please send me your free Radio Booklet.

Name _____

Street Address _____

City _____

R.F.D. _____

State _____

SAVE HALF - INSTALL YOUR OWN PLUMBING AND HEATING BY OUR *New Easy Method*



Get This Big Book

Any Handy Man can save half on Water Supply Systems, Bathroom outfits, heating plants, or plumbing materials. We show you how to install with simple diagrams and clear instructions. Do the work yourself and save high cost. Installing plans FREE. We even loan the tools if necessary. You are entitled to enjoy the modern conveniences of running water, up-to-date bathroom, and convenient kitchen plumbing.



BIG HANDY MAN BOOK

Our Handy Man Book tells the whole story. Shows the Hardin-Lavin easy way. Send coupon with 25c for your copy today. This big, instructive, well-bound "Handy Man" Book-Catalog combines our wholesale catalog with trade secrets, money-saving kinks, practical plans, many diagrams, sketches, elevations, etc. Every Handy Man, every home owner, contractor, farmer, mechanic and institution needs this book.

Plumbing Outfits—Heating Plants—Water Supply Systems—At Wholesale

Super Improved Automatic Water Supply System

\$108

AT HALF WHAT OTHERS ASK



This improved automatic Water Supply System gives you city water convenience at unheard of low cost. You can also use it where soft water pumping is required. Have running water day and night at the turn of a faucet. This is your opportunity to install a scientifically built-right, easily set up Water Supply System at low cost. Save the hard work of carrying water or pumping by hand. Order one of these high-grade systems now.

Moving Parts Run in Oil

Hardin-Lavin System is a product of advanced engineering skill, built right and yet so simple that anyone can install it. It is compact with few moving parts, all running in an oil bath, and easily accessible,

nothing to wear out. Guaranteed for years of satisfactory service. Complete diagrams and simple instructions show and explain in detail the ease of which system can be installed—no guesswork.

System Operates Automatically and Quietly

Outfit is controlled by automatic switch. When pressure is low switch throws in motor and starts pumps filling tank, then switch turns motor off, requiring no attention. Furnished with low speed powerful A.C. or D.C. motor (state which is wanted). Tank is galvanized in and out. Pumps is super, double acting, brass lined, 140 gal. cap, furnished complete with fitted pipes, gauges, valves, relief valve, unions, automatic air intake, built in line, and float valve as shown. Order from this ad and save. Special price complete with 42 gal. Tank \$108.00; special price complete with 80 gal. Tank \$112.00.

ORDER FROM THIS AD AND SAVE

For 50 years, we have been economy headquarters for everything in plumbing and heating. In our money saving Encyclopaedia-Catalog of plumbing and heating supplies, you will find bathroom outfits, plumbing systems, or heating plants that will give you the conveniences that are rightly yours.

Factory Fitted PLUMBING & HEATING

All connections and trimmings fitted at factory. You save waste labor, time, money and materials when you buy at wholesale from Big "Handy Man" Plumbing and Heating Encyclopaedia. Shows over 10,000 fixtures and supplies. Hot air, water or steam heating plants. Bathroom outfits, kitchen sinks, plumbing goods of every description, and water supply systems. Do your plumbing and heating by our new easy method and save half.

Ask for Estimate Our Help Free—No Obligation

Send us a rough sketch of the arrangements of your rooms and we will figure the wholesale cost of your heating plant or plumbing system. We will show you many kinks and wrinkles where you can make savings that will surprise you.

50 Years and Million Dollar Plants Behind Our Guaranty.

When you buy from us you get the benefit of 50 Years' Service to Economy Buyers. Quality merchandise with exclusive features. Trained experts who help you plan. Our personal interest in your needs. A guarantee of satisfaction or your money back.

Our combined Catalog-Encyclopedia represents many years' experience and expense in gathering the wealth of information it contains. To avoid sending so valuable a book broadcast, we request a deposit of 25c (regular price 50c) to cover wrapping and mailing. Deposit refunded on first order. Send for this money-saving book TODAY.



HARDIN-LAVIN Hot Water Boiler



HARDIN-LAVIN Pipeless Furnace

OUR BONDED GUARANTY AND LABEL PROTECTS YOU
We guarantee every Water Supply System, Heating Plant, and Plumbing fixture sold by us to be exactly as represented, and of highest quality Grade A materials. We guarantee that you can return to us at our expense any material that is not as represented, whereupon we will either replace your goods or refund your money. In other words we guarantee satisfaction or your money back.
(Signed) HARDIN-LAVIN COMPANY

This Label Protects You



Mail Coupon With 25c TO-DAY

HARDIN-LAVIN CO., 4547-57 Cottage Grove Av., Chicago, Ill.

Get this book. Enclosed please find 25c, regular price, for which send me your Big, Complete "Handy Man" Book-Catalog, with special wholesale discounts sheets. Also mail me your FREE Bulletin Service. I am interested in:

- Water Supply Systems
- Bathroom Outfits
- Plumbing Fixtures
- Hot Water Heating Plant
- Steam Heating Plant
- Hot Air Furnace
- Pipeless Furnace

Name.....
Address.....
City.....

HARDIN-LAVIN CO.

50 YEARS AT

4547-57 Cottage Grove Av., Chicago

Copyrighted material

A Problem in Invention Can You Solve It?

This simple test will show whether or not you have inventive ability; thousands have it and do not know it, or *do not develop it*. Yet invention is the easiest way to earn a fortune. No technical or scientific knowledge necessary. Read below a few instances of how little ideas have made millions of dollars for their inventors

HOW would you like to get the royalty paid to the inventor of the tin cap used on millions of bottles? Wouldn't you gladly be the inventor of the Gillette Safety Razor, who it is said made as much as TWO AND ONE-HALF MILLION DOLLARS a year or the man who invented the President Suspenders who is now worth \$5,000,000, or the inventor of the autographic attachment for cameras who sold his patent rights for \$300,000.

Ideas Worth Fortunes

Other inventors have made hundreds of thousands of dollars from such common things as the crimped hair-pin, the metal-tip shoe lace, the paper safety match, the ordinary wire paper clip. These inventions are so simple, that probably thousands of people thought of them but only one man DID anything about the idea when it came to him.

You, too, probably have ideas for needed inventions—and the only reason you have not turned your ideas into gold is because, like thousands of other persons, you believe that an inventor must be born; that he invents things as naturally as other people do their work as bookkeepers, mechanics, doctors or farmers.

Proof YOU Can Invent

But this is not true. You can prove to yourself that any invention, from the collar button to the colossal railroad engine, is the result of the same kind of thought that you use in adding a row of figures.

Just think, for a moment, what you do in any example in addition. You see a problem—the row of figures. You recognize that a result is wanted—the sum of the figures.

Exactly the same thing is true in invention. This is the proof. At the top right-hand corner of this page is shown a simple problem in invention. What would you put on a shaft "A" to force members "B B" to move back at the same time? A little thought will show you the correct answer within a few minutes.

This test of your inventive ability, simple as it is, illustrates the thought behind every invention. Like your arithmetic example you see first, a problem to be "fixed." Then you think of something which will "fix it." That is all—that is *everything*—to invention. Brought down to its plainest definition, invention is merely the science of "fixing things."

15 great inventors teach you every step in inventive science.

- How to develop your imagination
- How to develop your ideas
- How to get the facts you need for inventions
- How to keep legal records of ideas
- How to use scientific principles of mechanics
- How to avoid wasting time on impractical inventions
- How to apply for a patent
- How to organize a company
- How to protect your rights
- How to market a patent

and hundreds of other vitally important facts which EVERY successful inventor knows and uses.

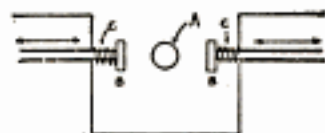

Here is an interesting little problem in invention. Its solution will be found very simple, if we really think.

"A" is the end of a shaft. The two members "B B" are free to move in either direction indicated by the arrows. If they are pushed back, the springs "CC" will immediately pull them forward again.

Our problem is to put some kind of an attachment on the revolving shaft "A" so that the members "B B" will be pushed back both at the same instant every time the shaft "A" makes a single revolution. The device on shaft "A" must also allow the two members "B B" to come forward once in every revolution. What would you suggest putting on the shaft "A"?

A leaking faucet, a rattling window, a wabby table—you fix hundreds of things like these every year. And, though you may never have realized it, every time you "fix things," you use the very definite exact principles which are the basis of Inventive Science!

What Edison Says

Could you ask the advice of any greater authority than Thomas A. Edison? He says: "Invention is a science and should be taught as a profession."

And now for the first time, you can actually learn invention as a profession—exactly as other people are learning electricity, automobile mechanics, law, medicine.

The Bureau of Inventive Science offers you the first course in practical invention ever devised. Fifteen famous inventors tell you WHAT TO INVENT and HOW TO INVENT. They tell you the secrets of invention which every successful inventor knows. They explain how to originate ideas, how to develop and perfect them, how to get patents. But they tell you even more. Thousands of inexperienced inventors have been defrauded of their rewards because they did not know how to protect their patent rights. This great course tells you everything you want to know—how to sell your invention, how to get royalties—how to get the most money for your ideas.

New FREE Book

The most fascinating part of this great new course is that it teaches invention by actual practice, right in your own home. With each lesson you are sent some problem in invention—just like the one you worked out here. This fascinating exercise in solving actual problems in invention sharpens your instinct to fix things; gives you an unforgettable, instinctive habit of thinking inventively, which is worth more than you realize. In fact, the lessons and exercises are so simple, so easy, so interesting, that they seem more like a pleasant game than like instruction which can make you a successful inventor.

A wonderful new book, just printed, tells you more about the Bureau of Inventive Science and its simple new course in invention. It costs nothing, so send the coupon at once.

This bureau is not connected with patent attorneys or manufacturers. Its only purpose is to teach you the principles of practical invention used by every successful inventor. Write for the FREE BOOK now.

Bureau of Inventive Science

Dept. 34, Wisner Building ROCHESTER, N. Y.

Bureau of Inventive Science,

Dept. 34, Wisner Building, Rochester, N. Y.

Please send me your free book, "The Science of Invention."

Name.....Age.....

Address.....

City.....State.....