

July

25 Cents

# POPULAR MECHANICS MAGAZINE

WITH WHICH IS INCORPORATED THE ILLUSTRATED WORLD

WRITTEN SO YOU CAN UNDERSTAND IT

REG'D. TRADE MARK, GREAT BRITAIN, No. 410426

REG. U. S. PAT. OFF.

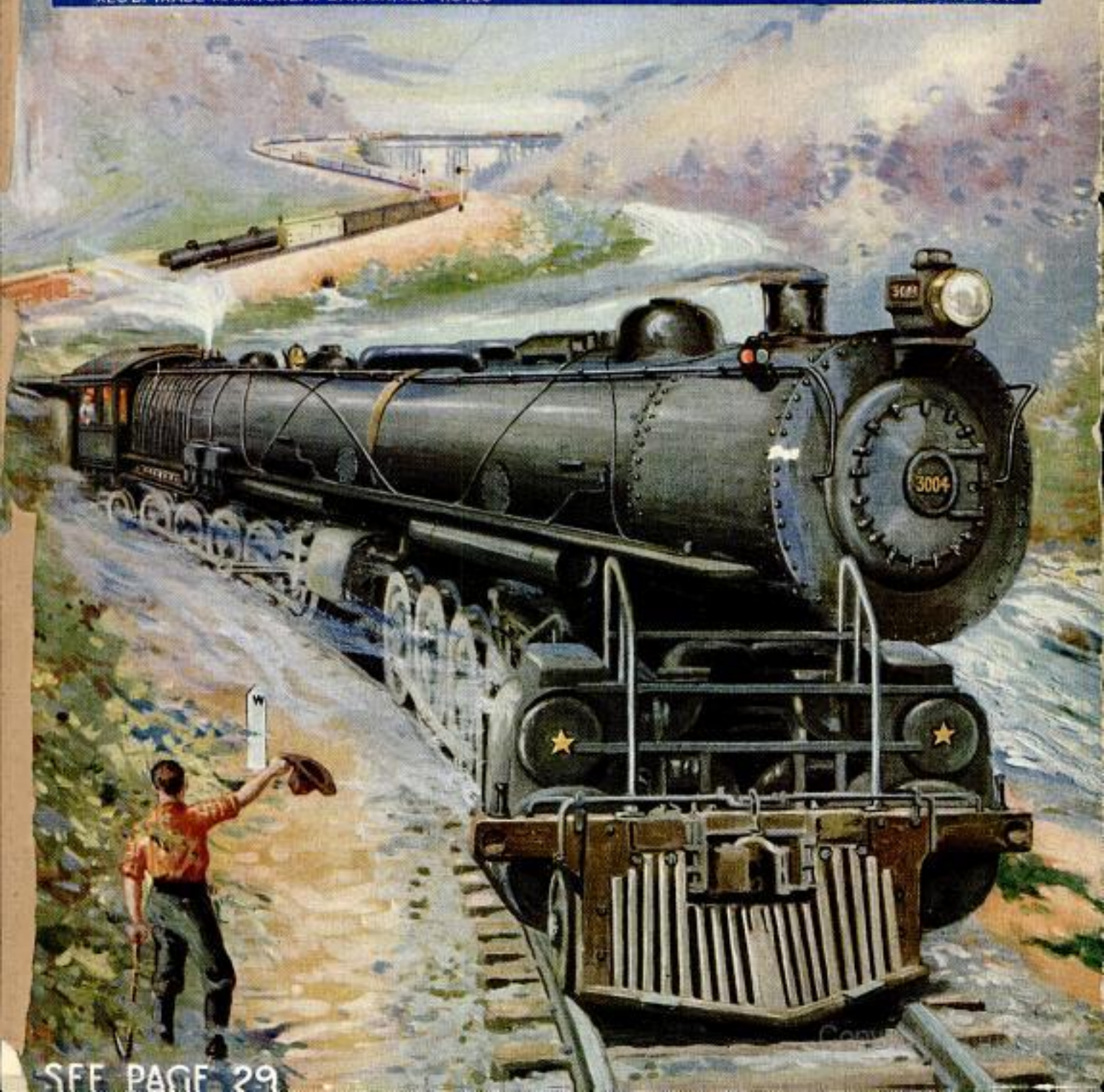

SEE PAGE 29

# It takes *only* 8 weeks to get a big job



O. H. Justus owns a big agency and repair shop at Parkersburg, W. Va. He says "that my schools give motor secrets that will put any man 'on easy street.'"



Emanuel Rushfeldt, Alberta, says: "Earning \$10 a day and only 20 years old."



W. W. Peace gets \$250 a month and expenses operating a tractor in the oil fields.



Louis Beimer at 24 was made foreman over men many years older. That's not luck—it's Rahe training.

## In the Auto and Tractor Business

Read what these men are doing—here is your big chance to get "on easy street." Come to these great shops on the biggest FREE offer ever made.

### Big Firms Need Trained Men

The Auto and Tractor Business is on the boom. Thousands of trained men will be needed during the next few months. I get calls every day from Garages, Battery Stations, Auto Repair, Welding Shops and other successful concerns for Rahe men. When the big fellows need high grade men they know where to come for them. They want Rahe trained men.

### MY TRAINING UNUSUAL

Scientific tool training—that's the secret. You do things here according to the latest engineering standards. Thousands of dollars have been spent in modern tools and equipments. That's why my men are at home in the biggest shops in the country. If you want to succeed the way Beimer and Justus and the rest have—qualify by the same method in only eight weeks or stay as long as you like.

### I'll Pay Your Railroad Fare and Board You

In order to fill the openings that now exist, I am making an offer no one has ever made before—**Free Railroad Fare, Free Board for eight weeks.** You Save Big Money by acting now. Pack your grip—get on a train—Come to school right now before it is too late—**OR WRITE TODAY.**

**SAVE**  
\$50 to \$75

**Send for FREE Book** My big illustrated training book tells how others are succeeding. It tells many things you ought to know about Autos and Tractors. Write for it and my **short time** offer NOW. It soon expires.

## Rahe Auto & Tractor Schools

**CHICAGO**  
4445 Grand Blvd.

Dept. 905

**CINCINNATI**  
Ninth and Walnut

**RAHE AUTO & TRACTOR SCHOOLS, Dept. 905**  
[address school nearest you]

4445 Grand Blvd., Chicago, Illinois or Ninth & Walnut, Cincinnati, Ohio.

Without any obligation, send me your big free book, "The Evolution of Transportation." Also information regarding special temporary offer.

Name.....

Street.....

City..... State.....

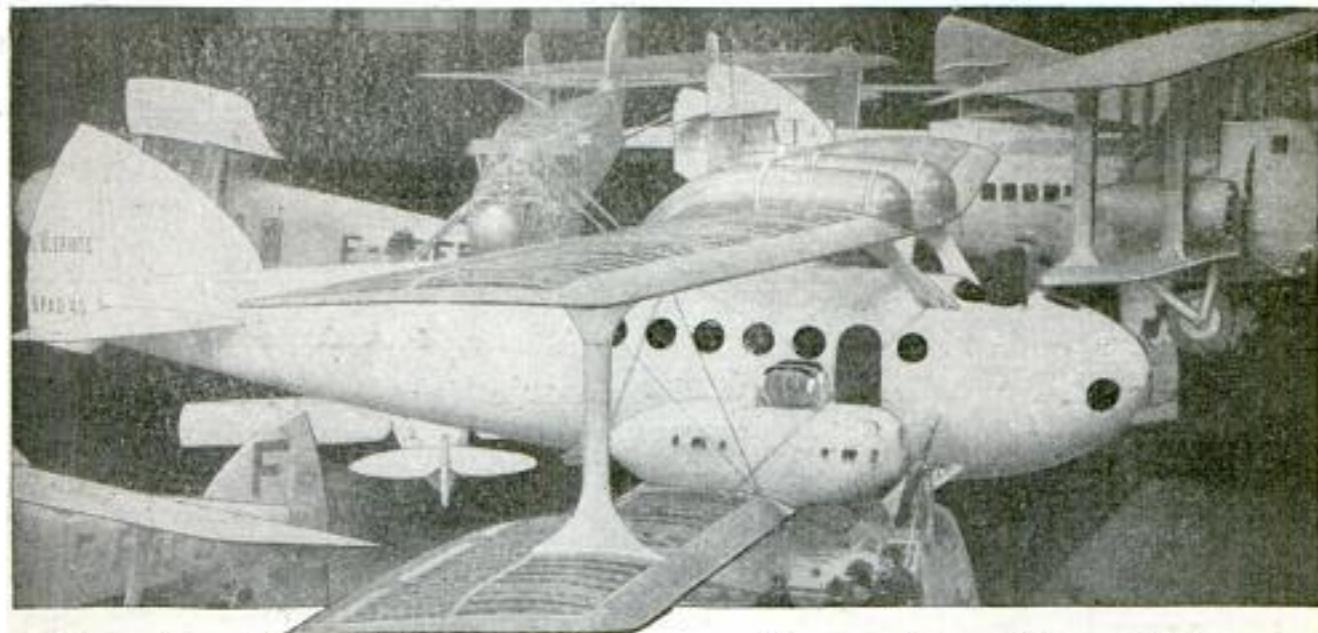

## Quick Success in Aviation Fascinating—Daring—Big Paying

To young men of daring, no other field of work offers such a fascination, such high pay, nor such opportunities for quick success as the field of Aviation. As yet, aviation is practically in its infancy. NOW is the time to get in.

### Amazing Opportunities in Airplane Industries

In the automobile industry and in the moving picture business hundreds of men got rich by getting in at the start. They made their success before others woke up. Today, these lines offer no greater opportunities than a hundred and one others. BUT AVIATION IS NEW. Get in while the opportunity and pay are big. All over the country there is a clamor for trained men. It is not a question of pay but of getting capable men.

### Here Are Real Positions, \$50 to \$150 Per Week

*Aeronautical Instructor, Aeronautical Engineer, Aeronautical Contractor, Airplane Repairman, Airplane Mechanician, Airplane Inspector, Airplane Salesman, Airplane Assembler, Airplane Builder.*



View in an Airplane Factory

### A Sure and Easy Way to Learn Aviation—at Home



A New Job—The Aerial Postman

The study of aviation is almost as fascinating as the actual work. Every lesson is full of interest. That is why it is easy to learn aviation. You do not have to make yourself study—it is like reading an in-

teresting book that tells you things you have always wanted to know. Only one hour each evening will give you the basic training in a surprisingly short time. You need only a common school education.

One of my students, James Powers, Pa., says, "I am indeed surprised that such a valuable Course can be had from such practical men for so little cost."



A New Seven-Passenger Airplane

### Personal Instruction by Experienced Men

Men who have had actual experience give you personal attention. They select the lessons, lectures, blueprints and bulletins. They tell you things that are essential in everyday practice. Each lesson is easy to read and understand.

### BIG BOOK FREE of Opportunities

Send coupon below for New Book, just out, "Opportunities in the Airplane Industry." It is interesting and instructive. It will show you many things you never knew before about aviation. Due to shortage of paper we could get only a limited supply of these books—send the coupon before they are all gone.

### AMERICAN SCHOOL OF AVIATION 3601 Michigan Ave., Dept. 119B, Chicago, Ill.

AMERICAN SCHOOL OF AVIATION  
3601 Michigan Ave., Dept. 119B, Chicago, Ill.

Without any obligation, send me your Free Book, "Opportunities in the Airplane Industry," also information about your Course in Practical Aeronautics.

Name.....

Street.....

City..... State.....

Never mind what the old home was BUILT of—you can  
**PUT A CYPRESS SLEEPING PORCH ON IT**

and by this use of "The Wood Eternal" enhance your property value by a touch of modern art, and guarantee the health and add to the joys of your family by adopting this vital doctrine of modern hygiene, without injury to the sentiment of the old place and at a cost you'd hardly notice. We have **six** special designs. Yours on request, **FREE**.

**DO YOU LIVE HERE?**

You know that style of bow window—with a tin roof and a railing—but not big enough to get out on?

**GET VOL. 35. FREE**



and see just what to do to fix it up like this.

**OR DOES THIS FIT BETTER?**

Cut two extra windows on the first floor, put in diamond panes (in Cypress sash) and you'll shortly produce this.

**ASK FOR THAT VOL. 35**



and you'll find Full Detail Plans and Specifications.

**OR THIS CLASSIC LOGGIA?**

How this chaste yet rich entrance would embellish the old brick homestead (or the wooden one)! Every stick of it Cypress—of course.

**IT'S IN VOLUME 35**



with Specifications and Full Working Drawings.

**ABOVE ARE BUT THREE OF THE SIX THAT ARE FREE**

in the *internationally* famous (fact) Vol. 35 of the CYPRESS POCKET LIBRARY—the Authoritative and Indispensable Reference Work for all well-ordered Home Builders. The plans and specifications are ample for any carpenter to build from—or for *you* if you can swing a hammer and take a day or two off. Balcony designs for any style of structure. All were designed to our order by eminent architects—none is for sale in any form—all are yours with our compliments. "WRITE TONIGHT."

Remember—We recommend Cypress Lumber only for uses in which it is best for YOU

Let our "ALL-ROUND HELPS DEPARTMENT" help YOU. Our entire resources are at your service free

**SOUTHERN CYPRESS MANUFACTURERS' ASSN.**

1219 POYDRAS BLDG., NEW ORLEANS, LA., or 1219 GRAHAM BLDG., JACKSONVILLE, FLA.

INSIST on TRADE-MARKED CYPRESS of YOUR LUMBER DEALER. IF HE HASN'T IT, *Let Us Know*

*Liquefied natural gases - P. 10.*  
*Jack Auto. operated by compressed air 34.*

# Popular Mechanics Magazine

200 E. Ontario Street, Chicago, U. S. A.

H. H. WINDSOR, Editor

London: Hachette & Co.,  
16-17 King William Street, Charing Cross, W. C. 2

Paris: Hachette & Co.,  
111 Rue Reaumur

Melbourne, Australia  
The Australasian News Co.

ISSUED MONTHLY

SUBSCRIPTION:

SINGLE COPY, 25 CENTS

In United States and its possessions, also Canada, Cuba, and Mexico, per year, postpaid - \$3.00

To all other countries in the Postal Union - 3.50

All subscriptions are discontinued at expiration. Please examine the date printed on your wrapper.

Entered as Second Class Matter Sept. 15, 1902, at the Post Office at Chicago, Illinois, under Act of March 3rd, 1879.

Entered as Second Class Matter at the Post Office Department, Canada.

Published monthly by POPULAR MECHANICS CO.

Copyright, 1923, by H. H. WINDSOR. Copyright in Australia

Vol. 40

Contents for July, 1923

No. 1

Aeronautics—Air Liners may Link London and Chicago .....	94	Chickens, 4,000, Uncle Sam Keeping Tab on.....	78
Aeronautics—Air Service, Automatic, Needs No Pilots .....	50	Christmas Tree Cutting, Washington State Prohibits .....	82
Aeronautics—Air Transport, Civil, Nations Plan to Promote .....	52	Church Carving, Salvation Army Doughnuts in.....	39
Airplane Flight, Dawn-to-Dark, 'Cross Nation Planned .....	76	Church Plates, Mormon, Arouse Interest.....	66
Airplane Mail Service across the Continent.....	58	Cloudburst Sweeps Tons of Mud on Mining Camp.....	96
Alleyways, City, Parks Suggested to Replace.....	113	Coin Collection Transferred to Washington Museum .....	82
Animals for the Ages, by H. H. Dunn.....	101	Color Scheme of Work Space Affects Output.....	79
Arch, Rustic, Lends Beauty to Factory Grounds.....	92	Columns, Heavy, Handled by Rolling Skid on Trailer .....	119
Armor, Bullet-Proof, Adopted by Paris Police.....	120	Comment and Review, by H. H. Windsor.....	45
Automobile, Cabin on, Provides Home for Hunters.....	64	Concrete Machine Casts Poles in Place.....	52
Automobile Device Gives Data on Gasoline System.....	121	Cotton Spinner's Bobbin Stop, Automatic.....	86
Automobile Engine Primer Starts Electrically.....	124	Cross, Illuminated, Revolves on Church Tower.....	116
Automobile, German, Built on Extreme Lines.....	17	Cross of Order of St. Andrew, of Russia.....	7
Automobile Has Aluminum Body.....	38	Devilfish Caught to Earn Pin Money.....	59
Automobile Headlight Aids Motorist to See around Curve .....	66	Diabetes, Sharks may Furnish Cure for.....	75
Automobile, Marooned, Takes Lake Ride on Ice Cake .....	106	Diamonds Set with Tool Attached to Lathe.....	48
Automobile Motor Heat Cuts Down Supply of Gas.....	25	Diamonds, World's Stock of.....	105
Automobile Radiator Cap, Light in, for Advertising .....	34	Ditching with Dynamite, by Joe Alexander.....	99
Automobile Service Station Specializes on Crank-case Oil .....	55	Dollhouse being Built for Queen.....	96
Automobile Signals Operated by Buttons on Steering Wheel .....	124	Door Panel Sign Lights as Knob is Turned.....	80
Automobile Truck, Light, Starts Airplane Engines.....	96	Dumping Scheme, Unusual.....	97
Automobile Van Body, Steel, Protects Silks in Transit .....	92	Duststorm Engulfs Oklahoma Town.....	54
Automobile Window Regulator Uses Gears.....	89	Dynamite Breaks Up Ship's Cargo of Potash.....	55
Automobile Work Stand Tilts Car at Angle.....	85	Earthquake Study, Explosions to Aid.....	44
Aviator, Pioneer, Death of, Recalls His Feats.....	4	Egg, Largest Hen's, Breaks Record.....	17
Balance, Most Accurate, to Test New Theory.....	118	Eggs are Growing Longer U. S. Scientists Find.....	44
Ball Bearing of Enormous Strength.....	11	Electric Light Guard, Portable, Easy to Attach.....	95
Balloon Motor Ship to Fight Moths.....	63	Electric Lines, Radio Helps Find Breaks in.....	73
Barn with Grain Elevator Is Automatic Feeder.....	50	Electricity, Million Volts of, Modern Jove Juggles.....	104
Baseballs, Home-Run Secrets Sought Inside of.....	3	Envelope Sealer, Self-Adjusting.....	105
Baseball in "Cracked" Window Attracts Attention.....	44	Farm Population Decreasing.....	110
Basket Liners Protect Delicate Fruit.....	116	Fig Groves, Hawaiian, Sown from Army Planes.....	38
Beach Land, Harnessing Waves to Build.....	86	Fire Fighters Protected by Sheet of Water.....	28
Bell, Huge, Germans Cast for Rhine Cathedral.....	76	Fire Turns Office into Oven.....	63
Blankets, Device Tests Moisture Absorbing Properties of .....	17	Fish—Herring Split and Dressed in Rapid Machine .....	98
Boat, Fish Propagation, Circulates Fresh Water.....	85	Fish Tagging with Buttons for Identification.....	31
Boat—From Kyak to Schooner, by Francis Dickie.....	61	Fishing Rod Joints, New Type, Make Rod Flexible.....	39
Boat—Schooner, San Francisco Burns, to Commemorate 1906 Fire.....	49	Flies, Millions of, Made to Tempt Fish.....	38
Boats, Shallow Freight, Have Four Pontoon Rudders .....	109	Fluid, Bottled, Has Power to Lift 30,000 Pounds.....	34
Boll Weevil, Smell to Lure, to Its Death.....	34	Food Charts Determine How Much to Cook.....	121
Boot Washer, Automatic, Used by Japanese.....	73	Fossils Prove Asia Once Part of America.....	38
Brain, Child's, Photographed.....	97	Fruit, Breathing of, Studied to Save Spoilage.....	113
Bridge Sag, False Rock Bottom Causes.....	93	Furs, Wrapping the World in, by T. Winfield Thackeray .....	67
Bridges, Natural, of the World, by J. Cecil Alter.....	41	Garage Doors Opened by Water Pressure.....	111
Broaching Tool, Improved, Aids Production.....	121	Gas Mask, All Purpose, Lets Wearer Talk.....	98
Building, Skyscraper Planned for University.....	7	Gasoline Efficiency Increased by Metal Compounds.....	81
Building, World's Largest, for Furniture Trade.....	64	Gauge Tool Combination for Machinists.....	89
Buildings Salvaged by Loading Ground with Pig Iron .....	106	Gear, Giant Reduction, Used on U. S. Navy Tenders .....	84
Buriats of Mongolia Have Queer Customs.....	9	Generator, World's Largest.....	90
Cable, World's Largest, for Atlantic Ocean.....	57	Girders, Mammoth, Shipped on Four Cars Each.....	93
Cablegram Time Reduced by Mechanical Relays.....	55	Glass Cutting Machine Cuts on Both Sides.....	119
Cascade, Italian, Beautifies City Street.....	107	Glanders, Upward Currents of Air Help.....	110
Chair, Screened Rocking, Foils Insect Pests.....	60	Goats, 10,000, Boy Scouts Round Up, by Everett W. Maquart .....	122
Change Giving Machines for London "Tubes".....	46	Gold and Silver in Kegs and Bricks Bound for India .....	82
		Goldfish, Swarms of, Netted by Lake Erie Fishermen .....	119
		Golf, "Aerial" Adaptation of, Makes Debut in Chicago .....	97
		Golf Bag Pockets, Locked, Used to Carry "Togs".....	3
		Grass—Eelgrass: A New England Coast Sea "Crop" .....	51
		Guns, Naval, Simulate Huge Pile Drivers.....	77
		Hair, Human and Goats', Old Chinese Weavers Used .....	118
		Hall of Fame Wipes Out Sex Distinctions.....	28
		Hangar, Airship, Could House Large Office Building .....	92
		Hat, Curiously Designed, to Attract Tourists.....	56

[Continued on Page 4]

This One



SDEE-1ZL-3PQL

aterial

## [Contents—Continued]

Hats, Cast-Off, How Dealers Make Profit on.....	97	Ship's Porthole Lenses, Sandblast Cuts.....	94
Hearse, Ornate, Gives Way to Simple Limousine Body.....	64	Ships, Weird Rites for, as They Sail for Orient....	1
Heater, Electric, Suspended from Light Socket.....	117	Sign, Hillside, Projected from Lettered Glass.....	33
Helicopters Better Records.....	77	Singers, Device Tests Voice of.....	48
Highway, Experimental, Tested with Trailer.....	56	Silver, Stainless, is Invented.....	123
Houst, Hand, of New Design Is Simple and Com- pact.....	100	Snakes—Rattlesnakes, Idaho, Shipped to Amsterdam, Holland.....	118
Hooks, Rail and Timber, Handle Heavy Loads.....	65	Spirit Hands, "Ectoplasm," and Rubber Gloves.....	14
Hose Clamp in Segments Fits Various Sizes.....	53	Stamp Affixing Machine for Mail.....	91
Hospital, Paris, to Serve Sick Americans.....	89	Stamp, U. S. 20-Cent, to Bear Scene at Golden Gate	53
Hotel Roof Garden, Japanese, in New York.....	37	Stamps, Freak, Bring High Prices at Auction.....	73
Hotel, World's Finest, for Japan.....	31	Staple, Wire Furring, Eliminates Wood Lathing.....	60
Household Devices.....	114	Statue, General Custer's, Damaged by Trains.....	72
Ice Cream Eggs, Baked, a New Confection.....	82	Stockyards, Western, Follow Chicago's as Model.....	112
Ice Cream "Noodles" Made with New Device.....	27	Street Car, Trackless, to Run on City Streets.....	90
Ice Plant, Mirrored Globe Reflects Use of.....	27	Street Car Trouble Reports by Radio and Trolley Wire.....	111
Indians, Islands Overpopulated with.....	72	Street Cars, Noiseless, for Twin Cities.....	57
Inner Tube, Self-Sealing, Defies Punctures.....	27	Street "Hairpin" Bends, Five, in Single Block.....	80
Iron Borings, Cast, Molded into Briquettes.....	83	Subdivision Entrance, New, of Rustic Stone.....	83
Island, Matador, Wiped from Charts.....	65	Submarines, Japanese, Make Warm Water Voyage	98
Jack, Handy Folding, for Motorcycles.....	65	Subway, London's, Model Helps in Handling Jam of	16
Japanese Thirst for Knowledge Makes Them Wait in Line.....	104	Surveys, Cloudy Days Best for.....	72
Jumpers Cover Bathing Suit While Walking to Beach	98	Swimming Pool Water, Nature Heats.....	9
Laundry Net Holding Devices Used by Large Con- cern.....	124	Tea, Cassena Plant a Delightful Substitute for.....	52
Lifeboat Lights, Electric, as Safety Beacons.....	37	Telegraph Code, Improved, Aids Radiotelephoning...	91
Lighthouse, Great, to be Erected in Honor of Co- lumbus.....	50	Tennis Anchor, Two Peg, Keeps Net Taut.....	9
Limb, Artificial, Made of Spring Steel Wire.....	65	Tent, Auto Camping, Made without Ridgepole.....	117
Locomotive, Monster, Pivots on Front Truck.....	29	Timber, Sound, 500 Years Old Found in London....	27
Locomotive, Runaway, Dives into Lake.....	10	Tire Gauge on Each Wheel Saves Time and Work..	86
Mail Box, New, Assures Safety and Privacy.....	116	Tomb, Old Inca, Adding Machine Found in.....	37
Mail Record, U. S. Aerial, of Five Million Miles....	65	Totem Pole, Hang Tire on for Charity.....	48
Mailing Tube Fastener, Metal, a Big Improvement..	60	Tourists, Far Away Lands Lure.....	18
Match Lighter, Safety, Prevents Accidents.....	107	Tourists, Michigan, Tour the Country.....	32
Medallions, Stained Glass, Work of Students.....	81	Tourmaline Has Queer Properties.....	17
Milk, Action of Metals on, Studied in Tests.....	117	Tree Device Checks Rising Sap to Protect from Late Frost.....	91
Minarets, Gleaming, Mark the Golden Horn.....	23	Tree Marker, Neat Bronze, Adopted by Colorado....	111
Mine Locomotive, Flame-Proof.....	105	Tree Seedling Roots Grown in "Splints".....	95
Monorail Taps Wealth of Death Valley, by John Anson Ford.....	36	Tricycle, Pedalless, Employs Unusual Running Gear..	83
Motion Picture Apparatus, Special, Films Forest Fire	109	Trouble Lamp on Cap Gives Strong Light.....	118
Motion Picture Camera Films Combustion Process..	107	Truck, Portable Lift, Loads Heavy Crates.....	49
Motion Picture Film Gauges Accuracy of Observa- tion.....	113	Truck, Small Industrial, Has Crane Attachment....	57
Motion Picture Theaters, Perfume to be Sprayed in.	11	Typewriter Word Counter Utilizes Space Bar.....	116
Motion Pictures, Animated, for Geometry Students, by F. N. Hollingsworth.....	5	Vacuum Bottle Cap Spring Holds Cork Tight.....	120
Motor Bus Repair Plant, London.....	87	Vault Vestibule, Reserve, Weighs over 100 Tons....	79
Motor Busses Haul Children to Consolidated Schools	81	Veterans, Electrostatic Machine Used to Treat....	11
Motor Trucks, Dumpless, Air Lift Raises and Dumps	72	Violin, Old Smashed, Successfully Restored.....	73
Motorcycle, Furniture Dealer Moves Goods on....	94	Vise, Spring Plunger, Grips Irregular Articles.....	124
Motorcycle Movie Plant Makes Quick Movies.....	16	Washer, Vibration-Proof, for Bolts and Screws....	57
Motorcycle Saddle Adds to Comfort.....	53	Water Waste Shown by Punched Metal Disk.....	118
Movies, "Depth," in One Strip of Film.....	3	Wave Lengths Photographed.....	95
Nail Collar for Withdrawing Nail.....	50	Weather Forecasting from Ships at Sea.....	80
Oil Industry to Break Record This Year.....	77	Whale, Dead, Used as Target by Naval Airmen....	123
Oil Shales, Rare Metals in.....	49	Whale Killer Ravages Cause Plea for Bounty.....	34
Pageant, Historic "Pony Express," to be Given....	75	Whiskers, World's Champion.....	48
Pail with Float Prevents Calf Drinking Too Fast..	107	Window Card Useful in an Emergency.....	121
Paint Remover, New, Also Cleans Cylinders.....	53	Window Guard, Collapsible, is Locked in Place....	120
Panama's Torrent Greater than That of Niagara....	40	Wire Furring Staple Eliminates Wood Lathing....	60
Paper from Pine Stumps.....	107	Wireless Support, Wind Dynamo Mast Used as....	121
Pavement, Rubber Block.....	40	Wolf, Automobile Races, to Its Death.....	76
Pen, Electric, Writes in Gold or Silver.....	10	X-Raying Heart Action of School Children.....	54
Piano Made by 25 Manufacturers.....	100		
Pipe, Pressure Forces Up, from Bottom of Pond..	56		
Plants, Crossbreeding of.....	112		
Poultry Nest, Automatic, Traps Hen and Egg.....	100		
Power Plants are Run by Phone Keys.....	33		
Pressroom, Rack with Many Rollers for.....	44		
Pyramid, Mexican, Rich Relics Found in.....	35		
Rabbits, Wild, Profitable Use Found for.....	60		
Rack, Musical Instrument, Aids Quick Changes....	9		
Radio Aerials, Balloon, to Replace Usual Poles....	120		
Radio Condenser Combines Interesting Features....	55		
Railroad Train Orders, Safety Arm Aids Delivery of.	33		
Railroads, English, Combine into Four Systems....	86		
Rake, Odd Looking, Used like Broom.....	113		
Rat Trap, Foot Set, and Rat Killer Latest Invention	39		
Relics of Washington in Masonic Memorial.....	12		
Rifle Bullets, "Boat Tail," Increase Accuracy....	35		
Road Center Line Painted with Wooden Wheel....	95		
Rug Pictures Jap's Conception of War.....	6		
Rug Rack, Revolving, Saves Floor Space.....	117		
Screwdriver, Ratchet Device Attaches to.....	82		
Ship Mast, Improved, Gives More Room on Deck..	105		
Ship, Old Deep Sea, Cut Up for Auto Material....	10		
Ships, Bulging Hulls for.....	104		
Ships—Liners to Carry Planes for Mail Delivery	34		

## SHOP NOTES

Ammonia Carrying Drum, Small.....	126
Automobile Tool Tray, Convenient.....	135
Automobile Tourist Camp, Equipment for.....	129
Bathtubs for Cooking Vessels.....	137
Battery Markers, Thumbtacks Used as.....	136
Belt, Cutting for Cone Pulleys.....	139
Boxes, Wooden, Method of Marking.....	140
Carbon Removing Tool for Auto.....	137
Cartons, Shipping, Bench Facilitates Making Up of..	128
Chuck, Interchangeable, for Woodturning.....	127
Drill Press, Homemade.....	128
Drill, Tripod, Used as Hand Drill.....	134
Gates, Wire, Tightener for.....	142
Grinder, Small, Increasing Usefulness of.....	136
Horn Fixture, Auto, Holds for Adjustment.....	127
Index Tabs, Metal.....	134
Latch, Secure, for Paddocks.....	135
Lathe Kink.....	142
Lines, Scribing on Round Work.....	134
Oil Container, Self-Closing.....	138
Oil Trucks, Practical Method of Draining.....	137
Pipe Joint Threads, Undersize, Making Tight.....	137
Screws, Broken, How to Remove.....	136
Shelf, Detachable Letter, for Desk.....	127
Slate, Sawing and Filling Holes in.....	134

# DRAKE'S PRACTICAL MECHANICAL BOOKS

## THEY WILL RAISE YOUR PAY—

### ORDER ON 5-DAY TRIAL

The books listed below will perfect you in your chosen trade — pave the way to the big positions. Written in non-technical language—easy to read and understand. *Every book covers its subject completely. An entire course of instruction condensed into one volume.* Your choice sent postpaid — you benefit 5 days — money refunded in full if not entirely satisfactory. Order direct from this page.



### Automobile Books

- Automobile Ignition, by Manly .....Leatherette \$2.00  
 Automobile Starting and Lighting, by Manly.....Leatherette \$2.00  
 Brookes' Automobile Handbook, .....Leatherette \$2.00  
 Ford Motor Car, Truck and Tractor, by Manly.....Cloth \$1.50  
 Starting and Lighting Troubles, Remedies and Repairs, by Manly .....Leatherette \$3.00  
 Automobile Battery, Care and Repair, by Manly.....Leatherette \$2.00  
 Automobile Catechism and Repair Manual.....Leatherette \$1.50  
 Tires and Vulcanizing, by Tafford .....Cloth \$2.00  
 Gas and Oil Engine Handbook, .....Cloth \$1.50  
 Automobile Upkeep and Care, by Manly .....Cloth \$1.50  
 Motorcycle Handbook, by Manly .....Cloth \$1.50

### Shop Practice Books

- Sheet Metal Workers' Manual, .....Leatherette \$2.00  
 Oxy-Acetylene Welding and Cutting .....Cloth \$1.25  
 Slide Rule and Logarithmic Tables .....Leatherette \$2.00  
 Handbook for Millwrights.....Cloth \$2.00  
 Modern Blacksmithing.....Cloth \$1.25  
 Machine Shop Practice.....Cloth \$2.00

- Mechanical Drawing and Machine Design .....Cloth \$2.00  
 Pattern Making.....Cloth \$1.50

### Carpentry Books

- Cloth Binding  
 Modern Carpentry, 2 vols.....\$3.00  
 The Steel Square, 2 vols.....\$3.00  
 Wooden Boat and Shipbuilding.....\$1.50  
 Modern Estimator .....\$1.50  
 Timber Framing .....\$2.00  
 Builder's Architectural Drawing.....\$2.00  
 Concrete .....\$1.50  
 Practical Bungalows .....\$1.00  
 Low Cost Homes.....\$1.00  
 Roof Framing, by Van Gasbeek.....\$1.50  
 Stair Building and Hand Railing .....\$1.50

### Electrical Books

- Practical Applied Electricity....\$2.00  
 Alternating Current .....\$1.50  
 Electric Motor Control Systems.....\$1.50  
 Wiring Diagrams and Descriptions .....\$1.50  
 Electrical Tables and Data.....\$1.50  
 Armature and Magnet Winding.....\$1.50  
 Modern Electrical Construction.....\$1.50  
 Modern Electric Illumination...\$1.50  
 Electricians' Operating and Testing .....\$1.50  
 Motion Picture Operation.....\$1.50  
 Drake's Electrical Dictionary...\$1.50  
 Electric Motors, D. & A.....\$1.50  
 Electrical Measurements and Meter Testing .....\$1.50  
 Drake's Telephone Handbook...\$1.50  
 Easy Experiments.....Cloth \$1.25  
 Wireless Telegraph and Telephone Handbook.....Cloth \$1.25  
 Telegraphy Self-Taught...Cloth \$1.25

### Steam Engineering

- Swingle's Handbook for Steam Engineers and Electricians...Leatherette \$4.00  
 Examination Questions and Answers for Marine and Stationary Engineers.....Leatherette \$2.00  
 Steam Boilers.....Leatherette \$2.00  
 Swingle's Catechism of Steam, Gas and Electrical Engineering .....Leatherette \$1.50

### Painting Books

- Scene Painting and Bulletin Art .....Cloth \$4.00  
 A Show at Sho' Cards.....Cloth \$4.00  
 Sign Painting .....Cloth \$4.00  
 Strong's Book of Designs.....Leatherette \$4.00  
 Strong's Art of Show Card Writing .....Cloth \$4.00  
 Signist's Alphabets.....Cloth \$1.50  
 Modern Painter's Cyclopedia.....Cloth \$2.00  
 Automobile Painting.....Cloth \$1.50  
 Estimates, Costs and Profits, Painting and Decorating.....Cloth \$1.50  
 New Hardwood Finishing.....Cloth \$1.50  
 The Amateur Artist.....Cloth \$1.50  
 New Stencils .....Cloth \$1.25  
 Chalk Talk and Crayon Presentation .....Cloth \$1.25

### Farm Books

- Farm Mechanics.....Cloth \$1.25  
 Farm Buildings.....Cloth \$1.25  
 Farm Engines.....Cloth \$1.25  
 Traction Farming.....Cloth \$1.50

### Business and Reference Books

- Better Business Letters.....Cloth \$1.00  
 Better Business English.....Cloth \$1.00  
 Better Advertising.....Cloth \$1.00  
 Finger Prints Simplified.....Cloth \$2.00  
 Practical Bricklaying.....Cloth \$1.25  
 Practical Instruction for Detectives .....Cloth \$1.00  
 Practical Plumbing .....Cloth \$1.50  
 Hot Water Heating.....Cloth \$1.50  
 Elementary Chemistry.....Cloth \$1.50  
 Courses in Civil Service.....Cloth \$1.50  
 Cyclopedia of Recipes.....Cloth \$1.50  
 American Star Speaker...Cloth \$1.50

### Modern Languages

- By Prof. P. S. Allen, U. of Chicago  
 French without a Teacher.....Cloth \$1.25  
 Spanish without a Teacher.....Cloth \$1.25  
 German without a Teacher.....Cloth \$1.25  
 Everyday French.....\$1.25  
 Everyday Spanish.....\$1.25

## ORDER DIRECT FROM THIS PAGE—ON OUR MONEY-BACK PLAN

The books listed above are only a few of the many in our catalogue, which you will receive promptly after filling out and mailing us the attached coupon. For quick action order direct from this page—cross name of each book wanted and send in with price quoted. We prepay postage and send the books on our money-back plan.

### FREDERICK J. DRAKE & CO.

PUBLISHERS

1008 Michigan Ave., Chicago

Drake Books Are For Sale at All Book Stores

FREDERICK J. DRAKE & CO.  
 1008 Michigan Avenue  
 Chicago, Ill.

GENTLEMEN:—Please send me free, postage paid, your illustrated catalogue which lists and describes over 100 Practical Mechanical Books for Home Study.

My name is .....

and my address .....

Mail Coupon For Free Catalogue  
 Your Guide to Home Study

# "SOME SUMMER SELLER"



Says Slade of N. J.  
Have made \$13,500  
in 3 months. Some  
summer seller.

## Every Woman Wants It Low Price—Big Profit

Representatives, salesmen, spare time workers are literally cleaning up fortunes with an amazing new invention—the Oliver Oil-Gas Burner that makes any range just like a city gas stove. No more sweltering summer kitchens, coal, soot or ashes.

### Amazing Invention Ends Summer Coal Fires

Right in her own range, the housewife can cook and bake quicker and better than ever before. She turns a valve—just as with city gas—and her own oven regulates to any temperature. Then, the instant she is through the heat is turned off, the kitchen is cool and clean the rest of the day. Saves 65% of all household work. No lifting or carrying dirty coal, wood, ashes—no wicks, no experimenting. Absolutely safe. Last a lifetime.



### \$100 a Week—Spare Time—Easy

You can see how Slade, N. J., made \$13,500 in 3 months. Why Russell makes \$660 a month, J. Carnegie makes \$1,000 a month, how hundreds of others make \$100 a week and more just in spare time. Here is an opportunity to make a Summer's work yield more than you ever made in a whole year. You don't need to be a super-salesman. The Oliver—sells itself. You take the money. Write at once for full details about our Free Sample Case and **OLIVER GIVES FORDS AWAY** Big Exclusive Territory Offer. Oliver gives Fords away—no contests. Write quick for Big Summer Profits.

## OLIVER OIL-GAS BURNER CO.

2014-S Oliver Bldg., St. Louis, Mo.  
Canadian office, 2014-S Webster Bldg., Toronto

### Drafting Plan Reading Building

Never before such a demand for skilled Draftsmen and Building Experts. More big jobs open than men to fill them.

### TRAIN BY MAIL

Let Chicago "Tech" give you the training that brings quick advancement and a high salary. Send for information. CHICAGO TECHNICAL COLLEGE 730 Chicago "Tech" Bldg., Chicago

## WRITE JOKES

EARN FROM \$50 TO \$150 PER WEEK

writing jokes, epigrams and humorous stories for publications. Tremendous demand for material. Our short course in Humor Writing teaches you to write humorous material that sells. Learn in your spare time—earn in your spare time. Complete marketing plan and markets furnished.

Write for full particulars

AMERICAN INSTITUTE OF HUMOR  
Office J, 414 Park Bldg., Cleveland, Ohio



### [Contents—Continued from Page 4]

Thumbtacks, Emergency, How to Make.....	142
Tool Cabinet, Upright, How to Make.....	139
Transom Control, Novel.....	141
Turret Lathe Bed, Reboring.....	139
Water Cooler, Cheap and Serviceable.....	138
Welding and Cutting Table, Convenient.....	125
Welding Hose Stand, Homemade.....	141
Window Display, Electric Push Button Lights.....	127
Windows, Casement, Hinge Stops for.....	142

### AMATEUR MECHANICS

Aster Seedlings, Why They Die.....	145
Automobile—Camp Car, How to Build.....	147
Automobile Hand Brake Pawl, Spring for.....	162
Automobile License Plate Vibration, Preventing.....	161
Automobile Trouble and Tonneau Light Combined.....	154
Boat Anchor, Red, for Shallow Water.....	145
Counterweight for Holding Lid Open.....	145
Darning Kink.....	162
Derrick, Simple, for Farm Use.....	156
Fishing Boat, Yardstick for.....	151
Fishing Rod Repairing.....	155
Flatiron, Gasoline, Used as Camp Stove.....	145
Golf Club Grooving File.....	162
Hedge Clipping Gauge.....	156
Ironing Board, Homemade Rigid.....	161
Lantern, Railroad, Used as Stove.....	162
Lathe Tool Holder for Small Model Making Lathes.....	153
Photograph Tone, Increasing Volume of.....	153
Photograph Paper, Stale, Method of Using.....	144
Photography—Using Cut Films in Plate Holder.....	161
Poultry Feeders, Built-In.....	144
Pump, Clamp Bolts for.....	157
Radio Aerials, Attic, How to Make.....	143
Row Marker, Lazy Tong, for Garden.....	146
Scales, Increasing the Capacity of.....	144
Scarecrow, "Live," How to Make.....	157
Scrapbook Making as Occupation for Shut-Ins.....	158
Seesaw, Novel Homemade.....	154
Smokehouse, Improvised.....	155
Spade Attachment Saves Shoes.....	157
Turnbuckle, Strong, Made of Pipe and Fittings.....	162
Washer, Clothes, Made from Wash Boiler.....	155
Washing Machine Motors, Oiling.....	146
Window, Bottle, for Log Henhouse.....	146
Window Device for Keeping Out Rain.....	146
Window Screens, Full Length, Fastening.....	156

## AUTO MECHANICS NEEDED

We have more positions available than graduates to fill them. Write today for catalog.

Address Dept. 328

AMERICAN MOTOR SCHOOLS, Inc., Washington, D. C.

## RAISE POULTRY FOR PROFIT

We teach you how. Easily learned at home. Our guaranteed methods make success certain—indorsed by leading Agricultural Colleges. Send TODAY for FREE BOOK—"How To Raise Poultry For Profit."



National Poultry Institute  
Dept. 312 Washington, D. C.

## WANTED—RAILWAY MAIL CLERKS

### \$133 to \$192 a Month for Life

Every second week off with full pay—no "lay offs" because of strikes, poor business, etc.—sure pay—rapid advancement to higher positions. City and country residents stand same chance. Common sense education sufficient—no political influence. Travel—See your country.

### DON'T DELAY—ACT AT ONCE

Send Coupon today—sure. Every day's delay means so much less chance of appointment from the next examinations—so write at once.  
FRANKLIN INSTITUTE, Dept. T178, ROCHESTER, N. Y.

Take the First Step for  
a U. S. Government Job  
Use Coupon Before You Lose It

### COUPON

FRANKLIN INSTITUTE, Dept. T178, Rochester, N. Y.  
Kindly send me, without any obligation whatever on my part and entirely free of charge, (1) A full description of the position checked below; (2) Sample examination questions; (3) Free copy of copyrighted book "Government Positions and How to Get Them;" (4) A list of U. S. Government Jobs obtainable; (5) Tell me how to get the position here checked.

..... Railway Postal Clerk (\$1600 to \$2300) ..... Customs Positions (\$1100 to \$2000)  
..... Postoffice Clerk (\$1400 to \$1800) ..... Internal Revenue (\$1100 to \$2000)  
..... City Mail Carrier (\$1400 to \$1800) ..... Rural Mail Carrier (\$1800 to \$2500)  
..... Income Tax Auditors..... (\$2040 to \$3060)

Name .....



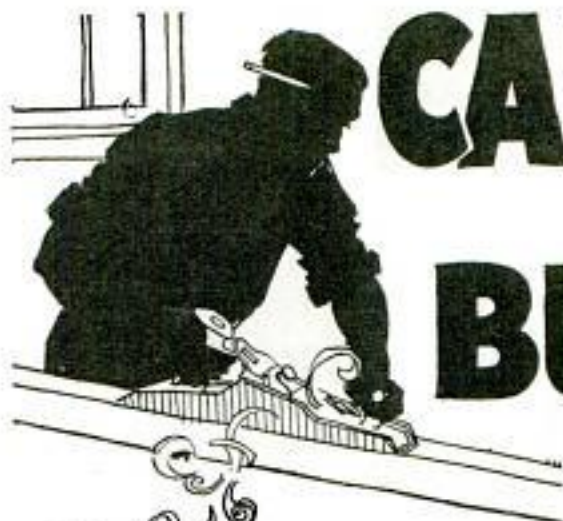

# CARPENTERS AND BUILDERS!

## JUST OUT!

Giving You the How and Why of Modern Carpentry  
**AUDEL'S CARPENTERS  
and BUILDERS GUIDES**

Just available — Audel's Carpenters and Builders Guides — the short cut, professional information you want.

A Guide that keeps you in close touch with your work and shows you how you may increase your earning power.

No need to guess or take chances. Every day you have before you in this set, exact, practical, useful information to help you with your daily work.

### HOW TO HANDLE THE JOB THAT PUZZLES YOU

How to use the different kinds of wood—complete detailed information on nails and screws—how to use the steel square—how to file and set saws—how to make wood joints—how to build furniture—how to make a mitre shooting board—how to plumb, and level work—how to lay out work—how to understand carpenter's arithmetic—how to solve mensuration problems—how to estimate the strength of timbers—how to proportion beams—how to read plans—how to draw up specifications—how to estimate

the cost of buildings—how to build houses, barns, garages, bungalows, etc.—how to build foundations—how to proportion foundation footings—how to frame houses—how to set girders and sills—how to frame joists—how to frame a studding—how to set window frames—how to cut rafters—how to use the settings 12, 13, and 17 on the steel square—how to put on wood, fibre and metal shingles—how to hang doors—how to frame windows—how to put on sheathing—how to put on exterior trim—how to do cornice work—how to build stairs—how to lay floors—how to paint.

# FREE

## EXAMINATION

Not a cent to pay until you see the books. No obligation to pay unless you are satisfied. Send coupon now—today—and get this fine, helpful new set for Carpenters and Builders. After you have looked them over 5 days send only \$1, then

\$1 a month until \$6 is paid—if you want to keep them. Return them if you do not.



**\$1 Per Month—Entire Set \$6**  
SIXTEEN HUNDRED PAGES  
3700 TRADE ILLUSTRATIONS  
POCKET SIZE—FLEXIBLE COVERS

There are thousands of examples of modern construction and building work—new methods, new ideas, proved efficiency plans, short cuts, time saving suggestions, new ways that cover the entire theory and practice of modern carpentry. Every point is easy to read and understand and clearly illustrated with sketches and forms. Decide for yourself whether they are worth the money to you. Pay only \$1 a month if you like them. Return the Guides if you don't. **USE COUPON NOW!**

**SEND NO  
MONEY**  
NOTHING to PAY  
To the POSTMAN



TEAR  
OFF  
COUPON  
ALONG  
THIS  
CHALK  
LINE

THEO AUDEL & CO., 72 Fifth Avenue, New York City.

Please submit me for approval and free examination:—AUDEL'S CARPENTERS AND BUILDERS GUIDES. Ship at once, prepaid, the 4 numbers. If satisfactory I agree to send you \$1 within five days and to further mail you \$1 monthly until \$6 is paid.

**SEND NO MONEY**  
FILL IN AND MAIL  
THIS COUPON NOW

Name.....Occupation.....

Address.....

Employed by.....Reference..... PM. July '23

# Look Here!

Are you ambitious—are you looking for the way to Success?  
Do you want an easy, pleasant job?  
Do you want to make from \$60 to \$100 a week?  
Do you want to enjoy the luxuries of life?

**Then Read  
My Offer!**



## FREE!

This Expert Draftsman's Complete Outfit gives you practical training. Includes complete set of fine "professional" drawing instruments with double set of compasses and dividers in velvet lined case, drawing board T square, triangles, pens, ink, all accessories. This superb complete outfit given free to every Coyne student. Coupon brings details of this great free offer.

**DRAFTSMAN'S POCKET RULE**

**FREE!** Ivorine Pocket Rule free to every man who's interested in Drafting. Coupon brings it. **DON'T WAIT. SEND TODAY!**

## COYNE SCHOOL OF DRAFTING

**B. W. COOKE, President**

Home Study Dept. 402, 552 to 598 So. Throop St., Chicago, Ill.

Without obligating me in any way, please send me Draftsman's Pocket Rule, and your two books, "Drafting, the Foundation of Industry" and "Learn Drafting by the Job-Method"—all absolutely free. Also complete information of your rapid home-study Drafting course, free instruments and other features.

Name.....

St. No.....

City..... State.....

## I Guarantee

to train you for the position of Expert Draftsman. Every factory, big or little—every railroad, every automotive plant, shipyards, the U. S. State, County and City governments, the Army and Navy, everywhere you turn Draftsmen are in demand at \$200 to \$500 a month. Take advantage of this money-making opportunity, the greatest you will ever see. *I positively guarantee to train you for the position of Expert Draftsman until you are earning at least*

## \$250 a Month!



## YOU CAN BE THIS MAN!

The Expert Draftsman is the key-man of Industry. Executives depend on him. Not a wheel can turn without him. Naturally, he is high-priced! Look at the picture! You'd almost rather be the draftsman than the boss! YOU—no matter what your job today, no matter how limited your schooling—can REMAKE yourself by learning Drafting the new way—by the "Job-Method" of home instruction. You "learn by doing" and train *quick* for the big pay job. I have done it for hundreds. I can do it for you!

## My 2 FREE BOOKS bring your BIG OPPORTUNITY!

Find out all about this wonderful system, the most complete Drafting instruction ever offered for home-study. Grasp this great money-making opportunity now! To supply the enormous demand for Cooke-trained draftsmen, I am offering special inducements to ambitious men everywhere. Coupon brings 2 free books, free draftsman's pocket rule and complete information. **Mail it in Me Today!**

**B. W. COOKE, President**

**COYNE SCHOOL OF DRAFTING**

**COYNE**  
SCHOOL OF DRAFTING

Dept. 402

552-598 So. Throop Street

CHICAGO



## Radio Course FREE!

For a limited time only! Enables you to build and operate any Radio Outfit. Coupon brings my free offer!

# What Do You Call an Opportunity?

**I**N my lifetime I have heard many men speak of opportunity. I have read some very fine definitions of this wonder-word. It has been the subject of many splendid speeches; authors have written abundantly about it in prose and poetry.

You have said, "I wish I had an opportunity."

But I am wondering what you call an opportunity.

Do you—as so many do—mistakenly associate it with "good fortune" or "good luck"?

Suppose tomorrow you heard of a \$10,000 position seeking a man. Could you fill it? If so, it would be an opportunity. If not, it would be no opportunity at all so far as you are concerned. It would be merely a bit of information from which you could not benefit.

Opportunity, I believe, is usually a recognition of worth.

The biggest opportunity that can ever come to you will never be any bigger than your preparation—your worth-whileness.

If you are not worth considering, Opportunity won't give you a thought.

The biggest job of all the big jobs open and

filled in the last twenty-four hours would have been an opportunity for you—

—if you had been prepared.

And I am not one who believes that Opportunity knocks but once.

The hundreds of opportunities which are here to-day will come again to-morrow—

—if you are prepared.

But you can be sure they will never be found on the door-steps of worthless prospects—men who are not ready.

Opportunity seeks and finds only those who have paid the price of preparation. She does not pick men as

you pick a number from a lottery; neither does she cover up what she has to offer. Her gifts are an open book—yours from which to choose.

Pick the thing you want, and get ready for it. Opportunities do not come except as you attract them. LaSalle training offers a sure way to increase your powers of attraction.

Just bear in mind that the biggest opportunity that can ever come to you will never be greater than your preparation.

*J. M. Sullivan*  
President LaSalle Extension University  
of Chicago, Illinois

## HOME-STUDY COURSES

THAT LEAD TO BUSINESS CAREERS

# LaSalle Extension University

The Largest Business Training Institution in the World

—INQUIRY COUPON—

LA SALLE EXTENSION UNIVERSITY

Dept. 764-R

CHICAGO, ILLINOIS

Please send me catalog and full information regarding the course and service I have marked with an X below. Also a copy of your booklet, "Ten Years' Promotion in One," all without obligation to me.

- |  |  |   |
|--|--|---|
| <input type="checkbox"/> <b>Business Management:</b> Training for Official, Managerial, Sales and Executive positions.   | <input type="checkbox"/> <b>Railway Station Management:</b> Training for Railway Auditors, Comptrollers, Accountants, Clerks, Station Agents, Members of Railway and Public Utilities Commissions, etc.                            | <input type="checkbox"/> <b>Modern Foremanship and Production Methods:</b> Training in the direction and handling of industrial forces—for Executives, Managers, Superintendents, Contractors, Foremen, Sub-foremen, etc. |
| <input type="checkbox"/> <b>Modern Salesmanship:</b> Training for Sales and Advertising Executives, Solicitors, Sales Promotion Managers, Salesmen, Manufacturers' Agents and all those engaged in retail, wholesale or specialty selling. | <input type="checkbox"/> <b>Industrial Management Efficiency:</b> For Executives, Managers, Office and Shop Employees and those desiring practical training in industrial management principles and practice.                      | <input type="checkbox"/> <b>Personnel and Employment Management:</b> Training for Employers, Employment Managers, Executives, Industrial Engineers.   |
| <input type="checkbox"/> <b>Higher Accountancy:</b> Training for positions as Auditor, Comptroller, Certified Public Accountant, Cost Accountant, etc.   | <input type="checkbox"/> <b>Modern Business Correspondence and Practice:</b> Training for Sales and Collection Correspondents; Sales Promotion Managers; Credit and Office Managers; Correspondence Supervisors, Secretaries, etc. | <input type="checkbox"/> <b>C. P. A. Coaching for Advanced Accountants.</b>   |
| <input type="checkbox"/> <b>Traffic Management—Foreign and Domestic:</b> Training for positions as Railroad or Industrial Traffic Manager, etc.  | <input type="checkbox"/> <b>Banking and Finance.</b>   | <input type="checkbox"/> <b>Commercial Law.</b>   |
| <input type="checkbox"/> <b>Law:</b> Training for Bar; LL. B. Degree.  |  | <input type="checkbox"/> <b>Expert Bookkeeping.</b>   |
|  |  | <input type="checkbox"/> <b>Business English.</b>   |
|  |  | <input type="checkbox"/> <b>Commercial Spanish.</b>   |
|  |  | <input type="checkbox"/> <b>Effective Speaking.</b>   |

Name..... Present Position..... Address.....

## A RAISE IN SALARY

In Two Weeks

By

RAYMOND A. McCUE



## BE A RAILWAY TRAFFIC INSPECTOR

SEVEN months ago I sat by the old farm fireside, discouraged, with no encouraged chance for a prosperous, active future.

Humbly inserted in a corner of a little farm magazine was a Railway Traffic Inspection ad. Through curiosity I invested a postage stamp and inquired.

When I read what the S. B. T. I. had done for others through their training, I made up my mind to let them do the same for me. They have lived up to their agreement.

When I commenced taking this course all I was good for was to pitch hay and milk cows. I was not contented with this life and every day was a day of drudgery.

### A DREAM COME TRUE

A dream of a future has come true inside of a term of a few short months. I am now a full-fledged Traffic Inspector on a large electrical system in one of the largest cities of the United States—thanks to the S. B. T. I.

This position pays more at the beginning than the Institute guaranteed me. I am told by the manager that my work is satisfactory and that he will give me a raise in salary in two weeks if it continues to be so.

My advice to the fellow who is on the fence, scratching his head, is to do as I wisely did. Enroll with the Standard Business Training Institute and let them build a future for you. I shall always be pleased to recommend this school to anyone.

### EARN UP TO \$250 A MONTH EXPENSES PAID

Pleasant, healthful, outdoor work; excellent chances for advancement through contact with railway executives. Travel or remain near home. Prepare at home in spare time. Position GUARANTEED paying at least \$110 a month and expenses or tuition refunded.

### YOU TAKE NO RISK

Send coupon at once for details of this fascinating, uncrowded profession. If we don't get you a position, the training costs you nothing. Act now!

Standard Business Training Institute  
Buffalo, N. Y.



Standard Business Training Institute  
Buffalo, N. Y.

Send me, entirely free, Booklet No. D-63, giving full particulars about course in Railway Traffic Inspection.

Name .....

Street .....

City ..... State .....

Please Mention Popular Mechanics

## Learn Expert Auto Painting



There is Big Money in auto painting and refinishing. Our Home Study Course in Practical Auto Painting will enable you to do the finest work and earn big wages. Wonderful opportunity for new money-making business of your own.

FREE circular tells all about this big new business. Be first. Write quick.

CHICAGO COLLEGE OF AUTO PAINTING  
Dept. 73, 140 S. Dearborn St., CHICAGO, U.S.A.



Violin, Hawaiian Guitar, Ukulele, Guitar, Mandolin, Cornet, Banjo-Ukulele, Tenor Banjo or Banjo  
Wonderful new system of teaching note music by mail. To first pupils in each locality, we give a \$20 superb Violin, Mandolin, Ukulele, Guitar, Hawaiian Guitar, Cornet, Tenor Banjo or Banjo absolutely free. Very small charge for lessons only. We guarantee success or no charge. Complete outfit free. Write now. No obligation.  
SLINGERLAND SCHOOL OF MUSIC, Inc., Dept. 214, CHICAGO, ILL.

## "HOW I BEAT THE GAME"

The Inspiring Story of how one poorly paid garage mechanic won success, his own business and a big income. Tells how you can increase your salary from 100 to 500%—  
Send for it today FREE.

AMBU ENGINEERING INSTITUTE  
Dept. 17, 2632 Prairie Ave. CHICAGO, ILL.

## LAW IN YOUR SPARE TIME

Learn law with only institution giving same course by correspondence as was given for years at resident classes of this college. DEGREE OF LL. B. CONFERRED. One year business law course prepares you for success in business. Law trained business men in demand. Three year university course covers preparation for bar examination. Money back guarantee if not satisfied. Low fee, easy terms, includes complete 1923 thirteen volume library, text material and all expenses. Write for FREE BOOK.  
Hamilton College of Law  
431 South Dearborn St., Dept. 60-B Chicago

## LEARN ENGINEERING

Courses, 3 months to 2 years practical-technical training under experts. Not a Trade School but a practical technical college teaching electricity, steam, gas, auto-electric, structure welding, drafting, radio. Extensive laboratory and shop equipment. Degrees awarded. Day and night sessions. Enrollment time.  
FINLAY ENGINEERING COLLEGE  
1001 Indiana Avenue  
KANSAS CITY, MO.

## BE AN ARTIST

Comics, Cartoons, Commercial, Newspaper and Magazine Illustrating, Pastel Crayon Portraits and Fashion. Our simple method quickly develops your talent in spare time. By Mail or Local Classes. Write for terms and list of successful Students.  
ASSOCIATED ART STUDIOS  
87-B Flatiron Building, NEW YORK

## If I can show

how you can make \$75.00 a week without money or experience and get your pay daily, selling men's \$50.00 suits for \$29.75, would you investigate?  
Write LOUIS SCHWARTZ, Mgr.  
PARK TAILORING CO., Dept. 632, Chicago

## SEND for the INTERNATIONAL CATALOG

FOR FORD—PRICES FROM \$27.65 UP.  
Factory to Consumer direct—Pay only one profit.  
Our jet price list. Full line of auto bodies and accessories for Fords at Wholesale Prices.  
Save big money on bodies by buying direct from factory.  
INTERNATIONAL BODY WORKS, Dept. 7, 914 W. Ohio Street, CHICAGO, ILL.

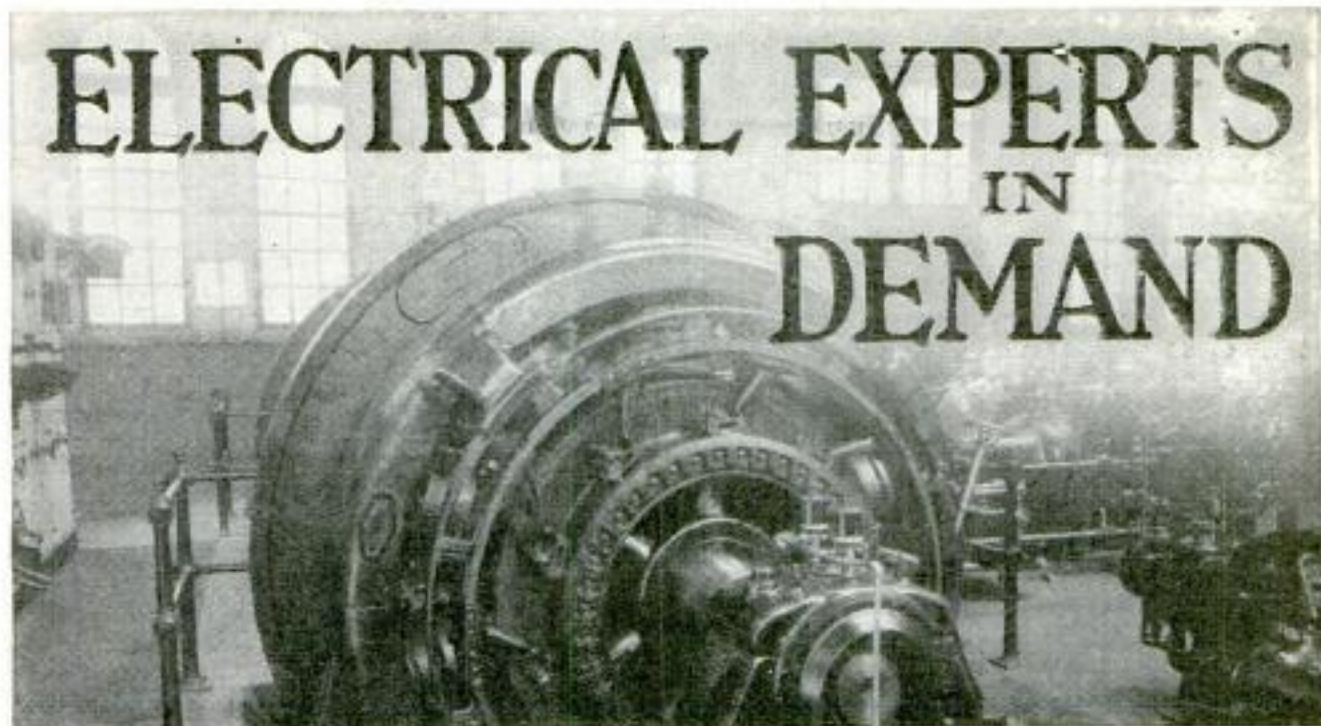

## Good Positions Await Trained Men

*Salaries of \$12 to \$30 a day not unusual*

**T**HE Electrical field needs men. It needs them badly. Hardly a week or a month passes but what some new use for electricity is discovered. And each new use means new positions—*better positions!*—for men who have trained themselves as experts in this wonderfully fascinating work.

The recent growth of Radio is simply an example of the progress that is yet to be made. No work offers greater opportunity to the man of an inventive turn of mind than Electricity. Salaries of \$12 to \$30 a day are not unusual.

Best of all, you can study Electricity in your own home in spare time, without losing a day or a dollar from your present work. The International Correspondence Schools will teach you everything you need to know, just as it has been teaching other men in just your circumstances for more than 31 years. There is no doubt about the ability of the I. C. S. to help you.

Thomas A. Edison says:—"I have watched the progress of the International Correspondence Schools almost from the very beginning. To me their rapid growth is easily understood, because

I realize the practical value that is back of them and know something too of the success attained by many ambitious men throughout the country who have taken their courses."

And Dr. Charles P. Steinmetz, the "electrical wizard" of the General Electric Co., says:—"I am familiar with the textbooks and method of instruction used by the International Correspondence Schools in their courses in Electrical Engineering, and I also know of a number of young men who have taken these courses with great benefit. I believe that any young man who is interested in electricity, but who cannot find an opportunity to go through an engineering college, if he will apply himself to one of these courses will find it a practical and economical way to acquire a knowledge of the profession."

Just mark and mail the coupon printed below and full information about Electrical Engineering, Electric Lighting, Electric Wiring, Electric Railways, Radio or any other work of your choice will come to you by return mail. Today—not Tomorrow—is the day to make that all-important start toward success.

----- TEAR OUT HERE -----

INTERNATIONAL CORRESPONDENCE SCHOOLS, BOX 5528-D, SCRANTON, PA.

Without cost or obligation on my part, please tell me how I can qualify for the position or in the subject before which I have marked an X in the list below:

- |   |  |   |   |
|---|--|---|---|
| <input type="checkbox"/> Electrical Engineering     | <input type="checkbox"/> Civil Engineer                              | <input type="checkbox"/> Business Management            | <input type="checkbox"/> Salesmanship           |
| <input type="checkbox"/> Electric Lighting and Rws. | <input type="checkbox"/> Surveying and Mapping                       | <input type="checkbox"/> Industrial Management          | <input type="checkbox"/> Advertising            |
| <input type="checkbox"/> Electric Wiring            | <input type="checkbox"/> Mine Foreman or Engineer                    | <input type="checkbox"/> Traffic Management             | <input type="checkbox"/> Stenography and Typing |
| <input type="checkbox"/> Radio                      | <input type="checkbox"/> Marine Engineer                             | <input type="checkbox"/> Business Law                   | <input type="checkbox"/> Teacher                |
| <input type="checkbox"/> Mechanical Engineer        | <input type="checkbox"/> Architect                                   | <input type="checkbox"/> Banking and Banking Law        | <input type="checkbox"/> Civil Service          |
| <input type="checkbox"/> Mechanical Draftsman       | <input type="checkbox"/> Blue Print Reading                          | <input type="checkbox"/> Accountancy (including C.P.A.) | <input type="checkbox"/> Railway Mail Clerk     |
| <input type="checkbox"/> Machine Shop Practice      | <input type="checkbox"/> Contractor and Builder                      | <input type="checkbox"/> Nicholson Cost Accounting      | <input type="checkbox"/> Common School Subjects |
| <input type="checkbox"/> Railroad Positions         | <input type="checkbox"/> Architectural Draftsman                     | <input type="checkbox"/> Bookkeeping                    | <input type="checkbox"/> High School Subjects   |
| <input type="checkbox"/> Automobile Work            | <input type="checkbox"/> Structural Engineer                         | <input type="checkbox"/> Business English               | <input type="checkbox"/> Illustrating           |
| <input type="checkbox"/> Gas Engine Operating       | <input type="checkbox"/> Chemistry <input type="checkbox"/> Pharmacy | <input type="checkbox"/> Business Spanish               | <input type="checkbox"/> French                 |

Name.....Street Address.....

City.....State.....Occupation.....

Persons residing in Canada should send this coupon to the International Correspondence Schools Canadian, Limited, Montreal, Canada.

**\$250—\$500—\$1000  
PER MONTH!**



**WANTED—Territorial Sales Managers**

**GAS FIRE** beats coal. Cheaper, cleaner and more efficient. Demand unlimited. Every user of coal wants **GAS FIRE**. The highest class heat producing appliances of the type. Simple, durable, satisfactory! Guaranteed! Construction—heavy, everlasting brass. De-carbonizing generators. Fits any cook stove, range or heating stove without alterations. Installed in a few minutes' time. No more coal worries. Lower price; bigger profits; easier to sell. Cost infinitesimal in comparison with results achieved.

**An absolute money-back guarantee**

**HEAT APPLIANCE CORPORATION**  
106 North May Street CHICAGO, ILLS.

*The Key to Success*  
**Stop forgetting**

**Make Your  
Mind a File—Not a Pile**

The Key to Success is the ability to remember.



I can make your mind an infallible classified index from which you can instantly select thoughts, facts, figures, names, faces. Enables you to concentrate, develop self-control, overcome bashfulness, forgetfulness, address an audience. Easy, 20 years' experience developing memories of thousands. Write Today for free booklet, "How to Remember," and Copyrighted Memory Test, and how to secure Free my \$3.00 book, "How to Speak in Public."  
**DICKSON MEMORY SCHOOL**  
Dept. 705-Y Evanston, Ill.



**Learn Illustrating**

**At Home—In Your Spare Time**

from the school that has trained many commercial illustrators now earning \$50 to \$200 or more weekly. Plenty of opportunities open for trained artists. Work can be done at home. The Landon Picture Chart Method makes original drawing easy to learn. Send 6¢ in stamps for full information and sample chart. Also state age.

**THE LANDON SCHOOL**  
138 National Bldg., CLEVELAND, O.



**JUST OUT**

**THE AUTOMOBILE PAINTERS' MANUAL**

By D. P. WOLF, A. T. P. E., Founder of The Detroit Auto Painting School  
For the auto painter, garageman and auto owner. Written to give precise information, pertaining to the Painting, Striping, Monogramming and Lettering of an automobile. Covers the subject of color mixing—color blending—and tinting with a hundred and fifty different shades. Considered by experts, the book of the hour. Self instructional and self educational. Also contains numerous and various styles of alphabets, monograms and initials. Special introductory offer. Edition limited. Post Paid \$3.50.  
DETROIT AUTO PAINTING SCHOOL, 426 Superior Street, Dept. P, DETROIT, MICH.

"THERE'S MONEY IN IT"

**AT HOME LEARN TELEGRAPHY AT HOME**  
**MORSE AND WIRELESS**



**TEACH YOURSELF**

In half usual time, at trifling cost, with the wonderful Automatic Transmitter, **THE OMNIGRAPH**. Sends unlimited Morse or Continental messages, at any speed, just as an expert operator would. Adopted by U. S. Government, and leading Universities, Colleges and Telegraph Schools. 3 Styles. Catalog free. **OMNIGRAPH MFG. CO., 16-22 Hudson St., NEW YORK**  
If you own a Radio Phone Set—and don't know the code—you are missing most of the fun.

*Whatever Your Question;*—be it the pronunciation of **Bolsheviki**, the spelling of a puzzling word, the location of **Murman Coast**—the meaning of **blightly, ace, tank, ukulele, etc.**, this Supreme Authority—

**WEBSTER'S NEW INTERNATIONAL DICTIONARY**

contains an accurate, final answer. 400,000 Words. 2700 Pages. 6000 Illustrations.  
Regular and India-Paper Editions. **G. & C. MERRIAM CO., Springfield, Mass.**  
Write for specimen pages, prices, etc. and **FREE Pocket Maps per Popular Mechanics**



**LEARN TO GET DOLLARS OUT OF WATCHES.**  
WATCH-REPAIRING, ENGRAVING, JEWELRY REPAIRING.  
**WRITE NOW.**  
**ENICAR TRADE SCHOOL**  
530 W MONUMENT SQUARE, RACINE, WIS.

**COLUMBIA SCHOOL OF DRAFTING**  
Specializing in training of professional Draftsmen—Mechanical, Architectural and others; personal instruction; complete course 3 to 9 months. For information address Local Dept: 2033, R. C. Claffin, Pres., 14th and T Sts., N. W., Wash., D. C.

**WANTED**  
**RAILWAY POSTAL CLERKS**  
**\$1600 to \$2300 Year**  
**MEN—BOYS 18 UP SHOULD**  
**MAIL COUPON IMMEDIATELY**

*Steady work. No layoffs. Paid Vacations*  
Common education sufficient:  
Travel—See the country



**FRANKLIN INSTITUTE, Dept. T179, Rochester, N. Y.**  
Sirs: Send me without charge, (1) Sample Railway Postal Clerk Examination questions; (2) List of Government jobs obtainable; (3) Tell me how I can get a Gov't position.

Name.....

Address.....

Copyrighted material

# Be An **ELECTRICAL** **TECHNICIAN**

**GET YOUR ELECTRICAL TECHNICIAN'S CERTIFICATE THROUGH ME AND YOU WILL BE GUARANTEED THE AID OF MY ORGANIZATION TO SECURE YOU A POSITION PAYING YOU THE HIGHEST SALARY YOU EVER RECEIVED TO START**

## Command \$250 to \$600 Monthly

My course is designed to fit you for a position as Electrical Technician, Supervisor, Foreman or Manager of Equipment. These positions cover the electro-technical field and pay a rate of compensation running into thousands of dollars a year. Take my Home Study course and prepare yourself in spare time by this most simple, direct and inexpensive method to become an expert in *MOTOR MAINTENANCE, ARMATURE WINDING, BATTERY, SUB-STATION AND POWER HOUSE WORK, AUTOMOTIVE, AIR-CRAFT, TRACTOR AND ILLUMINATING ENGINEERING, GENERATOR, SWITCHBOARD AND HOUSE WIRING, TRANSMISSION, INSTALLATION AND LINE CONSTRUCTION*, and I will not only guarantee your

success in this study, but I will undertake to train you until you are actually earning \$3,000 a year. More than that, when you graduate and are qualified to receive your Electrical Technician

S. V. Smith,  
Chief Engineer  
Home Study Dept.

Certificate from me, if you are not more than pleased with your training, or if you are not fully convinced your earning power has been **GREATLY INCREASED**, or if you are not completely satisfied you can hold down a high-class job at the highest rate of compensation paid men of your experience—either you may come in with me and finish your training here in my plant—at no cost to you—or

## I WILL GIVE YOU MY COURSE—FREE

There are no "ifs" nor "buts" about this offer. If you have a common school education and will agree to study a little evenings for a few months, I guarantee to train you to be a first-class man, or the course need not cost you one penny. Therefore, write at once or mail the coupon for full details of my truly remarkable proposition. **DO THIS NOW**—to avoid possible disappointment.

## Wonderful FREE OUTFIT Offer

With this electrical course you will get free and prepaid an up-to-date outfit of electrical apparatus, instruments and appliances for doing experimental and practical work at home, and, in addition, if you reply to this ad promptly, I shall give you, as my student, a complete **EXPERT'S** training in

**RADIO FREE.** This is a wonderful opportunity for you, for with this splendid, up-to-the-minute **FREE** Course in Radio, (covering construction, operation and installation) and my help, it is possible for you to make \$50.00 a week and up right at home while learning. I shall supply what you need to aid you to do this without one penny expense to you and you can start **RIGHT IN**. Get details of this great offer at once. Send Coupon or Write—**NOW**.

**S. V. SMITH, Chief Engineer**  
**Home Study Dept., S. & H. Electrical Works**  
**Desk G. G. 1, 1422 W. Monroe St., Chicago**

**Desk G. G. 1,**  
**S. V. Smith,**  
**Chief Engineer**  
**Home Study Dept.,**  
**S. & H. Electrical**  
**Works,**  
**1422 W. Monroe Street**  
**Chicago**

Dear Sir: I am interested in your guaranteed Home Study Course of Training in the best-paid divisions of Electricity; also how you aid me free to make money while learning. Send particulars at once free of charge.

Name.....

Address.....

**MAIL THIS FOR BIG FREE OFFER**

# NEW KIND OF HEAT BURNS 95% AIR

## Gives Three Times the Heat of Coal or Wood



Here's a new way to get as much or as little heat as you want—at the simple turn of a little valve.

A St. Louis inventor has discovered a wonderful new kind of heat that burns 95% air and yet gives three times the heat of coal or wood. What



No worry about heat when you can get 3 times the heat of coal by just turning a valve. No coal, wood, ashes.

this means to the householder in these days of mounting coal prices can readily be seen. Besides the expense-saving there are also big labor-saving features. With this invention in the home there are no more fires to build, bank or watch—no more dirty, heavy coal to carry and lift—no more clouds of ashes to breathe or back-breaking scuttles to empty—no more heating problems—no more cold rooms in Winter—no more suffering from lack of quick fires in uncertain Fall and Spring—no more worries about coal shortages, poor quality or high prices.

This new kind of heat therefore has really ended the days of woman's

back-breaking servitude to a hot, mussy stove or furnace! The wonderful invention of Mr. B. M. Oliver of St. Louis, in one minute, turns any coal or wood burner into a modern up-to-date gas stove.

Mr. Oliver calls his invention the Oliver Improved Oil-Gas Burner, because it uses 95% air and only 5% coal oil (ordinary kerosene)—the cheapest fuel there is, turning them into an actual gas that burns with an intensely hot, clean flame. It is cleanly and also saves its cost in cleaning bills alone.

This invention can absolutely be depended upon to heat rooms in coldest Winter weather—if gives 3 times the heat of coal. But you needn't worry about the high price of coal. Install this amazing new kind of heat and you can snap your fingers at coal shortages, poor quality or high prices.

The Oliver Improved Oil-Gas Burner is made in sixteen different models to fit any kind of cook stove, heating stove or furnace. It doesn't change your stove and simply sets in firebox. It is easily slipped in, in one minute—is absolutely safe and lasts a lifetime.

Just turn the valve and you have heat—as much or as little as you need. Physicians recommend the Oliver as a sure safeguard against colds, influenza, etc.

Now, once and for all time you can do away with household dirt and drudgery. End ashes, dirt, smoke, odor, chopping, shoveling, carrying, dirty heavy coal and wood. Mr. Oliver will be glad to send you immediately **FREE ATTRACTIVE BOOKLET**, "New Kind of Heat," telling all about this amazing new invention. Shows exactly how it works, how it is different from all other burners and tells how you can use it in your stove, 30 days, **FREE**. The famous Oliver Iron-Clad, Money-Back Guarantee protects you.

If you write at once you will be in time to receive Mr. Oliver's very low, introductory price offer and 30-day Free Trial. Get your Oliver installed immediately, before cold weather sets in.



The ideal thing for this winter when coal prices are high and you want to save work, time and expense.

### OLIVER OIL-GAS BURNER COMPANY

Oldest and Largest Manufacturers of Oil-Gas Burners in the World

2014-G Oliver Building, ST. LOUIS, MO.

Mr. Oliver is anxious to obtain agents interested in filling the tremendous demands, all over the country for his new invention. Oliver agents earn as high as \$100 a month—\$25 a day some time. Exclusive territory. Big, all-season seller. Write for Special Offer.

**BECOME  
AN  
AUTOMOBILE  
PAINTING  
ENGINEER**

**HERE**

is an amazing OPPORTUNITY to enter a new field and start in business for yourself. Learn

Automobile Painting, Paint Mixing, Etc.,

**The WULF WAY**

**LEARN IN 8 TO 10 WEEKS' TIME**

No talent or education necessary. Instructions are Individual. You can start any time. **TODAY—RIGHT NOW**—Write for our **SPECIAL OFFER** and catalogue.

**DETROIT AUTO PAINTING SCHOOL**  
27 D. A. P. S. Bldg., 426 Superior St., DETROIT, MICH.



**"BECOME A LIGHTNING TRICK CARTOONIST"**

MAKE MONEY QUICKLY TALKING. SEND \$1.00 FOR SNAGGY PROGRAM OF TRICK DRAWINGS WITH INSTRUCTIONS BY A PROFESSIONAL CARTOONIST. SATISFACTION GUARANTEED. CIRCULAR FREE. BALDA ART SERVICE, Q1, OSHKOSH, WIS.

**ELECTRICITY LEARN AT HOME**

Send for catalog which tells how Burgess Home Training enables men and boys to get good jobs and keep them. **BURGESS ELECTRICAL SCHOOL, Dept. P7, 744 E. 42nd Street, CHICAGO**

**FREE FIRST LESSON RECORD**

**Learn to Play**

Violin-Mandolin, and Banjo-Mandolin without embarrassment by the *World's Most Successful Method*. Personal instructions on Records taught by the famous Prof. F. M. Schneider. Six year combined course teaches all three instruments. Simple as A. B. C. Play for money in 2 months. 30,000 have learned to play beautifully.



**\$25 Instrument FREE With Course**

Your choice of any one instrument given absolutely free to one pupil in each locality. Only small charge for lessons—a few cents a week. Success assured.

**Write Today for Free Record**

Send no money. Just ask for first lesson Record on one week's approval. We want to prove to you as we have to thousands of others the wonderful advantages of learning music the more simple and easy way by our personal instruction lessons given on Records. Write at once! **TODAY!**

**SCHNEIDER SCHOOL OF MUSIC**

Dept. B-7, 238 Vermont St., Blue Island Ill. (A suburb of Chicago)



**THE PRACTICAL  
Automobile, Wagon,  
House and Sign Painter**

By **W. F. White**  
Postpaid \$1.00

This book is written for the man who wishes to paint his automobile, or his home, or wagon. It will tell the inexperienced just how to do it, and it will tell him how to mix paints. It also contains many painters' recipes and trade secrets of great value. Bound in Cloth—157 pages—Size 5 x 7½.

Postpaid \$1.00

**SHREWSBURY PUBLISHING COMPANY**  
5525 West Lake Street Chicago, Illinois



Times Square, New York

# Big Pay ~

## in the Automobile Business after 8 weeks in New York



**T**RAINED automobile men are in demand. You can qualify for a big job in just 8 weeks. Automobile experts earn big money. Thousands of Stewart trained men are doing it—so can you. Learn in the heart of New York, the retail automobile center of the world.

### New York's Leading School for 14 Years

Since 1909 the Stewart School has been recognized as the best school of its kind by the leading automobile companies and service organizations in the East. Send the coupon today for free booklet giving full information.

### Be An Auto Expert

You learn by doing actual practical work on standard types of motors. Complete up-to-the-minute equipment. Simple, easy system—no one can fail to learn. You stay without extra cost until you *do* learn. Send for the free book and learn about our guaranty. The automobile industry is beginning a tremendous expansion. Big firms are sending out hurry-calls for trained men. Expert men are hard to find. Don't miss your opportunity to learn in the heart of New York. Send for our free booklet today.

### Pay as you learn—Comfortable New York Home

Our deferred payment system makes it easy for you. Day and night classes make it possible for you to *earn as you learn*. Comfortable, cheap, home-like quarters available for Stewart men. **Negro students not solicited for our courses.**

### Advanced Electrical Course

Electricity is a puzzle to the average mechanic. 80% of auto troubles are electrical. Special advanced electrical and battery courses now starting in addition to our regular automobile course. Get in now on this uncrowded, big pay field.

### Send for FREE Booklet

Get our free opportunity-book today. No obligation. Learn how you too can live on Easy Street. Let us help you. Don't put it off. Just write your name and address plainly on the coupon and mail it. Act now!



57th Street at Broadway

### Own your own business in three months

Only a little capital is needed to start a garage or repair shop of your own. Then you are on Easy Street! The pay of trained men is so high that you can save enough out of your wages. Let us tell you about it. Send the coupon today without fail.

**STEWART AUTO SCHOOL 225 W. 57th St., Dept. A177, New York, N. Y.**

Please send me your free book that describes your school and the opportunities in the Automobile Business. I am under no obligation.

Name \_\_\_\_\_

Address \_\_\_\_\_

City \_\_\_\_\_

State \_\_\_\_\_

# DRAW THIS SUMMER

Cartoonists Trained by W. L. EVANS



## MAKE MONEY

SOME of the cleverest cartoonists in America today are former students. They studied during their spare time and are now making good money. Cartoonist Evans' system of teaching is so simple, easy and practical that it is not hard to learn to draw originals. The school has a long established reputation and is recommended by well-known cartoonists because they know the students are handled right.

If you like to draw, send us a sample of your work, either a copy or an original. You may have more ability than you think. We will send you a portfolio of cartoons and full details about the school.

The Course is NOT EXPENSIVE

THE W. L. EVANS SCHOOL  
OF CARTOONING

821 Leader Bldg. CLEVELAND, OHIO

## FREE a wonderful Book on Finger Prints

Full of thrilling crime mysteries solved through finger print evidence by America's greatest experts. Gripping illustrations. True stories.

**Special Offer** You can learn the Finger profession at home in spare time. Write today. Get full details. Big surprise in store for you. Book and offer Free.  
UNIVERSITY OF APPLIED SCIENCE  
1920 Sunnyside Avenue, Dept. B-935 Chicago, Illinois

## LEARN WATCHMAKING AND ENGRAVING



Earn while learning. Most practical watch school. Individual instructions. Graduates in great demand. Book free.  
Chicago School of Watchmaking, Dept. 20, 4840 Lincoln Ave., Chicago

## LAW High-Grade Instruction

By Correspondence  
Prepares You for  
the Bar—Est. 1892  
University Methods.



Standard Text-Books. Approved by Bench and Bar. Graduates practicing in every state. Send today for Free Catalog and Rules for Admission to the Bar.  
Chicago School of Law  
520 Reaper Block Chicago, Ill.



## How to Box 40c

By Terry McGovern, James J. Corbett, J. Gardner Smith, M. D., Arthur P. Keeley and Gus. E. Keeley.

How to Box to Win, How to Build Muscle; How to Punch the Bag and How to Stand, Walk or Run.

This interesting book written by experts is known also as "The Book of Health and Strength." It will greatly assist everyone in keeping fit, in putting them in condition to master a strenuous undertaking either physical or mental.

62 illustrations, Size 4 1/2 x 7 1/4 in. Paper copy, 125 pages  
SHREWSBURY PUBLISHING CO.  
5525 West Lake Street, Chicago, Ill.

# LAW

**STUDY AT HOME**  
Become a lawyer. Legally trained men win high positions and big success in business and public life. Greater opportunities now than ever before. Lawyers earn \$3,000 to \$10,000 Annually. We guide you step by step. You can train at home during spare time. Let us send you records and letters from LaSalle students admitted to the bar in various states. Money refunded according to our guarantee bond if dissatisfied. Degree of LL.B. conferred. Thousands of successful students enrolled. Low cost, easy terms. We furnish all text material, including fourteen-volume Law Library. Get our valuable 125-page "Law Guide" and "Evidence" books FREE. Send for them—NOW.  
LaSalle Extension University, Dept. 784-I, Chicago, Ill.

## Mount Birds

**Taxidermy Book FREE**  
We teach you by mail to stuff and mount all kinds of Birds, Animals, Game Heads. Also to tan skins and make rugs. Be your own taxidermist. Decorate your home with your beautiful trophies or increase your income selling specimens and mounting for others. Easily, quickly learned in spare time by men and women. Highest endorsements by thousands of students. Write today for our great free book "How to Mount Birds and Animals" Free—write today.  
N. W. School of Taxidermy, B177 Woodward Bldg., Omaha, Neb.

## FREE BOOK LEARN PIANO

**This Interesting Free Book** shows how you can become a skilled player of piano or organ at quarter usual cost. It shows why one lesson with an expert is worth a dozen other lessons. Dr. Quinn's famous Written Method includes all of the many important modern improvements in teaching music. Brings right to your home the great advantages of conservatory study. For the beginner or experienced player. Endorsed by great artists. Successful graduates everywhere. Scientific yet easy to understand. Fully illustrated. All music free. Diploma granted. Write today for free book.  
Quinn Conservatory, Studio PM67, 596 Columbia Road, Boston 25, Mass.

## LEARN SHOW CARD WRITING and DISPLAY ART

**BY MAIL OR LOCAL CLASSES**  
Study under the direction of Arnold Binger, the leading expert in the line. Positions await competent students. Write for our beautiful illustrated booklet and terms.  
BINGER SCHOOL OF SHOW CARD & DISPLAY ART  
2116 Flatiron Building, Broadway & 23rd Street, NEW YORK CITY

## TRI-STATE COLLEGE OF ENGINEERING

Makes you a Civil, Mechanical, Electrical or Chemical Engineer in two years, 48 weeks each. No entrance examinations. High School Diploma not required. Compact courses made up of essentials only. Expenses low.  
FOR CATALOG ADDRESS 100 M. Street, Angola, Indiana

Wonderful, new device, guides your hand; corrects your writing in few days. Big improvement in three hours. No failures. Complete outline FREE. Write C. J. Orment, D-34, St. Louis, Mo.

## LEARN MECHANICAL DENTISTRY

EARN \$35 TO \$125 A WEEK. Taught by actual practice—day or night. Three months' course. Modern laboratories. No previous training required. Established 30 years. For 36-page catalog, write Dept. 2.  
BODEE DENTAL INSTITUTE  
NEW YORK 136 W. 52d St. PHILADELPHIA 1305 N. Broad St. BUFFALO 1225 Main St. BROOKLYN 15 Flatbush Ave.

## BECOME A RAILWAY MAIL CLERK

Examinations soon. \$1600 to \$2300 a year. No strikes or lockouts. Common education sufficient. No "pull" necessary. Mail coupon for catalog.  
Patterson Civil Service School  
Dept. 87, Rochester, N. Y.  
Dept. 87  
Patterson Civil Service School  
Rochester, N. Y.

Sirs:—Send me without charge your Catalog, describing this and other fine U. S. Government positions.

Name.....  
Address.....



# NOW FREE!

## The Book That Has Shown Thousands the Way to Amazing Salary Increases

Do you want to leave the rut of routine work for a position that will grow daily in its fascination? Do you want to start right out making more money than you ever thought possible? We have done exactly this for thousands of men. Here is the book which gave them their start. Read how it is now offered to you—FREE!

**T**AKE this situation. A man who had worked all his life in a routine job at low pay suddenly surprises his friends by moving into a better neighborhood, taking a big house, buying a car and blossoming out as a well-to-do and influential citizen in his new community. How did he do it? What is the secret that he used? Simple enough. He knew that the biggest money in business is in selling and though he felt that he couldn't sell a thing, he learned the secrets that make Master Salesmen and then began to make big money.

If only one man had found inspiration enough in this remarkable book to make a brilliant success in the selling field—in a job paying him many times his former salary—then you might call it luck. But thousands have done it.

### Your One Chance to Make the Biggest Money of Your Life

Not one of the men whose names appear at the right had ever sold a thing before—not a dime's worth. If you had told one of them that he could sell he would have laughed at you.

Probably he would have come back with the old saw, "Salesmen are born, not made." They were frankly skeptical. Yet

every one of these men, through reading this book, discovered the fallacy of this vicious old idea that Salesmen are "born." They learned that **Master Salesmen are made!** And in this book they found a comparatively easy way to go from low pay to better earnings.

### Simple as A B C

Sounds remarkable, doesn't it? Yet there is nothing remarkable about it. There are certain ways to approach different types of prospects to get their undivided attention—certain ways to stimulate keen interest—certain ways to overcome objections, batter down prejudices, outwit competition and make the prospect act. If you will learn these principles there is awaiting you a brilliant success and more money than you ever thought of earning. This book, "Modern Salesmanship," tells exactly how the National Salesmen's Training Association will make you a Master Salesman.

As soon as you are qualified and ready the Employment Service of the National Salesmen's Training Association will help you to select and secure a selling position as city or traveling salesman. Many of the biggest, most reputable selling organizations in America turn to this Association for their Star Salesmen.

### Now Free to Every Man Who Will Act at Once

We are not making any extravagant claims about what we will do for you. We don't have to. The records of the real successes for which we are responsible are so overwhelmingly a testimonial of the fact that any man of average intelligence can become a Master Salesman that we are willing to leave

the decision entirely up to you. All of this proof and many important features about Salesmanship are contained in our salary raising book, "Modern Salesmanship." It is yours—FREE. Send the coupon for it today. It will show you how you can quickly become a Master Salesman—a big money maker. It will tell you about the National Salesmen's Training Association system of Salesmanship training that has meant prosperity to so many thousands of men—about the National Demonstration method that gives you actual experience while studying—and all about the fine opportunities that await you in the selling field. If you do not send this coupon we will lose merely the opportunity to train one more Master Salesman. But for you, failure to act may mean, that you lose the one big chance of your life to leave forever behind you the low pay of a routine job. It may mean the difference between this and a real success at a big salary. Is it worth 2c to find out? Then mail this coupon NOW.

**National Salesmen's Training Association**  
Dept. 12-H CHICAGO, ILLINOIS

**National Salesmen's Training Association**  
Dept. 12-H, Chicago, Ill.

I simply want to see the facts. Send me FREE your Book "Modern Salesmanship" and Proof that I can become a Master Salesman. Also tell how you can help me to a position.

Name.....  
Address.....  
City.....State.....  
Age.....Occupation.....

### Read!

*Charles Beery of Winterset, Iowa, stepped from \$18 a week as a clerk to a position making him \$1,000 the very first month. J. P. Overstreet of Dennison, Texas, read this book, left a job on the Capitol Police Force at a salary of less than \$1,000 a year and in six weeks earned \$1,800. F. Wynn, Portland, Ore., an ex-service man, earned \$554.37 in one week. Geo. W. Kearns of Oklahoma City found in this book a way to jump his earnings from \$60 a month to \$524.00 in two weeks and C. W. Campbell learned from it how he could quit a clerking job on the railroad to earn \$1,632 in thirty days.*



**"Don't tell me you never had a chance!"**

"Four years ago you and I worked at the same bench. I realized that to get ahead I needed special training, and decided to let the International Correspondence Schools help me. I wanted you to do the same, but you said, 'Aw, forget it!' You had the same chance I had, but you turned it down. No, Jim, you can't expect more money until you've trained yourself to handle bigger work."

There are lots of "Jims" in the world—in stores, factories, offices, everywhere. Are you one of them? Wake up! Every time you see an I. C. S. coupon your chance is staring you in the face. Don't turn it down.

Right now more than 180,000 men and women are preparing themselves for bigger jobs and better pay through I. C. S. courses.

You can join them and get in line for promotion. Mark and mail this coupon, and find out how.

TEAR OUT HERE

**INTERNATIONAL CORRESPONDENCE SCHOOLS**

Box 5332-D, Scranton, Penna.

Without cost or obligation, please tell me how I can qualify for the position or in the subject before which I have marked an X:

**BUSINESS TRAINING COURSES**

- |  |   |
|--|---|
| <input type="checkbox"/> Business Management                             | <input type="checkbox"/> Salesmanship                                     |
| <input type="checkbox"/> Industrial Management                           | <input type="checkbox"/> Advertising                                      |
| <input type="checkbox"/> Personnel Organization                          | <input type="checkbox"/> Better Letters                                   |
| <input type="checkbox"/> Traffic Management                              | <input type="checkbox"/> Foreign Trade                                    |
| <input type="checkbox"/> Business Law                                    | <input type="checkbox"/> Stenography and Typing                           |
| <input type="checkbox"/> Banking and Banking Law                         | <input type="checkbox"/> Business English                                 |
| <input type="checkbox"/> Accountancy (including C.P.A.)                  | <input type="checkbox"/> Civil Service                                    |
| <input type="checkbox"/> Nicholson Cost Accounting                       | <input type="checkbox"/> Railway Mail Clerk                               |
| <input type="checkbox"/> Bookkeeping                                     | <input type="checkbox"/> Common School Subjects                           |
| <input type="checkbox"/> Private Secretary                               | <input type="checkbox"/> High School Subjects                             |
| <input type="checkbox"/> Business French <input type="checkbox"/> French | <input type="checkbox"/> Illustrating <input type="checkbox"/> Cartooning |

**TECHNICAL AND INDUSTRIAL COURSES**

- |  |  |
|--|--|
| <input type="checkbox"/> Electrical Engineering                          | <input type="checkbox"/> Architect                                   |
| <input type="checkbox"/> Electric Lighting                               | <input type="checkbox"/> Blue Print Reading                          |
| <input type="checkbox"/> Mechanical Engineer                             | <input type="checkbox"/> Contractor and Builder                      |
| <input type="checkbox"/> Mechanical Draftsman                            | <input type="checkbox"/> Architectural Draftsman                     |
| <input type="checkbox"/> Machine Shop Practice                           | <input type="checkbox"/> Concrete Builder                            |
| <input type="checkbox"/> Railroad Positions                              | <input type="checkbox"/> Structural Engineer                         |
| <input type="checkbox"/> Gas Engine Operating                            | <input type="checkbox"/> Plumbing and Heating                        |
| <input type="checkbox"/> Civil Engineer                                  | <input type="checkbox"/> Chemistry <input type="checkbox"/> Pharmacy |
| <input type="checkbox"/> Surveying and Mapping                           | <input type="checkbox"/> Automobile Work                             |
| <input type="checkbox"/> Metallurgy <input type="checkbox"/> Mining      | <input type="checkbox"/> Navigation                                  |
| <input type="checkbox"/> Steam Engineering                               | <input type="checkbox"/> Agriculture and Poultry                     |
| <input type="checkbox"/> Radio <input type="checkbox"/> Airplane Engines | <input type="checkbox"/> Mathematics                                 |

Name.....  
Street.....  
Address.....

3-27-23

City..... State.....

Occupation.....  
Persons residing in Canada should send this coupon to the International Correspondence Schools Canadian, Limited, Montreal, Canada.

Please Mention Popular Mechanics



Aerial Photo Taken by Dan Kiser

**LEARN TO FLY**  
**\$100 Reduction for Short Time**

First class air pilots, with special training in Aviation Mechanics earn \$5,000 a year up. Operating companies' demand for specially trained Pilots, Field Managers, Superintendents and Airplane Mechanics growing every day. Mr. Dan Kiser, late of U. S. Air Mail Service and Army Flying Corps, will train you thoroughly in all branches of this profession and fit you for pilot license.

**Special Rate Now in Force**

For a limited time you can secure this training fitting you fully for the greatest red-blooded profession of them all at a big reduction in the cost of tuition. Write at once for particulars sent free and without obligation.

Address: **DAN KISER, Chief Engineer**  
Dept. G 1, S & H Works (Aircraft Div.)  
1422 W. Monroe Street CHICAGO, ILL.



**\$1400 to \$2600 Year**

Men, Boys, 18 or Over, Become

**Railway Postal Clerks—  
City Mail Carriers—  
Postoffice Clerks**

SEND COUPON BELOW

**FRANKLIN INSTITUTE**

Dept. T182, Rochester, N. Y.

Common education sufficient. This coupon, filled out as directed, entitles the sender to (1) free specimen examination questions; (2) a free copy of our book, "Government Positions and How to Get Them"; (3) free list of positions obtainable; and (4) tell me also how I can get the position here checked.

**COUPON**

..... Railway Postal Clerk (\$1600 to \$2300) ..... City Mail Carrier (\$1400 to \$1800)  
..... Bookkeeper (\$1400 to \$1800) ..... Rural Mail Carrier (\$1800 to \$2600)  
..... Postoffice Clerk (\$1400 to \$1800) ..... Customs Positions (\$1100 to \$2900)

Name.....  
Address..... T182

Use it before you lose it. Write plainly.

# Gee! it's Great to be Healthy

Up in the morning brimming with pep. Eat like a kid and off for the day's work feeling like a race horse. You don't care how much work awaits you, for that's what you crave—hard work and plenty of it. And when the day is over, are you tired? I should say not. Those days are gone forever. That's the way a strong, healthy man acts. His broad chest breathes deep with oxygen purifying his blood so that his very body tingles with life. His brain is clear and his eyes sparkle. He has a spring to his step and a confidence to tackle anything at any time.

## Pity the Weakling

Don't you feel sorry for those poor fellows dragging along through life with a neglected body? They are up and around a full half hour in the morning before they are half awake. They taste a bite of food and call it a breakfast. Shuffle off to work and drag through the day. It's no wonder so few of them ever succeed. Nobody wants a dead one hanging around. It's the live ones that count.

## Strength Is Yours

Wake up fellows and look the facts in the face. It's up to you right now. What do you plan to be—a live one or a dead one? Health and strength are yours if you'll work for them, so why choose a life of suffering and failure?

Exercise will do it. By that I mean the right kind of exercise. Yes, your body needs it just as much as it does food. If you don't get it you soon develop into a flat-chested, narrow-shouldered weakling with a brain that needs all kinds of stimulants and foolish treatments to make it act. I know what I am talking about. I haven't devoted all these years for nothing. Come to me and give me the facts and I'll transform that body of yours so you won't know it. I will broaden your shoulders, fill out your chest, and give you the arms and legs of a real man. Meanwhile, I work on the muscles in and around your vital organs, making your heart pump rich, pure blood and putting real pep in your old backbone. This is no idle talk. I don't promise these things—I guarantee them. If you doubt me, come on and make me prove it. That's what I like.

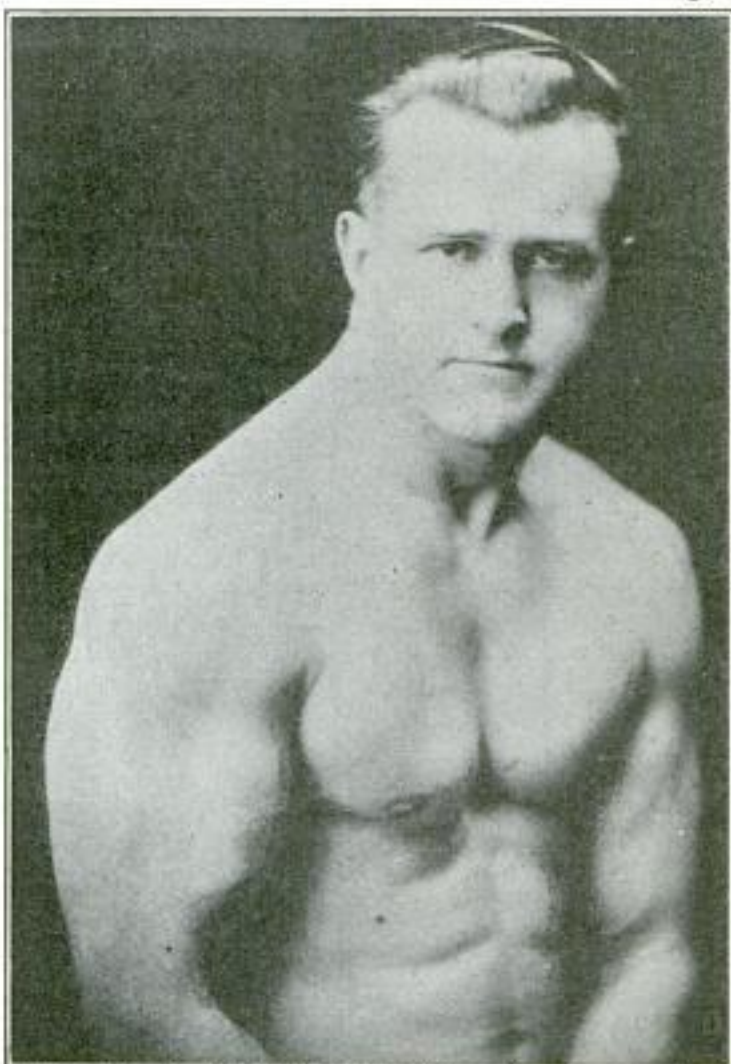

**EARLE E. LIEDERMAN as he is to-day**

Send for My New 64-Page Book,

## “Muscular Development”

It contains forty-three full-page photographs of myself and some of the many prize-winning pupils I have trained. Some of these came to me as pitiful weaklings, imploring me to help them. Look them over now and you will marvel at their present physiques. This book will prove an impetus and a real inspiration to you. It will thrill you through and through. All I ask is 10 cents to cover the cost of wrapping and mailing and it is yours to keep. This will not obligate you at all, but for the sake of your future health and happiness, do not put it off. Send today—right now, before you turn this page.

**EARLE E. LIEDERMAN**  
Dept. 2007, 305 Broadway, NEW YORK CITY

**EARLE E. LIEDERMAN**

Dept. 2007, 305 Broadway, New York City

Dear Sir:—I enclose herewith 10 cents for which you are to send me, without any obligation on my part whatever, a copy of your latest book, “Muscular Development.” (Please write or print plainly.)

NAME.....

STREET .....

CITY..... STATE.....



## "You're Right!" Where'd you learn that?"

Any employer is ready to say it, to give you credit for thinking ahead of your job. The world is too full of men who just wait and wish to be pushed into more responsible positions.

Be prepared to say and to show that you are using spare hours to put more into your head. Prove to your employer that you are really determined to win more responsibility, better pay, and the privileges and comforts that come fairly to "the man who knows."

A student of ours writes: "A short time ago the Boss, needing a man for more responsible work, asked me if I was doing any studying in my spare hours. You can bet I was proud to answer, 'I am.'"

After a quarter-century of experience in aiding men, through spare hours to become their Bigger Selves, the United Y. M. C. A. Schools offer their tested service by mail, so that wherever you may be, whatever you may need or whatever your hours of employment are, you can now get this valuable aid.

### Some of our 300 Correspondence Courses

**Agricultural Courses**  
 Architecture  
 Automobile Courses  
 Building Construction  
 Civil Engineering Courses  
 Concrete Engineering  
 Drafting Courses  
 Electrical Courses

#### Technical Courses

**Technical Courses**  
 Farm Management  
 Foremanship  
 Highway Engineering  
 Mechanical Engineering  
 Plumbing  
 Poultry Husbandry  
 Radio Engineering  
 Radio Telegraphy  
 Roof Engineering  
 Ship Courses  
 — Blacksmith — Machine  
 — Foundry — Pattern  
 Steam Engineering  
 Structural Drafting  
 Surveying

#### Commercial and Other Courses

**Commercial and Other Courses**  
 Accountancy  
 Advertising  
 Applied Psychology  
 Bookkeeping  
 Business Letters  
 Bookkeeping  
 Business Arithmetic  
 Business Administration

**Commercial and Other Courses**  
 Business English  
 Business Finance  
 Business Law  
 English Courses  
 Foreign Languages  
 Grammar School Courses  
 High School Courses  
 Illustrating

**Insurance Courses**  
 Mathematical Courses  
 Physical Directors' Training  
 Public Speaking  
 Salesmanship  
 Receipts and Typewriting  
 Show Card Writing  
 Traffic Management

Mark and mail this coupon and get our friendly counsel free.

Without obligating me, please advise regarding the course in.....

Name.....

Full Address.....

Dept. 2-Jy

Please write plainly

**United Y.M.C.A. Schools**

Correspondence  
Instruction

The most Service  
for the least Money

347 Madison Ave. New York City, N.Y.

Please Mention Popular Mechanics

# WE TEACH COMMERCIAL ART

**Meyer Both Company, the largest Commercial Art Organization in the World,** offers you an unusual opportunity for practical training, based upon twenty-three years of success. This nationally known organization each year produces and sells to advertisers over 15,000 commercial drawings. Meyer Both instruction is the difference between successful fact and experimental theory. This well paid profession equally open to men and women. Home study instruction.

#### Get Facts Before You Enroll in Any School

Ask the Advertising Manager of the leading newspapers in your city, anywhere in the United States, Canada, England or Australia about the Meyer Both Company—let them tell you about us. Write for our illustrated book telling about the success of our students—for one-half the cost of mailing—four cents in stamps.

### MEYER BOTH COMPANY

Department of Art Instruction  
Michigan Ave. at 29th St., Dept. 16. CHICAGO, ILL.

Note—To Art and Engraving Firms: Secure practical artists among our graduates. Write us.

## HOW TO BECOME A PROFESSIONAL PHOTOGRAPHER EARNING \$35 TO \$125 A WEEK



Three to six months' course. Motion Picture, Commercial, Portraiture. Practical instruction. Modern equipment. Ask for Catalog No. 49.

**N. Y. INSTITUTE OF PHOTOGRAPHY**  
 NEW YORK CHICAGO BROOKLYN  
 141 W. 36th St. 630 So. Wabash Ave. 505 State St.

### Music Lessons

UNDER MASTER TEACHERS

At Home

### Complete Conservatory Course by Mail

Wonderful home study music lessons under great American and European teachers. Endorsed by Paderewski. Master teachers guide and coach you. Lessons a marvel of simplicity and completeness.

**Any Instrument** Write, name course you are interested in: Piano, Harmony, Voice, Public School and FREE CATALOG. SEND for it NOW!  
 University Extension Conservatory, 736 Signet-Morris Bldg., Chicago

## Factory to Rider

Saves \$10 to \$25 on the Ranger Bicycle you select. You can have your choice of 44 Styles, colors and sizes. Delivered free on approval, express prepaid, for 30 DAYS' FREE TRIAL.

**12 Months to Pay** if desired. Possession and use at once on our liberal year to pay plan. Parents often advance first payment.

**Tires** best quality, at factory prices, express prepaid. Lamps, wheels and equipment, low prices. Send No Money, do business direct with makers.

**Mead Cycle Company**  
Dept. 106 Chicago

Write today for free Ranger Catalog, factory prices and marvelous easy payment terms



## LEARN WATCHMAKING

and become independent. Good-paying positions secured.

Easy to learn. Send for FREE CATALOG.

ST. LOUIS WATCHMAKING SCHOOL, Dept. 5, ST. LOUIS, MO.

# STAMMER

If you stammer attend no stammering school till you get my large FREE book entitled "STAMMERING, Its Origin and the Advanced Natural Method of Cure," bound in cloth and stamped in pure gold. Ask for special tuition rate and a FREE copy of "The Natural Speech Magazine." Largest, best equipped and most successful school in the world for the cure of stammering, stuttering, etc. No sing-song or time beat. Write today. The North-Western School, 2317 Grand Ave., Milwaukee, Wis.

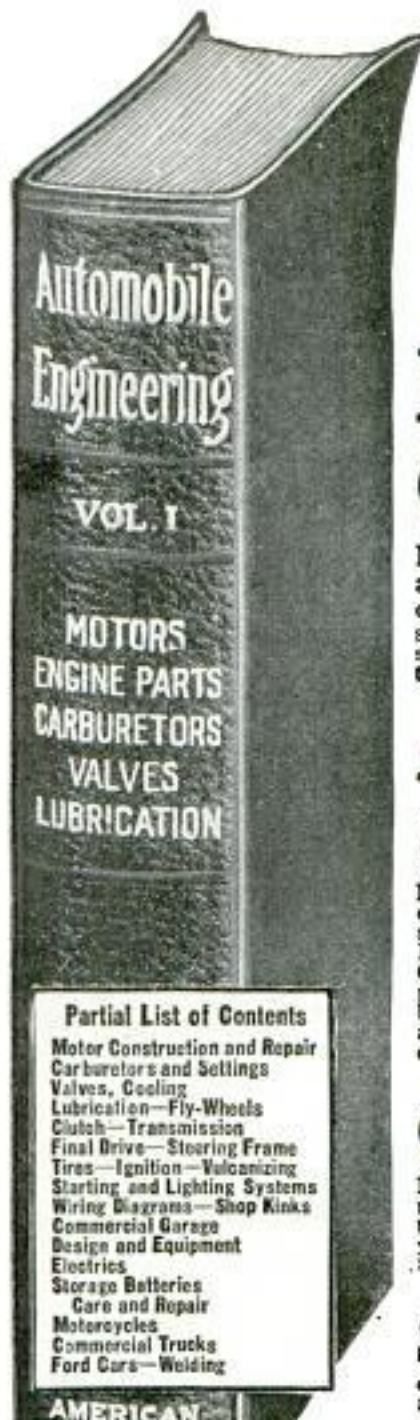

#### Partial List of Contents

Motor Construction and Repair  
 Carburetors and Settings  
 Valves, Cooling  
 Lubrication—Fly-Wheels  
 Clutch—Transmission  
 Final Drive—Steering Frame  
 Tires—Ignition—Vulcanizing  
 Starting and Lighting Systems  
 Wiring Diagrams—Shop Kinks  
 Commercial Garage  
 Design and Equipment  
 Electrics  
 Storage Batteries  
 Care and Repair  
 Motorcycles  
 Commercial Trucks  
 Ford Cars—Welding

AMERICAN

NAME	POSITION	SALARY
John	AUTOMOBILE ENGINEER	\$125 A WEEK
	REPAIR MAN	\$50 A WEEK
	CHAUFFEUR	\$40 A WEEK

## Put Your Name On this Pay-Roll

Men like you are wanted for big-pay positions in the fascinating field of automobile engineering. We have made it easy for you to fit yourself for one of these positions. You don't have to go to school. You don't have to serve an apprenticeship. Fifteen automobile engineers and specialists have compiled a spare time reading course that will equip you to be an automobile expert without taking any time from your present work.

## AUTO BOOKS 6 Volumes Shipped FREE

Now ready for you—at a big reduction in price—an up-to-the-minute six-volume library on Automobile Engineering, covering construction, care and repair of pleasure cars, motor trucks, tractors and motorcycles. Brimming over with advanced information on Lighting Systems, Garage Design and Equipment, Welding and other repair methods. Contains everything that a mechanic or an engineer or a motorcyclist or the owner or prospective owner of a motor car ought to know. Written in simple language that anybody can understand. Tastefully bound in flexible covers and gold stamped, 2700 pages and 2400 illustrations, tables and wiring diagrams. A library that cost thousands of dollars to compile but that comes to you free for 7 days' examination.

## Only 10 Cents a Day

Not a cent to pay in advance. First you see the books in your own home or shop. Just mail coupon and pay express charges when books arrive. You can read them and study them for seven whole days before you decide whether you want to keep them or not. If you like the books send \$2.80 in seven days and \$3.00 a month until the special price of \$21.80 has been paid. (Regular price \$45.00.)

**Send No Money Now** Don't take our word for it. See the books without cost. There is so much profit in this offer for you, that we urge you not to waste a moment in sending for the books. Put the coupon in the mails today. **SEND NO MONEY—only the coupon.**

**American Technical Society**  
 Dept. A-19-B Chicago, Illinois

#### American Technical Society, Dept. A-19-B, Chicago

Please send me a set of Automobile Engineering books in 6 volumes by express collect, for a week's free use. At the end of a week I will either send the books back at your expense or send you \$2.80 as first payment and \$3.00 each month thereafter until a total of \$21.80 is paid.

To insure prompt delivery, fill out all lines

Name.....  
 Address.....  
 City.....  
 State.....  
 Reference.....

Mail The  
 Coupon For  
 These Books

# LEARN CARTOONING the Right Way



**1.** Have your ability trained by the school that has developed many famous cartoonists.

If you like to draw—if you find pleasure in picking up a pencil and paper and trying to make sketches or cartoons, don't regard it merely as a hobby. Have your ability developed and earn a good income as a cartoonist.

Hundreds of nationally known cartoonists, such as Branner of the Chicago Tribune; Blosser, who draws "Freckles and His Friends"; Gene Byrnes, creator of "Reg'lar Fellers"; Thiele of the Sioux City Tribune; Fung, of the Seattle Times and others equally well known, took the Landon Course at home, in their spare time, and fitted themselves for their present positions at salaries ranging from \$50 to \$200 and more per week.

**2.** Have YOUR talent developed by the same method

What the above mentioned boys did you can do, with the same training. The Landon method of teaching makes cartooning easy to learn. By means of an extensive series of Big picture charts all the necessary details of ORIGINAL drawing are explained step by step, in a clear and simple manner.

**3.** **FACTS that determine the superiority of the Landon School:**

1. Landon School Students are securing the best cartooning positions which open up everywhere.
2. The picture chart method of instruction was originated and is used exclusively by the Landon School.
3. From the very beginning, the Landon Course teaches ORIGINAL drawing. No copy work.
4. Individual attention and criticism of student's work. Personal coaching whenever necessary.
5. Specialized instruction on how to originate cartoon ideas. This is an exclusive feature of the Landon Course.
6. Practical assistance in securing positions for students and help in marketing their work.
7. The price is within reach of everyone who is ambitious to succeed. Easy payments can be arranged.

Write today for full information about the Landon Course, and sample chart by means of which you can test your own ability. Find out what the possibilities are for YOU in this interesting profession. Please state your age.

**The Landon School**  
838 National Bldg. Cleveland, Ohio

## LEARN BY DOING

Every phase of all branches of

## ELECTRICITY

Taught by Actual Practice

In America's foremost and oldest institution for trade training

No Books Used  
Individual Instruction  
Start Any Day

A SPECIAL and SEPARATE Course in Ignition, Auto Lighting and STARTER Systems. Write for FREE 64-page catalog.

THE  
NEW YORK ELECTRICAL SCHOOL  
44 West 17th Street, NEW YORK CITY

## Learn Autos and Make Money

Our Graduates either get good Automobile Positions or make BIG MONEY in their own business. Let us tell you how to do the same. We have the *Oldest School—Lowest Rates—7000 Graduates. Catalog Free.*

Cleveland Automobile School  
1814 East 24th St., Cleveland, Ohio

## LEARN WATCH REPAIRING

Be a watchmaker—you can learn this profitable trade by correspondence in a few weeks in your own home by the DeSelms Chart System. After you complete the course you will know a watch from A to Z. You will know just what the matter is and how to repair one. When you graduate you will be a practical watchmaker and repairer and competent to fill any position. Position for our graduates.

Ask for our Free Book. It explains our system and terms

THE DeSELMS WATCH SCHOOL  
23 Perry Street ATTICA, INDIANA

## WHY NOT

spend Spring, Summer and Fall gathering butterflies, insects? I buy hundreds of kinds for collections. Some worth \$1 to \$7 each. Simple outdoor work with my instructions, pictures, price-list. Send 10c (not stamps) for my Illustrated Prospectus before sending butterflies.

Mr. Sinclair, Dealer in Insects, Dept. 6, Ocean Park, Calif.

## Learn Photography at HOME

Make \$75.00 a Week on the Side

Establish yourself as a Photographic Expert quickly—during your spare time—under a leading photographer. I'll show you how to start your own business—no crossed a large salary. Good for my seasonal offer—It's only temporary. Ask at once. A postal will do. H. H. VANT.

INTERNATIONAL STUDIOS, Inc.  
Dept. 119B, 3601 Michigan Ave., Chicago, U. S. A.



# Another Knockout!

**GREAT**  
**Marshall Stillman** \$1.97  
**BOXING** plus  
**Course now** 1 actual  
 postage

Marshall Stillman makes another price-cutting knockout! His great course in Boxing, Jiu-Jitsu and Wrestling is now only \$1.97—the same course that sold for \$5. We send it on 10-day trial—you send no money.

This short-cut method of teaching boxing right in your own home is based on the principles developed by famous Professor Mike Donovan who taught boxing for many years at the New York Athletic Club.

You learn the fundamentals in the first six lessons. Standing before a mirror, you start with such simple movements as the breast-stroke in swimming, reaching out your hand for a coin, etc. Subconsciously you are led into similar movements in boxing—hitting, guarding, ducking, feinting, side-stepping, etc. just as though you had a real opponent before you. When the fundamentals have been mastered, you are taught the more professional blows and guards such as the Benny Leonard Triple Blow, the Fitzsimmons Shift, the Jack Dempsey Triple Blow, etc.

Then comes three lively rounds of Shadow Boxing, cleverly combining these blows just as you will when you meet your first opponent.

We also teach you 15 Jiu-Jitsu Holds and 14 of the best holds in wrestling—how to disarm an opponent, how to break a strangle hold and how to cripple an assailant with bone-breaking holds.

With the course you get a History of 69 Great Prize Fighters with their pictures and "inside" stories seldom heard outside professional circles.



**Send No Money** Simply fill in and mail the coupon. When you have the course in your hands, deposit 97 cents, plus actual postage with the postman. Use the course for 10 days. At the end of ten days, either send us the small balance of \$1 in final payment, or return the course, and we'll send your deposit back at once. Mail the coupon **Now**.

**MARSHALL STILLMAN ASSOCIATION,**  
 Dept. 1223G, 42nd St. and Madison Ave., New York

You may send me on approval the Marshall Stillman Course. I will deposit 97c (plus actual postage) with the postman, with the understanding that if, after 10 days, I wish to return the course, I may do so and my money will be instantly refunded. If I keep the course I am simply to send you \$1 in final payment.

Name.....

Address.....

Canadian and foreign orders must be accompanied by cash (\$1.97 U. S. funds), subject to money back if not entirely satisfactory.

## You Can Easily Learn to Play Any Music on the HAWAIIAN GUITAR

Just As Hawaiians Do—Native Instructors Teach You QUICKLY!

### Here's Proof of our Remarkable Course

Rocharan, Va.  
 First Hawaiian Conservatory of Music, Inc.

It has been two months since I have finished your course on the Hawaiian Guitar and I can play anything I wish. The course was all that could be desired and I am perfectly pleased with my playing ability since finishing your course.

Respectfully yours,  
 Louise R. Hammond

Keanter School,  
 224 So. Franklin St.,  
 Chicago, Ill.

First Hawaiian Conservatory of Music, Inc.

I shall certainly be very glad to recommend your course whenever the chance is mine to do so. Mr. W. H. Johnson has not played me yet, and if he does not phone in a day or so, will write him. Am sending a letter to Miss Helen Slavic today which I think may help to secure her enrollment, and I shall be glad at any time to write a personal letter to anyone whom you may suggest.

Your former student,  
 W. L. Walker

Special Courses under famous Teachers. Tenor-Banjo, Violin, Banjo-Ukelele and Ukelele. Fine Toned Instruments **FREE!**

In Half an Hour You Will Be Playing "ALOHA". Soon You Will Be Winning Praise Everywhere Playing "Stumbling", "Three O'Clock in the Morning", "Hot Lips" and ALL Popular Music as well as the Beautiful Hawaiian Melodies

Here's the chance you've been waiting for—the opportunity to play popular music quickly on the most entrancing instrument of the age—the Hawaiian Guitar. No previous musical knowledge necessary.

### ONLY FOUR MOTIONS TO LEARN

and these you acquire in a few minutes. No troublesome scales or runs, you begin to play harmonious chords immediately! We don't care if you never saw a note of music in your life, we guarantee to teach you to play just as the Hawaiians do!

We furnish everything—a beautiful Hawaiian Guitar, Picks, etc., and 52 Pieces of Music FREE!

You have always wanted to play some instrument, so we have made it unusually easy for you by furnishing everything—a beautiful Hawaiian Guitar, complete Conservatory Course of instruction and 52 pieces of especially selected music.

### No Other Course Teaches as Quickly and Easily

This is the only Conservatory Course where you get the personal instruction of Native Hawaiian Experts—Frank Ferrera, Walter Kolomoku, Lawrence Kalaluki and Carl Seville, famous the world over and the most noted makers of phonograph records, supervise your playing.

### Mail Coupon for Details of FREE Offer

Don't wait another minute—clip, fill in and mail the coupon NOW and get full details of our remarkable offer to teach you how to play the Hawaiian Guitar just as the Hawaiians do.

Special Arrangements for Lessons if You Have Your Own Instrument

**FREE**  
 This \$15  
 Hawaiian  
 Guitar

You will be delighted with the fine tone of this splendid Hawaiian Guitar



First Hawaiian Conservatory of Music, Inc.,  
 Desk 48, 232 Broadway (Woolworth Bldg.), New York.

Send me at once details about your 52 easy lessons and FREE Hawaiian Guitar offer!

Name.....

Address.....

Town..... State.....

Print name and address clearly



# What Are You Thinking About?

Day-dreaming led many a man to make plans that brought him big success. Don't be ashamed when your thoughts are wandering away, when you dream that you are a leader of men—a doer of big things in the business world—a builder of lasting structures. Your day-dreams are an indication of your ambition and of your desire to accomplish things. The man who never dreams has no imagination, he will not get very far. But you can make your dreams real—You can materialize your ambition.

Just dreaming alone won't do. Hitch your dreams up to facts and you will go far. You will get the facts through special training along the line in which you want to succeed. And the place to get just that training is the American School. This is proven by the quarter of a century of successful experience we have in helping many thousands of men and women gain an enviable place in the business and social life.

Another reason why the American School is the place to get your training—it is not a business corporation but a chartered Educational Institution, incorporated not for profit.

Space here is too limited to tell you of all the advantages you will gain by getting your training from the American School, but the coupon will bring you full information and a descriptive book, without cost or obligation to you. Fill out and mail the coupon NOW, while you are thinking about it. No agents will bother you.

## American School

Dept. 6B-74, Drexel Ave. and 58th St., Chicago

### American School

Dept. 6B-74, Drexel Ave. and 58th St., Chicago

Send me full information on the subject checked and how you will help me win success.

- |                             |                           |
|-----------------------------|---------------------------|
| ....Architect               | ....Lawyer                |
| ....Building Contractor     | ....Machine Shop Practice |
| ....Automobile Engineer     | ....Photoplay Writer      |
| ....Automobile Repairman    | ....Mechanical Engineer   |
| ....Civil Engineer          | ....Shop Superintendent   |
| ....Structural Engineer     | ....Employment Manager    |
| ....Business Manager        | ....Steam Engineer        |
| ....Cert. Public Accountant | ....Foremanship           |
| ....Accountant and Auditor  | ....Sanitary Engineer     |
| ....Bookkeeper              | ....Surveyor (& Mapping)  |
| ....Draftsman and Designer  | ....Telephone Engineer    |
| ....Electrical Engineer     | ....Telegraph Engineer    |
| ....Electric Light & Power  | ....High School Graduate  |
| ....General Education       | ....Fire Insurance Expert |
| ....Vocational Guidance     | ....Wireless Radio        |
| ....Business Law            | ....Production Manager    |
| ....Advertising Manager     | ....Undecided             |

Name.....  
Address.....

Please Mention Popular Mechanics

# Learn to Write

## I Teach by Mail

I can make a good penman of you at your home during spare time, no matter where you live or how poorly you now write. My simplified system has shown thousands the way to good penmanship during the past twenty-five years — I CAN and WILL do the same for YOU.

My beautifully illustrated 32-page Book  
**"How to Become a Good Penman" FREE!!**

It contains many beautiful specimens of penmanship showing what others have accomplished by the Tamblin System, with testimonials and general information about our courses. (Four names eloquently written on a card if you enclose stamp for postage.) Ladies taught successfully as men. Write Today. Address  
**F. W. TAMBLIN**  
 418 Ridge Bldg. Kansas City, Mo., U. S. A.

# F. W. Tamblin

## BE A FORD MECHANICAL EXPERT LEARN AUTO BUSINESS AT HOME

**F** BIG MONEY is to be made repairing the 7 million Ford Cars in the U. S. Be a **SPECIALIST** in the Auto Game where the opportunities are greatest. 70% of autos are Fords. **I START YOU IN BUSINESS.** Earn \$3,500 to \$10,000 a year. Be your own boss. Write **AT ONCE** for **FREE** information, so you will be sure to get the **TOOLS** **E** **CHICAGO AUTOMOTIVE TRAINING SCHOOL** Dept. 43B, 4420 No. Ashland Avenue, CHICAGO, ILL.

## MUSIC LESSONS FREE

**IN YOUR OWN HOME**

You can read Music like this quickly

**Piano, Organ, Violin, Mandolin, Guitar, Banjo, etc.**

Beginners or advanced players. One lesson weekly. Illustrations make everything plain. Only expense about 2c per day to cover cost of postage and music used. Write for **FREE** booklet which explains everything in full.

**AMERICAN SCHOOL OF MUSIC, 511 Lakeside Building, CHICAGO**

## POSITION GUARANTEED

I  
Want  
You

**FREE**

The Finger Print profession wants men immediately. Big pay, interesting work, no lay-off or shut-downs. I will teach you quickly to become a trained Finger Print expert. I guarantee a position and back it up with a \$1,000 bank deposit. Write at once for full explanation and details about my free Secret Service course, free Secret Service reports and special low price. Offer is limited. Write at once. No obligation. **U. S. SCHOOL OF FINGER PRINTS, Dept. 5135, 7003 N. Clark St., Chicago.**

## STAMMERERS

You can be cured by our course of natural individual lessons. Write today for free booklet, "How To Stop Stammering."

**SAMUEL A. ROBBINS, Director,**  
 Boston Stammerers' Institute, Founded, 1867  
 246 Huntington Ave. Boston 17, Mass.

Learn to **PAINT** **SIGNS** and **SHOW CARDS**

Big field—unlimited possibilities—increasing demand for men with creative ideas. Our course develops ability and originality. Work intensely interesting.

**EARN \$25 TO \$75 WEEKLY**

You can quit if ambitious. Successful graduates everywhere. Our course thoroughly covers every phase of work. Our graduates command big salaries. Write for catalog, samples, guarantee and Free Quilt Offer.

**Detroit School of Lettering, 627 D. S. L. Bldg., Detroit, Mich.**

FLEXIBLE  
BINDINGPOCKET  
SIZE

ENTIRE SET ONLY \$12

\$1  
PER  
MONTH

# \$10,000. Master Set AUDEL'S ENGINEERS and MECHANICS GUIDES

THE BOOKS YOU HAVE  
BEEN WAITING FOR

4750 Pages—8754 Illustrations

Just completed—Audel's New Master Set for Engineers  
and Mechanics!

Every Engineer, Mechanic and Electrical worker will  
welcome this set as a sure source of advancement and higher  
pay because of the complete up-to-date information that is  
thoroughly and easily explained on every branch of Engineer-  
ing and Electrical practice.

**Why a \$10,000 Library?** Because it would cost the reader  
more than \$10,000 together with years of labor and experience  
to collect, plan, arrange and prepare for his own study and  
ready reference, the vast fund of knowledge printed in this  
Master Set.

The entire set costs you only twelve dollars—knowledge  
and instruction that has cost thousands of dollars and years  
of time—yours for \$12.00—\$1.00 a month.

## Study This Brief Table of Contents

Theory, Practice and Operation of  
ALL Steam Engines, Valve Motion—  
VALVE SETTING) complete information  
on ALL engines and pumps—  
CORLISS ENGINES and the Theory,  
Construction and Operation of all  
Steam Engines, including UNIFLOW  
and POPPET VALVE ENGINES,  
and LOCOMOTIVES—Locomotive  
Marine Engines, Vertical Rotary  
Engines—the Indicator—Lubrication  
—PRACTICAL MANAGEMENT,  
How to use Indicator—GAS, OIL,  
GLINE, OIL, SEMI and FULL  
DIESEL ENGINES—Accidents and  
Aviation—HOW TO SELECT AN  
ENGINE, working instructions, draw-  
ings on STEAM ENGINE DESIGN,  
including rules and formulae, Theory  
and Construction of ALL Steam  
Boilers; Heat-Combustion; Fuel and  
Flue Gas Analysis—CO<sub>2</sub> recorder—  
Characteristics of Boilers—Materials

—Construction of all types of Boilers,  
(THE LAYERS PRACTICE)—Boiler  
Construction—Mechanical Rickers  
—Oil Burners—Setting—Chimneys—  
Mechanical Drafts—HOW TO  
SELECT A BOILER—Complete in-  
structions and drawings on BOILER  
DESIGN based on A. S. M. E. BOILER  
CODE—OPERATION, including  
installation, FIRING; care and repair  
of Steam Boilers—Pipes, Fittings and  
Pipe Fitting—Hotting and Ventila-  
tion—Refrigeration—Cooling Towers  
—Condensers—Distilling Apparatus  
—Elevators—Cranes and Hoisting  
Machines—Ropes and Cables—Splic-  
ing—electric wiring in ALL branches;  
compendium of practical electrical  
engineering as an aid for engineers  
and electricians in obtaining a license  
—57 chapters—ready reference index,  
covering entire field of Modern  
Electricity.

*Helping Hand  
Books that answer  
Your Questions*

**FREE  
EXAM-  
INATION**



**Send No Money—Send Only This Coupon**

**THEO. AUDEL & CO.,  
72 Fifth Ave., New York City**

Please submit me for free examination, AUDEL'S \$10,000  
MASTER SET FOR ENGINEERS AND MECHANICS. Ship  
at once prepaid, the 8 numbers, total cost \$12.00. If satisfactory,  
I agree to send you \$1 within seven days and to further mail you  
\$1 each month until paid.

Name.....

Occupation.....

Employed by.....

Home Address.....

Reference.....

PM July 23

# Thousands of Opportunities for Auto Experts



## GREER Trained Men Earn \$50 to \$125 a Week

GREER Special Summer Course offers you chance to learn complete Automobile Mechanics in just eight weeks. Good jobs waiting for GREER graduates. The pay is BIG—\$50—\$125 a week! Opportunities in all sections of the country. Automobile business is booming. Count the cars now in use. Every one you see is a prospect for the mechanic who knows how to repair an automobile the right way.

GREER training puts you in the "Know How" class. You learn through practical experience with real motors. Course includes: Truck, Tractor and Automobile Repairing, Automobile Driving, Roadside Repairs, Primary Ignition, Electric Lighting and Starting Systems, Vulcanizing, Machine Shop Practice, Shop Management, Selling, etc.

### Employment Guaranteed

Demand for men so great we can now guarantee you a job that will pay living expenses and even more while you are learning! GREER employment department flooded with openings. Then with a GREER diploma, you can quickly qualify for a permanent position at good pay, or go into business for yourself. GREER Summer Course is your special opportunity! Now you can get complete instruction at greatly reduced cost.

### Write for FREE BOOK

Learn what GREER has to offer you. Our FREE BOOK "How to Succeed in the Automobile Business" tells all. Start today for a Better Job, Big pay and Permanent Employment! Mail coupon at bottom of this column.

# GREER COLLEGE

of Automotive Engineering

2057 S. Wabash Avenue, CHICAGO, U. S. A.

## Mail This Free Book Coupon

ERWIN GREER, President,  
Greer College of Automotive Engineering,  
2057 S. Wabash Ave., Chicago, Ill.

Send me your Free Book, "How to Succeed in the Automobile Business" and Special Tuition Offer.

Name .....

Address .....

Please Mention Popular Mechanics

# Why Miss Half the Fun In Life?

EVERYONE admires and wants to dance with the person who knows the latest steps. There is no need of being a wallflower! By my remarkable new easy method, anyone can learn the newest dances at home in a few hours. Much less expensive than from a personal teacher. No music or partner needed. So simple even a child can learn quickly. 90,000 have learned dancing by mail. Your own success is guaranteed.



### Five Dancing Lessons FREE

To prove I can quickly and easily make you an accomplished dancer, I will send you FREE, in plain cover, a lesson in Fox Trot, Secret of Leading, How to Gain Confidence, How to Follow and How to Avoid Embarrassing Mistakes. To help pay the cost of handling, mailing, etc., send 25c. Learn in private—surprise your friends. Act now and be a good dancer soon.

ARTHUR MURRAY, Studio 783, 290 Broadway, N. Y.

**ELECTRICAL** men with training are in demand. For more than a quarter of a century this school has been training men of ambition and limited time; for the electrical industries. Condensed course in Electrical

## ENGINEERING

enables graduates to secure good positions and promotions. Theoretical and practical Electricity, Mathematics; Steam and Gas Engines, Mechanical Drawing. Students construct dynamos, install wiring and test electrical machinery. Course with diploma, complete

### IN ONE YEAR

Thoroughly equipped fireproof dormitories, dining hall, laboratories, shops. Over 3000 men trained.

Write for catalog. 31st year begins Sept. 26, 1923.

### BLISS ELECTRICAL SCHOOL

104 TAKOMA AVENUE, WASHINGTON, D. C.

## LEARN WATCH REPAIRING



You can learn by our modern and original system of instruction every part of the Watch Repairing Trade at home as good or better than at a shop. You can earn money while learning and secure a well paying position or start in business after completing our course of instruction. Good watch repairers are always in demand and earn from \$30 to \$70 per week. For particulars apply to the Wisconsin School of Watch Repairing 166 Mason St., MILWAUKEE, WIS.

## STAMMER NO MORE

Kill the fear of stammering. Re-education the key. The widely famed Hatfield Method fully outlined in an accurate, dependable, worthwhile book—"HOW TO STOP STAMMERING." It has inspired thousands. Free copy today!

THE HATFIELD INSTITUTE, 109 N. Dearborn, Chicago, Ill.

## 30 Days' Free Trial

Select from 44 Styles, colors and sizes, famous Ranger bicycles. Delivered free on approval, express prepaid, at Factory Prices. You can easily save \$10 to \$25 on your bicycle.

12 Months to Pay on any Ranger if desired. Parents often advance first deposit. Boys and girls can easily earn small monthly amounts.

Tires best quality, at factory prices, express prepaid. Lamps, wheels and equipment, low prices. Send No Money, do business direct with makers.

Write today for free Ranger Catalog, factory prices and marvelous early payment terms.

Mead Cycle Company Dept. 108 Chicago



## BE A CARTOONIST

### Earn Big Money Drawing Pictures

"Money Hunches for the Artist" book instructs you, How and what to draw and where to sell. List of markets, etc. Opportunity to increase your salary and get into a fascinating and profitable profession. Learn to do at once and make pay. For the artist in the country as well as the city. Satisfaction guaranteed. Send \$1 TODAY for book, or stamp for particulars.



NOVEL ART STUDIOS, Dept. 5, 7 East 42nd St., New York City

# FREE Railroad Fare



## Learn Electricity in 3 Months in the Great Shops of Coyne

**WE PAY YOUR RAILROAD FARE TO CHICAGO**—the Electrical Center of the World—from any place in the United States. Grasp this opportunity to see the country at our expense. Don't stick in one spot—travel—get experience. Come to Coyne—the largest electrical school in the country specializing in electrical instruction only. Learn electricity in 3 months. Fit yourself for a big paying job. Get a complete training so you can make big money as Power Plant Operator, Superintendent, Telephone man, Construction worker, auto, truck or tractor electrician, battery man, radio expert, or you can go into business for yourself as electrical contractor, dealer, auto ignition or battery expert and make from \$3,000 to \$20,000 a year. Hundreds of our graduates today are making big money and you can do the same if you grasp this opportunity—act now.

### Fit Yourself for a Big Paying Job

No books or useless theory. You are trained on \$200,000 worth of electrical equipment. Everything from door bells to power plants. You work on motors, generators, house wiring, autos, batteries, radio, switch-boards, power plants—everything to make you an expert ready to step right into a position paying from \$45 to \$100 a week.

*Earn While You Learn. We help students to secure jobs to earn a good part of their expenses while studying.*

### Send Coupon Today!

Don't delay a minute; send that coupon *right now* for our big free catalog and full particulars of Free Railroad Fare offer. Remember this special offer is limited so act now.

**COYNE**  
Electrical School

Endorsed by Electrical Industry

1300-1310 W. Harrison St., Dept. B-135, Chicago, Ill.

### Radio Course FREE

We include the following free with the regular course:

- (1) A complete course in auto, truck and tractor electricity and storage batteries. Greatest outlay of auto, electrical and battery equipment in the country.
- (2) Course in Radio; the marvel of the age. Constructing, installing and operating. Build your own wireless telephone set.
- (3) Life membership in the Coyne school. Stay as long as you wish and return for further training at any time in the future.

**B. W. COOKE, Pres.**  
Coyne Electrical School

1300-1310 W. Harrison St., Dept. B-135, Chicago

Dear Sir: Please send me free your big catalog and full particulars of your special offer of Free Railroad Fare and two extra courses.

Name .....

Address .....



## "Another \$50 Raise!"

"Why, that's the third increase I've had in a year! It shows what special training will do for a man."

Every mail brings letters from some of the thousands of students of the International Correspondence Schools, telling of advancements won through spare-time study.

How much longer are you going to wait before taking the step that is bound to bring you more money? Isn't it better to start now than to wait for years and then realize what the delay has cost you?

One hour after supper each night spent with the I. C. S. in your own home will prepare you for the position you want in the work you like best.

Without cost, without obligation, mark and mail this coupon. *Do it right now!*

TEAR OUT HERE

### INTERNATIONAL CORRESPONDENCE SCHOOLS Box 5529-D, Scranton, Penna.

Without cost or obligation, please tell me how I can qualify for the position or in the subject before which I have marked an X:

#### BUSINESS TRAINING COURSES

- |   |   |
|---|---|
| <input type="checkbox"/> Business Management                              | <input type="checkbox"/> Salesmanship                                     |
| <input type="checkbox"/> Industrial Management                            | <input type="checkbox"/> Advertising                                      |
| <input type="checkbox"/> Personnel Organization                           | <input type="checkbox"/> Better Letters                                   |
| <input type="checkbox"/> Traffic Management                               | <input type="checkbox"/> Foreign Trade                                    |
| <input type="checkbox"/> Business Law                                     | <input type="checkbox"/> Stenography and Typing                           |
| <input type="checkbox"/> Banking and Banking Law                          | <input type="checkbox"/> Business English                                 |
| <input type="checkbox"/> Accountancy (including C.P.A.)                   | <input type="checkbox"/> Civil Service                                    |
| <input type="checkbox"/> Nicholson Cost Accounting                        | <input type="checkbox"/> Railway Mail Clerk                               |
| <input type="checkbox"/> Bookkeeping                                      | <input type="checkbox"/> Common School Subjects                           |
| <input type="checkbox"/> Private Secretary                                | <input type="checkbox"/> High School Subjects                             |
| <input type="checkbox"/> Business Spanish <input type="checkbox"/> French | <input type="checkbox"/> Illustrating <input type="checkbox"/> Cartooning |

#### TECHNICAL AND INDUSTRIAL COURSES

- |  |  |
|--|--|
| <input type="checkbox"/> Electrical Engineering                          | <input type="checkbox"/> Architect                                   |
| <input type="checkbox"/> Electric Lighting                               | <input type="checkbox"/> Blue Print Reading                          |
| <input type="checkbox"/> Mechanical Engineer                             | <input type="checkbox"/> Contractor and Builder                      |
| <input type="checkbox"/> Mechanical Draftsman                            | <input type="checkbox"/> Architectural Draftsman                     |
| <input type="checkbox"/> Machine Shop Practice                           | <input type="checkbox"/> Concrete Builder                            |
| <input type="checkbox"/> Railroad Positions                              | <input type="checkbox"/> Structural Engineer                         |
| <input type="checkbox"/> Gas Engine Operating                            | <input type="checkbox"/> Plumbing and Heating                        |
| <input type="checkbox"/> Civil Engineer                                  | <input type="checkbox"/> Chemistry <input type="checkbox"/> Pharmacy |
| <input type="checkbox"/> Surveying and Mapping                           | <input type="checkbox"/> Automobile Work                             |
| <input type="checkbox"/> Metallurgy <input type="checkbox"/> Mining      | <input type="checkbox"/> Navigation                                  |
| <input type="checkbox"/> Steam Engineering                               | <input type="checkbox"/> Agriculture and Poultry                     |
| <input type="checkbox"/> Radio <input type="checkbox"/> Airplane Engines | <input type="checkbox"/> Mathematics                                 |

Name.....  
Street..... 3-27-23  
Address.....

City..... State.....

Occupation.....

Persons residing in Canada should send this coupon to the International Correspondence Schools Canadian, Limited, Montreal, Canada.

Please Mention Popular Mechanics

# S Become An Expert SALESMAN

Men who have mastered salesmanship—who are really proficient—name their own salaries, \$5,000 to \$10,000 a year and better not uncommon. Big money and opportunities in business always open to trained salesmen. Success in selling field leads to highest executive positions. Demand enormous. Old theory about "born salesman" exploded. Any man of average intelligence can now learn to sell thru scientific coaching. Training, the secret. Write today for free book, MODERN SALESMANSHIP. Learn in spare hours at home principles and methods of ablest sales organizations in America. Successful salesmen report sales doubled and trebled thru scientific study of salesmanship under LaSalle Problem Method. Low tuition fee—easy terms. Write now for information, LaSalle Extension University, Dept. 764-S, Chicago  
The Largest Business Training Institution in the World

## LEARN Wrestling Secrets at Home by Mail

Yes, learn the secrets of World's Champions—how to wrestle expertly—how to handle big men with ease—how to win. Be athletic, be strong, be healthy. Learn how to defend yourself.

### Farmer Burns

the world's most scientific wrestler, who trained the undefeated Champion Frank Gotch—who also trained six other World's Champions, will now train you. Investigate today his wonderful methods—the secrets of Champions. Every man and boy in the world, no matter what age, needs this information on SCIENTIFIC WRESTLING—PHYSICAL CULTURE—JIU-JITSU—SELF DEFENSE.

**Free Book** Send your name and age and get my splendid 32 page illustrated wrestling and athletic book—absolutely free, —no obligation of any kind. Write NOW.  
FARMER BURNS, B 177 Ry. Exchange Bldg., Omaha, Neb.

## BE A JAZZ MUSIC MASTER

### PLAY PIANO BY EAR

Play popular song hits perfectly by ear. Hum the tune, play it BY EAR. No tedious, ding-dong daily practice—just twenty brief, entertaining lessons which you can master

At Home in Your Spare Time

Send for the FREE BOOK. It tells how to start if you want musical ability at which friends will marvel.

NIAGARA SCHOOL OF MUSIC, Dept. 562 Niagara Falls, N. Y.

Send for this Free Book

## Learn Watchwork, Jewelrywork and Engraving.

A fine trade commanding a good salary, and your services are always in demand. Address **Morological**, Dept. P, Bradley Institute, PEORIA, ILL., for our latest catalog.



Free List of Government Positions Open  
MEN AND WOMEN  
17 TO 45 YEARS Salary \$1600 to \$2600

UNITED GOVERNMENT TR. ASS'N., 214K Dinan Bldg., Detroit, Mich.

Please send me free booklet and list of Gov't. positions open.

Name.....

Address.....

City..... State.....

# Don't Envy Tom Perkins

**-do what he did!**

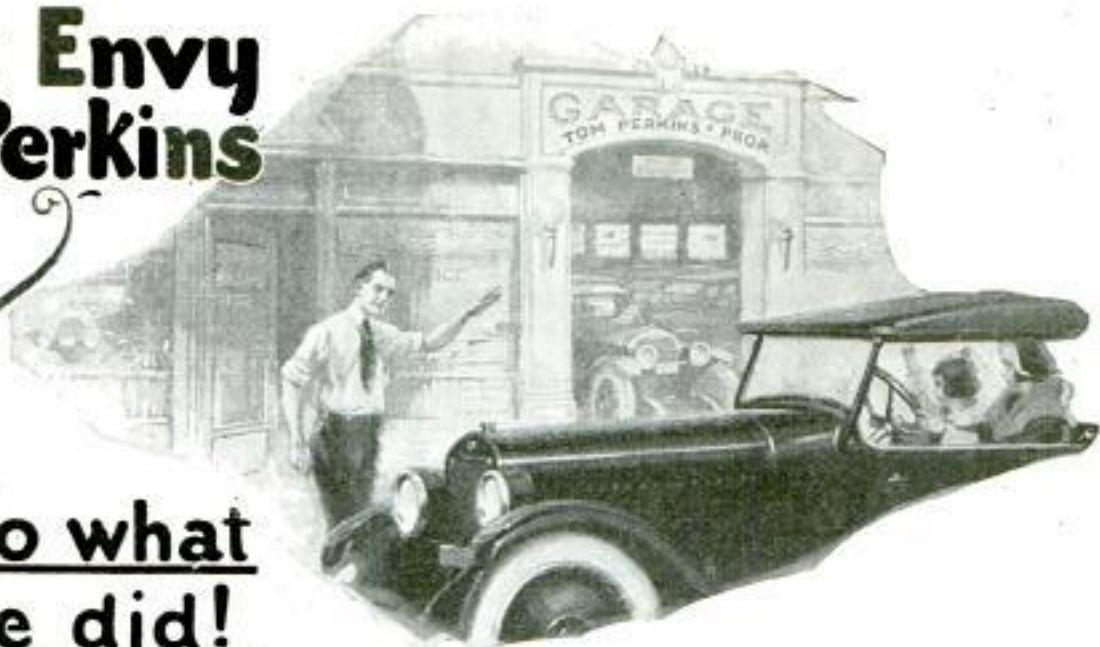

Tom Perkins liked the good things of life—he liked to attend the theatre; he liked to wear good clothes; he liked to travel on fast trains and live at good hotels. He *liked* all these—but that was as far as he got. The lack of money stood in his way.

His wife liked the good things of life too—she liked silk stockings and seal-skin coats; she liked to live in a cozy little home of her own; she liked the things that make life worth living. She *liked* all these—but she had to depend on Tom to earn them for her.

Tom had done the best he could. He always had a job of one kind or another—and he always gave an honest day's work in return for an honest day's pay. What more could he do? Was it any fault of his that he could never earn more than just enough to buy himself and his family the bare necessities of life?

The turning point in Tom's career came quite unexpectedly. A boyhood playmate, who had lived in the same town several years before, came back one week-end for a visit and told our friend Tom what a great success he had made in the garage business as the result of taking the M. S. A. S. Home Study Course in Automobiles. Then and there Tom decided to investigate the possibilities in the automobile field himself—and he was greatly surprised at what he found.

## A Wonderful Business

He found, among other things, that the automobile industry is the third largest business in the country today. He found that there are no less than twelve million cars and trucks in use in the United States and that the automobile factories were adding to this number at the rate of about ten thousand every day. He found that as the number of automobiles increased, more and more work was piling up for automobile mechanics to do. And, most important of all, so far as he was concerned, he found that the men who had trained themselves for this work were among the highest paid men in any line of industry.

Here, then, was a line of work that offered a real chance to get ahead in the world. There were jobs enough and to spare for all the men that the automobile training schools could turn out for years to come. And there was no chance of failure—unless people should some day stop driving cars, and he couldn't imagine anything like that happening.

It struck Tom that this was a good business to get into. Within two weeks he had enrolled in the M. S. A. S. Home Study Course and was spending his spare time evenings learning the automobile business—and it seemed only a short time until he had completed his training and had received his diploma.

## \$40 per Week to Start

This done, he went to the leading garage in the town, applied for a job, and got it—at \$40 a week, more than he had ever earned before. For the first time in his life he felt that he was really on the road to success.

At the end of a month, his pay was raised to \$55 and, in another month, it was again raised—to \$75 a week. Tom was truly getting up in the world.

That was three years ago. Today Tom is the owner of his own garage and has two mechanics working for him. Besides, he has secured the agency for Chevrolet cars and Willard Storage Batteries and has built up one of the leading auto electric service stations in his section of the country. He has won for himself the reputation of knowing his business—and, as a consequence, he gets not only the bulk of automobile repair work in his own town but also a great deal of work from car owners in neighboring towns where there are no first class garages.

Tom's earnings now average \$600 a month from the garage's repair work—and several times that amount from his sales of automobiles and batteries.

## No Experience Necessary

But, you may say, Tom must have been an exceptional man—he must have known something about automobiles before he took the M. S. A. S. Study Course. Quite the contrary—he had had no experience at all in automobile work. In fact, he couldn't even drive an automobile at that time and, as he himself says, he didn't know the difference between a carburetor and a wheel-base—didn't even know a car had a wheel-base. The only difference between him and the other young fellows in his town who are still working at \$15 to \$25 a week is that Tom made a step to better himself. He got off the short ladder that he was trying to climb and got his foot on a tall ladder where there was room to do some real climbing.

Any young man can start climbing the automobile ladder that leads to money and success by doing just what Tom did. As soon as he heard about the big money-making opportunity in the automobile business, he wasted no time in investigating it.

## Start Climbing Today

Do what Tom did—write today for particulars about the M. S. A. S. Home Study Course. All you have to do is fill out the coupon and mail it—and you will receive full information without charge.

The day that Tom first heard about the M. S. A. S. Home Study Course was the turning point in his life. This may be the turning point in yours—who knows? Mail the coupon today!

## MICHIGAN STATE AUTOMOBILE SCHOOL

67 Auto Bldg., Detroit, Mich.

Without expense or obligation to me, please send Outline of your Home Study Course and tell me about men like Tom Perkins who have made a big success in life by becoming automobile experts.

Name .....

St. or R. F. D. ....

City .....

State .....

If you would also like to receive, free of charge, a copy of the 100-page catalog of the mammoth Michigan State Automobile School in Detroit, to which students come from all parts of the country, make check mark in square.

# Learn to Make BIG MONEY As an Inventor



Raymond F. Yates, who with fourteen other famous inventors, now makes it easy for you to learn how to invent in your spare time at home.

Amazing new home-study course now teaches you inventive science in your spare time; shows how to develop, patent, sell your ideas; how to make big money from inventions.

## Famous Inventors Now Teach You!

"Invention is not a matter of luck, Edison says, 'Invention is a science, and should be taught as a profession.' Suppose you went home tonight and found a window rattling. Almost instinctively you would stop the rattle with a wedge. That instinct is the germ of your inventive ability, and you can develop it so

strongly that in a remarkably short time you will think and act inventively. Every invention is based on exactly the same principles that you use to 'fix' the rattling window—first to see a problem, and then to find some fact which solves that problem. And now, for the first time, 15 famous inventors teach you how to acquire these simple, easily learned principles of invention.

## A Fortune for One Little Idea

Even so small an idea as a new kitchen knife can bring you thousands of dollars. Waterman, the inventor of the fountain pen, became a millionaire. The inventors of the metal-tip shoelace, the "humpel" hairpin, the metal tape measure, the paper-match holder, have all received thousands of dollars for just one idea. It doesn't matter who you are, where you live, what you do—every day you meet problems which suggest ideas for money-making inventions.

## Learn How to Invent at Home

If you have ever had an idea for an invention, or if you would like to become a spare-time or professional inventor, see what this fascinating new course can do for you. Fifteen famous inventors now teach you at home the secrets of invention; show you how to get the information you want, how to perfect your ideas quickly, what to invent, and (just as important) what not to invent. You also learn how to avoid the mistakes which cost many inventors thousands and thousands of dollars. This complete course teaches you everything you want to know—how to get a patent, how to protect your patent rights, how to dispose of your invention to get the greatest possible profits, and hundreds of other facts about invention worth a fortune to you.

## FREE BOOK On Inventive Science

A wonderful book explaining this fascinating course will be sent to you free. It explains the course in detail, and proves that you can easily train your mind to think inventively so you may become a successful inventor. It shows how this course gives you, in a short time, a wealth of information which other inventors learned only after years of hard work and bitter experience. Get the advice of these fifteen famous inventors. Send for this book today. There is no cost or obligation. This bureau is not connected with patent attorneys or manufacturers. Our only work is to teach you how to develop your ideas so they will bring you big money.

### BUREAU OF INVENTIVE SCIENCE

Dept. 37, Wisner Building, ROCHESTER, N. Y.

BUREAU OF INVENTIVE SCIENCE,  
Dept. 37, Wisner Building, Rochester, N. Y.

Please send me without cost or obligation your free book "The Science of Invention."

Name.....Age.....

Address.....

City.....State.....

## BE AN ARTIST

We can teach you **DRAWING** in your own home during your spare time.

Our 35 years of successful teaching prove our ability. 30 Courses in Commercial and Illustrative Drawing. Teachers Normal and Applied Art. Endorsed by high art authorities. Students trained by members of our Faculty are filling high-salaried positions. Artist's Outfit **FREE** to Enrolled Students. Write today for Art Year **FREE** Book.

**OUR HANDSOME ART YEAR BOOK FREE TO YOU!**

### SCHOOL OF APPLIED ART

APPLIED ART BLDG. No. 2 BATTLE CREEK MICH.

## IT'S EASY TO PLAY THE TENOR-BANJO

**THIS \$15.00 TENOR BANJO FREE**

No Previous Musical Knowledge Necessary. Play Music Your First Lesson. Wonderful Method Only 5 minutes and you master them quickly. After a short period of easy practice you will be playing all the popular hits, just as you have heard experts play them on the stage, in Dance Orchestras—everywhere! It is the most popular instrument of the age and you can quickly learn to play it. Prof. Barker will teach you to **chord and harmonize** exactly as he does in an amazingly short time! And remember we furnish your **tenor banjo free**. Write for details of our course and free offer. Address:

**First Hawaiian Conservatory of Music, Inc.**  
Desk 60, 233 Broadway, (Woolworth Bldg.) N. Y.

## "STAMMERING Its Cause and Cure"

You can be quickly cured if you stammer. Send 10 cents, coin or stamps, for 288 page cloth bound book on Stammering and Stuttering. It tells how I cured myself after Stammering and Stuttering for 20 years. **BENJAMIN N. BOGUE** 6901 Beque Building, 1147 N. III. St. Indianapolis

## LEARN Penmanship

**I TEACH PENMANSHIP BY MAIL**

Small Cost. Spare Time. Write for my Free Book, "HOW TO BECOME AN EXPERT PENMAN." It contains specimens and tells how others became expert writers by the Tevis Method. Your name written on card if you enclose stamp. Write to-day.

**T. M. TEVIS, Box 25K, Chillicothe, Mo.**

## Clear-Tone FOR PIMPLES

Your skin can be quickly cleared of Pimples, Blackheads, Acne Eruptions on the face or body, Enlarged Pores, Oily or Shiny Skin. **\$1,000.00 Gold** Cash says I can clear your skin of the above blemishes. **WRITE TODAY** for my **FREE** Booklet—"A Clear-Tone Skin"—telling how I cured myself after being afflicted for fifteen years.

**E.S. GIVENS, 123 Chemical Bldg., Kansas City, Mo.**



STEAM TRACTOR AUTO & MFG. CO., INC.  
SIOUX CITY, IOWA.

Mr. A. F. Hegg,  
Dakotah, Ia.

Dear Sir:

I am sorry that I have not answered your letter sooner, but we have been busy getting ready for our fall fair and attending it, so will try and answer it now.

In regard to which are the best trained men of the different schools, wish to state that the M. S. A. S. of Detroit has the advantage in every way.

Having been through all of the schools, will state that outside of having men who can teach the course the others have not 1/10 of the equipment to work with or the advantages of factories and service stations such as the M. S. A. S. has at Detroit.

*In regard to courses, as you state, other schools give more courses for less money, but you do not get near the training in all of them that you do in any one at the M. S. A. S.*

I can assure you that if you take the course at the M. S. A. S. and apply yourself to the work, you will consider it the best investment you ever made.

Hoping this will be of benefit to you I remain

Yours very truly,  
C. F. Swanson.



## Meet Mr. Swanson

—a trained man  
in a big-paying business

When Charlie Swanson, of Sioux City, Iowa, came to Detroit to enter the Michigan State Automobile School, he was an untrained man. When he went back home a few months later, he was a *trained* man—an automobile man,—so well trained that he was soon earning \$500 a month, repairing and selling automobiles.

Hundreds and thousands of other young men have done just what Swanson did—jumped into a big money-making business after being trained to do automobile work. You can do the same—and the place to get this training (as Swanson says in the letter quoted above) is in Detroit, the heart of the automobile industry—where more motor cars are made than in all the rest of the world together.

Write today for Free 100 page illustrated Book telling about this Detroit automobile school to which students come from all parts of the country. Read in it why such well known motor car companies as Ford, Studebaker, Hudson, Paige, etc., are continually asking for M. S. A. S. graduates to work for them. Learn how easy it is for any graduate to start in the garage business in his own home town—and make \$2000 a year and up.

Think a minute!—Today, in the automobile business there are more jobs open than there are trained men to fill them. New shops, run by trained men, are needed. Become a trained man and start a shop of your own. Over 12 million cars and trucks are now running the highways, with new



Swanson's expert knowledge of automobiles enables him to invent a new kind of piston ring, as well as a farm tractor. Above is a picture of his present establishment

ones being added at the rate of 10,000 a day. More and more men are needed every day for the repairing of tires, batteries, motors, electrical systems, etc.

Find out at once how you can fit yourself to get into this profitable business. Send today for the Free book telling about the M. S. A. S. Course and about our money-back guarantee to all graduates. It costs you nothing. Just mail the coupon.

### MICHIGAN STATE AUTOMOBILE SCHOOL

447 Auto Bldg., Detroit, Mich.

Without expense or obligation to me, please send Free Book about your Complete Automobile and Tractor Course and about your money-back guarantee to graduates.

Name.....

St. or R. F. D.....

City.....State.....

If you would also like to receive Free Booklet telling about our Special Home Study Course, enabling you to start your training in your spare time at home, make check mark in square

# Make This Job YOUR JOB

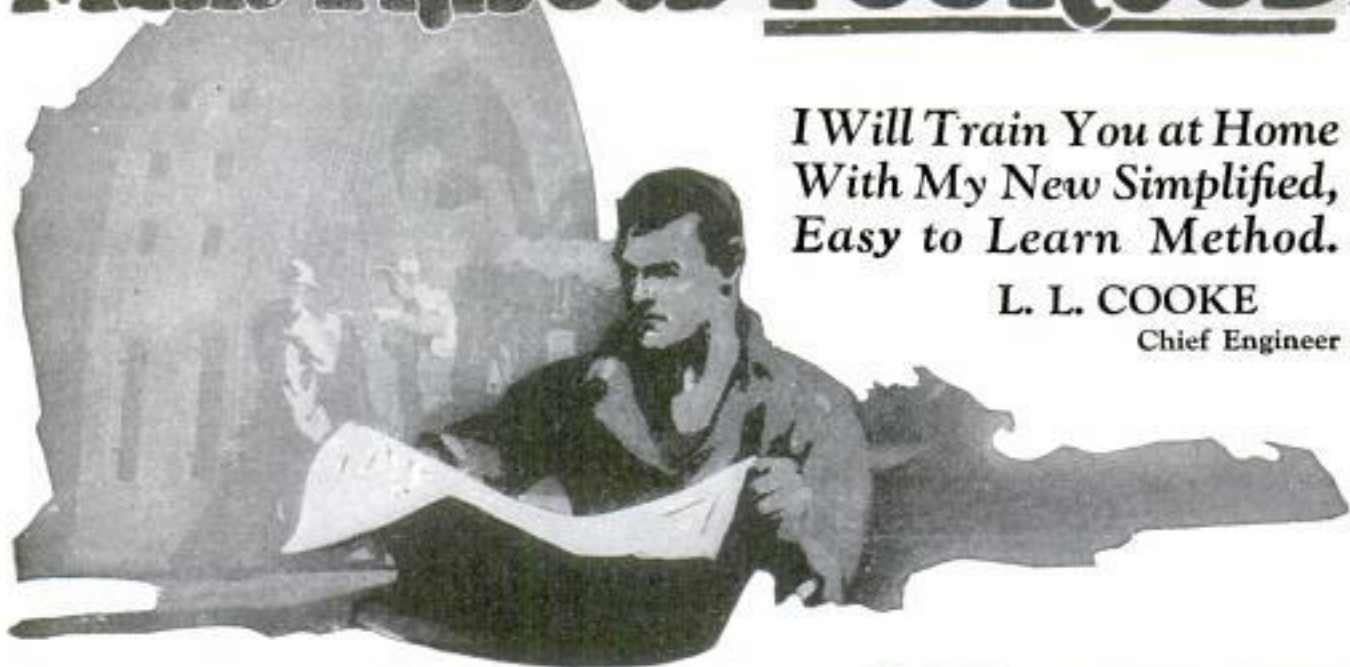

*I Will Train You at Home  
With My New Simplified,  
Easy to Learn Method.*

**L. L. COOKE**

Chief Engineer

## Be a **Certificated Electrical Expert** **EARN \$3500 to \$10000 a Year**

Men like you are needed right now in the fascinating Big Pay Field of Electricity. Never before was there such a demand for men at such high salaries. Get into this big pay game now. Get a real job doing work you will like. I have made it easy for you to earn \$70.00 to \$200.00 a week. Yes Sir—\$3500.00 to \$10,000.00 a year—and I'll help you get just the job you want and back it all up with a signed money back guarantee bond.

### Learn at Home to Earn \$12 to \$30 a Day

Even the common ordinary electricians are making money—big money—that outclasses all other trades. But I will make you more than an electrician. In a few short months you can be an Electrical Expert earning \$12.00 to \$30.00 a day. I will do this for you right in your own home and in your spare time. Follow my simplified, easy to understand method and you will quickly learn to fill any one of the many big jobs that are continually open to trained men.

### Other Men Like You Are Doing It. You Can Do It, Too

J. R. Morgan of Delaware, Ohio, earns from \$30.00 to \$50.00 a day since completing my course. He used to earn \$5.00 a day as a carpenter's helper. W. E. Pence, a \$35.00 a week mechanic of Chehalis, Wash., made almost \$10,000.00 last year doing electrical work in a town where he didn't think he could earn a dime. Harold Hastings of Somers, Mass., only 21 years old, cleans up \$480.00 a month. He was still in high school when he started on my course. Joe Cullari, 523 N. Clinton Ave., Trenton, New Jersey, increased his income 300% in one year and frequently makes the entire cost of his course back in one day's time. Fred Fritchman, 3959 Amundson Ave., New York City, makes \$450.00 every month. He was a \$15.00 a week man

when he first came to me for help. G. L. Sigety, 901 Standard Life Bldg., Pittsburgh, Pa., only 19 years old, jumped from \$10.00 a week to \$50.00 a week with his studies only half finished. Herbert Dickerson on a farm near Warrenton, Virginia, made \$7,500.00 last year applying the electrical training I gave him to farm work.

You might call it luck if one or a dozen of them jumped from little "two by four" jobs into the big pay class but when thousands have done it you know positively that my training alone was responsible and that it will do the same for you.

### Lack of Experience or Education Is No Handicap

If you have the average man's intelligence and can read and write, I can do what I said—quickly fit you to earn \$70 to \$200 a week—\$3500 to \$10,000 a year—as an Electrical Expert. My Course is so different from ordinary courses that it has revolutionized home study training. There is nothing else anywhere near like it.

It is the simplest, easiest to understand, and yet the most thorough and complete Course of electrical training in the country today. With it any ambitious man, regardless of age, lack of education or experience, can quickly become a big success in the wonderful, fast growing field of electricity.

### Electrical Outfit and Tools—FREE

A whole Outfit free. Everything you need—tools, instruments, material and a real workable motor. With this Outfit you do practical work

right on the jump. You don't have to buy a single thing—I give it all to you free because a good working outfit is necessary and I want my students to have the best.

### Send for My Free Book— the Vital Facts

I want every ambitious man in the United States to have this free book. I want them to see just what a big, magnificent thing the Electrical Industry is. Send for your copy now and learn what wonderful opportunities are before you this very minute and how they are increasing year after year.

### Mail Coupon NOW

With my book I will send you also a proof lesson, a credit check for \$45.50, my money back guarantee bond—a whole packet of interesting, money making facts. Mail the coupon now while the desire for success is upon you. Mail it and then decide if you want to stick on a small pay, no future job or be a \$3500 to \$10,000 a year Electrical Expert. **DO IT NOW!**

**The Cooke  
Trained Man  
is the Big  
Pay Man**

**L. L. COOKE**

CHIEF ENGINEER

CHICAGO ENGINEERING WORKS

Dept. 1-B, 2150 Lawrence Ave., CHICAGO

**L. L. COOKE, Chief Engineer**  
Chicago Engineering Works, Dept. 1-B  
2150 Lawrence Ave., CHICAGO

Dear Sir:—Send at once the "Vital Facts" containing Sample Lessons, your Big Book, and full particulars of your Free Outfit and Home Study Course—all fully prepaid, without obligation on my part.

Name.....

Address.....

Occupation.....

# CLASSIFIED ADVERTISEMENTS

WORLD'S BEST WANT AD MEDIUM

Advertisements in this section, 25 cents per word, each insertion, minimum 10 words, payable in advance. To be inserted under proper classification in August issue, copy should be in our office June 25th.

## ADVERTISING AGENCIES

ADVERTISING, Display, in this or other Magazines; Newspapers; Magnetic Trademark; Illustrated Booklet. Write The Capital Advertising Company, Inc., Munsey Building, Washington, D. C.

To secure agents or salesmen or for selling farms and reaching investors, use classified (want) ads in largest newspapers and magazines. Price list No. 30 sent free. Ankrum Advertising Agency, 20 W. Jackson Blvd., Chicago, Ill. The largest classified advertising agency in the U. S.

24 WORDS—20 big Sunday Newspapers \$11.00. Meyer, 4112-M Hartford, St. Louis, Mo.

## FOR ADVERTISERS

INCH Display 100 magazines, thrice \$8. Beck Agency, 3402 Alaska, St. Louis.

ADVERTISE in 24 Big Sunday Newspapers, 25 words \$15.00. Catalog listing 1,000 leading Dailies, Weeklies, Magazines, 40 stamps. Union Advertising, Baltimore Bldg., Chicago.

## AUTOMOBILE SUPPLIES

AUTOMOBILE Parts—Used parts for most any car at half factory list prices. Allen, Briscoe, Buick, Cadillac, Chalmers, Chevrolet, Dodge, Ford, Grant, Hudson, Hupacola, Oakland, Overland, Oldsmobile, Reo, Studebaker and many others. Send list of parts wanted. Maxwell Bros., 4106 Olive St., St. Louis, Mo.

INSYDE Tyres positively prevent punctures and blowouts. Guaranteed double tire mileage. Old worn-out casings will give 3 to 5 thousand miles more service. No tools needed. Just slip inside casing before replacing tube. Will not heat or pinch. Low priced. Agents wanted. American Accessories Co., B-1078, Cincinnati, Ohio.

GAS Zip—If you have used old-time highest gasoline you can understand what Gas Zip means in your Gas. Greater mileage—quick pick-up—snappy motor—increased efficiency—perfect combustion—motor free from carbon. One cent per gallon saves four or five cents in gasoline bill. 100 tablets energizes 100 gallons gasoline. Price \$1.00. Try it. Money maker for agents and dealers. Sealer Distributing Co., 1114 S. Michigan Ave., Chicago, Ill.

AUTO Parts at cut prices! All kinds of new and used, for all cars. Engines, Clutches, Transmissions, Axles, Radiators, Magnets, Generators, Batteries, Shafts, Gears, Bearings, Springs, etc., etc. If you have never known the House of Warshawsky, you had better write us and get acquainted. Think of buying the Osgood lens for \$50 per pair, and rims for any car at \$2.00 each. Windshields from \$8.00 to \$19.00. Spotlights \$1.75. Welding outfits at a low price. Specify make and model of car when writing. "Ask for Bargain List." Warshawsky & Co., 1935 S. State St., Chicago, Ill.

BRAKE Lining—Standard makes at a saving of 1/2 over your garage or dealers' list price. Get price from your dealer, then write us. In writing give make and model of car. Automobile Brake Supply, 1150 Book Building, Detroit, Mich.

LET us show you how to save 30% of your gasoline. Send your name and address; we'll do the rest. Southwestern Research Laboratories, Oklahoma City, U. S. A.

ONE Year Guaranteed Spark Plugs \$1.80 per dozen, any size, postpaid, cash with order. Kelly Lamp Works, Oak Park, Ill.

25% OFF list on Piston Rings, Clutch Facings, Brake Lining, and Ignition Parts for all popular cars. Standard goods only. Economy Car Parts Co., 333 Main St., Bowling Green, Ky.

USED parts for DeLco Brothers Cars, 50% from list. Satisfaction Guaranteed. Harris Motor Car Company, Cape Girardeau, Mo.

AUTOMATIC Air Compressor, quietest, most compact outfit on market. No noisy breaking belts. Motor and pump one unit. Thousands garages, filling stations, tire shops, using. Most economical to operate. Absolutely dependable. \$35 cash, balance terms. Iron Clad satisfaction or Money-back guarantee. Write for details. Hobart Brothers, Troy, Ohio.

STORAGE Batteries any make, one year factory guarantee. Cheaper than having old battery repaired. Immediate shipment. Ford \$18.65, Dodge \$17.65, Maxwell \$17.65, Packard or Cadillac \$23.15, check or money order. Reference any bank. Address T. R. Vandervort, 19016 Madison, Cleveland, Ohio.

MR. RADIATOR Repair Man, why pay big prices for radiator cores when you can buy our radiator core equipment and make your own cores? We make radiator core machines, lock saws, cutoff shears, adjustable dipping frames, radiator test plugs, etc. Write for details to Radiator Engineering Co., 626 Nesselwood Ave., Toledo, Ohio.

AUTOMOBILE Parts. All cars and trucks, motor parts, clutch parts, universal joints, axle shafts, gears, ball, roller, and thrust bearings, timing chains and gears. State make, model and parts wanted. Special prices. All new parts. In stock. Merrin Motor Parts Co., 1728 Michigan Ave., Chicago, Ill.

AUTOMOBILE parts, guaranteed new for all cars. Save money; get our wholesale prices on gears, shafts and bearings. State make of car, model and parts wanted. Parts shipped immediately from stock. We refund your money, including transportation charges, if not satisfied. Mechanics Gear Co., 3768 No. Halsted St., Chicago.

LIBERTY Air Compressors, for garages, tire-shops, filling stations, also paint spraying equipment. Air Compressor & Equipment Co., 1437 Carroll Avenue, Chicago, Ill. Distributors wanted.

AUTOMOBILE owners, garagemen, mechanics, send today for free copy America's most popular motor magazine. Contains helpful articles on overhauling, repairing, ignition, carburetors, batteries, etc. Automobile Digest, 505 Butler Bldg., Cincinnati.

8-HOUR Battery Charging with Constant Potential Pays Big, Easy Payments. Profits Pay. Postal brings details. Hobartco, Troy, Ohio.

BRAKE Lining—Standard makes at exceptionally low discounts to dealers and garages. Automobile Brake Supply, 1150 Book Building, Detroit, Mich.

MAGNETO Recharger; State Rights free. State Distributors, Reliable, 328 Jay St., Utica, N. Y.

## AUTOMOBILES

DYKE'S Automobile Encyclopedia, 13th edition, now greater than ever, entirely rewritten and rearranged. Contains greatest array of automobile facts ever published in one volume. Separate books containing same information cost \$21, over 1,200 pages and 4,100 illus. Cloth \$6. Flex. Amer. Morocco \$7.50 postpaid. Popular Mechanics Book Dept., 200 E. Ontario St., Chicago.

PATENTS Procured. Send sketch or model today for examination, prompt report and advice. No charge for preliminary advice. Write for free Booklet and blank form on which to disclose your idea. Highest references. Promptness assured. Clarence A. O'Brien, Registered Patent Lawyer, 562 Southern Building, Washington, D. C.

EARN \$100.00 Weekly—Make automobile specialties. New tops, repaint, retrim, old cars. Endorsed by trade experts. Unlimited demand. Start your own shop. Autofinishco, Sheboygan, Wis.

AUTOMOBILE owners, garagemen, mechanics, send today for free copy America's most popular motor magazine. Contains helpful articles on overhauling, repairing, ignition, carburetors, batteries, etc. Automobile Digest, 505 Butler Bldg., Cincinnati.

AUTO Trails Maps, Pocket Size—Rand McNally Official; Most Popular Road Guides. 21 maps, covering 21 touring districts, each complete in itself. Featuring marked auto routes with explanation of markers; all main traveled auto roads; mileage between towns; city maps of larger towns; reliable information concerning hotels, garages and service stations. Price 35c ea., postpaid. Send for further particulars. Popular Mechanics Book Dept., 200 E. Ontario St., Chicago.

REPAIRING Ford Cars, Trucks and Tractors in the most proper and efficient way is explained in a new 229-page book by the former director of the Ford Motor Co. Service School. This information is otherwise unavailable outside of the Ford plant. Written more especially for the mechanic and repairman. Price \$2 postpaid. Popular Mechanics Book Dept., 200 E. Ontario St., Chicago.

PATENTS—Write for our free illustrated Guide Book and Evidence of Conception Blank. Send model or sketch and description of your invention and we will give our opinion of its patentable nature. Highest references. Prompt service. Reasonable terms. Victor J. Evans & Co., 185 Ninth, Washington, D. C.

## FOR FORD OWNERS

FORD Owners! Learn About Wonderful New Power Maker. Practically eliminates spark lever—stops misfiring—adds power and speed—saves gas and is waterproof. Price is low. Ask for booklet and learn about Free Trial Offer. A. B. M. Co., Box Z, Brightwood, Mass.

FORD Car Repair Book Sent Free. This complete and well illustrated valuable book explains in a simple way how to overcome Ford car troubles; Repairing, Economical Winter Driving, Cold Weather Car Starting, Equipment for Fall and Winter, Curving Piston Ring Troubles, Carburetor Adjustments and Repairs, Connecting Rods, Timers, Transmission Troubles, and practically every phase of Ford car driving, repairing and equipment. Send 25c coin for three months' trial subscription and get the valuable repair book free. Ford Owner and Dealer Magazine, 531 Montgomery Bldg., Milwaukee, Wis.

FORD Owners save money—time—trouble. Read about Sun Automatic Timer on page 139.

UNDERSLING with "RKO" Swing Lo Irons \$7.51. See "Red-i-Kut" ad, page 150.

FORDS run 34 miles on gallon gasoline. Other cars show proportionate saving. Wonderful new carburetor. Starts easy in coldest weather. Fits any car. Attach yourself. Money back guarantee. Sent on 30 days' trial. Agents wanted. Air Friction Carburetor Co., Dept. 3221, Dayton, Ohio.

YOUR Ford runs 25 to 28 miles per gallon gasoline, saving \$25 yearly. My simple instructions \$1. Nothing to buy. Satisfaction or money back. Details free. J. M. Doyle, 120 Opera place, Cincinnati, Ohio.

## MOTORCYCLES, BICYCLES AND SUPPLIES

SEND for our Bargain Bulletin and Money-Saving Message. It will save you money on Motorcycles, Side Cars, Motor Wheels, Repair Parts and Accessories. Some used parts at less than half. Cleveland and Henderson Motorcycles our specialty. See our ad on page 136. American Motor Cycle Co., 2043-5-7 W. Chicago Ave., Chicago.

BICYCLES—Men's, small boys' girls', \$15; Tandems, frames, McDougal, 300 N. Wells St., Chicago.

1926 HARLEY-DAVIDSONS, \$90; 1919, \$65; 1917, \$55; 1915, \$40. Guaranteed. Money refunded if not satisfied. Circular free. Wisconsin Cycle Sales Co., 726 National Ave., Milwaukee, Wis.

**MOTORCYCLE and Bicycle Business for Sale.**—City of eighty thousand; established eighteen years. A. E. McCarthy, 928 Francis, St. Joseph, Mo.

**USED Motorcycles** fully guaranteed like new, \$25 to \$100. Motorcycle tires, \$3. Auto tires, \$3. Bicycle tires, \$1. Bicycles, \$5; tandem, \$10. Disk Talking Machines, \$9. Records for all Talking Machines, 25c. Send stamps for catalogues. Deuling Price Cutter, Rochester, N. Y.

**WONDERFUL bargains** in reconditioned motorcycles. Priced as low as \$35. Sidecars from \$25 up. Everyone expertly rebuilt and guaranteed in absolutely first-class condition. Don't delay. Send 2c for new big catalog showing 1923 bargains. Western Supplies Co., 539 Hayutin Bldg., Denver, Colo.

**USED parts** for all motorcycles, cheap. State using. Seluck Cycle Co., 1922 Westlake, Seattle, Wash.

**19 INDIAN 3 Speed \$75.00.** 20 Indian 3 Speed \$95.00. 21 Indian 3 Speed \$125.00. Howard A. French Company, Baltimore, Md., Washington, D. C.

**SEND** for big list of slightly used motorcycles on the easy payment plan. Howard Cycle Co., Trenton, N. J.

**DON'T** buy a Bicycle Motor Attachment until you get our new catalogue and prices. Also runs washers, pumps and shop machinery. Shaw Mfg. Co., Dept. 27, Galveston, Kans.

**LARGEST** stock of new and used motorcycle parts and accessories in the world at your disposal via Uncle Sam's mail. Write for quotations. Motorcycle Parts Mfg. Co., 2830-34 Wabash Ave., Chicago, Ill.

### AVIATION

**AIRPLANES,** Motors and Propellers, New or Slightly Used, about 1/3 of original cost. Aviators' Leather Coats. Smith Machinery Co., 463 Guggan Bldg., Houston, Texas.

**FLYING School**—Noted Ex-army instructor. New Planes Reasonable. Nimmo Black Airport, Peterson Ave., Chicago.

**TEX** lessons in the air, of twenty minutes each will make you a pilot, by our advanced method of training. This, together with our five-week shop course at \$100.00, makes America's oldest aircraft factory the most popular flying school. Week after class hours guaranteed. Heath Airplane Co., Chicago, Ill.

**"LEARN** to Navigate the Air" with Annapolis Flyers. Write for particulars. Address: H. A. Eggers, Box 439, Annapolis, Md.

**SAILPLANE:** Drawings, \$1.00; wing ribs for Sailydane or low-powered airplane, complete set \$18.00; Motors, \$70.00; Propellers, \$12.00. Burke Aircraft Co., Duquoin Grove, Ill.

**THE American School of Aviation** announces a new correspondence course in Mechanics of Aviation. A thorough training in Practical Aeronautics. American School of Aviation, Dept. 186-B, 3601 Michigan Ave., Chicago, Ill.

**"FLYING Instruction,"** Complete Course, \$164. Curtiss Planes. Fly the day you arrive. No waiting. Learn in one to three weeks. Low living expenses. All students "soloed" and given certificate. Aviation Engineering Co., Lawrence, Kan.

**28-H.P., 2-cylinder** Lawrence motor, weighs 117 pounds. New, \$160.00; slightly used, \$75.00. Extra wings and OX5 parts. Tipt & Smith, 403 Guggan Bldg., Houston, Texas.

**SEND** 10c for our latest aeronautical catalog listing a complete line of airplane goods at reduced prices. Propeller catalog 4c. Heath Airplane Co., Chicago, Ill.

**BIGGEST,** best catalogue Model Aeroplanes, Parts and Supplies: 5c Postpaid. Ideal Aeroplane Co., 7212 Green St., New York.

**INVENTORS** desiring patents should write for our Free Illustrated Guide Book and Exhibit of Conception Blank. Send model or sketch for our opinion of its patentable nature. Highest references. Prompt service. Reasonable terms. Victor J. Evans & Co., 187 Ninth, Washington, D. C.

### WELDING

**WELDING Encyclopedia**—A complete instruction book on all welding processes; oxyacetylene, electric arc, electric resistance and thermit. Welding of all weldable metals fully discussed. 320 pp., 375 illus. The accumulated experience of the welding brains of America is yours for \$5. Money back if not satisfied. Popular Mechanics Book Dept., 200 E. Ontario St., Chicago.

**ELECTRO** plating Generators. Make money doing Plating Work. Priced reasonable. Terms if desired. Write us, Holbertsons, Troy, Ohio.

**ACETYLENE** Brazing and Soldering Torches, \$2.00. Light welding and lead burning torches, \$7.00. Postage prepaid upon receipt of price, Marshall Mfg. Co., Kansas City, Mo.

### BOOKS AND PERIODICALS

**"LIGHTS,** Colors, Tones and Nature's Finer Forces," covering Vibrations; Odors; Auras; Cold-lights; Radio; Inventions; 270 pages. Satisfaction Guaranteed; \$2.00. Circulars Free. M. Stevens, Publisher, 212 Powell, San Francisco.

**INDUSTRIAL** Alcohol. Wright's book everybody wants. Full directions for making with drawings of necessary apparatus. \$2.50 postpaid. Spon & Chamberlain, 120 P. M. Liberty Street, New York, N. Y.

**1,000,000 INDUSTRIAL** Facts, Calculations, Receipts, Processes and Trade Secrets for every business are contained in the 1010-page book "Moore's Universal Assistant and Complete Mechanic," 500 Engravings, Cloth. Price \$2 postpaid. Popular Mechanics Book Dept., 200 E. Ontario St., Chicago.

**USED** Books, Bargains, Lists. Higene's, 2241 Post Street, San Francisco, Calif.

**LEFAX**—"Facts on Leaves." You make your own handbook, loose-leaf. From our complete list of Lefax data sheets you select only those that you actually need, then fill in your own notes or diagrams on extra blank sheets which come in 100 different styles. These in loose-leaf binder make up a book covering your individual needs. Send for complete information and price list to Popular Mechanics Book Dept., 200 E. Ontario St., Chicago.

**BARGAIN** price: Webster's 1922 New International Dictionary, Box 352, Youngstown, Ohio.

**SUCCESS** [all occupations] "Master Key," \$2.50; "Power of Will," \$3.00. Case's, 50c. All \$3.00 [New.] Phipps Library, 1014 Belmont, Chicago.

**HYPNOTISM** and Autosuggestion, 25 easy lessons \$1.00, Success guaranteed. Popular Institute, J-1014, Belmont, Chicago.

**ELECTRICIANS**—Examinations, Book of Questions and Answers, with diagrams, symbols, tables, notes and formulas for preparation for license, \$1.25. Aaron Shapiro, Dept. 18-206, Broadway, New York.

**NEW** Book—Where To Buy Ten Thousand Things At Wholesale, Worth \$10 per copy to anyone, says Professor Abbott. Postpaid 60c. G. O. Shaver, Publisher, Pm. 20, Oil City, La.

**PLANS** for Poultry Houses, All styles, 150 illustrations; secret of getting winter eggs, and copy of "The Full Egg Basket." Send 25 cents. Inland Poultry Journal, Dept. 74, Indianapolis, Ind.

**BIG** money in writing photoplays, stories, poems, songs. Send today for free copy America's leading writer's magazine, full of helpful advice on writing and selling. Writer's Digest, 708 Butler Building, Cincinnati.

**YOU** should have our New Illustrated List of Practical Books. Free. Spon & Chamberlain, 120 P. M. Liberty Street, New York, N. Y.

### PICTURES AND POSTCARDS

**JOIN** Live Postcard Club; Membership Lists, including Catalog, 10c. Harvey Tearle, Deatour, Ind.

**EXCHANGE** post cards with members of our club. Either sex. Write Good Fellowship Club, Woodhaven, N. Y. (Stamp appreciated.)

### NOVELTIES, CURIOS, ETC.

**MONEY-MAKERS:** Ever-New Writing Pads, Coin Folding Tricks, Wiggler Wooden Snakes, Ask for prices. H. P. Kalse, 423 Douglas Building, Los Angeles.

**RARE** Souvenir Photographs, World war, Curio-dies, etc. Miniature set with prices for dime. Photographic Holt, Villers-sur-Mer, Calvados, France.

**MOON-O-LIGHT** radium paint shines in darkness; 25c per Bottle. Gray & Bretz, 1463 St. Lawrence Ave., Bronx, N. Y.

**TWO** novelties and catalog 12c. Durso, 25 Mulberry, N. Y. City.

### GAMES AND ENTERTAINMENTS

**FOR** attractive Lawn Game, Neal Obstarle Golf, South Paris, Maine.

**VENTRILAQ'ISM** taught almost anyone at home. Small cost. Send 2c stamp today for particulars and proof. George W. Smith, Room M-738, 125 N. Jefferson Ave., Peoria, Illinois.

**BRIDGE** Whist: Following Sue's Simple Rules will make you an exceptional player. Only 25c. Address Aunt Mary, 310 West Superior St., Chicago.

**GREATEST** mind reading act ever sold. Not a toy. Easily mastered. Cannot be detected. Postpaid for \$1.99. The Ben-wills Co., P. O. Box 797, Macon, Ga.

**200 KINOS** Iron, wood and wire puzzles. Leader and Illustrated list 10c. Western Puzzle Works, St. Paul, Minn.

### MAGIC TRICKS, BOOKS AND JOKERS' NOVELTIES

**MAGIC** Disappearing Writing Pad. You simply write anything at all on the top sheet of the pad; then lift; Presto! the writing vanishes. Mystify your friends. Great fun. Price 25 cents postpaid. Popular Mechanics Book Dept., 200 E. Ontario St., Chicago.

**MASTER** Mind Calendar Feat, Wonderful. With 100 tricks 25c. Murphey, Box 1321-F, Asheville, N. C.

**PAPER** Magic—A new book by Houdini in which are described not only a large number of tricks with paper but also the amusing and puzzling articles which may be made of folded paper and tearing of paper. Paper Puzzles are also included, 206 pages, illus. Price \$2.50 postpaid. Popular Mechanics Book Dept., 200 E. Ontario St., Chicago.

**DISAPPEARING** spots, Best, most entertaining card trick on the market, 10c. Geo. Fenner, Louisville, Ky.

**NEW** 48-Page Magic Book 6c! Amaze and Mystify, Easy to learn. Send today. Lyle Douglas, Station A, Dallas, Texas.

**TRICKS,** magic, jokers' novelties, cards, books. Catalog free. Geo. Fenner, Louisville, Ky.

**FREE**—Our puzzle, trick, game, joke, Novelty Catalog. Wright & Son, 601-G Ind. Ave., Peoria, Ill.

**ENTERTAIN**—Mystify—Crystal Gazing Acts, Mindreading, Magical Apparatus, Cardtricks, Escapes, Novelties, Jokes, Ventriloquist Figures and instruction. Big illustrated catalog free. Write today. Heaney Magic Company, Berlin, Wis.

**PUN,** magic, mystery. 61-page book, 10c. Geo. Fenner, Louisville, Ky.

**TRICKS,** puzzles, jokes, magical apparatus, plays, stage supplies, mind-reading, sensational escapes. 160-page illustrated professional catalog, 10c. Oaks Magical Co., Dept. 548, Oshkosh, Wis.

**EVERYTHING** in Magic, Four Catalogs 15c. Gilmaglio, Morgan Park, Ill.

### STAMP COLLECTING

**FREE** 3 Abyssinian Stamps to approval applicants. 50% discount and premiums. Enclose 2c. Harry Icor, 801 State Life, Indianapolis, Ind.

**20 DIFFERENT** revenue stamps and coin century old, 25 cents. Box 205, Portland, Maine.

**BEST** one-cent approvals in America. F. P. Hand, 1117 So. 60th St., Philadelphia, Pa.

**100 FOREIGN** Stamps free to approval applicants. J. A. Platen, Fertile, Minn.

**GUARANTEED** postally used stamps. Old and recent issues. All countries. E. T. Nelson, 5056 Sangamon St., Chicago.

**SNAPS**—200 different stamps, 10c; 60 different United States Stamps, 12c. With each order we give free our price list of sets, packets, albums, etc., and our pamphlet which tells "how to make a collection properly." Queen City Stamp Company, Room 36, 604 Race, Cincinnati, Ohio.

**100 RARE** and valuable foreign stamps, all different, and big catalog, 7c. Stanton, Niantic, Conn.

**FREE** Rare stamp to approval applicants. Albert Behnke, Davenport, Iowa.

**FREE:** World's smallest stamp, Appalachia. Postage 2c. Cannon, 1417 Carey, Davenport, Iowa.

**SWITZERLAND** Aeroplane Set. Featuring Aeroplane crossing Alps; also 50 different Portuguese Colonial for 25c. Jacob Fischer, 1539 North Lawler, Chicago.

**FREE** set to applicants for 50% approvals. Dorval Stamp Co., Gloversville, N. Y.

106 DIFFERENT stamps free to approval applicants sending 2c for return postage. H. Anvelink, 2410 Prairie St., Milwaukee, Wis.

**RUSSIAN** Starvation Set. We have renewed our supply of this strange set, showing starving women and children, picture of Hades, etc. Great novelty. Price to applicants for Fenway Net approvals 5c. Fenway Stamp Co., Box 84, Fenway Station, Boston, Mass.

**FREE!** 25 British Colonials to approval applicants sending 2c. Nickles, 122 Florida, Washington, D. C.

**FIFTEEN** each, French, British, Portuguese, Colonies, 25c. Souled Stamp, Owen Sound, Ontario.

**ZAMBESIA**, Zanzibar, Abyssinia, Herzegovina, Allenstein stamps, menagerie collection, hinges, 10c. Liberty, 3974 Arsenal, St. Louis, Mo.

**FREE** Packet (No Junk) with approvals for 2c stamp. Sellen Stamp Company, 2416 Nicollet, Minneapolis, Minn.

**FREE**—Fifty Different Neurope to Approval applicants. Postage 3c. 1,000 Hinges 10c. Sunflower Stamp Company, Hutchinson, Kan.

500 DIFFERENT Stamps, 55c; 300, 25c. Michael, 5353 Calumet, Chicago.

**NYASSA** set Free for a request of my 1/2, 1 and 2c approvals, also the higher priced desirable stamps at 50% disc't. Send reference and get extra premiums. Chas. T. Egner, 4455 Frankford Ave., Phila., Pa.

**A DOVER** Bargain Stamp Outfit! 250 Peelable Hinges, 50 all diff. stamps, Fiume, (triangle), Nyassa, French Colon. (Pictorials), Malat (Tiger), etc.; 20 Vars. War and New Europe, 5 Blank Approval sheets, 26-page list and Bargain list, all for only 10c to those asking to see my choice 50% approvals. L. B. Dover (Dept. C), Basca Vista, Colo.

200 DIFFERENT stamps, list ten cents to those ask for 50% discount approvals. K. C. Stamp Co., 838 Lee Bldg., Kansas City, Mo.

50 DIFFERENT United States 10c; 10 Nyassa 100! 25c. Seldenberg, Merton, Wis.

**FREE**, Dollar Stamp Free to applicants for my 60% approvals. Norman Shultz, Colorado Springs, Colo.

**STAMPS** sent on approval at 70% discount. Reference required. Emory Benoit, Hanover, Pa.

\$3.00 FOR 12c! 100 different Neurope, catalogued \$2.10; triangle stamp, red-cross set, airplane set, perforation gauge, millimetre scale, fine wallet, 5 approval sheets, 250 hinges, scarce packet from Nyassa, Abyssinia, etc., price lists and approvals—all for 12c! Atlanta Stamp Co., Box 532, Atlanta, Ga.

**STAMPS**, 50 Varieties, Africa, Brazil, Peru, Cuba, Mexico, etc., 10c. 50 different U. S., 25c; 1,000 mixed, 40c; 1,000 hinges, 10c. List free. C. Stegman, 5948 Cote Brillante, St. Louis, Mo.

**LIKE** Triangular Stamps? To introduce our Sudden Service Approvals we'll send triangular Fiume, set China ships, large \$1.00 United States revenue, also packet 50 foreign, millimetre scale, perforation gauge, ruler and bargain lists for only 9c! Fennell Stamp Company, Dept. P, Fullerton Bldg., St. Louis, Mo.

153 GENUINE Foreign Stamps Mexico War Issues, Venezuela, Salvador and Italia Service, Guatemala, China, etc., only 10c. Finest approval sheets 50 to 60%. Agents Wanted, Big 72-p. Lists Free. We Buy Stamps, Estab. 29 yrs. Hussman Stamp Co., Dept. 54, St. Louis, Mo.

**UNIVERSAL** Packet, 100 varieties, all over the world, 10 cents. Covert Stamp, 30 State, Rochester, N. Y.

24 VARIETIES Cuban stamps, 10 cents. List of 4,000 low-priced stamps free. Address Chambers Stamp Co., 111P, Nassau St., New York City, N. Y.

**STAMPS**, 20 unused, all different, free. Postage 2c. Mention paper. Quaker Stamp Co., Toledo, O.

**PACKET** of 23 stamps, no two countries alike. Packet hinges. Set of \$1 and \$2 U. S. Rev., all for 5c. Mention paper. Miami Stamp Co., Toledo, Ohio.

20 UNUSED stamps free. All different. Postage, 2c. Fish Stamps, Toledo, Ohio.

**FOREIGN** Stamp Collection Sent Free. Cornish Company, Schenectady, N. Y.

**FRENCH** Colonies Free—Beautiful Picture set, including Native Chiefs, Tigers, Pictorials, 2c Postage. Empire Stamp Company, Toronto, Canada.

165 CHINA, etc., stamp dictionary, list, 2c. Album (500 illustrations), 3c. Bullard, Sta. A, Boston.

**BIG** Variety Packet Foreign Stamps free for 2c postage. Gear Stamp Co., Station E., Toronto, Canada.

**STAMPS** Free—War Stamps, Surcharged, Unused, Pictorials, British, French Colonials, 2c postage. Midland Stamp Co., Toronto, Canada.

1,000 DIFFERENT, \$2.00; 500, 75c; 325, 50c; 225, 25c. Fred Onken, 630 79th Street, Brooklyn.

**FREE**—50 varieties or set to approval applicants sending 2c. 500 different 60c. Richard P. Lamprecht, Valparaiso, Ind.

#### RARE COINS

**HAVE** you an odd or old coin or bill? It may be worth several dollars. Get posted. Send 4c for Coin Circular. May mean much profit to you. Send now. Numismatic Bank, Dept. H, Fort Worth, Texas.

U. S. CENT over hundred years old with my larger Selling list, 25 cents. Fred Greenclay, Box 2410, Denver, Colo.

**POLITICAL** Cent, Jackson cent or "Hard Times" Token, issued in 1834 to 1842. Highly interesting, some with jack-ass, turtle, etc. Get one now with my large 50-page illustrated Coin Catalog for only 20 cents. This is just a special "get-acquainted offer." B. Max Mehl, Numismatist, Mehl Bldg., Dept. P, Fort Worth, Texas. Largest Rare Coin Establishment in the United States.

**OLD** United States coins for sale; price list four cents. Ambrose Brown, Box 203, Marblehead, Mass.

10,000 GERMAN Marks 75c. 100,000 Rubles 25c. Craig Davy, 440 55th, Brooklyn, N. Y.

**BANKNOTES** of Russia, Germany, Poland and Austria in denominations up to 1,000,000. Write for information on same and how to start your own business. George Grigoletti, 20 E. Jackson, Chicago.

**GOLD** 1/4 27c, 1/2 53c, 3c Nickel and 2c piece 15c. German and Austrian Paper Money 10c. Price Lists and Wild Cat Bills 5c. Albert Bonsall, Richmond, Ind.

**CALIFORNIA** gold, 1/4 size, 27c, 1/2 size, 53c. 3c piece and catalogue, 10c. Address Norman Shultz, Colorado Springs, Colo.

#### FOR BOYS

**BOOKS** — "Ventriloquism," "Toymaker Book," "Boy Electrician," 10c each, all for 25c. G. Elsen, Bowling Green, Ohio.

**LEARN** to Swim—complete instructions 50c. Mercatus Co., Box 361, Indianapolis.

#### CAMERAS AND PHOTO SUPPLIES

**FILMS** developed 5c a roll. Prints 3c each, all sizes. Free enlargement with first \$1.00 order. Johnson's Studio, Towanda, Penna.

**EXPERT** Finishing and Enlargements—Superior quality work and individual attention of photographer with 5 years' U. S. Government experience, 5 years with Eastman Kodak, 10 years editor photographic publications. Write for price list. Carhuff Photo Finishing Co., 2129 W. Van Buren St., Chicago, Ill.

**ENLARGEMENTS**—Send \$1.00 and film for 10x12 sepia; water color \$2.80. Any size roll film developed and six gloss prints 25c. Price list free. Bilger Studio, Dept. 2, Freeport, Ill.

**GLOSSY** prints, any size, 3c. Developing 10c. Photo Works, Ashton, Ill.

**SEND** roll and 50c for finishing two styles and one enlarged. Barbeau's, Oswego, N. Y.

**TRIAL** offer: Six exposure roll developed and printed and one 8x10 enlargement 25c. Anderson Studio, 408 Wabasha St., St. Paul, Minn.

**JUST** Published—Our new complete 128-page catalog and bargain book of new and used cameras and supplies. Our goods are guaranteed finest quality obtainable. We have thousands of satisfied customers. Write at once for this bargain bulletin, just hot from the press. Address Central Camera Co., 124 S. Wabasha Ave., Dept. E-71, Chicago, Ill.

**KODAK** Films—Special trial offer: your next kodak film developed, 5c—prints, 2c each. Moser & Son, 1917 St. James Ave., Cincinnati.

**MODERN** Photography in all its branches now taught by mail. New Successful Method. Students earning \$300.00 while learning. Big Opportunity. Write for particulars and unusual offer open for short time. Dept. 3435 International Studios, Inc., 3601 Michigan Ave., Chicago.

**SPECIAL** Trial Offer: Any size Kodak film developed for 5c; prints 3c each. Overnight service. Get a Free Auto. Ask for details. Roanoke Photo Finishing Co., 289 Bell Ave., Roanoke, Va.

**SAMPLE** enlargement, dime and negative (returned). Sample 6-exposure roll finished glossy, 25c silver. Brown Studio, Lake Elmo, Minn.

**MAKE** money with your camera. Lancaster, Box 967, Los Angeles, Calif.

**FILMS**, 5c each; Prints, 3c each. Any size. One hand-tinted Free with each order. Azulykam, Bristol, Vt.

**HAVE** You a Camera? Write for Free sample of our big magazine, showing how to make better pictures and earn money. American Photography, 790 Camera House, Boston, 17, Mass.

#### MOTION PICTURES

**MOVIE** Film: For Home Use. Send \$5.00 Cash or Money Order and we will ship you postage prepaid, Big 1,000-foot Reel. Complete stories with best screen stars. Dramas—Comedies—Features—Westerns. Special—only while they last. Monarch Theatre Supply Co., Dept. P, 724 So. Wabash Av., Chicago.

**HOME** Projector, \$20; 1,000 Foot Projector, \$45; New Motor-Driven Suit-Case Projector, \$75; Road Show Projector, \$50; Movie Camera, \$60. Movie Films for Toy and Home Projectors, 800 feet, \$3. Dealers supplied. Ray, 324 Fifth Ave., New York.

**100-FT.** Pathe Motion-Picture camera. Complete outfit costs over \$1,200. For sale very cheap. Write for photograph, price and description. Empire Loan Bank, 649 No. Clark St., Chicago.

**FILMS** For Sale—\$2.50 per Reel up. Address Queen Feature Service, Birmingham, Ala.

**REMARKABLE** value: Light Weight Professional Motion Picture Projector, Mazda Illuminated, with 1,000 feet of film, \$37.50. Send for photograph. De-Franco, Importers, 169 No. Dearborn St., Chicago, Illinois.

**AMERICA'S** Greatest Fortunes have been made in the Moving Picture Business. Small investment needed. We furnish complete theatre equipment. Easy payments. Openings everywhere. Catalog free. Monarch Theatre Supply Co., Dept. P, 724 So. Wabash Av., Chicago, Ill.

**MOTION** Picture Projectors for home or school use. Wonderful values. Sold on easy payments. Write for photographs, terms and description. Sackholes, 649 No. Clark St., Chicago.

**JUST** in time to get in on the big money to be made! Bass will start you in the Motion Picture Making Business, enormous profits making Industrial Films, News Weeklies, etc. Catalogue and full information Free! The Cinema Handbook, 575 pages, for \$3.00 postpaid. Bass Camera Company, 105 No. Dearborn St., Chicago, Ill.

**\$35.00 PROFIT** nightly. Small capital starts you. No experience needed. Our machines are used and endorsed by government institutions. Catalog free. Atlas Moving Picture Company, 482 Morton Bldg., Chicago.

**FREE** to Writers—A wonderful little book of money-making hints, suggestions, ideas; the A B C of successful story and play writing. Absolutely Free. Just address Authors Press, Dept. 12, Auburn, New York.

**\$\$\$ FOR** Ideas. Photoplay plots accepted any form; revised, criticized, copyrighted, marketed. Advice free. Universal Scenario Corporation, 917 Western Mutual Life Bldg., Los Angeles.

**MAKE** money writing photoplays; details free to beginners. No correspondence course. Producers League, 239 Walnut, St. Louis.

**FILMS**—Comedies—Cartoons—Dramas—Westerns—Serials and Educational Subjects. Get our Big list and bargain prices before you buy. Monarch Theatre Supply Co., 228 Union Avenue, Memphis, Tenn.

## SCENERY TO RENT

SETTINGS for Opera, Plays, Minstrels, Flash Drops, Address Amelia Grain, Philadelphia.

## EDUCATIONAL AND INSTRUCTION

BE a Laboratory Expert. Earn \$300.00 to \$500.00 a month. Study Microbiology, Bacteriology, Laboratory Technology, Sanitation. Interesting Extension and Residential Courses. Diplomas and Degrees granted. 71-piece Urinalysis Outfit Free to students. Write for Free 48-page Prospectus Today, Int'l Physicians and Surgeons College of Microbiology, Room 955, 550 Garfield Ave., Chicago, Ill.

USED books and educational matter bought, sold, exchanged. Bulletin free. Instruction Correspondence Exchange, 1969 Broadway, New York.

CARTOONISTS—Improve your style by following the work of the greatest cartoonists found in the bound volumes of *Cartoons Magazine*. Eight volumes, each covering six months, Jan.-June, 1917, to July-Dec., 1920, inclusive. 1,200 cartoons, 900 pages to a volume, 7 by 9½ in., 3 in. thick. New books, durable and attractive binding. Sold separately at \$2 per vol. postpaid. Supply limited. Send at once. Popular Mechanics Book Dept., 200 E. Ontario St., Chicago.

SHORTHAND in 100 hours by reading and copying simple progressive illustrated exercises. Most rapid readable system. Send stamps. Manuscript Institute, Roanoke, Va.

STUDENTS of the Steam Engine—Get this book, "The Slide Valve Simply Explained," 83 pp.; illustrated. Paper cover, 25 cents postpaid. Popular Mechanics Book Dept., 200 E. Ontario St., Chicago.

USED correspondence courses, educational books, etc., bought, sold, and exchanged. Educational Service, 1093 Park Ave., Ithaca, Ohio.

POCKET Maps. We will send you a reliable and comprehensive Rand-McNally indexed pocket map, tourists' and shippers' guide of any state in the union, Canadian provinces, Alaska, Mexico or Central America, postpaid, upon receipt of 25 cents; also a splendid pocket reference map of practically any foreign country at 50 cents postpaid. Popular Mechanics Book Dept., 200 E. Ontario St., Chicago.

STUDENTS—Learn Marr's Light Line-Five Vowel Stenography, 25c. B-605, Nashville, Tenn.

ROPP'S Calculator and Shortcut Arithmetic shows the answer as quickly as a watch shows the time to all problems likely to occur in office, store, shop, bank, farm or factory. Price, pocket size, paper 25 cents; cloth 50 cents; leatherette \$1. Desk size, cloth, \$1.50 postpaid. Popular Mechanics Book Dept., 200 E. Ontario St., Chicago.

CITS made easily; chalk plate method 25c. M. E. Clarke, Ottawa, Kan.

YOU can have a business profession of your own and earn big income in service fees. A new system of foot correction; readily learned by anyone at home in a few weeks. Easy terms for training; openings everywhere with all the trade you can attend to. No capital required or goods to buy, no agency or soliciting. Address Stephenson Laboratory, 1 Back Bay, Boston, Mass.

LEARN the operating principles of the Corliss Engine from this book, "The Corliss Engine and Its Management," 92 pp., illustrated. Paper cover, 25 cents postpaid. Popular Mechanics Book Dept., 200 E. Ontario St., Chicago.

WORLD-ROMIC System. Mastery to All Languages. Primers, 23 languages, \$1.94 each language: Arabic, Bohemian, Bulgarian, Cantonese, Chinese, Danish, Dutch, English, Scotch English, French, German, Hungarian, Italian, Japanese, Latin, Panjabi, Polish, Portuguese, Rumanian, Russian, Sechuana, Spanish, Swedish, Pronunciation Tables, 94 languages, 30c each language. Languages Publishing Company, 8 West 46th Street, New York.

INVENTORS—Write for our illustrated guide book and Evidence of Conception Blank. Send model or sketch and description for free opinion of its patentable nature. Highest references. Prompt attention. Reasonable terms. Victor J. Evans & Co., 167 Ninth, Washington, D. C.

DOUBLE Entry Bookkeeping mastered in 60 hours with 8 keys; guaranteed; diploma. Our graduates lead in bookkeeping, auditing, accountancy, balance sheets, and financial statements. International Bookkeeping Institute, Dept. 8, Springfield, Mo.

WRITE articles, stories, news. In spare time for newspapers and magazines. Big pay. Copyright book free. Press Syndicate, 552, St. Louis, Mo.

BIG Money in writing photostats, stories, poems, songs. Send today for Free copy America's leading writer's magazine, full of helpful advice on writing and selling. *Writer's Digest*, 693 Butler Building, Cincinnati.

ARTIFICIAL Marble, sanitary flooring instructions, ornamental casting, concrete plaster, papier-mache decorations, garden furniture, statuary, Rubber-moulds, Electrometallurgy, particulars and 200 illustrations free. Chris Mahler, Box 122, Huntington, N. Y.

STUDY Bacteriology, Hygiene, Public Health. Laboratory technologists make good income. Interesting course, can be mastered at home or school in a few months. Also courses in Arts and Sciences, Chiropractic, P. O. Pharmacy, etc. 15th year. Diplomas conferred. Free announcement. National University of Sciences, 2923 So. Michigan Blvd., Chicago.

SHOW-CARD writing a pleasant, profitable profession easily and quickly learnt by our new, simple graphic block system. Artistic ability not necessary. We teach you how. Distance no object. Full particulars and booklet free. Wilson Methods, Limited, Dept. M, 64 East Richmond, Toronto, Canada.

USED books and educational matter bought, sold, exchanged. List 1,000 items free. Students' Exchange, 47-A West Forty-second Street, New York, N. Y.

MATHEMATICS taught by mail. Arithmetic, Algebra, Geometry, Mensuration, Trigonometry, Logarithms, and Mechanics courses. Harding School, 76 Brighton, Highland Park, Mich.

USED educational books sold, rented, bought and exchanged. Bargain list free. Lee Mountain, Pisgah, Ala.

## TELEGRAPHY

TELEGRAPHY—Morse and Wireless—taught at home in half usual time and at trifling cost. Omnigraph Automatic Transmitter will send, on Sounder or Buzzer, unlimited messages, any speed, just as expert operator would. Adopted by U. S. Govt. and used by leading Universities, Colleges, Technical and Telegraph Schools throughout U. S. Catalog free. Omnigraph Mfg. Co., 18 Hudson St., New York.

TELEGRAPHY—Both Morse and Wireless—taught thoroughly and quickly. Tremendous demand. Big salaries. Wonderful opportunities. Expenses low; chance to earn part. School established fifty years. Catalog free. Dodge's Institute, 11 St., Valparaiso, Ind.

## RADIO OUTFITS AND SUPPLIES

REAL Radio Receivers, prices \$15.00 up. Maker to user only. Money-back guarantee. Write for latest Bulletin, Trio Radio Laboratories, 9916 E. 14th St., Oakland, Calif.

AT Last. All stations tuned on One Dial Control. Easiest tuned. Cheapest to build. Particulars, Bokay Electric Company, Incomar, Ohio.

REAL Radio Posters, clever, nifty and neat; three different, \$1.00. Feature Service, Box 482, Youngstown, O.

RUSONITE multipoint crystal rectifier. The standard crystal. A synthetic crystal detector, sensitive over its entire surface. Extraordinary clearness and volume. Price mounted, 50c. Rusonite 14 karat gold supersensitive. Catchisher. Price 25c. Guaranteed. Rusonite Products Corporation, 15 Park Row, New York City.

BECOME Licensed Radio Operator. Quality one week. Others have. List free. Shortcut, Box 100, Mamaroneck, N. Y.

BLUE-PRINTS of twenty latest and most popular Radio circuits, including the Reflex, Neutrodyne, Heterodyne, Reinartz, Ultra Audion, etc., attractively shown in blue in our new 64-page Quality Radio catalogue. Postpaid ten cents. Each print worth double. Telephone Maintenance Co., 29 So. Wells St., Chicago.

FREE Instructions; Radio Parts; by mail. Engineering Sales Bureau, P. O. Box 35, Sta. K, Cincinnati, O.

FREE—Complete price list of radio parts. Write Aitken Radio Co., 504 Superior St., Toledo, Ohio.

TESTED Recipes. Transmitter Boston Hook-Ups. Amplification. Loud Speakers. Free Circular. K. Electric Co., 15 Park Row, New York City.

## TRADE SCHOOLS

LEARN Modern Barbering. It pays. Clean—care-free—short course. Can travel, see the World, or be your own boss. Will equip shop on payments. We have 31 branches. There is one near you. Write any address below for booklet B, telling all. (You do not need street address.) Moler System of Colleges, New York City, Chicago, Ill., St. Louis, Mo., Kansas City, Mo., Cincinnati, O., Cleveland, O., Detroit, Mich., New Orleans, La., Atlanta, Ga., Memphis, Tenn., Milwaukee, Wis., Omaha, Neb., Denver, Col., Dallas, Ft. Worth, San Antonio, Houston, Texas, or Toronto, Ont., Canada.

LET Us Place You in a Position to earn from \$10 to \$15 per day. We make an expert painter of you in a few weeks, better than if you went to work in a regular shop. Practical training in Sign, Pictorial, Auto Painting, Decorating, Paperhanging, Graining, Marbling. Catalogue Free. Chicago Painting School, 148 West Austin Avenue, Chicago.

## BUSINESS OPPORTUNITIES

STOP Flooding! Be Successful. Operate a Tire Repair Shop. Make big profits in any locality. We teach you and furnish complete equipments \$100 up. Back of Opportunity free. Haywood's, 1305 South Oakley Avenue, Chicago.

BECOME a Landscape Architect. Dignified, exclusive profession not overrun with competition. Crowded with opportunities for money-making and big fees. \$5,000 to \$10,000 incomes attained by experts. Easy to master through our correspondence methods. Established 1916. Get information today. American Landscape School, 56-K, Newark, N. Y.

ESTABLISH a Cash Business—no canvassing. Capital \$100 up. Information Dept. M. Paul Kaye, 149 Broadway, New York.

\$13,200 BUYS garage doing \$24,000 annually. Ranney, Kennel, N. Dak.

"GET into the Specialty Manufacturing Business" or "Why Work for Others?" may sound good to you, but you won't succeed in that business unless you possess Formulas that are absolutely reliable, the same required by leading manufacturers supplying the Best. Don't be bunked into buying a Collection of cheap "Formulas" and expect to succeed. Send today for my valuable literature and Formula Lists and Real Money-Makers in the Specialty Manufacturing Business. 26 years supplying the Best. Miller, Chemist, 805 De Leon St., Tampa, Fla.

MAKE Beautiful beveled glass license numbers; particulars free. Herman Stoffels, 407 No. 14th St., Paterson, N. J.

MARKET Help—How to Forecast, read swings, pick opportunities. Amazing new system with just the things you want to know. Eye-opening folder free. Write today. B. M. Marshall, Dept. M, Topeka, Kans.

ELECTRIC and Display Signs Pay Big Profits. You Can Easily Make These Signs with Our Aluminum Letters. Photos Free. The Indestructible Sign Co., Columbus, Ohio.

MAKE Money at Home—making toys. We show you how. Send \$1 for complete working drawings, instructions. Dekalb Designing Co., Dept. 6, Doratur, Ga.

LABORATORY Scientists are in demand. We teach you quickly and thoroughly and help secure positions. Extension and residential courses in Bacteriology, Microbiology and Sanitary Science. Taught by clear, concise, simple method. No preliminary training needed. Diplomas and degrees granted. The fascinating profession of Laboratory Scientist is recognized in business, detection of crime, disease prevention and cure. More experts needed daily. Become respected member of growing profession. Earn \$250 to \$500 a month. Students enrolling now will receive 48-piece Urinalysis outfit absolutely free. Write for Free 48-page prospectus today. Int'l Physicians and Surgeons College of Microbiology, Suite 971, 550 Garfield Ave., Chicago.

ENTER a new business. Earn \$2,000 to \$6,000 yearly in professional foot making and fitting a foot specialty, openings everywhere, with all the trade you can attend to; easily learned by anyone at home in a few weeks, at small expense; no further capital required, no goods to buy, job hunting, soliciting or agency. Address Stephenson Laboratory, (1) Back Bay, Boston, Mass.

**YOUR Opportunity.** Start a Magazine and Mail Order Business. Plan and Sample 10c. Circulars Free. Harvey Teeple, Decatur, Ind.

**688 WAYS to Make Money**—2,716 Formulas in "Encyclopedia Business Opportunities," 3 volumes; price, \$3; yours for \$1. Order at once. Ideal Book Shop, 5501-VG, North Robey, Chicago.

WE pay \$1 to \$50 for publishable ideas regarding uses for old razor blades. Also Royalties if idea has manufacturing possibilities. Write for details. The Astan Co., 315 Wesley Bldg., Columbus, Ohio.

**SIGN Painting Self-Taught.** Samples, 5c stamps. Healy Sign Co., 21 Old Colony Ave., Wollaston, Mass.

**UNLIMITED Possibilities,** making metal toys at home. No experience required. Particulars free. New Specialty Co., 448 E. 79th St., New York.

**MAIL Order Business for Sale**—Why waste hundreds of dollars on impossible schemes and plans when you can purchase an old established Mail Order Business for reasonable price? Write J. J. Williams, Mgr., Commercial Bank Bldg., Charleston, S. C.

**GOLD mine of opportunities in Mail Order field.** Send silver quarter for service ideas. W. Johnson, 5428 Wells St., Chicago.

**IS your life what you want?** Write for free circular on unused talents. Robert Knox, Box 728, San Francisco, Calif.

**LEARN Vulcanizing Business Free.** Get into business for yourself. Vulcanizing machines at reduced prices. Buy now. Now right time to start. Write for particulars. Willey Vulcanizing Company, Battle Creek, Mich.

**EARN \$10 daily silvering mirrors, plating and refinishing metalware, auto, chandeliers, bedsteads, headlights, outfits furnished.** E. Deete Laboratories, 1183 Broadway, New York.

**ATTENTION!!** You can have a business of your own. Establish and operate New System Real Estate Business, brokerage and insurance agency in your community. Office at home. Earn \$5,000 year. Representatives wanted everywhere. Send stamp form booklet. Hayes Realty Association, Cincinnati, Ohio.

**A NATIONAL Storage Battery Co.** changing distribution policy wants State Distributor. Guaranteed batteries and parts. Lifetime opportunity. Sample Ford size \$11.00, Dodge \$15.00. Address The Hazeltel Storage Battery Co., 2135 Columbus Road, Cleveland, Ohio.

**PREPARE—Sell Your Own Products.** Formulas, trade secrets. Different, dependable. Catalog free. B. Thaxly Co., Washington, D. C.

**3,800 FORMULAS**—Money-makers \$1. Ideal Book Shop, 5501-DB, North Robey, Chicago.

**DON'T Incorporate.** Organize any enterprise under common law; any capital; transact business any state; no corporation taxes or reports; no personal liability; raise capital; Booklet free. Herbert Company, 5 Rand-McNally Building, Chicago.

**PATENTS Procured.** Send sketch or model today for examination, prompt report and advice. No charge for preliminary advice. Write for free Booklet and blank form on which to disclose your idea. Highest references. Promptness assured. Clarence A. O'Brien, Registered Patent Lawyer, 561 Southern Building, Washington, D. C.

**PATENTS Procured; Trade Marks Registered**—A comprehensive, experienced, prompt service for the protection and development of your ideas. Preliminary advice gladly furnished without charge. Booklet of information and form for disclosing idea free on request. Richard B. Owen, 30 Owen Bldg., Washington, D. C., or 2276-R Woolworth Bldg., New York.

**SILVERBLACK Foxes \$200.00.** Time Payments. Booklet Dime. Arthur Schumacher, Lockland, O.

**OPEN Hat Cleaning Parlor.** Representatives wanted in every town. Big profits. Write Byron, 27 Sta. I, New York.

**FREE Book.** Start Little Mail Order business. Home employment evenings. Pier, 257-A, 74 Cortlandt St., New York.

**FREE Instructions** on how to start your own business. I am making \$20.00 to \$250.00 daily—you, too, can do it. Write for particulars. George Grigolet, 20 E. Jackson, Chicago.

**DROP Everything Else Quick** and handle our snappy, up-to-date "Quick Action" Novelty Salesorders. All new. Sell on sight. Write for list. Novix Specialty Co., Dept. 7, 29 East 27th St., New York.

**BEFORE Starting in Business** for yourself insure your success by letting us help you. Vital, comprehensive, practical ideas, hints, points, and information by experts on buying, selling, merchandising, banking and advertising. A new business. Unusual service. Write for free booklet today. Western Bureau Business Research, Room 509-B, 315 Montgomery St., San Francisco.

**CAPABLE men** wanted to open branch office and manage salesmen, \$300 to \$1,000 necessary; handle your own money. Possibilities unlimited. Address Manager, 603 N. Easton St., Baltimore, Md.

**CORPORATIONS** organized, security issues formulated, prospectuses prepared—moderate fee. Blanchet & Co., 347 5th Ave., New York City.

**RAISE Silver Foxes.** I pay \$200 to \$500 for pups. Gerald F. Todd, St. Stephen, N. H.

**SEND 25c** for paying mail order plan that brings big money quickly. Bookman, 63 Court St., Room 1, Boston, Mass.

**I MADE \$30 a Week Home.** French Breadmaking. 15 years' experience; Free Booklet tells. Ashbrook, 67, Marengo, O.

**"SCHEMER Magazine,"** Alliance, Ohio, prints big profit schemes; one subscriber making \$25,000 from three; another \$10,000 from one. Try your luck. Year, only \$1.00; three months, 25c.

**MAIL Order Business** is your opportunity. Brenner's Famous Handbooks teach how to start small, grow big. Sell merchandise, service, ideas; enormous profits. Spare time to begin. Get complete set, 11 books, \$3.00, and be posted. Brenner, 335 Walnut, Philadelphia. Descriptive Catalog and big batch interesting mail order information, 25c. None free.

**GET into the specialty manufacturing business.** Amazing profits. We will send you free book explaining our system. Write immediately. A wonderful opportunity awaits you. National Scientific Laboratories, 211 North Monroe, Richmond, Va.

**FREE Advice** on How to Become Successful in Real Estate and Insurance. Particulars. Macdonald Cooperative Realty, San Diego, Calif.

**MEN—Look into our proposition of Wallpaper Cleaning.** Take big cleaning contracts. Unlimited field. C. Swanson & Sons, Mankato, Minn.

**SILVERING Mirrors!** My exclusive French Tartaric method opens enormously profitable business. Booklet free. H. Barstow, 514 33d Street, Oakland, Calif.

**RAISE guinea pigs.** Pay better than poultry or rabbits; easy to raise; little space required. We guarantee market. Particulars and booklet how to raise free. Carter Distributing Co., 3102 Grand Ave., Kansas City, Mo.

**WE Start You in Business,** furnishing everything; men and women, \$30.00 to \$100.00 weekly operating our "New System Specialty Candy Factories" anywhere. Opportunity lifetime; booklet free. W. Hillier Ragsdale, Drawer 4, East Orange, N. J.

**MODERN Photography** in all its branches now taught by mail. New successful Method. Students earning \$300.00 while learning. Big Opportunity. Write for particulars and unusual offer open for short time. Dept. 2845, International Studios, Inc., 3601 Michigan Ave., Chicago.

**DOLLARS yearly** in your backyard. No minimum dose. Particulars free. Metz, 313 East 89th, New York, N. Y.

**CHEMICAL Expert** will furnish Formulas and Trade Secrets. All lines. Lists Free. W. L. Cummings, Ph. D., 228 Gordon Ave., Syracuse, N. Y.

**EXCEPTIONAL Opportunity** for Sales Manager capable of handling state distribution. Marvelous new Adding Machine. Retail \$15. Work equals \$350 machine. Tremendous possibilities. Unlimited profits. Write quick for details. Lightning Calculator Co., Dept. B., Grand Rapids, Mich.

**START a cleaning, dyeing, pressing shop.** Big profits. Experience unnecessary. Plans 25c. International, Dept. 19, Excelsior Springs, Mo.

**LEARN the collection business.** Good income, quick results, interesting booklet, "Skillful Collecting," free. National Collectors Assn., Long St., Newark, O.

**GOOD money** easily earned at home spare time silvering mirrors; no capital. Free instructive book tells how. Patterson & Co., Brooksville, Ky.

**\$3,000 To \$6,000 Yearly.** Want it? Others are making it. Send check or money order today for our invaluable books "How to Sell Real Estate," \$3.00—and "How to Conduct Real Estate and Insurance Business," \$1.50. Absolute satisfaction guaranteed. Free catalogs. Realty Sales Co., Dept. 52, Cleveland, Ohio.

**MARBLE mixing instructions,** covering wood or cement flooring 1/2 inch thick, fireproof, waterproof, low cost, sanitary, all colors. Particulars, 200 illustrations free. Chris Mahler, Box 122, Huntington, N. Y.

**\$80.00 WILL establish you in Cash Business.** Wonderful opportunities everywhere for making fortunes. Details Free. Monarch Theatre Supply Co., Dept. 46, 726 So. Wabash Av., Chicago.

**INCH Display Advertisement** 161 Magazines Thrice \$15, Year \$50, Page \$100. Wood's Popular Services, Atlantic City, N. J.

**AUTOMATIC Fly Ejecting Window Screens.** Your opportunity. Your own business at a cost of a hammer, saw and \$3.00 for all the particulars. Address F. Rohner, Box 173, Palo Alto, Calif.

#### CHEMISTRY

**PROCESSES.** Research, Analysis, Information. Consulting Chemists, Madison, Maine.

**YOUR chemical problem** solved and working process furnished Five Dollars. Write me, W. Stedman Richards, Consulting Chemist, address Box 2402, Boston, Mass.

#### FORMULAS AND TRADE SECRETS

**FORMULAS**—Best that Chemical Science can devise. Not "Better Sort" Formulas, but Guaranteed Reliable processes in all lines. Stamp brings Valuable Literature and Latest Summer Sellers from an Analytical Chemist. Miller, Chemist, 807 De Leon, Tampa, Fla.

**1,000,000 FORMULAS,** 1016 pages, \$2.50. Formulas Free if you order quick. Ideal Book Shop, 5501-MG North Robey, Chicago.

**10,000 SELECTED** chemical, technological and practical recipes and processes, including hundreds of so-called trade secrets for every business, alphabetically arranged in one large volume of 800 pages. Price \$4 postpaid. Popular Mechanics Book Dept., 200 E. Ontario St., Chicago.

**MAKE Money—Formula.** Auto Cleaner and Polish. One Operation. Cleans anything. Positively Guaranteed for One Dollar. Flaudt & Co., Waco, Tex., Ind.

**500 VALUABLE Formulas** 25c. Literature Free. Harvey Teeple, Decatur, Ind.

**FORMULAS—Guaranteed.** Catalog free. Restoval Laboratories, 4049-FG, North Whipple, Chicago.

**NEW Formulas.** Catalog free. B. Fitzgerald Laboratory, Stapleton, N. Y.

**FORMULAS of skin beautifiers** and treatments. Famous "Beauty Parlor" secrets 50c. Circulars 2c. The Eastman Co., Dept. A, 109 E. Dayton, Madison, Wis.

**20,000 FORMULAS,** 557-page volume, \$1.30. Ideal Book Shop, 5501-TG North Robey, Chicago.

**SILKPHOTOS!** Something new. Amateurs can make them. Formula \$1. P. Irs, 105 Division, Elizabeth, N. J.

**13 FAMOUS Formulas,** including Chewing Gum, Mirror Resilvering, Fish Bait, Fireproofing, etc., for Dime, Box 214, Marietta, Ohio.

**500 FORMULAS;** resilvering mirrors, valuable collection, 25c. Universal, 4049-EP, North Whipple, Chicago.

**3,400 FORMULAS.** Moneymakers. 400 pages, \$1. Restoval Laboratories, 4049-FG, North Whipple, Chicago.

**800 FORMULAS** 25c; Luminous Paint—Resilvering Mirrors—Renewing Dry Batteries—Mechanics Soap—Gas Torch—Carbon Remover—Puncture Plugger, 20c each. Entire collection 50c. Catalog Free. Ideal Book Shop, 5501-FG North Robey, Chicago.

5,000 RECIPES, \$1.25. Best formulas and processes for every business, trade or occupation are in "Youman's Guide." Many never before published. Worth \$1.25 each. 530 pages. Paper cover \$1.25. Cloth \$2.00, postpaid. Book catalog free. Wells and Edwards, 2882 George, Chicago.

FORMULAS of the better sort. Write for our free catalog. National Scientific Laboratories, 211 North Monroe, Richmond, Va.

### AGENTS WANTED

THESE Advertisements of mine have appeared in Popular Mechanics for sixteen years. Hundreds of Successful Manufacturers today owe their success to my formulas and valuable information. Majority started with practically nothing. You can do the same—write today for my valuable literature relative to my Guaranteed Manufacturer's Formulas for making Non-Thermic Ice-Saving Cloths, Delicious Beverages for Home, Bottlers and Fountain sale. Pure Food Products, Non-Alcoholic Flavors, Launderite Washing Marvel, Zeolite, greatest Stain remover, Sta-Comed, Marcel Hair Curler, and latest Toilet specialties, Mexican Yucca Soap, Laundry Soaps, Flynox, Senuol, and all latest disinfectants. Amazon Tire Repair, Toy Rubber Balloons and all latest selling goods in all lines. Don't compare these with "junk" commonly offered. Analytical work carefully done. Highest references. Miller, Chemist, Tampa, Fla.

\$500.00 MONTHLY. Few sales daily brings you this big money. Wholly advertised product. Sells to Dealers, Tremendous Repeater. Excellent sideline. Crew Managers, Sales Agencies, write quick. Bestever Chemical Co., 1940-P Irving Park, Chicago.

SELLS Like Lightning—Big Money—New Ironing Wax Pad and Asbestos Rest, Clamp Board, Perfumes Clothes. Outfit 10c. Yankee Mfg's, 380 Atlantic Ave., Brooklyn, N. Y.

INSTANT Rubber Weld. Repairs largest punctures without cement or heat. Lenn's profit one day, \$56. Write quick. Free sample; territory going fast. Tourists' Pride Mfg. Co., Desk T, Minneapolis, Minn.

AGENTS: We pack Beauty creams, face powders, perfumes, toilet preparations, with your label. Repeat orders guaranteed. Big profits. Write Chemist, A-944 No. Clark, Chicago.

AGENTS—150 Fast Sellers. Toilet and Household Preparations. Every woman a buyer. Big profits. Sale guaranteed. Colonial Chemical Co., 631 Penn Ave., Pittsburgh, Pa.

MAKE in the Coin—Get it all! Year round seller—no slack season. An average man made \$982.40 in the hot August of 1922. Spend six hours each day in actual selling and you may do better! Slide into your opportunity with the Alexander line, while there is territory left. A fascinating work—selling motion-picture advertising—the fastest growing industry today. Immense future with harmonious associations. Your postal will connect us! Alexander Film Company, 3389 Broadway, Denver, Colo.

AGENTS—Free sample Dr. Elliott's Vegetable Oil Soap. 19 full-sized packages right out of stock. Tea, Coffee, Extracts, Spices, Food Products, Laundry and Toilet Soap samples. Everything furnished. Send postal today. Department A-106, Harley Company, Dayton, Ohio.

LADIES—Do your own hemstitching and pinning; attachment fits any machine. Sent collect, \$2.50. Agents wanted. Colorado Attachment Co., Box 2218, Denver, Colo.

AGENTS—make money selling popular Ford Accessories; big demand; quick sales; liberal profits. Every Ford needs them. Write today. Stalder Mfg. Co., 125 S. Jefferson St., Chicago, Ill.

MY proposition produces Dollars. Write Truslet, Box 1274, San Francisco, Calif.

AGENTS: \$12 daily, easy, introducing Ladies' Summer Sweaters in silk and artificial silk; 12 colors. Latest novelties. Going like wildfire. You simply show samples we furnish; take orders; we deliver and collect. Your pay daily. Mac-O-Chee Mills Co., Form 1107, Cincinnati, Ohio.

AGENTS: \$16 a day. Latest improved portable talking machine. Does more than machines costing five times its price. Built-in just like a suitcase. Fully guaranteed. Pay you daily. Write Perry-Ludlow Co., 8-1962, Dayton, Ohio.

AGENTS to sell high-grade men's neckwear direct from manufacturer to consumer. Big profits, quick sales, free samples. S. Jarkel, 2831 Third Ave., New York.

AGENTS—W. F. Omels, a former brush salesman, made over \$5,000.00 during 1922 selling our \$1.50 kitchen specialty. He is now a district manager. We are offering you the same proposition—an opportunity as big as you want to make it. You can do what Omels did. Write today to M. H. Tyler Mfg. Co., Manager's Desk, Muncie, Ind.

AGENTS make \$10.00 a day or more selling Cuffield Tire Protectors. Prevents punctures and blow-outs. Doubles mileage. Easily applied, no cement or tools required. Absolute three-year guarantee. Nothing like them. No capital required. Big commissions paid weekly. No delimiting. Get our proposition. Write Cuffield Tire Protector Co., 283 Court St., Dayton, Ohio.

AGENTS—Make big profits selling raincoats; every home a prospect; experience unnecessary. Write for catalogue, Good-year Co., Inc., 329 Broadway, New York City, N. Y., Dept. 42.

AGENTS—men, women, something new. The "Mac" Weed Puller sells on sight—A necessary tool for gardens, lawns, parks, golf courses, etc.—Our agents make big money—\$500 on a money back guarantee—don't wait. Write for proposition, Grove Manufacturing Co., 1606 East 71st St., Chicago.

MOST Wonderful Seller. 96c profit every dollar. No stock to carry. License unnecessary. Sample free. Mission Factory PM, 519 No. Halsted, Chicago, Ill.

PATENTS Procured. Send sketch or model today for examination, prompt report and advice. No charge for preliminary advice. Write for free Booklet and blank form on which to disclose your idea. Highest references. Promptness assured. Clarence A. O'Brien, Registered Patent Lawyer, 562 Southern Building, Washington, D. C.

PORTRAIT and Medallion Agents—Our Goods Will Make You Big Profits; delivery guaranteed; prompt shipments; low prices; send for latest catalog. Adam J. Kroll & Co., 602 Blue Island Ave., Chicago.

MAKE \$31.00 Profit—Cost You \$1.50. Complete Gold Monogramming Outfit. Transferred Instantly on Automobiles, Trunks, Bags, Windows. Experience unnecessary. Free Samples. NuLife (A) Monogram, Hartford, Conn.

AGENTS, District Managers take orders for our exclusive Hosiery, French Seam, four pairs five dollars. Clifton, Lace Closs, Fancy Pointex Hosiery. Hosiery Mills, Chicago, 438 E. 43rd.

SPECIALTY Salesmen or Large Distributors have an unequalled opportunity handling Permanite, the marvelous invention that keeps Metals Bright for months. Sales guaranteed. Product guaranteed. Liberal profit. Good territory open. Consolidated Chemical Works, 233-F Broadway, New York.

AGENTS Make Immense Profits and build big permanent business selling our extensive line Men's and Women's wearables, novelties and specialties in your territory. Write quick for big free catalog and full particulars. Economy Sales Company, Manufacturers, Dept. 154, Boston, Mass.

\$10 DAILY and more to real workers. Marvellous new polishing cloth sells like hot cakes to homes, merchants, everybody. Over 100% profit. Popular price. Big repeater. Samples 25c. Write for money-earning sales plan. Denmar Co., 347-E Madison Ave., New York.

SUCCESS in Business and Personal Affairs! Read character by handwriting and features. Conlin System. Low price for entire course. Write, H. E. Conlin, Dept. B, 21 St. John's Place, Buffalo, N. Y.

AGENTS, Sell Rich Looking Imported 36x66 runs, \$1 each. Carter sold 115 in 4 days, his profit \$57. You can do the same. Write for sample offer. Sample prepaid \$1.39 each. E. G. Condon, Importer, 77 Bedford St., Boston, Mass.

RUBBER Goods Manufacturer offers big opportunity to men and women agents selling household and personal comfort necessities. Write Manufacturer—American Rubber Products Company, Dept. 708, Pittsburgh, Pa.

WORLD'S fastest agent's seller. 300% Profit. Needed in every home and store. Established Permanent business. Premier Mfg. Co., 813 E. Grand Blvd., Detroit, Mich.

ANY man handy with paint brush or light tools can start new mechanical business on nearly nothing; needed everywhere; nearly all profit; experience not required. John Braceband, 1457 So. Ninth, Philadelphia, Pa.

FORTUNE Maker—Thread-Cutting Thread. Live wires only. Sample, 15c. Autocut Mfg. Co., 3753 Monticello, Chicago.

AGENTS Wanted—\$4.00 to \$10.00 daily taking orders for "Super" and "Junior" Fyr-Fyter Extinguishers on our new Sales Plan. Commissions paid cash daily. Everyone who owns anything that will catch fire is a live prospect. Homes, farms, auto-owners, schools, churches, factories, all need them. Sell on sight. Sales limited only by calls you can make a day. Write today for exclusive territory and free booklet, "Building a Permanent Income as a Fyr-Fyter Representative." Fyr-Fyter Co., 163 Fyr-Fyter Bldg., Dayton, Ohio.

AGENTS: \$60 a week selling guaranteed hosiery for men, women and children. Must wear 12 months or replaced free. All styles and colors, including finest line of silk hose. Mrs. McClure makes over \$2,000 a year. Mrs. Schurman averages \$60 a month working spare time. Geo. Nobis made \$35 in one day. Write for sample outfit. Thomas Mfg. Co., Class 562, Dayton, O.

SALES Agents, Man or Woman: \$200 a month. Year round position. No layoffs. Take orders for Jennings New Style Hosiery. Written guarantee of satisfaction or new hose free. Write for outfit. Jennings Mfg. Co., Dept. 288, Dayton, Ohio.

EASY, pleasant work for Mechanics, Shop Men, Clerks, during spare hours; will add many dollars to their salaries. Also want persons who can give full time. Big wages assured. Novelty Cutlery Co., 67 Bar St., Canton, O.

AGENTS—Sell full line Interlock guaranteed hosiery for men, women, children. All styles, colors. 12 months demand. Satisfaction or money-back guarantee. Full or spare time. Samples to start you. Parker Mfg. Co., Sample 378, Dayton, O.

PORTRAITS, photo pillow tops, frames, sheet pictures, medallions, merchant's signs, water-proof and tea sprays, guaranteed hose, toilet requisites, luminous crucifixes; catalog, 50 specialties free. 20 days' credit. Jas. C. Bailey Co., Desk M-7, Chicago.

Big Profits Selling New \$3.50 Automatic Aiding Machine. Absolutely accurate. Fully guaranteed. Quick sales. Ten daily easy. No competition. Pocket size. Business people everywhere positive customers. Thousands being sold. Tremendous demand. Here's high-grade money-maker. Bassett Co., 1458-T, Hollywood Ave., Chicago.

27,000 RECORDS guaranteed with one Everplay Phonograph Needle; new—different; cannot injure records; \$15.00 daily easy. Free sample to workers. Everplay, McClurg Bldg., Desk 76, Chicago.

AGENTS, Salesmen, Demonstrators, you will have the devil's own time trying to find a better seller than "Zippe." If there was such a thing we'd have it. Splendid profit on 50c "Go-Getter" repeat article that sells on ten second demonstration. Works While You Watch It. Demonstrates value, while others waste time making claims. New Discovery! Greatest Scientific Triumph of the age. It's the berries. Haven't room to tell our story here. Write immediately. Karam-Smith Co., 667 Clark St., Fort Wayne, Ind.

AUTOMOBILE Safety Device. Sells at Sight. Men making \$10 a day alone, \$50 with assistants. No competition. Exclusive contracts. Lindl, 396 M & M Bank Bldg., Milwaukee.

AGENTS—\$15 a day—Easy, quick sales—Free Auto—Big weekly Bonus—\$1.50 premium Free to every customer. Simply show our Beautiful 7-piece, Solid Aluminum Handle Cutlery Set. Appeals instantly. We deliver and collect. Pay daily. New Era Mfg. Co., 803 Madison St., Dept. 21-P, Chicago.

AGENTS—Snappest household line on earth. Best-hot sellers, steady repeaters—100% profit. 500 light weight, fast selling, popular priced necessities. Agent's outfit free. Get busy quick—Write today; postal will do. American Products Co., 2684 American Bldg., Cincinnati, Ohio.

THIS is It—Fifty Fast Sellers. Everybody needs and buys. Fifty Dollars weekly easily made. R. & G. Rubber Company, Dept. 200, Pittsburgh, Pa.



**AGENTS**—"Nustile" combination aluminum Ladle-strainer. Patented. Hundred percent profit. Dollar seller. Exclusive territory. Rosen Mfg. Co., Utica, N. Y.

**SELL** home needle cases. Mail 10c for sample. Immense profits. National Needle Co., 5153 Washington Ave., St. Louis, Mo.

**AGENTS Wanted**—Product-O-Mats name brand sells to every home, office, place of business. Write Jackson & Co., 249 W. 34th, New York.

**CALIFORNIA** Rosebuds selling like hot cakes. Agents coinng money; new stuff. Big profits. Catalog free. Mission Factory PM, 519 No. Halsted, Chicago, Ill.

**FREE Sample**. "Rain Shield Wiper." Retail \$1.00—Costs (25¢) Solid, Clear and Rainy Days. No Cloth—No Paste—No Attachment. (1) Rub keeps Windshield Clear (48) Hours. Experience unnecessary. NuLife (H) Corporation, Hartford, Conn.

**PHOTO Medallion Salesmen** Earn \$100 to \$200 every week selling P. & G. Photo Medallions. No Investment—Free Equipment. Guaranteed 4-day Service. Send for Sales Plan and Free 1923 Catalogue with 162 beautiful designs, including clock and religious medallions. Paulin & Goldstein, 259 Bowery, Dept. A, New York.

**AGENTS Wanted**—Fortune for good hustler; write for free working model of our new Automobile Invention. Gives instant starting, saves gasoline, increases mileage, reduces carbon. Sold on a money-back guarantee. Singer Automatic Priming Cup Co., 823 Reed Building, Philadelphia, Pa.

**DISTRIBUTING** agents wanted for our Specialties. Sell one or entire line. Whole time or side line. Representatives wanted in each locality. Proven ready sellers; very liberal commissions. Barclay & Vaughan, 80 Boylston St., Boston, Mass.

**EARN \$10** daily silvering mirrors, plating and refinishing metalware, autos, chain-drivers, bedsteads, healthlights. Outfits furnished. E. Dele Laboratories, 1133 Broadway, New York.

**GOLD Leaf Sign Letters**; make and sell; profits exceed 1,000%; immense demand; particulars free. Johnston Co., Quincy, Ill.

**AGENTS, Distributors, Energetic Men** everywhere earn \$10 daily handling the HyKon Sewing Machine Belt; a new household necessity; sells on sight to homes, dressmaking and tailoring establishments. Be first; get this money-maker; put out sub-agents. Opportunity folder free. HyKon Mfg. Co., Alliance, Ohio.

**AGENTS**—Unlimited possibilities. Every automobilist, repairman, mechanic, and sportsman a prospect. No sales talk required. Article sells itself on sight. Dan Sales Co., 502 W. Division St., Chicago, Ill.

**AGENTS**: Lowest priced gold window letters. Sample and Particulars Free. Empire Letter Works, 79 East Chapel St., New Haven, Conn.

**AGENTS**—Best goods. Lowest prices. Catalog free. Clarence Edwards Co., Lancaster, Ohio.

**ENORMOUS Profits. Get Yours.** Everyone Keeps Buying Springfield Brushes. Don't Waste Time. Prove This. Write Today. Springfield Brush Company, 54 Taylor St., Springfield, Mass.

**AGENTS** with cars earn big money selling Health Adjustable Metal Visors on commission. O. B. Health Mfg. Co., Inc., Box 27, East Hartford, Conn.

**AGENTS Wanted**—Men and Women; Wumrub, the world's best polish for autos and furniture. Ready sales, big profits. Wumrub Co., 26 Bellevue Place, Chicago.

**BIG Money**—selling improved Vapor Gas cooking and Lighting Plants for farm and small-town homes. Exclusive territory now open for a few high-class men who can handle sub-agents and make a small investment. This product is far ahead of any of the kind ever offered. Covered by iron-clad guarantee. A good clean-cut cash business opportunity that returns quick profits. For full particulars write G. M. Tilford, Manager, 201 N. St. Francis Street, Wichita, Kans.

**AGENTS** with Ford: Sell U. C. Klear. Shields moisture. Polish their glasses or goggles—they buy. Big Repeater, U. C. Klear Co., 504 Exchange Bldg., Portland, Ore.

**HANDY** door stop, a mechanical marvel. Holds swinging doors open, eliminates prrs, etc.; always on the job. \$2.00 per pair, sample pair postpaid \$1.50. Rathban Mfg. Company, Jamestown, N. Y.

**AGENTS**—Make \$5.00 an hour; our beautiful silk knitted neckwear sells on sight; latest New York styles direct from mill to you; popular price; instant sales. Steady all year round proposition; big repeater; your own territory open. Write today. Knit-Art Silk Neckwear Co., 293 Broadway, New York.

**MAKE \$15** day introducing extraordinary fountain pen bargain. Purchaser's name engraved free in gold; agents cleaning up. Write Britsner, 286 Fifth Ave., New York.

**300% PROFIT**—Whirlwind Seller. Klean-Bite. New Washing Discovery. Washes clothes without rubbing. Women throw away washboards. Write Quick for Free Package and Special Offer. Bestever Products Co., 1941-K7, Irving Park, Chicago.

**DISTRICT** manager, exclusive territory, new device eliminating night glare grill. Big money for agents. Sample \$2.00. Particulars free. Glareclipse, 24 Exchange Street, Rochester, N. Y.

**ORANGEADE**, in powder—just add cold water—most delicious drink you ever tasted. Fine for home, parties, picnics, dances, etc. Start in this business—big money easily made. Send dime for ten glass package, postpaid, 7 kinds, Cherry, Grape, Lemon, Strawberry, etc., for 79 glasses only 50c, postpaid. Morrissy Company, 4417-25 Madison St., Chicago.

**\$5 To \$15 Daily Easy**—Introducing New Style Guaranteed Hosiery. Must wear or replaced free. No capital or experience required. Just show samples, write orders. We deliver and collect. Your pay in advance. Elegant outfit furnished, all colors and grades, including silks. Mac-O-Chee Mills Co., Desk 2567, Cincinnati, Ohio.

**GET posted**—Good prices paid for butterfies, insects. See Sinclair display advertisement, page 22.

**REAL** Agents earn \$75.00 weekly selling our fifty meritorious jewelry specialties. Exclusive proposition with liberal credit. Flexo Corp., Sheboygan, Wis.

**SELL "Amens"** Shirts. Wonderful opportunity, big profits. Made-to-measure and stock shirts; finest materials. Write for details. Mendin Shirt Co., 479-A, East Tremont Ave., New York.

**SELL** Our Beautiful Engraved Stationery, Announcements, etc. Liberal Commission. Northside Engraving Co., Valley at Troy, Dayton, Ohio.

**LARGE** manufacturer wants agents to sell guaranteed made to measure raincoats, Galatines and Reversible top and raincoat combined. Make \$75 to \$100 weekly. Profit in advance. We deliver and collect. Outfit free. Standard Raincoat Co., 127 West 17th Street, New York, N. Y.

**\$75-\$100 WEEKLY**, Ford Choker Spring. You install in two minutes. Sensational seller. Sample, Particulars, 25c. Associated Distributors, 6132 Eleanor Ave., Hollywood, Cal.

**WONDERFUL** invention—Eliminates all needles for phonographs. Saves time and annoyance. Preserves records. Lasts for years. 12,000,000 prospects. \$15.00 daily. Free sample to workers. Everplay, Desk 723, McClurg Bldg., Chicago.

**MAKE \$30.00** daily taking orders for \$3.95 Union made raincoats. Factory prices. Largest commission. Your pay daily. We deliver and collect. American Eagle Raincoat Co., 155 No. Union St., Dept. 332, Chicago.

**OUR 50c** Labor-saving Household Necessity sells on minute demonstration to 8 women out of every 10, and repeats; liberal profit; exclusive territory. Sample 17c. Write Today. The Mollard Chemical Company, Lafayette Station (P), Saint Louis.

**BULL & BEAR** Pad. Big sensation. Easy seller with big repeat orders. Send 10 cents for sample Pad. A. Ewig, 356 Main Street, Springfield, Mass.

**GOLD** Monograms on Automobiles, Musical Instruments, Bags, anything. Done instantly by anyone. No transfer, no paper. Wonderful \$2.00 Vest Pocket Outfit. Free samples. Autocold Monogram Co., 1619 Broadway, Brooklyn, N. Y.

**HANDKERCHIEFS**, "Quality" line. Agents get best rock factory prices. Write for the plan of this dependable business. Turnover Sales Company, 18-A East 17th St., New York.

**DISTRICT** manager, appoint agents—new discovery keeping windshields clear during rainy weather. Remarkable seller. Sample 50c. Information Free, Products, Times Union Building, Rochester, N. Y.

**EARN \$5,000** annually, selling well-known washing compound. Washes without rubbing. Greatest repeater on market. Credit given. Food furnished agents. Premium to customers. Write today for sample and terms. Sale of every package guaranteed. Buss-Beach Company, Dept. 23, Chippewa Falls, Wis.

**NEW** patented Article. Nothing like it. No competition. Sells on sight. Can use both men and women Agents, part or full time. No experience required. Write at once. Dept. 101, Arden Products, 52 W. Van Buren St., Chicago.

**AGENTS**—Don't miss this opportunity. Every Home, Office, Shop, Garage and Automobile a prospect. Cleans perfectly without water. Every automobile should carry it. Sells for 25c, with large profit for you. Write for details today. Nowater Cleanser Co., Warren, Pa.

**SALESMEN** and Agents: New Auto Accessory good for \$100.00 per week. Ezreka Engineering Co., Box 1512, Rockford, Ill.

**PREPARE-SELL** Your Own Products. Formulas, trade secrets. Different, dependable. Catalog free. S. Thaxly Co., Washington, D. C.

**AGENTS**—\$100.00 weekly, selling tailored caps. Commissions daily. Sample outfit to those selected. We deliver and collect. Kramer-Phillips Co., 453-A Monon Bldg., Chicago.

**MEN**—"Start a varnish polish business." Automobile, piano owners demand "Povar." Send 10c postage for free bottle. Demonstrate its merit and get year-around repeat business. Big profits, \$5 free advertising in your local paper. Povar Corp., 530 W. 58th, New York.

**100% PROFIT** each 50c sale. Staple tool indispensable to drivers. Sell to owners and chauffeurs. Profitable territory for workers. Easily earn \$50 weekly. Perkins, 113 Leonard Street, New York.

**AGENTS** make 100% profit selling Fibre Brooms, Push Brooms, Scrub Brooms, Mops, Dusters. Free Sample. National Fibre Broom Co., St. Louis, Mo.

**AGENTS**—Our Gold-eyed Needle Cases are wonderful sellers; immense profits; \$50 to \$200 weekly; write for proof and particulars. Buy from factory at wholesale. Paty Needle Co. (102), Somerville, Mass.

**RAINCOAT** Agents. Get Our Prices. Sell made-to-measure raincoats. We deliver and collect. Outfit free. World Raincoat Co., 639 Morris Park Ave., New York.

**TAILORING** Salesmen: Make \$75 a week selling our strictly All-Wool Made-to-Measure Suits and Overcoats, all at one amazing low price. You collect profits in advance and keep them. We supply finest selling outfit in America. Tailoring, raincoat and side-line men, part or full time, get in touch with us immediately. Goodwear Chicago, Inc., Dept. 502, Chicago.

**EASIEST** Seller on Earth. Senior Knife and Scissor Sharpener. Sells like Wildfire upon a minute's demonstration. 150 to 350 percent profit. Sample 25c. Particulars free. A trial will convince you. Senior Mfg. Co., 605 Commonwealth Bldg., Pittsburgh, Pa.

(1) **RUB** Metal Polish Chamols Cloth. Retail \$30c—Costs 10c. Cleans, Polishes Silverware, Brass, all Metals. Nu-Life (A) Metal, Hartford, Conn.

**SOLEBROWN**—New, different, wonderful six months' wear shoosole. Anyone applies quick. Lifelong repeater. Unusual commission. Exclusive territory. Guaranteed pair, 50c. H-M Company, Kent, O.

**SELL** wall and auto emblems, and town plates. Every lodge member and auto owner buys. Big money—all or spare time. Free sample and cash bonus plan. Kler Emblem Co., PM 7, 440 Como Bldg., Chicago.

**WHY** work for others? Make and sell your own goods. We show you how. Enormous profits. Write quick for free book explaining everything. National Scientific Laboratories, 211 North Monroe, Richmond, Va.

**MAKE** money silvering mirrors, all kinds plating, knives, spoons, auto headlights. Outfits furnished. Free booklet. International Laboratories, Dept. 25, 311 Fifth Avenue, New York.

**AGENTS** Earn \$50 to \$100 a Week selling flag holder for Auto running board. Every owner wants one. Retail for 75c—Costs \$4 per dozen for flag and holder; you make \$5 per dozen. Exclusive territory. Decoration Day and July 4th big selling days. Send 50c for sample and particulars. M. P. Lamoureux, Commerce Station, Minneapolis, Minn.

**\$100 MADE** in one week by young man in small town without capital or experience in local advertising business. Why can't you do likewise? Free book tells how. S. Meyer, 211 Seventh St., Louisville, Ky.

**IF** you need good live agents—fellows who can get the business—ask me how others are doing it. I'll gladly render the necessary assistance. Geo. F. Baker, Mgr. Classified Advertising, Popular Mechanics Magazine, Chicago.

**AGENTS:** World's greatest Necessity Specialties. Agents made \$90 a week. Valuable samples free with first mail. Ro-d-ex Co., 70-B, Council Bluffs, Ia.

**START** your own business as our sole agent, selling 100 famous home products. All or spare time. Dr. Hair Laboratories, Dept. 524, Lynchburg, Va.

**AGENTS**—If you have formerly sold felt caps, write for our new proposition concerning new goods. It's a winner. Newark Felt Rug Company, 50-C Bergen Street, Newark, N. J.

**AGENTS**—\$1.25 Profit on every sale of Niteo Service Set. Needed in every home and building. Get particulars quick. A. A. Silber-Chamberlin Company, Clayton, N. J.

**MYSTIC** Writing Pad. Send 25c for sample. Agents wanted. H. C. Simmons, 6520 N. Fairfield, Chicago, Ill.

**AGENTS** Sell Harper's Household Cleaning Set. Washes and dries windows, sponges, scrubs, chrome walls, hangs paper, sweeps, etc. Complete 8-ct sets for less than \$3. Over 100% profit. Can start without a cent. Harper Brush Works, 111 A St., Fairfield, Ia.

**EARN** big money easily with our casting Toy and Novelty forms, making Whistling Birds, Wild Animals, Crowing Roosters, Automobiles, Baseball Players, Statues of Liberty, Indians, Toy Soldiers, Cowboys, Barking Dogs, Wag-Tail Pups, Miniature castings of Capitol, Bathing Girl, Souvenirs and others. No experience necessary. We furnish you with Bronze casting Forms and necessary outfit from \$3.50 up. We buy large quantities of finished goods at highest prices. Spot cash. Send for catalogue and information free. The Improved Metal Casting Co., 342 East 145th Street, New York.

**\$100 TO \$300** a week. Men with slight knowledge of motors who can reach car owners can earn \$200 weekly without making single sale. If they can also make sales, profits may reach \$25,000 yearly. Only proposition of its kind ever offered. A. E. Phillips, 228 West 29th St., New York.

**AGENTS** sell Laundry Tablets under your own name and brand. Free samples and circulars furnished with every order. Particulars free; sample, fifteen cents. Write today. Krebs A Products, College Point, N. Y.

**PORTRAIT** agents earn big money selling our Photo medallions, Photo medallion clocks, Religious medallions, Photo pocket mirrors, Photo buttons, Photo jewelry, and Fraternal Photo medallions. Send for free catalogue. Satisfaction guaranteed. Four-day service. Address Gilson Photo Jewelry Co., Apartment 7, 698 Grandview Ave., Brooklyn, N. Y.

**WHY** work for others? Make and sell your own goods. We show you how. Enormous profits. Write quick for free book explaining everything. National Scientific Laboratories, 211 North Monroe, Richmond, Va.

**ICELESS** Refrigerators: How to make, how to sell them, and how to finance your business. Details from Sensible System, 1983 O'Farrell St., San Francisco, Calif.

**ROBERT** Wrench is a sensation in wrenches. It surprises everybody. Grasps pipes, nuts and bolts any size without adjusting. Over 30,000 sold. You make almost 100 per cent profit. If you call on stores, shops, garages, factories or homes, write us today for full particulars about "The Wrench With The Bull Dog Grip." Robert Wrench Co., 71 Murray St., New York.

**EVERYBODY** uses extracts. Sell Duo Double Strength Extracts. Complete line household necessities. Big repeaters. Write today. Duo Co., Dept. E1, Attica, N. Y.

**RUSSIAN**, German, Austrian money. Sensational street sellers! Wonderful sales-boosting premiums for anybody who sells anything! Hirschhorn, 847 Huntspoint Ave., New York. (Cheapest prices.)

**\$25.00 PROFIT** on \$1.50 Outfit; Gold Initials for Automobiles, Bags, etc.; Free Samples. National Monogram Co., Station D, Brooklyn, N. Y.

**\$8.00 TO \$20.00** per day. A wonderful seller. Any man, woman, boy or girl can make big wages Selling Crimp Grip Clothes Line Fasteners. It is a perfect rope holder and can be used for many purposes. Crimp Grips are a simple, time-saving device. They last a life time and will not rust; it holds the line tight, and saves time on wash days. Every buyer is a booster. Send for Mounted Sample and one pair of Crimp Grip Clothes Line Fasteners. Write for particulars. Crimp Grip Company, Belvidere, Ill.

**PICTURE** Man Friedman is giving away free \$2.00 samples and valuable book on canvasing. Prints, Portraits, Frames. Picture Man Friedman, Dept. 8-H, 673 Madison, Chicago.

**WANT** Distributing Agents everywhere for Hanslick, the new original powdered hand soap. Removes grease, grime, ink, paint, and most anything from the hands without injury to the skin. Every mechanic and auto-owner, everybodily who gets his hands dirty will be a customer. A great opportunity for a hustler to get in business for himself. Full information free. Send 10 cents, coin or stamps, for liberal sample can. Solar Products Company, 122 West Lake Street, Chicago.

**LARGE** Shirt Manufacturer wants Agents to sell complete line of shirts direct to wearer. Exclusive patterns. Big values. Free samples. Address Madison Mills, 503 Broadway, New York.

**AGENTS**—Send for sample "Fretnot"—the washday wonder. Be convinced you can do a whirlwind business. You can clear at least \$20 to \$100 weekly, according to spare or whole time. You don't have to talk; if she doesn't buy at sight, leave sample; she will be looking for you long before you are able to make the rounds again. Samples furnished free. Premiums for your customers. Exclusive territory guaranteed to agents who can produce. Credits given. Don't call. P. M. Motter & Sons, 20 E. Jackson Blvd., Chicago.

**AGENTS**—Best seller; Jem Rubber Repair for tires and tubes; supersedes vulcanization at saving of over 800 per cent; put it on cold, vulcanizes itself in two minutes, and is guaranteed to last the life of the tire or tube. Sells to every auto owner and accessory dealer. For particulars how to make big money and free sample, address Amazon Rubber Co., Amazon Bldg., Philadelphia, Pa., Dept. 505.

**AUTO** owner tire agent wanted each locality to use and take orders for handmade Mellinger fabric and cord tires; guaranteed bond 8,000 and 12,000 miles (no seconds); shipped prepaid on approval; set your tires free; no capital or experience required; make \$100 to \$200 weekly. Write for wholesale prices and sample kit. Address, Mellinger Tire Co., Dept. 100, Kansas City, Mo.

**AT** Last—World's Greatest Adding Machine. Almost human. Retail \$15; work equals \$200 machine. \$500 monthly easily made, demonstrating to stores, offices, garages, factories. Simple, easy; adds, subtracts, multiplies, divides automatically. Speedy, accurate, durable, handsome. Five year guarantee. Tremendous demand; amazing profits. Liberal trial offer. Protected territory. Write quick. Lightning Calculator Corp., Dept. F, Grand Rapids, Mich.

**GREATEST** Sensation! Eleven piece toilet article set selling like blazes at \$1.75, with \$1.00 dressmakers' shears free to each customer. Spring rush on. Foster Reid Co., 58 Winslow Bldg., Station C, Chicago.

**ONLY** One Policy Daily Means \$139 per Month Profit. Same on renewals. Policy pays \$5,000 death; \$25 weekly benefit for injury or sickness. Men and women both acceptable. Premium \$10 yearly. Full or spare time. Easy seller. Write quick for territory. Underwriters, Dept. R.L., 106 Market St., Newark, N. J.

**\$75.00 WEEKLY** with new specialty. Sells on sight to auto owners and trade. One man in Columbus, Ohio, sold 55 gross in 60 days, 100 to 200% profit on small investment. Write today for wonder-selling plan and information. C. L. Winegar, Dept. 13, West-Fort Ann, N. Y.

**500% PROFIT** selling Genuine Gold Leaf sign letters. Guaranteed never to fade. Easily applied. Experience unnecessary. Wonderful future. Free Samples. Guaranteed Sign Service, 363 W. Superior, Chicago.

**WANTED**—Tailoring Sales Agent—Make big money from very start—\$60.00 to \$75.00 weekly. Largest made-to-measure tailoring house, furnishing an equipment of five hundred woolsens, wants you to take orders. Satisfaction guaranteed. Biggest merchants in many towns have started with our line. If you want to establish yourself permanently in business and make big money write for full particulars, giving your experience as salesman or tailor's sales agent. H. P. Foster, Sales Manager, Lock Box 483, Chicago.

**DI'STLESS** Spangle Cloth. New Invention. Retail \$1.50—Costs (16c). (1) Rub Clean, Polishes Automobiles, Pianos, Furniture. NoLife (A) Sponge, Hartford, Conn.

**WHY** work for others? Make and sell your own goods. We show you how. Enormous profits. Write quick for free book explaining everything. National Scientific Laboratories, 211 North Monroe, Richmond, Va.

**AGENTS**—At last! Special machinery enables us to sell our patented curtain rods at the old price of Three Cents each. Big Spring sellers. Write Home Curtain Rod Co., Providence, R. I.

**EARN** big money fast applying gold initials to autos. Every owner buys—\$1.35 profit on \$1.50 sale—particulars and samples free. Write quick. Lithogram Co., Dept. 17, East Orange, N. J.

**\$75-\$150 WEEKLY** assured if you hustle. Sell attractive gold signs to stores, offices. Unlimited demand. Experience unnecessary. Free samples. Acme Letter Co., 363 W. Superior, Chicago.

**REX** India Fibre Broom; One of the biggest sellers on market. Outlasts five ordinary brooms—price no higher. 100% profit. Rex Fibre Products Company, 145-C New Jersey Ave., Brooklyn, New York.

**BIG** Money and Fast Sales. Every owner buys Gold Initials for his auto. You earn \$1.50; make \$1.35. Ten orders a day easy. Write for particulars and free samples. American Monogram Co., Dept. 40, East Orange, N. J.

**OUR** Ex-Cel Luminous Crucifix "shines brilliantly in the dark." Sells on first demonstration. Big profits. W. G. Hanson Co., Dept. B, 57 E. 18th St., Chicago.

**LIVE** Agents make \$10 Day selling Eureka Strainer and Splash Preventer for every water faucet. Takes on sight. Widely advertised and known. Get details today. A. B. Seed Filter Company, 73 Franklin, New York.

**PATENTS**—Write for our free illustrated guide book and Evidence of Conception Blank. Send sketch or model for our opinion of its patentable nature free. Highest references. Prompt attention. Reasonable terms. Victor J. Evans & Co., 163 Ninth, Washington, D. C.

**"\$10 A DAY** and More." our new book, shows clearly how you may gain sure success and large profits selling Guaranteed Hosiery and Underwear, factory to family. It is Free. Write today. C. & D. Company, 41-E, Grand Rapids, Mich.

**LIVE** man to distribute for great "Foot Ointment," hand or mail. Odor sells it. Splendid opportunity. Write now. The Elder Co., 294 Parkdale, Buffalo, N. Y.

**AGENTS**—\$3 per hour and more! Sell Iron Board Covers, Rubber Aprons, Shopping Bags, Embroidered Aprons, Satin Coverall Dresses. Free Sample offer! American Braiding Company, Dept. P, 329 W. Monroe, Chicago.

**MAKE** \$25 to \$50 Week representing Clow's Famous Philadelphia Hosiery, direct from mill—for men, women, children. Every pair guaranteed. Prices that win. Free book "How to Start" tells the story. George Clow Company, Desk 31, Philadelphia, Pa.

**AGENTS**—Genuine Gold Letters anyone can put on Store Windows. Guaranteed to not tarnish. Large profits. Enormous demand. Free samples. Write today. Genuine Gold Letter Co., 429-A North Clark, Chicago.

**YOU** can be your own boss with our Key-Check outfit. Good for \$5 a day stamping names on pocket key checks, fobs, etc. Sample check with your name and address, 20 cents. Pease Die Works, Dept. M, Winchester, N. H.

**AGENTS**—Big Money Monogramming by Transfer Method. Catalog Showing Over 50 Styles and Particulars Free. Motorists' Accessories Co., Mansfield, Ohio.

**AGENTS!** A sale in every home for our beautiful dress goods, silks and general yard goods. Quick sales! Big profits! Large book of nearly 1000 handsome fabric samples furnished to agents. Write today. National Importing & Mfg. Co., Dept. 6X, 573 Broadway, New York, N. Y.

**MAN** in each town to plate auto parts, reflectors, bathroom fixtures, refinish beds, mirrors, chandeliers; by new method. No capital or experience required. Simple plan of manufacturing at home starts you in big money-making business. Outfit furnished. Free particulars and proofs. Gun Metal Co., Atc. H., Decatur, Ill.

**AGENTS**—New discovery makes all Jelly "Jell." Big profits, constant repeater. Sample free. Address, Joy-Jel Company, 865 Grand, St. Joseph, Mo.

**AGENTS**—Stamping names on Pocket Key Protectors; sample Check with your name and address, 25c. Stamping outfits, Emblem Checks, Check Folds, Name Plates. Hart Mfg. Co., Desk 2, 303 Dugraw St., Brooklyn, N. Y.

**OUR Agents** make \$12 to \$20 every day and are getting it with new invention that sells to everybody. Low Price. Pocket sample. Write Edward Suren Company, 25 N. Dearborn St., Chicago.

**AGENTS:** Big profits, best and cheapest window letters made. Easily applied. Dime brings five samples. Particulars free. Stalbritt Co., 1115 Second Ave., New York.

**POLMET** Polishing Cloth cleans all metals; retails 25c; sample free. Gale & Co., Inc., 15 Edinboro St., Boston.

**SELL** Necessities. Everybody needs and buys the "Business Guide." Brilliant cleared \$800.00 in July. Send for sample. It's free. Nichols Co., Box 4-B, Naperville, Ill.

**AGENTS**—N-R-G Laundry Tablets, the old reliable moneymaker for live agents. Millions sold—used in many homes—sales waiting for you. Clothes washed spotlessly clean in 10 minutes without rubbing. Free samples. N-R-G Company, 732-A N. Franklin, Chicago.

**AGENTS:** Big Returns, fast office sellers; particulars and samples free. One Dip Pen Co., 2 Daily Record, Baltimore, Md.

**AGENTS** make \$10 daily—Big line guaranteed extracts, food products, perfumes, toilet goods, household necessities. No capital or experience needed. Free sample and instructions. Write for amazing offer. Perkins Products Co., Desk 6, Hastings, Neb.

**\$100 WEEKLY.** Agents, Crew Managers. Absolutely new article selling big to housewives. No capital required. Commissions paid in advance. No collections. No delivery. Exclusive territory. Write quick. Pioneer Corp., 6501 Yale Ave., Chicago, Ill.

**WHY** work for others? Make and sell your own goods. We show you how. Enormous profits. Write quick for free book explaining everything. National Scientific Laboratories, 211 North Monroe, Richmond, Va.

**AGENTS**—Clever Invention! Inkspoon makes every pen a fountain pen. Fast office seller; big profit, demand increasing everywhere. Exclusive territory offered. Sample free. H. Maral Company, Tribune Bldg., New York, N. Y.

**\$50-\$150 A WEEK.** Free Samples Gold Window Letters Easily Applied. Liberal Offer to general agents. Enormous demand. Metallic Letter Co., 438 N. Clark St., Chicago.

**SENSATIONAL** new vest pocket cigar lighter. Retail \$1.00 Triple plated, fastens to watch chain. Agent's sample and particulars, 60c. C. Thomas, 5236 Harrison, Chicago.

**AGENTS** make 500% profit handling Auto Monograms, New Pictures, Window Letters, Transfer, Flags; Novelty Signs. Catalog Free. Write Hinton Co., Star City, Ind.

**AGENTS,** control territory. Ediol Flavors, household necessities, perfumes, creams, toilet waters, famous "Eding's Herb Tablets." Jet Pharmaceutical Co., Allentown, Pa.

**GET** Our Free Sample Case—Toilet articles, perfumes and specialties. Wonderfully profitable. La Derma Co., Dept. A, St. Louis, Mo.

**AGENTS**—Good salary and commission selling "Ratskyl." new rat and mouse exterminator; ready for use; no bait required; non-poisonous; rodents die outside premises; no odor. Empire Specialties Co., 1549 N. Wells, Dept. 301, Chicago, Ill.

**AGENTS**—Sell Neverfall Iron Rust and Stain Remover. Huge profits. Big line. Sample. Write today. Sanford Road Co., Inc., Newark, N. Y., Dept. 6.

**FORDS** use kerosene and start instantly with new Super Carburetor. Seward's profit, one day, \$74.90. Write quick. 1306 Super, 1304 Fondulac, Milwaukee, Wis.

**AGENTS**—Crew men, novelty men. Gloop-Pen, a 50c mouchage fountain pen; everybody buys on demonstration. Write for big profit plan. Gloop-Pen Co., 75 (FF) Front St., New York.

**CABBAGE** Cutter, 5 knives, slices 20 vegetables, finer than aluminum; never dulls. 20,000 users Cincinnati alone; endorsed by Good Housekeeping Institute. Sample 48c. Meyer Cutter Co., Orland Ave., Cincinnati, Ohio.

**\$75-\$150 WEEKLY** assured if you hustle. Sell attractive gold signs to stores, offices. Unlimited demand. Experience unnecessary. Free Samples. Acme Letter Co., 363 W. Superior, Chicago.

**WANTED**—Representatives to sell Automobile necessity. Kills headlight and sun glare. Write for sample, Dept. P, The Clark Products Co., Springfield, Ohio.

**PORTRAIT** Agents—If you are looking for a better grade of work, we can satisfy you. Our enlargements have that finished appearance together with perfect likeness, which makes it a pleasure to deliver, and best of all our prices are not high. Export work a specialty. W. G. Hannan Co., Dept. A-5, 57 E. 18th St., Chicago.

**AGENTS:** Big profits. Genuine Gold Leaf Window Letters anyone can put up. Scripts and 57 varieties. Chicago Agency Co., 842 Alameda St., Chicago.

**PORTRAIT** Agents and Others. Get Big Profits. Sell Perry Photo Medallions. You charge \$2.98; make 400% profit, \$10 daily easy. Big exclusive line. 4-day service. Perry Photo Novelty Corporation, Section 16, 360 Bowery, New York.

**WE** start You Without a Dollar. Soaps, Extracts, Perfumes, Toilet Goods. Experience unnecessary. Carnation Co., Dept. 261, St. Louis.

**AGENTS** make a dollar an hour. Sell Mendets, a patent patch for instantly mending leaks in all utensils. Sample package free. Collette Mfg. Co., Dept. 404-B, Amsterdam, N. Y.

**AGENTS**—Clean up \$100 Weekly With "Nifty Nine." Weekly average, 100 sales—dollar profit each. 30-40 sales daily frequently made; demonstrating outfit cinches order. 30 other coin-coaxers, all daily necessities. Postal brings our unique plans. Dada Products Co., Dept. 568, Chicago.

**FIFTY "Ideal" Sidelines** for Mail Dealers and Agents. 500% profit. K. Home, 1937 Warren, Chicago.

**AGENTS**—Sell Patented Cigar Lighters and Cigar-Case Moisteners. Big Profits. Start making money at once. Write for circulars, cuts and sales plan. Drake Mfg. Co., Dept. M, Milwaukee, Wis.

**FOUR** \$7.50 sales to merchants net you \$20.00 daily; largest manufacturer of its kind in the World. Sayers Systems, 2815 Sheffield, Chicago.

**BIG,** quick profits taking orders for Swish. Clears clogged pipes; dissolves wood, rags, paper, hair; saves plumber—enormous field, great demand, fast returns. Sensational money maker. Get liberal offer now. Whitehouse Products Co., 426 S. Clinton St., Chicago.

**SELLS** Like Lightning; Big Money; New Ironing Wax Pad and Asbestos Rest; Clamps Board; Perfumes Clothes; Outfit 10c. Oder-Gloss, 380 Atlantic Ave., Brooklyn, N. Y.

#### HIGH-GRADE SALESMEN WANTED

**SALESMEN,** Sell State Pocket maps, showing auto roads, to advertisers and dealers. Easy to sell. Get our splendid offer. Standard Map Company, 127 West Ohio Street, Chicago.

**WANTED**—Salesmen for article bought by everyone selling cigars. Vest pocket sample. Quick seller. Costs you \$1.25 dozen. Sells \$2.00 dozen. Some dealers buy several gross. Dependable Sales Organization, Dallas, Texas.

**WE** teach Salesmen everywhere to sell high-grade "Peerless" Autowarning Signals and accessories to Jobbers and Dealers. We carry accounts. Commissions paid promptly. "Peerless" Products Co., Hobbs Bldg., Newark, N. J.

**SALESMEN**—High-grade Salesmen, Manufacturers' agents, business men, to sell Schick All-Steel Fire-proof Paper Balers to stores, factories, schools, office buildings, printers, public buildings and to anyone who has waste paper accumulating. Wastepaper prices going sky-high. Opportunity to earn big commissions. Full time and side line men wanted. Write Dept. 24, Davenport Manufacturing Company, Inc., Davenport, Iowa.

**MEN** who travel medium size and small towns regularly can add \$50 to \$150 weekly to their income with the famous K & S. line of salesboard assortments. Look up our rating in Dun's or ask your banker. Salesboard experience preferred, but not required. Write for complete information. K & S. Sales Co., Dept. 260, 4325 E. Ravenswood Ave., Chicago.

**SALESMEN**—Give German Money as a premium or sell it as a side line. Write for list 25. George Grigoletti, 20 E. Jackson, Chicago.

**IF** you can sell, you can make from \$75 to \$150 a week taking orders for our guaranteed all-wool tailored-to-measure suits all at one amazing low price. Tailoring experience not necessary. We teach you and supply you with finest selling outfit. We do all delivering. You just write orders and get your pay, cash with order. When you write, state experience and give references. Address Dept. 563, Goodwear Chicago, Inc., Chicago.

**SIDELINE** Salesmen Wanted; sell coal to your trade in carload lots. Earn week's pay in an hour. Washington Coal Co., Stock Yards Station, Dept. J, Chicago.

**DISTRICT** Managers: Are you making 250% on your sales? If not, get our proposition. High-grade line of Household Necessities. Write for territory and full particulars. Midwest Drug Co., 185 East Nagle St., Columbus, Ohio.

**SALESMEN**—New Ford accessory Henry overlocked. Each dozen sold represents \$2.00 cash commission. Write quick. Dollar pocket sample outfit, returnable. Universal Products Company, Memphis, Tenn.

**SPECIALTY** salesmen wanted, covering territory all over U. S. for best selling mechanical pencil and exclusive novelties. Bevoe Novelty Company, 4427 Kinzie St., Chicago, Ill.

**IF** you want \$6,000 the first year, write me. Strong line for retail stores. Nationally advertised; liberal weekly advance to producers. Geo. R. Williams, Mgr., 1920 Euclid, Cleveland, Ohio, Dept. 290.

**SALESMEN:** Secure exclusive protected territory, high class, permanent business, worth \$10,000 yearly. Only small capital needed; no risk. Address Box 1336, New Haven, Conn.

**SO** Can You! Cota sold 400 one city. Beadle nine—town nine stores. Merchants need "Zim's Peerless" (Collection System). Retail \$7.50. Creditor's Association, E-312 McKnight Bldg., Minneapolis, Minn.

**CALIFORNIA** Rosebuds selling like hot cakes. Agents coining money. Absolutely new. Big profits. Catalog free. Misonon Factory 8P, 519 No. Halsted, Chicago, Ill.

**SALESMEN**—Carry the most complete line of advertising pencils and penholders. Commissions paid promptly. Monogram Pencil Co., 1251 Fourth Ave., Cedar Rapids, Iowa.

**WANTED**—Live Salesmen to sell merchants established film advertising service. Real moneymaker. Give age, references, experience. Peerless Films, 772 Ninth, Des Moines, Iowa.

**DISTRICT** Salesmanagers—Hostery, mail to consumer; \$1.50 deposit. No charge backs. We deliver. No capital required. Write Prienti Silk Co., Station B, Cleveland, Ohio.

**SALESMEN** with auto—sell rebuilt spark plugs, commission \$75.00 weekly. Kelly Lamp Works, Oak Park, Ill.

**HOLD-TITE** Hat holders—sell on sight to car owners at 50c. Distributors, Side-line and Specialty salesmen wanted. Fits all model automobiles, holds any hat. Millions being sold. Nothing like it. Outline your territory. Kulek-Matson Co., One, Kansas City, Mo.

**\$4.00 PROFIT** on Every \$5.00 Sale. "Free Sample."—New Specialty. (Money Getter.) Every Storekeeper, Doctor, buys quickly. Experience unnecessary. Territories open. Drawer 596, Hartford, Conn.

**A WONDERFUL Seller!** Any man, woman, boy or girl can make big wages. Some agents make from \$8.00 to \$20.00 per day. Crimp Grip Clothes Line Fasteners are a simple, time-saving device for holding a rope—also used for many other purposes. It pays for itself quickly in time saved on wash days. No knots—it fastens and releases quickly. Every home a prospect. Every housewife who uses Crimp Grips and there are thousands of them—is a hustler. There is but one Crimp Grip. Write for particulars, or send 50c for one pair and a mounted sample, with full particulars to agents, Crimp Grip Company, Belvidere, Ill.

**BEST Seller:** Jem Rubber Repair for tires and tubes; supercedes vulcanization at saving of over 50%; put it on cold, vulcanizes itself in two minutes, guaranteed to last life of tire or tube; sells to every auto owner and accessory dealer. Get particulars how to make big money and free sample. Amazon Rubber Co., Philadelphia, Pa., Dept. 510.

**TRAVELING Salesmen** calling on retail stores wanted by large manufacturer to sell wonderful line of business-boosting articles. Year round, fast selling, main or side line. If not earning \$150 weekly, address Elbasser Works, 222 Charles St., Beaverville, N. Y.

**SALESMEN—Become Independent.** Own your business; experience unnecessary; selling our \$7,500 Accidental Death, \$50 Accident, \$25 Sick Weekly Benefits; \$12.50 yearly; other amounts proportionate. Guaranteed steady income from renewals. \$250,000 deposited Insurance Department. Registration Dept. A, Newark, N. J.

**WERE You Ever Offered a Grocery Store?** Our Proposition is Better. You can handle Sugar, Flour, Canned Goods, Dried Fruit, Coffee and entire line of Groceries, as well as Paints, Roofing, and Automobile Oils, with no rent to pay; no money invested; take large orders from samples. Goods are guaranteed and proven quality. Selling experience not necessary. Steady, profitable work for "workers." Address Hitchcock-Bill Co., Dept. 200, Chicago, Ill. Reference: Any Bank or Express Co.

**EASY to sell Groceries, Paints, Automobile Oils, Roofing, Stock Food** to consumers from samples, no capital or experience necessary; steady, profitable work. Commissions advanced. Satisfaction guaranteed. 50 years in business. Write for full particulars, Lovrin & Browne Co., Wholesale Grocers, 1775 S. State Street, Chicago, Ill.

**SIGN Letter Agents and Painters:** 500% Profit Gold and Silver Sign Letters for Stores and Office Windows. Anyone can put on. Big demand. Free samples. Metallic Letter Co., 431D N. Clark St., Chicago.

**SALESMEN** Can make \$5.00 a day selling our Calendars, Pencils, Signs, Advertising Novelties, Yardsticks, Whistles, etc. Liberal terms. Sells entire year. Plus side line. Local and traveling agencies. Model Calendar Co., Dept. 228, South Bend, Ind.

**SALESMEN—Side-line** pays five to ten dollars a day taking orders for Specially printed gummed advertising and Match Box Stickers. Write for proposition, samples, etc., today. Beardsley's Printery, Rock Island, Ill.

**TAILORING Salesmen—Fastest selling line, suits, made to measure—\$29.50—one price, all wool. Profits in advance. Biggest old reliable house. W. D. Smith Co., established 1895, Dept. 11, Chicago.**

**SPECIALTY Salesmen,** if you are convinced that it is "Good Business" to have a fire extinguisher in the home or car when a fire starts, you can sell others. Arrange with us for exclusive territory at a very good income. McMillen Fire Extinguisher Co., 4504 DuSable St., Detroit, Mich.

**\$5 PROFIT** selling \$7.50 necessity. Write for sample, Merchants Ass'n, Minneapolis, Minn.

**SPECIALTY Salesmen or State Distributors** for Auto replacement part. Sells to all leading dealers. Big repeats. Act quick. Good proposition. Keystone Sales Co., Pacific Bldg., San Francisco, Calif.

#### HELP WANTED

**WANTED—Railway Postal Clerks.** \$1,600 year. List positions obtainable—free. Franklin Institute, Dept. T-21, Rochester, N. Y.

**BE a Finger Print Expert.** Demand increasing. Write for special free offer. American Finger Print System, 1966 Broadway, New York.

**WANTED by U. S. Government—Railway Postal Clerks.** Men—boys, 18 to 35. Steady work. Commence \$132 month. Quick raise to \$192 month. Travel—see the country. Life position. Paid vacation. Experience unnecessary. Common education sufficient. List positions obtainable and schedule places—free. Write immediately. Franklin Institute, Dept. 73, Rochester, N. Y.

**FIREMEN, Brakemen, Baggage-men, Sleeping car, train porters (colored).** \$140-\$200. Experience unnecessary. 810 Railway Bureau, E. St. Louis, Ill.

**SALESMEN:** We pay larger commissions than any other Brush House in the country to men selling our line of Sanitary twisted-in wire brushes. Sanitary Wire Grip Brush Co., 15-17 Mercer St., New York.

**ALL men, women, boys, girls, 17 to 60, willing to accept Government Positions.** \$117-\$190, traveling or stationary. Write Mr. Orment, 101 St. Louis, Mo., immediately.

**GOVERNMENT Railway Mail Clerks** start \$133 month; expenses paid. Specimen questions free. Columbus Institute, Dept. E-2, Columbus, Ohio.

**YOUNG Men** over twenty-one, for service work on adding machines. Two years high school or equivalent necessary. Dalton Adding Machine Company, Cincinnati, O.

**WANTED—Railway Postal Clerks.** Commence \$1,600 year. Men 18 to 35. Examinations everywhere coming soon. Specimen questions—free. Write immediately. Franklin Institute, Dept. T-21, Rochester, N. Y.

**RELIABLE Men and Young Men** Wanted Everywhere to distribute free samples and almanacs, etc. No selling or soliciting. No experience or capital needed. Permanent business opportunity at big pay. Do not fail to write us at once for contracts and details. American Advertising Association, File AA-1, 4930 North Clark St., Chicago, Ill.

**SILVERING Mirrors, French plate.** Easily learned; immense profits. Plans free. Address, Wear Mirror Works, Excelsior Springs, Mo.

**EARN \$10 daily silvering mirrors, plating and refinishing metalware, autos, chandeliers, bedsteads, headlamps.** Outfits furnished. E. Decie Laboratories, 1133 Broadway, New York.

**\$5 TO \$15 Daily Easy—Introducing New Style Guaranteed Hosiery.** Must wear or replaced free. No capital or experience required. Just show samples, write orders. We deliver and collect. Your pay in advance. Elegant outfit furnished, all colors and grades, including silks. Mac-O-Chee Mills Co., Desk 2607, Cincinnati, Ohio.

**GET posted—Good prices paid for butterflies, insects.** See Sinclair display advertisement, page 22.

**SALESMEN, Part Time:** No interference with your present occupation. Your income trebled selling Accident and Sickness Protection to everybody. No examinations. No red tape. Experience unnecessary. Costs \$10.00 yearly. Big renewals. Write quick. United Department, Newark, N. J.

**RAILWAY Postal Clerks Wanted.** \$1,600-\$2,300. Examinations everywhere coming soon. List places—free. Franklin Institute, Dept. T-21, Rochester, N. Y.

**LOCOMOTIVE Firemen** for railroads nearest their homes—everywhere: beginners \$150-\$250 monthly. Address Railway Association, Desk M-1, Brooklyn, N. Y.

**START Silvering Mirrors, Headlamps, Tableware.** Replate stores, jewelry. Plans Free. Clarence Sprinkle, Dept. 28, Marion, Ind.

**AGENTS, Distributors,** capable of organizing sales force, make from \$3,000 to \$10,000 yearly; the best and fastest selling automobile accessory on the market; sells 4 to 8 at a time. Write for particulars, Continental Co., 912 7th Ave., New York City.

**GOVERNMENT positions.** \$1,400-\$2,300 yearly. Many openings. 36-page information booklet free. Chicago Civil Service College, A-41, Kessler Building, Chicago.

**WRITE articles, stories, news,** in spare time for newspapers and magazines. Big pay. Copyright book free. Press Syndicate, 533, St. Louis, Mo.

**OUR genuine gold window sign letters** are an excellent money-making proposition for handy men. Slann Sign System, Botham Ave., E., Detroit, Mich.

**LARGE corporation** wants a Service Man in every town to paste up its signs on store-keepers' windows. Excellent opportunity for reliable party. Steady work. No experience necessary. We also have attractive proposition for agents and salesmen. Guarantee Sign Service, 361 W. Superior, Chicago.

**EARN \$110 to \$250 monthly,** expenses paid, as Railway Traffic Inspector. Position guaranteed after 3 months' spare time study or money refunded. Excellent opportunities. Write for Free Booklet CM-46, Standard Business Training Inst., Buffalo, N. Y.

**\$35 WEEK.** Boys—Men, Become Automobile experts. Learn while earning. Write Franklin Institute, Dept. T-40L, Rochester, N. Y.

**INVENTORS** desiring to secure patents should write for our book "How to Get Your Patent," tells our terms and methods. Send sketch for our opinion of its patentable nature. Randolph & Co., Patent Attorneys, 620 F. Washington, D. C.

**SIGN Letter Agents and Painters:** 500% Profit. Gold and Silver Sign Letters for Stores and Offices, Windows. Anyone can put on. Big demand. Free Samples. Metallic Letter Co., 431-D N. Clark St., Chicago.

**WANTED: Railway Mail Clerks—\$1,600 to \$2,300.** Exams everywhere. Write today for full information. Patterson, Civil Service Expert, Box 4025, Rochester, N. Y.

**STORIES, poems, plays, etc.,** are wanted for publication. Good ideas bring big money. Submit manuscripts or write Literary Bureau, 522, Hannibal, Mo.

**HOTELS** Need Trained Men. Nationwide demand for high-salaried men; past experience unnecessary. We train you by mail and put you in touch with big opportunities. Big pay, fine living, interesting work, quick advancement; permanent. Write for Free Book, "Your Big Opportunity," Lewis Hotel Training Schools, Room 351, Washington, D. C.

**YOU Are Wanted, U. S. Government Jobs.** \$117-\$192 month. Many positions. Write immediately for list. Franklin Institute, Dept. T-21, Rochester, N. Y.

**BE a Finger Print Expert—Opportunities** opening everywhere. Write National System, 186 East 79th, New York.

#### ART AND ADVERTISING

**3,000 COLORS—Mixing Guide** (gives proportions), return mail \$1.00, (Pine Arts, 1125 West 27th, Indianapolis, Ind.

#### INFORMATION

**COMPLETE, accurate, information** on any subject \$1. National Information Bureau, 1429 Milton St., S. E., Grand Rapids, Mich.

**"MEXICO":** Reliable, expert and accurate information furnished about conditions and opportunities here. We have nothing to sell. Toltec International Service Co., Calle Lopez, No. 20, Mexico, D. F.

#### TYPEWRITERS AND SUPPLIES

**ALL Standard Makes, \$10 up.** Fully Guaranteed. Free trial. Write for illustrated lists, Northwestern Typewriter Exchange, 320 W. Goethe St., Chicago.

**ALL Makes, reconstructed, rebuilt** and guaranteed ten years. Remington, Monarch, Oliver, Underwood, others, \$15.00 up; thirty days' free trial allowed. Get our prices and agents' proposition before you purchase. Typewriter Manufacturers Exchange, 2316 University Ave., New York City.

**UNDERWOOD Typewriters** at far less than manufacturers' price; rebuilt, all worn parts replaced, guaranteed good as new. Cash, installment payments. Write for Catalog R-151, Shipman-Ward Mfg. Co., estab. 1892, Montrose and Ravenswood Ave., Chicago, Ill.

**BLACK Ribbons 33c.** Olivers, Underwoods, etc. Typewriter Supply, 7927-29 Cifax Ave., Chicago.

**TYPEWRITERS, All Makes.** Save one-half. Thoroughly Rebuilt in our factory by the famous "Young Process." Fully guaranteed. Free trial. We handle all standard makes. Cash or sold on easy terms. Write for Catalog, Young Typewriter Co., Dept. 502, Chicago, Ill.

**BARGAINS** in unredeemed good as new typewriters, all styles. Save you half or more. Write for list, Empire Loan Bank, 649 No. Clark St., Chicago.

### ADDING MACHINES

NEW \$3.50 Automatic Adding Machine. Adds, Subtracts, Multiplies. Absolutely accurate. Capacity \$999,999.99. Fully guaranteed. 75,000 pleased users. Makes adding easy, positive, quick. Eliminates mistakes. Saves time. Postpaid. \$3.50. Bassett Co., 1458-U Hollywood Ave., Chicago.

FREE Trial. Marvelous new Adding Machine. Adds, Subtracts, Multiplies, Divides, automatically. Work equals \$250.00 machine. Price only \$15.00. Speedy, durable, handsome. Five-year guarantee. Used by largest corporations. Write today for catalogue and free trial offer. Lightning Calculator Co., Dept. E, Grand Rapids, Mich.

### DUPLICATORS AND DEVICES

YOU can make 50 to 100 copies of a letter, notice, etc., at a cost of three cents on a Hoyer Quality Duplicator. Write for free trial offer. The Hoyer Duplicator Co., 14 S. Wells St., Chicago, Ill.

STENCIL Duplicator—Two Dollars; Note Size—Letter, Three-fifty. Prints Typewriting—Handwriting. On Approval. Primus Specialty Co., M-3, Primus, Pa.

"MODERN" Duplicators save Time, Labor, and Money. Gets Business. Reproduces Typewritten or Panned Letters, Drawings, Lessons, Music, Menus, Bills, Notices, Specifications, Maps or anything in one or more colors. Prints Two per minute. Special Sale On 30 Days' Free Trial. \$2.25 up. Booklet Free. J. E. Durkin-Reeves Co., Pittsburgh, Pa.

### BUSINESS SERVICE

HAVE a Chicago Office. For outside business, we will receive your mail, list your name in Chicago phone directory and receive your representative when in town. Giblea Letter Service, 218 S. Wabash Ave., Chicago.

COMPANIES Organized: Financed. Write, Harrison Bond—Mortgage, 32 Union Square, New York.

MANUSCRIPTS typed quickly and accurately. 500 per thousand words. One carbon copy. Dorothy Frey, Sidney, Ohio.

INCORPORATE. Our lawyers do the work, saving you time, annoyance and money in incorporating under the most liberal laws of Arizona. Laws and forms free. Southwestern Securities & Investment Co., Box D488, Phoenix, Ariz.

### PRINTING, ENGRAVING AND MULTIGRAPHING

"STAY-PUT" Gummed Labels. Business Stationery, Advertising Novelties, at Bargain Prices. Free catalogue. Erb Publishing Company, Vineland, N. J., Dept. A.

ALL Printing Prices Smashed. 5,000 Letterheads or Envelopes \$13.85. Samples. Quality Printshop, Marietta, Ohio.

250 LETTERHEADS, 250 white envelopes, printed and mailed, \$3.00. Samples printing free. Sunco, Mohawk, N. Y.

500 BOND Letterheads \$1.85 postpaid. Samples free. Grant Printery, 1713 12th, Detroit.

MULTIGRAPHING. Complete Mailing Service. Prices and Samples Furnished Upon Application. Giblea Letter Service, 218 S. Wabash Ave., Chicago.

QUALITY Printing Guaranteed. 150—8½x11 Hammermill Bond Letterheads and 150—6½ Envelopes \$2.00. Postpaid. Samples. Race Printing Company, Hudson, N. Y.

ATTRACTIVE Printing: 1,000 Letterheads or envelopes \$3.50. "Quality Printer." 120 Hamilton Ave., Trenton, N. J.

PRINTING! Advertising experts. Samples. Franklin Press, B-32, Milford, N. H.

1,000 HAMMERMILL Letterheads, Envelopes \$4.00 postpaid; 10,000 for \$30.00. Best printing. We do contract work. Free samples. Chicago Commercial Printing Co., 1218 S. Racine, Chicago.

LETTERHEADS, Envelopes, 1,000 postpaid, \$3.00, cash. Anything printed. Journal Printery, Tallapoosa, Ga.

500 BOND Letterheads—500 Envelopes—\$5.00. Stationery Specialists, Sentinel, Hurleyville, N. Y.

PRINTING Outfits—Presses, type supplies, type novelties. Send stamp for catalogue. Model Press, York, Penna.

ONE Hundred each Letterheads; Envelopes; \$1.50. Jacobus Service, Irrelington, N. J.

WE print anything. Stationery. Catalogs. 1,000 small 4-page Circulars, \$5.00. Samples Hammermill Cabinets, Commercial Press, Batavia, Ohio.

QUALITY Printing! Reasonable Prices! Tell us your wants and let us quote our Money-Saving prices. Best Work. We print anything. Ernest Fantus, 525 South Dearborn Street, Chicago.

1,000 LETTERHEADS, Envelopes or Statements \$3.50. Samples free. Johnson & Sharp, Bayfield, Wis.

PRE-USED Printing Presses, Type and supplies. List for stamp. Popular Bargains, Richland, Pa.

1,000 LETTERHEADS or Envelopes, \$3.00. Sent Prepaid. Samples Free. Monitor Press, Morrisville, Pa.

225 BOND letterheads, envelopes, billheads, cards, \$1.25 each. Combination, \$4.00. Economic Press, Leonia, N. J.

### FOR MEN

ARE You Old at Forty? See our advertisement on page 140 of this issue. The Electro Thermal Company, 2123 Main Street, Steubenville, Ohio.

### FOR SMOKERS

BUY Your Cigars Direct. Fifty hand made pre-paid \$1.50. Agents wanted. Havana Smokehouse, Homeland, Ga.

PURE Leaf Tobacco. Rich Red Color. Best Chewing, 4 lbs. \$1.35. 10 lbs., \$3.35. Smoking, 10 lbs. \$2.25. Prepaid. O. D. Collier, Martin, Tenn. ("Collier is reliable.")—Martin Bank.

ENJOY Life. Smoke Old Field Tobacco. Sample 10c. Hast Mailing Co., Paducah, Ky.

### RAZORS AND BLADES

BLADES resharpened 15c dozen. Agents wanted. Roseto Honery, Roseto, Pa.

BLADES, resharpened, one edge 2c; double 3c. New York Edge Co., Glen Cove, N. Y.

### BOATS AND LAUNCHES

ROWBOATS—easily made. Blueprint list free. Weesho-Uco, West Market, Detroit, Mich.

"HOW to make your boat leakproof." Send for booklet. L. W. Ferdinand & Co., 152 Kneeland St., Boston, Mass.

### FOR THE HOME

MAKE Inexpensive Iceless Refrigerator. Blueprint 35c. William Quenore, Camden, N. J.

GRANDFATHER Clock works, \$5.00. Build your own case; instructions free; make good profits selling your friends. Clock works with chimes for old or new cases. Write for full particulars. Clock Co., Ruffner St., Philadelphia.

### OPTICAL GOODS

BAUSCH-LOMB Microscope. Triple objectives, including oil immersion. Guaranteed like new, \$60.00. Send for complete description and photograph. Sackheim, 649 N. Clark St., Chicago.

### CANDY

CANDY—Very choicest. 1½ lbs. for \$1, postpaid. Superb hand-dipped chocolates; a pleasing variety of nuts, fruits, nougats, caramels, etc. So good your friends will ask where you got them. Aunt Mary's Chocolate Co., M-310 West Superior St., Chicago.

### ANTIQUES AND WAR RELICS

RELICS Collected from Europe's Battlefields. Medals, firearms, helmets, etc. Illustrated catalogue and sample War Photographs 25c. Lieut. Welsh, 2117 Regent Pl., Brooklyn, N. Y.

INDIAN Baskets, Blankets, Wampum. Mats. Wholesale. Catalogue. Gilham, Keiserville, Calif.

### PHONOGRAPHS AND RECORDS

BUILD your own phonographs. We can supply you with motors, tone arms and all accessories at wholesale prices. Write for catalogue AX. Pleasing Sound Phonograph Co., 204 East 113th St., New York, N. Y.

FOR Best Phonograph Parts Write to American Phonograph Co., 3515 North Crawford, Chicago.

DON'T hunt! Mark your records with gummed stickers. Keep them in place. 25c set files 156. Box 424, Fort Wayne, Ind.

100,000 NEW 10" 75c records 15c each. List free. Beck, Sta. B, Nashville.

BUILD Your Phonograph. Quality phonographs. Quality Sereznado motor and motors of other types. Electric Motors, tonearms, reproducers, amplifiers, case material, accessories. Free blueprints and building instructions. Big saving. Wonderful results. Prompt delivery. Catalog mailed for ten cents. Hoosier Manufacturing & Supply Co., 313 Baldwin Block, Indianapolis, Ind.

### MUSIC AND MUSICAL INSTRUMENTS

FOR Sale—Slide Trombone. Key of C, rotary change to B flat. Never used. R. P. Conrad, Williamstown, Ky.

CORNETISTS—Trumpetists—Saxophonists—Clarinetists. Send for "Free Pointers No. 2." Name instrument. Virtuoso School, Buffalo, N. Y.

EXCHANGE your old player rolls and records, for new 88 note \$1.00 word rolls. Send for plan. Standard Music Exchange, 30 E. Randolph St., Chicago, Ill.

CAN furnish anything in good as new unredemmed musical instruments. Save you half or more. No list published. Write stating what you want. Empire Loan Bank, 649 No. Clark St., Chicago.

VIOLINS—Deep, Mellow, Soulful—on credit. Easy terms for wonderful instrument. Get details today. Gustaf F. Hennings, 2424 Gaylord St., Denver, Colo.

WRITE Songs. Big money and reputation. Write for information. J. Gordon Pub. Co., 291 N. Hoyle Ave., Chicago.

"MUSIC Composed" to words. Bauer Bros. (formerly of Sousa's Band), Oshkosh, Wis.

I WANT song poems. Casper Nathan, Garrick Theatre Building, Chicago.

### PATENT ATTORNEYS

PATENTS—Before disclosing an invention the inventor should write for our blank form "Record of Invention." This should be signed, witnessed and returned to us together with model or sketch and description of the invention and we will give our opinion as to its patentable nature free. Our Three Books mailed free to inventors. Our Illustrated Guide Book, "How to Obtain a Patent," contains full instructions regarding patents. "List of Patent Buyers" sent free, contains unsolicited letters from manufacturers and others who are constantly writing us regarding the purchase or leasing of meritorious patents. We have recently received a number of requests, among which are the following: 45 requests for Miscellaneous Articles in all classes of invention, too numerous to mention. 14 requests for Household Novelties and Specialties. 11 requests for General Novelties and Mail Order Articles. 6 requests for Automobile Accessories and Specialties. 3 requests for Small Metal Articles and Metal Specialties. 2 requests for Radio Accessories and Equipment. 1 request for Amusement Apparatus. 1 request for Refrigerators. 1 request for Tractors and Similar Machines. 1 request for Farming Supplies. 1 request for Games. 1 request for Toys. We endeavor to assist our clients in the commercial development of their inventions. Owing to the growth of our business we have established for the benefit of our clients, Branch Offices in New York City at 1007 Woolworth Bldg., Philadelphia at 714 Liberty Bldg., Pittsburgh, Pa., at 514 Empire Bldg., Chicago, Ill., at 1114 Tacoma Bldg., and San Francisco, Calif., at 1010 Hobart Bldg. Victor J. Evans & Co. Main Offices, 146 Ninth, Washington, D. C.

PATENTS secured. Prompt service. Avoid dangerous delays. Send for our "Record of Invention" form and Free Book telling How to obtain a Patent. Send sketch or model for examination. Preliminary advice without charge. Highest Reference. Write today. Jacob & Jacob, 408 Ouray Bldg., Washington, D. C.

**PATENTS, Trademarks, Copyrights** procured; all countries; very reasonable; 20 years' experience; booklet free. H. Sanders, Registered Patent Attorney, 7 Rand McNally Building, Chicago.

**INVENTORS:** Send sketch or model of invention for opinion concerning patentable nature and exact cost of patent. Book "How to Obtain a Patent," sent free. Tells what every inventor should know. Established twenty-eight years. Highest references, prompt service, reasonable charges. Address Chandlee & Chandler, 438 Seventh, Washington, D. C.

**PATENTS, trade marks, copyrights.** Prompt, personal, reliable service. Over 30 years' active practice. Write for terms. Book free. Address E. G. Siggers, N. U. Bldg., 918 F St., Washington, D. C.

**PATENTS Procured; Trade Marks Registered**—A comprehensive, experienced, prompt service for the protection and development of your ideas. Preliminary advice gladly furnished without charge. Booklet of information and form for disclosing idea free on request. Richard B. Owen, 30 Owen Bldg., Washington, D. C., or 2276-R Woolworth Bldg., New York.

**MONROE MILLER, Ourray Building, Washington, D. C.,** patent attorney, mechanical and electrical expert. Best quality of work and results. Moderate charges.

**PATENT** application filed on partial payment plan. Trade-marks, copyrights, etc. Milo B. Stevens & Co., 685 F St., Washington; 352 Monadnock Bldg., Chicago, Estab. 1864.

**PATENTS and Trade-marks** obtained. Prompt service. Write for our new book on patents. Established in 1889. D. Swift & Co., 369 7th St., Washington, D. C.

**INVENTORS**—Send for form "Evidence of Conception," to be signed and witnessed. Form, fee schedule, information free. Lancaster and Allwine, 221 Ourray Bldg., Washington, D. C.

To proceed properly and safely, send sketch and description for personal advice in your particular case and estimate of costs. H. P. Lowenstein, Registered Patent Attorney, McLachlen Building, Washington, D. C.

**INVENTORS:** Record invention legally before disclosing to others. Our Invention Record and Data Sheet shows how. Sent free and valuable information given on patent procedure, costs, etc. Report on patentability includes copies of patents nearest your idea. O'Connell & O'Connell, Jenifer Building, Washington, D. C.

**PATENTS**—Booklet and full instructions without obligation. B. P. Fishburne, Registered Patent Lawyer, 331 McGill Bldg., Washington, D. C.

**MILLIONS** spent annually for ideas! Hundreds now wanted! Patent yours and profit! Write today for free books—tell how to protect yourself, how to invent, ideas wanted, how we help you sell, etc. American Industries, Inc., 500 Kresge Bldg., Washington, D. C.

**CASH** your Unpatented Invention Safely. Ask Sterling Book, Washington, D. C.

**PATENTS** Procured. Send sketch or model today for examination, prompt report and advice. No charge for preliminary advice. Write for free Booklet and blank form on which to disclose your idea. Highest references. Promptness assured. Clarence A. O'Brien, Registered Patent Lawyer, 561 Southern Building, Washington, D. C.

**EDWARD C. SANNETT**, formerly a Principal Examiner U. S. Patent Office, Personal Service, 516 McGill Bldg., Washington, D. C.

**LACEY Patent Sense.** See page 144.

**INVENTORS** should write us for our book, "How to Obtain a Patent," which clearly sets forth what may be patented and the necessary steps to protect an invention; it describes the procedure in patent office and tells about assignments, licenses and trade marks, and gives many useful facts about patents which every inventor should know; many persons well versed in patent matters have pronounced the book the best of its kind they have ever read; it is written so you can understand it; copy free upon request. Talbert & Talbert, Patent Lawyers, 481 McGill Bldg., Washington, D. C.

**PATENTING** and commercializing inventions explained by Lester E. Barnett, Master Patent Law, Drawer 829, Washington, D. C.

**PATENTS** promptly procured. Personal, careful and efficient service. Highest references. Moderate fees. Send sketch for model or actual search and advice. George P. Kimmel, Master of Patent Law, 54-J, Loan and Trust Bldg., Washington, D. C.

**PATENTS.** Booklet free. Highest references. Best results. Promptness assured. Send model or drawing for preliminary examination. Watson E. Coleman, Patent Lawyer, 624 F Street, Washington, D. C.

**"INVENTORS' Guide"** free on request; gives valuable information and advice for all who have original ideas or improvements. Frank Ledermann, Registered Attorney and Engineer, 15-P Park Row, New York.

**BEFORE** or after filing application for patent on your invention it will pay you to read over my "Inventor's Adviser No. 3," free for asking. M. Labiner, Registered Patent Attorney, 3 Park Row, New York.

**PATENTS.** My fees in installments. Advice book free. Frank Fuller, Washington, D. C.

**BOOK** on inventions, patents, trade-marks, sent free, advice given; excellent references. Twenty-three years' experience. Robb, Robb & Hill, 1345 Hanna Bldg., Cleveland, Ohio, 811 McLachlen Bldg., Washington, D. C.

#### FOR INVENTORS

**PATENTS** secured. Prompt service. Avoid dangerous delays. Send for our "Record of Invention" form and Free Book telling how to obtain a Patent. Send sketch or model for examination. Preliminary advice without charge. Highest Reference. Write today. Jacobi & Jacobi, 469 Ourray Bldg., Washington, D. C.

**INVENTORS!** Write Patent Office for free copy of "Information Concerning Patents." Send me sketch for preliminary search and advice. Low fees. Ralph Burch, Patent Lawyer, Jenifer Bldg., Washington.

**I SELL** Patents; Cullen & Verrier, Box 18, New Baltimore, Mich., placed their patent covering Evaporated Milk Can Holder, with me to sell or lease. I have placed it with the Apex Tool & Stamping Co., 4850 Southern Parkway, Louisville, Ky. Have you a patent to sell? Charles A. Scott, 773-PM Garson Avenue, Rochester, N. Y.

**IF** you have a practical, useful invention to sell, write us today. Patent number sufficient unless unpatented. American Patents Corporation, Barrister Building, Washington, D. C.

**UNPATENTED** ideas can be sold. I tell you how and help you make the sale. Particulars free. Write W. T. Greene, 166 The Atlantic, Washington, D. C.

**PROTECTIVE** Evidence and Full particulars, free. Sterling Book, Washington, D. C.

**PATENTS** Procured. Send sketch or model today for examination, prompt report and advice. No charge for preliminary advice. Write for free Booklet and blank form on which to disclose your idea. Highest references. Promptness assured. Clarence A. O'Brien, Registered Patent Lawyer, 561 Southern Building, Washington, D. C.

**PATENTS** Procured. Send sketch or model today for examination, prompt report and advice. No charge for preliminary advice. Write for free Booklet and blank form on which to disclose your idea. Highest references. Promptness assured. Clarence A. O'Brien, Registered Patent Lawyer, 562 Southern Building, Washington, D. C.

**PATENTS** Procured: Trade Marks Registered—A comprehensive, experienced, prompt service for the protection and development of your ideas. Preliminary advice gladly furnished without charge. Booklet of information and form for disclosing idea free on request. Richard B. Owen, 30 Owen Bldg., Washington, D. C., or 2276-R Woolworth Bldg., New York.

**PATENTS** sold for cash or royalty; quick action. Blanchet & Co., 347 5th Ave., New York.

**PATENT** Sense—"The book the inventor needs." Free. See Lacey ad, page 144.

**PATENTS** wanted; buy outright or distribute. Western Distributors, DeSoto, Iowa.

**WILL** buy good patent. What have you? Gordon, 111 N. Seventh Street, St. Louis, Missouri.

**PATENTS**—"How to Obtain a Patent" is the name of a book which every inventor should have. It will be sent free upon request, and will tell you what you want to know about patents. It contains the whole story. It describes the different parts of the application and explains in simple language the prosecution before the Patent Office. It tells about joint applications, reissues, agreements, assignments, licenses, interference, infringements, process patents, design patents, trade-marks, and prints and labels. If you are interested in patents either as an inventor, manufacturer or owner of a patent you will enjoy reading this book which was written by a lawyer who has had twenty-five years' experience in patent matters. If you have an invention and will send us a sketch, model or photograph of it we will promptly make a search of the Patent Office records and advise you whether or not, in our opinion, your invention is patentable, our charge for this service being \$5.00. We feel that our experience of twenty-five years has fitted us to render prompt and efficient service which will merit your confidence. Write today. Talbert & Talbert, 464 McGill Building, Washington, D. C.

**INVENTORS' Educator;** 900 Mechanical Movements, 50 Perpetual Motions. How to procure and sell patents. Mechanical Movements greatly assist inventors, suggest new ideas. Explains how to select an attorney and avoid Patent Sharks. Price \$1.50. Postage Free. Albert E. Dieterich, 621 Ourray Building, Washington, D. C.

**PATENTS.** If you have an invention which you wish to patent you can write fully and freely to Munn & Co. for advice in regard to the best way of obtaining protection. Please send sketches or a model of your invention and a description of the device, explaining its operation. All communications are strictly confidential. Our vast practice, extending over a period of seventy-seven years, enables us in many cases to advise in regard to patentability without expense to the client. Our Handbook on Patents is sent free on request. This explains our methods, terms, etc., in regard to Patents, Trade Marks, Foreign Patents, etc. "Scientific American" contains Patent Office Notes. Decisions of interest to inventors and particulars of recently patented inventions. Munn & Co., Solicitors of Patents, 623 Woolworth Bldg., New York; Scientific American Bldg., Washington, D. C.; 801A Tower Bldg., Chicago, Ill.; Hotel Bldg., San Francisco, Calif.

**GET** your own patents. Application blanks, complete instructions \$1. Cutting Sons, Campbell, Cal.

**INVENTORS**—Send your ideas for manufacturing development in our modern sheet metal and angle iron fabricating plant. Liberal payment for accepted inventions. Klitz & Blum Manufacturing Co., 2851 Spring Grove Ave., Cincinnati, O.

**INVENTORS,** write for free copy of Mod-craft, R. G. Clynne, St. Louis, Mo.

**PATENTS.** Write for free illustrated guide book. Send model or sketch and description for free opinion of its patentable nature. Highest references. Prompt attention. Reasonable terms. Victor J. Evans & Co., 157 Ninth, Washington, D. C.

**HAVE** you an invention? If so, write for our free book, "How to Get Your Patent," tells our terms and methods. Send model or sketch for our opinion of its patentable nature. Randolph & Co., Dept. 144, Washington, D. C.

**"INVENTORS' Guide"** free on request; gives valuable information and advice for all inventors. Frank Ledermann, Registered Attorney and Engineer, 15-P Park Row, New York.

**INVENTORS**—Prosecute your own patent applications under our supervision. Instructions and blanks \$1.00. Inventors Co-operative Ass'n. Station "B," Box 2115, San Francisco, Calif.

**INVENTORS:** Patents sold, leased, promoted; experienced handling; immediate action. Address Arthur S. Billings, 401 Dekum Bldg., Portland, Ore.

#### PATENTS FOR SALE

**MANUFACTURERS** wishing to make Plastering Machine, Motor drive. Address, Leo Lacle, Sandusky, N. Y.

**FOR** Sale, new automobile wheel. Permits clamping or loosening rim by one adjustable nut. Patent pending. Circulate on request. Henry G. Peterson, Rt. 2, Box 64, Chicago City, Minn.

**NIGHT Latch Knobs**, converts ordinary door lock into a Night Latch by replacing with Patented Knobs, No. 1,447,754. Murrie Wax Company, Sheboygan, Wis.

**UNIQUE milk bottle opener**. Manufactured cheaply. Cash or Royalty. Geo. M. Stafford, 4510 N. 15th St., Philadelphia, Pa.

**YOU** have a worth-while patent, haven't you? Why don't you tell our two million readers about it? Most of them are specially interested in patents and new inventions. Ask me to tell you how other inventors successfully sold their patents. Geo. F. Baker, Manager, Classified Advertising, Popular Mechanics Magazine, Chicago, Ill.

**HEAT Concentrator and Preheating Device for Blow Torch**. Cash or Royalty. B. L. Parham, General Delivery, Indianapolis, Ind.

**PARLOR game**, 1,450,874; offers solicited; sample set if interested. "Strombos," San Bernardino, Calif.

**PATENTED Ornamental, Illuminated Radiator Cap**—application for displaying Advertisements, Business Briefs, Fraternal Emblems, etc. Safety feature connected. Outright or royalty. For complete details, address Glen Bowen, 547 W. Broadway, Whittier, Calif.

**ENTIRELY new stenographer's and printer's copy-holder**. Every typewriter owner and printer a prospect. Cash or Royalty. E. W. Curtis, Selby, Calif.

**FOR Sale**—Automobile Window Lifter, A. Sawicki, 5430 St. Antin, Detroit, Mich.

**COMBINATION Ignition Lock**, fits any car; thief proof. No. 1,424,298. Marvin Gifford, Newaygo, Mich.

**PATENT on pea hullers** for sale that possesses four decided features over all others. Copy of patent on request. Safety singletree hooks for sale. Avery Tow, Waltham, S. C.

**MY Inventions**, Patented and Pending: Automatic dispensers of Mustard, Catsup, Soft Soap, Shaving, Facial and Dental Creams, Talcum Powder. Each easily controlled for owner's products. Periscope Auto Mirror, vision far ahead on sharp turns. Auto Extricator, uses sheet ropes speedily, cheaply, around tires. A. J. Fawcett, Glendale, Ore.

**FOR sale or royalty**—U. S. patent. (Canadian patent applied for.) Laundry Hanger. Every housewife wanted. Cheap to manufacture. Unlimited market. Write Investor, 2646 Trowbridge St., Hamtramck, Mich.

**PATENT Door Holder**; costs  $\frac{1}{2}$ ¢ to Mfg. and sells for 25¢. Marvin Gifford, Newaygo, Mich.

**ATTENTION!** Auto Accessory Mfg's: Patented "Automobile Side Chain Fastener," outright or royalty, and "Split Rim Tool," which will prove big money maker. I. L. Thiel, Derrick City, Pa.

**PATENT**, small, dry, can measure. Outright or royalty. Edw. Franco, Box 256, Racine, Wis.

**ABSOLUTE control Lever Latch**. Can be made the one standard form. Louis Schneider, Clinton, Mo.

**U. S. PATENT**. For sale or on royalty. Coin Sorting Machine. Cheap and efficient. W. L. Paul, Beaufort, N. C.

**TOY patent for sale**—Exceptional opportunity for someone who can handle same properly. H. Linder, 6319 Wayne Ave., Chicago.

**WILL sell patent on Fruit-Seeder**; satisfactory terms; device simple; seeds cherries, olives, damsons; pits pineapple. No waste or damage to fruit. Can be manufactured for 4 cts. or less; retails at 15 cts. or more. Mrs. H. C. Jones, 2523 Madison Ave., Baltimore, Md.

**SPARK-PLUG**. Cleans like a pipe; outright or royalty. Box 100, Worth, N. C.

#### SURVEYING INSTRUMENTS

**NEW** and used surveying instruments direct from factory. Satisfaction guaranteed or money refunded. Wissler, 619 Broadway, St. Louis.

#### MODELS AND MODEL SUPPLIES

**MODEL Boats and Power plants**: Boats ready to run. Hulls ready for power. Construction sets ready to put together, all fitting done. Steam and gasoline power plants, castings for engines, small spark plugs, coils, fittings of all kinds for model boats and engines. Send for catalog and circulars. Model Boat & Engine Co., 3446 Sheet St., New Orleans, La.

**DIES, Tools and General Manufacturing, Models, and Manufacturing of new Inventions** our specialty. Logan Machine Co., 222 S. Clinton St., Chicago, Ill.

**PATENTS** Procured. Send sketch or model today for examination, prompt report and advice. No charge for preliminary advice. Write for free Booklet and blank form on which to disclose your idea. Highest references. Promptness assured. Clarence A. O'Brien, Registered Patent Lawyer, 562 Southern Building, Washington, D. C.

**PUNCH** press and screw-machine work, tool and die making, model and special machine work wanted. Have doubled our manufacturing space and added machinery. Let our factory be your factory. Quality Hardware and Machine Co., Dept. A, 6150-56 N. Clark St., Chicago.

**WE** make working models for inventors and do experimental work and carry a complete stock of brass gears and model supplies. Send for catalogue. The Pierce Model Works, Tinley Park, Ill.

**BEFORE ordering your model** write for free copy of Modelcraft, R. G. Clyne Engineering Co., St. Louis, Mo.

**METALS**. Brass, bronze, copper, aluminum, German silver, zinc, iron and steel in rods, tubes, wire and sheets. No order too small. Jones Cut Metal Co., 58 Maspeth Ave., Maspeth, Long Island, N. Y.

**INVENTORS**—Write for our free illustrated guide book and Evidence of Conception Blank. Highest references. Prompt attention. Reasonable terms. Victor J. Evans & Co., 165 Ninth, Washington, D. C.

#### FOR MANUFACTURERS

**SPECIAL** labor saving machinery, Jigs and Fixtures and other production tools, Punches and Dies for all kinds of metal stampings, Gauges, manufacturing and machine work to order. Simplex Tool Company, Woonsocket, R. I.

**WANTED**—Metal Stamping and Model work taken on contract basis. We are ideally located and equipped to develop patents. Meyers Company, Box 326, Bedford, Ind.

**ROYALTY** Manufacturers, Distributors: Men's curved clip Hat-Comb. Sample 25¢. Fits behind leather band. Geo. T. Robinson, Calhoun, Ky.

#### MANUFACTURING

**LONG** established manufacturer of auto accessories which are daily sold by practically all wholesale and retail accessory houses will consider manufacturing and distributing new automobile products, capable of equally wide sale through same channels. Patented articles preferred. Address Auto Accessory Manufacturer, 1512 North American Bldg., Chicago, Ill.

**WE** design and build special machinery, make models, dies, stamping tools, do general machine work and light manufacturing. Marshall Mfg. Co., Kansas City, Mo.

**IRON**, Brass, Aluminum Castings. Models, Patterns. Light Manufacturing. Welch Brothers Co., North Chicago, Ill.

**WE** specialize on Dies, Stamping, Light Mfg. The Times Mfg., 419 Kimball St., Danville, Ill.

**PATTERNS**, wood and metal. Models, tools and dies. Brass, bronze, aluminum and iron castings. Screw machine work, production work of all kinds. Write Modern Machine & Pattern Co., Terre Haute, Ind.

**WE** manufacture Wood Turnings. Your inquiries solicited. Prices reasonable to responsible people. Large or small orders. Wood Specialty Co., Collins, Ohio.

**SPRINGS** made to order. Box of 20 Coil Springs for Autos Postpaid \$1.00. Wright Brok., 5616 Huron St., Chicago.

**PATENTED** Articles. Models. Brass Work, Machine Construction; Dies Made. Baum's Metal Specialties, Kansas City, Mo.

**If** you want dies and metal stamping write us. Lyons Machine Works, Lyons, Ia.

**WIRE** Goods, all kinds, made to order. Conley Mfg. Co., 524-530 N. Western Ave., Chicago.

**SCREWS**, nuts, screw machine products, all metals. Autoscrew Works, 355 West Broadway, New York City.

**WE** design and build special machinery. Send for free copy of Modelcraft, R. G. Clyne Engineering Co., St. Louis, Mo.

**SPECIAL** labor saving machinery, Jigs and Fixtures and other production tools, Punches and Dies for all kinds of metal stampings, Gauges, manufacturing and machine work to order. Simplex Tool Company, Woonsocket, R. I.

#### MACHINERY, TOOLS AND SUPPLIES

**FOR Sale**: Brand New Allen Model 43-4 Cyl. Motors,  $3\frac{1}{2}$ " bore, 5" stroke, with starter, generator and magneto. An ideal motor for Farm Work, Truck, Tractor, or Motor Boat. \$100.00 f. o. b. Chicago. Act at once. Auto Electric Sales & Service Company, 57 E. 26th St., Chicago, Ill.

**CONCRETE** Building Block Machines and Molds. Catalogue free. Concrete Machine Co., 303 South Third St., St. Louis, Mo.

**LIGHT** Power Transmission Machinery, Bearings, Hangers, Pullers, Reducing Gears. Send for Catalog. Winfield H. Smith, Buffalo, N. Y.

#### ELECTRICAL

**ELECTRICAL** Experimenters—Here is the book you have been waiting for—"How to Make Things Electrical." 256 articles, 427 pages, 353 illustrations. Price \$2.50 postpaid. Popular Mechanics Book Dept., 200 E. Ontario St., Chicago.

**TWO-LITE** sockets (black composition), per dozen \$3.50 postpaid. Kelly Lamp Works, Oak Park, Ill.

**LEARN** How to Wind D. C. Armatures. Engineering students will find in this book by W. E. Hennig a simplification of a difficult yet important subject. Mathematical and technical discussions have been avoided as far as possible. Contains all diagrams heretofore scattered in many books, 265 pp. Illustrated in colors. Cloth binding. Price \$3.50 postpaid. Popular Mechanics Book Dept., 200 E. Ontario St., Chicago.

**WHOLESALE** Prices Motors and Electrical supplies, including sockets, lamps, rosettes, switches, wire, conduit, chests, loom, porcelain goods. Illustrated Catalog free. Hyre Electric Co., 633-HR S. Dearborn St., Chicago.

**X-RAYS** Simply Explained. An excellent and practical book on radiography for only 25 cents postpaid. 93 pages. Illustrated. Paper covers. Popular Mechanics Book Dept., 200 E. Ontario St., Chicago.

#### ENGINES, MOTORS AND DYNAMOS

**ELECTRICITY** for 10¢ Per Hour. Motoco Auto Generator. Operates on any make automobile. Produces electricity for Moving Picture Machines, Theatres, Schools, Churches, Homes, Etc. Write for free particulars. Monarch Theatre Supply Co., Dept. AG, 724 South Wash Ave., Chicago.

**GOVERNORS** on used auto engines make good power plants. Circulars. Address Candace-Smith Governor Co., Springfield, N. Y.

**ALTERNATING** Current Motor Bargains. Reliable Makes only, including new  $\frac{1}{2}$  H. P.—\$13.00; new  $\frac{1}{4}$  H. P. General Electric \$19.00. Westinghouse, Crocker-Wheeler, Wagner, Emerson, Century motors, special prices. All guaranteed for one year. Buy now before prices advance. Motors repaired and exchanged. Hyre Electric Co., 633-PX South Dearborn St., Chicago.

**AUTOMOBILE** owners, garagemen, mechanics, send today for free copy America's most popular motor magazine. Contains helpful articles on overhauling, repairing, ignition, carburetors, batteries, etc. Automobile Digest, 507 Butler Bldg., Cincinnati.

#### FOR MECHANICS

**PATENTS**—Write for our free illustrated guide book and Evidence of Conception Blank. Send model or sketch and description of the invention for our opinion of its patentable nature free. Highest references. Prompt attention. Reasonable terms. Victor J. Evans & Co., 184 Ninth, Washington, D. C.

## FOR THE SHOP

**POPULAR Mechanics Shop Notes** are published annually in book form; price 50 cents postpaid. The latest volume containing all notes in the magazine during 1922 is ready. Better send \$1 today for the two latest issues and get acquainted with these wonderful aids in your work. Back volumes are in great demand and we can supply 15 of them at 50c each. Altogether they make an encyclopaedia of mechanical information that is priceless to the owner. Popular Mechanics Book Dept., 200 E. Ontario St., Chicago.

**BLUEPRINTS.** All subjects. List Free. Lasharis Bros., Union City, Pa.

## BLACKSMITHS

BE a tempering wizard. Secret method of tempering. Add life and strength to steel. All kinds of drills, springs, chisels, etc., toughened and tempered by this formula. Non-breakable, absolutely reliable. Never fails. You need it. \$1.00. The Cold Chisel King, 607 N. San Dimas Ave., San Dimas, Cal.

**BLACKSMITHS.** Listen: Any Handy man can make more money doing hard jobs easy. Forging and welding solid, with Toy's Modern Methods of Blacksmithing. Hardening and tempering to a standard with colored tempering charts. All for one dollar. Samples Free. W. M. Toy, Sidney, O.

**BLACKSMITHS, Plumbers, etc.** Here's what you have needed for years. Simple, Powerful, Inexpensive Universal Bending Machine. Bends Eres, U's, Angles, etc. Bends 1 1/2" standard Pipe cold. Also bends Automobile Spring Eres. Send for circular. Little Giant Bender Co., Lewiston, Minn.

## FOR SALE—MISCELLANEOUS

**ICE Cream Cone Confection** affords means of eating syrup, fruit, nuts with cone of cream. H. L. Hamilton, Gardon, Ark.

**BUY—Exchange—Sell** Many of our readers have for sale or exchange the article you are looking for—and lots of them are looking for the very items you want to turn into cash. Get together! Let our two million readers know your wishes—they'll help you! Send your ad today to Geo. F. Baker, Manager Classified Advertising, Popular Mechanics Magazine, Chicago.

**FOR Sale,** complete set of Watchmaker's Tools at a Bargain. R. Jaegermann, 5815 Easton Ave., St. Louis, Mo.

**GASOLINE Lamps and Lanterns,** Catalog Free. Little Wonder Light Co., Terre Haute, Ind.

## WANTED—MISCELLANEOUS

**CASH** for old gold, silver, platinum points, diamonds, false teeth, Liberty Bonds, unused stamps, and precious articles. Goods returned immediately if not satisfactory. Bush Products, 144 Fifth Ave., New York, N. Y.

**APPOINT** me your Agent for Burma. Novelties, Machines, anything. Dale 17, -51st Street, Bangoon, Burma.

**WE pay 2c each,** plus transportation charges, for old junk spark plugs, any make or condition. Kelly Lamp Works, Oak Park, Ill.

**MAIL** us your discarded Jewelry. Gold Coins and Bridges, Watches, Diamonds, Silver, Platinum, and Old False Teeth. Money promptly mailed. Goods returned if offer refused. United States Smelting Works (The Old Reliable), Dept. 71, Chicago.

## REAL ESTATE AND FARM LANDS

**ARKANSAS Land** \$10.00 per acre, in tracts five acres or more. Timbered land now in development. A sound investment with good speculative chances. Write for full details. H. J. McMullen, F. & M. Building, Fort Worth, Texas.

**LAND Opportunity!** 20, 40, 80 acres: in thriving city in lower Michigan; only \$10 to \$50 down; balance long time. Learn about this offer. Write for free illustrated booklet giving full information. Swartz Land Company, P-1259 First Nat'l Bank Bldg., Chicago.

**"THE Real Estate Educator,"** 208 pages of practical information for everybody who owns, sells, leases or controls real estate of any kind. \$2.00 postpaid. J. R. McGann, Dept. K, 1287 Pacific St., Brooklyn, N. Y. Descriptive folder free.

**FRUIT Farm** in Fruit Belt Columbia County; great opportunities. Lloyd Halbenbeck, Greendale-on-the-Hudson, N. Y.

**ATTENTION—"Get acquainted"** Cash for your property. Farm, Hotel or Retail Store, no matter where located; confidential service. Hayes' Business Agency, Cincinnati, Ohio.

**DO you want to buy property, Garage or Store?** Consult Hayes Business Agency, Cincinnati.

**PECAN-Orange Units, Easy terms.** Big returns. Write Dept. R, Suburban Orchards Co., Ocean Springs, Miss.

**FOR Sale—Three full sections** in McKenzie County and two sections in Billings County, North Dakota. Each section contains land suitable for crops, balance for cattle. Each section has valuable deposits of lignite which some day will alone be worth many times the present value of the land. This part of the state is developing very rapidly, with good schools within easy access. As owner cannot use this land himself, will sell one or more sections at a price which almost anyone can afford to pay. Address W., care Popular Mechanics, 200 East Ontario St., Chicago.

**SELL** your property quickly for cash, no matter where located. Don't pay big commissions. Particulars free. Real Estate Salesmen Co., Desk R., Lincoln, Neb.

**FARMS** wanted by cash buyers, various states. Describe, state lowest price. R. A. McNew, 312 Wilkinson Bldg., Omaha, Neb.

## DOGS

**FOR Sale—Coon, opossum, skunk, and squirrel dogs;** Fox, cat and rabbit hounds. Trial allowed. Catalog free. Mt. Yonah Farm Kennels, Cleveland, Ga.

**FOR Sale—Scottish Terriers;** good rat-terrs. German Shepherds. Police Dogs, puppies and grown stock. H. A. Zobel, Dyar, Ia.

**COLLIES** for Sale. Training Book 35c. Sunnybree Kennels, Bloomington, Ill.

**ENGLISH Toy Spaniel** puppies. Registered stock. Wonderful companions. Reasonable. Channon, Vineland, N. J.

**ARKANSAS Coon, Opossum, Skunk, Fox, Wolf, Deer, Cat, and Champion Rabbit hounds.** Raised and trained in best Game section of the Southwest. Coon hound pups in the Old-Fashioned Long-Eared Blackie, Redbone, Birdsong, and Black-and-Tans. Trained hounds shipped on trial. References in your State. Sixteen years a shipper. Henry Fort, Route One, Fort Smith, Ark.

**A FREE copy** descriptive booklet of world's largest dog kennels will be mailed on request listing for sale the famous Oorang Airedales specially trained as watch-dogs, farm dogs, stock drivers, automobile guards, companions and hunters on all kinds of game. Also choice breeding stock, puppy stock, kennel supplies, dog foods, dog medicines, etc. Satisfaction and safe delivery guaranteed. Oorang Kennels, Box No. 20, LaRue, Ohio.

**POLICE Pups—None better.** Prices \$65 up. Strongheart Kennels, Eastern Road, New Brunswick, N. J.

**GERMAN Police pups** from high-class stock bred by Champion Iwan vd. Mainkar. I. Jaidouski, 3831 Alder St., Indiana Harbor, Ind.

**COLLIES—Any color, any age;** world's largest breeders; kennels recommended by Albert Payson Terhune, judge and author. Send for free illustrated circular. Jefferson White Collie Kennels, Waucon, Ohio.

## POULTRY

**BABY Chick—11c each** postpaid to your door. White Leghorn and Brown Lechorn. Pure-bred heavy laying strains, 100% live arrival guaranteed. Order direct or send for catalogue. Royal Hatchery, R. 2, Box 10, Zeeland, Mich.

## PERSONAL

**YOUR** greatest asset is Personality. Add to your stock success tips and self-revealing chart 10c. Thomson-Heywood, Dept. PM, Chronicle Bldg., San Francisco, Cal.

**ARE you old at forty?** See our advertisement on page 140 of this issue. The Electro Thermal Company, 2123 Main St., Steubenville, Ohio.

**NEW Way To Keep Young** In Spite of Years. Get our startling Free Book, describing Safe, Scientific System for all men lacking Pop. Send for copy Today. The M. Applicator Company, 1527 King Bldg., Springfield, Ohio.

**FREE—Information** of a scientific nature that has brought happiness through perfect health to thousands. No charge; no obligation. Enclose stamp for reply. C. O. Wood & Co., 551 East 47th Street, Chicago, Ill.

**ARE you bashful, self-conscious, easily embarrassed?** These troubles overcome. Send dime for particulars. C. Veritas, 1460 Broadway, New York, N. Y.

**TOBACCO KILLS** Manly Vigor. Quit easily. Cigarettes, chewing, smoking, snuff conquered or no charge. Small sum if satisfactory. Stop craving; harmless. Full treatment on trial. Perkins Co., 34-A, Hastings, Neb.

**FREE—Stop using tobacco.** We will give free information how to conquer habit easily and permanently. Results guaranteed. Anti-Tobacco League, Box K, Omaha, Neb.

**TOBACCO or Snuff Habit, cured or no pay, \$1.00** if cured. Remedy sent on trial. Superba Co., TP, Baltimore, Md.

## MISCELLANEOUS

**LOCKSMITHS:** Send \$1.00 for valuable chart for cutting tumbler padlock keys. Globe System, 278 Washington St., Newark, N. J.

**CONCRETE Handbook, New,** for the Amateur. We have just published a book describing 173 ways of using concrete in the home, shop and on the farm, with full directions for doing these things yourself with ordinary tools. 138 illustrations. It is "written so you can understand it." Price 50 cents, postpaid. Popular Mechanics Book Dept., 200 E. Ontario St., Chicago.

**GET posted—Good prices** paid for butterflies, insects. See Sinclair display advertisement, page 22.

**ARE you old at forty?** See our advertisement on page 140 of this issue. The Electro Thermal Company, 2123 Main St., Steubenville, Ohio.

**ART Metal Workers—You will find** our book "Metal Work and Etching" a complete manual on making book ends, desk sets, pad corners, paper knives, letter openers, stationery racks, rocking blotters, desk calendars, arts and crafts jewelry, etc.; 96 pp. illus. Price 50 cents postpaid. Popular Mechanics Book Dept., 200 E. Ontario St., Chicago.

**INCORPORATION** in Arizona Completed in One Day. Any capitalization, least cost, greatest advantages. Transact business anywhere. Laws, by-laws and forms free. Stoddard Incorporating Co., Dept. 2, Phoenix, Arizona.

**ARTIFICIAL Eyes, \$3.** Booklet free. Denver Optic, 559 Barclay, Denver, Colo.

**CUTS** anybody can make. Simple, cheap process, \$1. Specimens, particulars, 20 stamp. M. Dax, Windfall, Ind.

**HOMEOPATHIC** and Biochemic preparations sent postpaid to all parts of the world. Manual and booklets free. Halsey Bros. Co., 111 N. Wabash Ave., Chicago, Illinois. Established 1855.

**STARTING a Company?** Save expenses and taxes by organizing on the popular, Common Law plan under a pure Declaration of Trust. No experience required to fill in Demaree Standard Forms, issue shares and begin doing business at once. Genuine Demaree Forms are nationally known, approved by attorneys and utilized by successful concerns throughout the United States. Send for large, free pamphlet (C-33) containing valuable information that you may need. C. S. Demaree, local blank publisher, 708 Walnut, Kansas City, Mo.





# Amazing *new* farm offer!

## OWN YOUR OWN FARM— FERTILE LANDS AT LOW COST—

Payments so small you will have a surplus for comfortable living

**T**HE Canadian Pacific Railway now offers you a Farm Home in Western Canada on a New Long-Term Plan of Easy Payment that is Extraordinary. Every farmer must be interested in any plan that makes it possible to own a farm home without taking all his profits to meet his land payments and still enable him to give his family the comforts and enjoyments of life. Under this New Plan this is made possible.

### Payments Extended Over 34 Years

Under this plan all you pay down is 7% of the purchase price, balance in 34 equal, annual payments figured on the basis of 7% of the balance of the cost of the land—which is the interest a bank would charge you for a loan. For example, if you purchase 160 acres costing \$3 000, your down-payment will be \$210 and your total payments each year thereafter, \$195.30. At the end of 34 years, you will get clear title to the land—unless, of course, you wish to pay sooner, which is your privilege.

#### Stop Paying a Penalty for the Privilege of Farming High-Priced Land

Whether you are a tenant, longing to own a farm home of your own, or a farm owner handicapped by the need of more land or capital, you are fighting with all the odds against you. The high-priced lands around you will forever hold you down—those fine producing acres are not going to be given up cheaply.

Without unusually high prices for your products you can't farm profitably on land bought at the price you'd have to pay. Farmers, in these circumstances, even though they make good profits, are no better off. The fences around you are the limits of your possible expansion. Turn now to the other picture—look to the virgin soil possibilities of Western Canada—vast open areas of prairie sod and park lands—lands that are yielding new wealth and happiness to real men, who not so long ago, may have been your unsatisfied, toiling neighbors.

**M. E. THORNTON** Superintendent  
of Colonization  
Room 43B, Canadian Pacific Railway Bldg.  
CALGARY, ALBERTA, CANADA

#### No Taxes on Improvements

Taxes are moderate and there are no taxes on your livestock, buildings, improvements, implements or personal effects. Good markets, modern schools, roads, churches, amusements make farm life in Western Canada desirable and attractive.

#### You Cannot Buy Until You Investigate

This offer justifies fullest investigation. You must see this land before you can buy it. In order that you may inspect the land—judge of its value and fertility—special inspection trips from points Chicago and West will leave on the first and third Tuesdays of each month. Single fare plus \$2.00 for the round trip. You have time now to go over this land. Let us arrange details. Canada's choice sections are becoming rapidly settled and we expect large numbers of far-seeing men to take advantage of this new plan.



#### —SEND THIS COUPON—

M. E. THORNTON, Supt. of Colonization  
Room 43B, Canadian Pacific Railway Bldg.,  
Calgary, Alberta, Canada

I am interested in learning more about:

- Prairie Provinces of Canada.  
 Irrigation Farming in Sunny Alberta.  
 Business & Industrial Opportunities in Western Canada.  
 Lloydminster & Battleford Districts.

My Name.....

Address.....

Town..... State.....

2381

Comd. H. A. Lumby, 2732 Prince St.  
Berkeley, Calif.

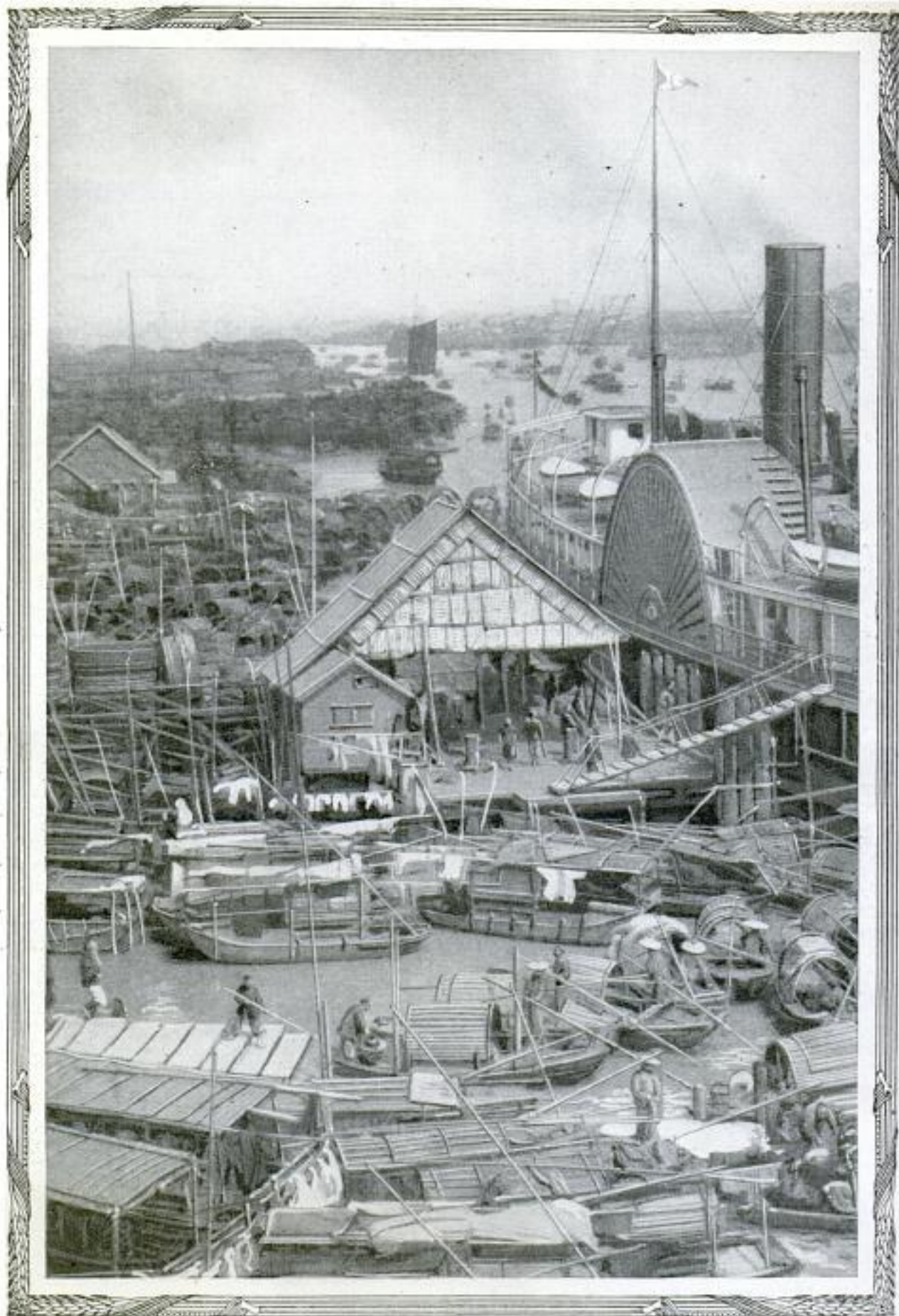

Looking Down the Pearl River into the Homes of Some 400,000 Persons Who Live Crowded Together in Boats at Canton, China. Surrounded by Age-Old Traditions

COPYRIGHT, UNDERWOOD & UNDERWOOD

(See page 18)

Cmt. L. W. Pedrose, 617 Pacific Bldg.  
Seattle Wash.

# Popular Mechanics Magazine

REGISTERED IN U. S. PATENT OFFICE

WRITTEN SO YOU CAN UNDERSTAND IT

Vol. 40

JULY, 1923

No. 1

2343

## Weird Rites Mark the Departure of Liners for Orient

**W**EIRD ceremonies, conducted by Chinese members of the crew, are one of the most interesting features of the departure of big ocean liners sailing out of Pacific-coast ports for the Orient. These observances have come down through thousands of years of tradition and are for the purpose of pleasing the good spirits of the sea and baffling the evil ones.

The "Wind God," according to the Chinese, follows a vessel and constantly attempts to swamp the ship, so this deity must be placated and the pursuit made as difficult as possible. The appetite of the Wind God is tempted with sacrifices of barbecued pork, fruits, and candies. And then thousands of firecrackers are set off—to frighten him. Huge white papers, traced with hand-drawn designs, are also offered up, to mislead the Wind God as to the route the ship will follow, the belief being that the stupid god will follow the lines and lose all trace of the ship, so that it will have a peaceful and untroubled voyage.

Next the spirit of "Good Luck," symbolized by a dragon, is invoked by means of a dance to the strains of music, while a dancer appears on deck with a huge papier-mâché dragon head. A Chinese bears the silken body of the dragon.

The music grows stronger and the dragon shakes with fury. Then the music becomes soft, the dragon becomes docile, and a head of lettuce is thrown in his path. The dragon takes it in his jaws and the ceremony is ended, the spirit of Good Luck having succumbed to the lure of the food offering.

When the liners touch at any port in China, the strange performances are continued, the members of the crew being joined by the other natives in their efforts to outwit the evil spirits and gain the favor of the good ones.

Because of these strange superstitions,

the very origin of which is lost in antiquity, navigation in Chinese waters presents many problems to the European mind. Even the speed of the ships must be cut down for fear of fatal accidents caused by the Chinese belief in the power of invisible pursuers.

A native fisherman, for instance, wakes up every morning convinced that nothing can be accomplished during the day until the evil spirits are thrown off his trail and that unless this is speedily accomplished they may even cause his death or serious injury. To do this he repeatedly risks his life.

One of the queer sights of China is a crowded junk risking to be cut down to cross the bow of an approaching steamer. Despite much profanity, many accidents and heavy loss of life, this practice continues because of the belief that, having passed in front of the larger boat, the evil spirits following the fishing craft will be deceived and pursue the steamer.

When the maneuver is successfully accomplished, the natives display the greatest joy, laughing at the wrath of steamer captains who have narrowly missed running down the junks, for they believe that they are then free to go about their business in peace for the day without any further thought for the evil spirits they have tricked.

The captain of one liner steaming up the coast to Hongkong, once noticed upon approaching a headland a wildly gesticulating figure, evidently signaling to some one below. Suddenly, as the liner approached, a large junk, its sails bellying out to the breeze and its rowers working frantically, dashed out.

Right across the bow of the liner the crazy craft was urged, and it was only the prompt action of the officers that prevented it from being cut in two. Then the junk drew off accompanied by the lurid comments of the steamer's captain.

## SEEKING THE FAVOR OF THE "WIND GOD"



Music is Supplied by a Chinese Drum, Cymbals, and a Brass Gong, with the Tune Improvised as the Dance Proceeds



The Dragon, Symbol of "Good Luck," is Borne by a Dancer and His Assistant. In the Inset Above is a Food Offering to the "Wind God"

*Mr. Walter Parkes  
310 Central Bank Bldg.,  
Oakland, Calif.*

**"DEPTH" IN MOVIES ON ONE STRIP OF FILM** *2466*

While heretofore the single eye of the ordinary camera has been able to record only two flat dimensions, length and width, a California inventor claims to have added a third—"depth." The result is said to give a stereoscopic effect, bringing the details of the picture into sharp relief. Previous efforts along this line have required the use of two strips of film and some special device before the eyes of the spectator. But the new invention is declared to use only a single strip of film. *2401*

**LOCKED GOLF-BAG POCKETS USED TO CARRY "TOGS"**

What bids fair to draw the hearty applause of every golfer, who has wanted to



Golf Bag with Showing Pockets

"Rip" Lock Open for Accessories

carry extra "togs," balls, and sundry other incidental supplies while pursuing the old Scotch game, is a new departure in golf bags. A "ripper" lock, that opens the bag from end to end, gives access to pockets of varied sizes. These pockets may contain quite a number of accessories, eliminating the necessity of carrying an additional bag. A "vanity" pocket finds particular favor with women.

*Photograms, 129 E  
24th St.,  
New York.*

**HOME-RUN SECRET SOUGHT INSIDE OF BASEBALLS**

Few of the thousands who annually watch baseball games know the part the ball itself plays in the national sport or



Baseballs Dropped from Different Heights and Rebounds Measured to Test Liveliness

realize the effect just a slight difference in the tightness of its cover, a tiny change in the weight of its rubber core, or the tension with which it is wound, may make in the hitting. But in an obscure corner

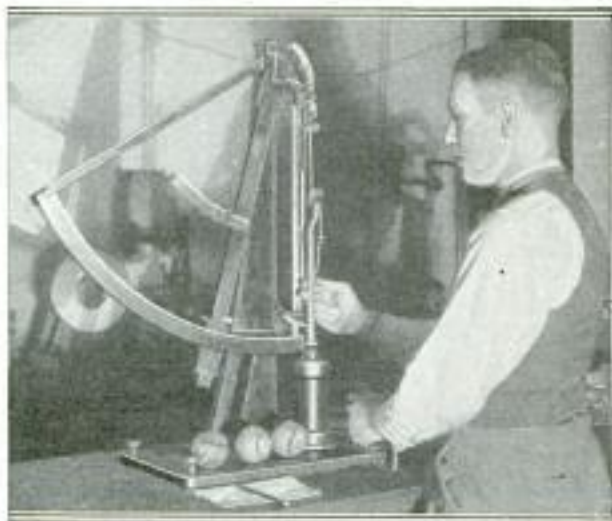

Gauge Registers Force Necessary to Tear One of the Stitches from Cover of Ball

*Es. H. Slacy, National Press  
Club, Washington, D. C.*

*Bureau of Standards, Cont.  
Washington, D. C.*

2404  
of Washington, D. C., there is a room filled with strange instruments presided over by learned government scientists. Perhaps they have never seen a big-

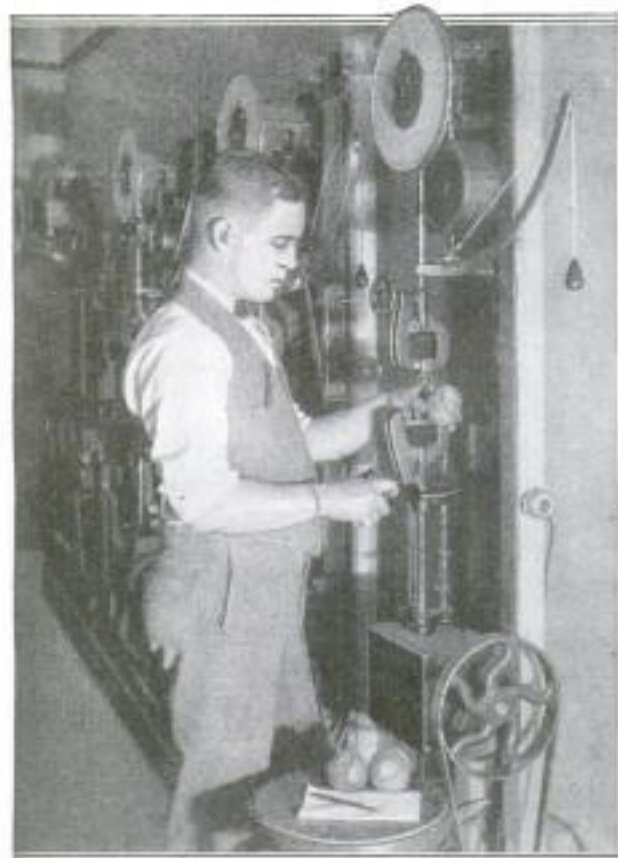

How the Strength of the Lacing Cords, Yarn, and String Wrappings of Ball are Determined

league baseball game in their lives, but they spend all of their time weighing and cutting apart baseballs and making tests to find out just what part every detail of the horsehide-covered sphere plays when the crack of a bat sends it sailing over the fence or bounding far away into the hands of the fielder.



Remnants of Balls After Government Scientists have Dissected Them for Study

These tests are conducted as a guide for the government in buying baseballs for the army, which uses thousands of them each year, but the experiments have developed many interesting facts. The lacing cords used in sewing the cover are said to be the weakest point of the ball. Tight covers prevent the pitchers from "roughing" the surface of the sphere in order to gain an advantage in throwing curves.

To determine the liveliness of the balls, a rebound test has been devised. Balls are dropped from different heights and the rebound measured on a yardstick. The liveliness of the ball, it has been learned, depends upon the size and the elastic nature of the rubber center, and the quality and tension of the yarn with which it is wrapped.

2468  
**AVIATION PIONEER'S DEATH  
RECALLS HIS FEATS**

With the death of Maj. Thomas Scott Baldwin, inventor of the modern parachute and one of the early pioneers in American military aviation, Army Air Service officials recalled many of his deeds.

According to the records, he had the distinction of being the first man in the United States to descend in a parachute, a feat he performed at San Francisco, Nov. 30, 1883. After lengthy experiments with balloons, and careful study of Santos Dumont's experiences along similar lines, he began the construction of his first airship in 1902. The machine cost \$5,000 to build, the balloon part being made of silk canvas covered with netting of heavy Irish linen. It was 25 feet wide and 90 feet long. Below the bag was slung a framework and a propeller operated by foot power, like a bicycle.

After giving exhibitions in various parts of the country, Major Baldwin engaged in the manufacture of airplanes for several years. During the World War he supervised the construction and inspection of the entire balloon program of the army.

Among his many prized keepsakes was a ring presented to him by the king of England in recognition of his early flying feats in that country. At the time of his death army officials asserted that there probably was no individual in the world who possessed the knowledge and experience of Major Baldwin in connection with the building and flying of heavier-than-air machines.

*New York Times*  
5/20/23



**T**O the majority of students geometry has been a difficult study, dry as dust. This has largely been due to the methods of teaching, and to the difficulty of presenting an abstract subject to youthful minds. A Boston instructor, however, has devised a method of teaching geometry by means of the motion-picture film, using so-called animated pictures similar to those seen in the picture theaters.

This brings to the geometry lesson the stimulating quality of animation, without which it does not enter the class of so-called interesting subjects, at least so far as the ordinary student is concerned. For example, a circle thrown on the screen with a written or verbal explanation of how it is drawn does not create the same interest as a picture showing the actual drawing of the circle.

With this principle in mind, a whole series of pictures were prepared, to explain and illustrate the definitions and ordinary problems of plane geometry. These are so planned that they may be continued right through more advanced studies.

One of the films starts with the picture of a Japanese performer lying on his back, juggling geometrical figures with his feet. These include spheres, circles, cones, prisms, cubes, and other shapes. Then are shown pictures of the great mathematicians of history, such as Pythagoras, Euclid, Plato, and others. A brief caption accompanies each subject, and an occasional explanatory sentence to enliven interest. Next appears the old theorem, that the square of the hypotenuse of a right triangle is equal to the sum of the squares of its sides. First the

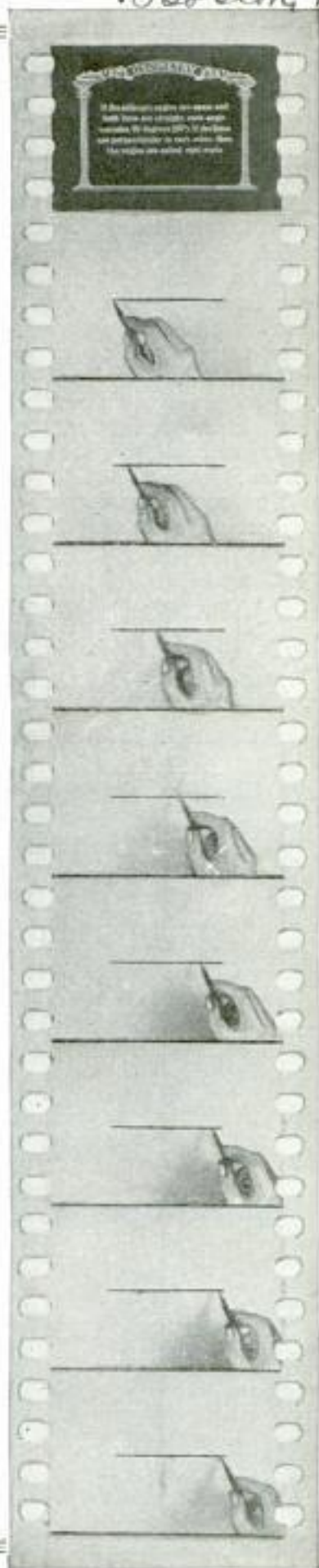

triangle is shown, then a hand draws the squares on its three sides, finally taking the squares from two sides and placing them upon the hypotenuse to prove the theorem correct.

Other geometric truths are illustrated and verified in the same interesting way. When angles are shown, they are made to merge into intersecting streets, dotted with trees, and passing over a stone viaduct. The picture of a table is shown with a straight edge moving on it to illustrate a plane surface. Another part shows a hand drawing a straight line, starting from a point and moving along until the line is formed. A T-square is shown moving along the edge of a drawing board and many other familiar geometric elements are similarly illustrated.

The same hand, moving about in this mysterious, interesting fashion, makes

curves of all kinds and then broken lines. In natural progression 360 degrees of a circle are shown, by the drawing of the circle in the picture, then a 180-degree arc. A clock is also used, with its hands in various positions to make different sectors of a circle.

Three glasses of different sizes, the larger of which contains a dark liquid are used to make clear the theory of "incommensurables"—or things which do not contain the same unit of measure a whole number of times. This is shown by the fact that after the two smaller glasses have been filled, there is part of the liquid left over in the larger container, as illustrated in one of the accompanying pictures.

In another instance, a hand is shown drawing lines to prove that if the adjacent angles are equal and both lines are straight, each angle contains 90 degrees and is called a right angle.

### JAPANESE VIEW OF WAR PICTURED IN RUG

A family of acrobats from Japan, now appearing in Paris, is displaying a rug, upon which is designed the Japanese

conception of the World War. Two tigers, representing France and England, are watching an eagle, representing Germany, carrying off a tiger cub, Belgium. The Japs have refused many attractive offers for the work of art.



Costly Rug Displayed by a Troupe of Acrobats in a Paris Circus: The Design Depicts the Japanese Conception of the World War in Such an Artistic Manner, That Many Connoisseurs have Tried to Purchase It

Wide World Photos  
New York City



2221

*Geo. Leamle Rogers, Architect*  
*Low + Wallenbacher, Associate*  
 POPULAR MECHANICS  
*Architects*

### SKYSCRAPER IS PLANNED FOR UNIVERSITY

One of the tallest university buildings in the United States, if not in the world, is included in a \$10,000,000 group of new

structures to be built for the Northwestern University of Evanston, Ill., on its so-called downtown campus on Lake Shore Drive, Chicago. Elevators and other conveniences of modern business structures will be part of the equipment.



One of a Towering Group of Buildings Planned for Northwestern University of Evanston, at Chicago

### 2476 RARE RUSSIAN DECORATION APPEARS IN NEW YORK

What is claimed to be the only decoration of its kind outside of Russian territory, is a highly ornamented chain of solid gold medals, given by the late czar to the Grand Duke Michael Nicolai-wich, and now owned by an American in New York. The decoration is that of the Order of St. Andrew, of Russia, and weighs two pounds. Twenty-three medals, wonderfully inlaid and worked, and one big jewel, make up the chain, which is intended to encircle the neck. Only five of the decorations have ever been made.

▲A new image of Buddha, made entirely of human bones, is soon to be dedicated at Jogwanji temple in Fukagawa, Japan. These are from the bodies of more than 2,600 persons who have died in the last 10 years, and were stored in the temple's charnel house.



COPYRIGHT, UNDERWOOD & UNDERWOOD  
Cross of the Order of St. Andrew, of Russia

Emt. A. L. Fluids. Manager,  
The Corp. of Independent Chautauque Co.  
Suite 550, Orchestra Bldg,  
Chicago

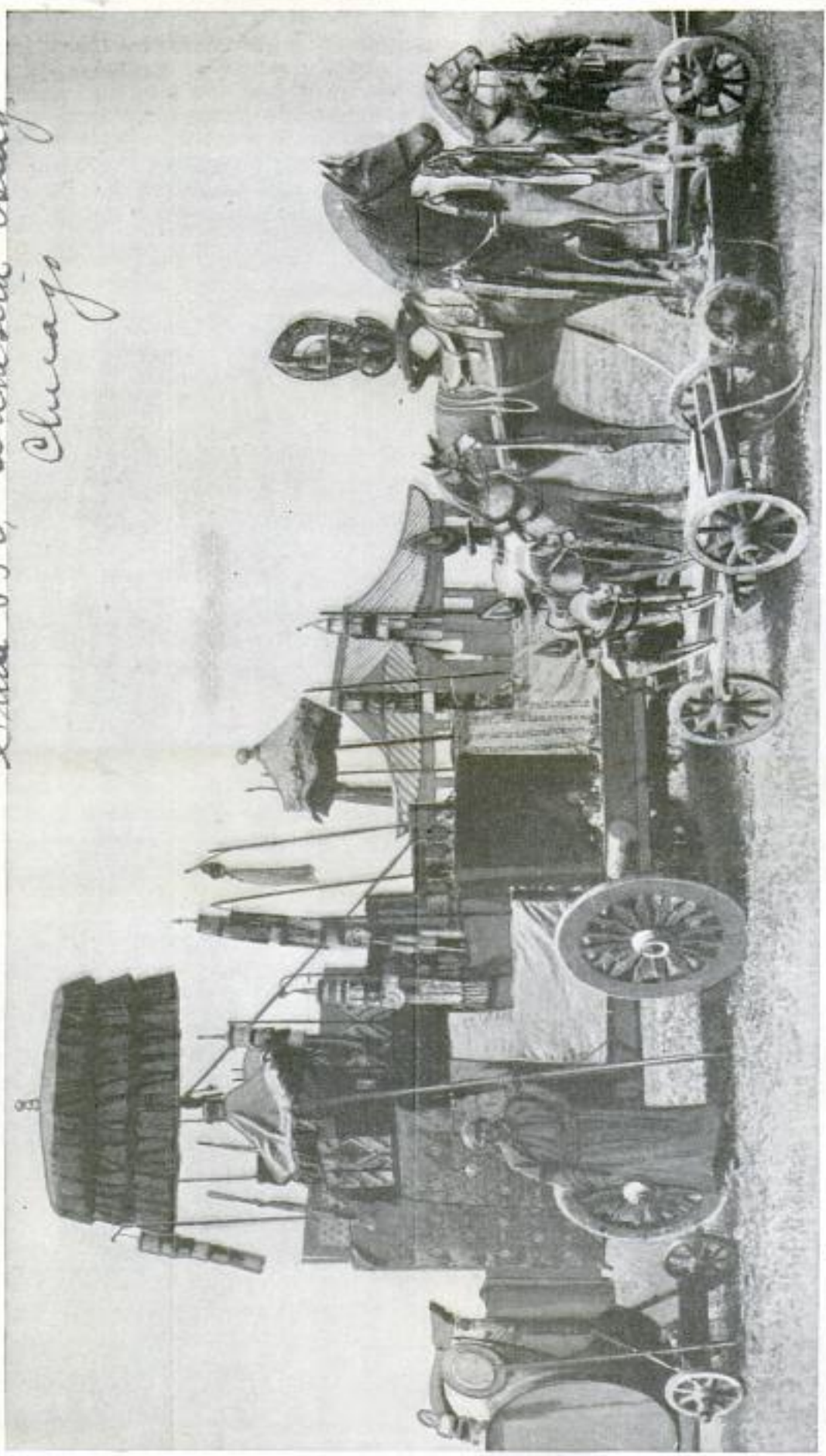

Funeral Chariot of a Burial Prince, Ready for its Appointed Place in the Procession to the Grave: Note the Various Indications of Rank of the Dead Potentate, and the Numerous Wooden Horses Which have been Fashioned for the Occasion. The Master's Horse is Supposed to be Offered Up as a Sacrifice at the Grave, but the Thrifty Burials Burn the Wooden Ones Instead

## BURIATS OF MONGOLIA HAVE QUEER CUSTOMS

Dwelling in the vicinity of the Baikal Lake, on the northern borders of the Gobi Desert of Asia, is a peculiar tribe of Mongolians, called Buriats. They are called the "cowboys of Asia," being expert riders and living almost constantly on horseback. The Buriat horse is famous for its powers of endurance, and the attachment between master and animal is very great. At death the horse should, according to their religion, be sacrificed at its owner's grave; but the frugal Buriat heir usually substitutes an old hack. At other times he goes through the pretense of tying up a valuable steed to the grave to starve, but he does so with the thinnest of cords, so that the animal soon breaks its tether and gallops off to join the other horses. In religion the Buriats are mainly Buddhists.

Great pomp and ceremony are displayed at a Buriat funeral, and sometimes a number of wooden horses accompany the procession to the grave, where they are burned to provide ample mounts for the spirit in his future life. An umbrella tops the hearse, and its size is an indication of the rank of the deceased. In the case of a dead chieftain or other important potentate, silk pendants adorn the funeral chariot, as well as umbrellas of varying size, and numerous other religious symbols. The Buriats are a peaceful tribe; broad-shouldered and inclined to stoutness, with small slanting eyes, thick lips, high cheek bones, and scanty beards. The men shave their heads and wear a pigtail. Their principal occupation is the raising of horses and cattle. Customs are much the same today among these people of the Gobi Desert as they were 2,000 years ago, and western culture has touched them but little.

## NATURE HEATS WATER FOR SWIMMING POOL

Water, flowing from a natural-gas well at a temperature of 96° F. the year around, supplies a swimming pool at Pierre, S. D., and makes outdoor bathing possible in the coldest of weather. The pool is built of concrete and was constructed when it was discovered an unlimited supply of warm water was available at all times. Electric lights, strung around the pool, enable patrons to bathe at night. A small wading pool has been built, in conjunction with the swimming pool, for the use of children.

The American City  
Sept. 1922

## RACK HELPS MUSICIANS IN QUICK CHANGES

As an aid to musicians who have to play several instruments, a rack has been made to enable them to change quickly. The instruments are kept in convenient positions, always ready for use at



Musicians' Rack and Way It is Used to Hold Instruments

the elbow of the player. This also eliminates the danger of breakage.

## TWO-PEG TENNIS ANCHOR KEEPS NET TAUT

Something new in tennis anchors has been devised for keeping the net taut without pulling up too readily. The ordinary staple, or screw anchor, is either driven or screwed into the ground, and has only a moderate amount of friction to hold it there. In the new type, a staple slotted at the top is driven into the ground, at an angle, and a second staple is driven through the slot at a similar angle, but away from the first one. This forms an

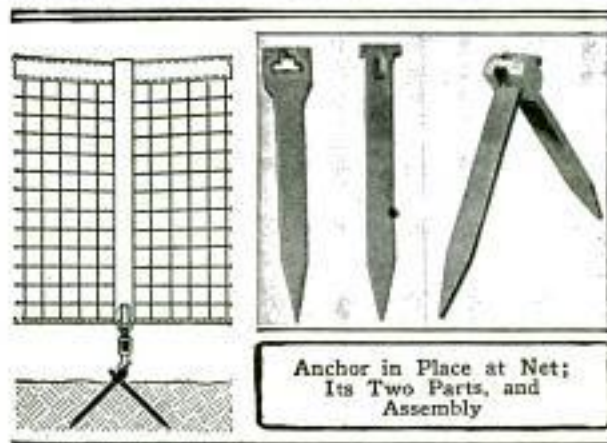

Anchor in Place at Net; Its Two Parts, and Assembly

anchor which can be pulled up only by first removing the second staple.

Wright & Stearns  
Victor Co. registered material  
615 S. Wabash, Chicago

Cml. Nelson Edwards  
 3054 Arundel Ave. Mfr. Post Electric Co.  
 30 E 42nd St  
 Baltimore, Md. New York

10

POPULAR MECHANICS

Baltimore, Md.

OLD DEEP-SEA SHIP CUT UP FOR AUTO MATERIAL

220

Old, worn, and useless, the "Santa Clara," familiar to shipping men for many years, is being demolished, and its all-



"Sawing" Up an Old Propeller with the Acetylene Torch, to Make Automobile Parts

steel hull will be converted into automobile parts. The "Santa Clara" was a schooner, 312 feet long, and plied the

RUNAWAY LOCOMOTIVE "DIVES" INTO LAKE

2315

Imagine a 100,000-pound locomotive running wild down a six-per-cent grade,

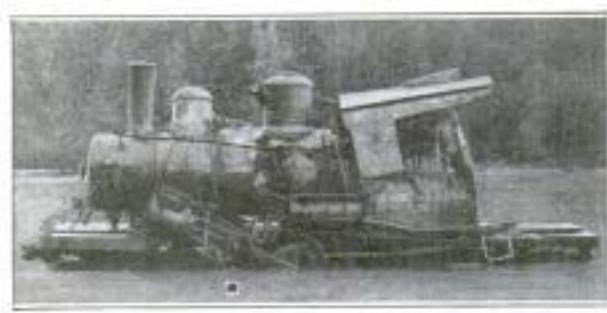

View of the Locomotive Set Up on the Submerged Track, Out in the Lake

followed closely by a runaway train of six loaded freight cars. This happened in British Columbia recently, and the inevitable smash-up occurred on a trestle over Harrison Lake. Engine and cars landed in about 35 feet of water, but by a strange freak of circumstances, were

waters for 27 years in the tropical-fruit trade. When first put into service, in the early '90s, it was considered a marvel of construction, and the launching was an event. Acetylene torches are being used to cut up the hull and propellers into easily movable sections. The latter are of manganese bronze, a metal much used in the construction of automobile parts.

ELECTRIC PEN THAT WRITES IN GOLD OR SILVER

2447

Gold, silver, or other colored designs or writing can be made on wood, leather, paper, ivory, parchment, silk, or metal by a new electrically operated pen. The pen is attached to any lamp socket by means of a flexible cord, and is operated by running the electrically heated point over a sheet of colored transfer paper. The pen is insulated so that no current comes in contact with the user or the material with which he is working. The heat of the hot point can be regulated so that a maximum of 900° F. can be reached. The pen is no larger than an ordinary fountain pen.

Shipping liquefied natural gas in steel tanks to localities where this gas is scarce is the latest improvement in gas service. Upon being released by the consumer, it turns instantly into gas again.

sandwiched in three layers. Two cars of rails were undermost, then came the engine, and four cars loaded with logs piled on top. Divers were rushed to the scene, and proceeded to salvage the wreck promptly, although with some doubt at first, and with considerable difficulty. A submerged track was laid out into the lake, and the wrecked equipment gradually worked to shallow water. All repairs were made on the lake shore.

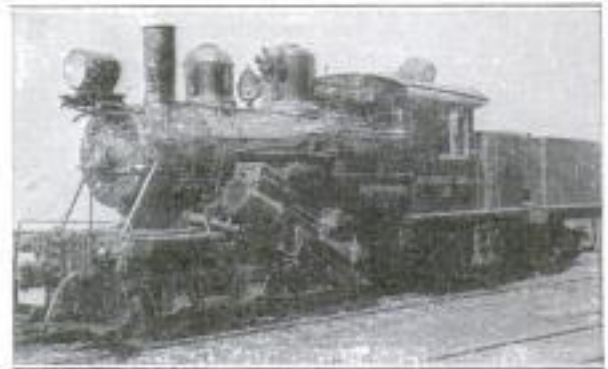

Locomotive after Undergoing Repairs on the Lake Shore

Cml. J. H. Moore, 358 Kingswood Road, Toronto, Canada.

Wash. - & Westfield & Co. Inc. Chicago, Pa.

**BIG ELECTROSTATIC MACHINE ALLAYS VETERANS' ILLS**

At the Kingsbridge hospital, London, for mental and nervous diseases, there is employed for the treatment of rheumatism and minor spinal troubles, one of the largest electrostatic machines in the world. When receiving this treatment the patient sits on a chair placed on the platform of the machine, and the afflicted parts are massaged with electricity discharged from a tube which is held by an attendant.



COPYRIGHT, UNDERWOOD & LINDENBLOM  
A Veteran at the Hospital for Nervous Cases, Undergoing Treatment from One of the Large Static Machines

224 B.

**PERFUMES WILL ADD REALITY TO MOTION PICTURES**

Pleasant odors, typical of the scene being shown, may be used in motion-picture theaters shortly, to add reality to

the screened picture story. This will be accomplished by working keys at the organ, which will be connected to suitable spraying apparatus. When an ocean scene appears, the bracing odor of salt air, with its pleasant tang, will be wafted through the theater, as a natural accompaniment of the setting. Similarly, a country background will call forth the characteristic fragrance of freshly mown hay. Exotic perfumes and incense will be used in Oriental presentations. At a demonstration given recently, picture-theater owners expressed the belief that this touch of reality would add materially to the enjoyment of the film.

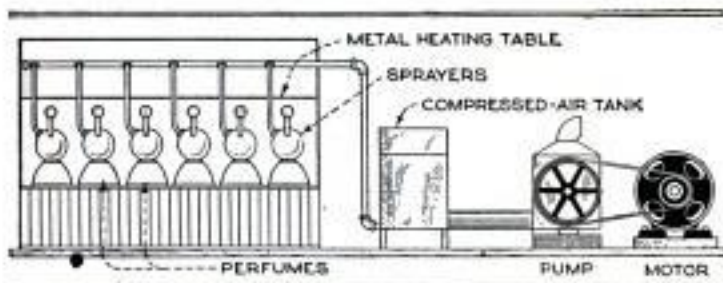

Perfuming Movie Theaters: The Perfumes are Sprayed on a Heated Surface, Then Wafted Away with Bellows

*Mr. D. Smith, 419 W. Erie, Chicago*  
*Mr. Raymond R. Taylor, 1526 N. Waller Ave. Chicago*

**LARGE BALL THRUST BEARING OF ENORMOUS STRENGTH**

With each ball built to withstand a pressure of 100,000 pounds without injury, the largest ball bearing of its kind in the world has been completed by an eastern machinery company and put into service. There are 40 balls in the bearing, each one 4 inches in diameter. It is estimated that it would require a pressure of 40,960,000 pounds to cause the bearing to collapse.

Ⓒ Pulverized coal, mixed with water, will be conveyed 200 miles in huge steel pipes, according to plans now being formulated by Dutch interests in Zululand, Africa. There will be a coal port on the coast, but export coal will be transported by railway. The project will involve an outlay of about 100,000,000 dollars.

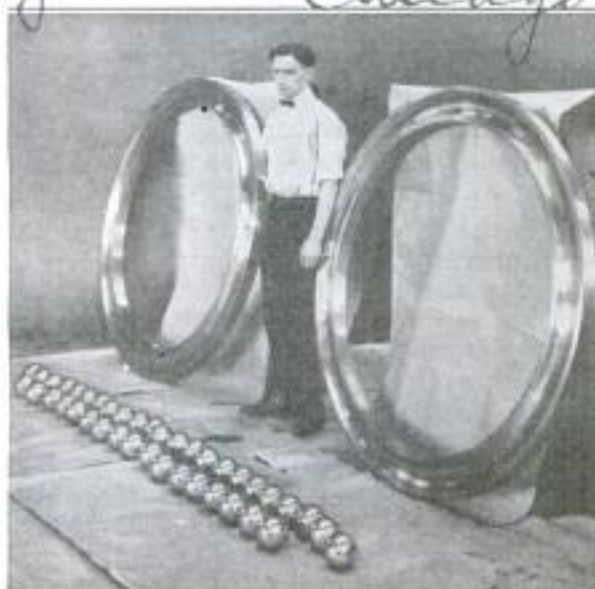

Bearing Nearly as Large as a Man, and Balls Four Inches in Diameter

*The Standard Machinery Co., Elmwood Station, Providence, R.I.*

# RELICS OF WASHINGTON IN MASONIC MEMORIAL

BY HAMILTON M. WRIGHT

1508 Park Row *Blk*  
15 Park Row, New York City

2232

George Washington Masonic National Memorial Association Alexandria Va.

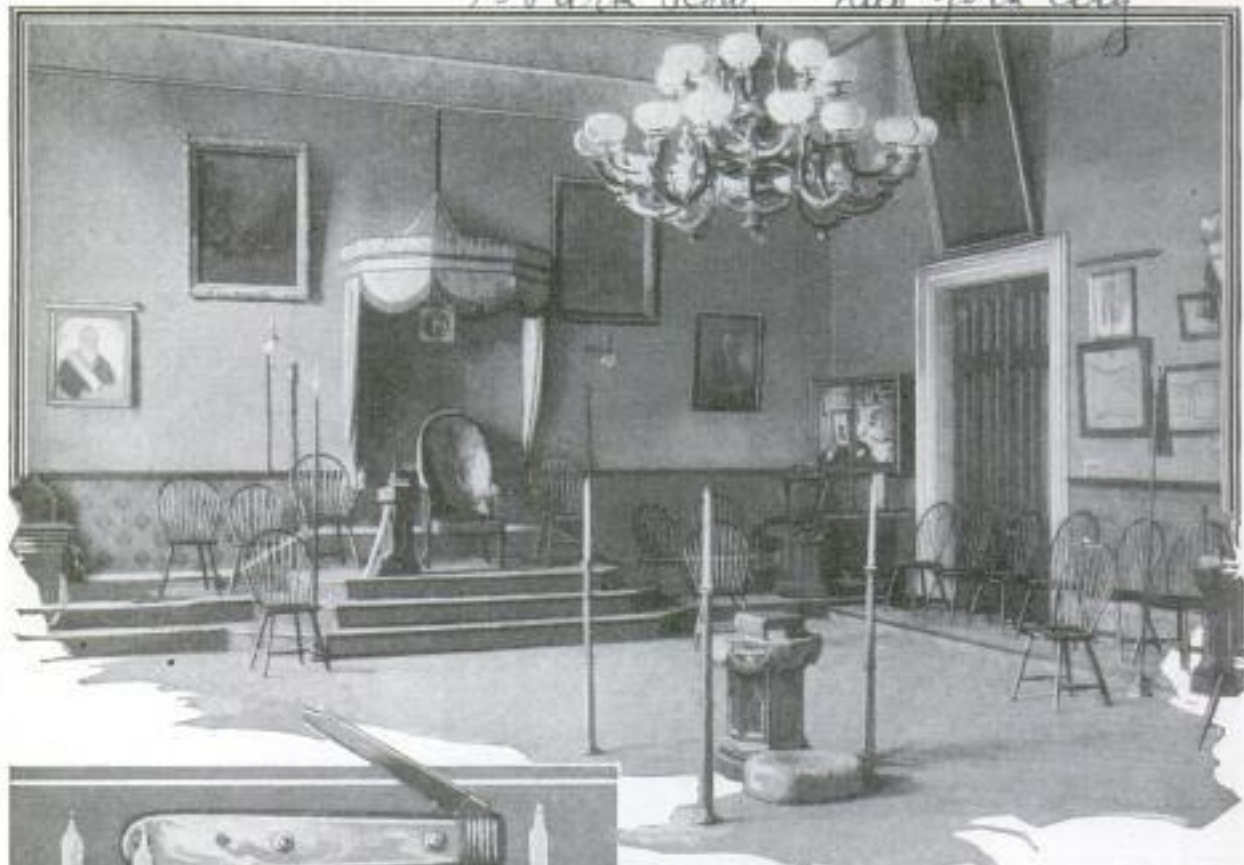

COPYRIGHT, GEORGE WASHINGTON MASONIC NATIONAL MEMORIAL ASSOCIATION

Exact Replica of the Lodge Room in Which Washington Sat as Master

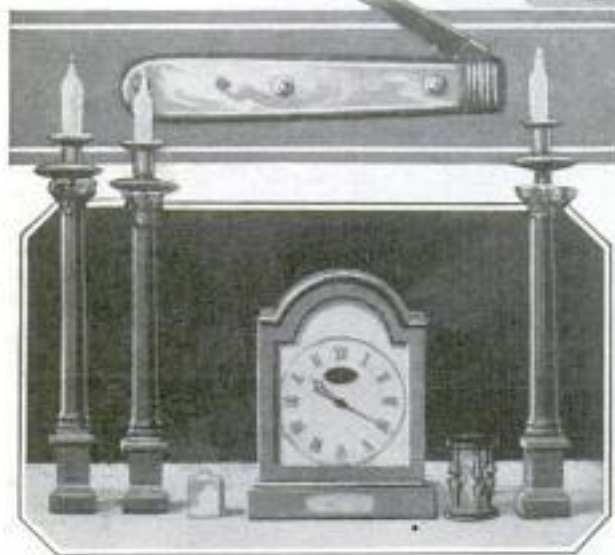

Clock Which Stopped When Washington Died, and Penknife He Used as Boy

ON the one hundred and ninetieth anniversary of Washington's birth, last year, the news was flashed from the nation's capital that the Masonic orders of the United States had accepted plans for a magnificent memorial edifice, the George Washington Masonic National Memorial, to be constructed at Alexandria, Va.

Now the memorial, which was described from the architects' plans in the October, 1922, issue of this magazine, is under construction and soon will be ready for the housing of the priceless collection of relics of George Washington, which have

been assembled under the direction of our first president's old lodge, the Alexandria-Washington Lodge, No. 22 (No. 39 in Washington's day).

While the idea has grown beyond the housing of the Washington relics, still there will be incorporated in the memorial building an exact replica of the original room in which Washington occupied the chair as master. This will be located in the southeast corner of the structure, on the ground floor. Even the wall paper used in the old lodge room will be faithfully reproduced, and there the relics of the "Father of His Country" will have a permanent home.

Collection of notable things used by Washington began almost at the moment of his death, when Dr. Elisha Cullen Dick, his lifelong friend and physician, and master of the Alexandria-Washington lodge at the time, cut the pendulum of the old clock that stood in the bed-chamber of the first president. It was 10:20 o'clock in the night, and the hands of the clock still point to the minute and hour that marked the close of that inspiring life.

After General Washington's funeral, Mrs. Washington presented the clock to Doctor Dick for the lodge of which Washington had been a devoted and beloved member, and of which he served as master for 20 months. He had become a first, or charter, member of the lodge in 1778, shortly after the application for its opening had been made to the Grand Lodge of Virginia. Upon the lodge walls still hangs the document containing his name, signed by Edmund Randolph, then governor of Virginia.

Among the most interesting features of the collection is Washington's Masonic apron, worn by him as a master and at the laying of the cornerstone of the nation's capitol. It is heavily fringed and embroidered in gold, of cream-colored satin, with the French and American flags intertwined. A beehive and fairies adorn the center. The apron was presented to the lodge in 1812 by a nephew of the general and husband of his adopted daughter.

Other relics now in the collection include Washington's farm spurs, bootstrap or garter, field compass, master chair as presiding officer of the lodge,

The knife was given to Washington in token of his obedience to his mother's request not to join the English navy after all preparations had been made, and a commission obtained for him. He carried it throughout his life, and when at Valley Forge, after signing his resignation when a timid congress failed to provide food and shelter for his half-starving troops, he was reminded of his mother's words when she gave him the knife, "Always obey your superiors," he tore up his resignation.

Presented to the first president by Lafayette, a key to the Bastille in Paris and said to be one of the five in existence, is another of the prized relics.

In 1871, the old lodge in which many of these relics were kept was visited by a disastrous fire, but the collection was saved. Then for nearly 40 years, the relics were closed to the public, but in 1907 they were opened for inspection under charge of a member of the lodge. During the Civil War, although Alexandria was overrun constantly by both armies, not a single article was harmed or removed from the lodge.

Striking in design, the new memorial

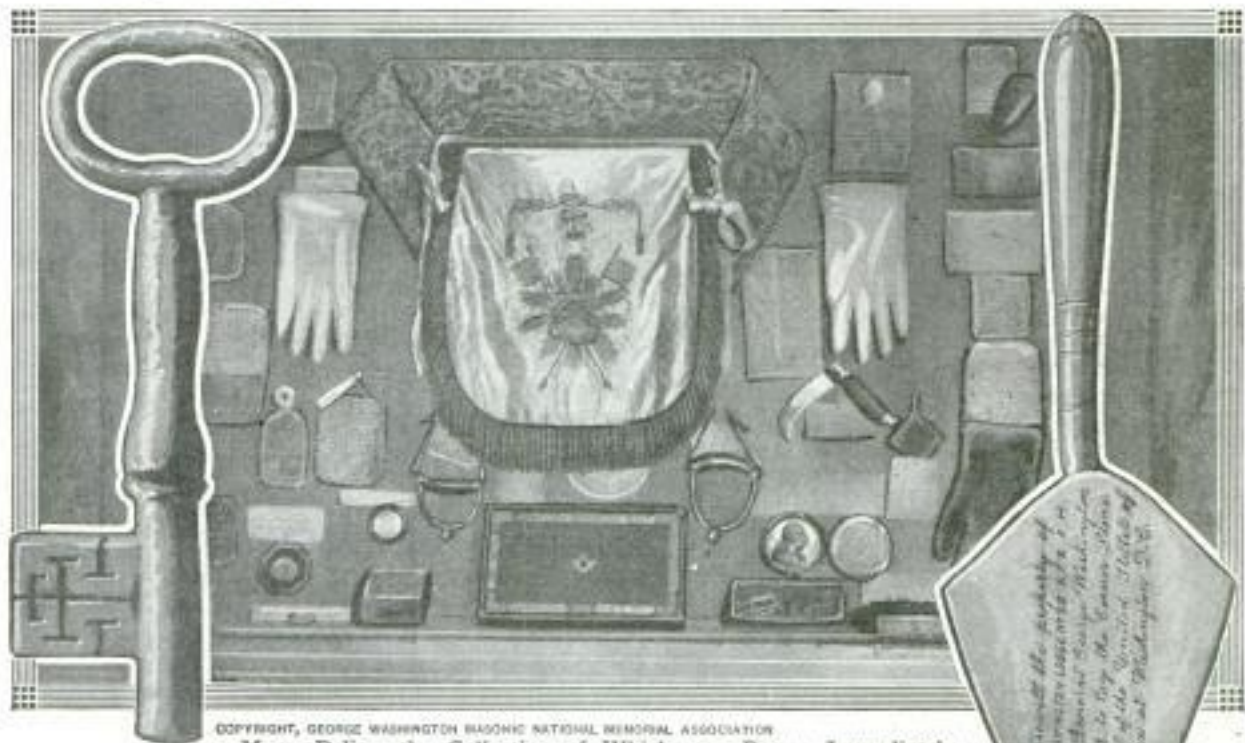

COPYRIGHT, GEORGE WASHINGTON MASONIC NATIONAL MEMORIAL ASSOCIATION  
Many Relics, the Collection of Which was Begun Immediately after the Death of the "Father of His Country"

wedding gloves, pruning knife, and a black glove worn at his mother's funeral, a little pearl-handled knife, a present from his mother; and a piece of sealing wax taken from his desk and used by the general before his death.

overlooks the scene of many of Washington's achievements. Erected at a cost of over \$2,000,000, it is surmounted by a square tower, notable for its simplicity and dignity.

2446  
 SPIRIT HANDS, "ECTOPLASM," AND RUBBER GLOVES

Having Filled the Rubber Glove with Water Father de Heredia Prepares to Dip It in Paraffin



Dipping the Glove: The Cold Water Inside the Glove is Causing the Paraffin to Harden



Withdrawing the Wax-Coated Glove: Note the Small "Wrist" That is Obtained

ITS dainty fingers crooked, the wrist smaller than that of any grown person, a waxlike mold of a woman's hand lay on the table, while an awed group of persons looked at it, fascinated. Forty seconds before, there had been nothing on the table but a glass jar of hot, melted paraffin, another similar jar of cold water and—"ectoplasm."

It had been explained to the little band of spectators that the mold of the hand had been made by a "spirit." The medium had produced some ectoplasm while in a trance, the spirit had been in the ectoplasm. The ghostly visitor, to prove itself a "real something," had put its hand into the hot paraffin, then dipped it into the cold water, thus hardening the coating of the wax, finally pulling its spiritual hand out of the hard-paraffin mold through the wrist opening, leaving the shell as evidence.

"No human hand could have made that mold," the medium's friends had pointed out, "because no human hand could have been withdrawn from that cast through that tiny wrist. Notice how the fingers and thumb are crooked—no human hand so held could have been pulled out of that mold without breaking it. Again, to dip the human hand into that jar of melted paraffin would certainly scald and burn unbearably."

Father C. M. de Heredia does not assert that beings from the "other world" could not or do not make these hands, but he does say he can



Pulling Out the Collapsed Glove After the Water is Emptied, Leaving the "Spirit" Shell



The "Spirit" Reproduction: "No Human Hand could Make This," Say the Believers



Several "Spirit Hands": The One with Fingers Bent Is a "Most Convincing Manifestation"



2496



Left to Right: Father de Heredia Feels the Approach of the Ectoplasmic Mystery; the "Ectoplasm" Makes Its Appearance, Taking On the Form of a Human Being, Yet Folded Up; and a Visitor from Realms of Ectoplasm All Puffed Up

make them, and in the laboratory of Popular Mechanics Magazine he made them, many of them, and produced ectoplasm of the most convincing sort.

The human hand does not serve as the mold for the paraffin, Father de Heredia admits, but the "human rubber glove" does. Filling a rubber glove with water, the priest dipped it into the jar of the liquid wax. A thin coat adhered to the lifelike "hand." A few seconds later he plunged the glove with its coating of wax into the jar of water. Then Father de Heredia emptied the water from the glove. As it collapsed it was easy to extract it from the molded hand. And in a trice, the "spirit" hand was produced.

By artfully "palming" the rubber glove, Father de Heredia was able to do the trick with ease and to the complete mystification of the beholder.

Then, the ectoplasm—

Within the rolled top of an ordinary 10-cent hair comb, the priest pulled out enough shreds of cloth—ectoplasm—to fill a good-sized hat. From a trick finger,

such as are used by magicians, he extracted some excellent spirit pictures and yards and yards of other ectoplasm.

Entangled in the ectoplasm are knotted strings. Securing a knot between her teeth, a medium might run the string up through her hair to the comb bearing its secreted load of "astral matter," as the shredded cloth and newspaper clippings are lovingly termed.

In the hour or more of time during which the séance lasts, she might gradually work out the "strange, unearthly" material with its attached spirit pictures. Another concealed string pulls forth the astral finger—the before-mentioned magician's digit—to point tremblingly at the bewildered audience. "I do not say the spirits do not do these things, but I do say anybody who knows how can do them;" that is the attitude of Father de Heredia. The quantity of ectoplasm that can be concealed in an ordinary 10-cent comb on one of these fingers is astonishing. And they are quite easy to handle in a séance.



Above: Ectoplasm and "Spirit Faces." Below: Magician's Finger and the Hollow-Topped Comb



The "Spirit Hand": Note the Small Wrist Hole and the Crooked Fingers—"Evidence" of Astral Origin

2296

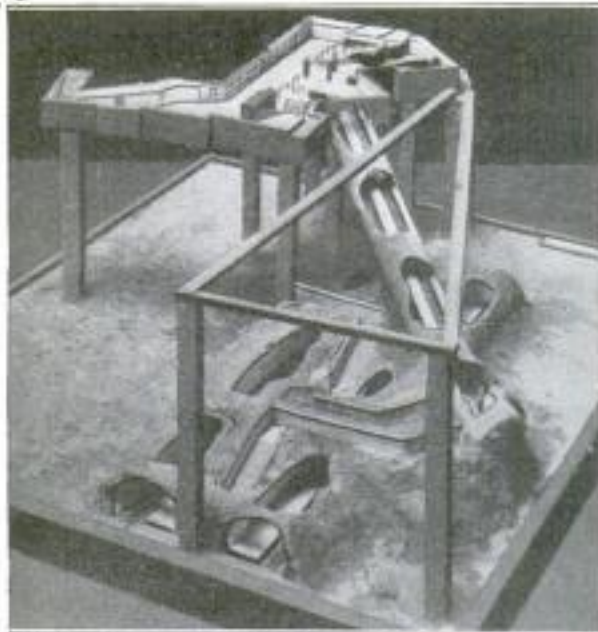

Model of a London Underground Railway Station, Showing the "Tubes," Stairways, and Platforms

### MODEL HELPS IN HANDLING JAMS ON SUBWAYS

Many ways for speeding up the heavy traffic which occurs at rush hours on subways have resulted from a study of a small model of one of London's new "tube" stations. With this before them, the engineers have been able to trace the exact movement of the crowds and plan for improvements. Moving stairways, change-making devices, platforms, and runways are all reproduced in the model, which is a graphic example of the application of this art to the needs of everyday life. When, with the increase in population, the passenger-carrying capacity of the trains had reached its limit, the experts turned their attention to the stations, seeking to care for the crowds more quickly, and it was to aid in the solution of this problem that the miniature station was constructed.

### MOTORCYCLE FILM PLANT MAKES QUICK MOVIES

To shorten the delay caused by having to send motion-picture films back from the spot where they were taken to a distant laboratory for developing, an English inventor has equipped a motorcycle sidecar with a miniature film-manufacturing plant. It is claimed that the plant will develop and print film at the rate of 200 feet an hour, assisting greatly in the quick production of news-reel features. By its aid news events have been thrown on the screen within two hours



Above: Film Plant Attached to Sidecar. Left: Reels on Which Film is Wound

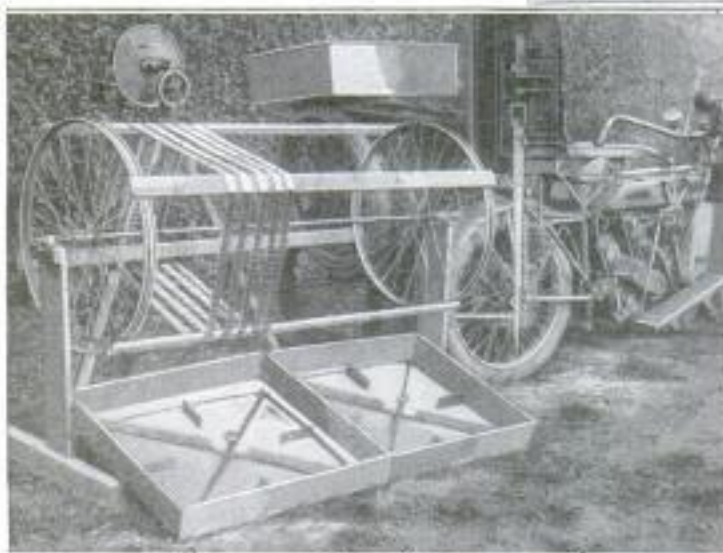

after they happened. The plant consists of a developing tank, the printer, and the drying drum around which the film is wound. A hood and screen also are fitted to the sidecar for use as a dark room. Because costly film is easily spoiled, especially in hot climates, it also is claimed that this portable plant will result in avoiding heavy losses. It may be set up anywhere water is obtainable. Where the water is not pure, a filter and a pump are provided. These are run by the motor of the cycle car.

Inw. & Co. Long, Town Hill Sandringham, England.

cmd. E. H. Lemonnier, 27, Rue St. Etienne, Paris, France

2331

Cml. Mr. Grassman

2297

MINERAL TOURMALINE HAS QUEER PROPERTIES

Tourmaline is a mineral of much interest to the physicist on account of its optical and electrical qualities. It has a great range of color, and in many cases the crystals are curiously particolored; sometimes it is colorless. A ray of light passing through it becomes bent at different angles, depending upon whether it enters the crystal parallel to or perpendicular to its axis. It is also known that when heated in peat ashes it acquires magnetic properties. Another strange property of tourmaline is that it becomes electric under pressure.

2317

GERMAN AUTOMOBILE BUILT ON EXTREME LINES

Peculiar designs in automobile bodies continue to appear. The latest comes from Germany, and is designed to offer the minimum of wind resistance when in motion. Even the wheels have been arranged to diminish it. The body is built like one of the lately developed thick airplane wings, partly with the end in view of preventing the large cloud of dust that

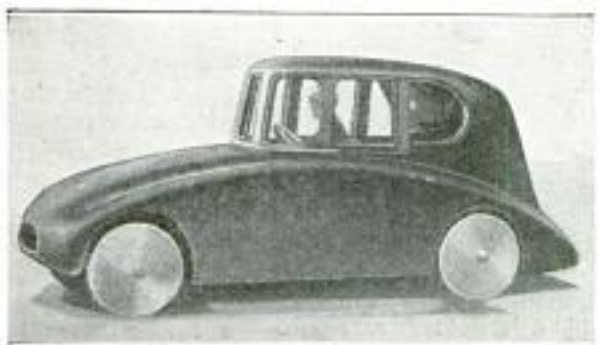

This Bullet-Shaped Automobile Produced by a German Builder, is Designed to Overcome Wind Resistance

usually trails behind a speeding auto by confining it under the rear end.

2413

HENS CONTINUE TO BREAK LARGEST-EGG RECORDS

While new dancing, aviation, and sporting records are a matter of almost daily occurrence, the attention of poultry raisers in all parts of the country has been challenged by our recent publication of a story of an egg which measured 7.87 inches by 6.75 inches and weighed 4 1/8 ounces. One hen in the Far West has presented its owner, E. T. Harvey, of Cottage Grove, Ore., with a sample egg measuring 8.25 by 7.5 inches and weighing fully five ounces.

Mr. Gabriel

SECRETS HIDDEN IN BLANKETS UNRAVELED BY SCIENCE

To the average person a blanket is a covering that affords protection from cold and wind; to the scientist it is an arrangement of fibers of wool,



The Apparatus Shown Above is Used to Test the Moisture-Absorbing Properties of Blankets

cotton, or other material, and has lately been under investigation at the Bureau of Standards. There, textile experts have been working to find out facts regarding the ability to transmit heat and exclude air, the moisture-absorbing properties, and the tendency to cling to the body, for different kinds of woven goods or felts used in the making of blankets.

In determining to what degree such materials prevent penetration of air, a metal cylinder 8 inches in diameter is used. Over its head the test piece is tightly stretched, and the amount of air that leaks through under standard pressure, is measured by a gas meter. The apparatus used for the moisture test is more elaborate and consists of a metal pan, in the top of which are eleven holes each holding a glass beaker. Heat supplied within the pan evaporates the water in the glasses, and the amount escaping measures the moisture-absorbing property of the sample of cloth stretched across the top of the glass. In order to test its ability to transmit heat, a sample of the blanket is stretched over an electrically heated metal surface, that is maintained at the normal temperature of the human body, and the heat that radiates from the top of the blanket is accurately measured by means of suitable electrical thermometers.

Paul Jarcy. Friedrichshafen, Baden, Germany. Mfr.

National Press Club, Washington, D.C. Cml. Es. H. Slay.

## FAR-AWAY LANDS LURE TOURISTS

*Emb. H. H. Dunn, 2922 Broadway, St. Calif.*

WITH steamship and railway companies prepared to care for a record-breaking rush of American tourists to the centers of old-world culture, as well as to the very outposts of civilization, this summer, a steadily rising tide of travel has turned toward the Orient, South America, and Europe.

The charm, romance, limitless wilds, background of age-old history and balmy climate, already have called shipload after shipload of tourists to South America, where the refinement of Europe, the traditions of Asia, and the savagery of Africa are more than matched by the continent over which the lofty Andes stand guard.

But the lure of the Orient has proved just as potent with thousands of others who are now crowding the luxurious liners sailing for Honolulu and the Far East from San Francisco and other Pacific-coast ports. Japan—the "Land of the Rising Sun"—situated at the crossroads of world traffic and the meeting place of two civilizations, has been the Mecca of many of these voyagers.

There they have found a country of picturesque quaintness, of kimonos, tea houses, cherry blossoms, wistaria, and geishas, over all of which towers the sacred Mount Fujiyama, a beacon and a symbol of manifold and endless charm. From Yokohama, the principal port, the fascination of China beckons like an ancient door slowly opening on what is the oldest civilization in the world, a culture that was vigorous before Rome was born.

Like a never-ending picture, in China there are a thousand things to see—rivers dotted with junks, camel caravans, temples, huge images, forbidden cities, monuments so old the human mind can hardly go back to their origin, dynastic tombs, and flowery pagodas.

Shanghai is a city of contrasts; a city with telephones—and firecrackers at funerals; a city with street cars—and silver dollars hung about children's necks to fool the devils into thinking them dogs.

The East and the West meet again at Manila where the harbor is full of strange craft, and the streets of the people of every race and tribe. From Hongkong and Manila the liners steam to Singapore, the most southern point of Asia, where the sun rises and sets at the same hour every day of the year.

But while the first rush of tourists this year has been toward the South and Far East, a greater number than ever before, it is estimated, are preparing to journey across the Atlantic to Paris, London,

Stockholm, Rome, and other points in Europe.

From these places many will continue their journey to Algiers, the "African Paris," where Arabs, Turks, Moors, and Bedouins throng the narrow, winding streets, and then cross the Mediterranean to visit Monaco and Naples.

Next, the usual course of the tourist is through the Suez Canal, Red and Arabian seas to India, land of many races, religions, and customs; a place of mystery, splendor, and squalor, strangely blended. Afterward comes Ceylon, so perfect that the natives say it is only "40 miles from heaven."

In transporting and safeguarding the untold thousands of tourists, every device of modern civilization will be taxed to the uttermost. Great liners equipped with stabilizing devices to prevent seasickness, oil-burning boilers to avoid dirt, and, in some cases, electrically driven to eliminate vibration, will be at their disposal.

Baseball scores, stock quotations, and the latest news events will be brought daily by radio and printed in small newspapers aboard the liners, or posted on bulletin boards. For amusement, there will be games, concerts, and orchestras.

Luxuries undreamed of a generation ago will be placed at the command of every tourist. The monotony of long train journeys will be broken by moving pictures projected in dining cars, while the trains are speeding over plains and mountains, and the radio will bring concerts and opera to passengers aboard both trains and liners.

Journeys which, within the memory of men still alive, could be made only by months of peril and hardship and at the risk of life itself, may now be undertaken in safety and completed in comparatively few hours. The telegraph, telephone, and radio all assist in protecting tourists and adding to their comfort and safety.

Vast armies of trainmen, seamen, dispatchers, telegraph and telephone operators, and lighthouse tenders keep ceaseless vigil over those whose lives depend upon their watchfulness. Most of these are men, but many women have found their way into some of the professions whose duty it is to protect others.

At the Golden Gate to San Francisco, for instance, a girl helps to guide the destinies of a thousand deep-sea craft from a lofty tower overlooking the bay. She is Miss Hilda Gohrman, and is officially known as the secretary of the Board of State Harbor Commissioners.

## SAILING OF LINER DRAWS WATERFRONT CROWDS



Now Flying the British Flag, the "Majestic," a Former German Liner Which was Purchased by England from the Reparations Commission, Attracted Much Attention When It Steamed Out of Hamburg Harbor, Germany, Recently, with Its Siren Shrieking a Farewell

## OLD NAVAL BASES TURN TO INDUSTRY

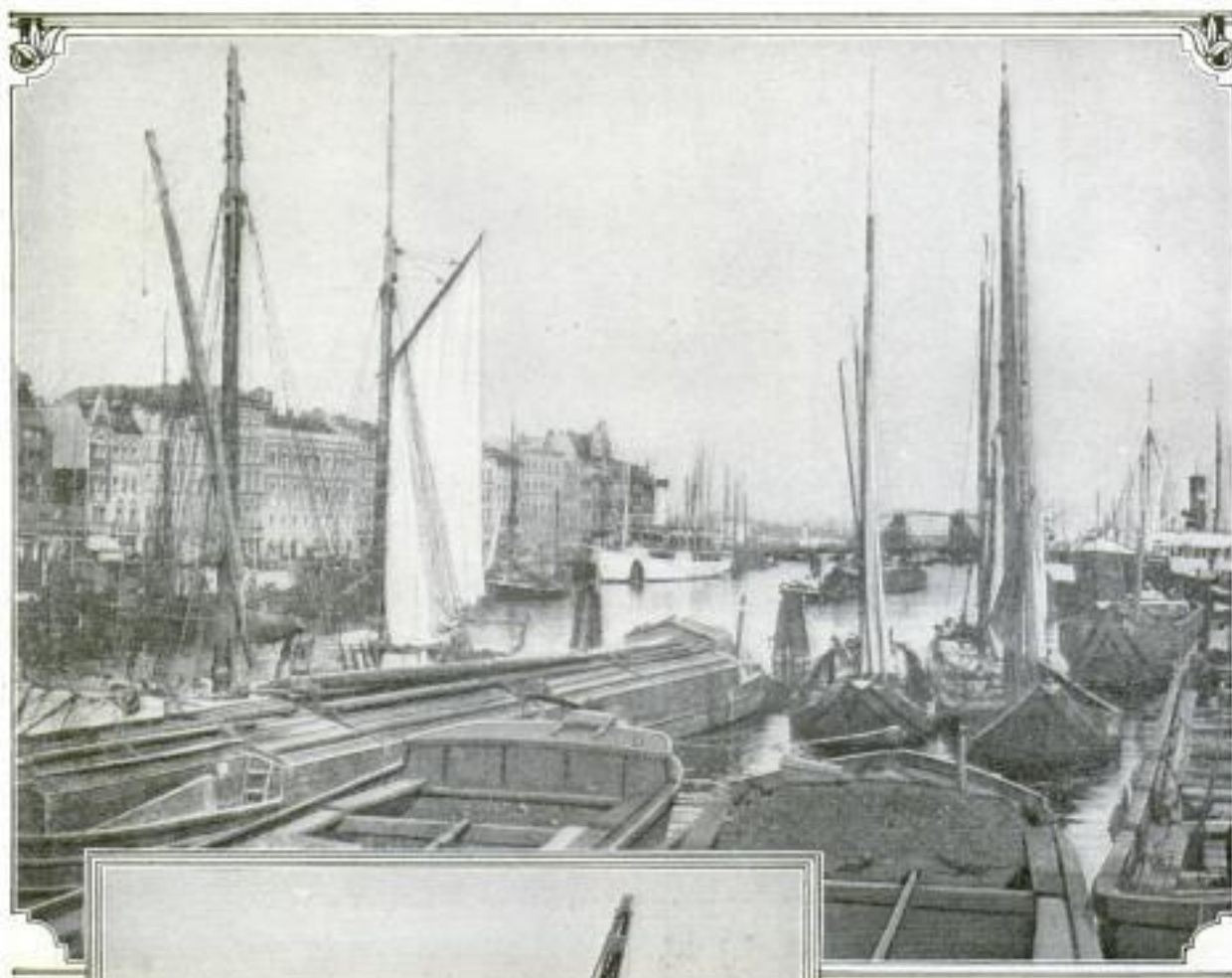

Stettin, Germany, Known as the Most Important Commercial Harbor on the Baltic: During the War It was Used as a Naval Base, but Now It has been Made an Industrial Center



Marseilles, the Greatest of the French Ports on the Mediterranean, Is Not Only a Mecca of Interest for the Tourist but a Beehive of Commercial Activity

## WOMEN UNLOADING STEAMER IN FOREIGN PORT

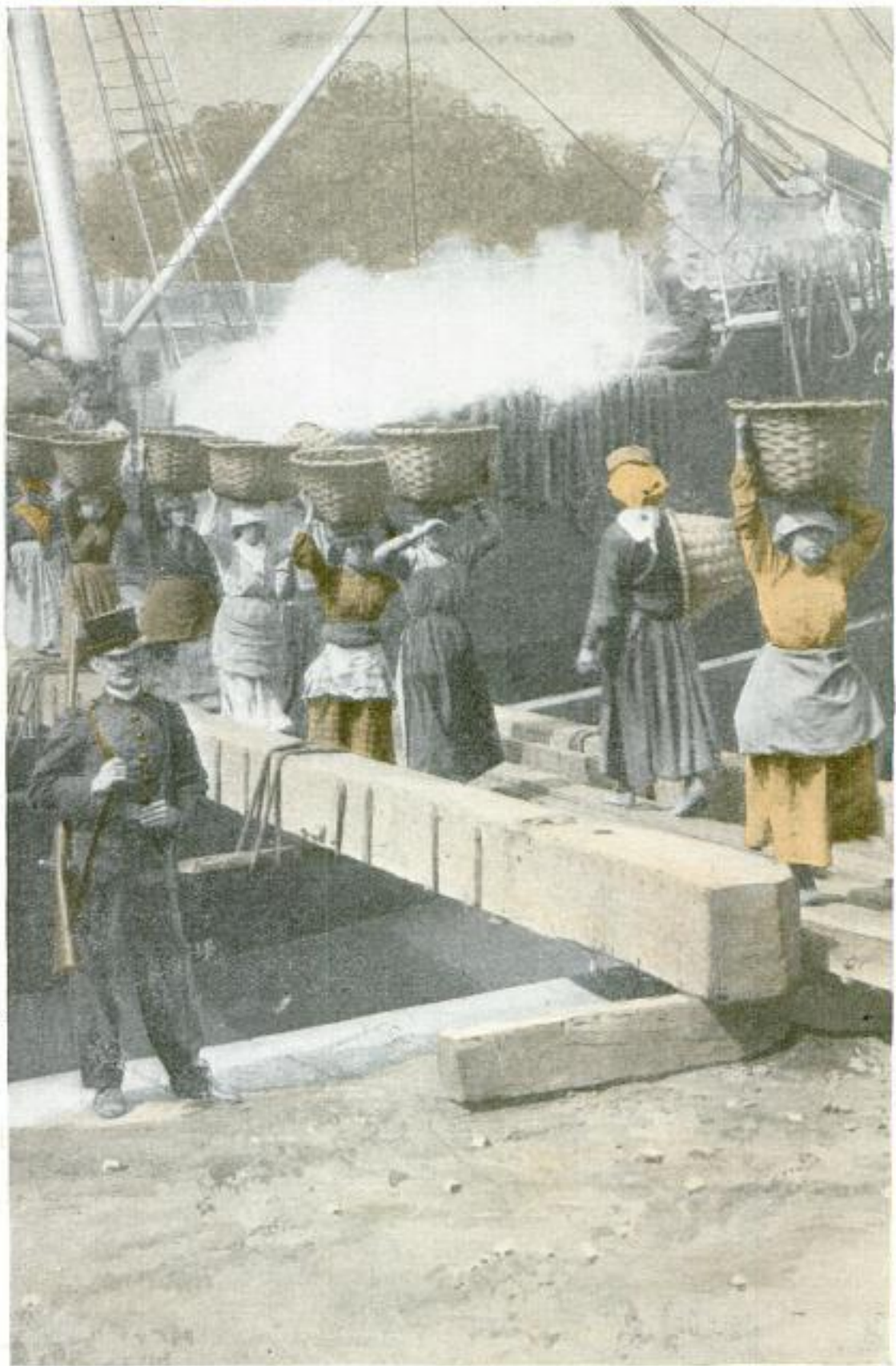

COPYRIGHT, UNDERWOOD & UNDERWOOD

One of the Most Picturesque Sights in Balboa, Spain, Is the Long Lines of Women Unloading the Steamers. They Carry the Goods on Their Heads in Big Baskets

2381

## FLAGS OF ALL NATIONS MEET IN PORTS



Where the Ships of  
Many Nations Meet  
in the Harbor of  
Hobart, Tasmania, a  
Part of Australia,  
on Their Way to and  
from the Orient.



One of the Ports of Malta,  
an Island in the Sunny  
Mediterranean, Where a  
Great Stadium has been  
Built in the Form of a  
Circle



GLEAMING MINARETS MARK THE GOLDEN HORN

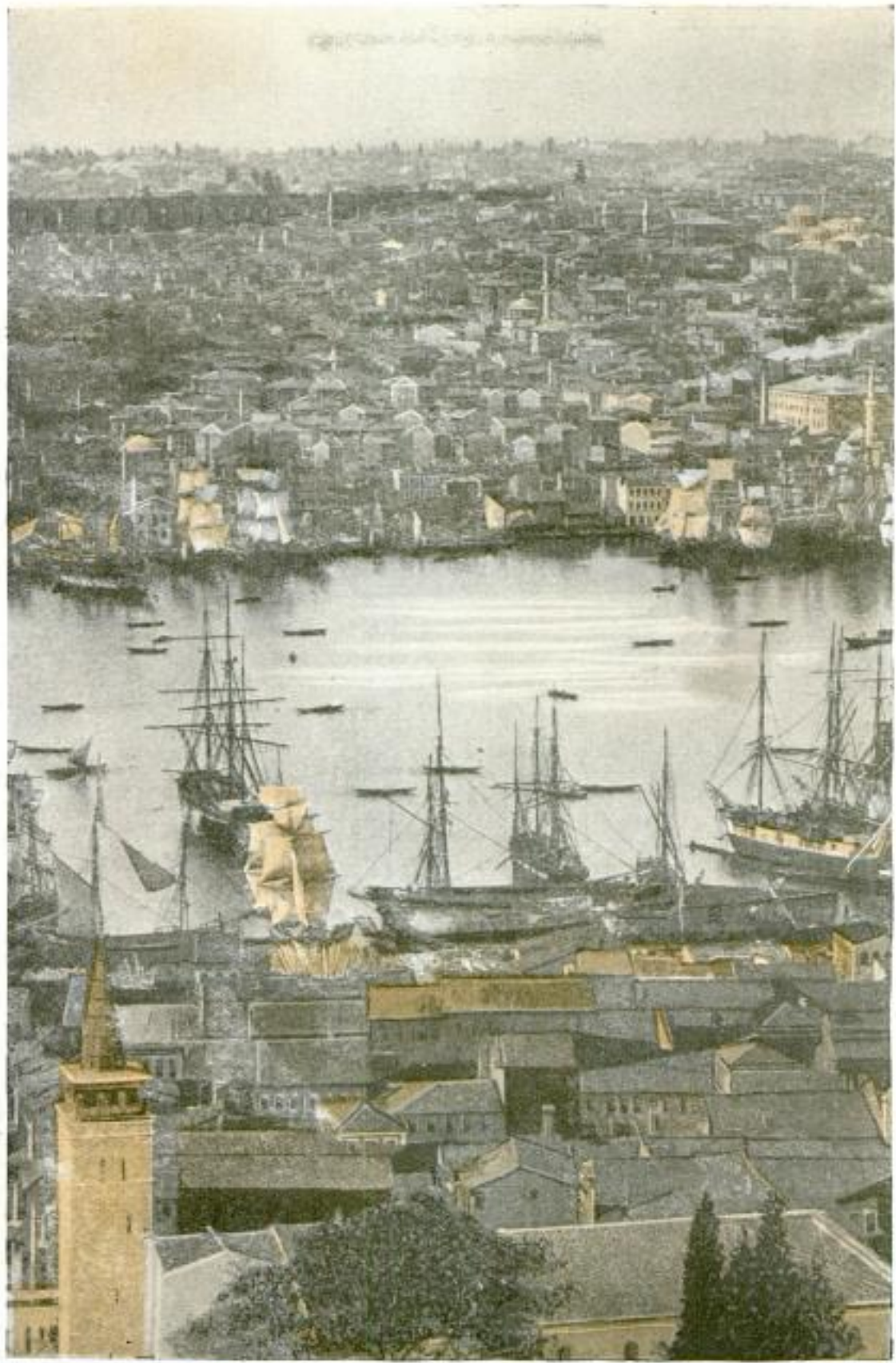

COPYRIGHT, INTERNATIONAL FILM SERVICE, INC.

Constantinople and Its Harbor, Long Objects of Con tention among the European Powers, Provide Striking Contrasts between Splendor and Squalor, the Civilization of the West and the Color of the Orient



Upon the Arrival of Any American Steamer, the Docks at Singapore Are Always the Scene of Great Activity by the Natives



Natives Coaling a Liner from the United States at Nagasaki, Japan, Known to Travelers as One of the Most Picturesque of All Oriental Ports

## SOUTHERN PORTS ARE BUSY MARTS OF TRADE

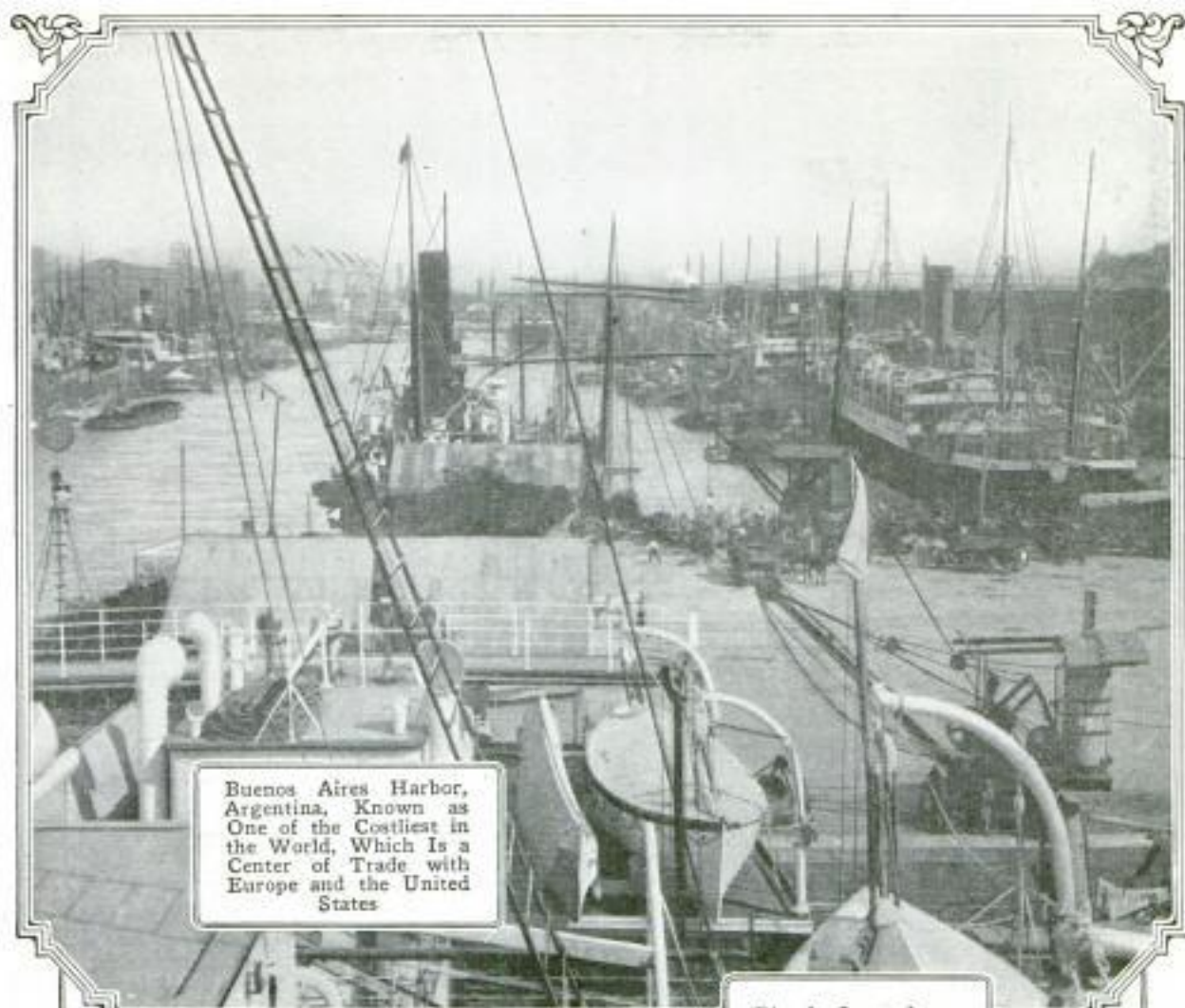

Buenos Aires Harbor,  
Argentina, Known as  
One of the Costliest in  
the World, Which Is a  
Center of Trade with  
Europe and the United  
States

Rio de Janeiro,  
Brazil, Showing the  
Suburb of Botafogo and  
Sugar Leaf  
Mountain, Which  
Towers above the  
Waterfront Like a  
Sturdy Sentinel

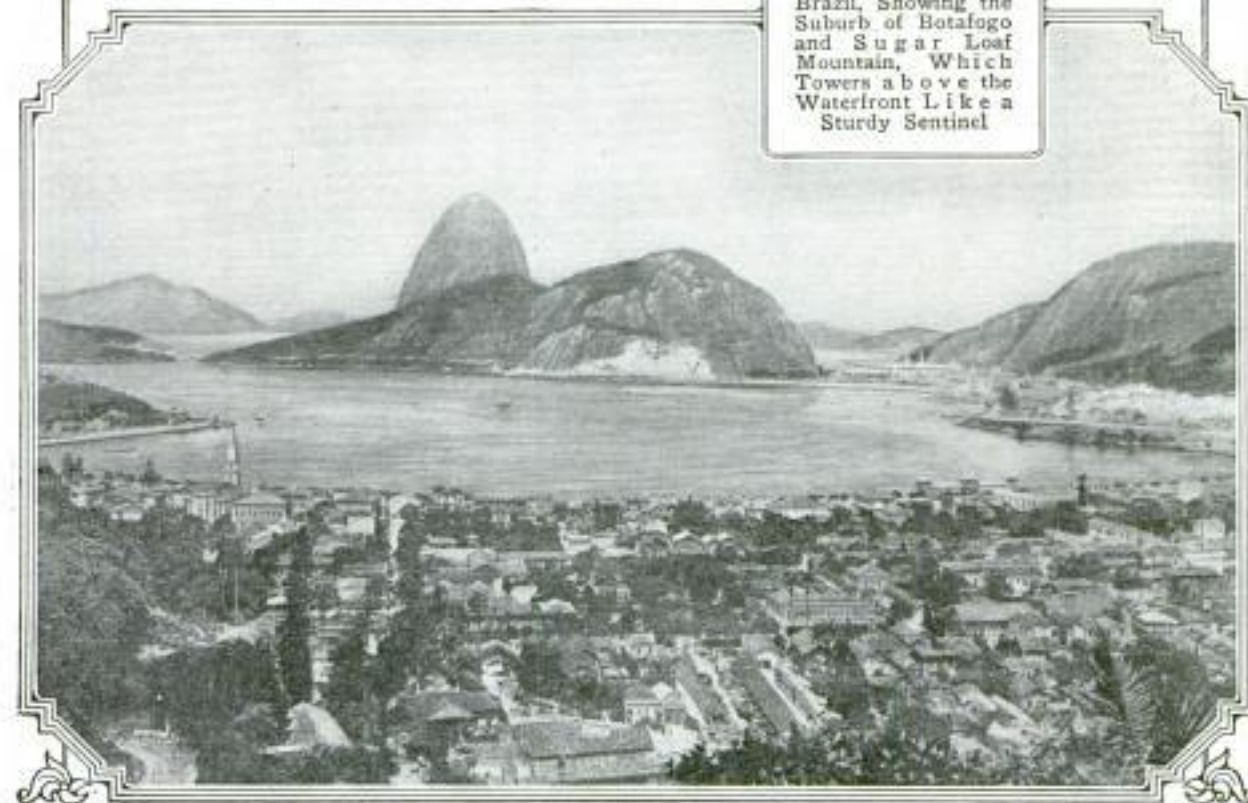

238'

# FISHING BOATS STILL CLING TO USE OF SAILS

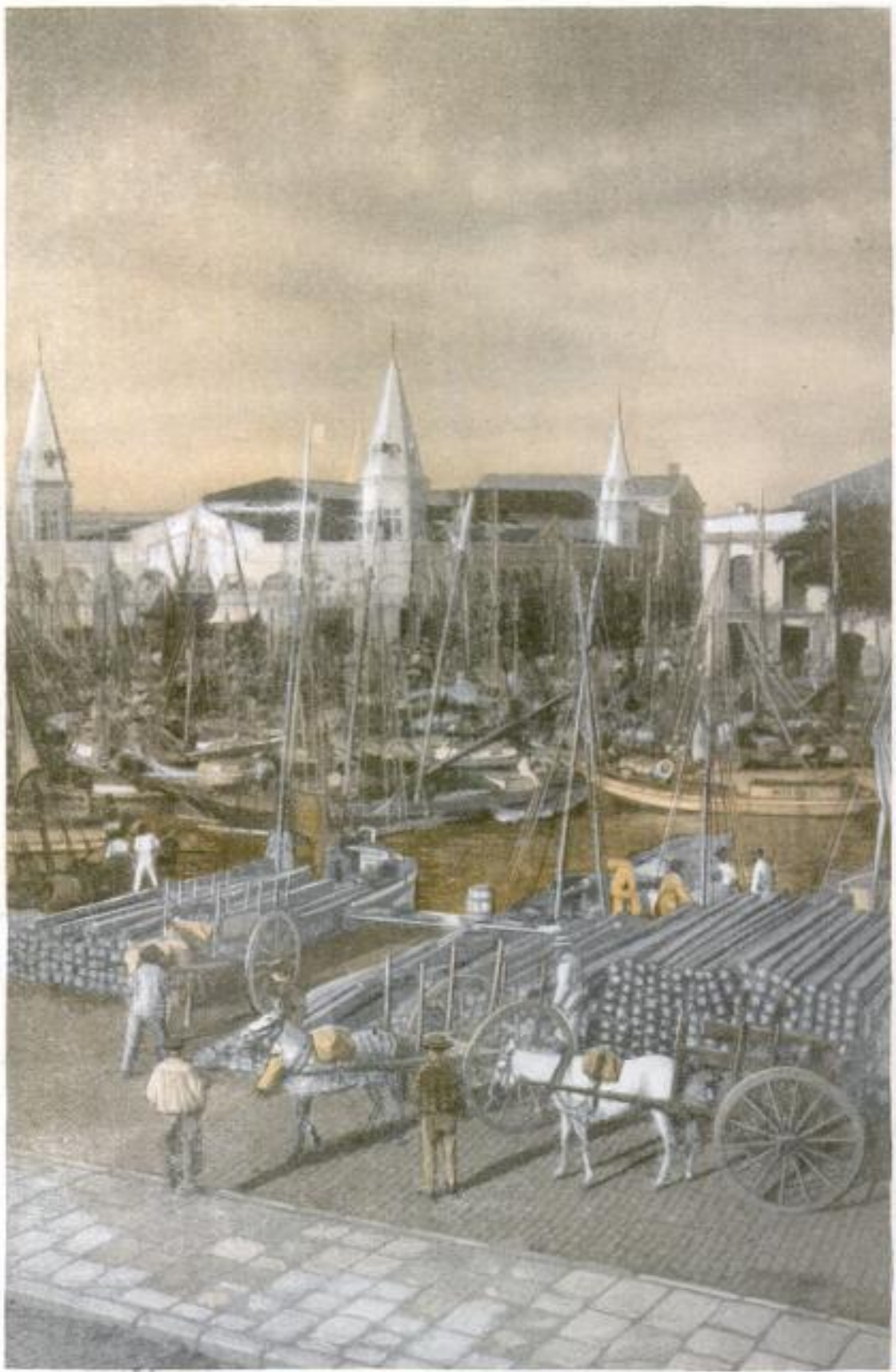

Like a Bare Forest, the Stripped Masts of Hundreds of Fishing Boats Fill the Harbor of Para, Brazil, on Market Days, While the Colorful Costumes of Their Owners Give a Romantic Touch to the Scene

COPYRIGHT, UNDERWOOD & UNDERWOOD

The Jeff Patent Tube, Ltd.,  
 POPULAR MECHANICS London, 27  
 Walthamstow, E. 17, England.

**SELF-SEALING INNER TUBE**  
**DEFIES PUNCTURES** **MIRRORED GLOBE REFLECTS**  
**USE OF ICE PLANT**

Self-sealing qualities are claimed for an inner tube of English make, which has a series of overlapping flaps arranged on its inner surface.



When the tube is punctured, the flaplike wall is pushed aside at that point, and when the piercing element is withdrawn, the flap shuts tight over the puncture. The surfaces of the flaps are moistened with glycerine at the time of manufacture. The tube made a creditable showing in an official test run of 100 miles, 19 stops being made at five-mile intervals for the purpose of driving a nail into the tube and withdrawing the nail driven at the preceding stop.

23757 2311

**ICE-CREAM "NOODLES" MADE WITH NEW DEVICE**

Ice cream served in a new manner seems to make that dish more palatable, and sought for. The latest novelty along this line is an aluminum contrivance which produces ice cream in a noodlelike form. The cream comes out in long coils, which fold and intertwine on the plate.



COPYRIGHT, UNDERWOOD & UNDERWOOD  
 A Dish of Ice Cream Served Up Like a Plate of Noodles by a Special Machine

Mounted on top of the tower of a western cold-storage warehouse, is a 15-foot-diameter globe suggestive of the uses of

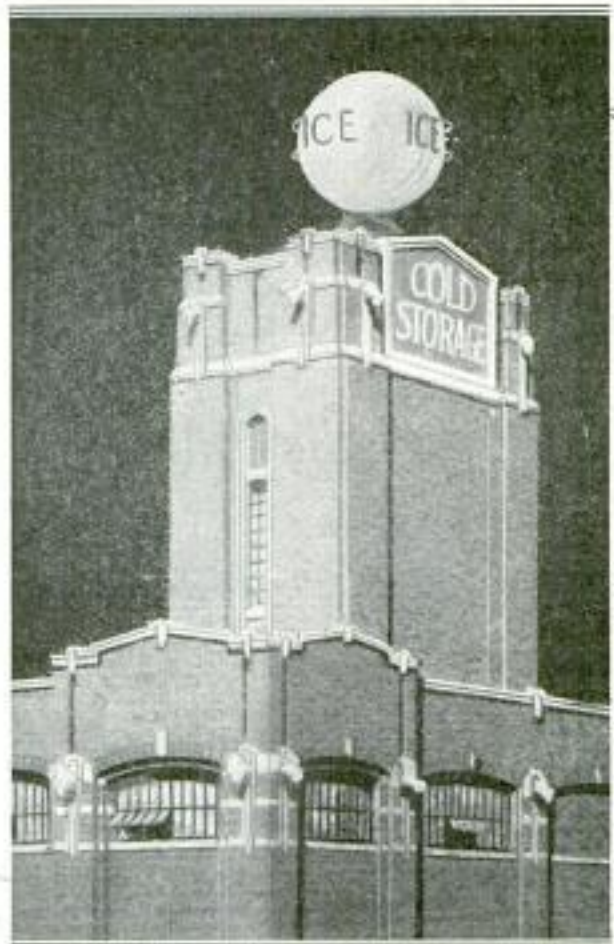

A View at Night of the 15-Foot Mirrored Sphere, Revolving and Gleaming on Its Lofty Station

the plant. The surface of the globe is completely covered by 450 mirrors, each 12 inches square, and at its circumference the word "Ice" appears several times in large letters. The continuously revolving globe reflects the sun's rays by day, and at night the light from electric flood lamps is directed on it from the four corners of the tower.

**SOUND TIMBER 500 YEARS OLD FOUND IN LONDON**

Recent tests of the original oak timber used in building the huge roof of Westminster Hall, London, proved that there had been no loss of strength in the wood during the more than five centuries since it was cut. While the roof itself is intact, its supports have been destroyed by the "deathwatch" beetle and have been replaced by steel.

*Kansas City Cold Storage & Warehouse Co.,  
 500 E. Third St.  
 Kansas City, Mo.*

*C. K. Nelson  
 % Russell Stover Co.,  
 5 S. Wabash, Chicago*

*Carl Frank H Jones  
 15 Row St  
 Auburndale, Mass*

Blazer Co.

Wj. Series

28  
Indianapolis, Ind.

POPULAR MECHANICS

5/13/23

2248  
**SHEET OF WATER PROTECTS  
FIRE FIGHTERS**

**HALL OF FAME WIPES OUT  
SEX DISTINCTIONS**

Ample protection is afforded the firemen of an eastern city with the adoption of an interesting type of fire-fighting equipment. The unit is portable, and mounted on a two-wheeled cart, so that it can be brought up quickly to be used against a fire at close range. The cart accommodates a fireman who sits in it, and is able to handle a powerful stream of water from a nozzle directly in front of him. A "gusher" pipe is mounted on the cart behind him, which sprays a curtain of water all around him, so that a "safety wall" of water protects him and serves amply to prevent blisters and burns. The nozzle proper is mounted in a ball socket, so that it can be swung in any direction with equal facility. Although adapted primarily for fire boats, its present service has proved a very desirable addition as a fire-fighting tool. It can be connected to four, and even six lines of hose, and throws a stream of water 125 feet into the air.



How the Fire-Fighting Apparatus is Used at Close Range: It Protects the Firemen against Injury from the Flames

2407  
With the unveiling of seven new busts in the colonnade of the Hall of Fame of New York University, on May 22, all evi-

dences of sex distinctions in the American "Westminster Abbey" have been wiped out. The senate of the University, which is the governing body of the hall, voted more than a year ago to abolish the then existing arrangement—that is, separate halls for the tablets of men and women honored by election. With the new ruling in force, workmen have been busy for a considerable time rearranging the tablets without regard to sex. Many of the tablets were imbedded so firmly that they could not be removed without damage, and new

ones had to be cast. Seven women have thus far achieved the rare distinction of a place in the Hall of Fame.

**HEAT OF MOTOR CUTS DOWN  
2385 SUPPLY OF GAS**

To make automobile starting easy in cold weather and at the same time prevent too rich a mixture of gas when the motor is warmed up, an automatic control has been devised. The heat of the motor as it warms up expands a spring which cuts down the amount of gasoline fed to the carburetor. When the motor is cold, the spring contracts and admits more gasoline.

Competitive kite flying—the first ever held in the United States under official sanction, with official observers and according to the rules of the International Aeronautic Federation—will be a feature of the home-coming festival at Clarksburg, W. Va., June 10-16. The performances will be authenticated in the same manner as air-craft records.

Buckley Accessories Co.,  
24 Rugby Place,  
Elgin, Ill.

2081

Cmt. H. J. Hoopes

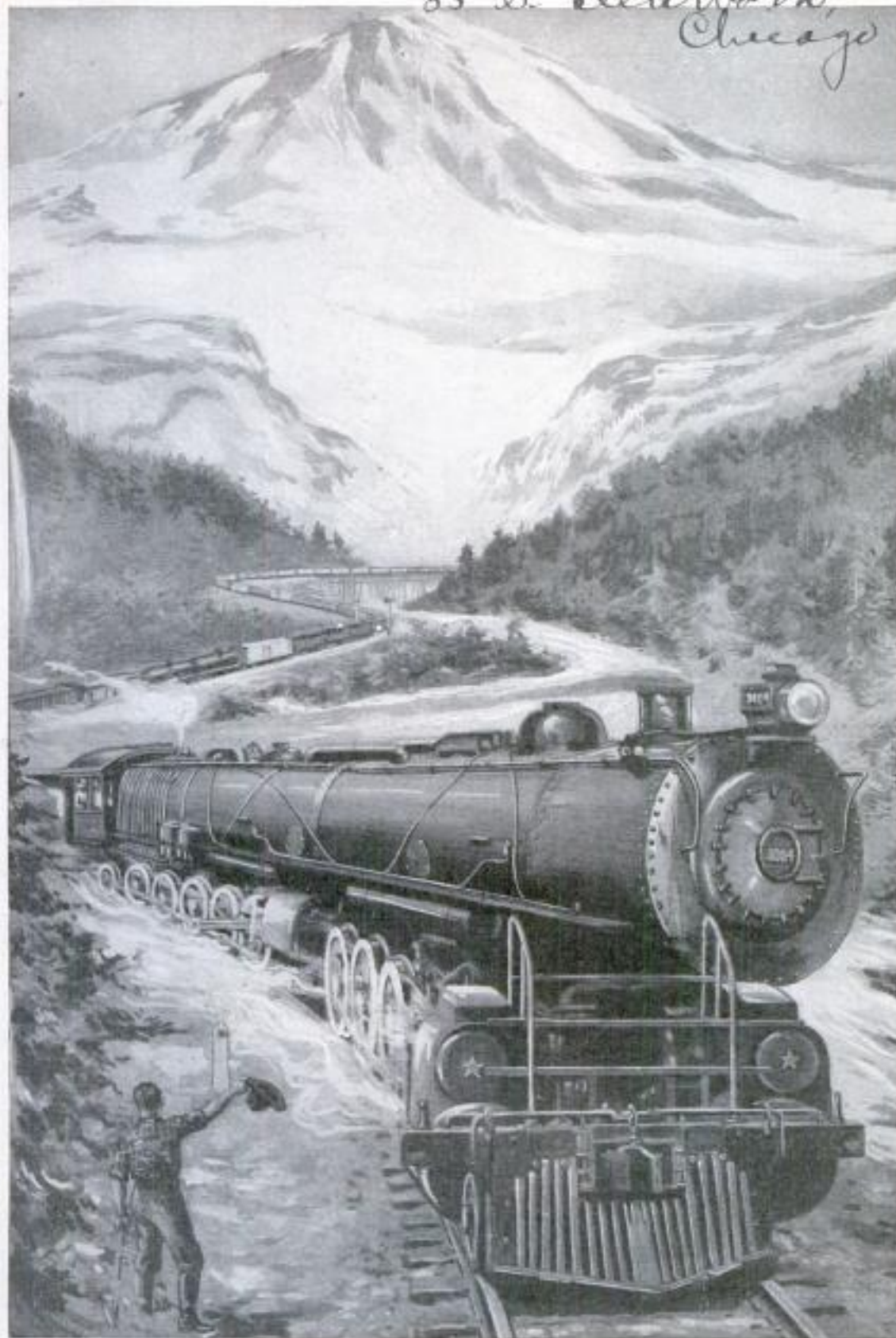
35 S. Dearborn,  
Chicago

#### MONSTER LOCOMOTIVE PIVOTS ON FRONT TRUCK

WHEN this big Mallet-type locomotive takes a curve in the track, it cannot make the turn as its smaller brothers do. Its boilers swing on pivots independently of the wheels, as here shown. The engine—one of the largest ever built—is 108 feet long. It has 12 driving wheels, weighs 850,000 pounds—425 tons—and carries 12,000 gallons of water and 4,000 gallons of oil. Its use has largely been confined to freight hauling, and it easily handles a hundred cars through the mountains of the West. The artist has pictured this giant of man's invention as it roars through a gorge on the line of a western road.

Santa Fe R. R.  
Copyrighted material

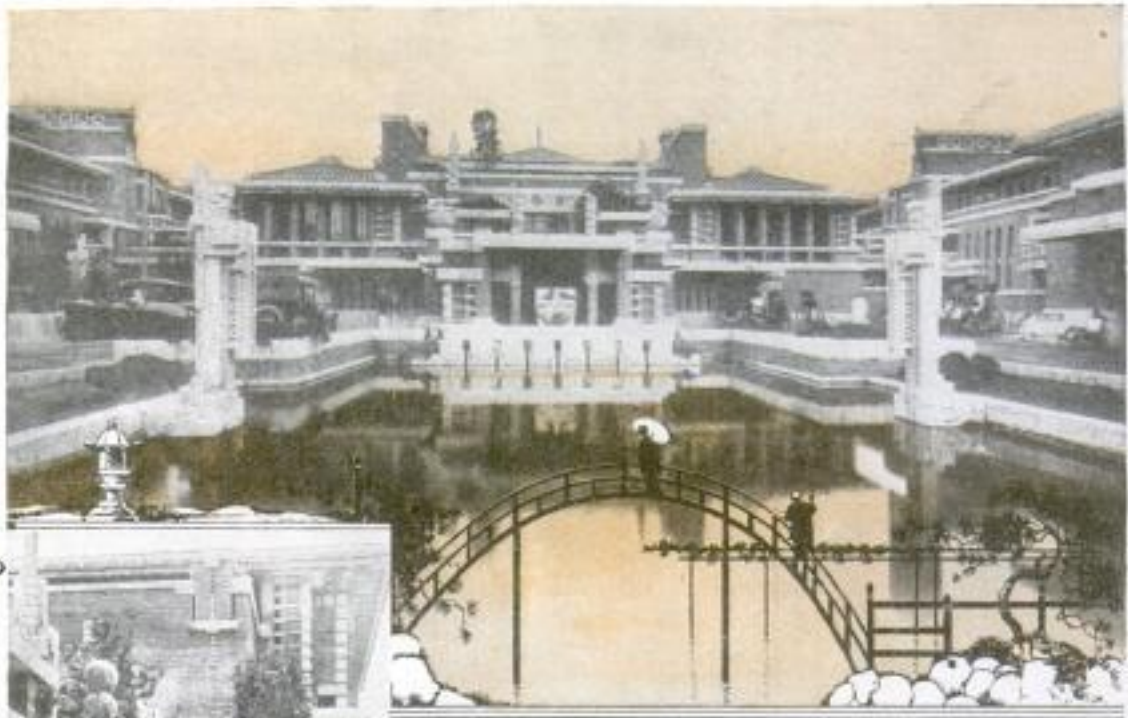

The Views Shown on This Page will Bring Home Some Conception of the Unusually Attractive Design of This Japanese Hotel. The Upper Scene Is a View from the Front. The Pool of Water Is One of a Series Designed to Catch Rainwater and Deliver It to an Underground Cistern. It will Then be Filtered and Pumped throughout the Hotel for Bathing Purposes. The Lower View Shows One of the Promenade Lounges, of Luxurious Simplicity, and the Small View to the Left Is a Portion of the Beautiful Outer Wall. All Materials Used will Be of the Most Durable Type, Such as Brick, Bronze, and Marble, Fashioned to Represent Strength, Simplicity, and Beauty



Architect, Frank Lloyd Wright,  
Chicago.



1791 Cmt. N. Sakata, #10, Seochome

POPULAR MECHANICS  
Iidamachi, Kojimachi-Ku,  
Tokyo,  
Japan.



The Entire Hotel Property in Perspective, as It will Look When Completed: The Two Long Sides, Right and Left, will House a Group of Cottages for Foreign Residents

"WORLD'S FINEST HOTEL"  
1791 FOR JAPAN

To an American, a prominent architect of Chicago, goes the credit for the design of a princely hotel now under construction in Tokyo. Its name—the Imperial—is in keeping with its regal appointments and fittings; but overornateness and excessive decorative effects have been omitted, as not in good taste. The guiding thought of its designer has been to impart character to the structure, and for this reason many conventional ideas as to hotel layout have been discarded, without, however, in any way sacrificing either beauty or comfort. All the power and service requirements of the hotel will be developed and supplied within the structure itself, so that, in reality, it will be a wholly self-contained and self-dependent hostelry. Beautiful gardens are being planned to surround the property and thus afford a suitable setting for its beauty.

Returning after an 18-months' survey in northern Siberia, a Russian mining expedition reported the discovery of new coal deposits about 4,000 square miles in extent. In the Yenisei region, graphite seams about 46 feet deep were also found. It is believed that these could be worked, even under polar conditions.

2333 TAGGING FISH WITH BUTTONS FOR IDENTIFICATION

Various more or less unsatisfactory methods of branding and marking domesticated fish for identification and proof of ownership have long been in use. A practical and comprehensive plan is now suggested by the Bureau of Fisheries, to help in studying the habits of various fish such as salmon, codfish, pollock and haddock. A device similar to a bachelor button of aluminum is riveted into the fish's tail. With this system the oceanic migration of fish, their rate of growth in various localities, and age can be determined. The bureau pays 25 cents each for tags sent in if accompanied by place and date of capture, length, weight and sex of fish, and how marked. Four thousand salmon were marked in 1922, and 10,000 more will be marked in 1923, each with the initials U. S. B. F. and a serial number.



Albion Island Ar. N.E.,  
Washington, D. C.  
Cmt. Verne S. Embury, 2577

g. H. Brown  
Director  
Michigan Auto Tours,  
Battle Creek, Mich.  
MICHIGAN MOTORISTS TOUR THE COUNTRY



Michigan State Police Directing the Loading of Tourists' Baggage into Official Baggage Trucks



A Camp Close-Up: Getting Breakfast in a Hurry

**E**ACH year a large caravan of tourists, mainly from Michigan, but including several other states, conduct an elaborate tour, en masse, and travel together over the entire route. All details, such as camp sites and delivery of mail while on the road, are planned in advance, so that the individual tourist may enjoy the outing to the limit, without petty worries to mar the trip. Similarly, deliveries of gasoline, oil, food supplies of all kinds, and other necessities, are made in camp, so that tourists do not even have to stop for any of these items. The 1923 tour will be from Battle Creek, Mich., to Washington, D. C., and a limit of 210 cars and 800 campers has been set for it.



Air View of One Section of an Earlier Tour Caravan, after a Halt, with 121 Cars in Camp

**LETTERED GLASS  
 PROJECTS  
 HILLSIDE SIGN**

In laying out a hillside sign with letters more than 70 feet high, a western real-estate man resorted to an unusual method in order to get the sign to appear in the proper perspective when viewed from the foot of the slope. The word "Lots," which was the only one in this advertisement, was printed on a small piece of glass and supported in front of a surveyor's transit located at some distance from the foot of the hill. An observer looking through the transit directed the placing of stakes by a man on the hillside. The letters thus outlined were later covered with boards and painted white, standing out undistorted from a distance.



Above: How the Huge Letters Look Viewed from the Slant. Below: As They Look in Proper Perspective from the Foot of the Hill

2406

**POWER PLANTS ARE RUN  
 BY PHONE KEYS**

Engineers have successfully adapted the use of a central telephone system to the control of a group of small power plants. The dispatching system, in charge of one man, is equipped with a small box containing several phone keys and an automatic dial. By connecting the device with any station desired, a series of tone pulses in the receiver indicate the power conditions. This is said to be quicker than if all orders had to be relayed verbally to the operators.

is attached to the signal bracket and is operated from inside the station. At night, it will be illuminated.



Above: Conductor Just About to Remove a Hoop. Below: After Removal

2313

**SAFETY ARM AIDS DELIVERY  
 OF TRAIN ORDERS**

Overcoming the disadvantages in the present method of delivering orders to conductors and engineers on moving trains, is the object of a safety device recently introduced. It consists of a forked arm provided with clips which hold the hoops to which the train orders are attached. Side springs permit lateral movement of the clips in two ways, thus allowing the hoop to be easily withdrawn by a man on a passing train. The apparatus

Cont. F. Christie, 120, Maryland St.  
 Winnipeg, Canada.

Westinghouse Electric & Mfg. Co., East Pittsburgh, Pa.

Inventor, Walter Josephson, The Nauticus

May 12, 1923

*New H. Josephson*  
**BOTTLED FLUID HAS POWER TO LIFT 30,000 POUNDS**

**LINERS TO CARRY PLANES FOR MAIL DELIVERY**

2382 Sindbad's genii flask has been outdone in real life by the invention of an expand-

452 Mail delivery to ports, located off the regular line of call of mail steamers, would be greatly speeded up by use of an aircraft-carrying steamer, the design of which has been submitted to naval architects in London. The plan calls for many changes in the customary lines of steamship construction, but engineers declare these variations can be made successfully. The funnels and ventilators of the new ship would be placed below the top deck, toward the stern, and would discharge either to the starboard or port side, according to the direction of the wind. The landing deck on top of the vessel would thus be left clear from obstructions. The idea in developing the plane carrier is that such a ship, running from Great Britain to New York City, could send off airplanes which would reach Montreal and Canadian points before the steamer docked at New York.



Child Lifting Truck with Force of Expanding Fluid in Steel Container Which is Easily Recharged

ing fluid easily carried in steel bottles by a child. The power may be released by a valve and used with jacks or other



Energy Stored in Small Bottle Used to Lift Heavy Steel Beam

lifting devices to raise street cars, autos, and heavy weights. It is estimated that the power of the expanding fluid will raise 30,000 pounds in three seconds if properly applied.

**RAVAGES OF KILLER WHALE CAUSE BOUNTY**

To hold in check the ravages of the oca, or killer whale, the government has been urged to pay whalers a bounty to destroy this terrible "wolf" of the north Pacific seas. More than 75,000 fur seals are declared to have been destroyed annually by the killer whale, which preys upon the fur seals in the Bering Sea.

**SMELL TO LURE BOLL WEEVIL TO ITS DEATH**

2438 Government chemists are now at work on a new method of attack on the cotton-boll weevil. An attempt is to be made to find out whether any odor from the cotton plant attracts the weevil, and just what it is. It is then hoped to duplicate the odor in the laboratory, and lure the insect to its doom with poisoned bait, if necessary.

*Science News*  
**LIGHT IN RADIATOR CAP FOR ADVERTISING**

237 To act both as a warning signal and for the display of advertisements, monograms, and lodge emblems, an illuminated radiator cap has been devised for motorists. Current from the storage battery of the car is used in the small electric light hidden in the cap.



*Inv. Electric*  
*Dowen 547*  
*Whittier Calif.*  
Copyrighted material

*Grand Central  
Terminal, New York  
City  
% The Great Air Corp.,  
68 Haverly Road  
New York City*

## RICH RELICS FOUND IN MEXICAN PYRAMID

Excavations in the "Pyramid of the Sun," recently discovered in Mexico, are daily bringing to light a wealth of relics through which it is hoped to learn something of one of the earliest civilizations

on the American continent. Strange utensils and wonderfully carved images have been found by the excavators. The carved "writings" of the builders fill the walls of the pyramid.

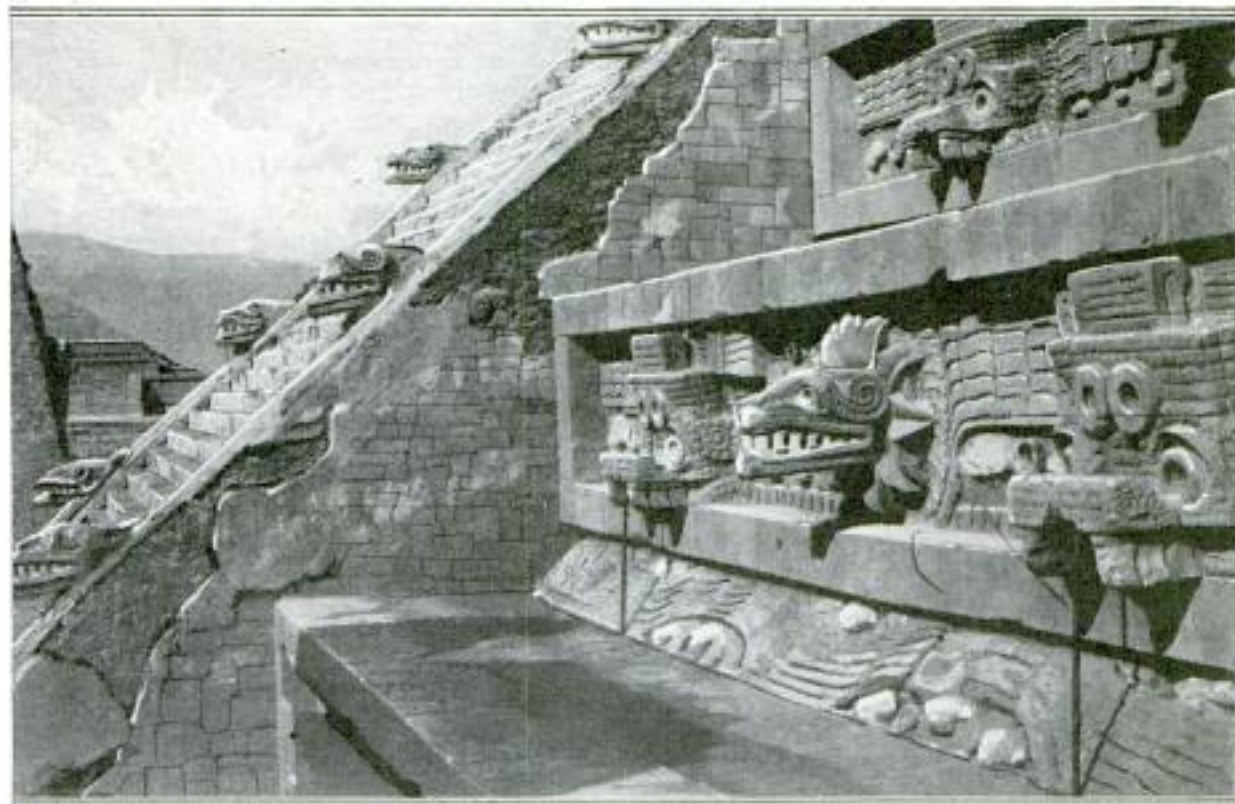

A Section of the "Pyramid of the Sun," Recently Discovered in Mexico: The Carved Images and Fresco Work Are in a State of Almost Perfect Preservation. Many Strange Relics were Found

2219

## "BOAT-TAIL" BULLETS INCREASE RIFLE ACCURACY

Tests conducted by the army, and the experience in competitive rifle matches, indicate that tapering the base of a bullet

builders. A 6° taper has increased the range of the new bullet about 1,400 yards, making a maximum range of 4,800 yards when used with an army rifle. In addition, the path of travel is much flatter, so that greater accuracy is possible. Changing the shape of the bullet has resulted in a "whispering" sound, and will therefore afford no information as to range or source.

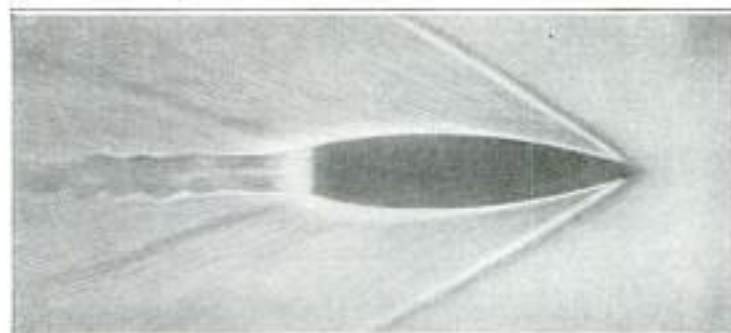

Enlarged View, Showing How the "Boat-Tail" Bullet Looks in Flight: Its Speed at the Muzzle Is About 30 Miles per Minute

has a marked effect on its range and accuracy. This is because the "streamline" shape reduces air friction, a principle long adopted by airplane and automobile-body

builders. Its principal advantage is that it gives a pilot an unobstructed view forward.

☛ Fighting airplanes may be fitted with inverted engines, if these prove successful in tests. The upside-down engine, which is an exact reversal of the ordinary one, has its crankcase at the top and its cylinders beneath.

Western Cartridge Co.  
East Alton, Mo. Copyright material

# TAP WEALTH OF DEATH VALLEY WITH MONORAIL

2405

BY JOHN ANSON FORD

416 Union League Bldg. Los Angeles, Calif.

ON the west slope of that strange and forbidding region in California known as Death Valley, an industrial development is taking place different in many respects from anything else in the world.

Death Valley's fame as a repository of exceedingly pure borax is now to be supplemented by the fact that immense deposits of high-grade Epsom salts have been found there. For years pictures of long mule trains hauling borax have been familiar features in school geographies. Now modern science has introduced into the region a new mode of transportation, a monorail system which is a hundred times more efficient than the multiple-mule team. This will be used not only to transport borax and Epsom salts, but also other minerals found there.

So clear and white are the deposits on the sides of the valley that they appear to be drifts of snow, and the fact that they have lain exposed for ages without being dissolved is due only to the extraordinary dryness of the air. There is absolutely no sign of vegetation on the sun-scorched slopes of the hillsides.

Many miles of the monorail which now taps this wealth is already in operation. Small tractors, altered to meet the demands of this single-rail line are used for power. The cars hauled by these engines are built in the form of an "A" which is balanced at the apex on the one rail, the load being carried on either side. The trains ordinarily travel at a speed of 10 to 15 miles an hour.

In removing the salt deposits it is proposed to use the hydraulic method of cutting down the hillsides by constructing a reservoir on the high ground and piping the water into the valley. Powerful streams of water will be directed against the hillsides, washing the mineral salts into sluiceways and then into settling tanks or vats. As it has been found that the salts dissolve more rapidly in hot water, the supply will be heated by using great solar heaters consisting of copper coils under glass set at an angle that will admit a maximum of exposure to the sun.

Desert heat also will be utilized to evaporate the brine carrying the salts in the settling tanks. The resulting deposits will then be taken to a refinery and subjected to several treatments designed to produce the desired separations. One of

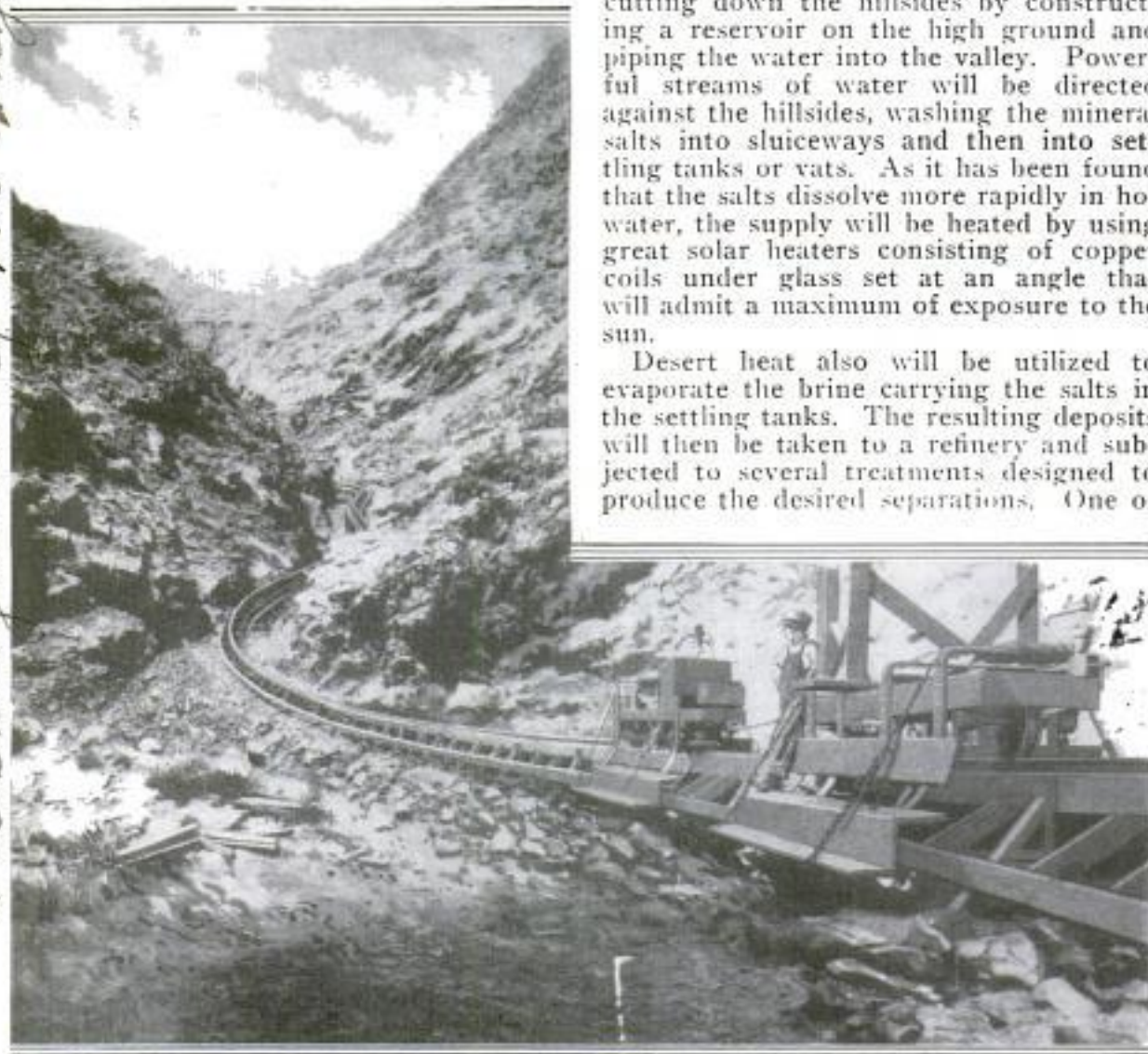

Curving Track of Monorail Road and One of the Engines Which have Supplanted the Familiar Mules in Handling Borax and Other Mineral Deposits

Operated by American Magnesium Co., Washington Bldg. Los Angeles, Calif.

the products resulting will be magnesium carbonate, large quantities of which are used in making automobile tires and other rubber goods.

By the use of these scientific methods it is expected that the cost of removing the salts will be considerably lowered, the carrying expense alone being placed at less than \$1 a ton.

2364  
**JAPANESE GARDEN ON NEW YORK HOTEL ROOF**

Unusually novel settings have been devised to add beauty to New York's hotel roofs, and the latest to appear makes a

2453  
**UNEARTH ADDING MACHINE IN OLD INCA TOMB**

That the ancient Inca civilization in Peru possessed an adding and calculating machine has been revealed in the recent discovery by excavators of a knotted cord, or "quipu," in the ruins of a pre-historic tomb. The cord is 16 yards long and contains 100 knots. Divided into 10 unequal sections, these knots represent the odd numbers from 1 to 19. The sections are of different colors, including red, brown, yellow, blue, and green, and are separated by silver beads, which represent the even numbers from 2 to 20. By using



Here is a Small Portion of Japan, Transplanted to the Top of a New York Hotel Roof; It Represents a Part of the Imperial Garden in Tokyo, and was Built Overnight

similar claim to attention. A Japanese landscape architect designed it to represent a tropical garden of the "Flowery Kingdom." It is supposed to be an exact likeness of a portion of the Imperial Garden at Tokyo, and is alive with typical Japanese flowers, plants, and other vegetation. Ducklings paddle about in a miniature lake to add reality to the scene.

Ⓐerial photography as a means of fire prevention in cities is being investigated by the fire-insurance companies. Fire hazards that escape the casual observer on the ground become strikingly apparent on a map made from photographs taken from an airplane.

this simple way of counting, based on the decimal system, rapid calculations can be made.

245L  
**ELECTRIC LIFEBOAT LIGHTS AS SAFETY BEACONS**

Designed to add to the safety of passengers in case of accident, an invention for the automatic lighting of lifeboats has been tested in London. By the new device, two small electric lights are switched on when the boat touches the water. A float, incased in a tube at the stern of the boat, operates the switch. Storage batteries, capable of giving 24 hours' continuous light, are carried on board.

The Electrical Record  
London, England  
5/4/23

The Detroit Free Press. Mich. 5/18/23  
Detroit.

George H. Pindar, Chairman 2455  
American Museum of Natural History  
POPULAR MECHANICS  
History, 77th + Central

**FOSSILS PROVE ASIA ONCE PART OF AMERICA**

2047

Fossils unearthed by the Third Asiatic Expedition, working in Mongolia, prove that a broad land connection once ex-

**SOW HAWAIIAN FIG GROVES FROM ARMY PLANES**

Sowing seeds is one of the latest services that United States army fliers have been asked to perform. When the Department of Agriculture recently wished to plant a number of barren areas in Hawaii with fig trees, it was found the project would require months of hard work in places that were almost inaccessible. Two planes with four airmen were assigned the task and planted the grounds in less than three hours. When matured, the fig trees bear large quantities of fruit each year, and will help in preserving the moisture of the islands. Some of them cover an area of 2,000 square feet and

The World, New York 5/20/23

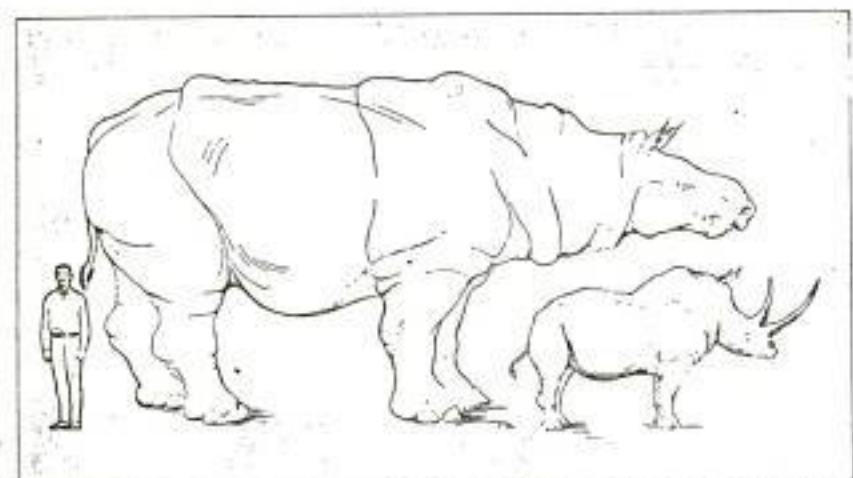

View Showing the Comparative Sizes of a Man, an African Rhinoceros, and the Giant Baluchitherium

isted between North America and Asia. Part of the remains has been identified as that of the "titanotherium," which roamed over Utah and Montana several million years ago. Perhaps the most important find is the skull of a "baluchitherium," a giant rhinoceros and one of the largest land mammals that ever lived. This animal is estimated to have measured at least 12 feet high and about 24 feet long.

have been known to bear 10,000 pounds of figs in a single year.

**MILLIONS OF FLIES MADE TO TEMPT FISHES**

2460

Search for the gamy trout, bass, or salmon has turned the making of artificial flies into an industry employing hundreds of persons. Every color of the rainbow, and every possible variety of bug or fly is cleverly imitated to lure the fish to the hook. Feathers form an important part of such bait. They come from the neck of the chicken, from peacocks, ducks, ostriches, gold and silver pheasants, and even African jungle birds—all to suit the whims of the angler. Formerly they were hard to get, but the industry has grown to such proportions that feather dealers now supply any kind wanted. They are dyed in more than 150 different shades and colors. For other necessary materials, not only the United States and Canada, but Norway and Spain as well are combed. Northern Europe furnishes just the right kind of hook, and the southern country silkworm gut. One of the largest American factories making artificial bait was started by a woman who first made them for her father. This plant alone now turns out upward of 5,000,000 artificial flies a year.

May 18th 1923  
Star Finances es. Coleman, Montpelier, Vt.  
Mrs. M. C. ...  
Romeas City

**OWNER DISGUISES HIS CAR WITH ALUMINUM BODY**

2465

In a search for variety, an owner of a small automobile recently built a body of aluminum for it which gave the machine the appearance of a far more costly car. Practically the only change he made in the chassis was to lengthen the frame

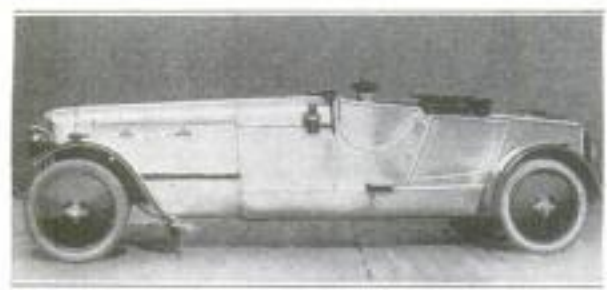

Aluminum Body Built by Owner Shows How Appearance of Car may be Improved

several inches. Of the roadster type, with pointed radiator and disk wheels, the body naturally improved the appearance of the car quite considerably.

Erection of a giant pipe organ is being planned for the so-called cathedral rocks in Zion National Park, Utah.



**2437 SALVATION ARMY DOUGHNUTS  
 IN CHURCH CARVING**

To commemorate the war service of the Salvation Army, a church in New York has placed a wood carving in its choir. The central figure is a woman in uniform carrying a tray filled with doughnuts. On each side are figures of doughboys in attitudes of appreciation and gratitude, and to the right, in the center of a scroll, is a group comprising a trumpet, a tambourine, and a bible, representing the principles and methods of the Salvation Army.

*2299*

**NEW TYPE OF JOINT MAKES  
 ROD VERY FLEXIBLE**

A new steel rod for bait casting with "staggered" joints, or joints that vary in length, has been invented. The first joint, in the heavy section, is short, the second one longer, and the third still longer, which gives the rod unusual balance and flexibility. This flexibility is further increased by wafer-thin sleeves of steel at the ferrules which reinforce the joints. These improvements are said to

*Richardson Rod & Reel Co.*  
*536 Lake Shore Drive*

**RAT KILLER AND FOOT-SET  
 RAT TRAP INVENTED**

*2195*

A mechanical rat killer with a heavy spring and a rotating double hammer which strikes the animal on the head and throws him from 5 to 8 feet, is the latest in traps. This device automatically resets itself for the next blow, and two safety catches prevent accidental discharge. The rat is thrown away at once and leaves no odor to scare away other rats. The trap is made in two sizes, one for rats and one for mice.

Another unusual trap, made of all steel,

give a very light rod and a perfect curve, and unusual distance and accuracy in practice, so that the angler has the com-

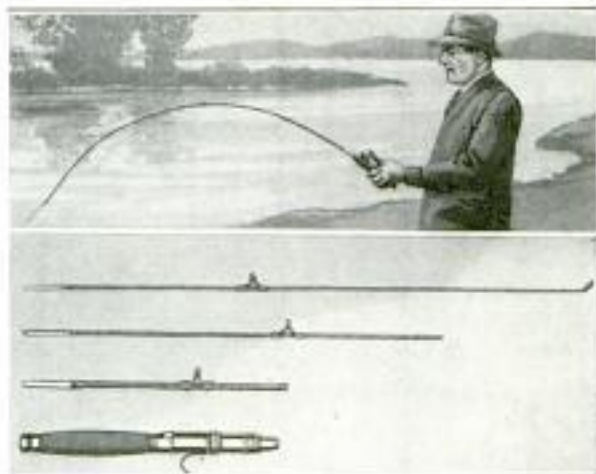

Upper View Shows How Much "Give" the Rod Has, and the Lower, Its Three Sections and Grip

combined advantages of a bamboo rod's lightness and a steel rod's strength.

Out of a total of \$76,757,040 expended by the Rockefeller Foundation in the past 10 years, over \$18,000,000 was distributed in the interest of public health.



is set by foot pressure, thus avoiding all danger of injury to the fingers. The jaw, when set, is at an angle of 90° instead of 180°, as in old-style traps, and the action is much

quicker. The trap, being steel, is easily disinfected by dipping in hot water.



This Rat Killer Knocks Its Victim on the Head, Then Flings It Promptly Away from the Machine. On the Left is a Close-Up of the Device When Set

*Snappy Mfg Co. & Huron*  
*18* *Copyrighted material.*  
*Chicago*

The India Rubber Works Similar - Wright  
 Rubber Products Co.  
 Racine, Wis.

2264

4/1/23

POPULAR MECHANICS



Copyright, Underwood & Underwood  
 An Experimental Rubber-Block Pavement in London

### RUBBER PAVEMENT MAY SAVE COST OF NEW BRIDGE

It is believed that rubber pavement, with which considerable experimenting has been done in recent years, may provide a solution for a bridge problem at Boston and save that city and Cambridge over \$6,000,000. Spanning the Charles River and connecting the two cities is a bridge that vibrates so excessively under street-car and vehicular traffic, that none of the types of pavement tried has remained long in place, and even the safety of the steel structure is threatened. The city of London, Eng., has experimented with pavements of rubber blocks for some time past, and found them durable and satisfactory in every way.

Recent tests made by the Imperial Institute indicate that the talipot palm, or fan palm, of South India may prove a promising paper-making material. The leaf stalks give a good yield of pulp, from which can be made a good quality of brown paper.

### PANAMA'S TORRENT GREATER THAN THAT OF NIAGARA

Tremendous as is the volume of water constantly rushing over Niagara Falls, recent statistics indicated that it is exceeded by that passing through the eight

spillways of the Panama Canal. It has been estimated by engineers that these gates pour out a flood amounting to 103,000 cubic feet of water every second. This figure will be considerably higher when present plans to increase the capacity of the canal locks are carried out.



Some of the 'Great Spillways' at the Panama Canal, Showing Torrents of Water Rushing toward the Ocean

Wide World Photo  
 New York City  
 Copyrighted material

Rubber Blocks for Pavement.  
 Royal Portland Rubber Co. Ltd  
 Edinburgh

2333

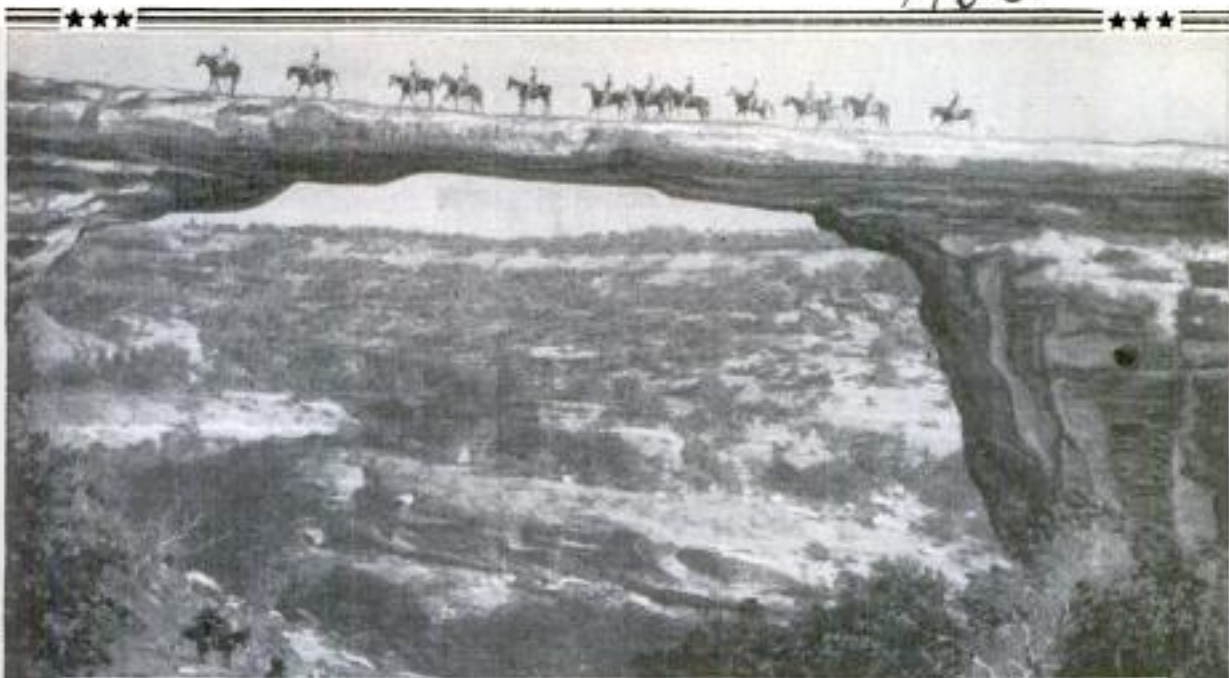

## WILDERNESS WONDERS TO BE MADE ACCESSIBLE

*By J. Cecil Alter*

1103

*Destiny Ridge, Utah  
Salt Lake City*

ONE of the world's most extensive known groups of natural bridges is to be made accessible to automobile tourists soon, according to present plans. These gigantic rock spans, notable for their scenic beauty, are in Utah, about 140 miles from the nearest railway.

To reach them it will be necessary to blaze a trail through a western wilderness, across several deep and rugged canyons, and span sandy washes, to Elk Mountain, which is about half a mile from the bridges.

From the top of this peak, a forest-covered table-land, there is a magnificent view for 50 or 75 miles, south into Arizona, and west into the central part of the state. Clad in a blanket of bushy cedars, the appearance is pleasing, but the close-set trees with their vicious snags and prongs repel invaders.

So extraordinary are the carvings and foldings of the watercourses in this region that many grotesque figures appear. Winding through intricate labyrinths of rocks, the burrowing streams, in entrenching themselves, have formed amazing cradlelike folds, overhung with wonderful arches and cornices in scores of places.

Cattlemen in quest of wandering stock first penetrated to the inspiring natural bridges in 1883. First to be encountered

was the Edwin, which was formed by a channel piercing the wall into Armstrong Canyon. Ages have elapsed since this breaking through occurred, and the channel is now 40 or 50 feet deeper than the original outlet, and the arch has been greatly widened. Bared by the weather, the span is exceptionally graceful, its abutments having been chiseled away by nature in outlines and dimensions so symmetrical as to suggest a studied engineering feat.

Rising more than 100 feet above the tourist's campfire, the span is 200 feet and the extreme width in the middle 30 feet. Horses are easily ridden to the top for the thrill afforded the rider in crossing the narrow causeway.

Fittingly named, the Sitting Duck is a colossal figure near the Edwin, the bird's bill and neck forming the abutment and a section of the span of what appears to be a fallen bridge. This monarch was evidently produced when a gooseneck in the canyon was holed through by the waters, finally leaving a causeway 200 feet above the stream.

Four miles away by a difficult trail is the Caroline Bridge, the opening of which is rather small compared with the other dimensions, and it is therefore considered to be one of the youngest. Its span is 250 feet, height 165 feet, and

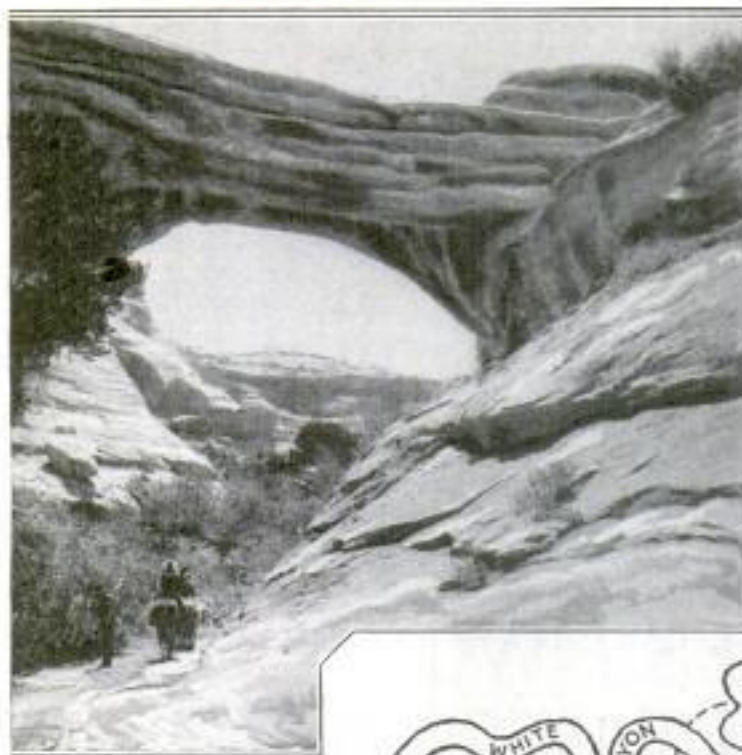

This is the Tourist's First View of the Augusta Bridge, some 600 Feet Distant, as Seen from the Southwest Approach. The Sketch at the Right Represents Part of the Canyon Layout, and Gives Some Idea of its Snake-like Course

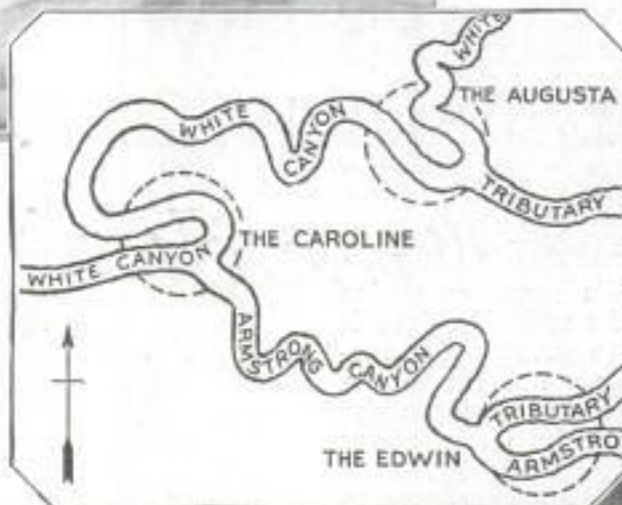

width 60 feet. About two miles farther on is the Augusta, said to be the most graceful and pleasing of the trio. It also is the largest and the most gorgeously decorated. Two great hummocks of sandstone surmount the abutments, tending to belittle the bridge when viewed from the canyon walls.

Access to the top is gained only by sure-footed travelers, or with the aid of ropes and skilled guides. Viewed from below, its enormous size seems to defy familiarity and close acquaintance, towering to the height of a 15-story building.

In all these 40 years since the first of the bridges was discovered, a mere handful of tourists have visited the forbidding, inhospitable region to view them. One party made an outline survey of the section for designat-

ing the Natural Bridges National Monument, which was created in 1908-09.

Previously, a group of scientists had penetrated the surrounding wilderness, ascertained the dimensions of the bridges, made the first photographs and paintings, and then christened these stupendous freaks of nature. In 1921, state officials visited the bridges and conceived the project for an automobile road.

Numerous relics of the cliff dwellers who formerly peopled the canyons have been found. Food caches in cribs and cairns appear in the crevices high along the walls and in the great cavernous overhanging shelves near the bridges.

Although work on a small section of the roadway already has been begun, it may be several years before it



The Beautiful Caroline Arch, at the Junction of Armstrong and White Canyons, Looking North: The Party of Tourists Look Like Pygmies under Its Lofty Portal

1903

is completed because of the engineering difficulties encountered.

Winding through the wilderness, the road, when completed, will run through the frontier town of Blanding, the nearest point of civilization, and Elk Mountain, noted for its scenic beauties. Local, state, and government officials are cooperating in the opening of the highway, as it will be of service not only to



The Scene Above Shows How Striking Is the View of the Edwin Natural Bridge, as Seen from a Knoll at Its Eastern End. Water from the Canyon at the Right Holed through the Thin Wall of the Rock Ledge, Forming the Bridge. At the Left Is the Ladder Ruin, Used by the Cliff Dwellers Ages Ago. Its Upper Shelf Is 90 Feet above the Canyon Floor. The Ancient Ladder Is Still Strong Enough to Carry a Heavy Man



tourists but to timber cutters and cattlemen as well.

Heretofore tourists who have penetrated to this region have had to use horses and go afoot part of the way. Few have penetrated farther than the Kigalia ranger station on Elk Mountain, from where they were afforded a clear view of the surrounding forests and rock formations.

Automobile tourists have not been able to reach this spot, but can do so as soon as the first section of road, now under construction, is completed. The first stretch of highway will cover 12 miles.

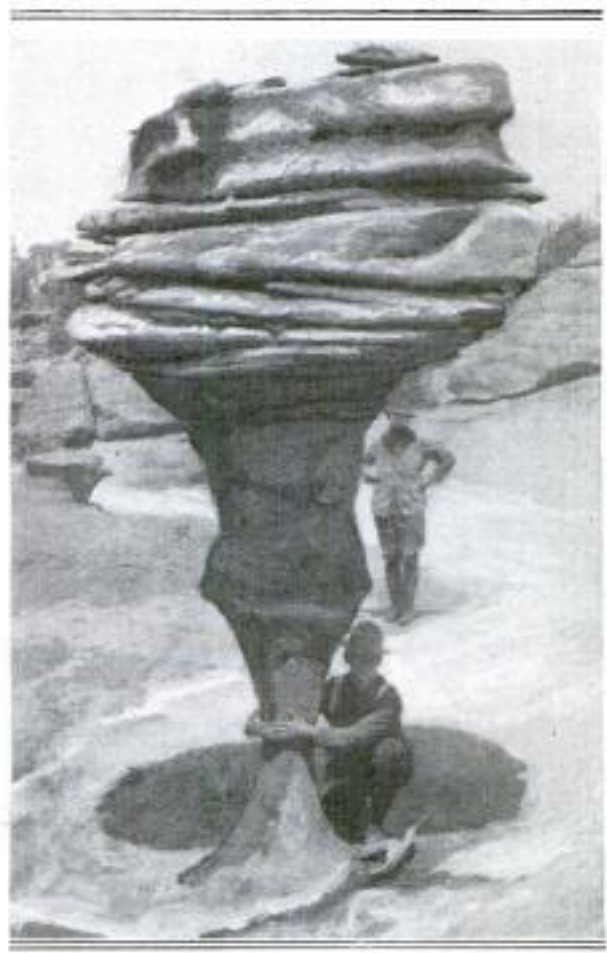

Here Is the "Wine Glass" Fashioned by Wind, Rain, and Sand Out of Solid Rock: Its Stem in Particular Is "Lifelike" in Formation

No data on this

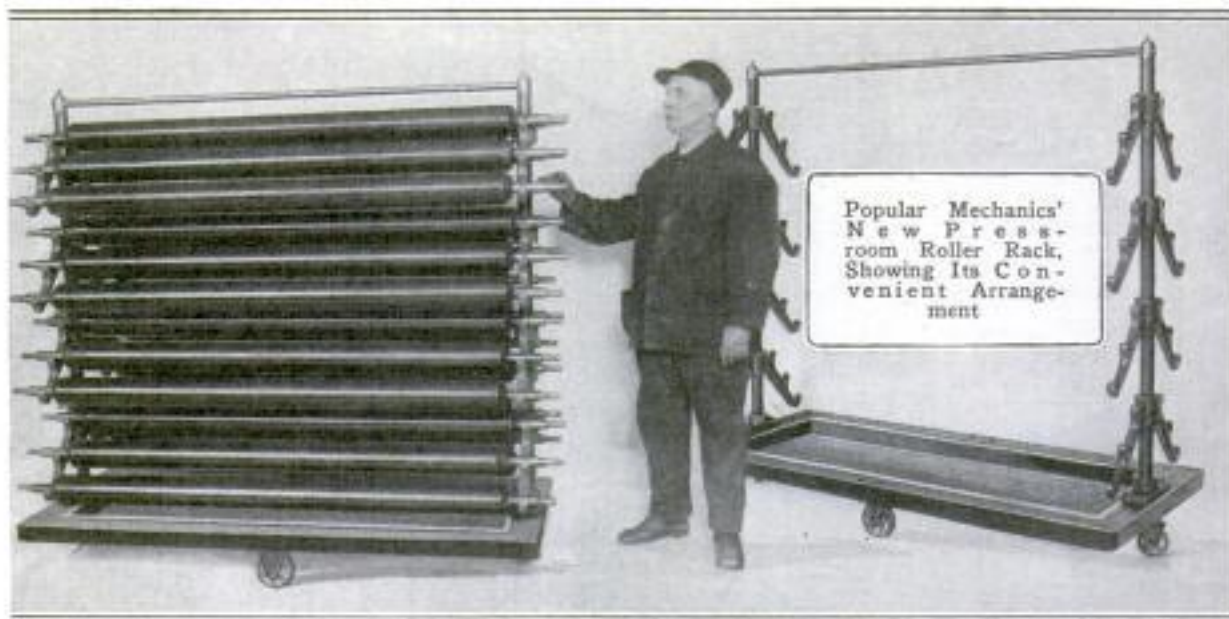

**NEW RACK FOR PRESSROOM HOLDS MANY ROLLERS**

Rollers for printing presses must be removed from time to time for cleaning, or while the presses are idle. To aid in this work, an improved type of rack has been devised by the head of the press-

room in Popular Mechanics' new building. Several brackets are arranged on the uprights of the rack, so that they are able to carry as many as 24 rollers. The platform is mounted on casters, so that it can be moved about easily, and is fitted with a drip pan for receiving the excess oil when the rollers are being cleaned.

**BASEBALL IN "CRACKED" PANE ATTRACTS ATTENTION**

Sawing a baseball in two and gluing the two halves opposite each other on a glass-window front was the clever trick resorted to by a sporting-goods merchant

to attract attention to his store. Chalk-lined "cracks" were drawn radiating from the baseball, and gave a realistic appearance to the fracture. During the first few days crowds gathered and commented on the freakish result of the "throw."

**EGGS ARE GROWING LONGER, U. S. SCIENTISTS FIND**

Due to scientific breeding and improved methods in the poultry industry, eggs are growing longer, government investigators have found. Research authorities, studying the cause of increased breakage of eggs packed for shipment, disclosed the fact that standard crates with honey-comb sections are no longer an assurance against damage in transportation. As a result, poultry growers, who wish to ship long eggs, have been urged either to pack a smaller number in each crate or to increase the size of the crate by nailing strips, about 1 inch high, on top of the two ends and the center dividing board. If these steps are not taken, it is advised that the farmer sell his long eggs locally and ship the shorter ones.

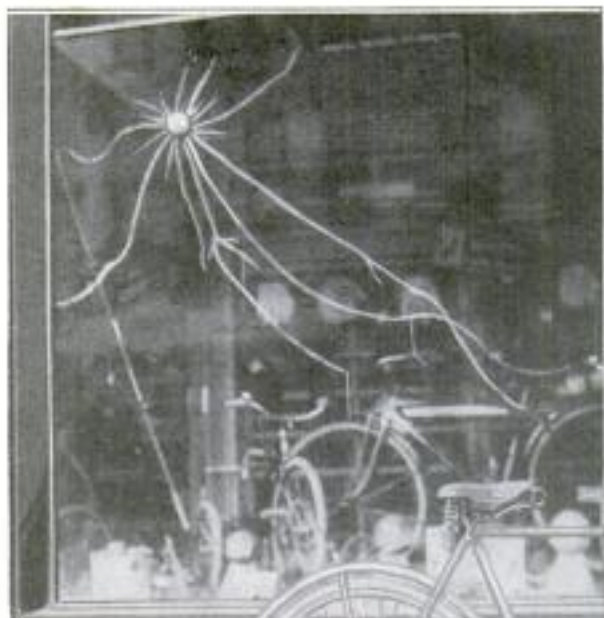

Baseball Which Attracted Crowds: It Looks Like a Freak "Throw"

Tests of a form of lead in the treatment of cancer are being made in England.

Chesler, Lyndelle  
Rear 750, Trenton, N.J.  
Cmt.

May 21, 1923  
New York Times

# COMMENT AND REVIEW

[These pages were printed May 26, 1923.]

**O**NLY a few months ago, a well-known advertising man, Will H. Dilg, found it impossible to any longer restrain himself and, on his own account, started a long-cherished campaign to save our great outdoors. The immediate results of his efforts were so amazing that a small group of wealthy men contributed \$25,000 to carry on the work. A few days ago the first national convention of the Izaak Walton League of America was held in Chicago, with hundreds of delegates, representing nearly every state. The local branches of the league are known as chapters. Already there are hundreds of these chapters, some of them reporting over 500 members, while the total membership is now over 100,000, with the prospect of a membership of 2,000,000 or more within another year or two.

*Saving  
the  
Outdoors*

While various bills have been introduced from time to time in state legislatures, and national legislation has helped preserve the migratory birds, there has never been, until the organization of the Walton League, a consistent, national effort to save those features of the great outdoors that are rapidly approaching the vanishing point by wanton destruction and needless waste.

Our mountains, lakes, and rivers remain, though the streams are rapidly becoming deadly to all fish life through pollution; and our forests, or what is left of them, will soon be only vast tracts of ugly stumps. It is to check this rapid, and largely needless, waste of bird, game, and water life, and the utter destruction of forests that the league was organized. In proportion as trees diminish, birds and streams decrease; and as the birds decrease, the number and ravages of all insect pests increase.

It is not generally known that the greater portion of wild game served on club and hotel tables in this country is imported from Europe. But by reason of well-considered regulations and protective measures, Europe, which has been taking game for centuries, actually shows a yearly increase, while in our country, comparatively a child in years of settlement, it is rapidly becoming extinct.

It is that the boys and girls of a generation hence may enjoy the same attraction of the outdoors which their grandfathers did, that the league has been formed. Cities try to meet this inborn desire with parks and bathing beaches. Excellent as far as they go; but no park is more than a poor imitation of nature, unless it be a reservation of virgin forests, occasionally snatched in time. Such an example is the Superior National Forest, in Minnesota, which owes its preservation, a few weeks ago, largely to the efforts of the Izaak Walton League.

Streams which only five or ten years ago teemed with fish are now almost or entirely fishless due to deadly chemicals discharged from factories, or sewer pollution from towns and cities. The league intends to restore these streams and see that they are restocked—but not in a day or year. It will use its influence to immediately stop further contamination, and allow a reasonable number of years for present offenders to otherwise dispose of their destructive waste matter. Incidentally, when this is accomplished, the factories and mills will discover an actual saving in dollars by the recovery of by-products now going to waste.

The league is not primarily for rich men and the residents of cities, though they need the native outdoors more than the dweller on farm and in smaller towns; quite the contrary. It is frankly acknowledged at Washington that many species of game birds would now be extinct in this country but for the efforts of rich men in maintaining preserves—in some cases entire large islands; the benefit from which is enjoyed by hunters one and two thousand miles away. The league plan contemplates an abundance of game and fish for everybody, in every state, within a very few years. It will also foster bird life other than game birds; it will restore our streams, making them fit to drink; it will conserve our remaining forests and secure the replanting of cut-over and other waste lands. It even hopes to line our country highways with beautiful shade and fruit trees. In short, its objects redound to the good of all, without depriving any (except the pot hunters) of any present pleasure.

There should be a chapter in every community. Ladies can join, and "juniors" are recognized and provided for as members. The movement is such an ideal one, and at the same time so practical and attractive, it deserves the support of all.

The league has a large monthly magazine contributed to voluntarily by such writers as Zane Grey, Dr. David Starr Jordan, Dr. Henry Van Dyke, Mrs. Jean Stratton Porter, Irvin S. Cobb, Mary Roberts Rinehart, James Oliver Curwood, and a host of equally brilliant writers who love the outdoors. Annual membership in the league, including the magazine, is two dollars; a large number of women have already enrolled. If no chapter has been organized in your community, there should be one, and full information will be sent, on request, from the Izaak Walton League, 336 West Madison St., Chicago.



**A** GOOD part of the money contributed for the support of churches comes from people who make a real sacrifice to do so. In these days of practical conduct of affairs, church managements may well apply more of the successful business methods of successful business men.

*Syndicating  
Sermons  
to Churches*

The word "syndicate" was once construed as an organization formed to "do" good people; this impression later came to mean often a desirable and laudable undertaking; the syndicate to be suggested has but one purpose and that is to do people good.

The telephone company is a fine example of what consolidation of small rival companies in the same town has accomplished in effecting great economies, improved service, and ability to provide the latest and best equipment, which the small individual companies would still be without.

This is a day of syndicate work, of which the country "daily" is a good illustration. The work of cartoonists and authors who are so high-salaried that only a few big metropolitan dailies could afford them, is now sent broadcast into every community, and read daily by millions instead of thousands. Yet the expense to the smaller papers is not prohibitive, because it is divided among so many.

The movies furnish another instance, bringing to even villages, at a small price, major attractions with star actors and scenery costing hundreds of thousands of dollars to produce.

In a small town in Illinois, there were five Protestant churches, each with its own building and minister. The membership of each was too small to properly compensate their clergy; which meant the clergymen were disgracefully underpaid, or the churches had to be satisfied with less qualified men. Also five buildings had to be lighted, heated, and kept in repair; five organists, five choirs, and new music for each had to be maintained. Now the five churches have combined to meet in one edifice, and will be able to pay enough to properly maintain one able clergyman and have the best of music, with ample funds to take care of the necessary local charities in a businesslike manner.

Is there any logical reason why our religious bodies cannot adopt the syndicate idea to advantage? It has seemed to me for a long time, that the method is simple and practical. It could be operated either by a combination of denominations working as one united interest, or by each denomination for its own churches exclusively. The plan is to select from their clergy the most brilliant men of national reputation, to furnish one sermon each per week. This sermon would be printed and syndicated to all the smaller churches and read by their pastors at the morning service. For the evening service the local pastor could provide his own discourse. But this would accomplish two things: first one very strong sermon each week; and second, the local pastor would have so much more time for the ever-increasing parish work of visiting the sick, conducting funerals, making secular addresses, and the endless demands on his time which no one but the clergyman himself can fully realize. It would be no more reflection on the ability of the local pastor than it is to invite a bishop or leading preacher from some large city to occupy his pulpit when the bishop happens to be visiting a small town.

These syndicate sermons would not only be the best thought of rare, unusual men, but each of them would take the time, and spare no effort, to produce the very best that is in him, for he would realize he was appealing to several million people instead of hundreds. Each denomination could easily furnish enough men to each prepare one or two sermons a year; they might even be sermons he delivered to his own congregation—and if a union of denominations was effected for the purpose of these syndicate sermons, even the best men could not hope to contribute more than once in any year. These kings of thought and oratory would not only contribute wonderful sermons but could also serve as a board of review—not as movie censors do, to eliminate the bad, but to strengthen and if possible



improve the matter submitted, with a view to making it as nearly perfect as possible. Obviously appointment on such a national board would be an honor as greatly prized as membership in the most learned and exclusive scientific societies. The expense of printing and mailing need not exceed three cents a week per church served.

In addition, if consolidations of local bodies were accomplished, as in the case described, the saving in money would be great, while the drawing power of such union churches would be tremendously increased.

The plan is not intended to serve large city churches—they do not need it—but if the thousands of small churches could adopt business methods to a greater extent, is it not at least probable that many pews at present empty might be filled?



**T**ODAY came a blotter, very fair as blotters go, but what impressed me was its message—a veritable tirade against motor cars—"the modern juggernaut; the rich man's funeral car." The protest against the tremendous and rapidly increasing loss of life cannot be too strongly expressed, but the reference to rich men is hardly fair. There are over ten million cars now in operation and several thousand trucks, and I am sure there are not ten million "rich" men in this country; the revenue department numbers them only in hundreds. As a matter of fact, I, personally, have had to jump from the path of numberless flivvers, but seldom from in front of any rich man's car.

*The  
Murderous  
Motor*

The well-to-do, barring an occasional wild-oats young man, are usually very considerate of pedestrians; and their drivers, generally experienced men, are required to use the utmost caution.

There are exceptions of course, as in all rules, and the penalty recently meted out to a Philadelphia banker, who was sentenced to several years in the penitentiary for what was proved to be inexcusable carelessness, should meet with universal approval. The mere incident that he was a rich man did not save him from punishment, and is to the credit of the Pennsylvania courts; and it is to be hoped the good work will be continued and widely extended, to take in all offenders, high and low. It makes little difference to a bereaved family what a man's social standing is, when his criminal carelessness has crushed the life from one of its members.

In the large cities the majority of fatalities to children seems to come from motor trucks, many drivers of which appear to assume, for some reason, that a loaded truck has the right of way over pedestrians and other cars. It is inevitable that some accidents must occur even with the utmost care, by reason of the vast number of motor vehicles operated. I suppose if there were ten million teams of horses in service on our streets and highways, there would be many fatalities, although a horse will usually endeavor to avoid running over a person, if it sees him in time. The truck has no such intuition, and far too often its driver seems about as regardless as the machine.

For a long time it has been evident that a fine of a few dollars utterly fails to stop or even check the mad impulse to go fast. Various expedients have been offered, such as a gear construction which will render a car unable to go faster than a determined speed under any circumstances; and a telltale light, inside or outside the car, which will burn when the speed limit is exceeded; loud-sounding gongs which ring at higher speeds have been proposed, and several other automatic safeguards to warn both drivers and police. But thus far little has been done except a very few convictions, the revocation of some licenses, and fines to be paid in money. There is one thing the great majority fear, and that is a jail sentence. Indeed, it is about the only penalty which comes close enough to all to really assert and impress itself. As cars increase to still more millions, conditions will inevitably become worse and worse. In the meantime, at the present rate, many thousand citizens are doomed to lose their lives. All the efforts exerted in welfare work will not compensate for this motor murder.

Why then prolong the slaughter? The earlier all the states enact and execute strict laws in this matter, the sooner the reform will come. We are already "lawed" almost to the point of extinction, but this is one law which is really needed. One accident-insurance company estimates the number of deaths from motors in 1923 at not less than 14,000—an increase over last year of 4,000 fatalities.

H. H. WINDSOR

**WORLD'S CHAMPION WHISKERS  
IN CALIFORNIA**

23 52

Two residents of San Francisco, who participated in the famous gold rush of '49, lay claim to what is believed to be the champion whiskers of the world. A



The Man at the Right Owns 17 Feet, and the One on the Left, 11 Feet 3 Inches of Whiskers

total of 28 feet 3 inches of whiskers is owned between them, the length of one set being 17 feet, and the other measuring 11 feet 3 inches. Each tapers down to a ropelike coil, which is thrown around the shoulders.

**DEVICE THAT TESTS VOICE  
IS AID TO SINGERS**

2454

To make it possible to study the human voice, a new instrument has been constructed in Vienna. It is declared to be a valuable asset in treating voice defects of singers, and also in the study of the causes of epilepsy. Deaf persons, using the instrument, can tell just how loudly they are speaking and pitch their voices accordingly. Epileptics, it is said, have a peculiar kind of speech record, indicating that the disease is not a brain defect, and that it is curable.

*The Denver Post  
5/16/23*

**DIAMONDS SET WITH TOOL  
ATTACHED TO LATHE**

2439

To enable jewelers easily to set diamonds and other stones in the new-style basket-ring mountings, an inventor has patented a tool which is attached to the ordinary jeweler's lathe. At present this work is done by hand, for the most part by skilled artisans and manufacturers. With the new tool, the mounting is set in the lathe and a seat drilled for the stone. At the same time, a shoulder is made, which is turned back over the edges of the jewel with a blunt instrument.

2397

**HANG YOUR TIRE ON TOTEM  
POLE, PLEA FOR CHARITY**

Red Cross workers in California have struck upon a novel plan for salvaging old tires, as a source of revenue for charity. A totem pole was set up on one of the main thoroughfares and passing motorists are invited to make a "ringer" with their worn-out casings. The tires are collected daily by the society and sold to junk dealers for the benefit of its funds.



Motorist in Berkeley, California, Putting Old Tire on Red Cross Totem Pole; The Rubber is Salvaged for Charity

*The Berkeley Red Cross  
Society, Berkeley, Calif.*

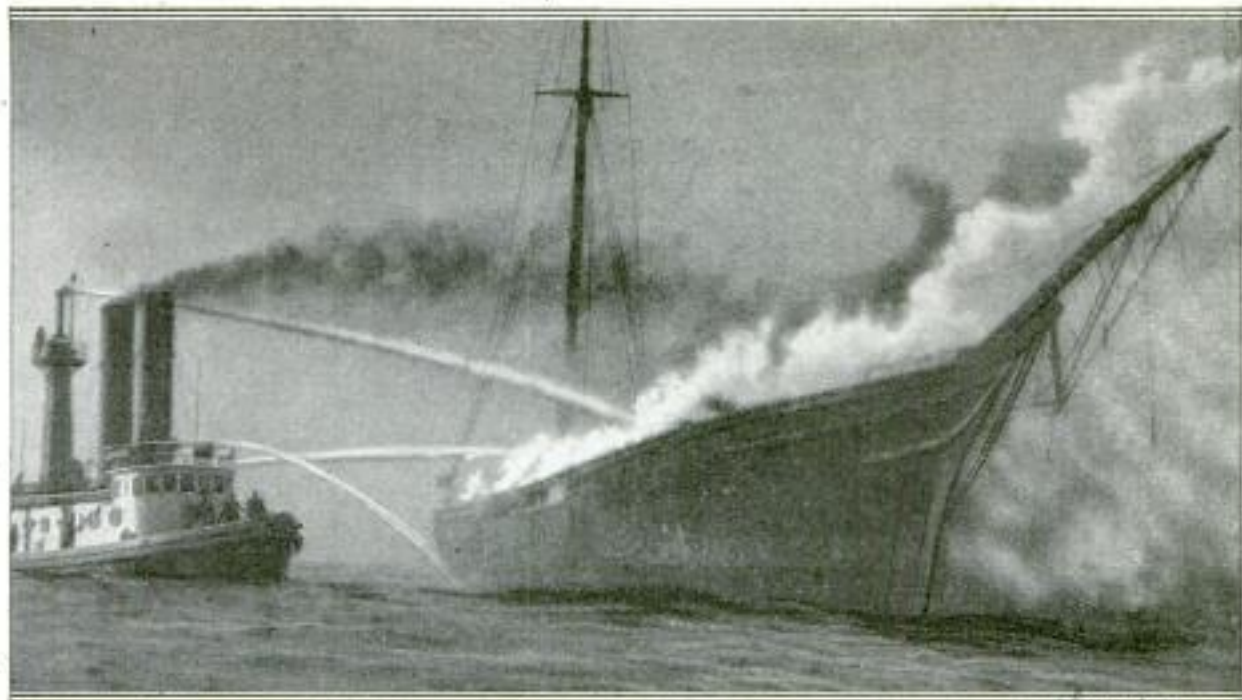

SAN FRANCISCO BURNS SCHOONER TO COMMEMORATE 1906 FIRE *International*

COMMEMORATING the seventeenth anniversary of the San Francisco fire, a schooner which was in active service at the time of the catastrophe was recently set afire in San Francisco Bay. Before the hull of the vessel was completely burned, the flames were put out by city fire boats. San Francisco has set aside an annual memorial day of the disaster, in which 500 people lost their lives, and property worth from \$350,000,000 to \$500,000,000 was destroyed. Out of the ruins arose a finer and greater city.

### RARE METALS IN OIL SHALES

Aroused by the reports that various investigators have obtained gold, silver, platinum, and potash in paying quantities from oil shales, the Bureau of Mines has conducted tests that disprove these claims. All the assays indicated it was not commercially possible to recover any of these materials. *Engineering*

### PORTABLE LIFT TRUCK LOADS HEAVY CRATES

A portable loading truck for quickly handling piano cases, heavy packing cases, and similar large, bulky loads, has been developed and placed on the market. A heavy U-shaped carriage forms the frame of the truck, which is mounted on a double swiveled wheel in front and two fixed wheels in the rear. At the front and inside the "U" is a foot piece. Attached to the frame is a steel yoke, roller-mounted, which travels back and forth on the carriage. In operation, the open end of the "U" is backed up to the load until it embraces the object. The

foot piece is then pushed under the load, and by means of suitable mechanism the piece lifts the end of the load sufficiently to allow the steel yoke to be slipped back along the arms of the "U" until it supports the rear of the load near its open

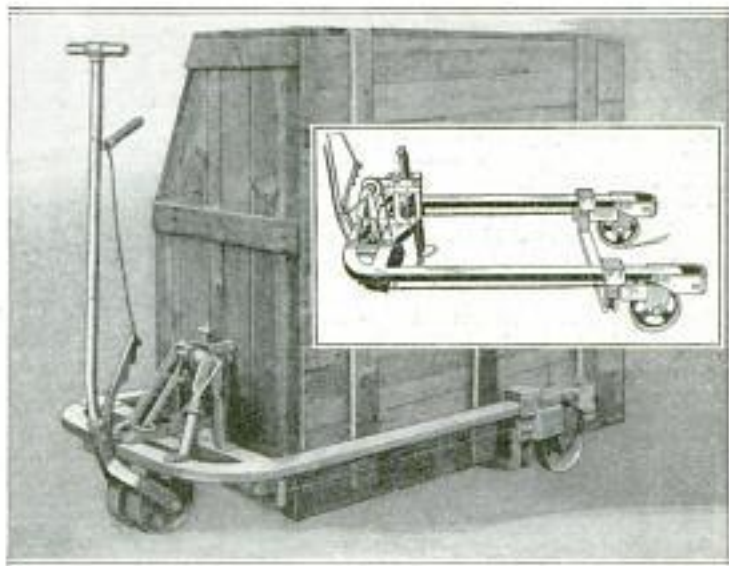

The Lift Truck Ready to Move Its Load: The Insert Shows the Arrangement of Its Parts on the U-Frame

end. The foot piece is then lowered until the load is level. The truck weighs 300 pounds and can carry 2,000 pounds.

*Inventor, V. E. Orledge*

*2407*

*Blake St, Alexandria Va.*

Copyrighted material

11/27/23

*McGregor & Co.*  
**BARN WITH GRAIN ELEVATOR  
IS AUTOMATIC FEEDER**

958

By application of the grain-elevator principle to a barn, an agriculturist has made a self-feeder for the stock in the



Barn with a Grain Elevator: From the Cupola on Top, the Grain is Distributed into Bins in the Second Story, and Thence by Chutes to the Mangers

stable on the ground floor. A second story of the structure has along its center a driveway that can be reached by teams hauling loads of corn or oats by an inclined driveway from the barnyard. In the second story is a power-driven elevator which carries the grain to a cupola above, from which it is distributed to bins along either side of the driveway. From these bins, chutes lead to the mangers in the stable below, and at feeding time all that is necessary is to open the chutes as required. A feed grinder also may be mounted between the second floor and the roof, and connected with a spout from the top of the elevator.

**TO ERECT GREAT LIGHTHOUSE  
IN HONOR OF COLUMBUS**

2812

Delegates from Santo Domingo to the recent Pan-American conference proposed that a lighthouse of unequalled height and power be erected on the island of Santo Domingo to commemorate the landing and founding there of the first Spanish city in the new world by Christopher Columbus, who lies buried there. The light would be 385 feet high and would be seen by all vessels traveling from Europe to the Panama Canal. The design suggested is that of a lighthouse built upon a globe, 150 feet in diameter, the light to be of the flash type, which will spell out in Morse code the word "Colon," in honor of the great discoverer.

**AUTOMATIC AIR SERVICE  
NEEDS NO PILOTS**

*invention  
military*

Maj. Gen. Mason M. Patrick, chief of the army air forces, made the astonishing announcement recently that a bombing air service has been developed that needs no pilots. The automatic service has been so highly perfected, he said, that even now, it would be possible to send a pilotless plane from Boston to New York. The plane could carry a cargo of bombs, fly at a given altitude, hold to a set course at a prearranged speed, and, at a given time and predetermined place, discharge its destructive cargo. Radio control is the secret of this scheme. A whole fleet of airplanes could be similarly controlled, with

exactness. The air service is also planning airplane-carrying dirigibles helium-filled, for making long cruises.

**COLLAR MAKES IT EASY  
TO WITHDRAW NAIL**

1321

A small metal collar, which slips on the nail before driving, has been made to hold the head of the nail away from the wood so that the claw of the hammer may grasp it easily. Aside from the time saved when tearing down scaffolding and other temporary structures, it is thought that the device will eliminate all necessity for hammering the boards apart, and accordingly will increase the life of the wood. The collar is made in three sizes to fit nails from 6 to 60 pennyweight.

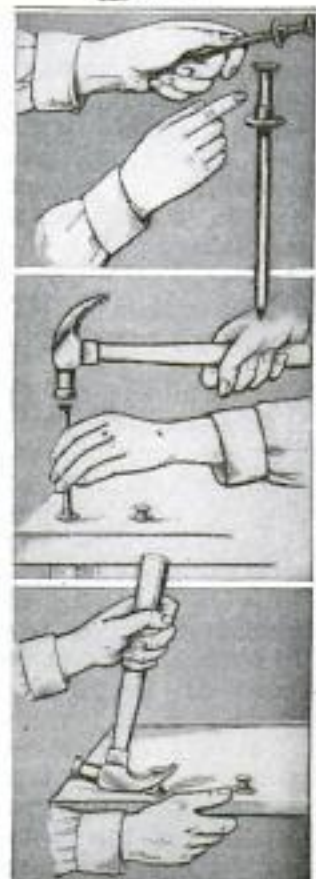

*Science May 4, 1923*

*Precision Metal  
Warrick 3100 Carroll  
Ave. Chicago*

*Copyrighted material*



"Quilts" of Eelgrass Coming through the Rollers: They are Stitched, and the Stitching is Glued in Place to Prevent Ripping. Heavy, Hot Rollers Then Compress the Quilts, Which Pass On to be Crimped

### EELGRASS: A NEW ENGLAND COAST SEA "CROP"

Botanists, having the scientist's viewpoint, call it *Zostera marina*, while seafaring folk prefer the terms "barnacle grass" or "grass wrack"; but the hardy natives of the northern New England coast, who know this interesting and valuable sea plant, have long called it "eelgrass." This latter name neatly describes it. Eelgrass is a salt-water plant, with long, narrow leaves, so long, in fact, that even in a tangled, crinkly state they attain a length of more than 10 feet. The New England tides toss it about and hurl it, in shredded masses, on shore, so that harvesting this peculiar "crop" is a simple matter.

The early settlers of Massachusetts were probably the first to discover and make use of its efficient heat-insulating qualities. The old Pierce House in Dorchester, built in 1635, was found to

have its walls stuffed with eelgrass, which was in perfect condition after more than two and a half centuries of service. It has since been found to be a very good sound deadener, and a large industry has grown up around the product.

A simple process makes the grass ready for commercial use. Curing, or drying, is the first step, and is done by spreading and separating the masses into small piles, beyond the reach of either water or spray. Here the long, tough, clinging

fibers dry out, and in doing so, are made fireproof because their cell structure becomes filled with the crystallized salts left by the drying sea water. The process also toughens them.

Next, the dried grass is hauled to the storage sheds, various types of conveyance being used for this purpose.

At one point motorboats carry loads across the bay, while at another the double-yoked ox team may still be seen in use. The grass



When the Bales of Eelgrass Arrive at the Plant, They are Broken Open and Spread Out, before Going through the "Picker"

must then be baled—great, shaggy bales it makes—and shipped to the manufacturing plant for further treatment. At the factory the bales are opened, then fed through a "picking" machine, which breaks up the lumps formed by the heavy pressing needed in baling. As the grass comes through the "picker," it is spread out evenly, passing between two heavy sheets of tough paper, later to be sewed into "quilts." Stitching is necessary, the sewing being reinforced by gluing the thread to the paper. For special purposes

fireproofed burlap, waterproofed paper, or asbestos is used in the making of the quilt.

The long roll is then hot-pressed, and crimped lengthwise, so that the layers of grass will better retain their positions. Eelgrass quilting has a wide range of uses. Being a resister of heat, cold, and sound, it is valuable for lining the walls and floors of houses, schools, hospitals, cold-storage plants, and similar structures. An added value is that it is not subject to decay.

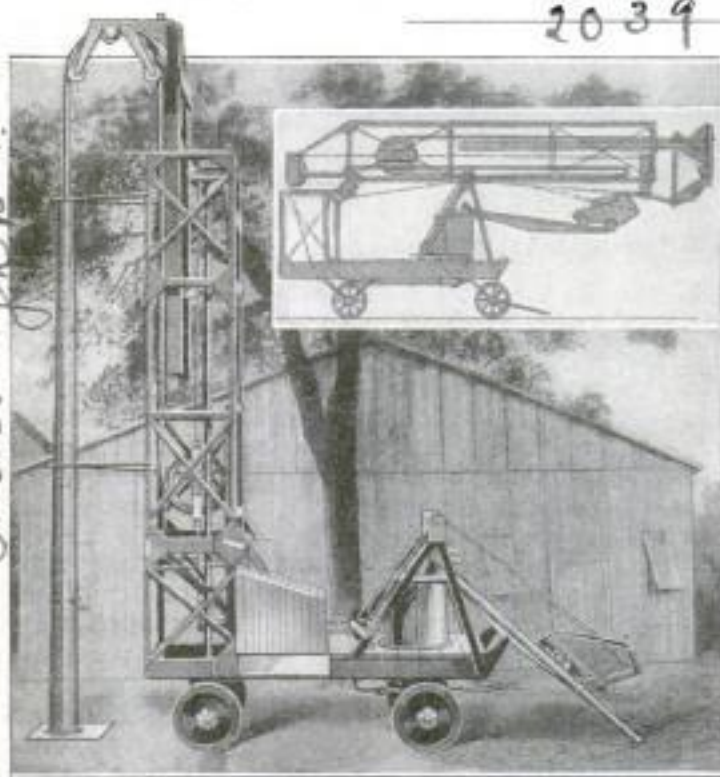

Set-Up of Machine Which Casts Concrete Poles in Place: Inset Shows Machine Ready to be Moved

### MACHINE CASTS CONCRETE POLES IN PLACE

There is on the market a new machine which casts concrete poles in place, thereby enabling the pole to be built solidly of concrete and with considerably less reinforcing steel than is required when poles are precast and must be made strong enough to be handled as a beam. The machine, which is mounted on a trailer truck, provides an air compressor for a pneumatic mixer served by a loader at one end of the truck, all driven by a gasoline engine. The concrete is delivered to the form through a vertical pipe mounted on a tower, and a hose that terminates in a nozzle, which is geared to move up the form as the concrete fills in. The mix is discharged from the nozzle with such force as to produce a dense concrete.

### CASSENA PLANT A DELIGHTFUL SUBSTITUTE FOR TEA

Cassena, a new rival of tea, and resembling tea in many respects, is said by the laboratory of the Department of Agriculture to produce a delightful beverage. It is a wild plant growing abundantly in the Gulf and south Atlantic States from Texas to Virginia. During Civil War days, when tea and coffee were scarce, it was drunk by the people of the South as a beverage, and the Indians have also used it.

It must be properly cured, however. Further investigations made by an experimental plant near Charleston, S. C., indicate that it is practical to cure it in quantities large enough to supply the general market. A hot-water extract

drawn from properly cured cassena leaves is also being used as a base or flavor in carbonated beverages, and cassena-flavored sodas will be manufactured.

### NATIONS PLAN TO PROMOTE CIVIL AIR TRANSPORT

At the recent meeting of the International Commercial Congress, at Rome, Italy, a resolution was adopted to the effect that national funds spent on aviation should in part be devoted to developing civil air transport. It was further agreed to establish a permanent international committee to furnish advice on financial, industrial, legal, and technical features of aviation. Air travel is regarded as more international in character than any other form of transportation.

*National Aeronautics Association, U. S. A.*

*Box 1107*

*Released 4/30/23*

*Blaw-Knox Co. Pittsburgh Pa.*

*Carl Allen P. Child,  
Box 4673,  
Kansas City,  
Mo.*

**NEW SOLVENT REMOVES PAINT  
 AND CLEANS CYLINDERS.**

A new solution, which dissolves and removes paint, japan, or varnish, as well as rubber, both pure and vulcanized, and resinous and glue binder substances, has been discovered by a scientist of the University of Wisconsin. Natural resins, glues, gelatin, celluloid, varnish, lacquer, and paints can also be dissolved. Selenium oxychloride—the solvent in question—is also effective in removing carbon from cylinders of gas engines, for it dissolves the partly carbonized or hardened oils which cause the clogging of the cylinders, and cleans them out. These hardened deposits are usually particles of carbon which have been cemented together with hydrocarbon, and selenium oxychloride dissolves this cementing element so that the carbon loosens and comes out.

**MOTORCYCLE SADDLE ADDS  
 TO COMFORT**

Several interesting improvements have been added to the motorcycle saddle to

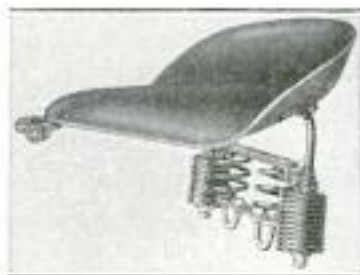

make that seat more comfortable. A high back to hold the rider when jumping into high speed, or when going upgrade, is one of them.

In addition, two pairs of springs are used, one within the other, for giving the necessary resiliency. These pairs are separated, so that the vibration of one will not affect the other.

By the granting of an annual pension to a resident of Manchuria, the local authorities proved their belief in the man's claim that he was 162 years old. His case was thoroughly investigated, and the records proved his claim to be true.

The Persons. Majestic Mfg. Co.,  
 Worcester, Mass.

**U. S. 20-CENT STAMP TO BEAR  
 SCENE AT GOLDEN GATE**

As the basis of the design to be used for the new 20-cent stamp, which will



"Arrived, All Well," Is the Title of This Picture, the Work of a San Francisco Artist, Which is to be Reproduced on a New 20-Cent Stamp

William A. Coulter, Marine Artist

soon be issued by the government, there has been selected a painting of a schooner entering San Francisco Bay, the whole entitled "Arrived, All Well." The picture, the work of William A. Coulter, of San Francisco, has long been an admired feature of the assembly room of the merchants' exchange department of the Chamber of Commerce of that city. Experts have praised its scenic detail.

**HOSE CLAMP IN SEGMENTS  
 FITS VARIOUS SIZES**

Uniform pressure over the circumference of the hose to which it may be attached is one

of the advantages claimed for a clamp that has recently appeared on the market. It is made in segmental pieces that bolt together to fit the hose on which the clamp is to be used. It permits the hose to be rolled to any desired location.



Knorr Mfg. Co., 821 Cherry St., Philadelphia, Pa.

Inventor, Mr. Max Schain, 801  
54 POPULAR MECHANICS  
La Salle Bldg., Minneapolis, Minn.

### X-RAYING HEART ACTION OF SCHOOL CHILDREN

1796

Fifty to 70 per cent of school children are to some extent physically defective,

By means of a metal framework the body of the child is made to support the picture-taking apparatus, so arranged that the box containing the X-ray tube hangs on his back, whereas the film holder is suspended in front of the heart region. The child is then directed to "ride" the bicycle as fast and hard as he can, and the picture of the heart is taken while he is in action. Changes in size and shape, which help to tell the story of health or disease, are thus easily recorded. The bicycle is also used to measure the child's capacity for physical work, and to determine the effect of exercise on pulse rate and blood pressure.

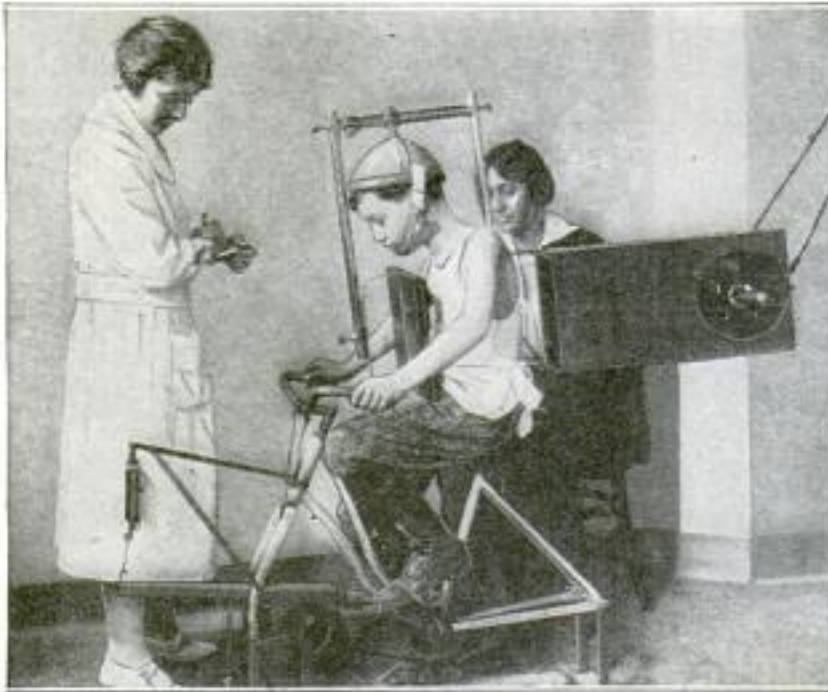

A Minneapolis Innovation: Here Is a Boy Ready to Have His Heart X-Rayed and Photographed While He Pedals on the Stationary Bicycle

a portion have curvature of the spine or other less obvious deformities, while fully two per cent suffer from diseases of the heart. Impressed by these facts, physicians of Minneapolis have introduced a new system of physical examination. Chief among new devices for this purpose is an X-ray camera for taking pictures of a child's heart while he is engaged in pedaling a stationary bicycle.

age, to the chest circumference, and to the breathing capacity; and, in the case of pedaling experiments and similar "leg work," to the circumference of the thigh. Contrary to general opinion, height and weight showed little relation to capacity for work. In children up to nine years of age the capacity for work varied with height and weight, but in older children it did not depend on these factors.

2098

### DUSTSTORM ENGULFS OKLAHOMA TOWN



Picture Taken during Approach of Duststorm That Later Enveloped the Town in Dense Reddish-Brown Clouds, Changing Daytime into Night

A duststorm, heralded by the rapid approach of a low, seething mass of brownish-mottled clouds rolling upward in most sections but tumbling earthward in others, recently engulfed the prairie town of Guymon, Okla. The dust was so dense that inhabitants could not see more than 100 feet in any direction, and the particles were so fine as to penetrate the best-built houses, covering everything and making it difficult to breathe. The storm made its appearance late in the afternoon.

Carl Jerome Rosewater,  
Guymon, Okla.



Western Steel Refining Co.

Pacent Electric Co

Indianapolis, Ind.

POPULAR MECHANICS

22 Park Place, New York City

SERVICE STATION SPECIALIZES ON CRANKCASE OIL

RADIO CONDENSER COMBINES INTERESTING FEATURES

Specialization is the object of a large automobile-service station in Indianapolis, which makes a business of dealing exclusively in crankcase oil. The plan of the structure was based upon that idea, and the station accommodates 20 cars at one time. Five driveways lead into it, each of which permits operations under the entering car. Funnels connected to swinging pipes drain the oil, then a fresh supply is pumped in, and the car is off. The level below the street floor has no dividing walls, so that a service man may quickly step from under one driveway to any other.

2188

DYNAMITE BREAKS UP SHIP'S CARGO OF POTASH

Dynamite has frequently been used with success for loosening up solid masses of bulk material, but generally in more or less open spaces. A daring departure was made recently when the method was used for prying loose a cargo of hardened potash in a ship's hold. At first picks were used in an attempt to loosen the mass, but were finally discarded as being too slow and costly. Dynamite was then suggested and used, although it proved difficult to persuade the captain that no injury would result to the ship. The charges were placed some 3 or 4 feet back from the ship's skin, and at about the same depth.

Radio fans are aware of the importance of the variable type of condenser, and keenly appreciate any improvements in its design. One of the latest to appear has bakelite heads and aluminum plates, the latter being machined to act as spacers without the use of washers. Refinements in the bearings permit very accurate adjustments, assuring proper plate alignment and smooth rotation. The lower bearing can be locked after adjustment has been made.



2279

REDUCE TIME FOR CABLEGRAM BY MECHANICAL RELAYS

Increased speed in the sending of cablegrams has recently been made possible by mechanical relay instruments which have taken the place of operators formerly stationed at the cable terminals. Through this and other improvements the speed has gradually been increased from 20 to 50 words a minute.

my James 4/30/23

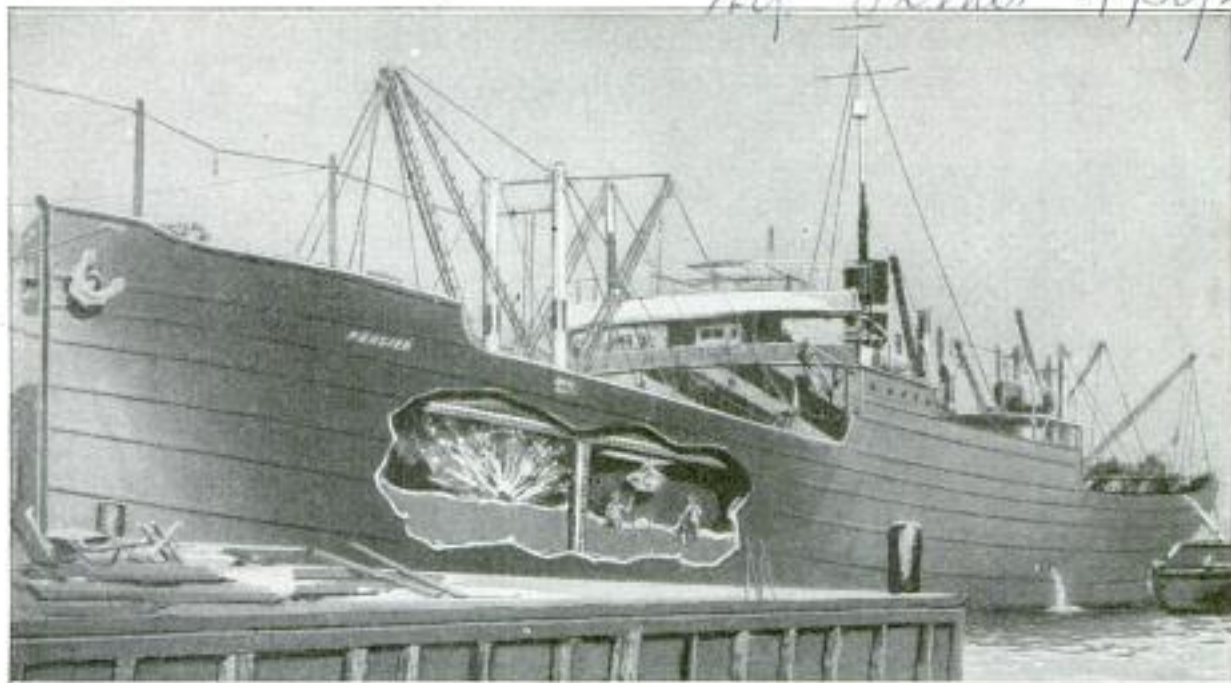

A Partial View of the Interior of the "Persier," in Its Dock at Charleston, South Carolina, Showing How Light Charges of Dynamite were Effectively Used for Breaking Up Its Solidified Cargo of Potash

Chas. A. Franklin Myndorf, 1108 Askeul Ave., Kansas City, Mo.

Copyrighted material

1973

Powell & Sutter San Francisco, Calif.  
TEST EXPERIMENTAL HIGHWAY WITH TRAILER

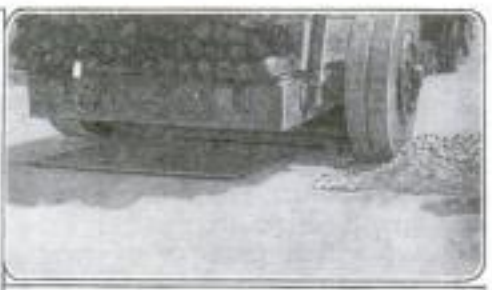

Planks and Steel Plates under Rear Axle Supported Trailer When Wheel Broke through Pavement

Above: Rear View of Special Five-Ton Trailer Carrying a 50-Ton Load Used in Making Pavement Tests on an Experimental Highway at Pittsburgh. Right: General View of Trailer, and Truck to Which It was Attached

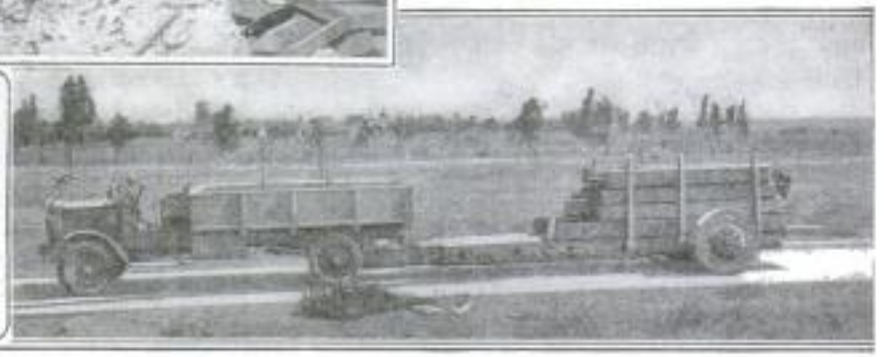

A special trailer, weighing five tons and carrying a gross weight of 50 tons, was used in recent experiments on the Pittsburgh Test Highway. The trailer, which was built on two wheels, was attached to the truck by means of a large bolt extending through two heavy cross members at the rear of the truck frame. The truck was able to pull the load until the

trailer wheels broke through the pavement, when it could not be moved by the combined efforts of four trucks and two tractors. At certain points the pavement was completely broken up under the pressure of the trailer wheels, which were prevented from sinking too deeply by planks and steel plates wired to the axle for this particular purpose.

Wearer. Miss Eleanor Posey  
Sacramento, Calif.

<sup>1209</sup> CURIOUSLY DESIGNED HAT TO ATTRACT TOURISTS

A hat made to represent the dome of the state capitol is being worn by a young



Hat Representing the Dome of the Capitol at Sacramento, California

woman of Sacramento, Calif., to attract tourist travel to that city. The young woman lectures throughout the state, using the hat as a "come-on." Surmounting the crown is a small orange, illuminated from a pocket storage battery.

2298

PRESSURE FORCES PIPE UP FROM BOTTOM OF POND

Recently the engineer of a town in Massachusetts, on starting as usual to pump water from the aqueduct, saw the end of the main, which runs through the pond to the aqueduct, rise above the water. He found this was due to the pipe having been emptied by mistake. The pipe weighs but 27 pounds per running foot, whereas the water displaced by each foot of pipe weighs 67 pounds, leaving a net upward pressure of 40 pounds, which forced the pipe to rise. The danger was that water from the pond might have been pumped into the town mains and used by the public.

Com. Frederick J. Winslow, 133 Hollis St. Framingham Mass.

NOISELESS STREET CARS FOR TWIN CITIES

2292  
5/6/23

Practically noiseless street cars are to be introduced in Minneapolis, St. Paul, and suburban territories, according to plans now rapidly nearing completion. The new car is of greatly reduced weight and will be rubber-cushioned over the spiral roller that supports the trucks, the car, and the passenger load. These new trolleys will weigh only 25,000 pounds, as compared with 43,000 pounds for the old car, yet they will have the same carrying capacity and will resist wear and tear equally well. Another important noise eliminator is the band brake, which will work on the wheel drum. This feature eliminates the shrieking brake shoes which work on the wheel face. Rattling will be greatly reduced by incasing the windows in rubber. The car trucks are equipped with what is known as a swinging spring plank, permitting the use of a combination of springs that take up the overload, and are easily adjustable.

VIBRATION-PROOF WASHER FOR BOLTS AND SCREWS

The problem of locking nuts, bolts, and screws, on machines subject to great vibration, has always been a puzzling one, particularly on pneumatic tools and similar devices. A simple type of washer is now being marketed which is said to solve this difficulty. It is made of thin, clock-spring steel, rust-proofed, and looks much like a watch gear, except for having longer teeth. These teeth are made to bend various ways so that when the head of the nut tightens down over them, they resist straightening. Part of the teeth becomes imbedded in the lower surface, and this condition tends to keep the nut tight even under vibration.

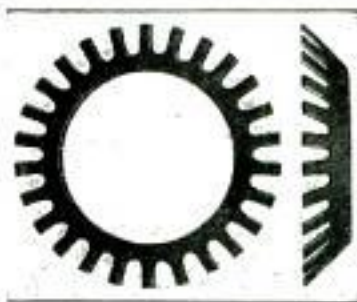

Shakeproof Screws  
+ Nut Lock Co.  
404 Wrigley Bldg  
Chicago

SMALL INDUSTRIAL TRUCK HAS CRANE ATTACHMENT

2162  
S. W. England.

Widely varied uses of the industrial truck in and about factories and yards are made possible by a crane-body attachment, which is easily applied. The two-wheel

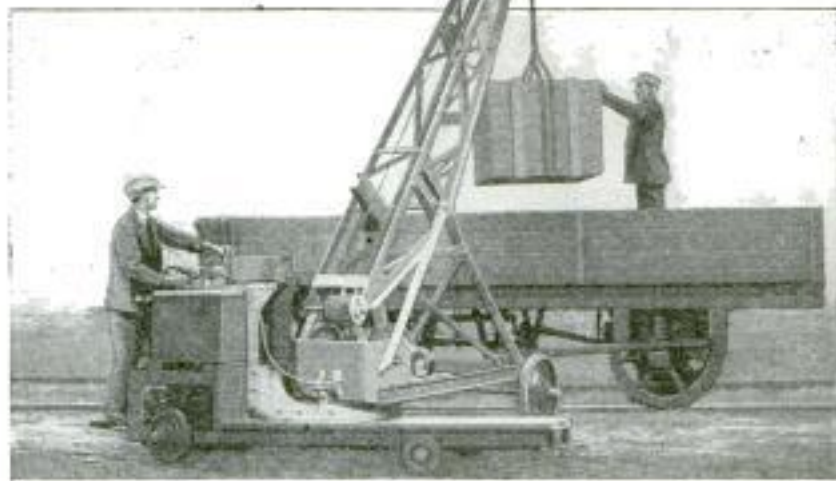

This Shows the Possibilities of the Crane Attachment in Handling Freight; When Detached, the Truck can be Used on Light Transfer Work

ing for firmness on the truck body proper, which it partly rests upon, and from which it receives a swiveling support. Storage batteries furnish the necessary power. The crane has a maximum capacity of 1,800 pounds, and can lift 1,500 pounds at a distance of 12 feet from its base.

LARGEST CABLE IN THE WORLD FOR ATLANTIC OCEAN

23 24

Completion of the laying of a new cable in the Atlantic Ocean, between New York and London, is expected by August 1, next, according to a recent announcement. It will be the largest ever laid in the Atlantic, or anywhere else in the world, and will have a capacity twice that of any other cable now in service between the United States and Europe. Engineers charged with the design of the new cable estimate that it will permit a sending speed of approximately 600 letters per minute in both directions at the same time, or a total of 1,200 letters per minute. This high transmission capacity will make it the fastest cable in the world. As is to be expected, its dimensions will exceed that of any other transoceanic cable now in use. Its conductor requires an average of about 1,100 pounds of copper per mile, as against an average of about 700 pounds of copper per mile for the heaviest now in service.

Chicago Tribune  
5/4/23

23584

Cont. N. C. No. 1917 St. Paul St.

POPULAR MECHANICS  
International Newsreel Corp. New York

**AIRPLANE MAIL  
SERVICE ACROSS THE  
CONTINENT**

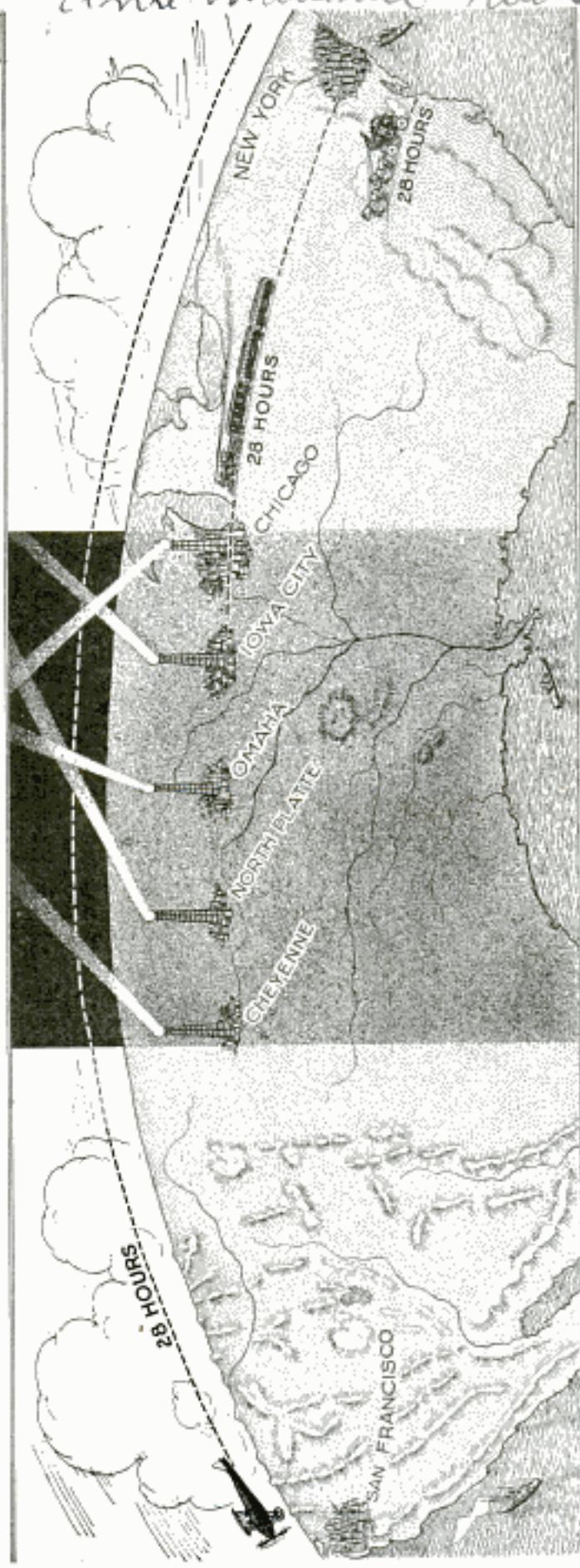

This View Shows How Our Artist has Visualized the Coast-to-Coast Airplane Service Which the Post Office Department will Inaugurate Shortly. Daylight Conditions will Govern East of Chicago, and the Shaded Portion between Chicago and Cheyenne Represents the Area Which the Postal Filters will Traverse at Night. The Mail Pilots Fly into Daylight Again West of Cheyenne, and Enjoy It through to San Francisco

Brilliant illumination along a pathway nearly 1,000 miles long will be one of the features of the cross-continent air-mail service to be inaugurated by the Post Office Department shortly. A line of beacons will extend from Chicago to Cheyenne, covering one-third of the route from New York to San Francisco. Over this part of the course mail-carrying planes will travel at night. The schedule calls for departure from New York daily at noon, and arrival at Frisco toward evening of the following day—an elapsed time of only 28 hours.

Previous transcontinental air-mail service has not been through service, but auxiliary to the regular schedules of the established railway mail routes. Early-morning mail planes have picked up late mails in New York, for example; have carried them to Cleveland, and then placed them on the Chicago express train which left New York the night before. The new system will lift the air mail out of its auxiliary status and give it the standing of an independent service from coast to coast.

As a result of the preparations undertaken during the last 12 months, night flights between Chicago and Cheyenne will be made under conditions offering scarcely more hazard than day flying. The pilot will be guided by a pathway of powerful lights which will point the way to the terminal fields. Each plane will carry powerful searchlights for use in making a forced landing, but emergency fields, also, have been located and lighted every 25 miles along the route. In addition to these precautions, the success of night flying is assured by the

CATCH DEVILFISH TO EARN  
 PIN MONEY

2205

Devilfish are all fearsome creatures. Nevertheless there are numbers of femi-

natural advantages of the traversed country. Noted for its levelness, it will provide natural landing fields, while the low humidity of the air will add to the value of the illumination plan. The most powerful lights will be located at each of the five regular flying fields—Chicago, Iowa City, Omaha, North Platte, and Cheyenne. Each is to be of 600,000,000 candlepower, and will swing slowly around on top of a tower mounting, where it will be visible for 50 miles. Not depending on these terminal lights alone, less powerful lights will be located at 25-mile intervals. They, too, will be of the swinging type, with a visibility range of 30 miles, and will mark the locations of the emergency landing fields.

When the "ceiling" is low—that is, when the clouds hang low—it may be necessary for a pilot to bring his plane close to the ground, in which case he might lose sight of the emergency field lights. As a final safeguard, therefore, flashing traffic lights, directed upward, will be located every three miles along the line of flight. On a clear night an air-mail pilot, 7,000 feet up in the sky, will be able to see a narrow line of light stretching for many miles over the prairie.

Perhaps the most impressive sight, however, will be the view of Maywood Field, Chicago, at night. This huge field will be outlined with lights spaced 200 feet apart. A 50-foot windmill tower will support the 600,000,000-candlepower beacon swinging its light around the sky. Hangars and shops will stand out almost in daylight perspective, illuminated on every side by powerful gooseneck floodlights. Tall chimneys and similar dangerous obstacles will carry red warning lights. In one corner of the field a large well-lighted arrow, pivoted like a weathercock, will give the pilot wind directions. Two cinder runways, 2,000 feet long, will traverse the field. These will be outlined with lights sunk in the ground, covered with glass and protected with a heavy iron grating, level with the surface.

Two purposes will be served by the establishment of through air-mail service from coast to coast; first, the American public will receive the fastest mail service in the world, over extensive distances, and secondly, another step will have been made toward keeping American pioneer work in the field of aviation in its premier position. During 1922 the air-mail personnel won recognition for the greatest achievement in American aviation, by flying 2,000,000 miles on the coast-to-coast route without a fatal accident.



A 48-Pound Devilfish Caught by a Woman: She had to Turn It on Its Back to Make Handling Easier

nine devilfishers of Salmon Beach, Wash., and some of these women have caught hundreds of the fish, being able to make from \$40 to \$50 a month at it.

The octopus come to shore with the tide and fasten themselves to the rocks with the suckers which cover the undersides of their tentacles. Thus anchored, they lie and wait for the soft-shell crabs, mussels, and small fish which swim right into their mouths. They are plainly visible, and can easily be "gaffed." They put up a stiff fight, but no worse than does a bullhead or a big salmon. They cannot bite, although they are able to raise cruel blisters, if they succeed in fastening a sucker on the bare flesh.

A day's catch is sometimes as much as six or seven fish, weighing from 45 to 50 pounds each. The market for devilfish is steady, and they bring 10 cents a pound, the Chinese and Japanese markets eagerly taking all they can get.

CA woman robber chief, it is reported from Hongkong, China, led the band of pirates that boarded the British excursion steamer "Sui An" not long ago.

### SCREENED ROCKING-CHAIR FOILS INSECT PESTS

Campers may have the benefit of a comfortable outside seat in mosquito or fly-



This Screened Rocking-Chair Is Collapsible, Folding Flat When Not in Use

infested regions by investing in a recently developed folding rocking-chair which, when set up, is entirely screened. The four sides, top, and bottom of the screen rest on two rockers, made slightly larger than usual. Inside is an adjustable seat and a rack for holding newspapers or other reading material.

### METAL TUBE FASTENER A BIG IMPROVEMENT

Something new in end fasteners for mailing tubes has been brought out recently.



Instead of the common method of pasting paper at each end and tucking it in around the inclosure, a narrow metal clamp is used, one end of which is attached to the end of the tube. This is easily bent inward about the rolled contents of the tube, and saves the user much time.

Instead of the common method of pasting paper at each end and tucking it in around the inclosure, a narrow metal clamp is used, one end of which is attached to the

*Cont. L. W. Pedrose  
617 Pacific Way  
Seattle, Wash.*

### PROFITABLE USE FOUND

2345 FOR WILD RABBITS

Each fall a drive on wild rabbits is made in various parts of eastern Washington, and thousands of the pests are slain to prevent them from overrunning the country. Large quantities have been sold in western markets, but enormous quantities have gone to waste. The Bureau of Biological Survey has now begun to trap the rabbits, in order to ship them alive to islands off the Alaskan coast. Many of these are devoted exclusively to the breeding of blue and gray foxes, and the rabbits will be turned loose to serve as food for them. Alaskan breeders will be saved thousands of dollars yearly by this procedure.

### WOOD LATHING ELIMINATED

1089 BY WIRE STAPLES

A special wire-furring staple has been invented to replace the wood lathing commonly used to secure the building paper and wire when plastering exterior walls. The staple is  $4\frac{1}{2}$  inches long and is raised in the center to hold the wire at a proper distance from the paper sheathing. Using this new device is said to result in a more uniform thickness of

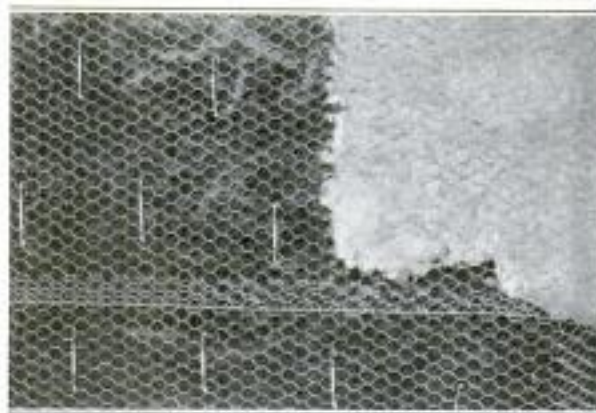

Wire-Furring Staples Used to Fasten Chicken Wire to Wood Sheathing for Outside Stucco Work

plaster, and the elimination of unsightly wood stains and cracked walls, due to the swelling of the laths by moisture.

CA new type of "earth-induction compass," similar to those used in airplanes, has been designed for use on war vessels. It is more heavily built, however, and is actuated by an alternating current instead of by wind cups. The generator may be put in a fighting top, while the control dial can be located on the navigating bridge.

*Cont. Gregory is the Vacher Brand  
C. P. #2, North  
sub*

224

*Chicago Mailing Tube Co.,  
425 S. Hoyne,  
Chicago*

*Planer Mfg. Co. 1101-15 E. 12th St.  
Oakland, Calif.*

# FROM KYAK TO SCHOONER

By Francis Dickie, Heriot Bay,  
B.C., Canada.



Eskimos Paddling the Kyak, the Native Boat Which They have been Accustomed to Use in Hunting the Seal and Walrus: The Kyak is Made of Skins Tightly Stretched over a Light Frame

THOSE things typical of the twentieth century—desire for speed, comfort, and the spirit of friendly competition—have spread even to the lonely and icy waters of the Canadian Arctic, where this summer Eskimos will imitate the famous Atlantic boat race sailed last year by Nova Scotian and American fishermen.

To anyone familiar with auxiliary schooners one of the illustrations tells the story better than words. In it are shown the schooners "Henry Ford,"

"Bluenose," and "Mayflower," the Eskimo examples, in name and intent at least, of the noted Atlantic boats. Around the naming of these three vessels the story is woven.

It is best for the full understanding of how rapidly methods are changing in the North to note the picture of the Eskimos in their kyaks. Only a few years ago they lived as had their forefathers for hundreds of years. With the coming of the white man the Eskimo was quick to make use of the rifle, and so increased his food and fur-gathering facilities. American whalers, pushing their way through Bering Strait, loaned them some of the ships' boats while the mother vessel was in the outside world selling a cargo. The understanding was that half of any valuable catch taken was to be

given to the boat owners on their return. Eventually, some Eskimos became possessed of whale boats of their own. Soon the first motorboats were introduced into the region of Beaufort Sea. The Eskimos were quick to see the value of the white man's small schooners. They began buying them, and several firms catered to their trade, which proved very profitable—for the Eskimos had money, getting cash for large quantities of white-fox skins and other furs annually.

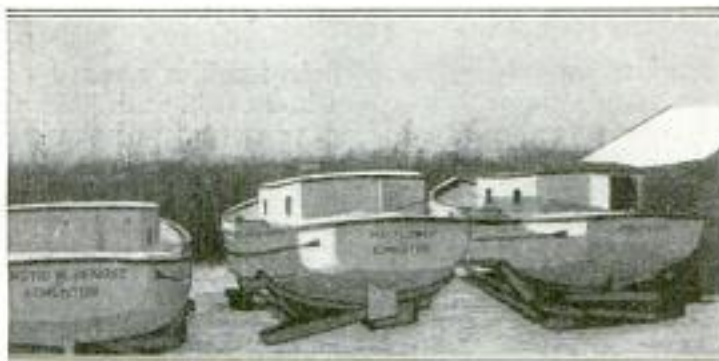

Eskimo Schooners at the Builder's Yard: They are Named for Atlantic Fishing Craft Famous as Racers

Today there are 43 little schooners, built in the outside world, which have traveled to the Arctic regions in Beaufort Sea and adjacent waters, to be taken over by Eskimo purchasers. A number of these boats

came to the Arctic under their own power over the rivers and lakes stretching from Fort McMurray and Peace River Crossing to the mouth of the Mackenzie. Some of them were shipped in "knockdown" shape and assembled at their destination.

When the steamer "Northland Trader" arrived last year at the Eskimo metropolis of Aklavik on the delta of the Mackenzie, the natives overheard its white crew discussing the Atlantic boat race. Now, the Eskimo is a keen sailorman, and loves a race. So, a few nights after the

steamer's arrival, the Eskimos, too, were talking racing.

Then there arrived one day at the "Northland Trader" three prominent Eskimos. They came separately, and the first to arrive was Innitok, already owner of four auxiliary schooners. Innitok stated that he wanted a very fast schooner, "same like white man talked," with which he could beat the other fellows. And Innitok particularly stipulated that this ship should carry "a white man name."

"You mean you want it called 'Henry Ford?'" the captain said, more in jest than earnest. But Innitok was in earnest: "Yes; yes, that's it, white man ship 'Henry Ford,' race other fellow."

So Innitok gave his order, and went his way. Shortly thereafter came Amatik, another man of substance in Eskimo land, also noted as a sailor. Amatik, too, had been filled with desire for fame.

At any rate, he put in an order for "fast boat with white man's name," and was assured that next year he should receive a vessel duly christened "Bluenose." Third and last came Pougjak, also a mighty sailor and leader in the community. He ordered the "Mayflower."

The orders for the three auxiliary schooners came to Edmonton, where they were built in the yards of Capt. John Matheson. The vessels have been hauled on sleighs to the railway, and thence to the banks of the Clearwater River. From that point they will go down the great inland waterway of the northland under their own power to their eagerly awaiting owners, who will give cash and fox skins

in payment for them.

Today an Eskimo knows a white man's boat. Before he pays, he thoroughly tests out its sailing qualities, and the engine, which he now fully understands, must be of the best. In addition, he insists on many "extras," such as batteries, coils, barometer, compass, and other modern aids to navigation.

Thus has the old order of the Stone Age passed in the North. And this summer, Innitok, Amatik, and Pougjak will take

their families aboard the "Henry Ford," "Bluenose," and "Mayflower" and stage a counterpart of the Atlantic fishermen's classic. The race will be from Herschel Island to King Williams Land and back, and the contestants will not be hampered by any of the rules of the Atlantic race.



Steamer "Northland Trader," Which Brought News of an Atlantic Boat Race to the Eskimo



Eskimo Fishing Boats in the Home Port: They are Mostly Bought from the Outside World, but the Eskimo is Careful and before Paying, Thoroughly Tests the Sailing Qualities of His Purchase



Duplicating actual fire conditions, the United States Bureau of Standards staged a miniature office fire, and tested the office to destruction. A small building was erected for the purpose, having hollow brick walls and concrete roof and floor. A top floor of wood was provided, which was separated from the concrete by a layer of cinders. When the building was completed, it was fitted up as an office, with desks, chairs, wooden and metal filing cases, bookcases, and fireproof safes. The latter were of steel, but asbestos sheets were built into the sides, doors, and tops. Thermocouples, for measuring temperature, were installed at suitable points. The fire was started rapidly, using a mass of oil-soaked waste, and had gained full headway in 15 minutes. A temperature of 1,900° F. was attained and kept up for a full hour before the flames began to recede and the temperature to fall. After the test, it was found that everything of a combustible nature had

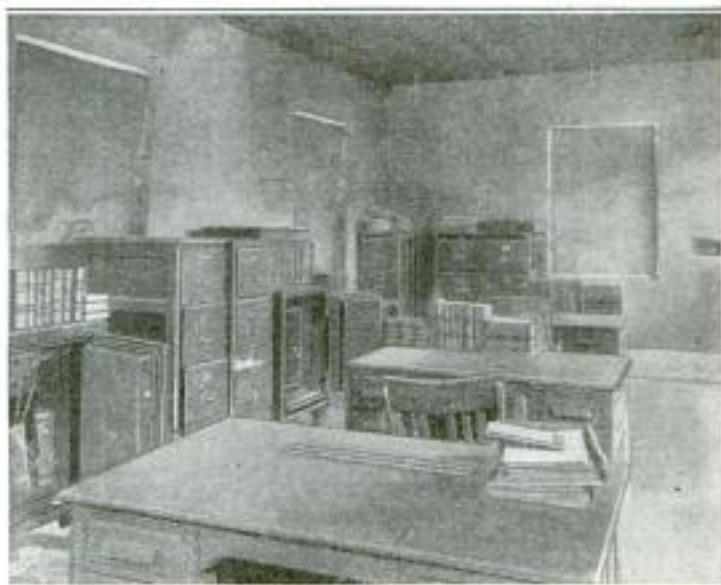

Before the Test: Note the Wire Connections in Both Safes for Determining the Internal Temperatures during the Fire



After the Test: Showing the Ravages of the Flames, Which Raged for an Hour, at 1,900 Degrees Fahrenheit. The Papers in the Safes Remained Intact

been destroyed, including the contents of the metal files, but the papers in the safes remained undamaged, and were clearly legible. Although the heat had warped the outer shells of the safes, the asbestos insulation amply protected the contents. Experts attached great value to the test, as it furnished valuable data

regarding the fire-resisting properties of the structure and its fixtures. Additional

tests will be made, in the hope of developing information regarding the efficiency of various types of fireproofing. The little office building will be remodeled for these tests, and will be used again to serve for another experimental fire, similar to the one described, but which will have in view the determination of different data.

### BALLOON MOTOR SHIP TO FIGHT MOTHS

2354  
Serious ravages by gypsy moths of the forests of northern New England has prompted the Department of Agriculture to wage active war against them. A motor balloon, equipped with two 75-horsepower engines, will soon take the air for the purpose of spraying the pests with various chemicals. The craft is supplied with a new type of mobile field equipment, so that it can be anchored to a folding mooring mast carried along by truck. The trucks will also carry a gas-compressor outfit for replenishing the hydrogen supply in the balloon. This feature will make the outfit entirely self-contained. A maximum crew of five men will be sufficient to man the ships. Airplanes have been used experimentally for similar purposes.

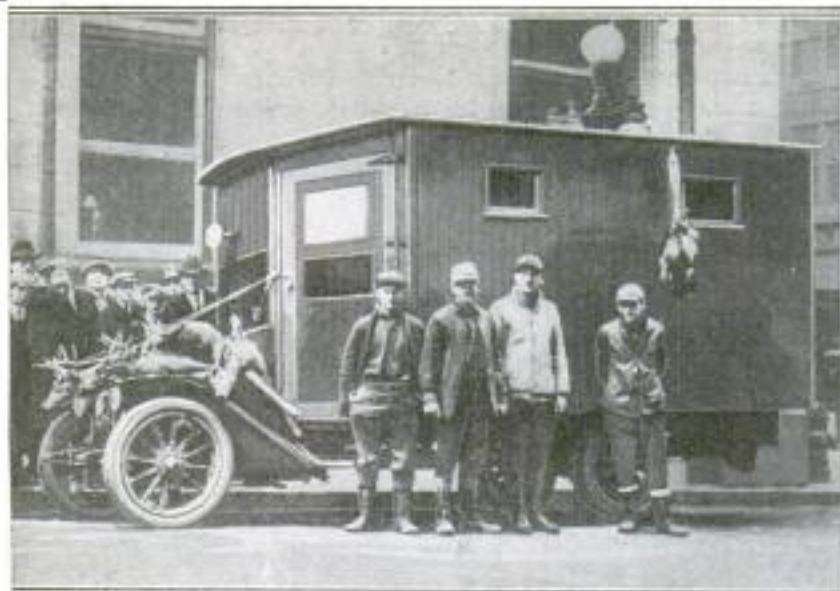
*Travelling*

Group of Hunters and the Portable Cabin Which Affords Them Shelter and Transport for Their Provisions and Equipment, as Well as Their Booty

### CABIN ON AUTO PROVIDES HOME FOR HUNTERS

By mounting a bunk house on an automobile chassis, four men from Minnesota have solved for themselves what is usually a constant problem for hunters in the big woods. The cruising cabin always insures them a comfortable shelter at any camp site they may select when the day's hunt is over, and also serves as a convenient means of transporting their equipment and provisions, as well as the game they have bagged.

### ORNATE HEARSE GIVES WAY TO SIMPLE LIMOUSINE BODY

The ordinary hearse, whose sumptuous carvings called instant attention to its sad mission, is a thing of the past in a certain Iowa town. The local undertaker, observing the gloomy effect it made in whatever neighborhood it appeared, had a hearse built to order, with limousine

### WORLD'S LARGEST BUILDING FOR FURNITURE TRADE

Ground was broken recently, in Chicago, for what promises to be the world's largest building, to be known as the "American Furniture Mart." The structure, although only 16 stories high, will contain 1,500,000 square feet of floor space, which will be used to house fur-

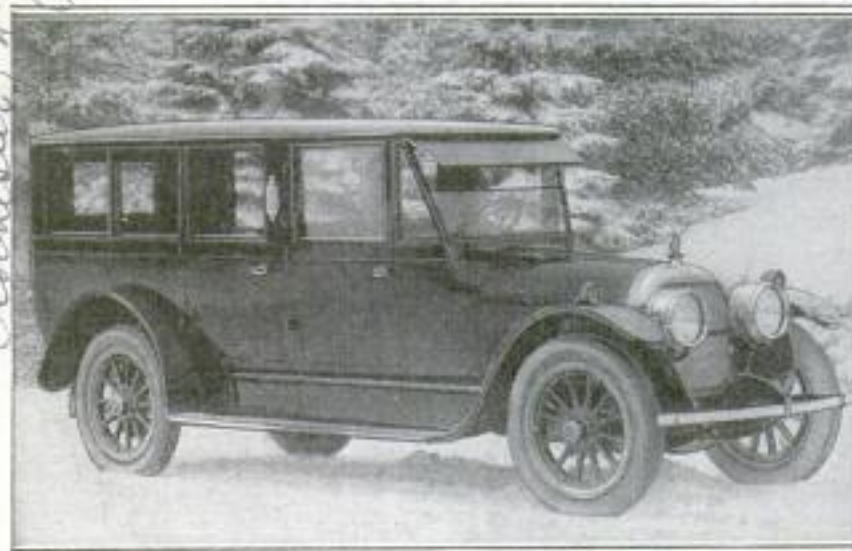

Left: Outward Appearance of the Funeral Car. Right: Interior View, from the Back Door; Note the Simplicity of the Upholstering, and the Absence in Both Views of the Usual Hearse Fittings

body. Except for a rear door, it gives no indication of its character. The interior upholstery is simple, being of plain cloth. As a consequence, its presence in the street does not advertise its mission.

niture exhibits of various manufacturers. In point of floor area, its nearest office-building rival is a motor-manufacturer's building in Detroit, with about 200,000 square feet less space.

*Chicago Tribune*  
5/3/13

Copyrighted material

*James Cunningham & Co. Rochester, N.Y.*

*2/23*

*5297*

no card -  
no data.  
no number.

**POPULAR MECHANICS**  
**FIVE MILLION MILES IN AIR**  
**U. S. MAIL RECORD**

Five million miles through the air is the sum total of the activities of the air-mail service since its inauguration May 15, 1918, to Dec. 31, 1922. The present schedule, it is estimated, requires nearly 2,000,000 miles a year, and it is planned to increase this total to 6,000,000 miles yearly as soon as new planes are completed.

**RAIL AND TIMBER HOOKS**  
**HANDLE HEAVY LOADS**

Operating somewhat on the principle of the farmer's hayfork, a hook for unloading rails is a device which saves time and an immense amount of lifting.



When the lock block on the jaws is down, the latter are locked tight on the rail. When the rail has been lifted and swung to the right place, the operator pulls a trip line running through a pulley on the crane, and the load is dropped.

Another hook working on the same principle, but with differently shaped jaws and block, handles heavy timbers.

**MATADOR ISLAND WIPED**  
**FROM CHARTS**

Disappearance of Matador Island, of the East Caroline group in the western Pacific Ocean, is now a matter of official record. The U. S. Hydrographic Office, after making a survey to determine the accuracy of previous reports of its disappearance, verified them, and has therefore erased the island from its charts. Many of the islands within the general group are subject to volcanic activity, as are the islands forming a long chain southeastward. Submarine vents on the ocean floor sometimes break forth, locally raising the level of the sea bottom and forming temporary islands or shoals; or submerging existing islands.

*Mr. Esraseman*

Patent Motor Products.

**HANDY FOLDING JACK**  
**FOR MOTORCYCLES**

A folding jack consisting of three parts, which can be taken apart and put together again in half a minute, has been

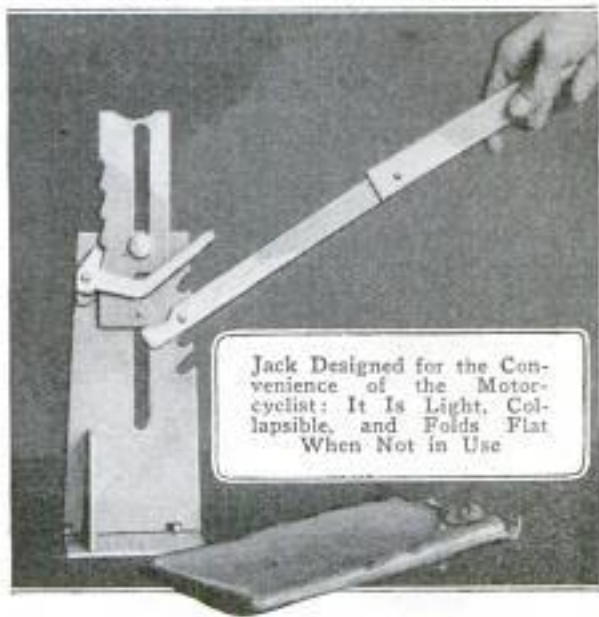

Jack Designed for the Convenience of the Motorcyclist: It Is Light, Collapsible, and Folds Flat When Not in Use

invented in England for motorcycle riders. The handle, which is also made to fold up, steps into one notch after another until the full lift is reached. The jack folds up flat in a cloth case and is easily carried in the machine, since it is both light and economical of space.

**ARTIFICIAL LIMB MADE**  
**OF SPRING-STEEL WIRE**

Patterning his model closely after the bone and muscle structure and natural action of the human leg and foot, an inventor has produced an artificial limb, which is constructed of piano spring-steel wire, and is claimed to work "as well as the old leg."



This limb does away with troublesome joints, and is neatly formed. The wires work like natural muscles, being "waved" at the heel and having a curl at the toe so as to permit easy walking. The inventor claims the limb will last anywhere from 10 to 20 years, on account of the elimination of joints. These have been a source of considerable trouble in the past.

*Inventor, Mr. George  
V. L. H. ...  
Monach Bldg. Porterville, Cal.*

*Chough, Supervisor of Track, N.Y.  
York Central R.R., Batavia, N.Y.*

*A. M. New*

*x*

**PLATES AROUSE INTEREST  
IN MORMON CHURCH**

2353

The discovery of two small pieces of copper plate, crudely stamped with im-



Small Piece of Crudely Stamped Copper Plate Discovered Recently on Mormon Hill, near Palmyra, New York

perfectly made Greek letters, on Cumorah, or Mormon, Hill, four miles south of

Palmyra, N. Y., has increased interest in the early history of the Mormon church.

The plates are said to have been found by a Methodist evangelist. One of the plates bore the Greek word, which, translated, means "Repent Ye." Mormon residents of the community attach no importance to the plates, the second of which also was inscribed with Greek words, meaning "Must Be from Above."

As the result of the action of ocean currents, the sand around the pilings of the Longport station of the Atlantic City and Shore Railroad Company at Atlantic City, N. J., was washed away so that the station collapsed and fell into the bay. Trolley service was not interrupted.

2339

**LIGHT AIDS MOTORISTS TO SEE AROUND A CURVE**

To minimize the danger of automobile accidents, a reflector for automobile headlights has been devised to improve the vision of the driver at night. It is claimed that one reflector clearly revealed objects a distance of 470 feet from the car during

a recent test near the top of the Laurel Cañon road in a suburb of Los Angeles. At the same time the light strongly outlined gutter, sidewalk, and fence without blinding motorists coming in the opposite direction.



Flood of Light Cast, by a Single Reflector of a New Type for Automobiles, on a Treacherous Stretch of Winding Trail near the Top of the Laurel Cañon Road in a Suburb of Los Angeles

Brown Reflectors, 560 Fourth Ave. Boston Mass.

Price not known

## WRAPPING THE WORLD IN FURS

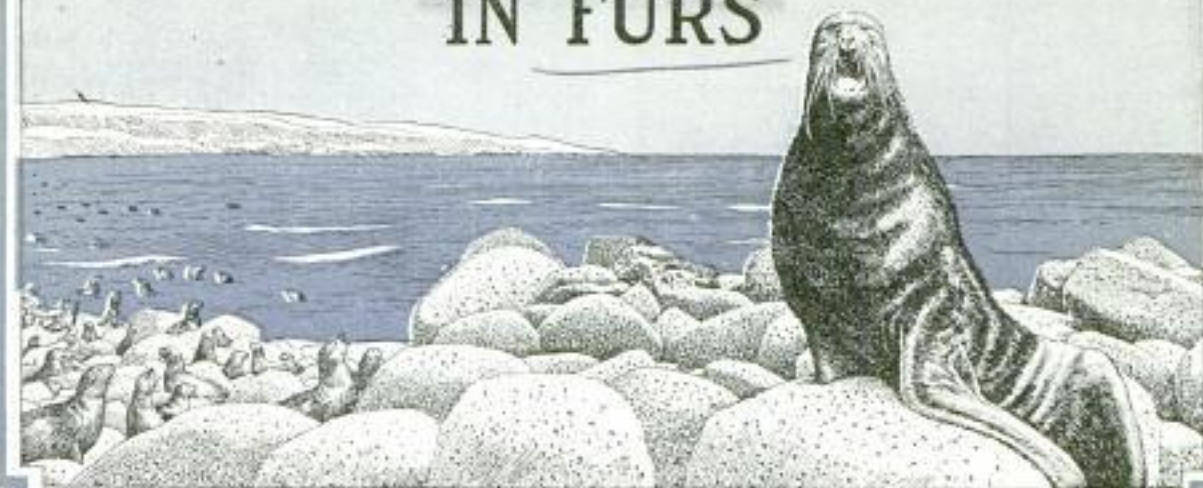

By T. WINFIELD THACKERY

WITH a last surging effort he shot his 2,000 pounds of body up out of the sea and onto the bowlder-strewn shore of the bleak, treeless, moss-covered islet lying mysterious and silent in the watery wastes miles off the coast of Alaska. It was toward the after part of May, and a heavy mist hung over the landscape, blending into the gray of the ocean in the direction he had come and hanging close to the tundra that covered the slight rocky rise toward the center of the bit of land.

But he wasted no time studying the somber beauties of nature. As he shuffled up the beach over the rocks, with a movement that suggested the lope of a bear, he reared up his nightmare of a head, with its great, quill-like whiskers, its staring eyes, its utter lack of forehead, and gave breath to a roar that again reminded of a bear's coughing grunt. He had caught sight of others of his kind, old bull fur seals, who had also reached this tiny isle—one of four making up the Pribiloff group—a few days or hours before him.

They were all huge animals, their hides covered with coarse grayish-brown hair, beneath which might be found the soft fur from which they obtained their name. They were scarred with the marks of countless battles for mates. On the ends of each of their front flippers were huge

claws, five in number, looking like bear's claws. And indeed these fur seals were bears—bears living in water. Ages ago their ancestors had either been forced or had naturally chosen to spend more and more of their time in water until at last they had become sea animals. Unlike the hair seals, those intelligent beasts seen in circuses and elsewhere, the fur seal is not a true seal but, as a study of his skeleton shows clearly, a bear. The five claws are of no use to him; they are simply remains—like man's appendix—from a former mode of living.

The old bull we have seen come from the sea—where he had been for the past nine months, living no white man knows where, but sometimes seen as far south as the coast of Mexico—soon picked out a spot his instinct told him would serve his purpose. There he sat down (if that is the way to express it, since he did not lay down nor yet stand at his full height), and there he waited.

Some two or three weeks later, early the following June, the older cow seals began to arrive on St. Paul Island, as they appeared on the other main bit of land, St. George Island, of the group. For it is only on these two islands that the finest of the fur seals have their yearly "rookeries," as their gatherings are called. Nowhere else in the world do they congregate in any number. The other two

[This is the first of a series of three articles by Mr. Thackery, dealing with the absorbing subject of furs—where they come from, curious and interesting facts about the animals that bear them, and how the skins are prepared for the market. Mr. Thackery is a Chicagoan and director of the fur division of the largest retail store in the world. His articles, therefore, bear the stamp of unquestionable authority.—Editor.]

2218

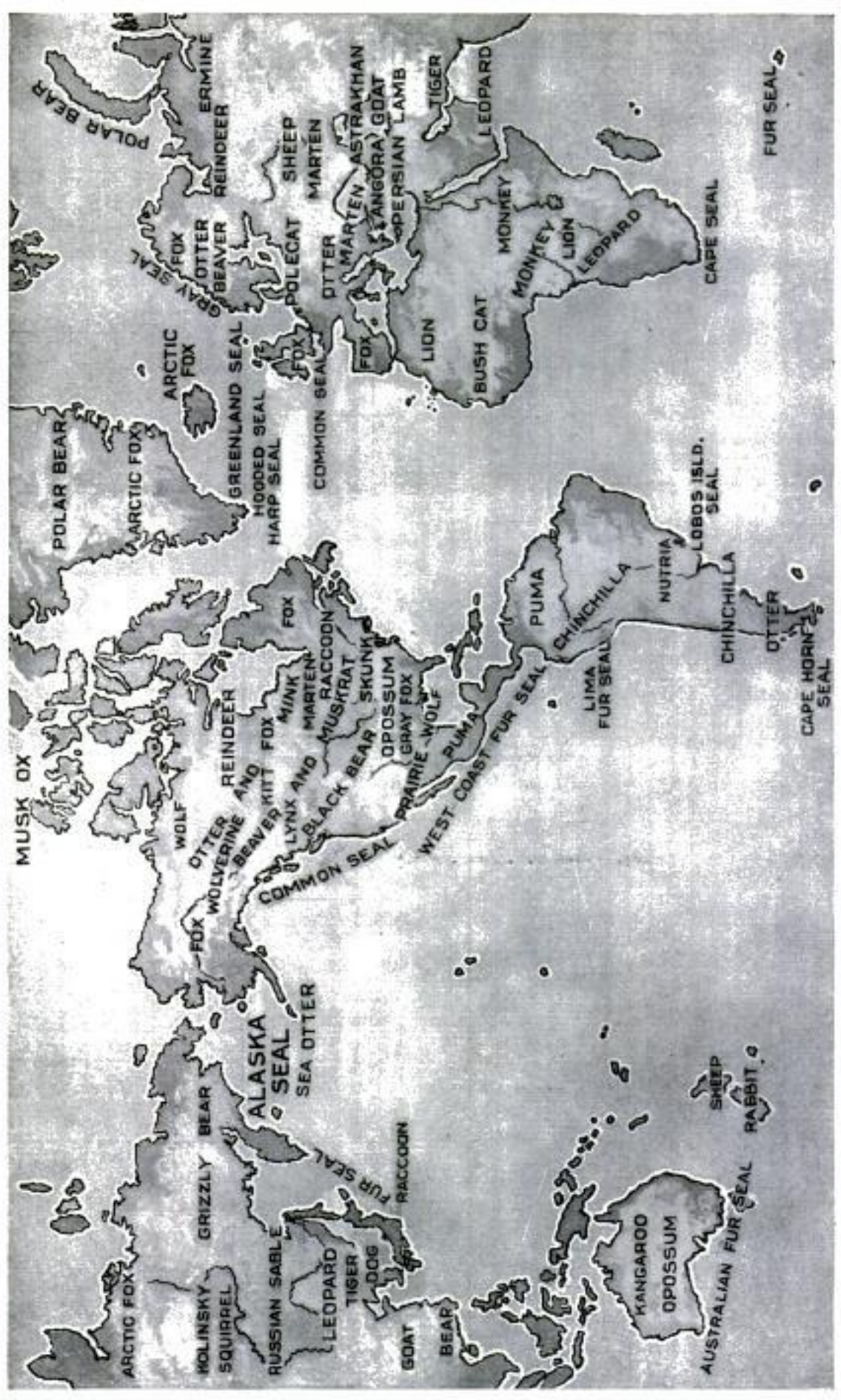

Map Showing Where Fur-Bearing Animals are Found

islets of the group are used only by birds that nest so thickly there that one cannot walk without stepping on eggs.

As more and more of the cows arrived, the noise and apparent confusion grew greater. Each cow tried by some mysterious method to find the old bull who had guarded her in his harem the year before. Most of the cows succeeded, but some were caught by the neck in the big teeth of another bull and thrown in with his harem, each bull trying to get as many cows as he could, some having but one or two, others having as many as 200. The bulls fought terribly. Four times the size of the cows, these latter did not resist them and stayed where they were thrown, or laid down by the bull of their choice, and even slept in the midst of the fighting and roaring, which sounded at a little distance like the noise of regiments of soldiers firing their guns and light artillery.

Within a few days the younger bull seals and more cows arrived. They would be coming all through the season, which lasts about three months. All the time the old bulls and some of those just come to big size—those six years and over—fought and were on the move constantly, guarding their charges.

Yet not once, since the time some weeks before when these bulls had taken up their first positions, had any of them eaten or had a drop to drink, or slept for even an instant. Nor would they do so until the three months were up. They lived entirely off the great masses of blubber and fat they had stored up within their bodies during the earlier part of the year.

About a month after the first cows had arrived, thousands of "pups," as the new-born seals are called, added their cries to the chorus of noise. For a few days each mother cared for her one child, then suddenly she dived into the sea and was gone, leaving the little ones



The Grizzly Bear

to care for themselves, which they seemed able to do. The cows were hunting food and drink, and contrary to what might

be thought, they did not simply hunt down the several kinds of fish in the waters around the islands, but swam sometimes as far as 100 miles hunting

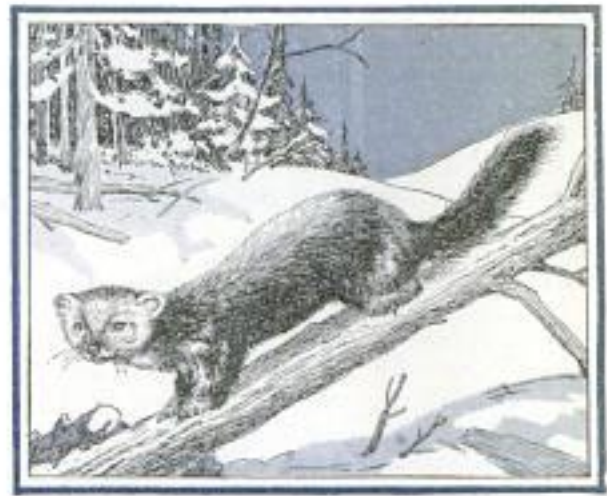

The Sable

their favorite diet—cuttlefish, the "octopuses' brother."

While the cows were gone, there was no let-up in the fighting and noise ashore. Other cows and other bulls were arriving constantly, but now they were almost all younger seals, although all two years or more old, since no one has ever seen a one-year-old seal, for these youngsters do not come to the Pribiloffs, although they are thought to swim up into the near-by waters, never coming into sight of land.

As the season wears on, there gather, about the closely packed rookeries (seals prefer to gather in batches of as many as 75,000, packing themselves so closely together as to look like moving patches on the otherwise empty shore, the big bulls looming up like black mountains amid and surrounded by the harem, yet never losing sight of the cows belonging to them), numbers of "bachelor" bulls—those not strong enough to capture or hold any cows. Other and younger bachelors enjoy themselves on a near-by beach, thousands of them in a herd.

It is of these bachelors, this surplus male life, that the U. S. government permits a limited number to be killed each year, to provide that most lovely of furs, Alaska seal, for the woman of civilization.

These animals are separated from the main herd and driven inland. They must be driven carefully, for they get overheated easily and then die, and once dead from this cause, their skins are worthless. As they are driven in—by the Aleut natives maintained on the island by Uncle Sam—they bunch together, the

bigger bulls in the center. The younger ones begin to run around the outskirts of the little band, faster and faster. They must be stopped, else they run themselves to death by the overheating route.

The men rounding them up carry clubs about 9 feet long. With these they finally kill the seals they select with a sharp blow on the skull. The men are trained and know just how to deliver the deathblow, and the method is humane. Following the clubmen come the "stickers," who make certain of the seal's death by stabbing it in the heart. The "splitters" next cut the pelt from head to tail, around the flippers and the tail, and in a certain way about the head. The actual taking off of the skin is then done by the "skimmers," who leave as much blubber as possible adhering to the skin.

After removal, the skins are laid flat so that the animal heat will be lost by contact with cool air as soon as possible. The skins are then salted and taken to the salt house, where they are thoroughly cured. When this is done, the skins are salted again and each one rolled up snugly and tied. They are then packed as tightly as possible in barrels, the spaces between skins being filled with salt to exclude, as far as possible, all air. Finally, they are shipped to the United States where, at St. Louis, they are made ready for the furrier, who makes them into wraps.

The seals chosen to be killed are those of from three to four or five years of age. The two-year-olds are not yet ready for the market and the six-year-olds are usually allowed to live for breeding purposes. The older bulls are also spared, both for this purpose and because their hides are usually scar-marked from battling with their kind, and so are useless for the trade. How many are killed depends on the government.

First, just about half of all the seals born in any one year are males. The pups are counted each year by the government, and about 160,000 are born annually. The natural enemies of the seal—of which the worst is the killer whale, one of the few denizens of the sea that can swim faster than the seal—kill about half of the animals yearly. This leaves, following the 160,000 figure, 80,000 which can reasonably be expected to live. Of these 80,000, 40,000 are females, and the government does not allow any cows to be killed at any time. Thus, there remain 40,000 male seals. Since the seals have the harem ideal, it is not necessary to preserve one male for every female seal, so the government permits—as it did in

1922—about 30,000 male seals, the bachelors before described, to be killed, the remaining 10,000 being allowed to live in order to replace the old bulls who die off. These figures are, of course, not exact, but are within a few hundred of the precise numbers.

To conclude the story of the big bull we first saw come out of the sea: As he continues, month after month, to go without food, water, and sleep, he gradually becomes weaker and weaker, as might be expected in view of his continual activity. Nature led him to store up just about enough fat and blubber to stand the three months' trial. He didn't think of it, for of all animals the fur seal is about the most brainless. He apparently cannot think at all. Finally there comes a day when the last of his harem is about to leave. The weather is showing signs of coming cold. Suddenly he and the hundreds of his brothers either fall down in a heap or crawl off a little way and lie down, and there they at once fall into a deep sleep, from which they do not awaken for as long as three weeks.

When they wake up, they are shadows of their former 2,000-pound vigorous selves. They can barely manage to drag themselves down to the sea, and as they disappear beneath the friendly waves, they are gone into a mystery, for no one, except perhaps some unknown tribe of wild men in the South Seas, ever sees them again until the following May, when they return to the Pribiloffs for their strange mating.

Contrary to the popular idea, the fur seal is not an arctic animal. He cannot stand the intense cold of the regions he visits every summer, and at the first touch of approaching winter he goes south.

Perhaps other of the animals man hunts in the northland will become seal-like creatures in time. The polar bear, once seen in relatively large numbers on land, is more and more taking to the water, the older natives of Alaska and near-by lands assert. It is really seldom now that a polar bear is met with on land, although he spends a great deal of his time on icebergs and on frozen reaches of the ice-locked arctic oceans. His pelt, once the pride of the home when made up into huge rugs, is now less in demand for that purpose, and, being very coarse, not of much use to civilized peoples, though worn by natives of the Far North.

Another arctic animal whose fur is perhaps the rarest and the most expensive of any kind, and who is changing from



a land to a water animal, is the sea otter, now nearly extinct. This beast, which Uncle Sam will not permit anyone to kill, formerly frequented stretches of the Alaskan coast. Now it never leaves the water, as far as can be learned, bearing its young and living its days in the sea. Its rich, almost black, fur is occasionally seen as collars and front-lining strips on men's coats. A small skin—only two of which among millions of other kinds changed hands on the St. Louis market in 1922—may bring as much as \$600 at auction.

Before leaving this land of the aurora borealis, it remains to note another curious animal—curious, at least, in his way of life—the blue fox.



The Raccoon

course, unknown, but it is assumed that they crossed over the ice from either Asia or North America during the winters, when the Arctic Ocean is frozen over for practically the entire distance, the winter ice sheet reaching just about to, and little farther than, the Pribiloffs.

In common with the seals, the blue foxes led for many years the life of all wild things hunted by men who give no thought to the morrow and care not if they kill them all and wipe out the species. Then, in 1911, when the United States acquired control of the Pribiloffs and began to save and increase the seals, which then numbered a scant 100,000, the blue foxes were studied and the remnants of the once large bands

cared for and protected. The seals now number more than 700,000 and the foxes, which cannot be counted since they are



The Silver Fox

not penned up, are much more numerous than formerly.

The foxes are allowed to run wild over the islands, being provided with food by the carcasses of the skinned seals in the summer, and by Uncle Sam's bounty in the winter months, when the millions of sea birds, that also visit the Pribiloffs, and the seals are gone. When the cubs are about to be born, the mothers are enticed into pens by tempting food, and there guarded against excitement and other foxes. When the young ones are born they are taken from the mother, for if she becomes excited she kills them;

whether knowingly or not, is a question. The habit is also noticed in the silver foxes, that other rare and costly animal. It is thought by some that the mother, frightened by the noise, whatever it may be caused by, grabs her babies by the scruff of the neck and, being penned in, carries them from place to place seeking a safe retreat, thus gradually choking them to death. Silver-fox mothers have been known frequently thus to carry their young about for an entire day, at the end of which the hardship and choking has killed the cub. Frequently the mother does not notice her cub's death.



The Sea Otter

Cont. Logg & Ford, 416 Union League Bldg

Los Angeles Calif

ISLANDS OVERPOPULATED WITH INDIANS

2283



An Airplane View of One of the San Blas Islands: Note the Congested Condition of the Thatched Houses, Each of Which Has Several Lofts Housing Separate Families

Centuries ago the San Blas Indians, in eastern Panama near Colombia, were forced by warlike neighbors to emigrate to a few small islands in the Caribbean Sea. Here, in spite of heavy infant mortality, the tribe has lived and multiplied until now every house and all the ground is overcrowded. A serious problem is lack of room for playgrounds for the children. The dead are not buried, but weighted with stones and dropped into the sea. Although the surrounding waters abound with fish and tortoises, and fruit is obtained from the mainland, there is a serious shortage of food.

CLOUDY DAYS THE BEST FOR SURVEYS

2388

Cloudy days are best for the making of accurate surveys. This is because there is no sun glare, and no excessive adjustments of the steel tape line, for temperature, are necessary. All sources of possible error must be eliminated, and this would be difficult, for example, if part of the tape were in the shade and the rest in sunlight. The tapes are adjusted for a definite temperature, and corrections applied according to the prevailing temperature. A scale is built into the tape, so that a constant pull can be exerted. When measuring angles, as many as six readings may be taken on the same angle, often by different observers to distribute the personal error, and then all

the readings are averaged. In precise surveys the limit of error does not exceed 1 in 500,000; that is, .0002 of 1 per cent.

GENERAL CUSTER'S STATUE DAMAGED BY TRAINS

2369

Excessive vibration, caused by passing trains, is believed to be responsible for cracks which have appeared in the base of a monument erected to General Custer at Monroe, Mich., his home town. The statue was authorized by the state legislature to honor the memory of the famous warrior against the Sioux Indians, and was erected only a few years ago. An appropriation has now been made to move the statue from its present site, and set it up again at a safe distance from the railroad tracks.

Mr. Esraseman

Cont. Cyril E. Lamb, St. Dallas, Tex. 1309

AIR LIFT RAISES AND DUMPS DUMPLESS TRUCKS

2273

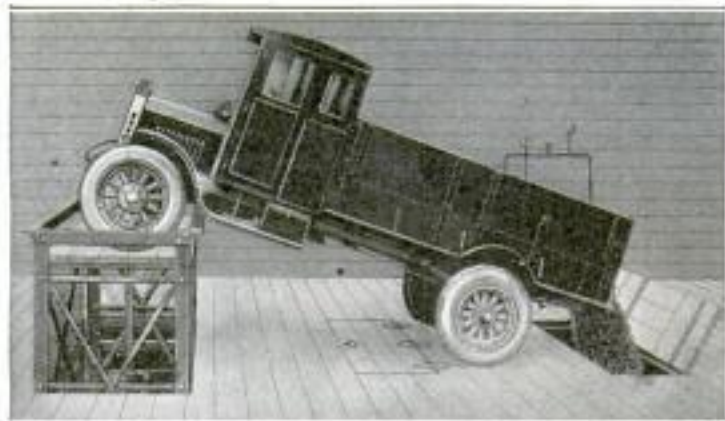

How the Air Lift Raises and Tilts the Body of a Truck or Wagon: Bulk Materials are Quickly Dumped

When trucks or wagons are not self-dumping, unloading by hand requires money outlay. A lift platform has been devised which quickly raises and dumps such vehicles. The lift is air-operated, and when not in use, is flush with the street level. Dumping is accomplished by driving the front wheels onto the platform. When the air is turned on, a steel guard rises, first about 6 inches, then both guard and platform rise together. The guard prevents the vehicle from slipping backward.

Kewanee Implement Co. Copyright Kewanee, Ill.

5/17/23

**FREAK STAMPS BRING HIGH PRICES AT AUCTION**

2424  
Freak United States stamps brought the highest prices of all the offerings at a recent auction sale of a portion of a famous New York collection. One 24-cent air-mail stamp, with center inverted, sold for \$610. The stamp was one of a sheet of 100, which got into circulation. An unused book of four of the 90-cent issue of 1890 brought \$199, and an unused four-cent Columbian issue, of 1893, printed in blue, the wrong color, was sold for \$130. A feature of the sale was the payment of \$171 for a repaired two-cent of the 1901 issue, with center inverted.

**SMASHED 86-YEAR-OLD VIOLIN SUCCESSFULLY RESTORED**

Unusually adventurous is the story of an old violin which was fashioned in 1842, at Prague, Czechoslovakia. While



Upper View: After the Accident, Shattered into 86 Pieces. Lower View: The Repaired Violin

the owner was on a concert tour in Canada, the instrument, valued at \$1,400, was stolen. It was then traced by the Royal Mounted Police, and finally recovered in Montana, but on his way back to Canada, the musician's car overturned, and the violin was smashed into 86 pieces. A violin maker in Spokane undertook to patch it up, and after two months of patient labor, delivered the restored instrument. So skillfully had he done his work, that the tone quality of the violin now is as excellent as before the accident.

Emt. P. E. Crosby  
Spokane Chronicle  
Spokane, Wash.

**AUTOMATIC BOOT WASHER USED BY JAPANESE**

642  
Because of the muddy roads often encountered in Japan, and the practice Japanese business men have of washing



Close-Up of Japanese Boot Washer, and, in the Background, Its Installation and Use at an Office Entrance

their boots before they enter an office, a unique boot washer has been patented to replace the doormat so familiar in other countries. The device contains a stand to fit both feet and is attached to a tank of water. When the feet are placed on the stand, the water is automatically turned on, washing away any mud or dust. The water continues to run as long as the feet are on the stand.

**RADIO HELPS FIND BREAKS IN ELECTRIC LINES**

2386  
One of the greatest difficulties encountered in modern long-distance electric-power transmission is to promptly find and repair the breaks that occur during windstorms which blow down poles and wires. As telephone and telegraph wires often suffer from the same cause, making communication between different points for checking up the trouble impossible, it has sometimes proved difficult to locate the break. At Minneapolis, during a recent storm that paralyzed all communication, this difficulty was overcome by using the radiophone, by means of which the break was promptly located.

Emt. N. Sakata, #10, Seachome, Iidamachi, Kojiyoguchi-ku, Tokyo, Japan.  
Electrical World  
5/12/23 p. 1096



© A View of San Francisco from the Bay, Taken from an Old Print, as It Looked in Mark Twain's Days, About 65 Years Ago



Note the Contrast in Skyline between This View of San Francisco Today, and That Above. The Tower Is the Ferry Building



HISTORIC "PONY EXPRESS" PAGEANT TO BE GIVEN

Much interest in the romantic "Pony Express" of western pioneer days in the '60's is being revived by the announce-

ment that a great pageant will be staged on this historic route, beginning August 28. Celebrations are being prepared in the states which will take part in this pageant—Missouri, Kansas, Colorado, Wyoming, Nevada, and California, and possibly Utah. Descendants of the first Pony Express riders, dressed in early-pioneer costumes, with mail bags, rifles, and pistols, are to ride once more the famous old trail which crosses more than half the continent, from St. Joseph, Mo., to Sacramento, Calif. Two of these riders will be John K. Baker, of Denver, Colo., adopted son of William F. ("Buffalo Bill") Cody, and William Frederick Cody, nephew of Buffalo Bill. United States Army men and cowboys will also ride.

By way of contrast, the riders will be followed by light and heavy motor trucks, passenger automobiles, motorcycles, a special railroad train which will have a clear right of way through to San Francisco, and lastly, several government airplanes. These riders and vehicles will make all the stations of the old trail to Sacramento, and thence will proceed to San Francisco for the California admission-day celebration, September 9 and 10.

One important feature will be the unveiling of a 20-foot bronze statue of Mark Twain on the top of Comstock Lode, in Nevada. This statue, which was designed by Roger Noble Burnham, of Berkeley, Calif., is said to be an excellent likeness of the world-famous humorist. It shows him in miner's garb, notebook in one hand and pencil in the other, as he looked in the days when he wrote his first sketches and edited a newspaper in a Nevada mining camp.

Com. H. H. Lunn  
2722 Prince St.  
Berkeley, Calif

SHARKS MAY FURNISH CURE FOR DIABETES

Promising results have been obtained in the treatment of diabetes by the use of an extract to which the name "insulin"

has been given. Physicians of the University of Toronto have been attacking various phases of the problem for the last two years. The substance is an extract that requires the greatest care in the preparation, and is derived from an animal gland. One of the problems that gave concern to the investigators was the assurance of a sufficient source at a reasonable price. The entire animal kingdom has been studied for this purpose, particular attention being paid to various kinds of fish. These could be bred in enormous quantities if necessary, and encouragement of their growth would assure a sufficiency of "raw material." Some attention has been paid to sharks, and experiments along this line are still continuing, but it is not yet definitely known whether fish will constitute an important source of the product. In the treatments to date, which were administered to numerous animals and



Clay Model for the Heroic Bronze Figure of Mark Twain

patients under close observation, it has been definitely established that the extract does exert a marked beneficial effect on diabetes. The most important uses of the product, in the opinion of the investigators, lie in the treatment of youthful sufferers, among whom the death rate has heretofore been nearly 100 per cent; in the treatment of patients who have additional serious infections; and in the treatment of those sufferers who are not relieved by diet. The actual manner of action of the remedy is not known, nor the "how and why" as yet understood. Medical researchers believe that the answer is to be found in the baffling reactions of the chemistry of the blood—a domain which still remains largely unexplored.

2383

Mr. D. J. ... Director ... for medical ...

### AUTOMOBILE RACES WOLF TO ITS DEATH

2213

One of the most exciting pursuits ever staged in South Dakota took place recently when an automobile was used to

run a wolf to its death. The animal, of unusually large size, had been raiding many of the farms in that vicinity, and was credited with having killed some 70 hogs on a single farm. A pack of dogs participated in the chase, and the wolf took to the prairie, traveling about 30 miles an hour, with the car close behind. When the machine had almost caught up with its prey, the dogs were loosed, and quickly accomplished a kill. So closely did the car maintain its position behind the wolf that the latter did not

even have the opportunity to dodge. It was the largest animal ever seen on the prairie section of the state, and measured 5½ feet from tip to tip.

### GERMANS CAST HUGE BELL FOR RHINE CATHEDRAL

242

Cologne Cathedral, on the Rhine in Germany, is to have what is declared to be the largest serviceable bell in the world. The new bell, to be known as the "St. Peter," will replace the 30-ton "Kaiser Bell," melted down for munitions in the war. It weighs more than 27 tons, is 11 feet high and the same distance in width. The upper half bears religious figures and inscriptions. The original Kaiser Bell was made from guns captured in the Franco-Prussian war of 1870-71.

### DAWN-TO-DARK AIR FLIGHT 'CROSS NATION PLANNED'

2423

Following the record-breaking nonstop flight of an army airplane from Hempstead, N. Y., to San Diego in a little less

than 27 hours, plans are being made to attempt to cover the same distance this fall between dawn and darkness. Both of the airmen who completed the transcontinental voyage have expressed the view that such a feat is possible, but that several stops would have to be made for gasoline, oil, and water. The distance to be covered is estimated at 2,625 miles, and the plane that made the nonstop flight was forced to carry such a heavy weight of supplies of gasoline, oil, and water that its speed was

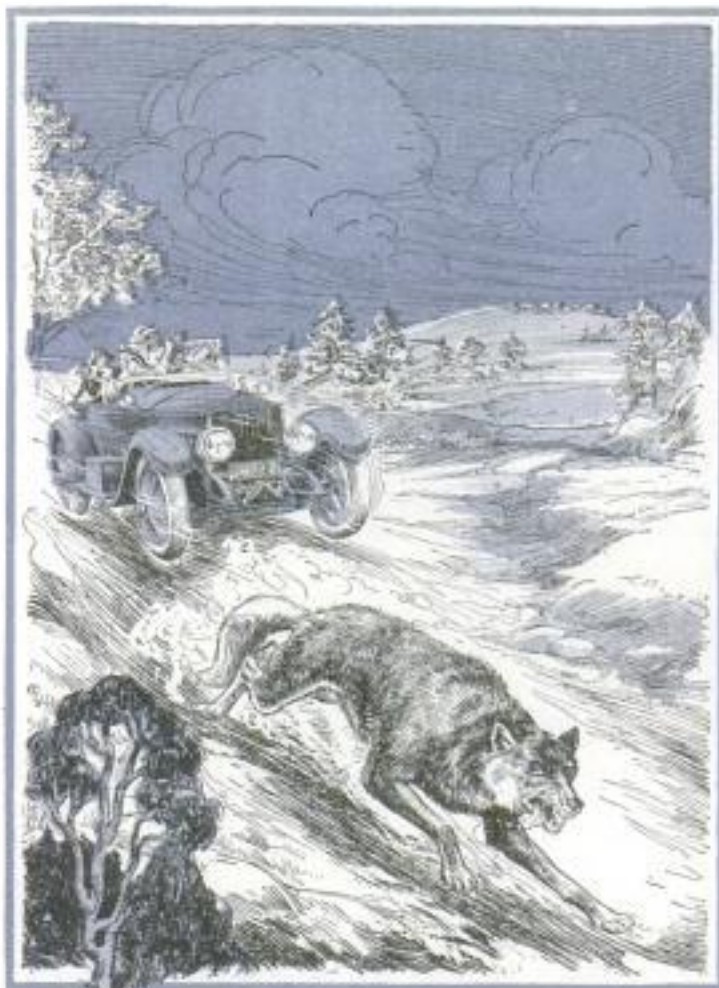

Our Artist's Conception of the Exciting Wolf Chase, Which Ended with the Animal's Death

greatly reduced. In the new attempt the weight would be considerably less, and it is expected that this would greatly increase the average speed. Only a small supply of fuel would be carried, the plane landing every few hundred miles for fresh supplies. In this way it is hoped that a sustained speed much in excess of a hundred miles an hour could be maintained. So great was the weight of supplies with which the nonstop plane was burdened on the start of its journey that it was nearly wrecked at the Hempstead flying field, because its powerful motor was barely able to lift the weight above the roofs of the surrounding hangars. But despite this heavy handicap, the plane covered the distance in the short time mentioned, or, to be exact, 26 hours 50 minutes 48½ seconds.

*W. J. James*  
5/14/23

2334

Investor & Trader -  
Pub'd by Jones & Baker

POPULAR MECHANICS

New York City. 5/7/23

**OIL INDUSTRY TO BREAK  
RECORD THIS YEAR**

The oil industry is expected to shatter all previous records this year with a total output of approximately 700,000,000 barrels of crude oil as against a total of

crude-oil production for the year is \$1,000,000,000, and that of gasoline, \$1,250,000,000. The capital investment in the industry is reported to be approximately \$8,000,000,000. While more than 300 different products are manufactured from crude oil, gasoline, because of its relation

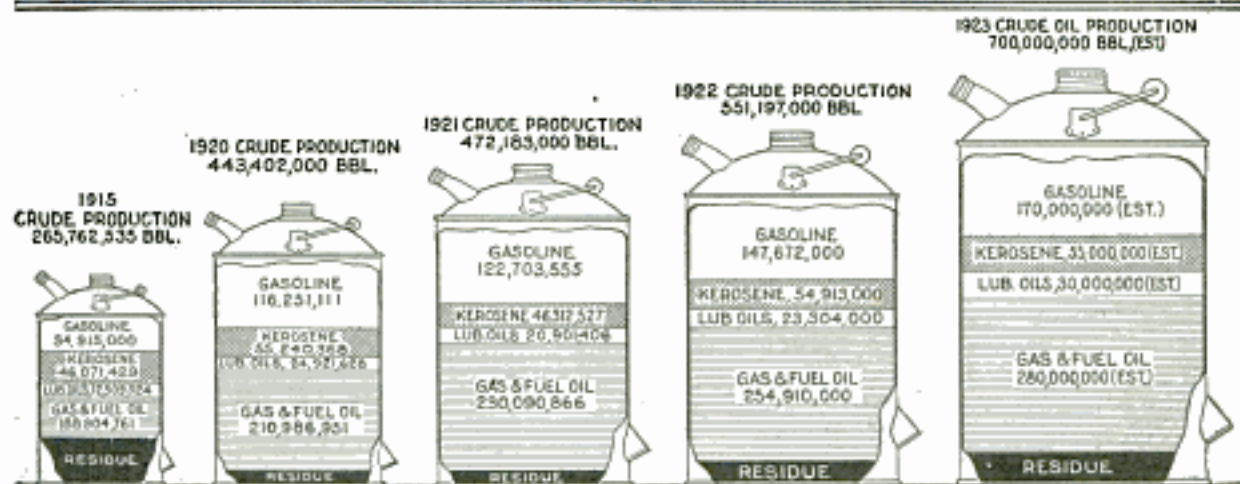

Figures Showing Tremendous Gains Made by the Oil Industry Since 1915 and the Growth in Importance of Gasoline as a Result of the Steadily Increasing Use of Automobiles, Trucks, and Tractors

551,000,000 barrels in 1922. This year's gasoline needs are estimated at 7,000,000,000 gallons. The estimated value of the

to the automobile, represents the biggest source of profit. Kerosene this year is valued at 250,000,000 dollars.

**HELICOPTERS BETTER RECORDS**

Rising vertically and flying horizontally was recently accomplished by two helicopters in France. One machine invented by the Frenchman Oehmichen, completed a circle 360 feet in diameter at Valentigney. The other, invented and piloted by Pescara, the Argentinian, made a 120-foot flight near Paris.

**NAVAL GUNS SIMULATE****HUGE PILE DRIVERS**

The pride of the United States Navy is the efficiency of the American gunner. To develop this efficiency constant practice is necessary. Obviously, however, the firing of a sufficient number of 14 or 16-inch shells to give the men proper training would be too costly, and so a system has been devised to train turret men and gunners by using dummy shells.

The dummy shell is loaded into the gun in the same manner as a real shell. Dummy powder bags are placed behind it and the breech is closed, the gun pointed on the target and "fired." In this kind of practice, of course, the dummy

shell does not leave the muzzle of the gun. The shell cannot be pulled from the breech so that the practice may be repeated, but must be forced out.

For this purpose, the breech is opened and a wooden block weighing about 150 pounds is dropped down the muzzle of the gun. The weight acts like the "monkey" of a pile driver and forces the dummy shell out of the breech.

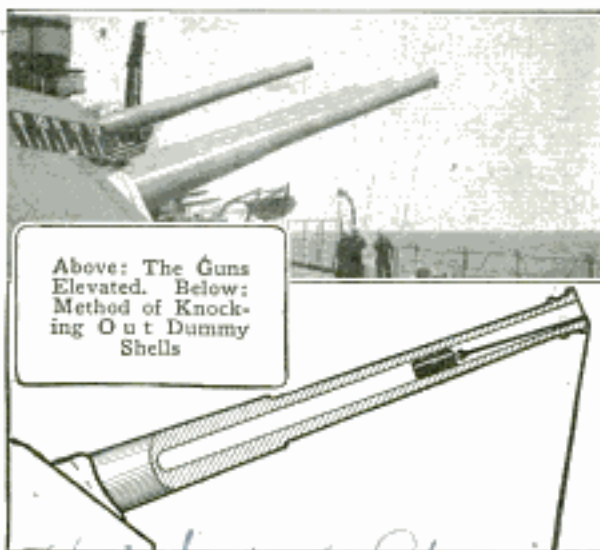

Above: The Guns Elevated. Below: Method of Knocking Out Dummy Shells

Cont. Hagg & Hord, 416 Union League Bldg. Copyrighted material  
Los Angeles, Calif.

2084 UNCLE SAM IS KEEPING TAB ON 4,000 CHICKENS



Eggs are Placed in Racks and Trays for Inspection before Going to the Incubator



Every Egg is Numbered So That an Accurate Record may be Kept of Its Progress



Ceaseless Care is Taken to Protect the Eggs from Breakage in Handling at the Farm



Numbered Bands are Put on the Legs of Each Chick for Identification



Full-Grown Chickens are Numbered on the Wings

Besides all his other activities, Uncle Sam also finds time to keep a faithful record of some 4,000 chickens from the time they burst from their shells until life is extinct.

At least six separate forms, involving more than a hundred different entries, are required for every chick in the government flock at the experimental farm conducted by the poultry-husbandry division of the Bureau of Animal Industry, at Beltsville, Md. Obviously, neither the farmer who markets his eggs in a basket at the crossroads store nor the housewife who obtains her pin money from the sale of eggs and fowls, can apply the system of keeping records in force on this 60-acre farm, but both profit from the knowledge acquired at it.

So when this government bureau recommends to poultry raisers a certain ration because of its virtue for increasing the egg yield, or when it announces that hen No. 514 is a champion egg producer, farmers may know that the information is not mere guesswork, but is the result of actual experience and exhaustive tests.

Information as complete as that required by an income-tax schedule is kept of every fowl on the farm, representing fourteen different breeds of poultry. Every egg is numbered as it is taken from the trapnest, and even its weight is recorded. No egg is used for breeding purposes that weighs less than 50 grams (about 1¾ ounces), and it has also been determined that a dozen eggs should weigh 24 ounces.

During the incubation period, every egg is tested several times, and the results are described in terms of "infertile egg," "dead germ," "broken egg," "dead in shell," "pipped," and "hatched." Infertile eggs are boiled, cut into fragments and used in feeds. Eggs containing a dead germ are burned. Experiments have determined that in the incubation season the percentage of fertile eggs is approximately 80 out of 100. As the hens wander about the fields and obtain more forage later in the season, the fertility of the eggs is said to reach as high as 90 per cent.

All of the chicks hatched on the experimental farm are identified by means of numbers attached to their legs with bands. The day on which they are hatched, the number of eggs produced daily, and every fact relating to their lives, are then carefully recorded and studied for the benefit of poultry raisers throughout the country.



The effects of various feeds, temperature, and fresh air on the health of the fowl, and their output of eggs, are kept, together with the date of their death and the causes. In addition there is a "poultry-pedigree card" giving the ancestry of

2340

### RESERVE VAULT VESTIBULE WEIGHS OVER 100 TONS

What is declared to be the largest vault vestibule in the world, has recently been installed in the Federal Reserve Bank at Cleveland, Ohio, where it will

### COLOR SCHEME OF WORK SPACE AFFECTS OUTPUT

2348

Eyestrain among modern workers has been discovered to be so common as to prompt serious investigations by experts in an effort to relieve that condition.

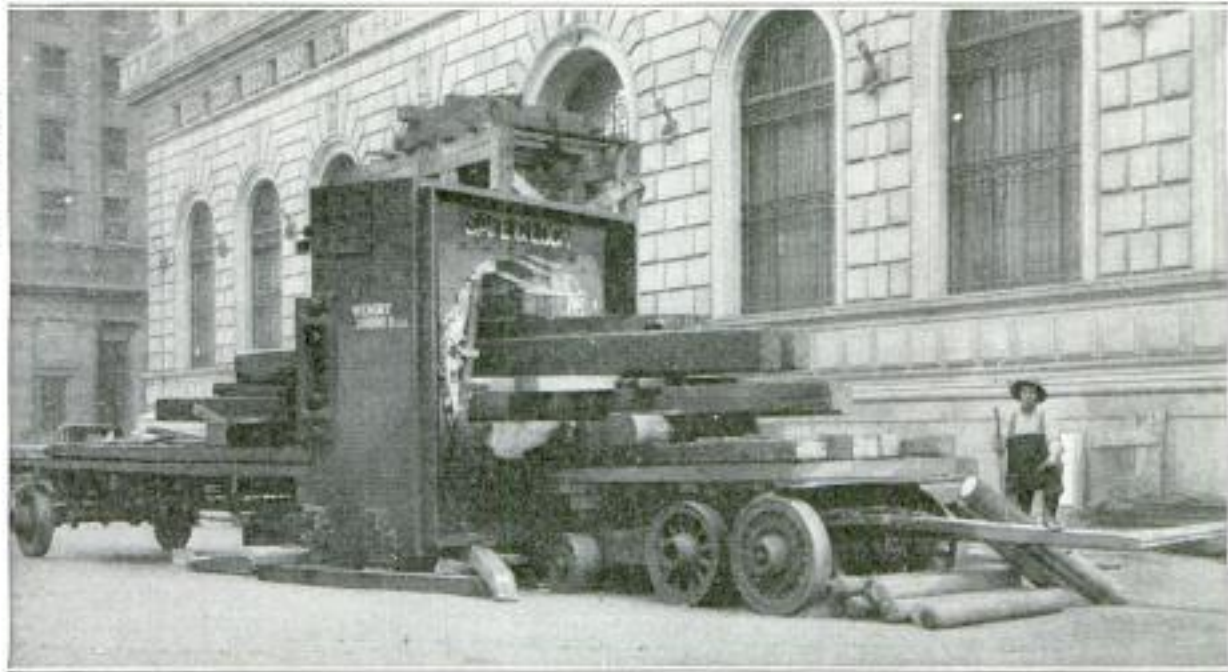

A View of the Special Steel-Wheeled Truck, Showing the Manner in Which the Huge 200,000-Pound Safe was Mounted and Transported through the City Streets

form the entrance to the gold-storage apartment. The vestibule, which is 4 feet thick, 15 feet wide, and 16 feet high, weighs over 100 tons, and the door that fits it weighs 90 tons. Both are constructed of hard and soft steel, so arranged that it is almost impossible to drill into them. Special steel-wheeled trucks and a fleet of power-winch motor trucks were used to haul them over the city streets, which were laid with steel plates on top of 3-inch oak planks to protect the water mains below.

One of the queer cities of central India is Ujjain, located in the state of Gwalior, on the right bank of the Sipra River. It is one of the seven sacred cities of the Hindus, and according to their reckoning it marks the first meridian of longitude. A great religious festival is held there every 12 years.

Some recent experiments along those lines have been productive of interesting results. It was found that if the workbench on which an operation is being carried out approximates the color of the material used, then eye fatigue is reduced, and the rate of production of the worker rises. It was also found that a girl operating a white typewriter does more work and makes fewer mistakes, with less eyestrain, than if using the standard black pattern. With a black machine, the typist, glancing from her "copy" to the keyboard and vice versa, must make an adjustment of her sight muscles with each change of focus; and when this occurs frequently, the muscles controlling it become exhausted. In both the cases cited the similarity in color between the work unit and the work made these adjustments easier and produced good results, with less eye fatigue to the worker.

London Times  
Supplement

Morris Bros. Co., Cleveland, Ohio.

**FIVE "HAIRPIN" BENDS  
IN SINGLE BLOCK**

2314

One of the queerest-looking streets in the country is to be found in Burlington, Ia. Here, Sixth Street, although its side-



One of the "Hairpin" Curves on Sixth Street, Burlington, Iowa: There Are Five in a Single Block

walk length is only 241 feet, rises about 60 feet in that short distance, with a grade of over 25 per cent. Between walks the roadway winds first toward one side, then toward the other, like a huge snake, and contains five "hairpin" turns between the foot and the top of the slope. This con-



At the Foot of the Brick-Paved "Hairpin" Road: Note the Winding Turns to the Top

struction was resorted to in order to reduce the grade for vehicles. The street now is a constantly used thoroughfare in spite of its considerably increased length.

**WEATHER FORECASTING  
FROM SHIPS AT SEA**

Returning from a test cruise on the French training ship "Jacques Cartier," E. H. Bowie, chief forecaster of the U. S. Weather Bureau, expressed the conviction that forecasting wind, weather, and storm conditions at sea is entirely practicable. During the voyage to and from France, the vessel received radio advices as to weather twice a day, not only from Europe and America, but from other vessels within range. Weather charts were then constructed, and broadcast twice each day. Forecasting at sea is a simpler matter than on land, because there is no ruggedness and variation of surface that might influence climatic changes. This uniformity results in greater regularity of wind motion.

**SIGN ON DOOR PANEL LIGHTS  
AS KNOB IS TURNED**

2255

Users of signs have long attached them to door panels to attract the attention of customers. It remained for a Chicago merchant to invent a similar sign which lights up automatically when the door knob is turned.

This store-keeper found that an ordinary sign "Pull" failed to be noticed by his customers, in spite of the fact that he used the largest one he could find. The new device is the result of his experience.

Placed at about the height of the eyes of the person entering, its brilliant flash coming as the knob is turned, instantly attracts attention. The sign is regulated by a switch so that it can be lighted constantly if desired. All wires are in the door casing, and so cannot easily be disturbed. The sign is so constructed as to be burglar-proof.

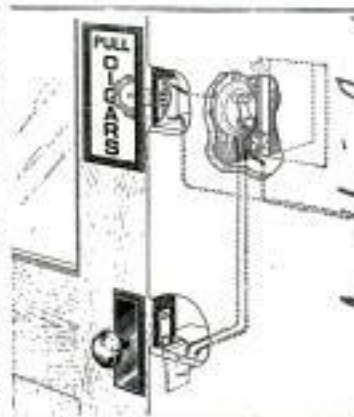

*see Mr. Leabriel for name*

At Loughborough, Eng., a 140-foot tower is being erected as a war memorial, which will house 50 bells. The tower will cost about \$75,000, and will contain perhaps the finest chime outfit in Europe. The largest bell will weigh four tons.

Com. E. J. Coye.

General Motors  
Stained Glass Medallions

2170

8 Popular Mechanics  
Flushing N.Y.

### METAL COMPOUNDS INCREASE GASOLINE EFFICIENCY

Doubling the mileage of an automobile on a gallon of gasoline is regarded as possible in the light of recent experiments where compounds of the metals selenium and tellurium were added to the mixture. The tellurium compound is said to be the more attractive because it lessens the "knock" that is liable to appear in the motor when it is pulling a heavy load.

2220

### MOTOR BUSES HAUL CHILDREN TO CONSOLIDATED SCHOOLS

Consolidation of public-school districts, which has become common lately, has brought with it the problem of transportation for the children, many of whom travel from the farthest edges of the new districts every morning. This is rapidly being solved by carrying them in motor busses, large autos, or even wagons and hacks.

One of the best illustrations of consolidated-school transportation systems is found in Kansas. There are now almost 150 such schools in this state, and over half have busses equipped with specially made bodies that accommodate from 15 to 35 children. These are driven and kept in repair by school mechanics and housed in school garages. The teachers sometimes are also drivers, and where there is a rural high school, its students serve in that capacity. The busses are fairly fast, and give good service.

There are, of course, occasional days when a "mud holiday" or a "snow holiday" must be called, on account of bad roads, but these are rare.

### STAINED-GLASS MEDALLIONS WORK OF STUDENTS

1999

Eleven stained-glass medallions, each the work of individual undergraduates, will be placed in a new arts-and-crafts building at the University of Oregon. The 11 students have each selected a particular craft to portray, designed an appropriate window, originated a legend for the border, and then completely fashioned the work without aid from anyone. One of the legends reads: "Ye Printer — Ye Printer Dothe His Papers Fille with News Which Is Both Goode and Ille." Another: "Ye Potter—Ye Potter Mouldes in Fynest Claies His Present Thoughte for Future Days." As a permanent exhibit of student work, it is claimed the medallions will be unique in American colleges. Antique English pot-metal glass is used to fashion them.



One of the legends reads: "Ye Printer — Ye Printer Dothe His Papers Fille with News Which Is Both Goode and Ille." Another: "Ye Potter—Ye Potter Mouldes in Fynest Claies His Present Thoughte for Future Days." As a permanent exhibit of student work, it is claimed the medallions will be unique in American colleges. Antique English pot-metal glass is used to fashion them.

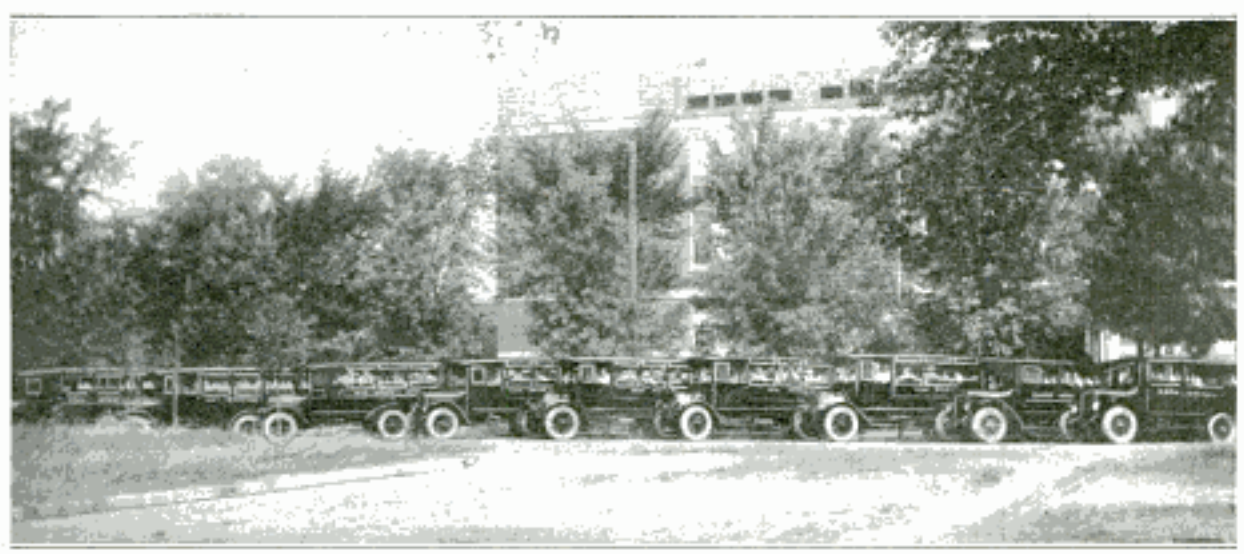

Convoy of School Buses, Gathered at the Trousdale School in Kansas: They Serve a Series of Consolidated School Districts in That State, and are Run by the Schools

Com. Alva Croodwin, 6112 Kimbark Ave. Chicago

Copyrighted material

Chicago Journal  
5-11-23

**MILLIONS BOUND FOR INDIA  
IN KEGS AND BRICKS**

2117

Just kegs and bricks on the chute of this boat docked at Liverpool, but—as



Unloading a \$2,000,000 Shipment of Gold Coin, in Kegs, and Bars of Pure Silver, at Hull, England

they are kegs of gold coin, and bricks of silver—worth millions of dollars. The precious cargo is from America and en route to Bombay, India, where the silver bars, 250 in all, will probably be coined, or turned into jewelry.

**RATCHET DEVICE ATTACHES  
TO SCREWDRIVER**

Screws can be set or removed by means of a simple screwdriver with a ratchet attachment that fits on the shank. By op-

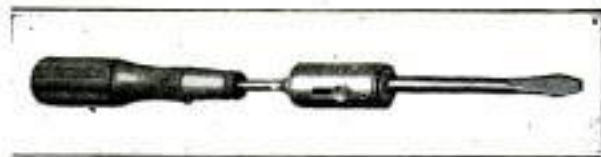

The Barrel-Shaped Attachment on the Shank Contains the Ratchet Arrangement

erating a button on the device the screwdriver handle may be turned either to the right or the left.

**TRANSFER COIN-COLLECTION  
TO WASHINGTON MUSEUM**

2291

The Philadelphia mint's collection of 1,688 coins, tokens, and medals, representing this and more than 40 other countries, is to be transferred to the National Museum at Washington. Among others, the collection contains shillings of 1651, Franklin pennies of 1787, and a rare old "five-eagle," or \$50 gold piece. Most of them are foreign coins, however, from Great Britain, France, Greece, Belgium, Norway, and Sweden, old free cities such as Augsburg and Bremen, and even coins minted by bishoprics in Germany.

**BAKED ICE-CREAM EGGS  
A NEW CONFECTION**

2263

Ice-cream eggs with centers of real ice cream, which are baked after filling, are the latest novelty in confectionery. The plates containing the molds, which are egg-shaped, are heated by electricity. Egg-shaped scoops place the ice cream in the batter after it has been poured into the molds, the latter are closed, and the baking is so quickly done that very little of the ice cream melts. The eggs

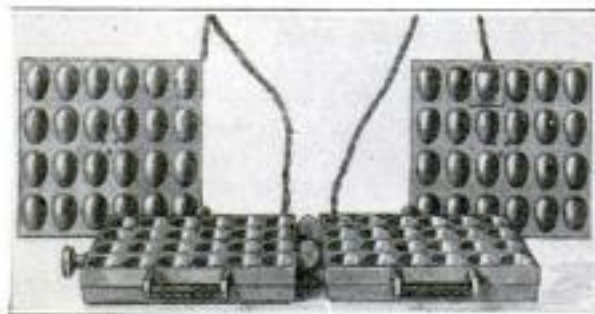

Ice-Cream Eggs, in Batter, are Baked in These Molds Before They Have Time to Melt

are then taken out of the molds and placed in a refrigerator, where the centers freeze hard.

**WASHINGTON STATE PROHIBITS  
CHRISTMAS-TREE CUTTING**

2344

Reforested areas in the state of Washington have been depleted to such an extent by private and commercial Christmas-tree hunters as to prompt the enactment of a law aimed at those offenders. A fine of \$1 per tree is named as the punishment for cutting down, topping, or otherwise destroying any tree without the permission of the owner. It is believed that this fine will take all the profit out of the trade.

Com. L. W. Pedrose.  
617 Pacific Bldg.  
Seattle, Wash.

A. Publ. Gen. City of Ill.

any to each. Calif.  
any to each. Calif.  
any to each. Calif.

reproduced material

1917 / Jno. M. Wendt, Real Estate  
 POPULAR MECHANICS  
 Wiggins Block, 83  
 Cincinnati, Ohio.

**RUSTIC STONE ENTRANCES FOR NEW SUBDIVISION**

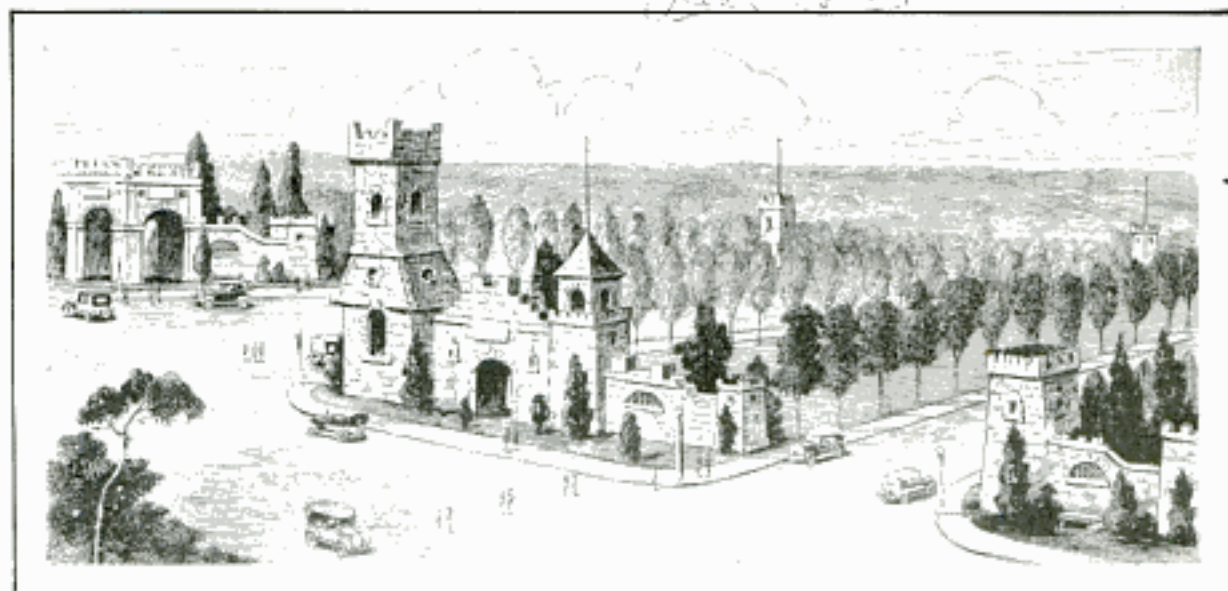

Artistic Stone Towers at Entrance to New Residence Section in Hyde Park, Cincinnati: Towers and All Lamp Standards are Built of Stone Taken from the Grounds

Castlelike stone towers are to decorate the entrance ways to a new subdivision now being opened in Hyde Park, a suburb of Cincinnati, and it is claimed, will form one of the most artistic entrances to any dwelling section in the city. All lamp standards and the offices on the site will also be constructed in this rustic style, which is to be followed out in all

houses built in the tract. In one of these structures, located on Erie Avenue, there will be a waiting room. The avenue will have an 80-foot flare at the gates, narrowing to the regular 60-foot width, and will be bordered by shade trees. The grounds will be separated from an adjoining golf course by transplanted full-grown trees, 35 to 40 feet high.

2325

**CAST-IRON BORINGS MOLDED INTO BRIQUETTES**

Coal briquettes, molded under high pressure, are a matter of common knowledge, but it is not so well known that cast-iron borings are similarly molded for foundry work. When fed into the cupola as scrap, or as fine borings, there is a considerable loss in the melting process, running as high as 50 per cent, which escapes as iron oxide in the slag. This loss has been reduced to as low as 4 per cent when the borings have been previously compressed into briquettes. A high-speed vertical steam hydraulic press is used in the process, making 30 strokes per minute, and exerting the enormous pressure of 120,000 pounds per square inch on the borings to form the briquette. The borings are unloaded directly from cars to a conveying machine, which carries them through a screening and blowing system, to sift out the dirt and clean them. The clean borings are then conveyed to the hoppers that feed the presses, or to storage piles.

Briquetting Co. of  
 Illinois, Cincinnati  
 Ohio.

2243

**PEDALLESS TRICYCLE EMPLOYS UNUSUAL RUNNING GEAR**

Exercise for the whole body is the chief merit claimed for a new tricycle without pedals. The saddle is mounted on a "walking beam" pivoted to the frame, and alternate pressure of the feet against the

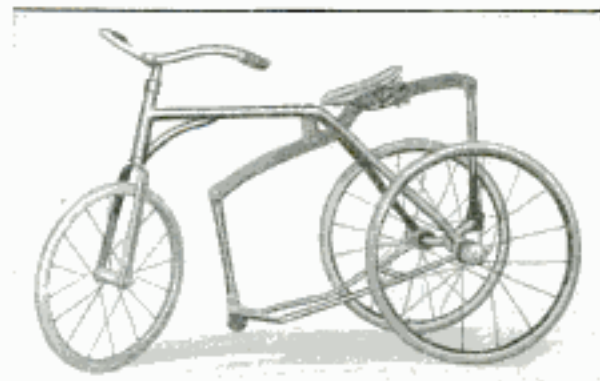

The Rider Propels This Pedalless Tricycle with a Sort of Seesaw Motion of the Body

footrest and of the body against the seat, drives the cycle forward.

Wm. William Hornig,  
 Paterson, N.J.

W.A. Hatorp Co., Landscaper  
 Architects, Cincinnati, Ohio.  
 W. 124 7th  
 new York  
 627  
 W. William D. Woodruff St.

2000 Cont. W. W. Morris, 2514 Linden St.  
Brooklyn, N.Y.

84

POPULAR MECHANICS

U. S. Navy Official Photos.

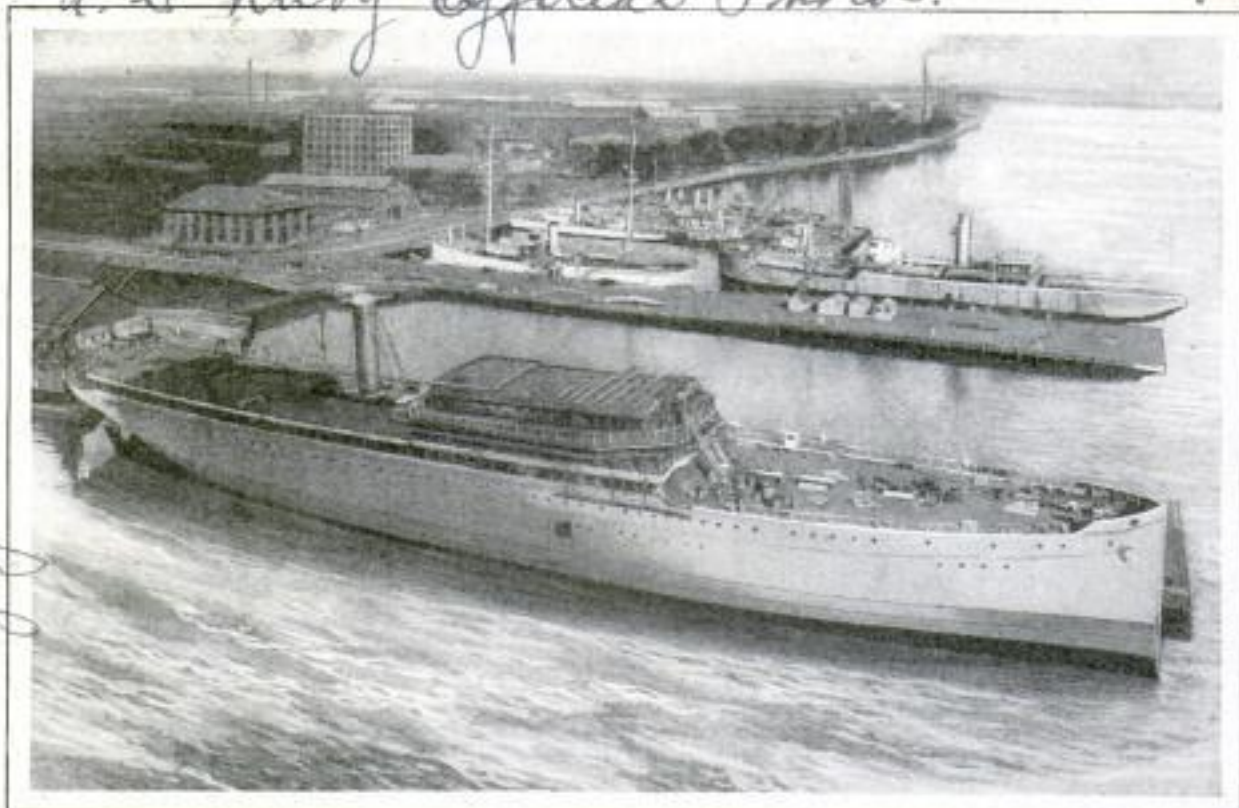

The United States Destroyer Tender "Dobbin": The Vessel will Be 482 Feet Long, with a Beam of 61 Feet, and a Displacement of 11,000 Tons

### GIANT REDUCTION GEAR USED ON U. S. NAVY TENDERS

The construction of the U. S. S. "Dobbin," now being rushed to completion, embodies various new departures in naval construction. With a sister ship, the "Whitney," the vessels will be the first

to be constructed by the navy for the express usage of destroyer tenders. When commissioned, each tender will carry 216 torpedoes, stored in such a way that six bulkheads will stand between the skin of the ship and the deadly machines. Behind these bulkheads will be stowage compartments for oil, gaso-

line, and alcohol. An immense reduction gear, 146½ inches in diameter and weighing 72,000 pounds, will be fitted to the propeller shaft of each ship for "tuning down" the speed of its mating pinion. It will transmit 7,000 horsepower at 105 revolutions per minute. This enormous gear, having what is known as herringbone teeth, measures a full 61 inches across its face, and is one of the largest ever constructed in the United States. When harnessed into service and meshing with its pinion, it will make only one revolution to every 15 of the driving pinion delivering power.

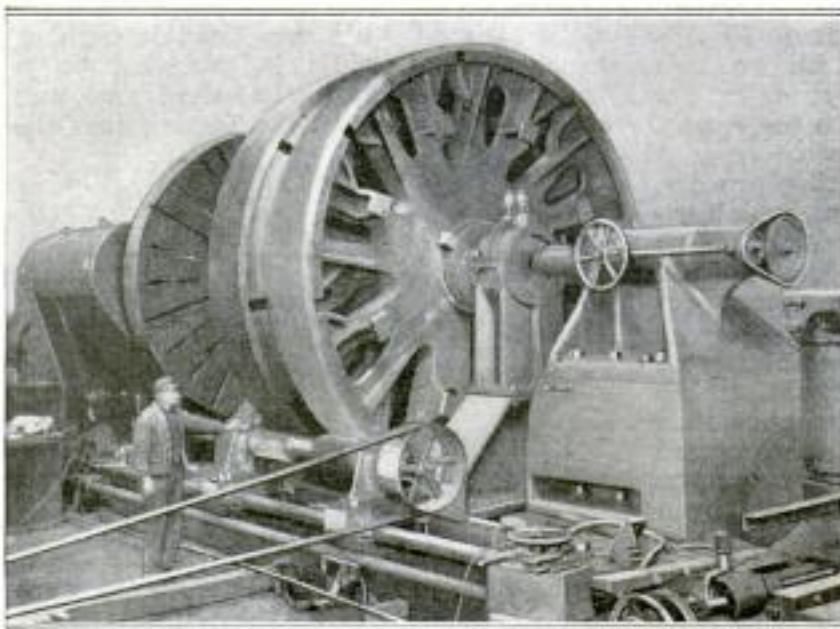

Mammoth Gear Mounted in the Machine Shop of the Philadelphia Navy Yard: It is Undergoing a Test for the Accuracy of Its Tooth Profiles

Garage Equip. 2133 *Leather Standard Garage*  
 POPULAR MECHANICS  
*Equipment Corp., Balboa Bldg.*  
 85  
*San Francisco Calif.*

**AUTOMOBILE WORK  
 STAND TILTS CAR  
 AT ANGLE**

Seeking to eliminate the inefficiency resulting from mechanics having to lie on their backs or descend into a dark pit in order to work on the underside of an automobile, an enterprising inventor has recently patented a work stand which tilts the disabled car to any desired angle, up to 90°, thus exposing the bottom of the vehicle. In this position the mechanic can sit naturally, or even stand, at his work, and an abundance of natural light will fall on the machinery. The car is run onto the stand under its own power and locked in position, and the tilting operation is quite easily executed by means of a simple mechanism.

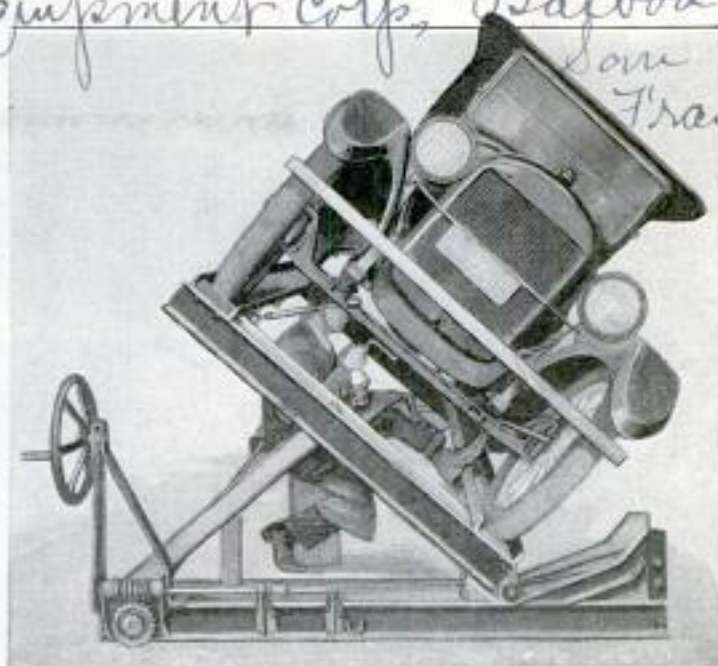

A Tilting Work Stand for Cars in the Garage: Garage Pits Are Unnecessary, and the Mechanic Need Not Crawl Under

2185

**FISH-PROPAGATION BOAT CIRCULATES FRESH WATER**

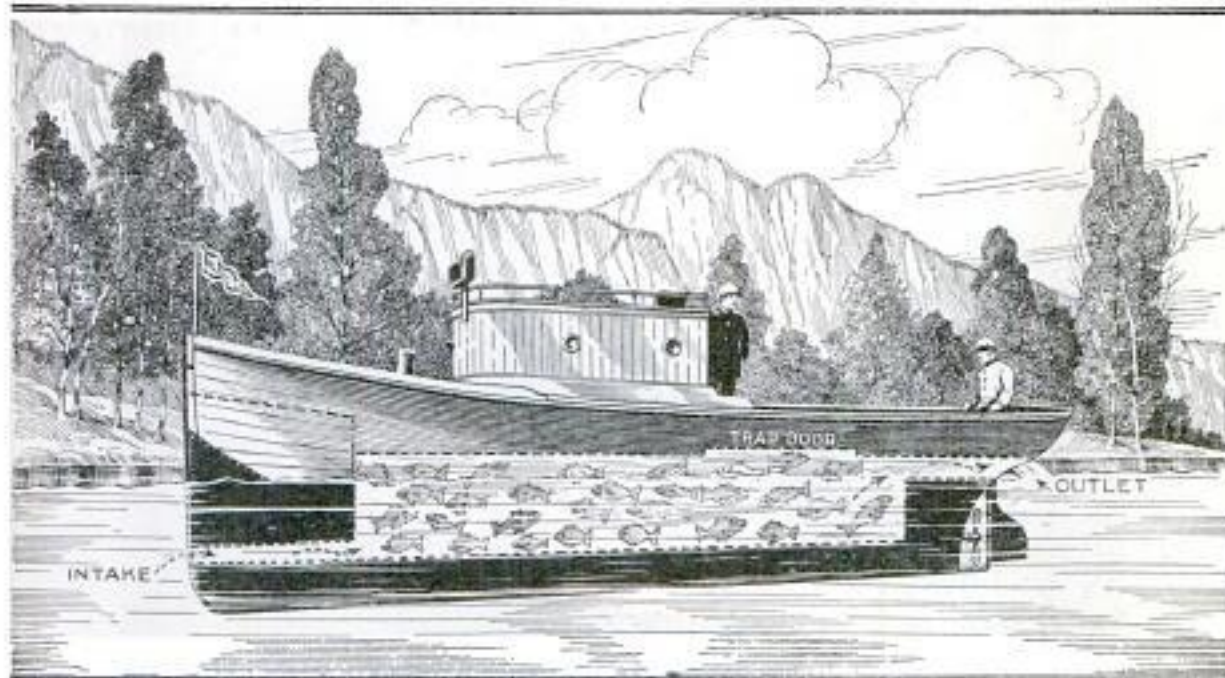

New Boat for Transporting Live Fish for Breeding Purposes: It Has Two Large Tanks in the Interior, with Continuous Circulation of Fresh Water

An unusual method of carrying live fish long distances for propagation purposes without bruising or injuring them has been adopted by the Ohio Fish and Game Commission. Instead of tanks or barrels, a boat is used for this purpose, which has two built-in tanks running lengthwise of the vessel, for the most

part below the water line. Each of the tanks is provided with an intake at the bow; below the water level, and with an outlet at the stern, above it. This arrangement assures the fish a continuously fresh supply of water. An additional advantage claimed is that no injury results from rolling of the vessels, as with tanks.

*C. W. Harry L. Crossley*  
*Lakeside, Ohio*  
 Copyrighted material

Originator, Wm. H. Carter, Commissioner  
of Public Works

86  
2226

POPULAR MECHANICS  
Santa Monica, Calif

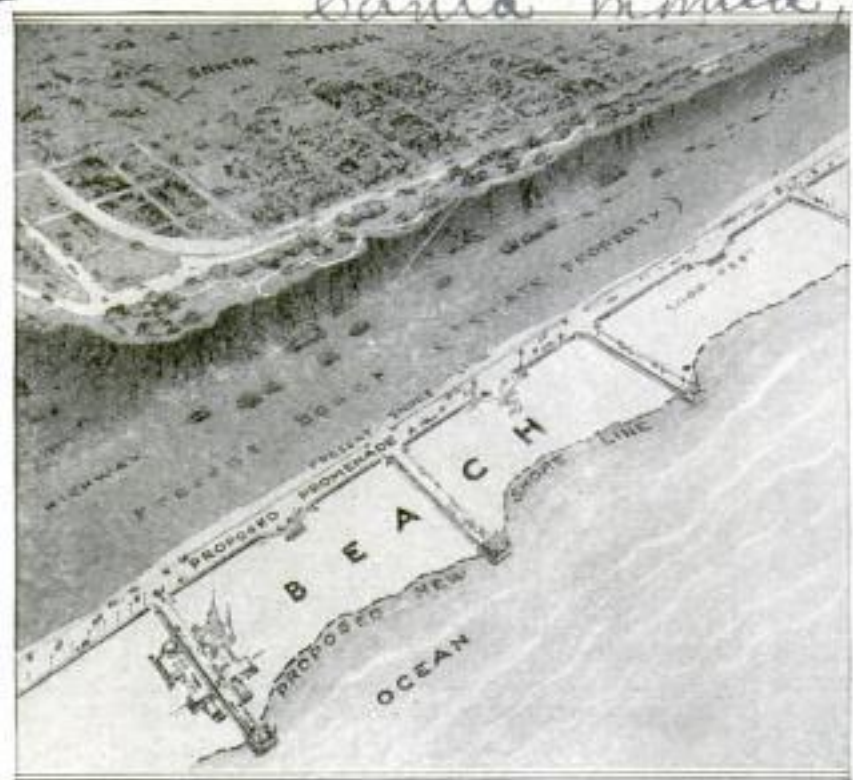

**HARNESSING WAVES TO BUILD BEACH LAND**

The commission of public works at Santa Monica, Calif., noting how the ocean currents built up the shore line by sweeping the sand between amusement piers, proposes to use this action of the waves to extend the shore line by building at regular intervals concrete jetties or quays, 200 feet into the water. This will add land valued at more than \$1,000,000. The quays will be ornamental and topped by promenades, to be illuminated at night. A second series of quays will be built after these, and it is likely other coast towns will build similar quays.

Jetties or Quays are to be Built into the Sea at Santa Monica, California, Permitting the Waves to Build Up a New Shore, as Shown by Dotted Line

2096 **ENGLISH RAILROADS COMBINE INTO FOUR SYSTEMS**

Practically all the numerous large and small railroads of England and Scotland



BY COURTESY OF THE ENGINEERING NEWS-RECORD

have been combined, forming four large consolidated systems. These are the London, Midland and Scottish Railway, with a mileage of 7,790; the London and Northeastern Railway, with a mileage of 6,500; the Great Western Railway, with a mileage of 3,800; and the Southern Railway, having a mileage of 2,200. All these roads have terminals in London, and own a total of 24,540 locomotives, 67,900 passenger cars, and 739,500 freight cars, exclusive of about 50,000 company cars and 148 steamships.

234 **AUTOMATIC BOBBIN STOP FOR COTTON SPINNERS**

Cotton mills are displaying interest in an automatic stop device which halts the bobbin when a predetermined quantity of yarn has been spun on it. The device is applied to the spinning frame without material structural change, and prevents the bobbin from getting too full and running over. This has been a source of considerable waste in the past.

2237 **TIRE GAUGE ON EACH WHEEL SAVES TIME AND WORK**



Much trouble and the mussy work of frequent tire examination are avoided by the use of a gauge which shows the air pressure of a tire at all times, on each wheel. It safeguards against the jolting strain on cars caused by hard tires, and the wear on tires by underinflation.

price of 7.50 per pair

Engineering News Record  
10th Ave + 36th  
New York  
4/5/23

Kelso Mfg Co,  
1208 Kresge  
Detroit, Mich



*Bulford maintained by*

2181 *London & General Omnibus Co. Ltd.,*  
**POPULAR MECHANICS**  
**LONDON'S MOTOR-BUS REPAIR PLANT**

*Electric Railway House, Broadway,*

**T**HE "bus" has always been the typical means of passenger transportation in Greater London, and still is, despite "tu'penny tubes" and all other means of travel—the only difference being that the modern chauffeur replaces the picturesque bus driver and the gas engine substitutes for the horse.

How important a rôle the motor bus plays in the Londoner's life may be judged by the facts that, in 1921, the biggest operating company carried a billion passengers, and its 3,000, or more, cars traveled over 100 million miles.

Until recently between 30 and 40 garages in different parts of London handled the repairs and rebuilding necessary

power. The first operation is the removal of the bolts holding the coach to the chassis. A hydraulic jack is swung into position and the body is lifted clear of the chassis. During this operation the engine remains running. After leaving the demounting shop, the chassis is driven to another department for attention.

Eventually the reconditioned body leaves the overhauling department and arrives at the mounting department at the same time the completely overhauled chassis leaves the works for its road test. This dovetailing of the two operations is necessary, for overlapping or delay in any department would result in a con-

*Westminster  
England.*

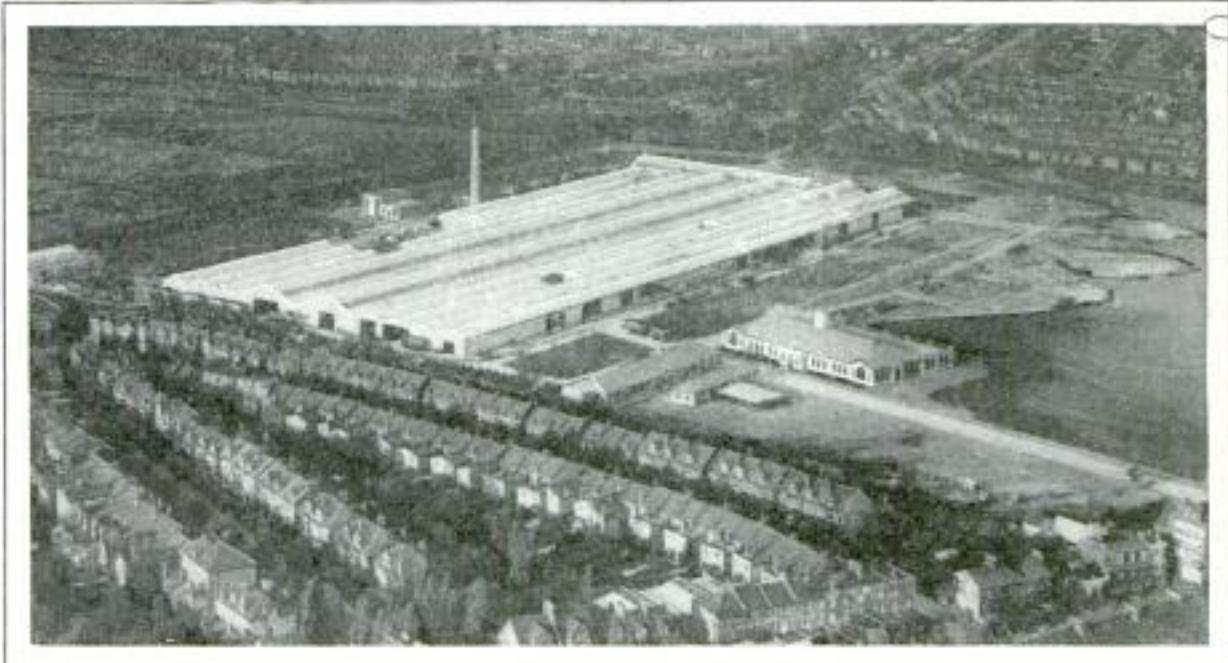

Aerial View of a London Motor-Bus Company's Repair Plant Which Occupies an Area of 300,000 Square Feet and Displaces Some 30 or 40 Small Garages Where the Repair Work was Formerly Done

for the maintenance of this huge fleet of busses. This was soon found to be impractical in many ways, and wasteful of time, and now a factory has been erected at Chiswick—claimed to be the most modern and best planned in Europe, if not in the world—where all repairs will be done. The buildings occupy an area of some 300,000 square feet, and a complete overhaul of a bus will take only four days as against 16 in one of the formerly used garages.

The works are laid out to accommodate a total of 100 units a week, but the system is elastic enough to enable the handling of 120 vehicles in that time.

When a vehicle is to be overhauled it is driven to the plant under its own

gestion that would block the entire organization.

In the body shops is room to handle 104 units. On one side are the lumber stores and alongside are supplies of screws, nuts, bolts, and glass. After the bodies have been completely stripped they are reconditioned, so far as their main parts are concerned, and then go into the paint shop, where 57 units may be accommodated. The whole of the body painting is done by hand and in four different colors. After being painted, the body passes into the mounting and finishing shops, where it is fitted with cushions, aprons, boards, etc., while the electricians complete the wiring and electric fitting.

The procedure in the chassis shop is as



Interior View of the Upholstery-Trimming Shop: In This Department the Cushions are Completely Renovated, New Material being Used Where the Old is No Longer Serviceable

follows: When the engine is stopped the gasoline tank is emptied and the fuel drained by an underground pipe into a storage tank. As each chassis part is taken out, it is moved by a conveyor and completely dismantled. Each part is tested and inspected before it journeys down the line of workers and benches.

One of the most difficult operations is the cleaning. A special washing machine takes the form of a large tunnel carrying on its inner surface coiled piping perforated with small holes. A hot caustic

solution is forced through the perforations by means of a pump, so that every part as it passes through the tunnel on an automatic conveyor, is thoroughly cleaned.

As the chassis passes along the shop, it is gradually stripped of engine, clutch, gear box, brakes, rear and front axles, steering gear, and all other fittings down to the bare frame. The wheels go into a special shop for re-tiring. The springs are reheated in a double-ended furnace, with a capacity of 120 springs a day. After



One Day's Output of Reconditioned Motor Busses from the Plant Which Has a Capacity of 100 Such Units a Week: In This Plant It Requires Only Four Days to Completely Overhaul a Bus

*Parsons Mfg. Co.  
5301  
Detroit, Mich.*

tempering each spring is tested to a 50-per-cent overload.

After the frames have been passed as fit for further service the process of re-assembling begins. The total length of the main assembling platform is 220 feet.

The rebuilding of the engines is as particular in every way.

By the time the chassis is overhauled and reassembled, it passes into position over a machine which, operating through the rear wheels, starts the engine, and the unit leaves the shop under its own power for the first test run. Then follows the remounting of the body as previously described.

*0289*

**COMBINATION GAUGE TOOL FOR MACHINISTS**

Making accurate layouts, for centering purposes, is often a difficult job for machinists and tool makers, and takes considerable time in some cases. To speed this operation, an ingenious tool has been devised, in which two slideways, one vertical and the other horizontal, are contained in a cast-iron frame. Each has a slidable scale running in its groove, which can be locked in place. The frame also contains two triangular scales, whose longest sides meet at right angles.

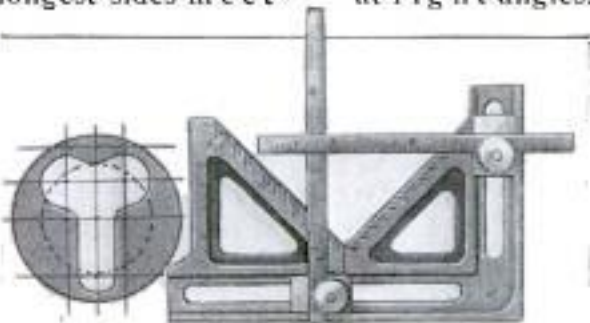

A Gauge Tool Which can Also be Used as a Depth Gauge, and as an Internal and External Try-Square

This intersection serves as a reference point when laying out the work, and facilitates accurate scribing of the stock.

While on a world tour in 1921 a resident of St. Louis dropped a corked bottle overboard between Auckland, New Zealand, and Honolulu, containing an offer of a reward for its return to him. Thirteen months later, after traveling about 1,200 miles, the bottle was found by a native of the island of Ulawa and delivered to a missionary in Siola in the British Solomon Isles, who reported the find to the sender.

**REGULATOR FOR AUTOMOBILE WINDOWS USES GEARS**

*939*

By the use of a recently invented type of regulator for automobile windows, the annoyance caused by imper-



Left: Gear-Driven Auto-Window Mechanism. Above: Car Occupant About to Close Window

fectly adjusted, rusty, or broken mechanisms, is eliminated. The new type uses a train of inclosed gears, the entire outfit being self-contained, nothing being visible to the car's occupants save the crank handle. The device can be easily installed in five minutes, and locks the window positively at any stage of the operation of raising or lowering the glass.

**HOSPITAL IN PARIS TO SERVE SICK AMERICANS**

*2350*

In 1913 the Congress of the United States granted a Federal charter to the American Hospital of Paris, which was organized to provide medical attention for Americans sick abroad. It is now erecting, at Neuilly-sur-Seine, near Paris, a larger and more modern hospital, to be known as the "American Memorial Building," funds for which are being received through voluntary donations and contributions made in the United States. Aside from its work of service, the structure will memorialize the lives of fallen soldiers, as well as those who fell while in the various American hospital services during the war. Many of these were organized by the original parent hospital at the outbreak of the war. In addition to the ward rooms, the new building will contain memorial rooms, beds, equipment, and other features which are being subscribed by American individuals, organizations, and communities. These will bear engraved plates, expressing the purpose of the gift.

*U. S. Campaign Hdqrs,  
41st floor,  
Ave., New York City*

*Parsons Mfg. Co.  
5301  
Detroit, Mich.*

*Sidney C. Hills,  
263  
Main St.  
Jorropington*

714

90  
2258

### WORLD'S LARGEST GENERATOR

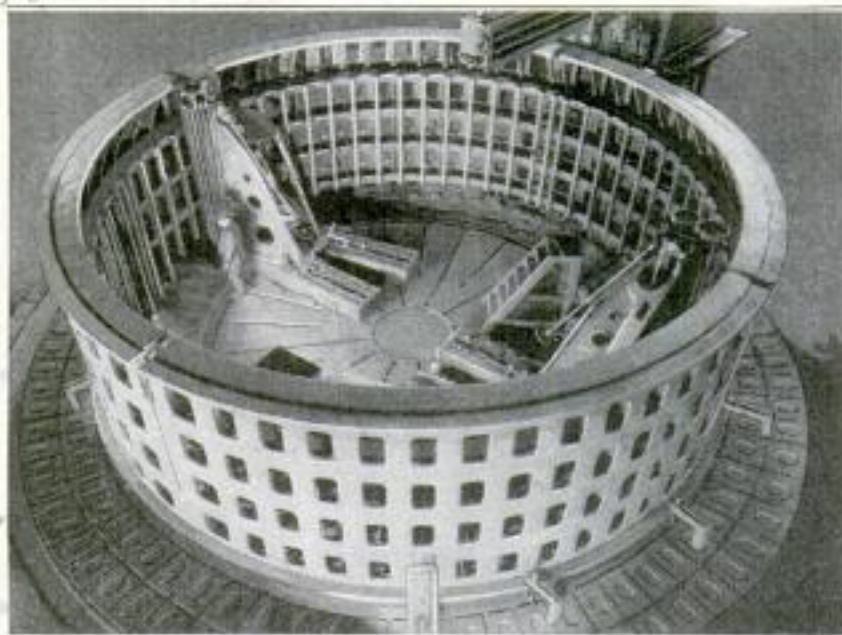

The Largest Generator in the World, in the Process of Erection at Niagara Falls: Note the Size of the Man as Compared with Its Height

There is now being installed at one of the hydroelectric plants at Niagara Falls, the largest power generator ever built. It will deliver 87,000 horsepower, and when in operation will furnish enough current to light more than 2,500,000 electric lamps of the size commonly used for house lighting. The machine will be 35 feet in diameter, 26 feet high, and will weigh 700 tons. Each generator—there will be two—would supply the electrical needs of a large modern city.

### TRACKLESS TROLLEY TO RUN ON CITY STREETS

Embodying many new features, a trackless trolley car with a seating capacity of 30, is to be introduced on certain streets in Philadelphia.



The Trackless Trolley in Perspective: It can Travel a Maximum of 16 Feet Each Side of the Overhead Wire

A car has been designed with great care as to the comfort of the passengers and the operation of the vehicle, which can be driven around or between obstacles with an ease that is surprising. It is, in fact, possible to operate it 16 feet on either side of the feed wires. It is equipped with two 25-horsepower 550-volt motors, mounted in tandem and driving the rear axle through a propeller shaft fitted with universal joints. The master controller may be either automatic or manually operated;

the service brake is operated by a pedal, and the emergency brake by a hand lever, both brakes being of the internal expanding type and mounted on drums on the rear wheels. A modified standard trolley base, mounted on the arch roof, carries two poles, which are necessary to complete the circuit with the overhead wires.

The car is built on a specially designed



Passengers Boarding One of Philadelphia's Trackless Trolleys, Which Has Stopped at the Curb to Receive Them

chassis with a wheel base of 137 inches, and has cushion tires on all four wheels.

Cmd. John A. Mc Claren 90 Pen  
Pencil Club, 1026 Walnut, Philadelphia, Pa

2176

### IMPROVED TELEGRAPH CODE AID RADIOTELEPHONING

As every radio enthusiast knows, one of the greatest difficulties in telephone reception is that of "tuning out" wireless-telegraph signals. This difficulty Maj. Gen. George O. Squire, chief signal officer of the U. S. Army, proposes to abolish by using an unbroken alternating current instead of the interrupted direct current, the sudden breaks in which, between dots and dashes, are the worst possible source of disturbance.

In the new code, there are no such breaks, although short spaces are used

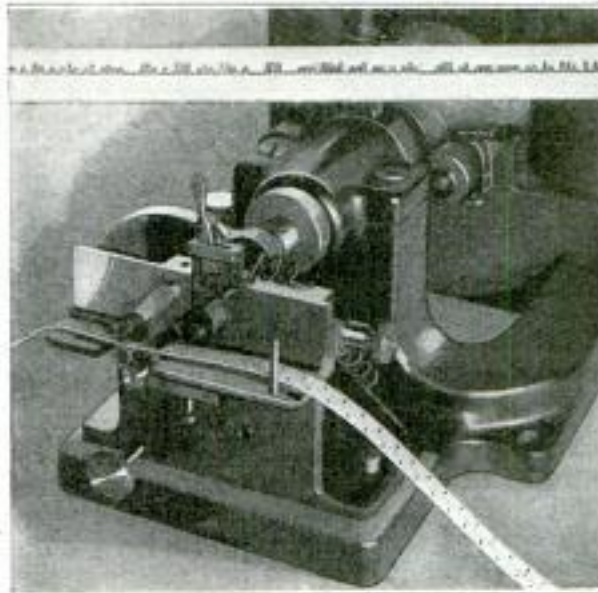

Transmitter for New Alphabet, Which Is Applicable to Radio, Land Lines, and Submarine Cables

between the letters and longer ones between the words, as heretofore, the message delivered on the receiver tape having the appearance of vertical projections of varying height from a horizontal base line. Of these the lower ones represent dots and the higher ones dashes.

2309

### CHECKS RISING SAP TO SAVE TREES FROM LATE FROST

Injury to fruit and other trees and vines by late frosts, can be guarded against by a method which retards the rising of the sap in the tree until danger from that source is passed. This prevents premature blossoming due to spells of unseasonably warm weather. It is accomplished by surrounding the trunk of the tree with an elastic rubber container through which is circulated ice-cold water supplied from a tank in which is a

*Inventor, Stevens, Arthur, Bernicia, Calif.*

refrigerating coil. This cold-water bag is insulated with sawdust packed in a wooden casing which surrounds it and the adjacent portion of the tree trunk.

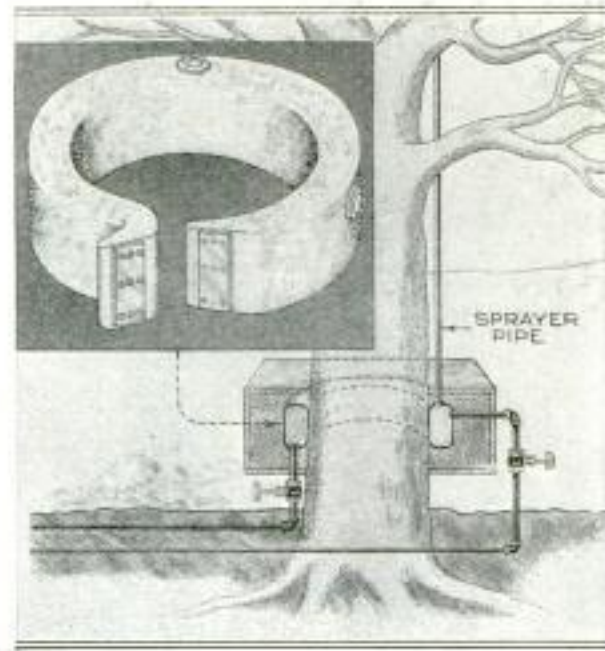

"Choking" a Tree to Prevent the Sap from Rising Prematurely and Becoming Frozen. Insert: Rubber "Choker"

Pipes may be run to various trees through the orchard and all cooled from the one cold-water tank. In one test the method was successful in holding back development of a prune tree for three weeks after other trees in the orchard were in bloom.

### SIMPLE POSTAGE-STAMP

### 22 AFFIXING MACHINE

There is said to be no danger of stamps sticking together in a new postage-stamp affixer, that automatically places one drop of water, of any size desired, on the envelope. The stamp is then pasted on the envelope by pressure on the handle. The water container is in the handle, and does not come in contact with the stamps; hence no moisture can get into the mechanism. The machine also counts the stamps. It has few parts and is of simple construction.



*William H. Eagle, Providence, R.I.*  
*16*

*Conf. Floyd A. Carpenter*  
*Central Bldg*  
*Los Angeles*  
**POPULAR MECHANICS**  
*International Motor Co.,*  
*West End Ave. + 64th St.,*

**AIRSHIP HANGAR COULD HOUSE  
 LARGE OFFICE BUILDING**

**STEEL VAN BODY PROTECTS  
 SILKS IN TRANSIT**

2206

At Scott Field, Ill., the Army Air Service has erected, at a cost of more than

2355

Safe and speedy delivery of silks from some eastern mills to the distributing

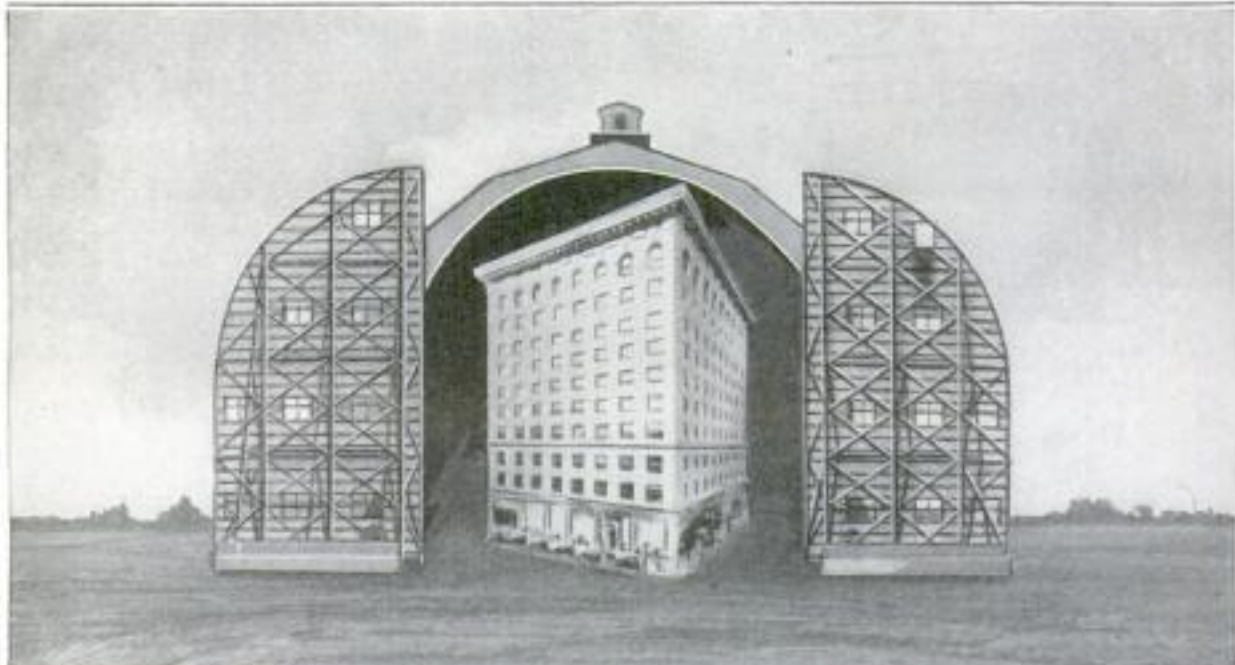

The Large Airship Hangar, at Scott Field, Illinois: The Picture Shows How Easily It could Inclose a Modern Ten-Story Office Building. This Structure was Recently Completed

\$2,000,000, a large airship hangar. The huge structure could contain a 10-story office building with a 50-foot tower on the roof. The hangar, which is built of steel, concrete, and glass, is 825 feet long and 225 feet high. At the end are large steel doors opened and closed by electric motors that travel on railroad rails.

houses in New York City, is assured by the use of a special van with an all-steel body. The cab is entirely covered with bullet-proof steel and the door so constructed that it may be locked from the inside as well as from without. The windshield and the windows contain bullet-proof glass and cannot be opened.

2254



This Quaint Rustic Entrance was Erected at the Factory Approach of a Fine Watch-Making Establishment in Cincinnati. It Is One of the Industrial Show Places of That City

**RUSTIC ARCH LENDS  
 BEAUTY TO FACTORY  
 GROUNDS**

Manufacturing plants are usually conspicuous for the lack of attractive surroundings, and it is of interest to note the attention given to beautifying the grounds of a factory for fine watches. The company bought and tore down several dilapidated structures along a road which was 150 feet from its line and 75 feet below the factory site. A rustic arch of stone was erected as the entrance to a footpath winding up the hill and leading to the plant. In the natural rock along the front of the plant, grow many varieties of evergreens.

*Walter Brinckman Times-Star,*  
*Cincinnati, Ohio.*

*Honolulu, H. I.***FALSE ROCK BOTTOM CAUSES BRIDGE TO SAG LIKE ROPE**

**D**ISASTER was averted in the nick of time recently at Hilo, Hawaii, when a loaded passenger train was flagged just as it was about to cross a collapsed bridge. A series of heavy rainfalls preceded the collapse of the structure, which spans the Wailuku River. Immediately after a passenger train had passed over it, a rumbling roar was heard; ten concrete supports crumpled like so many matchsticks, and the floor sagged down almost to the level of the water. More than 100 feet of track was left hanging in this dangerous condition. Insecure footing for the bridge supports is believed to be responsible for the collapse, in that they rested on rock underlaid by a shallow stratum formed by volcanic and earthquake disturbances. This layer, it is assumed, had been dislodged by further volcanic disturbances, causing the entire foundation to give way.

*2116***MAMMOTH GIRDERS SHIPPED  
ON FOUR CARS EACH**

Unusual measures were resorted to recently when it became necessary to ship, from Milwaukee to northern Michigan, a pair of extremely long, heavy girders.

Each covered a length of four flat cars, and needed a special pivot under each end to permit the cars to take the curves. It was also necessary to route the shipment very carefully, to insure that no limiting clearances of bridges, tunnels, or curves would interfere with safe passage.

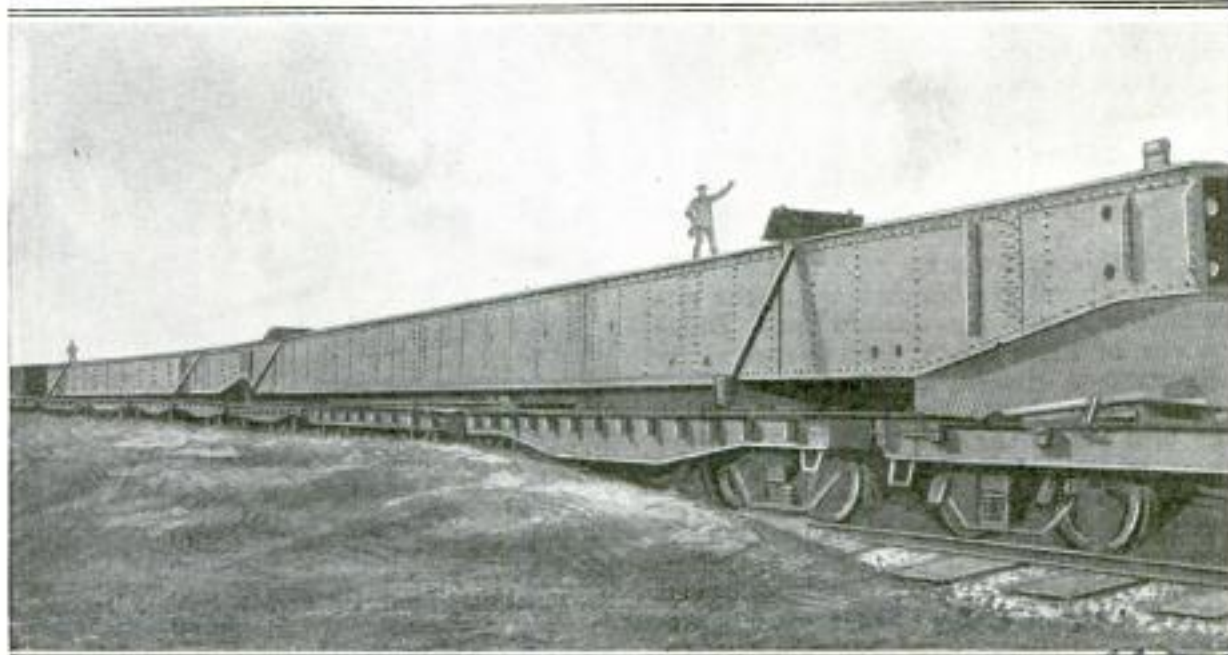

This View Gives Some Conception of the Size of the Monster Girders Recently Shipped into Northern Michigan, Each of Which Covered a Length of Four Flat Cars

### FURNITURE DEALER MOVES GOODS BY MOTORCYCLE

Moving household goods with a motorcycle is an interesting use to which this



Putting a Motorcycle to a New Use: The Miniature "Moving Van" Makes Better Time than a Truck

type of vehicle has been put by a London furniture dealer. Into the sidecar of his motorcycle he loads such articles as a couch, a table or two, and several chairs, which he delivers to his customers quicker than with the ordinary moving van.

### LONDON AND CHICAGO MAY BE LINKED BY AIR LINERS

Plans now under way in England have for their object the linking up of the entire British Empire by airship lines. Independent of these plans, but governed by their success, the same interests are laying the groundwork for a similar service that will link England and the United States in regular scheduled flights, with Chicago as the American terminus of the line. The practicability of the scheme is soon to be demonstrated on the Indian route, which will be established between London and Bombay. Six motored airships will be constructed for this service, each capable of carrying 200 passengers in addition to a cargo of mail. They will

be 700 to 800 feet long, have a diameter of 112 feet, a capacity of 5,000,000 cubic feet of gas, and a speed of 80 miles per hour. The ships will carry two classes of passengers; first-class in cabins, and second-class in bunks. That Chicago has been selected as the American terminal point depends on its more central location than New York. The running time, or rather, flying time, between London and Chicago has been set to about 40 hours, which will require an average speed of about 100 miles an hour. It is expected that this speed will be realized after the airships have been modified in the light of experience acquired on the London-Bombay route.

### SANDBLAST CUTS SHIP'S PORTHOLE LENSES

Considerable time and money were saved at a large eastern shipbuilding plant recently by the method adopted for cutting special-size porthole lenses. A sandblast was used, the glass being first protected with metallic disks, cut to the desired size, and bearing upon pasteboard cushions. When cut halfway through, the lenses were reversed, and finished from the opposite side. This prevented concaving the edge of the glass. Although the lenses were 1 inch thick



Sandblasting Porthole Lenses to the Proper Size: The Insert Shows a Close-Up of the Finished Operation

and 6 1/4 inches in diameter, only 10 minutes were needed to assemble and cut down each one.

Chicago Tribune  
5/11/23

Under supervision of  
Robt. McC. Figg  
masier moulding  
charleston, S.C.



PORTABLE ELECTRIC-LIGHT  
GUARD EASY TO ATTACH

Adjustable to any extension cord, a new lamp guard can be attached in a moment to any electric light without removing the socket. A hole running lengthwise through the split handle admits a large-size cord, and the guard locks with a key, preventing theft.



It covers any standard brass or weatherproof socket up to 1 1/4 inches in diameter, and fits lamps that have straight as well as those that have curved sides.

2288

ROOTS OF TREE SEEDLINGS  
GROWN IN "SPLINTS"

Artificial root distortion which causes disease and loss of young tree plants, is practically impossible in an improved method of raising trees and shrubs from seeds. Each little tree begins its growth in earth inclosed in a tube made from a piece of building paper, about 5 inches wide and 2 feet long, to which lath strips are cemented lengthwise. The roots are

thus forced to grow straight downward. After the seedlings have been transplanted, the lath and paper rot away,

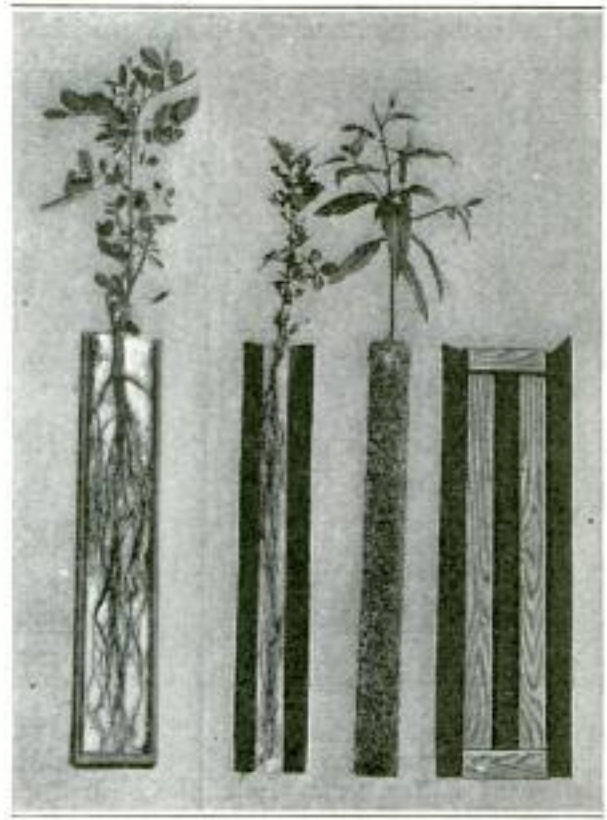

These Little Containers Help the Young Tree to Grow Straight. After a Good Start, They are Transplanted

thereby helping to supply nutriment to the roots.

Mr. Southard, 1500 S. Normandie Ave.  
2411 Los Angeles Calif.

PHOTOGRAPHS WAVE LENGTHS

Photographic exposures of one one-millionth of a second are used in a new instrument for measuring sound and light wave lengths. The instrument was developed for astronomical work and, in connection with a method of measuring the velocity of sound in metallic vapors, is a great aid, particularly in studying radiations from the sun.

the road as the wheel rolls along. From 6 to 7 miles a day can be painted by two

DEPT. OF COMMERCE,  
WASHINGTON, D.C.  
PAINTING ROAD CENTER LINE  
WITH A WOODEN WHEEL

In order to speed up the work of painting a white mark down the center of its concrete highways, Wayne County, Michigan, has mounted a 4-inch wooden painting wheel, covered with felt, behind a motor truck. A compressed-air painting machine sprays paint onto the felt tire, and this is at once transferred to

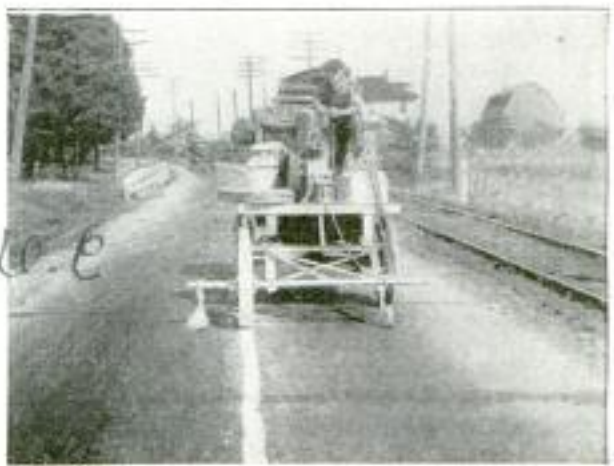

A Mechanical Road Marker: White Paint is Sprayed on a Felt-Rimmed Wheel, Which Rolls on the Road

men with this method, as against 1 mile with the old four-man stenciling outfit.

Board of County Road Commissioners  
Wayne County, Mich.  
Chairman, G. N. Hines 1103 Real Estate Bldg.  
Detroit, Mich.

Cml. C. E. Bacon  
 137 E 3rd St.  
 96 POPULAR  
 Los Angeles, Calif.  
 CLOUDBURST SWEEPS TONS  
 OF MUD ON MINING CAMP

The El Haviland  
 Aircraft Co., Ltd.  
 MECHANICS  
 Stag Lane Aerodrome  
 LIGHT AUTO TRUCK STARTS  
 AIRPLANE ENGINES

2305

2362

Excitement is never lacking in a gold-mining camp, particularly if it is located

Mechanical starters for airplane engines are coming into increasing use, particu-



A Graphic Picture of the Havoc Done in a Colorado Mining Town, When a 12-Foot Wall of Mud Avalanched Down upon It: A Cloudburst Loosened the Slide, Which Completely Covered 22 Houses

in the Colorado Rockies. Snow slides are of common occurrence in the winter, and mud slides take their place in the summertime. A recent cloudburst there let loose a wall of mud, 12 feet high, on the unsuspecting camp. Rocks, mud, and boulders flowed through the small town, covering the streets. The dining room of the leading hotel became filled to the ceiling with this oozy mass, which cov-

erly at aerodromes where an engine must be started cold. An interesting type now becoming popular is mounted on a light truck body, so that it can quickly get to wherever it is wanted. The starting element takes its power from the truck engine, transmitting it through an elevated horizontal shaft on a level with, and connected to, the propeller shaft. In addition to the advantage of portability for starting purposes, the "runabout" lends itself readily to a variety of uses about the field. These include the carrying of gasoline, oil, water, tools, or spare parts to planes, and fire extinguishers as permanent equipment in case of emergency.

2281

#### QUEEN BUILDING DOLLHOUSE

Leading architects of England have been working for two years on a miniature house for Queen Mary, to be 7 feet high and 8 feet long, which will be complete and perfect in every detail. There will be silk Persian rugs, electric elevators, a piano, a complete kitchen outfit, a midget auto before the door, a library filled with hundreds of books, each written by a famous author for the collection, flawless plumbing, and portraits of the royal family by noted painters. Another year will be required to complete the house, which may lay just claim to being the most elaborate plaything in the world.



One of the Houses Which a Colorado Mud Slide Swept from Its Foundations, and Crushed Like an Egg Shell

ered up 22 dwellings. Fortunately, only one person was killed outright, and one fatally injured, owing probably to the fact that the slide occurred at noon time.

When you want anything and do not know where to get it, write Bureau of Information, Popular Mechanics, Chicago.

Slender Post  
 1/22/23

Edward Leystens, England.  
 in charge of Sir Edward Leystens Ward, London, England.  
 Appleton

## HOW DEALERS IN CAST-OFF HATS MAKE A PROFIT

That a surprisingly large market for old hats exists is evidenced by the wide activities of junk dealers in retrieving old headgear from ash cans, city dumps, and from hat stores. The better grades of second-hand hats—those obtained from stores where they are left by purchasers of new hats—are renovated, graded, and sold back to hat manufacturers who reblock and resell them. Those badly battered and worn, are baled and sent to mills where, after suitable chemical treatment, they are made into rugs.



Interior of a Shop Where Discarded Hats are Renovated and Graded: The Better Ones are Sold for Reblocking and the Others to be Made into Rugs

2294

### UNUSUAL DUMPING SCHEME

Gravity will be one of the forces used to advantage at the new coal pier of the Virginian Railway Company in Norfolk. The loaded cars will be hauled up an incline, where the huge car dumpers will empty them into mammoth pans. As the empty cars are returned, the loaded pans, acting as counterweights for the cars, will be elevated still higher to the top of the pier for transfer to boats. The scheme eliminates heavy and expensive construction, which would be necessary if the loaded cars had to be raised clear to the top.

*Mining Press*  
*9/14/23*

### CHILD'S BRAIN PHOTOGRAPHED

2385

Photographing the brain of a living person was recently accomplished in a manner that produced no ill effects upon the patient. While working at a clinic in a New York hospital, physicians made several flashlight pictures of the inside of the brain of a 10-month-old baby. It is expected that photographs made in this manner may prove of great value in the treatment of brain diseases.

*Chicago Sunday Tribune*  
*7/29/23*

### "AERIAL" ADAPTATION OF GOLF MAKES DÉBUT IN CHICAGO

2196

Golf of an "aerial" variety, in which the ball is hit from a suspended sling to a small net hung on a pole some distance

away, is being demonstrated in Chicago. The outfit necessary to play the game consists of two poles, one supporting the sling, the other the net, and a special spoon-faced club or hammer. The distance between the "tee" and the "hole"



COPYRIGHT, UNDERWOOD & UNDERWOOD  
Playing "Aerial Golf": The Object Is to Drive the Ball from the Sling into the Small Net

may be varied from a few feet to 50 or 75 yards, as the player acquires greater skill.

*Inventor: Ben F. Allen*  
*Copyrighted material*

**JUMPERS COVER BATHING SUIT WHILE WALKING TO BEACH**

Wearing bathing suits through city streets or in beach restaurants is prohibited in many localities, and yet heavy outer clothing—especially after a swim—is quite bothersome and annoying. As a comfortable outfit meeting all requirements, there is being introduced a suit of light waterproof jumpers. These cover the entire body, from the hood to the straps fastening about the ankle.



Girls on the Way to the Beach, Wearing Waterproof Jumpers over Their Bathing Suits

**HERRING SPLIT AND DRESSED IN RAPID MACHINE**

A herring-dressing machine, which is claimed to have a capacity of 3,000 fish

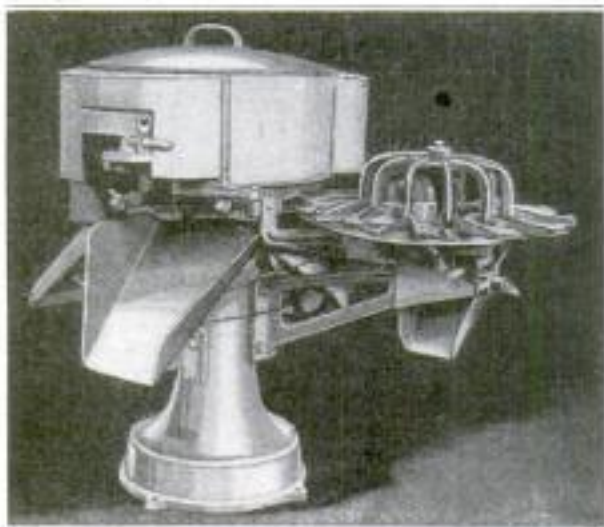

This Machine Splits, Cleans, and Removes the Backbone from Herring at the Rate of 3,000 an Hour

an hour, has recently been imported. The herring are placed on sliding plates on a star-shaped revolving table supported on an arm from the base of the machine, and the heads cut off. They are then drawn by the tail through a series of mechanical devices by which they are slit open, cleaned, and the backbone removed. Just before being discharged from the machine, the fish are washed by a rotary brush against which a stream of water is directed. A nonrusting alloy is used in the building of the machine.

**ALL-PURPOSE GAS MASK LETS WEARER TALK**

Investigations carried on since the great war have resulted in the development of a gas mask that permits the wearer to carry on conversation with about 80 per cent of the efficiency of the average speaking voice. This is accomplished by means of a diaphragm of water and gas-proof cloth held in an aluminum casting opposite the mouth. Improvements in the canister render the mask effective against ammonia fumes and carbon monoxide as well as the ordinary war gases. The equipment, which weighs only 5 pounds and is arranged to be carried under the left arm, is simplified by the elimination of the nose and mouth pieces.



**JAPANESE SUBMARINES MAKE WARM-WATER VOYAGE**

Five thousand miles will be covered by a Japanese flotilla of seven submarines in an effort to determine the practicability of traveling in warm waters. Compartment temperatures in submarines have always been too high, from a health standpoint, and the present journey, undertaken in the warm waters of the South Sea, will test the resistance of the crews to capacity. The test trip is said to be the first of its kind ever made by any navy in the world.

*Handwritten notes:*  
2184  
2158  
2087  
2247  
Mr. A. H. O. Klie  
Hoboken, N. J.  
1148 Garden St.  
N. Sakata #10,  
Isohonne, Teds. machi,  
Kojimachi - Ko. Japen.  
Copyrighted material

*Vertical handwritten text:* Chemical Warfare Service

Give to the manufacturer of the  
bathing suits, we beg to advise the  
graph was made at one of the beaches  
and the photographer did not get  
manufacturer.

endeavor to get it elsewhere  
I know if, in the event,

Sincerely yours,

HERBERT



780

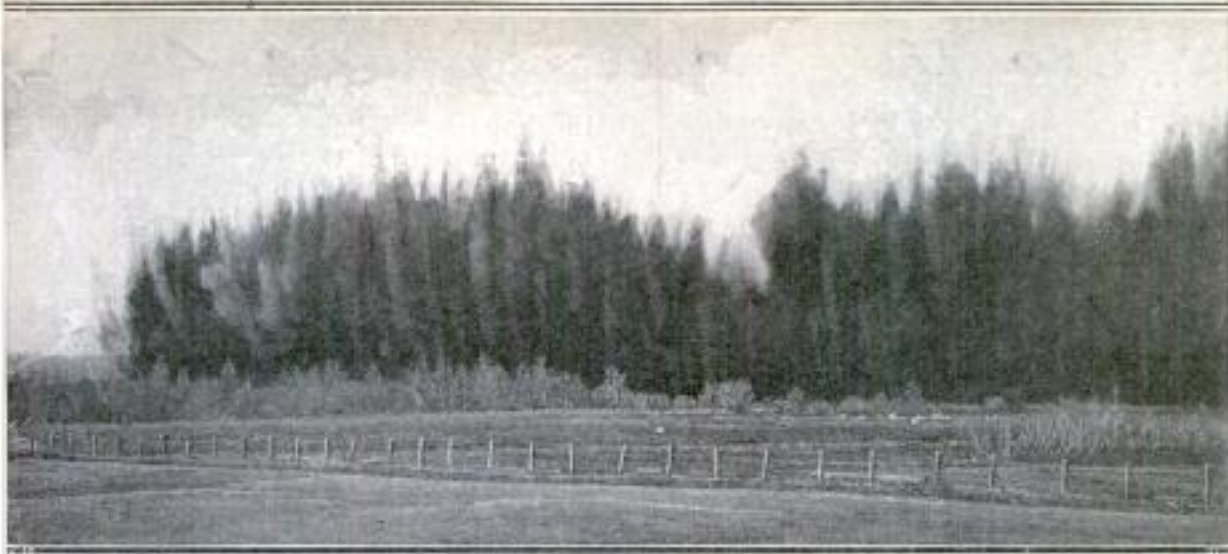

## DITCHING WITH DYNAMITE

What Appears to Be the Edge of a Dense Woods in the Background of This Picture Is Mud, Water, and Débris Flung High by a Single Explosion of Dynamite Which Opened a Quarter Mile of Irrigation Ditch

BY JOE ALEXANDER *915 Spaight St. Madison Wis*

**T**HE development of a new kind of dynamite which lends itself to a simplified method of blasting, has so reduced the difficulties of ditch making in wet ground, as to make feasible the draining of thousands of acres of marsh land. On many farms there are small areas of swampy land, that are usually susceptible to drainage if ditches could be made, but the latter is a problem. Hand labor is expensive, the work very difficult, and the use of a ditching machine not often warranted.

A solution of these difficulties is seen in the new low-freezing explosive, which is rated as a 50-per-cent straight nitroglycerin dynamite and is capable of being exploded according to the principle of "propagated blasting." By means of a crowbar, or other similar tool, a row of 20 holes, about 18 inches apart and each

18 inches deep, is made on the line of the proposed ditch, and each hole is loaded with approximately a half pound of dynamite, the difference from the common procedure of blasting being that the only hole to be fitted with fuse and cap, is the one in the middle of the row. The uncapped charges are exploded by the concussion transmitted through the wet ground from the centrally located detonating charge which is ignited. This method, which is only applicable in wet ground, makes for a considerable saving in blasting caps and fuse material as well as in labor in connecting up the charges. A reasonably clean-sided ditch, free from standing brush and roots and requiring little shoveling, and about 3½ feet deep and 4½ feet wide, will be formed. About 30 pounds of dynamite is required for each 100 lineal feet of ditch.



Left: Section of Ditch Blasted through a Swamp of Alder, Tamarack, and Cedar Trees. The Roots, Snags, and Stones Imbedded in the Wet Muck Offered Little Resistance. Right: Ditch Dynamited through Hardpan

*E. C. Du Pont de Nemours Co., Copyrighted material*  
*E. C. Manchester Wilmington, Del.*

The Power Plant Co.,

100

POPULAR MECHANICS

West Strayton, Middlessex, England

HAND HOIST OF NEW DESIGN  
SIMPLE AND COMPACT

1895 A new hand hoist of clever design employs no drum but a sheave over which

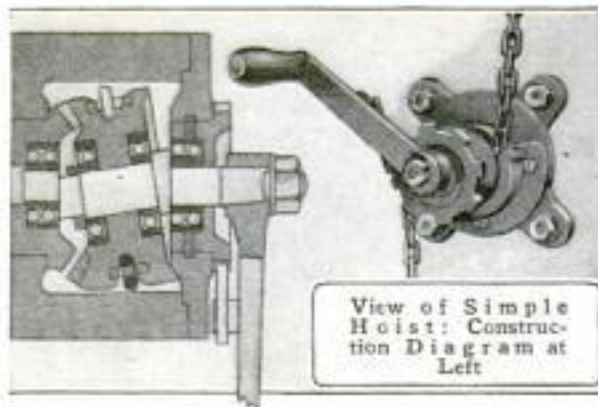

View of Simple Hoist: Construction Diagram at Left

a chain is passed, the slack end of the chain hanging loose from the winder. A novel feature of the invention is the winding head which consists of a crank-operated eccentric shaft carrying a bevel

gear engaging another gear attached to the housing. The eccentric gear has one more tooth than the gear in the housing, and as it is also integral with the chain-wheel sheave, each turn produces an advance equivalent to one tooth.

TWENTY-FIVE MANUFACTURERS JOIN TO MAKE ONE PIANO

1913 An unusually interesting and valuable piano is the one belonging to the Piano Club of New York City. The many manufacturers of nationally famous pianos who are members of the Piano Club each wished to give to the club an instrument of his own make, but which of the many was to be accepted could not be decided. The idea was finally adopted of making a composite piano, each of 25 manufacturers doing a part of the work or contributing part of the materials. The result, an expensive and high-grade instrument called "everybody's baby," is now installed in the club rooms.

2078

AUTOMATIC NEST TRAPS HEN AND EGG

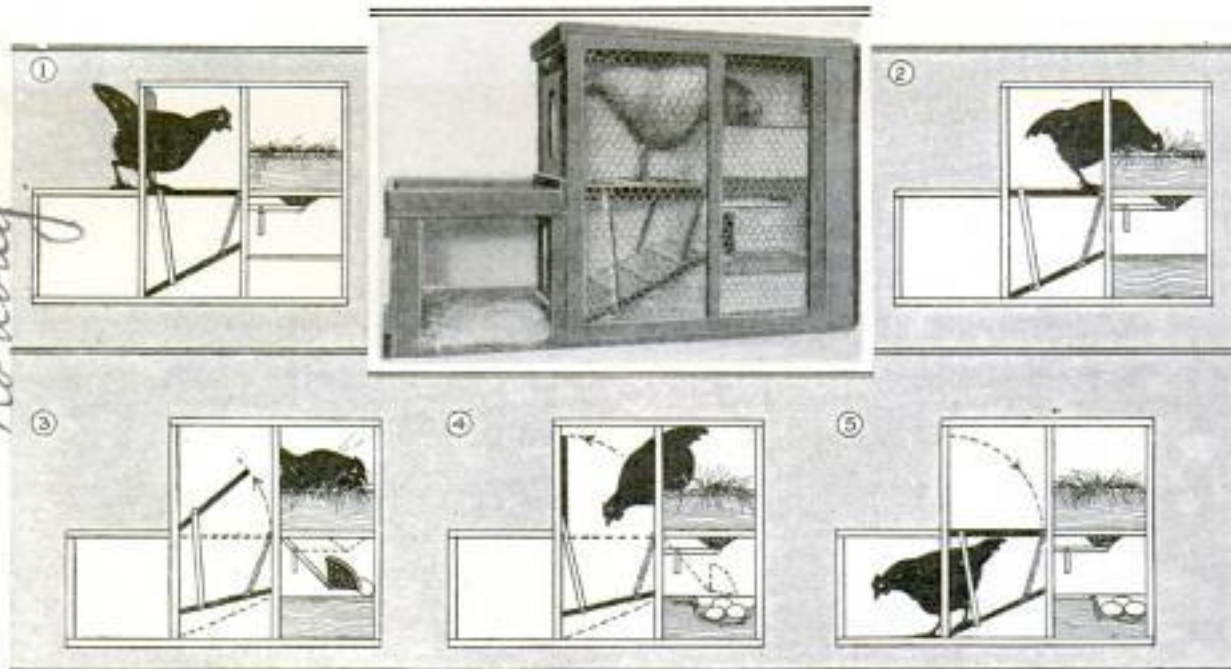

The Numbered Diagrams in This Cut Show Successive Positions of the Automatic Trap Nest for a Hen That Enters and Lays an Egg. A Nonlaying Hen Leaves by the Same Passage through Which It Entered

Unusual interest attaches to a trap nest invented by a Norwegian because of the simple way in which a nonproductive hen separates itself from the layers. The nest is divided into two sections with an upper and lower level. The hen enters through an opening at the upper level, walks across a trapdoor, and climbs onto the

nest. When an egg is laid it drops into a cup mounted on the end of a pivoted lever which swings down and rolls the egg into a separate compartment, at the same time unlatching the trapdoor, which swings upward. The hen then leaves by a platform on the lower level, which action resets the trapdoor.

Patented in U. S.

Erving Ahren, Ryukans, Norway



1691

*wild*  
**ANIMALS FOR THE AGES**

By H. H. Dunn, 2722 *Prunice St*  
*Berkeley, Calif.*

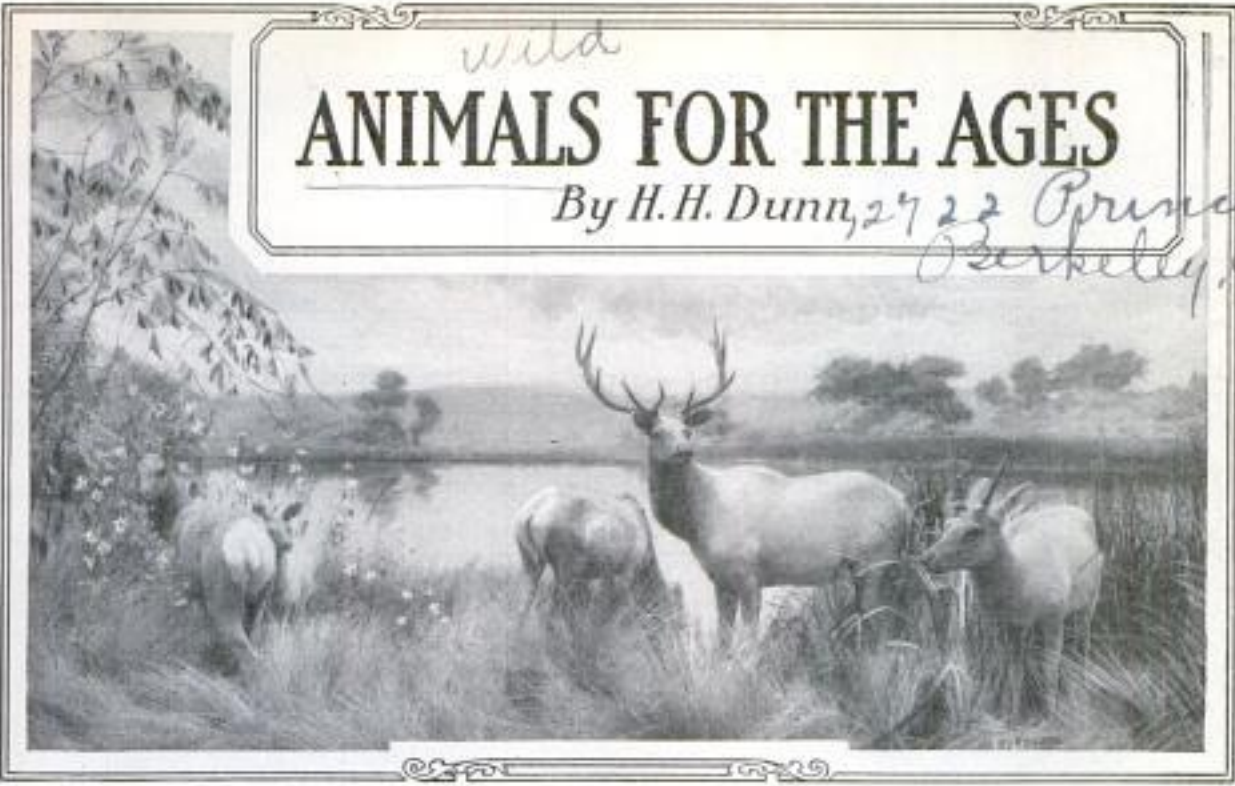

**T**HE silvertip, one of the most terrible fighting animals in the memory of man, has been extinct these many years; the grizzly, smaller brother of the silvertip, remains in small numbers in only two or three states; the bison persists in small and protected herds where he once roamed by millions; the elk is nearly gone, and the mountain lion is being hunted to extinction in order to save the few remaining deer. The most interesting fauna indigenous to any of the continents virtually has passed from the mountains and the valleys, the forests and the prairies of North America. The same is true of the Indian.

To see these animals one must go to museums, where, at large cost, habitat groups of nearly all our four-footed and winged life have been recreated by taxidermists. Now, however, the complaint comes from the museums that these bison, deer, bear, mountain lions, and other "stuffed" animals will not last long; that, within the next half century, they will be nothing but dust and hair, piles of rubbish ready for the janitor's broom. Then all that will remain will be the pictures of these animals, and of the native races of men of this continent.

In view of this, a proposal has been made which, supported as it is by museum authorities, national and state-park officials, ethnologists, zoologists, and conservation experts, will repeople the plains and the mountains, the river valleys and the deserts, with humans and animals, destined to remain there forever. The

transcontinental traveler, whether by train or by automobile, will see at the edge of the forest an Indian, his bow drawn to the arrow's head, with a deer, an antelope, or an elk, just within range. Rounding a curve, he will come upon a life-size silvertip and her cubs, half hidden and half revealed by the brush of the mountain wall. On a ledge of rock, above his head, he will be startled by a tawny mountain lion, or a pair of them, basking in the sun, or playing.

The motorist, following any one of the highways westward, will find his road through the various states marked with the animals of that state. In California, he will find bears along the trail, from the ton-and-a-half silvertip to the little 300-pound brown bear; in Washington, he will see the mountain lion and the puma along the highway; in Oregon, the elk will greet him in the valleys, the mountain lion in the lower hills, and the grizzly in the Cascades.

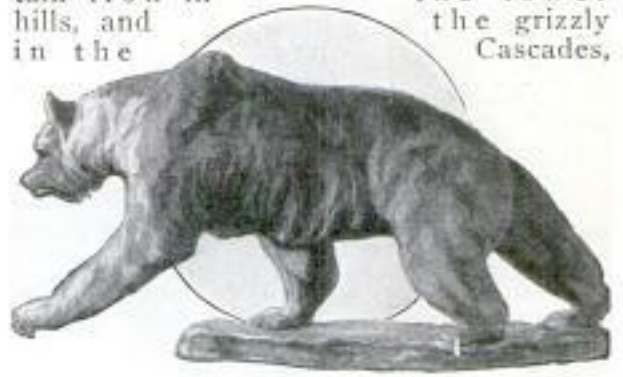

while from lofty pine trees, golden and bald-headed eagles will look down upon

*Paul J. Fair*  
*Berkeley, Calif.*

him. Through Arizona and New Mexico, he will meet the cliff dweller and the Pueblo Indian face to face along the



highway, while in the desert and in the low hills he will see again the antelope, the coyote, and the occasional gray puma, as the soldiers of Anza and Coronado saw them. The Indians, the bears, and the elk, and the northern and darker mountain lion, will be of bronze; the deer and the antelope, the coyotes, and the southern mountain lions, will be of concrete, accurately colored to represent the natural fur of the animal. Each figure will be exact as to size, form, expression, and color. The weapons and the implements of the Indians will be reproduced in bronze also. The whole plan is one of permanency—to present to all future generations the wild life of western America as it was when white men first set foot in the New World, and to insure the preservation of these primitive men and the native animals through all the years. Some of the larger birds, such as the California condor, now practically extinct; the golden eagle, the bald eagle, and even some of the lesser forms of winged life, will be similarly cast in bronze or concrete.

Along the seashore will be set up statues of individuals and groups of the rapidly disappearing sea otter, and of some of the seals which are threatened with extinction, as well as the sea elephant, now found only near one small island off the coast of Mexico.

The idea originated in the mind of Charles Keeler, poet, essayist, and dramatist, president of the Writers' Club of California, and managing director of the Chamber of Commerce of Berkeley. He first presented it to Paul J. Fair, con-

structor of educational exhibits for the U. S. Forest Service, himself a wild-animal sculptor of ability. The matter was later presented to museum and park officials, state officials, highway organizations, and others throughout California. It met with the immediate approval of these men, and of many chambers of commerce in the state.

Later, when life-sized figures of both Indians and animals have been placed in position in some of the California mountains, the project will be laid before the Smithsonian Institution, the director of national parks, and the Department of the Interior. Sculptors are to be invited to submit small figures of individuals of the various Indian tribes which once inhabited the western states, as well as of the larger animals of that territory. Figures, such as the various poses of the mountain lion made by Arthur Putnam, the silvertips, grizzlies, and brown bears of Douglas Tilden, and the coyotes and bears done by Mr. Fair, will be used as models for the bronzes and the concrete statues. Indian models are expected from Roger Noble Burnham, of Berkeley.

The bronzes are to be cast in the usual manner, and then securely anchored on the natural rocks.

As an example of the type of statuary contemplated may be mentioned "The Last Grizzly,"

an already executed magnificent life-size bronze, representing a battle between a



As an example of the type of statuary contemplated may be mentioned "The Last Grizzly,"

an already executed magnificent life-size bronze, representing a battle between a

As an example of the type of statuary contemplated may be mentioned "The Last Grizzly,"

an already executed magnificent life-size bronze, representing a battle between a



an already executed magnificent life-size bronze, representing a battle between a

mother grizzly and two Indians who have attempted to steal her twin cubs. The contest between men and beast is realistically pictured and the fighting instinct of this species of bear emphasized by the two snarling cubs, who are trying to aid the mother by biting at the red men.

A new and interesting method of handling the concrete for animal figures that must be painted, has been devised by Mr. Fair, who, with Mr. Keeler and Mr. Burnham, has been working on this problem for some time. The concrete can be colored before being cast, or painted with waterproof paint after casting, which would re-

quire repainting every four or five years.

Figures made of the colored material will not be "poured." The concrete will be made thicker and then modeled into the figure of the animal by the artists, just as clay is used in making the original small figure for the statue. Thus, differently colored concretes can be used for modeling different parts of the animal, and the delicate shading of the antelope or of the mountain lion developed to a point of accuracy which could not be attained were they cast in any metal, or poured from ordinary concrete.

The financial plans are as yet not quite worked out, but no difficulties are anticipated.



"The Last Grizzly": Statue Representing Conflict between Red Men and Mother Bear



"The Killer": Young Deer Fallen Prey to a Mountain Lion of the American Rockies, a Mounted Group Now in the Oakland Museum

### MODERN JOVE JUGGLES MILLION VOLTS

At an electrical show held at a western university not long ago, one of the students mystified the crowd with a display rivaling the mythical feats of Jove, who was believed by the ancients to be the wielder of the thunderbolt. Seated in a chair separated from a table by seven-ply insulators, the youth grasped a zigzag rod in one hand and in the other a wand with which he made contact with a ball from

### THIRST FOR KNOWLEDGE MAKES

2246 *Kojamachi by Tokyo*  
JAPS WAIT IN LINE

Libraries are very popular in Japan, particularly with students, who apply themselves zealously to their studies. As the date for the entrance examinations to higher schools approaches, this popularity increases, and the students begin to "cram" in earnest. Long lines form at the library entrance, and the students patiently wait their turn to be admitted. This congestion is most apparent in the

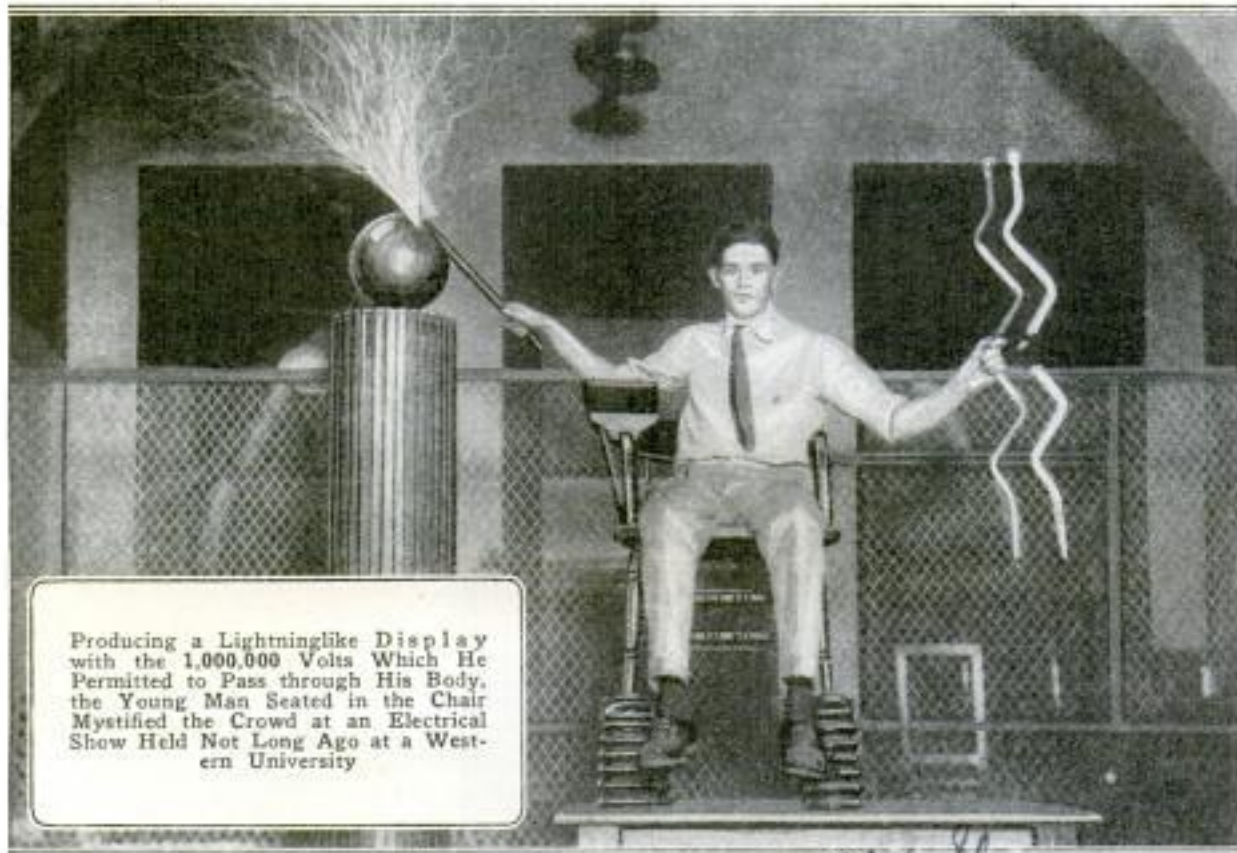

Producing a lightninglike display with the 1,000,000 volts which he permitted to pass through his body, the young man seated in the chair mystified the crowd at an electrical show held not long ago at a western university.

which the lightning effect was emitted. The impunity with which he handled the 1,000,000 volts is explained by the low amperage value of the current passing through his body and the insulators under the chair legs, which prevented the electricity from going to the ground and thereby establishing a flow of current that would have been disastrous to the daring young experimenter.

☞ That the American flag is too long in proportion to its width, and should have this ratio corrected, is the belief of the Fine Arts Commission of Washington. In consultation with a committee of government officials, a ratio of 1.67 to 1, instead of 1.90 to 1, was decided upon. Test flags were flown from the Arlington amphitheater flagpole.

*u + u.*  
large cities, as Tokyo, Osaka, Kobe, or Kyoto, where the student body is considerable.

### 2321 — BULGING HULLS FOR SHIPS

Freedom from rolling is the advantage claimed for vessels fitted with corrugated hulls, so shaped as to form two bulges on each side. In addition, this design is claimed to give additional cargo space and to lower the fuel consumption. On a recent voyage from Bangkok, India, to Hull, Eng., the vessel "Rio Azul," so fitted, consumed only a moderate quantity of fuel. The owners attribute this good showing to the freedom from rolling, which, in the ordinary steamer, causes the propeller to "race" out of the water, losing its propulsive power.

*The Engineer*

4/20/23

2127 Cont. N. O. Lane, 1624.

POPULAR MECHANICS <sup>105</sup>  
Castrano St. Berkeley.

IMPROVED MAST GIVES MORE ROOM ON DECK *Calif*

Departure from the usual mast construction made available more handling space for hoses on a Pacific-coast tank vessel, at the same time doing away with many guys and stays that would otherwise be necessary. Two steel channels, placed back to back so as to form an "H," constitute the mast, which is slightly higher than its two channel-shaped steel supports. Steel diagonals connect the inclined supports with the vertical mast. To cap the mast, a 4-foot wedge was cut out at the top, the flanges sprung toward each other, and welded together.

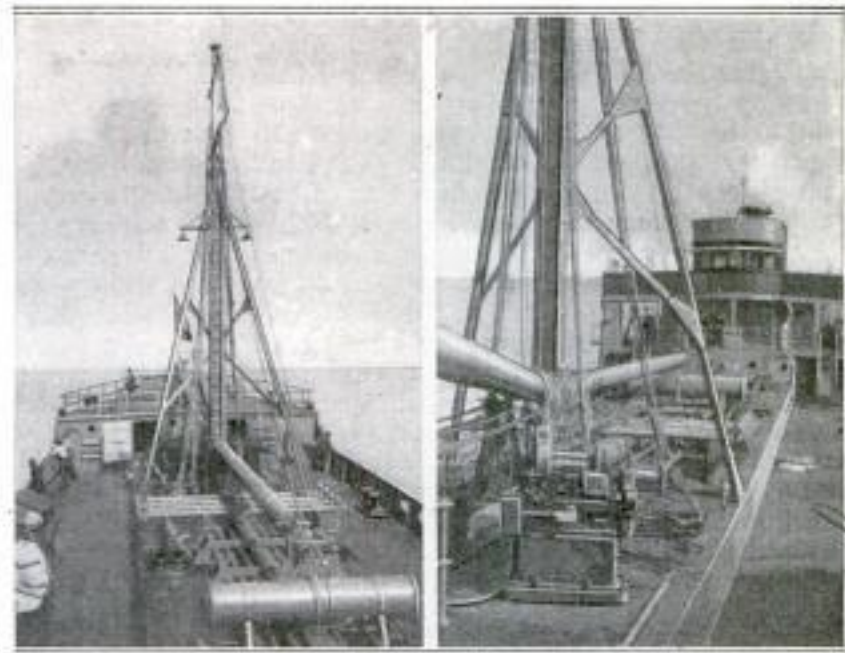

Left: Looking toward the Mast; Note the Unobstructed Appearance of the Deck. Right: Close-Up, Showing Two Booms at the Foot of the Mast

2322

WORLD'S STOCK OF DIAMONDS

Not counting those that are as yet unmined, there exists in the world 42.5 tons of diamonds, which is equivalent to 192,500,000 carats—the unit by which diamonds are usually weighed. Based on the average market value of diamonds today, the total represents approximately \$100,000,000,000. India, the sole source before the 18th century, has produced 4,400 pounds; Brazil, in the 18th and 19th centuries, 5,500 pounds; and Africa, in the last 40 years, 75,000 pounds.

2268

ENVELOPE SEALER IS SELF-ADJUSTING

Mail is easily sealed by merely pulling it through a new device that adjusts itself to irregularities in the thickness of the contents of the envelope. The flap of the envelope is first passed over rollers that run in water, to moisten the glue, and then pulled through a slot that folds the flap, which is sealed by means of a fingered closing spring.

FLAME-PROOF LOCOMOTIVE BUILT FOR MINE USE 2193

Guided by the exacting requirements of electrical equipment for use in gaseous mines, a builder of storage-battery loco-

motives has designed one that is assembled from a number of units, each of which is of flame-proof construction. The motor is inclosed in an air-tight case provided with handholes through which ordinary repairs can be easily made, and a special housing guards against danger from the controller. An air-tight shell also incloses the headlight lamps which are controlled by a revolving switch mounted in an explosion-proof compartment. Ample ventilation is provided for the battery compartment, which is so ar-



Electric Storage-Battery Locomotive Which is Made Flame-Proof for Use in Gaseous Mines

ranged that no tools or loose wires can come in contact with the cell terminals. All wiring is heavily insulated and protected, and leads enter the casings through special stuffing boxes. Locks prevent unauthorized persons from tampering with the apparatus.

*Jewels Circular 6/27/23*

*Mancha & Wray Battery Co. 1909 S. Kings Highway, St. Louis Mo.*

*The Pull Three Mfg. Co. Covington Ky.*

Cont Hogg & Ford

106

POPULAR MECHANICS

416 Union League Bldg.

LOAD GROUND WITH PIG IRON TO SALVAGE BUILDINGS

MAROONED AUTO TAKES LAKE RIDE ON ICE CAKE

2206

Los Angeles Calif 2300

While the Panama Canal was being dug, quantities of earth were dumped into swampy ground to form the site on which the city of Balboa was later built. Recently the error of having erected many costly buildings on this filled ground has been revealed by the sinking of the foundations. In some instances the settling has been so alarming as to make the evacuation of the buildings advisable. Instead of trying to counteract this sinking, the government engineers decided to help it along until no more settling would occur. Trenches were dug around the buildings and filled with water, and tons of pig iron were piled on the floors and on the ground. Gradually the buildings are being leveled, and it is believed the ground will become firm

Having been carried 20 miles out into Lake Superior, and drifted about on an ice floe for two days, a small automobile was at last dragged to safety across a temporary ice "joint" with cables and driven back to dry land uninjured. This series of adventures happened after the owner had driven out on the ice to fish. Though apparently stable, the ice field began to crack, and left the car marooned on a floating cake which drifted farther and farther from shore. Some peculiarity of the massive ice floes—a glancing collision, perhaps—caused the drifting cake to return toward the main sheet from which it had broken, and a lucky cold spell "cemented" the joint, making the recovery possible. A track had, literally, to be chopped through the rough edges of the



Upper Left: Government Building at Balboa, Vacated Because of Sinking Foundations. Lower Left: Cracks in Walls and Pig Iron Piled on the Ground. Above: Trench Dug around Building

enough before very long to support them in a plumb condition.

Write our Bureau of Information, if you wish to know who makes or sells any article described in this magazine. Send no postage; the service is free.

floe, an iron stake driven into the solid ice, and the car dragged to safety with cables. Its lucky owner, who had labored alone for two whole days and a night to effect the rescue, brought in a load of 300 pounds of lake trout which he had caught on his fishing trip.

Cont. John H. Henington  
Bayfield, Wis

COMBUSTION PROCESS FILMED WITH MOVIE CAMERA

Filming the combustion processes that actually occur in the burning of coal under a large modern boiler, is one of the movie camera's most recent uses. The boiler was fitted with a moving-grate type of furnace, carrying a thick bed of burning coal, the glowing surface of which radiated heat direct to the boiler tubes. By protecting the lens of the camera, it was possible to obtain a satisfactory picture of combustion at a furnace temperature of 3,000° F. Grate travel, too slow for ordinary observation, was clearly shown in two minutes by the film which was made by snapping pictures at intervals during four hours of actual furnace operation.

2323

PAPER FROM PINE STUMPS

After many extensive experiments a chemical engineer in Louisiana has developed a method of extracting the turpentine, resin, and other elements from long-leaf yellow-pine stumps to such an extent that a good grade of paper can be made from them. Heretofore the large content of resin, the many knots, and the charcoal surfaces caused by forest fires, have prevented this use of the material. Now, in addition to 20 tons of pulp per day, a plant which is being built at Elizabeth, La., will produce about 500 gallons of turpentine and 20,000 pounds of resin.

James Pycayune 1/7/23

SAFETY-MATCH LIGHTER PREVENTS ACCIDENTS

A novel match lighter which guards against accidents has been invented. When the match is inserted in the opening, a sawtooth blade which works automatically, scratches and lights the sulphur head. All danger of heads flying off and the flames burning the fingers is prevented. The box is in convenient pocket size.



W. I. Mosher 29 Fremont St. Rochester, N.Y.

BEAUTIFYING A CITY STREET WITH AN ITALIAN CASCADE

The problem of ugly, abandoned streets has been solved by Oakland, Calif., which



Oakland's Cascaded Street, Which Beautifies the Hillside over Which It Runs in Small Rivulets

has converted a hill street into an attractive Italian cascade, over which water flows continuously. At night each of the series of bowls in the cascade is illuminated from beneath by varicolored electric lights. This presents an attractive spectacle to the city's business district across Lake Merritt.

PAIL WITH FLOAT PREVENTS CALF DRINKING TOO FAST

Fast drinking is a habit which careful stock raisers are anxious to correct in young calves, for if allowed to continue, it is likely to cause digestive disorders that affect the animal in after life. An effectual check against this is believed to have been found in a simple metal float that fits into a straight-sided pail in which it slowly drops as the calf feeds. A hole in the center of the float, the upper surface of which forms an inverted cone, regulates the flow of milk, and prevents its being drunk too fast.

Calif. Dyer Co. 2164 Washington Ave. N. Minneapolis, Minn.

July 2/24

Hearts aflame

POPULAR MECHANICS

Frank Keenan and Anna D. Nilsson

E. L. Meador, Director of Advertising, Publicity and Exploitation, Metro Pictures Corporation, 1540 Broadway, New York City



A Forest Fire Staged for the Movies: Portable Searchlights were Used to Light Up the Blaze for the Cameramen, Who Worked in Pairs

PHOTO BY METRO PICTURES CORP.

Copyrighted material

cont.



## SPECIAL APPARATUS FILMS FOREST FIRE



PHOTO BY METRO PICTURES CORP.

Arrangements for Filming the Forest Fire: The Track in the Foreground is being Laid for a Locomotive That Later Made a Dash through the Flames

Specially designed hoods, gauntlets, and garments for the cameramen, and sheet-iron blinds to protect their instruments, were used recently in filming a forest fire set ablaze over a 20-acre tract as material for a motion-picture scenario. Twenty cameras were used, stationed in pairs at

various points around the tract of pines. In spite of the precautions taken, five of the cameramen were so severely burned as to require medical attention, and two of the cameras were put out of commission by the terrific heat of the flames which raged too closely.

9265

## SHALLOW FREIGHT BOATS HAVE FOUR PONTOON RUDDERS

With the development of inland waterways varied types of freighters have been

air-tight compartments, with bulkheads, render the vessel practically unsinkable. Being of shallow draft, the boat will carry all its freight on the upper and lower decks. It will be electric-driven,



Above, Side View of the New Erie Canal Freighters; Right, a View of the Underside on a Smaller Scale

designed to meet changing conditions. The latest to appear is a long, shallow craft, 272 feet in length and 42 feet wide, designed for service on the Erie Barge Canal. Its steering facilities are unusual, consisting of four pontoonlike rudders, two at each end, to permit turning rapidly. The propellers run in a "tunneled" hull, partly out of the water, but the depth of immersion may be adjusted to suit varying conditions of draft. Forty



power being generated by oil engines of the Diesel type.

After suffering from sleeping sickness for 12 days, a nine-year-old boy was completely cured by three injections of a new serum.

The Inland Lakes & Rivers  
Rapid Transit Co.,  
Buffalo, N. Y.

110

UPWARD CURRENTS OF AIR HELP GLIDERS

One of the mysteries of soaring flight with gliders and low-powered planes is the upward currents of air that usually exist in a hilly country, but frequently are found also over the sea and desert. If a sailplane is launched from an elevation, it will, unaided, glide through the air and gradually approach the earth at an angle dependent upon the skill of the pilot and the design of the plane. It is due to the air sailor taking advantage of the uprends of air that the remarkable records with motorless and low-powered planes have been made in recent months. An engine of low horsepower assists in driving the plane from one favorable air current to the next. A recent example is the flight of a plane with 13-horsepower motor, across the English Channel and back, a total of 80 miles.

2278  
FARM POPULATION DECREASING

Department of Agriculture figures show that in 1922 there was a net loss of 460,000 persons in the agricultural population, a decrease of about 1.5 per cent from the 1920 census, which gave the rural population as 31,359,000 persons. The greatest movement away from the farms was in the Pacific states, while in the south central and New England states the loss was greater than the average for the entire country. Italy, it is expected, will offer to supply the shortage with "hand-picked" farmers.

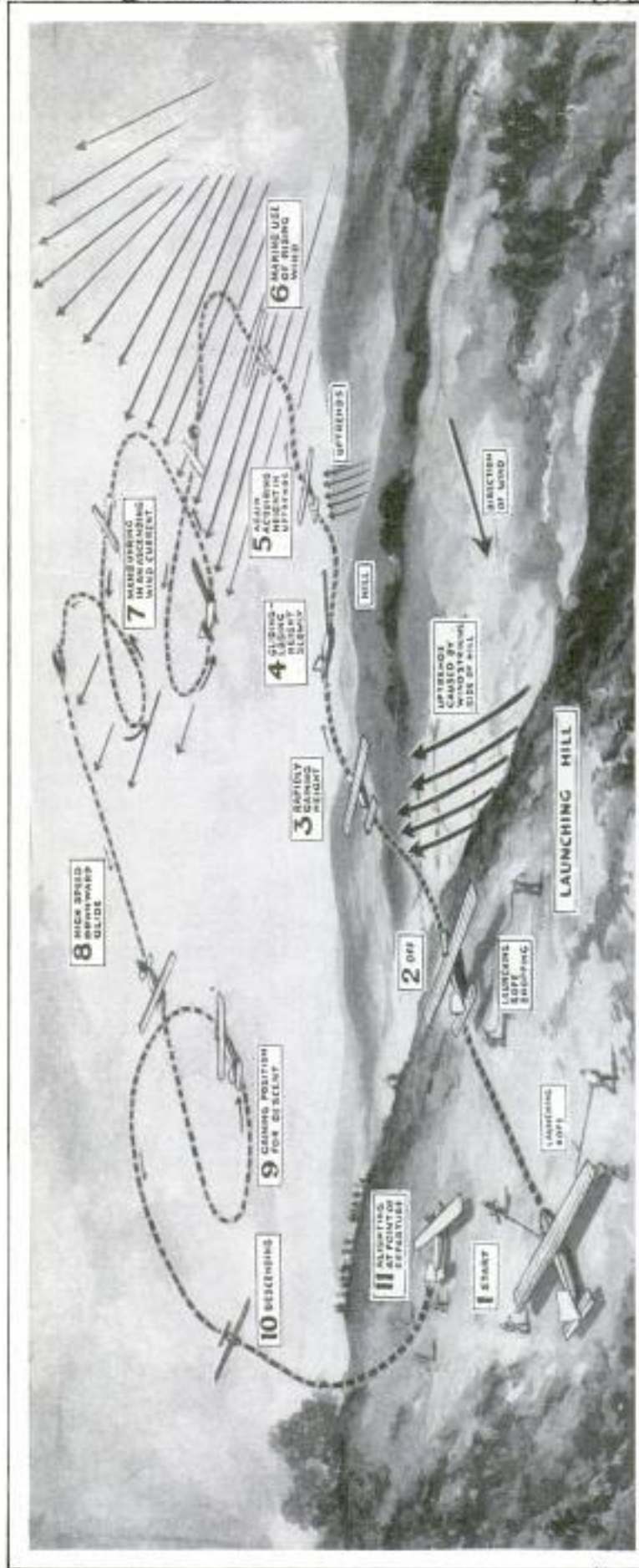

Diagrammatic Sketch, Showing by the Succession of the Numbers, How, When Launched from the Starting Hill, the Air Sailor Glides Outward and Downward and, by Skillful Maneuvering of His Plane to Take Advantage of the Upward Air Currents, Gains Altitude in Defiance of the Pull of Gravity

*St. Portland, Oregon.*



Coming In, the Owner Turns the Key Faucet, Opening the Doors

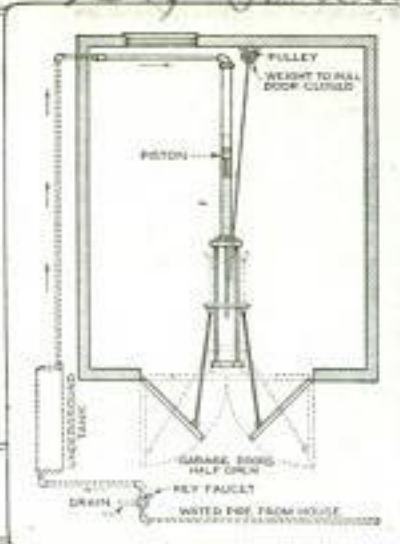

Garage and "Opening Post"; Left, Diagram of Operating System

2180  
**WATER PRESSURE OPENS GARAGE DOORS**

An ingenious owner of an automobile has devised an interesting method of operating his garage doors, merely tapping an ordinary service pipe of his household water supply for the purpose. As he drives up toward the garage, he stops at a post to which an extension from the kitchen water pipes has been led, and by means of a key faucet, turns on the water. This fills a small underground tank, and then the water begins to back up in the extension pipe. The pressure of the water upon the entrapped air operates a small piston, which is located in the pipe line at a point within the garage and under its roof. As the piston is forced outward, two lever arms, connecting the garage doors with the piston rod, are also forced out, causing the doors to swing open. When the key is turned off in the faucet at the post, a valve opens, draining off the tank water and relieving the pressure in the pipe. Door weights then pull the doors shut.

2199  
**STREET-CAR TROUBLE REPORTS BY RADIO AND TROLLEY WIRE**

Telephoning trouble reports over the trolley wires is an interesting use that an eastern street railway has shown to be possible with radio. Considerable experimenting has been done in this line and the recent tests between the dispatchers' offices and moving trolley cars, gave very satisfactory results. The transmitters and receivers used were similar in many respects to those employed in ordinary radio broadcasting. The wires form a network which provides ready means of contact at all important points

along the system and acts as a guide for the long-wave currents used. There is no interference, it is said, to the receiver of messages from short-wave broadcasting stations. Both at the point of origin of the message and at the receiving point facilities may be provided for two-way conversation; that is, each operator may talk as well as listen. This is possible without the use of switches alternately connecting transmitter and receiver to trolley wire.

2175  
**NEAT BRONZE TREE MARKER ADOPTED BY COLORADO**

Some 40 trees of rare varieties on the capitol grounds at Denver, Colo., are designated by neat bronze markers set into the ground. The title plate is 12 inches long, 4 inches high, and besides the name of the tree, bears the words "Colorado State House Grounds" and the seal of the state at the top. A 32-inch iron rod, painted white, supports the marker, which also gives the Latin name of the tree.

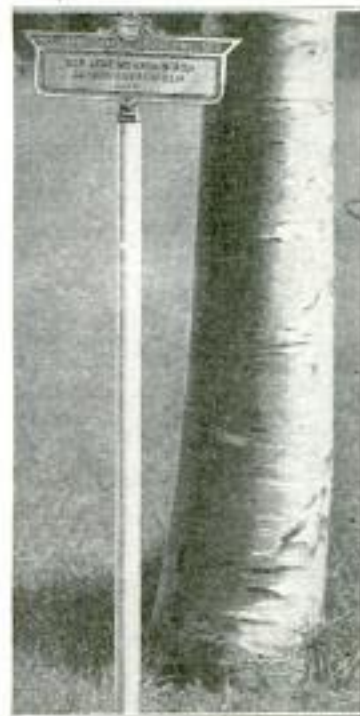

*Emb. Geo. H. Langer, % The Post, Denver, Colo.*

*Mechanics World 3/31/23*



Looking into the Concrete-Brick Plant, Where a Force of Only 10 Laborers will Eventually Turn Out 35,000 Brick a Day

2139  
**WESTERN STOCKYARDS FOLLOW CHICAGO'S AS MODEL**

Following the example of Chicago, where a so-called central manufacturing district is used to house the stockyards and other industries, Los Angeles is utilizing a 250-acre tract for establishing a similar manufacturing zone. Stockyards were rushed to completion in the

sand from the Los Angeles River, filled depressions in the tract, and were later used to pump sand for concrete. A concrete-brick plant was also built, with a capacity of 11,000 brick per day. The river sand was so fine that much of it was unsuitable for concrete, but after a screening and grading plant had been established, enough usable sand was salvaged for all operations. Considerable ingenuity was shown in dovetailing all operations, so that maximum progress resulted in spite of all difficulties.

2 x 83

**CROSSBREEDING OF PLANTS**

The crossbreeding of plants is as interesting to a botanist as the crossbreeding of races to a biologist, says a Swedish botanist, who has specialized in the study of willows. Crossbreeding occurs when willows go north, the female willow

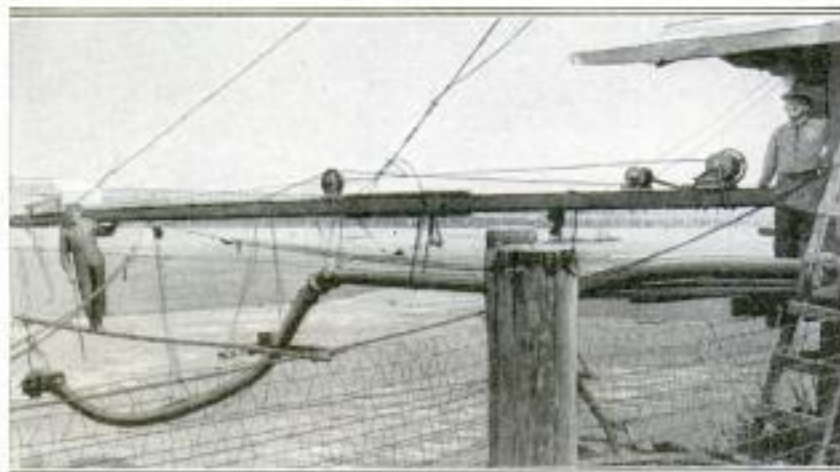

How a Six-Inch Hose and Nozzle were Slung from a Boom to Facilitate the Pumping of the Sand

as yet undeveloped area, and were built in the short time of 90 days. Numerous short cuts were devised during the course of construction to hasten progress. Six and 12-inch centrifugal pumps, sucking

being a hardier and more aggressive pioneer than the male, and mother of more than 70 varieties of sallows and crossbreeds of willows. The male finds migration hard and gives up.

Times Precayne

8338

H. J. James  
4/29/23

And W. P. Baughan,  
539 Pacific Av. 113

POPULAR MECHANICS

MOVIE FILM GAUGES ACCURACY OF OBSERVATION

Interesting experiments have been carried out in Germany recently for the purpose of gauging the value of the average individual's powers of observation. A specially prepared test film was used for that purpose, which showed a bit of dramatic action that could not fail to impress itself on the observer's mind. An unrelated incident, following on the heels of the major action, was interposed as a check upon the observer's deductive powers. Some 20 questions were later prepared, which the special audience had to answer. In no case were the answers more than 74-per-cent correct, ranging down to 52 per cent. The best answers came from those who, to be extremely cautious, concentrated on only five questions. Questions as to actual, observed happenings produced only 53 per cent of correct answers.

2/64

SUGGEST PARKS REPLACE CITY ALLEYWAYS

Unightly alleys in the rear of homes in Wichita, Kan., will be replaced by parks if the suggestion of a real-estate agent of that city is carried out. It is proposed that some of the present alleys, as well as all future ones, be made into parks with tennis courts, a golf-practice course, a large sand pile for children, stone benches, and other conveniences. To further improve the appearance, shade trees would be planted at appropriate spots, and a high inclosing hedge grown. City employes, tradesmen, and others would reach the houses from the street by way of a sidewalk running around to the rear. A fund would be established to provide for the upkeep.

ODD-LOOKING GARDEN RAKE USED LIKE A BROOM

Seeking to improve upon the common garden rake, a westerner has devised a tool that is not only used like a broom but looks like one. Extending from the lower edge of the perforated metal sheet that forms the "rake," is a row of slightly curved teeth that do the work of the ordinary teeth. It rakes without roughening the grass.



BREATHING OF FRUIT STUDIED TO SAVE SPOILAGE

Small fruit such as cranberries, cherries, strawberries, and raspberries are known to breathe. The respiratory action is not the same as with humans but in and out at the same time. Investigations of this fact have shown that the freedom with which the breathing takes place affects the length of time the fruit will keep in good condition after being picked. If berries are picked in the cool of the very early morning and kept at the same, or slightly higher, temperature until marketed, spoilage is greatly retarded.

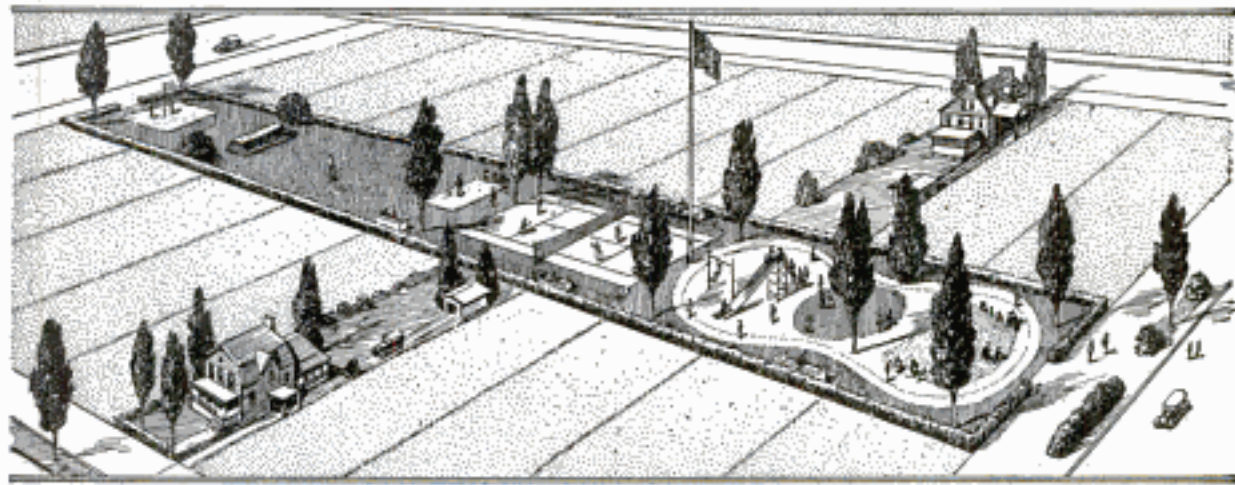

How the Converted Alleyways in Wichita, Kansas, would appear under the Plan of a Real-Estate Agent of That City: Among Other Features, Note, toward the Left, a Golf-Practice Course.

Earl Hutton, Realtor, Wichita.

Copyrighted material Kansas.

Long Beach Calif  
Michigan  
Ann Arbor Mich  
Prof. H. H. Csernyman,  
University

# SOME NOVEL AND LITTLE-KNOWN ACCESSORIES

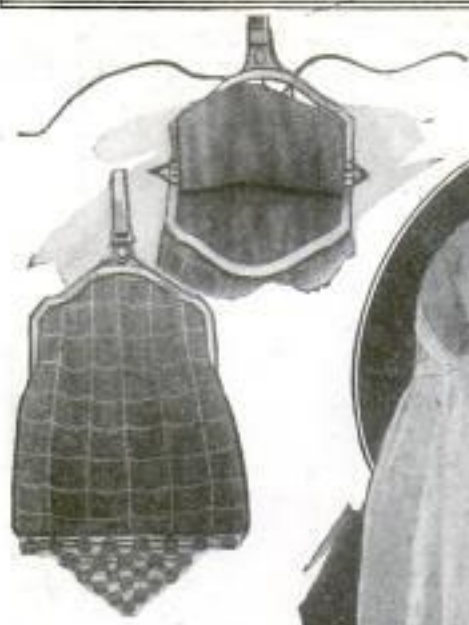

This Is the Latest Style in French Handbags. The Bags are Made to Match the Gowns Worn, and can be Detached from the Frame, So That Another Bag may be Substituted



Canning Fruit Is Easy with This Jar Holder. It is Readily Attached to a Table, and Holds the Jar Firmly in a Cushioned Grip, So That There Is No Danger of Breakage and Resulting Cuts

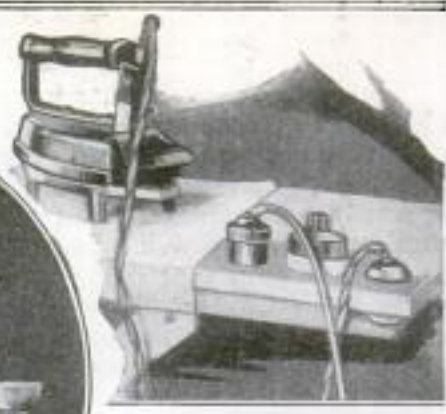

The Latest in Ironing Boards Has Its Own Switches, and Saves a Good Many Steps in an Ironing Day



In a Small Dining Room, This Cabinet Is Very Handy. Ordinarily It Conceals an Extension Table and Ironing Board, Which are Hidden behind a Swinging Door That Looks Like Drawer Fronts. Several Leaves may be Added to the Table

Right: Ten Feet of Wire are Reeled Up in This Electric Plug, So That a Lamp or Other Fixture may be Plugged In and Placed in Any Convenient Position



This Improved Doughnut Cutter Has a Trigger for Ejecting the Central Portion After the Doughnut has been Cut

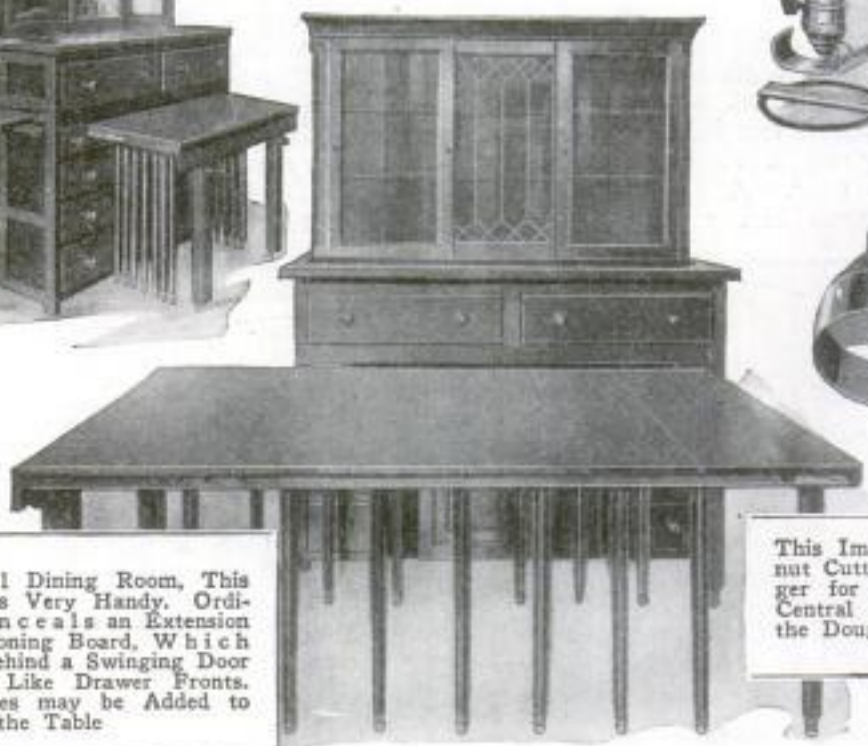

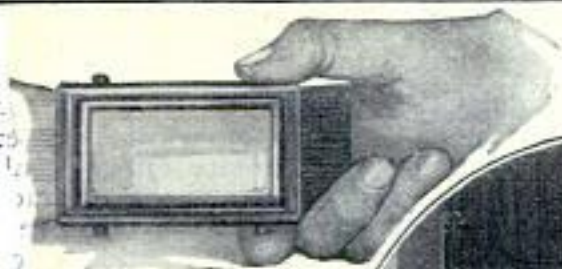

Two Brushes, as Well as Other Toilet Accessories, are Contained in This Small Vanity Case. A Push Button Releases Them for Use



A Bracket Arm Which is Easily Attached to Any Dresser; It is Fitted to Receive a Lamp. Below is Shown How This is Done



The Cooker, Standing beside the Kitchen Cabinet, is Electrically Heated at Its Top and Bottom, Making the Heat Practically Uniform throughout the Interior. It can Also be Used at Picnics, by Plugging In with the Automobile's Batteries

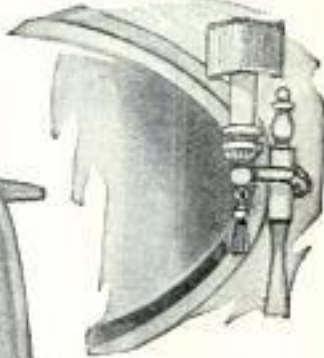

Below is Shown a Glass Pad That is Placed under the Stove Legs, to Make Cleaning Easier



A Tiny Electric Bulb, Fitted to a Magnifying Mirror, Which can Easily be Attached to the Dresser

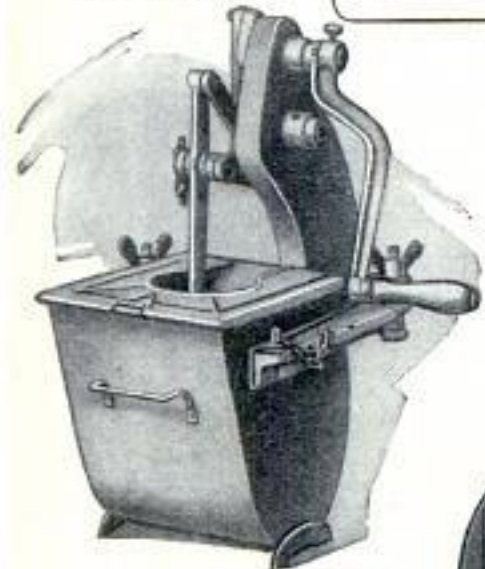

Flour can be Mixed, Dough Kneaded, and Fruits Strained with This Machine. It is Equipped with Two Troughs, One of Which is Perforated for Straining

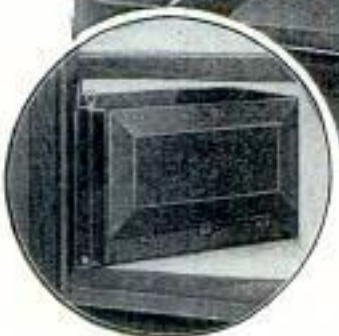

No Ice is Needed in This Refrigerator, Which is Fitted with a Bracket for Swinging Out from the Window Ledge. It will Not Rust, as It is Made of Galvanized Metal

ILLUMINATED CROSS REVOLVES ON CHURCH TOWER

A large cross, 12 feet high with a cross-arm 8 feet wide, was erected recently on

the top of a Cincinnati church tower, and presents a striking appearance, as it is strongly illuminated and caused to revolve at night. The cross is made of copper, and weighs 500 pounds. It is supported by a heavy wooden platform built in the church tower. A small motor, geared to the vertical branch of the cross, imparts motion to it. The "Queen City" is situated on the northern bank of the Ohio River, and the flashing cross is clearly visible in many of the Kentucky hills

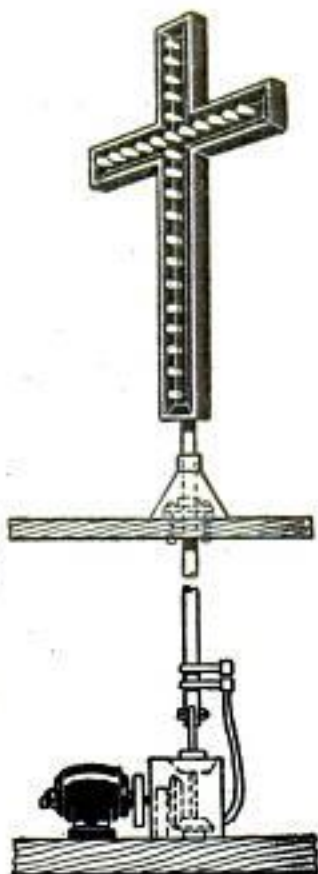

and towns across the river as well as in all parts of the city.

SAFETY AND PRIVACY ASSURED BY NEW MAIL BOX

A mail box, opening at any convenient place near the front door, extending down

between the inner and outer walls of the building and then projecting inside, has been made for private homes. A pivoted deflector plate inside the chute automatically locks the box as the lid is opened. Other advantages are that it is a more convenient receptacle, and that it will hold large packages which would not fit in an ordinary box.

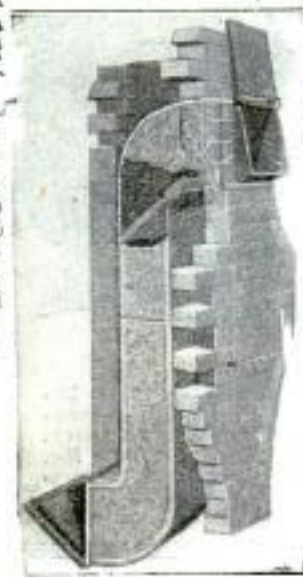

TYPEWRITER WORD COUNTER

UTILIZES SPACE BAR

A detachable typewriter device for registering the number of words written, which can be put in place on any machine, is sold in England. The attachment is composed of a T-flap that rests on the space bar and the counting mechanism, the whole hooking on to the front of the typewriter. The operator strikes the T-bar at the end of each word, thus registering the word and moving t

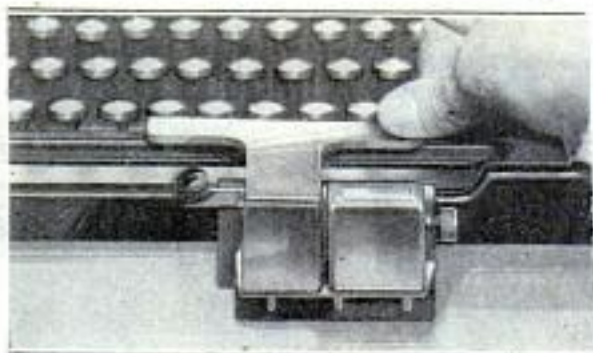

Striking the Detachable Word Counter and, Incidentally, the Space Bar of the Typewriter

space bar at one time. If space is desired without counting, the operator strikes the space bar to one side of the T-piece.

BASKET LINERS PROTECT DELICATE FRUIT

Fruits with thin skins or those easily bruised, such as peaches, or early apples, are afforded protection against injury by the use of a new basket liner just placed on the market. The liner is made of nonporous white Manila board, with locking ends, which, when brought together, form a lining conforming to the tapered inside of the basket. Fruit shippers are thus saved



the considerable loss due to spoilage which results from protruding staples, or the clinched ends of wire handles.

Package Sales Corp., 1020 Union Trust Bldg. South Bend, Ind.

4th Street Baptist Church

3807 Elyman Ave. South Bend, Ind.

Devere Cleary Co., Cincinnati, Ohio

The Word Counter Co., London, U.C.

1946

2143

1891

Copyrighted material



**ACTION OF METALS ON MILK  
STUDIED IN TESTS**

That milk absorbs some of the metal from the container in which it is placed has been shown in recent experiments. The amount absorbed varies with the metal and the condition of the milk, being highest for milk in iron vessels and lowest for sweet milk at normal temperatures and for vessels made of German silver and other nickel alloys. Ordinarily the effect is not important, but under certain conditions a metallic flavor will be given to butter that is made from ripe cream.

1859

**AUTO-CAMPING TENT MADE  
WITHOUT RIDGEPOLE**

For the convenience of the automobile camper, a khaki wall tent which may be set up without a ridgepole and with telescoping end poles, has been designed. The ridgepole is done away with by means of a strip of heavy flexible webbing which is stretched by levers to keep the peak of the tent from sagging. Pieces of enameled-steel tubing which telescope to a



The Poleless Tent as It Appears When Set Up: In the Foreground a Similar Tent is Shown Folded

length of 28 inches serve for end poles. The outfit goes into a bag 10 by 28 inches.

ⒸA variation of the "dunning" letter is used by a Western firm, with agreeable results. Its notice is headed with four bars of music. The words are also given, being a parody on an old Scotch folk song. They read: "May a body ask a body, Please remit today."

**REVOLVING RUG RACK SAVES  
MUCH FLOOR SPACE**

A rug rack, the supporting frame of which is circular, and can be swung com-

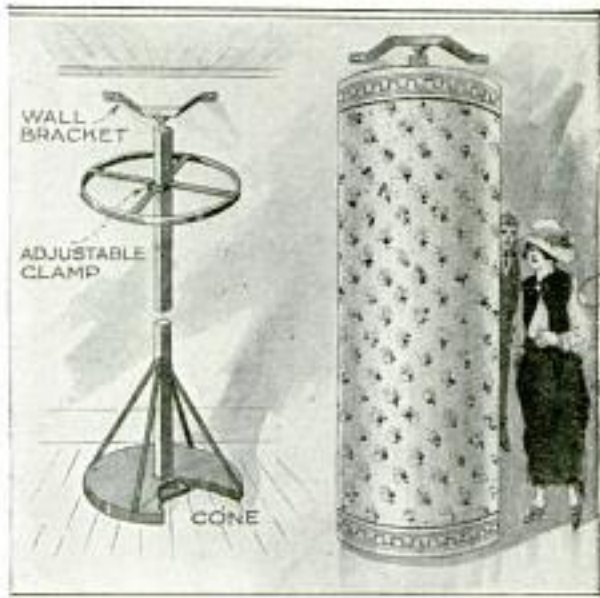

Left: Drawing, Showing Design of Space-Saving Rug Rack. Right: The Rack with a Rug in Place

pletely around, is being introduced. It is designed to save floor space. The support can be adjusted up or down to take any-size rugs up to 9 feet in width.

**ELECTRIC HEATER  
SUSPENDED FROM  
LIGHT SOCKET**

Features of a pendant electric heater now available are its ornamental design and simple operation, in addition to which the hot elements are always out of children's reach. The appliance is tubular in shape, 11 inches in length, weighs only 1 pound, consumes 620 watts at either 110 or 220 volts, and is suspended from a light socket by a 1-foot cord. Thus it is a useful and easily carried article when traveling, or for placing in a garage to keep the car radiator from freezing, as well as being entirely safe for use in the home. Deflecting chambers above the luminous unit prevent the heat from rising.



*Mrs. C. Jesse Mfg. Co.  
Canton, Ohio.*

*Eastern Electric Mfg. Co., New York.  
Carrick St.*

*101*

*H. Wenzel Tent & Truck Co.  
1035 St. Paul St.*

*Out of business?*

Cmt. J. Schriach

Cmt. C.A. Larside

3013 W. Grand Blvd. Detroit, Mich 2148

Boise, Idaho

**OLD CHINESE WEAVERS USED HUMAN AND GOATS' HAIR**

**IDAHO RATTLESNAKES SHIPPED TO AMSTERDAM, HOLLAND**

Human and goats' hair were used in weaving an old Chinese Moachang piece

Forty-seven full-grown rattlesnakes are resting in the window of a taxidermist of Boise, Ida., awaiting a trip to Amsterdam, Holland. There they will be sacrificed by scientists developing a serum for snake-bites to be used in India. A small party of men searching a near-by creek with forked sticks captured the reptiles. When more are caught they will all be boxed and shipped.



Chinese Wall or Floor Covering, Woven with Human and Goats' Hair

now treasured in the collection of a Detroit connoisseur. The 200-year-old bit of oriental art bears woven designs and painted figures and may be used for either wall or floor covering.

**TROUBLE LAMP WORN ON CAP GIVES STRONG LIGHT**

An interesting trouble light for the use of mechanics, which, like some others of its kind, can be easily carried about and used without hindering either hand, is featured by a small reflector case and two six-candle bulbs. The reflector is padded and held in place on the head by means of



Above is Shown the Interior of the Reflector. Left: The Lamp as It Looks When Held in Place

**PUNCHED DISK SHOWS WATER WASTE FROM TINY LEAKS**

As a means of showing the great quantity of water that will pass through a small leak, a water-supply company gives its customers a metal disk punched with three tiny holes, beneath each of which is marked the number of gallons of water, at 40 pounds' pressure, that would run through it in 24 hours. The smallest puncture, hardly as large as a pinhead, would allow 180 gallons to escape in the period mentioned.



an adjustable band. The cord attachment plugs into any lamp socket.

**USE MOST ACCURATE BALANCE TO TEST NEW THEORY**

In the most accurate weighing that science has yet successfully attempted, a balance so delicate that it will weigh three pounds with an error of not more than one part in a billion, is being used to test the Einstein theory of gravitation at the Bureau of Standards. The method involves the weighing of large crystals in different positions, and it was found that a change of less than one-half inch in the level of the center of gravity would be detected by the balance. Another refinement is the use of weights equal in volume to the crystal and its supporting frame. The balance is incased by cork walls in a closed room and is operated from the outside.

Our Bureau of Information is for your benefit. Use it as often as you please.

Science Supplement 4/20/13 Copyrighted material

A. W. Clark, National, Cl. U. 2020

W.H. Craig, Chicago

2079

*The Silvery - Raymond Granite Co., San Francisco, Calif.*

**HEAVY COLUMNS HANDLED BY ROLLING SKID ON TRAILER**

The safe and expeditious handling of six 23-ton granite columns was the problem confronting a San Francisco contractor in the erection of a large bank building in that city. A low-bed truck trailer was used to transport the heavy shafts through the streets, one end resting on a roller-mounted skid, or platform, on the trailer floor. The support proper consisted of a heavy wooden bolster on top of the skid, which was banked with sand bags to

prevent injury to the column. When the column was suitably rigged for unloading, the skid moved forward on its rollers, bearing the column with it, as the opposite end was raised. Block and tackle

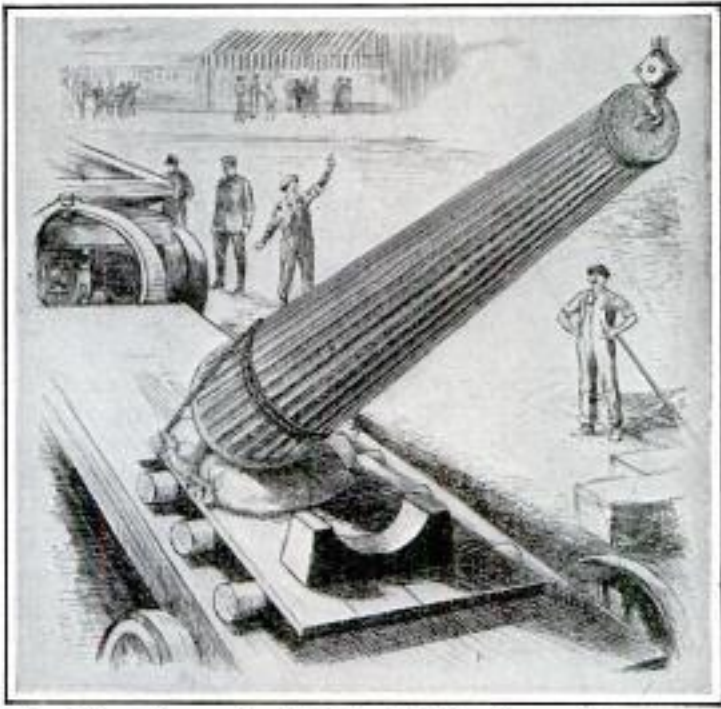

This View Shows the Method of Unloading and Setting in Proper Position a 23-Ton Granite Column in Front of Bank Building

were used to draw the tackle shears toward the building as the column swung free. This method proved so efficient that some of the columns were in position 30 minutes after arrival at the building site. On account of lack of space, shear legs were used for only two of the columns, the others being handled with a 55-foot gin pole, which slowed up the placing of the columns.

2231

**SWARMS OF GOLDFISH NETTED BY LAKE ERIE FISHERMEN**

Lake Erie fishermen each year are troubled more and more with a kind of fish they do not care to catch, and this is the species one would think the last to be found in this northern lake—goldfish. The origin of the trouble is 18 years old. That long ago a Toledo, Ohio, fish raiser conceived the idea of making an outdoor hatchery for goldfish. He leased the right to dam Ten Mile Creek, a small stream near Sylvania, Ohio. He placed 50,000 small fish and about 4,000 big ones in the pond thus created. All went well until a heavy flood hit the territory, and dam, fish, and all were swept into Lake Erie. Now hundreds of them are netted each year. Having little food value, they are thrown back into the lake.

2142

**GLASS CUT ON BOTH SIDES IN ACCURATE MACHINE**

Quick, accurate work and a saving in breakage are the advantages claimed for a glass-cutting machine, the feature of

which is a pair of cutting wheels mounted above and below the glass. The only place where pressure is applied is at the cutting wheels, and this pressure is equalized, due to the fact that one cutter is directly above the other. Scales and guides on the machine make for speed and ac-

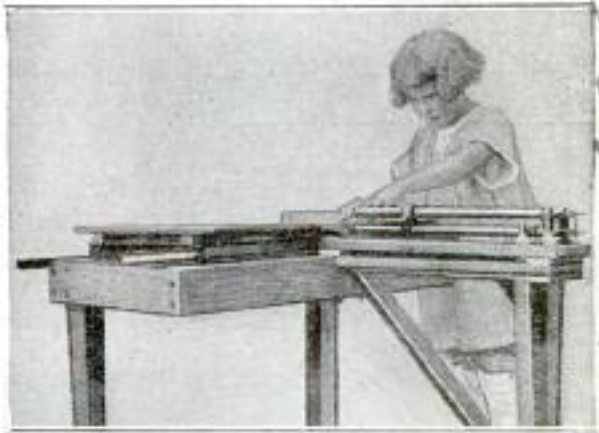

Easily Operated Glass-Cutting Machine That Does Quick, Accurate Work, and Saves Breakage

curacy. There is also an attachment that facilitates the cutting of circles. Curved glass may be cut as readily as flat.

*Mr. Tom Freeman, Suite 13, The Lorton, Monroe 7/6th St. Toledo, Ohio.*

*ms. F.C. Phillips, Stoughton, Mass.*

*Acorn Wire & Iron Works* *J. W. C. Curn*  
 120 *Low* **POPULAR MECHANICS** *Secy. Chamber*  
 5914 *Low Ave.* *Chicago* *Commerce, Burbank*  
**COLLAPSIBLE WINDOW GUARD** **MAKE BALLOON RADIO AERIALS.**  
**IS LOCKED IN PLACE** **TO REPLACE USUAL POLES**

20 An interesting feature of a window safety guard invented recently is the fact

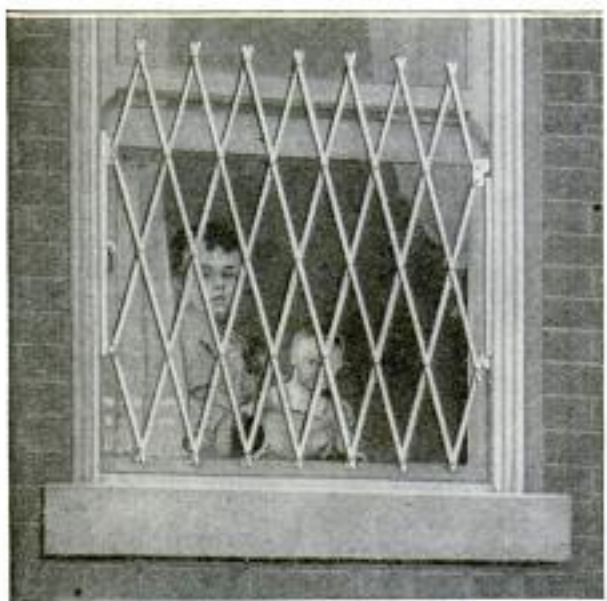

The Latticed-Bar Screen: The Holding Screws are Concealed in the Window Frame

that it can be locked across the window opening it protects in such a way as to foil attempts from the outside to open it. It is made of crisscrossed steel strips, forming a network which can be pulled out or collapsed at will. This adaptation of the window guards commonly used in jewelry stores as protection at night, also prevents children from accidentally falling through the window.

**CAP SPRING KEEPS VACUUM BOTTLE TIGHT**



in place. This is inserted in the cap, being soldered to the top, so that it cannot work loose.

2239 Balloon radio aerials to replace the usual poles and other supports, are being manufactured. They are gas-filled and—to present surface enough to enable them to rise to great heights and to withstand the buffeting of the wind at these altitudes—are designed somewhat in the shape of a cigar. Carrying one-strand antenna wire, the balloons will rise to an altitude of from 300 to 1,000 feet. Several sizes are contemplated, but all will be made of the same material: silk. This will be treated so as to insure resistance to atmospheric pressure. One of the incidental advantages claimed for the scheme is that it will be possible for all occupants of apartment buildings to tune in on distant stations, whereas now, because of the limited space available on the roofs, only a few aerials can be erected on any one building.

*2151 mfr. Curn-Knabenshue*  
**POLICE OF PARIS ADOPT BULLET-PROOF ARMOR** *Burbank Calif*

New styles in armor, declared to be bullet-proof and therefore protection against any lesser attack, have been adopted by the police of Paris for use in rounding up French criminals who often prefer to be killed rather than arrested. The cuirass, as the main part of the armor is called, covers the breast and lower part of the body with a series of overlapping plates. In addition, a shield to be used to safeguard his neck and head is provided for the policeman.



New Bullet-Proof Armor of Paris Police: Manner of Strapping It On Shown at Right

The shield has a crosscut made in it to permit the user to see where he is going. The cuirass weighs nearly 20 pounds.

*Emb. G. Frederich Lees*  
 166, Rue St. Honoré.  
 Paris, France

*Dr. William L. Fies*  
*was well mined.*  
*La Belle*

*developed by Knabenshue*  
*France*  
*Monseigneur Prefect de Police*  
*Prefecture de la P.S.*

H. C. C. Senior Electrician

School for Bakers + Cooks  
FOOD CHARTS DETERMINE HOW MUCH TO COOK

Tedious calculations by stewards and chefs are no longer necessary to determine just what quantity of each ingredient must be prepared to satisfy a given number of patrons. A circular chart has been devised for the purpose, with rows of figures like the spokes in a wheel, which indicate total quantities for any number of persons. The figures are calculated in basic units of consumption for each person. The chart is also available in booklet form.

2230 Sold by  
2004

IMPROVED BROACHING TOOL AIDS PRODUCTION

A broaching tool has recently become commercially available with which it is claimed 75 to 300 per cent more operations are possible than with the ordinary broaching tool, and which has the ability to withstand 45 to 50 per cent greater

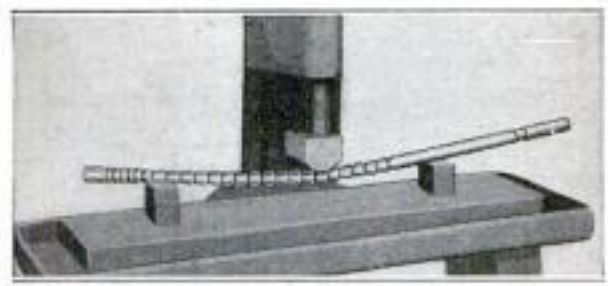

Bending Test on New Broaching Tool of High Tensile Strength and Toughness

strain than usual. Another quality is that it will hold a keen cutting edge with less frequent grinding than the common broach. The tool is furnished in round, square, and various other shapes.

American Broach + Machine Co. Ann Arbor  
DEVICE GIVES AUTOIST DATA ON GASOLINE SYSTEM

On the dial of a device for attachment to the instrument board of an automobile, are four windows that show the amount of gasoline in the tank; the amount of gasoline consumed on a trip; the total of gasoline used, and the condition of the gasoline-feeding system. It gives warning before trouble becomes serious.



Vacuumeter Mfg. Co  
2530 Superior St.  
Cleveland, Ohio.

WIND-DYNAMO MAST ALSO USED FOR WIRELESS SUPPORT

Of interest to farmers using wind dynamos, of which there are great num-

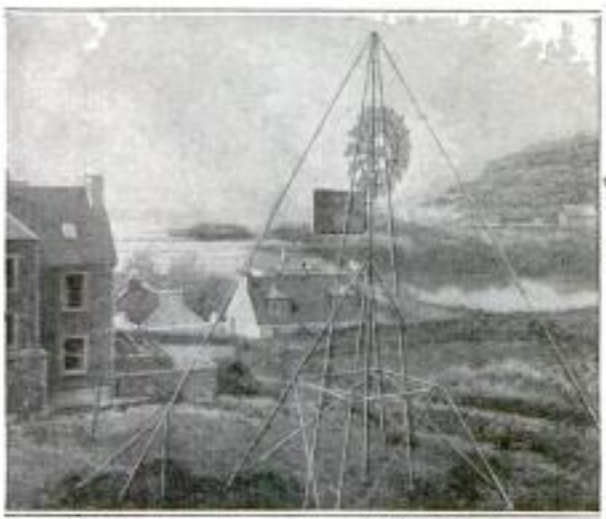

This Steel Mast Supports a Wind Dynamo and Storage Battery for Collecting Generated Current

bers in rural United States, is news from Scotland of the use of the tower as a support for wireless aerials. Two mills have recently been introduced, one with wheels 8 feet and the other 18 feet in diameter, the latter storing a surprising amount of power. It will operate 400 15-watt lamps when the wheel is making 30 to 60 revolutions a minute. Scottish improvements in design include ball-bearing shafts and extra-size carbon brushes.

NEAT WINDOW CARD USEFUL IN AN EMERGENCY

To enable the police or firemen to notify absent owners of buildings or offices in an emergency, there has been invented a small card holder which is swung into position at a conspicuous place in the window. The device is a square metal frame held by an arm which pivots on a small screw in the woodwork of the casing.

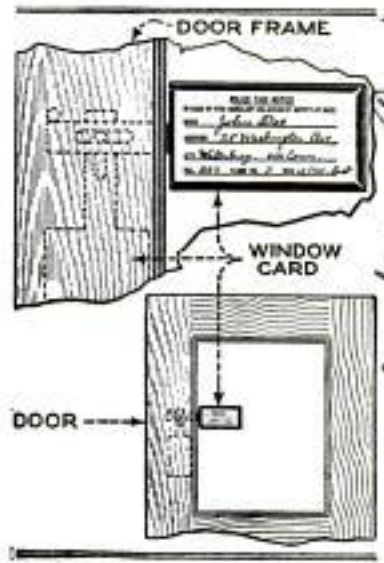

Glasgow Electrical Engineering Co., Ltd.  
45 Pitt St., Glasgow, Scotland

Cruse Mfg. Co  
721 Waterbury, Conn.

## BOY SCOUTS ROUND UP 10,000 GOATS

Driven to the Sea over Hawaiian Lava Beds—Long Trek Proves Grit of Lads Who Worked on Short Rations



One of the Armed Marines Posted to Shoot at Run-away Goats

*Club No. 4* ON the Island of Hawaii there are 100,000 wild goats scattered through the mountains, which have become a veritable pest. On the

western part of the island about 150 miles from Honolulu, the goats were recently forced from their mountain homes by an exceptionally dry season.

They migrated to the lower lava stretches in search of food and found the sparse grass of these lava beds excellent pasture. This land is used by the ranchers along the coast as grazing ground for their cattle, and the horde of goats threatened to deprive the cattle of their food.

One of the ranchers whose land the goats had invaded conceived the idea of using boy scouts to round up the goats and drive them down onto a peninsula where they could easily be imprisoned. This idea appealed to the Hawaii boy-scout commissioner as an outing for his boys as well as a means for saving the herds of the rancher, and 200 boy scouts were enrolled. A dozen Pearl Harbor marines, armed with rifles, and the nearby ranchers completed the band.

The plan was to drive the goats down the lava slope to the peninsula, and once there, the ranchers were to prevent their

BY EVERETT W. MARQUART

*Seaman's Water St. Yokohama, Japan*  
return. The first day's drive was to be 10 miles, but the boys were "green" at the work and could not keep the living line intact. The left wing of the line was composed of boys from 10 to 12 years of age, and it was through this that the goats escaped and returned to the slopes of Mauna Kea and Mauna Loa.

The second day's drive began at 6:00 in the morning with each boy stationed 75 yards from his neighbors, thus forming a living line 10 miles in length. Each boy carried a quart of water and an extra pair of shoes, but no food was taken, as plans had been made to lunch at Kiholo at 2:00 in the afternoon. For boys unused to walking over the jagged lava the play became tedious work and then torture. The lava somewhat resembles a waste of huge pieces of glass, splintered and lying in confusion. To add to the discomfort the sun beat down unmercifully. At two o'clock they were not in sight of Kiholo, yet they labored on, the weaker lads falling hopelessly behind. On through the heat of the afternoon they went, and just as the sun was setting in a wonderful Kona sunset the goats were pushed out onto the neck of land that was to be their prison. The Kanaka ranchmen estimated the full-grown goats in the flock at 10,000, not to mention the kids.

Fifteen of the scouts who had fallen behind were forced to spend the night alone on the lava beds without food



Gathering for the 15-Mile Drive over Jagged Lava Beds



Showing the Goats Herded Together at Kiholo, on the Eve of the Drive

water, or blankets. It was a successful drive for the rancher, but the scouts were forced to undergo hardships which would have deterred many men.

The goats were killed later by the ranchmen and the skins sold, while the carcasses were cast away, to be later used for bone meal. A windlass was invented to pull off the skins at the rate of two a minute.

Thus the Kona coast and the ranchers' cattle were saved from some of the 100,000 wild goats on the Island of Hawaii.

**NAVAL AIRMEN USE DEAD WHALE AS TARGET**

When a dead whale nearly 100 feet in length recently drifted inside the breakwater at Cristobal, the Atlantic terminus of the Panama Canal, the community found itself with a "white elephant" on its hands. In the tropical climate the huge carcass quickly became an intolerable nuisance. An attempt was made to hoist the carcass onto the shore, there to dispose of it. This idea was abandoned, however, when it was

discovered that no crane or derrick could be found able to hoist the mass.

The solution of the problem was finally given by a group of naval airmen, who were engaged in the maneuvers of the combined Pacific and Atlantic battle fleets then in those waters. They thought the dead whale would make an excellent bombing target, one very closely resembling a submarine. The whale was towed out to sea by a tug. The airmen dropped bombs at it from various altitudes. Some excellent practice was afforded, and a number of direct hits were scored before the huge carcass was broken up, when it was attacked by myriads of seagulls, sharks, and other ocean scavengers, and the nuisance which had threatened the public health of the city was averted.

**STAINLESS SILVER INVENTED**

Silver articles not susceptible to atmospheric conditions, and able to retain their polish for long periods of time, are being manufactured in Sheffield, Eng. The new composition is 92½-per-cent silver and is considered an important discovery in this field.



Novel Method of

Removing the Hide

emb. John Edwin Hagg H 16 Union  
League Bldg. Los Angeles  
Copyrighted material  
Ed. L.

1190  
123  
Londm James Trade & Engineering  
Wellingborough  
Cyprus St, Sheffield  
England  
Londm

Dr. Paul A. Syers  
 244<sup>124</sup> Central Ave.

**SPECIAL NET-HOLDING DEVICES  
 USED IN LARGE LAUNDRIES**

2137 *Wollanapols, Ind.*

Devices for holding laundry nets that signal when the capacity is reached, are

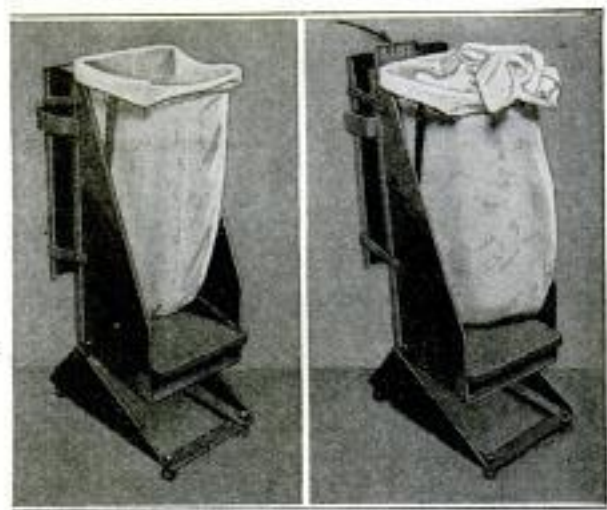

Left, the Device with the Bag Partly Filled; Right, Full: The Arrow Points to the Warning Signal

being introduced. One of the more interesting ones is three-sided, with two movable arms fastened to a platform on which the bag rests. The arms swing outwardly and automatically raise a warning indicator when the bag is full. Holders of this kind insure that the weight will conform to the standard previously determined as the most suitable for good washing.

**BUTTONS ON STEERING WHEEL  
 CONTROL AUTO SIGNALS**

The natural position of the driver's hands on the steering wheel is utilized

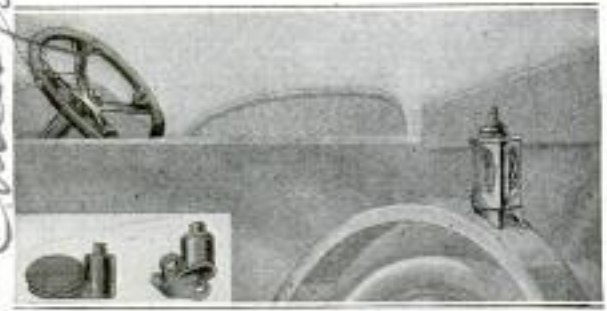

This Auto-Signal Device Has Audible Means of Calling Attention to Its Signals

to advantage in an improved type of automobile-signal device which is being received with favor by some car owners. In the ordinary position on the wheel, a neutral button is close to the right hand, while the "stop" button is close to the left. In turning to the right, however,

the driver's right hand naturally moves up the wheel, the better to make the turn, and it is in the upper-right quadrant of the wheel that the "right" button is located. Similarly, a "left" button is on the upper-left portion of the wheel. The buttons actuate a vertically mounted cylinder at the back of the car, lighted on the interior, and having "right," "left," and "stop" signs stenciled on its surface. A bell rings whenever warning signals are used.

**GAS-ENGINE PRIMER STARTS  
 1841 ELECTRICALLY**

An interesting type of primer for gasoline engines designed to facilitate starting such engines in cold weather, has been placed on the market. The outfit

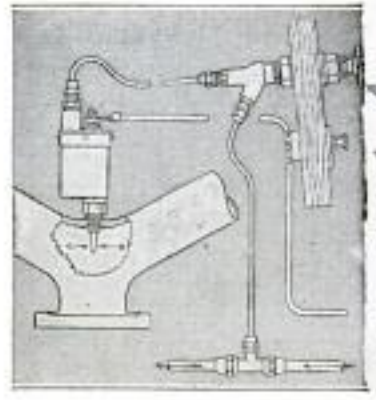

consists of a primer bowl which is screwed into the intake manifold, and contains a coil of tubing through which gasoline is forced by a pump located on the dash. This coil is electrically heated by means of current from the batteries, furnishing hot gas promptly. A switch on the dash controls the current, and a pilot light indicates when the current is flowing, also reminding the driver, by its presence, to shut it off when the engine has warmed up.

**SPRING-PLUNGER VISE GRIPS  
 2169 IRREGULAR ARTICLES**

Irregular-shaped objects can be securely gripped in a new vise of Swiss design which features jaws formed of a series of steel plungers, each actuated by a pair of springs. After conforming to the outlines of the object, each set of jaws is locked by a bolt, and tightened against the object by means of the vise screw.

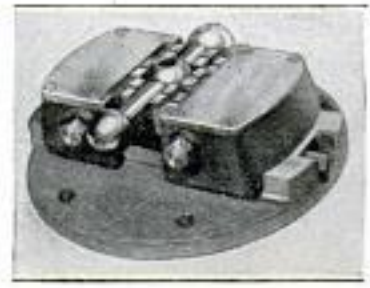

*Bruce Lawson & Co.  
 70, Finsbury Pavement,  
 London, E.C. 2, England*

*Wollanapols, Ind.  
 distributing Co.,  
 Auto*

*Dr. Oscar P. Lealdman,  
 5210 Harper St., Chicago*



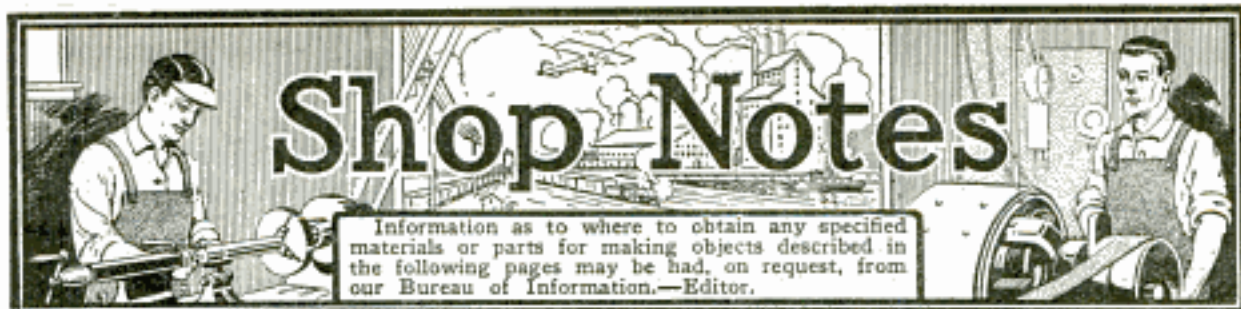

All Shop Notes published in 1922, in book form—Fifty Cents—from our Book Department.

## A Convenient Welding and Cutting Table

BY A. S. JAMIESON

A GREAT many pieces sent to the welding shop for repair are very awkward to set up or clamp while being welded. The illustration shows a table, in use in a shop doing much repairing, that will clamp and hold almost any

in. angle iron. The top is cut and assembled on the floor, and all joints "tacked"; the legs are clamped on and tacked also, whereupon all joints are securely welded. A 3-in. length of the same angle iron is welded to the inside

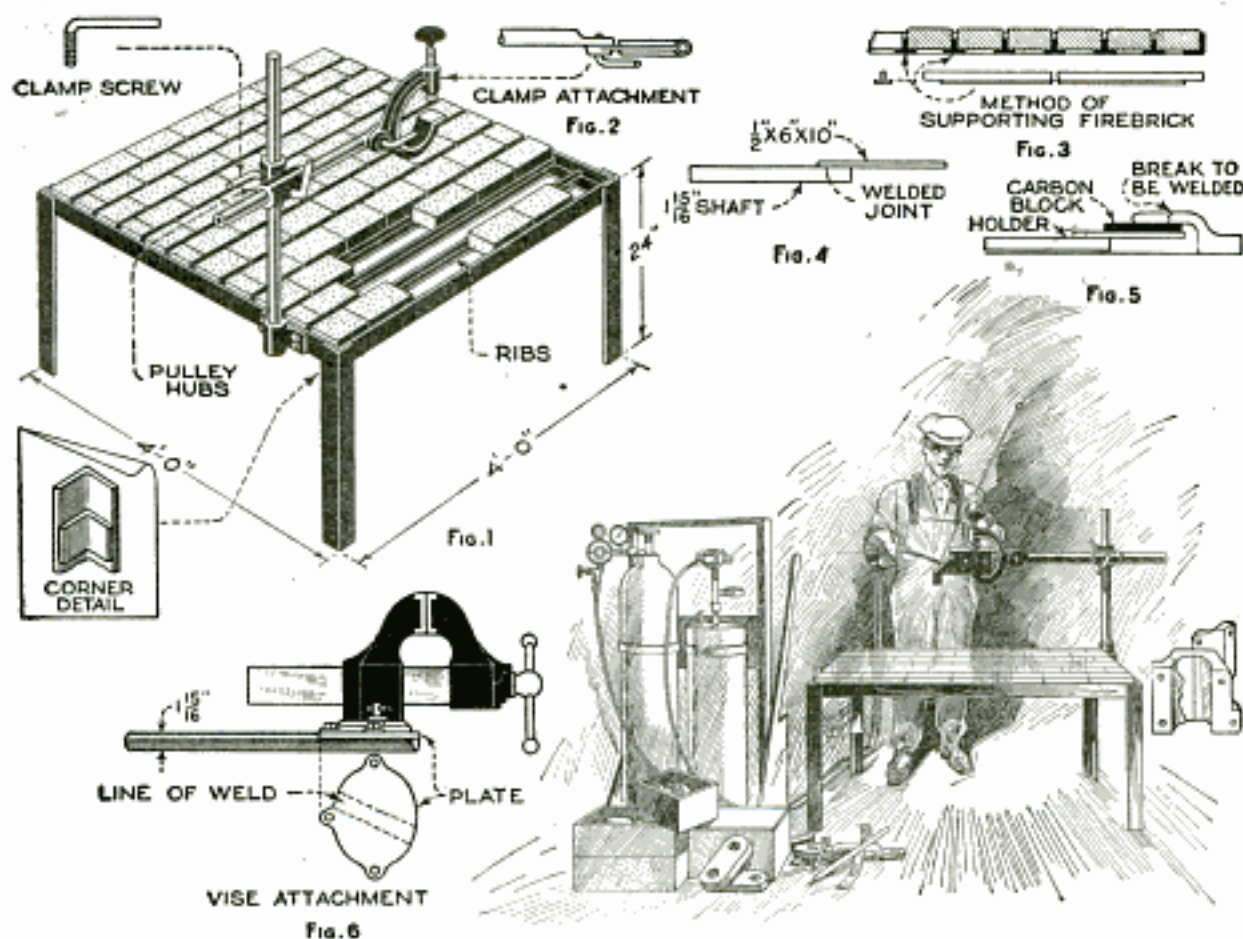

Convenient Worktable for the Welding Shop: By Means of the Attachments Shown, Work of Any Shape can be Held. The Firebrick Top Permits Cutting to be Done without Injury to the Table

piece in any desired position, and that has saved a great deal of time and money.

There is very little machining to be done on the table, beyond drilling and tapping. The top, which is 4 ft. square, and the legs, 24 in. high, are made of 2-

of each leg, to support the table top, as shown in the detail, Fig. 1; no other bracing is necessary.

The work support is made by welding a disk, of  $\frac{1}{2}$ -in. plate, on one end of an old pillow block, and bolting the block

to one side of the table; a 3-ft. length of  $1\frac{15}{16}$ -in. shafting fits in the block. Two old pulley hubs,  $1\frac{15}{16}$ -in. shaft size, are ground smooth and welded together, at right angles, drilled and tapped for clamp screws, and slipped on the upright, as shown. A second 3-ft. length of  $1\frac{15}{16}$ -in. shafting, forged or cut flat on one end, and fitted with a heavy C-clamp, as shown in Fig. 2, is then slipped into the horizontal hub, and the clamp fixture is complete. To attach the clamp to the shaft, an ear is welded onto it and drilled, the shaft being drilled and tapped for a clamp screw. The ends of the clamp screws are casehardened.

The top of the table is provided with a number of ribs, made of T-iron, as shown in Figs. 1 and 3, to support stand-

### Small Ammonia-Carrying Drum

The small ammonia-carrying drum described in this article was designed and built for the purpose of eliminating the

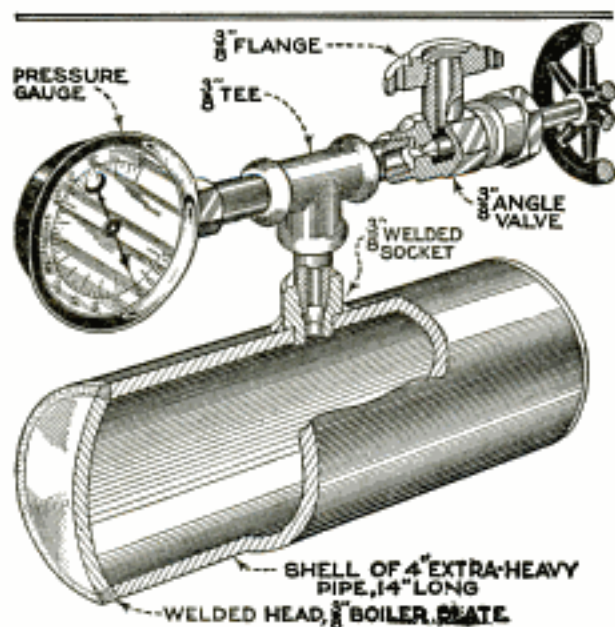

A Small Ammonia-Carrying Drum That Is Ideal for Carrying Small Quantities of Ammonia for Repair Work

necessity for handling large and heavy drums, when only small quantities of ammonia were needed, as in repair work or for charging, in small household plants, which need only from 2 to 5 lb. of refrigerant.

The drum is made of extra-heavy pipe, to the ends of which heavy boiler-plate disks are welded. The ends are dished after cutting, as shown, for strength. The angle between the edges of pipe and

ard firebrick. Considerable cutting is done in this shop, and, when this is done, several of the bricks are removed, and the work is placed over the hole in the table. The slag goes through the top and does not affect the table, nor does it fly all over the operator.

The attachment shown in Fig. 4 is simply a  $\frac{1}{2}$  by 6 by 10-in. plate, welded to a length of the  $1\frac{15}{16}$ -in. shafting. This is used, as shown in Fig. 5, for offset pieces, or for lining up work of uneven thickness, and is exceedingly useful.

The vise attachment, shown in Fig. 6, also adds considerably to the effectiveness of the table. The piece of  $\frac{1}{2}$ -in. boiler plate used to support the vise is welded to the shaft at an angle, so that there will be no interference with the vise bolts.

disks is just right for the reception of the welding metal. A steel socket, tapped for  $\frac{3}{8}$ -in. pipe, is welded in the side of the drum, and into it a  $\frac{3}{8}$ -in. nipple is fitted; on the nipple, in turn, is screwed a tee, and  $\frac{3}{8}$ -in. nipples connect the tee to a gauge and to an angle valve. The combination gauge is an essential part of the device; it should read to at least 15 in. vacuum, and up to 300 lb. pressure. The angle valve is of standard construction, and should seat tightly, in order to hold the high pressure of the ammonia. On the outlet side of the angle valve is mounted a  $\frac{3}{8}$ -in. companion flange that is used to connect the valve to a large drum, when charging. All fittings must be extra-heavy.

To fill the drum with ammonia, it is first exhausted by means of a vacuum pump, until the gauge shows a vacuum of 15 in. Connection is then made to a large ammonia drum, through a short nipple and a companion flange, and the two valves opened, until the pressure in the two drums is equalized, when the valves are closed, and the drum disconnected. To ascertain the weight of the charge, the drum should be weighed before and after filling. The nipple between the two valves should be short, as the amount of liquid between the two valves is lost when the flanges are separated.

Before using the drum it should be tested under high pressure for leaks. An all-steel or iron drum is necessary, as ammonia corrodes other metals suitable for valves.—J. V. Romig, Allentown, Pa.

☞ Beeswax makes a better lubricant for tail centers than the usual white lead, oil, or grease.

### An Advertising Novelty

One of the leading clothing houses in Denver has, in addition to a well-arranged window display, a small electric push-button switch on the outside of the building, so wired that any passer-by can illuminate the interior of the store at night, in order to obtain a good view of the elaborate clothing display inside, on models and in glass showcases. A small brass plate, reading "Press Button to See Interior of Store Lighted," calls attention to the arrangement. The lights remain on only as long as the button is pressed down, so that no current is consumed needlessly.—Edward H. Flaharty, Denver, Colo.

### Interchangeable Chuck for Woodturning

In pattern shops equipped with only a few lathes, but employing many pattern-makers, it frequently happens that one has to wait his turn to use the lathe. As the setting up of a job in the lathe often consumes just as much time as the turning operation itself, it has been found, in one

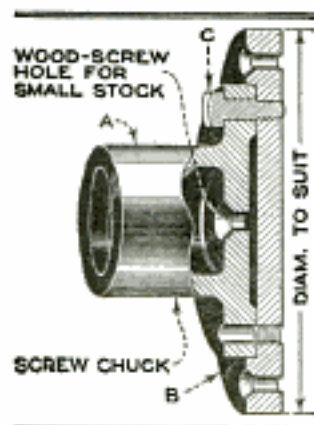

shop, that the provision of interchangeable chucks and plates enables the workmen to set up many of the jobs at their benches, and thus eliminates much of the lost time. The chucks are made in two parts, of cast aluminum, and finished all over. The illustration clearly shows the construction. The chuck A is drilled and countersunk in the center to receive a No. 14 or 16 chucking screw, for use on small jobs. For large jobs, a flat faceplate, B, is used. This is drilled and tapped to receive the clamp bolts C, and is recessed at the back to make a snug fit on the chuck. All chucks are made of the same diameter, and the bolt holes are all spaced alike, so that one plate will fit a chuck on any lathe. When another job is to be turned in a hurry, and work is already on the chuck, all that is necessary is to remove the faceplate from the chuck and substitute another plate. Also, when it is desired to change from one lathe to another, to facilitate the work, the plate is simply changed from one chuck to another.

### Detachable Letter Shelf for Desk

The desk worker will find the detachable shelf shown in the illustration serviceable for carrying reference books, cor-

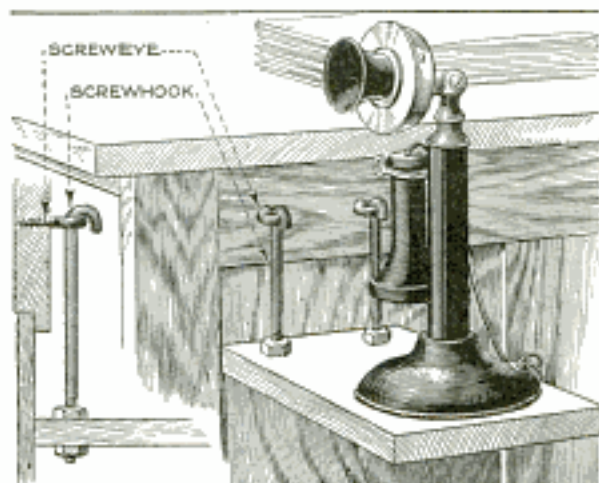

A Detachable Shelf on the Side of the Desk Provides Additional Space for Reference Books, or the Telephone

respondence, or the telephone, when the desk top is so covered with material that additional space is necessary. The shelf consists of a piece of 1-in. wood, hung from the side of the desk as indicated, the long hook bolts attached to one end of the board engaging with screweyes driven into the side of the desk. More than one shelf of this kind can be used, and, of course, the size of each may be varied to suit the user.

### Fixture Holds Horn for Adjustment

Anyone who has occasion to test and adjust automobile horns will find the fixture illustrated a great convenience and timesaver. It consists of two uprights mounted on a wooden base, one having a V-shaped cut, as shown, and the other a series of small holes, drilled in a vertical line to accommodate a pin. The horn is laid in the "V," and the end hooked under the pin, the weight of the mechanism at one end holding the horn securely in the fixture. Such a horn support not only leaves both hands free, but also eliminates the time-consuming adjustments that are necessary when clamps are used.—Emil J. Bachmann, Keene, New Hampshire.

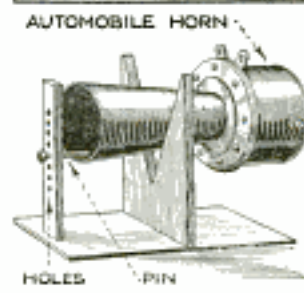

### A Homemade Drill Press

A small vertical drill press is at times a necessary tool in the home workshop, though there may not be sufficient use

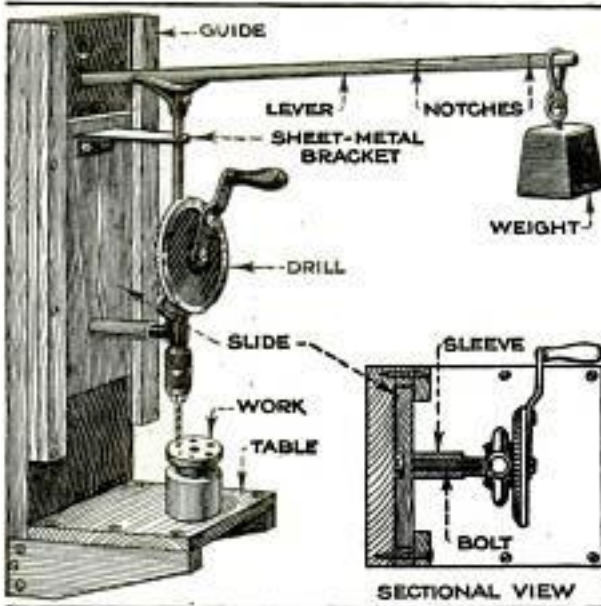

A Vertical Drill Press, for the Home Workshop, That Proves Quite a Time and Labor Saver

for it to justify the purchase of one. However, a drill press that will give satisfactory service can readily be made of material that is available in almost any shop.

An ordinary breast drill, mounted in the manner illustrated, is used. A machine bolt, pushed through a hole in a wooden slide, and also through a metal sleeve made of pipe, as shown, is substituted for the stationary handle. The head of the bolt is counterbored flush with the back of the slide. The upper end of the drill is held in place by a sheet-metal bracket, screwed to the slide and drilled to fit the breast-drill shank.

The slide fits neatly behind wooden guide strips, that hold it to a heavy wooden back so that it can be moved up or down. The table is securely attached to the lower end of the back with wooden braces and wood screws, and must be made strong enough to withstand considerable pressure.

A number of holes are drilled in the center of the back, as shown, about 1 in. apart and large enough to accommodate a wooden lever; a broomstick will serve for this. The lever is notched on one end at several points, as indicated, placed over the breastplate of the drill, and the end inserted into one of the holes in the back. By suspending a weight from the lever, as indicated, pressure is

applied to the drill. The pressure can be varied by moving the weight, the notches serving to keep the latter from slipping out of position.

If it is desired to run such an improvised drill press with an electric motor or from a shaft, the hand crank is removed and a suitable pulley is bolted to the large gear. Care must be taken, of course, to use a pulley of such size that the drill will be run at a suitable speed.—J. H. Garety, Charleston, S. C.

### Making Up Shipping Cartons

The homemade bench shown in the photo, which is used to make up corrugated-cardboard shipping cartons, is well adapted to the purpose, and the method employed for obtaining the greatest possible adhesion between the flaps, to which adhesive is applied, is rather novel. The boxes are mounted on wooden forms, fitting the inside closely, as shown, and hollow, hinged wooden lids, filled with bricks to make them weigh about 50 lb. each, are let down on the flaps after these have been given a liberal application of adhesive. The adhesive used is silicate of soda, which sets very quickly.

By using a double bench, having six sealing forms on each side, it is possible

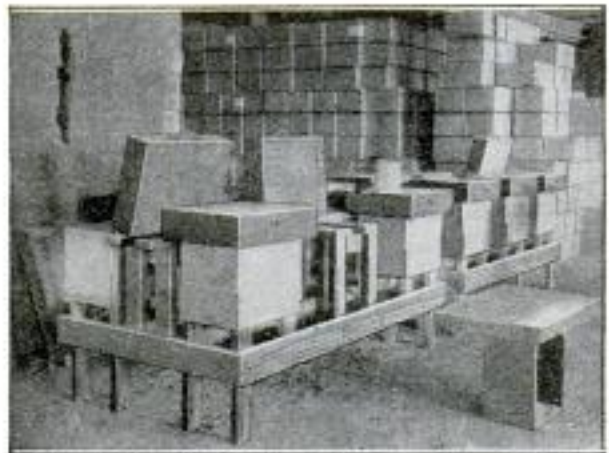

A Bench Used for Sealing Paper Cartons: One Hundred Boxes per Hour can be Sealed by One Man

for one man to keep busy working around the forms without pause; by the time he has sealed the twelfth box, the first may be removed. The boxes can be sealed at a rate of approximately 100 per hour.

Keep the spark plugs adjusted to the gap specified for the car. Do not guess at the distance, but use a gauge to test the gap.

# EQUIPMENT FOR AUTOMOBILE-TOURIST CAMPS

By A.J.R.Curtis and J.Tate

## Part I—Gateposts, Pump Base, Ranges, Seats, and Tables

AMERICA is rapidly getting acquainted with itself. The motorist who does any touring at all meets numerous transcontinental and interstate tourists on the roads around his city, and auto campers almost without number. Many people of means choose an extended tour, camping along the way, as the most interesting and restful vacation possible, while, to many a family of modest circumstances,

camp are numerous. In the first place, it keeps the camper from "squatting" where he is not wanted, and in the second, just as good roads have often trebled traffic in any section, so good camp facilities quickly increase the number of the better class of campers visiting a community, to the increased prosperity of local business.

The equipment described and illustrated in this article is very simple to construct.

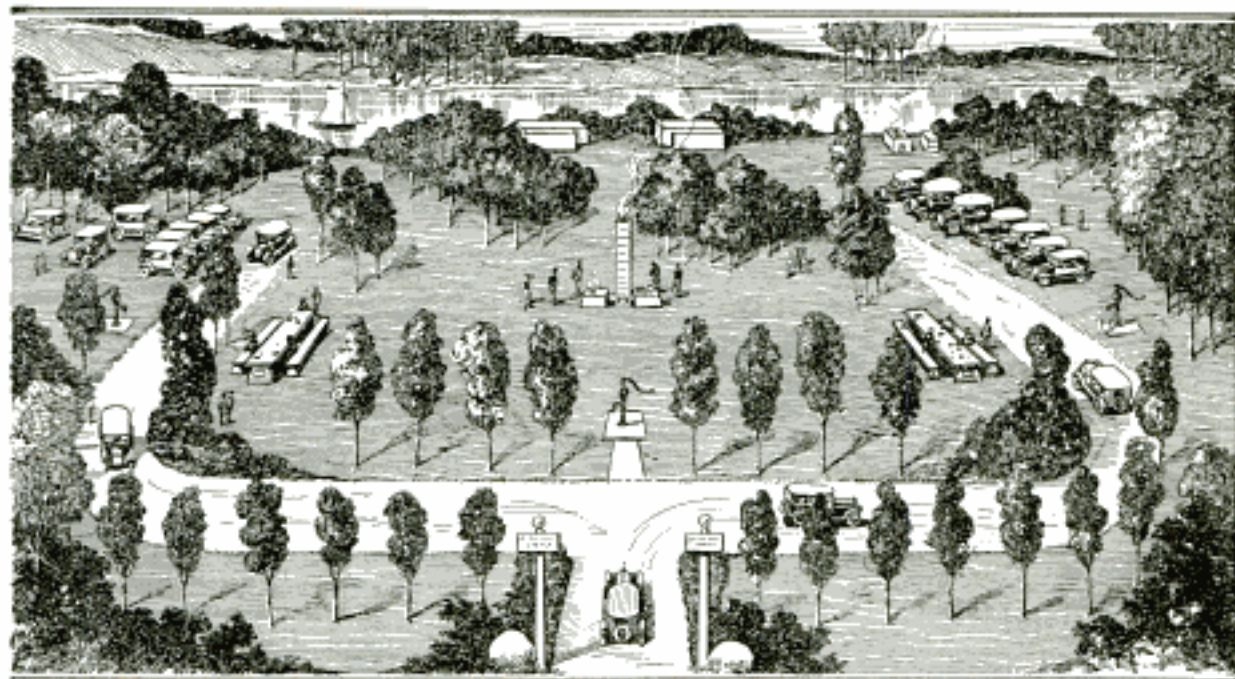

Layout of Small Automobile-Tourist Camp, Showing Minimum Amount of Equipment That should be Provided: Toilets, Incinerator, and Garbage Can are Shown in the Background

"camping out," via auto, offers the only opportunity of enjoying an inexpensive rest period.

Until quite recently, public-camp sites have been scarce, and, where they did exist, cooking and toilet facilities were primitive, and, in many cases, the camps were dirty, badly drained, and altogether uninviting.

Now, however, many communities are studying the question of how to make the automobile tourist comfortable, and are making provision for clean, attractive camp sites. The advantages of a public

Any man who can handle hammer and saw can quickly make the forms necessary. If a number of men in each community will give a few hours' time to the project, the only expense involved will be that of the lumber for the forms, and the materials for the concrete. This would even be a fine project for the local troop of boy scouts, and, under competent supervision, would not be at all beyond its powers.

These are merely suggestions; in many communities it may be preferable to turn the work over to the local contractor,

who, with the accompanying illustrations to guide him, can, in a very short time, transform the bare site into a splendid camp.

The layout shown in the first illustration is suggestive only, since the actual layout will depend entirely upon the size and shape of the plot of ground available, and upon the number of tourists expected. All the equipment shown, however, should be included at the start, and additional units erected if those shown are not sufficient to care for the campers.

When selecting a site, one that is level, well wooded, and well drained should be chosen, if possible. The last-named feature is one that is too often neglected, and while it may not always be possible to

designated by one or two large and attractive signposts; the design shown in Fig. 1 is an excellent one, as it carries a light so that it may easily be read at night, and is sufficiently heavy and rigid to resist chance knocks and sideswipes, such as tourists often heedlessly inflict.

The post is made long enough to allow at least 6½-ft. clearance under the sign, and should be imbedded in the ground for at least 3, and preferably, 4 ft. The post tapers from 8 in. square at the bottom to 6 in. square at the top, and carries a 12-in. globe. The signboard is 3 in. thick and is cast integral with the post; it is made from 24 to 40 in. high in order to accommodate the desired lettering. The form for making this post is shown

in Fig. 2, and is decidedly simple. It is so made that the flat side of the signboard is uppermost, and the 3-in. rib forming the continuation of the post, on the bottom. The beveled edges on post and signboard are formed by triangular molding, as shown. The 1-in. conduit for the electric-light wires is laid in place after the concrete has been filled in to half the thickness

AREA DRAINED BY TILE MAINS									
SIZE OF TILE	FALL PER 100 FEET								
	1½ IN. OR 0.1 FT.	2⅓ IN. OR 0.2 FT.	3⅞ IN. OR 0.3 FT.	4½ IN. OR 0.4 FT.	6 IN. OR 0.5 FT.	9 IN. OR 0.75 FT.	12 IN. OR 1.0 FT.	24 IN. OR 2.0 FT.	
INCHES	ACRES	ACRES	ACRES	ACRES	ACRES	ACRES	ACRES	ACRES	ACRES
4	3	6	7	8	9	10	13	18	
5	7	10	12	14	15	19	23	32	
6	12	17	21	24	27	33	38	53	
8	26	37	45	60	74	85	106	125	
10	50	70	85	100	110	140	195	225	
12	86	118	145	165	175	230	265	360	
15	152	215	270	310	355	430	500	720	
18	250	360	440	515	575	720	820	1150	

Table Showing Correct Sizes of Tile to Use for Draining Camp Sites: It is Based on a Run-Off of ¼ Inch in 24 Hours

obtain a naturally drained site, it is a very easy matter to drain one, using concrete tile. Where drainage is necessary, the accompanying table will be found very useful, as it will insure that the proper size of tile, installed to suit conditions, will be used.

The table shows the area that may be drained with various-size tile mains, and indicates the effect of the slope at which the tile is laid. The table is based on a run-off of ¼ in. in 24 hours; in sections where rainfall is extremely heavy, or is of the nature of downpours, a run-off of ⅜ in. or even ½ in. is used as a basis for calculation. For a ⅜-in. run-off, just two-thirds as many acres will be drained by a certain size of tile as the figure shown in the table, while, if ½ in. of water must be carried off in 24 hours, the tile will serve only half the acreage shown. For example, a 4-in. tile, laid with a 1¼-in. slope per 100 ft., will drain 3 acres, carrying off ¼ in. of water every 24 hours. If it must carry off ⅜ in., it will drain only 2 acres, and if ½ in., only 1½ acres. The amount of tile used, therefore, and the spacing of the mains, depend on local conditions of rainfall.

The entrance to the camp should be

of the post, and the reinforcing bars for post and signboard placed in like manner. The conduit and bars may be made up and held in position in the form by means of wire ties, if desired, and laid in place in the form before any concrete is placed, but, in this case, special care must be taken to work the concrete completely into the corners and between the bars and conduit, by means of small iron rods.

The lettering may easily be cast integral with the signboard by means of a form top, a part of which is shown in Fig. 3. The outlines of the letters are laid out on the top, the letters sawed out, as indicated, and the interior portions of letters such as O and A fastened in place by means of short sheet-metal straps. As soon as the form is filled, this top is nailed or screwed over the signboard portion, and the letter spaces filled in. The letter openings should be beveled slightly, so that the top may be removed easily when the concrete has set.

The concrete used should be a 1:2:3 mix, that is, mixed in the proportion of 1 part Portland cement to 2 parts sand, and 3 parts clean pebbles. The lettering form may be filled in with a mixture of 1 part cement to 2 parts marble dust; this

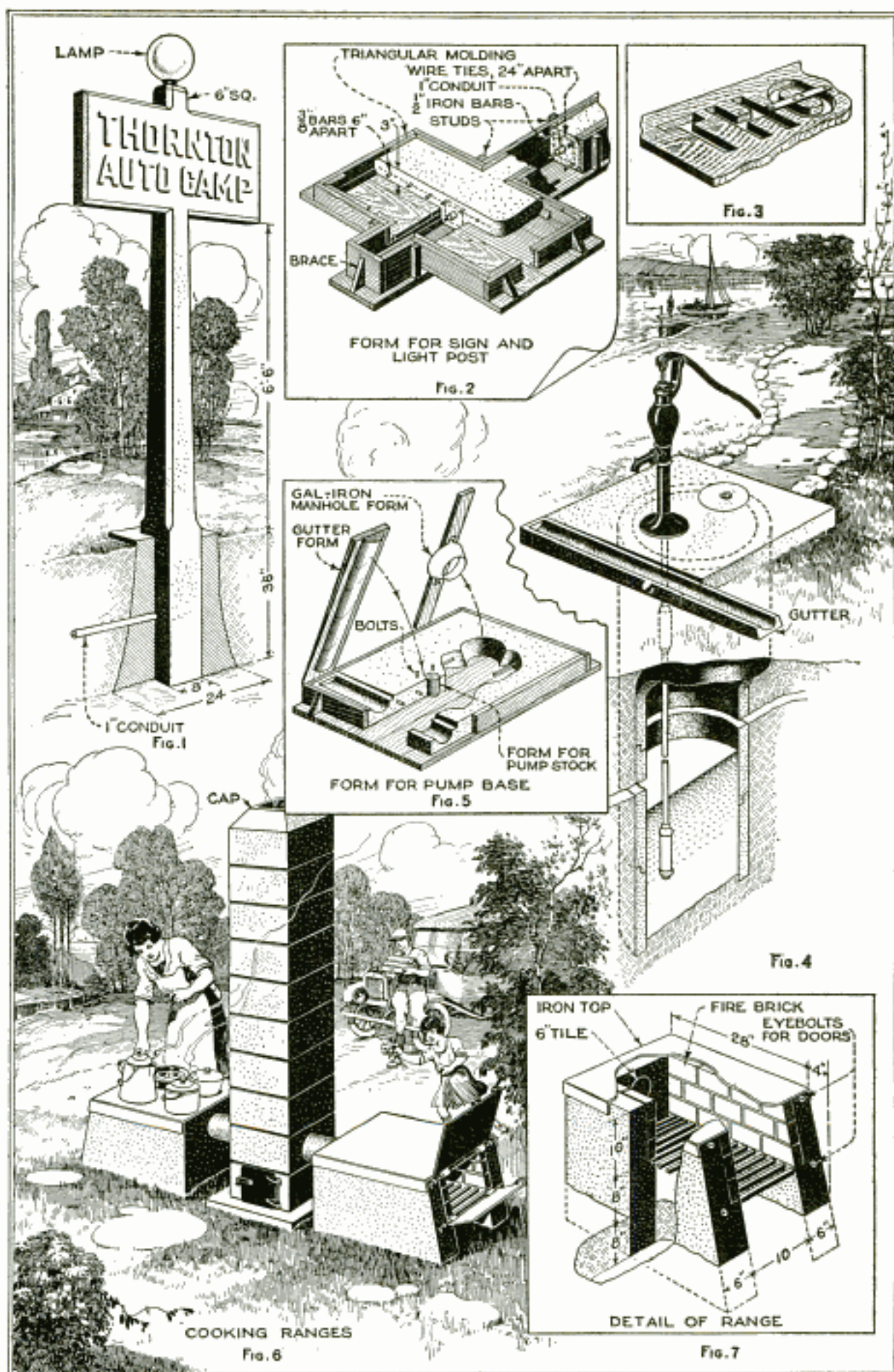

Figures 1 to 3, Signpost for Entrance of Camp, Detail of Main Form, and Form for Casting Letters; Figure 4, Well Curbing, Pump Base, and Gutter; Figure 5, Form for Pump Base, Showing Method of Making Manhole; Figure 6, Cooking Ranges and Chimney in Use, and Figure 7, Full Details of Individual Range

will make the letters stand out sharply against the background. The materials required for this post are  $1\frac{1}{2}$  sacks of cement, 3 cu. ft. of sand, and  $4\frac{1}{2}$  cu. ft. of pebbles.

A good water supply is essential within the camp, and unless city water mains are available, one or more good wells must be provided. The well curbing is generally built as shown in Fig. 4, and a 5 or 6-in. slab top, cast in the simple form shown in Fig. 5, placed over it, as indicated. The manhole form is simply made of galvanized iron, conical in shape, and provided with two ears, nailed to a cleat, which, in turn, is nailed in position on top of the form. The form for the pump stock is a tapered block of wood, oiled, and placed in position in the center of the bolts that are to hold the pump; these are wired in position. The gutter may be formed as indicated, or made by means of a trowel while the concrete is still green, and should be carried out a short distance from the well, by means of separate gutter units, to prevent puddles around the well.

The manhole cover may be cast, using the inside of the galvanized-iron form, at the same time as the rest of the slab. It should be reinforced with short lengths of iron rod, laid crisscross, and be provided with a lifting ring, made from half of an old bridle bit, or from a hitching-post ring, the end of which is provided with a large washer and nut. The iron form must be well oiled before pouring.

The slab top is reinforced with  $\frac{3}{8}$ -in. rods, spaced 6 in. apart, and placed as indicated. A 1:2:3 mix is used for this job also, and approximately  $4\frac{1}{2}$  sacks cement, 9 cu. ft. sand, and  $13\frac{1}{2}$  cu. ft. pebbles will be required for the cover; for each 10-ft. length of gutter,  $1\frac{3}{4}$  sacks cement,  $3\frac{1}{2}$  cu. ft. sand, and  $5\frac{1}{4}$  cu. ft. pebbles will be required, and for the curbing, for each foot of depth,  $1\frac{1}{2}$  sacks cement, 3 cu. ft. sand, and  $4\frac{1}{2}$  cu. ft. pebbles.

Stoves are necessary for the preparation of meals, and those shown in Fig. 6 will be found very satisfactory. They may be used singly, located back to back on each side of the chimney, or on all four sides, as necessary. The dimensions of the ranges are shown clearly in Fig. 7, and the form in Fig. 8. The top is made of No. 12 sheet iron, flanged as shown, and the grate of  $\frac{3}{4}$ -in. square bars, cemented onto the ledge that supports the fire-brick lining. The doors are made of sheet iron, with ears formed on the top for hinges, and swing on iron rods held in eyebolts cast in the concrete.

It is best to use commercial 16-in. concrete blocks for the chimney, but where these are not easily obtained, the blocks may be cast in the form shown in Fig. 8. Concrete tile, 6 in. in diameter, may be used to connect the ranges to the chimney, or where several stoves connect with one stack, common stovepipe may be used instead; the stovepipe allows considerable independent movement of stoves and chimney, without causing cracks. For each range,  $3\frac{3}{4}$  sacks cement,  $7\frac{1}{2}$  cu. ft. sand, and  $11\frac{1}{4}$  cu. ft. pebbles will be needed, together with one 6-in. concrete tile, thirteen 16 by 16 by 8-in. chimney blocks, one 16 by 16 by 4-in. cap, 1 sheet-iron top, 2 iron stove doors, 4 eyebolts, about 3 ft. of  $\frac{3}{8}$ -in. rod for hinges, and 1 cast-iron clean-out door.

The lunch tables and benches shown in Figs. 9 and 10 will prove very popular. They resist upsetting, do not rot or warp, and can be scrubbed easily.

Two forms are necessary for the bench, one for the pedestals and the other for the top slab. The pedestals are cast vertically, as indicated in the detail. The top slab is cast horizontally, and is reinforced with  $\frac{3}{8}$ -in. bars, placed 4 in. apart lengthwise, and 24 in. apart crosswise. The pedestals are set up on bases cast into the ground, the proper distance apart, as indicated by the dotted lines, Fig. 9, and may be joined to the bases by a cement-mortar joint as indicated in one of the details showing the pedestal-and-slab joint. Pedestals and bases may also be cast together, if desired, and set into holes dug in the ground. The top may be joined to the pedestal in two ways: by bolts, in which case the latter are cast into the pedestal, and holes for their reception cast into the top, as shown in the illustration of the table-top form; or by means of a cement-mortar joint, the upper edges of the pedestals being slightly beveled, and recesses formed in the slab to receive them. The tops and pedestals may be cast in one piece, reinforced as indicated in one of the details, but this method is not recommended.

The table, Fig. 10, is made in exactly the same manner as the benches, and the three units set up as shown in the plan lying on the table.

For each bench, the materials required are: cement,  $1\frac{1}{2}$  sacks; sand, 3 cu. ft., and pebbles,  $4\frac{1}{2}$  cu. ft.; for the tables: cement, 3 sacks; sand, 6 cu. ft., and pebbles, 9 cu. ft. For the complete assembly of two benches and table, 6 sacks cement, 12 cu. ft. sand, and 18 cu. ft. pebbles will be required.



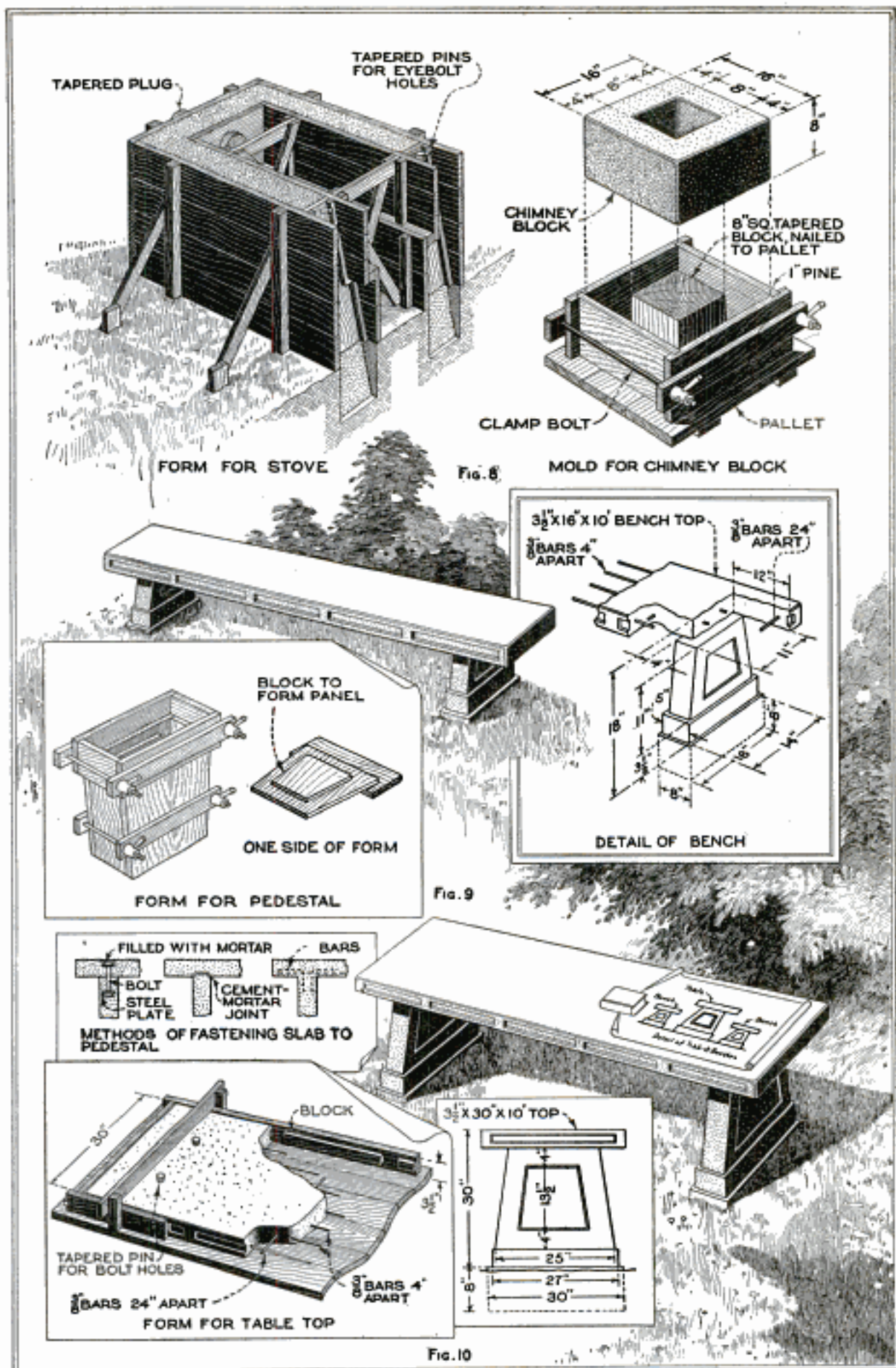

Figure 8, Forms for Stove and Chimney Blocks; Figure 9, Lunch Bench, Showing Method of Making Pedestals; Figure 10, Table, Showing Part of Form for Top, Methods of Joining Top to Pedestal, and End Elevation of Assembly of Benches and Table. Forms for Tables and Benches Are Alike, Except in Size

The forms for all these pieces are very simple; all there is to remember is that the interior of the form must be an exact duplicate of the piece to be made, and that the forms must be well enough braced to resist sagging or spreading under the weight of the concrete. Forms must always be oiled or greased before placing the concrete, and all blocks forming holes, recesses, or panels given plenty of taper, to permit easy withdrawal. The lumber used should preferably be green; if sea-

soned lumber is used, it should be thoroughly wetted. Forms that are to be used for only one piece need not be elaborate, and may be nailed together, but those used for duplicate pieces, such as the bench and table pedestals, must be made to be taken apart without damage, and must be fastened by means of clamp bolts, as shown, or by similar fastenings.

Additional equipment, suitable for larger and more pretentious camps, will be described in the August issue.

### Tripod Drill Used as Hand Drill

The engineer supervising the development of the Skagit River for power pur-



Adaptation of a Tripod Drill for Use as a Portable Hand Drill for Vertical Holes of 6 Feet and Over

poses, finding that the excavation for the power house would necessitate an unusual number of drill holes, improvised a drill that proved very speedy and serviceable.

A drill of the Leyner type was removed from its regular mounting, and, after suitable handles, made of round steel, had been attached to it as shown in the photo, was used as an ordinary hand drill. It had almost twice the drilling speed of the latter, but, of course, it was a little more difficult to move, owing to its weight. For vertical holes of 6 ft. and over, it was found highly satisfactory.—Aaron Evans, Rockport, Wash.

☛ If the auto fan belt slips, turn it over. The fresh surface will usually cling to the face of the pulley when the oily inner surface will not.

### Scribing Lines on Round Work

I have often tried to mark a true line around the circumference of a cylindrical body, such as a shaft, pipe, or piston, but have always experienced trouble in scribing it exactly, until I hit upon the following scheme: Take a piece of paper having a straight edge and wrap it around the cylinder so that the edges line up where they overlap. Then scribe a line along the edge and it will be found perfectly true.—John A. Blaker, West Auburn, Massachusetts.

### Metal Index Tabs

Brass letters and figures, embossed on the pattern-shop embossing machine, make good index tabs for the shop catalogs, books, or card files.

The tabs are cut to shape as shown, a couple of indentations punched in them with a center punch, and the backs then coated with shellac. When this is nearly dry, the tabs are pressed into place on the book pages or cards.

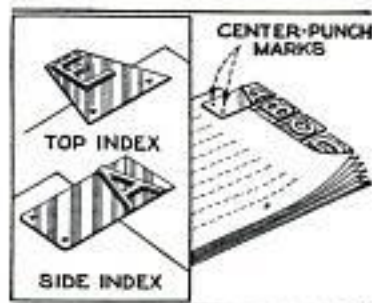

### Sawing and Filling Holes in Slate

When rebuilding a large power-house switchboard, one of the old panels was found to be 6 in. too wide for the new board. It was sawed down, on the job, in the manner shown in the illustration. The panel was placed on two wooden horses, 2 ft. high. A wooden handle was fitted on one end of a  $\frac{3}{4}$  by 14-in. power-hacksaw blade, and a coil spring fastened to the other end. A length of cord was

attached to the coil spring, passed through a staple driven into the floor, in line with the cut as indicated, and the end fastened to the horse so as to permit adjustment. Considerable pressure was thus placed on the saw, so that it was possible to saw the slate at a rate of 14 in. per hour, which is much faster than usual when sawing slate by hand.

The location of some of the instruments was changed on the panels; this left a number of holes, which were plugged in the following way: Just enough water was added to some Portland cement to enable it to set, making a very dry mixture. A block of wood was clamped over the hole to be plugged, and the cement tamped in until the hole had been filled to within  $\frac{1}{32}$  in. of the surface of the panel. The block of wood was then removed, and the other end of the hole tamped until the cement at this end was also  $\frac{1}{32}$  in. below the face of the panel. The cement was allowed to set for

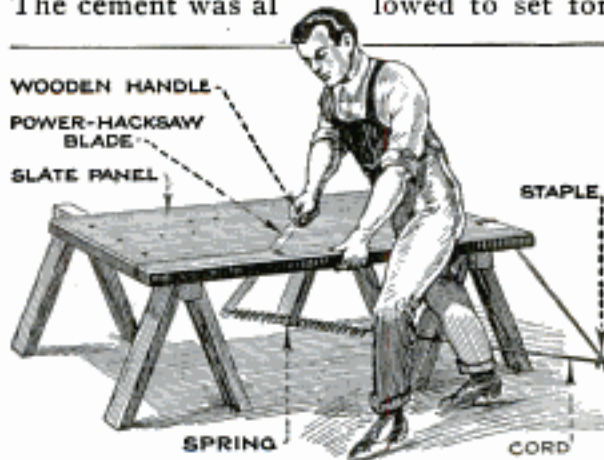

Sawing Slate Panels: The Pressure Applied by Means of the Spring Lessens the Time and Labor Required

24 hours. A thick paste, made of slate dust and boiled linseed oil, was then forced into each end of the hole, and allowed to project about  $\frac{1}{8}$  in. above the surface of the panels. When the mixture was dry, the material was dressed down flush with the face of the panel by means of very fine emery cloth, which had been almost worn out in polishing copper busbars. The panels were then polished with oil, and the places where the holes were plugged could not be detected.—Ben Buck, San Francisco, Calif.

### Convenient Tool Tray

The illustration shows a simple portable tool tray that has been found to be of considerable utility to automobile mechanics. It consists of a 1-in. board, about 12 in. wide and long enough to bridge

the distance between the radiator and cowl of an average-size car. A hole, about 3 in. in diameter, is cut at one

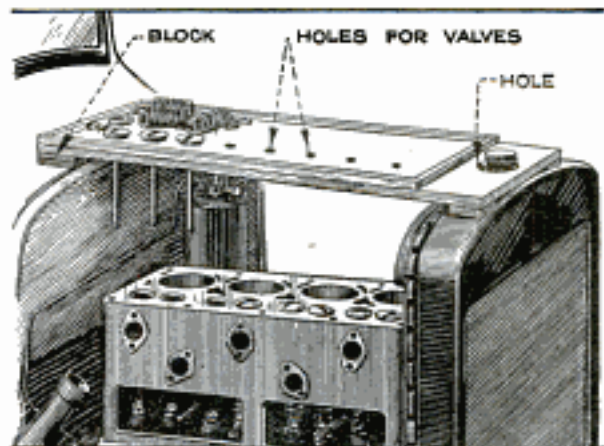

A Tool Tray for the Auto Repairman That Saves Many Trips to the Bench

end to fit over the radiator cap, and small blocks are tacked to the corners, to keep the board from rocking, or slipping over on either side. Strips of wood are nailed on top, at the edges, to prevent screws, small springs, etc., from rolling off, and a number of holes are drilled through the board, as shown, to accommodate engine valves.

The use of this tool tray does away with the habit of laying tools on fenders, which is highly objectionable, as it mars the varnished surface. The tray also saves the mechanic numerous steps, as all the tools needed for a job may be kept on the tray within easy reach.

### Secure Latch for Paddocks

It is desirable to have the gates of stables and paddocks provided with a latch that cannot be opened by the horses. A good latch, that is absolutely secure, and has been found to be very useful on the stallion paddock at the University of Illinois, is shown in the photo. The gate is made so that it touches the gatepost at the bottom first, and the top must be sprung in in order to hook the latch. There is not a chance for the gate to open when the latch is in position; the harder the stallion rubs or pushes against the gate, the tighter the latch becomes.



### Increasing Usefulness of Small Grinders

An ordinary small emery-grinder head can be converted into a most useful and

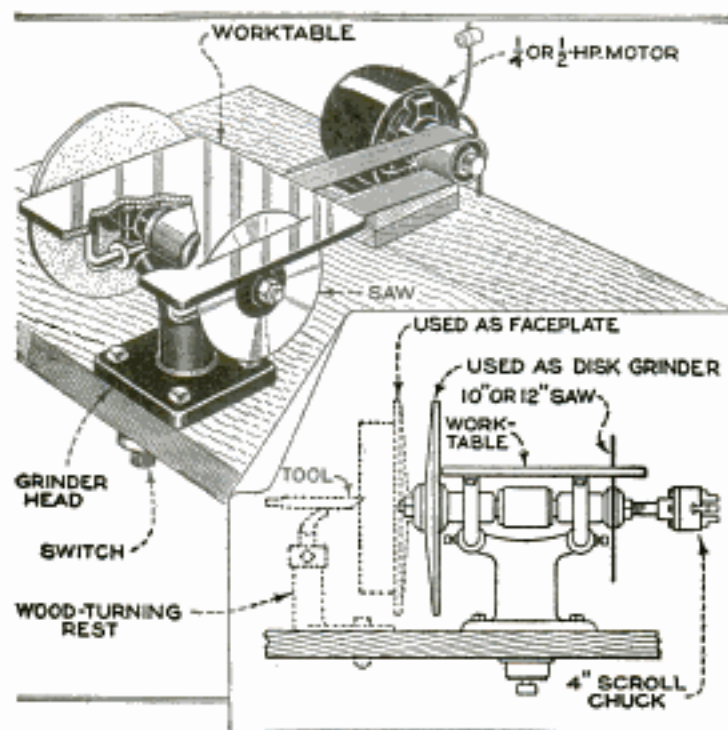

The Usefulness of the Ordinary Motor-Driven Grinder is Greatly Increased by Providing It with a Few Simple Attachments

versatile machine tool at slight cost, and with the expenditure of a little time. The tool can be used for disk grinding, sawing and ripping of boards, turning pattern work, and various other purposes.

A worktable, made of sheet steel or hardwood, is mounted on the grinder head. It is held by two round-steel brackets that slide into the usual work-rest holes and are locked by setscrews. In case a metal top is used, it is drilled and countersunk for flat-head screws, and the ends of the two brackets are tapped to receive them. For a wooden top, wood screws are used, the brackets being split and spread, and the ears drilled and countersunk on the underside. A slot is cut near one end of the table for a small circular saw that is attached to one end of the emery-grinder shaft. The other edge of the table should come within  $\frac{1}{8}$  in. of the disk grinder that is attached to the other end of the shaft. This is a simple faceplate, similar to that used on pattern-makers' lathes, with screw holes drilled in it for fastening the work. It is faced with abrasive disks for use as a disk grinder, or may be reversed, as shown by the dotted lines, and used as a faceplate for wood turning, a tool rest being bolted to the bench for this, as indicated.

If the length of the grinder shaft permits, a 4-in. scroll chuck, fitted with a screw flange, is attached as shown in the lower view. This chuck will be found useful for filing, polishing, and drilling, the latter being accomplished by pressing the work against the drill, which is held in the chuck.

An electric motor of  $\frac{1}{2}$  or  $\frac{1}{4}$  hp. is used, a snap switch being located on the underside of the workbench, near the edge, as indicated. As it is necessary to have a wide range of speeds, interchangeable pulleys of different sizes must be provided for the motor shaft. The motor should be mounted on a sliding base, so that one size of belt can be used for all pulleys.

### Removing Broken Screws

The acetylene torch, which is part of the necessary equipment of most shops and garages, is of considerable assistance in the removal of broken screws in metal. Weld onto the screw a piece of metal that will project above the surrounding surface. When the screw contracts upon cooling, it becomes loose in the threads, and can then readily be removed by gripping the projecting piece with a pair of pliers.

### Thumbtacks Used as Battery Markers

The owner of a battery-service station uses numbered thumbtacks on storage batteries to identify them while being repaired or recharged. Sets of thumbtacks, numbered from 0 to 9, are provided, the numbers being stenciled on with paint. The use of thumbtacks for marking is much better than using tags, as the latter are likely to be torn off. A record, corresponding with the number shown by the tacks, is made in the books, and the tacks remain in place until the job is complete and the battery called for, when they are removed and used again.

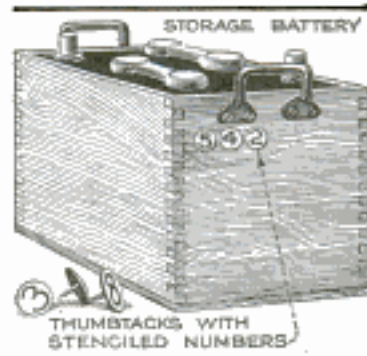

### Bathtubs for Cooking Vessels

A canning plant that is remarkable for its many cost-saving features, employs ordinary enameled bathtubs as cooking vessels, in which certain foods are given their preliminary heating. In this way the purchase of several expensive pieces of equipment has been avoided.

The tubs are mounted on trucks so that they can easily be moved from place to place about the factory. In use, a tub is filled with the food to be processed, and is then placed where a steam pipe carrying live steam, can be dropped into it. After the preliminary cooking is finished the truck is wheeled to the point where the cans are filled. An advantage of this method is that the tubs are easily cleaned and sterilized, and, besides, no discoloration is imparted to products heated in them. Furthermore, as they can be moved, they are more convenient than the ordinary stationary kettles. The tubs are also used for mixing sirups, and even brine.—Orin Crooker, Wheaton, Ill.

### Carbon-Removing Tool

Many uses can be found for discarded hacksaw blades fitted in a holder similar to the one shown in the illustration. The method of construction makes this tool particularly handy for breaking up the carbon that accumulates in automobile piston-ring grooves, as any number of blades necessary to fit in the grooves can be used while the others are folded back into the holder. The latter is made of  $\frac{1}{16}$ -in. sheet steel, bent over as shown, and drilled near the end—the same size as the holes in the blades—to take the screw and nut that hold the blades in place. Blades broken in the center are long enough for the purpose. The set of blades should be ground down on the end to make them all of the same length, which gives a better appearance to the tool and makes it more handy to use.

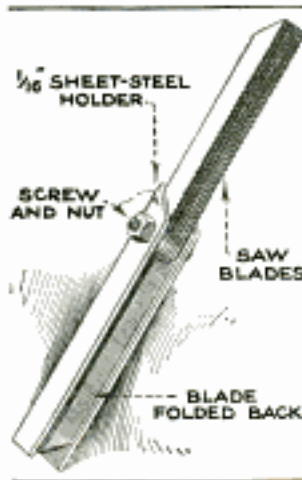

### Draining Oil Trucks

Large factories using oil for fuel usually have an underground concrete storage

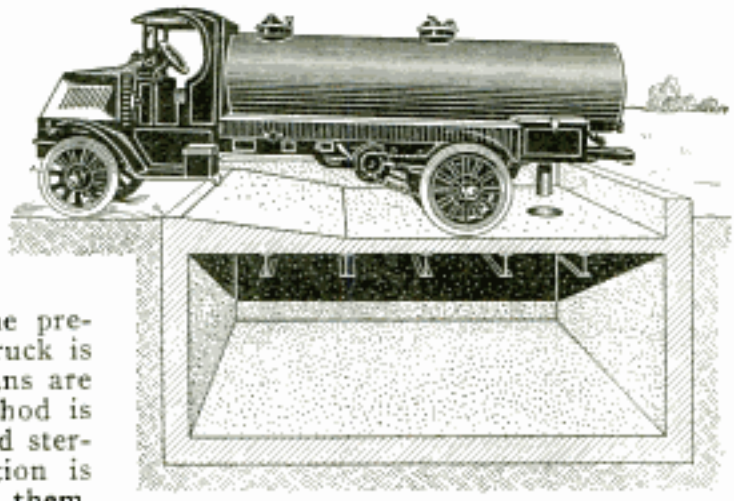

Trucks Unloading Oil or Gasoline by Gravity can be Drained Entirely If the Tank Top is Formed So That the Truck Inclines toward the Rear

tank to conform to the requirements of fire-insurance companies. These storage tanks are filled from large oil trucks that drive over the top of the tank and discharge the oil by gravity. Difficulty has been found in completely draining the oil trucks, owing to the fact that the tank on the truck has a slight pitch forward.

The illustration shows a very practical method of draining the trucks. The top of the tank is formed, as shown, with an 8-in. drop, and a ramp to enable the trucks to be driven on and off easily. When the truck is in position over the tank, the rear wheels are thus 8 in. below the front wheels, which allows all the oil to drain out of the tank. The truck will stand in position without the use of the brakes.—G. L. Munroe, Fall River, Mass.

### Making Tight Joints with Undersize Threads

When laying some 6-in. water pipe in a small town, all the pipes having been cut at the shop, it was found that the threads on two of the pipes had been cut so small that the pipe could be screwed into the fitting up to the last thread, with the result that the joints were not water-tight. To make them fit properly, the threads were first thoroughly cleaned, then tinned with solder, using a paste flux and wiping the surplus solder off with a cloth. The joints were then screwed up, and found to be perfectly water-tight.

### Cheap and Serviceable Water Cooler

The water cooler shown in the illustration will be found serviceable in shops and factories where a large supply of cool

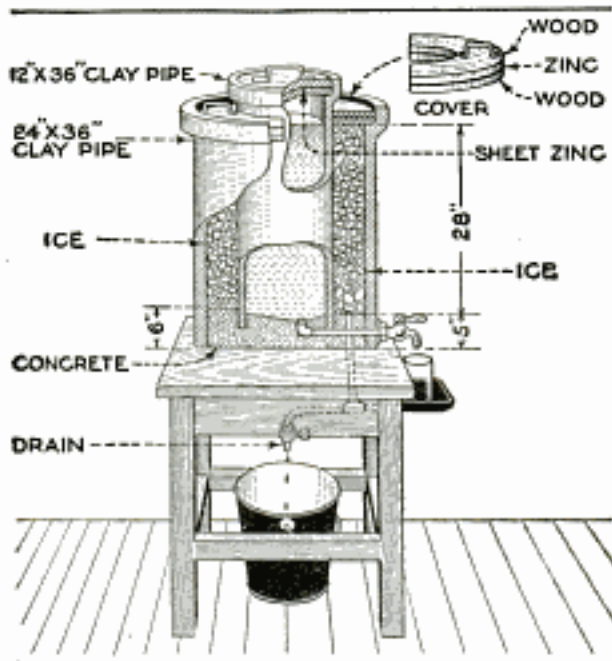

A Cheap and Serviceable Water Cooler for Use Where a Large Quantity of Drinking Water is Required

drinking water is required. It consists of two sections of vitrified-clay pipe; one section is 24 by 36 in., and the other 12 by 36 in. in dimensions. A cement base is made by setting the larger pipe on a flat surface, and pouring cement into it, then pressing the smaller pipe into the concrete as shown. The surface of the base between the pipes is slanted to the drain pipe, and the surface inside the smaller pipe is sloped to an outlet pipe, which, together with the drain pipe, is placed in position before the concrete is poured. The outlet pipe is provided with a faucet on the outside. As it is rather difficult to drill the hole through the outside clay pipe, this should be done at the yard where it is purchased.

The whole can be conveniently mounted on a sturdy wooden table or bench, and a drip pail provided underneath. Double-thickness wooden covers, with a piece of sheet zinc between the layers, are provided on both pipes as shown, that for the outer pipe being made in two sections. The space in the smaller pipe is used for the water, its capacity being about 13 gallons, and the space between the two pipes is packed with crushed ice. The entire cost of the water cooler is approximately \$9.—Louis Davis, Nashville, Tennessee.

### A Self-Closing Oil Container

In a shop that builds small meters, all shafts, before assembling, are inspected by being revolved by hand on bench centers, the centers being touched, before the shaft is mounted between them, by a fine wire carrying a drop of light oil. It is essential that the oil be kept perfectly clean, as a speck of dirt on either center might result in a false test, so the automatically closing oil container shown in the drawing is used.

The container is made of wood and brass tubing; the wood is used for the base and the two uprights, and the tubing for the oil container and cover. Before fastening the uprights to the base, a slot, about  $\frac{3}{8}$  in. wide and 2 in. long, is cut in the tube that is to hold the oil, and the ends of the tube are serrated, or "nicked" with a file, so that the tube will not turn in the upright. Leather washers are fitted tightly into the ends of the tube, and the ends pressed into the uprights. The cover is also made of brass tubing, and slips over the first piece. It is cut a little shorter than the first piece, for clearance, sawed lengthwise, and one edge of the cut bent outward. To one end of this edge is fastened a wire spring, as indicated; the curved edge also serves as a handle.

The photograph shows the container closed, and the other illustrations show the details of construction. When the operator desires to dip the wire in the oil, he turns the cover around until the open-

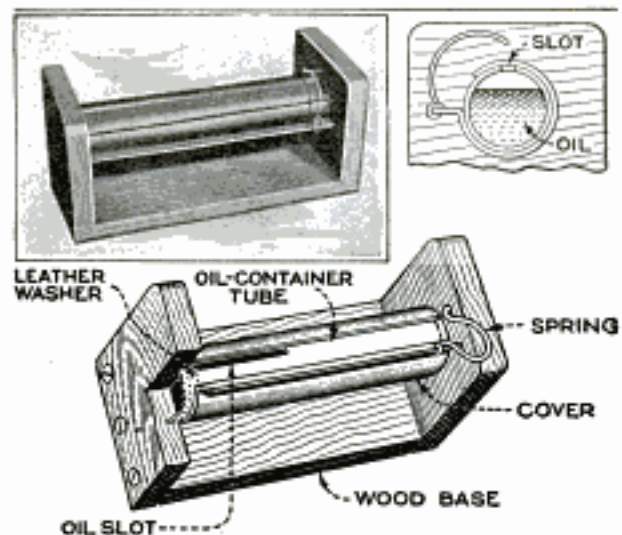

A Self-Closing Oil Container: Upper Left, the Container Closed; Right and Center, Details of Construction

ing is uncovered. As soon as the cover is released, it is snapped back to the closed position by the wire spring.—Harry Moore, Montreal, Can.

### An Upright Tool Cabinet

The tool cabinet shown in the illustration is made almost entirely of 1 by 12-in. finished lumber. It is divided into two parts: the cabinet proper and a drawer section. The cabinet section provides space for the larger tools, and the drawers contain nails, screws, small tools, and miscellaneous material.

Tools such as chisels, screwdrivers, pliers, etc., are conveniently supported on the wall of the upper section by means of strips of leather, attached to the wall with small round-head screws. Hammers and similar tools are held in place by long screws partly driven into the wood, while saws are slipped into the slotted shelf shown in the compartment at the left. Tools are also hung on the inside of the doors. A few shelves, arranged near the bottom of the larger compartment, provide space for small boxes of tools, such as taps and dies; or for books and catalogs relating to tools.

The drawers in the lower section may

be subdivided in any suitable manner, and one or both of the drawers provided with sliding trays for holding screws or nails of various sizes. All the major dimensions of the cabinet are given in the draw-

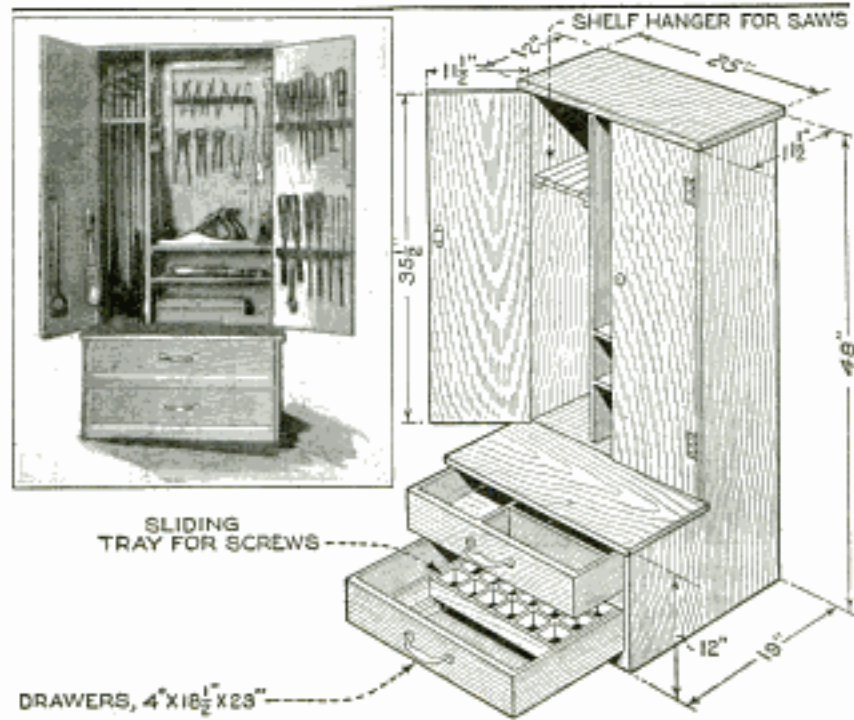

An Upright Tool Cabinet of Excellent Design: Left, Photo of Cabinet, Showing Arrangement of Tools; Right, Perspective Drawing, Showing All Important Dimensions

ing, and the construction is quite obvious. The details may, however, vary to suit the builder of the cabinet.—C. N. Schuette, San Francisco, Calif.

### Reboring a Turret-Lathe Bed

The drawing shows a simple method of reboring a turret-lathe bed, when it is not convenient to move the part to a machine shop for reboring. An angle plate, with a hole drilled through one side, is used as one bearing for the boring bar, and is clamped to the lathe bed as indicated.

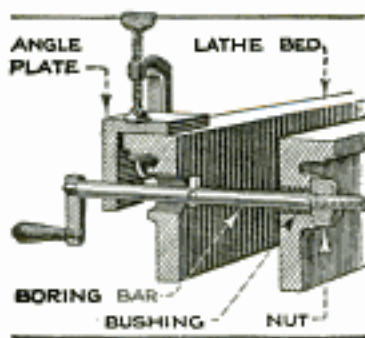

A bushing in the hole in the opposite side of the lathe bed serves as the other bearing. The bar itself has a fine thread on one end, and a nut is used to feed it.

### Cutting a Belt for Cone Pulleys

When cutting a belt to length for cone pulleys, the "cut-and-try" method occasionally gives good results, but more often does not. The following method, however, always gives correct results: Place the belt on the pulleys as shown in the drawing at the left; stretch the belt; mark and cut it, and make the joint in the customary way.

When the joint has been made, place the belt on the proper steps, as shown on the right. This method also saves time.

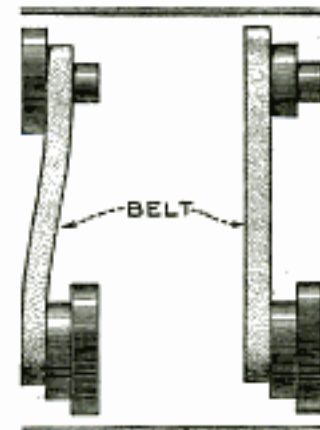

## Marking Wooden Boxes

The methods described in this article were used, with satisfactory results, for marking a large number of fruit boxes and trays with the owner's name and address, and will prove equally useful wherever quantities of wood surfaces are

letters should stand up from the surface from  $\frac{3}{32}$  to  $\frac{1}{8}$  in., the outlines should be as sharp and clean as possible, and, of course, the letters must be cut reversed, as shown in the drawing. If more than one line of lettering is required, it is best to make separate dies for each line, as it may be desirable, at times, to use but one

line—the owner's name, for instance.

The die should have a boss cast on the back, to be drilled and tapped for a handle, if the die is to be used for burning. A casting can be obtained at any brass foundry; if the pattern is supplied to the foundry, the dies should cost about \$1 each. Bronze is better than brass, as a rule, especially for a burning die; either of the two is preferable to cast iron, as a smoother casting is obtained, and one that is easily touched up with file and chisel. If a good casting is obtained, all that is necessary is to smooth up the faces and edges with a file, taking care to keep the surfaces true.

To use as a burning die, a long  $\frac{3}{8}$ -in. steel-rod handle is screwed into the boss, and fastened by a locknut. A sliding handle, made from a piece of pipe, is then slipped on, and a wooden cross handle fastened on the end by means of nuts and washers, as shown in Fig. 4. The die is heated nearly red-hot, in any convenient manner, pressed firmly on the surface to be marked, and removed as soon as the lettering is burned deeply enough.

If a large vise is at hand, a better job can be done by coating the faces of the letters with paint, and pressing the die into the wood, between the vise jaws. A large vise will take a single line of letters, but a double line, or a single line used in a smaller vise, demands the use of shoes or pads to take the pressure.

Two heavy iron or steel plates may be used, with the dies pinned to one of them, but a better method is to make a pattern and have two shoes, as shown in Fig. 2, made of cast iron. No machine work will be required on the shoes; if

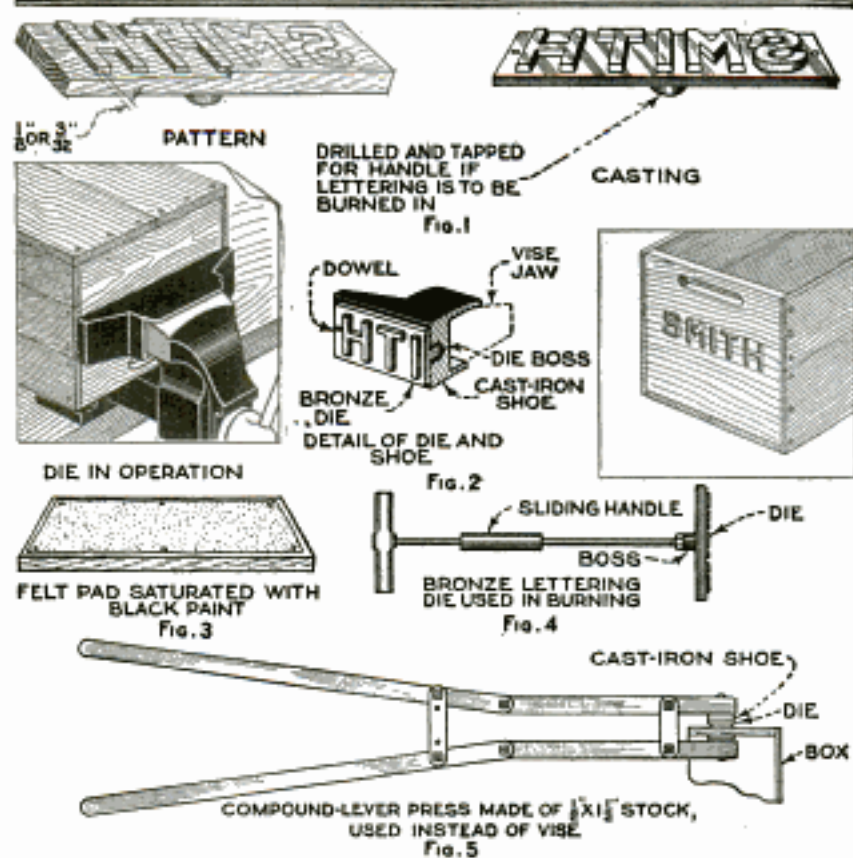

Figure 1, Method of Making Pattern for Die; Figure 2, Shoe for Holding Die in Vise, and Die in Use; Figure 3, Pad for Applying Paint; Figure 4, Die for Burning In Lettering; Figure 5, Press for Heavy Work

to be marked or lettered permanently. At first, a bronze burning die was used, and while the results were fairly satisfactory, depressed blackened lettering, formed with the same die under pressure, was found to be neater and could be made more quickly. For rough work, the burned lettering answers very well, and this method has the advantage of requiring no vise or press, and of ease of application, as the hot die can be applied while the surface is in any position.

For either method, the first operation is the making of the pattern for the die; this requires nothing more than skill with a pocketknife, although a set of small chisels or regular woodcarving tools will expedite matters. The letters should be made at least  $\frac{3}{4}$  in. high, and be as plain as possible, as this will help in producing a good casting. The wood used is cherry or mahogany, about  $\frac{1}{2}$  in. thick, and the



the die extends beyond the vise jaws, the shoes should extend the full length, as shown, and have lugs at top and bottom, to fit over the vise jaws. Holes drilled in the face of one shoe will accommodate the bosses on the dies, and dies and shoe should be drilled, and dowels fitted, to hold the dies in position. One shoe can be drilled for two dies, and the other for one, in case it is desirable, at some time, to use but one die.

A felt pad, tacked to a board, as shown in Fig. 3, is saturated with black paint, and applied to the die, being careful to get just enough paint on the die to cover

the letter surfaces. The box is then placed in position, and the vise closed; considerable pressure must be applied, and the die should be sunk into the wood about  $\frac{1}{16}$  in.; of course, this applies to soft wood, as so deep an impression cannot be made in hardwood.

Sometimes the use of a compound-lever press is preferable to using the vise, and Fig. 5 shows clearly how such a press may be made from  $\frac{1}{2}$  by  $1\frac{1}{2}$ -in. cold-rolled steel. The dies and shoes are used as before; by pressing the handles together, the die will be forced into the wood.

### Stand for Welding Hose

In most shops the welding hose is allowed to drag on the floor when the torch is in use. This not only wears the hose rapidly, but, where much cutting is done, the hose is constantly being burnt. To eliminate this trouble, one shop uses the hose stand shown in the illustration.

It consists of a  $\frac{3}{4}$ -in. pipe, 4 ft. long, threaded on both ends, one end being fitted with a reducing coupling, and the other with a tee. A  $\frac{3}{8}$  to  $\frac{1}{2}$ -in. coupling is used, a hole being drilled through the  $\frac{1}{2}$ -in. end and tapped for a thumb-screw. Short nipples are screwed into the run of the tee, and this end of the

fixture is anchored in a circular concrete base, a barrel hoop being used as a form. A length of  $\frac{3}{8}$ -in. iron rod is bent to the shape shown, and the straight end inserted into the coupling, where it can be locked at any desired height by

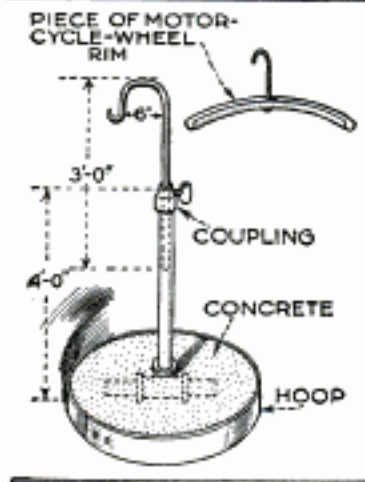

means of the thumbscrew. The hose hanger consists of part of an old motor-cycle rim, fitted with a hook, and a spring clip to keep the hose in place. In use, the standard is moved close to the work, and the part of the hose not in use is coiled on the hanger and clipped. This fixture not only saves the hose, but, if the hose is adjusted on the hanger properly, helps to balance the heavier torches.

### Novel Transom Control

The writer recently saw, in an old mill, an odd homemade control arrangement

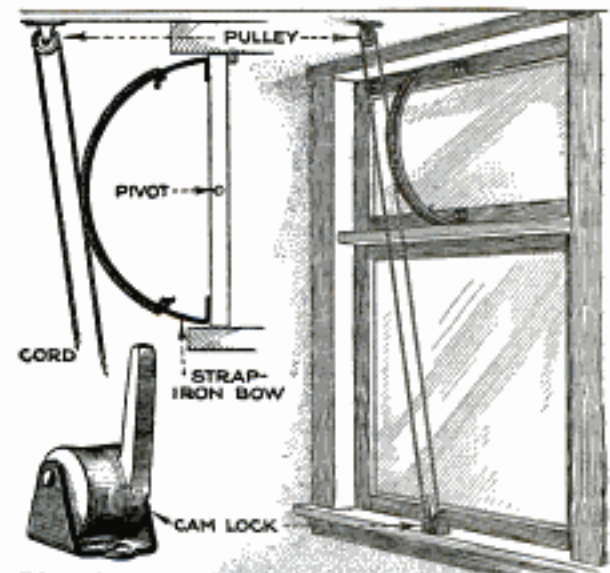

A Homemade Transom Control That Is of Considerable Usefulness, Where a Quick and Secure Adjustment Is Desirable

with which window transoms could be adjusted quickly and held securely.

The transom is pivoted at its center, and a length of strap iron, bent to the shape of a bow, is attached to the frame as indicated. Holes are drilled near the ends of the bow to permit a length of sash cord to be attached to it by passing the ends through the holes, and knotting them. The sash cord passes from one end of the bow over a V-pulley screwed into the ceiling, then through a cam lock attached to the lower window sill, and back again to the other end of the bow. The purpose of the cam is to hold the transom securely in any desired position. The operation of the device is apparent from the drawing.—W. Burr Bennett, Scranton, Pa.

### Wire-Gate Tightener

The device illustrated, which is used to tighten wire-fence gates, is of considerable utility, as it can be tightened or

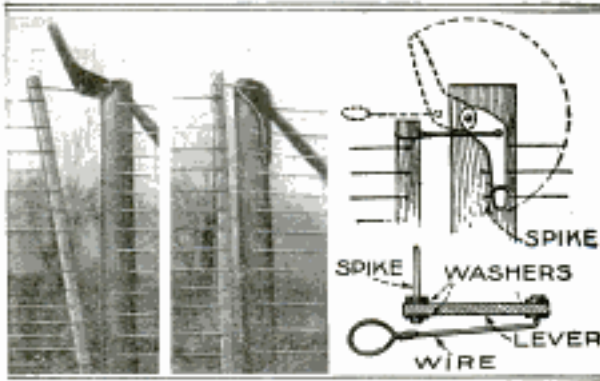

A Convenient Wire-Gate Tightener: Left, Photos Showing Device in Use; Right, Details of Construction and Assembly

loosened in a moment, and eliminates entirely the unsightly sagging of the gate.

A loop of wire or iron rod, fastened to the gatepost, and into which the end pole of the gate is set, is used at the bottom, as no trouble is experienced in keeping the gate tight here. The tightener is attached to the top of the gatepost; it consists of a thick hardwood cam or lever, cut to the shape shown, and fastened loosely to the post with a large spike so that it can swing freely, a washer being slipped on the spike on either side of the lever. A heavy-wire or iron-rod loop is attached to the lever, as shown, so that the wire will be drawn back a few inches when the lever is swung around and locked. A spike should be driven into the post at the point indicated, and bent so as to hold the lever in the closed position. On long gates, it is sometimes advisable to use a tightener at both top and bottom, but on smaller gates the one at the top is usually sufficient. To tighten the gate, put the gate pole in the lower loop, then, with the lever in the position shown by the dotted lines, slip the upper loop over the top of the pole, and draw the lever back.—Jonas Byberg, Silverton, Oregon.

### A Lathe Kink

It is usually found convenient to keep the compound rest of a lathe set at an angle of 30° to the cross slide. In reducing the length of a piece being turned, advantage may be taken of this practice, as it affords a simple means of accurately gauging the cut. At the 30° setting, feeding in the compound rest a certain dis-

tance gives the tool a lengthwise movement of exactly half that amount. For instance, if the work is found to be .007 in. too long, lock the carriage, bring the tool up against the end of the work with the compound rest, withdraw the cross slide, set the compound rest in .014 in., and the tool is in position to face the work to exact length.—J. Rouse, San Francisco, Calif.

### Hinge Stops for Casement Windows

Casement windows sometimes fold back against lighting fixtures, with the result that the window panes or fixture globes may accidentally be broken. To avoid this, a simple and inconspicuous hinge stop can be provided, consisting merely of a small machine screw, tapped into the hinge as shown.

Open the sash as far as possible, and make a scratch on each hinge, at the point where

the half of the hinge on the sash comes over that on the jamb. Close the sash, and make a prick-punch mark in the center of the middle portion of the hinge,  $\frac{3}{32}$  in. outside of the scratch.

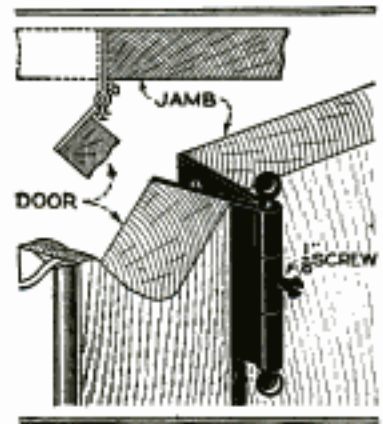

Drill and tap for a  $\frac{1}{8}$ -in. machine screw, and cut the screw to such a length that the head will project about  $\frac{1}{4}$  in. If something more ornamental is desired, special screws with fancy heads may be used.

### Emergency Thumbtacks

Emergency thumbtacks can readily be made from small pieces of thin sheet brass, slit on the edge and bent at right angles, as indicated. An old pair of ordinary paper shears can be used for cutting the slit. The cut is made at a slight angle from the edge to



make a sharp and thin point that can easily be pushed into the wood.—Ben Frantzreb, Indianapolis, Ind.



Information as to where to obtain any specified materials or parts for making objects described in the following pages may be had, on request, from our Bureau of Information.—Editor.

## How to Build Attic Aerials

BY F. L. BRITTIN

**A**TTIC aerials are easy to construct, and when properly made, the results obtained with them are nearly as good as those obtained with outdoor aerials. Attic aerials should not be confused with loop aerials, as they have no directional effects. They also have an advantage over outdoor aerials in that they do not need a lightning switch.

The end-to-end type of this aerial con-

instrument through a length of flexible loom.

In attics where less space is available, such as those with hip roofs, the aerial can be strung along the rafters, as shown in the upper right-hand drawing. One length of No. 14 wire, 150 to 200 ft. long, is strung in four parallel rows as indicated, the wire being attached to the rafters by means of round porcelain in-

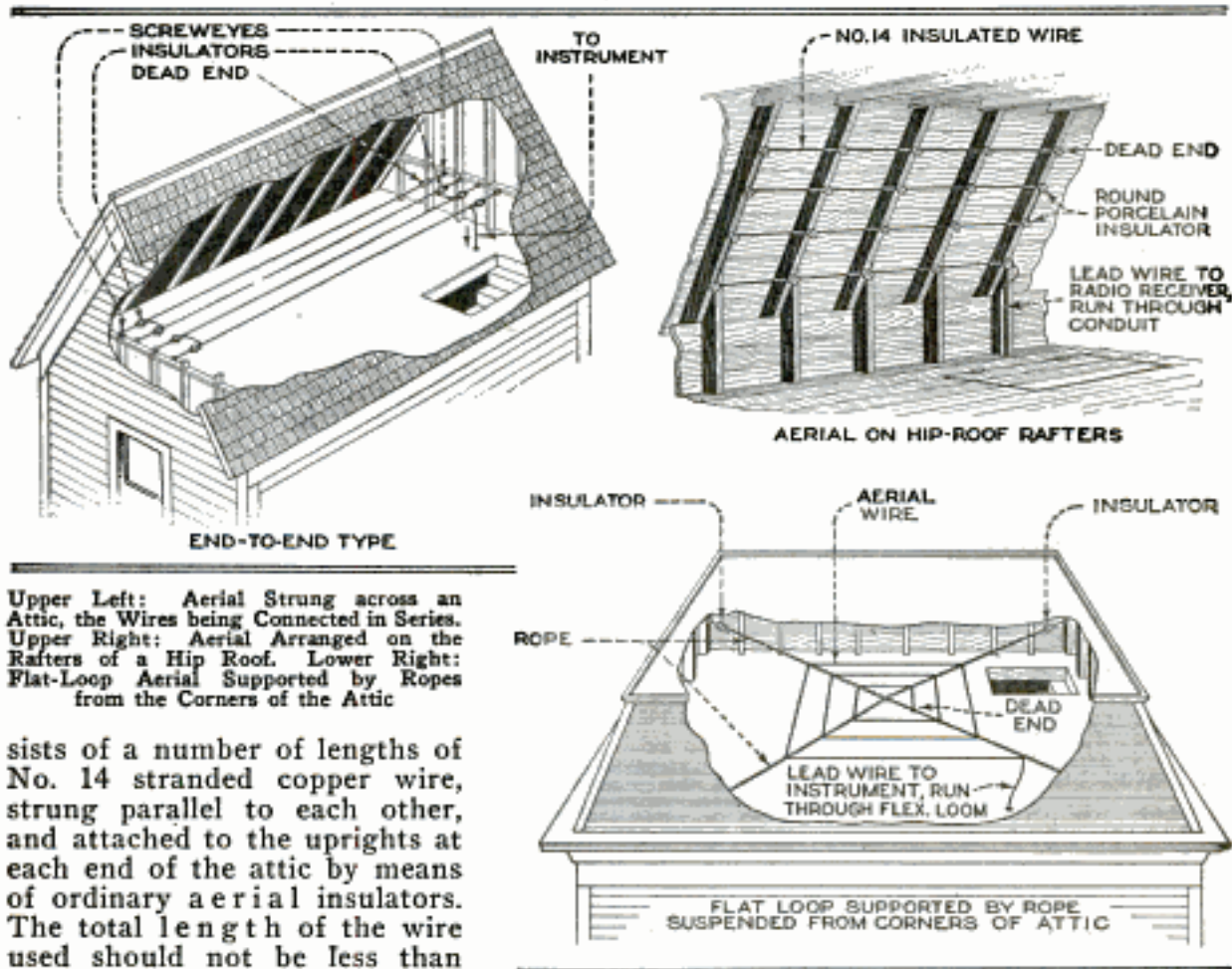

Upper Left: Aerial Strung across an Attic, the Wires being Connected in Series. Upper Right: Aerial Arranged on the Rafters of a Hip Roof. Lower Right: Flat-Loop Aerial Supported by Ropes from the Corners of the Attic

sists of a number of lengths of No. 14 stranded copper wire, strung parallel to each other, and attached to the uprights at each end of the attic by means of ordinary aerial insulators. The total length of the wire used should not be less than 150, nor more than 200 ft., and the wires should be spaced about  $1\frac{1}{2}$  ft. apart. One end is left dead; the wires are then connected in series, as shown, and the other end is soldered to the lead-in wire, which is brought down to the

insulators, which can be purchased at any electrical-supply store. One end is left dead, and the other is connected to the lead-in wire, as before.

The flat-loop aerial, shown in the lower

drawing, is designed for small attics. Two lengths of rope are strung across the attic from corner to corner, and are tied together at the point where they cross. The aerial wire is attached to the ropes, as shown in the drawing, being tied firmly at every point where it touches the ropes. The inner end is the dead one, and the outer end is connected to the lead-in wire. The turns should be spaced about 1 ft. apart.

In apartments where there are no attics, an inside aerial that gives good results with a tube set can readily be made by running several turns of annunciator wire behind the picture molding, leaving one end of the wire dead, and bringing the other down to the receiving set.

With such an aerial the writer has received stations 1,000 miles distant, using a two-step spider-coil receiving set, made as described in the February issue of this magazine.

To obtain the best results with any receiving set, just as much pains must be taken to secure a good ground as to construct the aerial. Number 14 wire should be used, and one end soldered to a water or radiator pipe. A clamp can also be used, the pipe, of course, being scraped where the clamp is attached. Gas pipes are not so good for grounding purposes, as they are often insulated from the ground by the meter. However, this can be remedied by shunting a wire around the latter.

### Built-In Poultry Feeders

Poultry feeders of the type shown in the illustration, built against the wall between two frame uprights, have been

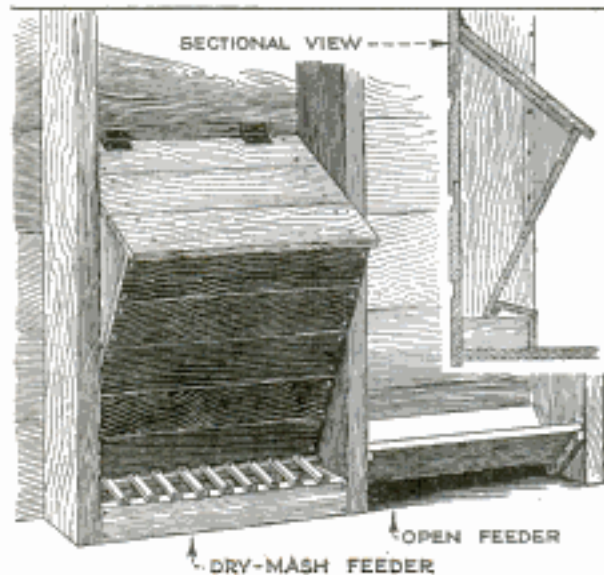

Feed Boxes Built against the Wall between the Uprights in a Poultry House Save Floor Space

found very convenient, and save considerable floor space. A dry-mash feeder is illustrated on the left, and shown in section at the right. The front side is slanted, to allow the feed to slide down freely, and the top is also built at an angle, to prevent the fowls from perching on it. Small strips of wood are nailed over the lower end, or mouth, of the feeder, as indicated, so that the feed cannot be scratched out. Open feeders, of the V-shaped type shown at the right, are also used. These are fastened to cleats nailed to the uprights.—Harry R. Shiffer, Brownstown, Pa.

### Using Stale Photograph Paper

Stale developing paper will give foggy, gray images in ordinary developing solutions. By exposing three times longer in printing, and using about four times as much bromide of potassium in the developer, the prints may be made clear and "contrasty." The exact amount of bromide to be used is easily ascertained by experiment.

### Increasing Capacity of Scales

The standard family scale usually has a weighing capacity of 25 lb., but it often happens that heavier articles must be weighed. To increase the capacity of such a scale, a coil spring may be placed on the stem of the platform, as indicated in the drawing. The coil spring should be made of No. 12 or 14 steel or brass spring wire, and can be wound so as to increase the capacity of the scale several times.

When the spring is in place, a body of known weight is placed on the platform, and the scale indication noted. The actual weight, divided by that indicated, gives a factor that is used to multiply the scale readings shown when weighing other articles. For example: if, as shown in the drawing, a 10-lb. weight is placed on the platform,

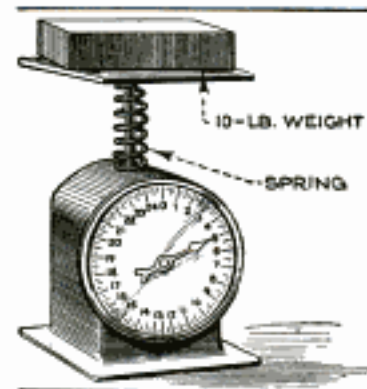

and the scale reading is 5, for all articles weighed subsequently the scale reading is multiplied by 2, to obtain the correct weight.

The results obtained with this method, while not absolutely correct, are close enough for practical purposes.—E. W. Kemp, Lexington, Ky.

### Counterweight Holds Lid Open

A counterweight, attached to the lid of a chest or bin, as shown, holds the lid either open or closed, and eliminates the need of a catch. Any heavy piece of metal can be used; it is screwed or bolted to the back edge of the lid so it will not overbalance the lid when closed, but exert sufficient force to draw the lid straight up when the latter is raised halfway. If desired, the weight

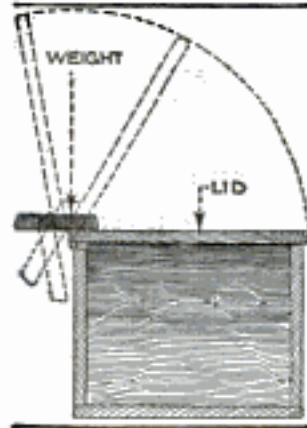

may also be adjusted to hold the lid in an intermediate position.—H. F. Grinstead, Columbus, Mo.

### Why Aster Seedlings Die

Florists are sometimes perplexed concerning the cause of asters wilting and turning black at the stem, near the ground, which usually happens just at the time when the flower is beginning to bud. As a general rule, more trouble of this kind is experienced with plants grown in a greenhouse than with those grown outdoors.

The grower usually attributes the loss to some kind of stalk borer, aphid, or fungus. The real cause is, however, excessive rainfall or heavy watering, which causes much trouble, especially among asters planted in rich soil. Low land, on which water has a tendency to remain long after heavy rains, is a very poor place for seedlings, although it is ideal in dry weather. The same indications of stem rot are found among asters allowed to remain too long in the greenhouse, and also among those that have slender stems, because they have been planted too thickly, and therefore have to be partly buried in soil to steady them.—A. C. Cole, Chicago, Ill.

### Shallow-Water Rod Anchor

The hunter, fisherman, or trapper who uses a light, flat-bottomed boat can im-

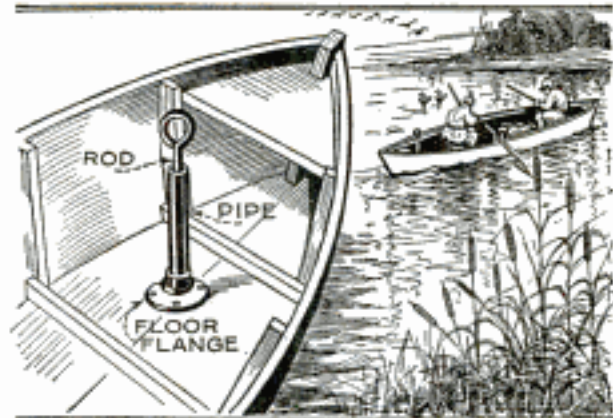

Handy Anchor for the Flat-Bottomed Fishing Boat: The Rod is Pushed into the River Bottom

prove his craft considerably by fitting it with an anchor of the type illustrated. It consists of a cast-iron floor flange and a short length of 1-in. pipe to fit, the flange being screwed securely over a 1-in. hole cut in the floor. The top end of the pipe must be above the water line of the boat. The remainder of the equipment consists of a  $\frac{5}{8}$ -in. iron rod with a ring formed at one end. This rod is dropped into the pipe and pushed into the bottom of the stream or lake. If desired, an anchor of this kind may be installed in each end of the boat, to insure stability.

### Gasoline Flatiron Used as Camp Stove

A convenient camp stove can readily be made from a gasoline flatiron. The handle is removed and two flat-iron legs are substituted for it, so that the flatiron may be inverted, the bottom serving as the top of the stove. The fuel tank is turned to the position shown, care being taken that the feed pipe is not twisted off while turning. A support of flat iron is provided to brace the fuel tank, and is attached to the iron by the screws that hold the nearest leg. The fuel is lighted in the usual way.

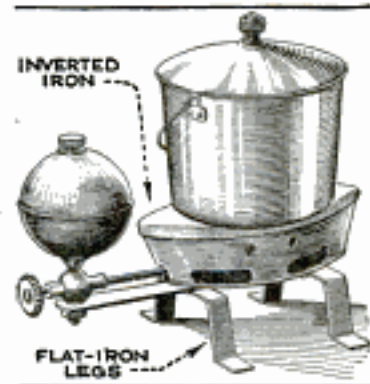

### Bottle Window for Log Henhouse

A northern farmer who did not have much time to spare or cash to spend, when erecting a log henhouse, used empty bottles instead of regular windows. Ordinary round bottles were used, as they

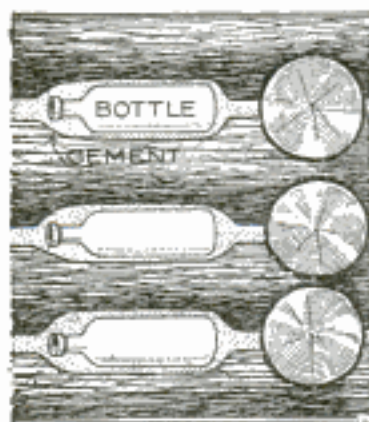

are stronger than flat ones. Notches were cut in adjacent logs with an adz, and the bottles fitted and cemented in place, care being taken to keep the glass clean. Owing to the small diameter of the bottle in comparison with that of the logs, it was necessary to bevel the notches deeply on the inside, to admit as much light as possible. Any number of these bottles can be arranged in a log wall without weakening it. The bottles admit as much light as ordinary windows, and prevent drafts. They have the additional advantage of keeping the henhouse warmer than ordinary windows during cold weather, as the dead-air space in each bottle prevents, to a great extent, the dissipation of the heat inside.—H. Webster, Spear Hill, Man.

### Oiling Washing-Machine Motors

Many small electric motors, used on washing machines, are made with dust-proof bearings, the oil hole in the top of each bearing

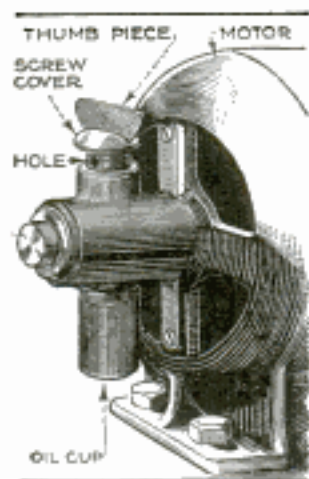

being fitted with a hollow screw cover that is set with a screwdriver. In cramped quarters this cap is very unhandy, as a very short screwdriver must be used to turn it, and for this reason refilling is often neglected. The simple improvement illustrated will help considerably to remove this trouble. A small piece of sheet brass is soldered in

the slot of the screw cap, as shown, thus making a thumbnut out of the screw cap. A hole, just large enough to receive the end of the oilcan spout, is drilled through the threaded side of the cap. With this improvement no screwdriver is needed, nor need the cap be removed entirely to oil the bearing.

### Keeping Out the Rain

The drawing shows a good method of keeping rain out of the open window of a sleeping room, where it is essential to

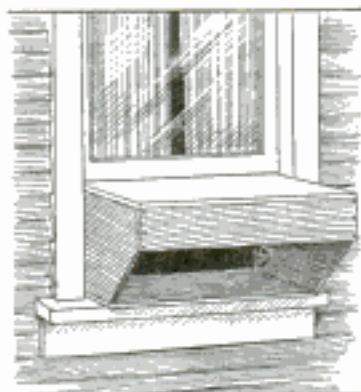

have fresh air at all times, even during rainy weather. A wooden box is made to fit between the window jambs and rest on the sill. It is held in place by means of thumb-screws on the sides, and also by the weight of the window on top. The opening is made on the underside of the box, so that rain cannot enter.—H. A. Palmer, Toledo, Ohio.

### Lazy-Tongs Row Marker

The garden-row marker shown in the illustration is of special convenience as it can be adjusted to any desired spacing.

The center "diamond" of the tongs is pivoted to the end of the handle, and a bolt on the opposite corner of the diamond fits in a slot cut in the handle, as indicated; a wingnut being fitted on

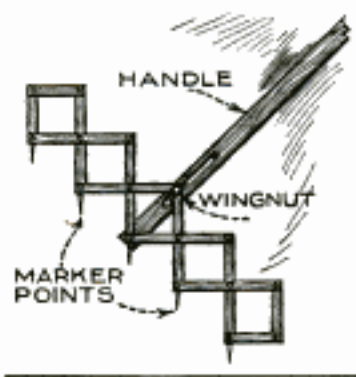

the bolt to clamp it at any point in the slot. Heavy nails, driven through the lower strips, at the points of the diamonds, are used as markers;  $\frac{3}{8}$  by 1-in. strips are used for the lazy tongs, and are fastened together by snug-fitting rivets and washers.

## BUILDING A CAMP CAR

By Ray F. Kuns

PRINCIPAL, AUTOMOTIVE TRADE SCHOOL,  
CINCINNATI, OHIO

### Part I

#### Chassis and Body Construction

**T**HE Camp Car, or land cruiser, described in this article was evolved after a number of years' experience in summer touring, and is the fruit of much thought and preliminary investigation.

Many plans were made, designs drawn up, checked over thoroughly, and then discarded, and much experimenting was done before the car was finally built; the car has, since being constructed, been driven over 5,000 miles, and has given every satisfaction.

Some of the considerations involved in the construction of a car of this type are the following: It must be of lightweight construction; everything must be contained under one roof—that is, there must be no sections extending beyond the protection of the roof, whether traveling or in camp; it must allow the driver good vision in every direction; it must afford comfort to all passengers when riding, and good beds when camping; it must have provision for carrying a supply of safe drinking water, and for the preparation of meals; it should have an ice box, and as many cupboards and lockers as possible. These provisions are only necessities, and were not at all hard to embody in the final design.

In designing the car, the body width was determined by the space necessary for the berths and seats, as it was desired, when carrying four passengers, that the seats should afford each a good view.

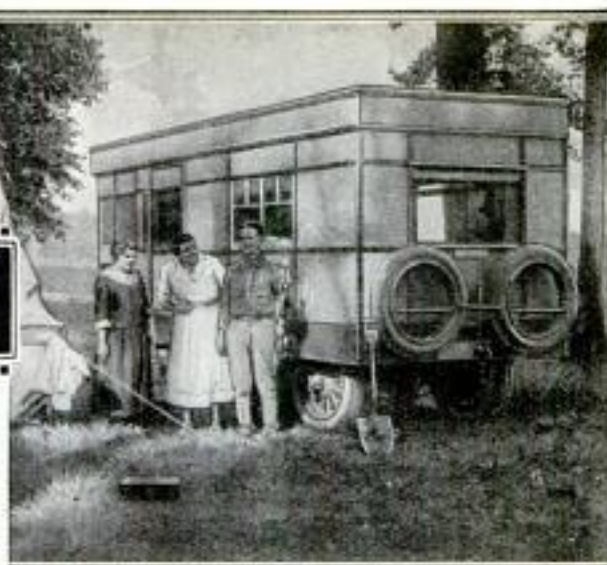

The seats were accordingly to be individual, and were located in the car as shown in the floor plan; they are held in this position by cleats, but may be removed and used in any part of the car, as desired.

The length was the next consideration. After some figuring, it was decided to allow the body to overhang the rear axle by 5 ft., and the body was so built; after one season's use, however, the wheelbase was lengthened, and the overhang reduced to 3 ft. It was found possible to

make the floor 12 ft. long. The headroom was determined by the writer's height, and this left only one main dimension to be determined—the length of the "snout," or overhanging part of the roof, needed to house the berth that is swung over the hood in front of the steering wheel.

The bed or berth was made 4 ft. wide, so as to take a regular mattress, and this, then, fixed the amount of overhang.

The first tour taught much about chassis design and construction. The 5-ft. overhang was found to impose too much weight on the rear axle, and while this was all right as far as steering and traction for hard pulls were concerned, it did not make for a steady-riding car or tire economy. The original wheelbase was 123 in.; by moving the rear axle back

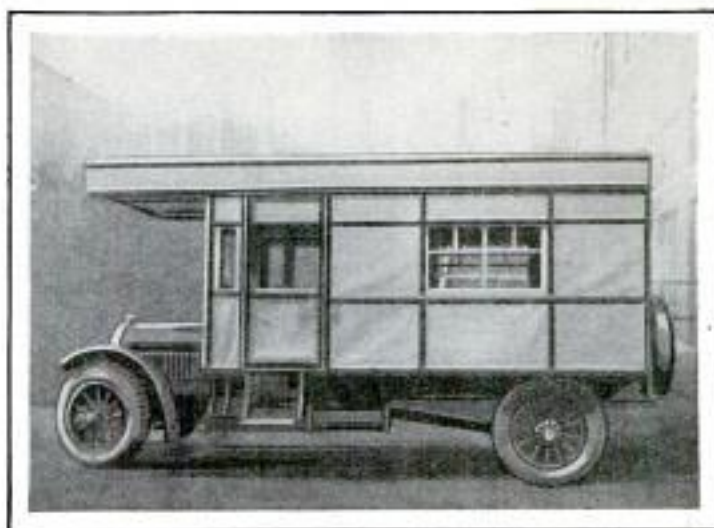

Side View of the Camp Car Ready for the Road: This Car has Given Excellent Service in Touring

24 in., a much better balance was obtained, and the body design was unaltered, except as to floor arrangement. The present wheelbase is 147 in., and the weight on each wheel, with full load, is about 1,500 pounds.

The first touring-car frame being too light, it was discarded, and two lengths of 4-in. channel iron were used instead. A short connecting length of the same-size channel was welded across the front, to form a bumper and brace the frame, and another length across the frame, to carry the front end of the torque arm. The remaining cross members are either 1½-in. pipe or sections cut from the old frame. The frame was made narrow enough to allow the springs to be mounted on the outside.

The front springs are 40 in. long, and are mounted under the frame in the usual manner; each has nine leaves, 2 in. wide. The rear springs are 56 in. long, and have fourteen 2-in. leaves each; the rear ends of the springs are fitted with sliding contacts instead of shackles.

The first season, the rear springs were underslung, with long shackles at the rear; this, however, allowed the springs to twist and the car to sway badly.

With the present construction there is no sideways, and riding comfort is all that can be desired. Four heavy snubbers are used to check rebound.

The rear axle was taken from a heavy touring car. It is of the full-floating type, having adjustable taper-roller bearings throughout. The gear ratio is 4½ to 1, but 5 to 1 would be better. The front axle is of the usual I-beam type, designed for touring-car service.

The 6-cylinder engine is of the standard L-head type, 3½-in. bore by 5-in. stroke, with a rating of 29½ hp. It is an engine designed for service in a passenger car weighing about 2,700 lb. The transmission is standard. The engine is powerful enough to keep the car moving even in very bad going, although, in hard pulls, the 5-to-1 gear ratio in the rear axle would help considerably.

The speed in high gear ranges from about 5 to over 45 miles per hour, although, of course, the average touring speed is around 30 miles.

The tires and rims are worthy of more consideration than they usually receive. Nothing less than a 4½-in. truck cord, or a 5-in. passenger-car cord tire, should be used for a car of this weight. The rims should be one of the several types that make contact with the felloe all the way around.

The foregoing information is given, not so much with the idea that others will assemble a special chassis, as the writer did, but rather that the main points of this design may be remembered when selecting a chassis. There are a number of fast, light trucks on the market, among which a suitable chassis may be found. If a touring-car chassis is used, it should

be one with a very rigid frame, an engine of the specifications outlined above, and good springs. A suitable chassis will be more commonly found among the higher-priced cars than among the low and medium-priced ones.

The chassis being ready, the framing of the body may proceed. The job will probably have to be modified to fit the chassis, but the dimensions given will be of material help,

and, in many cases, can be followed without change. When assembling, the road clearance must be watched; this should not be less than 10 or 12 in. If the body is to be framed on the chassis, it is well to set the latter in such a position that it will not be disturbed while work is in progress, and to block it level. If this is not done, every deflection of the springs, or change in tire pressure, will throw the job out of level, and result in delay.

The sills used for the frame are 2 by 4-in. oak, although any good hardwood will answer. The manner of attaching the sills to the frame will vary; in a touring-car chassis with a hump in it to run over the rear axle, the sills may be set on edge, in such a manner that the front ends rest on the top of the side members



Front View, Showing the Clear-Vision Windshield That Allows Each Passenger an Unobstructed View



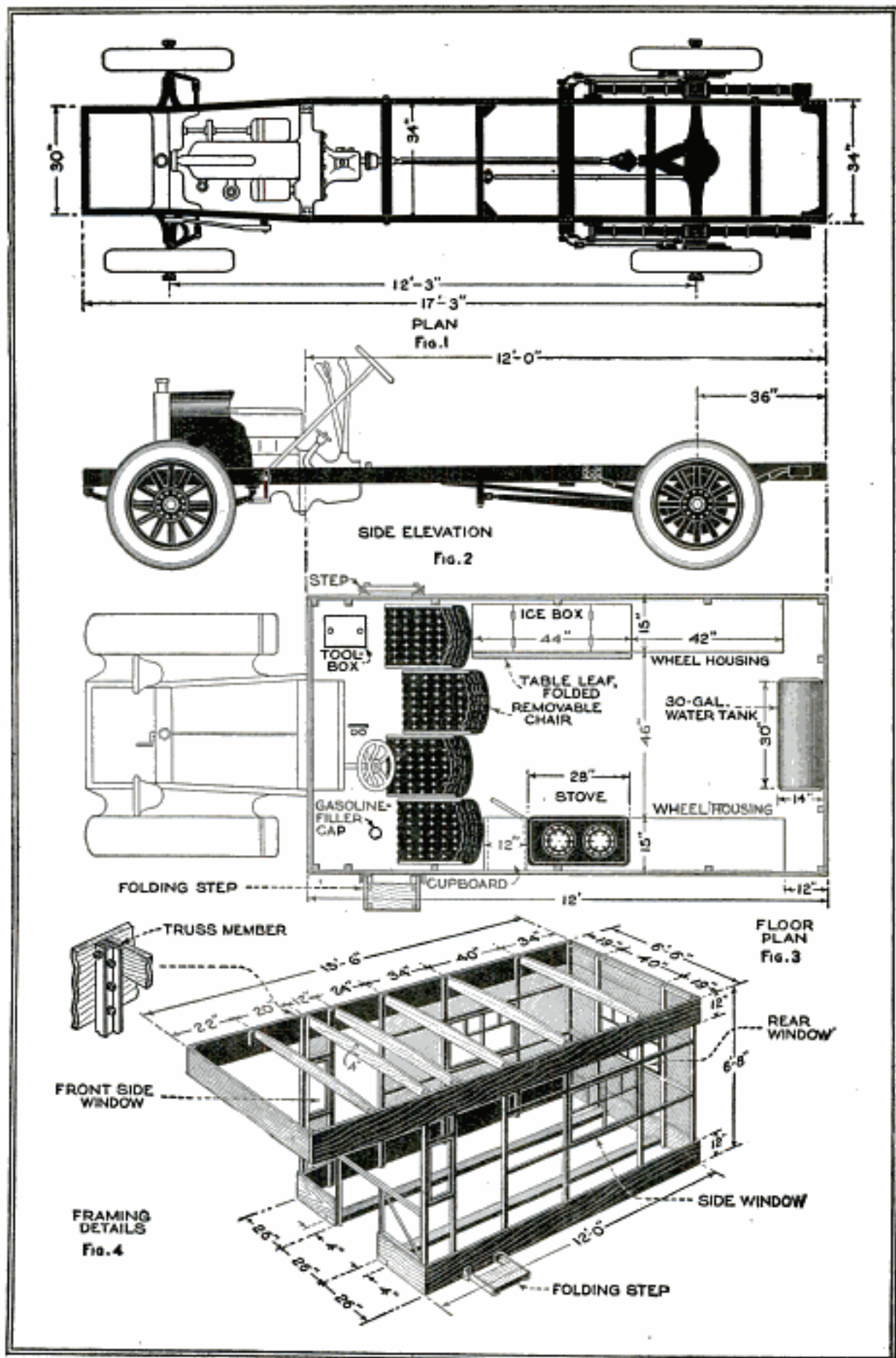

Figure 1, Plan, and Figure 2, Side Elevation of Assembled Chassis for Camp Car; Figure 3, Floor Plan, Showing Location of Chairs While Driving, Stove, Ice Box, and Other Equipment; Figure 4, Details of the Body Frame, Showing Window Frames in Place, and Connection of Front Posts and Rafter to Truss Member

of the frame. If the frame is straight on top, the sills may be laid flat, as shown in Fig. 4. Another method is to bolt the sills to the side of the frame. A point to keep in mind is that every inch that the sills project above the frame means an inch added to the height of the body, and this means much, not only in looks, but in sidesway, and in clearance under bridges, etc. In laying the sills, also, care must be taken to see that they will clear other parts of the car as they move up and down with the spring action.

Having bolted the sills to the frame as seems best, the floor, of No. 1 common pine, is laid. Two boards are cut to the necessary length, one being fastened to the front end of the sills, the other to the rear, at right angles, determining the four corners of the lower part of the body. The rear board may have the groove sides planed down, and the edge laid even with the ends of the sills, and must be squared carefully with the front board and sills before being nailed down. The flooring comes next.

Wherever possible, the floorboards are laid full length; that is, clear across the width of the body. There are no cross sills, for two reasons: They raise the floor from 2 to 4 in., and they tend to make the frame more rigid, and more subject to racking on rough roads.

The position of the engine, transmission, and wheels will determine the location of the parts that must be cut out of the floor. The old floorboards may be used, but it will usually be found necessary to use new lumber.

As cross sills are eliminated, other members must be used to take their place. The floor helps, but cannot be depended on to do the work alone. At the front, any wood sill or truss would prove too bulky and insecure. Accordingly, the truss member, Fig. 5, was evolved. This is made from  $1\frac{1}{4}$ -in. angle and T-iron. All joints are welded, and the rabbets formed are set to the front, in order that the windshield may have a proper seat when closed. The two short center posts are bolted to the front ends of the sills, and rest on a steel plate, fitted onto the top edges of the car frame. Two pieces of  $\frac{1}{4}$  by 1-in. steel are welded into the outer panels, as shown, for braces; these prevent sagging of the outer edges of the body. The space between the long posts is filled by the windshield, while traveling, and by the forward berth, while camping.

The side sills are pine or poplar, 2 by 2 in. in size, nailed under the edges of

the floorboards, when the latter are cut to length. Pieces of the same material are used to bind the edges of the floor cut-outs. The rear edge of the floor is strengthened with a 2 by 2, or 1 by 4-in. sill, depending on the method of attaching the main sills to the car frame.

Having the truss member erected and all edges of the floor bound and strengthened, the next step is to lay out the studs or posts.

The approximate position of the posts may be gathered from Figs. 3 and 4; good, sound oak or ash,  $1\frac{1}{2}$  in. square, is used for these. The posts are half-lapped, at the bottom, to the floor and 2-in. sills, and the joints fastened with screws, after coating the surfaces with white lead or paint, to prevent penetration of moisture. As the posts are set, they are plumbed, laths being used to brace them in position. The front posts are fastened to the truss angles with screws.

It will be noted, in Fig. 4, that there is a 12-in. board bolted to the bottom and top of the posts on each side. These are poplar, known as panel stock by lumber dealers; the bottom boards are  $\frac{3}{4}$  in. thick, and the top ones  $\frac{1}{2}$  in. thick. These boards take the place of heavy cross and longitudinal sills, and are fastened to the posts with  $\frac{5}{16}$ -in. bolts. This construction insures sufficient rigidity to prevent racking of the body, while permitting considerable twisting without damage; no corner or diagonal braces are used.

The rafters are of  $1\frac{3}{8}$ -in. oak or ash; they are 2 in. wide at the ends, and 4 in. at the center. If additional headroom is desired, they may be cut out to a curve on the underside, starting the curve at a point 16 in. from each end, and making the height of the chord  $1\frac{1}{2}$  in.; that is, the width at the center would be  $2\frac{1}{2}$  in. A rafter is set at each post, which results in uneven spacing, but is best for strength. One  $\frac{5}{16}$ -in. bolt is used to fasten the rafter, at each end, to the posts, which are notched  $\frac{3}{8}$  in. to take the ends of the rafters. In the overhanging end of the top, short posts are fastened, to support the rafters.

Short pieces of the post material are used in the corners of the top as bolting pieces for the panel boards, and similar pieces along the edges as nailing cleats for the roof sheathing.

The two rear side windows, and the rear window, are arranged to slide up, for ventilation. When traveling at touring speed, however, there is a great amount



of suction at the rear of the car, and the dust whipped up sifts in at every crevice. As it is hard to make a sliding joint snug enough to exclude this dust, it may be best to make only the side windows slide. The posts are used as the side frames. The window sills are  $\frac{1}{2}$ -in. stuff, set at a slight angle to insure drainage. The window cap is merely a piece of quarter-round molding, nailed over the lattice strip that holds on the duck covering. The window frames cannot be finished until the body has been covered.

The roof may be covered with the regular roof sheathing used by body makers, or, as in the present case, with  $\frac{3}{8}$ -in. oak flooring.

The smooth side is laid to the rafters, as this forms the ceiling, and is stained and varnished. The sheathing is fastened with 1-in. flat-head nails, well punched down. With the framing finished, as in Fig. 4, and the roof sheathing on, the duck roof covering is applied.

This may be obtained from a body-trimmer's supply house, in a width sufficient to cover the roof without a seam. The corners of the sheathing should be rounded, to prevent cutting the covering. Each edge of the covering is drawn down to a line on the panel board 3 in. from the top of the sheathing, and tacked fast. The edges are then trimmed, if necessary, and covered with a  $\frac{3}{8}$  by 2-in. lattice strip. These details are clearly shown in Fig. 6.

Before covering the sides, the posts are braced, on the inside, by means of lattice strips tacked to the centers, to prevent them from being pulled out of line as the material is stretched. One edge of the side covering is tacked to the rear door post, and the duck run back to the rear edge, making no allowance for the window opening. It is best to cut the material at the rear corner, putting on only one side at a time, and not to attempt to run around the rear and up the other side without cutting. Note, in Fig. 7, that the duck is fastened between panel board and posts, at top and bottom, the nuts being slacked, the material tucked in, and the bolts drawn tight again; this avoids cutting the material. With the top and bottom tacked in place, the lattice strips are applied. These are  $\frac{3}{8}$  by 2-in. molding strips. A strip is nailed, on the outside of the duck, so that it will just touch the bottom of the window sills when these are in place. A second strip is nailed 23 in. above this, to form part of the window cap. These strips run from the rear door post to the rear

corner post, on each side, and across the rear, in like manner. The strips do not meet at the corners, but are cut short to allow room for the vertical strips that cover the tacks fastening the duck to the corner posts. When fastening the vertical lattice strips at the window posts, they are allowed to project over the posts about  $\frac{3}{8}$  in., to form shoulders against which the windows rest and slide.

The temporary lattice strips tacked on the inside are now removed, and strips, long enough to reach between the posts, fastened on the inside of the duck by nailing to the outside strips. A helper, holding a heavy sledge or dolly against the strips, is necessary for this part of the job. Flat-head nails,  $\frac{3}{4}$  in. long, are used for this, heads inside, where they do not spoil the appearance of the job. No inside strips are placed above the windows, as they would interfere with raising the latter.

After the sides are finished, the window openings are cut out, and the body forward of the doors covered and paneled to conform to the rear. The front side-window frames are fastened to the posts, and the duck tacked to them.

The windows, shown in Fig. 8, have frames of poplar or pine, rabbeted  $\frac{1}{4}$  in. wide and  $\frac{1}{2}$  in. deep, to receive the glass. The glass is retained in the rabbets by  $\frac{1}{4}$ -in. square molding. All joints are mortise-and-tenon, and the panes may be arranged in any manner desired.

The windshield, the left half of which is shown in Fig. 9, is set in the upper part of the truss member. Each side is framed to fill half of the opening in the truss, the full width being 6 ft. 4 in. The halves are joined at the center by a  $\frac{3}{8}$ -in. rabbet. Aside from filling the opening properly, when used as a windshield, these parts also form the sides of the housing for the upper berth, when lowered, and carry part of the weight of the bed when raised. Therefore, the frame is made of hardwood.

When opened, the top edges overlap the panel boards 1 in., which prevents them from opening too far, and makes them weatherproof. Mortise-and-tenon joints are used throughout, and the glass panes are fastened in the same manner as in the side windows. The lower panels are filled in with light oak frames, carrying two panes of glass each; the frames are hinged at the bottom, and may be dropped for ventilation. When up, they are held in position by metal thumb buttons.

The halves are hinged to the truss

posts, and clear the web of the T-iron top rail by  $\frac{3}{16}$  in. Three hinges are used on each side. In framing, it must be borne in mind that the frames are right and left-hand, or they will not mate when hung.

The door frames, Fig. 10, are made of hardwood. Each door is provided with a sliding window that drops into a pocket—much like a sedan window. Double-strength glass is used, in a light wood frame. Duck is used to cover the top and bottom of the door; this is tacked, on the inside, in the rabbet provided for the window frame, and, where this does not run, strips of quarter-round molding are used. Edges where molding is not used are rounded with a rasp, so that all exposed edges are round. Corner joints are half-lapped and screwed, and cross rails ten-

oned into mortises in the sidepieces. The window frame is held in by means of a 20-gauge sheet-metal pocket, and by lattice strips screwed to the frame.

Three carriage hinges are used on each door, and deck locks, with a permanent handle, fitted. The sheet metal forming the pocket should be painted body steel or galvanized. It is so formed that any water blowing in at the window joint will run out over the flange at the bottom of the door. The edges of the doors are made snug by trimming them with aluminum T-molding, purchased from a body-builder's supply house. The windows are raised or lowered by straps attached to the frame, and are held closed by small "triggers" which swing under the frame.

Full details of the interior fittings, etc., will be given in the August issue.

### Tool Holder for Small Model-Making Lathes

The difficulty of forging tools for small lathes, and of keeping such tools in proper condition, is obviated by the use of the tool holder shown in the illustration.

The holder is made of cold-rolled steel, and the shank is easily bent in a vise by means of a large wrench. The square hole for the bit is made by drilling a  $\frac{1}{8}$ -in. hole through the end of the two parts of the holder, as shown, while the

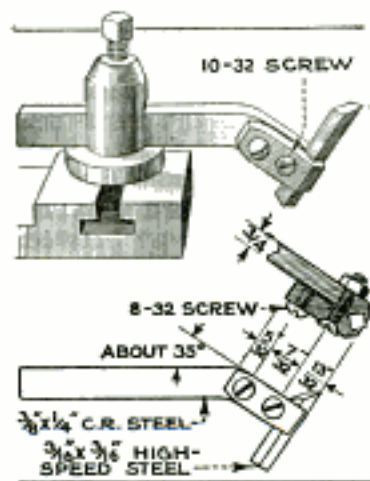

parts are clamped together, and then filing each half with a small square file. A length of  $\frac{3}{16}$  by  $\frac{3}{16}$ -in. high-speed steel is used for a bit, this size being the smallest that is usually carried by dealers. It is furnished annealed, and

can be cut to length with a cold chisel or hacksaw, then ground and hardened. The hacksaw must be used with light strokes, or the steel, being air-hardening, will harden under the saw and ruin the blade.

The advantages of this type of lathe tool for the amateur are the ease of hardening the high-speed steel, of grinding the bits for a new edge, and the elimination of reforging.

### Increasing Volume of Tone of Phonograph

The vibrations of the diaphragm of an ordinary phonograph reproducer are conducted to the amplifying chamber from one side only, although it is obvious that

both sides of the diaphragm vibrate equally. Advantage can be taken of this fact by providing an additional horn to amplify the volume of the tone. The horn can be made of fiber board, and the small end must be just large enough

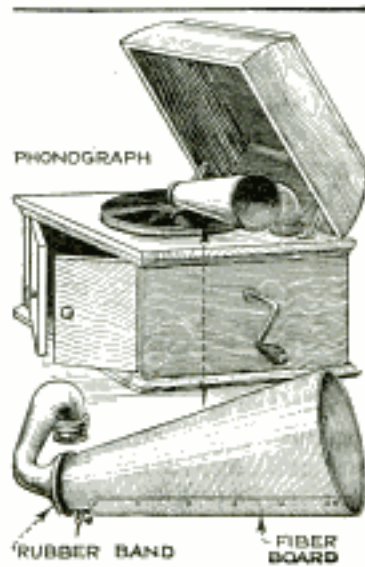

to fit over the outside of the reproducer, a notch being cut in it to fit over the needle arm. The horn is held in place on the reproducer by means of a rubber band. The sound is given out from both sides of the diaphragm, which not only results in increased volume, but also in a slightly different quality of tone.—Charles I. Reid, New York City.

☞Porch boxes for flowers and plants should be wider at the bottom than at the top, to afford additional growing space for the roots.

### A Novel Seesaw

The seesaw shown in the illustration is novel in that it combines a swinging mo-

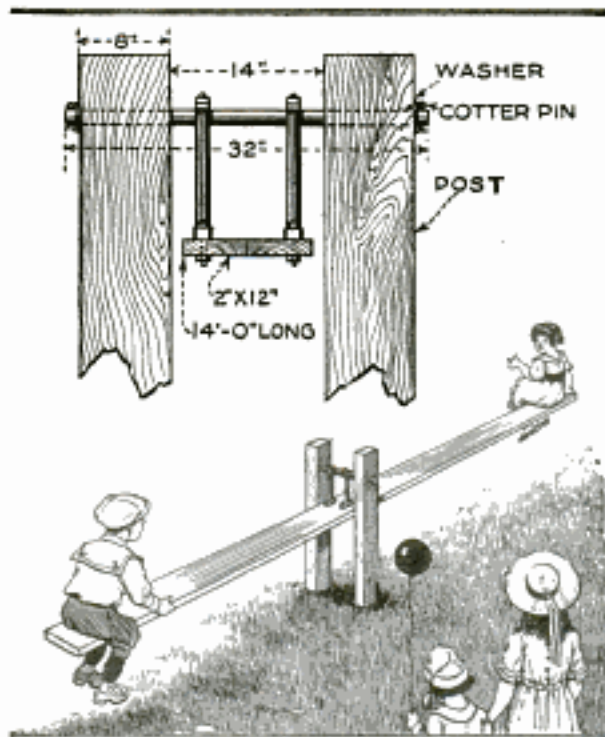

A Novel Seesaw That Provides Both a Swinging and a Tilting Motion

tion with the usual tilting one, providing the sensations of both a swing and a seesaw.

It is supported on two upright posts, spaced approximately 14 in. apart. Posts, 8 in. in diameter or 8 in. square, are large enough. The pivot on which the plank swings is a length of pipe or steel rod, running in holes bored in the posts, as indicated, about  $3\frac{1}{2}$  ft. above the ground. Both ends of the pivot are fitted with washers and cotter pins. The plank is underslung on the pivot by means of two old automobile connecting rods. The plank should be a strong one, of 2 by 12-in. stock, and about 14 ft. long. The "big-end" caps of the connecting rods are removed, and holes are drilled through the plank for the connecting-rod bolts; the plank is then bolted to the rods, and the rods to the pivot. The plank must, of course, be perfectly balanced when suspended from the pivot.—Lowell R. Butcher, Des Moines, Ia.

By holding the printing frame containing a negative that is thinner at one end than the other in such a way that the thin end is farther away from the light than the dense part, it is possible to obtain evenly exposed prints.

### Yardstick for Fishing Boat

Fish laws are becoming more stringent every year, and the fisherman is kept busy with his ruler to avoid arrest for keeping fish that are under legal length. To simplify matters, some fishermen mark off the lengths of various kinds of fish on their rods. However, a simpler method of measuring the fish is to tack a yardstick along the inside of the boat, near the bottom, marking the length limit of each variety of fish on it. When a fish is caught, it is placed against the measure and it can be seen at a glance whether or not the fish may be kept.—Robert Page Lincoln, Minneapolis, Minn.

### Combined Trouble and Tonneau Light

The owner of a light sedan car that was not equipped with a tonneau light, found the arrangement illustrated a most convenient one, as it provided a lamp for interior illumination, and one that could be used outside the car as a trouble lamp.

An ordinary portable hand lamp, such as may be purchased at any auto-supply house, and about 10 or 12 ft. of flexible cord, of a color to match the upholstery

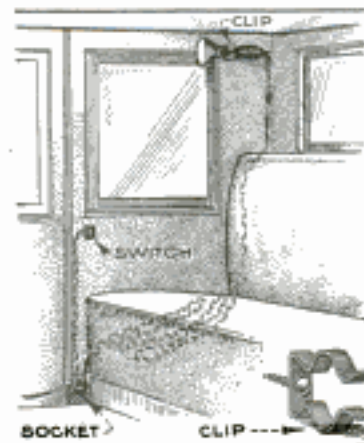

of the car, are obtained, and connected to a plug and socket fastened on the side wall, near the floor, and close to the rear seat of the car. The surplus cord is tucked away between the seat end and the side of the car, so that it is concealed, except for a short length running from the top of the back cushion to the clip that holds the lamp, near the ceiling. The clip is made from a piece of spring brass, bent as shown, so that the handle of the lamp may be pushed between its ends, and is secured to the wall with a round-head screw. Wires, concealed under the upholstery braid, may be run to a switch placed near the door. The wiring is, of course, connected to the storage battery. In case of trouble, the lamp is easily accessible, and the cord is long enough to reach any part of the car.—George R. Brown, Bridgeport, Connecticut.

### Simple Clothes Washer

A simple but efficient clothes washer of the type shown in the drawing has been used successfully for a number of years for cleaning clothes that will stand boiling.

It consists of a wash boiler, fitted with a 1-in. pine board that is perforated with  $\frac{3}{4}$ -in. holes and mounted on wooden legs. A larger hole at each end permits the insertion of two lengths of 1-in. pipe, 14 in. long, which are fitted at the upper end with an elbow, nipple, and cap, the cap being perforated with numerous small holes. The pipe should fit snugly in the holes in the board, and the lower ends, which are open, must be only a slight distance above the bottom of the boiler.

In use, the arrangement is fitted in the boiler as indicated, the clothes are packed in, and water is poured in to a depth not quite sufficient to cover the clothes. As soon as the water boils, the steam confined beneath the clothes forces the water up through the pipes and over the clothes. The water will then seep

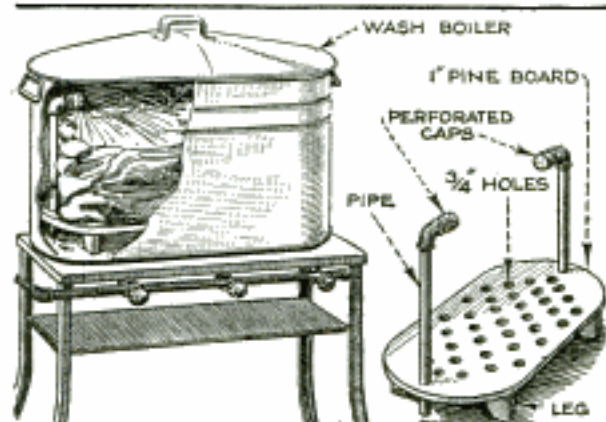

A Simple Arrangement for an Ordinary Wash Boiler That Converts It into an Efficient Washer

through the clothes, and in this way there is a continuous circulation, which cleans the clothes in a short time.—G. E. Hendrickson, Argyle, Wis.

### An Improvised Smokehouse

When it is necessary to smoke small quantities of meat, and no smokehouse is available, one can readily be improvised from a laundry stove, a barrel, and a support such as a sawhorse or wooden box.

One head of the barrel is removed, and a hole, 8 in. in diameter, is cut in the other head near the side, as shown. This hole is fitted over the short length of pipe projecting above the stove, the barrel being supported by the sawhorse and

by a brick placed on the stove. The meat is hung, by means of small wire hooks, from an iron rod placed across the top of the barrel. The whole arrangement



An Improvised Smokehouse, Consisting of a Laundry Stove, a Barrel, and a Support Such as a Sawhorse or Wooden Box

is placed outdoors in a place sheltered from the wind. Wood or corncocks is used for fuel.—Harold Jackson, Kankakee, Ill.

### Repairing a Fishing Rod

Many a broken fishing rod is laid aside because the owner does not know how to repair it properly. The ordinary method of repair is to cut the two ends at an angle, and, after applying glue to the surfaces, to join them and wind silk around the joint.

This method can be greatly improved upon by reinforcing the splice with a medium-size darning needle. The sharp end is driven into one piece and the other end is then ground to a point and pushed into the other piece. It may be necessary to drill a small hole in the second piece with a fine drill, in order to force the ground point into it without pushing the needle down farther in the first one. The joint, of course, is glued and wound with silk in the usual way. A splice thus made will be the strongest part of the whole rod.

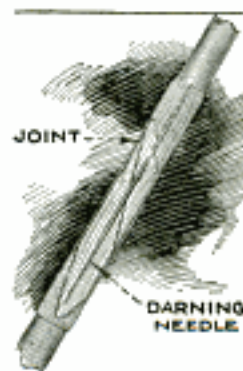

### Fastening Full-Length Window Screens

The drawing shows an excellent method of mounting full-length window screens. The frames are made of oak and must

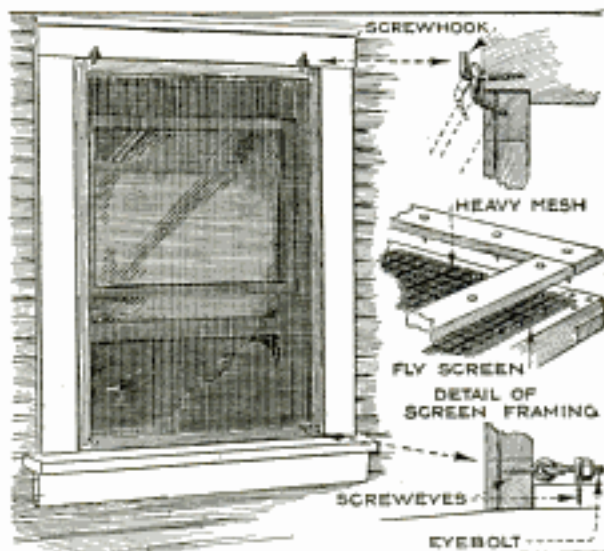

Full-Length Window Screens That can be Attached, Detached, or Swung Open Easily

fit exactly in the window opening. The screen is tacked to the frame in the usual way, light wooden strips being nailed over the edges. If additional strength is necessary, for protection against entrance, a double-screen construction is used: the fly screen and a heavy galvanized-wire screen. The frames are fastened at the top by means of screwhooks on the window casing and screweyes in the screen frame, and at the bottom by means of screweyes and eyebolts, the frames being drawn tight against the casing by means of the eyebolts.

### A Gauge for Clipping Hedges

A little time spent in making the hedge-clipping gauge shown in the drawing will

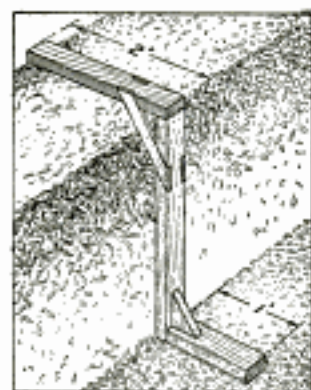

go far to improve the appearance of hedge fences by making it possible to clip the hedge uniformly, and without giving it the appearance of careless work.

The perpendicular member of the gauge is made from a piece of 2 by 4-in. material, but the horizontal

parts may be of lighter stuff, the dimensions to which such a gauge is made de-

pending upon individual requirements. In use, the trimming is begun at one end of the hedge, the gauge being held in an upright position by standing upon the bottom member. Clip as much of the hedge as projects above the top of the gauge, moving it along as the work proceeds.

### Simple Farm Derrick

A handy and efficient derrick can be built in a short time from material found on nearly every farm. It consists of a discarded wagon tongue, pivoted on a fence post so as to revolve freely, and fitted with a simple winch for raising the load.

An iron pivot yoke is forged to the shape shown, or one may be built up of flat and round iron. A hole is drilled in the post top to accommodate the shank, an iron disk and a steel ball, taken from an old ball bearing, being set in the hole as shown, to make an easy-running bearing. The yoke straddles the tongue at its balancing point, a bolt being passed through a hole drilled in each. The winch consists of  $\frac{3}{4}$ -in. pipe and fittings, and

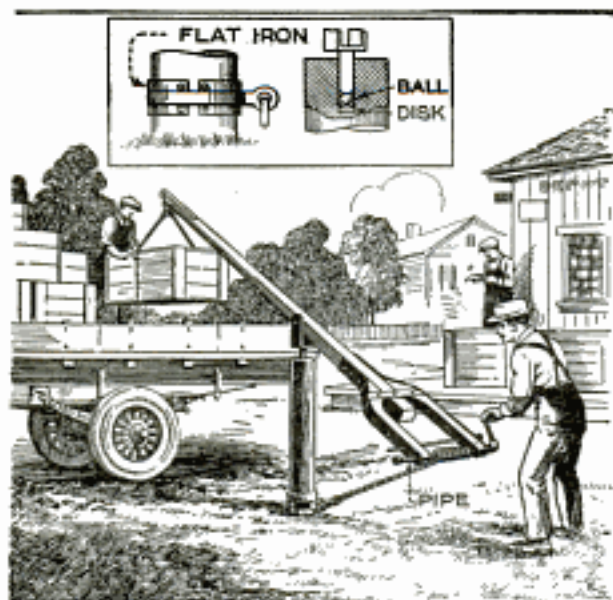

A Simple but Efficient Derrick Consisting of a Discarded Wagon Tongue, Pivoted on a Fence Post and Fitted with a Simple Winch

is arranged as indicated, the winch shaft passing through holes drilled through the ends of the "hounds." One end of a stout cable is securely fastened to the winch shaft, and the other end to an iron collar that is an easy fit around the bottom of the post. This collar is held in position by half collars above and below it, screwed to the post. Hooks or clamps to suit the load are suspended from the



outer end of the tongue. A rod, sliding through the ends of the hounds, near the winch shaft, as indicated, is pulled out to keep the crank from revolving when it is desired to swing the load. With this arrangement it is possible for one man to operate the derrick unassisted.

### Clamp Bolts for Pump

The clamp bolts shown in the illustration have been found very useful for bolting pumps to concrete foundations, as the pump can be easily attached or detached without damage to the bolt threads. In setting the bolts in the concrete, they are placed outside of the area

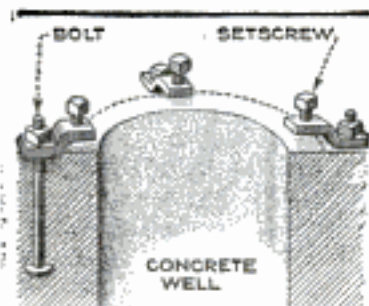

covered by the pump base, but close to the holes through which they would ordinarily have been inserted. When the concrete has set, the pump

is placed in position, and small steel clamps, bent as indicated, are fastened down by the nuts, so that the ends of the clamps project over the pump base. Setscrews in the ends of the clamps are screwed down against the pump base to hold it in place. To remove the pump, the nuts and setscrews are loosened, and the clamps are turned out of the way.

### Attachment on Spade Saves Shoes

The illustration shows a simple attachment for a spade, to save the shoes while digging. The attachment consists of a short length of  $\frac{3}{4}$  or  $\frac{5}{8}$ -in. pipe, about 4 in. long, with a hacksaw slot cut through it lengthwise as shown, to permit it to be pushed onto the spade. The slot should, of course, be of such a width that the spade will be gripped firmly. The use of this attachment not only saves the shoes of the workman, but since it is much wider than the narrow edge of the spade, it is not so tiring on the foot.—R. A. Danby, Dannevirke, New Zealand.



### A "Live" Scarecrow

Most scarecrows are inefficient because they show no signs of "life." The scarecrow shown in the drawing, however,

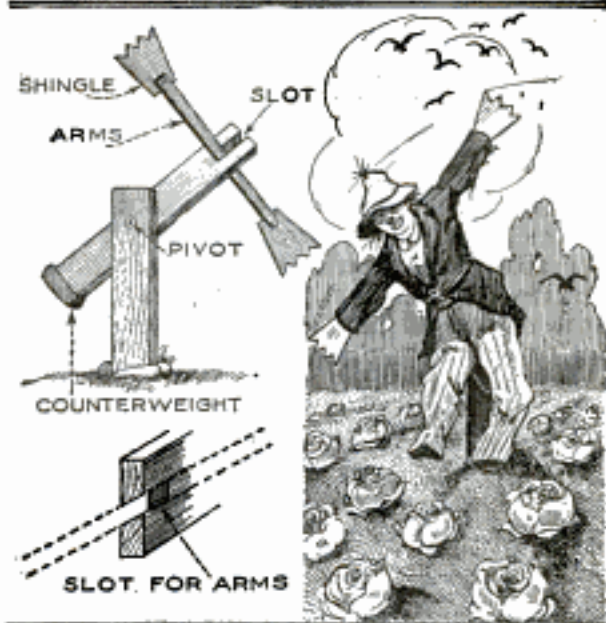

A "Live" Scarecrow, Actuated by Gusts of Wind, That Is a Sure Fright for Most Feathered Pests

which is made to swing on a post, and is actuated by the wind, has been found very effective.

It is constructed as follows: Sink a flat piece of timber into the ground, allowing it to project about 3 ft. Then pivot a similar piece to it with a loose-fitting bolt, as shown. Saw a slot across the top end of the second piece, at an angle, as shown in the detail, fasten to it a horizontal piece for the arms, and nail shingles, cut to represent hands, in slots on the ends of the arms. Nail a piece of lead or other metal to the bottom end of the pivoted piece, for a counterweight. After the frame is finished, dress the scarecrow up in the desired manner, allowing plenty of play at the pivot.

If the arms are at a considerable angle from the direction of swing, and the gusts of wind strong enough, the upper half of the scarecrow will move backward and forward, causing a bobbing motion that is a sure fright for most feathered garden pests. The intermittent gusts of wind keep the figure in constant motion. The counterweight must be heavy enough to bring the figure upright when the breeze abates, but must not, of course, be heavy enough to prevent the figure from swinging.—L. B. Robbins, Harwich, Mass.



# MAKING FINE SCRAPBOOKS



By R. S. ANDREWS

Awarded Third Prize—\$25.00—in Contest on Occupations for Shut-Ins

**T**HERE is a genuine need of a scrapbook that will serve the general purposes of such a volume and not fall to pieces inside of a year. Many of those commonly seen on the market are poorly constructed, in fact, they present all the appearance of having been made to sell instead of to use. A scrapbook, made of good materials, and called to the attention of those interested through the proper mediums, will find a ready sale.

The materials needed to make a book such as will please the purchaser are as follows:

50 sheets craft paper, 15 by 18 in.	\$ .40
50 strips craft paper, 2 by 18 in.	
2 pieces bookbinders' board, 14¼ by 18½ in. ....	.25
1 piece light canvas, 34 by 20½ in.	.60
1 piece light canvas, 12 by 18½ in.	
1 spool heavy linen thread.....	.10
1 can best liquid glue, ½ pt.....	.25
	<hr/>
	\$1.00

A much lower price can be secured by purchasing materials in lots sufficient for a dozen or more books at a time.

The tools needed are:

2 5-in. malleable-iron clamps.....	\$ .70
1 breast drill .....	3.85
1 ⅜-in. drill bit .....	.10
1 ½-in. drill bit .....	.20
1 packet 3-inch darning needles.....	.10
	<hr/>
	\$4.95

Two true and smooth 2 by 18½-in. pine boards are also needed.

Craft paper is tough, very durable, and well suited to this purpose. It can be bought from any paper-supply company, cut to the proper sizes. The binders' board must be bought from the bookbinders' supply houses. The other materials, as well as the tools, can be purchased at any department store. The canvas should be dyed, preferably bright red, although any other color will serve the purpose. While one can dye enough cloth for several books at home, better results can be obtained on larger quantities taking the work to a professional

always even on the edges when received, and in order to keep it so, the work should be done on a smooth bench or table.

The first step in making the book is to clamp one of the boards on each side of the paper, lengthwise, and flush with the edge, as in Fig. 2. Care should be taken that the boards and paper are even, and the clamps must be tightened until the paper forms a solid mass. A line should then be drawn, ½ in. from the outer edge, the full length of one of the boards. Marks are made on this line at points 3, 4, and 8½ in. from each end. The breast drill is now brought into play, and holes are drilled with the ⅜-in. bit at these six points, right through the paper, care being exercised, while drilling, to keep the drill perpendicular. The spacing of the holes is shown in Fig. 1.

When the six holes have been drilled through the boards and the paper, the clamps and boards can be removed and applied to the narrow paper strips, which should be drilled through the same holes in the board, the finished strips appearing as in Fig. 3. The drilling is now finished, and the book is ready to be assembled.

In order to keep the pages and strips even, a wooden pin, about 6 in. long, and slightly smaller than the drill, is set in each end hole in one of the boards. These two pins are to string the leaves on, and to keep the holes in alinement. Four pages of the large sheets are strung on the pins, followed by four of the strips. These strips form stubs used for the purpose of gluing in extra pages, and are to be found in all first-class scrapbooks. The alternate placing of four full pages and four stubs is continued, as shown in Fig. 4, until the entire lot is strung on the pins. The other board is now put in place, and the clamps once more adjusted and tightened. The pins can then be removed and all the holes swabbed and filled with glue, as in Fig. 5. The back edge of the book is also given an application of glue, and the work is left on a level surface for a day or more, to allow the glue to set. After it has dried

h and paper will present a better appearance in the finished book if from creases and wrinkles the process. The paper is

Paper } d. neyton 527 S. Jefferson } Chicago  
H. C. J. raver Paper Co. 358 W. Ontario }  
Gardner Steindler Co. 11 N. Green }

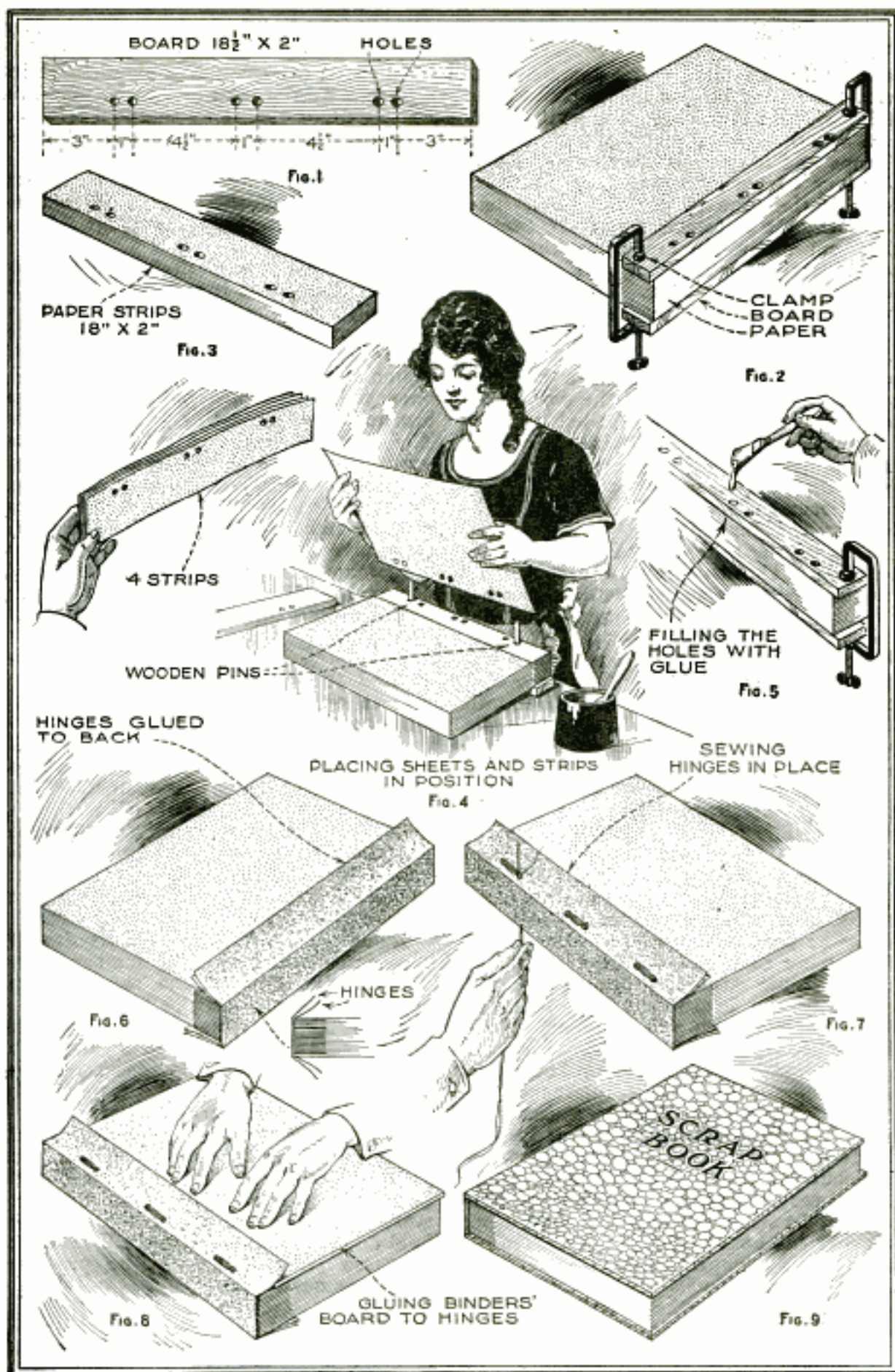

Figure 1, Clamp Board, after Drilling; Figure 2, Sheets Clamped for Drilling; Figure 3, Stub Strips Ready for Assembly; Figure 4, Assembling the Sheets and Strips; Figure 5, Gluing Sheets; Figures 6 and 7, Applying and Sewing Hinges; Figure 8, Placing Binders' Board in Position, and Figure 9, Completed Scrapbook

sufficiently, the holes are again drilled with the  $\frac{1}{8}$ -in. drill, which will clean the holes without removing all the glue.

When this second drilling is done, the clamps and boards can be removed, preparatory to sewing the volume together. Now is the time to use the small strip of cloth. It is folded down the center, then cut along the crease, making two pieces, each 6 by  $18\frac{1}{2}$  in., and one piece left on top of the other. The back edge of the book is again given a coat of glue and then set down lengthwise, as nearly as possible in the center of the two pieces of cloth. The volume is then laid flat on the bench or table, and the two pieces of cloth are carefully adjusted so that they extend around the back of the book and approximately 2 in. on each side, the work then appearing as in Fig. 6. The two pieces of cloth are known to bookbinders as "hinges."

The volume is now ready to be sewed together. The darning needle should be threaded with a piece of the linen thread, 16 ft. long, which has been doubled twice; this makes a four-ply thread, 4 ft. long. This should be sewed through the cloth hinges and the book, in the three sets of two holes, as shown in Fig. 7, until the holes are full of thread and the needle will no longer go through. The ends of the thread are then tied securely.

The hinges being sewed in place, one piece of binders' board is put in position on each side, between the two edges of the hinges. If the measurements have been fairly accurate, the boards will extend  $\frac{1}{2}$  in. over each end and the front of the book. The boards are pushed back as far as possible against the thread, and marked on each side at the edge of the cloth. Lines are then drawn, the full length of the boards on both sides, at these marks, which will be about  $1\frac{1}{2}$  in. from the edge of the board. An even layer of hot glue is brushed on both sides of the boards in this  $1\frac{1}{2}$ -in. space, and the backs are immediately replaced between the flaps of the hinges, as in Fig. 8. It is well to place some waxed paper between the backs and the book, when the hinges are glued, to prevent any glue that might soak through the cloth from sticking the boards and the first page together. The hinges should be smoothed down on the backs, a smooth board weighted down on them, and the whole left a day or two to dry.

The back is now complete, and the book ready for the cover. The piece of 34 by  $20\frac{1}{2}$ -in. cloth is spread out on the table, and the book laid on it so that

one-half of the cloth extends about 1 in. beyond the front edge and each end. The other half of the cloth should be folded over the top and the book moved carefully, if necessary, to divide the cloth equally between the two sides. When properly placed, the cloth will extend about 1 in. past the front edge of the book boards.

When the cover cloth is found to be properly fitted, the top cloth is laid back carefully so as not to move the book, and an even coat of hot glue is applied to the back edge, the top hinge, and the topmost board or back. The cloth is once more carefully put in place and brushed down smoothly with the hands. The book is then turned over, and the opposite side has the cover glued on just as the first one. The overlapping 1 in. of cloth is folded inside after an application of hot glue has been brushed on the board to receive it. The corners can be given a neat appearance by snipping them off diagonally with the scissors, and folding the sidepiece over the two ends, inside the cover.

The entire cover is then carefully inspected to see that the cloth is down smooth on the boards. If the canvas is all properly glued in place, the cover is complete except for a paper lining. This lining should be glued to the inside of each back, and must be of such a size that it will overlap the edges of the cover cloth, but not quite reach the edges of the board. Waxed paper should then be placed between the back and the leaves, and the volume weighted down on a level surface to dry for two days or longer.

When the book is thoroughly dry, its appearance will be greatly improved and its sale stimulated if the word "Scrapbook" is stamped on the front cover in bronze. The lettering can be done with ordinary liquid bronze and a large rubber stamp. Since quality is the principal selling point, care must be exercised to make the book neat and attractive.

Correct and careful work, however, will come to naught unless the books are properly marketed. They should be offered for sale in book and stationery stores, and also advertised in the household and authors' magazines. The names of these publications can be procured from any newsdealer.

❗ Do not forget to lubricate the auto fan. The fan is an important part of the cooling system, and failure to look after it properly may cause it to get out of order when it is most needed.

### Rigid Homemade Ironing Board

A laundress in a northern Michigan resort town, who employs a number of helpers, has found ironing boards of the type shown in the illustration exceptionally rigid and convenient, and, as they may be taken apart in a few minutes, they do not take up much space when not in use.

The fixture consists of three main parts: the ironing board proper, made of 1 or 1¼-in. stock, the upright, and the base. The base is made by nailing two pieces of 2 by 3½-in. stuff, 42 in. long, to a heavy block, 5 in. high, as shown. The upright is made by nailing another 5-in. block to the bottom of a ¾ by 12 by 36-in. board, and then nailing a three-sided box, as shown, to the plank. A space of 2¼ in. is left between the bottom of the box and the block, and the ends of the baseboards are put in position, and marked for the cleat, which should fit snugly against the inner side of the box.

A cleat, with a beveled face, is then nailed on the top of the upright, leaving enough space between box and cleat for the ironing board. Two cleats are nailed to the latter, the top one is beveled to fit under the cleat on the upright, and the bottom

one fits against the inside of the box. As there is no support at the middle of the board, skirts and dresses are not wrinkled when slipped over it. The un-

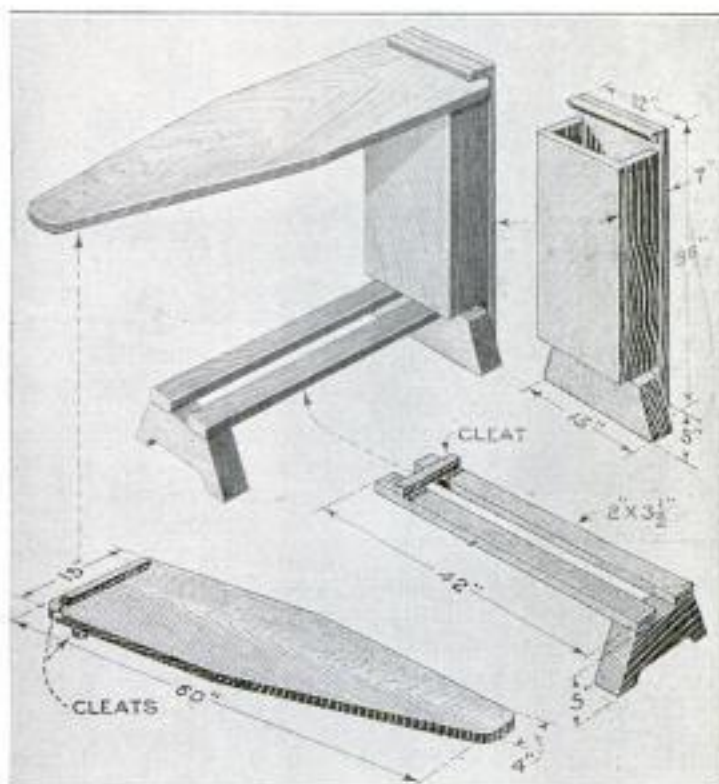

A Three-Piece Collapsible Ironing Board That Is Exceptionally Rigid, and Possesses Several Other Advantages over the Usual Type

usually narrow smaller end is an additional advantage.—Herma N. Clark, Chicago, Ill.

### Preventing Vibration of License Plates

The attachment of the auto-license plate to the front of the radiator by means of a bracket clamped around the filling tube makes it conspicuous, but the vibration of the engine soon causes the

plate to loosen and rattle.

To overcome this, and at the same time prevent the vibrating bracket from breaking the seam of the filler tube, one motorist has fastened the

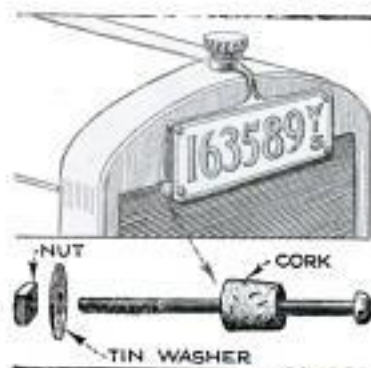

lower part of the plate to the radiator, as shown. The bolts pass through the lower holes in the license plate and

between the tubes to the inner side of the radiator. A cork, drilled through the center, is slipped on each bolt, between plate and radiator, to absorb the vibration, and tin washers are used between nut and radiator, to prevent damage to the latter.

If desired, the corks may be painted black to correspond with the radiator, and they will then be scarcely noticeable.

### Using Cut Films in Plate Holder

The cut films that have been placed on the market will probably supersede the glass plate entirely, owing to their freedom from "halation" and their unbreakable qualities. They can be loaded into an ordinary plate holder by the use of a stiff paper card, cut to the exact size of the film, and placed behind each film when loading the holders. The cards should be painted a dead-black color to prevent halation.

### Railroad Lantern Used as Stove

An ordinary railroad lantern can be used as a small stove on which the trainman can make his coffee.

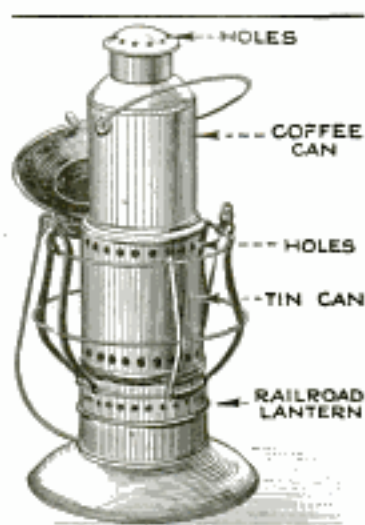

In converting the lantern to a stove, a 1-gal. tin pail, or similar can of suitable diameter, is substituted for the regular glass globe, nail holes being punched in the side near the bottom and the top as shown, and a hole cut in the bottom. The can is then placed, upside down, over the wick, and the stove is complete. If a pail is used for a coffee can, as shown in the drawing, small holes are punched in the cover or top to permit the steam to escape.—A. LaMont Burst, Washington, District of Columbia.

### Strong Turnbuckle Made of Pipe and Fittings

The illustration shows a homemade turnbuckle consisting of pipe and fittings. A piece of  $\frac{1}{2}$ -in. pipe, about 6 in., or so,

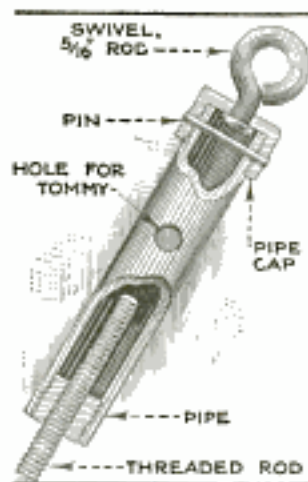

long, is drilled through the center for a "tommy." One end of the pipe is threaded for a cap, and the other end is tapped for a plug. A  $\frac{1}{16}$ -in. hole is drilled through the center of the cap, and a swivel, made of  $\frac{5}{16}$ -in. iron rod and bent to the shape shown, is pushed through this hole, the end being spread over on the inside of the cap. After screwing the cap into place tightly, both cap and pipe are pinned together to prevent unscrewing. A plug, screwed in the other end of the pipe, is drilled and tapped for a  $\frac{3}{8}$ -in. threaded rod, which is also bent at the end to form a ring.

long, is drilled through the center for a "tommy." One end of the pipe is threaded for a cap, and the other end is tapped for a plug. A  $\frac{1}{16}$ -in. hole is drilled through the center of the cap, and a swivel, made of  $\frac{5}{16}$ -in. iron rod and bent to the shape shown, is pushed through this hole, the end being spread over on the inside of the cap. After screwing the cap into place tightly, both cap and pipe are pinned together to prevent unscrewing. A plug, screwed in the other end of the pipe, is drilled and tapped for a  $\frac{3}{8}$ -in. threaded rod, which is also bent at the end to form a ring.

### A Darning Kink

By enameling one half of a darning "egg" black and the other half white, it will be found that the strain on the eyes incident to darning will be relieved considerably. When dark-colored stockings are mended the white part of the egg is turned upward, contrasting with the material, and in the case of light-colored stockings, the black part is used. The fatigue of the work is thus decidedly lessened.—C. L. Meller, Fargo, S. D.

### Grooving File for Golf Clubs

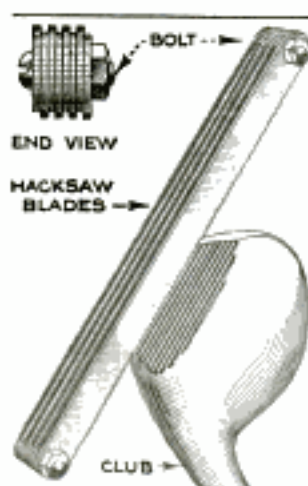

It does not take long for the face of a golf driver or brassie to wear down, but it can be quickly restored to its former condition by the use of the tool illustrated. This tool consists of eight hacksaw blades, bolted together at both ends with stove bolts, the cutting edge of every other blade being reversed as shown in the end view. The method of use is obvious.—F. S. Roots, Fall River, Mass.

### Spring for Hand-Brake Pawl

The pawl spring used on the hand brake of a light car frequently breaks, and this should be remedied immediately, as, otherwise, the car may run forward when the engine is cranked. A good repair can be effected in a few moments in the manner shown. Instead of replacing the usual spring, one of the coil springs used in a rear brake shoe is hooked over the brake rod and the ratchet-pawl pin, as indicated. It is not necessary to drill any holes.

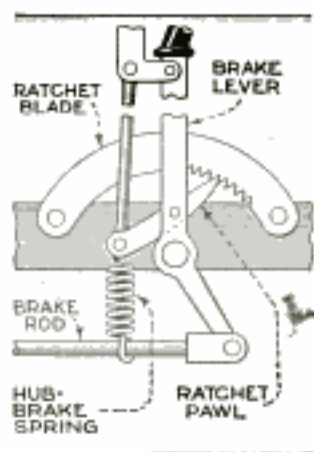

**10-Day Tube  
Free**



## What Men Use To get those glistening teeth

Note how many men and women show white teeth nowadays.

They are proud to show them when they smile—because they are attractive.

There is a new way of teeth cleaning which millions now employ. It means whiter, safer, cleaner teeth.

### It removes film

You can feel on your teeth a viscous film. It clings to teeth, gets between the teeth and stays. Food stains, etc., discolor it. Then it forms dingy coats. Tartar is based on film.

That's why teeth look cloudy.

Film also holds food substance which ferments and forms acids. It holds the acids in contact with the teeth to cause decay. Germs breed by millions in it, and they cause many troubles.

That's how teeth are ruined.

### You must do this

Old ways of brushing do not end that film. Some always

#### Avoid Harmful Grit

Pepsodent curdles the film and removes it without harmful scouring. Its polishing agent is far softer than enamel. Never use a film combatant which contains harsh grit.

remains to threaten serious damage night and day.

So dental science sought a film combatant and two methods were discovered. One acts to curdle film, one to remove it. Experts proved those ways effective. Then dentists everywhere began to advise their use.

A new-type tooth paste was created, based on modern research. The name is Pepsodent. Those two great film combatants were embodied in it, for daily application.

Now careful people of some fifty nations use this new way to clean teeth.

### Fights acid, too

Pepsodent also multiplies the alkalinity of the saliva. That is there to neutralize mouth acids, the cause of tooth decay.

Pepsodent multiplies the starch digestant in the saliva. That is there to digest starch deposits on teeth which may otherwise ferment and form acids.

Those are Nature's great tooth-protecting agents in the mouth. Every use of Pepsodent gives them manifold effect.

### The new-day way

Pepsodent is the tooth paste of today. Millions already use it. All careful people will adopt it when they know its benefits.

Send the coupon for a 10-Day Tube. Note how clean the teeth feel after using. Mark the absence of the viscous film. See how teeth whiten as the film-coats disappear.

Then you will realize what this method means to you, now and in the future. Cut out the coupon now.

**Pepsodent** PAT. OFF.  
REG. U.S.

### The New-Day Dentifrice

A scientific film combatant, which whitens, cleans and protects the teeth without the use of harmful grit. Now advised by leading dentists the world over.

### 10-Day Tube Free

1172

THE PEPSODENT COMPANY,

Dept. 130, 1104 S. Wabash Ave., Chicago, Ill.

Mail 10-Day Tube of Pepsodent to

.....  
.....  
Only one tube to a family.



## United for the Nation's need

We are a people scattered over three million square miles of territory—a people whose daily commercial transactions and social interests are as wide-spread as our boundaries. Only a unified telephone service, covering the whole country, can serve our needs.

Such a service, in turn, requires a national organization with uniform policies and operating methods; and also in each community a local organization with full authority and responsibility for the problems of that community.

Such a service is the service of the Bell System. Two hundred and fifty

thousand employees and approximately six thousand local operating units cover the length and breadth of the land. Uniting these community organizations are the Associated Companies of the Bell System, each responsible for service in its territory. Linking together the Associated Companies is the American Telephone and Telegraph Company. It operates the long distance lines, develops nationwide policies, standards of practice and equipment for the improvements of the service and for the benefit of all.

In this commonwealth of service the best interests of the nation and of the community are equally served.

### " BELL SYSTEM "

AMERICAN TELEPHONE AND TELEGRAPH COMPANY  
AND ASSOCIATED COMPANIES

*One Policy, One System, Universal Service, and all directed toward Better Service*



# 12,000,000

## Motorists Need Your Service

# BIG MONEY

*If You Know  
the GAME!*

### FREE Consulting Membership FREE

A resident staff of 18 practical experts is waiting to solve for you any auto, tractor or motorcycle problem you may have. A letter or a wire to the American Technical Society will bring you an immediate answer and the solution to your troubles. This advisory staff of practical automobile men plus your automobile library will enable you to handle every auto problem in the game. These men know of all the latest methods and the newest and best ways of doing things. Let this pay-raising consulting staff be YOUR SILENT PARTNER. You can use this service daily if necessary.

**This FREE MEMBERSHIP OFFER is good for a limited time only and can be withdrawn without notice.**

### An Example of What the Books Will Do

Fréd Shone, an experienced repair man of Lawrence, Mass., recently wrote: "Your books in Automobile Engineering have helped me a great deal. Several jobs have come to me and had it not been for the books I would have been lost. As a result of the books, I made the repairs; they came out O. K. and not one of the cars was returned to me." And this is only one of scores, yes thousands of those whose skill and earning power has been increased through the help of the books and membership.

Everyone of the 12,000,000 automobiles that will be in service in 1923 is a possible prospect for intelligent repair work. For the man who knows automobile construction—for the mechanic who handles his repair jobs with skill and precision—for the automobile factory man who works with his head as well as his hands, there lies in these 12,000,000 cars a tremendous money-making opportunity. You can cash in on it. Every man in any way associated with the welfare of these cars can cash in on it—if he knows the game! And this remarkable set of books on Automobile Engineering shows you exactly how.

These books are written by 15 automotive experts and cover from a practical standpoint, every phase of automobile engineering. They contain information that is vital to every automobile man. If you like to putter around a car, you can easily fit yourself to earn \$40.00 to \$125.00 a week through the instruction given in these books. If you are in the repair business, you can tackle successfully bigger jobs than ever—and jobs of every kind.

### 7 Days' Free Trial—No Money Down

You can never judge the full value of these books until you see them—read the table of contents—see the diagrams, blue prints and illustrations. We want to send them to you on a free make-good-or-no-sale basis. Just sign and send the coupon. We'll at once ship the books. Then look them over! If you don't say they are worth twice the money, ship them back at our expense. Otherwise pay for them as explained in the coupon—at a cost to you of only a dime a day. This will entitle you to a full consulting membership free for one year. Don't put off. ACT NOW! Send the coupon.

**AMERICAN TECHNICAL SOCIETY**  
Dept. G19B Chicago, U. S. A.

©A. T. S. 1923



AMERICAN TECHNICAL SOCIETY, Dept. G19B  
Chicago, U. S. A.

Please send me a set of Automobile Engineering for seven days' FREE EXAMINATION, shipping charges collect. I will examine these books thoroughly, and if satisfied, will send \$2.80 within seven days and \$3.00 each month until I have paid the special price of \$21.80. If I decide not to keep the books, I will return them within one week at your expense. It is understood that as a purchaser of these books, I am entitled to a full consulting membership in the automotive division of the society.

Name.....  
Address.....  
Reference.....  
(Please fill out all lines, give local merchant, bank or employer as reference.)

# Mechanical Engineering



## Learn at Home!

**E**MLOYERS everywhere are looking for men with mechanical ability. Splendid salaries and rapid advancement are offered those with special training.

There is an easy, delightful way in which you can learn right at home in spare time. For 31 years the International Correspondence Schools have been giving men and women just the training they need for success in mechanical engineering and more than 300 other subjects. Thousands of men and women have stepped into good positions through I. C. S. help, but never were opportunities so great as now.

Let the I. C. S. help you. Choose the work you like best in the coupon below, then mark and mail it to-day. This doesn't obligate you in the least and it will bring you information that will start you on a successful career. This is your chance. Don't let it slip by. Mark and mail this coupon now.

----- TEAR OUT HERE -----

### INTERNATIONAL CORRESPONDENCE SCHOOLS

Box 5531-D, Scranton, Penna.

Without cost or obligation, please tell me how I can qualify for the position or in the subject before which I have marked an X:

#### BUSINESS TRAINING COURSES

- |   |   |
|---|---|
| <input type="checkbox"/> Business Management                              | <input type="checkbox"/> Salesmanship                                     |
| <input type="checkbox"/> Industrial Management                            | <input type="checkbox"/> Advertising                                      |
| <input type="checkbox"/> Personnel Organization                           | <input type="checkbox"/> Better Letters                                   |
| <input type="checkbox"/> Traffic Management                               | <input type="checkbox"/> Foreign Trade                                    |
| <input type="checkbox"/> Business Law                                     | <input type="checkbox"/> Stenography and Typing                           |
| <input type="checkbox"/> Banking and Banking Law                          | <input type="checkbox"/> Business English                                 |
| <input type="checkbox"/> Accountancy (including C.P.A.)                   | <input type="checkbox"/> Civil Service                                    |
| <input type="checkbox"/> Nicholson Cost Accounting                        | <input type="checkbox"/> Railway Mail Clerk                               |
| <input type="checkbox"/> Bookkeeping                                      | <input type="checkbox"/> Common School Subjects                           |
| <input type="checkbox"/> Private Secretary                                | <input type="checkbox"/> High School Subjects                             |
| <input type="checkbox"/> Business Spanish <input type="checkbox"/> French | <input type="checkbox"/> Illustrating <input type="checkbox"/> Cartooning |

#### TECHNICAL AND INDUSTRIAL COURSES

- |   |  |
|---|--|
| <input type="checkbox"/> Electrical Engineering                               | <input type="checkbox"/> Architect                                   |
| <input type="checkbox"/> Electric Lighting                                    | <input type="checkbox"/> Blue Print Reading                          |
| <input type="checkbox"/> Mechanical Engineer                                  | <input type="checkbox"/> Contractor and Builder                      |
| <input type="checkbox"/> Mechanical Draftsman                                 | <input type="checkbox"/> Architectural Draftsman                     |
| <input type="checkbox"/> Machine Shop Practice                                | <input type="checkbox"/> Concrete Builder                            |
| <input type="checkbox"/> Railroad Positions                                   | <input type="checkbox"/> Structural Engineer                         |
| <input type="checkbox"/> Gas Engine Operating                                 | <input type="checkbox"/> Plumbing and Heating                        |
| <input type="checkbox"/> Civil Engineer                                       | <input type="checkbox"/> Chemistry <input type="checkbox"/> Pharmacy |
| <input type="checkbox"/> Surveying and Mapping                                | <input type="checkbox"/> Automobile Work                             |
| <input type="checkbox"/> Metallurgy <input type="checkbox"/> Mining           | <input type="checkbox"/> Navigation                                  |
| <input type="checkbox"/> Insulating <input type="checkbox"/> Airplane Engines | <input type="checkbox"/> Agriculture and Poultry                     |
|   | <input type="checkbox"/> Mathematics                                 |

3-27-23

State.....

Canada should send this coupon to the International Correspondence Schools, Montreal, Canada.

ion Popular Mechanics

The Music Pals  
of the Nation



New friends, new pleasures, new and interesting experiences, invitations galore—dinners, dances, week-end parties, outings,—are some of the good things playing a Gibson brings into your life.

**Gibson**  
Instruments

are easily learned in spare time without previous knowledge of music. A few weeks of pleasant, interesting study and you'll be able to play. And there's no other joy in life quite equal to hearing music you make on your own instruments.

**\$5.00 Monthly** buys a Gibson. The ultimate in construction, finish, tone quality and volume. Built like a violin. Adjustable bridge, non-warpable truss rod neck and thirty other exclusive Gibson features. **Guaranteed for life.** Non-Gibson instruments exchanged.

**Make \$25 to \$200** weekly, selling, playing, teaching. Own a high class, exclusive business. We furnish stock, advertise, help sell, carry accounts. Gibsons easily sold on confidential credit plan.

Send for **FREE** catalog, **FREE** music and information about Mandolin, Mandola, Mando-cello, Mando-bass, Guitar, Harp-guitar, Mandolin-banjo, Tenor-banjo, Cello-banjo, Guitar-banjo. If interested in Agency, check here..... Teacher..... Clip, check and mail this ad today. Address all mail to Kalamazoo,

**Gibson Mandolin-Guitar Co.**  
1587 Parsons St. Foreign Dept.  
Kalamazoo, Mich. 25 Broad St., N. Y. City

## Travel The D & C Waterway On The Great Lakes

*Restful—Economical—Healthful—Safe  
Traveling*

You'll enjoy a trip on the palatial, homelike D. & C. Steamers that make daily trips between Detroit and Buffalo, and Detroit and Cleveland. Direct rail connections at these three cities for all sections of the country.

<p><b>Detroit &amp; Buffalo</b> Lv. Detroit 5:30 p.m. Lv. Buffalo 6:00 p.m. Fare, \$6.00 one way, \$11.50 round trip</p>	<p><b>Detroit &amp; Cleveland</b> Lv. each city 11 p.m. * Daylight trips during July and Aug. Lv. each city 8:30 a.m. Fare, \$3.60 one way, \$6.50 round trip</p>
--	---

\*Operation subject to necessity for service.  
*Schedule subject to change without notice.*

Berths, \$1.80 up; staterooms, \$4.20 up; parlor, \$7.20 up.  
Rail Tickets are accepted. Automobiles transported. Gas must be removed. Wireless aboard.

For reservations and further information, address R. C. Stoddard, Gen. Pass. and Ticket Agt., Detroit, Mich.

**Detroit & Cleveland Navigation Co.**  
A. A. Schantz J. T. McMillan  
Pres. & Gen. Mgr. Vice-Pres.



Comb your hair any style. Part on the side, in the middle—combed back, pompadour, any way. It will stay smooth and lustrous, now. Here is your opportunity to find out *how*—free.

Simply send for the free tube of STACOMB. Millions use it.

Neat hair adds smartness to appearance. STACOMB brings out the natural lustre. Keeps hair immaculately neat all day. Just the thing for controlling the hair after it is washed.

Stars of filmdom and the stage—leaders of style—prefer it. Hundreds of imitations, but none have equalled STACOMB.

STACOMB means prettier hair for women, tidier hair for children.

Send coupon today, for free tube.

For sale at your druggist or wherever toilet goods are sold. (*Not a liquid.*)

(Ask your barber for a STACOMB Rub.)

Demand *STACOMB*. The original—has never been equalled.

Standard Laboratories, Inc.  
Los Angeles, California



Standard Laboratories, Inc.  
Dept. M10, 750 Stanford Ave.,  
Los Angeles, California.  
Please send me free trial tube of Stacomb.

Name .....

Address .....

Dealer's Name .....

# To lift your work out of the "amateur" class



Brass Bound  
Mahogany Level,  
No. 1224  
Price, \$7.70



Mr. Punch says:

*"The difference between working with and working without one of these levels is the difference between guessing you're right and knowing you're right."*

**T**HAT'S what this Goodell-Pratt Level is for. Instead of finding yourself a half or a quarter of an inch out of the way when the job is finished, you'll find the job plumbs up true all ways. And that's real satisfaction.

Made of five pieces of thoroughly seasoned mahogany, with brass binding-plates dovetailed the entire length and doweled to heavy brass end-plates. Side views protected by brass plates. The vial is accurately ground on the inside and is extremely sensitive. Set solid in the stock, as a double movable bar adjustment is used. Plumb glass has a similar adjustment.

Size, 24x3x1¼ inches.

### *Other tools you need*

In the Goodell-Pratt line of 1500 Good Tools are many that should be on your work-bench now. Each tool is made with the care and skill that only the best toolsmiths can give to it. Write for a copy of the Goodell-Pratt Catalog No. 15. It pictures and describes all the tools in which you are interested. The book is free.

**GODELL-PRATT COMPANY**

*Toolsmiths*

Greenfield, Mass., U. S. A.

# GODELL- PRATT

**1500 GOOD TOOLS**

**\$1.00  
A SUIT**

**HANES  
GUARANTEE**

We guarantee Hanes Underwear absolutely — every thread, stitch and button. We guarantee to return your money or give you a new garment if any seam breaks.

**5 Big  
HANES  
Features**

- 1 Hanes large, roomy armholes** taped instead of turned under. Can't curl or rip—but a friction-free surface that really wears.
- 2 Hanes webbing belt** guaranteed 2-thread elastic webbing instead of single thread, gives more elasticity and greater strength. Specially sewed to prevent tears and rips.
- 3 Hanes closed crotch** is cut and stitched in a special way that really keeps it closed. That means added hot-weather comfort.
- 4 Hanes crotch lap buttons** sewed on the seam. Won't come off. 4 thicknesses of material instead of customary 2. No patch used.
- 5 Hanes wide, full-length knees** cut so as to give greatest freedom without binding or creeping up the leg.

**—unbeatable  
Athletic Underwear**



**Full Cut  
ATHLETIC UNION SUITS**

**M**ONEY can't buy more comfort, service or better fashioning than is all yours for \$1.00 in "Hanes" Athletic Union Suits! "Hanes" stands the service racket! Our guaranteed word on that!

Roomy, because generously full cut, you certainly get comfort in "Hanes"! And, reinforced where the strain comes and an elastic web belt of twice ordi-

nary strength means double the wear! Pearl buttons sewed to stay on!

You have only to get the "feel" of "Hanes" and get into a suit to prove that "Hanes" is the greatest underwear value in the world for anywhere near its price!

"Hanes" Athletic Union Suits are also made for boys from 2 to 16 years, in sizes 20 to 34.

*If your dealer can't fit you with  
"Hanes" Underwear, write us immediately.*

**P. H. HANES KNITTING CO., Winston-Salem, N. C.**  
New York Office, 366 Broadway

*Next Winter You'll Want to Wear Hanes Winter Underwear*

# 4 New FREE Books for Home Builders

Chock-full of Quality Material  
at Big Money Saving Prices

Send Coupon Now!!

*Harris Homes Beautiful*

Agricultural Tools  
Heating Plants  
Pipe-Fittings  
Radiation  
Roofing  
Paint  
Hardware  
Wallboard  
Tanks, etc.  
Wire Fencing  
Structural Steel  
Plumbing Material

Bathroom Outfits  
Lighting Fixtures  
Steel Roofing  
Windows  
Lumber  
Doors  
Garages  
Millwork  
Plasterboard  
Harris Homes  
Cabinet Work  
Furniture & Rugs



Harris Home No. PB-1527, a semi-bungalow with five rooms, bath, sun parlor and large office. A hundred others in our free book of plans.

## Plumbing



\$23.50

### One-Piece Sink

PR-2—White porcelain enameled roll rim kitchen sink with right or left drain board. Complete with faucet and nickel plated trap. 34 in. long...\$23.50 48 in. long...\$27.50 60 in. long...\$29.00

2 Part Laundry Tub \$18.75



PR-4—Complete 2 part laundry tub complete with improved swinging raising front and latest style strong angle steel base; nickel plated brass trap. Each...\$18.75



### Complete Bathroom Outfit

PR-1—Consists of bathtub 5 ft. long and 30 in. wide. White porcelain enameled on the inside and over 3 in. roll rim. Deep apron lavatory size 15x24 inches. Low pattern white china closet outfit with pushover seat. Complete with all nickel plated fittings above floor. \$67.50

### Mail This Coupon for FREE BOOKS!

Dept. PB-7

Mark an "X" in squares to indicate books wanted. They are free and sent postpaid without obligation to you.

Building material and supplies  Presto-Up Garage Book  
 Plan Book Harris Homes Beautiful  Presto-Up Cottage Book

Name.....

Address.....

## Heating

### Hot Water, Steam, Warm Air

Complete steam, and hot water heating systems—pipe and pipeless furnaces planned for you by experts and guaranteed to heat your home comfortably, economically and efficiently. Our big stocks insure quick shipment of everything needed to the last fitting. Capable engineers are waiting to help you.

Send a rough sketch of your building showing size and location of rooms, number and size of windows and doors, height of ceilings and full information will be sent to you promptly.



### Builders' Hardware

Lock sets, buttons and a complete line of builders' hardware of every description. All new modern designs featuring best construction, latest style and newest finishes. The complete line is illustrated, described and priced wonderfully low in our big building material book. Mail coupon for your copy today.



### Lighting Fixtures

A complete line of lighting fixtures carefully chosen in sets for all rooms. Everything needed to wire your home. See them in our new book.



### Guaranteed Paint \$1.85 Per Gallon

PR-8—Best house paint in white, black and 26 non-fading colors. Per gallon.....\$1.85

PR-9—Barn and garage guaranteed paint. Per gal.....\$1.35



Harris Home No. PB-2012, an impressive Dutch Colonial home with six rooms, bath and sun parlor. See them all in our free book of plans.

Harris Home No. 1006, above, with 5 rooms and bath, size 30 ft. x 29 ft. 6 ins. is but one of more than a hundred beautiful, practical designs built many times with big economy in best residential districts.

**FREE!** Every prospective home builder should have this new plan book of Harris Homes Beautiful. More than a hundred designs—bungalows, cottages, residences. Explains the money-saving advantages of our guaranteed Ready-Cut and Not Ready-Cut home building systems; the splendid quality of Harris Home building material; our liberal plan offers which saves you from 50 to 100 dollars right at the start.



### Presto-Up, Bolt-Together Garages



The wonder buildings of the age. Wonderful because they are so simple. Complete to the last detail, with all windows, doors and hardware in place. Come to you in sections, painted and ready to bolt together. Quickly and easily erected in a few hours. Our new, free Presto-Up, Bolt-Together Garage Book is now ready. Mail coupon for your copy.

Numerous attractive designs, both single and double models, in every desired size, priced upwards from \$129.00.

**Harris Brothers Co.,** 35th & Iron Sts., CHICAGO



## “One Dollar buys Topkis Why should I pay more?”

“IF I PAID twice the price I wouldn't get a better athletic union suit—I've tried.

“Dollar Topkis has better material than most underwear I've paid a lot more for. It wears longer. And it fits better than any I ever saw at any price.”

Only the best nainsook and other high-grade fabrics are used in Topkis. And it isn't skimped; full size is guaranteed. Pre-shrunk to stay true to size.

Topkis fit is nearer ideal than any union

suit ever made. Loose and easy. Big armholes. Extra wide, extra long legs.

These are some of the advantages of the Topkis Men's Athletic Union Suit at One Dollar. No good dealer will ask more. But they'll say it's worth more.

Men's Shirts and Drawers, 75c a garment; 75c for Boys' Union Suits, Girls' Bloomer Union Suits, and Children's Waist Union Suits.

In Canada, Men's Union Suits, \$1.50.

*Write for free illustrated  
booklet of underwear facts*

TOPKIS BROTHERS COMPANY, Wilmington, Delaware  
General Sales Offices: 350 Broadway, New York City

*Ask your dealer for TOPKIS.*

*Look for the TOPKIS label*





# No Money Down Sent on Approval

Our determination to this year double our sales of the world famous *Santa Fe Special* and *Bunn Special Watches* prompts this matchless offer. While other watch dealers are raising their prices, asking you for larger monthly payments, and making payment terms harder for you to meet, we are offering you our new model *Santa Fe Special*, and the famous *Bunn Special*, no advance in price, no money down, easier terms and smaller monthly payments. We realize the war is over, and in order to double our business we **MUST** give you pre-war inducements, better prices, easier terms, and smaller payments.

## **LOOK!** **Santa Fe Special** AND **Bunn Special Watches**

Without one penny of advance payment let us place in your hands to see, to examine, to inspect, to admire, to approve a real masterpiece in watch creation.

### Page 12 of Our Watch Book Is of Special Interest to You!

Ask for our Watch Book free—then select the watch you would like to see, either the famous *Santa Fe Special* or the 6 position *Bunn Special*, and let us explain our easy payment plan and send the Watch, express prepaid, for you to examine. No money down.

**REMEMBER** No money down—easy payments buys a master timepiece—a 21 Jewel guaranteed for a lifetime at about half the price you pay for a similar watch of other makes. No money down—a wonderful offer.

**Santa Fe Watch Company**  
76 Thomas Bldg. Topeka, Kans.

Santa Fe Watch Co., 76 Thomas Bldg., Topeka, Kans.

Please send prepaid and without obligation your Watch Book free, explaining your "No Money Down" Offer on the *Santa Fe Special Watch*.

Name \_\_\_\_\_

Address \_\_\_\_\_

State \_\_\_\_\_



ONLY  
\$ **3**  
DOWN  
and you  
keep this  
typewriter



DIRECT  
to you  
from our  
Factory

Big Saving  
In Price

## Yes, we will ship you this Genuine Underwood

Rebuilt in our own factory just like new for  
**ONLY \$3 down — NOT ONE CENT MORE**

Until you have tried the machine 10 full days at our expense



Our Factory

**EVERY MACHINE** is fully guaranteed. New parts wherever needed. New enamel, new nickel, new lettering, new platen, new key rings—a complete, perfect typewriter. Impossible to tell it from a brand new Underwood either in appearance, durability or quality of finished work.

An up-to-date machine with two-color ribbon, back spacer, stoned device, automatic ribbon reverse, tabulator, etc. In addition we furnish **FREE** waterproof cover and special Touch Typewriter Instruction Book. You can learn to operate this Underwood in one day.

### Big Book FREE

Our big handsomely illustrated catalog will be sent **free** on request. It tells you all about the advantages of owning a **STANDARD SIZE UNDERWOOD**; how and why this machine will last for years, saving many dollars not only in the purchase price but in its operation.

Send in the coupon and let us send you this beautifully illustrated book **FREE** without any obligation whatever.

**Shipman-Ward Mfg. Co.**  
"Typewriter Emporium"  
Montrose and Ravenswood Aves., Chicago

### Write Right Now

and learn how it is possible for us to ship you this Underwood Typewriter upon our **free trial plan** and our **direct-to-you money saving methods**. Get the full details now—just sign the coupon and mail **today**. Get all the facts—then decide.

### No Obligation

—to buy. You don't have to order. Just sign the coupon, send it to us and we will mail you our big catalog absolutely free.

Send the  
Coupon  
Today

10 Days'  
Free Trial

You have ten full days in which to try the typewriter before deciding whether you want to keep it. Give it every test—see for yourself—make the Underwood prove its worth to you. Don't take our word for it—put the Underwood before you and see if you don't think it the greatest typewriter bargain ever offered.

You will be amazed at the liberality of our offer, the beauty and all around excellence of our typewriters.

This is the genuine Underwood Typewriter. We offer you the same three models of the Underwood Typewriter being made and sold by the manufacturers today. **Standard 4-row single shift keyboard. Absolutely visible writing—the full line of typewriting is visible at all times.** All the improvements and attachments that any high grade typewriter ought to have.

### Big Saving to You

Our plan of selling to you **direct** makes possible enormous savings, which are all for your benefit. **Send in the coupon and we will send you prepaid our big catalog, including "A Trip Through Our Factory."** This shows how the Shipman-Ward Rebuilt Underwood is the best that can be produced at our **Special Price**.

don't have to do a thing to get our big **Free** catalog and complete details of our amazing

**You**

typewriter offer except to sign and send in the coupon. There is no obligation.

**FREE TRIAL  
COUPON**

SHIPMAN-WARD MFG. CO.  
B-212 Shipman Bldg., Chicago

Please send me **FREE**, all charges fully prepaid, your **BIG NEW** catalog of **UNDERWOOD TYPEWRITERS** and complete details of your **FREE TRIAL Offer**.

It is understood that I am under no obligation whatever and that this is to be sent without one cent of cost to me.

Name.....  
Street.....  
City..... State.....

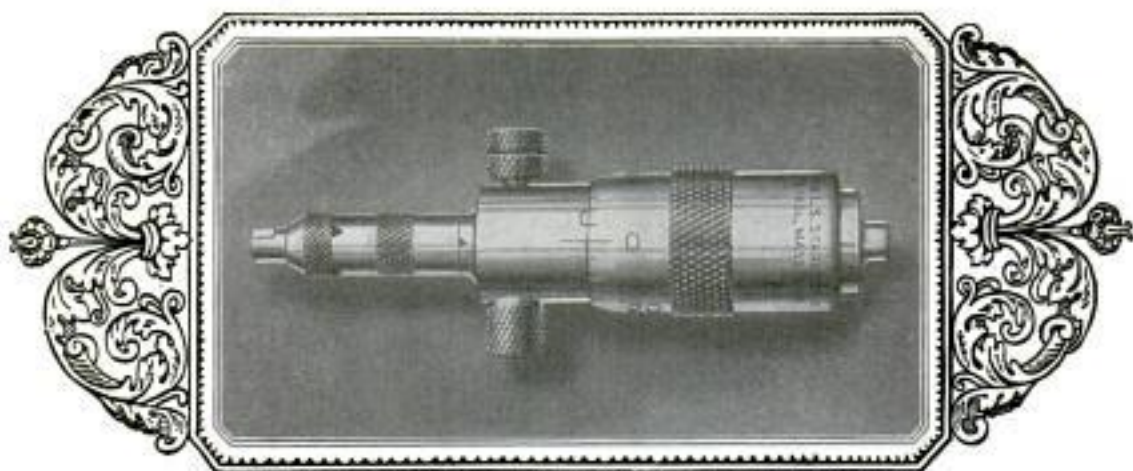

## No wonder a man is proud of his Starrett Tools

Some tools look well. Other tools are ingeniously designed—they're handy to use. And still others are built unusually well—they're good for a lifetime's use.

Starrett Tools combine *all* these features—convenience, finish and workmanship. And in addition they're the most *accurate* precision tools made. That's why a good machinist says "Starrett" when he's adding to his tool kit.

### THE L. S. STARRETT CO.

*The World's Greatest Toolmakers  
Manufacturers of Hacksaws Unexcelled*  
ATHOL, MASS.

The Micrometer Head illustrated above is part of our Inside Micrometer Set No. 124. A splendid "mike" which is furnished in four size combinations ranging from Set A (2 to 8 inches) to set D (2 to 32 inches). Turn to page 180 of the Starrett Catalog No. 22 A<sup>7</sup> for illustrations and complete description. Write for free copy if dealer can't supply you.



6351

# Use Starrett Tools



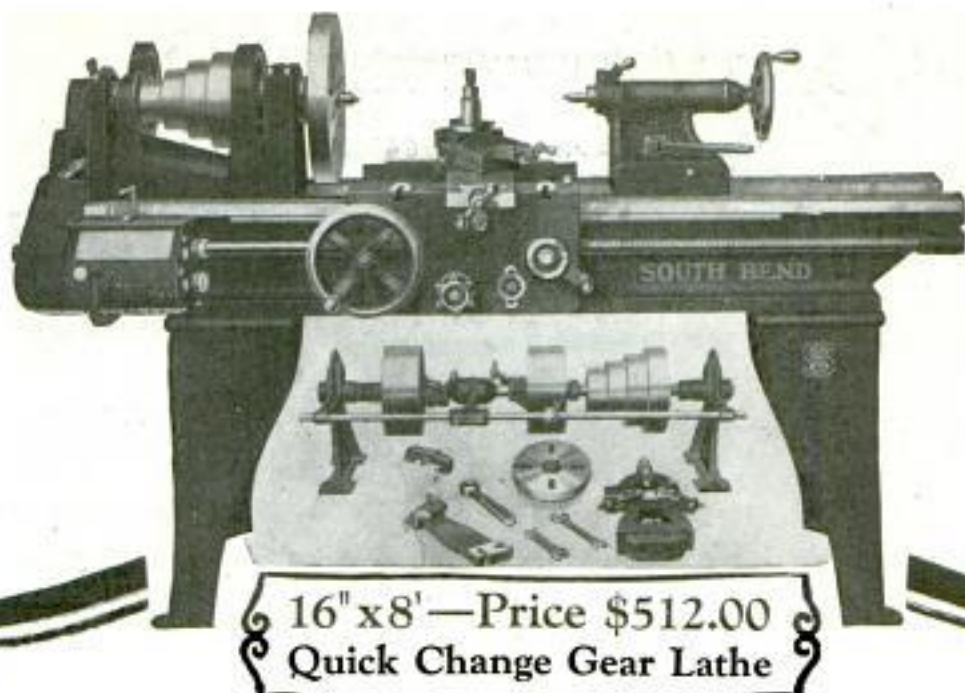

16" x 8'—Price \$512.00  
Quick Change Gear Lathe

# ***SOUTH BEND LATHES***

for the MACHINE SHOP      for MANUFACTURING      for the TOOL ROOM

Over 30,000 Satisfied Users

SIZE	Standard Change Gear	Quick Change Gear
9" x 3' Lathe.....	\$ 211.00.....	\$ 241.00
11" x 4' Lathe.....	248.00.....	288.00
13" x 5' Lathe.....	304.00.....	354.00
15" x 6' Lathe.....	376.00.....	431.00
16" x 8' Lathe.....	452.00.....	512.00
18" x 10' Lathe.....	656.00.....	721.00
21" x 12' Lathe.....	933.00.....	1016.00
24" x 16' Lathe.....	1254.00.....	1423.00

Send for new Catalog No. 81 which gives prices on the entire South Bend Lathe Line

South Bend Lathes can be purchased from Machinery Dealers in all principal cities.

## **South Bend Lathe Works**

725 East Madison St.

South Bend, Ind.

Established 1906  
South Bend, Ind.



Lathe Builders  
for 17 years.

# Only 10½ inches long

—yet the “YANKEE”  
Ratchet Hand Drill No. 1530  
has five adjustments



### Some other “YANKEE” Tools

Ratchet Screw-drivers  
Spiral Screw-drivers  
Plain Screw-drivers  
1½ to 30-in. blades  
Ratchet Breast Drills  
Ratchet Bench Drills  
Ratchet Chain Drills  
Vises, Removable Base

Dealers everywhere  
sell “Yankee” Tools

With the “Yankee” Ratchet Hand Drill No. 1530, you can quickly drill clean, accurate holes in cramped, awkward places where other hand drills would not work at all.

Even if you can move crank only an inch either way, the “Yankee” DOUBLE Ratchet keeps the bit cutting *continuously*.

Weighs only 20 ounces. Slips into pocket. Yet it has the same five ratchet adjustments as the big “Yankee” Hand and Breast Drills. Finger-touch on ratchet shifter gives you any adjustment. Drills up to 3/16 in. Magazine handle for carrying drill points.

### “YANKEE” Tool Book Mailed Free to You

Contains pictures and descriptions of all the ingenious “Yankee” Tools for saving your time and your muscles and doing “impossible” jobs. Send postal today.



NORTH BROS. MFG. CO., Philadelphia, U. S. A.

# “YANKEE” TOOLS

*Make Better mechanics*

**BUY HERE—SAVE MONEY**  
**JIFFY DOUBLE**  
**ADVERTISER NO. 34**  
**SELLS ON SIGHT**

**HERE IT IS!**  
*Another Big Hit!*  
**JIFFY**  
Changeable Signs

are sure making a killing. Lockwood, Olander, Henry, Woods, Young, Johnson and others clean up from \$10 to \$50 daily. No experience necessary. Merchants buy on sight. Just what they are looking for. If you must see a sample send 25c.

Retail Selling Price, \$1.00

12 by Express . . . \$3.25 | 50 by Express - \$19.50  
25 . . . 6.75 | 100 . . . 27.00

The Fastest Seller you ever saw. Order a dozen and see how fast they sell. Your money back if you want it.

**PEOPLE'S MANUFACTURING CO., Dept. 1**  
564 W. Randolph St. CHICAGO, ILL.  
*The HOUSE OF BIG HITS*

### Commutator and Valve Truing Lathe



Also Wood Lathes,  
Bench Band Saws,  
Bench Circular Saws

CENTRAL MFG. CO., Fairfield, Iowa

### TYPEWRITERS



**\$50** buys a brand new Corona, the Personal Writing Machine. Latest model with many improved features. Write for free booklet No. 8.

**Corona Typewriter Co., Inc.**  
GROTON, N. Y.

# Speaking of Making Money



Our records, which are open to anyone, will prove that from

**\$10,000 to \$25,000 PER ANNUM**

is being made by agents and distributors of

## OXO-GAS Heating Appliances

*Oxo-Gas Is the Cheapest  
and Most Efficient  
Fuel Known to Science!*

### THIS WONDERFUL INVENTION

converts any ordinary cook stove into a gas stove. OXO-GAS is made from kerosene and air. Cheaper, cleaner and more efficient than coal.

### Send for Catalog

illustrating and descriptive of twenty different, distinctive designs of heaters for all purposes, including the **WONDER RANGE**—the big Summer seller—a complete modern gas stove that makes and burns OXO-GAS at a cost of less than

**25c per Thousand Feet!**

1. **OXO-GAS** is made from Kerosene, Stanolin or Distillate.
2. **THE VAPOR** (4%) is mixed with air (96%).
3. **THIS MIXTURE** creates a non-carbon blue flame of high heating intensity.
4. **WHICH HEATS** indestructible perforated lava discs to incandescence, thus increasing the heat units of the fuel from 25 to 30% by refraction.
5. **WILL OPERATE** from eight to ten hours on one gallon of Kerosene, Stanolin or Distillate. Two gallons of kerosene (according to Government tests) will make heat units the equivalent of 1000 feet of city gas.
6. **FIFTY GALLONS** of kerosene equal to a ton of the best coal, a cord of wood or 25,000 feet of gas.
7. **KEROSENE** is the only fuel delivered anywhere in any quantity. The oil man can serve ten customers cleanly and efficiently while the coal man serves one.
8. **OVER A MILLION** Oxo-Gas plants are giving incomparable service to delighted users.
9. **OXO-GAS** appliances are absolutely guaranteed by a responsible corporation. References: Dun and Bradstreet Mercantile Agencies or any bank in the United States.
10. **OXO-GAS** is equally efficient Summer or Winter. An abundance of heat in the Winter. Cooler than any other method of cooking in the Summer, because the heat can be shut off instantly when not in use.

*OXO-GAS is, in fact, the only logical substitute for the diminishing supply of coal with its consequent high price!*

**Exclusive territorial assignments will be made to responsible, energetic men of good standing in their own communities!**



These two cuts show all there is to a complete outfit: The Heater, which is put in the stove, without making any alterations, and the tank to hold the oil. A small, flexible pipe conveys the oil to the Heater, where it is converted into OXO-GAS.



**GLORIA LIGHT COMPANY** 101-107 N. May St.  
CHICAGO, ILLINOIS

# F-F BATTERY CHARGER

ALL TYPES But "B"  
Charge AUTO  
Batteries  
Overnight  
Right In  
Your CAR

**\$15**



CHARGES  
RADIO & AUTO BATTERIES.

POPULAR. Eventually You Will Buy An F-F CHARGER & The Sooner You Buy One, The More You Save. A-B Charges All 6 Volt & up to 120 Volts Of "B" & Lead Speaker Storage Batteries in Series Inductively At Home Overnight. Disconnecting & Multiple Connections Unnecessary. Charging Circuits Separate. Nothing To Stop Over, Be Filled, Burn Out, Need Attention Or Cause Trouble. INFUSIBLE Rectifying Brushes Maintain Constant Efficiency Uninterruptedly. COMPLETE PORTABLE AUTOMATIC. No Skill Required. AMMETER Eliminates Guess Work. NOTHING Like It Made. Lasts A Lifetime. Leave Battery In Car, or Where Ever It Is; Screw Plug In Lamp Socket; Snap CLIPS on Battery Terminals. Turn Switch & Battery Is Charged In Morning. Charged Batteries Mean Fewer Expensive Replacements. It Costs Less To Buy An F-F CHARGER Than To Be Without One. INSIST on The F-F CHARGER. Built By A Master Of The Art In 7 TYPES. Thousands Sold Make Possible These POPULAR PRICES  
Type 6 charges 6 Volt Battery At 6 amperes \$15  
Type 12 charges 12 Volt Battery At 5 amperes \$15  
Type B charges Radio "B" Batteries Up to 120 Volts \$15  
Type A-B is a Combination Of 6 & B \$20  
Type 166 charges 6 Volt Battery At 12 amperes \$20  
Type 1612 charges 12 Volt At 7 amperes \$20  
Type 1626 is a Combination Of Types 166 & 1612 and Charges Both 6 & 12 Volt Batteries \$28  
Types B & A-B are Radio Specials. Types 166, 1612 & 1626 are For Heavy & Rapid Charging. SHIPPING WEIGHTS Complete with AMMETER & BATTERY CLIPS 11 to 15 lbs. PURCHASE from DEALER: Mail Check, or WRITE us to Ship TYPE desired C. O. D. ORDER Now, or WRITE Immediately for Free Descriptive CHARGER Bulletins 24 & 24A.

**FRANCE MFG. CO., CLEVELAND, OHIO.**

## A Plain Statement of Fact

When you say a circle is round or a man is "square" or a job is done you've told the *whole story*.

When we say that

**"UNITED"**  
Radio Condensers  
and Transformers  
Give Complete  
Satisfaction

we leave nothing more to be said. They satisfy because both design and construction are right.

United Variable Condensers have a wonderful new patented Vernier Dial Control, which makes possible twice as fine adjustment as any Vernier on the market.

43 plate .....	\$6.50	5 plate .....	\$5.00
23 plate .....	6.00	3 plate .....	4.75
11 plate .....	5.50		Postpaid

Vernier alone can be attached to any plate condenser by drilling one hole .....

"United" Amplifying Transformer Audio Frequency. Instrument is magnetically shielded, a very fine piece of precision workmanship .....

Show this ad to your Dealer and ask him to supply your needs at the above prices. If he cannot do so remit to us direct, under our money-back guarantee and give us name and address of Dealer you wish to favor.

**UNITED MFG. & DISTRIBUTING CO.**

536 Lake Shore Drive, Chicago, Ill.

NEW YORK OFFICE:

SAN FRANCISCO OFFICE:

50 Church St., New York City, N.Y.

309 Mission St., San Francisco, Cal.

## SIGNAL RADIO

Signal Radio Apparatus has long endured strenuous service by government, professional, and commercial users, as well as by beginners. Costs no more than experimental kind.

Send for Catalog.

**SIGNAL ELECTRIC MFG. CO.** 1910 Broadway  
Menominee, Mich.



Makes  
Your Radio  
Set Work Better

Perfect reception can be had only when wire connections are soldered. SOLDERALL and a match make perfect joints—guaranteed equal to wire or bar solder.

At leading Jobbers and Dealers or sent postpaid for 25c a tube

SOLDERALL CO., Dept. P, Newark, N. J.

**SOLDERALL**  
A Metal in Paste Form

Don't just ask for  
a Head Set—Say:

**DICTOGRAPH**

Choice of experts

Sold by all  
Responsible  
Dealers &  
Department  
Stores

**DICTOGRAPH PRODUCTS CORP.**  
220 W. 42nd St., New York

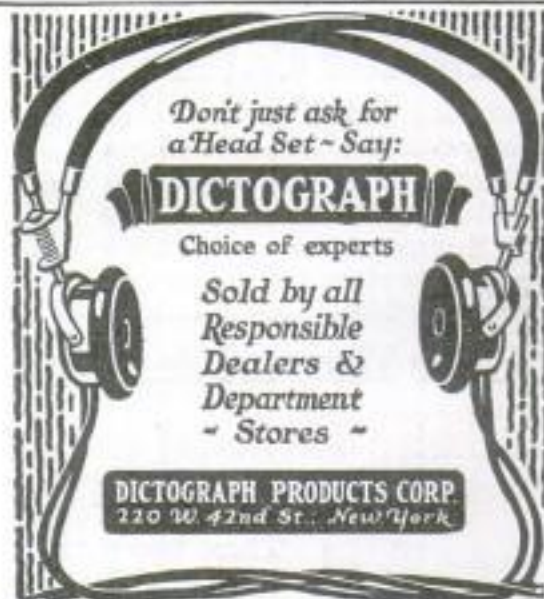

**Hit it anywhere!**

**MAGNETITE RADIO CRYSTAL**—the world's most sensitive and efficient Crystal Detector.  
**GIBBONS-DUSTIN RADIO MFG. CO.**  
518 West 9th St., Los Angeles, California



**THIS** Crystal Detector is unaffected by handling or moisture and will render efficient service indefinitely. Price 50c at all dealers—or mailed direct.

# ACME

for amplification



## Radio Apparatus of distinction

**ACME APPARATUS CO.**  
PIONEER TRANSFORMER AND  
RADIO ENGINEERS AND MANUFACTURERS  
CAMBRIDGE, MASS., U. S. A.

**FREE** — a book that tells how to get better results with radio tube sets. Address  
**WILLARD STORAGE BATTERY COMPANY**  
CLEVELAND, OHIO

### THE TRINITY LOUD SPEAKER

**THE BEST YOU CAN BUY** | TYPE A1 with 21" Horn..... \$25.00 | Literature  
| TYPE "B" for use with Phonograph 12.50 | upon request  
**TRINITY RADIO CORPORATION**  
168 Dartmouth St. BOSTON, MASS.

### RADIO BLUEPRINTS

Blue Print Design of Radio Receiver guaranteed range 1,000, 3,000 miles, using dry cell, ...	10c
Blue Print Two Stage Amplifier for above outfit.....	10c
Blue Print of Radio Frequency Amplifier for above.....	10c
Guaranteed 1,000 Ohm Phone Receiver Postpaid.....	\$2.00
Guaranteed Bakelite Couplers, Green Silk Prepaid.....	\$3.00

Send 10c for our complete Catalog. Agents Wanted. Liberal Commissions  
We sell Guaranteed Apparatus.

**BADGER RADIO CO., 497 E. Water St., Milwaukee, Wis.**

### FREE Radio Catalog



Our big stock of standard makes of radio sets, parts and supplies enables us to make prompt shipment from stock. Play safe — buy standard equipment from a reliable house. No cut price material.

Send \$5.00 for Murdock Complete Loud Speaker, 70c for "A" Battery Switch, 80c for pair Rubber Ear Muffs.

**JULIUS ANDRAE & SONS CO.**

In business since 1860

116 Michigan St. Milwaukee, Wis

## This is the New DICTOGRAPH RADIO Loud Speaker

with The Adjustable  
Air Gap That Tunes  
Out All Harshness

Invite your friends tonight. Surprise them with a real concert or dance. The wonderful new Dictogrand will create the illusion that the artists are in the very room with you. Just go to your dealer's and hear this remarkable, clear-toned instrument. Take it home and plug in for the finest entertainment you've ever known. You don't need extra batteries.

Like all the other famous Dictograph Products, the Dictogrand is guaranteed for one year.

If your dealer hasn't the DICTOGRAND in stock, write to us direct.

### DICTOGRAND

Mahogany Finish

\$28.50

**DICTOGRAPH  
PRODUCTS  
CORPORATION**  
220 W. 42nd St., N.Y.C.



**GUM**  
1¢ a  
pack

### Chewing Gum 1c per pack

Full size — 5 stick packs — spearmint, peppermint and fruit flavors. \$5.00 for 500 packs. Suitable for Premium or Scheme purposes. Deposit required. Prompt shipments.

**HELMET GUM MAKERS, Cincinnati, Ohio**



### "Read'em" Binding Posts

With knobs that won't come off

Anyone can "read 'em." All popular styles — Antenna, Ground, Fones, A and B Battery plus and minus — abbreviations of different names engraved on knobs. Ask your dealer for "Read 'em" — the kind for real Radio fans. If your dealer does not have them, write direct.

**The Marshall-Gerken Co.**  
Manufacturers

Dept. H. Toledo, Ohio



## WHITING-ADAMS BRUSHES

A brush expert says they are the best Hair Brushes made. They are penetrating. They go all through the hair to the roots and stimulate growth. They make a beautiful radiant sheen. The glory of woman is made more glorious with Whiting-Adams Hair Brushes.

Send for Illustrated Literature  
**JOHN L. WHITING-J. J. ADAMS CO.**  
Boston, U. S. A.

Brush Manufacturers for Over 114 Years and the  
Largest in the World

89

## How to Select Safe Bonds

Every investor wishing to learn about bonds of absolute safety yet paying an attractive yield (ranging as high as 7%) should write at once for this book, which will be sent for the asking. It has been prepared by George M. Forman & Company.

**YOUR COPY NOW READY**

In every banking circle the name of George M. Forman & Company has always been associated with sound investments and an attractive yield. Just a postcard or a letter will bring your copy of our interesting book, "How to Select Safe Bonds."

**GEORGE M. FORMAN & COMPANY, Dept. 447**  
105 W. Monroe Street, Chicago, Ill.  
"27 Years Without Loss to a Customer"

**\$25 A DAY**  
*Selling Shirts*

Large shirt manufacturer wants agents to sell complete line of shirts, pajamas, and nightshirts direct to wearer. Advertised brand—exclusive patterns—easy to sell. No experience or capital required. Entirely new proposition. Write for free samples.

Madison Shirt Co., 503 Broadway, N. Y. C.

## Summer Home in Maine

A gentleman's estate of 175 acres on the Maine coast, with frontage on a lake 9 miles long; master's house; large bungalow; caretaker's house; large garage; barns; private electric light and inexhaustible water works, and every modern improvement. Forty acres very large trees. Golf and yacht clubs only a few minutes away; good markets in the town.

The scenery of mountains, lake and ocean is pronounced one of the best five in New England. House and bungalow both completely furnished; steam heat.

Place will be sold at a great bargain as owner can no longer use it.

Address OWNER

206 East Ontario Street CHICAGO, ILL.

## Great NEW Invention for Seekers of Health—Power—Beauty

Revitalize yourself! Bring back energy. Be wholly alive. Elico Health Generator aids you to leave the lethargy and hopelessness of bad health behind forever. Yours for 10 days free trial.

**FREE Trial** **Elico Electric Health Generators** **Write for Free Book**

Write for free book that tells all about this great instrument that gives you Electricity, Violet Ray, Vibration and Ozone, the four greatest curative agents. Find out how you can have the Elico for 10 days free trial. Write today.

Lindstrom & Company  
442 N. Wells Street, Dept. B 135 Chicago

## \$1.00 MYSTERIOUS CHARM



Latest fad—keeps everybody guessing—IF YOU ARE A MASON—you should carry a Mysterious Charm. Spin it—instantly revealing the SQUARE AND COMPASS.

Gold plated. Sent postpaid, \$1.00 FREE. Masonic Catalogue listing publications, jewelry, paraphernalia.

**HEDDING & COMPANY**  
200-24th Ave., Dept. 25, N. Y. C.



Those who wear them say:  
**ERICKSON LEGS** are Wonderful  
because they do not chafe, overheat or draw end of stump.



Established 1892

If you have had a recent amputation send for new booklet on TEST LEGS for beginners.  
**E. H. ERICKSON CO.**  
38-A Washington Av. N.  
MINNEAPOLIS • MINN.





## Different from all others—the NEW BENJAMIN

### AIR RIFLE

Made on a different principle from all other Air-Rifles. The Benjamin is really a strong air-pump used to compress the air in the air chamber to any degree of power desired. From one to six strokes of the pump give all the force necessary. Each additional stroke gives increased power. The Benjamin works on the same principle as all air-drills and air-hammers—with this difference:

You control the shooting force as you desire. Look at this block of hardwood. It shows how Benjamin power is regulated as you wish.

You can't have accidents with a Benjamin. It's safe, always, because you control the power. The Benjamin never loses shooting force, and has no springs to get out of order or shake your aim. Write us for an interesting folder about this wonderful air-gun.

If your dealer does not handle them, send direct to factory—

**(PRICE \$5)  
(POSTPAID)**  
BENJAMIN AIR-RIFLE & MFG.  
CO., 115 N. Broadway, St. Louis, Mo.

Ask your dealer for demonstration.

Pacific Coast  
Representatives  
THAYER &  
BOWER  
Los Angeles,  
Calif., and  
San Francisco,  
Calif.



## We Pay \$8 a Day



Taking orders for New **Serenola**. Wonderful invention. Does more than machines costing many times its price. Easily carried with you anywhere. Built in just like a suitcase. Fully guaranteed.

### EASY TO TAKE ORDERS

The fastest selling musical invention the world has ever known. No experience needed. Full or spare time. Pay you every day. We deliver and collect. Write or wire for terms and territory.

PERRY-LUDLOW CO., S-1648, Dayton, Ohio

## BOYS!!!

LEARN HOW TO PLAY ANY  
TUNE IN ONE AFTERNOON

**FREE** Complete instructions for making real music with a Hohner Harmonica (Smooth Organ) sent free to any American Boy.

First learn the scale—"do, re, mi, fa" etc. Then try "Home Sweet Home." Diagrams and full explanations show you how you can do this easily with a

### HOHNER HARMONICA

After you've done this you can play any tune you can whistle—with chords and full accompaniment. Harmonica is most popular music on the radio. Biggest hit of the year in New York Orchestra. Be the first boy in your neighborhood to play a harmonica well. Astonish your folks and friends. Be sure to ask at the music store, general store, stationery or drug store in your town for a Hohner Harmonica and up. Write us this minute and say "Send me Hohner Harmonica instructions" and give your name and address. Write now, too—

M. HOHNER, Dept. 20, 116 E. 16th St., New York City



Get a Hohner at Your Local Store

Wesley Barry, Warner Bros. star is a Hohner fan.

Send now for free instructions

## 21 Jewel Burlington

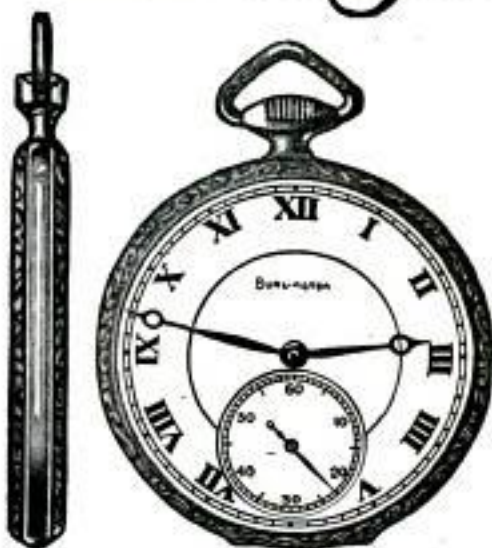

Adjusted to the Second 21 Ruby and Sapphire Jewels  
Adjusted to Temperature 25 Year Gold Strata Case  
Adjusted to Isochronism Your Choice of Dials  
Adjusted to Positions (Including Montgomery R. R. Dial)  
New Ideas in Thin Cases

# Only \$1.00 Down

Only One Dollar Down will buy this masterpiece of watch manufacture. The balance you are allowed to pay in small, easy, monthly payments. The Burlington—a 21-Jewel Watch—is sold to you at a price much lower than that of other high-grade watches. Besides, you have the selection of the finest thin model designs and latest styles in watch cases. Don't delay! Write for the FREE Watch Book and our SPECIAL OFFER today.

## Write While This Special Offer Lasts

Get the Burlington Watch Book by sending this coupon. Find out about this great special offer which is being made for only a limited time. You will know a great deal more about watch buying when you read this book. You will be able to "steer clear" of the over-priced watches which are no better. Remember, the Burlington is sent to you for only One Dollar down, balance in small monthly payments. Send the coupon for watch book and our special offer TODAY! Do not delay one minute!

### Burlington Watch Company

Dept. B-135 19th St. & Marshall Blvd., Chicago  
Canadian Address: 62 Albert St., Winnipeg, Manitoba

Please send me (without obligations and prepaid) your free book on watches with full explanation of your \$1.00 down offer on the Burlington Watch.

Name \_\_\_\_\_

Address \_\_\_\_\_



### Get This Wonderful Ring. If You Can Tell It From a Genuine Diamond Send It Back

These amazing, beautiful CORODITE diamonds positively match genuine diamonds in every way—same blazing flash and dazzling play of light rainbow fire. They, alone, stand the diamond tests, including terrific acid test of direct comparison. Lifetime experts need all their experience to see any difference. Prove this yourself.

### Wear a Corodite Diamond 7 DAYS FREE

Make this test. You risk nothing. Wear a genuine Corodite and a diamond side by side on the same finger for 7 days. If you or your friends can tell the difference, send it back; you won't be out a single penny. That's fair enough. If you keep the ring, price printed here is all you pay. No installments. Remember, Corodites alone have the same cutting as genuine diamonds.

Carat size gem. Beautiful settings of new modern design. Choice of gold or latest white platinum finish. Unusually 3-year guarantee. Hand-come artificial corodite free with each ring.

**SEND NO MONEY** Keep your money right at home. Just send name, address and number of ring wanted and size as shown by slip of paper, fitting end to end around finger joint. Your ring will come by return mail. When ring arrives deposit amount shown above with postman. If you decide not to keep ring after 7 days' wear, send it back and your money will be immediately returned. Send today.

**E. RICHWINE CO.**  
19 West Jackson Blvd., Dept. 643, Chicago, Illinois  
Sole Importers Genuine Corodite Diamonds

## Free Trial

Easy Payments arranged if desired. Conn has been recognized supreme for half a century by the world's greatest artists. Write for details, mentioning instrument.

C. G. CONN Ltd.  
731 Conn Building  
Elkhart, Indiana

**CONN**  
WORLD'S  
LARGEST MANUFACTURERS  
OF HIGH GRADE SAXOPHONES AND  
ORCHESTRA INSTRUMENTS



Design No. 303

Plans \$18.00

## California Bungalow Books

"Home Kraft" and "Draughtsman" each contain Bungalows and Two Stories. "Plan Kraft" Two Stories. "Kozy Homes" Bungalows. \$1.00 each—all four for \$3.00. De Luxe Flats \$1.00.

**DELUXE BUILDING CO.**

516 Union League Bldg., Los Angeles, Calif.

## Build a Sterling Home and Save Money

Buy direct from the mill—save middlemen's profit. All material comes in one complete shipment—cut to fit—ready to erect, all on ground when you start building. No waste. No guesswork. Send for beautiful book de luxe of

## Sterling Built Homes

and see for yourself the attractive Colonials, beautiful bungalows, cottages—homes to fit every purse. Don't delay. Building costs are going up.

Send 20c Today for 1923 Book

**International Mill & Timber Co.**

1906 S. Wenona Ave.,  
Bay City, Mich.

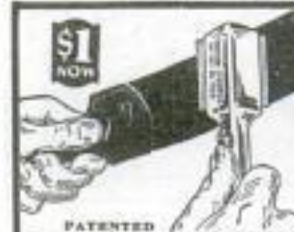

### STROPS ANY SAFETY Razor Blade Perfectly 100 Shaves per Blade

Nickel Steel Stropper, Leather Strop and Hanger, all postpaid for \$1. Or C. O. D. Money-Back Guarantee.

**TOMSON STROPPER CO.**  
Dept. 1275, KANSAS CITY, MO.

## \$3 Cash Buys Typewriter



### Balance Only \$5 Monthly

Save 35 to 60% on all standard makes—Underwood, Royal, Remington, etc. Every machine thoroughly rebuilt and GUARANTEED. Try five days at our expense before you buy.

WRITE at once for Free Descriptive Circular and Special Low Prices.

**5 DAYS FREE TRIAL**

**WYNN TYPEWRITER EXCHANGE** 11 Reliance Bldg. Kansas City, Mo.

## Wrestling Book FREE

Learn to be an expert wrestler. Know scientific wrestling, self-defense, and jct-fits. Develop a splendid physique, and have perfect health. Join this popular school and learn by mail. The famous world's champions—the marvelous

### Frank Gotch and Farmer Burns

offer you a wonderful opportunity. Wrestling is easily and quickly learned at home by mail. Men and boys write now for splendid free book. Learn all the science and tricks. Be able to handle big men with ease. Accept this wonderful offer NOW. Send for free book today, stating your age.

Farmer Burns School of Wrestling, BE 77, Range Bldg., Omaha, Neb.

## SQUAB BOOK FREE

Squabs are selling at the highest prices ever known. Breed them and make money. Write at once for free book, prices, etc.

Flymouth Rock Squab Co., 634 Howard St., Neiros Highlands, Mass.

## SELF-FILLING INK PENCIL "INDEPENDENT"

Meets all requirements. Self-filling, non-leakable, safety cap. Attached clip. Smooth writing gold style point.

Guaranteed Improved Fountain Pen. Eliminates fatigue. Promotes efficiency. Writes uniform. A business necessity.

**\$2** By Mail

Your Name in Gold—25 Cents Extra

AGENTS WANTED

**J. C. ULLRICH & CO.,** 161 Washington St., New York

**Whittemore's**  
Shoe Polishes

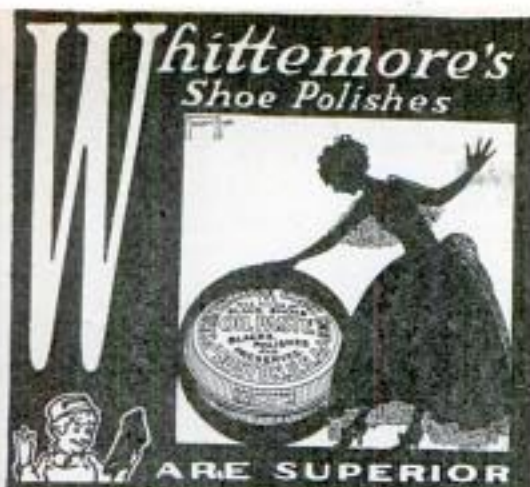

**ARE SUPERIOR**

## Which Way?

**D**ON'T take chances  
—you can *know*  
your direction every  
time if you carry one  
of the



## TAYLOR COMPASSES



Nine Styles. Ask your  
dealer for prices.

Taylor Instrument Companies  
Rochester, N. Y.

There's a *Treat* of Taylor  
Thermometer for Every Purpose.

## Starting a Company?

Save expenses and taxes by organizing on the popular, COMMON LAW plan under a pure DECLARATION OF TRUST. No experience required to fill in DEMAREE STANDARD FORMS, issue shares and begin doing business at once. Genuine DEMAREE FORMS are nationally known, approved by attorneys, and utilized by successful concerns throughout the United States. Send for large, free pamphlet (D-53) containing valuable information that you may need. C. S. DEMAREE, legal blank publisher, 708 Walnut, Kansas City, Missouri.

**Moore Push-Pins**  
Glass Heads—Steel Points

**Moore Push-less Hangers**  
To hang up things

Ask your dealer to show them

Sold  
Everywhere **10¢** per  
packet

Moore Push-Pin Co.  
Wayne Junction Philadelphia

**MONEY  
IN  
MUSHROOMS**

**NOW TIME TO START**  
BIG DEMAND. HIGH PRICES BEING PAID

An uncrowded occupation. Exceptional opportunities for live men and women. Raised at home. Only small space needed. Small expenditure will start you in a practical money-making enterprise. Big profits. Booklet telling all free. Write

**Nat'l Spawn Co.,** Dept. 12, Waban, Mass.

**\$4.00 Adding Machine**

The Gilson Adder will do your figuring easily, quickly and with absolute accuracy. Capacity 109,999,999 or \$1,099,999.99. It adds, subtracts, multiplies and divides and automatically carries from one column to the next. Made with aluminum case and steel operating parts, size 3½" x 6" x 1¼". **Written Two-Year Guarantee. Catalogue Free. Price, postpaid, \$4.00.**

Your money back if you are not satisfied.

**Gilson Slide Rule Co., Niles, Mich.**

TRADE MARK REG.  
**WURLITZER**  
SUPREMACY IN MUSICAL INSTRUMENTS



## Try It In Your Own Home

You may now have any known musical instrument for a week's free trial in your own home. Play it as much as you wish. See how easy it is to learn. There is no obligation to buy—no expense for the trial. You may return the instrument at the end of a week if you decide not to keep it.

Wurlitzer instruments are known the world over for unusual tone quality and excellence of workmanship. They are used by the greatest musicians, bands, and orchestras.

### Easy Payments

If you decide to buy, the Wurlitzer plan makes it easy for you to own the instrument you want. Payments are conveniently arranged in small monthly sums—a few cents a day will pay.

Special combination offers on complete outfits—velvet lined case, all accessories, self-instructor, etc.—everything you need at practically the cost of the instrument alone.

### Send For Free Catalog

The greatest musical catalog ever published—over 3000 articles—every known instrument described and illustrated—many of them shown in full colors. Gives you lowest prices and all details of the Wurlitzer plan.

### Send This Coupon

The Rudolph Wurlitzer Co., Dept. B177  
117 E. 4th St., Cincinnati 379 So. Wabash Ave., Chicago  
120 W. 42nd St., New York 250 Stockton St., San Francisco

Send me, absolutely free, your new illustrated catalog of musical instruments. Also tell me how I may try any instrument in my own home at your expense, and how the Wurlitzer plan makes it easy for me to buy. No obligation.

Name .....

Address .....

City..... State.....

Instrument .....

(State instrument in which you are interested.)

Copyright 1923, The Rudolph Wurlitzer Co.

Please Mention Popular Mechanics



## FREE Book on Saws

This new book gives you all the latest information on metal-cutting. It tells how to speed up the work and get longer and better service from your saws. Gives complete information on selecting the right saw for every job. Shows Atkins metal-cutting saws and machines, and explains their use. Also contains scores of helpful hints and tables. It is valuable to every man who uses or buys saws for metal-cutting. Send for it NOW.



Enclose 10 cents and tell us what metal you cut and we'll send you an Atkins Non-Breakable Hack-Saw Blade.

**E. C. Atkins & Co., Inc.**  
Dept. P. Indianapolis, Ind.  
Makers of "Silver-Steel" Saws and Tools



THE CRESCENT MACHINE CO., 83 Columbia Street, Leetonia, Ohio

It is the well known quality of CRESCENT machines that justifies you in selecting one of them each time you have need for wood working machinery. The CRESCENT line is better than ever and will always give you satisfaction in every particular. Ask today for catalog of hand saws, saw tables, jointers, shapers, planers, boreers, planers and matchers, swing saws, disk grinder, cut off table, hollow chisel mortiser, variety wood worker, Universal wood workers.

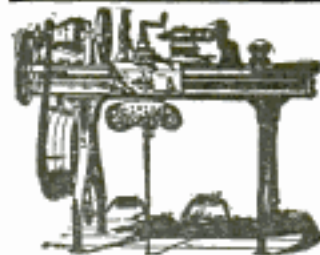

## LATHES

9 to 18-inch Swing

List price \$165 and up according to size. When ready to buy send for Lathe Catalog and prices.

**W. F. & John Barnes Co.**  
100 Ruby Street, ROCKFORD, ILL.

**Genuine Aluminum Level**  
NOW ONLY **\$3.95**  
DIRECT FROM FACTORY

Special limited offer, introducing new genuine Aluminum Level. Highest quality. Non-adjustable, always accurate. Light weight. Fine for over-head work. Wire bubble-markers. Easily read in poor light.

**Two Year Guarantee**  
Spirit tubes protected by glass on sides. Broken glass replaced within 2 years. Glass contains removable.

Just send your name and address. Pay postman on delivery. Use it and try it 10 days. Send it back if you can purchase a better level for less or you are not entirely satisfied. 18" 4 glass, \$3.95. 24", 6 glass, \$5.45. 36", 6 glass, \$8.95. 25", 6 glass, \$6.45. 30", 6 glass, \$6.95. Send Now.

**MASTER LEVEL & TOOL COMPANY**  
8926-C Seminole Ave. DETROIT, MICHIGAN

SEND NO MONEY

## The first machine to get

Parks' "Jewel"

**\$75**

complete with 3/4-in. Band Saw



The machine you need most in your shop is a Parks "Jewel" Band Saw. Speeds up every job, enables you to turn out accurate work rapidly, takes 90% of the tiresome handwork out of cabinet-making. Strong 2-inch angle steel frame, tilting table, ball-bearing saw-guides, 22-inch rubber-faced wheels, tension adjustment. Guaranteed 10 years.

Send for Parks' catalog of Lathes and Combination Woodworkers.

**THE PARKS BALL-BEARING MACHINE CO.**

1500-1540 Knowlton St.

CINCINNATI, OHIO

Canadian Factory: 200 Notre Dame East, Montreal, Canada

# PARKS

WOODWORKING MACHINES



## ALVAN CLARK TELESCOPES

Famous throughout the world as the highest grade Astronomical and Terrestrial Instruments. Now bringing to you at a reasonable price, these wonderful instruments—a source of pleasure and education—for the home—the school—the college. Send for circular and prices.

**ALVAN CLARK & SONS CO.**  
Makers of the great "YERKES" and "LOCK" Telescopes  
55 Henry Street Cambridge, Mass.



## TOOL CHESTS

for Machinists & Toolmakers

Every tool arranged in order. No up-to-date mechanic should be without one. A Gerstner Case costs no more than some tools, and will last a lifetime. Catalog free.

*Gerstner & Sons*

717 Columbia Street DAYTON, OHIO

## SARGENT PLANES

make it easier to do the careful, finished work you can be proud of. The Sargent Auto-Set Bench Plane is best for all-round work. The Pocket Plane and Steel Block Plane add the finishing touches to your handiwork. At hardware stores everywhere.

**SARGENT & COMPANY, 49 Water St., New Haven, Conn.**



**MCCORMICK & CO., Baltimore**

# Fix it with BERNARD PLIERS



**\$25.00**  
For An Idea

For what use are Bernard Pliers best suited? For what purpose do YOU use them? Send us your answer. For the BEST NEW use of widest appeal suggested before Aug. 1st, we will pay \$25.00, and in addition \$2.00 for every other NEW or general use that we consider practical. Mention Popular Mechanics Magazine, Bernard's grip like a vise and cut cleanly. They do a hundred jobs well.

Booklet "P" Free on Request



**BERNARD  
PLIERS**

Wm. SCHOLLHORN CO.  
NEW HAVEN, CONN.



PARALLEL JAWS

OUTSIDE CUTTER



Dealers and Agents; Request  
Attractive Proposition.

## Adjusts Instantly to Any Length

Just slide it out. Gives exact inside or outside diameter. No folding. Accurate, strong, brass-trimmed. Any length 2 to 8 feet, 20¢ per lineal foot. If not at dealer's, sent postpaid.

MASTER RULE MFG. CO., Inc.  
641-43 E. 136th St., N.Y. City

**Interlox**  
MASTER SLIDE RULE

## Beautiful HOUSES \$900 and BUNGALOWS

CAN BE BUILT FOR AND UP

This and many others in my new book, Building Plans for Modern Homes, will save you hundreds of dollars. One of the most complete and comprehensive books of plans ever published by any architect. New edition just off the press. Nearly 100 floor plans and photographs of bungalows, Colonial houses, etc., costing from \$200 up; gives sizes and cost to build.



FREDERICK H. GOWING  
ARCHITECT

Sent postpaid for \$2.00

111 Tremont St., BOSTON, MASS.

## RAISE BELGIAN HARES

New Zealand Reds - Flemish Giants - American Blues. BIG PROFITS, WE PAY \$1.50 TO \$8 EACH. Also Corles, Mink, Skunk, Fox, Muskrat, Etc. Easily raised anywhere. 32-page Catalog and Contract FREE! Illustrated book "COMMON SENSE RABBIT RAISING" quarterly journal, and copy of America's leading small stock magazine, all for 10 cents. Address Outdoor Enterprise Co., 1005 G. E. BLDG., KANSAS CITY, MO.

## NEW CHAMPION CORNET

OUTFIT \$6.85 Down - then pay month for four months! Fine imported Cornet, polished brass; excellent valve action, tone, intonation; near! finger-tips; EASY BLOWING; high or low pitch; in velvet-lined keratin case; mite and mouthpiece; self-instructor. For sale by your Music Merchant. Money-back Guarantee. ORDER NOW!

LYON & HEALY, 73-73 Jackson Blvd., Chicago

# Wear California's favorite Outdoor SHOE

for Men & Women



Patents  
Pending

Californians hike, hunt, fish and climb all year round. Our surveyors, woodsmen, ranchmen and oilmen consider "Buckhect" Shoes a necessary part of their equipment. We have had 65 years of experience in pleasing these western folks.

Long-lasting. Extremely comfortable. Unusually good looking. Made only by us. Exclusive features. A tough strip of leather is sewed around the vamp in moccasin style with strongest linen thread. Inside the regular vamp is a firm, soft leather lining, making a double vamp. This doubles the wear and helps keep out dampness. The "Backstrips" also hold the shoe in shape.

## BUCKHECT "Buckstrips"

Soles are tough oak-tanned leather. Uppers are chocolate colored, oiled storm-tanned calfskin. Each heel layer is one piece of solid leather. Not guaranteed waterproof, but they are as much so as a leather shoe can be made. On a basis of wear, "Buckhect's" actually cost you less.

Let us send you a pair

Men's 7-inch, Heavy Single Sole . . .	\$11.00
Men's 12-inch, Heavy Single Sole . . .	\$13.50
Men's 16-inch, Heavy Double Sole . . .	\$16.50
Women's 12-inch, Single Sole . . .	\$10.50
Women's 15-inch, Single Sole . . .	\$12.50

Three thousand retailers sell our shoes in the West. If your dealer does not have them or if you live east of Salt Lake City, we will be glad to fill your order. Send dealer's name, your size, and height desired. A pair will be sent postage prepaid. Satisfaction guaranteed or money back.

Write for Our Style Book of Outdoor Shoes. It illustrates a variety of styles for men and women and tells the best shoe for sport and work.

BUCKINGHAM & HECHT

29 First St., San Francisco, California

Manufacturers since 1857

DESIRABLE EASTERN RETAILERS WANTED

## DIAMONDS

### Here at 60% of Market Price

This Ring \$52.50  
1/2 - 3/4 Carat  
Perfectly Cut

This snappy perfectly cut diamond 7/8-3/32 ct. at \$52.50 among bargains in recent list. Many other big values in our list. Buy HERE! Prices based on loan values, not market values. This 75 year old diamond banking firm has thousands of unpaid loans and other bargains. Must sell NOW.

**Why Pay Full Prices**

Any diamond sent for absolutely free examination at our risk. No obligation. No cost to you.

**Send for Latest List**

Describes Diamond Bargains in detail, gives guaranteed loan values. Explains unlimited exchange privilege. Write for list today. Send NOW.

JOS. DeROY & SONS 1910 DeRoy Building  
Only Opposite Post Office Pittsburgh, Pa.



**S**UNKEN logs, hidden rocks, etc., hold no dangers for the Caille Liberty Motor for rowboats. Propeller automatically rises over them. And it will drive your boat through weeds so thick you couldn't row—through waters so shallow a boat will scarcely float—will drive boat well up on shore when landing—and it can be attached to boat on shore before starting out. No other motor regardless of price gives you so many advantages. Provides plenty of power, easily carried and has motorcycle control. Send for catalog and name of nearest dealer.

THE CAILLE PERFECTION MOTOR CO.  
6218 2nd Boulevard Detroit, Michigan

**CAILLE**  
PRONOUNCED "CAIL"  
**LIBERTY MOTOR \$85.00**  
**for ROWBOATS**

### FAULTLESS AUTO PRODUCTS

Faultless  
Raceboat

**Speed and Power Equipment**



Send for our new prices on Bodies and Accessories.

**AMERICAN TOP & BODY CO.**

Adams St., Delphi, Ind.

### HOME LOVERS' BARGAIN BOOK FREE

Showing Over 10,000 Furniture Bargains

All selections loaned free for a month. Take a year to pay if satisfied, paying little by little almost as you please.

SPiegel, MAY, STERN CO., 1108 W. 35th St., Chicago



**Safe -  
Sturdy - Comfortable**

Here at last is a motor boat, so simple in operation that any member of your family can safely drive it. Its unique propeller device permits you to run over submerged rocks—sandbars or beach it wherever your fancy dictates—same as a rowboat. The ideal boat for your camp or cottage. Beautiful—roomy—seaworthy—finished in natural wood—copper nailed throughout—economical to operate and moderately priced.

Write for illustrated booklet "150 Miles in Canadian Wilds" and descriptive folder.

DISAPPEARING PROPELLER BOAT CORP., 332 Robinson St., North Teawanda, N. Y.

**WATERFORD**  
**The Disappearing Propeller Boat**

## "Old Town Canoes"



### Have You Ever Gripped a Paddle?

**H**AVE you ever lazed along in a canoe? An occasional paddle stroke keeps you moving. Have you ever dug deep with the blade? The canoe shoots through the water. Did you ever mosey up a winding stream? Pick a good place to land, and broil a steak over an open fire? If you haven't, buy an "Old Town" and learn all the joys of canoeing.

"Old Towns" are the lightest, strongest, steadiest canoes made—and the lowest priced. \$54 up from dealer or factory.

The new 1923 catalog shows all models in full colors. It is free. Write for one to-day.

**OLD TOWN CANOE CO.**

1367 Middle St. Old Town, Maine, U. S. A.

### Delivered to You Free

for 30 days trial on approval. You can have your choice of 44 Styles, colors and sizes of the famous RANGER Bicycles. Express prepaid. Factory-to-Rider prices save you \$10 to \$25 on your bicycle.

**12 Months to Pay** easily save the small monthly payments. Parents often advance first payment.

**Tires** best quality, at factory prices, express prepaid. Lamps, wheels and equipment, low prices. Send No Money, do business direct with makers.

**Mead Cycle Company**  
Dept. W Chicago

Write today for free Ranger Catalog, factory prices and marvelous easy payment terms.



### MOTORCYCLE BARGAINS

Save 25% to 65%

on Slightly used and Rebuilt Motorcycles, Side Cars, Johnson Motor Wheels, Evans Power Cycles, Bicycles. Send for Free Bargain Bulletin and Money Saving Message. Notice hundreds of Bargains in used, rebuilt and new machines, supplies, accessories, etc.

AMERICAN MOTOR CYCLE CO. CHICAGO  
Dept. 722 2047 W. Chicago Avenue.



### Steady Work

in a fast growing business with Vanderpool Latest Improved Vulcanizer. Made in America.

Ask for Catalog  
**Vanderpool Co. Springfield, O.**

F. H. DIBB, Agent for British Isles  
26 Fairfield Rd. Winchester, England

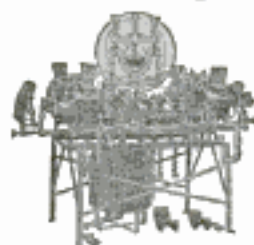

### MOTORCYCLES

RELIABLE STANDARD MAKES that you can DEPEND on.

Enjoy the glorious experience of going wherever you like—whenever you like. The price is within your means—35% to 50% less than others. These machines are slightly used, thoroughly overhauled or rebuilt.



Send for catalogue.  
**MYEROW BROS.**  
298 Columbus Ave. Boston, Mass.

**LOFTIS**  
BROS. & CO. 1883

**Genuine Diamonds GUAR- ANTEED**  
We import Diamonds direct from Euro-  
pean markets and sell direct to you by mail.

**DIAMONDS  
WATCHES  
CASH OR CREDIT**

**"Charlotte"**  
Diamond Ring  
Five radiant, blue  
white, perfect cut  
Diamonds. The en-  
tire ring is platinum  
**\$150**  
Others at \$200 and  
\$350

**SEND FOR  
CATALOG**  
Bargains in Dia-  
mond-set Jewelry,  
Watches, Wrist Watches,  
Pearls, Mesh Bags, Silver-  
ware, etc. Sent prepaid for  
your Free Examination.

**Wrist Watch**  
Rectangular Shape  
18-K Solid White Gold, 17 Jewels, \$39  
14-K Solid White Gold, 15 Jewels, \$32

**Credit Terms**  
on all articles: One-fifth  
down, balance in equal  
payments with no months

**LOFTIS BROS. & CO. National Jewelers** LIBERTY  
Dept. B-434 108 N. State St., CHICAGO, ILL. BONDS  
Stores in Leading Cities ACCEPTED

**MINT VENDING MACHINE**  
**Pays \$10 to \$20 Day Profit**

**Pays Rent for Store Owner**  
Install one in your store or any  
public place and get this easy  
money. Requires no attention.  
Always works. Machine's profits  
pay the rent. Write us about re-  
built penny and nickel machines.  
Finished like new. In excellent  
running order. Pay their cost in  
10 days.

Write or wire today for full par-  
ticulars. \$25 down payment. Bal-  
ance C. O. D. Export orders full  
down payment. Mints \$15 per  
case, 1,000 5 cent packages, \$1.50.  
Single boxes, 100 5 cent packages, \$1.50.

**SILVER KING NOVELTY CO.**  
400 Williams Bldg. Indianapolis, Ind.



**NO JOKE TO BE DEAF**  
—every Deaf Person Knows That I make  
myself hear, after being deaf for 25 years,  
with these Artificial Ear Drums.  
I wear them day and night. They  
are perfectly comfortable. No one  
sees them. Write me and I will  
tell you a true story, how I got  
deaf and how I make you hear.

**Address**  
**GEO. P. WAY, Artificial Ear Drum Co. (Inc.)**  
80 McKerby Building, 2631 Woodward Avenue, Detroit, Michigan



Medicated Ear Drum  
Pat. Nov. 2, 1908



**YOU NEED  
THIS BOOK**

IT illustrates and explains how  
you can permanently repair  
leaky kettles, motor radiators,  
cracked stove lids, fire pots and  
make dozens of other repairs  
economically with

**SMOOTH-ON CEMENT NO. 1**  
As easy to apply as putty—  
lasting as iron.

**SMOOTH-ON NO. 1** is sold by  
Hardware and General Stores in  
6-oz. tins, 30c (by mail  
add 6c); also in 1-lb.  
5-lb. and larger sizes.

**SMOOTH-ON MFG. CO.**  
Dept. 37-G, Jersey City, N.J.  
U. S. A.

**Write for it—it's FREE**





**The Famous  
YORK  
Saxophone**

**on  
free  
trial**

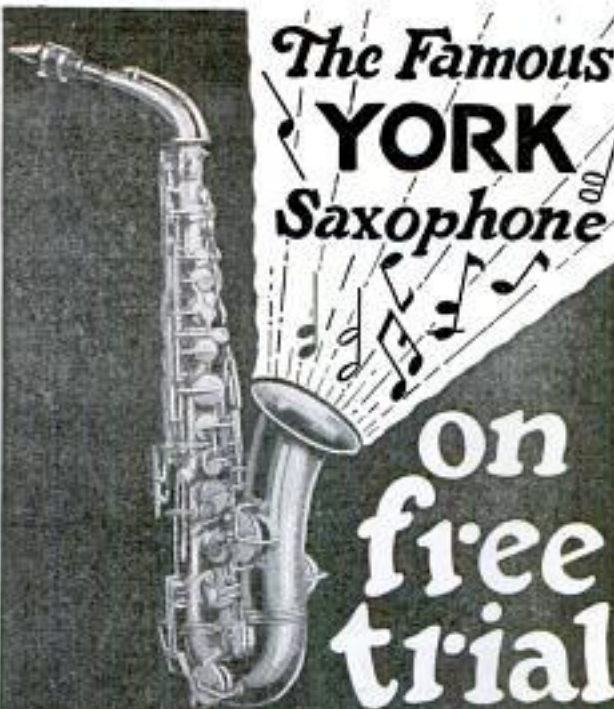

**Try the Easiest Instrument  
to Play for 6 Days, FREE**

Have the famous, professionally  
endorsed York Saxophone shipped to  
you for 6 days' free trial. Play on  
it at home. Learn the scales in an  
evening. Convince yourself of its  
superb quality, richness of tone and  
unexcelled workmanship. After 6  
days if the instrument does not  
come up to your expectations ship  
it back to us and it won't cost you  
a penny.

**EASY PAYMENTS**  
If you decide to buy, however, all you  
need to do is to make a small pay-  
ment down and the balance in easy  
monthly remittances. We  
send you everything you  
need—carrying case  
and necessary attachments.



**Take Your Choice**  
Remember, you can get any  
of the fine York Band Instru-  
ments on 6 days' Free trial.  
Just take your pick. Send  
coupon below for our illus-  
trated literature and indicate  
the instrument interested in,  
including: Saxophones—Clari-  
nets—Trombones—Drums—  
Alto—Basses—Cornets—  
Trumpets—Baritone.

**SEND COUPON NOW**  
Fill out this coupon and mail today  
and we will send you full and  
complete details of our free trial and  
easy payment plan.

**J. W. YORK & SONS**  
Dept. 221G Grand Rapids, Mich.



**J. W. YORK & SONS,**  
Dept. 221G, Grand Rapids, Mich.  
Gentlemen:  
Kindly mail, without cost to me, your beautifully illustrated lit-  
erature and details of your Free Trial and Easy Payment Offer.

Name .....

Address .....

Instrument .....

(Mention above the instrument most interested in)

Please Mention Popular Mechanics

## Johnson Motorwheel

Attaches to Any Bicycle  
Only Twin to Drive a Bicycle

Makes a regular motorcycle of any bicycle. 5 to 35 miles per hour, 100 miles on a gallon of gasoline. Chain Drive over Patent Cushion Sprocket. Two-inch clincher tire on heavy steel rim. Greatest of bicycle motor attachments. We can furnish motorbicycle complete if you have no bicycle.

### AGENTS WANTED

in every county. You can make big money working after school. Send for our Club Plan and

### FREE OFFER

of Johnson Motorwheel to agents. Wonderful opportunity for bright young men. Address

### EDWARDS AND CRIST COMPANY

Largest Motorcycle Dealers in the World  
Michigan Avenue at 13th Street, CHICAGO, ILL.  
Used motorcycles, all makes and models, \$50 to \$175.  
Send for Complete Bulletin.

### SEND for the INTERNATIONAL CATALOG

FOR  
FORDS—  
PRICES  
FROM  
\$27.85  
UP.

Factory to Consumer direct—  
Pay only one profit.

International Body Works, 914 W. Ohio Street, Dept. 7, Chicago, Ill.



Our net price list. Full line of auto bodies and accessories for Ford at Wholesale Prices.

Have big money on bodies by 3-cylinder direct from factory.

### FORD START HARD?



EASILY AND CHEAPLY FIXED WITH  
C-A Adjustable Center Bearing Cap

Corrects end-play and sets magnets for full efficiency without removing motor from car. Saves battery. Installed in few minutes. Guaranteed for year.

Ask your dealer or sent prepaid for \$3.75  
ADJUSTABLE BEARING CO., Dept. P, BRAZIL, IND.



## MONARCH Jr. LATHE

Ideal for Beginners or Experts

The MONARCH Jr. 9" Engine Lathe (illustrated) is simple and trouble proof—beginners soon turn out finished work—the choice of experts, too. A splendid lathe for inventors, mechanics, small shop owners. Compact; completely equipped; accurate; semi-quick change gear; automatic safety devices.



\$245  
9 in. Lathe—  
2 1/2 ft. Bed—  
with Bench Legs

SEND for Free Catalog of MONARCH Lathes which are built up to 30" swing  
**THE MONARCH MACHINE TOOL CO.**  
400 Oak Street SIDNEY, OHIO

## 5-Room House \$538

18 ft. x 26 ft.

Not Portable



You can buy all the material for a complete home direct from the manufacturer and save four profits on the lumber, millwork, hardware, and labor. Prices quoted include all lumber cut to fit, windows, doors, woodwork, glass, paints, hardware, nails, lath, and roofing. Complete drawings and instructions. Many styles to choose from. Highest grade lumber for all interior woodwork, siding, and outside finish. Send today for money-saving Aladdin Catalog No. 2848.

The Aladdin Co., Bay City, Mich., Portland, Oregon  
Wilmington, N. C., Toronto, Ontario

## MAKE OVER \$800.00 MONTHLY



Owning and operating an Anderson Vulcanizer which vulcanizes tires 3" to and including 5". You can vulcanize the smaller tires in all three molds. We guarantee no other vulcanizer will properly cure as many tires daily as the Anderson. It will do \$160 worth of work daily and will keep 8 men busy. You can run it ten hours daily, six days a week, for less than you can any other make, half a day. An Anderson School is near you.

**ANDERSON STEAM VULCANIZER CO.**  
Popp-Williams Bldg. Indianapolis, Ind.

## TAKE SOME ON YOUR TRIP!

**GIT HAND PASTE**  
Removes Dirt Grease  
Stains and Paint



10¢ at F. W. Woolworth Co., McCrory and other stores

## GOV'T 7x7 TENT \$10



Made of 10-oz. Govt. white canvas. Wonderful value; poles \$1.50 extra. Write for FREE 2,000-article catalogue No. 58.

**RUSSELL'S** 245 W. 42nd St. NEW YORK, N.Y.



**SEND NO MONEY**  
If You Can Tell it from a GENUINE DIAMOND Send it back

To prove our blue-white MEXICAN DIAMOND cannot be told from a GENUINE DIAMOND and has same DAZZLING RAINBOW FIRE, we will send a selected 1 carat gem in Ladies Solitaire Ring, 14K, price \$5.30 for Half Price to Intruders, \$2.63, or in Gentle Heavy Youth Richer Ring (14K) Price \$3.25 for \$3.25. Our finest 1/2 Gold Filled mounting, GUARANTEED 20 YEARS, SEND NO MONEY. Just mail postcard or this ad, State Size. We will mail at once. When ring arrives deposit \$1.00 for Ladies ring or \$3.25 for Gentle with postman. If not pleased return in 3 days for money back less handling charges. Write for Free catalog. Agents Wanted.  
**MEXICAN DIAMOND IMPORTING CO., Dept. ET-Las Cruces, N. Mex.**  
(Exclusive controllers Mexican Diamonds)



# GET FACTORY PRICES ON GALVANIZED ROOFING

## EDWARDS "REO" Metal Shingles

Absolutely rust-proof — edges as well as sides. Not the space of a pin point exposed to weather. Also fire and lightning proof. Reduces insurance. Outlast building. Need no repairs — and all roofing expenses. Easy to lay — one man can do the work — hammer and nails only tools needed. Lay over old shingles if desired. Patent Interlocking Device makes water tight seams — all nail heads covered — no rust or leaks possible.

### Exclusive "Tightcote" Process

Put all Edwards Galvanized Roofing in a class by itself. Bend, twist, strike it with a hammer as much as you like — you can't loosen or scale off the galvanizing — due to our "TIGHTCOTE" process which practically makes zinc covering a part of the metal sheet. No other galvanized roofing can withstand this test.

**FREE Roofing Book** if you get our big free book, describing Edwards famous "Tightcote"

Roofing, Siding, and Ceilings, and our lowest factory prices. We sell you direct and save you in-between dealers' profits. Write for Roofing Book No. 100.

### Low-Priced Garages

Lowest prices on Ready-Made Fire-Proof Steel Garages. Set up any place. Send postal for Garage Book showing styles.

**THE EDWARDS MFG. CO.**  
700-750 Pike St. CINCINNATI, O.



Corrugated



Patent Side Lock  
No nail heads in sight or exposed to the weather



Brick Siding

Roofing, Siding, and Ceilings, and our lowest factory prices. We sell you direct and save you in-between dealers' profits. Write for Roofing Book No. 100.

### Low-Priced Garages

Lowest prices on Ready-Made Fire-Proof Steel Garages. Set up any place. Send postal for Garage Book showing styles.

**FREE  
Samples &  
Roofing Book**

## You Can Save \$35.00



\$4.45 and up  
Facets Post Paid

Recover your old auto top frame yourself. Custom tailor made to fit all makes and models of cars. Any person that can drive a car can put it on. Roof and quarters sewed together, with rear curtain, fasteners, welts and tacks complete. Give name, year and model number of your car and we will send you catalog with samples.

**LIBERTY TOP & TIRE CO., Dept. E-7, Cincinnati, O.**

## Renews Baked Enamel

Marvel-o will keep the enameled finish of your car bright as new! Saves refinishing; adds greatly to re-sale value! Gives unequalled results. Absolutely harmless. Send name of auto accessory dealer and \$1 for full size 16-oz. can.

**MARVEL-O MFG. CO., San Diego, Calif.**



## Use Insyde Tyres



Positively prevent punctures and blowouts. Give double tire mileage, any tire—old or new. Use over and over again. Old worn-out casings will give three to five thousand miles more service. Low priced. Special representatives wanted. **WRITE TODAY.**

**AMERICAN ACCESSORIES CO., B-1176 Cincinnati, Ohio**

## AUTOMATIC TIMER

for Ford Cars—positively prevents all timer trouble—**Automatically** gives proper spark for all speeds—Does away with spark lever. Back-kick practically impossible—No more broken arms or ruined starting systems—saves gasoline, gives more power—easier starting—steadier pulling. Sold on money back guarantee—Every Ford owner will buy at \$3.50. Agents wanted. Big profits.

**AUTO SUN PRODUCTS CO., Dept. 47, Cincinnati, O.**



## Ride All Summer Without a Puncture!

**T**HINK of riding all summer without the least trouble from punctures. Think of the delays and expense you would avoid.

You can do it if you simply inject a 25c tube of old reliable Neverleak Tire Fluid into each tire. That is all that is necessary. Neverleak preserves both the rubber and fabric, thus doubling the mileage of your tires.

# NEVERLEAK TIRE FLUID

## Heals Punctures on the Run

Neverleak heals all punctures and thread leaks as fast as they appear and prevents trouble from porous condition of the tires.

Neverleak has been on the market for over a quarter of a century and has always given entire satisfaction to hundreds of thousands of riders.

Be sure you get the original. Don't let your dealer sell you something "just as good." Look for the signature on the yellow, green and white tube.

## Buffalo Specialty Company

103 Liquid Veneer  
Building  
**BUFFALO, N.Y.**



Please Mention Popular Mechanics

# Just Turn a Valve to Bake or Cook

**New Method Revolutionizes Summer Cooking and Baking—Makes Gas in Any Stove—On or Off with the Turn of a Valve.**

Cooking heat instantly. Heat exactly where and when you want it!—without building fires, without kindling, ashes, dust, dirt, wicks or odors—**IN ANY STOVE**, and without the sizzling heat of a coal or wood fire. A steady, reliable fire, producing perfect cooking in half the time. No more fallen cakes, no more sodden bread or biscuits from an unsteady oven, no more luck or chance in the cooking and baking.

## INSTANT-GAS

is a scientific combination of 95% superheated air and 5% kerosene (common coal oil)—the cheapest and safest fuel known. Never before has a product been offered which gives such *instant* and *perfect* control of the cooking and baking fire.

**START WITH A TURN OF THE VALVE.** Turn high or low to suit, and stop with another turn of the valve. No work, no untidy, overheated kitchen, no waste of fuel—*great money saver*. Instant-Gas is produced by a simple device, which is placed in the fire-box and enables you to cook and bake with gas instead of coal or wood.

**WORKS IN ANY STOVE.** No holes to drill, no injury to stove. Installed in a few minutes. Makes old stove work like new, makes new stove last twice as long, and makes kitchen the neatest, cleanest, pleasantest room in the home. Lasts a lifetime. For many years the markets have been flooded with oil burning devices—all using the same general principles; but a scientific improvement in the application of that principle makes the Instant-Gas Oil Burner the one great, outstanding success of its kind. Yet it costs no more than inferior, out-of-date makes. Insist on the **INSTANT-GAS**.

**TRY IT, 30 DAYS FREE.** We have hundreds of letters from grateful women who have gained health and strength by using the Instant-Gas, cutting their work in half, and doing away with overheated kitchens. Try the Instant-Gas in your own stove at our risk, see for yourself how much superior gas is to any other fuel, how much money it saves, how easy it is to turn on and off, how much cleaning and scrubbing it saves, how much better cooking and baking you can do. No obligation. Write today for free book and 30-day trial offer.

**INTERNATIONAL HEATING COMPANY** 122 S. 14th Street  
ST. LOUIS, MO.  
*Manufacturers of Scientific Heating and Cooking Equipment*



Note the scientific application of the air to the flame!

## AGENTS

We need a user agent in every locality, to whom we can refer new customers. Write for our \$60 a week sales plan, giving exclusive territory free.



**Big Sale NOW**

Prices Smashed on this better, faster cutting machine.

**\$91.50**  
F.O.B. Ottawa Kans.

Saws logs, limbs; falls trees. 10-year Guarantee. Cash or Easy Terms.

**FREE BOOK and SPECIAL OFFER.** Write quick before sale ends!

1741-G Wood St. OTTAWA, KANS.

Room 1741-G Magee Bldg. PITTSBURGH, PA.

From Pittsburgh, Pa., \$97.25

**N AGENTS 500% PROFIT**  
\$60 - \$200 per week. Free samples **GOLD SIGN LETTERS** for store and office windows. Anyone can put them on. Big demand everywhere. Liberal offer to general agents.  
**METALLIC LETTER CO., 433B N. Clark, Chicago**

**FREE Wonderful Book**

Tells how to learn taxidermy—how to mount birds, animals, game-keepers, snakes, tax skins.  
Learn by mail. A necessity for hunters and nature lovers. Best methods, quickly learned, very fascinating. Success guaranteed. Decorate your home and den with splendid art. Make big profits. Write today for this fine illustrated, free book and our amazing offer.  
**Northwestern School of Taxidermy, B977 Elwood Bldg., Omaha, Neb.**



**Salesmen \$10 or more per day**



**N. F. BORN, VIRGINIA**  
Made \$204.00 last week selling direct to wearer our guaranteed, all-wool, tailored-to-measure suits and over-coats at

**\$24.50 and \$27.50**

Latest styles; finest fabrics; linings and trimmings **High Grade** serge or alpaca. Our 25 years experience, perfect equipment, organization, and financial strength enable us to turn out such **Superior Garments** that sales are easy and repeat orders sure. No experience necessary, we teach you how. **Exceptionally Liberal Profits** paid you daily at the time each sale is made. We deliver and collect. Complete, attractive outfit **absolutely free** to salesmen with acceptable references. Territory rapidly being taken up. Make application today for our Fall line—ready early in July.

**INTERSTATE TAILORS**  
402 Pike St. Cincinnati, Ohio

**"73 Years Young"**

In my age writes H. B. Ruth, Colorado man, yet for years Mr. Ruth suffered with prostate gland disorder. "Used medicines with no avail—had about given up hope until a Doctor recommended your treatment," he writes.



Thousands of men like Mr. Ruth are finding renewed health and vitality thru a wonderful discovery that has brought the most amazing results in Prostate trouble, frequent nightly risings, sciatica, aches in back and feet and chronic constipation. Statesmen, Bankers, Lawyers, Doctors use and endorse this method. Yet you can use it right in your own home—no drugs, electric rays or book—a simple but quickly effective new hygienic principle. No matter what your age—or what you have tried, find out about this discovery at once. "Why Many Men Are Old at 40" is the **FREE BOOK** title of an interesting book that will be sent absolutely free. You may find relief from these distressing conditions the same as thousands of other men. Write at once to **THE ELECTRO THERMAL COMPANY, 2123 Main St., Steubenville, O.**

# PATENTS TRADE-MARKS AND COPYRIGHTS

## SPECIAL OFFER — Free Opinion as to Patentable Nature

Before disclosing an invention, the inventor should write for our blank form "Record of Invention." This should be signed and witnessed and if returned to us together with model or sketch and description of the invention, we will give our opinion as to its patentable nature.

## Our Three Books Mailed FREE to Inventors

OUR ILLUSTRATED GUIDE BOOK

### HOW TO OBTAIN A PATENT

Contains full instructions regarding Patents Trade-Marks, Foreign Patents. Our Methods, Terms, and 100 Mechanical Movements illustrated and described; Articles on Patent Practice and Procedure, and Law Points for inventors.

### OUR TRADE-MARK BOOK

Shows the value and necessity of trade-mark protection and gives information regarding Trade-Marks and unfair competition in trade.

### OUR FOREIGN PATENT BOOK

We have direct agencies in all foreign countries and secure foreign patents in the shortest possible time and at the lowest cost.

### LIST OF PATENT BUYERS SENT FREE

**IDEAS WANTED:** Send for LIST OF PATENT BUYERS containing unsolicited letters from Manufacturers and others WISHING TO BUY meritorious patents. There is a great demand for NEEDED INVENTIONS. We endeavor to assist OUR clients in the commercial development of their inventions.

### SPECIALIZATION—OUR STAFF

The field of invention is so vast that it is impossible for any one man to become an expert in all classes of invention. For this reason we employ a number of patent lawyers and mechanical experts selected for their special knowledge and ability in certain lines of invention.

### THE VALUE OF YOUR PATENT

depends on the skill and care with which your case is prepared and prosecuted in the United States Patent office. That every case receives our best efforts, and that our work is done skillfully and thoroughly, is evidenced by the many unsolicited letters of commendation that we receive constantly from our clients. We will furnish upon request lists of clients from any state in the Union for whom we have secured patents.

### Our New York, Philadelphia, Pittsburgh, Chicago and San Francisco Offices

We have established for the benefit of our clients Branch Offices in New York City, Philadelphia, Pa., Pittsburgh, Pa., Chicago, Ill., and San Francisco, Cal. These branch offices located in these large commercial cities together with our Main Office located near the U. S. Patent Office, in Washington, enable us to more promptly handle the business of our clients, particularly as the branch offices are in constant touch with the Main Office.

**Highest References — Prompt Attention — Reasonable Terms**

— FREE COUPON —

## VICTOR J. EVANS & CO., Patent Attorneys

NEW YORK OFFICES  
1007 Woolworth Building

CHICAGO OFFICES  
1114 Tacoma Building

PHILADELPHIA OFFICES  
714-715 Liberty Bldg.

PITTSBURGH OFFICES  
514 Empire Building

SAN FRANCISCO OFFICES  
Hobart Building

MAIN OFFICES: 765 9<sup>TH</sup> STREET, N.W., WASHINGTON, D. C.

Gentlemen: Please send me FREE OF CHARGE your books as described above.

Name ..... Address .....



# PATENTS

*Seventy-six  
Years of Practice*

**T**HE firm of Munn & Company filed its first application for a patent in 1846, and for seventy-six years has endeavored to keep pace with the inventive genius of the United States.

An experience of many years is at your disposal. If you have an invention which you wish to patent, send your sketches or model together with a description of your device, explaining its operation, and you will receive prompt, courteous attention.

*Write for our Handbook on*  
**PATENTS**

A full and complete booklet on Patents, Designs, Trade-Marks, Foreign Patents, Copyrights, Labels and Patent Office Practice with an explanation about our methods, terms, etc.

*All communications strictly confidential.*

Keep in touch with the inventions of the world by reading

## SCIENTIFIC AMERICAN

The MONTHLY MAGAZINE with a special appeal to every man of inventive genius. Recent rulings of the Patent Office, descriptions of the latest patented inventions, legislation and court decisions affecting patents, are noted in this authoritative publication.

## MUNN & COMPANY

*Patent Attorneys*

672 Woolworth Building, New York City

Scientific American Building, Room 2

625 F Street, Washington, D. C.

Suite 801, Tower Building, Chicago, Ill.

601 Hobart Building, San Francisco, Cal.

*Please Mention Popular Mechanics*

## Have You An Invention?

If so the WORLD PROGRESS will show you how to  
**PROTECT AND PROFIT FROM YOUR IDEAS**

This magazine is devoted entirely to the interests of Inventors. Sample copy free. One year's subscription \$1.00. Also send for free book,

### "WHAT TO INVENT"

containing SUGGESTIONS TO INVENTORS from prominent inventors and scientists of Inventions Needed. We invite manufacturers and promoters to address us regarding any inventions or patents they may want.

**WORLD PROGRESS PUB. CO., Inc.**  
Room 203 Victor Bldg. WASHINGTON, D. C.

## PATENTS

**C. L. PARKER**

Formerly Member Examining

Corps, U. S. Patent Office

**PATENT LAWYER**

MCGILL BLDG.

WASHINGTON, D. C.

Patents, Trade Marks, Copyrights, Patent Litigation

Handbook for Inventors, "Protecting, Exploiting and Selling Inventions," sent free upon request.

## PATENTS

Trade-Marks, Copyrights and Patent Litigation

Write for advice and instructions how to proceed, costs, etc. Hand Book with illustrations of 100 Mechanical Movements sent free on request.

**ALBERT E. DIETERICH**

*Patent Lawyer and Solicitor*

Successor to Fred E. Dieterich & Co. 621 Ouray Bldg., Washington, D. C.



## PATENTS

Send us sketch or model for patentability opinion and exact cost of patent. Our book "How to Obtain a Patent," sent free on request. It tells how to apply for Patents, Trade Marks, Foreign Patents, Copyrights, etc.; gives information on Patent Procedure; tells what every inventor should know. Thousands of Inventors, who are our clients, are our references.

Chandlee & Chandlee, 25 Years' Experience,  
435 7th St. Washington, D. C.

## PATENTS

TRADE-MARKS COPYRIGHTS

*Send for our free book of patent information.*

**Beale & Park** 802 F Street, Washington, D. C.  
16 S. Broad St., Philadelphia, Pa.



## GEARS ALL KINDS SMALL

The most accurate made and prices reasonable. We carry a complete line of gears in stock for immediate shipment. Can also quote on special gears of all kinds. Send us your inquiries.

WRITE FOR CATALOGUE

**CHICAGO STOCK GEAR WORKS**  
105-109 S. Jefferson St., CHICAGO

## TOBACCO

### HABIT CURED OR NO PAY

Any form, cigars, cigarettes, pipe, chewing or snuff. Guaranteed. Harmless. Complete treatment sent on trial. Costs \$1.00 if it cures. Nothing if it fails.

**SUPERBA CO., E-41, BALTIMORE, MD.**



*EXPERIENCE*      *SERVICE*

# CLARENCE A. O'BRIEN

## PATENT ATTORNEY

REGISTERED IN UNITED STATES PATENT OFFICE  
**MEMBER OF THE BAR OF**  
 SUPREME COURT OF UNITED STATES, COURT OF APPEALS DISTRICT OF COLUMBIA,  
 SUPREME COURT DISTRICT OF COLUMBIA, UNITED STATES COURT OF CLAIMS.  
 PRACTICE CONFINED TO PATENTS AND TRADE MARKS.



---

# PATENTS

SCIENCE

INVENTION

INDUSTRY

Any new article, machine, design or improvement thereof, or any new combination of parts or improvements in any known article which increases its efficiency or usefulness, may be patented, if it involves invention.

## If You Have Any New Ideas

which you feel are useful, practical and novel, *take prompt action toward protecting your rights.* If you have invented any new machine, or new combination of parts or improvement, or new process or design, **SEND DRAWING, MODEL OR DESCRIPTION** of it for information as to procedure to secure protection.

*Write Today for Blank Form*      *All Communications Are Held in*  
**"RECORD OF INVENTION"**      *Strict Confidence*

to be returned to me with drawing, description or model of your idea. Promptly upon receipt by me of your idea I will write you fully as to procedure and costs. No charge for the above information.

My personal, careful and thorough attention is given to each case. I offer you efficient, reliable and prompt service—based upon practical experience. *Highest references.* Write today for free book "*How to Obtain a Patent.*" This book will give you valuable information, and it may save you much time and effort. *Send for it NOW.* My practice is devoted exclusively to United States and foreign patents and trade marks. Very probably I can help you. Write today.

**CLARENCE A. O'BRIEN, Registered Patent Attorney**  
**1701 Southern Building      WASHINGTON, D. C.**

---

CLARENCE A. O'BRIEN, 1701 Southern Bldg.,  
 Patent Attorney, Washington, D. C.

Please send me your free booklet, "*How to Obtain a Patent*" and blank form "*Record of Invention*" without any obligation on my part.

NAME.....  
 ADDRESS.....

(WRITE PLAINLY)

ECONOMY

EFFICIENCY

INITIATIVE



# PATENTS

Booklet Free

Highest References

Promptness Assured

Best Results

Send drawing or model for preliminary examination

**ALL BUSINESS GIVEN PROMPT AND PROPER ATTENTION**

**WATSON E. COLEMAN, Patent Lawyer, 624 F St., Washington, D. C.**

## U.S. PATENTS



### DON'T LOSE YOUR RIGHTS TO PATENT PROTECTION

Before disclosing your invention to anyone send for blank form "EVIDENCE OF CONCEPTION" to be signed and witnessed. A sample form together with printed instructions will show you just how to work up your evidence and establish the same before filing application for patent. As registered patent attorneys we represent hundreds of inventors all over the United States and Canada in the advancement of inventions. Our schedule of fees will be found reasonable. The form "Evidence of Conception," sample, instructions relating to obtaining of patents and schedule of fees sent upon request. Ask for them—a post card will do.

PATENTS AND TRADE MARKS



480 Ouray Bldg. Washington, D. C.  
Originators of forms "Evidence of Conception."

## PATENTS and TRADEMARKS

We offer a strictly professional service to inventors and manufacturers in the protection of their patent and trademark rights. Validity and infringement investigations conducted. Correspondence solicited. Moderate fees. Preliminary advice without charge. No literature.

**MILO B. STEVENS & COMPANY**

Suite 100 Barrister Bldg., Washington, D. C.  
Suite 337A Menasha Block, Chicago  
ESTABLISHED 1864

WRITE TODAY for  
Our 168-PAGE  
FREE BOOK on

## Deafness

and learn how Perfect Hearing is now being restored in every condition of deafness or defective hearing. Our "Little Wireless Phones for the Ears" require no medicine, but effectively replace what is lacking or defective in the natural ear drums. They are simple devices, which the wearer easily fits into the ears, where they are invisible. Soft, safe and comfortable.

**WILSON EAR DRUM CO., Incorporated**  
1183 Inter-Southern Bldg. LOUISVILLE, KY.

## Can You

think of a simple, practical idea that will fill one of the many requests we have on file for new inventions? It may mean a fortune for you. Thousands of things are needed **right now**. Your brains can help. Send today for our great new book—

### "Inventions and Trade-Marks, Their Protection and Exploitation"

and learn more about making money from ideas than you ever knew before. It tells many things that are wanted, too.

**A postal will do—  
It is free**

## We Help Our Clients

without charge, to get the dollars out of their ideas—having facilities none others possess. Advice free. Don't delay—get the book at once.

**American Industries, Inc.**  
200 Patent Dept.  
WASHINGTON, D. C.

**Patents  
Advertised  
For Sale Free**  
in Invention and  
Manufacturing Supplement

Published for the man with an idea. Send for free sample copy. One year's subscription, 50c.

## PATENTS Secured

Prompt service. Avoid dangerous delays. Send for our "Record of Invention" form and Free Book telling How to Obtain a Patent. Send sketch or model for examination. Preliminary advice without charge. Highest Reference. Write TODAY.

**JACOBI & JACOBI, 410 Ouray Bldg., Washington, D. C.**

## INVENTORS

who derive largest profits know and heed certain simple but vital facts before applying for Patents. Our book *Patent-Sense* gives these facts; free. Write **Lacey & Lacey, 545 F St., Washington, D. C.** ESTABLISHED 1869.



## Buchstein's Fibre Limb

is soothing to your stump—strong, cool, neat, light. Easy payments. Braces for all deformities.

**D. BUCHSTEIN CO.**  
113 6th St. S., MINNEAPOLIS, MINN.

Send  
for Catalog Today

## \$2 Brings This Genuine DIAMOND RING

**SIMPLY send \$2.00 for the most sensational, price-smashing diamond ring offer ever made.**

A perfectly cut, guaranteed, blue white, fiery diamond is set in an 18 Karat white gold cup;  $\frac{3}{4}$  Karat size. Latest design, hand engraved mounting.

### 10 DAYS' FREE TRIAL

We take all chances—if you are not satisfied at the end of ten days for any reason whatsoever, return the diamond ring to us and your deposit will be refunded to you. Send only \$2.00, and receive this genuine steel blue white diamond ring exactly as illustrated; in a handsome gift box charges paid. A legal guarantee bond as to quality and value accompanies each ring. After ten days' trial pay balance \$6.46 a month for twelve months. Price only \$76.50.



## NO RED TAPE—NO DELAY

**Order Now!** This offer is limited. It may never appear again. Don't delay. Just send \$2.00 as a deposit. If you wish to return the diamond ring after trial, your deposit will be refunded.

### FREE BOOK OF GEMS

Most complete Jewelry Catalog ever issued of Diamonds, Watches and Jewelry—newest designs at lowest prices.

**A full year to pay on everything you order from our TWO MILLION DOLLAR STOCK.**

Address Dept. 788 Est. 1895

**ROYAL DIAMOND & WATCH CO.**  
35 Maiden Lane - New York

# PATENTS

## To the Man with an Idea

I offer a comprehensive, experienced, efficient service for his prompt, legal protection and the development of his proposition.

Send sketch, or model and description, for advice as to cost, search through prior United States patents, etc. Preliminary advice gladly furnished without charge.

My experience and familiarity with various arts frequently enable me to accurately advise clients as to probable patentability before they go to any expense.

*Booklet of valuable information and form for properly disclosing your idea free on request. Write today.*

**Richard B. Owen, Patent Lawyer**  
9-303 Owen Building, Washington, D. C.  
2276-E Woolworth Bldg., New York City



## "Been on a vacation Bill?"

"No, Jim—I've stopped smoking. Gained six pounds in a week. You know how I used to smoke—a package of cigarettes and a cigar or two a day—it sure had some hold on me. But I'm cured—took a scientific home to-

barco treatment—fixed me up in two weeks.

"Wasn't hard on me at all—noticed improvement the first day—I feel like a new man. It didn't interfere with my work—didn't leave any druggish after-effects—the money I saved in the last two weeks has paid for the treatment alone.

"Why don't you take it? It has cured men like you and me for over forty years—it is a doctor's individual prescription that sure fixes you up. Just send the coupon for full information NOW. No obligation. All correspondence is strictly confidential."

**THE KEELEY INSTITUTE**  
Dwight - - - Illinois

*A Doctor's  
Prescription*

The Keeley Institute, Dwight, Ill.  
Please send me, without any obligation on my part, your free booklet which will tell me how to rid myself of the tobacco habit.

NAME.....  
TOWN.....  
STREET.....STATE.....PM-7

# PATENTS If You Have an Invention and Desire to Learn How to Secure a Patent

Send for our Guide Book, **HOW TO GET A PATENT**, sent Free on request. Tells our terms, methods, etc. Send model or sketch and description of your invention and we will give our opinion as to its patentable nature.

**RANDOLPH & CO.**  
600 F St., N.W., Washington, D.C.

NAME.....  
STREET.....  
CITY.....STATE.....

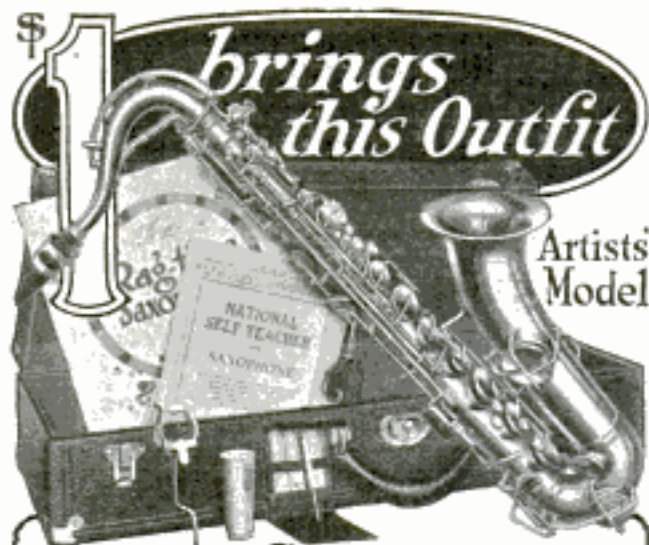

## "C Melody" SAXOPHONE

**Learn to play Saxophone!** The easiest instrument to learn, it is also the most popular! Pick out tunes in an hour, as quickly as with one finger on the piano. And there's no faster way to make extra money than playing Saxophone at dance or church or theatre. Makes you a social favorite, always welcome everywhere!

**10 MONTHS TO PAY!** The Standard "C Melody" Saxophone is the supreme grade "made in Elkhart." Choice of famous artists and teachers. The 1923 model with "beveled sockets" makes all other Saxophones "out of date." Sent to you for 6 days' trial, to prove to you its ease of blowing, simplified fingering and golden tone can't be equalled at any price. Complete 12 piece outfit direct to you from factory at only \$1 down and \$8.00 a month. Small first payment. Sensational cut in price during this sale, no interest, no tax, not one cent extra!—Saxophone, \$10 case, self-instruction system, book of music, reed, strap, pearl keys, etc., everything you need. Quality that enables you to buy once for a life-time.

**CATALOG FREE!** Tells you how you can secure the greatest of Saxophones on easy terms at less than cash prices! Write today for this free book and complete information of our sensational offer! Standard Music Co., Dept. 1122, P. O. Box 503, Chicago

## "Lighting Fixtures"

READY TO HANG

(Direct from Manufacturers)

Completely wired, including glassware. New designs. Send for catalogue No 24.

Send for DEALERS' proposition.

ERIE FIXTURE SUPPLY CO.  
STA. A. ERIE, PA.



## Do Your PRINTING

Cards, circulars, labels, tags, book, menus, paper, Press, \$12. Larger \$35. Job Press \$150 up. Save money! Print for others. BIG PROFITS. All easy, rules sent. Write factory TODAY for press catalog, TYPE, cards, paper. THE PRESS CO. D-37, MERIDEN, CONN.



## NEW GARTER

FOR

## CROOKED LEGS

(PATENTED)

## MAKES TROUSERS

## HANG STRAIGHT

If Legs Bend In or Out

Self-Adjustable

## It Holds Socks Up, Shirt Down

Not a "Form" or "Harness"

No Metal Springs

Free Circular — Plain, Sealed Envelope

THE T. GARTER CO., Dept. 29, NEW LONDON, NEW HAMPSHIRE

## FREE To Machinists

### POPULAR MECHANICS MAGAZINE

has prepared a table of decimal equivalents of the fractions of an inch, a copy of which will be mailed free to any machinist or auto repairman upon application. The table is 16½ in. wide by 23 in. long, printed on good, heavy paper, and will prove of great value in any shop.

There are no strings to this offer; simply send us your name, and the address of the shop or garage in which you work, and the table will be forwarded at once, carefully wrapped, and postpaid.

Address

### The Editor, Shop Notes Dept.

Room 512, Popular Mechanics Bldg.

200 East Ontario Street, Chicago, Ill.



## Straightens Shoulders— Increases Pep

**THE NATURAL BODY BRACE**—Corrects stooping shoulders, straightens the back, gives the lungs chance for normal expansion, induces proper breathing. Brings restful relief, comfort, energy and pep. For men and women.

Costs nothing to try it

Write for 30 days' free trial offer and free book.

**NATURAL BODY BRACE CO.**

HOWARD C. RASH, President 64 Rash Building, Salina, Kansas

## DEAFNESS IS MISERY



I know because I was Deaf and had Head Noises for over 30 years. My invisible Antiseptic Ear Drums restored my hearing and stopped Head Noises, and will do it for you. They are Tiny Megaphones. Cannot be seen when worn. Effective when Deafness is caused by Catarrh or by Perforated, Partially or Wholly Destroyed Natural Drums. Easy to put in, easy to take out. Are "Unseen comforts." Inexpensive. Write for Booklet and my sworn statement of how I recovered my hearing.

A. O. LEONARD, Suite 226, 70 5th Avenue, New York City

## Don't Wear a Truss

**BE COMFORTABLE**—Wear the Brooks Appliance, the modern scientific invention which gives rupture sufferers immediate relief. It has no obnoxious springs or pads. Automatic Air Cushions bind and draw together the broken parts. No salves or plasters. Durable. Cheap. Sent on trial to prove its worth. Never on sale in stores as every Appliance is made to order, the proper size and shape of Air Cushion depending on the nature of each case. Beware of imitations. Look for trade-mark bearing portrait and signature of C. E. Brooks which appears on every Appliance. None other genuine. Full information and booklet sent free in plain, sealed envelope.



MR. C. E. BROOKS

BROOKS APPLIANCE CO.,

126-H State St., Marshall, Mich.



## A NEW WAY TO GET YOUR CLOTHES ABSOLUTELY FREE

and Make Big Money during your spare time—something different, better, bigger, more liberal than any offer ever made. Lower prices—better clothes—bigger cash profits—express or postage paid on everything.

### DOUBLE PAY

**Free Clothes and Cash Profits Besides.** You can easily earn \$30.00 cash, extra, every week during your spare time, taking orders for our made-to-measure clothes. We don't ask you to use your cash profits for your own clothes. That's not our way of doing business. Ours is a new and better plan.

Fifty-six stylish, real cloth samples—FREE colored fashion plates; inside wholesale prices—everything FREE. Just drop us a line today and we will send complete outfit FREE.

**SPENCER MEAD CO., Dept. U-245, Chicago**



## ADD TO YOUR INCOME \$5 TO \$10 A DAY MADE EASY

The New Improved Am. Jr. No. 2 Is A Wonder

Sharpens and strops ordinary razors, Sharpens razor blades, scissors, etc.

Complete outfit for only \$95

**AM. SHARPENING MACHINE CO.**  
Dept. 7, 184 Washington St., Chicago



## "HOW I BEAT THE GAME"

The Inspiring Story of how one poorly paid garage mechanic won success, his own business and a big income. Tells how you can increase your salary from 100 to 500%.

Send for it today FREE.

**AMBU ENGINEERING INSTITUTE**  
Dept. 17-A 2632 Prairie Ave. CHICAGO, ILL.

## PILLIOD Tool Cases Excel

Machinists, Tool Makers and Carpenters find them most satisfactory in construction, appearance, service and price. Immediate shipment.

Booklet describing 20 styles on request.

**THE PILLIOD LUMBER CO.**  
Dept. 1 Swanton, Ohio



## \$600 to \$5,000 PROFIT FROM WASTE STORE SPACE

Business men! Send for amazing story of Butter-Kist Popcorn and Peanut Machine profits. Pays big in drug, department, candy, other stores, theatres, etc. Write

**HOLCOMB & HOKE MFG. CO.**

946 Van Buren St. Indianapolis, Ind

## AGENTS: \$6 PER DAY AND UP

Selling concentrated, non-alcoholic food flavors. Always fresh. Put up in collapsible tubes. Ten times the strength of bottled flavors. Guaranteed under U. S. pure food laws. All flavors. Sells in every home. Used every day. Not sold in stores. Big demand. Big repeater. 100% profit.

### MEN OR WOMEN

can make big money. Haut sold over \$300 in one month. You will find this a big, easy seller and a sure repeater. Must satisfy customers or money back. Write for territory and sample outfit. Get a big line of customers. Get repeat orders every month and have a steady income. Write quick.

**AMERICAN PRODUCTS CO.**  
8679 American Bldg., Cincinnati, O.



ACT  
QUICK  
WRITE  
TO-DAY

## Engine Prices HIT BOTTOM

Read this new schedule of prices; and then act! And, Remember—you are getting these Bargain Prices on the FAMOUS

## OTTAWA

—the most dependable engine on the market. Easier to start; Pulls more than its rated H.P.

### BOOK FREE

Write today for your copy of Big Free Engine Book and complete list of New Low Prices.

**Ottawa Mfg. Co.,**  
534-J King St.,  
OTTAWA, KANSAS  
DESK 534-J MADE 5126.  
PITTSBURGH, PA.

1½ H.P. \$37.00  
2 H.P. \$42.50  
3½ H.P. \$69.50  
5 H.P. \$97.50  
7 H.P. \$127.50

Above Prices  
L.S. Ottawa.  
For Shipment  
from Pitts-  
burgh and  
Carload Frt.

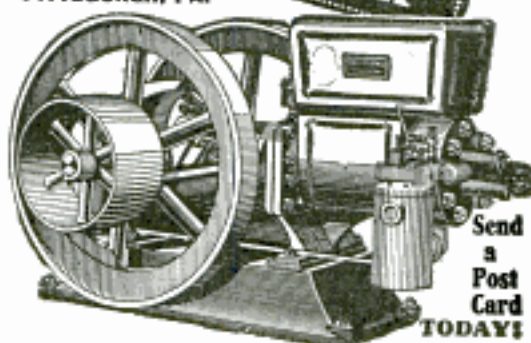

Send  
a  
Post  
Card  
TODAY!

## Great Bargain 2 SPLENDID SHIRTS \$3.79 2 SILK KNITTED TIES

Shirts, neat colored stripes, highest quality making and piping. Soft Cuffs. Finished inside only. Sizes from 14 to 17. Two of finest SILK KNIT. Fast colors. Full length.

Send No Money. Just name and size of shirts.

We pay postage. SATISFACTION GUARANTEED.

FREE A handy pair of snap on Cuff Buttons

FREE, if you send cash with order.

Rush Order Now. Send for Free Catalog of Bargains

PUBLIC TRADING CO., 263 5th Ave., Dept. 252, New York



## This Beautiful DIAMOND \$2 DOWN



A real bargain, 7 blue-white Diamonds set to look like a brilliant \$700.00 solitaire. Dainty 18 kt. White Gold, hand made mounting. Gentleman's ring, same price.

### 10 DAYS' FREE TRIAL

Merely send \$2.00. Shipment made without "red-tape." Examine it—wear it 10 days. If not convinced it is the Greatest Bargain in America, return it and your \$2.00 will be refunded. If you keep it pay only \$2.48 monthly—a matter of a few cents a day—until the Special Bargain Price of \$24.75 is paid. Sold under a gilt edge Protective Guarantee. You get 8 per cent yearly dividend on this purchase—also a 5 per cent bonus.

Send for it today. Thousands of bargains at your disposal. Save one-third by writing to Dept. J1177

**J.M. LYON & CO. INC.**  
2-4 Maiden Lane, New York

FREE

A Vitalic Bike Cap  
to boys who will  
write for it



1915 Ashby Ave.,  
Berkeley, Calif.  
March, 1923.

There has been but one set of Vitalic tires on my bicycle since Christmas 1918.

I have been almost every place with my Vitalic tires, in most every kind of weather, having delivered for a Drug Store for almost eight months, and for a meat market for one year.

I ride to school every day and my tires never give any trouble.

Yours Truly  
George R. Sanders

## What Boys Say the Best Proof of All

George Sanders has used one set of Vitalic bicycle tires nearly five years. His letter is typical of what all say who ride on Vitalics. And it's the kind of proof that counts most with buyers of tires.

Vitalics can be depended on. They have been the choice of boys and men for over ten years. For real endurance, freedom from punctures, no tires equal Vitalics.

Big bicycle makers like Excelsior, Iver Johnson and others put nothing except Vitalic tires on their finest wheels.

"Tougher than Elephant Hide" is a slogan that describes Vitalic qualities exactly.

Continental Rubber Works  
1946 Liberty Street Eric, Pa.

# VITALIC Bicycle Tires

"TOUGHER THAN ELEPHANT HIDE"

Boys: Tell your father or big brother that he can now get Vitalic Cords for his automobile with the same "Tougher than Elephant Hide" quality.

\$5<sup>00</sup>

2000 Ohms



\$5<sup>50</sup>

3000 Ohms

You are taking no chances when you use Murdock Headphones with your Radio Receiving Set. Experts have used them for over 17 years.

And Murdock prices are so reasonable that every Radio enthusiast can afford them.

Get a pair from your dealer. Also ask him to show you the new Murdock \$5 Loud-speaker. If he doesn't have them send direct.

## WM. J. MURDOCK COMPANY

General Offices and Factory

349 Washington Ave., Chelsea, Mass.

Sales Offices:

New York Chicago San Francisco  
Los Angeles Seattle

# MURDOCK RADIO

STANDARD APPARATUS SINCE 1904

## FORDS run 34 Miles on Gallon of Gasoline



Wonderful new carburetor. Reduces gasoline bills one-half to one-third. Increases power of motors from 30 to 50%. Start easy in coldest weather.

SENT ON 30 DAYS' TRIAL

Fits any car. Attach yourself. Fords make 34 miles to gallon. Other cars show proportionate saving. Send make of car. Special 30-day trial offer. Agents wanted.

AIR FRICTION CARBURETOR CO.

Dept. 3780

Dayton, Ohio

## I Need Branch Managers



LIGHTNING—WONDERFUL NEW ELECTRO-lytic charges discharged batteries instantly. Eliminates old sulphuric acid method entirely. Dissolves sulphation. World has waited half a century for this invention. One gallon, retails \$12.50, free to agents. Lightning Battery Co., St. Paul, Minn.

GALENA PATENT  
NICKEL DETECTOR  
CUP AND BINDING  
POST

## RADIO DETECTOR

SLIDING HARD  
RUBBER KNOB



This is the smallest and lowest priced detector on the market. It does a variety of things as well and better than many \$5.00 detectors. Has composition base; all metal parts nickel-plated; furnished complete with galena crystal. Study illustration and notice new features. Note particularly patent nickel detector cup and binding post. Size 1 1/2 x 1 1/2 x 1 inch. Sent prepaid anywhere. Price complete

50c

If you build your own radio set you must have the BASCO catalog containing 185 illustrations and 50 vacuum tube connection diagrams—the greatest collection published in any catalog. Catalog contains the greatest assortment of parts and raw materials in U.S. Send 15c in stamps or coin for this catalog. "Basco Has It."

RADIO SPECIALTY COMPANY, 98 E Park Place, N. Y. City

## Valuable BATTERY BOOK FREE

Tells how to reduce your battery expense—how to get **QUICKER START** from your motor. Shows how to have **BRIGHTER LIGHTS** and **PERFECT IGNITION** by knowing more about your battery. Also tells how to charge your battery at home for a nickel with

Send for  
Free Book today



Charges your  
RADIO Battery too!

### THE HOMCHARGER

The world's most popular rectifier.  
The Automatic Electrical Devices Co.  
129 W. Third St. Cincinnati, O.

Charge Your Battery at Home for a Nickel!

INSIDE  
FACTS  
ABOUT  
YOUR  
BATTERY



### Only \$45.00 For This Job Complete

Save exhibit freight and one-half original cost by buying Ford Speedster Bodies knocked-down. Simple, complete instructions furnished, all parts cut to exact fit. Anyone can assemble this job. Complete with hood, radiator shell, instrument board, upholstery, metal parts, wood parts, bolts, screws, etc. Flat radiator shell furnished extra up. Designed low with lack of wind resistance. Price set up \$95. Further particulars on request.



Not Paper Patterns

All Parts Complete

The Central Auto Supply Co. Eng. Dep. 124, Louisville, Ky.

### EVINRUDE WILL

To insure delivery of a new **SPORT TWIN**, order from your dealer at once. Send for catalog.

EVINRUDE MOTOR CO., 207 Fremont Block, Milwaukee, Wis.

**BE OVERSOLD**

### FREE RADIO BOOK

An easily understood explanation of Radio, written by Powell Crosley, Jr., President of Crosley Mfg. Co., Cincinnati, and The Precision Equipment Co., Cincinnati.

WRITE TODAY FOR THIS BOOKLET

Crosley Manufacturing Co.

715 Alfred Street Cincinnati, O.



## INLAND RUNNING BOARD TIRE PUMP

WORLD'S EASIEST  
AND EVERLASTING  
FOLDS COMPACTLY

\$5.50, WITH \$6.50  
GAUGE,

At your Dealer's, or prepaid by  
INLAND PUMP MFG. CO.  
610 Reaper Blk., Chicago



# Oh Mary

we won't be shut-ins  
anymore"

"I've bought an INDIAN Motorcycle and side car—and the open road is ours.

"Just think—we'll have all the joy of travel, the zest that comes from new scenes, the health of life out of doors.

"What wonderful times are ahead of us. You in the big, comfortable side car, with me to pilot you to mountains, shore, the length of the gypsy trail.

"It's sport we can afford, too. The price is so low, and the upkeep so little, that it costs no more than carfare.

"I can ride it to business; go later; get home earlier. And in the evenings—and week ends—we'll be free as the birds to come and go when and where we like.

"It won't cramp us to pay for it, either. Just a little each week, and we have the fun of riding while we're paying.

INDIAN Scout, the most popular middle weight, \$250; electrically equipped, \$285, F. O. B.

INDIAN Big Chief 74, ideal for heavy duty side car work, \$345, F. O. B.

Ask your dealer—or write us, Dept. N7—for free booklet and easy, ride as you pay plan.

Hendee Manufacturing Company  
SPRINGFIELD, MASS.

# Indian Motorcycle

Please Mention Popular Mechanics

**For This Genuine SELF-STARTING REMINGTON No. 10**

**\$38<sup>65</sup>**

**30 DAYS FREE TRIAL**

**5 YEAR GUARANTEE ALL LATE IMPROVEMENTS**

**ONLY \$2<sup>00</sup> DOWN**

### BIGGEST VALUE EVER OFFERED!

Think of it! A Genuine, Self-Starting Remington No. 10 (the greatest advancement ever made in a typewriter)—a standard, thoroughly reliable machine—(guaranteed 5 years) with all the late improvements—one that will give you years of dependable service—and you save practically 70.00!

#### Guaranteed Equal to New

as regards character of work and speed. Compare it with a new machine, and if you are not convinced beyond all doubt—if you do not feel it is all we claim after a 30 day trial, you'll not be out one cent!

**SEND TODAY** A postal will give details of our \$2.00 down direct, 5-year selling plan. Learn why we can sell a genuine Remington No. 10 at such a tremendous saving to you! Or send \$38.65 NOW and if not convinced it is the biggest value ever offered, your money returned promptly without question. Our references: Any Mercantile Agency or your bank. Address

**LINCOLN TYPEWRITER CO.** Dept. 131 298 BROADWAY NEW YORK

## Sell coal to your trade

IN CARLOAD LOTS

Earn week's pay in an hour Sideline salesmen wanted.

Washington Coal Co., Stock Yards Sta., Dept. AG, Chicago

**Auto Supplies**

Knowing **HOW** to buy is merely knowing **WHERE**

This is Chicago's Great Wholesale House

**AUTO SUPPLIES AND MOTOR PARTS**

**WHOLESALE ONLY**

Dealers send today for this big money-saving book

**ACCELL AUTO ACCESSORIES COMPANY**  
3074 South Michigan Avenue  
CHICAGO

**Amazing Hand-Made Tools**

**Make \$20 Every Day!**

That is a fact. Salesmen are making amazing incomes selling direct to mechanics, garages, shops, etc. These tools, put up in kits, are made by our famous Cornwell secret formula. Every tool guaranteed the finest made in the world. Salesmen make sensational demonstrations of chisels, wrenches, punches, bearing scrapers, etc.

**You Take No Money Risk!**

We take all the money risk. You make instant sales and big cash profits. Tools like these never made before. Repeat orders tremendous. You make big money the very first day.

**Write TODAY—Get Sample Outfit**

Write or wire for complete sales plan, describing tools, money-back guarantee and offering sample outfit. Don't delay! Territories closing fast.

**THE CORNWELL QUALITY TOOLS CO., Dept. 10, CUYAHOGA FALLS, OHIO**

## EASY FOR YOU TO OWN A FINE INSTRUMENT!

YEARS ago the famous King Brass Instruments were sold only for cash to famous musicians. But now due to our easy payment plan anyone can own one of these wonderful instruments.

#### SAVE MIDDLEMAN'S PROFITS

Simply order direct from the factory. You save middleman's profit—and you get a fine, new, sound-laboratory tested, acoustically perfect King Instrument. With it goes our guarantee plus free factory-service.

#### IT'S EASY TO OWN A KING

Rebuilt instruments, refinished to look like new, we sell for cash at low prices. New instruments on the easy-payment plan. Thus it's "easy to own a King". Send for our latest complete catalog and list of special bargains.

**THE H. N. WHITE COMPANY**  
5250 Superior Avenue Cleveland, Ohio

**KING BAND INSTRUMENTS**

Build low, with the economy tilted 30-in. seat rises under fully equip.

**MAKE your FORD into this SPORTCAR**

**Red-i-Kut** Life-Size Patterns Instructions and Tail Delivered

**\$640**

Pat. The "Pat" el Ford

Have finished for "Pat". It's a new jazz load. I go where you can't or where others fail to go. I can run thru mud on light wheels where others can't go on low. Here is a picture I see so good, I get called the Ace of Ford's. For I skip by them all kind of like a rabbit. — Cal Jones, Columbus, Ky.

You can build it. Over 11,000 in use. Order Today

Keen, Glossy. Up-to-the-minute. Order now while we can make good delivery and be ready for the happy summer days in your "Pat".

**KUMPEL CO.**  
38 Kueschel Bldg.,  
Guttenberg, Iowa

Send seven for bar-governments, wads, bodies, tips, underslung irons, etc.

**\$25 A DAY Clear Profit**

—every day you work. Make \$5,000 to \$10,000 a year in the Floor Surfacing Business with the American "Universal" method. Work for yourself. Experience, special training or large investment unnecessary.

**New Field; Big Profits**

Better floors are demanded everywhere. American "Universal" electric machine, doing work of six men, assures **BIG PROFITS** in this new uncrowded field. Every floor, —old or new, —in town or city, is your prospect. Work easy to net. Profit possibilities unlimited. Positive guarantee and 5-day trial offer protects you. Write today for complete details.

**AMERICAN FLOOR SURFACING MACHINE CO.**  
523 S. St. Clair St., TOL'DO, OHIO



## Big loads are easy for the Auto-Wheel

Two, three, four happy boys are an easy load for the sturdy Auto-Wheel Coaster Wagon. Auto-Wheel Coasters are built for hard play. See how the body is put together. Not just nailed, but mortised. Auto-Wheel Coasters are so strong that we use them in our factory for carrying loads up to a 1000 pounds (half a ton).

## Auto-Wheel Coasters and Auto-Carts

The mortised joints are only one of the features which make Auto-Wheel Coasters sturdy and substantial. Other features are: rubber-tired disc wheels, steel-tired disc or wood spoke wheels—all wheels interchangeable—hand brake, special hub cap and locking pin, special hound brace, self contained roller bearings.

Write for catalog which shows all models of the Auto-Wheel Coaster and the Auto-Cart, the Auto-Wheel's junior companion for little brother and sister. Send the names and addresses of three local coaster wagon dealers, and we will give you a year's subscription free to the "Auto-Wheel Spokesman," a dandy magazine for boys.



Big Short Story Writing Contest on. Write for Particulars and WIN A PRIZE

Auto-Wheel Coaster Co., Inc.  
North Tonawanda, N. Y.

## RAPID AUTOMATIC ELECTRIC COOKER

Saves 50% to 75% Fuel Cost. Home Science Book FREE. Write now. A post card will do.

WM. CAMPBELL CO., Dept. 64, DETROIT, MICH.

## MOVIES In Your Home

Our marvellous, practical Movie Machines sell as low as \$5.00—and what's more, we have wonderful films at lowest prices—with a new film exchange service. DON'T MISS THIS!

Write NGW for Free Catalogue

PARAMOUNT MFG. COMPANY  
Box 1371, Dept. M2, Boston, Mass., U.S.A.

## MOTORCYCLES ONE YEAR TO PAY

Know the joy of owning—for business or pleasure—a Harley-Davidson, Excelsior, Henderson, Indian, Cleveland, or any other standard make; thoroughly rebuilt in our own factory.

Write for Free Bargain Bulletin and Easy Payment Plan.

Haverford Cycle Co., of Penna.  
America's Largest Cycle House  
Established 26 years  
503 Market St., Phila., Pa., Dept. P. M.

## AMAZING BARGAINS in Auto Accessories



### Popular Make Horn

Electric Motor driven; 6 or 12 volts. Fully guaranteed. For all cars. \$4<sup>50</sup>  
Mention voltage wanted . . . . .

### Extension Gas-Lever HORN BUTTON



Fits most cars. Extends throttle 2 in. Nickel plated . . . \$1<sup>00</sup>



### All-Steel Socket Wrench Set

Handy road and garage outfit. \$1<sup>00</sup>  
\$2.00 value . . . . .



### Aluminum Step Plate

with rubber center, complete. Fits all cars. . . . Each \$1<sup>50</sup>



### Valve Lifter

Lifts valves for pin pulling in 1/10 the time, without barking knuckles. Safe, simple, sure. Special 75c



### Electric Solder Iron

Fits any standard appliance plug. Iron only \$1.50  
Plugs and cord . . . . . \$1.00  
Plain string solder . . . . . 60c lb.  
Acid or rosin core string solder . . . . . 90c lb.

Send cash with order plus 20c postage. Excess postage refunded. Shipped C. O. D. if desired.

Write for our SPECIAL BARGAIN CATALOGUE

M. A. SIMON CO.

Established 1919

207 N. Seventh St.

ST. LOUIS, MO.

**SAVE MONEY**  
Get This Book

**HANDY MAN BOOK**

Install Your Own  
**PLUMBING & HEATING**  
NEW EASY WAY - SAVE HALF

**25c**  
Reg. Price 50c

Brings you this big Plumbing and Heating Encyclopedia - Catalog. Write for your copy today without fail.



### Guaranteed Heating Plants

Our Handy-Man Book shows how. Big 250-page well-bound encyclopedia of Plumbing and Heating Outfits, Systems, Supplies, Fixtures and Accessories—10,000 items—illustrated. Hundreds of floor plans, elevations, diagrams, trade secrets, money and trouble-saving kinks, etc., "How to save coal in heating," "Easy repair methods." Every householder, contractor, farmer, mechanic, institution needs this book. Shows how to save wages, work and materials.

Hot Water Boiler



Pipeless Furnace

### BIG HANDY BOOK

Tells how we help you plan and install. From rough sketch or description we supply working plans and clear instructions. We loan the tools needed. Any handy man can install. This is the place to buy on money-back guaranty. Plumbing Outfits and Supplies; Water Systems; Hot-Air, Water or Steam Heating Plants; Radiators, Pipes, Boilers or Septic Disposal Tanks.

### Send 25c for Yours Today

We have spared no effort or expense to complete this remarkable and instructive book. To keep from sending it broadcast to disinterested persons, we request a deposit of 25c, which will be refunded on your first order—or send for our FREE Bulletin. Write today and save half.



Bathroom Outfit

**HARDIN-LAVIN CO.**

50 Years  
at 4547-57  
Cottage Grove Ave.,  
CHICAGO

## JOY—ADVENTURE—ROMANCE

LINGER NO LONGER

BY THE  
FIRESIDE



8-16  
Overhead Valves  
Selective Transmissions

Sport Fenders Underslung  
Sport Fenders for  
Standard Fords

You must seek them out in the City's White Lights; under the Country's Blue Sky; by the Rippling, Murmuring Waters. Get Busy! Buy a Ford and equip it with a Beautiful FORD-SPEED Sport Body and find the road to Happiness. We offer nine smart models to choose from \$20.00 up. Full line Racing Specialties to help you go faster. Free Catalog

### This Month's Specials

	Price	Now		Price	Now
Discs, set of 5, flat	\$32.00	\$ 5.95	Underslung Fenders	\$12.00	\$ 9.95
Flux, Ford Pump Oil		2.50	Wires Steering Gear	30.00	16.00
Power & speed Camshaft	19.00	11.95	Crank Case Motor Arm		
3:1 to 24:1 Gears	12.50	6.95	Support	5.00	2.95

SATISFACTION OR MONEY BACK guarantee, 50% with order, balance on delivery  
N. O. FORD SPEED & POWER EQUIPMENT MFRS., 250 West 54th St., New York

## A BETTER Engine

For Less Money

Only Engine Sold on Lifetime Guarantee



## THE NEW WITTE

### Throttling Governor

Easy to install—Easy to handle—Gives more power than rating—Increase or decrease speed at will—Run on cheap fuel, Gasoline, Kerosene, Distillate or Alcohol—Steady speed on variable load—Starts without cranking—So simple a boy can understand it.

Adaptable to any power job anywhere

Comes complete—Battery equipped, BOSCH Magneto at small cost extra. All other sizes and styles at proportionate low prices.

WRITE FOR CATALOG

2 H-P. — Pulls 3  
\$45.00  
Pg. 548.50  
Price \$57

3 H-P. — Pulls 4  
\$69.50  
Pg. 575.50  
Price \$87

5 H-P. — Pulls 6 1/2  
\$99.00  
Pg. 5107  
Price \$125

WITTE ENGINE WORKS (Write Nearest Address)

1748 Oakland Avenue, . . . . . KANSAS CITY, MO.  
1748 Empire Building, . . . . . PITTSBURGH, PA.  
1748 Fremont Street, . . . . . SAN FRANCISCO, CAL.

## STOP USING A TRUSS

Do Away With Steel And Rubber Bands

**FREE TRIAL**

TRADE MARK

STUART'S ADHESIVE  
PLAPAO-PAD

Inner surface is made adhesive to secure the PLAPAO-PAD firmly to the body, keeping the PLAPAO continually applied and the pad from slipping. No straps, buckles or springs attached. Soft as velvet—easy to apply.

PAT'D APRIL 6 1909

It's the Non-Slip- ping, yet Non-Rigid Pad and What is Within It That Counts

### FREE to 5,000 Truss Sufferers

To the extent of 5,000 sufferers who may apply I will send, ABSOLUTELY FREE, a sufficient quantity of the Plapao to positively convince them that this is the only logical, common-sense way of treating rupture. Plapao is a highly astringent medication placed within the Plapao-Pad and being absorbed through the skin, creates a wonderful feeling of relief and at the same time tends to strengthen the weakened muscles and thus permanently close the rupture opening. The process of recovery is natural, so you'll have no use for a truss—you can throw it away forever! Old and young have testified under oath that the Plapao-Pads cured their rupture—many of them long-standing, aggravated cases—without delay from work. Patent allowed in U. S. and foreign countries. Awarded Gold Medal at Rome and Grand Prix at Paris.

Send No Money—for a sufficient quantity of the Plapao is sent without charge to enable you to give it a thorough test; you pay nothing for this trial now or ever. Write for it and full information today. Address Plapao Laboratories, Block 1427 St. Louis, Mo.

# Swear Off Tobacco



Tobacco Tells on Nervous System



Tobacco Ruins Digestion



Tobacco Stunts Boy's Growth



Tobacco Robs Man of Vitality



Tobacco Steals from You the Pleasures, Comforts, Luxuries of Life

## Tobacco Habit Banished Let Us Help You

### Quick Results

Trying to quit the tobacco habit unaided is often a losing fight against heavy odds, and may mean a serious shock to your nervous system. So don't try it! Make the tobacco habit quit you. It will quit you if you will just take **Tobacco Redeemer** according to directions.

It doesn't make a particle of difference whether you've been a user of tobacco for a single month or 50 years, or how much you use, or in what form you use it. Whether you smoke cigars, cigarettes, pipe, chew plug or fine cut or use snuff—**Tobacco Redeemer** will positively remove all craving for tobacco in any form in a few days. Your tobacco craving will usually begin to decrease after the very first dose—there's no long waiting for results.

**Tobacco Redeemer** contains no habit-forming drugs of any kind and is marvelously quick, scientific and thoroughly reliable.

### Not a Substitute

**Tobacco Redeemer** is in no sense a substitute for tobacco, but is a radical, efficient treatment. After finishing the treatment you have absolutely no desire to use tobacco again or to continue the use of the remedy. It helps to quiet the nerves, and will make you feel better in every way. If you really want to quit the tobacco habit—get rid of it so completely that when you see others using it, it will not awaken the slightest desire in you—you should at once begin a course of **Tobacco Redeemer** treatment for the habit.

### Results Absolutely Guaranteed

A single trial will convince the most skeptical. Our legal, binding, money-back guarantee goes with each full treatment. If **Tobacco Redeemer** fails to banish the tobacco habit when taken according to the plain and easy directions, your money will be cheerfully refunded upon demand.

### Let Us Send You Convincing Proof

If you are a slave of the tobacco habit and want to find a sure, quick way of quitting "for keeps" you owe it to yourself and to your family to mail the coupon below or send your name and address on a postal and receive our free booklet on the deadly effect of tobacco on the human system, and positive proof that **Tobacco Redeemer** will quickly free you from the habit.

**Newell Pharmacal Company**  
Dept. 300 St. Louis, Mo.



### Free Book Coupon

**NEWELL PHARMACAL CO.,**  
Dept. 300 St. Louis, Mo.

Please send, without obligating me in any way, your free booklet regarding the tobacco habit and proof that **Tobacco Redeemer** will positively free me from the tobacco habit or my money will be refunded.

Name.....

Street and No.....

Town..... State.....



## Have you a **PRECISION** Tool Kit?

Every Mechanic whose tool kit is complete with Brown & Sharpe Tools is well prepared to do the close limit jobs that come up every day—he has a *precision* tool kit.

Brown & Sharpe Tools help him do the difficult jobs well—they have helped mechanics do accurate work for over 70 years.



Write for a No. 28 Small Tool Catalog and select the tools that will build up your kit for greater precision.

**BROWN & SHARPE MFG. CO.**  
PROVIDENCE, R. I., U. S. A.

# BROWN & SHARPE TOOLS

Offer You  
**\$48 a Week**  
and a

We want men and women as local representatives to demonstrate and take orders for Comer All-Weather Raincoats. New offer enables you to earn \$48 a week and Buick touring car. No experience necessary. Write quick.

Comer Mfg. Co., Dept. BW-58, Dayton, O.



## Rider Agents Wanted

Select from the 44 Styles, colors and sizes of Ranger Bicycles. Ride and exhibit sample Ranger and make money. Delivered free, express prepaid, on Approval. Factory-to-Rider prices save \$10 to \$25.

**12 Months to Pay** on any Ranger if desired. Boys and girls easily save the small monthly payments. Parents often advance first payment.

Best quality, at factory prices, express prepaid. Lamps, wheels and equipment, low prices. **Send Tires**

No Money, do business direct with makers.  
**Mead Cycle Company**  
Dept. 105 Chicago



Write today for free Ranger Catalog, factory prices and marvelous easy payment terms.

## PERSONAL STATIONERY

**SEND ONLY \$1.**

Be distinctive—have your own stationery. Send cash or money order for 200 sheets, 100 envelopes, postpaid, printed in blue ink with name and address, not over 3 lines (or 50 characters), on good white bond, sheets 6x7. Personal Printing Co., Box 3758, Boston, Mass.

Refuses: International Trust Co., Boston

## \$\$ For Photoplay Ideas

Protect your plots by copyright. Manuscripts accepted in any form; revised, criticized, copyrighted, marketed. Not a school—No courses or books to sell. We are on the ground in daily touch with the studios. **ADVICE FREE.**

**UNIVERSAL SCENARIO CORPORATION**  
939 Western Mutual Life Bldg., LOS ANGELES, CAL.  
Publishers SCENARIO BULLETIN-DIGEST. Send for free sample copy.



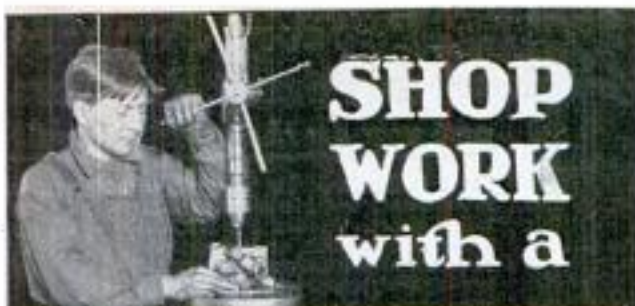

## SHOP WORK with a

# CARNES ARTIFICIAL ARM

FOR nearly ten years a Carnes Artificial Arm has kept Mr. Pahhe Yanze of Lawrence, Kan., on the payroll as a draftsman and machinist at a good salary. Thousands of other mechanics, artisans, office workers, farmers and laborers owe their independence to this improved arm.

### Life-Like in Action and Appearance

The Carnes Arm cannot be detected from the natural except by close inspection. Its user can dress himself, use knife, fork, pen, pencil and keys; pick up large or small objects, carry grips—in fact, do virtually everything that was possible before. He can bend the elbow of the Carnes Arm, bend and turn the wrist and open and close the fingers at will, even if the amputation is at the shoulder.

**192-Page Book FREE.** A book of 192 pages, profusely illustrated with photographs showing what can be done with this remarkable invention, will be sent free to any person interested. Send for it now.

**CARNES ARTIFICIAL LIMB CO.,**

208 Carnes Bldg., Kansas City, Mo.

**Clear-Tone**  
FOR  
**DIMPLES**

Your skin can be quickly cleared of Pimples, Blackheads, Acne Eruptions on the face or body, Enlarged Pores, Oily or Shiny Skin. \$1,000.00 Cold Cash says I can clear your skin of the above blemishes.

**FREE** WRITE TODAY for my FREE Booklet—"A Clear-Tone Skin"—telling how I cured myself after being afflicted for fifteen years.

**E.S. GIVENS, 129 Chemical Bldg., Kansas City, Mo.**

## NO MORE BALD HEADS



WHEN our VACUUM CAP is used a few minutes daily. We accept no pay until you have tried the Cap 60 days and are satisfied. The Vacuum Cap is an appliance that draws the blood to the Hair Roots and starts a new healthy crop of hair. It stops Dandruff, stops the hair from falling out.

Bought by Doctors and men who knew that it is the only reasonable HAIR GROWER known to science. No Drugs Used. Write for application blank, testimonials, and booklet on "HAIR," sent sealed in plain envelope, FREE.

**THE MODERN VACUUM CAP CO.**  
L 559 BARCLAY, DENVER, COLO.



## LOWEST PRICES GUARANTEED TYPEWRITERS

Send us only \$5.00 a month until the low total price of \$66.20 is paid, and the machine is yours.

**FREE TRIAL** This is absolutely the most generous typewriter offer ever made. Do not rent a machine when you can pay \$5.00 a month and own one. Think of it—Buying a \$110.00 Machine for \$66.20. Cash price, \$61.70, just a little more than half its original price.

**EASY TERMS**

**The Famous L.C. Smith Silent Model No. 8**

This is the famous L. C. Smith typewriter which has set the world's standard for quality and service for over twenty years. Perfect machines, Standard size, Keyboard of Standard Universal arrangement, 42 Keys, writing 84 characters—universally used in teaching the touch system. The entire line of writing completely visible at all times, has the decimal tabulator, the two color ribbon, with automatic reverse, the back spacer, ball bearing type bars, ball bearing carriage action, ball bearing shift action, in fact every late style feature and modern operating convenience. Comes to you with everything complete; tools, cover, operating book and instructions—nothing extra to buy. You cannot imagine the perfection of this beautiful rebuilt typewriter until you have seen it. We have sold thousands of these perfect late style machines at this bargain price and every one of these thousands of satisfied customers had this beautiful, strictly up-to-date machine on five days' free trial before deciding to buy it. We will send it to you F. O. B. Chicago for five days' free trial. It will sell itself, but if you are not satisfied that this is the greatest typewriter you ever saw, you can return it at our expense. You won't want to return it after you try it, for you cannot equal this wonderful value anywhere.

## SEND NO MONEY Order Now—Before They're Gone

When the typewriter arrives deposit with the express agent \$6.20 and take the machine for five days' trial. If you are convinced that it is the best typewriter you ever saw keep it and send us \$5.00 a month until our bargain price of \$66.20 is paid. If you don't want it, return it to the express agent, receive your \$6.20 and return the machine. We will pay the return express charges. This machine is guaranteed just as if you paid \$110.00 for it. It is standard. Over half a million people own and use these typewriters and think them the best ever manufactured. The supply at this price is limited, the price will probably be raised when next advertisement appears, so don't delay. Fill in the coupon today—the typewriter will be shipped promptly. There is no red tape. We employ no solicitors—no collectors—no chattel mortgage. It is plainly understood that we retain title to the machine until full \$66.20 is paid. You cannot lose. It is the greatest typewriter opportunity you will ever have. Do not send us one cent. Get the coupon in the mails today—sure.

**SMITH TYPEWRITER SALES CO., 300, 360 E. Grand Ave., Chicago, Ill.**

**SMITH TYPEWRITER SALES CO., 300, 360 E. Grand Ave., Chicago, Ill.**

Ship me the L. C. Smith Model No. 8, F. O. B. Chicago, as described in this advertisement. I will pay you \$5.00 monthly as rent until the \$60.00 balance of the Special \$66.20 sale price is paid. The title to remain in you until fully paid for. It is understood that I have five days in which to examine and try the typewriter. If I choose not to keep it I will carefully repack it and return it to the express agent. It is understood that you give the standard guarantee.

Name.....

Street Address.....

City..... State.....

Occupation or Business.....

## Easy to Play Easy to Pay



### Saxophone Book Free

Tells when to use Saxophone singly, in sextettes or in regular bands; how to play from alto parts in orchestra, and many other things you would like to know.

# BUESCHER

## TRUE-TONE SAXOPHONE

Easiest of all wind instruments to play and one of the most beautiful. You can learn the scale in an hour's practice and play popular music in a few weeks. You can take your place in a band within 90 days if you so desire. Unrivaled for home entertainment, church, lodge or school. In big demand for orchestra dance music. The portrait above is of Donald Clark, Soloist with the famous Paul Whiteman's Orchestra.

**Free Trial** You may order any Buescher instrument without paying in advance, and try it six days in your own home, without obligation. If perfectly satisfied, pay for it on easy payments. Mention the instrument interested in and a complete catalog will be mailed free.

## BUESCHER BAND INSTRUMENT CO.

Makers of Everything in Band and Orchestra Instruments  
2588 Buescher Block Elkhart, Indiana

Buescher Band Instrument Co.  
2588 Buescher Block, Elkhart, Ind.

Gentlemen: I am interested in the instrument checked below:

Saxophone ..... Cornet ..... Trombone ..... Trumpet.....  
(Mention any other instrument interested in.)

Name .....

Street Address.....

Town..... State.....

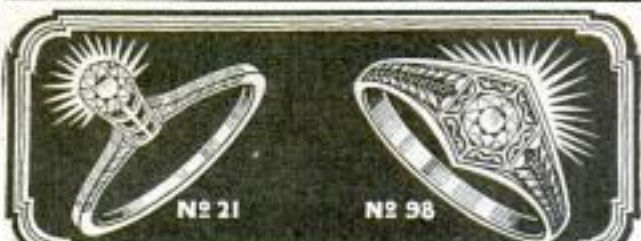

### WEAR IT FOR 7 DAYS FREE

These beautiful RAJAH diamonds have all the living fire and dazzling beauty of the genuine blue white diamond and are the result of years of scientific and chemical research. They stand the test of direct comparison. YOU CAN BE THE JUDGE. Wear one of these rings on the same finger with a genuine diamond seven days. If you or your friends can tell the difference, send it back and we will refund your money. YOU TAKE NO CHANCES.

#### SPECIAL INTRODUCTORY OFFER for Short Time Only

No. 21—Ladies' high Tiffany mounting—white platinum \$3.35

finish (reg. price \$9.70) now.....

No. 98—Gentlemen's gyzer mounting—white platinum 4.65

finish (reg. price \$9.00) now.....

Mountings are beautifully designed from latest patterns and are exact reproductions of high-priced platinum rings. Unconditional 20-year guarantee. Handmade leather finished case with each ring.

**SEND NO MONEY** Just mail your name, address, number of ring wanted and size as shown by slip of paper fitting ring to end around finger joint. You'll receive ring by return mail. When it arrives deposit payment shown above with postman. After wearing ring seven days, if you do not think it the biggest bargain ever offered, we want you to send it back and your deposit together with postage will be immediately refunded. **SEND TODAY.**

A. ROTHCHILD CO., 609 So. 14th St., Omaha, Neb.

## Kingery Popcorn Poppers and Peanut Roasters

put you on the road to profit

Start in business for yourself without much investment, without stock to carry, without much effort. Profits are BIG—3½ cents on every 5 cent sale or 8 cents on every dime. Here's a wonderful opportunity which will pay profit-dividends every day.

You can do what others are doing. No experience is necessary—start your machine and keep it going. KINGERY MACHINES are complete in every detail. They keep on turning out the popped corn and roasted peanuts with very little attention on your part.

### SEE WHAT ONE MAN DID

JAMES KIPWISS, P. O. Box 56, Waynesburg, Pa., writes: "Since I got your machine, in 15 days I have made \$227.50."



## Kingery Popcorn Poppers and Peanut Roasters

fit in very little space. And the entire population is your market—young or old, everybody likes and buys popcorn and peanuts.

### New Illustrated Catalog Free

Write for it TODAY. It shows all the new models and tells how easily you can buy a KINGERY on terms.

Dept. P. M.

## KINGERY MFG. CO.

Cincinnati, Ohio



### SOMETHING NEW!

#### A real LOUD TALKING DETECTOR

made of B-Metal. 100% superior to any crystal. Puts new life into your RADIO set. Guaranteed for ONE YEAR. CHEAPEST in the long run. If your dealer is unable to supply it, we will.

B-Metal Refining Co., 3134 Trumbull Ave. DETROIT, MICH.

**"BOW LEGS and KNOCK-KNEES" UNSIGHTLY**

SEND FOR BOOKLET SHOWING PHOTOS OF MEN WITH AND WITHOUT THE PERFECT LEG FORMS

**PERFECT SALES CO.**  
140 N. Mayfield Ave., Dept. S, Chicago, Ill.

## RELIABLE WATCHES at LOW PRICES

MODELS  
2 00

Ingersoll

TO  
10 00

**Tobacco** Special Bargain Introductory offer on Kentucky's Finest Good Old Melon Sweet Green River Smoking Tobacco. Two big 1-lb. cans, \$2.00 value for only \$1.00 postpaid. Satisfaction guaranteed or money back.

**OWENSBORO TOBACCO CO., Dept. 130, Owensboro, Ky.**



HOBART AUTOMATIC AIR COMPRESSOR

## EQUIP YOUR SHOP NOW

### FOR BETTER SERVICE AND BIGGER PROFITS

Small cash payment brings you HB Automatic Air Outfit and HB 8-Hour Battery Charging. Both big money-makers for you. HB 8-Hour Battery Charging increases profits, reduces labor and current cost, saves half on rental batteries, wins trade from competitors. Pays for itself on easy \$30 monthly terms. Dependable HB Free Air Service wins business, helps you sell tires, accessories, etc. Easy terms on all HB outfits. Money-back guarantee. Free trial. Write for information.

**HOBART BROS. CO., Box M-7, TROY, OHIO**



Only \$30 A Month  
Pays For  
8 HOUR Battery Charging

HOBART BROS. CO. 8-HOUR BATTERY CHARGING

**AUTO SUPPLIES  
and BEAUTIFUL BODIES  
at WHOLESALE  
PRICES**

**Big Free  
Catalog** **AUTO SUPPLIES  
FOR ALL CARS**

Know the latest prices  
before you buy. Send  
for our illustrated  
price list. Every page is  
filled with bargains.  
We buy for cash—and  
sell for cash.

**Save Money on  
Special Bodies**

We carry a complete  
line of "Fidelity" Bodies  
for Ford and Chevrolet  
"490" at bargain  
prices: \$29.95 and up.



Send for Catalog P

It shows over 3000 bargains in repair  
parts, tops, radiators and general  
accessories for Fords and other cars,  
all guaranteed standard quality.

**Fidelity Bodies  
\$29.85** and  
up  
For Fords and  
Chevrolet "490"

**NEMCO BARGAIN SUPPLY HOUSE**  
37 N. Peoria St. CHICAGO, ILL.

**IT'S EASY TO BUILD THINGS**

WITH A

**Junior  
Bench  
Saw**



Does your ripping, mitring, grooving, rub-  
bering, tenoning, sanding, grinding and many other operations with  
superior ease and accuracy. Top 10"x13". Saws 1 1/2" stock.  
Does 5/8"x3/4". Machine built entirely of metal. Driven by 1/2  
or 3/4 h. p. motor. Portable. Attaches to any light socket. Ex-  
tremely accurate. Descriptive circular tells many things of interest  
to workers in wood and soft metals.

**W. & J. BOICE, Dept. P.M.7, TOLEDO, OHIO**

**FREE** Book of Newest Styles just out. Women's,  
men's, children's clothing on credit and at bargain  
prices, less than cash prices everywhere. Very latest  
fashions; best materials. Open a charge account with us. Buy on credit  
and save money! Dress in newest styles. Send for Style Book absolutely  
FREE today! Elmer Richards Co., Dept. B177, W. 35th Street, Chicago.

**Prices Reduced**

**On All Standard Make  
Typewriters  
Lowest Prices in Years**



We will ship any make you  
choose for one week's trial,  
Underwood, Royal, L. C. Smith,  
Remington, Oliver, etc.

**Easy Terms** Pay less than rent each month and own a  
typewriter. Guaranteed good as new.  
Perfectly rebuilt by experts—the famous "Young Process."  
Send for our free trial offer and new low price list now. Write today.

**Young Typewriter Co.**

World's Largest Dealers in Standard Typewriters  
654 W. Randolph St., Dept. 1107, CHICAGO, ILL.

# Stop pedaling



**Motorize your bicycle with a  
Merkel Motor Wheel**

and ride in ease, go as you please,  
400 miles for a dollar

It makes your bicycle a long distance, low cost  
motor vehicle.

**Easy to install.** It slips right into the rear forks of  
any standard bicycle.

**Simple to operate.** Positive and sturdy throttle,  
clutch and rear wheel brake controls. All handy by  
the handle bar grips. And the gear drive and free  
engine clutch—allowing the motor to run during  
traffic stops—make it the most attractive proposition  
on the market to own—and ride!

Put a MERKEL MOTOR, mounted in its own  
specially constructed rear wheel, in the rear fork of  
your bike, and tour the country this summer. Special  
low price now in effect that makes it the cheapest  
motor transportation in the world.

Fill in the coupon and mail at once.

MERKEL WHEEL, Dept. 7, Hendee Mfg. Co.  
SPRINGFIELD, MASS.

Send me the MERKEL MESSAGE, giving full description of the  
MERKEL MOTOR WHEEL, with special low price offer. I have  
a bicycle I want to motorize.

Name .....

Town..... State.....

## The Merkel Motor Wheel

Please Mention Popular Mechanics

## Build a Business for Yourself

### SHARPEN SAFETY RAZOR BLADES



At last an opportunity for you to step out of the "Wage Earning Class" and into a "Money Making" business of your own. **You Need No Experience; Very Little Money Required.** Begin right at home, or small room anywhere. You will make money right from the start. Nearly everyone now uses Safety Razors. There are **Big Profits** for you in the Safety Razor blade re-sharpening business. The **New Velvet Edger** is a mechanically perfect machine. It leaves nothing to **Guess Work**. It is the only device now on the market "With a **Genuine Carborundum Hone**" which hones and sharpens the blades, step by step, until the finest edge that steel will take is obtained. No Cams, Springs or flopping of the blades, but an "Even Pressure" on both sides of the blade at the same time, insuring a **Straight, True, Hollow Ground and Keen Cutting Edge** which gives the shaver all the delights, and none of the bitter memories of imperfectly sharpened blades. **No Other Machine** has the accurate, direct action, of the **Velvet Edger**.

Machines are made in three sizes, Twelve, Eighteen and Twenty-four blades. Many have bought these machines and are now making from **Ten to Twenty dollars** daily. You have the same opportunity "If You Hurry." Don't let "The Other Fellow" beat you to it.

Send Now for **Free Booklet** giving full information. **Don't Delay.** Address **THE F. W. COCHRANE MFG. CO., 1316 W. Slauson Ave., Los Angeles, Calif.**

## CAR OWNERS SAVE MONEY

### Make Big Profits!

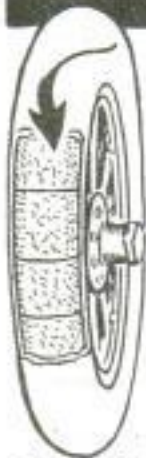

FOR ALL SIZES

Cut your own tire bills—and make good money selling **National Tirefiller** to others. A proven success for 12 years. Eliminates tubes, punctures and blowouts. Increases tire mileage 30 to 50% and still outwears several casings. Easily inserted; easy riding. Over 300,000 enthusiastic users. Big sales possibilities. Some good territory still open. Driver agents make good profits. Mail coupon today for proposition.

National Rubber Filler Co.,  
232 College St., Midlothian, Texas.

Please send me your agent's proposition and full information on National Tirefiller.

Name.....

Address.....

MAIL  
THIS  
Now

**TEN MONTHS TO PAY**

**Pay Nothing Down!**

We don't want you to send us a single penny—it won't cost you anything to see this beautiful Diamond Ring—examination is **ABSOLUTELY FREE.**

**PLATINUM SET**

Seven perfectly cut and matched blue-white Diamonds are expertly set in a hexagon-shaped top of Platinum, to resemble one large solitaire. Shank of Green Gold beautifully hand-carved and engraved. Price \$57.50.

**TEN MONTHS' CREDIT**

If, when you receive the Ring, you are perfectly satisfied, pay only \$10.00 and keep it—then send only \$4.75 for 10 successive months. Otherwise, return ring at once, and examination will have cost nothing. *Transactions strictly confidential. Guarantee Value Bond given with every Diamond purchase.*

**FREE Book of Diamond and Jewelry Insuring.** All wonderful values. Send for copy to Dept. 68-M.

**THE HOUSE OF QUALITY**  
CAPITAL \$1,000,000.

## L.W. SWEET INC.

1650-1660 BROADWAY, NEW YORK

## Las-Stik

the ORIGINAL Patch with a 5" x 1-1/2"

### The White Tube Patch That never fails

This white tube patch adheres instantly because made of pure para rubber, that stretches with the tube and can't creep or tear out even if tube is over-inflated. You can patch a pinhole or a seventeen inch blowout and the joint will become stronger than the tube itself.

Complete outfits 50c and \$1.00

LAS-STIK PATCH MFG. CO., Hamilton, Ohio

## Good Profits for Demonstrator Agents

**Elto**

**3 H.P. Twin Outboard Motor**

**ELTO OUTBOARD MOTOR COMPANY**  
Dept. AA Manufacturers Home Building Milwaukee, Wisconsin

**EVEN** spare time earns big money! Never such a chance to turn sport into profit! You get a new demonstrator at factory price. All winter we send you prospects. Only one agent in a locality—so write today for reservation of territory. This is Ole Evinrude's fast 3 H.P. light twin cylinder outboard motor—sold only under name of "Elto"



## You'll Smile, Too!

**H**OP into the saddle of a Harley-Davidson—give 'er gas—then smile at miles as you whiz down the straight-away like a zooming 'plane, or loaf along the road's edge till you see a speeding car you want to leave behind.

Wonderful Sunday outings with "the bunch"—week-end trips to seldom-fished lakes that automobiles never reach—cool rides into the quiet country when your day's work is done! All this, and more, at a travel-cost of only two cents a mile—why, it's cheaper than going to "movies", and a thousand times more sport.

*Pay-as-you-ride! Ask your dealer about his Easy Payment Plan and reduced prices. Take a free demonstration ride. Write us for illustrated literature.*

HARLEY-DAVIDSON MOTOR CO.  
Milwaukee, Wisconsin

### Harley-Davidson The Motorcycle

Money-making sales opportunities in open territory. Write Desk A-2.

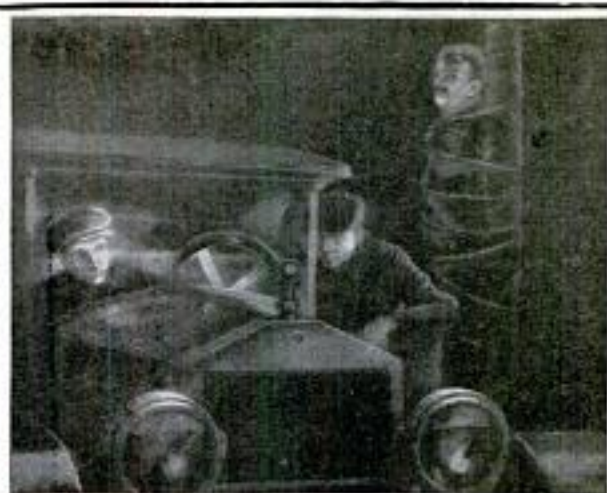

## FREE— Actual Reports of Secret Service Operator 38

**H**ERE is something money can't buy. More fascinating than detective stories. Confidential reports of a real operator—No. 38—to his Secret Service Bureau, headed by the most famous detective in America. Absolutely free. No cost. No obligation. Don't fail to send for them. They may point the way to Big Money for you. See how the modern detective works. Read these inside stories of the solution of great mysteries. See what possibilities this most fascinating and eventful of all professions offers to you—and how you may fit yourself for it.

## Be a Finger Print Expert

To command the highest fees, the Secret Service man must also be a Finger Print Expert. These reports show why. This profession may be easily learned at home, in your spare time. Wonderful opportunity in this UNCROWDED, PROFITABLE field.

## Make \$5,000 to \$10,000 a Year

The unfulfilled demand for trained Finger Print men is increasing daily. Opportunity is waiting for you. No time to lose. Send today for these reports, also our big Free book on Finger Prints. Gives all particulars and success stories of our graduates! Brilliant future ahead if you act now.

## Special Offer Limited Time



Everyone getting these Free Reports will also receive my Special offer of a Professional Finger Print Outfit, absolutely Free. Made for a limited time only. Send coupon today—sure. Reports, Finger Print Book, and special outfit offer, all Free and Prepaid. Don't delay and perhaps forget. Do this right now.

← **Also FREE**  
*Send the Coupon*

**UNIVERSITY OF  
APPLIED SCIENCE**

1920 Sunnyside Ave., Dept. B135 Chicago, Ill.

T. G. COOKE, Pres. University of Applied Science  
1920 Sunnyside Ave., Dept. B-135 Chicago, Ill.

Dear Mr. Cooke: Please send me FREE and prepaid, Reports of Operator 38, your new illustrated book on Crime and Crime Detection and your Special Outfit Offer. It is fully understood I assume no obligation.

Name ----- Age -----

Address -----

Town ----- State -----



## FAMOUS "ELECTRAHOT" \$2<sup>40</sup>

### Electric Soldering Iron

*Guaranteed for One Year*

Smallest, lightest, speediest practical soldering iron we know of. Gets into odd corners that others cannot reach. Easy to hold; does not tire. 13½ in. long, weighs 12½ oz. with cord and plug.

### Ideal for Radio and Other Electrical Work

Every radio fan needs it. Every motorist or repair man appreciates the quick, clean, efficient work it does. Electricians swear by it—would use no other. Ideal also for household soldering jobs. Jewelers, dentists, tinsmiths, home-tinkers—everybody needs it and can make it pay big dividends.

Nichrome wire heating unit generates quick, even heat from either AC or DC current, 110 volt. Cannot overheat.

Complete with two-piece attachment plug and 6 ft. of cord. Guaranteed for one year, \$2.40.

**SACKHEIM SUPPLY CO.,**  
647 No. Clark St., Chicago

Please mail me one *Electrahot Soldering Iron*, which you guarantee for one year. I will pay postman \$2.40, plus the postage.

Name.....

Street or R. D.....

State.....

**SEND NO MONEY!**

Just fill out C. O. D. coupon order and pay postman on delivery.

**Sackheim Supply Co.**  
647 No. Clark St., CHICAGO, ILL.

**FASTEN IT WITH AN AJAX EYELET FASTENER**



Binds Paper, Cardboard, Leather, Cloth  
It Saves Time by Punching the hole, feeding the eyelet and clinching it in one operation. Order from your Stationer

**Machine Appliance Corp.**  
Dept. P. M. BROOKLYN, N. Y.

### LONG RANGE RIFLE

SINGLE shot hunting rifle of finest blue case hardened steel, modelled after famous Springfield rifle. Bolt action, take-down model 36 inches over all. Shoots 22 calibre long, extra long and short cartridges. Special at \$6.95

Front and rear sights; automatic shell ejector.

**PAY POSTMAN ON DELIVERY** plus postage. Money back if Not Satisfied.

**CONSUMERS CO., Dept. 1-CB**  
1265 Broadway, New York

**FREE** Send for free catalog of other bargains in sporting goods.

\$47. **10 MONTHS TO PAY** \$49

**SEND \$200 DOWN**

450 PER MONTH      470 PER MONTH

**30 DAYS TRIAL**

Just pick out the ring you prefer, give finger size, and send deposit to show your good faith. WE WILL SEND THE RING WITHOUT ANY RED TAPE OR DELAY. DEALINGS CONFIDENTIAL. If you return it we will return your money. If satisfied, pay only a few dollars monthly.

**GUARANTEED \$75.00 VALUES**

The \$47.00 ring is 18-karat solid white gold, set with beautiful, blue-white, perfectly cut, sparkling, brilliant, GENUINE DIAMOND WORTH 50% MORE. The \$49.00 ring is 18-karat solid white gold, engraved with orange blossom design, and set with seven perfectly cut, blue-white, dazzling, genuine diamonds, CLUSTERED TOGETHER IN SOLID PLATINUM, looking like a \$600.00 solitaire 1½-carat size.

**WRITE FOR BIG CATALOG No. 677**  
It brings a large jewelry store right into your home.

**STERLING DIAMOND & WATCH CO.**  
63 PARK ROW, Dept. 677 NEW YORK (Est. 1879)

### INSTRUCTIVE AND ENTERTAINING BOOKS

These are bound in attractive covers and cover many subjects.

PRICE, 25c EACH, POSTPAID, 5 FOR \$1.00, or the entire set of 12 books for \$2.00, P. F. Select from this list:

Boxing and Boating	Beauty Secrets
Oriental Dream Book	How to Dance
How to Pitch Ball	Lover's Secrets
Book of Birthdays	Rope Splicing
Guide to the Stage	Heller's Magic
Thornton's Card Tricks	Love Letters

J. C. DORN, 725 S. Dearborn St., Dept. 76, Chicago, Ill.

### BLANK CARTRIDGE PISTOL

Protection Against Burglars, Tramps, and Dogs

Well made and effective; modelled on latest type of Revolver; appearance alone is enough to scare a burglar. When loaded it may be as effective as a real revolver without danger to life. It takes standard .22 Cal. Blank Cartridges obtainable everywhere. Price 50c. Superior quality \$1.00 postpaid. Blank Cartridges, by express, 90c per 100.

**PRICES 50c \$1.00**  
Post-paid



Johnson Smith & Co., 1218 Washington Ave., Dept. 948, Racine, Wis.

# CARPENTER'S *The Original* LIQUID COURT PLASTER



When your skin is injured DON'T use a clumsy, quickly soiled cloth! Liquid Court Plaster quickly protects any small break with a flexible, clean, washable covering. Send 10c for a 10c tube, to cover handling and packing.  
Carpenter Chemical Co., 60 Cadillac St., Detroit, Mich.

## \$80 Drafting Course

### FREE

If you accept an offer I am making now you need not pay for the course. I am doing this in order to enable deserving and ambitious men to get into this profession. I will also guarantee to train you until you are placed in a position drawing a salary of \$250.00 a month. Besides I will give you a free complete set of drawing instruments worth \$25.00. Write me for full information. Chief Draftsman Dehn, 1251 Lawrence St., Dept. B-135 Chicago

## Oh You Skinny!



**Strongfort**  
The Perfect Man  
Dept. 455

Why stay thin as a rail? You don't have to! And you don't have to go through life with a chest that the tailor gives you; with legs you can hardly stand on. And what about that stomach that flinches every time you try a square meal? Are you a pill-feeder?

**Do you expect Health and Strength in tabloid form—through pills, potions and other exploited piffles?**

**You can't do it; it can't be done.**

The only way to be well is to build up your body—all of it, through Nature's methods—not by pampering the stomach. It is not fate that is making you a failure; it's that poor emaciated body of yours; your half sickness shows plain in your face and the world loves healthy people. So be HEALTHY—STRONG—VITAL. That's living. Mark the ailments on the free consultation coupon upon which you wish special confidential information and send with a 10c piece (one dime) to help pay postage on my Special Talk on Thinness and my book "Promotion and Conservation of Health, Strength and Mental Energy." Don't put it off—send for my free book Right Now—TODAY.

## LIONEL STRONGFORT

Physical and Health Specialist

Newark, New Jersey

### FREE CONSULTATION COUPON

Absolutely Confidential

Mr. Lionel Strongfort, Dept. 455, Newark, N. J.—Please send me your book, "PROMOTION AND CONSERVATION OF HEALTH, STRENGTH AND MENTAL ENERGY," for postage on which I enclose a 10c piece (one dime). Send me special information on subjects marked (X) below, without obligation, also on those I may write on extra line below:

- |               |                 |                         |
|---------------|-----------------|-------------------------|
| .. Colds      | .. Diabetes     | .. Weaknesses (Specify) |
| .. Catarrh    | .. Debility     | .. Poor Memory          |
| .. Asthma     | .. Increased    | .. Rheumatism           |
| .. Hay Fever  | .. Height       | .. Falling Hair         |
| .. Obesity    | .. Pimples      | .. Weak Eyes            |
| .. Fear       | .. Blackheads   | .. Gastritis            |
| .. Headache   | .. Insomnia     | .. Heart Weakness       |
| .. Thinness   | .. Short Wind   | .. Poor Circulation     |
| .. Rupture    | .. Flat Feet    | .. Skin Disorders       |
| .. Lumbago    | .. Stomach      | .. Dependency           |
| .. Neuritis   | .. Disorders    | .. Round Shoulders      |
| .. Neuralgia  | .. Constipation | .. Lung Troubles        |
| .. Flat Chest | .. Biliousness  | .. Stoop Shoulders      |
| .. Deformity  | .. Torpid Liver | .. Muscular             |
| (Describe)    | .. Indigestion  | .. Development          |
|               | .. Nervousness  | .. Great Strength       |

Mention other ailment here.....

Name.....

Age..... Occupation.....

Street.....

City..... State.....

**\$1.00 DELIVERS to Your Home**

**Complete Outfit**

# Violet Ray

ONLY \$1.00 brings this complete, scientific Violet Rays outfit to you. Treat yourself and family at home, save delay, costly doctors and medicines. Thousands use Violet Rays at home to relieve pain and sickness. The identical outfits doctors have bought from us for years and with which they successfully treat many ailments, including those listed below.

## QUICK RESULTS—No Medicine

Violet Rays work quickly, it's scientific, goes after the cause. That's why results are quick, permanent. Dr. Duncan, Kewanee, Ill., writes, "Violet Rays is the finest thing I ever used to relieve pain, treatments are so pleasant all my patients like it." Use it yourself at home, you save Doctor's bills.

### BEAUTY AID

Brings natural, magnetic beauty of health, no dieting, exercise or drugs. FREE book tells in detail how high priced beauty specialists use it to improve scalp and skin.

### EARN CASH

Men, women, without experience earn liberal profits in spare time showing Violet Rays to neighbors. Proves results first demonstration. Sells on sight. Get attractive offer and wholesale prices now.

## SEND FOR FREE BOOK

Explains how Nikola Tesla discovered Violet Rays, how it works, why it heals. Tells what doctors and plain folks accomplish in conquering pain, disease and nervous trouble with Violet Rays.

**Reveals Marvelous Scientific Discovery** Shows charts of human body, explains where pains start, how to banish them. Offered FREE for a limited time only, to introduce Violet Rays. Send for FREE copy.

**Check Your Ailment Below for Free Advice** Here is a partial list of ailments successfully treated with Violet Ray:

- |              |              |             |                |
|--------------|--------------|-------------|----------------|
| Catarrh      | Eye Diseases | Lumbago     | Skin Diseases  |
| Chilblains   | Falling Hair | Nervousness | Sore Throat    |
| Colds        | Hay Fever    | Neuritis    | Sprains        |
| Constipation | Headache     | Paralysis   | Tonsillitis    |
| Earaches     | Gout         | Piles       | Whooping Cough |
| Eczema       | Insomnia     | Rheumatism  | Asthma         |

## Mail Coupon—Send No Money

**VI-REX ELECTRIC COMPANY**  
326 West Madison St., Dept. 27, Chicago

Please send me without cost or obligation your free book describing your Vi-REX Violet Ray outfits, and details of your \$1.00 offer.

Name.....

Address.....

City..... State.....

Please Mention Popular Mechanics



## Special Bargains—While They Last

# 500 FAMOUS SEABROOK RADIO CABINETS

## At Less Than Half Price

A large jobber, pinched for cash, sold us 500 beautiful high grade Seabrook Radio Cabinets, without regard to cost, enabling us to offer you:



**Medium Size**

Regular Price \$85.00

**Our Price \$37<sup>50</sup>—**

L. o. b. Chicago

Radio Chamber: 13½" wide, 10½" high, 10" deep.

**Large Size**

Regular Price \$125.00

**Our Price \$47<sup>50</sup>—**

L. o. b. Chicago

Radio Chamber: 14" wide, 10½" high, 10" deep.

**100 LOUDSPEAKING HORN CABINETS**

Handsome Mahogany Piano Finish. Come fully equipped with famous Seabrook Horn and Genuine Baldwin Loudspeaking Unit, cord and plug. Selling most everywhere at \$35.00. Our Price while this small lot lasts. **\$18<sup>25</sup>**

L. o. b. CHICAGO

**HELLER-LOEB COMPANY**

143 West Kinzie Street CHICAGO

## Big 3-Ft. Telescope

See people and objects miles-away, on land or sea, as if they were close. Wonder Telescope gives new pleasures to home, farm, camp, travel, sport. See moon and stars as never before. Opens out over 3 feet long; measures 12 inches closed. Brass bound; has powerful lenses. **Thousands pleased**—"Could tell color of aeroplane 4 miles away."—Mrs. Yarbrough. "Saw Provincetown Light, 28 miles away, as clear as if in front of me."—Cliff Scribner.

### Useful and Entertaining (In Five Sections)



CLIP THIS AD

# SEND NO MONEY

## SPECIAL OFFER!

While they last

"I have been watching submarines 3 miles off the coast."—P. Grush. "Can see children playing in school yard 6 miles away."—P. H. Huntington. "Head the numbers on freight cars mile away, see mountains on moon."—A. G. Palmer.

Because of a fortunate purchase from a large European manufacturer we can give you a big bargain. Be first in your neighborhood; entertain your friends. **Send no money**; send only name and address for telescope complete by parcel post. On arrival deposit with Postman only \$1.85 plus a few pennies postage. **Satisfaction guaranteed** or money refunded. Order today while the supply lasts.

"Woods' take \$10 for me."—L. H. McKee. "See objects miles away that were close at hand."—A. W. Stockholder. "I will always remember the Wonder. I have two of them."—Anton Borka. "Well pleased with Wonder; send my son one for his birthday."—W. H. Baker. "More than pleased."—J. H. George. "Please send telescopes to two of my neighbors and 3 books and battery, nature enclosed."—Jane Eldridge. "More than pleased, better than I expected."—Steve Rile. "Live a mile from town and have much pleasure seeing things that distance."—Mrs. C. M. Campbell.

FERRY & CO., 75 W. Van Buren St. Dept. 1775 Chicago, Ill.

## Custom-Made Tops Less Than Half Price

ASK US TO PROVE IT. You can attach them easily. Full instructions sent. Complete tops with beveled plate glass, tacks, fasteners and welts. Free delivery 1,000 miles. For all your special needs on Maxwell, Overland, Ford, Dodge and Chevcolets. Double your car. Samples and money-saving bulletins free.

S-C PRODUCTS CO., 758 Nicholas Bldg., Toledo, O.

## Earn \$20 to \$60 A WEEK

Household necessities, Summer drinks, Jewelry, Perfumes, Soaps, Extracts, Foods, Spices, Toilet Goods, Aluminum ware, bath towels, fancy boxes toilet soaps selling like hot cakes. Big Profits. Write today for catalogues.

WESTERN PRODUCTS CO., 635 North Oakley Ave., CHICAGO

## Make \$1500 to \$3000 a Year Charging Batteries!



New HB Constant Potential Outfit charges all sizes of batteries perfectly in 6 to 8 hours. You can clear \$150 to \$350 every month. No experience needed. Small cash payment brings your HB 8-Hour Charging Outfit. Easy terms of only \$30 monthly let your profits pay balance with nice surplus besides. Long free trial on money-back guarantee lets you try any HB outfit at our risk. Don't delay and let some competitor get ahead of you with 8-Hour Battery Charging. Take the lead yourself. Order your HB Outfit NOW on free trial. Write today for full information and our easy payment plan.

HOBART BROS. CO. Box M-77 TROY, OHIO



# WANTED

## RAILWAY POSTAL CLERKS

### \$1600 to \$2300 Year

MEN — BOYS, 18 TO 35

WRITE IMMEDIATELY

Steady work. No layoffs. Paid Vacations

Travel—See the Country

Common education sufficient. Send coupon today—SURE





MAIL CLERKS

FRANKLIN INSTITUTE, Dept. T180, Rochester, N. Y.

Sirs: Send me without charge, (1) Sample Railway Postal Clerk Examination questions; (2) List of government jobs obtainable; (3) Send sample coaching lessons and send list of examination places.

Name.....

Address.....

COUPON



## "Detroit" Belt Lacing Outfit

Costs only 10¢ an inch, outlasts the belt, is smooth, strong and flexible—easily and quickly applied. Same method used by 10,000 big factories.



Open Hook

Closed Hook

Complete outfit—lacing tool and big box of lacing—postpaid **\$5**

Price cut from **\$5.50 to \$5.00**  
We pay postage  
Money back if not satisfied

ASSORTED BOX **\$1.50**

WIRE TOOL **\$3.50**

"Detroit" Belt Lacing shows the least reduction of the belt strength, leaving the belt stronger than any other lacing in existence. "Detroit" Belt Lacing is the only machine closed wire lacing that takes a perfect staggered grip on your belt. Each hook has a pulling strength of over 100 lbs. Hooks put up (with rubberized paper side strip) in 12 hook sections cut to any length without waste. Does not stretch to form loose 54 inches of belt.

### GUARANTEED

Lacing tool shown in wire and box of lacing complete, postpaid, **\$5.00**

Tool made to last a lifetime. Lacing always obt. in use. Sold on money-back guarantee.

**DETROIT BELT LACER CO., DETROIT, MICH.**

## NEW CORDS

10000 MILES GET 10000 MILES SERVICE 10000 MILES

30x3 1/2 \$5.95



### Sensational New Cord Tire Sale!

Our big volume business enables us to sell brand new Cord tires at lowest prices. Don't miss this Sale. Every Cord guaranteed first quality and new. Order your season's supply now and cut your tire cost in two. Thousands of steady customers getting full mileage and you, too, can get **10,000 Miles**

Size	Cords	Tubes	Size	Cords	Tubes
30x3	\$5.95	\$1.05	36x4	\$11.75	\$1.45
30x3 1/2	6.90	1.25	32x4 1/2	13.70	2.00
32x3 1/2	5.70	1.00	32x4 1/2	14.40	2.10
32x4	9.90	1.40	34x4 1/2	14.90	2.15
32x4	10.65	1.45	32x4 1/2	15.40	2.25
32x4	11.20	1.60	32x5	20.00	2.50

### SEND NO MONEY

Just send your name and sizes of tires wanted. Don't wait! Prices soon to go up. Take advantage of this sensational tire sale. Shipment C.O.D. Section unwrapped for inspection. Order now. Dept. 61

**SUPREME TIRE CO., 3234 W. Jackson Blvd., Chicago**

## Join US for Profits

Become one of the big, happy and prosperous group of live-wire hunters who earn enough to pay for pleasures and luxuries above their everyday needs. If you put in your best ticks, we do the rest for you.

### Sell Tailoring

Earn from **\$75** up per week selling fine Gibson tailored all wool suits to wearer direct for **\$31.50**, over 100 styles all one price. Sell on sight. We pay biggest commission profits IN ADVANCE and tend to delivery and collections. Handsome big sample line sent you promptly, write today.

**W. Z. Gibson inc.**

MERCHANT TAILOR

Dept. U-11 CHICAGO 161 W. Harrison



## "\$60 More a Month!"

**L**AST night I came home with great news—a \$60 increase in salary! I took the money out of my pocket and asked Mary to count it. You should have seen her face light up when she found the extra \$60. I think she was even happier than I was, for it was the third increase in a year.

"Today I am manager of my department—earning more money than I ever thought it would be possible for me to make. I owe it all to the training I received from the International Correspondence Schools. That little coupon was the means of changing my whole life."

**H**OW much longer are you going to wait before taking the step that is bound to bring you more money? Isn't it better to start now than to wait for years and then realize what the delay has cost you?

One hour after supper each night spent with the I. C. S. in your own home will prepare you for the position you want in the work you like best.

Don't let another priceless hour go to waste! Without cost or obligation, let us prove that we can help you. Mark and mail this coupon.

TEAR OUT HERE

### INTERNATIONAL CORRESPONDENCE SCHOOLS

Box 5530-D, Scranton, Penna.

Without cost or obligation, please tell me how I can qualify for the position or in the subject before which I have marked an X:

#### BUSINESS TRAINING COURSES

- |   |   |
|---|---|
| <input type="checkbox"/> Business Management            | <input type="checkbox"/> Salesmanship           |
| <input type="checkbox"/> Industrial Management          | <input type="checkbox"/> Advertising            |
| <input type="checkbox"/> Personnel Organization         | <input type="checkbox"/> Better Letters         |
| <input type="checkbox"/> Traffic Management             | <input type="checkbox"/> Foreign Trade          |
| <input type="checkbox"/> Business Law                   | <input type="checkbox"/> Stenography and Typing |
| <input type="checkbox"/> Banking and Banking Law        | <input type="checkbox"/> Business English       |
| <input type="checkbox"/> Accountancy (including C.P.A.) | <input type="checkbox"/> Civil Service          |
| <input type="checkbox"/> Nicholson Cost Accounting      | <input type="checkbox"/> Railway Mail Clerk     |
| <input type="checkbox"/> Bookkeeping                    | <input type="checkbox"/> Common School Subjects |
| <input type="checkbox"/> Private Secretary              | <input type="checkbox"/> High School Subjects   |
| <input type="checkbox"/> Business Spanish               | <input type="checkbox"/> Illustrating           |
| <input type="checkbox"/> French                         | <input type="checkbox"/> Cartooning             |

#### TECHNICAL AND INDUSTRIAL COURSES

- |   |  |
|---|--|
| <input type="checkbox"/> Electrical Engineering | <input type="checkbox"/> Architect                                   |
| <input type="checkbox"/> Electric Lighting      | <input type="checkbox"/> Blue Print Reading                          |
| <input type="checkbox"/> Mechanical Engineer    | <input type="checkbox"/> Contractor and Builder                      |
| <input type="checkbox"/> Mechanical Draftsman   | <input type="checkbox"/> Architectural Draftsman                     |
| <input type="checkbox"/> Machine Shop Practice  | <input type="checkbox"/> Concrete Builder                            |
| <input type="checkbox"/> Railroad Positions     | <input type="checkbox"/> Structural Engineer                         |
| <input type="checkbox"/> Gas Engine Operating   | <input type="checkbox"/> Plumbing and Heating                        |
| <input type="checkbox"/> Civil Engineer         | <input type="checkbox"/> Chemistry <input type="checkbox"/> Pharmacy |
| <input type="checkbox"/> Surveying and Mapping  | <input type="checkbox"/> Automobile Work                             |
| <input type="checkbox"/> Metallurgy             | <input type="checkbox"/> Navigation                                  |
| <input type="checkbox"/> Steam Engineering      | <input type="checkbox"/> Agriculture and Poultry                     |
| <input type="checkbox"/> Radio                  | <input type="checkbox"/> Mathematics                                 |
| <input type="checkbox"/> Airplane Engines       |  |

Name.....  
Street.....  
Address.....

City..... State.....

Occupation.....  
Persons residing in Canada should send this coupon to the International Correspondence Schools Canadian, Limited, Montreal, Canada.

Please Mention Popular Mechanics



"Red Devil" Rapid Boring Auger Bits are 33 1/2% easier boring, have 10% greater clearance, and bore with or against the grain of any wood. Style 2400—10/16 in., shown here, 75c.

## Red Devil

REG. U. S. PAT. OFF.

# Pliers



**Stand  
the  
Gaff!**

**THEY** give you a powerful grip at just the right place—a non-slip hold on that rusty nut, that screw-eye you want to turn, that rod you want to loosen, that wire you want to cut.

"Red Devil" Pliers give long time service and satisfaction—drop forged of steel—will last for years.

Made in 100 styles—one for every purpose.

### "Red Devil" Slip Joint Plier

shown above, the most useful tool of its kind for the home, workshop or car. The handles fit the hand without pinching—the thin nose reaches hard-to-get-at places—the slip joint widens the range of objects that can be gripped.

"Red Devil" No. 1024—6 1/2 in.—at all good hardware dealers, or if not in stock send \$1.00 and dealer's name for a sample tool.

*Mechanics' tool booklet free*

**SMITH & HEMENWAY CO., Inc.**

Manufacturers of "Red Devil" Tools  
260 Broadway, New York, N. Y.

"Red Devil" Glass Cutters—the glaziers' standard tools of the world. "It's all in the wheel." Made in 40 styles. No. 024 shown here, 20c.



Please Mention Popular Mechanics

## \$400<sup>00</sup> ONE DAY!

### Ira Shook of Flint Did That Amount of Business in One Day

Making and Selling Popcorn Crispettes with this machine. Profits \$269.00. Mullen of East Liberty bought two outfits recently, and is ready for third. Iwata, Calif., purchased outfit Feb., 1920. Since, has bought 10 more—his profits enormous. J. R. Bert, Ala., wrote: "Only thing I ever bought equaled advertisement." J. M. Patillo, Ocala, wrote: "Enclosed find money order to pay all my notes. Getting along fine. Crispette business all you claim and then some." John W. Culp, So. Carolina, writes: "Everything going lovely. The business section of this town covers two blocks. Crispette wrappers lying everywhere. It's a good old world after all!" Kellog \$700 ahead end of second week. Mexiner, Baltimore, 250 in one day. Perrin, 380 in one day. Baker, 3,000 packages, one day.



### WE START YOU IN BUSINESS

Little capital, no experience. Furnish secret formula.

#### Build a Business of Your Own

The demand for Crispettes is enormous. A delicious food confection. Write me. Get facts about an honorable business, which will make you independent. You can start right in your own town. Business will grow. You won't be scrambling and crowding for a job. You will have made your own place.

#### Profits \$1,000 a Month Easily Possible

Send post card for illustrated book of facts. Contains enthusiastic letters from others—shows their places of business, tells how to start, when to start, and all other information needed. It's free. Write now.

#### LONG EAKINS COMPANY

728 High Street

Springfield, Ohio

## TAILORING SALESMEN

### We Pay You Salary and Commissions

Greatest money-making line in America. Made to measure suits, overcoats, one price, \$33.65, express prepaid, all wool, all wool linings, hand tailored, finest workmanship. No extra charges for style or oversize. Bigger advance commissions, weekly salary besides. Protected territory. Apply at once.

#### GREAT WESTERN TAILORING CO.

837-841 W. Jackson Blvd.

CHICAGO, ILL.



## THE 1923 New OLIVER SPEEDSTER

Send for 1923 Oliver Catalog Showing New Standard three bank Keyboard.

THE OLIVER TYPEWRITER CO., Chicago



## CAMERAS

Over a Hundred Styles and Sizes

Send for new 1923 illustrated catalog showing newest models and latest reduced prices.

IT'S FREE

10 days' free trial given

Seneca Camera Mfg. Co.

300 Central Ave., Rochester, N. Y.

# Here is the New Way To Fill a Ford and Measure Gasoline

*Without Lifting the Seat*

*Without Guesswork—Without Waste*

*Without Losing Your Temper*

## The **Kirstin** **Fil-O-Meter**

*(For Fords and Chevrolets)*

*A Gasoline Filler and Gauge Combined*

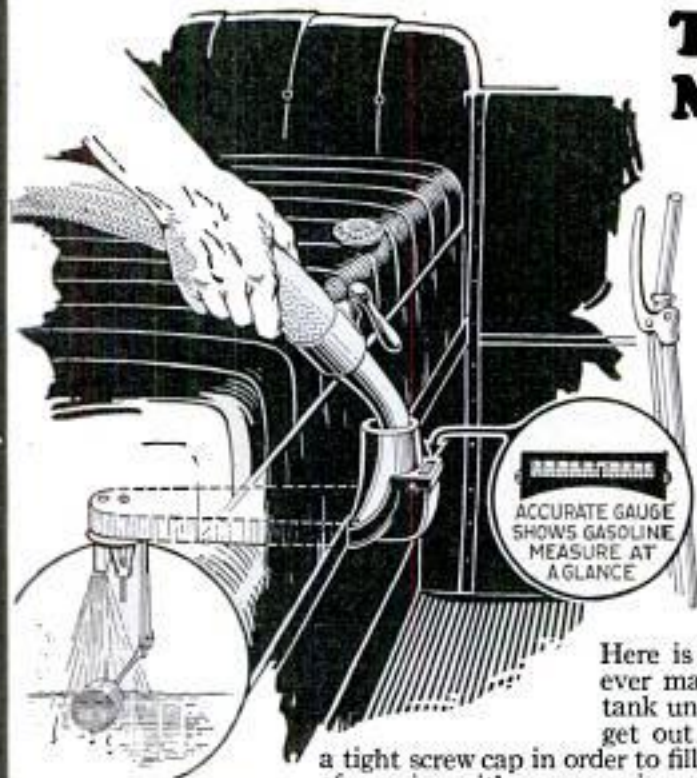

Here is the greatest time, trouble and temper saver ever manufactured for Ford and Chevrolet cars (with tank under the seat.) Now it is no longer necessary to get out of the car, raise the seat cushion, and fuss with a tight screw cap in order to fill the tank or measure gasoline. Here is the end of messing with a measuring stick. Say "good-bye" now to taking a chance on the amount of gasoline remaining for a trip. The Fil-O-Meter shows your gasoline at a glance. It saves the long walk you take for gasoline when you run short. Be safe. Attach a Fil-O-Meter.

### YOU CAN ATTACH IN 10 MINUTES

**Full Directions for Attaching Accompany Each FIL-O-METER**

Anyone can attach the Kirstin Fil-O-Meter. The cap is taken off the tank (a slot is made in the seat frame) the Fil-O-Meter is put in place and screwed down with the clamp where it can't shake loose or rattle—all in ten minutes. No mechanic required. With the Fil-O-Meter in place the Ford or Chevrolet fills like a regular car. No lifting cushions—no fuss, mess or inconvenience. The filling-station man simply lifts off snap cap—places hose in the opening—and fills your tank. You see every fraction of gasoline register, too, as it enters the tank. No more guessing about how much you get. No more counting the turns of the filling crank. Once in place the Fil-O-Meter is out of the way—but always where you can see and use it handily. The Fil-O-Meter weighs less than 2 lbs., is strongly made of pure aluminum, and will last a lifetime.

### TEN DAY, MONEY BACK TRIAL

Order a Kirstin Fil-O-Meter now. Put it on your car. Use it ten days. At the end of that time if you are not perfectly satisfied with it for any reason, you may return it at our expense and your money will be immediately refunded. Could any proposition be fairer? Especially on an article you absolutely NEED—and at such a LOW PRICE? The Kirstin Fil-O-Meter is absolutely GUARANTEED to satisfy in every respect, and to save its cost many times over in a very short time. Order now and let us prove it.

### Our Guarantee Protects You—ORDER NOW

You can order at once with the assurance that you must be satisfied or your money will be refunded. When ordering be sure to state make, year and model of your car (touring, roadster, sedan, etc.) If you require further information on the Kirstin Fil-O-Meter before ordering, we will give it to you gladly. But why delay your order? We take the risk that you must be perfectly satisfied. Use the coupon and address.

**A. J. KIRSTIN CO.**  
Mfrs., 10 FIRST STREET  
ESCANABA, MICHIGAN



The Kirstin Fil-O-Meter attaches like this on any Ford or Chevrolet tank in 10 minutes.



With the cushion in place the Fil-O-Meter is neatly out of the way but always handy for service.

### SALESMEN AND DEALERS

Here is a new device ready to sell to millions. No competition. Protected by iron-clad patents. Get full details on our distributing proposition before another day goes by.

### PRICE

\$ **5** <sup>00</sup>  
Except  
Ford  
Sedans  
\$6.00

Money Order, Check,  
or Sent C. O. D.

### MAIL WITH THIS ORDER

**A. J. KIRSTIN CO., 10 First St., Escanaba, Mich.**

Gentlemen:—Please send me a Kirstin FIL-O-METER for Ford, Chevrolet, year..... model..... with understanding that I will put it in use on my car and if not perfectly satisfied after ten days' trial I can return it and get my money back.

Money Order enclosed  Check enclosed  Send C. O. D.

NAME.....

TOWN..... STATE.....

I can sell FIL-O-METER Send me salesman's proposition.

# AGENTS! Are you making \$150 to \$250 a Week?

## "Co-operative" Agents do—join us!



**Wear this Button!**



## Don't Cost You a Penny!

No dues, no strings or obligations; mail the coupon today. A handsome illustrated booklet will be sent to you at once explaining how we help you to make more money immediately you join. Don't delay, membership limited.

**AGENTS CO-OPERATIVE ASSOCIATION**  
210 East Ohio Street, CHICAGO

If you are a good agent you cannot afford to stay out of this organization! Without a penny of cost to you membership in this Association brings you selling opportunities that you cannot find alone. We have only one object: **to help every member make more money!** We investigate selling opportunities; we find you best money-making products offered for sale in America; we protect you against injustice; we develop your efficiency by telling you the successful methods of our biggest money-makers! If you are making less than \$150 to \$250 a week, mail the coupon today and change your luck!

## 100,000 Agents in this big Co-Operative Association!

The Agents Co-Operative Association has nothing to sell. It has been organized to help agents get away from the poor little selling propositions that scarcely pay a living. It is our purpose to assist every member who wears the Co-operative button to turn his time into bigger profits than have ever before been possible.

### Look at the BENEFITS!

1. We find you the most profitable lines on the market.
2. We put you in touch with big concerns offering easiest selling lines at biggest profits.
3. We protect you against injustice on the part of manufacturers.
4. We tell you how our most successful agents get their results. We improve your efficiency and build up your earnings.
5. We are advertising the A. C. A. button, so that wearing it will help you get a hearing and sales everywhere.
6. Many more benefits, impossible to list here. Send for book and get the facts.

#### AGENTS CO-OPERATIVE ASSOCIATION, 210 E. Ohio St., CHICAGO

Without obligating me, please send me complete information about membership in the Agents Co-Operative Association. It is understood that I am not to pay a penny for membership or dues or anything else. Free booklet on request.

Name .....

Address .....

Territory covered .....

Number of years' experience as Agent .....

Lines handled .....



# WE WANT AGENTS

To introduce the Milburn Puncture Proof Inner Tube. Mr. P. H. Milburn, of the Milburn Puncture Proof Tube Company, Chicago, after many years of practical and theoretical experiments, has perfected an inner tube which in actual test suffered the loss of NO AIR after being punctured as many as 500 times. Many users have run over 20,000 miles without removing a tire from the wheel. Milburn Puncture Proof Inner Tubes are made of the best quality live red gum rubber—especially built and air inflated. Milburn Puncture Proof Tubes cost no more than other ordinary tubes.



## CAR OWNERS WANTED

To sell and demonstrate this wonder tube. Interests everyone immediately. Automobile owners buy on sight. It makes no difference what car they drive or what tires they use. Our salesmen are coining money on our "DIRECT FROM FACTORY" scheme of selling. Absolutely no competition. We control all basic patents. No capital required to start. Previous selling experience not necessary.

## Earn from \$5000 to \$10,000 a Year

Earn \$5000 to \$10,000 yearly or more. Get into business for yourself. Sell Milburn Puncture Proof Inner Tubes. Every car owner is a prospect. Your field is unlimited. Now is the season. Get in while it is good. Be independent.

### TESTIMONIALS

Convincing Statements from a Few of Our Agents

**J. D. Cooper**—"I have made 30,000 miles with my Milburn Puncture Proof Tubes and have not as yet removed a rim or casing and my casings are still in excellent condition."

**J. C. Jerves**—"I sold 50 Milburn Tubes in the first three days."

**Chas. Cayton**—"I sold twelve tubes yesterday in ten minutes."

**L. S. Knapp**—"My first few hours out I sold eight tubes, no trouble at all to sell them. The most wonderful tube on the market today, I think. I am hoping you will give me the agency for a big territory."

**D. Edelero**—"I have driven seventy-five miles in one of the 30x3 tubes and twenty were spike nails. It has gone above the test that you recommended to me it would do."

**S. W. Dow**—"Your tubes are fine; we have a 30x2½ that has certainly stood the gaff; it has been punctured anywhere from forty to forty-five or fifty times this week, and is standing up in great shape."

**Staples Brothers**—"Your tube arrived and proved satisfactory in every respect. We think we know a good thing when we see it and would be pleased to represent THE MILBURN PUNCTURE-PROOF TUBE COMPANY."

## FREE TUBE

### SPECIAL FREE TUBE OFFER

Send coupon or write today for special free tube offer and further details.

References, Industrial State Bank of Chicago, National Bank of the Republic, Chicago, Baker State Bank of Chicago.

Don't hesitate. Fill out the coupon and send it in or write and send name and we will send you all details. This is your opportunity so don't delay. Address

**P. H. MILBURN, Pres.**

**Milburn Puncture Proof Tube Co.**

335 West 47th Street

Dept. PM

CHICAGO, ILLINOIS

**MILBURN PUNCTURE PROOF TUBE COMPANY**  
 335 West 47th Street, Dept. PM, CHICAGO, ILLINOIS

Commitment: If the money making opportunity is as big as we claim, I am interested in getting the facts. If I don't see a way of the profit, please advise. My name is \_\_\_\_\_ and I will not be bothered without your permission. I am interested in \_\_\_\_\_ and I will not be bothered without your permission.

Name \_\_\_\_\_  
 Address \_\_\_\_\_  
 City \_\_\_\_\_  
 State \_\_\_\_\_



## Have You Seen It?

This wonderful fountain pen with a perfect check protector attached, which enables you to write and protect your checks, no matter where you may happen to be?

THE NAME IS

CHECK-PROTECTOR  
**Security**  
FOUNTAIN PEN

It enables you to protect your checks just as efficiently as the most expensive check writer on the market, **any time—any place**—and in addition to this unique and practical feature, the "SECURITY" has **five other new features** of equal importance not embodied in any other pen on the market, which place it in a class all by itself.

It has a **Screw Pressure Filling Device**. It has a **14 karat tempered iridium tipped gold pen**. It has an **air cushion feed bar**, which insures an even flow of ink ending forever the **curse of leaks and blots**. It has a **rolled gold spring clip**. And a **rolled gold band on cap**, which prevents same from breaking.

A **five-year unconditional written guarantee** is furnished with each pen. \$33,000,000.00 were lost in 1922 on account of raised checks, forgeries, and alterations of negotiable securities, and you are liable to be the next victim.

Your check or money order for \$3.00 or \$3.50 (if you prefer a small size pen), \$4.00 if you prefer a medium size, and \$5.00 if you prefer a large size pen, will bring you this marvelous writing tool, which will end forever your pen troubles and give protection on your checks without any extra cost.

### Where Can I Get One?

Security Pens are sold by our special representatives direct to the user. They are not sold in stores. If we have not as yet an established representative in your locality, order direct by using the coupon below.

**KRITIKSON BROS., Inc.**  
Dept. P. M.  
900 W. Jackson Blvd., Chicago



KRITIKSON BROS., Inc.  
900 W. Jackson Blvd., Dept. PM, Chicago, Ill.  
Gentlemen: Enclosed check or money order—please send me one Security pen, No. .... guaranteed for five years.

Style of point preferred

Fine  Medium  Coarse  Med. Stub  
 Broad Stub  Steno  Posting, in flexible   
 or stiff  action, long  or short  model.

Name .....

Address.....

No.  
400  
\$4.00

Please Mention Popular Mechanics



**\$100 to \$200 A WEEK!**  
Driver Agents! Put a Lu-Min-Us-Cap on your car free and write orders day and night! \$35 electric-lighted outfit free to men without cars. \$100 to \$200 a week and more made by agents. You can do the same. Ford size \$7.50, others \$8.50.



**ILLUMINATES,**  
**Theft-proofs MOTOMETER!**  
A millionaire can't buy a more gorgeous ornament for his car, but price within reach of all. Parking lights, driving lights, trouble lights, **ALL IN ONE!** Nothing like it! Sells on sight! Write for information and how to get your own *Free, today!*

**W. C. PERKINS & COMPANY**  
Dept. 206 '3949 Sheridan Road, CHICAGO

## How to Get the Most Out of One Tube



You will never know the full range and power of a single tube until you have operated Duo-Reflex, the most powerful one-tube circuit ever built.

Under conditions at all favorable, a wide compass of stations is heard on a loud speaker, and headphones extend the range from coast to coast.

Especially designed for Duo-Reflex, and the major essential of its power, is the Erla radio frequency reflex transformer, one of the greatest improvements in years. Be sure to look for the Erla trademark when buying!

Electrical Research Laboratories  
Dept. J, 2515 Michigan Ave., Chicago

**ERLA**

**FREE!**

Complete instructions for building the Duo-Reflex circuit are set forth in Erla Bulletin No. 13, obtainable gratis from radio dealers. Or write us direct.

**"LYON BODIES" \$27.50**  
For Fords, Chevrolets and Dodges

**SEND NOW**

For Our 1923

"Book of Bargains"



Containing a full line of bodies and accessories at exceptionally low prices. Buy direct from the factory.  
**AUTO TIRE SALES CO., Dept. PB**  
1346 S. Michigan Ave. CHICAGO Body Division



**Small Steam Engines and Boilers**

**Gas and Gasoline Engines**  
 $\frac{1}{8}$  H. P. Up

Pumps, gears, model makers' supplies. Sent postpaid (2 dimes preferred) or 20c stamps.

**Modern Engine & Supply Co.**  
334 Monadnock Bldg., Chicago

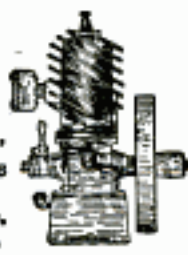

# I WANT YOU FOR MY AGENT

## Personal Read This!

Think of yourself, stepping up to a prospect making an installation in five minutes. Do it at the curb. It always creates interest. A second and even a third sale often results—right there on the spot! This means triple commissions. Think of the repeat business which is yours with no work at all. Think of the respect you will command as the representative of a half-million dollar concern backed by men who have already built an international business which is over thirty years old and the largest in the world of its kind. I offer you this—it is yours simply because you already know enough about motors to know how to sell this big money maker.

Why try to sell something you don't know about, when here is something you **do** know about!

You can sell a whole truck fleet just as quick as you can sell one car. You can sell MOTOR MASTERS to merchants or farmers for every car, truck, or tractor they may have—all with the one sale. Soon you will be selling dealers. That means hundreds of sets at one sale.

Remember we guarantee MOTOR MASTERS to prevent carbon—to prevent plug flooding and foaling—to increase power—to save gasoline or money back. You can demonstrate MOTOR MASTERS on sight. Put them in your customer's car while he waits. Cut down the gas from 10 to 20%. There will be an amazing increase in power—smoother running. No long time for installation, only five minutes for your sale—your profit—and on to the next customer! Send in the coupon and cash in on your own intelligence and knowledge. What others are doing you can do!

YOU can sell my product. YOU ALREADY KNOW HOW. And I need your knowledge. You can be a "star" salesman for me, because your knowledge of motors is all I need.

No "COACHING" necessary, if you know gasoline motors at all. That is why I want you for my agent. You know that gasoline today is "heavy". It doesn't evaporate like the old time gas. It gets on the spark plug firing points and "floods" the spark. You have often wished for something to stop this flooding and keep oil off the plugs, too. Something which will keep the plugs clean—give your motor the power it should have. You have often said to yourself "How easy it would be to sell a device which overcomes oil pumping, flooded plugs, and carbon. I could sell thousands of them". Well—here it is—THE MOTOR MASTER. The simplest device that ever was—solid brass, no moving parts—lasts forever.

I wish I could sit down with you and tell you all about the MOTOR MASTER—so simple—yet so wonderful. For it is more than a protection to the spark plug—it is a hot spot, which puts a perfect mixture right at the spark plug points and gives such a hot explosion that carbon is burned out while the motor runs. No lay up to remove carbon. No reboring to stop "oil pumping". A big increase in power. A big saving in gasoline.

And so easy to install; just screw a MOTOR MASTER into the spark plug hole and screw your old spark plug into it. That's all—except that you must cut down your gas from 10 to 20%. NO MORE FOULED SPARK PLUGS! NO MORE CARBON! MORE POWER! LESS GAS!

This is  
**MOTOR MASTER**



## CAR OWNERS WANTED

### To Sell and Demonstrate MOTOR MASTERS

You can do this while you drive. Use your own knowledge to make big money—right now. No instructions necessary—Just tell prospects what you already know—and clean up!

Every man you call on will want a set of MOTOR MASTERS. So answer this advertisement at once. It means big money in your pocket. You can start selling them now. Everybody needs them—everybody has trouble with spark plugs and carbon and oil pumping. MOTOR MASTERS are guaranteed to end all that trouble or money back.

## EARN \$200 WEEKLY

**Your outfit costs you nothing**  
FREE for the asking. Don't wait. Send in now and get your agent's stock, and your own FREE set of MOTOR MASTERS. Get them on your car and show them to a prospect. He wants them at once. Nearly a million sold already. Some of that money might just as well have been yours, if you had only been our agent before this. Don't let such a chance slip by again. Send in this coupon and get started quick selling an established article that is guaranteed or money back.

Please send me, without obligation on my part, your literature telling me how I can become your agent and make big money selling MOTOR MASTERS. Also tell me how I can secure my set free.

MOTOR MASTER CORPORATION  
646 No. Michigan Ave.,  
Chicago, Ill.



**DON'T DELAY. MAIL COUPON TODAY.**

Name .....

Address .....

City ..... State .....

**Motor Master Corporation**

646 No. Michigan Ave.  
CHICAGO, ILL.



## High School Course in Two Years!

Lack of High School Training has kept thousands of men and women from attaining **business and social position**. Without this training you are absolutely barred from a successful business career, from leading professions, from well-paid civil service jobs, from teaching and college entrance. In fact, all **preferred positions** are closed to you without this vital training. You can't stand this heavy handicap nor do you have to. The American School can give you the valuable training you missed.

**Put Your Idle Hours to Work** You can complete our simplified High School Course within two years by spare-time study. Then you will be mentally equipped to handle a worthwhile position. This course, prepared by some of America's leading professors, will broaden your mind, give you a wider outlook and make you keen, alert and capable.

### Remove Your Handicap

Whether you need High School Training or specialized instruction in your chosen line—NOW is the time to remove your handicap. You must know the short cuts and efficiency methods. You must know the HOW and WHY. Over 50,000 students owe their success to training received from the practical, money-making Courses in the coupon below. Let us tell you about this training—about the Course you are interested in. Check and mail the coupon.

### American School

Dept. H.B.74, Drexel Ave. and 58th St., Chicago

### American School

Dept. H.B.74, Drexel Ave. and 58th St., Chicago

Send me full information on the subject checked and how you will help me win success.

- |                              |                            |
|------------------------------|----------------------------|
| .....Architect               | .....Lawyer                |
| .....Building Contractor     | .....Machine Shop Practice |
| .....Automobile Engineer     | .....Photoplay Writer      |
| .....Automobile Repairman    | .....Mechanical Engineer   |
| .....Civil Engineer          | .....Shop Superintendent   |
| .....Structural Engineer     | .....Employment Manager    |
| .....Business Manager        | .....Steam Engineer        |
| .....Cert. Public Accountant | .....Foremanship           |
| .....Accountant and Auditor  | .....Sanitary Engineer     |
| .....Bookkeeper              | .....Surveyor (& Mapping)  |
| .....Draftsman and Designer  | .....Telephone Engineer    |
| .....Electrical Engineer     | .....Telegraph Engineer    |
| .....Electric Light & Power  | .....High School Graduate  |
| .....General Education       | .....Fire Insurance Expert |
| .....Vocational Guidance     | .....Wireless Radio        |
| .....Business Law            | .....Undecided             |

Name.....

Address.....

## The SHAW Speedster

Model 2B  
Price \$125



## A Real Auto at Low Cost!

### Build It Yourself or Buy It Complete

Everywhere the SHAW Speedster is making a big hit. It solves the motor car problem at low cost! The SHAW is a *real* automobile, equipped with the famous Shaw 2½ H. P. Motor. A light, classy, dependable car for pleasure and business. Takes you anywhere; fine for a light delivery car. Has speed of 4 to 25 miles an hour; economical, you get 60 to 90 miles per gallon of gas! Upkeep is

practically nothing.

We can furnish the SHAW Speedster in several different models, or furnish plans and any or all parts you need to build it yourself.

Model 2-B with wire wheels (battery ignition) . . . \$125.00

### Make Your Bike A Motorcycle

A high-grade 2½ H.P. motor attachment quickly clamped on any bike frame. Makes your bike a motorcycle! *Special Low Price Now!* Write for complete Description and Special Low Price.

### Complete Book of Plans 25c

Use the coupon below and send 25c in stamps for Book of Plans showing how to build a SHAW Speedster, quickly, easily, and at low cost. Any man or boy handy with tools can build it. Parts at Special Low Prices. Also ask for literature fully describing the SHAW Speedster and the SHAW Motor Attachment. Use coupon below. Send today!



### MAIL COUPON NOW!

SHAW MANUFACTURING CO.  
Dept. P5, Galesburg, Kansas

- Please send me your plan book for building the SHAW Speedster. (Enclose 25c in stamps.)
- Full Information on SHAW Speedster.
- Full Information on Shaw Bicycle Motor.

Name.....

Address.....



# AGENTS WANTED!

Will you sell **PART TIME** or **FULL TIME**  
for **\$100 to \$200 a Week?**

Forrest in Mississippi made a record of \$68 profits in one day. Weber in Wisconsin has averaged \$900 a month. Scores of part-time men are adding \$10 to \$20 a day to their income, taking orders for SAAL Heavy-Oil Systems. If you are not making big money now, get our free book—read how men no smarter than you are actually making their fortunes selling "SAALS" to motorists and dealers. Never mind what we claim—judge this big money-making opportunity by what our Agents tell you themselves!

**FREE OUTFIT FOR YOUR OWN CAR**

No money to invest, no stock to carry, no delivering or collecting, no experience necessary. A car of your own helps get sales, but not indispensable. We supply the merchandise, the capital, the selling plan and simple instruction which will enable you to get 7 to 9 orders out of 10 calls. We even supply absolutely free a sample outfit for your own car or to carry. All you supply is your time, and we pay you more for it than you ever got for it before!

**SAAL** HEAVY OIL  
"Makes cars ride better and last longer" *System*



**No waiting for Pay Day—Get your \$17 to \$34 Cash in pocket every Day!**

Whether you have succeeded or failed at selling other things, even if you never sold anything before **YOU CAN MAKE BIG MONEY SELLING "SAALS"!** We can promise **YOU** success, because among our successful Agents are a lot of everyday fellows who never made more cash ~~last~~ <sup>last</sup> ~~at~~ <sup>at</sup> a week before. Mark the coupon "Agents" proposition paying \$100 to \$200 a week"—get the **TRUE STORY** from our agents themselves, then decide!

Coupon brings Your big opportunity—make it today!

H. G. SAAL CO., Dept. 401,  
1800 Montrose Ave., Chicago

Please send me complete information about SAAL Heavy Oil System. I am marking X for proposition in which I am interested.

- Agents' proposition paying \$100 to \$200 a week.  
 Free trial offer to motorists.  
 Special profit-making offer to dealers, garage and repair men.

Name.....

Address.....

.....

## Heavy Oil 100% Lubrication

Grease cups, "greasing-systems" and all other methods of chassis lubrication are now out of date! Lubricating engineers say "Use heavy-oil for shackles, steering and chassis; force it into the bearings with the SAAL Oil Shooter. Heavy Oil is 100% lubrication, ordinary grease is 25% lubrication and 75% soap! With the SAAL SYSTEM, chassis lubrication is now a white-collar job with service-station results. Pays for itself many times each year by saving depreciation and repair bills. "Makes cars ride better and last longer!" Costs about 1/4 the price of other systems.

**\$5** For Ford, Ford Trucks, Chevrolet, Star, Overland and Gray.

For all large cars, complete

**\$8**

## Heavy Oil at 2000 lbs. Hydraulic Pressure

With no more pressure than you would use on a hand tire-pump, SAAL Oil Shooter actually generates 2000 pounds of hydraulic pressure which crushes through dirt and rust and forces the velvety flow of heavy oil into the bearings.

**2000 lbs. Pressure**



**42 Fittings**

fit ALL cars! Complete outfit includes OIL SHOOTER, 42 fittings more than enough for any car and steel holder which fastens to dash under hood.

**H. G. SAAL COMPANY**

Dept. 401  
1800 Montrose Ave.  
CHICAGO, ILL.



CAPITAL \$2,500,000  
Established 22 years

**5 SAAL FACTORIES**



**One of the World's Largest Manufacturers with unlimited resources Builds Cunningham Tubes**

**F**ORTY-THREE years ago the carbon filament electric lamp, at that time considered the finest development in the electrical art, came into general use.

The important and ever-growing demand revealed in the building and expansion of mighty factories, and the improvement of factory methods, until today the tungsten filament gas-filled lamp yields eight times the candle power for the same electric input.

In recent years these same highly skilled manufacturers have been devoting a part of their factories, and applying their engineering talent gained through years of experience, to the production of vacuum tubes.

The new Cunningham type C-301-A, Amplifier and Detector represents a combination of those years of manufacturing experience, and the engineering ability contributed by that great scientific organization, the Research Laboratory of the General Electric Company.

The low filament current of only one-fourth of an ampere and the extremely high mutual conductance of 200 micro-ohms make the C-301-A the most efficient vacuum tube ever built for amateur and entertainment use in radio.

**Patent Notice:** Cunningham tubes are covered by patents dated 1-7-35, 1-13-37, 2-13-38, and others issued and pending. Licensed for amateur, experimental and educational use in radio communication. Any other use will be an infringement.

*E. J. Cunningham Inc.*

Home Office: 244 First Street, San Francisco, Calif.  
Eastern Representative, Chicago, Ill.



A Specially Designed Tube For Every Radio Use

**Ford Goes 66 Miles On 1 Gal. Gasoline**

With wonderful new vapor Humidifier. Equals gas at 8c to 12c per gallon. For every make auto. Car Owners wanted in every locality to introduce it. Demonstration model furnished free. Write quick for particulars. Give make of car.

WALTER CRITCHLOW, Suite 320, 716 Madison Street, CHICAGO

**CAR OWNERS WANTED!**

To use and introduce the greatest improvement in Inner Tubes since autos were invented. Air gauge in valve stem of every Tube shows at a glance through the Unbreakable Transparent Valve Cover amount of air in tires.

**AIR-GAGE Heavy Duty Tubes**

—sell on sight to almost every car owner because they save trouble, time, worry and expense. Add one-third to life of tires. Paul salesman make big profits selling direct to car owners. Our million dollar factory can use 100 more salesmen at once. Experience not necessary. Big illustrated Free Book tells how the Paul Plan will start you in this big money-making business without capital. Write for Free Book Today. THE PAUL RUBBER CO., Dept. 25, Salisbury, N.C.



**REMINGTON PORTABLE TYPEWRITER Dealers and Branches Everywhere**



**AMPLIFYING TRANSFORMERS**  
(Radio and Audio Frequency)

**Reduce Your Troubles With Summer Static**

Build a Radio Frequency Receiving Set, using loop antenna, and get the full joy of radio.

**Neurodyne, Reflex and Cockaday Circuits**

reach their highest efficiency only when used with "All-American" Amplifying Transformers.

**FREE BOOK of Radio Hookups**  
Up to the minute and tremendously useful. Ask your Dealer, or send us 2c stamp and Dealer's name and address.



**RADIO FREQUENCY**  
R-10 (150-550 meters) \$4.50



**AUDIO FREQUENCY**  
R-12 (Ratio 3 to 1) \$4.50  
R-21 (Ratio 5 to 1) 4.75  
R-13 (Ratio 10 to 1) 4.75

**RAULAND MFG. CO.**  
200 No. Jefferson St., Chicago, Ill.



**SAVE 50% OF THE USUAL COST**

Buy a World Battery for your Auto or Radio set, save the difference, and get a **WRITTEN 2-YEAR GUARANTEE**  
Auto—6 Volt, 11 Plates ..... \$13.25  
Radio—6 Volt, 60 Amps. .... 10.00  
(Other prices on request.)  
Will ship C. O. D. subject to inspection or will allow 5% discount for cash with order. **WRITE TODAY—NOW**

**WORLD BATTERY CO.**  
Dept. 6, 1219 So. Wabash Ave., Chicago, Ill.

**THE SHAW MOTOR ATTACHMENT**  
Makes Your Bike Like a Motorcycle

A high grade 2 1/4 H. P. Motor attachment quickly clamped to any bike frame. Speed 4 to 40 miles an hour. 90 to 125 miles per gallon of gas.

**Special Low Price Now!** Write today for Complete Description and Special Low Prices on SHAW Motor Attachments and the SHAW Complete Motorbicycle.

**SHAW MFG. CO., Dept. 37, Galesburg, Kans.**



**GREAT 2 IN 1 LAMP**

**THE SECRET of QUICK SALES**

Remove Shade for Outdoor Use  
300 Candle Power



Burns 97% Air

There's a way that brings quick and certain sales of our brilliant Combination Handy-Lite. It's building profitable business for our agents—in spare time. This lamp meets the demand for a light brighter than gas or electricity but needing no wiring or piping. Lights with match. Smokeless, compact, handsomely nickeled, durable. Write for supreme selling secret and attractive agency proposition.

**ENTERPRISE TOOL AND METAL WORKS, Dept. 37**  
2441-9 No. Western Ave. Chicago, Ill.



# MEN!

**BREAK THE SHACKLES THAT BIND HER TO A ROASTING STOVE IN SUMMER**

No more sweltering kitchens—no more fires to build or watch—no dirty, heavy coal to lift—no wood to chop—no back-breaking scuttles to empty—no smelly oil stoves to clutter kitchen—no more spoiled roasts, bread or cake—this

## Amazing New Invention Makes Your Present Range A GAS STOVE

### DON'T

**DON'T** worry and fret with dirty coal and wood. The Oliver does away with all kitchen drudgery. No ashes, no smoke, no grimy hands; no unsanitary scuttles or wood boxes.

**DON'T** experiment with a makeshift oven—use your old, reliable oven—the Oliver makes a bad oven good and a good oven better.

**DON'T** buy a separate oil stove to clutter up your kitchen. The Oliver fits into your present range. No wicks, soot or odor—as convenient as city gas.

**DON'T** slave in a hot kitchen! With an Oliver you can cook or do your washing and ironing—and turn off the heat the instant you see through. Have a cool kitchen all summer.

**DON'T** waste your strength in thousands of needless steps a day. With the Oliver you have no building fires, no shaking, no watching, no poking, no carrying ashes and no needless dusting—you save hours every day!

### I need more Salesmen, Agents and Managers

Agents—cash in on this nation-wide sweep of Oil. F. W. Bentley of Pa. says, "Ye gods, some seller. I made \$215 today." Mrs. Selder made \$100 a month in spare time at home. If YOU want to make \$50 a week in part time or \$250 a week in FULL time; or if you can swing a territory at \$5,000 to \$15,000 a year, write me quick for Sales Plan and Exclusive Territory Franchise. I give Fords to producers. But you MUST act at once. Address B. M. Oliver, Pres., at address at right.

**Free Fords**

### Does Away with Dirty Coal and Wood

HERE is the amazing new invention that has ended forever woman's slavery to household drudgery. IN ONE MINUTE it turns your present coal and wood range into a real gas stove that turns on and off with a valve.

#### Wonderful Baking

You can bake in your own good old oven—better and quicker than ever before. No waiting for the oven to heat to the right temperature. No worrying over evenness of heat when you want delicious, light and fluffy cake, perfect biscuits, bread, pies, etc. In a jiffy your oven is at a fine,

even temperature—any degree you want. Put on your roast, stew or vegetables. Go away and forget them. Come back when they are done—turn off valve and fire goes out. Leaves your kitchen cool and sweet.

**Just Turn Valve—Burns 95% Air—5% Oil**

Mr. B. M. Oliver, the inventor, calls this wonderful device the Oliver Oil-Gas Burner because it uses 95% air and only 5% coal oil (ordinary kerosene, the cheapest fuel known)—turns them into real gas with intense, hot, clean, even flame—no wick, smoke or odor. 16 models to fit every kind of cook stove or range. No drilling holes—no change of any kind—simply set in firebox, in one minute. Absolutely safe. Lasts a lifetime.

## 30 DAYS FREE TRIAL

Use the Oliver—for 30 days—in your own home. See how it makes your oven bake perfectly—with immediate heat and even temperatures. See how it keeps the kitchen cool and avoids dirt and drudgery of coal, wood and ashes. Send at once for FREE booklet, "New Kind of Heat"—explains all about this amazing invention. If you act today you will be in time to receive Mr. Oliver's Special Low Introductory Price and 30-Day Free Trial Offer. Our factories are working night and day to supply the big Summer demand—but we can guarantee delivery if you hurry. Send no money. No obligation whatever. But mail coupon before you turn this page.

**OLIVER Oil-Gas Burner Company**  
2048-G Oliver Bldg., St. Louis, Mo.  
Canadian Offices: 2048-G Webster Bldg., Toronto

### No Money—Mail Coupon for Free Book and Trial Offer

Oliver Oil-Gas Burner Co.  
2048-G Oliver Bldg., St. Louis, Mo.  
Send your Free Book, "New Kind of Heat," and also your special low price and 30 day Free Trial offer. This does not obligate me in any way.

Name .....

Address .....

City .....

State .....



*The*  
**PROPER TREATMENT**  
*for*  
**FLOORS, WOODWORK**  
*and*  
**FURNITURE**  
 Price 25¢

**S. C. JOHNSON & SON.**  
*"The Wood Finishing Authorities"*  
 RACINE, WIS. U.S.A.

## This Beautiful Book on Wood Finishing FREE

**G**IVES complete instructions for finishing all wood—hard or soft—old or new. Explains just what materials to use and how to apply them. Tells how inexpensive soft woods may be finished so they are as beautiful and artistic as hard wood. This book is the work of experts—illustrated in color. Includes color card—gives covering capacities, etc.

### JOHNSON'S WOOD DYE

Use coupon below for a free copy of "*The Proper Treatment for Floors, Woodwork and Furniture.*" It is full of valuable ideas on Wood Finishing and Home Beautifying.

Johnson's Wood Dye is very easy to apply—dries in four hours and does not rub off or smudge. Penetrates deeply, bringing out the beauty of the grain. Made in fourteen popular shades, all of which can be easily lightened or darkened. Color card in book.

**S. C. JOHNSON & SON**

*The Wood Finishing Authorities*

Dept. P. A. 7

RACINE, WIS.

Canadian Factory—Brantford

S. C. JOHNSON & SON, Dept. P. A. 7 Racine, Wis.

Please send me, free and postpaid, your instruction Book on Wood Finishing and Home Beautifying.

NAME .....

ADDRESS .....

CITY & STATE .....

Dealer's Name .....

# Get your own tires free and pick up \$300. a month as a Mellinger Tire Agent!



**T**HIS picture shows how easy and fascinating it is to ride around in the open air in your

spare time and make ten or fifteen dollars a day showing Mellinger Tires. Notice the interest every one shows in the MASTER Salesman Kit which I send you free. Notice too the magnificent Cord Tire. This powerful cord tire is guaranteed for mileage half way around the world. YET YOU SELL IT at a price so low that competition is knocked out to start with. We give our good agents tires for their own use so they can demonstrate without trouble. We have thousands of agents. They are prosperous and content. You too can start. No capital or experience is needed.

## 12,000 *miles* GUARANTEED

**Lowest Wholesale Prices  
in America**

Mellinger Super Quality Cord Tires, always considered the best cord tires made, are now even better. The use of Ethyl-cured Rubber gives marvelous tough tread, wears down so slowly it reminds you of steel, yet so pliable that it feels like pure gum. Bead reinforced with two chafing strips; combed Egyptian cord; a double layer of cushion rubber; cured 2 1/2 hours on air bags. These high grade features on the **Mellinger Cord** cost more, yet you pay less than for ordinary unguaranteed tires and **I give a Guarantee Bond for 12,000 miles.**

Whether you want CASH or guaranteed mileage for yourself at **LOWER WHOLESALE PRICES, write me today.** Get my inside figures and discounts. My **new low prices amaze everyone.** **Better tires for less money** makes business roll in. One Billion Dollars will be spent for Tires in the next few months. Tires are shipped prepaid on approval.

**IF YOU OWN A CAR  
WRITE ME QUICK**

Be the first from your locality to get the **Mellinger Plan** and positive proof that you can make big money. I say it's your big opportunity—a big business—hosts of friends and customers—I don't ask you to risk one cent. Send the coupon today. My **Big FREE BOOK** explaining everything will be in your hands in a few days.

**Mellinger Tire & Rubber Co.**  
1703 Grand Ave., KANSAS CITY, MO.  
\$600,000 Capital

References: Any Bank or Trust Company or Any Publication

**Tire Agents Wanted—  
The Mellinger Plan**

is revolutionizing the tire business. A positive proven success. Different from anything you ever heard of. You can start a business of your own without any capital—you can begin part time if you wish. No previous experience needed. Tires shipped on approval. No risk. Saves car owners money. Just what millions of tire buyers have been looking for. Piles up profits for Mellinger Agents.

**FREE** For a little of your time in showing and recommending Mellinger Tires, I will make you a surprising offer that will give you a set of tires FREE. If you are in dead earnest I will send you the **Master Salesman Kit**, containing everything. As one Agent says, "It's like taking a prospect through the Factory. The Kit sells the prospect and I take the order."

**send this  
NOW**

**Mellinger  
1703 Grand Ave  
Kansas City, Mo.  
—Send Me  
free book  
and prices**

Name \_\_\_\_\_

Address \_\_\_\_\_

\_\_\_\_\_

\_\_\_\_\_



# Men Wanted in Auto and Electric Business

**Earn \$50 a Week and Up!**

If you like mechanics and want proof that you can make a real success in the auto and electric business look at the sixty thousand Sweeney trained men, many owning their own business, in all parts of the U. S. and foreign countries. These men learned their trade in eight weeks at the greatest trade school in the world, the Million Dollar Sweeney School. No previous experience is necessary. You will learn here by the Sweeney System of Practical Experience, with tools, not books, by doing the actual work with your own hands on all kinds of cars, engines, parts, etc. The cost of training is small. Real jobs, success and independence reward the trained man.

With over TWELVE MILLION automobiles running the demand for mechanics, demonstrators, chauffeurs, truck drivers, garage men, etc., is greater than ever before. Countless opportunities in cities and towns and even remote places. Probably I can give you the names of successful Sweeney men right in your locality.

If you are looking for work at \$50 a week and up, if you would like to get into something sure and solid that will give you success and independence, and can put in a few weeks this summer in TRAINING, write me today.

I am making a special THIRTY DAY OFFER. That is why you should not delay. The first step is to send for this big free illustrated catalog and learn of the practical and immediate opportunities for you in this business.

## The Sweeney System of Practical Instruction

is the ONLY WAY to learn if you want to save time and money and be properly trained. You get this at the WORLD'S greatest trade school, the MILLION DOLLAR SWEENEY SCHOOL and you get it nowhere else.

### FREE RAILWAY FARE

If you will come now I will help by paying your railway fare from any point in the U. S. to the Sweeney School. I will also tell you about my New Summer Offer—a wonderful opportunity for you! The first step is to send for my Free Catalog. **Get all the facts.**

### FREE

Simply send name today for my big 64-page catalog. Shows hundreds of pictures of men at work in the school. Tells all about wages, profits, opportunities in auto and tractor business. Explains step by step how you learn. Interesting letters from graduates telling how they made good. Shows how men come from all over the world to this big school. Makes you want to join the crowd. Tells everything you want to know. No cost, no obligation. Clip the coupon, or a postcard will do. Get the catalog now—that's the first step. Don't put it off one minute. No colored students accepted.

**E. J. SWEENEY, President**

**EMORY J. SWEENEY, President**  
 Dept. 1103, Sweeney Bldg.  
 Kansas City, Mo.

Send me free, without any obligation on my part, your 64-page catalog and Special Summer Offer!

Name.....  
 P. O. ....  
 State.....

**LEARN A TRADE—**  
**Sweeney**  
 AUTOMOTIVE & ELECTRICAL SCHOOL  
 1103 SWEENEY BLDG. KANSAS CITY, MO.