

March

25 Cents

POPULAR MECHANICS MAGAZINE

WRITTEN SO YOU CAN UNDERSTAND IT

REG'D TRADE MARK, GREAT BRITAIN, No. 410426

REG. U. S. PAT. OFF.

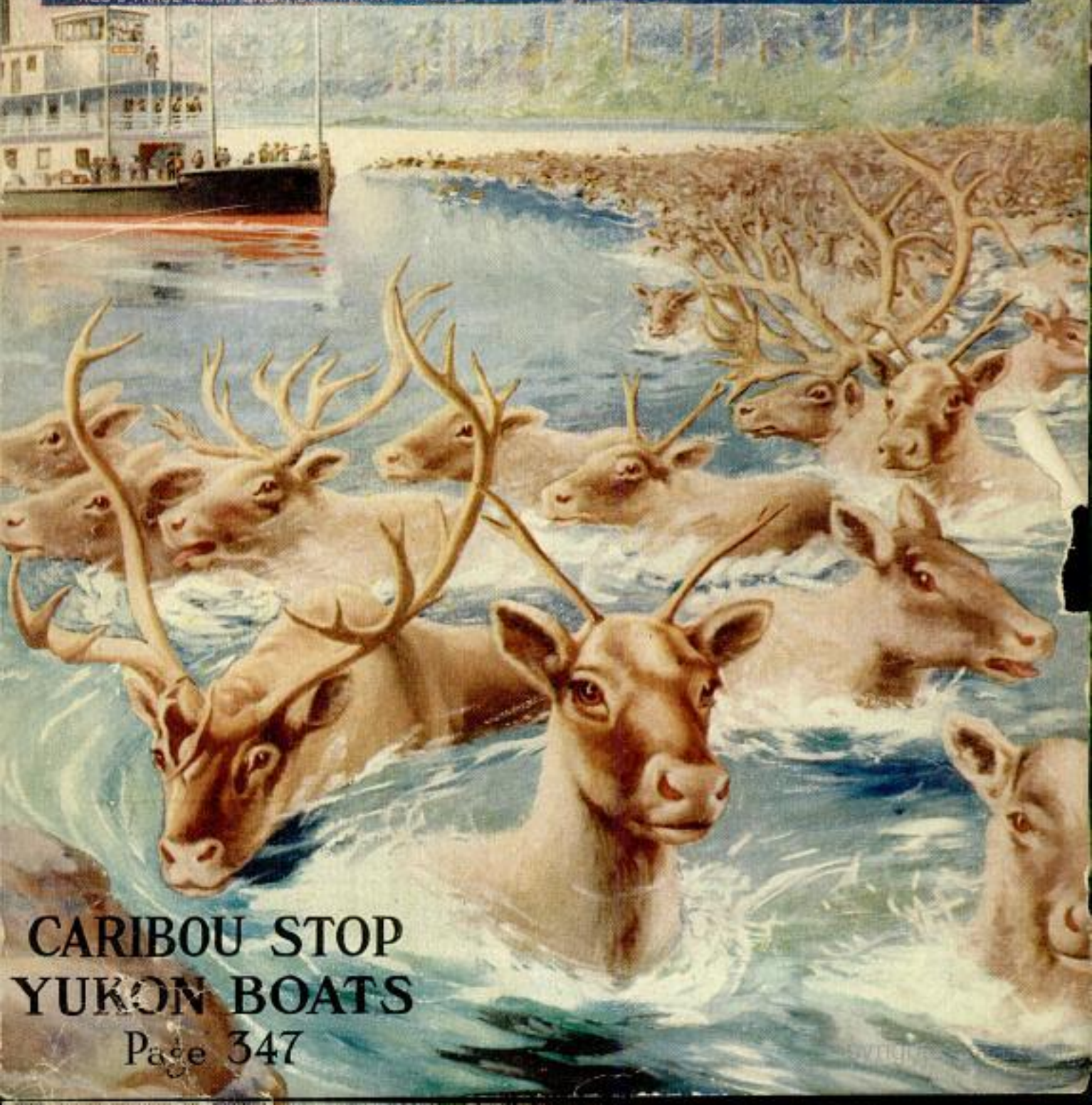

**CARIBOU STOP
YUKON BOATS**

Page 347

It takes *only* 8 weeks to get a big job



O. H. Justus owns a big agency and repair shop at Parkersburg, W. Va. He says "that my schools give motor secrets that will put any man 'on easy street.'"

In the Auto and Tractor Business

Read what these men are doing—here is your big chance to get "on street." Come to these great shops on the biggest FREE offer ever made.

Big Firms Need Trained Men

The Auto and Tractor Business is on the boom. Thousands of trained men will be needed during the next few months. I get calls every day from Garages, Battery Stations, Auto Repair, Welding Shops and other successful concerns for Rahe men. When the big fellows need high grade men they know where to come for them. They want Rahe trained men.

My Training Unusual

Scientific tool training—that's the secret. You do things here according to the latest engineering standards. Thousands of dollars have been spent in modern tools and equipment. That's why my men are at home in the biggest shops in the country. If you want to succeed the way Beimer and Justus and the rest have—qualify by the same method in only eight weeks or stay as long as you like.

I'll Pay Your Railroad Fare and Board You

In order to fill the openings that now exist, I am making an offer no one has ever made before—**Free Railroad Fare, Free Board for eight weeks.**

SAVE
\$50 to \$75

You Save Big Money by acting now. Pack your grip—get on a train—Come to school right now before it is too late—**OR WRITE TODAY.**

Send for **FREE** Book

My big illustrated training book tells how others are succeeding. It tells many things you ought to know about Autos and Tractors. Write for it and my **short time** offer NOW. It soon expires.

Rahe *Auto & Tractor Schools*

CHICAGO
4445 Grand Blvd.

Dept. 901 CINCINNATI
Ninth and Walnut

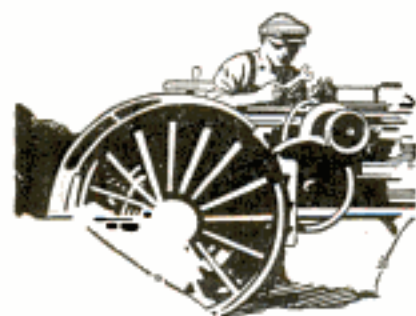

Emanuel Rushfeldt, Alberta, says: "Earning \$10 a day and only 20 years old."



W. W. Peace gets \$250 a month and expenses operating a tractor in the oil fields.



Louis Beimer at 24 was made foreman over men many years older. That's not luck—it's Rahe training.



Rahe Auto & Tractor Schools,
Dept. 901, (address school nearest you)
4445 Grand Blvd., or Ninth & Walnut,
Chicago, Ill. or Cincinnati, Ohio.

Without any obligation, send me your big free book, "The Evolution of Transportation." Also information regarding special temporary offer.

Name.....

Street.....

City..... State.....

Ten Mistakes in English

Thousands of people will make ten mistakes in the simple test shown at the right. Try it yourself.

How many will YOU make?

HERE is a simple test of your ability to speak and write English correctly. In the panel at the right you will find thirty simple points of English that come up every day. Yet the average man or woman will make TEN mistakes! Test yourself now. Then compare your answers with those shown in the panel below and see actually just where you stand in your knowledge of English.

Your English Reveals You

Every time you speak or write you show just what you are. Mistakes in English cause others to judge you as a person lacking in education and refinement. Lack of language power prevents you from presenting your thoughts in the strongest possible way. In business and in social life faulty English is an almost insurmountable handicap. No one can afford to make mistakes in spelling, punctuation, or grammar.

Sherwin Cody's New Invention

Why are so many persons deficient in the use of English? Sherwin Cody discovered the reason through scientific tests, which he personally gave to tens of thousands of people. **Most persons do not write and speak good English, simply because they never formed the habit of doing so!** Good English can be made a habit—and like all habits it can be made so instinctive that you will use flawless English at all times.

For many years Mr. Cody, probably the best-known teacher of practical English in America, worked to solve the problem of "How to make correct habits of speaking and writing stick in the



SHERWIN CODY

mind." After countless experiments he finally invented a simple method which actually finds and corrects your mistakes in English and by which you can quickly acquire a real command of English in only 15 minutes a day.

Only 15 Minutes a Day

One of the most striking features of Mr. Cody's method is the speed with which his habit-forming practice drills can be carried out. You write the answers to fifty questions in 15 minutes and correct your work in 5 minutes more. There is no drudgery, no tiresome studying of rules. Mr. Cody's method is as fascinating as playing a game. You concentrate on **your** mistakes and **your** mistakes only, until it becomes "second nature" to speak and write correctly.

New Book on English Free

A book explaining Mr. Cody's remarkable method is ready. If you are ever embarrassed by mistakes in grammar, spelling, pronunciation, or punctuation, if you cannot instantly command the exact words with which to express your ideas, this new free book, "How to Speak and Write Masterly English," will prove a revelation to you. Send the coupon or a letter or postal card NOW.

SHERWIN CODY SCHOOL OF ENGLISH

53 Searle Building Rochester, New York

Sherwin Cody School of English
53 Searle Building
Rochester, New York

Please send me your new Free Book, "How to Speak and Write Masterly English."

Name

Address

City..... State.....

Here is the Test

Check the form you believe correct. Then compare with the correct answers below.

1. Would You Write—

Between you and I	or	Between you and ME
I HOPE it would come	or	I WISH it would come
WHO shall I call	or	WHOM shall I call
It's just AS I said	or	It's just LIKE I said
How MANY are there	or	How MUCH are there
I WOULD like to go	or	I SHOULD like to go
The FIRST TWO lessons	or	The TWO FIRST lessons
He sat AMONG the three	or	He sat BETWEEN the three
The wind blows COLD	or	The wind blows COLDLY
You will FIND ONLY one	or	You will ONLY FIND one

2. How Do You Say—

evening	EV-en-ing	or	EVE-ning
ascertain	as-cer-TAIN	or	as-CER-tain
hospitable	HOS-pli-ta-ble	or	hos-PIT-able
abdomen	AB-do-men	or	ab-DO-men
majority	MAY-or-al-ty	or	may-OR-al-ty
amenable	a-ME-na-ble	or	a-MEN-able
acclimated	AC-cl-i-mate	or	ac-CL-i-mate
profound	PRO-found	or	pro-FOUND
beneficiary	ben-e-fi-shEE-nary	or	ben-e-FISH-a-ry
culinary	CUL-i-na-ry	or	CU-li-na-ry

3. Do You Spell It—

superCede	or	superSede	repEtition	or	rePitition
receIve	or	receIve	sepArate	or	sepErate
reprIve	or	reprIve	aCoMmodate	or	aCCoMModate
donkEYs	or	donKIEs	traFFicIng	or	traFFICKing
factorIes	or	factorYs	ACSeSible	or	ACCeSSible

ANSWERS

1.

Between you and me
I wish it would come
Whom shall I call
It's just as I said
How many are there
I should like to go
The first two lessons
He sat among the three
The wind blows cold
You will find only one

2.

EVE-ning
as-cer-TAIN
HOS-pli-ta-ble
ab-DO-men
MAY-or-al-ty
a-ME-na-ble
ac-CL-i-mate
pro-FOUND
ben-e-FISH-a-ry
CU-li-na-ry

3.

supersede	repetition
receive	separate
reprieve	accommodate
donkeys	trafficking
factories	accessible

"SEE WHAT PA AND ME
MADE, JUST FOR YOU."



Tide Water
Cypress
"The Wood Eternal"

"A Kitchen-Cabinet, a la Son"

When that boy, who has been so secretive the last few weeks (in collusion with his Dad) finally invites you into the Room of Mystery and exhibits a fine Cypress Kitchen Cabinet, home-made from the working drawings and specifications in Vol. 36 of the world-famous Cypress Pocket Library—well, what will you say? You will be so fond and so proud that you can hardly pick the words to tell it. And your affectionate appreciation, at just that moment, will go far toward making that boy a good man. Never mind if his part of the "job" was not *quite* perfect—just be proud that you have that kind of a boy. Nobody will ever know whether it was he or Father that sent for the Cypress Plan Book, Vol. 36, and of course nobody will ever tell who actually paid for the genuine Cypress boards that were used. But you will remember always that it's "the wood eternal" and that it does not rot nor shrink nor swell nor warp and that is why Cypress is the standard wood in hospitals and other places where they are very particular.

SOUTHERN CYPRESS MANUFACTURERS' ASSOCIATION



1219 Poydras Building, New Orleans, Louisiana
or 1219 Graham Building, Jacksonville, Florida



Insist on TRADE-MARKED CYPRESS at your local lumber dealer's.
If he hasn't it please advise us promptly and we will see that you are supplied.

Popular Mechanics Magazine

200 E. Ontario Street, Chicago, U. S. A.

H. H. WINDSOR, Editor

London: Hachette & Cie,
16-17, King William Street, Charing Cross, W. C. 2

Paris: Hachette & Cie,
111 Rue Reaumur

Melbourne, Australia,
The Australasian News Co.

ISSUED MONTHLY

SUBSCRIPTION:

SINGLE COPY, 25 CENTS

In United States and its possessions, also Canada, Cuba, and Mexico, per year, postpaid - \$3.00

To all other countries in the Postal Union 3.50

All subscriptions are discontinued at expiration. Please examine the date printed on your wrapper.

Entered as Second Class Matter Sept. 15, 1905, at the Post Office at Chicago, Illinois, under Act of March 3rd, 1979.
Entered as Second Class Matter at the Post Office Department, Canada.

Published monthly by POPULAR MECHANICS CO.

Copyright, 1923, by H. H. Windsor.

Copyright in Australia.

Vol. 39

Contents for March, 1923

No. 3

Aerodynamic Tests, Pendulum Apparatus Used in...	414
Air Liners, Large, Exhibited in Europe	341
Airplane Engine, World's Largest, Test Flight with	340
Airplane, Ordinary, Sets Astonishing Gliding Record	432
Airplane Race, Pulitzer, Minimum Speed of 175 Miles Set for	419
Apple Parer and Corer, Automatic	396
Asphalt Plant, Portable, Built in Three Units	366
Asphalt Resurfacing Heater Mounted on Auto Truck	375
Atoms, Flight of, Photographed, by W. D. Harkins	397
Auger, Earth Boring, Has Relief Valve	414
Automobile Bumpers, Short Pair of, Protect Rear Fenders	396
Automobile Displaces Broncho in Riding Test	352
Automobile Engine, Long Stroke, of Easy Accessi- bility	389
Automobile Fan, Reversible, Saves Frozen Radiators	401
Automobile for Legless Man Is His Own Design	393
Automobile Headlight, Adjustable, Eliminates Glare	392
Automobile Intake Air Heating Device	370
Automobile Mud Splash Guards Tested with White Screens	449
Automobile, New Type Armored, to Hold Men	370
Automobile Polo Game, Homemade Cars Used in	432
Automobile Radiator Bucket, Collapsible	407
Automobile Radiator Temperature Controlled by Driver	390
Automobile Sedan, Lightweight, with Tandem Motors	427
Automobile Step Plate Has Space for Owner's Name Plate	408
Automobile Trucks, City Service, Combine Several Duties	421
Automobile Warning Lights like Railroad System	416
Automobile Wheels, Improved Demountable Rims for	379
Automobile Windshield Cleaner Uses Wind Pressure	448
Automobiles Cross Sahara Desert, by Cleveland Gaines	355
Automobiles, Small, New Rear Spring System for	441
Bag Holding Device Accommodates Various Sizes	391
Bakeries, Wheeled Tray and Truck for	394
Balancing Machine, Simple, in Use in Germany	390
Balloon Device Protects against Lightning	395
Barrel Scale, Revolving Automatic	419
Beach Patrol, New Method of, by Frederick Herr	393
"Bean Town," World's Foremost, Dairen Is	430
Bearings, Limestone, Outwear White Metal Kind	398
Belts, Cartridge, Salvaged for Brass	432
Binocular Magnifier Allows Use of Both Hands	370
Blood Cell Counting, Automatic Machine Helps in	353
Bridge Collapse, Cowlitz, Fatal to Many	342
Bridge, Golden Gate, to Be World's Largest	399
Bridge Thrown across River by Unusual Method	384
Bridge Warning Signs Made Part of Structure	389
Buffalo Herd in Canada "Growing Too Large"	381
Building, Eight Story Office, Built Half at a Time	381
Buttons Made from Powdered Gypsum	412
Cabinet of 48,300 Pieces Takes Years to Make	424
Cable, New Submarine, Seven Miles Long	435
Canal Barges, New Erie, are Electrically Driven	430
Cans, Tin, Made at Home with Simple Outfit	349
Caribou, Treking of The, by Stratford F. Corbett	346
Causeway, Million Dollar, Illuminated for Night Driv- ing at Famous Florida Resort	376
Children's Picture Pages	450
China Burning Kiln Designed for Home Studio Use	432
Civic Features	438

Clover Harvester, Power Driven, Also Threshes	407
Coal, Huge Lump of, Is Largest Ever Mined	394
Comment and Review, by H. H. Windsor	357
Commutator Bar Soldering Machine	395
Concrete Mixer Has Rubber Tired Wheels	384
Concrete Mixing Equipment on Motor Truck Chassis	449
Cookstove with One Burner Suitably Adjustable	399
Crows, Millions of, Menace Canadian Fruit Crop	447
Dam, Huge Power, Projected in Province of Quebec	444
Dam, Hydraulic Fill, Solves Irrigation Problem	431
Decoy Has Space for Parts, and is Easily Carried	424
Dishwasher Has Two Sets of Pumps and Motors	396
Dock Equipment, Efficient, at Manchester, by Major Johnstone Taylor	386
Drug—Synthetic Thymol Cheaper Than Imported Drug	452
Drum Snare Device Equalizes Tension	371
Eaves Trough Hangers, Iron, Easy to Set Up	444
Electricity, Half of World's, Used in United States	396
Envelope Sealer, Automatic, with No Moving Parts	395
Fence Wires, Triangular Metal Clamp for Tightening	448
Flagman Builds Portable House for Winter	428
Flowers and Plants, Protection Laws Asked for	392
Flume, Wooden, Exacting Requirements Met by	440
Football Scoreboard, New, Has Many Attachments	436
Foundation Building on Muddy Site of Shanghai	437
Fountain Made of Towels Seen in French Store	396
Fumigator, Fireless, Kills Flour Moths	422
Furnace Calculator Figures Weight of Alloy Needed	446
Furnace, New, Produces Fine Steel	392
Gasoline Fumes, Permanent Poisoning from	424
Golf Ball, New Design, Has Great Resiliency	400
Golf, Bow and Arrow, Is Latest Diversion	404
Golf Course Tractor Mower and Roller	395
Gorilla Sanctuary Planned for Belgian Congo	452
Hay Bales, Little Machine Weighs and Counts	354
Headstones, Old, Preserved with Coat of Cement	490
Hedgehog Hunting Good Trade and Sport, by Sam E. Conner	378
Helicopter, Latest, Makes Flight	331
Highway, Columbia River, New "Loops" in, by Harace E. Thomas	350
Highway Exhibit, Model and Picture Combined in	398
Hoisting Machines, Recent Improvements in	397
Hose Coupling, Compressed Air, with Check Valve	403
House, Filipino Men Move on Shoulders	428
House Models, Ready Cut, for Builders, by Frank E. Howe	434
Household Devices	442
Ice Caverns, Dachstein, Exploring	405
Ice Chest, Movable, for Hospital Use	376
Incubator, Metal Electric, Also Used as Hover	399
Indian Massacre, Florida Park Commemorates	370
Ink, New Type, Dyes All Acids	408
Irrigation Pipe, Overhead, Oscillates Spray	409
Lamp, Miner's, Eliminates Sparking Troubles	414
Lawn Mower Blades, Spiral Grinding Machine for	381
Light Plant, Minnesota, Alarm Clock Tends	426
Lighthouse, Pacific Coast, Made of Cardboard	428
Lock, Temporary, Fits on Door Jamb	370
Locomotive Crane Saves Headroom in Shop	399
Locomotive, Old, Substituted for Disabled Boiler	429
Lord's Prayer Set on Pica Face with Monotype	352
Lunch Room Serving Counter, Automatic	447
Machine Parts, Small, Fast Counting of	374
Magnet, New Electrical Implement Is Similar to	430

[Continued on Page 4]



CSEZ-RZK-R1FN

[Contents—Continued]

Mail Box, Rural, Swings Around If Hit.....	374	Truck Driver, Quick Action of, Saves Load.....	402
Measuring Aid, Automatic, for Use of Chemists.....	416	Truck, Station, Adapts Itself to Platform.....	452
Mine Workings, Mountainside, Shown by Aerial Photo.....	427	Trunk Carrying Mattress Unfolds into Bed.....	442
Mixer, Traveling, Serves Battery of Vats.....	444	Turnbuckle Six Feet Long Made without a Weld.....	379
Motion Picture Projectors Tested in Tunnel.....	383	Ukulele Fingerboard Slide Transposes to Any Key....	410
Motion Pictures Show Benefit of Owning a Home....	354	Valve Regulator, Automatic, Has Great Flexibility..	365
Motor, New, Has One Piece Rotor Winding.....	330	Vending Machine, Automatic, Dispenses Soft Drinks..	432
Motor Truck Rides Railroad Tracks or Highways....	385	Vise, Hand, Made More Useful with Bench Clamp..	437
Motor Truck Transmission Flexibly Supported.....	447	Water Power, Surplus, Novel Means of Disposing of	446
Mud Bath Cure, Elaborate Equipment Built for.....	400	Water, Saving for Stricken Brazilian States, by A. S. Chapman.....	333
Oil Skimming Device for Baltimore Harbor.....	445	Water Supply System, New, Proposed for Manila....	426
Paint Made without Oil Is Cheap and Durable.....	414	Watering Trough, Improved, Heated by Two Lamps..	444
Parachute Beats Airplane to Earth.....	417	Waves, Heat and Electric, of Same Length Found..	420
Peacock, Giant, Wins Prize in Floral Parade.....	390	Wedding, Wireless, Thousands See and Hear.....	404
Peanuts, Hot Shelled, Vending Machine Sells.....	375	Weed Puller Saves Back Bending and Kneeling....	336
Pecans Sorted in Eight Sizes with Grading Machine	425	Weeder, Dry Farm, Cuts Wide Swath.....	364
Pier Shelter, Huge Canvas, Protects Workmen.....	428	Welding Special Steel to Surface of Machine Parts..	375
Pile Driver, Improved, Is Simple and Effective....	372	Wheat Load, Heavy, Team of 30 Animals Haul....	339
Pipe Gauges, Double Plug, for Internal Threads....	407	Winch, New Type, Mounted on Tractor.....	402
Pipes Mailed as Parcel Post Carried by Burros....	374	Wind Tunnel, New, in Huge Compressed Air Tank..	353
Piston Centering Machine Is Rapid and Accurate..	382	Wire Tying Machine, Simple, Binds Packages Rapidly.....	401
Plow, New Subsoil, Operated by Small Tractor....	390	Wireless, Headset Stand for.....	406
Plows, Rotary, Prepare Soil for Sugar Crops....	440	Wireless Messages 100 Feet Underground "Picked Up".....	408
Poles, Concrete, Support 132,000 Volt Line.....	366	Wireless "Superphone" Broadcasts with Secrecy....	349
Police Station, New Central, Completed in Detroit..	360	Wood, Utilization of, Scientific Methods in.....	417
Portfolio, Folding, Opens and Closes like Fan....	344	Writing Board, Chair Arm, Has Drawer for Papers..	446
Potato Harvester Digs, Picks, and Sacks.....	366	Zoning Systems Adopted in Smaller Towns.....	348
Prize Offers.....	491		
Radio—"Daughters of the Sea," by Lawrence Wm. Pedrose.....	329		
Railroad, Mexico's Scenic, to Be Electrified, by Geo. E. Paul.....	397		
Railroad Station, Chicago, Smoke Prevention in, by Robert H. Moulton.....	423		
Railroad Track Sweeper, Motor Driven, Halves Cleaning Cost.....	433		
Reptiles, Odd, from Santo Domingo, by E. A. Higgins.....	377		
Rifle, New Military, Is Self-Loading, by Capt. Edward C. Crossman.....	412		
Riveter, Portable, Works through Manhole.....	382		
Road Grader, Motor Driven, One Man Operates....	361		
Road System, Federal Aid, Nearly Outlined.....	382		
Roads, Concrete, Steel Mattresses Reinforce.....	383		
Rubber "Glass" One of New Line of Products.....	382		
Safety First Drive, "Fake" Horse Race Aids.....	441		
Salt Seam, Nearly Pure, Found in Nova Scotia.....	433		
Scale, Height and Weight, New Slot Machine Is....	413		
Shaving Outfit, Electrical, Heats Water in Case..	380		
Shelf Boxes, Heavy, Handled by Block and Tackle..	410		
Ship—Army Transport to Become Floating College..	429		
Ship for "Blimps" Discharging One of Its Broods..	393		
Ship Loading Methods in Manchurian Ports.....	338		
Ship Log Fixture, New Electric, Installed in Hull, by Carl Palmblad.....	403		
Ship, Old American Sailing, Preserved as Memorial..	420		
Ship "Orca" Completed for Atlantic Service.....	433		
Ship Propeller Design, Improved.....	372		
Ships, Safety Device for, While at Sea.....	371		
Ships, Stability of, Device Predetermines.....	402		
Signs, "Vacuum Tube," Yield Light at Small Cost..	361		
Silverware, Restaurant, Machine Washes and Dries..	446		
Skiers, Special Trolley Car for, on Norwegian Railway.....	435		
Slide Rule, Hundred Inch, Is Very Accurate.....	432		
Smokestack, Monster, Stands 257 Feet High.....	392		
Snow Removing Crane, City, Has Special Bucket....	380		
Soap in Form of Sheets for Individual Wash.....	452		
Stamp Printing Machine, New, French Try.....	380		
Steel Tempering, Magnetic Indicator Used in.....	372		
Stepladder, New, Maximum Safety Claimed for....	332		
Store Front Built with Stones and Split Logs....	419		
Street Car Rail Grinding Machine Uses Flat Stones..	410		
Street Car Signs Ask Clear Track for Cars.....	414		
Stumps Made into Paper by New Process.....	381		
Telephone Directory, Guide Helps Locate Names in..	342		
Telephone System, India's, to Have Wide Expansion	330		
Tennis Playing on Skates in Illinois.....	344		
Tent, Camping, without Stakes, Guys, or Posts....	415		
Theater Stage Effects, Clever, Scenic Artists Make..	418		
Tomb, New Found, Treasures of Ancient Thebes in, by R. C. Folger.....	367		
Tombs, Ancestral, Used as Washtubs by Greeks....	384		
Town—Nordhoff, Ugly, Becomes Beautiful Ojai, by C. Moran.....	411		
Toys, American Indian, Exhibited by Museum.....	374		
Tractor Fitted to Push or Haul Freight Cars.....	406		
Tractors, Endless Tread, Buck Snow in Utah.....	448		
Trapshooting Machine Has Star Shaped Markers..	420		
Trombone Slide, New Position Indicator for.....	446		
		SHOP NOTES	
		Automobile Body, Improved Board Supports.....	460
		Ball Turning Tool, Homemade.....	469
		Band Saw, Ball Bearing Guide Roller for.....	462
		Brooder Yard, Circular, Saves Chicks.....	461
		Brush, Improved, for Auto Cleaning.....	461
		Circumference Finding Tool, Simple.....	459
		Cistern, Cheap, Made of Vitriol Clay Pipe.....	453
		Clamp, Simple, for Holding Timbers.....	463
		Clutch, Friction, Substituted for Ratchet.....	463
		Concrete, Submerged and Exposed.....	456
		Concrete Work, Facing Mixtures for.....	470
		Connecting Rod Shims, Clips for Holding.....	458
		Crates, Rigid, How to Make.....	455
		Die Stamp for Marking Dismantled Machines.....	459
		File Handles, Tool for Removing.....	462
		Grooves, Cutting on a Power Saw.....	454
		Hacksaw, Power, Setting Work in.....	454
		Holes, Drilling True in Turret Lathe.....	454
		Holes, Enlarging in Wood.....	457
		Horse, Folding, Convenient for Shop or Garage....	469
		Index Plate, Emergency, for Spring Motor.....	460
		Labels Made of Adhesive Plaster.....	462
		Lagscrews, Overhead, Brace for.....	462
		Lathe Center Hole Mandrel.....	460
		Lathe Lap, Bench, Operated with Rubber Bands... 468	
		Lathe Tailstock Adapter for Standard Tapers.... 458	
		Micrometer Measuring Beyond Its Capacity..... 463	
		Motion Picture Film Rewinding Machine..... 456	
		Nipple Chuck, Proper Use of..... 468	
		Nuts, Starting in Slots..... 469	
		Oil Cup, Gas Engine, How to Keep Warm..... 469	
		Pipe, Method of Loading onto Trucks..... 457	
		Plow Handles, Protector for..... 455	
		Powder Loading Tool for Blasting..... 457	
		Sawdust, Simple Blower for..... 458	
		Scale, Hydraulic, for Crane..... 470	
		Screws, Broken Cylinder Head, Drilling Out..... 456	
		Shafts, Heavy, Method of Turning..... 459	
		Signs, Glass, Making by Sandblasting..... 464	
		Snowplow, Farm Tractor Used as..... 461	
		Tanks, Gasoline, Invisible Repair for..... 457	
		Valve Stems, How to Shorten..... 463	
		Wagon Wheel Rim Puller..... 461	
		Watches, How to Demagnetize..... 457	
		Wheelbarrow Handles, Adjustable..... 467	
		Wrench for Turning Large Pipe..... 454	
		Wrench, Valve, for Oxygen Tanks..... 455	
		AMATEUR MECHANICS	
		Audion Bulbs, Automatic Cut-Out for..... 482	
		Automobile Clutch Screw, Improving..... 484	
		Automobile Crankcase, Emergency Plug for..... 473	
		Automobile Curtains, Wire Mesh, for Children.... 488	
		Automobile Hood Covers, How to Fasten..... 474	
		Automobile Primer, Homemade..... 489	
		Automobile Wheel, Dished, Simple Repair for.... 484	
		Barrel Skirt, Foils Rodents..... 473	
		Birdcage Device Prevents Scattering Seed..... 481	

DRAKE'S PRACTICAL MECHANICAL BOOKS

THEY WILL RAISE YOUR PAY— ORDER ON 5-DAY TRIAL

The books listed below will perfect you in your chosen trade — pave the way to the big positions. Written in non-technical language—easy to read and understand. *Every book covers its subject completely. An entire course of instruction condensed into one volume.* Your choice sent postpaid — you benefit 5 days — money refunded in full if not entirely satisfactory. Order direct from this page.



Automobile Books

- Automobile Ignition, by Manly
Leatherette \$2.00
- Automobile Starting and Light-
ing, by Manly...Leatherette \$2.00
- Brookes' Automobile Handbook.
.....Leatherette \$2.00
- Ford Motor Car, Truck and
Tractor, by Manly.....Cloth \$1.50
- Starting and Lighting Troubles,
Remedies and Repairs, by
ManlyLeatherette \$3.00
- Automobile Battery, Care and
Repair, by Manly,Leatherette \$2.00
- Automobile Catechism and Re-
pair Manual.....Leatherette \$1.50
- Tires and Vulcanizing, by Tuf-
fordCloth \$2.00
- Gas and Oil Engine Handbook.
.....Cloth \$1.50
- Automobile Upkeep and Care,
by Manly.....Cloth \$1.50
- Motorcycle Handbook, by Manly
.....Cloth \$1.50

Shop Practice Books

- Sheet Metal Workers' Manual..
.....Leatherette \$2.00
- Oxy-Acetylene Welding and Cut-
tingCloth \$1.25
- Slide Rule and Logarithmic Ta-
blesLeatherette \$2.00
- Handbook for Millwrights.Cloth \$2.00
- Modern Blacksmithing....Cloth \$1.25
- Machine Shop Practice....Cloth \$2.00

- Mechanical Drawing and Ma-
chine DesignCloth \$2.00
- Pattern Making.....Cloth \$1.50

Carpentry Books

- Cloth Binding
- Modern Carpentry, 2 vols.....\$3.00
- The Steel Square, 2 vols.....\$3.00
- Wooden Boat and Shipbuilding..\$1.50
- Modern Estimator\$1.50
- Timber Framing\$2.00
- Builder's Architectural Drawing..\$2.00
- Concrete\$1.50
- Practical Bungalows\$1.00
- Low Cost Homes.....\$1.00
- Roof Framing, by Van Gasbeek..\$1.50
- Stair Building and Hand Rail-
ing\$1.50

Electrical Books

- Practical Applied Electricity...\$2.00
- Alternating Current\$1.50
- Electric Motor Control Systems..\$1.50
- Wiring Diagrams and Descrip-
tions\$1.50
- Electrical Tables and Data.....\$1.50
- Armature and Magnet Winding..\$1.50
- Modern Electrical Construction...\$1.50
- Modern Electric Illumination...\$1.50
- Electricians' Operating and Test-
ing\$1.50
- Motion Picture Operation.....\$1.50
- Drake's Electrical Dictionary...\$1.50
- Electric Motors, D. & A.....\$1.50
- Electrical Measurements and Me-
ter Testing\$1.50
- Drake's Telephone Handbook...\$1.50
- Easy Experiments.....Cloth \$1.25
- Wireless Telegraph and Tele-
phone Handbook.....Cloth \$1.25
- Telegraphy Self-Taught...Cloth \$1.25

Steam Engineering

- Swingle's Handbook for Steam
Engineers and Electricians...
.....Leatherette \$4.00
- Examination Questions and An-
swers for Marine and Station-
ary Engineers....Leatherette \$2.00
- Steam Boilers.....Leatherette \$2.00
- Swingle's Catechism of Steam,
Gas and Electrical Engineer-
ingLeatherette \$1.50

Painting Books

- Scene Painting and Bulletin Art
.....Cloth \$4.00
- A Show at Sho' Cards....Cloth \$4.00
- Sign PaintingCloth \$4.00
- Strong's Book of Designs.....
.....Leatherette \$4.00
- Strong's Art of Show Cart Writ-
ingCloth \$4.00
- Signalist's Alphabets.....Cloth \$1.50
- Modern Painter's Cyclopedin...
.....Cloth \$2.00
- Automobile Painting.....Cloth \$1.50
- Estimates, Costs and Profits,
Painting and Decorating.Cloth \$1.50
- New Hardwood Finishing.Cloth \$1.50
- The Amateur Artist.....Cloth \$1.50
- New StencilsCloth \$1.25
- Chalk Talk and Crayon Pre-
sentationCloth \$1.25

Farm Books

- Farm Mechanics.....Cloth \$1.25
- Farm Buildings.....Cloth \$1.25
- Farm Engines.....Cloth \$1.25
- Traction Farming.....Cloth \$1.50

Business and Reference Books

- Better Business Letters.....
.....Cloth \$1.00
- Better Business English.....
.....Cloth \$1.00
- Better Advertising.....Cloth \$1.00
- Finger Prints Simplified..Cloth \$2.00
- Practical Bricklaying....Cloth \$1.25
- Practical Instruction for Detec-
tivesCloth \$1.00
- Practical PlumbingCloth \$1.50
- Hot Water Heating.....Cloth \$1.50
- Elementary Chemistry...Cloth \$1.50
- Courses in Civil Service...Cloth \$1.50
- Cyclopedia of Recipes...Cloth \$1.50
- American Star Speaker...Cloth \$1.50

Modern Languages

- By Prof. P. S. Allen, U. of Chicago
- French without a Teacher.Cloth \$1.25
- Spanish without a Teacher.Cloth \$1.25
- German without a Teacher.Cloth \$1.25
- Everyday French.....\$1.25
- Everyday Spanish.....\$1.25

ORDER DIRECT FROM THIS PAGE—ON OUR MONEY BACK PLAN

The books listed above are only a few of the many in our catalogue, which you will receive promptly after filling out and mailing us the attached coupon. For quick action order direct from this page—cross name of each book wanted and send in with price quoted. We prepay postage and send the books on our money-back plan.

FREDERICK J. DRAKE & CO.

PUBLISHERS

1008 Michigan Ave., Chicago

Drake Books Are For Sale at All Book Stores

FREDERICK J. DRAKE & CO.
1008 Michigan Avenue
Chicago, Ill.

GENTLEMEN:—Please send me free, postage paid, your illustrated catalogue which lists and describes over 100 Practical Mechanical Books for Home Study.

My name is

and my address

Mail Coupon For Free Catalogue
Your Guide to Home Study

Invents New Way to Cook and Heat

No Dirty Coal and Wood



Mr. B. M. Oliver, St. Louis Heating expert, has invented an amazing New Kind of Heat that turns any range,

heater or furnace into a real gas stove. No more dirty coal or wood to carry and lift—no more clouds of ashes, soot, and smoke—no more sickness from lack of quick fires in damp, changeable Spring. No more roasting kitchens in Summer—no more cold rooms and worries about coal shortages and big prices in Winter.

Cheaper Than Coal or Wood

In one minute you slip this wonderful device into any stove, no matter what kind. Then just turn a valve and you have any degree of heat you want. Burns 95% air, 5% kerosene (cheapest fuel there is). No wicks, no odor, no smoke. Heats, cooks and bakes, quicker and better. Makes old stoves new. Lasts a lifetime. Over 150,000 already in use. Write at once for interesting Free Book "New Kind of Heat," which tells about this amazing invention. If you hurry you will be in time to get Mr. Oliver's Special Low Price Introductory Offer and 30 Days' Free Trial in your own stove. Don't risk losing this offer. Write immediately to

OLIVER OIL-GAS BURNER AND MACHINE CO.

2014-C Oliver Bldg.

St. Louis, Mo.

AGENTS!

Oliver representatives earn \$500 and more a month. \$25 a day in spare time is easy. Exclusive territories. Big selling season just ahead. Oliver Gives Fields Away—no contracts. Write for Special offer.

Be the best dressed man in your town

TAILORING PRICES SMASHED

The drop you have been waiting for is here. Now is your chance to get that new suit at such an unheard of startling low price you wouldn't believe it if you didn't see it with your own eyes. See for yourself. Send for our new

Be Our Agent

Big money in your spare time. \$3.00 to \$5.00 an hour easy taking orders for our fine tailor-made clothes from friends and neighbors. Write today.

SAMPLE BOOK FREE

The greatest book of its kind ever gotten out, showing samples of the newest and finest fabrics and all the very latest styles at the world's lowest wholesale prices.

Write for this great free sample and style book this minute.

BANNER TAILORING CO. DEPT. 732 CHICAGO

[Contents—Continued from Page 4]

Boats, Small, Novel Method of Bailing.....	484
Catapult Throws Tin Cans for Shooting.....	471
Chimney, Substantial Fireproof.....	476
Curbs, Concrete, Protection of.....	488
Diameters, Measuring without Calipers.....	481
Dowels, Pencil Sharpener Used in Making.....	489
Drawers, Guide for, Prevents Binding.....	483
Drawings, Pen, Making from Photographs.....	476
Electric Heating Appliances, Repairing.....	490
Foot Scraper, Removable.....	474
Gunstock, First Aid Kit Carried in.....	483
Hinges, Window Shade Brackets Used for.....	476
Ice Harvesting, Hint for.....	475
Ice, Tool for Cutting, from Watering Tanks.....	490
Irrigation System, Movable Overhead.....	475
Key Record, How to Keep.....	481
Lamp Shade, Novel, How to Make.....	473
Merry-Go-Round for Ice.....	485
Motion Picture Operators, Amateur, Hints for.....	474
Music Staff Lines, Device for Drawing.....	482
Oil Heater Fumes Disposed of with Electric Fan.....	489
Phonograph Records, Eliminating Scratches on.....	475
Piano Keys, How to Clean.....	475
Pigeon Trap, Simple.....	489
Range, Heat Shield for.....	488
Rattrap, Suspended, Proves Efficient.....	490
Screen Door Patch, Neat.....	484
Shelving, Portable, for Closets.....	484
Steps, Cement, Making Safe in Winter.....	478
Tire Reliners, Homemade.....	480
Tire Repairing, Emergency, Kinks for.....	483
Torch, Small, "Canned Heat" Used in.....	490
Tubes, Inner, How to Preserve.....	476
Wheelbarrow Runners Aid Pushing in Snow.....	473
Wireless Coils, Tapping.....	483
Wireless Receiver, Two or Three Step Spider Coil, How to Make.....	477
Wireless Variable Condenser, Easily Made.....	490

High School Course in Two Years

This simplified, complete High School Course—specially prepared for home study by leading professors—meets all requirements for entrance to college and the leading professions.

Whether you need High School training or specialized instruction in any trade or profession the American School can help you. Check and mail coupon for Free Bulletin.

30 Other Courses

American School
Drexel Ave. and 58th Street
Dept. H374,
Chicago

American School, Dept. H374, Drexel Ave. and 58th St., Chicago
Send me full information on the subject checked and how you will help me win success.

- | | |
|------------------------------|-----------------------------|
|Architect |Lawyer |
|Building Contractor |Machine Shop Practice |
|Automobile Engineer |Photoplay Writer |
|Automobile Repairman |Mechanical Engineer |
|Civil Engineer |Shop Superintendent |
|Structural Engineer |Employment Manager |
|Business Manager |Steam Engineer |
|Cert. Public Accountant |Foremanship |
|Accountant and Auditor |Sanitary Engineer |
|Bookkeeper |Surveyor (and Mapping) |
|Draftsman and Designer |Telephone Engineer |
|Electrical Engineer |Telegraph Engineer |
|Electric Light & Power |High School Graduate |
|General Education |Fire Insurance Expert |
|Vocational Guidance |Wireless Radio |
|Business Law |Undecided |

Name

Address

Let These Guides

Solve Your Problems

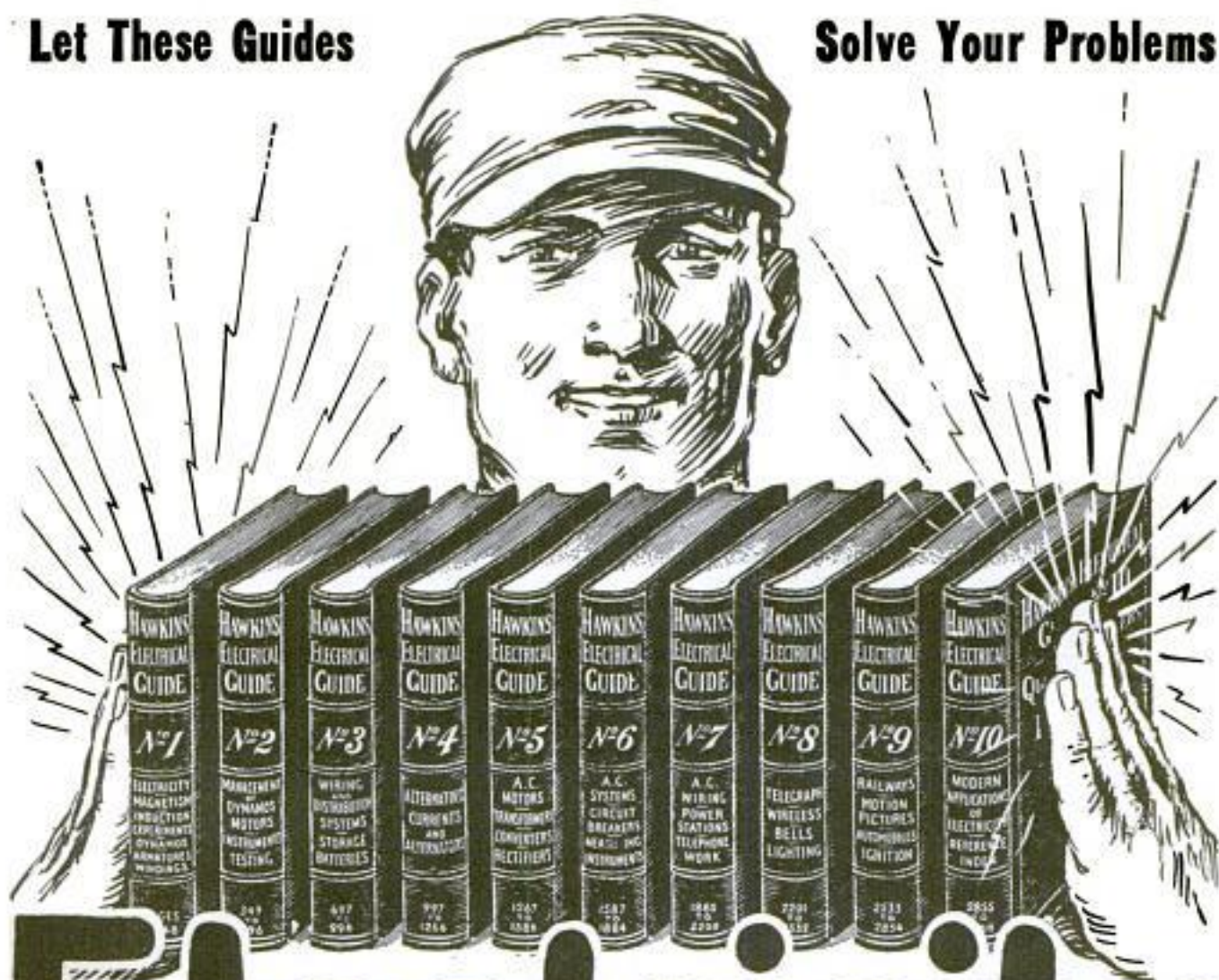

Electricity at your finger ends

HAWKINS ELECTRICAL GUIDES IN TEN VOLUMES

3500 PAGES
4700 PICTURES

\$1 A VOLUME
\$1 A MONTH

Send No Money--Send Only This Coupon

Know the facts in Electricity. They mean more money and better position for you. Hawkins Guides tell you all you need to know about Electricity. Every important electrical subject covered so you can understand it. Easy to study and apply. A complete, practical working course, in 10 volumes. Books are pocket size; flexible covers. Order a set today to look over.

LEARN ALL ABOUT

Magnetism—Induction—Experiments—Dynamoes—Electric Machinery—Motors—Armatures—Armature Windings—Installing of Dynamoes—Electrical Instrument Testing—Practical Management of Dynamoes and Motors—Distribution Systems—Wiring—Wiring Diagrams—Sign Flashers—Storage Batteries—Principles of Alternating Currents and Alternators—Alternating Current Motors—Transformers—Converters—Rectifiers—Alternating Current Systems—Circuit Breakers—Measuring Instruments—Switchboards—Wiring—Power Stations—Installing—Telephone—Telegraph—Wireless—Bells—Lighting—Railways. Also many Modern Practical Applications of Electricity and Ready Reference Index of the ten numbers.

SHIPPED FREE

Not a cent to pay until you see the books. No obligation to buy unless you are satisfied. Send Coupon now—today—and get this great help library and see if it is not worth \$100 to you—you pay \$1.00 a month for ten months or return it.

THEO. AUDEL & CO.,
72 Fifth Ave., New York City

Please submit me for free examination, HAWKINS ELECTRICAL GUIDE. (Price \$1 a number). Ship at once prepaid, the 10 numbers. If satisfactory, I agree to send you \$1 within seven days and to further mail you \$1 each month until paid.

Name

Occupation

Employed by

Home Address

Reference

PM Mar. '23.



FREE 10-Piece Kitchen Set

White Enamelled

Wonderful 32-Piece Aluminum Set consists of 2 Bread Pans; Doughnut Cutter; 2 Loose Bottom Jelly Cake Pans; Combination Tea-Kettle and Rice Boiler with lid; Saucepan Set with lid; Dipper; Colander; Measuring Cup; Percolator; 2 Pie Pans; Complete Castor Set; Tea or Coffee Strainer; Fry Pan; also cooker set of 5 pieces—makes 11 useful combinations: Preserving Kettle; Convex Kettle; Combination Cooker; Casserole; Pudding Pan; Tubed Cake Pan; Colander; Roaster; Corn Pone; Steamer Set; Double Boiler.

No Money Down!

Just mail the coupon and we send this 32-piece Aluminum Cooking Set, and the 10-piece Kitchen Set Free. When

the goods arrive, pay only \$2.00 on the Aluminum Set. Nothing for the Kitchen Set—it is FREE. Use both sets 30 days, and if not satisfied send them back and we will refund your money and pay transportation both ways. If you keep them, pay for the Aluminum Set, only a little every month.

Complete 32-Piece Aluminum Set and FREE Kitchen Set

Hartman's special, selected set of heavy gauge Aluminum Ware—a complete cooking outfit, light to handle, easy to clean, always bright as silver. Will never chip, crack or rust. We guarantee it for life. 32 utensils—everything for baking, boiling, roasting, frying. And—absolutely free—a Combination Kitchen Set, 10 utensils with pretty white handles.

Nearly a Year to Pay

You pay only \$2.00 and postage on arrival (on the Aluminum Set—not a penny to pay at any time on the Kitchen Set). The balance a little every month.

Order by No. 417EMA7. Price for Aluminum Set, \$17.95. No money down. \$2 and postage on arrival. Balance \$2 monthly. 10-Pc. Kitchen Set is Free.

HARTMAN Furniture & Carpet Co.

Dept. 5257 CHICAGO, ILLINOIS

Copyright, 1923, by Hartman's, Chicago

FREE BARGAIN CATALOG and FREE GIFTS

This great 500-page book offers the world's greatest bargains in home furnishings, jewelry and farm machinery—all sold on easy monthly payment terms and 30 days' free trial on everything.

Wonderful Gifts

Catalog explains how you can get Glassware, Lemonade Sets, Silverware, Tablecloths, Napkins, etc., free with purchases. Send for it today.

"Let Hartman Feather YOUR Nest!"



HARTMAN FURNITURE & CARPET CO. Dept. 5257 Chicago, Ill.

Send the 32-piece complete Aluminum Cooking Set No. 417EMA7 and 10-piece Kitchen Set. Will pay \$2 and postage on the Aluminum Set on arrival. Kitchen set is free. I am to have 30 days' free trial. If not satisfied, I will ship both sets back. If I keep them, I will pay you \$2 monthly until the price of the Aluminum Set, \$17.95, is paid. Title remains with you until final payment is made.

Name.....
 Occupation.....
 R. F. D., Box No.
 or Street and No.
 Post Office.....State.....
 (If your shipping point is different from your post office, fill in line below.)
 Send shipment to.....



Stop Wondering How I Teach Piano; I'll Show You, FREE



YEAR after year you've seen my advertisement in all the leading publications, offering to teach you piano in *quarter* the usual time. Year after year my school has grown and grown until now I have far more students than were ever before taught by one man. In 1921 over a thousand students *graduated* from my Piano or Organ course and received their diplomas.

Yet when I first started giving piano and organ lessons by mail in 1891 my method was laughed at. Could any conservatory have grown as it has, obtained students in every state of the Union and in fact practically every civilized country of the world unless it produced very unusual and satisfying **RESULTS** for its students? See for yourself what it is that has brought my method so rapidly to the front. Write for free booklet and sample lessons.

Now, for the first time, you can obtain sample lessons without charge. In the past I have always been opposed to sending out free lessons, even to persons who were seriously interested in my course. But my friends have insisted that I give everybody a chance to see for themselves just how simple, interesting and **DIFFERENT** my lessons are, and I have consented to try the experiment *for a short time*. Simply mail the coupon below or write a postcard, and the 64-page booklet and sample lessons will go to you at once absolutely free and without obligation.

Within four lessons you will play an interesting piece on the piano or organ, not only in the original key, but in all other keys as well. Most students practice months before they acquire this ability. It is made possible by my patented invention the Colorotone. Another invention obtainable only from me is my hand-operated moving picture device, Quinn-dex. By means of Quinn-dex you actually see my fingers in motion on the piano, and can learn just how to train your own fingers.

When I say that I can teach you piano in *quarter* the usual time, do not think that this is too good to be true. Modern inventions and improved methods have accomplished just as great wonders in other branches of education. You at least owe it to yourself to *investigate*. Send coupon or postcard at once, before the offer of free sample lessons is withdrawn.

Quinn
Conservatory,
Studio PM 63,
598 Columbia Road,
Boston 25, Mass.

Please send me, without cost or obligation your free booklet, "How to Learn Piano or Organ," free sample lessons, and full particulars of your method.

Name.....

Address.....

.....

Copy this Sketch



and Get This Rule

FREE

I AM anxious to find men with desire to become draftsmen. With business picking up everywhere many thousands of draftsmen will be needed at salaries ranging up to \$3,000 and \$3,600 per year.

To every person 16 years or older sending a sketch I am going to mail free and prepaid the Draftsman's Ivorine Pocket Rule shown here. This will come to you entirely with my compliments. With it I will send a 6 x 9 book on "Successful Draftsmanship." If you are interested in becoming a draftsman, if you think you have or may attain drafting ability, sit down and copy this drawing, mailing it to me today, write your name, and your address and your age plainly on the sheet of paper containing the drawing.

Salaries up to

\$250 and \$300 a Month

I am Chief Draftsman of the Engineers' Equipment Co. and I know that there are thousands of ambitious men who would like to better themselves, make more money and secure faster advancement. Positions paying up to \$250 and \$300 per month, which ought to be filled by skilled draftsmen, are vacant. I want to find men who with practical training and personal assistance will be qualified to fill these positions. No man can hope to share in the great coming prosperity in manufacturing and building unless he is properly trained and able to do first class practical work.

I know that this is the time to get ready. That is why I am making the above offer. I can now take and train a limited number of students personally and I will give to those students a guarantee to give them by mail practical drawing room training until they are placed in a permanent position with a salary up to \$250 and \$300 per month. You should act promptly on this offer because it is my belief that even though you start now the great boom will be well on by the time you are ready to accept a position as a skilled draftsman. So write to me at once.

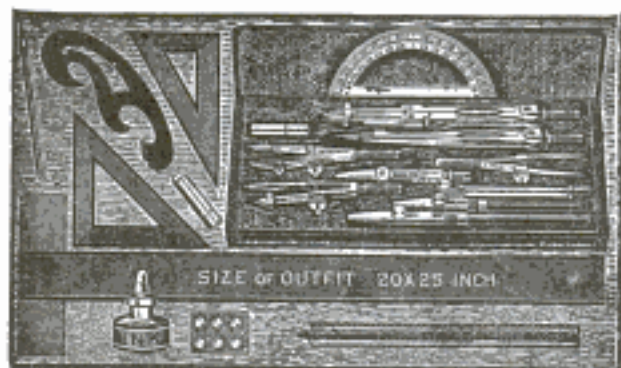

FREE

\$80 Drafting Course

To every student enrolling now I give an opportunity of getting an \$80 drafting course absolutely without cost to him. So send in your sketch today and learn all about this offer.

Mail Your Drawing at Once

— and Get an Ivorine Pocket Rule Absolutely **FREE!**

Ambitious men interested in drafting hurry! Don't wait! This is your opportunity to get into this great profession. Accept the offer which I am making now. Send in your sketch or request for free book and free Ivorine Pocket Rule.

FREE this \$25 Draftsman's Working Outfit

These are regular working instruments—the kind I use myself. I give them free to you if you enroll at once. Don't delay. Send for full information today.

Chief Draftsman, Engineers' Equipment Co., 1951 Lawrence Av. Div. 9353, Chicago



“Wouldn't you like to earn \$100 a week, too?”

“I KNOW you would, Bob—think what it would mean to both of us! It worries me to see you wasting precious months and years when you could make them count for so much.

“Can't you see it, Bob? Don't you see that the reason men get ahead is because they train themselves to do some one thing just a little better than others?

“It isn't that you haven't natural ability—for you have! I know you have. The trouble is, you've never learned how to use it.

“Here's that I. C. S. coupon you've seen so often in the magazines—the same coupon that has brought success and happiness to so many men we know. Won't you send it in for me, Bob?

“If the International Correspondence Schools can raise the salaries of other men, they can raise yours. If they can help other men to win advancement and more money, they can help you, too. I am sure of it.

“Don't let another year slip by and leave you right where you are to-day.

“Let's at least find out how the I. C. S. can help you. Let's send this coupon in right now!”

----- TEAR OUT HERE -----
INTERNATIONAL CORRESPONDENCE SCHOOLS
 Box 5505-D, Scranton, Penna.

Without cost or obligation, please tell me how I can qualify for the position or in the subject *de/vis* which I have marked an X:

- | BUSINESS TRAINING DEPARTMENT | |
|---|---|
| <input type="checkbox"/> Business Management | <input type="checkbox"/> Salesmanship |
| <input type="checkbox"/> Industrial Management | <input type="checkbox"/> Advertising |
| <input type="checkbox"/> Personnel Organization | <input type="checkbox"/> Better Letters |
| <input type="checkbox"/> Traffic Management | <input type="checkbox"/> Foreign Trade |
| <input type="checkbox"/> Business Law | <input type="checkbox"/> Stenography and Typing |
| <input type="checkbox"/> Banking and Banking Law | <input type="checkbox"/> Business English |
| <input type="checkbox"/> Accountancy (including C.P.A.) | <input type="checkbox"/> Civil Service |
| <input type="checkbox"/> Nicholson Cost Accounting | <input type="checkbox"/> Railway Mail Clerk |
| <input type="checkbox"/> Bookkeeping | <input type="checkbox"/> Common School Subjects |
| <input type="checkbox"/> Private Secretary | <input type="checkbox"/> High School Subjects |
| <input type="checkbox"/> Business Spanish <input type="checkbox"/> French | <input type="checkbox"/> Illustrating <input type="checkbox"/> Cartooning |
| TECHNICAL AND INDUSTRIAL DEPARTMENT | |
| <input type="checkbox"/> Electrical Engineering | <input type="checkbox"/> Architect |
| <input type="checkbox"/> Electric Lighting | <input type="checkbox"/> Blue Print Reading |
| <input type="checkbox"/> Mechanical Engineer | <input type="checkbox"/> Contractor and Builder |
| <input type="checkbox"/> Mechanical Draftsman | <input type="checkbox"/> Architectural Draftsman |
| <input type="checkbox"/> Machine Shop Practice | <input type="checkbox"/> Concrete Builder |
| <input type="checkbox"/> Railroad Positions | <input type="checkbox"/> Structural Engineer |
| <input type="checkbox"/> Gas Engine Operating | <input type="checkbox"/> Plumbing and Heating |
| <input type="checkbox"/> Civil Engineer | <input type="checkbox"/> Chemistry <input type="checkbox"/> Pharmacy |
| <input type="checkbox"/> Surveying and Mapping | <input type="checkbox"/> Automobile Work |
| <input type="checkbox"/> Metallurgy | <input type="checkbox"/> Navigation |
| <input type="checkbox"/> Steam Engineering | <input type="checkbox"/> Agriculture and Poultry |
| <input type="checkbox"/> Radio <input type="checkbox"/> Airplane Engines | <input type="checkbox"/> Mathematics |

Name.....
 Street.....
 Address..... 6-26-22

City..... State.....

Occupation.....

Persons residing in Canada should send this coupon to the International Correspondence Schools Canadian, Limited, Montreal, Canada.

"Recommended for appointment"

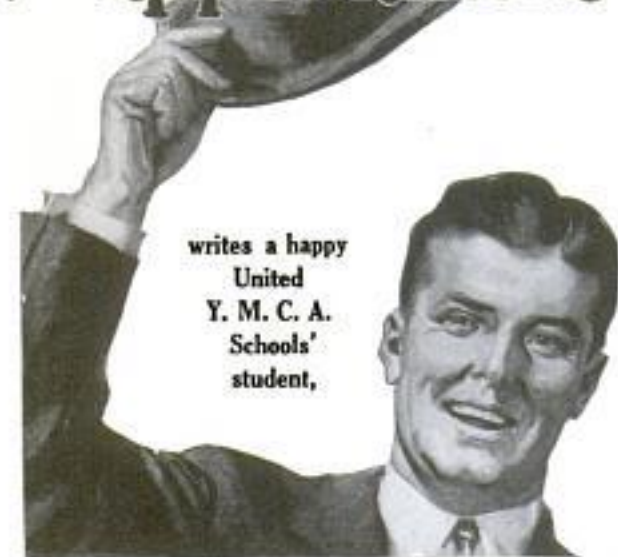

writes a happy
United
Y. M. C. A.
Schools'
student,

formerly of Scranton, Pa., and now in the employ of the United States government.

He was an office clerk, working long hours. He says "the light had dawned" that he was tied down to routine work for all time unless he trained himself. So he decided to devote spare evening hours to our excellent correspondence course in accountancy. He earned a salary increase of 60% before completing his course and in a year qualified for United States Internal Revenue service (Pittsburgh Division) as auditor of income taxes, with a further substantial increase of salary and responsibility.

The course he selected is just one of more than three hundred that we offer, all reasonably priced, all bringing the close personal service that is a feature of United Y. M. C. A. Schools instruction by mail.

Do you want more power, more money, a broader field? Write us about your ambition and get our friendly counsel free. Soon you, too, can be throwing up your hat over the advance you have made.

SOME OF OUR 300 CORRESPONDENCE COURSES

Accountancy
Advertising
Banking
Better Letters
Bookkeeping
Business Arithmetic

Business Courses
Business Administration
Business English
Business Finance
Business Law
Complete Letter-Writing

Office Management
Public Speaking
Salesmanship
Secretarial
Show Card Writing
Stenography
Traffic Management

Technical and Other Courses

Agricultural Courses
Applied Psychology
Architecture
Automobile Courses
Building Construction
Civil Engineering Courses
Drafting Courses
Electrical Courses
English Courses

Factory Management
Foreign Languages
Foremanship
Highway Engineering
High School Courses
Illustrating
Insurance Courses
Mathematical Courses
Mechanical Engineering

Own-Your-Home Course
Plan Reading
Plumbing
Poultry Husbandry
Radio Engineering
Radio Telegraphy
Steam Engineering Courses
Structural Drafting
Surveying
Use of the Slide Rule
Vocational Guidance



Correspondence Instruction

347 Madison Avenue
Dept. 2-M New York City

Without obligating me, please advise regarding the course in

Name.....

Full Address.....

(Please write plainly.)

LEARN RADIO

Here's your opportunity. Radio needs you. Win success in this fascinating field. Trained men in demand at highest salaries. Learn at home, in your spare time.

Be a Radio Expert

I will train you, quickly and easily, to design, construct, install, operate, repair, maintain, and sell all forms of Radio apparatus. My new methods are the most successful in existence. Learn to earn

\$1,800 to \$10,000 a Year

FREE Wonderful, home-construction, tube receiving set, of latest design.

Write for "Radio Facts" free. Engineer Mohaupt.
American Electrical Association
Dept. 13 4513 Ravenswood Ave., Chicago

START A BUSINESS OF YOUR OWN

There is Money in Show Card lettering. We will teach you how. Write To-Day. Illustrated booklet and terms free.

DETROIT SHOW CARD SCHOOL
214 Dinan Building Detroit, Michigan

Learn to Mount Birds



Learn at home by mail, to mount birds, animals, game heads; tan furs, make rugs and robes. Complete lessons. Easily and quickly learned by men, boys and women.

FREE Write today for Free Taxidermy Book. Tells all about it. Every Sportsman, Hunter, Trapper and Nature lover should know this wonderful fascinating art. Save your trophies. Big profits. Success guaranteed. Our school is 20 years old—75,000 graduates. Investigate today. Write for Free Book.

Northwestern School of Taxidermy 1773 Elwood Bldg., Omaha, Neb.

A FILE



Stop Forgetting

NOT A FILE



Make Your Mind an Index from which you select facts, figures, dates, facts. Develop concentration, well-controlled exercise business, organizations.

Write today for FREE memory and concentration test and illustrated booklet, "How to Remember."

PROF. HENRY DICKSON
Dept. 705-A Evanston, Ill.



Wrestling Book FREE

You can learn to be an expert wrestler at home—during your spare time. The book tells you how. The world's marvellous undefeated champion and his trainer Frank Gotch and Farmer Burns will now teach you. Learn wrestling, self-defense and Judo-like easily at home by mail. Know all the science and tricks. First chance to learn from world champions. Men and boys, here is your great opportunity. Send for free book today stating age.

Burns Sch. of Wrestling 8715 Range Hill, Omaha, Neb.

THIS HANDSOME VIOLIN



GIVEN

Perfect tone, handsome appearance, rose-wood finish, bow included. Given free for selling only 30 packets Garden Spot Seeds at 10 cts. a pkt. Send no money—we trust you. Write for seeds today. LANCASTER CO. SEED CO., Sta. D PARADISE, PA.



Get Expert Training in **DRAFTING** Raise Your Income

Here is a great and highly paid profession open to you. **Learn Drafting now.** No matter where you live or what you are doing you can become a master-draftsman by spare time study at home. No previous experience necessary. If you can read and write you can become a high-salaried expert draftsman by Chicago Tech's quick and easy method. In twenty years we have trained thousands who are now top-notchers in the drafting business.

Construction Lines Are Booming—Get Ready

Drafting is the very foundation of building and construction lines. The architectural, structural steel, mechanical and electrical industries are all calling for expert draftsmen. There is a boom coming in these lines—it's here now! This is a real opportunity which every ambitious man should grasp.

Let Us Send You This Big High Grade Drawing Outfit



We furnish this highest grade drawing outfit to our students in Drafting—no extra charge. Same tools in every particular that are used by high-salaried expert draftsmen.

Free Radio Course

Latest Up-to-the-minute Radio Course; just out. Tells how to build and operate your own set. We offer this big course FREE to our home-study students for limited time only.

Easy to Learn, Quick Results

By Chicago Tech's easy method you can learn Drafting quickly in your spare time right at home. Even though you cannot come and study Drafting in the day and evening classes of our big Chicago school, the same system of lessons used there with such pronounced success are sent to you. The same expert teachers guide you in your work at home.

Act Now. Mail the Coupon

Big jobs are waiting. We can train you to fill them. It takes only a little of your spare time. No experience or previous education required. Put your name on the coupon and get full information; it costs you nothing.

FREE Trial Lesson



While other schools ask you to enroll and send money first, we send the free lessons first. Read it, practice the exercises, and then decide for yourself whether to take the course or not.

Building Experts Wanted

The Building Business is booming. Splendid opportunities are open. Big money will be made in the next five years by men in the building trades who know how to read plans, make estimates, superintend jobs, take contracts, etc.

Special Offer for Men in Building Trades

We have a special plan of great interest to Bricklayers, Carpenters, Plumbers, Plasterers, Foremen, Superintendents, Contractors and other men in building lines.

Send Coupon for Free Book and Blue Prints

Mark "X" in the second square of the coupon if you have had experience in any building trade. We will send you free and postpaid, a book of drawings and blueprints, also our big new book, "How to Read Blue Prints." Tell every builder you know to send for these books—they're free to men in the building trades.

Chicago Tech. College, 330 Chicago Tech. Bldg., Chicago, Ill.

Without cost or obligation to me please send instructive matter about opportunities in line I have marked with "X".

- Drafting. (The Big Salary Course)**
No experience necessary.
- Building Trade Course.**
For men in the building lines.
- Surveying and Map Drafting.
- Automobiles, Gas Engines, Starting, Lighting, etc.
- Aeronautic, Engineering.
All about aeroplanes.
- Plumbing, Heating and Ventilating,
Plan Reading, Estimating, etc.
- Steam Engineering.
For Stationary Engineers.
- Plan Reading for Shop Men,
For Machinists, Assemblymen, etc.

Name.....

Address.....

Post Office..... State.....

The Automobile Business is THE Business to Get Into

Twelve Million Automobiles Need Service

Twelve Million Cars, sixty million tires, millions of batteries and electrical systems to overhaul, repair and keep in running order. Get that picture well fixed in your mind, then you can begin to appreciate WHY the AUTOMOBILE Business is THE Business to get into.

Think of the opportunities in the repair and re-sale end of the business alone! Thousands of additional garages, battery repair shops, tire shops and welding shops are needed to care for these millions of cars.

Try to picture in your mind what TWELVE

MILLION AUTOMOBILES mean—a line that would reach one and one-third times around the world! Think what that means as a business opportunity!! Can you think of a better field for ambitious, wide-awake men who have been specially trained for that kind of work?

Earn \$2,000 to \$10,000 Yearly



YOU CAN DO IT! Thousands of M. S. A. S. graduates are doing it right now! Both the manufacture and repair of these machines require skilled men—trained men—men who KNOW. The automobile industry employs millions of men and more are needed all the time. Factories, garages and service stations are continually asking us for M. S. A. S. Trained Men who can fill responsible jobs with good pay. The M. S. A. S. Trained Man doesn't have to worry—and wonder. He KNOWS—and that means SUCCESS.

Courses Complete and Practical

Our courses thoroughly cover every branch of the Automobile Business. And our teaching is made practical through practical training on the actual machines. When you have finished our Course you will be thoroughly trained in the construction, upkeep, repair and operation of autos, trucks, tractors, gas engines and farm lighting plants. That's why M. S. A. S. graduates are always in demand. They are thoroughly trained—they KNOW!

Read What the Auto Factories Say

The letters at the right written by Factory Executives speak for themselves. M. S. A. S. courses are the standard in Automobile training. The M. S. A. S. is the only FACTORY ENDORSED SCHOOL.

to think of the M. S. A. S. in the Auto Center when you think of Automobile Training. This is the Heart of the Auto Industry—the Automobile Center of the World. Practically 79% of the automobiles are made in the Detroit district. This is a big advantage for M. S. A. S. Students. They get the benefit of hearty co-operation from the big factories. They learn manufacturing methods first handed; they listen to lectures and talks by factory men; they learn about cars in a manner impossible away from the factories. That is why M. S. A. S. Trained Men are in demand with big factories and service stations.

Endorsed by Big Factories Read These Letters



Detroit, Mich., U.S.A.

Do not believe you would make any mistake in attending this school if you wish to become thoroughly experienced in the automobile business.

HUDSON MOTOR CAR COMPANY DETROIT, MICH., U. S. A.

This school is thought very highly of by the automobile men of Detroit. You will make no mistake by entering for a course.



BUICK MOTOR COMPANY

We believe the Michigan State Auto School located at Detroit would best meet your requirements, as its course in technical training is most thorough and complete in every detail.

THE STUDEBAKER CORPORATION OF AMERICA

We do not know a better automobile school that we could recommend to you than the Michigan State.

PREDICTS 1923 MOTOR BOOM

Alfred Reeves, of N. A. C. C., Avers, Production Will Far Exceed That of 1922.

Upon his arrival in Detroit Wednesday, after a swing around the factories in New York, Ohio, Indiana, Illinois and Michigan, Alfred Reeves, general manager of the National Automobile Chamber of Commerce, said that motor production this year would exceed 2,400,000 vehicles, or a 10 per cent increase over the previous year's record of 2,185,000. Of this production, about 15 per cent will be trucks and at least 25 per cent will be closed cars.

Among other things brought out by Mr. Reeves were the following:—

—The record sales of 1922—

If it's worth learning it's worth learning right.

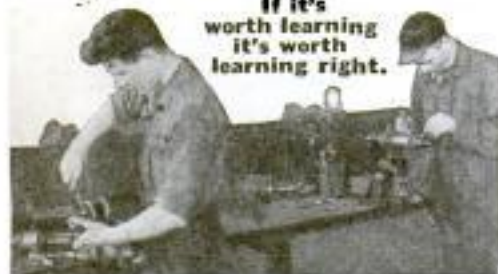

Michigan State

303 Auto Bldg. Detroit, Mich.

This Man Makes \$350 to \$400 per Month



in a little
shop of
his own

From uncertain jobs which paid scarcely enough to support his family, to steady earnings of \$350 to \$400 per month; that's the story of what John Grahek accomplished with the help of M. S. A. S. Training. But read his letter reproduced below. It is the story of a man who refused to become discouraged; a man who really wanted to get ahead and had the gumption to START.

Every man who wants to get ahead can find encouragement in Mr. Grahek's letter, for he was just an average fellow. His success is not unusual, but typical of thousands of men of all ages who have been equally successful through M. S. A. S. Training. Thousands of letters from these men tell of their success in the Automobile Business. Every one of them gives M. S. A. S. Training credit for what they have accomplished. And what this Training has done for Mr. Grahek and these thousands of others, it can do for YOU.



The Kind of Men Who Make Good

Endorsed by Graduates

Read Mr. Grahek's Letter

GRAHEK AUTOMOBILE GARAGE JOHN GRAHEK, Proprietor

AUTOMOBILES, BATTERIES, TIRES and ACCESSORIES

Repairing of Batteries, Electric Starters and Ignitions
A SPECIALTY

Chisholm, Minn.

Michigan State Auto School, Inc.
Detroit, Michigan.

Dear Mr. Zeller:

I wish to let you know that I am doing very well after taking my course in the MICHIGAN STATE AUTO SCHOOL. I am in business for myself. My wages average from \$350 to \$400 a month.

Before I went to your school I hardly made enough for my family to live on.

I surely recommend the MICHIGAN STATE AUTO SCHOOL to any one who would like to get something out of his work and who wishes to get into the automobile business.

With best wishes to all, I remain
Very truly yours,
John Grahek.

Read This Guarantee

We guarantee that a graduate of our Automobile and Tractor Course will be qualified to fill a position as assembler, demonstrator, tester, repair man, auto electrician, chauffeur, tractor operator or farm lighting expert, or we will refund his tuition fee.



This Is Your Opportunity

Don't say you never had a chance. A Big One faces you right now! Get Busy! Don't wait for some one to push you along. Send for our free literature. Learn what other fellows have done, then show the World what YOU can do. Be a Winner. Get Started! Fill out and mail the Coupon NOW—TODAY!

A lot of folks get the idea that a man must be a "natural mechanic" to make good in the Automobile business. Maybe he does have to "like machinery" but he doesn't need to be a mechanic. One of the best graduates we ever turned out was a \$13.50 per week "pencil pusher" who hardly knew what a wheel base was. We changed him into a \$42.50 per week automobile electrician, and he is still climbing.

Another man quit an office job to take our Course—and pushed himself into a \$10,000 per year garage business. Another came here as a High School graduate at 17, and about a year after finishing our Course was making nearly \$5,000 per year in a business of his own. Another real fellow who through hard luck was unable to support his family, borrowed the money to take our Course, and today has a successful business in Minnesota.

All these fellows had Gumption—they had Ambition—they wanted to Get Somewhere!—and they were willing to do the necessary plugging to get there. Mere wishing won't do it—neither will waiting. You must get Action! If you are willing to do that, Our Course will help you Get There!



Good Positions Await Our Graduates

Factories, garages and service stations continually call for M. S. A. S. trained men. These positions pay good salaries and offer excellent opportunity for advancement or to build a business of your own. There are more opportunities for trained men in Detroit and elsewhere than we can fill. Let the M. S. A. S. fit you for the wonderful future of the Automobile business.—A. G. Zeller, Pres.

SEND THIS COUPON TODAY!

Michigan State Automobile School
303 Auto Bldg., Detroit, Mich.

Gentlemen: Send me your FREE Catalog telling all about the opportunities in the Auto Business.

Name

Street or R. F. D.

City.....State.....

Automobile School

303 Auto Bldg. Detroit, Mich.



\$100.00 a Week

He Doubled His Pay

and now enjoys the comforts and pleasures of a real income

Why not double your pay? Thousands of our students have done it and thousands more will do it. You can be one of them. Do not think for a moment that it is luck or pull which brings success and real money—far from it. It is preparing for the big opportunity and knowing what to do when the right time comes that does it. The men who have made successes for themselves were ready when their main chance came. Your main chance, too, will come. Are you ready for it?

Remember the Empty Lot?

The older fellows were playing ball and you were watching, wondering if you would ever get a chance to play. You knew if you only got a chance you would show them. Sure enough, one day they boomed, "Come on, kid, grab a bat!" Your chance at the pill had come. That is the way with life. Your chance at the pill will come, but, if you want to stay on the team, you will have to deliver the goods—and that you can do only if you are prepared. The big money and the permanent job go to the man "who knows."

You Can be the Man "Who Knows"

We will show you how. Without loss to you of a single working hour, we can show you a sure way to success and big pay. A large number of men in each of the positions listed are enjoying their salaries because of our help. We want to help you. Make a check on the coupon against the job you want and we will help you get it. Write or print your name on the coupon and send it in today.

American School

Dept. G-374, Drexel Ave. and 58th St., Chicago

American School

Dept. G-374, Drexel Ave. and 58th St., Chicago

Send me full information on the subject checked and how you will help me win success.

- | | |
|-------------------------------|----------------------------|
|Architect |Lawyer |
|Building Contractor |Machine Shop Practice |
|Automobile Engineer |Photoplay Writer |
|Automobile Repairman |Mechanical Engineer |
|Civil Engineer |Shop Superintendent |
|Structural Engineer |Employment Manager |
|Business Manager |Steam Engineer |
|Cert. Public Accountant |Foremanship |
|Accountant and Auditor |Sanitary Engineer |
|Bookkeeper |Server (and Mapping) |
|Draftsman and Designer |Telephone Engineer |
|Electrical Engineer |Telegraph Engineer |
|Electric Light and Power |High School Graduate |
|General Education |Fire Insurance Expert |
|Vocational Guidance |Wireless Radio |
|Business Law |Undecided |

Name

Address

Please Mention Popular Mechanics



FREE

Write for your
**REVERSIBLE
COLLAR to-day**

For sheer comfort and economy, the Linene Reversible Collar illustrated above is unsurpassed. Note its graceful, rounded lines. BOTH sides are alike, of fine cotton cloth, so that when one side is soiled, reverse, and you have a clean collar. You save money because they stay clean twice as long as expensive collars, and because by wearing both sides they cost less than laundry. These Reversible collars are starch finished, but are light and flexible, and are always smooth around the neck—the most comfortable, economical collar you can buy. Try them and you'll never wear any other kind of collar.

FREE TRIAL OFFER

Prove these statements at our expense by writing for a free sample collar. State your size and send 2 cents in U. S. stamps for postage. Write TODAY

REVERSIBLE COLLAR COMPANY
DEPT. U
BOSTON, MASS.

PLAYA SAW



Hear Victor Record No. 18,767-A, a saw solo played on the "Musical Saw." You, too, can produce wonderful, soft, sweet music from a carpenter's cross-cut saw with violin bow or soft hammer. If you know how. No musical ability required—you need not know one note from another. Successfully instructed thousands. Have helped our students organize "sawing" trios and quartettes for Clubs, Lodges and Legion Posts.

Easy to Learn in Three Weeks

We absolutely guarantee to teach you to play popular and classical music within three weeks. No charge if we fail. Hundreds of dance orchestras and professional entertainers use our saws on the big time vaudeville circuits.

FREE—a special tempered Musical Saw is given FREE with course of instruction. Course is short and easy—only three simple lessons, one each week. No months of tedious practice. Price of course is so small you never miss the three easy payments. Write today for information, "How to Play a Saw" sent free.

MUSSELL & WESTPHAL, 354 Mack Bldg., Ft. Atkinson, Wis.



DRAW CARTOONS

and COMIC STRIPS IT WILL PAY YOU TO LEARN

Let a former staff cartoonist of the N. Y. World, N. Y. American, Life, and Judge, train you for success by

CORRESPONDENCE

Send 6c stamps for illustrated BOOKLET, comic strip folder and particulars.

Box 258 The Carl Anderson School Madison, Wis.

A WONDERFUL OPPORTUNITY!

The Eastern Division of the RADIO CORPORATION OF AMERICA accept no inexperienced applicants in their services as Wireless Operators other than our graduates. Investigate the advantages offered through taking either our HOME STUDY or RESIDENCE course in Radio.

RADIO INSTITUTE OF AMERICA

(Formerly Marconi Institute)

326A Broadway

New York City

Learn Watchwork, Jewelrywork and Engraving.

A fine trade commanding a good salary, and your services are always in demand. Address HOROLOGICAL, Dept. P, Bradley Institute, Peoria, Ill., for our latest catalog.

BE AN EXPERT
Penman

I TEACH BY MAIL. You can become an expert penman right in your own home by my method. Small Cost. All that is required is some of your Spare Time. Write for my book, "HOW TO BECOME AN EXPERT PENMAN." It contains specimens and tells how others became expert writers by the TEVIS METHOD. Your name written on a card if you enclose stamp. FREE BOOK. Write today. T. M. TEVIS, BOX 25K, CHILLICOTHE, MO.



NOW FREE!

The Book That Has Shown Thousands the Way to Amazing Salary Increases

Do you want to leave the rut of routine work for a position that will grow daily in its fascination? Do you want to start right out making more money than you ever thought possible? We have done exactly this for thousands of men. Here is the book which gave them their start. Read how it is now offered to you—FREE!

TAKE this situation: A man who had worked all his life in a routine job at low pay suddenly surprises his friends by moving into a better neighborhood, taking a big house, buying a car and blossoming out as a well-to-do and influential citizen in his new community. How did he do it? What is the secret that he used? Simple enough. He knew that the biggest money in business is in Selling, and though he felt that he couldn't sell a thing, he learned the secrets that make Master Salesmen and then began to make big money.

If only one man had found inspiration enough in this remarkable book to make a brilliant success in the selling field—in a job paying him many times his former salary—then you might call it luck. But thousands have done it.

Your One Chance to Make the Biggest Money of Your Life

Not one of the men whose names appear below had ever sold a thing before—not a dime's worth. If you had told one of them that he could sell he would have laughed at you. Probably he would have come back with the old saw, "Salesmen are born, not made." They were frankly skeptical. Yet every one of these men, through reading this book, discovered the fallacy of this vicious old idea that Salesmen are "born." They learned that Master Salesmen are made! And in this book they found a comparatively easy way to go from low pay to better earnings.

READ!

Charles Berry of Winterset, Iowa, stepped from \$18 a week as a clerk to a position making him \$1,000 the very first month. J. P. Overstreet of Dennison, Texas, read this book, left a job on the Capitol Police Force at a salary of less than \$1,000 a year and in six weeks earned \$1,800. F. Wynn, Portland, Ore., an ex-service man, earned \$554.37 in one week. Geo. W. Kearns of Oklahoma City found in this book a way to jump his earnings from \$60 a month to \$524 in two weeks, and C. W. Campbell learned from it how he could quit a clerking job on the railroad to earn \$1,632 in thirty days.

Simple as A B C

Sounds remarkable, doesn't it? Yet there is nothing remarkable about it. There are certain ways to approach different types of prospects to get their undivided attention—certain ways to stimulate keen interest—certain ways to overcome objections, batter down prejudices, outwit competition and make the prospect act. If you will learn these principles there is awaiting you a brilliant success and more money than you ever thought of earning. This book, "Modern Salesmanship" tells exactly how the National Salesmen's Training Association will make you a Master Salesman.

As soon as you are qualified and ready the Employment Service of the National Salesmen's Training Association will help you to select and secure a selling position as city or traveling salesman. Many of the biggest, most reputable selling organizations in America turn to this Association for their Star Salesmen.

Now Free to Every Man Who Will Act at Once

We are not making any extravagant claims about what we will do for you. We don't have to. The records of the real successes for which we are responsible are so overwhelmingly a testimonial of the fact that any man of average intelligence can become a Master Salesman that we are willing to leave the decision entirely up to you. All of this proof and many important features about Salesmanship are contained in our salary raising book, "Modern Salesmanship." It is yours—FREE. Send the coupon for it today. It will show you how you can quickly become a Master Salesman—a big money maker. It will tell you about the National Salesmen's Training Association system of Salesmanship training that has meant prosperity to so many thousands of men—about the National Demonstration method that gives you actual experience while studying—and all about the fine opportunities that await you in the selling field. If you do not send this coupon we will lose merely the opportunity to train one more Master Salesman. But for you, failure to act may mean that you lose the one big chance of your life to leave forever behind you the low pay of a routine job. It may mean the difference between this and a real success at a big salary. Is it worth 2c to find out? Then mail this coupon NOW.

National Salesmen's Training Association
Dept. 12C, Chicago, Illinois

National Salesmen's Training Association,
Dept. 12-C, Chicago, Ill.

I simply want to see the facts. Send me FREE your Book "Modern Salesmanship" and Proof that I can become a Master Salesman. Also tell how you can help me to a position and send list of lines with openings for Salesmen.

Name

Address

City..... State.....

Age..... Occupation.....

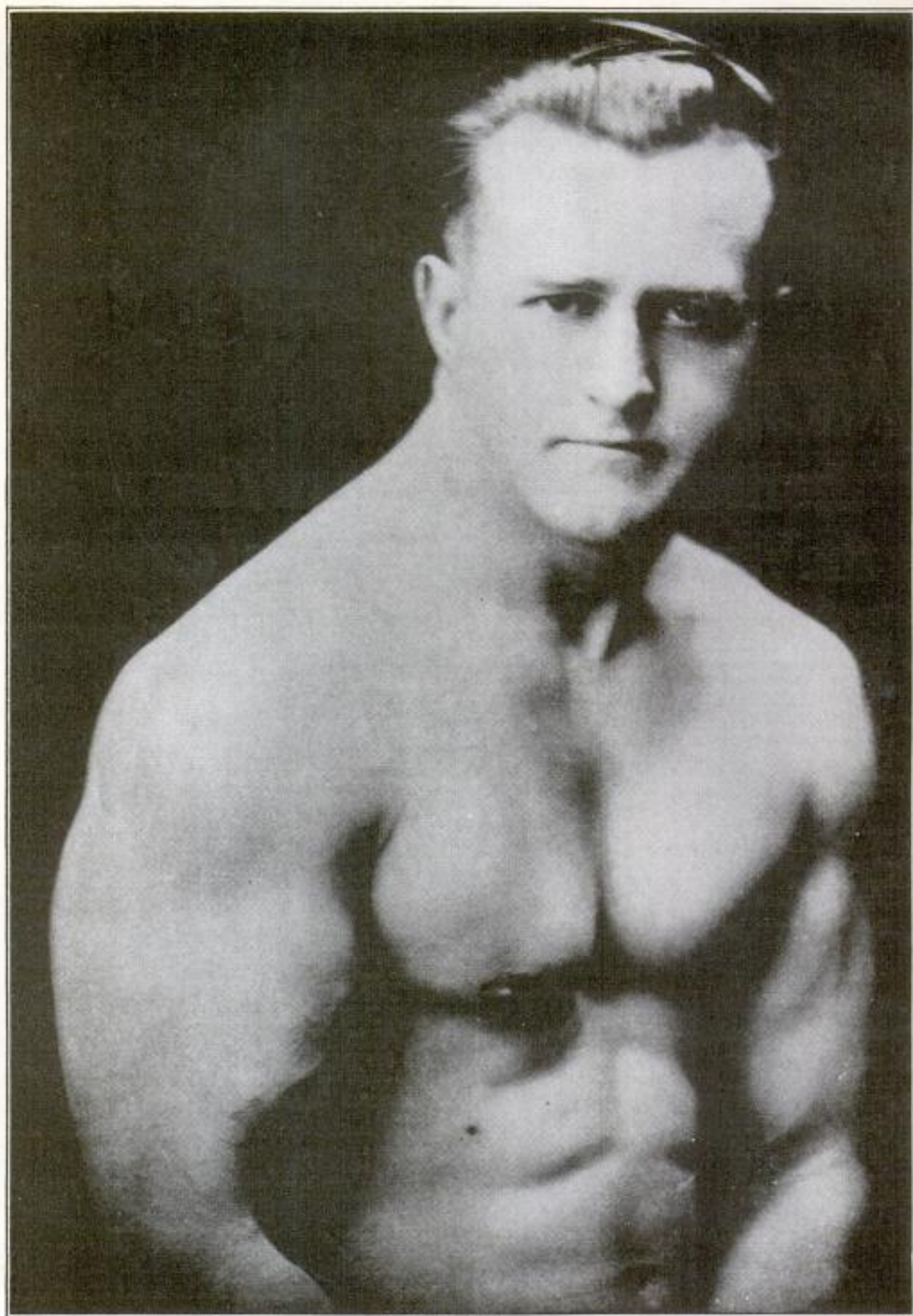

Earle E. Liederman
The Acme of Physical Perfection

Copyrighted material

A Personal MESSAGE

I have a PERSONAL MESSAGE which I would like to send to the home address of EVERY man or boy who is interested in possessing a strong clean, healthy body. I am not asking you to send me any money for this — not even a two-cent stamp. Just fill in the coupon below and make your letter PERSONAL so that you will receive this private letter. I will also enclose my 64 page book on Muscular Development which has just come off the press, if you wish. In either case don't send me one penny. It is a message of private nature which I wish you to have.

Earle Liederman
Dept. 2003
305 Broadway
New York City.

Earle Liederman (Personal)
305-309 Broadway N. Y. City

Dear Sir—

Please send me by return mail your personal message, also a free copy of your latest book "Muscular Development" — this does not obligate me in any way.

Name—

Street—

City— State—

(Address all mail to Dept. 2003 for personal attention.)



"We pay him \$100 a week"

AND he's worth every cent of it. Came here several years ago asking for a job. He got just that—a small job at a small salary.

"Then I forgot about him—hardly knew he was on the payroll until one day I got a letter from the International Correspondence Schools telling me that he had enrolled for a course of home study. It was remarkable the way he went ahead.

"We pay him \$100 a week now and he's going to be earning even a larger salary some day. I wish we had more men like him."

HOW do you stand when your employer checks up his men for promotion? Does he think of you? Is there really any reason why you should be selected? Ask yourself these questions fairly. You must face them if you expect advancement and more money.

One hour after supper each night spent with the I. C. S. in your own home will prepare you for the position you want in the work you like best.

Yes, it will! Put it up to us to prove it. Without cost or obligation, just mark and mail this coupon.

----- TEAR OUT HERE -----

INTERNATIONAL CORRESPONDENCE SCHOOLS Box 5506-D, Scranton, Penna.

Without cost or obligation, please tell me how I can qualify for the position or in the subject before which I have marked an X:

BUSINESS TRAINING DEPARTMENT

- | | |
|---|---|
| <input type="checkbox"/> Business Management | <input type="checkbox"/> Salesmanship |
| <input type="checkbox"/> Industrial Management | <input type="checkbox"/> Advertising |
| <input type="checkbox"/> Personnel Organization | <input type="checkbox"/> Better Letters |
| <input type="checkbox"/> Traffic Management | <input type="checkbox"/> Foreign Trade |
| <input type="checkbox"/> Business Law | <input type="checkbox"/> Stenography and Typing |
| <input type="checkbox"/> Banking and Banking Law | <input type="checkbox"/> Business English |
| <input type="checkbox"/> Accountancy (including C.P.A.) | <input type="checkbox"/> Civil Service |
| <input type="checkbox"/> Nicholson Cost Accounting | <input type="checkbox"/> Railway Mail Clerk |
| <input type="checkbox"/> Bookkeeping | <input type="checkbox"/> Common School Subjects |
| <input type="checkbox"/> Private Secretary | <input type="checkbox"/> High School Subjects |
| <input type="checkbox"/> Business Spanish <input type="checkbox"/> French | <input type="checkbox"/> Illustrating <input type="checkbox"/> Cartooning |

TECHNICAL AND INDUSTRIAL DEPARTMENT

- | | |
|--|--|
| <input type="checkbox"/> Electrical Engineering | <input type="checkbox"/> Architect |
| <input type="checkbox"/> Electric Lighting | <input type="checkbox"/> Blue Print Reading |
| <input type="checkbox"/> Mechanical Engineer | <input type="checkbox"/> Contractor and Builder |
| <input type="checkbox"/> Mechanical Draftsman | <input type="checkbox"/> Architectural Draftsman |
| <input type="checkbox"/> Machine Shop Practice | <input type="checkbox"/> Concrete Builder |
| <input type="checkbox"/> Railroad Positions | <input type="checkbox"/> Structural Engineer |
| <input type="checkbox"/> Gas Engine Operating | <input type="checkbox"/> Plumbing and Heating |
| <input type="checkbox"/> Civil Engineer | <input type="checkbox"/> Chemistry <input type="checkbox"/> Pharmacy |
| <input type="checkbox"/> Surveying and Mapping | <input type="checkbox"/> Automobile Work |
| <input type="checkbox"/> Metallurgy | <input type="checkbox"/> Navigation |
| <input type="checkbox"/> Steam Engineering | <input type="checkbox"/> Agriculture and Poultry |
| <input type="checkbox"/> Radio <input type="checkbox"/> Airplane Engines | <input type="checkbox"/> Mathematics |

Name.....
Street..... 6-26-22
Address.....

City..... State.....

Occupation.....

Persons residing in Canada should send this coupon to the International Correspondence Schools Canadian, Limited, Montreal, Canada.

Please Mention Popular Mechanics

WE TEACH COMMERCIAL ART

Meyer Both Company, the largest Commercial Art Organization in the World, offers you an unusual opportunity for practical training. If you like to draw develop your talent. Study this practical course—taught by the nationally known Meyer Both Company with twenty-two years success—who each year produces and sells to advertisers over 15,000 commercial drawings.

Our teachers give you the double advantage of being instructors of proven ability, as well as artists in this widely known organization. Meyer Both instruction is the difference between successful fact and experimental theory. Commercial Art is a highly paid, intensely interesting profession, equally open to men and women. Home study instruction.

Get Facts Before You Enroll in any School.

Ask the Advertising Manager of the leading newspapers in your city, anywhere in the United States, Canada, England or Australia about the Meyer Both Company—let them tell you about us.

Write for our illustrated book "YOUR OPPORTUNITY"—for one-half the cost of mailing—four cents in stamps.

MEYER BOTH COMPANY

Department of Art Instruction
Michigan Ave. at 29th St., Dept. 16, CHICAGO, ILL.

NOTE—To art and Engraving Firms: Secure practical artists among our graduates. Write us.

STAMMER

If you stammer attend no stammering school till you get my large FREE book entitled "STAMMERING, its Origin and the Advanced Natural Method of Cure," bound in cloth and stamped in pure gold. Ask for special tuition rate and a FREE copy of "The Natural Speech Magazine." Largest, best equipped and most successful school in the world for the cure of stammering, stuttering, etc. No sing-song or time beat. Write today. The North-Western School, 2317 Grand Ave., Milwaukee, Wis.



SHORTHAND IN ONE MONTH

Boyd—the Wonderful, New, Easy System. Writers hold World's record. 100 to 150 words a minute in 30 days guaranteed. New Principles—dictation first week. Best for Court Reporting and Secretaries. Also Typewriting, Bookkeeping and Commercial Law. Send today for Catalog and Money-Back Guarantee. CHICAGO HOME STUDY SCHOOLS, 802 Resper Block, Chicago, Ill.

LEARN ENGINEERING

Courses, 3 months to 2 years practical-technical training under experts. Not a Trade School, but a practical-technical college teaching electricity, steam, gas, auto-electric, structure wiring, drafting. Extensive laboratory and shop equipment. Degrees awarded. Day and night sessions. Enroll any time.

1001 Indiana Avenue Kansas City, Mo.

LEARN WATCHMAKING AND ENGRAVING

Earn while learning. Most practical watch school. Individual instructions. Graduates in great demand. Book free. Chicago School of Watchmaking, Dept. 20, 4840 Lincoln Ave., Chicago

MUSIC LESSONS FREE

IN YOUR OWN HOME
You can read Music like this quickly
Piano, Organ, Violin, Mandolin, Guitar, Banjo, etc. Beginners or advanced players. One lesson weekly. Illustrations make everything plain. Only expense about 2c per day to cover cost of postage and music used. Write for FREE booklet which explains everything in full. AMERICAN SCHOOL OF MUSIC, 51 Lakeside Building, CHICAGO

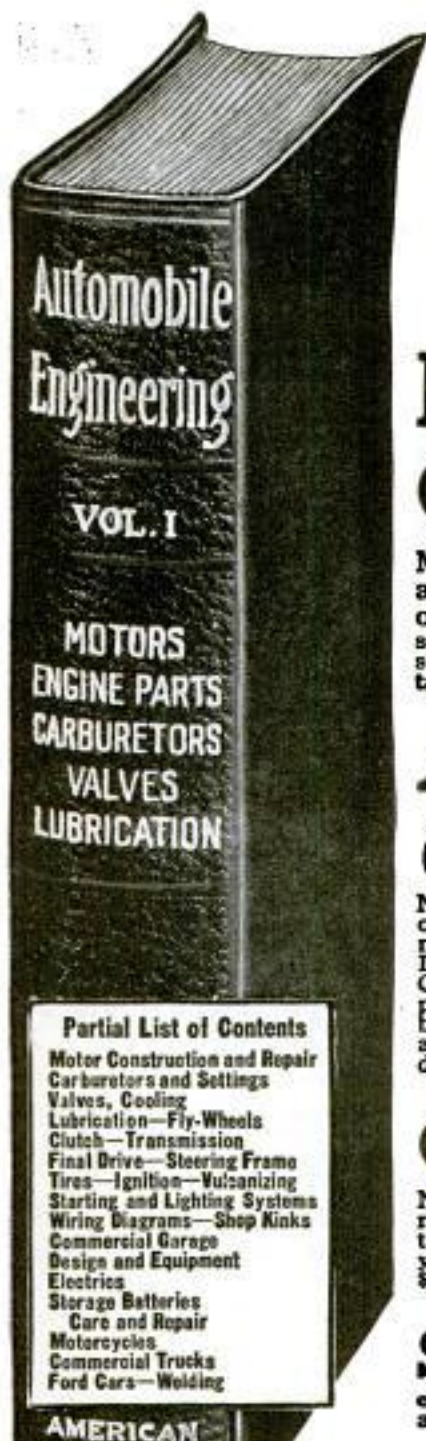

NAME	POSITION	SALARY
John	AUTOMOBILE ENGINEER	\$125 A WEEK
	REPAIR MAN	\$50 A WEEK
	CHAUFFEUR	\$40 A WEEK

Put Your Name On this Pay-Roll

Men like you are wanted for big-pay positions in the fascinating field of automobile engineering. We have made it easy for you to fit yourself for one of these positions. You don't have to go to school. You don't have to serve an apprenticeship. Fifteen automobile engineers and specialists have compiled a spare time reading course that will equip you to be an automobile expert without taking any time from your present work.

AUTO BOOKS 6 Volumes Shipped FREE

Now ready for you—at a big reduction in price—an up-to-the-minute six-volume library on Automobile Engineering, covering construction, care and repair of pleasure cars, motor trucks, tractors and motorcycles. Brimming over with advanced information on Lighting Systems, Garage Design and Equipment, Welding and other repair methods. Contains everything that a mechanic or an engineer or a motorcyclist or the owner or prospective owner of a motor car ought to know. Written in simple language that anybody can understand. Tastefully bound in flexible covers and gold stamped, 2700 pages and 2400 illustrations, tables and wiring diagrams. A library that cost thousands of dollars to compile but that comes to you free for 7 days' examination.

Only 10 Cents a Day

Not a cent to pay in advance. First you see the books in your own home or shop. Just mail coupon and pay express charges when books arrive. You can read them and study them for seven whole days before you decide whether you want to keep them or not. If you like the books send \$2.80 in seven days and \$3.00 a month until the special price of \$21.80 has been paid. (Regular price \$45.00.)

Send No Money Now Don't take our word for it. See the books without cost. There is so much profit in this offer for you, that we urge you not to waste a moment in sending for the books. Put the coupon in the mails today. **SEND NO MONEY—only the coupon.**

American Technical Society
Dept. A-193 Chicago, Illinois

American Technical Society, Dept. A-193, Chicago

Please send me a set of Automobile Engineering books in 6 volumes by express collect, for a week's free use. At the end of a week I will either send the books back at your expense or send you \$2.80 as first payment and \$3.00 each month thereafter until a total of \$21.80 is paid.

Name.....
Address.....
City.....
State.....
Reference.....

Mail The
Coupon For
These Books



More Money For You in RADIO

THE amazing expansion of Radio has opened up thousands of wonderful new positions on land and sea. Big salaries, fascinating, easy work, short hours, and a wonderful future are offered to ambitious men who get into Radio now.

Take advantage of these wonderful opportunities to step into a big paying position in this great new field. Radio offers you an opportunity to travel and see the world, with all expenses paid, and a fine salary besides. Or you can stay at home and work up to a position paying up to \$10,000 a year.

Easy to Learn Radio

Hundreds of men are already earning handsome incomes in this wonder science. If you want to get into a profession where opportunities are unlimited make Radio your career—become a Certified Radio-trician.

Thousands of Certified Radio-tricians are wanted to design Radio sets; to make new Radio improvements; to manufacture Radio equipment and to install it; to maintain and operate great Broadcasting stations and home Radio sets; to repair and sell Radio apparatus; to go into business for themselves; to operate aboard ship and at land stations.

You can easily and quickly qualify in your spare time at home through the help of the National Radio Institute. Prominent Radio experts will help you. Four wonderful instruments are furnished free. The same plan that has already helped hundreds of our graduates to real success and real money in Radio is open to you.

Big Book Free

No other field today offers such great opportunities as Radio. Take your choice of the many wonderful openings everywhere. Prepare now to step into the most interesting and best paid profession today. Read about the opportunities open now—the different kinds of work—the salaries paid. Write today for the free 32-page book that tells how America's first and biggest Radio school can make you a Certified Radio-trician in your spare time. Mail the coupon or write a letter NOW.

NATIONAL RADIO INSTITUTE

1345 Pennsylvania Ave., N. W.

Dept. 15-C

WASHINGTON, D. C.

National Radio Institute, Dept. 15-C
1345 Pennsylvania Ave., N. W.
Washington, D. C.

Send me your free book "How to Learn Radio at Home" which tells all about the opportunities in Radio, how spare time study at home will qualify me quickly as a Certified Radio-trician so I can get one of these splendid positions, and how your free Employment Service helps me to secure the job I want.

Name..... Age.....
Street.....
City..... State.....

Please Mention Popular Mechanics

WE TEACH YOU LAW AT HOME

From signing contracts to making verbal proposals over the telephone, from ordering materials to hiring employees, from posting a ledger to acting as Comptroller; every step has back of it some well defined legal principle. Without a knowledge of law, you are a man in the dark in a strange house. We have taught this subject successfully by mail for 31 years. 45,000 successful men and women have been trained in the fundamentals of success through our home study course. Send for our free booklet describing the scope and merit of our courses, and giving many helpful legal pointers.

BLACKSTONE INSTITUTE
Dept. 266, 4753 Grand Blvd., Chicago, Ill.

BE AN ARTIST

We can teach you **DRAWING** in your own home during your spare time.

Our 18-years of successful teaching prove our ability. 10 Courses in Commercial and Illustrative Drawing. Teachers Normal and Applied Art. Endorsed by high art authorities. Students trained by members of our Faculty are filling high-salaried positions. Artist's Outfit FREE to Enrolled Students. Write today for Art Year Book.

OUR HANDSOME ART YEAR BOOK is FREE to you!

SCHOOL OF APPLIED ART
ADDED ART BLDG. No. 2 BATTLE CREEK MICH.

BE A PIANO TECHNICIAN

Our Tune-a-Phone Guides You to Success

Tuning, Voicing, Regulating, Finishing and General Care of Piano Taught in ONE Complete Course. 25 years of successful Correspondence Instruction makes our guarantee worth while. Knowledge of music NOT necessary. Write for FREE BOOKLET and the plan that saves you all risk in testing our method of teaching.

NILES BRYANT SCHOOL, 24 Bryant Bldg., Augusta, Mich.

LAW

Learn law with only institution giving same course by correspondence as was given for years at resident classes of this college. **DEGREE OF LL. B. CONFERRED.** One year business law course prepares you for success in business. Law trained business men in demand. Three year university course covers preparation for bar examination. Money back guarantee if not satisfied. Low fee, easy terms, includes complete 1921 thirteen volume library, text material and all expenses. Write for **FREE BOOK.**

HAMILTON COLLEGE OF LAW 431 South Dearborn St. Dept. 62 Chicago

TELEGRAPHY

(Morse and Wireless) and RAILWAY ACCOUNTING taught thoroughly. Big salaries; great opportunities. Oldest, largest school. Endorsed by Telegraph, Railway, Radio, and Government officials. Expenses low—opportunities to earn large position. Catalog free.

DODGE'S INSTITUTE, Dyke Street, Valparaiso, Ind.

WHY

not spend Spring, Summer and Fall gathering butterflies, insects? I buy hundreds of kinds for collections. Some worth \$1 to \$7 each. Simple outdoor work with my instructions, pictures, price list. Get posted now. Send 10c (NOT STAMPS) for my Illustrated Prospectus.

Mr. Sinclair, Dealer in Insects, Dept. 6, Ocean Park, Calif.

LEARN WATCH REPAIRING

Be a watchmaker—you can learn this profitable trade by correspondence in a few weeks in your own home by the DeSelms Chart System. After you complete the course you will know a watch from A to Z. You will know just what the matter is and how to repair it. When you graduate you will be a practical watchmaker and repairer and competent to fill any position. Positions for our graduates.

Ask for our Free Book. It explains our system and terms.

THE DeSELMS WATCH SCHOOL
23 Perry Street ATTICA, INDIANA

FLEXIBLE
BINDINGPOCKET
SIZE

ENTIRE SET ONLY \$12

\$1
PER
MONTH

\$10,000. Master Set AUDEL'S ENGINEERS and MECHANICS GUIDES —

THE BOOKS YOU HAVE
BEEN WAITING FOR

4750 Pages—8754 Illustrations

Just completed—Audel's New Master Set for Engineers
and Mechanical!

Every Engineer, Mechanic and Electrical worker will
welcome this set as a sure source of advancement and higher
pay because of the complete up-to-date information that is
thoroughly and easily explained on every branch of Engineer-
ing and Electrical practice.

Why a \$10,000 Library? Because it would cost the reader
more than \$10,000 together with years of labor and experience
to collect, plan, arrange and prepare for his own study and
ready reference, the vast fund of knowledge printed in this
Master Set.

The entire set costs you only twelve dollars—knowledge
and instruction that has cost thousands of dollars and years
of time—yours for \$12.00—\$1.00 a month.

Study This Brief Table of Contents

Theory, Practice and Operation of
ALL Steam Engines, Valve Motion—
VALVE SETTING—complete in-
formation on ALL engines and pumps—
CORLISS ENGINES and the Theory,
Construction and Operation of all
Steam Engines, including UNIFLOW
and POPPET VALVE ENGINES,
and LOCOMOTIVES—Locomotive-
Marine Engines—Turbines; Rotary
Engines—the Indicator—Lubrication—
—PRACTICAL MANAGEMENT.
How to use Indicator—GAS, GAR-
OLINE, OIL, SEMI- and FULL
DIESEL ENGINES—Accidents and
Aviation—HOW TO SELECT AN
ENGINE—working instructions, draw-
ings on STEAM ENGINE DESIGN,
including rules and formulas. Theory
and Construction of ALL Steam
Boilers; Heat-Combustion; Fuel and
Flue Gas Analysis—CO₂ recorder—
Characteristics of Boilers—Materials

—Construction of all types of Boilers,
(THE LATEST PRACTICE)—Boiler
Construction—Mechanical Stokers
—Oil Burners—Setting—Chimneys—
Mechanics—Drafting—HOW TO
SELECT A BOILER—Complete in-
structions and drawings on BOILER
DESIGN based on A. S. M. E. BOIL-
ER CODE—OPERATION, including
installation, FITTING, care and repair
of Steam Boilers—Pipes, Fittings and
Pipe Fitting—Heating and Ventila-
tion—Refrigeration—Cooling Towers
—Condensers—Distilling Apparatus
—Elevators—Cranes and Hoisting
Machinery—Ropes and Cables—Splic-
ing—Electric Wiring in ALL branches;
compendium of practical electrical
engineering as an aid for engineers
and electricians in obtaining a license
—57 chapters—ready references index,
covering entire field of Modern
Electricity.

*Helping Hand
Books that answer
Your Questions*

FREE
EXAM-
INATION



Send No Money—Send Only This Coupon

THEO. AUDEL & CO.,
72 Fifth Ave., New York City

Please submit me for free examination, AUDEL'S \$10,000
MASTER SET FOR ENGINEERS AND MECHANICS. Ship
at once prepaid, the 8 numbers, total cost \$12.00. If satisfactory,
I agree to send you \$1 within seven days and to further mail you
\$1 each month until paid.

Name

Occupation

Employed by

Home Address

Reference

PM MCH. 24

Are you a Square Peg in a Round Hole?



Are you just marking time, getting little satisfaction out of your job, not developing yourself or rising in power?

You needn't keep on being a misfit. There's a sure way to solve your problem. Prepare for something definite and the world will give you the opportunity.

Use some of your spare evening hours—seven to ten—as thousands of young men all over the country are doing right now under our direction. Enroll for one of our practical correspondence courses and get our close personal service, which gives you "the most for the least money."

Employers everywhere are favoring the man who is studying ahead of his job. Write us about your ambition, or mark and mail the coupon below, and get our friendly counsel free. We can help you to prepare for a real turning point in your career.

SOME OF OUR 300 CORRESPONDENCE COURSES

Business Courses

- | | | |
|---------------------|-------------------------|--------------------|
| Accountancy | Business Administration | Public Speaking |
| Advertising | Business English | Salesmanship |
| Banking | Business Finance | Secretarial |
| Better Letters | Business Law | Show Card Writing |
| Bookkeeping | Complete Letter-Writing | Stenography |
| Business Arithmetic | Office Management | Traffic Management |

Technical and Other Courses

- | | | |
|-----------------------|---------------------|-----------------------|
| Agricultural Courses | Foreign Languages | Plan Reading |
| Applied Psychology | Foremanship | Plumbing |
| Architecture | Highway Engineering | Poultry Husbandry |
| Automobile Courses | Illustrating | Radio Engineering |
| Building Construction | Insurance Courses | Radio Telegraphy |
| Civil Engineering | Mathematical | Steam Engineering |
| Courses | Courses | Structural Drafting |
| Drafting Courses | Mechanical Engi- | Surveying |
| Electrical Courses | neering | Use of the Slide Rule |
| English Courses | Own-Your-Home | Vocational Guidance |
| Factory Management | Course | |



Correspondence Instruction

347 Madison Avenue
Dept. 74-M New York City

Without obligating me, please advise regarding the course in

Name.....

Full Address.....
(Please write plainly.)

The Music Pals of the Nation



New friends, new pleasures, new and interesting experiences, invitations galore—dinners, dances, week-end parties, outings,—are some of the good things playing a Gibson brings into your life.



are easily learned in spare time without previous knowledge of music. A few weeks of pleasant, interesting study and you'll be able to play. And there's no other joy in life quite equal to hearing music you make on your own instruments.

\$5.00 Monthly buys a Gibson. The ultimate in construction, finish, tone quality and volume. Built like a violin. Adjustable bridge, non-warpable truss rod neck and thirty other exclusive Gibson features. Guaranteed for life. Non-Gibson instruments exchanged.

Make \$25 to \$200 weekly, selling, playing, teaching. Own a high class, exclusive business. We furnish stock, advertise, help sell, carry accounts. Gibsons easily sold on confidential credit plan.

Send for FREE catalog, FREE music and information about Mandolin, Mandola, Mando-cello, Mando-bass, Guitar, Harp-guitar, Mandolin-banjo, Tenor-banjo, Cello-banjo, Guitar-banjo. If interested in Agency, check here..... Teacher..... Clip, check and mail this ad today. Address all mail to Kalamazoo.

Gibson Mandolin-Guitar Co.
1583 Parsons St. Foreign Dept.
Kalamazoo, Mich. 25 Broad St., N. Y. City

DO YOU STAMMER?

Same Methods based on many successful years' experience and scientific research, for the correction of all Speech Defects employed in the Speech Clinics at the Ithaca Conservatory of Music under the direction of

DR. FREDERICK MARTIN,
(himself once a confirmed stammerer)

Formerly Director of Speech Improvement, Board of Education, New York City. Lecturer, Post-graduate Medical Hospital, New York City. Normal Courses for Teachers of Speech Improvement. Dormitories and complete equipment.

MARTIN INSTITUTE FOR SPEECH CORRECTION
440 Dewitt Park, Ithaca, N. Y.

LAW High-Grade Instruction

By Correspondence
Prepares You for the Bar—Est. 1892



University Methods. Standard Text-Books. Approved by Bench and Bar. Graduates practicing in every state. Send today for Free Catalog and Rules for Admission to the Bar.

Chicago School of Law
520 Reaper Block Chicago, Ill.

LEARN WATCHMAKING

and become independent. Good-paying positions secured. Easy to learn. Send for FREE CATALOG.

ST. LOUIS WATCHMAKING SCHOOL, Dept. 5, ST. LOUIS, MO.

HOW TO PAINT Signs and Sho-Cards

MEN! Learn the Sign and Sho' Card business. Become independent. Easy to learn. Pays big money. Our remarkable book gives complete instructions.

STOREKEEPERS: This book will quickly teach you how to make your own signs.

CONTENTS: Alphabets, Colors, HOW TO MIX PAINTS, Show Cards, Window Signs, Banners, Board and Wall Signs, Ready-Made Letters, Gilding, Commercial Art and Tricks of the Trade. Contains 100 alphabets and designs. Bound in flexible, imitation leather, gold edges. \$2.00 postpaid or C. O. D.

OGILVIE INSTITUTE
57 Rose St. Dept. 5 New York

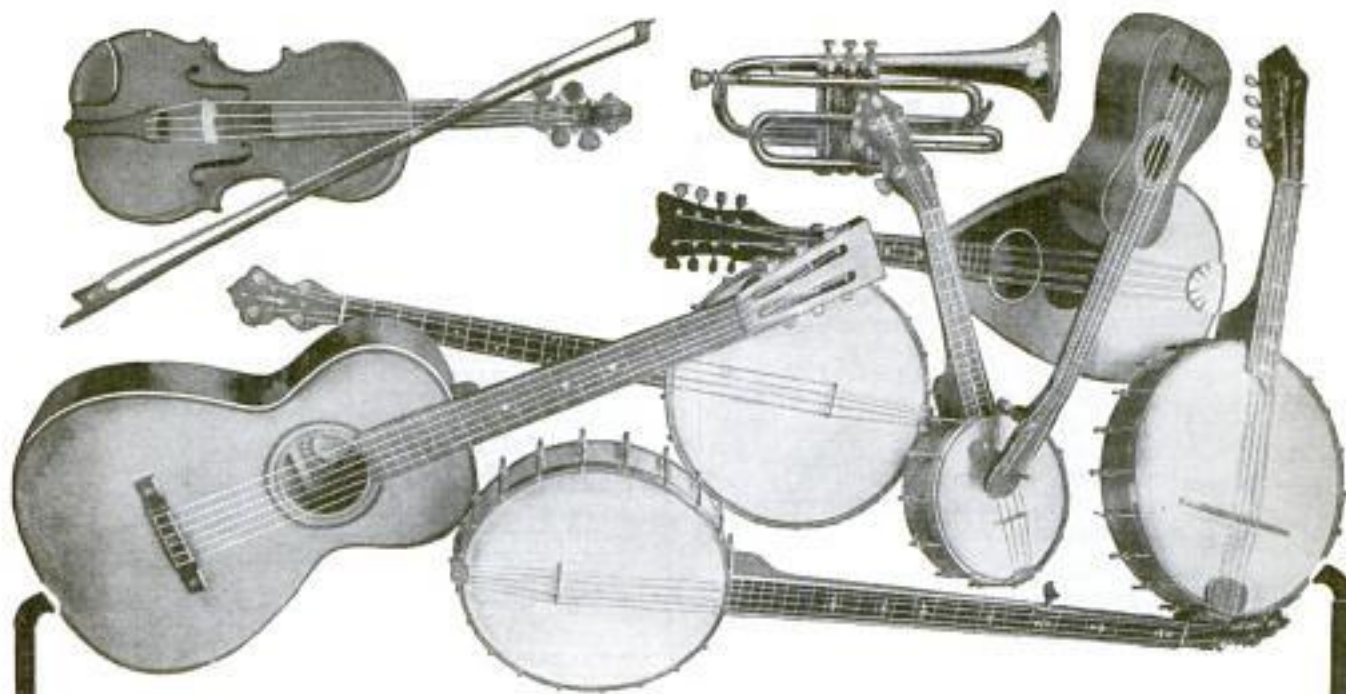

YOUR CHOICE \$ FREE 20

*Violin, Mandolin, Guitar,
Ukulele, Hawaiian Guitar,
Banjo, Banjo Mandolin,
Tenor Banjo, Cornet or
Banjo Ukulele.*

Actually given away, absolutely free, to pupils in each locality. Last year we gave away thousands of high-grade musical instruments on this sensational offer, now repeated for YOUR benefit.

We have the most wonderful new system of teaching NOTE music by mail. Take your choice of any of these magnificent instruments absolutely free and learn to play by this easy to learn method. Can have you playing standard note music in 4 lessons. A very small charge for lessons—just a few cents a week—your only expense. Your success guaranteed. Pay nothing if you fail to learn; you take no risk. Complete outfit free with every instrument. Don't wait a minute, but mail the coupon NOW.

To Advertise Our Copyrighted Course

Our plan is, \$2.00 monthly for lessons. No charge for instrument. Ukulele and banjo ukulele given free with 20 lessons at 50c a lesson. Tenor banjo, banjo and Hawaiian Guitar given free with 32 lessons at 50c a lesson; Violin, mandolin, guitar and banjo mandolin given free with 56 lessons, 43½c a lesson. Lessons are mailed one each week. Fill out the coupon and enclose \$2.00 or, we will send instrument and complete outfit subject to examination at express office C. O. D. \$2.00 for first month's lessons, and you will get an instrument you will be proud to own. At end of one week if you are not delighted with instrument and lessons, send outfit back and we will refund your money.

Do not delay, but mail the coupon today, before it is too late. Be sure to state whether you want a free Violin, Mandolin, Guitar, Ukulele, Hawaiian Guitar, Banjo, Banjo Mandolin, Tenor Banjo. We guarantee any one of these instruments positively worth \$20 or more. For cornet, piano, organ and further information, write for booklet.

SLINGERLAND'S CORRESPONDENCE SCHOOL OF MUSIC
Dept. 4, 1815 Orchard St., Chicago, Illinois

FREE INSTRUMENT COUPON

Slingerland's Correspondence School of Music
Department 4, 1815 Orchard Street,
Chicago, Illinois

Please send me one free.
(Name of Instrument)

- Plan No. 1. I am enclosing \$2.00 for first month's lessons.
 Plan No. 2. Send outfit and lesson C. O. D. \$2.00; but if I am not satisfied at end of one week's trial, I will return outfit and my \$2.00 is to be returned to me or, I will pay \$2.00 monthly until lessons are paid for.

Name.....
(Print or write plainly)

St. & Number.....

R. F. D.....

City..... State.....

LEARN CARTOONING the Right Way



1.

Have your ability trained by the school that has developed many famous cartoonists.

If you like to draw—if you find pleasure in picking up a pencil and paper and trying to make sketches or cartoons, don't regard it merely as a hobby. Have your ability developed and earn a good income as a cartoonist.



2.

Hundreds of nationally known cartoonists, such as Branner of the Chicago Tribune; Blosser, who draws "Freckles and His Friends"; Gene Byrnes, creator of "Reg'lar Fellers"; Thiele of the Sioux City Tribune; Fung, of the Seattle Times and others equally well known, took the Landon Course at home, in their spare time, and fitted themselves for their present positions at salaries ranging from \$50 to \$200 and more per week.



3.

Have YOUR talent developed by the same method

What the above mentioned boys did you can do, with the same training. The Landon method of teaching makes cartooning easy to learn. By means of an extensive series of Big picture charts all the necessary details of ORIGINAL drawing are explained step by step, in a clear and simple manner.



4.

FACTS that determine the superiority of the Landon School:

1. Landon School Students are securing the best cartooning positions which open up everywhere.
2. The picture chart method of instruction was originated and is used exclusively by the Landon School.
3. From the very beginning, the Landon Course teaches ORIGINAL drawing. No copy work.
4. Individual attention and criticism of student's work. Personal coaching whenever necessary.
5. Specialized instruction on how to originate cartoon ideas. This is an exclusive feature of the Landon Course.
6. Practical assistance in securing positions for students and help in marketing their work.
7. The price is within reach of everyone who is ambitious to succeed. Easy payments can be arranged.



5.

Write today for full information about the Landon Course, and sample chart by means of which you can test your own ability. Find out what the possibilities are for YOU in this interesting profession. Please state your age.

The Landon School
838 National Bldg. Cleveland, Ohio

Learn to Write

I Teach by Mail

I CAN make a good penman of you at your home during spare time, no matter where you live or how poorly you now write. My simplified system has shown thousands of others the way to good penmanship during the past twenty years—it can and will do the same for YOU!

Beautifully Illustrated Book "How to Become a Good Penman"

It contains general information, with testimonials and beautiful specimens

FREE!

of penmanship showing what others have accomplished by the Tamblin System. (Your name elegantly written on a card if you enclose stamp for postage.) WRITE TODAY. Address

F. W. TAMBLIN

418 Ridge Bldg., Kansas City, Mo., U. S. A.



"STAMMERING

Its Cause and Cure"

You can be quickly cured if you stammer. Send 10 cents, coin or stamps, for 238 page cloth bound book on Stammering and Stuttering. It tells how I cured myself after Stammering and Stuttering for 20 years. BENJAMIN N. BOGUE
747 Bogue Building, 1147 N. 111. St. Indianapolis

HOW TO BECOME A PROFESSIONAL PHOTOGRAPHER

EARNING \$35 TO \$125 A WEEK



Three to six months' course. Motion Picture, Commercial, Portraiture. Practical instruction. Modern equipment. Ask for Catalog No. 49.

N. Y. INSTITUTE OF PHOTOGRAPHY
NEW YORK CHICAGO BROOKLYN
141 W. 36th St. 630 So. Wabash Ave. 505 State St.



SAVE MAKE MONEY

You positively can install and repair any electrical job in the home or business place, without previous experience. Installations and repairs become like play when you own our new book **ELECTRICAL KINKS**, explaining everything about bells, lights, garage wiring, vacuum cleaners, washing machines, etc. Most complete book on everything electrical in the home. You can do work for others, thus making your spare time profitable. SEND TODAY, \$1 cash, or C. O. D. plus postage. Money back if not satisfied. Circulate free.

Home Book Co., 388AE Arcade Bldg., Cleveland, Ohio

LEARN WATCH REPAIRING



You can learn by our modern and original system of instruction every part of the Watch Repairing Trade at home as good or better than at a shop. You can earn money while learning and secure a well paying position or start in business after completing our course of instruction. Good watch repairers are always in demand and earn from \$20 to \$70 per week. For particulars apply to the **WISCONSIN SCHOOL OF WATCH REPAIRING**
166 Mason St., MILWAUKEE, WIS.

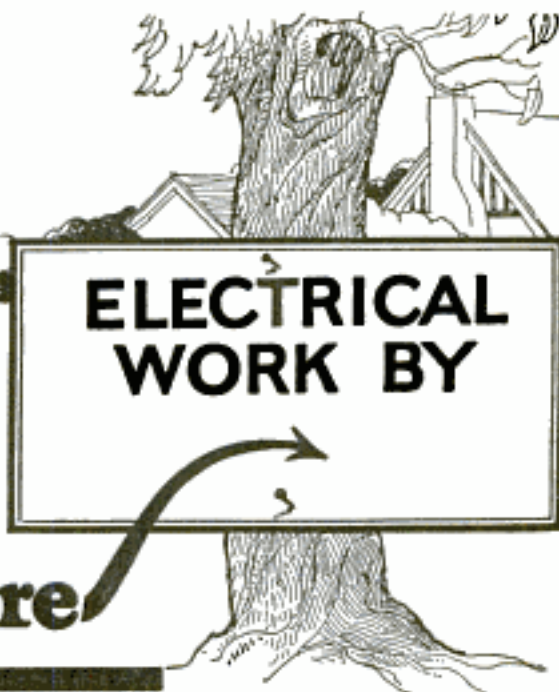

**ELECTRICAL
WORK BY**

**You Can Put
YOUR Name Here**

Learn Electricity at Home

Over a million new buildings are erected every year. Practically all of them wired for Electric Bells and Signals, Electric Light and Electric Power. Think what a wonderful opportunity this gives you to start a big-paying business of your own. Be an Electrical Contractor—and earn \$25 to \$50 a day.

It isn't necessary to leave home to learn the business. You don't even have to give up your present job. You can learn Electricity at home—in your spare time. In a few months you can equip yourself to start an Electrical business of your own. Hundreds of men have succeeded through our

Quick, Easy, Practical Instruction

Our 50 weeks' course in Practical Electricity shows you how every kind of Electrical Work is done. You are taught in a clear, simple interesting way to thoroughly understand Electricity. When you have completed this course—in less than a year!—you are ready for a good job with big pay, or you can secure your own contracts for making Electrical repairs or wiring new houses. Mail the Coupon now and get started!

Prepare to Earn BIG MONEY By Home Study

Once you have mastered the fundamentals of Electricity by our easy method of home-study your future is secure. Opportunities for big earnings are immediately presented to you—as proven by these letters.

Mr. Ernest F. Smith, Superintendent of Sub-Stations, Commonwealth Edison Co., Chicago, says: "We have employed hundreds of your students and graduates, and could use more of them if they were available."

Mr. Alfred J. Lynch, Grand Mound, Iowa, one of our students, writes: "Thought you might be interested in enclosed picture of a bank I wired last summer. Also enclosing picture of myself coming from a repair job. I find the American School Course very complete and filled with the most usable information."

American School

Dept. E374, Drexel Avenue and 58th Street, Chicago

**Get Into a Paying Business of
Your Own—Mail Coupon NOW**

American School

Dept. E374, Drexel Avenue and 58th Street, Chicago

I want to start a profitable Electrical Business of my own. Tell me how I can do it, and also send me, without cost or obligation, your Big Free Electrical Book, telling all about your course and what your other students have accomplished.

Name.....

Address.....

.....

.....

BE A RAILWAY TRAFFIC INSPECTOR



**POSITION
GUARANTEED**

**Earn Up to \$250⁰⁰ per Month
EXPENSES PAID**

Many fine opportunities for trained Railway Traffic Inspectors. Steady, pleasant outdoor work; travel or remain near home.

Easy to Qualify

Prepare in three months' spare-time study at home. Position then guaranteed at not less than \$110 per month and expenses, with many chances for advancement thru contact with big railway officials.

"My Experience—Most Gratifying"

Read what Mr. Leo Manning says:

"Words are inadequate to express the deep sense of appreciation for the many favors and acts of kindness extended by you during my training period. It is needless to say that I am proud of my diploma and shall consider it one of my most valued possessions.

"My experience with the Standard Business Training Inst. has been most gratifying and absolutely satisfactory in every respect. The treatment and cooperation received from the faculty members is all that it should be to conduct a proper appreciation among the students of its policy and intent. Any success I shall have with this work can be largely attributed to the knowledge secured from your course."

GUARANTEE

Our guarantee states that tuition will be refunded to you if, upon graduation, position is not obtained, paying at least \$110 per month and expenses.

You Take No Risk

Read Our Guarantee Notice:—If position is not obtained for you, entire enrollment fee is refunded without question. You have nothing to lose.

Send coupon for details and booklet No. D-63

STANDARD BUSINESS TRAINING INST.

BUFFALO, N. Y.

MAIL TODAY

Date.....

Standard Business Training Inst.,
Buffalo, N. Y.

Send me, entirely free, Booklet No. D-63, giving full particulars about course in Railway Traffic Inspection.

Name.....

Street.....

City..... State.....

Music Lessons

UNDER MASTER TEACHERS

At Home

A Complete Conservatory Course by Mail

Wonderful home study music lessons under great American and European teachers. Endorsed by Paderewski. Master teachers guide and coach you. Lessons a marvel of simplicity and completeness.

The only recognized Conservatory of Music giving lessons by the UNIVERSITY EXTENSION METHOD.

The ideal of a genuine Conservatory of Music for home study based upon lessons containing the cream of the life's teaching experience of Master Musicians, reinforced by the individual instruction of specialists, is now attained.

The instruction of a master—the individual touch of an accomplished teacher—is yours to command from the very moment you enroll.

The University Extension Conservatory, by adopting the Personal Instruction Method, has placed home music study beyond question as to results. Anyone can learn at home.

Any Instrument Write telling us course you are interested in—Piano, Harmony, Voice, Public School Music, Violin, Cornet, Mandolin, Guitar, Banjo, or Reed Organ—and we will send our Free Catalog with details of course you want. Send now.

UNIVERSITY EXTENSION CONSERVATORY
750 Siegel-Myers Building Chicago, Illinois

Learn Photography at HOME

Make \$75.00 a Week on the Side

Establish yourself as a Photographic Expert quickly—during your spare time—under a leading photographer. I'll show you how to start your own business—or command a large salary. Send for my unusual offer—it's only temporary. Act at once. A postal will do. H. R. VANT.

INTERNATIONAL STUDIOS, Inc.
Dept. 1193, 3601 Mich. Ave., Chicago, U.S.A.



STAMMER NO MORE

Kill the fear of stammering. Re-education the key. The widely famed Hatfield Method fully outlined in an accurate, dependable, worthwhile book—"HOW TO STOP STAMMERING." It has inspired thousands. Free copy today.

THE HATFIELD INSTITUTE, 109 N. Dearborn, Chicago, Ill.

LEARN SHOW CARD WRITING BY MAIL OR LOCAL CLASSES

Study under the direction of Arnold Binger, the leading expert in the line. Positions await competent students. Write for our Beautiful Illustrated Booklet and terms.

BINGER SCHOOL OF SHOW CARD & DISPLAY ART
2116 Flatiron Building, Broadway & 23rd Street, NEW YORK CITY

LEARN MECHANICAL DENTISTRY

Earn \$85 to \$125 a week. Taught by actual practice—day or night. Three months' course. Modern laboratories. No previous training required. Established 10 years. For 26-page catalog, write Dept. 2.

NEW YORK 116 W. 52d St. PHILADELPHIA 15th & Walnut Sts. BUFFALO 1226 Main St. BROOKLYN 15 Flatbush Ave.

LEARN TO GET DOLLARS OUT OF WATCHES.

WATCH-REPAIRING, ENGRAVING, JEWELRY REPAIRING.

WRITE NOW.
ENICAR TRADE SCHOOL
830 W. MONUMENT SQUARE, RACINE, WIS.

MINSTRELS

Musical Comedies and Reverses, with full instructions for staging. You can stage your own show with our books. Full line of plays, music, cross-fire, monologues, afterpieces, vaudeville acts and make-up. CATALOGUE FREE.

T. S. DENISON & CO., 623 So. Wabash, Dept. 19, Chicago

200 Kinds Iron, Wood and Wire Puzzles, tender and Illustrated list, 10c. Toy Maker book, 64 pages, 10c. Amateur Electrician book, 64 pages, 10c. Radio Building book, 25c.

Western Puzzle Works - St. Paul, Minn.



If He Had Passed It Up

He Would Still be a Laborer at \$2 a Day. No Money, Nothing Ahead but Hard Work, Longer Hours—and Regrets. But He Didn't Pass It Up

He decided to learn Mechanical Drawing. He buckled down to work with the Columbia School of Drafting. When he had a quiet half hour to spend he spent it—as a wise man spends money—to get full returns.

MADE \$275 EXTRA IN 3 DAYS. He recently received \$275 for one drawing that only took him three days to draw.

NOW HOW ABOUT YOU? Are you working up hill or down? Count the money in your pay envelope next pay day. You'll find the answer there.

MAKE \$35 TO \$100.00 A WEEK. We will train you to be an expert Draftsman in your spare time at home by mail. There's lots of room for you if you act now.

PROMOTION IS QUICK. WE'LL QUALIFY YOU for a high-salaried position in the drafting field and keep you in touch with openings for Draftsmen in the big machine shops, industrial plants and United States Government departments. Men who start as

Draftsmen are often advanced to Chief Draftsmen, Chief Engineers, Production Managers and so on.

GET THE RIGHT TRAINING. Mr. Claffin, the founder and director, stands personally in back of the Columbia School of Drafting. You spend no time in long-winded theories—useless and expensive to you. You start on actual drawing work the day you receive your first lesson.

YOU NEED NO PREVIOUS TRAINING. The course is easy to understand and easy to follow. Many students are qualified even before they complete the course.

SUCCESS CALLS MEN OF ACTION ONLY. If you are a man of action clip the coupon now and show that you are a man of action. Keep right on top of this opportunity to make real money. Don't go looking for a pair of scissors. Tear the coupon off and mail it right now. We have a special offer for those who reply promptly. Get started now.

What We Give You

PRACTICAL PROBLEMS. You are carefully coached in practical Drafting work.

WE HELP YOU GET A JOB. We help you get a position as a practical Draftsman as soon as you are qualified.

PERSONAL INSTRUCTION AND SUPERVISION THROUGHOUT THE COURSE. You receive the personal instruction and help of Roy C. Claffin, president of the Columbia School of Drafting and a practical Draftsman of many years' experience.

DRAFTSMAN'S EQUIPMENT. We furnish you with a full set of Drawing Equipment and Drafting Instruments as shown in the picture below when you enroll. You keep both etc on completing the course.

CONSULTATION PRIVILEGES. You are free to write us at any time for advice and suggestions regarding your success.

DIPLOMA. The diploma we give you on completing the course attests to your proficiency as a Draftsman. It is an "entering wedge" to success.

FREE SUBSCRIPTION TO DRAFTSMAN'S PUBLICATION "THE COMPASS." You are given free a subscription to our helpful, inspiring publication, "The Compass."

U. S. Civil Service Commission Needs DRAFTSMEN

The following are a few of the many positions open in Government Departments from time to time. The salaries are starting salaries, subject to increase. Practically all of them carry a bonus of \$240 a year additional.

Architectural Designer..... \$4,000
Chief Draftsman (Aeronautical) Naval Aircraft Factory, per day... 15.04
Aeronautical Draftsman—Field Service of Navy Department, \$5.20 per day to \$12 per day.

FREE BOOK

Send in this coupon today. Immediately on receipt of it we will send you our book, "Your Future in Drafting," which tells you all about our new method of teaching Mechanical Drawing and gives full details of our special offer to those who reply promptly.

THE COLUMBIA SCHOOL OF DRAFTING

Roy C. Claffin, President

Dept. 1948, 14th and T Sts., N. W., Washington, D. C.

Free Book Coupon

COLUMBIA SCHOOL OF DRAFTING,
 Dept. 1948, 14th and T Sts., N. W., Washington, D. C.

Enter my name for a free subscription to "The Compass" and also send me without charge your illustrated book on Drafting, telling me how I can secure your complete Home Study Course and your help in securing a position as Draftsman.

Name.....

Address.....

City.....State.....



FREE We give you free with our course this professional Drafting outfit. It is yours to keep when you complete the course.



The letter that raised my salary

I certainly was surprised when Mr. Jordan called me into his private office.

"I want to congratulate you, young man," he said, "on the splendid record you are making with the International Correspondence Schools. They have been sending me reports of your progress and this last letter is particularly fine.

"I want you to know that the firm never overlooks a man who cares enough about his work to study it in spare time. Beginning to-morrow, you are to take over Jim Hanna's position at an increase of \$50 a month. I wish we had more men like you."

Employers in every line of business are looking for men with ambition—men who really want to get ahead in the world and are willing to prove it by training themselves to do some one thing well. Prove that you are that kind of a man!

The way is easy. Without cost, without obligation, just mark and mail this coupon and get the full story of what the I. C. S. can do for you!

----- TEAR OUT HERE -----
INTERNATIONAL CORRESPONDENCE SCHOOLS
 Box 5508-D, Scranton, Penna.

Without cost or obligation, please tell me how I can qualify for the position or in the subject before which I have marked an X:

BUSINESS TRAINING DEPARTMENT

- | | |
|---|---|
| <input type="checkbox"/> Business Management | <input type="checkbox"/> Salesmanship |
| <input type="checkbox"/> Industrial Management | <input type="checkbox"/> Advertising |
| <input type="checkbox"/> Personnel Organization | <input type="checkbox"/> Better Letters |
| <input type="checkbox"/> Traffic Management | <input type="checkbox"/> Foreign Trade |
| <input type="checkbox"/> Business Law | <input type="checkbox"/> Stenography and Typing |
| <input type="checkbox"/> Banking and Banking Law | <input type="checkbox"/> Business English |
| <input type="checkbox"/> Accountancy (including C.P.A.) | <input type="checkbox"/> Civil Service |
| <input type="checkbox"/> Nicholson Cost Accounting | <input type="checkbox"/> Railway Mail Clerk |
| <input type="checkbox"/> Bookkeeping | <input type="checkbox"/> Common School Subjects |
| <input type="checkbox"/> Private Secretary | <input type="checkbox"/> High School Subjects |
| <input type="checkbox"/> Business Spanish <input type="checkbox"/> French | <input type="checkbox"/> Illustrating <input type="checkbox"/> Cartooning |

TECHNICAL AND INDUSTRIAL DEPARTMENT

- | | |
|--|--|
| <input type="checkbox"/> Electrical Engineering | <input type="checkbox"/> Architect |
| <input type="checkbox"/> Electric Lighting | <input type="checkbox"/> Blue Print Reading |
| <input type="checkbox"/> Mechanical Engineer | <input type="checkbox"/> Contractor and Builder |
| <input type="checkbox"/> Mechanical Draftsman | <input type="checkbox"/> Architectural Draftsman |
| <input type="checkbox"/> Machine Shop Practice | <input type="checkbox"/> Concrete Builder |
| <input type="checkbox"/> Railroad Positions | <input type="checkbox"/> Structural Engineer |
| <input type="checkbox"/> Gas Engine Operating | <input type="checkbox"/> Plumbing and Heating |
| <input type="checkbox"/> Civil Engineer | <input type="checkbox"/> Chemistry <input type="checkbox"/> Pharmacy |
| <input type="checkbox"/> Surveying and Mapping | <input type="checkbox"/> Automobile Work |
| <input type="checkbox"/> Metallurgy | <input type="checkbox"/> Navigation |
| <input type="checkbox"/> Steam Engineering | <input type="checkbox"/> Agriculture and Poultry |
| <input type="checkbox"/> Radio <input type="checkbox"/> Airplane Engines | <input type="checkbox"/> Mathematics |

Name.....
 Street.....
 Address.....

S. 26-22

City..... State.....

Occupation.....

Persons residing in Canada should send this coupon to the International Correspondence Schools Canadian, Limited, Montreal, Canada.

Please Mention Popular Mechanics

MECHANICAL DENTISTS

EARN \$200 to \$450 per month



A high grade, fascinating, dignified, and profitable profession. No experience or entrance requirements necessary. No license required. Big demand everywhere. Special Dentist Assistant's Course for women.

EARN WHILE YOU LEARN

In America's Greatest Practical School.

Individual instruction by modern up-to-date methods in America's best equipped Dental Laboratory and Clinic. Write for Free Trial Scholarship and Free Life Scholarship offer. Learn how easy it is to fit yourself for this big pay profession by the famous National Learn-by-Doing Method.

Send for Free Book "Mechanical Dentistry and Its Art" Today

NATIONAL SCHOOL OF MECHANICAL DENTISTRY
 Dept. 12, 506 S. Wabash Ave. Chicago, Ill.

ELECTRICAL men with training are in demand. For more than a quarter of a century this school has been training men of ambition and limited time, for the electrical industries. Condensed course in Electrical

ENGINEERING

enables graduates to secure good positions and promotions. Theoretical and practical Electricity, Mathematics, Steam and Gas Engines, Mechanics, Drawing. Students construct dynamo, install wiring and test electrical machinery. Course with diploma, complete



Thoroughly equipped fireproof dormitories, dining hall, laboratories, shops. Over 3000 men trained.

Write for catalog. 30th year opened Sept. 27, 1923.

BLISS ELECTRICAL SCHOOL

404 TAKOMA AVENUE, WASHINGTON, D. C.

STAMMERERS

For 55 years we have successfully corrected stammering by our simple and natural course of individual lessons. Attend no school until you have read our free booklet, "How To Stop Stammering," SAMUEL A. ROBBINS, Director, Boston Stammerers' Institute, 246 Huntington Ave. Boston 17, Mass.

LEARN JIU-JITSU

Know how to protect yourself and your loved ones against a bully or a ruffian. Muscle and weight are helpless before this marvelous science. Anyone can master it easily. Complete instructions in book entitled

JUDO (Improved Jiu-Jitsu)

by Sakuzo Yokoyama, Professor of Jiu-Jitsu in the Keio-Kwan (leading athletic university in Japan), 300 pages, illustrated with 96 actual photos. Special Reduced Price Only \$2.00 Postpaid. (Same edition originally sold for \$5.) Money cheerfully refunded within 5 days if not entirely satisfactory.

Will ship C. O. D. anywhere in U.S.A. if desired.

HISHODO BOOK COMPANY, Los Angeles, Cal.
 936 Wall Street



Wonderful, new device, guides your hand; corrects your writing in few days. Big improvement in three hours. No failures. Complete outline FREE. Write C. J. Ozment, D-34, St. Louis, Mo.

Clear-Tone FOR PIMPLES

Your skin can be quickly cleared of Pimples, Blackheads, Acne Eruptions on the face or body, Enlarged Pores, Oily or Shiny Skin. \$1,000.00 Gold Cash says I can clear your skin of the above blemishes. WRITE TODAY for my FREE Booklet—"A Clear-Tone Skin"—telling how I cured myself after being afflicted for fifteen years.

FREE

E.S. GIVENS, 128 Chemical Bldg., Kansas City, Mo.

How to Read Blueprints and Plans.

How to Use the Steel Square Successfully.

What You Should Know About Carpentry and Building.

How to Build a Frame or a Brick Structure.

What You Should Know About Sheet Metal Work.

How to Be a Successful Building Superintendent.

What You Should Know About Heating and Ventilating.

A Thousand Things You Ought to Know

How to Write and Read Building Specifications.

EVERY day in your work you get up against new problems—sometimes it is only some old "sticker" coming in a new way. Just the same, though, it takes a lot of time to figure them out. **Don't do it.** Here's everything worked out for you. Every problem, big or little, that you will meet in a day's work. Hundreds of new ideas and better ways of doing things. Hundreds of ways the other fellows are making money. Hundreds of ways you can make more out of the same work you are doing now.

What You Should Know About Water Supply and Drainage.

CARPENTRY AND CONTRACTING

How to Estimate the Cost of a Building.

Five great big volumes flexibly bound in genuine American Morocco with 2,138 pages and more than 1,000 blueprints, plans, pictures and diagrams. It is the newest, most complete, most practical work of its kind ever published. Twenty-five well-known experts prepared these great books, gathering the material from hundreds of different sources. Every man in the shop and on the job should have them. Written in such plain language that anyone can understand them.

What You Should Know About Plastering and Painting.

7 Days' FREE Examination

Send the coupon for these great Carpentry and Contracting books TODAY. You can't afford to be without them and you don't take any risk at all. The coupon brings the whole set by express collect for a week's free examination. Use the books a week and notify us to get them back if they don't please you. If you like them, send us only \$2.80 and \$3.00 each month thereafter until \$19.80 is paid. If you prefer to pay cash with order, send only \$17.50. The return privilege holds good just the same. Send the coupon NOW. Remember—sending for the books does not obligate you to buy.

AMERICAN TECHNICAL SOCIETY, Dept. G-193, Chicago

How to Know Material and Select the Best.

How to Build of Concrete and Steel.

How to Care for Tools.



American Technical Society,
Dept. G-193, Chicago

Please send me the five-volume Cyclopaedia of Carpentry and Contracting, shipping charges collect. I will send you \$2.80 in seven days and \$3.00 each month thereafter until \$19.80 has been paid, or return the books at your expense.

Name

Street and No.

City and State

Reference

(Please fill in all lines.)

I Want 1000 Men For Big Jobs in ELECTRICITY

Previous Experience Unnecessary

L.L. COOKE
CHIEF
ENGINEER



Men trained in Electricity—Electrical Experts are in greatest demand right now. Thousands of men are needed to keep pace with the amazing growth of this Wonderful Industry. The opportunities for advancement and a big success are the greatest ever known. I need more men to prepare for big paying jobs. No matter what kind of work you are doing or how much you earn, Electricity offers you more.

Be a Certificated **Electrical Expert** Earn \$70 to \$200 a Week

Today even the ordinary Electrician—the “screw driver” kind—is making money—big money. But it's the trained man—the man who knows the whys and wherefores of Electricity—the “Electrical Expert” who is picked out to “boss” ordinary Electricians—to boss Big Jobs—the jobs that pay. You, too, can learn to fill one of these jobs—spare time only is needed. Be an “Electrical Expert” earn \$70 to \$200 a week.

Age or Lack of Experience No Drawback

You don't have to be a College Man; you don't have to be a High School graduate. If you can read and write English, my course will make you a big success. It is the most simple, thorough, and Successful Electrical Course in existence, and offers every man, regardless of age, education or previous experience, the chance to become, in a very short time, an “Electrical Expert,” able to make from \$70 to \$200 a week.

I Give You a Real Training

As Chief Engineer of the Chicago Engineering Works I know exactly the kind of training a man needs to get the highest salaries. Hundreds of my students are now earning \$3,500 to \$10,000 a year. Many are successful ELECTRICAL CONTRACTORS.

Your Satisfaction Guaranteed

So sure am I that you can learn Electricity—so sure am I that after studying with me, you too, can get into the “big money” class in electrical work, that I will guarantee under bond to return every penny paid me in tuition if, when you have finished my course, you are not satisfied it was the best investment you ever made.

FREE Electrical Working Outfit, Radio Course and Employment Service

I give each student a Splendid Outfit of Electrical Tools, Materials and Measuring Instruments absolutely FREE. You do PRACTICAL work

AT HOME with this Outfit. You start right in after the first few lessons to WORK AT YOUR PROFESSION in a practical way. I also furnish them supplies, a complete Radio Course, Special Lessons for men going into business for themselves and free employment service and many other things that other schools don't furnish.

Get Started Now; Mail Coupon

I want to send you the “Vital Facts” of the Electrical Industry including my Electrical Book, Proof Lessons and a sample of my guarantee bond all FREE. These cost you nothing and you'll enjoy them. Make the start today for a bright future in Electricity. Send in the coupon—NOW.

L. L. COOKE, Chief Engineer

CHICAGO ENGINEERING WORKS
Dept. 13 2150 Lawrence Ave. Chicago, Ill.

Use This “FREE OUTFIT” Coupon

L. L. COOKE, Chief Engineer

Chicago Engineering Works, Dept. 13
2150 Lawrence Ave., Chicago, Ill.

Dear Sir:—Send at once the “Vital Facts” containing Sample Lessons, your Big Book, and full particulars of your Free Outfit and Home Study Course—all fully prepaid without obligation on my part.

Name.....

Address.....

Occupation..... Age.....

The “Cooke” Trained Man is the “Big Pay” Man

CLASSIFIED ADVERTISEMENTS

WORLD'S BEST WANT AD MEDIUM

Advertisements in this section, 25 cents per word, each insertion, minimum 10 words, payable in advance. To be inserted under proper classification in April issue, copy should be in our office February 25th.

AUTOMOBILE SUPPLIES

AUTO and Truck parts for all makes and models. Save time and money by dealing direct with Factory Distributors. Garage men and dealers, get our free catalog listing genuine new and replacement parts, differential and transmission gears, silent timing gears, Russell truck axle parts, parts for all types of Torbenson axles, axle shafts, drive shafts, pistons, pins, springs, etc. Complete line new parts at money-saving prices. Auto Parts Supply Co., 1518 Grand Ave., Kansas City, Mo.

AUTOMOBILE parts for all makes and models of cars. We save you 10 to 90% and ship same day your order is received. We have gears, shafts, springs, pistons, pins and rings, cylinder head gaskets, bushings, clutch leathers, radiators, coils, magnets, Timken, Hyatt, New Departure and connecting rod bearings, crank cases, crank shafts, connecting rods, Atwater Kent, Connecticut, Delco and Remy ignition systems and parts. When you want auto parts, write us, giving make, model and year of car and what parts are wanted. We will quote prices before making shipment. If you desire, we guarantee to please you or money refunded. Auto Tire & Parts Co., 561 Broadway, Cape Girardeau, Mo.

AUTOMOBILE parts, guaranteed new for all cars. Save money; get our wholesale prices on gears, shafts and bearings. State make of car, model and parts wanted. Parts shipped immediately from stock. We refund your money, including transportation charges, if not satisfied. Mechanics Gear Co., 3708 No. Halsted St., Chicago.

AUTO Owner Tire Agent wanted each locality to use and take orders for hand-made Mellinger extra ply and cord tires; guaranteed by bond for 8,000 and 10,000 miles (no seconds); shipped prepaid on approval; get your tires free; no capital or experience required; make \$100 to \$300 weekly. Write for wholesale prices and sample section. Mellinger Tire Co., 929-K Oak, Kansas City, Mo.

AUTOMOBILE Owners, garagemen, mechanics, send today for free copy of this month's issue. It contains helpful, instructive information on overhauling, ignition troubles, wiring, carburetors, storage batteries, etc. Over 120 pages, illustrated. Send for free copy today. Automobile Digest, 505 Butler Bldg., Cincinnati.

PROTECT your rights. Write for "Record of Invention" and booklet about Patents. Prompt personal service. Advice without charge. J. Reaney Kelly, 612-G, Columbian Building, Washington, D. C.

CAN You Beat This?—"Sure Hit" timer, use it 10 days. If not the best in every respect, return; your money refunded in full without question. 100% service guaranteed for one year. \$3.50. Reference—Any Omaha bank. Agents wanted. Omaha Accessory Mfg. Co., Crouse Block, Omaha, Neb.

BEAUTIFUL New Automobile Ash Tray, Combined with cigarette extinguisher, \$1.00 postpaid. Agents Wanted. Attractive offer. S. F. Parker Co., 943 Mitchell St., Milwaukee, Wis.

UPHOLSTER Automobiles, make your own tops, backs and windows, make big money, any one can do it. Full instructions and patterns, \$5.00. White Auto Top Co., Box 357, Pensacola, Fla.

AUTO Skis. Makes winter driving a pleasure. They are built for the snow. For information address, L. H. Wilcox, Inventor, 7 Shepard St., Brighton, Wash.

AUTO Parts—Save 25-90%. New gears, axles, bearings, springs, radiators, magnets —4,000 models. Bankrupt supplies, retopping outfits. Brightman Auto Exchange, 321 Windsor Ave., Hartford, Conn. Largest in the East.

"SURESTART" Electric Hot Spot. Motorists install it. Start instantly coldest weather. Saves battery and trouble. Once used, you'll never do without. Fit any car. Satisfaction guaranteed. Ask garageman or write for details. Wiegand Co., 423 1st Avenue, Pittsburgh, Pa.

CONSTANT potential 8-hour battery charging pays big profits. Eliminates competition. Comes on easy monthly payments, paid by profits. Send postal to Hobartson's, Troy, Ohio.

LIBERTY Air Compressors, for garages, tire-shops, filling stations, also paint spraying equipment. Air Compressor & Equipment Co., 1437 Carroll Avenue, Chicago, Ill. Distributors wanted.

AUTO top and seat recoveries for all cars. \$5, \$7, \$9, \$14 and \$19.50, with Plate Glass Lights, delivered at your door. Easy to apply. You drive 100 tanks and save \$25. Samples free. Equipment Co., 1637 Broadway, Los Angeles, Calif. Eastern orders shipped from Ohio.

FORD parts. Floyd Clymer, Distributor, Denver, Colo.

AIR compressors, for garages, tire shops, etc. Price \$25, new. Shaw Mfg. Co., Galveston, Kans.

BARGAINS — Radiators — Sport bodies. All makes and models; ask for price of your requirements. Chevrolet 490, \$17.95. Dodge and Maxwell Radiators, \$19.95. Ford, \$10.90. Wabash Radiator Co., 1117 Wabash Ave. A, Chicago.

UPHOLSTERY—New top covers, rear curtains, seat-covers, at manufacturer's prices. All ready for you to put on. See our ad on page 138. Liberty Top and Tire Co., Cincinnati.

EARN \$25-\$50 weekly, spare time, evenings, week ends and holidays selling guaranteed Auto tires, tubes. Direct from factory. Big savings. No seconds. Deposit for samples necessary. Belleville Tire Company, Belleville, N. J.

IMPROVED Aluminum Pistons for all cars, saves oil and gas; light weight; get more speed and power, less carbon; circular free. Egge, 7704 S. Main St., Los Angeles, Calif.

SPARK Plugs, highest grade, any size, each 15c; free delivery; terms C. O. D. Address Kelly Lamp Works, Oak Park, Ill.

STANLEY Automobile Owners. Everything for the steam automobile. Conservative reductions. Enclose stamp for "list" serviceable supplies, "Acme" superheaters, vaporizers, All-Welded boilers. "Doc" Palne, Denver, Colo.

COMPRESSORS, twin cylinder automatic air electric driven. \$28 cash, balance easy terms. Buffers, battery chargers, same easy payments. Send postal to Hobart's, Troy, Ohio.

AUTOMOBILES

PATENTS—Write for our free illustrated Guide Book and Evidence of Conception Blank. Send model or sketch and description of your invention and we will give our opinion of its patentable nature. Highest references. Prompt service. Reasonable terms. Victor J. Evans & Co., 185 Ninth, Washington, D. C.

FORDS run 34 miles on gallon gasoline. Other cars show proportionate saving. Wonderful new carburetor. Starts easy in coldest weather. Fits any car. Attach yourself. Money back guarantee. Sent on 30 days' trial. Agents wanted. Air Friction Carburetor Co., Dept. 3221, Dayton, Ohio.

PATENTS procured. Send sketch or model today for examination, prompt report and advice. No charge for preliminary advice. Write for free Booklet and blank form on which to disclose your idea. Highest references. Promptness assured. Clarence O'Brien, Registered Patent Lawyer, 562 Southern Building, Washington, D. C.

AUTOMOBILE owners, garagemen, mechanics, send today for free copy America's most popular motor magazine. Contains helpful articles on overhauling, repairing, ignition, carburetors, batteries, etc. Automobile Digest, 505 Butler Bldg., Cincinnati.

HANDY Men—Earn \$85.00 Weekly—In Automobile Business; Be your own Boss. Demand unlimited. Autorenuco, Sheboygan, Wis.

DYKE'S Automobile Encyclopedia. 13th edition, new, greater than ever, entirely rewritten and rearranged. Contains greatest array of auto facts ever published in one vol. Separate books containing same information cost \$21. Over 1200 pages and 3100 illus. Cloth \$6. Flex. Amer. Morocco \$7.50 postpaid. Popular Mechanics Book Dept., 200 E. Ontario St., Chicago.

UPHOLSTERY—New top covers, rear curtains, seat-covers, at manufacturer's prices. All ready for you to put on. See our ad on page 138. Liberty Top and Tire Co., Cincinnati.

GASOLINE engine cylinders reground, scored or cracked cylinders repaired, automobile, stationary and marine engines rebuilt. All work guaranteed. Jackson Piston Service Co., Jackson, Michigan.

REPAIRING Ford Cars, Trucks and Tractors in the most proper and efficient way is explained in a new 229-page book by the former director of the Ford Motor Co. Service School. This information is otherwise unavailable outside of the Ford plant. Written more especially for the mechanic and repairman. Price \$2 postpaid. Popular Mechanics Book Dept., 200 E. Ontario St., Chicago.

FOR FORD OWNERS

AVOID "turning turtle" leaving the road, locking over center. You can steer safely and easily out of ruts, through mud, sand, snow and on center-crowned roads, with a Sprague Worm Steering Gear. Same type as used on all larger cars. Prevents bumps in road from turning front wheels aside; gives you control of steering. Also absorbs shock, vibration and strain on arms and shoulders. Makes a far better and safer car. Easily, quickly installed; no holes to bore; outlasts car. Guaranteed to satisfy you. Write for particulars. Union Sales Co., Dept. 2, Omaha, Neb.

FORD Owners: Install Cooper Automatic Transmission Band Adjusters on your car. They will positively keep your brake and reverse bands properly adjusted at all times. Easily and quickly installed in a few minutes. They will double the life of your bands, increase mileage, reduce chattering, reduce danger of accidents, save time and money. Guaranteed for the life of your car. Money back if not satisfied. Send \$2.00 for complete set. Agents Wanted. A. C. Smith Mfg. Co., Inc., 1726 Champa Street, Denver, Colo.

FORD Car Repair Book Sent Free. This complete and well illustrated valuable book explains in a simple way how to overcome Ford car troubles; Repairing, Economical Winter Driving, Cold Weather Car Starting, Equipment for Fall and Winter, Curing Piston Ring Troubles, Carburetor Adjustments and Repairs, Connecting Rods, Timers, Transmission Troubles, and practically every phase of Ford car driving, repairing and equipment. Send 25c coin for three months' trial subscription and get the valuable repair book free. Ford Owner and Dealer Magazine, 527 Montgomery Bldg., Milwaukee, Wis.

FARM with your Ford. The Adapto Tractor makes your Ford a powerful tractor that will plow and do any three horses' work. Includes Belt Power Attachment that buzzes wood, fills silo, etc. Guaranteed not to injure your Ford or money back. Dealers wanted. Tractor Co., Geneva, Ohio.

FORD water circulator prevents freezing and overheating. Easily attached. Satisfaction guaranteed. Pay postman only three seventy. Tractor Co., Geneva, Ohio.

MAGNETO Recharger free. Alternating. State rights free. Reliable, Utica, N. Y.

NEW special Ford Carburetor guarantees easier starting, more power, more mileage. Costs only \$10. Send no money. Pay postman on arrival. Money refunded in 30 days if unsatisfactory. Brown Supply Company, Dayton, Ohio.

BRIGHT light and dimmer for magneto lighted Fords. Guaranteed. Sample, \$2.50. Sunlight, Box 394, Chicago, Ill.

FORD Valve Grinder 15c. Fits brace. C. W. Illingworth & Co., Racine, Wis.

FORD Owners save money—time—trouble. Read about Sun Automatic Timer on page 138.

SPEEDSTER Fans. Don't fail to see "Red-I-Kut" ad. Page 143.

MOTORCYCLES, BICYCLES AND SUPPLIES

WONDERFUL bargains in reconditioned motorcycles. Priced as low as \$35. Sidecars from \$25 up. Everyone expertly rebuilt and guaranteed in absolutely first-class condition. Don't delay. Send 2c for new big catalog showing 1923 bargains. Western Supplies Co., 539 Hayutin Bldg., Denver, Colo.

SAVE money—Order parts for all motorcycles from us. Largest stock now or was parts in America. Send 10c today for big Excelsior or Henderson parts catalogue. Nebraska Motorcycle and Bicycle Co., 1512 Howard, Omaha, Nebr.

SEND for our Bargain Bulletin and Money-Saving Message. It will save you money on Motorcycles, Side Cars, Motor Wheels, Repair Parts and Accessories. Some used parts at less than half. Cleveland and Henderson Motorcycles our specialty. See our ad on page 137. American Motor Cycle Co., 2943-5-7 W. Chicago Ave., Chicago.

MOTORCYCLE cylinders reground, fitted with new pistons and rings, \$8.00. Guaranteed. Muncie Piston Co., Muncie, Ind.

JUST Wrecking Late Models, Harley-Davidsons, Indians, Excelsiors, Frames, cylinders, bars, tanks, forks, wheels, \$5.00 each and less. Indian and Excelsior guards, carriers, gears, crank-cases, fly-wheels, connecting rods, \$1.00 each. Everything less than half price. Half cash. No lists. H. W. King, Des Moines, Iowa.

BRIGGS—Stratton Bicycle Motors (New) \$60.00. Beam, 816 Coleman, Johnstown, Pa.

CASH buyers, Bargains in Used Motorcycles. Lists free. Seeber & Hofmann, Buffalo, N. Y.

LARGEST stock of new and used motorcycle parts and accessories in the world at your disposal via Uncle Sam's mail. Write for quotations. Motorcycle Parts Mfg. Co., 2629-36 Wabash Ave., Chicago, Ill.

'19 INDIAN 3 Speed \$85.00. '20 Indian 3 Speed \$100.00. '21 Indian 3 Speed \$150.00. Howard A. French Company, Baltimore, Md.; Washington, D. C.

AVIATION

BIGGEST, best catalogue Model Aeroplanes, Parts and Supplies; 5c postpaid. Ideal Aeroplane Co., 72½ Green St., New York.

FOR Sale. 1 new Lawrence Spad Bi-plane. 1 8-cylinder Curtiss motor cheap. V. B. Kennemer, Como, Texas.

PATENTS—Send for our free book. Contains valuable information for inventors. Send sketch of your invention for Free Opinion of its patentable nature. Prompt service. (Twenty years' experience.) Talbert & Talbert, 472 Talbert Bldg., Washington, D. C.

AIRPLANE Bargains while they last. New JN4D Curtiss airplane, \$850.00. We teach buyers to fly free. Partridge, Inc., 430 S. Michigan Ave., Chicago, Ill.

THE American School of Aviation announces a new correspondence course in Mechanics of Aviation. A thorough training in Practical Aeronautics, American School of Aviation, Dept. 1863, 3691 Michigan Ave., Chicago, Ill.

FLYING—"The Limitless Future"—Build and fly your own plane. Gain a practical aeronautical education. C. E. Lay, 3727 Saybrook, Cincinnati, Ohio.

INVENTORS desiring patents should write for our Free Illustrated Guide Book and Evidence of Conception Blank. Send model or sketch for our opinion of its patentable nature. Highest references. Prompt service. Reasonable terms. Victor J. Evans & Co., 187 Ninth, Washington, D. C.

HEATH propellers represent the most efficient method of aerial drive. Each propeller individually designed for the particular work to be done, as laid out by America's oldest aeronautical engineers. Propeller catalog 4c. Heath Airplane Co., Chicago, Ill.

WHITE "666" sells for \$666 complete. flies 100 miles an hour, is manufactured by a \$50,000 corporation and is the finest and most modern sporting type aeroplane in the world. Working drawings \$3; circular free. White Aircraft Corporation, Los Angeles.

AIRCRAFT Supplies, Aerodrive Sled Blueprint 50c, Boat Type 50c. Ostergaard Aircraft, 4240 North Narragansett, Chicago.

A REAL proposition for real ambitious young men who want to learn to fly. Work with pay, while you are learning. One extra hour flying as bonus for all enrollments prior to April 1st on our six-hour flying course at \$190.00. Heath Airplane Co., Chicago, Ill.

SEND for information on the newest, lowest priced and most complete home study course in aviation ever issued. Capt. T. C. Wilkinson, 230 San Fernando Building, Los Angeles.

JERSEY aviator helmets 95c while they last; fine for motorcycling or winter auto-mobiling. Also heavy aviator leather coats \$15.00. State size. Restal goggles \$2.99. Heath Airplane Co., Chicago, Ill.

PROPELLERS for Aeroplane Propulsion, 5-foot diameters \$12; 6-foot for Fords \$15. Others in Proportion. Motorcycle Sleigh Blueprints 75c; Ford Sleigh \$1. Pictures free. We have a few brand new, also used Curtiss aeroplanes cheap. Send for Prices. Crawford Motor & Aeroplanes, Long Beach, Calif.

AIRPLANE Motors, 28 H. P., New, \$50. Curtiss OX5, Gnome and LeRhone, 99-100 H. P., \$50 to \$150. Airplanes, slightly used, \$150-\$250. New Propellers, \$5 to \$8.50. Smith Machinery Co., 463 Goggan Bldg., Houston, Texas.

NEW Hispano Sulza, 8 cylinder, 200 H. P. Aviation motor, complete, \$210. New 80 H. P. LeRhone, air-cooled motor, \$130. New Gnome, 100 H. P. air-cooled motor, \$120. Cash F. O. B. Cars. Heber H. Hunt, P. O. Box 1845, Washington, D. C.

SEND for Sale Sheet listing airplane material at reduced prices. Glider circular, also literature on our latest Ford or Motor-cyle Motored Airplanes, 4c each. Heath Airplane Co., Chicago, Ill.

NINE cylinder Gnome Aeroplane engine, practically new. No reasonable offer refused. Would trade. Box 792, Mobile, Ala.

FLYING Instruction, \$100, on Curtiss Planes. Building Plans for Sport Biplane, \$2.50. New Mahogany Propellers, two for \$12. Building Plans for Motorcycle Engine Monoplane, \$1. Motors and Knockdown Planes, cheap. Circular Free. Write today. Aviation Engineering Co., Lawrence, Kan.

LEARN to fly on the Aero Club of Illinois Field, Chicago, U. S. A. Complete course \$285.00. Send 5c for Booklet. Partridge, Inc., 430 Michigan Ave.

WELDING

WELDING Encyclopedia—A complete instruction book on all welding processes; oxy-acetylene, electric arc, electric resistance and thermit. Welding of all weldable metals fully discussed. 326 pp., 375 illus. The accumulated experience of the welding brains of America is yours for \$5. Money back if not satisfied. Popular Mechanics Book Dept., 290 E. Ontario St., Chicago.

BOOKS AND PERIODICALS

INDUSTRIAL Alcohol. Wright's book everybody wants. Full directions for making with drawings of necessary apparatus. \$2.50 postpaid. Spon & Chamberlain, 120 P. M. Liberty Street, New York, N. Y.

1,000,000 Industrial Facts, Calculations, Receipts, Processes, and Trade Secrets for every business are contained in the 1016 page Book "Moore's Universal Assistant and Complete Mechanic." 500 Engravings. Cloth. Price \$2 postpaid. Popular Mechanics Book Dept., 290 E. Ontario St., Chicago.

EVERYDAY Educator, 50c. Educational, Advanced thought, medical, mystic and occult books. 140-page illustrated catalogue, 12c. Money refund with dollar order. M. Chelsea Company, Station R, Box 34, New York City, N. Y.

ENCYCLOPEDIA Britannica, India Paper, half price. Dalton Buses, Crilly Bldg., Chicago.

LITERATURE, Fiction, Instructive. Lists. Higens's, A2441 Post Street, San Francisco, Calif.

SIX Different Business Publications covering Accounting, Advertising, Administration, Merchandising, Salesmanship and Taxation, all prepaid only 25c. Value \$1.50. Instructive, educational, practical. Walhamore Company, Lafayette Bldg., Philadelphia, Penna.

BIG money in writing photoplays, stories, poems, songs. Send today for free copy America's leading writer's magazine, full of helpful advice on writing and selling. Writer's Digest, 708 Butler Building, Cincinnati.

CONNOISSEUR, wonderful English collectors' magazine, copy \$1.00, yearly \$8.00, postpaid. Magazine list free! Toepp Magazine Agency, Middletown, N. Y.

BOYS' toy-maker book, 64 pages, illustrated, 10c. Amateur Electrician, 64 pages, illustrated, 10c. Radio Sets, how to build, illustrated, 25c. Western Puzzle Works, St. Paul, Minn.

DR. Coué's Own "Method" Self-Mastery through autosuggestion for attaining health, success and happiness, written in plain English, postpaid \$1.00. Special prices to dealers and agents. Johnson Co., 162 E. 32nd St., Brooklyn, N. Y.

GET the genuine "Master Key." \$5.00. Latest catalogue 2c. Sovereign Company, 49 Broadway, Buffalo, N. Y.

YOU should have our New Illustrated List of Practical Books. Free. Spon & Chamberlain, 120 P. M. Liberty Street, New York, N. Y.

500 THINGS to Sell by Mail. Remarkable new publication. Workable plans and methods. Looseleaf, cloth binder. Prepaid \$1.00. Walhamore Company, Lafayette Bldg., Philadelphia, Pa.

"ELECTRICAL Kinks." Most complete book on everything electrical in the home. See advertisement on page 24.

NEW Book—Where To Buy Ten Thousand Things at Wholesale. Worth \$10 per copy to anyone, says Professor Abbott. Price 60c prepaid. G. O. Shaver, Publisher, Pm. 20, Oil City, Louisiana.

DAY by Day, in every way, I'm getting better and better. Coué's authorized book, "Self Mastery Through Conscious Autosuggestion." Reduced price, seventy-five cents, postpaid. Zenith Book Co., St. Paul, Minn.

50 COPIES of different mail-order publications \$1.00. Address Hansen Company, Brookings, S. Dak.

SHORTHAND, easy to learn, rapid, self-teaching book, \$1.50. Boyd Business College, Washington, D. C.

GAMES AND ENTERTAINMENTS

250 MAGIC Tricks, Disce. Large Magical Goods Catalog, 3c. Hamilton's Co., Barnes City, Iowa.

GREATEST Fun Card Game, Boys, Girls, Old, Young. Introductory Offer. 35-cent game. Send 24 cents in stamps. Gastit Co., Dept. C23, Topeka, Kan.

PLAYS, musical comedies and revues, minstrel music, blackface skits, vaudeville acts, monologs, dialogs, recitations, entertainments, musical readings, stage handbooks, make-up goods. Big catalog free. T. S. Denison & Co., 623 So. Wabash, Dept. 11, Chicago.

NEW Plays For Children—The greatest plays being written for children today are those coming from the pen of T. C. O'Donnell. By special arrangement with the publisher we are able to make the first announcement of The "Just Imagine" Plays, the newest series of O'Donnell plays. The first two are "The Sandman's Brother" and "Ann's Half Birthday." Everyone interested in clean, wholesome, easily produced plays for little folks from five to twelve years of age will find these ideal. Artistically printed and bound, 50c each postpaid. Send \$1 today for the two. Popular Mechanics Book Dept., 290 E. Ontario St., Chicago.

470 TRICKS, Puzzles, Jokes and big catalogue 10c. Andco, 4049-TC, North Whipple, Chicago.

200 KINDS Iron, wood and wire puzzles. Leader and illustrated list 10c. Western Puzzle Works, St. Paul, Minn.

\$25 NIGHTLY. Chalk-talk entertainments. Instructions \$1. Comic Art Studios, Owatonna, Minn.

VENTRILLOQUISM taught almost anyone at home. Small cost. Send 2c stamp today for particulars and proof. George W. Smith, Room M-732, 125 N. Jefferson Ave., Peoria, Illinois.

HOYLE Up-To-Date—Official Rules 200 Card Games. 1923 edition—240 pages, 50c. Zibart Bros., Nashville, Tenn.

FREE—Our New Catalog of Puzzles, Tricks, Games, Jokes and Novelties. Wright & Son, 681G Ind. Ave., Peoria, Ill.

MAH-JONGG—The ancient, intriguing game of China is for the first time being introduced into America. Very fascinating. Price for complete set \$16 prepaid. Popular Mechanics Book Dept., 290 E. Ontario St., Chicago.

MAGIC TRICKS, BOOKS, AND JOKERS' NOVELTIES

TRICKS, Puzzles, Jokes, magical apparatus, plays, stage supplies, mind-reading, sensational escapes. 160-page illustrated professional catalog, 10c. Oaks Magical Co., Dept. 548, Oshkosh, Wis.

MAGIC, Ventriloquial, Punch Figures, Pocket Tricks, Books, Magazines, Escapes, Secrets, Illusions, Flowers, Roll Paper. Catalogs 10c. Address, Gilmagic, Morgan Park, Ill.

67 TRICKS, 250 jokes, riddles, 73 toasts, 8 Fortune Telling secrets, 52 moneymaking secrets, 22 funny readings and big catalog 10c. Ideal Novelty Shop, 5591-TC North Robey, Chicago.

JOKER'S novelties. Great fun. List free. C. Fenner, 2401 Jefferson, Louisville, Ky.

MAGIC—Tricks, Books and Supplies. For Amateurs as well as the great professionals. Anyone can learn through our instructions. Feature Acts in Mind Reading, Spiritualism, Rope Ties, etc. Large illustrated Professional Catalog, 10c. Chicago Magic Co., Dept. B, 140 S. Dearborn St., Chicago, Ill.

"IMPROMPTU Magic, With Patter"—New book teaches how to mystify with cards, coins, etc., and what to say. No skill required. Postpaid, 75c. T. S. Denton & Company, Dept. 123, 623 So. Wabash, Chicago.

PAPER Magic—A new book by Houdini in which are described not only a large number of tricks with paper but also the amusing and puzzling articles which may be made of folded paper and tearing of paper. Paper puzzles are also included. 206 pages. Illus. Price \$2.50 postpaid. Popular Mechanics Co., 290 E. Ontario St., Chicago.

MYSTERIOUS Spirit Pad writing appears and disappears; no pencil or any other device used, 50c. 24 invisible photos, 15c; Wizard's Manual, 30c; Heller's Magic, 30c; 375 magic tricks, 40c; 140-page illustrated catalogue, 12c. Money refund with dollar order. Chelsea Trick & Mystery Company, Station RT, Box 24, New York.

AMAZE and Mystify your friends! New 48-page Magic Book tells how—explains 33 Mystifying Effects. Sent with Catalog of 300 Tricks and Novelties, only 6c. Write today. Lyle Douglas, Station A, Dallas, Texas.

32-PAGE trick and novelty catalog for 2-cent stamp. Royen, One East 42 Street, New York, N. Y.

NOVELTIES, CURIOS, ETC.

LOOK! Artistic name cards, samples free. Prince, 130 W. 104th, New York.

BEAUTIFUL Sea Shells, Coral and Sea Beans. 80 in Package, Prepaid \$1.25. 6 Packages to one address, \$6.00, Prepaid. Marine Curios, 250 Riverside Ave., Jacksonville, Fla.

LORD'S Prayer medallion, smallest in existence, 25c. Durso, 25 Mulberry, New York City.

PICTURES AND POSTCARDS

JOIN Live Postcard Club, membership lists including catalog 10c. Harvey Teeple, Decatur, Indiana.

EXCHANGE post cards and books. Members everywhere. Write Century Club, Box 57, Copley Square, Boston, Mass.

EXCHANGE Postcards, letters, curios with foreigners. Membership \$1 (bill), Delcavefer, 252-M d'Entraigues, Tours, France.

STAMP COLLECTING

SPECIALLY "Worth While" small collections. Clean, perfect stamps selected from stock and offered to acquaint new customers with Osborn variety, quality and service. 112 different foreign, including **Barbados, Mozambique, Dominica, St. Vincent, etc.** 229 different foreign, including **Bosnia, Hayti, Paraguay, Shanghai, etc.** 30c. 318 different foreign, including **Hawaii, Iceland, Malta, Panama, German, China and Morocco, etc.** \$1.00—and well worth it. Price List and Approval Selections to collectors seeking "worth while" stamps at fair prices. C. Osborn, 486 Park Ave., Westchester, N. J.

106 DIFFERENT, Abyssinia, etc., 10c. Premium free. Buckley, 712 Bowen, Dayton, Ohio.

125 DIFFERENT stamps, including Nyassa, Ukraina, White Russia, etc. 250 Hinges, Millimeter Gauge, 15 cents. Heatherdale, 4940 Lyndale So., Minneapolis, Minn.

1000 AMERICAN Hinges and Premium set 10c. Finest Approvals 50% to 75%. Albums and Supplies Cheap. Big list free. Send reference. Write today! Supreme Stamp Co., 2 Bradford, Pa.

ARGENTINE—20 Different, only 15c. Browne, 111 Willow, Wollaston, Mass.

BEST one-cent approvals in America. F. P. Hand, 1117 So. 60th St., Philadelphia, Pa.

2,000 ITEMS price list from 10c to \$50 each for five cents, redeemable with first dollar purchase. Broadway Stamp Co., 115 Nassau St., New York City.

RUSSIAN Starvation Set, showing starving woman and children, picture of Hades, etc.; should be in every collection; sent postpaid with 250 hinges and perforation gauge for 5c. Fenway net approvals with every order. Fenway Stamp Co., Fenway Station, Boston, Mass.

LIKE Triangular Stamps? To introduce our Sudden Service Approvals we'll send triangular Fiume, set China ships, large \$1.00 United States revenue, also packet 50 foreign, millimetre scale, perforation gauge, ruler and bargain lists for only 9c! Fennell Stamp Company, Dept. P, Fullerton Bldg., St. Louis, Mo.

153 GENUINE Foreign Stamps Mexico War Issues, Venezuela, Salvador and India Service, Guatemala, China, etc., only 10c. Finest approval sheets 50 to 60%. Agents Wanted. Big 72-p. Lists Free. We Buy Stamps, Estab. 29 yrs. Hussman Stamp Co., Dept. 54, St. Louis, Mo.

FREE! Sectional Loose Leaf Postage Stamp Album at the rate of 8 pages each month given with subscription to our monthly Journal. Send two-cent stamp for prospectus. United Stamp Co., 140 S. Dearborn St., Chicago, Ill.

NYASSA set Free, for a request for my No. 1 and 2c approvals, also the higher priced desirable stamps at 50% Disc't. Send reference and get extra premiums. Chas. T. Egner, 4455 Frankford Ave., Fk'd, Phila., Pa.

SNAPS—150 different stamps, 18c; 60 different United States Stamps 12c. With each order we give free our price list of sets, packets, albums, etc., and our pamphlet which tells "how to make a collection properly." Queen City Stamp Company, Room 38, 694 Race, Cincinnati, Ohio.

24 VARIETIES Cuban stamps, 10 cents. List of 5,000 low-priced stamps free. Address Chambers Stamp Co., 111P, Nassau St., New York City, N. Y.

NEWFOUNDLAND stamp bargain! Lists sent. Rev. Butler, St. Georges, Newfoundland.

20 UNUSED stamps free. All different. Postage, 2c. Fisk Stamps, Toledo, Ohio.

1,000 DIFFERENT, \$2.00; 500, 75c; 225, 50c; 225, 25c. Fred Onken, 630 79th Street, Brooklyn.

PACKET of 23 stamps, no two countries alike. Packet hinges, Set of \$1 and \$2 U. S. Rev., all for 5c. Mention paper. Miami Stamp Co., Toledo, Ohio.

100 DIFFERENT foreign, many rare unused, 7c. Stanton, Niantic, Conn.

STAMPS—100 different 10c. Approvals. Ahwahnee Stamp Co., Ahwahnee, California.

STAMPS sent on approval at 70% discount. Reference required. Emory Renoll, Hanover, Pa.

47 DIFFERENT Scandinavian Stamps, 5c. Harma, 1713 Waverly, Detroit, Mich.

FREE—Beautiful set Barbados, gauge, \$1. U. S. stamp, lists, etc., for 2c stamp. 100 diff. U. S., 10c. Hawkeye Stamp Co., Cedar Rapids, 39, Iowa.

SEND 25c for 500 Mixed U. S. Perforation Gauge, and 6 months' subscription to The Junior Philatelist. Best Ever. Medina, Ohio.

ZANZIBAR, Abyssinia, Allenstein, Hyderabad, Herzegovina stamps, Menagerie packet, Hinges, 10c. Liberty, 3974 Arsenal, St. Louis, Mo.

CUSTOMERS Wanted, 100 varieties—free—to applicants. 1 and 2c approvals—other premiums to steady customers. 100 New Europe and Hinges, 15c. Elmer, 12 Albe-marle St., Boston.

FOREIGN Stamp Collection Sent Free. Cornish Company, Schenectady, N. Y.

300 DIFFERENT Stamps, 25c; 200, 15c. Michael, 5602 Prairie, Chicago.

BIG Variety Packet Foreign Stamps free for 2c postage. Gray Stamp Co., Station E., Toronto, Canada.

FRENCH Colonies Free—Beautiful Picture set, including Native Chiefs, Tigers, Pictorials, 2c Postage. Empire Stamp Company, Toronto, Canada.

200 STAMPS and Bargain Stamp Magazine 15c. Harvey Teeple, Decatur, Indiana.

STAMPS Free—War Stamps, Surcharged, Unused, Pictorials, British, French Colonials, 2c postage. Midland Stamp Co., Toronto, Canada.

TEDDY ROOSEVELT 5c blue unused, 11-50 50 different British Colonials only 25c. Jacob Fischer, 1539 North Lawler, Chicago.

\$2.10 FOR 10c. To introduce our finest 50% approvals we offer Haitian stamps, 30 British Colonies, package hinges, large perforation gauge and pict. Midwest Stamp Company, Kemper Building, Kansas City, Mo.

100 DIFFERENT Stamps and Perforation Gauge, 10 Cents. Sonnee Stamp Co., 675 Ivy Street, St. Paul, Minn.

105 CHINA, etc., stamp dictionary, list, 2c. Album (500 illustrations), 2c. Bullard, Sta. A, Boston.

200 DIFFERENT Stamps 10c; 500, 46c; 1,000, \$1.49; to approval applicants only. W. Stadler, 437 Beach Ave., Bronx, N. Y.

50 DIFFERENT United States 10c; 10 Nyassa 1901 25c. Seidenberg, Morton, Wis.

STAMPS, 20 unused, all different, free. Postage 2c. Mention paper. Quaker Stamp Co., Toledo, O.

STAMPS, 50 Varieties, Africa, Brazil, Peru, Cuba, Mexico, etc., 10c. 50 different U. S., 25c; 1,000 mixed, 40c; 1,000 hinges, 10c. List free. C. Stegman, 5948 Cote Brillante, St. Louis, Mo.

FREE—100 Different to Approval Applicants. Sellem Stamp Co., 2416 Nicollet, Minneapolis, Minn.

\$1.00 PACKET Stamps for 5c. Hull, 12 West 101st, New York.

FINEST grade approvals, 75% discount. Penna. Stamp Co., Manor, Pa.

50 VARIETIES Portuguese Colonies, 25c; 50 varieties French Colonies, 25c; 50 varieties British Colonies, 15c. Ray Bovard, Utica, Kansas.

FREE—50 varieties or set to approval applicants sending 2c. Richard P. Lamprecht, Valparaiso, Ind.

FREE! 25 British Colonials to approval applicants sending 2c. Nickles, 122 Florida, Washington, D. C.

STAMP Collectors: Send for our Approval Sheets. Cat. 2 to 25c at from 1/2 to 3c each. Cat. 1c. Free on Application. Seacoast Stamp Co., Asbury Park, N. J.

FREE—40 Dandy Stamps, 2c postage. Mitchell, 4529 N. Racine, Chicago, Ill.

1000 MIXED Newfoundland, etc., 25c. Eisen, 3918 13th Avenue, Brooklyn, N. Y.

100 STAMPS—15 different countries, 2c. Harland Burgett, Lima, Ohio.

HAVE you tried Cole's Approvals? They Satisfy. W. Jay Cole, 3019 Wallace St., Chicago.

A GOOD Stamp Free to applicants sending postage for our high-class approvals. Address Pioneer Stamp Co., Dept. P, 731 Prospect, Kansas City, Mo.

200 DIFFERENT stamps 10c, to those asking for 50% discount approvals. Atlas Stamp Co., Box 182, Kansas City, Mo.

100 VARIETIES Free! Including Abyssinia, Ukraina, etc., to serious approval applicants. Wilmar Edgar, Cherokee, Iowa.

RARE COINS

CALIFORNIA gold, $\frac{3}{4}$ size, 27c. $\frac{3}{4}$ size, 53c. 3c piece and catalogue, 10c. Address Norman Shultz, Colorado Springs, Colo.

FLYING Eagle Cents are now out of circulation, but you can get one now together with a 50 page Illustrated Coin Catalog by mailing this slip and 10 cents with your name and address. This is "just to get acquainted." Send now. H. Max Mehl, Numismatist, Mehl Bldg., Dept. P, Fort Worth, Texas. Largest Rare Coin Establishment in the United States.

100,000 **RUSSIAN** Roubles 50 Cents; to a millionaire; one million roubles only \$3.00; 10,000 German Marks \$3.00. Austrian kronen, 100,000, only \$4.00. Representative wanted. Write for quotations. George Grignett; 20 East Jackson Blvd., Chicago, Ill.

40 **OLD** Coins, all different, \$1.00. 20 old bills, all different, \$1.00. Claud Denney, Box 315, Dallas, Texas.

3c **NICKEL** and 2c Piece 15c. \$100 Ohio bill, 1838, and \$100 Indiana bill 25c. California gold $\frac{3}{4}$ 27c; $\frac{1}{2}$ 53c. Price lists 4c. Al E. Bonsall, Richmond, Ind.

25 **DIFFERENT** Silver, nickel, copper coins \$1.00. Otto Oddehon, Dallas, Texas.

OLD coins wanted. Have you an odd or old coin or bill? It may be worth several dollars. Get posted. Send 4c for coin Circular. May mean much profit to you. Send now. Numismatic Bank, Dept. H, Fort Worth, Texas.

OLD coins, large fall selling catalogue of coins for sale, free. Catalogue quoting prices paid for coins, ten cents. William Heselton, 101B Tremont St., Boston, Mass.

1835 **DIME** 25c; $\frac{3}{4}$ Lincoln, \$1.40; California gold half 53c. A. Wylie, Wheaton, Ill.

\$2 TO \$500 each paid for hundreds of Old Coins. Keep all Odd or Old money. It may be very valuable. Send 10c for New Illustrated Coin Value Book, 4x6. Get posted. We pay cash. Address Clarke Coin Co., Ave. 2, Le Roy, N. Y.

FOR BOYS

BOYS build three foot model airplane at small cost. Write Aero Shop, 3050 Huribut Ave., Detroit, Mich.

OUTDOOR Winter Sports—How to Make Devices for. Plain instructions and clear drawings for building motor-driven sleds, snow speedsters, air propelled sleds and ice boats, ski sleds and gliders, skis and ski running, ice yachts, coasting toboggans, etc. Price 25c postpaid. Popular Mechanics Book Dept., 200 E. Ontario St., Chicago.

MOUTH-ORGAN Instructor, 25c. Learn in one hour. Address G. Elsea, Bowling Green, Ohio.

BOYS! Ten different Magic and Invisible Inks, only 25c. G. W. Zoll, Lead, S. Dak.

BO-LO Horse Bike ready to assemble. Boys are wild about it. \$2.00 postpaid. Address Norton Toy Co., South Easton, Mass.

BUILD From Blueprints. List free. Plans for workbench, two dimes. Laskaris, Box 418, State College, Pa.

CAMERAS AND PHOTO SUPPLIES

SELL Your Snap Shots at \$5.00 each. Kodak prints needed by 25,000 publishers. Make spare time pay. We teach you how and where to sell. Write, Waltham Institute, Lafayette Bldg., Philadelphia, Pa.

KODAK Films—Special trial offer: your next kodak film developed, 5c—prints, 2c each. Messer & Son, 1917 St. James Ave., Cincinnati.

TRIAL order. Film developed, six prints, and one enlargement, 50c. Price list free. Wholesale Kodak Finishing Shop, Box 69, Ann Arbor, Michigan.

SPECIAL Trial offer: Any size Kodak film developed for 5c; prints 2c each. Overnight service. Expert work. Roanoke Photo Finishing Co., 253 Bell Ave., Roanoke, Va.

HAVE You a Camera? Write for Free sample of our big magazine, showing how to make better pictures and earn money. American Photography, 790 Camera House, Boston, 17, Mass.

ESTABLISH yourself at home—as an Expert Photographer and train with R. Vant, director International Studios, 3431—3601 Michigan Ave., Chicago.

JUST Published—Our new complete 128-page catalog and bargain book of new and used cameras and supplies. Our goods are guaranteed finest quality obtainable. We have thousands of satisfied customers. Write at once for this bargain bulletin, just hot from the press. Address Central Camera Co., 124 S. Wabash Ave., Dept. E-47, Chicago, Ill.

BIG Money Saved on Photographic Lenses and Apparatus—goods exchanged; repairing done. Ralph J. Golsen, 1128 Argyle St., Chicago, Dept. P.

FILM developed and six glossy prints, 20c. Photo Works, Ashton, Ill.

3,000 **FORMULAS**, 400 pages, \$1.00. Hillside Laboratories, 7021-AC South Winchester, Chicago.

SEND us that Kodak film you prize so much with \$1.00 and we will send you a beautiful 8x10 enlargement, in folder, and return film. C. Weitzel, 836 S. Main St., Akron, Ohio.

"SOMETHING NEW!" Pictures without films. Free booklet. Film developed, six prints, Free enlargement, 25c silver. Alvas Photo Service, Braintree, Mass.

SAMPLE enlargement, dime and negative (returned). Sample 6-exposure roll finished glossy, 25c silver. Brown Studio, Lake Elmo, Minn.

KODAK Finishing, Copying, Enlarging. Send for prices. Kodafin, 387 Bellevue Place, Milwaukee, Wis.

MOTION PICTURES

SEND \$3.00 for the Cinema Hand Book. Everything pertaining to motion-picture making, taking protecting studio laboratory work. 572-page book, pocket size, only \$3.00 postpaid. Also the new complete courses of the New York Institute of Photography. Motion Picture Photography, postpaid, \$4.00. Motion Picture Projection, postpaid, \$6.00. Motion Picture Directing, postpaid, \$3.00. Screen Acting, postpaid, \$3.00. Photoplay Writing, postpaid, \$3.00. The most elaborate works ever written on this subject. **Base Special Offer:** The five books at \$17.50 postpaid. Free Cinema catalog. Bass Camera Company, Motion Picture Division, 109 N. Dearborn, Chicago.

AMERICA'S Greatest Fortunes have been made in the Moving Picture Business. Small investment needed. We furnish complete theatre equipment. Easy payments. Openings everywhere. Catalog free. Monarch Theatre Supply Co., Dept. F, 724 So. Wabash Ave., Chicago, Ill.

FREE to Writers—A wonderful little book of money-making hints, suggestions, ideas; the A B C of successful story and play writing. Absolutely Free. Just address Authors Press, Dept. 12, Auburn, New York.

\$35.00 PROFIT nightly. Small capital starts you. No experience needed. Our machines are used and endorsed by government institutions. Catalog free. Atlas Moving Picture Company, 482 Morton Bldg., Chicago.

FILMS—Standard size for Toy and Professional machines. Special Bargain—500 ft. lengths \$3.00. We sell everything for "The Movies." Monarch Theatre Supply Co., Dept. P, 724 So. Wabash Avenue, Chicago.

SELLING Out—Used projectors \$35-\$125. Films cheap. Movie Sales, High Ridge, Mo.

MOVIE Films for Toy Projectors, 100 feet, \$1.00 postpaid; 500 feet, \$3. Home Projector, \$25. Cameras, \$60. Ray, 326 5th Avenue, New York, N. Y.

FREE. Story writers send stamp for successful hints on how to make your stories bring results. Authors' Service Bureau, Box 341, Oklahoma City, Okla.

FILMS For Sale—\$2.50 per Reel up. Address Queen Feature Service, Birmingham, Ala.

\$\$\$ FOR Ideas. Photoplay plots accepted any form; revised, criticized, copy righted, marketed. Advice free. Universal Scenario Corporation, 917 Western Mutual Life Bldg., Los Angeles.

MAKE money writing photoplays; details free to beginners. No correspondence course. Producers League, 230 Wainwright, St. Louis.

FILMS: Comedies—Cartoons—Dramas—Westerns—Serials and Educational Subjects. Get our Big list and bargain prices before you buy. Monarch Theatre Supply Co., 228 Union Avenue, Memphis, Tenn.

BIG Money Nightly—Get my installment figures Complete Moving Picture Outfit before buying. Ralph J. Golsen, 1128 Argyle St., Chicago.

MOVIE Film \$1.00 per hundred feet postpaid. Send Money Order. Gamble Bros., Mt. Airy, Philadelphia, Pa.

FILMS—\$2 up per reel. Marlborough Film Service, Twenty Hundred East Seventy-third, Kansas City, Mo.

SCENERY TO RENT

SETTINGS for Opera, Plays, Minstrels. Plush Drops. Address Amelia Grain, Philadelphia.

EDUCATIONAL AND INSTRUCTION

LEARN to be a Laboratory Expert. Study interesting profession of Bacteriology, Microbiology, Sanitary Science, Extension and Residential courses. Diplomas and degrees granted. Help in securing positions. 46-piece Urinalysis outfit with carrying case free to students enrolling now. Our graduates members of respected, fast-growing profession with large incomes. Safety, health, advancement of the world now depends upon laboratory experts. Blood analysis, detection of poisons, blood-stains, serology, Wasserman tests, etc., quickly and thoroughly understood. Experience in laboratory work or chemistry unnecessary. Send for free prospectus today. Physicians & Surgeons College of Microbiology, Suite 971, 350 Garfield Avenue, Chicago.

WORLD-ROMIC System, Masterkey to All Languages. Primers, 23 languages, \$1.94 each language; Arabic, Bohemian, Bulgarian, Cantonese, Chindau, Danish, Dutch, English, Scotch English, French, German, Hungarian, Italian, Japanese, Latin, Panjab, Polish, Portuguese, Rumanian, Russian, Sechuana, Spanish, Swedish, Pronunciation Tables, 94 languages, 50c each language. Languages Publishing Company, 8 West 40th Street, New York.

ENTER a new business. Earn \$3,000 to \$6,000 yearly in professional fees making and fitting a foot specialty, openings everywhere, with all the trade you can attend to; easily learned by anyone at home in a few weeks, at small expense; no further capital required, no goods to buy, job hunting, soliciting or agency. Address Stephenson Laboratories, 11 Back Bay, Boston, Mass.

ROPP'S Calculator and Short-Cut Arithmetic shows the answer as quickly as a watch shows the time to all problems likely to occur in office, store, shop, bank, farm or factory. Price, pocket size, paper 35 cents, cloth 50 cents, leatherette \$1. Desk size, cloth \$1.50 postpaid. Popular Mechanics Book Dept., 200 E. Ontario St., Chicago.

DOUBLE Entry Bookkeeping mastered in 60 hours with 8 keys; guaranteed; diplomas. Our graduates lead in bookkeeping, auditing, accountancy, balance sheets, financial statements, International Bookkeeping Institute, Dept. 8, Springfield, Mo.

SHOW card writing a pleasant, profitable profession, easily and quickly learned by our new simple graphic block system—Artistic ability not necessary. We teach you how. Distance no object. Full particulars and booklet free. Wilson Methods, Limited, Dept. M., 64 East Richmond, Toronto, Canada.

HEATING Men, Plumbers, Steamfitters, Salesmen, advance in your industry—make better earnings. Learn Heating and Ventilating at home, from practical experienced engineers. Northern Institute, 1951 E. 57th St., Cleveland, Ohio.

ARTIFICIAL Marble, sanitary flooring instructions, ornamental casting, concrete plaster, papier-mache decorations, garden furniture, statuary, Rubber-moulds, Electro-metallurgy, particulars and 200 illustrations free. Chris Mahler, Box 122, Huntington, N. Y.

SALESMANSHIP. Sheldon can tell you how to sell. Literature free. Also a message "It Can Be Done." The Sheldon School, 929 North American Bldg., Chicago.

INVENTORS—Write for our illustrated guide book and Evidence of Conception Blank. Send model or sketch and description for free opinion of its patentable nature. Highest references. Prompt attention. Reasonable terms. Victor J. Evans & Co., 167 Ninth, Washington, D. C.

CHOOSE the Right Vocation. Ask for Free Vocational Self-Analysis Chart PM-2. Vocational Service Bureau, 20 E. Jackson, Chicago.

USED books and educational matter bought, sold, exchanged. List 1900 items free. Students' Exchange, 47 West Forty-second Street, New York, N. Y.

HARMONICA, Violin, Piano, Ukulele, or Mandolin instructors, 25c. Address G. Elsen, Bowling Green, Ohio.

MATHEMATICS taught by mail. Arithmetic, Algebra, Geometry, Mensuration, Trigonometry, Logarithms, and Mechanics courses. Address, Harding School, 76 Brighton, Highland Park, Mich.

BIG Money in writing photoplays, stories, poems, songs. Send today for Free copy America's leading writer's magazine, full of helpful advice on writing and selling. Writer's Digest, 603 Butler Building, Cincinnati.

WRITE articles, stories, news, in spare time for newspapers and magazines. Big pay. Copyright book free. Press Syndicate, 552, St. Louis, Mo.

CARTOONISTS—Improve your style by following the work of the greatest cartoonists found in the bound volumes of Cartoons magazine. Eight volumes, each covering six months, Jan.-June, 1917, to July-Dec., 1920, inclusive. 1,200 cartoons, 900 pages to a volume, 7 by 9½ in., 3 in. thick. New books; durable and attractive binding. Sold separately at \$2 per vol. postpaid. Supply very limited. Send at once. Popular Mechanics Book Dept., 200 E. Ontario St., Chicago.

CUTS made easily. Method 25c. Mac Clarke, Ottawa, Kan.

"WHAT to Invent for Profit" free. Patent News, N. Washington, D. C.

LEARN Auto Radiator Repairing. New profitable trade. Write for full information, Free. Address, F. L. Curfman Mfg. Co., Desk A, Maryville, Mo.

GET Job You Want or get more money present job. Success sure if follow my plan. Try it out. Complete 20c, dimes or stamps. Mr. Trainor, Station B, Box 94, Brooklyn, New York.

DRAWING Instruments—Slide Rules. Highest quality—lowest prices. Direct from importer. Circular free. Automotive Engineering Co., Castle Hall, Indianapolis, Ind.

ARE you mechanically inclined? Learn watch and clock repairing as a trade or for spare time. Big Money. Drexler's Simplified System makes it easy. Write for particulars. B. P. Co., Security Bldg., Milwaukee, Wis.

SHORTHAND. Learn the best, easiest, accurate, rapid, Self-teaching text \$1.50. Boyd Business College, Washington, D. C.

TELEGRAPHY

WANTED—Young men and women to learn Morse and Wireless Telegraphy. Railroads and Wireless Companies in great need of operators. We teach you quickly, and procure positions at big salaries. Great opportunities for advancement. All expenses low; can earn part. Write today for free catalog. School established 1874. Dodge's Telegraph Institute, "H" Street, Valparaiso, Ind.

TELEGRAPHY—Morse and Wireless—taught at home in half usual time and at trifling cost. Omnigraph Automatic Transmitter will send, on Sounder or Buzzer, unlimited messages, any speed, just as expert operator would. Adopted by U. S. Govt. and used by leading Universities, Colleges, Technical and Telegraph Schools throughout U. S. Catalog free. Omnigraph Mfg. Co., 18 Hudson St., New York.

RADIO OUTFITS AND SUPPLIES

FIBRE Panels, any size; ¼ inch, 1½c; ½ inch, 1c square inch, delivered. With front and edges buffed and polished, 5c inch extra. Ohio Comb Co., Orrville, O.

LOUD Speaker for Any Crystal Set. Hear music over entire house, with Steinmetz Amplifier, \$8.50; easily constructed by amateurs. Eliminates storage battery. Instructions complete, 25c. Catalog Free. Representatives wanted. Steinmetz Wireless Mfg. Co., Eastend, Pittsburgh, Pa.

RADIO Solder for construction and repairing radio outfits. Three six-inch bars 25c postpaid. Hamilton Lead Company, Hamilton, Ohio.

SAVE Money on Radio Apparatus. Lowest Prices. Ray, 326 5th Avenue, New York, N. Y.

INTERESTING Proposition for Radio Fans. Write—Howard Lindsey, Sacandaga, N. Y.

RADIO Books—Send for our specially selected list of 20 leading volumes among the reliable radio publications and also our complete book catalog. They are sent free upon request. Popular Mechanics Book Dept., 200 E. Ontario St., Chicago.

BUILD your own Radiophone. Instruction book ten cents. Radio Service Inst., U. S. Bank Bldg., Washington, D. C.

REPAIR your automobile or Radio battery; send 25c for instructions. C. M. Steertz, Charleston, W. Va.

ARMSTRONG Regenerative Tuner Licensed. Using coil similar to Rheingartz. Complete \$10.00 and postage. Knocked down parts \$5.00. Catalog 10c. Address, Treaco, Davenport, Iowa.

1,000-MILE Tube Radio Outfits, everything complete, \$39.50. Address, Movie Sales, High Ridge, Mo.

VARIABLE Condensers, \$1.45, postpaid. Cherpeck Company, 3125 Davlin, Chicago.

FREE—Antenna, Man-Radio Station (Patented). "Tune in" with Ocean of Intellectual Pressure. Instructions \$1.00. Radio-Colortone Co., St. Joseph, Mo.

TWO-STAGE Long Range Receiver complete, ready to hook up, \$40. F. R. R. Radio Corp., Dept. P, Detroit, Mich.

SHAW Wonder Coil. Whole United States on Detector. Coil, only \$2.50. Complete Detector parts, \$12.50. Results Guaranteed. H. W. King, Des Moines, Iowa.

TRADE SCHOOLS

LEARN Photo-Engraving — Unrewarded, highly paid profession. Six months' course. Positions secured. Modern equipment, terms reasonable. For catalogue address: Eaton School of Photo-Engraving, Ethingam, Ill.

START a Lucrative Business of Your Own. We teach you how to establish and operate a successful collection business and refer items to you. Capital unnecessary. Practically no competition. Walter Sanford, Nashville, reports \$62,021.94 gross commissions last year. Joseph Cullen, Washington, sends sworn statement showing gross earnings \$8,639.97 for one month. Orrin Overholzer, Dayton, says: "I averaged nearly \$400 net commissions monthly last year. Such earnings bought my home and farm." Start now in spare time. You can succeed like 4709 others. Write today for New Plan. American Collection Service, 802 Shelby Block, Detroit, Mich.

MAIL Order Business is your opportunity. Brenner's Famous Handbooks teach how to start small, grow big. Sell merchandise, service ideas; enormous profits. Spare time to begin. Got complete set, 11 books, \$5.00, and be posted. Brenner, 335 Walnut, Philadelphia. Descriptive Catalog and big batch interesting mail order information, 25c. None free.

EXCEPTIONAL Opportunity for Sales Manager capable of handling state distribution. Marvelous new Adding Machine. Retail \$15. Work equals \$350 machine. Tremendous possibilities. Unlimited profits. Write quick for details. Lightning Calculator Co., Dept. B., Grand Rapids, Mich.

RESPONSIBLE Corporation wants general sales manager to open branch office, manage salesmen. \$500 to \$5,000 necessary; expenses allowed to Baltimore if you qualify. Address Manager, 603 N. Eutaw St., Baltimore, Md.

HAVE a business of your own; the most fascinating, best paying business-profession in the World, a foot correctionist; easy terms for training you at home in a few weeks, a new protected system that has enabled men and women to rise in one step to greater earnings than they ever thought possible; no capital required or goods to buy, no agency or soliciting. Address, Stephenson Laboratories, 1 Back Bay, Boston, Mass.

AUTO-LAC: Completely refinishes Auto in one hour. Not a paint or varnish. No skill required. Wonderful opportunity for you. Write me, Richards, Chemist, Box 214, Boston, Mass.

MEN Wanted to earn \$3,000 to \$10,000 a year. Prepare quickly and easily through our amazing system for profitable and permanent business reclaiming waste paper for largest manufacturers in country. Boys do the work—you simply direct. Practically no investment necessary—a few dollars will start you. Simply send name for big free opportunity book—a post card will do. Write The Traub System, 303 Traub Bldg., Kansas City, Mo.

BUSINESS OPPORTUNITIES

PATENTS Procured—Trade Marks Registered. A comprehensive, experienced, prompt service for the protection and development of your ideas. Preliminary advice gladly furnished without charge. Booklet of information and form for disclosing idea free on request. Richard B. Owen, 30 Owen Building, Washington, D. C., or 2276-B Woolworth Bldg., New York.

PATENTS procured. Send sketch or model today for examination, prompt report and advice. No charge for preliminary advice. Write for free Booklet and blank form on which to disclose your idea. Highest references. Promptness assured. Clarence O'Brien, Registered Patent Lawyer, 561 Southern Building, Washington, D. C.

PROTECT your rights. Write for "Record of Invention" and booklet about Patents. Prompt personal service. Advice without charge. J. Reaney Kelly, 612-G, Columbian Building, Washington, D. C.

PREPARE—Sell Your Own Products. Formulas, trade secrets. Different, dependable Catalog free. B. Thaxly Co., Washington, D. C.

START Profitable Mail Order Business at Home. We teach you by successful method. Particulars free. Waltham Company, Mail Order Dept., Lafayette Bldg., Philadelphia, Pa.

MAKE money at home. New process. Painting signs, name plates, show cards. Gold lettering. Outfit Free. Thomas Clark, 505 Lane Ave., Ellwood City, Pa.

6% INTEREST Paid on Deposits for 6, 9 or 12 months. Farmers & Merchants Bank, Lucas, N. D. Capital and Surplus, \$37,500.00.

"SCHEMER Magazine," Alliance, Ohio, prints big profit schemes; one subscriber making \$25,000 from three; another \$10,000 from one. Try your luck. Year, only \$1.00; three months, 25c.

SILVERING Mirrors! My exclusive French Tartaric method opens enormously profitable business. Booklet free. H. Barstow, 514 23d Street, Oakland, Calif.

TERRITORIAL representatives wanted as jobbing distributors for Electricite. Retail \$50c. Only generator repair preventative on market. Address Standard Generator Service, 1482 Broadway, New York, N. Y., Room 1114.

\$125 TO \$2,000 will establish you in cash business. Free information. Dept. M, Paul Kaye, 149 Broadway, N. Y.

BUSINESS—Buy, sell, trade, any kind, anywhere. Listing Service, 1827 Wetton, Denver.

ADVERTISE. Newspapers, magazines. List on request. Pencil Company, Covington, Ky.

500 FORMULAS. Resilvering Mirrors—Renewing Dry Batteries—10 Luminous Paints, 25c. Ideal Book Shop, 5501-BC North Robey, Chicago.

DOLLARS yearly in your backyard. No Mushroom dope. Particulars free. Metz, 313, East 89th, New York, N. Y.

SEE What I can do for You and what you can do for yourself manufacturing these Biggest Selling Specialties from Miller's Guaranteed Manufacturer's Formulas and detailed Simple Instructions. No Machinery Required—Investment Small. Start in Home Office store or Factory, making 30-Minute White Beauty Clay, Mexican Yucca Soap, Merte's Toilet Specialties, Vanil, Fifteen Pure Food Specialties, Concentrated Summer Drinks, Washing Marvel Powder, Amazon Tire Repair, Rubber Toy Balloons, White Floating Laundry soap, and many other largest sellers in all lines. Stamp brings all lists and valuable descriptive literature. Don't compare these High Grade processes with anybody's "Bargain Collection" of cheap Recipes. 24 years supplying the Best. Highest references. Miller, Chemist, Tampa, Florida.

PEARL necklaces. Genuine imported, indiscretable pearls, perfectly matched, exquisitely colored Japanese or French pearls. 14" length strands \$10.50; 18" and 24" lengths, \$12.50—in nice gift case. Opera length De Luxe (70" length) perfectly matched, large pearls \$30.00—cannot be duplicated elsewhere for less than \$100.00. These pearls are not to be confused with the ordinary kind. Send Money Order, Express Order or Cashier's Check. All orders promptly filled. Sent via insured parcels post. J. Bennett, 1040 Lawrence Ave., Chicago, Ill.

53 GREAT Money-Making Plans Free. Universal Bureau-M, Boston, Mass.

SHAKER-SEAL is a rubber ring which is quickly applied to two tumblers, providing a perfect transparent mixer for eggs, drinks, medicines, etc. Handier than a mechanical beater; better than a metal shaker. United States patent officially allowed Nov. 2, 1922. Have mold and all manufacturing and cost data. Will consider any equitable proposition for marketing this device. If interested, write for particulars; better still, enclose 15 cents for sample seal. Address Leonard Foote, Pedro Miguel, Canal Zone.

BECOME a Laboratory Expert—Learn interesting, Profitable Profession of Bacteriology, Microbiology, Extension and Residential Courses. Diplomas—degrees granted. Help secure position. 46-piece urinalysis outfit free to students. Send today for free 34-page Prospectus. Physicians & Surgeons College of Microbiology, Room 955, 550 Garfield Ave., Chicago.

"HOW to Sell Patents" free. Patent News-H, Washington, D. C.

STREAM of quarters in every mail for you. Send stamped envelope for particulars. Walter Johnson, 5319 Princeton Ave., Chicago, Ill.

COMPLETE Show Card and Sign Painting Course, \$1.10, postpaid. Write for Bargain Lists of Books and Courses. Book Exchange, A-21 Elm, Lowell, N. Y.

GET into the specialty manufacturing business. Amazing profits. We will send you free book explaining our system. Write immediately. A wonderful opportunity awaits you. National Scientific Laboratories, 211 North Monroe, Richmond, Va.

BE your own Boss. Learn Shoe Repairing at Home. Be Independent. You cannot Fail with our Book of Instructions. Postpaid One Dollar. American Bench Shoemakers, Dept. 2, Aurora, Ill.

FREE Book. Start little Mail Order business. Home employment evenings. Pier, Dept. 173-A, 74 Cortland St., New York.

SEND \$1.50 for formula, sample and directions for manufacturing cream to make hair stay combed. Large profits manufacturing this preparation. Money returned if not satisfied. School of Cosmetics, Box 370, Omaha, Neb.

RAISE guinea pigs. Pay better than poultry or rabbits; easy to raise; little space required. We guarantee market. Particulars and booklet how to raise free. Carles Distributing Co., 3102 Grand Ave., Kansas City, Mo.

START in business. Samples and stock 15c. Cochran, Graysville, Ohio.

CHEMICAL Expert will furnish Formulas and Trade Secrets. All lines. Lists Free. W. L. Cummings, Ph. D., 228 Gordon Ave., Syracuse, N. Y.

AMBITIOUS Men, write today for attractive proposition, selling subscriptions to America's most popular automobile and sportsman's magazine. Quick sales. Big profits. Pleasant work. Digest Pub. Co., 8545 Butler Bldg., Cincinnati, Ohio.

MARBLE mixing instructions, covering wood or cement flooring 1/2 inch thick, fireproof, waterproof, low cost, sanitary, all colors. Particulars. 200 illustrations free. Chris Mahler, Box 122, Huntington, N. Y.

START business Electric Lawn Mower Sharpening Machine. Capacity \$3.00 per hour. Write Springer, Knais, 415 South Lawndale, Kansas City, Mo.

EARN \$10 daily silvering mirrors, plating and refinishing metalware, autos, chandeliers, bedsteads, headlights. Outfits furnished. E. Dele Laboratories, 1133 Broadway, New York, N. Y.

BIG Money. Paint signs, bill boards. Success guide free. John A. Buchanan, Columbus, Ga.

MEN—Look into our proposition of Wallpaper Cleaning. Take big cleaning contracts. Unlimited field. C. Swanson & Sons, Mankato, Minn.

MAKE money with your camera. B. Lancaster, Box 961, Los Angeles.

MAKE big money manufacturing Skived Boots and Rollers out of old tires. Small capital equips you with necessary machinery. Maxwell Manufacturing Company, Wichita, Kan.

GOOD money easily earned at home spare time silvering mirrors; no capital. Free instructive book tells how. Patterson & Co., Brooksville, Ky.

\$400 CLEAR each day, anybody can do that with our Equipment. This is worth looking into. One district alone uses 20,000,000 articles of the product each year. Experience unnecessary. Send 30c in silver, with Reference, for particulars. Triple Block Motor Works, Garfield, Wash.

WE Start You in Business, furnishing everything; men and women, \$30.00 to \$100.00 weekly operating our "New System Specialty Candy Factories" anywhere. Opportunity lifetime; booklet free. W. Hillyer Ragdale, Drawer 3, East Orange, N. J.

\$3,000 TO \$6,000 Yearly. Want it? Others are making it. Send check or money order today for our invaluable books "How to Sell Real Estate," \$3.00—and "How to Conduct Real Estate and Insurance Business," \$1.50. Absolute satisfaction guaranteed. Free catalogs. Realty Sales Co., Dept. 52, Cleveland, Ohio.

START a cleaning, pressing, dyeing shop. Splendid field. Big profits. Booklet free. International System, Dept. 19, Excelsior Springs, Mo.

PEOPLE who want to realize on their oil and mining stock, write us. Central Sales Agency, 715 Baltimore Bldg., Chicago, Ill.

SEND \$1.00 for drawings with instructions for manufacturing New Idea Clothes Pole. Satisfaction guaranteed. W. J. Hill, 53 Austin St., Rochester, N. Y.

WET Wash Laundry for Sale. Will sacrifice for quick sale. Northside Chicago. H. B. Siebecker, 6630 Neugard Ave., Chicago, Ill.

PROSPEROUS Real Estate business of your own or position worth \$5,500? Our graduates have choice. Training at home prepares you in short time. We help you make good. Bulletin free. Penn Realty School, 1909 Ellsworth, Philadelphia.

HANDY Men Earn \$85 Weekly in Automobile Business. Be your own Boss. Demand unlimited. Autorentuco, Sheboygan, Wisconsin.

CEMENT Masons, plasterers, contractors, Build successful business stuccoing old and new buildings with Corkstone Everlasting Magnesia Stucco and Installing Corkstone Floors. Yielding as Cork—Lasting as Stone. Write immediately for agency proposition. Corkstone Products Corporation, 119 N. Collington Avenue, Baltimore, Maryland.

FREE—Formula Catalog. S. & H. Laboratories, Boylston Building, Chicago.

LEARN Real Estate—Big Room Sweeping Country. Earn \$2,400 to \$10,000 Year. New Method. Investigate today. Stephens Realtor Institute, Muncie, Ind.

ATTENTION!! You can have a business of your own. Establish and operate New System Real Estate Business, brokerage and insurance agency in your community. Office at home. Earn \$5,000 year. Representatives wanted everywhere. Send stamp free booklet. Hayes Realty Association, Cincinnati, Ohio.

I MADE \$30 a Week Home. French Breadmaking. 15 years' experience. Free Booklet tells. Ashbrook, 67, Marengo, O.

FORMULAS Furnished or improved by chemical expert. All lines. Reliable service; charges reasonable. Correspondence invited. Dr. Arthur Vanheden, 2236 Campbell Park, Chicago.

YOUR own Business, unlimited field just opening up. Big money. Our "Income-Producing Plan" puts you in wholesale business. Bona-fide business opportunity out of ordinary. Write Arthur Hansen, Manager, 3749 Maple Square Ave., Chicago.

"WHAT to Invent for Profit" free. Patent News-C., Washington, D. C.

CHEMISTRY

YOUR chemical problem solved and working process furnished five dollars. Write me. W. Stedman Richards, Consulting Chemist, Box 2402, Boston, Mass.

CHEMICAL and bacteriological examinations guaranteed accurate. Formulas, processes. Write me about your chemical problems. List free. J. F. Mazur, M. B., 937 W. 20 St., Lorain, Ohio.

WE solve your chemical problems; match samples; furnish trade secrets. Somers Laboratory, 160 N. Wells, Chicago, Ill.

BECOME a Laboratory Expert. Study Microbiology, Bacteriology, Interesting, profitable. Urinalysis outfit free. Write for Free Prospectus. Physicians & Surgeons College of Microbiology, Room 855, 550 Garfield Ave., Chicago.

CHEMICAL Analysis. Chemical formulas. Burson Chemical Laboratory, Ottumwa, Iowa.

FORMULAS AND TRADE SECRETS

800 FORMULAS 25c; Luminous Paint—Resilvering Mirrors—Renewing Dry Batteries—Mechanics Soap—Gas Tonic—Carbon Remover—Puncture Plugger, 20c each. Entire collection 50c. Ideal Book Shop, 5501FC North Robey, Chicago.

BE a tempering wizard. Secret method of tempering. Add life and strength to steel. All kinds of drills, springs, chisels, etc., toughened and tempered by this formula. Non-breakable, absolutely reliable. Never fails. You need it, \$1.00. The Cold Chisel King, 607 N. San Dimas Ave., San Dimas, Cal.

MAKE and sell automobile specialties. List for dollar bill, Flemming, 157 E. 47th St., New York City, N. Y.

5,000 RECIPES, \$1.25. Best formulas and processes for every business, trade or occupation are in "Youman's Guide." Many never before published. Worth \$1.25 each. 530 pages. Paper cover \$1.25, Cloth \$2.00, postpaid. Book catalog free. Wells and Edwards, X852 George, Chicago.

SIXTEEN Beauty Formulas for 35c. Make your own beauty preparations. Adam Jankoski, Bristol, Conn.

FORMULAS of the better sort. Write for our free catalog. National Scientific Laboratories, 211 North Monroe, Richmond, Va.

FORMULA Catalog Free. Big Selling Specialties. Fast Money-makers. Allen's Enterprises, 1227 Milwaukee Ave., Chicago, Ill.

"BEAUTY Clay." Widely advertised Beautifier. Women wild over it. 500% profit. Guaranteed Formula. \$1. Bestoval Laboratories, 4047-CE North Whipple, Chicago.

STRANGE Compound charges discharged storage batteries instantly. Formula, \$5.00. R. Somers, 168 N. Wells, Chicago, Illinois.

MAKE Imitation Vanilla 50c gallon. Fifty other guaranteed Formulas One Dollar. Arthur Schwartz, 1439 American Ave., Milwaukee, Wisconsin.

DON'T Waste Money on "junk." Stamp brings Valuable Literature of High-Grade, Reliable Formulas of Best Sellers in all lines. Buy from chemist and get real service. Miller, Chemist, 807 De Leon Street, Tampa, Florida.

FORMULAS—Guaranteed. Catalog free. Bestover Laboratories, 4049-FB, North Whipple, Chicago.

KORNS, Kallouses Corrected. Send kwater quick and get formula. H. Krohett, 386 Westford St., Lowell, Mass.

500 VALUABLE formulas 25c; Circular 2c. Harvey Temple, Decatur, Indiana.

1,000,000 FORMULAS. 1016 pages, \$2. 500 Formulas Free if you order quick. Ideal Book Shop, 5501-MC North Robey, Chicago.

3,000 FORMULAS. Money-makers. 400 pages, \$1. Bestover Laboratories, 4049-BC, North Whipple, Chicago.

FREE—Formula Catalog. S. & H. Laboratories, Boylston Building, Chicago.

FORMULAS—Catalog of Money-makers Free. Clover Laboratories, 5501-CC, North Robey, Chicago.

10,000 SELECTED scientific, chemical, technological and practical recipes and processes including hundreds of so-called trade secrets for every business alphabetically arranged in one large volume of 800 pages. Price \$4 postpaid. Popular Mechanics Book Dept., 280 E. Ontario St., Chicago.

AGENTS WANTED

MONEY—Money—Money! Make it selling Hanslick, the new and unbeatable hand-cleaner—the original powdered hand soap! Removes grease, grime, ink, paint, etc., without injuring skin. Spreads like wildfire. Cheaper than all others. Sells in cans (or bulk with dispensers) to garages, autoists, auto supply companies, mechanics, factory and office folks, to housewives, hardware stores. Huge quantities used weekly by mercantile houses. Big repeat business assured. Exclusive agencies, crews working for you, fast sales, splendid profits, permanent business for hustlers. Live ones can clean up \$500 a month. Send 10c (coin or stamps) for liberal sample can. Complete sales plan goes with it. Write quick to Solar Products Co., 124 W. Lake St., Chicago, Ill.

300% PROFIT—Sells like Wildfire. Klean-Rite Magic Washing Compound. Washes Clothes Without Rubbing. Sells for 25c. You can make 19c. Sales guaranteed. Distributing Samples Free. Premium Plan gets business. Exclusive territory. Write quick for proof and free sample. Bestover Products Co., 1941-K3 Irving Park, Chicago.

RAINCOAT Agents. Get Our Prices. Sell made-to-measure raincoats. We deliver and collect. Outfit free. World Raincoat Co., 659 Morris Park Ave., New York.

FORD Owners Earn Money—Buick, originator of valve-in-head motor and founder of Buick Automobile wants men to demonstrate his wonderful, new, Hi-Power Carburetor for Fords. They sell quick—because they pay for themselves and give 25% more power, better pick up, easy starting. Agents making \$10 to \$30 per day. David Buick Carburetor Corporation, 5932 Commonwealth Avenue, Detroit.

AGENTS Wanted—Something New—Fire Fighter sells easily. Makes a spectacular demonstration; car owners, homes, factories, stores, practically buy on sight. Our men make \$10.00 to \$50.00 a day; exclusive territory. If you wish to establish a business of your own with unlimited possibilities for making big money, write us today. Fyr-Fyter Co., 103 Fyr-Fyter Bldg., Dayton, Ohio.

AGENTS—Best seller: Jem Rubber Repair for tires and tubes; supersedes vulcanization at saving of over 80 percent; put it on cold, vulcanizes itself in two minutes, and is guaranteed to last the life of the tire or tube. Sells to every auto owner and accessory dealer. For particulars how to make big money and free sample, address Amazon Rubber Co., Amazon Bldg., Philadelphia, Pa., Dept. 505.

LARGE Shirt Manufacturer wants Agents to sell complete line of shirts direct to wearer. Exclusive patterns. Big values. Free samples. Address Madison Mills, 503 Broadway, New York.

AUTOMOBILE Free to Tailoring Agents—Make \$75.00 a week and up and get an automobile free taking orders for our fine tailored-to-measure suits. Big assortment of All-Wool Fabrics all at the one low price of \$29.75. Every order pays you big cash profit in advance. We supply finest selling outfit and give an automobile free to every man who qualifies. Write quick for startling offer. Dept. 546, Park Tailoring Company, Chicago, Ill.

\$100 WEEKLY. Agents, Crew Managers. Absolutely new article selling big to housewives. No capital required. Commissions paid in advance. No collections. No delivery. Exclusive territory. Write quick. Pioneer Corp., 6391 Yale Ave., Chicago, Ill.

PATENTS procured. Send sketch or model today for examination, prompt report and advice. No charge for preliminary advice. Write for free Booklet and blank form on which to disclose your idea. Highest references. Promptness assured. Clarence O'Brien, Registered Patent Lawyer, 562 Southern Building, Washington, D. C.

SALESMEN—Agents! Unusual opportunity. \$50 to \$125 weekly. Semiautomatic Double Vacuum Washers, easily attached to tub. No cleats or posts; air pressure and suction. Superior to power machines in many ways. Easily carried, sells on sight. Guaranteed success. Selling plans, advertising free. Extremely liberal terms. Write Burlington Mfg. Co., Dept. 2, Syracuse, N. Y.

WANTED—Distributors for staple household necessity. Exclusive territory. Great repeater. \$200 to \$1,000 required. Should net over \$10,000 yearly. Address: Manager, 636 Real Estate Trust Bldg., Philadelphia, Pa.

AGENTS to sell high grade men's neckwear direct from manufacturer to consumer. Big profits, quick sales, free samples. S. Jackel, 2831 Third Ave., New York.

AGENTS—W. F. Omels, a former brush salesman, made over \$5,000.00 during 1922 selling our \$1.50 kitchen specialty. He is now a district manager. We are offering you the same proposition—an opportunity as big as you want to make it. You can do what Omels did. Write today to M. H. Tyler Mfg. Co., Manager's Desk, Muncie, Ind.

AGENTS, Salesmen—Big money selling complete Radio Sets—Experience unnecessary. Cash in on our advertising. Protected territory. Home Radio Co., 115 N. Desplaines, Chicago.

AGENTS—Send for sample "Fretnot"—the washday wonder. Be convinced you can do a whirlwind business. You can clear at least \$20 to \$100 weekly, according spare or whole time. You don't have to talk; if she doesn't buy at sight, leave sample; she will be looking for you long before you are able to make the rounds again. Samples furnished free. Premiums for your customers. Exclusive territory guaranteed to agents who can produce. Credits given. Don't call. P. M. Motter & Sons, 20 E. Jackson Blvd., Chicago.

AGENTS—Genuine Gold Letters anyone can put on Store Windows. Guaranteed to not tarnish. Large profits. Enormous demand. Free samples. Write today. Genuine Gold Letter Co., 429-A North Clark, Chicago.

DON'T Risk One Penny for Anyone's Formulas for Information to "Make and Sell your own Goods" till I've sent you my Valuable Literature and Many Formula Lists of Guaranteed Reliable Formulas for Manufacturing Biggest Selling Specialties in all lines. Highest References. Twenty-six years supplying the Best. Miller Chemist, 865 De Leon, Tampa, Florida.

BIG Profits Selling New \$3.50 Automatic Adding Machine. Absolutely accurate. Fully guaranteed. Quick sales. Ten daily easy. No competition. Pocket size. Business people everywhere positive customers. Thousands being sold. Tremendous demand. Here's high-grade money-maker. Bassett Co., 1458-N Hollywood Ave., Chicago.

AGENTS—\$60 to \$200 a week. Free samples gold and silver sign letters for office windows, store fronts and glass signs of all kinds. Anyone can put them on. No experience necessary. Big demand everywhere. Over 500% profit. Fred Foley, Binghamton, N. Y., made \$485.00 first month. Albert Gibbons, Kansas City, made \$212.00 in ten days. Liberal offer to general agents. Write today for sample of our high-grade window letters. Address, Metallic Letter Co., 431-C North Clark St., Chicago, Ill.

AGENTS—If you are making less than \$300 a month our proposition on Sentinel Burglar Alarms for windows and doors will interest you. Many agents earn \$20 daily. Brand new inventions. No wires, batteries or nails. Instantly attached to any door or window. Handsomely nickel plated. Sell on sight. No competition. Provides cheap burglar insurance. Big money makers. Write today for extremely liberal terms to agents. Sentinel Alarm Co., 140 S. Dearborn St., Chicago, Ill.

FREE Sample. "Rain Shield Wiper." Retail \$1.40—Costs 25c (330% Profit). Just Invented. Sold on Clear and Rainy Days. Automobiles buy quickly. No Cloth—No Paste—No Attachment. (1) Rub keeps Windshield Clear (48) Hours. Riley made \$108.00 three days. Experience Unnecessary. Wonderful Sideline. NuLife (O) Corporation, Hartford, Conn.

WHY work for others? Make and sell your own goods. We show you how. Enormous profits. Write quick for free book explaining everything. National Scientific Laboratories, 211 North Monroe, Richmond, Va.

AGENTS: Sell Boyer's Wonderful Beauty Creams, face powders, perfumes, etc. Big line. Exclusive agency. Make \$1 to \$3 every hour. Women wonderfully successful; we trust you. Write Boyer International Co., 944 N. Clark, Chicago.

HOUSEHOLD and office necessity, endorsed by "Good Housekeeping." An article of daily use. Large profits. Everett & Barron Co., Providence, R. I.

OUR Ex-Col Luminous Crucifix "shines brilliantly in the dark." Sells on first demonstration. Big profits. W. G. Hannan Co., Dept. B, 57 E. 18th St., Chicago.

ANY man handy with paint brush or light tools can start new mechanical business on nearly nothing; needed everywhere; nearly all profit; experience not required. John Braeland, 1437 So. Ninth, Philadelphia, Pa.

MEN and Women Wanted. Big Money sure and quick selling Dr. Blair's famous toilet and household preparations. Permanent business. Exclusive territory. Complete line. Remarkable Selling Outfit. Investigate. Write today. A. B. Blair Laboratories, Lynchburg, Va.

BUILD Your Own Business—Renewing and dyeing rugs and carpets on floors of offices, hotels, homes. New method. Big profits. \$10.00 Day easy. Write for full information. Texply Company, 15-A Somerville, N. J.

PORTRAIT Agents—If you are looking for a better grade of work, we can satisfy you. Our enlargements have that finished appearance together with perfect likeness, which makes it a pleasure to deliver, and best of all our prices are not high. Export work a specialty. W. G. Hannan Co., Dept. A-3, 57 E. 18th St., Chicago.

ONLY One Policy Daily Means \$130 Per Month Profit. Same on renewals. Policy pays \$5,000 death; \$25 weekly benefit for injury or sickness. Men or women acceptable. Premium \$10 yearly. Full or spare time. Easy seller. Write quick for territory. R. L. Lindley, 196 Market St., Newark, N. J.

TEN Rapid Sellers—all profitable. Windshield Cleaners, spark plugs, transformers, visors, etc. No investment. Generous commissions. Jubilee Mfg. Co., 63 Sta. C, Omaha, Nebr.

PROTECT your rights. Write for "Record of Invention" and booklet about Patents. Prompt personal service. Advice without charge. J. Reaney Kelly, 612-G, Columbian Building, Washington, D. C.

AGENTS Wanted to sell "Havana Treat" 5c cigars to smokers and stores. Havana Treat Cigar Co., Utica, N. Y.

MAKE \$5,000 every year—\$2,000 in spare time. You share profits besides. Just show and write orders for "Weather Monarch" Raincoats. We deliver and collect. Commissions in advance. Ask about "Dool Coat" No. 999. Free raincoat for your own use. Associated Raincoat Agents, Incorporated, 442 North Wells, Div. 221, Chicago.

TAILORING Salesmen. Make \$75 a week selling our strictly All-Wool Made-to-Measure Suits at \$26.50. You collect profits in advance and keep them. We supply finest selling outfit in America. Many exclusive money-making features. Tailoring, raincoat and side-line men, part or full time, get in touch with us immediately. Goodwear Chicago, Inc., 846 W. Adams St., Dept. 257, Chicago, Ill.

AGENTS: Big Money Monogramming by Transfer Method. Catalog Showing Over 50 Styles and Particulars Free. Motorists' Accessories Co., Mansfield, Ohio.

AGENTS: More Money when you need it. We want Agents right now to handle our two educational Poultry Books. Write for details. Erb Publishing Co., Washington Ave., Vineland, N. J.

AGENTS. Secure exclusive agency for your city. High class, permanent proposition, worth \$10,000 yearly. No investment, everything furnished. Address Box 1622, New Haven, Conn.

AGENTS Wanted:—Sells everywhere. Magic Electro Cleaning plate for silver, silverware and gold. No rubbing or polishing. Sample, 50c. Electro Co., Box C, Mayberry, W. Va.

SELL something everybody buys. Write for our money making proposition. Victoria Sales Co., 205 Anderson Bldg., Hamilton, Ohio.

AGENTS for our Sanitary Window Ventilator, for Homes, Offices, Hospitals, Hotels, To Hardware, House Furnishing and House Canvasers—write for territory. The Champion Sales Company, Euclid-46th St. Market Bldg., Cleveland, Ohio.

YOU Can Make Good Durable Paint and Varnish 50c per gallon. Write Dept. 2, Emmelmann Bros. Mfg. Co., Indianapolis, Ind.

SELL Furniture, whole or spare time. Write Wm. White, Box 457, Pensacola, Fla.

HANDKERCHIEFS. "Quality" line. Standard grades. Bedrock factory prices to agent. Get into solid, dependable business. Turnover Sales Co., 18A East 17th, New York.

AGENTS: \$1.25 an hour, \$8.50 a day. Light easy work near home showing samples, distributing foods. Big assortment full-sized packages free. Write quick. Dept. 75, Harley Company, Dayton, Ohio.

MEN, women, sell the Coué book—everybody is buying, no experience necessary; big profits; spare or whole time; no investment; free particulars. American Library Service, 500-N Fifth Avenue, New York.

CRYSTAL Compound softens the hardest water. Lightens Washday. No Rubbing. No Boiling. Enormous Profits. Big Demand. Sample Free. Address Utility Co., Chippewa Falls, Wis.

ROBERT Wrench is a sensation in wrenches. It surprises everybody. Grasps pipes, nuts and bolts any size without adjusting. Over 30,000 sold. You make almost 100 per cent profit. If you call on stores, shops, garages, factories or homes, write us today for full particulars about "The Wrench With The Bull Dog Grip." Robert Wrench Co., 71 Murray St., New York.

AGENTS: New Reversible Raincoat. Not sold in stores. Two coats in one. Guaranteed waterproof. You take orders. We pay you daily. No experience necessary. Sample furnished. Parker Mfg. Co., Coat 1178, Dayton, Ohio.

AMATEUR Agents Wanted to sell high-class radio sets and parts. Splendid proposition. Liberal commission. Catalog free. Columbia Radio Corp., 2759 Diversey Ave., Chicago.

AGENTS—Something new—everyone buys Ever-Radiant and Luminous Glass Name Plates, House Numbers, etc. You sell for \$1.75 and make \$1.45. Ten sales per day easy. Start big-paying business of your own. No experience necessary. Mail card for complete money-making plans. Address Crystal Products Co., 51 Wayne St., Big Prairie, Ohio.

AGENTS, Salesmen, Demonstrators, you will have the devil's own time trying to find a better seller than "Zigpe." If there was such a thing we'd have it. 150% profit on 50c "Go Getter" repeat article that sells on ten second demonstration. Works While You Watch It. Demonstrates value, while others waste time making claims. New Discovery! Greatest Scientific Triumph of the age. It's the berries. Haven't room to tell our story here. Write immediately. Karam-Smith Co., 603 Clark St., Fort Wayne, Ind.

AGENTS—Fifty-five Fast Sellers Needed in every home. \$6 to \$15 a day easily made. B. & G. Rubber Co., 618 Penn Ave., Pittsburgh, Pa., Dept. 240.

AGENTS Wanted—To sell Instant-Service salt and pepper sifters. Write us today for amazing offer. Free folder. The Oster-Barr Co., Rockford, Ill.

MAKE Big Money selling delicious puddings, polishing cloth, stain remover. 100 other tiptop sellers. Equipment free. Write, Newton Co., 11 Main, Newark, N. Y.

AGENTS—Self-threading Needles find sales in every home. Fine sideline, easily carried. Big profits. Sample free. Prentice-Lee, 145 East 23rd, New York.

WANTED agent to sell Timers for Ford. Will last life of motor. Sample, \$2.00. O. A. Ekre, Kindred, No. Dak.

EASY To Make \$10.00 Daily. Samples Free. New Inventions. Sponge Dusting Cloths. Velvet Metal Polishing Cloths. Brushes, Dusters, Mittens. Sell Homes, Automobiles, Stores. No Competition. NuLife Home (E) Ald, Hartford, Conn.

WHY work for others? Make and sell your own goods. We show you how. Enormous profits. Write quick for free book explaining everything. National Scientific Laboratories, 211 North Monroe, Richmond, Va.

AGENTS: Sell full line of guaranteed hosiery for men, women and children. Must wear 12 months or replaced free. All styles, colors and finest line of silk hose. Often take orders for dozen pairs in one family; permanent customers and repeat orders make you steady income. Write for sample outfit. Thomas Mfg. Co., Class 462, Dayton, Ohio.

MOST Wonderful Seller. 50c profit every dollar. No stock to carry. License unnecessary. Sample free. Mission, 2421-PM, Smith, Detroit.

\$75-\$150 WEEKLY assured if you hustle. Sell attractive gold signs to stores, offices. Unlimited demand. Experience unnecessary. Free samples. Acme Letter Co., 363 W. Superior, Chicago.

BIG Profits With Exclusive Territory—\$50 to \$100 weekly easy. More has been made repeatedly in one day's work. Wonderful invention delights householders. Automatic hot and cold water bath outfit without plumbing; only \$7.50. Eager buyers everywhere. Send no money. Terms. Write today. Allen Manufacturing Co., 698 Allen Bldg., Toledo, Ohio.

MANUFACTURER offers exceptional opportunity to those capable of organizing sales force of women to handle a product universally in demand by women. Write American Rubber Products Co., Dept. 611, Pittsburgh, Pa.

AGENTS—\$3 per hour and more!! Sell Iron Board Covers, Rubber Aprons, Shopping Bags, Embroidered Aprons, Sateen Coverall Dresses. Free. Sample offer! American Braiding Company, Dept. P, 329 W. Monroe, Chicago.

PORTRAITS, photo pillow tops, frames, sheet pictures, medallions, merchant's signs, waterproof and tea aprons, silk and wool hose, luminous crucifixes; catalog, 50 specialties free, 30 days' credit. Jas. C. Bailey Co., Desk 3, Chicago.

WE pay \$200 monthly salary, furnish rig and expenses to introduce our guaranteed poultry and stock powders. Bigler Company, X368 Springfield, Illinois.

\$8.00 TO \$20.00 per day. A wonderful seller. Any man, woman, boy or girl can make big wages Selling Crimp Grip Clothes Line Fasteners. It is a perfect rope holder and can be used for many purposes. Crimp Grips are a simple, time-saving device. They last a life time and will not rust; it holds the line tight, and saves time on wash days. Every buyer is a booster. Send 50c for Mounted Sample and one pair of Crimp Grip Clothes Line Fasteners. Write for particulars. Crimp Grip Company, Belvidere, Ill.

WE start You Without a Dollar. Soaps, Extracts, Perfumes, Toilet Goods. Experience unnecessary. Carnation Co., Dept. 201, St. Louis.

AMBITIOUS Men, write today for attractive proposition, selling subscriptions to America's most popular automobile and sportsman's magazine. Quick sales. Big profits. Pleasant work. Digest Pub. Co., 9505 Butler Bldg., Cincinnati, O.

EVERYBODY uses extracts. Sell Duo Double Strength Extracts. Complete line household necessities. Big repeaters. Write today. Duo Co., Dept. E1, Utica, N. Y.

AGENTS—Sell Patented Cigar Lighters and Cigar-Case Moisteners. Big Profits. Start making money at once. Write for circulars, cuts and sales plan. Drake Mfg. Co., Dept. M, Milwaukee, Wis.

300% PROFIT Selling Silk Stove Dressing. Write for Particulars. Edwards Mfg. Co., Mendota, Ill.

PATENTS—Write for our free illustrated guide book and Evidence of Conception Blank. Send sketch or model for our opinion of its patentable nature free. Highest references. Prompt attention. Reasonable terms. Victor J. Evans & Co., 163 Ninth, Washington, D. C.

27,000 RECORDS guaranteed with one Everplay Phonograph Needle; new—different; cannot injure records; \$10.00 daily easy. Free sample to workers. Everplay, McClurg Bldg., Desk 36, Chicago.

LIGHTNING, wonderful new electrolyte, guaranteed to charge discharged batteries instantly and permanently. Send \$3.50 for agent's proposition and sample to R. H. Julien, Copas, Minn.

AGENTS—Stamping names on Pocket Key Protectors; sample Check with your name and address, 25c. Stamping Outfits. Emblem Checks, Check Fobs, Name Plates. Hart Mfg. Co., Desk 2, 303 Degraw St., Brooklyn, N. Y.

SELFOLITE—Agents, Streetmen—Selfolite lights any fire while user sleeps, or any time. Performs surprising stunts. Newly patented. Sample 25c, postpaid; money back. Particulars. Kaytwo Mfg. Co., C195 Station A, Boston, Mass.

AT Last—World's Greatest Adding Machine. Almost human. Retail \$15; work equals \$30 machine. \$500 monthly easily made, demonstrating to stores, offices, garages, factories. Simple, easy; adds, subtracts, multiplies, divides automatically. Speedy, accurate, durable, handsome. Five year guarantee. Tremendous demand; amazing profits. Liberal trial offer. Protected territory. Write quick. Lightning Calculator Corp., Dept. F, Grand Rapids, Mich.

BIG Money-Makers. Large factory offers you big profits. Over 200 fast sellers. Toilet gift sets, flavoring extracts, remedies, soaps, bring you \$8.00 to \$25.00 daily. Howe of Illinois makes \$4.00 an hour. Sample outfit free to workers. Lincoln Chemical Works, Dept. 155, 2956 No. Leavitt, Chicago.

GET Our Free Sample Case—Toilet articles, perfumes and specialties. Wonderfully profitable. La Derma Co., Dept. A., St. Louis, Mo.

AGENTS—Clever Invention! Inkspoon makes every pen a fountain pen. Fast office seller; big profit, demand increasing everywhere. Exclusive territory offered. Sample free. H. Marul Company, Tribune Bldg., New York, N. Y.

500% PROFIT selling Genuine Gold Leaf sign letters. Guaranteed never to fade. Easily applied. Experience unnecessary. Wonderful future. Free Samples. Guarantee Sign Service, 263 W. Superior, Chicago.

AGENTS make 500% profit handling Auto Monograms, New Pictures, Window Letters, Transfer Flags, Novelty Signs. Catalog Free. Write Hinton Co., Star City, Ind.

AGENTS—New patented curtain rod, necessity in every home; big profit; 4 to 10 sales at every house. Write for free sample. Home Curtain Rod Co., Providence, R. I.

FIFTY "Ideal" Sidelines for Mail Dealers and Agents. 500% profit. K. Home, 1957 Warren, Chicago.

WE pay \$26 a week and expenses and give a Ford Auto to men to introduce poultry and stock compounds. Imperial Co., 45, Parsons, Kan.

MEN'S Shirts, Easy to sell. Big demand everywhere. Make \$15.00 daily. Underseal stores. Complete line. Exclusive patterns. Free samples. Chicago Shirt Co., 9 So. Clinton, Factory 205, Chicago.

AGENTS—C. T. A. prices reduced again. Suits \$18.00 made to order, any size or style. Orders easy to get. Big profits. Sample outfit free. Write Chicago Tailors Ass'n, World's largest tailors, Dept. 207, Station C, Chicago.

AGENT: To sell rebuilt typewriters. Underwood, Remington, Royal, Monarch and Smith Bros. Write today for particulars. City Typewriter Exchange, Room 319, Rochester, N. Y.

AGENTS make a dollar an hour. Sell Mendets, a patent patch for instantly mending leaks in all utensils. Sample package free. Collette Mfg. Co., Dept. 401-B, Amsterdam, N. Y.

\$75-\$150 WEEKLY assured if you hustle. Sell attractive gold signs to stores, offices. Unlimited demand. Experience unnecessary. Free Samples. Acme Letter Co., 363 W. Superior, Chicago.

A WONDERFUL Seller! Any man, woman, boy or girl can make big wages. Some agents make from \$8.00 to \$20.00 per day. Crimp Grip Clothes Line Fasteners are a simple, time-saving device for holding a rope—also used for many other purposes. It pays for itself quickly in time saved on wash days. No knots—it fastens and releases quickly. Every home a prospect. Every housewife who uses Crimp Grips—and there are thousands of them—is a booster. There is but one Crimp Grip. Write for particulars, or send 50c for one pair and a mounted sample, with full particulars to agents. Crimp Grip Company, Belvidere, Ill.

AGENTS—Clean up \$100 Weekly With "Nifty Nine." Weekly average, 100 sales—dollar profit each. 30-40 sales daily frequently made; demonstrating outfit cinches order. 30 other coin-coaxers, all daily necessities. Postal brings our unique plans. Davis Products Co., Dept. 508, Chicago.

AGENTS—Crew men, novelty men. Gloo-Pen, a 50c mucilage fountain pen; everybody buys on demonstration. Write for big profit plan. Gloo-Pen Co., 58-FF Pine St., New York.

AGENTS—Earn \$25 to \$100 weekly introducing Ho-Ro-Co. toilet goods, extracts, and household necessities. Men or women wanted for full or spare time. Ho-Ro-Co. Tonic and Medicated Skin and Scalp Soap are great profit makers. Repeat orders easy and sure. Over 100 other fast sellers. Free sample case offer; free samples and advertising matter. Write today. Ho-Ro-Co. Mfg. Co., 188 Locust St., St. Louis, Mo.

SPIRAL Curtain Rods, beam protectors, Ironing Sheet Clips, factory prices. Other fast sellers. Hunt Mfg. Co., Box 1652-P, Paterson, N. J.

WHY work for others? Make and sell your own goods. We show you how. Enormous profits. Write quick for free book explaining everything. National Scientific Laboratories, 211 North Monroe, Richmond, Va.

\$5 TO \$15 Daily Easy—Introducing New Style Guaranteed Hosiery. Must wear or replaced free. No capital or experience required. Just show samples, write orders. We deliver and collect. Your pay in advance. Elegant outfit furnished, all colors and grades including silks. Mac-O-Chee Mills Co., Desk 2583, Cincinnati, Ohio.

\$15.00 DAILY Easy selling Unbreakable Amberoid Combs. kind can hit with a hammer, saw wood with the teeth, etc. Top-notch sellers with agents. Many street-men selling over \$100.00 worth on Saturday afternoon and evening. You can do as well. Terms and money-making proof free. Oliver Gandy, Crisfield, Maryland.

SOMETHING Big, 10c puts your name on our mailing list one year. You receive latest money-making propositions, opportunities, from supply houses, manufacturers, everywhere. Kentucky Agency, Coalington, Ky.

SHEEP Wool polishes, cleaners, dusters. Box 26, East Boston, Mass.

AGENTS: Big money selling great household necessities. Sample quarter. Webster Co., 2545 N. Clark St., Chicago.

GOLD Leaf Sign Letters, make and sell; profits exceed 1,000%; immense demand, particulars free. Johnston Co., Quincy, Ill.

MAKE \$75-\$100 Weekly, New Patented Safety Hatpin creating sensation. No competition. Sample 50c. Write quick. Modern Specialty Co., Los Angeles.

PORTRAIT Agents—Sample Rolls, Sample Cases and Samples of all kinds furnished to the portrait trade. Write for catalog. Chicago Sample Roll Co., Dept. P, 57 East 18th St., Chicago.

\$5 TO \$15 Daily Easy—Introducing New Style Guaranteed Hosiery. Must wear or replaced free. No capital or experience required. Just show samples, write orders. We deliver and collect. Your pay in advance. Elegant outfit furnished, all colors and grades, including silks. Mac-O-Chee Mills Co., Desk 2543, Cincinnati, Ohio.

AGENTS—Big Profits. Selling Warrub Polish for Furniture, Woodwork, Automobiles, etc. Cleans and Polishes. Write for Big Free Offer. Fritch's Laboratories, 312-C North Carpenter, Chicago.

MAKE \$25 to \$50 Week representing Clows' Famous Philadelphia Hosiery, direct from mill—for men, women, children. Every pair guaranteed. Prices that win. Free book "How to Start" tells the story. George Clows Company, Desk 81, Philadelphia, Pa.

SPECIALTY Salesmen making \$10.00 daily selling Ball Valve Non-Splash Water Filters on sight. Best canvassers' article ever put on market. Sample for details. C. A. Shinn, Manufacturer, 73 Franklin, New York.

HOUSEWIVES Buy Harper's Invention on sight. New business. No competition. Ten-Use Set is combination of ten indispensable household necessities. \$7.50 to \$30.00 daily, easy. Write for free trial offer. Harper Brush Works, 111-A Street, Fairfield, Iowa.

AGENTS Wanted—Build a permanent year-round business selling great "Foot Ointment." Big profits, wonderful opportunity. Write now. Elder Co., 293 Parkdale, Buffalo, N. Y.

RADIO Agents wanted in every town to sell Ames Radio Products. We manufacture long distance Radio receiving sets and parts. Big profits. Write for plan. Picard Radio Corp., Dept. Ma., 18 West 48th St., New York.

BIG Agent's and Mail Order Magazine of Opportunities and Information including "Supply" Guide, three months 25c. Harvey Temple, Decatur, Indiana.

EASY, pleasant work for Mechanics, Shop Men, Clerks, during spare hours; will add many dollars to their salaries. Also want persons who can give full time. Big wages assured. Novelty Cutlery Co., 67 Bar St., Canton, O.

CALIFORNIA Rosebuds selling like hot cakes. Agents raising money; new stuff. Big profits. Catalog free. Mission, 2121-PM, Smith, Detroit.

FORTUNE Maker—Thread-Cutting Thimble. Live wires only. Sample, 15c. Auto-Mote Mfg. Co., 3753 Monticello, Chicago.

VANILLA, Lemon, Orange, etc., Flavors, concentrated—add water, make your own. We furnish flavor, labels, everything. Samples Free. Lawrence Chemical Co., Marietta, Ohio.

AGENTS—\$15 a day—Easy, quick Sales—Free Auto—Big weekly Bonus—\$1.50 premium Free to every customer. Simply show our Beautiful 7-piece, Solid Aluminum Handle Cutlery Set. Appeals instantly. We deliver and collect. Pay daily. New Era Mfg. Co., 803 Madison St., Dept. 21-K, Chicago.

SELL Necessities. Everybody needs and buys the "Business Guide." Bryant cleared \$300.00 in July. Send for sample. It's free. Nichols Co., Box 4-B, Naperville, Ill.

AGENTS: Big Returns, fast office sellers; particulars and samples free. One Dip Pen Co., 2 Daily Record, Baltimore, Md.

IF you need good live agents—fellows who can get the business—ask me how others are doing it. I'll gladly render the necessary assistance. J. Roy McClellan, Mgr. Classified Advertising, Popular Mechanics Magazine, Chicago.

AGENTS: Big profits. Best and cheapest window letters made. Easily applied. Dime brings five samples. Particulars free. Stalbrittle Co., 1115 Second Ave., New York.

\$15.00 DAILY selling Radio Gas Lighter. Sells on sight. No matches or friction required. Sample, 10c. Rapid Mfg. Co., 10 E. 14 St., New York, N. Y.—Dept. P.

SIGN Agents: Bigger profits, putting up our patented flexible genuine gold leaf letters. Something entirely new. Look exactly like hand glided work on glass. Sell on sight. Write for folder A and free samples. Beakart Sign Letter Co., Lock Box 855, Chicago.

SELL Wall Emblems. Every Lodge Member wants one. Big money—all or spare time. Free sample and cash bonus plan. Kier Emblem Co., Dept. PM-3, 538 So. Clark, Chicago.

AGENTS to sell the latest Radio Receiving Set. Retail \$8.50; easy to sell. A sale in every home. Send \$4.35 for complete sample. Martian, 171 Washington St., Newark, N. J.

AGENTS—Sell Bamboo Fountain Pens. Sells on sight; serviceable. Sample 50 cents. Specialty Sales Co., Friend, Neb.

CLARKE made \$18 an hour selling vest-pocket windshield cleaner needed by every autoist, motorist, engineer; one rub keeps glass clear 24 hours; 60,000 sold; amazing proposition free. Security Mfg. Co., Dept. 662, Toledo, Ohio.

LARGE manufacturer wants agents to sell guaranteed made to measure raincoats, Gabardines and Reversible top and raincoat combined. Make \$75 to \$100 weekly. Profit in advance. We deliver and collect. Outfit free. Standard Raincoat Co., 163 West 21st Street, New York, N. Y.

AGENTS—Quiet sales, big profits, outfit free. Cash or credit. Sales in every home for our high-class line of Pure Food Products, Soaps, Perfumes, Toilet Articles, etc. Write today for money-making plans. American Products Co., 8431 American Bldg., Cincinnati, Ohio.

AGENTS make \$10 daily—Big line guaranteed extracts, food products, perfumes, toilet goods, household necessities. No capital or experience needed. Free sample case and instructions. Write for amazing offer. Perkins Products Co., Desk 6, Hastings, Neb.

BIG Money and Fast Sales. Every owner buys Gold Initials for his auto. You charge \$1.50; make \$1.25. Ten orders a day easy. Write for particulars and free samples. American Monogram Co., Dept. 46, East Orange, N. J.

TREMENDOUS Opportunity for ambitious agents. The indispensable, rapid selling Speedy Dish Washer. Price \$3.50. No competition. No investment. Easy selling plan. Convenient sample. Commission daily. Make application today—exclusive territory. Sheppard-Lath Mfg. Co., 18-G Hudson St., New York.

BUILD a permanent business of your own with the high-grade, quick-selling "Nibeo" Specialties. Exclusive territory. \$10.00 to \$20.00 profits a day easy for earnest salespeople. Send for interesting folder. A. A. Silver-Chamberlin Co., Clayton, N. J.

EITHER Sex make \$50.00 weekly selling Bleachrite Washing Compound; big profit, enormous repeater. W. E. Garrett Co., Tulsa, Okla.

LIVE Agents make \$10 Day selling Eureka Strainer and Splash Preventer for every water faucet. Takes on sight. Widely advertised and known. Get details today. A. R. Seod Filter Company, 73 Franklin, New York.

VIOLINS—Deep, Mellow, Soulful—on credit. Easy terms for wonderful instrument. Get details today. Gustav F. Hemming, 2424 Gaylord St., Denver, Colo.

EARN big money fast applying gold initials to autos. Every owner buys—\$1.25 profit on \$1.50 sale—particulars and samples free. Write quick. Lithogram Co., Dept. 17, East Orange, N. J.

"\$10 A DAY and More," our new book, shows clearly how you may gain sure success and large profits selling Guaranteed Hosiery and Underwear, factory to family. It is Free. Write today. C. & D. Company, 41-E, Grand Rapids, Mich.

SELL "Amens" Shirts; best-looking, biggest value. Manufacturer to wearer. Every order nets profit \$1.50-\$2.25. Write for winning sales plan. Menzin Shirt Co., 2863-A, Third Ave., New York.

PORTRAIT Agents and Others. Get Big Profits. Sell Perry Photo Medallions. You charge \$2.98; make 400% profit. \$10 daily easy. Big exclusive line. 4-day service. Perry Photo Novelty Corporation, Section 18, 380 Bowery, New York.

AGENTS—Steady Income. Large manufacturer of Handkerchiefs and Dress Goods, etc., wishes representative in each locality. Factory to consumer. Big profits, honest goods. Whole or spare time. Credit given. Send for particulars. Address: Freepost Mfg. Co., 59 Main St., Brooklyn, N. Y.

WORLD'S fastest agent's seller. 300% Profit. Needed in every home and store. Establish Permanent business. Premier Mfg. Co., 813 E. Grand Blvd., Detroit, Mich.

WANTED—Representatives to sell Automobile necessity. Kills headlight and sun glare. Write for sample. Dept. P, The Clark Products Co., Springfield, Ohio.

AGENTS Wanted. Big Money Maker. Sells to Ford owners on simple demonstration. Gives 20% to 50% more miles. New and patented. Write Marvel Gas Saver Co., Dept. A, Bockford, Ill.

PORTRAIT Agents: Our goods will make you big profits. Delivery guaranteed. Refunds credited. Prompt shipments. Send for latest catalog and prices. Adam J. Kroll & Co., 602 Blue Island Ave., Chicago, Ill.

HURRY—Little modern article used in every home, every day; light to carry; 300% profit. Sample free. Shillings Chemical Works, Hamlet, Ind.

AGENTS and Others: Learn a business in one day that will eventually make you prosperous; no book or medicine scheme. We teach you every detail for only 25c. A. S. Ritter, Elkhorn, Wis.

ATTENTION Agents. Biggest money-making brush proposition on the market. Lower retail prices; higher commissions. Write for proposition. Springfield Brush Works, Springfield, Mass.

YOU can be your own boss with our Key Check outfit. Good for \$5 a day stamping names on pocket key checks, fobs, etc. Sample check with your name and address, 20 cents. Pease Die Works, Dept. M, Winchester, N. H.

AGENTS! A sale in every home for our beautiful dress goods, silks and general yard goods. Quick sales! Big profits! Large book of nearly 1000 handsome fabric samples furnished to agents. Write today. National Importing & Mfg. Co., Dept. 6X, 573 Broadway, New York, N. Y.

AGENTS: Big profits. Genuine Gold Leaf Window Letters anyone can put up. Scripts and 57 varieties. Chicago Agency Co., 842 Altgeld St., Chicago.

OUR new Adjustable Handle Floor Sweep, durable and attractive in appearance, is a big money-maker. Made in styles to suit all requirements. Paxson Mfg. Company, 219 Sanson Street, Philadelphia, Pa.

YOUNG Men to sell the latest Radio Receiving Set. Retail \$4.50, easy to sell. A sale in every home. Send \$4.35 for complete sample. Martian, 171 Washington St., Newark, N. J.

AGENTS—Drop your dead ones. The Universal Sanitary Milk Bottle Cover is the new home necessity. Converts bottle into pitcher. Cannot spill if tipped over. Sanitary and easily cleaned. Best 25c seller out. Sample 25c. Write now. E. Z. Art Needle Co., 513 N. Dearborn, Chicago, Ill.

POLMDT Polishing Cloth cleans all metals; retails 25c; sample free. Gale & Co., Inc., 15 Edinboro St., Boston.

AGENTS Wanted, sell men's shirts direct to consumers at wholesale prices. Write for Samples Dept. M, The Seneca Co., 145 West 45th St., New York.

SALESMEN—Agents! \$1.00 to \$5.00 an hour on liberal commission, plus monthly and yearly bonus. Fast sellers. 8 sales every 10 demonstrations. Also big opportunities for field men, crew managers, district managers. Write for "The North Ridge Way to Bigger Pay." J. H. Nortridge, 307 N. Chicago Ave., Freeport, Ill.

EARN \$10 daily silvering mirrors, plating and refinishing metalware, autos. Chandlers, bedsteads, headlights. Outfits furnished. E. Deede Laboratories, 1133 Broadway, New York, N. Y.

\$50,000 **PICTURE** Man Friedman made taking orders. Beginners can make \$100.00 weekly with my canvassing spiel, experienced men make more. Free circular. "Profits in Portraits," explains. Samples free. Picture Man Friedman, Dept. 8, 673 Madison, Chicago.

WRITE and learn how to start profitable business without capital or experience. Silvering mirrors, refinishing auto headlights, tableware, plating. Outfit furnished. International Laboratories, Dept. 26, 309 Fifth Ave., New York.

WHY work for others? Make and sell your own goods. We show you how. Enormous profits. Write quick for free book explaining everything. National Scientific Laboratories, 211 North Monroe, Richmond, Va.

FASTEST Selling Ford Necessity just out. Seward's profit one day \$74.00. Territory going fast. Write quick. Super, 1304 Fondulac, Milwaukee, Wis.

DAVIS sold 24 Sprayers and Auto-washers in 24 hours; Profits \$3.50 each; Square Deal; Particulars Free. Sprayer Co., Johnstown, Ohio.

FREE Book. Start little Mail Order business. Home employment evenings. Pier, Dept. 171-A, 74 Cortland St., New York.

AGENTS—Just like selling gold dollars at 60c each. That's what J. A. Saunders of Pawtucket, says about our wonderful pure all virgin wool made to order suits, retailing at \$29.50—none higher—Finest selection of fabrics—serges, worsteds, cassimeres and flannels of superb quality. Fit, style and quality unexcelled. Satisfaction guaranteed. This is a line that will bring repeat business and big money. A big opportunity for hustlers. No experience needed. We will teach you. Write today—state ter. desired. J. B. Simpson, Inc., Dept. 513, 831 W. Adams St., Chicago.

MAKE \$31.00 Profit With Only \$1.50 Selling Gold Leaf Monograms for Automobiles, Trunks, Bags, Window and Wagon Letters. Applied Instantly. Experience Unnecessary. Outfit brings \$32.50—Costs \$1.50—You Make \$31.00 Profit. Free Samples (36 Designs). NuLife Auto (A) Aid, Hartford, Conn.

OLD worn out casings will give 3 to 5 thousand miles more service with Insyde Tires. Positively prevent punctures and blowouts. Double tire mileage—any tire, old or new. Use over and over again. Low priced. Agents wanted. American Accessories Co., B-878, Cincinnati, Ohio.

AUTOMATIC Kuff-Buttons Greatest Convenience on Earth. Fifty other Dependable Jewellery Specialties. Master Jewelers, Sheboygan, Wisconsin.

SALES Agents, Men or Women; Year round position. No layoffs. Take orders for Jennings new guaranteed hosiery. Must wear and give satisfaction or replaced free. Write for outfit. Jennings Mfg. Co., Dept. 168, Dayton, O.

"HOW to Sell Patents" free. Patent News-O, Washington, D. C.

AGENTS Newest Money Getter; 35c profit every 35c sale; sample free; Empires Branch, Ventnor, N. J.

LIVE Agents, Automobile necessities. Quick sales. Big profits. Exclusive territory. No triflers. Kennos Engineering Company, 50 Church Street, New York, N. Y.

WINDSHIELD Cleaner, one rub keeps glass clear 24 hours from rain, snow, sleet, fog. Agents wanted. Auto Owners Supply Company, Davenport, Iowa.

AGENTS—Sell latest imported pocket pencil sharpener. Sample mailed 25c. Voigt Novelty, West Frankfort, Ill.

AGENTS, Mail-Order Men, Beginners: More good news for you. Three new articles in constant demand, 100 to 400% profit. Valuable inside information. Also big sensational seller, complexion clay. Particulars free. Nite Mail Order & Supply Co., 609 27th St., Denver, Colo.

AGENTS wanted, young men and women to sell the Big Four Crystal Radio receiving set. Big seller, no competition. A sale in every home. Martian Sales Co., 171 Washington Street, Newark, N. J.

MINT for Agents, Distributors—Earn \$300 per month and over. New Household Necessity. Saves owners Hundreds of Dollars per year doctor bills. Sells on sight. Premium plan gets big business. Research System, 2329 W. Chicago Ave., Chicago.

ONE hundred dollars weekly and more selling genuine oil portraits painted on canvas from photographs. Not tinted enlargements. New field. Easy seller. Cleveland Studios, Redmond, Wash.

WORLD'S Fastest Selling Household necessity. Guaranteed! County Distributors wanted. Write today. William Products Co., 1225 East 60th St., Cleveland, Ohio.

FREE—Formula Catalog. S. & H. Laboratories, Boylston Building, Chicago.

AGENTS wanted. Every man, woman and child buys. Disappearing Pencil. Sample 15 cents. Beven, One East 42 Street, New York, N. Y.

"NO Splash" Milk Bottle Opener and Cap. "Nof sed." Sample 25c. Dollar per dozen. J. M. Montgomery, 1424 Howard St., Chicago, Ill.

AGENTS—Mason sold 18 Comet Sprayers and Auto-washers one Saturday. Profits \$2.50 each. Particulars free. Established 30 years. Busler Co., Johnstown, Ohio. Dept. D.

WANTED—Tailoring Sales Agent—Make big money from very start—\$40.00 to \$75.00 weekly. Largest made-to-measure tailoring house, furnishing an equipment of five hundred woolsens, wants you to take orders. Satisfaction guaranteed. Biggest merchants in many towns have started with our line. If you want to establish yourself permanently in business and make big money write for full particulars, giving your experience as salesman or tailor's sales agent. H. F. Foster, Sales Manager, Lock Box 483, Chicago.

SELLS Like Lightning, Big Profits; New Laundry Starch perfumes clothes with Lasting Violet. Outfit 10c. Ezy-Wash, 380 Atlantic Ave., Brooklyn, N. Y.

AGENTS—To sell the famous Alaska Diamonds. They have the same dazzling rainbow fire of genuine diamonds and baffle experts. Send for sample in heavy gold-filled mounting. Special agents' price \$1.75. State size. The Alaska Diamond Co., 566 East 45th St., Chicago.

OUR Agents makes \$12 to \$20 every day and are getting it with new invention that sells to everybody. Low Price. Pocket sample. Write Edward Suren Company, 25 N. Dearborn St., Chicago.

AGENTS: \$75-\$100 weekly taking orders for popular \$3.98 raincoats. Commissions advanced. We deliver and collect. Free coats to workers. Eagle Raincoat Co., 414 Lees Bldg., Chicago.

AGENTS—Sell Neverfall Iron Rust and Stain Remover. Huge profits. Big line. Sample. Write today. Sandford Beal Co., Inc., Newark, N. Y., Dept. 6.

AGENTS—\$100-\$200 weekly putting on ready-made window letters, easily applied. Samples, particulars free. Peerless Sign Letter Co., 3735 N. Clark St., Chicago.

AGENTS:—Marvelous cloth-rub over windshield prevents rain, snow blurring. Agents making \$10 to \$30 daily. Puritan Products Co., B947, Johnstown, Pa.

FREE Coal for a few hours' spare time. Write today. Peoples Coal Co., 1120 W. 35th St., Dept. 60, Chicago.

AGENTS and Distributors: study this proposition. "FLASHDASH," low gasoline signal for Fords, New invention. No competition. Exclusive territory. Large profits. Write for details. Auto Gas Gauge Company, 536-D Hackett Road, Toledo, Ohio.

AGENTS—Our Dish Cloths sell like "hot-cakes." Sample, 15c. Utility Mfg. Co., Norwich, Conn.

MILLION Dollar Business, nationally known, wants one man to take charge each county. 75 Different household necessities, "Sure-Shot" selling plan with Free Gift makes sales easy. Wizard Products Co., 1400 W. 57th St., Chicago.

HIGH-GRADE SALESMEN

BEST Seller: Jem Rubber Repair for tires and tubes; supercedes vulcanization at saving of over 80%; put it on cold, vulcanizes itself in two minutes, guaranteed to last life of tire or tube; sells to every auto owner and accessory dealer. Get particulars how to make big money and free sample. Amazon Rubber Co., Philadelphia, Pa., Dept. 510.

EVERYBODY Eats Every day and every time they eat some one makes a profit. Sell groceries and be in the biggest business in the country. No capital or experience necessary. Just show samples and take orders for Sugar, Flour, Canned Goods, Dried Fruits, Coffee and entire line of "every day eating" groceries, as well as Paints, Roofing, and Automobile Oils. Finest quality. Our prices in many cases are lowest. We have men making \$8,000 to \$8,900 yearly. Address Hitchcock-Hill Company, Dept. 200, Chicago. References—any bank or express company.

SELL Nifty little "Cataract." Washes Automobiles quickly. Cataract Auto Washer Company, Topeka, Kan.

LET us send you the proof from salesmen now earning \$50.00 daily selling collection systems to merchants. Sayers Manufacturers, 2815 Sheffield, Chicago.

TEN Rapid Sellers—all profitable. Windshield Cleaners, spark plugs, transformers, visors, etc. No investment. Generous commissions. Jubilee Mfg. Co., 62 Sta. C, Omaha, Nebr.

SALESMEN—Become Independent. Own your business; experience unnecessary; selling our \$7,500 Accidental Death, \$50 Accident, \$25 Sick Weekly Benefits; \$12.50 yearly; other amounts proportionate. Guaranteed steady income from renewals. \$250,000 deposited Insurance Department. Registration Dept. A, Newark, N. J.

SALESMEN, Sell State Pocket maps, showing auto roads, to advertisers and dealers. Easy to sell. Get our splendid offer. Standard Map Company, 127 West Ohio Street, Chicago.

ALL Salesmen make good with this. Something new. Best, cheapest truck tire chain. Over 100% profit. Every truck owner orders. Circular. Address, Herman Mfg. Co., 1210 H St., Washington, D. C.

SALESMEN: To call on retail stores. Easy to make \$20 a day. Write to Supreme Radio Co., 407 Century Bldg., Cleveland, Ohio.

SPECIALTY Salesmen—Sell the Ever-Ready Sanitary Comb Cleaner, Sells to everybody. Every one that uses a comb needs one. 3 dozen costs you only \$3.00, delivered. You get \$9.00 for them. Sample 25c. K. W. McKeehan, 2802 Oakland Ave., Dallas, Tex.

CALIFORNIA Rosebuds selling like hot cakes. Agents coining money. Absolutely new. Big profits. Catalog free. Mission, 2421-SP, Smith, Detroit.

SUBSTANTIAL corporation manufacturing several articles under valuable patents can place several more general sales managers, open branch offices, manage salesmen. \$500 to \$2,000 necessary to finance agency; expenses allowed to Chicago if you qualify. Mr. Inman, 9 South Clinton St., Chicago, Ill.

SPECIALTY Salesmen wanted to sell patented Self-Locking Egg Cartons. Excellent side line. Some good territory open to live wires. Self Locking Carton Company, 589 E. Illinois St., Chicago, Ill.

SALESMAN. Strong line for general retail and drug stores; nationally advertised; revision of territory leaves unusually good position open. Liberal commission; weekly advance to producers; annual bonus. If You Want \$4,000 this Year, Write Now. The Continental Co., 1929 Euclid, Cleveland, Ohio, Dept. 200.

SALESMEN Can make \$5.00 a day selling our Calendars, Penells, Signs, Advertising Novelties, Yardsticks, Whistles, etc. Liberal terms, Sells entire year. Fine side line. Local and traveling agencies. Model Calendar Co., Dept. 226, South Bend, Ind.

SOMETHING New, a Necessity. All business and professional men need it. Sells \$7.50, costs you \$2.50. Big repeater. Write for sample. Merchants Ass'n, Minneapolis, Minn.

SIGN Letter Agents and Painters; 500% Profit. Gold and Silver Sign Letters for Stores and Office Windows. Anyone can put on. Big demand. Free samples. Metallic Letter Co., 431D N. Clark St., Chicago.

SELL something original! Something every merchant needs—"Zim's Peerless Collection System." Exclusive collecting features has collected for 1% cost. Sells \$7.50. Creditors' Association, E-312 McKnight Bldg., Minneapolis, Minn.

AMBITIOUS Men, write today for attractive proposition, selling subscriptions to America's most popular Automobile and sportsman's magazine. Quick sales. Big profits. Pleasant work. Digest Pub. Co., 9505 Butler Bldg., Cincinnati, O.

TRAVELING Salesmen calling on retail stores wanted by large manufacturer to sell wonderful line of business-boosting articles. Year round, fast selling, main or side line. If not earning \$150 weekly, address Elmer Works, 222 Charles St., Boonville, N. Y.

EASY to sell Groceries, Paints, Automobile Oils, Roofing, Stock Food to consumers from samples, no capital or experience necessary; steady, profitable work. Commissions advanced. Satisfaction guaranteed. 50 years in business. Write for full particulars. Lovrin & Browne Co., Wholesale Grocers, 1775 S. State Street, Chicago, Ill.

SALESMEN—Bonded Aspirin on Easels. All merchants. Side line or regular. \$35 a week and expenses guaranteed against liberal commissions. Tiffin Laboratories, La Crosse, Wis.

57 MILES per gallon made with new patented gasoline Vaporizer. Write for particulars. Vaporizer Co., Pukwana, S. Dak.

YOU May make \$2,000 per month selling Alexander Publicity Film Service. It is being done. We will train you to sell a service that advertises its own money-making effectiveness, to the most successful bankers and business men. It helps sell itself. A new man learned, in a week, to make \$94.00 per day. Alexander Film Company, 1151 Main, Spokane, Wash.

SALESMAN fond of automobiles, who likes to solve their difficulties and make them run smooth, can make a connection worth \$3,000 to \$10,000 in an automotive accessory line. Prefer man without salesmanship experience to good salesman who doesn't like machinery problems. Permanent and will be as big as the man himself. Address Bridgers Corporation, Florence, S. C.

"OUTOSITE" Aluminum hip-suspenders. (Not over shoulders.) Shirt down, trousers up. Enormous seller. Sample pair 50c. Woods, Suite B, 3533 Lafayette, St. Louis.

ENORMOUS Salesmen's Profit. Twelve Guaranteed Auto essentials. Leather bill-fold free. Reviving Co., Oblong, Ill.

THE Magnetic Hair Waver sells on sight—an unbeatable sideline for man or woman selling drygoods, variety, notion or drug-store trade. Exclusive features. A-1 repeater. Big commission, pocket samples. Magnetic Mfg. Co., 519 Corn Exchange Bldg., Minneapolis, Minn.

TRAVEL in automobile and build tire selling business of your own. Earn \$25-\$50 weekly spare time or double for full time. Office at home. Stock in cellar. We start you and teach you. Belleville Tire Co., Belleville, N. J.

SALESMEN sell long range, low price radio receiving sets \$10.00 monthly payments. No investment, we finance responsible district representatives. Ten sales monthly assures you \$350.00 steady monthly income. Every home a prospect. Our plan is sweeping the country. Don't wait to write; telegraph, giving references. Ozarka Radio, 6342 North Clark Street, Chicago.

FREE Coal for a few hours' spare time. Write today. Peoples Coal Co., 1120 W. 35th St., Dept. 67, Chicago.

HELP WANTED

\$100 MADE in one week by young man in small town without capital or experience in local advertising business. Why can't you do likewise? Free book tells how. S. Meyer, 211 Seventh St., Louisville, Ky.

WE want a few more men to take orders for our one-price line of Tailoring, offering All-Wool Made-to-Measure Suits, guaranteed \$50.00 values, at only \$29.75. Every order you take pays you a good profit, in advance. Experience not necessary. Hustlers can clean up big. Write today. Park Tailoring Company, Dept. 517, Chicago, Ill.

BE a Finger Print Expert. Demand increasing. Write for special free offer. American Finger Print System, 1966 Broadway, New York.

WANTED—District Purchasing agents, experience unnecessary. National Instrument Co., 4704 North Hamilton, Chicago.

FIREMEN, Brakemen, Baggage-men, Sleeping car, train porters (colored). \$140-\$200. Experience unnecessary. 810 Railway Bureau, East St. Louis, Ill.

MEN wanting positions, firemen, brakemen, colored train or sleeping-car porters, write for application blank; experience unnecessary; first-class roads; no strike. Name position wanted, Railway Institute, Dept. 49, Indianapolis, Ind.

BE a Finger Print Expert. Learn on easy payment plan. Write, Vigilant Identification Co., Mt. Vernon, Ill.

WANTED—Men and women, take orders for plain, fancy, sport wool and silk hosiery. We deliver. Big money. Territory for capable organizers. Write today for terms. Edana Hosiery Mills, 1614 West 7th St., Los Angeles, Calif.

MEN, age 18 over, wanted for Government Postal Mail positions. Salary \$1,400-\$2,300. Experience unnecessary. Full particulars free. Write G. W. Robbins, Civil Service Expert, 411 Pope Bldg., Washington, D. C.

REPRESENTATIVES wanted. Exclusive territory. Sorel Lock Limited, Sorel, Que., Canada.

AGENTS—\$60-\$200 a week. Free Samples. Gold Sign letters anyone can put on store windows. Liberal offer to general agents. Metallic Letter Co., 431-C, N. Clark St., Chicago.

AMBITIOUS Men, write today for attractive proposition, selling subscriptions to America's most popular Automobile and sportsman's magazine. Quick sales. Big profits. Pleasant work. Digest Pub. Co., 9505 Butler Bldg., Cincinnati, O.

STORIES, poems, plays, etc., are wanted for publication. Good ideas bring big money. Submit manuscripts or write Literary Bureau, 522, Hannibal, Mo.

\$75 TO \$125 weekly organizing for fastest growing fraternal society. Don't answer unless capable of financing yourself several weeks. Opportunity to control territory with deputies. \$12,000 yearly. Address Order of Stags, St. Louis, Mo.

BOYS—MEN— Become Auto Experts. Earn \$35 week. Sample lessons free. Franklin Institute, Dept. P401, Rochester, N. Y.

HOTELS Need Trained Men. Nationwide demand for high-salaried men; past experience unnecessary. We train you by mail and put you in touch with big opportunities. Big pay, fine living, interesting work, quick advancement; permanent. Write for Free Book, "Your Big Opportunity." Lewis Hotel Training Schools, Room 351, Washington, D. C.

GOVERNMENT Railway Mail Clerks start \$133 month; expenses paid. Specimen questions free. Columbus Institute, Dept. E-2, Columbus, Ohio.

\$5 TO \$15 Daily Easy—Introducing New Style Guaranteed Hosiery. Must wear or replaced free. No capital or experience required. Just show samples, write orders. We deliver and collect. Your pay in advance. Elegant outfit furnished, all colors and grades, including silks. Mac-O-Chee Mills Co., Desk 2603, Cincinnati, Ohio.

WE pay big money for painting pillow tops. Simple, easy, quick. Experience unnecessary. Nibcart Company, 2241 Ft. Wayne, Ind.

EARN \$110 to \$250 monthly, expenses paid, as Railway Traffic Inspector. Position guaranteed after 3 months' spare time study or money refunded. Excellent opportunities. Write for Free Booklet CM-46, Standard Business Training Inst., Buffalo, N. Y.

OUR genuine gold window sign letters are an excellent money-making proposition for handy men. Slann Sign System, Bethune Ave. E., Detroit, Mich.

FREE Plans. Stop daily grind. Silver mirrors, headlights, tableware, etc. Clarence Sprinkle, Dept. 28, Marion, Ind.

SILVERING Mirrors. French plate. Easily learned, immense profits. Plans free. Wear Mirror Works, Dept. 25, Excelsior Springs, Mo.

INVENTORS desiring to secure patents should write for our book "How to Get Your Patent," tells our terms and methods. Send sketch for our opinion of its patentable nature. Randolph & Co., Patent Attorneys, 620 F. Washington, D. C.

MAKE money writing Photo-plays; details free to beginners. No correspondence course. Producers' League, 230 Wainwright, St. Louis.

WRITE articles, stories, news, in spare time for newspapers and magazines. Big pay. Copyright book free. Press Syndicate, 553, St. Louis, Mo.

WANTED: Railway Mail Clerks—\$1,600 to \$2,300. Exams everywhere. Write today for full information. Patterson, Civil Service Expert, Box 4025, Rochester, N. Y.

ALL men, women, boys, girls, 17 to 60, willing to accept Government Positions, \$117-\$190, traveling or stationary. Write Mr. Oxment, 101 St. Louis, immediately.

BE a Finger Print Expert—Opportunities opening everywhere. Write National System, 186 East 79th, New York.

EARN \$10 daily silvering mirrors, plating and refinishing metalware, autos, chandeliers, bedsteads, headlights. Outfits furnished. E. Decie Laboratories, 1133 Broadway, New York, N. Y.

FIREMEN, Brakemen, Baggage-men, Sleeping car, train porters (colored). \$140-\$200. Experience unnecessary. 810 Railway Bureau, E. St. Louis, Ill.

FREE Coal for a few hours' spare time. Write today. Peoples Coal Co., 1129 W. 35th St., Dept. 65, Chicago.

RAILWAY Mail Clerks, Postoffice and other help wanted by Government. \$1400 to \$2300. Examinations everywhere soon. Write today for full information. Chicago Civil Service College, A-41 Kesnet Building, Chicago.

FREE Book. Start little Mail Order business. Home employment evenings. Pier, Dept. 172-A, 74 Cortland St., New York.

HANDY Men—Earn \$85.00 Weekly in Automobile Business. Be your own Boss. Demand unlimited. Autorenco, Sheboygan, Wisconsin.

FIREMEN, Brakemen, for railroads nearest their homes—everywhere: beginners \$150-\$250 monthly (which position?). Address Railway Association, Desk M-1, Brooklyn, N. Y.

FOR ADVERTISERS

INCH Display Advertisement 100 magazines thrice, \$8. Beck Agency, 5406 Alaska, St. Louis, Mo.

ADVERTISE, 30 words 100 magazines \$1.50. Pennell Company, Covington, Ky.

INCH Display Advertisement 161 Magazines Thrice \$15. Year \$50. Page \$100. Wood's Popular Services, Atlantic City, N. J.

ADVERTISE in 24 Big Sunday Newspapers, 25 words \$15.00. Catalog listing 1,000 leading Dailies, Weeklies, Magazines, 4c stamps. Union Advertising, Baltimore Bldg., Chicago.

COMMERCIAL Engraving and Printing—the most practical and complete book on engraving, printing and allied subjects ever published. Over 800 pages and 1500 illustrations presenting over 3500 distinct ideas on 85 separate subjects. Cloth, Price \$15.00 prepaid. We highly recommend this book. Popular Mechanics Book Dept., 290 E. Ontario St., Chicago.

I WRITE booklets, folders, letters, complete follow-up for manufacturers, mail-order dealers. Long experience. Write for prices. L. Taylor, Box 44, Freeport, Ill.

ADVERTISE—Your ad in 100 magazines for 4c per word. Sample free. Small Publishing Co., 1021 State Ave., Cincinnati, Ohio.

IF its advertising write Jacobus Advertising Service, Irvington, New Jersey.

ART AND ADVERTISING

CARTOONISTS—make the Chalk Talk. Particulars. Truman's Studio, Box 585 Perryville, Ohio.

INFORMATION

ALL practical questions human need and interest answered, 10c each. Remedies, formulas. Where buy, sell. Address General Information, Ann Arbor, Mich.

ADVICE, Information, Correspondence, \$1 per Subject. Literary, Vocational, Technical, etc. Box 74, Brooklyn, N. Y.

BUYING, selling, manufacturing, investigations, representation, mail-order opportunities. Pamphlet free. Cottrell's Business Service, Chicago.

RELIABLE information furnished on any subject or money refunded, 75c. Co-operative Service, Times Plaza, Box M64, Brooklyn, N. Y.

BUSINESS SERVICE

INCORPORATE your company in Colorado. Low cost. No stockholders' liability. Do business anywhere. Nothing need be paid in. Stock may be issued for patents and services. Booklet free. Continental Corporations Co., 501 Engineers Bldg., Denver, Colorado.

INCORPORATE. Our lawyers do the work, saving you time, annoyance and money in incorporating under the most liberal laws of Arizona. Laws and forms free. Southwestern Securities & Investment Co., Box D-188, Phoenix, Ariz.

HAVE a Boston office. Small expense. All services. Write Copley Business Service, Box 87, Copley Square.

MAILING LISTS

HOUSEWIVES, \$1.00 thousand. Any list procured. Walter Miller, Berwick, Pa.

5,000,000 FARMERS, housewives, mail order buyers, \$5.00 thousand. Mention State. Many other classifications. Martinek Company, Corona, N. Y.

450 NAMES Arkansas Mail Order Buyers \$5c. C. C. Dry, Fort Smith, Ark.

TYPEWRITERS AND SUPPLIES

TYPEWRITERS, all standard makes, \$10 up. Fully guaranteed. Free trial. Write for illustrated Bargain List. Northwestern Typewriter Exchange, 320 West Goethe St., Chicago.

TYPEWRITERS. All Makes. Save one-half. Thoroughly Rebuilt in our factory by the famous "Young Process." Fully guaranteed. Free trial. We handle all standard makes. Cash or sold on easy terms. Write for Catalog. Young Typewriter Co., Dept. 504, Chicago, Ill.

UNDERWOOD Typewriters at far less than manufacturers' price; rebuilt, all worn parts replaced, guaranteed good as new. Cash, installment payments. Write for Catalog 1513. Shipman-Ward Mfg. Co., estab. 1892, Montrose and Ravenswood Ave., Chicago, Ill.

ALL makes rebuilt, refinished, guaranteed five years. Remingtons, Underwoods, Monarchs, Oliverts, \$15.00 up. Thirty days' trial allowed. Send for catalogue and agents' proposition. Address Typewriter Exchange, 2316 University Ave., New York City, N. Y.

TYPEWRITER ribbons, carbon papers. Ask for price lists. Adco, 444 Broadway, Albany, N. Y.

ADDING MACHINES

NEW \$3.50 Automatic Adding Machine. Adds, Subtracts, Multiplies. Absolutely accurate. Capacity \$999,999.99. Fully guaranteed. 75,000 pleased users. Makes adding easy, positive, quick. Eliminates Mistakes. Saves Time. Postpaid, \$3.50. Bassett Co., 1458-M Hollywood Ave., Chicago.

FREE Trial. Marvelous new Adding Machine. Adds, Subtracts, Multiplies, Divides, automatically. Work equals \$350.00 machine. Price only \$15.00. Speedy, durable, handsome. Five-year guarantee. Used by largest corporations. Write today for catalogue and free trial offer. Lightning Calculator Co., Dept. E, Grand Rapids, Mich.

DUPLICATORS AND DEVICES

"MODERN" Duplicators save Time, Labor and Money. Gets Business. Reproduces Typewritten or Penned Letters, Drawings, Lessons, Music, Menus, Bids, Notices, Specifications, Maps or anything in one or more colors. Prints Two per minute. Special Sale On 30 Days' Free Trial. \$2.25 up. Booklet Free. J. E. Durkin-Reeves Co., Pittsburgh, Pa.

YOU can make 50 to 100 copies of a letter, notice, etc., at a cost of three cents on a Heger Quality Duplicator. Write for free trial offer. The Heger Duplicator Co., 162 N. Wells St., Chicago, Ill.

DUPLICATOR—make your own. Small cost instruction \$2.00. Sample work free. M. Thaxly Co., Washington, D. C.

HAND Mimeograph Outfit—Two dollars. On approval. Primos Specialty Co., Primos, Pa.

PRINTING, ENGRAVING AND MULTIGRAPHING

QUALITY Printing at Reasonable Prices. Tell us your printing wants and we will quote prices which will save you money. Best work. We print anything from a letterhead to a catalog. Fantus Co., 535 S. Dearborn St., Chicago.

LETTER and Bill Heads, statements, cards, envelopes per thousand, \$3.00; samples free. Export Paper Products Co., New Orleans, La.

PRE-USED Printing Presses. Type and supplies. List for stamp. Popular Bargains, Richland, Pa.

250 LETTERHEADS, 250 white envelopes printed and mailed \$3.00. Samples printing free. Sano, Mohawk, N. Y.

1000 GUMMED Stickers, 5c. Printed with Name and Address or equivalent. No Stamps. LeBeus, Fairview Station, Detroit.

FINEST carbon paper 100 letter Greenfield Silk Bond, \$2.00 Box. 100 sheets prepaid. Guaranteed Silk Ribbons, 70c each; \$4.00 doz. Greenfield Carbon and Ribbons. Davis & Davis, 614 Jefferson, Greenfield, Ohio.

WE print anything. Circulars, stationery, Catalogs. Samples. Commercial Press, Batavia, Ohio.

USED hand and foot power printing presses, Type and Supplies. Lewis, Printer, North Troy, N. Y.

1000 2x4" TWO-COLOR gummed labels \$2.25. Samples, Grinnell, Kansasville, Iowa.

PRINTING Outfits—Presses, type supplies, type novelties. Send stamp for catalogue. Model Press, York, Penna.

NEW YORK'S latest novelty. Name and address cards 2 1/2 x 1 1/2 Old English Type. Genuine Leather Case, 60c. Address Senyah Company, 105 S. Oxford St., Brooklyn, N. Y.

WE Print Anything—Quality work. 1000 Good Bond Letterheads, \$3.75. (\$1 with order). Other work in proportion. Samples. Service Printery, 601 Plume St., Norfolk, Va.

GOLD lettered advertising pencils for you; buy direct, save entire middleman's profit. Samples free (60 agents). Address, S. Muesel & Co., 422 Walnut St., Yonkers, N. Y.

GUMMED Labels. Interesting samples free! Edward Harrison, "Advertising Station," Baltimore.

ATTRACTIVE Printing Reasonable Prices. Work Guaranteed. "Quality Printer." Address 120 Hamilton Ave., Trenton, N. J.

BETTER Printing—Everything—250 Bond Letterheads, Envelopes, \$1.40 each; Combination \$2.50. Hicksville Printing Co., Hicksville, Ohio.

225 BOND Letterheads, Envelopes, Billheads, Cards, \$1.25 each; Combination, \$4.00. Economic Press, Leonia, N. J.

1,000 LETTERHEADS or Envelopes, \$2.00. Sent Prepaid. Samples Free. Monitor Press, Morrisville, Pa.

PRINTING: Quality Guaranteed, Samples Free. Reliance Print Shop, Box 192, Elyria, Ohio.

500 20-LB. HAMMERMILL Bond Letterheads, \$2.75. Samples free. Johnson & Sharp, Printers, Bayfield, Wis.

MULTIGRAPHING, printing. Low prices. Quality work. 1,000 20-lb. bond letterheads \$3.00. ADCO, 444 Broadway, Albany, N. Y.

5,000 5 1/2 x 8 1/2 CIRCULARS, \$9.00; 10,000, \$15.00. All Printing Low Prices. Bargain List. Samples. Good's Printery, Harrisonburg, Va.

1,000 HAMMERMILL Letterheads or Envelopes, \$4.00. Full Line Samples Free. Quality Printshop, Marietta, Ohio.

FOR MEN

EXTRA Pants to match any Coat. Send measure with sample. Fit-Well Trousers Co., Dept. 38, Kansas City, Mo.

ARE You Old at Forty? See our advertisement on page 144 of this issue. The Electro Thermal Company, Steubenville, Ohio.

FOR SMOKERS

HOMESPUN Smoking Tobacco—Mild and Mellow—10 lbs., \$1.50; 20 lbs., \$2.75; delivery guaranteed. We furnish free recipe for preparing. Smoking Tobacco Exchange, Sedalia, Kentucky.

TOBACCO—Extra Smoking, 5 lbs., \$1.00; 10 lbs., \$1.50; 20 lbs., \$2.75. Chewing, 5 lbs., \$1.50; 10 lbs., \$2.75. Quality guaranteed. O'Connor Smokehouse, 8140 Mayfield, Ky.

HOMESPUN Tobacco, Smoking—5 lbs., \$1.25; 10 lbs., \$2.00; 20 lbs., \$3.50. Chewing—5 lbs., \$1.75; 10 lbs., \$3.00. Furnish free recipe for preparing. Send no money. Pay when received. O'Connor Smokehouse, Mayfield, Ky.

HOMESPUN Smoking Tobacco, Mild and Mellow—10 lbs., \$1.75; 20 lbs., \$3.00; delivery guaranteed. We furnish free recipe for preparing. Smoking Tobacco Exchange, Sedalia, Ky.

HOMESPUN Tobacco, Chewing, 5 pounds \$1.75; 10 pounds \$3.00; 20 pounds \$5.00. Smoking, 5 pounds \$1.25; 10 pounds \$2.00; 20 pounds \$3.50. Send no money, pay when received. Co-operative Tobacco Growers, Paducah, Ky.

RAZORS AND BLADES

SLICKEST way to sharpen clippers you ever saw. No grinding, no honing. Full particulars \$1. The Klipper King, 697 N. San Dimas Ave., San Dimas, Calif. H. A. Keshart.

BLADES, resharpened, one edge 2c; double 3c. New York Edge Co., Glen Cove, N. Y.

BLADES resharpened, 1 1/2c each. Mays, 4810 No. 25th Ave., Omaha, Neb.

C. BROCH SOHNE, Salinger, Germany, razors: best hollow-ground steel, \$1.95 post-paid or C. O. D. Satisfaction guaranteed. C. Vann Wyatt, Wallace Bldg., Salisbury, N. C.

"BETTER Shaving" Blades Resharpened, 3c. Any Make. Guaranteed Service. Standard Safety Razor Corporation, Pittsburgh, Pa.

BOATS AND LAUNCHES

16' ROWBOAT—Easily made. Construction blueprint 30c. Weasche-Uco, West Market, Detroit, Mich.

12 1/2' ROWBOAT—Easily made. Construction blueprint 30c. Weasche-Uco, West Market, Detroit, Mich.

"HOW to make your boat leakproof." Send for booklet. L. W. Ferdinand & Co., 152 Kneeland St., Boston, Mass.

FOR THE HOME

GRANDFATHER Clock works, \$5.00. Build your own case; instructions free; make good profits selling your friends. Clock works with chimes for old or new cases. Write for full particulars. Clock Co., Ruffner St., Philadelphia.

ORNAMENTAL rugs of South American leopard and deer skins. Albert Gerlach, Box 814, New Orleans, La.

FURS

YOUR raw furs made up into beautiful garments. Enormous savings. Catalog Free. Arthur Felber Fur Co., 25 N. Dearborn St., Dept. P. M. 4, Chicago, Ill.

OPTICAL GOODS

THE Invisible World Revealed! Microscopes, magnifying 500 times, by mail 75c. George Mayerle, Expert Optical Service, 960 Market St., San Francisco, Calif.

ULTRA-LENS microscopes give magnifications of from 2,500 to 250,000 times at small cost. New system of lens construction. Models at \$3.00, \$4.00 and \$5.00. Interesting circular on request. The Specialty Mfg. Co., Milton, Pa.

DIAMONDS, WATCHES AND JEWELRY

WONDERFUL, mysterious, scientific discovery, "Rainbow Sapphires" changes color every different light, morning green, afternoon purple, nights red. Stands all tests, wear forever. Do not confuse with imitation diamonds. Mystify the friends in your district. Stone only three dollars carat, or mounted solid gold lady's ring seven, man's nine dollars, examination free, exclusive agencies. Pauer (Importer), 152 Dewitt, Buffalo, N. Y.

WEAR a Lucky Nugget. Creates sensation. Like real gold. Defies detection. Costs but fraction of genuine. Wonderful scarf-pins, cuff links, charms and watch chains. Send 50c for sample stickpins. Agents wanted. Big profits. Write Specialty Sales, Box 623, Central Postoffice, Toledo, Ohio.

BRACELETS: Hand made by natives in West Indies for ladies of refined taste. Beautiful design and workmanship. Made in one piece. Solid gold \$25.00; silver \$10.00. Satisfaction or money returned. Jasil & Co., 50 Norfolk St., Belmont, Port of Spain, Trinidad, B. W. I.

ANTIQUES AND WAR RELICS

INDIAN Baskets, Blankets, Wampum, Mats. Wholesale. Catalogue. Gilham, Kelsville, Calif.

INDIAN Relics and Printers' Type. Lists free. Grutzmacher, Mukwonago, Wis.

WORLD War Relics from Europe's Battlefields. Completely illustrated catalogue with sample war Photos, 25c. Lieut. Welsh, 2117 Regent Place, Brooklyn, N. Y.

PHONOGRAPHS AND RECORDS

BUILD Your Own Phonograph. Big saving. Pleasant, instructive work. Complete instructions, blue-prints, etc., absolutely free. Write today. Associated Phonograph Co., Dept. AP-10, Cincinnati, Ohio.

CASH Buyers 30% off on New Columbia Gramophones. Seiber & Hofstetter, Buffalo, N. Y.

BUILD Your Phonograph, Quality phonographs. Quality Serenado motor and motors of other types. Electric Motors, tonearms, reproducers, amplifiers, case material, accessories. Free blueprints and building instructions. Big saving. Wonderful results. Prompt delivery. Catalog mailed for ten cents. Hooper Manufacturing & Supply Co., 312 Baldwin Block, Indianapolis, Ind.

SUPERIOR Phonograph equipment assures you finest results. Wholesale prices with catalogue. Superior Phonographs Company, Erie, Pa.

BUILD your own Phonograph. We furnish everything at lowest prices. Write for catalog today. American Phonograph Company, 3515 North Crawford, Chicago.

BUILD a genuine Choralion phonograph and save over half. Big profit building and selling. We furnish motors, tone-arms, full instructions and all necessary parts. Send for catalog and free blueprint offer. Choralion Phonograph and Radio Co., 323 11th St., Elkhart, Ind.

FINEST quality "Perfection" phonograph motors and parts, assuring best results. Lowest prices. Catalog free. Federal Supply Company, Indianapolis, Ind.

MUSIC AND MUSICAL INSTRUMENTS

SONG Writers—Have you poems? I have wonderful proposition. Ray Hibbler, D110, 6040 Dickens Ave., Chicago.

I HAVE different proposition. Lester G. Blain, 3292 40th St., Sacramento, Calif.

CORNETISTS — Trombonists — Saxophonists — Clarinetists. Send for "Free Pointers No. 2" Name instrument, Virtuoso School, Buffalo, New York.

WRITE Songs. Big money and reputation. Write for information. J. Gordon Pub. Co., 201 N. Hoyne Ave., Chicago.

I WANT song poems. Casper Nathan, Garrick Theatre Building, Chicago.

"MUSIC Composed" to words. Bauer Bros. (formerly of Sousa's Band), Oshkosh, Wis.

PATENT ATTORNEYS

PATENTS promptly procured. Personal, careful and efficient service. Highest references. Moderate fees. Send sketch for model or actual search and advice. George P. Kimmel, Master of Patent Law, 51-F, Loan and Trust Bldg., Washington, D. C.

BEFORE or after filing application for patent on your invention it will pay you to read over my "Inventor's Advisor No. 3," free for asking. M. Lahner, Registered Patent Attorney, 3 Park Row, New York.

PATENTS. Booklet free. Highest references. Best results. Promptness assured. Send model or drawing for preliminary examination. Watson E. Coleman, Patent Lawyer, 624 F Street, Washington, D. C.

PATENTS Procured—Trade Marks Registered. A comprehensive, experienced, prompt service for the protection and development of your ideas. Preliminary advice gladly furnished without charge. Booklet of information and form for disclosing idea free on request. Richard B. Owen, 30 Owen Bldg., Washington, D. C., or 2276-R, Woolworth Bldg., New York.

PATENTS procured. Send sketch or model today for examination, prompt report and advice. No charge for preliminary advice. Write for free Booklet and blank form on which to disclose your idea. Highest references. Promptness assured. Clarence O'Brien, Registered Patent Lawyer, 561 Southern Building, Washington, D. C.

PROTECT your rights. Write for "Record of Invention" and booklet about Patents. Prompt personal service. Advice without charge. J. Beane Kelly, 612-G Columbian Bldg., Washington, D. C.

PATENT application filed on partial payment plan. Trade-marks, copyrights, etc. Milo B. Stevens & Co., 635 F St., Washington, 354 Monadnock Bldg., Chicago. Estab. 1864.

PATENTS—Prompt, personal efficient service by an attorney-at-law skilled in all branches of Patent Practice. Over 15 years actual experience; full information upon request. B. P. Fishburne, 331 McGill Bldg., Washington, D. C.

PATENTS—Before disclosing an invention the inventor should write for our blank form "Record of Invention." This should be signed, witnessed and returned to us together with model or sketch and description of the invention and we will give our opinion as to its patentable nature free. Our Three Books mailed free to inventors. Our Illustrated Guide Book, "How to Obtain a Patent," contains full instructions regarding patents. "List of Patent Buyers" sent free, contains unsolicited letters from manufacturers and others who are constantly writing us regarding the purchase or leasing of meritorious patents. We have recently received a number of requests, among which are the following: 45 requests for Miscellaneous Articles in all classes of invention, too numerous to mention. 14 requests for Household Novelties and Specialties. 11 requests for General Novelties and Mail Order Articles. 6 requests for Automobile Accessories and Specialties. 3 requests for Small Metal Articles and Metal Specialties. 2 requests for Radio Accessories and Equipment. 1 request for Amusement Apparatus. 1 request for Refrigerators. 1 request for Tractors and Similar Machines. 1 request for Farmers' Supplies. 1 request for Games. 1 request for Toys. We endeavor to assist our clients in the commercial development of their inventions. Owing to the growth of our business we have established for the benefit of our clients, Branch Offices in New York City at 1067 Woolworth Bldg., Philadelphia at 714 Liberty Bldg., Pittsburgh, Pa., at 514 Empire Bldg., Chicago, Ill., at 1114 Tacoma Bldg., and San Francisco, Calif., at 1010 Hobart Bldg. Victor J. Evans & Co., Main Office, 146 Ninth, Washington, D. C.

PATENTS—"How to Obtain a Patent" is the name of a book which every inventor should have. It will be sent free upon request, and will tell you what you want to know about patents. It contains the whole story. It describes the different parts of the application and explains in simple language the prosecution before the Patent Office. It tells about joint applications, reissues, agreements, assignments, licenses, interferences, infringements, process patents, design patents, trade-marks, and prints and labels. If you are interested in patents either as an inventor, manufacturer or owner of a patent you will enjoy reading this book which was written by a lawyer who has had twenty-five years' experience in patent matters. If you have an invention and will send us a sketch, model or photograph of it we will promptly make a search of the Patent Office records and advise you whether or not, in our opinion, your invention is patentable. Our charge for the service being \$5.00. We feel that our experience of twenty-five years has fitted us to render prompt and efficient service which will merit your confidence. Write today. Talbert & Talbert, 463 Talbert Building, Washington, D. C.

INVENTORS: Send sketch or model of invention for opinion concerning patentable nature and exact cost of patent. Book "How to Obtain a Patent," sent free. Tells what every inventor should know. Established twenty-eight years. Highest references, prompt service, reasonable charges. Address Chandler & Chandice, 438 Seventh, Washington, D. C.

INVENTORS—Send for form "Evidence of Conception" to be signed and witnessed. Form, fee schedule, information free. Lancaster and Allwine, 221 Ouray Bldg., Washington, D. C.

MILLIONS spent annually for ideas! Hundreds now wanted! Patent yours and profit! Write today for free books—tell how to protect yourself, how to invent, ideas wanted, how we help you sell, etc. 500 Patent Dept., American Industries, Inc., Washington, D. C.

MONROE MILLER, Ouray Building, Washington, D. C., patent attorney, mechanical and electrical expert, Best quality of work and results. Moderate charges.

PATENTS and Trade-marks obtained. Prompt service. Write for our new book on patents. Established in 1888. D. Swift & Co., 349 7th St., Washington, D. C.

INVENTORS: Patents procured, Trade-marks registered, prompt personal services, fees reasonable, request free "Inventor's Guide" giving detailed information. Franklin H. Hough, Inc., 522 Washington Loan & Trust Bldg., Washington, D. C.

PATENTS. My fees in installments. Advice book free. Frank Fuller, Washington, D. C.

INVENTORS! Write to U. S. Patent Office for free copy of "Information Concerning Patents." Send sketch for preliminary search and advice. Ralph Burch, Patent Lawyer, Jenifer Bldg., Washington.

PATENTS! Send sketch for search of pertinent U. S. patents and Report, including copies of patents nearest your idea. Earlier patents may offer valuable suggestions for improving or perfecting your invention. Preliminary information or advice without charge. O'Connell & O'Connell, Jenifer Bldg., Wash., D. C.

INVENTORS—Expert professional service at lowest cost. Write for explanatory literature. Amon-Baxter, 2240 Ryer Ave., New York.

"**INVENTOR'S Guide**," free on request; gives very valuable information and advice. Write Frank Ledermann, 15-P Park Row, New York.

PATENTS Procured and Trade-Marks Registered. Advice and terms upon request. Robb, Robb & Hill, 1343 Hanna Building, Cleveland, Ohio; 811 McLachlen Bldg., Washington, D. C.

PATENT Sense—"The book the inventor keeps." Free. See Lacey ad, page 146.

INVENTORS desiring patents should read the treatise, "How to Reduce Your Invention to a Property Right," free on request. Lester E. Barrett, Patent Lawyer, Drawer 830, Washington, D. C.

PATENTS, Trademarks, Copyrights procured; all countries; very reasonable; 20 years' experience; booklet free. H. Sanders, Registered Patent Attorney, 7 Rand McNally Building, Chicago.

PATENTS Secured. Prompt service. Avoid dangerous delays. Send for our "Record of Invention" form and Free Book telling How to obtain a Patent. Send sketch or model for examination. Preliminary advice without charge. Highest References. Write Today. J. L. Jackson & Co., 493 Ouray Bldg., Washington, D. C.

SURVEYING INSTRUMENTS

NEW and used surveying instruments direct from factory. Satisfaction guaranteed or money refunded. Wissler, 619 Broadway, St. Louis.

FOR INVENTORS

PATENTS procured. Send sketch or model today for examination, prompt report and advice. No charge for preliminary advice. Write for free Booklet and blank form on which to disclose your idea. Highest references. Promptness assured. Clarence O'Brien, Registered Patent Lawyer, 562 Southern Bldg., Washington, D. C.

I SELL Patents: Mr. Edward W. Ogden, 331 Lumber Exchange, Minneapolis, Minn., placed his patent covering a Screen and Storm Sash Hanger with me to sell. I have placed it with the Apex Tool & Stamping Co., 4330 Southern Parkway, Louisville, Ky. Have you a patent to sell? Charles A. Scott, 773PM Garson Avenue, Rochester, N. Y.

PATENTS Procured—Trade Marks Registered. A comprehensive, experienced, prompt service for the protection and development of your ideas. Preliminary advice gladly furnished without charge. Booklet of information and form for disclosing idea free on request. Richard B. Owen, 30 Owen Bldg., Washington, D. C. or 2276-B Woolworth Bldg., New York.

PROTECT your rights. Write for "Record of Invention" and booklet about Patents. Prompt personal service. Advice without charge. J. Reaney Kelly, 612-G, Columbian Bldg., Washington, D. C.

PATENTS procured. Send sketch or model today for examination, prompt report and advice. No charge for preliminary advice. Write for free Booklet and blank form on which to disclose your idea. Highest references. Promptness assured. Clarence O'Brien, Registered Patent Lawyer, 561 Southern Bldg., Washington, D. C.

UNPATENTED ideas can be sold. I tell you how and help you make the sale. Particulars free. Write W. T. Greene, 105 The Atlantic, Washington, D. C.

PATENTS—"How to Obtain a Patent" is the name of a book which every inventor should have. It will be sent free upon request, and will tell you what you want to know about patents. It contains the whole story. It describes the different parts of the application and explains in simple language the prosecution before the Patent Office. It tells about joint applications, reissues, agreements, assignments, licenses, interferences, infringements, process patents, design patents, trade-marks, and prints and labels. If you are interested in patents either as an inventor, manufacturer or owner of a patent you will enjoy reading this book which was written by a lawyer who has had twenty-five years' experience in patent matters. If you have an invention and will send us a sketch, model or photograph of it we will promptly make a search of the Patent Office records and advise you whether or not, in our opinion, your invention is patentable. Our charge for this service being \$5.00. We feel that our experience of twenty-five years has fitted us to render prompt and efficient service which will merit your confidence. Write today. Talbert & Talbert, 463 Talbert Building, Washington, D. C.

PATENTS. If you have an invention which you wish to patent you can write fully and freely to Munn & Co. for advice in regard to the best way of obtaining protection. Please send sketches or a model of your invention and a description of the device, explaining its operation. All communications are strictly confidential. Our vast practice, extending over a period of seventy-seven years, enables us in many cases to advise in regard to patentability without expense to the client. Our Handbook on Patents is sent free on request. This explains our methods, terms, etc., in regard to Patents, Trade Marks, Foreign Patents, etc. "Scientific American" contains Patent Office Notices. Decisions of interest to inventors, and particulars of recently patented inventions. Munn & Co., Solicitors of Patents, 423 Woolworth Bldg., New York; Scientific American Bldg., Washington, D. C.; 891A Tower Bldg., Chicago, Ill.; 611 Hanna Bldg., Cleveland, Ohio; Hobart Bldg., San Francisco, Calif.

PATENTS Secured. Prompt service. Avoid dangerous delays. Send for our "Record of Invention" form and Free Book telling How to obtain a Patent. Send sketch or model for examination. Preliminary advice without charge. Highest References. Write Today. J. L. Jackson & Co., 493 Ouray Bldg., Washington, D. C.

INVENTORS and Manufacturers: Have your inventions, labor-saving devices, models and automatic machinery designed and constructed by mechanical experts. Coin-controlled dispensing machines a specialty for any purpose. John Frick, Mechanical Engineer, 1105 Arch St., Philadelphia.

PATENTS. Write for free illustrated guide book. Send model or sketch and description for free opinion of its patentable nature. Highest references. Prompt attention. Reasonable terms. Victor J. Evans & Co., 157 Ninth, Washington, D. C.

GET your own patents. Application blanks, complete instructions \$1. Cutting Sons, Campbell, Cal.

INVENTOR'S Educator. 900 Mechanical Movements. 50 Perpetual Motions. How to procure and sell patents. Mechanical Movements greatly assist inventors, suggest new ideas. Explains how to select an attorney and avoid Patent Sharks. Price \$1.50. Postage free. Fred G. Dieterich & Co., 621 Ouray Building, Washington, D. C.

MODEL Making and experimental work; Modern Shop; expert workmen. Manufacturing. Lamson Model and Experimental Works, 625 W. Jackson, Chicago.

IF you need blueprints or drawings of any kind, it will pay to write me. Send sketch. Address Fosco, New Richmond, Wis.

"**INVENTORS' Guide**," free on request; gives very valuable information and advice. Write Frank Ledermann, 15-P Park Row, New York.

EVERY inventor should have a copy of "First Patent in America" granted in 1646. My supply is limited. Price \$1.00. Simplicity Co., 734 8th Street, Washington, D. C.

HAVE You an Invention? If so, write for our free book. "How to Get Your Patent," tells our terms and methods. Send model or sketch for our opinion of its patentable nature. Randolph & Co., Dept. 144, Washington, D. C.

FINANCING Unpatented Inventions: Free explanation. Sterling Price Buck, Washington, D. C.

INVENTIONS Developed, Models and Special Machines built. Patented Articles made. Haffel Model & Machine Works, 4532 Palmer St., Chicago, Ill.

PATENTS Sold—leased—promoted; Experienced handling; Immediate action. Send copy of Patent and receive Free, my booklet, "The Business End of a Patent." Address Arthur S. Billings, 401 Dekum Bldg., Portland, Oregon.

CONSULTING ENGINEERS

SCIENTIFIC Designs and Working Models of valuable inventions prepared and guaranteed. Consulting Engineer, 2 East 23 Street, Room 714, New York City.

PATENTS FOR SALE

SELLING patent or finished product of auxiliary valve for tire pump. A wonderful and most useful improvement in tire pump since the introduction of pneumatic tire. The valve is screwed into the pump coupling and serves as a connection between the pump and the tire valve. The device is simple and durable, and its efficiency makes the pumping of the tire a quick job without effort. P. Firpo, New York Hotel, Stockton, Calif.

COMPOSITION and method for fruit tree protection. Broad American patent. Right to use State or States for sale to nursery and seed firms, manufacturers insecticides, etc. Particulars to competent investors only. Patent just issued. Sidney Hockridge, Redlands, Calif.

FOR SALE, waist line garment support; neat and attractive; will find a large market. Address C. Bascome, 116 Mound St., Dayton, O.

To proceed properly and safely, send sketch and description for personal advice in your particular case and estimate of costs. H. F. Lowenstein, Registered Patent Attorney, McLachlen Bldg., Washington, D. C.

PUMP—13170-1; Folding Chair—13537-1. Talbert & Talbert, Talbert Bldg., Washington, D. C.

"SELL Your Patent." Harrison Engineering Company, Box 621, Lynn, Mass.

SERIAL 2583,446 Motor Accessory, Punch Press. Cost 10c, sells \$2.00. Address Wm. Martin, H. I. Box 191, Mt. Clemens, Mich.

FOR SALE—Patents 1,395,759 and 1,439,494. 506 Hammond Ave., San Antonio, Texas.

PATENTED attachment, converts grain shovel into non-spillable grain scoop. Best offer takes this real opportunity. J. Padam, Flaxcombe, Sask., Can.

PATENT on "Churn," \$5,000 cash, Oscar Hensrud, Meckinock, No. Dak.

PATENT for Sale—Registering check-row anchor; have working model. William Bierman, Wisner, Neb.

PATENT for Sale—Fruit-picking extension platform; may be used as fire-fighting apparatus, window cleaner's and sign painter's stand, street light cleaner, and for construction work. U. S. and Canadian rights for sale. James Wolff, Box 711, Croton-on-Hudson, N. Y.

LOCK protector; for common locks; outright or royalty. Frank Gillson, E 3801 Bridgeport Ave., Spokane, Wash.

LIGHTING fixture, bracket and pendant patent. U. S. and Canada; Low production cost, quantity market, for sale outright. C. A. Kopfstein, 3124 East 98th St., Cleveland, Ohio.

PATENT—Most scientific invention on carpenter's plane. Elmer Gutknecht, 445 Idaho St., Milwaukee, Wisconsin.

PRACTICAL Pliesse Clothes Line, holds anything; manufactured cheaply. Sell outright. For details write Wm. F. Cushing, 952 Court Circle, Los Angeles, Calif.

REALIZING that motorizing of large Bus Lines, motor trucks and touring cars are reaching the point where they, as street cars and railroads will soon be compelled to have Air Brakes, I have for sale a Patent No. 1322377 on Air Brakes for Motor Cars. Address W. H. Utherbaugh, 812 A Street, S. E., Washington, D. C.

AUTOMOBILE Patent for Sale—Non-Slipping and non-skidding device. Address, Gustave Meyer, 28 Wilmer Ave., Cohoes, N. Y.

FLOUR Sieve, Five siftings one operation. Whirlwind seller. Sale or Royalty. Get details. J. E. Trice, 204 Wabash, Wichita, Kansas.

FOR SALE—Portable farm derrick just patented; money maker. Fred Walker, Rhodes, Iowa.

YOU have a worth-while patent, haven't you? Why don't you tell our two million readers about it? Most of them are specially interested in patents and new inventions. Ask me to tell you how other inventors successfully sold their patents. J. Roy McClellan, Manager, Classified Advertising, Popular Mechanics Magazine, Chicago, Ill.

FOR SALE or Royalty—Improved flue clean out for every chimney erected—market for millions. Investigate. Address, Fred Newman, 311 North 42nd Street, Louisville, Ky.

NEW Improved Battery Hold-down for Automobile. Locks battery securely, saves time installing. Cheap to manufacturer. Patent applied for. Price & Wilmert, 109 Broadway, Lincoln, Illinois.

PATENTS For Sale: To sell, buy or obtain patents write Patent News—P, Washington, D. C.

PIN holds measuring tape. One man measures. Hand or machine made. A. H. Sell, 858 So. 13 Street, Newark, N. J.

LACEY Patent Sense. See page 146.

WANTED 10 Million adjustable Kitchen-sinks. I have one that is cheap, costs nothing to install, makes dishwashing pleasure. Patent 1411684; outright; make offer. Fred Debnay, 405 W. 37th St., Milwaukee, Wis.

"SLIP-EASY Collars," Patented Nov. 1919. Saves collars, neckties and trouble. Lessens friction. Get details. Frist, 1090 American Ave., Long Beach, Calif.

FOR SALE or on Royalty—Patented Extension Fly Swatter. Agnes Youngs, Lamar, Mo.

MUST sell patent on new, pretty checker game. Sample on request. Michael Di Luchio, P. O. Box 137, Wilmington, Del.

PATENTED adjustable "Hose Clamp," outright or royalty; splendid device that will prove big money-maker. Lewis Crook, 2514 Haste St., Berkeley, Calif.

ROYALTY or cash. U. S. Kitchen Utensil; Toy Vehicle; Runabout. Description sent to responsible parties only. Address Joseph G. Gadiak, Monongahela, Pa., R. 2, Box 22.

MODELS AND MODEL SUPPLIES

MODEL Making and experimental work; Modern Shop, expert workmen. Manufacturing. Lamson Model and Experimental Works, 425 W. Jackson, Chicago.

MODELS. We have fully equipped model shop and carry full line of model supplies. Modern Machine & Pattern Co., Terre Haute, Ind.

INVENTORS—Write for our free illustrated guide book and Evidence of Conception Blank. Highest references. Prompt attention. Reasonable Terms. Victor J. Evans & Co., 165 Ninth, Washington, D. C.

MODEL Steam Engines, Boilers, Boats, Model Ship and Naval Fittings, Model Makers' supplies. Send 20c for new, enlarged illustrated catalogue and handbook. Batho Mfg. Co., Dept. D, 5214 Woodland Ave., Philadelphia, Pa.

PUNCH press and screw-machine work, tool and die making, model and special machine work wanted. Have doubled our manufacturing space and added machinery. Let our factory be your factory. Quality Hardware and Machine Co., Dept. A, 6150-56 N. Clark St., Chicago.

WE make working models for inventors and do experimental work and carry a complete stock of brass gears and model supplies. Send for catalogue. The Pierce Model Works, Tinley Park, Ill.

WE build models, design, develop and manufacture articles in large or small quantities. Homeyer Mach. Prod. & Mfg. Co., 1385 East 17th Street, Cleveland, O.

WOODEN Models and Patterns made for inventors. W. H. Gall, 746 Wealthy St. S. E., Grand Rapids, Mich.

PATENTS procured. Send sketch or model today for examination, prompt report and advice. No charge for preliminary advice. Write for free Booklet and blank form on which to disclose your idea. Highest references. Promptness assured. Clarence O'Brien, Registered Patent Lawyer, 542 Southern Bldg., Washington, D. C.

PRACTICAL model steam engines, boilers, blow-lamps, pumps, fittings. Send 10c in stamps for new catalogue. Model Machine Shop Co., 415-17 East 71st St., New York City.

MODELS and Patterns made. Light manufacturing. Address H. W. Hathorn, Mason City, Iowa.

DIES, Tools and General Manufacturing. Models, and Manufacturing of new inventions our specialty. Logan Machine Co., 222 S. Clinton St., Chicago, Ill.

FOR MANUFACTURERS

PATTERNS, wood and metal. Models, tools and dies. Brass, bronze, aluminum and iron castings. Screw machine work, production work of all kinds. Write Modern Machine & Pattern Co., Terre Haute, Ind.

MANUFACTURING

WE are equipped to manufacture all kinds of wire and light metal goods. Stampings, Dies and Tools. Punch press work. Patented articles wanted. Safety Wire Gas Globe Company, Columbus, Ohio.

MANUFACTURERS, let us make your jigs, fixtures and special tools and do your manufacturing in our plant. We can make almost anything in the electrical or mechanical line if made of metal. Correspondence solicited. F. Jos. Lamb Co., 1966 Franklin St., Detroit, Mich.

WANTED—Metal Stamping and Model work taken on contract basis. We are ideally located and equipped to develop patents. Meyers Company, Box 263, Bedford, Ind.

WIRE Goods, all kinds, made to order. Cooley Mfg. Co., 524-530 N. Western Ave., Chicago.

PATENTED Articles, Models, Brass Work, Machine Construction; Dies Made. Baum's Metal Specialties, Kansas City, Mo.

IF you want dies and metal stampings, write us. Lyons Machine Works, Lyons, Ia.

OLD-ESTABLISHED firm offers you its facilities to manufacture any article or device you wish to place on the market. Its Engineering Department is at your disposal to help develop your device and place it on a basis where it can be manufactured economically. If it is your intention to manufacture yourself, will furnish proper manufacturing tools, such as Jigs and Fixtures, Punches and Dies, and special machinery. Simplex Tool Company, Woonsocket, R. I.

GEARS, tools and metal specialties. Send for price list. Weldon Machine Works, 2940 Healdon St., Chicago.

SCREWS, nuts, screw machine products, all metals. Autoscrew Works, 355 West Broadway, New York City.

WE specialize on Dies, Stamping, Light Mfg. The Times Mfg., 410 Kimball St., Danville, Ill.

MANUFACTURE 15 novelty toys in one evening. Write Tinco Co., Box 389, Virginia, Minn.

MACHINERY, TOOLS AND SUPPLIES

MACHINERY for Sale—Boring mills, lathes, milling machines, grinders, planers, drill presses, shapers, inspection room equipment and small tools. Send for our bargain list. F. Jos. Lamb Co., 1962 Franklin St., Detroit, Mich.

FOR SALE—3 large planers suitable for working stone. J. L. Lucas, Bridgeport, Conn.

CONCRETE Building Block Machines and Molds. Catalogue free. Concrete Machine Co., 112 South Second St., St. Louis, Mo.

\$6.75 COMBINATION bench drill and hand-bread drill. When a bench drill, it's self-feeding. Capacity 9-16. Address, Frank Lemieux, 78 Front, Woonsocket, R. I.

LIGHT Power Transmission Machinery, Bearings, Hangers, Pulleys, Reducing Gears. Send for Catalog. Winfield H. Smith, Buffalo, N. Y.

JUST Published—Popular Mechanics Shop Notes for 1923—Vol. XIX, 544 articles, 436 illustrations, 224 pages. Price 50 cents, postpaid. Popular Mechanics Book Dept., 200 E. Ontario St., Chicago.

SPECIAL labor saving machinery. Jigs and Fixtures and other production tools. Punches and Dies for all kinds of metal stampings, Gauges, manufacturing and machine work to order. Simplex Tool Company, Woonsocket, R. I.

ENGINES, MOTORS AND DYNAMOS

FOR Sale—Settling estate, 4-cylinder 4-cycle marine motor (new). This motor contracted for but cannot take delivery March 1st. X Y Z, care Popular Mechanics.

AUTOMOBILE Owners, garagemen, mechanics, send today for free copy of this month's issue. It contains helpful, instructive information on overhauling, ignition troubles, wiring, carburetors, storage batteries, etc. Over 120 pages illustrated. Send for free copy today. Automobile Digest, 507 Butler Bldg., Cincinnati.

STEAM Engines, 1 H. P., \$18.00; ½, \$12.00. James Chambliss, 631 Monroe, Evansville, Ind.

ALTERNATING and direct current motor bargains. New and rebuilt. All guaranteed for one year. Special prices. Get our price list before buying. Motors exchanged and repaired. Hyre Electric Co., 633-RM South Dearborn St., Chicago.

ELECTRICAL

ELECTRICITY For 10c Per Hour. Motoco Auto Generator. Operates on any make automobile. Produces electricity for Moving Picture Machines, Theatres, Schools, Churches, Homes, Etc. Write for free particulars. Monarch Theatre Supply Co., Dept. AG 724 South Wabash Ave., Chicago.

ELECTRIC motors and supplies, including sockets, wire conduit, chisels, loom, rosettes, switches. New revised wholesale prices. Illustrated Catalog free. Hyre Electric Co., 633-GH, South Dearborn St., Chicago.

ELECTRICAL Experimenters—Here is the book you have been waiting for—"How to Make Things Electrical." 256 articles, 427 pages, 353 illustrations. Size 4½x7, cloth binding. Price \$2.50 postpaid. Popular Mechanics Book Dept., 209 E. Ontario St., Chicago.

ARE you old at Forty? See our advertisement on page 141 of this issue. The Electro Thermal Co., Steubenville, Ohio.

FOR THE SHOP

SIX-INCH Bench Lathe, Small Bench Grinder, Small Bench Miller, are some of the valuable articles found in Shop Notes Vol. 18. Full details of construction are given. In addition hundreds of other important articles make up one of the best book values recently offered the shop man. Price 50c postpaid. Popular Mechanics Book Dept., 209 E. Ontario St., Chicago.

LATHE Work for Beginners—opens up a new world for the amateur worker in wood and metal. A practical treatise on Lathe Work with complete instructions for properly using the various tools including complete directions for wood and metal turning, screw cutting, measuring tools, metal spinning and instructions for building home-made lathes with their attachments, etc. 240 pages, 147 illus. Cloth. Price \$2.50 postpaid. Popular Mechanics Book Dept., 209 E. Ontario St., Chicago.

FOR MECHANICS

PATENTS—Write for our free illustrated guide book and Evidence of Conception Blank. Send model or sketch and description of the invention for our opinion of its patentable nature free. Highest references. Prompt attention. Reasonable terms. Victor J. Evans & Co., 181 Ninth, Washington, D. C.

SHOP Notes Volume 17 contains 702 practical articles such as Half-ton Traveling Crane, Boring Machine, Toggle Press, Gas-Fired Forge, Oil-Gas Generator, Movable Table for Drill Press, etc., 224 pp., 496 illus. 50 cents postpaid. Popular Mechanics Book Dept., 209 E. Ontario St., Chicago.

BLACKSMITHS

BLACKSMITHS. Listen: Any Handy man can make more money doing hard jobs easy. Forging and welding solid, with Toy's Modern Methods of Blacksmithing. Hardening and tempering to a standard with colored tempering charts. All for one dollar. Samples Free. W. M. Toy, Sidney, O.

FOR SALE—MISCELLANEOUS

SMALL, efficient. Fruit or Grape Press. W. Gay, Essex, Iowa.

FOR Sale—Fine new \$20 mechanical drawing outfit, Bargain \$4.75. National Instrument Co., 4700 North Hamilton, Chicago.

JAPANESE Hambo Fountain Pen, \$1.25. Writes carbon copies, unequaled seller for price and quality, money refunded if not satisfied. Agents wanted. Fomos, New Richmond, Wis.

GOLD, self filling Fountain Pen, \$1. postpaid. Dozens sold, guaranteed. None returned. Sunny Service, Madison, Florida.

GASOLINE Lamps and Lanterns. Catalog Free. Little Wonder Light Co., Terre Haute, Ind.

MICA Isinglass stove glasses. Send for price list free. Joseph Curin, 1807 Flak Street, Chicago, Ill.

SPRINGS, assortment of 50 small springs \$1.00 postpaid. Springs made to order. Wright Bros. Spring & Wire Works, 5616 Huron St., Chicago, Ill.

ADDRESSOGRAPHS. Letter Folders, Multigraphs, Envelope Sealers, Duplicators, less than half price. Guaranteed. Pruitt Co., 112-B N. La Salle, Chicago.

BUY—Exchange—Sell! Many of our readers have for sale or exchange the article you are looking for—and lots of them are looking for the very items you want to turn into cash. Get together! Let our two million readers know your wishes—they'll help you! Send your ad today to J. Roy McClellan, Manager Classified Advertising, Popular Mechanics Magazine, Chicago.

WANTED—MISCELLANEOUS

CASH for Gold, Platinum, Silver, Diamonds, Liberty Bonds, War Thrift, Unused Postage Stamps, False Teeth, Magneto Points, Jobs, any valuables. Mail in today. Cash sent, return mail. Goods returned in ten days if you're not satisfied. Ohio Smelting Co., 306 Hippodrome Bldg., Cleveland, Ohio.

MAIL us your discarded jewelry, Gold Crowns and Bridges, Watches, Diamonds, Silver, Platinum, War Savings Stamps and Old False Teeth. Money sent at once. Goods Ret. if offer is refused. United States Smelting Works, (Old Reliable) Dept. 71, Chicago.

MOULDS, Patterns, Forms—Wanted—for concrete garden Furniture, Lawn Ornaments, Jardinieres, Urns, etc. What have you? P. O. Box 149 Easton, Penna.

WANTED, National Distribution Specialties. Will buy patents or manufacture and distribute on royalty basis. Alexander Sales Co., Box 147, Spokane, Wash.

REAL ESTATE AND FARM LANDS

NEW Farm Catalog. Equipped bargains throughout 23 states. \$10 to \$150 acre. Ready for spring planting. Copy free. Strout Farm Agency, 150P Nassau St., New York City.

FARM Bargain: 326 A. Improved, 3 mbes Harlow, Benson County, N. D. on Soo Line. 3 room house; barn; granary; well; 250 acres cultivated; balance pasture. \$30.00 acre; \$2000 down, balance easy 6%. Farmers & Merchants Bank, Leeds, N. D.

LANDOLOGY, Free; Special Number just out, containing many facts of cloverland in Marinette County, Wisconsin. If for a home or an investment you are thinking of buying good farm lands, where farmers grow rich, send at once for this special number of Landology. It is free on request. Address Skidmore-Riehle Land Co., 617 Skidmore-Riehle Bldg., Marinette, Wis.

LAND Opportunity! 20, 40, 80 acres; in thriving city in lower Michigan; only \$10 to \$50 down; balance long time. Learn about this offer. Write for free illustrated booklet giving full information. Swigart Land Company, P-1259 First Nat'l Bank Bldg., Chicago.

SELL your property quickly for cash, no matter where located. Don't pay big commissions. Particulars free. Real Estate Salesmen Co., Desk B., Lincoln, Neb.

PROPERTY Owners—Get cash for your real estate business or other property. To quickly sell, exchange or buy property any kind anywhere, write Western Security Co., 104 Hannibal, Mo.

FOR Sale—Three full sections in McKenzie County and two sections in Billings County, North Dakota. Each section contains land suitable for crops, balance for cattle. Each section has valuable deposits of lignite which some day will alone be worth many times the present value of the land. This part of the state is developing very rapidly, with good schools within easy access. As owner cannot use this land himself, will sell one or more sections at a price which almost anyone can afford to pay. Address W., care Popular Mechanics, 209 East Ontario St., Chicago.

FARM—10 acres, Orange County, Fla.; \$150; railroads, town, live community; bargain. Mason Roberts, 719 Clark, St. Louis, Mo.

FARMS Wanted by cash buyers, spring delivery. Describe, state lowest price. R. A. McNown, 312 Wilkinson Bldg., Omaha, Neb.

FREE Homestead Land, beautiful Ozarks. Raise corn, cotton, vegetables, fruit; deer, turkey, fishing. Particulars free. Maurice S. Decker, Norfork, Ark.

ATTENTION! "Get Acquainted." Cash for your property. Farm, Hotel or Retail Store, no matter where located; confidential service. Hayes' Business Agency, Cincinnati, Ohio.

\$100 DOWN, balance ten years, pays itself. Choicest Wisconsin for home. Big market, sure crops, grain, clover, fruit, garden, dairy. No drouth, sand, swamp, rock. Free fuel. Health-pure water. Write now. Owner, K. Loveland, Plymouth Bldg., Minneapolis, Minn.

FOR Sale—165-Acre Farm, Reasonable. J. C. Dunkin, Hulcomb, Wash.

RAT AND INSECT EXTERMINATORS

ROACHES are easily killed with Furman's Guaranteed Roach Powder. It kills them all no matter how many there are nor how big they are. 3 oz. can 35c; 7 oz. 65c; 16 oz. \$1.25 mailed anywhere. Money refunded if it fails. Furman Company, San Antonio, Texas. Agents Wanted.

DOGS, BIRDS AND OTHER PETS

BREED Squabs. Book free. E. Rice, Melrose Highlands, 77 Massachusetts.

SILVERBLACK Foxes \$200. Worm Medicine \$1. Muskrats. Booklet dime. Arthur Schumacher, Lockland, O.

POULTRY

PEAFOWL, Pheasants, Bantams, Wild Geese, Ducks, Twenty Varieties Pigeons, John Haas, Bettendorf, Iowa.

BABY Chicks, Eggs—Five Leading Varieties. Catalog describing 73-Acre Poultry Farm free. Goshen Poultry Farms, Route 29, Goshen, Ind.

SEEDS, PLANTS, TREES, ETC.

GARDEN Tractor for large or small truck gardens; Saves labor; Easy to operate. Shaw 2½ H.P. Tractor will run from 4 to 8 hours on gallon of gasoline, depending on work. Write for particulars. Shaw Mfg. Co., Dept. T, Galzburg, Kans.

PERSONAL

ARE you interested in the power of Vibration and Color? Forceful facts free. Address Robert Knox, Box 728, San Francisco, Calif.

YOUR complete reading, 35c. Give birth-date. Noumenon Dept., Goshen, Indiana.

Additional Classified Ads Page 50



Go as High as You Like No Limit to Salaries in Aviation

No other industry offers the wonderful chances for big money-making that the Airplane Industry offers to ambitious men. Many more trained men will be needed to fill big paying jobs. The airplane has come to stay—it will soon be a part of our everyday life. The men who get in now are the ones that will cash in big. Look at the "big fellows" in the automobile game today. They represent power and wealth because they got in early—you can do the same in Aviation and you have an advantage because you can be trained before you start.



A New Seven-Passenger Airplane



A New Job—The Aerial Postman



View in an Airplane Factory

Thousands of Airplane Mechanics Will Be Needed

The airplane industry is going forward by leaps and bounds. Transportation—passenger carrying and mail carrying lines are being opened up everywhere. This means men—men—men! Trained men only are wanted—men who know what's what. Get ready now to make big money. The industry is calling for real red-blooded fellows—heed the call—now is the time to get started—while the industry is still in its infancy.

Here Are a Few Jobs That Will Pay \$50 to \$250 a Week:

- | | | |
|--------------------------------|------------------------------|--------------------------------|
| <i>Aeronautical Instructor</i> | <i>Aeronautical Engineer</i> | <i>Aeronautical Contractor</i> |
| <i>Airplane Repairman</i> | <i>Airplane Mechanician</i> | <i>Airplane Inspector</i> |
| <i>Airplane Salesman</i> | <i>Airplane Assembler</i> | <i>Airplane Builder</i> |

Learn at Home In Your Spare Time

is simplified for home instruction and is endorsed by airplane manufacturers, aeronautical experts, aviators and the leading aero clubs. Any man that can read English can understand it. The Lessons are self-explanatory and are made plain as day with Blueprints, Diagrams, etc.

Our Advisory Council and Instructors are behind you all the time giving you everything you must know. The entire field of Practical Aeronautics and Science of Aviation is laid right before your eyes. You are bound to succeed with this training. This means for you a man's size job with a man's size pay.

Keep right on with the work you are doing now. A little spare time is all you need. Our Special Course



Get It While It Lasts

BIG BOOK OF OPPORTUNITIES FREE!

Send for our big free book showing just what is going on in the Airplane Industry. It also shows what other men have done in this fascinating field and what you can do, too. It gives a list of some large manufacturers and dealers in airplanes and some of the jobs that are open to trained men. With the book we will send you a special offer that you will be glad to know about. This special offer may be withdrawn at any time without notice. Send the coupon now and take advantage of this offer.

American School of Aviation
Dept. 1193 3601 Michigan Ave. Chicago, Ill.

Mail This Coupon for FREE Book



AMERICAN SCHOOL OF AVIATION
Dept. 1193, 3601 Michigan Ave., Chicago, Ill.

Without obligation on my part you may send me your book entitled "Opportunities in the Airplane Industry" and your SPECIAL Limited offer.

Name
Address
City
State

Continued from Page 48

YOUR Horoscope, Business, Changes, Social, Opportunities. Send birthdate and 10 cents (stamp) for remarkable test reading. Zanya, 292-N, West 165th Street, New York.

WILL Melvin J. F. kindly write to Mary at Priest River, Idaho, Box 141.

HOROSCOPE—Scientific reading. Send 10c, birthdate. St. Germain Society, Sharpshurg, Pa.

TOBACCO quitting made easy. Any form. Send no money. The Ni-Ko System, Wichita, Kansas.

YOUR Horoscope covering full year 50c. Includes extensive reading, valuable daily guide, large pictorial chart, and special forecasts for each month. Scientific, complete. Try it. Money back if dissatisfied. Give birthdate. Address H. Daniels, Flatbush Station, Box 32, Brooklyn, N. Y.

ARE you old at Forty? See our advertisement on page 144 of this issue. The Electro Thermal Co., Steubenville, Ohio.

WILLS—No matter how little value your estate, make your will. Free booklet. Public Trust Protective Society, 222 North Wabash Avenue, Chicago.

ASTROLOGY Reveals—Dime, birthdate and red stamp brings 2000-word trial reading. Two questions considered. Write Prof. Audrey, Section M-5, Box 884, Washington, D. C.

FREE—Stop using tobacco. We will give free information how to conquer habit easily and permanently. Results guaranteed. Anti-Tobacco League, Box K, Omaha, Neb.

STUDY Your Type—Do More—Be More—Have More. Self-Revealing Chart and Personal Development Guide for 10c. Write Thomson-Heywood, Dept. 985, Chronicle Bldg., San Francisco, Cal.

TOBACCO or Snuff Habit cured or no pay. \$1.00 if cured. Remedy sent on trial. Superba Co., TP., Baltimore, Md.

UNUSUAL Horoscope—Five pages, consisting of extensive three-page Astro-analysis and Special Horoscope Reading, and two-page valuable guide containing useful daily advice covering entire year. Send 35c and birthdate. Money returned if dissatisfied. Prof. Bolles, Box 5, Fordham Station, New York, N. Y.

TOBACCO Kills Manly Vigor. Quit easily. Cigarettes, chewing, smoking, snuff conquered or no charge. Small sum if satisfactory. Stops craving; harmless. Full treatment on trial, Perkins Co., 34-A, Hastings, Neb.

FARM PRODUCE

KUDZU: World's Best Hay and Pasture Plant. C. E. Peas Plant Co., Introducing, Chipley, Fla.

MISCELLANEOUS

STARTING a Company? Save expenses and taxes by organizing on the popular, Common Law plan under a pure Declaration of Trust. No experience required to fill in Demaree Standard Forms, issue shares and begin doing business at once. Genuine Demaree Forms are nationally known, approved by attorneys and utilized by successful concerns throughout the United States. Send for large, free pamphlet (C-53) containing valuable information that you may need. C. S. Demaree, legal blank publisher, 768 Walnut, Kansas City, Mo.

INCORPORATION in Arizona Completed in One Day. Any capitalization, least cost, greatest advantages. Transact business anywhere. Laws, by-laws and forms free. Stoddard Incorporating Co., Dept. 2, Phoenix, Arizona.

CUTS anybody can make. Simple, cheap process. \$1. Specimens, particulars. 2c stamp. M. Day, Windfall, Ind.

ARTIFICIAL Eyes, \$3. Booklet free. Denver Optic, 559 Barclay, Denver, Colo.

5 MASTER Keys. Work like magic in emergencies or prove whether your home is burglar-proof. Test and open thousands of locks. Send \$1 today. Novel key chain Free. Master Key Co., 3 P Manhattan Block, Milwaukee, Wis.

INCORPORATE any enterprise under common law; any capital; transact business any state; no corporation taxes; no personal liability; raise capital; keep control; total cost \$40; Booklet Free. Reinshagen, Rand McNally Building, Chicago.

LOCKSMITHS: Send \$1.00 for valuable chart for cutting tumbler padlock keys. Globe System, 278 Washington St., Newark, N. J.

LOCKSMITHING from A to Z—500 tricks of the locksmith trade, \$1.50—money back if dissatisfied. H. Routson, 3406 Andover St., Oakland, Calif.

MAKE Big money Opening Safes and Setting Combinations. Wayne Strong, Box 22, Eagle Rock, Calif.

HOMEOPATHIC and Biochemic preparations sent postpaid to all parts of the world. Manual and booklets free. Halley Bros. Co., 111 N. Wabash Ave., Chicago, Illinois. Established 1855.

MUSIC, rubber stamps, Egg daters, burning brands, photo type, rubber type catalogue 25c. School alphabets, sign marker catalogue 25c. W. Karstedt, Dayton, Ohio.

GOLD, Copper, Silver Ore Specimens. Address H. J. Bennett, Engineer, Box 151, Phoenix, Arizona.

ART Metal Workers—You will find our book "Metal Work and Etching" a complete manual on making book ends, desk sets, pad corners, paper knives, letter openers, stationary racks, rocking blotters, desk calendars, arts and crafts, jewelry, etc., 96 pp. illus. Price 50 cents postpaid. Popular Mechanics Book Dept., 209 E. Ontario St., Chicago.

Let Me Pay You \$12 for 15 Minutes

Right Thru the Summer

FORDS GIVEN AWAY Mail Coupon

We give every help and co-operation to our representatives. Fords given free to producers, no contests. Our big, exclusive territories are sold direct. Every burner you sell brings other sales from your customers' friends and neighbors.

Do you want to make \$5,000 or more a year, easily? Do you want an exclusive territory with private selling rights on this wonderful invention? Your common sense tells you that this is an opportunity of a lifetime.

Then write or mail this coupon to us right away. There is no obligation, but territories are being taken fast. Write now and close up this summer.

**OLIVER OIL-GAS BURNER AND
MACHINE CO.,
2014-O Oliver Bldg., St. Louis, Mo.**

**Oliver Oil-Gas Burner and Machine Co.,
2014-O Oliver Bldg., St. Louis, Mo.**

Please send me full facts about how I can make at least \$5,000 a year representing you in my territory. Also your plan if I just wish to make big money in my spare time.

Name.....

Address.....

City and State.....



B. M. Oliver

I want to show you how to make \$12 in 15 minutes of your time. Read what I have done for others right on this page.

\$215 IN ONE DAY

Ye Gods—some seller—made \$215 today.

F. W. Bentley of Philadelphia.

BUYS CAR WITH PROFITS

Have earned enough in one month to buy me a new auto.

S. W. Knappes, Cal.

SELLS LIKE BEER IN A DRY TOWN

Am sending today for 7 Oliver's. This is one day's orders (\$82 profit). "Selling like beer in a dry town."

W. H. Drew, Mich.

Yes, all over the country, people working for me, are making that much—and you can do as well. This wonderful invention—the Improved Oliver Oil-Gas Burner sells like wildfire. Already over \$1,000,000 worth have been sold. Representatives just show it, taking about one minute to connect and light it, and this amazing invention sells itself. About 15 minutes work and a good liberal profit is yours. Why Bentley actually made \$215 in one day! And Russell of Conn. made \$3,500 in 5 months. Berger, Ont., makes \$258.50 a week. But no wonder agents are making fortunes!

Try to think what it means to housewives to do away forever with dirty coal and wood—with the soot, ashes, dirt, grime, the drudgery of carrying, lifting, soaking and chopping. In the summertime when every woman dreads the coal fire that stays alight for hours, here is a device that gives her a cool kitchen all day long. Heat, whenever she wants it for cooking, baking, preserving, steaming, etc., right in her own stove, but of the minute she is through with it. Think of the advantage of having instant heat, in damp, changeable Spring, right at the turn of a valve 2 times the heat of coal in Winter, with no worry about prices, strikes or shortages.

BIG PROFITS—SELLS ITSELF

You can see for yourself why Carnegy makes \$1,000 a month—how hundreds of others are making the biggest money of their lives. You don't have to be a salesman. It sells itself and the Big Profits are yours.

BIG MONEY SEASON STARTING

Right now is the very best time you could start. Housewives are thinking of the Summer months ahead. They dread the thought of roasting summer kitchens and jump at a chance to buy this wonderful burner.

Ticket to Chicago FREE



WE pay your railroad fare to Chicago—the Electrical Center of the World—from any place in the United States. Grasp this opportunity to see the country at our expense. Don't stick in one spot—travel—get experience. Come to Coyne—learn electricity in 3½ months. Fit yourself for a big paying job.

Learn Electricity in 3½ Months

Get a complete training so you can make big money as Power Plant Operator, Superintendent, Telephone man, Construction worker, auto, truck or tractor electrician, battery man, radio expert, or you can go into business for yourself as electrical contractor, dealer, auto ignition or battery expert and make from \$3,000 to \$20,000 a year. Hundreds of our graduates today are making big money and you can do the same if you grasp this opportunity—act now.

Great Shops of Coyne

No books or useless theory. You are trained on \$100,000 worth of electrical equipment. Everything from door bells to power plants. You work on motors, generators, house-wiring, autos, batteries, radio, switch-boards, power plants—everything to make you an expert ready to step right into a position paying from \$45 to \$100 a week.

RADIO COURSE FREE. We include the following free with the regular course:

- [1] A complete course in auto, truck and tractor electricity and storage batteries. Greatest outlay of auto, electrical and battery equipment in the country.
- [2] Course in Radio—the marvel of the age. Constructing, installing and operating. You can build your own wireless telephone set.
- [3] A life scholarship in the Coyne school. You can stay as long as you wish and return for further training at any time in the future.

Earn While You Learn! We help students to secure jobs to earn a good part of their expenses while studying.

Send Coupon

Don't delay a minute—send that coupon *right now* for our big free catalog and full particulars of Free Railroad Fare offer. Remember this special offer is limited so act now!

B. W. Cooke, Pres.
Coyne Trade and Engineering School
1300-1310 W. Harrison St., Dept. 9003 Chicago



Student Winding a Stator

B. W. Cooke, Pres.

Coyne Trade and Engineering School
Dept. 9353 1300-1310 W. Harrison St., Chicago, Ill.

Dear Sir: Please send me free your big catalog and full particulars of your special offer of Free Railroad Fare and two extra courses.

Name _____

Address _____

Why haven't
you
clipped this
coupon

TEAR OUT HERE
INTERNATIONAL CORRESPONDENCE SCHOOLS
Box 5507-D, Scranton, Penna.

Without cost or obligation, please tell me how I can qualify for the position or in the subject before which I have marked an X:

BUSINESS TRAINING DEPARTMENT

- | | |
|---|---|
| <input type="checkbox"/> Business Management | <input type="checkbox"/> Salesmanship |
| <input type="checkbox"/> Industrial Management | <input type="checkbox"/> Advertising |
| <input type="checkbox"/> Personnel Organization | <input type="checkbox"/> Better Letters |
| <input type="checkbox"/> Traffic Management | <input type="checkbox"/> Foreign Trade |
| <input type="checkbox"/> Business Law | <input type="checkbox"/> Stenography and Typing |
| <input type="checkbox"/> Banking and Banking Law | <input type="checkbox"/> Business English |
| <input type="checkbox"/> Accountancy (including C.P.A.) | <input type="checkbox"/> Civil Service |
| <input type="checkbox"/> Nicholson Cost Accounting | <input type="checkbox"/> Railway Mail Clerk |
| <input type="checkbox"/> Bookkeeping | <input type="checkbox"/> Common School Subjects |
| <input type="checkbox"/> Private Secretary | <input type="checkbox"/> High School Subjects |
| <input type="checkbox"/> Business Spanish <input type="checkbox"/> French | <input type="checkbox"/> Illustrating <input type="checkbox"/> Cartooning |

TECHNICAL AND INDUSTRIAL DEPARTMENT

- | | |
|--|--|
| <input type="checkbox"/> Electrical Engineering | <input type="checkbox"/> Architect |
| <input type="checkbox"/> Electric Lighting | <input type="checkbox"/> Blue Print Reading |
| <input type="checkbox"/> Mechanical Engineer | <input type="checkbox"/> Contractor and Builder |
| <input type="checkbox"/> Mechanical Draftsman | <input type="checkbox"/> Architectural Draftsman |
| <input type="checkbox"/> Machine Shop Practice | <input type="checkbox"/> Concrete Builder |
| <input type="checkbox"/> Railroad Positions | <input type="checkbox"/> Structural Engineer |
| <input type="checkbox"/> Gas Engine Operating | <input type="checkbox"/> Plumbing and Heating |
| <input type="checkbox"/> Civil Engineer | <input type="checkbox"/> Chemistry <input type="checkbox"/> Pharmacy |
| <input type="checkbox"/> Surveying and Mapping | <input type="checkbox"/> Automobile Work |
| <input type="checkbox"/> Metallurgy | <input type="checkbox"/> Navigation |
| <input type="checkbox"/> Steam Engineering | <input type="checkbox"/> Agriculture and Poultry |
| <input type="checkbox"/> Radio <input type="checkbox"/> Airplane Engines | <input type="checkbox"/> Mathematics |

Name.....
Street.....
Address..... 6-26-22
City..... State.....

Occupation.....
Persons residing in Canada should send this coupon to the International Correspondence Schools Canadian, Limited, Montreal, Canada.

Please Mention Popular Mechanics

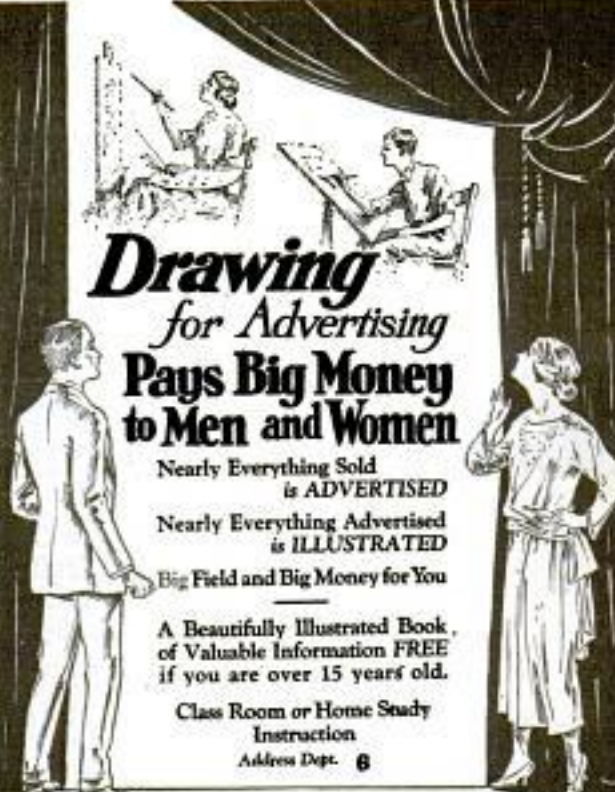

Drawing
for Advertising
Pays Big Money
to Men and Women

Nearly Everything Sold
is ADVERTISED

Nearly Everything Advertised
is ILLUSTRATED

Big Field and Big Money for You

A Beautifully Illustrated Book
of Valuable Information FREE
if you are over 15 years old.

Class Room or Home Study
Instruction
Address Dept. 6

NATIONAL ACADEMY
of **COMMERCIAL ART**
230 East Ohio St. CHICAGO III.

RAISE POULTRY FOR PROFIT

We teach you how. Easily learned at home. Our guaranteed methods make success certain—indorsed by leading Agricultural Colleges. Send TO-DAY for FREE BOOK—"How To Raise Poultry For Profit."



National Poultry Institute
Dept. 312 Washington, D. C.

NO JOKE TO BE DEAF

—Every Deaf Person Knows That I make myself hear, after being deaf for 25 years, with these Artificial Ear Drums. I wear them day and night. They are perfectly comfortable. No one sees them. Write me and I will tell you a true story, how I got deaf and how I make you hear.

Address
GEO. P. WAY, Artificial Ear Drum Co. (Inc.)
80 Adelaide St., Detroit, Mich.



Medicated Ear Drum
Pat. Nov. 3, 1906

ELECTRICITY LEARN AT HOME

Send for catalog which tells how Burgess Home Training enables men and boys to get good jobs and keep them.
Burgess Electrical School, Dept. P-1, 744 E. 42nd St., Chicago



How to Box 40c

By Terry McGoen, James J. Corbett, J. Gardner Smith, M. D., Arthur P. Keeley and Gus. E. Keeley.

How to Box to Win. How to Build Muscle, How to Punch the Bag and How to Stand, Walk or Run.

This interesting book written by experts is known also as "The Book of Health and Strength." It will greatly assist everyone in keeping fit, in putting them in condition to master a strenuous undertaking either physical or mental.

Illustrations Size 4 1/2 x 7 1/4 in. Paper copy 135 pages
SHREWSBURY PUBLISHING CO.
5525 West Lake Street, Chicago, Ill.

Copyrighted material

Big Pay ~

in the Automobile Business after 8 weeks in New York



TRAINED automobile men are in demand. You can qualify for a big job in just 8 weeks. Automobile experts earn big money. Thousands of Stewart trained men are doing it—so can you. Learn in the heart of New York, the retail automobile center of the world.

New York's Leading School for 14 Years

Since 1909 the Stewart School has been recognized as the best school of its kind by the leading automobile companies and service organizations in the East. Send the coupon today for free booklet giving full information.

Be An Auto Expert

You learn by doing actual practical work on standard types of motors. Complete up-to-the-minute equipment. Simple, easy system—no one can fail to learn. You stay without extra cost until you *do* learn. Send for the free book and learn about our guaranty. The automobile industry is beginning a tremendous expansion. Big firms are sending out hurry-calls for trained men. Expert men are hard to find. Don't miss your opportunity to learn in the heart of New York. Send for our free booklet today.

Pay as you learn—Comfortable New York Home

Our deferred payment system makes it easy for you. Day and night classes make it possible for you to *earn as you learn*. Comfortable, cheap, home-like quarters available for Stewart men.

Advanced Electrical Course

Electricity is a puzzle to the average mechanic. 80% of auto troubles are electrical. Special advanced electrical and battery courses now starting in addition to our regular automobile course. Get in now on this uncrowded, big pay field.

Send for FREE Booklet

Get our free opportunity-book today. No obligation. Learn how you too can live on Easy Street. Let us help you. Don't put it off. Just write your name and address plainly on the coupon and mail it. Act now!



Own your own business in three months

Only a little capital is needed to start a garage or repair shop of your own. Then you are on Easy Street! The pay of trained men is so high that you can save enough out of your wages. Let us tell you about it. Send the coupon today without fail.

STEWART AUTO SCHOOL 225 W. 57th St., Dept. 1773 New York, N. Y.

Please send me your free book that describes your school and the opportunities in the Automobile Business. I am under no obligation.

Name _____

Address _____

City _____

State _____



HOW MUCH do ARTISTS EARN?

WOULD you like to earn \$100 a week as a commercial artist? If you like to draw, you should develop your talent, for well-trained artists earn \$75, \$100, \$150 a week, and oftentimes much more. Beginners who can do practical work soon command \$30 a week.

The Federal home-study course develops your talent on a sure foundation by the **quickest possible method**, and makes the work truly a pleasure. It is the **original, practical course** in commercial art, created by men with more than 25 years' experience in the field, and after 8 years of unequalled success today stands supreme as America's Foremost Course in Commercial Designing. It contains **exclusive lessons** from leading American artists, gives you individual personal criticisms on all lessons and teaches you the methods that make your drawings worth real money.

Send Today for
"YOUR FUTURE"

If you are sixteen years old or more, and in earnest about your future, send today for this book. It is beautifully illustrated, tells every detail about the Federal Course, gives you convincing proofs of its merits and shows work done by Federal Students. Fill out and mail the coupon NOW, kindly stating your age.



COUPON

Federal School of Commercial Designing
688 Federal Schools Bldg., Minneapolis, Minn.
Gentlemen: Please send me "YOUR FUTURE" without charge or obligation.

Name

Age . . . Occupation

Write your address plainly in margin.

Please Mention Popular Mechanics

LEARN BY DOING

Every phase of all branches of

ELECTRICITY

Taught by Actual Practice

In America's foremost and oldest institution for trade training

No Books Used
Individual Instruction
Start Any Day

A SPECIAL and SEPARATE Course in Ignition, Auto Lighting and STARTER Systems. Write for FREE 64-page catalog.

THE
NEW YORK ELECTRICAL SCHOOL
44 West 17th Street, NEW YORK CITY

Learn How to WRESTLE

In Your Own Home
By Mail

Yes, learn to become an expert wrestler right in your own home, by mail, from the greatest wrestlers the world has ever known. Be an athlete, be strong, be healthy. Learn how to throw and handle big men with ease. Learn to defend yourself. All taught in our course of lessons, and illustrated with hundreds of charts and actual photographs by

Farmer Burns and Frank Gotch

Farmer Burns, "the grand old man of the mat," taught Frank Gotch, the World's Champion, all he knew about wrestling, so Gotch said. He will now teach you Scientific Wrestling—Physical Culture—Jiu-Jitsu—Self Defense. Every man and boy in America, of any age, needs this wonderful course of lessons. Write today—your name, age and address on a postcard or letter brings you our fine book absolutely free,—no obligation of any kind. A splendid book on wrestling and physical culture. Write today stating your age.

Farmer Burns School of Wrestling 1773 Range Bldg., Omaha

This Wrestling Book FREE

Don't Wear a Truss

BE COMFORTABLE—Wear the Brooks Appliance, the modern scientific invention which gives rupture sufferers immediate relief. It has no obnoxious springs or pads. Automatic Air Cushions bind and draw together the broken parts. No salves or plasters. Durable. Cheap. Sent on trial to prove its worth. Never on sale in stores as every Appliance is made to order, the proper size and shape of Air Cushion depending on the nature of each case. Beware of imitations. Look for trade-mark bearing portrait and signature of C. E. Brooks which appears on every Appliance. None other genuine. Full information and booklet sent free in plain, sealed envelope.



MR. C. E. BROOKS

BROOKS APPLIANCE CO.,

126-H State St., Marshall, Mich.

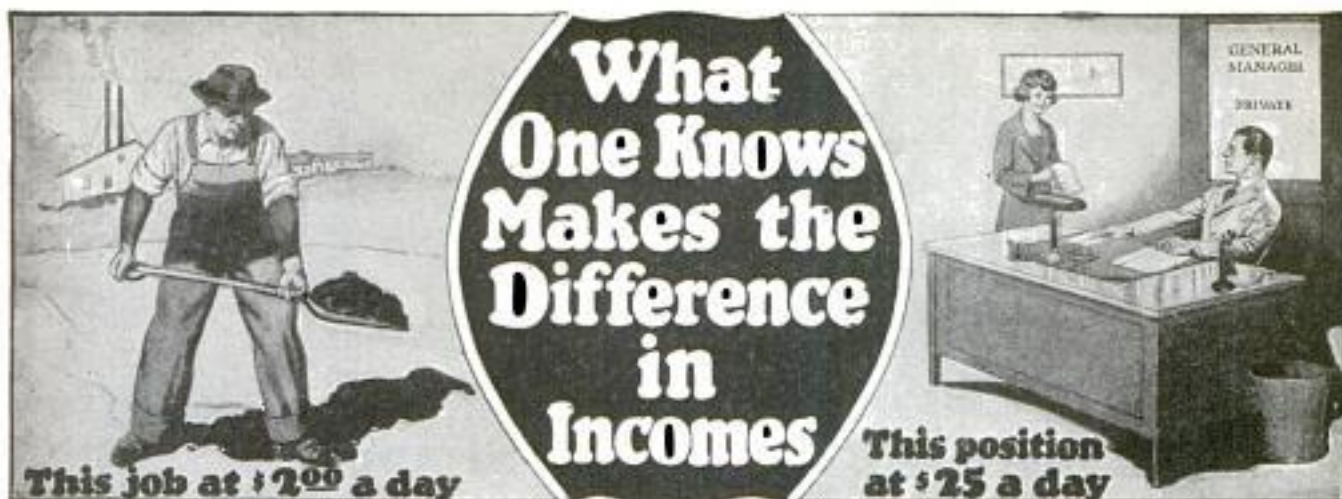

**What
One Knows
Makes the
Difference
in
Incomes**

This job at \$2.00 a day

**This position
at \$25 a day**

Put yourself in the big pay job

You can do it—if you want to. It is up to you. You can be a laborer or clerk, plodding along at starvation wages or you can win success—a real success with a real income. The man who fits himself for the big job always finds a place waiting for him. He never has to walk the streets looking for something to do—the owners of big business concerns are looking for him, anxious to have his services at a worthwhile salary. The man who understands

BUSINESS MANAGEMENT

Is the fellow who draws down \$5000 or more a year. He is the last man that any concern will part with. His services are invaluable—they can't afford to get along without him. We want to see you fit yourself for a position of trust, honor and big pay. We are here to help you do it—just as we have helped thousands of others during the past twenty-five years. Our training in **Business Management** gives you the very latest ideas of business—the way business is conducted since the great war changed the whole industrial and commercial world. You take no chances when you enroll in the American School.

We Guarantee Satisfaction

You will soon realize the advantages of the training which we offer you. If, after you have completed your course, you are not thoroughly satisfied in every way—if you do not feel that our help is going to be worth hundreds, yes thousands of dollars—you can get back every cent you have paid us—you cannot lose a penny. Mark and mail the coupon today—start right now.

American School
Dept. B374, Drexel Ave. & 58th Street
CHICAGO

Our remarkable book on MANAGERIAL CONTROL

FREE The great war has changed business methods everywhere. Our new treatise on **Managerial Control** tells how modern business is conducted successfully. We will mail this interesting book to you absolutely **Free** upon receipt of the coupon below. Act now—don't delay your own success another minute.

American School Dept. B374, Drexel Avenue and 58th Street, Chicago

Send me full information on the subject checked and how you will help me win success.

- | | | |
|------------------------------|-------------------------------|----------------------------|
|Architect |Electrical Engineer |Steam Engineer |
|Building Contractor |Electric Light and Power |Foremanship |
|Automobile Engineer |General Education |Sanitary Engineer |
|Automobile Repairman |Vocational Guidance |Surveyor (& Mapping) |
|Civil Engineer |Business Law |Telephone Engineer |
|Structural Engineer |Lawyer |Telegraph Engineer |
|Business Manager |Machine Shop Practice |High School Graduate |
|Cert. Public Accountant |Photoplay Writer |Fire Insurance Expert |
|Accountant and Auditor |Mechanical Engineer |Wireless Radio |
|Bookkeeper |Shop Superintendent |Undecided |
|Draftsman and Designer |Employment Manager | |

Name

Address



\$1,000 Reward For the Capture of This Man

CONVICT 6138, escaped from the State Penitentiary; Name, Charles Condray; age 37; Height, 5 feet 8 inches; Weight, 141 pounds; Hair, light brown; Eyes, gray.

Easy enough to identify him from his photograph and this description, you may say—but, Condray took the name of "Brown," dyed his hair, darkened his skin, grew a mustache, put on weight and walked with a stoop.

Yet he was captured and identified so positively that he knew the game was up and returned to the penitentiary without extradition. How was it accomplished? Easy enough for the Finger Print Expert. They are the specialists, the leaders, the cream of detectives. Every day's paper tells their wonderful exploits in solving mysterious crimes and convicting dangerous criminals.

More Trained Men Needed

The demand for trained men by governments, states, cities, detective agencies, corporations, and private bureaus is becoming greater every day. Here is a real opportunity for YOU. Can you imagine a more fascinating line of work than this? Often life and death depend on finger print evidence—and big rewards go to the expert. Many experts earn regularly from \$3,000 to \$10,000 per year.

Learn At Home in Spare Time

And now you can learn the secrets of this science at home in your spare time. Any man with common school education and average ability can become a Finger Print Detective in surprisingly short time.

Free Course in Secret Service

For a limited time we are making a special offer of a Professional Finger Print Outfit, absolutely Free and Free Course in Secret Service Intelligence. Mastery of these two kindred professions will open a brilliant career for you.

Write quickly for fully illustrated free book on Finger Prints which explains this wonderful training in detail. Don't wait until this offer has expired. Mail the coupon now. You may never see this announcement again! You assume no obligation. You have everything to gain and nothing to lose. Write at once. Address

University of Applied Science
Dept. 1353 1920 Sunnyside Avenue, Chicago

UNIVERSITY OF APPLIED SCIENCE
Dept. 1353 1920 Sunnyside Avenue, Chicago, Ill.

Gentlemen:—Without any obligation whatever, send me your new, fully illustrated, FREE book on Finger Prints and your offer of a FREE course in Secret Service Intelligence and the Free Professional Finger Print Outfit.

Name.....

Address.....

Age.....



New Simplified Method of Learning Drawing

Amazing shortcut method now teaches you Illustrating, Cartooning, and Designing in half the usual time. You learn at home in spare time, yet your work receives the personal criticism of one of America's foremost Artists. No matter what your previous experience or education has been, this method qualifies you for the fascinating, high-salaried profession—Commercial Art.

FREE BOOK

Write today for our handsomely illustrated Free Booklet, which tells you how at the cost of but a few cents a day you can learn to draw pictures that bring you from \$50 to over \$500. Read about the big demand for Artists by Newspapers, Magazines, Department Stores, Advertising Agencies and Business Concerns—about the amazing success of our students. Special short-time offer of Complete Artist's Outfit Free to new students. Write for Free Booklet and details of this offer. Mail card today. Address

Washington School of Art, Inc.
1984 Marden Bldg. Washington, D. C.

STOP USING A TRUSS

Do Away With Steel And Rubber Bands

FREE TRIAL

TRADE MARK

STUART'S ADHESIVE PLAPAO-PAD

Inner surface is made adhesive to secure the PLAPAO-PAD firmly to the body, keeping the PLAPAO continually applied and the pad from slipping. No straps, buckles or springs attached. Soft as velvet—easy to apply.

It's the Non-Slipping, yet Non-Rigid Pad and What is Within It That Counts

PATD APRIL 6 1909

FREE to 5,000 Truss Sufferers

To the extent of 5,000 sufferers who may apply I will send, ABSOLUTELY FREE, a sufficient quantity of the Plapao to positively convince them that this is the only logical, common-sense way of treating rupture. Plapao is a highly astringent medication placed within the Plapao-Pad and being absorbed through the skin, creates a wonderful feeling of relief and at the same time tends to strengthen the weakened muscles and thus permanently close the rupture opening. The process of recovery is natural, so you'll have no use for a truss—you can throw it away forever! Old and young have testified under oath that the Plapao-Pads cured their rupture—many of them long-standing, aggravated cases—without delay from work. Patent allowed in U. S. and foreign countries. Awarded Gold Medal at Rome and Grand Prix at Paris.

Send No Money—for a sufficient quantity of the Plapao is sent without charge to enable you to give it a thorough test; you pay nothing for this trial now or ever. Write for it and full information today. Address: Plapao Laboratories, Block 1427 St. Louis, Mo.



PLAY PIANO BY EAR

Be a Jazz Music Master

Anyone who can remember a tune can easily and quickly learn to play popular jazz or American rhythm *by ear* at a very small cost. The new Niagara Method makes piano playing wonderfully simple.

No matter how little you know about music—even if you “have never touched a piano”—if you can just remember a tune, you can quickly learn to *play by ear*. The Niagara Method is entirely new—so simple, so easy and teaches so many little tricks of playing that it just comes natural to pick out any piece you can hum. Why not master our 20 lessons and be playing catchy, jazzy music—all *by ear*—in three months’ time? Thousands of others who could not learn by the old-fashioned method have grasped the Niagara idea readily—and succeeded.

A Simple Secret to Success

No need to devote years in study to learn piano nowadays. Special talent unnecessary. Every lesson is so easy, so fascinating that you just “can’t keep your hands off the piano.” Give it part of your spare time for 90 days and you will be playing and entertaining almost before you realize it. No tiresome scales, no arpeggios to learn—no do-re-mi—no difficult lessons or meaningless exercises. You learn a bass accompaniment that applies to the songs you play. Once learned, you have the secret for all time—your difficulties are over and

You Become Master of the Piano

Even talented musicians are amazed at the rapid progress of Niagara School students and can’t understand why this method was not thought of years ago. Naturally, the Niagara Method is fully protected by copyrights and cannot be offered by any other school. A special service department gives each pupil individual attention.

Learn at
home in
90 days

Be Popular in Every Crowd

One who can sit down at any time *without notes or music*, reel off the latest jazz and popular song-hits that entertain folks, is always the center of attraction, the life of the party, sought after and invited everywhere. Make yourself the center of attraction—master the piano by spending an hour a day studying the fascinating Niagara Method.

As easily as thousands of others have learned, so you too, can learn and profit—not only through the pleasure it provides, but also by playing at dances, motion picture houses and other entertainments.

Decide to Begin Now!

Just spend a part of your spare time with a few easy, fascinating lessons and see how quickly you “catch on” and learn to play. You will be amazed, whether you are a beginner or an advanced student.

Write for interesting, illustrated booklet, “The Niagara Secret”—it describes this wonderful new method of playing piano by ear. This booklet sent FREE.

Niagara School of Music, Niagara Falls, N. Y.

CLIP THIS COUPON NOW

Niagara School of Music, Dept. 528 Niagara Falls, N. Y.
Without obligation mail me your booklet, “The Niagara Secret.”

Name.....

St. and No. or R. F. D.....

Town.....State.....

Age..... Ever take piano lessons?..... How many?.....



This Book
FREE

LEARN TO DRAW AND MAKE MONEY

Study in the **SCHOOL** that has the **LONG ESTABLISHED REPUTATION**

Here is a **SIMPLE WAY** **TRY IT**
To Draw a Comic Face



Take your pencil and draw lightly a square (any size). Then add to it with pencil as shown in the small squares above. Erase all pencil guide lines after the drawing is completed. You can draw any kind of comic face by simply changing the shape of the nose, forehead, chin, etc.

Send in your drawing and let us see what you can do. You may have more natural ability than you think. Some of the **cleverest cartoonists** are former students. They had **no experience** before enrolling, but worked at the lessons **during their spare time**, and found Cartoonist **EVANS' METHOD "easy to learn"** and are now **making good money**. It is not hard to learn to draw **originals** when you are shown in a **practical way**. The method above is only one of many **simple methods** explained in the course.

We don't offer any "grand prizes," or "free materials" to encourage enrollments. The school is endorsed by well known cartoonists because they know the students are handled **right**.

Write today for **Portfolio of EVANS Cartoons** and **full information** about the school, and learn how to draw pictures **which you can sell**. The Course Is Not Expensive.



THE W. L. EVANS SCHOOL OF CARTOONING
821 Leader Bldg. CLEVELAND, OHIO



LEARN AUTO PAINTING

Here is a new uncrowded field. There are about 12 million autos in use in the United States. Two-thirds of these are used cars and need painting. There are but few shops at present and they are poorly managed and prices are not stabilized. Our school, here in Detroit, the auto center of the world, teaches you factory methods and practices. You can put a factory finish on any car. Our instructors have held important positions in auto factories and body plants.

Make \$45 to \$300 Weekly

When you graduate you will be able to hold a **GOOD** factory job or go into business for yourself. Any locality that will support a garage will also support a paint shop. Every car you do is your moving advertisement. It boosts your business and brings others to you. Our graduates have no trouble getting factory or paint shop positions here or anywhere. You can go into business on very small capital. You need only a few brushes and cans of paint. We teach you every operation.

Start Any Time—Any Day

Previous experience unnecessary. Start the day you arrive. You finish in 8 to 12 weeks. Our Welfare Department finds you good room and board when you arrive. The instructions are simple, clear, thorough and complete. Tuition is reasonable, life membership **FREE**. You work on regular jobs getting actual experience.

Get literature and special offer. Write NOW.

THE DETROIT AUTO PAINTING SCHOOL
23 D. A. P. S. Bldg. 426 Superior Street
Detroit, Mich., U. S. A.

DEAFNESS IS MISERY



I know because I was Deaf and had **Head Noises** for over 30 years. My invisible Antiseptic Ear Drums restored my hearing and stopped Head Noises, and will do it for you. They are **Tiny Megaphones**. Cannot be seen when worn. Effective when Deafness is caused by Catarrh or by Perforated, Partially or Wholly Destroyed Natural Drums. Easy to put in, easy to take out. Are "Unseen comforts." Inexpensive. Write for Booklet and my **sworn statement** of how I recovered my hearing.

A. O. LEONARD, Suite 226, 70 5th Avenue, New York City

TOBACCO

Habit Cured or No Pay

Any form, cigars, cigarettes, pipe, chewing or snuff Guaranteed. Harmless. Complete treatment sent on trial. Costs \$1.00 if it cures. Nothing if it fails. **SUPERBA CO., E-41 BALTIMORE, MD.**

NO MORE BALD HEADS



WHEN our **VACUUM CAP** is used a few minutes daily. We accept no pay until you have tried the Cap 60 days and are satisfied. The Vacuum Cap is an appliance that draws the blood to the Hair Roots and starts a new healthy crop of hair. It stops Dandruff, stops the hair from falling out.

Bought by Doctors and men who know that it is the only reasonable **HAIR GROWER** known to science. No Drugs Used. Write for application blank, testimonials, and booklet on "HAIR," sent sealed in plain envelope. **FREE.**

THE MODERN VACUUM CAP CO.
H 559 BARCLAY, DENVER, COLO.

I Guarantee You Results Worth \$1000⁰⁰ in One Year

Money talks! No matter what business you're in or how much you are earning, I absolutely GUARANTEE you at least \$1,000 value within one year—or it won't cost you a cent! If you want the proof—entirely free—simply mail the coupon below.

By A. L. Pelton, "The Man Who Helps People Succeed"



WITHOUT wasting a single word I'll come straight to the point! I've discovered a method that is performing wonders for those who follow it. It isn't a secret! Thousands of the world's greatest men have used it and are using this method to bring them wealth—fame—happiness! But now, for the first time, it's been put down in black and white—so that anybody who has learned to read and write can use it to bring him almost anything he wants.

No longer need you be content with an ordinary job at an ordinary salary! Here's a new, easy, positive way to achieve the kind of success you have always wanted! I'll show you how to acquire the remarkable power to earn more money than perhaps you ever dreamed of, and I absolutely guarantee that it will bring at least \$1,000 value the first year—or it won't cost you a cent.

If you want to know how this method works let's take some actual examples.

A Few Actual Examples

John Watson was born a helpless cripple. His parents were poor. He had little schooling. Yet, despite his handicaps, Watson—that's not his real name, although every word here is true—has become a very rich man: He owns a huge factory in Louisville, Ky., and is consulting engineer for many concerns at \$100 an hour! Recently he refused a \$40,000 a year job. He's an artist, an orator, an inventor, and a lawyer. He had only a brain to start with, yet he won wealth, fame and happiness!

Take Wrigley—the chewing gum king started as a newsboy and now makes many times more money in a day than thousands earn in a year! Douglas, the millionaire shoeman, was a shoemaker's helper. I could mention thousands of others.

Read your history and you'll find that Napoleon, Grant, Lincoln, and countless others became famous by using this simple method. Yet you, too, possess the magic that made millions for Rockefeller, Vanderlip, Schwab and Edison! The ease with which you'll climb will seem miraculous once you learn to use it.

Anyone Can Use It

If you can only read and write you can make this marvelous discovery unlock the doors to the world's greatest treasures! You can learn quickly. And the minute you do, you become more forceful, persuasive, confident. You think better, clearer, quicker. Your success becomes rapid—sure—easy.

Today thousands are using this method to bring them wealth, power, happiness. Results are astounding! Clerks become executives almost over night. Salesmen are doubling and tripling their commissions. Adding \$20, \$40 or even \$100 a week to a man's salary is not at all

unusual. This new method cannot fail. That's why I guarantee you \$1,000 value the very first year!

Will you let me show you the easiest way in the world to get the things you want? Whether it be money, health, power, fame, happiness, I'll show you how to get it!

How It Works

The method is simple, too. Prof. Frank Channing Hadcock, the world famous psychologist, has discovered, after years of patient research, that out of thousands of successful men and women, practically every one possessed certain fundamental qualities which were directly responsible for his success. He found that once a person acquired such qualities as foresight, imagination, will-power, confidence, fearlessness, and thinking ability—his success in life was absolutely certain.

But even more important was the discovery of how **anyone** can easily, quickly and positively develop these characteristics. His whole method is embodied in his great new course, "Mastery of Self," which already has performed thousands of seeming miracles.

Free Book Tells How

I wish I had space enough to tell you all the wonderful things "Mastery of Self" has done for thousands of people. But it is impossible, so we have written a new booklet—"The Power That Compels Success"—which is chock-full of all the things you want to know. This book will show you how to double your power of accomplishment—how to double your ability to think—how to banish your fears, self-consciousness, worries, timidity; how to acquire the courage to do seemingly impossible things—how to think straight—clearly—accurately. It contains some of the most fascinating and marvelous information you ever expected to read—and it's yours absolutely free! Send for it now. It may mean the turning point in your life. It will show you the new easy way to greater health—wealth and happiness! Mail the coupon today. And remember my guarantee of at least \$1,000 value the very first year.

READ THIS AMAZING FREE BOOK IF YOU WANT TO KNOW

- How to attract success.
- How to banish sensitive-ness.
- How to analyze yourself.
- How to acquire nerve force.
- How to make people like you.
- How to create money making ideas.
- How to influence men in business.
- How to get a powerful memory.
- How to conquer fear and worry.
- How to develop a man's courage.



Pelton Publishing Co.

13-F Wilcox Block

Meriden, Conn.

FREE BOOK COUPON

Pelton Publishing Co.,

13-F Wilcox Block, Meriden, Conn.

Without obligation please send me at once a FREE copy of your booklet, "The Power That Compels Success."

Name

Address

21 Jewel Burlington



Adjusted to the Second
Adjusted to Temperature
Adjusted to Isochronism
Adjusted to Positions
21 Ruby and Sapphire Jewels
25 Year Gold Strata Case
Your Choice of Dials
(Including Montgomery H. R. Dial)
New Ideas in Thin Cases

Only \$1.00 Down

Only One Dollar Down will buy this masterpiece of watch manufacture. The balance you are allowed to pay in small, easy, monthly payments. The Burlington—a 21-Jewel Watch—is sold to you at a price much lower than that of other high-grade watches. Besides, you have the selection of the finest thin model designs and latest styles in watch cases. Don't delay! Write for the FREE Watch Book and our SPECIAL OFFER today.

Write While This Special Offer Lasts

Get the Burlington Watch Book by sending this coupon. Find out about this great special offer which is being made for only a limited time. You will know a great deal more about watch buying when you read this book. You will be able to "steer clear" of the over-priced watches which are no better. Remember, the Burlington is sent to you for only One Dollar down, balance in small monthly payments. Send the coupon for watch book and our special offer TODAY! Do not delay one minute!

Burlington Watch Company

Dept. 1353, 19th St. & Marshall Blvd., Chicago
Canadian Address: 62 Albert St., Winnipeg, Manitoba

Please send me (without obligations and prepaid) your free book on watches with full explanation of your \$1.00 down offer on the Burlington Watch.

Name _____

Address _____

Please Mention Popular Mechanics

Make \$10 a Night Be a Drummer



Exceptional Drum Offer!

A real hi-mass Snare drum for orchestra work. Finest quality. Unusually low price. Write for descriptive folder—no obligation.



Will you be the drummer for a high class dance orchestra or theatre, or band? Professional drummers are in demand all over the country. You will be popular with your friends and have lots of fun. You can make **BIG MONEY** in your spare time. I have taught hundreds of leading professional drummers—and I can teach YOU. Easy and requires only short time by my simple home study method. For complete information on "Modern Drumming," write today—NOW!

The Herman H. Rinne Correspondence
School of Modern Drumming
3150 Park Ave. Indianapolis

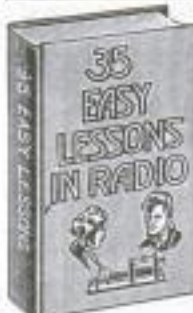

THIRTY-FIVE EASY LESSONS IN RADIO 50c

A systematic course of elementary principles written in a simple and concise lesson course, easily understood. Thousands have taken up Radio for entertainment and are operating their own amateur sets.

This book embodies all the principles and application of everyday radio for the home and in business. Paper cover.

Price postpaid 50c

SHREWSBURY PUBLISHING CO.
5525 West Lake Street Chicago, Ill.

BE A NEWSPAPER ARTIST!



Win fortune and fame, MANUEL ROSENBERG COURSE IN NEWSPAPER ART tells you how. 71 Lessons and 150 illustrations. Drawing made easy. Complete instruction in layouts, lettering, illustration, cartooning and sketching. Ten years' experience as staff artist of important American dailies. Price only \$5. Order TODAY. Your money refunded if you do not agree that this is the greatest art course value ever offered.

MANUEL ROSENBERG, Butler Bldg., Cincinnati, O.

5 Magic Keys

Work like magic in emergencies or prove whether your door or padlocks are burglar-proof. Open and test thousands of different locks. Recommended by users in ten different nations. Most wonderful and only keys of their kind. Send \$1 today. Novel key chain FREE with set. **MASTER KEY CO.,** 25P Manhattan Block, Milwaukee, Wis.



WRITE TODAY for
Our 168-PAGE
FREE BOOK on

Deafness

and learn how Perfect Hearing is now being restored in every condition of deafness or defective hearing. Our "Little Wireless Phones for the Ears" require no medicine, but effectively replace what is lacking or defective in the natural ear drums. They are simple devices, which the wearer easily fits into the ears, where they are invisible. Soft, safe and comfortable.

WILSON EAR DRUM CO., Incorporated
773 Inter-Southern Bldg. LOUISVILLE, KY.

STOP TOBACCO

If you cannot stop it, do you know why? Do you know its effect on efficiency? This subject discussed in common-sense manner in booklet written by one who conducted anti-cigarette clinic for L. A. Police Dept. for over a year. Treated thousands—all forms. Booklet free as long as they last. Write

Dr. T. H. Trinwith, Black Bldg., Los Angeles, Calif.



Knowing how
wins on
Pay Day

Pay-Raising BOOKS

Select From This List for
Free Use in Your Own Home

Automobile Engineering. 6 volumes, 2600 pages, 2000 pictures. Was \$45.00.....	Now \$21.80
Carpentry and Contracting. 5 volumes, 2138 pages, 1000 pictures. Was \$37.50.....	Now 19.80
Civil Engineering. 9 volumes, 3900 pages, 3000 pictures. Was \$67.50.....	Now 34.80
Accountancy and Business Management. 8 volumes, 2500 pages, well illustrated. Was \$52.50.....	Now 29.80
Fire Prevention and Insurance. 4 volumes, 1500 pages, 600 pictures. Was \$30.00.....	Now 14.80
Electrical Engineering. 8 volumes, 3500 pages, 3000 pictures. Was \$60.00.....	Now 29.80
Machine Shop Practice. 6 volumes, 2500 pages, 2500 pictures. Was \$45.00.....	Now 21.80
Steam and Gas Engineering. 7 volumes, 3300 pages, 2500 pictures. Was \$52.50.....	Now 24.80
Telephony and Telegraphy. 4 volumes, 1728 pages, 2000 pictures. Was \$30.00.....	Now 14.80
Sanitation, Heating and Ventilating. 4 volumes, 1454 pages, 1400 pictures. Was \$30.00.....	Now 14.80
Drawing. 4 volumes, 1578 pages, 1000 pictures, blue-prints, etc. Was \$30.00.....	Now 14.80
American Law and Practice. (Including reading course.) 13 volumes, 6000 pages illustrated. Was \$97.50.....	Now 49.80
Employment Management and Safety Engineering. 7 volumes; 1500 pages, 540 illustrations, charts and diagrams. Was \$52.50.....	Now 24.80

KNOWING HOW is the thing that puts the big pay in the pay-envelope. It's the thing that lifts men out of a poor-paying job into a man's size job with a man's size pay. *The man with the "know how" under his hat always wins out.* No matter what kind of work you are doing, or what you expect to do—you can learn more about that work and get more money for doing it. You don't have to go to school. Neither do you take any special training. One of these home study courses in book form gives you all the "know how" you need.

Some of the world's greatest experts prepared these books just to help ambitious men get ahead. They are written in plain, good old U. S. language that anyone can understand. No puzzling technical terms. Everything is explained. Thousands of pictures, plans, blueprints, diagrams, etc., in each set. Over 100,000 sets have been sold. Pick out a set in line with your ambition and send the FREE TRIAL coupon that brings the books without your sending any money in advance.



This picture shows the Automobile Engineering Books, five volumes closed and one open. The bindings will last a lifetime.

FREE Examination!

Don't send one penny. Just fill out the coupon and mail it. This will bring any set you select (the whole set, not a sample) by express collect. The books will be yours to use as you please for an entire week. You be the judge and decide whether or not they will do for you what they have done for thousands of other men. If you don't think they will help you, send them back at our expense and you won't owe a cent.

75 Cents a Week

Pay only \$2.50 within 1 week if you keep the books and send us \$3 each month until the special reduced price is paid. This amounts to about 16 cents a day. Mail Coupon NOW. You'll be mighty glad you did when pay day comes round.

AMERICAN TECHNICAL SOCIETY, Dept. X-193, Chicago

AMERICAN TECHNICAL SOCIETY, Dept. X-193, Chicago, U. S. A.

Please send me set of.....
for **7 DAYS'** examination, shipping charges collect. I will examine the books thoroughly and, if satisfied, will send \$2.50 within 7 days and \$3.00 each month until I have paid the special price of \$..... If I decide not to keep the books I will return them within a week at your expense.

Name.....

Address.....

Reference.....

Please fill out all lines.

**You Can
Earn More
Money**

**—Send for
Our Free 9279
Word Book
on Character
Reading**

YOU want to get ahead. Every man does. You want to know in what line of business or in what profession you can achieve the greatest success or how you can get ahead faster in your present business. You want to know how to influence others and to win their good will and co-operation. L. Hamilton McCormick's new epoch-making science of character reading will tell you what your own greatest abilities are, and enable you to know at a glance the strengths and weaknesses of those with whom you come in contact.

**Surely You Can Do What
Many Others Have Done**

Scores of men and women are forging ahead today by leaps and bounds because they have learned the secrets of reading character. Business men, employment managers, professional men, all ambitious men and women will find this new science an amazing help. Send for our free descriptive book—TODAY.



RAND McNALLY & COMPANY,
Dept. Q-61, 536 S. Clark Street, Chicago.

Send me your free book on how to get ahead faster by reading character.

Name.....
Street.....
City.....State.....

Factory Executives Needed at Big Salaries



Employers are having a hard job finding enough of the right kind of men to fill RESPONSIBLE POSITIONS in their production departments. THE DEMAND FAR EXCEEDS THE SUPPLY! These positions pay BIG SALARIES and offer unlimited opportunities for ADVANCEMENT to those who are SPECIALLY TRAINED.

Through our complete course in "Modern Factory Management" YOU can receive the SPECIAL TRAINING required—by studying right in your own home—during spare hours at a very low cost.

Training is under supervision of leading practical factory experts—and you are most sure to enjoy the entire course. You receive the principles you are after in a way they will stick.

If you want to become a bigger FACTORY PRODUCTION MAN—if you want more CONGENIAL WORK—if you want a SALARY that will put you in the class where YOU belong—THIS IS YOUR BIG OPPORTUNITY.

Write today for a copy of our FREE BOOK:—"Forging To The Front." It outlines a definite method for helping you to a BETTER POSITION and a BIGGER SALARY. Send today! Don't wait!

LINCOLN EXTENSION UNIVERSITY, Inc.
576-G Kirby Building - - Cleveland, Ohio

PLUMBERS AND HEATING MEN

thinking of going into business for yourself soon, can hasten that time by writing at once for interesting information about financing, estimating, accounting for the plumber, and many other things that you should know before risking anything—money, time, prestige. You will need ideas, information, experience and examples. Make your business successful from the start by learning now in spare time at home how to overcome your inexperience in the "business side" of plumbing. Don't wait, but write today for booklet "Making Plumbing Profits," free to plumbers and fitters. 25c to others.

NIEBUHR PLUMBING BUSINESS SCHOOL Desk PM La Crosse, Wis.

BE AN ARTIST

Comics, Cartoons, Commercial, Newspaper and Magazine Illustrating, Patent Office Portraits and Fashions. Our simple method quickly develops your talent in spare time. By Mail or Local Classes. Write for terms and list of successful Students. ASSOCIATED ART STUDIOS 87-D Flatiron Building, NEW YORK



THROW YOUR VOICE

Under the table, down in the collar, into a trunk or any old place. With our VENTRILO which fits into the mouth you can have lots of fun fooling your friends. Also full instructions in the art of Ventriloquism, and big book of jokes. Sent by mail for 10 cts. Stamps or coin.



WONDERFUL WIRELESS TELEGRAPH



Two instruments and 2 Codes in a box. Can Telegraph from room to room or house. Full instructions. By mail 12 cents.

AERIAL AIRSHIP

UP IT GOES!

Climbs in the air by its own power. The propeller spinning automatically at a lively rate.



Floats around

a room or outdoors
Lots of fun. By mail 10c

Invisible Ink

Letters written with this ink look like blank paper. Can be brought out plainly by heating over lamp or stove. Bottle in wooden box, 10 cents.



SKULL RING



The eyes in this ring are either Emeralds or Rubies and would scare the timid. Either Roman Gold or Oxidized Silver. 25c by mail.

All the Above by Mail for 50c. Stamps or Coin.
UNIVERSAL DISTR., Dept. 708, STAMFORD, CONN.

BECOME

**Railway Mail Clerks
\$1600 to \$2300 Year**

**MEN-BOYS
SHOULD WRITE IMMEDIATELY**

Steady work. No layoffs. Paid Vacations
Common education sufficient.
Send coupon today—SURE



FRANKLIN INSTITUTE, Dept. N179, Rochester, N. Y.

Sirs: Send me without charge, (1) sample Railway Mail Clerk Examination questions; (2) tell me how I can get a U. S. Government job; (3) send list of Government jobs obtainable.

Name.....
Address.....

Your Physical Weakness is a Crime



LIONEL STRONGFORT

Dr. Sargent, of Harvard, declared that "Strongfort is unquestionably the finest specimen of physical development ever seen."

consultation coupon (write other ailments on extra line) on which you want special confidential information and send to me with a 10c piece (one dime) to help pay postage, etc. I'll do the rest. Send for my free book **Right Now TODAY**,

LIONEL STRONGFORT

Physical and Health Specialist

Dept. 208 Founded 1895 Newark, New Jersey

Special Notices—Lionel Strongfort, the World's Famous Athlete and Physical and Health Specialist, has achieved wonderful results with the Principles of Strongfortism. Thousands of pupils throughout the world have testified to the benefits gained under his guidance. He enjoys an excellent reputation in his profession and can be depended upon to do exactly as he promises.

HOW have you cared for your body? Have you prized it as a sacred responsibility as your most precious possession? Have you kept it clean and wholesome, externally and internally, free from the results of abuse and neglect? Are you proud of your physique? Are you a **real** man in the fullest sense of the word?

Or are you a weak ailing creature—one of the thousands who are leading wretched lives—a physical weakling, a failure in the home—in business—in society? Stop and answer these questions frankly and honestly.

Slipping Back—to the Old Habits

Instead of being in the pink of condition and getting the joy out of life as you ought to be, you may be one of those whose violations of natural law have weakened you so that you are degenerating, slipping back into your old, neglectful habits again and have become a wretched human being, shunning society and being shunned—getting old long before your time—sinking through life, dejected, discouraged, hopeless.

Get a Grip on Yourself

If you are one of these victims, let me caution you to call a halt now to this slow suicide. Don't delude yourself with dope and drugs. Day by day you will step farther and farther into the chasm from which there will be less and less hope of rescue. It looks dark and gloomy to you—but cheer up—if you truly desire to win back your health and vigor—if you long to be clean, wholesome and a **real** man—I want to help you—I can help you with

STRONGFORTISM

The Modern Science of Health Promotion

Through my scientific methods I extend a helping hand to all who are in the frightful grip of disease, drugs and dope. Strongfortism reclaims human wreckage. If you feel down and out, it will brace you up, fill you with renewed life and energy, put pep into you and restore your confidence and manhood. It is not an ordinary physical culture course that I give you, but a unique system of individual assistance, which gives permanent health to any one who follows my simple directions. I give you personal attention, pointing out to you the surest, speediest way of recovering. No one need know you are following my methods—all your friends will be astonished at the improvement that has come over you immediately after you begin following my instructions.

I'll Be a Brother to You

Don't be afraid to write me in full confidence as you would to a brother. Everything you tell me will be held in the strictest confidence. I will understand. I know human nature and I know the applications of Natural Law that will free you from the misery of physical weakness and impaired health. Your success with Strongfortism is guaranteed irrespective of your age, sex, occupation or surroundings.

Send for My Free Book

"Promotion and Conservation of Health, Strength and Mental Energy" will bring you a message of hope and good cheer that will mean more to you than anything else in all your life. It's absolutely free. Just mark the subjects on the free consultation coupon (write other ailments on extra line) on which you want special confidential information and send to me with a 10c piece (one dime) to help pay postage, etc. I'll do the rest. Send for my free book **Right Now TODAY**,

FREE CONSULTATION COUPON

ABSOLUTELY CONFIDENTIAL

Mr. Lionel Strongfort, Dept. 208, Newark, N. J.—Please send me your book, "PROMOTION AND CONSERVATION OF HEALTH, STRENGTH AND MENTAL ENERGY," for postage on which I enclose a 10c piece (one dime). Send me special information on subjects marked (X) below, as well as those I may write on extra line, without obligation.

- | | | |
|-------------------------|-------------------------|-------------------------|
| .. Colds | .. Neurasthenia | .. Rheumatism |
| .. Asthma | .. Catarrh | .. Pimples |
| .. Hay Fever | .. Blackheads | .. Falling Hair |
| .. Obesity | .. Insomnia | .. Weak Eyes |
| .. Headache | .. Short Wind | .. Heart Weakness |
| .. Thinness | .. Flat Feet | .. Poor Circulation |
| .. Rupture | .. Stomach Disorders | .. Skin Disorders |
| .. Gastritis | .. Constipation | .. Dependency |
| .. Lumbago | .. Biliousness | .. Increased Height |
| .. Neuritis | .. Torpid Liver | .. Round Shoulder |
| .. Neuralgia | .. Indigestion | .. Lung Troubles |
| .. Flat Chest | .. Nervousness | .. Stoop Shoulders |
| .. Diabetes | .. Poor Memory | .. Muscular Development |
| .. Deformity (Describe) | .. Weaknesses (Specify) | .. Great Strength |
| .. Fear | | |

Mention other ailments here

Name

Age

Street

City



"Here's an Extra \$50!"

"I'm making *real* money now! Yes, I've been keeping it a secret until pay day came. I've been promoted with an increase of \$50 a month. And the first extra money is yours. Just a little reward for urging me to study at home. The boss says my spare time training has made me a valuable man to the firm and there's more money coming soon. We're starting up easy street, Grace, thanks to you and the I. C. S."

Today more than ever before, money is what counts. You can't get along on what you have been making. Somehow, you've simply got to increase your earnings.

Fortunately for you there is an unfailing way to do it. Train yourself for bigger work, learn to do some one thing well and employers will be glad to pay you real money for your special knowledge.

You can get the training that will prepare you for the position you want in the work you like best, whatever it may be. You can get it at home, in spare time, through the International Correspondence Schools.

It is the *business* of the I. C. S. to prepare men for better positions at better pay. They have been doing it for 30 years. They have helped two million other men and women. They are training over 150,000 now. And they are ready and anxious to help you.

Here is all we ask—without cost, without obligating yourself in any way, simply mark and mail this coupon.

----- TEAR OUT HERE -----

INTERNATIONAL CORRESPONDENCE SCHOOLS
Box 5509-D, Scranton, Penna.

Without cost or obligation, please tell me how I can qualify for the position or in the subject before which I have marked an X:

BUSINESS TRAINING DEPARTMENT

- | | |
|---|---|
| <input type="checkbox"/> Business Management | <input type="checkbox"/> Salesmanship |
| <input type="checkbox"/> Industrial Management | <input type="checkbox"/> Advertising |
| <input type="checkbox"/> Personnel Organization | <input type="checkbox"/> Better Letters |
| <input type="checkbox"/> Traffic Management | <input type="checkbox"/> Foreign Trade |
| <input type="checkbox"/> Business Law | <input type="checkbox"/> Stenography and Typing |
| <input type="checkbox"/> Banking and Banking Law | <input type="checkbox"/> Business English |
| <input type="checkbox"/> Accountancy (Including C.P.A.) | <input type="checkbox"/> Civil Service |
| <input type="checkbox"/> Nicholson Cost Accounting | <input type="checkbox"/> Railway Mail Clerk |
| <input type="checkbox"/> Bookkeeping | <input type="checkbox"/> Common School Subjects |
| <input type="checkbox"/> Private Secretary | <input type="checkbox"/> High School Subjects |
| <input type="checkbox"/> Business Spanish <input type="checkbox"/> French | <input type="checkbox"/> Illustrating <input type="checkbox"/> Cartooning |

TECHNICAL AND INDUSTRIAL DEPARTMENT

- | | |
|--|--|
| <input type="checkbox"/> Electrical Engineering | <input type="checkbox"/> Architect |
| <input type="checkbox"/> Electric Lighting | <input type="checkbox"/> Blue Print Reading |
| <input type="checkbox"/> Mechanical Engineer | <input type="checkbox"/> Contractor and Builder |
| <input type="checkbox"/> Mechanical Draftsman | <input type="checkbox"/> Architectural Draftsman |
| <input type="checkbox"/> Machine Shop Practice | <input type="checkbox"/> Concrete Builder |
| <input type="checkbox"/> Railroad Positions | <input type="checkbox"/> Structural Engineer |
| <input type="checkbox"/> Gas Engine Operating | <input type="checkbox"/> Plumbing and Heating |
| <input type="checkbox"/> Civil Engineer | <input type="checkbox"/> Chemistry <input type="checkbox"/> Pharmacy |
| <input type="checkbox"/> Surveying and Mapping | <input type="checkbox"/> Automobile Work |
| <input type="checkbox"/> Metallurgy | <input type="checkbox"/> Navigation |
| <input type="checkbox"/> Steam Engineering | <input type="checkbox"/> Agriculture and Poultry |
| <input type="checkbox"/> Radio <input type="checkbox"/> Airplane Engines | <input type="checkbox"/> Mathematics |

Name.....

Street.....

Address.....

City..... State.....

Occupation.....

Persons residing in Canada should send this coupon to the International Correspondence Schools Canadian, Limited, Montreal, Canada.

SHOP WORK with a

CARNES ARTIFICIAL ARM

FOR nearly ten years a Carnes Artificial Arm has kept Mr. Pabbe Yazze of Lawrence, Kan., on the payroll as a draftsman and machinist at a good salary. Thousands of other mechanics, artisans, office workers, farmers and laborers owe their independence to this improved arm.

Life-Like in Action and Appearance

The Carnes Arm cannot be detected from the natural except by close inspection. Its user can dress himself, use knife, fork, pen, pencil and keys; pick up large or small objects, carry grips—in fact, do virtually everything that was possible before. He can bend the elbow of the Carnes Arm, bend and turn the wrist and open and close the fingers at will, even if the amputation is at the shoulder.

192-Page Book FREE. A book of 192 pages, profusely illustrated with photographs showing what can be done with this remarkable invention, will be sent free to any person interested. Send for it now.

CARNES ARTIFICIAL LIMB CO.,
208 Carnes Bldg., Kansas City, Mo.

Learn Illustrating

At Home—In Your Spare Time

from the school that has trained many commercial illustrators now earning \$50 to \$200 or more weekly. Plenty of opportunities for men or women—fascinating work—can be done at home. The Landon Picture Chart Method makes original drawing easy to learn. Write for full information and sample chart. Please state age.

THE LANDON SCHOOL

138 National Bldg., Cleveland, Ohio



BIG ENTERTAINER

Book with 83 Parlor Games, and Pastimes, 175 Jokes, Riddles, and Conundrums, 36 Funny Readings, 15 Tricks with Cards, 5 Comic Recitations, 71 Toasts, 3 Monologues, 50 Money Making Recipes, All for 10c, 3 for 25 cents. Postpaid.

J. C. Dorn, 709 So. Dearborn St., Dept. 5, Chicago, Ill.

BIG NOVELTY BARGAIN! 8 Cts.

THROW YOUR VOICE

Into a trunk, under the bed or anywhere. Lots of Fun fooling the Teacher, Policemen or Friends. Barrels of Fun.

THE VENTRILO,

a little instrument, fits in the mouth out of sight, used with above for Bird Calls, etc. Sent with full instructions; anyone can use it. NEVER FAILS. Also a 32-PAGE BOOK ON VENTRILOQUISM. Formula for Secret Writing, 12 Money-Making Secrets and the marvelous

NOVELTY X-RAY WONDER

With it you can apparently see the bones in your fingers, lead in pencil, etc.—lots of fun with this outfit. A Set 10 Big Magic Tricks Free with every order. All the above Novelties by mail prepaid for **8c**

VENTRILO COMPANY
Dept. 751
LARGEST and OLDEST Mail Order House in Connecticut
South Norwalk, Conn.

We Pay Railroad Fare to Chicago



ERWIN GREER, President

—Direct to GREER COLLEGE of Automotive Engineering!

For Limited Time Only! Get This Big Offer!

AMBITIOUS men in every State of the Union will welcome this remarkable offer. Think of it—Railroad Fare paid direct to America's Wonder City—right to the famous GREER COLLEGE where men of no previous experience are trained to fill high pay positions in the Automobile Business. Calls received daily for our graduates.

Automobile Business is Booming!

Millions of motors in use—hundreds of thousands need daily repair and adjustment. No secret to Motor Mechanics other than practical training with plenty of modern, up-to-date equipment and GREER Master Mechanics at your elbow to show you how to do the work. Good positions are waiting for men—GREER Trained Men.

\$50 to \$125 a Week for Capable Men
Here's The Famous GREER Super-Course—

Truck, Tractor and Automobile
Repairing and Overhauling
Vulcanizing and Tire Repairing
Acetylene Welding and Cutting
Garage and Repair Shop Management
Roadside Repairs
Automobile Driving

Primary Ignition
Electric Lighting and Starting Systems
Machine Shop Practice
Storage Batteries
Business and Sales Management
How to Sell Autos, Tractors and Trucks

Get this FREE BOOK: Learn all about this

Free Railroad Fare Offer. Send at once for our 64-page book, "How to Succeed in the Auto and Tractor Business," —tells you about waiting opportunities, how to start a business of your own; how to get a sales agency, etc. Use the coupon below and send NOW.

The Success School— More successful graduates than any similar institution. More than just an "automobile school." The GREER Diploma insures your success.

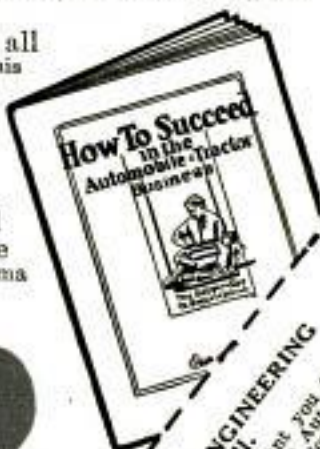

Greer Bldg.

Take Your Pick

Mechanic - -	\$ 50.00
Foreman - -	75.00
Shop Manager -	100.00
Electrical Ignition and Starting Expert	100.00
Demonstrator -	75.00
Salesman - -	100.00

These positions now open. You can earn more in a business of your own. All GREER graduates receive diploma of certified automotive engineer.

GREER COLLEGE

of Automotive Engineering

Don't wait—
write at once—NOW!

2053 S. Wabash Ave., Chicago, Ill.

ERWIN GREER, President
GREER COLLEGE OF AUTOMOTIVE ENGINEERING
2053 S. Wabash Ave., Chicago, Ill.

I am interested in making more money and want you to send me your book, "How to Succeed in the Auto-Tractor Business," without obligation.

Name.....
Address.....
Present Occupation.....

LEARN MODERN BARBERING the SHORT WAY



A Clean, Carefree, Good Paying Business

that you can acquire easily. A trade that enables you to TRAVEL AND SEE THE WORLD, one that pays in tips and commission, in addition to salaries, MORE THAN MOST MEN EARN.

Modern barbering includes the electric hair cutter, the mechanical massage and scientific treatments. It also affords a study—if one desires—on hair and skin, and makes the barber of today a MAN AMONG MEN.

TO BE YOUR OWN BOSS is a worthy ambition. You can own your shop with small capital, and be independent. We equip your place on easy terms.

OUR SHORT PRACTICAL COURSE has more than doubled the earning power for thousands. We can do this for you. The average annual income exceeds most tradesmen's because it is steady work the year around.

Our booklet B, that we mail free, tells how we enable you to EARN WHILE LEARN-

ING, how we put you into the BEST CITY JOBS, how we equip your shop on EASY PAYMENTS; in fact, how we take you just as you are, make your life work easier, better paying and more independent.

We have 33 branch schools in leading cities. We have one near you.

Write any one of the following addresses for our booklet B. Do it today.

THE MOLER SYSTEM OF COLLEGES

Moler System of Colleges
Address Nearest Branch

Please send me without obligation on my part your booklet B.

Name.....

Address.....

157 Third Ave.
105 S. Wells St.
810 N. 6th St.
344 Main St.
341 W. 5th St.
215 Huron Rd.
1045 Cass Ave.
1229 17th St.

New York, N. Y.
Chicago, Ill.
St. Louis, Mo.
Kansas City, Mo.
Cincinnati, Ohio
Cleveland, Ohio
Detroit, Mich.
Denver, Colo.
198 Queen St., E.

110 S. 14th St.
513 E. Water St.
1005 Canal St.
192 Marietta St.
80 N. 2nd St.
910 Main St.
712 Franklin Ave.
727 W. Commerce St.
Toronto, Ont., Can.

Omaha, Nebr.
Milwaukee, Wis.
New Orleans, La.
Atlanta, Ga.
Memphis, Tenn.
Dallas, Texas
Houston, Texas
San Antonio, Tex.

Whatever Your Question;—be it the pronunciation of Bolsheviki, the spelling of a puzzling word, the location of Murman Coast—the meaning of blighty, ace, lank, ukulele, etc., this Supreme Authority—

WEBSTER'S NEW INTERNATIONAL DICTIONARY

contains an accurate, final answer 400,000 Words, 2700 Pages, 6000 Illustrations.

*Regular and India-Paper Editions. G. & C. MERRIAM CO., Springfield, Mass.

Write for specimen pages, prices, etc. and FREE Pocket Maps per Popular Mechanics



"THERE'S MONEY IN IT"

AT HOME

LEARN TELEGRAPHY

AT HOME

MORSE AND WIRELESS



TEACH YOURSELF

in half usual time, at trifling cost, with the wonderful Automatic Transmitter THE OMNIGRAPH. Sends unlimited Morse or Continental messages, at any speed, just as an expert operator would. Adopted by U. S. Government, and leading Universities, Colleges and Telegraph Schools. 3 styles. Catalog free.

OMNIGRAPH MFG. CO.

16-22 Hudson St., NEW YORK

WANTED—RAILWAY MAIL CLERKS

\$135 to \$190 a Month for Life

Every second week off with full pay—no "lay offs" because of strikes, poor business, etc.—sure pay—rapid advancement to higher positions. City and country residents stand same chance. Common sense education sufficient—no political influence.

DON'T DELAY—ACT AT ONCE

Send Coupon today—sure. Every day's delay means so much less chance of appointment from the next examination—so write at once.

FRANKLIN INSTITUTE, Dept. N177, Rochester, N. Y.

Take the First Step for
a U. S. Government Job
Use Coupon Before You Lose It

COUPON

FRANKLIN INSTITUTE, Dept. N177, Rochester, N. Y.

Kindly send me, without any obligation whatever on my part and entirely free of charge, (1) a full description of the position checked below; (2) Sample examination questions; (3) Free copy of copyrighted book "Government Positions and How to Get Them"; (4) A list of U. S. Government Jobs obtainable; (5) Tell me how to get the position here checked.

.. Railway Mail Clerk (\$1600 to \$2300) .. Customs Positions (\$1100 to \$2000)
.. Postoffice Clerk (\$1400 to \$1800) .. Internal Revenue (\$1100 to \$2600)
.. City Mail Carrier (\$1400 to \$1800) .. Rural Mail Carrier (\$1100 to \$2600)
.. Income Tax Auditors .. (\$2040 to \$3000)

Name.....

Address.....



MAKE BIG MONEY WRITING ADVERTISEMENTS

You can earn big money writing advertisements right in your home town. Retail merchants, jobbers and manufacturers are constantly on the lookout for men and women who can write copy that sells goods!

Our concise, "boiled-down" course is a series of lessons based on fundamentally sound advertising principles. **Don't waste your time and money** wading through a useless, tiresome, expensive course costing from \$75 to \$100!

Chicago Institute of Advertising gives you **only advertising essentials**. With every lesson, we give you a definite copy assignment which we carefully correct, grade and return to you. Thousands of men and women are bettering themselves in their present positions, or stepping out into new jobs through their **copy-writing ability to sell on paper!** Send \$25 today for 10 complete lessons, or write for further information to

CHICAGO INSTITUTE of ADVERTISING
4105-4113 S. LaSalle St. Chicago, Ill.

**Complete Copy - Writing
Course ----- Only \$25.00**



Would You Give \$1 for 16 Dancing Lessons *If* —

Learning to become a good dancer made you so popular that everyone would be anxious to have you attend their social affairs,—and if learning to dance the Murray Way gave you poise, ease, self-confidence and helped develop your personality,—would you be willing to pay \$1 for 16 dancing lessons from America's foremost authority on social dancing?

Arthur Murray, instructor to the Vanderbilts and many other fashionable people in America and Europe, has perfected a wonderful new method by which you can learn any of the latest dance steps in a few minutes—and all of the dances in a short time.

Even if you don't know one step from another—or whether you already know some of the steps—through Arthur Murray's method you can easily and quickly master any dance without a partner and without music, right in your own home,—or the lessons won't cost you a cent. More than 90,000 have learned this new easy way. Your own success is guaranteed.

Proof You Can Learn at Home in One Evening

To show you how easily anyone can learn to dance at home, without music or partner, Arthur Murray has consented to send, for a limited time only, his 16 Introductory lessons for only \$1.00.

All you need to do is just fill in and mail the coupon—or a letter will do—enclosing \$1.00 in full payment and the special course will be promptly sent you.

Keep the course for 5 days; and if within 5 days you are not perfectly satisfied in every way, return it and Mr. Murray will return your dollar promptly without question. Learn in Private—Surprise your friends. Act now and be a good dancer soon.

ARTHUR MURRAY, Studio 670, 801 Madison Ave., New York

ARTHUR MURRAY, Studio 670, 801 Madison Ave., New York
To prove that you can teach me to dance in one evening at home, you may send the 16-lesson new course in plain cover. I am enclosing \$1.00 in full payment but it is understood that this is not to be considered a purchase unless the course in every way comes up to my expectations. If within five days I decide to return the course I may do so, and you will refund my money promptly and without question.



Arthur Murray

13th Edition A NEW AND GREATER DYKE'S AUTOMOBILE ENCYCLOPEDIA

Entirely rewritten—rearranged and new illustrations from beginning to end. Mr. Dyke devoted almost two years of constant application to rewriting this book. We are confident that you will agree with us that it is the best book in the world today on the automobile, truck and tractor.

A PRACTICAL BOOK ON THE AUTOMOBILE FOR EVERYBODY

Over 1,200 Pages. Over 4,100 Illustrations
Over 14,000 Lines of Index

This book teaches the underlying fundamental principles of each and every part of an automobile—mechanical and electrical—in a simplified manner, and that is why the largest auto schools are using it as a textbook. Auto owners, students and repair men say that it contains the greatest array of automobile facts ever published in one volume.

This book will teach you to become an expert automobile repairman and also an electrical expert. You will understand fundamental principles, diagnosing troubles, testing, adjusting and repairing. If you were to purchase separate books on the subjects covered the lot would cost about \$21.00. The price of Dyke's book is

Cloth Binding, \$6.
Flexible American } Postpaid
Morocco, \$7.50

Complete table of contents mailed
free upon request

Popular Mechanics Book Dept.
200 E. Ontario St., Chicago

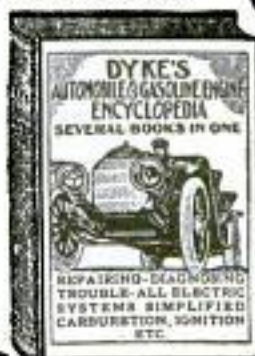

Name

Address

City..... State.....

(Price outside U. S. \$1.10.)

NAVIGATION



**Taught
in Your
Home
or on
Board
Ship**

Salaries to \$315.00

Per Month and Expenses

Sail the Seven Seas as a ship's officer. See the world and get an education which can be secured in no other way. Earn more money than you can on land.

Join America's Mighty Merchant Fleet

America's great, modern passenger and freight vessels now sail to all parts of the world—India, Africa, Asia, China, Japan, Europe, South America, Australia, New Zealand, etc.

Course Adopted by U. S. Navy Education System

The U. S. Navy officials, in search for the simplest, most thorough, best course, on Navigation for the use of enlisted men, have officially adopted the Sheppard Course on Ocean and Coast Navigation. It is the only course of its kind in the world. It enables you to completely master the most fascinating subject in existence in six months or less, during your spare time.

First Lesson Free

First lesson of 52 pages and 36-page illustrated prospectus will be sent free without obligation, upon receipt of coupon below.

Lose no time. You can begin actual training in navigation upon receipt of this free lesson.

"Shove Off"—Join America's Mighty Merchant Fleet—Return This Free Coupon Today

**WORLD TECHNICAL INSTITUTE,
Fuller Building, Jersey City, N. J.**

Send by return mail free booklet, entitled, "Your Future Is on the Seven Seas," which gives every particular about Captain Warren Sheppard's Course on Ocean and Coast Navigation, also Lesson No. 1 of the Course.

Signature

Address

Present Position PM 3-23



YOU Can Become a Chief Electrician

You don't have to attend a technical school to rise high in the Electrical profession. If you have a common school education and are willing to devote a little of your spare-time to home-study, you can easily get into the big-pay Electrical field.

Electricity is the Big-Pay Field

No other line of industry has grown so fast as Electricity. The supply of trained men is always behind the demand. That is why the pay is big. Employers must outbid one another to obtain enough Electrically-trained men. An expert Electrician can easily make from \$50 to \$150 a week or even more. You can get one of these big-pay jobs if you take our

50 Weeks Home-Study Course in Electricity

In less than a year you will know all about Electricity. You will learn just how everything is done and why. Everything is put before you in simple language, and clearly explained with actual photographs. You find it interesting and easy. You rapidly acquire a thorough knowledge of Electricity. You make practical tests and experiments with free laboratory outfit given with every course. And you learn at home—in your spare time—without wasting hours in classrooms, spending your money on long trips or giving up your job.

Mail Coupon Today! It will bring our big free book "Your Future in Electricity"—which describes the wonderful opportunities awaiting you in this big-pay field and how you can easily learn to be an Electrical Expert. Do it—right now!

American School

Dept. E374A, Drexel Ave. and 58th Street, Chicago

American School,

Dept. E374A, Drexel Ave. & 58th St., Chicago

Please send me your free book on Electricity and tell me how I can become an Expert Electrician through spare time home-study.

Name

Address

Please Mention Popular Mechanics

Copyrighted material

You Can Easily Learn to Play Any Music on the HAWAIIAN GUITAR

Just As Hawaiians Do—Native Instructors Teach You QUICKLY!

Here's Proof of our Remarkable Course

Buchanan, Va.
First Hawaiian Conservatory of Music, Inc.

It has been two months since I have finished your course on the Hawaiian Guitar and I can play anything I wish. The course was all that could be desired and I am perfectly pleased with my playing ability since finishing your course.

Respectfully yours,
Louis R. Hammond

Koester School,
214 So. Franklin St.,
Chicago, Ill.

First Hawaiian Conservatory of Music, Inc.

I shall certainly be very glad to recommend your course whenever the chance is mine to do so. Mr. W. R. Johnson has not phoned me yet, and if he does not phone in a day or so, will write him. Am sending a letter to Miss Helen Slavik today which I think may help to secure her enrollment, and I shall be glad at any time to write a personal letter to anyone whom you may suggest.

Your former student,
W. L. Walker

Special Courses under famous Teachers, Tenor-Saxophone, Violin, Banjo-Ukelele and Ukelele. Fine Toned Instruments FREE!

In Half an Hour You Will Be Playing "ALOHA". Soon You Will Be Winning Praise Everywhere Playing "Stumbling", "Three O'Clock in the Morning", "Hot Lips" and ALL Popular Music as Well as the Beautiful Hawaiian Melodies

Here's the chance you've been waiting for—the opportunity to play popular music quickly on the most entrancing instrument of the age—the Hawaiian Guitar. No previous musical knowledge necessary.

ONLY FOUR MOTIONS TO LEARN

and these you acquire in a few minutes. No troublesome scales or runs, you begin to play harmonious chords immediately! We don't care if you never saw a note of music in your life, we guarantee to teach you to play just as the Hawaiians do!

We Furnish Everything—a Beautiful Hawaiian Guitar, Picks, etc., and 52 Pieces of Music FREE!

You have always wanted to play some instrument, so we have made it unusually easy for you by furnishing everything—a beautiful Hawaiian Guitar, complete Conservatory Course of instruction and 52 pieces of especially selected music.

No Other Course Teaches as Quickly and Easily

This is the only Conservatory Course where you get the personal instruction of Native Hawaiian Experts—Frank Ferera, Walter Kolomoku, Lawrence Kalaluki and Carl Seville, famous the world over and the most noted makers of phonograph records, supervise your playing.

Mail Coupon for Details of FREE Offer

Don't wait another minute—clip, fill in and mail the coupon NOW and get full details of our remarkable offer to teach you how to play the Hawaiian Guitar just as the Hawaiians do.

Special Arrangements for Lessons if You Have Your Own Instrument

FREE

This \$15
Hawaiian
Guitar

You will be delighted with the fine tone of this splendid Hawaiian Guitar

First Hawaiian Conservatory of Music, Inc.,
Desk 48, 233 Broadway (Woodworth Bldg.), New York.

Send me at once details about your 52 easy lessons and FREE Hawaiian Guitar offer!

Name.....

Address.....

Town..... State.....

Print name and address clearly

Learn an Auto Trade

Big Pay Jobs Open in California

Learn It Right--at National Automotive

Under California's sunny skies, in wonderful Los Angeles, the city that everybody wants to see, is an auto school that's second to none in the country—NATIONAL AUTOMOTIVE, an institution founded away back in 1905 on the big idea of training men to be as near 100% efficient as possible.

It's the expert that always has a job. There's no job today for the half-trained man. It's the expert that earns big pay. And it's NATIONAL AUTOMOTIVE that trains men to be auto experts. Don't be content with an ordinary auto mechanic's training. Get Advanced National Training and be sure of a higher salaried position. You can be an auto expert. There's a big pay job for you in California. Think of it! One out of every five owns an auto. A million autos in the State. Garages are needed. Auto experts are needed. You're needed in this interesting, money-making business.

Learn autos in National Automotive's big, practical training shops. Actual work on Packards, Cadillacs, Fords, etc. Use tools, not books. Expert mechanic instructors give you thorough training. You know autos when you're a NATIONAL graduate.

Like College Life at National Automotive

The big, new National Building is across the street from 130-acre Exposition Park. Stadium, hall grounds, swimming pools, entertainment—all FREE to you. Find out about our special low tuition offer. SEND FOR BIG FREE AUTO BOOK—explains everything. Full of auto facts, and illustrations of auto construction. Tells how you can earn your room and board while learning. How NATIONAL finds YOUR job for YOU. Get this wonderful auto book now—it's FREE. Send the coupon today.

New Building
New Equipment **Free Auto Book**

Established
1905

National Automotive School
Dept. 25, 811 S. Figueroa,
Los Angeles, Cal.

Please send me your 73-page illustrated auto book—absolutely FREE.

Name.....

Street No.....

City..... State.....





"The Best Hunch I Ever Had!"

"I was feeling pretty blue. Pay-day had come around again and the raise I'd hoped for wasn't there. It began to look as though I was to spend the rest of my life checking orders at a small salary!

"I picked up a magazine. It fell open at a familiar advertisement, and a coupon stared me in the face. Month after month I'd been seeing that coupon, but never until that moment had I thought of it as meaning anything to me. But this time I read the advertisement twice—yes, every word. And this time I tore out the coupon!

"That was the turn in the road for me. The Schools at Scranton suggested a course that would give me a real understanding of our business and they worked with me every hour I had to spare.

"In six months I was in charge of my division. In a year my salary had been doubled! And I've been advancing ever since. Today I was appointed manager of our Western office at \$5,000 a year. Tearing out that coupon three years ago was the best hunch I ever had."

You, too, can have the position you want in the work you like best. No matter what your age, your occupation, your education or your means—you can do it.

All we ask is the chance to prove it. Just mark and mail this coupon. It takes but a moment, but it's the most important thing you can do today. Do it right now!

----- TEAR OUT HERE -----

INTERNATIONAL CORRESPONDENCE SCHOOLS
Box 5510-D, Scranton, Penna.

Without cost or obligation, please tell me how I can qualify for the position or in the subject before which I have marked an X:

BUSINESS TRAINING DEPARTMENT

- | | |
|---|---|
| <input type="checkbox"/> Business Management | <input type="checkbox"/> Salesmanship |
| <input type="checkbox"/> Industrial Management | <input type="checkbox"/> Advertising |
| <input type="checkbox"/> Personnel Organization | <input type="checkbox"/> Better Letters |
| <input type="checkbox"/> Traffic Management | <input type="checkbox"/> Foreign Trade |
| <input type="checkbox"/> Business Law | <input type="checkbox"/> Stenography and Typing |
| <input type="checkbox"/> Banking and Banking Law | <input type="checkbox"/> Business English |
| <input type="checkbox"/> Accountancy (including C.P.A.) | <input type="checkbox"/> Civil Service |
| <input type="checkbox"/> Nicholson Cost Accounting | <input type="checkbox"/> Railway Mail Clerk |
| <input type="checkbox"/> Bookkeeping | <input type="checkbox"/> Common School Subjects |
| <input type="checkbox"/> Private Secretary | <input type="checkbox"/> High School Subjects |
| <input type="checkbox"/> Business Spanish <input type="checkbox"/> French | <input type="checkbox"/> Illustrating <input type="checkbox"/> Cartooning |

TECHNICAL AND INDUSTRIAL DEPARTMENT

- | | |
|--|--|
| <input type="checkbox"/> Electrical Engineering | <input type="checkbox"/> Architect |
| <input type="checkbox"/> Electric Lighting | <input type="checkbox"/> Blue Print Reading |
| <input type="checkbox"/> Mechanical Engineer | <input type="checkbox"/> Contractor and Builder |
| <input type="checkbox"/> Mechanical Draftsman | <input type="checkbox"/> Architectural Draftsman |
| <input type="checkbox"/> Machine Shop Practice | <input type="checkbox"/> Concrete Builder |
| <input type="checkbox"/> Railroad Positions | <input type="checkbox"/> Structural Engineer |
| <input type="checkbox"/> Gas Engine Operating | <input type="checkbox"/> Plumbing and Heating |
| <input type="checkbox"/> Civil Engineer | <input type="checkbox"/> Chemistry <input type="checkbox"/> Pharmacy |
| <input type="checkbox"/> Surveying and Mapping | <input type="checkbox"/> Automobile Work |
| <input type="checkbox"/> Metallurgy | <input type="checkbox"/> Navigation |
| <input type="checkbox"/> Steam Engineering | <input type="checkbox"/> Agriculture and Poultry |
| <input type="checkbox"/> Radio <input type="checkbox"/> Airplane Engines | <input type="checkbox"/> Mathematics |

Name.....
Street..... 6-26-22
Address.....

City..... State.....

Occupation.....

Persons residing in Canada should send this coupon to the International Correspondence Schools Canadian, Limited, Montreal, Canada.

Please Mention Popular Mechanics

Every Welder Should Have The Welding Encyclopedia

It is America's most complete and authoritative reference and instruction book on welding. It gives you a vast fund of expert knowledge on all forms of welding, conveniently arranged, fully illustrated by drawings and photographs and written in language you can understand. It has the approval of the leading manufacturers in the trade. You need this book in your shop.

326 Pages--375 Illustrations--Clothbound

Edited and Compiled by the Editors of the Welding Engineer with the help of many experts in the welding trade

CONTENTS

Illustrated encyclopedia covering all words, terms and trade names used in welding—Oxy-acetylene Welding—Aluminum, Steel, Cast Iron, Copper, Brass, Bronze, Full instructions for welding each of these metals—Electric Arc Welding—Electric Resistance Welding, includes Butt, Line, Percussion and Spot Welding—Thermit Welding—Use and Misuse of Oxy-acetylene Equipment—Boiler Welding—Heat Treatment of Steels—Rules and Regulations—Charts and Tables, including temperature color chart—Condensed Catalogs and Buyers' Index.

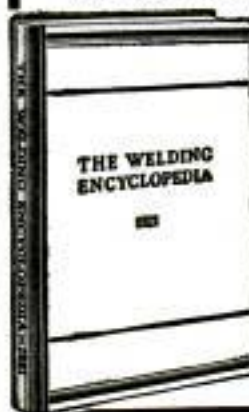

The Accumulated Experience of the Welding Brains of America

Yours for \$5.00

Absolute Refund Guarantee:—If, after having ordered and examined this book, you are not satisfied with same, return it to us and your money will be refunded.

Popular Mechanics Book Dept.
200 E. Ontario St. Chicago

Cartoonists!

The inspiration so necessary for success, as well as valuable hints regarding technique, methods of work and style will be yours if you equip yourself with portfolios of the work of the greatest cartoonists. Just such portfolios are the

BOUND VOLUMES OF CARTOONS MAGAZINE

Here you find the best cartoons of Darling, Cesare, McCutcheon, Carter, Kirby and scores of other master cartoonists of this and other countries.

PRICE \$2 PER VOLUME POSTPAID WITHIN THE REACH OF ALL

Think of it! These durable and attractively bound books (all new) each covering six months and containing 1200 cartoons, 900 pages (7 x 9 1/2 in.) 3 in. thick will be sold separately as long as the limited supply lasts at little more than cost of binding.

Make your selection from the following list and send in an order at once.

- | | |
|------------------------------|----------------------------|
| Vol. 11—January—June - 1917 | } Part of World War Period |
| Vol. 12—July—December - 1917 | |
| Vol. 13—January—June - 1918 | |
| Vol. 14—July—December - 1918 | |
| Vol. 15—January—June - 1919 | |
| Vol. 16—July—December - 1919 | |
| Vol. 17—January—June - 1920 | |
| Vol. 18—July—December - 1920 | |

Address:
POPULAR MECHANICS BOOK DEPT.
200 E. Ontario St. Chicago



Ever
Get Stuck
On a Job?

SHOP NOTES FOR 1923

The latest volume of Popular Mechanics series of year books tells

544 Easy Ways to Do Hard Things

of daily use to every mechanic. Among the many useful articles are Shop Crane—Testing Motors—Power Hammer—Arbor Press—Air Compressor—Turret Lathe—Bench Punch—Concrete Mixer—Bench Grinder—Drug Saw—Concrete Tile.

224 Pages—436 Illustrations
Price 50 Cents, Postpaid

Nine of the volumes of Shop Notes issued previously are also obtainable at 50 cents per copy postpaid.

POPULAR MECHANICS BOOK DEPT.
200 E. Ontario St., Chicago



How to Make Devices for Outdoor Winter Sports

MOTOR-DRIVEN
SLEDS
ICE YACHTS
BOB SLED
SNOW SPEEDSTER
SKI SLED
PORTABLE FISHING
SHACK

COASTING TOBOGGAN
SLIDING BOARD
ICE GLIDER
SKI GLIDER
SKIS AND SKI
RUNNING
AIR-PROPELLED
SLEDS and ICE BOATS

64 Pages—Price 25c Postpaid

POPULAR MECHANICS CO.
200 E. Ontario St., Chicago, Ill.



What Every Criminal Fears!

It's easy enough to make a "getaway"—But, What will he leave behind him?

What will tell the police he has been there?

Just one tiny finger print—and his game is up! He might as well leave his name, address and photograph as leave a finger print at the scene of the crime.

That is why finger print identification has become one of the most important phases of detective work. That is why its uses are being increased every day. That is why ambitious men looking for jobs that offer real opportunity prepare themselves to take up this fascinating work.

There are more jobs now than trained men to fill them. And with the rapid growth of this science, new positions and offices are being created every day.

Be a Finger Print Expert

Learn at home—30 minutes a day for a short time. You need not give up your present occupation while studying this fascinating profession. I am a finger print expert myself and I give you just the kind of training that prepares you to be a finger print expert—that assures you of a position. The finger print expert is always in demand. Get into this big paying profession.

FREE Finger Print Outfit

To those who enroll right now I am going to give absolutely free a professional finger print outfit—the kind that is used by all finger print experts. Besides, a valuable course in Secret Service intelligence is given free to all my students. This information in itself is worth many times the cost of the complete course. But you get it Free.

Write to me today for full information.

You get free the finger print outfit—Secret Service Course is also FREE. Position is guaranteed you. Send in the coupon. Hurry.

U. S. SCHOOL OF FINGER PRINTS
7003 No. Clark St., Dept. 1353, Chicago, Ill.

Positions Guaranteed

In what other line of work can you always be assured of a position? Here is my offer to you. I GUARANTEE YOU A POSITION. As soon as you have finished my course you have a position waiting for you. Get started right now.

U. S. SCHOOL OF FINGER PRINTS
Room 1441, Dept. 1353, 7003 No. Clark St., Chicago, Ill.

Without any obligations whatsoever please send me full information about your "Guaranteed Position Offer—Free Finger Print Outfit." Also tell me how I can become a Finger Print Expert.

Name.....Age.....

Address.....

City.....State.....

EARN \$150 to \$400
a MONTH
 Be a trained Auto Mechanic

This big
FREE BOOK
tells you
how

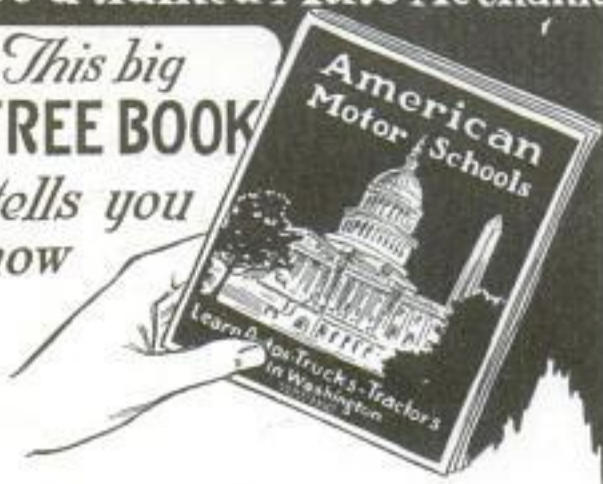

Cut out the coupon below right **now** and send for your copy of our new **FREE BOOK** that gives you interesting and complete information about our courses in auto mechanics.

BE A TRAINED AUTO MECHANIC
 We'll Make You One in From 6 to 8 Weeks

We teach you how to do things. No time wasted on useless theory. Actually working under the eye of our practical shopmen instructors, we can soon make you a general auto repair man, battery expert, welder, tire expert, auto electrician, tractor engineer, auto salesman or chauffeur. Choose the job you want. They all pay **big**—from \$150 to \$400 a month. The demand for trained auto men is increasing. We help you find a job.

A MAGNIFICENT NEW \$250,000 SCHOOL

Our new, big \$250,000 school building is finished. It is equipped with every practical device for auto construction and repair. It is right in the heart of Washington, the Nation's wonder capital. In your spare time you can see the sights in and around Washington—an opportunity that no one should "pass up."

YOU NEEDN'T PAY A CENT until you, yourself, have made a personal investigation of our school and our methods. Hundreds say that we have the standard automobile training of America. Come and see for yourself.

SEND FOR THE FREE BOOK TO-DAY

The first step is to send for the **FREE BOOK** that describes the training. Don't put it off for a moment. It means your start towards a big pay job. Clip the coupon below right now.

AMERICAN MOTOR SCHOOLS, Inc.
 Dept. 323 Washington, D. C.

AMERICAN MOTOR SCHOOLS, Inc.
 Dept. 323
 1612-1622 U Street, N. W., Washington, D. C.

Without cost or obligation, please send catalog.

Name.....
 Address.....
 City.....
 State..... Age.....

Please Mention Popular Mechanics



Quick Easy Way
to Become
a MUSICIAN

Learn music by playing actual selections—instead of tiresome exercises. When you've quickly mastered a lesson you've thoroughly learned to play a new musical composition. As simple as A, B, C. As delightful as a fascinating game. You'll astound yourself by your rapid progress. You can surprise friends by performing in public before they even suspect that you've taken up music. You learn real notes, too—no "numbers" or trick music. You learn by mail—in your own home.

Play by NOTE. Piano, Organ, Violin, Cornet, Mandolin, Harp, Cello, Trombone, Flute, Clarinet, Piccolo, Saxophone, Ukulele, Guitar, Harmony and Composition, Banjo, Tenor Banjo, Voice and Speech Culture, Drums and Traps, Automatic Finger Control, etc.

FREE BOOK Shows How you may quickly become a master of your favorite instrument. It also tells about our wonderful invention—"Automatic Finger Control"—whereby your fingers are guided, trained and made so adept that they fall into their proper places almost automatically. Write today before free edition is exhausted. Mention your favorite instrument or whether you prefer vocal. Instruments supplied when needed, cash or credit.

U. S. School of Music, 73 Brunswick Bldg., New York City

BE A SHORT-STORY WRITER!

Let the **IDEAL METHOD** teach you how. Big Course of 25 Lessons bound in loose-leaf-form, additional lessons specially prepared each month and sent you—**FREE**—keeping the **IDEAL COURSE** absolutely up to date. **THE ONLY COURSE ON THE MARKET WITH THE IDEAL PROGRESSIVE FEATURE.** Makes plot building easy. Teaches you to write clever dialogues, description, narrative—how to create suspense and surprise—how to get ideas—where and how to sell. The result of years of a successful experience in teaching by mail. Price only \$1, postpaid. Your money gladly returned if you do not find this the most practical Course ever offered. Order—**TODAY.**

THE IDEAL SHORT-STORY COURSES, Butler Bldg., Cincinnati, Ohio



Earn Money at Home
 In Your Spare Time

Our men are making as high as \$500 per month—all and part time. You can make and sell glass sign, name and number plates by new United method. **No art training needed.** Big demand for signs, everyone wants a United. Write today for full details about our complete, fascinating outfit for sign making and selling by our easy system.

UNITED LETTERING COMPANY, 1092 Jones Law Bldg., Pittsburgh, Pa.

PRACTICAL ELECTRICAL EDUCATION

Learn by the thorough approved scientific methods which our seventeen years of specializing enable us to give you.

A. C. and D. C. Armature Winding, Wiring and Testing, Practical Electricity, Drafting, Electrotechnics, Commercial Engineering, Electrical Engineering with B. S. Degree. "Earn While You Learn." Radio Broadcasting WIAO. Every Day. 18th year opens April 2nd. Write for Illustrated Catalog. It's Free. Mention Age, Education and Course interested in.

SCHOOL OF ENGINEERING of Milwaukee
 PM-3, 415 Marshall Street, Milwaukee, Wis.



MODEL MAKING

New 400-page book covering workshop practice, design and construction of models. The work described is real model engineering and not the construction of mere toys. **303 Illustrations. Cloth. Price, \$3.00 Postpaid.**
POPULAR MECHANICS BOOK DEPT., 200 E. Ontario St., CHICAGO

ELECTRICITY

Two-Year Course in Six Months in Your Own Home

The teaching of electricity has been revolutionized. All the mystery and all the complications have been removed. Now, by reading simple, easily understood booklets—fascinating as novels—right in your own home, you can fit yourself for one of the big positions now open.

Thousands of Men Needed Thousands and thousands of men are needed in electricity. The industries of the entire world are more and more coming to depend upon the magic power, electricity. The greatest opportunity of modern times lies before you.

\$70 to \$200 a Week Electrical experts make \$70 to \$200 per week. World Technical men are holding jobs like that now. You can do it, too. You do not need to be a college graduate, or even a common school graduate. The World Technical Course is as simple as A B C. All you need is the ability to read the English language.

\$18 Working Outfit Free There are no extras to buy. No expensive experimental materials to spend money for in the World Technical Course. Every student receives absolutely free an \$18 outfit consisting of seventeen standard tools and instruments, including a genuine motor and voltmeter. You couldn't duplicate the outfit for \$25. But when you start on your way to the \$200 a week job with the World Technical Institute you get the whole outfit free.

Send the Coupon NOW Don't let a minute go by. Find out now about the opportunities in electricity, and how you can qualify for one of the big jobs. Read what men high up in the industry say about the opportunities and the World Technical Institute. No obligation. The coupon brings you full information. Send it in now. Let your ambition guide you—mail the coupon to us today. To delay an instant may mean you will put it off forever. We repeat, SEND THE COUPON NOW.

WORLD TECHNICAL INSTITUTE
Fuller Building Jersey City, N. J.



Wayne C. Robinette,
President
WORLD TECHNICAL INST.

FREE COUPON

WORLD TECHNICAL INSTITUTE,
Fuller Bldg., Jersey City, N. J.

Gentlemen:—Send to me postpaid and without obligation: your valuable illustrated book entitled "Electricity Taught by a Master Teacher," also full particulars in regard to your course and the remarkable offers you are making to students.

Name.....

Address.....

PM 3-23

Learn Autos and Tractors



Wonderful opportunities constantly offered trained men; we train you thoroughly to start your own business or make good money as motor expert, driver, shop foreman, etc.

7,000 Graduates making good. Catalog Free

Cleveland Automobile School, 1814 E. 24th St., Cleveland, O.



"BECOME A LIGHTNING TRICK CARTOONIST"

MAKE MONEY CHECK TALKING. SEND \$1.00 FOR SAMPLE PROGRAM OF TRICK DRAWINGS WITH INSTRUCTIONS BY A PROFESSIONAL CARTOONIST. SATISFACTION GUARANTEED. CIRCULAR FREE. BALDA ART SERVICE, DR. OSHKOSH, WIS.

Learn Radio Code

Quick, easy method of learning Radio Code. Learn sending and receiving at the same time. Be able to pick up all messages. Instrument complete when attached to dry cell batteries, including full alphabet and code abbreviations, sent, C. O. D.; postage paid, for \$4.35. Order now.



WOLVERTON & HOLST
2175 N. Clark St., Chicago, Ill.

BE A U. S. Government

Railway Mail Clerk \$1600 to \$2300 Year

MEN—BOYS 18 TO 35

Steady work. No layoffs. Paid Vacations

Common education sufficient:
Send coupon today—SURE

AUCTIONEERS MAKE BIG MONEY

16 years one of the largest Auction Schools in the World. Four weeks term opens June 18, Winnipeg, Can. Write MISSOURI AUCTION SCHOOL, KANSAS CITY, MO.



BECOME A RAILWAY MAIL CLERK

Examinations soon. \$1600 to \$2300 a year. No strikes or lockouts. Common education sufficient. No "pull" necessary. Mail coupon for catalog.

Patterson Civil Service School
Dept. 83, Rochester, N. Y.

Sirs:—Send me without charge your Catalog, describing this and other fine U. S. Government positions.

Name.....

Address.....

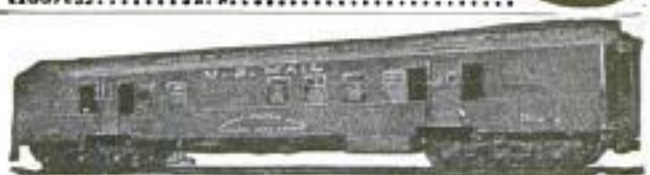

FRANKLIN INSTITUTE, Dept. N178, Rochester, N. Y.
Sirs: Send me without charge, (1) Sample Railway Mail Clerk Examination questions; (2) Tell me how to get a position; (3) Send list of many Government jobs obtainable.

Name.....

Address.....

Announcing The New- Electrical Course

Learn Practical Electricity

FIT YOURSELF FOR ACTUAL WORK

This is the greatest and most interesting news I have ever published. I have spent 15 years and hundreds of thousands of dollars getting ready. Now I announce the opening of what I firmly believe is the world's best equipped and most useful Electric School—and I am teaching Electrical Work by a new system, new—that is for electrical schools, but a system that has proven a world-famous success in teaching auto-mechanics to over 50,000 men—that is, the Sweeney system of Practical Experience; using tools—not books.

Operate and Repair Electric Machinery

What you young men want isn't to be Engineers, or Designers, or Theorists, or Scientists. What you want is the actual ability to go out and install, operate and repair all kinds of Electrical Machinery. How to handle, as a competent workman, Electrical Power Plants, Electric Signs, Farm and City Lighting Plants, Storage Batteries, Radio Sets, Wiring, Electric Driven Machinery of all kinds—such as Elevators, Street Railway Motors, etc. When you get thru this Course, you will know how to handle Electrical Machinery, because I don't fill your head with hazy ideas; but I train your hands with the real work you will be called on to do.

\$150,000 Special Equipment

The Million Dollar Sweeney School has \$150,000 worth of Special Electrical Equipment and teachers specially trained, men who take a personal interest in you—and teach you by the Sweeney System of Practical Experience. Some of this wonderful equipment simply can't be duplicated. For example, a \$50,000 radio broadcasting station (Call W.H.B., famous the world over), and a factory where we build radio sets; a factory where we build storage batteries; a 100-kilowatt complete electric power plant; the largest mechanical electrical sign in America. Look at the pictures on this page. They show some of the material with which you will work.

The Real Way to Learn

Quit thinking about electricity as something "deep" and hard to learn. All I ask is that you like mechanics and realize the opportunities for a man in the electrical business. This is an Electrical age. Train yourself for the countless opportunities that every new day brings. The world is calling for electrical trained men—you don't need to be an engineer or designer or scientist, but you must know how to fix, repair, build, install, operate all kinds of electrical machinery. This is what gets you a real job the minute you are qualified.



Instructor showing student how to control the current as transmitted from over 100 kilowatt generator.



Instructor Hyde giving student practical training on generator.



Rear view of one switch board. Students making repairs under personal direction of instructor Dillon.

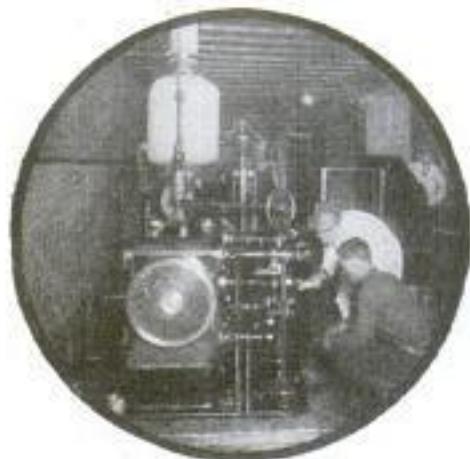

Murray Corliss Engine driving a 100 Kilowatt Generator used in lighting the Sweeney Bldg. and furnishing light for our large electric sign which has 4800 electric lights.

Real Jobs for Electrical Workers

Conduit Man.....	\$160
Electric Light Service.....	160
Trouble Shooter.....	160
Installing Radio.....	200
Power Plant Foreman.....	200
Block Signal Man.....	240
Auto Electric Work.....	250
Elevator Electrician.....	210
Plant Building Installation.....	400
Electrical Construction.....	300
Power Plant Installation.....	400
Ry. Electrician.....	300

Send for this Big Special Offer Today

If you like electricity, if you want to get profitable employment, if you want to get into the liveliest and fastest growing industry in the whole world, if you want to make a real success of life, send for my big circular and special Opening Offer. You bet I am going to make the men who start the first class, graduates to be proud of. Come in, you live ones, for here's your chance! I don't care how much education you have. You don't need any previous experience. I teach with tools. So get my offer and learn the particulars of this amazing course. Write me today—just send name—sign coupon, or postcard will do.

E. J. SWEENEY, President

LEARN A TRADE—

Sweeney

AUTOMOTIVE & ELECTRICAL SCHOOL
1180 SWEENEY BLDG. KANSAS CITY, MO.

E. J. Sweeney, Pres., Sweeney
Automotive Electrical School,
1180 Sweeney Bldg., Kansas
City, Mo.

Rush me your big Electric Circular
and your Opening Offer.

Name

Address



Get in for Yourself— Sweeney Men Make Good In Auto Business!

Young man, consider the case of E. M. King. A year ago he was reading an advertisement just as you are doing now. Today Mr. King is independent and prosperous. From farm hand to independent successful business man was his jump in one year

Dear E. J.:

Elida, Ohio, October 28, 1922.

I must write and tell you of the success I have had since I left your school last March.

As soon as I left school, I bought a new Ford Roadster and rigged it up to haul all kinds of tools, and then went right to a man's home to overhaul his car. I had twice the work that I could do. Once I fixed a car in ten minutes that two other mechanics had worked on for six hours. I made enough in four months to buy me a five-ton "White" stone truck and now my daily average is \$75.00 a day.

So you see how well it paid me to come to your School. From a \$3.00 a day farm-hand to a \$75 a day truck owner and operator.

If anyone doubts this statement, I can furnish an affidavit with a hundred signers if necessary. You are welcome to use this letter in any way that you wish that will help the Sweeney School.

Yours respectfully,

Signed: E. M. KING.

Learn Mechanics In 8 Weeks At Sweeney's

I PAY YOUR RAILWAY FARE

I want you to come now—not to wait and postpone—I am making it easy for you—I will help you—the first step is to send for my free catalog.

FREE

The first step is to send me the coupon or write a postcard for my 72-page illustrated catalog. It tells all about this Million Dollar Trade School.

How thousands of men just like you, without any special knowledge, but simply a liking for mechanics, MADE A LIFETIME SUCCESS as a result of this simple training.

I don't care how old you are. I don't care how small your education, for I teach with TOOLS, NOT BOOKS. I need 5000 salesmen and representatives to handle Sweeney batteries and radio supplies. I want managers for branch offices. I WILL PAY YOUR RAILWAY FARE to Kansas City. Write me NOW! No colored students accepted.

E. J. SWEENEY, President.

LEARN A TRADE—
Sweeney
AUTOMOTIVE & ELECTRICAL SCHOOL
1179 SWEENEY BLDG. KANSAS CITY, MO.



GADAGE OWNED BY A
SWEENEY STUDENT DOING
\$20,000 A YEAR BUSINESS



GARAGE IN AUSTRALIA OWNED
BY SWEENEY STUDENT



GADAGE IN INDIANA OWNED
BY STUDENT HUTSELL

EMORY J. SWEENEY, President

1179 Sweeney Bldg., Union Station Plaza
KANSAS CITY, MO.

Please send me free, without any obligation, your big 72-page catalog and your Sweeney School News. Tell me of the opportunities in the Auto and Tractor Business.

Name.....

P. O.....

State.....

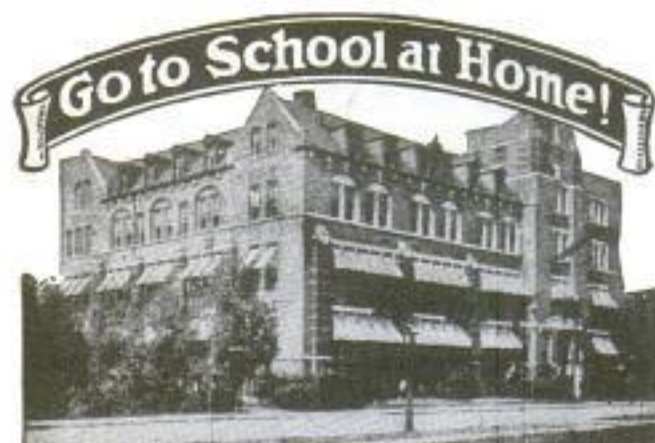

High School Course in Two Years!

You Want to Earn Big Money!

And you will not be satisfied unless you earn steady promotion. But are you prepared for the job ahead of you? Do you measure up to the standard that insures success? For a more responsible position a fairly good education is necessary. To write a sensible business letter, to prepare estimates, to figure cost and to compute interest, you must have a certain amount of preparation. All this you must be able to do before you will earn promotion. Many business houses hire no men whose general knowledge is not equal to a high school course. Why? Because big business refuses to burden itself with men who are barred from promotion by the lack of elementary education.

Can You Qualify for a Better Position

We have a plan whereby you can. We can give you a complete but simplified high school course in two years, giving you all the essentials that form the foundation of practical business. It will prepare you to hold your own where competition is keen and exacting. Do not doubt your ability, but make up your mind to it and you will soon have the requirements that will bring you success and big money. **YOU CAN DO IT.**

Let us show you how to get on the road to success. It will not cost you a single working hour. Write today. It costs you nothing but a stamp.

American School

Dept. H374A, Drexel Ave. and 58th St., Chicago

American School

Dept. H374A, Drexel Ave. and 58th St., Chicago

Send me full information on the subject checked and how you will help me win success.

- | | |
|-----------------------------|---------------------------|
|Architect |Lawyer |
|Building Contractor |Machine Shop Practice |
|Automobile Engineer |Photoplay Writer |
|Automobile Repairman |Mechanical Engineer |
|Civil Engineer |Shop Superintendent |
|Structural Engineer |Employment Manager |
|Business Manager |Steam Engineer |
|Cert. Public Accountant |Foremanship |
|Accountant and Auditor |Sanitary Engineer |
|Bookkeeper |Surveyor (& Mapping) |
|Draftsman and Designer |Telephone Engineer |
|Electrical Engineer |Telegraph Engineer |
|Electric Light & Power |High School Graduate |
|General Education |Fire Insurance Expert |
|Vocational Guidance |Wireless Radio |
|Business Law |Undecided |

Name.....

Address.....

Please Mention Popular Mechanics



BIG PRICES PAID TO ARTISTS

YOU are indeed fortunate if you like to draw! Develop your talent—become a commercial artist! Thousands of business firms pay millions of dollars yearly for good advertising drawings and designs. Well-trained artists command \$50, \$75, \$100, \$150 a week—sometimes even more. "Top-notch" designers receive \$250, \$500, \$1000 and up for single drawings.

Learn Quickly at Home in Your Spare Time

Get into this fascinating profession which has a future as big as modern advertising and modern business. The Federal "Master Course" teaches you the methods and ideas that make your drawings worth real money. It gives you individual personal criticisms on your lessons. No previous training or experience needed. And best of all—Leading successful artists are authors of exclusive lessons in the Federal Course. They will give you the benefit of their experience and advice, only in this Course.

Get This Free Book "YOUR FUTURE"

Investigate now—by all means send for this book. It's free to anyone 16 years old or more who is in earnest about his or her future. Beautifully illustrated in colors, it gives facts about the field of commercial art, names of the famous artists who are Federal Authors, and every detail you will want to know about the Course. It is a proven result-getter. Mark and mail the coupon **right now**—kindly stating your age and occupation.

-----COUPON-----

Federal School of Commercial Designing
687 Federal Schools Building
Minneapolis, Minn.

Please send me "YOUR FUTURE", without charge or obligation.

Age..... Occupation.....

Name.....

(Write your address plainly in margin.)

\$80 Drafting Course Free

There is such an urgent demand for practical, trained Draftsmen that I am making this special offer in order to enable deserving, ambitious and bright men to get into this line of work. I will teach you to become a Draftsman and Designer, until you are drawing a salary of \$250.00 a month. You need not pay me for my personal instruction or for the complete set of instruments.

\$250 a Month

Starting salary according to my agreement and guarantee. Draftsmen's work is pleasant and profitable. Positions are open paying \$3,600.00 a year in the best surroundings. They are open everywhere. Thousands of men are needed who have just the kind of training I will give you. You can get this training during spare time in your own home.

Mail the Coupon

for my valuable book — "Successful Draftsmanship." It explains how YOU can become a Successful Draftsman in a short time. The book is free at present, so write **AT ONCE**.

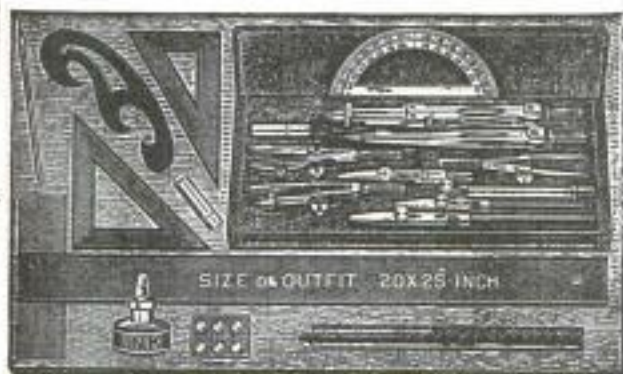

Earn While Learning

You can be earning a handsome income while learning at home. This is a special offer I am making. Absolutely no obligations of any kind in sending coupon. But you must write at once, as I limit the number of my students.

Mail the FREE Coupon at once

for my book — "Successful Draftsmanship," also list of open positions and for the free offer to be earning good money at once while learning at home. This offer is limited and in order to benefit thereby — **act at once**.

Chief Draftsman Dobe

1951 Lawrence Ave., Div. 1353, Chicago, Ill.

Chief Draftsman Will Train You Personally

on practical Drafting-room work **Until** you are competent and **Until** you are in a permanent position at a salary paying at least \$250 per month. This is an exceptional opportunity for a few selected ambitious men, between the ages of 16 and 50 whom I will train personally.



Send the Coupon or a letter and let me tell you how you can become a Draftsman in your spare time and earn a good salary. Don't delay — send the coupon at once.

I Guarantee
To instruct you until competent and in a permanent paying position at a regular Draftsman's salary of at least \$250 per month and guarantee to furnish you free complete Draftsman's working outfit at once from the start.

FREE—this \$25.00 Draftsman's Working Outfit

These are regular working instruments, the kind I use myself. I give them free to you if you enroll at once. **Send the Free Coupon today.**

Free Course Offer Coupon Chief Draftsman Dobe

1951 Lawrence Ave. Div. 1353 Chicago
Without any obligation to me please mail your book, "Successful Draftsmanship" and full particulars of your liberal "Personal Instruction" offer to a few students. It is understood I am obligated in no way whatever.



Name _____

Address _____



Copyrighted—Pat. Pending

LEARN TO PLAY MUSIC THE PHONOGRAPH WAY SCHNEIDER'S SIMPLEX SYSTEM

A Six Year Combined Course for VIOLIN—MANDOLIN—
BANJO-MANDOLIN, via: 2 years Violin, 2 years Mandolin, 2
years Banjo-Mandolin.

For \$9.50

NEW WAY TO PLAY. Most Fascinating, Simplest, Quickest
Method Ever Devised. 30,000 Have Learned to Play Beautifully.
WHY NOT YOU?

**PLAY FOR MONEY
IN TWO MONTHS**

You Learn
to Play or
No Charge

**PLAY BY NOTE
IN A FEW DAYS**

Marvelous New Way to Be a Musician

Nothing ever like it. Each course has lessons for all three instruments. Entire substance of a six year term of lessons "as you would receive them from the average teacher." Put on 6 Phonograph Records (12 sides). We ask you to let us PROVE our statements to your satisfaction or you pay nothing. No previous knowledge of Music required.

Anyone can learn. Send no money. Simply fill in and mail the coupon below. We can furnish instruments when so desired.

HOW IT IS DONE

You just listen to the clear commanding voice on the records while you look at a book—the voice tells you where to look, what to do and how to proceed. You then hear the instruments being played, thereby showing you how it should sound and at the same time the voice tells how and what you should do. Your every action is guided by the voice of F. M. Schneider himself as though he stood before you.

Try this course for five days. No money in advance. See for yourself how easy it is to learn to play music.

Condensing Thoughts Has Made This Course Possible

Each course consists of 6 regular sized double disc phonograph records, 3 small appliances with directions for fitting on your instrument, 1 instruction book, 1 book on "How to Teach."

Records are playable on any machine that will play Victor or Columbia records.

These instructions bring instant results.

Saves being humiliated before a human teacher.

Information given would cost hundreds of dollars the ordinary way.

A MONEY MAKER FOR ADVANCED STUDENTS

Those now studying the violin who wish to teach, will be enabled to earn considerable because this course shows how to teach three instruments, thereby giving a broad field and variety of instruments to teach.

Schneider School of Music, 233 Vermont St., Blue Island, Ill.

Without money in advance send me your complete record course with appliances and books. I will pay the postman \$9.50 plus the small postage charges in full on arrival, with the understanding that I have the guaranteed privilege of returning course, appliances and books and of having my money promptly refunded after 5 days if I am not delighted with results.

Name

Address

City..... State.....

If you wish you may send cash with order and save postage.
(Price outside U. S. \$10.50 cash with order.)

Everyone who is looking for

NEW PLAYS FOR CHILDREN

will be interested in this announcement

The greatest plays being written for children today are those coming from the pen of T. C. O'Donnell. Whimsical, full of color and charm, imaginative, these plays make a universal appeal to the child because of their delightful humor and naturalness, and to the teacher because they lend themselves so readily to the very simplest stage. Every play has a well-worked out plot, plenty of action, surprise—and yet can be "put on" in the living room as easily as on a thoroughly equipped stage.

THE "JUST IMAGINE" PLAYS

is the newest series of O'Donnell plays. The first two numbers are just off the press. They are:

"THE SANDMAN'S BROTHER" AND "ANN'S HALF BIRTHDAY"

Through a special arrangement with the publishers we are able to make the first announcement of this series to teachers of expression, grade and high-school teachers, Sunday-school teachers, teachers of dramatics in neighborhood center work, mothers and others interested in clean, wholesome, easily produced plays for little folks from five to twelve years of age.

(Even if you are not interested in producing children's plays, you will find these plays fascinating for the story or bed-time hour.)

Each play is artistically printed and bound—the price, only 50c each, postpaid. Send \$1 today for the two.

**POPULAR MECHANICS BOOK DEPT.
200 E. Ontario St. Chicago, Ill.**

Become An Automotive Electrician

\$75 to \$100 a Week

GET into the highest paying branch of the continually expanding automobile industry. 78% of all automobile repair work is electrical. Yet not one out of fifteen garage men know enough about automotive electricity to cash in on this field. No matter what you now know about automobiles, this is your big chance to quickly qualify for this uncrowded, big money field. \$75 to \$100 a week is gladly paid to men who know how to repair batteries, ignition, lighting and starting systems, magnetic gear shifts, signalling systems and other electrical units.



PREPARE—AT HOME OR IN CHICAGO

Enjoy the thousand pleasures and broadening educational advantages of America's great western metropolis, while you learn a business that will put you far ahead in the Automotive Field.

Visit the immense stockyards. See the great mile long Municipal Pier, the interesting exhibits in the new Field Museum, the old Masters in the Art Institute. Attend the theatres—spend Sundays at your favorite sport. There is no place like Chicago. It is the playground and the Educational Center of the West. Come to Chicago and have the happiest and most profitable visit of your life while you learn Automotive Electricity in America's most practical and thorough school.

PROOF

Earns \$75 to \$100 a Week

I have earned \$75 to \$100 a week ever since I left school.
N. Klecker, Chicago.

Doubles Salary in Two Weeks

Before I went to Ambu my salary was \$30.00 a week. In two weeks I was raised twice to \$60.00. Now doing even better in my own business.
Wm. Deas, Louisiana.

Ambu Course Gets 70% Increase

Earning 70% more than ever before. The course at Ambu did it.
S. K. Kigore Batavia.

Big Dividends in New York

Want to work in largest service station in New York the day after nine men were let out. My course at Ambu is paying big dividends.
Lewis D. Jones, New York.

Ambu Men in Demand

Believe me, they sure grab you off when you say you've been thru Ambu.
J. L. Bailey, Rockford.

Ambu: Then Double Earning

My earning capacity has been more than doubled since my training with Ambu.
R. M. Bernhardt, Greenosette.

\$1000 a Month

I'm starting my own business as my boss has been taking in over \$1,000 clear profit every month.
Wyrose J. Edward

Forced to Open Service Station

After graduation, I set did spare time work. But my reputation spread so fast that I had to open a service station of my own.
Ernest Casares.

Gets 50% More Than Before

With wages going down all over the country my electrical repair business is booming. Thanks to Ambu. My earnings are 50% more than ever before.
Eugene A. Chaput, Holyoke.

Increased Income 4 Times

Have my own shop. Earning four times what I did before I went to Ambu.
Willard W. Ludlow.

NEW EASY WAY TO LEARN In Chicago or at Home

The automobile business is here to stay. The last few years have been only a start. Tremendous additional expansion is on the way. And the highest paid and uncrowded branch of this enormous field needs you. There are plenty of auto mechanics to take up a bearing, tighten a bolt, grind out carbon. But, suppose your starter won't start, your battery won't charge, your lights won't light. Just try to get his aid. They're a Chinese puzzle to the average mechanic. You'll visit from 5 to 10 garages before you find an Automotive Electrician. In a short time you too can become a highly-paid Automotive Electrician who knows his work and his worth—not a dabbler or a guesser. The special method developed by the Ambu Engineering Institute does not saturate you in theories and rules—it shows how to do things and why to do them. Things ordinarily considered complicated are now made amazingly easy.

FREE BOOK ABOUT AUTOMOTIVE ELECTRICITY

12,000,000 cars in America are equipped with electrical units constantly getting out of order and defying the ingenuity of the ordinary garage men. The specialist is the man who makes money today. The Automotive Electrician is a specialist and the demand is far ahead of the supply.

Mail the coupon for FREE book about this big money field. If you want to learn at home the special Ambu Method has made it practical and thorough. If you want to learn at our school in Chicago, a staff of experts (the same men who developed our Home-Study method) will take you in hand. ANY man with a common school education can now become an Automotive Electrician in eight short weeks. The facts about this field are so interesting and can mean so much to you that you should inquire about them right away. A special limited time offer is open now—so mail the coupon at once.

AMBU ENGINEERING INSTITUTE
Dept. 13, 2632 Prairie Avenue
Chicago, Illinois

This 32-page book tells all about the field of Automotive Electricity and how hundreds of men have broken out of the rut and entered this field with good money and a future. Already 18% of them own their own businesses. Mail this coupon at once for full facts and special limited time offer.



Ambu Engineering Institute,
Dept. 13, 2632 Prairie Ave.,
Chicago, Illinois.

Please send me FREE booklet and complete information on Automotive Electricity. Tell me of the rich rewards which await me in this uncrowded field. I am interested in your

- Residence Course.
 Home Study Course.

Name.....
Occupation.....
Address.....City.....

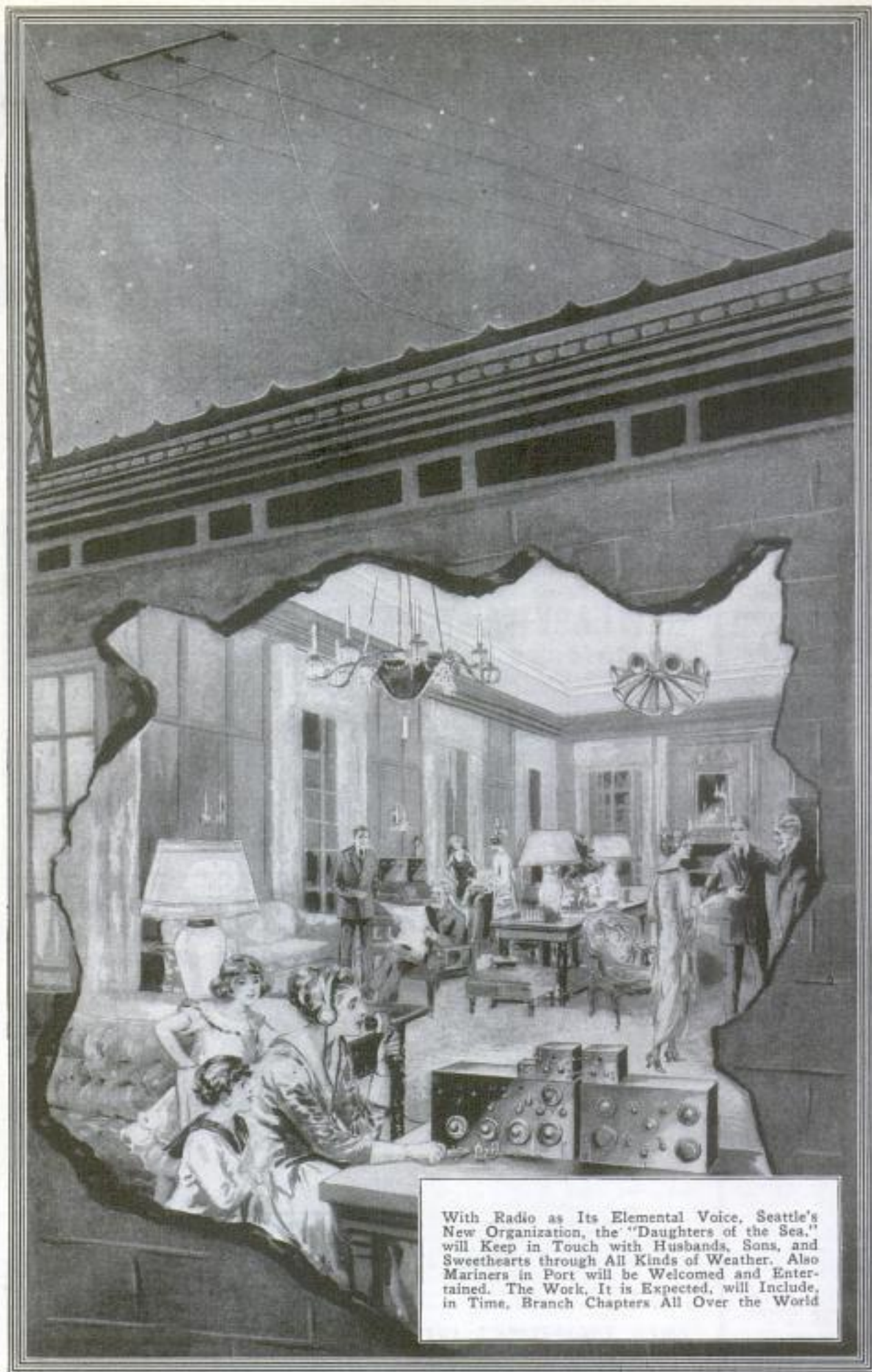

With Radio as Its Elemental Voice, Seattle's New Organization, the "Daughters of the Sea," will Keep in Touch with Husbands, Sons, and Sweethearts through All Kinds of Weather. Also Mariners in Port will be Welcomed and Entertained. The Work, It is Expected, will Include, in Time, Branch Chapters All Over the World

Popular Mechanics Magazine

REGISTERED IN U. S. PATENT OFFICE

WRITTEN SO YOU CAN UNDERSTAND IT

Vol. 39

MARCH, 1923

No. 3

332

"THE DAUGHTERS OF THE SEA"

BY LAWRENCE WM. PEDROSE,

*617 Pacific Bldg,
Seattle, Wash*

FOR the purpose of making more comfortable and pleasant the hours spent in their home ports by the masters, mates, and pilots of the Pacific, and developing radio broadcasting to their ships while at sea, wives, daughters, and sweethearts of mariners living at Seattle have formed an

organization called the "Daughters of the Sea."

The Daughters of the Sea plan to bring the home closer to the ship, and the radio will be their chief means toward that end. The club has undertaken the fitting up of quarters on the top floor of one of the



city's tall buildings, and is furnishing them with a library, comfortable chairs, smoking accessories, and marine glasses, so that seafarers may watch from the windows the ships making and leaving port.

A powerful radio sending and receiving apparatus is to be installed on the roof of the building, and entertainments, concerts, etc., held in the club rooms will be broadcast to the ships at sea. The personnel of vessels in any storm area will be cheered by the voices of loved ones at home. A practical service also will be maintained; the location of all ships from the home port will be recorded from day to day. The plans also include

the entertainment of visiting captains from other ports of the world. There will be a committee supplying all arriving ships with flowers, and seamen strangers will be provided with comfort and entertainment.

One of the chief duties of members of the new organization is to see to it that every captain has in his ship's quarters the photographs of those dearest to him. Another obligation on the part of members is that of planning pleasant surprises in the homes of mariners when they return from voyages. Eventually, it is expected, the Daughters of the Sea will extend their work to all countries by establishing branch chapters.

1058
Auto Act
RADIATOR'S TEMPERATURE CONTROLLED BY DRIVER

By a newly devised combination of automobile-radiator shutter and an automatic control, the shutter opens when the

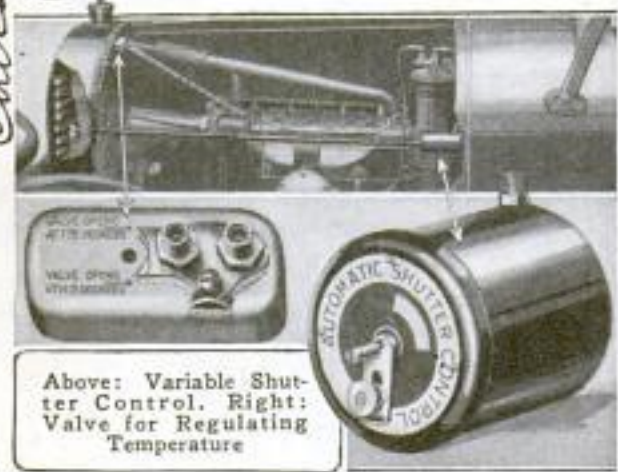

Above: Variable Shutter Control. Right: Valve for Regulating Temperature

water becomes too warm and closes as it cools. The water temperature may be varied as the driver wills, by means of a valve operated by a thermostatic control that regulates the flow of water through the cylinder jackets and radiator, increasing or diminishing the flow as more or less heat is desired.

1405
INDIA'S TELEPHONE SYSTEM TO HAVE WIDE EXPANSION

The long-distance telephone system of India is having a rapid expansion under the plans of the government telegraph department. The program provides for the line from Bombay to Calcutta, under the Arabian Sea, as the first link, to be followed by one from Bombay to Delhi in the north, close to the Himalayas. These

will be completed in about 12 months. Progress of the work depends mainly on appropriations by the civil divisions, as it is to be done by the provincial governments. With the work complete, Kashmir, just south of wild Turkestan, may be rung up from Bombay, on the Gulf of Bengal, or Cape Comorin on the Indian Ocean.

1322
Electric
NEW MOTOR HAS ONE-PIECE ROTOR WINDING

A departure from standardized electric-motor construction has been made in a rotor winding which is formed in one piece. In the ordinary type of squirrel-cage motor, each bar is individually joined to the end rings, making a number of joints. In the form described, the entire winding consists of an integral sheet of copper, punched, formed, and machine-wrapped around the motor core, the copper bars being swaged into the core slots.

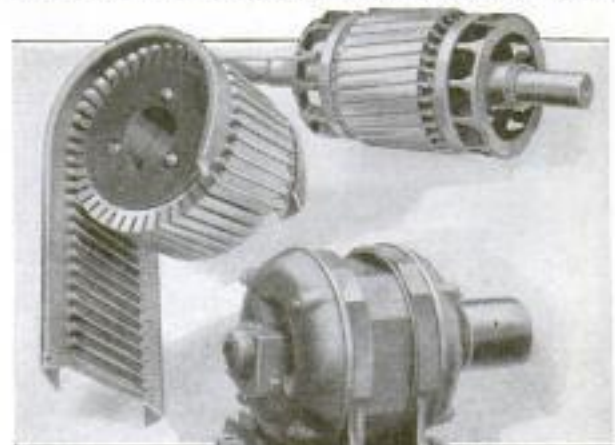

Rotor and One-Piece Winding for It: The Partly Wound Shows and Manner of Winding to Form Integral Joint with End Rings

Copper Sheet Punching

The Electrical Review
1/5/23

The Louis Allen Co
Milwaukee, Wis

Driving Engineering Sales Co.
3282 N. Hubbard Ave.
Chicago

1400



Latest Flying Machine of the Helicopter Type Just After It had Taken Off from the Ground in One of Its Recent Trial Flights: The Machine Has Four Six-Bladed Propellers, Each with a Lifting Capacity of About 1,000 Pounds

LATEST HELICOPTER MAKES FLIGHT

THE latest in the helicopter type of flying machine made its initial flight a short time ago when it remained in the air for 1 minute 40 seconds and reached a height of 8 feet. In several later ascensions the machine, carrying two passengers, rose 3 feet above the ground. Helicopters continue to attract considerable attention on account of their ability to rise vertically from the ground and to land in a small area. While the height attained by this helicopter may not seem very impressive, it can be argued that the first trial trip of the Wrights lasted only 59 seconds. The machine was built at McCook field under the supervision of the inventor, Dr. Geo. de Bothezat, a Russian scientist. It is equipped with four lifting propellers, each having six blades and a diameter of 10 feet, and it has provision for flying horizontally. The machine measures 60 feet from tip to tip and has a total lifting capacity of nearly 4,000 pounds.

205 Lexington Ave., Dayton, Ohio

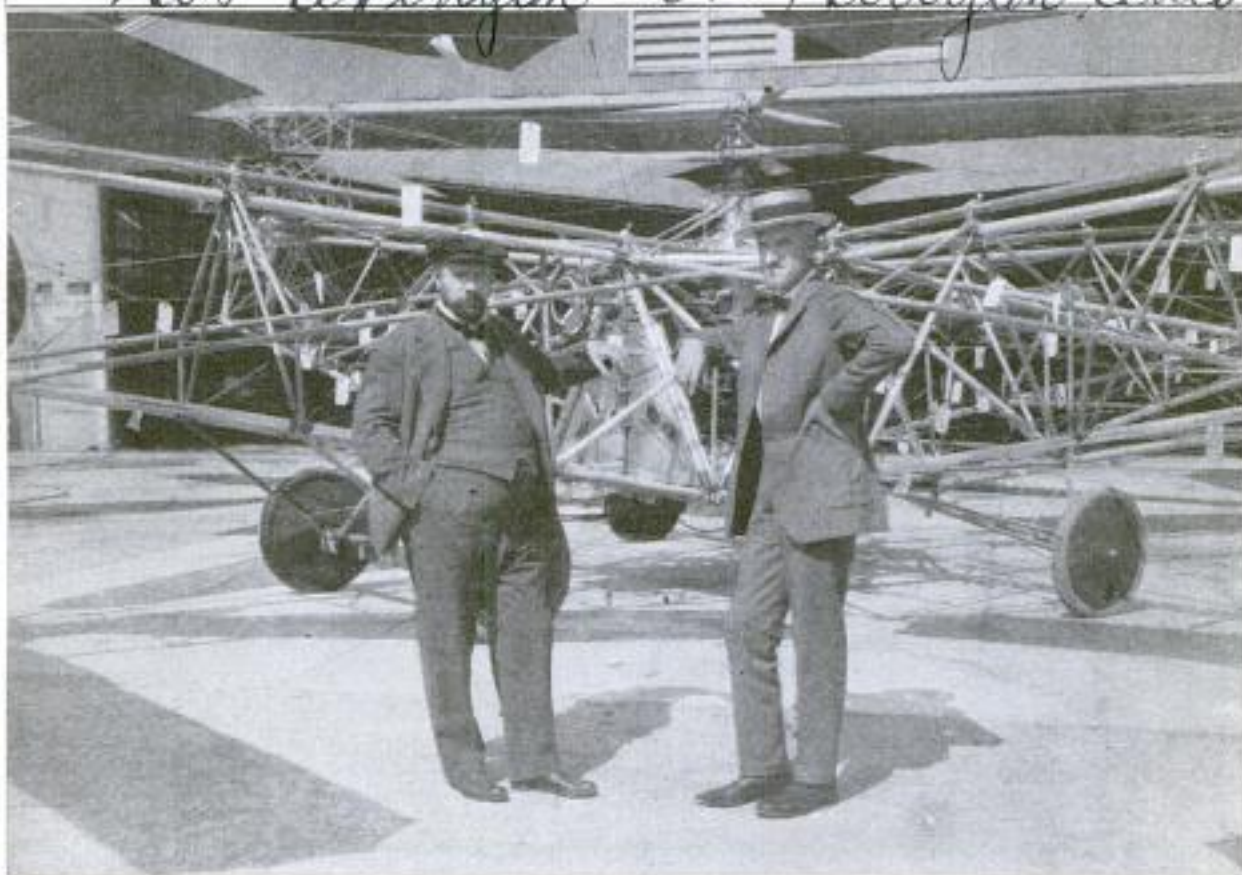

Doctor Geo. de Bothezat, Inventor of the Latest Helicopter, Stands at the Left. Colonel Thurman H. Bane, Until Recently Commandant at McCook Flying Field, Who Piloted the Machine on Its First Flight, Appears at the Right, Leaning against the Machine

MAXIMUM SAFETY CLAIMED FOR NEW STEPLADDER

A maximum degree of safety is claimed for a new folding stepladder built with

widely separated legs and a large working platform at the top. Two benefits are derived from the construction of the legs, one that shaking and upsetting are practically eliminated, and the other that it is possible to place the ladder over machinery or other obstructions. The platform itself provides a large railed-in space on which the workman may stand, confident that he will not fall. There is room enough for a pail or other material, though if desired the back half of the platform may be raised and used for this purpose. This raised portion also serves as an extra step when reaching toward particularly high places.

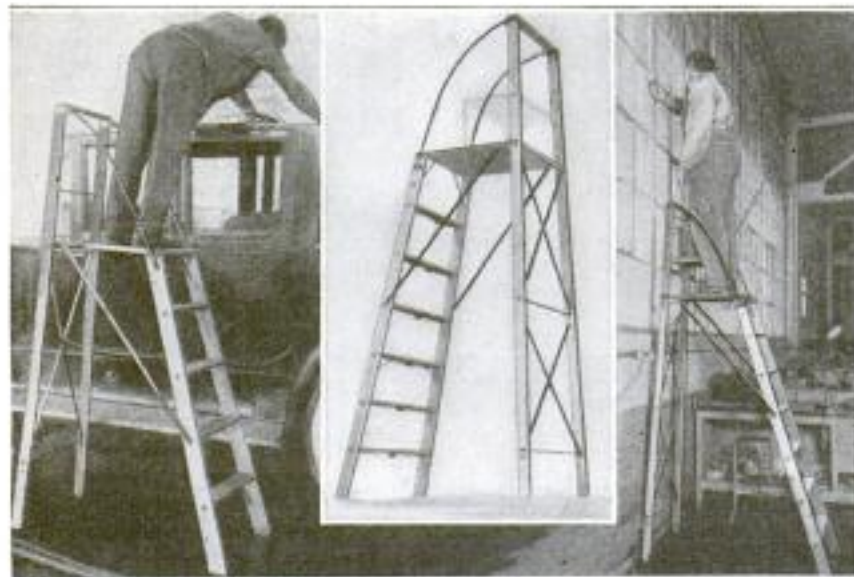

New Stepladder Which is Claimed to Have a Maximum Degree of Safety: Right, Note the Raised Portion of the Platform; Left, a View Indicating the Stability of the Ladder

972 **IMPROVEMENTS IN HOISTING MACHINES**

In the design of hoisting apparatus, several new features have been incorporated.

For hoists using standard electric motors without solenoid brakes, a patented automatic brake holds the load suspended, preventing it from falling, in case of failure of the electric current. A third-drum extension is provided for converting a double-drum steam or electric hoist into a triple-drum machine. It can be attached to any existing hoist by bolting it onto the main frame. Another innovation is a nonburning friction block, made of metallic asbestos, which is said to increase the efficiency 35 per cent. For use on heavy-duty derricks with long hoists at high speed, the brake flanges are cooled by means of openings through which the air can circulate. An improved cut-steel friction screw with special thread, makes the clutch operate more easily.

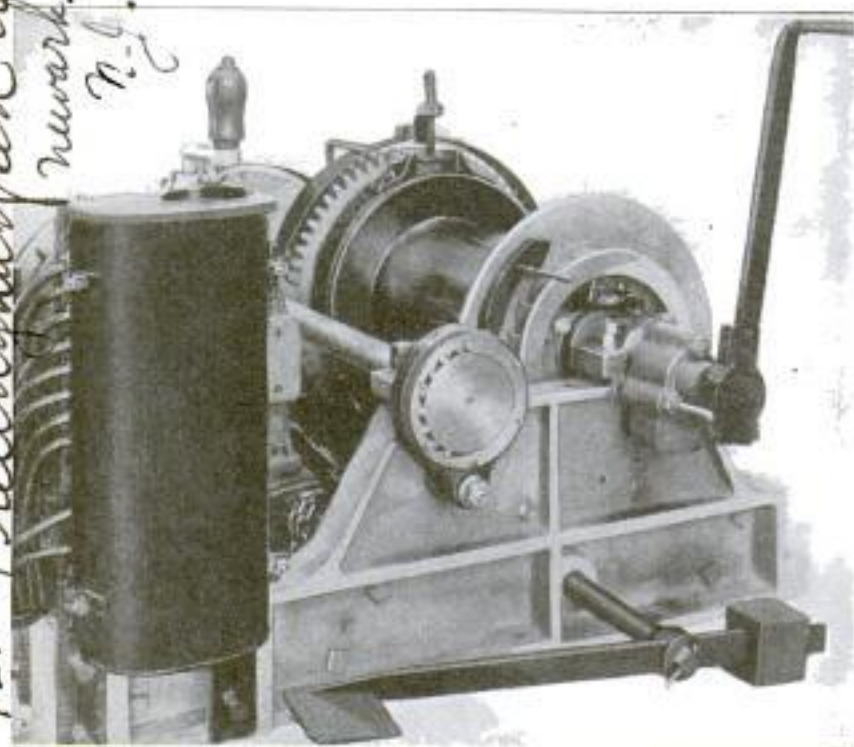

Hoist for Use with Standard Electric Motors without Solenoid Brakes, Which Has an Automatic Safety Brake and an Improved Screw That Reduces the Work of Operating the Friction Clutch

J. D. Mundy Hoisting Engine Co.
 722 Delaware Street
 Newark, N.J.

1333 Dwight P. Robinson + Co. d no.
125 E. 46th Street

New York City

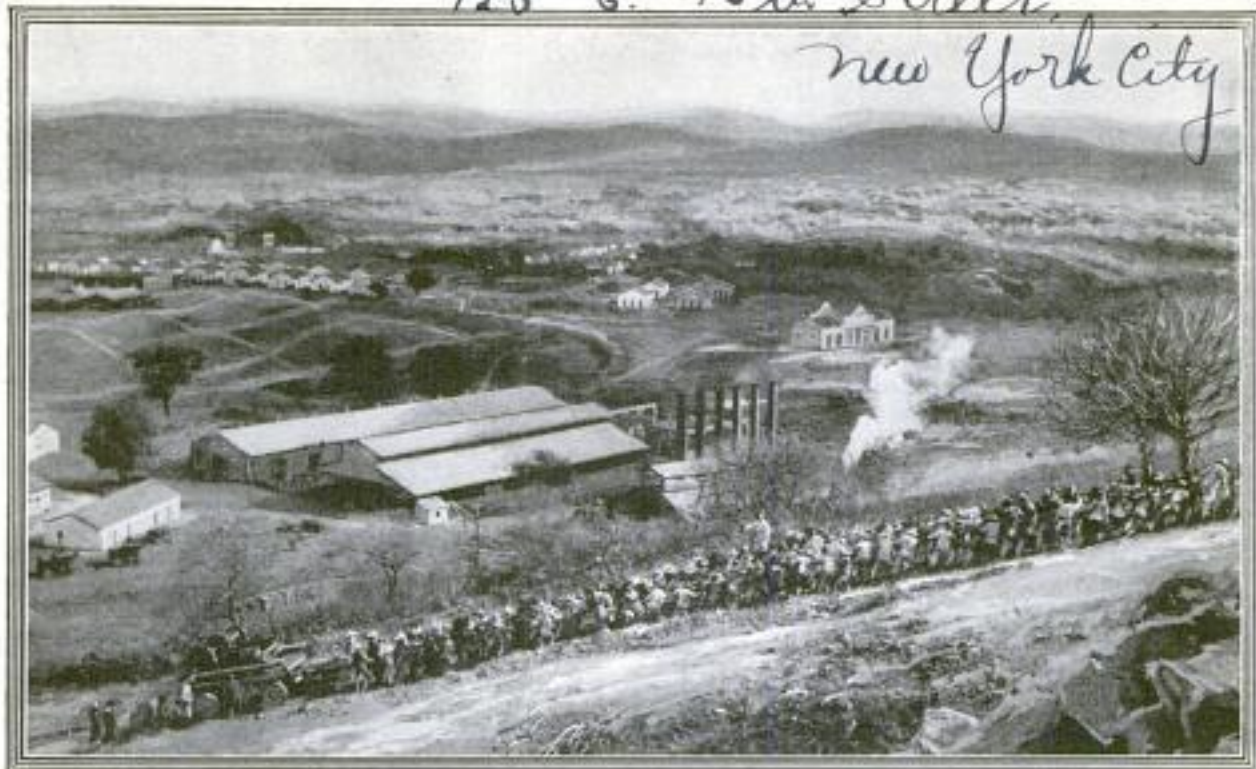

Pulling Equipment Uphill by Man Power, with 250 Men in Line, for Construction of Great Dam, to be Built by American Engineers: Buildings, Sheds, and Mills in the Background Are in the Basin, to be Filled with Water Later. Owing to Primitive Conditions, Man Power is Used

SAVING WATER FOR BRAZILIAN STATES

One of the World's Greatest Conservation Projects—Dams and Reservoirs to Hold Back and Store Torrential Rains—Supply for Five Years Required—
Scourge to be Lifted from Stricken Provinces

BY A. S. CHAPMAN

PLANS of the Brazilian government for water storage and irrigation in several states of its territory now being put into execution make them one of the greatest engineering projects ever undertaken in the world. In brief, their object is the reclaiming from drought and making permanently habitable the states of Ceara, Parahyba, Rio Grande do Norte, and parts of Piahy, Bahia, and Pernambuco, in northeastern Brazil, with a population in the neighborhood of 2,500,000. Ever since their first settlement by Portuguese colonists, these states have been subject to periodic droughts, which dried up vegetation, baked the earth hard, killed the live stock, and drove the people from their homes.

Droughts such as those which made these states uninhabitable for years at a time are almost beyond belief in comparison with the ordinary "dry spell" as it is known to us. In 1723, a drought began which lasted for five years. Another, beginning in 1877, had a duration of two and a half years. Yet in spite of these visitations, the country is so fertile under normal conditions, the climate so agreeable, and living conditions so at-

tractive, that the people returned and attempted to make homes again, only to be driven out by another scourge of the same kind.

Following the drought of 1877, Dom Pedro, the last emperor of Brazil, undertook on his own responsibility plans for reclaiming these fertile lands. Work was continued in an intermittent way till now a project is being worked out by two English engineering companies and one New York company.

The problem is not that of conserving rainfall and distributing it during the dry season of the year, but the collection and storage of a total supply sufficient to carry the people and their crops and animals during a prolonged absence of rain. The reservoirs will be called upon with certainty, every five or six years, to furnish a large part of the total supply without replenishment for a period of 30 months. The problem is complicated by many factors. There are occasional seasons when the rainfall is in excess of 60 inches, and the rivers carry tremendous floods. The streams are on steep gradients, and they drain themselves down to the sandy beds soon after the rains

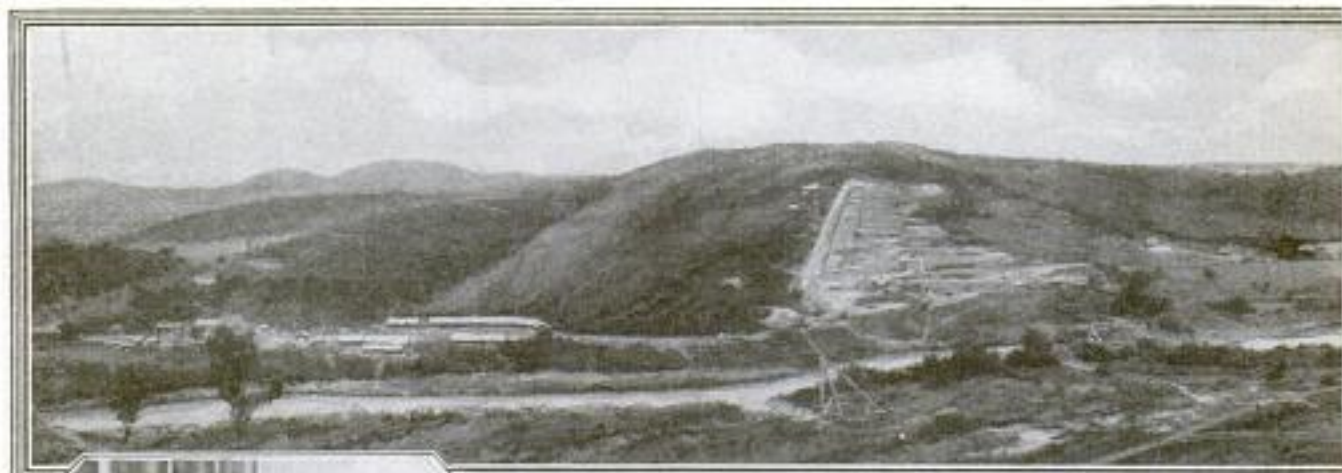

PHOTOS BY COURTESY OF

Panorama of East Side of Dam Site at Poco dos Paus, Which Gives Dam and Reservoir: High Hills, Valley, and Watercourse are Included Irrigation. Owing to the Lack of Railways, All Equipment and Build

Left: Boilers Complete Except

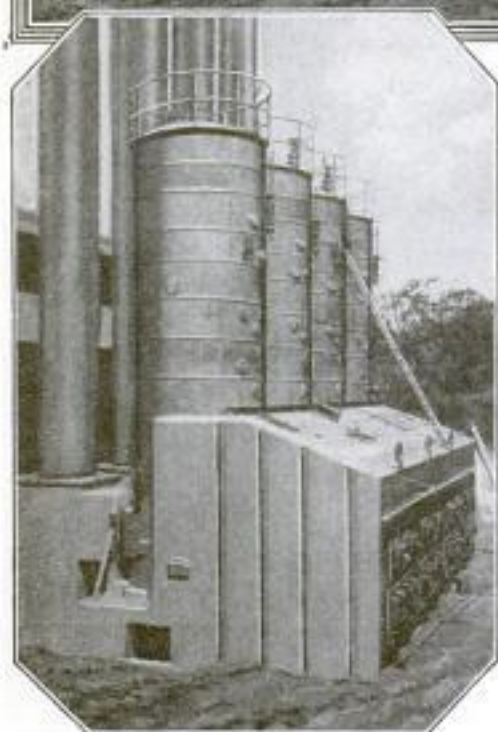

cease. There are no snows nor accumulations of ice to melt slowly, no swamps to give up their stores of water gradually. After the rainy season, with its torrential falls running quickly to the sea, comes the regular dry season—perhaps, a drought lasting several years.

The reclamation is executed under the supervision of a special federal department that is in charge of all works to overcome the effects of these prolonged droughts. The first to be undertaken was the construction of a network of railroads and highways, of immediate use to the country and indispensable in carrying on the work. Next came the construction of great reservoirs. Three contracts have been made for the project. One English engineering company has the port works at Fortaleza, Ceara, completion of a dam at Acarape, and construction of dams at

Patu and Quixeramobim, also in the state of Ceara. Another English company has the contract for dams at Gargalheira and Parelhas in Rio Grande do Norte, and for port works at Parahyba. The New York company is administrators for the construction of dams at Poco dos Paus, Oros, Piranhas Piloes, and Sao Gonçalo, in Rio Grande do Norte. All the contracts are identical and call for work to be paid for on a cost-plus basis. The present year should see some of the reservoirs in partial operation.

All of the dams are of the first magnitude, com-

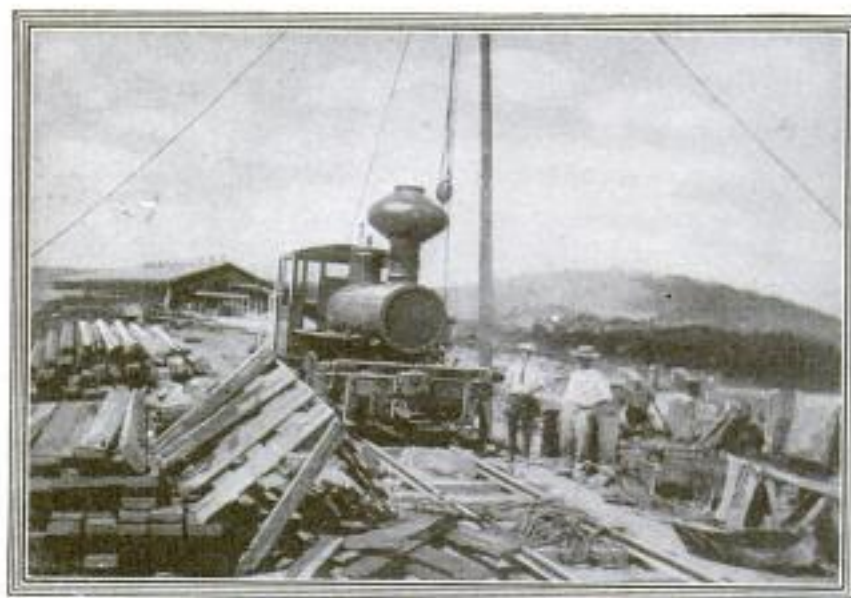

American Engineers Supervising the Erection of a "Dinkey" Locomotive, with Its Shed and Tracks: The Engine Is a Wood Burner, as Coal would Be Entirely Too Costly, and There Is, Fortunately, an Abundant Timber Supply



SWIFT P. ROBINSON, INC.

an Idea of the Magnitude of Operation in the Construction of a Single in Its Scope, Converting It into a Lake for Impounding Water for ing Material had to be Moved to the Dam Sites by Primitive Methods. Walkways. Right: Tail Tower

paring with the greatest engineering operations of the world in difficulties of construction. According to present plans, all construction equipment of the American company will be operated by electricity, to be generated by steam boilers using wood for fuel. Dams will be equipped with aerial cableways, concrete-spouting systems, steel derricks, compressed-air drills, and all minor appliances for construction.

To reduce transportation costs, the works will be supplied with cement ground in a mill now under erection at Fortaleza (or Ceara), the unground clinker being bought in foreign markets and transported to Fortaleza in bulk.

The reservoirs constructed by the American engineers will have a total capacity of 120,000,000,000 cubic feet of water. If the full contents of these reservoirs were poured over the land area of Connecticut and one-third of Rhode Island, it would cover them with water to the depth of a foot.

The big project has an important economic value. But for the drought, the states would be fertile and produce abundant crops of rubber and other commodities. Cattle, goats, and sheep are raised in great numbers, and their hides and skins form a considerable article of commerce. But under dry-weather conditions the production of the country is uncertain and the people are likely at any time to be driven out and compelled to seek new homes.

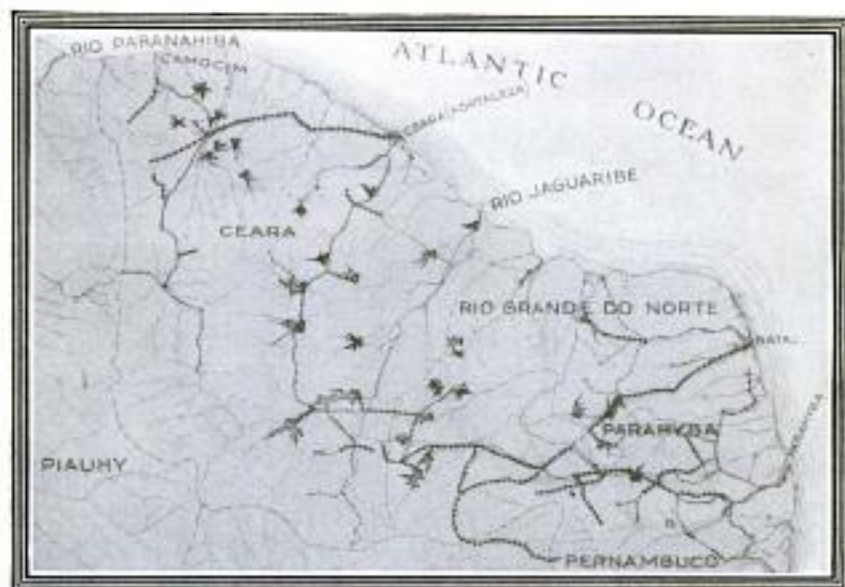

Map of Territory in Northeastern Brazil, Where American and English Engineers are Carrying Out the Gigantic Conservation Project, Which has Gone On Intermittently for Some 40 Years: The Dark Areas Show the Reservoir Sites

1291
 Frank & Betty Co
 336 308 Randolph,
 POPULAR
 Chicago
 MOVABLE ICE CHEST MADE
 FOR HOSPITAL USE



A small movable chest for holding chipped ice has been made for use in hospitals. The chest, mounted on a rubber-wheeled carriage, resembles a fireless cooker in appearance and construction, and has a faucet for draining off water. Aluminum is used as the lining on

the interior. In small spaces, it turns in its own length.

139
 BRIDGE ACROSS GOLDEN GATE
 TO BE WORLD'S LONGEST

A combined suspension and cantilever bridge with a span of 4,000 feet and a total length of 6,700 feet, will soon be built across Golden Gate, San Francisco Bay, if a proposition to that effect in the California legislature is passed. It is said that there is no opposition to the bill and all that remains to be done is to complete the financial details.

Extending centerward from the towers, which are to rise 1,010 feet above the water level, or slightly higher than the Eiffel

1396
 Jno. McFadden
 of the Grove Mfg Co
 MECHANICS

6642 Cottage Grove, Chicago
 Tower, triangular trusses will reach out for a distance of 700 feet and form anchorages for the suspension cables of the 4,000-foot span. Only one deck is to be built, and that will be 200 feet above the water level, as compared with the 135-foot clearance of the Brooklyn Bridge of New York.

The bridge will connect Fort Point, on the San Francisco side, with Line Point, in Marin County, on the north. The cost will be about 20,000,000 dollars.

WEED PULLER SAVES BACK
 BENDING OR KNEELING

1396
 A newly devised weed puller makes it possible to rid the lawn of plantains, dandelions, or other weeds without the back-breaking work of bending over to cut them with a knife. With one motion of the hands the puller is opened, another forces it into the ground, and a third pulls the weed. It may be used also in gardens or places hard



to get at by hand. A feature that most home gardeners will appreciate as much as the usefulness of the tool, is that it saves the hands from dirt stains.

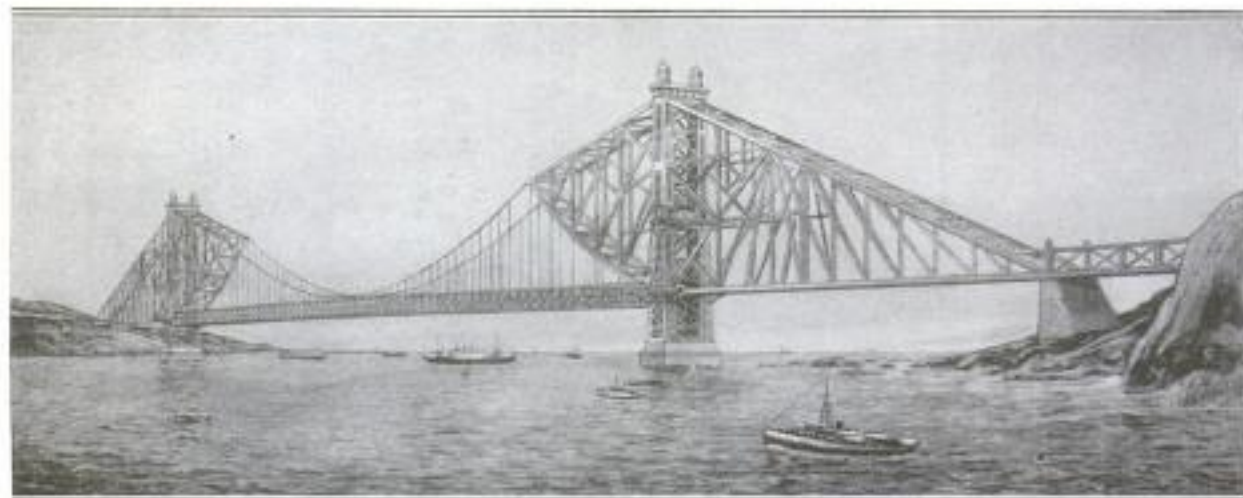

Bridge with 4,000-Foot Suspension Span and 6,700-Foot Total Length Which It is Expected will be Built across Golden Gate, San Francisco: Two Piers, to Rest on Rock Ledges 50 Feet below Water Level, will Support the Towers, 1,010 Feet High. The Deck will Be 200 Feet above Water Level

Strauss Bascule Bridge Co. Inc.
 225 N. Michigan Chicago

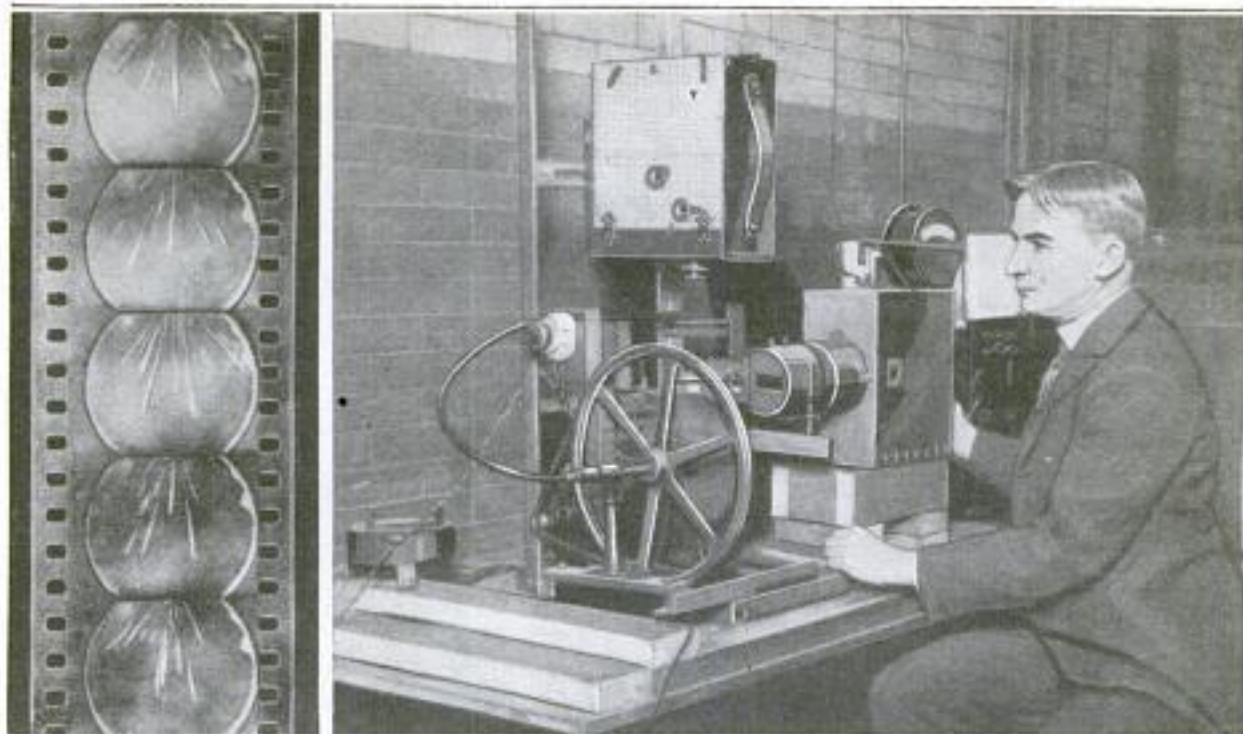

COPYRIGHT, INTERNATIONAL NEWSREEL CORP.

Left: Moving-Picture Film, Showing the Tracks of Helium Nuclei Traveling through Air at 20,000 Times the Speed of a Rifle Bullet. Right: Professor Harkins and the Apparatus, Made by His Assistant, R. W. Ryan, That was Used in Photographing the Flight of Atoms

THE FLIGHT OF ATOMS PHOTOGRAPHED

Rev. BY W. D. HARKINS + Mr. R. W. Ryan

Professor of Physical Chemistry, University of Chicago

AN atom is 2,000 times too small to be seen through a microscope and it is apt to stagger the imagination of most people to hear about photographing atoms in flight. Not so long ago an atom was spoken of as the smallest particle of matter, but now it is believed to represent a grouping of electrons around a nucleus, much in the manner that the planets arranged around the sun constitute the solar system.

Air that is not too dry, confined in a cylinder and alternately compressed and expanded under the action of a piston, will produce a mist of minute water particles similar to a rain cloud. If the cylinder is vertical, and the head and upper part of the walls are made of glass, and with sufficient illumination, this phenomenon can be seen with the naked eye as the miniature fog settles toward the piston.

In further developing the apparatus, the terminals of an electric circuit of high voltage are connected at the top and

bottom of the cylinder and in circuit with a device that makes contact at the proper instant during the stroke of the piston. Charged helium atoms, or nuclei, emanating from a speck of radioactive material, called polonium, located on the side of the cylinder, are projected through the air, and about 200,000 minute water drops deposited in the path of each helium atom, each making what appears like the trail of a tiny skyrocket. The helium nuclei, or part atoms, travel at a speed 20,000 times that of a rifle bullet, and as they pass through the atoms in the air, they bump into the atom parts, called electrons, knocking them out of the atoms, which is called ionizing or charging the atoms, producing the effect seen in the trails in one of the illustrations. On

each electron thus knocked out, and on each ion left by tearing an electron out of an atom, a minute water drop deposits itself. A great number of these drops, as described above, constitute each atom

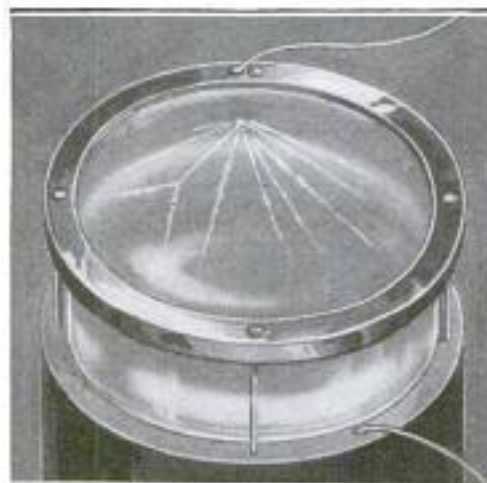

Appearance of Upper Glass Portion of Cylinder When Brilliantly Illuminated, at the Instant Atom Tracks are Formed: Note Collision between Two Atom Nuclei Shown by Forked Trail at the Left

track, which when illuminated by a powerful arc light, are extremely bright. When one of the helium nuclei collides with the nucleus of another atom, the result is similar to one billiard ball hitting another, but usually it shoots through 400,000 atoms without striking a nucleus.

A motion-picture camera can be mounted directly above the top of the cylinder and arranged to operate in synchronism

with the movements of the piston so as to photograph each series of flights as it occurs. It is interesting to note that out of 30,000 tracks photographed, only one indicated a nearly direct collision between a helium nucleus and the nucleus of another atom. By measuring the angles of incidence and deflection shown in such a collision, it is possible to compute the diameter of the atom nucleus involved.

9582

carries
SHIP-LOADING METHODS IN MANCHURIAN PORTS

American sailors hail with joy the entry of their vessels into Manchurian ports.

unloading equipment of any sort at the Dairen docks. At the rush time of the



Scenes at the Port of Dairen, Manchuria: The Native at the Left is Receiving a Tally Stick from the Checker, Who Keeps Count of the Number of Sacks or Boxes Stowed. Right: Coolies Boarding the Ship

year, which is summer, 16,000 coolies are employed in stevedoring pursuits at the busy port. One of the most important articles of export is linseed, which is brought by mule team or train to the docks. One sack or box at a time is carried by each coolie. Checking is done with sticks. When a coolie picks up a parcel and places it on his shoulder, he is given a wooden stick about the size of a lead pencil. At the end of his journey, the coolie deposits his burden and gives the tally stick to another checker. By counting the sticks at the end of the day, the exact number of sacks that have been loaded or unloaded is known.

Cmt. Incl Wharfton 135-8-12 H. St. Portland Oregon.

There is no work for them at Dairen, the ocean terminus of the South Manchurian Railway, situated 28 miles east of Port Arthur, and full shore leave is allowed. Native coolies, working for 20 cents a day, load and unload the ships. The automatic conveying machinery on board the American vessels making this harbor is never uncovered while in port, because coolies perform the labor more cheaply.

There is no mechanical



Linseed, One of the More Important Exports, is Often Brought to the Docks by Mule Team. From the Carts the Sacks are Stacked in Piles and Finally Carried Aboard by Native Stevedores

1144 Cmt. Effie Mc Kay Webber
Parkland, Alta., Canada

Ran O. K. Ranch,
Buffalo Hills, Canada.



Team of 20 Horses and 10 Mules, Hauling a Wagon Train Loaded with More than 1,000 Bushels of Wheat, and Driven by Only One Man, en-Route to Vulcan, Alberta, amidst Interested Onlookers

1144 TEAM OF 30 ANIMALS HAUL HEAVY WHEAT LOAD

Driving single-handed a team of 20 horses and 10 mules, hitched to a wagon train loaded with more than 1,000 bushels of wheat. Ralph Morehouse, of Alberta, has established what is said to be a record in western Canada. The trip was made recently over a 22-mile stretch from his ranch near Buffalo Hills to a grain

elevator at Vulcan, Alta., where, without unhitching any of the animals, the entire load was disposed of in 1 hour 17 minutes. In turning corners, Morehouse, ignoring the leading teams, swung the hind teams over the pulling cable and started them in the proper direction. These animals would then pull the lead teams until they, too, were headed in the direction desired. About 2,000 persons gathered to watch the performance.



The Wagon Train Entering Vulcan: In Turning the Corners Encountered from This Point On, the Driver Swung the Hind Teams over the Hauling Cable, and Forced These Teams to Pull the Other Animals Until They, Too, were Headed in the Direction Desired

1357

Wide World Photos 229 W. 43rd, New York
Typical Press Agency, 10-11 Red Lion Court,
TEST FLIGHT OF LARGEST AERO ENGINE
Fleet St, London, E.C. 4, England.



ABOVE is shown the "Napier Cub," a large bombing plane and the biggest single-engined machine ever built, on the occasion of its official test in the air at the Avro Aerodrome, Southampton, Eng. Below is a group of officials, including Air Vice-Marshal Sir Geoffrey Salmond, Director of Research; A. V. Roe, the designer, and H. T. Vane, of the Napier Company, inspecting the 1,000-horsepower engine. This is the largest motor ever built for airplane purposes, and its future performance will be watched with considerable interest.



1357

LARGE AIR LINERS EXHIBITED IN EUROPE

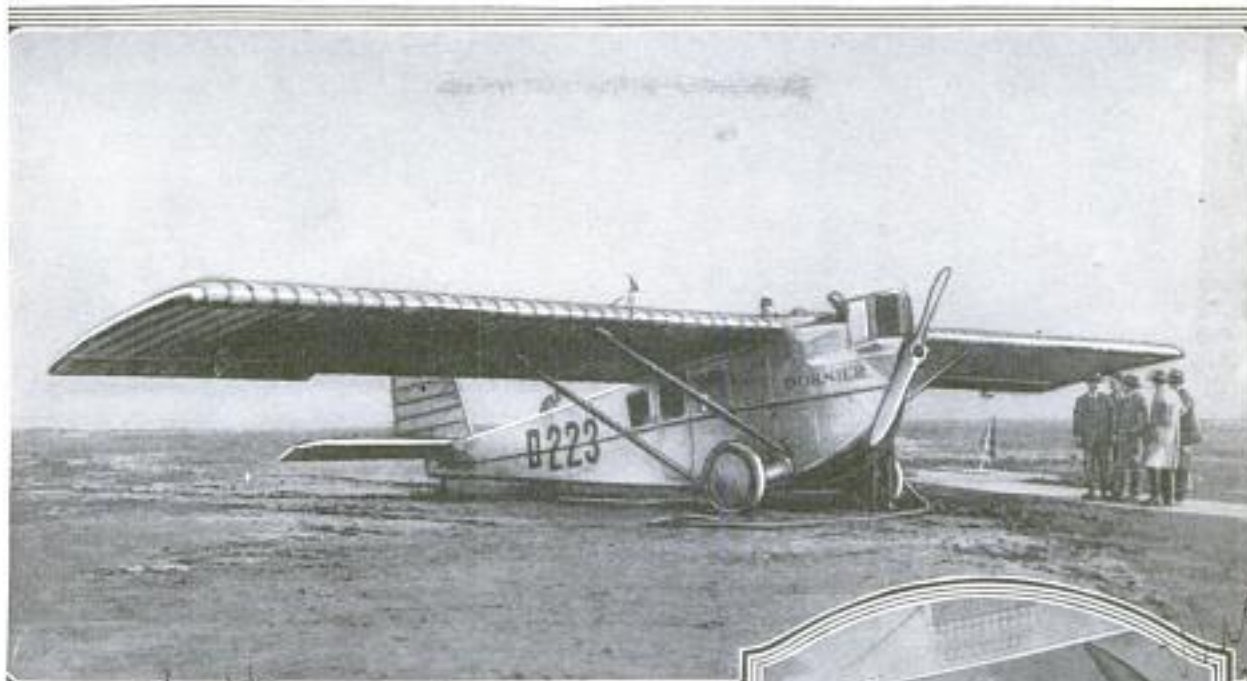

K+H

AT the present time there is a good deal of activity along the lines of developing safe and comfortable airplanes for the established and contemplated passenger routes in Europe. Above is a picture of the first German passenger plane that has arrived in England since the war, shown soon after landing near London, after a flight from Berlin. It is a large all-metal monoplane, and this was a trial trip for a permanent service between the two countries. At the right can be seen a portion of the cabin and one of the propellers of the Breguet "Leviathan," a giant commercial plane which was exhibited at a recent aero show in Paris. The "Leviathan" is equipped with the comforts of an overland train. The interior of a giant passenger airplane exhibited at the show, is shown below. The apparent passengers and attendants are really wax figures, placed in the cabin to give an idea of the comfort and security that a modern air liner affords.

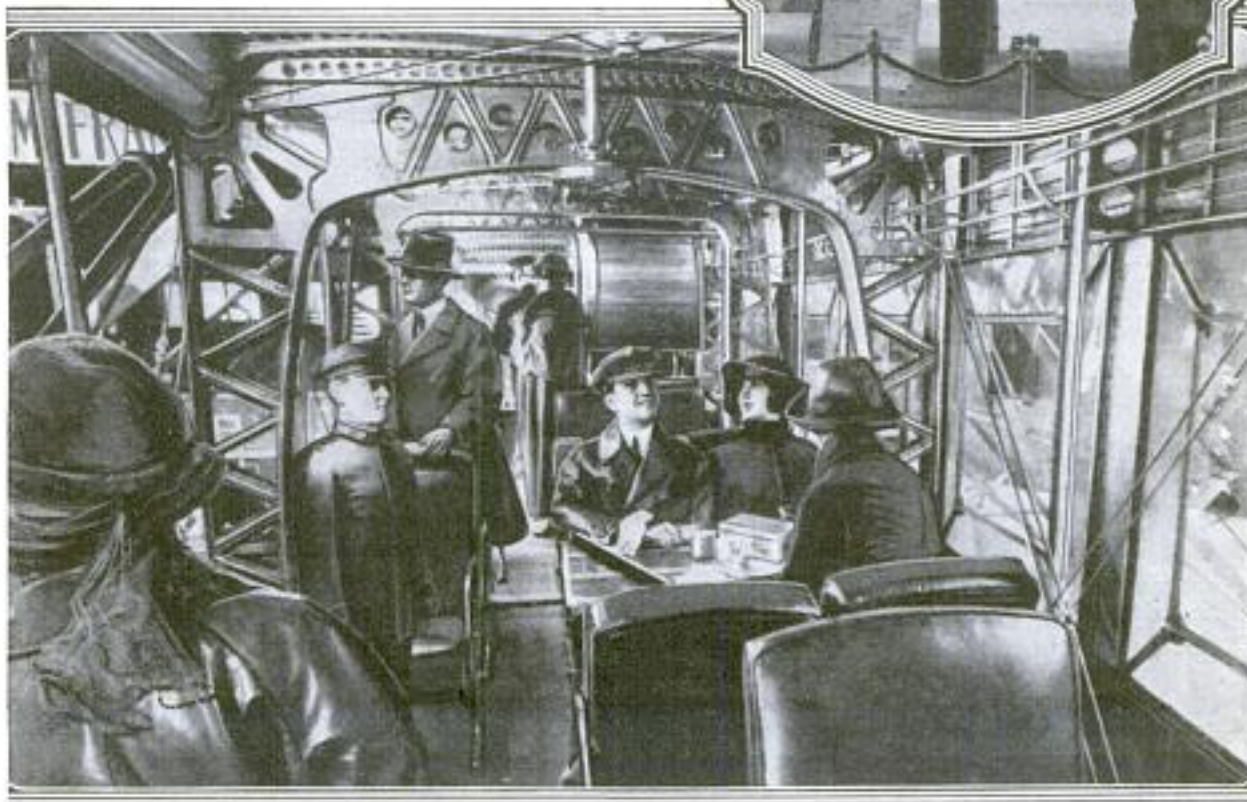

I. W. Chas. Es. Throop 4862 Kenmore
Ave. Chicago

POPULAR MECHANICS

342
1345

attached

NAME-FINDING GUIDE FOR TELEPHONE DIRECTORY

An index-guide system with which names in a telephone directory are found much more quickly than at present is being tried by the Chicago Telephone Company. At the front of the book is a page having printed in a vertical column along its outer edge a series of letters and subdivisions, beginning with A at the top and running to Ku at the bottom; while a page at the back is printed with the rest of the alphabet similarly subdivided. Extending across the front edge of the book are parallel lines marking these divisions, the beginning of each letter and its subdivisions being indicated by special vertical marks. To find the name Harris, for example, the finger is placed at "Ha" in the vertical column, run along the parallel lines to the special mark, and the book opened at that place.

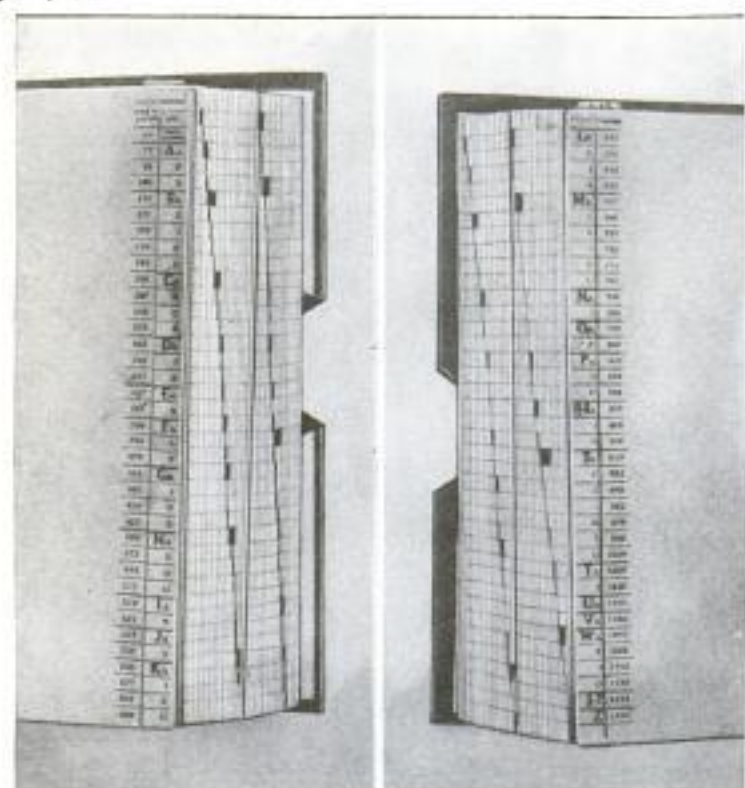

Left and Right are Shown the Front and Rear Key Pages of the Index-Guide System Which has been Proposed for Use with the Telephone Directories of Large Cities

1385

COWLITZ BRIDGE COLLAPSE FATAL TO MANY

The folly of persisting in the use of a bridge after it was known to be unsafe had a demonstration at Kelso, Wash., when a bridge, built in 1907 and known to be weak, fell into the turbulent water of the Cowlitz River, carrying at least 100 people and 10 automobiles with it. The exact number who went down will never be known, and it is likely that the loss of life, at least 25, will remain only an estimate, as it is expected that comparatively few of the bodies will be recovered.

The bridge crashed at 5 o'clock in the afternoon in the early darkness, when a tie cable, anchoring one of the great steel cables at the east end of the bridge, parted without warning. With the screech of metal racing through the pulleys of the towers, the cable snapped out over the river. The west span wavered and leaned far out over the river, where the current caught it and with a single wrench dragged towers and drawspans into the stream.

Kelso is an industrial town in the lumber district. Near by, on the opposite side of the Cowlitz, a great lumber company is establishing another town to be known as Longview. The disaster occurred just after the day's operations had

ended at Longview and hundreds were hurrying homeward to Kelso, accounting for the heavy load on the bridge at the time. Those close to the ends of the bridge felt it begin to fall and scrambled to safety. Most of those on the bridge, however, were plunged into the river. There were heroic rescues, and many succeeded in clinging to the wreckage until help reached them.

The day after the collapse, rescue crews pulled apart the tangled timbers and cables and hoisted out the automobiles, but failed to find the body of a single victim. All had been swept away by the swift current. The junction of the Cowlitz River with the Columbia is just two miles below Kelso, so it is likely that most of the victims were carried into the Columbia and, probably, to sea.

The work of clearing out the debris was facilitated by the use of a new bridge, not yet completed, a short distance downstream from the old one. This structure caught much of the wreckage, and power hoists were used to lift from the river automobiles and other salvage. Within perhaps two months, the new bridge would have been ready and the old one abandoned.

1385 Cont. H. E. Thomas,) Portland
911 Hunchley Ave) Oregon

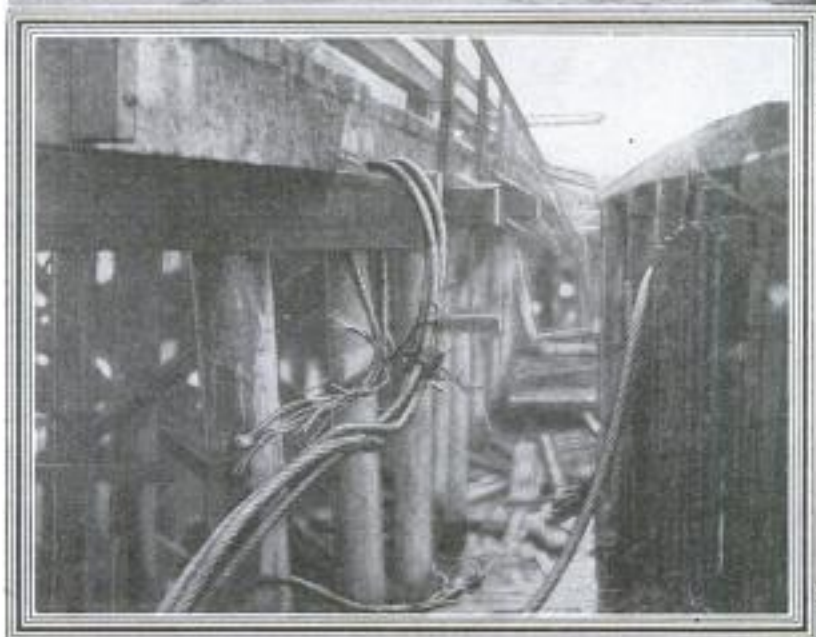
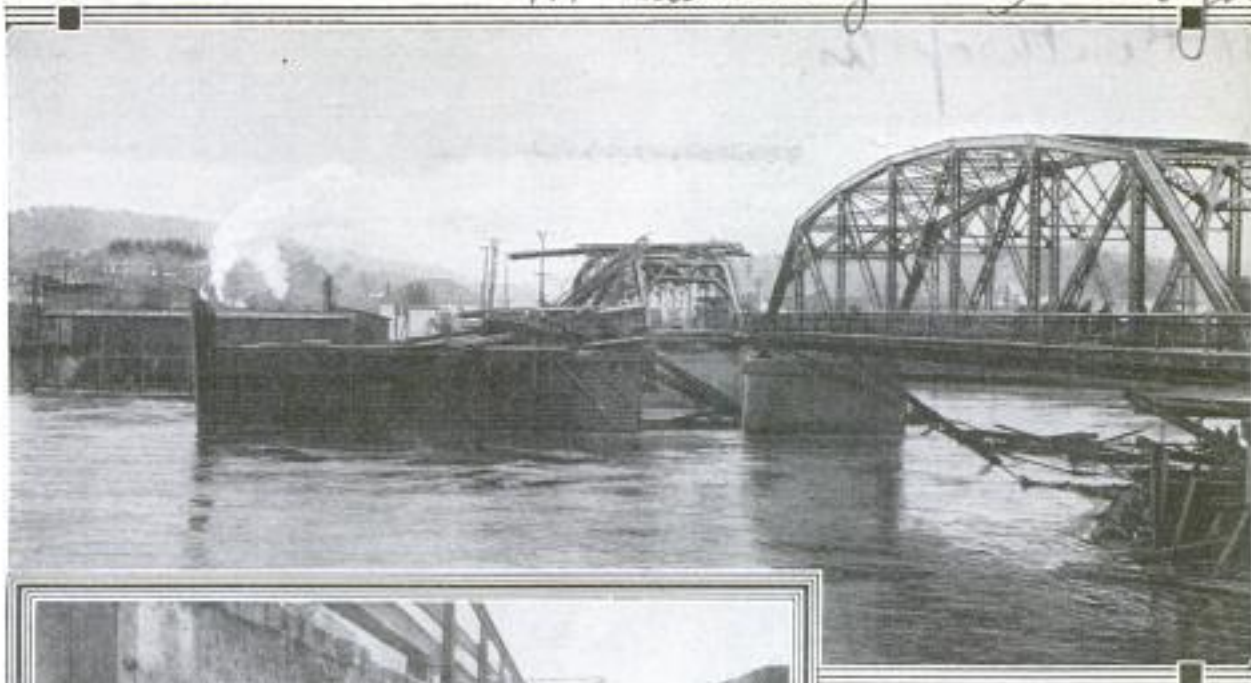

Above: Collapsed Bridge over Cowlitz River, Oregon, Which Fell from Breaking of Cable, and the Ruined Piers Which Supported It. At the Extreme Right is Shown the New Bridge, Some Distance Downstream, and Wreckage Thrown against It. This New Bridge Helped in Rescue Work. Left: The Cable Used in Anchoring a Large Cable at One End, and Its Broken Strands, Which Parted and Caused the Disaster. It was Pulled Out of the Wreckage the Day After and Found to Be Responsible for the Falling of the Old Bridge, Which had been Condemned, But Was Still in Use While the New One Was under Construction



Lifting Automobiles from Cowlitz River after the Disaster, with Floating Derrick: Ten Machines Which Went into the River were Pulled Out

Universal Stylyty
Unyts Co

A. L. Hansen Mfg. Co
5037 Ravenswood Ave
Chicago

344
6111 Winthrop Ave
1328
POPULAR MECHANICS
FOLDING PORTFOLIO OPENS
AND CLOSES LIKE FAN.
Chicago

1353
MINER'S LAMP ELIMINATES
SPARKING TROUBLES

Instant accessibility is claimed to be the outstanding feature of a new port-

In coal-mining operations, dependable miners' lamps are extremely important.

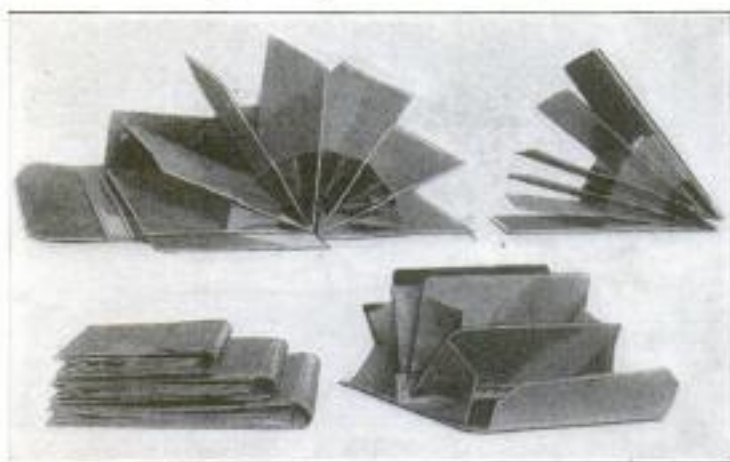

Several Views of Folding Portfolio, the Partitions of Which are Connected with Cloth Plaited like the Blades of a Fan, and Pivot at the Back

folio which can be carried about or used as a file on the corner of the desk. The case is 9 inches wide, and the partitions are connected with plaited cloth like the blades of a fan, and pivot at the back. One style has a leather flap which snaps over the edges, preventing the contents from falling out when carried, while on the desk this piece is slipped under and out of the way. The portfolio is particularly convenient for sorting small clippings, cartons, or miscellaneous data required for quick reference. Another advantage is that when on the desk it conceals contents of a private nature.

The carbide type carries a gear-wheel for sparking a flint and thereby igniting the gas, but working conditions have made it a source of trouble to the miner. If his hands are wet or greasy, the moisture or oil may be carried to the flint by the gear wheel, spoiling its action. A new lamp avoids the troublesome sparking wheel by using a snap light. Moisture and oil have no effect, and even gloves do not interfere with lighting the lamp. The inventor has also put a small plunger at the base of the water outlet, for pushing away the sludge which tends to form there.



Left: Lamp in Miner's Hand.
Right: Close-Up of Snap Lighter

1397
Chicago Evening Post
1/17/23



PLAY TENNIS ON SKATES IN ILLINOIS

COPYRIGHT, UNDERWOOD & UNDERWOOD

THE thrills of ice skating and tennis have been combined by outdoor enthusiasts of a club near Glencoe, Ill. Mapping off a court and erecting a net on an ice pond near by, the members have inaugurated tennis on skates—an adaptation of the old sport that, according to some, furnishes even more opportunity for spectacular playing and excitement. It is expected that the idea will be imitated by many clubs throughout the country.

323

Inw. A. Crossley, Radio Division,
Bureau of Engineering, U. S. Navy Dept.
POPULAR MECHANICS
Washington, D.C. 345



Captive Balloon Equipped for Protection against Lightning and Static Electricity: The Cone-Shaped Discharger on the Topmost Part Connects, through Flat Braided Copper-Wire Conductors around the Bag, to the Haul-Down Cables Which are Grounded to an Iron Pipe

DEVICE PROTECTS BALLOONS

AUTOMATIC ENVELOPE SEALER

323 AGAINST LIGHTNING

1096 WITH NO MOVING PARTS

In order to afford protection against lightning and the static electricity of the clouds, for captive balloons and kite balloons, used in securing meteorological data, a radio engineer of the United States Navy Department has developed a new apparatus. The discharging element is a vertical conductor located on the topmost part of the balloon and connected with suitable conductors to the down-haul cables, which are grounded to an iron pipe driven into the ground. To prevent the balloon circuits from being affected by the atmospheric discharge, a carbon resistor of 5,000 ohms is connected in series with the cables. The discharger consists of a leather cone with a copper tip fastened to it by means of copper rivets, and the conductors around the body of the balloon are of flat braided copper. It is said that one balloon equipped with this rig will lend considerable protection to a number of others in its immediate vicinity. This protective system has already been installed on eight balloons.

Automatic in action, a new envelope sealer is operated by simply passing the envelope through the sealer with a single movement of one hand. The envelope flap is lifted, the gum moistened, and the envelope sealed without any hand pressure. The sealer can be screwed to a desk or table. It has a reservoir for water and a moistening pad that is easily re placed or removed for the purpose of cleaning.



Philadelphia, Pa.

M. J. Brown Mfg. Co.
2671 Salomon St.

WHEN THE CARIBOU TREK

Migrating Herds of Wild Caribou Delay Alaskan River Steamers and Interfere with Domesticated Reindeer—Government Drives Latter to New Feeding Grounds, 1,100 Miles Away

BY STRATFORD F. CORBETT

IN the Yukon district of Canada, and in Alaska, are thousands upon thousands of caribou, large, splendid animals, defiant of man's efforts to domesticate them. So many of them are there, in fact, that herds swimming the Yukon have seriously interfered with the progress of river steamers en route to Dawson City. Captains have found that, until they have passed, it is useless to attempt going ahead—even though the delay might be a matter of hours.

During these stops, many of the animals are shot by passengers, for a caribou in water is quite helpless. But in spite of relentless hunting by white man and Eskimo alike, the vast herds still continue to be the largest evidences of wild-

It is interesting to note that one of the principal reasons for this move was to take the reindeer herd, considered one of the finest in Alaska, out of the vicinity of the annual caribou migrations. The reindeer is closely related to the caribou, and, if permitted, they will run together and interbreed. The offspring of this union, however, is not a reindeer, but a caribou with all the nomadic instinct of its prototype. Hence the precaution of the government agency.

The drive was over snowy tundra and mountainland, the herders native Eskimo. Near Bethel, on the Kuskokwin River, the first rest was made. Then the reindeer, foraging as they went, were driven leisurely to the foothills of the McKinley Mountains, where another halt was called. After four months, they continued to Mt. McKinley Park and thence on to Cantwell Station.

It was while resting near Bethel that one of the most exciting incidents of the journey occurred. Early one morning, a passing herd of caribou was sighted. In a few minutes the entire herd of reindeer became nervous, restive, and eager to break away. The herders, working heroically, ran here and there endeavoring to calm the animals and distract their attention. Yet, in spite of their best efforts, a hundred or

more of the deer succeeded in breaking away and joining their wilder brothers.

Then followed a strenuous chase across country, in which the guards, assisted by men from the reindeer station in the vicinity, recovered all but fifteen of the truant deer. Throughout the rest of the drive, the greatest difficulty encountered was in keeping the herd intact. That more were not lost was due entirely to the skill and watchfulness of the herders.

Men were first employed for work of this kind in 1892, when the Federal government imported 80 reindeer from Siberia. Introduced primarily to take the

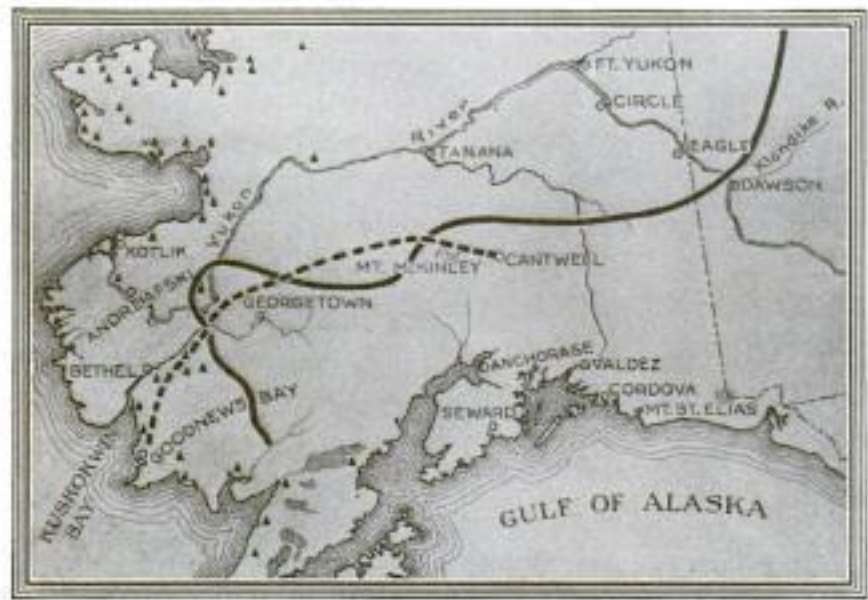

The Dotted Line Indicates the Route Taken in Driving the Reindeer from Goodnews Bay to Cantwell, While the Black Line Shows the Path of the Caribou Migrations. The Black Pyramids Represent Reindeer Stations

animal life in existence in the Far North. As they trek, each year, through forest and mountain stream on their long journey to new feeding grounds, they present a strange and magnificent spectacle.

Another great migration of a slightly different nature, but throwing interesting sidelights on the habits of the caribou, recently took place under the direction of the Alaskan division of the Bureau of Education. The herd, in this case, was a band of 1,500 reindeer owned by the government, and the route lay from Goodnews Bay, on the Bering Sea, to Cantwell Station, in the Broad Pass District.

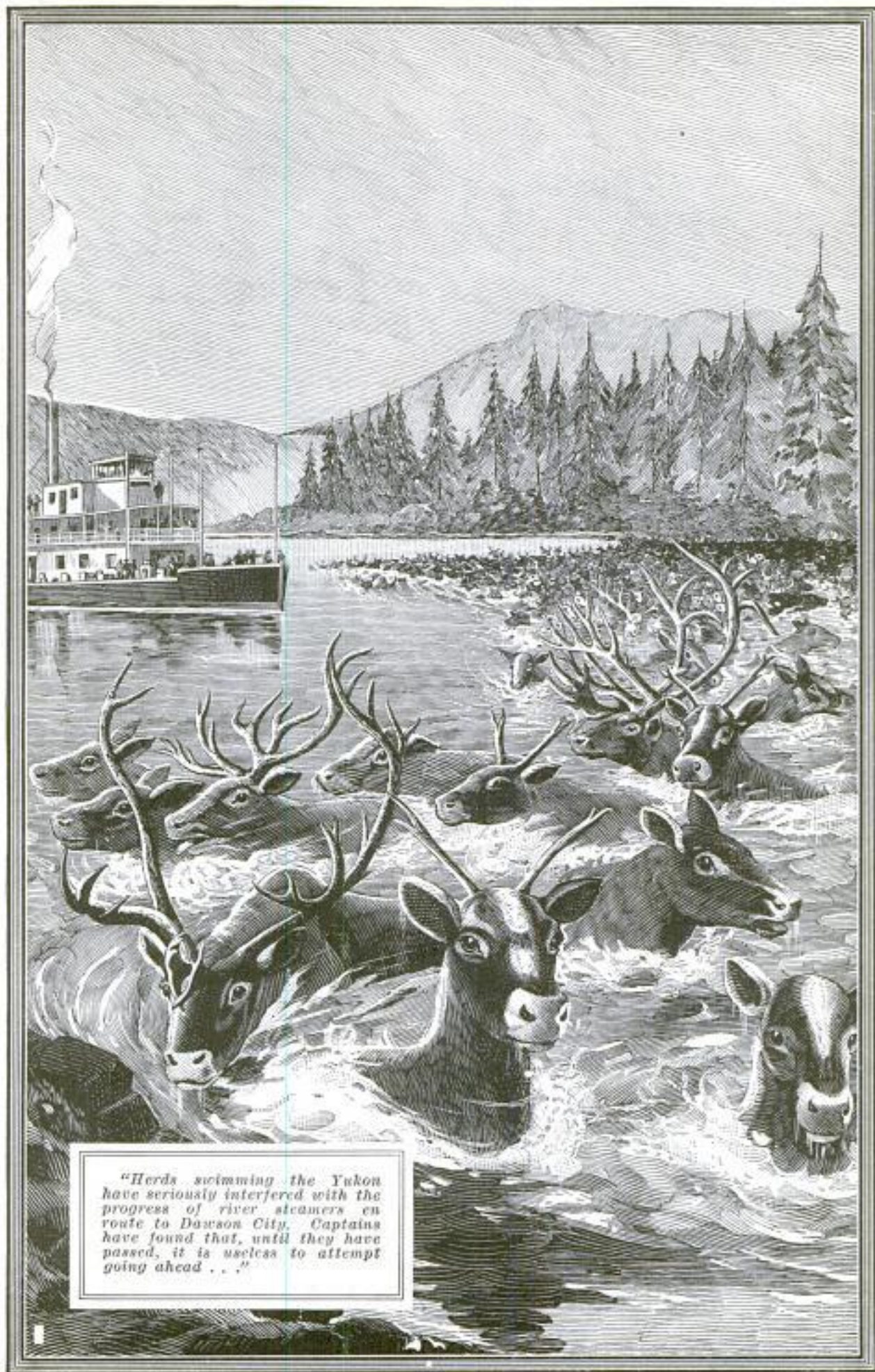

"Herds swimming the Yukon have seriously interfered with the progress of river steamers en route to Dawson City. Captains have found that, until they have passed, it is useless to attempt going ahead . . ."



The Reindeer Herd as It Appeared en Route to Cantwell: The Drive was Made Leisurely So the Animals could Forage for Their Food as They Traveled



Left: The Summer Home of a Government Herder: The Boy with the Lasso in His Hand is Practicing, That He, Too, may Some Day Become a "Reindeer Man"

place of the depleted wild-game resources of the territory, the reindeer has now become an economic factor in the development of Alaska. It is well known that to the native the reindeer has long symbolized food, clothing, shelter, and a means of transportation.

Now, with the aid of the white man, there is being developed the reindeer industry, the most tangible evidence of which is found, perhaps, in the fact that reindeer meat can now be purchased in many of the larger cities of the Pacific coast. It was principally to make the markets of the United States more accessible to Alaskan reindeer men that the government established the large herd in the Broad Pass country.

In the expectation that it will be possible to slaughter the male reindeer of this and other herds, meat-chilling plants are being constructed at various points in Alaska, including Cantwell Station in the Broad Pass district, so that the herds can be driven to these plants, the meat prepared for shipment, and carried to the States in refrigerator vessels.

An indication of what the future may develop, is to be found in the reports of privately operated refrigerator plants, which show that during the winter there

were shipped 6,200 carcasses, as compared with 1,800 in the preceding year.

The most serious, perhaps the only serious, menace to successful reindeer raising are migrating caribou herds, and so it is that government agents are wont to exclaim, "When the caribou treks, watch out!"

1432
1932

ADOPT ZONING SYSTEMS IN SMALLER TOWNS

Many of the country's smaller towns and villages are adopting zoning systems, according to the Department of Commerce. In the entire country 109 cities, towns, and villages were zoned on Jan. 1, 1923, as compared with 55 for the same day last year. Of those zoned in 1922 there were 14 towns with populations of from 5,000 to 10,000, while 12 had 5,000 inhabitants or less. The state of New Jersey ranks highest in the number of places zoned, New York being second, and California third.

Dept. of Commerce, Washington D.C.

ⓐ A typesetting machine with a special attachment by which copy may be set by radio is reported to have been invented by a French engineer.

1301 R. H. Dunbar, Jr. Chief Engineer,
Signal Corps Research Laboratory,

POPULAR MECHANICS

349

Bureau of Standards Washington

SECRET CONVERSATIONS BY RADIO "SUPERPHONE"

The apparently impossible feat of transmitting conversation while confining it to the speaker and the person for whom it is intended has been accomplished recently in Washington. It was done by a combination of the "superphone," the invention of Maj. Gen. George C. Squier, chief signal officer of the army, and the principle of using electric light or telegraph wires, as in the receiving station at Chatham, Cape Cod.

"Wired wireless" and high-frequency alternating current traversing telegraph or light wires, are used in connection with an ordinary microphone at the transmitting end. The message is picked up by radio instruments and directed into a telephone receiver at the other end. A number of conversations may be carried on simultaneously over the same wires. Where secrecy is important, as in military or business matters, the invention's value is apparent.

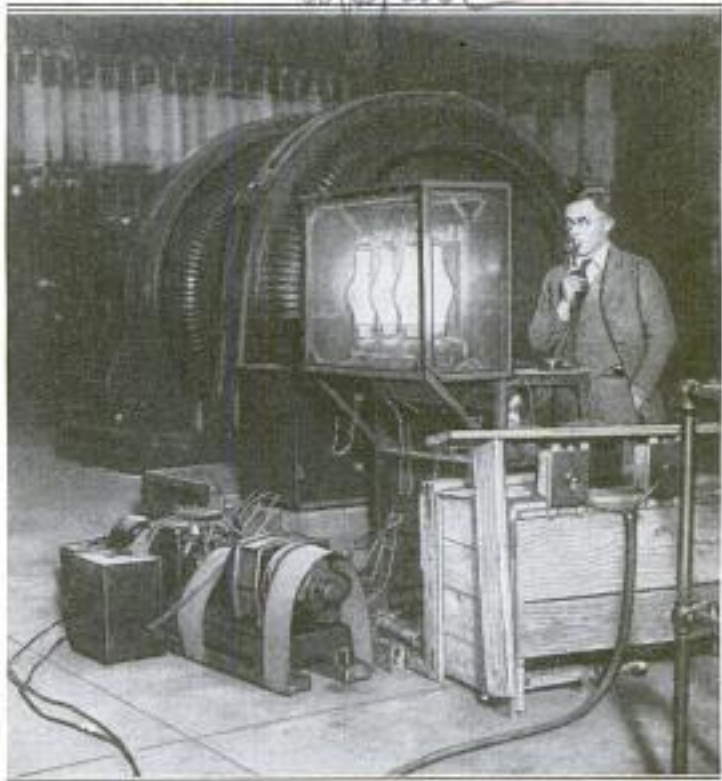

By Combining the "Superphone" with "Wired Wireless," the Operator is Talking from the Georgetown Power Station to the Bureau of Standards in Washington, Five Miles Away

764

TIN CANS MADE AT HOME WITH SIMPLE OUTFIT

Among the interesting devices lately put on the market, is one for making tin cans at home. It consists of three small

machines that are easily fastened to any workbench. A piece of tin, previously cut to size and

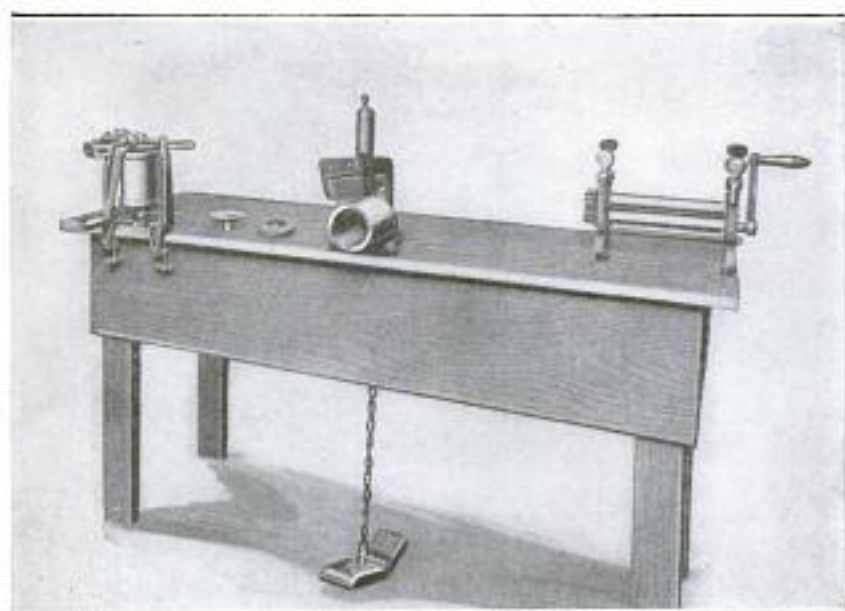

shape, is formed by the first machine into a cylinder which is next put into the "seamer," where it is held by a glass clamp, while the 1/8-inch lap joint is sweated together with solder and a hand soldering copper. The third machine is used for flanging the ends of the cylinder and in crimping on the circular pieces of tin that form the bottom and top of the can. This equipment is comparatively inexpensive, and was developed to meet an insistent demand from localities where the cost of a can factory is not warranted or to which the transportation charges on empty cans are excessively high.

Price - \$100.00 for set of three machines.

With This Simple Device, Tin Cans may be Made and Soldered, Saving the High Cost of Shipping. From Left to Right, the Machines Are the Crimper, That Puts on the Ends, the "Seamer," and the Shaper

Burpee Can Sealer Co. Chicago
2635 N. Kildare *215 W. Huron* *Copyrighted material*

NEW LOOPS IN COLUMBIA RIVER HIGHWAY

1314

By HORACE E. THOMAS *911 Duackley Ave
Portland, Ore.*

ONE of the most spectacular sections of road in the United States was completed recently as a portion of the upper Columbia River Highway in Oregon. It is known as the Rowena Loops and is quite as striking as any of the older sections of this great highway which wind down the gorge of the Columbia River from the plains of eastern Oregon to the Pacific Ocean, piercing the Cascade Mountains at the only place where this lofty barrier is broken.

In addition to its scenic beauty, the Columbia River Highway is becoming of national importance as a link in one of the great transcontinental routes. The Columbia Highway itself now extends from Pendleton to the sea, a distance of 340 miles, of

which 219 miles is continuous hard-surface pavement and the rest macadam. At Pendleton it connects with the Old Oregon Trail, a road which follows the route taken by the ox teams that took the early pioneers into the West and which joins the Lincoln Highway at Salt Lake City.

For 90 miles east from Portland the Columbia River Highway penetrates the Cascade Range. Rowena Loops is on the eastern side of the mountains, beyond Hood River and between Mosier and Rowena. It was completed and paved a few months ago.

The construction of Rowena Loops was a dangerous and exacting engineering feat. The roadway is cut in the side of a rock cliff with precipitous sides dropping to the Columbia

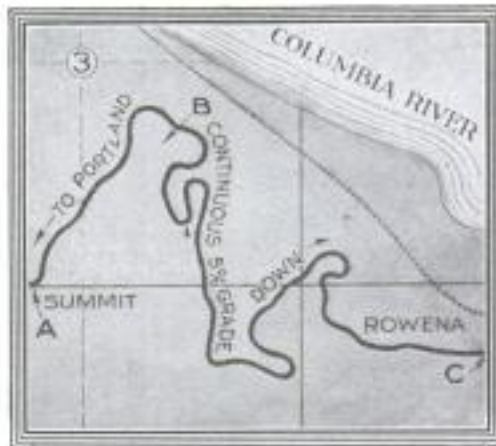

From the Summit "A," 750 Feet above Sea Level, to "B," a Distance of 2,500 Feet, the Grade Averages Three per Cent, and from "B," at an Elevation of 680 Feet, the Road Drops to 130 Feet at "C"



This Panorama of the Loops Gives a Good Idea of the Beauty of the Surrounding Country, and the Care Which has Been Taken in Its Construction. The Total Cost of the Highway, the Entrance to One being Built of Stone, Was Approximately \$185,000, and the Cost of Paving the Section About \$90,000.



Near the Top of the Rowena Loops, Showing How the Road has been Cut through Solid Rock and Made to Wind about the Edge of the Cliff: Note, Too, the White Fence Guards Which are Built at Curves in the Highway and Other Possible Points of Danger



been Taken in Keeping the Average Grade of the Road below Five per Cent. The Complete Cost of the Grading Inserted at the Left and Right Are Picturesque Views of Two Tunnels on the While the Other Is Entirely without Artificial Support

River hundreds of feet below. The view of the Columbia, which is visible for many miles in either direction, is one of entrancing beauty, but at places the traveler is likely to be more concerned with the deep cañon into which he would plunge if his machine left the highway. There is no real danger, though, for the construction is of the most permanent kind, and where it skirts the edge of the cliff, a low stone barrier protects the autoist.

Rowena Loops covers a distance of 2.75 miles, and in that distance rises from an elevation of 130 feet to 750 feet above sea level. Skillful engineering has kept the grade to a minimum, so that it averages about three per cent, with none of it more than five per cent. In most places the roadbed was cut from solid rock, as is indicated by the fact that of a total of 138,000 cubic yards of excavation, 105,000 was rock. The grading alone cost over 180,000 dollars.

**LORD'S PRAYER SET ON PICA
325 FACE WITH MONOTYPE**

The Lord's Prayer has been set on a piece of pica type in a box one-sixth of an inch square with a monotype machine in a Philadelphia shop. The inscription consists of 225 capitals, four commas, four periods, one semicolon, and two dashes. The letters are .006 of an inch high. Duplicates were made and distributed by the company, but because of the delicacy of the type no attempt was made to print the inscription.



**1293
AUTO DISPLACES BRONCHO
IN RIDING TEST**

In the one-time wild and woolly West, riding the bucking automobile may give way to the honored test of skill in horsemanship—riding the bucking broncho. For it has been found that a seat on the radiator of a small auto with the wheels off center gives all the thrills of a broncho-busting contest, with an element of novelty. In a recent performance of this sort in California, a saddle was placed on the hood, and a prize of \$25 offered for riding two blocks. At 10 miles an hour, the rider had difficulty; at 15 miles, he went off. With the hub of each of the wheels of the car removed and reset 2 inches off center, it gives a realistic imitation of the bucking broncho, though, having no reins, the rider is, perhaps, even more helpless than on the "ornneriest" animal.

Langston Monotype Philadelphia Pa. 24th & Locust

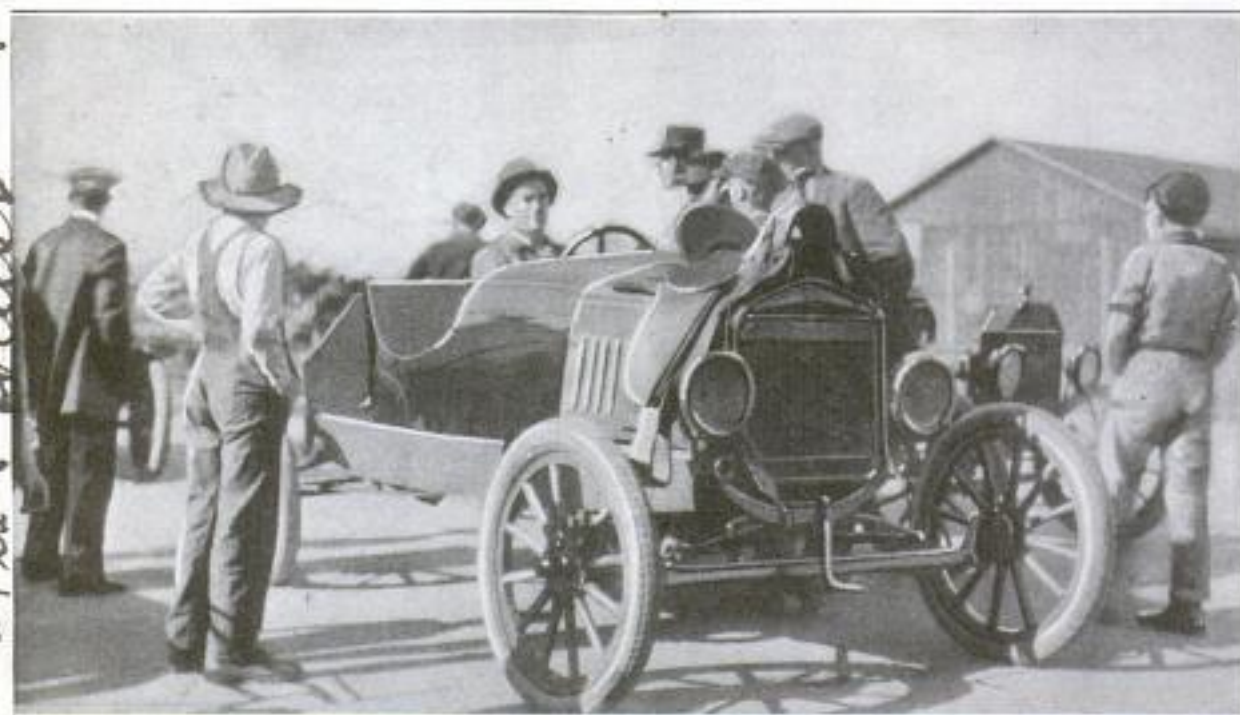

Small Automobile Altered to Provide Imitation Ride on Bucking Broncho: All Four Wheel Hubs are Set Two Inches off Center and the "Cowboy" Takes His Seat in the Saddle on the Hood. One Rider was Thrown When the Car was Driven at 15 Miles an Hour

Mr. Isewig B. Bowers, Drawer 668
Escudido, Calif.
Copyrighted material

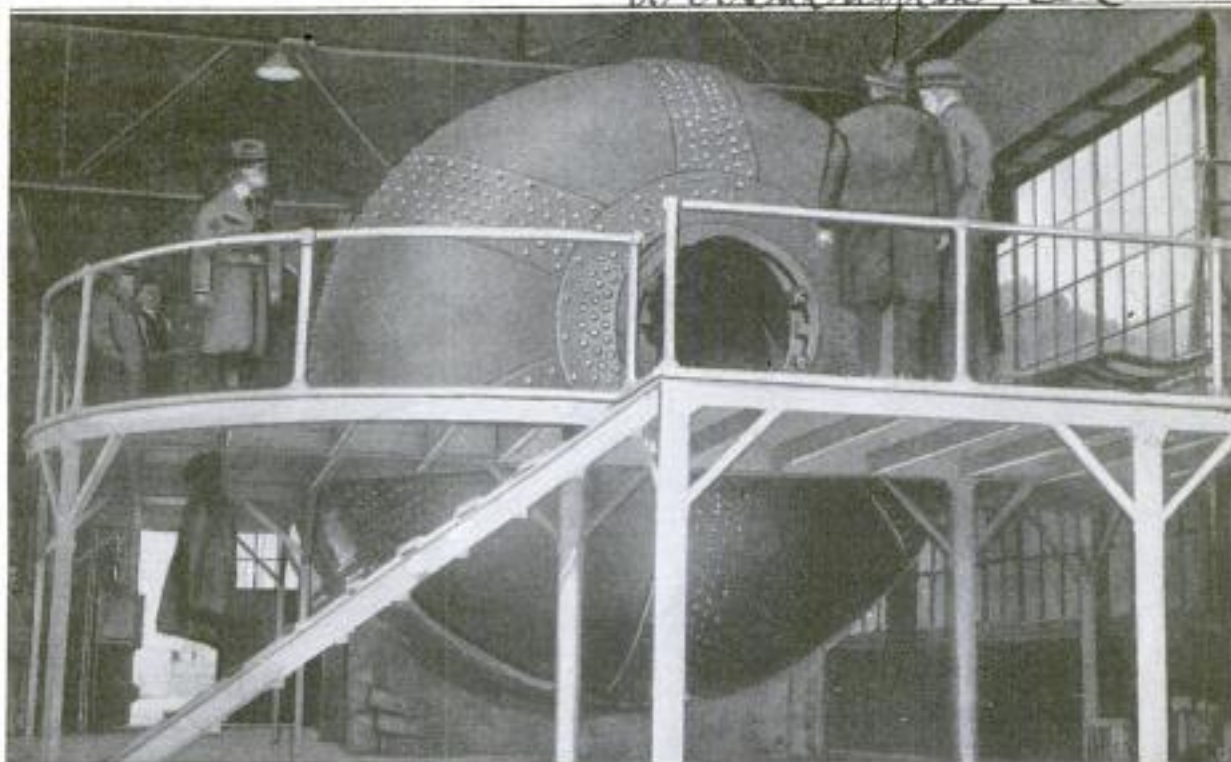

End of Compressed-Air Tank Inclosing Wind Tunnel Used in Testing Models of Airplanes: The Opening Shown is Closed by a Door Weighing Two Tons, Opening Inward. The Tank Operates under an Average Pressure of 300 Pounds per Square Inch

1341
NEW WIND TUNNEL IN HUGE COMPRESSED-AIR TANK

The wind tunnel recently completed for experimental work by the National Advisory Committee of Aeronautics, will operate in the greatest compressed-air tank yet built. The 5-foot diameter tunnel is inclosed within a steel tank, 15 feet in diameter and 34 feet long. The walls of the cylinder, which is designed for an average working pressure of 300 pounds per square inch, are made of plates 2¼ inches thick. At the ends and along one side are platforms and observation windows from which may be viewed the instruments in the test chamber. A fan located inside the chamber can be regulated from the outside to give the desired wind velocity. Test of models, which may have a span up to 2 feet, will yield data comparable to those from a full-sized airplane by eliminating the "scale effect" that is common to wind tunnels.

1347
AUTOMATIC MACHINE HELPS IN BLOOD-CELL COUNT

As a help to physicians in the blood analysis which counts for so much in modern diagnosis, a Chicago doctor has invented a machine to register the count of blood cells. In making a blood analysis, there are five species of cells of which

a count is made. On the rectangular case of the machine are five keys for recording these five species. Two extra tabulator keys record the cells not classified by these five. These are connected with a



Automatic Machine Invented by Chicago Physician to Count Cells in Blood Analysis: With One Hand He Operates Keys for Five Cell Species

series of gears and numbered registering disks. An automatic bell notifies the operator when 100 cells have been counted.

Canadian waterfalls supplied 3,000,000 horsepower of electrical energy in 1922, Ontario furnishing 1,300,000 horsepower, the most for any one province. There is a total of \$620,658,731 invested in this development.

Dr. Wm. M. Mabel
 333 S. Morgan, Chicago

LITTLE MACHINE WEIGHS AND COUNTS HAY BALES

BENEFITS OF OWNING A HOME SHOWN BY PHOTOPLAY

1262

1402

After a day's work in baling hay, the owner of a hay press need only look at

A five-reel motion picture depicting in story form the many benefits derived from owning a home, and using an actual home in process of construction as its principal setting, is being prepared by a film company for production by community centers, clubs, churches, and similar mediums. The story is woven about the life of a young married couple who are first shown living in an apartment building where they experience continual annoyances. Finally, they decide to build a home of their own, and the film then pictures the consultations with the architect, the laying of the foundation, installation

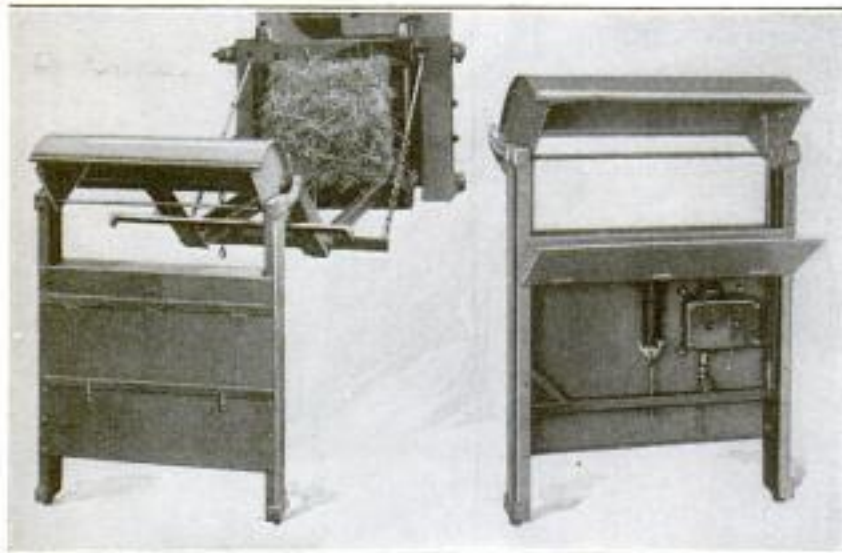

Left: Bale of Hay Coming from Press in Background to be Weighed and Counted. Right: Front of Machine Which Receives It from the Press and Registers the Weight and Number

the recorder of a new automatic weighing and counting machine to know how many bales his machine has turned out and their weight. As the bales come out of the press, they fall upon the device, weigh and count themselves, and then tumble off, ready to be loaded. It is light, takes little space, and may be stowed away on the press when not in use, and saves considerable time.

tion of the plumbing, and various other steps necessary for the realization of their plans.

▲A steel cast, enameled in black on white, to represent the ideal form of the Holstein cow, has been made by a national association interested in dairying, and replicas are to be sent to the various local chapters of the organization.

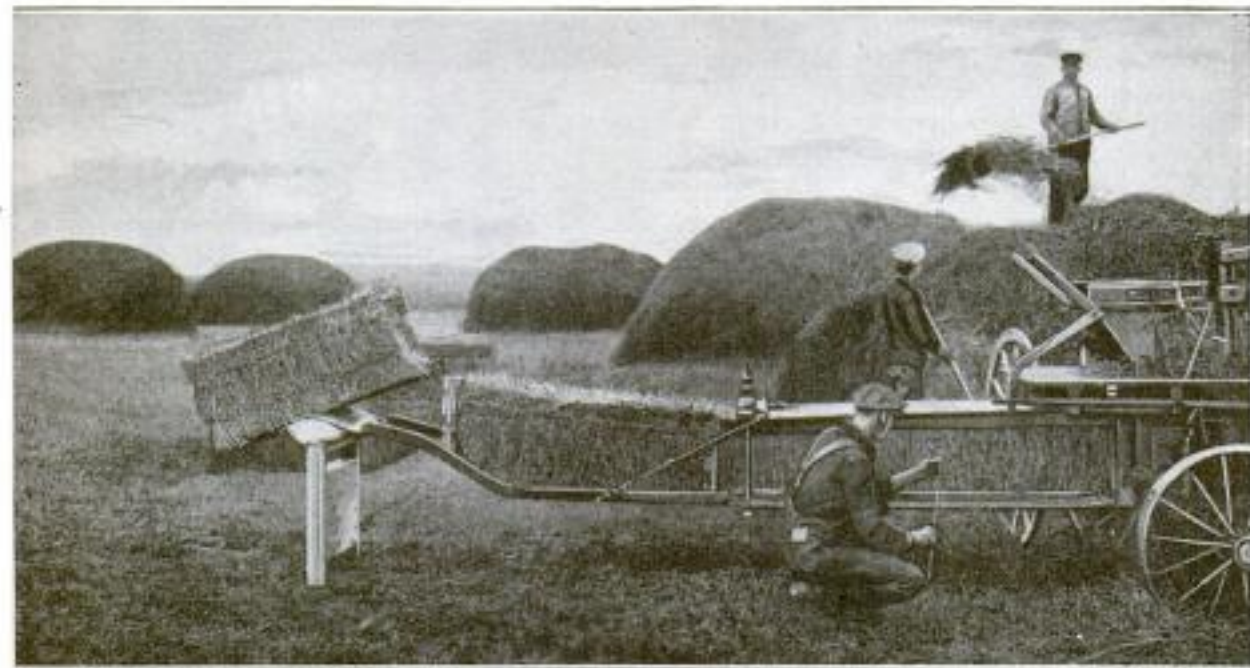

Hay-Baling Press at Work in the Field: As the Bales are Pushed from the Press Proper, They Pass over the Automatic Weighing Apparatus, Attached at the End of the Bale Conveyor, and are Weighed and Counted

*Atlas Educational Film Co.
 111 S. Boylston St. Boston, Mass.*

1402 The Fleet Agency, 152 Fleet St
& E. London

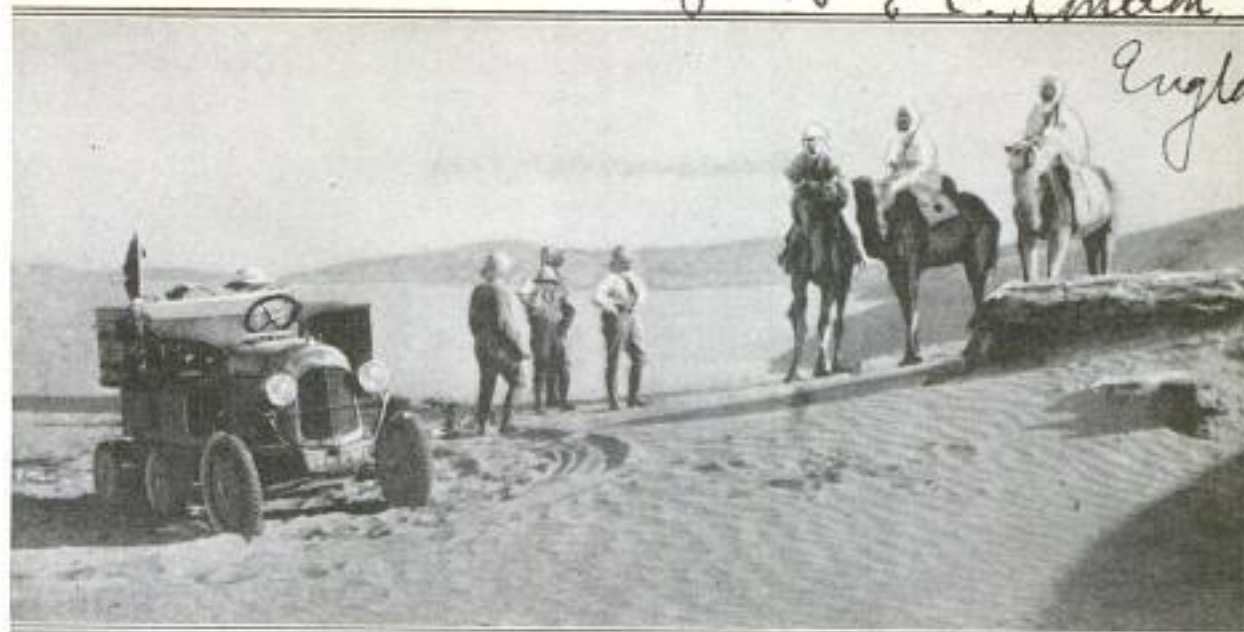

England.

Members of the Expedition are Shown Here Conversing with Natives about the Difficulties Which might be Encountered. Though Many of the Tribes Were Friendly, There Was Also Danger of being Attacked by One of the Numerous Bands of Desert Robbers

MOTOR CARS CROSS SAHARA DESERT

By CLEVELAND GAINES

FIVE motor cars, all equipped with special endless-tread drives of rubber to plow through the deep sand, and some mounted with machine guns to repel anticipated attacks from desert robber bands, recently completed a journey across the Sahara Desert of approximately 2,000 miles, from Tuggurt, in Algeria, to Timbuktu, in French West Africa.

The caravan left Tuggurt on December 18, last year, but first, in order to insure a proper supply of fuel, water, and food, other cars were sent ahead as far as Insala to establish depots, while a similar outfit left Dakar in the south and approached north to a military station at Kidal. The expedition proper then set forth, arriving at Timbuktu on January 7, just 20 days later, the time being several months faster than average camel time for the same distance.

The cars had, in addition to the endless-tread arrangement, a platform at the back for holding two gasoline storage tanks. These tanks each had a capacity of 35 gallons. Water tanks containing 13 gallons, and aluminum chests filled with ammunition, food, tools, and other necessities, were also carried. A tent for each car, and a motion-picture camera outfit completed the equipment. Trial

tests had shown that the sand had no effect on the lubrication or operation of the motor, nor were any modifications in the radiator or any other part of the machine found necessary. The drive itself consisted of two wheels, several

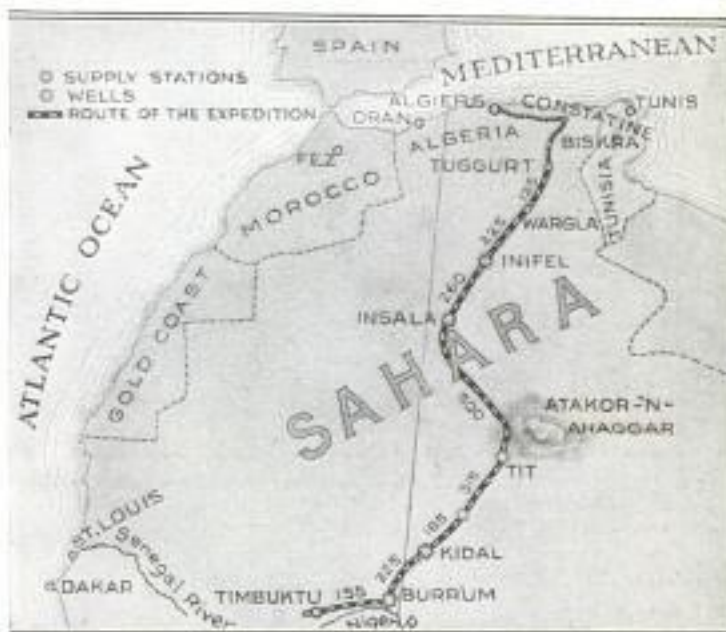

The Figures Represent the Approximate Distances in Miles between the Various Stations along the Route. Some of the Regions Traversed Were Little Known to Man. This Was Particularly True of the Section between Tit and Kidal

feet apart, around which was stretched the rubber belt, with smaller intermediate wheels between the two helping to distribute the load.



Above: Fully Equipped Car of the Expedition Proper. Right: One of the Gasoline-Supply Cars Sent Ahead of the Main Party

While no part of the journey could be considered devoid of hardship, it was from the Ahaggar Mountains to Tit and Kidal that travel was especially difficult. This region is practically unknown, and the route had to be determined by compass. Tuggurt to Wargla is a vast, sandy desert with some vegetation; from Wargla for some distance south, a somewhat similar coun-



try, then for miles there is nothing but barren desert until the Ahaggar Range is reached. After that comes the "great unknown," also called the "land of thirst," and finally more sandy stretches with occasional vegetation, to Burrum on the Niger, and Timbuktu.

One of the principal reasons for the trip was to determine whether or not the cars would be practicable for desert travel, though data of a scientific nature were also collected.

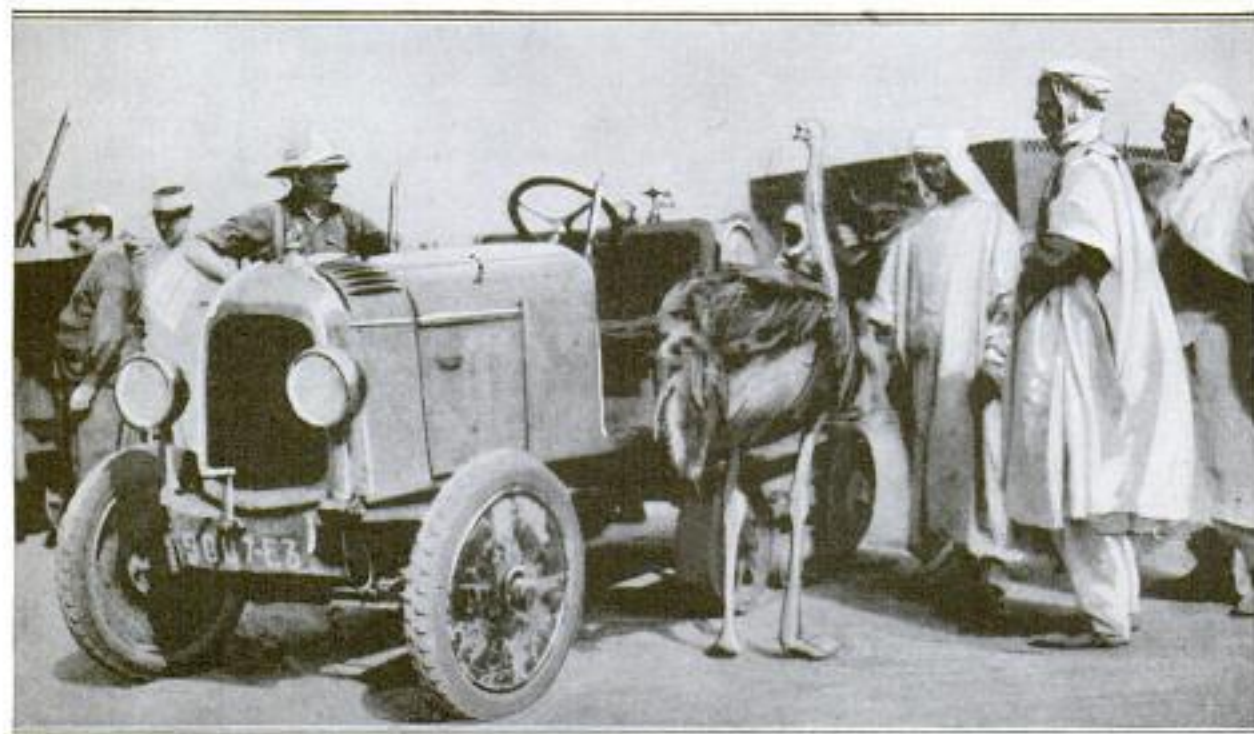

The Natives had Seen No Car of This Description Before and Were Curious to Learn Just How It was Constructed and How It would Run through the Sand. The Little Group Shown Here Also Thought It Was Quite Proper to Bring a Pet Ostrich Along

COMMENT AND REVIEW

[These pages were printed January 27, 1923.]

THE count of the death toll from revolvers and automobiles for 1922 is completed and rolls up the astounding total of 10,000 from pistols and revolvers, and about the same number from automobiles. In both counts many hundred, if not several thousand, who died weeks or months after the accident, and in the case of revolvers, many more who were killed and the bodies concealed and not yet found, were not included.

*Pistols and
Automobiles
Kill 20,000*

Following the article in this magazine on revolvers, a few months ago, I received many letters, some couched in evidently sincere but bitter terms, protesting against the article and what it proposed. In some cases, such as explorers, woodsmen, frontiersmen, and some hunters, I frankly admit a law prohibiting the manufacture and use of such small arms would unquestionably work a great hardship. Some of the protests sounded rather foolish, such as the farmer in Connecticut who must have a revolver "to defend himself against snakes, skunks, and hawks." In the case of the skunks, most of us will agree a long-range weapon would be more advisable, and when it comes to hitting snakes and hawks, most people will regard a shotgun as likely to score a larger number of hits.

The chief of police of Los Angeles seems to think guns should be freely and generally toted, but he is quite the exception among police officials, especially of large cities.

The ease of smuggling, or of making revolvers at home, was likened by many to the inefficiency of the enforcement of the 18th amendment. But this is not true. It is manifestly much easier to make "home brew," which can be done with a teakettle, than to make a revolver of sufficient accuracy to be worth having. While one undoubtedly can be homemade with a few simple tools, the output from this source would be in the ratio of about 1 revolver to 10,000 gallons of "moonshine."

Anyway, the murderous killing goes on, and is now estimated to be in the ratio of 1 murder to each 10,000 population, each year. In other words, the average risk of either being murdered or killed by auto, is 1 in each 5,000 population, yearly, or in terms of 10 years, at this same rate, your chance of being killed is 1 in 500.

If a single city of 20,000 were wiped out in an instant, the entire world would gasp; but this decimation is so regular and so diffused, few outside the immediate relatives and friends are much affected. It is almost impossible to safeguard machinery under the best conditions, and with most skillful operators, to the point of absolute safety. It seems impossible to insure that the more than 10 million drivers who operate the 10 million automobiles, shall each and all possess the mental balance, training, eyesight, judgment, and skill to preclude any loss of life. It is far, very far, from human possibility. The chief trouble rests not so much on the lack of these qualifications, necessary as they are, but rather in a selfish indifference of the great potential power they control, and the lack of thought that the least relaxation to carelessness may cause a death any minute. Even the most careful have their moments of unconscious disregard. Appeals for safety first undoubtedly are very helpful; the road signs marking grades, railroads, curves, etc., are good, and should be uniform in all states. But as men working in powder mills become careless, so men and women, boys and girls driving cars, come to think more of caution as it affects their own bodies, and less of others. The only thing which will check, for it can never wholly cure, the evil, will be greatly increased and rigidly enforced penalties for killing and maiming people, even unintentionally. The story of the chauffeur arraigned in court for running over a woman, illustrates the mental attitude of many. He pleaded he commenced sounding his horn when the woman was still some distance away. When the judge asked if he used his brake he replied, "I never thought of that, your honor."

Indianapolis proposes to submit all persons arrested for auto speeding to an insanity test, and to keep them in padded cells pending the decision. Better far to decide that point before the license is issued. And it can be done. The Yellow Cab Co., of Chicago, submits every applicant for position of driver to a test which begins with good physical health, and includes eyesight, 92-per-cent good, heart and lungs perfect, no epilepsy in family, and no insanity as far back as grandparents. The inspection is nearly three times as severe as insurance companies demand. And the company has found 5,000 men competent to qualify. Aside from all moral obligations to the public it serves, the resulting freedom from accidents amply repays all the cost of examination and investigation.

This may be taking unusual precautions, but sooner or later some such condition, though less severe, will have to be imposed upon all drivers, of both public and private cars.



NEVER in our history had anything to be sold received the urge and publicity which was put forth to dispose of Liberty bonds and war stamps. Every paper and magazine was full of display advertisements and columns of reading notices. Trainloads of printed circulars were sent broadcast, every billboard and available wall was plastered with posters, and both men and women orators spoke from theater platforms, pulpits, vehicles, and soap boxes. It was a most remarkable course in educating the masses to buy securities, in which were enlisted—chiefly voluntary—the best advertising talent in the country—which means in all the world.

Blue-Sky Stocks

Millions of people who never in their lives had bought a share of stock or a bond, became bondholders. The number of these is placed at 20 million. Like many other things, the second time was easier than the first, and almost before the war was over, and the appeal to buy government bonds ceased, there sprang up an army of unscrupulous schemers who took advantage of the psychological condition to market their worthless "securities." The public, having in mind and sight the fortunes which the war conditions had brought to many, almost overnight, were easy marks for plunder. Most anything which could be made to read like a get-rich-quick enterprise found willing listeners, and a ready and welcome reception. Oil and mines were the most favored subjects, and to make it easy for everybody to get in—on the ground floor, of course—many of these shares were offered at a price as low as one dollar, or even a few cents each.

The "clean-up" by these fraudulent promoters is estimated at anywhere from two to three billion dollars since the war closed. The conservative estimate for 1922 is placed at five hundred million dollars, very little if any of which is now, or ever likely to be, worth the paper on which the shares are printed. It is a terrible drain, as a large percentage of it comes from people who cannot afford to lose.

Some of the states already have what are known as "Blue-Sky Laws," which make it difficult to issue or sell fake securities. In other states there is so much latitude permitted incorporators, it is very easy to juggle a few hundred dollars worth of land into alleged assets represented by the hundreds of thousands or even millions. Bankers and other reputable financial institutions have tried constantly to caution the public against being robbed in this genteel manner, but too often the very ones they tried to warn, have been made to believe the warning came from some selfish or ulterior motive. And so this semilegalized or apparently legalized system is still going on. This magazine has repeatedly urged in the past, that before investing any funds in an enterprise of which your knowledge is limited to its own advertising matter, or its glib salesman, you submit the proposition to your banker. And even if you do not have a bank account, there are few bankers in the whole United States that will not cheerfully give a few minutes to even the poorest man, to tell him if the proposition is bad, or how to find out. Few of us would have the temerity to amputate our own leg or try our own case at law; we seek the counsel of men experienced in such matters. In consulting a banker the only difference is the service doesn't cost us anything.



RECORDS show that fully four per cent of all the boys and girls born in this country are left-handed from birth. An English scientist believes that the ratio is much higher in his country and around 10 per cent. The doctors are able to explain the physical condition of nerves which makes it natural for a child to use its left hand in preference to the other, but as to the cause of this condition they can only say, Nature willed it so.

What Causes Stuttering?

However, a most curious result has been discovered where attempts are made to force a left-handed child to use its right hand instead. Not in all cases, to be sure, but as far as the investigation has gone, a surprisingly large number of cases have been found, where parents or teachers used severe measures to force the use of the right hand, in which the child became a stutterer or had an impediment of speech. These varied in degree from a few years to life, and from acute stuttering to an impediment quite slight and hardly noticeable in ordinary conversation, but greatly aggravated under excitement.

It has been interesting to me, when coming in contact with people having impeded speech, to ask them if they were originally left-handed, and forced at home and in school to use the right hand. So far no one has been offended at such a personal question but all have shown great interest. In the instance of the most acute case of stuttering I have ever known, and whom I met daily for several months, the man could scarcely make himself understood and would appear at times almost to choke in the effort to articulate. Today he can shoot and throw a stone with unusual accuracy with his left arm, and very poorly with his right. He told me that during six or seven years, as a child, he was severely thrashed almost every day, both at home and in school, as his father was determined to "break him of the habit of using the wrong hand." In this case I judge both father and son possessed the same unyielding spirit—the son certainly has it now, and thinks, acts, and works with the speed of a hair trigger—but the father evidently dominated with his parental authority and strength.

Thus far nearly four out of five cases of impeded speech I have investigated, turn out to have been left-handed in childhood. Several left-handed persons, on whom no special effort was made to change, show no evidence of retarded utterance.

Scientists declare that it is much better not to try to force a left-handed child to become right-handed; that, if he does not readily and easily accept the change, to let nature have its way, and that in reversing nature, a mental-nervous clash arises which apparently in the majority of cases shows its disapproval of such outside interference by a greater or less disturbance of the speaking function. In these days we are becoming more enlightened and considerate in such matters as compared with 30 or more years ago, but it is pitiful to reflect on the thousands of cases, probably hundreds of thousands, where thoughtless, though well-meaning parents stifled and killed the natural inclination and individuality of promising, budding ambition, God-implanted.

It will be a greatly appreciated favor if any of our readers, knowing instances of people naturally left-handed, would report whether the effort to make them right-handed had any effect upon their speech or not.



AN editor is known by his readers to be absolutely misinformed on subjects in which they disagree with him; and the average reader is doubtless entitled to his doubts many times, but it remains apparently for the city salesman to really demonstrate, in almost brutal fashion, the completeness of the editorial mental density.

*How
Not to
Sell*

Having had occasion the past three months to purchase a great variety of office-building supplies, this hitherto unsuspected condition has been effectually demonstrated in my own case.

The first disillusion came with the salesman who represented letter-filing cases. Having stated our requirements, in terms of approximate number of letters daily, the young man

looked wise, considered a minute, and decided what we needed was their C. S. 1.

"What is C. S. 1?" I inquired.

"Why," came in a somewhat grieved and condescending tone, "that's our letter file you want."

"Is it made of paper, metal, or wood?" I ventured.

"Oh, in case you are considering metal you want our F. D. X. and probably two N. C. O. for each F. D. X."

"Some of our manuscripts are pretty long," I confessed.

"In that event you will need F. D. X. with two N. C. O. for transfer for ordinary correspondence; and P. L. 1, with R. I. P. transfer for manuscripts."

By this time I recovered a little of my lost nerve and remarked, "Young man, what you say strikes me as R. O. T. What I am trying to buy is office furniture, not alphabets. If you will only talk Greek, Turkish, Armenian, or western Chinese, our translator could probably get a little intelligence out of it, as to the material, size, operation, capacity, color, and price of your goods."

"But," quoth he, "those are our catalog numbers."

"Sorry," I replied, "that I have not subscribed to your catalog all these years and hence am a bit shy on its terms; but do you want your pay P. D. Q., or W. W. R., and should it be, O. V. P., N., B. C., or S.?"

It was his turn to register ignorance, but he managed to say, "I don't get you."

"Well, these are our trade terms; P. D. Q. means immediately; W. W. R.,

when we're ready; and O. V. P. is our verbal promise; N. means notes; B. C. is bank check, and S. stands for 'simoleons'. I'm a bit surprised a lively young salesman like you is not familiar with our private marks for these things."

After a questioning which would have done credit to a lawyer on cross-examination, I managed to worm out of him the size, capacity, material, color, and cost of his various file cases, but it was like pulling back teeth with tweezers, and he seemed to realize he had grossly betrayed secrets belonging exclusively to his firm.

If he had been the last and only one, these lines would never have been written. But, unfortunately, he merely opened the ball. They came in droves; fine, clean, bright-faced, earnest young fellows; every one good to look at; and all talking the same catalog lingo which, of course, was unintelligible to me. Even when I got down to scrubbing brushes one tried to sell me F. H. B., which turned out to be "fiber and hog's bristles," and when the stuff came, C18 turned out to be some kind of a mop.

With scarcely an exception they all reeled off yards of (to me) utterly meaningless trade letters and numbers with a confident air of profundity which at first was amusing but quickly became exasperating. My conclusion was that if these young salesmen were selling my goods I would get some friend to send for one of them, and I would sit concealed where I could hear their puzzle talk and then I would go home, call the boys all in, and give a few first easy lessons in salesmanship, or buy a course in some correspondence school for each of them, or both.

H. H. WINDSOR

NEW CENTRAL POLICE STATION COMPLETED — IN DETROIT

Prisoners' quarters occupy the two top floors of the new central police station recently opened in Detroit. It is thought that this arrangement will be more healthful and, at the same time, will have a moral effect for the better on those who may be confined there. Another means used to carry out this latter idea is the prisoners' entrance. This is built adjoining the police garage, from which the prisoners enter a private reception room and thence go up in a special elevator, removed from the other occupants of the building. Telephone equipment enabling a message to be transmitted over 50 lines at once, and a powerful radio outfit, are other new features. The station is nine stories high and cost about 1,700,000 dollars.

☐ A \$2,000,000 wireless plant, operating direct to Australia and England, will be built at Vancouver, B. C.



Recently Completed Central Police Station of Detroit, in Which the Prisoners' Quarters Are on the Two Top Floors: A Powerful Radio Outfit Is Another Feature

W. K. Crosson, 4429 Townsend Ave
Detroit, Mich

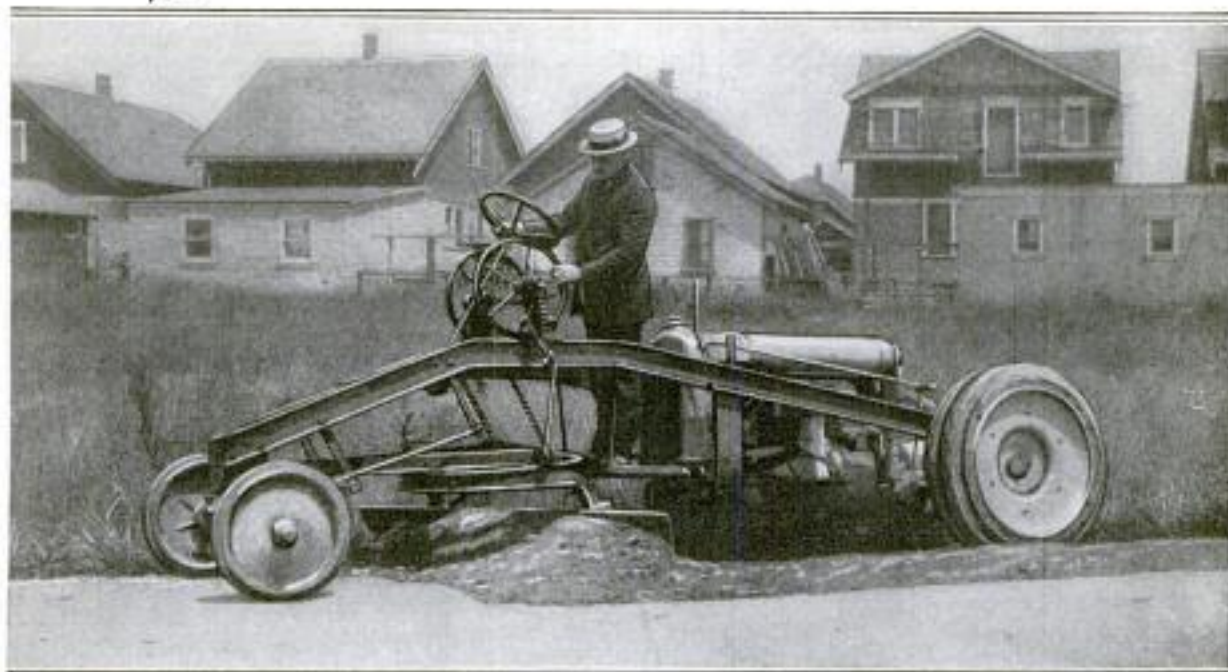

The New Road-Grading Outfit, Pictured Here, is Run Entirely by One Man, Who Stands on a Platform Built in Front of the Gasoline Engine. Within Easy Reach of the Operator Are Controls for Steering the Machine, and for Raising, Lowering, or Turning the Blade

¹²²³
ONE MAN OPERATES MOTOR-DRIVEN ROAD GRADER

A road-grading outfit operated entirely by one man is one of the latest improvements in road-building machinery. The frame of the grader rises and runs pyramid-fashion from an axle joining two small front wheels to two larger wheels in the rear. Just ahead of these wheels is placed a gasoline motor, while in front of the motor is the operator's platform and, within easy reach, controls for steering the outfit and for adjusting the blade.

¹²³⁵
LABOR-SAVING STAND FOR BAGS HOLDS VARIOUS SIZES

Not a few industrial concerns that ship their small metal products in bags find it

necessary to have extra men hold the bags as they are being filled. To do away with this waste of labor, one company has originated an inexpensive metal holder. It is simple, consisting merely of two semicircular sections of



malleable iron Fittings Co
Branford, Conn.

metal, one larger than the other, connected by three uprights. Either of the semicircular pieces can serve as a base, and removable pins in them hold the bag.

¹⁰⁵⁶
"VACUUM-TUBE" SIGNS YIELD LIGHT AT SMALL COST

"Vacuum-tube" signs, consisting of continuous glass tubing bent into letter-

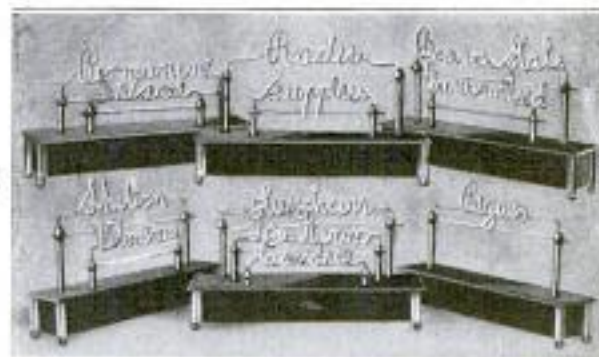

These Novel Window Signs are Made with Colored Glass Tubes Which are Illuminated with a Continuous or Alternating Current

ing or numerals, the whole being lighted by either direct or alternating current at common voltages, are new advertising features. As many as three lines of script or number units may be arranged in one sign, which displays a deep-red or orange color when illuminated. The operating cost is negligible, as only from 8 to 10 watts are required for any length or number of units. No noticeable heat is radiated from the tubing, which is thus said to yield a "cold" light.

Electric Co 42nd St, New York City
16 E. 42nd St.
Shelton

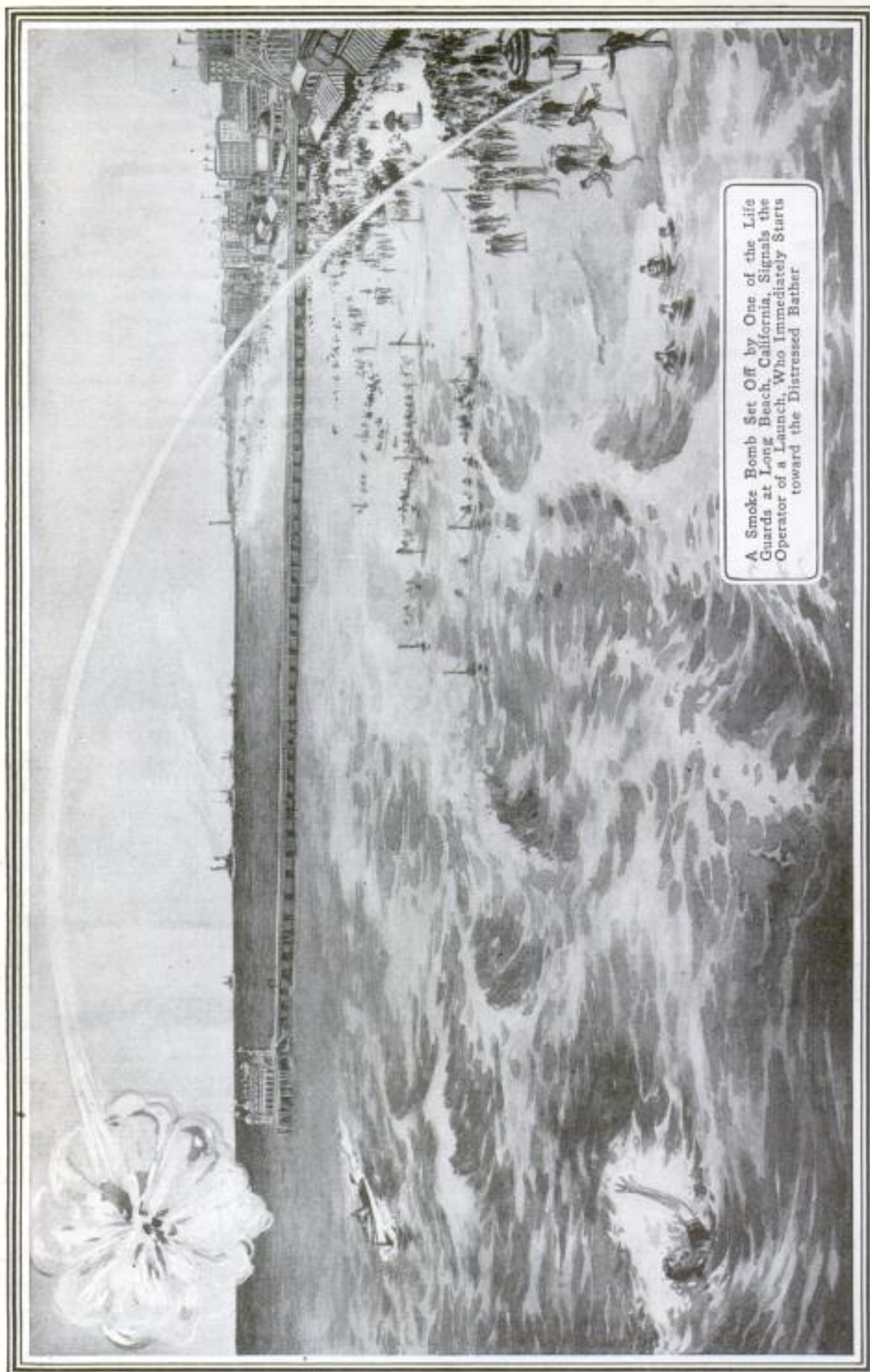

A Smoke Bomb Set Off by One of the Life Guards at Long Beach, California, Signals the Operator of a Launch, Who Immediately Starts toward the Distressed Bather

NEW METHOD OF BEACH PATROL

By FREDERICK HERR

WITH more than five miles of beach and surf-bathing facilities, Long Beach, Calif., has the largest bathing beach on the Pacific coast. More than 100,000 weekly gather here from Los Angeles and other parts of southern California, and Sunday crowds during the summer months have reached as high as 70,000 in one afternoon.

To train and equip an efficient life-guard corps for the adequate protection of such vast numbers of bathers, had long been a subject of study to the Long Beach municipal authorities. The old plan of stationing life guards at intervals along the beach and the various piers, and making rescues by launching a boat from shore, had been in practice for many years. This system offered a certain amount of safety, but fell short of the perfection which was the aim of the authorities.

After experimenting with various methods of life-guard arrangement, a system was devised that has no counterpart either on the west coast or elsewhere in the United States.

Under the supervision of Squire Duree, commissioner of parks and recreation of the town, the so-called "Duree system" was adopted. The beach is divided into nine life-saving districts. The system involves the use of smoke bombs to signal the pending rescue of a bather who has ventured into treacherous water. A look-

out is on guard at the end of an 1,800-foot pier, which extends into the ocean midway between the nine life-saving stations. A 21-foot power launch, equipped with first-aid necessities, pulmotor, and stretcher bearers, is moored at the end of the pier, ready to be dispatched to any part of the sea front at a moment's notice. When a life guard is about to make a rescue and needs assistance, he sends up a smoke bomb. The lookout at the pier's end sees this signal, and immediately sets forth with the launch to the scene of trouble.

It has been found from experience that a boat can approach a bather in distress more rapidly and more safely from the sea side than were it to set out from shore through the breakers. When a bather has been picked from the sea and is in immediate need of medical assistance, a white flag is hoisted on the power boat. This is the signal of distress for the men on the pier to communicate with a doctor. In many cases the prompt arrival of the physician, made possible by the distant signals, has saved lives.

The system is taking hold in the East and will be put into effect at some of the east-coast resorts next summer. Its application was explained in detail at the World's Congress of Community Service, at Atlantic City, in August last year, and was indorsed as a decided step forward in life-saving.

*Owner - Arthur H. Van Rensselaer
of a machine for Crippled & Disabled
101 E 23rd New York*

Auto 961

LEGLESS MAN DRIVES CAR OF HIS OWN DESIGN

A small automobile that can be driven by a legless man, was recently designed by a New Yorker who lost the use of both legs during service in the Mexican-border campaign. The machine, which was successfully demonstrated at the Institute for Crippled and Disabled, in New York City, is a motor-driven, three-wheeled vehicle, 76 inches long and 32 inches wide, and can carry three persons. All the controls are hand-operated.

As many as 50,000 persons in France have wireless outfits in their homes, according to a report recently published by the post and telegraph department.

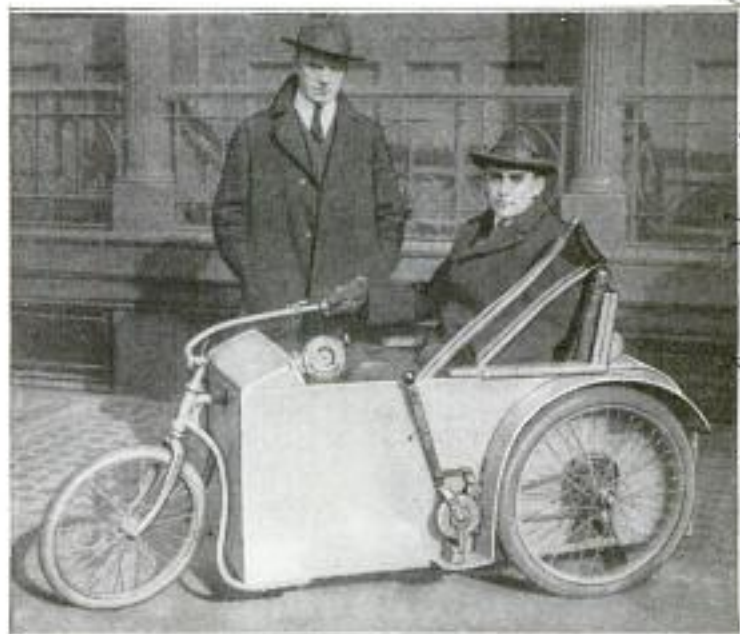

Motor Car of Special Design Which is Successfully Operated by a Legless Man: It Is 76 Inches Long and 32 Inches Wide, and can Carry Three Persons

*Mfr. Motor Chair Co
522 Fifth Ave, New York.*

Mr. August Alexander,
W. 48th South St.

88³⁶⁴

POPULAR MECHANICS
Murray, Utah.

WEEDER FOR DRY FARM LANDS CUTS WIDE SWATH

For use on western dry farm lands, during the fallow year, a weeder with two blades, cutting a 9-foot swath, is now

on the market. The machine is mounted on two widely separated wheels with an axle offset eccentrically for its whole length. This axle supports an iron frame, the center portion of which extends forward rectangularly. Suspended from this frame, and on either side of the forward extension, are the two cutting blades. From his seat above the frame the driver swings the offset axle forward and down, setting the blades just below the ground with a lever at his right-hand side, while other levers enable him to regulate the pitch of the blades, or to return them to their raised position. The implement saves about one-half the time usually required for this work.

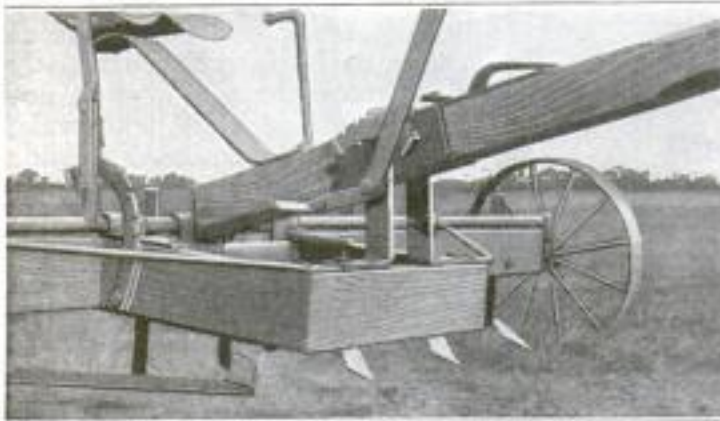

Weeder for Use on Dry Farm Lands: The Levers, Seen Handy to the Driver's Seat, Raise and Lower the Cutting Blades That are Suspended below the Frame of the Machine

484

BRIDGE THROWN ACROSS RIVER BY UNUSUAL METHOD

Logging operations in the big timber tracts of British Columbia frequently call upon the engineers for emergency exhibitions of their skill. In an operation on the Cheakamus River, it became neces-

sary to put a single span across 130 feet of raging torrent. The approaches and piers were first constructed, then a single truss was built of timbers, those in the sills, or lower chords, being single sticks, 20 by 26 inches. A spar tree used in one setting of the logging operations stood right alongside the pier on one side of the river. The completed truss was run out on rollers until it nearly balanced on the pier. The carriage on the sky line was run out to the outer end of the truss, a heavy steel cable was fastened to that end, and the truss was carried across just as a log would have been handled. The end was then dropped on the pier at the other side. The actual time required to swing the truss was not more than a few minutes.

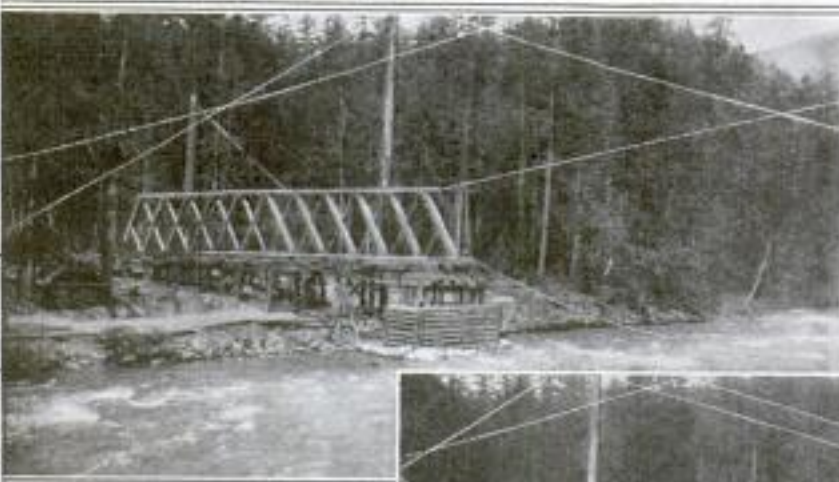

In the Photograph Above, the Completed Truss is Shown as It Appeared Just before being Pulled Out of, and over, the River

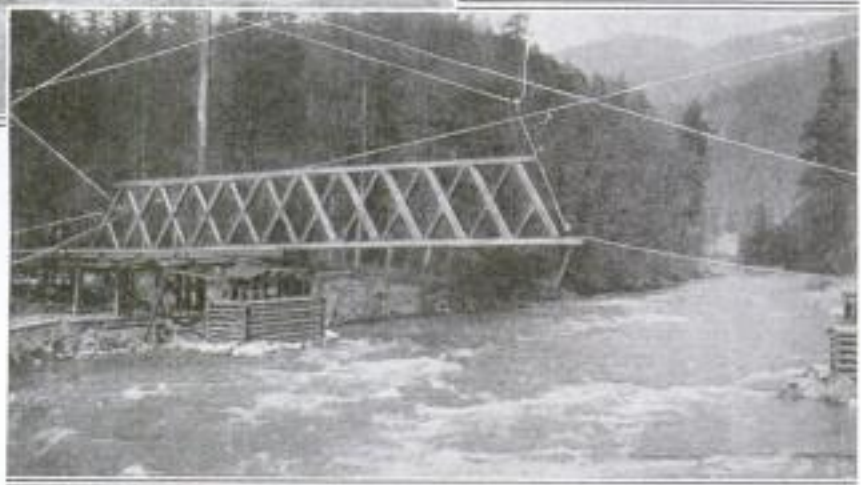

This Picture of the Truss was Taken as Its Right End Reached a Point About Midstream. A Few Moments Later It was Dropped in Place on the Piers, Which had Already been Constructed

Emb. Henry C. Copeland
10 14 Metropolitan Bldg
Vancouver, B.C. Canada

sary to put a single span across 130 feet of raging torrent. The approaches and piers were first constructed, then a single truss was built of timbers, those in the sills, or lower chords, being single sticks, 20 by 26 inches. A spar tree used in one set-

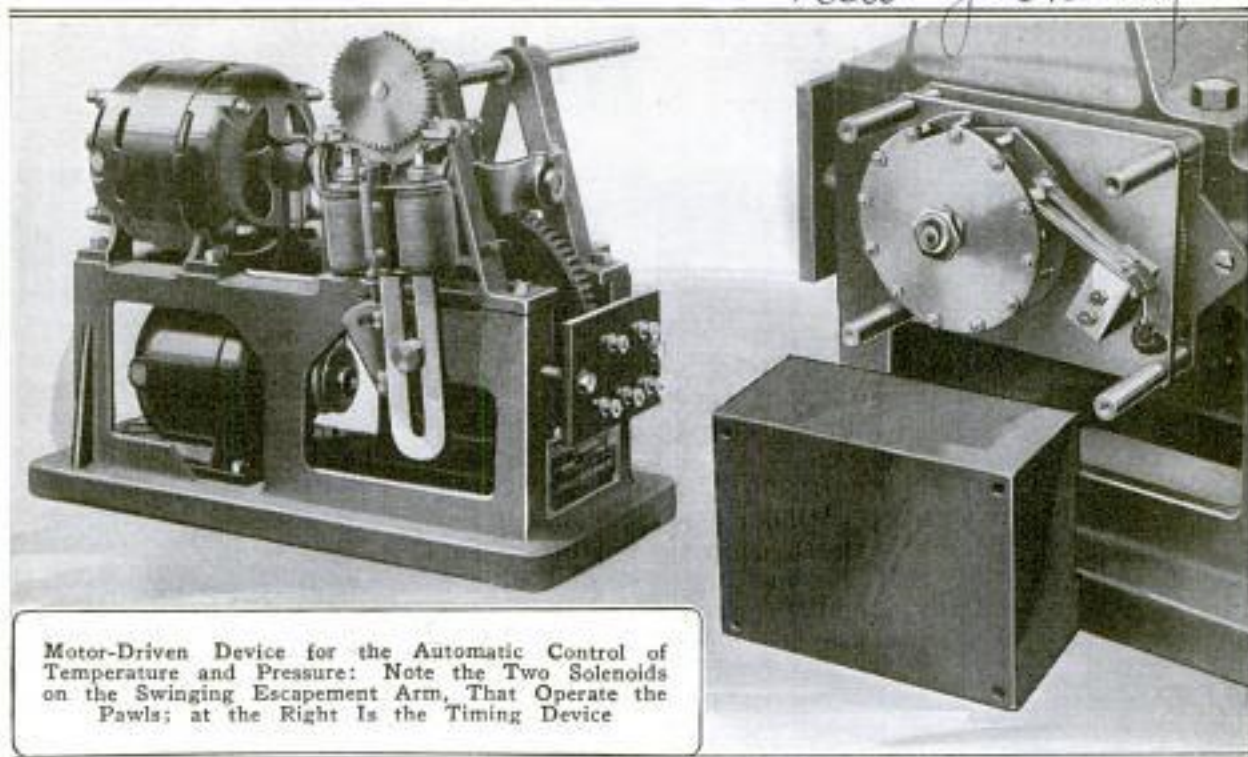

Motor-Driven Device for the Automatic Control of Temperature and Pressure: Note the Two Solenoids on the Swinging Escapement Arm, That Operate the Pawls; at the Right Is the Timing Device

1189 AUTOMATIC VALVE REGULATOR HAS GREAT FLEXIBILITY

The feature of a new valve regulator is its accuracy over a wide range. It is adapted to the automatic control of temperature or pressure, for a variety of service in connection with the use of oil and gas-burning systems, electric and steam-heated apparatus, refrigeration apparatus, and compressed-air and vacuum lines. It is designed so that each individual adjustment of the control valve can be made a small part of the total movement, and with a time element that allows one adjustment to take effect before the next can be made. The escapement, which directly controls the movement of the valve and by means of which the adjustments are made, consists of a ratchet-and-pawl mechanism governed by two solenoids mounted on a swinging arm hung from the ratchet shaft. A timing device capable of fine adjustment, constantly interrupts the circuit that energizes the solenoids. A small motor transmits power through a worm and gear and an adjustable cam to the lever arm on the escapement. The solenoid circuit is connected to a temperature or pressure element located in the apparatus which it is desired to control.

Free medical advice by radio is to be given ships at sea by the Bureau of Public Health Service. It is expected that most requests for advice will come from vessels not carrying a ship's doctor.

1217 MACHINE FOR SOLDERING COMMUTATOR BARS

All motors and generators using commutators have a very large number of joints that must be soldered, and for doing this a machine has been designed that will solder all the segments of a commutator at once, making better joints, it is said, than when this work is done by hand. Burners are provided which can be adjusted for either natural or artificial gas, and they are covered with a jacket to protect the operator from the heat. The products of combustion may be piped to the outside. During soldering, the armature is held stationary by the machine, the position being independent of any skill of the operator. Hand and foot controls are located within convenient reach of the man using the machine.



Walnut St. St. Louis, Mo.
P. E. Chapman Electric Works
N. E. Cor. Tenth +

Exhibition at Printemps
Department Store

Electrical World
1/13/23

366 256 Paris, France POPULAR MECHANICS

**FOUNTAIN MADE OF TOWELS
SEEN IN FRENCH STORE**

Seven thousand towels were used in fashioning an imitation fountain made en-



Imitation Fountain, Made with More than 7,000 Towels, Which is Now being Exhibited in a French Department Store

tirely from this material and recently exhibited at a large department store in Paris. The work, about 15 feet high, has a solid architectural background, topped by a cornice 10 feet in length. Beneath the cornice and between two side columns is a niche occupied by a peacock standing on a rough-cut "rock." The "water" flows from the bottom of this rock.

**CONCRETE POLES SUPPORT
1364 132,000-VOLT LINE**

Steel-reinforced concrete poles have been used over a portion of a 132,000-volt transmission line recently built in Sweden. Each support consists of two 61-foot poles carrying a crossbeam 57 feet above the ground, on which the conductors are arranged horizontally, 20 feet apart. Each pole is designed for a pull of 1,320 pounds at the top, with a factor of safety of four. One underwent a test pull of 6,750 pounds and deflection of 4.6 feet without showing cracks or permanent deflection. They are made of steel rods circumferentially placed and interwoven with steel wire. This skeleton is placed in a hollow mold and the whole made to revolve rapidly while the concrete is poured in.

1042
**NEW IMPLEMENT DIGS, PICKS,
AND SACKS POTATOES**

A recently invented potato harvester combines simplicity with adaptability to different ways of handling the potatoes after they are dug. It can be used to dig, pick up, and load the potatoes into a wagon or into sacks as a continuous operation; as a plain digger, or just for the purpose of picking up the potatoes. It consists of a drum, 8 feet in diameter and 7 feet wide, built up of hardwood slats spaced about 1 inch apart on iron hoops, with iron spirals inside, to which are attached the digging disks. As the drum is pulled along the ground, the action of the spirals picks up the potatoes and carries them to a basket which is automatically inverted at the top of the drum. The absence of gears and other mechanisms makes the harvester very light and easy to maintain.

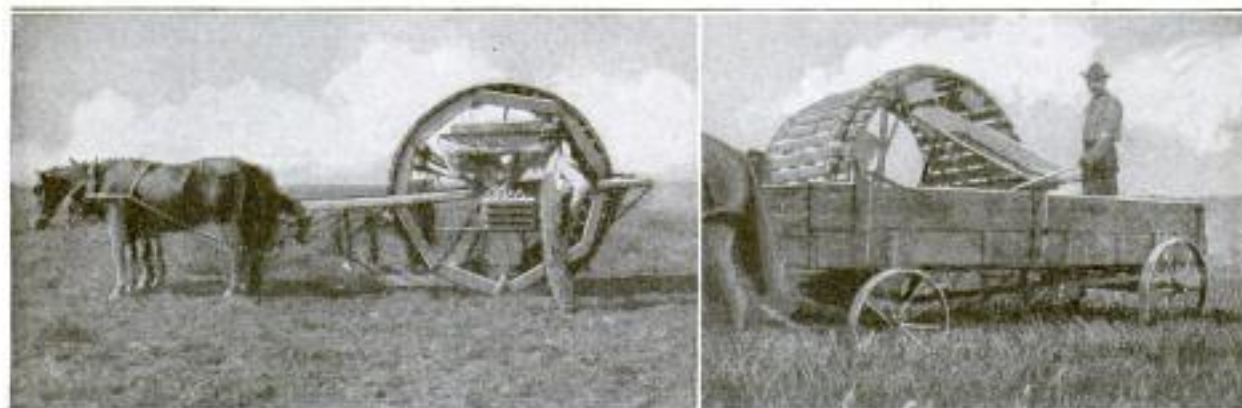

Left: Drum-Type Harvester Picking Up and Crating Potatoes: Two Horses Haul the Machine with Ease, and as There Are No Gears or Other Mechanisms, Upkeep Is Low. Right: Harvester Delivering Potatoes through a Canvas Chute to a Wagon Alongside

Drawn by A. E. Stebbins, Clayton
Munn

Copyrighted material



The "X" below the Gateway of Another Tomb in the Center, Marks the Entrance to the Recently Discovered Tomb of Tutankhamen

TREASURES OF ANCIENT THEBES IN NEW-FOUND TOMB

By R.C. Folger *Fol*

TREASURE that has been variously estimated to be worth from \$15,000,000 to \$40,000,000, has recently been brought to light upon the opening of a tomb believed to be that of Tutankhamen, who ruled in Egypt over 3,000 years ago.

The first objects to greet the eyes of the entrants to the tomb, were three magnificent state couches, each made of gilt wood with exquisite carvings and decorated with a lion's head and other emblematic figures. On these rested gilt beds also beautifully carved and inlaid with ivory and jewels, and a number of boxes of rare workmanship. These boxes were inlaid with ivory and ebony with gilt inscriptions. One box, hung with painted hunting scenes, contained royal robes richly embroidered, precious stones, and golden sandals. Beneath one of the couches was the state throne of Tutankhamen, the first of the thrones of ancient Egypt revealed to modern eyes and re-

ported to be one of the most beautiful objects of art ever discovered. There were also four chariots richly decorated with gold and studded with semiprecious stones, the charioteer's apron of leopard's skin still hanging from the seat. Two life-size statues of the king, holding a golden stick and mace, stood facing each other, the features delicately carved and the head-dress studded with gems. A number of quaint-looking musical instruments made of gilt bronze were in the rooms. There were also alabaster vases with a very intricate design of an unknown origin, and some handsome pieces of glazed art pottery. Quantities of provisions for the dead were found packed in boxes, according to the peculiar custom of the times. Among these was some embalmed beef, in containers resembling huge Easter eggs, which was in an excellent state of preservation though not wholly palatable. In one of the boxes were rolls

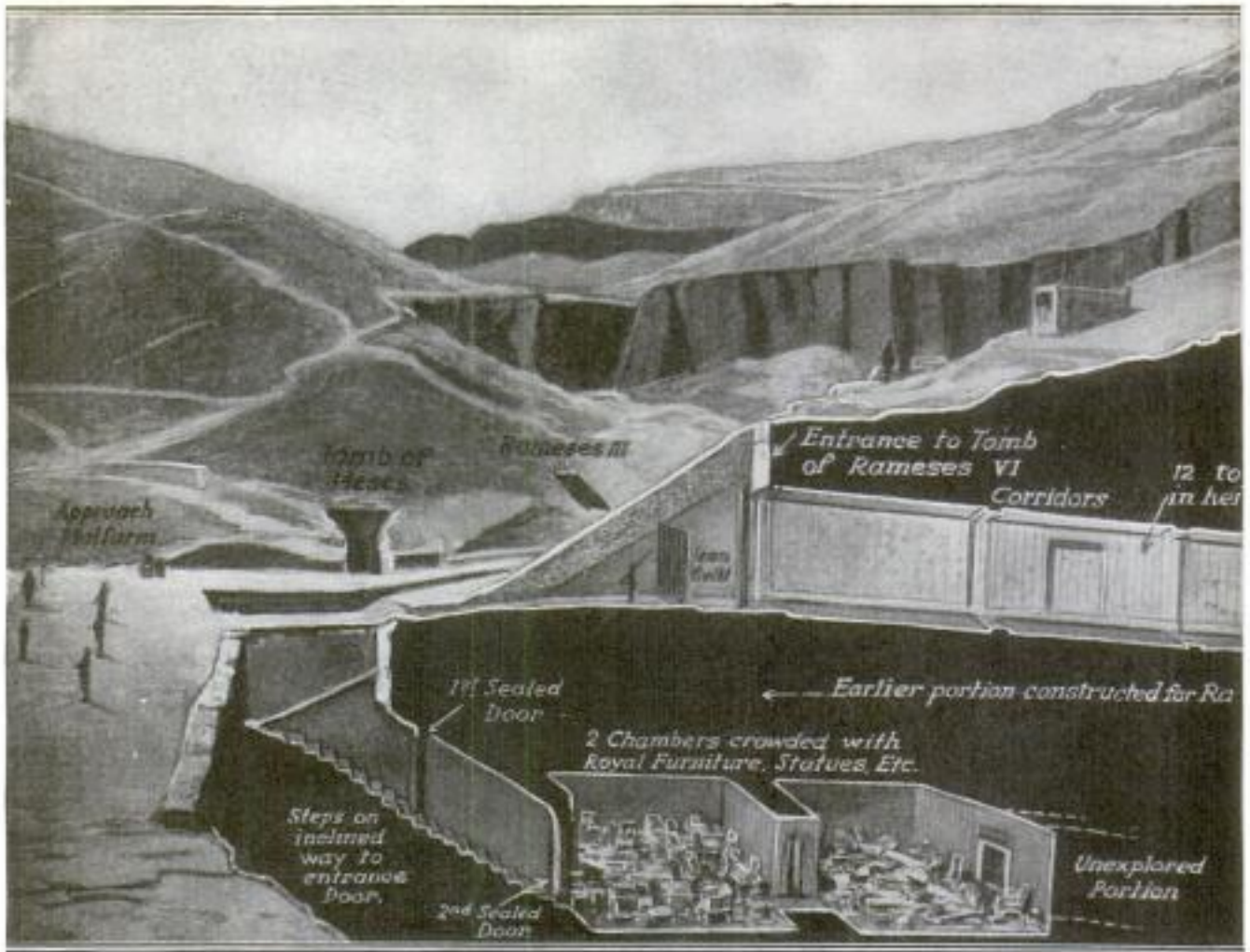

COPYRIGHT IN THE UNITED STATES

It Was in the Tomb of King Tutankhamen, the Successor of the Famous Akhenaten and Smenkhkara, Who Were Co-Unearthed were Found. The New-Found Tomb Lies below That of Rameses VI, and Its Discovery Is a Credit to Ceased Their Search. It will Be Interesting to Learn What Is in the Unexplored Portion of the Tomb That

of manuscript which are expected to yield much valuable archaeological information.

The second of the two first chambers, connected by an open doorway, was in such a state of confusion as to indicate that the tomb had not remained undisturbed after the doors had been sealed, following the funeral rites to the dead king. Furniture and other objects, similar to those found in the first chamber, were piled high, and closely packed in a manner that led the investiga-

tors to believe that part of the funeral paraphernalia had been hurriedly removed to this chamber to keep it from thieves.

What lies beyond the sealed doors of a third chamber lends interest to the discovery, for it is there that the two figures of the king stand guard. It is hoped this may turn out to be the actual burial chamber of Tutankhamen and the members of his family, but until the material has been cleared from the other chambers, this question cannot be settled.



Front of an Ancient Theban Temple—Covered with Hieroglyphs—Unearthed at Luxor by the Discoverers of Tutankhamen's Tomb

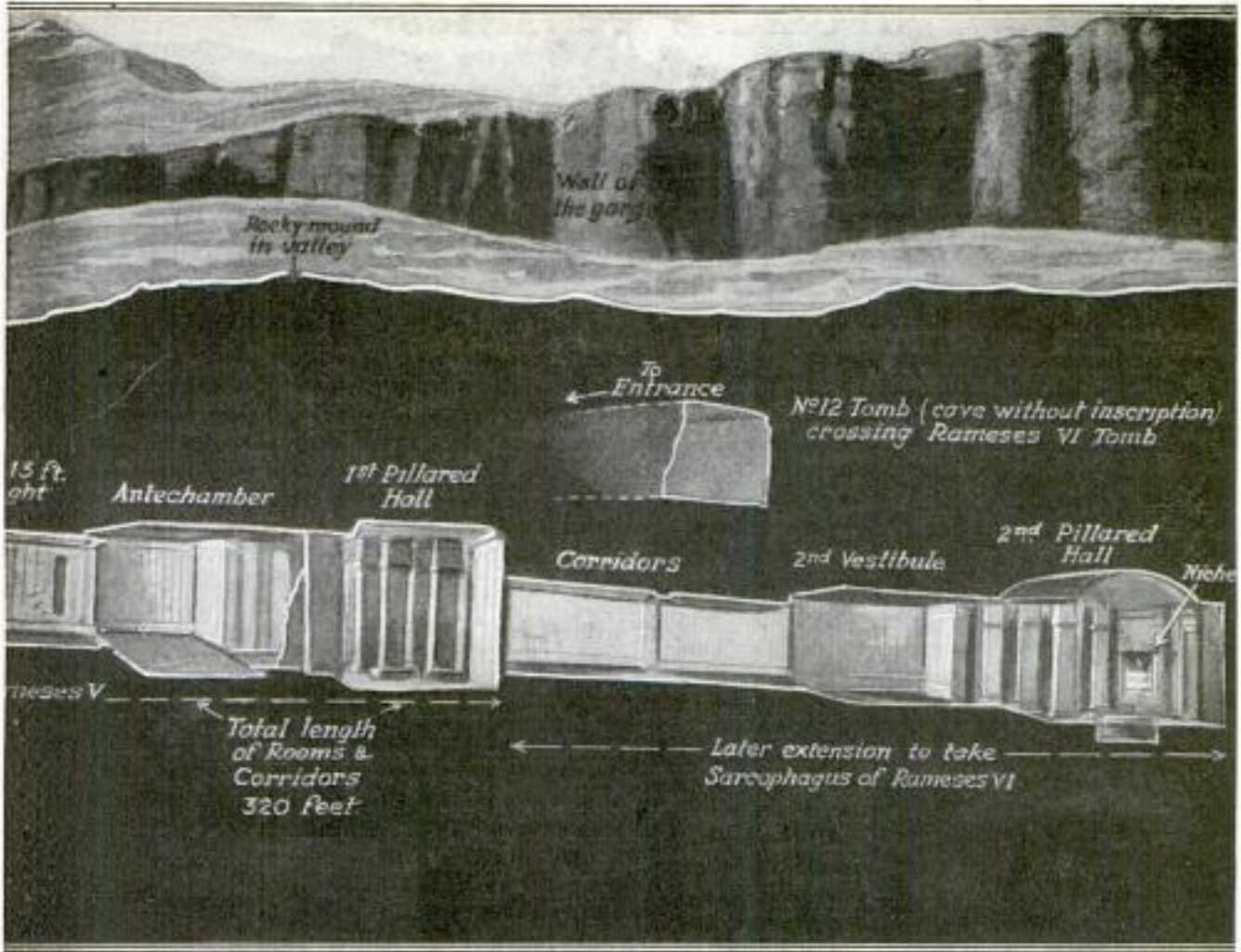

BY THE SPHERE, LONDON

Regents in Egypt from 1375 to 1358 B. C., That Some of the Greatest Treasure and Relics of Antiquity Ever the Persistence and Instinct of the Men Who have Kept Digging Away at the Mound Years after Earlier Explorers Lies beyond the Second Chamber. This was Closely Packed with the Funeral Paraphernalia of Tutankhamen

The tomb lies below that of Rameses VI, which was discovered a few years ago, and is chambered out of the rock in a low hill formed at the foot of a cliff in the famous Valley of the Tombs of Kings, located near the site of ancient Thebes. There are also the tombs of other kings that have been discovered in this hill. It is remarkable that the entrance to Tutankhamen's tomb is so close to grounds where scores of workmen and many a skilled excavator must have passed

while engaged in search for the secrets of the Theban necropolis. Perhaps its very nearness to these already explored sites led them to think that there was no need to search the unexplored strata below.



Entrance to the Recently Discovered Tomb Which has Remained Unopened for Over 3,000 Years: Note the Descending Row of Steps

The discovery is the result of the persistence of Lord Carnarvon and his two assistants, Howard Carter and B. Callender, who for 16 years have been following the discouraging work abandoned by those who made the earlier discoveries. In dig-

ging among the stones below the entrance to the tomb of Rameses VI, they uncovered what was to their experienced eyes traces of an opening in the wall. Continued digging disclosed a carefully hidden and tightly sealed door. This doorway opened into a stairway of some 16

steps, and a passageway, about 25 feet long, at the end of which was another door even more securely sealed than the first. After the second door had with difficulty been opened and the three men managed to squeeze through, they were rewarded by the sight of the first chamber.

1045
BINOCULAR MAGNIFIER ALLOWS USE OF BOTH HANDS

An improvement over the single magnifying glass worn like a monocle by watchmakers, jewelers, and others who do close work, is seen in a new binocular magnifier.

This device, which is built like the modern prism binocular, is held on by a band that passes around the head and enables the wearer to use both eyes simultaneously,



both hands being free for work. A small electric light with a condensing lens provides illumination for intricate work.

1136
INTAKE-AIR HEATING DEVICE FOR AUTOMOBILE MOTORS

Easily installed between the carburetor and the intake-manifold flanges, a device designed for the delivery of gas and air mixtures of proper proportions and temperature to the cylinders of internal-

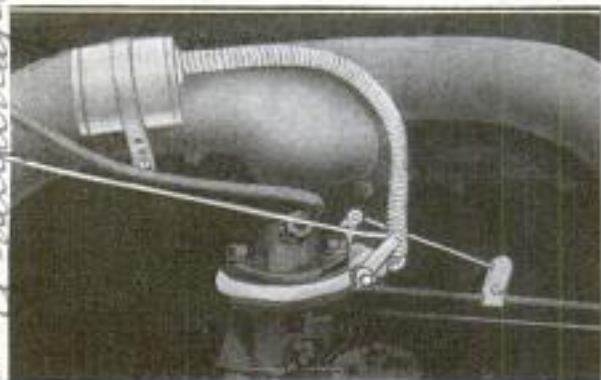

Air-Heating Device Installed on an Automobile Engine, Showing Its Controlling Attachment to the Carburetor-Throttle Rod, and the Auxiliary Control for Fine Adjustment

combustion engines, is now on the market. Like other devices of the kind, it operates in connection with the hot exhaust manifold, and is said to keep the intake manifold at a temperature of about 150° F., thus insuring complete vaporization of the gasoline in the mixture. It is controlled by the carburetor-throttle rod, to which it is attached, and has an auxiliary dash control for fine adjustment.

394
SAFETY DEVICE FILLS NEED OF TEMPORARY LOCK

Sometimes the need is felt for a temporary lock to be used on doors or windows of a summer cottage, or other building, and then detached and taken away.

Locks on the doors may be out of commission and a feeling of greater security will be enjoyed with an additional lock. Such a lock is provided by a new safety device which



may be attached with nails or screws or by pressing into the door jamb. It is said to be so strong that it will withstand the pressure of three men.

1027
ARMORED CAR OF NEW TYPE TO FOIL HOLDUP MEN

An armored car for the foiling of hold-up men has a body entirely constructed of armor plate, fitted with bulletproof glass windows, windshield, and side wings, the whole closely resembling an ordinary town car or limousine. A steel-armored safe has been built into the rear, or inclosed part of the machine, which is designed to carry only two passengers, the

Paunch & Luml. N.Y. Rochester, N.Y.
The Thermidor Mfg. Co. 3319 N. Capital Bldg. Wash. D.C.

Wm. B. H. Wickwire Carbondale Pa.

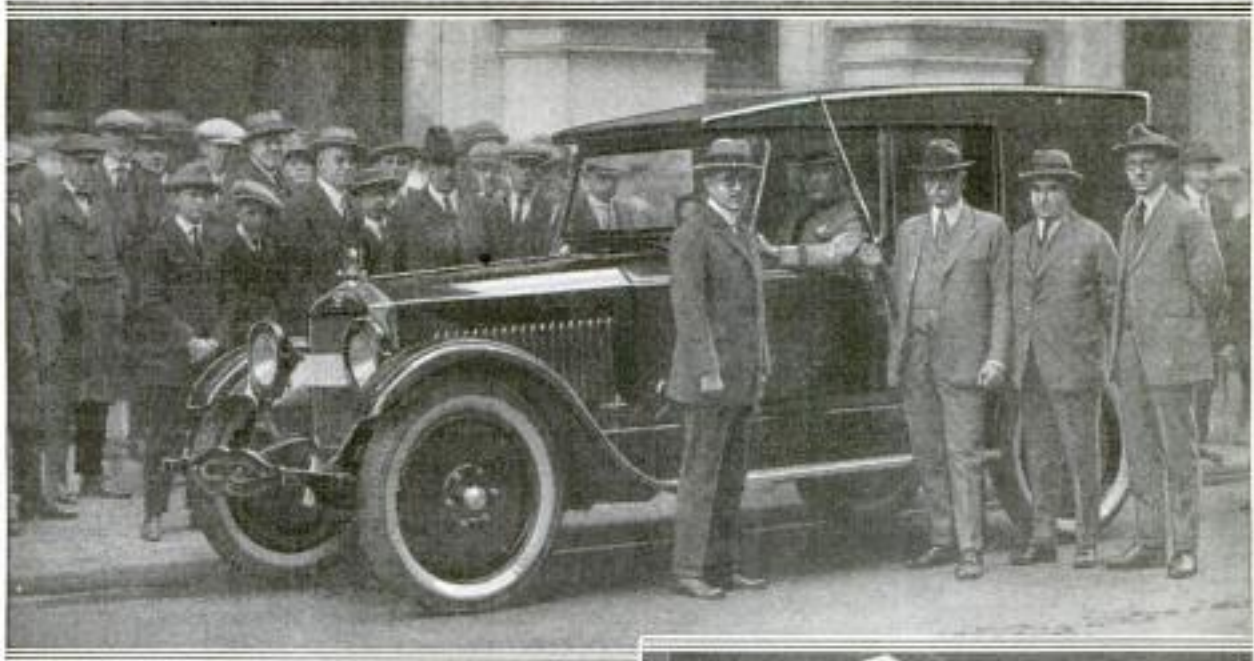

This Armored Car, Made to Foil Bandits, Has Only One Entrance to the Rear Compartment, There Being a False Door on the Left Side

driver and the messenger in charge of the money. The driver sits in front in the usual position, while the messenger locks himself in the rear. Loopholes with sliding armor-plate covers are provided at both sides and rear of the car so that the messenger may shoot in any direction. In the event of an accident to the driver, the messenger can assume full control of the machine by means of a tandem brake and other necessary arrangements. A special feature of the car is the construction of a "blind" door on the left side, which has been noted to be the usual point of entrance when a holdup takes place, thus assuring any would-be bandits a disconcerting surprise at the outset.

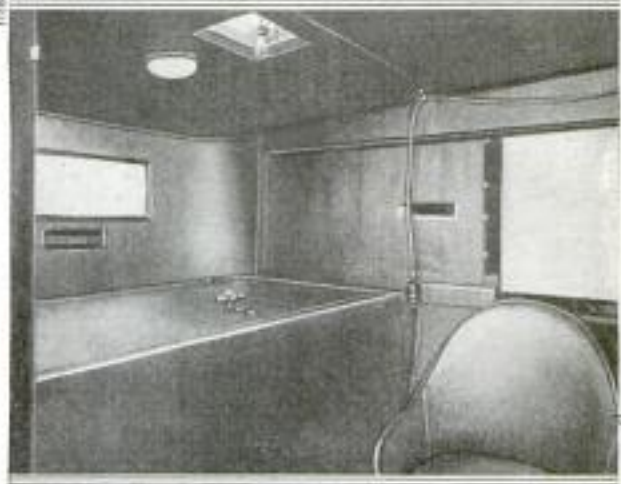

Interior of Rear Compartment of Armored Car, Showing Messenger's Seat and Safe in the Place of the Usual Rear Seat

1284 —
DEVICE EQUALIZES TENSION OF DRUM SNARES

A device for equalizing the tension of the strings of a snare drum has recently been patented.



It consists of a steel arm running across the drum head and extending a few inches beyond at each side. The

snare wires are fastened at both ends in such a way that all of them have an equal tension, and retain this whether the device is released or not.

INVENTION ADDS TO SAFETY OF SHIPS AT SEA

By means of an apparatus for producing extra-sonorous waves, it is hoped to reduce the danger of collision and of ships running aground at sea. A spark emitted from an ordinary radio-broadcasting outfit is transformed by the new apparatus into sound waves that travel through the water at a speed of nearly 5,000 feet a second. The same device registers the echo returned from an obstacle and transforms it into electrical oscillations which are also recorded by the instrument.

☐ The Pavlof volcano, at the tip of the narrow Alaska Peninsula stretching toward Asia, is reported to have lost its top in a great eruption occurring late in December, last year.

Langevin from Paris
 Article taken from Prof.

Wm. Walter S. Soderberg
 414 Second Ave W.
 Duluth, Minn.

Capt. Weldon,
Wichita Falls

IMPROVED PILE DRIVER IS SIMPLE AND EFFECTIVE

A homemade pile driver, constructed in the short space of three hours from some 2 by 4 and 4 by 4-inch lumber and a few bolts, proved to be as practical to operate as it is economical to build, to the resourceful contractor who devised it. Two 4-by-4's formed the

4-inch lumber bolts, practical to build, to contractor it. Two 4-by-runways for

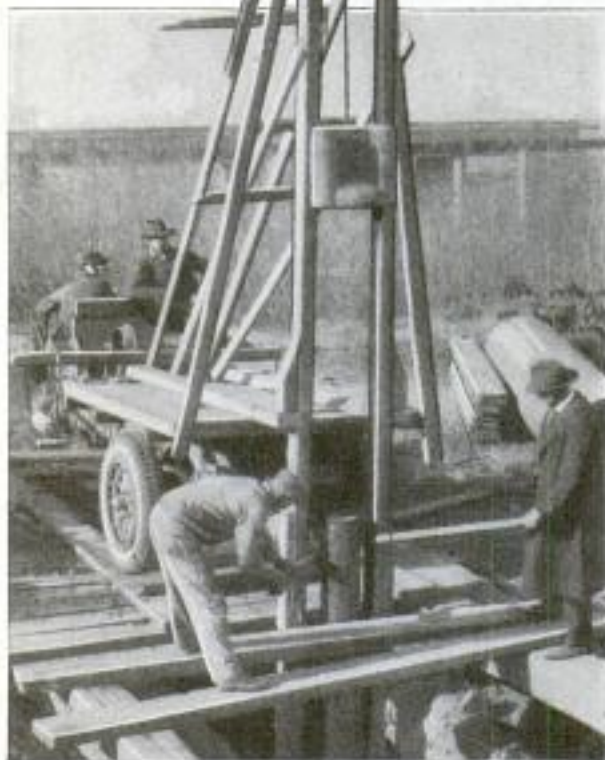

Effective Pile Driver Constructed in Three Hours' Time from Stock Lumber, and Fastened to the Rear of a Contractor's Truck

the 2,500-pound hammer, which was raised by a cable passed through a sheave at the top and wound around the drum of a winch on a motor truck.

IMPROVED PROPELLER DESIGN

1352 APPLIED TO SHIPS

What is called a contra-propeller has been applied to ships in Europe and has effected an increase of 12 to 18 per cent in propulsive force. It consists of a number of blades—usually six—affixed to the rudder stem about 18 inches behind the main propeller in such a way as to turn the revolving stream of water coming from the main propeller, into a straight flow, this action being responsible for the increase in propulsive effect upon the ship. It is said, also, that the vibrations

of the ship are decreased, and the steering qualities improved, while the ability to run astern is undiminished. The idea can be applied to reduce the quantity of fuel consumed, instead of increasing the speed. The contra-propeller is designed to break should anything come between it and the main propeller.

MAGNETIC INDICATOR USED IN TEMPERING STEEL

It is a well-known fact that drill steel, in order to be tempered for the greatest possible toughness and resistance to wear, should be quenched at the lowest possible temperature above the critical point, which is the point at which the structure of the steel changes. This point coincides with that at which steel loses its magnetism, and advantage has been taken of this coincidence in the production of a magnetic indicator to assist the blacksmith in quenching his steel at the proper point. The indicator consists of a brass or bronze casing, inside which is a horseshoe magnet hung on a pivot at its point of balance. At the top is a small window, and a white indicator tab which is so balanced that when the bottom of the magnet is pulled forward the top will strike a lever and push the indicator into view. A shelf at the bottom of the casing is used as a rest for the steel. When the blacksmith judges the steel to be approaching the critical stage, he rests the

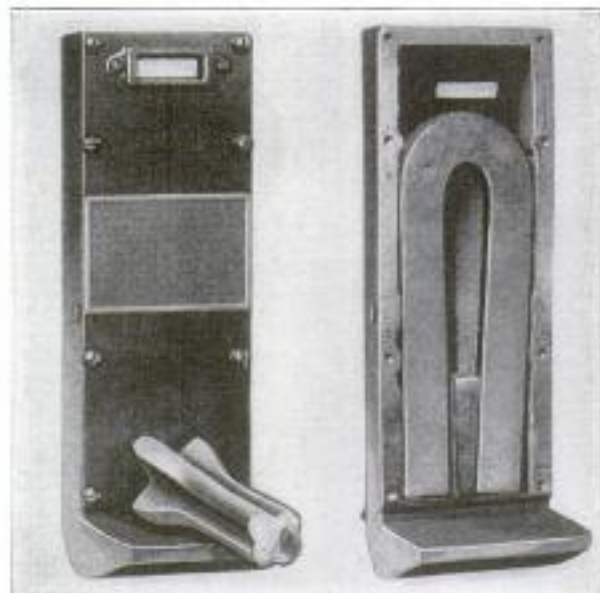

Left: Magnetic Indicator with Cover On, and a Drill Bit on the Shelf. Right: Cover Removed, Showing Horseshoe Magnet

heated end on this shelf, and if the tab does not show in the window, he knows the steel is ready for quenching.

Ans Mr. Wagner. 'Vulcan' yard, Staten, Germany.

Dullmage Machinery Co
122 S Michigan
Chicago

Linwood Hunt, North Waterford Maine

HEDGEHOG HUNTING GOOD TRADE AND GOOD SPORT

1260

BY SAM E. CONNER, 486 Turner St.
Auburn, Maine

TRAPPING hedgehogs does not sound like a very attractive pursuit, but a man in Maine has found it to be a profitable business, as well as one that has an element of danger, and therefore offers excitement in excess of that which comes to a rabbit or fox hunter. While it is not generally known, there is a steady demand for these ugly-looking creatures from all sections of America and Europe. They are desired for zoos and menageries, both private and public, and country-fair and street venders, who use them to aid in selling preparations, disposed of under the name of hedgehog oil, hedgehog liniment, and like titles, provide still another market.

All of these buyers are in constant need of the hedgehogs, for the animals do not live long in captivity. This man has been catching hedgehogs more than 20 years and has shipped thousands of them. In a single month, a few years ago, he shipped three tons; and one shipment to England, which, by the way, is one of the largest customers for hedgehogs, in the spring of 1922, required four horses to haul it to the railroad station.

The trapping is all done in the summer and at night. The best time for catching the animals is between 9:00 p. m. and 2:00 a. m., and there is no better hunting ground than an apple orchard. The

hedgehogs come there to feast upon the apples, of which they are exceedingly fond. The outfit for catching them consists of an old washboiler, the cover

fastened on one side by means of a wire hinge; a long pole, and a pair of heavy gauntlet gloves for protection against the quills, which the animal has a disagreeable habit of "throwing" when in danger. The pole is used to dislodge the hedgehog from the tree limb on which it may be found. Once the animal is on the ground, the trapper must step lively or his prize is gone. Clumsy as it looks, the hedgehog makes a quick getaway when frightened, and the darkness of night is a further help to it. It is a rush forward, a quick throw of the boiler over the escaping animal, a deft overturning of the boiler, and closing of the cover. It is all over in a jiffy, providing the trapper's aim is good. A specially constructed box, lined with galvanized iron, is part of the outfit, and is used for taking the night's catch back home.

Ordering various qualities and sizes of steel by number will soon be a general practice in the United States, if plans of engineering organizations materialize. The present method requires long and detailed specifications. Germany, Switzerland, and several other European countries already use number systems.



A Maine Man's Outfit for Catching Hedgehogs: It Is Simply an Old Washboiler with the Cover Hinged by a Wire; in Addition He Sometimes Uses a Stick to Poke the Animals Loose from Tree Limbs



The Boiler is Thrown over the Hog and the Cover Then Quickly Slid into Place While the Boiler is Turned Over; Usually the Hunter Wears Gauntletted Gloves to Protect Himself against the Sharp Quills

tailed specifications. Germany, Switzerland, and several other European countries already use number systems.

374
1286

FAST COUNTING OF SMALL MACHINE PARTS

Filling boxes or cartons with small machine parts rapidly and accurately is the result accomplished with the specially de-



A Special Tray with Chute for Rapidly Counting Small Machine Parts and Filling Boxes with the Proper Number

vised tray and the "counting-by-five" system used by an Illinois manufacturing company. With three fingers of one hand and two of the other, the operator sweeps the small parts rapidly into the container until it is filled with the correct number.

TOYS OF AMERICAN INDIANS EXHIBITED BY MUSEUM

Crude dolls, tiny imitation horses, and other playthings recently put on exhibition by the U. S. National Museum, indicate that the children of the American Indian played with toys in a manner very similar to the practice of present-day children. Animal dolls appear to have been most popular. A wild duck which an Eskimo had stuffed for his baby and a beaver fitted with an imitation tail of leather, are among the more original ones.

American Indians

RURAL MAIL BOX SWINGS AROUND IF HIT

If struck by a moving vehicle or other object, a new rural mail box revolves about its supporting pole, and by the force of gravity swings back to its normal position. The keynote of the arrangement is found in a wide metal disk around the pole, beneath the box, which is tipped at an angle, and, at its lowest end, connected to the bottom of the box. Smaller bands hold the box to the pole.

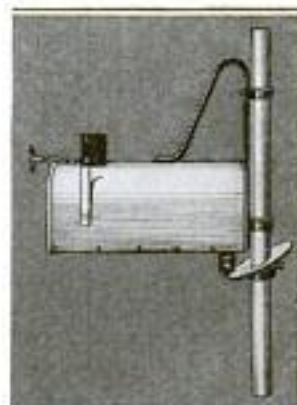

Law M. L. Vick Sheyenne N. D.

BURROS CARRY PIPES MAILED AS PARCEL POST



The Pipes Carried by These Burros were Sent by Parcel Post by a California Road Contractor. When He Found This would Be Cheaper than to Do the Transporting Himself

Finding that transporting corrugated-iron culvert pipe to an isolated region between the Klamath Mountains and the Pacific coast would cost much more than he had planned, a California road contractor solved the problem by mailing it. The postal authorities making the delivery through the rugged country had to resort to burros, two sections of pipe being strapped to each animal. The shipment was to be used in building a road through that region, to be called the Klamath River Forest Road.

Emt. Norman C. McLeod
1719 St. Paul St Baltimore, Md.

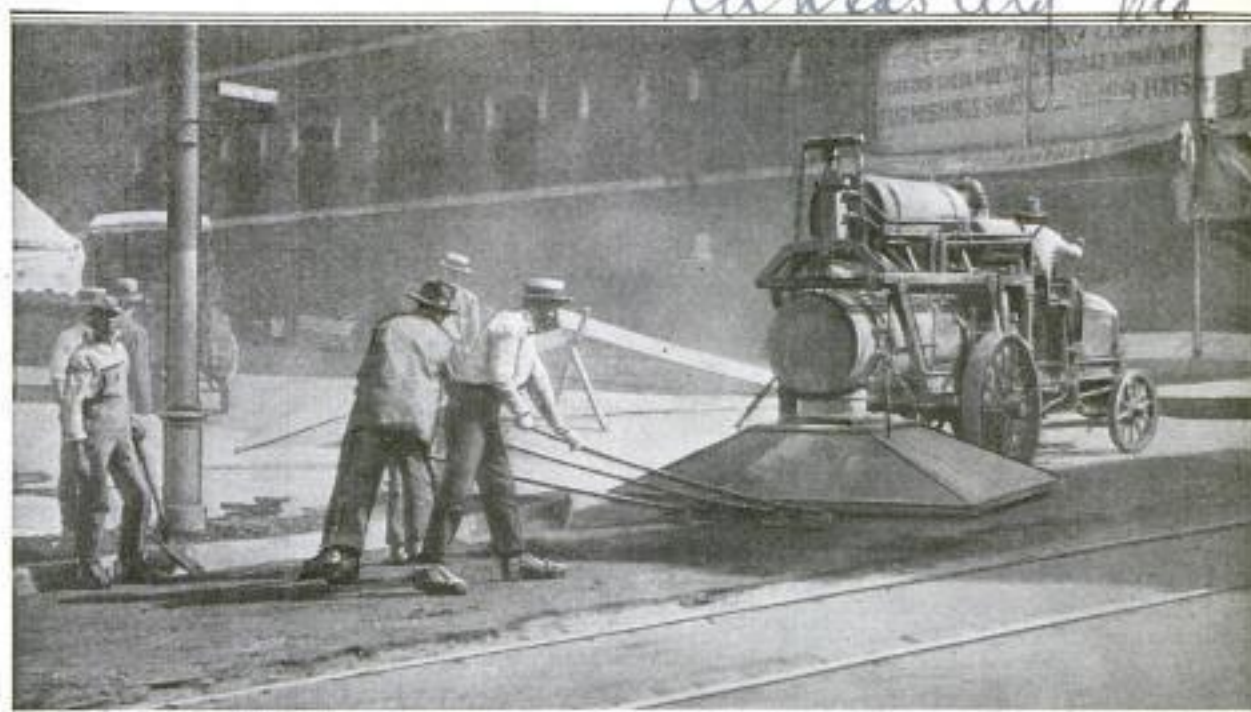

New Apparatus for Heating Asphalt Pavements Which are to be Resurfaced: Connected to the Steel-Plated Hood, Shown Here Resting on the Ground, Are Oil Burners, and Air-Blast Pipes Which Blow the Flame Downward

1254
HEATER ON AUTO TRUCK USED IN RESURFACING ASPHALT

An improved apparatus for heating asphalt pavements which are to be resurfaced, is mounted on a small auto truck. Behind the driver's seat is arranged an air tank, a blower, a fuel-oil tank, and an air-heating chamber with oil burners, connected to a steel-plated hood. Both hood and heating chamber are raised or lowered by a hydraulic hoist, while coil springs, attached to a high metal frame, counterbalance this weight and permit the hood to rest gently on the pavement. The capacity of the machine is said to be about 1,000 square yards per eight-hour day.

1361
WELD SPECIAL STEEL SURFACE TO MACHINE PARTS

Encouraging results have been obtained from experiments conducted to determine the practicability of welding special steel to ordinary machine-steel working parts. This was shown in the case of some internal-combustion motor valves to which was welded a thin layer of chrome-steel alloy, the valve being finished in the usual way. Tests made under actual operating conditions failed to show any defects, and a micrographic examination disclosed no weakening of the joint. This corresponds to the practice of welding special steel bits to shanks of ordinary steel.

1289
VENDING MACHINE SELLS HOT SHELLED PEANUTS

Delivering shelled peanuts hot into the hand of the purchaser who drops a coin in it, is the novel feature of a new vending machine, which is designed to be placed in cigar stores, railroad stations, or other public and semipublic places. It weighs eight pounds, and the electric current which keeps the peanuts warm also flashes out a light at intervals. Two to three cents for a 10-hour day is claimed to be the cost of current. It takes about half an hour to heat the reservoir full of peanuts, and thereafter they are kept automatically at the right temperature.



manchester guardian
1/4/23

W. A. Payne
 General Agent
 of
 W. A. Payne
 Co.
 711 1/2 St.
 W. A. Payne
 Electric
 968

1164 Commissioners of Glade County, Florida

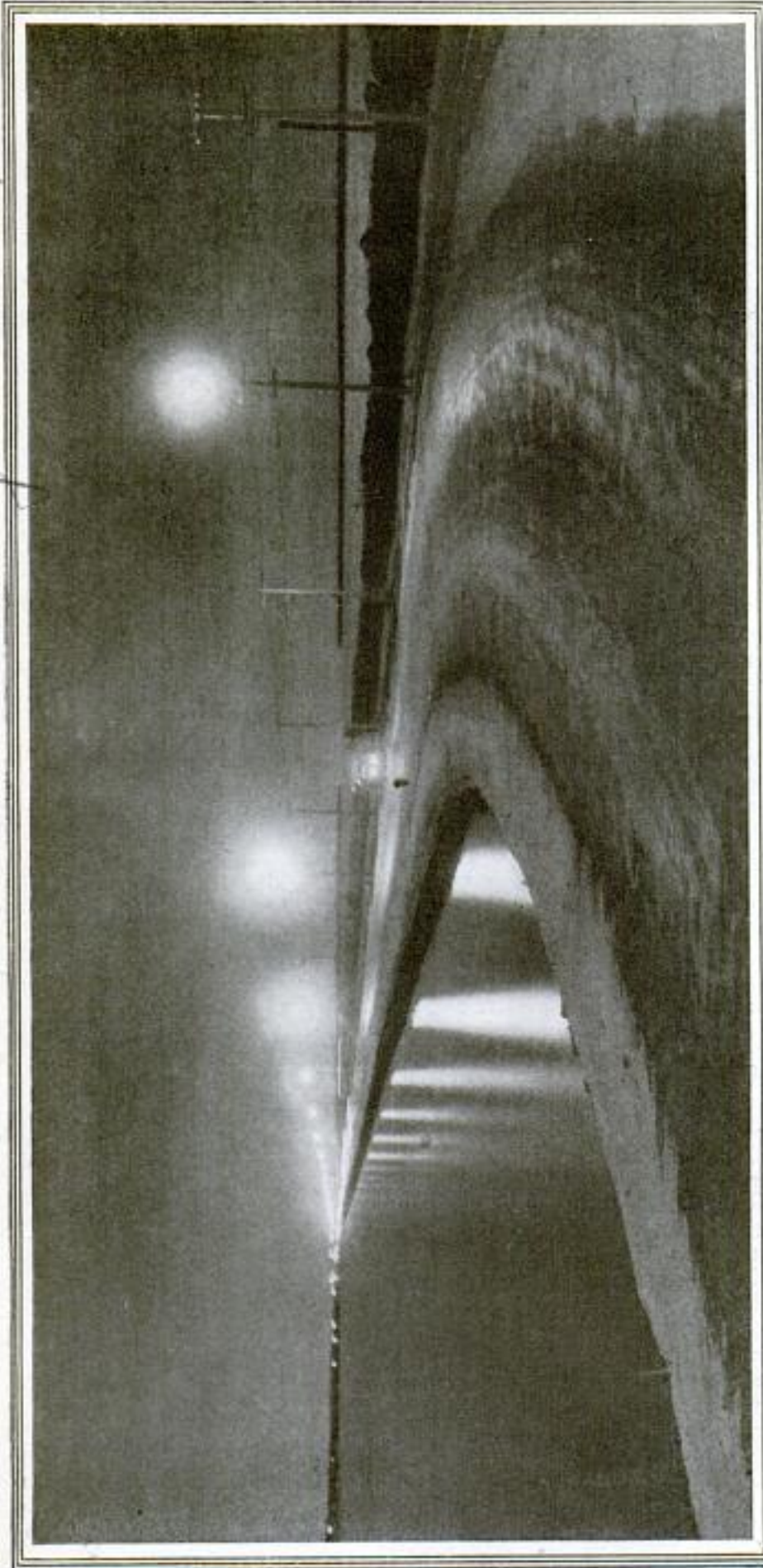

COPYRIGHT, W. A. FISKENBAUM

MILLION-DOLLAR CAUSEWAY ILLUMINATED FOR NIGHT DRIVING AT FAMOUS FLORIDA RESORT

BRILLIANTLY lighted, the million-dollar concrete causeway, $3\frac{1}{2}$ miles long, that connects Miami, Fla., with the beach across Biscayne Bay, has been opened to the public recently. The driveway, which takes the place of a wooden bridge, is 105 feet wide, has a double automobile roadway, a two-way drive for heavy traffic, and the track of an electric line in the middle. Twelve thousand motor cars a day is a common record here.

Electric lights, giving sufficient illumination for driving at 30 miles an hour with lights dimmed, are placed on poles 30 feet above the surface, 400 feet apart on the straightaway course, and 300 feet apart on the curves. Lamps of 250 candlepower are used.

Absence of guide posts and fences on the sea wall made driving dangerous till these lights were installed. A thorough trial proves that they make driving safe, with the flood of light that they give.

1222 W. Kingsley Noble, American
Museum of Natural History,
New York City

ODD REPTILES *from* SANTO DOMINGO

By E. A. Higgins, Archivist
S. C., New York.

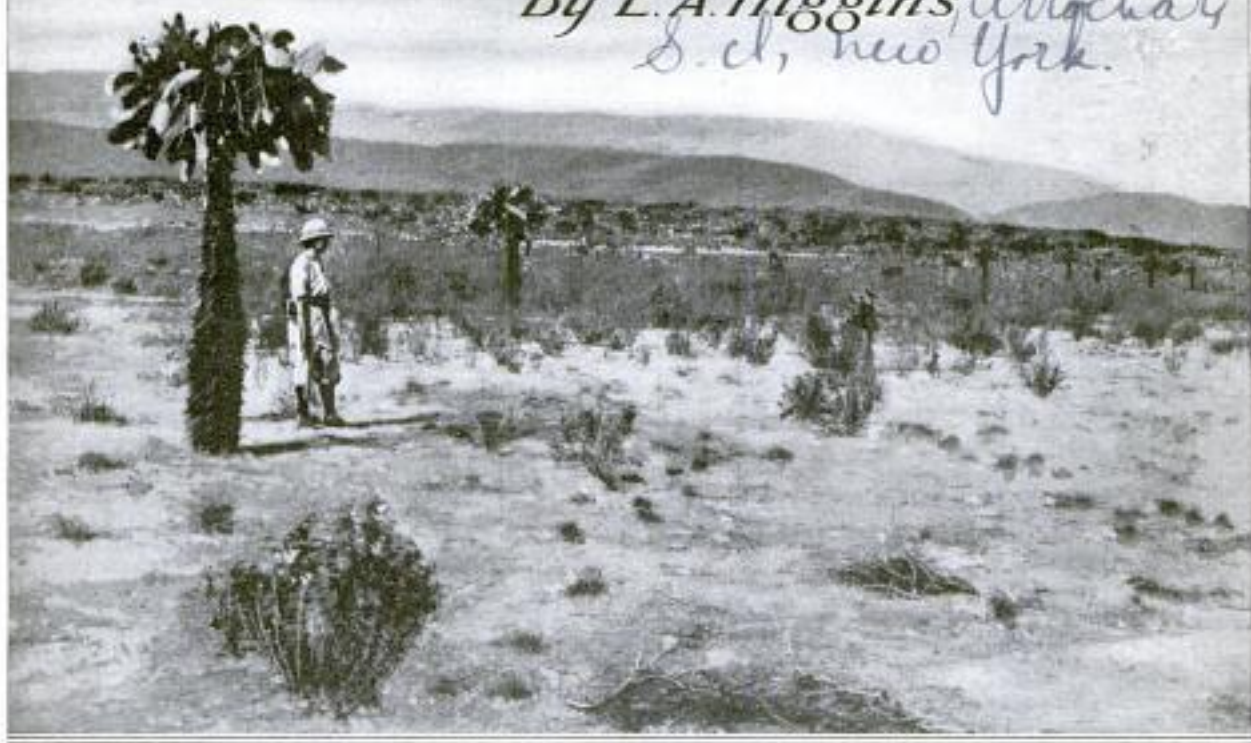

View of Reptile-Ridden Island in a Salt Lake, 160 Feet below Sea Level, on the Island of Haiti, near Santo Domingo, Capital of the Dominican Republic: Here the Explorer Found Great Numbers of Rhinoceros Iguanas and Other Queer Representatives of the Reptile Class

A LARGE collection of curious reptiles has been brought recently to the American Museum of Natural History in New York, by Dr. G. Kingsley Noble, who, accompanied by Mrs. Noble, spent three months in Santo Domingo at the head of a scientific expedition which went there to hunt and study its reptile fauna.

Doctor Noble, who is an authority on these animals, had often heard stories of unusual specimens which were said to live in that region. Therefore it was with great interest that he set out on the expedition, which was organized by the American Museum of Natural History and financed by the Angelo Heilprin Fund. And he met with odd experiences and odd reptiles, too. The experiences, of course, are not on exhibition, but the reptiles are,

many of them alive, some in jars, and some mounted.

The most interesting creatures in the collection, from a natural-history standpoint, are 40 living rhinoceros iguanas. These are the largest lizards in the world. They grow to a length of 5 feet and attain great weight, and are more like the



The Rhinoceros Lizard in Profile: This Animal Grows to a Length of Five Feet and Corresponding Weight, and Is Very Fierce and Fearless When Disturbed

great prehistoric reptiles than any known living creature. They acquire their name from three hornlike growths that project from the ridge of the nose like the horn of the rhinoceros, and are the only lizards possessing them. Their peculiar feet, resembling the talons of an eagle, are another unusual characteristic. This enormous lizard is very fierce, even in captivity, and nature has armed it with sharp teeth and a strong, swiftly



Native with Captured Giant Iguana: The Dog at the Native's Feet Is of Very Gentle Disposition, but Assists with Enthusiasm in the Hunt

striking tail. When thoroughly roused, the rhinoceros iguana presents an alarming spectacle. Opening wide its large jaws, it reveals a mouth lined with glistening black skin and rimmed with short, sharp teeth which are reinforced by two great crushers set far back in the roof, while its round, white tongue lies at the bottom like a marble. Its dull eyes flash with rage, its tail lashes rapidly, and it sometimes rises to such a pitch of fury that it leaps directly at its enemy.

This strange lizard comes from a strange place. Doctor Noble found it on an island near Santo Domingo which was situated in a salt lake 160 feet below the level of the sea. The island was uninhabited except for reptiles, and these completely overran it. Although the native dog is a frail-looking creature, it is the only one which will go near the hideous iguana. Oddly enough, however, it enters into the hunt with much zest and

shows great courage in tracking down and holding the smaller lizards until the hunter arrives. The larger lizards are "too much" for the dogs, and they are usually shot by the hunter after they have been rounded up. At times an imprudent dog will even follow an iguana into its cave, but backs out swiftly, badly scratched and bitten, and yelping its chagrin. Moreover, a dog which has once been attacked by an iguana usually loses its nerve and is of no further value in hunting.

The minute tree frog, which is so small as to be scarcely visible on the tip of a man's finger, is a neighbor of the rhinoceros iguana. The bottom of a pill box would seem like a large ballroom floor to several of these tiny frogs, seated in it. Yet, incredible as it may seem, its loud, bold note can be heard at a distance of almost half a mile.

Doctor Noble captured two other kinds of tree frogs which are the first of their species ever brought to this country. For want of better names, they have been called the "barking frog" and the "poison-gas frog." The barking frog is heard only at night, when it climbs high up in the trees and barks loudly. One frog was traced by its barking, and a photograph was taken at the instant a flashlight was turned on it. Later, when an attempt was made to seize it, it startled its captors and proved its versatility by open-

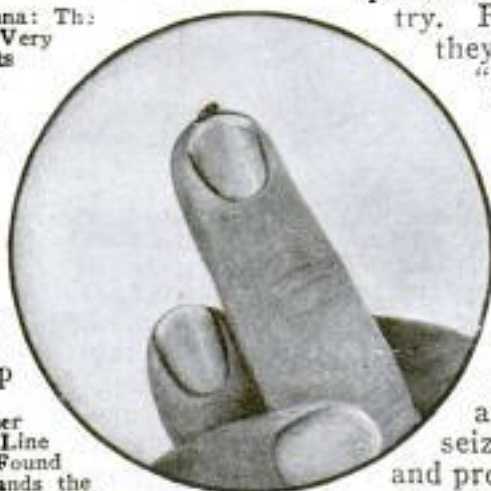

At the Other End of the Line of Reptiles Found in Haiti Stands the Minute Tree Frog, Here Shown Sitting on the Tip of a Man's Finger. Below, at the Right, Are Two Specimens of the "Poison-Gas Frog," Turned Over on the Back to Show the Sucking Disks on Their Toes, Which Enable Them to Run up a Tree as Easily as a Fly up a Wall



ing its mouth and squealing like a pig. This in itself was an unprecedented performance, as every other species of frog keeps its mouth closed in making sounds. The barking frog seems to start life with the firm intention to be original, for its first act is to emerge from its shell a fully-formed frog, evidently disdaining the tadpole stage through which other species pass.

But Doctor Noble's most spectacular capture is the poison-gas frog. This weird, nightmarish version of our modest little domestic tree toad is as much a giant among its kind as is the rhinoceros iguana, for it attains a weight of 10 pounds and is larger than any tree frog

known. Owing, possibly, to the snake-ridden character of its habitat, the poison-gas frog is supplied with protective devices unheard of among land animals. Its toes are supplied with disks, or suckers, which enable it to run up a tree as easily as a fly runs up a wall. The legs are extraordinarily long—twice the length of the body. Thus it is able to make long jumps from one branch to another, even leaping straight into the air, at times, to reach upper branches. Its most unusual means of defense, however, is the ability to eject in times of danger, a corrosive, volatile secretion which envelops it like a cloud, and at the same time chokes and burns its enemy.

1089

IMPROVED DEMOUNTABLE RIM FOR MOTOR-CAR WHEELS

An improved motor-vehicle wheel, with a demountable rim that can be installed without the use of lugs or bolts, is about to be placed on the market. Around the outer face of the felly of the wheel, just beneath the rim, there is an annular groove nearly half the thickness of the felly and about a third of its width. Around the top of the felly is an encircling metal band, flanged at one end, and stepped down at the other to fit into the bottom of the groove. On this felly band fits the rim, which may be of the straight-side or clincher type to accommodate the tire. The flange on the felly band holds the rim on one side, and it is clamped on the other side by a similar flange on a ring that tightly fits the felly groove into which it is driven. A wheel thus equipped presents a very neat appearance.

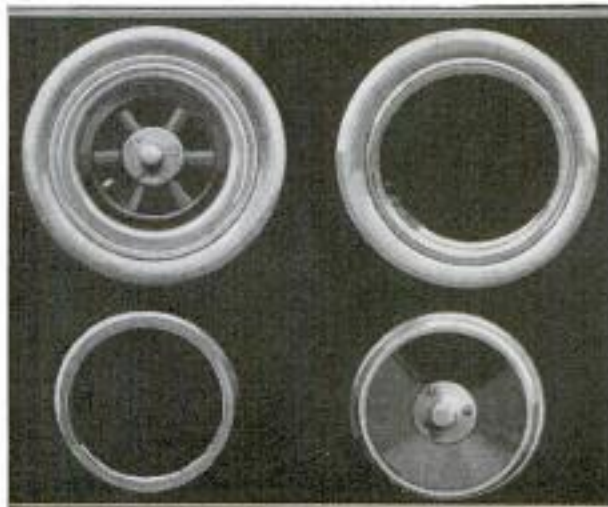

Illustrating the Assembly and Parts of a New Demountable Rim That can be Applied or Removed without Bolts or Lugs

*Wm. Thos. R. Williams,
Leadwell, Ala.*

1147

SIX-FOOT-LONG TURNBUCKLE MADE WITHOUT A WELD

Turnbuckles of great length, such as are used for tightening the guy ropes on



Weldless Turnbuckle, Over 6 Feet Long, Made as a Solid Forging of Uniform Strength, and without the Element of Unreliability Resulting from Welds

derricks, are now being made weldless. Hitherto, the presence of welds in each head has been the cause of an element of unreliability, and possibility of failure, which in the case of a derrick in operation has often had disastrous results. The weldless turnbuckle, in lengths of 6 feet and over, is a solid forging without welds, and, therefore, exceptionally strong.

*Marine Hardware Equipment Co.
South Portland, Maine*

Electrico Limited,
105 Old Church Road,

1362

1163 380

POPULAR MECHANICS

Bournemouth, England.
ELECTRICAL SHAVING OUTFIT
HEATS WATER IN CASE

FRENCH TRY NEW MACHINE
FOR PRINTING STAMPS

~~1188~~
An electrical shaving outfit which heats water in the same small case that holds

A machine that prints, perforates, numbers, cuts, counts, and makes up into bundles 3,000 sheets of 100 stamps, each hour, has recently been installed by French postal authorities. In the Bureau of Printing and Engraving similar work is done with several machines, one printing and gumming the stamps while others are engaged in perforating and cutting them into sheets. With the exception of the gumming, which is done beforehand, the French machine combines all these steps and, as may be expected, turns out the finished product at less cost. Only two operators are required, while as many as 12 were needed previously.



Above: Shaving Outfit, the Case of Which Is an Electric Water Heater. Right: Appliances Neatly Packed in Case

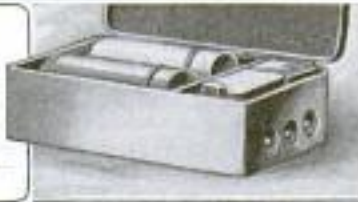

the brush and soap in nickelplated tubes, a beveled mirror, safety razor, and extra set of blades, is now available. When these accessories have been lifted from the case and water placed within it, an extension cord carrying either 110, 150, or 220 volts, is attached to the proper combination of contacts of the heating element in the lower half of the case, and the water is raised to the desired temperature in one minute.

Manchester Guardian 1/4/23

CITY SNOW-REMOVING CRANE
HAS SPECIAL BUCKET

~~1188~~
A crane and bucket, mounted on a motor truck, is used to load piles of snow onto trucks in New York and Detroit. Besides lessening the number of men needed for this work, the crane permits the sides of the trucks to be built higher, thereby increasing their carrying capacity. The bucket itself is made with extra-wide jaws

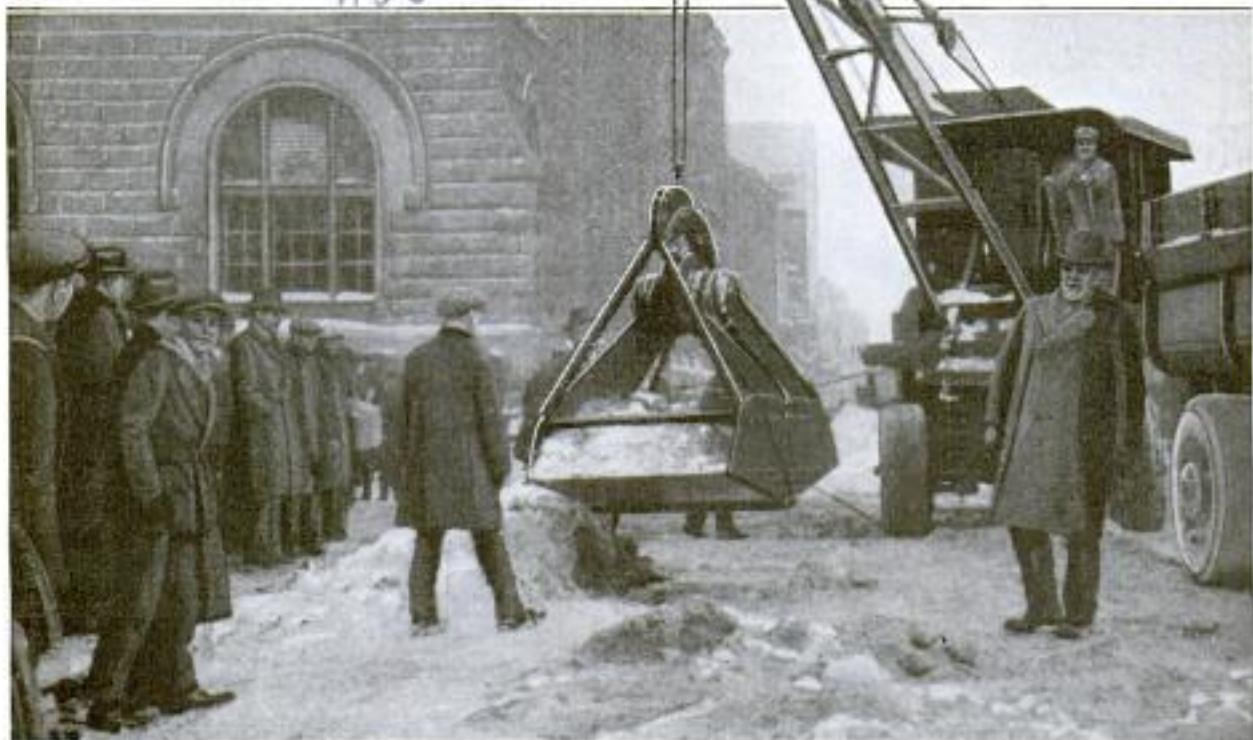

Cranes of This Kind with Extra-Wide Buckets have been Found Useful in Loading Street Piles of Snow onto Trucks in New York and Detroit. It is Estimated That Three of the Regular Five-Ton Trucks can be Loaded by This Method in 10 Minutes

*Coffman Crane Service
Detroit, Mich.*

Dr. J. F. Carter
Elizabeth, La.

The Otto Mich Co
159 E. Columbia St
Detroit Mich 381

POPULAR MECHANICS

and holds a cubic yard of snow. It is stated that the crane has loaded three 5-ton trucks in 10 minutes.

1031 STUMPS MADE INTO PAPER BY NEW PROCESS

In order to utilize pine stumps on cut-over and burned-over timber lands in the South, a process has been devised that converts this material into acceptable grades of paper. The stumps are first put through a machine that removes any charcoal that may be on them, and then go to machines that cut them into small chips. The tar, turpentine, and resin are next extracted, and the residue converted into a pulp from which the paper is made.

1178 SPIRAL GRINDING MACHINE FOR MOWER BLADES

For sharpening any size of lawn-mower blade, a recently patented spiral grinder is composed of a motor-driven emery wheel mounted on a table that moves along guides on top of the supporting base of the machine. Brackets connected to this base have means for holding the lawn-mower cutters without removing the reel, so that the emery wheel of the grinder lines up with the cutter blade of the mower. Between the emery wheel and the mower blade, there is an engagement which, as the grinder moves along on its guides, causes the blade to revolve, and thus the grinding wheel traverses the entire length of the blade.

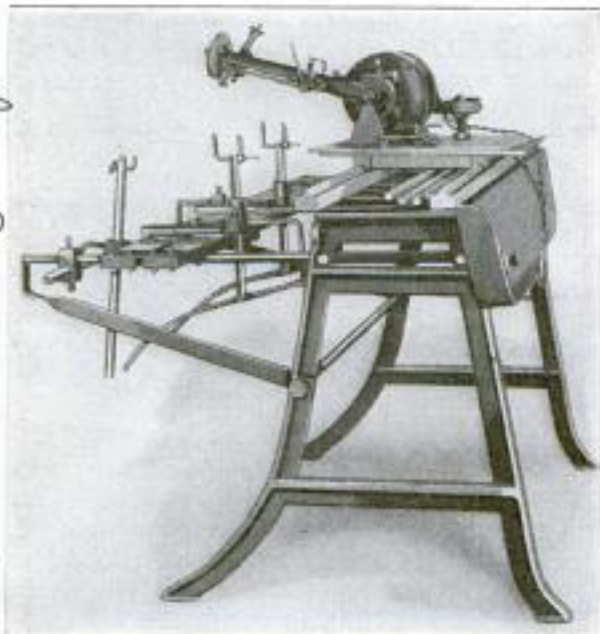

Machine for Grinding Any Size of Lawn-Mower Blade, Large Units of Which can be Set in the Machine and Ground without Removing the Reel

Brown Mfg. Co.
Greenville, Tenn.

1202 EIGHT-STORY OFFICE BUILDING BUILT HALF AT A TIME

A new office building being erected in Detroit has one half already occupied while the other half is still under construction.



The Left Half of This Building is Completely Finished and Occupied by Tenants, While the Second Half is Still under Construction

struction. For various reasons, it was decided that completing and fully equipping the corner half would be a better plan than to wait until the whole building was ready for interior finishing. This unusual arrangement enables the owners to realize an immediate return on the offices of the completed section.

1337 BUFFALO HERD IN CANADA "GROWING TOO LARGE"

Because the buffalo herd in the National Park at Wainwright, Alta., is "growing too large," sportsmen in the vicinity are anxious that an open season on buffalo be declared next year. It is said that the plan has been suggested to the National Parks Board, and that favorable action is expected. A somewhat similar arrangement proposed for this year fell through, when it was found that the animals were suffering and losing weight from the unusually cold weather. The herd, reputed to be one of the largest in existence, numbers more than 8,000 and is increasing rapidly.

National Park
Wainwright, Alta., Canada.

Complaints about this firm to Advertising Dept.

**PORTABLE RIVETER WORKS
THROUGH MANHOLE**

1228

A portable riveting machine, designed for driving up the last heads in boilers

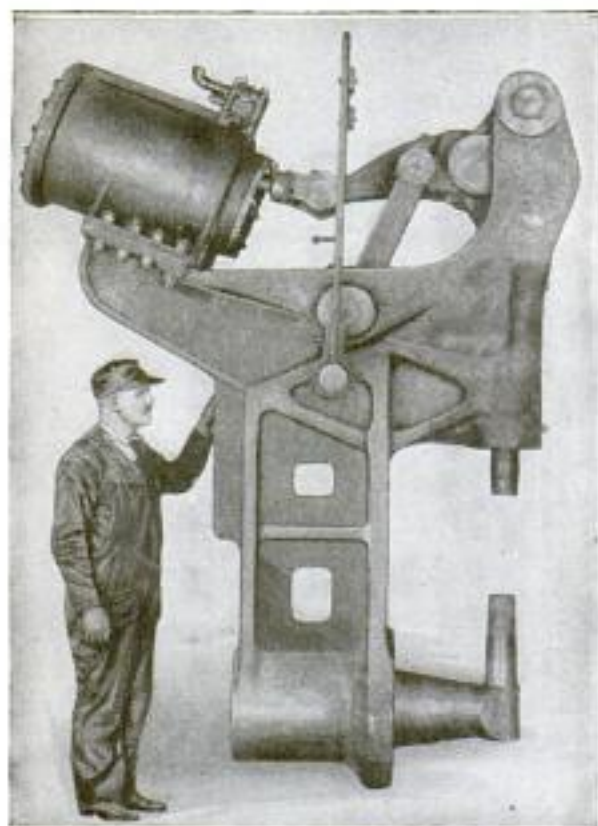

Portable Riveter, with a Capacity of 100 Tons, Designed for Driving Up the Last Heads in Boilers through the Manhole

through the manhole, has recently been put on the market. The machine has the form of a large "Y," with the pneumatic actuating mechanism extending from the left to the right arm, and the stake running parallel to the leg. The dies are vertically arranged, and the machine rocks about a point near the center of gravity. The reach of the unit is from 14 to 18 inches; the gap 35 inches; cylinder diameter 18 inches, and the die stroke 5 3/4 inches. The capacity is 100 tons, and the weight about 9,000 pounds.

946

**RUBBER "GLASS" ONE OF NEW
LINE OF PRODUCTS**

Rubber "glass," or transparent rubber, is one of an interesting number of new products that have recently been developed as the result of a discovery of a compound which permits ordinary commercial solutions of rubber and celluloid to form a permanent mixture. About 10 per cent of rubber in celluloid results in a very resilient product, and about 10 per cent of celluloid in rubber produces a

substance having relatively high tensile strength and waterproof qualities. The rubber in the mixture can be treated, by a special process, to any degree of vulcanization without impairing the transparency of the product. Any desired color can be had by the aid of coal-tar dyes. Great possibilities are suggested in the way of surgical rubber goods, hot-water bottles, bathing caps, windows for motor vehicles, and the like.

**FEDERAL-AID ROAD SYSTEM
NEARLY OUTLINED**

1363

In outlining the 187,000 miles of road comprising the Federal-aid system of highways, it has been arranged that not more than seven per cent of the total road mileage of any one state be included. Not to exceed three-sevenths of this will be designated as primary or interstate highways, and the remainder secondary or intercounty highways. The plans cover a 15 to 20-year construction program, with provision for enlargement at the end of that time.

**PISTON-CENTERING MACHINE
IS RAPID AND ACCURATE**

A machine in the form of a compact drill press specially designed for centering engine pistons, and adjustable to any size of casting up to 6 inches, is now on the market. On the horizontal circular table of the machine are four vertical, adjustable fingers. Over these the casting is slipped with a loose fit, and then, by turning a disk gently to the left, all four fingers expand till they bear lightly on the casting walls. On an arm above the piston is the drill spindle, which is pulled down by a lever, and the piston is accurately centered by the drill. The machine is then in condition for centering any number of similar castings, without further adjustment. The machine can also be used as a speed drill.



Engineering News Record
London Incorporated, 107 Western Ave., Minneapolis, Minn.

The Reliance Rubber Co. Ltd., 212 Upper Thames St., London E.C.4, England

NY

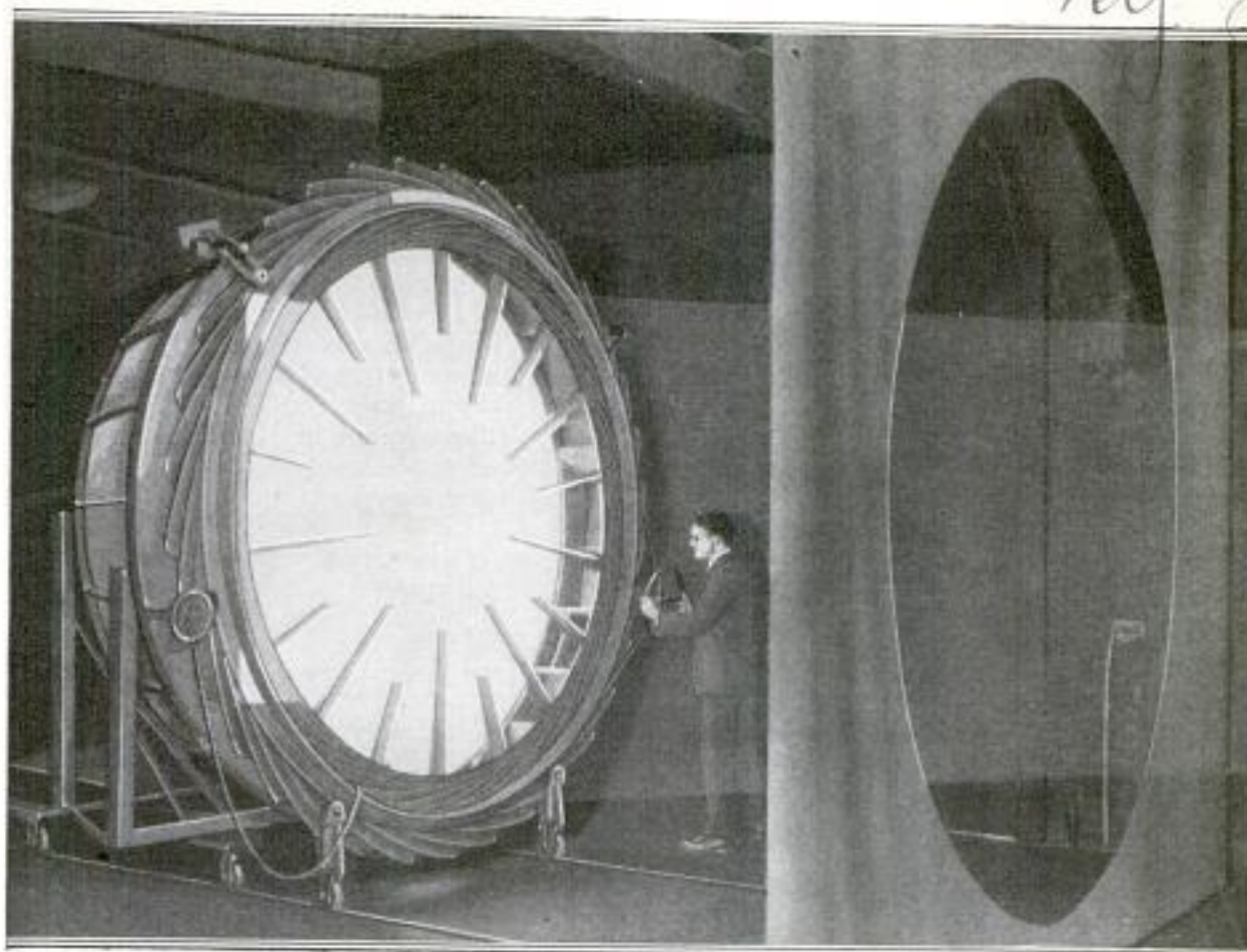

Close-Up of the Photometer, Which is Mounted at the End of the Tunnel to Measure the Light Received from a Motion-Picture Projector: The Radial Prongs, Extending Inward from the Shutter Ring, Are Black, and Serve to Correct Certain Optical Effects

MOTION-PICTURE PROJECTORS TESTED IN TUNNEL

Projecting the light through a long tunnel, formed by a series of circular curtains mounted on rollers, onto a photometer, or illumination measurer, placed at the end, was the method recently employed in testing the light output of a motion-picture lamp. Formerly the intensities of illumination were measured in various parts of the beam, a process requiring frequent re-

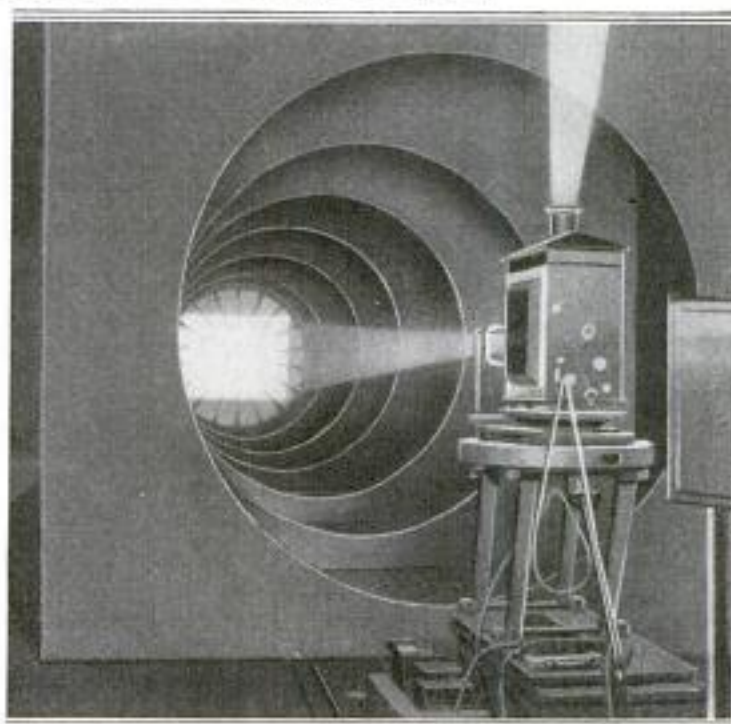

How the Projector is Set Facing the Tunnel: The Photometer and Curtains are Mounted on Rollers So That the Tunnel may be Adjusted to Various Lengths

trials before accurate data can be obtained. With this new arrangement, it is said to be possible to determine, at one time, the entire effective output of a motion-picture lamp under conditions similar to those found in theaters. The photometer, as well as the curtains, is mounted on rollers, and can be moved 150 feet from the lamp. In the test, it was placed 65 feet away.

1250



Greek Women Doing the Family Washing in Stone Sarcophagi Over 2,000 Years Old, near Khasia

GREEKS USE ANCESTRAL TOMBS AS WASHTUBS

Near Khasia, a little village 10 miles northwest of Athens, Greek peasant women do their washing in stone sarcophagi that are at least 2,200 years old. Washtubs of any kind, owing to the scarcity of wood and metals in Greece and the poverty of the peasants, are rarely to be seen in the country villages, and, for this reason, the women of Khasia, possessors of these ready-to-hand washtubs, are doubtless greatly envied by their less fortunate sisters in the neighboring villages who wash their clothes in the stream.

CONCRETE MIXER HAS RUBBER-TIRED WHEELS

A new concrete mixer, now being offered for contractors' use, is mounted on a rubber-tired two-wheel truck so that it can be easily and quickly moved from one job to another. Whereas the usual portable type of mixer cannot be hauled faster than about 10 miles an hour, this one will trail behind a light auto truck at a speed of 30 miles an hour. A leg, set on the ground when the mixer is in use, supports it in a level position. It travels noiselessly and without jarring, and is no hindrance to traffic.



Concrete Mixer Mounted on a Rubber-Tired Two-Wheeled Truck, Which can be Hauled behind an Auto Truck at a 30-Mile Pace Instead of the Usual 10 Miles an Hour

The Jaeger Machine Co. Columbus, Ohio.

969

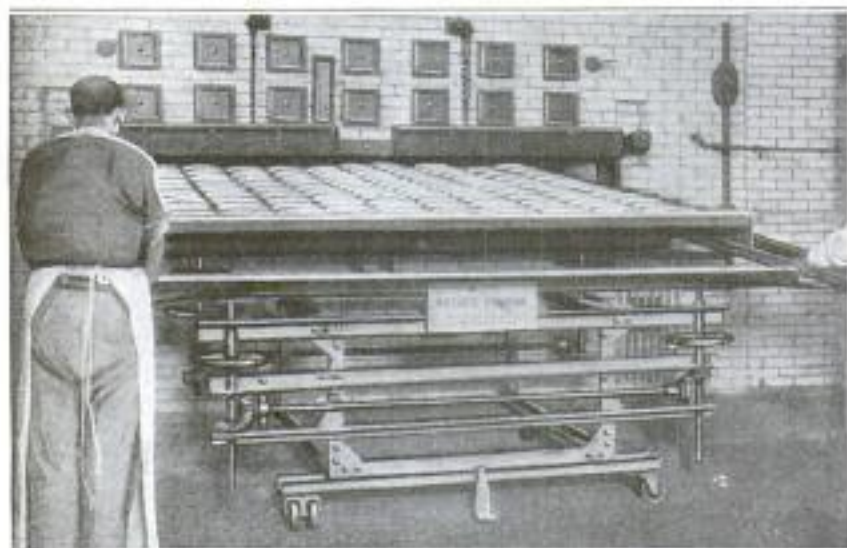

Showing How the Removable Tray, Accommodating 200 Loaves of Bread, is Rolled into the Oven from the Truck on Which It is Wheeled about the Shop Interior

898

WHEELED TRAY AND TRUCK FOR BAKERIES

A special removable tray, accommodating 200 ordinary-sized loaves of bread, has been designed for use in bakeries. The tray may be readily rolled into or out of the oven on angle-iron "tracks" installed at each side of the baking compartment, while a truck having an attachment for adjusting the tray to the level of the oven opening, carries the heavily loaded container about the shop interior.

d.w. George Mueller, Pres. Royal Baking Co. 1232 S Main, Salt Lake City, Utah

1233 Mack International Motor

Truck Corporation,
POPULAR MECHANICS

385

Los Angeles, Calif.
TRUCK RIDES RAILROAD TRACKS OR HIGHWAYS

A big auto truck has been recently developed which runs with equal ease on railroad tracks or smooth highways, and turns from one to the other without difficulty. For rail travel, its wheels are equipped with flanges inside of

track, the pilot is raised, automatically disengaging the steering apparatus, so that the driver can turn the front wheels and run onto the highway, without stopping or otherwise interfering with the travel.

The pilot wheels are carried in

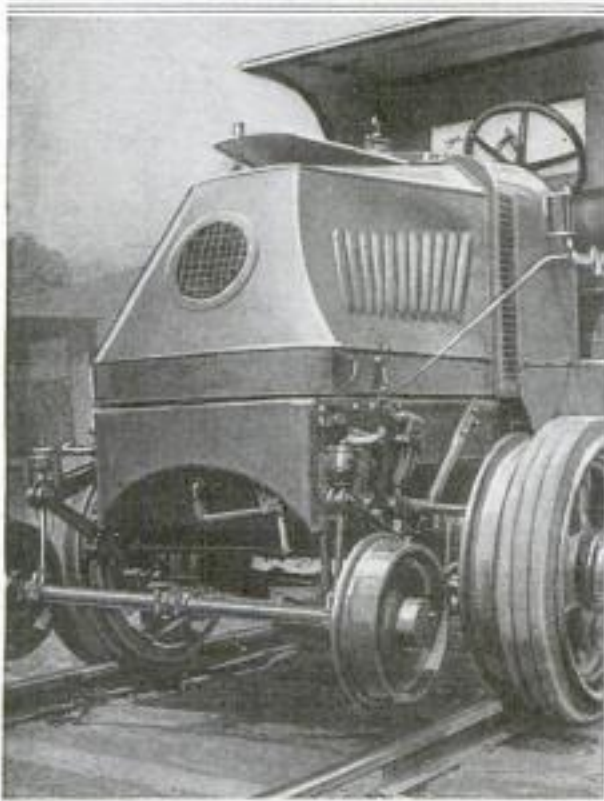
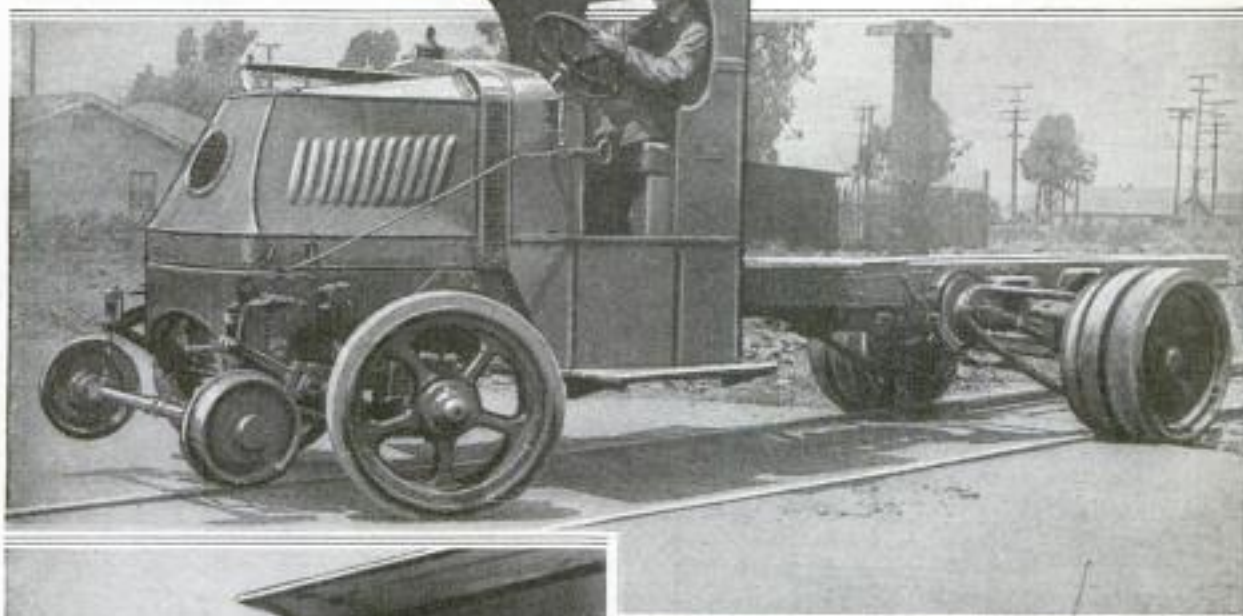

Front End of Motor Truck with Pilot About to be Lowered for Rail Travel: Four Coil Springs Hold the Pilot Wheels in Engagement with the Rails, After They have been Lowered

the rubber tires, and a special pilot truck is arranged in front, which, when let down to the rails, locks the steering mechanism. When about to leave the

The New Double-Duty Motor Truck Running off the Track and onto a Smooth Road: The Lifting of the Pilot Wheels Unlocks the Steering Mechanism of the Motor Truck

front of the front axle and attached to it by a ball and socket joint. When these wheels are lowered onto the rails, the lifting device automatically applies tension through four coil springs, making it impossible for the wheels to bounce off or leave the rails while in motion. When the pilot wheels are engaged with the rails, an automatic device locks the standard steering gear in such a way that the pilot entirely controls the truck front wheels. By using this method of control, it is possible to pass frogs, switches, and highway crossings without any danger of the truck getting out of alignment with the rails while riding on the rubber tires.

In the attachment of the pilot, the possibility of its breaking and dropping down on the highway while the truck is traveling has been carefully considered, and provision made for the truck to be steered in the ordinary manner.

▶ A motion picture showing the advantages of Philadelphia as a seaport has been prepared by that city and will be distributed throughout the country.

1124

PORTABLE ASPHALT PLANT BUILT IN THREE UNITS

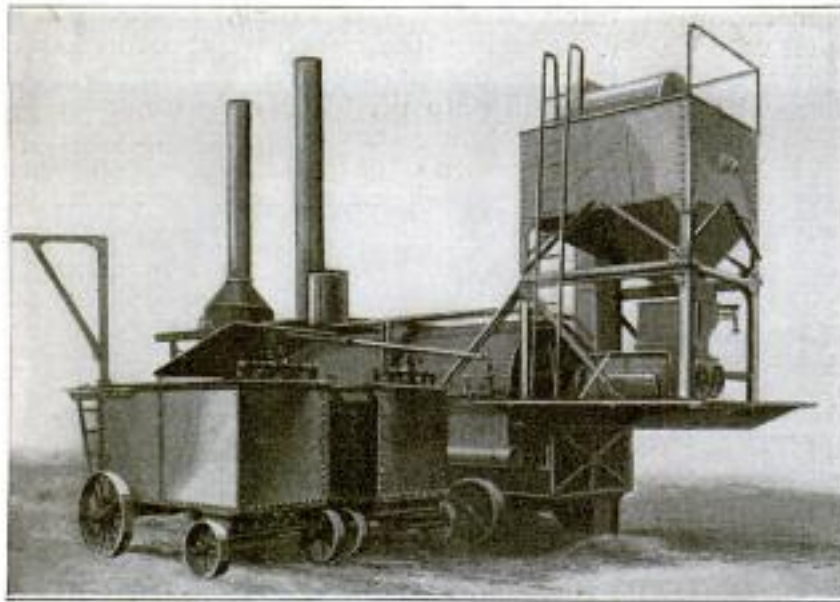

bin holds 10 tons. Sand containing not more than two per cent of moisture will be heated to 350° F. at the rate of 120 tons a day by the drier, which has three drums, giving the effect of one continuous drum. The plant, which also includes a chain-driven pug mill of 1,000 pounds' capacity, will prepare the asphalt for over 1,000 square yards of 2-inch top in an eight-hour day.

A New Portable Asphalt Plant in Which the Power Plant and Drier Form One Unit, and Two Kettles Are Separate: The Kettles are Heated by Means of Jointless Steam Coils

A portable asphalt plant recently announced is designed so that the drier and power plant, and the two asphalt kettles are built as separate units. The kettles have a capacity of 2,500 gallons and are heated by jointless steam coils, which prevent damage to the asphalt likely to occur with open fire. The three-compartment sand

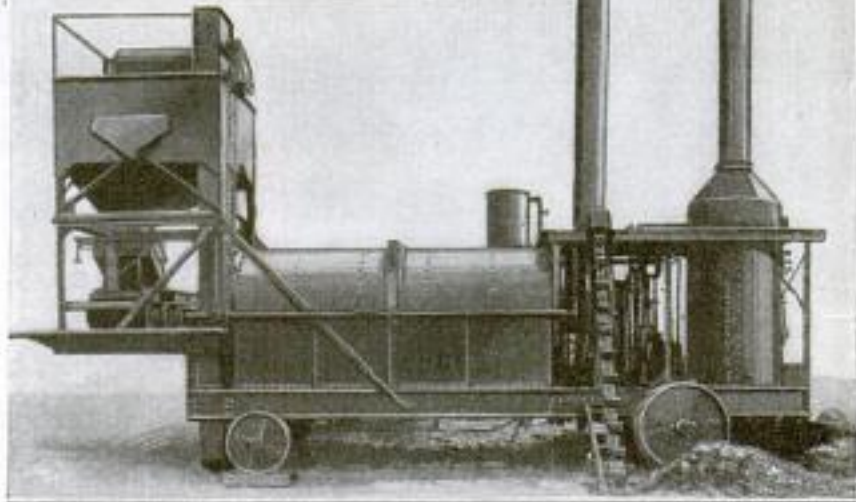

View of the Power Plant and Sand-Drier Unit: The Three-Compartment Bin Holds 10 Tons of Sand, and the Three-Drum Drier will Handle 120 Tons of Sand a Day

EFFICIENT DOCK EQUIPMENT AT MANCHESTER

368

By MAJOR JOHNSTONE TAYLOR

c/o The Bunglads, Shrewsbury, England

THE inland city of Manchester, Eng., has dockage for the largest ocean-going vessels afloat. This, as is well known, is made possible by the \$60,000,000 ship canal, opened in 1894, that connects the city with the sea, 35 miles away. During the last 28 years Manchester has gradually developed from an inland city to the third largest seaport of the United Kingdom in point of tonnage. This has resulted, as much as from any one thing, from the unwavering policy of dispensing with any manual handling of goods. The 44 warehouses of the port can accommodate 500,000 tons of perishable goods, be-

sides 500,000 bales of wool, 100,000 bales of cotton, 40,000 barrels of liquor, and 4,000 tons of tobacco, and they have 1,000,000 cubic feet of cold-storage capacity. All antiquated methods of handling this vast quantity and variety of goods have been from the first avoided, and in their place have been adopted the most modern mechanical means, such as electric cranes, belt conveyors, gravity runways, overhead cranes, and electric and pneumatic hoists. In unloading a shipment of American cotton, for instance, a series of overhead electric traveling cranes, each with an operator in its



The Docks at Manchester are Fully Equipped with Modern Labor-Saving Devices, Many of Them Ingenious and Unfamiliar to the General Public. Above, to the Left, is Shown a Gravity Runway with Which Cases are Lowered from the Piles to Railroad Cars or Trucks, While on the Right is an Endless-Chain Arrangement Used in Stacking. Below are Shown Some of the Cranes Used in Transporting Bulky Loads

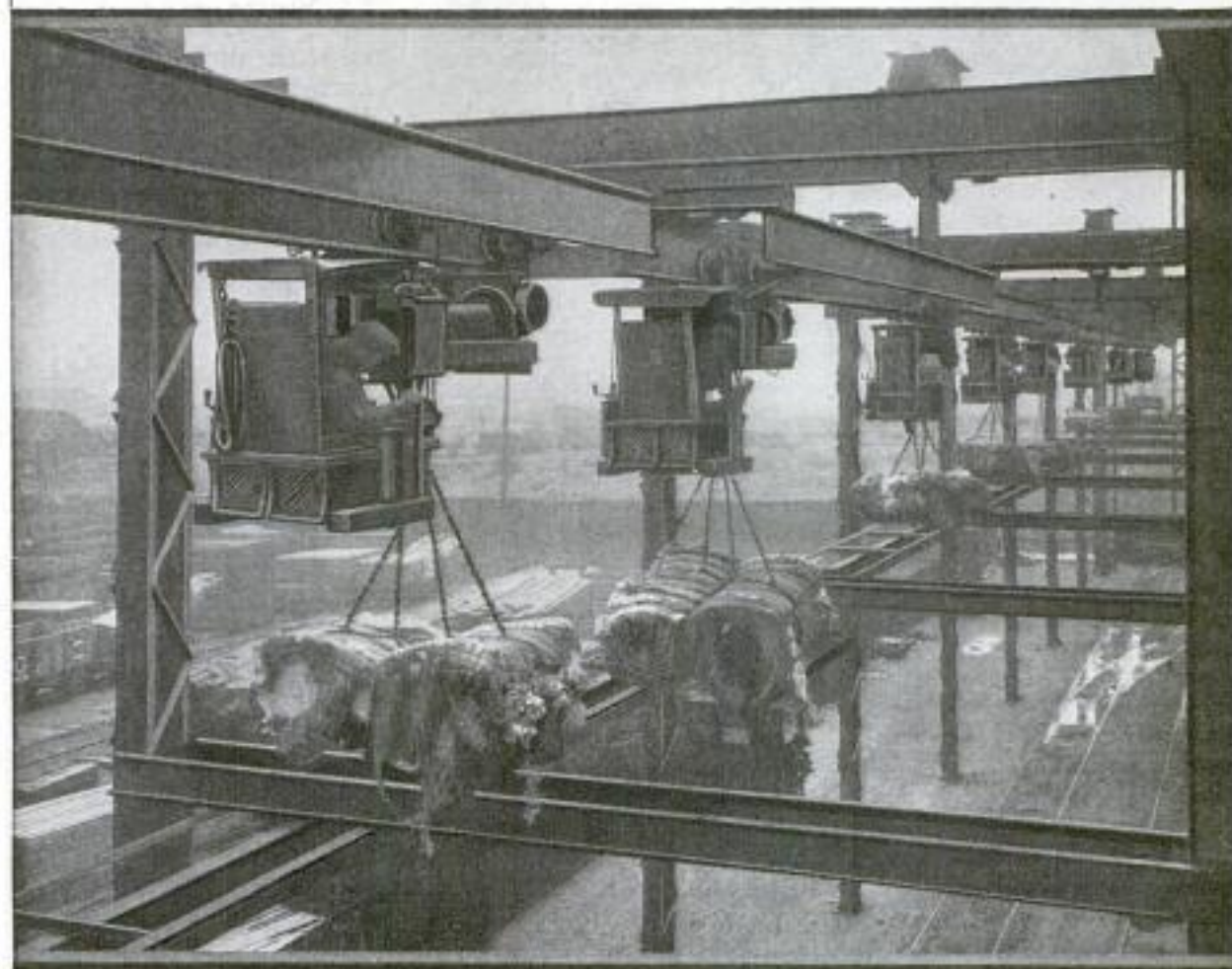

cab, hoist the bales from the cars, and travel rapidly to the storage warehouse, where the bales are dumped conveniently for arrangement by hand. Meat going into cold storage is handled similarly. Sacks of all kinds of goods are unloaded from the railroad cars onto a conveying belt, which carries them rapidly to the interior of the warehouse, and then, with an adjustable hoisting extension, deposits them in piles of any required shape or height. Wooden boxes or cases are conveyed on roller runways by gravity, and are then transferred to belt conveyors

that deliver them for loading onto railroad cars.

There are many other ingenious and efficient means of handling freight with the greatest facility and dispatch, all of which have made it possible for a new inland port to surpass all but two of the largest and oldest seaports of the United Kingdom, and to place it in the ranks of the largest.

☐ Total savings deposits in the United States at the end of 1922, were \$1,500,000,000 greater than on Dec. 31, 1921.

STEEL MATTRESSES REINFORCE CONCRETE ROADS

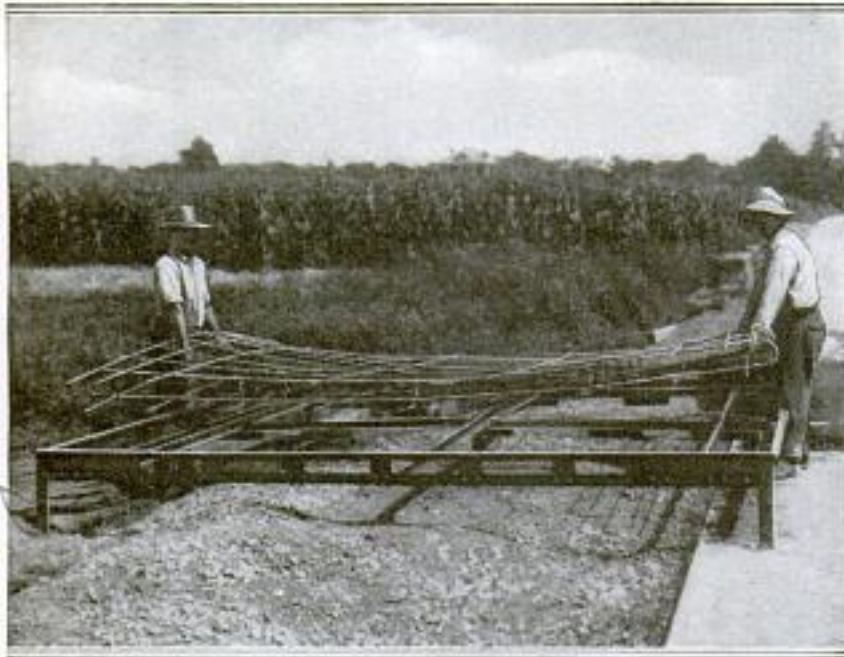

series of looped steel bars, all parallel and equally spaced. Other steel bars are laid across the upper and lower sides of these looped bars, and are wired to them, thus forming a rigid mattress of reinforcing bars. This is placed on the dug surface of the road, followed by others made in the same way. The concrete is then poured and the surface leveled off with boards in the usual way. It is said that the mattresses are not expensive and that little time is sacrificed, in view of the improvements gained by their use.

The Illustration Above Shows One of the Mattresses About to be Laid on the Roadbed. At the Right Is a View of Another Section of the Road After the Frames have been Filled with Concrete. The Workmen in the Foreground are Leveling the Surface with Boards in the Usual Way

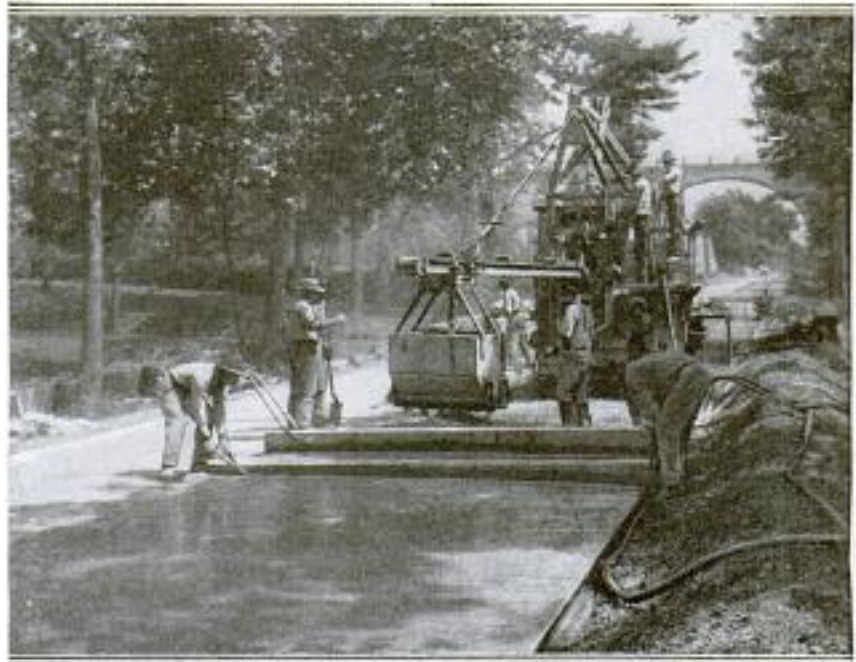

In concrete-road building a new method of making the reinforcement is said to have been found to be economical, and effective in preventing damage by frost. After the road has been dug up for a depth of about 10 inches, and its surface rolled smooth, a large rectangular steel frame is placed above it. Upon this are laid a

Emb. Fred Mergin
Box 157, Trenton, N.J.

Wm. C. B. Klingman
c/o Anderson Engine Co.

POPULAR MECHANICS

389

4036 N. Rockwell, Chicago

LONG-STROKE AUTO ENGINE

WARNING SIGNS MADE PART

1133 OF EASY ACCESSIBILITY

OF BRIDGE STRUCTURE

A new automobile engine has several novel features of design, one of which is its unusually long stroke in pro-

1055 Signs warning of the proximity of live wires or other dangers are so neatly developed as a part of new concrete bridges

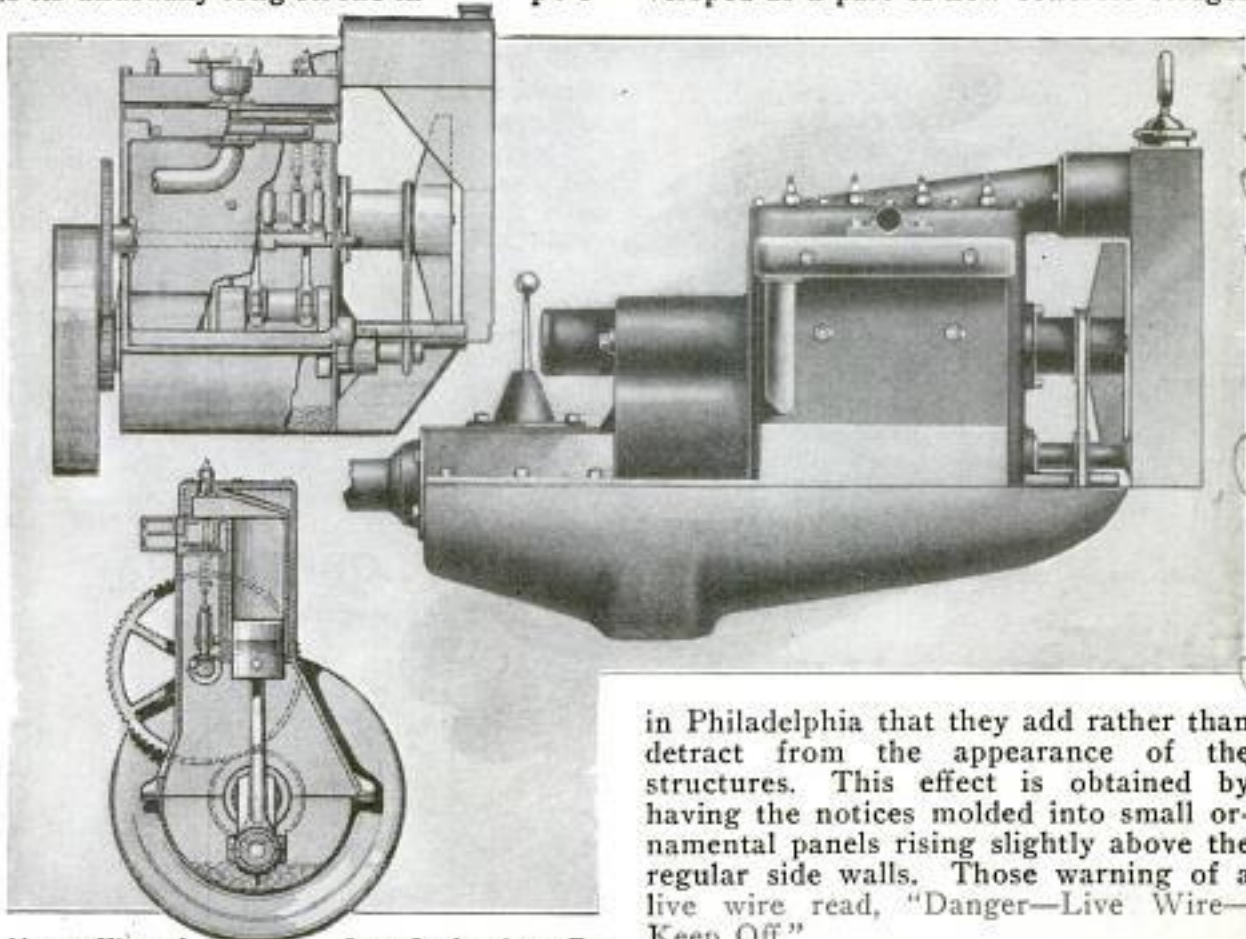

Above: View of Long-Stroke Auto Engine with Side Walls Partly Cut Away. Below: Cross-Sectional View. Right: Engine Fully Inclosed

portion to the bore, accompanied by means of restricting the inlet valve so that the charge fills the cylinder at less than atmospheric pressure. This results in more complete expansion, with lower temperatures and greater facility for cooling. One of these new engines, that has been demonstrated in an automobile over several thousand miles of travel, has four cylinders with a 3½-inch bore and 7-inch stroke, which develops 25 brake horsepower at 1,500 revolutions per minute. It is said to have proved to be economical in fuel consumption, and to have been always very easily cooled. An outstanding feature of the design is the means of accessibility. It is of the L-head type, entirely inclosed in a rectangular case, the whole of which on the valve side is easily removable. All the valve tappets and guides can then be taken out at one time, making it exceptionally easy to attend to the operating parts of the engine.

in Philadelphia that they add rather than detract from the appearance of the structures. This effect is obtained by having the notices molded into small ornamental panels rising slightly above the regular side walls. Those warning of a live wire read, "Danger—Live Wire—Keep Off."

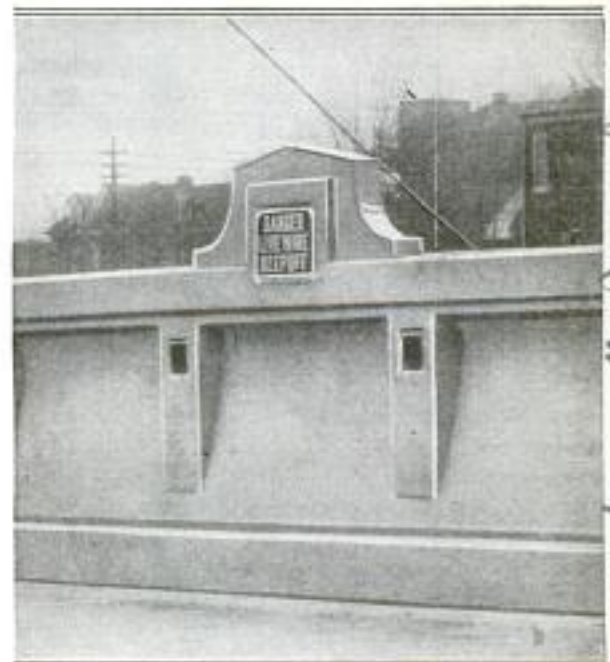

Attractive Warning Signs of This Kind are Made a Part of New Reinforced-Concrete Bridges being Built in Philadelphia

Peru Pennil Club,
Walnut St., Philadelphia, Pa
1026
Comd. John F. Mc Clarren,

NEW SUBSOIL PLOW OPERATED BY SMALL TRACTOR



A new subsoil plow for use in breaking up the hardpan that forms where there is continuous irrigation, and adaptable to small tractor operation is now being manufactured. It has the advantage that it can be easily raised and lowered by the tractor driver by means of an oscillating standard to which it is attached. The depth adjustment can be made without taking the point from the soil, and the point and standard can be raised to clear obstacles.

Subsoil-Plow Attachment Adapted for Use in Connection with Small Tractors, Which can be Adjusted to Pass over Obstructions and for Depth

GIANT PEACOCK WINS PRIZE IN FLORAL PARADE

A gorgeous peacock made entirely from flowers, and so large that it had to be carried on two floats, won first prize in the annual Tournament of Roses held at Pasadena, Calif. In its plumage were represented nearly a score of different colors, while the body itself was so big that the long tail had to be carried on a second float, following quite a distance behind the first. The neck of the "bird" extended as high as the telegraph poles bordering the line of march.

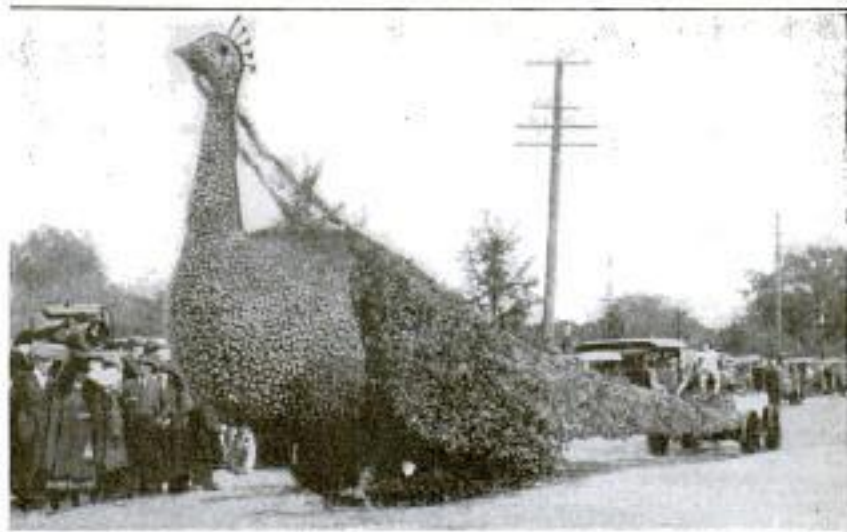

This Giant Peacock Won First Prize in a Recent Floral Parade Held at Pasadena. It was Made Entirely from Flowers

FLORIDA PARK COMMEMORATES INDIAN MASSACRE

Marking the battleground where in 1835 Maj. Francis L. Dade and all but one of his entire command of more than 100 men were massacred in a one-sided fight with the Seminole Indians, there has been recently dedicated near Bushnell, Fla., a memorial park named in honor of this commander and his troops. An attractive arch, built by the people of Sumter County with stones from the surrounding country, forms an entrance to the grounds, while inside is a monument topped by a bronze figure of an infantryman of the

time, and a three-sided breastwork of logs, arranged on the exact spot where the last stand was made. The troops were en route from Fort Brooke, Tampa Bay, to Fort King, when, almost without warning, the Indians, 1,400 strong, swooped down upon them. Warlike, well-armed, and finding ample protection in the hummocks and palmetto thickets of the country, they had little trouble in overcoming the small band of soldiers, of whom only one man escaped to tell the story.

*Emb. Roy Alden
1041 W. Estabro
Los Angeles Calif*

1200

12 00 Fred Cubberley, Chairman,
Dade Memorial Commission
Leavesville, Florida



The Arch Which is Shown Above was Built by the People of Sumter County, Florida. It is at the Entrance to a Park Recently Dedicated as a Memorial to Major Dade and His Command, All Except One of Whom were Massacred Close By in a Battle with the Seminole Indians, in 1835. The Stones Used were Collected from the Surrounding Country. To the Right is Shown the Monument Erected within the Park in 1922. The Figure is That of a Soldier of the Time, and is Done in Bronze. Below is Given a View of the Breastworks Marking the Exact Spot Where the Last Stand was Made. The Logs Are of Concrete, Colored to Resemble Wood

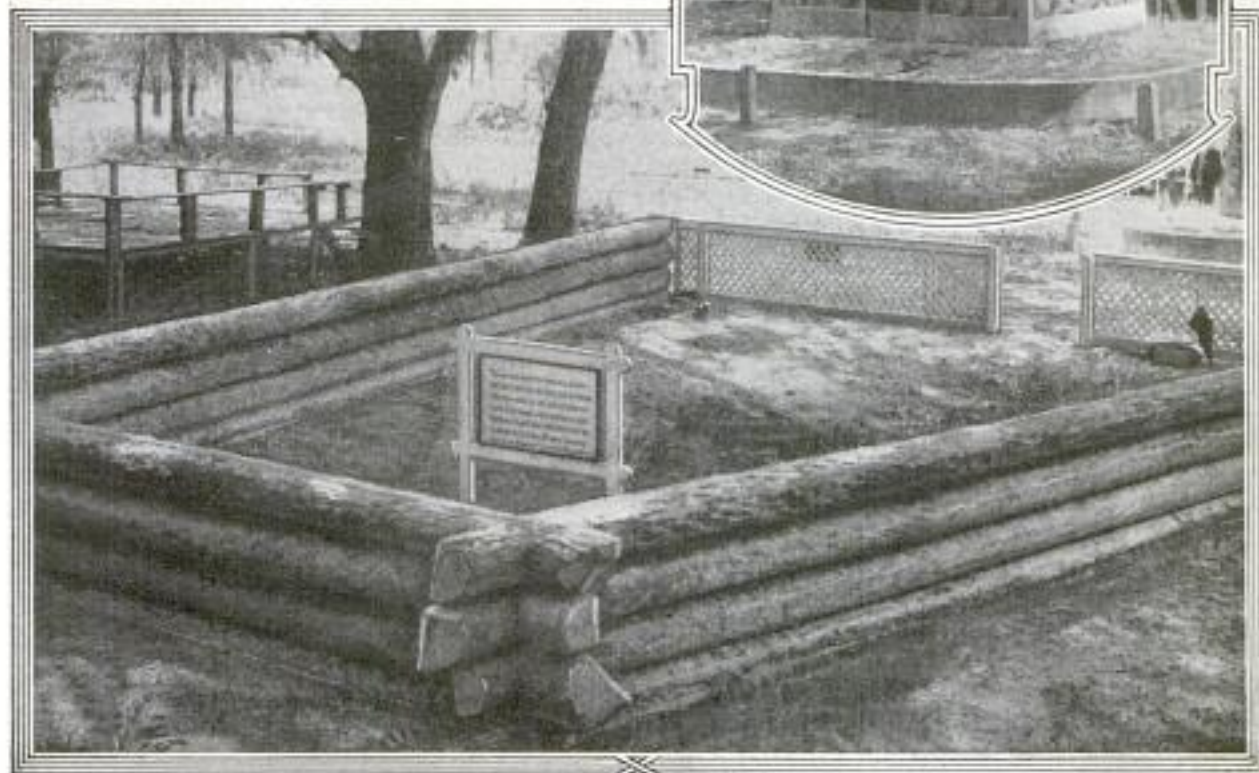

Science
Jan. 12, 1923

MONSTER SMOKESTACK STANDS 257 FEET IN HEIGHT

A monster smokestack which stands 257 feet in height, thus taking rank among the tallest in the country, has recently been completed for the University

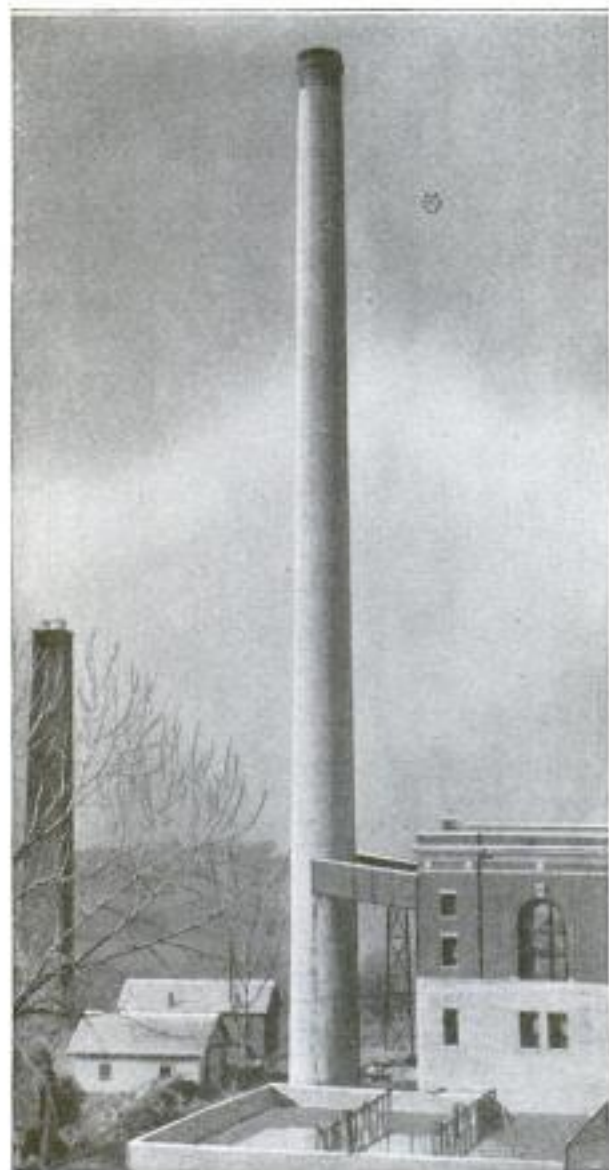

Reinforced-Concrete Stack, 257 Feet High, Recently Completed for the Power Plant of the University of Kansas

of Kansas, at Lawrence. The reinforced-concrete stack was erected to serve the new heating and power plant recently completed at a cost of \$300,000. On a clear day it is said that Topeka, some 40 miles west, and Kansas City, about 46 miles east, can be plainly seen from the top. The square brick stack of the old power plant, built in 1908 to a height of 127 feet, then considered great, is entirely overshadowed by the new chimney. It will furnish draft for eight boilers having a combined rating of 2,100 horsepower.

LAWS ASKED FOR PROTECTION OF FLOWERS AND PLANTS

The success of Vermont in preserving wild flowers and plants, as game is protected, and preventing their extinction, has aroused an interest among botanists and lovers of wild flowers which may result in more legislation for their protection. Commercial collectors were found to be responsible for the extermination of wild flowers and rare plants. A law passed by the Vermont legislature prohibits commercial collecting and restricts botanists to two specimens of each plant in a year. The very existence of orchids, arbutus, and rare alpine plants was threatened. Other states are suffering from the same abuse. Such ferns as the climbing fern in Connecticut and the hart's tongue in New York, are endangered by the draining of swamps and the opening of quarries.

ADJUSTABLE AUTO HEADLIGHT ELIMINATES THE GLARE

A new automobile headlight that eliminates the glare, and throws the light always in one and the same place, has been thoroughly tested with, it is said, very satisfactory results. The lights are automatically adjustable, being fastened to a rod that swings in bearings at each end of the machine. They are counterbalanced by weights that may be slid along an arm to change the center of gravity of the mounting to suit the motorist. When once set, the lights automatically adjust themselves so that in going up or down grade, they throw light directly onto the road, instead of into the air in the former case, or into the eyes of an approaching driver in the latter.

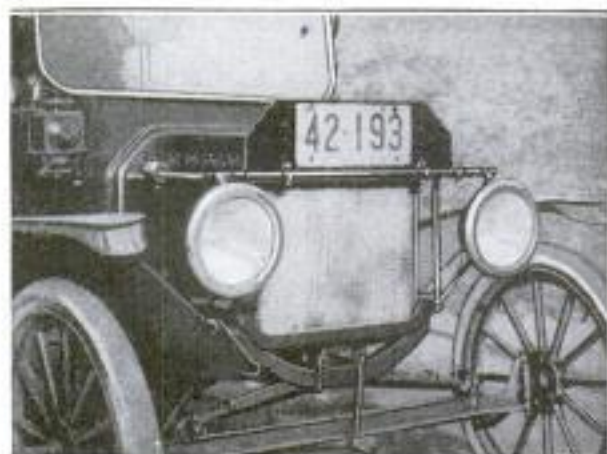

Automobile Headlights Which Automatically Adjust Themselves So That in Going up or down Hill, the Light is Directly on the Road

Law. U. M. C. Matthias
Bureau of Electricity, Dept.
& Public Safety, Reading, Pa.

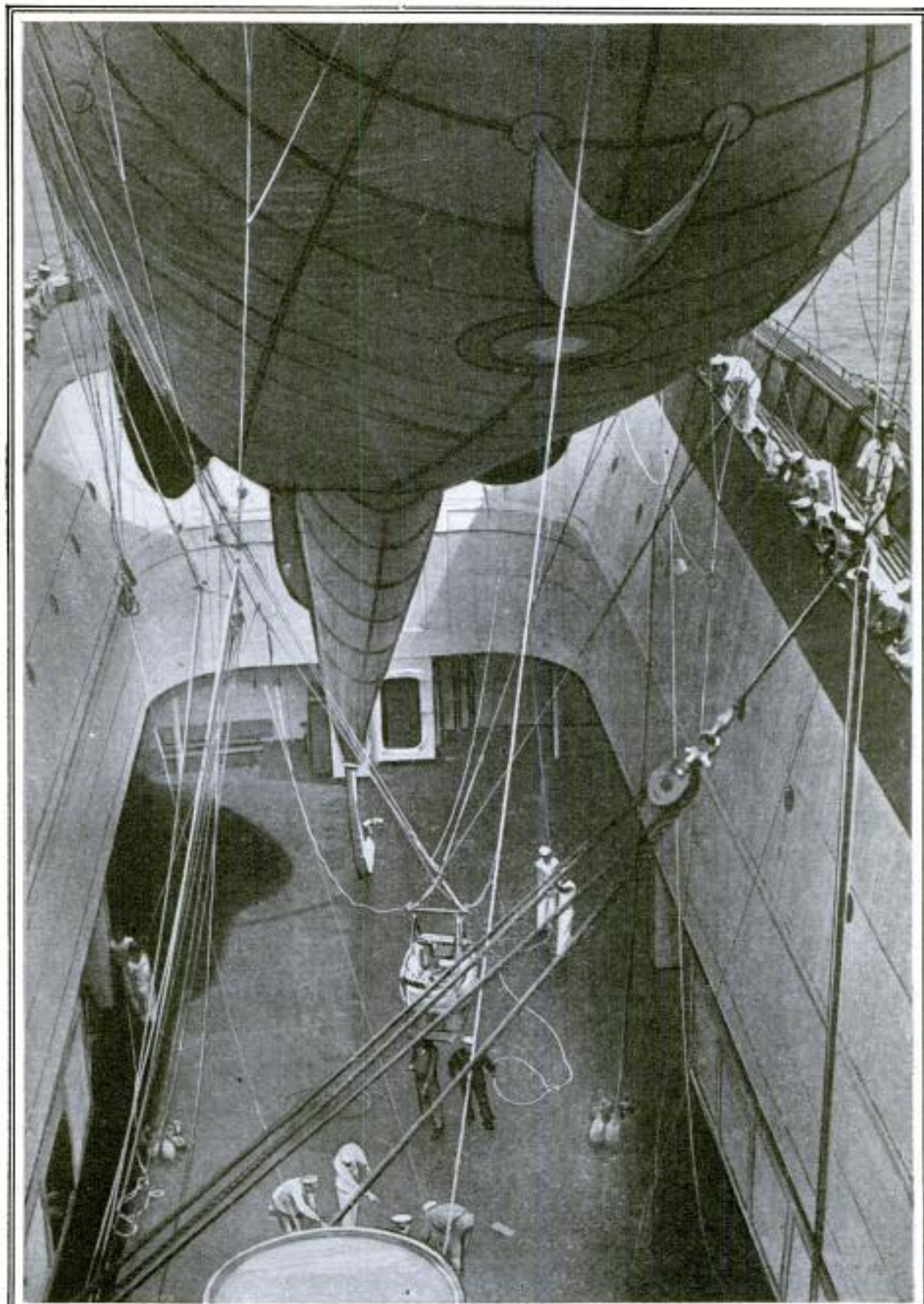

MOTHER SHIP FOR "BLIMPS" DISCHARGING ONE OF ITS BROOD

THE above picture shows one of the naval observation balloons being unloaded for transfer ashore from the U. S. S. "Wright," which was converted into a carrier for "blimps." The decks of the ship were cut away so that the hull could receive several seagoing balloons, which have to be carefully bedded down in order to prevent injury to the balloon fabric and permit them to be easily launched into the air.

Capt. Ernest Jones.
 806-17th St. N.W.
 Washington, D.C.

HUGE LUMP OF COAL IN UTAH THE LARGEST EVER MINED

A gigantic lump of coal, believed to be the largest ever mined, has been placed

proved to be a difficult job. At first 11 horses were hitched to the wagon on which the coal was placed—five in front and three on either side. As the horses did not possess sufficient strength, the five at the front of the wagon were retained, and a five-ton motor truck was attached to the wagon tongue, while 20 men were used as ballast for the truck. Then the huge sample of Utah's coal fields slowly ascended the Main Street grade to the capitol. The block is 5 feet square by 10 feet long and weighs 22,900 pounds, exclusive of the bands of iron which form its crate.

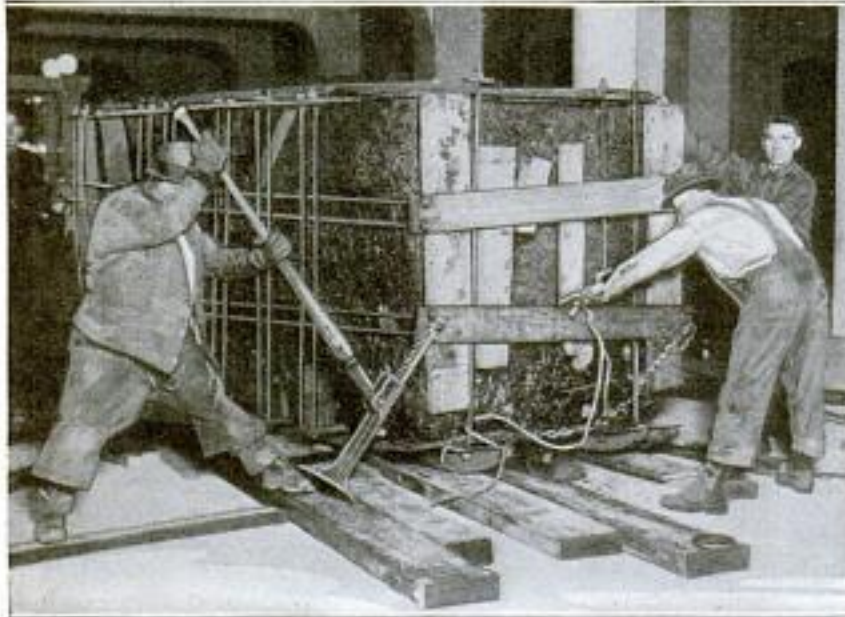

Huge Lump of Coal, Supposed to Be the Largest Ever Mined, being Placed in Position for Exhibition at the Utah State Capitol in Salt Lake City: It Contains 250 Cubic Feet, and Weighs 22,900 Pounds

on exhibition at the Utah State capitol. It was taken from a seam 30 feet in thickness and 3,000 feet underground. A machine was used to undercut it, and the ends and back were sheared by hand. The approximate cost of getting out the coal, mining it, loading it, transporting it, unloading, hauling to the capitol, and placing it in the exhibition room on the main floor, was \$2,000. To get the coal to the capitol after reaching Salt Lake City,

ported to turn out steel that produces castings comparable with those obtained from the crucible process. A high temperature is obtained in the furnace by the use of preheated air for mixing with the hot gas from the producers, and the molten steel is run into a large ladle heated nearly white-hot before it is poured into the molds. Such strong and accurate castings have been made, that they can be used in place of bronze forgings.

1270
NEW FURNACE
PRODUCES
FINE STEEL



Over 11 Tons of Coal in a Single Lump Loaded onto a Wagon in Salt Lake City: To Haul It up the Steep Street Grade to the Capitol It was Found Necessary to Help the Five Horses by Hitching to the Wagon Tongue the Five-Ton Motor Truck, Carrying 20 Men as Ballast

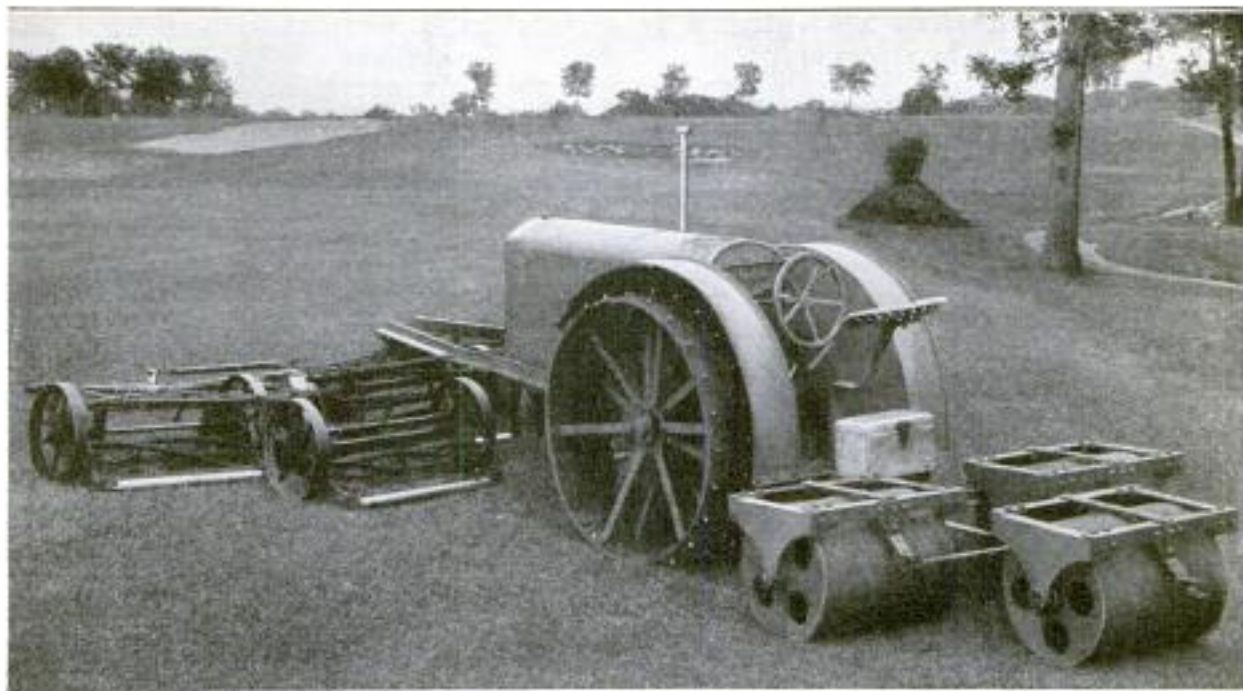

Combination of Tractor-Driven Roller and Mower That Cuts 80 Acres of Grass a Day on a Golf Course: The Five 30-Inch Mowers Cut a Swath 142 Inches Wide, and Are Flexible Enough to Conform to Irregularities in the Ground

TRACTOR MOWER AND ROLLER FOR GOLF COURSES

The latest power equipment for maintaining the fairways and roughs of golf courses consists of a tractor from which the front wheels have been removed and an extension frame or wheel truck substituted. The wheel truck is designed so that mowing units and various other implements for work on golf courses can be attached. Five 30-inch mowing units can be attached to this truck at one time, three in line in front and two following directly back of them. These will cut a width of 142 inches and will mow up to 80 acres in a day. An 18-hole course can be "manicured" with this outfit in two days. Rollers can be attached to the tractor and pulled at the same time.

The mowing units can be detached easily and the tractor used for many other kinds of work requiring motor power about the golf course or in city parks. In fact, it is claimed that with this equipment a golf club can eliminate every horse and half of the men required to maintain its course. The tractor travels at a speed of about three miles an hour.

The attachment of the mowing units is flexible so they can conform to rolling ground, clipping the grass on saucer-shaped ground, on the inside of bunker banks, around steep banks, etc. The two end units can be raised and held securely in an upright position for cutting in nar-

row places or between trees, for transporting over rough ground or going through gates. The outfit is easily operated by one man.

NEW SHORT PAIR OF BUMPERS PROTECTS REAR FENDERS

Projecting beneath the rear end of the auto frame to a point beyond the rear fenders, a new set of bumpers has been made to protect the fenders in case of a collision from behind. The bumpers are curved, double strips of metal fastened about the bolts that hold the rear springs to the auto frame. While they afford the same protection as the usual long bumper, they are not in the way of the rear tire carrier or gasoline tank, nor when jacking the car. They are also lighter



Only a Wrench is Needed to Install These Bumpers Which, though Light, Afford Adequate Protection for the Fenders

and less costly than the ordinary rear bumper. Only a wrench is needed to install them.

Wrench Guard Corp.
Springfield, Mass.
Copyrighted material

DISHWASHER HAS TWO SETS OF PUMPS AND MOTORS

939

An automatic dishwasher having two independent sets of pumps and electric

motors as a precaution against shut-downs during the rush hours, is now available. In operation, an endless belt, driven by either motor, draws a tray or carrier of dishes into one end of the washer every 10 seconds.

The dishes remain under a first spray for this period, and are then drawn along until they rest beneath a second spray, where they remain for the same length of time, after which the belt carries them out at the other end of the machine. The trays in which the dishes are placed have wooden frames for the china to rest upon instead of the usual cast-iron kind, thus eliminating one cause of breakage. A large hotel has cut in half its yearly bill for broken dishes by using a machine of this improved type.

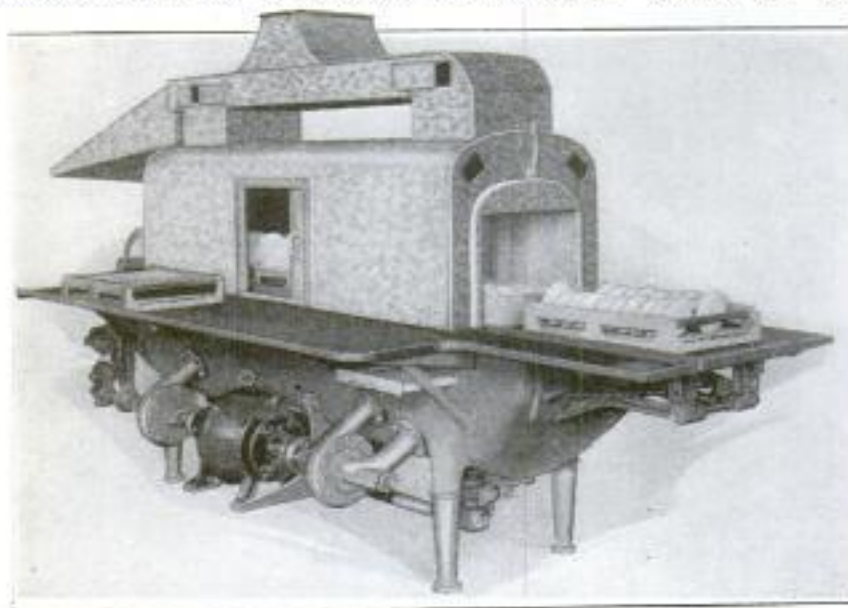

Automatic Dishwasher for Restaurant and Hotel Use, Which Has Duplicate Driving Motors and Pumping Units to Guard against Break-down, and Wooden Trays to Reduce Breakage

HALF OF WORLD'S ELECTRICITY USED IN UNITED STATES

1316

Recently compiled figures show that of the total 115,000,000,000 kilowatt-hours of electrical energy produced in the world during 1920, the United States consumed about one-half but that in per-capita consumption Switzerland led with 700 kilowatt-hours. Of the amount used in the United States, about 15 per cent

was for lighting purposes, and the balance for industrial activities. It is estimated that one out of every 16 persons who inhabit the world, lives in an electrically lighted dwelling, and that of the nearly 500,000,000 horsepower available from the waterfalls of the world, about one-twentieth part is being utilized. Only a little more than one-third of the electric power at present produced in this country is derived from hydroelectric sources.

Electrical World 1/6/23

AUTOMATIC APPLE PARER AND CORER

1170

A new motor-driven machine that represents years of development, is said to core and pare 30 apples a minute, automatically performing all the operations except placing the apple on the holding fork at the start. Three of these forks are provided, and they revolve from the loading position to the one where the apple is cored and pared, and then to the point where the cored and pared apple is discharged. The paring knife operates somewhat like a safety razor and adapts itself to the contour of the apple.

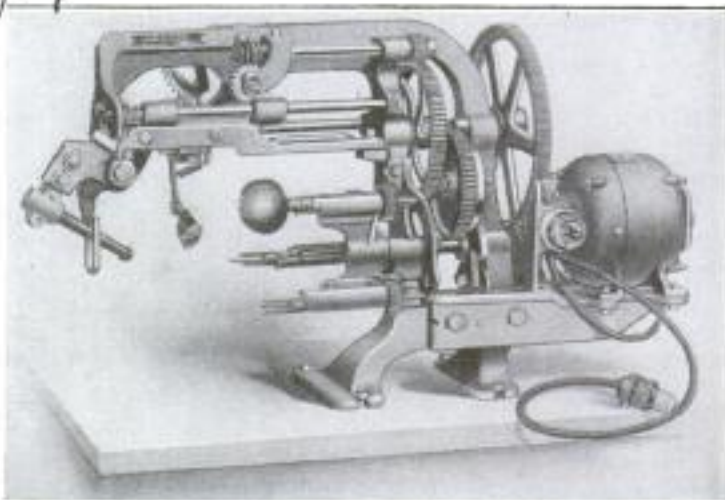

Motor-Driven Machine Which Automatically Cores and Pares 30 Apples a Minute: All the Operator Does Is to Place the Apples on the Holding Fork

Goodell Co, Antwerp, N.H.

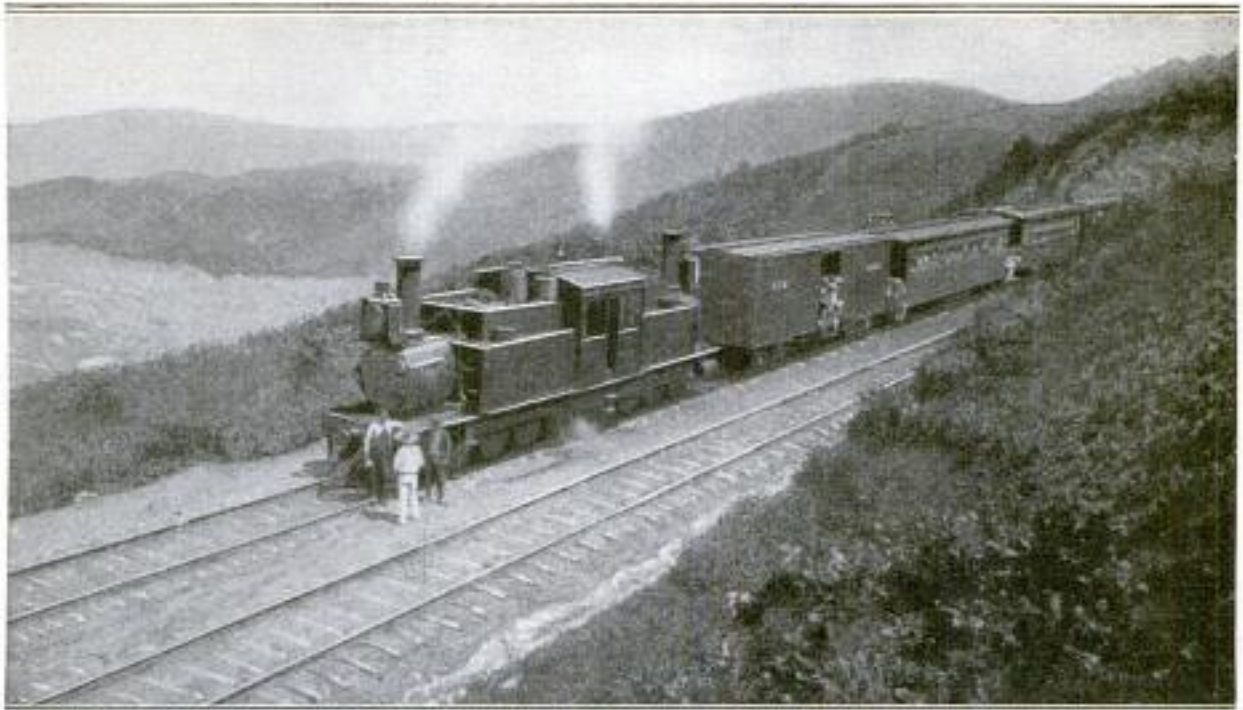

A Scene near Alta Luz on the Railway between Mexico City and Vera Cruz: It is Expected Work will Soon Start on the Electrification of 30 Miles of This Mountain Road, Which Is Part of the Oldest Railway System in Mexico

MEXICO'S SCENIC RAILROAD TO BE ELECTRIFIED

BY GEORGE F. PAUL,

*900 Ellsworth Bldg.
Chicago*

GREAT interest is attached to the announcement just made by the Mexican Railway Company that it will soon start work on the electrification of 30 miles of single track between Esperanza and Orizaba, on the main line between Mexico City and Vera Cruz.

This is the first main-line steam-road electrification to be undertaken in Mex-

ico, and is on the oldest railway system in the country. On the eastern slope of the mountains the grades run as high as five per cent, and traffic is steadily increasing, making it difficult to maintain service up to standard under present conditions. It has been carefully estimated that results will pay for the entire cost of electrification within five or six years.



A Point above the Clouds on the Railway between Mexico City and Vera Cruz, Which Reaches a Height of 9,000 Feet above Sea Level at One Place: When Modernized, It is Predicted This Route will Be a Favorite with Tourists

The system will be operated by direct current at 3,000 volts. The power is to be supplied by a company which has a modern hydroelectric plant a few miles from the city of Orizaba. For this mountain service ten 150-ton locomotives will be required. They will be interchangeable for freight and passenger service. An automatic substation will be one of the features of the new equipment. The road climbs from sea level, at Vera Cruz, to a height of 9,000 feet, a few miles east of Esperanza.

This section, between Esperanza and Orizaba, is one of the great scenic delights of Mexico. Few mountain roads can surpass it, for at Esperanza the traveler is on the bleak tableland of the interior and at Orizaba he is among the orange groves and coffee plantations.

Viewed from the dizzy heights of Boca del Monte, the valley below suggests a delicate piece of patchwork, with soft browns and greens and grays blended to form a harmonious whole. The road itself that wriggles along the rugged mountainside, is one of man's greatest achievements. Spidery trestles span bottomless gorges; a foaming torrent rushing along its depth makes the beholder dizzy. He readily understands why this great gap is called the Barranca del Infiernillo (the Ravine of the Little Hell), and appreciates the better the smiling contrast of the glorious valley of La Joya (the Gem).

It can readily be predicted that when this scenic road is modernized, it will prove a favorite route for visitors from distant lands.

1298 ———
**LIMESTONE BEARINGS OUTWEAR
WHITE-METAL BEARINGS**

Street-car bearings of limestone are reported to have had a life of 35,000 to 45,000 miles in a service where those made of white metal lasted 6,000 to 7,000 miles. White metal is poured into a mold around the limestone and the latter bored out with a diamond tool. The porous stone absorbs oil, and in use quickly takes on a polished surface.

1162 ———
**COMBINE MODEL AND PICTURE
IN HIGHWAY EXHIBIT**

Combining a model of road-building work and an oil painting so skillfully that an observer is unable to detect where the two join, is the result achieved recently by a model maker and an artist who were employed by the U. S. Bureau of Roads, to prepare an exhibit for the Brazilian Centennial Exposition now being held at Rio de Janeiro. The model, which is 25 feet in length and 8 feet in depth, displays a gravel-type road, suitable for Brazilian conditions, with a concrete bridge in the foreground and a gravel pit in the background. Behind this, the painting, which

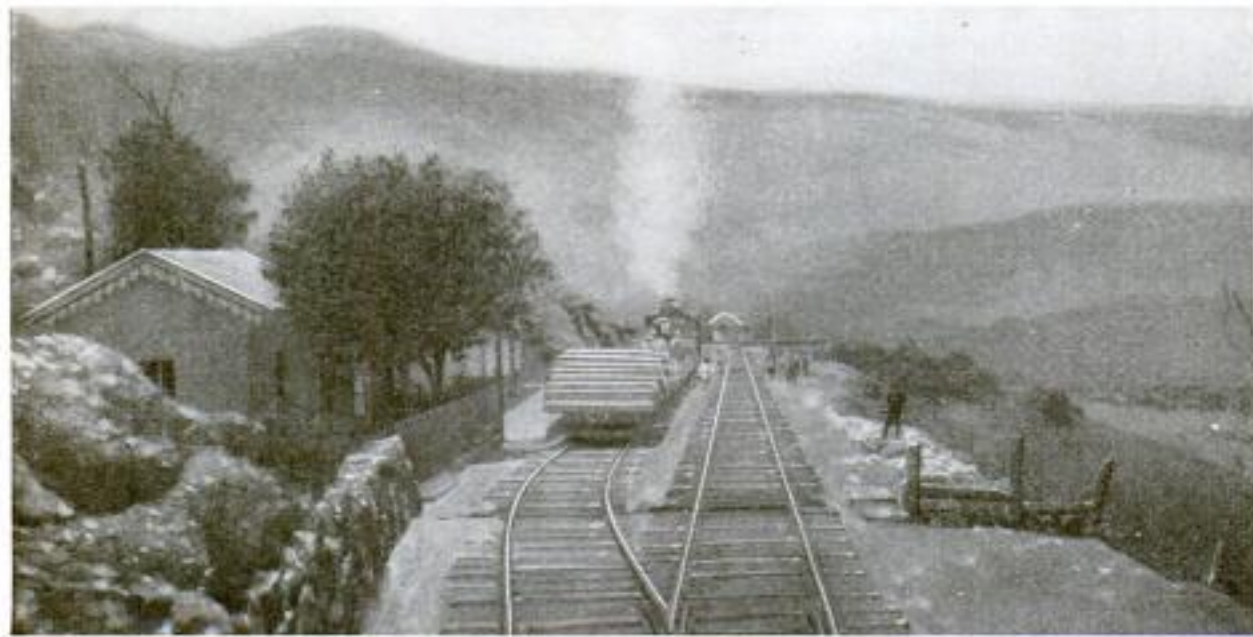

Station at Alta Luz on the Mexican Railway, Which Climbs the Mountains with Grades as High as Five per Cent: Under the Proposed Scheme, 150-Ton Electric Locomotives, Interchangeable for Freight and Passenger Service, will be Run over This Section

1162 Comb. Newman & McLaughlin,
1717 St. Paul St.



Combination Painting and Model, Skillfully Blended, Which Serves as the Exhibit of the Bureau of Public Roads at the Brazilian Centennial Exposition: It Is 25 Feet Long and 10 Feet High, and the Model Is 8 Feet in Depth

is 10 feet in height and as long as the model, presents an appropriate farmland and hill view. Semblance of reality is produced by the operation of tiny gravel-digging and screening machines, and a road roller, these being driven by a concealed motor. Another realistic feature is a stream, painted in the far background, but as it winds its way forward, a real stream of water is introduced at one of the turns and flows down under the bridge in the foreground, the whole presenting, in addition to a practical working model, an artistic scene of beauty.

922
**COOKSTOVE WITH ONE BURNER
SUITABLY ADJUSTABLE**

A cookstove that will burn gas, gasoline, or kerosene, and has all the burners in one oval-shaped pipe that can be swung



under any part of the cooking top of the stove, is being manufactured in England. Underneath the top of the stove is a flat iron box of nearly the same size. The swinging burner is in close contact with the bottom of the box. The stove has four, six, or eight potholes with disks, which, if removed, are immediately replaced by cooking utensils to preserve the heat in the box. The stove can be connected with a copper boiler, and will thus furnish hot-water service.

*The London Manufacturing Co. Ltd.
20 Newman St. Arford St.
London, W.C. England.*

**METAL ELECTRIC INCUBATOR
ALSO USED AS HOVER**

1131
A round electric incubator which hatches the eggs and may then be used as a hover for the tiny chicks, is now avail-



This Electric Incubator Is Round So That the Heat is Uniformly Distributed to the Eggs That are being Hatched

able. From 60 to 100 eggs are placed in a metal pan, a hinged cover containing a heating element is closed over them, and the current switched on. The temperature of the interior is kept constant by the usual thermostat arrangement, the only care necessary being an occasional turning of the eggs by hand. After the eggs are hatched, the cover is removed, and a set of legs, together with a double brooder curtain, is attached to it, the whole providing an effective shelter.

*Clarks Mfg. Co.
Boston, Mass.*

*Edw. Wm. J. Pentland
Brattleboro, Vt.*

**PRESERVE OLD HEADSTONES
WITH COAT OF CEMENT**

1125

A process that will probably result in the reclamation and preservation of old headstones in many cemeteries throughout the United States has been found by a Vermont man. Not satisfied with a copper cap he had previously devised, he conceived the idea of incasing the markers in a thin layer of cement, thus protecting the sides and back of the stone, and leaving only the chiseled wording on the front exposed.



The Stones, after being Coated with Cement on the Sides and Back, the Front being Left Untouched So That the Faint Inscriptions may Still be Read

The old headstones, marking the resting places of some of the country's early pioneers, were first removed from the cemetery and carefully and thoroughly cleaned, special attention being given to



Side View, Showing the Condition of the Headstones before being Treated: This Type of Marker is Seldom Used at Present

cracks in the stones where the constant exposure to the weather had split them.

A wooden form was then made, somewhat larger than the dimensions of the stone to be treated. On the inside was placed a lining of zinc, so that the stone, when finished, would have a smooth surface. The ends, of course, were made to conform to the tops of the stones, which in some cases were semicircular and in others leaf-shaped.

At this stage the stone itself was laced on the sides and back with 1/4-inch iron mesh to form a reinforcement for the rolled edges and back. Next, cement and a fine grade of sand were mixed and poured into the form to a height of 2 inches. Upon this mixture the stone was placed, face up, then "puddled" into the cement until it squeezed up between the sides and top of the stone and the form.

1279

**GOLF BALL OF NEW DESIGN
HAS GREAT RESILIENCY**

Maximum resiliency when driving and sufficient "rigidity" when putting, are merits said to be combined in a new make of pneumatic golf ball. The ball has a hollow center with a cross, or "wagon-spokes" arrangement, of rubber through it. Thus, while having enough elasticity to permit a long drive, the ball is hard enough to provide the proper resistance for accuracy on the putting green.

1092

**BUILD ELABORATE EQUIPMENT
FOR MUD-BATH CURE**

Elaborate equipment for the taking of mud-bath cures, has recently been installed in one of the finest hotel-sanitariums in this country. Tubs of imitation Italian marble, fashioned after the ancient couch baths of the Romans, are located in rows in the large main bathroom. In each tub, 8 inches of mud, brought from an adjacent sterilizing and preparation room, is placed and the steam turned on underneath. When the tub

*Edw. Augustus S. Chasefield 38 S. Parsons Ave
Fitchburg, Vt., New York.
New York City*

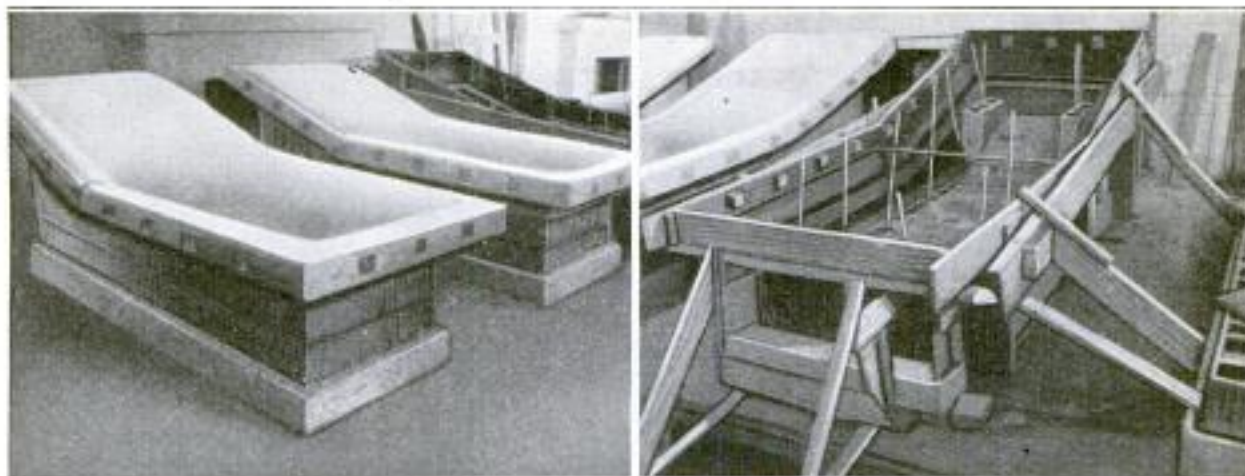

Left: Two of the Elaborate Mud-Bath Tubs are Seen in the Foreground, While a Partly Completed Tub is Shown in the Background. Right: Close-Up, Showing the Method of Constructing the Tubs with Hollow Tile and Reinforced Concrete in a Special Form

temperature reaches 95 to 100°, according to the physician's orders, the bath is ready. While the patient is reclining in the mud, a special ventilating system is constantly forcing fresh and warmed air up through vents in the flooring to the base of the tubs. It then passes up and around the hollow-tile sides, escaping through holes near the top, thus providing the patient with plenty of fresh air.

REVERSIBLE AUTO FAN SAVES FROZEN RADIATORS

An automobile fan is now being introduced with adjustable blades that reverse the flow of air through the radiator so that in cold weather the radiator will be kept from freezing by warm air from the engine. It is made with a hub that fits the standard fan pulleys, into which the rounded end of the fan blades fit. A small pin through this rounded portion fits into one or the other of two recesses in the hub, according to the direction of air flow desired, and two small springs prevent the pins from slipping out.

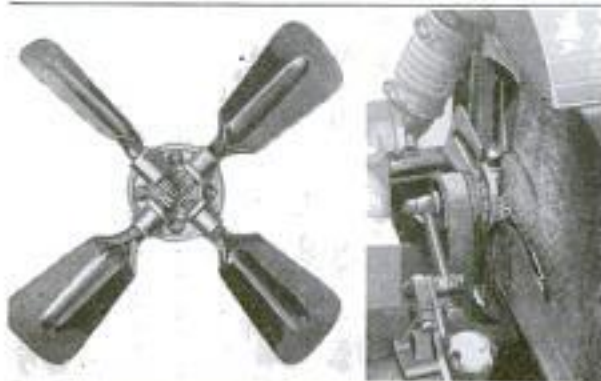

Left: Automobile Fan with Adjustable Blades for Reversing Flow of Air through Radiator. Right: Fan Installed in Car

SIMPLE WIRE-TYING MACHINE BINDS PACKAGES RAPIDLY

A wire-tying machine that tightens the wire around any kind of shipping case or container, twists the wire, and cuts it off neatly, is now on the market. When strapping a package, the end of

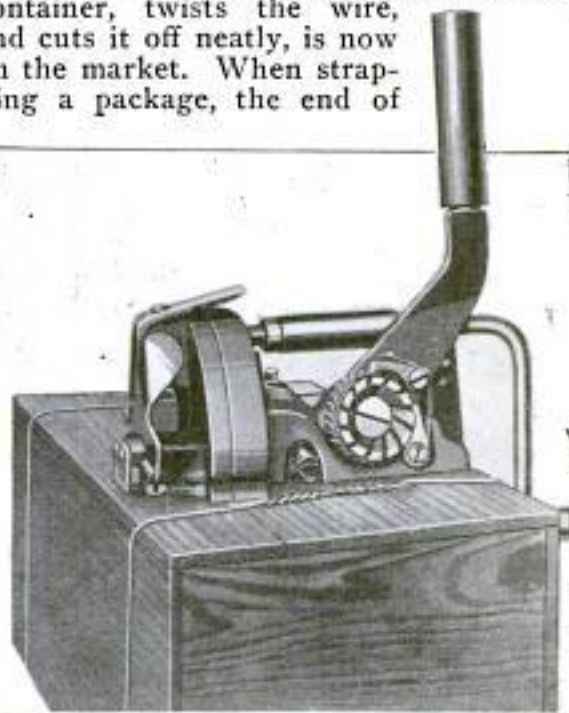

Wire-Tying Machine for Binding Packages: The Upright Handle Tightens the Wire, and the Crank Handle Ties It and Cuts It Off

the wire is put in the slotted end of a holding post, through a latch for retaining the machine in place, and also through a second binding post. The wire is then passed around the package in any desired way, and after being brought back through the holding posts, it is slipped into a notch in a ratchet wheel with which, by means of an upright handle, all the slack in the wire is taken up. By turning a crank handle three times, the wire is tied and cut off.

The Colby Reversible Auto Fan Co.
5724 W. Madison, Chicago.

Waukesha Mudbaths Co. d. inc. Cicero, Ill.
J. S. Lawrence
Wire Tying Machine
1942
Copyrighted material

Mr. Shirley B. Dalrymple, Glasgow, Scotland
Mr. E. B. Hugh, Ltd
 402 POPULAR MECHANICS & C 3 London
 53 *3 Lloyd's Ave. E.C. 3*
DEVICE PREDETERMINES STABILITY OF SHIPS *England*

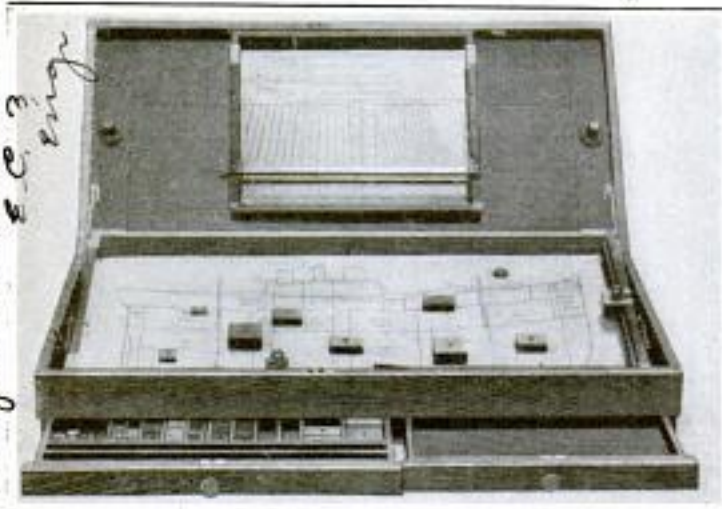

A novel instrument for ascertaining, correctly and in advance, the stability of a ship with a given cargo or ballast, or both, has been devised by a Scotchman. It consists of a diagram of a vessel, with scales along the vertical and horizontal sides. Weights connected with the scales may be adjusted to different positions on the diagram to represent the cargo arrangement, and by reference to two sets of curves on a chart furnished with the instrument, the stability and trim of the ship are quickly predetermined. Another advantage is that it enables the shipmaster to predict the effect of fuel consumption.

Arrangement of Charts and Weights by Means of Which the Stability of a Ship can be Readily Found for a Given Cargo or Ballast Loading, or a Combination of Both, and the Vessel Trimmed to Suit

NEW TYPE OF WINCH MOUNTED ON A TRACTOR

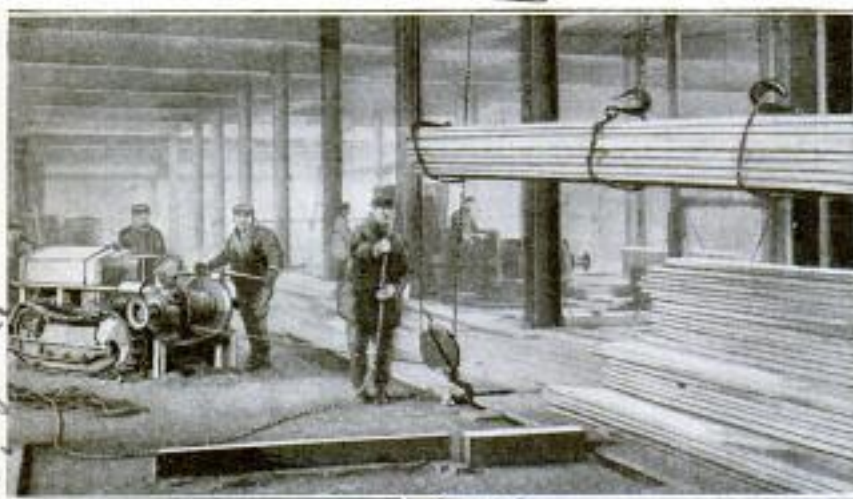

745, and a maximum of 6,900. The standard drum has a diameter

Tractor-Type Winch, Hoisting 50,000 Feet of Lumber a Day on Large Construction Job



The Same Winch at Work Pulling an Oil-Well Casing, Which was Anchored at the Bottom by Several Feet of Closely Packed Sand, Long Undisturbed

Ruggedly built, and simple in construction, is a new type of traveling winch for the use of road contractors and others. The winch is mounted on a compact tank-type tractor, having therefore a small turning radius, and occupying very little space. The winch and its niggerhead are driven by the tractor motor through worm gearing, with a minimum rope speed of 105 feet, and a maximum of 960 feet per minute, and with a minimum pull in pounds of

of 6 inches, with a flange diameter of 18 inches, the same as the distance between flanges. Its capacity is from 1,230 feet of 1/2-inch to 3,030 feet of 5/16-inch rope.

Mr. E. B. Hugh Ltd
3 Lloyd's Ave. London E.C. 3
 479
Mr. Allison
Deaver, Pa.
Mr. Dwight

1241 *Low. Capt. B. Chernicheff*
33 Eastcheap, London
NEW ELECTRIC LOG FIXTURE OF SHIP'S HULL
 By CARL PALMBLAD *E. C. 3, England.*

A NEW ship's log which is electrically operated has recently been given its first trials in England, where it was developed by a former officer of the Russian navy.

There is no line connected with the instrument, for the log proper is not thrown overboard, but is fixed to the hull of the ship at a depth where there can be neither wave nor propeller disturbance. It may be briefly described as follows: The part outside the hull contains a terminal contact for insulated wires running to the electrical supply and to the indicating apparatus; a spring, also insulated, engages this contact and also the commutator, 20 revolutions of which represent a mile; the motion of the shaft of the rotator, which is in the form of a four-bladed propeller,

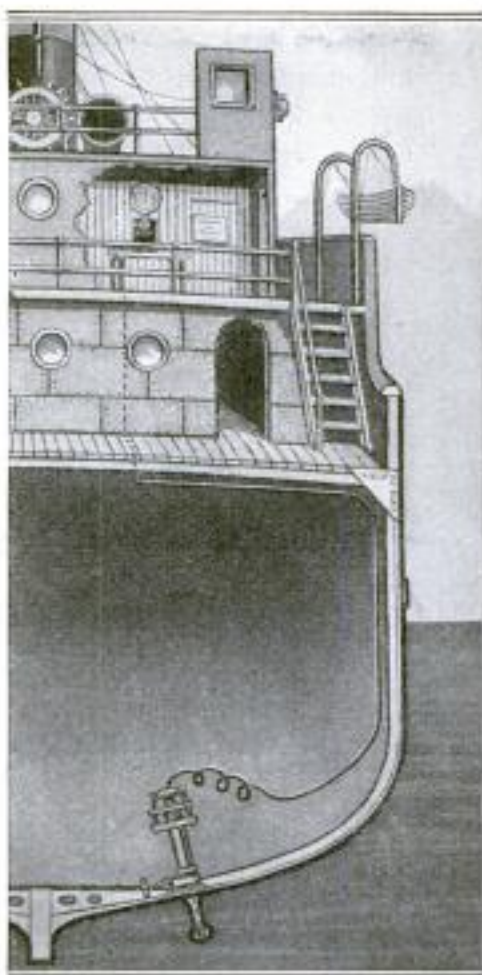

The Electric Log, Greatly Exaggerated in Size, as Installed in a Ship

is transmitted, through a double worm and wheel, to the commutator. As no packing is used around the rotator shaft, the resistance to its rotation is constant at all speeds and practically negligible. The indicating dial is graduated to record distances from .05 to 10,000 miles. There is also a panel with a table of speeds, a voltmeter, and three switches, for connecting the voltmeter to the battery for test; to throw the dial mechanism into the circuit, and to connect a buzzer, which signals every twentieth of a mile, so that the ship's speed can be obtained with the aid of a stop watch.

The new log was first tested over a carefully measured half-mile course on the Serpentine, Hyde Park, London, when it was fitted



Parts of the Log and Recording Apparatus: Left, Outboard Part Disassembled, with Rotator and Contact Spring to the Right of It; Center, Recording Dial with Switch Panel and Speed Table Below; Right, the Log Proper Complete

to a rowboat, which was pulled over the course at a constant speed of about 3 miles an hour. Later it was taken to Portsmouth and tested on a submarine. Several runs over a nautical mile, at varying speeds, were made there, with highly accurate results.

"With this log," says the inventor, "correctness to a fraction of a foot per mile has been easily obtained, and this correctness stands for any speed of a ship. The majority of navigators up to the

present have been inclined to charge all errors of the log to the account of the current, and therefore we have had rather misleading information regarding the currents. Navigators have been trying to do their best and have checked their log by the revolutions of the ship's propellers—but the first rough weather has upset all their calculations, and at the very time when there was the greatest need for reliable information, the log was obviously showing false."

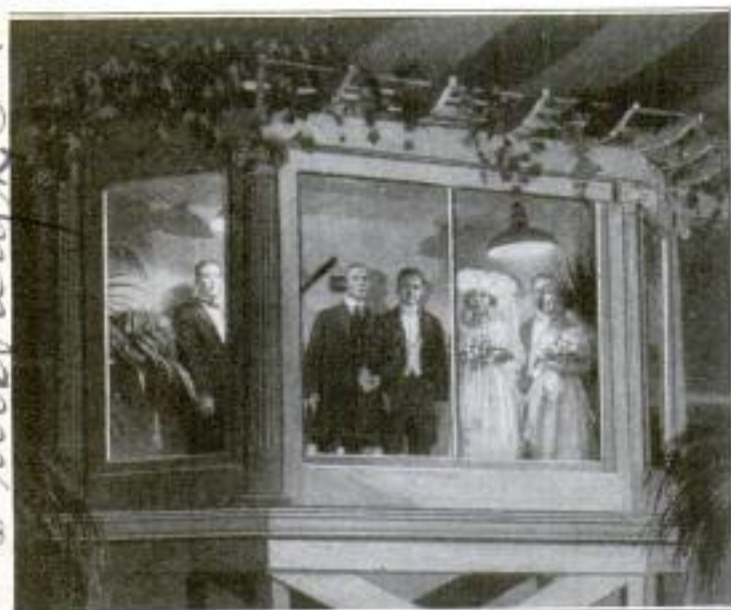

The Wedding Party as It Appeared to Those Who had Gathered in the Exposition Hall: The Booth Was Soundproof and Connected with a Broadcasting Station

THOUSANDS SEE AND HEAR RADIO WEDDING

What is believed to be the first performance of its kind occurred in Pittsburgh recently when a wedding ceremony was performed in a large glass booth, visible to thousands attending an electrical exposition, while radio apparatus broadcast the words spoken to those at the show and countless others listening in. The booth, specially constructed for the occasion, was soundproof and connected by telephone to a station at East Pittsburgh, where the sending apparatus was located. Loud-speaker receivers in the exposition hall carried the words to those who had gathered there.

1212 BOW-AND-ARROW GOLF IS LATEST DIVERSION

Playing golf with bows and arrows, instead of the usual clubs and balls, is the latest diversion in the sporting world. Golfers of no mean ability have been defeated by as many as 20 strokes in contests with archers who shoot arrows from the tees to the cups. With the bow and arrow, "drives" of 250 and 300 yards are said to be a common occurrence, while the accuracy of approach to the greens would make any golfer envious. One thing is certain, any archer making the rounds of a course is never troubled by the "ball" overrunning the putting green. Neither do wet greens and fairways, nor the scientifically placed bunkers and traps, prove a hindrance to his game, or to the serenity of his temper.



Putting Green of a Golf Course, Showing the Players "Holing Out," One with the Regulation Ball, and the Other with an Arrow

Emb. Lyle Abbott, Prescott Arroy

Copyrighted material

Westinghouse Electrical Mfg. Co
East Pittsburgh, Pa
1242

EXPLORING THE DACHSTEIN ICE CAVERNS



Views Taken by an Exploring Expedition Recently Conducted into the Famous Dachstein Ice Caverns, Located in the Austrian Alps: The Illustration at the Top of the Page Shows Three of the Explorers in One of the Beautiful Caverns, Each Bearing a Special Type of Torch, by the Aid of Which These Unusual Photographs were Taken. In the Center Picture is Shown the Means Used to Scale the Almost Perpendicular Sides of the Ice Walls. At the Bottom of the Page is Seen One of the Large Glacial Formations Traversed by the Travelers.

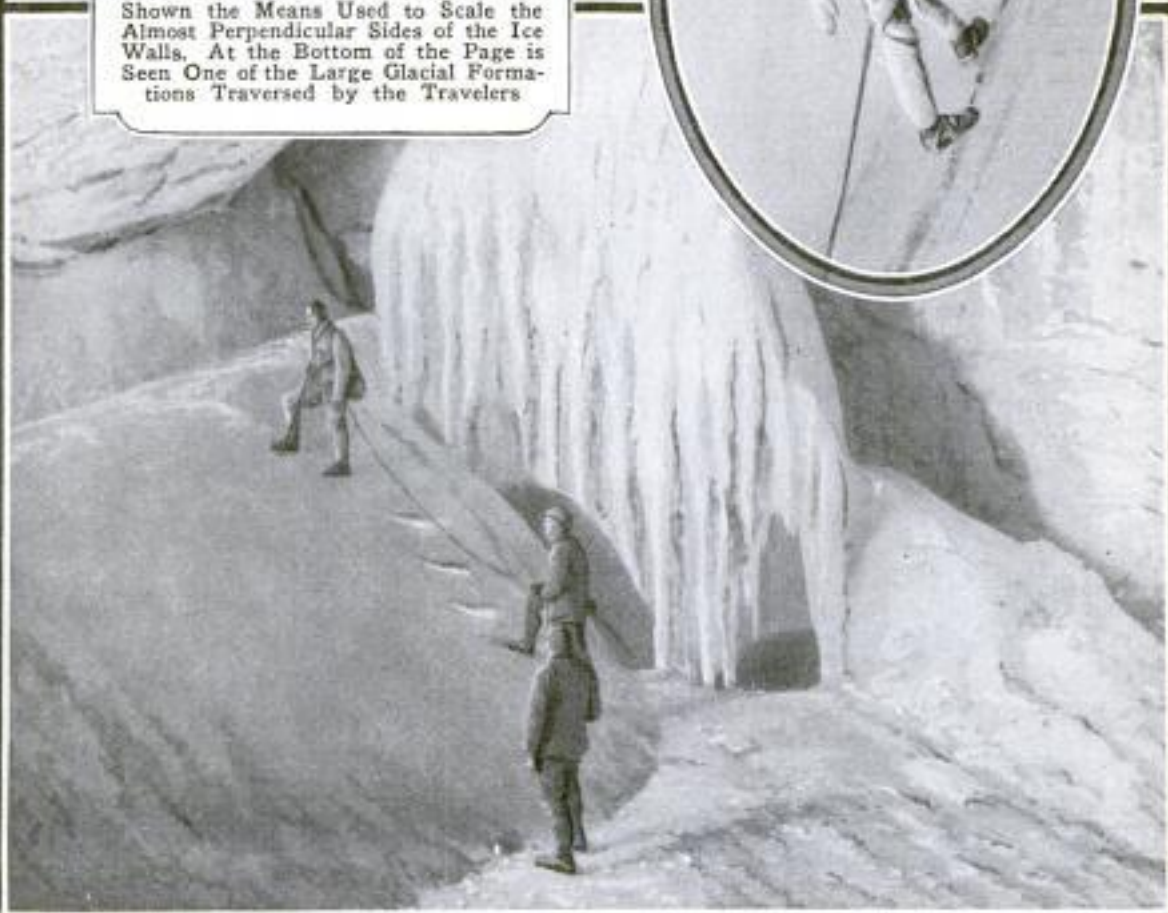

406*
 774

**HEADSET STAND
 FOR RADIO**

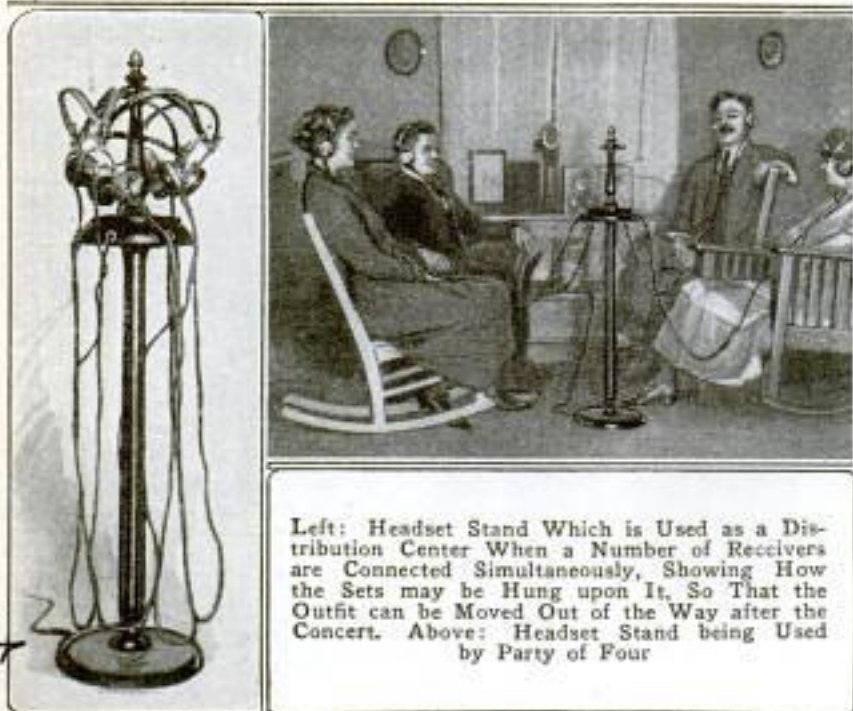

Left: Headset Stand Which is Used as a Distribution Center When a Number of Receivers are Connected Simultaneously, Showing How the Sets may be Hung upon It, So That the Outfit can be Moved Out of the Way after the Concert. Above: Headset Stand being Used by Party of Four

An ornamental wooden headset stand, for use as a distribution center when a number of receivers are used simultaneously, and as a rack for holding the headphones when these are idle, has been introduced. This appliance eliminates any crowding near the equipment. The stand may be moved around a room at will, and when the concert is finished, it may be conveniently placed in a corner or closet, out of the way. The outfit has a switch to disconnect any receivers not in use.

at parat
 Headset

1181

TRACTOR FITTED TO PUSH OR HAUL FREIGHT CARS

Equipped with a standard coupling device at the rear and a heavy perforated steel plate at the front, a tractor has been made which can both push and haul freight cars with equal ease. Switching with various kinds of tractors has been a steadily growing custom in industrial yards, but this is the first time these practical features have been adopted. Numerous advantages

are claimed for a tractor so equipped, greater convenience, and cheaper cost of upkeep being the two most emphasized. As many as seven loaded cars have been pulled at one time, although the engine is of a type not unusual on tractors, and no attempt was made to give it greater power or improve it in any way.

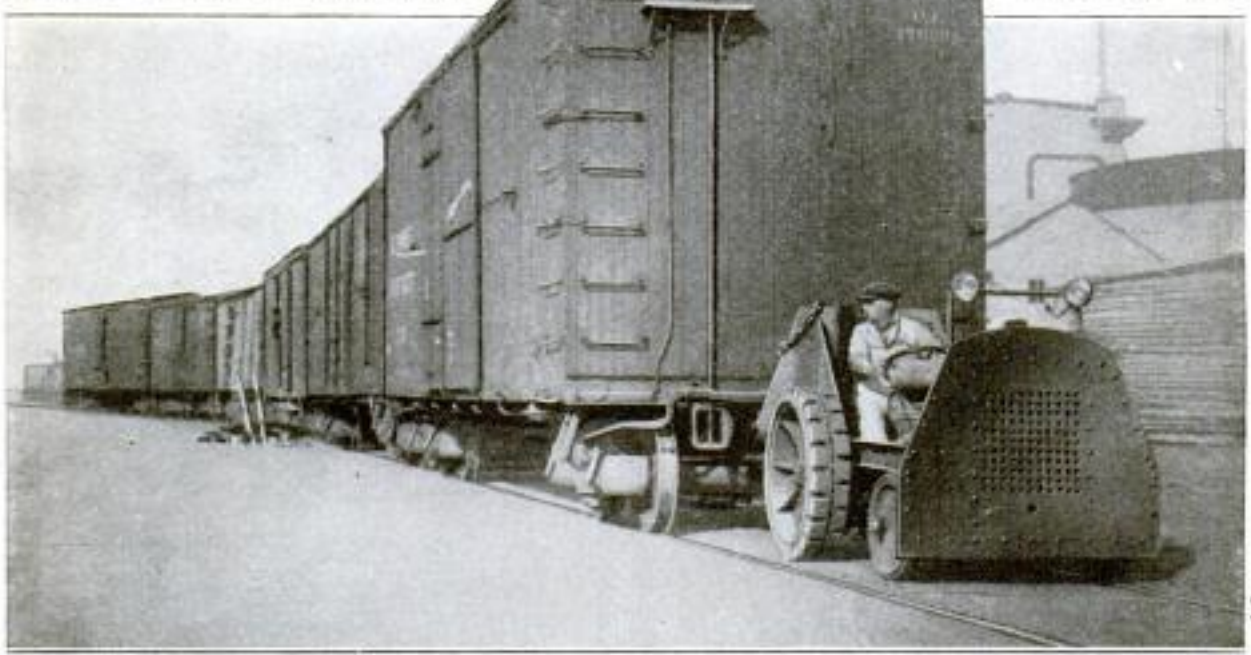

The Tractor, Fitted to Push or Haul Freight Cars, is Shown Here Backing into a String of Cars Which It Is to Move. The Automatic Coupling Device Makes It Possible for the Tractor to Complete This Operation with a Speed Equal to That of a Locomotive

H. M. Lawrence Co. Oakland, Calif.
 12th & Harrison Sts.

1181

1005

Merriman Cultivator Co
Hickerville Mich.

POPULAR MECHANICS

407



Above: Side View of Power-Driven Thresher That Removes the Seed from Clover as It Travels across the Field. Note How the Thresher Mechanism Overhangs the Front of the Tractor. Right: Front View of Thresher, Showing the Beat-ers and the Troughs into Which the Clover Seed Falls. Practically All the Seed is Said to be Recovered.

POWER-DRIVEN HARVESTER FOR THRESHING CLOVER

A new power-driven harvester for cutting and threshing sweet clover is said to be capable of securing all the seed in the clover, none of it being lost as in the ordinary method of cutting sweet clover with a binder. The machine is mounted on two rear tractor and two front steering wheels between which is the power plant. Behind this is the driver's seat, and in front of the machine are the harvesting and threshing devices.

BUCKET FOR AUTO RADIATORS HANDY AND COLLAPSIBLE

Water is conveniently carried and poured with a new collapsible auto-radiator bucket.



The bucket, fitted with a number of circular rings to support it when full, has at the bottom a converging neck which is equipped with a special valve.

When the crossbar of the radiator, the weight of the bucket automatically opens the valve and the water pours freely. Collapsed, for storing away, the bucket is only 2½ inches high.

DOUBLE-PLUG PIPE GAUGES FOR INTERNAL THREADS

For measuring the taper of inside pipe threads, a new gauge is made with an inner plug which is first screwed into the thread by hand, and over its handle an outer plug is then screwed in, both being set hand-tight. On the handle of the inner plug there is a line which, if the taper is correct, will register with the zero line of graduations on the handle of the outer plug, these graduations being spaced in divisions showing variations of .002 inch in the pitch diameter in a length of 2 inches, which is the distance covered by the gauge.

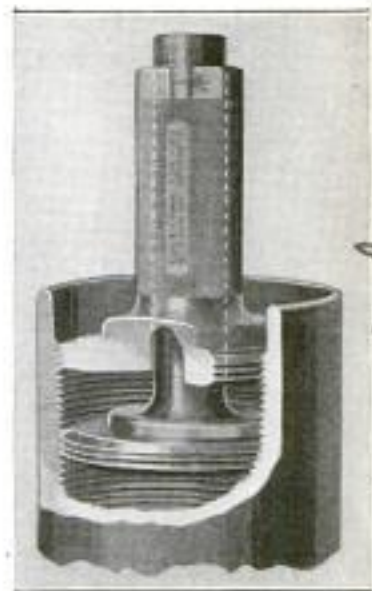

Since January 1, this year, weather summaries and forecasts, together with storm, hurricane, frost, and cold-wave warnings, and advisory messages, have been broadcast from the naval radio station, known as "NAT," which is located at New Orleans, La.

Chas. S. Kinney & Sons Mfg. Co.
198 S. Front St. Cayahoga Falls Ohio

Copyrighted material
17

Pratt & Whitney Co., 111 Broadway, New York City

Dubuque Chemical Co
108 First St.

408

POPULAR
Dubuque, Iowa

DEFIES ALL ACIDS, CLAIM FOR NEW TYPE OF INK

1225

An ink recently invented is said to defy all efforts of the professional forger to



Result of Test in Which Ordinary Ink was Removed from a Check, While a Name Written with a New Ink was Not Affected

remove it without destroying the paper itself. In an interesting test held to demonstrate this claim, a check blank was partly covered with ordinary ink, and a name written over this section with the new ink. Acids were then used to eradicate the name, but while white could be made to show in the blotch of ordinary ink, the letters written with the new ink were not affected.

1205

COUPLING WITH CHECK VALVE FOR COMPRESSED-AIR HOSE

A patented automatic air-hose valve takes the place of a globe valve, and at the same time acts as a coupling in compressed-air lines. In one half of the coupling is a check valve so constructed that it is held closed on its seat by the pressure from the air line. Two projections beyond the valve seat, with a cross pin between them, form a protection for the seat when this half of the coupling is dragged across the ground at the end of the hose. The cross pin also forms a pivot for hooking on the other half of the coupling, when

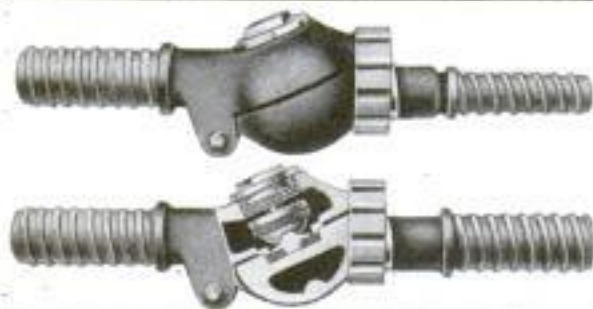

Top: Automatic Hose Coupling Which Takes the Place of a Globe Valve in an Air Line. Bottom: Sectional View of the Coupling

the two halves are coupled and locked together by means of an eccentric clamp-

Engineering Mining Press
1/6/23

MECHANICS

ing ring. When this is done, a projection on the hose-shank half of the coupling pushes the valve open and admits the air pressure.

1307 "PICK UP" RADIO MESSAGES 100 FEET UNDERGROUND

"Picking up" radio messages with a receiving set installed 100 feet underground in a mine, from a broadcast station 18 miles away, is the latest wireless achievement. The set was located not far from the point where the light and power wires entered the mine, and when removed to some distance from these, the signals were found to diminish in force and clearness. Although the tests did not actually lead to any practical method of using wireless waves for underground communication, they did prove clearly that electromagnetic waves, contrary to the former theory, may be made to travel through solid strata. The fact that radio signals were detected below the surface of the earth, will doubtless be sufficient evidence of possible transmission through the ground, to encourage further experiments.

1091 AUTO-STEP PLATE HAS SPACE FOR OWNER'S NAME PLATE

Using a triangular open space left in the center of a new auto-step plate, the owner may now buy and insert his own name plate. Two other features of the step plate are a raised rear guard, to protect the side shields, extending lengthwise above the running board, and a small shoe scraper built into the plate at its outer edge.



Proper packing of bolts, nuts, washers, and rivets for shipment to Chile is an important matter, because freight is transhipped to barges in the open roadsteads, and it is urged that shippers send these materials to that market in heavy double sacking or iron containers rather than wooden kegs.

Triangle Automobile Specialties Co. New York
1931 Broadway

Robinson Machine Co.
39 Eighth St., Michigan

1155 H. T. Ferguson Co.
6823 Euclid Ave.

POPULAR MECHANICS

Cleveland, Ohio

LOCOMOTIVE CRANE SAVES HEADROOM IN SHOP

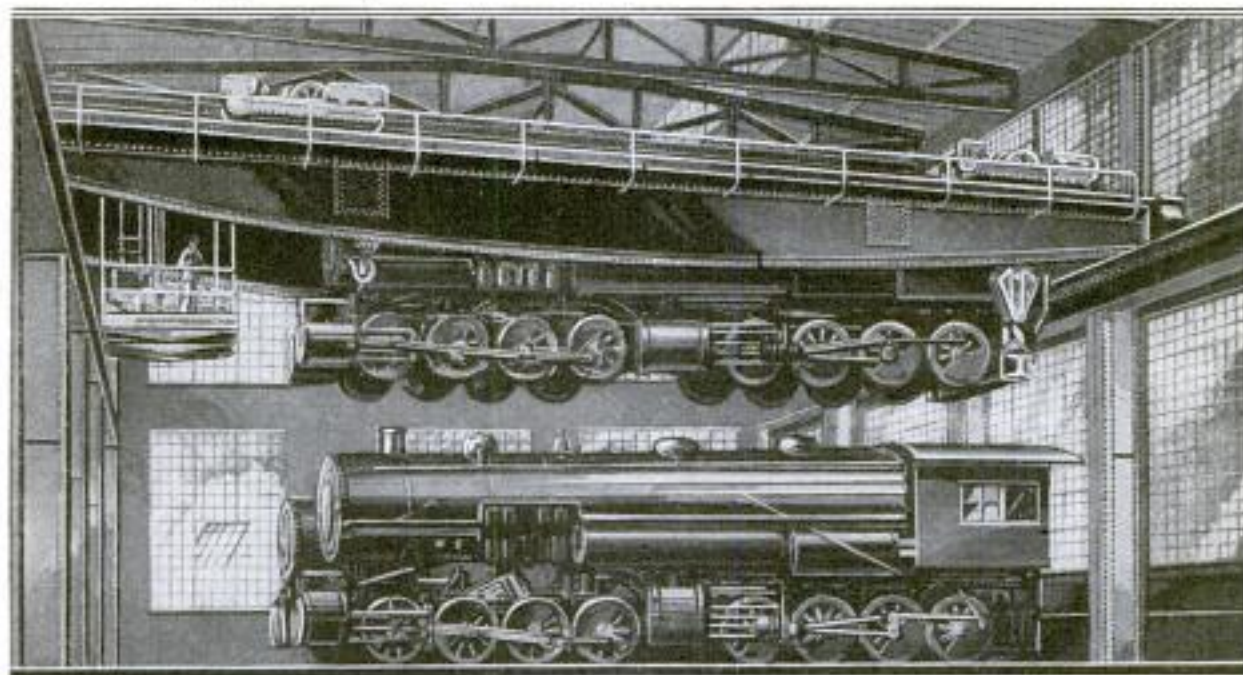

Large Gap Crane Which Allows the Locomotive to be Hoisted Well Up between the Crane Girders, Thereby Saving Considerable Headroom in Repair and Erection Shops: This Idea can be Made to Effect Considerable Economies in the Design of New Plants

1155
The gap crane adapted to locomotive repair or erecting shops saves 15 to 18 feet of headroom, which in the case of new shops will effect a considerable saving in the building cost. In this design, the girders that form the bridge are spaced, and the trolleys that carry the hoists are arranged, so as to allow the locomotive to be hoisted well up between

the girders. Each of the two trolleys is equipped with two hoists instead of one, as in the usual crane, and the crane can be fitted with lighter auxiliary hoists for general shop service. In a shop equipped with this type of crane, the messenger cranes are placed above, where the lift-over operation does not interfere with the crane running the full length of the shop.

926

OVERHEAD IRRIGATION PIPE OSCILLATES SPRAY

An oscillating arrangement for overhead irrigation pipes has been designed by the Department of Agriculture of Massachusetts. The mechanism, run automatically by the pressure of the incoming water, reverses the pipe from right to left and back again so that the plants on each side receive the benefit of the spray. Formerly it has been the practice to turn the pipe over by hand, or spray the water on one side only. About a minute is required for the complete movement of the pipe.

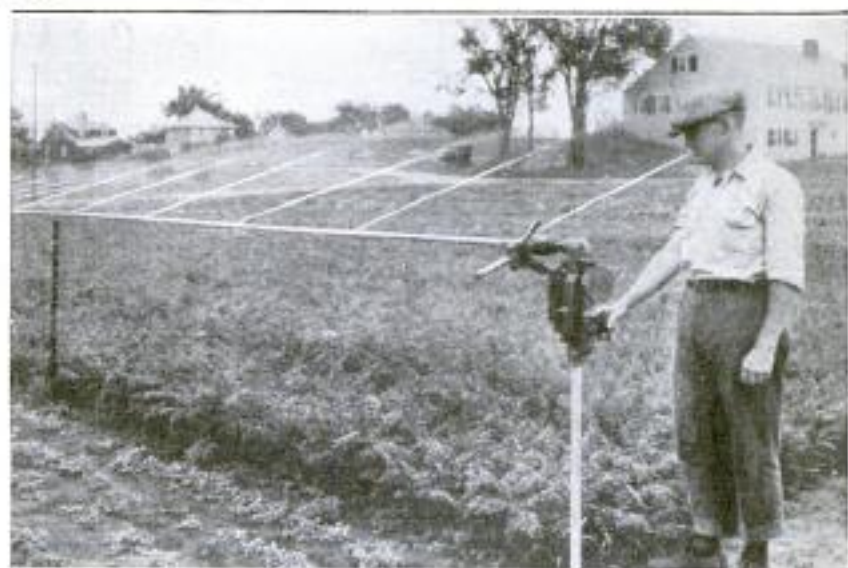

The Oscillating Device Shown at the Right Turns the Pipe from Left to Right So That the Stream Reaches Both Sides of the Garden. It can Also be Made to Spray One Side Continuously.

Skinner System, Troy Ohio

Copyrighted material

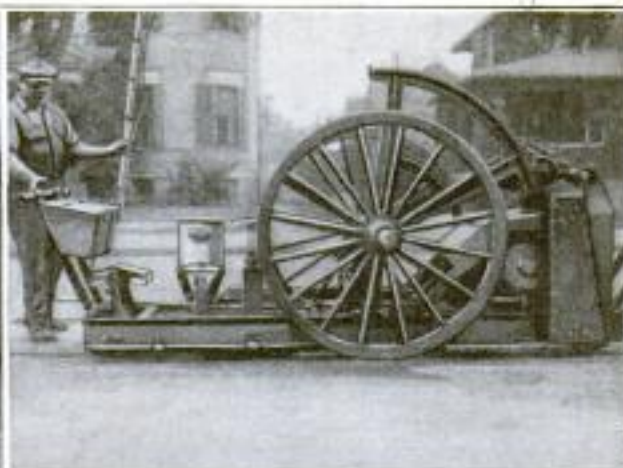
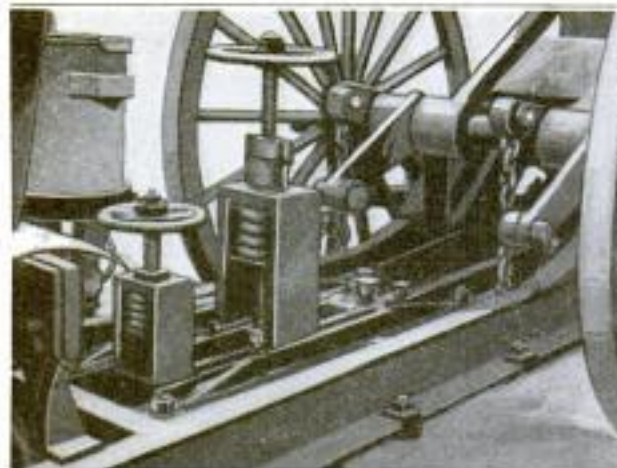

Left: Close-Up of Rail-Grinding Machine, Showing the Two Handwheels, by Means of Which the Pressure on the Stones is Regulated. Right: Side View of the Grinder at Work; Note the Large Wheels Used in Moving the Machine

889 **HEAVY SHELF BOXES HANDLED BY BLOCK AND TACKLE**

Shelf boxes in hardware stores, or similar places, where the merchandise is



Heavy-Metal Shelf Box being Handled by Means of Block-and-Tackle Outfit, to Facilitate Lifting

heavy, may be handled in an efficient manner with a block-and-tackle arrangement. The boxes, usually of metal, are first perforated in three places so that the hooks of a saddle appliance may be inserted. This saddle is raised or lowered by a rope and pulley. Thus the bulky boxes are easily taken down or replaced on the higher shelves.

☞The "Leviathan," now being reconditioned at Newport News, will be placed in transatlantic service on June 1, this year, according to a tentative arrangement made by the Shipping Board.

1093 **RAIL-GRINDING MACHINE USES FLAT STONES**

A grinding machine for resurfacing worn rails, recently put in use by the Boston street railway, differs from the common type in that the grinding wheel is replaced by four flat stones, mounted in a reciprocating holder that is driven by a connecting rod and crankshaft geared to an electric motor. Two handwheels regulate the pressure between the rail and the stones, which are supplied with water from a tank at the side of the machine. When in operation, the machine rests on two small wheels, from which the load is transferred, by means of a crank-operated gear and sector, to two large wheels when it is desired to move it. Although slower than the older method, a true surface is produced, insuring a more permanent repair of the track, and consequently economy.

1086 **UKULELE FINGERBOARD SLIDE TRANSPOSES TO ANY KEY**

Placed on the fingerboard of a ukulele and held by spring pressure against the strings, a metal slide is so constructed that it can be shifted, thus transposing to any desired key. A transposing chart is furnished with the slide, which can be put on or taken off in a second. It is said to improve the tone and make fingering easy. It can be used on all stringed instruments of the banjo type.



Clifford A. Butterworth, 15 Chase St. Newton Centre, Mass.

L. A. Ellington, 1-9 Bethune St. New York City

L. A. Ellington, 1-9 Bethune St. New York.

Cmt. C. Moran, 3825-13th St., N. W.
Washington, D. C.

UGLY NORDHOFF BECOMES BEAUTIFUL OJAI

1122

By C. MORAN

Jan

THE transformation of a shack-and-shanty town into a place of architectural delight, virtually overnight, is the accomplishment of the citizens of Ojai, Calif. Cement turned the trick.

The town—formerly called Nordhoff—was a typical frontier settlement. Ramshackle buildings lined the main street. Treacherous mud-holes filled the road. Then, as if touched by a magic wand, the town was changed into a thing of beauty. The shacks and shanties are still there, but they wear a disguise. A long, Spanish arcade hides their ugliness. A stately Spanish tower rises above and incloses the post office. Across the road a low wall with arches surrounds a natural park, tennis courts, and clubhouse. Smooth boulevards, towering shade trees, riding paths, country places, hotels, and homes with wide verandas and beautiful vistas, have been built.

One of the town's leading citizens had a vision. He purchased 10 acres of land on the side of the street opposite the stores, laid out the park, and built the pergola along the street. The storekeepers were quick to see the contrast between their old worn-out buildings, and began a campaign of improvement. A

uniform arcaded concrete front connecting all the stores was built. At a cost of a few hundred dollars, each storekeeper soon found himself the owner of a building not only of considerably greater value but also of more attractive appearance.

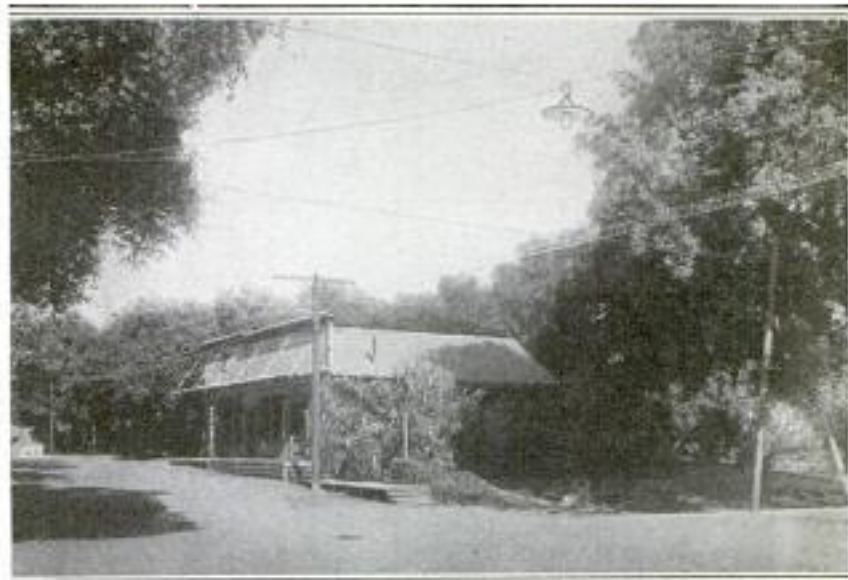

A Store Building on Main Street in the "Shack-and-Shanty" Town of Nordhoff, California, before Its Transformation: Similar Buildings Lined the Whole Street

The post office was faced with cement and the tower built over it. A new hotel along the same architectural lines was erected, and visitors found some inducement to remain in the town instead of passing quickly through.

The whole undertaking furnishes encouraging proof that the craving for beauty pervades even smaller communities, whose former isolation, perhaps, was the only reason why this spirit has not



View of Main Street in the Renamed Town Ojai: The Improved Appearance of the Street Is Striking, Despite the Fact That the Buildings Themselves were Not Materially Altered but Only Concealed from View by an Arcade of Cement Construction, as Seen to the Left. The Tower on the Church, However, Is an Addition to the Old Structure



This Picture Offers a Closer View of the Arcade behind Which are Hidden the Old Business Buildings, of Which That to the Extreme Left Is the Post Office. The Smooth Condition of the New Cement Street Is Also Apparent. The Pergola and Vaulted Entrances on the Other Side Lead to the New Park

before expressed itself in visible improvement.

The entire work cost \$50,000. Nordhoff was an eyesore; Ojai is a popular resort. Other communities use it as a pattern.

COMPRESS POWDERED GYPSUM 129 TO MAKE BUTTONS

Buttons are now being made of powdered gypsum, which is first compressed to the desired shapes in molds and then dampened with a fine spray of water to effect a "setting," or hardening, process. It is said that buttons are manufactured economically, rapidly, and with exceeding exactness in this manner, in addition to which they possess great durability. Buttons may also be made by this method from burnt magnesite, or from a mixture of burnt magnesite and gypsum. If burnt magnesite is used, the hardening must be done with a chloride-of-magnesium solution, the result being an especially strong and durable material.

U. S. Patent 1,427,100



Here Is Another Street View, Which Even Better Illustrates the Monotonous Character of the Old-Fashioned Shops and Their More or Less Dilapidated State. The Building in the Left Foreground Houses the Post Office

*Dr. v. Gerthus Haemische
Berlin
Sempelhof, German*

1238 A NEW MILITARY SELF-LOADING RIFLE

BY CAPTAIN EDWARD C. CROSSMAN

SEVERAL years ago a board of navy officers made the surprising discovery that a perfectly strong and well-designed navy rifle for one of the battleships would unlock its massive breech and open itself when fired with the light charges used for saluting, but when used with the high-pressure full-service charges, would remain as firmly locked as the

vault of a great city bank during the hours of darkness.

The resulting line of investigation terminated in the application for a patent by Commander Blish on a form of breech-locking device for big and little guns which would remain firmly locked during the high and dangerous pressure of the explosion in the gun chamber, but would

then unlock itself and permit the breech to open when the pressure had fallen to a safe point, and the projectile had left the barrel.

A great American arms factory has produced two arms using this queer principle, one of them the now well-known sub-machine gun, the other a self-loading infantry rifle submitted to several testing boards of the American army. The little submachine gun, using pistol cartridges, has been adopted by many American police forces, and was the "machine gun" forming the cargo of the steamer billed to Ireland and seized a year or two ago in New York harbor.

The Thompson self-loading infantry rifle is less well known, as it has been made only in experimental form for test by the ordnance boards of our army. This rifle, designed by the former assistant chief of ordnance, and using the Blish patents, fires the 1906 U. S. Army cartridge, fed from a box magazine, which is in turn loaded by the regulation army clip, with which we are all familiar.

As submitted to the army board, the rifle was made with the retractor, or recoil spring, in a tubular housing in the rear of the breech mechanism proper. The bolt is locked by a modification of the Blish principle, in this case turning out of engagement with the receiver shoulders when chamber pressure and friction have fallen to a low enough point to free the engaging surfaces. The little brother of the infantry rifle, the sub-machine gun, makes use of a wedge-shaped locking bolt, sliding at nearly right angles to the bolt of the rifle and lying below it.

Retraction of the bolt, to load the first shot from the magazine, is accomplished by a bolt handle at the rear of the receiver, but after this first cartridge is

loaded into the chamber, the rifle requires no further aid than a pull of the trigger for each shot until the 10-shot magazine is empty.

Unlike the submachine gun, there is no device to change the fire to truly automatic—that is, fire continuing as long as the trigger is held back and the magazine contains ammunition. The heavy recoil of the infantry service cartridge and the relatively light weight of the rifle would make the arm unmanageable with automatic fire. Even the 17-pound Browning rifle for this ammunition requires very short bursts of automatic fire to keep its bullets in the vicinity of the object fired at.

As the Blish principle is based upon friction and as friction is a variable, depending upon the presence of grit or grease, both the submachine gun and the Thompson self-loading infantry rifle require oil for their successful working. The inventors argue that, as motor cars and their engines operating at lower speeds and with less heat than is developed by smokeless powder, require oil, there is no sound reason why the automatic or semiautomatic war gun should not also be oiled.

Whether oil can be successfully used on a rifle intended for issue to the ordinary infantry private remains a question, in view of the dirt and neglect that mark the use of the infantry rifle in actual fighting.

☐ An accurate spirit level with the bubble constant at all ordinary temperatures, in which the proportion of air and liquid and the shape of the bubble tube are so arranged that a variation in temperature affects only the cross-sectional area and not the length of the bubble, has just appeared.

E. A. Watts + Son, Ltd.
 121 Gamberwell Road, London, E. C. 6.

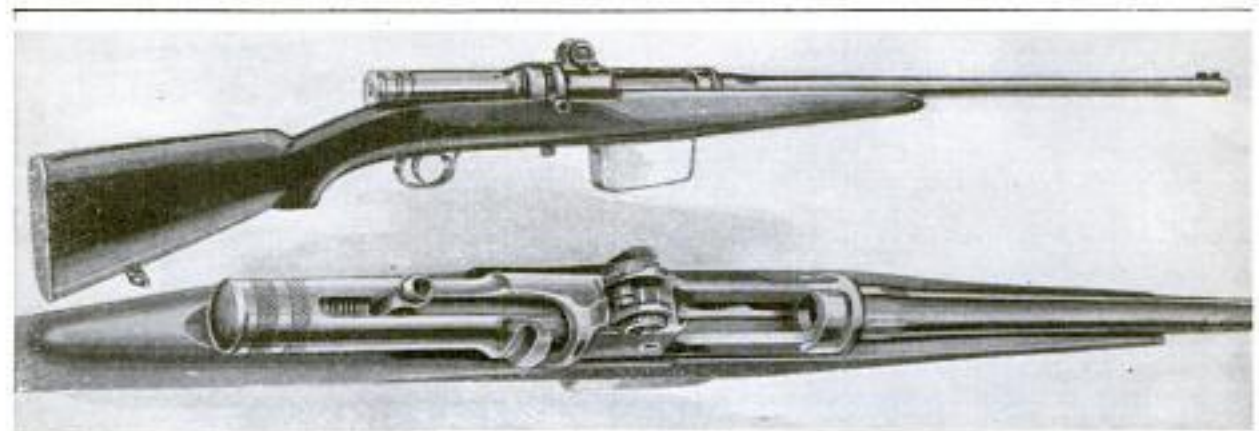

Top: Self-Loading Rifle Which has been Introduced for Use by the Infantry, Showing the Tubular Recoil-Spring Chamber and the Boxlike Magazine for the Cartridge Clips. Bottom: Looking Down upon the Rifle Mechanism at Close Range, Showing the Peculiar Bolt Action and the Recoil Spring

1165 Los Angeles Street
 Railway Co.
 Los Angeles, Calif.
 POPULAR STREET-RAILWAY SIGNS ASK
 CLEAR TRACK FOR CARS

Failing in an attempt to make it unlawful for motorists to operate their



Signs Placed on Los Angeles Street Cars, as Shown Above, have Proved an Effective Means of Enlisting the Cooperation of Motorists in Keeping the Tracks Clear

machines on street-car tracks in the business district, a Los Angeles car company is directing an appeal to the drivers themselves. Each week a new series of posters, placed at the front and rear ends of the cars, urge the motorists to keep off the tracks, or at least to keep moving if on them. One reading, "Mr. Autoist: Give the Street Car Riders Fair Play—Please don't Block Traffic—Thanks!" and another, "Mr. Autoist: Street Car Riders Are in a Hurry, Too.—Be Fair—Thanks!" may be taken as typical of the series.

1310 PAINT MADE WITHOUT OIL
 CHEAP AND DURABLE

Paints and varnishes of various kinds in which oil or shellac will not be required as a mixing body, or medium, may now be made by a recently discovered process. The new paints and varnishes can be produced at approximately half the cost of those now on the market, according to the inventor. In addition, the product is said to present the same appearance as oil paint, to have no noticeable odor, and not to blister in the hottest sun, nor crack at low temperatures.

Dr. Chas. H. & Co. Ltd.,
 c/o Plaster Chemical Co.,
 Glasgow, Scotland

Dr. W. O. S. Snodgrass
 c/o Institute Aeronautical
 MECHANICAL ENGINEERS

PENDULUM APPARATUS IS USED
 IN AERODYNAMIC TESTS

A pendulum apparatus for making aerodynamic experiments such as testing airplane models, has been developed with a view to the needs of those who do not have access to a wind tunnel, since it can be easily and cheaply constructed from materials available in any engineering workshop. The model is carried in a tubular frame at the lower end of a hollow pendulum, 12 feet long, which is suspended from a pivot on the ceiling. With the pendulum in motion the lift force of the model is measured by the deflection of the pendulum and indicated by a pencil mark on a piece of paper on the floor. The drag can be calculated from reduction in height of the pendulum swing. The apparatus can also be used for plotting the pressures on the surfaces of the model.

EARTH-BORING AUGER HAS RELIEF VALVE

An auger that has recently been introduced abroad for the purpose of boring holes for fence posts and poles, has an ingenious valve arrangement in the wing that allows earth to pass through while boring, and keeps it from going back into the hole when the auger is pulled out. A toothed guard pushes stones out of the way of the valve. A size that can be handled by one man without unduly tasking his strength, will make holes ranging from 2 to 15 inches in diameter and about 7 feet deep.



Wahrenburg, Minn. H. H. 9. - Bureau.
 Fred Webster, 12. Adon's plate 12.
 mfr. Hersteller, 7.

208 *The Collapse Auto Bed Co.*
Aut. 2110 N. Broadway
CAMPING TENT WITHOUT STAKES, GUYS, OR POSTS
Los Angeles, Calif.

A new lightweight camping tent for automobile tourists, which requires neither posts, stakes, nor ropes, is supported by steel braces running from sockets at the corners of two beds, stretched along the side walls, to a framework of steel bows under the tent roof. The beds, of light

ingenious method of support is that it relieves the canvas of strain, and consequently prolongs its life. With the smaller size one-bed tents, it is possible to make the overhead framework horizontal, thereby converting the tent into a canopy.

Another innovation is a cooking unit



Above: View of the "Kitchenette," Aluminum-Lined and Weighing But 37 Pounds. Below: The Tent as It Appears When Set Up. Note the Absence of Tent Poles, Stakes, and Guy Ropes

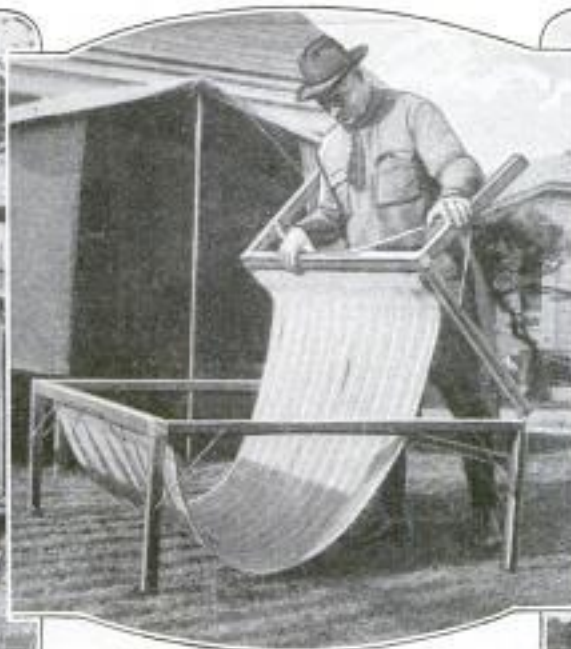

The Folding Auto Bed Which Forms an Integral Part of the Camping Outfit: The Webbing is So Arranged That It Remains Taut after Long Use



Here is Shown the Entire Framework of a Two-Bed Tent, Weighing Only a Few Ounces and Nesting in Telescoping Tubes. On the Ground is One of the Beds Folded



pine and nonstretching webbing, weigh 32 pounds, and when folded occupy only a small space. The braces are carried in two brass tubes which are partly telescoped and used as the ridgepole when the tent is to be erected.

One of the advantages claimed for this

or "kitchenette," a canvas-covered aluminum chest that serves both as a cupboard and a stove stand. The sides are so made that they can be extended to furnish a windshield for the stove, while the whole outfit can be hung on the rear wall of the tent, set up on the ground anywhere, or

placed on the auto running board. Still another practical piece of camp equipment included is a webb-topped table, which can be adjusted and used as a chair.

669

HEIGHT AND WEIGHT TOLD BY NEW SLOT MACHINE



In a novel improvement of the ordinary weight machine, the scale is placed in the middle of the upright section, which in this case is glass-covered. Above the scale is painted a series of horizontal lines, at the left of which appear small black squares. When the coin is inserted, the weight shows as usual, and the squares drop, each revealing a height corresponding to its horizontal line. The center of the eyes being on a level with the top of the ears, height is indicated by the horizontal line upon which vision alights.

Dr. W. V. Slegnick, 143 W. Austin Ave. Chicago

WARNING LIGHTS FOR AUTOS LIKE RAILROAD SYSTEM

1064

Protective lights for the rear of automobiles, patterned after the railroad sys-



Automobile Signal Device Which Uses Red and Green Lights: The Day Lights Are Brighter than Those Used at Night

tem of red and green signals, are a recent development. When the machine is mov-

Dr. W. Harry Burden, 131 Bleacher St. Newark, N.J.

Dr. W. Dr. Lem H. Cornell, Pathological Laboratory, City Hospital, New York

ing, a green light shows constantly, but when the brakes are applied, the green signal is extinguished and a red one flashes a warning to following motorists. Two sets of green and red lights are used, one set for daylight driving and the other for night travel, the former being more powerful so that they may be plainly seen in the sunlight. Interlocking shutters are provided for each pair of lights and the signal has two 1-inch red side lights.

1151 AUTOMATIC MEASURING AID FOR USE OF CHEMISTS

Measuring small quantities of fluids, such as is required of chemists or those

engaged in similar pursuits, has been facilitated by the introduction of an automatic appliance. The outfit, which may be clamped onto the neck of a bottle, or other container, or attached to a stand or bench, consists of a compressed-air cylinder actuated by a rubber bulb, the cylinder in turn operating a syringe.



To the bottom of the syringe a rubber tube may be affixed, this tube extending into the bottle or other vessel from which the liquid is to be taken. A regulating, adjustable nut on the cylinder may be manipulated so as to control the amount of fluid drawn up when the bulb is pressed, this measured amount being then ejected from the tip, or nozzle, of the syringe when the bulb pressure is released. The apparatus will be particularly useful in places where a large number of routine tests are performed.

Dr. W. Dr. Lem H. Cornell, 55 E. 76th St. New York

ⓂA long-distance telephone installation between Peshawar, India, and Kabul, the capital of Afghanistan, is under consideration at the instance of the ameer of the latter country. The line will pass through the famous Khyber Pass.



COPYRIGHT, INTERNATIONAL NEWSREEL CORP.

PARACHUTE BEATS AIRPLANE TO EARTH

THIS picture shows Dick Cruikshank, famous parachute jumper, lighting on the ground, as he won, by a few seconds, a race to the earth with E. Hamilton Lee in an airplane. The race started 1,500 feet in the air, when Cruikshank dropped from the wing of the airplane, which dived abruptly in an attempt to make a record landing. By delaying the opening of the parachute, a jumper can shorten the time of his descent.

1019



SCIENTIFIC METHODS IN THE UTILIZATION OF WOOD

SCIENTIFIC methods in the utilization of wood are believed to be as profitable and as practical in the forest as in the later stages of manufacture, this fact being illustrated in the accompanying picture. Some of these methods are: the cutting of "low stumps" so as to secure maximum log lengths; the peeling of felled logs to facilitate seasoning and to minimize insect or fungus attack, and leaving the small growth of sufficient desirable seed trees to insure reproduction. The slash, or trimmed-off branches, is burned as soon as it is cut from the trees, together with all underbrush. This clearing of the ground aids in "skidding out" the logs, and also leaves it in a condition that will not favor fires which might sweep the cut-over land and retard a second growth of timber.

Forest Products Laboratory,
U. S. Forest Service, Madison, Wis.

Painters Harry + Bertha Typer, Oakland Calif.
Hartman-Steindorff Comic Opera Co.
SCENIC ARTISTS MAKE CLEVER STAGE EFFECTS

793 The realistic scenes and spectacular theatrical effects shown on the stage and

in Turkish rugs, and the effect on the imagination seemed all that could be desired.

In making artificial trees, of which one was to be hollow and house a man-sized owl, the trunk was made of laths, rattan hoops, wire-bound into form, and loosely covered with canvas, which was soaked with glue and squeezed into ridges, corresponding to bark and knurls. Florists' moss, stuck into the wet glue, gave a final touch of realism. A trick elephant was made up of a canvas-covered skeleton formed of flexible ribs and strands of rattan, over which cardboard was laid, and the whole properly painted. It was arranged that the men, who were to support the form on their shoulders and furnish the legs of the animal, should operate the ears, eyes, and tail by means of strings, and manipulate the flexible trunk with the aid of a rod, so as to pick up articles, like a bottle. Various trappings of Oriental design were put on to give a final touch of realism to the animal.

Ⓢ A race track to be used in trying out new types of cars is to be built by motor-car builders and the Automobile Club of France in a wooded district north of Paris. It is planned to acquire 900 acres and make the track from four to six miles long.

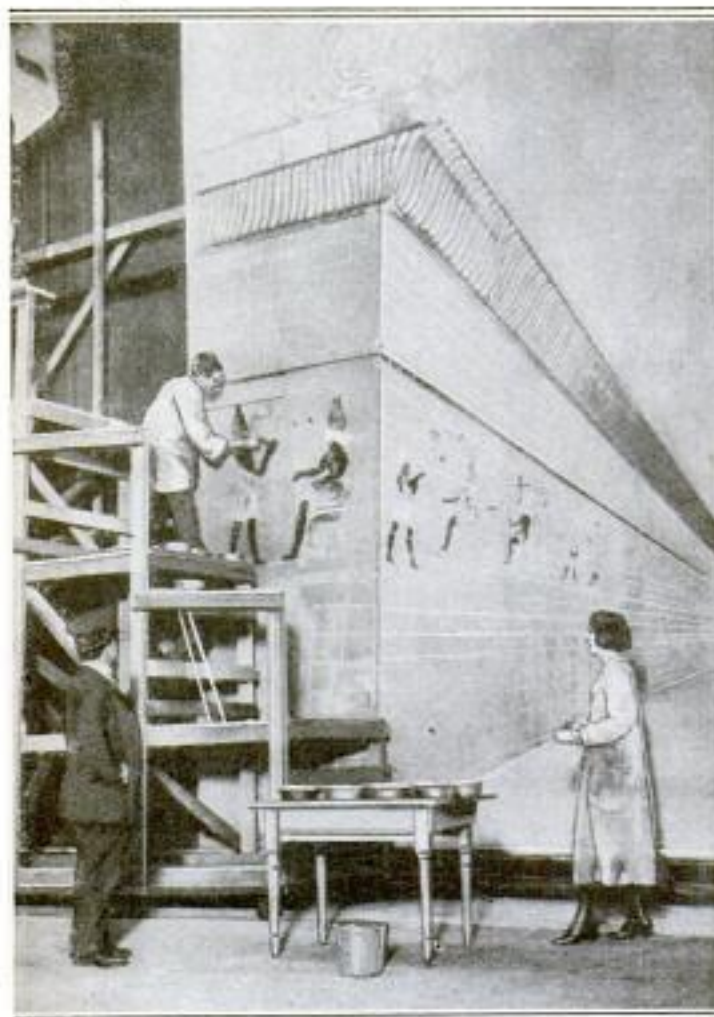

Clever Young Scenic Artist and His Wife Busily Engaged in Painting One of Their Striking Settings for a Comic-Opera Production

on the screen are not often what they seem to be, and it is interesting to know a little of the way they are created by clever scenic artists and craftsmen.

The work of two young artists who design and paint the scenery for a western comic-opera company, is attracting considerable attention for the type of their scenery, which is based on the psychology of the relation of colors to moods and actions; to suggest rather than reveal. In a comic opera, of Oriental setting, for instance, in one scene they used designs and colors found

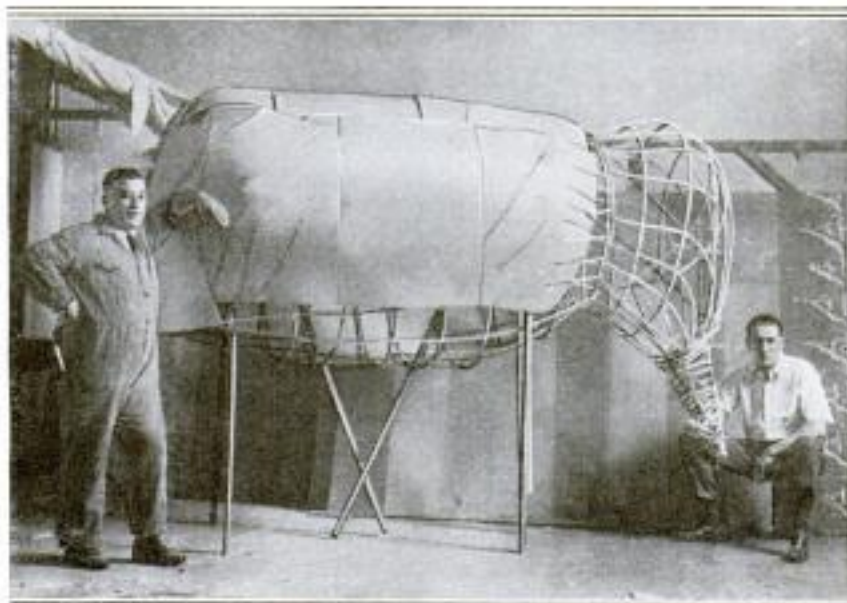

A Stage Elephant in the Process of Construction: The Skeleton, Formed of Flexible Ribs and Strands of Rattan, is Covered with Canvas. A Man, Front and Rear, will Furnish the Legs

957 Dr. W. Fred L. Sawyer,
Jacksonville Fla.

70 P. No. Hall, of the Times-Union
REVOLVING BARREL SCALE IS AUTOMATIC

419

Jacksonville Fla

There has lately been invented a revolving scale for the automatic filling of barrels with an accurately weighed quantity of oil or other liquid. Two distinct weighing elements are mounted on a frame that surrounds a vertical shaft, with the intention that one barrel will be filling while another is being removed. Each scale has a tare beam and poise and a separate blade and poise for the liquid, which is automatically shut off when the desired amount has run into the container. The filled barrel is quickly revolved to the unloading position while an empty barrel is swung under the filling spigot.

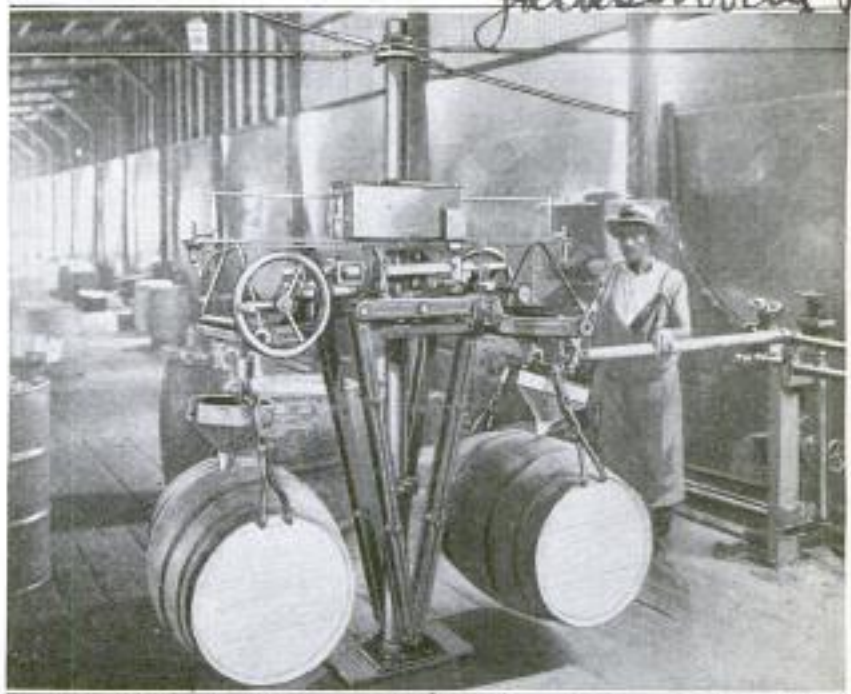

Revolving Scale for Filling Barrels with Oil and Other Liquids: When the Desired Amount has Run In, the Flow is Automatically Shut Off, and the Scale is Then Turned Halfway Around

663

STORE FRONT IS BUILT WITH STONES AND SPLIT LOGS

A store front of cobblestones and split logs has been built by a Pacific-coast retailer of outdoor equipment in an attempt to create a suitable atmosphere for the display of his goods. Carrying out the rustic theme, in the interior of the store,

desks, shelving, and other fixtures have been made of split logs, and model camps set up as in actual use.

MINIMUM SPEED OF 175 MILES SET FOR PULITZER RACE

It was decided that an airplane not capable of making better than 175 miles an hour would be ineligible to compete in the 1923 Pulitzer Cup races, at a recent meeting of the National Aeronautic Association. At the same time the maximum landing speed for this race was fixed at 75 miles an hour. On account of the dangers of making abrupt turns at such extraordinary speeds, and the inability of the heart to force blood to the brain against the centrifugal force that occurs, the committee has arranged for the race to be four laps around a 50-kilometer equilateral triangle with two towers at the angles so as to insure a wide turn.

Journal 12/23/22

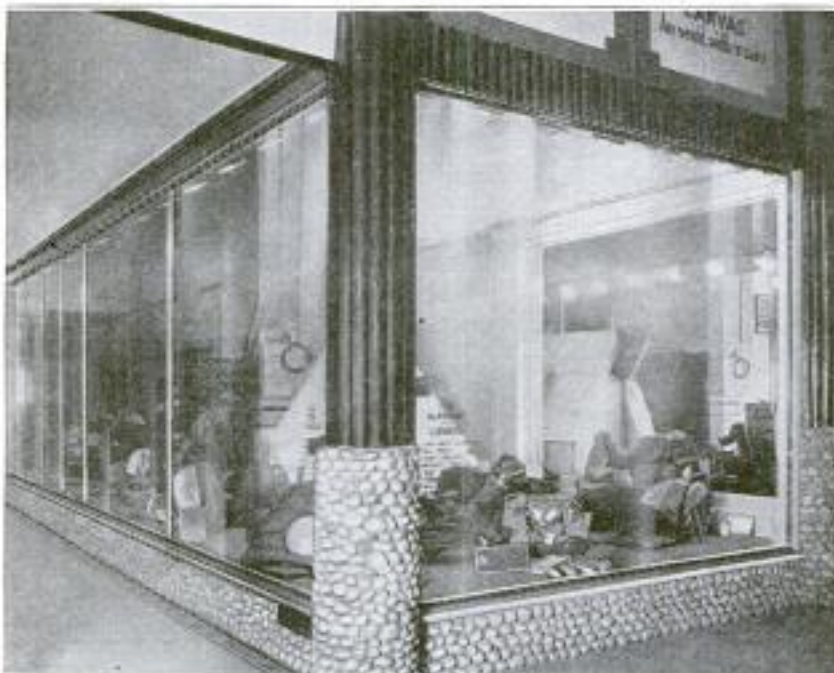

The Rustic Effect of This Store Front is Also Carried Out in the Interior of the Store, the Goods being Displayed as if in Actual Use

Cont. L. W. Pedrose
1453 W. 54th St. Seattle Wash.

Copyrighted material

**TRAPSHOOTING MACHINE HAS
STAR-SHAPED MARKERS**

991

A newly invented trapshooting machine, which automatically fires and reloads on the pulling of a cord, has peculiar star-shaped markers that are flung high into the air. The markers are stored on a vertical shaft, from which they drop, one at a time, onto the shooting bar as the mechanism is

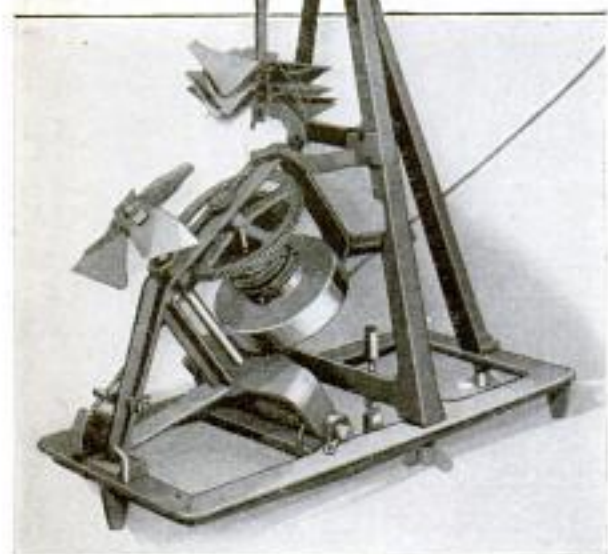

Automatic Trapshooting Machine That Fires and Reloads by Pulling a Cord: The Star-Shaped Markers Are Practically Indestructible and can be Used Again

drawn back by the pull of a cord. This movement also rewinds the drum for the next shot, and at the release of the spring, the large gear starts the shooting bar revolving rapidly.

remaining examples of the clipper-ship age, was being towed to a beach on the shores of Puget Sound, there to be burnt for the salvage of the iron and copper in the hull, when its destruction was halted by a telegram from Boston. It was announced that east-coast shipping interests are endeavoring to make arrangements to tow the ship back to its old home port, where it will be rerigged and set up as a permanent memorial of the American sailing-ship days. Meanwhile, old "Glory of the Seas" will remain moored on the beach where it was to have become its own funeral pyre.

1302

**HEAT AND ELECTRIC WAVES
OF SAME LENGTH FOUND**

According to the ether-wave theory of energy radiation, heat, electricity, and light are essentially of the same nature, differing in their manifestations only by reason of their different wave lengths. Thus heat waves, so far as investigators have hitherto been able to ascertain, are much shorter than electric waves, and between the longest heat wave and the shortest electric wave there has been a break or gap in continuity, which scientists have been anxious to fill, because

Science 1/5/03



**OLD AMERICAN SAILING SHIP
PRESERVED AS A MEMORIAL**

124

The hulk of the famous old American sailing ship "Glory of the Seas," built in East Boston in 1869, and one of the few

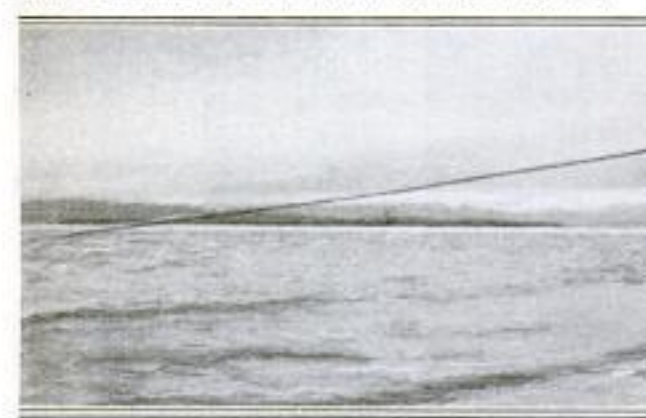

The "Glory of the Seas," an Old-Time Clipper Ship, as It Lies Beached on the Shores of Puget Sound, Awaiting Its Fate: Boston Interests are Endeavoring to have It Restored to Its Former Beauty, and Preserved at Its Home Port

Emb. J. P. Esrahams, 823 North Hill Ave
Seattle, Wash

1802

Elgin Sales Co
10 S La Salle St.
Chicago

the intermediate wave lengths might represent some unknown form of energy. Success has now come to the searchers in this field, and it is announced that two scientists of the Nela Research Laboratories, Cleveland, Ohio, have been able to generate, receive, and measure electric

CITY-SERVICE AUTO TRUCKS COMBINE SEVERAL DUTIES

Two motor-driven municipal-service trucks which will perform duties that heretofore required independent units, have been developed and are now in use. One is

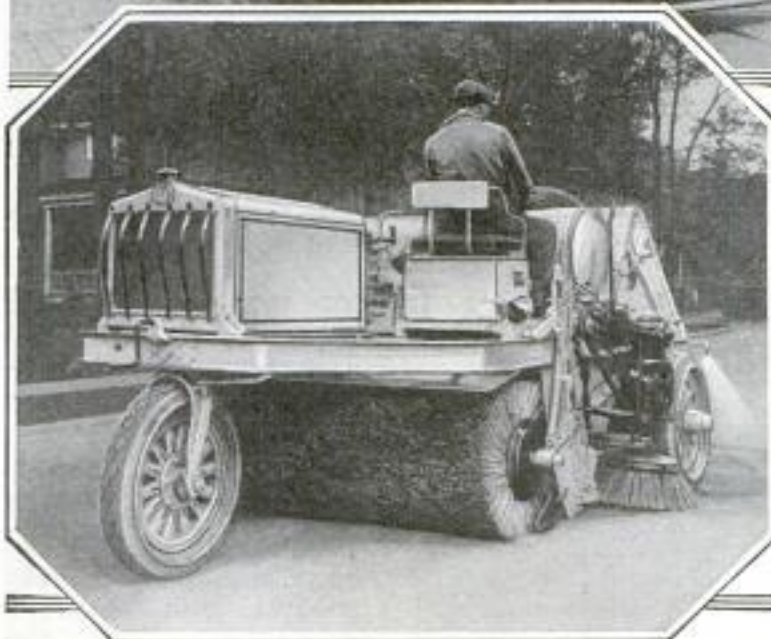
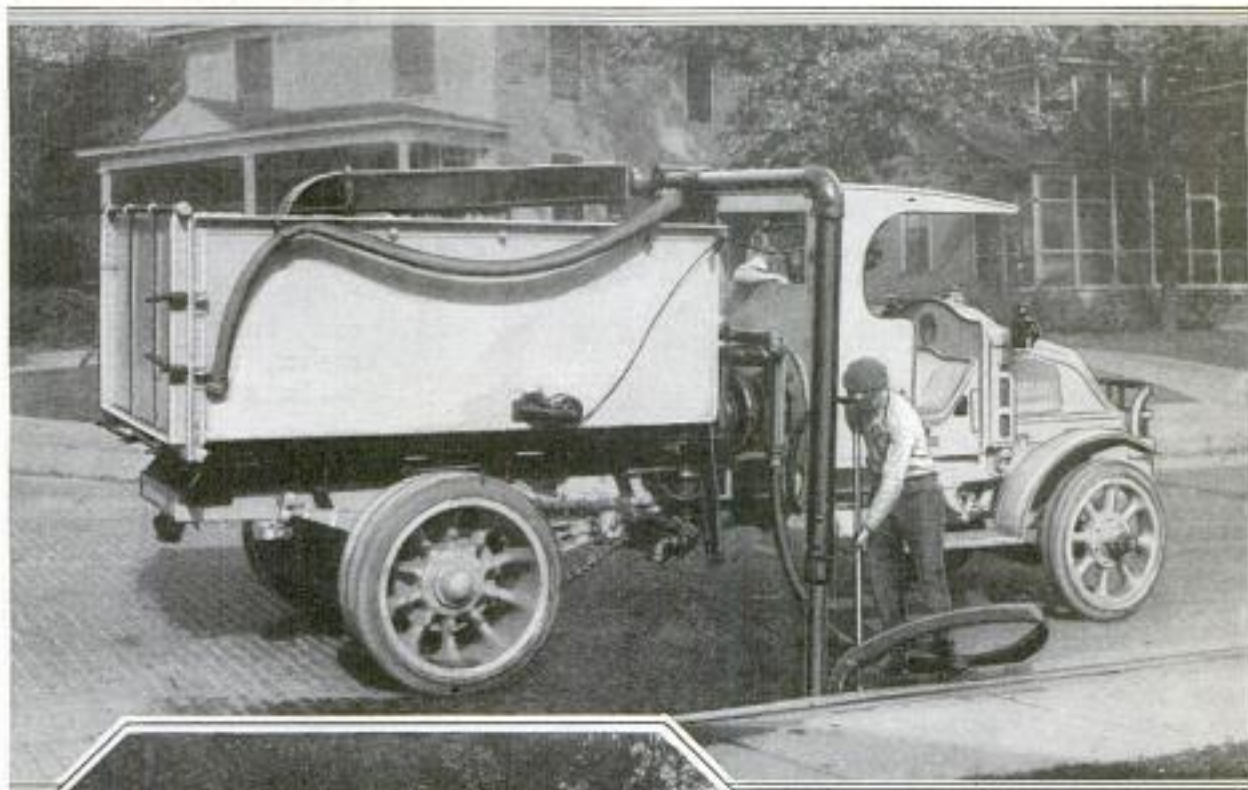

Combination Street Sweeper and Sprinkler Which Wets the Surface Ahead of the Revolving Brush and Prevents the Clouds of Dust That Usually Accompany Such Operations

waves of only half a millimeter, or about $\frac{1}{50}$ of an inch long, that is, of practically the same length as the longest heat wave.

When you want anything and do not know where to get it, write Bureau of Information, Popular Mechanics, Chicago.

The Above Illustrates a Machine That Is a Combination Street Flusher, Tree Sprinkler, Emergency Fire Pump, Cesspool Cleaner, and Snowplow Tractor, with the Various Attachments Easily Removable So That Changes can be Made Quickly

a combined street sweeper and sprinkler. The water is applied to the street surface before it is touched by the brooms, and thus are avoided the clouds of dust that usually accompany the passage of an independent rotary sweeper. The rotary broom is suspended in floating bearings, and automatically adapts itself to any unevenness of the pavement. The other machine is a combined street flusher, tree sprinkler, emergency pump for fires, cesspool cleaner, snowplow

tractor, and ordinary motor truck. Any of its various attachments can be removed at will. These machines will be particularly appreciated in the smaller municipalities where conditions do not warrant the purchase of equipment adapted to only one class of work.

**HOMEMADE CARS
USED IN AUTO-
POLO GAME**

480

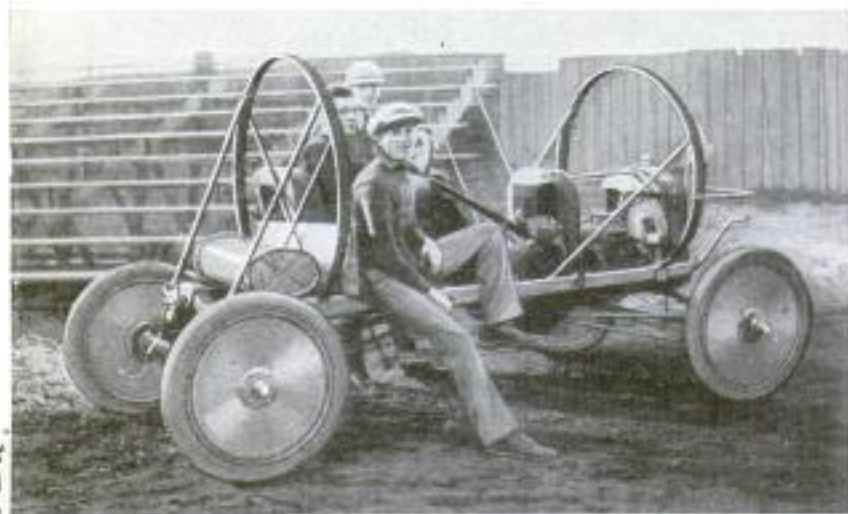

One of the Homemade Auto-Polo Cars Used in an Exciting Contest: Neither Cars nor Players Suffered Injuries in the Strenuous Game

In staging an auto-polo contest not long ago, students at the University of Indiana used some light cars that they rigged up to withstand the hard knocks of that strenuous game. The chassis was stripped of all the nonessentials, and equipped with an iron bumper in front and one large iron hoop front and rear. In spite of hard crashes, no damage or accidents occurred.

**FIRELESS FUMIGATOR KILLS
1034 FLOUR MOTHS**

Fumes emanating from a noncombustible powder, are circulated by means of an electric fan in a new method of exterminating flour moths that are such a nuisance in mills where flour is processed and stored. The powder is placed on a fireless and well-insulated electric hot-plate that drives off the volatile constituents, leaving a residue to be thrown away. This method is said to assist in the eradication of other insects that have a tendency to infest flour mills, by stupefying them so that they can be easily collected.

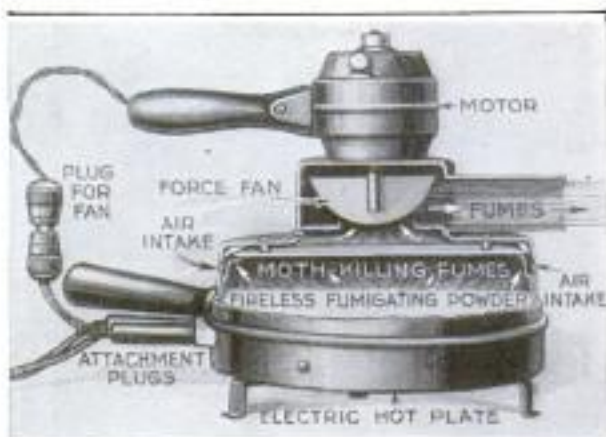

Fireless Electric Fumigator Reported to Be Effective in Destroying Insects That Infest Flour Mills

559 **CARTRIDGE BELTS SALVAGED FOR BRASS**

Huge quantities of cartridge belts, said to have cost the government \$1.75 each,

have been burned in the furnaces of a smelting and refining company, to salvage their brass content. The value of the brass in each is about 1½ cents. As is well known, these belts consist mainly of heavy canvas, the only brass being in the snaps and clasps. Thus, the ratio of the initial bulk to the ultimate concentration is striking. The metal obtained from a pile of belts that would cover the area of an ordinary city block, may be contained in a bin of but a few cubic yards' capacity.



Impressive-Looking Pile of Army Cartridge Belts to be Salvaged for the Brass Buckles, Each Worth Only About 1½ Cents

Balback Smelting Refining Co.
280 Broadway, New York City.

Insect Products Co.
5107 Brush St.
Detroit, Mich.

Copyrighted material

SMOKE PREVENTION IN CHICAGO UNION STATION

BY ROBERT H. MOULTON, *Comm. L.**Board of Trade, Chicago*

ONE of the most serious problems to be faced in the construction of modern railway terminals is that of abolishing the smoke nuisance created by loco-

which overhang the station tracks at a number of street crossings. Because of the peculiar construction of the station, it was known that, if smoke and gases

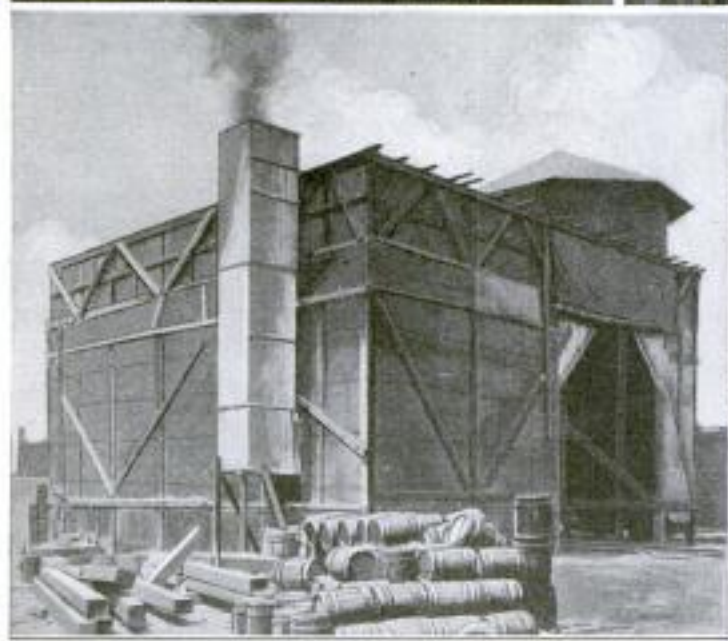
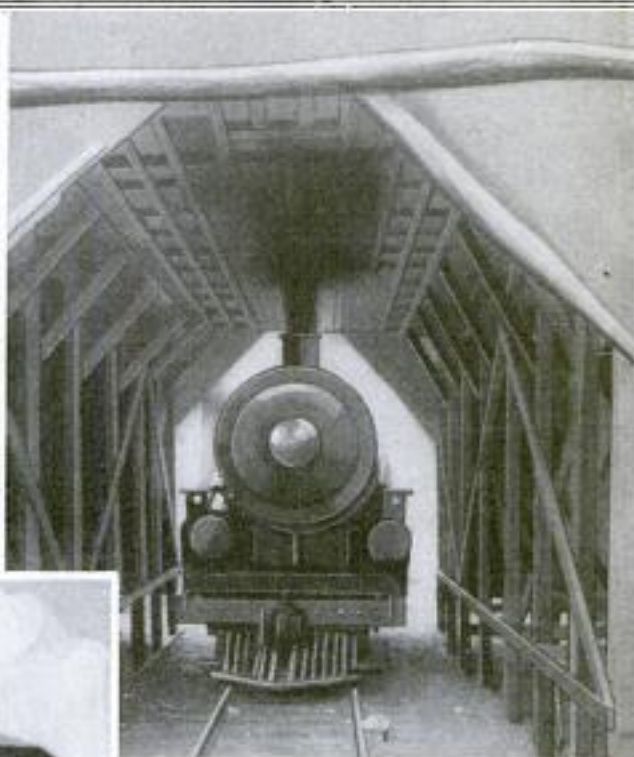
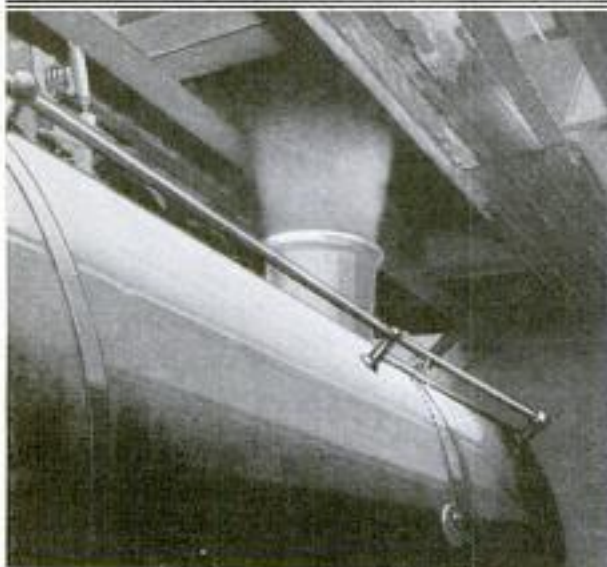

Upper Left: Locomotive Stack Discharging Smoke through Experimental Slots in Roof of Test House. Above: Locomotive in Test House Built to Determine Best Way of Eliminating Smoke Nuisance in New Union Station at Chicago

Outside View of Structure in Which Smoke Tests were Conducted: It was Built to Create, as Nearly as Possible, Conditions That would Exist in the Train Shed

motives while standing in the train sheds. Special devices on locomotives, mechanically operated ducts, and others operated by the blast from the locomotives, have all proved more or less unsatisfactory. Therefore, in constructing Chicago's new \$60,000,000 Union Station, the engineers decided to experiment along new lines.

For this purpose they erected a special structure which was, in effect, a section of the viaducts that pass over the depressed tracks in the train shed and those

were permitted to accumulate under these viaducts, they would quite likely sift into the concourse and produce an extremely undesirable condition in one of the most used and important spaces in the entire station, which would be difficult to remedy later.

The test house, as it was known, represented a two-track section with just room enough for a single locomotive and with a curtain which could be dropped at each entrance in order to create conditions as they would be in the station itself, and so make the tests more thorough.

It was decided in the beginning that the only device which would be entirely satisfactory would be one that could perform its function entirely independent of the locomotive under all conditions of standing and running, and which could

also be installed in a manner that would not require any structural changes in the viaduct design.

Accordingly, a design was made of a system of open slots in the ceilings of the viaducts over the track center line. These slots were continuous in length, except where broken by the bottom of the flange of the viaduct girders, and were first made 30 inches wide at the bottom and 12 inches at the top, the space under the floor of the viaduct and above the ceiling being used as a gas or smoke chamber, and these chambers in turn connected to a series of flues and ducts leading to ventilating fans.

The device worked successfully from

the start, the only trouble being that, when the locomotive was laboring very hard, the smoke and gas had such great velocity that they would slightly overcome the suction of the fan, with the result that a small quantity of smoke escaped down through the smoke duct over the next track.

This difficulty was overcome by the use of a suction-flue design with the openings in the form of a continuous slot at the top and a baffle arranged to stop the smoke and gases from passing this point and at the same time guiding them into a slot, the space below the flue being closed. The experiments have shown the engineers that the device is practical.

100 57

**CABINET OF 48,300 PIECES
TAKES YEARS TO MAKE**

A cabinet consisting of 48,300 pieces has just been completed by a patient workman who spent the greater part of 13 years in accomplishing his self-appointed

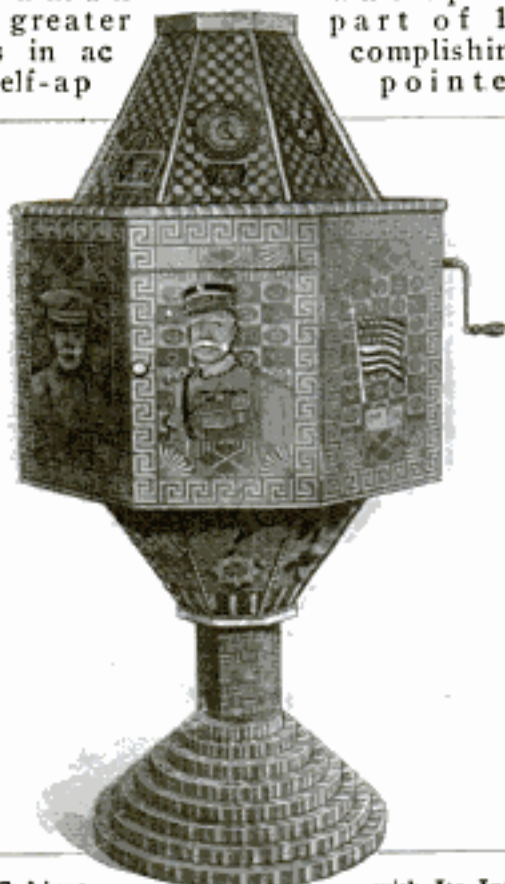

This Cabinet, with Its Intricately Patterned Pedestal, Pictures, Flag, Decorative Borders and Corners, and a Clock, is Built Up of 48 300 Pieces of Wood

task. The finished product is of pedestal design, with many decorative borders and corners, and an ornamental clock. Pictures of noted men and an American flag, made of tiny bits of wood, are also incorporated in the cabinet.

*made by - Richard Roy,
Augusta Maine*

1308 **PERMANENT POISONING FROM
GASOLINE FUMES**

Symptoms all the way from drowsiness to a state of talkativeness and foolishness, commonly called a "jag," have been found to result from working where gasoline fumes arise and the ventilation is not adequate. Inhaling the fumes, according to the United States Public Health Service, brings about sooner or later what is termed "gasoline poisoning." This disease results in blurred vision, constant dryness of the throat, insomnia, constipation, loss of appetite, extreme nervousness, and other conditions, depending upon the temperament of the individual and whether or not the poisoning is in a mild, acute, or chronic form.

U.S. Public Health Service
**DECOY HAS SPACE FOR PARTS
AND IS EASILY CARRIED**

1094 A wooden decoy with a detachable head, which, together with the anchor and anchor cord, can be carried in a cavity made in the underside of its body, is a recent innovation in duck-hunting equipment. The head, resting on a small pivot, can be swung about to various positions. It is said that the duck floats without the objectionable side roll usually noticeable with wooden decoys.



It is said that the duck floats without the objectionable side roll usually noticeable with wooden decoys.

*Specialty Mfg. Co.
St. Paul*

Referat No. 786-9/22/22

University

2362

*wood material
mum*

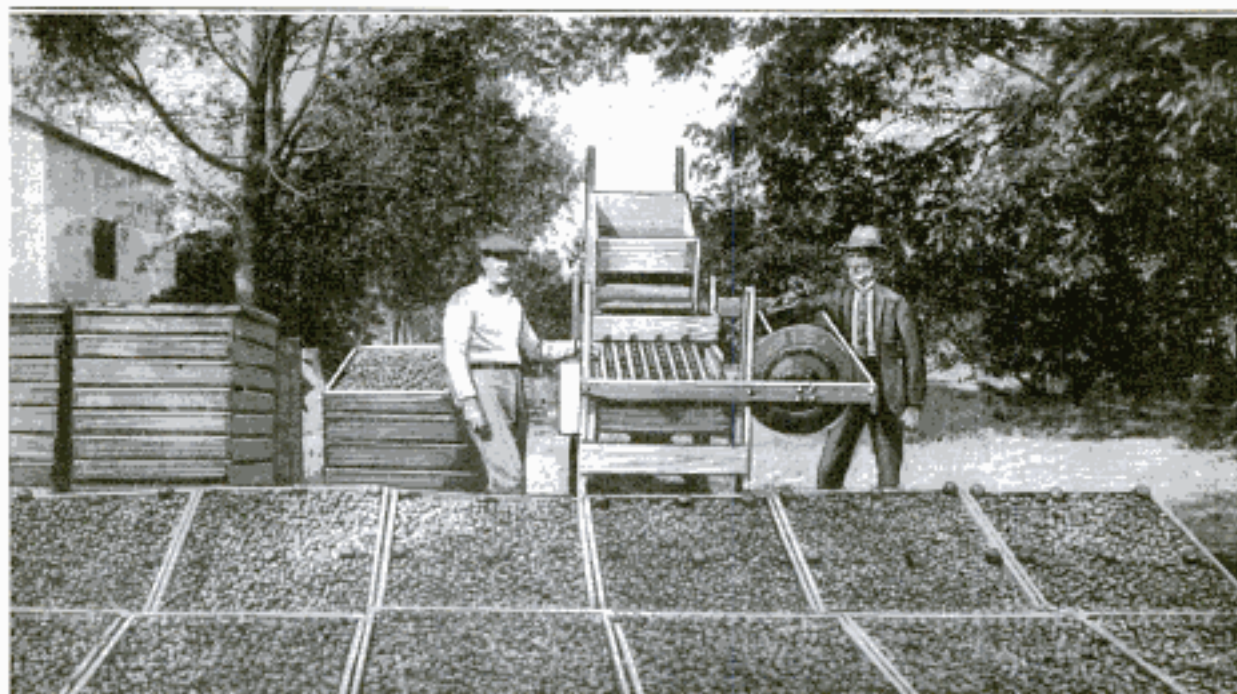

Using the Grading Machine Shown Above, Eight Sizes of Pecan Nuts can be Quickly Sorted. The Nuts Pass from the Hopper onto Rollers, with Various-Sized Openings between Them, Thence along Gutters Leading to Baskets on the Ground

1159
SORT EIGHT SIZES OF PECANS WITH GRADING MACHINE

Eight sizes of pecan nuts, ranging from $\frac{1}{2}$ inch to $1\frac{1}{4}$ inches, are quickly graded with a new machine. The nuts are dumped into a hopper at the top, and then fall by gravity into seven channels in front, the bottom of these being made of steel rollers with graded openings. As these rollers slowly revolve, the nuts work down until they pass through their respective openings, and thence along special gutters leading to baskets on the ground. A large hand-turned wheel with a belt transmission to the rollers is the only power used.

103
ALARM CLOCK IS LIGHT TENDER IN MINNESOTA VILLAGE

Yes, that's a fact! It's done in the village of Elba, Minn., and the arrangement by which the clock is made to perform this duty is simplicity itself.

The village light plant is a small hydro-electric one, driven by a turbine set in the tailrace of the village mill. Each day, before going home for his evening meal, the miller winds and sets the alarm of the clock to go off at 11:00 p. m. When the time arrives, the alarm goes off, and by means of a cord, a trigger is pulled. This moves a hinged lever sufficiently to permit a heavy spring to recoil and pull its support away from a brace, which, up to the appointed time, holds the turbine

lever in open position. When this brace falls, the lever automatically assumes the

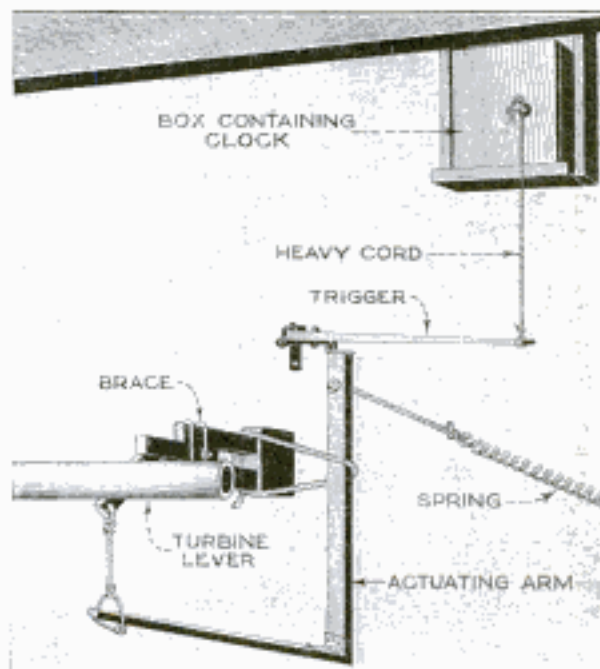

Crude but Thoroughly Practical Apparatus Which was Devised by a Miller to Extinguish the Lights in a Minnesota Village Automatically

closed position, thus shutting off the power and extinguishing the lights.

Ⓐ practical standard of night illumination for automobile license tags is being sought by the U. S. Bureau of Standards. The tests will determine the nature of light needed to make the tags visible at a reasonable distance.

Cont. P. A. Franklin, 121, Sixth Ave. S. E., Rochester, Minn.

Emt. H. E. Zimmerman
2661 Independence Ave.

426

POPULAR MECHANICS

Kansas City, Mo.
FLAGMAN BUILDS PORTABLE
HOUSE FOR WINTER

To render himself "immune" against the rigors of winter, a street-railway flag-

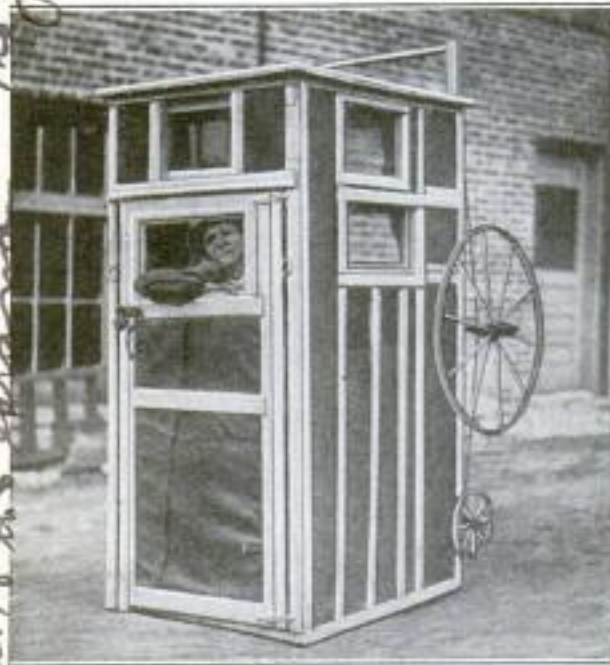

Wheels Arranged on the Back of This House. Made as a Winter Shelter by a Flagman. Enable Him to Bring It along to Work Each Day

man of Kansas City, Mo., has built a small portable house which he can bring to work with him. Attractively painted and with several small windows, the house cost the flagman just \$21.10, besides labor. Four wheels, two large and two small, arranged at the rear wall in a baby-carriage effect, and handles at the same side, enable him to transport the house easily.

1224

NEW WATER-SUPPLY SYSTEM
PROPOSED FOR MANILA

The water-supply system of Manila, P. I., considered inadequate for many years, must soon be enlarged or replanned entirely, according to the manager of the metropolitan water district. At a meeting of the Manila Chamber of Commerce three projects were proposed, the first to improve the present leaky reservoir, the second to construct two new large dams and a new pipe line, and the third to build a dam in connection with the Angat River, from which the water would be brought to the city by a tunnel. The capacity of this latter project, which seems to be the most favored of the three, would be 80,000,000 gallons and would take care of the city's needs for many years to come. Although subject to continual repairing, the present reservoir still has a leakage of 9,000,000 gallons a day.

1320

HUGE CANVASES SHELTER
MEN BUILDING PIER

With huge canvas covers protecting them from wind, snow, and sleet, and a steam-heating plant keeping the temperature up, the men engaged in building a pier on the Delaware River, at Philadelphia, find that they can work no matter what the weather conditions are. A heavy support and framework prevent the roof from collapsing with heavy loads of snow, while the side covers, though put up more simply, have been found sufficient to withstand both wind and sleet. An 80-horsepower boiler feeds the heating system.

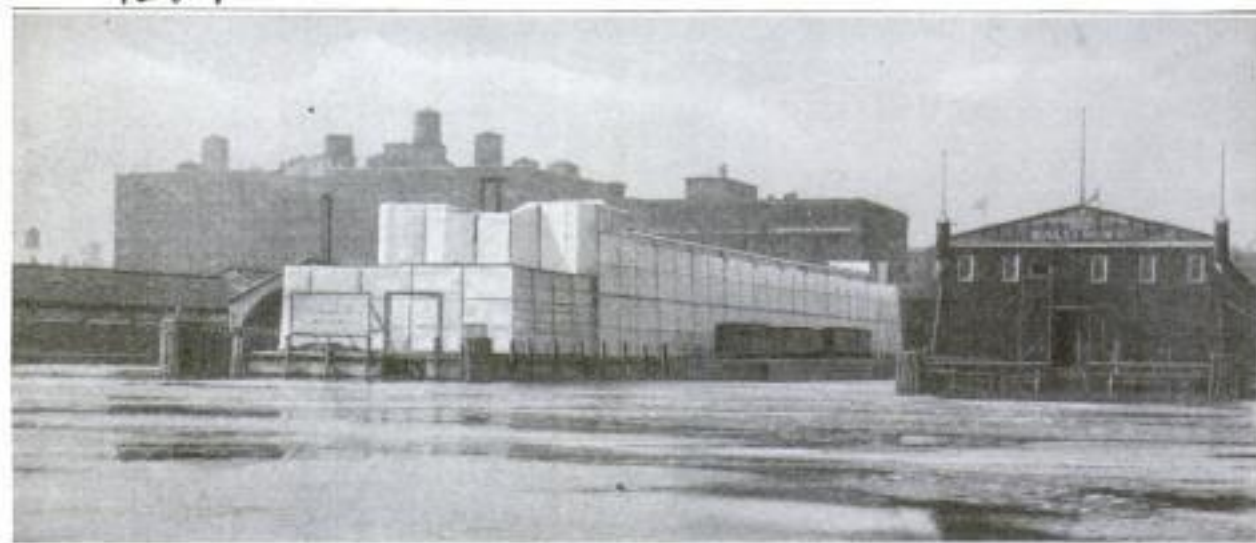

With the Huge Protecting Canvases Shown Above, Erected over the Steel Structure, and a Heating System Inside, the Men Building This Pier on the Delaware River Found They could Continue Working No Matter How Cold or Stormy It Was Outside

J. S. Rogers Co., Philadelphia, Pa.

Copyright material

Owner - J. W. Brown, Metropolitan Street Railway Co. Kansas City
Flagman at 15th St. Springfield

The Far Eastern Review
December, 1922



MOUNTAINSIDE MINE WORKINGS SHOWN BY AERIAL PHOTO

THE large scale on which surface mining of copper is conducted, is vividly shown by a photograph taken from an airplane which flew over a large mining property at Bingham, Utah. The picture shows so clearly the series of terraces formed by the steam shovels cutting their way into the side of the mountain, that the engineers use it as a means of planning future operations. It is only by large-volume mine operation such as this, where thousands of tons of crude ore are taken out daily, and by the complementary milling equipment, that the present development of the extensive deposits of low-grade copper ores has been economically possible.

425

LIGHTWEIGHT AUTO-SEDAN WITH TANDEM MOTORS

With the object of increasing its power and range of operation, a standard lightweight automobile has two of its regular motors installed in tandem upon an extension of the chassis of the car. Each motor has its independent carburetor and ignition system, and the standard radiator serves both of them. This construction about doubles the power of the car, and necessarily greatly increases the wheel base, which becomes as much as 138 inches. One car so constructed is said to have operated well in a number of road tests, and the builder predicts better results from this construction in the future.



Standard Lightweight Automobile with Two Motors Instead of One: The Motors Are in Tandem upon an Extension of the Chassis That Increases the Wheel Base by About 38 Inches

Builder - Mr.

Kepler, Jr. - inventor, call (2)
Ford car

428
1024

FILIPINO MEN MOVE HOUSE ON SHOULDERS



The high cost of moving is unknown to natives of the Philippine Islands, where they not infrequently pick the structure up and carry it away on their shoulders. The roof being the heaviest single piece, it is usually carried by the stronger of the men, while other members of the family trot behind with the other parts of the house. Moving in this amusing fashion is not a particularly easy task, but most of the men are strong and do not mind it.

These Natives of the Philippine Islands, having Decided upon a Change of Residence, are Carrying Their House along with Them. The Practice is Said to Be Common in That Country

406

PACIFIC-COAST LIGHTHOUSE MADE OF CARDBOARD

Cardboard has never been recommended by the government for use in building lighthouses, but there is a lighthouse on a beach in southern California which is built almost entirely of this substance. It is not officially

listed, however, for it is the property of a motion-picture company and is only used in this kind of work. Even close up, it is difficult to distinguish the lighthouse from the real thing.

By charging \$2.20 per year for a license to operate a radio-receiving set and turning one-half of this amount over to the broadcasting stations, radio broadcasting is put on a paying basis in Great Britain. The companies make up any additional expense by the sale of receiving sets. Programs will be kept to a very high standard.

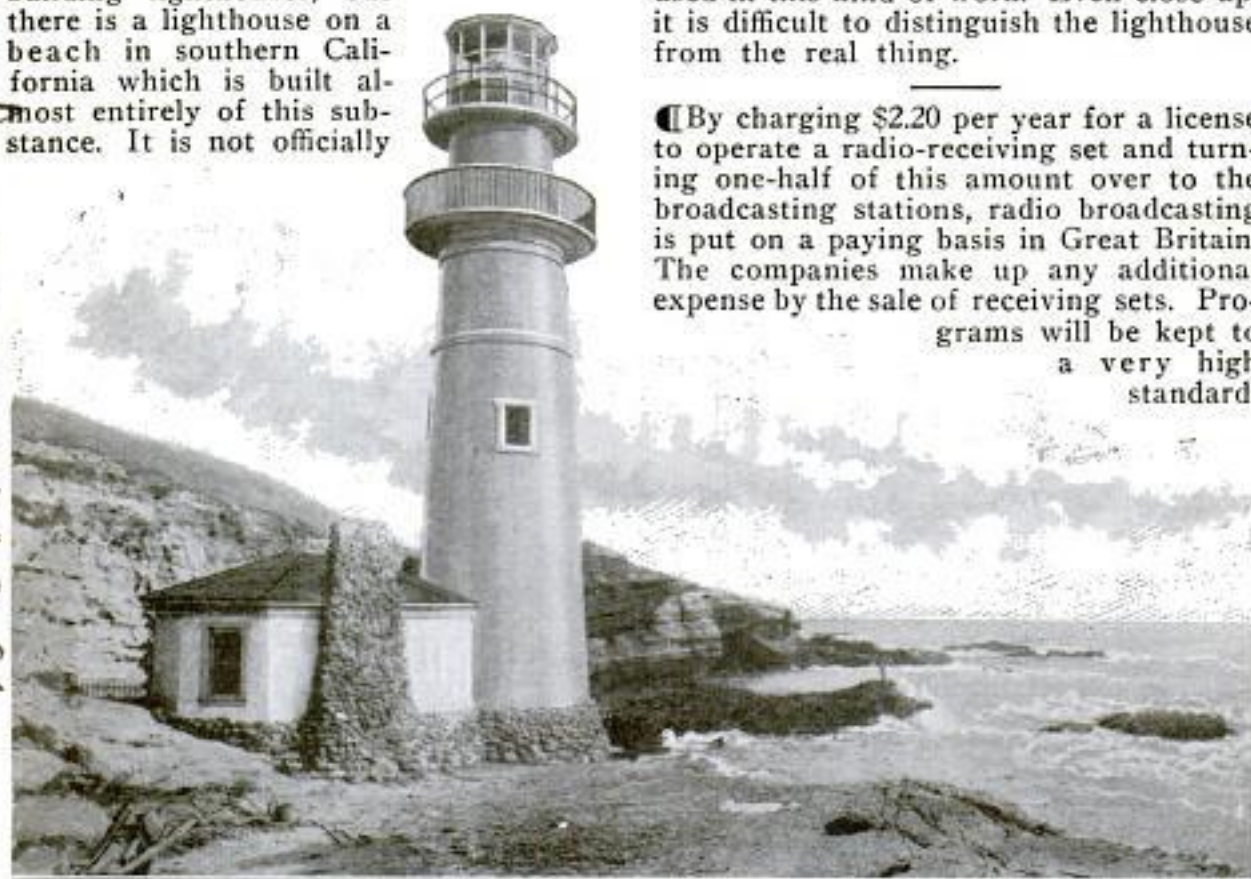

The Lighthouse Shown Here was Made Almost Entirely from Cardboard, Though Its Outward Appearance would Lead One to Suppose the Structure was Made of Stone. It is Located on a Beach in California, and is Used Only in Taking Motion-Picture Scenes

Radel + Herbert
1538.42nd St. New York.

Berkeley, Calif.

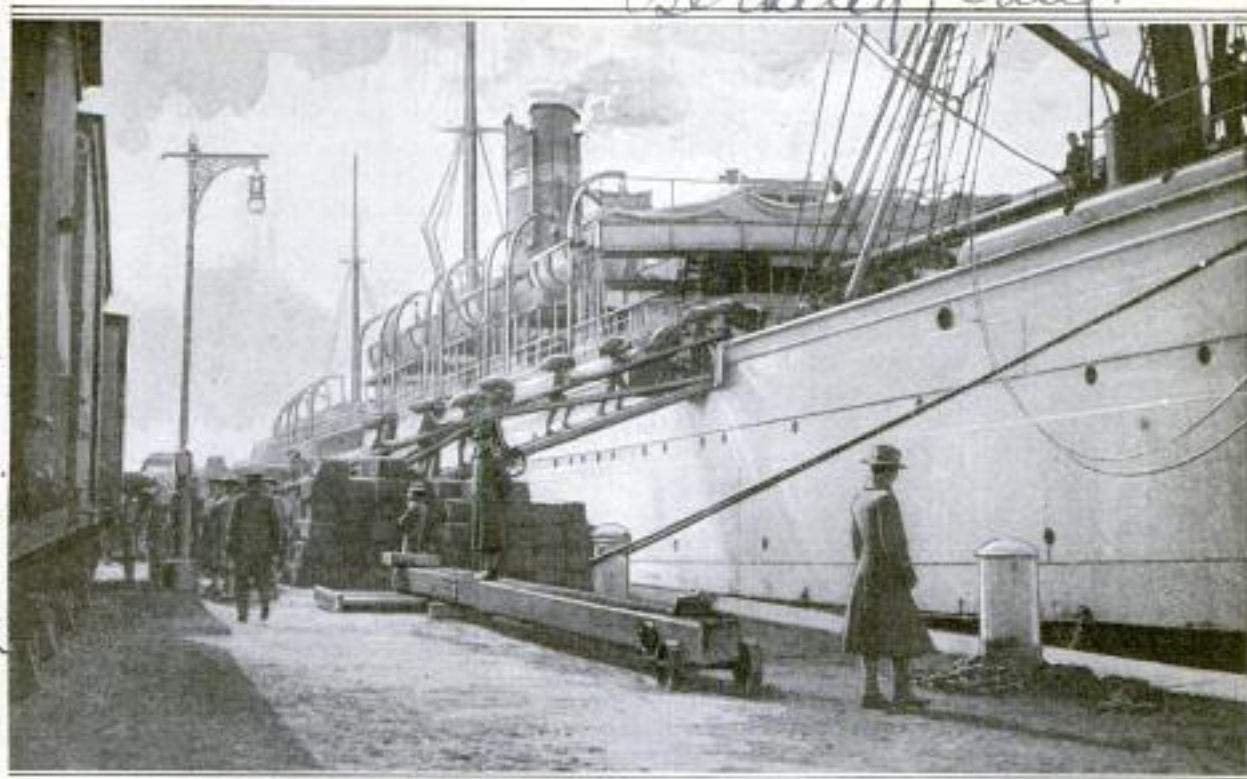

The "Logan," a Discarded United States Army Transport Which has been Sold by the Government and will be Converted into a Floating College by Its New Owners: The Yearly Fee at This Floating School will Be \$3,000, and Each Year will Include a Trip around the World

ARMY TRANSPORT TO BECOME FLOATING COLLEGE

The former United States army transport "Logan," one of several of the old-timers in the transport service, is to be converted into a floating college, on which American youths, from 13 to 18 years of age, will be given high-school and college courses at sea. Each year's studies will be conducted in the usual school months, from September to May, during which time the "Logan," or whatever the transport's new name may be, will cruise completely around the world, its home port being Baltimore. This will be the first time that a privately owned American vessel has been used for purposes of this kind, though the United States government and other governments as well, by means of training ships, have given educational advantages to youths while on long cruises.

The "Logan" has just been purchased by a syndicate of Georgia capitalists, who have subscribed funds to finance the deep-sea collegiate experiment. The transport was delivered to their representative at San Francisco in November, last year, and was sent to Baltimore to be refitted as a school ship. Navigation, seamanship, and foreign trade also will be taught on board, in addition to the regular high-school and collegiate branches, but unless students so desire, they need

not take these three courses. The ship will start on its first educational cruise at the beginning of September, this year, and students entering will matriculate for full four-year courses.

Prof. Zebulon Judd, dean of the Alabama Polytechnic Institute, has been named head of the educational department, and Captain Williams, who has been in command of the "Logan" for 12 years, is to remain in charge. The plan back of the project is to give the students practical first-hand knowledge of geography, history, commerce, and peoples. The floating school will be expensive, since, according to present announcements, the cost of each nine months aboard the ship will be \$3,000 for each boy registered.

1283 OLD LOCOMOTIVE SUBSTITUTES FOR DISABLED BOILER

During the busy season at a plant the loss of a week's production was threatened by a boiler being put out of commission. The emergency was met by obtaining from the nearest roundhouse an old locomotive that served the purpose of generating steam to keep the plant going, although it had reached the point where it was unfit for active road service.

Comd. John H. Amusewood
227 W. State St.
Ontario, Calif.

Candler Floating School, #31, Candler Bldg. Atlanta, Ga.

1210
430

J. M. Thompson, Mechanical Engineer
Buffalo, N. Y. Lakes & River Rapid Transit Co
POPULAR MECHANICS

NEW BARGES FOR ERIE CANAL ARE ELECTRICALLY DRIVEN

A type of barge, recently developed at Buffalo, N. Y., is expected to revolutionize inland water travel. This new vessel was designed primarily for use on the Erie Barge Canal, but it can, and ultimately will, be used upon other inland waterways of the country, such as the Ohio, Mississippi, Missouri, and other shallow streams which will be navigable to these fast, light-draft, electric-driven boats.

The boat is of entirely new design, and it has required many years of intensive study to bring it to a successful completion. It is a double-decker, with a length over all of 272 feet, and a width of 42 feet. The bottom is flat, and along its center is built an open tunnel running nearly the entire length of the hull. The water contained in this tunnel—120 tons of it, to be exact—serves as ballast. In reality, this tunnel divides the hull into two parts, each containing 42 airtight compartments with bulkheads, thus making the boat practically unsinkable.

Something new in the way of a steering apparatus has been evolved for use on it. This consists of four swinging pontoon rudders, two at each end of the hull, which make it possible to take sharp turns or warp into dock very quickly. It has two pilot houses, one at each end, from either of which the boat can be controlled. The 12 by 16-foot gangplank can be lowered at any point along the banks of a river, and produce or merchandise can be taken aboard very conveniently. Docking facilities are necessary only at towns and cities where large quantities of freight are handled. At these points loading and unloading are done with electric trucks.

Motive power is furnished by the very latest type of Diesel engine, electric generators and motors, and all auxiliary machinery is electric. Two propellers are used, one at each end of the boat, and each of these can be lowered or raised according to the depth of water navigated. A refrigerator system with a capacity of three carloads is another feature of the boat.

The cost of building a boat of this type is \$150,000, of which 75 per cent represents machinery and labor-saving devices. A comparison of this new boat with the old type now in use is rather interesting. The average size of the latter has a deck area of about 1,425 square feet; the crew's living quarters are generally antiquated, and the boats have to be towed. The new type has every possible convenience—hot and cold running water, staterooms, a splendid kitchen and dining room, baths and showers, with electric lights in all parts of the boat, and it possesses about 15 times the deck area of the older boats. And, most important of all, the building cost per square foot is practically the same.

NEW ELECTRICAL IMPLEMENT 1303 SIMILAR TO MAGNET

An electrical device which has the curious similarity to a steel magnet, that it is permanently charged with positive electricity at one end and with negative at the other, and that, if broken into pieces, each part retains this polarity, has been made by a Japanese university student. The process of manufacture is rather involved, but the finished product consists of a rod or bar of a special dielectric material, and is called an "electret," the name being derived from electricity in the same manner as magnet from magnetism.

1137 Marine Blvd Buffalo, N.Y.

Mr. W. H. Ator of Sendai, University of Sendai, Japan 12/23/22

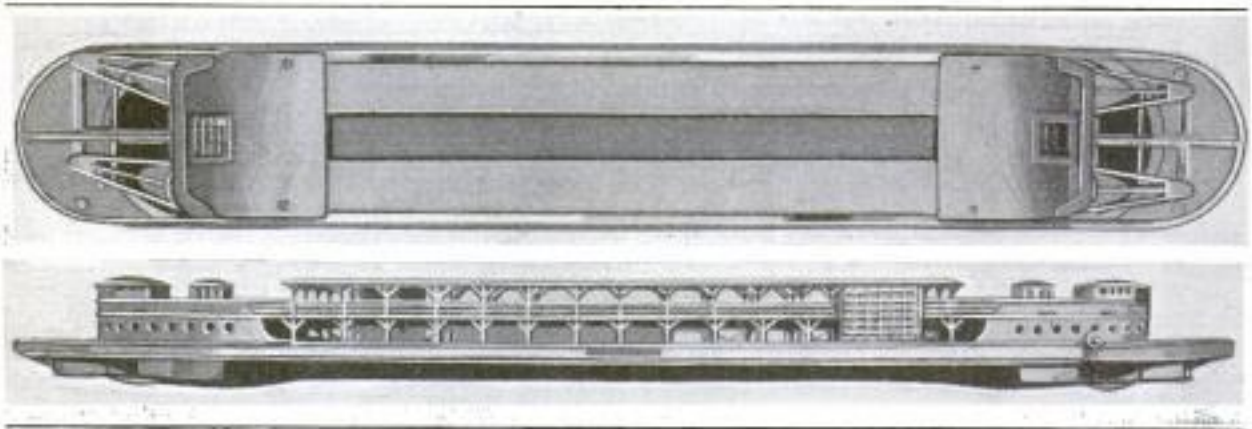

Top View of Hull and Side View of Completed Electrically Driven Barge for Erie Canal: It Has a Deck Space of Over 20,000 Square Feet, or About 15 Times That of the Average Canal Barge. Note the Peculiar Pontoon Rudders at Both Ends

1220 William L. Henschaw

Santa Fe Railroad, San Diego
Calif

HYDRAULIC-FILL DAM SOLVES IRRIGATION PROBLEM



Below: Hydraulic Monitor Washing Clay from Bank Used as Fill for the Dam. Right: Measuring Level of Clay Settlement Pumped into the Dam as Indicated by Discharge in Lower Left-Hand Corner



BECAUSE bedrock was too far down to make feasible the building of a concrete dam, the huge mound of earth shown at the center of the picture at the top of the page, was built to impound water in a large irrigation reservoir formed between the hills in San Diego County, California. It contains 435,000 cubic yards of clay, is 600 feet thick at the base, 1,600 feet long, and 117 feet high.

The Denver Fire Clay Co. Christian Science Monitor 1/4/23
 Denver Colo. POPULAR MECHANICS

432 Round muffle - 15 in dia } 120.00.
 CHINA-BURNING KILN DESIGNED FOR HOME-STUDIO USE

1157 Firing kilns for the burning of hand-painted china and glassware are now be-

ASTONISHING GLIDING RECORD SET IN ORDINARY AIRPLANE

An aerial gliding record, recently set by a French military airman, is remarkable not only for the length of time he remained in the air—7 hours 3 minutes—but also by reason of the fact that he accomplished the feat in an ordinary army plane. The performance took place in Algeria, northern Africa, and the plane was in no way altered except that the propeller was immobilized by means of wedges. Besides, the plane carried 500 pounds of extra weight in addition to its normal fuel and oil supply.

AUTOMATIC VENDING MACHINE DISPENSES SOFT DRINKS

A novel application of the idea long used in the familiar penny-in-the-slot chewing-gum and peanut-vending machines, has been made for the automatic dispensing of soft drinks. The purchaser drops his coin in the slot, pulls the operating lever, and shortly receives a sanitary paper cup into which the proper portions of flavoring sirup and carbonated water have been discharged. A supply of flavoring sirup is kept in a glass container on top of the machine, and the carbonated-water drum is placed in the bottom part of the case on which the machine is mounted.

Journal of the Royal Society of Arts
 1329
 1922
 1157
 432
 120.00



Firing Kiln for Use in the Home Studio: It may be Equipped with a Kerosene or Gas Burner

ing manufactured in a size designed to be convenient for, and easily operated by, amateurs. The kiln has an inside diameter of 15 inches, is 18 inches in height, and may be equipped with either a kerosene or gas burner. To those interested in this line of work, the new kiln offers an economical means of completing their own product in the home studio.

HUNDRED-INCH SLIDE RULE IS VERY ACCURATE

A slide rule in which the scale is 100 inches in length and which can be relied upon to give results in multiplication and division with an error of less than one in 1,000, has recently appeared in England. The scale is laid out in 20 parallel lines, each about 5 inches long, and the rule arranged so that it can be manipulated with one hand.

The Banff-Windermere Motor Highway, the last link in the great 6,500-mile scenic route through western Canada and the United States, will be officially opened on June 30, this year.

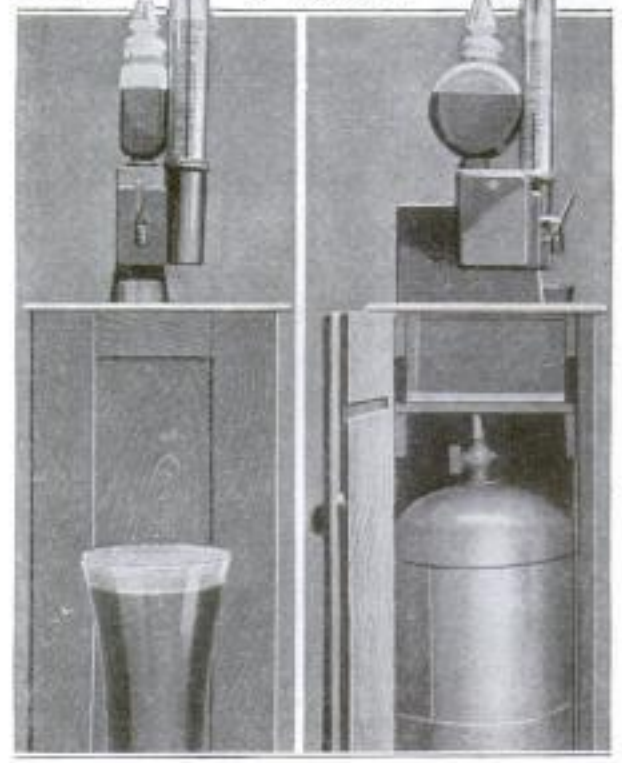

Left: Front View of Automatic Vending Machine for Soft Drinks. Right: Machine with Front Panel Removed, Showing Carbonated-Water Drum

Messrs. C. & Cooper Ltd., Haddon Hall St., Loddon, England.
 Messrs. Samuel J. Butterfield & Co., 1116 Randall Court, Los Angeles, Calif.

1306 Manchester Guardian 1/22/22

Pennsylvania R.R. Central System

POPULAR MECHANICS

433

"ORCA" FINALLY COMPLETED FOR ATLANTIC SERVICE

The "Orca," a new liner having a length of 575 feet, a beam of 67 feet, and a tonnage of 16,000, and intended for Atlantic

MOTOR-DRIVEN TRACK SWEEPER 1176 HALVES CLEANING COST

One-half the usual cost of cleaning tracks is saved with a power-driven track sweeper used by the Penn sylv-

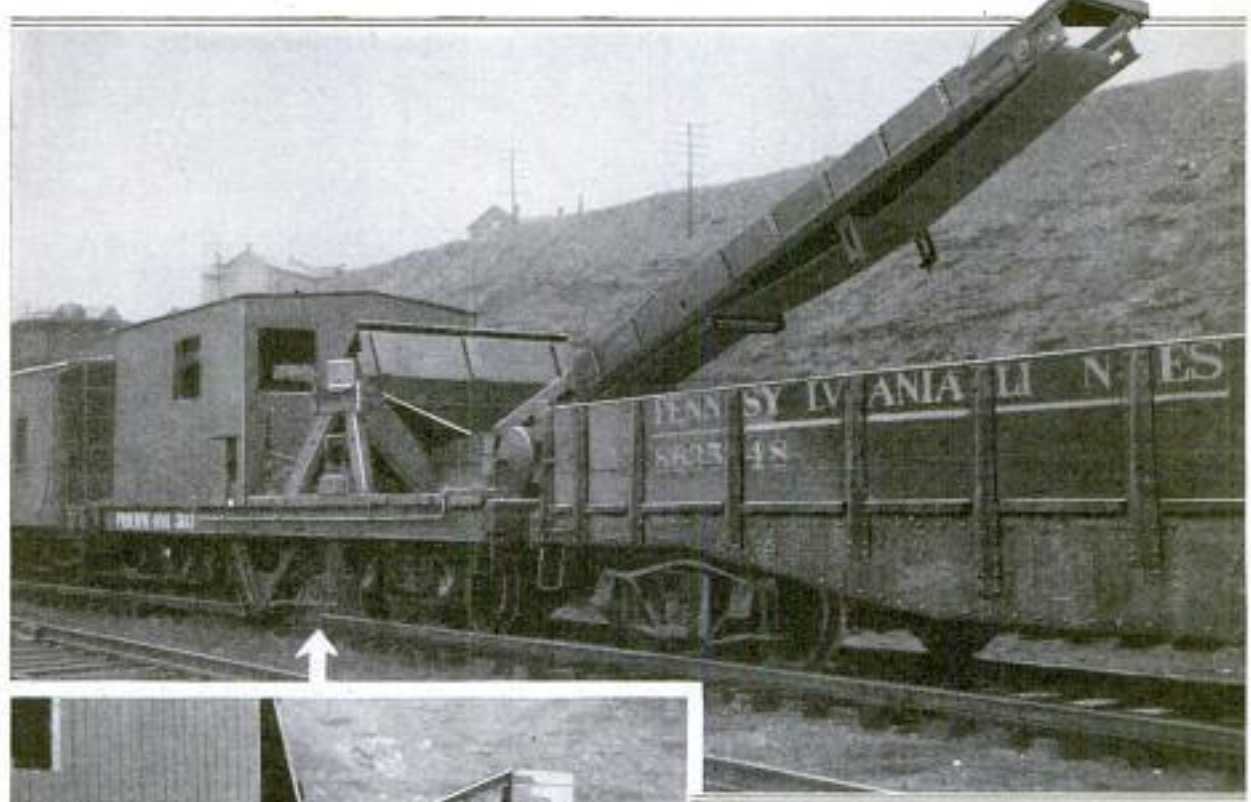

General View of the Track Sweeper Used by the Pennsylvania Railroad, Showing the Conveyor Belt and Receiving Car

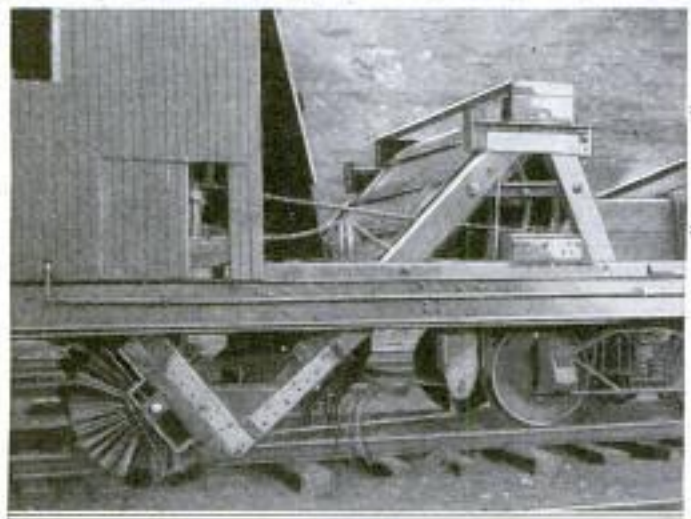

Close-Up of Steel Broom, Showing the Manner of Its Mounting and a Set of "Fingers" Ahead of It That Loosens Up the Dirt

service, was recently berthed for the first time at Southampton, England. Construction of this ocean liner was commenced some 10 years ago, the beginning of the late war causing the builders to suspend operations. During the war, the shortage of ships caused the owners to resume construction, although not according to original plans, but as a supply ship. At the conclusion of the conflict, however, the hull was overhauled, the war-time equipment and fittings removed, and the ship refitted as a liner.

nia Railroad in its Allegheny Mountain sections. The sweeper consists, fundamentally, of a rotary steel broom, 3 feet in diameter and 7 feet long, suspended beneath an old flat car. Driven by a gasoline engine mounted on the car, the broom sweeps the dirt and ashes onto a steel pan. Then a conveyor belt carries the accumulations up and forward, and deposits them in an open-top car, coupled ahead.

Four miles an hour is the average speed of the car during operation.

ALMOST PURE SEAM OF SALT FOUND IN NOVA SCOTIA

Salt recently discovered at Malagash, Nova Scotia, was pronounced 99.1 per cent pure after analysis. The seam is at a depth of 200 feet, and is 6 feet thick. Potash has also been encountered at two levels in the salt strata, and it is thought that more will be found at greater depth.

at Malagash Nova Scotia

7273

Robert L. Harrison
708 Pacific Electric Bldg Los Angeles
Calif

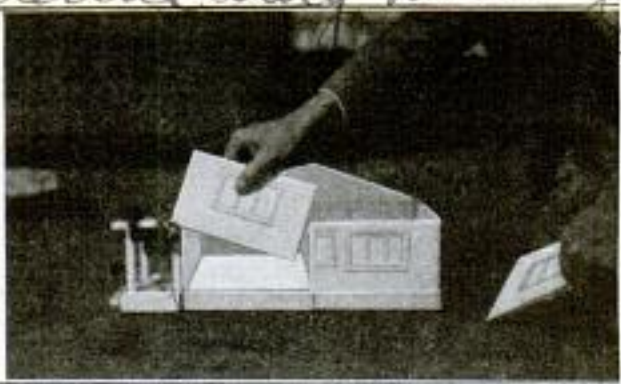
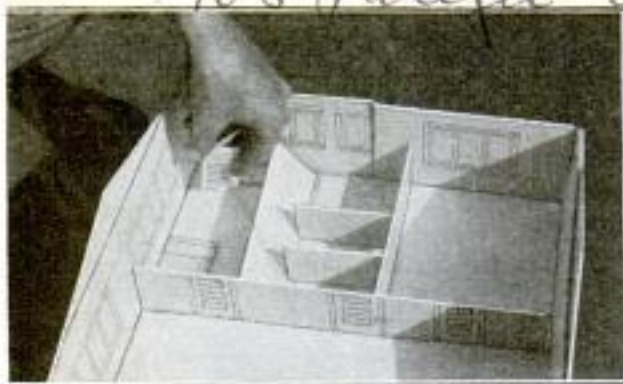

The Design of a House being Carried Out by Placing Together Sections of the Building, Made to a Scale of One-Half Inch to the Foot: This Scheme Enables the Prospective Builder to Produce a Model for His House with Any Desired Interior Arrangement and General Appearance. The Sections are Made of Cardboard

SUPPLEMENTING THE ARCHITECT AND DRAFTSMAN

BY FRANK B. HOWE

A SYSTEM which not only is of value to the architect and the draftsman, but also enables the home builder, who probably can tell little from plans and blueprints, to see exactly what his finished house will look like, has been patented and used to advantage in the West.

The inventor of the system is also the inventor of a method of building ready-cut houses, and this work led him to develop a "unit" system. This new type of house consists of standard sections, which can be fitted together and arranged in any one of innumerable combinations, instead of the limited number of styles of ready-cut houses. Hence the prospective builder can visualize his own plans and style of house, yet have the advantage of the low cost of materials which the quantity production of the factory-built house affords. The

inventor has made his system of designing conform to these standard sections. However, there seems to be no reason why the method should be restricted to that field only. It is easily applicable to any other.

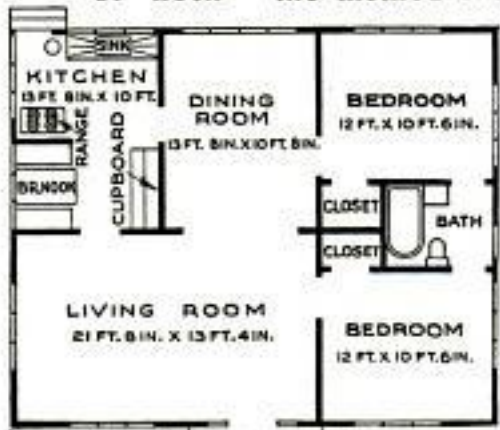

Plan of a Six-Room House with a Porch, Standard Sections

The plan is nothing more than a glorified doll-house building. Sections of siding, roof, partition, etc., are supplied, reduced to a scale of 1/2 inch to 1 foot, and built of cardboard. The intending builder takes these pieces and with them builds miniature houses according to his taste, until he gets a style and appearance that suit him. He

sees just what his house will look like when it is done, for the miniature pieces are cut exactly to scale.

When a model house that suits the buyer has been put together, he simply turns it over to the builders and says, "Go ahead." There is much less need of blueprints and wash drawings; and no hope-



Two Completed Miniature Models of Houses: The Full-Size Buildings are Erected in Accordance with the Models with Standard Sections That Correspond on an Enlarged Scale with the Cardboard Sections of Which These Models are Constructed. The Latter Sections Are Interchangeable, Permitting Great Variation in Design

less endeavor on the part of the architect to convey to the amateur mind what the house is going to look like. Instead, the builder of the house puts his model together exactly as he wants the house to look. If anyone in the family has a liking for painting, different color combinations for the rooms can be tried out by painting the model with water colors. A furniture company cooperates by supplying little models of various pieces of furniture, all made exactly like the

1319

NEW SUBMARINE POWER CABLE IS SEVEN MILES LONG

A seven-mile submarine cable, reported to be the largest and longest ever employed for this purpose, has just been laid across San Francisco Bay to bring additional hydroelectric power into San Francisco and reduce the load on the steam-driven plants. It is a three-conductor cable, slightly over $\frac{3}{4}$ inch in diameter, and at 11,000 volts will be capable of transmitting 10,000 kilowatts. Because of its unusual size, the cable was not placed on reels but was shipped from the factory in nine gondola cars in which it was coiled in 4,800-foot lengths. These lengths were later spliced together into one 38,500-foot length which was coiled on a special cable-laying barge. This method has long been used for telegraph and telephone cables but never before for a power cable.

Consuming 102 pounds per person, America in 1922 established a record as a sugar-eating nation, according to data collected by a large refining company. The figures were based on an estimated population of 110 million.



original and corresponding to the scale of the house.

In short, the resourceful inventor plans to offer his customers a method of seeing just what kind of houses they are getting, before they get them.

Claiming that radio aerials attached to light poles or stretched across light wires were too dangerous to be tolerated, the head of the Kansas City light and power plant ordered more than 300 torn down.

SPECIAL TROLLEY FOR SKIERS ON NORWEGIAN RAILWAY

Native devotees en route to the skiing ground at Holmenkollen, near Kristiania, Norway.

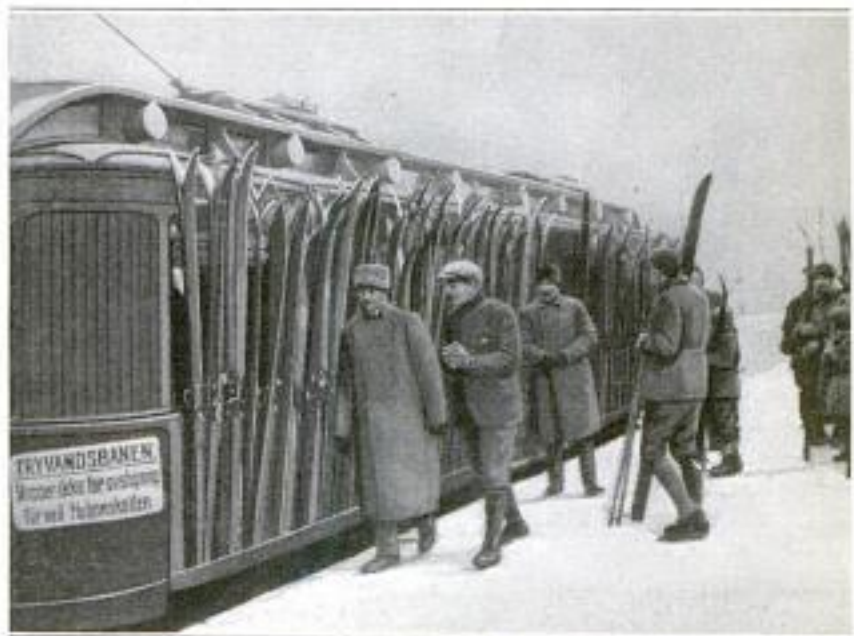

This Trolley Car is Run as a "Special" for Skiers en Route to the Skiing Ground at Holmenkollen, near Kristiania, Norway. Chains along the Middle of the Car Hold the Skis

tiania, Norway, have a special car to carry them and their skis. On the outside, along the bottom of the car, is a narrow troughlike projection holding the end of the skis, and supporting them, while chains along the middle of the car keep them from falling off. It is not uncommon to see the skis piled on so thickly that the windows of the car are almost entirely hidden.

International Newsreel
Copyrighted material

Invs } Mr Zawadzick
+
Mr. Heyman

**NEW FOOTBALL SCOREBOARD
HAS MANY ATTACHMENTS**

1081

A new football scoreboard, recently erected on an athletic field at Montgomery, Ala., has several novel attach-

**SIMPLE BALANCING MACHINE
IN USE IN GERMANY**

1269

In rapidly rotating parts, such as pulleys, flywheels, crankshafts, and rotors, it has long been the practice in this country to establish in them as perfect a dynamic balance as possible, apart from any simply static balance, and to do this, elaborate and expensive balancing machines are necessary.

In a new method, recently put into practice in Germany, the body to be tested is mounted in two bearings, fitted to vertical springs so that, when rotating, if there are any unbalanced parts the body will oscillate. When being tested, the body is driven till it reaches a high speed, when the driving power is cut off, and the body is allowed to run freely in the flexible bearings. As it gradually slows down, the oscillations are recorded graphically by means of an indicator coupled to the rotating body. The whole operation is repeated with the work rotating in an opposite direction. By this means the necessary balancing weights are easily determined in two or three comparative tests.

For bodies rotating at high speed, a third and even a fourth balancing operation, similar to the first, is advisable.

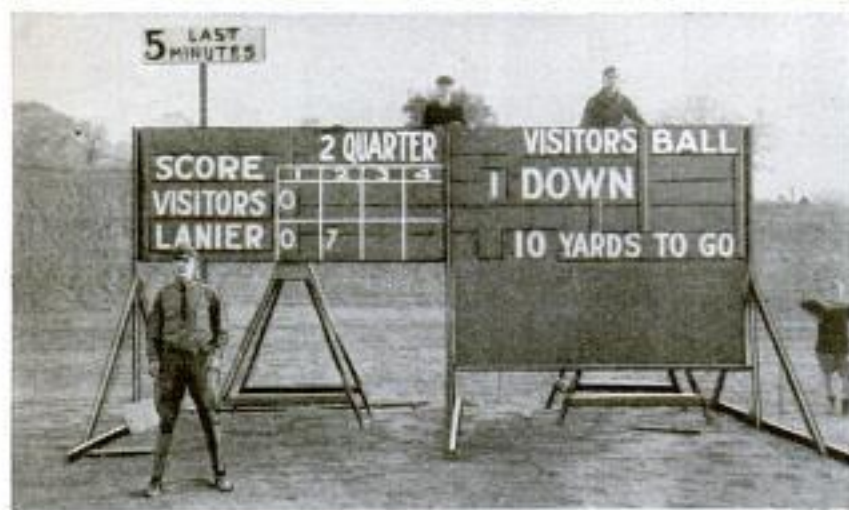
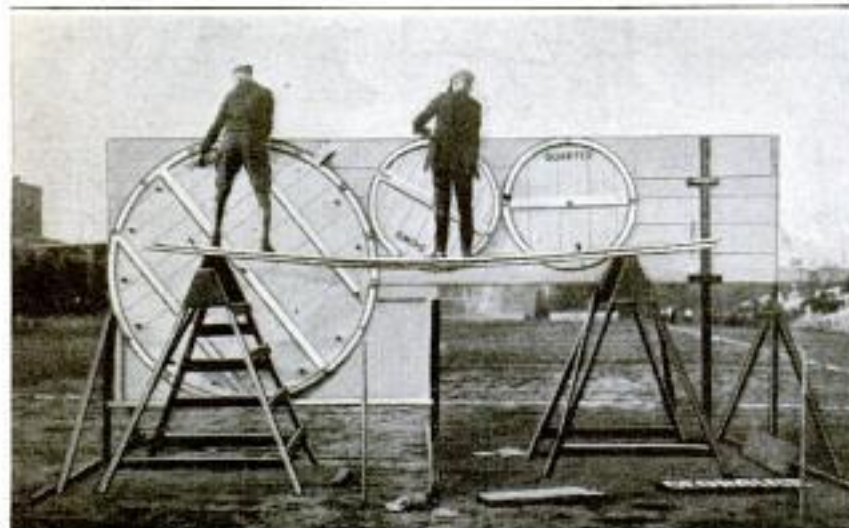

Above: Rear of Football Scoreboard, Showing the Wheels That are Revolved to Change the Notices on the Front of the Board. Below: Front of Board as It Appears When in Use

ments for displaying the score. The board is mounted within easy "reading distance" of the spectators and has revolving disks that indicate the "quarter," whose "ball" it is, what "down" and how many "yards to go," whether or not it is the "last five minutes," and also the total score by quarters. The result of every play during the game is wigwagged from the sidelines by a cadet, the signals being interpreted at the board by another cadet, who orders the changing of the marking mechanism in accordance with the progress of the contest, thus giving the spectators timely information.

Our Bureau of Information will answer all questions regarding articles appearing in this magazine.

**DAIREN, NOT BOSTON, WORLD'S
FOREMOST "BEAN TOWN"**

1281

With a never-ending procession of ships carrying away tons of soy beans, Dairen, a Japanese city in Manchuria, is challenging Boston's reputation as the "bean town" of the world. Dairen, according to reports, is the port of what is becoming the greatest bean-raising country of today. The product, also used in making soy-bean sauce and soy-bean oil, is exported to various markets. The soy-bean sauce is familiar to patrons of "China-town" restaurants.

National Geographic Society
Washington, D.C.
Copyrighted material

295 *Cmch Roy C. Bennett*

POPULAR MECHANICS

1800 N. 57th St.

Philadelphia, Pa. 437

MUDDY SITE OF SHANGHAI BAD FOR FOUNDATIONS

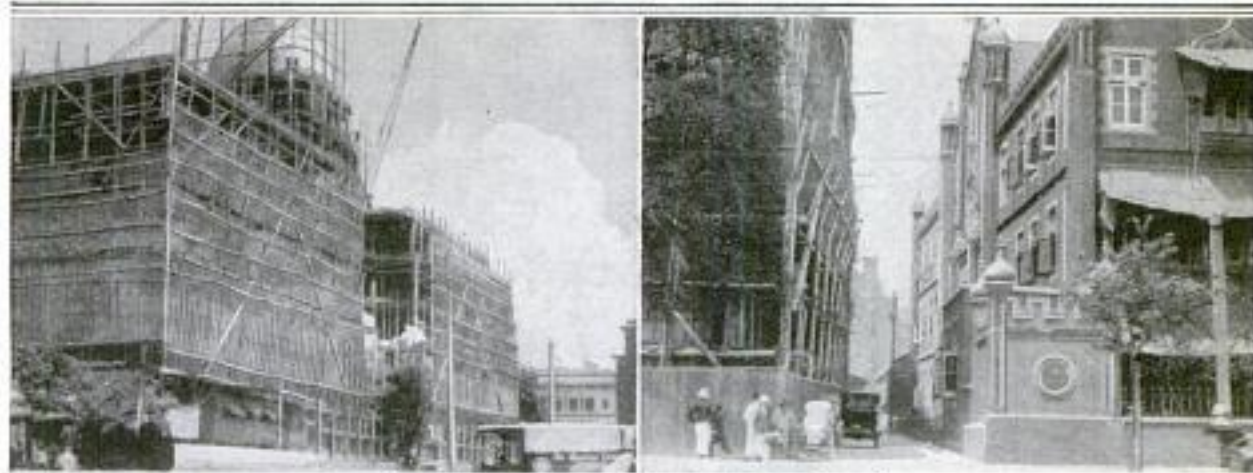

New Building of the Hongkong and Shanghai Bank Which Has Sheet Piling Surrounding the Foundation

Corner of New Bank Building: Opposite to It Is the Customhouse, the Foundation of Which was Endangered

While not in quite so precarious a predicament as a house built upon sand, Shanghai, China, is not much better off, for it is a city built upon mud, and very slimy mud at that. From this, naturally, results a great deal of difficulty with foundations for heavy structures. The first step necessary before erecting the superstructure of anything like a large building, is to surround the whole foundation with a wooden inclosure like the cofferdam used in laying the foundation



Driving Sheet Piling by Man Power for the Purpose of Holding the Slimy Mud in Place beneath the Foundation of the New Bank Building in Shanghai

of a bridge pier. While erecting a large reinforced-concrete building recently on the river front of Shanghai, the foundation of the neighboring large customhouse began to move, on account of the displacement of the slimy mud by the weight of the new building. It was necessary to sink heavy upright timbers, like sheet piling, along the walls of the customhouse, and to tie them together with long steel rods to prevent the pressure of the mud from forcing them outward.

1128

BENCH CLAMP MAKES HAND VISE MORE USEFUL

A hand vise of recent design that has a grip capacity up to 1½ inches, is furnished with a bench clamp that greatly increases its usefulness for home and shop work. Applied to a bench, the vise can be turned to any point in a circle to suit the convenience of the user. The ball-end handle for tightening the jaws, instead of the wingnut commonly used on hand vises, is an added feature.

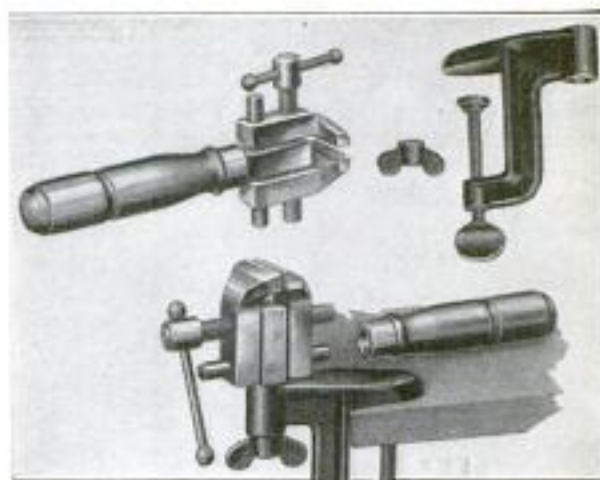

The Usefulness of the Hand Vise is Increased by Means of the Bench Clamp Which Fastens It to a Bench Where It can be Turned to Any Point in a Circle

☐ Pint and half-pint bottles of chocolate-flavored milk are being sold by a Chicago dairy company in addition to its regular supply. The new drink tastes somewhat like a chocolate malted milk.

Wieland Dairy Co
3674 Broadway
Chicago

L. S. Starrett Co
Atol. Mass.

Copyrighted material

CIVIC FEATURES THAT PROMOTE THE COMFORT

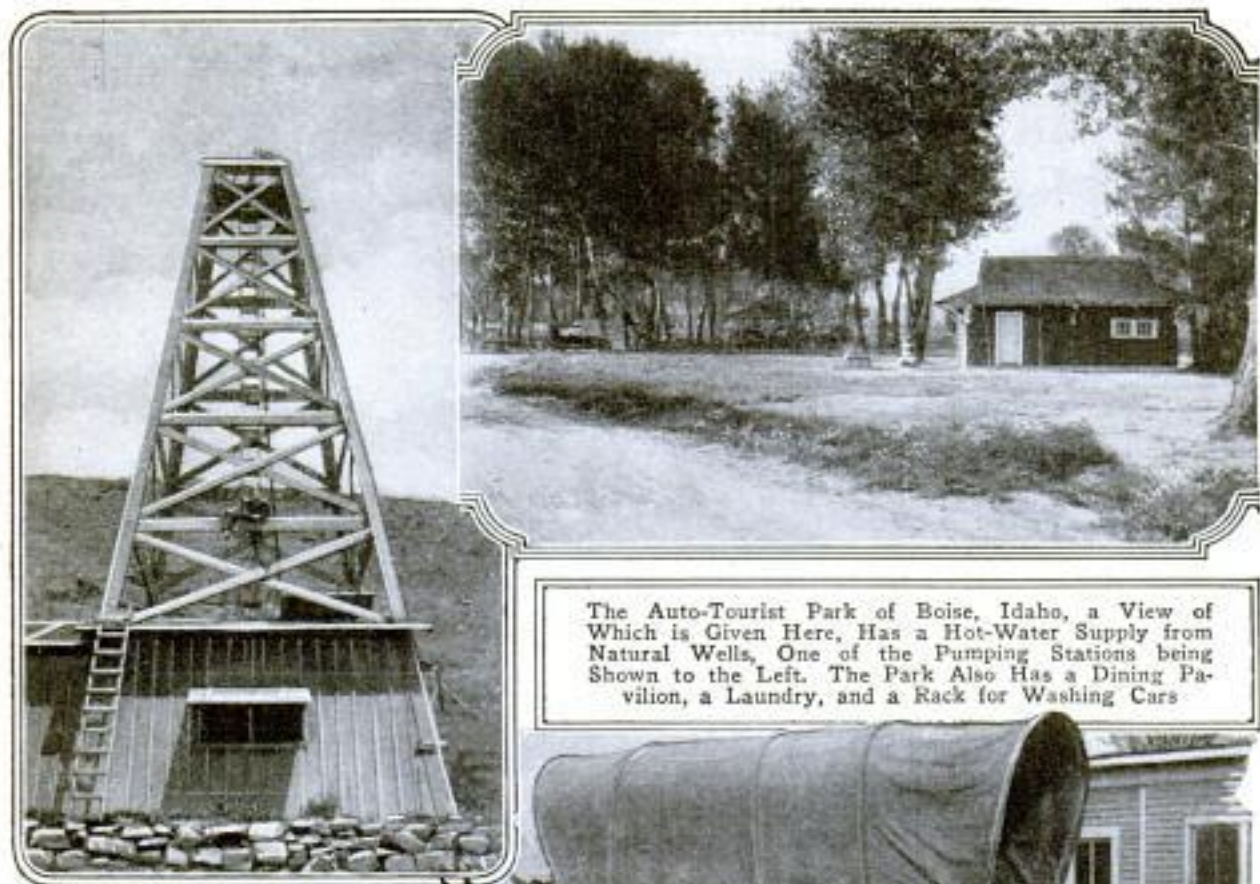

The Auto-Tourist Park of Boise, Idaho, a View of Which is Given Here, Has a Hot-Water Supply from Natural Wells, One of the Pumping Stations being Shown to the Left. The Park Also Has a Dining Pavilion, a Laundry, and a Rack for Washing Cars



Mail Reaching Burkesville, Kentucky, must Come 40 Miles over Red-Clay Roads and Bridgeless Creeks. In Winter, It is Brought in Covered Wagons of This Type, Two Days Often being Required to Make the Trip

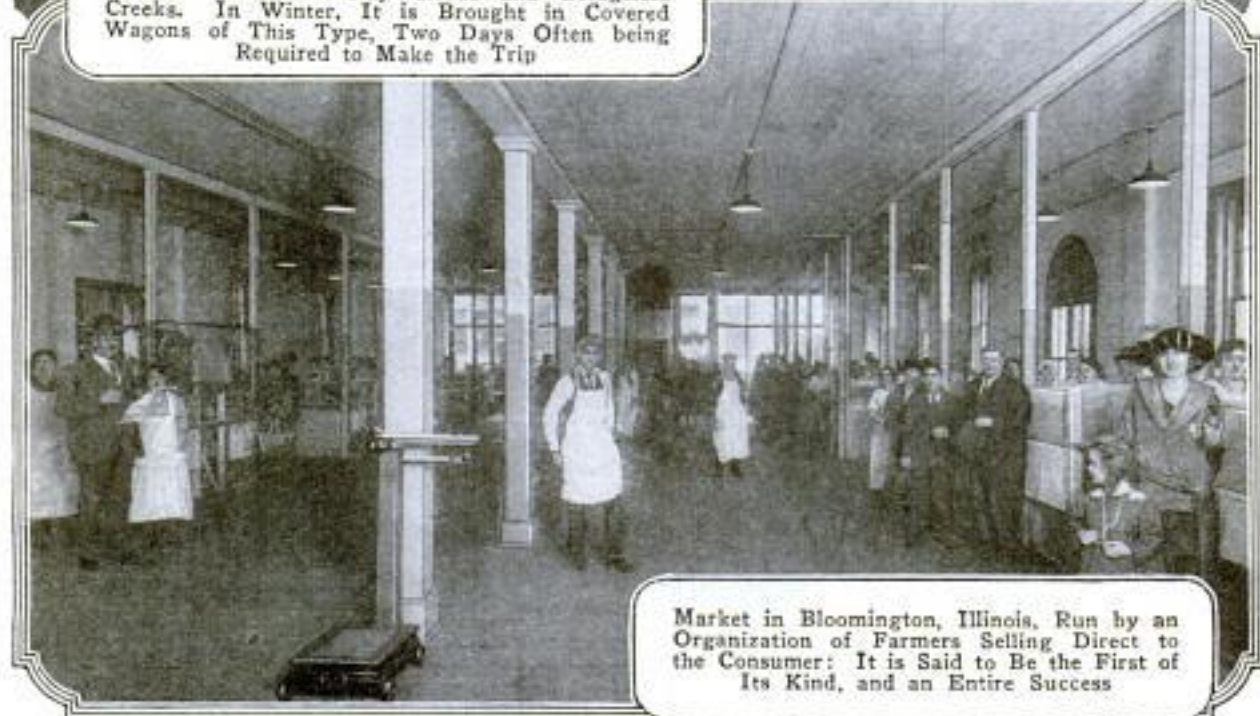

Market in Bloomington, Illinois, Run by an Organization of Farmers Selling Direct to the Consumer: It is Said to Be the First of Its Kind, and an Entire Success

AND ENJOYMENT OF VISITORS AND RESIDENTS



Sign Marking Land Acquired by the City of Santa Rosa, California, and Its Chamber of Commerce, to be Made into a Memorial Garden in Honor of Luther Burbank, Who Lives in That City and Was Present at the Dedication.



Once a Bandstand Erected by the Women's Civic Club and Presented to the City, This Structure Now Serves as the Chamber of Commerce Building in Pacific Grove, California



The Observatory Pictured Here was Built by the City of Des Moines, Iowa, with Funds Obtained from a Bond Issue



By Building This Dam below the Falls of a Creek, the Citizens of Pendleton, Indiana, Made a Swimming Pool Which is Filled with Fresh Water Every 10 Minutes

1079 American Wood Pipe Co
Tacoma, Wash.

410

POPULAR MECHANICS

Engineer, John S. Deegan.

EXACTING REQUIREMENTS MET BY WOODEN FLUME



View Showing the Curve of 100-Foot Radius to Which This Wooden Flume was Constructed in Spite of the Fact That It was Pronounced by Many to Be Impossible

A wooden flume was recently built to conform to conditions that had been considered by some as being impossible of execution. The flume, which was elliptical in section with the bottom forming a curve of about 10-foot radius and the sides one of 6-foot radius, was constructed on a curve of 100-foot radius. The length of the section was 200 feet, and after 100 feet of the flume had been laid, the thickness of the staves was reduced from $2\frac{1}{4}$ inches to $1\frac{1}{8}$ inches, requiring a very difficult joint to be made. The principal staves of this flume were made of carefully selected kiln-dried Douglas fir.

745 ROTARY PLOWS PREPARE SOIL FOR SUGAR CROP

A powerful machine that plows and pulverizes the ground to a depth of 20 inches, and opens up furrows for the planting of sugar cane, has lately been shipped to Porto Rico for trial under actual working conditions. A heavy hinged

they reach the full depth. The soil is not turned over as with the ordinary plow, but the lumps are forced against one another so that they are broken up. The machine is driven through gears by means of a 100-horsepower gasoline engine, and

when plowing to a depth of 20 inches, will prepare about one acre of light soil an hour. The plows cut more than the width of the machine.



Side View of Powerful Machine Recently Built for Tillage of Sugar-Cane Soil in Porto Rico: Note Inclined Plow Frame

frame at the rear carries two sets of plows arranged in a circle and geared to revolve in opposite directions. The plows rotate on an incline so that they enter the ground gradually, going deeper as they move toward the rear until



Rear View of Tillage Machine in Operation: It Plows More than the Width of the Machine and So does Not Travel over the Freshly Broken Ground

Norman C. Storey
44 Ayer's and Passaic, N.J.

DEPARTMENTS	1 ST QUAR.								2 ND QUAR.								3 RD QUAR.								FINISH.						
	1	2	3	4	5	6	7	8	9	10	11	12	13	14	15	16	17	18	19	20	21	22	23	24	25	26	27	28	29	30	31
HORSES																															
SHIPPING DEPT	X																														
FINISHING MILL		X																													
ELECTRICAL DEPT																															
MACHINE SHOP																															
KILNS																															
RAW MILL																															
CARPENTER SHOP	X																														
YARD																															
QUARRY																															

This Chart was Designed in the Form of a Horse Race to Add Interest to a Safety-First Drive at a Large Cement Plant. Each Day a Department Passed without an Accident was Marked by an Advance of One Square on the Chart

916
"FAKE" HORSE RACE AIDS SAFETY-FIRST DRIVE

A novel contest was recently staged in a large cement plant, the object being to eliminate accidents. The contestants were the employes of the nine departments of the plant. They were divided into nine groups, each provided with a horse, and the contest was entitled "safety horse race."

The horse of each department was started from "scratch" on a chart divided into squares. Each square on the chart represented a day. For each day in which no accident occurred in a department, the horse representing that department was advanced one day, or a square on the board. The horses all had names, some of them indicating the work or special hazard in the particular department represented.

For minor accidents which were a little too serious for first-aid treatment only, one-half day was marked off, and for accidents requiring only first-aid treatment, the department lost one-fourth of a day.

The human element is a strong factor in 90 per cent of the accidents, it is claimed, and it was for the purpose of overcoming this human-element problem that a concerted drive to eliminate accidents, by instilling unusual interest in it, was worked out in this manner.

912
NEW REAR-SPRING SYSTEM FOR SMALL CAR

A new rear-spring system for light-weight cars is said to act in the capacity of a shock absorber or snubber in lessening the effects of a jolt when one of the rear wheels drops into a depression or strikes an obstruction, as well as to serve the primary function of the usual spring which it replaces. It consists of two separate cantilever springs, the ends of each being attached to the rear axle and

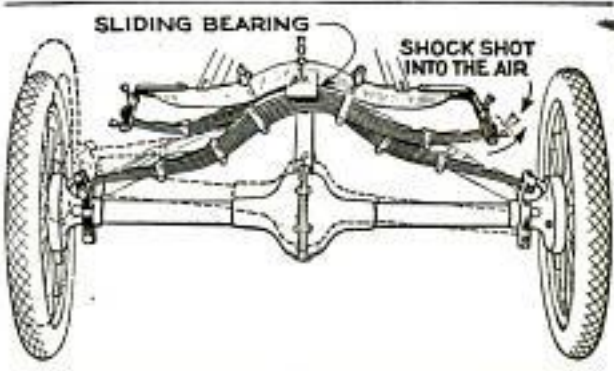

Illustrating Action of New Rear-Spring System When Left Wheel of Car Strikes an Obstruction, Shock being Deflected to Right

frame in such a way that they cross at the center of the rear cross member of the frame, which they support at that point by means of a sliding bearing.

*The Detroit approved Spring Co
 55-51 Woodward at Detroit, Mich.*

SOME NOVEL AND LITTLE-KNOWN ACCESSORIES



Fork Cleaner Which Consists of Four Small Brushes through Which the Prongs are Pushed Back and Forth to Remove Any Foreign Matter Adhering to Them

Comb for Applying Hair Preparations without Getting the Fingers Dirty: The Prongs are Hollow and Exude the Liquid When the Rubber Magazine is Squeezed

Mixer Which Aids in Preparing Mayonnaise Dressing for Sea Foods, Salads, Vegetables, and the Like: The Ingredients are Placed in the Bowl and the Funnel is Filled with Olive Oil Which Drops Out

Separator That Removes the Cream from a Milk Bottle by Merely Squeezing the Rubber Bulb on the Handle

Boiler That is Perforated, Thus Permitting the Water to be Drained from Vegetables without Burning the Hands

Manicuring Buffer in Which the Scissors, Nail File, Orangewood Stick, and Emery Board may be Concealed

The Chair and Smoking Stand Above, Made of Palm-Tree Stems, Are Artistic, Light, and Durable

Toothbrush Sterilizer Which Holds Five Brushes and Paste While being Disinfected by Antiseptic Fumes

NOVELTIES March.

Fork Cleaner--R. H. Macy & Co.,
Broadway & 34th St., New York.

Brilliantine Comb --data lost.

Mayonnaise Mixer--Marshall Field & Co.
Household Department, Chicago.

Cream Remover--Inv. Benjamin Somerville,
§ William E. Goodwin, 527 W. 124th St.,
New York City.

Perforated Boiler--Inv. P. Combriata,
§ William E. Goodwin, 527 W. 124th St.
New York City.

Manicuring Buffer--Data lost.

Palm Tree Furniture --Cornell Emery Co.,
16 E. 40th St., New York City.

Toothbrush Sterilizer--R. Kuhn, Friendly
Hall, Eugene, Oregon.

Knife Sharpener--Data lost. *Jiffy - York*
Auto Tool & Steel Co., (P.O.) n. Chicago Ill

Shade Roller Hood--Kirsch Mfg. Co., *York Pa.*
Sturgis, Mich.

Marcel Waver--Midland Electric Sales Co.,
3018 S. Wabash, Chicago. \$6.50.

Clothesline Reel--Household Appliance Co.
Neenah, Wis.

Pillow for Motorists--F. Lewald & Co.,
330 S. Franklin, Chicago.

Combined Hook and Button --L. S. Brown,
316 N. 6th St., Saginaw, Mich.

Sanitary Sink Strainer--C & D. Mfg. Co.,
2540 Prospect Ave., Cleveland, Ohio.

Talking Machine--Inv. S. Hecop or Hecox,
Zeeland, Mich.

*Sold by Mon Lengerke
& Ailoin*

*130 S. Wabash
npr. Ace Hardware Chicago
npr. Co 1614 n. Park n.e. Phila.*

the 1990s, the number of people in the UK who are aged 65 and over has increased from 10.5 million to 13.5 million (19.5% of the population) (ONS 2002).

There is a growing awareness of the need to address the needs of older people in the UK. The Department of Health (2000) has published a strategy for older people, which sets out a vision for the future of care for older people. The strategy is based on the following principles:

• Older people should be able to live in their own homes for as long as possible, and to be supported to do so.

• Older people should be able to live in their own homes, and to be supported to do so, in a way that is safe, secure, and of good quality.

• Older people should be able to live in their own homes, and to be supported to do so, in a way that is affordable.

• Older people should be able to live in their own homes, and to be supported to do so, in a way that is accessible.

• Older people should be able to live in their own homes, and to be supported to do so, in a way that is inclusive.

• Older people should be able to live in their own homes, and to be supported to do so, in a way that is empowering.

• Older people should be able to live in their own homes, and to be supported to do so, in a way that is enabling.

• Older people should be able to live in their own homes, and to be supported to do so, in a way that is enabling them to live their lives to the full.

• Older people should be able to live in their own homes, and to be supported to do so, in a way that is enabling them to live their lives to the full.

INTENDED FOR THE HOME AND ITS MEMBERS

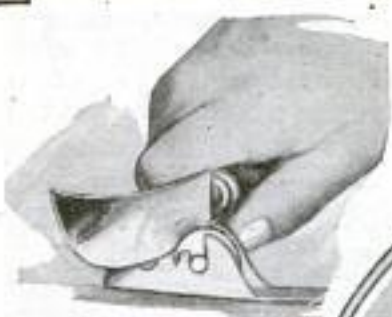

This Knife Sharpener Consists of Two Stone Rollers, between Which the Blade is Drawn from the "Heel" to the "Toe," Thus Producing a Very Keen Cutting Edge

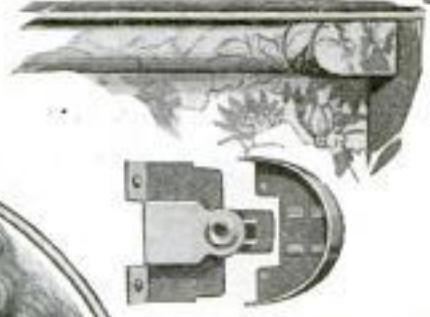

Two Views of a Shade-Roller Hood Which Permits the Artistic Covering of the Shade-Roller Ends and Brackets, and Consequently Aids in Beautifying the Interior of the Home



Electrical Marcel Waver Which Is So Simple to Operate That Any Woman may Quickly Learn to Wave Her Own Hair, Thus Saving the Expense of a Hairdresser; It is Claimed to Be Equally Effective on Dry or Oily Hair

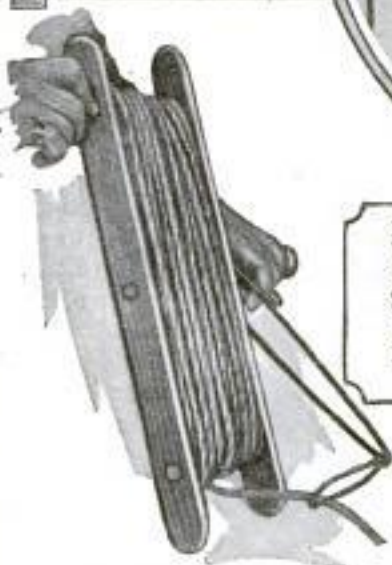

Clothesline Reel with a Special Handle That Acts as a Brake, Preventing the Line from becoming Soiled



Inflated Pillow for Motorists That Gives the Body an Even Balance at All Times, Thus Preventing Backache



Sanitary Sink Strainer That Has a Special Lid to Catch the Drippings When the Strainer is being Emptied

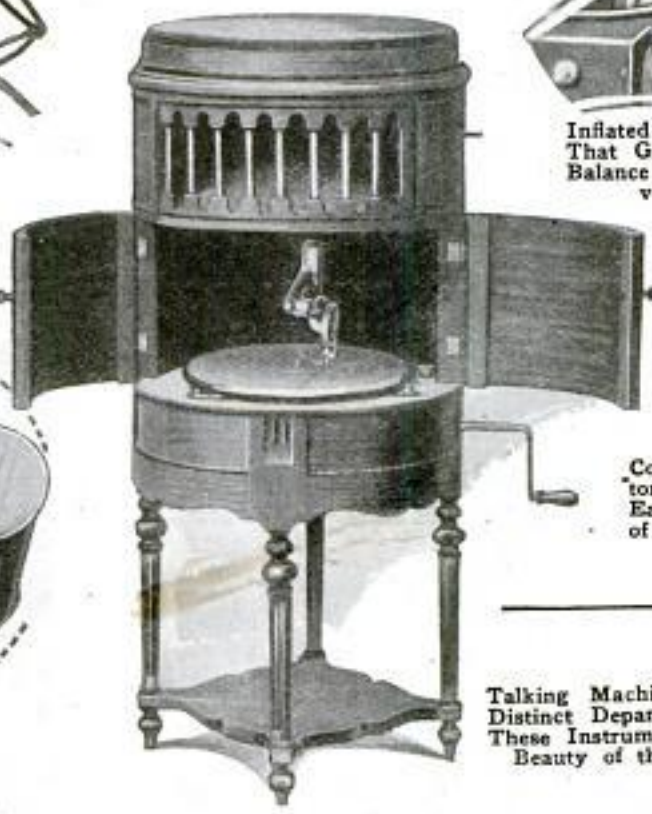

Talking Machine Which Presents a Distinct Departure in the Design of These Instruments and Adds to the Beauty of the Home Furnishings



Combined Hook and Button Which Provides an Easy and Efficient Means of Fastening Suspenders or Belt

1140 TRAVELING MIXER SERVES BATTERY OF VATS

A traveling mixer has been designed that eliminates the necessity of an individual stirring device for each tank or vat in a plant where a large number are used in the same or similar stages of the process. It consists of a traveler suspended from a single rail that carries the agitator drive, which is fitted with an extension shaft long enough to accommodate the deepest tank to be served. To



the lower end of the shaft is fastened a heavy-duty rotor or paddle wheel. It is driven by an electric motor.

the lower end of the shaft is fastened a heavy-duty rotor or paddle wheel. It is driven by an electric motor.

1174 IMPROVED WATERING TROUGH HEATED BY TWO LAMPS

The water need never freeze in a new trough designed to be heated by two small lamps. Of medium capacity and lined with galvanized iron, there is nothing unusual in the construction of the tank, except that beneath what would ordinarily be the bottom of the trough,

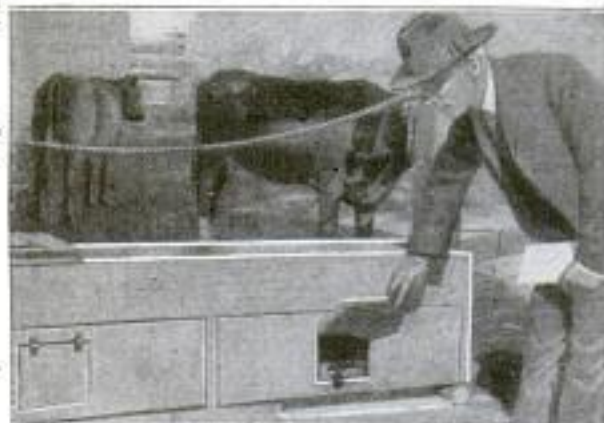

The Water in This Trough is Kept from Freezing by Two Lamps in a Lower Compartment, One Section of Which is Shown Open

is a long compartment, built somewhat in the nature of a false bottom, and it is here that the lamps are placed. In addition to the heating feature is a float-and-valve arrangement which keeps the trough always filled.

1211 HUGE POWER DAM PROJECTED IN PROVINCE OF QUEBEC

For the development of 1,200,000 horsepower, a dam is to be built at the Grand Discharge from Lake St. John, the headwaters of the Saguenay River, in the Province of Quebec. In the erection of the dam an expenditure of \$12,000,000 is contemplated. A Quebec development company has announced its intention of making use of the water power in two large mills to be erected for the manufacture of wood products and paper.

584 IRON EAVES-TROUGH HANGERS THAT ARE EASY TO SET UP

For eaves troughs, or hanging gutters, wrought-iron supports that can be connected to the rafters, or nailed against ogee moldings, have recently been patented. In both cases each support is connected to a channel-iron shank which is perforated at short intervals along its whole length for bolting to it a bracket for the gutter. The



shanks are of different lengths, enabling the roofer to arrange them so that the gutter can be given a suitable slope. There are no crossbars over the top of the trough, and nothing to hold leaves or other rubbish, and thus interfere with the drainage.

□An independent police force under the direct command of the president has been formed with the thirty-odd policemen detailed at the White House. The new organization will wear a uniform of navy-blue serge, and will probably become a permanent institution.

Enterprise Mfg. Co., Oakland, Calif.

M. J. James 12/28/22 5.8
M. R. Deering 59 N. 2nd St. Philadelphia Pa.

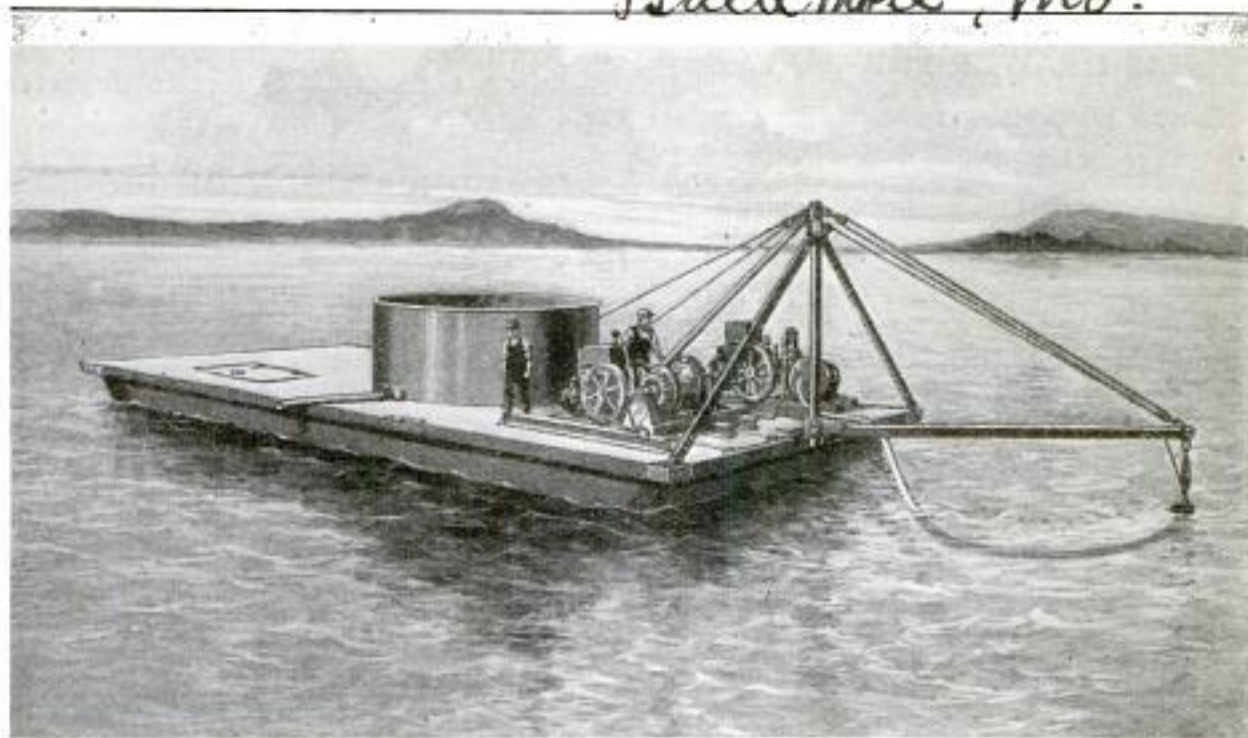

Apparatus for Skimming Waste Fuel Oil from the Surface of the Water in the Harbor of Baltimore, Maryland: On Board the Scow Is a Pump in Connection with the Hose, the Intake End of Which is Suspended from the End of the Boom. The Tank Is for Separating the Oil from the Water

FUEL-OIL SKIMMING DEVICE FOR BALTIMORE HARBOR.

To keep Baltimore harbor free from floating fuel oil, which is a constant fire menace, the city authorities have constructed an effective skimming apparatus. It consists of a suction pump mounted on a scow and connected with a hose which is slung overboard with its intake end suspended from a boom and held just below the surface of the water. When the pump is in operation, water and oil, after being sucked through the hose, are discharged into a settling tank on board the scow. In this tank, when the water has been separated from the oil by settling, it is discharged through an outlet pipe, and the oil is then removed for storage in barrels. This oil-skimming scow will be operated in the same manner as a fire boat, being maintained at a permanent station, ready at a moment's notice to respond to calls sent in by the inspector who patrols the harbor for the detection of oil.

MACHINE WASHES AND DRIES RESTAURANT SILVERWARE

The flat silverware of restaurants, hotels, or other large catering establishments may be quickly washed and dried with a new improved machine. It consists of a copper cylinder, about 3 feet in diameter and 6 feet long, laid lengthwise

on a low stand. A removable section is at the top of the cylinder, and beneath are three compartments, the first two fitted with perforated baskets which revolve on racks, while the third is connected with a fan and a radiator just under it. In use, the silverware is placed in the baskets of the first compartment and revolved through a hot washing solution, then removed to the second, where it is whirled about in a rinsing solution, and finally put into the drying chamber, where the heated air evaporates all the moisture.

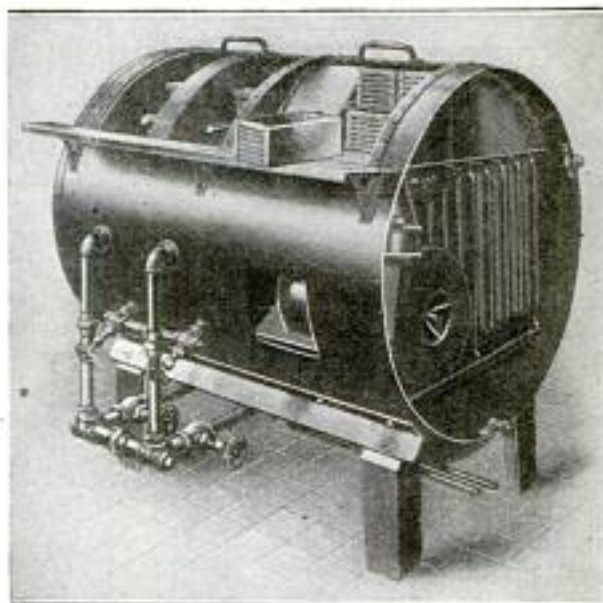

The Washer with One End of the Cylinder Exposed, Showing the Radiator and Fan under the Drying Chamber

M. V. Bauer, Mc Lachlin Pittsburgh Electric
 Bldg., 10th & Es Sts. N. W. Furnace Corp.
 416 POPULAR MECHANICS Union Bank Bldg.
 1138 20 Washington, D. C. Pittsburgh Pa.

**CHAIR-ARM WRITING BOARD
 HAS DRAWER FOR PAPERS**

A new portable writing "desk" consisting, roughly, of a rectangular board so padded that it may rest on the arms of a chair without marring the finish, has been especially



Below, the "Desk" is Shown in Use, and Above with Its Top Opened, Displaying the Drawer for Writing Material, and the Book Rest

fitted with a drawer for holding writing material. This drawer runs lengthwise under the forepart of the desk and is reached by lifting the upper surface of the board, hinged at the front edge. Another feature is a small finger, on the edge nearest the writer, which may be swung up to serve as a book rest.

**NOVEL MEANS FOR DISPOSING
 OF SURPLUS WATER POWER**

In many water-power stations it is necessary to provide for the escape of surplus water, and in high-head installations this causes trouble, especially in instances where there is no natural channel of easy gradient for the escape of the water. In such cases this difficulty has been overcome in England by the use of a hydraulic brake. This consists of a ring of small nozzles mounted around a cast-iron box, which is placed in the center of a shallow concrete basin. The water is delivered by a pipe to this box, from which it escapes in the form of radial jets. The eddy currents established when the basin is full of water dissipate the energy, and the water flows quietly over the brim of the basin to the tailrace. Brakes of this kind

have been built that handle 18 cubic feet of water per second with a head of 500 feet in a basin only 20 feet in diameter and 6½ feet high.

**FURNACE CALCULATOR FIGURES
 WEIGHT OF ALLOY NEEDED**

A calculator of the circular slide-rule type has been marketed to simplify the work of determining the quantity of ferro-alloy or pig-iron addition necessary to a furnace charge of a given mixture. It consists of a large and a small circular disk, and one segmental disk, on which are provided scales for weight of charge, percentage of alloy or carbon to be added, grade of alloy, and efficiency of absorption, per cent melting loss, and weight of alloy addition.

**NEW POSITION INDICATOR
 FOR TROMBONE SLIDE**

Of great help to the student is a new attachment for the trombone that not only indicates the position of the slide but also points on a scale to the corresponding note. The position is indicated on a revolving spool on which is wound a wire that is attached to the trombone slide. This spool is geared to a pointer that moves around a drum above the spool. On the outside rim of the drum

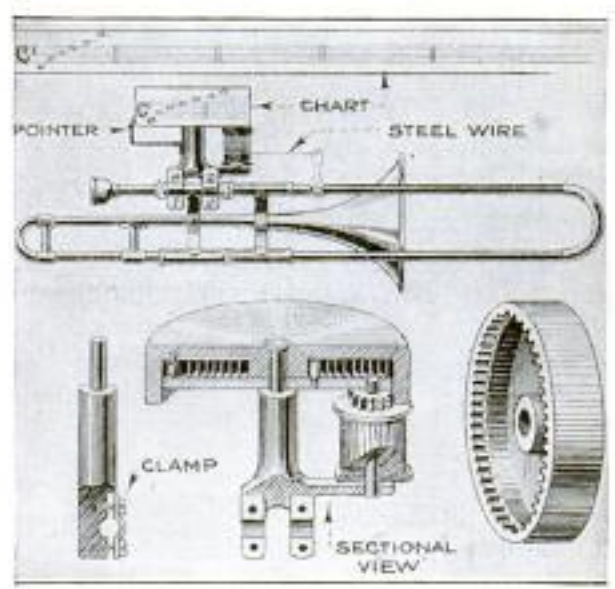

Complete Assembly of the Indicator is Shown and Noted on the View of the Trombone. Below, the Various Parts are Shown Enlarged and Partly in Section

are printed scales, and the indicator always points to the note corresponding to the position of the slide. The device is readily attachable and detachable.

J. no. George J. Little
 36 Terrace
 Hasbrouck Heights, N.J.

Manchester Guardian
 11/14/22

690 d no. M. A. High.
 3 W. Eighth St.
 POPULAR MECHANICS

AUTOMATIC SERVING COUNTER FOR LUNCH ROOMS

An automatic serving counter for lunch rooms and restaurants is intended to eliminate the need of waiters. When the customer enters a restaurant where one of these appliances is installed, he finds a clean tray, having tiny wheels, and a menu card before his seat. After checking off his order on the card, which is later used as a pay check, he places it on the tray, pushes a button, and the wheeled tray travels on a track to the kitchen. Here, the cook fills the order and sends the tray back to the counter. At the completion of the meal, when the customer rises from his seat, the tray travels again to the kitchen with the soiled dishes.

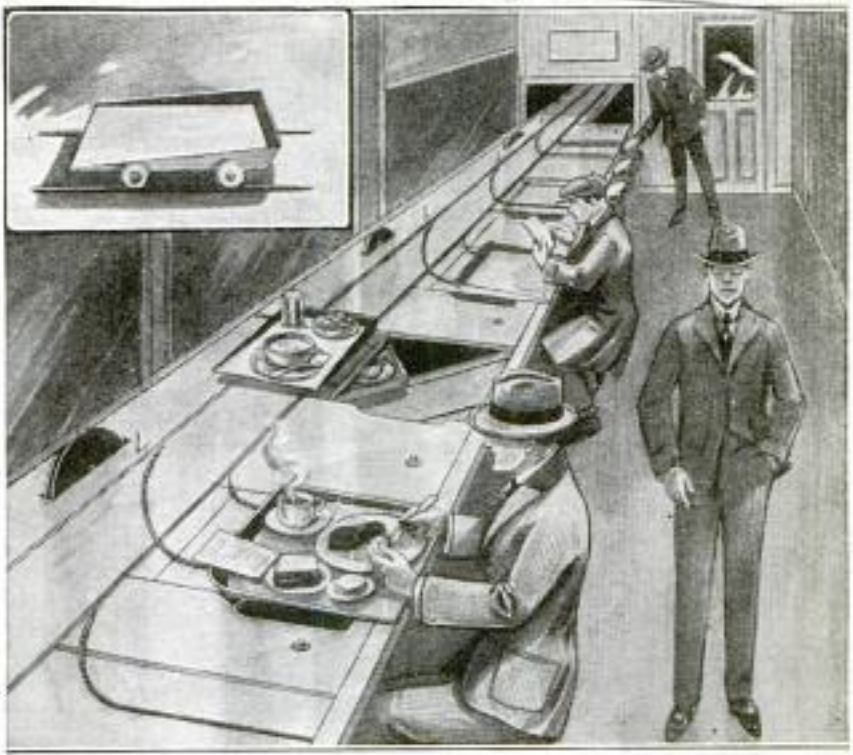

Automatic Serving Counter, Showing How the Wheeled Trays are Operated over Tracks to Bring the Food from the Kitchen and to Carry Back the Soiled Dishes: Insert Shows One of the Wheeled Trays

MILLIONS OF CROWS MENACE CANADIAN FRUIT CROP

Although more than 70,000 crows have been killed in British Columbia in the last two years, and thousands more are being slaughtered each month, the Game Conservation Board of that province estimates that there are still 7,000,000 of

these birds within its borders. The crows, according to the board, not only destroy corn and fruit crops, but, in feeding upon the eggs of the smaller insect-eating birds, harm the farmer to an extent that cannot be calculated. To encourage the shooting of these pests, a bounty of 20 cents is paid for each crow. Owls and eagles are paid for at the rate of \$1 each.

ent. Francis Luchie, Heriot Bay, B.C.

MOTOR-TRUCK TRANSMISSION FLEXIBLY-SUPPORTED

In an extra-long motor truck, where the transmission is located at the center of the frame in order to shorten the unsupported length of the drive shaft, the transmission has to be carried on two parallel cross members, the ends of which must be connected to the side members of the frame. If such end connections are rigid, any torsion of the frame when riding over rough roads will be transmitted to the transmission case, and in order to take care of this, special joints between the cross members and the

frame have been devised, and are the subject of a recent patent. The cross members carrying the transmission case are hinged at each end, where they connect to the side members of the frame.

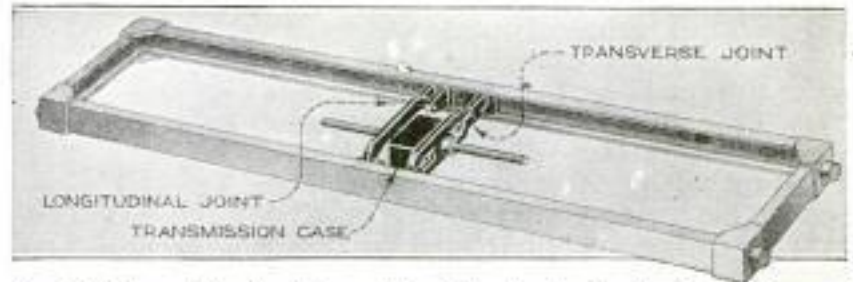

Flexible Support for the Transmission Case in the Center of the Frame of an Extra-Long Motor Truck: The Cross Members Carrying the Transmission Case are Hinged at Each End to Provide Thorough Flexibility

In one case, the hinges act longitudinally, and in the other transversely, so that there is flexibility in both directions.

*d no. Maurice Leo Kerr Truck Corp
 Supt. Indiana marion d no.*

Welflecta Ltd. 36-A, Queen's Road, W.2, Raywater London England.

448

POPULAR MECHANICS

**NEW WINDSHIELD CLEANER
USES WIND PRESSURE**

A new windshield cleaner, that is entirely automatic in action, utilizes the wind pressure against the windshield

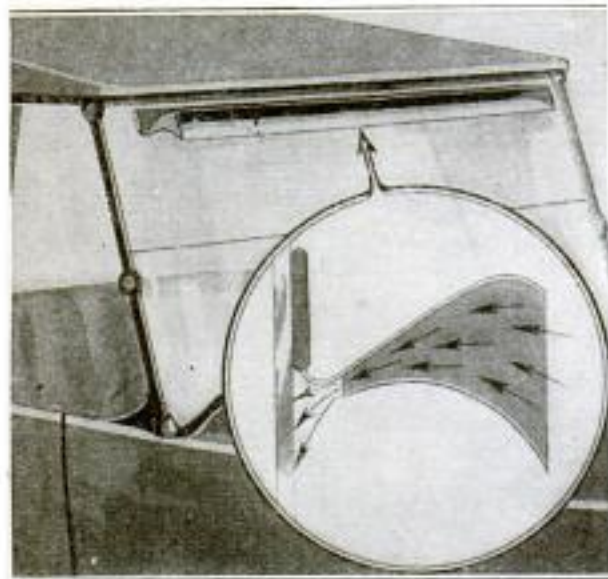

This Device, Which Attaches to Windshield by Means of Adhesive, Utilizes the Wind Pressure to Clear the Glass of Rain

when the car is in motion, as a means of keeping the glass clear in rainy weather. It consists of a nozzle-shaped piece of metal, which is attached to the windshield with a suitable adhesive and which directs a current of air against the glass, causing the rain spots to merge and run off at the bottom.

**ENDLESS-TREAD TRACTORS
BUCK SNOW IN UTAH**

The United States mails for the Uinta Basin in northeastern Utah, an isolated agricultural empire of more than 25 villages and a population of many thousands, are being forced through the snow-muffled mountain passes in automobile trucks piloted by a fleet of track-laying tractors, this winter.

Heretofore the basin has been served with the mails—when it was served—from Colorado points in a very round-about way; in fact the towns of Vernal, Roosevelt, and Duchesne, which are among the best country towns in Utah, have often been without mail for weeks when the snow was deep in the mountains.

An immense amount of parcel-post matter goes into the basin, including such articles as building bricks, certain forms of lumber, all kinds of merchandise and foodstuffs, and in fact everything a thriv-

ing region needs. A stoppage of the mails even temporarily causes a great accumulation at Price and Helper, the railroad supply points.

The crest of the divide on the road to Duchesne is nearly 9,000 feet above sea level, and for nearly 20 miles the snow sometimes accumulates several feet in depth. The tractors have been shuttled over the pass continually since the first deep snow of the winter, often going through rather than over the snow, but managing to pack a roadway for the passage of the heavy mail trucks.

The trucks, however, lose their traction in the tractor tread, and the latter are thus used to tow the trucks over the hump. As a demonstration, recently, two tractors hauled a train of seven loaded parcel-post trucks and one touring car over the summit, where but a few hours previously the snowdrifts had been 10 feet in depth and the general layer 4 or 5 feet deep.

**TRIANGULAR METAL CLAMP
FOR TIGHTENING WIRES**

A metal clamp for taking up the slack in fence wires, and thus tightening them, has recently been patented. The clamp is in the form of a small triangular plate with fingers at one corner for engaging the wires and extensions at the other corners. In the center of the plate is a square hole for the insertion of a tool by

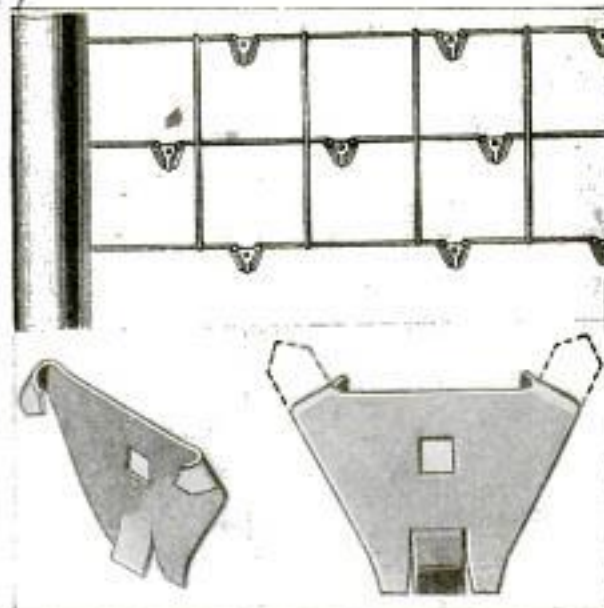

Triangular Clamp for Taking Up the Slack in Fence Wires, Operated by Inserting a Tool in the Square Hole in Center of the Plate, and Twisting the Wire

means of which the wire is twisted, until the two extensions can be bent over it, clamping the wire in a triangular loop.

Chas. E. Sussman, 613 S. Main, Elkhart, Ind.

Emil J. Cecil Allen, 1103 Proctor's Lake, Utah

23

at the 12:11

Copyrighted material

Manchester Guardian
Commercial 12/21/22

Chas. Fred Moore
Aurora, Ill.

**MUD-SPLASH GUARDS TESTED
WITH WHITE SCREENS**

1271

Automobiles fitted with various devices for preventing mud splashing were run through a muddy lane and past white screens, in a recent contest held by the British Royal Automobile Club. None of the guards was considered sufficiently efficient to merit an award, though more than 36 were entered in the trial. Among the many types seen was a flangelike attachment that revolved with the wheel, a hanging curtain suspended from the hub cap, and a curtain device supported by braces running to the auto frame. The screens, however, recorded large splashes with all of them, and, in addition to failing in this first essential, some of the guards proved altogether too heavy to be practical for common use.

**CONCRETE-MIXING EQUIPMENT
ON MOTOR-TRUCK CHASSIS**

To facilitate road-building work, a complete concrete-mixing outfit has been recently installed upon the chassis of a motor truck. The mixer, which is of one-bag capacity, is driven by the engine of the truck. The charging hopper is pivoted to the front of the truck, and the measured aggregates are conveniently loaded into the hopper when it is resting with one end on the ground. By means of pulleys and cables, it is then swung up to the mouth of the mixer, which discharges the concrete from the rear end of the truck. The outfit can be driven rapidly from job to job, and in road building keeps up easily with the progress of the work.

**MATTRESS CARRIED IN TRUNK
UNFOLDS INTO BED**

638

A trunk and a bed have been combined in a large boxlike container, capable of holding a folded mattress and a number

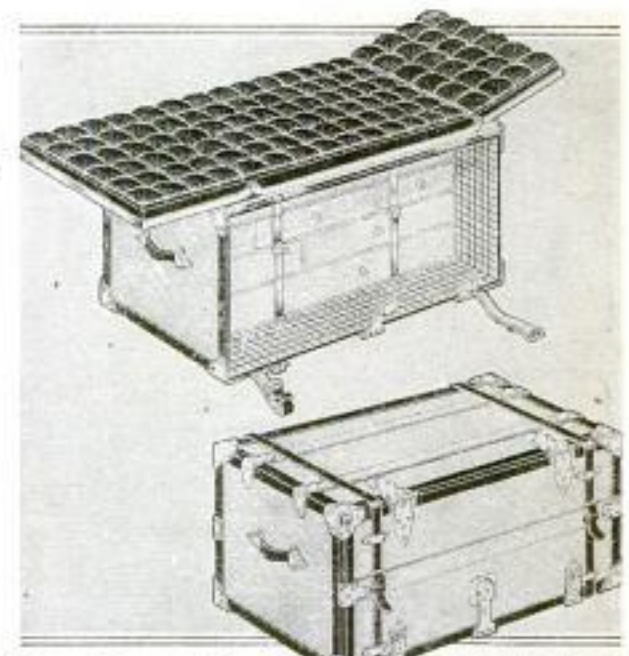

Top: Mattress Removed from, and Placed on Top of, the Trunk, Showing Bedding Drawers. Bottom: Outfit Packed for Traveling

of drawers. When traveling, the mattress fits against and keeps the drawers closed. In preparing the combination for a bed, the trunk is placed on its side and the mattress taken from the end, thus giving access to the bedding in the drawers. A comfortable bed may then be made up on the top of the trunk, providing a convenient means for accommodating a guest.

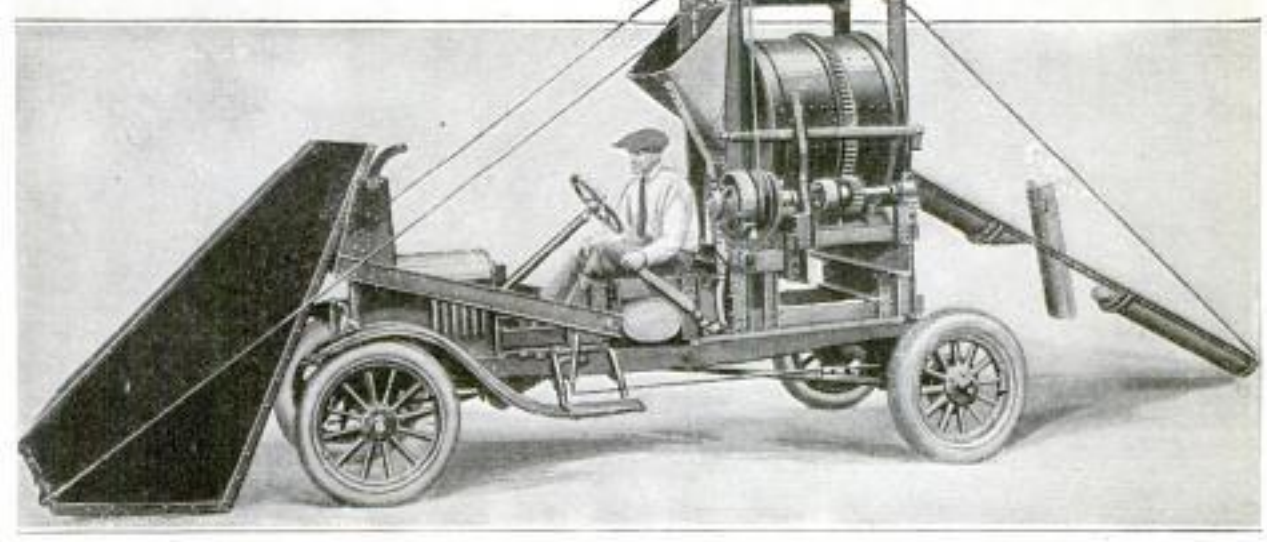

Complete Concrete-Mixing Outfit Installed upon the Chassis of a Motor Truck: The Mixer is Driven by the Engine of the Truck, and is Charged by Swinging Up the Hopper Seen Pivoted in Front of the Truck. The Concrete is Discharged by the Chutes in the Rear

Archer Iron Works 2438
2034th Place Chicago



A Modern Lilliput That Has No Lilliputians, Being an Uninhabited Miniature Village Constructed by the Children of a Denver Man near His Summer Home in the Rocky Mountains: The Church Has Spires Three Feet High. To the Right Is an Electrically Lighted Brick Block in the Village



South Pasadena, California, Is Proud of Possessing What Is Doubtless the Youngest Band in the World. Including the Bandmaster, Seen in the Foreground, Each of the 60 Members of the Band Is Seven Years Young or Younger. All Are First and Second-Grade Pupils of the Local Public Schools, Where They were Trained. Left: Close-Up of Three of the Musicians

PHOTO COPYRIGHT, 1917,
WEBB & CO.,



OF MODERN ACTIVITIES AND INTERESTS



Four Spanish Boys, in the Suburbs of Madrid, Using Their Own Peculiar Kind of Scooter to Give Them Greater Speed in a Foot Race: Their Name for This Kiddie-Car Is "Rado"



This Stone Football was Awarded as a Trophy to the Friends University of Wichita, Kansas, When the Quaker School Defeated Fairmount College, of the Same Town, by a Score of 26 to 3. It Weighs 500 Pounds, and was Given by the Midian Shrine Temple Circus Committee

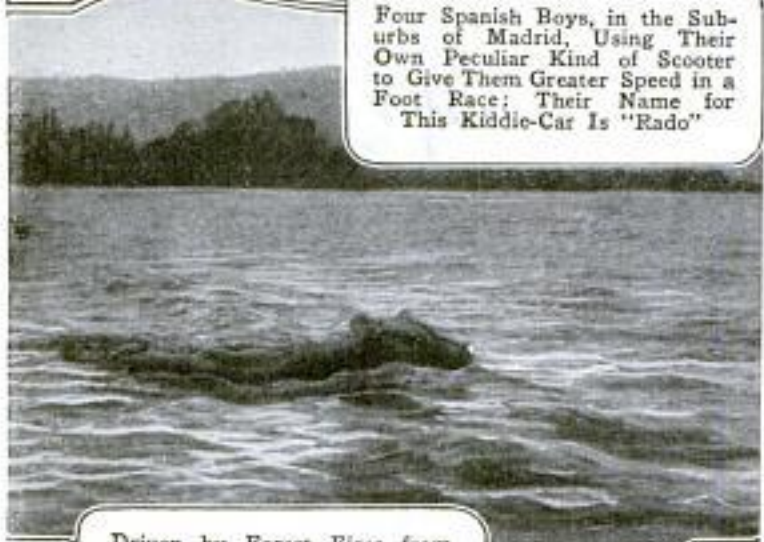

Driven by Forest Fires from the Shore While Fishing for Salmon, This Grizzly Bear had to Swim for His Life. A Boat Put Off from the Other Shore, and This Remarkable Photo was Taken, in Spite of the Grizzly's Efforts to Avoid It



Theft Insurance is Not Needed by the Owner of This Car, in London, England. He Considers It Perfectly Theft-Proof When Guarded in This Manner by the Watchful Cheetah, the Hunting Leopard of India, as Fierce as He Is Wary

452
152
d. w. A. C. Zink
#1 Birch St.
Worcester Mass

Herald Examiner
12/20/22

POPULAR MECHANICS

SOAP IN FORM OF SHEETS FOR INDIVIDUAL WASH

Intended for office buildings, shops, and public places generally, a new "sheet soap" is dispensed from cabinets in somewhat the same manner as paper towels. The sheets are about 2 by 3 inches, and may be folded or rolled repeatedly, without tearing. It is claimed, in addition, that the sheets will not attract insects, and may be printed for advertising purposes. Another form of soap is like a tablet and can be crushed open, permitting the user to spread it as a paste over his hands.



975

GORILLA SANCTUARY PLANNED FOR BELGIAN CONGO

1240
A great jungle sanctuary for gorillas is to be mapped out in the Lake Tanganyika region of the Congo by an American scientist, working for the Belgian government. Here the huge beasts are to be left entirely unmolested. It is probable that only zoologists and others with a special permit from the government will be allowed to visit the region.

SYNTHETIC THYMOL CHEAPER THAN IMPORTED DRUG

1249
Synthetic thymol, which is a drug used extensively as an antiseptic and in the treatment of the hookworm disease, is being made by chemists in this country, from a waste product of the paper industry. It is said to cost only about one-half as much as the drug imported from India, where it is obtained from a plant.

Dept. of Agriculture
In addition to being fined, traffic violators of Sioux City, Ia., are required to spend two hours in a special class in which they are made to study and recite a long list of traffic rules.

STATION TRUCK ADAPTS ITSELF TO PLATFORM

An improved truck used for hauling baggage and express around the plat-

18 inches. This permits loading and unloading of heavy and bulky articles from points at different heights above the railroad platform. A crank, easily operated by one man, turns a worm and gear attached to a drum, from which cables connect to levers that bear against the four corners of the truck platform, thus effecting the raising or lowering.



Above: New Station Truck Raised to Height of Floor in Baggage Car. Right: Man in the Act of Elevating the Truck Floor, Which can be Raised and Lowered through a Range of 18 Inches

forms of railroad stations, has for its main feature a provision for raising and lowering the truck floor through a range of



Mc Cullough & Sims Co., Alliance, Ohio.
Copyrighted material



Cheap Cistern Made of Vitrified Clay Pipe

By LOUIS DAVIS

A SANITARY, substantial, and economical cistern can be constructed of 36-in. vitrified clay pipe, in the manner indicated in the drawing.

After the excavation is completed, a substantial base is made by laying a brick floor on the bottom and pouring a 6-in. layer of concrete over this. While the concrete is still soft, two units of 36-in. vitrified clay pipe, each with side outlet, are set into it and connected as shown. The connection is also covered with concrete to prevent any possible leakage. After the base has hardened, the other units of pipe are placed in position and cemented at the joints.

A filter is made by filling the lowest unit of one section with a mixture of fine and coarse gravel and charcoal. A wire strainer is inserted in the side outlet, and some coarse gravel and stones are placed around it, to hold it in position and to prevent the fine gravel and particles of charcoal from passing into the other section. The filter unit is covered with a circular piece of

galvanized screen wire, held in place by bricks, as shown in the drawing.

The covers are made of 2-in. boards, nailed together to make a double thickness. A pump is fastened on the cover of the section containing the filtered water, and is fitted with a galvanized pipe extending to within an inch or two of the bottom.

A float gauge is attached to the other cover; this consists of a cedar ball and block connected by a length of No. 10 copper wire. The wire passes through a hole in the cover. When the water reaches the wooden block, it causes it to float and pushes up the ball, indicating that the well is full. A shut-off should, of course, be fitted in the downspout leading to the cistern, so that, when the latter is full, the water can be diverted to a drain.

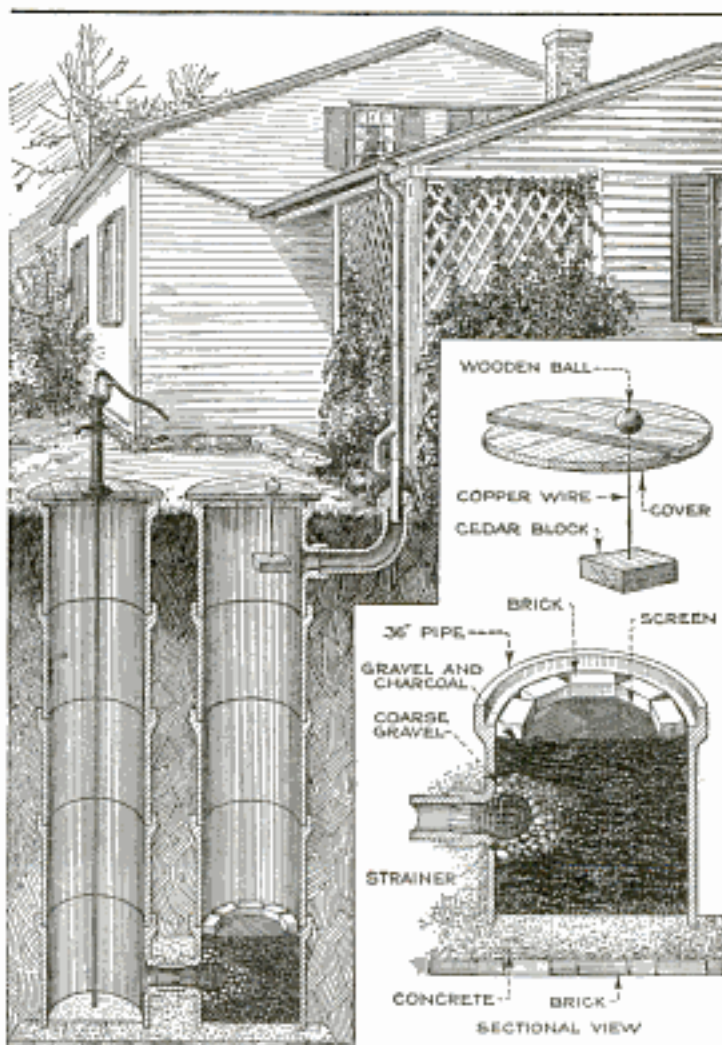

A Two-Section Farm Rain-Water Cistern Constructed of 36-Inch Vitrified Clay Pipe: It Is More Sanitary than Most Cisterns

A well of greater capacity can be made by adding sections, excavating deeper than is shown in the drawing.

This type of cistern is very sanitary, as it is immune from soil and rodent contamination, and there can be no seepage.

Furthermore, as the usual walling, bricking, and cement plastering are eliminated, considerable expense is avoided. A two-section cistern of this type can be built for approximately \$100 and is virtually indestructible; it will not cave in, cannot be penetrated by tree roots, and is not affected by moisture.

Wrench for Turning Large Pipe

The wrench shown in the illustration can be made in a very short time, and is

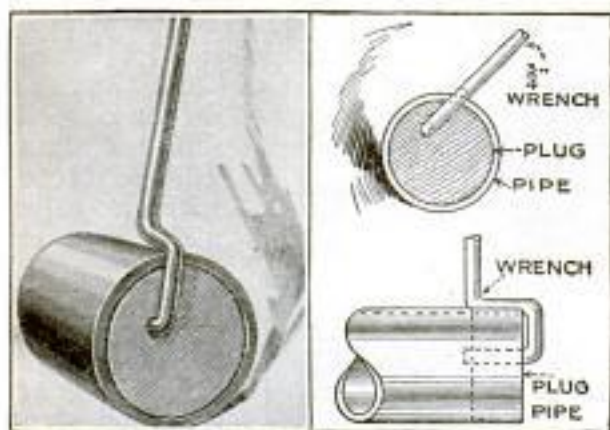

A Simple Wrench, Consisting of a Lever and a Wooden Disk, Makes a Good Substitute for a Large-Size Pipe Wrench

of great value when one is confronted with a job requiring the use of a large pipe wrench, a tool that is usually not carried in the mechanic's tool box.

It consists of a lever made of $\frac{3}{4}$ -in. bar stock, bent to the shape indicated, and a wooden disk that fits loosely in the end of the pipe and has a hole drilled through it, off center, to fit the end of the lever. The manner of using the tool is obvious from the illustration.

Drilling True Holes in Turret Lathe

The drill holder shown in the drawing will be found a very convenient means of drilling a hole true in the turret lathe.

Any attempt at drilling a deep hole with a long drill, without previous preparation, will nearly always end in a "drunken" or untrue hole. A twist drill has a certain amount of spring, and if the hole is started slightly out of true, the error will increase with the depth of the hole. A

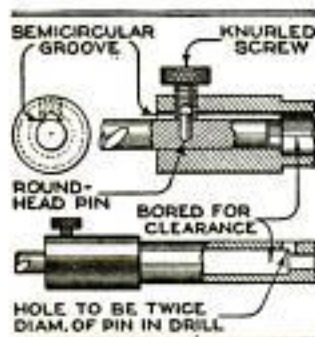

short, stubby drill makes an ideal centering tool for starting a drill, but since the number of holes in the turret will not always allow the use of this, the same effect has been obtained by the use of this holder. The shank of the holder is turned to fit the turret, and left a little larger on the front end; a circle, the same diameter as that of the drill to be used, is scribed on the nose of the tool, and a punch mark made on the circumference of the circle. A hole, about $\frac{1}{4}$ in. in diameter, is then drilled, parallel with the axis of the holder, from this mark; thus, when the holder is bored for the drill, a semicircular groove is left along the top of the hole. A $\frac{1}{4}$ -in. round-headed pin is driven into a hole drilled in the shank of the drill; this slides in the groove just mentioned. Near the rear of the holder, a hole, about twice the diameter of the pin in the drill, is drilled. The holder is then tapped for a knurled screw. This screw has a hole, the same size as the pin in the drill, drilled a short distance into the point. When in use, the screw is loosened and the drill pushed back until the pin enters the hole drilled in the back of the holder. The work is then centered and drilled part way; then the drill is pulled out until the pin touches the knurled screw, when the latter is tightened onto it and the work drilled to the proper depth.

Setting Work in Power Hacksaw

Most power hacksaws have a length-gauge attachment of some sort to be used when cutting off a large number of pieces. To use this, however, when cutting off an occasional piece, requires too much time, and it is the usual practice to measure off the length wanted, file a mark, and set the saw to this. This method also takes time, as the saw frame must be lowered and lifted, and the piece adjusted in the vise, until the mark lines up with the saw. The drawing shows a simple fixture that is designed to be attached to the fixed jaw of the vise, so that the operator can set up a piece very quickly. The body of the fixture is screwed to the vise and has

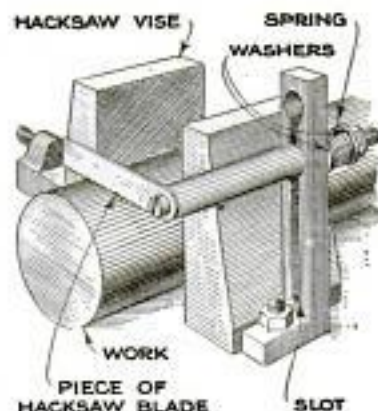

its upright part slotted, a hole about twice the width of the slot being drilled at the top. Next, a piece of cold-rolled steel is grooved so that the smaller diameter will fit into the slot, and the larger diameter easily into the hole at the top of the slot. This horizontal piece holds a piece of saw blade at one end and is threaded on its opposite end for a nut, which bears against a spring and washer. The fixture should be attached to the vise in a position that will bring the piece of saw blade into the exact position of the saw blade in the frame of the machine. After the work has been set, the horizontal arm is pulled up until it enters the hole, in which position it can be pushed out of the way.

Valve Wrench for Oxygen Tanks

Opening the valves of oxygen tanks, usually a more or less difficult job by hand, can be done very easily by means of the wrench shown in the illustration. It is made by cutting out a piece of $\frac{1}{8}$ or $\frac{3}{16}$ -in.

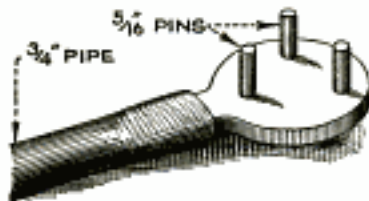

boiler plate with a cutting torch, to the shape shown, and then brazing or welding the shank or tang in a 6-in. length of $\frac{3}{4}$ -in pipe, flattened to fit the tang. Three $\frac{5}{16}$ -in. pins, 1 in. long, are welded to the face of the tool so that they will fit in the notches of the hand-wheel.—A. S. Jamieson, Springfield, Mass.

Making Rigid Crates

No method of joining the corner members of a crate is alone sufficient to give rigidity to a crate. Some kind of bracing across the faces is necessary.

Figure 1 shows a kind of bracing found in many crates sent to the U. S. Forest Products Laboratory for testing. Although this construction appears to be very strong, partly because of the amount of material used, it has been demonstrated by actual tests that crates so made are very weak when a diagonal strain is applied, and are therefore apt to "weave" and "skew" during transportation. Fig. 2 shows a crate with diagonal braces on six sides. This kind of bracing gives maximum strength for a minimum amount of lumber used. It has been found that crates so braced can withstand, with much less distortion, a diagonal strain twice as great as that applied

to crates braced as shown in Fig. 1. Fig. 3 shows a combination of cross bracing

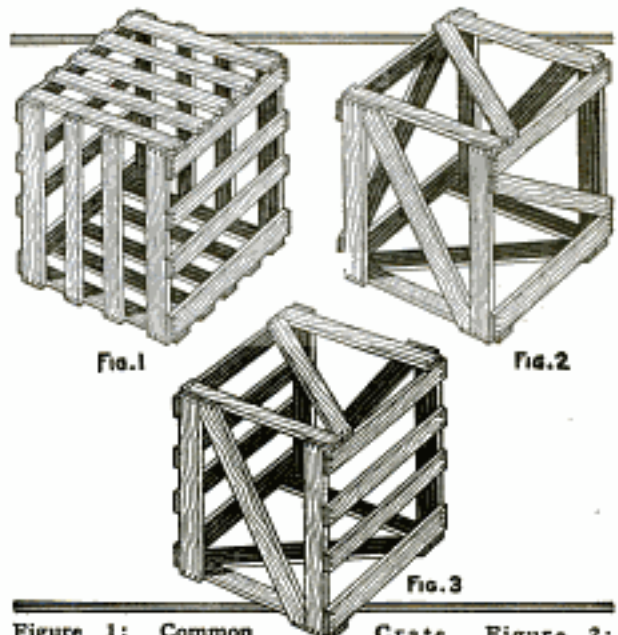

Figure 1: Common Crate. Figure 2: Bracing Giving Maximum Strength with Minimum Lumber. Figure 3: Type Recommended for Rigid Material

and diagonal bracing that is recommended for use with products that need protection on the sides, and that are rigid enough in themselves to withstand stresses in the direction in which the crate is weak.

Solid sheathing on all faces does not make a crate so rigid as diagonal bracing, except, perhaps, sheathing made of wide boards, with tighter joints than usually obtained. The crate with common sheathing might withstand as great a load, but the distortion caused by that load would be greater than in a crate with diagonal braces, and would, ordinarily, be great enough to cause damage to the contents.

Protector for Plow Handles

A flat-iron guard, bent and attached on the outside of a plow handle as shown in the illustration, protects the handle from being broken or splintered

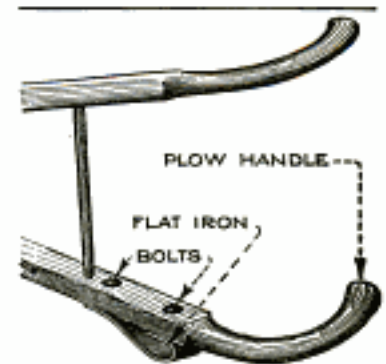

while dragging the plow on its side over the ground, the customary way of moving a plow for short distances.—J. Howard Hughes, Henriette, Tex.

Rewinding Machine for Motion-Picture Films

A spring motor, taken from an old phonograph, has been used for several

upon a wooden angle plate, as shown in the photograph, so that its shaft extends horizontally through the plate; this shaft is provided with an extension to hold the film reel. It is necessary to provide a dog

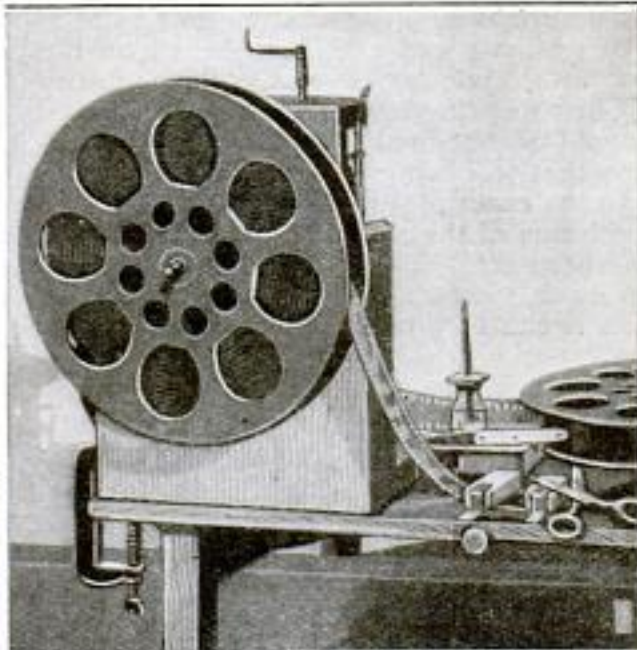

Left: Rear View of Film-Rewinding Machine, Showing How the Phonograph Motor is Attached. Right: Front View, Showing Reel in Place

years in the laboratory of a western photographer for rewinding motion-picture films.

The phonograph motor is mounted

on the shaft, with the tail fitting in one of the holes of the film reel for the purpose of driving it. The brake on the phonograph motor enables the operator to start or stop at will, to run slowly while examining the film, or fast while taking it up.—F. J. Hiscock, Cody, Wyo.

Drilling Out Broken Cylinder-Head Screws

A frequent job in the garage is that of drilling out broken cylinder-head screws. To do this, without the danger of spoiling the threads of the hole in the cylinder block, the drill should be guided by a bushing, fitted into the hole in the cylinder head. The bushing should fit snugly, so that light tapping is necessary to remove it. Its length should be equal to the depth of the hole in which it fits, and its inside diameter should be the same as the root diameter of the threaded end of the capscrew; this can be determined by consulting a table of tap and drill sizes.

The broken screw is chipped off flush with the surface of the cylinder block. The cylinder head is then put in place, and held by two or three screws. After the broken screw has been drilled out,

the cylinder head is removed, and the hole is tapped to its original size, to clear it from the remainder of the screw. Care must be taken to back out the tap frequently to clean out the broken pieces. The bushing should be hardened to prevent it from wearing quickly. It can then be used indefinitely.—Fred H. Wadden, New Glasgow, Can.

Submerged and Exposed Concrete

Concrete laid under water will set much better than concrete laid in air. This is due to the fact that a far better hydration of the lime results in submerged work than in ordinary work, where the concrete dries out quickly. Work that is exposed to air, such as walks and driveways, should be kept covered for several days with old wet carpet or canvas, or even with moist earth, to prevent it from drying out too quickly.

Demagnetizing Watches

When a watch is brought within the magnetic field of a powerful generator or magnet, it frequently occurs that the hairspring becomes magnetized, and renders the watch useless.

To demagnetize it, pass a shoestring, or a similar cord, through the bow of the watch and bring the ends together. Suspend the watch by holding the doubled shoestring in one hand, and twist the string tightly by turning the watch with the other hand. Then place the watch close to the field magnets of the generator, or to the magnet, and allow the string to unwind, which will cause the watch to revolve. While the watch is revolving, gradually draw it away from the generator or magnet, so that when it stops revolving, it will be out of the magnetic field. The watch will thus be completely demagnetized. The explanation of this is that the revolving movement of an object in a magnetic field prevents its molecules from assuming any definite arrangement or relation to each other, as they do when the object is at rest in a magnetic field.

If one has no access to a strong magnet or generator, a magnetic field can be created by forming a hollow coil, 3 to 4 in. in diameter, of about 200 turns of No. 16 insulated copper wire. Connect a flatiron or incandescent lamp in series with the coil and pass the house current through the circuit, which will set up a strong magnetic field inside of and around the coil. Hold the watch suspended on a twisted shoestring inside of the coil and gradually draw it out, while it is revolving.—R. R. Spencer, Denver, Colo.

Enlarging Holes in Wood

To enlarge a hole with an ordinary wood bit, fit a wooden plug, about 1 in. long, with its grain running lengthwise, into the hole. Drill a small hole in the center of the plug to admit the screw end of the bit. Then drill as usual, as if the wood were solid. When the cutting edge of the bit strikes the plug, it will not cut it easily, as the grain runs lengthwise, and, as the plug does not fit tightly, it will be pushed through the hole, guiding the bit. The plug may be greased if the work permits, and can be used repeatedly for holes of the same size.—Adolph Rietter, Marinette, Wis.

Loading Pipe onto Trucks

By using the simple method shown in the photograph for loading pipe onto a truck, the work is accomplished in less than one-half the time otherwise required.



A Method of Loading Pipe onto a Truck That Enables the Work to be Accomplished in One-Half the Time Otherwise Required

A 6 by 6-in. beam is carried crosswise under the truck in specially made U-irons. When the truck is to be loaded, this beam is pulled out so as to project a few feet beyond the side. Then, by lifting one end of the pipe so that the center is rested on the beam, it is an easy matter to swing first one and then the other end onto the truck.

A Powder-Loading Tool

When tamping powder into a hole for blasting a large tree, or similar purposes, trouble is usually experienced in pressing the powder down firmly without damaging the fuse. To overcome this difficulty, a tool like that illustrated can be used. It is made from a long bolt, a ring of flat stock being welded around the end to form a boss the size of the hole. A groove is cut in this, as shown, so that the fuse will slide in this groove without being damaged, while the powder is being tamped.



When tamping powder into a hole for blasting a large tree, or similar purposes, trouble is usually experienced in pressing the powder down firmly without damaging the fuse. To overcome this difficulty, a tool like that illustrated can be used. It is made from a long bolt, a ring of flat stock being welded around the end to form a boss the size of the hole. A groove is cut in this, as shown, so that the fuse will slide in this groove without being damaged, while the powder is being tamped.

Cutting Grooves on a Power Saw

The illustration shows how grooves of varying width and depth can be cut very

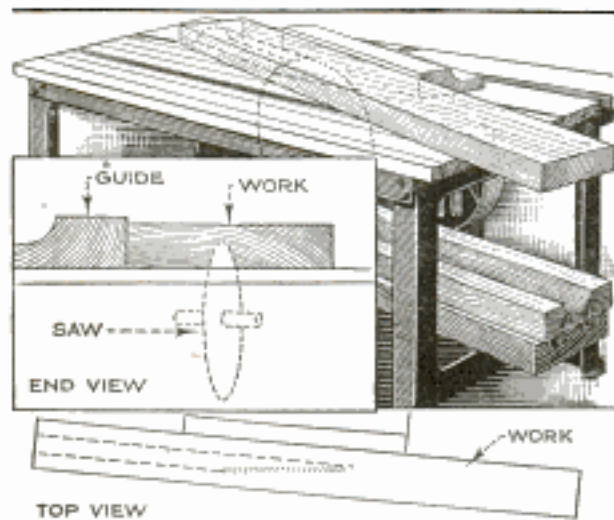

A Practical and Timesaving Method of Cutting Grooves of Varying Depth and Width in Wood, with a Power Saw

quickly on a circular saw with a wooden table.

A wooden strip is tacked at an angle across the table; this angle determines the width of the groove. Tilting the table up and down determines the depth of the groove, and the work is pressed along the edge of the guide strip as usual.

A woodworker who specializes in dentists' tool cabinets and work of a similar nature, where it is necessary to cut a great number of grooves, finds this a very practical and timesaving method.

Clips Hold Connecting-Rod Shims

Small brass clips of the kind shown in the illustration have been found to be of

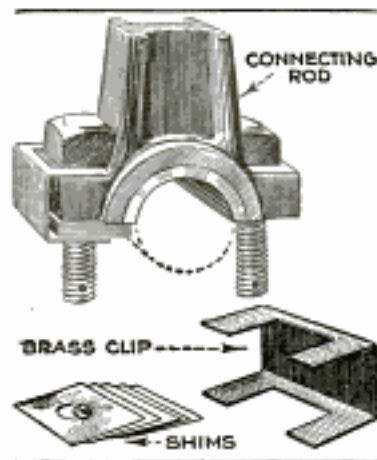

considerable assistance for holding connecting-rod shims in place while replacing the caps. The shims on one bolt are held in place with a clip while other shims are being put on the opposite bolt, and these are also held by a clip while the cap is put in place and the nuts are turned on. The clips are pulled off just before the cap is tightened.

Simple Blower for Sawdust

After experiencing considerable trouble owing to accumulation of sawdust in a sawmill, the following scheme was devised to blow the sawdust away: The sawdust was led into a 15-ft. wooden pipe, and steam pressure was applied behind the sawdust to blow it through. The wooden pipe was made from four 1 by 4-in. boards nailed together. A 1/2-in. steam pipe was led to a point opposite the center of the end of the pipe, and about 3 in. away from it. The steam blast picked up the sawdust, forced it through the pipe and blew it to a point 40 ft. from the farther end.—E. C. Smith, Barney, Ga.

Tailstock Adapter for Standard Tapers

When there is frequent need of turning tapered work in the lathe, to standard or identical tapers, it is difficult to set over the tailstock every time, and always to obtain the correct amount of setover.

The drawing shows an adapter that clamps to the end of the tailstock quill and carries an offset center, permanently set for turning a certain taper, such as that of the machine handle shown.

The adapter body, of cast iron, is counter-bored to a push fit over the quill, and the counterbore assures that it is set in the same position each time. A cast lug, bearing against the end of the tailstock, fixes the longitudinal position of the adapter, while it is prevented from rotating, as well as set for its angular position, by means of a setscrew, the end of which is turned down to fit into the quill keyway.

The offset dead center is made of drill rod, with the point hardened and tempered. It is set into the adapter body at an angle, so that it will line up with the center line of the work. This angular setting allows a slight adjustment of the amount of taper, by moving the center in or out and then clamping it in place by means of the heavy setscrew provided for the purpose.

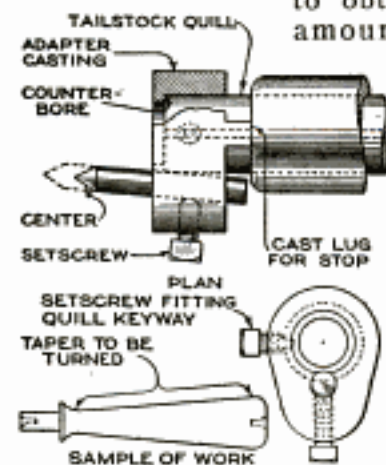

For work having a very slight taper, the construction of the adapter body must be modified by extending it beyond the end of the quill, to allow room for the insertion of the dead center without interfering with the quill.—H. H. Parker, Oakland, Calif.

Tool Marks Circumference by Measuring Diameter

The tool illustrated is valuable to the sheet-metal worker, as it shows the circumference of a circle at once, by measuring its diameter, thus effecting a considerable saving in time, in making cylinders, and the like, and eliminating calculation.

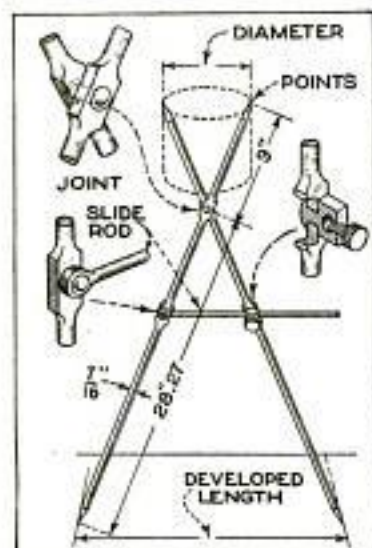

The construction of the tool is simple. It consists of two lengths of $\frac{1}{4}$ -in. iron rod, flattened at the joint and drilled for a snug-fitting rivet. The center of the joint is exactly 9 in. from one end and 28.27 in. from the other, which is the ratio of the diameter of a circle to its circumference. A slide rod, riveted to one leg, below the joint, so as to move freely, but without shake, and passing through a swivel on the other leg, locks the tool at any desired measurement. Measurements may be taken from a full-size drawing or from metal parts already made. While the dimensions given in the drawing cover a tool suitable for average work, it can be made as large or as small as desired, providing the proper ratio of leg lengths from joint to ends is maintained.

Marking Dismantled Machines

When dismantling machines for repair, it is always wise to place an identifying mark on various parts before removing them, so as to avoid mistakes in replacing them and to save time in reassembling. It is often difficult to distinguish the correct marks from other similar marks that have been made either acci-

dentally during use, or purposely during previous repairs. A method that makes it easy to distinguish the correct marks is to punch a circle around them

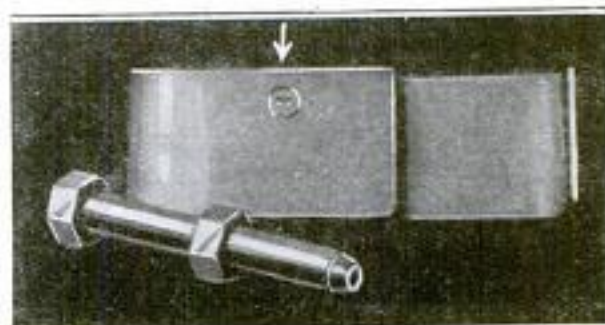
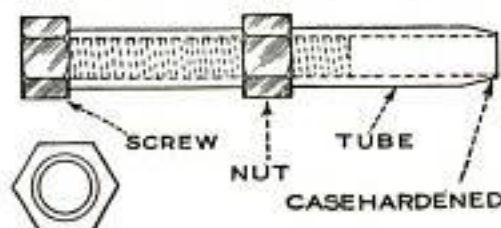

A Steel Die Stamp That Punches a Circle around Identifying Marks on Parts of Machinery Dismantled for Repair

with a steel die stamp of the kind shown in the illustration.

This stamp consists of two short pieces of steel tubing, a capscrew, and a nut. One piece of tubing is ground on the end to a cutting edge and this end is case-hardened. The other end of this piece and the entire length of the other piece of tubing are tapped so that the capscrew can be screwed in to hold both pieces together. The nut is run onto the screw between the tubes. This makes the tool solid so that it will sustain the tapping of a hammer. The nut in the center makes it easier to press the cutting edge squarely on the work, and the hexagonal shape of the screw head and nut prevents the tool from rolling when laid down.—Harry Moore, Montreal, Can.

Turning Heavy Shafts

The method shown in the illustration makes it easy to turn a heavy shaft around. By placing the end of a crowbar under one of the nuts on a coupling and using the hub of the coupling as a fulcrum, sufficient leverage is obtained to turn the shaft around.

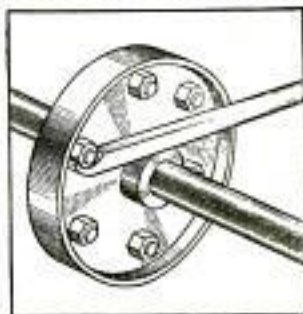

Board Supports Auto Body

The malleable castings, trussed by two rods that extend crosswise under the chassis, that support the running boards

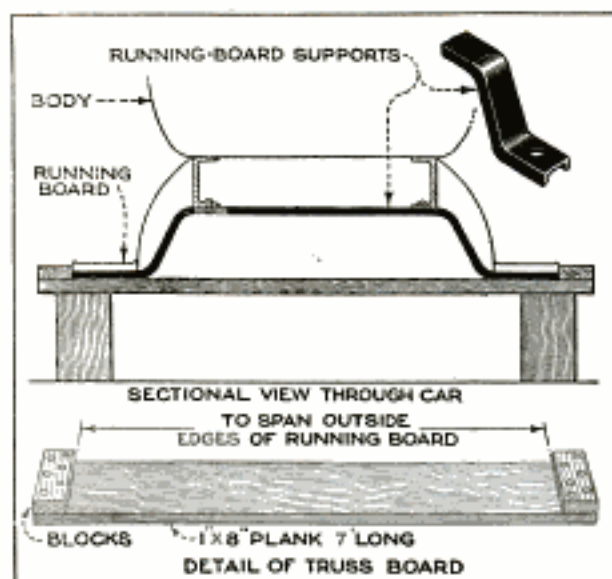

A Plank Support Prevents Running Boards and Dust Shields from being Bent by the Blocking Used during Repairs

of a light car, have been dispensed with on the latest models, and two supports, made of channel iron, bent to the shape indicated in the drawing, have been substituted for them. This change of construction necessitates a change in the method of supporting the body while removing the rear end for repair.

If the usual method is employed, of blocking under the running boards, the latter, and the dust shields, are bent and otherwise damaged. To prevent this, a strong plank with blocks of wood securely attached to the ends, as indicated, has been found very satisfactory. The blocks fit on the outer edges of the running boards as shown, and prevent them from spreading apart when the car is jacked up and blocks placed under the plank.

Emergency Index Plate

In the course of experimental work on a spring motor, it was found necessary to use a 24-pitch pinion having 11 teeth. As no index plate for this size of pinion was available, the following method was used to make the pinion:

The index plate was removed from the miller and shellacked to the center of a smooth piece of wrapping paper, 3 ft. square. A circle of 3-ft. diameter was drawn on the paper, concentric with the circumference of the index plate. With

the dividers, the circumference of the 3-ft. circle was divided into 11 equal parts, and radii drawn with a sharp-pointed pencil to the center; this was, of course, done as accurately as possible. The paper was then trimmed off to the size of the index plate, after which the latter was replaced in the miller. A surface gauge was clamped to the machine so that its scriber touched one of the radii, near the circumference. The locating finger of the head, which was adjustable, was set in place in one of the notches. After a cut had been made in the pinion blank, the index plate was set with the scriber at the next radius line in the same way as before, the finger moved into another notch and fastened, and a second cut made. In this way all 11 teeth were cut.—Dexter W. Allis, Whitman, Mass.

A Lathe Center-Hole Mandrel

For light turning in the lathe, a mandrel with a taper shank, fitting into the live-center hole, is a useful attachment, as no faceplate and dog are then needed, and the cutting tool can work up close to the end of the mandrel. If the live-center hole is true, the taper shank may be fitted and the mandrel body finish-turned and ground while in place. Under such conditions the mandrel should run true whenever replaced, but in any event, the best way is to scribe a line or make a chisel mark on the shank in line with a corresponding mark on the face of the

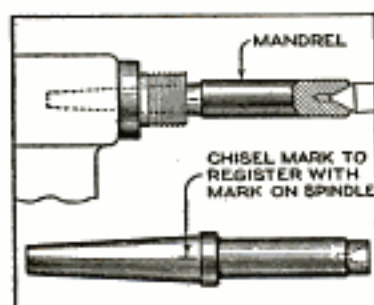

nose. In replacing the mandrel, the two marks are made to register, and the mandrel should then run true, even if the hole is slightly "out."

Several mandrels of different lengths and diameters, to suit the work at hand, may be made; they should be center-drilled for the tailstock center, though short pieces could be finish-turned, by taking light cuts at fairly high speed, without the use of the tailstock-center support. The mandrel body is preferably hardened and ground in place, but the temper of the shank should be drawn until soft enough to scrape; then Prussian blue is used for testing the fit in the center hole, and the shank is scraped until it fits accurately all over. It will hold tightly enough for all ordinary work.

Circular Yard Saves Brooder Chicks

In my first years of experience in raising brooder chicks I used an inclosed "yard," 10 ft. sq., that could be moved about to give the chicks a space of fresh grass occasionally. While watching the chicks one day, I noticed that several of them, that appeared to be suffering from the cold wind, would run along one side of the inclosure until they came to a corner, where they remained, huddled together as if they could go no farther. I picked them up, placed them in the brooder, and returned to watch the yard again.

As soon as the cool breeze again swept over the yard, another dozen or more huddled together in one corner.

Satisfied that the corners were to blame, I placed all the chicks in the brooder, and rebuilt the yard in the form of a circle. The chicks were then released into this yard, and, when desirous of returning to the warmth of the brooder, simply followed the fence until they came to the open door. The result was that the loss of chicks due to chilling was greatly reduced.—G. E. Hendrickson, Argyle, Wis.

A Handy Auto-Cleaning Tool

A stiff scrubbing brush, such as commonly used about the house, with a piece of stiff sheet metal fastened to one



end to serve as a scraper, makes a very convenient tool for cleaning the inaccessible parts of an automobile chassis. By mounting the brush on the end of a handle, as indicated in the drawing, almost any part of the machine, even the oil pan, can easily be freed of mud and dirt without the necessity of crawling underneath the car. The scraper will be found particularly convenient for removing accumulations of road tar, and dislodging clods of mud on the brake mechanism and frame, the brush being then used to clean the scraped surface.

Farm Tractor Used as Snowplow

Following a snowstorm that blockaded traffic in a Kansas town, a farm tractor



A Tractor Used to Clear the Snow from the Streets in a Kansas Town after a Heavy Snowstorm: The Work was Accomplished by One Man at the Rate of Three Miles per Hour

was used to clear the streets. The blade of a road-grading machine was attached at an angle under the frame, as shown. A roadway, 20 feet wide, was cleared in two trips, the snow being pushed to both sides of the road. The work was accomplished by one man at the rate of three miles per hour.

Wagon-Wheel Rim Puller

During dry weather, wagon-wheel rims have a tendency to slip to one side or the other of the fellyes, owing to the shrinking of the wood. Where this occurs,

it is necessary to force them back into place, a job usually done with a heavy hammer. A better tool for the purpose, made from a $\frac{3}{4}$ -in. iron or steel rod, is shown in the illustration. A 5-in. length of the same material is welded to the



rod, near one end, and both arms are forged as shown. In use, the hooked arm is caught on the side of the rim, and the longer arm pressed against the felly.

Tool for Removing Handles from Files

In shops where a box of files is carried around from one job to another, each one is not fitted with a handle, because of the space that this would require. Two or three handles are used, and these are usually knocked off and then fitted to other files, as required. Using the files themselves to do this, as is commonly done, is very injurious to the teeth, as both faces are scraped together, and furthermore, the files are frequently broken in this way. The photograph shows a simple tool for removing the handles. It is made of flat stock with a tapered slot cut in one end. By holding this tool in one hand, to grip the file, as shown, it is an easy matter to pull the handle off with the other hand.

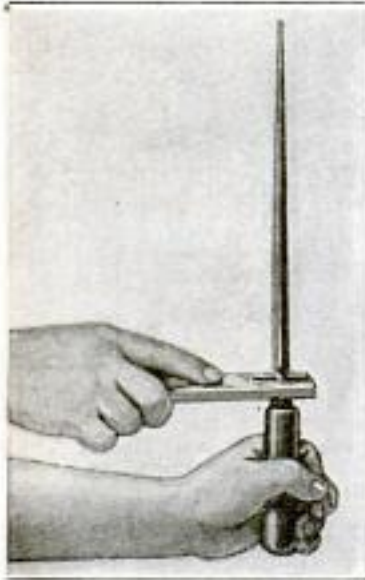

Ball-Bearing Guide Roller for the Band Saw

Anyone who has used the band saw as a woodworking tool is familiar with the troubles that result from a loose roller guide. The usual method of making these guides is to mount a hardened roller on a hardened pin, but, after a few months of operation, wear causes the roller to "wobble." This defect, however, is not found in the ball-bearing roller shown, which is practically everlasting, and, besides, is adjustable in three directions.

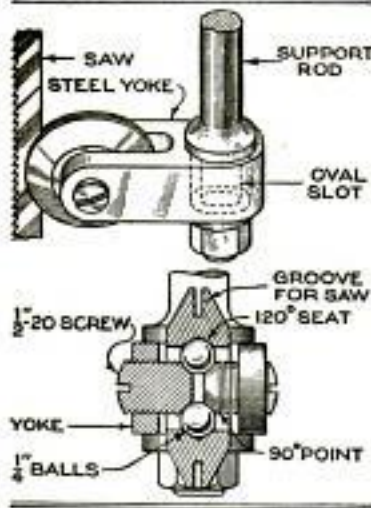

The roller is made of tool steel,

machined with a groove around its circumference. The cold-rolled steel yoke is drilled and tapped for $\frac{1}{2}$ -20 screws, the points of which are ground to an included angle of 90° , as shown in the drawing. Quarter-inch steel balls are nested into the raceway with a liberal amount of grease, to make them stick until the roller is assembled. Adjustment for play and proper running fit is obtained by tightening the screws, which should be made of hardened tool steel, and be a tight fit in the yoke. When, after using, looseness develops in the guide roller, the slack can easily be taken up.

A Brace for Overhead Lagscrews

Much of the difficulty and danger connected with erecting or removing overhead line shafting is eliminated if the lagscrews are loosened or tightened with a brace of the type shown in the illustration.

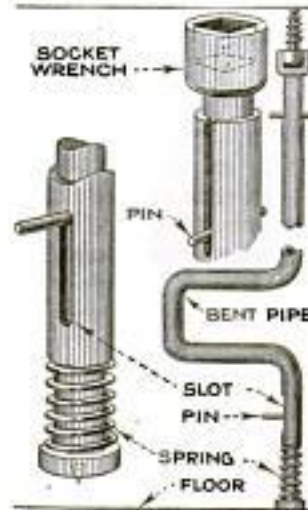

The brace is made of pipe, bent to the shape indicated, and extends from the floor to the ceiling. At the bottom end an extension leg fits loosely inside of the pipe; this leg has a coil spring around it, and a collar and small point are turned at its lower end. A pin, driven into the leg through a slot cut in the pipe, keeps the leg from falling out, and also allows the brace to adjust itself to suit the height of different line shafts. Two slots are cut opposite each other in the top end of the brace, to allow the insertion of a pin-driven socket wrench.—S. A. McDonald, Brooklyn, N. Y.

Labels Made of Adhesive Plaster

It is often difficult, and sometimes impossible, to stick gummed-paper labels to oily or rough surfaces. In such cases, a strip of adhesive plaster, properly lettered in ink, makes an excellent substitute, as it will stick to almost any surface. Adhesive plaster can also be used satisfactorily to fasten samples to the outside of boxes.—Thos. W. Benson, Philadelphia, Pa.

Friction Clutch Substitute for Ratchet

A friction clutch, of the type illustrated in the drawing, is used in place of a ratchet when it is not advisable, or possible, to use the latter. The clutch consists of two double-leaf springs, fastened to a hub block as indicated. Double-leaf springs are used, as they are stiffer than

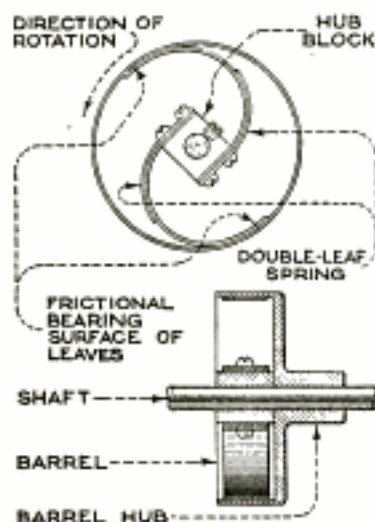

single-leaf springs and do not add to the friction when working in the reverse direction. There are several advantages gained by using this type of clutch. It is well balanced and therefore does not give a one-sided pull, which

wears the shaft and bearings. Another feature is its reversibility; by simply turning the hub block over, the operation of the clutch is reversed.

Measuring beyond Capacity of Micrometer

A shop kink that will enable the mechanic to get the micrometer measurement of large bushings and similar cylindrical work when only small micrometers are at hand, is shown in the drawing. The anvils of the two instruments are placed together and inserted inside the cylinder, with the spindles in contact against the outside wall. The correct measurement is the sum of the two readings.



Colored crayons are recommended instead of water colors for tinting drawings. The crayon should be rubbed on the drawing lightly and spread by means of a soft brush dipped in gasoline. The color does not readily rub off, although, unless the paper is very porous, it may be erased with a soft rubber.

Shortening Valve Stems

The illustration shows a simple method of shortening valve stems without removing them.

Raise the valve high enough to allow the insertion of a flat file under the stem, as shown. The tension of the valve spring will hold the stem solidly against the file teeth. Turn the valve with the valve grinder; this will grind away the end of the stem in contact with the file. Remove the file occasionally and test with a feeler gauge to keep the clearance within the proper limits.

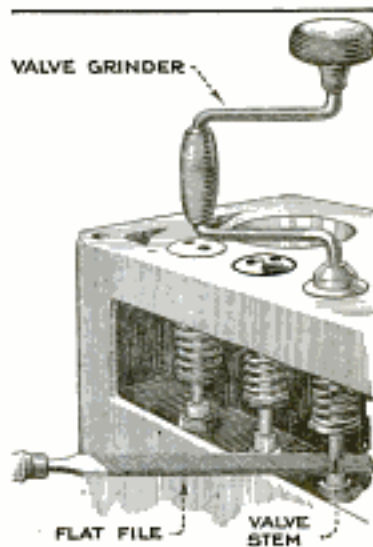

Simple Clamp Holds Timbers

The illustration shows a serviceable clamp for holding together the ends of timbers of uniform width while putting in bolts or screws, or accomplishing other work that requires the timbers to be held in position firmly. A clamp of this type has been used by a builder for holding 6 by 6-in. beams temporarily while bolting them together.

A length of iron rod is bent to a U-shape, as shown, to straddle the beams. Both ends of the rod are turned over to form hooks to fit over the edge of the cam plate. The cam is cut from a piece of steel plate. Raising the handle to a vertical position tightens the clamp, and bringing the handle slightly over the center position locks it. The length and thickness of the iron rod, and also the thickness of the steel plate, depend on the work for which the clamp is to be used.—G. A. Luers, Washington, D. C.

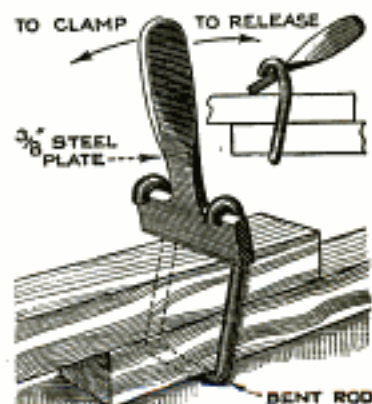

MAKING GLASS SIGNS BY SANDBLASTING

By JAMES TATE

COMPARATIVELY few persons, aside from the limited number engaged in the commercial side of the work, are aware of the possibilities latent in the process of decorating glass by means of the sandblast.

The process is a simple one, and with some artistic talent, and the proper facilities for the work, there is no reason why any reader could not build up a good business in this field.

The first necessity, of course, is some form of sandblast machine. These are made commercially in a wide variety of types, but the man starting on a small scale may use any of the homemade forms shown in Figs. 1 to 3 with perfect satisfaction. It is assumed, of course, that a supply of compressed air is available; for experimental work, this may be furnished by a small garage compressor, or even by a more simple apparatus, consisting of a tank capable of withstanding a pressure of about 60 lb. per square inch and a hand air pump.

The pressures used in sandblasting vary from 8 to 60 lb. per square inch; the higher the pressure, within these limits, the better, as, with a high pressure, the sand is projected against the work with greater force and velocity, and the abrasive action of the sand is heightened, thus lessening the time required for the work.

A word about the sand used will be pertinent here; any clean, sharp sand will answer for the purpose, although there are a number of dealers around the country who can supply special sand for the work. Sand of various grades of fineness should be kept in stock, as the texture of the "frosting" on the glass can be varied by their use. For example, with a coarse sand, the surface of the treated portions of the work will be quite rough to close inspection, while, if a very fine sand is used, the surface will be practically smooth. The sand used should be chosen with regard to the character of the work to be done, using very fine sand for such work as monogramming tableware and similar small pieces, and coarser sand for door panels, large signs, and

the like. The use of the coarse sand for large work will also speed up the work considerably.

The equipment shown in Fig. 1 is made, for the most part, of pipe and fittings, with a few feet of rubber hose, and a hopper for the sand. The size of the latter, of course, may be varied to suit individual desires, space, or type of work. The sand is fed from the hopper by gravity, and the flow may be controlled by means of a sliding shut-off valve fitted in the bottom of the hopper, or by a butterfly valve in the $\frac{3}{4}$ -in. pipe below it. This control valve has been omitted in the drawing, for the sake of simplicity.

The outfit shown in Fig. 2 has proved to be very practical for this work. The sand tank is made from an old range boiler, which is quite suitable for use with pressures not exceeding 20 lb. per square inch. If higher pressures are employed, it is recommended that a new range boiler be used; these are usually tested to 150 lb. per square inch, and will thus stand pressures up to 60 lb. with an ample margin of safety. Before using an old boiler it would be well to have it tested to about 75 lb., and thereafter use it for not more than 20 lb., using a gauge, as shown, to insure that this pressure will not be exceeded.

Practically all of the piping used is $1\frac{1}{2}$ in., and it will be noted that the tank is not completely filled with sand, an air space being left at the top, and a connection from the air pipe made to this space. This puts the sand under pressure, and insures a steady flow. A cross may be used instead of the tee shown below the tank, and the lower outlet plugged; then, if the sand valve becomes choked, the plug may be unscrewed, and a wire run through the valve, to clear it. The pipe at the nozzle is reduced to $\frac{1}{2}$ in., and a valve must be provided in the line between the sand and air tanks. When filling the tank, the sand should always be run through a fine sieve, to remove foreign matter and small pebbles, as the former might choke the valves or pipes, and the latter break the work, and the tank should not be filled higher than the level shown,

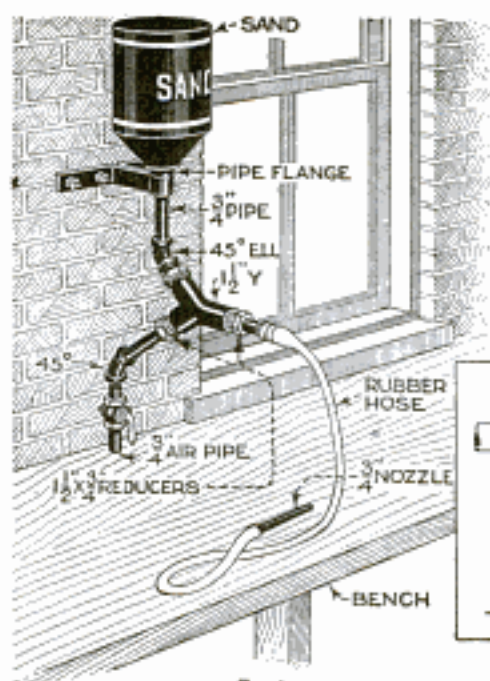

Fig. 1

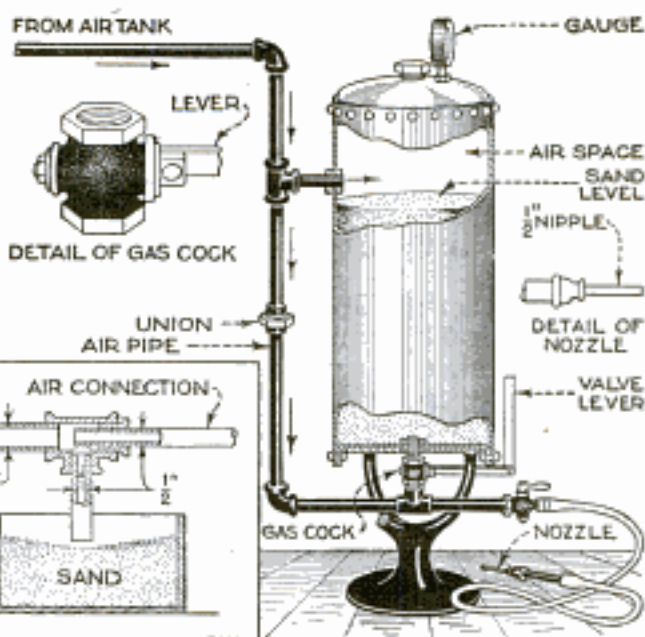

Fig. 2

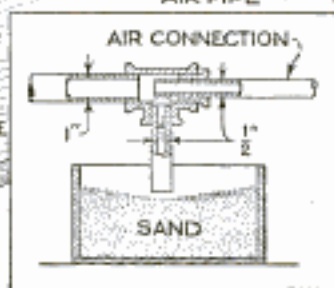

Fig. 3

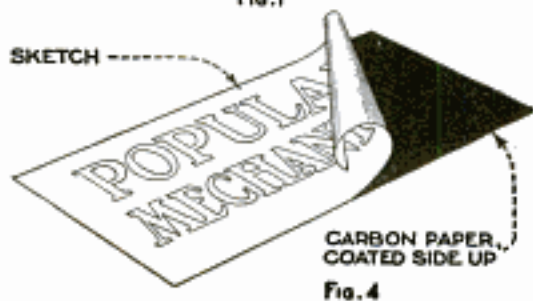

Fig. 4

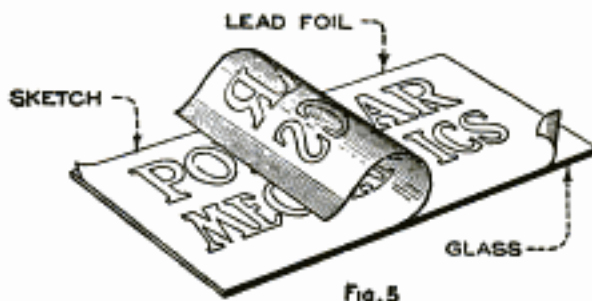

Fig. 5

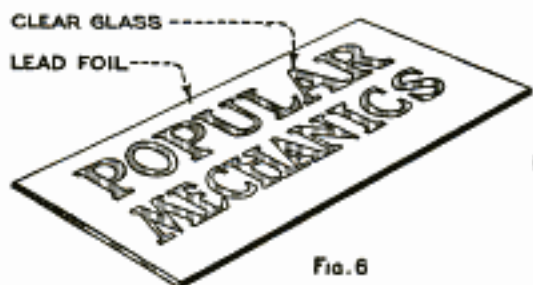
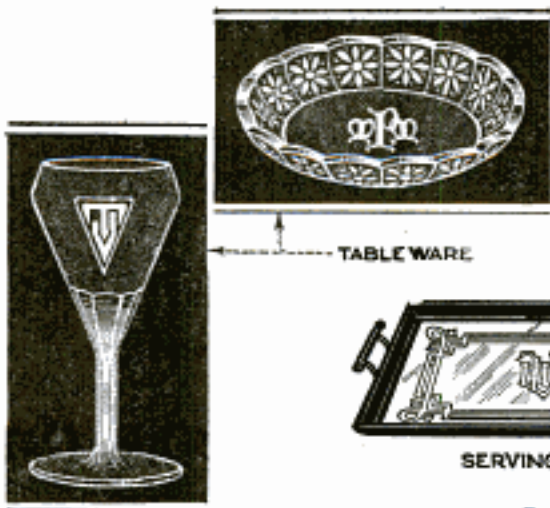

Fig. 6



Fig. 7



TABLEWARE



SERVING TRAY



DESK SIGN



Fig. 8

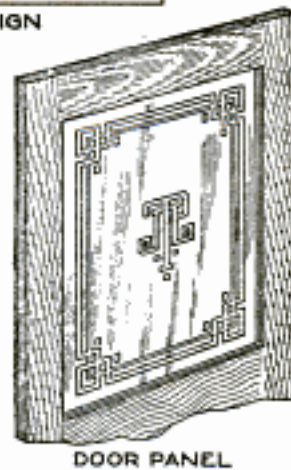

DOOR PANEL

Figures 1 to 3: Simple Forms of Homemade Sandblast Machines, Made, for the Most Part, of Pipe and Fittings. Figures 4 to 7: The Various Steps in Making a Glass Sign by the Sandblast Process. Figure 8: A Few Examples Illustrative of the Wide Variety of Decorative Work to Which the Process may be Applied

to prevent sand from choking the air pipe.

The equipment shown in Fig. 3 is very simple, and may be used for a variety of small work. Only the details at the sand box are shown, as the other connections are the same as those shown in the preceding figures.

It is a peculiar quality of the sandblast that soft, yielding materials, such as paper, lead foil, etc., are not attacked or abraded nearly as quickly as hard ones like glass. This makes it possible to protect, by means of masks, the parts of the glass that are not to be acted upon by the sand. The masks are usually made of lead foil; brown paper can be used, but the foil is preferable. A supply of suitable foil can be obtained from any florist.

Figures 4 to 7 show the various steps in the work of making a plain sign; this example, while a simple one, completely illustrates the process.

The glass having been cut to the proper size, a pencil sketch of the lettering, the exact size of the work, is made on good paper. The sketch is laid on a piece of carbon paper, the coated side of the latter being up, as shown in Fig. 4, and the outline of the letters gone over again with a stylus or medium-hard pencil. This leaves a carbon impression of the lettering on the back of the sketch sheet.

The glass is now coated with melted beeswax, a sheet of foil placed on it, and rubbed into close contact with a piece of hard felt, or the rounded edge of a piece of leather belting. The glass should be kept warm while this is being done—by laying it on a radiator, for instance—so that the foil will adhere firmly to the wax. When this is done, the foil is also coated with wax. Both applications of wax may be made with an ordinary paintbrush. The sketch, with the carbon impression down, is laid on the waxed surface of the foil, in the proper position, and rubbed all over with the bottom of the bowl of a spoon, or a like article, then lifted off. This leaves the carbon lettering on the wax surface, as in Fig. 5.

The foil is then cut, along the lines of the lettering, with a mat knife, or photographer's etching knife, and the cut-out portions removed by inserting the point of the knife under the foil. The foil, when stripped, brings with it practically all the wax on the glass, and leaves the sign as shown in Fig. 6, ready for sandblasting.

If the work in hand is a sign that must be "printed" in reverse, the foregoing

procedure is varied a little—no carbon paper is employed. The sketch is made with a soft, black pencil, placed, face down, on the waxed foil, and rubbed as described before; this leaves the reversed lettering, in pencil, on the wax, and the foil is cut as before. This makes a rather nice effect, after the work is done, as the lettering is read through the glass.

The sandblasting is simplicity itself, consisting in nothing more than directing the blast of sand and air against the exposed glass. The sandblast is capable of producing any effect from a light surface frosting to a very deep etching, or even to cutting completely through the glass. The method of handling the blast for best results depends upon several factors, and can best be learned by experience.

Any kind of glass can be used in the process, although, for signs and work of a similar character, plate glass is preferable. Particularly pleasing results, for some purposes, especially where a light is used behind the sign, are obtained by using what is known to the trade as "flashed" blue or ruby glass. In this, the color is only on, or rather a part of, the surface, and, when the letters are frosted as described, they stand out white against a sharply contrasting background.

The samples of work shown in Fig. 8 indicate but a few of the many uses to which this process may be put. Glass is not the only material that may be decorated by means of the sandblast; metals and woods may also be treated exactly as described. Wood, being softer than glass or metal, will require more time than either, but very elaborate effects can be produced in it, providing the design is deeply blasted, say, to a depth of about $\frac{3}{16}$ in. In all work of this character, the result, of course, will depend almost entirely upon the artistic talent of the worker.

It is essential, in this work, that the eyes, nose, and throat be protected against flying particles of sand. The simplest method of doing this is to wear close-fitting goggles, and tie a moistened handkerchief or sponge over the nose and mouth. Special helmets may be obtained also, with an air hose that is led to a source of pure air. An old army gas mask, which is obtainable from any of the so-called army stores about the country, can be adapted to this purpose and will make a very good helmet.

☛ A general principle in fastening members together with wood screws is to hammer them before final tightening.

An Invisible Tank Repair

An excellent method of repairing punctured gasoline tanks is shown in the illustration. After the repair is finished, it is practically invisible, and very strong.

A rectangular opening is cut at the spot where the puncture occurs, and two metal plates are cut to form a patch for this opening. One plate, which may be of any convenient thickness, is cut slightly larger than the opening, so that it laps about $\frac{1}{2}$ in. over the edges. The other plate is cut to fit exactly in the opening, and its thickness must be the same as the thickness of the tank wall. A wire is soldered at right angles to the center of the larger plate, as shown, so that it can be held firmly against the inside of the opening. The edges of this plate are tinned with solder, and it is then slipped through, and drawn into place. The smaller plate has a hole drilled in its center to fit over the wire and is pushed down into the opening against the inner plate. Solder is applied between the plates along the edges, and a blowtorch is then used to sweat the two plates together. The wire is pulled out after melting the solder that holds it,

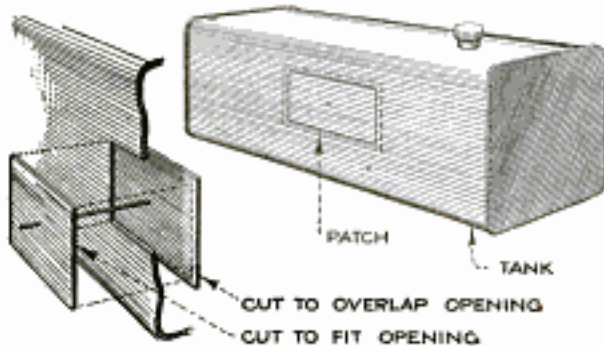

An Inconspicuous and Strong Repair for a Punctured Gasoline Tank Made by Sweating Two Plates Together

and the small hole in the outer plate is filled with solder.

Adjustable Wheelbarrow Handles

The difficulty of handling a wheelbarrow with a heavy load is eliminated by providing it with a set of adjustable handles. This enables the body to be lowered, to suit a high load, or, in other words, to lower the center of gravity. Although wheelbarrows differ in size and design, they can all be reconstructed along the lines shown in the drawing.

The original handles are cut off where the sideboards end. Two plow handles, straight style, are swung on a pivot rod fastened just underneath this point. This

rod is run through small wooden blocks, A, fastened on each side of the body with

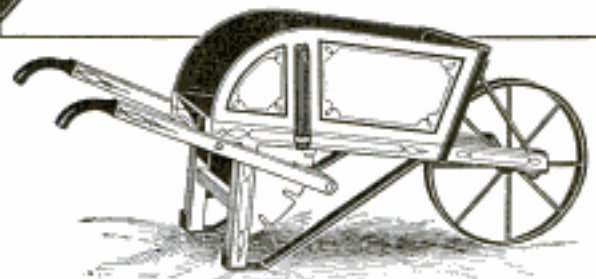
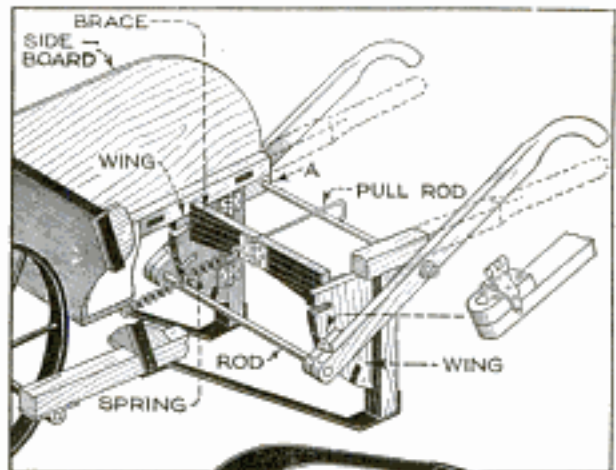

Wheelbarrow Handles That can be Raised or Lowered and Locked as Desired, Make It Easy to Handle Heavy Loads

3-in. wood screws. A quadrant-shaped wing is hinged on each leg to swing toward the inside; these are 1 in. thick, and 6 in. wide at the top. The curvature of the wings depends on the radius of the handle and can be marked off accurately, before sawing, by holding a pencil in the proper position, near the lower end of the handle, while moving it. Three or more slots are cut in a radial line with the pivot on which the handle moves. Hinges, bent and mounted on blocks at the end of the handles as shown, fit into the slots in the wings. A wooden rod runs through the lower end of both handles. A two-piece brace is hinged to the inside of the wings in the position indicated. The two parts of this brace are connected by a hinge, which holds them together firmly, yet allows them to be pulled outward by means of the pull rod that is attached to the front side of one piece. When the pull rod is released, both pieces are instantly brought back into their end-to-end position by a coil spring, connected to the brace and to the underside of the wheelbarrow. To change the pitch of the handles, they are unlocked by pulling the pull rod; then, after moving the bent hinges to another slot, the handles are locked by releasing the pull rod.—R. B. Cutler, Springfield, Vt.

A Folding Horse

The photograph shows a folding horse that has been found to be of great con-

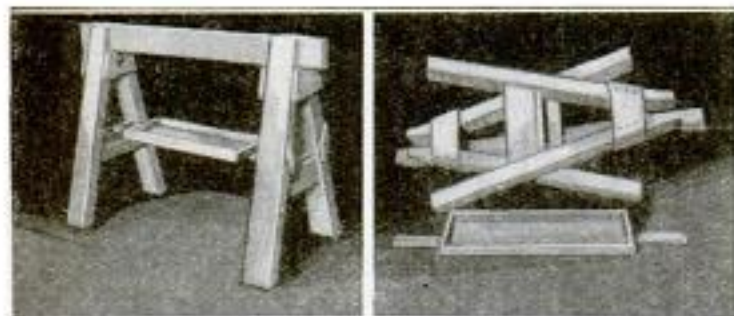

A Folding Horse, Consisting of Four Members, That Takes Little Space When Folded, and Proves Very Convenient around the Shop and Garage

venience around the shop or garage. The tray, attached to the lower cross rail, is used to hold tools and materials such as

screws and nails; it is an added convenience, but can be omitted if desired.

The upper cross rail is fastened to the legs with hinges, so that the three members can be folded compactly, as shown. The hinges are attached to the underside of the rail, and to the braces nailed to the upper end of the legs, on the inside. The corresponding braces on the outside fit under the extending ends of the cross rail when the horse is set up, to prevent the legs from swinging out at more than 90° from the rail. The lower rail fits between the legs in notches cut for this purpose. When folded, this horse takes up very little space and may be carried from job to job in an automobile.—Donald W. Clark, Buffalo, N. Y.

Bench-Lathe Lap Operated with Rubber Bands

A simple but effective method of making an ordinary bench lathe work automatically is shown in the accompanying photograph. In this case the lathe happens to be used for lapping a small hole through a diamond wire-drawing die. The toolholder A moves back and forth while the work revolves. The movement is kept up by means of a cam, C, and rubber band, E. The cam C is driven by a

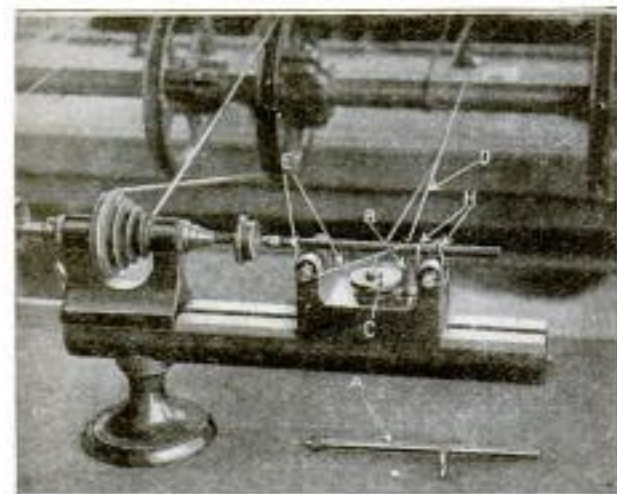

Lapping Diamond Wire-Drawing Dies in a Bench Lathe: The Toolholder is Reciprocated by Means of a Cam and Rubber Bands

belt, D, and bears against the vertical post B. At every half turn the cam pushes the toolholder away from the work. At the other half turn of the cam, the rubber band E pulls it back toward the work. The band E also holds the toolholder down in the V-pulley in front

of the tailstock. A second rubber band, H, keeps the toolholder down in the rear V-pulley.

A common sewing needle, ground and lapped to the correct size, is used to lap the hole through the diamond. A thin paste, made of diamond dust and oil, is applied to the end of the needle and the hole. The movement of the lap in and out of the hole enables the paste to flow into the latter, and keeps the end of the lap covered. Once the lathe is arranged as shown, and started, it is only necessary to keep the lap well supplied with paste. In the shop where this method was employed, it required only one-third of one man's time, per day, to attend to 20 machines.—E. F. Lake, Detroit, Mich.

Proper Use of the Nipple Chuck

Many a good mechanic will spoil a perfectly good short nipple, after threading it in the chuck, by trying to unscrew it by means of a pipe wrench gripping the newly cut threads. The nipple, with threads cut on one end, is screwed into the nipple chuck, consisting of a piece of pipe of the same size as the nipple, and about a foot long, with an ordinary pipe sleeve or long coupling screwed on for about two-thirds of its length.

The nipple, having one end threaded,

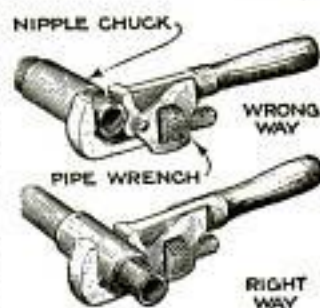

will bottom against the pipe and prevent it from screwing too far into the sleeve when the die is rotated. All this is common practice; it is the removal of the completely threaded nipple without spoiling the thread that constitutes the trick. Instead of catching the threads with the pipe wrench and crushing them, the wrench is applied to the sleeve and turned far enough to separate the abutting ends of the pipe, where the nipple can easily be unscrewed by hand.—Edwin J. Bachman, Fullerton, Pa.

A Sphere-Turning Tool

The illustration shows a tool that will finish a ball in one operation, except for cutting off the work on either side of the shank. It consists of a tube made of solid steel. The inside diameter is drilled out to the measurement required. Two slots are cut opposite each other on the

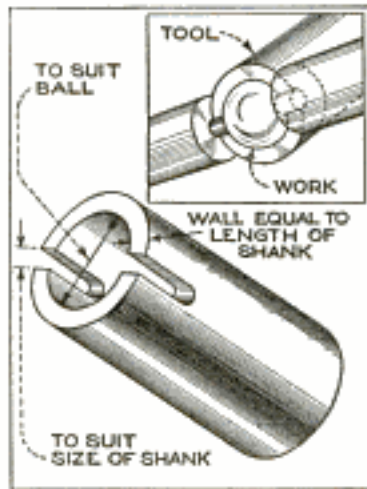

end where the drilling is finished, as this end is usually more true to size than the end where the drilling is begun. For greater accuracy, the hole should be ground to size. The width of the slots is equal to the diameter of the

shank desired, and the depth about two-thirds greater than the diameter of the sphere to be turned. A handle may be made to hold the smaller sizes, as for model work, so that the tool can be held in the hand and steadied on the hand toolrest while pressing it against the stock as it turns. Small balls can be made in one operation. Work of larger size should first be roughed off in the ordinary way, as this is quicker and saves wear on the tool.

A tool of the above description was used for turning one hundred 2½-in. balls, with shanks, that had to be finished accurately to size. In this case the tool was tapered on the inside, from the rear, to give it a better cutting edge. It was held stationary on a V-block in the toolrest of the lathe, the end being held on a dead center also clamped to the toolrest.

Starting Nuts in Slots

The tool shown in the illustration has proved of considerable assistance in placing washers and starting nuts on bolts located in a hole, or slot, so deep that one cannot get at them with the fingers.

The tool is made of a short length of ⅜-in. steel rod of the same diameter as the bolt threads. A groove is cut around it near one end, to allow a spring-wire ring, or retainer, to be snapped in. This ring is

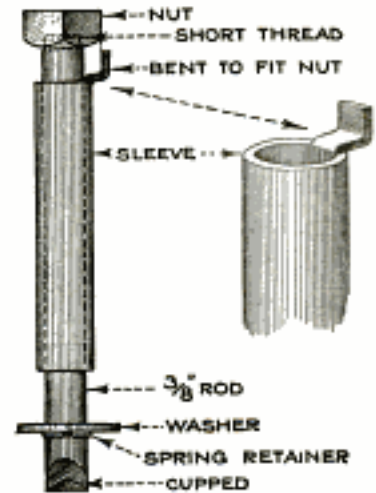

cut so that it can be compressed in the groove, to allow a washer to be slipped over it. When released, the retainer will spread out and prevent the washer from slipping off. The end of the rod, near the retainer, is cupped so that it will fit on the round end of a bolt. The other end of the rod is threaded to the same pitch as the nut to be screwed in place; only a few threads are required. A sleeve, made of steel tubing, and fitting neatly on the rod, is cut and bent to grip the nut.

The tool is loaded for use by pushing a washer over the spring retainer, and screwing a nut on the threaded end. Then the cupped end of the tool is rested on the end of the bolt, and the sleeve is pushed down, forcing the washer over the retainer and onto the bolt. The other end of the tool is then placed in the slot, and the nut is screwed on the end of the bolt. While the threaded end of the tool is being unscrewed from the nut, the hook on the sleeve is held against it, to prevent it from being screwed off again.

Warming the Gas-Engine Lubricator

During cold weather, when oil thickens in the oil cup of a gas engine, preventing proper lubrication, place an old tin can upside down over the oil cup. Punch a hole in the bottom of the can to allow the feed-regulating lever to project. The heat and steam rising from the water hopper enter the tin can and keep the oil warm. The can also prevents chaff and dirt from sticking to the oil-cup glass.

Hydraulic Scale for Crane

The hydraulic scale shown in the illustration is a novel adaptation of hydraulic pressure as a means of weighing directly

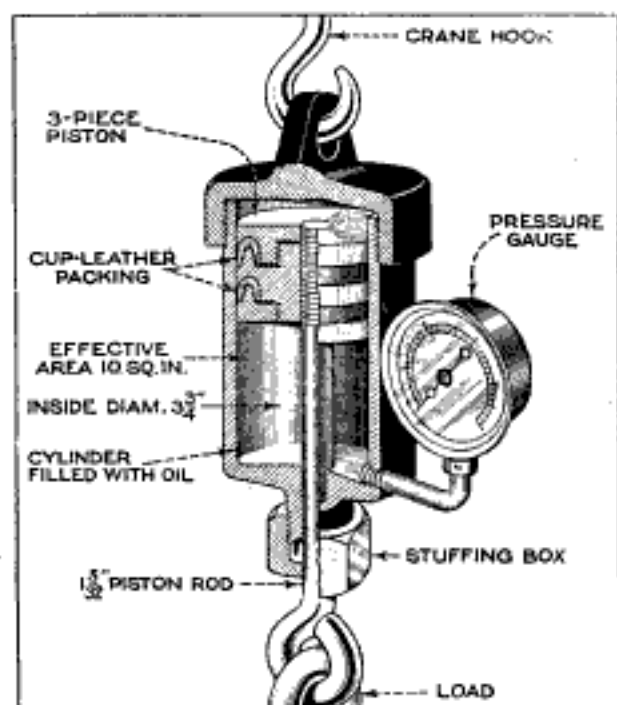

A Hydraulic Scale for Use on a Crane as a Safeguard against Overloading, Which can be Readily Detached

any machinery or parts lifted by a crane. It is not necessary for a workman to attend to this scale, as there are no sliding weights or springs needed. The entire scale weighs only about 30 lb., and is interposed between the load and crane hook so that it registers every load that the crane carries, and thus safeguards the equipment against overloads.

A cylinder, about $3\frac{3}{4}$ in. in inside diameter, is fitted with a piston provided with cup-leather packing, as shown. The piston rod is $1\frac{1}{2}$ in. in diameter, and the effective piston area is thus about 10 sq. in. The cylinder contains oil, and a pressure gauge, on which the pressure reading is shown in pounds per square inch, is connected to it. The weight of a load is obtained by multiplying the pressure-gauge reading by 10, which can be done mentally in an instant.

Facing Mixtures for Concrete Work

Many workers in concrete are more or less of the impression that the familiar, and frequently hideous, smooth, gray, monotonous, and uninteresting surface left by the forms is the only effect obtainable. However, a surface almost identical in appearance with granite or

other pleasing stonework may be produced in a simple and inexpensive manner. This is accomplished by using a thin facing of cement mixed with small crystals of crushed quartz, or similar materials of different colors.

If the section is thin, say up to 4 in., it generally would not be too expensive to cast it entirely of the facing concrete, which is composed of 1 part of white cement to 2 parts of the crushed quartz. However, if the portion to be poured is more than 4 in., so that the expense of using the quartz particles for the entire thickness would be too great, a thickness of about $1\frac{1}{2}$ in. of the finer materials will be found sufficient, and a less expensive and coarser mixture can be used for the rest of the piece. This is accomplished by placing a piece of expanded metal, of the smallest available mesh, inside the forms and about $1\frac{1}{2}$ in. from the face. The facing mixture, prepared as previously explained, is then poured into this small outside space until it has piled up about a foot deep, when it is rammed down well with a rod. As the mixture begins to run through the expanded metal, the common concrete mixture, composed of the usual materials, is poured into the space between the expanded metal and the back of the form, until it has piled up to a point several inches below the facing mixture.

It is very important that the front, or facing concrete be always kept at a greater height than the backing concrete while the pouring is being done, so as to prevent any of the latter from running forward and getting into the front part of the mold, thus spoiling the effect. Also, the facing mixture should be mixed "dry," so that it will not flow too easily. A dry mix is one that uses just enough water to hydrate the cement.

A variety of finishes is possible. The form may be stripped while the concrete is still "green" or incompletely hardened, and the surface wire-brushed so as to show the quartz and produce a rough effect, or it may be ground down until absolutely smooth, when it will take the appearance of polished granite. Still another possible method is to bush-hammer it in lines, either narrow or wide.—Gilbert I. Stodola, New York City.

☞ In grinding, a fast work speed will wear out the wheel faster than a slower work speed. The work speed should be adjusted so as to secure the longest life of wheels consistent with efficient production.



Tin-Can Pigeons Catapulted by Simple Machine

By JOHN EDWIN HOGG

SHOOTING at flying targets is an alluring pastime, but the cost of clay pigeons, and machines for throwing them, is usually too high for the amateur. However, one need not, for this reason, abandon the idea of enjoying the sport, since with a little ingenuity, an excellent catapult can be constructed from material that is available everywhere and

can be procured at a very small cost. By using such a homemade catapult to hurl tin cans, as much sport can be provided for the marksmen as with the expensive purchased machines, with the additional advantage of eliminating the cost of clay pigeons. If there is plenty of clay available in the vicinity, it may be found desirable to use lumps of thoroughly dried

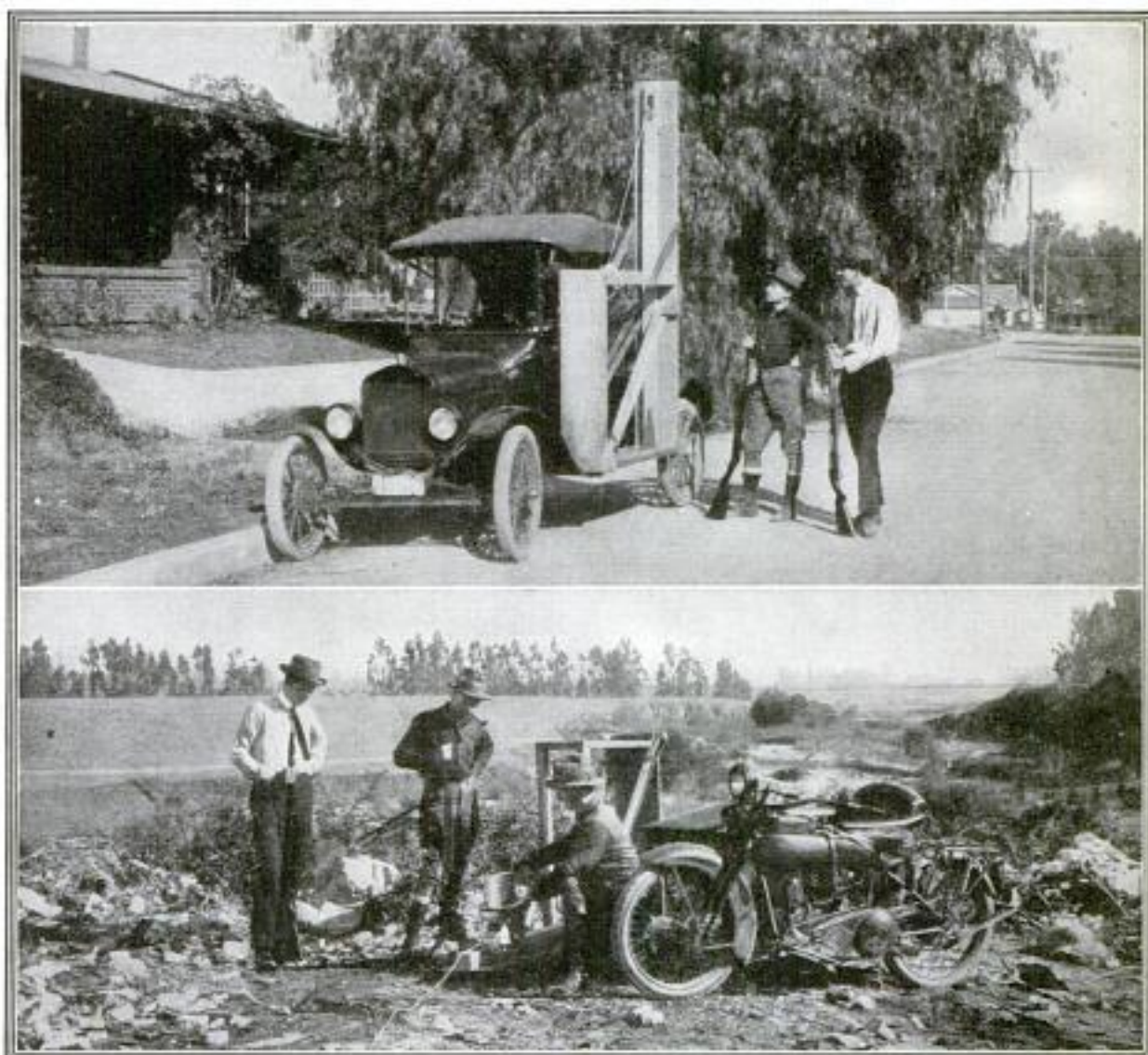

Above: The Enthusiastic Marksmen Strap the Catapult on the Running Board of a Small Car, to Convey It to the "Hunting Grounds." Below: Loading the Catapult; All That Is Necessary Is to Draw the Arm Down, Catch It to the Base by the Bolt, and Place the Cans on the End

clay instead of tin cans, as these lumps, upon being hit in the air by a bullet, are shattered and thus give visible proof of having been hit.

In appearance, the catapult, as made by an ingenious trapshooter of Alhambra, Calif., is not very different from the type of catapult used in medieval times; it is, however, somewhat modernized in

As soon as one of the marksmen calls out "pull," the cord is pulled, and the targets are hurled into the air with considerable force. They are frequently thrown to a height of 100 ft., and remain in the air long enough to give the marksmen sufficient time to shoot four or five times. The cord that releases the bolt can be pulled by foot, or, if desired, by a small

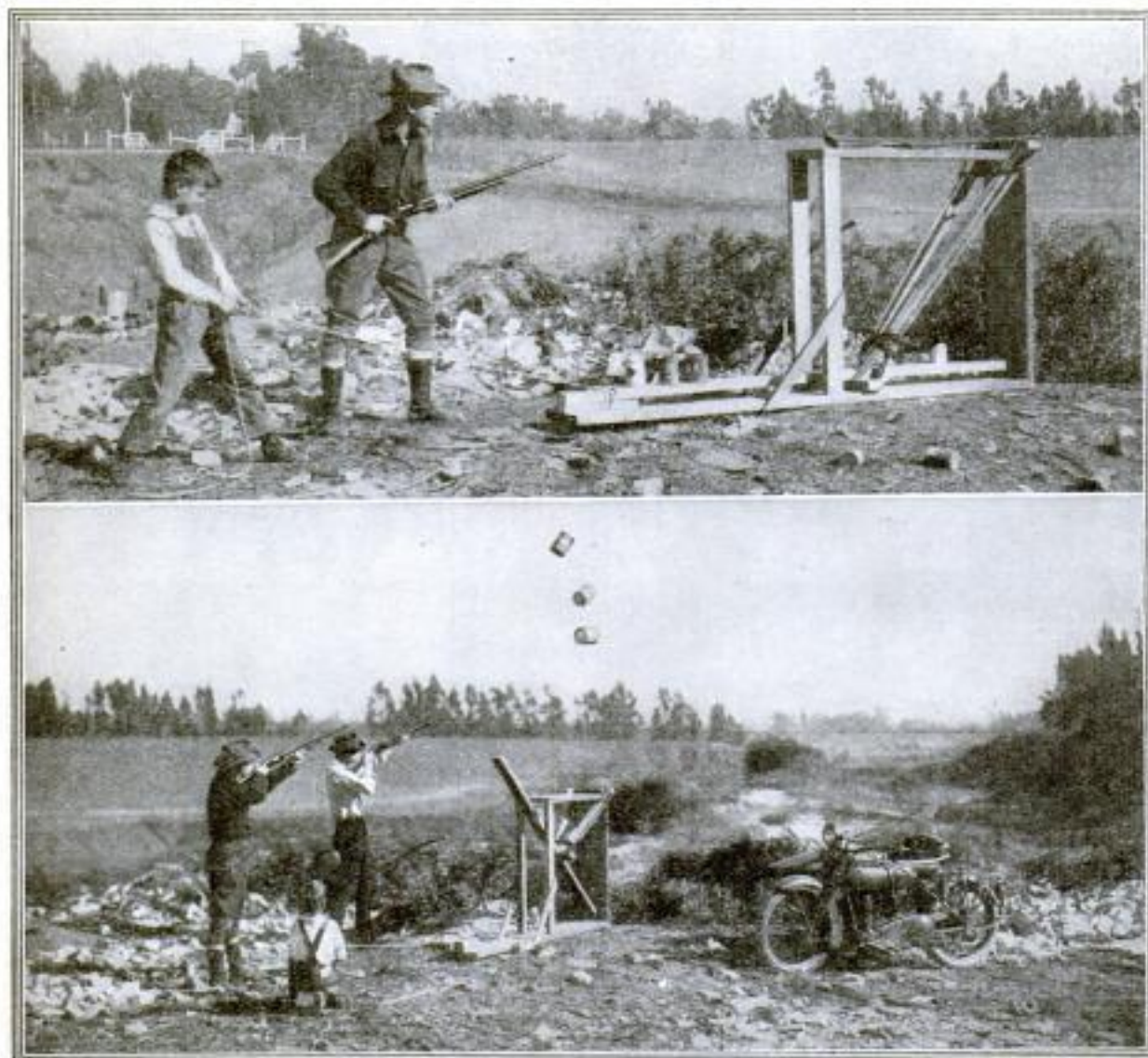

Above: The Catapult Loaded, and About to be Released; a Cord Pulls Out the Bolt and Releases the Arm. Below: A Snapshot, Showing How Effectively the Device Operates; the Load can be Thrown as High as 100 Feet, Giving the Marksmen Time to Shoot Four or Five Times

that the motive power is supplied by a pair of discarded automobile inner tubes, attached to the top of the upright, and to the throwing arm.

When the arm is brought down against the base, the tubes are placed under tension. The end of the arm is then hooked to the base by a common door bolt, fastened to the end of the base, that can be released by pulling a cord. The tin cans are then loaded on the end of the arm as shown in one of the photographs.

boy, who will usually be only too eager to do so. By changing the tension of the tubes, the height can be varied to suit the taste of the marksmen. When the targets hit the ground, the process is repeated.

The construction of the catapult is quite simple, and is shown very clearly in the photos. The frame is made of 2 by 10 and 2 by 4-in. planks. The base is about 8 ft. long. The catapulting arm is a little shorter than the base, and one

end is hinged securely to the latter. The arm, after release, is suddenly arrested when it strikes the top piece of the frame, throwing the cans into the air.

Emergency Plug for Crankcase

Having broken off the drain plug under the crankcase of an automobile, while driving over a rough road, and not having a large-size cork to substitute for the plug, a quick repair was made with an old inner tube. The tube was cut across, and a small piece, about 4 in. wide, was cut from one end. The small piece was folded and placed directly over the hole, the remainder of the tube being stretched tightly over the folded piece, and wired firmly to the frame on each side. It was found that this plug was quite effective, and it was used for a week before a new drain plug was obtained.—George Auringer, New Rockford, N. D.

Novel Lamp Shade

The illustration shows an inexpensive but beautiful lamp shade that is well worth the slight trouble of making. A



wood or metal frame of the desired size and shape is constructed as indicated, each side of the frame being rabbeted, or bent, to hold two sheets of clear glass, separated from each other about $\frac{1}{4}$ in. Glass bottles, and broken glass ornaments of all colors, are crushed into

small fragments, which are thoroughly mixed and packed between the glass sheets. After all the sections are filled with the fragments, the frame is fastened together and mounted on the lamp. It will be found that a beautiful tint results when the light is turned on.—Marshal South, Oceanside, Calif.

Runners for the Wheelbarrow

Pushing a heavily loaded wheelbarrow through deep or crusted snow is hard work, but if runners are substituted for the wheel, the task becomes easy.

Obtain two equally wide and thick bar-

rel staves. Cut out triangular blocks of 2 by 8-in. wood. Place the blocks on the concave side of the barrel staves, and fasten with wood screws, countersinking



By Substituting a Pair of Runners for the Wheel of a Barrow, It Is Easier to Push a Load through Snow



rel the heads. Fit a trunnion, made of pipe, to the top of each block by means of flat-iron brackets, as shown. After removing the wheel from the barrow, pass the trunnion through the brackets and the wheel bearings to serve as a pivot. The runners should be braced securely by means of two iron rods, passed through the blocks, as shown, and fastened by means of nuts, inside and out.

Skirt on Barrel Fools Rodents

Light, roughly constructed barrels, such as are made for shipping lime, are often used as containers for animal feed, and the like, but are not immune to mice and rats. To prevent the rodents from getting at the contents by climbing over the side, tack a skirt of heavy paper, or fairly wide and thin sheet metal, around the bilge of the barrel, as shown in the illustration.—Louis Schneider, Clinton, Miss.



Removable Foot Scraper

The ordinary foot scraper, although simple to make, is often a source of dan-



A Removable Foot Scraper That Is Both Practical and Safe. Left: Scraper Swung Out of the Way and Held by a Pipe Strap Screwed on the End of the Step Above. Right: Scraper in Use

ger, especially to children, because one is apt to catch the foot in it, especially when

mounting the steps carelessly from the side. It has been found, however, that a removable foot scraper, of the type shown in the photograph, not only retains the advantage of simplicity, but is comparatively safe, as it is easily swung out of the way when not required.

The scraper consists of three parts: two short lengths of $\frac{1}{2}$ -in. pipe, and a strip of flat iron or steel. Slots are cut in the ends of the pipes and the steel strip is fitted and riveted in place. The pipes fit in $\frac{1}{2}$ -in. holes drilled in the end of a step. When not in use, as in fine weather or when the children are playing around the steps, the scraper can either be removed entirely or can be swung around and one leg

screwed on the end of the step above.—Glen McWilliams, Detroit, Mich.

Hints for Amateur Motion-Picture Operators

Direct current is preferred to alternating current for arc lighting in motion-picture projection, as it gives a clearer and steadier light. The carbons used should be soft, as soft carbons are much superior to hard ones with soft centers. The tighter the carbons are held, the better the light will be. After the carbons heat up, the ends can be brought much closer together than at first.

The mechanism of a motion-picture projector is delicate, although not frail, and frequent oiling is necessary. If a part of the machine breaks, do not try to substitute something for the broken part; this usually only means more trouble, and more annoyance to the spectators. Close the show, and replace the broken part with a new one.

Clearness of the picture depends largely upon the screen. A sheet hung across the room is not satisfactory, as the surface is never perfectly smooth, and the slightest breeze will wrinkle and bulge it, causing the picture projected on it to become distorted. A good screen can be purchased at a very reasonable price, and the investment will be repaid by better pictures.

One thing that especially tries the patience of an audience is the delay involved in changing reels in one-machine booths. To avoid this operation as much as possible, obtain reels that are about

twice as large as the ordinary reels, and wind the film of two small reels on a larger one, connecting the ends. It is necessary, of course, to rewind the film twice, so that the parts will be projected in proper sequence, and to use a large reel in the lower magazine.—Thomas Duncan, Des Moines, Ia.

Fastening Automobile-Hood Covers

To keep automobile-hood covers neatly in place, drill a small hole through the

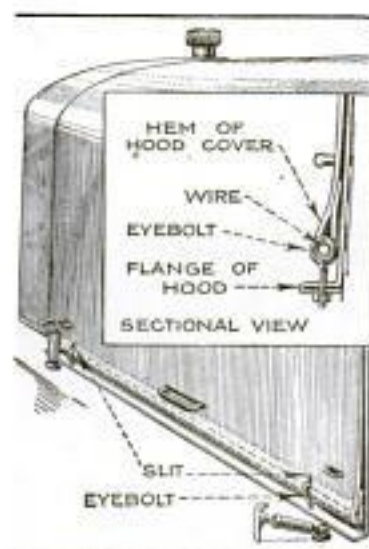

lower flange of the hood, about 3 in. from each corner, and insert a small eyebolt in each hole. Cut slits in the hem of the hood cover to fit over the eyebolts. Run a wire, about $\frac{3}{16}$ in. in diameter, through each hem and through the eyebolts.

Then tighten the eyebolts with the nuts; this will draw the cover smoothly and tightly over the hood.—John A. Blaker, West Auburn, Mass.

Movable Overhead Irrigation System

A very convenient overhead irrigation outfit is made by spacing four buggy wheels about 15 ft. apart along a line of galvanized-iron pipe of approximately the same diameter as the axles. One end of the pipe should be capped and the other threaded for a hose connection. Holes are then drilled at suitable intervals along the center of the pipe. Small standpipes, placed at 50-ft. intervals along one side of the plot to be watered, will provide a fine overhead irrigating system for which but 25 ft. of hose will be needed. The entire system is easily moved wherever it is needed. The illustrations show an outfit of this type in operation on

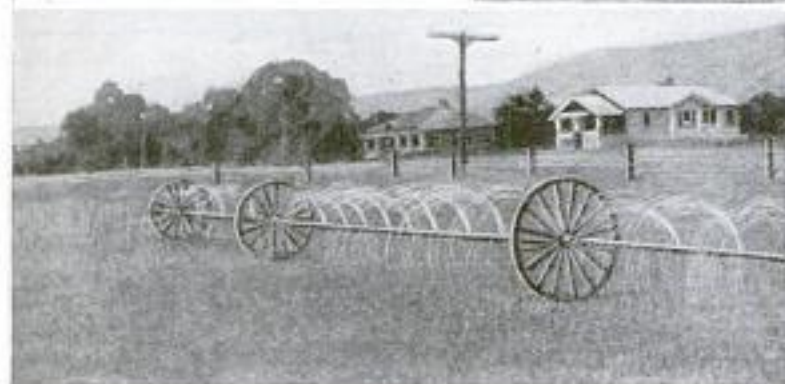
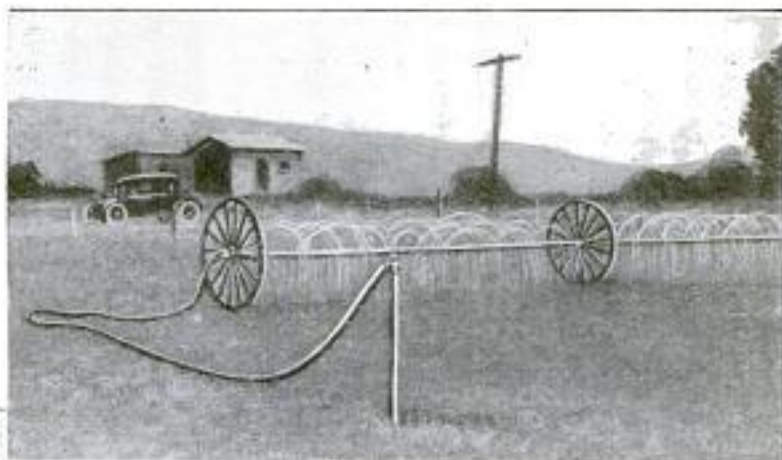

A Movable Irrigation Outfit Made from Perforated Pipe and Four Buggy Wheels: It is Shown Watering an Alfalfa Patch. Standpipes, 50 Feet Apart, Make It Possible to Use Only 25 Feet of Hose

an alfalfa patch, in which the standpipes are set in the middle of the plot. The sprinkler is moved down one side and up the other, and serves an area 90 ft. wide.—S. D. Hooper, Spokane, Wash.

Eliminating Scratch from Phonograph Records

It has been found that the objectionable scratching of phonograph records can be eliminated to a great extent by applying lycopodium powder, obtainable at any drug store for a few cents an ounce. This powder is extremely fine and will penetrate the smallest pores. When used on phonograph records, it fills up the minute crevices that cause the scratching. The record should be warmed a little before applying the powder, and afterward allowed to cool thoroughly.—C. I. Reid, Millersburg, Pa.

Cleaning Piano Keys

Yellow keys on a piano give the keyboard a very unrepresentable appearance. After some experimenting, it has been found that the original whiteness can be restored by applying a weak solution of nitric acid and water.

Add 1 oz. of nitric acid to 12 oz. of soft

water. Be sure to pour the acid into the water, and do so very slowly, stirring with a stick at the same time. Apply the solution sparingly to the keys, taking care that no acid gets on the black keys, on the woodwork, or between the keys. Rub the keys with a piece of cheesecloth to remove the stain. Then wash off all traces of the acid with a piece of flannel dipped in clean water, and wipe with a dry cloth.

It is sometimes necessary to give the keys two applications.

The solution may be put in a rubber-corked bottle, and kept for future use if desired. As nitric acid is a corrosive poison, the bottle should be marked to distinguish it from others, should be kept entirely out of reach of children, and should not be allowed to touch the fingers.

Harvesting Ice

A layer of snow lying on the surface of ice that is to be harvested, acts as a blanket and retards the formation of new ice underneath. It is therefore necessary to dispose of this snow. The simplest way to do so is to flood the ice field with water; this dissolves the snow, and upon freezing, forms a new layer of ice over the old ice.—John M. Smith, Chicago, Ill.

Making Cement Steps Safe in Winter

Owing to the accumulation of ice on the surface of cement steps during winter, they not infrequently cause accidents.

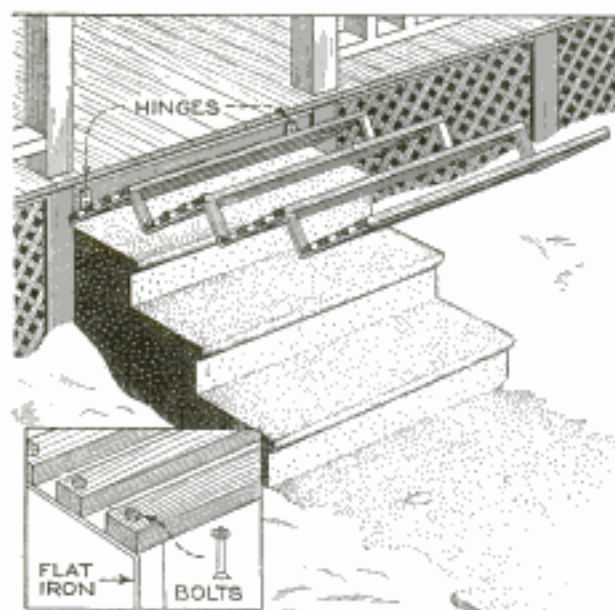

An Iron Frame, Provided with Wooden Treads, Eliminates the Danger Caused by Ice Accumulating on the Surface of Concrete Steps

The danger can be eliminated, to a large extent, by covering the steps with a frame, as shown in the illustration.

Two lengths of flat iron are bent to conform to the shape of the steps, and 1 by 1½-in. wooden strips are bolted across them, as shown. The strips are spaced about ¾ in. apart. Hinges are screwed to the riser of the upper step on the porch, so that the whole frame can be swung up when it is necessary to clean the steps. The hinges should have loose pins, so that the frame can be detached entirely when the winter is past.

Window-Shade Brackets Used for Hinges

Ordinary brackets that are used on window shades have been found to make good hinges for the covers of small boxes

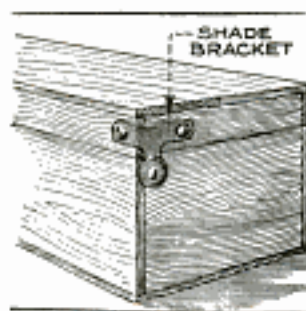

and tool chests. The brackets are bent to make them fit around the corners, as indicated. The ears of each bracket are screwed to the cover, and the brackets are pivoted on wood screws driven in-

to the sides of the box.—Harold Jackson, Kankakee, Ill.

Pen Drawings from Photographs

To produce a neat pen drawing from a photograph, carefully trace and shade the photograph with India ink, using a very fine and flexible pen point. When dry, immerse the print in a solution of sodium oxide, then in a solution of tincture of iodine and water, just enough iodine being added to the water to give the solution a bloody color. When the print is immersed in this solution, the iodine immediately attacks the emulsion of the print. After remaining in the iodine bath for a few minutes, until the back turns blue, the print is transferred to a hypo bath, which bleaches out the iodine, the lines of the sketch remaining unaffected. While the print is immersed, care must be taken not to touch the drawing, as the India ink will easily rub off in water.

Substantial Fireproof Chimney

A substantial fireproof chimney was built by a tinner at a cost far lower than that of an ordinary brick chimney. It consists of 8-in. clay tile, concrete, and 28-in. lengths of galvanized-iron pipe, 14 in. in diameter. The tile and pipe are set in a concrete base and the 3-in. annular space between them filled with concrete.—H. V. Smith, Wauseon, Ohio.

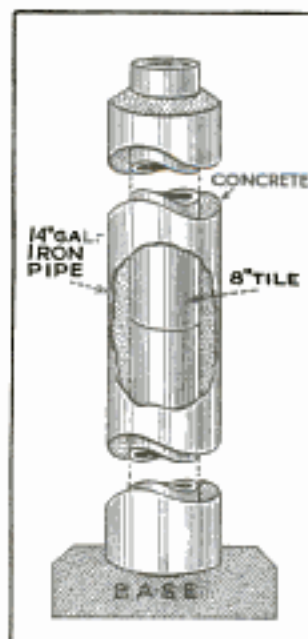

Preserving Inner Tubes

The motorist will find the purchase of an inner-tube bag, or box, to be an excellent investment; or a wrapping of soft cloth, placed around the tube in such a manner that the folds of the rubber cannot chafe against each other, will add considerably to the life of the tube. Tubes, even repaired ones that are carried as spares, should never be thrown carelessly into the tool box, where they are likely to be injured by the sharp cutting edges of the tools and rendered useless for an emergency.

Two-wire transformer was made by Alkye Radio Co. 909 Irving St. Blvd. Chicago

Building a Two or Three-Step Spider-Coil Receiver

BY F. L. BRITTIN

THE type of instrument described in this article is very similar to the one-step receiver described in the February number, and it is recommended that the reader study that article, if he has not already done so, before attempting the construction of the sets described here. In fact, this is essential, because, as the spider coil employed is identical in construction in all three instruments, no attempt is made herein to give instructions for winding.

The condensers used in these instruments are also the same as those used in the one-step receiver. Rotary-plate condensers may also be used, of course, but, when using this type, the rotary plates, in the feed-back condenser, must be connected to the aerial, and, in the tuning condenser, to the ground. These condensers are plainly marked in both circuits.

The rheostat used in the detector-tube filament circuit should be of the vernier type, as a close adjustment of the filament current is necessary at this point, to obtain the best results from the detector tube. The rheostat for the first step is of the ordinary type, in the two-step set, and that for the second step of the jack type. In the three-step set, all amplifier-tube rheostats are of the jack type.

Jacks and plugs, with ordinary rheostats, can be used in both circuits, if desired, but the jack rheostats are now generally available, and have certain advantages that make their use desirable.

It will be noted, in the two-step set, that the set only operates on either of the amplifying steps, and not on the detector; this set was purposely designed in this manner, to make its operation simpler for the amateur, who is interested only in receiving from the broadcasting stations.

In the design of the three-step instrument, however, the circuit is so arranged that the detector can be used alone, or in combination with one, two, or three steps of amplification, as the operator desires.

The first and second steps are the ones most used, the second always with a loud speaker. The loud speaker shown in the photo of the three-step outfit is highly recommended for the reception of broadcast matter. The horn is of "die-cast" wood, used in combination with a popular and efficient type of microphone, and is free from the characteristic vibration and overtones of the metal horn.

The audio-frequency transformers used in both instruments have a 10-to-1 winding for the first step, and a 5-to-1 winding for the second step. The third-step transformer, in the three-step set, has a 3-to-1 winding. These transformers are of the shielded type.

In both instruments, there are six binding posts, for the phones, at the front of each panel, connected by a brass strip at the rear. These permit the use of either phones or a loud speaker, as desired. It will be found, when using a loud speaker, that it is best to disconnect the phones.

The panel used for the two-step set is $\frac{3}{8}$ by 6 by 21 in. in dimensions, and that for the three-step instrument $\frac{3}{8}$ by 6 by 24 in.—both of bakelite. All holes should be drilled before any instruments are mounted, and all connections must be carefully soldered, the enamel being scraped from enameled wire before soldering; this last may seem a useless warning, but cases are on record where a soldered joint was made on enameled wire, without first scraping it, and, as the cut ends of the wires were not covered by the solder, each wire was insulated from the other—and the builder was highly indignant because he could not get any results from his set.

Use plain solder and a good soldering paste, tin the copper well, and use only enough solder to insure a good connection. Wire the various units neatly, using No. 14 tinned copper wire, covered with "spaghetti" tubing, and remember that the shorter the connections, the greater the efficiency of the instrument.

The detector tubes used are U.V.-200, and the amplifier tubes U.V.-201. Detector tubes vary; some will oscillate at a lower filament temperature than others. If the operator finds that he must burn the filament at an excessive brilliancy in order to make it oscillate, a small extra inductance can be inserted in the circuit. Make a small form, similar to that used for the large spider coil, and on it wind six turns of the same wire as used in the large coil. Wind the wire under and over every other "tooth," not skipping one as in the large coil.

Note carefully, on the two-step wiring diagram, the point where the lead from the tickler switch is soldered to the wire leading from the detector plate to the primary of the 10-to-1 transformer, and locate the same point on the instrument.

Between this point, and the trans-

Part from Elgin Radio Supply Co. Elgin, Ill. 207 East Chicago St.

Recommended for sale by all dealers. Get American Supply.

American Art Works

Papier Mache 6 B 11 N. Clark

Chicago

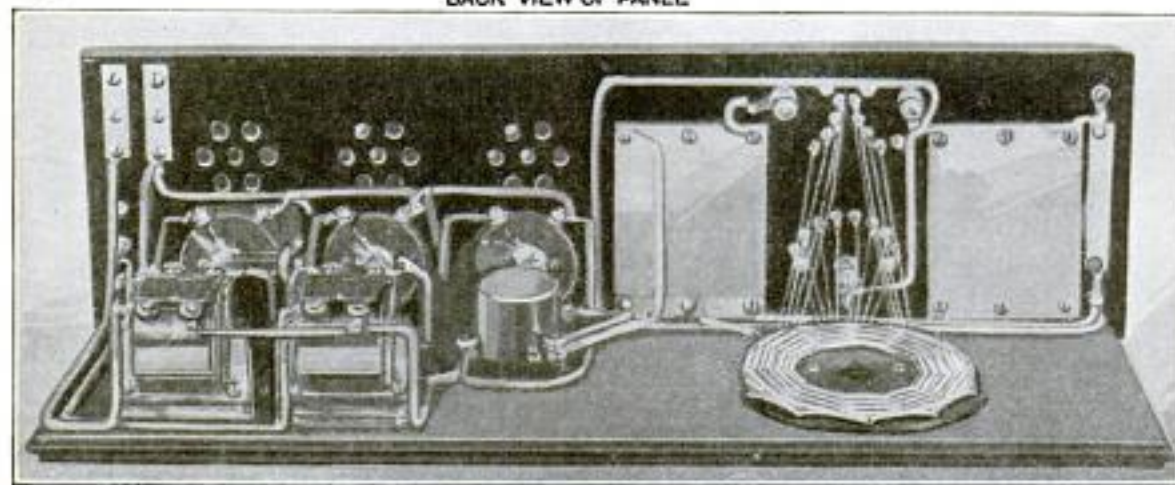
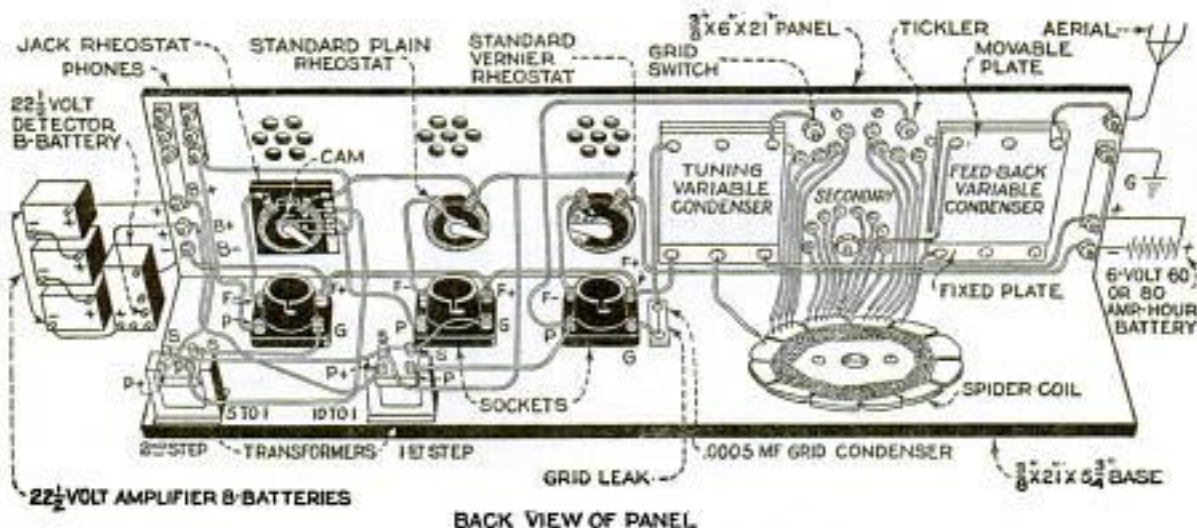
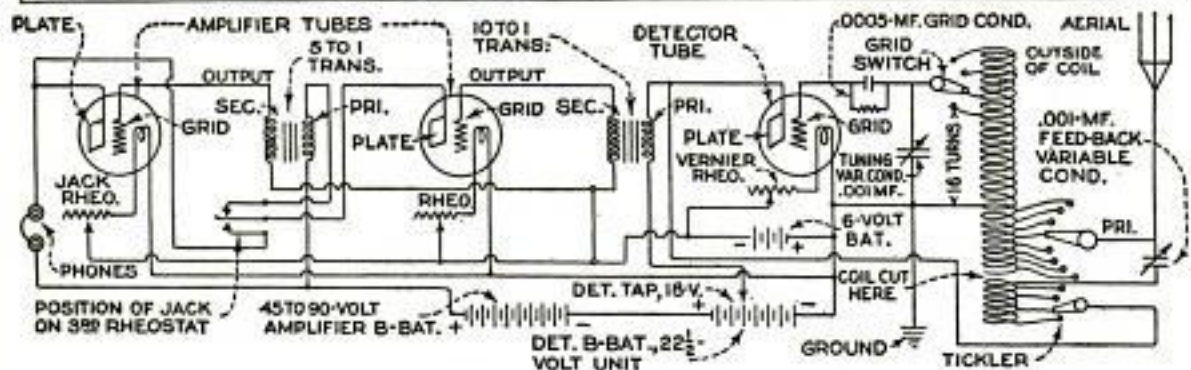
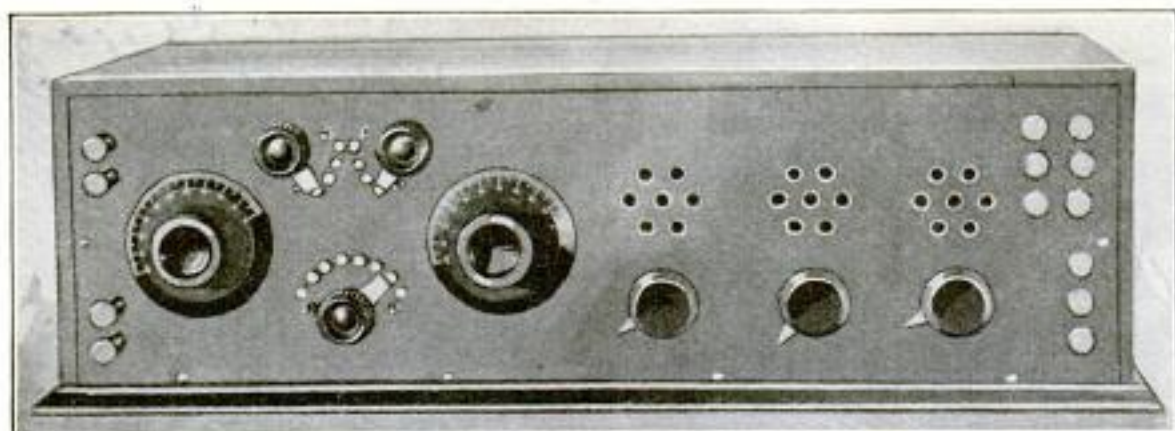

Receiver with Two-Step Amplifier: Above, Front View of Completed Instrument; Center, Wiring Diagram and Drawing of Back of Panel, Showing Arrangement of Parts; Below, Rear View of Completed Instrument, Removed from the Cabinet. The Tubes are Removed from Their Sockets

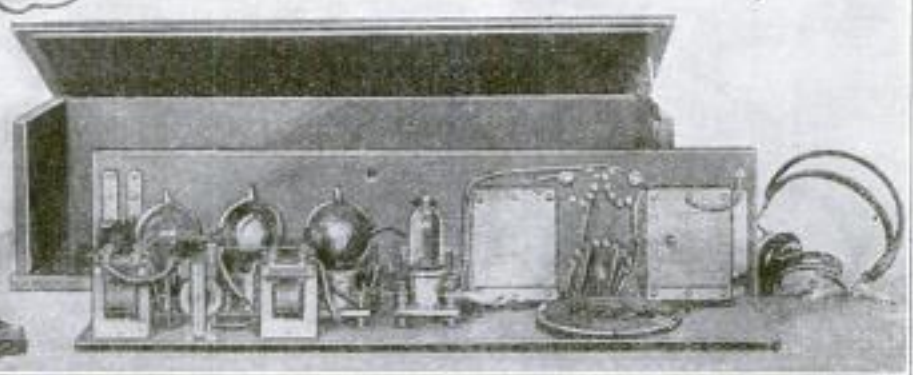
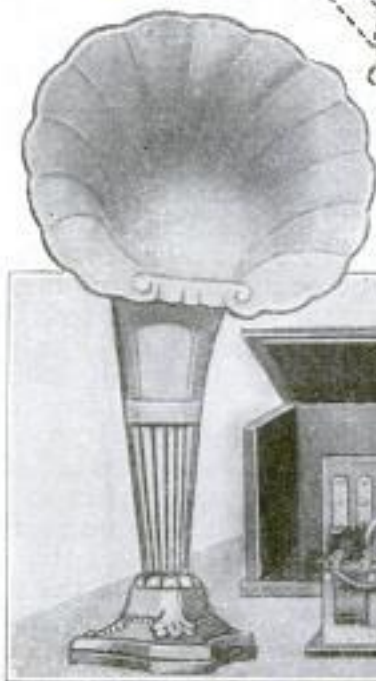
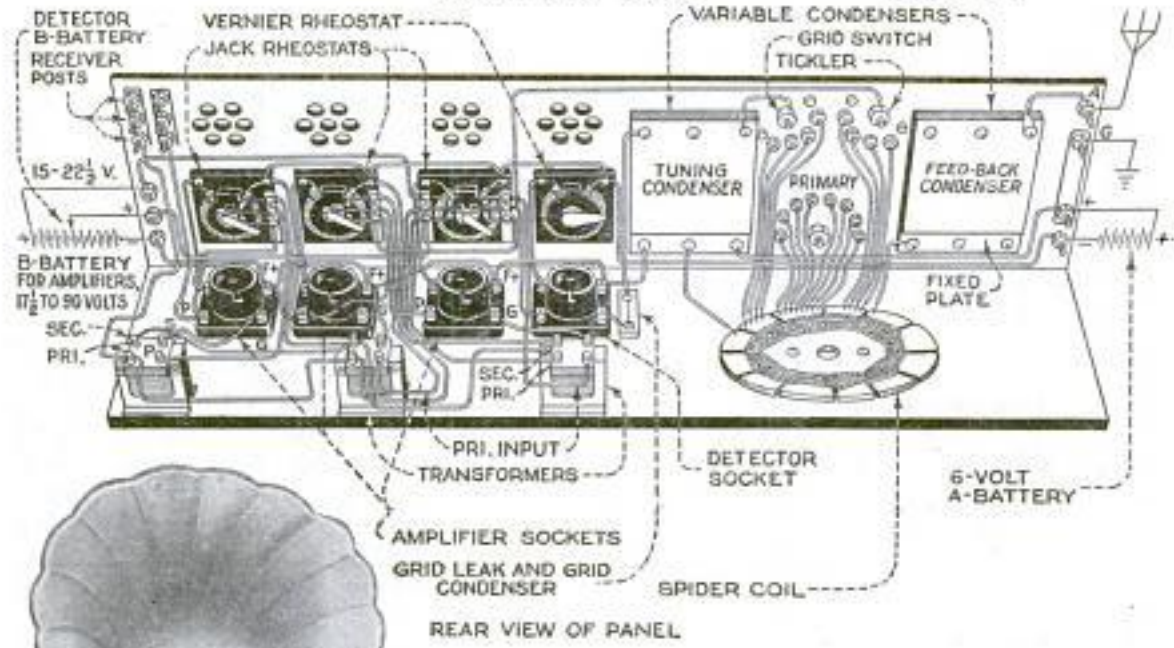
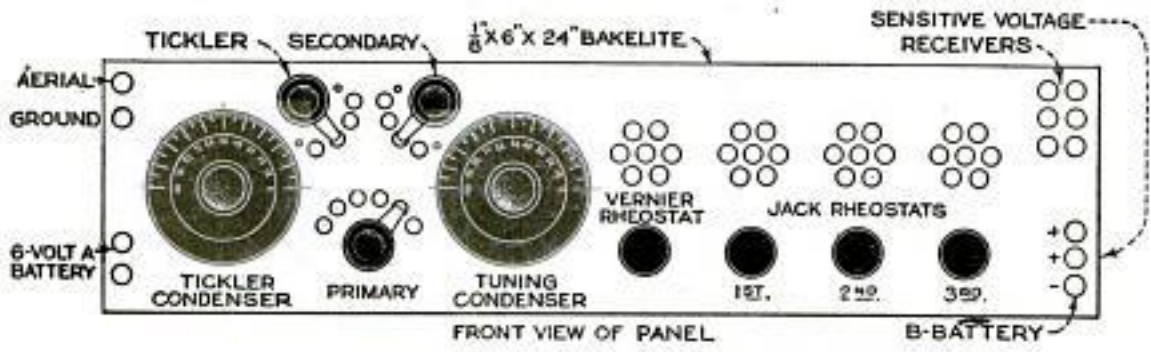
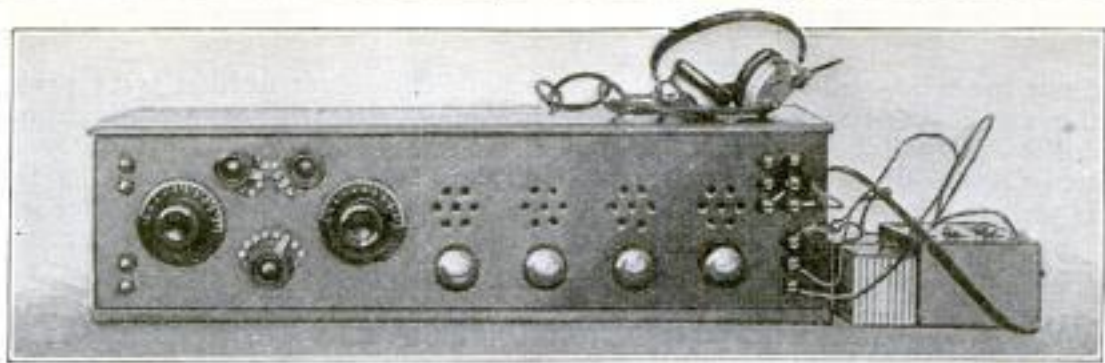

Receiver with Three-Step Amplifier: Above, Front View of Instrument, with Phones, and Detector and Amplifier Batteries; Center, Layout of Panel Front, and Rear View of Instrument, Showing Connections; Below, Rear View of Instrument, Cabinet, and Type of Loud Speaker Recommended

former, cut the wire, and solder the leads from the small inductance to the ends, so that the coil will be in series. Only one tube in 20 or 30 needs this treatment, but it is well to know it.

The best type of aerial to use with these instruments is either a two-wire, 75-ft., flat-top antenna, or a single wire, 125 ft. long. It should be at least 40 ft. above ground. No. 14 copper wire is used for the aerial, the lead-in, and ground connections.

A few words on the operation of the instruments will, no doubt, be welcomed by the amateur.

The instruments will tune over a range of from 150 to 400-meter wave lengths. Supposing, for example, it is desired to tune in a station broadcasting at 360 meters. Set the primary-switch lever on the third or fourth point from the left, the grid-switch lever on the lowest point, and the tickler-switch lever on either of the two lower points. These are the usual positions, using an aerial as specified. The tuning is now done by means of the condensers. Turn the rheostats of the detector and first steps, burning the filaments no brighter than necessary. A point on the vernier rheostat will be found where the signals will come in best; vary the tuning by means of the

tuning condenser until it is as perfect as possible, increasing the voltage on the first-step tube, if necessary. "Smoothing-out" is accomplished by varying the capacity of the feed-back condenser. If more volume is desired, the second step may be switched in.

Most of the fine tuning is done with the tuning condenser, and by the proper adjustment of the voltage of the various tubes, especially the detector. A good guide for the proper adjustment of the tubes is to increase the voltage until a hiss is heard in the phones, then reduce the voltage until the hiss just disappears; this is the point of best operation, and, especially when receiving distant stations, this adjustment is important.

Use a 6-volt, 60 or 80 ampere-hour storage battery as A-battery, and keep it well charged. Buy the best possible B-batteries—cheap ones are a waste of money; good B-batteries should last approximately a year.

The instruments may be inclosed in cabinets, as shown in the photos, if desired, and this is recommended. The author's experience with these instruments has been highly satisfactory, and they are recommended to amateurs who want an efficient instrument at a reasonable price.

Homemade Reliners

It is an easy matter to make excellent and serviceable liners, that will add hundreds of miles to the life of a set of tires, from old fabric tires. If properly made and cemented in place, these liners will hold the worst blow-outs, and

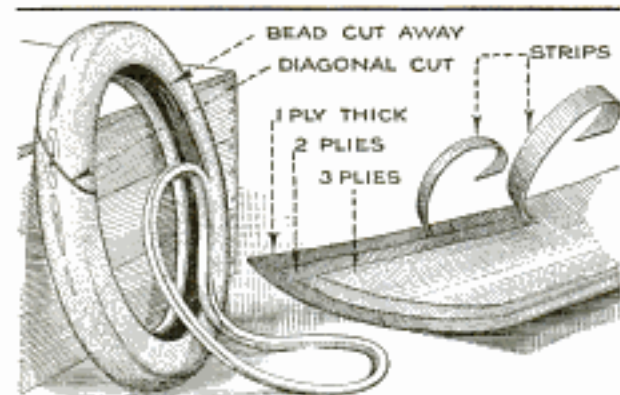

Homemade Reliners, Made from the Three Inner Plies of Old Fabric Tires, Greatly Increase the Mileage of a Set of Tires

make it possible to use tires until the tread and most of the fabric are worn off. It is almost impossible to puncture tires fitted with these liners.

To make a reliner, use an old fabric tire of the same size as the tire in which the reliner is to be fitted—a cord tire will not do. The condition of the tread and the outer plies of fabric is of no importance, as only the three inner plies are used. Neither does one bad blow-out matter, as the joint can be made at this place.

Cut the beads off both sides of the tire. The reliner will be 1 in. or more longer than the inside circumference of the tire, and it is necessary to make a diagonal cut across it. This can be done at the place where a blow-out or other weak part happens to be. Separate the three inner plies from the remainder of the fabric and the tread, using two pairs of pliers to start this operation. After a few inches have been separated, one part can be held in a vise, or placed on the floor and held under the foot, while the other part is pulled off. To make a feather edge on the reliner, to prevent chafing of the inner tubes, cut a strip, $1\frac{3}{4}$ in. wide, along the edge of the first ply, and pull it off, as indicated. Care must be taken not to cut the ply underneath. Then cut a strip from the second ply, about 1 in.

wide, and pull this off in the same way. Let the third ply remain as it is. Feather the ends of the reliner the same way.

The reliner is then ready to be inserted in the tire. Wash the inside of the tire to remove the talc or soapstone. Apply a thin coat of rubber cement to the back of the reliner and press it against the inside of the tire. After replacing the inner tube and putting the tire on the rim, inflate to the usual pressure, or about 5 lb. less, and let the car stand for a few hours before using.

The writer has picked up old worn-out tires on the desert roads in the western part of the country, and found it possible to use them from 300 to 1,500 miles, after fitting them with reliners made as described. To get the best results in using these reliners, insert them in the tires while the latter are still in fairly good condition, and before the tread becomes too badly worn. Reliners of any kind, however, should never be used in new tires, as they tend to stiffen them, and damage the tire in a manner similar to underinflation. Besides, the additional weight and thickness produce more heat, interfere with proper radiation, and cause the inner layers of fabric to be chafed and burned. In old tires, where bad breaks are present in the side walls, reliners will usually prove of benefit, enabling them to be used for many more miles before they finally give out.—F. L. Denton, Pasadena, Calif.

Preventing Birds from Scattering Seed

The old idea of tying a bag around the lower part of a bird cage, or running a gathered band of cloth around it to prevent the bird from scattering seed over the floor, is considerably improved by the method shown in the illustration. Small pieces of sheet brass, or other sheet metal, about 1 in. wide and 3 in. long, are bent as shown, and soldered

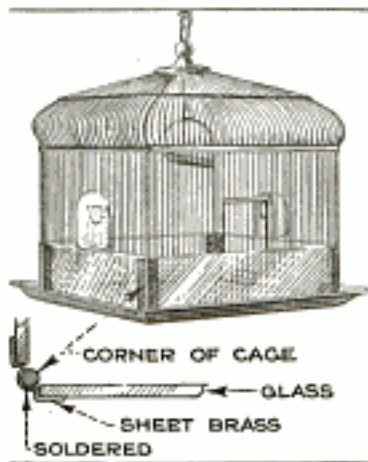

to the four corners of the cage, to hold strips of glass, 3 in. wide, in place. These strips present a much neater appearance than either bag or runner.

Keeping a Key Record

It is a wise precaution to keep a key record such as shown in the illustration, in order to eliminate the necessity of

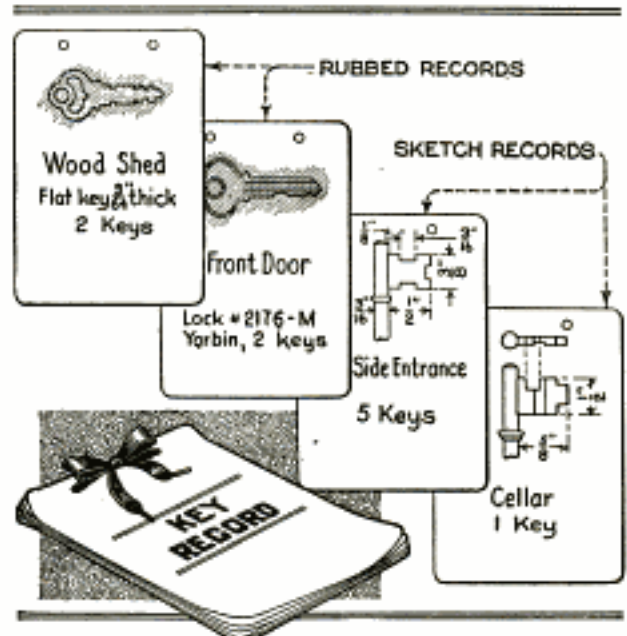

A Key Record Containing "Rubbings" and Sketches of the Keys, and Such Data as Numbers and Designation of Locks to Which Keys Belong

taking locks off the doors, to fit keys to them when the originals have been lost.

The key record illustrated consists of a loose-leaf book containing the "rubbings" and sketches of the keys; also such information as the key numbers, manufacturers' names, the designation of the locks to which the keys belong, and if possible, the exact dimensions of the keys. To make a distinct and accurate outline of a tumbler or flat key on paper, put the key under a sheet of paper and rub over the surface with a soft pencil. Some keys have grooves running parallel to the shank; the width and depth of these must be recorded accurately. Since keys with round shanks are more difficult to shade than flat keys, they are measured with calipers and a scale, and are then sketched accordingly. The thickness of the shank and the exact location of the collar must be shown.

Measuring Diameter without Calipers

To measure the outside diameter of a pipe, shaft, or like object, when no calipers are available, tie two nuts or screws to the ends of a length of string and throw one end over the object. When the ends stop swinging, measure the distance between the cords. The measurement thus obtained is sufficiently close for ordinary work.

Drawing Staff Lines for Music

The device shown in the illustration enables anyone to draw staff lines on ordi-

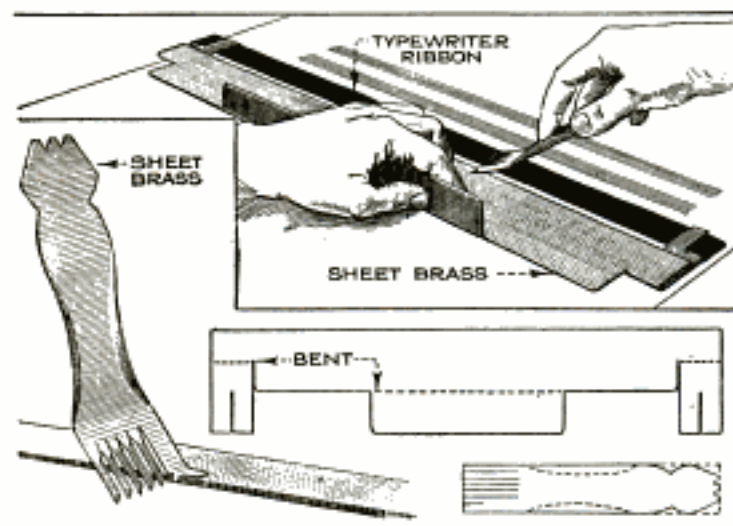

Above: Staff-Ruling Instrument in Use, Showing How the Special Ruler and Inker is Used. Below: Ruling Instrument Proper, and Patterns for Both Instruments

nary paper, and thus produce music paper that is equal, for all practical purposes, to the commercial article.

The ruling instrument is illustrated in

the lower left-hand corner. It is cut from a piece of $\frac{1}{16}$ -in. sheet brass, 5 in. long and $\frac{3}{4}$ in. wide. At one end, 5 slits are cut, $\frac{5}{8}$ in. long and $\frac{1}{8}$ in. apart, and $\frac{1}{16}$ in. from one side a short slit is cut. Five of the prongs are twisted at right angles, as indicated. The sixth prong is bent as shown, to form a lip that will bear against the edge of a ruler.

Using this instrument, carbon paper, and a ruler, very good music paper may be made, but the carbon lines are apt to rub off, so the combined ruler and inker, shown at the upper right, was developed. This makes permanent lines. It is made from a sheet of $\frac{1}{16}$ -in. brass, $1\frac{1}{2}$ in. wide and 7 in. long, cut as shown. The ears at the ends are $1\frac{1}{8}$ in. long, and about $\frac{1}{2}$ in. wide, and are bent back as shown, and slit to take a wide typewriter ribbon, which is passed through the

slits and drawn taut. The lip of the ruling instrument slides on the straight edge, and the prongs on the typewriter ribbon. —H. P. Tevonian, New York City.

Automatic Cut-Out for Audion Bulbs

Many vacuum detector and amplifier bulbs are damaged by allowing an excess of current to flow through the filament. Fuses are unreliable because the exact fusing point is seldom known to the operator,

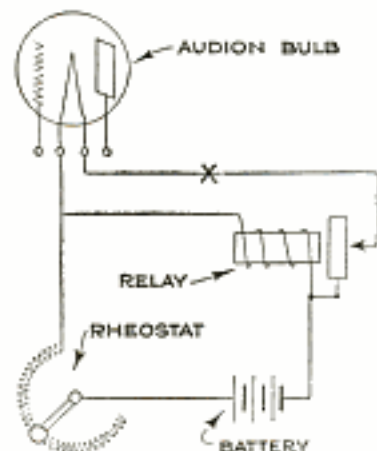

and even a small excess in the flow, if continued, will result in injury to the bulb. An automatic cut-out that will prevent this is shown in the diagram. The only extra equipment necessary is a

small adjustable spring-type relay of from 75 to 250 ohms' resistance, and with the contacts arranged to break when the relay is operated.

The relay is wired in the filament circuit in the manner shown. An ammeter is required to make the proper adjustment of the relay, and should be connected in series with the filament at the point X.

All the resistance on the rheostat should be cut in to start with; if the relay operates at this point, put enough tension on the armature spring to keep it inoperative. Resistance should then be cut out of the circuit slowly, the ammeter being watched for the maximum current flow that the manufacturer has specified for the particular bulb being used. Should the relay operate before that point is reached, more tension should be put on the spring, and if necessary, the armature should be set back farther from the core. This adjusting should be continued until the relay operates at the point of maximum allowable current as shown by the ammeter, and fails to operate at any lower point. The ammeter can then be removed from the circuit. Thereafter, whenever too much resistance is cut out on the rheostat, the relay will operate, cutting off the current from the filament. By cutting the resistance in again, the relay will drop back to normal, and the filament will again be lighted. The adjustment of the relay should be checked by means of the ammeter whenever a change in bulbs is made.

☛ Broom handles make good rollers for moving heavy boxes and other flat-bottomed articles.

First-Aid Kit Carried in Gunstock

Hunters who are accustomed to carry a first-aid kit with them will find the method of keeping the kit in the gunstock very convenient. The butt plate is removed, and the gunstock hollowed out between the screw holes, to provide space for the kit, which consists of such articles as a caustic pencil, plaster, absorbent cotton, iodine, a tourniquet, and a roll of cotton gauze. After these articles have been inserted in the gunstock, the metal butt plate is screwed down again over the opening.—Fred J. Pooler, Waterville, Me.

Tapping Radio Coils

In the construction of radio coils, one should never attempt to bare the wire and make taps after the coils have been wound. This method is not only difficult but shows poor workmanship. The proper method is to make the taps during the winding process. Do not scrape the wire bare with a knife, which frays the braiding or sewing, but hold the portion to be tapped over the flame to char about 1 in. of the cotton or silk insulation. Then rub the copper with a piece of fine sandpaper or emery cloth until the wire is bright. Double the bare part and give it one full twist around. Having formed all the taps in this way, solder to them the wires that lead to the switch points.

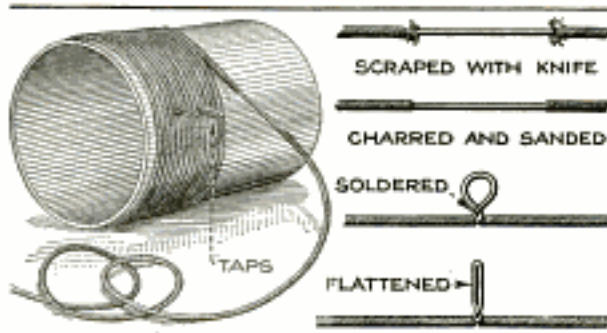

The Correct Method of Tapping Radio Coils by Charring the Insulation and Twisting the Bare Wire in a Loop While Winding the Coil

When completely finished, slip lengths of rubber tubing over the joints to make a neat-looking job. No. 16 or 18 copper wire should be used for leads from the taps to the switch points.—E. J. Bachman, Fullerton, Pa.

Guide Prevents Drawers from Binding

The sides of a drawer are often planed down to eliminate binding, but usually this only increases the tendency to "cant." An excellent way of preventing drawers

from binding or canting, is to provide each drawer with an additional guide, as shown in the drawing. The guide consists of a narrow strip of wood nailed

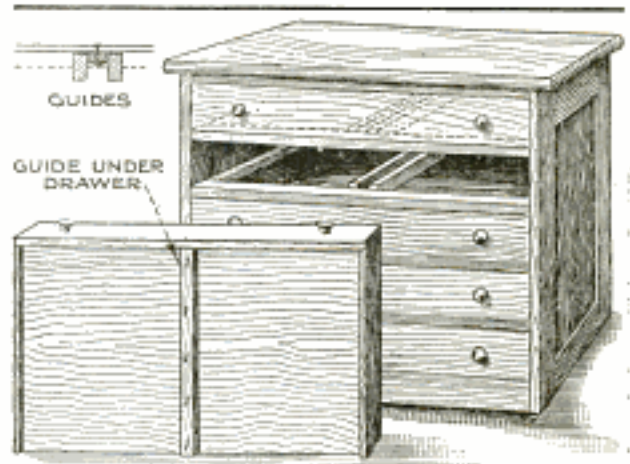

Binding and "Canting" of Drawers are Eliminated by Providing an Extra Slide in the Center

crosswise under the center of the drawer; it slides between two other strips that are fastened to the frame as shown.

Kinks for the Tire User

An inner shoe, made from part of a tin sign picked up along the road, proved to be an excellent repair for a large blow-out. The piece of tin, 8 in. wide and 12 in. long, was made to fit snugly inside of the casing. The ends of the tin were allowed to project over the beads, and a length of old tube, slit open, was slipped around the inner tube to prevent the tin from cutting or chafing it. When the tire was inflated, the tin shoe reinforced the weak part of the casing effectively, and the repair, although intended to be only temporary, lasted as long as the tire, and did not cause any trouble. I now carry several of these tin "shoes," and some sections of inner tubes, in readiness for future blow-outs.

Small holes and cuts in casings should be filled with some "liquid rubber," a thick preparation that solidifies upon exposure to air. It can be procured at most any cycle shop. This treatment will help lengthen the life of a tire considerably, as it prevents small sharp stones from entering the cuts and penetrating the casing, and also prevents water from coming in contact with the fabric. The coating will wear off, and must therefore be renewed occasionally.

It will be found that the cutting of rubber is greatly facilitated if the blade of the knife is kept wet.—William J. Helm, Tampa, Fla.

Portable Shelving for Closets

The portable shelving shown in the illustration can be installed in any closet, and can be removed in a short time with-

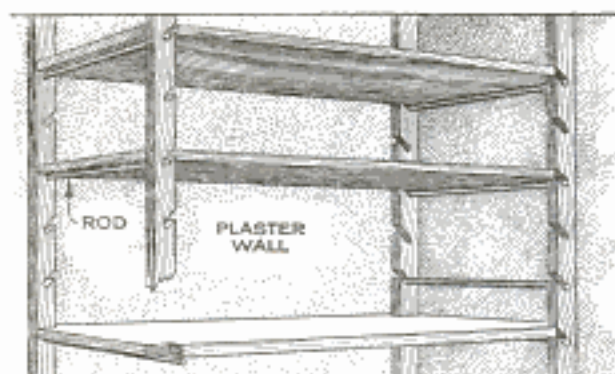

Portable Shelving for Closets That does Not Mar the Walls and can Readily be Removed When Necessary

out any trouble; it will not mar the walls, as no nails are used.

Obtain four pieces of 1 by 2-in. wood, as long as the closet is high. Drill $\frac{1}{2}$ -in. holes every 6 in. along the wide side, and saw out slots, as shown, to fit the $\frac{1}{2}$ -in. wooden rods that support the shelves. Set the four uprights against the side walls of the closet and insert the top and lower shelves first. The shelves keep the uprights tightly against the walls, and are made to fit snugly by cutting out the corners as shown. Only one side wall is shown in the drawing, for the sake of simplicity.—P. A. Dasche, Astoria, N. Y.

Improving Clutch Screw on Light Car

The adjusting screw that bears on the neutral cam of a light car, and is used to throw the engine into neutral automati-

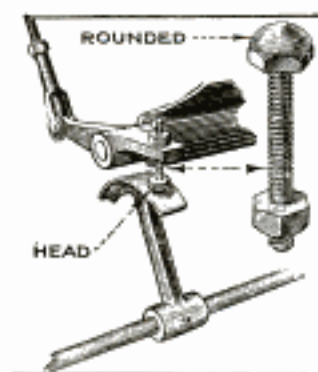

cally when the lever is pulled back, is quickly worn out and hence must be replaced frequently. The cause is that the end of the screw that makes contact with the cam is rather small. If the screw head is

rounded, as shown in the illustration, and the screw is turned in from underneath, so that the head bears on the cam, it will last longer than if merely dressed and replaced as before, as the area of contact is much larger, and will not need adjustment so often.

Novel Method of Bailing Small Boats

With an 8-ft. length of common garden hose as the only implement, water can be bailed out of small boats in a simple manner. The hose is first filled completely with water by submerging it, then one end is held under the water with the left hand. The hose is grasped, near the middle, with the right hand, and, with a quick, rotary motion, the free end is made to whirl around the head. This will throw the water out of the hose, but as fast as the water is discharged, more is drawn in, making the flow continuous. It is astonishing to note how much water can be removed in a few minutes by this method.—D. C. Cox, Pittsfield, Mass.

Screen-Door Patch

To cover a hole in a screen neatly and effectively, cut a rectangular piece of screen a trifle larger than the hole, and pull one or two wires from each edge. Bend the ends of the projecting wires

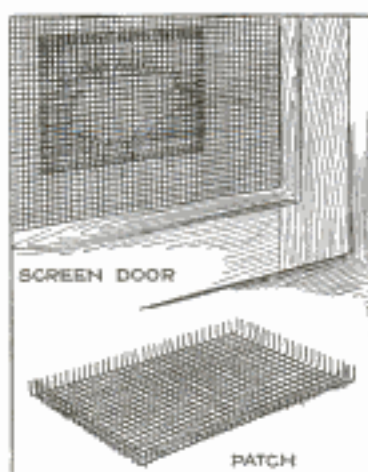

over as shown in the illustration. This may be done by placing on the patch a piece of thick cardboard of the same shape, but a little smaller, and then bending the ends of the wires against the sides of the cardboard.

Place the patch over the hole so that the points will project on the other side of the screen, and flatten them down toward the center of the patch.—P. F. Schecker, St. Marys, Kan.

Simple Repair for Dished Wheel

After a front wheel of a car had been badly dished in an accident, it ran untrue and consequently caused uneven wear on the tire. To remedy this, I took out the hub bolts and hub, replaced the latter from the other side of the wheel, and drew the hub bolts up tightly. The wheel, repaired in this way, ran perfectly true, and it was found unnecessary to purchase a new one.—A. Bronson, Argyle, Wis.

A MERRY-GO-ROUND FOR THE ICE

BY L. B. ROBBINS



EXHILARATING sport is furnished open-air enthusiasts by the novel ice merry-go-round described in this article. The device, although it reminds one of an ice boat, is, however, a new departure in ice coasting, the novelty consisting in the fact that the merry-go-round, which is itself stationary, swings the riders, who are carried on sleds, in circles around it. When desired, the cord or rope that holds the sled to one of the revolving arms, is released, and the sled with its rider is sent flying off over the ice. With a good breeze blowing, the merry-go-round revolves with considerable speed, yet is perfectly safe, if constructed according to the instructions. It can be built by anyone who has some knowledge of tools and how to use them, and who pos-

sesses enough ingenuity for details of construction.

The device consists, essentially, of three parts: the base, the revolving arms, and the sails. The construction of the base is shown in the plan and side elevation, Figs. 1 and 4, and the details of the lower works in Fig. 5. To make the base, cross two pieces of 2 by 6-in. spruce, 6 ft. long, at right angles to each other to form four legs. The surfaces of these crosspieces should be flush, which can be accomplished by half-lapping them at the junction. Bore a $\frac{1}{2}$ -in. hole through the end of each leg so that a long spike can be driven through it and into the ice. Bolt the crosspieces together, and screw a $1\frac{1}{2}$ -in. pipe flange over the exact center of the joint, as shown in Fig. 5. Thread a 6-ft. length of $1\frac{1}{2}$ -in.



An Ice Merry-Go-Round That Provides All the Exhilarating Sport of the Ice Boat on a Pond or Small Lake: It is Equipped with Four Sails That Keep It Revolving at Considerable Speed. To Stop, the Sleds are Disengaged by Releasing the Ropes, and a Simple Form of Brake, Operated by a Long Lever, is Applied

pipe on one end, and screw it into the flange, so that it will stand exactly vertical; this is the shaft around which the arms are to revolve. Next rivet four iron braces to an iron collar, as shown. Slip the collar over the $1\frac{1}{2}$ -in. pipe, and bolt the lower end of the braces to the legs, the bracing being fitted so that the top of the collar will reach about $1\frac{1}{2}$ ft. above the flange. Just above this collar, slip on another, provided with a set-screw. Then saw off part of a large pipe cap to form a shallow cup, about $\frac{3}{4}$ in. deep, and cut a circular hole in its bottom so that it can be slipped over the pipe to rest on the second collar. This forms a race for the ball bearing that supports the revolving arms; the balls should project a trifle above the edge of the cup. If available, a roller or ball thrust bearing should be used at this point.

The revolving arms consist of two 16-ft. lengths of 2 by 6-in. straight-grained spruce planks. Cross them at right angles to each other in the same way as the base legs. Do not half-lap them, however, as this would greatly impair their strength, but set one directly on the other, and bolt them together, countersinking the bolt heads. Then fasten four wooden braces around the center as indicated, lapping the ends so as to make them lie horizontal. Bore a $1\frac{3}{4}$ -in. hole in the center of the joint, and bolt a 2-in. pipe flange to the upper timber directly over the hole. Thread a 3-ft. length of 2-in. pipe on both ends, screw one end into the flange, and fit the other end with a coupling. Fasten four wire stays to eyes welded to the coupling, or through holes drilled in the side and to eyebolts on the revolving arms. These stays should be provided with turnbuckles. On the underside of the joint of the revolving arms, bolt a wooden disk, about 18 in. in diameter, and drill a $1\frac{3}{4}$ -in. hole in the exact center, so that it will line up with the hole in the pipe flange on the other side. Then screw a large steel washer, about 6 in. in diameter, with a $1\frac{3}{4}$ -in. hole in the center, to the wooden disk. This washer rides on the steel balls in the race.

With some one to assist, pick up the revolving-arm assembly and place it over the $1\frac{1}{2}$ -in. pipe on the base. The metal washer will then rest on the steel balls, and about 3 or 4 in. of $1\frac{1}{2}$ -in. pipe will project above the coupling on the 2-in. pipe. Fit a collar over the $1\frac{1}{2}$ -in. pipe, with about $\frac{1}{16}$ -in. play between it and the coupling on the 2-in. pipe. Drill a

$\frac{1}{2}$ -in. hole through both collar and pipe and bolt or pin them together.

A mast and sail is located on the end of each revolving arm. The mast is made of 2 by 3-in. spruce, 7 ft. long. After rounding or chamfering the edges, square off the end and taper it; also taper the whole mast toward the top. Saw a square hole in each arm about 1 ft. from the end, for the mast to fit in. Make a mast step by bolting three blocks together, as indicated in Fig. 3. Cut another square hole in the lowest block, in line with the one above, and step the mast, which will be held quite securely.

The booms can be made of lighter spruce. They should be provided with jaws, made of flat iron, to fit loosely around the mast. The sails are all of equal size, triangular shape, 6 ft. at the leach or mast side and 5 ft. along the foot or boom. Use 8-oz. white ducking and double-hem the edges. Sew in eyelets, about 6 in. apart, along the boom edge, and larger eyelets along the leach, to take mast rings. The mast rings can be made of stiff wire or can be purchased ready-made. Lace the bottom edge of the sail to the boom with stout braided cord. After placing the masts and sails in position, connect the outer ends of the booms, with lengths of rope, to the eyebolts that hold the wire stays. The ropes should be just long enough to prevent the sail from swinging out too far when gybed, or swung out. The correct position is shown in Fig. 1. Fasten a long bolt through each arm, as a stop for the boom when the sail is filled, and provide a large hook on the end of each arm to hold the rope that is fastened to the sled.

When completed, assemble the merry-go-round on smooth ice of sufficient thickness. Set the base on the ice and drive spikes down full length. Additional strength and stability will be obtained by heaping snow around the spikes and legs, splashing water over it, and allowing it to freeze.

Figure 1 indicates clearly how the merry-go-round works, the various positions of the sails being shown. Two of the sails are always catching the wind; one is completely filled just before the one ahead of it is gybed.

The sleds are equipped with strong rope, about 20 ft. long; one end is tied to the sled, while the other end is held in the hand, and the middle section, or bight, is slung over the hook on the end of the revolving arm. A better method of releasing the sled would be to have

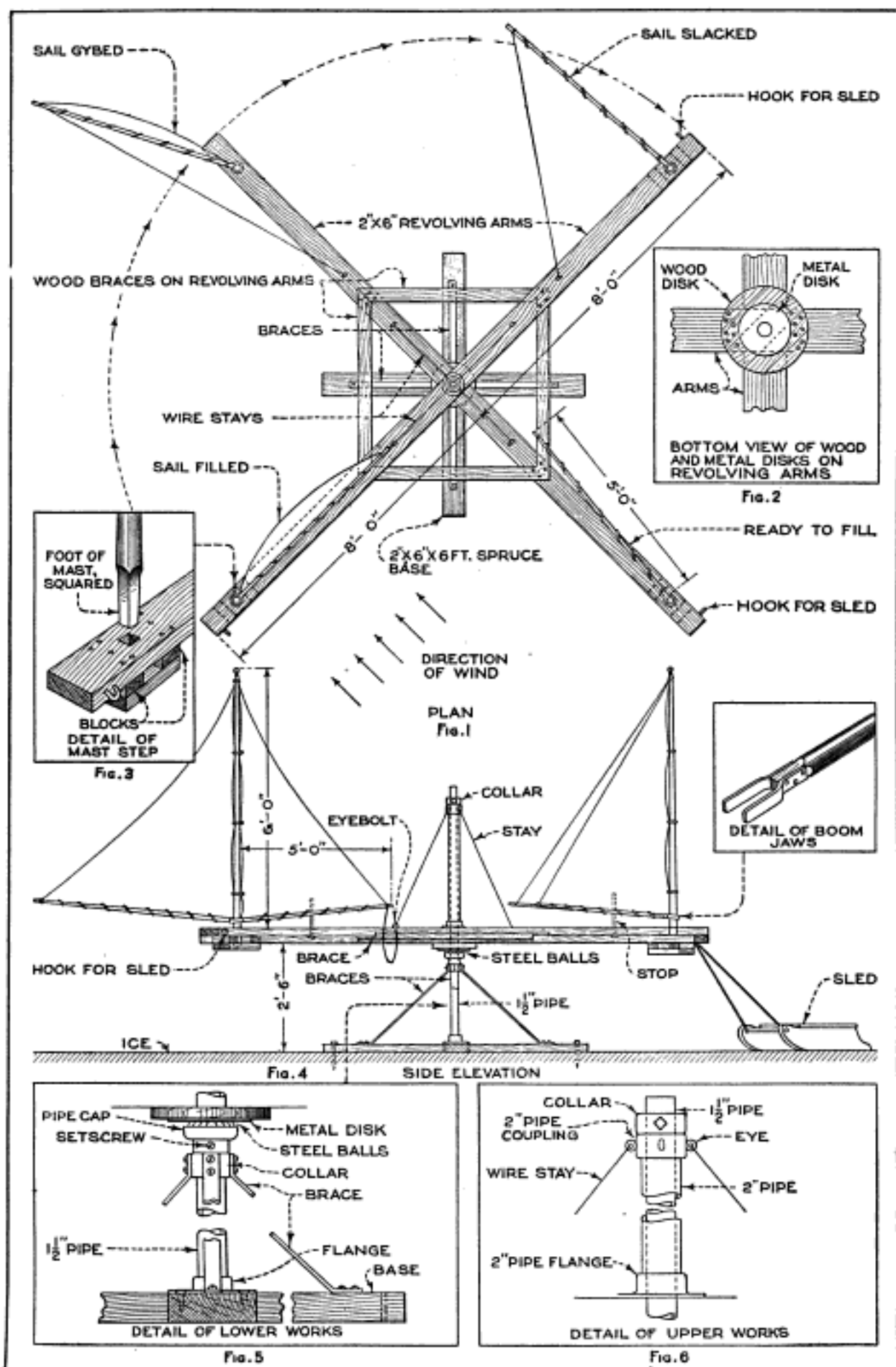

Figure 1: Plan Showing Base, Revolving Arms, and Braces; Also Positions of Sails in Relation to the Wind. Figure 2: Detail Showing Wood and Metal Disks on Revolving Arms. Figure 3: Squared Foot of Mast and Detail of Mast Step. Figure 4: Side Elevation, Showing Assembly of Merry-Go-Round. Figure 5: Detail of Lower Works. Figure 6: Detail of Upper Works

the sled ropes fastened to the arm, and attached to a screweye in the front of the sled by a slip knot, firmly tied, or by one or two turns around a hook. Then, when the rope is released, and the sled flies off, there is no danger of its being overturned by a long, hanging rope getting under the runners.

It is necessary to provide some kind of brake for stopping, especially when a strong breeze blows. A practical way

to do this is to provide means of raising the whole revolving assembly, after all the sleds have been released, so that the coupling on the 2-in. pipe bears tightly against the upper collar on the 1½-in. pipe. This can be done in a number of ways, and one will quickly suggest itself to the builder.

By raising the booms of all four sails and lashing them to the masts, the merry-go-round can be kept at rest.

Protection of Concrete Curbs

The photograph shows a simple method that has been employed to protect the



A Runway Used by a Gardener to Protect Concrete Curbing from being Damaged When Pushing a Heavily Loaded Wheelbarrow over It

concrete curbs of garden walks from being damaged by a wheelbarrow passing over them.

Two short 2 by 12-in. planks, fastened end to end by means of large hinges, are laid across the curb. No matter how heavily loaded a wheelbarrow may be while passing over the runway, no damage will result to the curb. In addition to this, the work of the gardener is considerably lightened.

Heat Shield for Range

Many fires in residences can be attributed to the fact that the kitchen range is placed too close to the woodwork or wall behind it. As a precaution against this danger, a sheet of metal is usually tacked to the wall. However, this is not at all satisfactory or effective as the metal, being an excellent conductor of heat, transmits the heat to the wood under it, and also prevents the radiation of heat from the wood.

A shield that has been found very efficient is arranged as follows: A piece of galvanized sheet iron, about 30 in. wide and 1 ft. longer than the range, is hung between the range and the wall. The sheet iron is suspended by means of two small angle brackets screwed to the top of the wainscoting, behind the stove. The shield is attached to the brackets with stove bolts, placed through the screw holes in the ends of the brackets, and through small holes punched in the shield.

The air between the wall and the shield rises upon being heated, and the space is continually filled with cooler air from underneath, so that the woodwork cannot become very hot.—W. S. Standiford, Youngstown, Ohio.

Safety Car Curtains Made of Wire Mesh

While motoring with small children in the rear seat, it is necessary to watch the youngsters continually, to prevent them from falling out. This constant watchfulness was entirely eliminated by one tourist, who used common wire mesh to cover

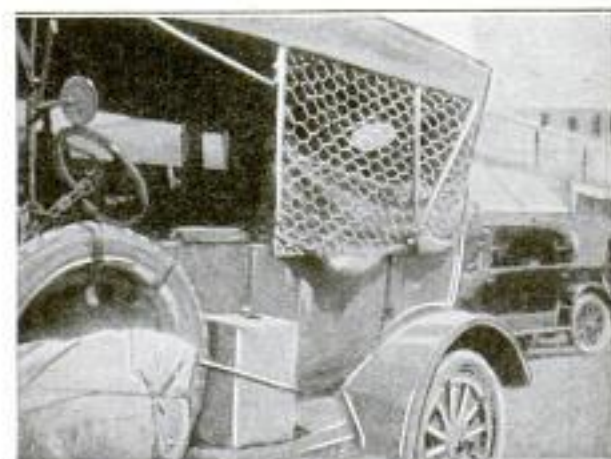

Wire Mesh Covers the Open Sides of the Car, and Prevents Children from Falling Out

the open sides of the rear seat, as shown in the photograph.—Jane Fredrickson, Los Angeles, Calif.

Pencil Sharpener Makes Dowels

Our woodworking department was called upon to make several thousand small pointed dowels, and no cutter of the proper size was available. As it was necessary to turn the work out at once, a small rotary pencil sharpener was pressed into service, and was found to perform the work satisfactorily. The sharpener was fastened to a board, and a small wooden pulley substituted for the crank. The board was then fastened to a high-speed machine so that the small pulley was pressed against the belt. By employing this method, the job was finished completely in less time than it would have taken to make a cutter. The pencil sharpener stood up well, considering the hard use to which it was put.—Charles Thiel, N. Andover, Mass.

Winter Use for the Electric Fan

The illustration shows an excellent method of disposing of the fumes produced by a gas or oil heater, when there is no chimney near, and when the heater is used on the first floor of the house.

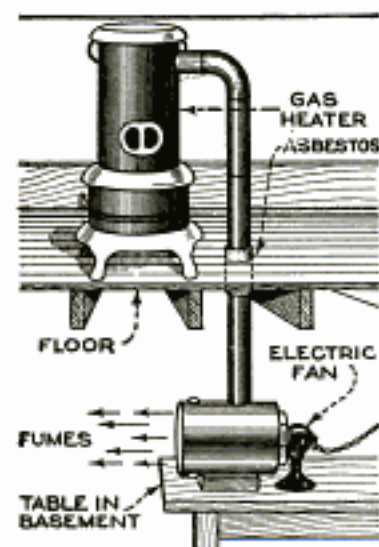

Connect one end of a flue to the top of the heater, as shown, and pass it through a hole in the floor into the basement. The hole in the floor must be lined with asbestos. Pass the lower end of the flue through a hole cut in the side of a lard pail, or similar container, laid horizontally on a table. An elbow is fitted on the end of the flue, the open end of the elbow being pointed toward the open end of the pail, and fitted as exactly as possible in the center of the latter. Cut a hole in the end of the pail, equal in diameter to the guard of a small electric fan, which is placed directly behind the hole. When the fan is operated, the strong current of air causes a strong draft in the flue.

The cost of running the fan is about the same as that of burning a 40-watt lamp.

A Homemade Primer

The illustration shows a simple primer for a car using a pressure gasoline feed. Cut the gasoline pipe leading to the car-

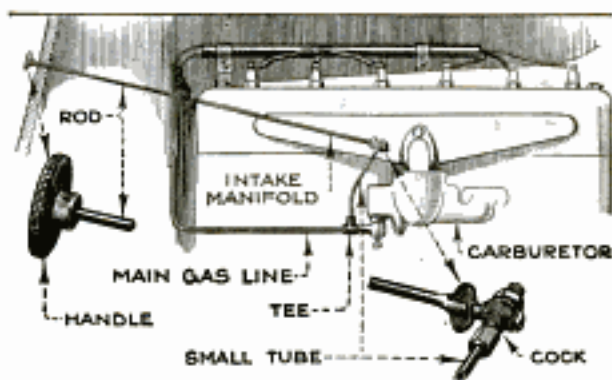

A Simple Primer for Automobiles That Have a Pressure Gasoline Feed: It is Operated by Turning a Small Knob on the Dash

buretor, and braze a tee in it, about 1 in. from the carburetor. Drill and tap the intake manifold as shown, and screw in a small petcock. Connect the petcock and tee with a length of copper pipe as shown. Rivet an iron rod loosely to the petcock valve, and bring it through the dash. Fit a handle or knob to the end. The primer can then be operated by the driver. A quick opening and closing of the valve will provide sufficient gasoline to start the engine in one or two turns.

A Simple Pigeon Trap

The trap shown in the illustration is built in one of the upper corners of a pigeon house. It is 1 ft. square, and has a wooden floor, two screen sides, and an open top. A small hole, that just allows a pigeon to pass through, is cut in one side, as indicated.

A few grains of corn are thrown on the floor of the trap to attract the birds. After a pigeon has alighted in the trap and eaten the corn, it finds the small opening and passes through it into the house. It is impossible for the pigeon to escape by returning through the trap, as the hole in the screen allows only the body to pass through without the wings spread.—Herman Kurth, New York City.

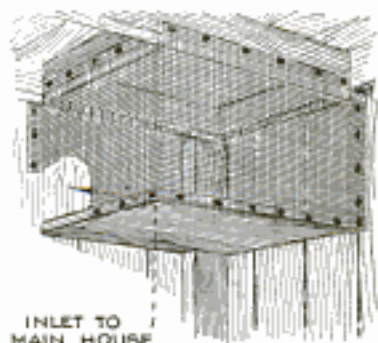

An Easily Made Variable Condenser

A simple and efficient variable condenser that can be made by any amateur radio operator at slight cost is shown in the il-

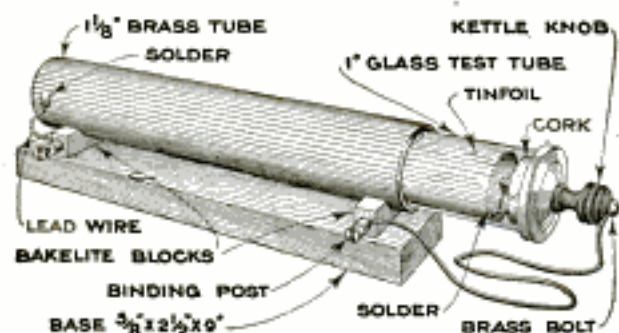

A Simple Type of Variable Condenser That Meets a Variety of Requirements in the Amateur's Radio Laboratory, is Easily and Inexpensively Built

lustration. Many times the experimenter needs a small-capacity condenser but does not care to buy one of the rotary type for the work in hand. This condenser will answer all requirements, and if constructed as described, the capacity will be approximately .0005 microfarad. The base may be of hardwood or bakelite, and the supporting blocks, or saddles, are made of 5/8-in. bakelite, with a small binding post screwed into one end of each. The brass tube is 1/8 by 1 1/4 by 8 in., and has an inside diameter of 1 1/8 in.; it should be clamped securely to the supporting blocks. The sliding unit is an ordinary 8-in. test tube with an inside diameter of 1 in. A sheet of heavy tinfoil, such as used by florists in the preparation of floral designs, 3 1/2 by 7 1/2 in. in size, is then fitted around the inside of the test tube, and a short lead soldered to it and to the inner end of the knob bolt shown; a long flexible lead is then soldered to the bolt at the end of the knob and connected to the binding post. This lead must be of sufficient length to allow the test tube to be withdrawn. A short length of wire is soldered to the brass tube at the rear and connected to the remaining binding post.

Suspended Rattrap Proves Efficient

To get results in catching rats, hang a spring-snap rattrap on the wall so that it will clear the floor about 4 1/2 in., which is just high enough to enable the rat to reach the bait by standing on its hind legs. When the trap springs, either the back or the neck of the rat is broken. Common brown laundry soap has proved to be an excellent bait for these spring traps.—W. Norman Fox, Atlantic City, New Jersey.

Using "Canned Heat" in Small Torch

It very often happened that I found the fuel in my small alcohol torch had evaporated when I needed it and had no additional fuel on hand, so I bought a tin of "canned heat," and poured the contents, while melted, into the torch. Now when I wish to solder, I hold the wick end downward, and apply a lighted match to the end of the metal tube, causing sufficient fuel to be melted to saturate the wick so that it will ignite. If the flame dies down, it can instantly be revived by holding the torch down so that the flame will heat the tube.—J. R. Weyrich, Washington, D. C.

Repairing Electric-Heater Elements

To repair a break in the resistance element of a heating appliance, straighten the ends of the wire for about 1/2 in., and scrape them clean. Take a short length of 3/32-in. brass rod and drill two small holes through it, about 1/8 in. apart, and pass the ends of the resistance wire through each hole twice, as shown. Close the holes down on the wires by hammering the rod. The resulting job will be neat and very effective. Merely twisting the wires around each other does not insure a good electrical connection, as the oxidation of the wire tends to insulate the wires, and solder cannot be used.



Cutting Ice from Watering Tanks

The tool shown in the illustration has been found to be more useful than an ax to cut ice from watering tanks. It consists of an old plow tooth, riveted to a length of 3/4-in. pipe. A plow tooth 5 in. wide is most suitable; it is cut off at the point where the sides begin to taper, and is sharpened to a cutting edge. The pipe is flattened at the end riveted to the plow tooth, and the other end is bent to form a handle. This tool is also of assistance for fitting ice cakes in the ice house.



PRIZE OFFERS AND ANNOUNCEMENTS

1268 FOUR PRIZES FOR THE BEST STUDIES IN THE ECONOMIC FIELD

In order to arouse interest in the study of topics relating to commerce and industry, and to stimulate those who have a college training to consider the problems of a business career, a committee composed of five prominent men connected with various universities and newspapers has been enabled, through the generosity of Hart, Schaffner & Marx, of Chicago, to offer four prizes for the best studies in the economic field. The committee proposes six different subjects, but a competitor is not necessarily confined to these topics, and may choose any other subject, which must, however, first be approved by the committee. There are two classes, A and B, the latter to include only those who, at the time the papers are sent in, are undergraduates of any American college, and the former any other American without distinction. In class A there will be a first prize of \$1,000, and a second prize of \$500. In class B the prizes are \$300 and \$200, respectively. There is no limit as to the length of the papers, and they should be sent on or before June 1, 1923, to Prof. J. Laurence Laughlin, University of Chicago, Chicago, Ill.

MAGAZINE'S BUREAU OF INFORMATION

1382 ANSWERS OVER 19,000 INQUIRIES

Nearly 20,000—to be exact 19,842—inquiries were received by the Bureau of Information of Popular Mechanics Magazine in the year 1922, an increase of 7,762 over the preceding year. Of these inquiries more than 19,000 were answered by letter, while 133 were answered by telephone, and 17 by telegraph.

All walks of life from day laborer to college professor are found among the questioners, many of them, too, living in far-away corners of the globe, southern Australia, Africa, and Alaska being often heard from. India is another country taking an interest in American products, though, according to the number of inquiries received, artificial limbs constitute the Indian's chief point of interest.

Two questions frequently asked are, "Where can I buy a 'divining rod' for locating minerals or buried treasures?" and, "Can you furnish us with details concerning the prize for perpetual motion?" Once in a while some man writes asking where he can find a wife.

1326 ENCOURAGEMENT OF UNKNOWN WRITERS REASON FOR LITERARY CONTEST

The belief that there may be in this country "greater poets than have yet been heard from and writers as excellent as any that have lived," is given as the reason for a \$1,500 literary contest to be held by the New Pearson's magazine. Nine prizes are offered, three for the best short stories submitted, and an equal number for the best poems and best essays. It is suggested that the stories approximate 5,000 words, the poems 300 lines, and the essays 3,500 words. With the exception of the essays, which must be confined to "What Is Wrong with American Journalism?" there are no limitations as to theme or treatment. The closing date is May 1, 1923, at noon, and the address of the magazine, 799 Broadway, New York City.

1384 PRIZE FOR MIDSHIPMAN SHOWING BEST QUALITIES OF LEADERSHIP

A sword will be given annually to the midshipman at the U. S. Naval Academy who has given best evidences of leadership, and who has contributed most to the loyalty of the service. The award is to be made by the superintendent of the academy on behalf of the class of 1897, which has provided a trust fund of \$2,000 for that purpose. A member of the class graduating this year will receive the first award.

AMERICAN-SCANDINAVIAN SOCIETY

1373 TO AWARD SCHOLARSHIPS

Twenty traveling scholarships of at least \$1,000 each will be awarded this year by the American-Scandinavian Foundation to worthy students desiring to study in the universities of Denmark, Norway, and Sweden. Candidates must have received the equivalent of the training usually given for a bachelor's degree, must be of American parentage, and must be nominated by faculty members of the college or school they are attending.

The students chosen will be permitted to select any line of work they care to follow, and may attend school in any of the Scandinavian countries. All applications must reach the secretary of the Foundation at 25 W. 45th St., New York City, before March 15.

PRIZE AWARDS FOR NEW OCCUPATIONS FOR SHUT-INS

FIRST PRIZE, \$100

Bertha Graves*Morey

327 West Fourth Street, Ottumwa, Ia.

A New Method of Designing, Making, and Selling Artificial Flowers from Various Materials.

SECOND PRIZE, \$50

Mrs. E. W. Hitchcock

Hannawa Falls, N. Y.

Plan for Organizing and Operating an Employment and Information Bureau by a Shut-In.

THIRD PRIZE, \$25

R. S. Andrews

221 South Kenilworth Ave., Oak Park, Ill.

Plan and Directions for Making Scrapbooks for General and Special Purposes on a Commercial Basis.

THE suggestions on which these prizes were awarded will be printed in the future issues of Popular Mechanics Magazine. In addition to the prize-winning articles, from the long list of suggestions, many others have been selected for publication in Popular Mechanics Magazine which will be paid for at regular rates. A large amount of valuable material for the occupation of shut-ins will be made available through this magazine.—Editor.

When answering prize offers please mention Popular Mechanics Magazine

CLEARING HOUSE AIDS SCIENTISTS ENGAGED IN RESEARCH WORK

1266

Persons engaged in scientific research wishing to communicate with others working along similar lines, now have available a comprehensive clearing house through which information leading to this end may be obtained. The service is supplied by a special bureau of the National Research Council, which has installed a personnel file of 14,000 names, together with a cross index listing the character of investigations being carried on. This latter record shows that research work is now under way in practically all branches of science, including agriculture, animal biology, astronomy, and geography. The council also has a bibliographic service for any who may desire to take advantage of it.

Research information service

SUNDAY SCHOOL STAGES "AUTO RACE" TO INCREASE ATTENDANCE

1329

Washington, D.C.

An interesting attendance contest was recently put on with success by the Sunday school connected with the First Presbyterian Church of Fort Wayne, Ind. A large map of the Lincoln Highway, marked by lines every 50 miles, was placed on the front wall of the school, and each class assigned a card bearing the photograph and name of some popular racing car. Starting from San Francisco the cars were advanced each Sunday a distance proportionate to the attendance of the class for that day. Decreases in the number of pupils present meant that the cars were sent back for a corresponding number of miles. The contest closed when the first car reached New York.

FIVE THOUSAND DOLLARS FOR WINNER OF MOTORBOAT RACE IN SOUTH

1389

Boats, placing in a motorboat race to be run between Miami Beach, Fla., and Havana, Cuba, next winter, will receive \$10,000 in prizes, the money being donated by the city of Havana. The winner will be awarded \$5,000, the runner-up \$3,000, and the third \$2,000. The Chamber of Commerce of Miami will supply additional information.

STUDENTS INVITED TO WRITE ESSAY ON ECONOMIC SUBJECT

1388

Two prizes, of \$1,000 and \$500, respectively, are offered by Alvan T. Simonds, a member of the board of directors of the United States Chamber of Commerce, for the best essays written by students of a high school, trade school, or normal school on "The Lack of Economic Intelligence, and Some of the Injuries It has Caused to Individual and General Welfare in the United States Since 1860."

For particulars address the Simonds Economic Prize Contest, 470 Main St., Fitchburg, Mass.

CONTESTS PREVIOUSLY ANNOUNCED

Medals, Diplomas, and Money Awards: Announced August issue, 1921; awards offered by the Franklin Institute. The Franklin medal is for workers in technology; the Elliott-Cresson is for original research work and invention; the Howard N. Potts is for important development of previous discoveries and inventions. Each award consists of a gold medal with a diploma. There are also a silver medal, and a Certificate of Merit awarded for meritorious discoveries, and cash premiums for certain work in optics.

One Million Francs for Best Motor: Announced January issue, 1922; closes June 1, 1923; address, Aero Club of France, Paris.

Research Thesis by a Woman: Prize \$1,000; announced October issue, 1921; awarded annually; address, Dr. Lillian Welsh, Goucher College, Baltimore, Maryland.

Annual Commercial Airplane Contest for "Italy's Great Trophy": Announced July issue, 1922; address, Aero Club of Italy.

Best Novel by an American Author: Prize \$2,000; announced August issue, 1922; closes March 1, 1923; address, Harper & Brothers, New York City.

National Contest for Professional Musicians: Announced January issue, 1923; closes March 1, 1923; address, Mrs. Charles A. McDonald, 205 Shorb Ave., Canton, Ohio.

Best Treatise Regarding Immortality: Prize \$1,000; announced January issue, 1923; closes Dec. 1, 1923; address, Contest Editor, 2 West 47th Street, New York City.

Awards to Further Science of Electricity: Medals and prizes, amounting in all to about \$20,000; announced February issue, 1923. For particulars address General Electric Company, Schenectady, N. Y.

For Best Paper on Technical Phase of Aeronautics: Prize \$125; closes March 31 of each year. Announced February issue, 1923; address Royal Aeronautical Society of England, 7 Albemarle St., London, W. I., England.

Names for Great Lakes Steamers: Two prizes of \$50 each; announced February issue, 1923; suggested names must reach the company before the opening of navigation season in 1924; address the Detroit and Cleveland Navigation Company, Detroit, Mich.

For Best Work by American Chemist: An annual award of \$25,000; announced February issue, 1923; address the Allied Chemical and Dye Corporation, New York City.

Best Short Story or Poem: Prizes \$100 and \$25; announced January issue, 1923; closes March 1, 1923; address, Contest Secretary, Kansas City Chapter, Missouri Writers' Guild, Kansas City, Mo.

Articles on Chemistry: Prizes \$50 and \$25; announced January issue, 1923; closes May 1, 1923; address, Secretary, Canadian Institute of Chemistry, Toronto, Ont.

QUICK ACTION OF TRUCK DRIVER SAVES LOAD



More like a scene from a motion-picture comedy than a bit of real life is the plight of the rather distressed young man shown here engaged in holding a truck's load of empty vegetable crates. It happened in Seattle, Wash., during a recent cold spell. Shooting along the avenue the driver underrated the skidding possibilities of the street-railway tracks. The result was that the load took a list to one side, whereupon the driver hopped out and began a heroic fight to prevent the crates from toppling over. Fortunately some passers-by came to his assistance, and the load was finally righted. Taking exceptional care to keep at a safe distance from the street-railway tracks, the driver completed the trip without further mishap.



The Bell System's transcontinental telephone line crossing Nevada.

Highways of Speech

Necessity made the United States a nation of pioneers. Development came to us only by conquering the wilderness. For a hundred and fifty years we have been clearing farms and rearing communities where desolation was—bridging rivers and making roads—reaching out, step by step, to civilize three million square miles of country. One of the results has been the scattering of families in many places—the separation of parents and children, of brother and brother, by great distances.

To-day, millions of us live and make our success in places far from those where we were born, and even those of us who have remained in one place have relatives and friends who are scattered in other parts.

Again, business and industry have done what families have done—they have spread to many places and made connections in still other places.

Obviously, this has promoted a national community of every-day interest which characterizes no other nation in the world. It has given the people of the whole country the same kind, if not the same degree, of interest in one another as the people of a single city have. It has made necessary facilities of national communication which keep us in touch with the whole country and not just our own part of it.

The only telephone service which can fully serve the needs of the nation is one which brings all of the people within sound of one another's voices.

“BELL SYSTEM”

**AMERICAN TELEPHONE AND TELEGRAPH COMPANY
AND ASSOCIATED COMPANIES**

One Policy, One System, Universal Service, and all directed toward Better Service





"You're on the right track-son"

Your selection of Starrett Tools does you credit. I'm always glad to see a youngster start off the Starrett way—it's the right way. I've seen a lot of them start in my day and those that stick and go the farthest are the ones who've got the tools to handle every job right.

Any of the "crack" men in the metal working trades will tell you the same thing—some of them right in our own shop have been living with Starrett Tools for forty years now. They know it pays to own the best.

*Send for Catalog No. 22AP and the Supplement
showing the newest Starrett Tools*

THE L. S. STARRETT CO.

The World's Greatest Toolmakers—Manufacturers of Hardware Unexcelled
ATHOL, MASS.



Use Starrett Tools



**Yankee One Inch Micrometer
Caliper (No. 650)**

For measurements by thousandths up to one inch. Frame is made of drop forged steel, nickel plated, dull finish. Has improved speeded screw with means for adjusting to compensate for wear. An unusually accurate "mike" at a most attractive price.

4811



Magic

Lies in pretty teeth—Remove that film

Why will any woman in these days have dingy film on teeth?

There is now a way to end it. Millions of people employ it. You can see the results in glistening teeth everywhere you look.

This is to offer a ten-day test, to show *you* how to beautify the teeth.

Film is cloudy

Film is that viscous coat you feel. It clings to the teeth, enters crevices and stays. When left it forms the basis of tartar. Teeth look discolored more or less.

But film does more. It causes

most tooth troubles. It holds food substances which ferment and form acid. It holds the acid in contact with the teeth to cause decay.

Germs breed by millions in it. They, with tartar, are the chief cause of pyorrhea.

You leave it

Old ways of brushing leave much of that film intact. It dims the teeth and, night and day, threatens serious damage. That's why so many well-brushed teeth discolor and decay. Tooth troubles have been constantly increasing. So dental science has been seeking ways to fight that film.

A new-type tooth paste has been perfected, correcting some old mistakes. These two film combatants are embodied in it. The name is Pepsodent, and by its use millions now combat that film.

Two other foes

It also fights two other foes of teeth. It multiplies the starch digestant in the saliva. To digest starch deposits on teeth which may otherwise cling and form acids.

It multiplies the alkalinity of the saliva. To neutralize mouth acids which cause tooth decay.

Lives altered

Whole lives may be altered by this better tooth protection. Dentists now advise that children use Pepsodent from the time the first tooth appears. It will mean a new dental era.

The way to know this is to send the coupon for a 10-Day Tube. Note how clean the teeth feel after using. Mark the absence of the viscous film. See how teeth whiten as the film-coats disappear.

See and feel the new effects, then read the reasons in the book we send.

Cut out the coupon now.

Pepsodent PAT. OFF.
REG. U.S.

The New-Day Dentifrice

A scientific film combatant, which whitens, cleans and protects the teeth without the use of harmful grit. Now advised by leading dentists the world over.

10-Day Tube Free 1053

THE PEPSODENT COMPANY,
Dept. 705, 1104 S. Wabash Ave., Chicago, Ill.

Mail 10-day tube of Pepsodent to

.....
.....
Only one tube to a family.

Look! Only \$3.50 a Month

See It First—No Money Down

Our determination to this year double our sales of the world famous

**Santa Fe Special
and
Bunn Special Watches**
prompts this matchless offer

While other watch dealers are raising their prices, asking you for larger monthly payments, and making payment terms harder for you to meet, we are offering you our new model Santa Fe Special, no advance in price, no money down, easier terms and smaller monthly payments. WE realize the war is over and in order to double our business we MUST give you pre-war inducements, better prices, easier terms and smaller payments.

Without one penny of advance payment let us place in your hands to see, to examine, to inspect, to admire, to approve, a real masterpiece in watch creation.

A watch which passes the most rigid inspection and measures up to the exacting requirements of the great Santa Fe Railway System, and other great American trunk lines.

Page Twelve of Our Watch Book Is of Special Interest to You!

Ask for our Watch Book free—then select the Watch you would like to see, either the famous Santa Fe Special or the 6 position Bunn Special, and let us explain our easy payment plan and send the watch express prepaid for you to examine. No money down.

SANTA FE WATCH CO.

36 Thomas Bldg., Topeka, Kans.

Please send prepaid and without obligation your Watch Book free, explaining your "No Money Down" Offer on the Santa Fe Special Watch.

Name.....

Address.....

State.....

Remember —No money down—easy payments buys a master timepiece—a 21 Jewel guaranteed for a lifetime at about half the price you pay for a similar watch of other makes. No money down—a wonderful offer.

SANTA FE WATCH CO.
36 Thomas Bldg. Topeka, Kans.

Trade Mark Registered

WURLITZER

200 YEARS OF MUSICAL INSTRUMENT MAKING

Wurlitzer Saxophones

The most popular of all wind instruments. Improvements in fingering and special conical bore make Wurlitzer Saxophones the easiest to play and unusual for rich tone values. Blows and fingers so easily that playing is as simple as whistling a tune.

Wurlitzer Cornets

Noted for accurate pitch, and clear even tones in both soft and loud playing. Valve pistons individually ground to insure smooth, easy action and absence of leakage. Once "lipping" is mastered very little practice is required to play simple band music.

Wurlitzer Violins

The Wurlitzer collection of Old Violins is internationally famous. Wurlitzer modern violins are made by experts, and accurately patterned after Stradivarius, Guarnerius, and other famous models. We especially urge young people to take up the violin.

Any Musical Instrument

On Trial

WURLITZER will send you *any instrument* for a week's trial in your own home. No obligation to buy — no expense for the trial — you do not risk a penny. Wurlitzer instruments are known the world over for artistic quality and excellence of workmanship. Used by the greatest musicians, bands, and orchestras. The house of Wurlitzer has made the finest musical instruments for over 200 years.

Easy Payments

Payments are conveniently arranged in small monthly sums — a few cents a day will pay. All instruments to you at lowest factory prices. Special combination offers on complete musical outfits — velvet lined case, all accessories, self-instructor, etc. — everything you need at practically the cost of the instrument alone.

Send for New Illustrated Catalog!

The greatest musical catalog ever published! Over 3,000 articles — every known instrument described and illustrated — many of them shown in full colors. No matter where you live, you can buy Wurlitzer instruments direct by mail the same as at any of the 27 Wurlitzer stores.

Send the coupon today!

Wurlitzer Stringed Instruments

Wurlitzer banjos, guitars, mandolins, ukeleles, etc. are made with particular attention to close fit at all joints, to give true vibration and full resonance. Stringed instruments are the easiest of all for beginners to "pick up" — some can become good players almost without effort.

Wurlitzer Trap Drum Outfits

Every conceivable drummer's trap is included in the Wurlitzer outfits — nothing is lacking. A sense of rhythm usually means that playing the trap drums will be almost instinctive.

Wurlitzer Trombones

Tone remarkable for sonority and clearness, absolutely pure in all registers. Slides are drawn to a great hardness and perfect line, insuring easy action and perfect intonation.

The Rudolph Wurlitzer Co., Dept. 1773

117 E. 4th St., Cincinnati — 329 So. Wabash Ave., Chicago
120 W. 42nd St., New York — 250 Stockton St., San Francisco

Send me your new catalog with illustrations in color and full description of every known musical instrument. Also tell me how I may have any instrument for free trial in my own home, and may pay for it in easy installments. No obligation.

Name

Address

(State instrument in which you are especially interested)

Copyright 1925.
The Rudolph Wurlitzer Co.

This Big Building Material Book is NOW Ready

Heating Plants
Plumbing Material
Paint
Roofing
Hardware
Radiation
Wallboard
Tanks, etc.
Pipe-Fittings
Wire-Fencing
Structural Steel
Agricultural Tools

Bathroom Outfits
Furniture and Rugs
Lighting Fixtures
Cabinet Work
Harris Homes
Steel Roofing
Plasterboard
Millwork
Lumber
Windows
Garages
Doors



Plumbing

Heating



\$23.50

One-Piece Sink

PJ-2—White porcelain enameled roll rim kitchen sink with right or left drain board. Complete with faucets and nickel plated trap. 44 in. long.....\$23.50
48 in. long.....27.00
52 in. long.....29.00

2 Part Laundry Tub \$18.75



PJ-4—Composition cement and granite 2 part laundry tub complete with improved swinging mixing faucet and latest style straining angle steel base; nickel plated brass trap. Each.....\$18.75



Complete Bathroom Outfit

PJ-1—Consists of bathtub 5 ft. long and 30 in. wide. White porcelain enameled on the inside and over 3 in. roll rim. Deep spray lavatory size 18x24 inches. Low pattern white china closet outfit with mahogany seat. Complete with all nickel plated fittings above floor line.....\$67.50

Mail This Coupon for FREE BOOKS!
Dept. PK-7

Mark an "X" in squares to indicate books wanted. They are free and sent postpaid without obligation to you.

- | | |
|---|---|
| <input type="checkbox"/> Building material and supplies | <input type="checkbox"/> Presto-Up Garage Book |
| <input type="checkbox"/> Plan Book Harris Homes Beautiful | <input type="checkbox"/> Presto-Up Cottage Book |

Name.....
Address.....



Harris Homes Beautiful

Harris Home No. 1006, above, with 5 rooms and bath, size 30 ft. x 29 ft. 6 ins. is but one of more than a hundred beautiful, practical designs built many times with big economy in best residential districts.

FREE! Every prospective home builder should have this new plan book of Harris Homes Beautiful. More than a hundred designs—bungalows, cottages, residences. Explains the money saving advantages of our guaranteed Ready-Cut and Not Ready-Cut home building systems; the splendid quality of Harris Home building material; our liberal plan offers which save you from 50 to 100 dollars right at the start.



Presto-Up, Bolt-Together Garages
The wonder buildings of the age. Wonderful because they are so simple. Complete to the last detail, with all windows, doors and hardware in place. Come to you in sections, painted and ready to bolt together. Quickly and easily erected in a few hours. Our new, free Presto-Up, Bolt-Together Garage Book is now ready. Mail coupon for your copy.

Numerous attractive designs, both single and double models, in every desired size, priced upwards from \$129.00.

Hot Water, Steam, Warm Air

Complete steam, and hot water heating systems—pipe and pipeless furnaces planned for you by experts and guaranteed to heat your home comfortably, economically and efficiently. Our big stocks insure quick shipment of everything needed to the last fitting. Capable engineers are waiting to help you. Send a rough sketch of your building showing size and location of rooms, number and size of windows and doors, height of ceilings and full information will be sent to you promptly.



Builders' Hardware

Locksets, butts and a complete line of builders' hardware of every description. All new modern designs featuring best construction, latest style and newest finishes. The complete line is illustrated, described and priced wonderfully low in our big building material book. Mail coupon for your copy today.



Lighting Fixtures

A complete line of lighting fixtures carefully chosen in sets for all rooms. Everything needed to wire your home. See them in our new book.



Guaranteed Paint

Per Gallon \$1.85
PJ-8—Best house paint in white, black and 26 non-fading colors. Per gallon.....\$1.85
PJ-9—Barn and garage guaranteed paint. Per gal.....\$1.35



Harris Brothers Co., CHICAGO

Dept. PK-7
35th & Iron Sts.,

Combination Roaster Set

Adapted to the Following Uses
 Self Basting Roaster
 Milk or Pudding Pan
 Steamer Combination
 Double Boiler
 Egg Poacher Combination
 Stewed Pudding Moulds
 Muffin Pan
 Bean Baker
 Sherbet, Custard or Corn Cake Cups
 Jelly Moulds
 Handled Bake Pan or Serving Dish

**6 Quart Combination Cooker**

Eleven Uses Fully Described Below



6 Piece Funnel
 6 Separate Uses
 2 of them Shown



**COMBINATION
 TEA KETTLE
 AND DOUBLE
 BOILER**

USE AS YOUR OWN 30 DAYS FREE!

Former Price \$23.75 Now \$11.95
 Easy Monthly Payments

Every Piece Guaranteed
 To Give Absolute Satisfaction

50 Useful Pieces
 High Grade Aluminum

\$1 ONLY Here is your chance to try for a whole month a Handsome, Useful, and High-Grade Panellied Aluminum Set at my risk. Send the coupon and first payment today. The complete set will be sent you immediately. Learn the big difference between percolator coffee and coffee-pot coffee; enjoy the richer aroma, the finer flavor, the clearer color. Know the many uses of the Big Combination Roaster. See for yourself how it saves fuel, time and labor. Experience, by daily use, the pleasure in handling and the profit in using all the pieces. Enjoy the spick-and-span appearance the 50 pieces give your kitchen. This Colonial Panellied Aluminum Set must be its own salesman. You must be entirely satisfied with its High Quality, its Low Price, and its Easy Terms. If your satisfaction is not thorough, no matter how much you have used the set during the 30 days, you can return it. Your first payment and all transportation costs will be refunded. The trial will not cost you a penny. **Important!** Every piece in this set is genuine high-grade, pure aluminum, mirror-like in finish, with a polish that cannot wear away, seamless, sanitary, and easy to clean. Will not flake, crack, chip or peel. **EACH AND EVERY PIECE IS GUARANTEED TO GIVE ABSOLUTE SATISFACTION.** Heats rapidly and evenly, and so saves fuel. Heavier and better than ordinary grades. These pieces are heavy, extra hard high-grade Aluminums, and will give years of hard, bloodless, Faithful Service. All the articles are of a large serviceable size. This set must not be confused with ordinary sets that include many useless thin pieces. You must judge this set by its big value, rather than its little price. And this you can do during your 30 Days' Free Trial. Price Last Year \$23.75, which we have slashed to rock bottom. Order No. PA2550. Terms: \$1 with order, \$1 monthly. Total price \$11.95. Will be shipped by express unless otherwise requested.

\$1
 With
 Order

With Order This Aluminum Set is only one of my Sensational Slashed - Price Bargains. I have Thousands. All my prices are Down - Away Down! My Big Free 30th Anniversary Catalog is jammed with these Big Bargains. Write for it Today without fail.

SPEAR & CO. Dept. P-301
 Pittsburgh, Pa.
 Home Furnishers for the People of America

\$1 ONLY
 Monthly

- 9-Piece roaster of large capacity—diameter 10 1/2 inches—6 inches high. Inside milk pan 2 1/2 inches high, 8 1/2 inches in diameter.
- 1 Colonial Panellied six-qt. tea kettle with double boiler inset (two qts.) and cover; 3 pieces.
- 1 Colonial Panellied six-qt. combination cooker, 11 uses. Pudding pan, strainer or colander, kettle cover, casserole, or bake dish, convex kettle, preserving kettle, self-basting roaster, combination cooker, corn popper or corn flake toaster, cereal cooker or double boiler, steamer set (4 pieces).
- 1 One-qt. lipped sauce pan
- 1 Two-qt. lipped sauce pan
- 1 Fry pan
- 2 Pie plates—Diam. 10 in.
- 2 Jelly or layer cake pans with loose bottoms (4 pieces), diam. 10 in.
- 1 Colonial Panellied percolator with inset, capacity 7 cups (2 pcs.)
- 2 Bread pans, 9 1/2 x 5 1/2 in.
- 1 Pancake turner, 1 ladle
- 1 Coffee or tea strainer
- 1 Combination biscuit and doughnut cutter (2 pcs.)
- 1 Measuring cup
- 1 Combination funnel (6 pcs.) & separate uses
- 3 Measuring spoons
- 1 Lemon juice extractor
- 1 Sugar shaker
- 2 Colonial Panellied salt and pepper shakers
- 1 Tea ball
- 1 Colonial Panellied tooth-pick holder

**BIG
 FREE
 BOOK**

SPEAR & CO., Dept. P-301, Pittsburgh, Pa.

Send me at once the 50-piece Panellied Aluminum Set as described above. Enclosed is \$1.00 first payment. It is understood that if at the end of 30 days' trial I decide to keep it, I will send you \$1.00 monthly. Order No. PA2550. Total price, \$11.95. Title remains with you until paid in full. Send me your Big Free Catalog also.

Name..... Occupation.....

R. F. D., Box No. or Street & No.....

Post Office..... State.....

If your shipping point is different from your post office fill in line below

Send shipment to.....

FREE { If you want the Free Catalog Only, Send No Money, put an X here

CATALOG } and write your name and address plainly on the above lines.



Radio

Catalogue FREE

One copy of this complete Catalogue of Radio Outfits, parts, Dictionary of Radio Terms, Instruction Book, and Guide to Successful Radio Work—one copy is yours Free.

Simply write us a post card and we will mail the complete book to you Free, by return mail.

It quotes the lowest prices, amazingly low prices on everything for the expert and the amateur. Every improved part, the most up-to-date outfits, everything that is needed of the most modern type—at the lowest possible prices.

It gives a list of broadcasting stations, and gives much information about radio construction and operation. Every one interested in Radio needs this complete catalogue and book of instruction.

Why Pay Higher Prices?

Montgomery Ward & Co. has for fifty years dealt on a Money-Back basis, absolutely guaranteeing everything they sell. With quality absolutely assured, why pay higher prices elsewhere? Write today for this Free Radio Book and see for yourself the Saving it will bring you.

One copy is yours Free. You need only write us a post card.



Write to the house nearest you

ADDRESS DEPARTMENT 6-R

Chicago Kansas City St. Paul
Fort Worth Portland, Ore.

Montgomery Ward & Co.

≡ The Oldest Mail Order House is Today the Most Progressive ≡

1088 Diamond Bargains

YES—1088 of the best diamond bargains you have ever seen. See these—also hundreds of diamonds and other jewels in the latest issue of "The Diamond Bargain List." Send today for this money-saving book. See the wonderful offerings that give amazing opportunities to purchase diamonds and other bargains at special low prices.

60% of Market Price

will Buy Diamonds Here

Here's why we can offer such remarkable values: This famous 75 year old firm—rated at over \$1,000,000.00 capital—the largest and oldest diamond banking institution of its kind in the world, has made loans on diamonds, watches, and jewels in excess of \$25,000,000.00.

Why Pay Full Prices Costs Nothing to See

We now have thousands upon thousands of unpaid loans and other special advantage bargains that we must sell to get back our cash. Loan Value—not market value is our price basis on unpaid loans. Send now for Bargain List. Don't delay. Learn all about the startling offerings that you can get at a fraction of their real value. The Buys of a lifetime. Costs nothing to see.

FREE—On Approval!

The "Buys" of a Lifetime!

At our risk—we send you any bargain you wish for absolutely free examination. No red tape. No reference required. No obligation. Compare it carefully. Have it valued any way you wish. Don't buy unless satisfied you can not match the bargain at 60 per cent more. If you decide not to buy, you are not out one penny. See how much we can save you—or see how much more we can give at other's prices.

As Low As \$60 Per Carat

Not all, but some. Yes, some even lower priced, also finest gems obtainable at higher per carat, but proportionately low Bargain Prices. Get a diamond now around half its market price.

Send for Latest List of Diamond Loans

Entirely different from the ordinary catalog. You will find hundreds of Diamond Bargains described in full detail with exact weight, color, quality, etc., which hardly any others do. You know what you're buying before you buy. Besides the Bargain List tells of Guaranteed Loan Values, unlimited exchange privilege at full price paid, and complete details of free examination offer.

Use Coupon Now!

Or just send name. Postal will do. We'll send our latest Bargain List. It's free. No obligation. No expense. Write now.

Jos. De Roy & Sons

1996 De Roy Building
Only Opposite Post Office
Pittsburgh, Pa.

References by permission—
Bank of Pittsburgh—N. A.
Marine National Bank
Union Trust Co. Pitts-
burgh, Pa. Your bank
can look us up in mer-
cantile agencies.

Name _____

Address _____

Guaranteed Cash Loan!

Diamonds bought here are like insurance policies. You know what you can borrow before you decide to buy—SEE OUR CASH BACK GUARANTEE!



JOS. DE ROY & SONS

PITTSBURGH, PA.

And Now—



A Six Inch Rule (Pocket Size) of
STAINLESS STEEL

BY
BROWN & SHARPE

RUST-PROOF—will not stain or discolor, but will always retain its bright finish—clean cut graduations in 8ths, 16ths, 32nds and 64ths, of the characteristic Brown & Sharpe accuracy.

Get one from your dealer today—
 Ask for No. 350—you'll like it



BROWN & SHARPE MFG. CO.
 Providence, R. I., U. S. A.

SELF-FILLING INK PENCIL
"INDEPENDENT"

Meets all requirements. Self-filling, non-leakable, safety cap. Attached clip. Smooth writing gold style point.

Your Name in Gold—25 Cents Extra

AGENTS WANTED

J. C. ULLRICH & CO., 161 Washington St., New York

Guaranteed Improved Fountain Pen. Eliminates fatigue. Promotes efficiency. Writes uniform. A business necessity.

\$2 By Mail

Moore Push-Pins
 Glass Heads—Steel Points
Moore Push-less Hangers
 To hang up things
 Ask your dealer to show them
 Sold Everywhere **10¢** per packet
 Moore Push-Pin Co.
 Weyne Junction Philadelphia

GREEN AUTOMATIC MACHINE



ADD TO YOUR INCOME WITH LITTLE EFFORT **\$5 to \$10** A DAY MADE EASY WITH

New Improved Green Automatic Machine

Sharpens, Hones and Straps all kinds of safety razor blades, in one operation, from four to six blades per minute. For both Quality and Quantity, this machine is in a class by itself. There is nothing like it on the market. Let us send you our descriptive literature explaining everything, including the "AMERICAN" Key Cutter—cuts square, angular or round slots.

AMERICAN SHARPENING MACHINE CO. (Inc.), Dept. 3, 114 W. Washington St., CHICAGO

"AMERICAN" Key Cutter



ONLY
\$ **3**
DOWN
and you
keep this
typewriter



DIRECT
to you
from our
Factory

Big Saving
In Price

Yes, we will ship you this Genuine Underwood

Rebuilt in our own factory just like new for
ONLY \$3 down — NOT ONE CENT MORE

Until you have tried the machine 10 full days at our expense



Our Factory

EVERY MACHINE is fully guaranteed. New parts wherever needed. New enamel, new nickel, new lettering, new platen, new key rings—a complete, perfect typewriter. Impossible to tell it from a brand new Underwood either in appearance, durability or quality of finished work.

An up-to-date machine with two-color ribbon, back spacer, stencil device, automatic ribbon reverse, tabulator, etc. In addition we furnish FREE waterproof cover and special Touch Typewriter Instruction Book. You can learn to operate this Underwood in one day.

Big Book FREE

Our big handsomely illustrated catalog will be sent **free** on request. It tells you all about the advantages of owning a **STANDARD SIZE UNDERWOOD**; how and why this machine will last for years, saving many dollars not only in the purchase price but in its operation.

Send in the coupon and let us send you this beautifully illustrated book **FREE** without any obligation whatever.

Shipman-Ward Mfg. Co.
"Typewriter Emporium"
2123 Shipman Bldg.
Montrose and Ravenswood Aves., Chicago

Write Right Now

and learn how it is possible for us to ship you this Underwood Typewriter upon our **free trial plan** and our **direct-to-you money saving methods**. Get the full details now—just sign the coupon and mail today. Get all the facts—then decide.

No Obligation

—to buy. You don't have to order. Just sign the coupon, send it to us and we will mail you our big catalog absolutely free.

Send the
Coupon
Today

10 Days'
Free Trial

You have ten full days in which to try the typewriter before deciding whether you want to keep it. Give it every test—see for yourself—make the Underwood prove its worth to you. Don't take our word for it—put the Underwood before you and see if you don't think it the greatest typewriter bargain ever offered.

This is the genuine Underwood Typewriter. We offer you the same three models of the Underwood Typewriter being made and sold by the manufacturers today. **Standard 4-row single shift keyboard. Absolutely visible writing—the full line of typewriting is visible at all times.** All the improvements and attachments that any high grade typewriter ought to have.

Big Saving to You

Our plan of selling to you **direct** makes possible enormous savings, which are all for your benefit. **Send in the coupon and we will send you prepaid** our big catalog, including "A Trip Through Our Factory." This shows how the Shipman-Ward Rebuilt Underwood is the best that can be produced at our **Special Price**.

You don't have to do a thing to get our big **Free** catalog and complete details of our amazing

**FREE TRIAL
COUPON**

SHIPMAN-WARD MFG. CO.
2123 Shipman Bldg., Chicago

Please send me **FREE**, all charges fully prepaid, your **BIG NEW** catalog of **UNDERWOOD TYPEWRITERS** and complete details of your **FREE TRIAL Offer**.

It is understood that I am under no obligation whatever and that this is to be sent without one cent of cost to me.

Name.....
Street.....
City..... State.....

\$1 brings this Outfit



Artists Model

"C Melody" Standard SAXOPHONE

Learn to play Saxophone! The easiest instrument to learn, it is also the most popular! Pick out tunes in an hour, as quickly as with one finger on the piano. And there's no faster way to make extra money than playing Saxophone at dance or church or theatre. Makes you a social favorite, always welcome everywhere!

10 MONTHS TO PAY! The Standard "C Melody" Saxophone is the supreme grade "made in Elkhart." Choice of famous artists and teachers. The 1923 model with "bevelled sockets" makes all other Saxophones "out of date." Sent to you for 6 days' trial, to prove to you its ease of blowing, simplified fingering and golden tone can't be equalled at any price. Complete 12 piece outfit direct to you from factory at only \$1 down and \$7.50 a month. Small first payment. Sensational cut in price to only \$89.50, no interest, no tax, not one cent extra—Saxophone, \$10 case, self-instruction system, book of music, reed, strap, pearl keys, etc., everything you need. Quality that enables you to buy once for a life-time.

CATALOG FREE! Tells you how you can secure the greatest of Saxophones on easy terms at less than cash prices! Write today for this free book and complete information of our sensational offer! Standard Music Co., Dept. 722, P. O. Box 503, Chicago

Sell the Sensation of 1923

SENTINEL BURGLAR ALARMS



Every home, hotel, office, warehouse, a prospect for 2 to 24 of these alarms.

Operate without wires or batteries. Sentinel-equipped doors or windows cannot be opened without ringing loud bell. Provide cheap burglar insurance. Easily demonstrated—sold—installed. Fully guaranteed. Send \$1.50 for sample. Sent C. O. D. if desired. Start taking orders. Big opportunity. Write immediately!!



SENTINEL ALARM CO., 1460 Marquette Bldg., CHICAGO

1000 SHOT
ALL STEEL
MAGAZINE
AIR RIFLE

WE GIVE
TO BOYS
WITHOUT COST
Choice of six guns (on four easy plans) for selling our Magic Healing

HAMILTON
22 CAL.
HUNTING
RIFLE

Wav-o-lens at 25c box. We Trust You! Order Seven Boxes Today On Postal Card—we send promptly, prepaid. Easy to sell—used in every home. Return money as instructed, choosing your gun according to one of the plans shown in our Big Premium List. Also 200 other Gifts or Big Cash Commission if you prefer. If you are prompt, a special Free Gift. Waverly Co. 219 Towner Bldg. Monongahela, Pa.

Wrestling Book FREE



Be an expert wrestler. Learn at home by mail. Wonderful lessons prepared by world's champion Farmer Burns and Frank Gotch. Free book tells you how. Secret holds, blocks and tricks revealed. Don't delay. Be strong, healthy. Handle big men with ease. Write for free book. State your age. Farmer Burns School, 977 Railway Bldg., Omaha, Neb.

Learn to Write



I Teach By Mail

I can make a good penman of you at your home during spare time, no matter where you live or how poorly you now write. My simplified system has shown thousands the way to good penmanship during the past twenty-five years—it CAN and WILL do the same for YOU.

My beautifully illustrated 32-page Book "How to Become a Good Penman" **FREE!!**

It contains many beautiful specimens of penmanship showing what others have accomplished by the Tamblin System, with testimonials and general information about our courses. If your name depends written on a card if you enclose stamp for postage. Ladies taught as successfully as men. **WRITE TODAY.** Address **F. W. TAMBLIN** 418 Ridge Bldg. Kansas City, Mo., U. S. A.

F. W. Tamblin

\$3 Cash Buys Typewriter



Balance Only \$5 Monthly
Save 35 to 60% on all standard makes—Underwood, Royal, Remington, etc. Every machine thoroughly rebuilt and **GUARANTEED.** Try five days at our expense before you buy.

WRITE at once for Free Descriptive Circular and Special Low Prices.

5 DAYS FREE TRIAL

WYNN TYPEWRITER EXCHANGE 11 Reliance Bldg. Kansas City, Mo.



SEND NO MONEY

If You Can Tell it from a GENUINE DIAMOND Send it back

To prove our blue-white MEXICAN DIAMOND cannot be told from a GENUINE DIAMOND and has same DAZZLING RAINBOW FIRE, we will send a selected 1 carat gem in ladies' Solitaire Ring. (Cat. price \$3.25) for Half Price to introduce, \$2.63, or in Gentle Heavy Tooth Holder Ring (Cat. Price \$2.50 for \$3.25). Our finest 18K Gold Filled mountings. **GUARANTEED 20 YEARS. SEND NO MONEY.** Just mail postcard or this ad, state size. We will mail at once. When ring arrives deposit \$2.63 for Ladies ring or \$3.25 for Gents with postman. If not pleased return in 2 days for money back less handling charges. Write for Free catalog. Agents Wanted.

MEXICAN DIAMOND IMPORTING CO., Dept. ET-Las Cruces, N. Mex. (Exclusive controllers Mexican Diamonds)

W. L. DOUGLAS

\$5 \$6 \$7 \$8 & \$9 SHOES FOR MEN AND WOMEN

W. L. Douglas shoes are actually demanded year after year by more people than any other shoe in the world

BECAUSE W. L. Douglas has been making surpassingly good shoes for forty-six years. This experience of nearly half a century in making shoes suitable for Men and Women in all walks of life should mean something to you when you need shoes and are looking for the best shoe values for your money.

W. L. DOUGLAS shoes in style, quality, material and workmanship are better than ever before; only by examining them can you appreciate their superior qualities.

No Matter Where You Live

shoe dealers can supply you with W. L. Douglas shoes. If not convenient, to call at one of our 110 stores in the large cities, ask your shoe dealer for W. L. Douglas shoes. Protection against unreasonable profits is guaranteed by the name and price stamped on the sole of every pair before the shoes leave the factory. Refuse substitutes. The prices are the same everywhere.

If not for sale in your vicinity, write for catalog.

TO MERCHANTS: If no dealer in your town handles W. L. Douglas shoes, write today for exclusive rights to handle this quick selling, quick turn-over line.

W. L. Douglas
President
W. L. Douglas Shoe Co.
128 Spark St. Brockton, Mass.



BOYS SHOES
\$4.50 & \$5.00

HANES ATHLETIC UNDERWEAR
is guaranteed absolutely—every thread, stitch and button. We guarantee to return your money or give you a new garment if any seam breaks.
Trade Mark P. H. HANES KNITTING CO. WINSTON SALEM, N. C.



AGENTS SELL THIS WONDERFUL ALUMINUM PENCIL SHARPENER: renewable razor-steel blade. Guaranteed perfect cutter or new one free. Sample 25c. Special offer gross lots.
LITTLE BROS. 619 So. Main Los Angeles, Calif.

ENGINEERING SUCCESS EASY WITH THIS TRANSIT

\$25⁰⁰
BRINGS IT TO YOU

Make the Most of Your Opportunities!

Why plod along? Thousands of engineers and surveyors have greatly increased their efficiency and have won success with this great Transit Outfit. You too can capitalize your knowledge and practical experience with it. This outfit will make you more money, increase your standing and enable you to do the work more easily and rapidly. Success is for those who will reach out and grasp it. It can't be attained with an antiquated or a rented instrument. Don't overlook this exceptional offer.

30-DAY FREE TRIAL

The Standard of the World!

The Aloe Engineer's Transit, New and Improved Model, with 20 points of superiority, is the Standard of the World. Comes complete with telescope, vertical circle, compass, variation plate, two double verniers reading to single minutes graduated on solid silver, etc.

Simplify Engineering Projects

FREE!



Trautwine's Handbook and Ives's "Adjustments and Easy Directions," both profusely illustrated, give you the key to every phase of engineering work. Solve all your problems. Tell you clearly and plainly how to proceed at once. Look in index; turn to text; they make work with the transit easy and successful. Equipped with this Transit and these invaluable text-books, your engineering experience can be made to pay real dividends.

Investigate this Great Opportunity!

Be alert—be wide-awake—be fair to yourself—know what tremendous possibilities this outfit opens up to you. Learn of the big saving in price offered you. Realize that by our Easy Payment Plan the instrument pays for itself. Our offer is so fair, so straightforward and so interesting that you cannot afford to overlook it. Don't let procrastination rob you of this chance—it may be the turning point in your career. Sign and mail this coupon today.

619 OLIVE STREET A. S. ALOE CO. ST. LOUIS, MO.



These Men Achieved Success

"It brought me prosperity."—E. D. Edinger, El Paso, Tex.
"Your outfit makes the work easy."—Francis Chianterini, Providence, R. I.
"Best transit I ever used."—H. W. Lee, O'Fallon, Ill.

Easy Terms—Guarantee

Just \$25.00 brings you this outfit; try it 30 days on the job; if perfectly satisfactory pay balance in easy monthly installments. No interest, no red tape. If not satisfactory return it and get back every cent you paid us. You take no risk.



Comes Complete

with mahogany carrying case, tripod, sunshade, reading glass, plumb-bob, adjusting pins, screw-driver and two hand-books.



MAIL COUPON NOW!

A. S. ALOE CO.
619 Olive Street,
St. Louis, Mo.

Dear Sirs: Without obligation on my part whatsoever, send me full particulars of your Engineer's Transit Outfit and Free Trial and Easy-Payment Plan.

Name.....
Street.....
City.....State.....

Kingery

Start A Profitable Business for Yourself

—and make **MONEY** right away

KINGERY POP CORN POPPERS AND PEANUT ROASTERS often prove a gold mine for the ambitious person. The investment is small—practically no attention is required to machine while in operation—little expense for stock or power—and profits are **BIG: 3½¢ on every 5¢ sale or 8½¢ on every 10¢ purchase.**

KINGERY MACHINES are complete in every way. They turn out the buttered popcorn and hot roasted peanuts with little effort on your part.

VERY LITTLE SPACE IS REQUIRED—for KINGERY POP CORN POPPERS AND PEANUT ROASTERS can fit in practically any space.

Everybody—**young or old—rich or poor—every person is a possible customer.**

James Kipwits, P. O. Box 56, Waynesburg, Pa., writes: "Since I got your machine, in 15 days I have made \$227.55."

INVESTIGATE TODAY

WRITE FOR FREE ILLUSTRATED CATALOG showing a model for every purpose at a price for every purse.

Dept. PM

KINGERY MFG. CO.
CINCINNATI, OHIO



Tailoring Agents Wanted

Make \$75.00 a Week and Up

selling our fine made-to-measure, all wool suits at \$29.50 retail, direct to wearer. Biggest values ever offered—positively sell on sight. Liberal profits paid in advance. We attend to delivery and collections. Write at once giving full particulars as to your past experience. Full line of samples—everything to work with—will be sent with the least possible delay.

W. Z. GIBSON, INC., Dept. Q-1003
161 W. HARRISON ST. CHICAGO

Only \$2 Down

Play Well in 4 Weeks

—Ten months to pay

Write for Free Catalog Folder telling all about the **Masterbilt**—the world's finest Saxophone outfit. Price now lowest ever quoted—5 days' trial—very easy monthly payments. No interest to pay—no extras. **Outfit** includes finest nickel trimmed and richly lined Case, Instruction Book, Album of Popular Saxophone Solos, Music Lure, Carryin' Strap, Mouthpiece and three fine Reeds.

"Masterbilt" Saxophones

Used by leading Bands and Orchestras. Highest quality, built in perfect tune, assembled and tested by experts. All latest key improvements. Neat, quick action and beautiful finish. Write today for FREE Catalog Folder fully describing these handsome Masterbilt outfits.

The Saxophone Shop, 429 S. Wabash Ave., Chicago
Largest Exclusive Dealers in Saxophone Supplies in the World



Tom Mix Uses RenuLife

"I own a complete set of RenuLife Violet Ray and find it of immense value in retaining a robust physique. I find it especially helpful in curing the sprains and bruises that I often incur in my strenuous career."

Tom Mix

Do You, Too, Want Health and Strength?

YOU can have vigor, energy, health, strength and beauty. You need not suffer from aches and pains—from rheumatism, neuritis or other ailments. The soothing, healing RenuLife drives out aches and pains without shock or unpleasant sensation and searches deep down in your body to eliminate the cause. It carries ozone into the blood, enriching and purifying it.

Free Trial Hundreds of people have been rejuvenated and strengthened by the health-giving RenuLife Violet Ray.

Prove to yourself how quickly it will aid you. Our free trial plan enables you to use RenuLife for that ailment of yours. Write for this Free Trial Plan—we take the risk.

RenuLife Electric Company
314 Newberry Bldg. Detroit, Michigan

(In Canada: Pitt St. E., Windsor, Ont.)

NEW-KANT-KLOG COAL OIL BURNER

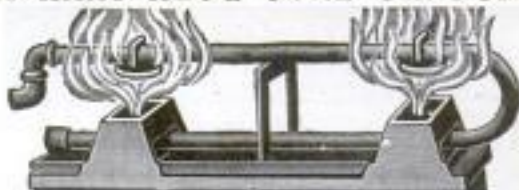

Nothing else like it. New-patented. Not sold in stores. Big seller. 100% profit. Most perfect burner ever invented. Absolutely safe. Can't clog up. Turns any coal or wood stove into a gas stove. Cheaper than coal. Popular price. Write quick for agency and territory.

PARKER MFG. CO., Burner 378, Dayton, Ohio

BOATS

Canoes, rowboats, hunting and fish boats, outboard-motor boats and motor boats 16 to 26 foot. **Catalog Free. Save money. Order by mail.** State kind of boat in which interested. Immediate shipment from stock.

THOMPSON BROS. BOAT MFG. CO.,

163 Ellis Ave., Peshtigo, Wis.

Easy to Build this SHAW Cycle Car

Here's a **Real Automobile** with a **Real Motor** that any handy man or boy can build. The **SHAW Speedster** carries two passengers anywhere. Power supplied by famous 2½ H. P. Shaw Motor. If you have a Shaw Motor get plans. If not, we supply everything. **Write for FREE particulars** or send 25c now for Easy-to-follow plans. Write today!

SHAW MFG. CO.

Dept. S-1

Galesburg,

Kansas



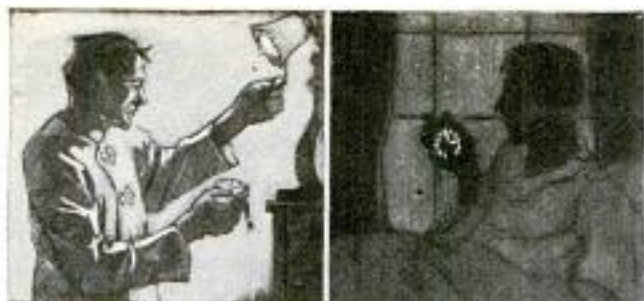

This man woke up in the middle of the night and wanted to know the time. To find out, he had to get out of bed, find the light chain, turn on the light and then let his eyes get adjusted to the glare before he could know.

This man had an Ingersoll Radiolite under his pillow. He knew the time at a glance. How about you? Only \$2.50

Ingersoll

Radiolites

Tell Time in the Dark

THIS WONDERFUL INVENTION



converts any cook stove into a gas stove. Oxo-Gas made from kerosene and air is cheaper, cleaner and more efficient than coal. Send for catalog illustrating Oxo-

Gas appliances for all purposes where coal is used. We have openings for General Sales Managers and distributors. Only those who can finance themselves considered.

GLORIA LIGHT COMPANY

111-119 N. MAY ST.

CHICAGO, ILL.

\$2 Puts this
ELGIN WATCH
In Your Hands

No Red Tape, No Waiting

Simply send \$2.00 and receive watch. Full seven Jeweled Elgin in stylish Octagon Case. Thin model, guaranteed 20 years.

30 DAYS FREE TRIAL

Send only \$2.00 and watch comes charges paid. Carry for 30 days and if not satisfactory your deposit is returned. Pay balance \$2 a month for 10 months. Price only \$22.00. Send for FREE ROYAL BARGAIN BULLETIN, addressing Dept. 481.

ROYAL DIAMOND & WATCH CO.
35 Maiden Lane, New York



Your European Trip need cost you little ~ ~

IF YOU are planning a trip to Europe learn today at what a moderate expense you can have the vacation of your life! Your Government has prepared a booklet of suggested itineraries and their costs. It is now possible to go to Europe and return on one of the finest ships afloat, first class passage, spending three weeks abroad, for only \$750!

Great Government Ships

U. S. Government ships, operated to Europe by the United States Lines, are marvels of luxury, speed and safety. A voyage on the famous George Washington, the President Harding, or President Roosevelt, constitutes a supremely memorable experience. The ships ply between New York and Plymouth, Cherbourg and Bremen. You should know about them. You will be proud of your ships, and the unsurpassed service they offer at low cost.

Send This Blank

INFORMATION BLANK
To U. S. Shipping Board
Info. Sec. U.S. 1773 Washington, D. C.

Please send without obligation the U. S. Government literature described above. I am considering a trip to Europe , to The Orient , to South America . I would travel 1st class , 2d , 3d .

My Name.....

Address.....

For information regarding sailings address

United States Lines

45 Broadway New York City

110 So. Dearborn St., Chicago, Ill. 75 State St., Boston, Mass.

155 Congress Street West, Detroit, Michigan

Managing Operators for

U. S. SHIPPING BOARD

Please Mention Popular Mechanics

Kentucky's Finest Good Old Melon Sweet Green River Tobacco

Direct From Factory to You At Money Saving Prices

The finest genuine Homespun Smoking Tobacco Green River's Famous Fertile valley can produce—nature's finest, air-cured, pure, natural leaves—with that good old lasting flavor and fragrance—just as nature intended it to be—sweet—pure—satisfying. Aged and mellowed in the wood for years as only we Kentuckians know how to do it. Its old melon sweet, natural flavor and smoothness cannot be equalled. Comes to you as pure as when it left the field years ago—no dope—no flavoring. Guaranteed free from chemicals and adulterations. Simply ground up ready for the old pipe—the most satisfying smoke you ever had. Sold direct from factory to you at lowest prices ever offered.

A Trial Costs You Nothing

To quickly introduce our famous Green River Tobacco, to every reader of this magazine, we are making a special offering for a short time only of two \$1-lb. cans for only \$1.00. Send no money. Just send now your name and address and pay postman \$1.00 and postage on delivery. If after thirty days' trial you are not absolutely satisfied, your money will be refunded. This offer is absolutely guaranteed, so don't hesitate to make the test.

Comes in three blends—mild, medium or strong. In ordering state which blend you prefer. This tobacco must be just as represented. Must satisfy you or your money will be refunded without quibble or question. Rush your order today, sure.

OWENSBORO TOBACCO CO.
Dept. 119, Owensboro, Ky.



Two brothers, Alton and William Livingston, both born with Club Feet, were treated at McLain Sanitarium with the splendid results set forth by their mother in this letter:

My oldest boy, Alton, was treated for Club Feet when 3 yrs. old at the McLain Sanitarium with such satisfactory results that when William was born with Club Feet, 10 years later, we took him to McLain's when 11 wks. old. 8 wks. later we brought him home with straight, perfect feet. Inquiries gladly answered.

MRS. CLARENCE LIVINGSTON,
205 Washington St., Salisbury, Maryland

Pictures show William at 11 weeks, and his present condition.

CRIPPLED CHILDREN

You may know some. Tell their parents of the McLain Sanitarium, a thoroughly equipped private institution devoted exclusively to the treatment of Club Feet, Infantile Paralysis, Spinal Diseases and Deformities, Diseases of the Joints, Wry Neck, etc., especially as found in Children and young adults. Write for their book, "Deformities and Paralysis," and "Book of References," mailed free.

The L. C. McLAIN ORTHOPEDIC SANITARIUM
902 Aubert Avenue St. Louis, Mo.
F4138

Amazing Bargain!
Lincoln Wren House \$1.00
Unusually attractive bird house—that ONLY wrens can use. Looks like a miniature log cabin. Made of wood, tinted a soft brown color that attracts the wren, whose song is melodious and beautiful; song-log ways make it a favorite. It destroys large numbers of obnoxious insects. The equal of wren houses costing \$5.00 to \$7.00. And yet because we build in tremendous quantities—we are able to sell, knocked down, for only \$1.00—prepaid. (West of Denver and Canada \$1.25.) Attract wrens—they liberally repay attention. Send \$1.00 for each Lincoln Wren House you want. If you aren't delighted—money back. Write now. (Dealers write for proposition.)
John Lloyd Wright, Inc., 709 N. Wells St., Chicago

\$3.00 per Month

A Whole Year to Pay

"Lady Lorraine"
Large solitaire, peridot cut blue white diamond, 14 kt. solid gold ring. Special \$47.75

Why wait longer when a few cents a day places this fiery brilliant, genuine blue white, perfect cut diamond on your finger. No risk, no delay. Satisfaction guaranteed. Regular \$80.00 value, our price, \$47.75.

REDUCED PRICES
Klein smashes prices on great million-dollar stock of diamonds, watches and jewelry—saves you one-third and trusts you for what you want. **WRITE FOR CATALOG**

It tells the whole story—beautifully illustrates sensational bargains and explains credit plan that places them within easy reach. Why wait longer? Write for the catalog today—sure!

KLEIN & CO. 122 West Madison Street
Dept. B-715 Chicago, Ill.
Nearly One-Fourth Century Same Location

Make \$5000 Every Year \$2000 in Your Spare Time

You share in our profits besides. Just show and write orders for "Weather Monarch" Raincoats and Wind and Waterproof Overcoats.

Commissions In Advance

We deliver and collect. Ask about "Duol Coat" No. 999. Free raincoat for your own use.

Associated Raincoat Agents, Inc.
442-450 No. Wells St., Division 200, Chicago, Ill.

Army Auction Bargains

20 ga. Hand and Shoulder Gun, \$14.85
Luger pistol \$21.50 | Haversacks, 15 up
Krag rifle \$12.50 | TENTS \$1.95 up
Pulley Army steel letters and figures, \$1.00
15 acres army goods. Illustrated catalog for 1922—372 pages—including full and highly interesting information (specially secured) of all World War small arms, mailed 60 cents. NEW circular, 16 page, 10 cents. Established 1888.

Francis Bannerman Sons, 501 Broadway, N.Y.

Every boy loves boats and trains

Send 10 cents to The Ives Manufacturing Corporation, Bridgeport, Conn., for complete catalog of boats and trains. **IVES TOYS MAKE HAPPY BOYS**

MUSIC LESSONS FREE

IN YOUR OWN HOME

You can read music like this quickly

Piano, Organ, Violin, Mandolin, Guitar, Banjo, etc.
Beginners or advanced players. One lesson weekly. Illustrations make everything plain. Only expense about 2c per day to cover cost of postage and music used. Write for FREE booklet which explains everything in full.

AMERICAN SCHOOL OF MUSIC, 50 Lakeside Building, CHICAGO

Different from all others—the NEW BENJAMIN



AIR RIFLE

Made on a different principle from all other Air-Rifles.

The Benjamin is really a strong air-pump used to compress the air in the air chamber to any degree of power desired. From one to six strokes of the pump give all the force necessary. Each additional stroke gives increased power. The Benjamin works on the same principle as all air-drills and air-hammers—with this difference:

You control the shooting force as you desire. Look at this block of hardwood. It shows how Benjamin power is regulated as you wish.

You can't have accidents with a Benjamin. It's safe, always, because you control the power. The Benjamin never loses shooting force, and has no springs to get out of order or shake your aim. Write us for an interesting folder about this wonderful air-gun.

If your dealer does not handle same, send direct to factory.

(PRICE \$5) POSTPAID

BENJAMIN AIR-RIFLE & MFG. CO., 615 N. Broadway, St. Louis, Mo.

Ask your dealer for demonstration.

Pacific Coast Representatives
SHAYER & BOWEN
Los Angeles, Calif., and
San Francisco, Calif.



MYSTERIOUS CHARM

\$1.00 Gold-Plated
each

A very mysterious watch charm until revolved—then it produces a Square and Compass

Write for free catalogue of Masonic publications, Jewelry and paraphernalia.

REDDING & COMPANY

200 Fifth Avenue Dept. P New York City

FREE Wonderful Book

Tells how to learn taxidermy—how to mount birds, animals, game-birds, fishes, sea animals. Success guaranteed. Decorate your home and den with splendid art. Make big profits. Write today for this fine illustrated, free book and our amazing offer.

Northwestern School of Taxidermy, 9773 Elwood Bldg., Omaha, Neb.

AGENTS WANTED

Men and Women

Housewives all over the country want Stuart's—the original—non-alcoholic food-flavors and colors in tubes, toilet articles and kitchen specialties. The only way they can get them is through our agents, who easily make

\$5 to \$8 a Day

C. W. BACK, Mich., says he sold \$52 worth in two days; Mrs. DINE, Iowa, got \$10 worth of orders over the phone in four hours. You can do it with our plan. No experience needed. Write at once for details.

C. H. STUART & CO.

667 Union St. Newark, New York



21 Jewel Burlington

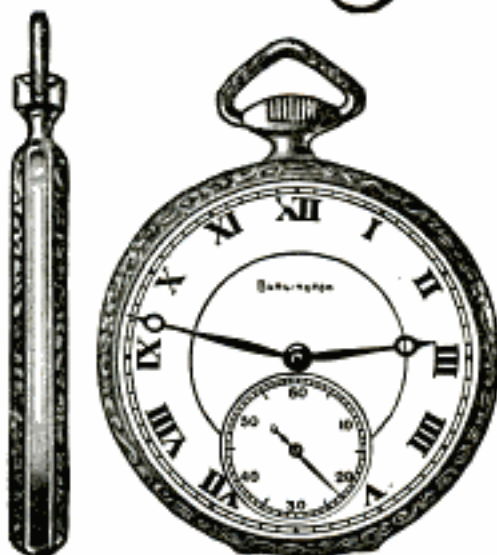

Adjusted to the Second 21 Ruby and Sapphire Jewels
Adjusted to Temperature 25 Year Gold Strata Case
Adjusted to Isochronism Your Choice of Dials
Adjusted to Positions (Including Montgomery R. R. Dial)

New Ideas in Thin Cases

Only \$1.00 Down

Only One Dollar Down will buy this masterpiece of watch manufacture. The balance you are allowed to pay in small, easy, monthly payments. The Burlington—a 21-Jewel Watch—is sold to you at a price much lower than that of other high-grade watches. Besides, you have the selection of the finest thin model designs and latest styles in watch cases. Don't delay! Write for the FREE Watch Book and our SPECIAL OFFER today.

Write While This Special Offer Lasts

Get the Burlington Watch Book by sending this coupon. Find out about this great special offer which is being made for only a limited time. You will know a great deal more about watch buying when you read this book. You will be able to "steer clear" of the over-priced watches which are no better. Remember, the Burlington is sent to you for only One Dollar down, balance in small monthly payments. Send the coupon for watch book and our special offer TODAY! Do not delay one minute!

Burlington Watch Company

Dept. 9353, 19th St. & Marshall Blvd., Chicago
Canadian Address: 62 Albert St., Winnipeg, Manitoba

Please send me (without obligations and prepaid) your free book on watches with full explanation of your \$1.00 down offer on the Burlington Watch.

Name _____

Address _____

Please Mention Popular Mechanics

Let Me Quote a Special Price

On My New Automatic Electric Fireless Cooker

Here is the easiest, cheapest method known to prepare the family meals. Same electric current that lights your home can do all the cooking and save you 50% to 75% fuel cost. This new practical invention gives you every cooking, baking, roasting, frying, boiling and toasting facility of the most expensive electric range, plus every advantage of the fireless cooker at less than you would pay for a good gasoline or oil stove.

No special wiring necessary; attaches to any electric socket. No radiators to heat; no thermometers to watch or break. Guaranteed Wear-Ever aluminum utensils furnished with it.



Wm. Campbell
The Original
Fireless Cooker
Man

Get My Special Offer

Try this great new invention in your own home for 30 days at my risk. Right now I am making a big special offer that means extra savings for every customer. Write today for FREE Home Science Cookbook and new low price.

WM. CAMPBELL COMPANY

Dept. 164, Detroit, Mich.

Canadian Address: Georgetown, Ontario

Made in
one, two
and three
Oven Sizes



Please Mention Popular Mechanics

\$538

Buy this

Not Portable



5-Room House

You can buy all the material for a complete home direct from the manufacturer and save four profits on the lumber, millwork, hardware, and labor. Write today for Free Aladdin Catalog No. 478.

BUY DIRECT—SAVE PROFITS

Prices quoted include all lumber cut to fit, windows, doors, woodwork, glass, paints, hardware, nails, lath, and roofing. Complete drawings and instructions. Many styles to choose from. Highest grade lumber for all interior woodwork, siding, and outside finish. Send today for money-saving Aladdin Catalog No. 478.

The ALADDIN Co., BAY CITY, MICHIGAN

Also Mills and Offices at Wilmington, North Carolina; Portland, Oregon; and Toronto, Ontario

TIRRO

THE IDEAL MENDING TAPE

At Drug Stores

BAUER & BLACK, 2500 DEARBORN ST., CHICAGO



IRON GLUE

AT ALL 5 and 10 cent STORES

10¢-15¢ SIZES

QUICK TO STICK

SOLD TO HOLD

MCCORMICK & CO., Baltimore

BURN Home Made GAS COAL STOVES

In Your Old Wood or

Change your coal or wood stove into a gas stove in 3 minutes. A child can do it. Burn kerosene Vapor Gas—hotter than coal or wood and costs less. Safe and simple.

FREE TRIAL

Just turn a valve and get even heat instantly. No ashes, no dirt, no smoke, no wood to chop or carry. No fires to build and feed. No fuel wasted. Cooks and bakes better. No damage to stoves. Makes its own gas from common coal oil, cheapest, cleanest fuel. Guaranteed five years. Money back if not satisfied after 10 days trial.

Write for FREE folder with proof and SPECIAL OFFER

SIMPLEX UTILITIES MFG. CO.

310 Simplex Bldg.

2537 S. State St., Chicago

SAVE YOUR BODY

Conserve Your Health and Efficiency First

"I Would Not Part with it for \$10,000"

So writes an enthusiastic, grateful customer. "Worth more than a farm," says another. In like manner testify over 100,000 people who have worn it.

The Natural Body Brace

Overcomes WEAKNESS and ORGANIC AILMENTS of WOMEN AND MEN. Develops erect, graceful figure.

Brings restful relief, comfort, ability to do things, health and strength.

Wear It 30 Days Free at Our Expense

Does away with the strain and pain of standing and walking; replaces and supports misplaced internal organs; reduces enlarged abdomen; straightens and strengthens the back; corrects stooping shoulders; develops lungs, chest and bust; relieves backache, curvatures, nervousness, ruptures, constipation, after effects of flu. Comfortable and easy to wear.

Keep Yourself Fit Write today for illustrated booklet, measurement blank, etc., and read our very liberal proposition.

HOWARD C. RASH, Pres. Natural Body Brace Co.
223 Rash Building SALINA, KANSAS



For Boys and Girls Also

TALKING MACHINE GIVEN

A real machine which reproduces talking, singing and dance music. Guaranteed lots of fun. Given free for selling only 30 pkts. Garden Spot Seeds at 10 cents a pkt. Send no money—we trust you. Write for seeds today. Lancaster Co. Seed Co., Sta. 83, PARADISE, PA.



Do Your PRINTING

Cards, circulars, labels, tags, book, menus, paper, Press, \$12. Larger \$35. Job Press \$150 up. Save money. Print for others. BIG PROFITS. All easy, rules sent. Write factory TODAY for press catalog, TYPE, cards, paper. THE PRESS CO., D-37, MERIDEN, CONN.

Given

This .22 Cal. Hamilton Rifle

Boys—let me give you this straight shooting, long range Hamilton Rifle for introducing our beautiful magazine, Fruit, Garden & Home, to a few of your friends. You will be surprised how easily you can get this good gun. Send me a post card today for particulars. E. T. MEREDITH, 63 Success Bldg., Des Moines, Iowa

We Pay \$7 a Day



Wonderful invention. The SERENOLA does more than machines costing 10 times its price. Orders taken by our agents for over a thousand a week—making from \$7 to \$21 a day. Big demand. Easily carried with you anywhere. Built in just like a suitcase. Fully guaranteed. Low price.

Easy to Take Orders

No collecting. Pay you every day. Get started at once. Territory given. Write for terms.

PERRY-LUDLOW CO.
S. 648 DAYTON, O.

Help Wanted

We require the services of an ambitious person to do some special advertising work right in your own locality. The work is pleasant and dignified. Pay is exceptionally large. No previous experience is required, as all that is necessary is a willingness on your part to carry out our instructions. If you are at present employed, we can use your spare time in a way that will not interfere with your present employment—yet pay you well for your time. If you are making less than \$150 a month, the offer I am going to make will appeal to you. Your spare time will pay you well—your full time will bring you in a handsome income.

It costs nothing to investigate. Write me today and I will send full particulars by return mail and place before you the facts so that you can decide for yourself.

ALBERT MILLS, Gen. Mgr., Employment Dept.
7574 American Bldg., CINCINNATI, OHIO



Clear-Tone
FOR

PIMPLES

Your skin can be quickly cleared of Pimples, Blackheads, Acne Eruptions on the face or body, Enlarged Pores, Oily or Shiny Skin. \$1,000.00 Cold Cash says I can clear your skin of the above blemishes. WRITE TODAY for my FREE Booklet—"A Clear-Tone Skin"—telling how I cured myself after being afflicted for fifteen years.

FREE

E.S.GIVENS, 129 Chemical Bldg., Kansas City, Mo.

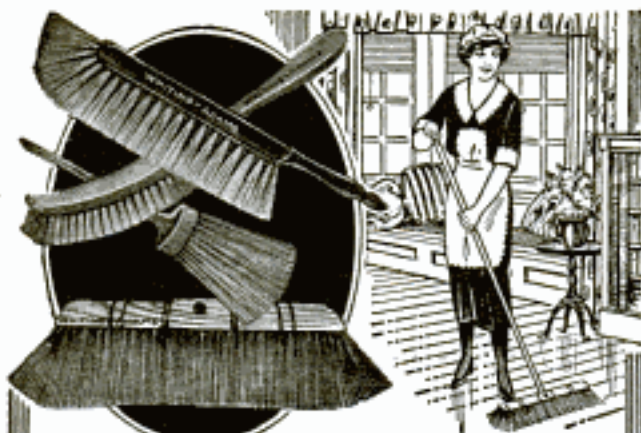

WHITING-ADAMS BRUSHES

For Household and Family requirements. Best quality, long wearing, perfect working. Extensive assortment,—every brush needed for home life.

Send for Illustrated Literature

JOHN L. WHITING-J. J. ADAMS CO.
Boston, U. S. A.

Brush Manufacturers for Over 112 Years and the Largest in the World

Going to Build Remodel or Repair?

DON'T think of planning a new home or repairing an old one without copies of our two free books.

Our Building Material Catalog shows latest ideas and most advanced styles for everything in building. We ship everywhere everything in the way

of high grade lumber roofing, doors, windows, porchwork, screens, builder's hardware, paints, wallboard, interior woodwork, plumbing, heating and water supply outfits—all at money saving prices direct to you. Plan Book shows skillfully planned homes of all kinds, bungalows, city homes, suburban residences, country homes, barns. Tells you how to get building plans FREE. Write today. No obligation.

Let us develop plans from your rough sketches, send your normal bills for free estimate price.



Material Complete for Houses from \$500.00 up

Catalog of 6000 Price Bargains

Beautifully Illustrated PLAN BOOK

CHICAGO MILLWORK SUPPLY CO., 1144 W. 27th St., Chicago, Ill.
PLEASE SEND ME YOUR FREE BOOKS.

Name _____ St. No. _____
Town _____
State _____
Occupation _____

Books Are Free

Please Mention Popular Mechanics

AMAZING DIAMOND ON CREDIT OFFER

Blue White Genuine Diamond 18K Solid Gold \$48*



LADIES' SOLITAIRE RING

The opportunity to buy a beautiful gem set in 18 Karat solid white gold mounting at a marked down price on liberal credit terms, comes once in a life time. Your chance to wear and own it yourself, or give as a present—without a drain on your pocketbook.

Send No Money

No risk. Sent FREE for examination. If satisfied pay only 1-4th (25¢) per cent on arrival—balance \$1 a week. Returns it without paying a cent. If you don't agree it is, an amazing bargain.

FREE Send for DeLuxe Catalog showing other wonderful bargains in Diamonds, watches and jewelry from \$10 to \$1000. All on long credit.

Address Dept. 326

BAER BROS. CO.
6 Maiden Lane, New York

MONEY IN MUSHROOMS
NOW TIME TO START
BIG DEMAND. HIGH PRICES BEING PAID
An uncrowded occupation. Exceptional opportunities for live men and women. Raised at home. Only small space needed. Small expenditure will start you in successful money-making enterprises. Big profits. Booklet telling all free. Write
Nat' Spawn Co., Dept. 12, Waban, Mass.

WHITE FLAME
BURNERS make your old kerosene lamps and lanterns give a brilliant, white light better than electricity or gas. Doubles your light. Saves oil. **NO MANTLE TO BREAK.** Guaranteed safe and reliable. Delights every user. Send now for complete sample printed 30 cents, stamps or coin. 3 for \$1.25. Money Back if Not Satisfactory. Live Representatives Wanted. Exclusive Territory.
WHITE FLAME LIGHT CO., 68 Clark Bldg., Grand Rapids, Mich.

Beautiful HOUSES \$900 and BUNGALOWS
CAN BE BUILT FOR AND UP
This and many others in my new book, Building Plans for Modern Homes, will save you hundreds of dollars. One of the most complete and comprehensive books of plans ever published by any architect. New edition just off the press. Nearly 500 floor plans and photographs of bungalows, Colonial houses, etc., costing from \$200 up; gives sizes and cost to build.
Sent postpaid for \$2.00
FREDERICK H. GOWING ARCHITECT
101 Tremont St., BOSTON, MASS.

KEITH'S \$2.50 OFFER
A new, big \$1.00 Plan Book, showing 112 designs and floor plans of artistic homes in frame, stucco, and brick, (your choice of bungalows, cottages or two story houses) and 8 months' subscription to Keith's Magazine—all for \$2.50.
Keith's Magazine for over 20 years an authority on planning, building and decorating homes—25¢ a copy on newsstands. With its help and Keith's Plans you can get the most distinctive, comfortable and satisfactory home with greatest economy.
3 big plan books (336 plans) and Keith's for 12 months—\$4.50
Keith Corporation, 609 Abbay Bldg., Minneapolis, Minn.

Detroit Incubator \$12⁴⁵

140-Egg Size—Guaranteed—has double walls, copper tank, full-size nursery, automatic regulation thermometer held so that chicks cannot break it when hatching. Detroit Brooders, too. Double walled, hot water heated. Write for special low price on both machines.

**Detroit Incubator Co.**

Dept. 32

Merritt St., Detroit, Mich.

MUSHROOMS**HAVE PRODUCED PROFIT FOR 2000 YEARS**

Get your share by growing them easier, quicker and surer than ever with our newly discovered, highly concentrated spawn.

An easy way to establish your own business with only a few dollars. Free Booklet. Mushroom Products Corporation, 725 Ninth St., Wash., D. C.



GREIDER'S FINE CATALOG of fine bred poultry and incubators and brooders for 1933; choicest breeds illustrated and described; how to make hens lay, grow chicks—all facts. Low price on breeding stock and hatching eggs. 80 years in business. This book only 10c. B.H. Greider, Box 19, Rheems, Pa.

Miller's Poultry Guide

FREE Tells how experts hatch, feed and raise poultry for profits. Also quotes low prices on baby chicks, pure bred poultry, eggs for hatching, incubators, Mammoth hatchery, poultry supplies, etc. Fully illustrated. Write today. J. W. MILLER CO., Box 12, Rockford, Ill.

**PLANS FOR POULTRY HOUSES!**

All styles 150 Illustrations; secret of getting winter eggs, and copy of "The Full Egg Basket." Send 25 cents. INLAND POULTRY JOURNAL, Dept. 74, Indianapolis, Ind.



64 BREEDS Most Profitable chickens, Choice, pure-bred northern raised. Poultry, eggs, incubators at reduced prices. America's great poultry farm, 30th year. Valuable new 100-page book and catalog free.

R. F. NEUBERT Co., Box 101, Mankato, Minn.

SQUAB BOOK FREE

Squabs are selling at the highest prices ever known. Breed them and make money. Write at once for free book, prices, etc.

Plymouth Rock Squab Co., 634 Howard St., Melrose Highlands, Mass.



WEBER'S Best Laying, best paying chickens, ducks, geese & turkeys. Fine pure-bred quality. Poultry, Eggs, incubators all at cut prices. 40 years poultry experience, and my 100 page Catalog and Breeders Guide Free. W. A. Weber, Box 111, Mankato, Minn.

**RAISE BELGIAN HARES**

New Zealand Reds—Flemish Giants—American Blues. **BIG PROFITS, WE PAY \$1.50 TO \$5 EACH.** Also Cavies, Mink, Skunk, Fox, Muskrat, Etc. Easily raised anywhere. **FREE!** Illustrated book "COMMON SENSE HARE Raising," quarterly journal, and copy of America's leading small stock magazine, all for 10 cents. Address Outdoor Enterprise Co., 1005 S. E. BLDG., KANSAS CITY, MO.

Buchstein's Fibre Limb

is soothing to your stump—strong, cool, neat, light. Easy payments. Braces for all deformities.

D. BUCHSTEIN CO.,
113 6th St. S., MINNEAPOLIS, MINN.

Send for Catalog Today

**DOLLARS IN HARES**

Raise hares; quick easy profits. Small space; little capital necessary. Hares breed all year. 6 to 12 in litter, 4 to 6 litters a year. Sell locally for meat and fur or ship to us. We guarantee you \$7 to \$25 cash a pair and pay express. Book free—write today.

STANDARD FOOD & FUR ASS'N
407B Broadway New York City

Great New**Invention
for seekers of
Health
Power
Beauty**

Elco Health Generators at last are ready for you! If you want more health—greater power to enjoy the pleasures and delights about you, or if more beauty is your desire—write! Ask for the book on these inventions which has just been prepared. It will be sent to you without cost. It tells you how Elco Health Generators aid you in leaving the lethargy and hopelessness of bad health and weakness behind forever. Re-vitalize yourself. Bring back energy. Be wholly alive. Write today!

10 Days Free Trial—Write for Free Book!



These great new inventions generate Violet Ray, Vibration, Electricity and Ozone—combined or separate

Free Trial

They operate on the electric light in your home or on their own motive power at less than 50 cents per year. Elco Health Generators are positively the only instruments which can give you in one outfit Electricity, Violet Ray—Vibration and Ozone—the four greatest curative agents. Send the coupon below. Get the Free Book NOW!

**For All These:**

Paralysis	Catarrh
Pimples	Insomnia
Falling Hair	Skin Diseases
Headache	Hay Fever
Lumbago	Neuralgia
Nervousness	Deafness
Rheumatism	Pain
Sore Throat	Development
Asthma	Neuritis
Black Heads	Obesity

**Mail Coupon
for FREE Book!**

Do not put this paper down without sending the coupon. Don't go on as you are with pains and with almost no life and energy. You owe it to yourself to be a better man or woman. You were put here to enjoy life—not just to drag through it. So do not rest another day until you have put your name on the coupon here. That will bring the whole story of these great new inventions. Do it today—now.

Lindstrom & Company

442-448 N. Wells Street, Dept. 1353, Chicago, Ill.

Please send me your free book, "Health—Power—Beauty" and full information of your 10-day Free Trial Offer.

Name _____

Address _____

Please Mention Popular Mechanics

SAVE MONEY
Get This Book

HANDY MAN BOOK

Install Your Own
PLUMBING & HEATING
NEW EASY WAY - SAVE HALF



Bathroom Outfit

WHAT USERS SAY:

"I am pleased with my HARDIN-LAVIN Plumbing. I will recommend you to all who inquire."
C. B. LAWRENCE,
New Madison, O.
"Received HARDIN-LAVIN Equipment O. K. Am well satisfied and saved BIG money. You will get my future orders."
FRED SITTLOW,
Knoxville, Wis.

"The HARDIN-LAVIN Boiler is working fine. We are very satisfied. We are glad to answer any questions about its merits."
MRS. B. W. DRIBBLE, Chicago, Ill.

Our Handy-Man Book shows how. Big 256-page well-bound encyclopedia of Plumbing and Heating Outfits, Systems, Supplies, Fixtures and Accessories—10,000 items—illustrated. Hundreds of plans, elevations, diagrams, trade secrets, money and trouble-saving kinks, etc. "How to save coal in heating," "Easy repair methods." Every householder, contractor, farmer, mechanic, institution needs this book. Shows how to save work and materials.

BIG HANDY MAN BOOK

Tells how we help you plan and install. From rough sketch we supply working plans and clear instructions. We loan the tools needed. Any handy man can install. This is the place to buy on money-back guaranty. Plumbing Outfits and Supplies; Water Systems; Hot-Air, Water or Steam Heating Plants; Radiators, Pipes, Boilers, etc.

Send 25c

We have spared no effort or expense to complete this remarkable and instructive book. To keep from sending it broadcast to disinterested persons, we request a deposit of 25c, which will be refunded on your first order.

Write today and save half.



Pipeless Furnace



Hot Water Boiler

Quality **HARDIN-LAVIN CO., CHICAGO** Quality
50 Years at 4547-57 Cottage Grove Avenue,
\$500,000.00 Plants Behind Our Guaranty

Our BUREAU OF INFORMATION will answer all questions regarding articles appearing in this magazine.

**Get This Wonderful Ring. If You Can Tell It From a Genuine Diamond Send It Back**

These amazing, beautiful CORODITE diamonds positively match genuine diamonds in every way—same blazing flash and dazzling play of living rainbow fire. They, also, stand the diamond tests, including terrific acid test of direct comparison. Lifetime experts need all their experience to see any difference. Prove this yourself.

Wear a Corodite Diamond 7 DAYS FREE

Make this test. Your risk nothing. Wear a genuine Corodite and a diamond side by side on the same finger for 7 days. If you or your friends can tell the difference, send it back; you won't be out a single penny. That's fair enough. If you keep the ring, price printed here is all you pay. No installments. Remember, Corodites alone have the same cutting as genuine stones.

No. 1—Ladies' Solitaire 14K Gold S. Ring \$2.84
No. 2—Gents' Heavy Belcher 14K Gold S. Ring \$3.49
No. 3—Gents' Massive Hexagon Gray Ring \$4.27
No. 4—Ladies' Hand-Carved Basket Setting, platinum finish \$3.96
No. 5—Ladies' Tiffany Bridal Blossom Engraved \$3.54

Caratage gems. Beautiful mountings of new modern design. Choice of gold or latest white platinum finish. Unqualified 20-year guarantee. Hand-some all-leather case free with each ring.

SEND NO MONEY Keep your money right at home. Just send name, address and number of ring wanted and also as shown by slip of paper, fitting and to end around finger joint. Your ring will come by return mail. When ring arrives deposit amount shown above with postman. If you decide not to keep ring after 7 days' wear, send it back and your money will be immediately returned. Send today.

E. RICHWINE CO.

333 S. Dearborn Street, Dept. 367, Chicago, Illinois

Sole Importers Genuine Corodite Diamonds

WOW! YOU'D BE SURPRISED!

The Maji-Glass shows you the Hidden Secrets of Nature—the Invisible Beings you never expected to see. Also the wondrous creatures in "Lifeless Matter"—the terrifying animals in stagnant water—the funny chess-moves with babies on their backs.



In the Maji-Glass they look like monsters! You never had so much fun and excitement! Imported outfit and how to use it, \$1. Cash or money order. \$1.50 if sent C.O.D.
ORIENTAL EXCHANGE,
21 Park Row, New York, Dept. M

TYPEWRITERS
We Save You 50 %

FREE TRIAL—EASY TERMS

Your choice of all STANDARD MAKES, UNDERWOOD, ROYAL, SILENT L. G. SMITH, Self-starting REMINGTON, etc. Rebuilt by the Famous "Young Process." Guaranteed good as new. Lowest cash prices. Easy payments or rentals with special purchase privileges. Largest stock in U. S. Write for special prices and terms.

YOUNG TYPEWRITER CO., Dept. 494 CHICAGO



This Palatial Florida Home

can be purchased at a very reasonable price. It is the finest estate in a community of 30,000 situated amid 5 acres of orange, grape fruit, sweet bay, palmetto and a large variety of semi-tropical trees and foliage. A water front of 400 feet, with entrance from a Boulevard, affording every modern convenience. House recently completed and never occupied. Has every modern improvement, large sun parlors, sleeping porches and 8 bath rooms. Inexhaustible supply of soft water, steam heat, high, light basement under entire house. Surf bathing all winter within 5 minutes walk.

For full details, photographs and price address the owner,

H. H. WINDSOR,
200 E. Ontario St. CHICAGO, ILL.



2 TIRES FOR \$9.95
FREE TUBE WITH EACH TIRE
(SIZE 28 X 3)

Standard Tire Prices Smashed Again!

—and some sensational cut, too! Think of it—two tires for almost the price of one and a FREE inner tube with every tire. No double treads or sanded tires. Thousands of customers are getting maximum mileage out of these used tires, and you, too, can get up to

8,000 MILES

Here's your opportunity—if you act at once. This is a special lot selected for this record-breaking sale. Order today—right now. They're going fast.

Compare These Amazing Reductions on Two Tires of Same Size

SIZE	1 TIRE	2 TIRES	SIZE	1 TIRE	2 TIRES
28x3	\$6.75	\$ 9.95	31x4	\$10.65	\$17.45
30x3	7.25	11.95	32x4	11.85	19.75
30x3 1/2	8.25	13.95	33x4	12.45	20.99
32x3 1/2	9.45	15.95	34x4	13.25	21.95

Prices on larger sizes quoted on request. Prices f. o. b. Chicago.

SEND NO MONEY! We ship subject to examination, by Express before payment of C. O. D. charge, or by Parcel Post after payment of C. O. D. charge. Examine tires on arrival, and if not absolutely satisfied, return same unused and your money will be promptly refunded. Specify straight side or sliasher. ACT NOW.

ROCKWELL TIRE COMPANY

1506 S. Michigan Ave., Dept. 164C, Chicago, Ill.

16,000 MILES without a Puncture

Wonderful invention. Inside Tyres—Inner Armor for automobile tires. Positively prevent punctures and blowouts. Guaranteed to give double tire mileage, any tire—old or new.

Over 100,000 Satisfied Customers

Easily applied without tools. Just slip inside casing before replacing tube. Will not heat or pinch. Use over and over again. Old worn out casings will give 3 to 5,000 miles more service. Low priced. Agents wanted in every country.

American Accessories Co., B-1676, Cincinnati, O.

MOTORCYCLE BARGAINS

Save 25% to 65%

on Slightly used and Rebuilt Motorcycles, Side Cars, Johnson Motor Wheels, Evans Power Cycles, Bicycles. Send for Free Bargain Bulletin and Money Saving Messages, listing hundreds of Bargains in used, rebuilt and new machines, supplies, accessories, etc.

AMERICAN MOTOR CYCLE CO., CHICAGO
Dept. 322 2047 W. Chicago Avenue.



MOTORCYCLES



RELIABLE STANDARD MAKES that you can **DEPEND** on. Enjoy the glorious experience of going wherever you like—whenver you like. The price is within your means—35% to 50% less than others. These machines are slightly used, thoroughly overhauled or rebuilt. Send for catalogue.

MYEROW BROS., Boston, Mass.
258 Columbus Ave.

Put a CARTER OIL GAUGE

on your instrument board. Absolutely accurate in any kind of weather. Only \$4.85 for Ford, Dodge Only \$5.85 for Buick, Oakland

\$4.85 for Chevrolet. \$5.85 for Cadillac. You can attach one without special tools in 15 minutes. Satisfaction guaranteed or money back.

CARTER MOTOR ACCESSORIES, Inc., 390 Pearl St., Buffalo, N.Y.

THE SHAW MOTOR ATTACHMENT Makes Your Bike a Motorcycle

A high grade 2 1/4 H. P. Motor attachment quickly clamped to any bike frame. Speed 4 to 40 miles an hour. 90 to 125 miles per gallon of gas.

Special Low Price Now! Write today for Complete Description and Special Low Prices on SHAW Motor Attachments and the Shaw Complete Motorbicycle.

SHAW MFG. CO., Dept. 37, GALESBURG, KANS.



\$1727 in Two Months

Made by J. W. Plumb of Shreveport, La.



HE SOLD 314 COPPOCK INTERNALLY HEATED MANIFOLDS. SOLD THREE OUT OF FIVE CALLS, ON A "MONEY BACK GUARANTEE." SO CAN YOU. CAR NOT NECESSARY TO SELL COPPOCK. GET EXCLUSIVE TERRITORY.

You Can Make Big Money Selling

THE COPPOCK INTERNALLY HEATED MANIFOLD. It has been on the market two years. It has proven so successful that we are selling it on a "SIX POINT GUARANTEE." (1) We guarantee to save one-third of gas bills. (2) Better motor performance. (3) The "Coppock" does not reduce power on hills or sandy roads. (4) It will not over-heat motor summer or winter. (5) That the motor will start just as easy in winter or summer. (6) It will perform as good in winter as in summer. Money will be refunded on anyone of the six points. Customer is the only judge.

A Tested Sales Plan Assures Success

and BIG MONEY for YOU. Write for this plan. It shows how easy it is to sell the COPPOCK. Mr. Plumb sold three out of five calls. You can do the same. Your commission is large. Get exclusive territory and place sub-agents. We guarantee sale of all orders. You can sell COPPOCK without a car. Sales plan explains.

WRITE FOR SALES PLAN. EXPLAINS HOW YOU CAN MAKE BIG MONEY. GRAB THIS OPPORTUNITY. WRITE NOW.

MACAULAY CO.

702 Lincoln Bldg. Detroit, Mich

6 FUSES IN ONE PLUG



"Turn To The Right—Back Comes Your Light" Approved by Underwriters' Laboratories. New Fuse Brought in Place by Turning Button. Ends Fuse Troubles Due to Use of Washers, Ironers, etc. as a new Fuse is Always ready.

DISTRIBUTING AGENTS

Repeater 6 is one of the finest agent's propositions on the market. Every house is a live prospect, also office buildings, stores, factories, etc. You can carry the sample in your pocket. Deliveries are easy, sales are quick, market enormous. Send 25c for sample and full particulars or send \$1.00 for five.

MOSS-SCHURY MANUFACTURING CO., Inc.
442 E. Woodbridge Street Detroit, Mich.



Auto Supplies
Knowing **HOW** to buy is merely knowing **WHERE**. This is Chicago's Great Wholesale House. **AUTO SUPPLIES AND MOTOR PARTS** **WHOLESALE ONLY**. Dealers send today for this big money-saving book.

ACCELL AUTO ACCESSORIES COMPANY
307A South Michigan Avenue CHICAGO



ONLY \$29.85 THE BARGAIN OF THE SEASON. This is only one of the many exceptional offers in our catalogue just off the press. A full line of bodies and accessories to satisfy your season's need. Buy direct from the factory.

SEND NOW

For Body

AUTO TIRE SALES CO., Dept. P6. Body Division
1346 S. Michigan Ave. Chicago

Secret Service



Stop That Leak

The only liquid that will silently and quickly find all leaks anywhere in cooling system and stop them permanently in from 5 to 10 minutes.

Simply pour contents of a 75c can of Radiator Neverleak into the water in your radiator. That is all that is necessary.

RADIATOR NEVERLEAK

Is absolutely guaranteed not to impair or clog the cooling system in any way. It will add years of life to your radiator by preventing rust and scale from forming.

This secret formula, the result of 25 years' experience in manufacturing leak mending preparations, is at your service in 50c and 75c cans. Entire satisfaction guaranteed or money refunded. Write for free "Secret Service" booklet.

Buffalo Specialty Company
357 Elliecott St.
Buffalo, N. Y.



Agents Splendid Profits

Introducing the New Sun Automatic Regulator and Timer for Ford Cars. Gives proper spark automatically for every speed of motor. Does away with Spark Lever. Back-kick impossible - Insures instant start in all weather. Prevents fouling of spark plugs and forming of carbon. Engine remains clean giving more power on hills, more speed on level roads at less cost. Grease, dirt and water-proof - Fully guaranteed. Sold on 30 days trial. Retail price \$3.50. Large income for active workers. Tremendous sales opportunities.



AUTO SUN PRODUCTS CO., Dept. 24 Cincinnati, O.

The Auto Hoté

(Fits any Car)

MAKE IT YOURSELF



"Most Complete Camping Outfit ever built"

Five people can cook, eat and sleep in car. No flies, mosquitoes, bugs or worms. Top is a boat that holds six people. Running water in car. Drawings with detail instructions HOW TO BUILD and Inventor's License to build or have one built for OWN USE ONLY sent on receipt of \$5.00.

JOHN A. COWAN

1515 Linwood Blvd., Kansas City, Mo.

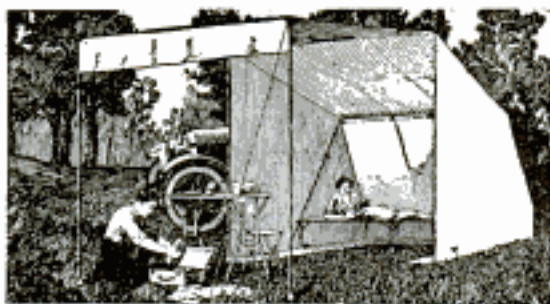

DRI-KAMP

Most practical outfit for tourists and campers. Can be set up or taken down in five minutes. Guaranteed rain-proof. Outfit includes comfortable full sized bed for two people. (Extra bed furnished if desired.) Most compact outfit on market. Rolls up 48 inches long, 8 inches in diameter. Light in weight. Satisfaction guaranteed to every customer.

Write today for catalog and prices

DRI-KAMP CO., CHICAGO

Dept. 5, 218 S. Wabash Ave.

Agents or dealers wanted in all parts of the country. Every auto owner should have one. They pay for themselves in a few nights of use, saving expensive hotel bills.

FORDS run 34 Miles on Gallon of Gasoline



Wonderful new carburetor. Reduces gasoline bills one-half to one-third. Increases power of motors from 30 to 50%. Start easy in coldest weather.

SENT ON 30 DAYS' TRIAL

Fits any car. Attach yourself. Fords make 34 miles to gallon. Other cars show proportionate saving. Send make of car. Special 30-day trial offer. Agents wanted.

AIR FRICTION CARBURETOR CO.

Dept. 3780

Dayton, Ohio

Only \$45.00 For This Job Complete

Save exorbitant freight rates and one-half original cost by buying Ford Speedator Sledge knocked-down. Simple, complete instructions furnished, all parts cut to exact fit. Anyone can assemble this job.

Complete with hood, radiator shell, instrument board, upholstery, metal parts, wood parts, bolts, screws, etc. Flat radiator shell furnished made up. Designed low with look of wind resistance. Price set at \$90, further particulars on request.

The Central Auto Supply Co.

Not Paper Patterns

All Parts Complete

Eng. Dep. 123, Louisville, Ky.



You Can Save \$35.00

By recovering your old auto top frame yourself. Our recovers are custom tailor made in our own factory to fit all makes and models of cars. Any person that can drive a car can put it on. We furnish instructions. Roof and quarters are sewed together with rear curtain, fasteners, welts and tacks complete. Give us the name, year and model number of your car and we will send you catalog with samples.

LIBERTY TOP & TIRE CO., Dept. E-7, Cincinnati, O.



More than 10,000



Fishermen have written for HILDEBRANDT'S HINTS on flies and spinners. It's brimful of live tips for catching bass, trout, pike, muskallonge, and every game fish. Write for it today.

THE JOHN J. HILDEBRANDT CO.
337 HIGH STREET, LOGANSPORT, IND.

FREE

MAKE OVER \$800.00 MONTHLY



Owning and operating an Anderson Vulcanizer which vulcanizes tires 3" to and including 5". You can vulcanize the smaller tires in all three molds. We guarantee no other vulcanizer will properly cure as many tires daily as the Anderson. It will do \$160 worth of work daily and will keep 8 men busy. You can run it ten hours daily, six days a week, for less than you can any other make, half a day. An Anderson School is near you.

ANDERSON STEAM VULCANIZER CO.
Popp-Williams Bldg. Indianapolis, Ind.



68° is a
healthful temperature
for your home
SAVE COAL
Tycos
THERMOMETERS
Taylor Instrument Companies
ROCHESTER, N.Y.
There's a Tycos in Every Home for Every Purpose #127



"Lighting Fixtures"
READY TO HANG
(Direct from Manufacturers)
Completely wired, including glassware.
New designs. Send for catalogue No 24.
Send for DEALERS' proposition.
ERIE FIXTURE SUPPLY CO.
STA. A. ERIE, PA.



CAMERAS
Over a Hundred Styles and Sizes
Send for new illustrated catalog showing
latest reduced prices. It's Free.
10 days' trial given
SENECA CAMERA MFG. COMPANY
300 Central Avenue Rochester, N. Y.



\$25 A DAY
Selling Shirts
Large shirt manufacturer wants agents
to sell complete line of shirts, pajamas,
and nightshirts direct to wearer. Ad-
vertised brand—exclusive patterns—easy
to sell. No experience or capital re-
quired. Entirely new proposition.
Write for free samples.
Madison Shirt Co., 503 Broadway, N. Y. C.

AGENTS 500% PROFIT
\$60 - \$200 per week. Free samples **GOLD SIGN LETTERS** for store and office windows. Anyone can put them on. Big demand everywhere. Liberal offer to general agents.
METALLIC LETTER CO., 433B N. Clark, Chicago



GIVEN This Reliable Ingersoll Yankee
Get one of these wonderful value watches. A genuine Ingersoll "Yankee," guaranteed, for introducing our beautiful magazine, Fruit, Garden & Home, to two of your friends. You will be surprised and delighted with my wonderfully liberal offer. Write TODAY for my easy plan. A post card will do.
E. T. MEREDITH
62 Success Bldg., Des Moines, Iowa



Lacassia
VEGETABLE OIL Soap
Big Money
Made by agents selling our wonderful Facial Soap, Perfumes, Toilet Articles, Spices, Extracts, etc. Free cake of soap and agents' terms mailed to any address.
LACASSIAN CO. Dept. 455 ST. LOUIS, MO.

GET FACTORY PRICES ON GALVANIZED ROOFING



EDWARDS
"REO" Metal Shingles
Absolutely rust-proof — edges as well as sides. Not the space of a pin point exposed to weather. Also fire and lightning proof. Reduce insurance. Outlast building. Need no repairs — end all roofing expense. Easy to lay — one man can do the work — hammer and nails only tools needed. Lay over old shingles if desired. Patent Interlocking Device makes water tight seams — all nail heads covered — no rust or leaks possible.
Exclusive "Tightcote" Process
Put all Edwards Galvanized Roofing in a class by itself. Bend, twist, strike it with a hammer as much as you like — you can't loosen or crack off the galvanizing — due to our "TIGHTCOTE" process which practically makes zinc covering a part of the metal sheet. No other galvanized roofing can withstand this test.
FREE Roofing Book Don't buy roofing until you get our big free book, describing Edwards famous "Tightcote" Roofings, Sidings, and Ceilings, and our lowest factory prices. We sell you direct and save you in-between dealers' profits. Write for Roofing Book No. 160.
Low-Priced Garages
Lowest prices on Ready-Made Fire-Proof Steel Garages. Set up any place. Send postal for Garage Book showing styles.
FREE Samples & Roofing Book



THE EDWARDS MFG. CO.
100-108 Pike St. CINCINNATI, O.



No mixing
No Spreading
No Muzz
No Trouble
Just crumble up a
Rat Bis-Kit
about the house. Rats and mice will seek it, eat it, die outdoors. Easiest, quickest, cleanest way. 25c and 50c. All druggists or general stores.
THE RAT BISCUIT COMPANY
Springfield Ohio

SEND NO MONEY
2 GENUINE DIAMONDS $\frac{4}{100}$ Each
Solid Gold \$25
14 kt. White Gold Top. Gold Emblem Inlaid in Genuine
Hope Ruby
Can be had in all initials (Old English); also in all lodge emblems, including American Legion. Send size of finger and ring will be sent for inspection.
This registered trade-mark guarantees you real diamonds.
Buffalo Jewelry Mfg. Co., "The Mail-Order House"
Dept. P-2, Eriebank Bldg., Buffalo, N. Y.



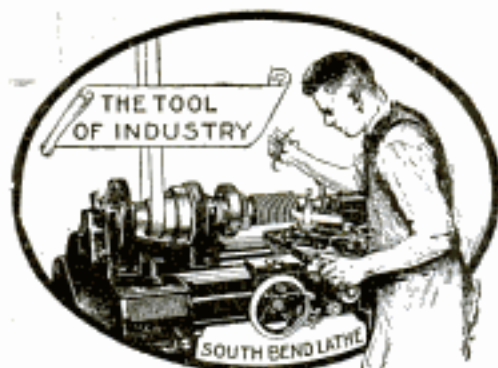

SOUTH BEND LATHES

Screw Cutting Engine Lathes

STANDARD CHANGE GEAR		QUICK CHANGE GEAR	
9"x 3' Lathe.....	\$ 176.00	9"x 3' Lathe.....	\$ 216.00
11"x 4' Lathe.....	228.00	11"x 4' Lathe.....	273.00
13"x 5' Lathe.....	304.00	13"x 5' Lathe.....	354.00
15"x 6' Lathe.....	376.00	15"x 6' Lathe.....	431.00
16"x 8' Lathe.....	452.00	16"x 8' Lathe.....	512.00
18"x 10' Lathe.....	656.00	18"x 10' Lathe.....	721.00
21"x 12' Lathe.....	933.00	21"x 12' Lathe.....	1016.00
24"x 14' Lathe.....	1254.00	24"x 14' Lathe.....	1353.00

Catalog No. 77 sent free to any address

SOUTH BEND LATHE WORKS

625 E. Madison St.

SOUTH BEND, IND.

How to Run a Lathe:—New 80-page book, Revised Edition No. 24, for 10 cents postpaid, silver or stamps.

NORTHWESTERN

$\frac{1}{4}$ H.P. 110 Volt \$13.50

A. C. Motor . .

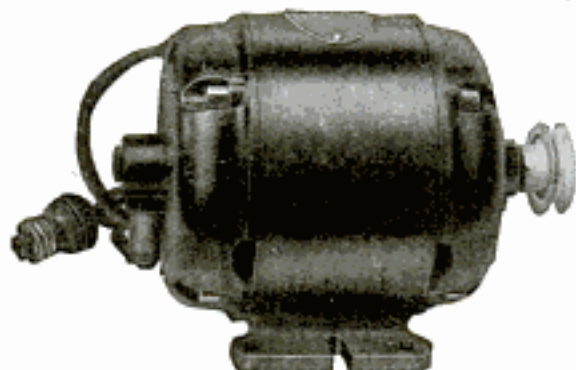

Same Motor equipped as buffer and grinder . . . \$25.00
(Send cash with order.)

We guarantee to satisfy you or return your money.

Write for free descriptive bulletin covering these and other sizes

NORTHWESTERN ELECTRIC COMPANY
408 So. Hoyne Ave., Chicago

Sargent Door Closers

Close all doors surely and silently and keep them shut.

SARGENT & COMPANY
Hdwe. Mfrs. 49 Water St., New Haven, Conn.

1923 MODEL INTRODUCTORY SALE

Wonderful new engine—5 years ahead. Get full information about the

OTTAWA

Throttle Governor Kerosene Engine. Sold direct, at Factory Prices. Free Book—Write today!

OTTAWA MFG. CO.
531-S King St., Ottawa, Kans.
Desk 531-S Maple Bldg., Pittsburgh, Pa.

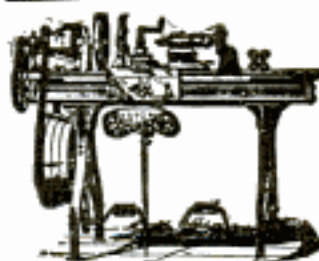

LATHES

9 to 18-inch Swing

List price \$165 and up according to size. When ready to buy send for Lathe Catalog and prices.

W. F. & John Barnes Co.
100 Ruby Street, ROCKFORD, ILL.

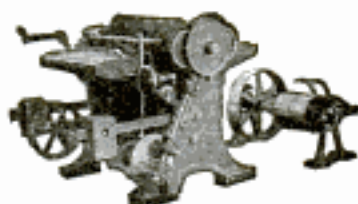

It is the well known quality of CRESCENT machines that justifies you in selecting one of them each time you have need for wood working machinery. The CRESCENT line is better than ever and will always give you satisfaction in every particular. Ask today for catalog of band saws, saw tables, jointers, shapers, planers, borers, planers and routers, swing saws, disk grinder, cut off table, hollow chisel mortiser, variety wood worker. Universal wood workers.

THE CRESCENT MACHINE CO., 93 Columbia Street, Leetonia, Ohio

A BIG PAYING BUSINESS OF YOUR OWN

New uncrowded field. Permanent. Good year round. Make \$100 to \$300 a week. No experience necessary. Be your own boss.

BE A FLOOR SURFACING CONTRACTOR
AMERICAN UNIVERSAL FLOOR SURFACING MACHINE does more and better work than six men. Makes new floors perfect; old floors like new. Big field in towns or city. Machine often pays for itself first month with good profit besides. Investigate! Write today.

THE AMERICAN FLOOR SURFACING MACHINE CO.
523 So. St. Clair St. Toledo, O., U. S. A.

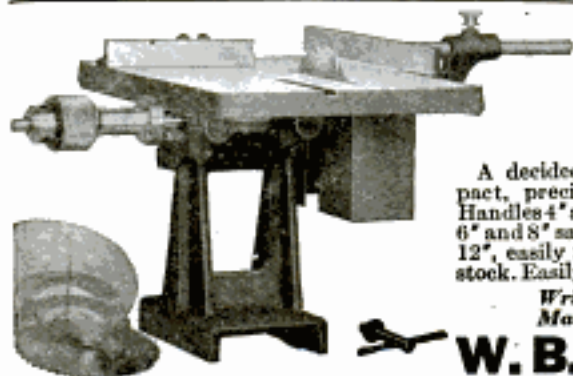

SIX MACHINES IN ONE

Saw, Sander, Drill, Grinder, Polisher and Buffer
BOICE PONY BENCH MACHINE

A decidedly practical, extremely compact, precision machine. Height 10". Handles 4" and 5" grinding wheels; 6" saws; 6" and 8" sand discs; $\frac{3}{4}$ " chuck. Top, 10"x 12", easily removable. Saws up to 1 $\frac{1}{2}$ " stock. Easily driven by $\frac{1}{4}$ or $\frac{1}{2}$ h. p. motor.

Write today for descriptive literature on the Boice Pony Bench Machine and other BOICE-BUILT Bench Machines and Motors.

W. B. & J. E. Boice, Dept. P. M. 3, 114-23rd St., Toledo, Ohio

Dept. P. M. 3, 114-23rd St., Toledo, Ohio



SPECIAL FORD TAP AND DIE SET, ONLY \$3.00 DIRECT FROM THE FACTORY TO YOU!

Our Special Ford Set furnished in our highly finished chestnut box contains 5 each taps and dies (1-4, 5-16, 3-8, 7-16 & 1-2"), in the S.A.E.-thread, 1 die stock, and one tap and reamer wrench (No. 12).

Send us your order at once and be one of our many satisfied customers. Let us also send you one of our circulars illustrating our full line of Handy Tools. Worcester Steel Products Co., Dep't. P 3, 25 Union St., Worcester, Mass., U. S. A.

It Will Pay You to Own a MONARCH Junior Lathe

Hundreds of things, of metal or wood, for the shop, auto and home can be made with a MONARCH Junior Lathe. This sturdy, small engine lathe, guaranteed to work with 1/1000 of an inch accuracy, was especially designed for inventors, experimenters and small shop owners. It is easy to learn to operate—even beginners can't jam it. Equipped with automatic safety devices.



\$225 9 in. lathe—2 1/2 ft. bed—with bench legs.

SEND for Free Catalog of MONARCH lathes which are built up to 30" swing
THE MONARCH MACHINE TOOL CO.
400 Oak Street Sidney, Ohio

Dealers and Agents: Request Attractive Proposition

Adjusts Instantly to Any Length

Just slide it out. Gives exact inside or outside diameter. No folding. Accurate, strong, brass trimmed. Any length 2 to 8 feet. If not at dealer's, sent postpaid.

Master Rule Mfg. Co., Inc.
841-43 East 136th Street
NEW YORK CITY

Interlox

MASTER SLIDE RULE



ALVAN CLARK TELESCOPES

Famous throughout the world as the highest grade Astronomical and Terrestrial Instruments. Now bringing to you at a reasonable price, these wonderful instruments—a source of pleasure and education—for the home—the school—the college. Send for circular and prices.

ALVAN CLARK & SONS CO.
Makers of the great "YERKES" and "LICK" Telescopes.
55 Henry Street Cambridge, Mass.

LOST

Another expensive tool. Prevent this by getting a
UNION TOOL CHEST



It keeps your tools safe from dust, harm, theft or loss. Union Chests are substantially made in more than 50 different sizes and styles. There are zinc or leatherette covered and quartered oak models.

Your hardware dealer carries Union Chests. Ask him to show you his assortment, or write us to send you free illustrated booklet describing our entire line.

UNION TOOL CHEST CO.
22 MILL ST. ROCHESTER, N. Y.

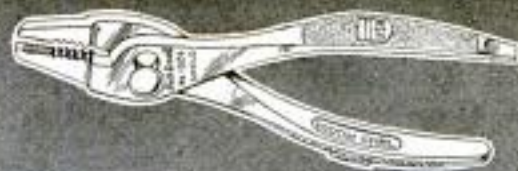

"Red Devil" Pliers made in 100 styles—one for every need. Known and used the world over. Style 1024—6 1/2 inch shown above, \$1.00.

Every Good Tool for the Mechanic!

—and every good tool for the motorist, house-holder and glazier, too!

"Red Devil" Tools are sturdy—designed for hard work and long wear. They make hard jobs easy. With them you can do many repair jobs yourself that you would otherwise pay to have done.

"Red Devil" Tools are high quality tools, not high-priced. Over a quarter century's reputation behind them for strength, durability and perfection of workmanship.

Red Devil

Tools Comprise:

Pliers	Wrenches
Glass Cutters	Cold Chisels
Chain Drills	Hack Saw Frames
Screw Drivers	and Blades
Auger Bits	Electricians' and
Snips	Linemen's Tools

and many other tools.

"Red Devil" Tools can be purchased at every reliable hardware store.

The "Red Devil" mechanic's tool booklet will help you select the tools best suited for your particular purpose—send for it—it's free.

SMITH & HEMENWAY CO., Inc.

Manufacturers of "Red Devil" Tools
260 Broadway New York, N. Y.

"Red Devil" Glass Cutters—the glazier's standard tools of the world. "It's all in the wheel." Made in 40 styles. No. 024 shown below, 20c.



Please Mention Popular Mechanics

ATKINS

METAL CUTTING SAWS

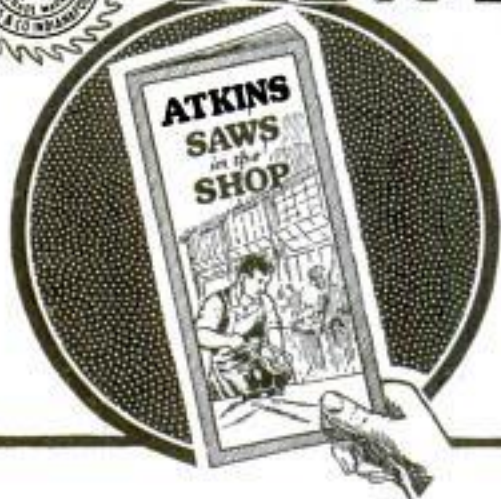

Get This FREE Book on Saws

THIS new edition of "Saws in the Shop" just off the press, gives you all the latest information on metal cutting and shop practices. It tells how to speed up the work and get longer and better service from your saws. Gives complete information on selecting the right saw for every job. Shows Atkins metal cutting saws and machines, and explains their use. Also, contains scores of helpful hints and tables. This book is based on the experience of practical saw makers and users. It is valuable to every man in the shop. Send for it NOW.

Atkins "Non-Breakable" Hack Saw Blades cut faster, run easier, hold their edge longer, and do not break. They save you time, money and labor on every metal cutting job. "Saws in the Shop" tells you all about them. When you write for the book enclose 10 cents and tell us what metal you cut and we'll send you a sample blade.

Saws for Every Use

No matter what saws you need for cutting wood or metal, Atkins Saws will do the work quicker, easier and better. Write for our booklets on any saws you require.

E. C. ATKINS & CO., Inc.
Dept. P, Indianapolis, Ind.
*Makers of "Silver-Steel"
Saws and Tools.*



Fix it with BERNARD PLIERS



For keeping
Wire
Fences

in shape, Bernards are the real thing. They cut cleanly, they grip like a vise, and the "open throat" swallows the wire to any length and is great for bending or stretching. None but Bernards do the three jobs so well. At good Hardware Stores.

Booklet "P" Free On Request



BERNARD PLIERS

Wm. SCHOLLHORN CO.
NEW HAVEN, CONN.



PARALLEL JAWS

OUTSIDE CUTTER



TOOL CHESTS

for Machinists & Toolmakers
Every tool arranged in order. No up-to-date mechanic should be without one. A Gerstner Case costs no more than some tools, and will last a lifetime. Catalog free.

Gerstner & Sons

717 Columbia Street DAYTON, OHIO

USE A LOG SAW!

This outfit easily cuts 15 cords a day, falls trees, buzzes up branches. Does work of many men. **\$91.50**

OTTAWA 1923 MODEL F.O.B. Ottawa \$97.25, Pittsburgh

80 Days' Trial



Easy to move. Mechanically Operated Valves, Throttling Governor, Burns Kerosene. Write today for Free Book.

OTTAWA MFG. CO.

1741-P Wood St., Ottawa, Kans. Room 1741-0-1800 Bldg., Pittsburgh, Pa.

NEW SINGLE PHASE A. C. MOTORS

$\frac{1}{4}$ H. P.—110 volt, 60 cycle, 1725 speed, complete with cord, plug and grooved pulley... \$13.00

General Electric
 $\frac{1}{2}$ H.P., \$39.00
Includes pulley.



EMERSON

$\frac{1}{4}$ H.P. \$61.00
1 H.P. 67.50
 $1\frac{1}{2}$ H.P. 85.00
2 H.P. 97.00

Include Pulley and Base—All Motors, $\frac{1}{4}$ H. P. or larger, 110-220 Volt Rep. Ind. Type.

ONE YEAR GUARANTEE

Satisfaction guaranteed or money refunded
Illustrated Catalog of Motors and Supplies FREE
HYRE ELECTRIC CO., 615-X So. Dearborn St., Chicago

3 Piece SUIT MADE TO ORDER SAVE \$3.45

To prove our unbeatable values and get your steady trade, will make 3-piece suit consisting of coat, pants and vest to your measure for only \$18.45. Style shown in the picture or any one of 135 style combinations to select from. One year's satisfaction guaranteed or every penny back—quick.

NO EXTRA CHARGES

You pay just what we say, not one penny of extras for anything. We even pay all postage and express. You save one-half—like before the war.

Earn \$60 Cash Weekly

You can take orders easy for these clothes in spare time and make \$6000 a year and up at home. Friends and neighbors buy on sight. Young Fred Green made **SEND NO CASH**, \$174.50 in seventeen days.

FREE—BIG SAMPLES

New samples show latest styles and 80 real cloth samples. Buy at inside Wholesale prices. Write now for Big Free Outfit.

WASHINGTON TAILORING CO.

Wholesale Tailors Dept. Q-345 Chicago



BURN YOUR NAME ON TOOLS WITH ARKOGRAF

Protect your tools from theft. Write any name, engrave any design on metal with electricity like writing on paper with pen or pencil. Complete outfit \$3.50, prepaid anywhere. Interesting descriptive circular free. Write today. Agents Wanted, Arkograf Pen Company 8007 Yeon Building Portland, Oregon



MAKE YOUR FORD INTO THIS SPORT CAR \$6.40 ONLY

Other types down to \$3.50. Famous size fit. **FREE** life-size patterns and simple pictorial instructions show how. You can easily convert your Ford into this fast, easy Sport Car as hundreds have done with a few dollars worth of material from the hardware store. No need to lay up the car. The "PAL" with special steel wheel patterns. Pressed Metal Streamline Rear only \$6.40 delivered. Built low, fits wonderfully easy. Order NOW while we can make good delivery. Send for our illustrated prospectus or 10-cent Order "Jiffy"



Little Giant Drill Press

Drill Radio Panel Just the thing for shop and experimental work. Mechanically right and well made. Weight 22 lbs. Price \$15.00. Send for Circular. **SYPER MANUFACTURING COMPANY** Dept. "D" Toledo, Ohio

5 Master Keys

Work like magic in emergencies or prove whether your door or padlocks are burglar-proof. Open and test thousands of different locks. Recommended by users in ten different nations. Most wonderful and only keys of their kind. Send \$1 today. Novel key chain FREE with set.

MASTER KEY CO.

2P MANHATTAN BLOCK

Milwaukee, Wis.



A Marvel of Utility! \$1.50

For fixing the wiring on your car, mending kitchen utensils, repairing electric fixtures, working around your Radio set.

Absolutely automatic—blows itself—produces a 1400° needle-point flame instantly.

Used by electricians, mechanics, and experimenters.

- 60' coil self-fluxing (acid or rosin core) solder . . . 25c
- Lenk "Super" Mouth Blow Torch . . . 75c
- Lenk "Jumbo" Mouth Blow Torch . . . \$1.00
- Marvel Soldering Kit—one Lenk Automatic and one coil each of self-fluxing acid and rosin core solder, in neat leatherette case . . . \$2.00

If your dealer does not carry them, order direct

LENK MANUFACTURING COMPANY, 30 Portland St., BOSTON, MASS.



The Midget "FIVE-IN-ONE" Slide Rule is a combination Mannheim, Log-Log, Add and Subtract, Polyphase and Binary Slide Rule. It will instantly add, subtract, multiply and divide any combination involving whole numbers, fractions, decimals and mixed numbers; gives every possible root and power of every quantity. The graduations are printed on metal, coated with white celluloid and are green and waterproof. While it is the most versatile calculator ever invented, its operation is simple and easily understood. Diameter 4 inches. Price with 16-page Instruction Book, \$1.50. Leatherette carrying case \$2c extra. Catalog free. Your money back if you are not satisfied.

GILSON SLIDE RULE CO., Niles, Mich.

Build Your Own PHONOGRAPH

IT'S EASY WITH OUR HELP

A few hours' interesting work saves over half and gives you a machine to suit your ideas. We furnish motors, tone arms, case material, blue prints and full instructions. Plays any record. Make fine profit building phonographs for your friends.

Write today for our **FREE** Blue print offer.

GET YOUR RADIO SUPPLIES FROM US

Choraleon Phonograph & Radio Co.
323 1st St., Elkhart, Ind.



Direct at Factory Prices

This \$2 KNIFE \$1.18 Postpaid
Hand Forged Razor Steel Blades
Handy shaped Blade makes this knife best for mechanics, sportsmen and farmers; light but strong; re-sharpened easily. Stag handle. German silver finish; blades file tested, hand forged from razor steel and warranted.

Sample \$1.18 3 for \$3.00 Postpaid.

Send for our 100-page List and "HOW TO USE A RAZOR" **FREE**

MAHER & GROSH CO., 106 A St., Toledo, Ohio



Whoops, Boys! It Beats 'em All

When you hop into your Auto-Wheel Coaster, with real steel disc wheels, roller bearings, and spin down the street, you go right ahead of the gang—race or no race!

An Auto-Wheel is the speediest coaster you ever saw. Goes so easy it almost runs itself. That's due to the patented self-contained roller bearings—and they are thoroughly greased at the factory.

Auto-Wheel

Is sturdily built—steel disc wheels with rubber or steel tires; specially constructed hound brace that makes steering easy and safe; auto type hub caps, just like on Dad's machine. It has a brake,—'n everything. Also comes with spoke wheels—all wheels interchangeable. The Auto-Wheel is built to withstand years of hard play and work.

Below is Auto-Wheel's Junior Companion—The Auto Cart—for your little brother or sister. Substantially built just like the Auto-Wheel Coaster.

Write for catalog. It shows all models and sizes and explains the mechanical construction. If you send the names of three coaster wagon dealers in your town, telling which ones sell the Auto-Wheel Coasters, we will give you a year's subscription free to the Auto-Wheel Spokes-man, a dandy magazine for fellows like you.



**Auto-Wheel Coaster
Company, Inc.**
North Tonawanda, N. Y.

I WILL sell you any Emblem Ring, Button, Pin or Charm of any Secret Society, and guarantee to save you 50%. Quality and workmanship the highest. Full-sized Charms like our 1 1/4 inches high, any Society, heavy Solid Gold, each \$13.75. Gold Emblem, \$8.00. Gold Filled, \$4.25. Agents wanted.

W. S. Stanley, 273 North Main St., Springfield, Mass.



A Discovery that Gives New Meaning to the Years that Follow 40

A remarkable discovery has already restored to health thousands of men suffering from the distressing ailments common to men past 40. Every man should read the facts given here.

DO YOU suffer with sciatica, pains in back, legs and feet, frequent nightly risings, painful micturition, mental or physical depression? Doctors and Scientists have long recognized that the cause of these, and many other painful con-

Send No Money

Ladies' Solitaire Examination Free

This perfectly cut Diamond will be sent free of charge for your complete examination and approval. No money in advance. If satisfied, pay only \$2.00 on arrival and keep it. Price \$30.00.

10 MONTHS TO PAY

The balance you send in 10 small monthly payments—only \$2.80 a month. Take advantage of this amazing offer today.

FREE De Luxe Catalog in colors. Write for details of Great Diamond Offer and Book to Dept. 63-H.

Capital \$1,000,000



\$2.80
a month



THE HOUSE OF QUALITY
L. W. SWEET INC.
1650-1660 BROADWAY, NEW YORK

BLANK CARTRIDGE PISTOL

Protection against Burglars, Tramps, & Dogs

PRICES
50c.
\$1.00



Well made and effective model on latest type of Revolver; appearance also is enough to scare a burglar. When loaded it may be as effective as a real revolver without danger to life. It takes standard .38 Cal. Blank Cartridges obtainable everywhere. Price 50c. Superior quality \$1.00 post-paid. Blank Cartridges, by express, 50c per 100.

Johnson Smith & Co., 1218 Washington Ave. Dept. 944, Racine, Wis.

ditions, was the disturbed condition of a little gland called the prostate. And now a certain Scientist has discovered a wonderful new hygienic principle that has already been used with phenomenal success by thousands of men in restoring this little gland to health. Many cases are reported where relief was obtained when a surgical operation had seemed the only recourse.

What this Discovery Can Mean to You

An authoritative medical treatise says that 85% of all men past a certain age suffer with a disorder of this gland. If you experience any of the conditions mentioned—have chronic constipation or prostatic disorders—you should not delay in finding out about this discovery. Do not let "approaching age" encroach upon your mental and physical vigor and alertness. If you will write at once you can get Free an interesting booklet called, "Why Many Men Are Old at 40," written by the scientist who discovered this new method. Don't risk your health by delay. There is no obligation. Simply send name and address, mentioning ailment, if you want specific information. Address.

THE ELECTRO THERMAL CO., 2119 MAIN ST., STREUBENVILLE, OHIO

PATENTS TRADE-MARKS AND COPYRIGHTS

SPECIAL OFFER — Free Opinion as to Patentable Nature

Before disclosing an invention, the inventor should write for our blank form "Record of Invention." This should be signed and witnessed and if returned to us together with model or sketch and description of the invention, we will give our opinion as to its patentable nature.

Our Three Books Mailed FREE to Inventors

OUR ILLUSTRATED GUIDE BOOK

HOW TO OBTAIN A PATENT

Contains full instructions regarding Patents, Trade-Marks, Foreign Patents. Our Methods, Terms, and 100 Mechanical Movements illustrated and described; Articles on Patent Practice and Procedure, and Law Points for inventors.

OUR TRADE-MARK BOOK

Shows the value and necessity of trade-mark protection and gives information regarding Trade-Marks and unfair competition in trade.

OUR FOREIGN PATENT BOOK

We have direct agencies in all foreign countries and secure foreign patents in the shortest possible time and at the lowest cost.

LIST OF PATENT BUYERS SENT FREE

IDEAS WANTED: Send for LIST OF PATENT BUYERS containing unsolicited letters from Manufacturers and others WISHING TO BUY meritorious patents. There is a great demand for NEEDED INVENTIONS. We endeavor to assist OUR clients in the commercial development of their inventions.

SPECIALIZATION—OUR STAFF

The field of invention is so vast that it is impossible for any one man to become an expert in all classes of invention. For this reason we employ a number of patent lawyers and mechanical experts selected for their special knowledge and ability in certain lines of invention.

THE VALUE OF YOUR PATENT

depends on the skill and care with which your case is prepared and prosecuted in the United States Patent office. That every case receives our best efforts, and that our work is done skillfully and thoroughly, is evidenced by the many unsolicited letters of commendation that we receive constantly from our clients. We will furnish upon request lists of clients from any state in the Union for whom we have secured patents.

Our New York, Philadelphia, Pittsburgh, Chicago and San Francisco Offices

We have established for the benefit of our clients Branch Offices in New York City, Philadelphia, Pa., Pittsburgh, Pa., Chicago, Ill., and San Francisco, Cal. These branch offices located in these large commercial cities together with our Main Office located near the U. S. Patent Office, in Washington, enable us to more promptly handle the business of our clients, particularly as the branch offices are in constant touch with the Main Office.

Highest References — Prompt Attention — Reasonable Terms

---FREE COUPON---

VICTOR J. EVANS & CO., Patent Attorneys

NEW YORK OFFICES
1007 Woolworth Building

CHICAGO OFFICES
1114 Tacoma Building

PHILADELPHIA OFFICES
714-715 Liberty Bldg.

PITTSBURGH OFFICES
514 Empire Building

SAN FRANCISCO OFFICES
Hobart Building

MAIN OFFICES: 765 9TH STREET, N.W., WASHINGTON, D. C.

Gentlemen: Please send me FREE OF CHARGE your books as described above.

Name Address



PATENTS

*Seventy-six
Years of Practice*

THE firm of Munn & Company filed its first application for a patent in 1846, and for seventy-six years has endeavored to keep pace with the inventive genius of the United States.

An experience of many years is at your disposal. If you have an invention which you wish to patent, send your sketches or model together with a description of your device, explaining its operation, and you will receive prompt, courteous attention.

*Write for our Handbook on
PATENTS*

A full and complete booklet on Patents, Designs, Trade-Marks, Foreign Patents, Copyrights, Labels and Patent Office Practice with an explanation about our methods, terms, etc.

All communications strictly confidential.

Keep in touch with the inventions of the world by reading

SCIENTIFIC AMERICAN

The MONTHLY MAGAZINE with a special appeal to every man of inventive genius. Recent rulings of the Patent Office, descriptions of the latest patented inventions, legislation and court decisions affecting patents, are noted in this authoritative publication.

MUNN & COMPANY

Patent Attorneys

672 Woolworth Building, New York City

Scientific American Building, Room 2
625 F Street, Washington, D. C.

Suite 801, Tower Building, Chicago, Ill.

Suite 611, Hanna Building, Cleveland, O.
601 Hobart Building, San Francisco, Cal.

Please Mention Popular Mechanics

HAVE YOU AN INVENTION?

If so the WORLD PROGRESS will show you how to
PROTECT AND PROFIT FROM YOUR IDEAS

This magazine is devoted entirely to the interests of Inventors. It opens the mysteries of Science and Invention to the student of every day problems. Sample copy free. Also send for free book,

"WHAT TO INVENT"

containing SUGGESTIONS TO INVENTORS from prominent inventors and scientists of Inventions Needed. We invite manufacturers and promoters to address us regarding any inventions or patents they may want. We will publish such inquiries without charge. Address

WORLD PROGRESS PUB. CO., INC.
Room 203 Victor Bldg. Washington, D. C.
One year's subscription \$1.00



PATENTS

Send us sketch or model for patentability opinion and exact cost of patent. Our book "How to Obtain a Patent," sent free on request. It tells how to apply for Patents, Trade Marks, Foreign Patents, Copyrights, etc.; gives information on Patent Procedure; tells what every inventor should know. Thousands of Inventors, who are our clients, are our references.

Chandlee & Chandlee, 25 Years' Experience,
435 7th St. Washington, D. C.

PATENTS

TRADE-MARKS COPYRIGHTS

Send for our free book of patent information.

Beale & Park 802 F St., Washington, D. C.
16 S. Broad St., Philadelphia, Pa.

PATENTS

C. L. PARKER

Formerly Member Examining
Corps, U. S. Patent Office

PATENT LAWYER

MCGILL BLDG.
WASHINGTON, D. C.

Patents, Trade Marks, Copyrights, Patent Litigation

Handbook for Inventors, "Protecting, Exploiting
and Selling Inventions," sent free upon request.

PATENTS

Protect Your Idea!

Send data of invention for information as to costs.

REASONABLE FEES. Correspondence Solicited.
Old Established Firm. Highest References.

E. E. VROOMAN & CO. PATENT LAWYERS
871 F St. N.W. WASHINGTON, D. C.

PATENTS Secured

Prompt service. Avoid dangerous delays. Send for our "Record of Invention" form and Free Book telling How to Obtain a Patent. Send sketch or model for examination. Preliminary advice without charge. Highest references. Write TO-DAY. J. L. Jackson & Co., 410 Ouray Bldg., Washington, D. C.

INVENTORS

who derive largest profits know and heed certain simple but vital facts before applying for Patents. Our book Patent-Sense gives those facts; free. Write Lacey & Lacey, 645 F St., Washington, D. C. ESTABLISHED 1869.

EVERY BOY WANTS THIS BOOK

Gilbert Boy Engineering for 1923
Wonderful articles on radio, sports and magic
10c postpaid

The A. C. Gilbert Company, 312 Blatchley Ave., New Haven, Conn.

CLARENCE A. O'BRIEN

PATENT ATTORNEY

REGISTERED IN UNITED STATES PATENT OFFICE

MEMBER OF THE BAR OF

SUPREME COURT OF UNITED STATES COURT OF APPEALS DISTRICT OF COLUMBIA

SUPREME COURT DISTRICT OF COLUMBIA UNITED STATES COURT OF CLAIMS

PRACTICE CONFINED TO PATENTS AND TRADE MARKS

EXPERIENCE

SERVICE

Protect Your Ideas

Any new article, machine, design or improvement thereof, or any new combination of parts or improvements in any known article which increases its efficiency or usefulness, may be patented if it involves invention.

IF YOU HAVE ANY NEW IDEAS

which you feel are useful, practical and novel, **take prompt action toward protecting your rights.** If you have invented any new machine, or new combination of parts or improvements, or new process or design,

SEND DRAWING, MODEL OR DESCRIPTION

of it for information as to procedure to secure protection.

WRITE TODAY FOR BLANK FORM

"Evidence of Conception"

to be returned to me with drawing, description or model of your idea. Promptly upon receipt by me of your idea I will write you fully as to procedure and costs.

NO CHARGE FOR THE ABOVE INFORMATION

All communications are held in strict confidence. My personal, careful and thorough attention is given to each case. I offer you efficient, reliable and prompt service—based upon practical experience. *Highest references.*

Write today for free book, "How to Obtain a Patent." This book will give you valuable information, and it may save you much time and effort. *Send for it NOW.*

My practice is devoted exclusively to United States and foreign patents and trade-marks. Very probably I can help you. Write today.

CLARENCE A. O'BRIEN, Registered Patent Attorney

1700 Southern Building

Washington, D. C.

CLARENCE A. O'BRIEN, 1700 Southern Bldg.,
Patent Attorney, Washington, D. C.

Please send me your free book, "How to Obtain a Patent," and blank form "Evidence of Conception" without any obligation on my part.

Name.....

Address.....

(WRITE CLEARLY)



SCIENCE

ECONOMY

INVENTION

EFFICIENCY

INDUSTRY

INITIATIVE

INVENTORS

PROFIT FROM YOUR OWN IDEAS. We show you how. Thousands of men, and women, too, have ideas that would bring in fortunes if properly developed and protected.

HAVE YOU AN IDEA FOR THE IMPROVEMENT OF ANY THING? HAVE YOU AN IDEA OF SOMETHING ENTIRELY NEW? The smallest improvements, or new ideas, sometimes bring the biggest fortunes.

Can you think of a simple, practical idea that will fill one of the many requests we have on file for new inventions? Thousands of things are needed, NOW.

WE SHOW YOU HOW TO PROTECT YOUR IDEA; HOW TO GET THE MOST OUT OF IT.

SEND FOR THIS FREE BOOK

Tells you all you want to know about inventions, patents and trade marks. Valuable information. Patents advertised, for our clients, free, in "INVENTION and MANUFACTURING," a magazine for inventors, for the man with an idea. (One year's subscription 50c.)

A postal will do; but **DO IT NOW; IT MAY MEAN THE STEPPING STONE TO FUTURE SUCCESS.**

AMERICAN INDUSTRIES, Inc.

517 KRESGE BUILDING, WASHINGTON, D. C.



PATENTS

Booklet Free

Highest References

Promptness Assured

Best Results

Send drawing or model for preliminary examination

ALL BUSINESS GIVEN PROMPT AND PROPER ATTENTION

WATSON E. COLEMAN, Patent Lawyer, 624 F St., Washington, D. C.

PATENTS If You Have an Invention and Desire to Learn How to Secure a Patent

Send for our Guide Book, **HOW TO GET A PATENT**, sent Free on request. Tells our terms, methods, etc. Send model or sketch and description of your invention and we will give our opinion as to its patentable nature.

RANDOLPH & CO.
600 F St., N.W., Washington, D.C.

NAME.....

STREET.....

CITY.....STATE.....

WANTED IDEAS



Inquiries from Manufacturers and Others Who Are Looking for Good Ideas

PROTECTED BY PATENTS

are constantly being received. Manufacturers are always interested in any new device for which there is a market, which fills a long felt need, which makes production possible at a lower cost, or which will do the work BETTER. There is undoubtedly a great demand today for really worth while inventions.

Your First Step

If you have an idea, send immediately for my blank form "TO RECORD YOUR INVENTION." You should serve your own best interests by filling out and signing this form before you disclose your invention TO ANY ONE. This document will help you determine and establish evidence of invention before filing an application in the U. S. Patent Office. A copy, with full instructions, will be gladly sent free on request.

NEW BOOK "SUCCESSFUL PATENTS" SENT FREE

Every man who has an invention, or ever hopes to have one, should send for a copy of my book "SUCCESSFUL PATENTS." It tells what everyone should know about patents, trademarks, copyrights, etc. It describes my methods, fees and terms, gives information relative to assignment or sale of rights, and instructions in detail. Mail coupon today for a free copy of this book or a post card request will do.

To the Man with an Idea

I offer a comprehensive, experienced, efficient service for his prompt, legal protection, and will endeavor to aid him in the commercial development of his proposition—my service is distinguished by over 12 years' successful practice, and by thousands of satisfied clients and by reasonable fees.

Send sketch, or model, and description, for advice as to cost, opinion as to its patentable nature, etc. Preliminary advice gladly furnished without charge.

-----COUPON-----

RICHARD B. OWEN, Patent Lawyer

Main Office, 9-303 Owen Bldg., Washington, D. C.

Branch Office, 2276-E Woolworth Bldg., New York City.

Please send me, without charge, or other obligation, a copy of your book, "SUCCESSFUL PATENTS," your form "TO RECORD YOUR INVENTION," and information concerning patents, etc.

Name.....Address {

Great Inventors Now Teach You How to Invent

How to develop, patent and market your ideas; amazing new course teaches science of invention by mail.

Every man, woman, and child is born with *creative imagination*. Some develop this faculty to a greater degree than others, and those who develop it to the *greatest* extent are successful inventors. Invention is an orderly process of the mind, which combines two or more known facts to produce a new fact. Anyone who develops the right mental process can become an inventor. Every successful inventor has this type of mind, developed by constant experience over a period of perhaps many years. Heretofore those who succeeded in the field of invention had to discover all the principles themselves. But, now, just as any student of medicine, law, or engineering can take full advantage of all the recorded experience in these fields of study, so can YOU take the same kind of short cut to the habits of thought, and the methods of work required of successful inventors.



Raymond Francis Yates
author of the New Course in Inventive Science, in collaboration with 18 other inventors. Mr. Yates is known throughout the country as Editor of scientific magazines, writer of hundreds of articles and inventor of many practical devices and machines.

Edison says: "Invention should be taught as a profession." Every inventor realizes the hopelessness of groping in the dark for the habits of thought and methods of work required for successful invention. Trying to invent without knowing the fundamental requirements of invention is like trying to build a bridge without knowing engineering.

Don't Waste Ideas! Every man at some time or other has an idea for something he would like to invent, but his mind doesn't know how to work. He doesn't know what to do about it—doesn't know how to think along inventive lines—and soon someone whose mind is trained along inventive lines invents just the thing you may have thought of.

BUREAU OF INVENTIVE SCIENCE

Dept. 33, Wisner Bldg.
Rochester, N. Y.

Please send me your free book
"The Science of Invention."

Name.....

Address.....

City.....

State.....

Bureau of Inventive Science, 33 Wisner Bldg., Rochester, N. Y.

WRITE FREE BOOK FOR

A wonderful book explaining this wonderful new course in detail has been written and will be sent free to those genuinely interested. This book explains the course in detail, and proves that anyone can become an inventor who trains his mind—may be the beginning of a fortune for you. If you have ever had an idea for an invention, or if you would like to become a spare-time or professional inventor and if you would like to know what to invent, send in your name at once on the coupon **NOW!** Only a limited number of these books are available for free distribution.

MAKING MONEY from Your Invention

You are entitled to get the most
out of your ideas

We advise inventors concerning the **commercial development** of ideas, before or after obtaining patent. We save you money in experimental work and design. Commercial development carried out without expense to inventor where conditions warrant.

We shall be glad to demonstrate the value of our service—better patent protection—larger returns. Write us concerning your problem. It does not obligate you and may mean much to you.

All service confidential

ASSOCIATED INDUSTRIAL ENGINEERS, Inc.
Dooly Block Salt Lake City, Utah



GEARS ALL KINDS SMALL

The most accurate made and prices reasonable. We carry a complete line of gears in stock for immediate shipment. Can also quote on special gears of all kinds. Send us your inquiries. WRITE FOR CATALOGUE.

CHICAGO STOCK GEAR WORKS
105-109 S. Jefferson St., CHICAGO



MAKE A MOTOR CYCLE

OUT OF YOUR BICYCLE with a STEFFEY MOTOR ATTACHMENT. RELIABLE—ECONOMICAL—EFFICIENT. Easy to attach. Fits any wheel. Send stamp for circular.

STEFFEY MFG. CO., Dept. P, 5425 Brown St., Phila., Pa.

MECHANICS SAVE

TIME & MONEY BY DOING
BLACKSMITHING AND REPAIRING
— AT HOME —
THIS WONDER FORGE
IS USED AND ENDORSED BY
MECHANICS AND FARMERS
IN EVERY STATE AND IN ALL
COUNTRIES IN THE WORLD
POSITIVELY GUARANTEED TO EQUAL ANY \$15 FORGE ON THE MARKET

ROCK KEY
11 1/2 INCH BLOWER
WILL LAST A LIFETIME

PRICE \$6.85
WILL WELDER
4 IN WAGON TIRE

Saves expensive blacksmith bills. Ideal for garage and shop repair work. Soon pays for itself. Price only \$6.85. Orders shipped promptly. Send for catalog.

C. A. S. FORGE WORKS
Box 400 Saranac, Mich.

U.S. PATENTS

FREE → FORM & BULLETIN EVERY INVENTOR SHOULD USE:

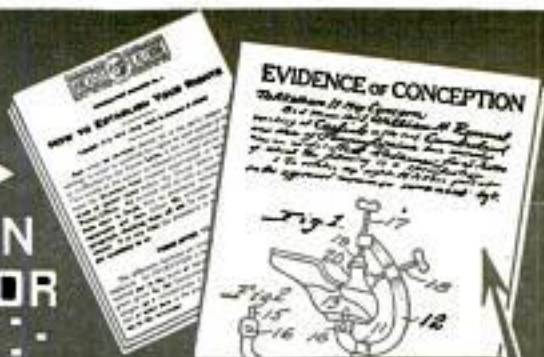

Registered Attorneys

SERVICE

**DON'T
LOSE
YOUR
RIGHTS**

Without charge or obligation, we will inform you on any questions you may put to us touching on patent, trade mark and copyright law, not requiring research. You may ask: "Should I protect myself by a patent, or register under the trade mark or copyright laws? What kind of a patent should I obtain? What will it cost? Will it sell?" and many other questions that may occur to you. These are vital points to consider, and questions will be cheerfully answered.

IMPROVEMENTS WANTED

Ask for copies of unsolicited letters from parties desiring to purchase outright new inventions and patents or to obtain licenses to manufacture and sell on a royalty basis.

EVIDENCE OF CONCEPTION

Before disclosing your invention to anyone send for blank form "Evidence of Conception", to be signed and witnessed. A sample form together with printed instructions will show you just how to work up your evidence and establish your rights before filing application for patent. As registered patent attorneys we represent hundreds of inventors all over the U. S. and Canada in the advancement of inventions. Our schedule of fees will be found reasonable. The form "Evidence of Conception", sample, instructions relating to obtaining of patents and schedule of fees sent upon request. Ask for them—a postcard will do.

LANCASTER & ALLWINE

204 Ouray Building

Washington, D. C.

Originators of Form "Evidence of Conception"

----- SIMPLY MAIL COUPON -----

Lancaster & Allwine, 204 Ouray Bldg., Washington, D. C.

Send me free, bulletin "How to Establish Your Rights" and blank form "Evidence of Conception."

Name

Address

You can't be finally content until you have
THE STANDARD ENGINE

in a motor boat

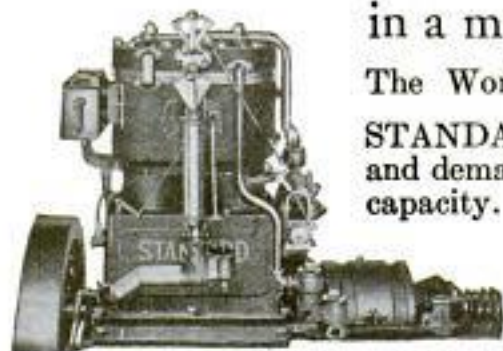

The World's most honored marine engine.

STANDARD prices are on a pre-war basis and demands for deliveries tax our factory's capacity.

We shall be glad to send you the 1923 STANDARD catalogue and price list sheet.

Back of the STANDARD Guarantee is the

STANDARD MOTOR CONSTRUCTION COMPANY
 120 Whiton St. Jersey City, N. J.

KENNEBEC
CANOES
"Safest to Use"

Because the "Tumble Home" makes them so. The dotted line here is the "Tumble Home" of the ordinary canoe—and the heavy line of the Kennebec.

"Tumble Home" is the bilge of a canoe. You should get our 1923 illustrated book giving the fullest particulars about this wonderful feature of the Kennebec. Mailed to any address, postpaid. KENNEBEC BOAT AND CANOE CO., 28 E. R. Square, Waterville, Me.

FAULTLESS AUTO PRODUCTS

Faultless Runabout speed and Power Equipment

Send for our new prices on Bodies and Accessories.

AMERICAN TOP & BODY CO.
 Adams St., Delphi, Indiana

HAWAIIAN IM. DIAMONDS

The Greatest Discovery the World Has Ever Known

Just to advertise these famous im. diamonds we will send you one of these 14kt. gold f. rings, postage paid. When it arrives pay postman \$2.98 G.O.D. charges to cover cost, etc. Only 10,000 rings given away. Money refunded if you can tell it from a genuine diamond. Send one of these.

KRAUTH & REED
 Dept. C
 Masonic Temple Chicago

No. 8010 Special price \$2.98

No. 8011 Special price \$2.98

The BEST LAUNCH Ever Built at Lowest Price Ever Quoted

Write For Catalog

of Mullins Steel Launches, Motor Boats, Row Boats, Fishing and Hunting Boats.

Sporting Goods Dealers

Write for dealers discounts, and our liberal proposition to Authorized Mullins Agents.

MULLINS BODY CORPORATION
 Boat Dept., 745 Depot St., Salem, Ohio

This new type, 1923 model, 16 Foot Mullins Special Steel Launch is without doubt the best value ever offered. It is graceful in design, comfortable, speedy, and safe. *Equipped with air-tight compartments like a life boat — it Can't Sink.* Handsomely finished, and well equipped, with 3 H. P. Lockwood-Ash, single cylinder, two cycle motor, vertical contact timer, mixture oiling system, Mullins Silent Underwater Exhaust, and steel guard which protects the shaft and propeller. It's a sturdy, well built, highly efficient launch, sold at a remarkably low price.

Write now — for specifications, dimensions, our low price, and complete information.



Tom Brown
as he appears
in "Ty-Toy"

Be the "Tom Brown" of Your Town

You may have the talent to develop into a Saxophone wizard like Tom Brown, of the famous Tom Brown's Clown Band, the highest priced musical act, and enjoy this most pleasant of vocations. Buescher Instruments have helped make famous Tom Brown, Paul Whiteman, Joseph C. Smith, Clyde C. Doerr, Bennie Krueger, Dan Russo, Paul Specht, Carl Fenton, Ross Gorman, Arnold Johnson, Nathan Glantz and thousands of others. \$500 to \$1,000 weekly for but two hours a day is not uncommon for musicians of such ability to earn.

BUESCHER True-Tone Saxophone

The Buescher Saxophone is so perfected and simplified that it is the easiest of all musical instruments to learn. It is the one instrument that everyone can play—and it wholly satisfies that craving everybody has to personally produce music. You can learn the scale in an hour's practice, play popular music in a few weeks and take your place in an Orchestra or Band within 90 days, if you so desire. Nothing can take the place of a Saxophone for home entertainment, church, lodge, school. It increases the pleasure you get out of life, increases your popularity and your opportunities.

Saxophone Book FREE

After nearly 300 years' supremacy, string instruments are almost entirely displaced by Saxophones in all nationally popular orchestras. Our Free Saxophone Book tells which Saxophone takes violin, cello and bass parts, and many other things you would like to know. Ask for your copy.

Buescher Band Instrument Co.
Makers of Everything in Band and
Orchestra Instruments
2541 Buescher Block, Elkhart, Indiana

Free Trial—Easy Payments

You may order any Buescher Saxophone, Cornet, Trumpet, Trombone or other Band or Orchestral Instrument without paying in advance, and try it six days in your own home, without obligation. If perfectly satisfied, pay for it on easy payments to suit your convenience. Mention the instrument interested in and a complete catalog will be mailed free.

BUESCHER BAND INSTRUMENT CO.

2541 Buescher Block, Elkhart, Ind.

Gentlemen: I am interested in the instrument

checked below.

Saxophone... Cornet... Trombone... Trumpet...

(Mention any other instrument interested in)

Name.....

Street Address.....

Town..... State.....



Catch Fish, fish, mink, muskrats and other fur-bearing animals, in large numbers, with our new, Folding, Galvanized Steel Wire Trap. It catches them like a fly-trap catches flies. Made in all sizes. Strong and durable. Write for Descriptive Price List, and our Free Booklet on best bait known for attracting all kinds of fish.
J. F. GREGORY, Dept. 24, Lebanon, Mo.



Build This Phonograph Yourself

TREMENDOUS SAVING IN COST

Easy, fascinating work with our SIMPLIFIED PLANS. We furnish blue prints, diagrams, motor, cabinet pieces, ready-built horn, etc. You don't need to be a cabinet maker. A few hours assembling and you will have a fine instrument at one-quarter the regular retail price. AGENTS MAKE MONEY making and selling these instruments. Write today for full details and our FREE OFFER. Address:

MODERN PHONOGRAPH SUPPLY CO.
213 N. Morgan St. Dept. 706 CHICAGO, ILL.



MOTORISTS You Need This Free Book

Repairs such as leaky radiators, radiator edges, etc., can be made easily and quickly at a few cents' expense by using

SMOOTH-ON IRON CEMENT NO. 1

Write for FREE Book and learn how.

Smooth-On is also recognized for making household repairs. Sold by Hardware and General Stores in 6 oz., 1 lb., and 5 lb. cans. Also in larger sizes.

SMOOTH-ON MFG. CO.

Dept. 37-C Jersey City, N. J., U. S. A.

No Matter Where
the Leak **SMOOTH-ON**
Will Stop It.



VULCANIZE Your Punctures and Cuts in Five Minutes

Do not "stick on" a cold patch when you can make a VULCANIZED repair that will not come off. You need only a match. No danger of fire.



\$1.50 at All Accessory Stores

C. A. SHALER CO., 2002 FOURTH ST., WAUPUN, WIS.



There's an EVINRUDE for Every Boating Need

Evinrude now offers a complete line of small-boat motors. Evinrude Outboard motors are made in both single and twin cylinder models, 2, 3½ and 4 H. P. For a permanent "job" select from the two Evinrude Inboard models—single and twin-cylinder. No need now to consider a "doubtful" make.

An Evinrude is the best of vacation pals. It gives you ten seasons of wonderful outdoor sport, takes you fishing, hunting, picnicking, exploring—without oarwork.

Ask your sporting goods or hardware dealer about these genuine Evinrude motors. Or write for free catalog.

Evinrude Motor Company
135 Evinrude Block, Milwaukee, Wis.

DISTRIBUTORS:

69 Cortlandt St., New York, N. Y.
730 Commonwealth Ave., Boston, Mass.
211 Morrison St., Portland, Ore.
119 Broadway, Oakland, Calif.

EVINRUDE

"Old Town Canoes"



ALONE— with the Only Girl

AN "Old Town Canoe" means happiness for you and the only girl. Means afternoons together, drifting down winding streams—lazy-paddling on quiet waters.

Canoeing is one of the greatest of summer pleasures—and the cheapest. For an "Old Town Canoe" will last you for years. And it is the lowest-priced canoe made, \$54 up from dealer or factory. It is the lightest and steadiest of canoes, too!

The new 1923 catalog shows all models in full colors. Write for one to-day. It is free.

OLD TOWN CANOE CO.
1363 Middle St. Old Town, Maine, U.S.A.

TIRES WITH 500 NAIL HOLES LEAK NO AIR

Mr. N. E. Coats of Chicago has invented a new puncture-proof inner tube, which, in actual test, was punctured 500 times without the loss of any air. Increase your mileage from 10,000 to 12,000 miles without removing this wonderful tube from the wheel, and the beauty of it all is that this new puncture-proof tube costs no more than the ordinary tube, and makes riding a real pleasure. You can write Mr. N. E. Coats at 333 West 47th St., Chicago, as he wants them introduced everywhere. Wonderful opportunity for agents. If interested write him today.

"THE BROADWAY"

The K-37 is the classic sport body for Fords in America. Built of 20 Gauge Lead-Coated Steel, upholstered in very high grade black or Spanish brown material. Spring Cushions. Stylish one-man top with side curtains. Door on right side of body with inside nickel lever.



12-gal. gas tank. Adjustable plate glass windshield.
SEND FOR DESCRIPTIVE CIRCULAR AND PRICE LIST.
CHAMPION RACING BODY CO., Dept. P. M., 7-9 E. 28th St., CHICAGO, ILLS.

Drive 100 Tacks and Save \$25.00

Ford Top Re-covering \$5.00, \$6.95 and \$9.95. Chevrolet, Dodge or Maxwell, \$13.95. All other 5 passenger cars \$16.50 with plate glass lights. Side curtains that open with doors \$11.00 up. Seat covers \$3.15 up. Quality the best and guaranteed to fit. Printed instructions given how to apply. Send for samples. Prices above include delivery at your door. Eastern orders shipped from Ohio.
AUTO EQUIPMENT CO. 1055 So. Broadway, Los Angeles, Calif.

\$520 up
Delivered

"BOW LEGS and KNOCK-KNEES" UNSIGHTLY

SEND FOR BOOKLET SHOWING PHOTOS OF MEN WITH AND WITHOUT THE PERFECT LEG FORMS

PERFECT SALES CO.
140 N. Mayfield Ave., Dept. S. Chicago, Ill.



ACME

for amplification

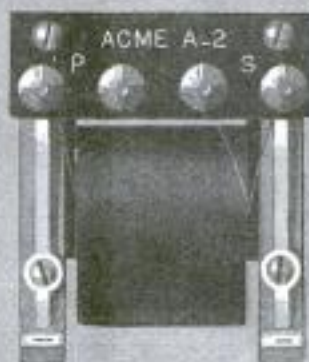

Radio Apparatus of distinction

ACME APPARATUS CO.

PIONEER TRANSFORMER AND
RADIO ENGINEERS AND MANUFACTURERS
CAMBRIDGE, MASS., U. S. A.

Our BUREAU OF INFORMATION will answer all questions regarding articles appearing in this magazine.



RADIO
HEAD SETS, JACKS, PLUGS,
MICROPHONES

Manufacturers

American Electric
COMPANY

State and 64th Sts., Chicago, Ill.

Starting a Company?

Save expenses and taxes by organizing on the popular, COMMON LAW plan under a pure DECLARATION OF TRUST. No experience required to fill in DEMAREE STANDARD FORMS, issue shares and begin doing business at once. Genuine DEMAREE FORMS are nationally known, approved by attorneys, and utilized by successful concerns throughout the United States. Send for large, free pamphlet (D-33) containing valuable information that you may need. C. S. DEMAREE, legal blank publisher, 708 Walnut, Kansas City, Missouri.

Build and Fly Model Aeroplanes



Build your own Model Aeroplane; make trial flights and learn the principles of Aerostation. With IDEAL Scale Drawings and Building and Flying Instructions you can easily build exact 2-ft. duplicates of Real Planes. Send now for the plans for the one you want to build. Curtiss JN-4B-2 Training Plane; DeHavilland Buffalo Plane; NC-4 Naval Scoutplane; Curtiss Military Trainer; Bleriot, Nieuport or Taube Monoplanes also Cecil Paul Nacer.

25 CENTS EACH, POSTPAID.

Set of 6 Sent for \$1.50

Catalogue Aeroplane Supplies—5c p.p.

Ideal Aeroplane & Supply Co., 73-76 Greene St., near Spring, New York City

**\$1.00 DELIVERS
to Your Home**

 An illustration of a family—a man, a woman, and a child—gathered around a table. The man is holding a device, and the woman is looking at it. A child is also present. In the foreground, an open suitcase contains various items, including a long tube, a coil of wire, and other components of the Violet Ray outfit.

Complete
Outfit

Violet Ray

ONLY \$1.00 brings this complete, scientific Violet Rays outfit to you. Treat yourself and family at home, save delay, costly doctors and medicines. Thousands use Violet Rays at home to relieve pain and sickness. The identical outfits doctors have bought from us for years and with which they successfully treat many ailments, including those listed below.

QUICK RESULTS—No Medicine

Violet Rays work quickly, it's scientific, goes after the cause. That's why results are quick, permanent. Dr. Duncan, Kewanee, Ill., writes, "Violet Rays is the finest thing I ever used... to relieve pain, treatments are so pleasant all my patients like it." Use it yourself at home, you save Doctor's bills.

BEAUTY AID

Brings natural, magnetic beauty of health, no dieting, exercise or drugs. FREE book tells in detail how high priced beauty specialists use it to improve scalp and skin.

EARN CASH

Men, women, without experience earn liberal profits in spare time showing Violet Rays to neighbors. Proves results first demonstration. Sells on sight. Get attractive offer and wholesale prices now.

SEND FOR FREE BOOK

Explains how Nikola Tesla discovered Violet Rays, how it works, why it heals. Tells what doctors and plain folks accomplish in conquering pain, disease and nervous trouble with Violet Rays.

Reveals Marvelous Scientific Discovery Shows charts of human body, explains where pains start, how to banish them. Offered FREE for a limited time only, to introduce Violet Rays. Send for FREE copy.

Check Your Ailment Below for Free Advice Here is a partial list of ailments successfully treated with Violet Ray:

Catarrh	Eye Diseases	Lumbago	Skin Diseases
Cold	Falling Hair	Nervousness	Sore Throat
Cold	Hay Fever	Neuritis	Sprains
Constipation	Headache	Paralysis	Toxemia
Earaches	Goitre	Piles	Whooping Cough
Eczema	Insomnia	Rheumatism	Asthma

Mail Coupon—Send No Money

VI-REX ELECTRIC COMPANY
326 West Madison St., Dept. 23, Chicago

Please send me without cost or obligation your free book describing your VI-REX Violet Ray outfit, and details of your \$1.00 offer.

Name _____

Address _____

City _____ State _____

Please Mention Popular Mechanics

Want to Get
More Distant Stations
and Bring in All
Signals Twice as
Clear and Strong?

THEN INSTALL
"All American"
Audio and Radio Frequency
Transformers

- R-10 Radio Frequency
(150-550 meters) - \$4.50
R-12 Audio Frequency
(Ratio 3 to 1) - 4.50
R-13 Audio Frequency
(Ratio 10 to 1) - 4.75
R-21 Audio Frequency
(Ratio 5 to 1) - 4.75

FREE

Book of Radio Hook-ups

Send 2-cent stamp to cover postage. Over 25 different
Audio and Radio circuits. Write today for this valuable
book. It's yours for the asking.

RAULAND MFG. Co.
Crilly Bldg. Chicago, Ill.

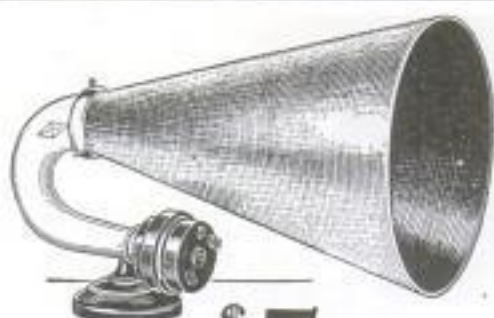

\$5

You can now get a genuine Murdock Loudspeaker for
\$5.00, complete with new Loudspeaker phone unit,
Murdock quality throughout.

"Tune in" with Murdock Headphones, then switch
on the Murdock Loudspeaker and a room full of people
can hear your radio.

Get one from your dealer.

WM. J. MURDOCK CO.
349 Washington Ave. Chelsea, Boston, Mass.

Sales Offices
Wilson Bldg. New York
509 Mission St. San Francisco
524 Marquette Bldg. Chicago

**MURDOCK
RADIO**

STANDARD APPARATUS SINCE 1904

ELECTRIC SOLDER IRON

Fits Any Standard Appliance Plug



\$1.50

IRON
ONLY

100 Watts 108-115 Volts
RADIO—AUTO—HOME

Does Work of Any \$15.00 Iron. Use Your Own
Appliance Plug, or Send \$1.00 Extra for Plugs
& Cord as Shown.
Plain String Solder, 60c lb.
Acid or Rosin Core String Solder 90c lb.
Add 10c for Postage

M. A. Simon Co., 520 Pine St., St. Louis, Mo.

FREE Radio Catalog



Our big stock of standard
makes of radio sets, parts
and supplies, fully illustrat-
ed. Play safe—buy stand-
ard equipment from a re-
liable house. We ship from stock.

Send \$4.50 for genuine Westinghouse WD-11 "peanut"
tube—no storage battery needed. 60 cents extra for signal
socket. \$1.00 for Bradley adapter. Wonderful results.

JULIUS ANDRAE & SONS CO.

116 Michigan St. In business since 1860 Milwaukee, Wis.

See your dealer for information about
RADISCO Radio Products
THE RADIO DISTRIBUTING CO.
Newark, N. J. U. S. A.



Makes
Your Radio
Set Work Better

Perfect reception can be had only when
wire connections are soldered.
SOLDERALL and a match make per-
fect joints—guaranteed equal to wire
or bar solder.

At leading Jobbers and Dealers or
sent postpaid for 25c a tube.
SOLDERALL CO., Dept. P, Newark, N. J.

SOLDERALL
A Metal in Paste Form

CROSLY RADIO APPARATUS

BETTER—COSTS LESS
If interested in Radio, write for free
copy of a Crosley Catalog. In it are
helpful suggestions as to selection of
right instrument or parts, if you wish
to build your own outfit. Sold by
dealers and jobbers everywhere.
CROSLY MFG. CO.
215 Alfred St. Cincinnati

FREE CATALOG

MOVIES We'll swap you—your name and
address for our catalogue on the
greatest real home MOVIE-
MACHINES in the world with
dazzling models as low as \$5.00 postpaid. And
say folks! We've also got the slickest regulation
film at ridiculously low prices—and we don't
have to tell you our films are the best. **NOW**
Let's not miss this opportunity—Write TO-DAY—
PARAMOUNT MFG. COMPANY, BOX 1371
Dept. M, Boston, Mass., U. S. A.



WAVELAND RADIO CO.

INCORPORATED
1348 NORTH CLARK STREET, CHICAGO, ILL.

The Cost of a Radio Has Come Down

Why pay the patent royalty on your regenerative license, when you can BUILD YOUR OWN radio set at a low cost? We furnish everything needed so that you can quickly install in your home a

Long Distance
One Vacuum-Tube
Receiving Set
Sent Prepaid for

\$38.00

Set includes handsome mahogany cabinet, Formica panel beautifully engraved, W. D. 11 Vacuum tube, batteries, headphone, aerial—everything you need, nothing more to buy. You can begin listening in an hour after the package is delivered.

"Waveland pays the postage"

With each set we give you our GUARANTEE that you will be able to receive concerts, etc., from broadcasting stations over 1,000 miles away, and if, for any reason, you are not satisfied, we will instantly return your money.

Our \$38.00 WAVELAND CONCERT RECEIVER can be connected up in numerous ways, but we suggest the simple circuit endorsed by the UNITED STATES BUREAU OF STANDARDS, described on page 21, Chapter 2, Figure 14, of Lefax Radio Handbook. We send this \$3.50 handbook free with every set.

Send for Circular

WAVELAND RADIO COMPANY
Incorporated

1348 N. Clark St., Dept. 14
CHICAGO, ILL.

BUILD YOUR OWN RADIO

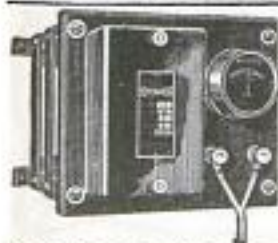

The Homcharger

Charges your
AUTO or RADIO
BATTERY

AT HOME for a Nickel

Price - - - \$18.50

Send for FREE Bulletin

THE AUTOMATIC ELECTRICAL DEVICES CO.

129 W. Third St., Cincinnati, O.

RADIO & AUTO Storage BATTERIES CHARGED

FROM A LAMP SOCKET At Home For a Few Cents, With An F.F. BATTERY BOOSTER, a FULL WAVE AUTOMATIC MAGNETIC RECTIFIER for 105, 125 Volt 50 Cycle A.C., Type A-B Charges 6 Volt "A" & Auto & Up to 120 Volts of "B" & Loud Speaker Storage Batteries In Series Inductively At Home Overnight, Disconnecting & Multiple Connections Unnecessary. No Grounds, Charging Circuits Separate. No Skills Required. AMMETER



circulates GUESS WORK. Infinitely Electrodes Recharge Current. With Charge A Load & 1/2 C.Y. Lower Battery Connected. Screw Plug In Lamp Socket. Snap Rectifier Clips On Terminals. Turn Switch & Battery Is Charged In Minutes. NOTHING LIKE IT MADE. Is It Not Good To Feel Your Radio Batteries Are Ready For All Radiophone Music & News? Never Having To Tell Friends Your Batteries Are Dead? Fully Charged Batteries. By Starting Car Quick. Recharge From Express Replacements. Do Not Think Your Battery Is Dead & Wear Out Simply Because It Will Not Start Your Car. Buy A BOOSTER, which fills it with life, saves more than its cost & lasts a lifetime. 7 TYPES BUILT BY A MASTER OF THE ART & POPULARLY PRICED.

Type 6 charges "A" 6 volt Battery, at 5 amperes \$15
Type 12 charges 12 volt Battery at 5 amperes \$15
Type 6 charges Radio "B" Batteries up to 120 volts \$15
Type A-B is a Combination of Types 6 and B \$20
Type 60 charges 6 volt Battery at 12 amperes \$20
Type 1612 charges 12 volt Battery at 7 amperes \$20
Type 1620 is a Combination of Type 1044-1612 \$25
The 3 Lower TYPES are Recommended For Heavy Batteries, only here Time Is Limited. Shipping Weights Complete with AMMETER & BATTERY CLIPS 11 to 15 posts. Purchase from Your Dealer or Mail Check for Prompt Express Shipment. If for Parcel Post add Postage & Insurance Charges. Or ORDER us to forward TYPE desired C.O.D. ORDER Now or WRITE Immediately for FREE Descriptive BULLETINS 24 & 24A.

THE FRANCE MFG. CO., CLEVELAND, OHIO, U.S.A.

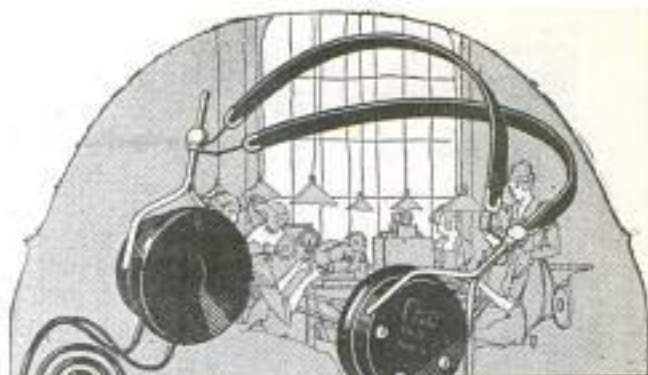

Super-Inspected Quality

FROST-FONES

have always been true to an engineering ideal. Built for precision and sensitivity, they quickly won national repute.

Today Frost Fones are the largest selling head fones in the world. Frost ideals of quality—of precision in manufacture—of rigid inspection during every stage of the making of these famous Fones—insure permanent satisfaction to every one who buys a pair.

Each item in the Frost Radio line is made up to highest standards of radio engineering. You can order Frost Fones, Plugs, Jacks and other apparatus from your dealer with the certain assurance that your money buys the best that can be made, at prices which only quantity production makes possible.

Your dealer sells Frost Fones
See him today

No. 162

2000 Ohm Set

\$5.00

No. 163

3000 Ohm Set

\$6.00



HERBERT H. FROST, Inc.
154 WEST LAKE STREET, CHICAGO, ILLINOIS.

Please Mention Popular Mechanics

RADIO

\$15 Down
\$10.00
a Month



An Amazingly Easy Way to Own a Radio Set

Good Radio sets are expensive—but here's the opportunity to buy the very best on such easy terms that you can afford to have the best.

The air is full of music—pick out the concert which pleases you—listen to a dozen concerts in one evening. Lectures by the most famous speakers—sermons by world-renowned preachers. Baseball scores, returns from the prize fights, news reports of the day sent out hourly by leading newspapers, bed time stories for the little tots. A blessing to the sick, invalids or shut-ins. Brings the world to your door. Far more entertaining than anything else you could buy.

So simple a child can operate—nothing to learn—turn a couple of dials and you have a concert—turn again and you have another. Nothing to buy—the "SENSITONE" comes complete, including "A" and "B" batteries, head phones, vacuum tube and complete aerial equipment.

SENSITONE

Regenerative Radio Receiving Set

Only \$15 Down—\$10 a Month

A Thoroughly Reliable Set, manufactured by the Klitzken Radio Mfg. Co., under the Armstrong License (U. S. Patent No. 1,113,149 and pending letter patent 807,388.)

Shelbyville, Mo., hears concerts in Havana, Cuba. A user in Winnipeg, Can., listens to Los Angeles, Calif., while Stanton, N. D., hears Ft. Worth, Texas, and Schenectady, N. Y. A party in Denver, Colo., hears concerts from Havana, Cuba. Let us send you copies of hundreds of such letters. A payment of only \$15.00 cash and \$10.00 monthly brings the "SENSITONE" to you.

Sign the coupon to-day and your receiver will go forward at once.

HAROLD R. WAKEM & CO.

835 W. Washington Blvd. Chicago, Ill.

Please ship me one complete "Sensitone" Radio Receiving Set as described above, for which I agree to pay \$15.00 here-with and \$10.00 per month until the full purchase price of \$95.00 is paid. Set to remain the property of Harold R. Wakem & Company until fully paid for.

Name.....

Address.....

COMPLETE RADIO SET \$26.50

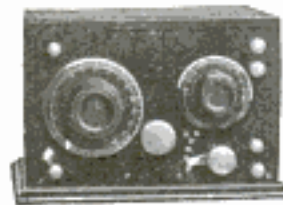

Vacuum tube set with "A" battery, "B" battery, detector tube & double head-set, complete ready to operate, \$26.50. Receiving range equal to any set. This is an efficient vacuum tube set at a price less than the average crystal set and with many times the range. Money back guarantee. Also power amplifiers and larger sets.

Central Mfg. Co., Fairfield, Iowa

Make Your
Crystal Set
100% Efficient

by Using

MPM

Million Point Mineral

The WORLD'S GREATEST RADIO CRYSTAL

THE discovery of M. P. M. has revolutionized the possibilities of ordinary crystal sets. Concerts have been clearly heard over 600 miles. M. P. M. is super-sensitive—reproducing from every point on its surface. It increases audibility as well as radius, and makes the purchase of an expensive tube set unnecessary.

Send 25c and name of your Radio Dealer for a sample M. P. M. crystal—concert tested and guaranteed.

Address Dept. P.

M. P. M. Sales Company

247 S. Central Ave.

Los Angeles, Calif.

DOUBLE HEAD PHONES



BOYS! A REAL RADIO SET ABSOLUTELY FREE

RUSH your name and address and we will tell you HOW you can get this RADIO SET ABSOLUTELY FREE.

RADIO SET comes to you complete, with single slide tuning coil, crystal detector and phone condenser. AND DOUBLE HEAD PHONES. No batteries required; no experience.

Write Today for Free Radio Plan

HOME SUPPLY CO.

131 Duane St., Dept. 675
New York City

SPRINGFIELD
16 Strand Braided

ANTENNA

Will increase your range with your present equipment, giving 15% to 100% increase. 125 feet in your attic, in strands 3 feet apart, gives better results than 150 feet of ordinary wire out doors.

Buy of your dealer, or send us \$2.50 for 100 feet.

SPRINGFIELD WIRE & TINSEL CO.
387d Main St., Springfield, Mass.



Regenerative Radio Set — *Manufactured under Armstrong Patents*

Easy Payments

Radio Outfit Complete

No Accessories to Buy. Lamp, Head Phone and Batteries are included

FIRST get this straight. This outfit is absolutely complete. Batteries, tube, vario coupler, condenser, rheostat. The aerial, connections and head phones are contained in the outfit. Nothing more to buy. Nothing to assemble. No experience necessary. All bother and muss done away with. Even the costly, inconvenient storage battery.

You will be receiving in half an hour after this outfit arrives. Just string the single wire aerial from the house to barn or tree or post — attach the ground wire to radiator or water pipe. Then you are ready! Tune in on the wonderful Concerts, Grand Operas, and speeches that are now filling the air all about you. Get news flashes, stock and market reports before newspaper publication. Hear famous ministers preach their Sunday sermons. Everything broadcasted by scores of stations within reach of your home is yours without expense or bother when you have this splendid set installed in your home.

LOOK 
\$15⁰⁰
Brings It

DETAILED LIST OF COMPLETE OUTFIT

Mahogany Finish Cabinet, with "Formica" panel, fitted with necessary dials and knobs.

Vario Coupler

Variable Condenser

Vacuum Tube Socket

Socket Adapter

W. D. 11 Vacuum Tube (This is the wonderful new type tube which operates from a dry cell, making it possible to do without a storage battery)

Rheostat

"A" and "B" Batteries (All of the above equipment is neatly arranged inside the cabinet)

Standard 2200 Ohm Head Phones

Aerial, Lightning Arrestor, Insulators

All necessary insulated wire for making connections

Full instructions for installation and operation

This regenerative receiver is manufactured for us by the Precision

Equipment Co., under Armstrong

U. S. Patent No. 1,115,149

For only \$15.00 down and small monthly payments you can enjoy all the marvelous advantages of this wireless age. The air you breathe at this very moment is alive with radio waves just waiting for you to pick them up. There is something for the entertainment and education of every member of the family at almost every hour of the day and evening. But without a radio outfit you are deaf to it all.

Remember, there are scores of different types of radio sets sold at all kinds of prices. If you buy a cheap set,

its short range, limited selective qualities, and lack of clear loud tone will soon fail to satisfy you. This is a high-grade *Regenerative Receiver*, made under the same Armstrong patents as the highest priced receivers.

Everyone will marvel at the clear toned music and voice you will be able to receive right at the start. Your home concerts will be the envy of friends and neighbors who are trying to receive with inferior sets. You will get stations far beyond their range. You can tune out powerful nearby stations that your friends cannot get rid of.

Send Coupon Today

Satisfaction Guaranteed

Fully illustrated circular gives full details—sent free. But why wait for that? You are missing the greatest thrill of your life. Have your outfit at once. All you have to do is to fill in and mail the coupon with your money order for \$15.00. The outfit will be shipped promptly, and may be returned anytime within 10 days if not entirely satisfactory. You may pay for it as you enjoy it. Only \$10.00 a month. How easy it is! Don't put it off a single day. Mail the coupon NOW — or mail postcard requesting illustrated circular.

BABSON BROS.

Dept. 1353, 19th St. and Marshall Blvd., Chicago

Babson Bros., 19th St. and Marshall Blvd., Dept. 1353 Chicago, Ill.

I enclose money order for \$15.00 which you are to send me your complete Regenerative Receiver outfit, as described in this ad. I agree to send you \$10.00 a month for four months and \$5.00 the fifth month, making the full purchase price of \$55.00. It is understood that this outfit may be returned within 10 days after arrival, and my deposit refunded if it is not fully satisfactory.

Name _____ Age _____

Street Address _____

City _____ State _____

I give you below the names and addresses of two references (Business or business houses preferred)

Name and Address _____

Name and Address _____

RADIO BROADCASTING of current events can be brought to your home by the use of the AERIAL-A which is sold complete and ready to use. Simple to operate and elegantly constructed. Can be set up in less than an hour.

Price Complete

\$35



INCLUDING PHONES, TUBE, AERIAL and BATTERIES

The Aerial-A is guaranteed to receive 500 miles in winter; 250 miles in summer. If for any reason you are not satisfied your money will be cheerfully refunded. Write for our illustrated folder.

FREE: with every purchase of \$10.00 and over a \$1.50 22½ volt variable "B" Battery.
TERMS: Mail orders must include postage. Money Orders with Orders—checks not accepted. All merchandise offered is Standard, Guaranteed and is of perfect workmanship.

SOCKETS:		CONDENSERS:		DETECTORS:	
\$1.00 Gensico Bakelite Socket.....	58.45	\$1.00 Battery, 22½ V. Variable, highest quality guaranteed. Large size.....	11.45	\$1.00 Rheostat.....	5.22
\$1.00 Sockets.....	15	\$1.25 B. Battery, 22½ V. Variable, highest quality guaranteed. Small size.....	7.5	Homercharger De Luxe.....	11.25
\$1.00 Gensico Bakelite Dial—3-in. 4½; 4-in. 68		\$7.00 Westinghouse Storage B. Battery.....	5.50	John-Maxville Bk. Conn. Tubes, 3-4th.....	15
VARIOCOUPPLERS:		\$1.50 W. D. 11 A. Battery.....	5.5	DETECTORS:	
\$7.00 Guaranteed Gensico Bakelite Pioneer Variocoupler, silk wound.....	4.75	CONDENSERS:		\$.75 Crystal Detector.....	15
\$4.50 Variocoupler, guaranteed high quality.....	1.25	\$5.00 23-pf. Variable Condenser.....	1.45	\$.40 R. D. Crystal Detector.....	15
\$5.00 Mousled Variocoupler, highest quality.....	4.50	3-plate Variable Variable Condenser.....	70	\$1.50 Multi Jack.....	1.15
\$5.00 Staywick Variocoupler.....	2.50	50c Mica Condensers.....	25	\$1.50 Twin Adapter.....	1.15
TRANSFORMERS:		Thordarson Grid Condenser.....	25	\$1.25 Universal Plug.....	7.5
\$5.00 Aame Transformer.....	1.40	Brown Gas Bar, tin-plated, ft.....	62	BATTERY CHARGERS:	
\$1.00 Radio Frequency Transformers.....	1.45	PANELS:		\$18.00 Westinghouse Battery Charger.....	14.40
\$6.50 Wesco Audio Transformers, highest quality guaranteed.....	1.25	Guaranteed Gensico Bakelite Panels—7x10½		\$19.50 Westinghouse Battery Charger for A. & S. Batteries.....	15.60
\$2.00 Thorburn Transformer.....	2.40	1 7x8; 7x8, \$1.85; 9x10, \$1.90; 6x9, 9x5;		7c Open Circuit Jack.....	25
\$2.00 Radio Frequency Transformer.....	1.50	1 8x8, 47c; 9x9, 55c; 6x12, \$1.20; 7x12,		8c Double Circuit.....	10
VARIOMETERS:		\$1.50; 7x9, \$1.15; 12x14, \$3.00; 7x24.....	1.00	7c Sensitive Hydrometer.....	15
\$6.50 Pioneer Variometer, genuine bakelite, silk wound.....	4.50	\$1.50 Microstays.....	54	KNIFE SWITCHES:	
\$6.00 Wesco Variometer, highest quality guaranteed.....	1.25	Spaghetti, per length.....	97½	Knife Switch S. P. D. T.....	14
\$4.50 Variometer, guaranteed high quality.....	2.40	SPECIAL ELECTRIC SOLDERING IRON,	4.95	Knife Switch S. P. D. T.....	22
\$6.00 Mousled Variometer, highest quality.....	1.50	4 TWIN HEAT.....	15	Knife Switch D. P. D. T.....	15
BATTERIES:		PHONES:		Wooden Horn.....	5.50
\$6.75 Westinghouse Storage B. Battery.....	4.75	\$4.00 Brandee Phones.....	5.75	Contact Points.....	64
\$24.00 A. Battery, 100 amp., 6 V.....	14.75	\$5.00 Murdoch Phones.....	1.55	\$5.00 Standard Metal Horn.....	4.50
\$19.00 A. Battery, 80 amp., 6 V.....	11.45	\$1.00 Freshman Variable Grid Leak.....	75	\$7.50 Standard Metal Horn.....	7.00
\$14.50 A. Battery, 60 amp., 6 V.....	9.75	WIRE:		\$12.00 Radio Loud Speaker.....	15.00
		100 ft. coil No. 14, 7-strand pure copper		\$20.00 WESCO Battery Charger.....	12.95
		Aerial Wire.....	50		

Dept. P.M.3

W.E. Supply & Service Corp

18 Murray Street New York City

For Clear-Tone Long Distance Radio Reception Use Only "UNITED" Condensers and Transformers

Products of an \$800,000.00 plant, equipped with the highest type of precision machinery, manned by expert mechanics, and backed by a seasoned staff of radio engineers.

The guarantee of this old established Electrical House stands back of our products.

"United" Variable Condensers

Cannot short-circuit, because hard aluminum plates are held mechanically in true and permanent alignment. Ends are Bakelite; trimmings brass, nickel plated.

Prices, without Dial or Knob	
43 plate.....	\$4.50
23 plate.....	4.00
11 plate.....	3.50
5 plate.....	2.75
3 plate.....	2.25

Postpaid

"United" Audio-Frequency Amplifying Transformers

A fine example of precision-workmanship; completely shielded, in shell of original design. Amplifies detected signals, bringing them to phone or loud speaker, clear, strong, pure-toned.

Price, postpaid,..... \$4.50

Try your dealer first, before ordering by mail. Send name and address of dealer with order. Circular free.

United Manufacturing & Distributing Co.
 536 Lake Shore Drive Chicago, Ill.



PAT. APPLIED FOR

MUSCLE SHOALS POWER WILL MOVE MOUNTAINS, DO IT NOW



SPECIALS		Price	New
Diets, Flat (Set 8) Black	\$12.00	\$8.95	\$18.00
Speed-Power Camshaft	19.50	9.95	17.00
Disc Magneto, Brand New	\$5.00	14.75	14.95

Write for 1925 Catalog. Retailer selection or money back guarantee.

A. S. FORD SPEED & POWER EQUIPMENT MFRS., 250 West 54th St., New York



World Radio and Auto Batteries
SAVE YOU 50%
 WRITTEN 2 YR. GUARANTEE

We defy price competition; a glance at the prices below will convince you that the World Battery is the best buy on the market. Batteries shipped immediately. Express C. O. D. Begin now to get 100% battery service at half cost. Mail order today.

Automobile Prices		RADIO PRICES	
6 Volt, 11 Plate - \$12.50		6 Volt, 40 Amps. \$ 8.50	
Ford, Chev., Mitchell, Hup.,		6 Volt, 60 Amps. 10.00	
Geat, Elco, Vaco, Saxon,		6 Volt, 80 Amps. 12.50	
6 Volt, 13 Plate - \$14.50		6 Volt, 100 Amps. 14.50	
Overland, Buick, Geo, Paige,			
Hudson, Nash, Stude., Dorr,			
12 Volt, 7 Plate - \$18.00			
Maxwell, Dodge, Regal, Frank,			
Briscoe and Crow-Elihart,			
Give year and model of car			

World Battery Co., 1219 S. Wabash Ave., Dept. 6, Chicago

A New Radio Achievement

Since the beginning of general radio broadcasting, Air-Way engineers have unceasingly striven to simplify design, and to rectify operation, so that a receiving set could be made which the average man or woman could easily "tune in" with and get the most pleasing and uninterrupted results.

Out of this research, experiment and application to an ideal, the new Air-Way Radio Frequency Sets have come as an answer to the great and insistent public demand for **genuine quality** of radio reception.

Air-Way
TOLEDO

By **genuine quality** we mean good, full, natural tone, loud and distinct; with sharpness of tuning, which gives protection against interference from other stations, and allows you to hold and enjoy quietly the station you desire to hear; with ease of tuning, which makes the instrument practical and dependable in the home for all the family; and with long range, which multiplies the pleasures and opportunities of radio possession.

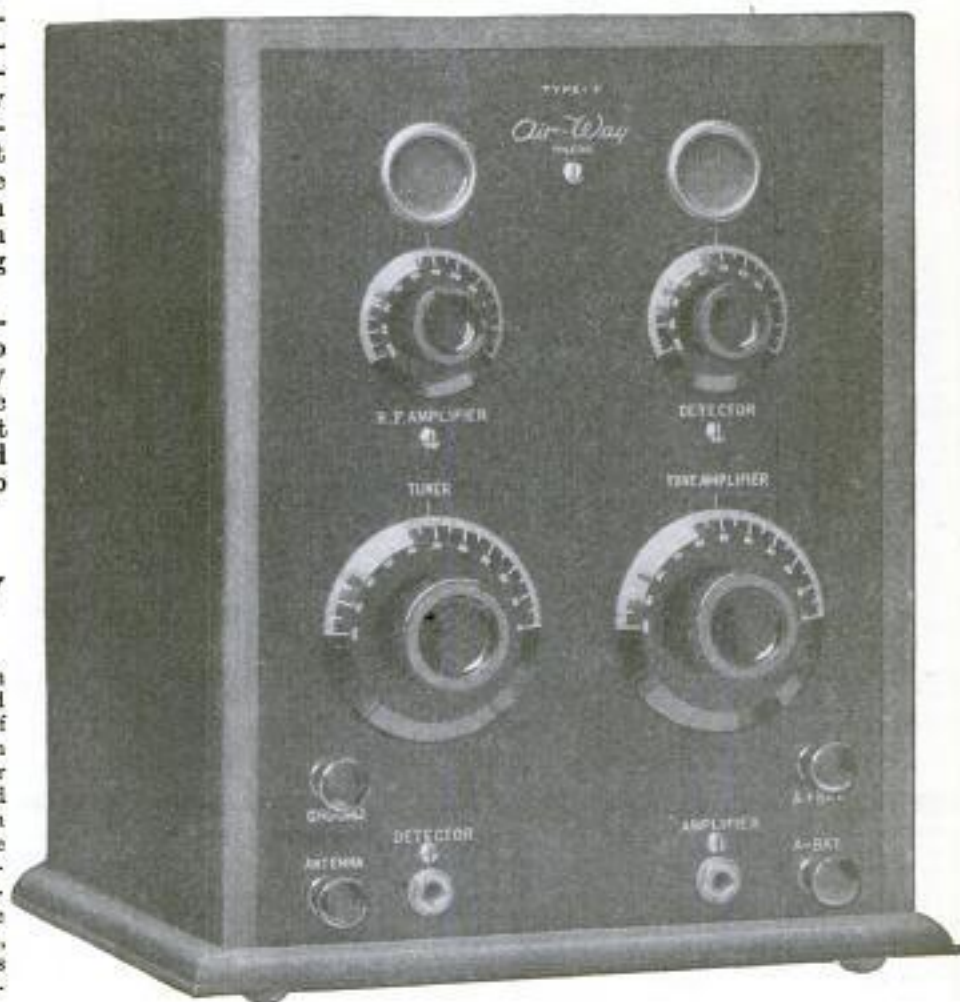

This Beautiful Four Tube Set Only \$50

This instrument is not only a remarkable value, but it is a new radio achievement, marking a distinct advance in the science of radio reception. In it the long sought success in the use of Radio Frequency Amplification has been accomplished.

And in this achievement Air-Way engineers have not only embodied skill and genius of design, but have given that care and precision to the manufacture of each and every part which is the only certain guarantee of true quality.

Air-Way Type F Receiving Set is a four-tube instrument. It has one step of Radio Frequency, Detector, and two steps of Audio Frequency amplification, compactly housed in a cabinet artistic in its simplicity of line and beauty of finish. This is a long-range receiving set that can be operated to its full capacity by the different members of the family. It thus meets every practical and pleasurable need for genuine quality of reception upon all the avenues of radio broadcasting.

Jobbers should address our Wholesale Dept.: The Zinke Company, 1323 S. Michigan Blvd., Chicago, Ill.

To Dealers: Although this new Type F Set was only announced in January, our big factories are already taxed to capacity by the spontaneous demand for this nominally priced genuine quality instrument. This set will give you unchallenged radio leadership. Wire your orders for delivery through your jobber.

In Toledo homes on this set broadcasting is reproduced from the distant stations of Denver, Los Angeles, Dallas, Minneapolis, Duluth, Newark, Atlanta and Havana. It is suitable either for head phones or loud speaking apparatus, and the volume and quality of tone is a genuine surprise to those accustomed to ordinary radio instruments.

To market this valuable instrument at the nominal price of only \$50 is a notable example of Air-Way policy to give to the public the advantages of scientific production economy in the Air-Way factories.

In price and merit this instrument is distinctly in a class by itself—clearly the outstanding value on the radio market.

Have your dealer get this fine instrument for you at once. Catalog, illustrating and describing Air-Way Receiving Sets together with all parts for those who build their own sets, will be mailed free, postpaid, upon request. Give name of your dealer and send for this catalog today.

Export Dept.,
120 Liberty St.,
New York.
Cable Address:
"AIRWAYVAC"
New York

Air-Way Electric Appliance Corporation, Toledo, O.

Do You Want a Real Headset?

*The Dictograph is the Best Headset
in the World at Any Price*

This is the same supreme Dictograph Headset that has always sold for \$12—same in quality, same in guarantee, same in everything but the price—\$8 complete. Made by the makers of the world standard Dictograph Products—the marvelous "Acousticon" for the Deaf, the famous Detective Dictograph, the Dictograph System of Interior Telephones and the Dictograph Radio Loud Speaker for the Home.

Read a few of the many letters we have received from Dictograph Headset users. You, too, can enjoy the utmost in Headsets if you own one.

U. S. Marine Hosp. No. 43,
Ellis Island, N. Y.

"The undersigned has for the past sixteen years been an amateur, commercial, and government operator, and has used every known make of radio receiver on the market. On April 21st, one of your Type R-1 3000 ohm receivers was purchased and it can be safely said without dispute that they are absolutely the best radio receivers on the market today; bar none."

C. H. West, U. S. P. H. S.

LAPORTE, IND.

"I wish to compliment you on the 3000 ohm Headset you now have on the market retailing at \$12.00 (now \$8.00). I have been experimenting with the radio game for the past year. In my experience I have tried out 14 different headsets, including the which I purchased for \$16.50. I at last have found the ideal phone where tone quality excels, and harshness is eliminated, and I cannot express myself in words as to the wonderful results I have obtained."

J. T. Bachman.

Go to your dealers today and listen in with this supreme instrument. Note the difference. Buy two or three Dictograph Headsets and let the rest of the family enjoy your set. Always insist on Dictograph Products. **They are fully guaranteed.**

Dealers:—The Dictograph is the fastest selling Headset on the market today. Order through your jobber or write direct for names of authorized distributors.

DICTOGRAPH PRODUCTS CORPORATION
Suite 1302 220 W. 42nd Street New York City

Branches in All Principal Cities



*The Standard
of the World*

Type R-1, 3000 ohms. For all types of crystal and vacuum tube receiving sets.

The
\$20

Wessco Battery Charger \$12.95

DE LUXE

Special
Introductory Price



The WESSCO Battery Charger is so efficient and economical that no owner of a tube radio set or automobile can afford to be without one. Pays for itself in a short time. Operates on any 110 volt light circuit. Just "plug in" on the light socket, attach clips to battery terminals and turn on the "juice." Charges over night. Has double size vibrator. Only one adjustment. Regular price \$20.00. Special introductory price \$12.95 complete ready to use. Satisfaction guaranteed or money refunded. Weight 11 lbs. Send money order plus postage. Illustrated folder sent on request.



Fully Guaranteed

W.E. Supply & Service Corp

18 Murray St. Dept. M.P.-3, New York City
Radio and Electrical Goods—Lowest Prices

**5 CENTS
Charges
your A & B or
your Auto
BATTERY**



**8 HOUR Battery
Charging Pays Big**

OWN A MONEY MAKING BUSINESS Make \$1500 to \$3000 Yearly Charging Batteries

HB 8 Hour Battery Charging is your big business opportunity. New Constant Potential system charges all sizes of auto batteries perfectly in 6 to 8 hours, while old systems take 2 or 3 days. You can clear \$150 to \$300 every month. No experience needed. HB Outfit comes complete ready to connect to service lines and operate. Universal demand for quick, dependable battery charging means big business and steady profits for you.

\$30 Monthly Pays for Your HB Outfit

Small cash payment brings your HB 8 Hour Charging Outfit. Easy terms of only \$30 monthly let your profits pay balance with nice surplus besides. Long free trial on money-back guarantee lets you try outfit at our risk. Don't delay and let some competitor get ahead of you with 8 Hour Battery Charging. Take the lead yourself. Order your HB outfit NOW on free trial. Write today for full information and our easy-payment plan.

HOBART BROS. CO., Box M 3, Troy, Ohio
Your Satisfaction Guaranteed or Money Back

THE TRINITY LOUD SPEAKER

The only device of its kind in the radio field.

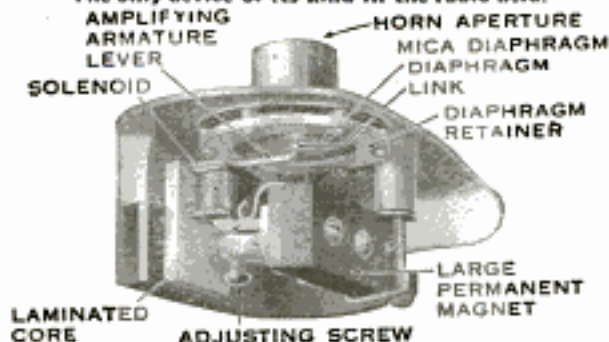

TYPE B \$12.50

Study the illustration carefully and you will understand why it produces full, clear natural tones with perfect reproduction of all vocal and instrumental music. May be used with phonograph or built into your set.

The Trinity Loud Speaker is an instrument that combines the best qualities of a phonograph reproducer in combination with electro magnetic principles best fitted for radio amplification. Absolutely perfect reproduction of all music and speech without distortion. The volume may be regulated from that required for a room in your home to a tremendous output that can be heard hundreds of feet out of doors by simply increasing "B" battery voltage. No storage batteries required. The instrument is of a heavy duty type and is guaranteed for life by the manufacturer. For sale by all wide-awake dealers.



TYPE "A" \$25.00

TRINITY RADIO CORPORATION
168 DARTMOUTH ST., BOSTON, MASS.

RADIO PRICES SMASHED

We now announce drastic cuts in our quality lines. All goods prepared and sold subject to return for rebate or exchange. You simply must be pleased. A sample saving follows. Order from following or send for full list today. You'll be sure to tell your friends.

REGENERATIVE VACUUM TUBE RECEIVER		
	Our price	Others
Range approximately 1000 miles		
Panel of bakelite 7 in. x 12 in. drilled.....	\$1.75	\$2.50
Cabinet of 3 ply wood to fit panel.....	1.50	2.50
2 three inch dials at \$50 each.....	.70	1.40
10 switch points with nut at .01.....	.14	.48
4 switch stops with nut at .02.....	.04	.12
8 binding posts, Nickel plated at .05.....	.24	.48
2 switch levers at 25c each.....	.50	.80
1 filament rheostat, High grade.....	.65	1.10
1 variocoupler with forty ten gaps.....	2.25	4.00
1 25 plate variable condenser.....	1.95	3.50
1 tube socket of high quality.....	.45	.85
1 phone and 1 grid condenser at .10 and .20.....	.35	.80
10 feet spaghetti tubing at .05.....	.50	.84
1 tube socket support.....	.15	.35
15 feet copper connecting wire at .01.....	.15	.45
1 set blueprints for assembling.....	.10	.25
	\$11.44	\$20.12

Some other articles taken from our price list are—

Transformer—Audio frequency.....	2.95	4.50
Frost Fuse—2000 ohms.....	3.95	5.00
Two-step amplifier parts including cabinet and blueprints.....	12.95	21.50
Cathay-type detector tubes.....	4.25	5.00

Radio Parts Manufacturing Company

Dept. "M"—2150 Montclair - Detroit, Michigan, U. S. A.

FREE—a book that tells how to get better results with radio tube sets. Address Willard Storage Battery Company, Cleveland, Ohio.

\$104 PROFIT IN 3 1/2 HOURS



G. A. Barton, Indiana, made that amount—making and selling Candy Floss. Others send in amazing reports: Small, Chicago, says— "Did \$125 business on Sunday." Wendel, Kansas, writes, "Averaged \$128 a day for 3 weeks." Gardner reports, "2,437 sacks of candy sold from 11 a.m. to 10:15 p.m. Big Money in Candy Floss! Rees says: "Cleaned up \$225 in 4 nights in Greenville, Ohio." Candy Floss is a delicious, novelty confection—fluffy, soft as cotton, white as snow, or any color or flavor. Can be made anywhere—in store window, in parks, on street corners, at picnics, summer resorts, base ball games, or wherever crowds gather. Machine easy to operate. Raw materials plentiful and cheap. Send name and address for free illustrated book of facts. Drop postal. Act NOW! Address

A. T. DIETZ

44 Sayre Bldg.

Toledo, Ohio

FREE
NEW BOOK
"CANDY SUCCESS"

Talk
Number
2

Facts from the Factory

This radio game is just as much fun at our end as it is at yours. There's genuine satisfaction in knowing that our radio parts and radio sets will "deliver the goods" to some eager experimenter, or unfailingly convey a message of international importance to the ear of a waiting world.

At the SIGNAL plant we never forget that if we scrimp on material or slight our work then someone will surely be disappointed, and perhaps a despairing call for help may be made in vain.

So it is our joy to perform each operation, little or big, with the utmost of conscientious precision, knowing, thus, that no life can ever be charged against defective SIGNAL apparatus.

Radio equipment bearing the name of SIGNAL may safely be depended upon for good, honest service.

SIGNAL Vernier Rheostat
The first successful vernier using a single knob control. Fine adjustment is easily obtained. Simple in design and sturdy in construction.



Furnished with or without knob and pointer, so dial to match others of set may be used.

SIGNAL Electric Mfg. Co.

Factory and General Offices
1910 Broadway, Menominee, Mich.

Atlanta
Boston
Chicago
Cleveland
Minneapolis
Montreal
New York
Pittsburgh
St. Louis
San Francisco
Toronto
You'll find our local address in your Telephone Directory

INFORMATION COUPON

Signal Electric Mfg. Co.
1910 Broadway
Menominee, Mich.

Please send catalog and bulletins giving complete information about SIGNAL Radio equipment to name and address written in margin.

(2161)

The Turner "Master"

Safest, Hottest, Speediest and Most Convenient Blow Torch Ever Built

\$8²⁵

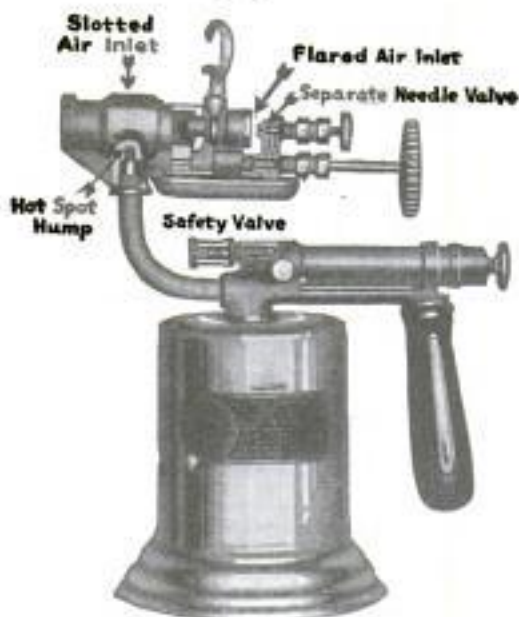

Only blow torch with **safety valve** (Turner patent). Therefore, the only **safe** blow torch.

Burns **Kerosene** or **Gasoline**.

Patented **Hot-Spot Hump** instantly converts fuel to a hot, dry, gas which is mixed with maximum percentage of oxygen at the patented **Flared Air Inlet**.
400° More Heat!

A torch that won't blow out in a gale of wind.

Patented, self-lubricated parachute-principle pump that will always work.

Patented **Pistol Grip** wooden handle—Cool—comfortable.

No opening in tank below fuel line—no fire hazards.

If your dealer does not have it, send us \$8.25 and his name and address and torch will be sent you by express or parcel post.

THE TURNER BRASS WORKS

Sycamore, Ill. U. S. A.

OHIO STREET

FREE! Duo-Reflex!



For the first time, a single tube circuit operates a loud speaker, and this with a loop aerial. The new Duo-Reflex, the most powerful single tube circuit ever built, an Erla product, does this. Ask your dealer for blueprints, or write us.

Electrical Research Laboratories
Dept. J, 2515 Michigan Ave., Chicago

ERLA



The foundation of Duo-Reflex efficiency is the Erla radio frequency transformer. Ask your dealer or write us. Price \$4.00.

Erla bezels improve any receiving set 100%. Patent rim fits 1 1/2" hole in any 1/2" to 1 1/4" panel. Ask your dealer or write. Price 20c.

NEW Self Heating IRON



AGENTS MAKE \$12 A DAY

New scientific development makes ironing remarkably easy. No wires or attachments—all self contained. Gives clean, quick heat, easily regulated. Costs one cent for 3 hour's use. Saves steps. Cuts ironing time in half.

Sells fast. Mrs. Wagner, Ohio, sold 25 in few hours spare time. Moyer, Pa., made \$154.00 in one week. You can do as well. No experience necessary. Work all or spare time. You simply take orders, we deliver by parcel post and do collecting. Commissions paid same day you take orders. Send for Catalog and FREE OUTFIT OFFER. Write today.

AKRON LAMP CO. 33 Iron St., Akron, O.



Catch Fish,

Felt, Mink, and Muskrat in large numbers **SURE**—with our new folding, galvanized **Wire Mesh Traps**. They catch them like a fly-trap catches flies. Made strong, in all sizes. Write for catalog showing sketches of four traps, many other specialties for fishermen, and booklet on best baits known.
WALTON SUPPLY CO., E-27, St. Louis, Mo.

TYPEWRITERS



\$50 buys a brand new Corona, the Personal Writing Machine. Fold it up, take it with you, typewrite anywhere! Write for free booklet No. 8.

Corona Typewriter Co., Inc.
GROTON, N. Y.



CATALOG No. 22 IS READY

Small Steam and Gasoline Engines, 1/4 H. P. up. Pumps, gears, model makers' supplies. Sent postpaid (2 dimes preferred) or 20c stamps.

Modern Engine & Supply Co.
314 Menashaek Bldg., Chicago



FREE LIGHTING FIXTURE CATALOGUE

Our prices are 50% LOWER than elsewhere in the United States. We manufacture our own electric fixtures and eliminate the dealer's profits by selling **DIRECT FROM OUR FACTORY** to you. Special 8-room sets complete ready to hang as low as \$24.50. Write at once for latest catalog.

UNITED LIGHTING FIXTURE CO.
280 Bowery Dept. C New York City

\$2 AND 10 MONTHS TO PAY
DOWN

NEW LOW PRICES—SAVE 1/3

You can now buy on credit at lower prices than even cash jewelers charge, because we import our diamonds from Antwerp and sell at wholesale prices. Your dealings with us are strictly confidential. There is no red tape nor delay.

30 DAYS FREE TRIAL
Select article desired and send deposit to show good faith. If you are not satisfied we will return your money. This is the most liberal offer ever made. You cannot lose.

ORDER FROM THIS LIST

A—\$99.00	Send \$10.00	Down
B—\$39.00	"	2.00 "
C—\$48.00	"	2.00 "
D—\$98.00	"	10.00 "
E—\$59.00	"	5.00 "
F—\$67.00	"	7.00 "

ALL BLUE WHITE DIAMONDS
Perfectly cut, sparkling, brilliant, genuine diamonds, set in 14 Kt. and 18 Kt. solid gold rings. 8% yearly increase in value allowed. Guarantee certificate with each sale.

24 in. PEARLS—DIA. CLASP \$22

WRITE FOR CATALOG NO. 673
It brings a big jewelry store right into your home

PLATINUM FINISH \$16.00

14 Kt. 4 Genuine Diamonds \$42.00

\$32.00
Only \$2.00 Down

Address Div. 673

STERLING DIAMOND & WATCH CO.
63 PARK ROW WORLD BLDG. NEW YORK

"DETROIT" BELT LACING OUTFIT

Cuts only 10 an inch, outlasts the belt, is smooth, strong and flexible—easily and quickly applied. Same method used by 10,000 big factories.

Complete outfit, lacing tool and big box of lacing \$5

Price cut from \$8.50 to \$5.00
We pay postage Money back if not satisfied

Open Hook
Closed Hook

ASSORTED BOX \$1.50

WISE TOOL \$3.50

"Detroit" Belt Lacing shows the least reduction of the belt strength, leaving the belt stronger than any other lacing in existence. "Detroit" Belt Lacing is the only machine closed wire lacing that takes a perfect staggered grip on your belt. Each hook has a pulling strength of over 100 lbs. Hooks put up with rubberized paper side strips in 12 inch sections cut to any length without waste. Dozen sections to box, laces 24 inches of belt.

GUARANTEED
Lacing tool shown in view and box of lacing complete, postpaid, \$5.00 (Vise not included)

Tool made to last a lifetime. Lacing always obtainable. Sold on money-back guarantee.

DETROIT BELT LACER CO., DETROIT, MICH.

TIRE
AIR
LYNER TYRE
TUBE

AGENTS 100% Profit

\$60.00 to \$100.00 a week. Wonderful new tire protector. Prevents punctures and blowouts. Installed without tools. Sells on sight. Wilson made \$100.00 first week. Territory going fast. Write at once for interesting money-back proposition.

PELLETIER TIRE CO.
115 So. Dearborn Chicago, Ill.

Please Mention Popular Mechanics

The Famous YORK Saxophone

Easiest Instrument to Play!

Sent to Your Home for 10 Days



FREE TRIAL

It's a fact! You can have a York Saxophone in your own home for 10 days Free Trial. Learn the scales in an evening, play on it, convince yourself of its superb tone, its high quality. Examine the richness and perfection of its workmanship. Note particularly the ease of playing. If, after this 10 day trial, you are not delighted simply send the instrument back to us and it won't cost you a penny. If you decide to keep it you can make small monthly payments while learning to play.

TAKE YOUR CHOICE

You can have any of the famous York band instruments sent to you on 10 days free trial. Send the coupon below for our beautifully illustrated literature and pick any one of the following instruments:

Saxophones Clarinets Trombones
Cornets Baritones Drums

EASY PAYMENTS

We send you everything you need—carrying case and all necessary attachments, including first lesson FREE. You can pay while playing. Make one small payment down and the balance in small monthly remittances.

SEND COUPON NOW

Use the coupon below. Fill out with your name and address and mention instrument—or instruments—you are interested in, and we will send you at once full details of our Trial offer and Easy Payment Plan—also how to practice and how to learn to play.

J. W. YORK & SONS

Dept. 2218

Grand Rapids Mich.

J. W. YORK & SONS,
Dept. 2218, Grand Rapids, Mich.

Gentlemen:—

Kindly mail, without cost to me, your beautifully illustrated literature and details of your Free Trial and Easy Payment Offer.

NAME.....

ADDRESS.....

INSTRUMENT.....
(Mention above the instrument most interested in)



Skunk: A menace to the chicken yard. Unsettling in fighting that are not considered exactly fair.

RETAIL PRICE
including tax \$15.00
Stevens "Visible Loading." An accurate .22 Cal. Repeater. You know when it is loaded, and you know when it is empty.

**A steady hand
—a clear eye
and a sturdy Stevens rifle—**

Knocking over a skunk, keeling over a rabbit, or bringing down a red squirrel—doesn't make any difference. If you're holding a Stevens and sighting straight, you've got your game every shot.

For a Stevens is always accurate.

When a Stevens barrel is bored or drilled, the final cutting removes less than one-half of a thousandth of an inch. It's slow, painstaking work—but when finished there's not a flaw—that Stevens barrel is accurate.

And the same painstaking care is given to every detail—to getting a handsome finish; to striking just the right balance. Once you get the feel of a Stevens, you'll hate to lay it down.

Handsome guns are these Stevens—the new 1923 Stevens special finish places them among the best looking guns at any price.

And Stevens turns out these sturdy, accurate, good-looking shotguns and rifles at unusually modest prices.

Ask at your dealer's or write for the interesting catalog describing in detail the Stevens complete line of rifles and shotguns.

J. STEVENS ARMS COMPANY
Dept. 563, Chicopee Falls, Mass.

Owned and operated by the
Savage Arms Corporation



RETAIL PRICE
including tax \$9.85
Stevens "Favorite." 24-in. take-down .22 long rifle, .22 short, .25 Stevens and .32 long rim-fire. A favorite for three generations.

Stevens

Please Mention Popular Mechanics

How to Select Safe Bonds

Every investor wishing to learn about bonds of absolute safety yet paying an attractive yield (ranging as high as 7%) should write at once for this book, which will be sent for the asking. It has been prepared by George M. Forman & Company.

YOUR COPY NOW READY

In every banking circle the name of George M. Forman & Company has always been associated with sound investments and an attractive yield. Just a postcard or a letter will bring you a copy of our interesting book, "How to Select Safe Bonds."

GEORGE M. FORMAN & COMPANY, Dept. 443
105 W. Monroe Street, Chicago, Ill.
"27 Years Without Loss to a Customer"



MAKE MORE MONEY TORIT ACETYLENE TORCH NO. 13

For soldering, heating, melting, tempering, auto radiator repairing, battery repair work, and for all kinds of small jobs requiring a hot flame instantly.

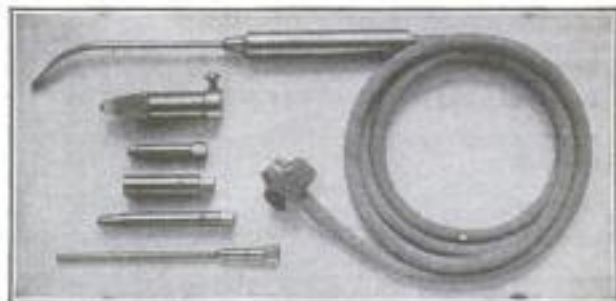

USES ACETYLENE GAS ONLY

Torch with 4 tips for different kinds of work, soldering copper, 5 ft. tubing and connections for auto-acetylene tank.....\$7.50
Order from your jobber. If he cannot supply you send your order to us.

St. Paul Welding & Mfg. Co., 177 W. 3rd St., St. Paul, Minn.

A LATHER THAT SOOTHES

Palmolive Shaving Cream gives a full, creamy lather that makes the beard waxes. The razor moves smoothly. Palmolive is also a lotion. Contains both Palm and Olive oils. Write for free trial tube. Largest tube at drugstore 35c.

THE PALMOLIVE COMPANY, Milwaukee, U.S.A.
PALMOLIVE SHAVING CREAM



Hunting With the Bow and Arrow

By Saxton Pope

An illustrated book - 200 pages making tackle-hunting with Ishi the Indian - shooting small game, deer, lion, bear with the bow. Price \$3.00

THE JAMES H. BARRY COMPANY
1122 Mission Street - San Francisco, California



AGENTS Make Big Money

Selling D-REX-U Safety Signal to automobile owners; complies with safety laws; guaranteed. Write today for wholesale price to agents and get territory quick. Big Winter Seller. Address Comstock-Bolton Co., Dept. K, 1925 E. 15th St., Kansas City, Mo.

SAVE MONEY

New 1923 Edition Ready

Send today for our new, big 1923 catalog which is crowded with bargains from cover to cover. It takes a dollar to do the duty of two. Write now - before you forget. It's free!

PARAMOUNT TRADING CO.
DEPT. 448
34 WEST 28th St. NEW YORK, N.Y.

Bargains in everything for Men & Women
SPORTING GOODS
SHOT GUNS, SHOES
KNIT GOODS
CLOTHING

FREE BARGAIN CATALOG

AGENTS *Some Seller*
At **\$200**
Looks Like \$5.00 Worth
Gives You \$1.10 Profit!



\$12 AN HOUR!

W. H. Marion, a beginner made 36 sales in three hours, first day, \$36 profit! How? Our representatives introduce our products with a first sale of beautiful combination sets of Toilet Articles, Soaps, etc. You sell at half store prices—no fancy talk—sell on sight. Make 20 to 30 sales a day with \$1.10 profit on each. Easy to average \$100 a week. Could you ask more while introducing line, establishing a permanent business for yourself? Another plan calls for no deliveries, no investment, no delays. You bank immediate profits. Also a plan with winning premium to each sale. Write quick for full details.

FORD FREE! No contest. Every producer gets a Ford Car absolutely free. Most amazing offer ever made. Don't waste a minute. Write TODAY for illustrated circulars explaining our **Unique Plans** including 30 other packages. **ACT NOW.**

E. M. DAVIS CO. Dept. 5603 Chicago

ROLLING BATH TUB WITH WATER HEATER

For Homes Without Running Water

Full size white enamel tub and 12 gal. nickel water heater, attached to frame fitted with casters. Rolls anywhere. Heater attachment for kerosene, gasoline or gas. Supplies hot water in few minutes. Tub drains through rubber hose. No plumbing required. Tub can be raised upright when not in use. Guaranteed.

SPECIAL OFFER

Send for complete facts and special price from factory-to-you. Offer is for limited period only.

Write for particulars about our Kerosene Heater, the best on the market.

Agents and dealers wanted. Write for territory

ROBERTS METALLIC BATH TUB COMPANY
Dept. 14, 736 Meldrum Ave. Detroit, Michigan

Mathematics Made Easy by ROPP'S CALCULATOR AND SHORT-CUT ARITHMETIC

Shows the Answer as Quickly as a Watch shows the Time to all Problems likely to occur in the Office, Store, Shop, Bank, Farm, or Factory.



Explains and simplifies every principle in Arithmetic, Mechanics, and Mensuration.

PRICES POSTPAID
Desk Size...\$1.50
Leatherette, Pocket Size...\$1.00
Pocket Size, Cloth...\$0.50
Pocket Size, Paper...\$0.35

PopularMechanicsBookDept., 200 E. Ontario St., Chicago



A Week's Free Trial (Read below)

New Style Oliver Now Ready
The New 1923 Model

Send now for complete details on the wonderful new Oliver Typewriter—NOW READY—"The Quiet Speedster"—the new 1923 model.

More than 1,000,000 Oliviers have been made and sold. That fact alone is proof of the service and satisfaction rendered by this typewriter. And now comes the crowning achievement of twenty-eight years' experience in building typewriters—"The New Quiet Speedster."

NEW FEATURES

1—Three-Bank Standard Keyboard The new Oliver is equipped with a standard three-bank keyboard. Any operator who operates a standard three- or four-bank keyboard can operate the new Oliver without practice, without loss of speed or output.

2—Silent Action The new Oliver is practically silent in its action.

3—Velvet-like Touch The very slightest touch moves the keys of the new Oliver.

And, besides, the Oliver is the most durable typewriter you can obtain anywhere. You get this wonder typewriter at the famous Oliver money-saving price.

\$50 Saved and the World's Best Typewriter shipped to you direct

If there ever was a machine worth \$100 or more it is the new Oliver "Quiet Speedster." Because of high manufacturing efficiency and because we have no money-eating branch offices or organizations, we can save money in the producing and selling of this machine. You get the benefit of these economies. You can save over \$30 on the Model 11, or, if you prefer, you can save \$50 on the Model 9, which is the same as the Model 11, less a few of the more recent improvements.

Oliver No. 9 with 1923 Model Standard Three-Bank Keyboard—the highest class machine—Monthly price \$85.00. Net cash price

\$49.50

Oliver No. 11 Newest Improvements. Monthly payment price \$75.00. Net cash price

\$67.50

Free Trial The new Oliver will be shipped to you for a week's free trial. Use it in every way you know how. Put it to every test. If not satisfied, simply send it back at our expense. If you decide to keep it, pay on terms as low as \$5 a month. Get the complete details of the free trial offer.

Catalog FREE SEND NOW

for the beautifully illustrated catalog just off the press. It tells you all about Models No. 9 and No. 11. Get the facts on the new standard three-bank keyboard, the quiet action and light touch of the new Oliver. Learn why it is the speediest, yet the most durable typewriter. Get the complete details of our money-saving offer and the FREE TRIAL offer and easy payment plan. You will be under no obligation to buy. GET THE CATALOG NOW.

The Oliver Typewriter Company
1093 Oliver Typewriter Bldg., Chicago, Ill.

Without obligation send me booklet on Model No. 9 and on the New "Quiet Speedster" Model No. 11; full details of your free trial offer and cash and easy payment plans.

Name.....

Address.....

City.....

State.....

The Oliver Typewriter Company
1093 Oliver Typewriter Bldg., CHICAGO ILL.

Please Mention Popular Mechanics

Orlando is Calling You

Do you want to get away
From the grind of every day—
From the drudgery of things you have to do?
Do you want to settle down
Near a lively, busy town,
Where the joy of living will appeal to you?

Do you want to scent the breeze
Coming through the orange trees?
Do you want to hear the birds call—loud
and clear?
Are you seeking perfect health
That's combined with certain wealth
And an income from an orange grove each
year?

Do you want a piece of land
That will grow to beat the band
All the different garden crops that you
enjoy?

Do you want to make a "Nest,"
And a permanent bequest
For the future welfare of each girl and boy?

Do you want a sunny clime
Where there's fishing all the time?
Where there's ducks and deer and quail
and other game?

Where the summer climate's cool,
And within each lake and pool,
You can swim in January—just the same?

Do you want to buy this land
On an easy-payment plan,
With about your monthly outlay for cigars?
Do you want to read a book
That will make you want to look
On the finest land that lies beneath the
stars?

Send a letter right away;
Put it in the mail to-day,
We will send this Booklet absolutely FREE.
After you have read it through,
If a thought occurs to you—
Just address another letter here to me.

We will answer, straight and true,
Questions that occur to you.
We have nothing to evade or to conceal.
On an Orange County Farm
Life will take on added charm,
And you'll never lack a dollar—nor a meal.

Send for our Big, FREE Illustrated Book—
"TWENTY ACRES AND PLENTY." It
tells of almost unbelievable profits made
from trucking and fruit-growing in our
part of FLORIDA. Also about sick-and-out-
of-work Clauses, and other protective fea-
tures of our contract. Address Sylvester
E. Wilson, Dept. J 13, Orlando, Florida.

EASY FOR YOU TO OWN A FINE INSTRUMENT!

YEARS ago the famous King Brass Instruments were sold only for cash to famous musicians. But now due to our easy payment plan anyone can own one of these wonderful instruments.

SAVE MIDDLEMAN'S PROFITS

Simply order direct from the factory. You save middleman's profit—and you get a fine, new, sound-laboratory tested, acoustically perfect King Instrument. With it goes our guarantee plus free factory-service.

IT'S EASY TO OWN A KING

Rebuilt instruments, refinished to look like new, we sell for cash at low prices. New instruments on the easy payment plan. Thus it's "easy to own a King". Send for our latest complete catalog and list of special bargains.

THE H. N. WHITE COMPANY
5246 Superior Avenue Cleveland, Ohio



Why Burn Coal

When you can get twice the heat at half the cost, by installing, in 5 minutes time, Uni-Hete Oil-Gas Burner in your range or heater. Thousands of homes now ending coal expense! Uni-Hete generates gas from common kerosene—cheapest fuel known. Red hot fire instantly. Cooks, bakes, heats. Sets in fire box of any stove. FREE TRIAL. Saves its small cost in 30 days. Lasts for years. Made by factory making heating devices for 35 years.



Agents—Special Offer—Act Quick
High coal cost makes Uni-Hete a big profit maker for agents. Write at once.

Acorn Brass Mfg. Co., 367 Acorn Bldg., Chicago, Ill.

BIG VALUE for 10 Cts.



6 songs, words and music; 25 Pictures Pretty Girls; 40 Ways to Make Money; 1 Joke Book; 1 Book on Love; 1 Magic Book; 1 Book Letter Writing; 1 Dream Book and Fortune Teller; 1 Cook Book; 1 Base Ball Book, gives rules for games; 1 Toy Maker Book; Language of Flowers; 1 Morse Telegraph Alphabet; 12 Chemical Experiments; Magic Age Table; Great North Pole Game; 100 Conundrums; 3 Puzzles; 12 Games, 30 Verses for Autograph Albums. All the above by mail for 10 cts., and 2 cts. postage.

ROYAL SALES CO., Desk 723, South Norwalk, Conn.



Those who wear them say:
ERICKSON LEGS are Wonderful
because they do not chafe, overheat or draw end of stump.



Established 1892

If you have had a recent amputation send for new booklet on BEST LEGS for beginners.

E. H. ERICKSON CO.
38-A Washington Av. N.
MINNEAPOLIS MINN.



Swear Off Tobacco

Tobacco Habit Banished Let Us Help You

Quick Results

Trying to quit the tobacco habit unaided is often a losing fight against heavy odds, and may mean a serious shock to your nervous system. So don't try it! Make the tobacco habit quit you. It will quit you if you will just take Tobacco Redeemer according to directions.

It doesn't make a particle of difference whether you've been a user of tobacco for a single month or 50 years, or how much you use, or in what form you use it. Whether you smoke cigars, cigarettes, pipe, chew plug or fine cut or use snuff—Tobacco Redeemer will positively remove all craving for tobacco in any form in a few days. Your tobacco craving will usually begin to decrease after the very first dose—there's no long waiting for results.

Tobacco Redeemer contains no habit-forming drugs of any kind and is marvelously quick, scientific and thoroughly reliable.

Not a Substitute

Tobacco Redeemer is in no sense a substitute for tobacco, but is a radical, efficient treatment. After finishing the treatment you have absolutely no desire to use tobacco again or to continue the use of the remedy. It helps to quiet the nerves, and will make you feel better in every way. If you really want to quit the tobacco habit—get rid of it so completely that when you see others using it, it will not awaken the slightest desire in you—you should at once begin a course of Tobacco Redeemer treatment for the habit.

Results Absolutely Guaranteed

A single trial will convince the most skeptical. Our legal, binding, money-back guarantee goes with each full treatment. If Tobacco Redeemer fails to banish the tobacco habit when taken according to the plain and easy directions, your money will be cheerfully refunded upon demand.

Let Us Send You Convincing Proof

If you are a slave of the tobacco habit and want to find a sure, quick way of quitting "for keeps" you owe it to yourself and to your family to mail the coupon below or send your name and address on a postal and receive our free booklet on the deadly effect of tobacco on the human system, and positive proof that Tobacco Redeemer will quickly free you from the habit.

Newell Pharmacal Company
Dept. 300 St. Louis, Mo.

Free Book Coupon

NEWELL PHARMACAL CO.,
Dept. 300 St. Louis, Mo.

Please send, without obligating me in any way, your free booklet regarding the tobacco habit and proof that Tobacco Redeemer will positively free me from the tobacco habit or my money will be refunded.

Name.....

Street and No.....

Town..... State.....



Tobacco Tells on
Nervous System



Tobacco Ruins
Digestion



Tobacco Stunts
Boy's Growth



Tobacco Robs
Man of Vitality



Tobacco Steals
from You the
Pleasures, Com-
forts, Luxuries
of Life



Made \$1400 First Season

Made it with an Ideal Lawnmower Grinder

Let Mr. Brown tell his own story:

The Fate-Root-Heath Co., Windsor, Can.
Plymouth, Ohio.

Gentlemen: I have made over \$1400.00 with the Ideal Lawnmower Sharpener since I bought it last June. My boy, 14 years old runs it as good as I can. I have built me a nice shop with this money in which to sharpen mowers this year. I did 700 mowers at \$2.00 for each mower, and this year I expect to do 2000 mowers.

A. Brown.

E. W. McCormick, of Saginaw, Mich., writes:

Five years ago I purchased from you an Ideal Lawnmower Grinder with which I ground over 5000 mowers. If I could not buy another I would not take \$1000 for it.

E. W. McCormick.

WRITE FOR CATALOG

and little booklet, "LET GEORGE SAY IT." It tells the stories of profit as the boys tell it. Mr. Brown bought early, made \$1400 by fall, and built a new shop with the money. Write today.

THE FATE-ROOT-HEATH CO.
PLYMOUTH, OHIO

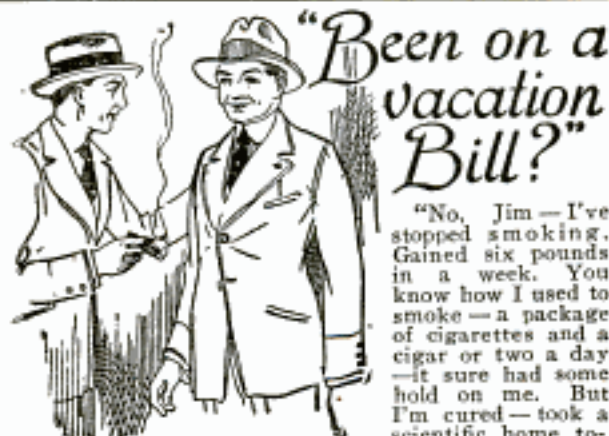
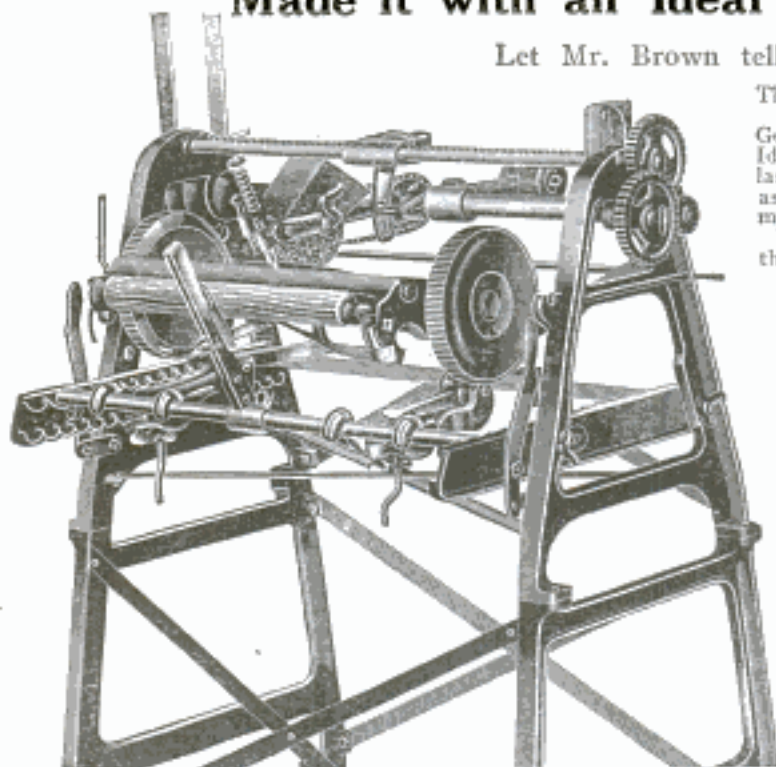

"Been on a vacation Bill?"

"No, Jim—I've stopped smoking. Gained six pounds in a week. You know how I used to smoke—a package of cigarettes and a cigar or two a day—it sure had some hold on me. But I'm cured—took a scientific home to-

bacco treatment—fixed me up in two weeks.

"Wasn't hard on me at all—noticed improvement the first day—I feel like a new man. It didn't interfere with my work—didn't leave any druggish after-effects—the money I saved in the last two weeks has paid for the treatment alone.

"Why don't you take it? It has cured men like you and me for over forty years—it is a doctor's individual prescription that sure fixes you up. Just send the coupon for full information NOW. No obligation. All correspondence is strictly confidential."

THE KEELEY INSTITUTE
Dwight - - - Illinois

The Keeley Institute, Dwight, Ill.
Please send me, without any obligation on my part, your free booklet which will tell me how to rid myself of the tobacco habit.

Name.....
Town.....
Street..... State..... PM-3

Please Mention Popular Mechanics



\$35 Brings Your Shop GUARANTEED
FREE AIR SERVICE
With HB Automatic Twin Compressor

Increased excitements and profits from new business gained by improved service easily pay balance on small monthly terms. Good free air service Day and Night pulls trade, brings new customers, helps you sell tires, oil, gas and accessories. Extremely compact construction enables you to run the HB Compressor in limited space. QUIETEST OPERATING outfit on the market. Entirely automatic. Weighs 135-145 pounds or higher on air base 24 hours per day. 4 cubic feet capacity. Saves current, due to compact single unit construction. Fully equipped, ready to connect up and operate. Comes to you on easy terms. Satisfaction guaranteed under our money-back guarantee. Write for information. HOBART BROS. CO., Box M 30, Troy, Ohio

Absolute Satisfaction Guaranteed or Money Back

TYPEWRITERS

Renewed Underwoods, Royals, Remingtons, Smiths, Coronas, Nationals, Fox; less than 1/2 price original price. Write for our rate price list.

MFRS. TYPEWRITER CLEARING HOUSE
193C North Dearborn Street CHICAGO



FREE Book of Newest Styles just out. Women's, men's, children's clothing on credit and at bargain prices, less than cash prices everywhere. Very latest fashions; best materials. Open a charge account with us. Buy on credit and save money! Dress in newest styles. Send for Style Book absolutely FREE today! Elmer Richards Co., Capt. 1773, W. 35th Street, Chicago.



**For Luck
in Love**

Love is the greatest thing in the world. Why not have good luck in love? The Sheik, the world's most famous lover, the outstanding hero of gorgeous Arabian Nights conquers love. The Sheik Ring with his image on it is the symbol of this great lover's

charm and power. Amazing stories are being told of good luck in love by prominent wearers. Get this Arabian Sheik Ring of unique design and unusual beauty adorned with gorgeous Ahmed ruby and emerald. **SEND NO MONEY.** Simply your name and address, also a strip of paper for size. Say whether lady's or gentleman's. When it arrives, simply deposit \$1.75 with mailman. Order today. Deposit promptly returned if not satisfied after 5 days.

SHEIK AHMED, Rand McNally Bldg., Dept. 83, Chicago

Your Wrist Wasn't Made With a Ratchet

That's why "YANKEE" Ratchet Screw-drivers *were* made—to save your muscles from the strain of gripping and letting go the handle dozens of times in driving each screw. Save time, too.

Just grasp the handle and twist it to and fro. Your first good grip need not be relaxed until the screw is all the way home. It's like winding your watch.

To *draw* screws, move ratchet shifter to back notch. A finger-touch does it. To make tool rigid, move shifter to center notch.

"YANKEE" Ratchet Screw-drivers

No. 10—(Illustrated). Blades of best cast steel, specially tempered, ground, polished and tested. Blade lengths 2, 3, 4, 5, 6, 8, 10 and 12 inches.

No. 11—Same as No. 10, except that ratchet shifter moves *across* barrel.

No. 15—(Illustrated). Has handy knurled thumb turn for starting small, wobbly screws. Blade lengths 2, 3, 4, 5, 6 and 8 inches.

Write today for Free Tool Book

Illustrates and describes all the ingenious "Yankee" Tools for saving time and labor and doing otherwise impossible jobs.

NORTH BROS. MFG. CO., Philadelphia, U. S. A.

"YANKEE" TOOLS

Make Better mechanics

COZY COT AUTO SEAT—Lowers, Reclining or in line with back-seat forming bed. Neat, simple construction, works automatically by pressing button. Manufacturing details worked out by special mechanics, fully patented, designed for tourists; emergency ambulance, etc. **Will sell patent or manufacturing rights on royalty.**

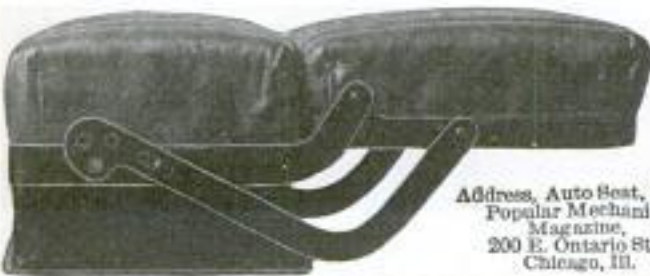

Address, Auto Seat, Care
Popular Mechanics
Magazine,
200 E. Ontario St.,
Chicago, Ill.



Some other "Yankee" Tools

Ratchet Breast Drills
Ratchet Hand Drills
Ratchet Bench Drills
Ratchet Tap Wrenches
Automatic Push Drills
Bench Vises, Removable
base
Quick-Return Spiral
Screw-drivers
Plain Screw-drivers
1½ in. to 30 in. blades

*Dealers everywhere
sell "Yankee" Tools*





Elto

3 H.P. Fast Light Twin
"As light as right"

FULL 3 H. P. by piston displacement. That's a full extra H. P. over any other outboards in the light-weight class—the needed extra H. P. to give speed to sea-worthy boats, to buck currents, winds and tides. The Elto is the most powerful light-weight and has greatest H. P. per pound over all outboards.

Built around big bearings—Elto's 21 square inches of perfection-ground, case-hardened crankshaft and connecting-rod bearings give almost double the bearing area of other light-weight motors. Trust Ole Evinrude, the pioneer designer of outboards, to build "as light as right" at no sacrifice of power or durability.

Safe Rudder Steering—no chance of dangerous pivot turning. Easy tiller rope steering from any part of boat. No shaky steering handle. **Instant starting.** No ropes needed. Hot spot battery starts the Elto on first quarter turn. Atwater-Kent Unisparker prevents "juice wastage." Battery lasts full season. Every hardware store a service station. No parts to be returned for re-magnetizing. **Folding rudder.** Goes in carrying case without taking apart. Write for catalog.

Dealer and Demonstration Agents—

The Elto is the fast, powerful, durable outboard that builds you a permanent business. A profitable proposition if your territory is open. Write today.



**ELTO OUTBOARD
 MOTOR CO.**

Dept. AA

*Manufacturers Home
 Building*

MILWAUKEE
 WIS.

Designed
 by
 Ole Evinrude

CONN

WORLD'S
 LARGEST MANUFACTURERS
 OF HIGH GRADE BAND AND
 ORCHESTRA INSTRUMENTS

Instruments of the Worlds Great Artists.

For two score years the world's most celebrated artists have hailed Conns supreme in quality because of perfect tune, beautiful tone and exclusive features which make them easier to play.

Conn is the only manufacturer of the complete band instrumentation. Choose the instrument that suits your talent—to be sure it's the best insist on Conn. **Free Trial; Easy Payments.** Send for Free Book and details on any instrument. *Highest Honors at World's Expositions.*

Dealers and agents throughout the country. Factory branches in many large cities.

C. G. CONN, Ltd.
 331 Conn Bldg. Elkhart, Ind.

SOUSA
 Endorses Conn
 supreme quality



AUTO DRIVING AT NIGHT MADE SAFE

By the use of this wonderful little device, you can gaze directly into the most intense light without any eye strain whatever. By its use, night driving is now made absolutely safe. You can see the road ahead clearly at all times—yet your eyes are protected from all blinding rays. Carried easily in pocket. Adjusted instantly with one hand. Don't be without one—50c postpaid. Agents write today—great seller anywhere.

Guaranteed as represented or money refunded.

G. O. SMITH, Box 352, Oakland, Calif.



LUCKY HORSESHOE RING

Change Your Luck

The famous Kosmos Lucky Ring is a thing of beauty; it's odd, it's attractive. Made of solid Gold and Silver, set with Sparkling Garnet. It's the symbol of good luck in business, love or anything. Send your ring measure (strip of paper around finger) and we will send you this wonderful Ring.

When it comes pay this special price of \$3.97. Wear it seven days and follow the seven rules which come with it. If not fully satisfied, your money back. Be in luck—order now!

KOSMOS CO., Dept. 124, 124 W. Randolph St., Chicago

MEN WANTED

If you are interested in a New big Money making proposition write me at once. Positively no money needed. \$5 to \$12 a day. Full or spare time. We want good reliable men to distribute a new household necessity to be given free to every housewife. This is no fake or catch scheme. This means just what we say. If you are now selling for some other concern, it will pay you to carry this wonderful new article right with you. Takes up no space—easy to carry—will give you an additional income. If you are ready and want to start at once to distribute this new article let us hear from you today. Territory being filled rapidly.

JENNINGS MFG. CO., Secretary 226, Dayton, Ohio

Your Old "Bike" and The SHAW Motor



Makes A Complete Motorbicycle

Gives speed of 4 to 40 Miles an Hour!
90 to 125 Miles per Gallon of Gasoline!
1,200 to 1,800 Miles per Gallon of Lubricating Oil!

Easy to Ride—Easy to Control—Dependable.

Easy to Attach—No Special Tools! No Mechanical Skill Required!

Shaw Specifications

Power Plant—2½ H-P SHAW Super Motor, 4-cycle type; Bore 2¼ inches; Stroke 3 inches.
Transmission—Two roller chains with countershaft clutch on crank hanger shaft, giving free engine.
Ignition—American magneto; water and oil proof.
Carburetor—Celebrated Kingston float feed type.
Lubrication—Sight feed; automatic.
Control—Grip control.
Fuel Tank—Two compartments; one for oil and one for gasoline; round tank for single bar frame, or flat tank for double bar frame, is furnished without extra cost.

Something New—The SHAW Cycle Car

A real automobile you can build yourself. Power supplied by SHAW 2½ H-P motor. Speed 4 to 25 miles an hour. We furnish all parts. Get Low Prices and Complete Details at once.

The Complete Shaw Motorbicycle

The SHAW Motorbicycle is a light-weight, powerful motorbicycle, complete in every detail. All latest improvements. 2½ H-P 4-cycle motor of highest efficiency. Special Low Price now.



You don't have to do any filing, fitting or boring to make your old "foot-power" bike a dependable motorbicycle with the SHAW Attachment. A monkey wrench and a screw driver are the only tools you need. You can clamp the SHAW Attachment to your bike in 30 minutes time. Just follow the simple directions that come with it.

Fits Any Make Bicycle

The SHAW fits any standard bicycle frame. No cutting or making over. Nothing at all complicated.

Prices Reduced Now

We have made tremendous price reductions—effective **at once!** You can now get the SHAW Motor Attachment at a lower price than ever before. Take advantage—**ACT!**

Write Today—

For Complete Descriptive Literature and New Low Prices on SHAW Motor Attachments and Motorbicycle. Use the Coupon below. Fill out and mail it **NOW!**

SHAW MFG. CO., Department 37,
GALESBURG, KAN.

Send This Coupon for New Low Prices

SHAW MFG. CO.,
Dept. 37 Galesburg, Kansas.

Please send me New Low Prices and Full Particulars on the SHAW Motor Attachment, Complete Motorbicycle, and the New Shaw Cycle Car, all without obligating me.

Name

Address

R. F. D. State

1923 Indian Scout Motorcycle



Electrically Equipped \$285

Costs less to run than carfare

Come and go when you like, enjoy the greatest sport in the world.

INDIAN Scout is the biggest value for the least money.

75 miles to the gallon, all up-keep low. 100 pounds lighter than the average motorcycle. Powerful enough for any hill or road.

You'll like the INDIAN Scout.

Your dealer will be glad to demonstrate. Write Dept. 37 for nearest dealer's name.

Hendee Manufacturing Company

Largest Motorcycle Manufacturer in the World

SPRINGFIELD, MASS., U. S. A.

An Indian Sales Franchise is too good a proposition to be passed by a live dealer. Write for full particulars.



Free!

Just Off The Press Send for this big "Nemco" Book today. It is chock-full of money-savers for you—you'll be surprised how low priced you can now buy **guaranteed standard** accessories. Here's the secret:—

We Buy for Cash and Sell for Cash

Look over this partial list of bargains for Fords, Headlights, pair 3.30, 6-volt horn 1.15, Set of four fenders 9.95, Radiator 11.95, Front spring 1.17, Rear spring 4.00, Set of four demountable wheels and fiverrims 16.00, 17-inch steering wheel 1.20, and hundreds of other similar bargains—Speedster Bodies, tools, tires and other accessories for all cars. Send for your copy today and start saving money by buying from

NEMCO BARGAIN SUPPLY HOUSE

37 N. Peoria St.

Chicago, Ill.

TIRE Agents Wanted

An auto owner in each locality to use and introduce

Mellinger EXTRA-PLY and CORD Tires

Make big money part or full time. No capital or experience needed. Sample Sections furnished. **GUARANTEED**

8,000 and 10,000 Miles (No Sec-onds)

Hand made. Finest materials. Shipped prepaid on approval.

FREE Tires for Your Car to one user in

each locality for taking a few orders. He first to write quick for Special Agents Offer and Low Wholesale Prices.

MELLINGER TIRE & RUBBER CO.

910 North Oak Street Kansas City, Mo.

Save \$10 to \$25 On Custom-made Re-covers

Easily attached; instructions sent. Top and back with

oblong beveled plate glass,

tacks, welts, etc. Special

low prices on Dodges, Maxwells and Chevrolets.

Ask for Bulletin T.—give name and year of car.

S-C PRODUCTS CO., 1273 Nicholas Bldg., Toledo, Ohio

BRAND NEW CORD TIRES

Thousands of our customers are getting 12,000 miles out of these tires, you too can get this mileage. These tires are firsts.

SIZES	CORDS	TUBES
30x3 \$ 3.95 \$.90
30x3 1/2 6.9595
32x3 1/2 8.85 1.05
31x4 9.95 1.10
32x4 10.45 1.15
33x4 11.10 1.20
34x4 11.90 1.25
32x4 1/2 16.50 1.45
33x4 1/2 16.75 1.50
34x4 1/2 17.05 1.55
33x5 19.95 1.75
35x5 20.10 1.80

30X3 1/2

\$6.95

Send No Money

Write us and tell us the size of your tires and how many you want. Shipped C.O.D. with section unwrapped for inspection. Money back if not satisfied.

CHARLES TIRE CORPORATION

Dept. 756

1440 Michigan Avenue, Chicago, Ill.

A MOTOR FOR YOUR BICYCLE



No pedaling. You go faster and easier. Eliminates all fatigue. Just take off your front wheel and fork. Replace with reinforced fork, new wheel and ROLL-AWAY motor, all furnished by us. Gives you that safe, positive front-wheel drive. Motor fully guaranteed. Extremely economical. 100 to 150 miles to gallon gasoline. Speed from 6 to 30 miles an hour. Fits any bicycle. Anybody can quickly attach. All controls on handlebar. Hundreds in use. Marvel of simplicity and dependability. Increases utility and pleasure of cycling one hundred per cent. Write for FREE circular.

BE OUR SALESMAN

Buy demonstrator. Show and sell. Big commissions. Get our liberal proposition. Address

THE ROLLAWAY MOTOR CO.
321 Southard St. Toledo, Ohio



Easily Attaches to any Bicycle

Rollaway

TRADE MARK

STANDARD ELECTRIC SERVICE FOR EVERY CAR

WELLS' AUTO ELECTRICIANS' HANDBOOK

Gives the exact performance, the construction, the method of testing, and explains all adjustments, settings and peculiarities of operation. Blueprint internal wiring diagrams for each generator, motor, cut-out and regulator—drawn just as the machine is built. Covers 1324 models of 270 different makes of cars from 1911 to date, showing more than 1000 changes of equipment. Loose-leaf with forty pages of index.

PRICE \$12.50 PREPAID

WELLS' AUTOMOTIVE WIRING MANUAL

Real car wiring diagrams for shop work—showing the parts and wires the way they are placed on the cars themselves. All in big, clear blueprint diagrams—from 1912 to date. Every diagram correct, the last word in usefulness. The sixth consecutive year of issue—your guarantee of continued service in keeping up to date. Loose-leaf binder.

PRICE \$12.50 PREPAID

WELLS' AUTO ELECTRICIANS' CYCLOPEDIA

combining both of above in loose-leaf binder. PRICE \$22.50 PREPAID

POPULAR MECHANICS BOOK DEPT.
210 E. Ontario St., CHICAGO



\$365⁷⁵ One Day



Ira Shook of Flint, did that amount of business in one day making and selling CRISPETTES. Net profit, \$269!



Mullen of East Liberty bought two outfits and is ready for the third. Ivata, Calif., purchased outfit in Feb. 1920. Since, has bought 10 more. His profits enormous. J.R. Bert, Ala., wrote: "Only thing I ever bought equalled advertisement." J.M. Patislo, Ocala, wrote: "Enclosed find money order to pay all my notes. Getting along fine. Crispette business all you claim and then some." John W. Culp, S. Car., writes: "Everything going lovely. The business section of this town covers two blocks. Crispette wrappers lying everywhere. It's a good old world after all!" Kellogg \$700 ahead end of second week. Masters sold \$40 first four hours. Perrin, \$350 in one day. Baker 3,000 packages in one day. And so on.

WE START YOU IN BUSINESS!

Very little capital. No experience. Furnish secret formulas.

BUILD a BUSINESS OF YOUR OWN!

The demand for CRISPETTES is enormous. A delicious food confection. Write me. Get facts about an honorable business which may make you independent. You can start right in your own town. Business will grow. You won't be scrambling and crowding for a job. You'll have made your own place.

PROFITS, \$1,000 a MONTH POSSIBLE!

Send post card for illustrated book of facts. Contains enthusiastic letters from others—shows their places of business, tells how to start, when to start, and all other information needed. It's FREE. Write now.

LONG EAKINS COMPANY

328 High Street

Springfield, Ohio

SEND for the INTERNATIONAL CATALOG

FOR FORD—PRICES FROM \$27.85 UP. Factory to Consumer direct—Pay only one profit.



Our set price list. Full line of auto bodies and accessories for Fords at Wholesale Prices. Save big money on bodies by buying direct from factory.

International Body Works, 214 W. Ohio Street, Dept. 7, Chicago, Ill.

Get this Book of Factory Prices



Stoves
Ranges
Furnaces

Don't wish for a good range—write to Kalamazoo Manufacturers and own one. \$4 to \$15 down brings any range in our catalog on easy-payment plan. 200 styles and sizes. Porcelain enamel, cast iron, steel, malleable, etc. Furnaces, too. Special profit-sharing sale now on for limited time only—greatest money-saving event in years. Write today.

KALAMAZOO STOVE CO.
393 Rochester Ave.

A Kalamazoo Direct to You

Kalamazoo, Mich.



"COME out for a ride!—a brisk, bracing spin into the country, over any roads, at any speed, up any hills you choose!

"Let me show you that motorcycling—with a Harley-Davidson—is 'the greatest sport in the world'. And the most economical, too, for it costs only two cents a mile—gas, oil, tires 'n everything.

"Come out with me! I am your Harley-Davidson Dealer—an' I'm waiting to give you a demonstration ride, any time! Maybe you don't know about my new Pay-as-You-Ride plan. Let me tell you about it'.

Write, now, for your FREE copy of "The Open Road". It tells you all about the 1923 Harley-Davidson Motorcycles and Sidecars (reduced prices—10 improvements this year).

Harley-Davidson Motor Co.
Milwaukee, Wisconsin

Money-making sales opportunities in open territory Write Desk A-2.



Harley-Davidson
The Motorcycle

Please Mention Popular Mechanics

LOFTIS
BROS. & CO. ESTD. 1856

Genuine Diamonds GUARANTEED
We import Diamonds direct from Europe and sell direct to you. We invite comparisons.

DIAMONDS WATCHES CASH OR CREDIT

Send for Catalog

Over 2,000 illustrations of Diamond-set Jewelry, Watches, Wrist Watches, Pearls, Mesh Bags, Silverware, etc. Select as many articles as you wish and have all charged in one account. Sent prepaid for your Free Examination. Catalog explains everything. Our long service to the public (established 1856) is our Guarantee of absolute satisfaction to you and the safeguard of your interests.

CREDIT TERMS on all articles: One-fifth down, balance divided into equal payments within eight months. *Send for Catalog.*

Charlotte
Diamond Ring
Five radiant, blue white, perfect cut Diamonds. Entire ring is platinum.
\$150
Others at \$200 and \$250

Wrist Watch
Rectangular Shape
18-K Solid White Gold, 17 Jewels, \$29
14-K Solid White Gold, 15 Jewels, \$22

Loftis Leads in Low Prices
Our Diamonds are distinctive in beauty, blue white, perfect cut, of great brilliancy, set in the latest fashionable Solid Gold mountings. Wonderful bargains in men's standard Guaranteed Watches. We guarantee absolute satisfaction or money refunded.

LIBERTY BONDS ACCEPTED

LOFTIS OLD RELIABLE CREDIT JEWELERS
Dept. L-894
108 N. State Street, CHICAGO, ILL.
Stores in Leading Cities

Pearl Beads . . . \$10.00 up
Diamond Cut Links \$25.00 up
Wedding Rings . . . \$5.00 up

START IN BUSINESS FOR YOURSELF

IF YOU ARE INTERESTED IN OWNING YOUR OWN BUSINESS ON A SMALL INVESTMENT—
Income \$600.00 and up monthly—
Write for our **SPECIAL SPRING OFFER** both for **CASH AND EASY TIME PAYMENT PLAN** on **DUNCAN No. 10 or 3B COMPLETE TIRE REPAIR SHOP EQUIPMENT.**

We teach approved factory methods—Experience not necessary—Big field open for Progressive men to start in business for themselves and reap the harvest of the Big Early Spring Business.

Special inducement on all orders received prior to March 15th—
Write NOW for descriptive folders—prices and Special Spring Offer.

F. M. DUNCAN COMPANY
341-49 East Ohio Street, Department P, Chicago, U. S. A.

BIG MONEY!

\$4.75
SPECIAL TODAY
EXT. SALE
BOOKS \$1.50

BIG MONEY IN SPARE TIME for one man in each locality making embossed show cards and price tickets for stores and others. Easy, quick work. No training needed. New embossing machine does it all. 400% profit. Signs sell on sight. T. W. Cushing of Chicago sold \$76 first call. S. D. Downes averaged \$15 a day for 6 months. Many sell \$5 to \$20 daily. No speculation. Before you invest a penny we send you free sample cards to show merchants and convince yourself they sell at sight. Write today.

PRAEMAFIX CORPORATION OF AMERICA
Dept. 600 Geneva, N. Y.

Factory Sale

NEW Model BOILER and Storage Can

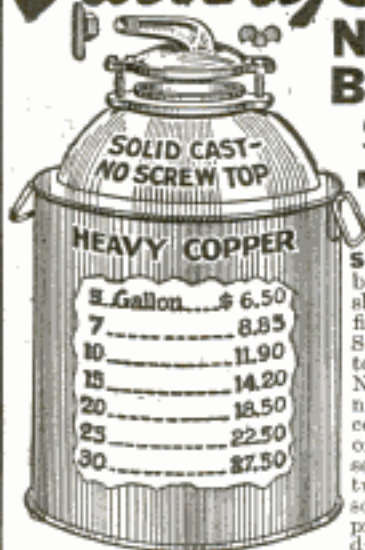

Made of extra strong, heavy pure copper, with a 5-inch Solid Brass Cap and Spout. Rubber gasket between cover and shoulder makes airtight fit. Easily cleaned. No Screw Cap, no threads to get out of order. No burning of bands, no trouble in taking off cover. Cap can be put on or taken off in a second by a simple twist of the thumb-screws on the side. Safe, practical, simple and durable. No article of such quality and utility

ever sold at such low price. Costs only a little more than the light weight spun cover cans which bend and easily get out of order. It lasts a life-time and gives real service and satisfaction. Above are strictly cash with order. Factory prices. Send money order or check. Prompt shipment in plain, strong box. Order the only can worth having. Catalogue Free.

HOME MANUFACTURING CO.
Dept. M-21 321 West Chicago Avenue Chicago

\$50 a Week EASY AGENTS Free Sample Offer



You can start a big paying business at once. Don't wait. Get big money. We tell you how—selling the famous E-Z Self-Heating Sad Iron. No experience necessary. *Easy to sell.* Possibilities great. Every home a prospect. *Satisfaction guaranteed.* Absolutely safe. Thousands in use. Write today for proposition.

Enterprise Tool & Metal Works, Dept. 33, 129 So. Clinton St., Chicago

PIMPLES Blackheads, Acne Eruptions, Oily and Shiny Skin quickly removed by using SMOOTH-SKIN. \$1,000 money-back guarantee mailed with every bottle.

FREE! Valuable booklet explaining cause and cure of Skin Eruptions sent on request. Read what SMOOTH-SKIN has done for others after years of suffering.

Special Offer To New Customers.
Puritan Chemical Co. Dept. 20, Kansas City, Mo.

VITALIC Bicycle Tires TRADE MARK REGISTERED Tougher Than Elephant Hide

You Can Earn \$500 a Month

No experience or investment necessary. We teach you how to earn \$250 to \$500 a month by taking orders for wonderful new All-Weather Coats of waterproofed Gaberdines—Whipcords—Tweeds that sell fast because raincoat and cloth coat combined. **Wayne Manufacturing Co.** Dept. B2, 144 West 36th St., New York City



A Home and Income For You in Sunny Florida



Be Independent—Own a Grapefruit and Orange Grove—A Truck or Poultry Farm. Increase Your Income

You Can Start a Grove Today Under Our New Plan

Develop a profit-earning fruit farm without leaving your present position—provide for your future. A small payment now and a few dollars invested each month.

A profit-producing fruit grove is a permanent investment and provides protection against old age.

THE RIGHT LAND IN THE RIGHT LOCATION AT THE RIGHT PRICE

We Have It—Any Size Farm

These splendid lands are suburban to Tampa, the metropolis of South Florida. Here you find the most healthful, the most delightful climate in North America. For ten years we have been right here helping develop Hillsboro—the banner agricultural County of Florida, and we are still here to serve you and to help you obtain the farm you want, on very easy payments extending over 2 or 3 years' time to suit.

Groves Developed for Non-Residents

If you want to remain in your present position for a few years we can develop a grapefruit and orange grove for you. When you are ready we will clear your land, furnish fruit trees, plant and care for your grove until you are ready to look after it.

We Raise Our Own Guaranteed Citrus Trees in Our Own Nurseries

This insures every purchaser the best fruit trees that can be grown. This also insures a successful grove. We can save you money on planting and caring for your grove.

\$300.00 to \$500.00 Per Acre Profit

This is not an unusual return for truck farmers in the Famous Tampa district. All kinds of vegetables can be grown. Big prices are paid for early potatoes, Winter cabbage, Bermuda onions, tomatoes, celery and dozens of other vegetables during the Winter and early Spring, when the north is covered with ice and snow. Strawberries, Melons, and other small fruits also yield large profits.

Write for Facts About Sunny Florida

IT COSTS YOU NOTHING TO LET US PROVE TO YOU that we have the land you want—in the location you want—at a price you can afford to pay and on the easiest terms you can imagine. Let us show you.

Fill out and mail us the coupon today and receive our large descriptive book FREE!

NORTH TAMPA LAND CO.

Suite 500 Monon Bldg. CHICAGO

Coupon for FREE Book on Florida

NORTH TAMPA LAND CO.
Suite 500 Monon Bldg., CHICAGO

Please send me your large illustrated Book, "The Call of the Southland," on choice Citrus Fruit and Truck Farms suburban to Tampa, Florida, and information on how I can have a grove developed on the monthly payment plan. P.M. 3-23.

Name.....
St. No.....
City.....
State.....

? WHERE WERE YOU ?

When all those thousands of other bright "up-and-comers" were writing for the Pressed Metal Book? (It tells how to capitalize your own ingenuity—how to get cash for your clever thoughts.)

From all over the nation they came, and still are coming. It seems that almost everybody is suddenly (and most intelligently) interested in PRESSED METAL. Can you suggest some new way to utilize its practically unlimited usefulness and economy?

Just remember that Pressed Metal is *anything* that can be produced by stamping from sheets of steel, brass, aluminum, copper or any other useful metal.

The Pressed Metal Industry today totals about \$20,000,000.00 a year. When it realizes its full field of utility by a wider public knowledge of its value as a public service, it will crowd ten times that annual output.

Pressed Metal is one of the greatest blessings that American mechanical genius has given the world.

Pencil tips are Pressed Metal. Auto and truck frames are Pressed Metal. Battery boxes, auto-bodies, washing machines and door-knobs are mostly Pressed Metal. You begin to get an idea of its wonderful range of use.

SELL US AN IDEA

of some new and practical way to utilize Pressed Metal. The Pressed Metal Trade Extension Council will promptly pay for every acceptable suggestion approved by our Engineering Advisory Board.

Please do not trifle with this, as our purpose is serious and constructive and in the public interest. The membership of the undersigned Council includes many of the largest manufacturing corporations in the United States and their purpose and plans are broad, businesslike and practical.

The Plan briefly outlined above is already releasing the *hidden genius* and *practical intelligence* now bottled up in thousands of ambitious workers.

After you receive the *PRESSED METAL* booklet, which, of course, you will write for immediately, you will follow this schedule:

1st: Get your inspiration, either by a flash or by deliberate study. 2nd: Formulate it so that it is perfectly plain. Sketch it if it will help any. 3rd: Send it *with no money and no references*, to the Pressed Metal Trade Extension Council, as undersigned, and await the decision of the Pressed Metal Engineering Advisory Board. If you—but *our space is used up*—so you will have to get the rest of it out of the Pressed Metal Booklet.

Write Right Away for the Free



It contains full explanation of what we want from you and how you can get it to us in the way most profitable to you. It tells you

HOW TO CAPITALIZE YOUR MECHANICAL TALENT

or inventive genius—or maybe just your "good old common-sense." It tells all the conditions and the amounts to be paid for the successful ideas, and also how to protect yourself against misappropriation of your creative thoughts by others. WRITE TODAY. (A post card will do, but please make it easily legible so it can be properly filed and acknowledged.) Address

DEPT. A **PRESSED METAL TRADE EXTENSION COUNCIL**
27 QUINCY STREET, CHICAGO





LATEST STATISTICS

\$53,000,000.00 Lost in 1922!

By Raised Checks, Forgeries and Alterations

DO YOU PROTECT YOUR CHECKS?

Yes! No! Yes! No! Which?

AT YOUR PLACE OF BUSINESS

Yes 50% No 50% In which class are you?

AT YOUR HOME, CLUB, HOTEL, OR WHEN YOU ARE SHOPPING? NO!

\$53,000,000.00?

It might be of interest to you to know that in 70% of the above amount of checks tampered with, the crook followed the line of least resistance by altering the PAYEE'S NAME and substituting the word BEARER, CASH, CURRENCY, PAY-ROLL OR ANY OTHER NAME. If you had a check lost or stolen could you stop payment on it, if the above alteration had occurred? NO!

Could your bankers stop payment on it? NO!

The crook can change the date and even the number of the check to make the job safer and complete.

HOW CAN A BANKER STOP PAYMENT ON SUCH A CHECK?

How many machines on the market can protect the payee's name?

How many machines on the market can protect the date?

WITH A SECURITY CHECK PROTECTOR FOUNTAIN PEN YOU CAN PROTECT NOT ONLY THE AMOUNT, LEGAL LINE, AND PAYEE'S NAME BUT ALSO THE DATE AND THE NUMBER OF YOUR CHECK, DOING THE WORK JUST AS EFFICIENTLY AS THE MOST EXPENSIVE CHECK WRITER ON THE MARKET

ANY TIME—ANY PLACE

The knife-edged steel cutting wheel macerates the paper and any changes or alterations will swell up the pulp causing the ink to spread and making check entirely worthless.

Do You Protect Your Checks?

Order a "SECURITY" today.

A \$3.00 check or money order will bring you one of these wonderful writing instruments (if you prefer a small size pen), \$4.00 if you prefer a medium size pen, and \$5.00 if you prefer a large size pen in either long or short models. If you send cash, register your letter.

ABOVE ALL, DO NOT FORGET THE AMOUNT, \$53,000,000.00.

And you are liable to be the next victim.

In addition to this unique, novel and practical feature, the "SECURITY" has four

other equally important new features of merit not embodied in any other pen on the market. IT HAS an air cushion, double channel feed bar that ends forever the curse of leaks and blots. IT HAS a screw pressure filling mechanism that insures a large supply of ink and prevents air bubbles. IT HAS a tempered gold pen, made by a special process in our own factory, tipped with hard iridium and ground into a ball point. ALSO A ROLLED GOLD SPRING CLIP that prevents wear or tear of your pocket and is attached or removed by a pressure of one finger.

In addition to the above we give you an unconditional written guarantee of free repairs for five years covering every part of the pen if such repairs are made necessary by reason of defective materials or workmanship.

TEAR OUT THE COUPON AND MAIL IT IN TODAY.

High Grade Specialty Salesmen Wanted

If you are a wide awake, ambitious, hard working, enthusiastic, and high pressure salesman and are looking for permanent and profitable business connections; if you have pep and plenty of it, perseverance and stick-to-it-iveness we have a very interesting proposition for you. Write us today. Remember there are MILLIONS OF MEN AND WOMEN WHO WRITE CHECKS and MANY MORE MILLIONS who WRITE. They are all good prospects for the "SECURITY".

PRICES

No. 200	\$3.00
No. 300	3.50
No. 400	4.00
No. 500	4.50
No. 600	5.00

KRITIKSON BROS., Inc., Dept. PM.
122 W. Illinois St. CHICAGO, ILL.

KRITIKSON BROS., Inc.
122 W. Illinois St., Dept. PM, Chicago, Ill.
Gentlemen: Enclosed check or money order—please send me one Security pen, No. guaranteed for five years.

Style of point preferred
 Fine Medium Coarse Med. Stub
 Broad Stub Steno Posting. in flexible
 or stiff action, long or short model.

Name.....

Address.....

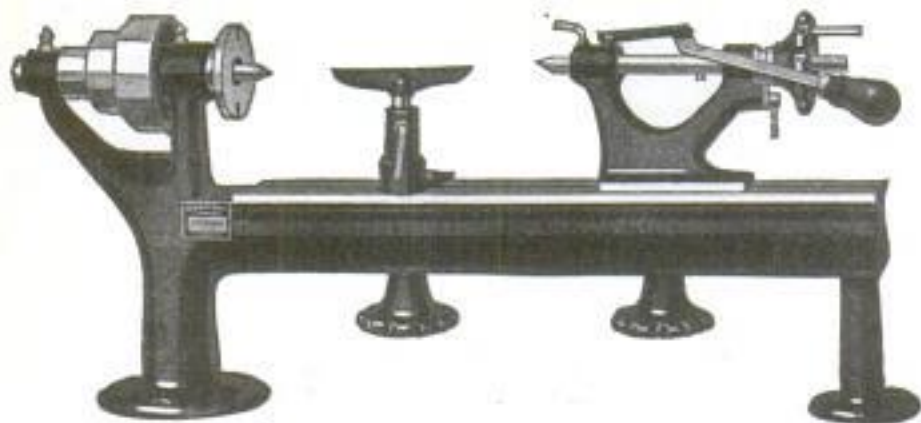

Bench Lathe No. 125
Price \$36.00

This lathe puts any handy man in the mechanic's class



Mr. Punch says—

"Show me a man who owns a bench lathe and I'll show you a man who was born to handle tools—a man with the instinct of a true craftsman."

Slide Rest No. 132
Price \$17.00
Countershaft No. 130
Price \$12.00

The difference between being merely a handy man and an amateur mechanic is often a matter of owning or not owning a bench lathe.

The man with a good bench lathe is generally able to handle most any kind of turning or boring job—often saving himself money as well as time, and having a lot of fun in the bargain.

The Goodell-Pratt Bench Lathe illustrated is just about the right size for amateur mechanics. Length over all, 25 inches. Height, 11½ inches. Swing, 7 inches. Extreme distance between centers, 12 inches.

With this lathe is included an adjustable Tee Rest, a Slotted Face Plate, a Saw Arbor and a Drill Chuck with a No. 1 Morse Taper Shank. The chuck holds round shanks of all sizes from 0 to ¼ inch.

Just One of 1500 Good Tools

If you are familiar with the Goodell-Pratt line, you know that there is a tool made for almost every conceivable kind of a job that an amateur mechanic might want to tackle.

Each of the 1500 Goodell-Pratt Tools is made for good workmen by good workmen—toolsmiths who have spent their lives in the business.

Write for complete details concerning the Goodell-Pratt Bench Lathe, and whatever other tools in which you are interested.

GOODELL-PRATT COMPANY

Toolsmiths

Greenfield, Mass., U. S. A.

GOODELL-PRATT

1500 GOOD TOOLS

COOK-BAKE-HEAT

With Amazing New Invention

Just Like Using City Gas



Turn a valve for any heat. No wicks, no smoke, no odor.

A St. Louis man has invented a wonderful new kind of heat that gives better heat for cooking, baking and heating, right in your own stove, the whole year round. Does away entirely with the mess, dirt and drudgery of coal and wood fires. Keeps kitchen cool all summer, for it gives any degree you want, off and on, at the turn of a valve—and cheaper than wood or coal.

Does Away With Dirty Coal and Wood

\$215 in One Day

Is what Bentley, our Philadelphia agent made. J. Carney, S. Dakota, writes, "Making \$1000 a month." A. M. Russell says, "Averaged \$600 for last six months." R. Berger made \$255 per week. Others make \$75 to \$150 a week Spare or Full Time.

If you want to earn \$40 to \$200 a week in spare time, write me.

Oliver Gives Fords Away

I am giving Fordways to representatives who produce. The big selling season is just ahead. Write at once while you can get Exclusive Territories with private selling rights. Get Free Sample Case Offer. Address, Mr. E. M. Oliver, 2048C Oliver Bldg., St. Louis, Mo.

Mr. Oliver calls his wonderful invention the Oliver Oil-Gas Burner because it burns 95 per cent air and only 5 per cent kerosene (coal oil), the cheapest fuel there is. No wicks, no odor, no smoke. It can be slipped right into the firebox of any stove, without changes, in one minute, by any one. Absolutely safe. It lasts a lifetime.

Keep Kitchen Cool in Summer—

Think of the work this wonderful device saves, the whole year round. In summer you can cook three meals a day, using your own trusty old range, you can preserve, can fruits, and bake any time you want to and still have a cool kitchen—you don't have to turn the heat on until the minute you are ready for it. The instant you are through you can turn the heat off—leaving your kitchen cool and clean. No more burned, soggy, or underbaked food. A perfect oven, moderate or hot as often and as long as you want it.

In damp, changeable Spring or jumpy Fall weather, you have instant heat right at your finger tips—much or little, by simply turning a valve.

30 Days Free Trial

Don't be a slave to coal and wood. Right now Mr. Oliver is making a Special Low Introductory

Price—and a 30 Day Free Trial Offer. He wants every housewife to use his invention in her own stove—to see for herself how much better it cooks, heats and bakes—how it eliminates two-thirds of household work.

FREE BOOK—MAIL COUPON

By mailing the coupon below you will be entitled to this offer and will get the full facts about it—also, an interesting Free Book, "New Kind of Heat." Get this wonderful all season heat installed at once. Thousands will mail this coupon. Don't risk losing Mr. Oliver's offer. Mail the coupon right now.

OLIVER OIL-GAS BURNER & MACHINE CO.
2048C Oliver Bldg., St. Louis, Mo.

30 DAYS FREE TRIAL

Oliver Oil-Gas Burner & Machine Co.
2048C Oliver Bldg., St. Louis, Mo.

Send your Free Book about the Oliver and also your Special Low Introductory Price, Money-Back Guarantee and 30-Day Trial Offer. This does not obligate me in any way.

Name.....

Address.....

City.....State.....

DIAMONDS

FOR A FEW CENTS A DAY

\$1.50 a Week

SEND NO MONEY

Looks like \$350 Solitaire NO. 91 only \$59.50

We Trust You

MONEY BACK GUARANTEE

Million Dollar Bargain Book FREE

Don't send a cent. Ten days Free Trial. If you are not convinced it is the Greatest Bargain in America, send it back at our expense. Only if pleased do you send \$11.50 as first payment. Then send \$1.50 weekly—at the rate of a few cents a day. This Bargain Cluster Ring with 7 Blue-White Perfect Cut Diamonds can be yours. No red tape. No Risk. Send today. It pleases thousands of buyers. Address Dept. 1173.

MILLION DOLLAR BARGAIN BOOK

J.M. LYON & CO.
2-4 Maiden Lane N.Y.

Clothing Agents

PROFITS IN ADVANCE

Selling from our All Wool tailoring Line. New low prices. Express prepaid. Satisfaction guaranteed. Profits in advance. You collect a deposit when you make the sale and keep it as your profit. No waiting.

Salesman's Outfit Free

No deposit required for big sample outfit. Our Golden Rule Clothes have been worn by good dressers for 25 years. The Old Woolen Tailoring Co. is the old reliable house. We treat you right. Work spare time or full time and make \$25.00 to \$75.00 a week. Get your own clothes at low wholesale prices.

Send no Money Just writes letter telling us what you have sold. We'll send complete sample outfit by prepaid post. Write us today.

The Old Woolen Tlg. Co. Dept. G Chicago, Ill.



BECOME
U.S. RAILWAY
MAIL
CLERKS

Get \$1600 to \$2300 a Year

MEN--BOYS 18 OR OVER SHOULD MAIL COUPON IMMEDIATELY

Franklin Institute, Dept. N181, Rochester, N. Y.

Sirs: Send me, without charge, (1) sample Railway Mail Clerk Examination questions; (2) tell me how to get a U. S. Government job; (3) send list of Government jobs obtainable.

STEADY WORK NO LAYOFFS PAID VACATIONS
Common Education Sufficient
Send Coupon Today--SURE

Name.....
Address.....

NEW CORD TIRES



Guaranteed 10,000 Miles

Positively the greatest value ever offered in sturdy—FIRST QUALITY—BRAND NEW CORD tires. The wonderful quality and long wear of these tires has taxed our factory to the limit. Special shipment just arrived and every one fresh, brand new cords backed by our Iron-Clad Guarantee and adjusted on that basis.

Wonderful Prices—Direct from Factory

	Tires	Tubes		Tires	Tubes
30x2	\$ 7.00	\$1.10	32x4 1/2	\$18.50	\$1.75
30x3 1/2	7.95	1.30	34x4 1/2	19.85	1.80
32x3 1/2	11.25	1.35	35x4	20.25	1.85
31x4	12.50	1.40	35x4 1/2	21.45	1.90
32x4	13.45	1.45	36x4 1/2	23.70	2.00
33x4	14.35	1.50	38x5	27.00	2.25
34x4	15.45	1.60	37x5	28.50	2.50

Send No Money—Examine First!

We don't ask a penny in advance. Just send your name and size of tires you want. But you must HURRY! Write today to be sure of getting the sizes and number of tires you want. All tires shipped C. O. D. Section unwrapped for your inspection. Save 5% by sending remittance with order.

MOTORIST TIRE CO.

2611-13 S. Wabash Ave.

Chicago, Ill.

Our BUREAU OF INFORMATION will answer all questions regarding articles appearing in this magazine. Address Bureau of Information, Popular Mechanics Magazine, Chicago.

Popular Mechanics Books

EACH one of the following books has been published by Popular Mechanics and is characterized by the same careful editing and authoritative presentation of the subject matter as is the magazine itself. All are unusually good values for the prices asked.

THE BOY MECHANIC—BOOK ONE 480 Pages—700 Articles—800 Illus.	\$2.00
THE BOY MECHANIC—BOOK TWO 480 Pages—1000 Articles—995 Illus.	2.00
THE BOY MECHANIC—BOOK THREE 480 Pages—800 Articles—802 Illus.	2.00
MISSION FURNITURE, HOW TO MAKE IT, PART 1 128 Pages—30 Designs, Illus.	.50
MISSION FURNITURE, HOW TO MAKE IT, PART 2 128 Pages—32 Designs, Illus.	.50
MISSION FURNITURE, HOW TO MAKE IT, PART 3 128 Pages—36 Designs, Illus.	.50
WOOD-WORKING FOR AMATEUR CRAFTSMEN 128 Pages—125 Illus.	.50
ARTS-CRAFTS LAMPS, HOW TO MAKE THEM 96 Pages—18 Designs, Illus.	.50
METAL WORK AND ETCHING 96 Pages—Illus.	.50
ELECTROPLATING 112 Pages—62 Illus.	.50
PRACTICAL COURSE IN MECHANICAL DRAWING 160 Pages—157 Drawings.	.50
HEAT 128 Pages—Illus.	.25
KINGDOM OF DUST 128 Pages—40 Illus.	.50
HOW TO MAKE DEVICES FOR OUTDOOR WINTER SPORTS. 64 Pages—Illus.	.25
SHOP NOTES FOR 1923 224 Pages—544 Articles—436 Illus.	.50
SHOP NOTES SERIES 10 Vols.	5.00
PATTERN MAKING 224 Pages—312 Illus.	1.00
POWER GAS AND THE GAS PRODUCER 192 Pages—Illus.	1.00

Above prices are postpaid.

POPULAR MECHANICS BOOK DEPT.

200 E. Ontario St., Chicago

10,000 Practical Recipes

HENLEY'S

Twentieth Century
Book of
Recipes, Formulas
and Processes

Edited by
GARDNER D. HISCOX, M. E.

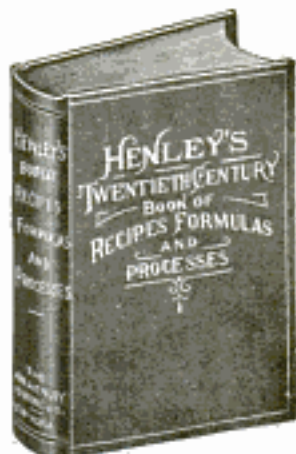

Contains over 10,000 Selected Scientific, Chemical, Technological and Practical Recipes and Processes, including Hundreds of So-Called Trade Secrets for Every Business. This book of 800 pages is the most complete Book of Recipes ever published, giving thousands of recipes for the manufacture of valuable articles for every-day use. Hints, Helps, Practical Ideas and Secret Processes are revealed within its pages. It covers every branch of the useful arts and tells thousands of ways of making money and is just the book everyone should have at his command. A book to which you may turn with confidence that you will find what you are looking for. A mine of information up-to-date in every respect. Contains an immense number of formulas that everyone ought to have that are not found in any other work.

Price \$4.00

Cloth Binding

Popular Mechanics Book Dept.
200 E. Ontario St., Chicago

THE PROPER AND MOST EFFICIENT WAY TO REPAIR FORD CARS TRUCKS AND TRACTORS

Here is a book that presents the information given in the Ford Service Course for Superintendents and Service Managers of Ford Agencies at the home plant in Detroit. It gives you information which cannot be secured otherwise outside the Ford plant. It describes for dealers, repairmen, garage mechanics and owners the proper and most efficient way to repair the products of the Ford factories.

Published April, 1922

FORD CAR, TRUCK AND TRACTOR REPAIR

By **Alfred A. Good**

Formerly Director, Ford Motor Company's Service School

328 pages, pocket size, flexible, 32 Illustrations

PRICE \$2 POSTPAID

There have been a number of books written on the Ford car; but they only tell what the average Ford driver or mechanic already knows. This book gives you real practical information that shows you just how to locate troubles quickly and how to remedy them efficiently. It gives you a complete understanding of the mechanical principles underlying the operation of Ford cars, trucks and tractors—a thorough knowledge of the mechanical and electrical action of every unit of these machines—an explanation of how to get at the cause of the various troubles—and a step-by-step description of repair operations. The book covers the Ford car, truck and tractor in such a way that the mechanic who reads it is ready to answer any question concerning them which may be put to him by anyone.

Sent to any address postpaid upon receipt of price by

Popular Mechanics Book Dept.
200 E. Ontario St., Chicago



Make A Gas Range out of Your Old Stove in Five Minutes



FOR HEATING STOVES

The Standard Oil Burner fits any heating stove. Heats your living rooms in a few minutes on the coldest day. Think of keeping your home at an even, beautiful temperature all day, without constant filling, shaking and poking.



IDEAL FOR FURNACE

The Standard Oil Burner can be installed in any hot air, pipeless, steam or hot water furnace. So simple and safe a child can light and regulate it. Clean, even heat all over the house, all the time.

Think of it! Your old coal or wood stove can be made into a regular gas range in less time than it takes to tell you about it. You don't have to alter your stove one bit. You don't even have to bore a hole or insert a bolt. Just set a marvelous new kind of burner in your fire box, attach it to a tank of coal oil by means of a copper tube, turn a valve, strike a match, and instantly you have a heating flame as steady, reliable and easy to adjust as city gas, at one-third the cost.

WHY HOME-MADE GAS IS CHEAP

The burner mentioned above is the Standard Oil Burner, a wonderful device that mixes 96% air and 4% kerosene (common coal oil) to form a gas whose heat is two or three times as great as that from coal or wood, and as convenient and easily controlled as city gas. You get instant heat at the turn of a valve. There's no waste of fuel or time in starting a fire. Light it only when you need it—no need to "keep the stove going" to save building a new fire, like you do with coal and wood. No need to sweat and slave in a hot kitchen all summer.

SPECIAL PRICE AND 30 DAYS' TRIAL

to the first user of a Standard Oil Burner in your community. Act quickly and get the benefit

SAVES HOURS OF DRUDGERY

The Standard Oil Burner saves you all the exhausting, disagreeable work of carrying heavy buckets of coal, splitting firewood and hauling dirty ashes. Burning gas does away with smoke, soot and dirt—makes your housework easy and lessens your weekly wash. Your meals are prepared quicker. With the Standard, you don't have to stay in the kitchen constantly while food cooks. A turn of the valve regulates the heat. Once installed, you'll wonder how you ever did without a Standard.

of this generous offer. Make this trial on our absolute Money-Back Guarantee.

FREE BOOKLET

Use Coupon to get our attractive Booklet, HOME HEATING.

STANDARD OIL BURNER CO. Dept. 10-A
103 North Main St., St. Louis, Mo.

Agent Made \$200 in One Day

The Standard sells like hot cakes. A demonstration means a sale nearly every time, because the Standard fills a long felt need. Everybody wants one. In a single day I made \$200. Wm. J. Finlay, Agent Webster Groves, Mo.

AGENTS WANTED

Big money is being made by our agents selling Standard Oil Burners. Start Now. Sells easier in Spring than any other season. Part time or full time work. Exclusive territory. We give you every help in selling. Write today for money-making proposition.

ONE USER WRITES:

I find the use of coal oil in the Standard 51% cheaper than coal, and 64% cheaper than gas. In convenience, cleanliness and comfort coal does not compare with it.

Standard Oil Burner Co. Dept. 10-A
103 North Main St., St. Louis, Mo.

Send me details of your 30 days' Trial Offer, with special Price and Money-Back Guarantee. Also send me your Free Booklet, HOME HEATING. This puts me under no obligation.

Name

Address, Box or R. R.

P. O. State

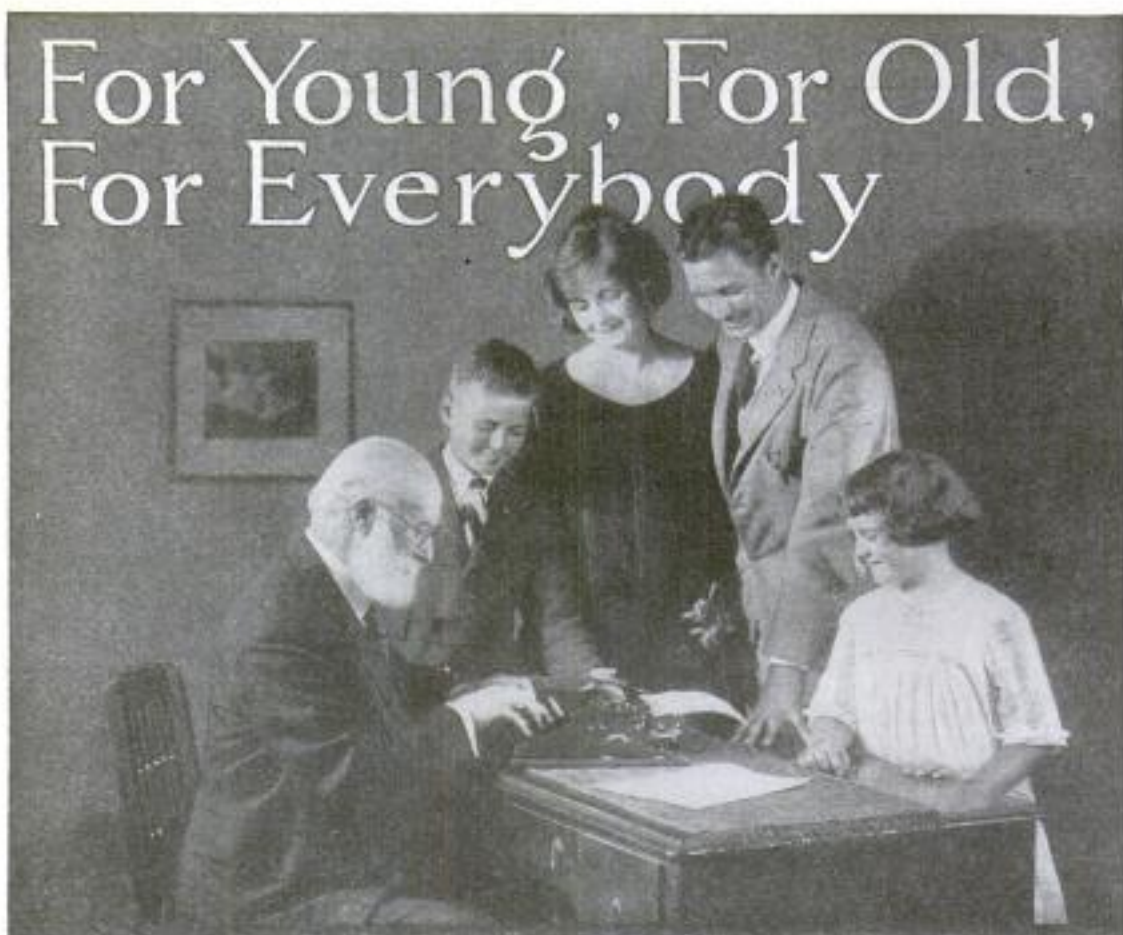

Remington Portable Typewriter

is the universal machine for personal writing. It has every quality demanded by the individual user.

Compact—fits in a case only four inches high.

Convenient—can be used anywhere; on your lap, if you wish.

Complete—with STANDARD KEYBOARD and other "big machine" conveniences.

It also resembles the big machines in efficiency, for don't forget it's a Remington—with every merit for which Remingtons are famous.

Write for our illustrated, "For You, For Everybody". Address Department 12

REMINGTON TYPEWRITER COMPANY

374 Broadway, New York

Paragon Ribbons for Remington Portable Typewriters. Made by us. 50 cents each. \$5 per dozen.

Sold by 2,500 dealers and Remington branches everywhere



A New Butter-Kist Popcorn Machine at Half Former Price!

HERE'S a marvelous money-making opportunity—a beautiful, new automatic Butter-Kist Popcorn Machine at *half* what former models cost.

For a small down payment this new Gold Mine Model will be shipped immediately to any responsible retailer. Within a few hours after its receipt you can be earning big profits, selling the world-famous Butter-Kist Popcorn, out of which you should easily and quickly pay the balance.

The "Gold Mine" is a beauty. Attractive mahogany-finished cabinet. Handsome plate-glass sides. Highly-polished nickel parts. Takes up little room. Feeds, discharges, pops and butters the corn automatically. Keeps the corn warm and crisp after popping. Produces thirty 10-cent packages an hour.

Butter-Kist Popcorn sells fast. It's nationally known and advertised. People go out of their way to buy Butter-Kist. F. J. Studer writes, "My Butter-Kist Popcorn profits have averaged over \$900 per year for six



BUTTER-KIST Popcorn "America's Oldest Treat"

years". R. C. Haegg says, "First six months' sales went over \$2500". Many are making even more. And remember out of every dollar's worth you sell, you keep 65 cents as *your* profit.

The Butter-Kist Popcorn Machine attracts customers. Builds trade. Makes big profits. Write immediately for the new Butter-Kist Easy Payment Plan.

HOLCOMB & HOKE MFG. CO.

World's Largest Manufacturers of Popcorn Machines and Peanut Toasters

2152 Van Buren Street • • Indianapolis

The coupon filled in, will give you a quick start towards big profits. No obligation on your part. Fill in and mail TODAY.

HOLCOMB & HOKE MFG. CO.,
2152 Van Buren St., Indianapolis, Ind.

Please send me, without obligation on my part, your free Butter-Kist book. I also want the Location Chart which I will fill out and return to you.

Name _____
Street _____
City and State _____
Business _____

BUTTER

KIST

POPCORN AND PEANUT MACHINES

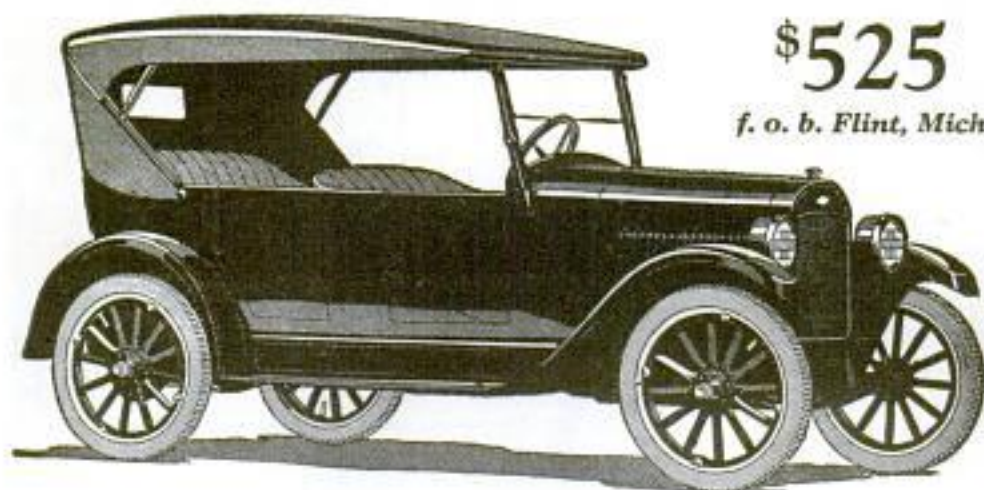
for Economical Transportation**\$525***f. o. b. Flint, Mich.*

What Transportation Means to Civilization

Civilization is the result of interchange of individual thought and the product of thought.

This interchange depends entirely on transportation.

For transportation of products or people in the mass, major transportation units such as ships and railroad trains are most economical, yet limited to fixed ocean lanes or tracks on the land.

The automobile has passed the railroad in passenger transportation, and will soon surpass it in transportation of merchandise. It is not limited to mass movements nor fixed routes, but oper-

ates economically even for a single person or for few products, over highways and byways. It links city and country, pioneer settlements with railroad trunk lines, and unites all America in one co-operative community.

In supplying the public with modern, fully equipped automobiles that deliver the utmost per dollar in economical transportation and average the lowest cost per mile, we feel that we are an important factor in still further extending the benefits of civilization and progress to every home in America.

Prices f. o. b. Flint, Michigan

Two Pass. Roadster	-	\$510	Two Pass. Utility Coupe	\$680	Five Pass. Sedan	•	•	•	\$860
Five Pass. Touring	-	525	Four Pass. Sedanette	850	Light Delivery	•	•	•	510

See these Remarkable Cars. Study the Specifications

Chevrolet Motor Company, Detroit, Michigan
Division of General Motors Corporation

This Stylish, Goodyear All Weather Coat FREE!



For advertising purposes we offer to send this handsome Goodyear All Weather Coat Free to one person in each locality who will show and recommend it to friends and take orders. It is a beauty, of rich triple texture tweed, cut in the season's latest style with all around belt, semi-dent lapels, convertible collar and storm tabbed sleeves. Guaranteed rain, dust and wind proof. A handsome topcoat, overcoat, raincoat and motor coat combined. Good for all year 'round wear.

Send No Money

Write your name and address in the coupon below and mail today. Send no money. Prove by your promptness that you are the one we seek. MAIL IT NOW.

Big Pay for Spare Time

When people see your wonderful sample All Weather Coat they will admire it, ask about it, and want one like it. That is why we make this Unparalleled Free Offer.

You can make big money just taking these orders. Have all the money you want to spend. Don't lag behind and miss this great offer. Fill in the Coupon and Mail NOW!

THE GOODYEAR MFG. CO.
1743-R Goodyear Bldg.
KANSAS CITY, MO.

Here's
the
**BigFREE
COUPON**

THE GOODYEAR MFG. CO.
1743-R Goodyear Bldg.
Kansas City, Mo.

Without any obligation on my part please send me by return mail your FREE COAT and AGENCY OFFER.

**Don't
Lose
Time
Act
NOW
!**

Mail The Coupon NOW!

**This Sensational Free Offer
May Never Be Made Again.**

NAME _____

ADDRESS _____

TOWN _____

STATE _____

Tear out here and mail before you forget it.



Let Me Tell You About My New Improved Throttling Governor ENGINE

NEW CATALOG — NOW READY

I HAVE brought out a simple, efficient, Throttling Governor Engine. It is particularly desirable NOW, for general power use, and will be in big demand for years to come—when low grade fuels will of necessity be largely used. In producing this new engine, I have worked out every detail of design and construction so as to provide an engine that does not require an expert to handle it—starts without cranking.

Years Ahead—Dollars Better!

I consider the New Improved WITTE the most wonderful Throttling Governor engine of its time—the crowning achievement of 38 years of practical engine building experience.

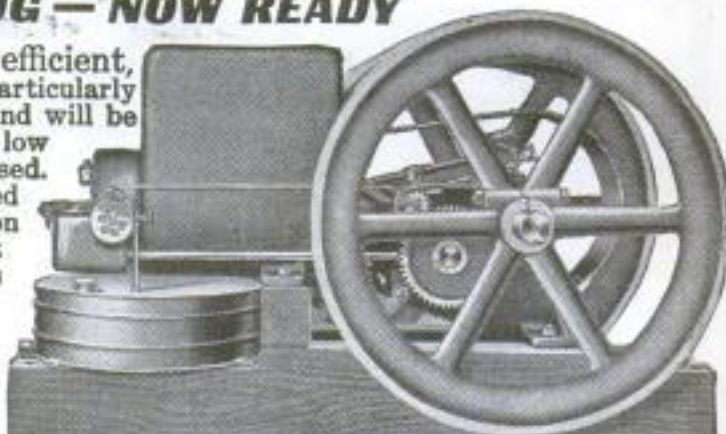

The New Improved WITTE

**Is Different—Better—Less Parts—More Power—Less Cost
Operates on Either Kerosene, Gasoline, Distillate or Gas**

New Sizes, 2, 3, 5, 7, 10, 15 and 25 H-P. BOSCH Magneto or Battery as specified

SOLD ON A LIFETIME GUARANTEE—CASH OR TERMS

Think of having economical and adaptable power for years to come—an engine so simple in construction a boy can understand it. Power increased or decreased at will by merely turning a thumb screw.

Takes Less Space Weighs Less

Mechanically correct in every particular—every part carefully designed—made of the best materials—accurately machined and easily interchangeable. Superior accuracy and workmanship throughout applies to every engine or outfit in the WITTE line.

Engines and Outfits All Throttling Governor

The WITTE catalog gives complete description of Stationary and Portable Engines—Log and Tree Saws—Cord Wood and Pole Saws—Power Boring Machines—and WITTE "Power-Lite" Plants that furnish both energy and electricity for farm and suburban use.

2 H-P Pulls 2½ at normal speed
or 3 H-P at maximum speed
COMPLETE — READY TO USE
(Columbia Battery)

\$45.00
F. O. B.
Kansas City

At Pittsburgh \$49.50

At San Francisco \$57.00

**OTHER SIZES AND STYLES
AT PROPORTIONATE PRICES**

You can order one of these superior engines or outfits with full assurance that it will give you longer and better service than any engine of equal rating, while my prices are extremely favorable as you will find.

Tell Me What You Want

If you have a particular need, write me for special information as to your power requirements. Bear in mind that the WITTE is an engine for every conceivable power use, winter or summer, anywhere.

Send for My New Catalog and Price List

Get acquainted with the New Improved WITTE—the power you need for today and for the future. It is the engine you will eventually buy and use because of its wonderful simplicity and low cost. Whether you order one now, or not, do me the favor of investigating the many improvements and advantages offered.—ED. H. WITTE.

**Big New
Catalog
FREE**



WITTE ENGINE WORKS

(Write
Nearest
Address)

1749 Oakland Ave., Kansas City, Mo. 1749 Empire Bldg., Pittsburgh, Pa. 131 Fremont St., San Francisco, Cal.

ELECTRICITY

Needs You To Boss Jobs Like This



Be a **Certificated Electrical Expert**
EARN \$3500 to \$10000 a Year

Some Features of My Course That Have Revolutionized Home Study Training

1. Practical Instruction—no useless, high-sounding theory.
2. Free Electrical Outfit—Finest outfit ever sent out for home experiment.
3. Free Employment Service.
4. Free Consulting Service.
5. Free Engineering Magazine.
6. Free use of my Electrical Laboratory.
7. Extra Courses Free.—Radio—Electrical Drafting.
8. Spare time work—Special earn-while-you-learn lessons.
9. Reduced prices on all Electrical Supplies.
10. Cash Refund Guarantee Bond.

These features are all explained in my big Free Book.

IT'S a shame for you to earn less than \$100.00 a week when trained Electrical Experts are in such great demand. You ought to get more. You can get more.

Cooke Trained "Electrical Experts" earn \$70 to \$200 a week. Fit yourself for one of these big paying positions. Get into a line of work where there are hundreds and hundreds of opportunities for advancement and a big success.

What's YOUR Future? Today even the ordinary Electrician—the "screw driver" kind—is making money—big money. But it's the trained man—the man who knows the whys and wherefores of Electricity—the "Electrical Expert"—who is picked out to "boss" ordinary electricians—to boss the Big Jobs—the jobs that pay up to \$10,000 a year.

Age or Lack of Experience No Drawback

You don't have to be a College Man; you don't have to be a High School graduate. My Course in Electricity is the most simple, thorough and successful in existence, and offers every man regardless of age, education or previous experience, the chance to become, in a very short time, an "Electrical Expert," able to make from \$70 to \$200 a week.

I Give You a Real Training As Chief Engineer of the Chicago Engineering Works I know exactly the kind of training a man needs to get the best positions at the highest salaries. Hundreds of my students are now earning \$3,500 to \$10,000. Many are now successful ELECTRICAL CONTRACTORS.

Your Satisfaction Guaranteed So sure am I that you can learn Electricity—so sure am I that after studying with me, you, too, can get into the "big money" class in electrical work, that I will guarantee under bond to return every single penny paid to me in tuition if, when you have finished my course, you are not satisfied it was the best investment you ever made.

FREE-Electrical Working Outfit-FREE

I give each student a Splendid Outfit of Electrical Tools, Materials and Measuring Instruments absolutely FREE. I also supply them with Drawing Outfit, examination paper, and many other things that other schools don't furnish. You do PRACTICAL work at HOME. You start right in after the first few lessons to work at your profession in a practical way—make extra money while you learn.

Get Started Now - Mail Coupon

I want to send you an Electrical Book and Proof Lessons both FREE. These cost you nothing and you'll enjoy them. Make the start today for a bright future in Electricity. Send in coupon—NOW.

L. L. COOKE, Chief Engineer Chicago Engineering Wks.
Dept. 513, 2150 Lawrence Avenue, Chicago, Illinois

Name.....

Address.....

L. L. COOKE,
Chief Engineer
Chicago
Engineering
Works

Dept. 513, 2150 Lawrence Ave., Chicago, Ill.

Dear Sir:—Send at once the "Vital Facts" containing Sample Lessons, your Big Book, and full particulars of your Free Outfit and Home Study Course—all fully prepaid, without obligation on my part.

The "Cooke" Trained Man is the "Big Pay" Man

FREE—Book on Wood Finishing

S. C. JOHNSON & SON, Dept. P. A. 3,
Racine, Wis. (Canadian Factory—Brantford)
Please send me free and postpaid your instruction book on Wood Finishing and Home Beautifying.

My dealer is.....

My Name.....

My Address.....

City & State.....

This book explains how inexpensive soft woods may be finished so they are as beautiful and artistic as hard wood. Tells what materials to use and how to use them. Includes color charts—gives covering capacities, etc. It is the work of experts beautifully illustrated in color. Fill out and mail this coupon.



Tells How to Brighten Up Your Home



WELL finished furniture, woodwork and floors add materially to the beauty and attractiveness of your home. You, yourself, can easily re-finish dingy, shabby, scratched wood. Our method involves practically no expense. All you need is a little time, a brush and

JOHNSON'S WOOD DYE

Johnson's Wood Dye is very easy to apply—it goes on easily and quickly, without a lap or a streak. It penetrates deeply, bringing out the beauty of the grain without raising it—dries in 4 hours and does not rub off or smudge.

Johnson's Wood Dye is made in fourteen beautiful shades, all of which may be easily lightened or darkened—full directions on every label.



\$100 Brings 9x12^{FT} Congoleum Rug and 3 Small Rugs to Match—

All Four only

\$15⁹⁵

Less than the Price of One



The price of the famous Congoleum Gold Seal Art Rug is just as well known, absolutely as standard, as sugar, salt or flour used to be.

Go anywhere, look everywhere, in stores, catalogs, magazines and newspapers—and once more refresh your memory of the actual universal standard price of a full size Gold Seal Congoleum Art Rug.

Here we bring you not one rug alone, but four—and all four for less than the regular price of one. A full room size, 9 foot by 12 foot, Congoleum Rug and three small companion Congoleum Rugs to match—each small rug 18 x 36 inches.

30 Days Free Trial

We'll send all four rugs on trial for 30 days. We want you and urge you to put them down on the floor and use them for a whole month—free of expense and without promise or obligation of any kind.

We guarantee that if you would rather return the rugs after making this kind of a trial, just say so and send them back. We will refund to you every penny of transportation charges, both going and coming.

Pay Little by Little Take a Full Year

And that's not all! No matter who you are, or where you live—regardless of your circumstances—we'll send all four rugs immediately, without waiting, red tape or bother, for just a dollar pinned to the coupon.

And we'll wait a year for the balance of the money. If you keep your rugs after making a 30 day's trial, you can pay little by little, almost as you please, taking a full year. That's the way we sell everything.

The Most Famous of All Congoleum Patterns

Congoleum Gold Seal Art Rugs are rapidly becoming the national floor covering—universally used in the kitchen, bathroom and dining room in good homes.

They lay flat from the very first moment without fastening. They never curl or kick up at edges or corners. No need to tack them down. Dirt cannot accumulate underneath.

Less work. Congoleum floors mean less worry and no back breaking drudgery. Dirt, ashes, grit, dust or mud cannot "grind into" Congoleum Rugs, because the surface is hard and does not absorb. A damp rag keeps a Gold Seal Congoleum Art Rug clean and doesn't hurt it.

Waterproof. These rugs are guaranteed waterproof. There is no burlap in Gold Seal Congoleum Art Rugs for water to rot. The surface is hard and smooth and wear resisting.

This stunning pattern is a superb tile design that looks exactly like the finest mosaic tile that you have ever seen, in lovely robins' egg blue and stone gray colorings. Such a rug in your kitchen will change the appearance of the whole room. In the dining room it gives an effect impossibly beautiful to describe. For a bedroom it is the most appropriate pattern imaginable. For the bathroom it is absolutely ideal.

This Offer Ends in 30 Days Send Your Dollar NOW

We cannot hold this offer open long. We make it for quick action to prove to you our ability to sell you similar bargains in all kinds of house furnishings from collar to garret, on the same wonderful terms.

Clip the Coupon and pin a Dollar to it.

No. D4C408 9 ft. x 12 ft. Genuine Congoleum Gold Seal Art Rug and 3 companion rugs to match, ea. 18 x 36 in. **\$15.95**



FREE

Mail Postcard for Book of 10,000 Bargains

This Congoleum Rug bargain is just a sample of the ten thousand other bargains in our great big furniture book. A postcard will bring it to you free for the asking. It shows everything for the home. It is probably the largest book of the kind published. A great many things are shown in their actual colors.

Always a Year to Pay

You never need to ask for credit. It's the way we sell everything. And we always loan articles free for a whole month before you need to decide.

A Few Departments

Wood Beds	Steel Beds	Curtains
Furniture	Clocks	Sewing
Linens	Floor	Machines
Cooking	Coverings	Brass Beds
Utensils	Silverware	Dishes
Musical Instruments	Lamps	Bedding
		and Pillows

Rugs and carpets in all weaves and patterns and colors. All sorts of odds and ends like wringers, irons, drees, tools, fixtures, trunks and bags. And a great big department of diamonds, watches and jewelry.

Ask for it now. A plain letter or postcard will do.

Spiegel, May, Stern Co.

1586 35th Street, CHICAGO, ILL.

Spiegel, May, Stern Co.

1586 Thirty-fifth Street, CHICAGO, ILL.

I enclose \$1. Send me on approval the 4 Gold Seal Congoleum Art Rugs here described, No. D4C408—on 30 days Free Trial. If I am not delighted with the rugs, I can return them and get my \$1 back, also all transportation costs. Otherwise I will pay easy terms, \$1.25 monthly, until special bargain price, \$15.95, is paid

Name.....

Street R. F. D.

or Box No.....

Shipping Point.....

City..... State.....

Also Send Me Your Latest Free Style Book

Prices Are Down

Material costs and labor costs are going up. Protect yourself at these Rock-bottom prices. NOW IS TIME TO BUY!

MEAD Ranger BICYCLES

World Leaders in style, popularity, service and durability.

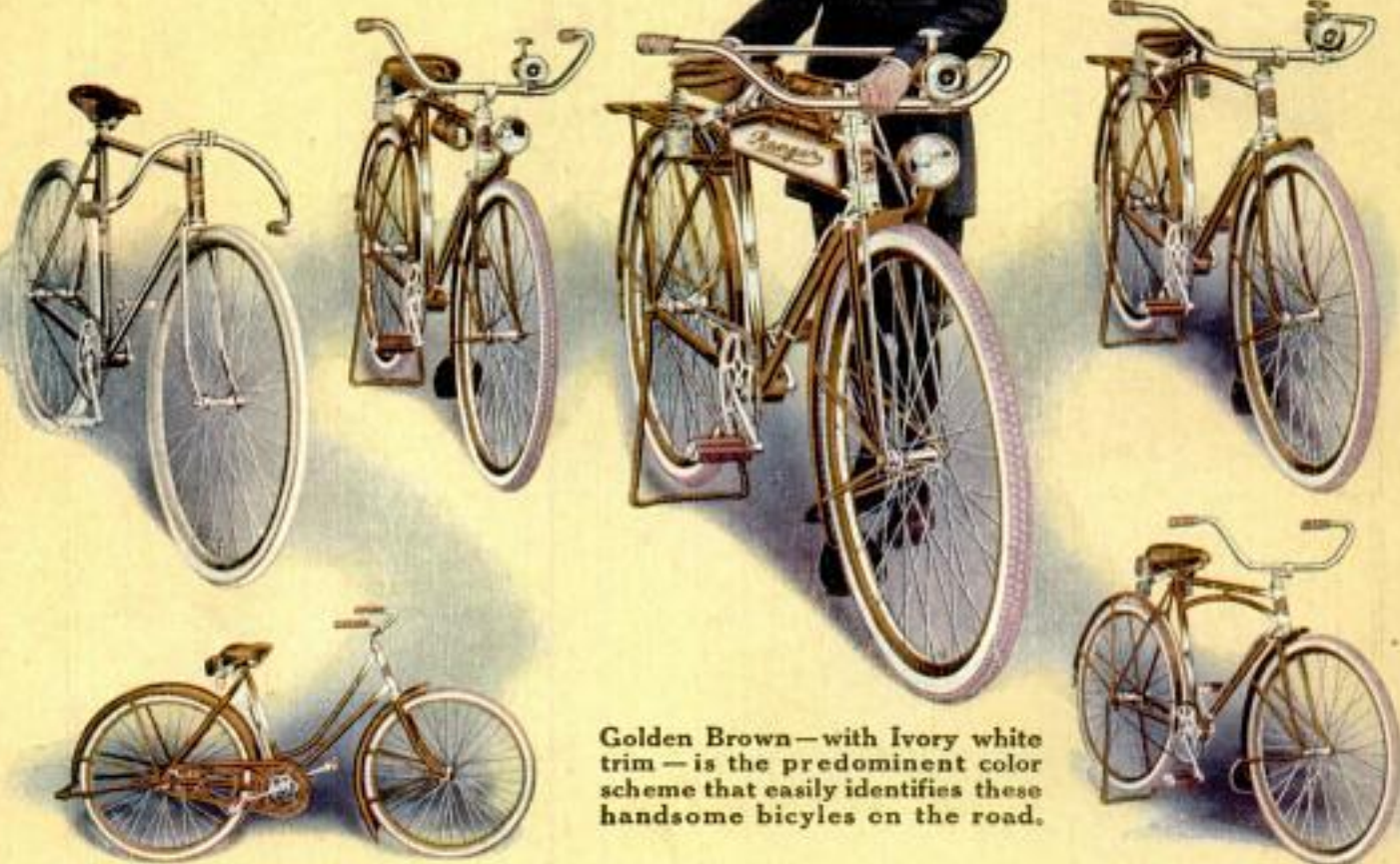

Golden Brown—with Ivory white trim—is the predominant color scheme that easily identifies these handsome bicycles on the road.

30 Days' Free Trial

exclusive features. If at the end of thirty days you

See for yourself the values found in Ranger bicycles with their complete equipment of accessories and extras. Send to-day for catalog and select the model you prefer. Ride it thirty days, test its speed, sturdy qualities, de luxe equipment and want to return it for any reason, send it back and you will not be out one cent.

Factory-to-Rider When you buy a Ranger you are dealing direct with the makers at Factory Prices. Your "Ranger" is waiting for you. The breath of Spring is in the air. Write for our catalog today. When we get your order your bicycle will leave on a fast express train (all charges prepaid) packed in a waterproof paper bag and enclosed in a strong wooden crate. Safe delivery in perfect condition guaranteed.

There are 44 styles, colors and sizes in the famous line of **RANGER Bicycles** a model to suit every taste and any pocket book.

5-Year Guaranty Every Mead "Ranger" is warranted for five years. This means we make good trouble arising from any defect in workmanship or material at no cost to you. Our guaranty is a written contract—we are directly responsible for the satisfaction and general performance of your bicycle because we made it.

12 Months to Pay If not convenient to pay cash for your "Ranger" bicycle, we will ship it to you at once and arrange with you to accept twelve small monthly payments which will enable you to take advantage of our rock-bottom factory-to-rider cash price with only a slight amount added to cover the cost of extra bookkeeping. Parents frequently advance the initial payment and energetic boys and girls save and earn the later small monthly payments.

Tires and Equipment

Our big free catalog illustrates and describes parts, equipment and sundries that our more than a million riders may need. All are carefully selected from the leading parts makers of the world, to Save You Money at our Factory Prices.



Get this FREE Catalog

We have a copy all ready for you and it will be sent as soon as we receive the coupon in the lower corner of this page. If you prefer send a postcard—only write your name and address plainly. Turning the pages of the "Ranger" catalog is like walking down the aisles of the largest and greatest of bicycle stores seeing bargains, new ideas and conveniences that you never saw or heard of before.



Send No Money Ask for the big catalog and full particulars of our Factory Prices, marvelous offers and Easy Payment terms. Read especially about our extra \$5.00 FREE Premium set which goes with every "Ranger" bicycle.

MEAD CYCLE COMPANY
Dept. M108, Chicago, U. S. A.

Send me the new Ranger Catalog, factory-to-rider wholesale prices, 30-day Free Trial Offer and Easy Payment Terms.

Name.....
R. F. D. or
Street No.....

Town.....State.....

FACTORY DISTRIBUTORS IN 305 CITIES

The nearest city (with a population of 25,000 or more) which I can conveniently visit to select a Mead Ranger is.....
If you have a Special Factory Distributor there, send me letter of Introduction to him so I can inspect the Ranger and take delivery from there at Factory prices or on Easy Payment Plan if I prefer.

MEAD CYCLE COMPANY
DEPT. M-108 CHICAGO U.S.A.