

# POPULAR MECHANICS MAGAZINE

WRITTEN SO YOU CAN UNDERSTAND IT

REG'D TRADE MARK, GREAT BRITAIN, No. 410426

R.F.G. U.S. PAT. OFF.

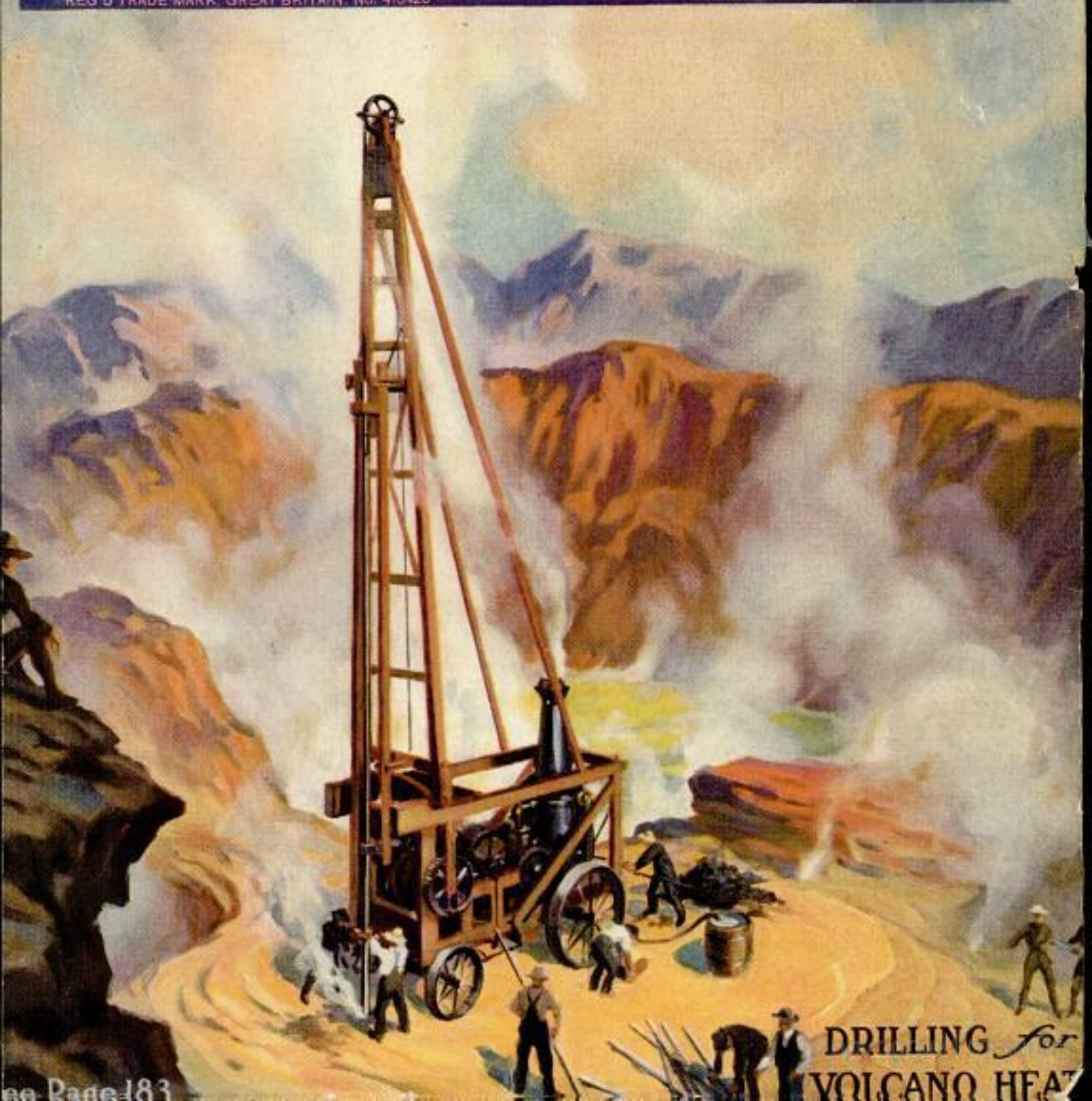

Here is a story of a boy who was made foreman over men many years older. Was it ability—was it luck—or was it training? Read in his own words how he did it.



LOUIS BEIMER  
who says Rahe training put him on "Easy Street" in two months.

# A Foreman at 24

**By This Unusual Method Anyone can Qualify in 8 Weeks to fill Splendid Positions paying from \$2400 to \$10,000 a Year in the Auto and Tractor Business.**

*By Louis Beimer*

"At the age of 20 years I was drawing \$12.50 a week—laborer's pay.

"At the age of 24 I am a foreman and my salary is \$2,400.00 a year.

"But it didn't take me four years to make the jump. I qualified for the advancement by only 8 weeks' scientific practice with tools. Then, in two quick steps, I reached my present position.

"Those eight weeks were spent in one of Rahe's big auto and tractor schools. I earned \$50 a month before I went there. On my return home, I went to work for \$150 a month and in a very short time was made foreman at \$200 a month—a total salary increase of \$150 a month, due entirely to Rahe training.

"If you want to get ahead QUICKLY, take the quick, easy, thorough course at a Rahe School."—*Louis Beimer.*

## I'll Pay Your Railroad Fare to CHICAGO or CINCINNATI

I am going to start hundreds of men to quick success in the next few weeks just as I started Beimer. Here is the chance of a life-time to travel free to my nearest school, no matter where you live. I am making this offer for a limited time only and will withdraw it without notice.

**My Method Unusual** No one else teaches Motor Maintenance Engineering the way I do. That is why my students make such striking and rapid progress. The only way to be sure of climbing as rapidly as Louis Beimer is to qualify by the same method. Hundreds of others have climbed even more rapidly than he. I guarantee that any man who is ambitious can succeed by my extraordinary method.

## Send for FREE Book

My big illustrated book tells how others are succeeding; it tells many things you ought to know about the auto and tractor business. Write TODAY. Remember my free fare offer is only temporary.

**Rahe Auto & Tractor Schools**  
CHICAGO Michigan & Ontario Dept. 494 CINCINNATI Ninth and Walnut

## EVIDENCE

**Wayne Russell**, 20 years old, of Waldo, Ark., says Rahe training multiplied his pay by TEN. "I earned \$1.50 a day before," he writes. "My salary is now \$1.50 an hour."

**W. W. Peace**, another Rahe graduate, writes of getting \$250 a month and expenses operating a tractor in the oil fields.

**Emanuel Rushfeldt**, Vulcan, Alberta, says, "Earning \$10 a day. Formerly earned \$50 a month; 20 years old."

## Big Season Expected More Men Needed

Farmers are buying cars and tractors. City people are ordering cars far ahead. Calls are coming in daily for trained men who know auto and tractor construction. This is the biggest opportunity you ever had. NOW is the time to start. Take advantage of the big season ahead.

## Scientific Tool Training

—that's the secret. You do things here according to the latest scientific engineering standards. Fine modern tools furnished free. Thousands of dollars have been spent on our laboratories for modern equipment and tools. No wonder auto and tractor men want my students.

**Rahe Auto & Tractor Schools,**  
Dept. 494, (address school nearest you)  
Chicago, Ill., or Cincinnati, Ohio.

Without any obligation, send me your big free book, "More Money." Also information regarding special temporary offer.

Name.....

Street.....

City..... State.....



## Sousa's Band plays for *you*

and it plays music of your own choosing. The band of the great March King plays as many encores as you wish—such playing as is possible only when Victor records and Victrola instruments are used together. You can hear not only Sousa's Band, but Conway's Band, Pryor's Band, Vessella's Band, U. S. Marine Band, Garde Republicaine Band of France, Band of H. M. Coldstream Guards, Banda De Alabarderos—the greatest bands of every nation and the best music of all the kinds the whole world has to offer.

Victrolas \$25 to \$1500. New Victor Records demonstrated at all dealers in Victor products on the 1st of each month.



"HIS MASTER'S VOICE"

# Victrola

REG. U. S. PAT. OFF.

Important: Look for these trade-marks. Under the lid. On the label.  
**Victor Talking Machine Company, Camden, New Jersey**



"THE VALUE OF MONEY  
IS MEASURED BY THE  
PERMANENCY OF  
WHAT IT BUYS."

*John Bemer Crosby*

*Tide Water*  
**Cypress**  
*"The Wood Eternal"*

## Why Not Have a "Glory Room"?

"That is the inviting and inspiring term which a famous publisher applied to his own Cypress Sun-parlor. The same idea begets a hunger for a Cypress Sleeping Porch. It is not at all necessary to wait until we build a new house. Why not 'tack one onto our present home'? It is always possible—and always a fine investment, entirely aside from the delight of using it. That very helpful, foresighted, broadminded and kindly-intentioned group of men known as the Cypress Association have employed some of the best talent in the country to provide thoroughly practical—*really usable*—as well as highly artistic, plans for the free use of those who really care. Of course, they hope to thereby broaden still further the wide preference for Cypress, 'the Wood Eternal' for all non-rot applications, but that is only natural and does not detract from the great and lasting benefit to the public due to 'an educated insistence on the best wood for the given purpose'".—J. B. C.

Vol. 35 is the Sun Parlor & Balcony Book. 48 pages. 32 pictures. 1 "For Health," a special supplement. 7 working plans with full specifications. FREE on request. Write. (Also ask for Vol. 43, a surprise book.)

### SOUTHERN CYPRESS MANUFACTURERS' ASSOCIATION

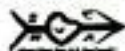

1219 Poydras Building, New Orleans, Louisiana  
or 1219 Graham Building, Jacksonville, Florida



Insist on TRADE-MARKED CYPRESS at your local lumber dealer's. If he hasn't it please advise us promptly and we will see that you are supplied.

Carbon Briquettes

# Popular Mechanics Magazine

6 N. Michigan Avenue, Chicago, U. S. A.

H. H. WINDSOR, Editor

London: Hachette & Cie,  
16-17, King William Street, Charing Cross, W. C. 2

Paris: Hachette & Cie,  
111 Rue Reaumur

Melbourne, Australia,  
The Australasian News Co.

ISSUED MONTHLY

SUBSCRIPTION:

SINGLE COPY, 25 CENTS

In United States, and its possessions, Cuba, Mexico, and Canada, per year, postpaid . . . \$3.00

To all other countries in the Postal Union \* . . . . . 3.50

All subscriptions are discontinued at expiration. Please examine the date printed on your wrapper.

Entered as Second Class Matter Sept. 15, 1903, at the Post Office at Chicago, Illinois, under Act of March 3rd, 1879.

Entered as Second Class Matter at the Post Office Department, Canada.

Published monthly by POPULAR MECHANICS CO.

Copyright, 1922, by H. H. Windsor.

Copyright in Australia.

Vol. 38

Contents for August, 1922

No. 2

Accident—Collision, Fatal Head-On, at Columbia River . . . . .	207
Air Motor, Double Cylinder, Smaller Than Match Box . . . . .	268
Airmen, Portuguese, Finish Flight across Ocean . . . . .	191
Airplane Cockpit, Modern, is Mass of Instruments and Controls . . . . .	276
Airplane Controls, Position of, Shown on Record . . . . .	219
Airplane, Loening, Makes Fast Trip from Florida . . . . .	215
Aluminum Solder Applied without Using a Flux . . . . .	270
Apple, All-Winter, Developed at State Fruit Farm . . . . .	203
Arc Lamp, Mercury Vapor, Self-Starting . . . . .	182
Ashes Removed by and Stored under Water . . . . .	168
Automobile Body Convertible for Truck or Camping . . . . .	286
Automobile Camp Sites, Lincoln Highway . . . . .	182
Automobile Engine Attachment Saves Gasoline . . . . .	229
Automobile Exhaust Used for Cooking Purposes . . . . .	239
Automobile Indicator Makes Gear Changes Noiseless . . . . .	227
Automobile Instruction Unit Teaches Owners About Their Car . . . . .	230
Automobile Radiator Condenser Made in Form of Still . . . . .	254
Automobile Radiator, New Water Level Indicator for . . . . .	277
Automobile Running Gears, Large Washbowl for Cleaning . . . . .	178
Automobile Shock Absorber Works on Lever Principle . . . . .	200
Automobile, Traveling, with Many Conveniences . . . . .	233
Automobile Vaporizer, New, Installed in Manifold . . . . .	180
Automobile Warning Signal for Day or Night Use . . . . .	272
Automobile Warning Signal, Improved . . . . .	244
Aviation—British Fliers Start Air Tour around the World . . . . .	186
Baby Carriage Driven by Gasoline Motor . . . . .	215
Balloon Models, Dirigible, Method of Testing . . . . .	225
Bank, Calendar Savings, to Encourage Thrift . . . . .	227
Bathhouses, Election Booths on Wheels Used as . . . . .	226
Bathing Beach Water, Piping System will Purify . . . . .	211
Beavers Become Menace by Damming Ditches . . . . .	224
Belt Covering Prevents Slipping . . . . .	283
Belt Shifter, Safety Stop Automatically Acts as . . . . .	239
Blanket Represents Strange Tribal Legend . . . . .	261
Book, Sales, Foreign Trade Committees Publish . . . . .	272
Bridge, Concrete, over Housatonic River . . . . .	185
Bridge, New, Increases Tone of Stringed Instruments . . . . .	281
Broom, Metal, Uses Steel Wire Fillers . . . . .	281
Camping Outhit, Auto, Compact and Collapsible . . . . .	241
Canal Terminal, World's Largest, by Gordon P. Gleason . . . . .	264
Cantons, Swiss, Hold Elections in Open Air . . . . .	166
Causeway, Galveston's Great, is Formally Dedicated . . . . .	213
Chair, Metal Folding, is Strong and Neat . . . . .	273
Children's Picture Pages . . . . .	284
Chuck, Sectional Wheel, for Face Grinding . . . . .	262
Church Window, Ornamental, is War Memorial . . . . .	248
Civic Features . . . . .	274
Clock Dial Tells Time Everywhere at Any Time . . . . .	176
Clothes, Hanger and Brush Combination for . . . . .	196
Coal Conveyors, Portable, Avoid Damage to Lawns . . . . .	243
Coffee Percolating Machine for Continuous Service . . . . .	214
Coffee Percolator, Electric, is Self-Pouring . . . . .	282
Coin, Large Swedish Copper, is Ancient Relic . . . . .	270
Coins, Old Gold, Unearthed . . . . .	174
Comment and Review, by H. H. Windsor . . . . .	269
Copra, Canoeing over Reefs and Shallows . . . . .	189
Corn Popper, New Rotary for Home Use . . . . .	186
Cotton Boll Weevil, Suction Machine Destroys . . . . .	193
Dental Machine Casts Gold Under Air Pressure . . . . .	281
Draft Gauges, Many, Combined in One Instrument . . . . .	254
Draftsmen's Instrument is Combination of Three . . . . .	272
Drydock, Huge Mississippi, Breaks Away . . . . .	235
Eagle Family, Motion Picture Camera Used to "Shoot" . . . . .	168
Electric Batteries Quickly Tested by Simple Hydrometer . . . . .	194
Electric Fixture, Significant Word Adopted for . . . . .	277
Electric Lamps, Two, with Double Filament . . . . .	234
Electrical Equipment, Record Shipment to S. America . . . . .	185
Elephant Family Group, Largest African . . . . .	273
Engines, German Submarine, Drive English Light Plant . . . . .	263
Fabrics, Bursting Point of, Apparatus for Testing . . . . .	171
Farm, Model Electric, Planned in Sweden . . . . .	185
Fence on Glacier Peak Protects Visitors . . . . .	191
Filter, Water Separating, on Gasoline Feed Pipe . . . . .	270
Fire Engine Has Detachable Pumping Unit . . . . .	216
Fire, Hotel, Demonstrates Worth of Concrete . . . . .	211
Fish—Halibut, Huge, Caught with Wooden Hook . . . . .	241
Fishhook, Grab, Automatically Opens and Closes . . . . .	180
Flashlight, Automatic Pistol Combined in . . . . .	244
Flatiron, Electric, Made in Complete Sections . . . . .	246
Fountain Pen Eraser like Rubber Tip on Pencils . . . . .	180
Fuel, Made, Show Merits of, in Outdoor Fireplaces . . . . .	208
Garage, Portable Concrete, Easy to Assemble . . . . .	233
Gasoline Tank Handy for Garage Repair Work . . . . .	247
Gear Teeth, Inspection of, by Enlarged Projection . . . . .	237
Glasses, Brush Machine Quickly Cleans . . . . .	238
Glider, Experimental, Built for Technical College . . . . .	220
Glue Container Is Like Fountain Pen . . . . .	182
Grapevine Roots Planted with Electric Drill . . . . .	233
Grass Cutting Machine with Three Mowers . . . . .	269
Grinder, Portable Disk, Has Graduated Index Table . . . . .	220
Hat Holder for Automobiles . . . . .	280
Helicopter, Man Carrying, Makes Short Flight . . . . .	181
Hoist, Hand, Machine Hung on Its Chain to Operate . . . . .	235
Horses, Farm, Breaking, Still a Big Business, by Florence L. Clark . . . . .	249
Hotel, Luncheon Guests Furnished Free Taxi by . . . . .	232
House on Wheels, Compact, Has Many Comforts . . . . .	183
House, Queer, Sea Furnishes Material for . . . . .	222
Household Devices . . . . .	278
Hydrants Made Conspicuous by Yellow Paint . . . . .	282
Ice Boat, Air Propelled, with Motor Bus Body . . . . .	271
Ice Cream Bricks, Machine Cuts Eight at a Time . . . . .	192
Ice Hoisting Carriage, New, with Automatic Action . . . . .	248
Incubator, Electric, Turns All Eggs at Once . . . . .	280
Insects, Bug Catcher Lures with Bright Light . . . . .	206
Invalid Walking Chair Displaces Crutches . . . . .	248
Knee Control, Artificial, Practically Self-Locking . . . . .	242
Lamp, Ornamental Cardboard, Can be Folded . . . . .	210
Lathe Headstocks, Expansion Relieving Center for . . . . .	282
Laundry Adopts Mechanical Handling Devices . . . . .	228
Lawn Checkers, Squares of Grass Used in . . . . .	250
Lifeboat, Motor, with Hospital Equipment . . . . .	191
Life Saver, Hazards of, and Incidents of His Work . . . . .	258
Lighting Principles, Suitcase Outfit Shows . . . . .	239
Lock, New Safety, Requires Two Keys . . . . .	272
Locomotive, Most Efficient and Most Powerful Ever Built . . . . .	187
Locomotive's Exhaust Steam Saves Coal . . . . .	189
Locomotives, Train of, Half a Mile Long . . . . .	165
Lodge Temple, New Masonic, Built by Members . . . . .	178

[Continued on Page 4]

This One



CSHR-U62-X5ZL



# DRAKE'S PRACTICAL MECHANICAL BOOKS

## THEY WILL RAISE YOUR PAY—

### ORDER ON 5-DAY TRIAL

The books listed below will perfect you in your chosen trade — pave the way to the big positions. Written in non-technical language—easy to read and understand. *Every book covers its subject completely. An entire course of instruction condensed into one volume.* Your choice sent postpaid — you benefit 5 days — money refunded in full if not entirely satisfactory. Order direct from this page.



### Automobile Books

- Automobile Ignition, by Manly .....Leatherette \$2.00  
 Automobile Starting and Lighting, by Manly.....Leatherette \$2.00  
 Brookes' Automobile Handbook, .....Leatherette \$2.00  
 Ford Motor Car, Truck and Tractor, by Manly.....Cloth \$1.50  
 Starting and Lighting Troubles, Remedies and Repairs, by Manly .....Leatherette \$3.00  
 Automobile Battery, Care and Repair, by Manly,Leatherette \$2.00  
 Automobile Catechism and Repair Manual.....Leatherette \$1.50  
 Tires and Vulcanizing, by Tufford .....Cloth \$2.00  
 Gas and Oil Engine Handbook, .....Cloth \$1.50  
 Automobile Upkeep and Care, by Manly.....Cloth \$1.50  
 Motorcycle Handbook, by Manly .....Cloth \$1.50

### Shop Practice Books

- Sheet Metal Workers' Manual, .....Leatherette \$2.00  
 Oxy-Acetylene Welding and Cutting .....Leatherette \$1.75  
 Sound Welds .....Cloth \$2.00  
 Slide Rule and Logarithmic Tables .....Leatherette \$2.00

- Handbook for Millwrights,Cloth \$2.00  
 Modern Blacksmithing.....Cloth \$1.25  
 Machine Shop Practice.....Cloth \$2.00  
 Mechanical Drawing and Machine Design .....Cloth \$2.00  
 Pattern Making.....Cloth \$1.50

### Carpentry Books

- Cloth Binding  
 Modern Carpentry, 2 vols.....\$3.00  
 The Steel Square, 2 vols.....\$3.00  
 Wooden Boat and Shipbuilding.....\$1.50  
 Modern Estimator .....\$1.50  
 Timber Framing .....\$2.00  
 Builder's Architectural Drawing.....\$2.00  
 Concretes .....\$1.50  
 Practical Bungalows .....\$1.00  
 Low Cost Homes.....\$1.00  
 Roof Framing .....\$1.50  
 Stair Building and Hand Railing .....\$1.50

### Electrical Books

- Practical Applied Electricity.....\$2.00  
 Alternating Current .....\$1.50  
 Electric Motor Control Systems.....\$1.50  
 Wiring Diagrams and Descriptions .....\$1.50  
 Electrical Tables and Data.....\$1.50  
 Armature and Magnet Winding.....\$1.50  
 Modern Electrical Construction.....\$1.50  
 Modern Electric Illumination.....\$1.50  
 Electricians' Operating and Testing .....\$1.50  
 Motion Picture Operation.....\$1.50  
 Drake's Electrical Dictionary.....\$1.50  
 Electric Motors, D. & A.....\$1.50  
 Electrical Measurements and Meter Testing .....\$1.50  
 Drake's Telephone Handbook.....\$1.50  
 Modern American Telephony.....\$2.00  
 Easy Electrical Experiments, .....Cloth \$1.25  
 Wireless Telegraph and Telephone Handbook.....Cloth \$1.25  
 Telegraphy Self-Taught...Cloth \$1.25

### Steam Engineering

- Swingle's Handbook for Steam Engineers and Electricians.....Leatherette \$4.00  
 Examination Questions and Answers for Marine and Stationary Engineers.....Leatherette \$2.00

- Steam Boilers.....Leatherette \$2.00  
 Swingle's Catechism of Steam, Gas and Electrical Engineering .....Leatherette \$1.50

### Painting Books

- Scene Painting and Bulletin Art .....Cloth \$4.00  
 A Show at Sho' Cards.....Cloth \$4.00  
 Sign Painting .....Cloth \$4.00  
 Strong's Book of Designs.....Leatherette \$4.00  
 Strong's Art of Show Card Writing .....Cloth \$4.00  
 Signist's Alphabets.....Cloth \$1.50  
 Modern Painter's Cyclopaedia.....Cloth \$2.00  
 Automobile Painting.....Cloth \$1.50  
 Estimates, Costs and Profits, Painting and Decorating.Cloth \$1.50  
 New Hardwood Finishing.Cloth \$1.50  
 The Amateur Artist.....Cloth \$1.50  
 New Stencils .....Cloth \$1.25

### Farm Books

- Farm Mechanics.....Cloth \$1.25  
 Farm Buildings.....Cloth \$1.25  
 Farm Engines.....Cloth \$1.25  
 Traction Farming.....Cloth \$1.50

### Business and Reference Books

- Better Business Letters.....Leatherette \$1.50  
 Better Business English.....Leatherette \$1.50  
 Better Advertising.....Leatherette \$1.50  
 Finger Prints Simplified..Cloth \$2.00  
 Practical Bricklaying.....Cloth \$1.25  
 Practical Instruction for Detectives .....Cloth \$1.00  
 Practical Plumbing .....Cloth \$1.50  
 Hot Water Heating.....Cloth \$1.50  
 Elementary Chemistry.....Cloth \$1.50  
 Courses in Civil Service.....Cloth \$1.50  
 Cyclopaedia of Recipes.....Cloth \$1.50  
 American Star Speaker...Cloth \$1.50

### Modern Languages

- By Prof. P. S. Allen, U. of Chicago  
 French without a Teacher.Cloth \$1.25  
 Spanish without a Teacher.Cloth \$1.25  
 German without a Teacher.Cloth \$1.25  
 Everyday French.....\$1.25  
 Everyday Spanish.....\$1.25

## ORDER DIRECT FROM THIS PAGE—ON OUR MONEY-BACK PLAN

The books listed above are only a few of the many in our catalogue, which you will receive promptly after filling out and mailing us the attached coupon. For quick action order direct from this page—cross name of each book wanted and send in with price quoted. We prepay postage and send the books on our money-back plan.

### FREDERICK J. DRAKE & CO.

PUBLISHERS

1008 Michigan Ave., Chicago

Drake Books Are For Sale at All Book Stores

FREDERICK J. DRAKE & CO.  
 1008 Michigan Avenue  
 Chicago, Ill.

GENTLEMEN:—Please send me free, postage paid, your illustrated catalogue which lists and describes over 100 Practical Mechanical Books for Home Study.

My name is .....

and my address .....

Mail Coupon For Free Catalogue  
 Your Guide to Home Study

## New Way to Keep Your Kitchen Cool All Summer

Mr. B. M. Oliver, of St. Louis, has discovered a new kind of heat that dispenses entirely with coal and wood. It burns 95% air and 5% kerosene. The device is installed in one minute in any cook stove, heater or range. This new invention is already sweeping over the country like wildfire. It eliminates hours of work, perspiration and drudgery for the housewife in sweltering Summer kitchens. Just turn a valve and you have plenty of heat for cooking or baking. Another turn and the heat is off.

It fits any stove without change of parts—simply sets in the firebox. It generates its own gas from kerosene. Mr. Oliver will send an attractive booklet to anyone who writes for it. Just address him at 2014-H Oliver Bldg., St. Louis. He is making a special introductory offer including a thirty-day free trial plan. He is looking for good live local distributors. He will tell you how you can earn \$500 a month easily. Request his sales plan.—Adv.



## Play UKULELE

### Like They Play it in Hawaii

Be the central figure at parties, outings, "song-fests," etc. Play solos as well as accompaniments. Become skilled player by wonderful new method.

### Simple As A.B.C.

Through this amazing method you play actual selections almost from the start. Instead of tiresome "exercises," you learn real notes, no "trick music"—in your own home. Suddenly—before you can scarcely credit it yourself—you are able to play anything, from the weird, sweet, haunting melodies of old Hawaii to the music of America and Europe.

**FREE BOOK SHOWS HOW** to become expert on your favorite instrument, quickly and thoroughly. It is FREE—act quick before the edition is exhausted.

It puts you under no obligation whatever. You will be thrilled with the revelations it makes. Never before have you been offered such an amazing opportunity to become a musician so quickly. Send coupon or letter NOW. Please write name and address plainly.

#### LEARN TO PLAY ANY INSTRUMENT

Piano	Mandolin
Organ	Drums and Traps
Violin	Harmony and Composition
Banjo	Sight Singing
Clarinet	Ukulele
Flute	Harp
Cornet	Piccolo
Cello	Trombone
Guitar	Saxophone

Voice and Speech Culture  
Automatic Finger Control

U. S. School of Music  
78 Brunswick Bldg., New York City

"Largest in the World"

Send me your amazing free book "Music Lessons in Your Own Home." This does not put me under any obligation.

Name.....

Address.....

Instrument.....

### [Contents—Continued from Page 4]

Winch Improved for Lathe.....	290
Woodwork, Interior, Salvaging.....	298
Wrench, Tubing, Made from Coil Spring.....	300

#### AMATEUR MECHANICS

Automobile Brakes, Tool for Adjusting.....	309
Automobile Driving, Aid for, on Dark Roads.....	323
Automobile Pedal Device for Driving with One Foot.....	328
Automobile Springs, Oiling through a Tube.....	310
Automobile "Towing" without a Towrope.....	310
Bedstead, Clothes Hook for.....	315
Boat—Rowboat, Sectional Flat-Bottom, Building.....	307
Burglar Alarm, Connecting to Light Circuit.....	322
Canoe, Mounting Rowboat Motor in.....	317
Curtains, Stretching without a Frame.....	316
Dandelion Destroyer, Homemade.....	311
Dog Leash, Safety, for Automobiles.....	315
Enlarging Maps and Drawings Quickly.....	324
Envelopes, Small, Making from Large Ones.....	311
Fishing Rod, Re-Serving a.....	322
Flower Bed Borders Made from Auto Rims.....	316
Funnel Arrangement Prevents Air Binding.....	326
Hanger, Clothes, for Closetless Rooms.....	316
Headlight Bulbs, Preventing Vibration of.....	316
Hinges, Small, How to Make.....	323
Hose, Garden, as Substitute for Spray Pump.....	318
Identification Cards, Protecting.....	312
Inner Tubes, Air Releaser for.....	315
Lawn Mower Handle, Extension.....	315
Lawns, Cutting in Dry Weather.....	317
Lawns, Edging Tool for.....	321
Mail Box That is Always Locked.....	310
Mirror, Making Handy for Camp Use.....	317
Music Rack Attachment Holds the Instrument.....	310
Paint, Removing from the Hands.....	308
Paper Holders, Attachment for.....	321
Partitions for Catalog Files.....	318
Phonograph, Making Portable for Schools.....	312
Photography—Positives Direct from the Camera.....	310
Photography—Reel for Developing Roll Films.....	326
Picnic Kit, Motor, Suitcase Made into.....	325
Pipe Stems, Loose, Tightening.....	316
Puzzle, Ring-and-Peg.....	312
Rake, Litter, Made from Pitchfork.....	317
Rat Alarm, Improved.....	309
Rims, Split, Remover for.....	324
Rugs and Carpets, Hanging on Clothesline.....	322
Seesaw, Making Adjustable.....	317
Sickle Sections, Removing.....	324
Siphon Support and Float.....	311
Spark Intensifiers, Automobile, Explanation of.....	325
Spark Plug Terminals, Novel.....	328
Telephone Pad Holder and Desk.....	323
Tractor, Toy Farm.....	309
Typewriter, Eraser Holder for.....	322
Typewriter Stand, Portable, Made from Camera Tripod.....	324
Washer, Hand Power, Attaching an Electric Motor to.....	318
Water Tanks, Leaking, Repairing.....	323
Wheelbarrow, Making Rubber Tires for.....	324
Wind Wagon, How to Build.....	319
Wireless Antenna, Insulator for.....	312
Wireless Receiver, Short-Wave, Honeycomb Coils for.....	313

## RADIO For Everybody

Make Radio a profession instead of a plaything. You can earn big money as a Radio-trician. Learn by mail, in spare time, how to design, construct, install, repair, maintain, operate, sell and demonstrate complete radio outfits. Write for free 32-page catalog describing our course entitled, "How to Learn Radio at Home."

National Radio Institute, Dept. 1192, Washington, D. C.

## ELECTRICITY LEARN AT HOME

Send for catalog which tells how Burgess Home Training enables men and boys to get good jobs and keep them. Burgess Electrical School, Dept. P-8, 744 E. 42nd St., Chicago

## "HOW I BEAT THE GAME"

The Inspiring Story of how one poorly paid garage mechanic won success, his own business and a big income. Tells how you can increase your salary from 100 to 500%. Send for it today FREE.

Ambu Engineering Institute  
Dept. 18 2632 Prairie Ave., Chicago, Ill.



Let These Guides

Solve Your Problems

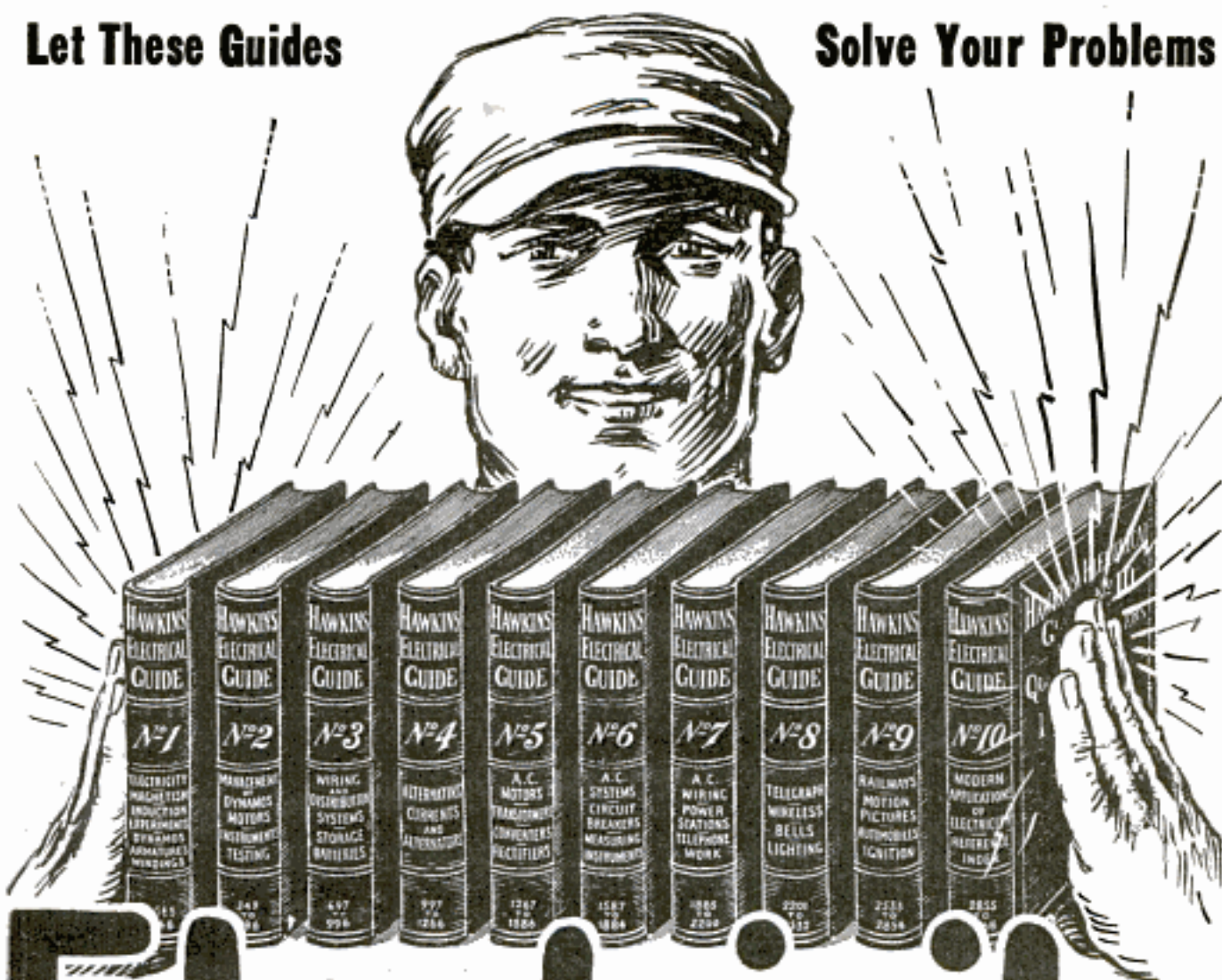

# Electricity at your finger ends

**HAWKINS ELECTRICAL GUIDES IN TEN VOLUMES**

3500 PAGES

4700 PICTURES

\$1 A VOLUME

\$1 A MONTH

Send No Money—Send Only This Coupon

Know the facts in Electricity. They mean more money and better position for you. Hawkins Guides tell you all you need to know about Electricity. Every important electrical subject covered so you can understand it. Easy to study and apply. A complete, practical working course, in 10 volumes. Books are pocket size; flexible covers. Order a set today to look over.

**LEARN ALL ABOUT**

Magnetism—Induction—Experiments—Dynamometers—Electric Machinery—Motors—Armatures—Armature Windings—Installing of Dynamometers—Electrical Instrument Testing—Practical Management of Dynamometers and Motors—Distribution Systems—Wiring—Wiring Diagrams—Sign Flashers—Storage Batteries—Principles of Alternating Currents and Alternators—Alternating Current Motors—Transformers—Converters—Rectifiers—Alternating Current Systems—Circuit Breakers—Measuring Instruments—Switchboards—Wiring—Power Stations—Installing—Telephone—Telegraph—Wireless—Bells—Lighting—Railways. Also many Modern Practical Applications of Electricity and Ready Reference Index of the ten numbers.

**SHIPPED FREE**

Not a cent to pay until you see the books. No obligation to buy unless you are satisfied. Send Coupon now—today—and get this great help library and see if it is not worth \$100 to you—you pay \$1.00 a month for ten months or return it.

**THEO. AUDEL & CO.,**  
72 Fifth Ave., New York City

Please submit me for free examination, HAWKINS ELECTRICAL GUIDE, (Price \$1 a number). Ship at once prepaid, the 10 numbers. If satisfactory, I agree to send you \$1 within seven days and to further mail you \$1 each month until paid.

Name .....

Occupation .....

Employed by .....

Home Address .....

Reference .....

FM AGC.22



# A Big Raise in Salary!

*Is Very Easy to Get, If You Go About It in the Right Way*

You have often heard of others who have doubled and trebled their salaries in a year's time. You wondered how they did it. Was it a pull? Don't you think it. When a man is hired he gets paid for exactly what he does, there is no sentiment in business. It's preparing for the future and knowing what to do at the right time that doubles and trebles salaries.

## Remember When You Were a Kid

and tried to ride a bike for the very first time? You thought that you would never learn and then—all of a sudden you knew how, and said in surprise: "Why it's a cinch if you know how." It's that way with most things, and getting a job with big money is no exception to the rule, if you know how.

## We Will Show You How

Without loss to you of a single working hour we can show you a sure way to success and big pay. A large number of men in each of the positions listed are enjoying their salaries because of our help—we want to help you.

Make check on the coupon against the job you want and we will help you to get it. Write or print your name on the coupon and send it in today.

## American School

Dept. G. C. 74, Drexel Ave. and 58th St., Chicago

**American School, Dept. G. C. 74, Drexel Ave., and 58th St., Chicago**

Send me full information on the subject checked and how you will help me win success.

.....Architect  
 .....Building Contractor  
 .....Automobile Engineer  
 .....Automobile Repairman  
 .....Civil Engineer  
 .....Structural Engineer  
 .....Business Manager  
 .....Cert. Public Accountant  
 .....Accountant and Auditor  
 .....Bookkeeper  
 .....Draftsman and Designer

.....Electrical Engineer  
 .....Electric Light and Power  
 .....General Education  
 .....Vocational Guidance  
 .....Business Law  
 .....Lawyer  
 .....Machine Shop Practice  
 .....Photoplay Writer  
 .....Mechanical Engineer  
 .....Shop Superintendent  
 .....Employment Manager

.....Steam Engineer  
 .....Foremanship  
 .....Sanitary Engineer  
 .....Surveyor (& Mapping)  
 .....Telephone Engineer  
 .....Telegraph Engineer  
 .....High School Graduate  
 .....Fire Insurance Expert  
 .....Wireless Radio  
 .....Undecided

Name..... Address.....



## Stop Wondering How I Teach Piano; I'll Show You, FREE

**Y**EAR after year you've seen my advertisement in all the leading publications, offering to teach you piano in *quarter* the usual time. Year after year my school has grown and grown until now I have far more students than were ever before taught by one man. In 1921 over a thousand students *graduated* from my Piano or Organ course and received their diplomas.

Yet when I first started giving piano and organ lessons by mail in 1891 my method was laughed at. Could my conservatory have grown as it has, obtained students in every state of the Union and in fact practically every civilized country of the world unless it produced very unusual and satisfying RESULTS for its students? See for yourself what it is that has brought my method so rapidly to the front. Write for free booklet and sample lessons.

Now, for the first time, you can obtain sample lessons without charge. In the past I have always been opposed to sending out free lessons, even to persons who were seriously interested in my course. But my friends have insisted that I give everybody a chance to see for themselves just how simple, interesting and DIFFERENT my lessons are, and I have consented to try the experiment for a short time. Simply mail the coupon below or write a postcard, and the 64-page booklet and sample lessons will go to you at once absolutely free and without obligation.

**Within four lessons** you will play an interesting piece on the piano or organ, not only in the original key, but in all other keys as well. Most students practice months before they acquire this ability. It is made possible by my patented invention the Colorotone. Another invention obtainable only from me is my hand-operated moving picture device, Quinn-dex. By means of Quinn-dex you actually see my fingers in motion on the piano, and can learn just how to train your own fingers.

When I say that I can teach you piano in *quarter* the usual time, do not think that this is too good to be true. Modern inventions and improved methods have accomplished just as great wonders in other branches of education. You at least owe it to yourself to *investigate*. Send coupon or postcard at once, before the offer of free sample lessons is withdrawn.

Please send me, without cost or obligation your free booklet, "How to Learn Piano or Organ," free sample lessons, and full particulars of your method.

Name.....

Address.....

**Quinn**

**Conservatory,**

Studio PM 48,  
598 Columbia Road,  
Boston 25, Mass.

# \$80 Drafting Course Free

for best copy of sketch

# \$25 Drawing Outfit Free

for next best copy of sketch

## A Special Ivory Pocket Rule FREE!

for sending any copy of drawing shown at left hand side

**Y**OU may enter this *Free Prize Drawing Contest* if you give your age when writing or sending your sketch. There are no conditions requiring you to buy anything. So, if you are interested in drawing, send in your sketch right away. Whether you obtain one of the big prizes or not, you are sure to be given *free* a 6-inch Ivory Pocket rule and a 6 x 9 book on "Successful Draftsmanship."

Chief Draftsman Dobe, of the Engineers' Equipment Company, offers these prizes to interest ambitious men who would like to better themselves at bigger salaries, doing work which brings big pay and at the same time leading more to advancement. There will be 72,000 open positions this year paying from \$3,000 to \$3,600 a year. The great building boom all over the country is causing this great demand, and industrial activity in the mechanical line makes it worth your while to give this opportunity your immediate attention.



## \$250 to \$300 a Month

Positions paying \$250 to \$300 per month, which ought to be filled by skilled draftsmen are vacant everywhere. There are in every part of this country ambitious men, who with practical training and personal assistance, will be qualified to fill these positions.



Copy this sketch

Mr. Dobe is very much interested in finding these men and calling to their attention the great future in draftsmanship—how when a man enters into this profession, he is in an uncrowded field and how with surprisingly little effort he may rise to the salary of from \$3,000 to \$3,600 a year.

Ambitious boys and men, between the ages of 16 and 50, are wanted by great business concerns, and the man who is ready when opportunity calls him, gets the high grade positions and the highest pay.

No man can hope to share a part in the great coming prosperity in manufacturing and building, unless he is properly trained and able to do first class, practical work and is ready when he is called.

Mr. Dobe knows now is the time to get ready and he knows that few men realize this so well as he. So in order to interest men everywhere he is offering special prizes mentioned above.

If you send in what the judges decide to be the best drawing of the sketch above, you will be awarded a complete \$80 Practical Drafting Room Course, being trained by Mr. Dobe personally. This training is given by mail and he guarantees to train a limited number of students under this agreement to give practical drafting room training UNTIL placed in a permanent position at a salary of \$250 to \$300 per month.

To any student that Mr. Dobe accepts for his personal training, he will furnish a complete \$25 draftsman's working outfit absolutely free. This outfit consists of all instruments and tools required by any first class draftsman.

Considering that Mr. Dobe selects and limits the number of students for training, it is very important that you act promptly and send in your reply either with your sketch or without a sketch at once, asking for full particulars.

He will also send you a free book entitled "Successful Draftsmanship" in addition to all other information, telling you how you may learn drafting at home.

## Mail Your Drawing At Once— and Get Ivory Pocket Ruler Absolutely FREE!

Ambitious men, interested in drafting, hurry! Don't wait! This is your opportunity in this great profession. Accept this offer which Mr. Dobe makes. Send in your sketch or request for FREE Book and Ivory Pocket Rule. Address:

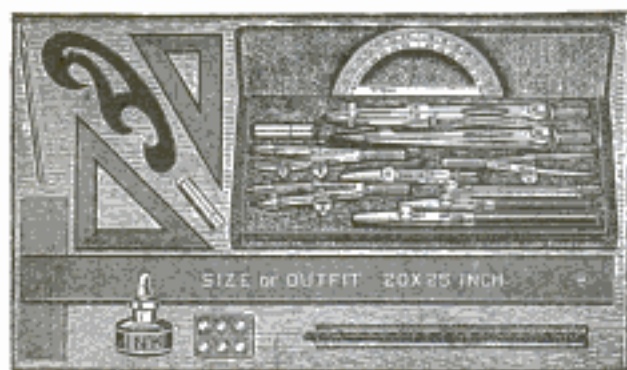

## FREE — this \$25 Draftsman's Working Outfit

These are regular working instruments, the kind I use myself. I give them free to you if you enroll at once. Don't delay. Send for full information TODAY!

Chief Draftsman, Engineers' Equipment Co., 4001 Broadway, Div. C-135, Chicago, Ill.

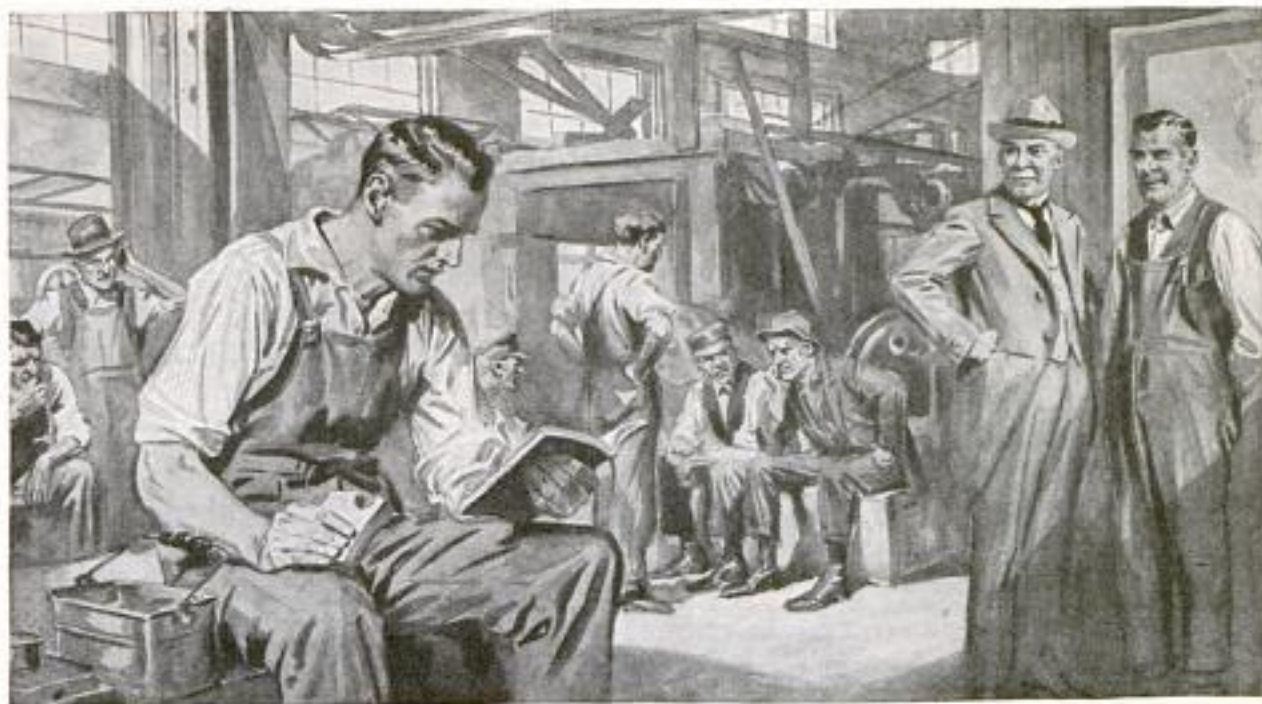

## “There’s one man we’re going to keep”

“**E**D WILSON, there, is one of the most ambitious men in the plant. I notice that he never fools away his spare time. He studies his International Correspondence Schools course every chance he gets.

“It’s been the making of him, too. He hasn’t been here nearly so long as Tom Downey, who was laid off yesterday, but he knows ten times as much about this business.

“I’m going to give him Tom’s job at a raise in salary. He’s the kind of man we want around here.”

**H**OW do you stand in your shop or office? Are you an Ed Wilson or a Tom Downey? Are you going up? Or down?

No matter where you live, the International Correspondence Schools will come to you. No matter what your handicaps or how small your means, we have a plan to meet your circumstances. No matter how limited your previous education, the simply-written, wonder-

fully-illustrated I. C. S. textbooks make it easy to learn.

This is all we ask: Without cost, without obligating yourself in any way, put it up to us to prove how we can help you. Just mark and mail this coupon for full particulars.

### INTERNATIONAL CORRESPONDENCE SCHOOLS Box 3656-C, Scranton, Penna.

Without cost or obligation, please send me full information about the subject before which I have marked an X in the list below:

#### BUSINESS TRAINING DEPARTMENT

- |   |   |
|---|---|
| <input type="checkbox"/> Business Management                              | <input type="checkbox"/> Salesmanship                                     |
| <input type="checkbox"/> Industrial Management                            | <input type="checkbox"/> Advertising                                      |
| <input type="checkbox"/> Personnel Organization                           | <input type="checkbox"/> Better Letters                                   |
| <input type="checkbox"/> Traffic Management                               | <input type="checkbox"/> Foreign Trade                                    |
| <input type="checkbox"/> Business Law                                     | <input type="checkbox"/> Stenography and Typing                           |
| <input type="checkbox"/> Banking and Banking Law                          | <input type="checkbox"/> Business English                                 |
| <input type="checkbox"/> Accountancy (including C.P.A.)                   | <input type="checkbox"/> Civil Service                                    |
| <input type="checkbox"/> Nicholson Cost Accounting                        | <input type="checkbox"/> Railway Mail Clerk                               |
| <input type="checkbox"/> Bookkeeping                                      | <input type="checkbox"/> Common School Subjects                           |
| <input type="checkbox"/> Private Secretary                                | <input type="checkbox"/> High School Subjects                             |
| <input type="checkbox"/> Business Spanish <input type="checkbox"/> French | <input type="checkbox"/> Illustrating <input type="checkbox"/> Cartooning |

#### TECHNICAL AND INDUSTRIAL DEPARTMENT

- |   |  |
|---|--|
| <input type="checkbox"/> Electrical Engineering                           | <input type="checkbox"/> Architect               |
| <input type="checkbox"/> Electric Lighting                                | <input type="checkbox"/> Contractor and Builder  |
| <input type="checkbox"/> Mechanical Engineer                              | <input type="checkbox"/> Architectural Draftsman |
| <input type="checkbox"/> Mechanical Draftsman                             | <input type="checkbox"/> Concrete Builder        |
| <input type="checkbox"/> Machine Shop Practice                            | <input type="checkbox"/> Structural Engineer     |
| <input type="checkbox"/> Railroad Positions                               | <input type="checkbox"/> Plumbing and Heating    |
| <input type="checkbox"/> Gas Engine Operating                             | <input type="checkbox"/> Chemistry               |
| <input type="checkbox"/> Civil Engineer                                   | <input type="checkbox"/> Pharmacy                |
| <input type="checkbox"/> Surveying and Mapping                            | <input type="checkbox"/> Automobile Work         |
| <input type="checkbox"/> Mine Foreman or Engineer                         | <input type="checkbox"/> Navigation              |
| <input type="checkbox"/> Steam Engineering                                | <input type="checkbox"/> Agriculture and Poultry |
| <input type="checkbox"/> Radioc <input type="checkbox"/> Airplane Engines | <input type="checkbox"/> Mathematics             |

Name.....  
Street.....  
Address.....

City..... State.....

Occupation.....

Persons residing in Canada should send this coupon to the International Correspondence Schools Canadian, Limited, Montreal, Canada.

## Does your English Help or Hurt you?

Does your English reveal your lack of education or does it prove that you are a person of culture and refinement? English is the one weapon you must use every day. Here is how you can improve it almost at once.

**M**ANY people say, "Did you hear from him today?" They should say, "Have you heard from him today?" Some people spell calendar "calender" or "calander." Still others say "between you and I," instead of "between you and me." It is astonishing how many people use "who" for "whom," and mispronounce the simplest words. Few people know whether to spell certain words with one or two "c's" or "m's" or "r's," or with "ie" or "ei," and when to use commas in order to make their meaning absolutely clear. And most people use only common words—colorless, flat, ordinary. Their speech and their letters are lifeless, monotonous, humdrum.

Every time you talk, every time you write, you show what you are. When you use the wrong word, when you mispronounce a word, when you punctuate incorrectly, when you use flat, ordinary words, you handicap yourself enormously. An unusual command of English enables you to present your ideas clearly, forcefully, convincingly. If your English is incorrect it hurts you more than you will ever know, for people are too polite to tell you about your mistakes.

### Wonderful New Invention

For the past five years Mr. Cody has been working almost day and night on the study of the problem, "How to make correct habits in speaking and writing stick in your mind." After countless experiments he finally invented a simple method by which you can acquire a better command of the English language in only 15 minutes a day. Now you can stop making the mistakes in English which have been hurting you. Mr. Cody's students have secured more improvement in five weeks than had previously been obtained by other pupils in two years!

### Learn by Habit—Not by Rules

Under old methods, rules are memorized, but correct habits are not formed. Finally the rules themselves are forgotten. The new Sherwin Cody method provides for the formation of correct habits by constantly calling attention only to the mistakes you make.

One of the wonderful things about Mr. Cody's course is the speed with which these habit-forming practice drills can be carried out. You can write the answers to fifty questions in 15 minutes and correct your work in 5 minutes more. The drudgery and work of copying have been ended by Mr. Cody. You concentrate always on your mistakes until it becomes "second nature" to speak and write correctly.

### Write for Free Book

A booklet explaining Mr. Cody's remarkable course is ready. If you are ever embarrassed by mistakes in grammar, spelling, pronunciation, or punctuation, if you cannot instantly command the exact words with which to express your ideas, this book will prove a revelation to you.

Write for this new free book, "How to Speak and Write Masterly English." Merely mail the coupon or a letter, or even a postal card. You can never reach your greatest possibilities until you use correct English. Write to-day for the free booklet that tells about Mr. Cody's simple invention.

**SHERWIN CODY SCHOOL OF ENGLISH**  
58 Searle Building - Rochester, New York

SHERWIN CODY SCHOOL OF ENGLISH,  
58 Searle Bldg., Rochester, N. Y.

Please send me your new Free Book, "How to Speak and Write Masterly English."

Mr. ....

Address.....

City..... State.....



SHERWIN CODY

## BE AN ARTIST

We can teach you **DRAWING** in your own home during your spare time.

Our 18 years of successful teaching prove our ability. 10 Courses in Commercial and Illustrative Drawing. Teachers Normal and Applied Art. Endorsed by high art authorities. Students trained by members of our Faculty are filling high-salaried positions. Artist's Outfit FREE to Enrolled Students. Write today for Art Year Book.

**OUR HANDSOME ART YEAR BOOK** is FREE to Enrolled Students.

**SCHOOL OF APPLIED ART**  
APPLIED ART BLDG. NO. 2 BATTLE CREEK MICH.

## Learn Chemistry at HOME

Chemistry offers the greatest opportunities to-day of any profession. If you want to know how you can learn chemistry at home, in your spare time, write to one of the foremost authorities on Chemistry, Dr. T. O'Connor Sloane, care Chemical Institute of New York, Home Extension Division 8, 140-F Liberty St., New York City. Dr. Sloane will send you full information FREE, by return mail.



**FREE \$20**  
Violin, Hawaiian Guitar, Ukulele,  
Guitar, Mandolin, Cornet, Tenor Banjo or Banjo

Wonderful new system of teaching note music by mail. To pupils in each locality, we give a \$20 superb Violin, Mandolin, Ukulele, Guitar, Hawaiian Guitar, Cornet, Tenor Banjo or Banjo absolutely free. Very small charge for lessons only. We guarantee success or no charge. Complete outfit free. Write now. No obligation.  
**SLINGERLAND SCHOOL OF MUSIC, Inc., Dept. 114, CHICAGO, ILL.**

## SWIM ENJOY YOUR OUTDOORS

For Sport, Safety, Recreation and Health

### LEARN TO SWIM CORRECTLY

A practical course. Lessons graded in logical steps. Sent postpaid to any address for only \$1.

**C. G. DOWD**  
Box P, 105 Palmetto Street, Brooklyn, New York

## RADIO For Everybody

Make Radio a profession instead of a plaything. You can earn big money as a Radio-trician. Learn by mail, in spare time, how to design, construct, install, repair, maintain, operate, sell and demonstrate complete radio outfits. Write for free 32-page catalog describing our course entitled, "How to Learn Radio at Home."

**National Radio Institute, Dept. 1192, Washington, D. C.**

## LEARN WATCHMAKING

and become independent. Good-paying positions secured.

Easy to learn. Send for FREE CATALOG.  
**ST. LOUIS WATCHMAKING SCHOOL, Dept. 5, ST. LOUIS, MO**

## Factory to Rider

Saves \$10 to \$25 on the **Ranger Bicycle** you select. You can have your choice of **44 Styles**, colors and sizes. Delivered free on approval, *express prepaid*, for **30 DAYS' FREE TRIAL**.

**12 Months to Pay** if desired. Possession and use at once on our liberal year to pay plan. Parents often advance first payment.

**Tires** Large, wheels and equipment, low prices. Send No Money, do business direct with makers.

**Mead Cycle Company**  
Dept. F106 Chicago

Write today for free Ranger Catalog, factory prices and marvelous easy payment terms



# 5,000,000 Men Are After the Routine Jobs—

*Break Away From  
This Competition—*

## Command Big Pay!

When business slackens, can your employer "let you go"—and tomorrow hire almost any routine man from this army of 5,000,000 men and find him competent to take your place?

Observe that when a business trims its crew, it is almost never the *big-pay* men who walk the plank.

Not only are the specialists retained—the Accountants, Production Managers, Traffic Managers, and, in fact, the managers of any of the important departments of a business—but they are frequently promoted. Other concerns are in need of their ability, and come bidding for their services.

Many of these men who today are going rapidly ahead were no better off than you, several years ago. Today, while others walk the streets, these men walk into the better jobs.

There is no mystery about their swift advancement. There is a way that's interesting and practical whereby any man of average intelligence can get the training that will put him in the big-pay class. Literally thousands of ambitious men have found this way in the LaSalle Problem Method. They have chosen the line of work that most appealed to them—then, right in the quiet of their own homes, without losing an hour from work or a dollar of pay, they have solved the problems they today are meeting in the better jobs.

Situations which they face today are identical with those they faced in spare-time study. They have been shown exactly how to meet them—guided every step of the way by some of the ablest business men, in their respective fields, in America.



Read these statements, typical of over 1,000 which we will send you in booklet form and which represent but a small part of the many thousands of similar letters in our files:

- "The most efficient and most rapidly promoted men in our whole organization are LaSalle-trained."
- "Promoted to General Manager."
- "Now a director in two banks."
- "From bookkeeper advanced to chief accountant—salary increased 500%."
- "Passed bar examination with highest grade, in competition with many resident school graduates."
- "The Problem Method increased my income \$2,500 a year."
- "Passed C. P. A. examination. You will be interested to know that 50% of the successful candidates were LaSalle-trained men."

An analysis of the letters from 1,089 LaSalle members reporting definite salary increases during 3 months' time shows an average increase per man of 56%.

While the axe hangs over every business office, it's the time of all times to free yourself forever from the treadmill jobs.

Mark on the coupon the training that attracts you, sign and mail it to the University. It will bring you full information, together with particulars of our convenient-payment plan; also your free copy of the inspiring book—"Ten Years' Promotion in One."

Break away from the crowd of routine pluggers. Find out today what YOU must do to put yourself among the men who command big money. Mail the coupon NOW.

### INQUIRY COUPON

**LASALLE EXTENSION UNIVERSITY, Dept. 846-R CHICAGO, ILLINOIS**

Please send me catalog and full information regarding the course and service I have marked with an X below. Also a copy of your booklet, "Ten Years' Promotion in One," all without obligation to me.

- |  |  |  |   |
|--|--|--|---|
| <input type="checkbox"/> Business Management                       | <input type="checkbox"/> Law—Degree of LL. B.                        | <input type="checkbox"/> Banking and Finance                     | <input type="checkbox"/> Expert Bookkeeping |
| <input type="checkbox"/> Salesmanship                              | <input type="checkbox"/> Commercial Law                              | <input type="checkbox"/> Personnel and Employment Management     | <input type="checkbox"/> Business English   |
| <input type="checkbox"/> Higher Accountancy                        | <input type="checkbox"/> Industrial Management Efficiency            | <input type="checkbox"/> Modern Foremanship & Production Methods | <input type="checkbox"/> Commercial Spanish |
| <input type="checkbox"/> Traffic Management                        | <input type="checkbox"/> Modern Business Correspondence and Practice |  | <input type="checkbox"/> Effective Speaking |
| <input type="checkbox"/> Railway Accounting and Station Management |  |  | <input type="checkbox"/> C. P. A. Coaching  |

Name..... Present Position.....

Address.....

# Come to the

**Drive and Repair Autos. Learn Me Welding, Radio. Eight weeks' course ployment. Get in before expiration of**

**Y**OUNG man, if you are mechanically inclined, you don't need any previous experience or book learning to become an expert mechanic by the Sweeney System.

I teach you in the most simple and practical way how to run and repair automobiles and tractors. How to build batteries. How to vulcanize tires. How to weld. How to do machine work. How to build and operate and install radio sets.

Here is a picture of myself and of my Million Dollar School. Notice the radio broadcasting station over which I talk to people all over the United States. I give you a radio course free.

You can save a lot of money and your railroad fare to Kansas City by accepting my special offer which is just about to expire. If you are in earnest write me today.



Simply send name today for my big free catalog. That's the first step on the road to success. This is a fine 72 page book in colors that explains all about the Sweeney School and the opportunities in mechanical training. It also tells how thousands of men just like you made a life-time success as a

**LEARN A**  
**Sweeney**  
**SCHOOL OF AUTO**  
 1050 SWEENEY BLDG



# Sweeney School

**chanics, Battery Work, Vulcanizing, now leads to guaranteed profitable em- Summer Rates and Free Railroad Fare**



I WANT to pay your railroad fare to Kansas City. I also want to give you a guarantee of profitable employment. I have several thousand jobs open as branch managers. Do you want one of these?

Or do you want a job as chauffeur? To drive around and see the world? Would you like to be a mechanic and earn \$6 to \$1 a day? How would you like to earn to vulcanize tires and run a tire shop of your own? Or manage a garage at \$150 a month and up?

Remember, you can't go any place in the U. S. without running into Sweeney graduates who have made good. Pretty near 50,000 men now who will O K the Sweeney School. What they did you can do.

If you want to be independent and do the work you like and get real money now is the time to start. You haven't any idea of the possibilities in the auto business. Let me tell you what I can do for you.

result of this simple training. It gives hundreds of interesting pictures and shows what a fine time Sweeney students have while learning the best business in the world. This book is absolutely free and there is no obligation on your part in sending for it. Clip the coupon or just send a postcard and I'll mail you the book and also a copy of the Sweeney News right away.

For  
Big Offer  
and Catalog  
Mail This Coupon

Emory J. Sweeney, President,  
Dept. 1050, Sweeney Bldg.,  
Kansas City, Mo.

Send me your offer of a guaranteed position, your big free catalog, and full details of the Sweeney eight weeks' course leading to an immediate money-making opportunity.

TRADE -  
**Sweeney**  
TRACTOR AVIATION  
KANSAS CITY, MO.

Name.....

Address.....



## "Another \$50 Raise!"

"Why, that's the third increase I've had in a year! It shows what special training will do for a man."

Every mail brings letters from some of the two million students of the International Correspondence Schools, telling of advancements won through spare-time study.

How much longer are you going to wait before taking the step that is bound to bring you more money? Isn't it better to start now than to wait for years and then realize what the delay has cost you?

One hour after supper each night spent with the I. C. S. in your own home will prepare you for the position you want in the work you like best.

Without cost, without obligation, mark and mail this coupon. *Do it right now!*

### INTERNATIONAL CORRESPONDENCE SCHOOLS Box 5659-C, Scranton, Penna.

Without cost or obligation, please send me full information about the subject before which I have marked an X in the list below:

#### BUSINESS TRAINING DEPARTMENT

- |   |   |
|---|---|
| <input type="checkbox"/> Business Management            | <input type="checkbox"/> Salesmanship           |
| <input type="checkbox"/> Industrial Management          | <input type="checkbox"/> Advertising            |
| <input type="checkbox"/> Personnel Organization         | <input type="checkbox"/> Better Letters         |
| <input type="checkbox"/> Traffic Management             | <input type="checkbox"/> Foreign Trade          |
| <input type="checkbox"/> Business Law                   | <input type="checkbox"/> Stenography and Typing |
| <input type="checkbox"/> Banking and Banking Law        | <input type="checkbox"/> Business English       |
| <input type="checkbox"/> Accountancy (including C.P.A.) | <input type="checkbox"/> Civil Service          |
| <input type="checkbox"/> Nicholson Cost Accounting      | <input type="checkbox"/> Railway Mail Clerk     |
| <input type="checkbox"/> Bookkeeping                    | <input type="checkbox"/> Common School Subjects |
| <input type="checkbox"/> Private Secretary              | <input type="checkbox"/> High School Subjects   |
| <input type="checkbox"/> Business Spanish               | <input type="checkbox"/> Illustrating           |
| <input type="checkbox"/> French                         | <input type="checkbox"/> Cartooning             |

#### TECHNICAL AND INDUSTRIAL DEPARTMENT

- |   |  |
|---|--|
| <input type="checkbox"/> Electrical Engineering   | <input type="checkbox"/> Architect               |
| <input type="checkbox"/> Electric Lighting        | <input type="checkbox"/> Contractor and Builder  |
| <input type="checkbox"/> Mechanical Engineer      | <input type="checkbox"/> Architectural Draftsman |
| <input type="checkbox"/> Mechanical Draftsman     | <input type="checkbox"/> Concrete Builder        |
| <input type="checkbox"/> Machine Shop Practice    | <input type="checkbox"/> Structural Engineer     |
| <input type="checkbox"/> Railroad Positions       | <input type="checkbox"/> Plumbing and Heating    |
| <input type="checkbox"/> Gas Engine Operating     | <input type="checkbox"/> Chemistry               |
| <input type="checkbox"/> Civil Engineer           | <input type="checkbox"/> Pharmacy                |
| <input type="checkbox"/> Surveying and Mapping    | <input type="checkbox"/> Automobile Work         |
| <input type="checkbox"/> Mine Foreman or Engineer | <input type="checkbox"/> Navigation              |
| <input type="checkbox"/> Steam Engineering        | <input type="checkbox"/> Agriculture and Poultry |
| <input type="checkbox"/> Radio                    | <input type="checkbox"/> Mathematics             |
| <input type="checkbox"/> Airplane Engines         |  |

Name.....  
Street.....  
Address.....

City..... State.....

Occupation.....

Persons residing in Canada should send this coupon to the International Correspondence Schools Canadian, Limited, Montreal, Canada.

Please Mention Popular Mechanics



## Why Miss Half the Fun in Life?

**BE POPULAR**—Learn to dance well! Arthur Murray, America's greatest dancing teacher, has invented a remarkable new easy method which enables anyone to learn all the newest dances at home—in a few hours—at very little cost!

No music or partner needed. Success positively guaranteed! "60,000 learned dancing by mail."

**FREE DANCING LESSON**—To prove you can learn easily and quickly, Arthur Murray will send you a lesson absolutely free. Also, the Secret of Leading, How to Gain Confidence and other dancing helps, in plain cover. For mailing, send 10c. Act now and be a good dancer soon.

Arthur Murray, Studio 407  
100 Fifth Avenue New York

Radio for amateurs and beginners taught in a new, rational and practical way.

Write for our interesting, informative,  
**FREE BOOK** to

**BRYN MAWR SCHOOL OF RADIO**  
of The **DCK** Radio Corporation  
DEPT. A BRYN MAWR, PA.



## NAVIGATION TAUGHT BY MAIL

Hundreds of Ship Officers needed in Merchant Marine and Navy. Salaries up to \$412 monthly and living expenses. You can qualify through Captain Warren Sheppard's Home Study Course on Navigation. Chance of a lifetime to see the world as a ship's officer at a big salary. Write for free Book, "Your Future is on the Seven Seas." World Technical Institute, Dept. 100A, Fuller Building, Jersey City, N. J.

## FREE Lesson in Drafting

Send for our free lesson which shows how easily you can master Drafting by the Chicago "Tech" Method and prepare for a high salaried job. You get this training in spare time by mail under the direction of our experts. The fees are moderate, the terms easy.

Find out about this now. The lesson is free and we send our catalog with it. Write today.

Chicago Technical College, 830 Chicago "Tech" Bldg., Chicago, Ill.

## LAW IN YOUR SPARE TIME

Learn law with only institution giving same course by correspondence as was given for years at resident classes of this college. **DEGREE OF LL. B. CONFERRED.** One year business law course prepares you for success in business. Law trained business men in demand. Three year university course covers preparation for bar examination. Money back guarantee if not satisfied. Low fee, easy terms, includes complete 1921 thirteen volume library, text material and all expenses. Write for **FREE BOOK.**  
Hamilton College of Law  
431 South Dearborn St.,  
Dept. 66 Chicago

## RADIO For Everybody

Make Radio a profession instead of a plaything. You can earn big money as a Radio-trician. Learn by mail, in spare time, how to design, construct, install, repair, maintain, operate, sell and demonstrate complete radio outfits. Write for free 32-page catalog describing our course entitled, "How to Learn Radio at Home."

National Radio Institute, Dept. 1192, Washington, D. C.

## Delivered to You Free

for 30 days trial on approval. You can have your choice of 44 Styles, colors and sizes of the famous **RANGER** Bicycles. Express prepaid. **Factory-to-Rider** Prices save you \$10 to \$25 on your bicycle.

**12 Months to Pay** if desired. Many boys and girls easily save the small monthly payments. Parents often advance first payment. best quality, at factory prices, express prepaid. Tires, lamps, wheels and equipment, low prices. Send **NO MONEY**, do business direct with makers.

Write today for free **Ranger** Catalog, factory prices and marvelous easy payment terms.  
**Mead Cycle Company**  
Dept. F108 Chicago



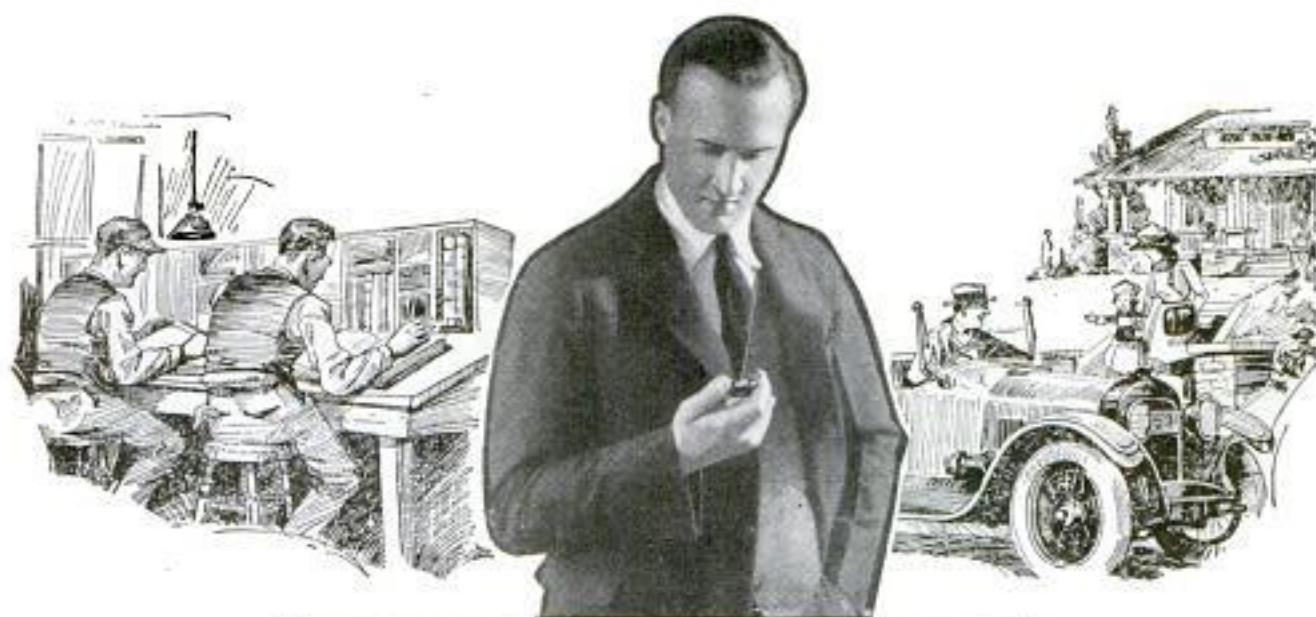

*In every man's life there is one Big Moment when he makes the decision that either robs him of success—or leads on to fortune.*

# Your One Chance to Earn The Biggest Money of Your Life!

**H**AVE you ever considered why our richest men come from our poorest boys? Isn't it a strange thing that it is almost invariably a young fellow who starts life without a cent in the world, without education, without influential friends—in short, without one single solitary advantage—who accumulates millions of dollars? Isn't it a miracle that inside of a comparatively few years a man can rise from abject poverty to fabulous wealth?

## The Secret That Makes Millionaires

Astonishing, certainly—but more important, it is wonderfully inspiring. For it means that no man need be held down by circumstances. Once he knows the "millionaires' secret," he can put it into operation regardless of all obstacles that seem to block his path. He suddenly finds that everything he touches turns to gold—money flows in upon him—fortune showers him with its favors. Everything he wants seems to come to him just as surely and easily as day comes after night.

What is this amazing secret that can work such wonders? It is just this: **The thing behind all big achievement is Opportunity.**

To every man there comes one BIG Opportunity—the golden chance of his life. And in the moment he decides for or against that opportunity—whether he will seize it or let it pass—he decides the whole future course of his life.

## Choose Between Low Pay and Magnificent Earnings

This very minute you may be face to face with your BIG opportunity—your one chance to earn the biggest money of your life! Right now your decision may mean the difference between a life of plodding, routine work at low pay and a career of inspiring success and magnificent earnings.

For now you are offered the very opportunity that has made other men rich, that has brought them more money than they ever dreamed of earning.

It is the same opportunity that lifted Warren Hartle of Chicago, out of a job in the railway mail service where in ten years he had never gotten beyond \$1,600 a year, and landed him in a \$10,000 a year job. It jumped Charles Berry of Winterset, Iowa, from \$60 a month as a farm-

hand, to \$1,000 a month. It brought to C. W. Campbell of Greensburg, Pa., a clerk on the railroad, a position that paid him \$1,562 in thirty days.

These men and hundreds more have found their **Big Opportunity** in the wonderful field of Salesmanship. They are all Master Salesmen now. They are earning the biggest money of their lives—more than they ever thought possible—they are engaged in the most fascinating work in the world—they are independent, come and go as they please—they meet big men—every minute of the day is filled with thrilling variety.

Your Big Opportunity may be here, too, in the wonder field of Salesmanship. Perhaps you say you have never even thought of becoming a Salesman. But before you decide one way or the other, examine the facts for yourself. See what Salesmanship offers you—why it is the best paid of all vocations—why there is no limit to what you may earn. Read the amazing proof that no matter what you are doing now, you can quickly become a Master Salesman in your spare time at home—read how the National Salesmen's Training Association in its nation-wide search for men to fill the great need of Salesmen, has devised a wonderful system that reveals to you every Secret of Selling without interfering in the least with your present work. See how this famous organization helps you to a good position in the line of Selling you are best fitted for.

## Facts That Will Amaze You—Sent FREE

Mail the coupon below. This will not cost you a penny—it places you under no obligation. It simply means that you will receive, entirely FREE, a wonderful, illustrated Book "Modern Salesmanship" and Proof that you can be a Master Salesman. You will receive, also, the personal stories of men throughout the country who to-day are enjoying magnificent success and earning five, ten and fifteen times as much money as ever before.

Send NOW—this minute may be the turning point in your life. Address, National Salesmen's Training Association, Dept. 12-K, Chicago, Ill.

National Salesmen's Training Association,  
Dept. 12-K, Chicago, Ill.

I simply want to see the facts. Send me FREE your Book, "Modern Salesmanship" and Proof that I can become a Master Salesman. Also tell how you can help me to a position and send list of lines with opening for Salesman.

Name .....

Address .....

City..... State.....

Age..... Occupation.....



## Three Salary Increases in 1921 Writes this Omaha Student

*"Not only has my course with the United Y. M. C. A. Schools given me more interesting work but it brought me three salary increases in 1921—when other salaries were cut. I am grateful for the help you have given me."*

This experience of one of our Business-Course students shows what an ambitious, industrious man can accomplish with the aid of the kind of correspondence instruction furnished by the United Y. M. C. A. Schools.

You may not be fortunate enough to win three increases in one year, but you can be sure of qualifying for bigger responsibility, bigger pay, bigger usefulness, more comfort and greater satisfaction with life if you let the United Y. M. C. A. Schools help you to make profitable use of your spare hours.

Tell us what you are doing, what you want to be, and get our friendly counsel free. We will not paint dreams that you cannot realize, but we will tell about a wholehearted service that in the last two years has solved the problems for many thousands of young men.

Tear Out and Send This Slip

United Y. M. C. A. Schools' Correspondence Courses,

or positions for which they afford training:

Accountant	Factory Management	Radio Telephony for Amateurs
Advertising Man	Farm Management	Salesman
Agricultural Courses	Foreign Languages	Secretarial
Architect	Foremanship	Shorthand and Typewriting
Auto Mechanic	High School Subjects	Steam Engineer
Banking	Highway Engineering	Structural Drafting
Better Letters	Leadership Courses	Surveyor
Bookkeeper	Locomotive Operator	Tool Designing
Building Construction	Machine-Shop Practice	Tractors and Farm Machinery
Business English	Mathematical Courses	Traffic Management
Business Law	Mechanical Engineer	Use of the Slide Rule
Business Organization	Own-Your-Home Course	Are You an ex-Service Man?
Civil Engineer	Plumber	
Civil Service	Poultry Husbandry	
Concrete Engineer	Radio Engineer	
Dairy Farming	Radio Operator	
Draftsman	Railroad Engineering	
Electrician		
Electrical Engineer		

**United Y.M.C.A. Schools**  
375 Lexington Ave.  
New York City.

Dept. 2-A2

Without obligating me, please advise regarding the

..... course in  
Age and Occupation.....  
Name.....  
Full Address.....  
(Please write plainly.)

# VALPARAISO UNIVERSITY

Founded 1873



VALPARAISO, INDIANA

The Fiftieth Year Will Begin September 19, 1922

*Known for Democracy,  
Economy, Hard Work*

**Departments**—Education, Arts and Sciences, Engineering, Pharmacy, Law, Pre-Medicine, Home Economics, Public Speaking, Music, Manual Training, Preparatory, High School, Commerce, Stenography and Typewriting.

This university is governed by a board of trustees—all of whom are influential men with the welfare of the students at heart. Because Valparaiso is not operated for profit, because sound business principles are applied to its management, you get the benefit of an exceedingly

## Low Cost of Living

The most satisfactory accommodations for board and room may be had from \$54 to \$90 per quarter of 12 weeks. Tuition, \$30 per quarter of 12 weeks or \$115 per year of 48 weeks, if paid in advance. If the entire tuition is paid in advance for a year, it includes instruction in all departments except Law, and private lessons in Music. Valparaiso University is beautifully situated forty miles from Chicago.

For Free Catalog Address President  
Box 11 University Hall, Valparaiso, Ind.

**ELECTRICAL ENGINEERING IN ONE YEAR**  
men with training in demand. For more than a quarter of a century this school has been training men of ambition and limited time, for the electrical industries. Condensed course in Electrical Engineering enables graduates to secure good positions and promotions. Theoretical and practical Electricity, Mathematics, Steam and Gas Engines, Mechanical Drawing. Students construct dynamos, install wiring and test electrical machinery. Course with diploma, complete



Thoroughly equipped fireproof dormitories, dining hall, laboratories, shops. Over 3000 men trained.

Write for catalog. 30th year begins Sept. 27, 1922.

**BLISS ELECTRICAL SCHOOL**

404 TAKOMA AVENUE, WASHINGTON, D. C.

## BE AN ARTIST

Comics, Cartoons, Commercial, Newspaper and Magazine Illustrating, Fashion Plates and Portraits. Our simple method quickly develops your talent in spare time. By Mail or Local Classes. Write for terms and list of successful students. ASSOCIATED ART STUDIOS 87-B Flatiron Building, NEW YORK



Wonderful, new device, guides your hand; corrects your writing in few days. Big improvement in three hours. No failures. Complete outline FREE. Write C. J. Osment, D-34, St. Louis, Mo.

## Learn Photography at HOME

Make \$75.00 a Week on the Side

Establish yourself as a Photographic Expert quickly—during your spare time—under a leading photographer. I'll show you how to start your own business—or command a large salary. Send for my special offer—it's only temporary. Act at once. A postal will do. H. H. VANT, INTERNATIONAL STUDIOS, Inc. Dept. 119C, 3601 North Ave., Chicago, U.S.A.



# AUTO BOOKS

**We've Cut the Price in Half**

## SAVE 23 DOLLARS

**Earn increased hundreds.** The biggest paying field in the world is the automotive industry. In it there is big pay and a steady job for every man who qualifies for a place. You can qualify with these books, they are the finest, most comprehensive automotive reference library ever compiled. It covers every phase of the industry. With these books within easy reach you can solve at once any problem that may confront you. Everyone who has purchased a set says they are the real

## PAY RAISING BOOKS

They contain absolutely everything you want to know about the upkeep, care and repair of motor vehicles and tractors. Written in plain, easy to understand English; there are 2600 pages, 2300 pictures, diagrams and blue prints—bound in flexible morocco, gold stamped.

If you want to be the man in your shop who can solve any automotive problem—if you want to get ahead—if you want to make more money—if you want to succeed in the automobile or tractor game—send today for this library of reference books. They are yours for a week's

## FREE EXAMINATION DON'T SEND MONEY

Just fill in the coupon and the entire library will be shipped you by express, collect, so that you may use them right in your own home or shop for seven whole days without any obligation. Put them to work—show them to your friends—ask them what they think of them, and if you are not absolutely satisfied that they are the greatest reference library in the world, send them back without cost of another penny to you—if you decide to keep them, send us \$2.80 within 7 days and balance \$3.00 month, until the special reduced price of \$21.80 is paid. Mail the coupon TODAY.

**American  
Technical  
Society**

Dept. A-19-c  
Chicago, U.S.A.

### FREE EXAMINATION COUPON

American Technical Society, Dept. A-19-c Chicago, Ill.

Send me the 6 volume set of Automobile Engineering books for a week's free trial, by express collect. I will either return the books in one week at your expense or send you \$2.80 as first payment and \$3.00 every month until a total of \$21.80 is paid.

Name .....

Address .....

City ..... State .....

Employed by .....

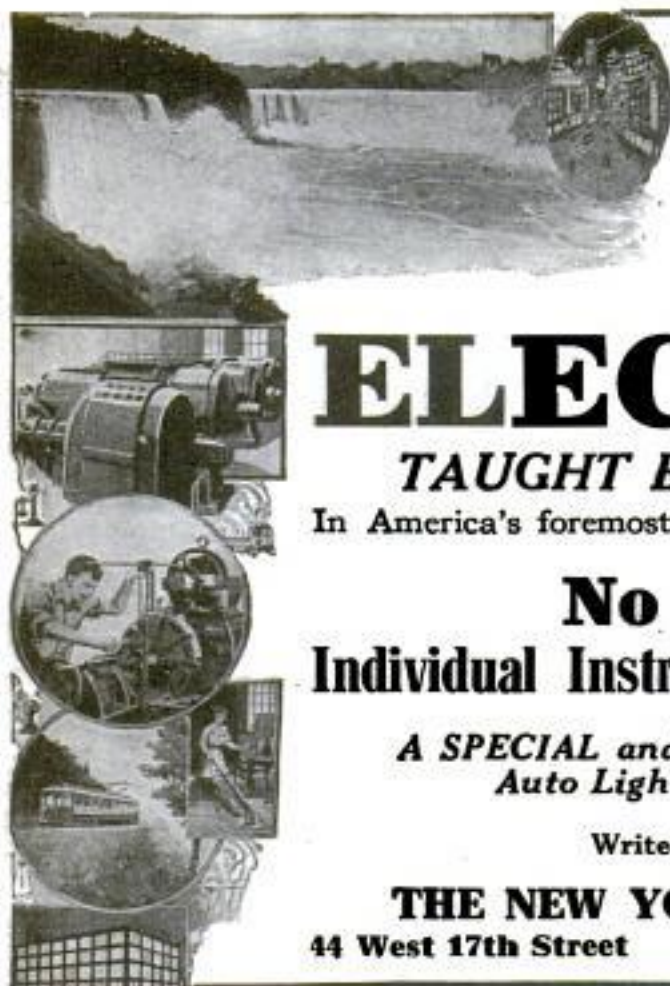

# LEARN BY DOING

Every phase of all branches of

## ELECTRICITY

TAUGHT BY ACTUAL PRACTICE

In America's foremost and oldest institution for trade training.

### No Books Used

Individual Instruction

Start Any Day

A SPECIAL and SEPARATE Course in Ignition,  
Auto Lighting and STARTER Systems

Write for FREE 64-Page Catalog

### THE NEW YORK ELECTRICAL SCHOOL

44 West 17th Street

NEW YORK CITY

Genuine  
\$20.00  
Imported

## VIOLIN FREE

Will Be  
Given  
To You

Help me introduce this beautiful Violin in your district. Be first to show how easy it is to play with help of three new inventions and my scientific instructions. You can play it in one week.

**10,000 Students Found Easy to Learn**  
Violin Playing

You can learn as easily as others. Surprise your friends. My three new inventions make it very easy. Have been teaching 40 years. Write your name and address on bottom of page and send for free violin offer and three new violin inventions.

**PROF. A. HINCHCLIFFE, 233 Broadway**  
Woolworth Bldg. Dept. 50-B NEW YORK

# STAMMER

If you stammer attend no stammering school till you get my large FREE book entitled "STAMMERING, Its Origin and the Advanced Natural Method of Cure," bound in cloth and stamped in pure gold. Ask for special tuition rate and a FREE copy of "The Natural Speech Magazine." Largest, best equipped and most successful school in the world for the cure of stammering, stuttering, etc. No sing-song or time beat. Write today. The North-Western School, 2317 Grand Ave., Milwaukee, Wis.

### Learn Watchwork, Jewelrywork and Engraving.

A fine trade commanding a good salary, and your services are always in demand. Address HOROLOGICAL, Dept. P, Bradley Institute, Peoria, Ill., for our latest catalog.

"THERE'S MONEY IN IT"

AT HOME

## LEARN TELEGRAPHY

AT HOME

### MORSE AND WIRELESS



TEACH YOURSELF

in half usual time, at trifling cost, with the wonderful Automatic Transmitter THE OMNIGRAPH. Sends unlimited Morse or Continental messages, at any speed, just as an expert operator would. Adopted by U. S. Government, and leading Universities, Colleges and Telegraph Schools. 3 styles. Catalog free.

OMNIGRAPH MFG. CO.

16-22 Hudson St., NEW YORK

# WANTED

## Railway Mail Clerks

\$1600 to \$2300 Year

MEN-BOYS OVER 16  
SHOULD WRITE IMMEDIATELY

Steady work. No layoffs. Paid Vacations

Common education sufficient.  
Send coupon today-SURE



FRANKLIN INSTITUTE, Dept. F177, Rochester, N. Y.

Sirs: Send me without charge, (1) sample Railway Mail Clerk Examination questions; (2) Schedule showing places in all coming U. S. Government examinations; (3) list of many government jobs now obtainable.

Name.....

Address.....

# Draftsman's Complete Outfit

# FREE



## Everything Used by Expert Draftsmen Given You Absolutely FREE

Outfit includes "professional" complete set of fine drawing instruments with double set of compasses and dividers all in velvet lined case. Drawing board, T square, two triangles, protractor, universal curve, triangular, standard scale, water-proof ink, pens, pencils and all accessories—furnished you free in this expert's complete outfit.

## Draftsmen Make \$225.00 to \$500.00 a Month

There is a tremendous demand for trained draftsmen. Now is the time to start. Draftsmen get good pay from the start and can work up to \$500 a month *and more*. Draftsmen are needed everywhere. Once you are trained you can choose your own business and work in any part of the country you please. Coyne training makes everything easy for you. Coyne student, L.T. Dubendorf, writes: "Immediately after completing Coyne course I went to work for Armour & Co. Work was easy for me. Five months later I accepted a position in New York at a large increase in salary."

### 3 Months' Course at School

You can qualify as an expert draftsman by 3 months' intensive training at the school in Chicago. Living

sleep. Possibilities of earning way while studying. If you prefer to come to school instead of the "Home Study" course, check coupon and send it for complete information.



B. W. Cooke

President

# COYNE

HOME STUDY DEPT.

## TRADE & ENGINEERING SCHOOLS

Recognized Producer of Successful Men

39-51 E. Illinois St., Dept. C177, Chicago, Ill.

## Easy to Learn at Home from Great School Known all over the World

The Coyne Home Study course guarantees to train you. Remember, the Coyne Trade and Engineering Schools are recognized by educators all over the world. Students come from all over the *world* to get Coyne training. Why? Because of the Coyne school's long established, tremendous reputation for successful teaching by its great staff of experts. Coyne is not a "one man" school, but a great educational institution, 22 years old, an acknowledged leader and originator. Coyne originated the "Learn by Doing" method now endorsed by educators everywhere. Coyne has graduated thousands of successful, prosperous men all over the world. You can't make a mistake if you write for the Coyne free book. Coyne students say every minute of the course was enjoyable. Some students took *good positions three months before their course was finished.*

## Send for FREE Book

Mail this coupon for our interesting book, "Drafting, the Foundation of Industry," sent you free. It explains all about the Coyne home study method and shows you how to become a draftsman in the quickest and easiest way. You want to know all about this great institution. Don't put it off. Send for this book now. It's absolutely free, no obligation. It contains the most valuable information you will ever get in your life. Send the coupon now.

Check Coupon Below and Mail Now!

Coyne Trade and Engineering Schools,  
Department C177 39-51 E. Illinois St., Chicago, Ill.

Dear Sirs:—Please send me, absolutely free, without obligation, your book, "Drafting, the Foundation of Industry," also full information about the Course in Drafting. (Check which course you prefer.)

Home Study Course  School Course

Name .....

Address .....

City.....State.....

# WANTED!

## \$1,000 REWARD

**C**ONVICT 6138, escaped from the State Penitentiary; Name, Charles Condray; Age, 37; Height, 5 ft. 8 in.; Weight, 141 pounds; Hair, light brown; Eyes, gray.

Easy enough to identify him from his photograph and this description, you may say—but, Condray took the name of "Brown", dyed his hair, darkened his skin, grew a mustache, put on weight and walked with a stoop.

Yet he was captured and identified so positively that he knew the game was up and returned to the penitentiary without extradition. A Finger Print Expert made this identification and secured the reward.

### MORE TRAINED EXPERTS NEEDED NOW!

There is a big chance for you in this uncrowded, fascinating profession. State, City, and Private Bureaus being established and expanded constantly. Trained men in great demand. Many earn \$3000 to \$10,000 yearly.

### LEARN AT HOME IN SPARE TIME

Common school education, common sense and ambition, the only requirements. Many of the country's greatest experts learned their profession in this great school. A few hours' spare time a week soon fits you for a fine position as a Finger Print Expert.

**UNIVERSITY OF  
APPLIED SCIENCE**  
1920 Sunnyside Avenue,  
Dept. C135, Chicago, Ill.

Gentlemen:—Without any obligation whatever, send me your Dew, fully illustrated FREE Book on Finger Prints and your offer of a FREE course in Secret Service Intelligence and the Free Professional Finger Print Outfit.

Name.....

Address.....

Present.....

Occupation.....

**FREE!** for a limited time. A professional Finger Print Outfit—a course in Secret Service Intelligence. Also a complete book on Finger Prints sent at once if you will mail this coupon. Write today.

**UNIVERSITY OF  
APPLIED SCIENCE**  
1920 Sunnyside Ave.  
Dept. C135  
CHICAGO, ILL.



**SHOP  
WORK  
with a**

**CARNES  
ARTIFICIAL ARM**

FOR nearly ten years a Carnes

Artificial Arm has kept Mr. Pahbe Yasse of Lawrence, Kan., on the payroll as a draftsman and machinist at a good salary. Thousands of other mechanics, artisans, office workers, farmers and laborers owe their independence to this improved arm.

### Life-Like in Action and Appearance

The Carnes Arm cannot be detected from the natural except by close inspection. Its user can dress himself, use knife, fork, pen, pencil and keys; pick up large or small objects, carry grips—in fact, do virtually everything that was possible before. He can bend the elbow of the Carnes Arm, bend and turn the wrist and open and close the fingers at will, even if the amputation is at the shoulder.

**192-Page Book FREE.** A book of 192 pages, profusely illustrated with photographs showing what can be done with this remarkable invention, will be sent free to any person interested. Send for it now.

**CARNES ARTIFICIAL LIMB CO.,**  
208 Carnes Bldg., Kansas City, Mo.

Please Mention Popular Mechanics

WRITE TODAY for  
Our 168-PAGE  
FREE BOOK on

## Deafness

and learn how Perfect Hearing is now being restored in every condition of deafness or defective hearing. Our "Little Wireless Phones for the Ears" require no medicine, but effectively replace what is lacking or defective in the natural ear drums. They are simple devices, which the wearer easily fits into the ears, where they are invisible. Soft, safe and comfortable.

**WILSON EAR DRUM CO., Incorporated**  
1045 Inter-Southern Bldg. LOUISVILLE, KY.

## TOBACCO

### Habit Cured or No Pay

Any form, cigars, cigarettes, pipe, chewing or snuff Guaranteed. Harmless. Complete treatment sent on trial. Costs \$1.00 if it cures. Nothing if it fails. **SUPERBA CO. E-41 BALTIMORE, MD.**

## Don't Wear a Truss

**Brooks' Appliance**, the modern scientific invention, the wonderful new discovery that relieves rupture, will be sent on trial. No obnoxious springs or pads.



MR. C. E. BROOKS

### Brooks' Rupture Appliance

Has automatic Air Cushions. Binds and draws the broken parts together as you would a broken limb. No salves. No lies. Durable, cheap. Sent on trial to prove it. Protected by U. S. patents. Catalog and measure blanks mailed free. Send name and address today.

**BROOKS APPLIANCE CO., 1266 State St., Marshall, Mich.**





# You too

## Can have the things you want

**W**HY is it some men make such enormous salaries, and others with just as many brains work a lifetime for meager wages? Why is it that in every line of sales work some men are so amazingly successful while others who have just as pleasing a personality and work just as hard, or even harder, are miserable failures, or at best, only average plodders?

**A master Sales Manager who has personally fitted hundreds of men from every walk of life to make big money in special sales work has solved the question.**

**He will personally fit you for a special line of sales work where you can make from \$4800 to \$12,000 a year**

**B**UT you must become a **SPECIALIST**. The "hale-fellow-well-met" salesman of the past is no more. In his place is the keen, alert, young business man who has been specially fitted for his particular line of sales work. He knows the fundamentals of salesmanship—Yes! But he knows more! He knows his product thoroughly—its advantages—its uses—and how it will best serve. His knowledge is power. With it he renders real service to his customers. And because of this he gets the big orders and earns an amazingly large income.

### Fortunes Made by Specialists

No work offers greater opportunities than the paint industry. Over Four Hundred Million Dollars were spent for paint and varnish in 1921. The national advertising campaign, "Save the Surface and You Save All," is emphasizing the vital importance and true economy of keeping everything well painted. Each year paint sales are increasing. Over a thousand well rated and reputable paint companies employ traveling salesmen. Their biggest problem is to secure men who know how to sell paint. Such men make astonishingly large incomes. Some of them fortunes in a single year. Mr. C—of one company made over \$60,000 in one year. Mr. B—representing another, over \$50,000 the same year. Mr. G—a salesman for still another company made over \$25,000 the same year. Many more make from \$4800 to \$12,000 yearly. These are facts. We can prove them.

But all of these men are trained paint salesmen. Paint is a semi-technical product. Only men with real paint knowledge can ever hope to enjoy these extraordinary earnings. Yet it is possible for nearly everyone. All that is required is average intelligence, a willingness to work, and the proper **knowledge**.

**Bank References**  
The State Banking & Trust Co.  
Cleveland, Ohio.

### NOW—Same Opportunity for YOU

Now!—you too, thanks to the Cleveland Paint Salesmen's Training School, can easily acquire the knowledge that makes possible such rich earnings in the paint industry.

And when you obtain this knowledge by completing the course we place you immediately. A number of successful and highly rated companies endorse this course. They want to secure men who have completed it. This is without any cost to you whatsoever. No fees. No extras of any kind. It's the way we co-operate with our graduates.

The course has been worked out by one of the most able paint sales managers in the country, in conjunction with one of the foremost paint chemists. The science of paint salesmanship is covered from every angle. You are taught the general fundamentals of salesmanship, and in addition just how to sell a special product—a universal one that is always in demand. You are taught about the different paint products, how and when to use them; and how to prepare every sort of surface for their use. In short you are equipped with the knowledge that fits you to make thousands of dollars a year more than you have ever hoped for.

### Take the First Step NOW

Remember this course is endorsed by leading paint manufacturers. Remember they want to secure men who have completed it. So give yourself the opportunity you have longed for. The coupon below will bring you complete details. It does not obligate you in any way. It does explain how, by a little work and study you can fit yourself to earn enough to afford the luxuries of life that all of us crave. Make to-day the turning point in your career—mail the coupon NOW!

Cleveland Paint Salesmen's Training School,  
315 Bangor Bldg., Cleveland, O.

Please send me free literature and complete information regarding your course.

Name .....

Street .....

City.....State.....



## "I Got the Job!"

"I'm to be Manager of my Department starting Monday. The boss said he had been watching all the men. When he found I had been studying at home with the International Correspondence Schools he knew I had the right stuff in me. Now we can move over to that house on Oakland Avenue and you can have a maid and take things easy. I tell you, Nell, taking that course with the I. C. S. was the best thing I ever did."

Spare-time study with the I. C. S. is winning promotions for thousands of men and bringing happiness to thousands of homes all over the world. In offices, shops, stores, mines, mills and on railroads, I. C. S. trained men are stepping up to big jobs, over the heads of older men, past those whose only qualification is long service.

### There is a Job Ahead of YOU

Some man is going to be picked for it. The boss can't take chances. He is going to choose a trained man with sound, practical knowledge of the work.

Get busy right now and put yourself in line for that promotion. You can do it in spare time in your own home through the I. C. S., just as more than two million men have done in the last 30 years, just as more than 130,000 men are doing today.

The first step these men took was to mark and mail this coupon. Make your start the same way—and make it now.

#### INTERNATIONAL CORRESPONDENCE SCHOOLS Box 3637-C, Scranton, Penna.

Without cost or obligation, please send me full information about the subject before which I have marked an X in the list below:

##### BUSINESS TRAINING DEPARTMENT

- |   |   |
|---|---|
| <input type="checkbox"/> Business Management            | <input type="checkbox"/> Salesmanship           |
| <input type="checkbox"/> Industrial Management          | <input type="checkbox"/> Advertising            |
| <input type="checkbox"/> Personnel Organization         | <input type="checkbox"/> Better Letters         |
| <input type="checkbox"/> Traffic Management             | <input type="checkbox"/> Foreign Trade          |
| <input type="checkbox"/> Business Law                   | <input type="checkbox"/> Stenography and Typing |
| <input type="checkbox"/> Banking and Banking Law        | <input type="checkbox"/> Business English       |
| <input type="checkbox"/> Accountancy (including C.P.A.) | <input type="checkbox"/> Civil Service          |
| <input type="checkbox"/> Nicholson Cost Accounting      | <input type="checkbox"/> Railway Mail Clerk     |
| <input type="checkbox"/> Bookkeeping                    | <input type="checkbox"/> Common School Subjects |
| <input type="checkbox"/> Private Secretary              | <input type="checkbox"/> High School Subjects   |
| <input type="checkbox"/> Business Spanish               | <input type="checkbox"/> Illustrating           |
| <input type="checkbox"/> French                         | <input type="checkbox"/> Cartooning             |

##### TECHNICAL AND INDUSTRIAL DEPARTMENT

- |   |  |
|---|--|
| <input type="checkbox"/> Electrical Engineering   | <input type="checkbox"/> Architect               |
| <input type="checkbox"/> Electric Lighting        | <input type="checkbox"/> Contractor and Builder  |
| <input type="checkbox"/> Mechanical Engineer      | <input type="checkbox"/> Architectural Draftsman |
| <input type="checkbox"/> Mechanical Draftsman     | <input type="checkbox"/> Concrete Builder        |
| <input type="checkbox"/> Machine Shop Practice    | <input type="checkbox"/> Structural Engineer     |
| <input type="checkbox"/> Railroad Positions       | <input type="checkbox"/> Plumbing and Heating    |
| <input type="checkbox"/> Gas Engine Operating     | <input type="checkbox"/> Chemistry               |
| <input type="checkbox"/> Civil Engineer           | <input type="checkbox"/> Pharmacy                |
| <input type="checkbox"/> Surveying and Mapping    | <input type="checkbox"/> Automobile Work         |
| <input type="checkbox"/> Mine Foreman or Engineer | <input type="checkbox"/> Navigation              |
| <input type="checkbox"/> Steam Engineering        | <input type="checkbox"/> Agriculture and Poultry |
| <input type="checkbox"/> Radio                    | <input type="checkbox"/> Mathematics             |
| <input type="checkbox"/> Airplane Engines         |  |

Name.....

Street.....

Address.....

City..... State.....

Occupation.....

Persons residing in Canada should send this coupon to the International Correspondence Schools Canadian, Limited, Montreal, Canada.

Please Mention Popular Mechanics

Learn to Write

## I Teach by Mail

I CAN make a good penman of you at your home during spare time, no matter where you live or how poorly you now write. My simplified system has shown thousands of others the way to good penmanship during the past twenty years — it can and will do the same for YOU!

Beautifully Illustrated Book

### "How to Become a Good Penman" FREE!

It contains general information, with testimonials and beautiful specimens of penmanship showing what others have accomplished by the Tambllyn System. (Your name elegantly written on a card if you enclose stamp for postage.) WRITE TODAY. Address

F. W. TAMBLYN

418 Ridge Bldg., Kansas City, Mo., U. S. A.

F. W. Tambllyn

## MUSIC LESSONS FREE

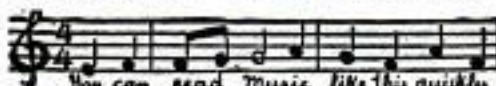

You can read Music like this quickly

IN YOUR OWN HOME

Piano, Organ, Violin, Mandolin, Guitar, Banjo, etc. Beginners or advanced players. One lesson weekly. Illustrations make everything plain. Only expense about 2c per day to cover cost of postage and music used. Write for FREE booklet which explains everything in full.

AMERICAN SCHOOL OF MUSIC, 51 Lakeside Building, CHICAGO

### Taxidermy Book FREE.



Write Today.

### Stuff Beautiful Birds.

Learn by mail to stuff and mount all kinds of birds, animals, fish and game heads; make rugs, tax skins. Mount your own specimens and make money preserving for others. Men, women and boys learn easily and quickly. Success guaranteed or no tuition. Write today for our wonderful FREE book "How to Learn to Mount Birds and Animals. N.W. School of Taxidermy, C177 Elwood Bldg., Omaha, Neb.

## LEARN WATCH REPAIRING

Be a watchmaker—you can learn this profitable trade by correspondence in a few weeks in your own home by the DeSelms Chart System. After you complete the course you will know a watch from A to Z. You will know just what the matter is and how to repair one. When you graduate you will be a practical watchmaker and repairer and competent to fill any position. Positions for our graduates.

Ask for our Free Book. It explains our system and terms.

THE DeSELMS WATCH SCHOOL  
23 Perry Street ATTICA, INDIANA



SELL US YOUR SPARE TIME

You can earn money writing show cards in your own home. No canvassing—A pleasant, profitable profession easily and quickly learnt by our new simple graphic block system—Artistic ability not necessary—We teach you how, and supply you with work—Distance no object. Full particulars and booklet free.

Wilson Methods, Ltd.,

Dept. M, 64 Richmond East, Toronto, Canada.

# A Wild Man

once lived in the forest. He had no fear of man or beast. He carried a mighty club with which he fought his enemies of the jungle. His rough and active life in the open gave him the strength of the beasts themselves. He was a superman in health and strength. But who wants to be a wild man?

## The Modern Man

There are men in our midst today enjoying the same abundance of health and strength. They are not of the wild man type, however. They are men of intellect, who have become leaders of industry. They realize that brains are essential, but of little value if placed in a weak body with sluggish blood circulation, or troubled with various disorders of the vital organs.

## The Miracle Man

The wild man took years of active out-door life to attain his strength. How then can a business man acquire this same strength when his days are spent in the office?

*One year ago a famous musician traveled from Toronto, Canada, to see Earle E. Liederman. This musician was most popular throughout Canada. People came miles to hear him. He was wealthy, but he was unhappy. He was a physical weakling. He worked nine hours a day, so he had no time for athletics. He asked Mr. Liederman to help him. Mr. Liederman asked him to give twenty minutes' time each day for three months in his own home. The musician went back with Mr. Liederman's famous apparatus and one week later the first lesson in "Progressive Muscular Development" followed him. Today he is the champion weight lifter in his county and his earning capacity has almost doubled.*

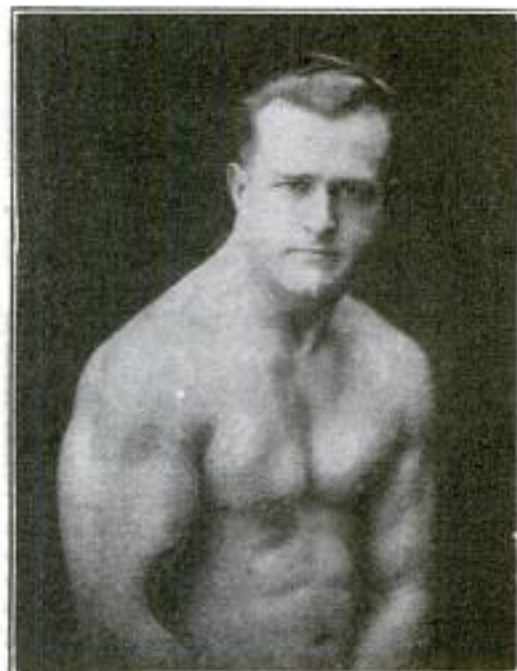

Latest photograph of Earle E. Liederman

## What Kind of a Man Are You?

Do you arise in the morning full of ambition for the day before you? Do you feel the thrill of life pulsing through your veins? Can you finish a hard day's work still feeling full of pep and vitality? Do you have the deep, full chest and the brawny arms of an athlete? If not, you are not the man you were meant to be.

How would you like to increase your arms one full inch in just 30 days, and your chest two full inches in the same length of time? But that's only the foundation. From then on you build up an armour plate of muscle both inside and out that will fire you with ambition, giving the spring to your step and flash to your eye that only an athlete can know. This is what I promise to do for you. Come on then and make me prove it.

Send for my book

## "MUSCULAR DEVELOPMENT"

It is chock full of photographs of myself and my numerous pupils. Also contains a treatise on the human body and what can be done with it. This book is bound to interest you and thrill you. It will be an impetus—an inspiration to every red blooded man. All I ask you to cover is the price of wrapping and postage—10 cents. Remember this does not obligate you in any way. Don't delay one minute—this may be the turning point in your life to-day. So tear off the coupon and mail at once while it is on your mind.

**EARLE E. LIEDERMAN**  
Dept. 2008, 305 Broadway, New York

**EARLE E. LIEDERMAN**

Dept. 2008, 305 Broadway, N. Y. City

Dear Sir:—I enclose herewith 10 cents for which you are to send me, without any obligation on my part whatever, a copy of your latest book, "Muscular Development."

Name.....

Address.....

City.....State.....



## High School Course in Two Years!

Lack of High School Training has kept thousands of men and women from attaining business and social position. Without this training you are absolutely barred from a successful business career, from leading professions, from well-paid civil service jobs, from teaching and college entrance. In fact, all preferred positions are closed to you without this vital training. You can't stand this heavy handicap nor do you have to. The American School can give you the valuable training you missed.

**Put Your Idle Hours to Work** You can complete our simplified High School Course within two years by spare-time study. Then you will be mentally equipped to handle a worthwhile position. This course, prepared by some of America's leading professors, will broaden your mind, give you a wider outlook and make you keen, alert and capable.

### Remove Your Handicap

Whether you need High School Training or specialized instruction in your chosen line—NOW is the time to remove your handicap. You must know the short cuts and efficiency methods. You must know the HOW and WHY. Over 50,000 students owe their success to training received from the practical, money-making Courses in the coupon below. Let us tell you about this training—about the Course you are interested in. Check and mail the coupon.

### American School

Dept. H.C.74, Drexel Ave. and 58th St., Chicago

### American School

Dept. H.C.74, Drexel Ave. and 58th St., Chicago

Send me full information on the subject checked and how you will help me win success.

- |                               |                             |
|-------------------------------|-----------------------------|
| ..... Architect               | ..... Lawyer                |
| ..... Building Contractor     | ..... Machine Shop Practice |
| ..... Automobile Engineer     | ..... Photoplay Writer      |
| ..... Automobile Repairman    | ..... Mechanical Engineer   |
| ..... Civil Engineer          | ..... Shop Superintendent   |
| ..... Structural Engineer     | ..... Employment Manager    |
| ..... Business Manager        | ..... Steam Engineer        |
| ..... Cert. Public Accountant | ..... Foremanship           |
| ..... Accountant and Auditor  | ..... Sanitary Engineer     |
| ..... Bookkeeper              | ..... Surveyor (& Mapping)  |
| ..... Draftsman and Designer  | ..... Telephone Engineer    |
| ..... Electrical Engineer     | ..... Telegraph Engineer    |
| ..... Electric Light & Power  | ..... High School Graduate  |
| ..... General Education       | ..... Fire Insurance Expert |
| ..... Vocational Guidance     | ..... Wireless Radio        |
| ..... Business Law            | ..... Undecided             |

Name .....

Address .....

Please Mention Popular Mechanics



## CARTOONISTS MAKE BIG MONEY

EVERY time Sid Smith makes a stroke of his pen, millions of people laugh. Every laugh means money for the man who creates it. "Andy" and "Min" earn big money for Sid Smith every day.

Illustrating and cartooning are paying men like Briggs, Smith, Fontaine Fox and J. N. Darling from \$10,000 to \$100,000 a year. You may have ideas that are equally good. Let Federal training develop your talent and give you the skill to put your ideas on paper.

### GET THIS FREE BOOK

Write to-day for a free copy of the book, "A Road to Bigger Things." Send 6 cents in stamps to cover postage. It tells of opportunities in the art world and explains the Federal Course of instruction under 60 of America's leading illustrators and cartoonists. Mention your age.

Federal Schools, Inc.

803 Federal Schools Building Minneapolis, Minn



## SHORTHAND IN ONE MONTH

Boyd—the Wonderful, New, Easy System. Writers hold World's record. 100 to 150 words a minute in 30 days guaranteed. New Principles—dictation first week. Best for Court Reporting and Secretaries. Also Typewriting, Bookkeeping and Commercial Law. Send today for Catalog and Money-Back Guarantee. CHICAGO HOME STUDY SCHOOLS. 802 Reager Block, Chicago, Ill.

### Music Lessons

UNDER MASTER TEACHERS

At Home

**Any Instrument** Write your name on the coupon if you are interested in: Violin, Cornet, Mandolin, Guitar, Banjo or Reed Organ—and we will send FREE CATALOG. SEND FOR IT NOW!  
University Extension Conservatory, 623 Siegel-Myers Bldg., Chicago

### Complete Conservatory Course by Mail

Wonderful home study music lessons under great American and European teachers. Endorsed by Paderewski, Master teachers guide and coach you. Lessons a marvel of simplicity and completeness.

### LEARN WATCHMAKING AND ENGRAVING



Earn while learning. Most practical watch school. Individual instructions. Graduates in great demand. Book free. Chicago School of Watchmaking, Dept. 20, 4840 Lincoln Ave., Chicago



## HOW TO BECOME A PROFESSIONAL PHOTOGRAPHER

Earning \$35 to \$125 a Week

An interesting illustrated booklet (free) on choosing a vocation, the exceptional opportunities Photography offers you and how to avail yourself of these advantages.

### Motion Picture—Commercial—Portraiture

Three to six months' Practical course. Modern equipment. Day or evening classes. Easy terms. Call or write for Catalog No. 49.

**N. Y. INSTITUTE OF PHOTOGRAPHY**  
NEW YORK CHICAGO BROOKLYN  
141 W. 36th St. 630 So. Wabash Ave. 505 State St.

# How YOU Can Write Stories and Photoplays

By ELINOR GLYN

Author of "Three Weeks," "Beyond the Rocks,"  
"The Great Moment," Etc., Etc.

FOR years the mistaken idea prevailed that writing was a "gift" miraculously placed in the hands of the chosen few. People said you had to be an Emotional Genius with long hair and strange ways. Many vowed it was no use to try unless you'd been touched by the Magic Wand of the Muse. They discouraged and often scoffed at attempts of ambitious people to express themselves.

These mistaken ideas have recently been proved to be "bunk." People know better now. The entire world is now learning the TRUTH about writing. People everywhere are finding out that writers are no different from the rest of the world. They have nothing "up their sleeve"; no mysterious magic to make them successful. They are plain, ordinary people. They have simply learned the principles of writing and have intelligently applied them.

Of course, we still believe in genius, and not everyone can be a Shakespeare or a Milton. But the people who are turning out the thousands and thousands of stories and photoplays of to-day for which millions of dollars are being paid ARE NOT GENIUSES.

You can accept my advice because millions of copies of my stories have been sold in Europe and America. My book, "Three Weeks," has been read throughout the civilized world and translated into every foreign language, except Spanish, and thousands of copies are still sold every year. My stories, novels and articles have appeared in the foremost European and American magazines. For Famous Players-Lasky Corporation, greatest motion picture producers in the world, I have written and personally supervised such photoplays as, "The Great Moment," starring Gloria Swanson, and "Beyond the Rocks," starring Miss Swanson and featuring Rodolph Valentino. I have received thousands and thousands of dollars in royalties. I do not say this to boast, but merely to prove that YOU can be successful without being a genius.

Many people think they can't write because they lack "imagination" or the ability to construct out-of-the-ordinary plots. Nothing could be further from the truth. The really successful authors—those who make fortunes with their pens—are those who write in a simple manner about plain, ordinary events of every-day life—things with which everyone is familiar. This is the real secret of success—a secret within the reach of all, for everyone is familiar with some kind of life.

Every heart has its story. Every life has experiences worth passing on. There are just as many stories of human interest right in your own vicinity, stories for which some editor will pay good money, as there are in Greenwich Village or the South Sea Islands. And editors will welcome a story or photoplay from you just as quickly as from any well-known writer if your story

is good enough. They are eager and anxious for the work of new writers, with all their blithe, vivacious, youthful ideas. They will pay you well for your ideas, too. Big money is paid for stories and scenarios today—a good deal bigger money than is paid in salaries.

The man who clerked in a store last year is making more money this year with his pen than he would have made in the store in a lifetime. The young woman who earned eighteen dollars a week last summer at stenography just sold a photoplay for \$500.00. The man who wrote the serial story now appearing in one of America's leading magazines hadn't thought of writing until about three years ago—he did not even know that he could. Now his name appears almost every month in the best magazines. You don't know whether you can write or not until you try.

I believe there are thousands of people who can write much better stories and plays than many we now read in magazines and see on the screen. I believe thousands of people can make money in this absorbing profession and at the same time greatly improve present-day fiction with their fresh, true-to-life ideas.

I believe the motion picture business especially needs new writers with new angles. I believe this so firmly that I have decided to give some simple instructions which may be the means of bringing success to many who have not as yet put pen to paper. I am going to show YOU how easy it is when you know how!

Just fill out the coupon below. Mail it to my publishers, The Authors' Press, Auburn, N. Y. They will send you ABSOLUTELY FREE, a handsome little book called "The Short-Cut to Successful Writing." This book was written to help all aspiring people who want to become writers, who want to improve their condition, who want to make money in their spare time. Within its pages are many surprises for doubting beginners; it is crowded with things that gratify your expectations—good news that is dear to the heart of

all those aspiring to write; illustrations that enthuse, stories of success; new hope, encouragement, helps, hints—things you've long wanted to know.

"The Short-Cut to Successful Writing" tells how many suddenly realize they can write after years of doubt and indecision. How story and play writers began. How many rose to fame and fortune. How simple plots and ordinary incidents become successful stories and plays when correctly handled. How new writers get their names into print. How one's imagination properly directed may bring glory and greatness. How to WIN.

This book and all its secrets are YOURS. You may have a copy ABSOLUTELY FREE. You need not send a penny. You need not feel obligated. You need not hesitate for ANY reason. The book will be mailed to you without any charge whatever.

Get your pencil—fill out the coupon below. Mail it to The Authors' Press before you sleep to-night. This little act may be the turning point of your whole career. Who knows?

THE AUTHORS' PRESS, Dept. 165, Auburn, N. Y.

Send me ABSOLUTELY FREE "The Short-Cut to Successful Writing." This does not obligate me in any way. (Print your name and address plainly in pencil.)

Name.....

Address.....

City and State.....



Elinor Glyn

# BE A RAILWAY TRAFFIC INSPECTOR

## YOU CAN EARN UP TO \$250 per Mo.

Expenses Paid

## POSITION GUARANTEED

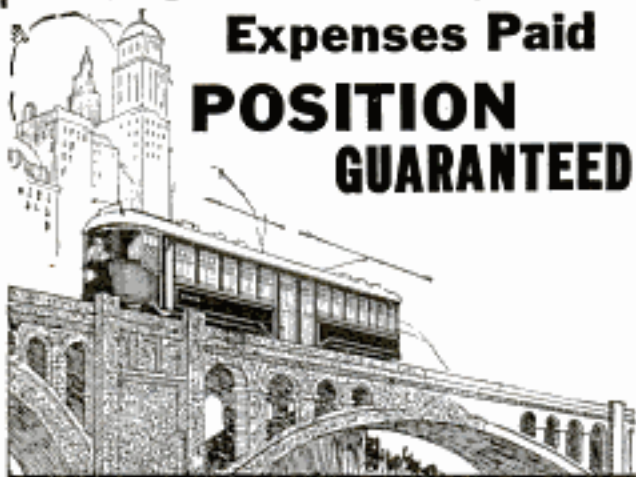

### HUNDREDS OF OPENINGS!

Railway Traffic Inspectors earn good money, enjoy most interesting work, have splendid chances for advancement. Travel, see the country or remain near home. Healthful, outdoor work; something new every day.

More men are wanted than are trained. Start at \$110 per month minimum, expenses paid. Meet big railway officials. Earn up to \$250 and \$300 per month as you gain experience.

### EASY TO QUALIFY

Prepare in 3 months' spare-time study at home. Any average man can qualify. Position is then guaranteed paying at least \$110 per month and expenses or enrollment fee is refunded! You have nothing to lose.

### READ WHAT M. C. EVES SAYS:



"I have never found work so interesting as my present position has been since I became familiar with the system used on these lines. Your Course of Study on Traffic Inspection together with the experience received here and in Providence fits me for most any position in this line of work which I may have offered me."

### YOU TAKE NO RISK

Send coupon today for Free Booklet. Remember, if position is not secured you, your enrollment fee is returned! That is our Guarantee. Don't delay; investigate now.

Standard Business Training Institute  
Buffalo, N. Y.



Standard Business Training Institute  
Buffalo, N. Y.

Send me, entirely free, Booklet No. D-723 giving full particulars about course in Railway Traffic Inspection.

Name .....

Street .....

City .....

## WE TEACH COMMERCIAL

# ART

Properly trained artists earn \$100 a week and up. Meyer Both College—a Department of the Meyer Both Company—offers you a different and practical training. If you like to draw, develop your talent. Study this practical course—taught by the largest and most widely known Commercial Art Organization in the field with 20 years' success—which each year produces and sells to advertisers in the United States and Canada over ten thousand commercial drawings. Who else could give you so wide an experience? Commercial Art is a business necessity—the demand for commercial artists is greater every year. It's a highly paid, intensely interesting profession, equally open to both men and women. Home study instruction. Get facts before you enroll in any school. Get our special booklet, "Your Opportunity"—for half the cost of mailing—4c in stamps.

MEYER BOTH COLLEGE  
of COMMERCIAL ART  
Michigan Ave. at 20th St.  
Dept. 16 CHICAGO, ILL.



## Learn Photography

Good-paying positions in the best studios of the country await men and women who prepare themselves now. For 28 years we have successfully taught

Photography, Photo Engraving and Three-Color Work. Our graduates earn \$35 to \$100 a week. We assist them to secure these positions. Now is the time to fit yourself for an advanced position at better pay. Terms easy; living inexpensive; largest and best school of its kind. Write for catalog today.

ILLINOIS COLLEGE OF PHOTOGRAPHY  
Le Grand A. Flack, Pres., Box 472, Effingham, Illinois

## PIANO JAZZ

By note or ear. With or without music. Short Course. Adult beginners taught by mail. No teacher required. Self-Instruction Course for Advanced Pianists. Learn 67 styles of Bass, 180 Syncopated Effects, Blue Harmony, Oriental, Chime, Movie and Cafe Jazz, Trick Endings, Clever Breaks, Space Fillers, Sax Shurs, Triple Bass, Wicked Harmony, Blue Obligato, and 247 other Subjects, including Ear Playing, 110 pages of REAL Jazz, 25,000 words. A Postal brings our FREE Special Offer. Waterman Piano School, 259 Superba Theatre Bldg., Los Angeles, Calif.

# STAMMERERS

For 55 years we have successfully corrected stammering by our simple and natural course of individual lessons. Attend no school until you have read our free booklet, "How To Stop Stammering."  
SAMUEL A. ROBBINS, Director,  
Boston Stammerers' Institute  
248 Huntington Ave. Boston 17, Mass.

## TRI STATE COLLEGE OF ENGINEERING

Makes you a Civil, Mechanical, Electrical or Chemical Engineer in two years, 48 weeks each. No entrance examinations. High School Diploma not required. Compact courses made up of essentials only. Expenses low. For catalog address:

100 "M" STREET, ANGOLA, IND.

## Wrestling Book FREE



Learn to be an expert wrestler. Know scientific wrestling, self-defense, and jiu-jitsu. Develop a splendid physique, and have perfect health. Join this popular school and learn by mail. The famous world's champions—the marvelous

Frank Gotch and Farmer Burns

offer you a wonderful opportunity. Wrestling is easily and quickly learned at home by mail. Men and boys write now for splendid free book. Learn all the science and tricks. Be able to handle big men with ease. Accept this wonderful offer NOW. Send for free book today, stating your age.

Farmer Burns School of Wrestling, C177 Rampe Bldg., Omaha, Neb.

# Earn \$35-125 a Wk



## Your Opportunity in MECHANICAL DENTISTRY

Ambitious men of all ages can rise above small salaried positions into this profession of unlimited possibilities.

Taught by actual practice—day or evening. Three months' course. Modern laboratories. No previous knowledge or experience required. No charge for tools or equipment. The men we train are in demand. Established 30 years. Catalog free.

Address your inquiry to Dept. 2

## BODEE SCHOOLS OF MECHANICAL DENTISTRY

NEW YORK  
136 W. 52 St.

PHILADELPHIA  
15 1/2 and Walnut Sts.

BROOKLYN  
15 Flatbush Ave.

# BECOME A LAWYER



Study At Home. Legally trained men win high positions and big success in business and public life. Greater opportunities now than ever before. Be a leader. Lawyers earn

\$3,000 to \$10,000 Annually

We guide you step by step. You can train at home during spare time. Let us send you records and letters from LaSalle students admitted to the bar in various states. Money refunded according to our Guarantee Bond if dissatisfied. Degree of LL. B. conferred. Thousands of successful students enrolled. Low cost, easy terms. We furnish all text material, including fourteen-volume Law Library. Get your valuable 120-page "Law Guide" and "Evidence" books free. Send for them today.

LASALLE EXTENSION UNIVERSITY  
Dept. 846-L Chicago

## Keystone Institute

"The Service School"

A fully equipped school with expert instructors, organized to give intensive instruction in

2-Year Courses

Electrical Engineering

Mechanical Engineering

Accounting and Business Administration

16 weeks' course in Automotive Engineering

Day and Night Classes. Graduates are sought by large and small industrial establishments and are filling important positions in all sections of the country. Write for information on subject that interests you to Keystone Institute. Address The Vice President, 133 North 4th Street, Reading, Penna.

## Learn Autos and Tractors



Wonderful opportunities constantly offered trained men; we train you thoroughly to start your own business or make good money as motor expert, driver, shop foreman, etc.

7,000 Graduates making good. Catalog Free

Cleveland Automobile School, 1814 E. 24th St., Cleveland, O.



## "BECOME A LIGHTNING TRICK CARTOONIST"

MAKE MONEY CHECK TALKING. SEND \$1.00 FOR SNAPPY PROGRAM OF TRICK DRAWINGS WITH INSTRUCTIONS BY A PROFESSIONAL CARTOONIST. SATISFACTION GUARANTEED. CIRCULAR FREE. BALDA ART SERVICE, 91. OSHKOSH, WIS.

## ELECTRICAL Training Book FREE

Send me your name and address and I will send you my big new Electrical Training Book Free. It will show you how to qualify for high paying jobs in Electricity. Thousands now open. Prepare at home—quickly—during spare time under an Electrical Engineer. Take advantage of this unusual offer—only today.

A. W. WICKS, President WICKS ELECTRICAL INSTITUTE  
Dept. 119-C 3601 Michigan Ave. CHICAGO



## This Man is Sure of His Job

He saw the handwriting on the wall. Men in his department were being dropped right and left.

He might have been the next to go but for a familiar coupon which he saw in a magazine. He tore it out, marked it, and mailed it to Scranton.

Then one day his employer called him in.

"Young man," he said, "I have just received a letter from the International Correspondence Schools telling me you have enrolled and have received a mark of 93 for your first lesson.

"I don't mind saying that this letter has saved your job. I had you on the list of men to be dropped. But I'm going to keep you now. And there are bigger things ahead of you. The man who thinks enough of his future to study his job is the kind of a man we want."

HOW about you? Are you sitting on the anxious bench wondering if you will be the next to go? Or are you training yourself so that you will not only be sure of your present job but will be ready for the job ahead? Your future depends on your answer.

This is all we ask: Without cost, without obligating yourself in any way, put it up to us to prove how we can help you. Just mark and mail this coupon.

INTERNATIONAL CORRESPONDENCE SCHOOLS  
Box 3661-C, Scranton, Penna.

Without cost or obligation, please send me full information about the subject before which I have marked an X in the list below:

### BUSINESS TRAINING DEPARTMENT

- |   |   |
|---|---|
| <input type="checkbox"/> Business Management            | <input type="checkbox"/> Salesmanship           |
| <input type="checkbox"/> Industrial Management          | <input type="checkbox"/> Advertising            |
| <input type="checkbox"/> Personnel Organization         | <input type="checkbox"/> Better Letters         |
| <input type="checkbox"/> Traffic Management             | <input type="checkbox"/> Foreign Trade          |
| <input type="checkbox"/> Business Law                   | <input type="checkbox"/> Stenography and Typing |
| <input type="checkbox"/> Banking and Banking Law        | <input type="checkbox"/> Business English       |
| <input type="checkbox"/> Accountancy (including C.P.A.) | <input type="checkbox"/> Civil Service          |
| <input type="checkbox"/> Nicholson Cost Accounting      | <input type="checkbox"/> Railway Mail Clerk     |
| <input type="checkbox"/> Bookkeeping                    | <input type="checkbox"/> Common School Subjects |
| <input type="checkbox"/> Private Secretary              | <input type="checkbox"/> High School Subjects   |
| <input type="checkbox"/> Business Spanish               | <input type="checkbox"/> Illustrating           |
| <input type="checkbox"/> French                         | <input type="checkbox"/> Cartooning             |

### TECHNICAL AND INDUSTRIAL DEPARTMENT

- |   |  |
|---|--|
| <input type="checkbox"/> Electrical Engineering   | <input type="checkbox"/> Architect               |
| <input type="checkbox"/> Electric Lighting        | <input type="checkbox"/> Contractor and Builder  |
| <input type="checkbox"/> Mechanical Engineer      | <input type="checkbox"/> Architectural Draftsman |
| <input type="checkbox"/> Mechanical Draftsman     | <input type="checkbox"/> Concrete Builder        |
| <input type="checkbox"/> Machine Shop Practice    | <input type="checkbox"/> Structural Engineer     |
| <input type="checkbox"/> Railroad Positions       | <input type="checkbox"/> Plumbing and Heating    |
| <input type="checkbox"/> Gas Engine Operating     | <input type="checkbox"/> Chemistry               |
| <input type="checkbox"/> Civil Engineer           | <input type="checkbox"/> Pharmacy                |
| <input type="checkbox"/> Surveying and Mapping    | <input type="checkbox"/> Automobile Work         |
| <input type="checkbox"/> Mine Foreman or Engineer | <input type="checkbox"/> Navigation              |
| <input type="checkbox"/> Steam Engineering        | <input type="checkbox"/> Agriculture and Poultry |
| <input type="checkbox"/> Radio                    | <input type="checkbox"/> Mathematics             |
| <input type="checkbox"/> Airplane Engines         |  |

Name.....  
Street.....  
Address.....

6-23-22

City..... State.....

Occupation.....

Persons residing in Canada should send this coupon to the International Correspondence Schools Canadian, Limited, Montreal, Canada.

Please Mention Popular Mechanics

# LEARN CARTOONING the Right Way



1.

Have your ability trained by the school that has developed many famous cartoonists.

If you like to draw—if you find pleasure in picking up a pencil and paper and trying to make sketches or cartoons, don't regard it merely as a hobby. Have your ability developed and earn a good income as a cartoonist.



2.

Hundreds of nationally known cartoonists, such as Branner of the Chicago Tribune; Blosser, who draws "Freckles and His Friends"; Gene Byrnes, creator of "Reg'lar Fellers"; Thiele of the Sioux City Tribune; Fung, of the Seattle Times and others equally well known, took the Landon Course at home, in their spare time, and fitted themselves for their present positions at salaries ranging from \$50 to \$200 and more per week.



3.

Have YOUR talent developed by the same method

What the above mentioned boys did you can do, with the same training. The Landon method of teaching makes cartooning easy to learn. By means of an extensive series of Big picture charts all the necessary details of ORIGINAL drawing are explained step by step, in a clear and simple manner.



4.

**FACTS that determine the superiority of the Landon School:**

1. Landon School Students are securing the best cartooning positions which open up everywhere.
2. The picture chart method of instruction was originated and is used exclusively by the Landon School.
3. From the very beginning, the Landon Course teaches ORIGINAL drawing. No copy work.
4. Individual attention and criticism of student's work. Personal coaching whenever necessary.
5. Specialized instruction on how to originate cartoon ideas. This is an exclusive feature of the Landon Course.
6. Practical assistance in securing positions for students and help in marketing their work.
7. The price is within reach of everyone who is ambitious to succeed. Easy payments can be arranged.



5.

Write today for full information about the Landon Course, and sample chart by means of which you can test your own ability. Find out what the possibilities are for YOU in this interesting profession. Please state your age.

**The Landon School**  
1138 National Bldg. Cleveland, Ohio

## I Can Train You For A \$3500 Hotel Job in 20 weeks



The Hotel Business offers wonderful opportunities to the trained man or woman! Now fourth largest industry in America. Hundreds of high-salaried executive positions now standing open—waiting for the trained worker. You can easily qualify for one of these big-paying jobs—in your spare time at home. No previous experience necessary.

### I Guarantee to Teach You

in my 50-lesson home-study course on hotel work, all that the leading hotel experts know about the business—men making from \$5,000 to \$50,000 a year! My students are eagerly sought by the biggest and best hotels in the country. You won't have to start at the bottom. You won't have to look for a job. Big pay, fine living, free meals and apartment, fascinating work—these are only a few of the many advantages of hotel work.

### Send for FREE Book

20 Years' Experience in 20 Weeks is what this wonderfully complete course gives you. Course prepared by Clifford Lewis, a hotel expert of national reputation. Endorsed by managers of such hotels as Biltmore, Waldorf-Astoria, Copley-Plaza, Commodore, etc. Interesting free book explains all. Send for it today.

CLIFFORD LEWIS, President

LEWIS HOTEL TRAINING SCHOOL

Founded 1916

Room 330

Washington, D. C.

## LAW Course In 2 Years

Be a lawyer. Law trained men earn big money and occupy top positions in social, business and public life.

**\$5,000 to \$10,000**  
a year is what you can earn. Our improved system guides you step by step until you have passed the bar examination in any state. Low cost, easiest terms. We furnish everything, including complete Law Library. Send for free catalog.

AMERICAN SCHOOL, Dept. L, C, 74, Drexel Ave. & 98th, Chicago

BE AN EXPERT  
*Penman*

I TEACH BY MAIL. You can become an expert penman right in your own home by my method. Small Cost. All that is required is some of your Spare Time. Write for my book, "HOW TO BECOME AN EXPERT PENMAN." It contains specimens and tells how others became expert writers by the TEVIS METHOD. Your name written on a card if you enclose stamp. FREE BOOK. Write today. T. M. TEVIS, BOX 25K, CHILlicothe, MO.

## AVIATION INFORMATION FREE

Send us your name and address for full information regarding the Aviation and Airplane business. Find out about the many great opportunities now open and how we prepare you at home, during spare time, to qualify. Our new book "Opportunities in the Airplane Industry" also sent free if you answer at once.

AMERICAN SCHOOL OF AVIATION

Dept. 119-C 3601 Michigan Ave. CHICAGO

## LEARN WATCH REPAIRING



You can learn by our modern and original system of instruction every part of the Watch Repairing Trade at home as good or better than at a shop. You can earn money while learning and secure a well paying position or start in business after completing our course of instruction. Good watch repairers are always in demand and earn from \$30 to \$70 per week. For particulars apply to the WISCONSIN SCHOOL OF WATCH REPAIRING 166 Mason St., MILWAUKEE, WIS.



# Which job can you fill?

All these jobs were advertised in a single issue of a Chicago newspaper under "Help Wanted." Which one can you fill?

There are good jobs like these with big pay everywhere for men capable of holding them. Why don't you get one? If you haven't the knowledge necessary to make you capable of holding down the best kind of a job, *make up your mind right now to get it.* There is a set of Home Study Books listed below that will quickly fit you to hold any job you want—spare time only is needed.

These books were written by some of the greatest experts in each line. Nothing but plain everyday English is used—thousands of pictures, diagrams and tables help to make everything as simple as A B C. You can't go wrong with these books before you—they explain everything you need to know. Pick out the set you want and see our *free trial* offer below.

## Cut Prices on Practical Books

**Carpentry and Contracting**, 5 vols., 2138 pp., 1000 pict. Was \$37.50...Now \$19.80  
**Civil Engineering**, 9 vols., 3900 pages, 3000 pictures. Was \$67.50...Now \$34.80  
**Electrical Engineering**, 8 vols., 4100 pages, 3300 pictures. Was \$60.00...Now \$29.80  
**Automobile Engineering**, 6 vols., 2600 pp., 2000 pictures. Was \$45.00...Now \$21.80  
**Machine Shop Practice**, 6 vols., 2300 pp., 2500 pictures. Was \$45.00...Now \$21.80  
**Steam and Gas Engineering**, 7 vols., 3300 pp., 2300 pict. Was \$52.50...Now \$24.80

**Law and Practice (with reading course)**, 13 v., 6000 p., illus. Was \$97.50...Now \$49.80  
**Fire Prevention and Insurance**, 4 vols., 1500 pp., 600 pict. Was \$30...Now \$14.80  
**Telephony and Telegraphy**, 4 vols., 1728 pp., 2000 pict. Was \$30.00...Now \$14.80  
**Sanitation, Heating, Ventilating**, 4 vols., 1454 pp., 1400 pict. Was \$30...Now \$14.80  
**Accountancy & Bus. Management**, 7 vols., 2700 p., 800 pict. Was \$52.50...Now \$29.80  
**Drawing**, 4 vols., 1578 pages, 1000 pictures, blueprints, etc. Was \$30.00...Now \$14.80

## 7 DAYS' FREE TRIAL

We'll gladly send you any set of these books you want for seven days' free examination. Don't send us a cent. Just pay the small shipping charges when the books arrive. Examine them carefully. Use them at your work for an entire week. If you feel that the books are not worth more than we ask for them, send them back at our expense. If you keep them, pay only the bargain price on the easy terms explained below.

**75c a Week** That's all you pay if you keep the books you select. Send \$2.80 within 7 days and the balance of the cut price at the rate of \$3.00 a month (75c a week). Did you ever hear of a more generous offer? Remember, you take no chances—you don't pay us anything if you don't keep the books. *Mail the coupon NOW—before you turn this page.*

**AMERICAN TECHNICAL SOCIETY, Dept. X-19c, Chicago**

## Wanted

### Office Men

Auditors, Accountants, Office Managers, Credit Men, Cashiers, Bookkeepers and Cost Clerks—\$2,000 to \$7,500 a year.

### Factory Men

Electrical and Mechanical Engineers, Factory Managers, Superintendents, Foremen, Designers and Draftsmen—\$2,000 to \$12,000 a year.

### Construction Men

Civil and Structural Engineers, Transmitters, Construction Superintendents and Foremen, Estimators, Designers and Draftsmen—\$2,500 to \$10,000 a year.

### Trades

Machinists and Toolmakers, Auto Repairers, Electricians, Stationary Engineers, Firemen, Plumbers, Carpenters, Pattern Makers and Telephone Men—\$2,000 to \$4,000 a year.

## A Real Bargain

The price of these Pay Raising Books is cut in half

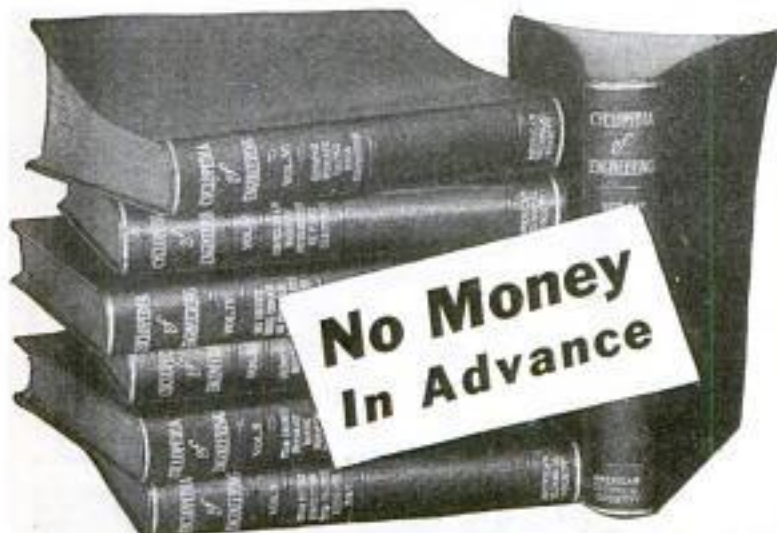

## SPECIAL DISCOUNT COUPON

AMERICAN TECHNICAL SOCIETY  
Dept. X-19c, Chicago, U. S. A.

Please send me set of.....

for 7 DAYS' examination, shipping charges collect. I will examine the books thoroughly, and, if satisfied, will send \$2.80 within 7 days and \$3 each month until I have paid the special price of \$..... If I decide not to keep the books I will return them at your expense at the end of one week. Title not to pass to me until the set is fully paid for.

Name.....

Address.....

City..... State.....

Reference.....

Please fill out all lines

# Be a Certificated "Electrical Expert"

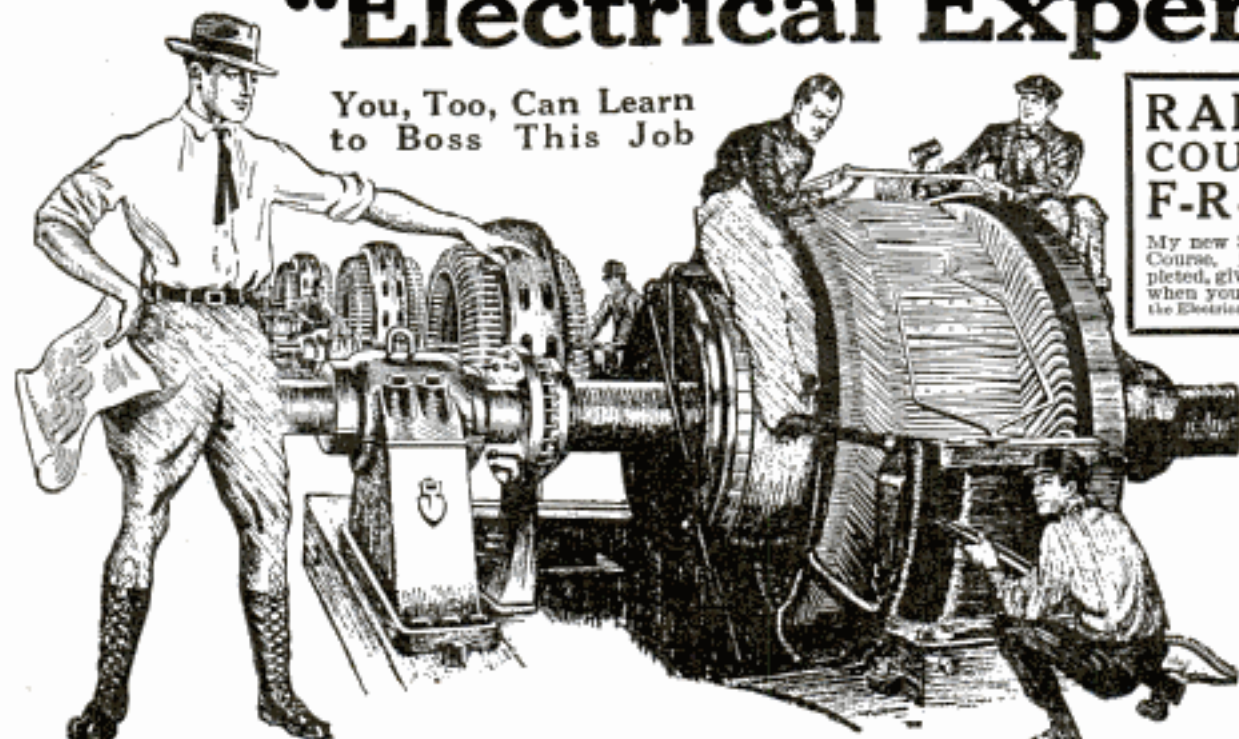

You, Too, Can Learn  
to Boss This Job

**RADIO  
COURSE  
F-R-E-E**

My new \$45 Radio Course, just completed, given FREE when you enroll for the Electrical Course.

## "Electrical Experts" Earn \$12 to \$30 a Day WHAT'S YOUR FUTURE

Trained "Electrical Experts" are in great demand at the highest salaries, and the opportunities for advancement and a big success in this line are the greatest ever known.

"Electrical Experts" earn \$70 to \$200 a week. Fit yourself for one of these big paying positions.

### Be an "Electrical Expert"

Today even the ordinary Electrician—the "screw driver" kind—is making money—big money. But it's the trained man—the man who knows the whys and wherefores of Electricity—the "Electrical Expert"—who is picked out to "boss" ordinary Electricians—to boss Big Jobs—the jobs that pay.

### \$3,500 to \$10,000 a Year

Get in line for one of these "Big Jobs" by enrolling now for my easily learned, quickly grasped, right-up-to-the-minute, Spare-Time Home-Study Course in Practical Electricity.

### Age or Lack of Experience No Draw-Back

You don't have to be a College Man; you don't have to be a High School graduate. My Course in Electricity is the most simple, thorough, and successful in existence, and offers every man, regardless of age, education or previous experience the chance to become, in a very short time, an "Electrical Expert," able to make from \$70 to \$200 a week.

### I Give You a Real Training

As Chief Engineer of the Chicago Engineering Works I know exactly the kind of training a man needs to get the best positions at the highest salaries. Hundreds of my students are now earning \$3,500 to \$10,000. Many are now successful ELECTRICAL CONTRACTORS.

### Your Satisfaction Guaranteed

So sure am I that you can learn Electricity—so sure am I that after studying with me, you, too, can get into the "big money" class in electrical work, that I will guarantee under bond to return every single penny paid me in tuition if, when you have finished my course you are not satisfied it was the best investment you ever made.

### FREE—Electrical Working Outfit—FREE

I give each student a Splendid Outfit of Electrical Tools, Materials and measuring Instruments absolutely FREE. I also supply them with Drawing Outfit, examination paper, and many other things that other schools don't furnish. You do PRACTICAL work—AT HOME. You start right in after the first few lessons to WORK AT YOUR PROFESSION in a practical way.

### Get Started Now—Mail Coupon

I want to send you my Electrical Book and Proof Lessons both FREE. These cost you nothing and you'll enjoy them. Make the start today for a bright future in Electricity. Send in coupon—NOW.

L. L. COOKE, Chief Engineer,

**CHICAGO ENGINEERING WORKS,**

Dept. 1-C 2150 Lawrence Ave., CHICAGO, ILL.

L. L. COOKE,  
Chief Eng.,  
Chicago Engi-  
neering Works,  
Dept. 1-C  
2150 Lawrence Ave.,  
Chicago, Ill.

Dear Sir: Send at once Sample Lessons, your Big Book, and full particulars of your Free Outfit and Home Study Course—all fully prepaid, without obligation on my part.

Name.....

Address.....

**YOU CAN DO IT**

# CLASSIFIED ADVERTISEMENTS

WORLD'S BEST WANT AD MEDIUM

Advertisements in this section, 25 cents per word, each insertion, minimum 10 words, payable in advance. To be inserted under proper classification in September issue, copy should be in our office July 25th.

## AUTOMOBILE SUPPLIES

**PERFECTO Top Repair**—An economy leather dressing product guaranteed to stop small leaks in Auto Tops at minimum cost. Application over entire top gives brilliant finish and makes it like new. Also for similar use on leather-covered chairs, shoes, gloves, pocket-books, etc. All colors. 75c per pint, \$1.40 per quart. J. & H. Products Company, Arlington, N. J.

**GET Real Value Out of Your Old Car**—Turn it into a practical two or three plow tractor or heavy truck by simply attaching a Stauda Mak-A-Tractor. Fits any car. Thousands used. Price only \$148.25 F. O. B. factory. Write for free information. E. G. Stauda Manufacturing Co., 2690 University Ave., St. Paul, Minn.

**PASCO Wire Wheels**—Economical, safe, beautiful, strong, and serviceable. Price \$65.00 set five for Ford, \$70.00 for Chevrolet. Optional color. Order from your dealer or direct. Circulars free. Maryland Metal Products Company, Hagerstown, Md. Department M.

**BIG Money made charging magnetos.** Fords charged for one cent, without removing bolts. Use any light socket, storage or dry batteries. Guaranteed magnetizers, \$5.00 up. Benner Mfg. Co., Webb City, Mo.

**LIBERTY Air Compressors**, for garages, tire-shops, filling stations, also paint spraying equipment. Air Compressor & Equipment Co., 1433-37 Carroll Avenue, Chicago, Ill. Distributors wanted.

**AUTOMOBILE Parts**, guaranteed new, for all cars. Save money; get parts direct at wholesale. We ship immediately from stock, transmission and differential gears, bearings, shafts, gaskets, flywheel gear rings, pistons, rings and other parts for any car. When necessary we make gears special from old samples. Get our wholesale prices today. Wire or write us when you need parts in a hurry. State make of car, model and parts wanted. We refund your money, including transportation charges, if not satisfied. Mechanics Gear Works, 3708 North Halsted Street, Chicago, Ill.

**SOMETHING Different (Pat. Pend.)** Thermo Gas-Friction Fuelizer will absolutely vaporize every particle of present day heavy fuel before it enters cylinders. Principle is absolutely and scientifically correct. More miles less carbon and smoother running motor guaranteed. The latest and most efficient vaporizer on the market installed with ordinary wrench in 10 min. Send for descriptive literature or send \$3.00 postpaid for Ford size. Money back guarantee. Thermo Friction Co., Lenox Iowa.

**AGENTS—50% to 60% profit!** Every auto owner a prospect. New switch, clamps on steering wheel spider; permits operation of headlights and blowing of horn without removing either hand from wheel; particularly adapted to Fords and similar cars. Completely equipped with cables, terminals, etc.; many other features. Real opportunity—write for detailed information if mean business. Patton-MacGuyer Co., Providence, R. I.

**AMAZING** automobile necessity. C-M-G neutralizes carbon—increases mileage and horsepower. Quart \$2.50, with test questionnaire. Money back if it doesn't amaze you. C-M-G Co., 323-X First Avenue, Milwaukee, Wis.

**PROTECT your rights**—write for "Record of Invention" and booklet about Patents. Prompt personal service. Advice without charge. J. Reaney Kelly, 612-G Columbian Building, Washington, D. C.

**PISTON rings**, Bard High Compression, leak proof, list price \$1.50; our price 18c, sample 25c. Hungerford Bros., 823 W. 2nd Street, Elmira, N. Y.

**KEEP your car like new**; 50c secures my home made receipt for cleaning and polishing. H. Charles, 361 Kent, Wash.

**SPEEDOLINE**—Quart equals 53 gallons gasoline; big money maker. Write for exclusive distributing agency. Speedoline Co., Dept. 73, Dallas, Texas.

**AMERICAN Golden Eagles for Radiator Cap Ornament.** Sent postpaid, 60c. T. and M. Co., 1605 Bennett Ave., Chattanooga, Tenn.

**G. M. C. TRUCK** unit power plant, nearly new, \$125.00. E. M. F. Motors, \$30.00. Rear Axles, \$25.00. Ketzman & Durnell, Lakota, N. D.

**AIR compressor automatic buffers, motors, battery chargers.** Attractive terms. Profits pay. Write needs on postal. Hobart, Troy, Ohio.

**ELECTRIC Service and Battery Stations** send your jobber's name for booklet entitled "The Testing and Repairing of Automotive Electrical Equipment as a Profitable Business." Electric Machine Corporation, Indianapolis, Ind.

**BIG Profits Battery Charging.** \$20 starts you. Profits pay balance. Send postal. Hobartsons, Troy, Ohio.

**AUTO Top Roof Covers** easy to put on. You drive 100 tacks and save \$15 to \$40. Ford Roadster \$5.28, Touring \$6.95 and \$9.95. Chevrolet, Dodge or Maxwell \$13.95. All other cars \$16.50 with plate glass lights. Ford regular side Curtains, \$5.95 up. For other cars \$11.50 up. Ford Seat Slips, Roadster \$3.15, Touring \$6.25, or tailored, Roadster \$6.20, Touring \$9.90, other cars \$4 to \$82. Ford Cushions \$5.95. All goods same as car manufacturers use and guaranteed to fit. Printed instructions given how to apply. Send for samples. Prices delivered at your door. Equipment Co., 30 Canal, Cincinnati, Ohio.

**AMERICAN Garage & Auto Dealer** publishes each month interesting and helpful suggestions and information on sales, merchandising, advertising, business management, accounting, welding, cutting, brazing, practical and progressive hints for office and shop for "small-town" automotive dealers, garagemen, repairmen, mechanics. Subscription price \$1.00 per year. Sample copy on request. American Garage & Auto Dealer, 1904 Lake View Bldg., Chicago.

**AUTOMOBILE Owners, Garagemen, Mechanics, Repairmen**, send for free copy of our current issue. It contains helpful, instructive information on overhauling, ignition troubles, wiring, carburetors, storage batteries, etc. Over 140 pages, illustrated. Send for free copy today. Automobile Digest, 505 Butler Bldg., Cincinnati.

**SAVING fuel and oil, stopping oil pumping, decreasing carbon deposits** is accomplished by Zelec, the zinc-coated piston ring, price 45c each; peened by special process. If your dealer doesn't handle, order of Zelec Piston Ring Division, Zelnicker, St. Louis. Distributors wanted.

**AUTO Owner Tire Agent** wanted each locality to use and take orders for hand-made Mollinger extra ply and cord tires; guaranteed by bond for 8,000 and 10,000 miles (no seconds); shipped prepaid on approval; get your tires free; no capital or experience required; make \$100 to \$300 weekly. Write for wholesale prices and sample section, Mollinger Tire Co., 929-K Oak, Kansas City, Mo.

**VULCANIZING and Repairing** is a paying business. Forty million tires need repairing every day. Make big profits in tire repair. Easy to learn. Instructions free. No hard times. Always busy. Get into this money-making business quick! Plants \$200 up. Write for free catalog. Equipment Co., 1 Canal, Cincinnati, Ohio.

**AIR Compressor with Tank and Hose \$50.** With Motor \$72.50. Suitable for private or public garage, tire shop, painting or cleaning. Also Motor in the Head Buffer. Home size \$18.50, Shop size \$25. Garage size \$106. Battery charging outfit, home or garage size \$14. Send for our large 100-page catalogue, describing all kinds of Air Compressors, Vulcanizers, Garage and Battery outfits. Equipment Co., 21 Canal St., Cincinnati, Ohio.

**OIL Tanks**, all sizes. Oil Stations, Garages, Repair Shops, Small Stores, all of steel. Lowest prices. J. O. Dickson, Hammond, Indiana.

**AIR Compressors**—Genuine Brunner Compressors, new, on very attractive terms; send post card. Brunner Mfg. Co., Dept. A, Utica, N. Y.

## AUTOMOBILES

**AUTOMOBILE Repairman's Helper.** In two vols. An excellent new work that gives every operation required to adjust or repair the troubles likely to be found in all standard cars. Vol. 1—Repairshop Practice—Passenger Cars—Trucks. 535 pp. 417 figs. Price, \$2. Vol. 2—General Shop Practice—Passenger Cars—Parts and Accessories. 528 pp. 428 figs. Price, \$3. Popular Mechanics Book, Dept. 6, N. Michigan Ave., Chicago.

**AUTOMOBILE Electrical Systems** are fully treated in the new addition of the book entitled "Automobile Starting, Lighting and Ignition Systems." Over 250 complete wiring diagrams. 800 pp. 492 illus. \$3. postpaid. Popular Mechanics Book Dept., 6 N. Michigan Ave., Chicago.

**AUTOMOBILE Mechanics, Owners, Garagemen, Repairmen**, send for free copy America's Popular Motor Magazine. Contains helpful, instructive information on overhauling, ignition wiring, carburetors, batteries, etc. Automobile Digest, 505 Butler Bldg., Cincinnati.

**PATENTS**—Write for free illustrated Guide Book and Evidence of Conception Blank. Send model or sketch and description of your invention and we will give our opinion of its patentable nature. Highest references. Prompt service. Reasonable terms. Victor J. Erans & Co., 185 Ninth, Washington, D. C.

**AUTOMOBILE Repairshop Shortcuts**—Over 1,500 time and labor saving hints from more than 1,000 of the best repairshops in the U. S. 256 pp. 1,500 figs. Price, \$3.50, postpaid. Popular Mechanics Book Dept., 6 N. Michigan Ave., Chicago.

**DYKE'S Automobile Encyclopedia** contains the greatest array of automobile facts ever published in one volume. Several separate books containing the same information would cost in the neighborhood of \$21.00. New, enlarged edition, 968 pp., 3,342 illus; cloth, \$6.48; American morocco, \$7.96, postpaid. Popular Mechanics Book Dept., 6 N. Michigan Ave., Chicago.

## FOR FORD OWNERS

**FORD Car Repair Book** sent free. This complete, well illustrated, valuable book explains in a simple way the Causes and Cures of Overheating; Repairing Ford Timer; Curling Piston Ring Troubles; Carburetor Adjustments and Repairs; Connecting Rods; Transmission Troubles; Care and Repair of Rear Axle; Stopping Axle Grease Leaks; also covers practically every other phase of Ford Car Repairing. Send 25c coin for three months' trial subscription and get the valuable repair book free. Ford Owner and Dealer Magazine, 520 Montgomery Bldg., Milwaukee, Wis.

**FORD 220 Simplex Starter** Guaranteed. American-Simplex Co., Anderson, Ind.

**FORD owners** and all other makes. Increase your mileage 75%; eliminate 75% of spark plug and carbon troubles. Put 100% more pep into your car. Buy a Sturdevant Aerator. Sample, \$3.50. Mail prepaid. Agents wanted—Make big money. Federal Engineering Company, 711 Eighth St., Detroit, Mich.

**REPAIR your own Ford Car, Truck, Tractor.** New 229-page book describing proper and most efficient way to repair products of Ford factories by former director Ford Motor Co. Service School. This information otherwise unavailable outside of Ford plant. For owners, repairmen and dealers. Price, \$2 postpaid. Popular Mechanics Book Dept., 6 N. Michigan Ave., Chicago.

**FORD Owners, 10,000 miles for \$1.00.** Haskins Timer Brush makes your old timer better than new. Absolutely guaranteed. Price, \$1.00. Send \$7.20 for dozen and sell them to your friends in an hour. Evans-Phillips Co., Inc., 1929 Broadway, Denver, Colorado.

**NOTICE—Oil Gauge for Ford, \$2.00.** Guaranteed to satisfy. Write for particulars. Address E. D. Trerathan, Wichita Falls, Texas.

**SPEEDSTER Fans:** Don't fail to see "Red-I-Kut" ad. Page 140.

**\$6.00 WILL make your Ford Thief-Proof.** For that amount we will send you a Venn Manifold Lock, prepaid. The best lock for Ford cars on the market. Quickly and easily installed. Money back if dissatisfied. Taylor-Shantz Co., 478 St. Paul St., Rochester, N. Y.

**JULES Oil Circulator stops any Ford** from pumping oil, doubles oil mileage. Guaranteed. \$1.00 each. Special introductory price, \$2.00. C. O. D. Money back if dissatisfied. Electric Machine Corporation, Indianapolis, Ind.

**GASIFIER saves gasoline, prevents carbon;** applied ten minutes; no changes. Special price Fords \$2.65. Write for information. Detroit Gasifier Co., 743 Book Building, Detroit.

**CONVERT Ford into one ton Truck.** Complete Auxiliary Springs \$29. Unwin, 305 Broadway, New York.

#### MOTORCYCLES, BICYCLES AND SUPPLIES

**SEND for our Bargain Bulletin and Money-Saving Message.** It will save you money on Motorcycles, Side Cars, Motor Wheels, Repair Parts, and Accessories. Some used parts at less than half. Cleveland and Henderson Motorcycles our specialty. See our ad on page 139. American Motor Cycle Co., 2943-5-7 W. Chicago Ave., Chicago.

**LARGEST stock of new and used motorcycle parts and accessories** in the world at your disposal via Uncle Sam's mail. Write for quotations. Motorcycle Parts Mfg. Co., 2036-36 Wabash Ave., Chicago, Ill.

**MOTORCYCLES, Motor Wheels, new and used.** Low prices for good running motors. List free. Seiber Hofheins, Buffalo, N. Y.

**BEFORE buying get our list.** See ad Page 140. Wisconsin Cycle Sales Co.

**THREE speed Indian twin;** good condition. \$50. Geo. Leitch, Altamont, Ill.

**FOR Sale—Indian Motorcycle,** \$75.00. Harold Lambert, Haverstraw, N. Y.

**'19 INDIAN 3 Speed \$85.00, '20 Indian 3 Speed \$100.00, '21 Indian 3 Speed \$150.00.** Howard A. French Company, Baltimore, Md.; Washington, D.C.

**SEND for big list of slightly used motorcycles on our easy payment plan.** Howard Cycle Co., 152 N. Broad St., Trenton, N. J.

**USED parts for all motorcycles cheap.** State wants. Schuck Cycle Co., 1922 Westlake, Seattle, Wash.

**DON'T buy a Bicycle Motor Attachment until you get our catalogue and prices.** Shaw Mfg. Co., Dept. 27, Galesburg, Kan.

**NEW motorcycles have been reduced 10%.** Our prices have been reduced 25%. Send for big bargain list of rebuilt motorcycles. Western Supplies Co., 359 Hayatts Bldg., Denver, Colo.

**BOYS, build your own cycle car!** Send 25c for building plans and list of parts. We can supply motor with clutch and all parts at low prices. Shaw Mfg. Co., Car Dept., Galesburg, Kan.

#### AVIATION

**PROPELLERS for Aeroplane Propulsion;** small Propellers for Motorcycle-Driven Snow and Ice sleds, Road Speedsters, and Hydroplanes; 5-foot diameters, \$12; 6-foot for Fords, \$15. Others in proportion. Hub Mountings, Bearings, Sprockets and Countershafts, complete; full scale, Blue Prints for building motorcycle sleighs, 75c. Ford type, \$1.00. Crawford Motor & Aeroplane Mfrs., Long Beach, Calif.

**REAL aeronautical bargains—turnbuckles,** 25c; aero cloth, 35c; shock absorbers, 5c; (some motors, \$150.00); tubing, 5c per ft., aeroplane sheet steel, 5c per lb., tape, 3c; sparkplug, 25c; high tension wires with terminals, 20c; wheels 20x1, \$6.00; brass screws, 40c per gross; plywood, 20c; aircraft nuts, 1/2c. Many other bargains. Sale sheet, 2c. Heath Aeroplane Co., Chicago, Ill.

**AERODRIVE Boat Blueprint, 75c.** Set Motorcycle Airplane Wings, \$25. Fuzelages, \$100. Everything Aeronautical. Ostergaard Aircraft Works, 4269 N. Narragansett, Chicago.

**INVENTORS** desiring patents should write for our Free Illustrated Guide Book and Evidence of Conception Blank. Send model or sketch for our opinion of its patentable nature. Highest references. Prompt service. Reasonable terms. Victor J. Evans & Co., 157 Ninth, Washington, D. C.

**HEATH propellers represent the most efficient method of aerial drive.** Each propeller individually designed for the particular work to be done, as laid out by America's oldest aeronautical Engineers. Propeller catalog 4c. Heath Airplane Co., Chicago, Ill.

**BIGGEST, best catalogue Model Aeroplanes, Parts and Supplies;** 5c postpaid. Ideal Aeroplans Co., 67 1/2 West Houston, New York.

**A WONDERFUL opportunity to learn to fly** by our new method. Includes three hours' instruction in the air and one month intensive shop course, complete at \$100.00. Heath Airplane Co., Chicago, Ill.

#### WELDING

**WELDING Encyclopedia.** A complete instruction book on all welding processes; oxy-acetylene, electric arc, electric resistance and thermit. Welding of all weldable metals fully discussed. 326 pp., 375 illus. The accumulated experience of the welding brains of America is yours for \$5. Money back if not satisfied. Popular Mechanics Book Dept., 6 N. Michigan Ave., Chicago.

#### BOOKS AND PERIODICALS

**"MONEY and Health"—20 different ways** to make money in Landscape gardening; send \$3.00 money order and get complete instructions, which will start you at once. David Hansen, Landscape Architect, 1243 Thorndale Ave., Chicago, Ill.

**ELECTRICITY** Taught by experts; earn while you learn at home; electrical book and proof lessons free; your success guaranteed and position secured. Chicago Engineering Works, Dept. 51-C, 2144 Lawrence Ave., Chicago.

**SOVEREIGN Publishers, 291 Rhode Island, Buffalo, Catalogue, Rare, Famous Books, 2c. Voice "Senam" 39c. "Master Key" Course \$5.00.**

**THE Agent's Guide—Tells where to buy almost everything.** Copy 10c. Wilson Publishing Co., 1490 Broadway, New York.

**"MIND-READING"—Any distance;** wonderful! 39c. "Hypnotism" controls others—25 easy lessons, \$1.00. "Radio" easily made; instructions, 50c. Science Institute, PM82, 1014 Belmont, Chicago.

**1,600,000 INDUSTRIAL Facts, Calculations, Receipts, Processes, and Trade Secrets** for every business are contained in the 1016 page book. "Moore's Universal Assistant and Complete Mechanic," 509 Engravings. Cloth, Price, \$2, postpaid. Popular Mechanics Book Dept., 6 N. Michigan Ave., Chicago.

**BOOK Bargains, Six Books on any Six Subjects you select.** Prepaid, Two Dollars; original value over Ten Dollars. Follett Book Company, 408 South Wabash Ave., Dept. M, Chicago, Ill.

**550 RARE Formulas for 25c (coin).** We can furnish any formula wanted for 5c. Catalog Free. Allen's Enterprises, 1227 Milwaukee Ave., Chicago, Ill.

**USED Books, educational nature;** sold, rented, bought, exchanged. Bargain list Free. Lee Mountain, Dept. 6d., Pisgah, Ala.

**OUR new catalogue listing over five hundred carefully selected practical books under eighty different subject groupings will be sent free upon request.** Popular Mechanics Book Dept., 6 N. Michigan Ave., Chicago.

**"MAGIC,"** Edward M. Massey. Just published. 26 entirely new and original effects, clearly described. Illustrated with 25 full-page plates and 11 smaller illustrations. Attractively bound, elaborate gold stamping 8 1/2 x 5 1/2. \$3.00 postpaid. Spon & Chamberlain, 120 P. M. Liberty Street, New York, N. Y.

**RADIO Outfits, etc.** Radio receiving sets how to make and operate; illustrated book, 25c. Western Puzzle Works, St. Paul, Minn.

**MONEY-MAKING Secrets Exposed:** The newest book published, revealing important money-making secrets. Postpaid 50c. Address Thomas Game, Box 184, Highland Park, Mich.

**AMATEUR Electrician or Toy maker** book, 64 pages, illustrated. Postpaid 10c each. Western Puzzle Works, St. Paul, Minn.

**RADIO books, Automobile books, Lists** free. Wells & Edwards, X852 George, Chicago.

**BOOKS, All Kinds, Lists, Higene's, A2141 Post Street, San Francisco, Calif.**

**STUDY Human Nature, know people,** make more money. Send 10 cents for "Personal Power," a little book that points the way. Address, Progress League, C-31 Union Square, New York, N. Y.

**"36 ACCOUNTING Problems Solved by C. P. A."** Cloth bound, loose leaf, new, original, up-to-date, valuable. Prepaid, \$1.00. Walhamore Company, Lafayette Bldg., Philadelphia, Pa.

**THIRTY-FIVE Cent Electrical and Mechanical Books.** Fully illustrated. Other popular subjects. Send for list. Spon & Chamberlain, 120 P. M. Liberty St., New York.

**AMBITIOUS Writers** send today for Free copy America's leading magazine for writers of photoplays, stories, poems, songs. Instruction, helpful. Writer's Digest, 603 Butler Building, Cincinnati, Ohio.

**LIGHTNING Cartoonist's Book, Secrets,** Tricks, \$1.00. Christian, 2925 Euclid, Kansas City, Mo.

**PLANS for Poultry Houses.** All styles, 150 illustrations; secret of getting winter eggs, and copy of "The Full Egg Basket." Send 25 cents. Inland Poultry Journal, Dept. 73, Indianapolis, Ind.

**INDUSTRIAL Alcohol, Wright's book** everybody wants. Full directions for making with drawings of necessary apparatus, \$2.50 postpaid. Spon & Chamberlain, 120 P. M. Liberty Street, New York, N. Y.

**INSTRUCTION Book (for shop use)** on vulcanizing auto tires, boots and shoes, \$1 bill. Equipment Co., 3 Canal, Cincinnati, O.

#### PICTURES AND POSTCARDS

**JOIN Live Postcard club;** Sample paper, list, catalog, 10c. Harvey Teeple, Decatur, Ind.

#### NOVELTIES

**LUMINOUS Paper.** Novelty of the year. Emits bright glow; different colors. With book of instructions, \$1. John B. Long, 18 N. Madison, Iowa City, Iowa.

**"BOLIVIAN Lucky Beans,"** something original; each bean everlasting, natural, brilliant, scarlet and black; for earrings, brooches, watch chains, rings, bangles, etc., \$2.50 per dozen. Address, Woods, Chacabuco, 433 Valparaiso, Chile, South America.

#### GAMES AND ENTERTAINMENTS

**VENTRILQUISM** taught almost anyone at home. Small cost. Send 2c stamp today for particulars and proof. George W. Smith, Room M-289, 125 N. Jefferson Ave., Peoria, Illinois.

**TRICKS, jokes, magic, puzzles, joker's** novelties. Catalog free. C. Fenner, 2401 Jefferson, Louisville, Ky.

**250 MAGIC Tricks 25c.** Big Catalog 2c. Harvey Teeple, Decatur, Ind.

**67 TRICKS, 409 Jokes, Riddles, Toasts,** Fortune Telling Secrets, Funny Readings and big catalog, 10c. Ideal Book Shop, 5501NC, North Robey, Chicago.

**REDUCED Prices!** Tricks, Jokes, Puzzles, Imported Novelties. Catalog and "Ten Pocket Tricks," 6c. Send today! Lyle Douglas, Station A, Dallas, Texas.

**HOUDINI'S Paper Magic—by Houdini.** All who are looking for "something different" for instructive amusement will welcome this book on tricks with paper, puzzles, paper-folding, etc. Price, \$2.50 postpaid. Popular Mechanics Book Dept., 6 N. Michigan Ave., Chicago.

**PUN—New Joker's Goods, Pocket Novel-** ties, Tricks, Puzzles. Send 2c for illustrated catalogue. Grandefelt, 1288 Theriot Ave., Bronx, New York.

**FREE—68-page Illustrated Magic Cata-** logue from factory. C. Pentz, Minneapolis, Minn.

**250 MAGIC Tricks, only 10c.** Andco, 6049-T, North Whipple, Chicago.

**TRICKS, Puzzles, jokes, magical apparatus, plays, stage supplies, mind-reading acts, and sensational escapes.** 100-page illustrated professional catalogue, 10c. Oaks Magical Co., Dept. 548, Oshkosh, Wis.

**200 KINDS** iron, wood and wire puzzles. Leader and illustrated list 10c. Western Puzzle Works, St. Paul, Minn.

**MAGIC—Tricks, Books and Supplies.** For Amateurs as well as the great professionals. Anyone can learn through our instructions. Feature Acts in Mind Reading, Spiritualism, Rope Ties, etc. Large illustrated Professional Catalog, 10c. Chicago Magic Co., Dept. B, 140 S. Dearborn St., Chicago, Ill.

### STAMP COLLECTING

**START** a Stamp Collection—65 different stamps from 65 different foreign countries, including Africa, Asia, Australia, Europe, West Indies, etc. Our pamphlet which tells "How to make a collection properly," and price list of albums, packets and sets, all for only 15 cents. Queen City Stamp Co., Room 36, 604 Race St., Cincinnati, O.

**LIKE** Triangular Stamps? To introduce our Sudden Service Approvals we'll send triangular Fiume, set China ships, large \$1.00 United States revenue, also packet 50 foreign, millimetre scale, perforation gauge, ruler and bargain lists for only 2c! Fennell Stamp Company, Dept. P, Fullerton Bldg., St. Louis, Mo.

**START Your Own Stamp Business!** Double your money selling fine stamps received from our Foreign Trade. Send \$1.00 for Big Sample Stock, Satisfaction Guaranteed. Frank Hook, 4715 Lincoln, Detroit, Mich.

**FOR Sale—\$3,750** Rarely nice European Stamp Collection; Standard Catalog price \$3,250; will sell at 90 per cent discount. 9228 So. Park Ave., Chicago.

**1,000 U. S. and foreign**, including Mexican Villa Dollar and Indian Arrow Head 25 cents. C. W. Parker, 77 Kensington Heights, Meriden, Conn.

**BEGINNER'S Special—Loose-leaf album** (complete)—1,000 different stamps; liberal quantity hinges, etc., \$6.00 postpaid. Lists free. Baumann, 1033 Levick, Philadelphia.

**500 MIXED U. S. and foreign**, including 100 different Foreign, 10c; 1,000 hinges, 10c; Stamp Album, 15c. Weatherby, Medina, Ohio.

**ZAMBESIA, Abyssinia, Herzegovina, Holkar, Ukraine Stamps, Menagerie Pack-** et, 250 Hinges, 10c. Liberty, 3974 Arsenal, St. Louis, Mo.

**BEST one-cent approvals in America.** F. P. Hand, 1117 So. 60th St., Philadelphia, Pa.

**STAMPS sent on approval at 70% discount.** Reference required. Emory Remoll, Hanover, Pa.

**200 STAMPS and Bargain Stamp Magazine,** 15c. Harvey Teagle, Decatur, Ind.

**LIBIA, New Venus picture set,** 4 values, 10c postpaid. Price list free. Send for a selection of Midwest approvals. Address, Midwest Stamp Company, Kemper Building, Kansas City, Mo.

**FREE** packet of desirable stamps, exceptional quality, to approval applicants sending satisfactory references. H. Argonbright, Box 352, Staunton, Va.

**AUSTRIAN Battle Scenes, complete set;** also 300 different stamps for 40c. Jacob Fischer, 1539 North Lawler, Chicago.

**FOREIGN Stamp Collection Sent Free.** Cornish Company, Schenectady, N. Y.

**LICHTENSTEIN Stamps,** 20 Different, 10c. Nickles, 122 Florida, Washington, D. C.

**3,000 MIXED stamps,** 25c; 15,000, \$1.00. Alvin Johnson, Hawarden, Iowa.

**FREE** 7 beautiful French Colonials to new approval applicants. Frank Hadley, Plainfield, N. J.

**STAMPS—50 different Jamaica, Venezuela, etc., only 7c; 100 all diff., 10c; 1000 all diff., \$2.50; 100 diff., U. S. 25c; 1000 Hinges, 10c; 50 per cent approvals with every order.** List free. I buy stamps. Write L. B. Dover, Dept. A, Longmont, Colo.

**STAMPS Free—War Stamps, Surcharged, Unused, Pictorials, British, French Colonials** 2c postage. Midland Stamp Co., Toronto, Canada.

**158 GENUINE Foreign Stamps—Mexico** War Issues, Venezuela, Salvador and India Service, Guatemala, China, etc., only 10c. Finest approval sheets, 50 to 60%. Agents Wanted. Big 72-p. Lists Free. We Buy Stamps. Estab. 29 yrs. Hussman Stamp Co., Dept. 54, St. Louis, Mo.

**200 DIFFERENT Stamps 15c.** Lists Free. Michael, 5692 Prairie, Chicago.

**FREE,** 25 U. S. stamps with 60% approvals to reliable parties. 100 different U. S. 25c. C. Seidenberg, Merion, Wis.

**FRENCH Colonies Free—Beautiful Picture** set, including Native Chiefs, Tigers, Pictorials. 2c Postage. Empire Stamp Company, Toronto, Canada.

**3 NYASSA Giraffe stamps free to approval** applicants. Wilmar Edgar, Cherokee, Iowa.

**STAMPS, 50 Varieties, Africa, Brazil,** Peru, Cuba, Mexico, etc., 10c. 50 different U. S., 25c; 1,000 mixed, 40c; 1,000 hinges, 10c. List free. C. Stegman, 5948 Cote Brillante, St. Louis, Mo.

**FREE! Sectional Loose Leaf Postage** Stamp Album at the rate of 8 pages each month given with subscription to our monthly Journal. Send two-cent stamp for prospectus. United Stamp Co., 140 S. Dearborn St., Chicago, Ill.

**BIG Variety Packet Foreign Stamps free** for 2c postage. Gray Stamp Co., Station E., Toronto, Canada.

**24 VARIETIES Cuban stamps, 10 cents.** List of 8,000 low-priced stamps free. Address Chambers Stamp Co., 111P, Nassau St., New York City, N. Y.

**20 UNUSED stamps free.** All different. Postage, 2c. Fisk Stamps, Toledo, Ohio.

**PACKET of 23 stamps, no two countries** alike. Packet hinges. Set of \$1 and \$2 U. S. Rev., all for 5c. Mention paper. Miami Stamp Co., Toledo, Ohio.

**STAMPS, 20 unused, all different, free.** Postage 2c. Mention paper. Quaker Stamp Co., Toledo, O.

**FREE 10 different Scandinavian, milli-** metre scale, gauge, book, lists, etc., to all sending 10c for 57 different Stam. Ceylon, Guatemala, etc. 200 different, 25c; 300 different, 60c; 100 different U. S., 25c. Hawk-eye Stamp Co., Cedar Rapids, Ia.

### RARE COINS

**MAIL** This Slip with your name and address and 10 cents and you'll get a large U. S. Copper Cent nearly as big as half dollar, and large 50-page illustrated coin catalog. You'll find it fascinating and profitable. Send Now. B. Max Mehl, Numismatist, Mehl Bldg., Dept. P, Fort Worth, Texas. Largest Rare Coin Establishment in the United States.

**PRICE List Coins and Paper Money 2c.** \$100 Ohio Bill 15c; California Gold  $\frac{1}{4}$ , 27c;  $\frac{1}{2}$ , 53c. Al E. Bonsall, Richmond, Ind.

**\$2,500.00 FOR One Dollar—Mr. Manning,** of Albany, N. Y., received this amount from us for one silver dollar. You may not have this dollar, but we buy all other rare coins and pay high cash premiums. Send 4c. Get large coin circular. It will pay you to be posted. Send now. Numismatic Bank, Dept. H, Fort Worth, Texas.

**THREE Large United States Cents 25c.** Moore Coin Company, Commerce, Texas.

**CALIFORNIA Gold, Quarter size and Col-** ombia nickel coin only 30c. Italy 20 cents and catalog 10c. Homer Shultz, King City, Mo.

**CALIFORNIA gold,  $\frac{3}{4}$  size, 27c.  $\frac{1}{2}$  size, 53c, 3c piece and catalogue, 10c.** Address Norman Shultz, Colorado Springs, Colo.

**OLD coins, large Spring selling catalogue** of coins for sale, free. Catalogue quoting prices paid for coins, ten cents. William Hesselein, 101B Tremont St., Boston, Mass.

### FOR BOYS

**ELECTRICITY** Taught by experts; earn while you learn at home; electrical book and proof lessons free; your success guaranteed and position secured. Chicago Engineering Works, Dept. 51-C, 2144 Lawrence Ave., Chicago.

**MOUTH-ORGAN Instructor, 25c.** Learn in one hour. Address, G. Elsen, Bowling Green, Ohio.

**BOYS, Get flying model aeroplane free.** Write to Aero Shop, 3050 Hurbit Ave., Detroit, Mich.

**BOYS!**—You who like gripping, thrilling stories of achievement will want to read "Victories of the Engineer," a book that tells in a way you can understand it how the great feats in railroad engineering, building great bridges, ships, dams, canals, harbors, tunnels, mining, etc., have been accomplished. By A. Williams, 487 pp., 259 illus. Price, \$2.00 postpaid. Popular Mechanics Book Dept., 6 N. Michigan Ave., Chicago.

### CAMERAS AND PHOTO SUPPLIES

**JUST Published—Our new complete 128-** page catalog and bargain book of new and used cameras and supplies. Our goods are guaranteed finest quality obtainable. We have thousands of satisfied customers. Write at once for this bargain bulletin, just hot from the press. Address Central Camera Co., 124 S. Wabash Ave., Dept. E-69, Chicago, Ill.

**TRIAL Order—Mail us 20c with any** size film or six negatives for development and six velvet prints. 24-hour service. Get premium list. Roanoke Photo Finishing Co., 209 Bell, Roanoke, Va.

**AMATEUR Photographers—Go into busi-** ness for yourself. Print photos of "Movie Stars." Pays 90% profit. No experience necessary. We furnish negatives. Write for particulars. Film Exchange, 837 Bowery, Akron, Ohio.

**BETTER Pictures—Kodak films developed** 4c, prints 4c each. Remember—satisfaction or money back. Cameron Photo Company, C-3418 Burch Avenue, Cincinnati, Ohio.

**GLOSSY Prints three cents, rolls de-** veloped seven cents. MacFarlanes Studio, 4150 Hamilton, Cincinnati, Ohio.

**5x7 KODAK Enlargement, beautifully** hand-painted, fifty cents. Holt Studio, Quincy, Ill.

**FILM Developed and 6 prints 20c. Or** 6 prints from negatives 20c. Trial offer. Young Photo Service, 16 E. Alden Ave., Albany, N. Y.

**SAMPLE Enlargement, dime, and negative** (returned). Roll developed and six prints, 25c silver. Brown Studio, Lake Elmo, Minn.

**KODAK Prints 3c, Postcards 5c, de-** veloping 5c. Altine Photo Co., Dept. P, 1982 Kinney, Cincinnati, Ohio.

**FADED Pictures, Tintypes, Daguerre-** types restored and enlarged. New Process. Perfect results. Reasonable costs. Roanoke Photo Finishing Co., 512 Bell Ave., Roanoke, Va.

**KODAK Finishing—Kodak, Camera re-** pairing. Developing and printing for amateurs. One-day service. Complete line of photo supplies. Write Radium Studio No. 21, 847 Belmont, Chicago.

**ESTABLISH yourself—at home—as an** Expert Photographer and train with R. Vant, director International Studios, 343-B—3601 Michigan Ave., Chicago.

**KODAKS, Cameras, Lenses, Photo Sup-** plies, Radio outfits. Ask for bargain list. Hyatt's Supply Co., 417 N. Broadway, St. Louis, Mo.

**BIG Money Saved on Photographic Lenses** and Apparatus—goods exchanged; repairing done. Ralph J. Golsen, 1123 Argyle St., Chicago, Dept. P.

**BASS Camera Bargains are known the** world over. Write your needs. Largest stock of Graflex, Kodaks and Motion Picture Cameras in the world. Bass Camera Company, Mail Order Division, Chicago, Ill.

**KODAK films developed and finished** with attractive margin designs 25c. Something new. New England Photo Service, Box 1202, Boston, Mass.

**HAVE You a Camera? Write for Free** sample of our big magazine, showing how to make better pictures and earn money. American Photography, 790 Camera House, Boston, 17, Mass.

**SEND your next Roll Film and 20c or** six Film Negatives, one hand-tinted free. Address, Az-U-13k-M, Dept. C, Bristol, Vt.

### MOTION PICTURES

**WE buy, rent, sell Motion Picture and** still cameras, lighting equipment, home projectors, films, etc. Address, Seiden, 835 Eighth Ave., New York City.

**CHEAP—Asbestos Booth, \$6. Powers** Five, Mazda Equipped, \$50. Edison, \$25. Movie Camera, \$50. Films, \$3. Wetmore, 47 Winchester, Boston.

**MACHINES, films, supplies.** Bargain lists. National Equipment Co., Duluth, Minn.

**FILMS**—Cheap. Send stamp. William Bass, West Haven, Conn.

**FORTUNES for Thousands in Motion Pictures.** The only authoritative text-books covering the field. Acting, \$3.00; Photoplay Writing, \$3.00; Directing, \$3.00; Projection, \$5.00; Cinematography, \$6.00. Falk Publishing Company, Department 12, 145 West 36th Street, New York, N. Y.

**MOTION Picture Operation, Stage Electric and Illusions**—The only practical handbook and guide published for motion picture operators, theater electricians and managers. Pocket size, cloth, 293 pp., fully illus., Price \$1.50 postpaid. Popular Mechanics Book Dept., 6 N. Michigan Ave., Chicago.

**FILMS \$3.00 per reel; Movie Camera, 200 foot, \$85.00; tripod and tilt, \$25.00; Motor-driven projector, \$75.00. Ray, 526 Fifth Ave., New York, N. Y.**

**BIG Money Nightly**—Get my installment figures Complete Moving Picture Outfit before buying. Also have excellent complete Movie Camera Outfit #98, description application. Ralph J. Goelsen, 1128 Argyle St., Chicago.

**WE buy used portable suitcase and professional moving-picture machines.** Highest prices paid. What have you for sale? Monarch Theatre Supply Co., 724 So. Wabash Ave., Chicago, Ill.

**AMERICA'S Greatest Fortunes have been made in the Moving Picture Business.** Small investment needed. We furnish complete theatre equipment. Easy payments. Openings everywhere. Catalog free. Monarch Theatre Supply Co., Dept. F, 724 So. Wabash Ave., Chicago, Ill.

**\$35.00 PROFIT** nightly. Small capital starts you. No experience needed. Our machines are used and endorsed by government institutions. Catalog free. Atlas Moving Picture Company, 482 Morton Bldg., Chicago.

**JUST Out! Send for one at once!** The Complete Cinema Hand Book. A complete course in motion-picture making from raw film to the projected image. 508 pages crammed full of authoritative information. Postpaid to any part of the world on receipt of \$3.00. Everything in Motion Picture Apparatus. Cameras from \$20.00 to \$1500.00. Write for information to the Motion Picture Headquarters of the World. Bass Camera Company, Dept. 114, 109 No. Dearborn St., Chicago, Ill.

**CLEARANCE Sale**—500 reels high-grade film. Two to six reel subjects Famous Movie stars. Special \$3.50 per reel only while they last. Stock up now. List free. Monarch Theatre Supply Co., Union and Fourth, Memphis, Tenn.

**BUY direct from Manufacturers**—New or rebuilt Moving Picture Machines for Homes, Schools, Lodges, Churches, Traveling Shows and Theatres. Mazda—Arc or Gas complete outfits—Film and Supplies. Dept. X, Monarch Theatre Supply Co., Memphis, Tenn.

**FILMS for Toy and Professional Machines.** All famous movie stars, \$3.00 per reel and up. Machine bargains also. Write for big list free. Monarch Theatre Supply Co., Dept. P. M., 724 S. Wabash Ave., Chicago, Ill.

**FILMS For Sale**—\$2.50 per Reel up. Address Queen Feature Service, Birmingham, Ala.

**MAKE money writing photoplays;** details free to beginners. No correspondence course. Producers League, 230 Wainwright, St. Louis.

**FREE to Writers**—A wonderful little book of money-making hints, suggestions, ideas; the A B C of successful story and play writing. Absolutely Free. Just address Authors Press, Dept. 12, Auburn, New York.

#### SCENERY TO RENT

**SETTINGS for Opera, Plays, Minstrels, Plush Drops.** Catalog. Amelia Grain, Philadelphia.

#### EDUCATIONAL AND INSTRUCTION

**BECOME a Laboratory Expert**—Learn interesting, profitable, Profession of Bacteriology, Microbiology, Extension and Residential Courses. Diplomas—degrees granted. Help secure position. 46-piece urinalysis outfit free to students. Send today for free 34-page Prospectus. College of Microbiology, 955 Belden Ave., Chicago.

**HARDING** Correspondence School offers spare-time, home-study courses by mail in the following subjects: Arithmetic, Plane Geometry, Mensuration, Physics, Elementary Algebra, Plane Trigonometry, Logarithms, Mechanics, Mechanical Drafting, and Tool Designing. J. A. Harding, 76 Brighton Ave., Highland Park, Mich.

**LEARN My Process**—"Engravepaint" on glass. Fine Arts First Premium in South Florida Exposition, 1922. Ornamental, demonstrative, framed plate with complete information, 50c. Frank J. Martinez, 1406 Spring St., Tampa, Fla.

**DOUBLE Entry Bookkeeping** mastered in 60 hours with 8 keys; guaranteed; diplomas. Our graduates lead in bookkeeping, auditing, accountancy, balance sheets, financial statements. International Bookkeeping Institute, Dept. 8, Springfield, Mo.

**SWIM**—Learn correctly. New practical method just published. Send only \$1 today and receive course postpaid. C. Dowd, 105 Palmetto St., Brooklyn, New York.

**ARCHITECTURAL** draftsmen offered big pay. Opportunities everywhere. Quick, practical, inexpensive instruction. Easy payments. No bank. Designer Evers, Englewood, Denver, Colo.

**WORLD-ROMIC System.** Masterkey to All Languages. Primers, 15 languages, \$1.94 each language: Arabic, Chinese, Danish, Dutch, English, French, German, Italian, Japanese, Panjabi, Polish, Portuguese, Russian, Spanish, Swedish. Pronunciation Tables, 80 languages, 30c each language. Languages Publishing Company, 8 West 40th Street, New York.

**ROPP'S Calculator and Short-Cut Arithmetic** shows the answer as quickly as a watch shows the time to all problems likely to occur in office, store, shop, bank, farm or factory. Price, pocket size, paper 35 cents, cloth 50 cents, leatherette \$1. Desk size, cloth \$1.50 postpaid. Popular Mechanics Book Dept., 6 N. Michigan Ave., Chicago.

**LEARN Advertising** by mail in spare time—pays big salaries, requires little effort. \$2 starts you; balance as you proceed; \$30 in all; no other expenses; no books to buy; easily mastered. Curtis Newton, Dept. P4, 5145 Wentworth Ave., Chicago.

**WHAT'S Your Future?** Develop winning personality, be popular. Success depends largely on personality, ability and application. Free literature. Write today. Personal Service Bureau, Box 2235, West Palm Beach, Fla.

**CARTOONISTS**—Improve your style by following the work of the greatest cartoonists found in the bound volumes of Cartoons magazine. Eight volumes, each covering six months, Jan.-June, 1917, to July-Dec., 1920, inclusive. 1,200 cartoons, 900 pages to a volume, 7 by 9½ in., 3 in. thick. New books; durable and attractive binding. Sold separately at \$2 per vol. postpaid. Supply very limited. Send at once. Popular Mechanics Book Dept., 6 N. Michigan Ave., Chicago.

**STUDY Bacteriology**—become a laboratory expert. Course interesting, can be mastered in few months at home or in school. Good paying positions open. Degree granted our graduates, School 13 years old. Send for Announcement, American College of Bacteriology, 2823 S. Michigan Ave., Chicago, Ill.

**SUCCEED:** Home Shorthand, \$2.50. Send money order. We are responsible. Byrne Publishing Company, Tyler, Texas.

**WANTED:** Information exchanged about commercial uses for air compressors. Address Engineering Dept., Brunner Mfg. Co., Utica, N. Y.

**AMBITIOUS** writers—send today for free copy America's leading magazine for writers of photoplays, stories, poems, songs; instructive, helpful. Writers Digest, 708 Butler Bldg., Cincinnati.

**WRITE** articles, stories, news, in spare time for newspapers and magazines. Big pay. Copyright book free. Press Syndicate, 552, St. Louis, Mo.

**HAVE a business of your own;** the most fascinating, best paying business-profession in the world, a foot correctionist; easy terms for training you at home in a few weeks, a new protected system that has enabled men and women to rise in one step to greater earnings than they ever thought possible; no capital required or goods to buy, no agency or soliciting. Address, Stephenson Laboratory, 1 Back Bay, Boston, Mass.

**ARTIFICIAL Marble, sanitary flooring instructions, ornamental casting, concrete plaster, papier-mache decorations, garden furniture, statuary, Rubber-moulds, Electro-metallurgy, particulars and 200 illustrations free.** Chris Mahler, Box 122, Huntington, N. Y.

**INVENTORS**—Write for our illustrated guide book and Evidence of Conception Blank. Send model or sketch and description for free opinion of its patentable nature. Highest references. Prompt attention. Reasonable terms. Victor J. Evans & Co., 167 Ninth, Washington, D. C.

**"WHAT to Invent For Profit"** free. Patent News, N. Washington, D. C.

#### TELEGRAPHY

**TELEGRAPHY**—Morse and Wireless—taught at home in half usual time and at trifling cost. Omnigraph Automatic Transmitter will send, on Sounder or Buzzer, unlimited messages, any speed, just as expert operator would. Adopted by U. S. Govt. and used by leading Universities, Colleges, Technical and Telegraph Schools throughout U. S. Catalog free. Omnigraph Mfg. Co., 18 Hudson St., New York.

**TELEGRAPHY** (both Morse and Wireless) and Railway Accounting taught quickly. Big salaries. Great opportunities. Oldest and largest school; established 46 years. All expenses low—can earn large part. Catalog free. Dodge's Institute, H St., Valparaiso, Ind.

#### WIRELESS

**HIGH-GRADE** regenerative receiving set \$30.00. Satisfaction guaranteed. Harry Cook, Fairfield, Iowa.

#### RADIO OUTFITS AND SUPPLIES

**TRIO** Radio Receiving Sets, complete with double standard phones, aerial and full instructions. Will receive news, music, reports, etc., within 50-mile area, telegraph code within 150 miles. Bakelite panel 6x7 mounted with nickelplated parts. Cabinet ½-inch Mexican birch, lock-cornered. Walnut finish. Eus-bar wiring, all soldered connections. No batteries or tubes to burn out. Costs nothing to keep up. No experience needed to install or operate it. Maker to user only. Price, complete, \$15 C. O. D. We pay postage in U. S. A. Trio Radio Laboratories, 9916-9922 E. 14th St., Oakland, Calif.

**RADIO** Receiving Sets complete with aerial \$15. Larger sets and supplies listed in our Radio Bulletin No. 100. Send 4c for bulletin and list of over 70 Radio Text Books. None free. Radio & Electric Supply, Robinson, Ill.

**STANDARD** radio supplies, Westinghouse, DeForest, Clapp-Eastman and others, \$35 up. Immediate delivery. Write for price list. Address Wheeler-Thomas Radio Co., Holland, N. Y.

**MAKE** big money selling Radio-phones. Clinton Radio, 29 S. Clinton, Chicago.

**MAHOGANY** Radio cabinets sent knocked down, parcel post C. O. D. Sizes in stock, length, 29 inches, height, seven, depth, seven, price \$3.50. Length 12, height seven, depth seven, \$3.00. Radio Cabinet Co., 1215 Geary St., San Francisco.

**BUILD** your own Radio set. Complete parts for crystal receiver including mahogany finished cabinet, \$5.00; blue print and list of parts, 25c; tube set, 50c; mounted galena, 30c; switch points, 25c per dozen; binding posts, 8c each. Send for list. Girard Model Works, Girard, Pa.

**MAKE** and sell Radio sets. Illustrated Instruction Book, 25c. Genuine large Pyrites crystals, 20c. Loose leaf book, Audion and Frequency "Hook Ups" twenty-six by nine diagrams complete, 50c, postpaid anywhere. Wedel Company, Seattle, Wash.

**RADIO** for the Amateur—Building, Installing, Operating Stations for Radio Communication treated simply in "Practical Amateur Wireless Stations" a 136-page book compiled by Editor of Wireless Age. 115 Ills. and diag. Size 6 x 9 in. Price, 75c post. Popular Mechanics Book Dept., 6 N. Michigan Ave., Chicago.

**GALENA**—The world's famous super-sensitive, double tested Vit O Ray. Doubles the efficiency of crystal receiving sets. Used, recommended and endorsed by some of the largest Radio manufacturers. We are sole American Distributors for Vit O Ray. Send \$3.50 now for a sample pound by prepaid Parcel Post. K F K Radio Manufacturing Company, 31st and Downing St., Denver, Colo.

**RADIO** Receiving Sets, \$7.50. Write for description. Galena crystals, 25c. Erclet Phone Condensers, .001 MFD, 17c prepaid. Dealers and agents write for discounts. Address Busch-Murphy, 145 Mason St., Rochester, N. Y.

**VACUUM-TUBE** receiving sets, \$35.00. High-class material and workmanship. Prompt delivery. Central Mfg. Co., Fairfield, Iowa.

**DIALS**—Celluloid, 0 to 100, for Radio use. Ten cents each, postpaid, Johnson Printing Co., Louisville, Ky.

**BUILD** 500-mile Radio receiver for \$15.00; 14x20 plan, 5c. Ray, 326 Fifth Ave., New York, N. Y.

**COMPLETE** sets and parts. Write for price list. Address Security Supply Co., 1724 Lafayette, St. Louis, Mo.

**NEW Radio Books**—Construction of Radiophone and Telegraph Receivers for Beginners, 75c—How to Make Commercial Type Radio Apparatus, 75c—A B C of Vacuum Tubes Used in Radio Reception, \$1. Prices postpaid. Popular Mechanics Book Dept., 6 N. Michigan Ave., Chicago.

**BUILD** your own Radiophone. Instruction book ten cents. Radio Service Inst., U. S. Bank Bldg., Washington, D. C.

**WRITE** for catalog showing complete line of Elmo Shielded Radio Apparatus, tuners, detectors, amplifiers, transformers and sockets. Electric Machine Corporation, Indianapolis, Ind.

**CRYSTAL** Set that gets radio concerts. Build it right, boys. Plans and full instructions for building at small cost, high-grade, fine adjustable Crystal Receiving Set, fifty cents postpaid. Dept. 27-R. Shaw Mfg. Co., Galesburg, Kans.

**DO** you know anyone who is not interested in radio outfits and equipment? In 11 days we received 393 inquiries concerning radio outfits—and every mail brings many others. These inquiries, in most cases, could be converted into actual orders, so you see what you are missing by not advertising in this column. Send us your copy and remittance for our August issue, forms for which close June 25th. Get the business. J. Roy McClellan, Manager Classified Advertising, Popular Mechanics Magazine, Chicago.

#### BUSINESS OPPORTUNITIES

**TAILORING** explosion! Competition knocked out! One-price line, \$50 all-wool suits at \$29.75, including a good profit for you. You get your profit the minute you take the order. Big Swatch Line—80 different fabrics in handsome carrying case. Salesmen make \$109 a week. Can use a few more good men. Write fully; state experience. Park Tailoring Company, Dept. 335, Chicago.

**AN** opportunity for workers. High-grade automobile fabric accessories, top recoverings, curtains, seat covers and many other articles. Manufacturers selling direct. Each article guaranteed and lowest priced in market. Every car owner a customer. Exclusive territory now open for hustlers. Big profits, no investment. Write today. A. E. Schneider Mfg. Co., 4265 Hudson Blvd., West Hoboken, N. J.

**I HAVE** over 100 stores paying \$5 monthly maintenance. You can do the same in your city. Six weeks' Detroit practice qualifies. Only one person in each city chosen. Midnight Alarm System, 6411 Mack Ave., Detroit, Mich.

**"MONEY and Health"**—20 different ways to make money in Landscape gardening. Send \$3.00 money-order and get complete instructions, which will start you at once. David Hansen, Landscape Architect, 1243 Thorndale Ave., Chicago, Ill.

**ELECTRICITY** Taught by experts; earn while you learn at home; electrical book and proof lessons free; your success guaranteed and position secured. Chicago Engineering Works, Dept. 51-C, 2144 Lawrence Ave., Chicago.

**LEARN** Tattooing. Particulars; stamp. Prof. Miller, 326 Main, Norfolk, Va.

**AMBITIOUS** Men, write today for attractive proposition, selling subscriptions to America's most popular automobile and sportsman's magazine. Quick sales. Big profits. Pleasant work. Digest Pub. Co., 9505 Butler Bldg., Cincinnati, Ohio.

**\$30 A WEEK** evenings; I made it with small mail order business. Booklet for stamp tells how. Sample and plan 25c. Al W. Scott, Cohoes, N. Y.

**MAKE** Money at Home Making Toys—We show you how. Send \$1 for complete working drawings and instructions. DeKalb Designing Co., Dept. 6, Decatur, Ga.

**MAKE** money manufacturing Skived Boots and Rollers out of old tires. We furnish special machinery. Maxwell Mfg. Co., Wichita, Kans.

**MAKE** money with your camera. Information for stamp. Lancaster Studios, 409B, Wright-Caldwell Building, Los Angeles.

**PATENTS.** Protect your rights. Before disclosing invention write for booklet and blank form Evidence of Conception to be signed, witnessed and returned with rough sketch or model of your idea, upon receipt of which I will promptly give opinion of patentable nature and instructions. No charge for preliminary advice. Highest references. Prompt, personal attention. Clarence B. O'Brien, Registered Patent Lawyer, Southern Building, Washington, D. C.

**PATENTS** procured—trade marks registered—A comprehensive, experienced, prompt service for the protection and development of your ideas. Preliminary advice gladly furnished without charge. Booklet of information and form for disclosing idea free on request. Richard B. Owen, 30 Owen Building, Washington, D. C., or 2276R Woolworth Bldg., New York.

**A CLOTHING** store of your own without investment. Everything men and boys wear. Merchandise that repeats. Permanent business of big profits. Spare time at first if preferred. Write for full particulars and proof of what you can do. Deal with million-dollar concern. Write today. Wright & Company, Dept. C-935, Congress, Throop and Harrison Streets, Chicago.

**SUBSTANTIAL** corporation manufacturing several articles under valuable patents, can place several more general sales managers, open branch offices, manage salesmen, \$500 to \$2,000 necessary to finance agency; expenses allowed to Chicago if you qualify. Mr. Inman, 9 South Clinton Street, Chicago, Ill.

**A HOME** Factory—Sewing ladies, you can make waterproof all soft dolls at home. We furnish beautiful rubber-set colored faces with patterns and selling methods. No canvassing or advertising. Beginners' outfit complete, 63c (not stamps). Wonderful opportunity. Novelty Print Shop, Prairie du Chien, Wis.

**ATTENTION!** Go into business for yourself. Establish and operate New System real estate; business brokerage and Insurance Agency in your community. Office at home; earn \$5,000 year. Representatives wanted everywhere; send stamp for booklet. Hayes Realty Association, Cincinnati, Ohio.

**HAVE** small factory with steam power, office and warehouse facilities to offer, together with my services for the manufacture and sale of product that can be developed into large proportions. R. H. Hoover, Freeport, Ill.

**CONVERT** each spare moment into cash. My dignified methods, requiring no merchandise nor peddling, will enable you to increase your income, tremendously, without study, capital, experience or delay. Stokely, Box 708, Dallas, Texas.

**GET** into the specialty manufacturing business. Amazing profits. We will send you free book explaining our system. Write immediately. A wonderful opportunity awaits you. Thos. Steel, President, 624 Main, Richmond, Va.

**PROTECT** your rights. Write for Record of Invention and booklet about Patents. Prompt personal service. Advice without charge. J. Heaney Kelly, 612 G. Columbian Bldg., Washington, D. C.

**EARN** health and \$5 a day gathering Evergreens, Roots and Herbs in the fields and roadside; book and prices free. Address Botanical, 8-a, West Haven, Conn.

**\$30 A WEEK** evenings; I made it with small mail order business. Booklet for stamp tells how. Sample and plan 25c. Al W. Scott, Cohoes, N. Y.

**PIES** and Profit are synonymous when you work the Smith way. I help you start baking pies, the home-made kind, delicious and satisfying; in demand everywhere at fancy prices. Also teach how to sell to cafes, lunch rooms, and private consumers. Can start home and earn a few dollars weekly at beginning, gradually working up to hundreds profit. Ask me about this. Address F. N. Smith, 447 Huntington, N. Y.

**ENTER** a new business. Earn \$3,000 to \$6,000 yearly in professional fees making and fitting a foot specialty, openings everywhere, with all the trade you can attend to; easily learned by anyone at home in a few weeks, at small expense; no further capital required, no goods to buy, job hunting, soliciting or agency. Address Stephenson Laboratory, 11 Back Bay, Boston, Mass.

**"WHAT To Invent for Profit"** free. Patent News-C, Washington, D. C.

**MAIL** Order Business is your opportunity. Breniser's Famous Handbooks teach how to start small, grow big. Sell merchandise, service, ideas; enormous profits. Spare time to begin. Get complete set, 11 books, \$3.00, and be posted. Breniser, 335 Walnut, Philadelphia. Descriptive Catalog and big batch interesting mail order information, 25c. None free.

**EXCEPTIONAL** Opportunity for Sales Manager capable of handling state distribution. Marvelous new Adding Machine. Retail \$15. Work equals \$350 machine. Tremendous possibilities. Unlimited profits. Write quick for details. Lightning Calculator Co., Dept. B, Grand Rapids, Mich.

**\$100,000 CORPORATION** wants capable man; open office; manage sales for High Class New Device. Every Home a Prospect. Big money-making possibilities for the right man. Opening in every city. Cost \$2.00, retails \$5.00. \$500 to \$2,000 necessary to finance exclusive agency. Scott Corporation, 82 W. Washington, Desk G, Chicago.

**RESPONSIBLE** Corporation wants general sales managers to open branch office, manage salesmen. \$500 to \$5,000 necessary; expenses allowed to Baltimore if you qualify. Address Manager, 603 N. Eutaw St., Baltimore, Md.

**WE** Start You in Business, furnishing everything; men and women, \$30.00 to \$100.00 weekly operating our "New System Specialty Candy Factories" anywhere. Opportunity lifetime; booklet free. W. Hillier Ragsdale, Drawer 4, East Orange, N. J.

**"SCHEMER** Magazine." Alliance Ohio, prints big profit schemes; one subscriber making \$25,000 from three; another \$10,000 from one. Try your luck. Year, only \$1.00; three months, 25c.

**CHEMICAL** Expert will furnish Formulas and Trade Secrets. All lines. Lists Free. W. L. Cummings, Ph.D., 228 Gordon Ave., Syracuse, N. Y.

**MAKE** money at home making toys—we show you how. Send \$1 for complete working drawings and instructions. DeKalb Designing Co., Dept. 6, Decatur, Ga.

**BIG** money maker; new invention (Hot-Air Pipe Furnace Cleaner); cost \$3,500. Terms. Standard Mfg. Co., Box 656, Uhrichville, Ohio.

**LARGEST** vulcanizing business in this prosperous city for sale. Splendid opportunity. Address, New Process Tire Co., Durham, N. C.

**MAKE** money at home making toys and novelties. Particulars free. New Specialty Company, 417 East 71st Street, New York.

**WAKE** up sales by mail! Use authentic, reliable mailing lists. 20,000,000 new names. Martineke Company, Corona, N. Y.

**SIGNS,** cards, banners, easily painted with letter patterns. Samples free. Address, Outdoor Adv. Service, Lockport, N. Y.

**MAKE** money at home with a Casting-Form. Write 5909 Wakefield Ave., Cleveland, O.

**LEARN** about "Business Service." H. L. Woodward, 712 9th St., Washington.

**SLOT** machines; Headquarters for Premium Machines, 1016 Germantown Ave., Philadelphia.

**START** Profitable Mail Order Business at Home. We teach you by successful method. Particulars free. Walthamre Company, Mail Order Dept., Lafayette Bldg., Philadelphia, Pa.

NO money needed if you are responsible or have excellent reputation; big commissions; prefer men calling on power plants, railways, large factories. You can make plenty of money if you are right; have a real article. We are nationally known and highly rated in Dun's and Bradstreet's. Manufacturers, 1690 Kingsland Ave., St. Louis.

DOLLARS yearly in your backyard. No Mushroom dope. Particulars free. Meta, 313 East 89th, New York, N. Y.

\$3,000 TO \$6,000 Yearly. Want it? Others are making it. Send check or money order today for our invaluable books "How to Sell Real Estate," \$3.00—and "How to Conduct Real Estate and Insurance Business," \$1.50. Absolute satisfaction guaranteed. Free catalogs. Realty Book Co., Dept. 52, Cleveland, Ohio.

BE Independent. We teach by mail how to manufacture unexcelled Toilet Preparations. Earn while you learn. Results guaranteed. Particulars Free. School of Cosmetics, Box K, Omaha, Nebr.

"HOW TO Sell Patents" free. Patent News-H, Washington, D. C.

LEARN the collection business. Good income, quick results. Interesting booklet, "Skillful Collecting," free. National Collectors Assn., Long St., Newark, O.

START a Paying Business of Your Own. Be a business man. Any location. 8,000 new Tire Vulcanizing and Repair Stations needed. Business always good. Are you ambitious? \$200 will start you. Write at once. Wonderful opportunity. Equipment Co., 11 Canal, Cincinnati, Ohio.

MARBLE mixing instructions, covering wood or cement flooring 1/2 inch thick, fireproof, waterproof, low cost, sanitary, all colors. Particulars, 200 illustrations free. Chris Mahler, Box 122, Huntington, N. Y.

SILVERING Mirrors! My exclusive French Tartaric method opens enormously profitable business. Booklet free. H. Barstow, 514 23d Street, Oakland, Calif.

UNLIMITED Possibilities; Formula, Trade Secret Business. Particulars Dime. Co-operative Service Bureau, Kokomo, Ind.

FREE—Formula Catalog. S. & H. Laboratories, Boylston Building, Chicago.

GOOD money easily earned at home, spare time silvering mirrors; no capital. Free instructive book tells how. Patterson & Co., Brookville, Ky.

If you have about \$1,000 and capable of organizing sales force, to sell article needed by every merchant, wholesaler and retailer, which should net you \$10,000 profits first year, write Sales Director, 826 Reaper Block, Chicago.

#### CHEMISTRY

YOUR Problem solved for Five Dollars. Write me. W. Steadman Richards, Consulting Chemist, Box 2402, Boston, Mass.

#### FORMULAS AND TRADE SECRETS

500 FORMULAS, 20c. Luminous paint—Resilvering Mirrors—Renewing dry batteries—Mechanics' Soap—Gas Tonic—Carbon remover. Puncture Plugger, 20c each. Entire collection, 50c. Ideal Book Shop, 5501FG, North Robey, Chicago.

3,000 FORMULAS. Moneymakers. 400 pages, \$1. Bestvall Laboratories, 4049-DB, North Whipple, Chicago.

Next to Radio; fascinating instructive formulas: Chemical Gardens, Crystal Ornaments, Bengal Lights, Colored Fires, Luminous Paper, Metallic Vegetation, Duplicate Pad, Iron Cement, Fire Works—entire list, \$1.00. Fred I. Conner, 18 Boston Ave., Youngstown, Ohio.

CHEWING Gum is easier made than candy. Three different recipes 25c. Address, Anas Sullivan, Fairport, N. Y.

3,000 ENGLISH Formulas (300 pages) \$1.00 greenback prepaid. Wilkes Publishers, Stockton, Rugby, England.

600 WAYS to get rich, \$1.50. Novelty House, 697 Evergreen Ave., Brooklyn, N. Y.

1,000,000 FORMULAS, Trade Secrets, 1616 pages, \$2.00. Ideal Book Shop, 5501M, North Robey, Chicago.

GREAT seller, Luminous Paint Formula, 15 cents. Eagle Novelty Co., 37 Weybosset Street, Providence, R. I.

10,000 SELECTED scientific, chemical, technological and practical recipes and processes including hundreds of so called trade secrets for every business alphabetically arranged in one large volume of 800 pages. Price, \$4, postpaid. Popular Mechanics Book Dept., 6 N. Michigan Ave., Chicago.

MONETARY Formulas—Catalogue free. Cluver Laboratories, 5501C, North Robey, Chicago.

FORMULAS; guaranteed. Catalog free. Bestvall Laboratories, 4049-F, North Whipple, Chicago.

FORMULAS of the better sort. Write for our free catalog. Thos. Steel, President, 624 Main, Richmond, Va.

MECHANICS—Grease remover, make your own—leaves hands soft and white. Instructions, 50c. De Prime, Jackson, Minn.

1,000,000 FORMULAS, Trade Secrets, \$2.00 postpaid. Co-operative Service Bureau, Kokomo, Ind.

FREE—Formula Catalog. S. & H. Laboratories, Boylston Building, Chicago.

"500 THINGS to Sell by Mail!" A valuable up-to-date compilation of fast selling suggestions, plans and methods. Prepaid, \$1.00, Waltham Company, Lafayette Bldg., Philadelphia, Pa.

500 SUCCESSFUL money-making formulas and trade secrets for 50c. Postpaid. Rudolph Bjerzgaard, Rollag, Minn.

1,000,000 FORMULAS and recipes—1016 pages, \$2.00. Englewood Book Shop, 7021A, South Winchester, Chicago.

#### AGENTS WANTED

AGENTS! Money, Money, Money! Make it selling Hanslick, the new and unbeatable hand-cleanser—the original powdered hand soap! Removes grease, grime, ink, paint, etc., without injuring skin. Use spreads like wildfire. Cheaper than all others. Sells in cans for bulk with dispensers to garages, autoists, auto supply companies, mechanics, factory and office folks, to housewives, hardware stores. Huge quantities used weekly by mercantile houses, big repeat business assured. Exclusive agencies, crews working for you; fast sales; splendid profits, permanent business for hustlers. Live ones can clean up \$500 a month. Send 10c (dime or stamp) for liberal sample can. Complete sales plan goes with it. Write quick to Solar Products Company, 124 W. Lake St., Chicago, Ill.

QUICK profits! Permanent Business Monstrous proposition offered to agents to handle our Sanitary Aluminum Soap Dispenser. At the same time create a substantial and permanent income. We manufacture a milk powdered soap, highly scented for the machines, costing agents 15c per pound and selling for 50c. Agents establish themselves in permanent business by selling the machines to hotels, office buildings, private homes, and physicians. All future orders for soap would be supplied by agents. This soap dispenser means absolute cleanliness. One turn of the handle discharges sufficient for a washing. Consumers save 100% and avoid using sloppy contaminated unsanitary piece of soap. Don't miss this great opportunity to establish yourself in a business making from \$5,000.00 to \$10,000.00 income per year. National Milling & Chemical Company, Fox Chase, Philadelphia, Pa.

WANTED—Agents and Salesmen to handle Europe's Famous Wonder Glass, the newly imported Prism "Binoculette." For theatre, hunting, yachting, races, touring, aviation, etc. This is the smallest and of its size the most powerful Glass in the world. Can be carried in vest pocket or ladies' bag. Details at \$25.00. Confidential wholesale price to agents \$12.50. Sent with privilege of examination, if satisfied pay expressman, otherwise return at our expense. George Mayerle Optical Co., General Importers, established 1894, 960 Market St., San Francisco, Calif. (Order before the new tariff doubles prices.)

800% PROFIT—Quick, easy seller, Kleen-Rite. New Clothes Washing Compound. No rubbing. Women simply amazed. Free premiums make sales easy. Fast repeater. Distributing samples free. Everybody grabbing for territory. Write quick. Bestever Products Co., 194-K8, Irving Park, Chicago.

WHY work for others? Make and sell your own goods. We show you how. Enormous profits. Write quick for free book explaining everything. Thos. Steel, President, 624 Main, Richmond, Va.

NEW Invention. Hailed by all! Schrade's Snap-on rubber heels eliminate run-down heels at the corners. Transferring them from shoe to shoe, by hand, causes them to wear down evenly, maintaining a neat appearance; giving real heel comfort, increased wear and saving time and money. New heels are snapped on in a jiffy. Sells direct to wearers, stores and cobblers. Orders repeat. Sample pair, 25c. Send size, mark around heel on paper; state color. March Popular Mechanics describes it. George Schrade, 282 Kosuth St., Bridgeport, Conn., U. S. A.

A WONDERFUL Seller! Any man, woman, boy or girl can make big wages. Some agents make from \$8.00 to \$20.00 per day. Crimp Grip Clothes Line fasteners are a simple, time-saving device for holding a rope—also used for many other purposes. It pays for itself quickly in time saved on wash days. No knots—it fastens and releases quickly. Every home a prospect. Every housewife who uses Crimp Grips—and there are thousands of them—is a booster. There is but one Crimp Grip. Write for particulars, or send 50c for one pair and a mounted sample, with full particulars to agents. Crimp Grip Company, Belvidere, Illinois.

TAILORING Salesmen: Make \$75.00 a week selling our strictly All-Wool Made-to-Measure Suits at \$25.50. You collect profits in advance and keep them. We supply finest Selling Outfit in America. Many exclusive money-making features. Tailoring, raincoat and side-line men, part or full time; get in touch with us immediately. Goodwear, Chicago, Inc., Dept. 116, 343 W. Adams St., Chicago, Ill.

TAILORING Explosion! Competition knocked out! One-price line, \$50.00 all-wool suits at \$29.75, including a good profit for you. You get your profit the minute you take the order. Big Swatch Line—80 different fabrics in handsome carrying case. Salesmen make \$100.00 a week. Can use a few more good men. Write fully; state experience. Park Tailoring Company, Dept. 330, Chicago.

\$5 AN Hour made by boys, men and women working a few hours evenings selling the Rain King Sprinkler—a new and wonderful device with features never before shown. Sells like hot cakes and a big profit. Write for terms, etc. Chicago Flexible Shaft Company, Dept. RK101, 5600 Roosevelt Rd., Chicago.

TAILORING Agents—We've got a wonderful line of all-wool tailored to order suits and overcoats to retail at \$29.50. They're all one price. \$20 cheaper than store prices. You keep deposits, we deliver and collect. Protected territory for hustlers. Write J. B. Simpson, Dept. 167, 831-843 W. Adams Chicago.

AGENTS—Steady income, large manufacturer of Soaps, Perfumes, Toilet Articles, and Pure Food Products, etc., wishes representative in each locality. Manufacturer direct to consumer. Big profits. Honest goods. Whole or spare time. Cash or credit. Send at once for particulars. Amerit Products Co., 3888 American Bldg., Cincinnati, Ohio.

AGENTS—\$5 to \$15 daily—Introducing new style guaranteed hosiery—latest modes and shades—nude, camel, silver, etc. Big profits. Repeat orders bring you regular income. You write orders—we deliver and collect. Experience unnecessary. Outfits contain all colors and grades, including silks. Mac-O-Chee Mills Co., Desk 108, Cincinnati, Ohio.

AGENTS. Distributors, Salesmen wanted in every city to handle Arctic Cowl Ventilators, for all makes of cars. Easy to install; sell on sight; practical necessity for all-season driving. \$50-\$100 weekly in this for you. Send for Our Income Plan. National Aluminum Co., Dept. 6, Racine, Wis.

AGENTS—\$15 a day—Easy, quick sales—Free Auto—Big weekly bonus—\$1.75 premium free to every customer. Simply show our beautiful, 7-piece, solid aluminum handle cutlery set. Appeals instantly. We deliver and collect. Pay daily. New Era Mfg. Co., 803 Madison St., Dept. 21-B, Chicago.

AGENTS average 43 sales daily selling Aunt Caroline's Dixieland Recipes. Chicago's leading department stores bought out entire first edition. It is new and different. Sells on sight to housewife for \$1. Send fifty cents for sample copy. Gold Seal Corp., 28 E. Jackson, Chicago.



**MONEY** easily earned during leisure hours, day or evening, by young men and women. No experience necessary. Fine opportunity. \$50.00 to \$60.00 profits weekly. Work pleasant and out of ordinary. Write today. Gem Novelty Co., 732c Ocean Parkway, Brooklyn, N. Y.

"\$10 A DAY and More." our new book, shows clearly how you may gain sure success and large profits selling Guaranteed Hosiery and Underwear, factory to family. It is Free. Write today, C. & D. Company, 41-E Grand Rapids, Mich.

**EASY**, pleasant work for Mechanics, Shop Men, Clerks, during spare hours; will add many dollars to their salaries. Also want persons who can give full time. Big wages assured. Novelty Cutlery Co., 67 Bar St., Canton, O.

**AGENTS** Wanted—To represent our line of household mops and brushes. Best opportunity; experience not necessary. Be your own boss. Make over 100% profit. For full particulars, write to Guarantee Brush Co., 1478 Dwight St., Holyoke, Mass.

**AGENTS**, Men, Women \$10 to \$15 daily selling silk hosiery. Just show samples, secure orders. We deliver and collect. Commissions paid daily. Full commissions, all repeat orders. Write Norwalk Hosiery Mills, 2 Well St., Norwalk, Conn.

**AGENTS** can make big profits introducing to business and club men the only practical mechanical pencil ever made; outlasts all others; sells on sight; pleasant association. Write Dura Pencil Co., 115 Broad St., New York City.

**GOLD** Sign letters for stores and office windows. Photo pillow tops, portraits, frames, sheet pictures, medallions, waterproof aprons, novelties. Samples, catalogue free. Thirty days' credit. James C. Bailey Co., Desk J-8, Chicago, Ill.

**AGENTS**: Sell Peck's Rivets for mending any kind of pots and pans. Every housewife a prospect. 100% profit. Trial box 10c. Regular size, 25c. Address Peck Co., Dept. A1, Medina, N. Y.

**INSYDE** Tyres inner armor for automobile tires. Prevent punctures and blow-outs. Double tire mileage any tire. Tremendous demand. Big profits. Sample and details free. American Accessories Co., R-178, Cincinnati, Ohio.

**MEN**, \$12 daily and cash bonus. Beautiful cutlery set, genuine cocobolo handles; sells everywhere; new sales plan; we deliver; spare time satisfactory. Write Eastern Knewear Co., Dept. P., Franklinville, New York.

**AMBITIOUS** Men, write today for attractive proposition, selling subscriptions to America's most popular automobile and sportsman's magazine. Quick sales. Big profits. Pleasant work. Digest Pub. Co., 2505 Butler Bldg., Cincinnati, O.

**AGENTS**: Something new. Wireless guaranteed umbrellas. Adjust new top in minute. Handles collapse to fit suitcase. Other features. Popular prices. Free sample. Parker Mfg. Co., 278 Dike St., Dayton, Ohio.

**EARN** big money fast applying gold initials to autos. Every owner buys—\$1.35 profit on \$1.50 sale—particulars and samples free. Write quick. Lithogram Co., Dept. 17, East Orange, N. J.

**AGENTS** make sixty dollars per week selling new Sallie Mae Dressup Aprons. Write and learn how to obtain samples without cost. Moss Apron Company, 95 Searle Bldg., Rochester, N. Y.

**MUCILAGE** Fountain Pen—Agents, big profits. Sells Home or Office. Lasts Lifetime. Never Dry. No Sticky Fingers. Fountain Pen Size. Sample 50c. Macilage Fountain Pen Co., Steger, Ill.

**CANVASERS**—Either sex, to sell the Concannon scissors. Just patented, sold on our silent salesman plan; experience not necessary. Address, W. F. Concannon Shear Company, Milford, Conn.

**YOUR** chance to make big money resilvering mirrors, auto reflectors, metal-plating. Outfit furnished. Write for particulars. International Laboratories, Dept. 26, 309-311 Fifth Ave., New York.

**LARGE** Shirt Manufacturer wants Agents to sell complete line of shirts direct to wearer. Exclusive patterns. Big values. Free samples. Madison Mills, 593 Broadway, New York, N. Y.

**LARGE** Profits, ready seller. Combination Mop—Scrubber. Eastway Cleaner, 405 St. Paul, Baltimore, Md.

**WHY** work for others? Make and sell your own goods. We show you how. Enormous profits. Write quick for free book explaining everything. Thos. Steel, President, 324 Main, Richmond, Va.

**AGENTS**—Independence for life. Tremendous profits. Patented article everybody uses. No competition. Sample free—full set 25c coin. Wabash Co., 1554 Wabash Ave., Chicago.

**AGENTS**, exclusive territory, permanent repeat business, enormous profit selling Verdina Coconut Oil Shampoo, Soaps, Perfumes, etc. Special inducements; Verdina, A-16 East 13th, New York City.

**WE** want 50 more representatives to sell our children's and ladies' gingham dresses direct. New, exclusive styles. Loretta Frock Co., Dept. 14, Dayton, Ohio.

**SELL** Guaranteed Hosiery; lowest prices, manufacturer's complete line direct to wearer. Samples submitted without charge. We deliver. Joseph Bros., 343-R Broadway, New York City, N. Y.

**GET** our Big Money proposition and Free Samples on Easy Applied Transfer Letters and be convinced. Auto Monogram Supply, 16 Green St., Newark, N. J.

**WE** have an unusual big money opportunity for regular or sideline salesmen selling to public the best headache-relief. Germsan, 1429 Lexington, N. Y.

**A BUSINESS** of Your Own—Make sparkling glass name plates, numbers, checkerboards, medallions, signs; big illustrated book free. E. Palmer, 511, Wooster, O.

**AGENTS**—Make 100%. Toilet articles, Perfumes, Extracts, Household necessities. Sample Case Free. LaDerma Co., Dept. A, Main and Walnut, St. Louis, Mo.

**ONE** Student sells \$24.00 worth of "Success" Products in two hours. Write for information. Sales Department Elms Commercial College, Newark, N. Y.

**SPARKLING** Water, all Flavors, Tablets. Samples, 10 drinks, 10c. Handy for outings, picnics. Nothing better. Particulars, Joe Huttner, Lamanda Park, Calif.

**AGENTS**—Sell patented article, the Fangreen Skirt Marker. Every housewife prospective customer. Liberal commission. Efantis-Greenstein, 416 S. Dearborn, Chicago.

**FORTUNE** Maker—The only Thread-Cutting Thimble. Live wires only. Sample, 15c. Automote Mfg. Co., 3753 Monticello, Chicago.

**BIG** profits selling patent Automobile horn-blowing device. Postal brings particulars. Boonville Mfg. Co., Boonville, N. Y.

**PHENOMENAL** Sales! Record breaker! Send postal. Warren & Howell, 461 Eighth Ave., New York, N. Y.

"**IDEAL**" Sideline. "Starshot" Selling Method Free. K. Home, 1957 Warren, Chicago.

**AGENTS**, \$60 to \$200 a week. Free samples gold and silver sign letters for office windows, store fronts and glass signs of all kinds. Anyone can put them on. No experience necessary. Big demand everywhere. Over 500% profit. Fred Foley, Binghamton, N. Y., made \$485.00 first month. Albert Gibbons, Kansas City, made \$212.00 in ten days. Liberal offer to general agents. Write today for sample of our high-grade window letters. Address, Metallic Letter Co., 431-C North Clark St., Chicago, Ill.

**SALES** Agents: You can count on a steady income by selling some of the small manufactured articles which we import. The "Tearless" Onion-cutter, the "Knockout" mechanical pencil and the "Retainer" vacuum bottle are just a few of our big money-makers. Write today for full particulars. Ostra Corp., 116 East 25th St., New York City, N. Y.

**MAKE** \$50 daily. Something new! 400% profit. All business, professional men need it. Sells \$5. Costs \$1. Brooks, Texas, sold 20 first day, profit, \$80. Big weekly repeater. Sells quickly. Experience unnecessary. Write today for territory wanted. Sample outfit free. Federal Association, 71-K, Asylum St., Hartford, Conn.

**SPECIALTY** Salesmen—Big money while developing a permanent business of your own. A complete clothing store yours without investment. Quick selling, big profit line. A repeater. Full information and proof of what you can do. Write today. Wright & Co., Dept. C-835, Congress, Throop and Harrison Streets, Chicago.

**SELL** Minutemen for tires and tubes—cost 2c repair; surpasses vulcanizing, saves 500%. Every auto and accessory dealer buys. Profits amazing. Shaw made \$21 first day. Hart \$155 first week. Particulars and free sample. The Colonial Rubber Co., Dept. 85, Philadelphia, Pa.

**AGENTS**—New Invention. Harper's Ten-Use Brush Set and Fibre Broom. It sweeps, washes and dries upstairs windows, scrubs and mops floors and does five other things. Big profits; easy seller. Free trial offer. Harper Brush Works, Dept. X, Fairfield, Iowa.

**AGENTS!** A sale in every home for our beautiful dress goods, silks and general yard goods. Quick sales! Big profits! Large book of 1000 handsome fabric samples. Write today. National Importing & Mfg. Co., Dept. 6X, 573 Broadway, New York, N. Y.

**AGENTS**, no capital required. Selling our combination child's swing and chair, \$10 per day easily made. A novelty that is a real seller. We deliver by parcel post C. O. D. to your customer. E. Condon, 77 Bedford St., Boston, Mass.

**FASTEST** 50c seller in 25 years—Wonderful new invention—just out. Nothing else like it. 50 to 100 sales a day easy. Your profit 100%. Make \$15 to \$25 every day. Write quick. Sales Manager, Box 718, Springfield, Ill.

**AGENTS**—Make 100% selling our "Quality Brand Sponge Cloths" for dish-washing. Sale at every house. Send 15c for full size sample and particulars if you mean business. Ufford Textile Co., Sales Department, Norwich, Conn.

**AGENTS**—\$5 to \$10 daily selling Snow Dust Washing Compound. Washes clothes without rubbing. Women wild about it. Big repeater. Free samples boost sales. Exclusive territory. 300% profit. Sample free. Norman E. Conrad, Wabash, Ind.

**AGENTS**: See our display advertisement on page 125, then write us immediately. Need not consider any other line. A household and office necessity, endorsed by "Good Housekeeping." Large profits. Everett & Barron Co., Providence, R. I.

**SALES** Agents, men or women: Year-round position. No layoffs. Take orders for Jennings new guaranteed hosiery. Must wear and give satisfaction or replaced free. Write for outfit. Jennings Mfg. Co., Dept. 168, Dayton, Ohio.

**BIG** earnings and steady repeat business assured agents selling to women and homes, finest, most complete line toilet preparations and specialties. Sure Success Plan. Get details today. Colonial Chemical Company, 631-N, Penn Avenue, Pittsburgh, Pa.

**THEY** sell quickly—autoists' delight. No-spark Patented Smoking Pipe, tamps automatically. Prevents sparks. Italian, French Briar. Write for proposition. Address, Nospark Pipe & Manufacturing Co., Box 238, Montclair, N. J.

**GERMAN** razors for barbers. Hand-made. Manganese steel. Highest quality. Guaranteed. Sell for \$2.25. Cost you \$13.50 doz. Sample, \$1.45. Money Order. Schwartz, Importer, 880 East 141st Street, Cleveland, O.

**ASKO**—Agents to sell auto accessory. Can carry sample in vest pocket. Exclusive county rights open. Big commission. Send for sample. Allen Spec. Co., 2751 W. Lake St., Chicago.

**AGENTS!** Selling dealers, jobbers, owners, meritorious automobile accessory. Quick sales. Repeats. 300% profit. Retail \$1.00. Particulars and samples, \$1.00. S. & M. Mfg. Co., 148 West 83rd St., New York.

**SELL** "Amens" Shirts; best-looking, biggest value. Manufacturer to wearer. Every order nets profit \$1.50-\$2.25. Write for winning sales plan. Men's Shirt Co., 3863-A, Third Ave., New York.

**PROTECT** your rights. Write for Record of Invention and booklet about patents. Prompt personal service. Advice without charge. J. Reaney Kelly, 612 G, Columbian Bldg., Washington, D. C.

**AGENTS**: Get into a good repeat proposition. Sell our high-grade flavoring extracts. Build up steady income. Liberal terms. Acme Extract Co., 520 West Broadway, New York.

**MEN-Women.** Sell Yarborough hair products. Quick sales, large profits. Write today. Colored agents preferred. Territory going fast. Address, Yarborough Mfg. Co., Winston-Salem, N. C.

**MANUFACTURER** with reputation for putting over "Big Hits" wants agents to sell three most profitable, fastest selling household necessities. Write quick, Flomar, 2530 Drake, Chicago.

**WHY work for others?** Make and sell your own goods. We show you how. Enormous profits. Write quick for free book explaining everything. Thos. Steel, President, 624 Main, Richmond, Va.

**\$8.00 TO \$20.00 per day.** A wonderful seller. Any man, woman, boy or girl can make big wages selling Crimp Grip Clothes Line Fasteners. It is a perfect rope holder and can be used for many purposes. Crimp Grips are a simple, time-saving device. They last a life time and will not rust; it holds the line tight, and saves time on wash days. Every buyer is a booster. Send 50¢ for Mounted Sample and one pair of Crimp Grip Clothes Line Fasteners. Write for particulars. Crimp Grip Company, Belvidere, Illinois.

**"OUT-O-SITE"** aluminum hip-suspenders (not over shoulders), shirt down, pants up, no pressure, no harness. Enormous seller. Sample pair, 50¢. Woods, 501 North Seventh, St. Louis.

**AGENTS and demonstrators,** new garter, no knobs, no pads, etc. Change elastic in a minute. Free sample. B. D. Garter Co., 417 N. Clark, Chicago.

DO not fail to read our advertisement on page 138. Send 50 cents for sample and our big money proposition to agents. Gordon Specialty Works.

**FREE Samples Rolly's Washday Wonder**—new chemical diet solvent—harmless—no rubbing. \$100 weekly. Enormous profits, repeat orders. Rolly Chemical Co., Al, Hastings, Nebr.

**AGENTS,** double your money. Polmet Polishing Cloth cleans all metals. Retail 25¢. Sample free. A. A. Gale Co., 17 Edinboro St., Boston, Mass.

**AGENTS—A patented specialty** that fills real need in every home; agents clearing \$35-\$100 weekly. Spangler-Loomis Mfg. Co., 1399 Garland Bldg., Chicago.

**AGENTS—A demonstration** sells our Marvel Can Opener, and doubles your money. Clinch your success with our proposition. Staples Mfg. Co., Mt. Vernon, Ind.

**AGENTS—Sell Golden Snow Drop,** finest auto, furniture, piano polish made; big repeater; good profit; exclusive territory; free samples. Box 594, Detroit, Mich.

**EARN \$10 daily** silvering mirrors, plating and refinishing metalware, autos, chandeliers, bedsteads, headlights. Outfits furnished. E. Decle Laboratories, 1133 Broadway, New York, N. Y.

**PREPARE and sell your own products.** Formulas by experts. Trade secrets, commercial information, Particulars free. Address, B. Thaxly Co., Washington, D. C.

**FOOD products,** toilet preparations, etc., year-around sellers. Big line—big commissions. Fletcher Production Company, Manufacturers, 415 E. 89th, Chicago.

**SELL** Serpentine Garters, \$1.00 doz., \$7.50 gross. Third cash, bal. C. O. D. Serpentine Garter Mfg. Co., 513 N. Dearborn, Chicago.

**AGENTS—Sell 98% of your calls.** Tremendous demand—big profits. Write today for territory. Aluminum Flux Co., Rhineland, Wis.

**HOME** employment evenings. Start little Mail Order business anywhere. Stamp brings instructive booklet. Alfred Pier, 72 Cortlandt Street, New York.

**SOMETHING new!** Sixonone, 200% profit. Retail 25¢ to houses and offices. Gale & Co., Inc., 15 Edinboro St., Boston.

**WE Start You Without a Dollar.** Soaps, Extracts, Perfumes, Toilet Goods. Experience unnecessary. Carnation Co., Dept. 291, St. Louis.

**RUMMAGE** sales make \$50 daily. Representative wanted everywhere. Permanent business. We start you. Crosby Co., 809 Division, Chicago.

**HIGHER Sales, Bigger Profits.** Sell on demonstration. Magical results. Particulars free. Lezoulu Dee Products, 598-P, Takoma, Washington, D. C.

**SUCCESSFUL** plan appeals to all theatre managers; sets you \$50 weekly. Theatre Bulletin Company, Washington Bldg., Los Angeles.

**NEW Garden Hose Washer** that won't lose out. Free sample. Rempe, 2827 Myrtle St., Oakland, Calif.

**A BIG Money Maker and a Pleasure** for Men, Women and Children. You can make the most beautiful Marble, Turquoise, Agate, Tile and art work from common Portland Cement, also beautiful pictures, picture frames and scenery. I will also tell you how you can make from twenty-five to one hundred dollars in an hour's time after learning how to do the work. Will pay five dollars if you cannot do the work by following instructions. My twenty-five-dollar course of instructions for twenty-five cents silver. Based on 40 years' experience. B. F. Spencer, Instruction Dept., Elsinore, Calif.

**WHY-Buy Your Goods.** Use Miller's Guaranteed Manufacturer's Reliable Formulas for Manufacturing Agent-Specialty Salesman's Big Selling Specialties—all lines. Free Descriptive Literature Concerning Non-Thermic Ice Cloths, Grape-Oil, and Flavors for all beverages, New Food Specialties. Launderite and New Laundry products. All latest Automobile Specialties including 666 Polish and Amazon Rubber Repair and many other meritorious sellers which can be manufactured in your home, store or office without machinery. Make your start now. Stamp brings Valuable Information. Miller, Chemist, Tampa, Fla.

**OUR New Angora Cleaning Mitt** for Autos, Stores, Offices and Household. A big seller at good profit. Send \$2.50 for sales outfit and proposition. If you sell the Auto Trade, our Strait-Jacket Belting Service will surely interest you. It is new and offers a wonderful opportunity. F. Rantville Company, 249 Pearl Street, Grand Rapids, Mich.

**AT Last—World's Greatest Adding Machine.** Almost human. Retail \$15; work equals \$300 machine. \$500 monthly easily made, demonstrating to stores, offices, garages, factories. Simple, easy; adds, subtracts, multiples, divides, automatically. Speedy, accurate, durable handsome. Five year guarantee. Tremendous demand; amazing profits. Liberal trial offer. Protected territory. Write quick. Lightning Calculator Corp., Dept. F, Grand Rapids, Mich.

**AGENTS.** Sell lightning needle threaders. \$10 daily. Costs 5¢, sells 25¢. Address Maher Co., Dover, N. J.

**WONDERFULLY** fascinating pocket novelty just patented; mammoth profits; sample, 25¢. Martin Co., Box 1635, Paterson, N. J.

**IMPORTED,** automatic, revolving fans; enormous demand, big profits. Address, Gordon, 930 French St., Washington, D. C.

**AGENTS—Something new.** Big profits selling Fruit Jar Openers. Sample, 20¢. H. L. Jenney, Greenfield, Mass.

**\$30.75 PROFIT** on \$2.50 outfit; gold initials for automobiles, etc. Write National, Station D, Brooklyn, N. Y.

**FASTEST** selling Ford necessity, just out. Seward's profit one day, \$74.00. Territory going fast. Write quick. R Super Co., 425 National, Milwaukee, Wis.

**TWENTY** big money-making opportunities free. Lawrence Products Company, Dept. M, Beaver Dam, Wis.

**\$75 A WEEK:** Legitimate business agency for the fastest selling Ford necessity on the market—The Spad Magneto Timer. Price \$2.50. Quick sales, big profits. Nationally advertised in Motor Age, Ford Owner and Dealer, American Automobile Digest. Write Dept. A, Spad Mfg. Co., Inc., 44 West 29th St., New York City.

**LARGE** manufacturer wants agents to sell guaranteed made to measure raincoats, Gabardines and Reversible top and raincoat combined. Make \$75 to \$100 weekly. Profit in advance. We deliver and collect. Outfit free. Standard Raincoat Co., 163 West 21st Street, New York, N. Y.

**FREE—Formula Catalog.** S. & H. Laboratories, Boylston Building, Chicago.

**ANY** man handy with paint brush or light tools can start new mechanical business on nearly nothing; needed everywhere; nearly all profit; experience not required. John Braceland, 1457 So. Ninth, Philadelphia, Pa.

**\$12 DAILY** and cash bonus. Beautiful Cutlery Set, Genuine Osceola handsets sells everywhere. New sales plan. We deliver and collect. Spare time satisfactory. Address, Eastern Keenware Co., Franklinville, N. Y.

**IMMEDIATE** Commissions—no investment—no delivering—no collecting. Pay-day every day. Profits larger than usual. That's our proposition No. 1. For the agent that buys to resell—our proposition No. 2 would instantly appeal. 100% profit and Free Goods. High grade guaranteed aluminum cooking utensil specialties and staples. Our Free Goods Offer is unusually interesting. We maintain a 24-hour shipping schedule. Exclusive territories granted and protected. Get yours before it's too late. Perfection Aluminum Mfg. Co., Desk A., Lemont, Ill.

**WOULD \$18** an hour interest you? Clarke made this selling amazing windshield cleaner; for autoists, motormen, engineers; works like magic; one rub keeps glass clear 24 hours; cleans entire windshield; works while you drive; chemical-felt sheds water like a duck's back; snappy metal holder fits pocket; guaranteed year; sells \$1; Smeed sold 2,000 few days; amazing details free. Security Mfg. Co., Dept. 622, Toledo, Ohio.

**AGENTS—Send** for sample "Tretnot"—the washday wonder. Be convinced you can do a whirlwind business. You can clear at least \$20 to \$100 weekly, according to spare or whole time. You don't have to talk; if she doesn't buy at sight, leave sample; she will be looking for you long before you are able to make the rounds again. Samples furnished free. Premiums for your customers. Exclusive territory guaranteed to agents who can produce. Credits given. Don't call. P. M. Motter & Sons, 20 E. Jackson Blvd., Chicago.

**CENTRAL** Indiana Manufacturers now marketing an entirely new auto accessory that makes night driving safe, eliminating glare from approaching headlights. Want general sales managers to open branch office, handle exclusive territory and manage salesmen. Some investment necessary. Profit possibilities practically unlimited. Ray Auto Filter Co., Marion, Ind.

**\$195 EARNED** by Schleicher in first twelve hours. Self-selling proposition establishes new money-making records. Automatic hot or cold running water bath equipment, without plumbing or waterworks, only \$7.50. Exclusive territory. Investigate. Send no money. Terms. Write today. Allen Mfg. Co., 678 Allen Bldg., Toledo, O.

**MOST Wonderful Seller.** 96¢ profit every dollar. No stock to carry. License unnecessary. Sample free. Mission, 2421-MP, Smith, Detroit.

**WANTED—District** Purchasing Agents, \$250 per month. Steady employment and exclusive territory. Write now. Experience unnecessary. National Instrument Company, 4764 North Hamilton, Chicago, Ill.

**PORTRAIT** Agents—Earn big money selling our Photo Medallions. Everybody buys. You charge \$3.00; make \$2.40 each sale. \$10 daily easy. Big variety designs. 4-day service. Perry Photo Novelty Corporation, Section 16, 360 Bowery, New York.

**LATEST,** nicest, simplest folding automobile and camping stool ever devised. Sells also like wildfire at parades, public gatherings, etc. 100% profit. Mincke, Alhambra, Calif.

**SELL** Pudding Powders—Delicious dessert. Fast sellers; quick repeaters; big profit. Send for terms and sample. C. H. Stuart Co., 74 Broadway, Newark, New York.

**EVERYBODY** uses extracts. Sell Duo Double Strength Extracts. Complete line household necessities. Big repeaters. Write today. Duo Co., Dept. El, Attica, N. Y.

**AGENTS—Sell** Skimit Kitchen Cream Separator; nationally advertised; sells on sight; attractive terms; big profits; retails \$1. Skimit Mfg. Co., Okaloosa, Ia.

**BIG Money Makers.** Large factory offers you big profits on 150 fast sellers. Toilet gift sets, flavoring extracts, remedies, soaps bring you \$8.00 to \$25.00 daily. Howe of Illinois makes \$4.00 an hour. Sample outfit free to workers. Lincoln Chemical Works, Dept. 155, 2955 No. Leavitt, Chicago.

**PORTRAIT Agents—\$50,000** is what "Picture Man Friedman" made canvassing. Free circular "Profits in Portraits" tell how. 24-hour service prints, finished portraits, frames. Samples free. "Picture Man Friedman," Dept. 8, 127 N. Dearborn St., Chicago.

**AGENTS Wanted—Something New—Fire Fighter sell:** easily. Makes a spectacular demonstration—car owners, homes, factories, stores practically buy on sight. Our men make \$10 to \$50 a day—exclusive territory. If you wish to establish a business of your own with unlimited possibilities for making big money, write us today. Fyr-Fyter Co., 103 Fyr-Fyter Bldg., Dayton, Ohio.

**INTRODUCE Whig,** delicious beverage. Great demand. Big repeater. Hundred other fast sellers. Fine profit. Write at once for terms and sample. Address Newton & Co., 61 Main St., Newark, N. Y.

**AGENTS—Crew men, novelty men, Gloo-Pen,** a 5¢ mucilage fountain pen; everybody buys on demonstration; sample 25¢; big profit plan free. Gloo-Pen Company, 50-FF Pine Street, New York.

**BIG money** selling our Auto Specialties. Olin Russell sold one day \$185.00; others did equally well. Free sample and particulars. Jackson Mfg. Co., B 2097, Denver, Colo.

**AGENTS—Make big money** selling the Wizard Self-Heating Flat Iron. Investigate. Wizard Mfg. Co., 1605 Fulton St., Chicago.

**AGENTS—Earn \$50 to \$100** a week selling Marquette Tire Tool. Simple demonstration sells it. Removes tires in a jiffy. Every owner wants it. Thousands in use. Exclusive territory going fast. Agent's sample \$1.25, retails at \$2.50. Write for full particulars or send \$1.25 for sample and particulars. Marquette Mfg. Co., Dept. A, 218 S. Wabasha Ave., St. Paul, Minn.

**CALIFORNIA Rosebuds** selling like hot cakes. Agents coinng money; new stuff. Big profits. Catalog free. Mission, 2421-PM, Smith, Detroit.

**MEN'S shirts.** Easy to sell. Big demand everywhere. Make \$15.00 daily. Undersell stores. Complete line. Free samples to workers. Chicago Shirt Co., 9 So. Clinton, Factory 205, Chicago.

**WIRE twisted sanitary Brushes—Mops, Dusters, Automobile Brushes, etc.,** are the leaders in specialties. Restricted territory for live wires. Steelset Brush Co., 487 Broadway, N. Y. City.

**AGENTS—Enormous profits** selling Genuine Gold Leaf sign letters. Guaranteed not to fade. Establish a permanent business or travel. Anybody can do it. Free samples. Guarantee Sign Service, A 430 South California Ave., Chicago.

**MOTOR Ignition Amplifier—A Wonder Invention!** Gives new power to an old motor and more power to the new. Sell to garages, accessory dealers and users. Quick action, big money and satisfaction. Write for prices and literature. Motor Ignition Corporation, Mfgs., Albany, N. Y.

**AGENTS coinng money** with our women's household aprons and other rubberized goods; children's aprons, pinafores and sun-bonnets, utility bags, etc. Best goods made at least prices. Write for catalog 11. The Schafuss Corporation, 466 Broome St., New York, N. Y.

**SALES Representative** wanted every county to give all or spare time. Position worth \$1,200 to \$3,000 yearly. No previous experience or capital necessary. Write for full particulars, A. A. Silver-Chamberlin Co., Clayton, N. J.

**AGENTS: Men and women,** in spare or full time, make big money selling household necessities. Every home a prospect. Quick sales, big profit. Territory open. Write for particulars. Judd & Leland Manufacturing Company, Box 31, Clifton Springs, N. Y.

**AGENTS—Sell Patented Cigar Lighters and Cigar-Case Moisteners.** Big Profits. Start making money at once. Write for circulars, cuts and sales plan. Drake Mfg. Co., Dept. M., Milwaukee, Wis.

**AGENTS—Sell Electric Body Batteries for Nervous Diseases and Rheumatism.** Nealeigh & Co., Indianapolis, Ind.

**SIGNS** for stores and offices. Entirely new. \$50 week easily made. Chicago Sign System, F150 W. Austin Ave., Chicago.

**AGENTS Sell Neverfall Iron Rust and Stain Remover.** Hugo profits. Big line. Sample. Write today. Sanford Beal Co., Inc., Newark, N. Y., Dept. 6.

**AGENTS—Advertising Pencils,** ready sellers, excellent sideline. Write for proposition. North American Pencil Works, 310 So. Canal St., Chicago.

**GALLAGHER** made \$336.00 in one week selling guaranteed Collection Systems, used by all business men. Sayers Mfg., 2815 Sheffield Ave., Chicago, Ill.

**AGENTS: 1922's Greatest Sensation,** 11-piece toilet article set selling like blazes at \$1.75 with \$1.00 dressmaker's shears free to each customer. Line up with Davis for 1922. E. M. Davis Co., Dept. 506, Chicago.

**LIVE Agents** make \$10 Day selling Eureka Strainer and Splash Preventor for every water faucet. Takes on sight. Widely advertised and known. Get details today. A. B. Seed Filter Company, 13 Franklin, New York.

**MAKE 600% Profit.** Free Samples. Lowest priced Gold window letters for stores, offices. Anybody can do it. Large demand. Exclusive territory. Big future. Sideline. Acme Letter Co., 2800-D, Congress, Chicago.

**SELPOLITE—Agents, Streetmen—Selfolite** lights any fire while user sleeps, or any time. Performs surprising stunts. Newly patented. Sample 25c, postpaid; money back. Particulars. Kaytwo Mfg. Co., C195 Station A, Boston, Mass.

**AGENTS: Big Profits.** Genuine Gold Leaf Window Letters anyone can put up. Scripts and 57 varieties. Chicago Agency Co., 842 Altgeld St., Chicago.

**AGENTS—Big Profits, Gold Sign letters** easily applied, samples free. Liberal offer to General Agents. Dept. C, Interstate Sign, 2629 No. Halsted St., Chicago.

**GOOD income,** spare time, refinishing chandeliers, brass beds, automobiles, etc., by new method; producing amazing results; every household possible customer; experience unnecessary; simple plan of manufacturing at home starts you in big money-making business. Write for free samples, showing finishes, etc. Gunmetal Finish Co., Ave. H, Decatur, Ill.

**GOLD Leaf Sign Letters; make and sell;** profits exceed 1,000%; immense demand; particulars free. Johnston Co., Quincy, Ill.

**AGENTS make 500% profit** handling Auto Monograms, New Pictures, Window Letters, Transfer Flags, Novelty Signs. Catalog Free. Write Hinton Co., Star City, Ind.

**PORTRAIT Agents,** who want good work and prompt service and who desire to purchase their frames at factory prices, should write us at once for catalog and price list. W. G. Hannan Co., Dept. A-5, 57 E. 18th St., Chicago, Ill.

**AGENTS—New patented curtain rod,** necessity in every home; big profit; 4 to 10 sales at every house. Write for free sample. Home Curtain Rod Co., Providence, R. I.

**AGENTS—Clever Invention!** Inkspoon makes every pen a fountain pen. Past office seller; big profit, demand increasing everywhere. Exclusive territory offered. Sample free. H. Marul Company, Tribune Bldg., New York, N. Y.

**AGENTS: Big Money Monogramming** By Transfer Method. Catalogue Showing Over 50 Styles and Particulars Free. Motorists' Accessories Co., Mansfield, Ohio.

**\$200 WEEKLY.** Free samples. Sell gold sign letters to stores, offices. No experience. Big future guaranteed. Can travel. Exclusive territory. Become our general agent. Acme Letter Co., 2800D Congress, Chicago.

**MAKE \$25 to \$50 Week** representing Clow's Famous Philadelphia Hosiery, direct from mill—for men, women, children. Every pair guaranteed. Prices that win. Free book "How to Start" tells the story. George Clow's Company, Desk 31, Philadelphia, Pa.

**WHY work for others? Make and sell your own goods.** We show you how. Enormous profits. Write quick for free book explaining everything. Thos. Steel, President, 624 Main, Richmond, Va.

**AGENTS—If you are making less than \$300** a month our proposition on Sentinel Burglar Alarms for windows and doors will interest you. Many agents earn \$20 daily. Brand new inventions. No wires, batteries or nails. Instantly attached to any door or window. Handsomely nickel plated. Sell on sight. No competition. Provides cheap burglar insurance. Big money makers. Write today for extremely liberal terms to agents. Sentinel Alarm Co., 140 S. Dearborn St., Chicago, Ill.

**BEST Proposition on Earth.** Kitchen Specialty Every Woman Wants. Nothing like it in existence. 200% profit. Best Novelty Mfg. Co., Dept. C, 160 N. Wells, Chicago.

**MAKE \$2 an Hour.** Article that removes iron rust, grass, medicine, fruit, mildew stains. Cleans Panama and Straw Hats. Bleaches clothes. Sells Every home. Write for free demonstrating outfit and start taking orders at once. Christy, 81A Union, Newark, N. Y.

**AGENTS: Big Returns, fast office sellers;** particulars and samples free. One Dip Pen Co., 2 Daily Record, Baltimore, Md.

**AGENTS make a dollar an hour.** Sell Mendels, a patent patch for instantly mending leaks in all utensils. Sample package free. Collette Mfg. Co., Dept. 404-B, Amsterdam, N. Y.

**BIG money and Fast Sales.** Every owner buys Gold Initials for his auto. You charge \$1.50; make \$1.35. Ten orders a day easy. Write for particulars and free samples. American Monogram Co., Dept. 40, East Orange, N. J.

**OUR Ex-Cel Luminous Crucifix** shines brilliantly in the dark. Churches, hospitals and individuals are only waiting for a demonstration before buying. Agents make handsome profits. W. G. Hannan Co., Dept. B, 57 E. 18th St., Chicago.

**AGENTS and portrait men, Crew managers.** We give you more for your money. Better and quicker service. Lowest prices on frames and glass. Rejects credited. Catalog free. The Pioneer Corporation, 1259-A West 63rd St., Chicago.

**AGENTS—Stamping names on Pocket Key Protectors;** sample Check with your name and address. 25c. Stamping Outfits, Emblems Checks, Check Fobs, Name Plates. Hart Mfg. Co., Desk 2, 303 Degraw St., Brooklyn, N. Y.

**YOU can be your own boss** with our Key Check outfit. Good for \$5 a day stamping names on pocket key checks, fobs, etc. Sample check with your name and address, 29 cents. Pease Die Works, Dept. M, Winchester, N. H.

**PATENTS—Write for our free illustrated** guide book and Evidence of Conception Blank. Send sketch or model for our opinion of its patentable nature free. Highest references. Prompt attention. Reasonable terms. Victor J. Evans & Co., 163 Ninth, Washington, D. C.

**PORTRAIT Agents:** Our goods will make you big profits. Delivery guaranteed. Rejects credited. Prompt shipments. Send for latest catalog and prices. Adam J. Kroll & Co., 602 Blue Island Ave., Chicago, Ill.

**AGENTS—Best seller: Jem Rubber Repair** for tires and tubes; supersedes vulcanization at saving of over 800%; put it on cold, vulcanizes itself in two minutes, and is guaranteed to last the life of the tire or tube. Sells to every auto owner and accessory dealer. For particulars how to make big money and free sample, address Amazon Rubber Co., Amazon Bldg., Philadelphia, Pa., Dept. 505.

**AGENTS: Big profits.** Best and cheapest window letters made. Easily applied. Dime brings five samples. Particulars free. Stalbritte Co., 1115 Second Ave., New York.

IF you need good live agents—fellows who can get the business—ask me how others are doing it. I'll gladly render the necessary assistance. J. Roy McClellan, Mgr. Classified Advertising, Popular Mechanics Magazine, Chicago.

**AGENTS** make 140% profit. Iridium (luminous) crucifix shines in the dark. Sells for \$2.00. Costs \$1.40. Complete line religious articles, crucifixes, bulbs, switch plates, house numbers and match boxes. Novel! Ornamental! Useful! Every home a prospect. Big sales. Get free demonstrating outfit. The Pioneer Corporation, 1259 W. 63d St., Chicago, Ill.

**AMERICO** Rooster auxiliary water carburetor makes autos burn water. Eliminates carbon. Low cost; liberal profits; details free. Americo Co., Dept. 178, Cincinnati, Ohio.

**SELL** Necessities. Everybody needs and buys the "Business Guide." Bryant cleared \$800.00 in July. Send for sample. It's free. Nichols Co., Box 4-B, Naperville, Ill.

**WANTED**—Tailoring Sales Agent—Make big money from very start—\$60.00 to \$75.00 weekly. Largest made-to-measure tailoring house, furnishing an equipment of five hundred woolsens, wants you to take orders. Satisfaction guaranteed. Biggest merchants in many towns have started with our line. If you want to establish yourself permanently in business and make big money write for full particulars, giving your experience as salesman or tailor's sales agent. H. P. Foster, Sales Manager, Lock Box 483, Chicago.

**BIG** Profits Selling New \$3.50 Automatic Adding Machine. Absolutely accurate. Fully guaranteed. Quick sales. Ten daily easy. No competition. Pocket size. Business people everywhere positive customers. Thousands being sold. Tremendous demand. Here's high-grade money-maker. Basset Co., 1458-J, Hollywood Ave., Chicago.

**AGENTS** Don't pass this up. Something new. No competition. Big profits. Saves dollars in every home, money savers are good sellers. Write Sales Manager, 388A Arcade Bldg., Cleveland, Ohio.

**RED** Cup Lubricator Stops Ford Chatter by scientifically treating transmission bands. Operated from driver's seat. Easily installed. \$3.75 with compound. Guaranteed satisfaction. Dealers and Agents wanted. Red Cup Lubricator Co., 1603 S. Michigan Ave., Chicago.

**MAKE** \$31.00 Profit With Only \$1.50 Selling Pure Gold Leaf Monograms for Automobiles, Trunks, Bags—Window and Wagon Letters. Applied instantly. No experience necessary. No. 1 Outfit brings you \$32.50—cost only \$1.50—you make \$31.00 profit. Get colored catalog. Full particulars—free samples (36 designs). "Hurry." Nulife Auto Aid, Hartford, Conn.

**TAILORING** Agents Wanted—Must be big producers—We have snappy Fall and Winter Swatch line at prices you can't help but sell (Union Made). Write for samples. Leeds Woolen Mills, Chicago.

#### HIGH-GRADE SALESMEN WANTED

WE lead the U. S. A. in placing in the hands of high-grade salesmen a campaign of exceptional earning possibilities. Last year, the year of business depression, one man earned \$23,757.45. Several of our masterful fighters are earning better than \$200.00 per week. With proven sales ability you need no experience. Our 133-page manual explains fully the plan whereby you may study and immediately start producing business. You sell a rental service of forceful advertising films to bankers and successful business men on an easy-payment plan. They are displayed on local screens before the audiences seated in concentrated attention in darkened theatres. This high-quality service is now sold in 32 states in successful competition with all other mediums. Alexander Film Advertising sells through the summer as well as the winter. Alexander Film Co., 1151 Main Ave., Spokane, Wash.

**TAILORING** explosion! Competition knocked out! One-price line. \$50.00 All-Wool suits at \$29.75, including a good profit for you. You get your profit the minute you take the order. Big Swatch Line—80 different fabrics in handsome carrying case. Salesmen make \$100.00 a week. Can use a few more good men. Write fully, state experience. Park Tailoring Company, Dept. 336, Chicago.

**ONLY** one policy a day means \$130 per month profit; same on renewals. Policy pays \$5,000 death; \$25 weekly benefit for injury or sickness. Premium \$10 yearly. Pull or spare time. Easy seller. Write quick for territory. Underwriters, Dept. K-32, Newark, N. J.

**SALESMEN.** Local or traveling, can make \$10.00 a day selling our new, practical advertising specialties. Pencils, yardsticks, rulers, ice picks, shoe horns, etc. Attractive outfit. Excellent "side." Sell year round. Liberal terms. Pershing Mfg. Co., Southbend, Ind.

**AMBITIOUS** Men, write today for attractive proposition, selling subscriptions to America's most popular Automobile and sportsman's magazine. Quick sales. Big profits. Pleasant work. Digest Pub. Co., 3505 Butler Bldg., Cincinnati, O.

**SALESMEN**—Exclusive Distributors. High-grade necessity for every Home, School, Church, Large Building, throughout America. Thousands in use. Handsome profit. Permanent business. Season just opening. Write today. Crown, Richmond, Ind.

**SOMETHING** New—a necessity—Zim's Peerless Collection System. Salesmen making big money. Exclusive collecting features add salesmen. Creditors' Association, 312-E McKnight Bldg., Minneapolis, Minn.

**SUBSTITUTE** for leather belting; mills, factories, farmers, dealers; guaranteed belt, good income, repeat orders credited. Super-Speed Belting, 179 Summer St., Boston, Mass.

**MAKE** big money selling Radio-phones. Clinton Radio, 29 S. Clinton, Chicago.

**SIDELINE:** Hardware, Accessories, big Commission. Whitman, 731 Cypress, Santa Ana, Calif.

**SALESMEN** Wanted to Solicit Orders for paints and oils. Good pay, no experience needed. Write Gill Company, Wisconsin Rapids, Wis.

**WANTED**—Salesman, a man who has a knowledge of belt power transmission; one who can earn at least \$5,000 annually. Address Kingsley Mfg. Co., Indianapolis, Indiana.

**A BUSINESS** of your own. Aggressive, ambitious men who seek new and larger business opportunities and expect to scratch and hustle to build real property. Such men can secure factory sales connection and exclusive wholesale distribution on high-grade automobile necessities becoming well-known through national advertising. More than sales job; an opportunity to build permanent and profitable business with "Money back" merchandise that sells and repeats. Must have references, financial standing, evidence of past success and business promotion experiences outlined. Waste no time on postal cards or letters that do not state particulars requested. Correspondence with new, wide-awake specialty distributors solicited. Write Robert Bowes Company, Indianapolis, Ind.

**ADVERTISING** and Novelty Salesmen of ability, experience and large earning capacity can connect with manufacturer leather and advertising specialties in ready demand among banks and big business concerns. Fine contract, commission basis. \$150 on single order not unusual. Selling aid extended. Write us fully about your experience. David H. Zell, Inc., Dept. F, 532 Broadway, New York.

**MAKE** \$50 Daily. Something New! 400% Profit. All business. Professional Men Need It. Sells \$5. Costs \$1. Brooks, Texas, sold 20 first day, profit \$80. Big weekly repeater. Sells quickly. Experience unnecessary. Write today for territory wanted. Sample outfit free. Federal Association, 71-D Asylum St., Hartford, Conn.

**ROOF-FIX.** Empire Paints, Enamels, Varnishes, Specialties. Direct to Buyer (half of dealers) prices sell everywhere. Almost anyone can sell them and make ten dollars day; hustlers double, triple that and establish permanent, steady business. Empire Co., 1537 Chestnut, Philadelphia.

**SALESMEN** and distributors earn \$100.00 per week selling mechanical stop signal and accessories to dealers and car owners. Big commissions and profits. Simplex Sales Company, 341 N. Crawford Ave., Chicago.

**DEMONSTRATE** Cyclo "Modified Vapor" System with your Ford and make \$3.50 on every sale. Most powerful of all hot-spots. Cyclo Manifold Co., South High St., Akron, Ohio.

**SALESMEN** calling on general stores, side-line. Fast selling special boys' overalls. One sample. Big commissions. Repeat orders. Cincinnati Overall Manufacturing Co., Cincinnati, Ohio.

**RADIO**—Our \$15.00 (tube) detector sets selling like hot cakes. Big opportunity. Write today. Simplicity Radiophone Factories (2), Cincinnati, Ohio.

**WANTED**—Salesman calling on department stores, to sell Sponge Cloths for dish-washing, as side line. Ufford Textile Co., Norwich, Conn.

**MANUFACTURER** and patentee of a new necessity of sound commercial value; fully guaranteed. Want first-class general agents and salesmen to introduce through house salesmen. Apply Dundee Mfg. Co., Inc., 17 Edinboro St., Boston, Mass.

**SIDE-LINE** Salesman wanted to sell coal to your trade in carload lots. Earn a week's pay in an hour. For particulars write Washington Coal Co., 3537 So. Racine, Chicago.

**SALESMEN** make good side money selling small acetylene torch to garages and shops. Easy to sell. St. Paul Welding & Mfg. Co., St. Paul, Minn.

**SALESMEN** Can make \$5.00 a day selling our Calendars, Pencils, Signs, Advertising Novelties, Yardsticks, Whistles, etc. Liberal terms. Sells entire year. Fine side line. Local and traveling agencies. Model Calendar Co., Dept. 226, South Bend, Ind.

**SOMETHING** New, a necessity. All business and professional men need it. Sells \$7.50, costs you \$1.40. Big repeater. Write for sample. Merchants Assn., Minneapolis, Minn.

**MAKE** big money selling new, self-adjusting Robert Wrench. Most wonderful tool on market. Sells for \$1.85. You make almost 100% on each. No free samples. Robert Wrench Co., 71-C Murray St., New York.

**MINUTES** pay dollars demonstrating world's greatest specialty. Wonderful new three-pound Adding Machine. Retail \$15. Work equals \$300.00 machine. Adds, subtracts, multiplies, divides, automatically. Speedy, accurate, durable, handsome. Five-year Guarantee. Tremendous demand everywhere. Amazing profits, main or side-line. Experience unnecessary. Write quick for liberal trial offer and protected territory. Lightning Calculator Co., Dept. G, Grand Rapids, Mich.

**EVERYBODY** Eats Every Day. You can handle Sugar, Flour, Canned Goods, Dried Fruit, Coffee, and entire line of groceries, as well as Paints, Roofing, Aluminum Ware and Automobile Oils, with no rent to pay; no money invested; take large orders from samples. Goods are guaranteed and proven quality. Selling experience not necessary. Steady, profitable work for "workers." Address Hitchcock-Hill Co., Dept. 290, Chicago, Ill. Reference: Any Bank or Express Co.

**AGENTS**—\$40-\$200 a week. Free samples. Gold sign letters anyone can put on store windows. Liberal offer to general agents. Metallic Letter Co., 431-E N. Clark St., Chicago.

**THOUSANDS** of Climax Oil Burners in use. Very successful in residence furnaces. Liberal proposition. Address E. L. Miller Mfg. Co., Kansas City, Mo.

**57 MILES** per gallon made with new patented gasoline Vaporizer. Write for particulars. Vaporizer Co., Pukwana, S. Dak.

**CALIFORNIA** Rosebuds selling like hot cakes. Agents coining money. Absolutely new. Big profits. Catalog free. Mission, 2421-8P, Smith, Detroit.

**EASY** to sell Groceries, Paints, Automobile Oils, Roofing, Stock Food to consumers from samples, no capital or experience necessary; steady, profitable work. Commissions advanced. Satisfaction guaranteed. 50 years in business. Write for full particulars. Loverin & Browne Co., Wholesale Grocers, 1775 S. State Street, Chicago, Ill.

**BEST Seller: Jem Rubber Repair** for tires and tubes; supercedes vulcanization at saving of over 80%; put it on cold, vulcanizes itself in two minutes, guaranteed to last life of tire or tube; sells to every auto owner and accessory dealer. Get particulars how to make big money and free sample, Amazon Rubber Co., Philadelphia, Pa., Dept. 510.

### HELP WANTED

**WHAT** is it worth to you—Distributor, District Manager, Salesman or Agent, to have the agency for the best line of Rubber Specialties on the market? Hot-water Bottles, Bathing Caps, Combination Shopping Bags, Pure Rubber and Rubberized Aprons, Rubber Gloves, and forty other fast-selling articles needed in every home. Profits range from 100 to 150 per cent. Write, B. G. Rubber Mfg. Co., Dept. 506, 618 Penn Avenue, Pittsburgh, Pa.

**TAILORING** Explosion! Competition knocked out! One-price line, \$50.00 All-Wool suits at \$29.75, including a good profit for you. You get your profit the minute you take the order. Big Swatch Line—80 different fabrics in handsome carrying case. Salesmen make \$100.00 a week. Can use a few more good men. Write fully, state experience, Park Tailoring Company, Dept. 337, Chicago.

**DISTRICT Managers—Big Profits:** Men capable of organizing and managing crews of lady solicitors can easily clear \$100 to \$200 per week with the B. & G. Protector, the original and best Protector on the market. Every woman needs and buys it. Two grades. B. & G. Rubber Co., Dept. 505, 618 Penn Avenue, Pittsburgh, Pa.

**PLUMBERS** and Heating Men thinking of going into business for themselves soon, can hasten that time by writing at once for interesting information regarding financing, estimating, accounting, etc., and free booklet "Making Plumbing Profits." Home study. No obligation. Address Niebuhr Plumbing Business School, Desk PM, La Crosse, Wis.

**\$100 MADE** in one week by young man in small town without capital or experience in local advertising business. Why can't you do likewise? Free book tells how. S. Meyer, 211 Seventh St., Louisville, Ky.

**\$2,600 TO \$4,500 yearly;** permanent positions occurring everywhere. Particulars for any locality free; distance immaterial. Inspectors—Canneries, Dairy Products, Factories, Fisheries, Food, Sanitary, Weights and Measures, International Technological Institute, Dept. W, Box 595, Toronto, Canada.

**AMBITIOUS Men,** write today for attractive proposition, selling subscriptions to America's most popular Automobile and sportsman's magazine. Quick sales. Big profits. Pleasant work. Digest Pub. Co., 9595 Butler Bldg., Cincinnati, O.

**BOYS—Men.** Become Automobile experts. \$35 week. Learn while earning. Write Franklin Institute, Dept. F-401, Rochester, N. Y.

**BOOKLET, "The Right Position—How To Get It,"** one dime. McCampbell Ins. Agency, Goliad, Texas.

**MEN** wanted to qualify for Firemen, Brakemen. Transportation furnished. Write W. Bogness, St. Louis.

**WANTED: Railway Mail Clerks—\$1,600 to \$2,500.** Exams everywhere. Write today for full information. Patterson, Civil Service Expert, Box 4025, Rochester, N. Y.

**BE a Finger Print Expert.** Particulars Free. Write J. Gaiser, St. Louis.

**GOVERNMENT positions.** Men, women, 18, over. Wanted for railway mail, post-office, other government positions. Examination soon. Salary \$1,400-\$1,800 year. Experience not required. Particulars free. Write Columbia School of Civil Service, 411 Pope Bldg., Washington, D. C.

**SIGN Letter Agents and Painters: 500% Profit.** Cold and Silver Sign Letters for Stores and Office Windows. Anyone can put on. Big demand. Free Samples. Metallic Letter Co., 431D N. Clark St., Chicago.

**ALL men—women over 17,** willing to accept Government Positions \$135 (Traveling or Stationary), write Mr. Osment, 101 St. Louis, Mo.

**SILVERING** mirrors, French plate taught. Easy to learn, immense profits. Plans free. Wear Mirror Works, Excelsior Springs, Mo.

**UNITED States Government Wants Men.** Excellent positions at attractive salaries. Railway Mail Clerk Examination soon. Let our expert (former United States Civil Service Examiner) prepare you for this and other fine positions. Write today for free catalog PM, Patterson Civil Service School, Rochester, N. Y.

**BE a Railway Traffic Inspector! \$110 to \$250 monthly;** expenses paid after 3 months' spare-time study. Splendid opportunities. Position guaranteed or money refunded. Write for free booklet CM-48, Stand. Business Training Inst., Buffalo, N. Y.

**STORIES, poems, plays, etc.,** are wanted for publication. Good ideas bring big money. Submit manuscripts or write Literary Bureau, 523, Hannibal, Mo.

**START a Paying Business of Your Own.** Be a business man. Any location. \$,000 new Tire Vulcanizing and Repair Stations needed. Business always good. Are you ambitious? \$100 will start you. Write at once. Wonderful opportunity. Equipment Co., 175 Canal, Cincinnati, Ohio.

**WRITE** Articles, stories, news, in spare time for newspapers and magazines. Big pay. Copyright book free. Press Syndicate, 553, St. Louis, Mo.

**MAKE** money writing Photo-plays; details free to beginners. No correspondence course. Producers' League, 230 Wainwright, St. Louis.

**INVENTORS** desiring to secure patents should write for our book, "How to Get Your Patent," tells our terms and methods. Send sketch for our opinion of its patentable nature. Randolph & Co., Patent Attorneys, 620 F, Washington, D. C.

**OUR** genuine gold window sign letters are an excellent money-making proposition for handy men. Flann Sign System, St. Antoine St., Detroit, Mich.

**WANTED: Men—Women.** Government jobs. \$95 month. Write for list, Franklin Institute, Dept. G-21, Rochester, N. Y.

**MEN—Boys,** over 17. Become U. S. Government Railway Mail Clerks. Big opportunity. Commence \$135 month. Quick, sure raise to \$195. Pleasant work, traveling constantly. Every second week off—with pay. No layoffs. Common education sufficient. Pull unnecessary. Write immediately for free list Government positions. Franklin Institute, Dept. G-3, Rochester, N. Y.

**PREPARE** for Railway Mail Clerk and eleven other desirable Government positions. Special Introductory Price \$3. Bonafide offer. Send today and be continued. Shuttleworth System, 271 West 125th Street, New York City, N. Y.

**MEN,** over 17, wanted. Steady work. Commence \$135 month. Government Railway Mail Clerks. Common education. List positions free. Write today. Franklin Institute, Dept. G-21, Rochester, N. Y.

**LOCOMOTIVE** Firemen, beginners \$159, later \$250 monthly, for railroads nearest their homes, everywhere in United States and Canada. Address Railway Association, Desk M-1, Brooklyn, N. Y.

**WANTED—Earn** vacation money selling Forman's visiting, business cards, social stationery. Nice work, large profits. Write today. Forman Printery, Box 75x, Plantsville, Conn.

**MEN, Women,** over 18, desiring Government positions, \$1,400 up, write immediately for full information. Chicago Civil Service College, A-41 Kessler Building, Chicago.

**EARN \$10** daily silversing mirrors, plating and refinishing metalware, autos, chandeliers, bedsteads, headlights. Outfits furnished. E. Decie Laboratories, 1133 Broadway, New York.

**MEN—Women,** Wanted—\$95-\$195 month. Government jobs. Steady work. List positions free. Write today. Franklin Institute, Dept. G-21, Rochester, N. Y.

**FINGER** Print Experts—Splendid opportunity for live experts. Address First National Identification Service Co., 722 Ninth St. So., Minneapolis, Minn.

**HOME** employment evenings. Start little Mail Order business anywhere. Stamp brings Instructive Booklet. Arthur Pier, 72 Cortlandt Street, New York.

**\$135 MONTH** commence. Railway Mail Clerks. Steady work. List positions free. Write today. Franklin Institute, Dept. G-21, Rochester, N. Y.

**GOVERNMENT** needs Railway Mail Clerks, \$133 to \$192 month. Write for free specimen questions. Columbus Institute, E-2, Columbus, Ohio.

**WANTED, Men—Boys—\$35 week.** Become automobile experts. Sample lessons free. Franklin Institute, Dept. G-401, Rochester, N. Y.

**SHOP** Agents—Sell Micrometers. Liberal commission. Reed Small Tool Works, Baker Bldg., Worcester, Mass.

**GOOD** pay for names. (Send postage.) John David Black, Los Angeles, Calif.

**HANDY** Men—\$2.00 an hour in your spare time. Write for particulars. Home Book Co., 388B Arcade Bldg., Cleveland, Ohio.

### FOR ADVERTISERS

**24 WORDS** 37 biggest Sunday papers. \$48.96. Proof guaranteed. Kline, Kline Bldg., Kent, Ohio.

**COMMERCIAL** Engraving and Printing—The most practical and complete book on engraving, printing and allied subjects ever published. Over 800 pages and 1,500 illustrations presenting over 3,500 distinct ideas on 35 separate subjects. Cloth, price \$15.00 prepaid. We highly recommend this book. Popular Mechanics Book Dept., 6 N. Michigan Ave., Chicago.

**ADVERTISERS** get our lists. Jacobus Advertising Service, Irvington, N. J.

**ADVERTISE** in 24 Big Sunday Newspapers, 25 words \$15.00. Catalog listing 1,400 leading Dailies, Weeklies, Magazines, 4 stamps. Union Advertising, Baltimore Bldg., Chicago.

**INCH** Display Advertisement 161 Mazines Thrice \$15. Year \$50. Page \$100. Wood's Popular Services, Atlantic City, N. J.

### MAILING LISTS

**100 GARAGE** addresses. \$2.00 cash. Brownly, Ward's Farm, Westboro, Mass.

**NAMES** and addresses of Mail order Buyers and Agents, 25 cents per 100. Eagle Novelty Co., 37 Weybosset Street, Providence, R. I.

**100 AGENTS' names** \$2.00. Send for list of classifications. Pennell Company, Covington, Ky.

**20,000,000 NEW names!** Authentic, reliable lists are order pullers. Martineau Company, Corona, N. Y.

**100 LIVE Agents' names** \$2. W. Bixby, Warren, N. H.

### INFORMATION

**RELIABLE** information furnished on any subject or money refunded, 75c. Co-Operative Service, Times Plaza, Box H 64, Brooklyn, N. Y.

### TYPEWRITERS AND SUPPLIES

**RIBBONS,** Visible Makes, Black, 32c. Typewriter Supply, 7927-29 Colfax Ave., Chicago.

**TYPEWRITERS,** All Makes. Save one-half. Thoroughly Rebuilt in our factory by the famous "Young Process." Fully guaranteed. Free trial. We handle all standard makes. Cash or sold on easy terms. Write for Catalog. Young Typewriter Co., Dept. 322, Chicago, Ill.

**UNDERWOOD** Typewriters at far less than manufacturers' price; rebuilt, all worn parts replaced, guaranteed good as new. Cash, installment payments. Write for Catalog C-151 Typewriter Emporium, estab. 1892. Montrose and Ravenswood Ave., Chicago, Ill.

**TYPEWRITERS,** all standard makes, \$10 up. Fully guaranteed. Free trial. Write for illustrated Bargain List. Northwestern Typewriter Exchange, 329 West Goethe St., Chicago.

### DUPLICATORS AND DEVICES

"MODERN" Duplicators save Time, Labor, and Money. Gets Business. Reproduces Typewritten or Penning Letters, Drawings, Lessons, Music, Menus, Bids, Notices, Specifications, Maps or anything in one or more colors. Prints Two per minute. Special Sale On. 30 Days Free Trial. \$2.25 up. Booklet Free. J. E. Durkin-Reeves Co., Pittsburgh, Pa.

ONE Thousand Copies Imitation typewritten letters without hectograph or stencils. Inexpensive. Last copy clear as first. Instructions, \$1. Murray's, Sturgis, Mich.

YOU can make 50 to 100 copies of a letter, notice, etc., on three cents' worth of Heyer Quality Compound. Write for free catalog and samples. The Heyer Duplicator Co., 162 N. Wells St., Chicago.

WANT a "Modern" Duplicator to print Typewritten or Pen Written Letters, Drawings, Lessons, Music, Bids, Menus, Maps, Specifications or anything in one or more colors? Prints two a minute. \$2.25 up. Special sale on; 30 Days Free Trial. Booklet Free. J. E. Durkin-Reeves Co., Pittsburgh, Pa.

### ADDING MACHINES

NEW \$3.50 Automatic Adding Machine. Adds, Subtracts, Multiplies. Absolutely accurate. Capacity 999,999.99. Fully guaranteed. 75,000 pleased users. Makes adding easy, positive, quick. Eliminates Mistakes. Saves Time. Postpaid, \$3.50. Bassett Co., 1158-H. Hollywood Ave., Chicago.

FREE Trial. Marvelous new Adding Machine. Adds, Subtracts, Multiplies, Divides, automatically. Work equals \$350.00 machine. Price only \$15.00. Speedy, durable, handsome. Five-year guarantee. Used by largest corporations. Write today for catalog and free trial offer. Lightning Calculator Co., Dept. E, Grand Rapids, Mich.

### PRINTING, ENGRAVING AND MULTIGRAPHING

250 LETTERHEADS, 250 white envelopes, printed and mailed, \$3.00. Samples printing free. Address Sunco, Mohawk, N. Y.

1,000 LETTERHEADS or Envelopes, \$3.00, sent prepaid. Samples Free. Mat-tax's Print Shop, Tremont, La.

1000 FULL-SIZE Hammersmill Bond Letterheads \$3.65. Postpaid. Other stationery in proportion. Business building Multigraph letters cheap. Samples free. Charles B. Hatfield, Box 353, Owego, N. Y.

WEDDING Invitations and Announcements neatly printed. Write for samples, prices. William Helm, Printer, 2138 N. Sayre Ave., Chicago, Ill.

ONE Thousand Letterheads or Envelopes, watermarked bond, \$3.75. Sample free. The Automatic Print Shop, Newcastle, Ind.

2,000 LETTERHEADS or Envelopes \$6.25, prepaid. 3rd zone. Samples Free. Quality Printshop, Marietta, Ohio.

QUANTITY Users save 30%. Wolf Roll Labels, Sta. E. Philadelphia.

500 BUSINESS Cards \$1.75. Pilot Press, 105 Diana St., Fresno, Calif.

REDUCED prices for better printing. 1,000 Bond letter-heads, \$5.00; 1,000 good envelopes, \$4.25; 1,000 four-page folders, 3 1/2 x 6 1/4 inches, \$12.00. Catalogues, circulars, booklets our specialty. All printing at reduced prices. Samples free. Pantus, 525 S. Dearborn St., Chicago.

100 LINEN finish note sheets and 100 envelopes to match, neatly imprinted your three line address \$1.00 prepaid. Samples of quality printing for stamp. Model Company, Manchester, Iowa.

LOWEST prices on advertising-pencils in quantity. Sample, with your ad imprinted in Gold, 10c. S. Musial & Co., 422 Walnut St., Yonkers, N. Y.

PRE-USED Printing Presses. Type and supplies. List for stamp. Popular Bargains, Richland, Pa.

250 GOOD Bond Letterheads or Envelopes printed and mailed \$1.50, or 1,000 for \$4.50. Address Hatton Printing Co., Hatton, N. Dak.

WE print anything. Circulars, stationery, Catalogs, Samples. Commercial Press, Batavia, Ohio.

PRINTING Outfits—Presses, type supplies, type specialties. Send stamp for catalogue. Model Press, York, Penna.

### RAZORS AND BLADES

BLADES Resharpener 3c, any make. Guaranteed Service. Standard Safety Razor Corporation, Pittsburgh, Pa.

BLADES for Gillette razors 40 cents dozen. Address, Yinging Store, Bethlehem, Pa.

FREE—Two Safety Razor Blades sharpened free to show our work. St. Louis Safety Razor Sharpening Co., 61, St. Louis, Mo.

BLADES, resharpened, one edge 2c; double 3c. New York Edge Co., Glen Cove, N. Y.

### FOR SMOKERS

HOMESPUN Smoking Tobacco—Mild and Mellow—10 lbs. \$1.50; 20 lbs. \$2.75; delivery guaranteed. We furnish free recipe for preparing. Smoking Tobacco Exchange, Sedalia, Kentucky.

PURE Red Leaf Tobacco, quality guaranteed. Best chewing, 4 lbs. \$1.25, 10 lbs. \$3.10. Mild smoking, 4 lbs. \$1.00, 10 lbs. \$2.10, delivered. O. D. Collier, Agent, Martin, Tenn. "Collier is absolutely honest and reliable." Martin Bank, Raymer, Cashier.

### BOATS AND LAUNCHES

16 FOOT Rowboat—Easily made. Construction blueprint 30c. Wee-Sho-U Co., West Market, Detroit, Mich.

"HOW to make your boat leakproof." Send for booklets. L. W. Ferdinand & Co., 152 Kneeland St., Boston, Mass.

### ANTIQUES AND WAR RELICS

FOR Dens—Relics from Europe's Battlefields. Catalogue and War Photos, 10c. Lieut. Welsh, 2117 Regent Pl., Brooklyn, N. Y.

GENUINE Indian Baskets and Wampum. Wholesale catalog. Gilham, Kelseyville, Cal.

### FOR THE HOME

MAKE Inexpensive Iceless Refrigerator. Blueprint 35c. Will'am Quemore, Camden, New Jersey.

### OPTICAL GOODS

ARTIFICIAL Eyes, Special Selections of finest make. Reform eyes with blinded iris. Direct by mail at Pre-war Prices. Perfect fit guaranteed. Otis Balcom, O. D., Shelby, O.

### LANDSCAPE ARCHITECTURE

IF you are going to build a Home you can save at least a thousand dollars by proper arrangement before starting. This is something never thought of by any contractor or building architect. Send \$10.00 and we will mail to you 3 different sets of plans in color and specifications for landscape; also full instruction for proper arrangement. Write David Hansen, Landscape Architect, 1243 Thorndale Ave., Chicago, Ill.

### PHONOGRAPHS AND RECORDS

BUILD a genuine Choraleon phonograph and save over half. Big profit building and selling. We furnish motors, tone-arms, full instructions and all necessary parts. Send for catalog and free blueprint offer. Choraleon Phonograph Co., 822 11th St., Elkhart, Ind.

PHONOGRAPH Records at less than wholesale. Write C. E. Dewey, Canton, Pa.

EXCHANGE phonograph records; particulars 25c. Martin Co., Box 1635, Pater-son, N. J.

BUILD your own Phonograph. Write for prices of Cabinets, Motors and Tone Arms, Arthur Davis, Livingston, Ill.

BUILD your own phonographs. We can supply you with motors, tone arms and all accessories at wholesale prices. Write for catalogue AX. Pleasing Sound Phonograph Co., 204 East 113th Street, New York, N. Y.

BUILD your phonograph. Quality Phonographs. Highest quality spring and electric Motors, Tone Arms, Reproducers, Amplifiers, Case Material and Accessories. Free Blue Prints and Building Instructions. Big saving. Wonderful results. New catalog mailed for ten cents. Hoosier Manufacturing & Supply Co., Phonograph Supply Department, 313 Baldwin Block, Indianapolis, Ind.

### MUSIC AND MUSICAL INSTRUMENTS

SONG Writers—Have wonderful proposition for poem or melody writers. Ray Hibbeier, D110, 4940 Dickens Av., Chicago.

VIOLINS—Deep, Mellow, Soulful—on credit. Easy terms for wonderful instrument. Get details today. Gustav P. Henning, 2424 Gaylord St., Denver, Colo.

"MUSIC Composed" to words. Bauer Bros. (formerly of Sousa's Band), Oshkosh, Wis.

CORNETISTS—Trumpeters—Saxophonists—Clarinetists. Send for "Free Pointers." Name Instrument, Virtuoso School, Buffalo, New York.

WRITE Songs. Big money and reputation. Write for information. J. Gordon Pub. Co., 261 N. Hoyne Ave., Chicago.

I WANT song poems. Casper Nathan, Garrick Theatre Building, Chicago.

TRADE—\$75 set trap drums for new Remington Portable typewriter. Waldron Lathrop, Robinson, Ill.

### PATENT ATTORNEYS

PATENTS—"How to Obtain a Patent" is the name of a book which every inventor should have. It will be sent free upon request, and will tell you what you want to know about patents. It contains the whole story. It describes the different parts of the application and explains in simple language the prosecution before the Patent Office. It tells about joint applications, reissues, agreements, assignments, licenses, interferences, infringements, process patents, design patents, trade-marks, and prints and labels. If you are interested in patents either as an inventor, manufacturer or owner of a patent you will enjoy reading this book which was written by a lawyer who has had twenty-five years' experience in patent matters. If you have an invention and will send us a sketch, model or photograph of it we will promptly make a search of the Patent Office records and advise you whether or not, in our opinion, your invention is patentable, our charge for the service being \$5.00. We feel that our experience of twenty-five years has fitted us to render prompt and efficient service which will merit your confidence. Write today. Talbert & Talbert, 463 Talbert Building, Washington, D. C.

PATENTS Secured. Prompt service. Avoid dangerous delays. Send for our "Record of Invention" form and Free Book telling How to obtain a Patent. Send sketch or model for examination. Preliminary advice without charge. Highest References. Write Today. J. L. Jackson & Co., 244 Ouray Bldg., Washington, D. C.

PATENTS promptly procured. Personal, careful and efficient service. Highest references. Moderate fees. Send sketch or model for actual search and advice. George P. Kimmel, Master of Patent Law, 54-K, Loan and Trust Bldg., Washington, D. C.

INVENTORS. Send sketch or model of invention for advice. Write for Evidence of Disclosure form and Book on Patents. Free. Prompt Service. Merton-Roberts & Company, 181 Mather Building, Washington, D. C.

PATENTS. My fees in installments. Advice book free. Frank Fuller, Washington, D. C.

**PATENTS.** Protect your rights. Before disclosing invention write for booklet and blank form Evidence of Conception to be signed, witnessed and returned with rough sketch or model of your idea, upon receipt of which I will promptly give opinion of patentable nature and instructions. No charge for preliminary advice. Highest references. Prompt, personal attention. Clarence B. O'Brien, Registered Patent Lawyer, Southern Bldg., Washington, D. C.

**PATENTS** Procured. Trade Marks Registered. A comprehensive, experienced, prompt service for the protection and development of your ideas. Preliminary advice gladly furnished without charge. Booklet of information and form for disclosing idea free on request. Richard B. Owen, 30 Owen Bldg., Washington, D. C., or 2276-B Woolworth Bldg., New York.

**MILLIONS** spent annually for ideas! Hundreds now wanted! Patent yours and profit! Write today for free books—tell how to protect yourself, how to invent, ideas wanted, how we help you sell, etc. American Industries, Inc., 500 Patent Dept., Washington, D. C.

**PATENT** Your Invention. But note: A patent is no better than its claims. Be sure your patent is as good as your invention. Patent claims skillfully drafted by Lamb & Co., Patent Attorneys, 1419 G Street, Washington, D. C.

**PATENTS.** Trade-Marks—Thirty-five years' experience. Send model or sketch for opinion as to patentability. Free "Inventors' Guide." Highest references and personal attention assure best results. Franklin H. Hough, 522 Washington Loan & Trust Bldg., Washington, D. C.

**PATENTS**—Prompt, personal, efficient service by an attorney-at-law, skilled in all branches of Patent Practice. Over 12 years' actual experience; full information upon request. B. P. Fishburne, McGill Bldg., Washington, D. C.

**PATENTS.** Trade-Marks, Designs and Copyrights. Registered firm of attorneys-at-law. Careful, Prompt personal service assured. Moderate fees. Full information free upon request. Gross & Collins, 606 Guray Building, Washington, D. C.

**PROTECT** your rights. Write for Record of Invention and booklet about Patents. Prompt personal service. Advice without charge. J. Reaney Kelly, 612G-Columbian Bldg., Washington, D. C.

**PATENTS** and Trade-Marks obtained. Prompt service. Write for our new book on patents. Established in 1889. D. Swift & Co., 349 7th St., Washington, D. C.

**PATENT** application filed on partial payment plan. Trade-Marks, Copyrights, etc. Milo B. Stevens & Co., 685 F St., Washington, 352 Monadnock Bldg., Chicago. Estab. 1861.

**SHREVE,** Crowe & Gordon, Attorneys and Counsellors at Law. Patent and Trade-Mark Practice. Correspondence invited. Address, Federal Building, Washington, D. C.

"**INVENTORS' Guide,**" free on request; gives very valuable information and advice. Write Frank Ledermann, 15 Park Row, New York, N. Y.

**PATENTS.** Booklet free. Highest references. Best results. Promptness assured. Send model or drawing for preliminary examination. Watson E. Coleman, Patent Lawyer, 624 F Street, Washington, D. C.

**ROBB,** Robb & Hill offer a strictly professional service to manufacturers and inventors in patenting inventions and registering trade-marks, a service which is the result of 20 years' experience. Write for free booklet and names of prominent manufacturers and inventors represented by us. Send sketch for preliminary advice, 811 McLachlen Bldg., Washington, D. C.; 1348 Hanna Bldg., Cleveland, Ohio.

**PATENTS**—Trademarks—Write for our free illustrated guide book and Evidence of Conception Blank. Send model or sketch and description and we will give our opinion of its patentable nature free. Highest references. Prompt attention. Reasonable terms. Victor J. Evans & Co., 166 Ninth, Washington, D. C.

**PATENTS.** Trade-Marks. Moderate fees. Monthly payments. Eugene Stevens, Jr., Washington, D. C.

**INVENTORS!** Send sketch or model of your invention for opinion concerning patentable nature and exact cost of applying for patent. Book, "How to Obtain a Patent," sent free. Gives information on patent procedure and tells what every inventor should know. Established twenty-eight years. Chandlee & Chandlee, 426 Seventh St., Washington, D. C.

**PATENTS**—Herbert Jenner, patent attorney and mechanical expert, 622 F St., Washington, D. C. I report if a patent can be had and its exact cost. Send for circular.

**INVENTORS**—Send for form "Evidence of Conception" to be signed and witnessed. Form, fee schedule, information free. Lancaster and Allwine, 221 Ouray Building, Washington, D. C.

**HERBERT JENNER,** Patent Attorney and Mechanical Expert, 624 F St., Washington, D. C. I report if a patent obtainable and exact cost. Send for circular.

**INVENTIONS** Patented; Trade-Marks Registered; reasonable charges; prompt service; plain advice; request detailed information. Jaynes & Jaynes, 700 Kellogg, Washington, D. C.

**MONROE MILLER,** Ouray Building, Washington, D. C., patent attorney, mechanical and electrical expert. Best quality of work and results. Moderate charges.

**WOODWARD**—New Book. Submit your ideas. H. L. Woodward, 714 9th St., Washington.

#### FOR INVENTORS

**PATENTS.** If you have an invention which you wish to patent you can write fully and freely to Munn & Co. for advice in regard to the best way of obtaining protection. Please send sketches or a model of your invention and a description of the device, explaining its operation. All communications are strictly confidential. Our vast practice, extending over a period of seventy-seven years, enables us in many cases to advise in regard to patentability without expense to the client. Our Handbook on Patents is sent free on request. This explains our methods, terms, etc., in regard to Patents, Trade Marks, Foreign Patents, etc. "Scientific American" contains Patent Office Notes, Decisions of interest to inventors, and particulars of recently patented inventions. Munn & Co., Solicitors of Patents, 623 Woolworth Bldg., New York; Scientific American Bldg., Washington, D. C.; 801 A Tower Bldg., Chicago, Ill.; 811 Hanna Bldg., Cleveland, Ohio; Hobart Bldg., San Francisco, Calif.

**PATENTS** Secured. Prompt service. Avoid dangerous delays. Send for our "Record of Invention" form and Free Book telling how to obtain a Patent. Send sketch or model for examination. Preliminary advice without charge. Highest References. Write today. J. L. Jackson & Co., 242 Ouray Bldg., Washington, D. C.

**GET** your own patents. Application blanks, complete instructions \$1. Cutting Sons, Campbell, Cal.

"**INVENTOR'S Guide,**" free on request; gives very valuable information and advice. Write Frank Ledermann, 15 Park Row, New York, N. Y.

**PATENTS**—"How to Obtain a Patent" is the name of a book which every inventor should have. It will be sent free upon request, and will tell you what you want to know about patents. It contains the whole story. It describes the different parts of the application and explains in simple language the prosecution before the Patent Office. It tells about joint applications, interferences, infringements, process patents, design patents, trade-marks, and prints and labels. If you are interested in patents either as an inventor, manufacturer or owner of a patent you will enjoy reading this book which was written by a lawyer who has had twenty-five years' experience in patent matters. If you have an invention and will send us a sketch, model, or photograph of it we will promptly make a search of the Patent Office records and advise you whether or not, in our opinion, your invention is patentable, our charge for the service being \$5.00. We feel that our experience of twenty-five years has fitted us to render prompt and efficient service which will merit your confidence. Write today. Talbert & Talbert, 464 Talbert Building, Washington, D. C.

**INVENTORS.** Send sketch or model of invention for advice. Write for Evidence of Disclosure form and Book on Patents. Free. Prompt Service. Merton-Roberts & Company, 182 Mather Building, Washington, D. C.

**PATENTS**—Protect your rights. Before disclosing invention write for booklet and blank form Evidence of Conception to be signed, witnessed and returned with rough sketch or model of your idea, upon receipt of which I will promptly give opinion of patentable nature and instructions. No charge for preliminary advice. Highest references. Prompt personal attention. Clarence B. O'Brien, Registered Patent Lawyer, Southern Bldg., Washington, D. C.

**PATENTS** Procured; Trade-Marks Registered. A comprehensive, experienced, prompt service for the protection and development of your ideas. Preliminary advice gladly furnished without charge. Booklet of information and form for disclosing idea free on request. Richard B. Owen, 30 Owen Bldg., Washington, D. C., or 2276-B Woolworth Bldg., New York.

**INVENTORS**—Before you invest money in patents, it pays to make sure your invention is mechanically right and practical. Consult a technical expert first for opinion, advice and improvements. Confidential, reliable service. E. J. Gibson, Developing Engineer, Box 94, Olean, N. Y.

**MANUFACTURERS** and inventors we can furnish complete tool and die equipment for your job. Special machinery designed and built. Address Sheldon Tool Company, 1174 Southwest Blvd., Kansas City, Kans.

**PROTECT** your rights. Write for Record of Invention and booklet about Patents. Prompt personal service. Advice without charge. J. Reaney Kelly, 612-G Columbia Bldg., Washington, D. C.

**INVENTORS:** If you have an idea, before spending unnecessary money for a patent, write Inventors & Engineers Consulting Co., P. O. Box 344, Washington, D. C.

**SEND** sketch for search report. Get my latest book on patents. H. L. Woodward, 711 9th St., Washington.

**500 MECHANICAL** Movements and 50 Perpetual Motions Illustrated and explained in my book, Inventor's Universal Educator, 5th Edition—Tells how to procure and sell patents, Government and other costs. Covers the matter from A to Z—160 pages—Elegantly bound. Contains noted decisions of U. S. Supreme and State Courts on Patent cases. Mechanical Movements greatly assist inventors—suggest new ideas that might prove of great aid in perfecting inventions. Tells how to select an Attorney. Has valuable information regarding Patent Sharks, Selling Agents and promoters. Price, \$2. Postage free everywhere. Fred G. Dieterich, 621 Ouray Bldg., Washington, D. C.

**MODEL** Making and experimental work; Modern Shop; expert workmen. Manufacturing, Lamon Model and Experimental Works, 625 W. Jackson, Chicago.

**I SELL** Patents. Established 1900. Address, Charles A. Scott, 775PM Garson Avenue, Rochester, N. Y.

**PATENTS.** Write for free illustrated guide book. Send model or sketch and description for free opinion of its patentable nature. Highest references. Prompt attention. Reasonable terms. Victor J. Evans & Co., 157 Ninth, Washington, D. C.

**HAVE** You an Invention? If so, write for our free book, "How to Get Your Patent," tells our terms and methods. Send model or sketch for our opinion of its patentable nature. Randolph & Co., Dept. 144, Washington, D. C.

#### PATENTS FOR SALE

**FOR** Sale or Royalty or Partnership—Improvement on stovepipe. The improvement consists of getting hot air from the hot coal gas, that goes to stovepipe to chimney. This economizes coal and the stovepipe pays for itself 500 times its cost. Great Seller. Big money-making proposition. Get the chance while it lasts. Albert Russo, Old Boston Settlement, R. F. D. Box B-4344, Avoca, Pa.

**ATTENTION, Manufacturers:** Cash or royalty—Kettle-Lid-Holder. Millions to be used; inexpensive to manufacture; also have Canada, Belgium, Argentine Pending. U. S. Patent granted. Address, Earl P. Sidle, 3111 E. 61st St., Kansas City, Mo.

**PATENT** Pipe Wrench, simple and durable. Five parts in all. Cheap to manufacture. Sell outright or royalty. Address, John Van Horn, 1637 Fillmore St., San Francisco, Calif.

**FORCE** Feed Egg Mash Hopper. What every poultryman needs. Saves labor. Recently patented. Manufacturers, don't hesitate to investigate. 'Tis a winner. F. T. Skuse, Kirkland, Wash.

**PATENT** for sale or royalty; has unlimited market; all light stamping work. Address Joseph Hren, 211 W. Chestnut St., Kingston, N. Y.

**PRESSED** Steel Wheel and Method of Producing same—13,709-1; Water Gate—12,622-1. Talbert & Talbert, Talbert Bldg., Washington, D. C.

**ROYALTY** or cash, patent 1,267,145. Automobile spring suspension to eliminate pneumatic tires. Write, Jas. Treanor, 310 West 121 Street, New York.

**THE** only patented Sink Drain and Strainer in the world for sale. Marie Niblo, patentee, 1210 1/2 Second Ave., Seattle, Wash.

**FOR** Sale: Folding Coat Hanger; also dies for same. J. L. Weber, 901 W. Harrison St., Chicago, Ill.

**IMPROVED** safety locking device. Superior, most distinguished, real proposition. Stalder, Box 61, White Sulphur, W. Va.

**PATENT** for sale. For particulars, write to W. Erickson, 65 Winding Way, San Francisco, Calif.

**WILL** go 50-50 with man or woman who will sell my patent on Electric Bowling Alley Machine. Something entirely new. No pin-boys needed. O. K'd by experts. References required. Address, Max A. Drows, 481 15 Ave., Milwaukee, Wis.

**CIGARETTE** maker for home and office use. Small cost to manufacture. Turns out cigarettes as perfect as ready-made ones. Cash or royalty basis. U. S. and Canadian patents pending. F. V. Lindsey, P. O. Box 1073, Winnipeg, Man., Canada.

**FOR** Sale—2 U. S. patents, including all latest and various improvements of screens for R. R. passenger car windows and parting strips. Passengers able to operate screen themselves. C. G. Morgner, 4311 Lincoln Ave., Chicago, Ill.

**FOR** Sale—Two patents: Window lock. Window opened to any height. Burglar and tramp proof. Jimmyming impossible. Also novelty match scratcher. Pinned on inside of garment. Hane, 3346 Warner Ave., Chicago, Ill.

**NEW** Electric Automatic Auto Valve Grinder with many features superior to anything on the market can be made reasonable. Write for particulars. G. W. Boulds, 129 Prospect St., Bristol, Conn.

**FOR** Sale—Patent on stove, under test saved 50% of fuel, produced greater heat. This invention should make millions for manufacturer. Further particulars address Geo. G. Scarborough, Girdletree, Md.

**FOR** Sale: Patent 1,419,838 and twin invention; patent applied for. Revolutionary shock-absorbing mechanism. Of interest to racers. Address W. H. Gaines, Estill Springs, Tenn.

**PATENT** 1,253,145 for sale; novelty pipe cleaner; cheap to manufacture; good mail order article. Thos. J. Carroll, 316 E. 4th St., Amarillo, Texas.

**PATENT** on moving picture projectors. Automatic fire protector. For sale or royalty. N. A. Nicholson, 509 Main St., Johnstown, Pa.

**FOR** Sale. Application: Self-Adjusting Connecting Rod Bolts for internal combustion engines. Will sell outright. A. H. Porter, Hosierville, Ill.

**FOR** Sale—Outright or interest in Patent Portable Automobile Wheel. Address, D. S. Greenberg, Warren Point, New Jersey.

**FOR** royalty only. Contracting and Expanding Piston Ring. Seven distinct features. J. I. Monan, Brownsville, Tenn.

**PATENT** 1,402,254. Ford specialty. Sell outright or eastern territory. W. A. Calvin, 123 Steiner, San Francisco, Calif.

**FOR** Sale—Non-Slipping and Non-Skidding device. Gustave Meyer, 28 Wilmer Ave., Cohoes, N. Y.

**DON'T** buy or manufacture without look by H. L. Woodward, 701 9th St., Washington.

**PATENT** 1,351,762. Valve and Valve Gear for steam engines. William Smith, Cartersville, Mo.

**FOR** Sale—Patent on a combined Collision Mat and Torpedo-Deflecting Device. This invention should find a place on every vessel of any size. Will sell patent outright or under suitable royalty contract. For full particulars, etc., address James McMillan, Jr., Piedmont, W. Va.

**LACEY** Patent Sense. See page 142.

**NEW** book on patents. H. L. Woodward, 713 9th St., Washington. Submit your ideas.

**FOR** Sale—Patent Expandable Steel Rim Split pulley. J. Muller, 1343 Norman St., Brooklyn, New York.

**CASH** or Royalty; U. S. Patent 1,412,343. Machine for boring post holes. Edward Decker, Center, Mo.

**FOR** Sale—Patent on quickly adjustable lock wrench. For information write to C. E. Vandenberg, Cherry Grove, Pa.

**PATENTS** For Sale: To sell, buy or obtain patents write Patent News—P, Washington, D. C.

**YOU** have a worth-while patent, haven't you? Why don't you tell our two million readers about it? Most of them are specially interested in patents and new inventions. Ask me to tell you how other inventors successfully sold their patents. J. Roy McClellan, Manager, Classified Advertising, Popular Mechanics Magazine, Chicago, Ill.

#### MODELS AND MODEL SUPPLIES

**MODEL** and experimental work developed; special machinery, tools, dies, designed and built. Twenty-four years' practical experience. Information free. Address, Guyer Engineering Co., 1269 W. 11th St., Cleveland, Ohio.

**PUNCH** Press work, tool and die making, model and special machine work wanted. Completely equipped with new machinery of the latest type. Prompt delivery, reasonable prices guaranteed. Quality Hardware & Machine Co., Dept. A, 6154-56 N. Clark St., Chicago.

**MODEL** Making and experimental work; Modern Shop expert workmen. Manufacturing. Lamson Model and Experimental Works, 625 W. Jackson, Chicago.

**MODELS** and Patterns made. Light manufacturing. Address H. W. Hathorn, Mason City, Iowa.

**WE** make working models for inventors and do experimental work and carry a complete stock of brass gears and model supplies. Send for catalogue. The Pierce Model Works, Tinley Park, Ill.

**INVENTORS**—Write for our free illustrated guide book and Evidence of Conception Blank. Highest references. Prompt attention. Reasonable Terms. Victor J. Evans & Co., 165 Ninth, Washington, D. C.

#### FOR MANUFACTURERS

**WANTED**—Concern to manufacture Bakte-Timer. Alma Billingsley, Gainesville, Tex.

**MANUFACTURERS** and Inventors. For developing your invention, designing and constructing Automatic Machinery, Labor-saving Devices for all purposes. Coin-Controlled Beverage and Food-Dispensing Machines. Consult John Frick, Mechanical Engineer, 1105 Arch St., Philadelphia, Pa.

**MODEL** making and experimental work; Modern Shop expert workmen. Manufacturing. Lamson Model and Experimental Works, 625 W. Jackson, Chicago.

**WANTED**—Metal Stamping and Model work taken on contract basis. We are ideally located and equipped to develop patents. Meyers Company, Box 263, Bedford, Ind.

**EXPERT** Drafting and Engineering Service. Designs furnished. Rates reasonable. Fellishek Engineering Company, Clintonville, Wisconsin.

#### MANUFACTURING

**SOMETHING** to manufacture wanted. Write Dept. M-201, Evans Bldg., Washington, D. C.

**USE** our factory. Half million dollars invested in special and automatic machinery. Wire and metal products in quantity our specialty. Send sample your product for quotation. The Autoyre Company, Oakville, Conn.

**LET** us be your factory! Write today. Logan Machine Company, 222 South Clinton Street, Chicago, Illinois.

**WE** are equipped to manufacture all kinds of wire and light metal goods. Stampings, Dies and Tools. Punch press work. Patented articles wanted. Safety Wire Gas Globe Company, Columbus, Ohio.

**LET** us be your machine shop! We build models and will do your manufacturing. Victor Eng. Co., 2524 W. Chicago Avenue, Chicago.

**MODEL** making and experimental work; Modern Shop expert workmen. Manufacturing. Lamson Model and Experimental Works, 625 W. Jackson, Chicago.

**EXPERIMENTS** developed, dies, models and manufacturing, machine designing. Estimates and information promptly given. Address Schroer Bros. Machine Works, 512 East 25th Street, Kansas City, Mo.

**IF** you want dies and metal stampings, write us. Lyons Machine Works, Lyons, Ia.

**SPECIAL** Devices and Machinery developed and built at reasonable rates. Jigs and fixtures designed and built for interchangeable and economical manufacturing. Punches and dies made for all kinds of metal stamping. Machine work to order. Simplex Tool Company, Woonsocket, R. I.

**WIRE** Goods, all kinds made to order. Cooley Mfg. Co., 524-530 N. Western Ave., Chicago.

#### SURVEYING INSTRUMENTS

**NEW** and used surveying instruments direct from factory. Satisfaction guaranteed or money refunded. Wissler, 619 Broadway, St. Louis.

#### MACHINERY, TOOLS AND SUPPLIES

**THE** Bulldog Driftbolt Puller (Pat. May 27, 1919). An especially designed tool for withdrawing driftbolts, large spikes and rods from heavy wood timbers; to be operated with a common crowbar. Can be carried in the workman's pocket. Useful in bridge building, car repairing, logging chutes, wharf and dock work, etc. Order direct from Electric Steel Foundry, Portland, Ore. Fred Engstrom, Calder, Ida.

**BENCH** Lathes, Johnston "Monitor Nine" Hi-Duty Screw Cutting Engine Lathe, actual swing 9 1/2 in.; center distance 13 in.; hole through spindle 3/4 in. Stamp for catalog. The Johnston Mfg. Co., Arlington, N. J.



**BENCH** Saw, rip, cutoff, table, 18x20 in.; 8-in. saw. Write for circular and price to Porter Morrow, Utica, Ohio.

**LIGHT** Power Transmission Machinery, Bearings, Hangers, Pulleys, Reducing Gears. Send for Catalog. Winfield H. Smith, Buffalo, N. Y.

**BELTING** waterproof fibre belt; substitutes leather; costs less; written guarantee. SuperSpeed Belting, 170 Summer St., Boston, Mass.

**ONE** 18" Jungst crank shaper, \$185.00. One power hack saw, \$25.00. One 12"x4" artisan engine lathe, \$139.00. One 24" Foster-Burt drill press, can be used for boring auto cylinders, \$170.00. Everything in machinery and supplies. Cntl. Machinery Supply Co., 1524 Central Ave., Cincinnati, O.

**BELTS**, nuts, rivets. O. L. Dickey Co., Bayonne, N. J.

**CONCRETE** Building Block Machines and Molds. Catalogue free. Concrete Machine Co., 303 South Third St., St. Louis, Mo.

**WANTED:** Information about new air compressors. Write for free manual, Engineers Dept., Brunner Mfg. Co., Utica, N. Y.

**12-TOOL** Handy Set, made of best steel. The most useful and practical tool on the market. Postpaid \$1.25. National Specialties, 324 Union Sq., New York City.

**OTHERS** have successfully sold their machinery through our columns—so can you. Ask me for proof, J. Roy McClellan, Manager, Classified Advertising, Popular Mechanics Magazine, Chicago.

#### ENGINES, MOTORS AND DYNAMOS

**USED** auto engines for power. Rebuilt auto engines up to 60 horsepower, fully equipped for power purposes. Mounted on heavy steel foundations, equipped with governor, clutch and pulley. Cylinders re-bored and engine thoroughly overhauled. Send for descriptive matter. Will D. Candee, 1015 South Los Angeles Street, Los Angeles, Calif.

Also governors for used engines. For governors and mountings address Candee-Smith Governor Co., Springfield, N. Y., or 1015 South Los Angeles Street, Los Angeles, Calif.

**SEND** Stamp for Bargain Bulletin No. 10, for used Machinery or Engines. We buy and sell. Modern Engine & Supply Co., 334 Monadnock Bldg., Chicago.

**AUTOMOBILE** Owners, Garagemen, Mechanics, Repairmen, send for free copy of our current issue. It contains helpful, instructive information on overhauling, ignition troubles, wiring, carburetors, storage batteries, etc. Over 140 pages, illustrated. Send for free copy today. Automobile Digest, 507 Butler Bldg., Cincinnati.

**ALTERNATING** and direct current motor bargains. New and rebuilt. All guaranteed for one year. Special prices. Get our price list before buying. Motors exchanged and repaired. Hyre Electric Co., 633-EM South Dearborn St., Chicago.

#### ELECTRICAL

**ELECTRICITY** Taught by experts; earn while you learn at home; electrical book and proof lessons free; your success guaranteed and position secured. Chicago Engineering Works, Dept. 51-C, 2144 Lawrence Ave., Chicago.

**BALL** bearing motors save power. Furnished on easy payments. Send postal. Hobart Motors, Troy, Ohio.

**ELECTRICITY** For 10c Per Hour. Motosco Auto Generator. Operates on any make automobile. Produces electricity for Mowing Picture Machines, Theatres, Schools, Churches, Homes, Etc. Write for free particulars. Monarch Theatre Supply Co., Dept. AG 724 South Wabash Ave., Chicago.

**ELECTRIC** motors and supplies, including sockets, wire conduit, cleats, loom, sockets, switches. New revised wholesale prices. Illustrated Catalog free. Hyre Electric Co., 633-GH, South Dearborn St., Chicago.

**\$1 REPAIRS** at home. 100 Elec. Irons, Heaters or Stoves. Simple. Sure. Full directions. Weldo Repairs, Elec-Chem Lab., 2423 N. Union, Tacoma, Wash. Agents write.

#### FOR MECHANICS

**SOLUTION** of right triangles. Dove-tail formulas. Revolving tool formulas. Others. Concise, Neatly bound, 800 pages wanted. 50c P. O. Money Order. J. J. Dunn, 5 Topliff St., Dorchester 22, Mass.

**PATENTS**—Write for our free illustrated guide book and Evidence of Conception Blank. Send model for sketch and description of the invention for our opinion of its patentable nature free. Highest references. Prompt attention. Reasonable terms. Victor J. Evans & Co., 184 Ninth, Washington, D. C.

#### BLACKSMITHS

**BLACKSMITHS**, Contractors, Inventors: Here's what you've been looking for. New powerful Iron Bender. Bends Eyes, U's, and Angles. Bends cold up to 1/2"x3" bars, or 1 1/2" pipe. Price only \$15. Send for circular. Little Giant Bender Co., Box 134, Lewiston, Minn.

**BLACKSMITHS**, Listen: Any Handy man can make more money doing hard jobs easy. Forging and welding solid, with Toy's Modern Methods of Blacksmithing. Hardening and tempering to a standard with colored tempering charts. All for one dollar. Samples Free. W. M. Toy, Sidney, O.

#### FOR THE SHOP

**SHOP** Notes for 1922—Bench Lathe, Electric Soldering Outfit, Jib Crane, Pump Troubles, Road Roller, Bench Grinder, Bench Miller, are among the 655 articles in this new volume 224 pp. 50 cents postpaid. Popular Mechanics Book Dept., 6 N. Michigan Ave., Chicago.

#### FOR SALE—MISCELLANEOUS

**FIELD** Glasses. Tourist style. Strong magnification. Clear Definition. With carrying case and straps. Extra fine value. Order No. 1099. Price \$7.50. The Lion Optical Co., Cincinnati, Ohio.

**HEMSTITCHING** and pleating attachment, works on any sewing machine. Easily adjusted. Price \$2.50, with full instructions. Oriental Novelty Co., Box 11, Corpus Christi, Texas.

**WATCH** used as compass. 25c. Brownly, Ward's Farm, Westboro, Mass.

**\$17.50 GENUINE** Carl Zeiss Field. Machine and Aviation Glasses, eight power, adjustable focus and eye pieces; cost \$38.00 with carrying case. Sent C. O. D. subject to examination. Money refunded. We have other Glasses, Binoculars and merchandise. Well's Curiosity Shop, 20 S. 2nd St., Philadelphia, Pa.

**PATENTED** automatic winding mechanism for automobile clocks. Connects when clock has run five days, disconnects automatically when wound up full. Write S. Strommer, 421 W 57th St., New York City.

**A BARGAIN**—Garage for sale; Ford Agency included. Real bargain. On east coast of Florida. O'Neals Garage, Delray, Fla.

**FOR SALE**—24 Ligne Field Glass. Fine optics. Leather case. \$10. Address, W. Bixby, Warren, N. H.

**AIR** Compressor with Tank and Hose, \$50. With Motor, \$72.50. Suitable for private or public Garage. Tire Shop, Painting or Cleaning, also Motor in the Head Buffer. Home size, \$18.50. Shop size, \$25. Garage size, \$106. Battery Charging outfit, Home or Garage size, \$14. 6 Tools in one. Forge, Vise, Anvil, Pipe Vise, Die Press, Emery Grinder, \$25.00. Send for our large two-page catalogue, describing all kinds of Air Compressors, Vulcanizers, Garage and Battery Outfits Equipment Co., 167 Canal, Cincinnati, Ohio.

**ADDRESSOGRAPH**, Letter Folders, Multigraphs, Envelope Sealers, Duplicators, less than half price. Guaranteed. Pruitt Co., 112-B N. La Salle, Chicago.

#### REAL ESTATE AND FARM LANDS

**FOR SALE**—Three full sections in McKenzie County and two sections in Billings County, North Dakota. Each section contains land suitable for crops, balance for cattle. Each section has valuable deposits of lignite which some day will alone be worth many times the present value of the land. This part of the state is developing very rapidly, with good schools within easy access. As owner cannot use this land himself will sell one or more sections at a price which almost anyone can afford to pay. Address, W., care Popular Mechanics, 6 North Michigan Ave., Chicago.

**LAND Opportunity!** \$10 to \$50 starts you on 20, 40, or 80 acres near bustling city in Lower Michigan. Balance on long time. Let us help you get a farm home and business of your own. Write today for Free Illustrated booklet, giving full information. Swigart Land Co., P-1259, First National Bank Building, Chicago.

**165-ACRE** Boulevard Farm with Furnished House, 6 Cattle, 3 Horses, poultry, tools, 13 acres growing crops. 8-room house, barn, garage, only \$3,200, part cash. Page 13 Free Catalog. Strout Farm Agency, 1501<sup>1</sup>/<sub>2</sub> Nassau St., New York City.

**\$5.00 DOWN, \$5.00 monthly:** 20 acres unimproved fruit, stock, poultry, woodland; \$100; Ozarks. Fishing, hunting, trapping. Address, Alfred Zimmerman, 1800 N. Fifth, Kansas City, Kansas.

**FLORIDA** Oranges are most profitable as well as most delicious. Grow your own in a land of sunshine, away from winter blizzards and coal bills. Money you'll not miss will buy you land for a grove in a high, rolling, lake-jeweled land of many golden acres. If you mean business, write today for Book of Facts and Photos, Lake County Land Owners' Association, 98 Arbor Avenue, Fruitland Park, Fla.

**I WANT** Farms for cash buyers; will deal with owners only. R. A. McNow, 312 Wilkinson Bldg., Omaha, Neb.

**SELL** your property quickly for cash, no matter where located. Don't pay big commissions. Particulars free. Real Estate Salesmen Co., Desk B, Lincoln, Neb.

**HOMESEEEKERS:** Send for Virginia farm list; best climate. Dept. 50, Emporia, Va.

**ATTENTION!** "Get Acquainted." Cash for your property. Farm, Hotel, or Retail Store, no matter where located; confidential service. Hayes' Business Agency, Cincinnati, Ohio.

#### WANTED—MISCELLANEOUS

**WANTED** profitable, quick selling article to sell by mail, R. H. Hoover, Freeport, Ill.

**CASH** Paid. Mail us your discarded jewelry, gold crowns and bridges, watches, diamonds, silver, platinum, War Savings Stamps and old false teeth. Highest prices paid. Money sent by return mail. Packages held 4 to 12 days and returned at our expense if our offer is refused. United States Smelting Works (The Old Reliable), Dept. 71, Chicago, Ill.

#### DOGS, BIRDS, POULTRY, PETS

**HEGER'S** Song Restorer, a delightful treat for Canaries, 25c postpaid. The Heger Bird Food Co., St. Paul, Minn.

**RABBIT** Hounds, Foxhounds, Coon, Opossum, Skunk, Squirrel, Groundhog dogs, Setters, Pointers, Circular 10c. Brown's Kennels, York, Pa.

**1,000 RINGNECK** Pheasants and Pheasant Eggs for sale. All other game birds and eggs and animals. Charles C. Garland, Oldtown, Maine.

**MUSIC** masters canaries. Guaranteed songsters, young singers, \$10.00. Imported Chinese cages, \$3.50. Henry Dwillard, Fennimore Ave., Kalamazoo, Mich.

**COONHOUNDS**—Thoroughly trained, sent on trial—puppies. Description, 10c. Alva Moffett, Memphis, Mo.

**REGISTERED** pit bull pups, \$15. 501 Rockwood Kennels, Dallas, Texas.

**SILVERBLACK** Foxes \$300, Skunks \$10. Airedale; traps; Time Payments; booklet dime. Arthur Schumacher, Lockland, O.

**BREED** Squabs. Book free. E. Rice, Melrose Highlands, 77 Massachusetts.

#### BELGIAN HARES, GUINEA PIGS, ETC.

**RAISE** guinea pigs. Pay better than poultry or rabbits; easy to raise; little space required. We guarantee market. Particulars and booklet how to raise free. Cavies Distributing Co., 2102 Grand Ave., Kansas City, Mo.

#### PERSONAL

**HINDU** Astrologist and world's noted medium. Dr. Himilha of East India, tells your past, present and future by stars. If worried, troubled or discouraged send 25c. and birthdate, and I will send a horoscope of importance. Address, Dr. W. Himilha, Savannah, Ga. Box 1088. Send addressed envelope.

**IF** your feet perspire and burn, we have the right thing. Send a one dollar bill for the receipt. B. F. B. Co., Warsaw, Ind.

**CIGARETTE** habit positively cured or money back. Scientific method—no drugs. State number of cigarettes used daily, enclosing one dollar. Address The Antitine System, 563 Bensen Street, Camden, N. J.

**BE Wise! Be Cheerful! Be Prosperous!** New way plan brings wonderful results. Valuable pointers and your personality revealed for 10c and birthdate. Thomson-Haywood, Dept. 985, Chronicle Bldg., San Francisco, Calif.

**YOUR** Horoscope covering full year for 35c. Includes an extensive reading, valuable daily guide, large pictorial chart and special forecasts for each month. Scientific, complete. Try it! Money back if dissatisfied. Give birthdate. Address, H. Daniels, Flatbush Sta., Box 32, Brooklyn, N. Y.

**TOBACCO** Kills Manly Vigor—Quit easily. Cigarettes, chewing, smoking, snuff, conquered or no charge. Small sum if satisfactory. Stops craving; harmless. Full treatment on trial. Perkins Co., 314, Hastings, Nebr.

**FREE**—Stop using tobacco. We will give free information how to conquer habit easily and permanently. Results guaranteed. Anti-Tobacco League, Box K, Omaha, Nebr.

**TOBACCO** or Snuff Habit cured or no pay. \$1.00 if cured. Remedy sent on trial. Superba Co., TP., Baltimore, Md.

**ASTROLOGY** revealed—2000 word trial reading, 25c; two questions free. State birth date. Prof. Audrey, Desk E, Departmental Bank Bldg., Washington, D. C.

**HOROSCOPE**—Truthful reading. Send birth date, 10c. AstroLite Company, Sharpshurg, Pa.

#### MISCELLANEOUS

**ARIZONA** Incorporation completed day papers are filed, without nominal or par value shares. Least cost. Greatest advantages. Operate anywhere. Forms Free. Stoddard Incorporating Company, 8-B, Phoenix, Ariz.

**GREAT** seller. Permanent radium paint for house numbers, auto monograms and numerous possible uses. Send for information. Edward Mease, 852 14th St., Des Moines, Iowa.

**"WEEGLA-RAYDEO"** Latest craze. Always gives message. Entertaining, mystifying. 25c prepaid with directions. Raydeo Purcalex, 126 South Third, Minneapolis, Minn.

**BUILD** with brick. Bricklaying made faster and easy with Manua Patented Trowel, \$2.50 each. Mann, 4309 Central, Indianapolis.

**CARE** of the band saw, electric water heater, modern barn construction, motor-cycle trailer, tent house, correcting dynamo troubles, home-made metal fence, auto turntable, are among the hundreds of practical articles in Shop Notes, Vol. 13. Price, 50 cents, postpaid. Popular Mechanics Book Dept., 6 N. Michigan Ave., Chicago.

**LOCKSMITHS**—Send \$1, get valuable chart for cutting tumbler padlock keys, Globe System, 278 Washington St., Newark, N. J.

**THE** Camp, Ideal, inexpensive designed bungalow. Complete descriptions and plans, One Dollar. Address, Boycraft, Box 724, New London, Conn.

**MAKE** big money opening safes and setting combinations. Wayne Strong, Box 1489, Los Angeles, Cal.

**ART** Metal Workers—You will find our book "Metal Work and Etching" a complete manual on making book ends, desk sets, pad corners, paper knives, letter openers, stationery racks, rocking blotters, desk calendars, arts and crafts jewelry, etc., 96 pp. illus. Price, 50 cents, postpaid. Popular Mechanics Book Dept., 6 N. Michigan Ave., Chicago.

**CUTS** anybody can make. Simple, cheap process. \$1. Specimens, particulars, 2c stamp. M. Day, Windfall, Ind.

**SAVE** incorporating expenses and excess profit taxes and avoid personal liability by organizing your company on the Common Law Plan under a Declaration of Trust. Anyone, anywhere, can fill in Demaree Standard Forms, issue shares and begin doing business same day. Pamphlet B-53 free. C. S. Demaree, Legal Blank Printer, 613 Walnut, Kansas City, Mo.

**ARTIFICIAL** Eyes, \$3. Booklet free. Denver Optic, 559 Barclay, Denver, Colo.

**WANTED**—Stamping work for power presses. The W. & P. Toy Mfg. Co., Lawrence, L. L. N. Y.

## BUILDING TRADES HAND BOOK



409 Pages  
263 Illustrations

A reference book for every man connected with the building trades. Contents:—Blue Prints, Weights and Measures, Formulae, Mensuration, Geometric Drawing, Structural Design, Materials of Masonry Construction (stone, brick, terra cotta, lime, cements, sand, mortar, concrete), Carpentry and Joinery, Roofing, Plumbing, Heating, Estimating, etc.

409 pages, 263 Illustrations. Only \$1. Money back if desired. Address International Correspondence Schools, Box 5682-C, Scranton, Pa.



## Work while learning Electricity

Set of tools given to producers. Write

S & H ELECTRICAL WORKS, Dept. H. 1, 316 So. Green St., CHICAGO

## WANTED RAILWAY MAIL CLERKS \$1600 to \$2300 Year

MEN—BOYS OVER 16 SHOULD

SEND COUPON IMMEDIATELY

Steady Work No Layoffs Paid Vacations

Common education sufficient

Send coupon today—SURE

## RADIO For Everybody

Make Radio a profession instead of a plaything. You can earn big money as a Radio-trician. Learn by mail, in spare time, how to design, construct, install, repair, maintain, operate, sell and demonstrate complete radio outfits. Write for free 32-page catalog describing our course entitled, "How to Learn Radio at Home."

National Radio Institute, Dept. 1192, Washington, D. C.

## STUDY CHIROPODY

The rapidly growing, dignified, highly profitable profession for men and women. Day and evening classes leading to degree, Doctor of Surgical Chiropody. Excellent faculty of leading chiropodists and physicians. Thoroughly equipped, modern laboratory. Largest foot clinic in America. School occupies entire 4-story building, 9th successful year. Write for catalog. ILLINOIS COLLEGE OF CHIROPODY, 1327 N. D. Clark Street, CHICAGO



## Big Money

Made by agents selling our wonderful Facial Soap, Perfumes, Toilet Articles, Spices, Extracts, etc. Free cake of soap and agents' terms mailed to any address.

LACASSIAN CO. Dept. 455 ST. LOUIS, MO.



Franklin Institute, Dept. F176, Rochester, N. Y.

Sirs: Send me, without charge, (1) sample Railway Mail Clerk Examination Questions; (2) schedule showing places of all coming U. S. Government examinations; (3) list of many Government jobs now obtainable.

Name .....  
Address .....

# FREE RAILROAD FARE

**Learn  
Electricity  
in 3½  
Months**

**Earn  
\$150  
to  
\$400  
per  
Month**

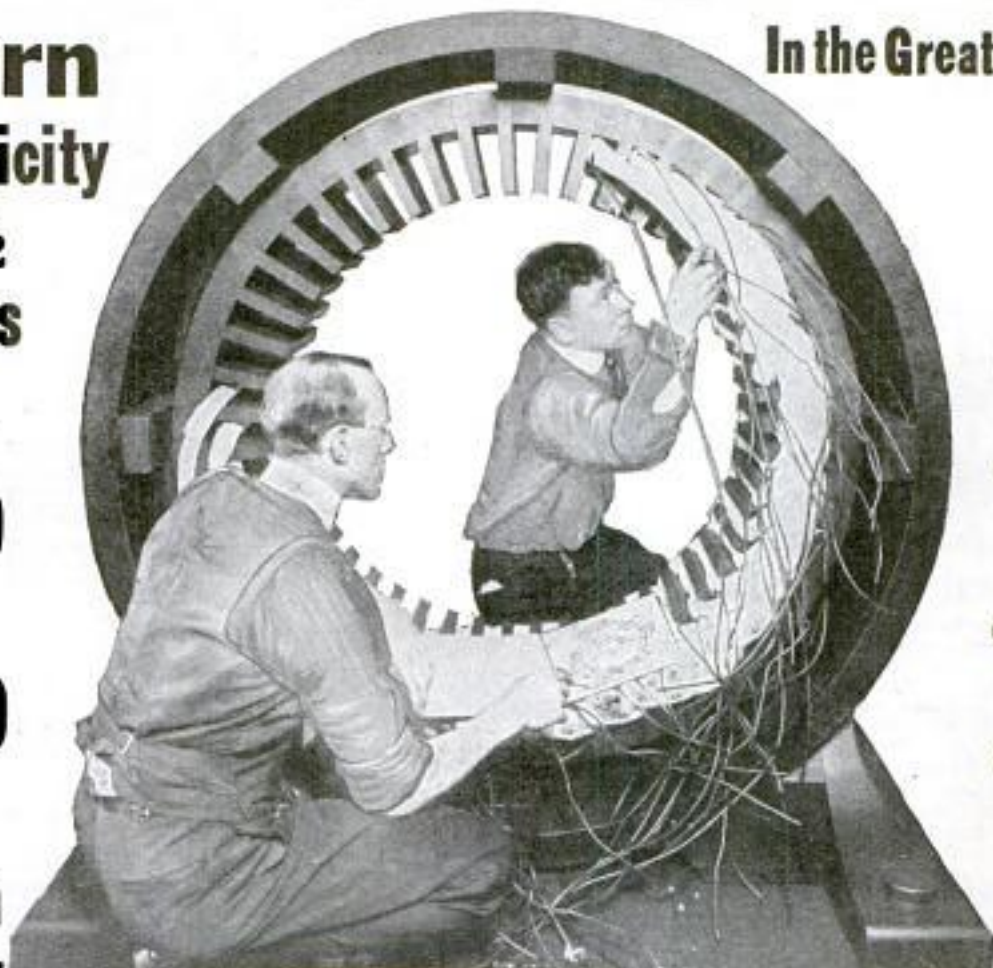

In the Great Shops of

# COYNE

### Student Winding Stator

Make this the most profitable and enjoyable summer of your life. Come to Chicago, the greatest summer resort city in the country on beautiful Lake Michigan, and the greatest electrical center in the world. We pay your railroad fare from any place in the United States. See the country at our expense. Become a skilled electrical expert in the great shops of Coyne.

## Complete Electrical Training in 3½ Months

No books or useless theory—everything is practical. You are trained on \$100,000 worth of electrical equipment. Everything from door bells to power plants. You work on motors, generators, house wiring, autos, batteries, radio, switchboards, power plants—everything to make you an expert ready to step right into a position paying from \$45 to \$100 per week. A Coyne trained man is trained completely. He can take his place any-

where in the electrical world. Auto ignition and battery experts make from \$3,000 to \$20,000 a year. Hundreds of our graduates are making big money and you can do the same if you grasp this opportunity. Send the coupon today!

### Radio Course FREE

Besides paying your railroad fare, we include free a course in Radio—the marvel of the age. Also, a complete course in auto, truck and tractor electricity and storage batteries. Greatest outlay of auto electrical and battery equipment in the country.

### Great Summer Resort City

Chicago, on beautiful Lake Michigan, is the Nation's summer playground. Free bathing beaches, beautiful parks, excursion boats and the great Municipal Pier, zoos, ball parks. Coyne is near the Lake and bathing beaches.



### Earn While You Learn

Our employment department helps you get a job to earn a good part of your expenses.

### Send Coupon NOW!

This is the greatest offer ever made by a school and it is for a limited time. Don't delay a single minute. Send the coupon in right away for our big free catalogue and full particulars of this wonderful offer. Act now!

B. W. COOKE, Pres.

**COYNE TRADE & ENGINEERING SCHOOL**

Dept. 18, 39-51 E. Illinois St., Chicago, Ill.

Dear Sir:—Please send me free your big catalogue and full particulars of your special offer of free railroad fare and 2 extra courses.

Name.....

Address.....

**B. W. COOKE, President  
COYNE TRADE & ENGINEERING SCHOOL**

39-51 E. Illinois Street

Dept. 18

CHICAGO, ILL.



## High School Course in Two Years!

### You Want to Earn Big Money!

And you will not be satisfied unless you earn steady promotion. But are you prepared for the job ahead of you? Do you measure up to the standard that insures success? For a more responsible position a fairly good education is necessary. To write a sensible business letter, to prepare estimates, to figure cost and to compute interest, you must have a certain amount of preparation. All this you must be able to do before you will earn promotion. Many business houses hire no men whose general knowledge is not equal to a high school course. Why? Because big business refuses to burden itself with men who are barred from promotion by the lack of elementary education.

### Can You Qualify for a Better Position

We have a plan whereby you can. We can give you a complete but simplified high school course in two years, giving you all the essentials that form the foundation of practical business. It will prepare you to hold your own where competition is keen and exacting. Do not doubt your ability, but make up your mind to it and you will soon have the requirements that will bring you success and big money. YOU CAN DO IT.

Let us show you how to get on the road to success. It will not cost you a single working hour. Write today. It costs you nothing but a stamp.

### American School

Dept. H.C.74, Drexel Ave. and 58th St., Chicago

### American School

Dept. H.C.74, Drexel Ave. and 58th St., Chicago

Send me full information on the subject checked and how you will help me win success.

- |                             |                           |
|-----------------------------|---------------------------|
| ....Architect               | ....Lawyer                |
| ....Building Contractor     | ....Machine Shop Practice |
| ....Automobile Engineer     | ....Photoplay Writer      |
| ....Automobile Repairman    | ....Mechanical Engineer   |
| ....Civil Engineer          | ....Shop Superintendent   |
| ....Structural Engineer     | ....Employment Manager    |
| ....Business Manager        | ....Steam Engineer        |
| ....Cert. Public Accountant | ....Foremanship           |
| ....Accountant and Auditor  | ....Sanitary Engineer     |
| ....Bookkeeper              | ....Surveyor (& Mapping)  |
| ....Draftsman and Designer  | ....Telephone Engineer    |
| ....Electrical Engineer     | ....Telegraph Engineer    |
| ....Electric Light & Power  | ....High School Graduate  |
| ....General Education       | ....Fire Insurance Expert |
| ....Vocational Guidance     | ....Wireless Radio        |
| ....Business Law            | ....Undecided             |

Name.....

Address.....

Please Mention Popular Mechanics



New friends, new pleasures, new and interesting experiences, invitations galore—dinners, dances, week-end parties, outings,—are some of the good things playing a Gibson brings into your life.

**Gibson**  
Instruments

are easily learned in spare time without previous knowledge of music. A few weeks of pleasant, interesting study and you'll be able to play. And there's no other joy in life quite equal to hearing music you make on your own instruments.

**\$5.00 Monthly** buys a Gibson. The ultimate in construction, finish, tone quality and volume. Built like a violin. **Guaranteed for life.** Non-Gibson instruments exchanged.

**Make \$25 to \$200** weekly selling, playing, teaching. Own a stock, advertise, help sell, carry accounts. Gibsons easily sold on confidential credit plan.

Send for FREE catalog, FREE music and information about Mandolin, Mandola, Mando-cello, Mandobass, Guitar, Harp-guitar, Mandolin-banjo, Tenor-banjo, Cello-banjo, Guitar-banjo. If interested in Agency, check here..... Teacher!..... Clip, check and mail this ad today.

**Gibson Mandolin-Guitar Co.**

1588 Parsons St.  
Kalamazoo, Mich.

Foreign Dept.  
25 Broad St., N. Y. City

### BIG PROFITS FROM POULTRY

We Teach You How; Easily Learned at Home;

our guaranteed methods make success certain; write for free booklet

"How to Raise Poultry for Profit"

The National Poultry Institute, Inc., Dept. 31, Washington, D. C.

### RADIO For Everybody

Make Radio a profession instead of a plaything. You can earn big money as a Radio-trician. Learn by mail, in spare time, how to design, construct, install, repair, maintain, operate, sell and demonstrate complete radio outfits. Write for free 32-page catalog describing our course entitled, "How to Learn Radio at Home."

National Radio Institute, Dept. 1192, Washington, D. C.



### Buchstein's Fibre Limb

is soothing to your stump—strong, cool,

nest, light. Easy payments.

Braces for all deformities.

D. BUCHSTEIN CO., 113 6th St. S., MINNEAPOLIS, MINN.



### BECOME A RAILWAY MAIL CLERK

Examinations soon. \$1600 to \$2300 a year.

No strikes or lockouts. Common education

sufficient. No

"pull" necessary.

Mail coupon for

Catalog.

**Patterson Civil Service School**  
Dept. 88, Rochester, N. Y.

Sirs:—Send me without charge your Catalog, describing this and other fine U. S. Government positions.

Name.....

Address.....

# Stop Forgetting



## Make Your Mind a File—Not a Pile

Let me show you how to make your mind as forget-proof as a card index file. When you wish to recall a name, place or date, must you grope in vain in a pile of miscellaneous knowledge? Summoned to give facts and figures does your mind become a blank? Be master of your mind's infinite resources—instead of a victim of its disordered details.

## KNOWLEDGE IS POWER

and Memory Is the Basis of All Knowledge

## I HAVE HELPED THOUSANDS

The Dickson Method of Memory and Mental Training, perfected by 20 years experience, is recognized as the most thoro, efficient of its kind. Highly endorsed—easy to master. Give me 10 minutes a day and I will train your memory so you can classify ideas, names, faces, etc., and recall them instantly. Develop self-control, concentration; overcome bashfulness.

## Perfect Your Memory and Command What Salary You Will

Send name and address and I will send you free, my interesting booklet, "How to Remember," and unique, copyrighted Memory Test; also tell you how to secure free of charge my \$3.00 book, "How to Speak in Public."

Prof. Henry Dickson, Principal  
DICKSON MEMORY SCHOOL  
Dept. 705  
Evanston, Ill.



Stop Forgetting

The Key to Success



## He Starts at \$5,200 a Year

One hundred dollars a week!—And only a few years ago his weekly wage was less than \$30. Didn't dream he could do it when he first took up the study of Higher Accounting under the LaSalle Problem Method; but he just couldn't help getting ahead—so he wrote—because he found it the most interesting thing he ever tackled.

Knew nothing about bookkeeping, but LaSalle quickly gave him the necessary foundation. Then, step by step, he was trained in the practical work of Cost Accounting, Auditing, Business Law, Organization, Management, Finance, Income Tax Procedure—not theoretically, mind you, but by the solving of actual problems lifted bodily from business life. As a result, he sits at a big mahogany desk and commands a salary of \$5,200 a year.

## His Chance is Yours!

Typical, this man's experience, of that of thousands of ambitious men who have found their path to success in the LaSalle Problem Method. During three months' time, 1,089 LaSalle members wrote to the University telling of the "raises" they got as a result of their training. *The average increase per man was 56 per cent.*

These men were not unusual; they had no "pull" or "luck;" they got their start by signing just such a little coupon as appears directly below this text. Mark that coupon, sign and mail today—and get the facts. Remember, the cost of LaSalle training is small and can be covered in easy monthly payments, if you so desire. The decision that you make this moment is important. Mail the coupon now.

**LASALLE EXTENSION UNIVERSITY**  
*The Largest Business Training Institution in the World*  
Dept. 846-HR Chicago, Illinois

Please send me catalog and full information regarding the course and service I have marked with an X below. Also a copy of your book, "Ten Years' Promotion in One."

### Higher Accountancy

Training for positions as Auditors, Comptrollers, Certified Public Accountants, Cost Accountants, etc.

### Other LaSalle Training Courses

LaSalle is the largest business training institution in the world. It offers training for every important business need. If more interested in any of these courses, check here:

- |  |  |
|--|--|
| <input type="checkbox"/> Business Management                         | <input type="checkbox"/> Banking and Finance                       |
| <input type="checkbox"/> Salesmanship                                | <input type="checkbox"/> Modern Foremanship and Production Methods |
| <input type="checkbox"/> Traffic Management                          | <input type="checkbox"/> Personnel and Employment Management       |
| <input type="checkbox"/> Railway Accounting and Station Management   | <input type="checkbox"/> Expert Bookkeeping                        |
| <input type="checkbox"/> Law—Degree of LL.B.                         | <input type="checkbox"/> Business English                          |
| <input type="checkbox"/> Commercial Law                              | <input type="checkbox"/> Commercial Spanish                        |
| <input type="checkbox"/> Industrial Management Efficiency            | <input type="checkbox"/> Effective Speaking                        |
| <input type="checkbox"/> Modern Business Correspondence and Practice | <input type="checkbox"/> C. P. A. Coaching                         |

Name .....

Present Position .....

Address .....

Please Mention Popular Mechanics

## DEAFNESS IS MISERY



I know because I was Deaf and had Head Noises for over 30 years. My invisible Antiseptic Ear Drums restored my hearing and stopped Head Noises, and will do it for you. They are Tiny Megaphones. Cannot be seen when worn. Effective when Deafness is caused by Catarrh or by Perforated, Partially or Wholly Destroyed Natural Drums. Easy to put in, easy to take out. Are "Unseen comforts." Inexpensive. Write for Booklet and my sworn statement of how I recovered my hearing.

A. O. LEONARD, Suite 226, 70 5th Avenue, New York City

## STOP TOBACCO

Can you quit tobacco? If not, do you know why? Do you know its effect on mental and physical efficiency? These and other questions answered in booklet written by one who has treated thousands for the tobacco habit. Free for the asking. Write

DR. T. H. TRINWITH, Black Bldg., LOS ANGELES, CALIF.

Clear-Tone  
FOR

# PIMPLES

Your skin can be quickly cleared of Pimples, Blackheads, Acne Eruptions on the face or body, Enlarged Pores, Oily or Shiny Skin. \$1,000.00 Cold Cash says I can clear your skin of the above blemishes. WRITE TODAY for my FREE Booklet—"A Clear-Tone Skin"—telling how I cured myself after being afflicted for fifteen years.

**FREE**

E.S. GIVENS, 129 Chemical Bldg., Kansas City, Mo.

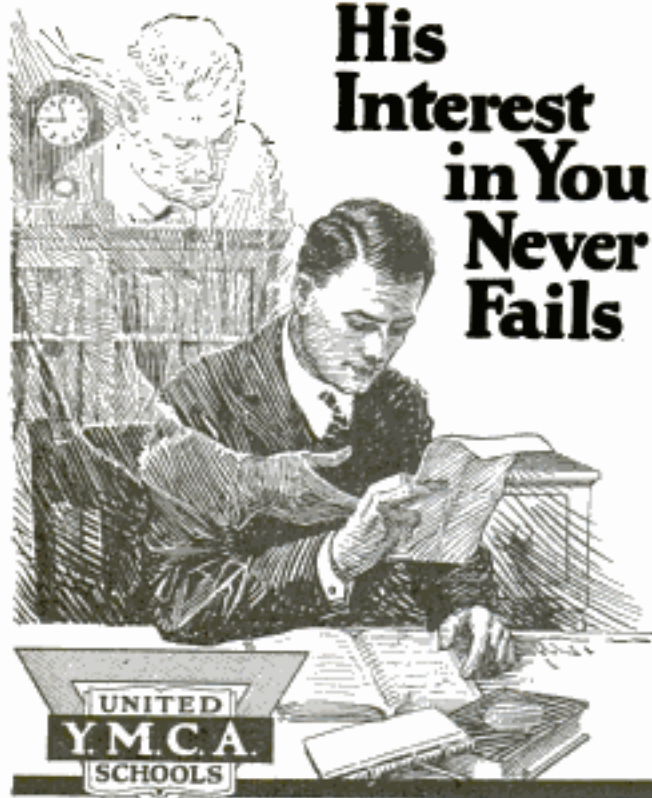

**WHEN** you enroll for a United Y.M.C.A. Schools correspondence course you have the constant attention of a competent instructor who takes an interest in all your problems—personal as well as those relating directly to the course of home-study selected.

His counsel is always available in your effort to improve yourself and your opportunities. The kind of service he gives brings hundreds of expressions like the following from a Pittsburgh, Pa., student:

"I am certainly well pleased with the way you clear up all the rough spots I encounter. It is a mystery how you can make a student feel as if the Whole School is run for his personal benefit."

But this kind of attention is only one of "Six Reasons" why the United Y. M. C. A. Schools correspondence teaching gives the "most service for the least money."

Send the Inquiry Coupon below for the other reasons, get our friendly counsel on how you can realize your ambition, and let us tell you what we are doing for thousands of other men whose opportunity was no better than yours. Tear out and send slip below.

### United Y. M. C. A. Schools' Correspondence Courses, or positions for which they afford training

Accountant	Highway Engineering
Advertising Man	Leadership Courses
Agricultural Courses	Locomotive Operator
Architect	Machine-Shop Practice
Auto Mechanic	Mathematical Courses
Banking	Mechanical Engineer
Better Letters	Own-Your-Home Course
Bookkeeper	Plumber
Building Construction	Poultry Husbandry
Business English	Radio Engineer
Business Law	Radio Telephony for Amateurs
Business Organization	Radio Operator
Civil Engineer	Railroad Engineering
Civil Service	Salesman
Concrete Engineer	Secretarial
Dairy Farming	Shorthand and Typewriting
Draftsman	Steam Engineer
Electrician	Structural Drafting
Electrical Engineer	Surveyor
Factory Management	Tool Designing
Farm Management	Tractors and Farm Machinery
Foreign Languages	Traffic Management
Foremanship	Use of the Slide Rule
High School Subjects	<i>Are You an ex-service Man?</i>

**United Y.M.C.A. Schools**  
375 Lexington Ave.  
New York City,  
Dept. 74-Ag.

Without obligating me, please advise regarding the course in

Age and Occupation.....

Name.....

Full address.....

(Please write plainly.)

## Will YOU Get the Next Promotion?

**T**OBACCO slows up your mental activity—that, in addition to other physical effects. Tobacco makes you dull, unresponsive to the opportunities for advancement that are presenting themselves constantly.

Older business men look for the man whose mind is keen and alert, quick to catch mistakes and find opportunities for advancing his firm's interests.

You will not be the man selected if you keep your mental processes fogged by tobacco.

Quit it now! It is easy! Our tobacco treatment is pleasant to take, definitely effective and the result of years of research in our laboratories. Write us **today** for our booklet. It's free and confidential. Your address on the margin of this page is enough—Do it now.

## The KEELEY INSTITUTE

Dept. P. M.  
DWIGHT, ILL.

### Light Fibre Legs and Arms

636  
Deah Bldg.  
RAY TRAUTMAN Minneapolis, Minn.

**LOOK 50¢ Look** Wonderful Instrument. Greatest thing yet. Nine separate articles in one. Everybody delighted with it. Odd, curious and interesting. Lots of pleasure as well as very useful. It is a double Microscope for examining the wonders of nature. It is also an Opera Glass, a Stereoscope, a Burning Lens, a Reading Glass, a Telescope, a Compass, a Pocket Mirror, and a Laryngoscope—for examining eye, ear, nose and throat. It is worth all the cost to locate even one painful cinder in the eye. Folds flat and fits the pocket. Something great—you need one. Don't miss it. Sent by mail, with 300 page Novelty Catalog, ONLY 50c or 3 for \$1.25. JOHNSON SMITH & CO., Dept. 957 2224 N. Halsted St., CHICAGO.

## NO MORE BALD HEADS



**W**HEN our VACUUM CAP is used a few minutes daily. We accept no pay until you have tried the Cap 60 days and are satisfied. The Vacuum Cap is an appliance that draws the blood to the Hair Roots and starts a new healthy crop of hair. It stops Dandruff, stops the hair from falling out.

Bought by Doctors and men who know that it is the only reasonable HAIR GROWER known to science. No Drugs Used. Write for application blank, testimonials, and booklet on "HAIR," sent sealed in plain envelope, FREE.

**THE MODERN VACUUM CAP CO.**

A 559 BARCLAY, DENVER, COLO.

# STOP USING A TRUSS

Do Away With Steel And Rubber Bands

## FREE TRIAL



TRADE MARK

STUART'S ADHESIF  
PLAPAO-PAD

Inner surface is made adhesive to secure the PLAPAO-PAD firmly to the body, keeping the PLAPAO continually applied and the pad from slipping. No straps, buckles or springs attached. Soft as velvet—easy to apply.

It's the Non-Slip- ping, yet Non-Rigid Pad and What is Within It That Counts

PATD  
APRIL 6  
1909

PLAPAO

### FREE to 5,000 Truss Sufferers

To the extent of 5,000 sufferers who may apply I will send, ABSOLUTELY FREE, a sufficient quantity of the Plapao to positively convince them that this is the only logical, common-sense way of treating ruptures. Plapao is a highly astringent medication placed within the Plapao-Pad and being absorbed through the skin, creates a wonderful feeling of relief and at the same time tends to strengthen the weakened muscles and thus permanently close the rupture opening. The process of recovery is natural, so you'll have no use for a truss—you can throw it away forever! Old and young have testified under oath that the Plapao-Pads cured their rupture—many of them long-standing, aggravated cases—without delay from work. Patent allowed in U. S. and foreign countries. Awarded Gold Medal at Rome and Grand Prix at Paris.

**Send No Money**—for a sufficient quantity of the Plapao is sent without charge to enable you to give it a thorough test; you pay nothing for this trial now or ever. Write for it and full information today. Address: Plapao Laboratories, Block 1427 St. Louis, Mo.

## BLANK CARTRIDGE PISTOL



PRICE  
\$100

Well made and effective; modelled on latest type of Revolver; appearance alone is enough to scare a burglar. When loaded it may be as effective as a real revolver without danger to life. Does not shoot real bullets but takes standard .22 Cal. Blank Cartridges, obtainable everywhere. A Great Protection Against Burglars, Tramps and Dogs. You can have it lying about without the danger attached to other revolvers. PRICE \$1.00 Postpaid. Blank Cartridges .22 Cal., shipped express, 50c per 100. JOHNSON SMITH & CO., Dept. 857, 3224 N. Halsted St., CHICAGO

## I Make Strong Men



That is my business. I make no other claims. But what I promise, I fulfill. I will increase your arm one full inch in 30 days and your chest in proportion. In three months I will make you a finished strong man. Are you interested? Read my book "Physical Perfection." It tells you how. All I ask is 10 cents to cover postage and wrapping. Don't put it off. Send today.

**Arthur L. Hyson**  
198 Laegden Bldg. New York City



\$20<sup>00</sup>aWeek



\$100<sup>00</sup>aWeek

## This Man Wouldn't Stay Down

He was putting in long hours at unskilled work. His small pay scarcely lasted from week to week.

He saw other men promoted. Then he learned the reason. They had special training. He made up his mind to get that kind of training.

He sent to Scranton a coupon like the one below. That was his first step upward.

The reward was not long in coming—an increase in salary. Then he was made Foreman. Now he is Superintendent.

It just shows what a man with ambition can do! What about you? You don't have to stay down. You can climb to the position you want. The way to do that is easy. Without cost—without obligating yourself in any way, mark and mail this coupon.

### INTERNATIONAL CORRESPONDENCE SCHOOLS

Box 5660-C, Scranton, Penna.

Without cost or obligation, please send me full information about the subject before which I have marked an X in the list below:

#### BUSINESS TRAINING DEPARTMENT

- |   |   |
|---|---|
| <input type="checkbox"/> Business Management            | <input type="checkbox"/> Salesmanship           |
| <input type="checkbox"/> Industrial Management          | <input type="checkbox"/> Advertising            |
| <input type="checkbox"/> Personnel Organization         | <input type="checkbox"/> Better Letters         |
| <input type="checkbox"/> Traffic Management             | <input type="checkbox"/> Foreign Trade          |
| <input type="checkbox"/> Business Law                   | <input type="checkbox"/> Stenography and Typing |
| <input type="checkbox"/> Banking and Banking Law        | <input type="checkbox"/> Business English       |
| <input type="checkbox"/> Accountancy (including C.P.A.) | <input type="checkbox"/> Civil Service          |
| <input type="checkbox"/> Nicholson Cost Accounting      | <input type="checkbox"/> Railway Mail Clerk     |
| <input type="checkbox"/> Bookkeeping                    | <input type="checkbox"/> Common School Subjects |
| <input type="checkbox"/> Private Secretary              | <input type="checkbox"/> High School Subjects   |
| <input type="checkbox"/> Business Spanish               | <input type="checkbox"/> Illustrating           |
| <input type="checkbox"/> French                         | <input type="checkbox"/> Cartooning             |

#### TECHNICAL AND INDUSTRIAL DEPARTMENT

- |   |  |
|---|--|
| <input type="checkbox"/> Electrical Engineering   | <input type="checkbox"/> Architect               |
| <input type="checkbox"/> Electric Lighting        | <input type="checkbox"/> Contractor and Builder  |
| <input type="checkbox"/> Mechanical Engineer      | <input type="checkbox"/> Architectural Draftsman |
| <input type="checkbox"/> Mechanical Draftsman     | <input type="checkbox"/> Concrete Builder        |
| <input type="checkbox"/> Machine Shop Practice    | <input type="checkbox"/> Structural Engineer     |
| <input type="checkbox"/> Railroad Positions       | <input type="checkbox"/> Plumbing and Heating    |
| <input type="checkbox"/> Gas Engine Operating     | <input type="checkbox"/> Chemistry               |
| <input type="checkbox"/> Civil Engineer           | <input type="checkbox"/> Pharmacy                |
| <input type="checkbox"/> Surveying and Mapping    | <input type="checkbox"/> Automobile Work         |
| <input type="checkbox"/> Mine Foreman or Engineer | <input type="checkbox"/> Navigation              |
| <input type="checkbox"/> Steam Engineering        | <input type="checkbox"/> Agriculture and Poultry |
| <input type="checkbox"/> Radio                    | <input type="checkbox"/> Mathematics             |
| <input type="checkbox"/> Airplane Engines         |  |

Name.....

Street.....

Address.....

City..... State.....

Occupation.....

Persons residing in Canada should send this coupon to the International Correspondence Schools Canadian, Limited, Montreal, Canada.

Please Mention Popular Mechanics

# Do You Like to Draw?

Here Is a Simple, Easy Way  
to Draw a Comic Face

## TRY IT



Make a square with pencil, then add to it with pencil as shown in the small squares above. Erase all pencil guide lines after the drawing is completed.

We will not give you any "grand prize," if you draw this picture. Nor will we claim to make you "rich in a week." But if you are anxious to develop your talent with a **successful cartoonist**, so you can **make money**, send a copy of this picture with six cents in stamps for portfolio of cartoons and sample lesson plate, and let us explain more in detail. Some of the **most successful cartoonists** are former students of this school. It is not hard to learn to draw **originals** when you are shown how in a practical way.



**THE W. L. EVANS SCHOOL OF CARTOONING**  
"The School That Has the Reputation"  
821 Leader Bldg. CLEVELAND, OHIO

## DYKE'S AUTOMOBILE ENCYCLOPEDIA

Contains the Greatest Array of Automobile Facts Ever Published in One Volume

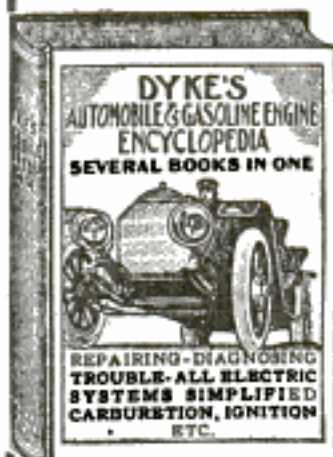

12th edition, revised and enlarged; has 968 pages. Size 6 1/2 x 9 3/4 inches. 3362 Illustrations. 6700 Lines of Index.

Will Teach You How to Become:

1. Automobile Repairman
2. Engine Expert
3. Electric "Trouble Shooter"
4. Ignition Expert
5. Tire Repair Expert
6. Storage Battery Expert
7. Carburetor Expert
8. Tractor Expert
9. Truck Expert
10. Automobile Tractor and Truck Operator, Radiator Repairman.

and Truck Operator, Radiator Repairman.

This book fairly oozes information. Facts tumble over each other, there are so many. This practical, useful information is all indexed so that you can put your finger on just what you wish to know. If you were to purchase separate books on the subjects covered the lot would cost about \$21.00.

Dyke's Book { Regular Cloth Binding, \$6.46 prepaid  
Amer. Morocco Limp, \$7.96 prepaid

You Need It—Order at Once from  
**POPULAR MECHANICS BOOK DEPT.**  
6 N. Michigan Ave. Chicago

## THE PROPER AND MOST EFFICIENT WAY TO REPAIR FORD CARS TRUCKS AND TRACTORS

Here is a book that presents the information given in the Ford Service Course for Superintendents and Service Managers of Ford Agencies at the home plant in Detroit. It gives you information which cannot be secured otherwise outside the Ford plant. It describes for dealers, repairmen, garage mechanics and owners the proper and most efficient way to repair the products of the Ford factories.

Published April, 1922

### FORD CAR, TRUCK AND TRACTOR REPAIR

By Alfred A. Good

Formerly Director, Ford Motor Company's Service School  
229 pages, pocket size, flexible, 32 illustrations

PRICE \$2 POSTPAID

There have been a number of books written on the Ford car; but they only tell what the average Ford driver or mechanic already knows. This book gives you real practical information that shows you just how to locate troubles quickly and how to remedy them efficiently. It gives you a complete understanding of the mechanical principles underlying the operation of Ford cars, trucks and tractors—a thorough knowledge of the mechanical and electrical action of every unit of these machines—an explanation of how to get at the cause of the various troubles—and a step-by-step description of repair operations. The book covers the Ford car, truck and tractor in such a way that the mechanic who reads it is ready to answer any question concerning them which may be put to him by anyone.

Sent to any address postpaid upon receipt of price by

Popular Mechanics Book Dept.  
6 N. Michigan Ave. Chicago





# This Professional Drawing Outfit FREE

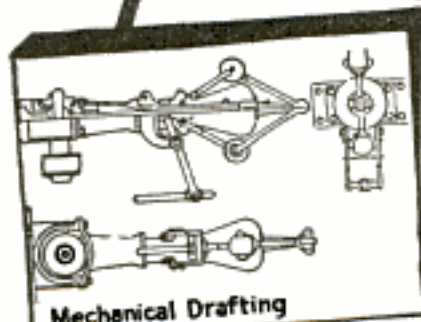

All these Free to  
Columbia Students  
and Graduates

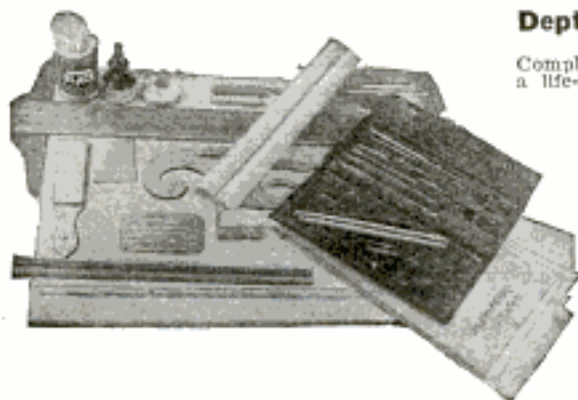

Good tools go a long way toward making a good draftsman. The set shown is of highest quality, and comprises the identical articles used by thousands of draftsmen holding top-notch positions. Consists of 16 pieces and 11-piece instrument set in plush-lined case. You get the COMPLETE OUTFIT FREE.

## Make Drawings With this Set and Get \$35 to \$100 a Week

This FREE drawing set, together with the instruction we furnish will enable you to do expert drafting work—mechanical, architectural, map, radio, automobile, electrical, etc. We'll make a real draftsman of you. And we'll send this complete drawing outfit FREE with your first lesson.

You don't need artistic talent or "pull" to get a draftsman's job paying \$35 to \$100 a week. Our training has put thousands of men in these fine jobs. We teach **everything** you need. Never mind what work you've been doing all your life—we can fit you for these big, BETTER jobs.

## Draftsmen Get Quick Promotions

Columbia graduates climb fast. We have hundreds of letters on file from graduates who have been promoted to Assistant Chief, Chief Draftsman, Production Manager, Engineer, etc. It is because the training we give is the **very best**. We promote **initiative** in our students, and that in turn promotes them to bigger jobs. The training we give is more complete than you'd get in many years work in the ordinary Drafting Room. Our instruction covers **all** the phases of drafting, while the draftsman who tries to learn at "the school of experience" gets training along only one line.

## Easy Money "On the Side"

A draftsman can make a lot of money "on the side." Many of our graduates make as much and more than their large salaries this way. There is always a lot of side-issue work to be had. Many graduates have built up businesses of their own this way. Wouldn't you like to see **your** name on the door of an office of your own as a Drafting Engineer or Consulting Draftsman? You CAN! We show you how.

## Get the Right Training

"Training" is the whole secret of success as a draftsman. Columbia training is simple, sure, **complete**, PRACTICAL. Roy C. Claffin's method of practical mechanical drawing will make a Master Draftsman of you in a few months of home study. Mr. Claffin personally supervises your instruction—personally criticises and corrects your work. He makes the study pleasant and easy. You get plain, commonsense, brass-tack instruction.

## Columbia Draftsmen in Big Demand

The largest concerns in America, and the U. S. Government, employ Columbia draftsmen. We help you get a position. We have constant demand for our graduates. We keep employers advised as to your abilities, and thus help you get quick promotion.

## Send for this Book

Send the coupon **to-day** for illustrated book, "Your Future in Drafting." It tells all about the Columbia Course. **SPECIAL OFFER FOR THOSE WHO SEND THE COUPON NOW.** Do it.

## THE COLUMBIA SCHOOL OF DRAFTING

Roy C. Claffin, President

Dept. 1779, 14th and T Sts., N. W., Washington, D. C.

Complete Drawing Outfit free. Employment service! free. Consultation privilege for a life-time free. Diploma free. Publication for Draftsmen, "The Compass" free.

### Send This Coupon Now

COLUMBIA SCHOOL OF DRAFTING,  
Dept. 1779, 14th and T Sts., N. W., Washington, D. C.

Without obligation to me, please enter my name to receive "The Compass," and send me your illustrated book, "Your Future in Drafting," telling me about your complete home study course and your help in securing me a position as draftsman.

Name.....Age.....

Address.....

City.....State.....



# Big Money

# for Auto Experts

**H**ARD times don't worry the Auto Expert. He is in constant demand. Did you ever know of an experienced auto engineer hunting a job? No, and you never will. The job hunts him.

Just consider for a moment that there are 9,000,000 automobiles in this country today. These millions of cars are in constant need for experts—repairmen and auto engineers.

A smattering knowledge won't get you very far in this line, but if you are willing to get down to brass tacks and really master this well paying line of work, then there will be no limit to what you can earn.

It is only one step from Auto Expert to Garage Owner, but think of the big money that is earned by the up-to-date garage. Here is your chance to become independent—to be your own boss with our help. Now don't say "Well, I'll think about it," but make up your mind right now to be a real success.

The coupon will give you full information on how to do it. Fill out and send it in right now while you are thinking about it.

### American School

Dept. A. C. 74 Drexel Ave. and 58th St., Chicago

### American School

Dept. A. C. 74, Drexel Ave. and 58th St., Chicago

Send me full information on the subject checked and how you will help me win success.

- |                                |                              |
|--------------------------------|------------------------------|
| ..... Architect                | ..... Lawyer                 |
| ..... Building Contractor      | ..... Machine Shop Practice  |
| ..... Automobile Engineer      | ..... Photoplay Writer       |
| ..... Automobile Repairman     | ..... Mechanical Engineer    |
| ..... Civil Engineer           | ..... Shop Superintendent    |
| ..... Structural Engineer      | ..... Employment Manager     |
| ..... Business Manager         | ..... Steam Engineer         |
| ..... Cert. Public Accountant  | ..... Foremanship            |
| ..... Accountant and Auditor   | ..... Sanitary Engineer      |
| ..... Bookkeeper               | ..... Surveyor (and Mapping) |
| ..... Draftsman and Designer   | ..... Telephone Engineer     |
| ..... Electrical Engineer      | ..... Telegraph Engineer     |
| ..... Electric Light and Power | ..... High School Graduate   |
| ..... General Education        | ..... Fire Insurance Expert  |
| ..... Vocational Guidance      | ..... Wireless Radio         |
| ..... Business Law             | ..... Undecided              |

Name .....

Address .....

Please Mention Popular Mechanics

# "Learn to Draw in One Evening



"—just as I did. I made actual pictures in an hour after my course arrived. Charles Lederer's wonderful method of drawing, as he calls it, makes drawing almost as easy as writing. Before long, I was holding down a well-paid position as a newspaper artist."

## Complete Course Sent FREE

Just mail letter or post card to Lederer's publishers. Address them as "Independent Corporation, Dept. D-438, 22 West 19th St., New York." Say "Without obligation on my part send me the Lederer Complete Art Course for five days' free examination." Examine this course. See how easily you can become an artist almost "while you wait." Then, if you decide to keep this wonderful shortcut to a new, dignified, well-paid profession, all you have to do is to mail them only \$3.00 in full payment. There will be no further charges. If you do not wish to keep this course just re-mail it to them within 5 days. You do not risk a penny. But act quickly. Better mail letter today.

# RADIO

MADE EASY

Be a Radio expert. Study at home in spare time. Get a good job at a good salary. Wonderful opportunity to get in on the ground floor of a fast growing profession. Easy, fascinating, profitable. Write today for full particulars.

International Correspondence Schools  
Box 5563-C, Scranton, Penna.

## LEARN TO PITCH



Lessons by "MATTY" WALSH, WHITE, JOHNSON, RUCKER, WOOD—PITCH THE FADE-A-WAY, SPITTER, KNUCKLER, SMOKE BALL, etc., clearly described and illustrated by 56 Pictures. Entire COURSE OF LESSONS sent p. p. for 25c.

J. C. DORN, 721 S. Dearborn St., Dept. 65, Chicago, Ill.

## Fibre-Lite Limbs



Easy Payments—Do Nature's Work.  
AGENTS WANTED who use Artificial Leg. GOOD PAY.  
FREE Free Sample  
DESCRIBE STUMP TO WORMAN CO. 252-P HENNEPIN AVE. MINNEAPOLIS, MINN.

## "I Would Not Part With It For \$10,000"

So writes an enthusiastic, grateful customer. In like manner testify over 100,000 people who have worn it. Conserve your body and life first.

## The Natural Body Brace

Overcomes WEAKNESS and ORGANIC AILMENTS of WOMEN and MEN. Develops an erect, and graceful figure. Brings restful relief, comfort, energy and pep, ability to do things, health and strength. Does away with the strain and pain of standing and walking; replaces and supports misplaced internal organs; reduces enlarged abdomen; straightens and strengthens the back; corrects stooping shoulders; develops lungs, chest and bust; relieves backache, curvatures, nervousness, ruptures, constipation, after effects of Flu. Comfortable and easy to wear.

Costs You Nothing to Try It

Write today for illustrated book, free, with full information and measurement blank. Address

HOWARD C. RASH, Pres. Natural Body Brace Co.  
223 Rash Building SALINA, KANSAS



# Be A Master AUTOMOBILE MECHANIC

## —A Certified Automotive Engineer

You can learn every branch of the Automobile, Truck and Tractor Business *easier and quicker* at the GREER COLLEGE OF AUTOMOTIVE ENGINEERING. Become a "C.A.E." (Certified Automotive Engineer) and you are assured a *preferred* position at highest pay. Write for my Free Book, "How to Succeed in the Automobile Business"—explains everything you want to know.

Erwin Greer, President

GREER Trained Men are **better** trained because the policy of the GREER COLLEGE OF AUTOMOTIVE ENGINEERING is now, as it always has been, to give its students the very best instruction possible, enabling men without previous experience to quickly qualify as Expert Mechanics, Garage Foremen, Demonstrators, Battery and Ignition Experts, Automobile Salesmen, etc. Calls are received daily for capable men to fill positions now open, with splendid pay assured.

## Earn \$50 to \$125 a Week

Ambitious men with the determination to succeed and a thorough knowledge of Motor Mechanics gained through the GREER Super-Course of Automobile Instruction, are recognized as Master Mechanics and naturally entitled to Master Mechanic pay. The GREER College is something **more** than an "automobile school." This is a **real college** that makes **real** Master Mechanics—men who can qualify as Certified Automotive Engineers and are awarded **preferred** positions.

## Greer Training is Complete

The GREER Super-Course of Automobile Instruction covers the following subjects—all included in the complete course long experience has proved necessary:

Truck, Tractor and Automobile Repairing and Overhauling	Vulcanizing and Tire Repairing Machine Shop Practice	Garage and Repair Shop Management
Automobile Driving Roadside Repairs	Acetylene Welding and Cutting	How to get an Auto- mobile Truck or Tractor Agency
Primary Ignition Electric Lighting and Starting Systems	Storage Batteries Business Management	How to Sell Autos, Trucks and Tractors

### FREE RADIO COURSE

Limited number of Free Radio Scholarships available now. Cash in on the demand for mechanics with this additional knowledge. WRITE AT ONCE.

## The GREER Diploma Insures Your Success

—because it means you are a Graduate Master Mechanic—a **Certified Automotive Engineer**—"The Man Who Knows." With GREER training behind you, you can quickly qualify for a permanent position at Big Pay, or go into business for yourself and be certain of success from the very start. Use the coupon below and mail at once for FREE BOOK, "How to Succeed in the Automobile Business."

Erwin Greer, Pres.,

## GREER College of Automotive Engineering

### MAIL THIS—

Greer College of  
Automotive Engineering,  
Dept. 18—2024 So. Wabash Ave.,  
Chicago, Ill.

Send me your Free Book, "How to Succeed in the Automobile Business" and Special Tuition Offer.

Name .....

Address .....



## —Finds His Way to \$100 a Week

It was a lucky day for Joe Phillips when he signed that LaSalle coupon!

"Here I am, a clerk"—that was how he figured it—and unless I get out of this rut I'm condemned to a low-pay job for the rest of my life.

"If a knowledge of Traffic Management adds only twenty dollars a week to my earnings, I'll be making practically one thousand per cent on my investment—and I'll be making it every year of my business life! I would sure be asleep at the switch if I didn't find out the facts!"

Good sound common-sense, we believe—and in Phillips' case it paid!

Phillips had thought that training by correspondence was impractical. He discovered that under the PROBLEM METHOD, distinctive with LaSalle Extension University, he could master Traffic Management by solving actual problems—just the sort that the competent traffic man meets every day in the practice of his profession. Under the direction of a Traffic Advisory Council of 150 leading traffic experts (headed by C. O. Frisbie, for many years Traffic Manager of Armour & Company), he quickly learned the practical technique of freight classification, rates, claims, law of carriers, procedure before the Interstate Commerce Commission, express service and rates, ocean traffic and trade—all in his spare time, without interference with his daily work.

As a result, he swings a job as Traffic Manager of a large manufacturing corporation—and commands a salary of \$5,200 a year.

Why not find out about the splendid opportunities in this attractive and rapidly growing profession? The coupon below will bring you without obligation an interesting book entitled "Skillful Traffic Management," together with particulars of our convenient-payment plan.

If you are working toward a bigger and better job, mail the coupon NOW.

### — INQUIRY COUPON —

## LaSalle Extension University

The Largest Business Training Institution in the World  
Dept. 846-TR Chicago, Illinois

Please send me catalog and full information regarding the course and service I have marked with an X below.

### Traffic Management— Foreign and Domestic

Training for position as Railroad or Industrial Traffic Manager, etc.

### Other LaSalle Training Courses

LaSalle is the largest business training institution in the world. It offers training for every important business need. If more interested in any of these courses, check here:

- |  |  |
|--|--|
| <input type="checkbox"/> Business Management                       | <input type="checkbox"/> Modern Business Correspondence and Practice |
| <input type="checkbox"/> Salesmanship                              | <input type="checkbox"/> Modern Foremanship and Production Methods   |
| <input type="checkbox"/> Higher Accountancy                        | <input type="checkbox"/> Personnel and Employment Management         |
| <input type="checkbox"/> Railway Accounting and Station Management | <input type="checkbox"/> Expert Bookkeeping                          |
| <input type="checkbox"/> Law—Degree of LL. B.                      | <input type="checkbox"/> Business English                            |
| <input type="checkbox"/> Commercial Law                            | <input type="checkbox"/> Commercial Spanish                          |
| <input type="checkbox"/> Industrial Management Efficiency          | <input type="checkbox"/> Effective Speaking                          |
| <input type="checkbox"/> Banking and Finance                       | <input type="checkbox"/> C. P. A. Coaching                           |

Name.....

Present Position.....

Address.....

Please Mention Popular Mechanics

# Lefax

LOOSE-LEAF FACTS

## RADIO HANDBOOK

helps you get expert results in radio every time. Whether you buy a complete outfit, or build one yourself, Lefax will explain clearly just how it works and how to change it to get best results under varying conditions. The authors are the heads of the United States Bureau of Standards Radio Laboratory. Every page is technically correct in every day language. Lefax

**knows all—tells how—  
never grows old!**

New pages, covering new events as fast as they happen, will be sent free to every owner up to July 1st 1923. Get your Handbook now for a full year of Lefax Service free! Order through your dealer or send \$3.50 direct to

**LEFAX, INC.,**  
175F South 9th St.,  
Philadelphia,  
Pa.



## \$150 to \$400 a Month for YOU

### As an Expert Auto Mechanic



### EASY TO LEARN HOW

In 6 to 8 Weeks' Time

Come down to Washington—the Nation's Capital. Drop in at the American Motor Schools. Go all

thru our big new \$250,000 building. Watch the young men who are learning, by actual practice, every detail of auto construction and repair, auto electricity, battery building, vulcanizing, tire repairing, and welding. Lots of these fellows will soon own their own garages

and be making from \$5,000 to \$10,000 a year. Many of them will soon be holding down good jobs paying from \$150 to \$400 a month.

You too can get your start towards success in the Auto business with the help of the American Motor Schools.

### FREE CATALOGUE

Fill in and send the following coupon and we will send you free our illustrated catalogue telling about your opportunity in the auto business and how we will help you to make good. By acting promptly you can save \$50. Mail the coupon NOW.

**American Motor Schools, Inc.,**  
Dept. 282 16th & You Sts. Washington, D. C.

Send the Coupon

The American Motor Schools, Inc.,

16th & You Sts., N. W.,

Dept. 282, Washington, D. C.

Please send me, free of charge, illustrated catalogue and information regarding your Auto Mechanics Course.

Name.....

Address.....

City.....State.....

# You Can Play the Hawaiian Guitar Just Like the Hawaiians!

Because Our Native Hawaiian Instructors Will Help You

**OUR STUDENTS SAY**

Konster School,  
314 So. Franklin St.,  
Chicago, Ill.

First Hawaiian Conservatory of Music, Inc.

I shall certainly be very glad to recommend your course whenever the chance is mine to do so. Mr. W. R. Johnson has not phoned me yet, and if he does not phone in a day or so, will write him. Am sending a letter to Miss Helen Sivick today which I think may help to secure her enrollment, and I shall be glad at any time to write a personal letter to anyone whom you may suggest.

Your former student,  
W. L. Walker.

San Quentin, Calif.

First Hawaiian Conservatory of Music,  
403 Woolworth Building, N. Y. City.

Dear Sirs:—

Lessons 18 and 19 came last evening and I was pleased to see that they are beginning to get hard, or at least a little bit more to learn in them. I have a great deal of spare time to put in on the guitar and I enjoy it. Your course is the simplest and most interesting I have ever tried to learn. I am getting along fine and can play every lesson up to the last one and I can readily see that when I have finished with all of the lessons I will be able to play most anything and play it good. I am, in appreciation,

Yours truly, J. E. FERGUSON.

P. S. If at any time you wish to use my name as a reference for your course you may do so, as I think that any one who takes it up will derive a great benefit from it and never regret it.

Our improved method of teaching is so **simple, plain and easy** that you begin on a piece with your first lesson. **In half an hour you can play it.** Thousands of successful students prove this to be true.

**ONLY 4 MOTIONS** We have reduced the necessary motions you learn to only four, and you acquire these in a very few minutes. Then it is only a matter of a little practice to acquire the weird, fascinating, tremolos, staccatos, glurs and other effects that make this instrument so delightful. **The Hawaiian Guitar plays any kind of music,** both the melody and the accompaniment.

**FREE** Just think of it. 52 lessons on this wonderful guitar. You get a beautiful large sized **Genuine Hawaiian Guitar absolutely free as soon as you enroll for the lessons.** All the necessary picks, the steel playing bar and **52 pieces of music are included without cost to you.**

**Special Arrangements for Lessons if You Have Your Own Guitar**

## Play Any Music

In half an hour after you get the free Hawaiian Guitar and the first lesson, you can play Hawaiian Melodies.

In a very short time after a little practice you can play any kind of music as well as Hawaiian, both the melody and accompaniment.

[TEAR OUT COUPON]



## Tear Off and Mail Today

First Hawaiian Conservatory of Music, Inc.  
233 Broadway (Woolworth Bldg.), New York City

Please send me full information about your 52 easy lessons and FREE GUITAR OFFER.

NAME.....

ADDRESS.....

TOWN..... STATE.....

Print name and address clearly. P.M.S.

## How to Get Rid of Moles



A simple, safe home treatment—  
15 years' success in my practice.  
**Moles (Also BIG Growths) Dry Up.**  
Ask for Free Booklet of Full Particulars  
**WM. DAVIS, M. D.**  
124-5 Grove Ave., Woodbridge, N. J.

## NO JOKE TO BE DEAF

—Every Deaf Person Knows That I make myself hear, after being deaf for 25 years, with these Artificial Ear Drums. I wear them day and night. They are perfectly comfortable. No one sees them. Write me and I will tell you a true story, how I got deaf and how I make you hear.

Address  
**GEO. P. WAY, Artificial Ear Drum Co. (Inc.)**  
80 Adelaide St., Detroit, Mich.



Medicated Ear Drum  
Pat. Nov. 8, 1906

## MAKE MONEY AT HOME

YOU can earn money in your spare time writing show cards. Quickly and easily learned by our new, simple "Instructograph" method. No canvassing or soliciting; we teach you how, guarantee to supply work at home no matter where you live, and pay cash for the work you do.

Full particulars and booklet free  
**AMERICAN SHOW CARD SCHOOL**  
2030 RYRIE BUILDING TORONTO, CAN.

**MURDER** Police Dept., factories, banks, industries adopt finger print method of identification to find criminals. **BE A FINGER PRINT EXPERT.** Train at home in spare time. **WILL OUT** Write for FREE reports telling uses of finger prints and how to learn this profitable profession. **POSTALION GUARANTEED.**  
**U. S. SCHOOL OF FINGER PRINTS, Room 43C, 7003 N. Clark St., Chicago, Ill.**

## AUTO REPAIRMEN!

**FACTS YOU NEED** are found in this practical, up-to-date manual—"Automobile Construction and Repair," by Morris A. Hall. The repair methods given are of the very best. 796 pages; 568 illustrations; flexibly bound in leatherette.

Price \$3.50 Postpaid  
**POPULAR MECHANICS BOOK DEPT., 6 N. Michigan Ave., CHICAGO**

## ARTIST'S OUTFIT FREE



Write quick for our remarkable offer. Learn **NOW** at home, in spare time, by our new instruction method. Commercial Art, Cartooning, Illustrating, Designing. Delightful/fascinating work is big demand. \$35.00 paid for one drawing. Handsome book free explains everything. **SEND FOR IT TODAY.**  
**WASHINGTON SCHOOL OF ART, Inc.**  
1868 Marden Bldg. Wash'ton, D. C.

Whatever Your Question;—be it the pronunciation of Bolsheviki, the spelling of a puzzling word, the location of Murman Coast—the meaning of blighty, ace, tank, ukulele, etc., this Supreme Authority—

## WEBSTER'S NEW INTERNATIONAL DICTIONARY

contains an accurate, final answer 400,000 Words, 2700 Pages, 6000 Illustrations.  
Regular and India-Paper Editions. **G. & C. MERRIAM CO., Springfield, Mass.**  
Write for specimen pages, prices, etc. and FREE Pocket Maps per Popular Mechanics



# Come to Detroit

In Detroit business is going fine. The big factories are in full production. Most of them are normal; some are producing more than their normal output. Detroit is the pulse of the country. When Detroit is busy, every place in the country is busy. The Auto, Truck and Tractor business is the most active business there is today. Garages, Tire and Battery shops have been making money through these hard times. They are now back to normal, making big money.

## Learn the Automobile Business

Training is needed badly, but to succeed in the biggest way Michigan State Auto School Training is absolutely essential. M. S. A. S. training is not one man's idea, it is the result of years of keen co-operation with the big factories here in the "Heart" of the Auto Industry. The biggest, best and most successful men in every branch of the industry have helped in outlining our course. The factories loan equipment, send us the heads of the departments for practical lectures and assist us in every way.

**Make \$125 to \$500 or More Monthly**  
**FACTORY LETTERS** In a Fine Job or in Business for Yourself



**HUDSON MOTOR CAR COMPANY**

DETROIT, MICH., U.S.A.

This school is thought very highly of by the automobile men of Detroit. You will make no mistake by entering for a course.



DETROIT, MICH., U.S.A.

I do not believe you would make any mistake in attending this school if you wish to become thoroughly experienced in the automobile business.



**BUICK MOTOR COMPANY**

We believe the Michigan State Auto School located at Detroit, would best meet your requirements, as its course in technical training is most thorough and complete in every detail.

**THE STUDEBAKER CORPORATION**  
OF AMERICA

We do not know a better automobile school that we could recommend to you than the Michigan State.

**MAXWELL MOTOR SALES CORPORATION**  
AUTOMOBILES  
DETROIT, MICH.

We heartily recommend the Michigan State Auto School of this city.



### Money Back Guarantee

We guarantee that a graduate of our Automobile and Tractor Course will be qualified to fill a position as assembler, demonstrator, tester, repair man, auto electrician, chauffeur, tractor operator, or farm lighting expert, or we will refund his tuition fee.

With Detroit training at the M. S. A. S. our graduates are successful—we have trained more than 18,000 men who are located in all parts of the world, either holding big pay jobs or in business for themselves. Thorough training in our excellently equipped school fits our graduates for success. Men often leave our school to go right into business and make money from the start—it's the M. S. A. S. thorough training that makes the successes. There's really no limit to the money that can be made.

**10,449,785 Motor Vehicles in Use**  
**1,237,327 Added During 1921**

Just think what that means—over one million and a quarter more motor vehicles added in 1921, the dullest auto year in history. Thousands of new garages and dealers are needed—thousands of M. S. A. S. trained men are needed. This year, 1922, will add nearly one and three quarter millions more and men who get started NOW at our school surely will succeed.

### Quality Instruction—Complete Equipment

Our school is thoroughly and well equipped—we have about \$250,000 in equipment just for students to study and work on; there is nothing slighted in the entire course that could help the student. In fact, our policy is to give the best course in the land and to hold our tuition within the reach of all. Anything that is worth having is surely worth paying reasonably for and at the M. S. A. S. you get the biggest money's worth to be had.

### Start Any Time

You start the day you arrive, if you wish. The welfare department arranges for fine rooms and board. You have nothing to worry about—just get right down to business. The instructions are very practical and easily understood—no previous experience is necessary. Now is the time to get started.

We can secure positions for our graduates—we have more calls for men than we can supply.

### Jump on the Train and Come NOW

Hundreds of men have not waited, but after reading our advertisement have jumped right on the train and come to Detroit. The factories say you will make no mistake by coming to the M. S. A. S. The tuition is reasonable and board and room moderate in price. There never was such an opportunity as now. If you prefer, just fill in the coupon and mail it at once. It will bring you catalog and complete information FREE.

# Michigan State

**"The Detroit Auto School"**

**308 Auto Building 3729 Woodward Ave.**

# the Auto Center

Study and

Learn Now—it is the thoroughly trained men who make the big successes in the auto truck and tractor business. M. S. A. S. training will make you independent the rest of your life. You will secure in a few weeks of pleasant, practical study and training what hard times or adverse conditions can never take from you. Trained heads and hands always get first call on big money and in business.

## Original and Only Factory Endorsed School

When the Michigan State Auto School first started in 1910, we called in the big men of the industry. Detroit was first in this tremendous field. It has maintained the lead until now 73% of all motor vehicles are made right here and a total of 94% within 100 miles. The big factories gave us their hearty co-operation at first and have continued to do so, for they needed the highest type of men and this school was giving the thorough training needed. Write to any automobile factory, business house or bank in Detroit and ask them about us.

## Visit Detroit Factories

Training in Detroit at the M. S. A. S. gives you another advantage enjoyed by no other school any place. Regular trips are made weekly or oftener through the factories. The Packard, Paige, Jewett, Ford, Fordson, Studebaker, Lincoln, Cadillac, Hudson, Essex, Maxwell, Chalmers, this is only a partial list and the big engine and accessory factories are also visited. You meet the factory heads, study factory methods of assembly and repair. This is a big advantage over all the rest and cannot be enjoyed except in Detroit at the M. S. A. S.

### Factory Trained Instructors

Many of our instructors had early training in the big factories—they practically grew up in the business. Those who did not, have gone into the factory methods in co-operation with the factory heads and give you the result of this intense research and training.

### Instructors Long With School

Most of our instructors at the heads of departments have been with us a long time. Some, three years; others, eight years. These men have developed in their departments and are able to pass on their experience to you.

### Complete Auto, Truck and Tractor Course

Our complete course includes training in the construction, operation, upkeep and repair of automobiles, trucks, tractors, farm lighting plants and stationary engines of every kind. Basically the instructions are alike, but we teach how to apply the knowledge to all motor vehicles. We have a large general garage for actual garage practice. We own a farm with all types of tractors for operation and upkeep practice. The course includes thorough training in automotive electric with actual practice in overhauling, rebuilding all types of starting, lighting and ignition systems. You get everything from A to Z. We educate the head and train the hand in a thorough, complete way.

### Tire Repairing

We have a separate course in this branch of the auto business—the best equipment and instructors train you. Our graduates are very successful.

### Battery Repair

This important branch of the industry is also taught in a separate and complete course which equips our graduates to immediately go into this big profit business.

### Welfare Department Gets Good Rooms

Our Welfare Department is every student's friend. The day you arrive, it locates you in a nice room and directs you to good table board. It helps you with personal matters, tells you where your church is located, helps you get the best care and attention. The M. S. A. S. Welfare Department is known around the world.

Mail the coupon for catalog and Auto News—all FREE—or, better still, just jump on the train and come right to the school.

# Automobile School

"Endorsed by all Leading Manufacturers"

**Detroit, Mich., U. S. A.**

## GRADUATES' LETTERS

J. H. Goodwin, New Jersey state distributor for the Crow-Kirkhart and Jackson cars, writes:

"I thought I knew something about an automobile when I went there, but after going through and looking back, I find I did not know anything. The benefit I have derived from the training that I received cannot be described, as I owe all my success to it. M. S. A. S. graduates are always given preference by me."

Mr. Goodwin's address is care Goodwin Automobile Co., 228 Central Ave., Newark, N. J.

L. C. Beyer, of Deary, Idaho:

"The training I received in your Welding Department and your special electrical course has paid me larger dividends per dollar, than any money I ever spent."

Samuel Thomas, New Kensington, Pa., says he has one of the good jobs, due to his M. S. A. S. training. He writes:

"I graduated from the M. S. A. S. in 1920. I returned home and got a job immediately and worked three months as mechanic and then became foreman of the Dodge and Liberty garage at a salary of \$200 a month, which job I still hold."

Thomas' address is 1322 Woodmont Ave.

H. S. Brooley, 2345 E. 55th St., Cleveland O., rose from a job as shipping clerk at \$12.00 a week, to a garage owner making \$400 a month. He now has a fine place in Cleveland.

F. W. Johnson, . . . . . Cleveland, was a "pencil pusher" at \$12.50 a week before coming to the M. S. A. S., now is an auto electrician averaging more than three times that.

J. E. Navarro, is Service Manager for the Dodge Bros. branch, Rosencroft, W. Va. He says:

"I have worked with men who have had fifteen years experience, but my schooling has put me up with them or ahead of them."

J. B. Nelson, Worcester, N. Y., took our course when 17 years old, now has five men working for him.

E. R. Greve, Fowler, Cal., writes:

"Last year's business brought us a nice little home here, and we have started buying another for this year."

Geo. H. Purvis, 9111 Charlevoix Ave., writes:

"Am now experimental electrician with the Packard Motor Car Company. Here we get about everything there is in auto electrical work. I give your school all the credit."

John Grshak, Chisholm, Minn.—

"I am in business for myself. My wages average from \$350 to \$400 a month. Before I went to your school I hardly made enough for my family to live on."

## SEND THIS COUPON TODAY!

**Michigan State Auto School**  
308 Auto Bldg., Detroit, Mich.

Gentlemen: Send me your Catalog and Auto News FREE.

Name .....

Street or R. F. D. ....

Town .....

State .....



## Here's The Winner of The \$5000 Cup

Gentlemen—meet Mr. Otto Loesche, winner of the \$5000 Penrose Trophy in the annual Pike's Peak Automobile Race in 1920 and first in his class in 1921.

Mr. Loesche is not only a champion automobile racer, but he's chief of the experimental department of the Lexington Motor Company. That's a pretty good job for a young man.

Recently, when asked for a statement concerning the one thing that had contributed most to his success, he said:

"I believe the greatest source of assistance and encouragement came to me when I became interested in trying to better my position. I wanted an education—that is, a foundation on which to build. So I enrolled as a student in the Mechanical Engineering Department of the International Correspondence Schools, of Scranton, Pa., and began to study. There is no question in my mind but that was the most important step of my life."

Why don't you at least find out what the I. C. S. can do for you? It doesn't cost you a penny or obligate you in any way to mark and mail the coupon printed below, but that seemingly simple little act may be "the most important step" in your life, too.

Today—not "Tomorrow"—is the day to make the first definite move toward Success.

### INTERNATIONAL CORRESPONDENCE SCHOOLS Box 5658-C, Scranton, Penna.

Without cost or obligation, please send me full information about the subject before which I have marked an X in the list below:

#### BUSINESS TRAINING DEPARTMENT

- |   |   |
|---|---|
| <input type="checkbox"/> Business Management                              | <input type="checkbox"/> Salesmanship                                     |
| <input type="checkbox"/> Industrial Management                            | <input type="checkbox"/> Advertising                                      |
| <input type="checkbox"/> Personnel Organization                           | <input type="checkbox"/> Better Letters                                   |
| <input type="checkbox"/> Traffic Management                               | <input type="checkbox"/> Foreign Trade                                    |
| <input type="checkbox"/> Business Law                                     | <input type="checkbox"/> Stenography and Typing                           |
| <input type="checkbox"/> Banking and Banking Law                          | <input type="checkbox"/> Business English                                 |
| <input type="checkbox"/> Accountancy (including C.P.A.)                   | <input type="checkbox"/> Civil Service                                    |
| <input type="checkbox"/> Nicholson Cost Accounting                        | <input type="checkbox"/> Railway Mail Clerk                               |
| <input type="checkbox"/> Bookkeeping                                      | <input type="checkbox"/> Common School Subjects                           |
| <input type="checkbox"/> Private Secretary                                | <input type="checkbox"/> High School Subjects                             |
| <input type="checkbox"/> Business Spanish <input type="checkbox"/> French | <input type="checkbox"/> Illustrating <input type="checkbox"/> Cartooning |

#### TECHNICAL AND INDUSTRIAL DEPARTMENT

- |  |  |
|--|--|
| <input type="checkbox"/> Electrical Engineering                          | <input type="checkbox"/> Architect               |
| <input type="checkbox"/> Electric Lighting                               | <input type="checkbox"/> Contractor and Builder  |
| <input type="checkbox"/> Mechanical Engineer                             | <input type="checkbox"/> Architectural Draftsman |
| <input type="checkbox"/> Mechanical Draftsman                            | <input type="checkbox"/> Concrete Builder        |
| <input type="checkbox"/> Machine Shop Practice                           | <input type="checkbox"/> Structural Engineer     |
| <input type="checkbox"/> Railroad Positions                              | <input type="checkbox"/> Plumbing and Heating    |
| <input type="checkbox"/> Gas Engine Operating                            | <input type="checkbox"/> Chemistry               |
| <input type="checkbox"/> Civil Engineer                                  | <input type="checkbox"/> Pharmacy                |
| <input type="checkbox"/> Surveying and Mapping                           | <input type="checkbox"/> Automobile Work         |
| <input type="checkbox"/> Mine Foreman or Engineer                        | <input type="checkbox"/> Navigation              |
| <input type="checkbox"/> Steam Engineering                               | <input type="checkbox"/> Agriculture and Poultry |
| <input type="checkbox"/> Radio <input type="checkbox"/> Airplane Engines | <input type="checkbox"/> Mathematics             |

Name.....

Street.....

Address.....

City..... State.....

Occupation.....

Persons residing in Canada should send this coupon to the International Correspondence Schools Canadian, Limited, Montreal, Canada.

Please Mention Popular Mechanics

## LEARN The BUSINESS of Advertising



### QUICKLY BY MAIL

We guarantee to teach you. It's easy to learn—and easy to get into! Make the start *this week*. This free book tells how.

## \$75 to \$100 a Week

—frequently paid beginners. There is no limit to opportunities which men and women trained in advertising meet on every hand.

### FREE AD-WRITER'S COMPLETE WORKING OUTFIT

Wonderful outfit of working instruments given free on special offer. Write for details before offer expires. We will also send you free and prepaid this stirring book on advertising. Tells you everything you want to know about getting into this fascinating field. Write today. Postcard will do.

PAGE-DAVIS SCHOOL, Dept. A28, Page Bldg., Chicago

## \$ EARN MONEY \$ AT HOME

Be your own Boss. Make money at home in your spare time. We guarantee to make you a Show Card Writer by our New Simple Method. No Canvassing or Soliciting. We sell your work and pay you cash each week no matter where you live. Illustrated booklet and terms free.

### THE DETROIT SHOW CARD SCHOOL

U. S. Office: 214 Lehman Building, Detroit, Michigan  
Canadian Office: 14 Lord Security Building, Toronto, Ontario

Our BUREAU OF INFORMATION will answer all questions regarding articles appearing in this magazine. Address Bureau of Information, Popular Mechanics Magazine, Chicago.

## 10,000 Practical Recipes

### HENLEY'S

Twentieth Century  
Book of  
Recipes, Formulas  
and Processes

Edited by

GARDNER D. HISCOX, M. E.

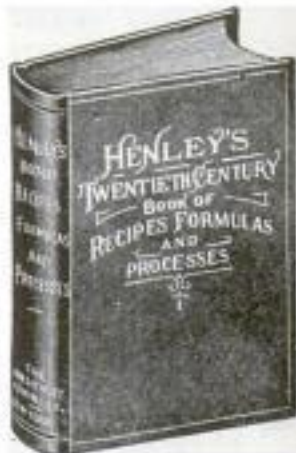

Contains over 10,000 Selected Scientific, Chemical, Technological and Practical Recipes and Processes, including Hundreds of So-Called Trade Secrets for Every Business. This book of 800 pages is the most complete Book of Recipes ever published, giving thousands of recipes for the

manufacture of valuable articles for every-day use. Hints, Helps, Practical Ideas and Secret Processes are revealed within its pages. It covers every branch of the useful arts and tells thousands of ways of making money and is just the book everyone should have at his command. A book to which you may turn with confidence that you will find what you are looking for. A mine of information up-to-date in every respect. Contains an immense number of formulas that everyone ought to have that are not found in any other work.

Price \$4.00  
Cloth Binding

Popular Mechanics Book Dept.  
6 N. Michigan Ave., CHICAGO



# \$100 a Week FOR DRAWING

**H**OW would you like to make \$100 a week as a commercial artist? If you like to draw, you are indeed fortunate—for well-trained artists are always at a premium. They readily earn \$75, \$100, \$150 a week, and even more. You will not have to wait for years to get a good income, for beginners with practical ability soon command \$50 a week.

## Learn Quickly at Home in Your Spare Time

Get into this fascinating profession where you can put your natural ability to its best use. Thousands of business firms pay millions of dollars annually for good advertising drawings and designs. Develop your talent—learn the methods and secrets that make your drawings worth real money. Without previous training or experience, the Federal Course carries you rapidly forward, each step clearly explained, and gives you individual personal criticisms on all your lessons by men who themselves have made good as commercial artists.

## The Federal Course Brings You the Experience of Leading Successful Artists

Leading illustrating companies, designers, artists, and hundreds of successful Federal Students have enthusiastically endorsed Federal Training. You get the advice and experience of men who have produced and sold hundreds of thousands of dollars' worth of commercial art—through exclusive lessons contained only in the Federal Course.

Think of having the help of such men as **Franklin Booth**, the wonderful pen-and-ink artist called the "Painter with the Pen"; **Charles E. Chambers**, a leading magazine and story illustrator; **D. J. Lavin**, formerly head of Chicago Tribune Art Dept.; **C. Matlack Price**, a poster authority; **Neysa McMein**, magazine covers; **Charles Livingston Bull**, the animal painter; **Harold Gross**, **Edw. V. Brewer**, **F. E. Shoonover**, **L. V. Carroll**, **Gayle Porter Hoskins** and **N. C. Wyeth**, all illustrators and designers, who have made reputations for themselves.

## Get this Free Book "YOUR FUTURE"

Now is the time to investigate! By all means send for this book. It is beautifully illustrated in colors, and tells every detail you need to know about the Federal Course. Shows work of Federal Students, many of whom **earn more than the course costs** while they are studying. The almost unlimited opportunities in this field will surprise you. The Federal Course is aimed at practical results—and gets them. If you are ambitious to succeed in commercial art, you cannot afford to be without this book.

Sent free to any one sixteen years of age or more. State age and occupation.



**Federal School of  
Commercial Designing**  
679 Federal Schools Bldg.  
MINNEAPOLIS, MINN.

Please send me "Your Future," without charge or obligation.

My Age is.....

Name.....

Write your address plainly in margin.



# THE SCIENTIFICALLY BUILT WATCH

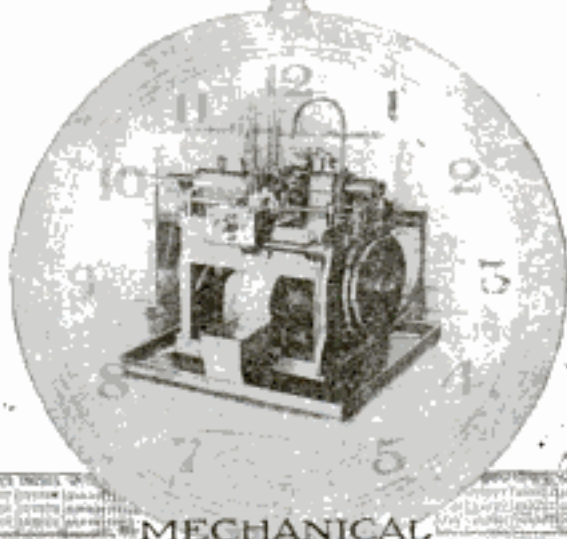

MECHANICAL

## PERFECTION



*The Balance Staff*

It has been said—that in simplicity is found perfection. The movement of a Waltham Watch is one of the most simple motor mechanisms, in relation to its marvelous year in and year out performance, ever created and perfected by man.

To reach this perfection, invention and advancement marks the progression of a seventy year old history and reputation. For instance—

The Balance Staff is a most important part of a watch movement. Its "accuracy" when made and finished determines the time-keeping quality of the whole movement. Balance Staffs were once finished by hand and were correspondingly inaccurate and unsatisfactory.

After years of experiment, Waltham invented the Balance Staff turning machine (illustrated) which is one of the most important additions to watchmaking of the past fifty years. This remarkable machine "turns" and completes staff after staff before they are cut off from the special steel wire of which they are made.

This means that each pivot or staff is absolutely a true counterpart of every other, giving Waltham Watches an advantage found in no other watch.

And this Waltham interchangeable Balance Staff is not "staked" to the Balance Arm. Therefore if through accident or repair, the Staff has to be replaced, the trueness of the Balance is never disturbed.

That is why the upkeep cost of Waltham Watches is so low—and why a jeweler would rather repair a Waltham Watch than any other.

There are many more reasons why your watch selection should be a Waltham.

*Makers of the famous Waltham air-friction quality Speedometers and Automobile Time-pieces used on the world's leading cars*



*Ribbon loops patented*

**Waltham Cushion 10 Ligne  
Ribbon Wrist Watch**

# WALTHAM

## THE WORLD'S WATCH OVER TIME

*Where you see this sign they sell Waltham Watches*

**GIFTS THAT LAST**

# Popular Mechanics Magazine

REGISTERED IN U. S. PATENT OFFICE

WRITTEN SO YOU CAN UNDERSTAND IT

Vol. 38

AUGUST, 1922

No. 2

9433

## Train of Locomotives Half a Mile Long

AS the first consignment of 50 Baldwin locomotives, of the "2-10-2" type, completed for the Southern Pacific lines, 20 of them in one long train recently traveled from the works at Philadelphia, to Corsicana, Tex., giving tangible evidence, everywhere along the route, that a new era of activity is at hand. For this reason the builders called it the "Prosperity Special," but it was characterized by the interested observers as the "Wonder Train of the World." It was the long-

est train of locomotives ever moved in a single unit, over anything like such a distance, and its journey, via East St. Louis, Ill., took over two weeks. On account of the care that had to be exercised in handling such a heavy train, it moved in the daytime only. These locomotives are equipped for burning oil fuel. The total length of each locomotive is nearly 100 feet, and its total weight is 621,000 pounds. Thus the train was nearly half a mile long, and weighed over 6,000 tons.



The "Prosperity Special," a Train of Southern Pacific Locomotives, of the "2-10-2" Type, That Traveled from the Baldwin Works, at Philadelphia, to Corsicana, Texas: Each Locomotive with Tender Is Nearly 100 Feet Long, and When Loaded Ready for Service, Its Total Weight Is 310 Tons

*The Baldwin Locomotive Works, Philadelphia, Pa.*

*A. C. E. Typewriter Corp. 41 E. 42nd St. Manchester Guardian Commercial*

*9258 106*

**POPULAR MECHANICS**  
*New York City*  
**STANDARD AND WORD-WRITING TYPEWRITER AIDS SPEED**

*5/4/22*

*Letter noted 9/6/23*

Speed in typewriting should be considerably increased by the use of a newly developed machine that has, besides a single-shift standard keyboard, a set of 22 keys, each of which will write a whole word with one stroke. The words selected are those of most frequent occurrence, and are all of one syllable. On the machine is an escapement lock that makes it possible to write in any direction. Two special

write straight up and down in a column. The carriage-shifting lever, instead of being on the right or left-hand side of the carriage, is on the right-hand side of the keyboard, accessible to the little finger, so that the carriage can be returned without removing the hand from the keyboard.

**EUROPEAN PROGRESS IN GAS AND HYDRAULIC TURBINES**

*9492*

Later developments in the experimental work on gas and oil turbines that is being carried out at Mulheim, Germany, as mentioned in previous issues of this magazine, show very interesting results. With the object of avoiding the overheating of the turbine blades, without being compelled to pre-cool the products of combustion, hitherto an insuperable difficulty in gas turbines, the principle is employed of burning the fuel in each of from 6 to 10 combustion chambers successively, and of subjecting the blades to the hot gases for only a fraction of the revolution. During the remainder of the revolution the blades have time to cool off to such an extent that their mean temperature is less than 750 degrees. The consequence is that though formerly no known material would stand up against the high temperatures of the gas turbine, in this German machine the blading, made of soft electric iron, is perfectly satisfactory and durable.

In connection with hydraulic turbines there has also been considerable development in Europe in runner wheels that operate efficiently under low and variable water heads. High efficiency has

been obtained with a wheel having blades which resemble those of a ship's propeller, few in number, short, and supported only by the hub to which they are connected.

*No price.*



Word-Writing Typewriter: The Enlarged Keyboard Shows the Keys for Writing Words at One Stroke. The Carriage-Shifting Lever Is at the Right of the Keyboard

keys, just behind the back row of the standard keys, rotate the platen in either direction for moving the paper up or down, and these keys, in conjunction with the escapement lock, make it possible to

*9310*

**SWISS CANTONS HOLD ELECTIONS IN OPEN AIR**

Switzerland, long noted for the intense patriotism of its inhabitants, and its freedom from political strife and dissension, is a confederation of 22 sovereign states called cantons. In the four older cantons the ancient custom of democratic assemblies has been preserved, in which the burghers gather in the open air to elect

the officers for the coming year. The election takes place each year on the last Sunday in April or the first Sunday in May and is always held in the open air. The requirements for citizenship are very rigid and must be carefully observed before a person is qualified to vote, and only resident voters have full suffrage.

9310 International Newsreel Corp  
New York City



This Shows the Burghers of One of the Four Older Cantons of Switzerland Meeting in Their Open-Air Assembly to Elect Officers for the Coming Year. The Meeting is Held on the Last Sunday in April or the First Sunday in May, and Always in the Open

Cml. L. R. Tichenor,  
Box 11, Station 7,  
Cincinnati, Ohio

931 USE MOVING-PICTURE CAMERA TO "SHOOT" EAGLE FAMILY

When a family of American eagles built their nest in the top of a tall tree near Vermilion, Ohio, it afforded scientists a wonderful opportunity to study their habits at close range. To preserve a rec-

and ten-inch sizes, and permits recording and reproduction of any sound without changing the reproducer of an ordinary phonograph. Ordinary steel needles are used to make the record and to play it.

The records are of about the same weight as steel and have the appearance of aluminum. The actual composition of the disks is, of course, kept secret, but the metal is comparatively soft, and the expansion and contraction is not as great as in wax records.

In making a record on a blank, it is possible to speak into the sound box of an ordinary phonograph and the impressions will be recorded on the disk. Better results, however, can be obtained by using a special reproducing horn, which can be attached to any machine by merely placing it on the turntable. It is stated that the record can be played about 1,000 times with a steel needle or several thousand times with a wooden needle.

An instrument is now under development and will soon be placed on the market, for recording on phonograph blanks sound waves sent by radiotelephone. The use of this instrument will permit persons to make permanent records of concerts being sent out from broadcasting stations. It is claimed that

the metal disks will record about 80 per cent of the actual sound volume. Unlikely as it may seem, the metal records do not give the voice or music a metallic sound when reproduced.

Because of the ease with which records may be made and the almost indestructible character of the disks, it will be possible for persons traveling to send home spoken messages by mail in place of written letters. In this case it would only be necessary to speak the message into any convenient phonograph, attach postage to a label on the disk, address it, and drop it in the mail box. When the record had been received and heard by the home folks, it could be readdressed and sent to other members of the family.

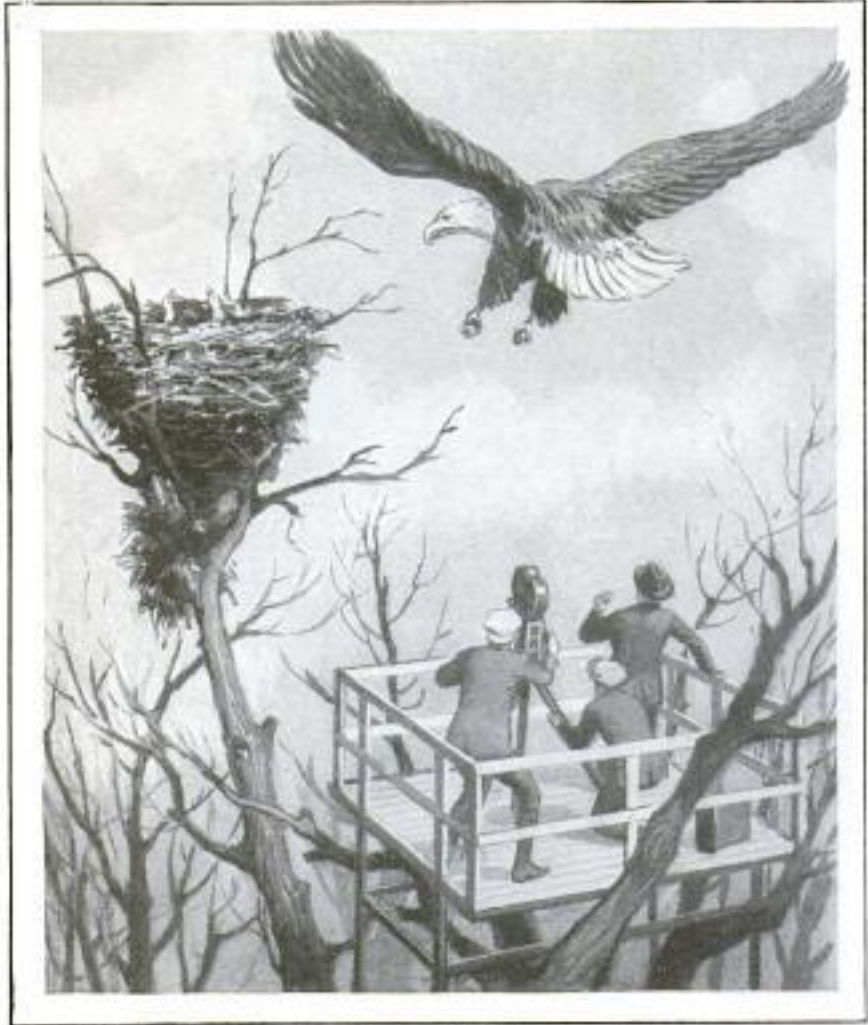

By Building a Platform High Up on Adjoining Branches of the Tree Where Eagles Had Their Nest, Scientists Thus Took Moving Pictures of the Birds

ord of their observations, a platform was built high up on neighboring branches of the tree, and moving pictures were taken of the birds as they went about their family life.

9401 MAKE NONBREAKABLE METAL PHONOGRAPH RECORDS

A nonbreakable blank for phonograph records, made of a metallic composition, has recently been patented, and will soon be on sale in music stores at a very low price. The new records are not limited to any one kind of reproduction, but will record the voice, musical instruments, and band or orchestra music.

This new record is made in six, eight,

Metals Slick Record Corp.  
Fish Fire Bldg. New York.

9439 California Transit Co.,  
Oakland, Calif.  
MOTOR BUSES EQUIPPED WITH RADIO APPARATUS

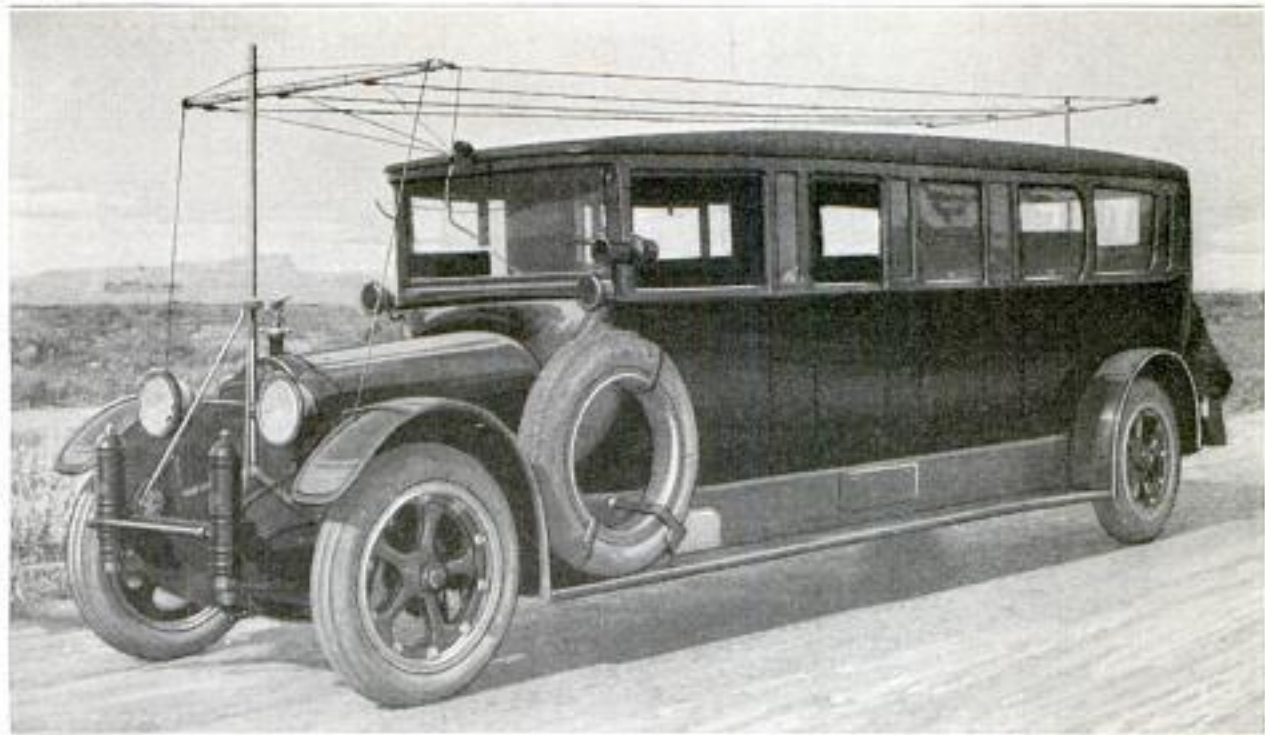

One of the Motor Buses Which have been Equipped with Radio Apparatus by the Owners for the Purpose of Overcoming Competition in the Tourist-Carrying Business: The Low but Efficient Aerial is Clearly Shown, and Also the Way It has been Braced to Withstand Vibration

**E**QUIPPING motor busses with radio apparatus is a departure inaugurated by a transit company operating some 85 of these vehicles on the Pacific coast. This innovation is the result of the keen rivalry of the bus concerns to obtain for

their respective lines the patronage of the thousands of tourists who annually visit the western states. That the venture is practical, has been fully demonstrated by extensive experiments, numerous obstacles having been overcome during the

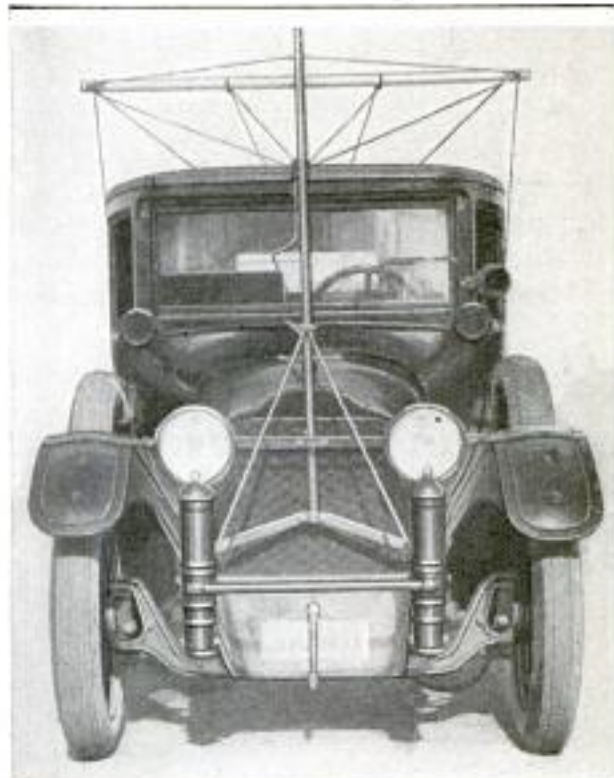

Left: Elaborate Radio-Instrument Installation, Which was Placed on the Dashboard of the Machine So the Driver could Also Do the "Tuning In." Right: Front View of the Motor Bus, Showing the Method of Mounting the Aerial on the Machine

Dept of Commerce  
Bureau of Standards

6/8/22  
J N B 62, P. 3

Chicago Agent.  
9445  
1008 N. Dearborn St.  
Hush A. Phone Agency

19 Madison Ave  
Hush A. Phone Corp.  
44 E. 42nd St. New York City

trial trips of the first car so equipped. Possessing only a two-step radio short-wave receiving outfit, the experimenters could hear concerts at a distance of 15 miles from the broadcasting station, and this despite the obvious necessity of employing a low antenna. The latter is of the most improved type available, being raised about one foot above the top of the car and securely supported on uprights which are strongly braced.

The instrument installation is made on the dashboard of the car so that the driver can "tune in" the equipment without leaving the wheel. Inside the bus, a

loud-speaking horn is placed, so that individual receivers for the passengers are not required. According to the officials of the transit company and radio experts interested in the project from a scientific standpoint, several minor problems yet remain to be solved before the novelty can be termed a complete success. Notwithstanding these deficiencies, however, all parties concerned are determined to continue their efforts until, in addition to mere transportation, the passengers of this line of motor busses will be given the best radio entertainment broadcast in that part of the country.

*Attach wires*  
**TELEPHONE ACCESSORY GIVES PRIVACY OF SPEECH**

Privacy of speech is possible with the use of a telephone accessory introduced by a New York corporation, and which can be fitted over the mouthpiece of any standard instrument.



The speaker places his lips inside a special sound box having flared ends, each of which contains an antiseptic, removable sound-absorption unit. These units prevent any surrounding noises from being heard on the line, and in addition the person conversing can speak freely without being overheard by anyone standing at his side.

*\$10.00*  
**FABRIC VENTILATION TUBING UNDERGOES SEVERE TEST**

For carrying ventilating air in mines, fabric tubing has many marked advantages over metal pipe, the great objection to its use being its rapid deterioration. A fabric tubing has now been placed on the market, which, after a severe seven-months' test in a mine where the temperature was high and the dripping of acid mine water excessive, is still in good condition. Other samples of tubing, in use underground more than two years, are still delivering air and are in good working order.

*9496*  
**RATE OF HEATING HAS EFFECT WHEN HARDENING STEEL**

Preliminary investigations by the Bureau of Standards indicate that the rate of heating when hardening steels, has an effect on changes in dimensions of the piece heated. A series of 16 samples of die steel was hardened, using different rates of heating, and changes in dimensions of the finished pieces were noted. While the results obtained were not uniform, they indicate that the metal did not have the required uniformity. Further similar tests on different steels are to be carried out.

*9498*  
**RHEOSTAT FOR VACUUM TUBES HAS GOOD QUALITIES**

Rheostats for controlling the current in vacuum tubes and constructed for mounting on panels varying from one-eighth to one-half inch in thickness, are now being manufactured by a Milwaukee, Wis., concern. Two styles, one with vernier adjustment

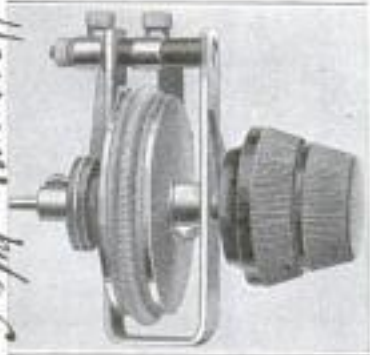

for detector tubes, and the other for amplifier tubes, are available, each designed for an operating range from zero to four ohms.

A Junior Red Cross children's hospital has been opened at Calgary, Alberta, for the free treatment of children whose parents cannot afford to pay for medical attendance.

E. C. Du Pont de Nemours Co., Inc. Wilmington Delaware



9438 Cmt. S. Q. Winters  
 703 District National Bank Bldg  
 POPULAR MECHANICS  
 Washington, D. C. 171

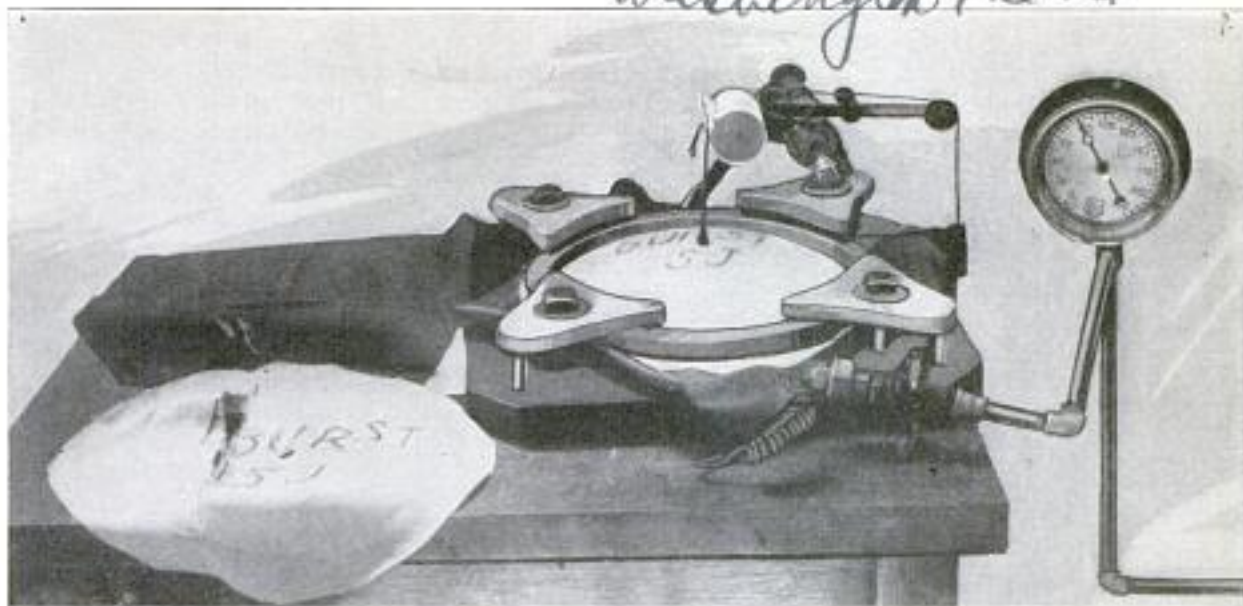

A Sample of Fabric to be Tested is Clamped under the Steel Ring, and Compressed Air is Admitted to a Rubber Diaphragm under the Sample, the Pressure being Increased Until the Piece of Fabric is Ruptured

9438  
**APPARATUS TO TEST FABRICS  
 TO THE BURSTING POINT**

In fabrics used for special purposes, the actual resistance to rupture is of greater importance than the wearing qualities of the cloth; for example, the fabric used in the manufacture of balloon envelopes. To test this quality, the Bureau of Standards has designed an apparatus for testing samples of fabric to the bursting point. The sample to be tested is clamped under a steel ring, and air pressure is applied to a rubber diaphragm under the sample. The amount of deflection at the center of the sample is automatically recorded on the drum of a common steam indicator, while the air pressure is registered by a gauge. When the sample bursts, the strength is easily computed by the aid of a formula.

9506

**CHILDREN GIVEN PLAYGROUND  
 IN NATIONAL FOREST**

Dedicated to the children of Butte, Mont., a playground located in the Deer Lodge National Forest has recently been turned over for the pleasure of the youngsters by an act of congress. The land is situated in Nine Mile Cañon (about nine miles south of the city), which is a narrow defile in the mountains. Marvelous and purely natural scenic beauties render this recreation spot in the foothills of the majestic Rockies, a veritable wonderland for the enthusiastic kiddies, who, without a doubt, will make excellent use of their gift.

Christian Science  
 Monitor 5/25/20

9447  
**ELECTRIC WIRING IN HOMES  
 USED AS RADIO AERIAL**

Utilizing the wiring in any building as a radio aerial by simply screwing an attachment into a light socket, is made possible with the use of a small article manufactured by an eastern concern. Simple receiving sets of the crystal-detector type, or the more elaborate vacuum-tube outfits, can be "hooked up" without danger by means of this innovation.

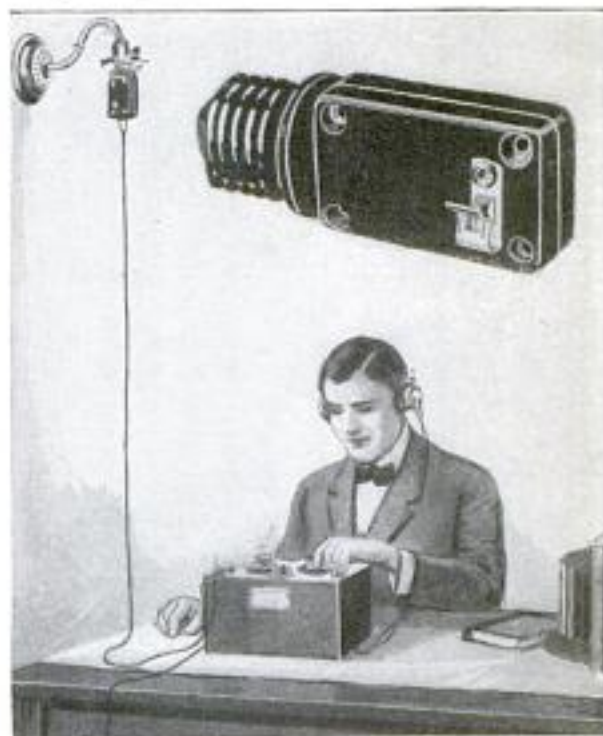

Radio Set Connected by Means of Special Plug to Wiring of Building. Insert: Close-Up of Plug Which is Screwed into Socket

Lubliner Condenser  
 Radio Corp.  
 217 Centre St. New York City

9414

Cent. A. H. Kolbe, #16 E. 2nd St.  
Brooklyn, N.Y.

## SCIENTIFIC METHODS USED IN MUSICAL EDUCATION

BY HENRY S. WHITE

**M**ODESTLY but earnestly, there have been in progress at a few educational

The method is based largely on psychology, and various instruments have been

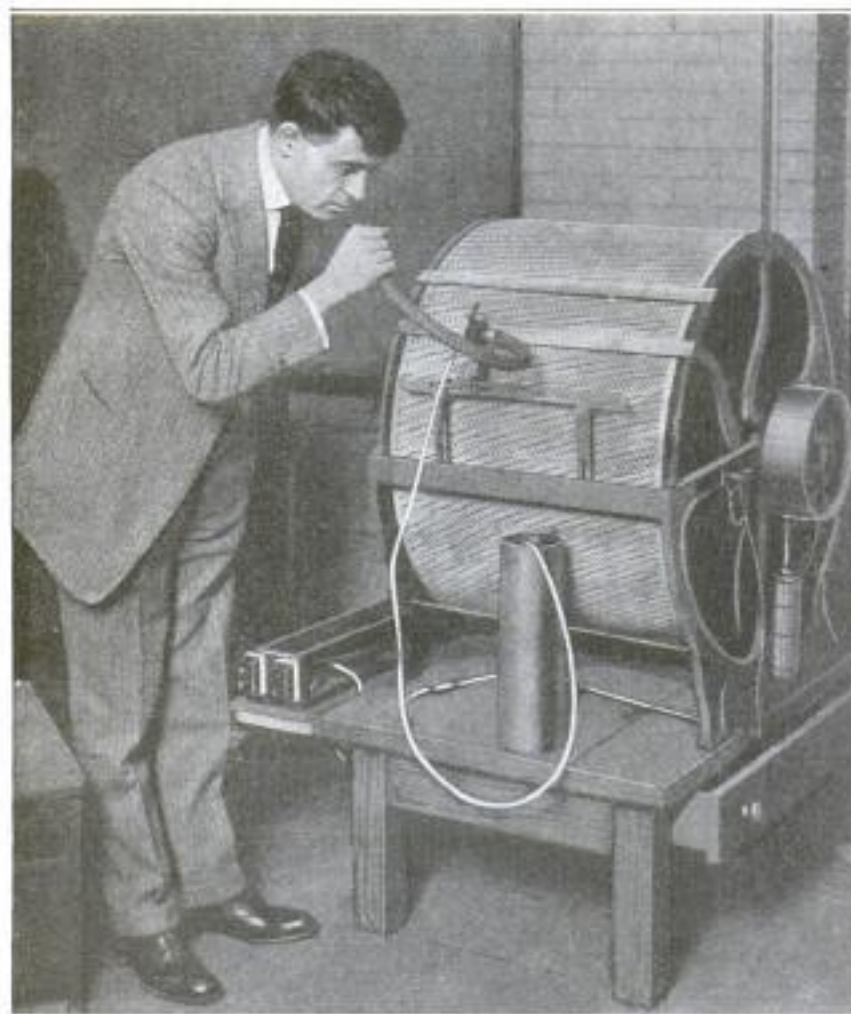

Demonstrating the Tonoscope: At the End of the Speaking Tube, Directly in Front of the Revolving Drum, Is the Apparatus That Causes a Flame to Vibrate. By Means of the Dots on the Drum, Which may Also Be Perforations, the Vibrations per Second are Counted

devised not only for making tests of nerve reactions, but also for measuring musical talent and classifying it. Apart from the psychological element, an instrument for visibly registering tonal vibrations, known as a tonoscope, has been under development for some 20 years, though it is only within the last few years that it has been practically applied. This instrument indicates the exact number of vibrations per second of any tone, tested by it, and as, of course, the number of vibrations of all tones are known, the instrument determines whether the pitch is correct. It consists of a perfectly balanced drum that rotates horizontally, making exactly one revolution per second. The white face of the drum is covered with black dots arranged in rows, which, in connection with a scale, enable the operator to read the number of vibrations per second made by a small gas flame in front of the

centers of this country, during recent years, most interesting efforts to develop a scientific method of musical education.

drum, which is caused to vibrate in accordance with the tone of a voice or instrument conducted to it through a speak-

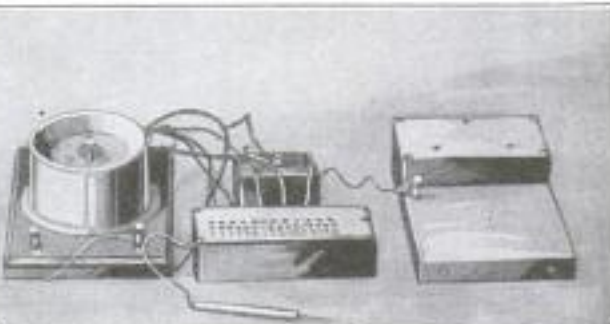

Above is Shown the Apparatus for Testing Accuracy and Rapidity of Movement. At the Left a Schoolgirl is Shown being Tested for Precision of Movement. With Watch in Hand, the Operator Times Each Movement Made by the Girl with the Pointer in Her Right Hand

9414 Mr. Carl Seashore, University of Iowa, Iowa City, Iowa.

POPULAR MECHANICS 173  
 Mr. Max Scholw, Carnegie Institute

ing tube. The attachment in connection with the speaking tube and the flame is moved along the face of the drum until the number of vibrations of the flame and the number of dots concur, and that number is then read on the scale. When the number of vibrations of the flame and the number of the dots in any one line are exactly the same, the line of dots has the appearance of standing still. The neighboring lines of dots appear to continue to revolve. In this manner the tonoscope will detect an error of only one vibration per second.

ing nerve reaction to discover the degree of susceptibility to pitch of sound, others for testing precision, and still others for

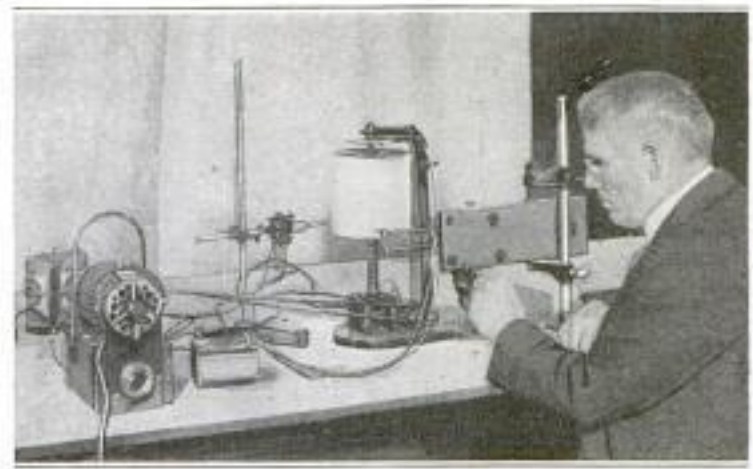

This Instrument Is for Testing Free and Controlled Rhythm. It Is One of Several Different Musical-Testing Instruments in Use at the Northwestern University, at Evanston, Illinois

The tonoscope was first developed at the University of Iowa. It has since been used at San Francisco, Calif., Rochester, N. Y., at the Carnegie Institute of Technology, Pittsburgh, Pa., and at the Northwestern University, at Evanston, Ill. Other instruments have also been developed for making various tests to determine the natural aptitude and musical talent of students. Many of these are now being practically ap-

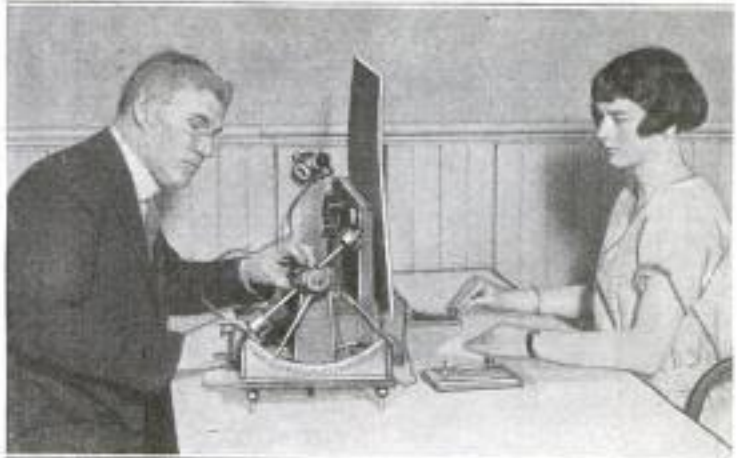

Apparatus Used for Measuring Nerve-Reaction Time, Known as the Chronoscope, in Use in the Public Schools of Evanston for Making "Mood Charts" of the Students

testing free and controlled rhythm. From these tests made on students, "mood charts" are made that give an accurate record of the musical aptitude of each student, so that it can be positively decided which individuals have the natural mental and physical qualifi-

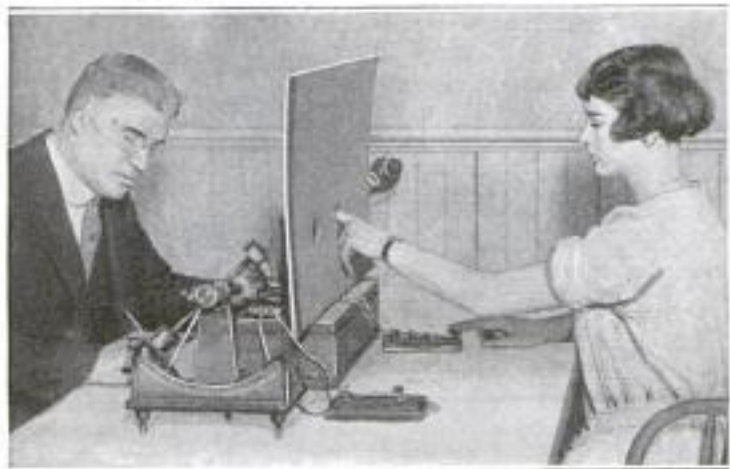

Another Instrument, in Use in the Evanston Public Schools, for Measuring Nerve Reaction, to Discover Degree of Susceptibility to Pitch of Sound, and for Precision of Movement

cations best suited for the acquirement of ability as performers on the piano, the violin, a wind instrument, or as vocalists. Henceforth, there need be no time wasted in trying to make a born pianist into a vocalist, or a born poet into a musician.

Announcement has been made of the invention of an automatic shocker for placing sheaves of grain in shocks as they come from the binder. The sheaves are collected on a platform until there are sufficient for a shock and are then dropped, butt-end down, and consolidated at the top as firmly as though placed by expert farm hands.

plied at the public schools in Evanston. Among them are instruments for measur-

of Technology, Pittsburgh, Pa.

**SHOW SPAN OF HUMAN LIFE  
COMPARED WITH TREE'S**

When one of the giant trees in Yosemite National Park was blown down a few years ago, the park naturalist had a



The White Marks on the Section of This Giant Sequoia Show the Dates of Different Historical Events. The Man is Measuring between Thumb and Finger the Span of a Long Human Life

section cut from the trunk as an exhibit to show the life of the tree. This tree was 14 feet in diameter at the base and was found to be 996 years old. In order to visualize this lapse of time, white marks were drawn on the surface of the section representing the years in which occurred various historical events.

**UNEARTH GOLD COINS MINTED  
BEFORE CHRISTIAN ERA**

In the ruins of Sardis, the ancient capital of Lydia in Asia Minor, scientists have recently recovered 30 gold coins minted during the reign of Croesus, sometime between 560 and 546 B. C. The coins were found in a stone jar buried in an ancient tomb, only a few feet below the surface. Some of the coins are as fresh and bright as newly minted coins, while others show signs of having been in circulation. The remarkable state of preservation is due to the fact that the coins are of pure gold. In size, they are

about like a five-dollar goldpiece and are called "staters." Croesus is credited with being the first one to mint gold coins, the method being to stamp the coins from solid metal. The figures on the coins were formed by a die during the stamping. Before this discovery only five of these coins were known to exist.

**ADD WAX TO RENDER VARNISH  
MORE ACID-RESISTING**

Recent investigations have shown that the addition of small quantities of wax to a varnish that is resistant to water or acid fumes, will make it considerably more resistant. Various kinds of wax may be used, and as the amount of wax added is small, it has no appreciable effect on the toughness or other desirable qualities of the varnish. The explanation offered in the case of baking varnishes is that the wax melts and fills all the pores of the varnish film.

*Chemical Age May, 1922*

**SAFETY SIGNS ARE CARRIED**

**BY TAXICAB COMPANY**

Safety campaigns in Pittsburgh, Pa., have caused a taxicab company to place in each of its 100 machines, a sign which is clearly visible through the rear glass. This sign reads: "We are Co-operating with the National Safety Council to Prevent Accidents. Will You Help?" Thus the following autoists are constantly reminded of the value of safe driving, the sign exerting a silent per-



One of the Machines of a Pittsburgh Taxicab Company, Showing the Sign It Carries to Aid in the Prevention of Accidents

suasive force for the promotion of extra care.

*Pittsburgh, Pa.*  
Copyrighted material  
*Pittsburgh, Pa.*

948<sup>3</sup>

950<sup>5</sup>

950<sup>4</sup>

*How?*

*New York Times  
6/14/22*

TANDEM TRIPLANE HAS NOTEWORTHY FEATURES



This Passenger and Freight-Carrying Triplane is Now being Constructed in Kansas City, Missouri, and is Designed to Carry 30 Passengers and 1,000 Pounds of Freight. The Fuselage is Built on a True Wing-Shape Section and is Over Eight Feet Wide and Six Feet High

That commercial aviation in this country is not lagging behind the rest of the world, is evidenced by news which comes from Kansas City of a giant tandem triplane now being built. Designed for passenger and freight carrying between Kansas City, St. Louis, and Chicago, the plane will carry 30 passengers, including the crew, and 1,000 pounds of freight. Several noteworthy features of construction are being introduced, the most striking of which is the novel form adopted for the fuselage, which will be built in a true wing section. The wings will be of movable type, allowing a variable angle of incidence. This will result in giving the plane a slower landing speed (23 miles per hour) and a quick take-off (30 miles per hour). The flying speed will be 120 miles per hour. The plane will be powered by two Liberty engines and will have a cruising range of 500 miles. The span of the front wings is 60 feet and of the rear wings 40 feet, the over-all length of the machine being 45 feet. The wing-sectioned fuselage is a

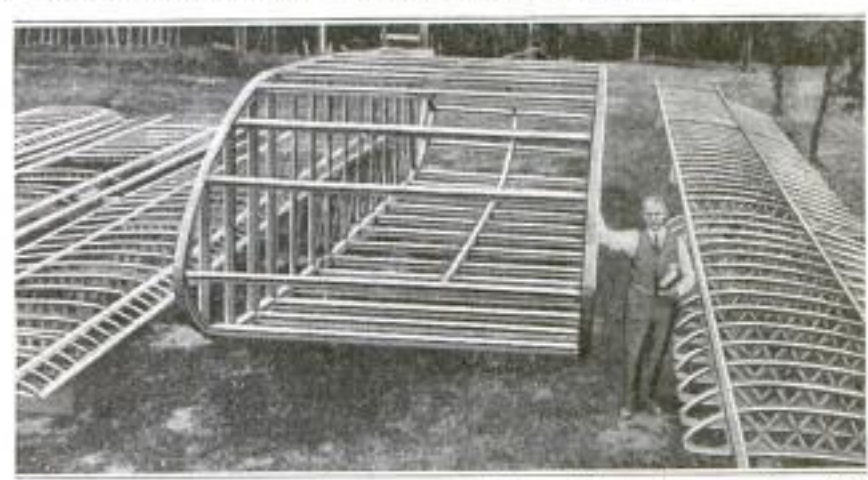

The Framework for the Fuselage and Wings being Constructed: The Fuselage is Shaped like an Enlarged Wing Section, with the Idea of Increasing the Lifting Power

little more than 8 feet wide and 6 feet high. The craft has dual control, and two pilots will always be on duty. It is planned to make one round trip daily between the points on the route, a distance of approximately 900 miles.

During the recent investigations by the Bureau of Mines on the quality of oil produced from the Colorado shales, it was found that a superior quality of oil was produced when the vapors were condensed rapidly. This result was unexpected and will be verified by further investigations.

*Aerial Navigation Co.,  
1012 Baltimore Ave. Kansas City, Mo.*

R. W. Savini; Savini Films,  
Inc., 63 Walton St.,

908<sup>176</sup> Atlanta, Ga. POPULAR MECHANICS

### CLOCK DIAL TELLS THE TIME EVERYWHERE AT ANY TIME

A clock dial has been designed, and several have been installed, that gives the

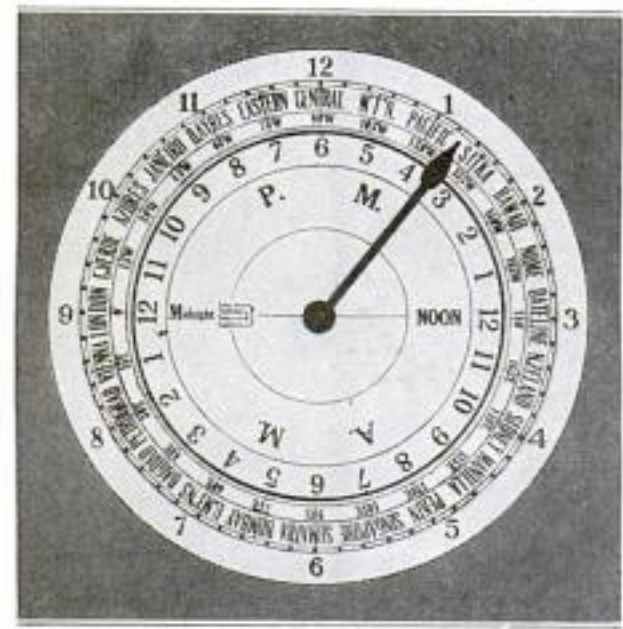

COPYRIGHT, J. C. CORE

Clock Dial Set to Show the Time in All Parts of the World in Relation to United States Central Time, Which Reads 6 1/2 Minutes Past 6 after Noon

correct time in all parts of the world in relation to either eastern, central, mountain, or Pacific time of this country. An outer ring designates the 24-hour belts of the world, each hour representing 15° of longitude. At each of these points is printed the name of the U. S. time zone, of the largest city in the belt, or some other geographical name identifying it. If the clock is located in the American

central belt, this point is placed at the top of the clock. Mounted on the clock spindle in place of the hour hand is a disk which, as it revolves, indicates the hour in this belt, and also the corresponding hour in every other belt in the world. An ordinary minute hand indicates in the usual way the number of minutes before or after the hour, which, of course, is the same in relation to the various hours in all other time belts. The central disk indicates whether the hour is forenoon or afternoon. Any ordinary clock can be fitted with this dial.

### 9278 WORN-OUT PAVING MATERIAL RECRUSHED FOR BALLAST

When a certain paving material for roadways, consisting of 93 per cent stone and 7 per cent coal tar, wears out and is taken up, it is usually of no further value. At Hutchinson, Kan., the interurban-railway company has recrushed this material, and used it as ballast for their roadbed. The material is easily crushed when the temperature is 40° to 45° or lower, but at higher temperatures it is soft and difficult to crush. For this reason the work was done at night, or with a stream of cold water poured upon it. A crusher of the oscillating type was mounted on a low-wheeled truck with a motor driven by the current from the railway trolley wire. Powerful electric lights were used at night. The material was crushed to particles about an inch in diameter, and was then thrown on the roadbed and tamped into it.

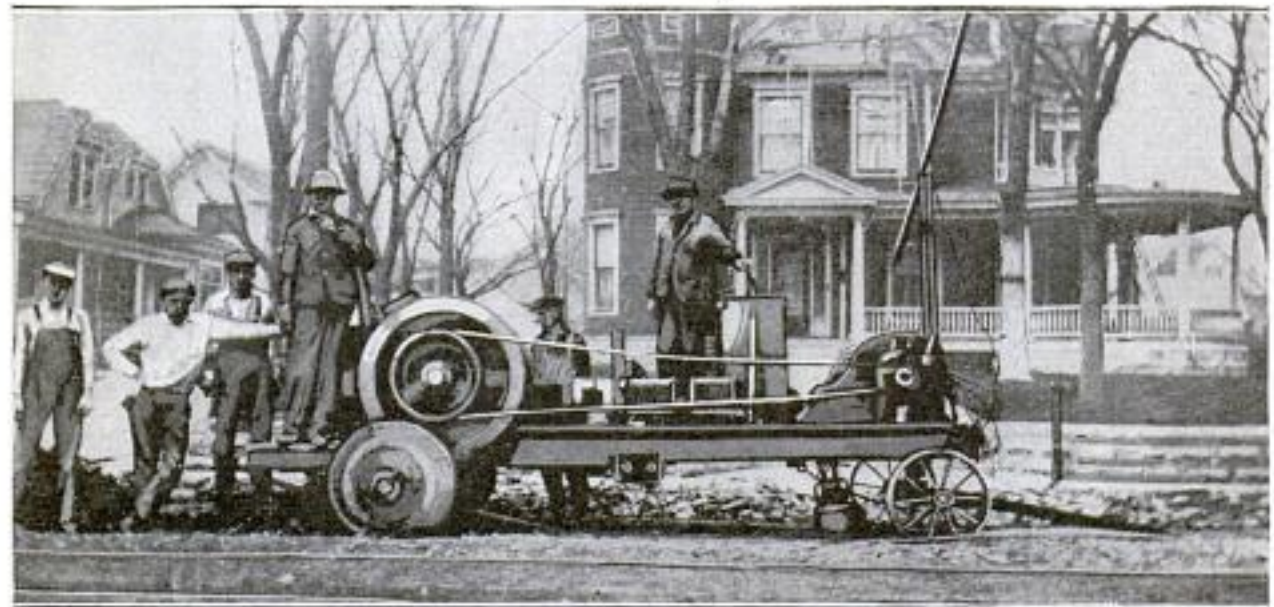

Crusher and Motor Mounted on a Truck, and Used for Recrushing the Worn-Out Paving Material beside the Car Track: It can be Seen Already Torn Up from the Roadway, Ready to be Thrown into the Crusher. The Material is Then Used as Ballast for the Roadbed

Hutchinson Interurban Railway Co.  
Kans. Copyrighted material

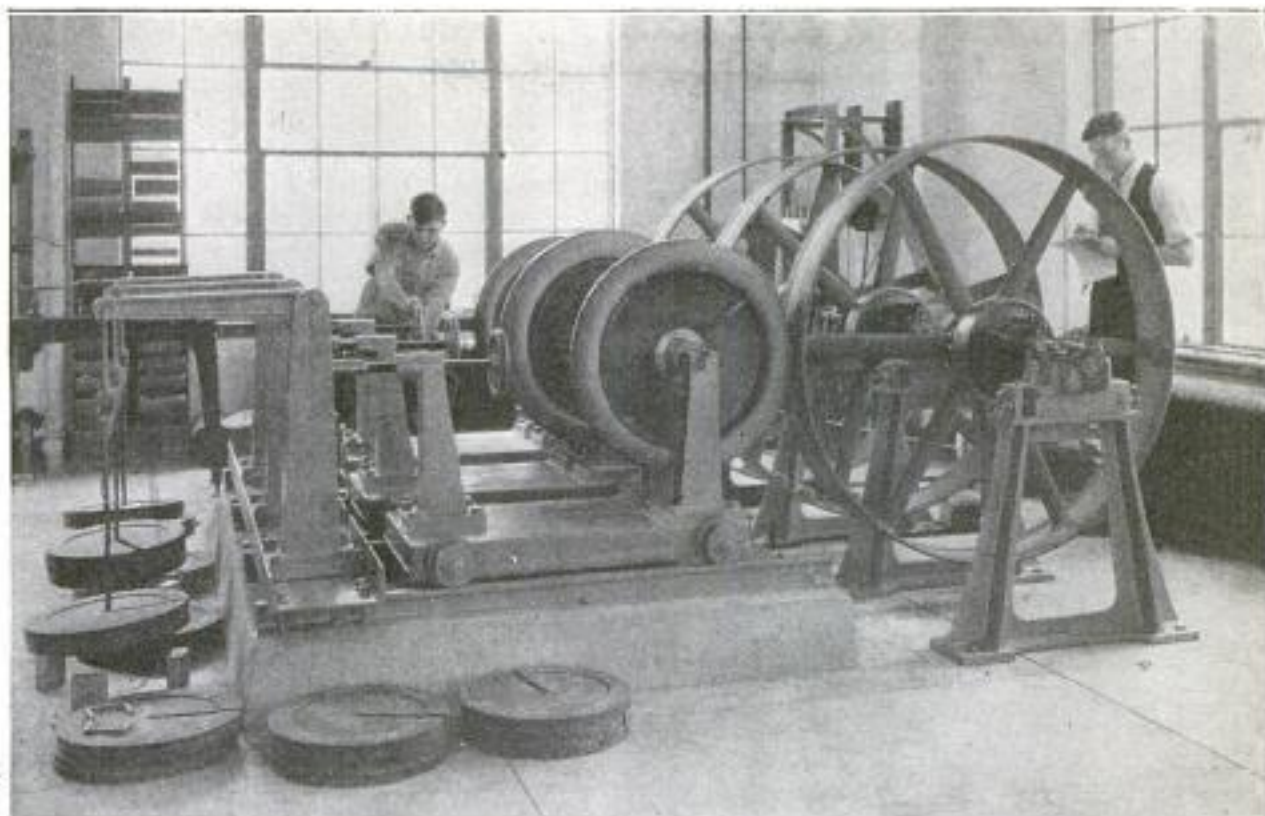

This Machine Tests Automobile Tires by Wearing Them Out. The Weighted Levers Force the Tires against the Revolving Metal Drums, and Speedometers Keep a Record of the Mileage Covered Until the Tire Fails

**BUILD MACHINE TO WEAR OUT  
 AUTOMOBILE TIRES**

Buying automobile tires on a basis of actual-performance records may soon become a fact, should the new testing machine of the Bureau of Standards fulfill expectations. This machine was designed for the sole purpose of testing tires under conditions approximating those met in actual service. The tires, inflated to the proper pressure for their size, are placed on automobile wheels mounted on platforms free to move along metal tracks. Weighted bell cranks force the tires against five-foot metal drums with a pressure equal to the weight they would sustain in actual service. The metal drums are then revolved at the desired speed and kept in operation until the tires collapse. When failure occurs, an automatic electric switch stops the revolving drum. It has been found possible to make a tire travel the equivalent of 9,600 miles in 10 days of testing.

☞ The advisability of equipping their respective stations with radio apparatus was recently discussed by the police superintendents of six large eastern states. A system similar to that under discussion has but lately been installed in Pennsylvania.

**RADIO-RECEIVING APPARATUS  
 RESEMBLES TABLE LAMP**

Resembling an ordinary table lamp, a complete receiving set consisting of a radiophone, detector, tuner, two-stage amplifier, and loud speaker, has been produced by an eastern corporation. When the top of the lamp is raised, the equipment is exposed on a neat circular panel, the base containing the loud-speaking horn. A common plug and extension cord permits the utilization of the electric wiring of a building as an aerial, by the simple process of screwing the plug into any light socket in the place.

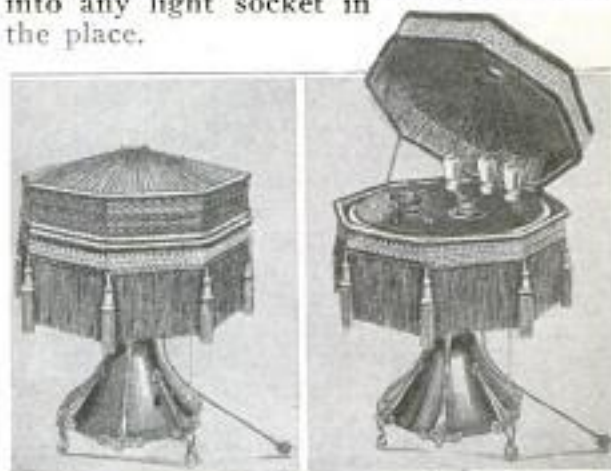

Left: Radio-Receiving Set Mounted in Box in the Form of a Table Lamp. Right: Top of Lamp Raised, Exposing Equipment

The Capitol Phonograph Corp.  
 897 Union St. New York

Cool Edward J. Inc Cool. Master  
Townley Lodge, no 220, F. & A. U.

178  
9338

## POPULAR MECHANICS

Palisades Park N.J.

### NEW MASONIC-LODGE TEMPLE BUILT BY MEMBERS



Masonic Temple of Townley Lodge, Palisades Park, New Jersey, Built with Their Own Hands by Members of the Lodge: The Structure is Very Solidly Built, with the Intention of Making It Almost Imperishable

The members of Townley masonic lodge of Palisades Park, N. J., have proved that they are masons in the literal sense of the word, for with their hands they have built and equipped their own \$75,000 lodge temple. Among the 150 members of the lodge there were enough craftsmen to enable them to carry out all branches of the work. The structure is built solidly of stone, with the intention of making it "almost imperishable, so that future generations may derive therefrom inspiration to nobler undertakings."

### 9366 WOOD SAW FITS FRONT OF TRACTOR

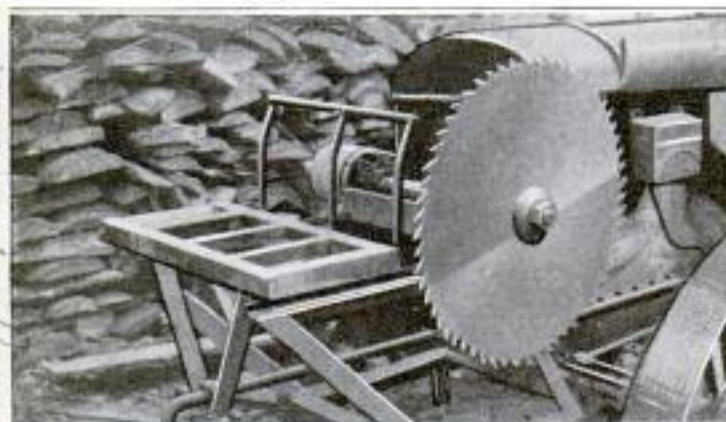

This Belt-Driven Wood Saw is Supported on a Substantial Steel Frame That can be Attached to the Front of a Tractor without Interfering with Its Operation

Instead of placing the wood saw on a separate stand, a western inventor has patented an attachment with which it is possible to fasten the saw to the front of a tractor. The saw is driven by a belt and pulleys, and can be left running when the tractor is moved, as neither the belt nor the saw interferes with the front wheels. The extension for the starting handle can be released and put to one side after the engine is started, leaving the space in front of the saw clear of all obstructions.

*Laundry*

### 9475 CLEANING AUTO RUNNING GEAR IN A WASHBOWL

The automobile owner who cleans his own car and who, after hours of back-breaking effort and at the expense of bruised knuckles, has removed all the mud from the running gear only to find the paint underneath caked and chipped, will welcome a novel aid in the auto-washing job. This consists of a shallow concrete basin filled with water to a certain fixed level, and built with easy-sloping ramps for driving the cars into and out of it. Corrugations in the bottom of the bowl cause the car to vibrate as it is driven around, and the accumulated mud is

jarred loose and washed off. Before the car is driven into the pool, an attendant straps a rubber cover over the radiator to protect the engine from being splashed. A nominal charge is made for the "bath," and the owner may "stay in" until he is satisfied that all dirt has been washed off. The cars are driven in the bowl at a speed of 10 to 12 miles per hour, and three minutes generally suffice to remove the most stubborn mud. Inlet and outlet pipes in the pool provide means for washing out the accumulated sediment and changing the water.

Cool. C. P. Bohland, Service Station  
Construction Co. St Paul, Minn.

*Mr. Sydney C. Lawson  
Deer Lodge, Mont.*



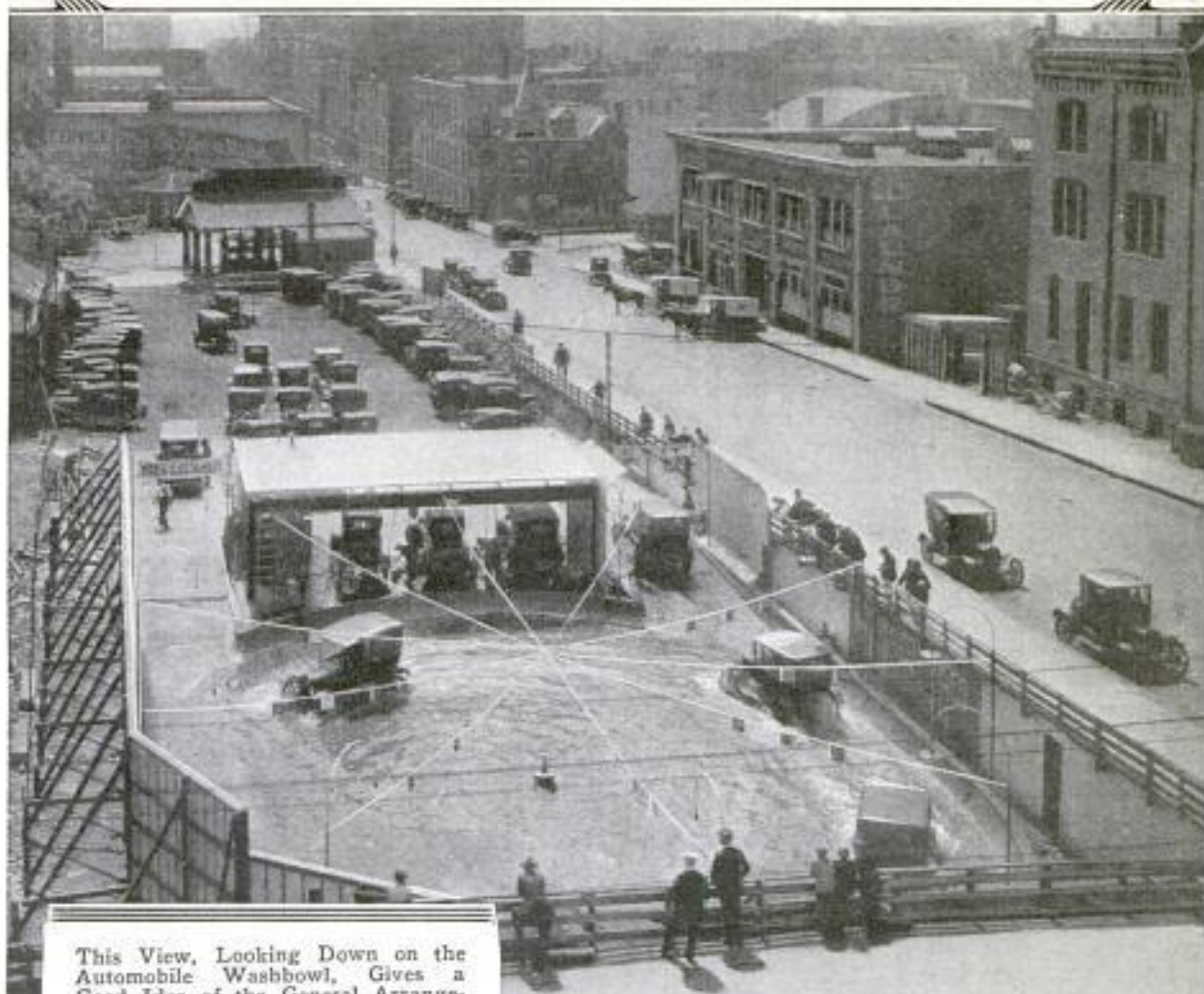

This View, Looking Down on the Automobile Washbowl, Gives a Good Idea of the General Arrangements. Gently Sloping Ramps at Either Side Permit Easy Entrance and Exit. Below: Automobiles Driving around the Bowl at a Speed of 10 to 12 Miles per Hour and Shaken by the Corrugations in the Bottom of the Pool, Soon Wash the Mud from the Running Gear



915<sup>180</sup>  
 Thos. W. Cappon,  
 Newark, N.J.  
 93 Fourth Ave.

The Higgins Mfg. Co.  
 126 E. Main St.  
 Bellevue,  
 Ohio.

**POPULAR MECHANICS**  
**FOUNTAIN-PEN ERASER LIKE RUBBER TIP ON PENCILS**

Resembling the rubber tip in its application to the lead pencil is a newly patented ink eraser for connection to the end of a fountain pen. The eraser consists of a small piece of glass tubing that is sheathed in the end of the fountain pen opposite the pen nib. The open end of this tube is closed with a rubber stopper, through which passes a smaller glass tube, of about 1/8-inch diameter, containing a small piece of glass rod that fits it loosely, and acts as a plunger. Inside the glass tubes is an ink-erasing liquid, and when by a little pressure on the end of the plunger it is pushed into the liquid, a small amount runs down the side of



the plunger and lodges on the ink to be erased. A small cap covers the eraser, and the removal of this cap draws out the plunger, leaving it ready for operation.

**NEW AUTOMOBILE VAPORIZER INSTALLED IN MANIFOLD**

Complete vaporization of the gasoline is claimed to be possible with a recently patented attachment that is installed in the manifold of an automobile engine. Besides the resulting increase of mileage per gallon of fuel, there is also a reduction of carbon deposit that, it is said, causes a noticeable increase in

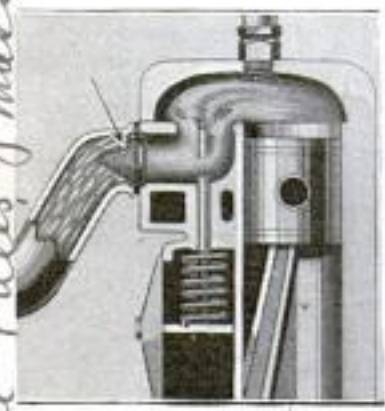

power after the vaporizer has been in use for some time. The device consists simply of a cone-shaped screen placed in the manifold at its junction with the cylinder block next to the intake-valve chamber. The cone points into the manifold, and

as the incoming fuel strikes the fine gauze, it is broken up into a finely diffused vapor, while any product of condensation in the mixture is diverted to the base, where the heat of the block causes vaporization.

**GRAB HOOK AUTOMATICALLY OPENS AND CLOSSES**

A three-pronged fishhook makes it about three times as easy as with a single prong for an angler to hook a fish.



The smaller center hook is the only one baited, and the others, one on either side of it, close on a fish that is nibbling the bait when a strike is made with the line. In

raising or lowering the hooks in the water, they open or close automatically.

**ELECTRICALLY HEATED BATH TESTS THERMOMETERS**

For comparing the accuracy of clinical thermometers, the Bureau of Standards has developed an electrically heated apparatus in which 24 thermometers may be tested at one time. The container is roughly cylindrical and is divided into two compartments. A pump driven by a small motor circulates the water from the heating space to the testing compartment. A telescope sight is provided for taking the readings of the thermometers under test. There is also arranged a cooling coil for use when testing at temperatures lower than that of the surrounding atmosphere.



Electrical energy furnished to the Chicago union railroad terminal would supply the entire demands of a city of 50,000 population.

U. S. Bureau of Standards,  
 Department of Commerce.

Parrott Stamping Co.  
 Shelburne Falls, Mass.

9536 Mrs. } Emilio Berliner } 1458  
 Henry A. Berliner } Columbia  
 Road  
 Washington,  
 D. C.



This Berliner Helicopter has Risen as Much as 10 Feet in the Air during Preliminary Flights. The Two Large Propellers Not Only Supply the Lifting Force, but Also Drive the Machine Forward. The Propellers and Special Balancing Vanes are Carried on a Stout Cross Member

9536 *air machine*  
**MAN-CARRYING HELICOPTER MAKES SHORT FLIGHT**

Since the early days of aviation, the development of a successful helicopter has been one of the most fascinating problems for the experimenters in aeronautics. The two chief advantages of such a machine would be its ability to rise or descend in a vertical line, and to hover in the air much in the manner of a balloon. That advances are being made toward the solution of this problem is shown by the announcement of some successful flights by the Berliner helicopter, at College Park, Md.

The machine has followed standard air-

plane design as far as practicable, having a fuselage and landing gear similar to the ordinary airplane's. The wing surface is replaced by two large propellers, revolving in a horizontal plane, and supported on a substantial cross member which also carries the special balancing vanes that act as ailerons. The propellers, besides supplying the lifting force, are so arranged that they drive the machine ahead after it has risen from the ground. No extended flights have yet been made, but in official preliminary flights the machine has risen as much as 10 feet in the air.



A Closer View of the Machine, Giving a Good Idea of the Size of the Propellers, and the Arrangement of One Set of the Balancing Vanes That Function as Ailerons

*Clavistone Co.*  
 2905 W. Madison,  
 182 Chicago **POPULAR**  
*apparatus*  
**USE NONVIBRATING MATERIAL  
 IN RADIO LOUD SPEAKER**

9475

The enjoyment of the radio concerts now being broadcast would become much greater if some form of loud speaker were produced which transmitted the sound clearly and without distortion. For this purpose there is now being manufactured a loud speaker made of a

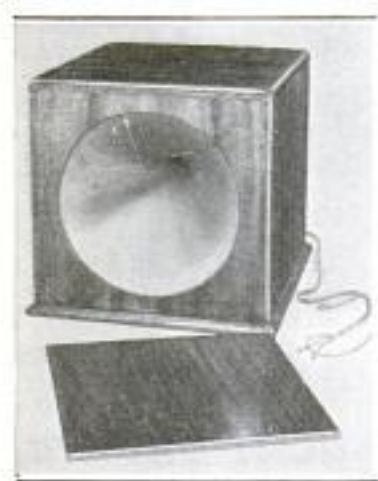

vibrating material, which is said to give much better results than the older devices, not only as regards volume of sound, but also with respect to quality and purity of tone.

*Light. Rec.*

**MERCURY-VAPOR ARC LAMP IS SELF-STARTING**

Mercury-vapor arc lamps, despite their many merits, are commonly known to possess several deficiencies, chief of which are the length of time required to obtain the maximum luminosity and the starting of the arc by outside means. These defects have been remedied by a French scientist who has produced a lamp having a coiled tungsten filament inside the glass tube, which also



contains a proportionate amount of mercury and an inert gas, such as argon, neon, or helium. When a current passes through the filament, the latter becomes incandescent, and the resultant heat dilates the gas. This dilation causes enough movement of the mercury to start the arc, bringing it to its fullest intensity in from five to ten seconds.

*And. by Hand and Keef Paris, 166 Rue St. Honore, France*

*National Headquarters*  
 9570 Lincoln Highway  
**MECHANICS Association**  
*Detroit, Mich*  
**MUNICIPAL AUTO-CAMP SITES  
 ALONG LINCOLN HIGHWAY** *Journal*

For the benefit of automobile tourists, the following list of camp sites along the Lincoln Highway has been compiled. Many communities provide free camping grounds that are elaborately equipped. At all the points listed, special grounds have been set aside for the free use of campers, and tourists are made welcome and treated with consideration.

CITY	STATE	CITY	STATE
Caledonia Park, between Gettysburg and Chambersburg	Pa.	Gibbon	Neb.
Ligonier	Ind.	Elm Creek	"
Laporte	"	Lexington	"
Dyer	"	Cozad	"
Plainfield	Ill.	Gothenburg	"
Dekalb	"	North Platte	"
Aurora	"	Sutherland	"
Clinton	La.	Ogallala	"
Dewitt	"	Brule	"
Calamus	"	Chappell	"
Clarence	"	Lodgepole	"
Marion	"	Sidney	"
Cedar Rapids	"	Potter	"
Belle Plaine	"	Dix	"
Tama	"	Kimball	"
Marshalltown	"	Bushnell	"
Nevada	"	Cheyenne	Wyo.
Ames	"	Laramie	"
Boone	"	Rock River	"
Grand Junction	"	Medicine Bow	"
Jefferson	"	Fort Steele	"
Scranton	"	Rock Springs	"
Dennison	"	Green River	"
Woodbine	"	Fort Bridger	"
Council Bluffs	"	Evanston	"
Omaha	Neb.	Coalville	Utah
Fremont	"	Salt Lake City	"
Valley	"	Tooele	"
North Bend	"	Ely	Nev.
Schuyler	"	Fallon	"
Columbus	"	Reno	"
Silver Creek	"	Carson City	"
Clarks	"	Placerville	Calif.
Central City	"	Sacramento	"
Grand Island	"	Stockton	"
Wood River	"	Tracy	"
		Haywards	"
		Dutch Flat	"
		Auburn	"

**GLUE CONTAINER IS SHAPED LIKE FOUNTAIN PEN**

Carrying glue in the vest pocket or handbag, and in a container no larger than a fountain pen, is possible with a novelty lately introduced.

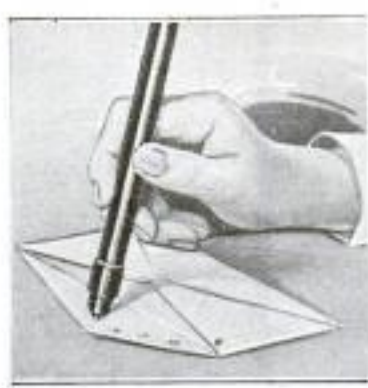

The barrel of the innovation is filled from the top, and in using, the contents are ejected, one drop at a

time, by a slight pressure of the point on the article to be glued.

*The Jax Novelty Co.*  
 292, Copyrighted material  
*Steger, et al.*

Col. R. M. Clutterbuck, Box 3461,  
Honolulu, Hawaii.

## Drilling Holes in Active Volcano

Daring Scientists to Drill Holes, from 50 to 200 Feet Deep,  
into the Vast Crater of Kilauea, the Ever-Active  
Volcano on the Island of Hawaii

7293

By EVERETT J. LOVETT

TO the man who complains that the days of adventure are past, who feels that life has settled down into a humdrum pursuit of the dollar, who longs for the thrill that comes from accomplishment at

volcano of Kilauea, on the island of Hawaii. This is the largest island of the Hawaiian group, and the volcano has been extremely restless during the last three or four years. Many cracks and

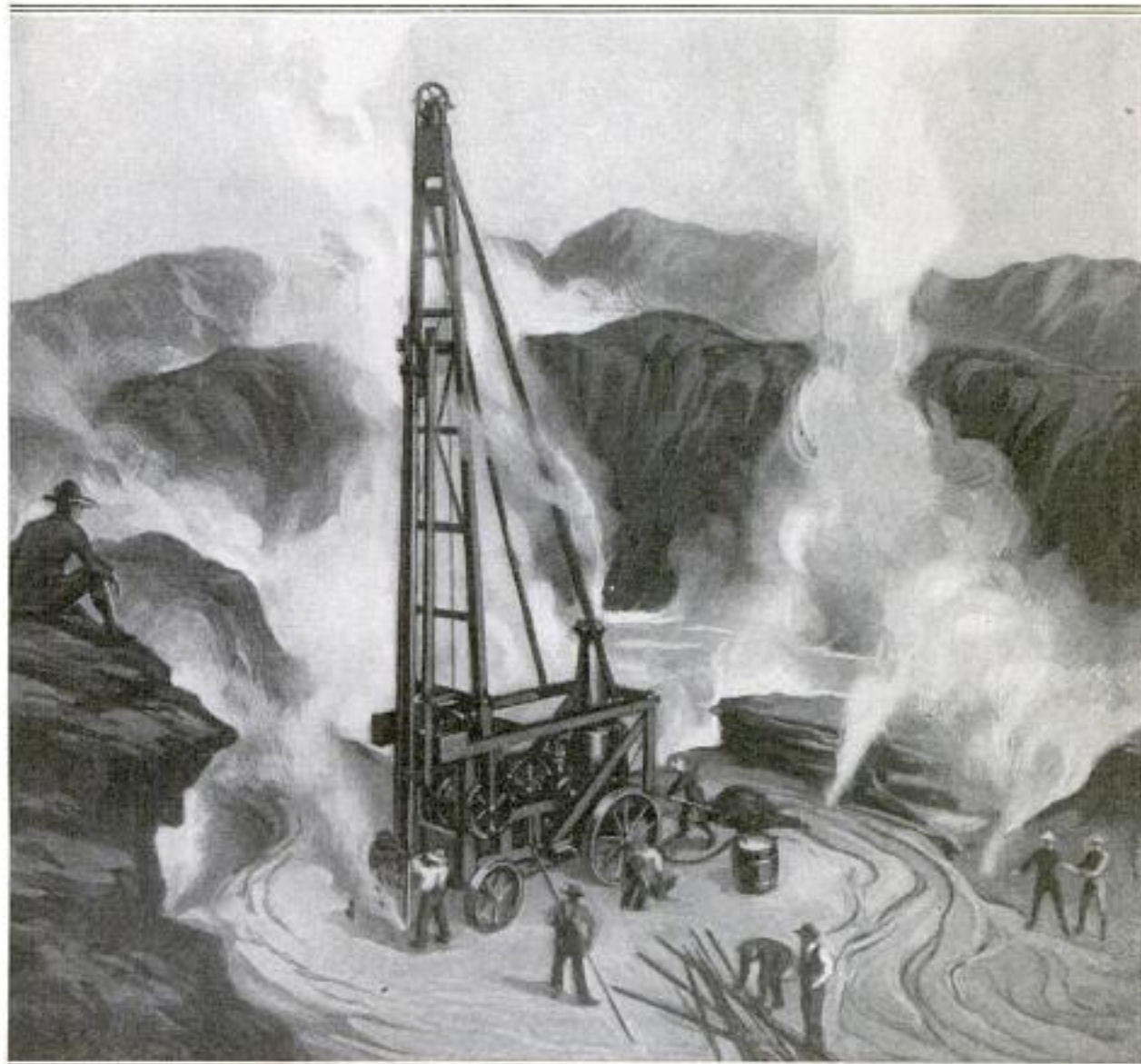

The Drilling Machine as It will Appear in the Crater of the Volcano: Numerous Holes Ranging in Depth from 50 to 200 Feet are to be Drilled. Jets of Hot Vapors Issuing from Many Cracks Indicate That the Hot Interior Is Not Far Distant

the expense of personal risk, the drilling of holes in the crater of an active volcano should appeal as an undertaking sufficiently perilous to satisfy his craving for excitement. Yet, heralded only by the dry announcement that "the borings are for the purpose of obtaining scientific information," men are today engaged in drilling holes into the molten heart of the active

fissures on the surface, from all of which issue extremely hot vapors, testify to the proximity of the internal fire pit.

For the more shallow borings a churn drill will be used, and arrangements have been made for drilling a large number of holes from 50 to 200 feet deep. Accurate temperature readings will be taken in all holes at varying depths, and a vast

Hawaiian Volcano Research Association. 183

Copyrighted material

Howard W. Case, Star Bulletin, Honolulu, J. H.



The Crater of the Volcano of Kilauea, the Largest in the World: The Drilling will be Done on the "Islands" of More Solid Lava Rock, One of Which Appears in the Center of the Photograph

amount of scientific data on earth temperatures will be collected and classified. Holes will be drilled, not only in the crater itself, but also in the rim and sides of the volcano.

If sufficient financial aid is forthcoming, it is planned to continue the investigations by drilling some deeper holes, using a core drill for the purpose.

While the question of the development of industrial power from the internal heat of the volcano has not been touched upon, the results of the investigations

will be watched with great interest by persons who might find such power available.

Several interesting engineering problems will be met in the actual drilling operations, among others the question of preventing the formation of steam from the water used in drilling and pumping operations. As technical details of the operations are not yet available, it is impossible to say how this problem is to be overcome, but that it will be overcome is not for a moment to be doubted.

9515  
**FRESH AIR WITHOUT DRAFT  
WITH NEW VENTILATOR**

Projecting only 3 inches above the roof, a new ventilator manufactured by a Chicago concern will properly change the

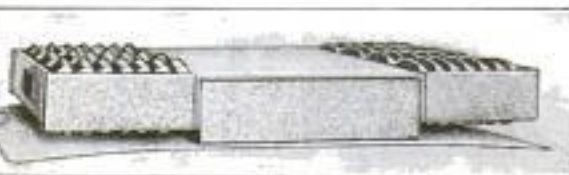

Ventilator Which, When Mounted in the Top of Any Vehicle, Changes the Air without Causing Any Annoying or Dangerous Draft

air in a conveyance accommodating 25 to 35 persons without causing any annoying or dangerous draft. The ventilator, which has been adopted by several rail-

road and motor-bus companies, is so constructed that it functions efficiently in all kinds of weather, regardless of the movement of the car. *Aeromobile*

9517  
**RECORD PARACHUTE JUMP IS  
MORE THAN FOUR MILES**

A new record for parachute jumping was established on June 12, when a member of the air force stationed at McCook flying field, Ohio, jumped from a height of 24,206 feet. A twin-motored bombing plane was used for the ascent and was driven to a point where it failed to climb higher; the parachute leap was then made, and the daring jumper drifted about 25 miles before he finally landed at Jamestown, 30 minutes being required for the descent.

*Chicago Tribune*  
6/13/27

Railway Utility Co. Chicago  
22 nd. Chicago  
141 10

Detroit Free Press  
5/21/22

Comb. L. J. Jellison,  
2506 Windsor Ave.  
8666 Dubuque, Iowa 185

9540

POPULAR MECHANICS

ELECTRIC FARM IS PLANNED  
AS MODEL IN SWEDEN

COMBINATION OF FIVE TANKS  
PLACED ON MOTOR TRUCK

Training Swedish farmers to utilize electric power is the intention of the National Association for Electrification of Rural Sweden, which has requested the government to establish a model electrified farm near Stockholm. It is proposed to equip the farm with all the latest implements, so that the visiting farmer can see electrically operated plows, harrows, seeders, harvesters, and threshing machines in actual use. Motors of different sizes will drive the milk separators and churns, while the method of passing an electric current through cattle fodder to increase its nutritive value, will also be demonstrated.

Five tanks have been incorporated in one and will be mounted on the chassis

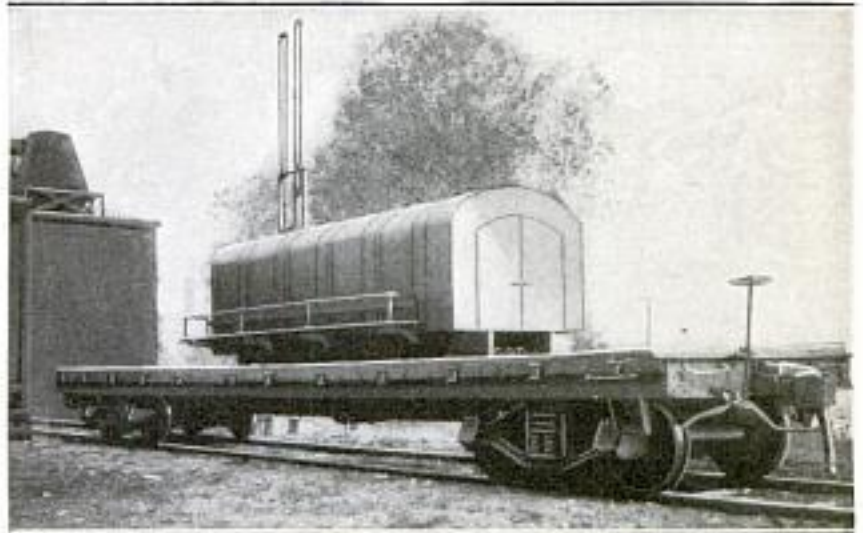

Combination Tank with Five Separate Compartments, Shown Ready for Shipment to Oil-Distributing Company, for Mounting on a Motor Truck

9140  
CONCRETE BRIDGE COMPLETED  
OVER HOUSATONIC RIVER

Nearly all the motor traffic of eastern New England, both to and from New York City, passes through Stratford, Conn., and to accommodate this travel properly the Washington Bridge over the Housatonic River has recently been completed. The new structure is of reinforced concrete, and has two car tracks with a vehicle road on either side.

of a motor truck, for the delivery of various liquids, according to the present plans of an oil-distributing company. Each tank has been made separately so as to prevent any seepage from one compartment to another, and the combined capacity of them all will be 2,750 gallons. The drainage cocks from the different compartments are at the rear.

RECORD ELECTRICAL SHIPMENT  
9525 TO SOUTH AMERICA

Representing the initial consignment of equipment for the electrification of the Chilean state railways, in South America, the largest shipment of this nature ever made was recently sent out from a large eastern manufacturing concern at East Pittsburgh, Pa. The vast amount of material was the first lot of a \$7,000,000 order and was placed on a train of cars about 1,300 feet, or almost one-quarter of a mile, in length. This is said to be the biggest single order for electrification equipment ever received in this country, and constitutes a tribute to American leadership in the electrical industry.

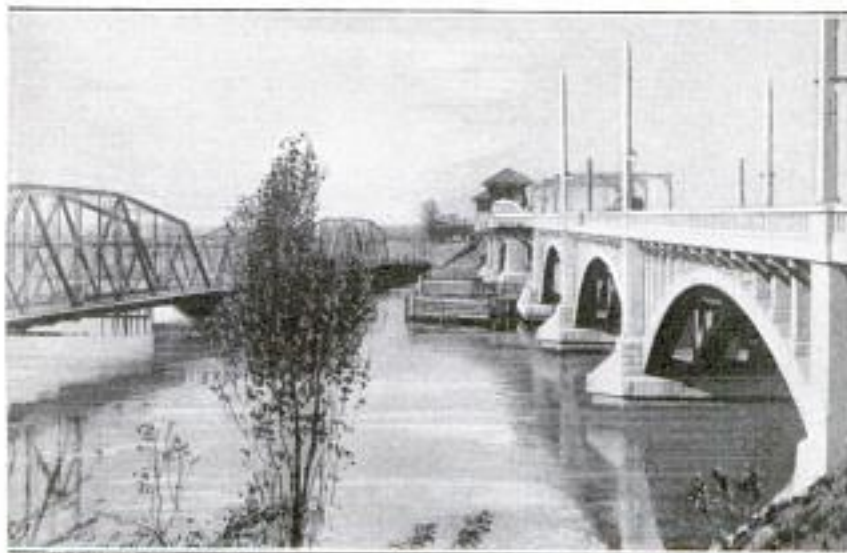

The Washington Bridge across the Housatonic River, at Stratford, Connecticut: It was Constructed to Accommodate the Heavy Motor Traffic between New England and New York City. The Old Bridge is Shown at the Left

Comb. A. W. Peebles, 81 Nash St.  
Bridgeport, Conn

Westinghouse Electric & Mfg. Co. East Pittsburgh, Pa.

*International Geographic Society 6/12/22*  
*Chicago Journal. Tribune 5/24*  
**POPULAR MECHANICS**

186

**BRITISH FLIERS START AIR TOUR ROUND THE WORLD**

Cheered by a large crowd, gathered to watch the start, and carrying the best wishes of the civilized world, the three



These British Airmen Started on May 24 on Their Round-the-World Flight: Major W. T. Blake, Commanding, in Center, with Lieutenant Colonel L. E. Broome, Left, and Captain MacMillan, Right

British airmen, Maj. W. T. Blake, Lieut. Col. L. E. Broome, and Capt. Norman MacMillan, "hopped off" on May 24, from Croydon air field on the first leg of their round-the-world flight. They plan to use four different machines for the journey and hope to be back in England about the middle of September. As planned, the route will mean a flight of some 30,000 miles. The commercial air route to India will be followed for the first leg of the trip. From there the fliers will follow up the coast of Asia to Siberia, thence along the Aleutian Islands to Alaska, down the western coast of Canada and across Canada and the United States to New York. From there, if time permits, they will follow the eastern coast of America to Labrador, then across to Greenland, Iceland, and back to England by way of Scotland. The alternative course for this part of the journey is via the Azores and Portugal. On May 28 the plane suffered some slight damage when making a landing at Marseilles, France, delaying the fliers some five or six days.

The first trials of a new apparatus for the control of the ticker system of the New York Stock Exchange indicates that it will increase the speed of the tickers quite materially and eliminate two steps in placing reports on the tape.

**ASHES REMOVED BY AND STORED IN WATER**

7604

A complete hydraulic system for the removal and storage of ashes has just been completed as a part of the new Hell Gate power station in New York. This is the first large system of this type ever installed, and is designed to handle as much as 25 tons of ashes every hour. The clinkers, as they come from the boiler fires, are first passed through grinders, and the ashes, thus freed from large lumps, are discharged continuously into an inclined, tile-lined concrete trough, through which a stream of water is continuously flowing. These troughs, of which there is one to each row of boilers, empty into a common discharge pit, located well under water, and here the ashes are stored awaiting removal by means of a small dredging bucket and crane. The wet, compact mass is thus easily handled, and is carried away either on motor trucks or in scows, doing away with the dust incident to old ash-collecting systems.

**NEW ROTARY CORN POPPER 9521 FOR HOME USE**

Popping corn, as a home operation, has been improved upon by the introduction of a contrivance having a sheet-iron base, 7 inches square at the bottom and sloping to 4 by 7 inches at the top. In this base, a wire-mesh "squirrel-cage" cylinder for holding the corn is mounted and turned by a crank. The efficiency of the popper is claimed to be greater than that of other types because it is open at top and bottom, so that the moisture can pass out freely.

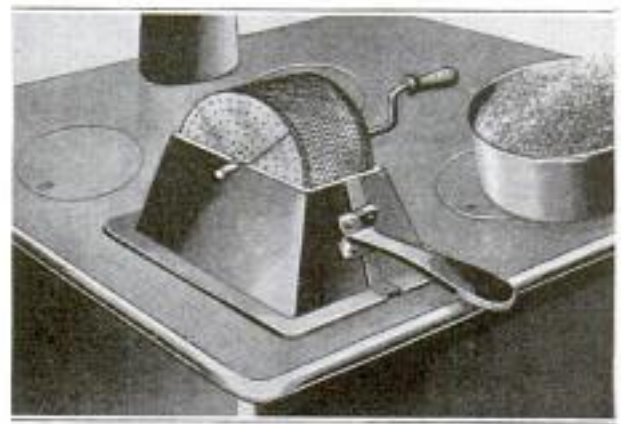

Rotary Corn Popper, Showing the Wire-Mesh Cylinder in the Sheet-Iron Base, and Operating Crank

*Chas. A. ... 828 W. ... Oklahoma City, Okla*

*Denver Post Detroit News 5/23 London Times 6/122*

*and Frank H. Jones 15 Rowe St. Cambridge Mass.*



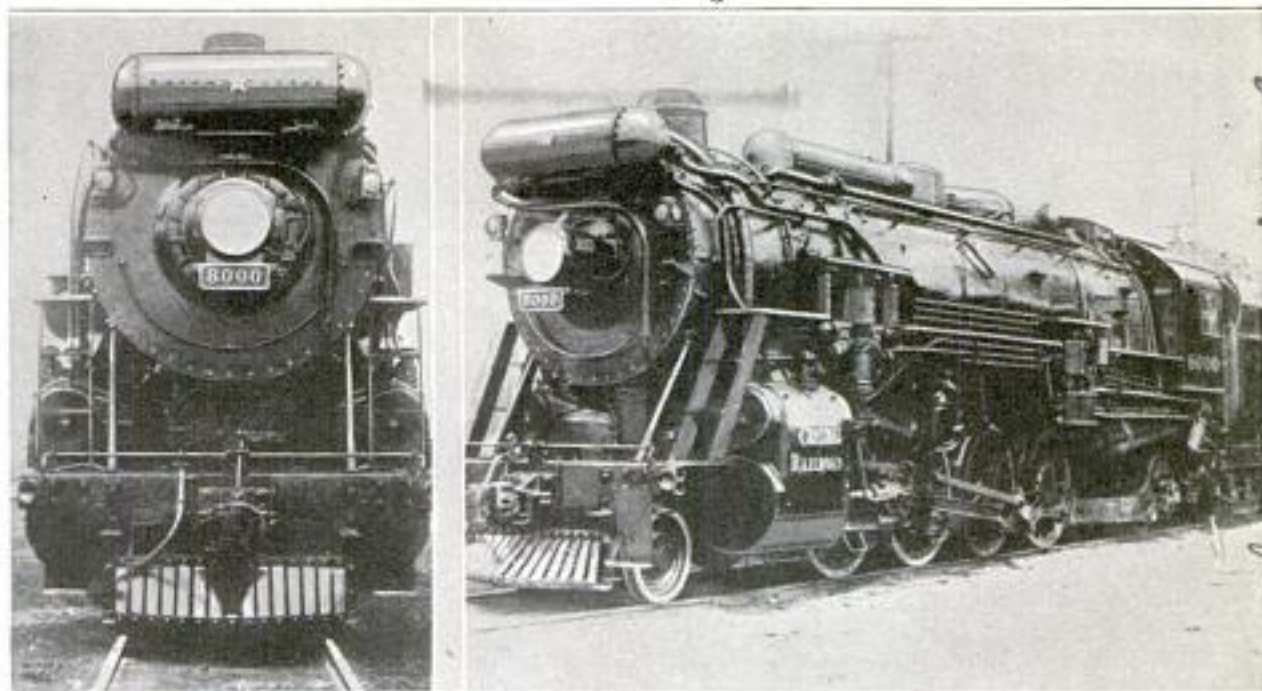

Wm. Locomotive Works  
Ohio.

COPYRIGHT, KADEL & HERBERT  
Front and Side Views of the Most Powerful Locomotive in the World, Recently Built for the Michigan Central Railroad: Above the Boiler, in Front of the Smokestack, Is the Feed-Water Heater; All the Improved Accessories are Run by Steam from a Superheater Connected by a Pipe to the Center Steam Dome

9614 **LOCOMOTIVE MOST EFFICIENT  
AND POWERFUL EVER BUILT**

Most imposing in appearance is a new freight locomotive, built for the Michigan Central Railroad, and the result of 12 months' secret and concentrated effort. In many of its details this monster locomotive is an improvement on anything previously accomplished, and it may fairly be called the last word in locomotives. Recently it made its maiden trip from Detroit to Toledo, Ohio, hauling a mile-long train of 100 loaded coal cars, an unprecedented load. It has been demonstrated to be, for its weight, the most powerful locomotive in the world; it delivers more tractive power per ton of coal consumed than any locomotive ever built, and the means of control have been greatly improved, so that the work of the engineer and fireman is both simplified and made easier.

9579  
**PRINCE OF WALES HAS NOVEL  
EXPERIENCES IN JAPAN**

The prince of Wales will long remember his recent visit to Japan because of some of the experiences that featured his stay there. As a mark of special honor he was invited to cross the Sacred Bridge at Nikko, but he tactfully declined. The same invitation was tendered to Gen. U. S. Grant at the time of his visit to Japan, but he also declined on the grounds that the bridge was too sacred.

In Kyoto, the imperial gates of the temples and shrines were opened for the prince to pass through, and when he en-



BY COURTESY OF THE JAPAN ADVERTISER  
The Prince of Wales is Here Shown Pulling Admiral Halsey of His Party in a Jinrikisha during His Recent Visit to Japan

tered the imperial palace, he used the gate which is opened only for the mikado's consort.

Of a different nature, but fully as interesting, was the prince's experience when he took the business end of a jinrikisha, and pulled Admiral Halsey of his party in it, near the Kegon waterfall, Nikko.

The Japan Advertiser 5/5/22

Clayton, Mrs. Doris Bell  
of Hotel Scarborough New York



House on Wheels Which is Constructed on the Chassis of a Motor Truck: The Outfit has Come to a Stop for the Night, and the Tourists are Lowering the Canoe, Which is Carried on the Top of the Vehicle While Traveling

Traveling into 9482

**COMPACT HOUSE ON WHEELS HAS MANY COMFORTS**

Numerous conveniences have been incorporated in a compactly built house on wheels which has been constructed on the chassis of a light motor truck of well-known make. Special springs enable the tourists to travel over the roughest roads

**FIRST-CLASS ACCOMMODATION AT SECOND-CLASS RATES**

Demand for a new classification of passenger-tonnage on Atlantic liners has resulted from the recent addition to the trade of the monster high-speed ships that have seriously affected the business of the older and slower vessels, which, under conference rules, have to observe the same ratings as their much more attractive newer competitors. It is, therefore, proposed to adopt, in the older ships, a one-cabin system, wherein there will be no first nor second classification. A passenger will be either cabin or third class, and the cabin will be charged at second-class rates, although actually affording precisely the same accommodations for which first-class rates were formerly paid.

Christian Science Monitor 7/22/22



Interior of the House on Wheels, Showing the Roomy Cooking and Eating Space: The Small Stove can be Seen behind the Woman Who is Removing Food from the Ice Box

without fear of causing damage to the elaborate interior. Comfortable sleeping quarters and a roomy cooking and eating space are provided in the vehicle, while on the top is carried a canoe. The outstanding features of this traveling home are its neatness and the shipshape disposition of the equipment.

24 hours' time. The apparatus used was of the type originally developed by Dr. Arthur Korn, of Berlin, for telegraphic reproduction of pictures. He now has a laboratory in the Italian city, and has been cooperating with the U. S. Navy radio station at Otter Cliffs, near Bar Harbor.

Chicago Tribune  
6/11/22

Copyrighted material

L. W. Mr. Sugiyami, Kobe Railway Bureau, Japan

*Notice*

*May 2, 1922*

*9509*

POPULAR MECHANICS

*S. H. Bowser Co  
9441 Fort Wayne, Ind 189*

### LARGE LINER IS CONVERTED TO OIL-FUEL BURNING

Ocean liners which burn coal are gradually being converted into the oil-fuel type for economy of operation, and one of the latest of these ships to be so changed is the 52,000-ton "Berengaria." This vessel, formerly the "Imperator," owned by a German company, has been equipped with tanks holding 6,200 tons of oil, which amount is sufficient for one trip across the Atlantic, allowing for reasonable delays. There are 32 of the fuel containers, of which 24 are for storage and the remaining eight for settling purposes. Four stations are provided on deck, two on each side of the craft, for filling the huge tanks, which form part of the ship's structure for a length of 300 feet at each side of the boiler rooms, in the space previously occupied by the coal bunkers.

*9543*

### LOCOMOTIVE'S EXHAUST STEAM SAVES COAL CONSUMPTION

Economy in the use of coal on locomotives is claimed for a new Japanese device that utilizes the exhaust steam to heat the water in the tank on the tender. Tests made by the Kobe railway bureau are said to have demonstrated a saving of about 20 per cent in the consumption of coal.

*N. Sakata, #10, 5 Chome, Idemachi, Kojimachi-Ku, Tokyo, Japan.*

### OIL-DELIVERY PUMP SIMILAR TO GASOLINE CURB PUMP

Believing that motorists would welcome such a device, a manufacturer of filling-

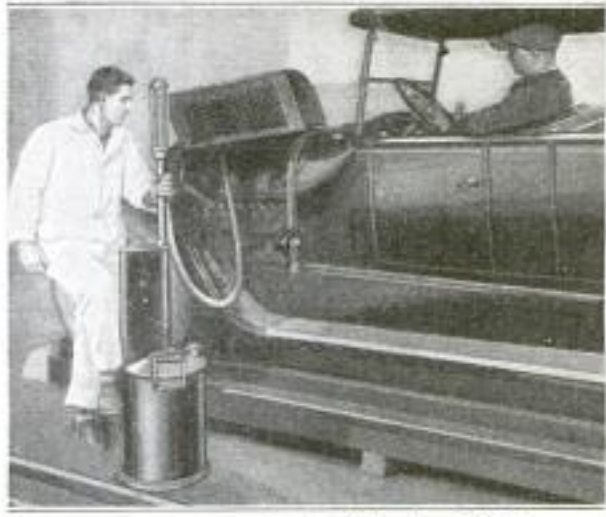

By Using This Portable Lubricating-Oil Pump, a Measured Quart of Oil can be Delivered to the Automobile in a Remarkably Short Time

station equipment has brought out a portable pump for delivering lubricating oil to the automobile. A storage space in the base of the device holds 10 gallons of oil, and a visible piston in a glass cylinder on a standard makes it possible for the motorist to see that he obtains the exact amount of oil paid for. One quart of oil is delivered in a few seconds.

*9097*

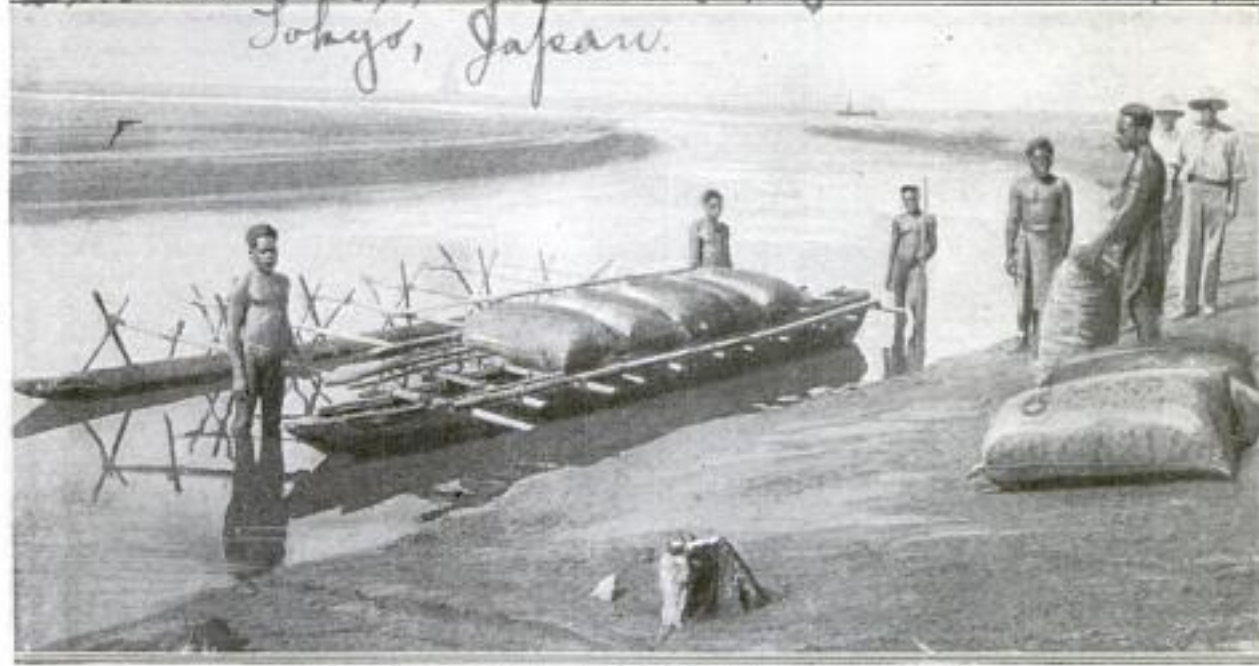

### CANOERING COPRA OVER REEFS AND SHALLOWS

IN delivering copra, the dried meat of the coconut, to a ship anchored in deep water beyond intervening reefs and shallows, the islanders of the South Pacific make use of their canoes. The copra, in sacks, is loaded onto a canoe with the usual outrigger float, and the natives pole the canoe through the shallows until they reach the ship just beyond the reef.

*Cont. Chas. G. McWhorter,  
Bank of Australasia, Place, Sydney, Australia.*

9565 Mrs. J. Bennie Barnett & Co. L. Watson & Co.  
153 Saint Vincent St. Glasgow Scotland.

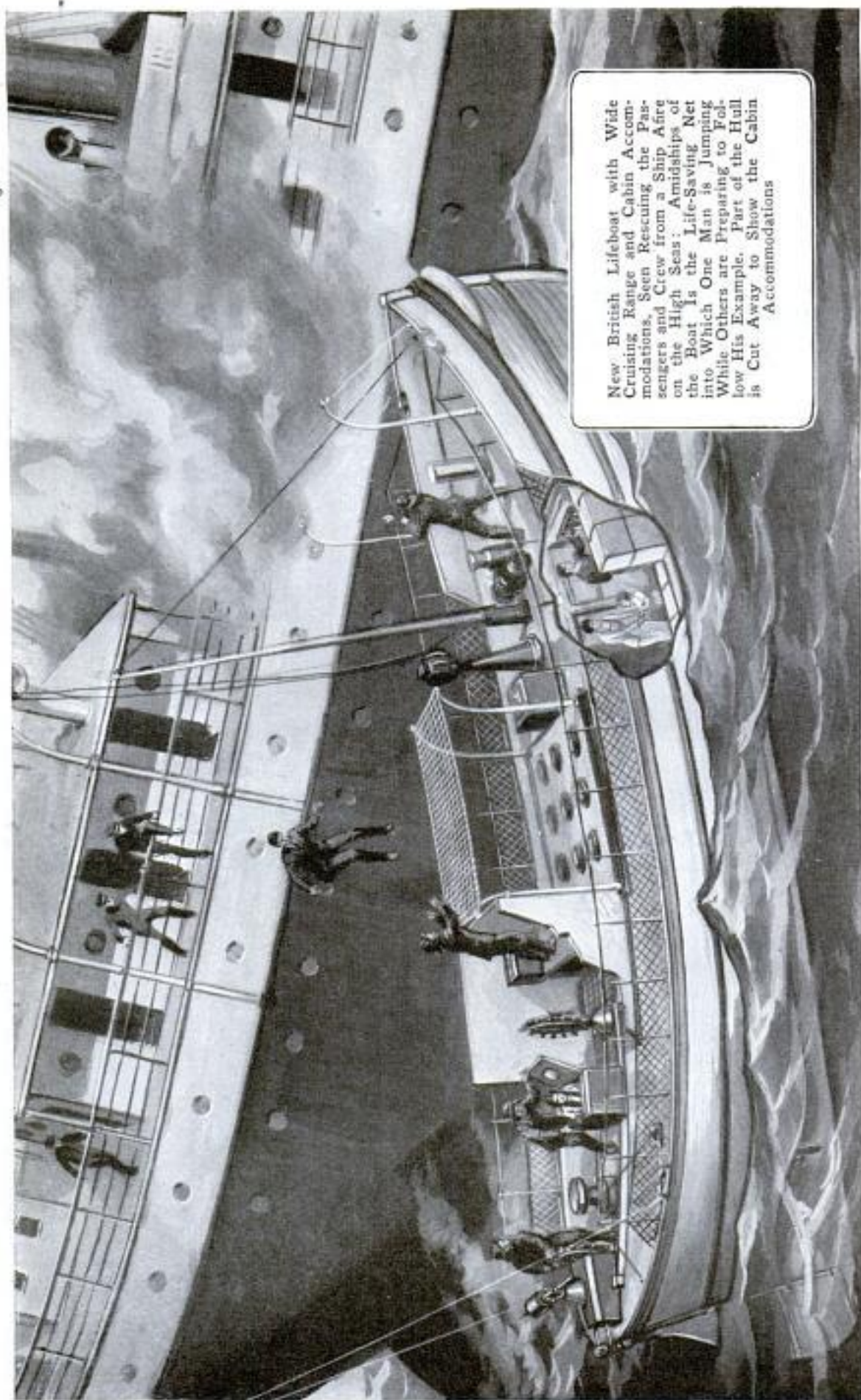

New British Lifeboat with Wide Cruising Range and Cabin Accommodations, Seen Rescuing the Passengers and Crew from a Ship Afire on the High Seas: Amidships of the Boat Is the Life-Saving Net into Which One Man is Jumping While Others are Preparing to Follow His Example. Part of the Hull is Cut Away to Show the Cabin Accommodations

9565

### MOTOR LIFEBOAT WITH HOSPITAL EQUIPMENT

For the rescue of the occupants of ships on the high seas in imminent danger of destruction by fire, collision, or otherwise, a large motor lifeboat is now being built in England that will have a cruising range of 150 miles or more, at a speed of 11½ miles an hour. When the scene of the disaster is reached, rescues will be facilitated by the use of a life-saving net similar to those used for rescuing persons from burning buildings. Those rescued will immediately receive medical attention, for the lifeboat has two cabins, each accommodating 50 persons, which are

heated and equipped with appliances for resuscitation and other treatment. Thus the vessel is a hospital as well as a lifeboat. It has a teakwood double hull, and is subdivided by a number of transverse and longitudinal steel bulkheads into compartments through which are distributed nearly 100 buoyant air flasks, making the boat absolutely unsinkable. This new lifeboat is 60 feet long, 15 feet wide, and is driven by two 75-horsepower gasoline engines housed in separate compartments. There was a brief description of this boat in the July Popular Mechanics.

9542. *As per magazine*

### PORTUGUESE AIRMEN FINISH FLIGHT ACROSS OCEAN

Undaunted by the destruction of two airplanes, the Portuguese fliers, Captains Sacadura and Coutinho, have finally completed their trip from Lisbon to Rio de Janeiro, Brazil, where they arrived on June 17. Leaving Lisbon on March 30, the first two legs of the flight were successfully accomplished to the Canary Islands and from there to the Cape Verde Islands. The first accident occurred on April 18 when landing at St. Paul's Rocks, the plane being so badly damaged that it was abandoned. The second plane, sent out by steamer from Portugal, suffered a mishap between St. Paul's Rocks and the island of Fernando de Noronha, the airmen having a miraculous escape. Upon the arrival of the third plane, the cost of which was defrayed by public subscription, the flight across the ocean was completed when the airmen landed at Pernambuco, Brazil, on June 5. Flying along the coast they finally reached Rio de Janeiro, after what was in some respects the most hazardous flight on record. The distance, as flown, is a little less than 4,200 miles, and on one leg of the journey the airmen flew for nearly 1,000 miles over the ocean with only their navigating instruments to guide them. No extensive ship patrol was maintained along the route as a safety measure, and the seaplanes used were of a much smaller type than that ordinarily used for such an extended flight.

### FENCE ON GLACIER POINT PROTECTS VISITORS

Because certain reckless persons, instead of viewing the wonderful panorama spread out before them, have insisted on

9495

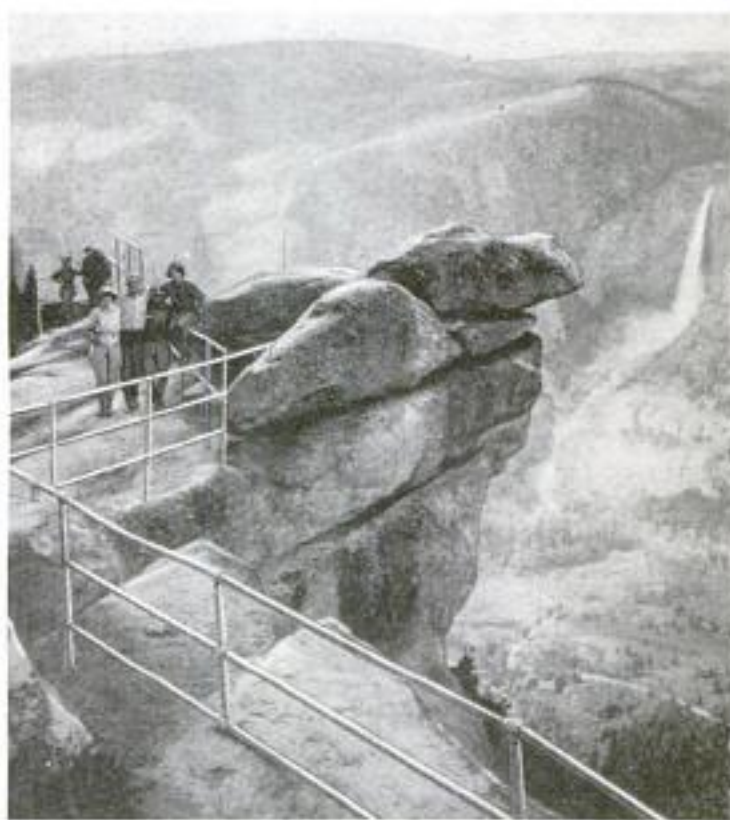

This Substantial Fence was Built to Keep Reckless Persons from Venturing upon the Overhanging Rock at Glacier Point

venturing out upon the overhanging rock at Glacier Point. Yosemite National Park, the government has built a substantial fence about the rock as a means of discouraging this hazardous practice. The distance is about 3,000 feet from the top of the rock to the valley floor below.

*International Newsreel Corp. New York City*

*NY Times 6/6/22  
Aerial Age Weekly 6/10/22  
Christian & Science Monitor 6/9/22  
Lissart Tribune 6/6/22*

Chas. J. Doddard

5626 Arroyo Place

192

Los Angeles Calif

"STRONG MAN" LIFTS TRUCK EASILY IN MOVIE COMEDY

9221

In one act of a motion-picture comedy one of the actors discovers that his derby



When the Moving Picture of This Act was Taken the Camera was Focused So That the Framework and Lifting Tackle would Not Show

hat is underneath the front wheel of a heavily loaded truck. After expressing his anger, he tries to lift the front of the car in order to regain his hat. The spectators of the picture naturally assume that he is attempting the impossible. Then, with another exaggerated effort he puts his shoulder against the bumper and apparently raises the truck. He holds the truck in mid-air while he leisurely draws his hat from underneath the wheel.

To produce this one little act, a large overhead framework had to be built. It was not shown in the picture, of course, being cleverly barred from the field of the camera. A wire cable was run from the bumper to a block overhead, then back to a point where half a dozen men hauled up the front of the car, the rear end of which was ballasted with bags of cement.

The fact that the picture brings a good hearty laugh only shows that one likes to be hoodwinked, even when he knows it is being done.

Serial 2388

Bureau of Mines

Washington

20c

POPULAR MECHANICS

CHEAP METHOD OF TREATING MIXED ORES OF COPPER

9606

Because of the great amount of interest shown by mine operators and metallurgists in the sulphur-dioxide process of leaching mixed copper ores, the Bureau of Mines has just issued a pamphlet dealing with the subject. The process was devised to provide a cheap and efficient method of treating the so-called porphyry copper ores of the Southwest, containing both "sulphide" and "nonsulphide" copper minerals. Two of the advantages claimed for the process are that it requires only an inexpensive, compact plant, and that the power requirements are quite low. The operation of the plant is simple and easily controlled. The process may be applied to large or relatively small operations without unduly increasing the operating cost for the smaller plant.

2524

MACHINE CUTS EIGHT BRICKS OF ICE CREAM AT ONCE

Makers of ice cream who do much business in the brick ice-cream trade will welcome a newly designed machine that cuts the slab of ice cream into eight bricks at one operation. The bricks are cut on the same board on which the slabs are dropped from the molds. The knives cut with a shearing action, and pass through the ice cream only once, the cut bricks being removed before the

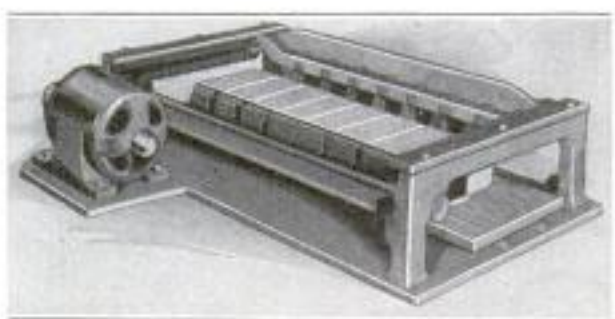

This Machine Cuts Eight Bricks of Ice Cream at One Time, the Bricks being Removed Before the Knives Return to the Starting Position

knives return to the starting position. A small motor drives the machine, and all movements are controlled by a clutch.

Because of the greater strength of cables made of high-grade steel as compared with ingot-iron bars, experiments have been made to determine if these cables could be used as girders by molding concrete around them. Preliminary tests have shown the idea feasible.

46 Rachel + Crews  
454 2nd Street  
Chicago  
Copyrighted material

9534 The Turbchron + Car Co.  
50 Broad St. New York City



The Suction Machine, with the Flexible Pipes Raised to Clear the Ground When Moving from One Field to Another: In Operation, These Pipes are Lowered Close to the Ground and Pick Up Weevils and Slugs, Dislodged by the Spring-Wire Agitators in Front

9534  
**SUCTION MACHINE DESTROYS COTTON BOLL WEEVIL**

The ever-increasing damage and loss caused by the cotton boll weevil has stimulated inventors to search for some means of destroying the pest. To be successful, a machine must not only collect and destroy the live weevils, but must also gather and destroy the flower buds and young cotton bolls in which the eggs and grubs exist. One of the most ambitious attempts along strictly mechanical lines, is a suction machine that

has shown excellent results in its preliminary trials. A large exhaust fan is mounted on a light but substantial wheeled frame, and tubes lead from the suction side of the fan to flexible tubes which terminate near the ground. Spring-wire agitators and adjustable gathering arms are mounted on the frame in front of the suction tubes, and as the machine is hauled through the cotton field by a team, the weevils and infected buds and

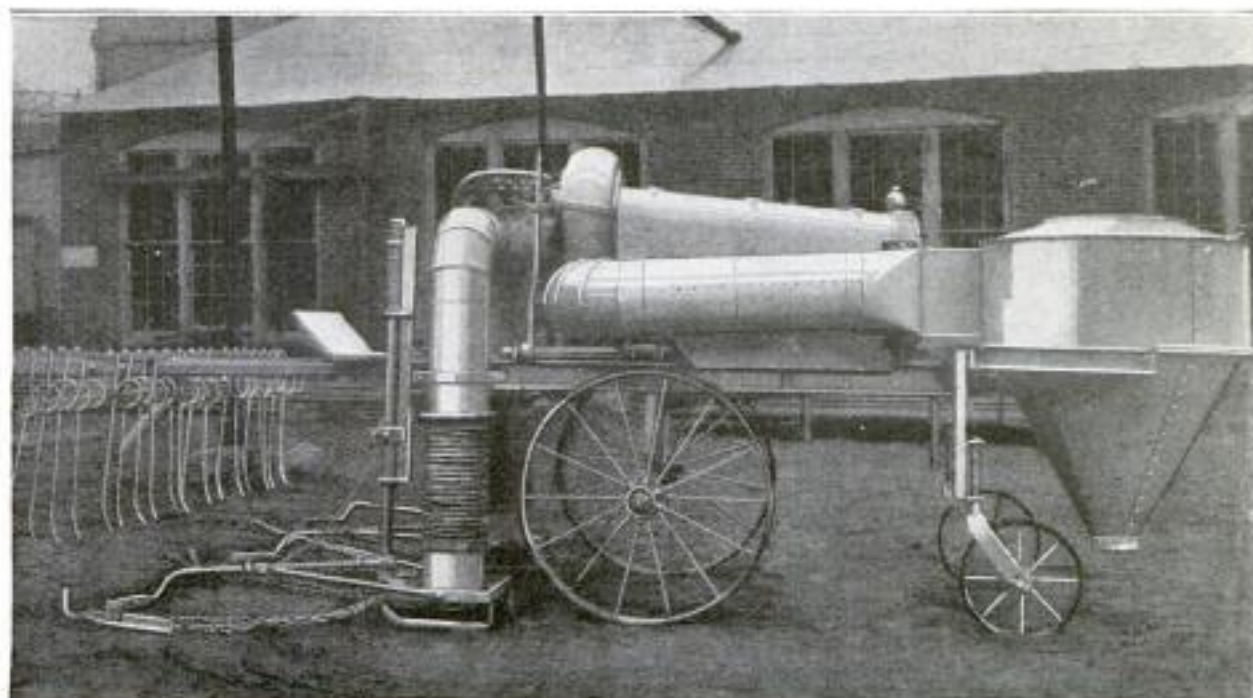

This Gives a Good Idea of the Arrangement of the Different Parts of the Machine: From Left to Right are Seen the Spring-Wire Agitators, Gathering Arms, Suction Pipes, Exhaust Fan and Piping, and the Dust Collector at the Rear of the Machine

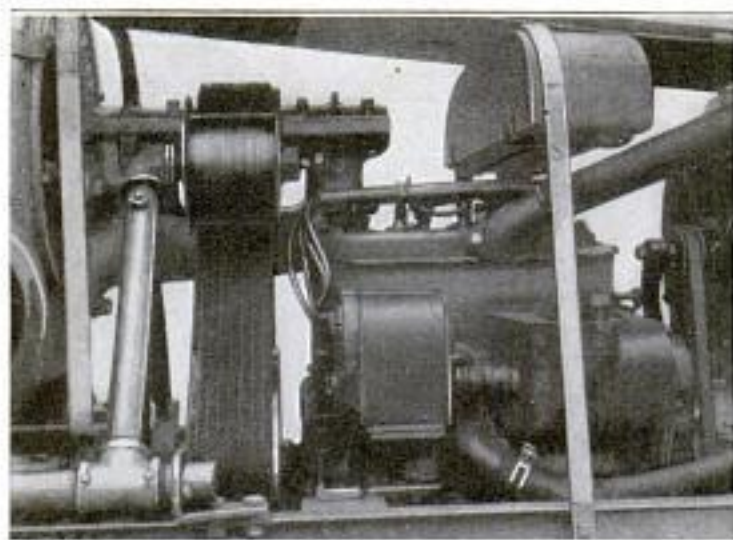

A 10-Horsepower Gasoline Engine Drives the Exhaust Fan by Means of a Short Belt Supplied with a Spring Idler Tightener, and the Entire Power Plant is Protected by a Substantial Hood

bolts are dislodged from the plants and drawn into the exhaust fan. As they pass through the fan, they are dashed against baffle plates and destroyed. After they have gone through the fan, they pass into a dust collector and separator, in which all the heavier particles are sifted out and dropped on the ground, while the air escapes at the top of the collector.

It is estimated that one machine can cover 20 acres of cotton per day, and that five treatments, given at intervals of 10 days, should entirely rid the field of all weevils and destroy the eggs and grubs in the infected bolls.

9183  
**BATTERIES QUICKLY TESTED BY SIMPLE HYDROMETER**

Hydrometer readings are usually puzzling to the novice, but with a recently introduced battery tester no confusing calculations are necessary. The innovation has three colored balls—white, green, red—each of a different and known specific gravity. When the glass tube of the instrument is filled, these balls, by either floating or sinking, indicate the difference in specific gravity between them and the contents of the battery under test, and it is thus possible to form a reliable opinion of the condition of the cells, and to properly dilute the electrolyte.



9603  
**BOY'S VOICE OUTRANGES PIANO KEYBOARD**

In a test recently conducted, 12-year-old Robert Murray, of Tacoma, Wash., was able to reach, with his clear soprano voice, half an octave above the upper limit of a piano keyboard—so high that the use of a testing whistle was made

necessary to determine the exact note reached. The accomplishment is made possible through the abnormal development of his larynx. In singing he is often accompanied by a flutist. An earlier instance of extreme range is that mentioned by Mozart, of a woman, Lucretia Agujari, who sang three octaves above middle "C." This record was equaled by the American singer Ellen Beach Yaw, about 20 years ago. Robert Murray's range is five octaves above middle "C."

9484  
**ADVANTAGE OF SNUG PACKING SHOWN BY "TUMBLE DRUM"**

A box with cells into which the contents fitted loosely and a box with cells which held their contents snugly, were "shipped" the same "distance" recently, in the "box-tumbling drum" at the Forest Products Laboratory, at Madison, Wis. When inspected, it was found that not only were the partitions of the loosely packed box broken, but one of its sides had been rent as well. The snugly fitted box was undamaged.



Results of "Tumbling" Test with Two Boxes, One Packed Tightly and the Other Loosely

*Shuman & Pomeroy d. m.  
117 N. Dearborn, Chicago*

*Cont. Frank H. Jones  
15 Rowe St.  
Auburndale, Mass*

*Forest Products Laboratory  
U. S. Forest Service  
Madison, Wis.*



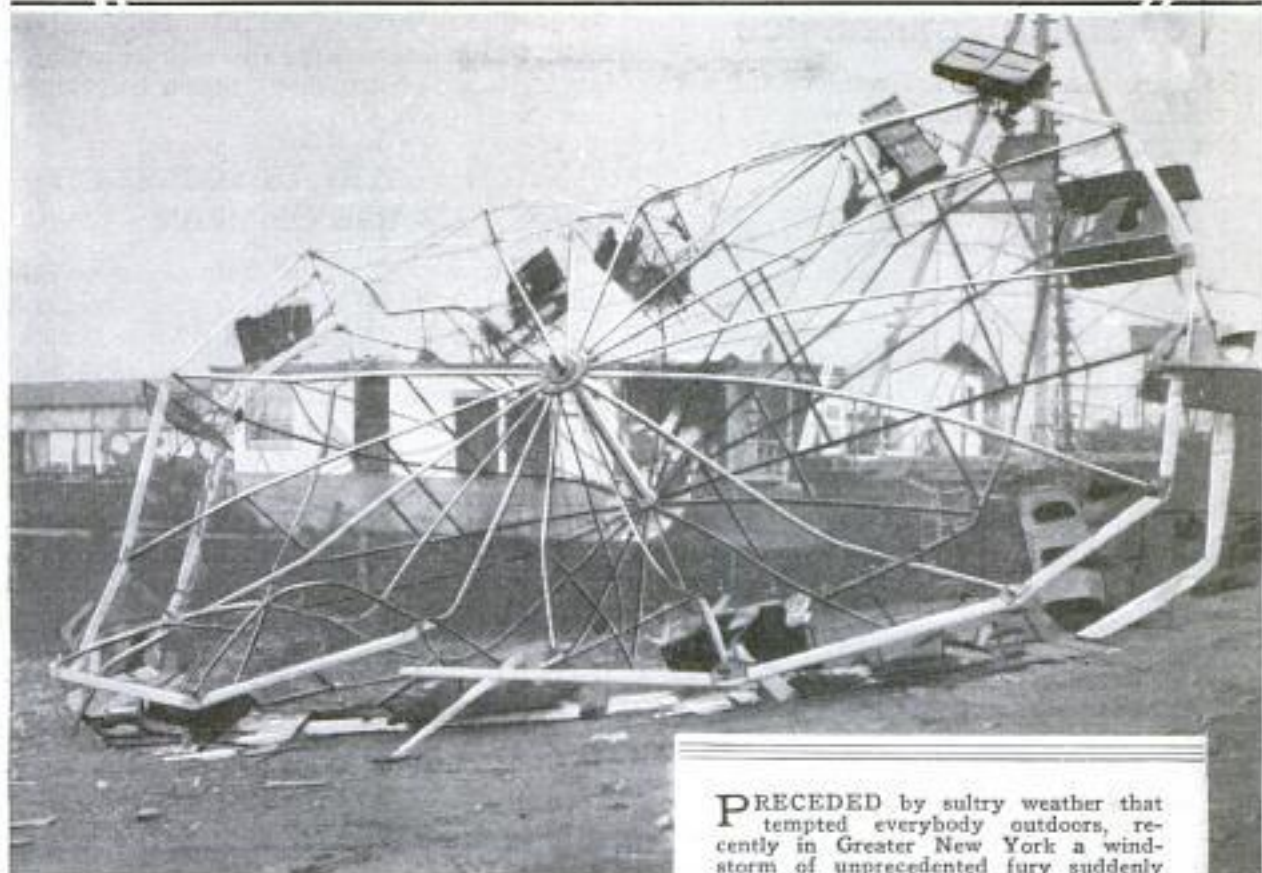

**P**RECEDED by sultry weather that tempted everybody outdoors, recently in Greater New York a wind-storm of unprecedented fury suddenly converted many pleasure resorts into shambles. The large Ferris wheel shown above, was blown from its moorings. Five passengers were killed and 26 injured. Below is the wreck of the Red Lion Inn which was smashed by an uprooted tree that crashed through its roof. Two inmates were killed and seven were injured.

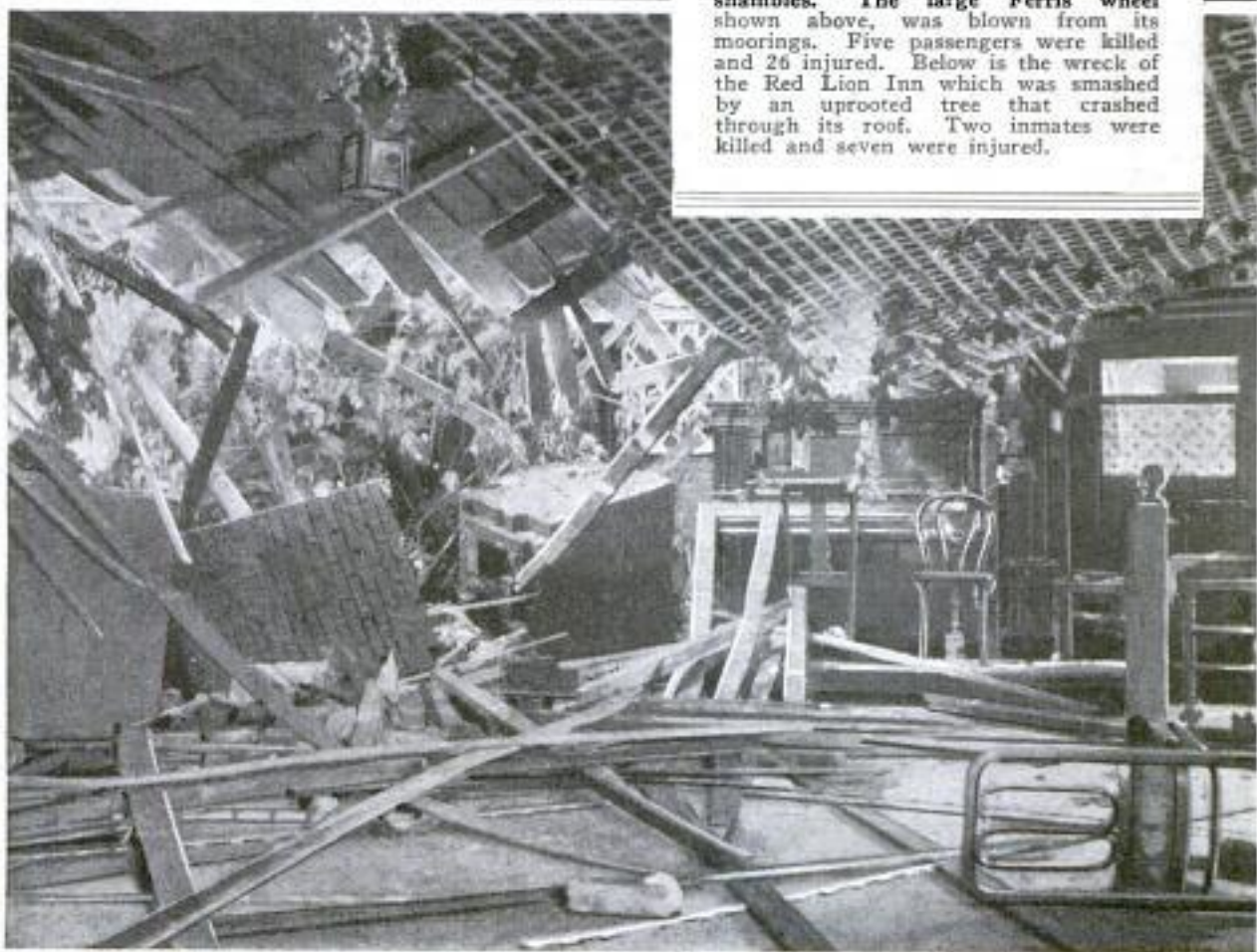

Kadel + Herbert  
New York City

**MAMMOTH VIOLIN IS FEATURE  
OF MUSIC CONFERENCE**

Featuring a recent national conference of the music industries, the world's largest member of the violin family was



This Giant of the Violin Family, Recently on Display at New York City, Stands 11 Feet 7 Inches High and Has a Corresponding Girth

placed on display in New York City. Measuring 11 feet 7 inches high, 4 feet

7 inches wide, and 13 inches deep, and weighing 150 pounds, the mammoth instrument which has strings the size of a man's finger, was the cause of much interested comment.

**HARD WATER IS SOFTENED**

9545 **BY USE OF PEAT**

Hard water can be softened by merely pouring it through a bed of raw peat, the softening being caused by the formation of insoluble calcium and magnesium salts by reaction with acids that are normal constituents of the peat, and all the hardness is taken out of the water in passing through it. It is thought that if this process could be profitably adopted, the result would be quite an achievement, as an economical outlet for peat would thus be found.

*The Engineer 5/12/22*  
**COMBINED HANGER AND BRUSH**  
9392 **FOR CARE OF CLOTHES**

Combining a clothes hanger and brush, an eastern man has presented a handy means of giving any garment a quick "going over" before it is hung in the closet. The brush is round and of the twisted-wire core type, being placed just below the crossbar of the hanger, which is similar to the common wooden kind, except that the handle is longer.

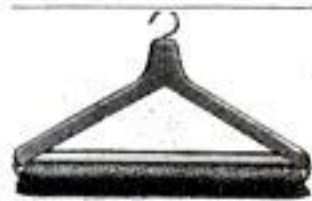

*d. no. John H. Esoldberg  
147 Florida Ave. N.W.  
Washington, D.C.*

9457



**TONS OF POWDER IN SIX BARGES TOWED BY A SINGLE TUG**

DOWN the Mississippi, all the way from Cairo, Ill., to New Orleans, La., a single tug, the "Mamie S. Barrett," towed six barges, three deep, that were loaded with 2,612½ tons of powder, packed in 33,500 boxes. Each box, with a total weight of 203 pounds, contained 150 pounds of powder. Although, on account of flood conditions, the towboat operated only during daylight, the whole trip occupied only eight days. At New Orleans the powder was transferred from the barges to a Pacific-coast freighter for transportation to San Francisco via the Panama Canal.

*Emb O. H. Lippitt, The Cairo Evening Citizen, Cairo, Ill.*

9485

Emb. Hogg + Ford,

416 Union League Bldg  
Los Angeles Calif

**RATTLESNAKE**  
for **TOURIST**



**ETIQUETTE**  
and **CAMPER**

By JOHN EDWIN HOGG

**W**ALKING through the shopping district of a large western city recently, my attention was attracted to a drug-store window wherein was displayed an assortment of hypodermic outfits, packages of medicine, etc. The display had much the appearance of a conspiracy against the drug laws, until my eye fell upon a card which read: "This Is Rattlesnake Season. Buy Your Snake-Bite Outfit Before You Start on Your Vacation." Here is one firm that has been able to commercialize the rattlesnake, I mused; and even as I gazed into the show window, a newsboy on the sidewalk bawled: "City policeman dies from rattlesnake bite! Read about it! It's terrible!" I bought a paper, and on the first page read how the policeman had been rushed to the city from his vacation in the near-by mountains where he had been bitten by a "rattler," and how he had died at the receiving hospital a few hours later, because the crude first-aid treatment at his disposal in the wilderness had failed to counteract the deadly poison. In the same newspaper was a story of a city park being closed by order of the board of health, because numerous rattlesnakes make it

their summer home, and pointing out the danger to pedestrians of coming upon rattlers at a season of the year when the snakes are shedding their skins, and therefore fail to sound the characteristic rattle which at other times usually serves as a warning of their presence.

Although the chambers of commerce of southwestern cities endeavor to suppress all rattlesnake publicity because it is not especially desirable for the development of the country, the snake menace is a genuine one. And it is, besides, a menace that will never be eliminated by refusing to recognize it.

Years ago, some one who evidently had some horse-hair ropes to sell, started the story that a rattlesnake will not crawl over such a rope. Therefore, all the camper had to do to protect himself, it was claimed, was to string a loop of such rope around his camp and sleep with complete assurance that no rattlesnake would crawl within the confines of that barrier. This story gained weight, like a snowball rolling downhill, until today thousands of horse-hair lariats are sold each year for that particular purpose. Because I do a great deal of mountain and desert camping, and



This Camper, in His Sleeping Bag, may Be Comfortable, but He Is Apt to Awaken and Find That He Has a Rattlesnake as a Bedfellow

94 8 7

have had many disagreeable experiences with rattlesnakes, I swallowed the story myself—and immediately bought two horsehair ropes.

For more than a year I slept on the ground in the mountains and in the desert, feeling perfectly secure within that "magic circle." I probably had my money's worth in the mental satisfaction I enjoyed during that period, but eventually there came a night in the desert when the horsehair-rope theory was knocked into a cocked hat, and I quit sleeping on the ground. A friend, whom I will call "Wells," and I had motored into Death Valley. We had been in that hell hole for 10 blistering summer days, camping out, of course, for in that time we had not set eyes upon a human being. When nightfall overtook us, we would cook supper, throw our blankets on the ground, and sleep on top of them, because it was too hot to get underneath. Here, each night the horsehair ropes were stretched around our beds, for a rattlesnake bite would have caught us altogether too far from medical assistance. On the eleventh night a brilliant full moon arose very early, and we made our

camp as usual. A little later we had finished supper, lighted our pipes, and stretched out to talk over our plans for the next day before going to sleep. I was very tired, and had stretched out full length, while Wells reclined upon his elbow, talking between puffs at his pipe.



A Diamond Rattlesnake Ready to Strike: The Position of Its Body Gives Its Fangs a Striking Radius of About Two-Thirds of Its Length

Suddenly rising to a sitting posture, he pointed across the desert, and said: "What's that thing moving around over there?" I sat up and looked, reaching instinctively for my pistol. There was a scattering of sagebrush on the mesa, and wiggling through it in the moonlight, I could make out indistinctly some sort of an animal moving along on the

ground. It was headed straight for our camp as fast as it could travel, and over our horsehair barrier it came, to within ten feet of us before we recognized its species. It was a desert "sidewinder," and both of us were on our feet instantly. Wells' automatic roared, and the snake crumpled up in a lead-ridden mass. The incident was closed, but it did not make for peacefulness of slumber that night. That "rattler" came over our horsehair rope as if it had never been there, and had he called upon us after we had gone

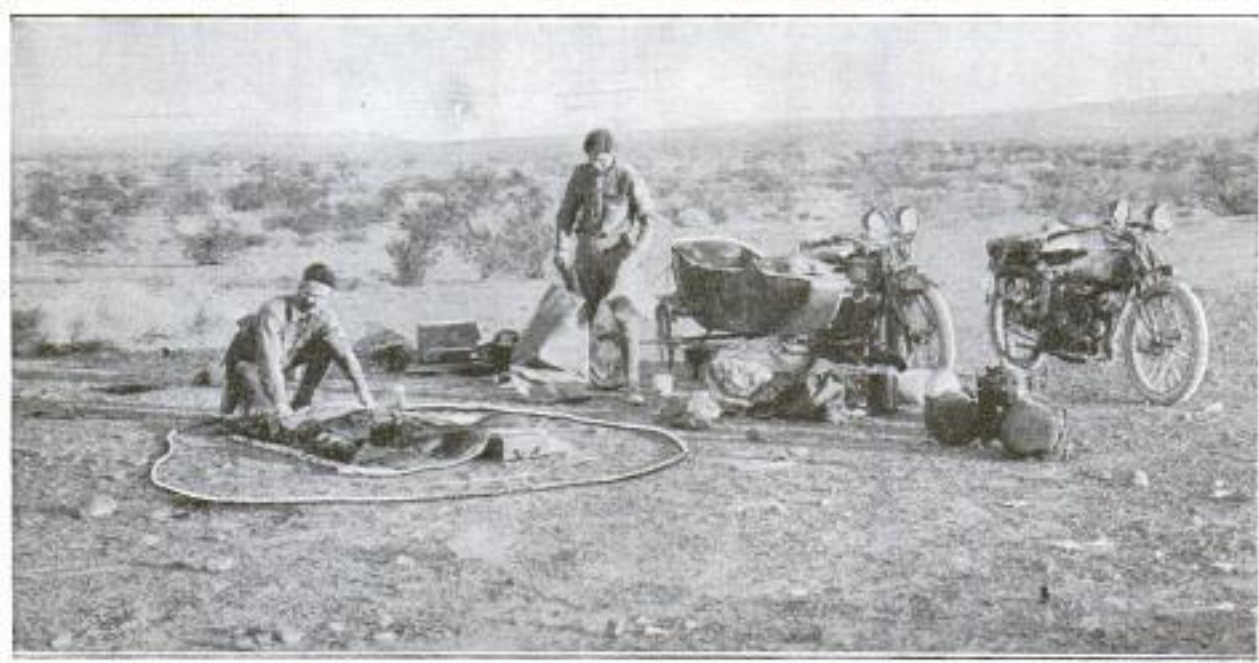

In This Camp a Horsehair Rope was Laid on the Ground in a Circle about the Blankets, to Keep the Snakes Out, but a "Sidewinder" Crawled over the Rope into the Camp

9487



**A Desert "Sidewinder,"** So Called Because of Its Peculiar Method of Traveling: These Snakes can be Distinguished from the Diamond Rattlers by Their More Slender Body. The Snake in the Picture was Run Over by the Heavily Loaded Motorcycle without being Injured

to sleep, he would undoubtedly have crawled into our blankets, with a strong probability that one of us would have been awakened by the grip of his fangs.

Another rattlesnake theory that should have the "skids eased under it," is that which has led a multitude of people to believe that the rattler always rattles before it strikes. Sometimes it does and sometimes it doesn't. As a matter of fact the snake uses its rattle for about the same reason that a dog snarls. If you come upon a rattler except during the season that it sheds its skin, and it sees you first, the chances are ten to one that it will make its presence known by lifting the tip of its tail, vibrating it so rapidly that it becomes almost invisible to the eye. The noise it lets out depends largely upon its size. If it is a little desert sidewinder, its note of warning is similar to the buzzing of the eastern summer locust,

but there is an odd metallic twang about it that cannot be compared with any other noise I have ever heard. Once having heard it, one is not likely to mistake it for anything else.

The sidewinder, or desert variety of the rattlesnake family, never becomes very large. I have seen and killed dozens of them, and never saw one more than three feet long. The diamond rattler of the semiarid plains and plateau regions, so called because of the peculiar diamond shape of its head and the similar markings of its skin, grows much larger. I have killed probably a score of this variety, and they averaged about five feet in length.



**This Is a Good-Sized Black Mountain Rattler That Never Sounded Its Rattle Until Aggravated into Doing So**

The biggest one I ever saw was one that I killed in Diamond Cañon, one of the tributary cañons of the Grand Cañon of the Colorado, in Arizona. I stumbled onto this fellow while exploring up the cañon between nearly mile-high walls that

I could almost touch with my outstretched hands. Through this narrow crack, I was making my way over a jumbled mass of boulders, when "Mr. Snake" poked his head up about two feet and let out a hiss like a punctured tire. He didn't rattle, although the season was early spring, when a rattlesnake ought to do it. I found a stick, and keeping at a safe distance, poked him out of the rocks. This action peeved his dignity terribly, and without further ado, he struck vigorously at the stick, and rattled until the cañon echoed with the noise. For fully ten minutes he kept rattling and striking while a motion-picture man, who accompanied me, reeled off yard after yard of film. This ceremony completed, a single well-aimed pistol ball sent him where all rattlesnakes belong.

That rattler measured 6 feet  $2\frac{3}{4}$  inches, and had 21 rattles and a "button." The point I wish to make about this particular snake is that it didn't rattle at all when we came upon it, nor, indeed, until aggravated by my actions.

Besides the sidewinders and the diamond rattlers, the third and most dreaded variety of these southwestern serpent pests is the black rattler, which is found in the mountains, chiefly between 3,000 and 6,000-foot elevation. These fellows run to about the same size as the diamond rattler, and living as they do in comparatively temperate climatic conditions, they seem to be much more vigorous and pugnacious than either diamond rattlers

or sidewinders. Nature seems to have created all snakes with a view to giving them protective coloration. Thus we find the sidewinder a mottled light-brown, or even grayish, color to harmonize with its desert surroundings so that it isn't likely to be seen unless it moves. The diamond rattler is colored somewhat more brilliantly, but it, too, blends wonderfully with the color scheme of the plains and the landscape surroundings in which it lives. The black rattler, living chiefly in forested country, among low bushes and pine trees, is very dark, some being almost the color of a rubber garden hose, so that they contrast little against dead pine boughs, pine cones, needles, and other forest backgrounds. These three varieties of southwestern rattlers, however, are all about alike in so far as their venom is concerned. The bite of all is almost certain death if the poison is not counteracted by proper treatment within a reasonable time. The size of the snake makes little difference except as to the amount of leather or clothing they are capable of biting through, and the quantity of poison they inject into a victim.

The rattler is the one snake of the West universally condemned by all scientists who have investigated the subject. They destroy a great many gophers, field mice, and other harmful rodents, but on the other hand they also kill harmless creatures, such as birds, small game, and snakes of genuine value to mankind, and the menace they constitute to human life

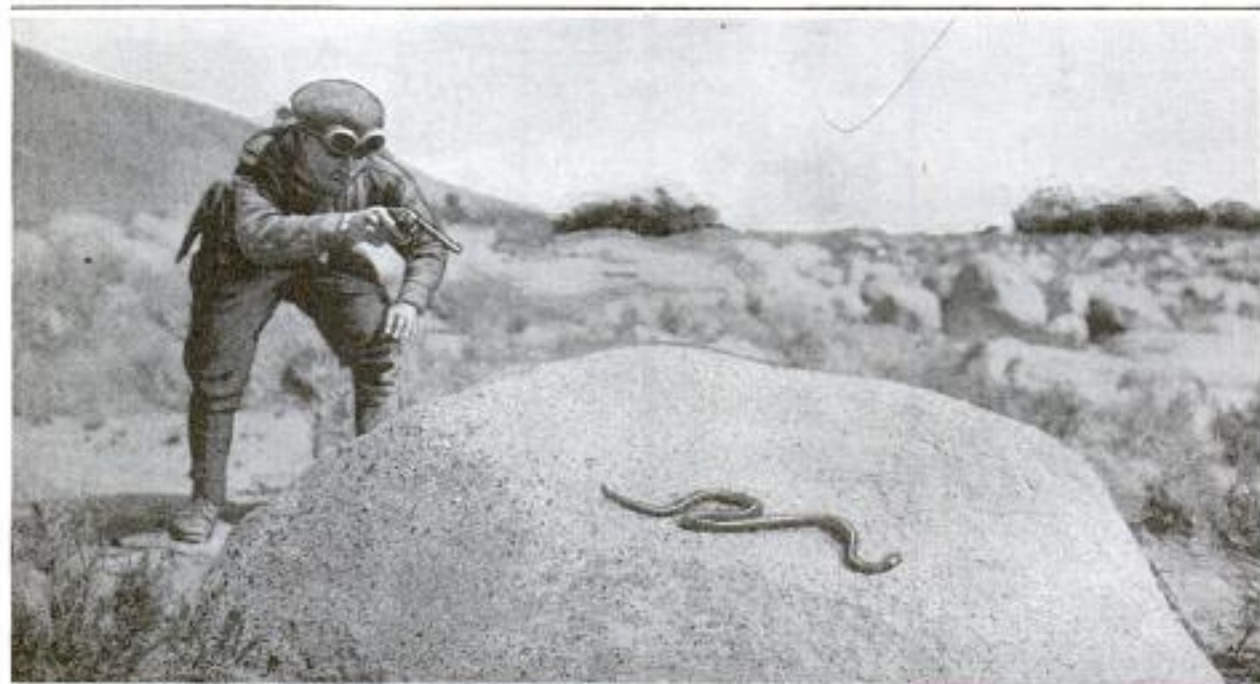

This Is the Safest Method of Disposing of Venomous Snakes: Stand Back at a Safe Distance from Their Fangs and Shoot the Head Off with a Small Pistol. One may Waste Some Cartridges but That Is Better than Taking a Chance of being Bitten



**This Mountain Camp Has Snake-Proof Sleeping Quarters. A Canvas Floor is Sewed to the Tent, and an Upright Piece of Canvas across the Door Opening Prevents the Snakes from Crawling Inside. This Adds But Little to the Weight Carried, and Enables the Campers to Sleep in Peace**

and that of domestic live stock alone far outbalances their good points. Some one who could accomplish for the Southwest what Saint Patrick is said to have done for Ireland, would be acclaimed a public benefactor to California, Arizona, Nevada, New Mexico, Colorado, and Texas, not to mention Kansas, Oklahoma, Wyoming, and several other states where rattlesnakes are not altogether unknown.

While I spend almost half my time in the mountain and desert regions of the Southwest, and spend considerable money each year for pistol cartridges used for sending rattlesnakes to their just deserts, I do not fear them. I have seen two men turn black and die from rattlesnake bites—in agony too horrible to picture; yet I have little fear of being bitten myself because experience has taught me to guard against such misfortune. If I am ever bitten, I shall be prepared with the proper first-aid treatment when the time comes. A few words on this subject, however, may be the means of saving from untimely death some one who has not the experience I have gained. The precautionary measures that should be followed may be summed up as follows: Don't take a chance of sleeping on the ground without rattlesnake protection! You may "get away with it" indefinitely, but again you may be nipped by a rattler the first night you try it. The best plan is to play safe, and this is not in the least difficult.

Since my experience of having a sidewinder invade my camp, I have slept in a snake-proof tent. This tent is made by having a canvas floor sewed into the walls, and a snake-proof door, which is merely a strip of canvas about a foot wide, sewed to the floor and sidewalls of the tent in such a way that it stands upright at the foot of the door regardless of whether it is open or closed. No snake can get into such a tent, and it is also a protection against ants, spiders, tarantulas, scorpions, and crawling insects.

If the limited capacity for carrying camp equipment prevents the use of the snake-proof tent, a thoroughly effective snake fence for sleepers on the ground may be made by pegging down a strip of canvas to stand perpendicularly in a circle completely inclosing one's camp. The fence should be of ample length to give one all the camp room required, and have snap fasteners at the ends for closing the circle. The strip of canvas is provided with sharp steel rods, sewed into it about every three feet, to be driven into the ground to hold the canvas taut and upright. Such a fence is quickly set up or taken down, and will roll into a compact bundle for transportation. The width of the canvas should be sufficient to let three or four inches of it trail on the ground, and this part is weighted down with earth or stones to prevent a snake from crawl-

ing under it. Snakes, and other crawling things, cannot get past this fence, but the camper steps over it with ease. It is cheap insurance against possibly disastrous experience, and will pay for itself in mental comfort, if in no other way.

If you come upon a rattlesnake, the thing to do is to kill it by the simplest and safest method. With a shotgun the job is as easy, and quite as safe, as swatting a fly. A rifle is as sure death as the shotgun, but not quite so easy unless one is a fairly good marksman. To use a pistol successfully, one must be a good shot to nip off the snake's head with a single ball. It should be remembered in all cases, that the head is the snake's most vulnerable spot, as well as its weapon of warfare, and should therefore be "knocked out of commission." Without a firearm, the best way to finish a rattler is with rocks, or with a stick of sufficient length to enable one to swat it without getting within range of its fangs. The rattler's range is about two-thirds of its length, so if you keep that distance away while endeavoring to club it, or throw rocks on its head—you are perfectly safe. I once stumbled onto a fat desert sidewinder while traveling in the country by motorcycle. I had no firearm, and there was not a stick nor a rock within miles. Lacking other means of killing it except with my boot heels (a very dangerous method), I got my tin cup out of my camping outfit, filled it with gasoline from the fuel tank and doused the liquid upon the

snake. The "aroma" and suffocating pungence of the motor fuel set the snake into convulsions, and while it was writhing in the sand, I lighted a match and threw it at the snake. There was a puff of flame, and "Mr. Sidewinder" started across the desert like a crazy comet. He only traveled a few yards, however, before he quit—all nicely roasted for the first wandering coyote that came along.

One should never venture into any rattlesnake country without providing himself with a first-aid kit for snake bites. Most such outfits for sale by sporting-goods houses and drug stores are quite complete, and carry full instructions for use. The kit should include a tourniquet, and if it does not, one should by all means be provided. The human blood circulates too fast to permit effective use of hypodermic remedies unless the member bitten is immediately "shut off" to prevent the snake poison from reaching the heart, which it affects violently. Thereafter the antidote drugs are injected hypodermically into the wounded part. Strychnine, which is widely recommended as a heart stimulant following rattlesnake bite, is almost as dangerous as the bite itself, except when administered by a physician. For this reason great care should be taken in connection with its use. A far safer heart stimulant, which will accomplish the same results, and one which has not been prohibited by the eighteenth amendment, is the medicinal use of that liquid which has been outlawed as a beverage.

**A WALKING STICK OR VIOLIN INTERCHANGEABLE AT WILL**

A combination walking stick and violin is decidedly a novelty in musical instruments. When closed and used as a cane, it is rather large in diameter, and looks more like a wooden umbrella than a walking stick. When opened up by the re-

moval of part of its outside shell, there is disclosed a complete violin and a bow, with which, it is stated, good music can be produced. The violin is tuned in the usual way.

**MEMORIAL OF THE "LUSITANIA" TO FLOAT OVER ITS GRAVE**

Most befittingly located on the exact site of the torpedoing of the "Lusitania," a striking monument, the creation of the French sculptor Georges du Bois, is under consideration to commemorate the most inglorious deed of the World War. The base of the monument will consist of a raft, securely anchored, which will represent a fragment of wreckage bearing the name "Lusitania." Supported by this raft, and rising 80 feet above it, will be the kneeling figure of a mother, holding her child at arm's length and imploringly appealing for the rescue of her offspring, who obviously does not com-



Combination Walking Stick and Violin: A Wooden Cover, Not Shown, Incloses the Bow and the Strings

9500  
Chas. W. Albert Meritt  
22 W. 12th St. Cincinnati, O.





The Torpedoing of the "Lusitania" is to be Commemorated by Permanently Anchoring This Floating Monument at the Exact Site of the Tragedy. The Figure of the Kneeling Mother, at the Right, Is 80 Feet High



COPYRIGHT, UNDERWOOD & UNDERWOOD

prehend the tragic situation. It will be possible to connect the raft by wires with the shore, and thus to illuminate it at night so that it may serve as a beacon as well as a memorial.

9531  
**DEVELOP ALL-WINTER APPLE AT STATE FRUIT FARM**

After years of experimenting at the Minnesota State Fruit Farm, a hardy apple of superior quality has been developed that will keep through the entire winter. Instead of being grafted, the new apple tree must be grown from seed. The apple was produced by crossing the best varieties of hardy and tender apples that grow in the state. Trees grown from the resulting seed bear fruit that have the qualities of both varieties.

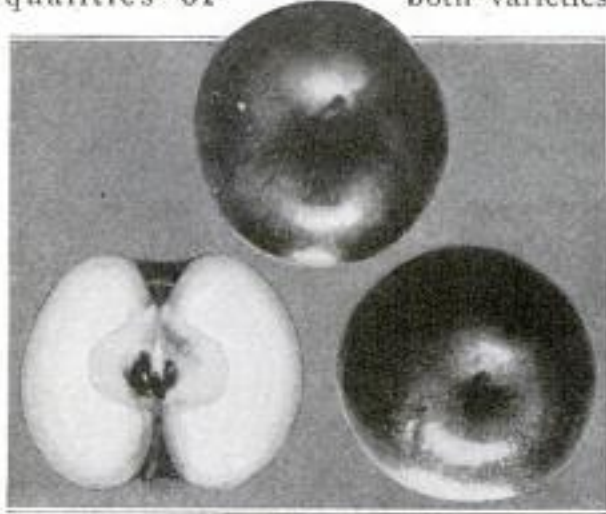

This Bright Red Apple, About Four Inches Across, Is One of a New Variety That will Keep All Winter

Minnesota State Fruit Farm, University of Minnesota

9546  
**AIR-FILLED SWIMMING PADS GIVE FREE ARM ACTION**

Equally useful for the expert swimmer or the beginner, a new swimming pad is

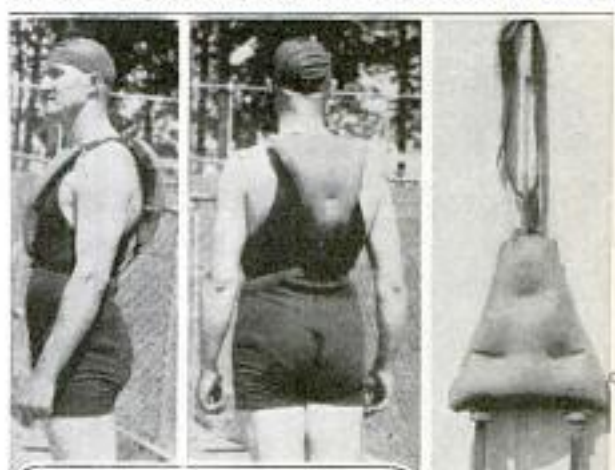

These Air-Inflated Swimming Pads are So Shaped That They do Not Interfere with the Free Movement of the Arms. They are Joined by Elastic Straps Passing over the Shoulders, and Fasten to a Belt That Passes around the Waist

being introduced that does not interfere with the free movement of the arms. An air-filled rubber pad of triangular shape is held on the person's chest and another on the back, both pads being attached to a belt that passes around the waist. The upper parts of the pads are joined by elastic bands passing over the shoulders. The pads, when inflated, support the person without hindering his movements.

Lamparter St., Akron, Ohio. 446

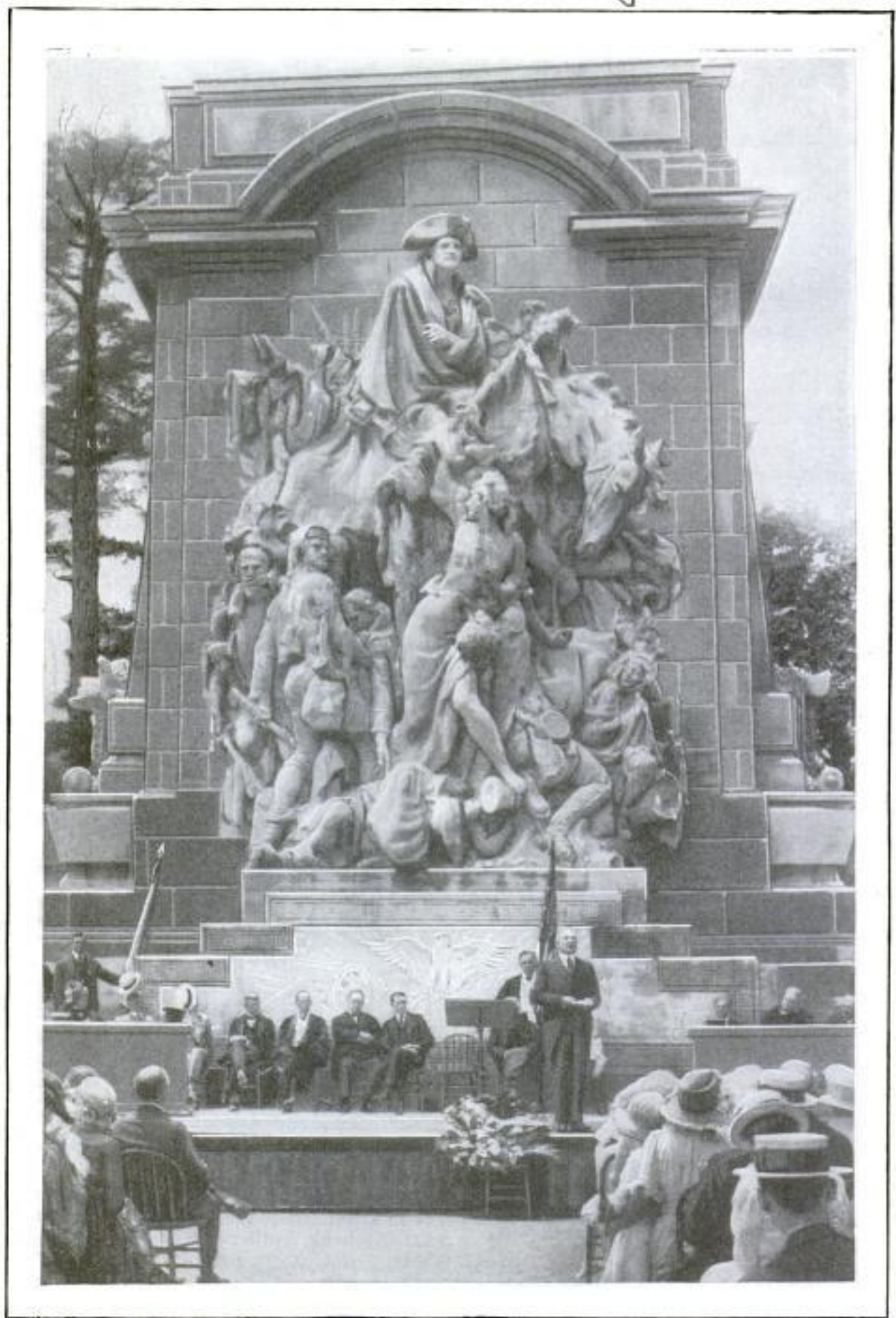

President Harding Addressing the Distinguished Gathering That Was Present at the Unveiling of the Princeton Battle Monument on June 9: The Monument Portrays in a Vivid Manner Some of the Hardships Endured by the Pioneer Heroes during the Days of the Revolutionary War

ANTHEM COMMEMORATED IN STATELY MONUMENTS



The Francis Scott Key Memorial, Dedicated by President Harding at Fort McHenry, near Baltimore, Maryland: The Symbolical Figure Represents the Nation's Tribute to the Man Who Wrote Our National Anthem at a Time When the Very Foundations of the Union were Threatened

cl w. James E. Cross U. S. Mr. Schmidt, a  
 206 Kenton, Tenn. Danish Scientific Chem  
 9415 POPULAR MECHANICS

**BUG CATCHER LURES INSECTS WITH BRIGHT LIGHT**

Working on the principle that flying insects are attracted by a bright light, a southern inventor has devised a bug



A Bright Light in the Funnel of This Bug Catcher Attracts the Winged Pests, and a Suction Fan Draws Them into a Screened Trap

catcher that has shown remarkable results. An electrically driven suction fan and a large metal funnel are mounted on a pair of wheels, and a bright electric

light in the throat of the funnel attracts the flying pests. When they approach the light, the suction fan draws them into a screened trap. The inventor has found that different bugs are attracted by different-colored lights. The machine was designed primarily to combat the boll-weevil pest. In trials it has caught 10 to 15 bushels of bugs in a single night.

9529  
**IMPROVED PROCESS DEvised IN CANE-SUGAR INDUSTRY**

Simplification of the cane-sugar industry is expected to result from the adoption of a new process devised by a young Danish scientific chemist. The necessity for refining the sugar juice by means of lime is avoided. The juice rolled out of the cane is purified directly into a clear sirup, which is ready for evaporation into pure sugar.

Sugar 183 Waverly Ave New York  
 5/19/22  
**STRANGE-APPEARING MACHINE TESTS ROAD SMOOTHNESS**

A machine, which at first glance appears to be an elongated bicycle, is in reality an instrument devised by the Bureau of Public Roads for measuring and recording the condition of the road surface after traffic tests. A small wheel in the center of the span moves a pointer which draws a record on a revolving drum, and an accuracy of a small fraction of an inch is easily possible on the record.

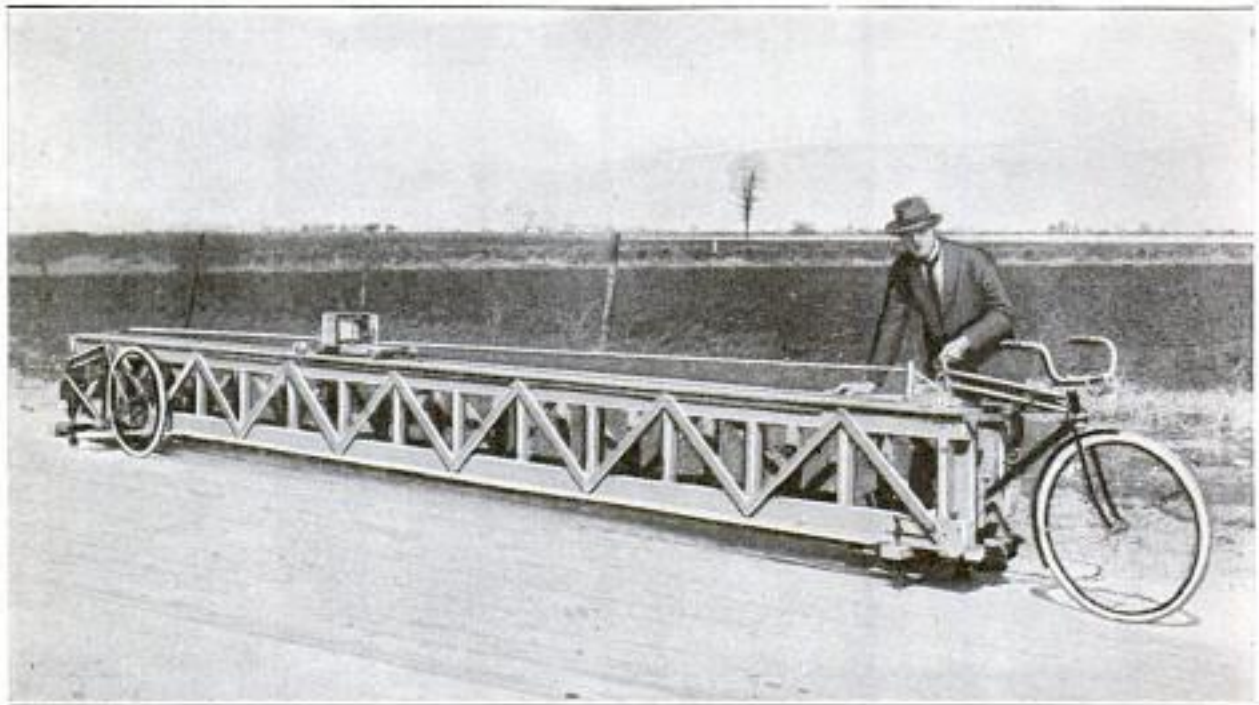

Supported on Three Bicycle Wheels, This Road-Testing Machine Has a Small Wheel in the Center, Which Moves a Pointer and Records the Condition of the Road Surface on a Revolving Drum. The Record Comes within a Fraction of an Inch of Accuracy

9451 U. S. Dept. of Agriculture  
 Press Service 5/23/22 Copyrighted material

### FATAL HEAD-ON COLLISION ON COLUMBIA RIVER

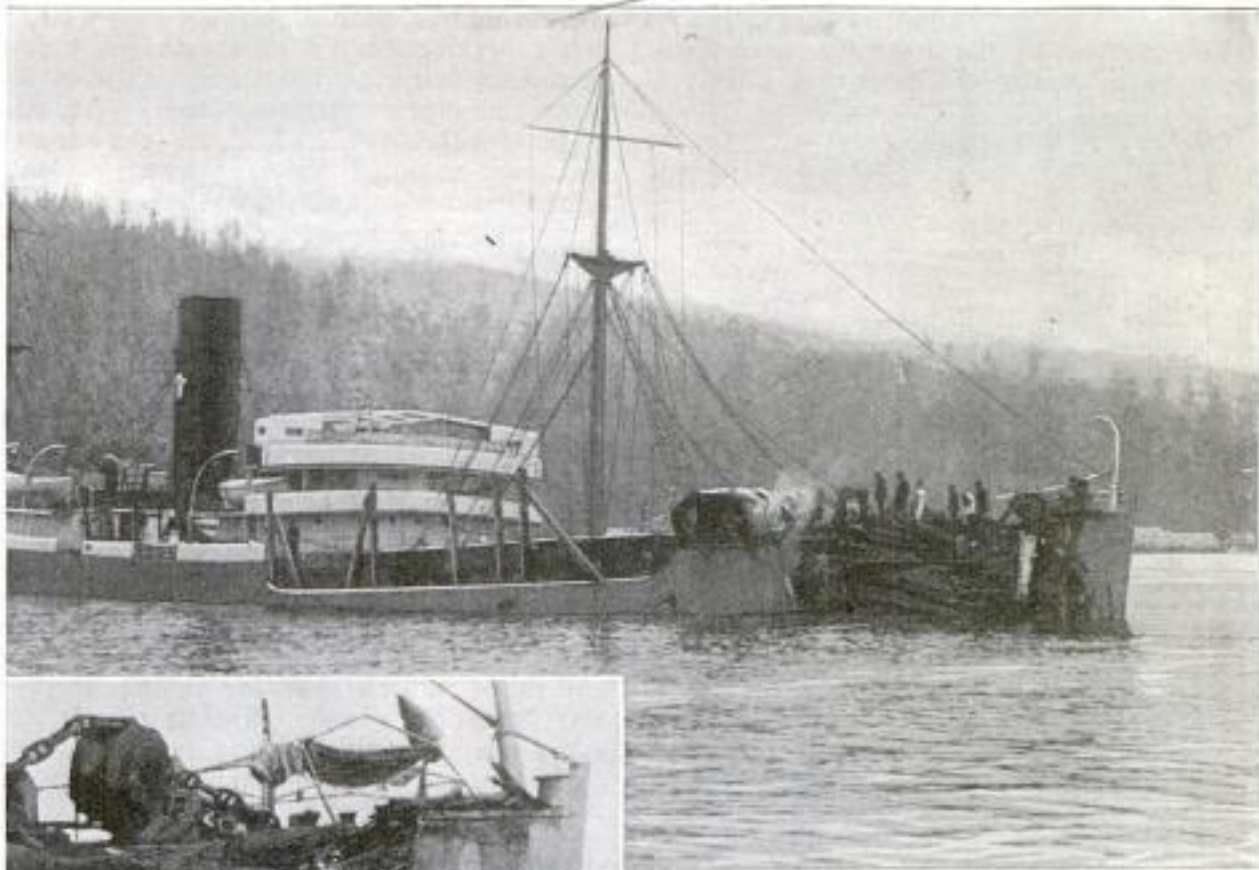

The Steamship "Welsh Prince," Resting on the Bottom of the Columbia River, near Astoria, Oregon  
water, and it required three days' work with acetylene torches to cut through the hull and recover the bodies.

Hole Torn in the Bow of the "Welsh Prince": When This Picture was Taken the Bodies of the Seven Men Killed Were Still on Board the Vessel

While passing down the Columbia River, bound for the Orient, the steamship "Welsh Prince" came into violent collision recently, a few miles above Astoria, Ore., with the steamer "Iowan," which was traveling in the opposite direction. It was a clear night, and as the vessels had sighted each other when three miles apart, the cause of the collision is obscure, but it is supposed that some action of the tide caused the "Welsh Prince" to fail to respond to the rudder, throwing its bow in the path of the "Iowan." The result was that a large hole was torn in the bow of the "Welsh Prince," and seven members of the crew, who were asleep in the forecabin, were crushed to death, while several others were injured. The vessel settled to the bottom of the river in about 30 feet of

9479  
**USE RADIUM-DIAL FACE  
ON KEYLESS PADLOCK**

A novel application of radium is seen in the invention of a combination lock with a "radium dial" which can be opened at night without the usual fumbling for keys and matches. Eight guide lines and an outer circle of tiny radium dots make its manipulation easy. The pointer is also self-luminous. The lock is of a size to be conveniently used on garages.



Wells, Alexander Co.  
A-804, Tribune Bldg.  
Chicago

U. S. Dept. of Agriculture

Frank H. Jones  
15 Rome St.  
Berkeley, Cal.

208

Office Service 6/19/22  
Briquettes

# POPULAR MECHANICS

News

9604  
9402

## SHOW MERITS OF MADE FUEL IN OUTDOOR FIREPLACES

The merits of the glowing open fireplace as a means of producing cheerful



One of the Outdoor Fireplaces, Built along the Motor Highway, Where the Carbon Briquettes were Burned to Demonstrate Their Good Qualities

that also had advertising value, the company recently leased a large field not far from the gas plant, and here the summer's production of briquettes is being placed, in full view from one of the city's principal motor thoroughfares. At the edge of this field, and along the motor highway, at intervals of about 100 feet, huge brick fireplaces have been erected. A fireman is employed to keep the fires burning in these fireplaces.

## AERIAL TAX-ASSESSMENT

### 9605 MAPS CONVENIENT

One of the latest uses of aerial photography is in the making of tax-assessment maps. The mosaic—or pasted-together altitude snapshots—is first made, and then the property owners' names and tax data are plotted on it. Changes in buildings, improvements, and supplementary factors, such as the effects of near-by improvements, can be studied carefully, and these data checked for comparison by a system of yearly photographs. The maps are made to accurate scale, and the saving in cost over yearly check-up of surveys is considerable.

## SHOW MOUNTAIN-ROAD WORK

### 9607 IN GOVERNMENT FILM

That the general public may see the results of the government's activities in road building, the Department of Agriculture has made a moving-picture film of some of the most difficult road-building jobs carried on by the Bureau of Public Roads. The picture, one reel in length,



This Immense Pile of Briquettes Represents the Accumulation during the Summer, and is Stored near the Highway as an Advertisement

warmth is so firmly established that there is little ground for comparing it with other methods of household heating, and advantage has been taken of this fact to stimulate the sale of carbon briquettes as a household fuel.

The carbon briquettes are a by-product of the manufacture of gas from crude oil. Large quantities of the residue from this oil accumulated about a western company's plant, and, until a few years ago, was a worthless waste. Then it was discovered that the residue could be molded into briquettes, and commercialized as household fuel. The output during the winter is insufficient to meet the demand, but in summer great reserves are accumulated for the following winter. Seeking a means of storage

is the first of a series dealing with road building in the national forests, and will be loaned by the Department of Agriculture, or prints may be purchased at cost by authorized institutions.

Los Angeles Gas + Electric Corp.  
Los Angeles, Calif.

# COMMENT AND REVIEW

[These pages were printed June 24, 1922.]

**I**T IS so seldom one finds opportunity to commend anything done by the I. W. W.—in fact this seems to be the very first—that we can all take genuine satisfaction in their latest undertaking.

*Good Work  
by  
I. W. W.*

"Big Bill" Haywood, their leader, who found it advisable to transfer his residence from the United States to Russia, and in whose absence we have managed to get along fairly well, has established a colony in the Volga district of Soviet Russia.

A few days ago 50 additional recruits drawn from the choicest ranks of I. W. W. here, sailed from New York to join the gradually increasing colony over there.

This is an enterprise to which all loyal Americans can well afford to lend their assistance, to the end that what is our loss in I. W. W. shall be Russia's gain. A few thousand more or less over there will make little or no difference, while every one we rid ourselves of is a distinct advantage. The ideals they stand for are being practiced there and never will be here, hence the logical thing is for them to go where they can enjoy their heart's desire to the full. Those who never before felt inclined to contribute of their means to the cause, might now well give liberally to a transportation fund to enable worthy I. W. W.'s to reach their promised land. As Bill Haywood says, the statement from time to time in the capitalistic press that his colony is not all a bed of roses, is neither to be believed nor worth considering. Of course not.



**T**HE publishers of the country have borne with amazing patience the burden—even the unnecessarily heavy burden—which was laid upon them during the war and which still exists. Nearly all other emergency war taxes have been repealed,

*Reduce  
Newspaper  
Postage  
Rate*

and of those which remain, few, if any, have not been lessened. The rate of postage on newspapers and magazines remains unchanged. During the war this rate of postage was increased not once but four times, and even if, as some contend, the original rate was too low, there can be no argument that the present rate is several times too high, being an increase from 100 per cent for the initial zone to 900 per cent in the last zone.

As other things have not yet touched prewar level, the publishers do not ask a restoration of the original rate, although it was undoubtedly of immense profit to the Post Office Department, but a substantial reduction. Even as a war measure, the emergency did not justify any such increase. Newspapers and magazines are the one big explanation of the difference between Russia and the United States today. Then why throttle those mediums which more than all others combined make for patriotism and good Americanism?



**U**NTIL now wireless messages have fallen like the rain from heaven, and anyone who had a proper instrument could reach out his cup and receive his fill. A message intended for the information only of the sender and addressee is poured

*Wireless  
Wonders*

into the ears of thousands of waiting listeners, and except for what protection a private code provides, it is known to all the world. And now Marconi, the original wireless wizard, announces through the American Institute of Radio Engineers his newly discovered method of so directing radio waves as to concentrate them on a desired spot; instead of the rain driving where it will, broadcast, Marconi now forces it through an invisible hose as it were, and delivers his waves on a selected object. Not only can

he already project thus definitely to a distance of 100 miles, but the reflector used in sending serves to catch the echo of the wave thus hurled toward the unseen mark, and this enables the sending operator to determine both distance and direction. In the case of navigators seeking out the location of the lighthouse which they can neither see nor hear, this "sounding" of distance through the air will be quite as dependable as the time-honored custom of locating position in fog or darkness by sounding bottom. With the two methods to check against each other, the mariner should be able to navigate in fog through difficult courses and around

unseen islands and projecting points of land. The sailor's dream for centuries has been of some magic vision which would permit him to see through fog, and while actual sight is not yet available, this "second sight" promises to be hardly less important and serviceable. More and more the sailor's life comes to be one of safety compared to that of the landsman who must cross streets where automobiles are passing.

What will be the next surprise of this astounding radio?

We have already had so many evidences of things accomplished which were previously "known" to be impossible, that should Marconi or one of his thousands of disciples succeed in communicating with Mars or other planets, I fear we would not be half properly shocked with that surprise and unbelief which such an event really deserves.

H. H. WINDSOR

**RADIO SET AND PHONOGRAPH MOUNTED IN ONE CABINET**

A one-control radio-receiving set with a super-amplifier that accomplishes with three tubes what has previously required five, has been mounted



Radio-Receiving Set Mounted in a Console Phonograph Cabinet: No Outside Aerial and Ground are Needed. With Only One Control, It Is Very Easy to Tune In

in a console phonograph cabinet and is connected to the horn of the phonograph. The outside aerial and ground are dispensed with by the use of a special loop antenna, contained in the instrument, which eliminates a large amount of static disturbance. The one control makes the tuning very simple. It has a dial that is graduated in definite wave lengths so that all that is necessary is to turn to the wave length on which any particular broadcasting station is operating. In the cabinet are storage batteries, but these need not be used where an

alternating-current lighting service is available, for the set is provided with an attachment which will make it operate by connection to a light socket.

**ORNAMENTAL CARDBOARD LAMP CAN BE FOLDED FLAT**

Beautiful in appearance and requiring but a minimum of space when not in use, an ornamental cardboard lamp has been recently introduced which can be folded flat and mailed in an envelope. The novelty has a stiff base, artistically tinted, and semitransparent shade, printed in many colors and capable of being bent in a circular shape, for which purpose small tongues are provided that fit in special grooves. At the top of the easel, or support for the lamp, is fastened a steel-wire loop that projects upward, ending in a point on which the shade is placed. A neatly arranged holder is incorporated in the lamp to receive an electric-light socket.

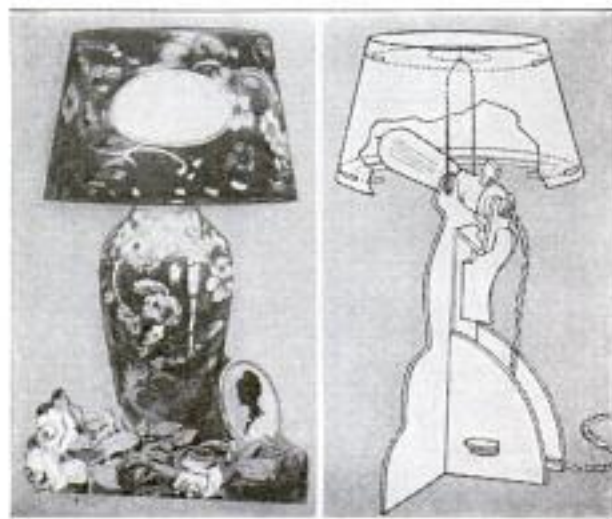

Left: Folding Cardboard Lamp Seen from Front. Right: Diagram Showing Construction

937

950

*in usual*

*Mr. Benjamin F. Miesner  
5934 Magnolia Ave  
Chicago*

*Sold by Brunswick-Balke-Livernore & Knight  
Collender Co 528 S. 36 Pine St.  
Wabash, Chicago Providence, R.I.*

Copyrighted material



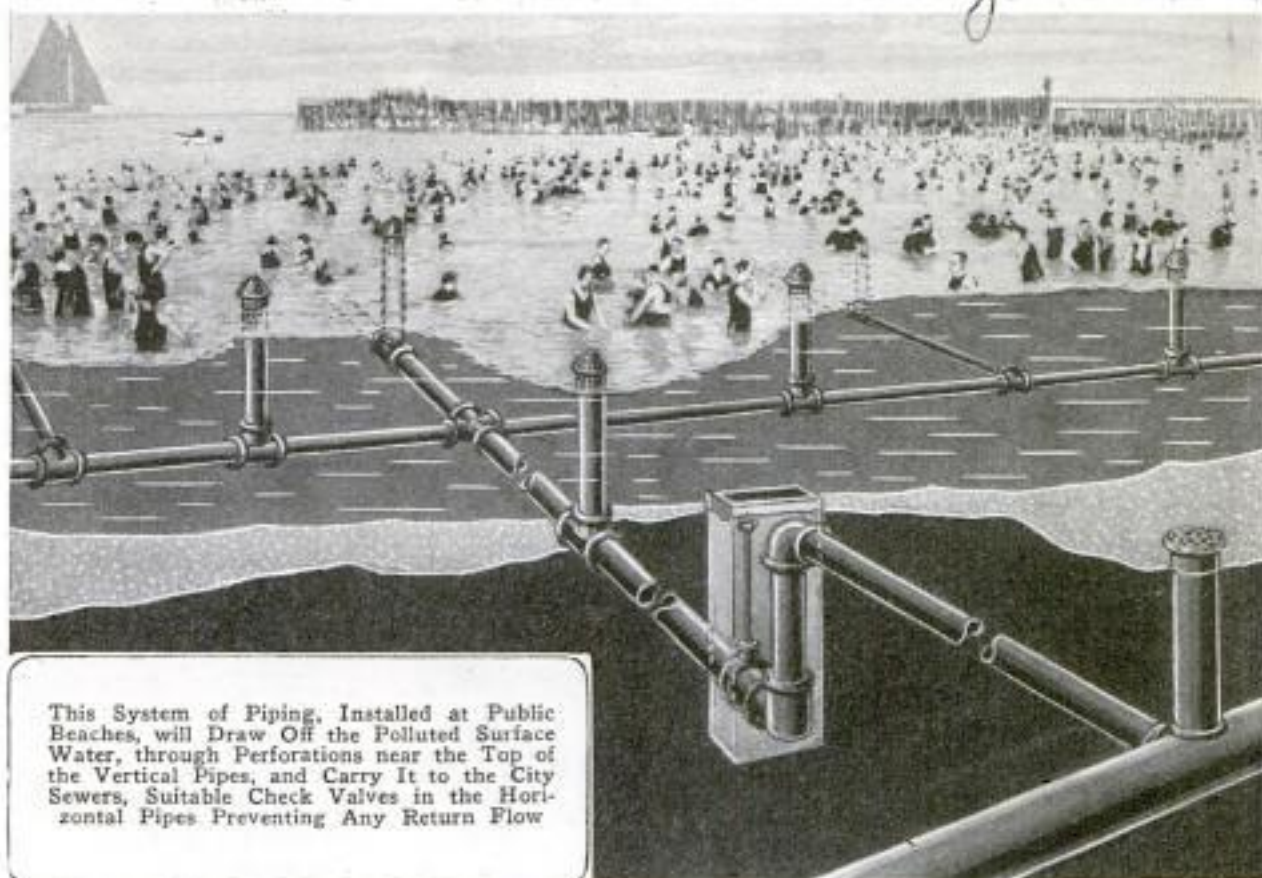

This System of Piping, Installed at Public Beaches, will Draw Off the Polluted Surface Water, through Perforations near the Top of the Vertical Pipes, and Carry It to the City Sewers, Suitable Check Valves in the Horizontal Pipes Preventing Any Return Flow

**9514 PIPING SYSTEM WILL PURIFY BATHING-BEACH WATER**

In cities having bathing beaches on lakes where there is little or no current of water, many people are deterred from swimming by the fear of infection from polluted water. Recent inquiries by the American Public Health Association among a number of medical specialists and health officers, elicited the fact that three-fifths of them considered swimming pools and bathing beaches important factors in the spread of disease.

To remedy this condition of polluted water at one of Chicago's most popular bathing beaches, a system of piping is to be installed that bids fair to solve the problem. A number of vertical pipes will be set up in the water, extending a little above the surface, the lower ends being connected with horizontal pipes under the beach. Perforations near the tops of the vertical pipes will continually draw off a portion of the surface water and pass it to the city sewers by means of the horizontal pipes. The horizontal pipes will be buried deep enough to be unaffected by frost during the winter, and will be supplied with valves so that the amount of water drawn from the lake can be controlled. A check valve will also

be placed in the line so that there will be no danger of sewer water passing into the lake, as might be the case during a severe rainstorm.

**9443 HOTEL FIRE DEMONSTRATES WORTH OF CONCRETE**

Fire destroying the wooden half of a wood-and-concrete-constructed hotel in Minneapolis, Minn., failed to cause a complete cessation of business. By bridging the ruined basement and erecting an iron stairway to the second floor, the flame-scarred hostelry is still able to accommodate guests.



Fire-Damaged Hotel, Showing the Bridging of the Basement and the Stairway to the Second Floor

Carl E. C. Mueller  
 314 - 2nd St. S. E. W.  
 Watertown, S. D.

9601 **DIRECTIONAL RADIO WAVES  
 FOR GUIDING SHIPS**

Directional control of radio waves, of which mention was made in the July issue of Popular Mechanics, is the latest invention of Signor Marconi and was successfully demonstrated by him in New York

City recently. Using waves only one meter in length, the famous inventor sent, or "shot," these accurately across 20 feet of space with a midget wireless outfit. In shooting the waves, a reflector was used, the wave being caught at the receiving end on a horizontal metal standard. The reflector is a skeletonized semicircular apparatus, with the open or flat surface toward the receiving station, and throws the radio wave in somewhat the same manner as a mirror in the hand throws a ray of light. While this method does not insure absolute privacy of messages, yet it prevents them from being "picked up" by any persons except those chancing to be in the direct line of communication. The innovation can be adapted to guide ships through fog, for determining the location of a lighthouse when coming into port, and to prevent collisions in mid-ocean by detecting the proximity of another ship, thus serving as a protection for shipping.

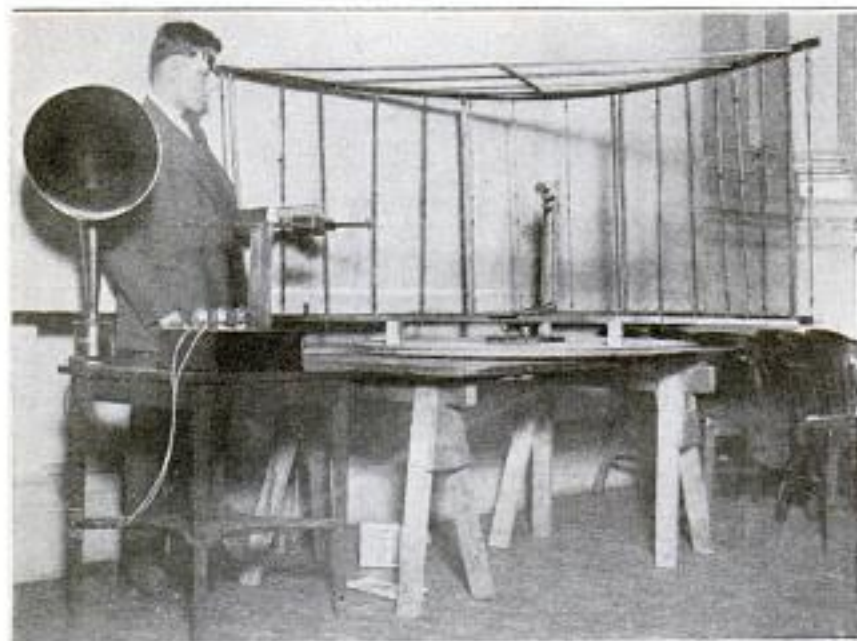

Directional-Radio Wave-Control Apparatus, Which was Used by Signor Marconi in Demonstrating the Sending of Messages in a Direct Line of Communication through Space: This New Apparatus will Be of Great Service to Shipping, and Aid in Assuring Greater Privacy for Messages in General

Train  
 9533 **FIRST CANADIAN RAILROAD  
 TO INSTALL RADIO**

Radio apparatus has been installed on a train of 17 cars, which is now touring the western provinces of Canada in the interests of better farming and to encourage breeding of high-grade live stock. This equipment is the first of its kind to be placed on a railway train in that country, being maintained by the Canadian Pacific under the personal supervision of two Marconi representatives. Thus the passengers are enabled to hear concerts broadcast from Winnipeg and receive news of the world in general, even while journeying through quiet rural communities. The live-stock improvement-

train project is fostered jointly by the Department of Agriculture and the Agricultural College of Canada, and the live-stock exchange, the packing companies, and the cattle breeders of Manitoba.

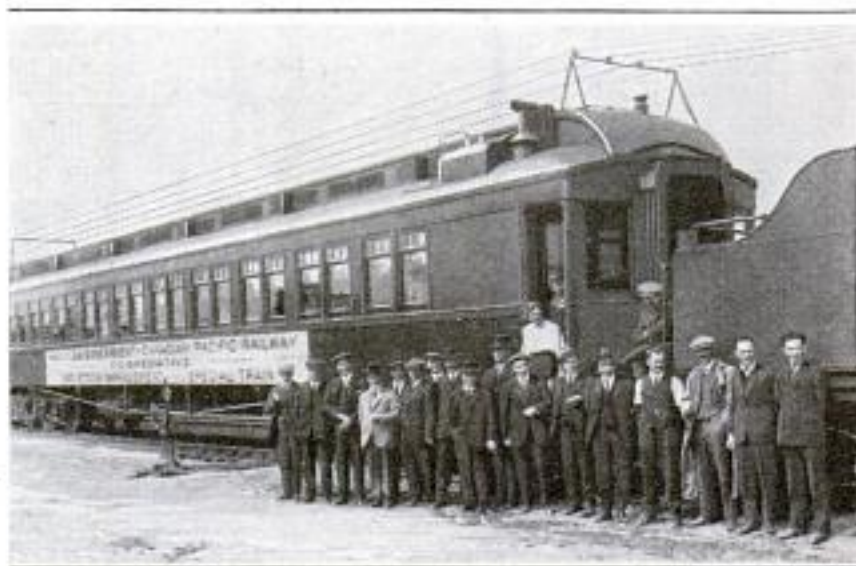

Live-Stock Improvement Train of Canadian Pacific Railroad, Which Was the First in the Dominion to be Equipped with Radio: The Aerial is Seen Extending along the Top of the Coaches

Canadian

Pacific Railway Co  
 New York City

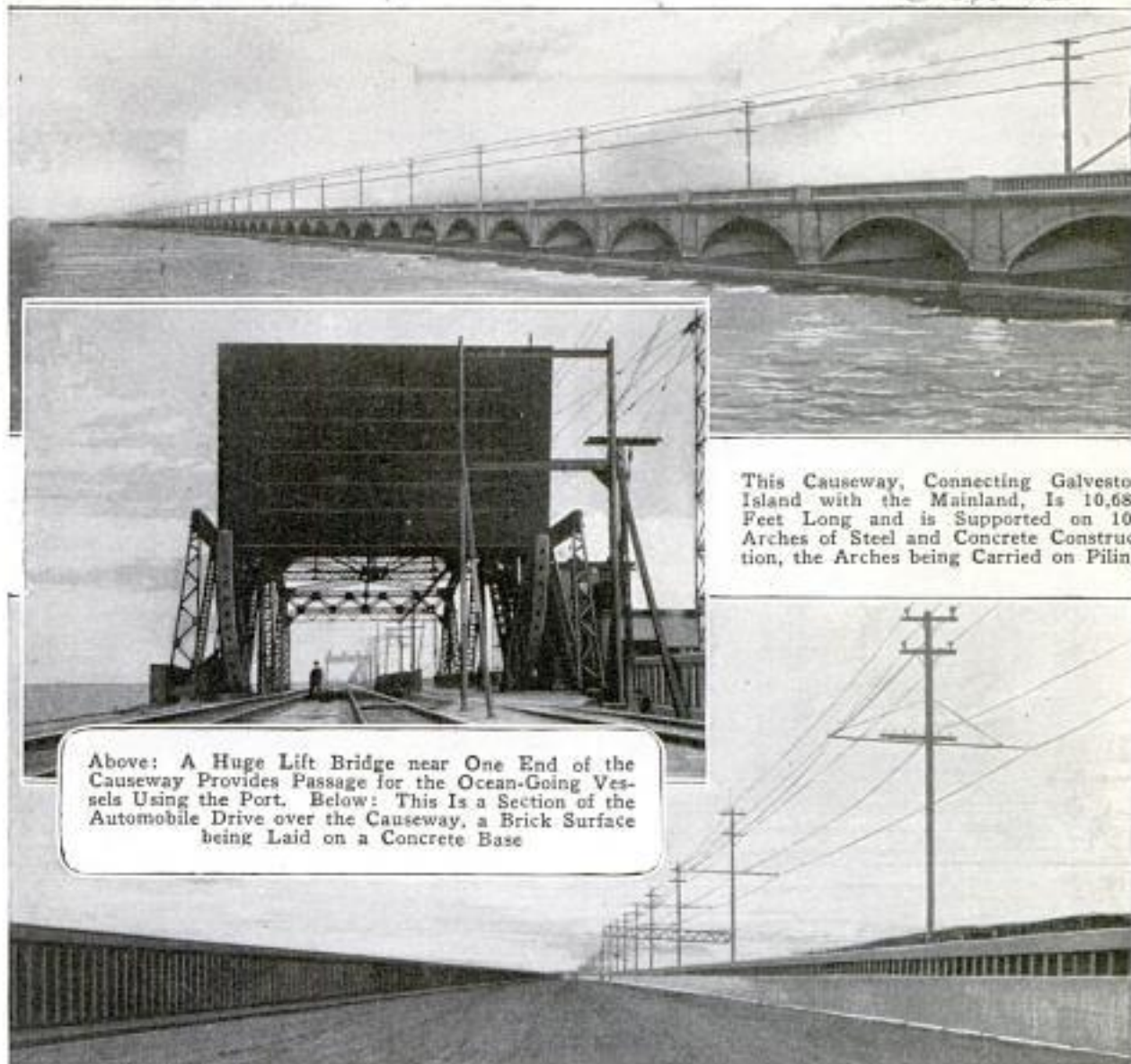

This Causeway, Connecting Galveston Island with the Mainland, Is 10,685 Feet Long and is Supported on 107 Arches of Steel and Concrete Construction, the Arches being Carried on Piling

Above: A Huge Lift Bridge near One End of the Causeway Provides Passage for the Ocean-Going Vessels Using the Port. Below: This Is a Section of the Automobile Drive over the Causeway, a Brick Surface being Laid on a Concrete Base

## GALVESTON'S GREAT CAUSEWAY IS FORMALLY DEDICATED

In commemoration of San Jacinto Day—the anniversary of the date on which Texas won its independence from Mexico—the great causeway joining Galveston Island with the mainland was formally opened to traffic. The causeway stands as a fitting tribute to the skill and ability of the men who were responsible for its construction. It is 10,685 feet long and 63 feet wide, with space provided for steam and electric railways and a wide thoroughfare for automobiles. The causeway is supported on 107 arches of steel and concrete construction, the bases of the arches being carried on piling driven some 40 feet below the bottom of the bay. A giant lift bridge near one end of the causeway provides passage for ocean-going vessels using the port. The cost of the project was nearly \$4,000,000.

## ROLLER JEWELS IN WATCHES

937, SET WITH NEW TOOL

Watchmakers will be interested in a new electrical tool which will greatly assist them in the delicate task of setting roller-table and pallet jewels. The simple contrivance, no larger than a fountain pen, has two small jaws for holding the work, which is locked in place by a fiber



Electrically Heated Tool for Setting Roller-Table and Pallet Jewels in a Watch, Showing the Two Small Jaws and Fiber Ring

ring. A cord attachment to an ordinary dry-cell battery furnishes sufficient heat to enable proper and rapid setting of the jewel, making the appliance a valuable addition to the tools of the trade.

Chas. Harry Seely  
Vinton & Co.

*Wm. V. C. Krueger*  
 25 2 Third St. S.  
 214  
 9263 *Portland Oregon*  
**POPULAR MECHANICS**  
**COFFEE-PERCOLATING MACHINE**  
**FOR CONTINUOUS SERVICE**

To meet the demands for continuous service of new-made coffee, as in restaurants and cafeterias, a

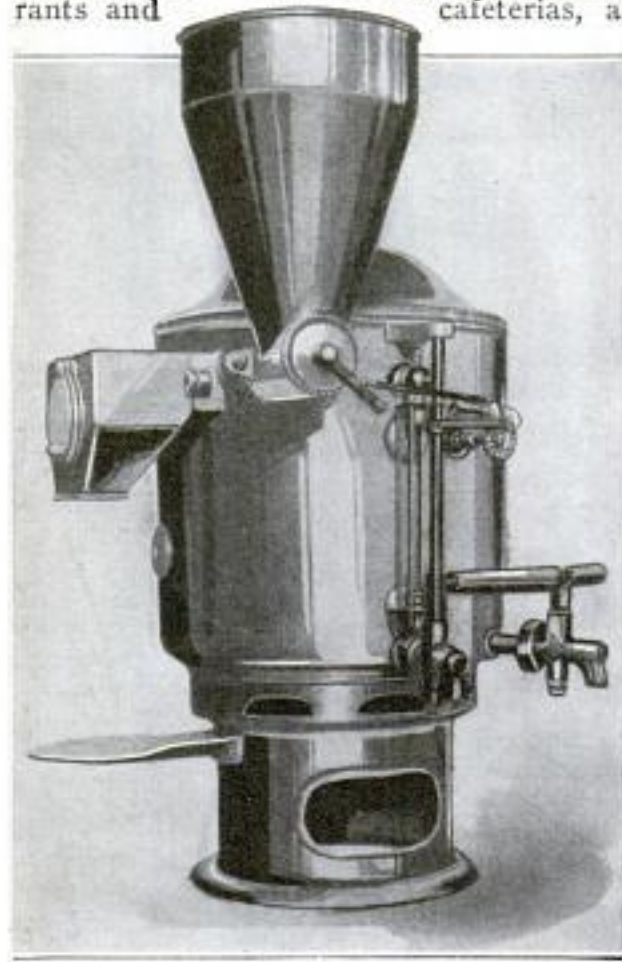

**A Coffee-Percolating Machine Which Automatically Keeps the Supply of Ingredients Replenished as the Coffee is Drawn from the Faucet**

percolator has been devised in which the supply of ingredients is automatically replenished. When the faucet lever is turned to draw a cup of coffee, it operates a valve in the top of the machine which deposits a small amount of ground coffee on the percolator screen. The same action also turns the screen, and after one complete revolution, the used grounds are removed by a scraper. The water level is automatically maintained by a float in the urn.

**9493 ODD MUSEUM RECORDS VOICES OF DISTINGUISHED MEN**

Recording the voices of distinguished men is now being carried on in connection with the Prussian State Library, in Berlin, for the instruction and historical entertainment of future generations. The method of obtaining the records, or plates,

*Christian Science Monitor*  
 5/26/22

*Detroit School Equipment Co*  
 Panobscot Bldg  
 Detroit, Mich.

is similar to that employed in making those of the ordinary talking machine, except that these plates are prepared with special chemical substances to make them more durable. Heretofore only prominent personages of Germany have delivered addresses for reproduction, but it is the intention of the directors to operate the innovation on an international basis. Thus for many years the admirers and students of famous men in history will be enabled to hear their voices and views on varied subjects.

**9343 MOVABLE SCHOOL DESK TAKES UP LITTLE FLOOR SPACE**

Instead of making the school children accommodate themselves to the style of desk provided, a movable desk has now been designed that can be adjusted to their stature. The desk is really a desk and chair rigidly combined into one piece of furniture. It is made in two sizes and is provided with a footrest which, if not needed, may be pushed back under the seat. A roomy book compartment is built along the right-hand side of the desk top, while a shelf under the seat provides space for school bags.



**This Movable School Desk Accommodates Children of Different Statures, the Footstool being Pushed Back under the Seat When Not Needed**

9430

Aeromarine  
Hydro-aeroplan  
Commercial

Loening Aeronautical Engineering  
Corporation, 31st St. + East River,  
New York City

POPULAR MECHANICS

215



This Loening Air Yacht, of Remarkably Graceful Lines, Seats Four Passengers Besides the Pilot, and is Noted for Its Successful Long-Distance Flights and Rapid Climbing Ability

9430  
**LOENING AIR CRUISER MAKES FAST TRIP FROM FLORIDA**

After having been used for a remarkably large number of successful flights near Palm Beach and Miami, Fla., a Loening air yacht made a trip from Florida to New York in the startling flying time of 9 hours 56 minutes. The distance was approximately 1,220 miles and the average speed 123 miles an hour. The air yacht accommodates comfortably, four passengers and the pilot, and is of monoplane type driven by a four-blade propeller, acting as a pusher, the engine being mounted on the wing.

9275  
**MILK KEPT FROM FREEZING BY TWO LAMPS IN BOX**

To safeguard the early-morning milk against freezing, was the desire of a Chicago man who designed a receiving box having two compartments, one for the milk bottle and the other fitted with two



Box Designed to Keep Milk from Freezing: The Bottle can be Seen in One Compartment and the Lamps in the Other

Wm. E. Sawyer  
Chicago

60-watt lamps. The milkman switches on the lamps when he makes the daily delivery, sufficient heat then passing through the perforated partition in the box to keep the milk fluid despite the coldness of the weather.

9452  
**BABY CARRIAGE IS DRIVEN BY GASOLINE MOTOR**

A baby carriage driven by a gasoline motor is the latest novelty in England.



Baby Carriage, Showing Motor, Extra Wheel, and Footrests at the Rear: The Control Mechanism is Shown on the Handle

The small motor is geared to an extra wheel at the rear, and there are footrests on either side of this wheel for the nurse-chauffeur, who stands upright and controls the carriage by means of levers on the handlebar. The odd vehicle attains a speed of four miles an hour and is so constructed that no engine vibration can possibly reach and disturb the sleeping or irritable child.

Mess. Dunkley, Ltd.  
Jamaica Road  
Birmingham, England

### TEST ROAD CONSTRUCTION WITH IMPACT MACHINE

The increasing use of motor trucks for commercial hauling over the highways of the country, has induced the Bureau of

Public Roads, to investigate the wearing qualities of various types of construction. In order that a large amount of information

may be gathered in a relatively short space of time, an impact machine has been constructed to simulate the action of a loaded truck on the highway. The specimen of highway being tested is placed under the machine, and a truck wheel, supported in a substantial frame, is caused to drop repeatedly on the test slab under varying conditions of height and weight. After every 250 blows the condition of the test slab is inspected and noted, until failure becomes apparent. The machine then moves to the next slab.

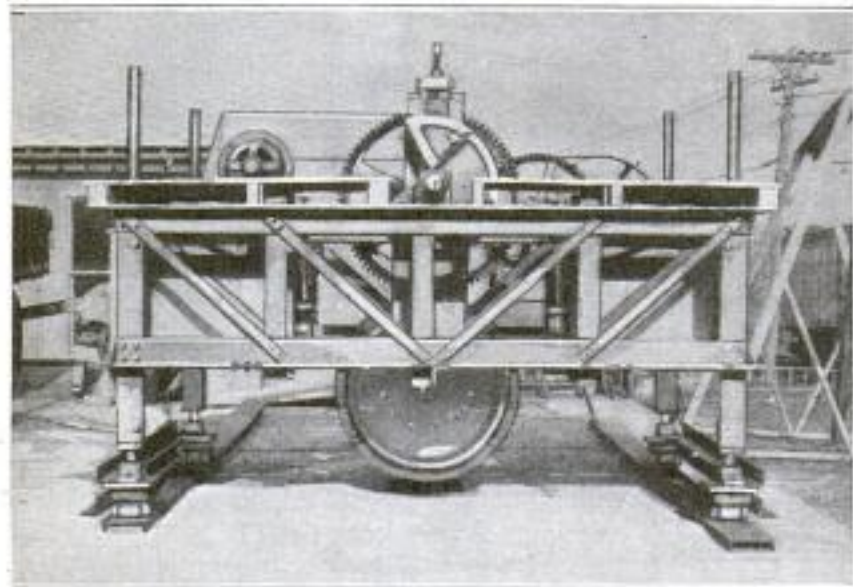

This Impact Machine Causes the Truck Wheel to Drop Repeatedly on the Slab of Highway Pavement being Tested, the Force of the Blows being Increased Until the Specimen Fails

### FIRE ENGINE HAS DETACHABLE PUMPING UNIT

A special development in fire-fighting apparatus is the fire engine with a detach-

able rear wheels for propelling the truck. In addition, it serves as a source of power for the motor which drives the centrifugal-pump unit. This unit is supplied with separate wheels, so that it can be detached and wheeled to the source of water supply, the truck remaining at some convenient location, perhaps quite some distance away.



The Detachable Electric-Driven Pump Shown at Work, Power being Supplied from the Truck

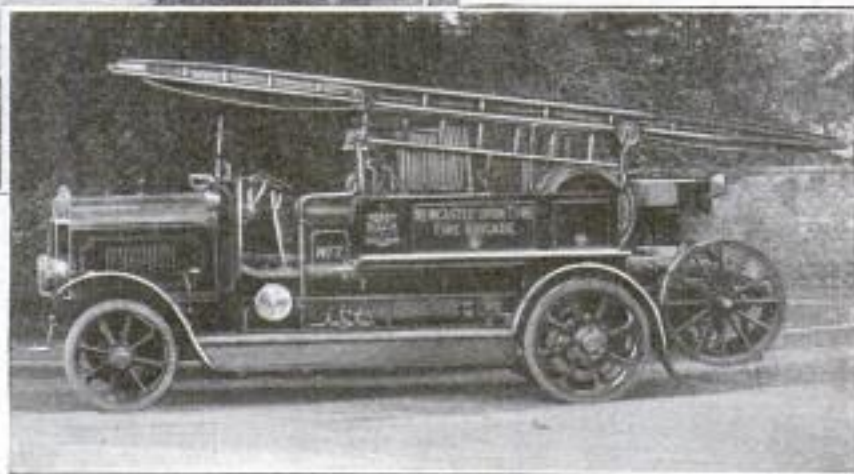

This Gasoline-Electric Fire Engine Carries a Detachable Pumping Unit at the Rear That can be Wheeled to the Source of Water Supply

9427  
Tilling-Stevens Motors, Ltd. Maidstone, England

able pumping unit for use where the source of water supply is a river or a lake. The gasoline engine of the truck drives an electric generator, which supplies current to motors connected to the



One of the Buckets, Containing 800 Pounds of Ore, Passing a Supporting Tower of the Tramway: The Cable for Loaded Buckets Is One Inch in Diameter and the Return Cable a Little Smaller

## FAR-NORTH TRAMWAY HAS LONGEST CABLE

Transportation Problem of Canadian Gold Mine Solved  
by Cableway Crossing the International Boundary  
and Ending at Stewart, Alaska

BY F. H. MASON,

*5 Hampton Court  
Victoria B.C. Canada*

WITH an endless cable 22½ miles in length, the Premier Gold Mining Company's aerial tramway, which was put into operation in December last year, is believed to be the longest single-rope aerial cableway in the world.

It will be well to explain, perhaps, that this mine is situated in a rugged mountainous country, 15 miles from Stewart, at the head of the Portland Canal, which is the nearest shipping point to the mine. The Portland Canal

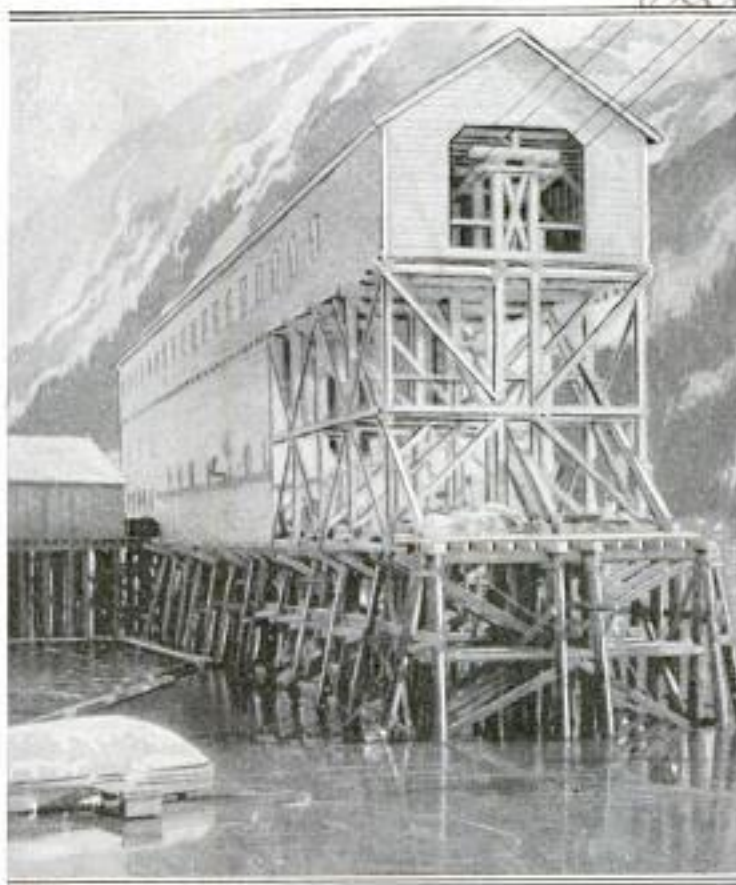

The Discharge End of the Tramway, Where the Buckets Automatically Discharge Their Loads of Ore into Bins: Chutes Then Convey the Ore to Waiting Vessels. This Method of Moving the Ore Results in a Minimum of Handling

is a narrow natural inlet, some 100 miles in length, that forms the boundary line between the southernmost part of Alaska, on the west, and British Columbia, on the east. Owing to the nature of the country and to the climate, with its heavy rains in summer and its severe winters, it has proved impossible, except at unwarrantable expense, to maintain a road between the mine and tidewater suitable for the transportation of heavy traffic, such as ore and

mining machinery. A road was built between the mine and Stewart with the idea of transporting ore over the winter snows, but despite the fact that an average of 50 horses and two five-ton endless-tread tractors were employed in the work, only 488 tons of ore were moved in 1919, and 799 tons in the following year.

Under these conditions it was impossible to ship any but the highest-grade ore, and it became evident that if the mine were ever to become the big producer that its richness gave promise of, some better form of ore transportation must be employed. Consequently, it was decided to build this aerial tramway, which during the first three months of this year has fully justified expectations by transporting approximately 18,000 tons of ore from the mine to Stewart.

The tramway has many interesting features. It was impracticable to build it in a straight line, and there are, therefore, three angle stations, deflecting it 46, 26, and 99°, respectively, all in the same direction, so that the tramway makes almost a half turn. The tramway is exactly 11¼ miles long, and the loading end is 1,337 feet above the discharging terminal. The main-track cable, which carries the loaded buckets, is 1 inch in diameter and so constructed as to be particularly smooth. The return-track cable,

carrying empty buckets and supplies for the mine, is 7/8-inch diameter. These two cables were shipped in about 1,000-foot lengths, which are connected by 110 nickel-steel couplings. The cables are supported on 153 towers, and at the angle stations and terminals, where the tension is adjusted. The running cable is made of 5/8-inch plow steel, and is in one piece, 22½ miles long; it hauls 125 buckets, each of which carry about 800 pounds of ore, and is operated by a 50-horsepower electric motor. The normal running speed is 500 feet per minute, and the starting speed 125 feet per minute. This speed is estimated to give the tramway a capacity of 100 tons of ore per eight-hour shift, but, as a matter of fact, it is now delivering about 1,600 tons per week of seven two-shift days. It took some time to tune it up to this capacity.

The ore bunkers at the loading terminal have a capacity of 200 tons and discharge through a chute directly into the buckets. At the discharging terminal the bunkers hold 1,500 tons, and the buckets discharge automatically, by means of a trip, into them. Delivery from these bunkers into ships and barges is effected through a chute and by means of belt conveyors.

For the purpose of sending supplies to the mine, there is at Stewart an incline from the wharf onto the floor on which



This Shows One of the Angle Stations Constructed Where the Tramway Makes a Turn. There Are Three Turns, All in the Same Direction, in the 11¼ Miles between the Mine and the Dock



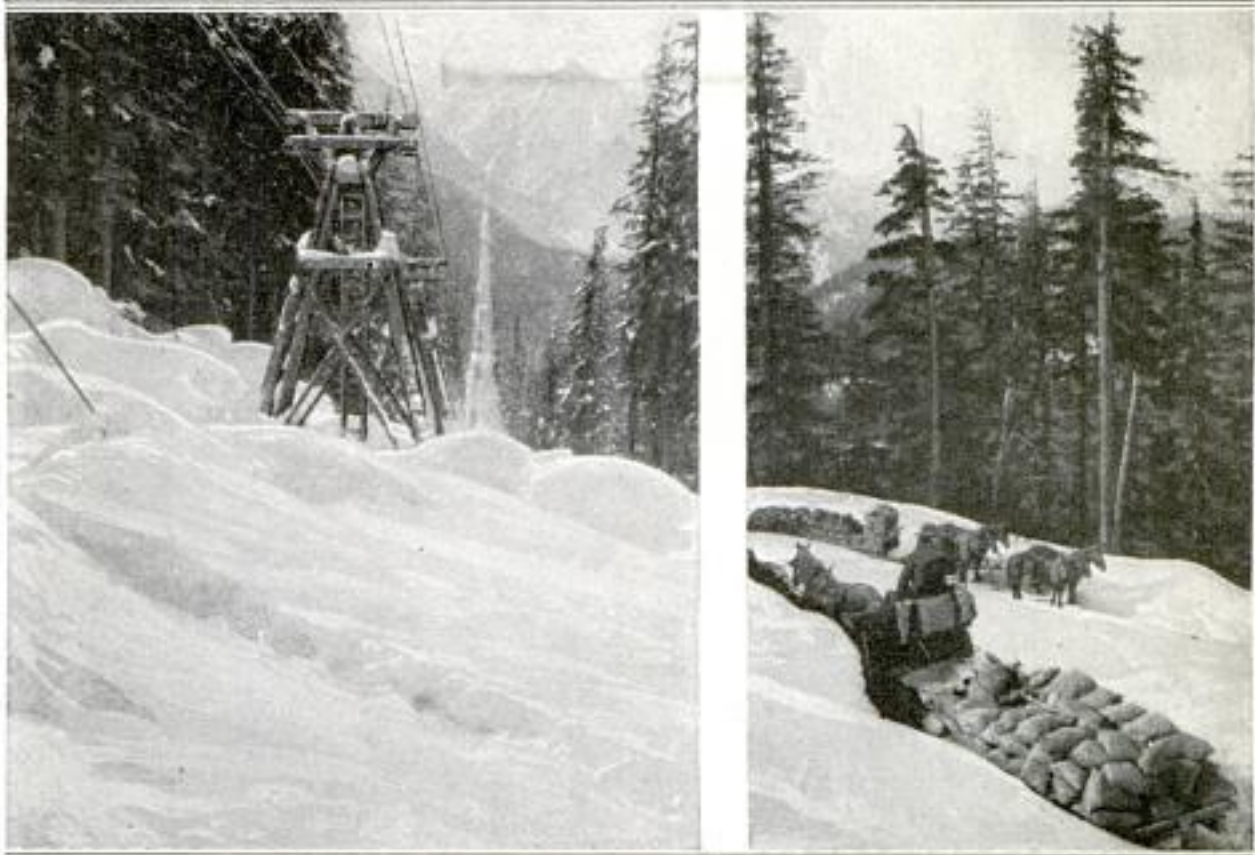

The Tramway Goes up and down Hill in a Straight Line, While with the Older Method of Hauling with Teams It Was Necessary to Make Switchbacks on the Steeper Slopes to Reduce the Grade

the tramway enters the terminal, and a gasoline-driven hoisting engine that hauls up the supplies to this floor. A small electric-lighting plant supplies light for operating the tramway and for loading ships by night. This is necessary in this northern latitude, where during the winter the days are very short. The terminals and angle stations are connected by telephone. A continuous patrol of three

men is maintained throughout the whole length of the line while the tramway is in operation, each man being responsible for one-third of the line. The installation cost \$250,000, and, it is said, will easily pay for itself within a year because of the increased ore-carrying capacity.

The mine and about one mile of the tramway are in British Columbia, the remaining part in Alaska.

9400 *Aeromantic Access*

**SHOW POSITION OF AIRPLANE CONTROLS ON RECORD**

Scientific observation of the behavior of airplanes in flight, and their response to the controls, will be much advanced by an instrument lately constructed. The device records on a moving drum the position of the three controls at all times while the airplane is in flight. The record is made photographically on a film wound around the drum, beams of light being reflected from three mirrors moved by the controls. By revolving a shutter in front of two of the mirrors, broken lines are made to appear on the film, and in this way the movements of the three controls can be identified on the record, as a full line, and as short or long dashes.

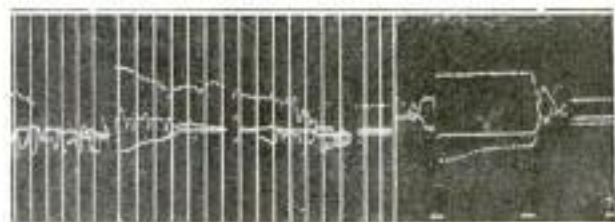

Above: A Portion of the Photographic Record, Showing the Positions of the Airplane Controls during a Flight. Below: The Recording Device That is Operated by the Controls

*Designed by Natural Advisory Committee for Aeronautics*

220  
9332

**PORTABLE DISK GRINDER HAS  
GRADUATED INDEX TABLE**

For the use of industrial schools, shops,  
or factories, a portable disk grinder is  
being manu factured with all the

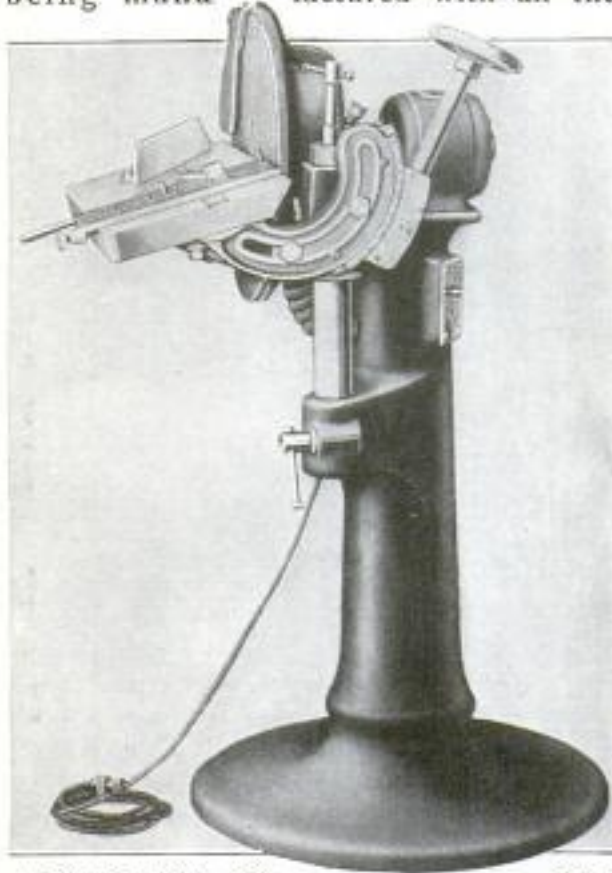

A Portable Motor-Driven Disk  
Grinder That can be Attached to Any Electric-  
Light Socket Has Graduated Index Table

features of a precision instrument. It is  
motor-driven and can be attached to any  
electric-light socket, while a push-button  
switch on the supporting column fur-  
nishes convenient control. The table is  
provided with a graduated index. An ex-  
haust system deposits the dust in the  
hollow column of the machine.

9368

**BUILD EXPERIMENTAL GLIDER  
FOR TECHNICAL COLLEGE**

A new glider is being finished at the  
Massachusetts Institute of Technology  
that differs in a number of respects from  
the gliders that have been built abroad,  
and tried out with notable success in  
Germany and England. The designers of  
the new machine have replaced practical-  
ly all metal fittings, except screws and  
nails, with plywood web construction, and  
this has been done without sacrificing  
strength. Front and tail skids replace the  
customary landing gear and wheels of an  
aeroplane. The wing is 24 feet long and  
has an area of 110 square feet. The  
fuselage is 10 feet long and the wood-  
work is chiefly of spruce. The wing and  
tail are being covered with balloon fabric  
which weighs only 1.9 ounces per square  
yard, or about one-third as heavy as  
ordinary aeroplane fabric.

How to launch the glider is one of the  
greatest problems facing the builders. Ac-  
cording to present plans, it will be cata-  
pulted into the air by means of a power-  
ful rubber cord, fastened to the under  
part of the plane. The glider, with the  
pilot in the seat, will rest upon the sum-  
mit of a hill, and three men will walk  
down the hill pulling on the rubber cord,  
while a third will hold down the glider's  
tail. At a signal the tail will be released,  
and the contraction of the rubber cord  
will start the glider on its flight.

While some of the foreign gliders have  
been built without the usual number of  
control surfaces, this machine has three  
controls, namely, for the elevators, ruder,  
and ailerons. The glider will be a per-  
manent feature at the institute for the  
study of aeronautics, to test wind currents,  
and to ascertain why one can often gain  
altitude without using a motor.

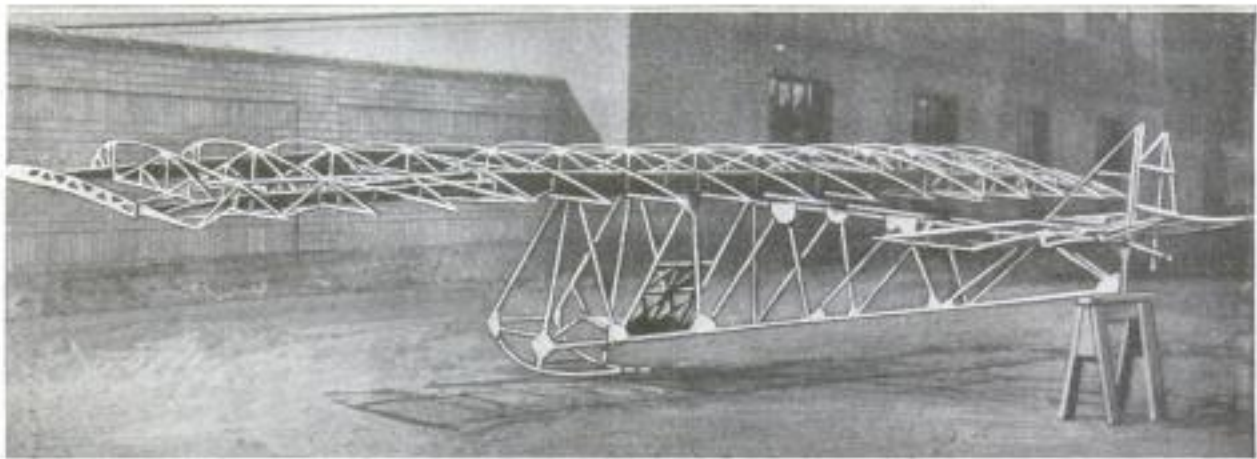

This Glider, Now being Finished at the Massachusetts Institute of Technology, Is of Plywood Construction and  
will Be a Permanent Unit for the Study of Aeronautics and Gliding Flight

Edmund J. Allen, Aeronautical  
Engineering Society of Massachusetts  
Copyrighted material  
C. E. Kopman

Mason City, Iowa

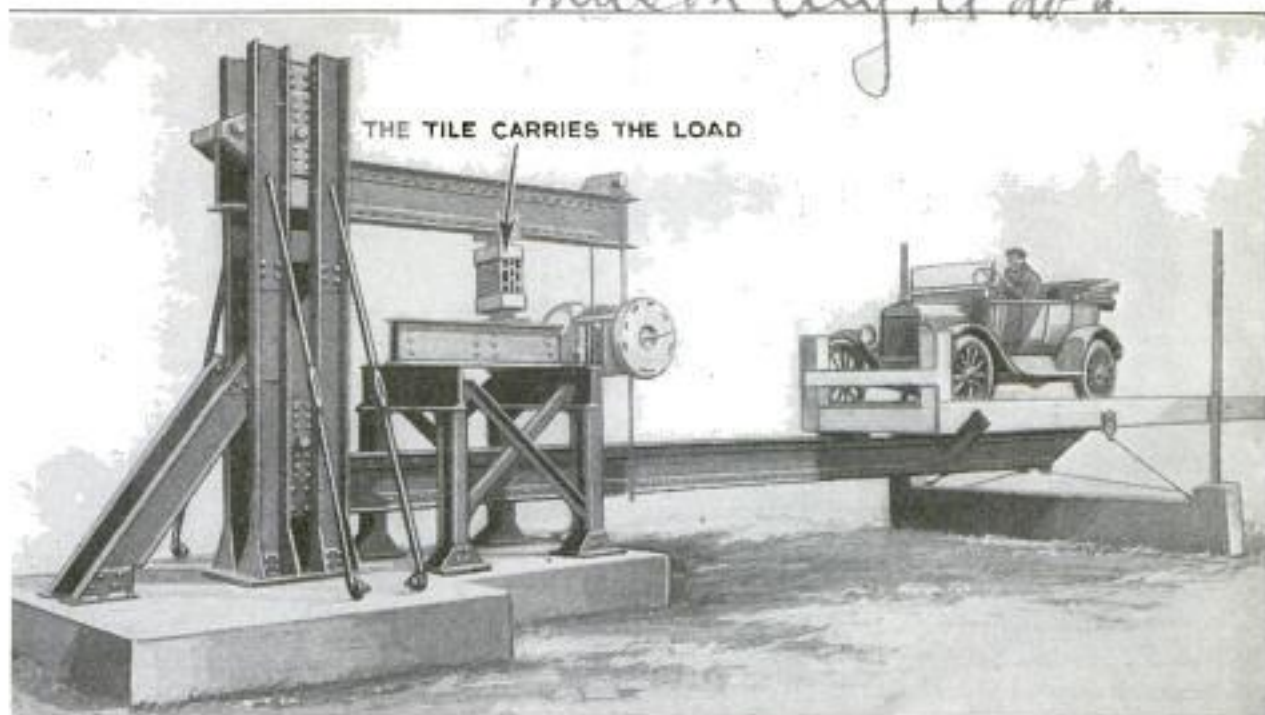

Tile-Testing Contrivance Which was Erected for the Purpose of Demonstrating the Strength of This Product: The Single Tile is Seen between the Two Steel Beams and Sustains the Impact of the Motor Car When This is Driven Forward on the Runway

## 7866 DEMONSTRATE TILE STRENGTH BY CONVINCING TESTS

Strength and durability are essential factors in the choice of building materials, and a manufacturing concern recently demonstrated these qualities of its product in a most convincing manner. A vertical support of steel I-beams was constructed, upon which was placed a single tile. On top of the tile rested a massive beam, free to swing up and down, and hinged at one end to a second support. From the extreme other end of this beam, were suspended two steel bars to carry the testing weight, consisting of a motor car upon a pivoted platform, or short runway, which rested upon another huge beam, likewise hinged to the second support. In demonstrating, the driver first backed the car to the rear of the runway, causing the front end of it to rise in the air, and then drove quickly ahead, with the effect that the platform came down on the beam with a tremendous bang. This impact, measured to be 100,000 pounds, was sustained by the tile.

9274

## NAIL HOLES FOR SLATE SHINGLES

Punching nail holes in slate shingles requires a hammer with one tooth. Its point penetrates a  $\frac{1}{4}$ -inch shingle and makes a clean hole without splitting the slate, although a pile of small chips col-

lects underneath the T-iron that forms the "anvil" upon which the shingles rest. Slate shingles may now be bought with the nail holes already punched, but punching them by hand is really a timesaver, as the man with the hammer can punch and cull them at the same operation, while those punched at the quarry must be culled before going to the roofers. Besides this, the unpunched shingles are much cheaper and the difference in price represents a big saving on all shingles not over  $\frac{1}{4}$  inch thick. Heavier ones must be drilled by machinery. Being put on with rustproof copper spikes, a good slate roof is at the same time waterproof, weatherproof, and fireproof.



Workman Illustrating Method of Punching Nail Holes in Slate Shingles by Using Sharp-Pointed Hammer

Curt. J. Benjamin, Fancett  
402 Parkside Ave. Brooklyn N. Y.

*Mr. Hagg & Ward*  
*416 Union League Bldg*  
*Los Angeles Calif*

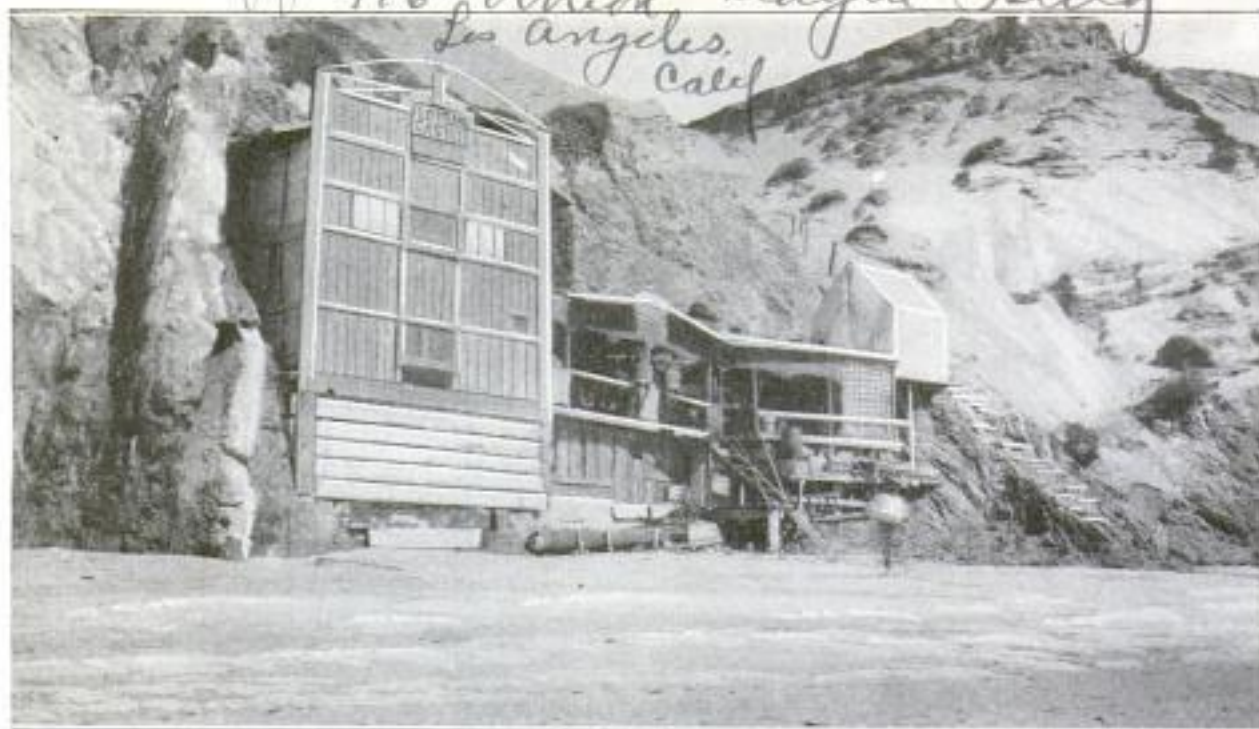

This Strange Dwelling was Built by One Man from Materials Cast Up by the Sea. The Main Structure Boasts Two Stories and a Basement, While at the Right Is an Open-Air Pavilion Where Refreshments are Served

## SEA FURNISHES MATERIAL FOR QUEER DWELLING

AS an indication of our rebellion against the sameness of our daily lives, let some one do something out of the ordinary, and visitors will flock to see it. Whether it be a new machine, a new toy, or a different sort of dwelling, the reaction is the same. A day-to-day example of this urge to get away from the beaten paths, are the scores of tourists who visit "Flotsam Castle," as it has been appropriately named.

Perched on the side of a rocky bluff at the edge of the ocean near Redondo, Calif., this dwelling was built by one man at an estimated expense of about one dollar. Convalescing from a serious illness, to this man the problem of building a shelter for himself was further complicated by the fact that he was without money. Instead of going to the dealer in building materials and giving an order for his requirements, he was obliged to bide his time and allow the needed mate-

rials to come to him. In this respect the sea was a bountiful provider, and it was only necessary for him to exercise his ingenuity to use the materials sent him.

The first shelter was a rather crude affair and has been replaced by a more pretentious structure that boasts two stories and a basement. There are included a living room, kitchen, sleeping quarters, and an open-air pavilion housing a lunch counter. The stairs by which a visitor mounts to the "castle" once graced some vessel. At the top of the stairs, in lieu of a doorbell, one finds a little paddle inscribed with the words, "Please Ring." A pull on the paddle causes a bit of iron to strike a metal buoy that had been salvaged and hung from the ceiling.

One of the interesting bits of furnishing in the interior of the building is the visitors' register. Instead of the usual heavy volume, there are small smooth boards strung on a curved



Louis Dart, Owner and Builder of "Flotsam Castle," Constructed with Materials Salvaged from the Ocean



Left: Water Issuing from a Spring in the Side of the Bluff above the "Castle" has been Crudely Piped to the Firkin Set Close at Hand. Center: The Visitors' Register Consists of Small Smooth Boards Strung on a Curved Wire. Right: Part of the Narrow Trail That Leads to the Top of the Bluff. Crude Steps and a Handrail have been Provided to Make the Journey Easier. Below: A Corner of the Open-Air Pavilion Where Refreshments are Served. The Round Table Was Once Part of a Large Spool for Holding Rope or Cable, While Cushioned Seats have been Made by Padding the Tops of Reclaimed Kegs



wire. As soon as the space on one of the boards is filled with names of guests, it is moved to the other end of the wire and a fresh board placed in position to receive further signatures.

The stools in the lunch room are fashioned from kegs of various dimensions that have been cast up from time to time. The ends have been padded to make cushioned seats. Circular tables from which guests are served, were once large spools for holding cables or ropes. Some of the sea's best offerings in the way of large boards are used for the lunch counter itself. The only expenditures for the castle have been the purchase of a few window sash, as the ocean failed to furnish any of these in an unbroken condition.

A spring issuing from the side of the bluff above the castle supplies drinking water, and crude piping leads the water to a firkin set in the side of the bluff near at hand. Some of the seepage from the spring flows over rocks at the back of the lunch room, where a cooler has been made for keeping soft drinks.

If a well-paved automobile road passed near this strange dwelling, it would not be surprising that curiosity should draw a few visitors to it, but the fact that it requires a two-mile walk along the beach or a stiff climb over a narrow trail down the side of the bluff, shows to what length thousands of persons will go to have a glimpse of something that departs from the commonplace or routine sights of their daily existence.

9406  
**BEAVERS MENACE IRRIGATION  
 BY DAMMING DITCHES**

Beavers, those sagacious little dam builders, have become such a nuisance in the state of Washington that the authorities have permitted trappers to capture them for their valuable pelts. The hereditary instincts of these animals led them to build dams across the irrigation ditches, thus proving a menace to the proper cultivation of the land. Formerly

so plentiful in this country, beaver hides have become so costly that the animals are practically extinct except where protected by state laws.

9205  
**MOVING A BIG PILE DRIVER  
 ON TWO GREASED POLES**

To overcome the difficulty of moving a pile driver over soft ground, while at work on the new filtration plant at Detroit, Mich., heavy timbers were first laid



Beavers in Such Quantity That Their Pelts Covered the Side of the Trappers' Cabin were Caught When the State Authorities Withdrew Protection to the Animals Because They had Become a Nuisance by Damming Irrigation Ditches

Cmd. H. E. Thomas, 911 Blunckley Ave.  
 Portland Oregon

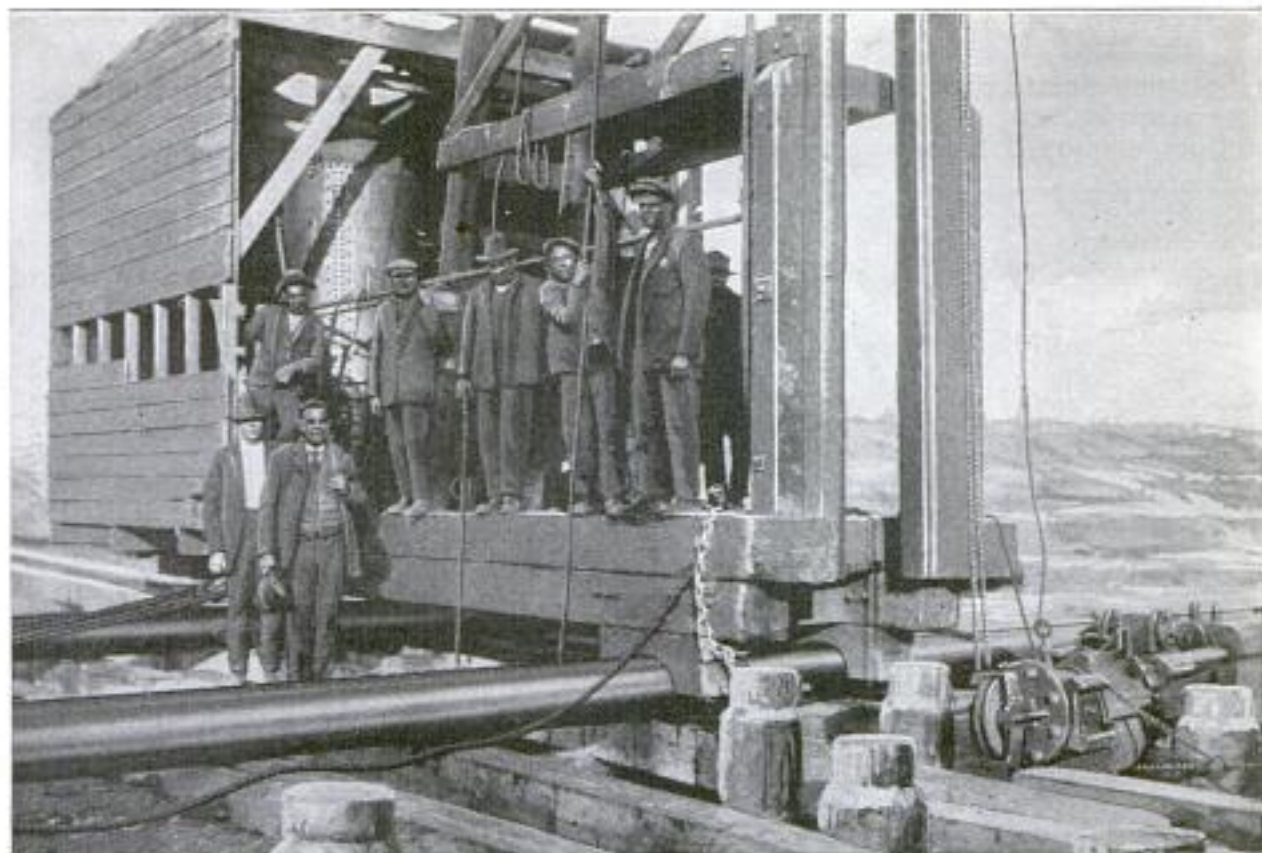

Means Adopted for Moving a Pile Driver over Soft Ground in Connection with Work on the New Filtration Plant at Detroit, Michigan: The Two Greased Poles under the Pile Driver Make It Possible to Move It in Any Direction on the Heavy Timbers Laid on the Soft Ground

on the ground to serve as a base, and the pile driver was then mounted on two greased poles, 14 inches in diameter and 55 feet long. By this means, with the help of block and tackle in connection with the winch, it was comparatively easy to slide the pile driver from side to side, or to roll it backward and forward as needed to reach the various piles.

9412  
**METHOD OF TESTING MODELS  
OF DIRIGIBLE BALLOONS**

In spite of the accidents that have befallen dirigible balloons, aeronautical engineers continue to test models of the gas bags in anticipation of the time when this form of air craft shall be less hazardous than it is today. Models are suspended in an inverted position and are filled first with air and then with water, and the condition of the fabric noted. If points of unequal strain show, the suspension cords are adjusted until the envelope shows a uniform distribution of the loading. Should the development of one of the noninflammable gases bring the dirigible balloon back to favor, this testing will prove of great value to designers and engineers, for the governing principles of proper suspension and uniform distribution of loading apply equally

well to models and full-sized balloons. Small ballonets inside the envelope aid in distributing the load on the fabric and in controlling the balloon in flight.

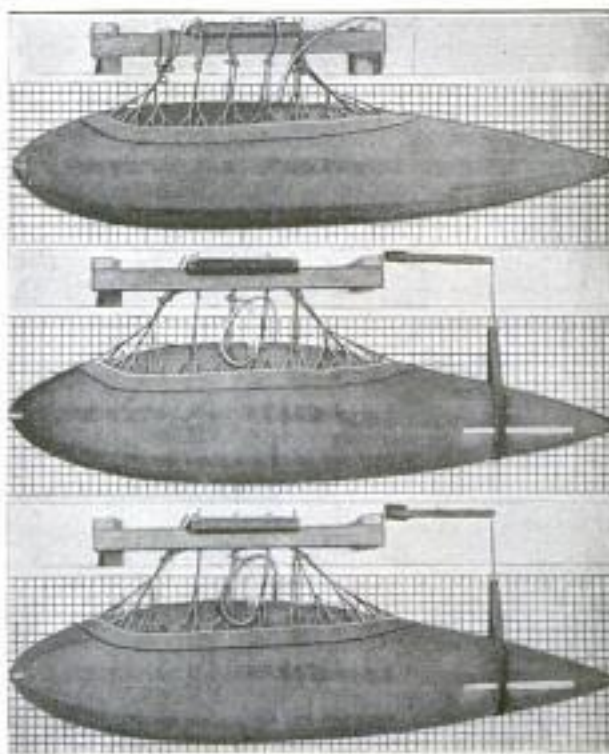

These Balloon Models are being Tested. In the Upper View the Envelope is Filled with Air, and in the Lower Views Water is Used

Cont. John W. Keaw, Navy Department,  
Bureau of Navigation, Washington, D. C.  
Copyrighted material

9391

*Mr. Theodore Schroeder,  
Eslyndon, Minn.*

226

POPULAR MECHANICS

**POTATO-PLANT SPRAYER MOUNTED ON MOTORCYCLE**

Spraying potato plants with an apparatus mounted on a motorcycle is the method employed by a western grower

this contrivance, which operates efficiently at 15 miles per hour, the farmer is enabled to cover 20 acres in the same length of

time, this being approximately five times as fast as is possible with a horse-drawn spraying outfit. It is claimed that the cost of placing the apparatus on the motorcycle was less than five dollars.



Upper Left: The Motorcycle-Mounted Potato-Plant Sprayer as Seen from the Side. Lower Right: Spraying Outfit Seen from Rear, Showing How the Machine Sprays Four Rows at Once

who protects a quarter-section farm from bugs in this manner. In place of the usual body, an ordinary sprayer has been bolted on the three-wheeled machine, which is geared down to about one-third of its normal speed. With

**9388 ELECTION BOOTHS ON WHEELS  
USED AS BATHHOUSES**

One city in Ohio—Newark—has found the solution of its problem of municipal bathing houses for use in the summer time, and, incidentally, is obtaining double service from its portable polling booths. Two of the booths are moved to the edge of the most popular bathing beach on the Licking River and connected by a

platform, and stairs are built to the water's edge. One house is for use by men and boys, and the other for women. A small charge is made for the service, which defrays the expense of the caretaker and pays for moving the booths to and from their summer location.

To promote better trade relations, Canada has been offered an exhibition building by the city of Lucerne, Switzerland.



Left: These Portable Election Booths are Moved, in the Summer Time, to the Bank of the River and Used as Municipal Bathing Houses. Right: The Bathing Houses as They Appear from the Road Which Runs along the River Bank

*Emt. George A. Paul  
900 Ellsworth Bldg. Chicago*





Left: Old Mexican Wearing "Rubber Sandals" Which He Uses on His Travels with His Burro to Deliver Wood to Prospectors. Right: Close-Up of the Old Mexican's Feet, Showing the Shoes Made from Auto Tires. Unlike the Tires, His Shoes Are Puncture-Proof and Nonskidding

9461  
**NEAT CALENDAR SAVINGS BANK  
 TO ENCOURAGE THRIFT**

To encourage the formation of a daily-savings habit, a neat home calendar has been devised



which can be kept at the proper date only by the insertion of a coin each day. A special slot is also provided in which coins may be inserted without affecting the calendar numbers, and this slot has under it the appropriate inscription, "Conscience Fund." The money saved during the month may be deposited in the regular savings bank at convenient times.

9384  
**RUBBER FOOTWEAR FASHIONED  
 FROM AUTOMOBILE TIRES**

In a little town in northern Mexico, where the old rubs shoulders with the new, where the burro holds its own with the modern automobile, there lives an old man, still active and spry in spite of his more than fourscore years, who is a quaint illustration of those mixed conditions. He is old-fashioned as regards his burro—his only means of carrying wood to the many prospectors of the vicinity—and quite modern as to his footwear, made from auto tires—he calls them "rubber sandals." Like the automobile, he is

rubber-tired, but unlike the motorist he fears no punctures, blow-outs, or rim cuts, and he has never yet skidded. So dependable are his shoes that he does not carry even a single "spare."

9420  
**INDICATOR FOR AUTOS MAKES  
 GEAR CHANGES NOISELESS**

To do away with the objectionable noise so often made in gear changing on automobiles, an instrument has been devised that shows the driver when the rate of rotation of the gears is suitable for throwing them into mesh noiselessly, and without any danger of damaging them. The instrument is in the form of a dial graduated to revolutions per minute and miles per hour, on which are three marked pointers, one being longer than the others, that represent the three gear ratios. Below these graduations is a standard speedometer. The revolution indicator is driven by the shaft between the clutch and the gear box. To engage noiselessly in any gear ratio, the driver increases or reduces the revolutions of this shaft, with the clutch or accelerator, until the long pointer and the pointer of the gear he wishes to use coincide.

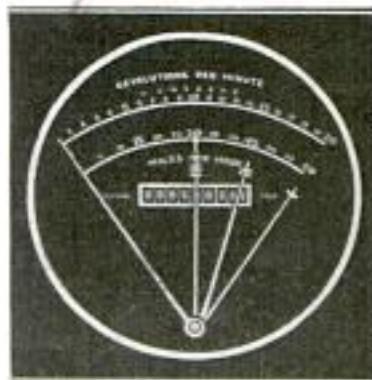

Mexico  
 Andrew J. MacLean Bldg. 349 Adelaide St. W., Toronto, Canada  
 202 Travellers Bldg. 211 Milwaukee, Canada  
 d m. Andrew J. MacLean Bldg. 349 Adelaide St. W., Toronto, Canada

216 Spear-Rosefelt Calendar Bank Co. 226 Milwaukee Bank Bldg. Milwaukee, Wis. Copyrighted material

9409  
228  
Hinsbury Road, London

Knowles + Co  
Mountain House  
POPULAR MECHANICS

Winchester  
Repeating Arms Co  
New Haven Conn

**GLASSES QUICKLY CLEANSSED WITH BRUSH MACHINE**

**ROLLER-SKATING CARNIVAL HELD ON BUSY STREET**

Washing glasses or cups is simplified by a new machine that has a brush mounted

That it is not necessary to have a rink in order to hold a roller-skating carnival, was shown in New Haven, Conn., recently. A portion of one of the busy downtown streets was roped off, and some 700 boys and girls of the seventh and eighth grades, besides about 5,000 spectators, enjoyed the fun. So successful was the first carnival, that the city authorities have given their consent to skating carnivals to be held every Saturday morning in various parts of the city. The street sections are roped off between 9:00 and 11:00 o'clock, and the children enjoy the sport without fear of accident.

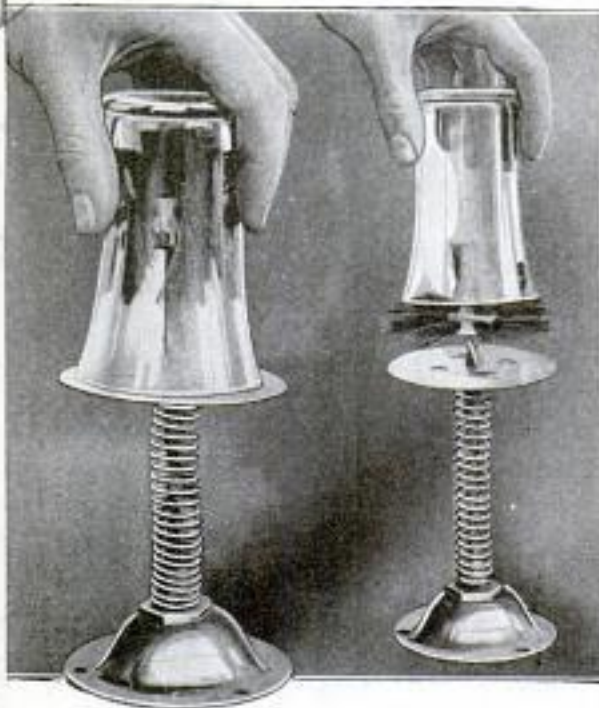

Left: Glass-Cleaning Machine, Showing Platform Depressed. Right: Glass Raised from Platform, Showing Brush on Shaft

on a spiral shaft, a platform which slides up and down on the shaft, and a spring attachment. In use, the outfit is placed in water and a glass fitted over the brush, after which the depression of the platform revolves the brush, the spring serving to bring the platform back.

**LAUNDRY ADOPTS MECHANICAL HANDLING DEVICES**

The growth of business done by laundries in the so-called wet-wash or family-wash departments, has led them to seek means of speeding up their work, with a consequent reduction of costs and an increase in profits. One progressive laundry has adopted a system of conveyors, similar to those used in automobile factories, by which the various garments and household articles are moved from point to point. This not only speeds up the work, but it saves valuable floor space formerly required for aisles for trucking purposes. The conveyors are arranged in such a way that the manual efforts of the workers are reduced to a minimum.

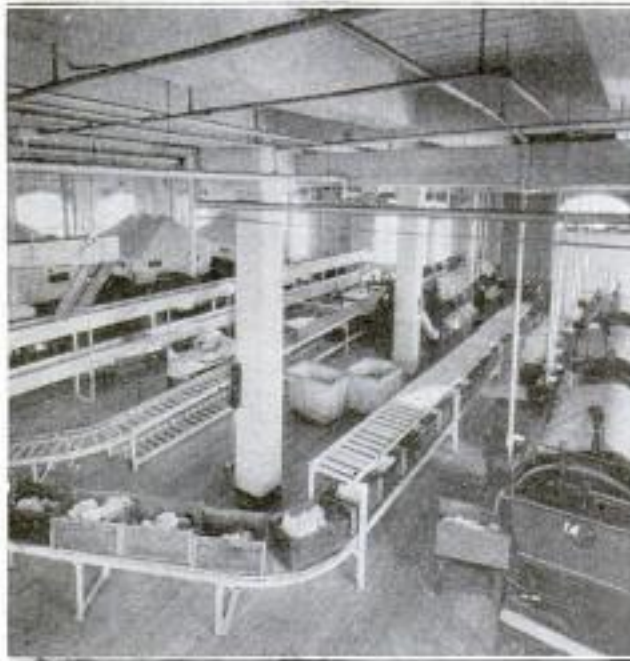

Roller and Belt Conveyors are Used in This Laundry for Transferring the Wet Clothes or Finished Bundles from Point to Point with a Minimum of Labor

Mrs. The Lamson Co., 100 Boylston St. Boston, Mass.

The Pilgrim Laundry, Brooklyn, N.Y.

Copyrighted material

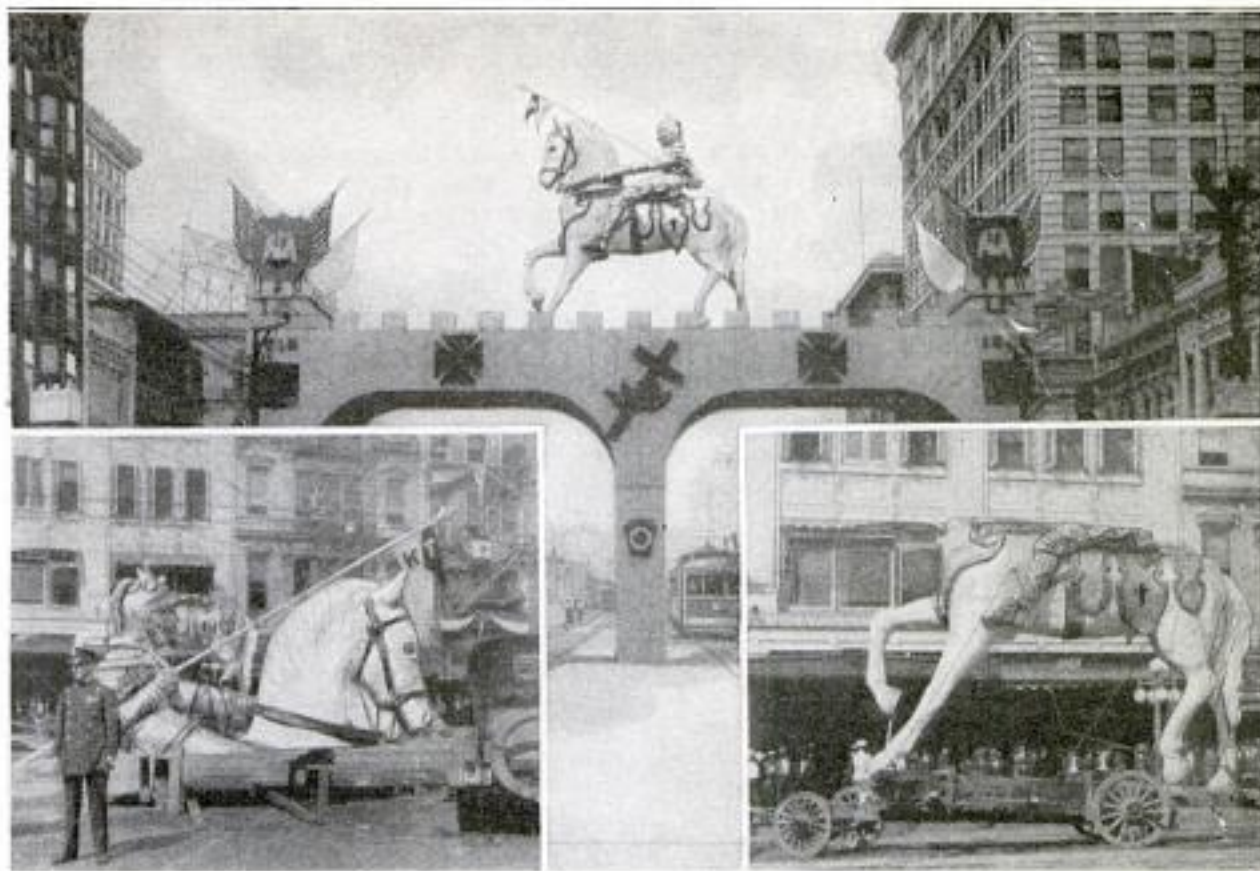

This Statue of a Mounted Templar, Towering Some 55 Feet above the Street Level, was Erected as a Distinctive Decoration for a Convention in New Orleans, Louisiana. The Inserts Show the Sectional Construction of the Papier-Mâché Figure, and How It was Transported to Its Location

**ERECT HUGE MOUNTED FIGURE  
9340 OF KNIGHT TEMPLAR**

When the visitors to the Knights Templar convention arrived at New Orleans, La., recently, they were greeted by the sight of a giant figure of a mounted Templar of the Middle Ages, the statue being supported on an arch across one of the principal streets. The figure was made of papier-mâché and was completed in less than 30 days by workers of the city who have developed a high degree of speed and skill through making the floats for the Mardi Gras carnival. The figure of the armored knight on his white charger stood some 55 feet above the street.

9316

**ATTACHMENT SAVES GASOLINE  
IN AUTOMOBILE ENGINES**

A gas-saving attachment for a certain low-priced automobile has been produced by a New Orleans inventor that, it is said, has enabled one of these small light cars to run 40 miles on a gallon of gasoline. The attachment is in the form of a box bolted to the hot-spot manifold, with communication between them through two vent holes. Inside the box is

a bar of copper, which expands and contracts more than other metals under changes of temperature. This bar is connected by a rod to the gasoline control of the carburetor in such a manner that changes of temperature in the manifold automatically control the flow of the gaso-

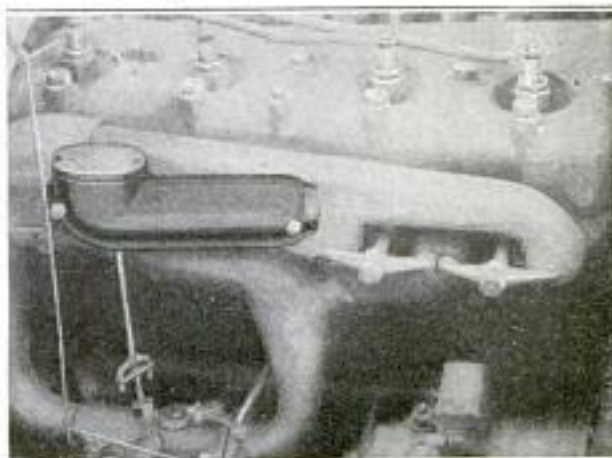

Attachment to the Manifold of an Automobile Engine Automatically Controls the Flow of Gasoline in the Carburetor

line in the carburetor. Thus, when the engine is cold, the supply is liberal, and when hot, the supply is reduced, and the fuel mixture is always best suited to existing conditions.

Inv. Albert Sinclair, New Orleans, La.

Engine Co. + Sinclair Foundry + New Orleans, La.  
Also under + New Orleans, La.

9312  
230

*Auto School*  
**INSTRUCTION UNIT TEACHES OWNERS ABOUT THEIR CAR**

The belief that the more familiar a person becomes with the mechanical parts of his car, the less trouble will he have, has

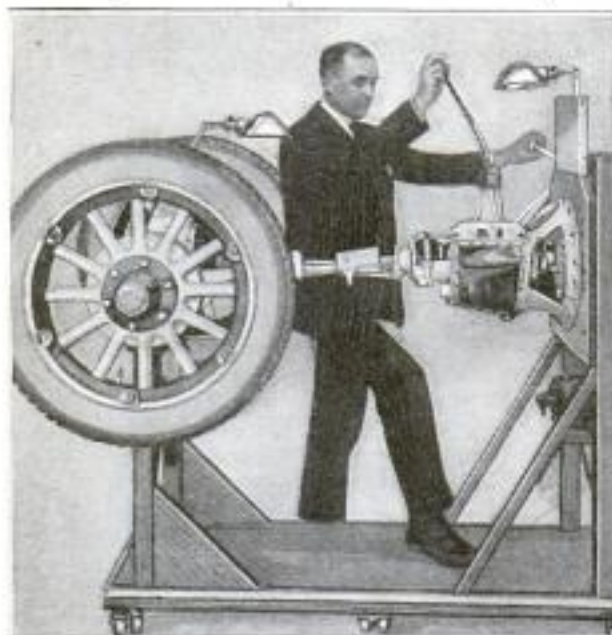

The Instruction Unit Used for Demonstrating the Functions of the Various Parts of a Car

led one automobile company to conduct classes teaching the functions and operations of the different parts. In this connection is used an instruction unit containing all the parts of the car. The clutch and transmission housings are transparent so a person can see just what takes place when the gears are shifted. Lectures and demonstrations are given in simple nontechnical language.

*9464*  
**COILS OF WIRE ARE BOXED INSTEAD OF WRAPPED**

Vulcanized-rubber covered wire, formerly wrapped with Hessian tape, or long strips of material similar to burlap, is now being shipped in fiber-board boxes or cartons. Advantages of the departure are, that the time is saved which was previously required to unwrap the coils, and the litter resulting from tearing or cutting the wrappings is prevented. The carton can be opened quickly, the coil taken out, and if not entirely used, the remaining part can be replaced in the container, which serves as a protection against possible damage; all advantages that will be appreciated by persons using this product.

*London Times Eng. Sup. 5/20/22*

**REMODELING A RIVER CHANNEL**

BY IVAN E. HOUK, *City Engineer Dayton Ohio*

9305

**M**ANY cities in the United States, situated on rivers, would gain in appearance as well as in flood security by remodeling the river channels. Four years ago the Great Miami River at Hamilton, Ohio, flowed through an irregular channel filled with sand bars, bushes, weeds, and detritus of all kinds. Today it flows through a smooth, clean, regular channel with gradually sloping sides, protected from erosion by flexible concrete-block mattresses and concrete-slab revetment along the lower portions of the banks, and by tough mats of sod above.

The improvements were made by the Miami Conservancy District as a part of the general flood-prevention work. Careful measurements by the engineers show that the channel will now carry safely about 200,000 cubic feet per second, or practically twice as much as it could carry before the improvements were made. While flood prevention was the primary object in this instance, esthetic considerations also received attention. Consequently the new channel is well-kept in appearance and quite different from the old. The work involved the movement of

about 2,000,000 cubic yards of earth, the rebuilding of a water-power plant, the relocation of some trunk-line sewers, and various other incidental matters. A drag-line excavator, with a 4½-cubic-yard bucket, was used in digging out the sand bars and smoothing the banks. This machine loaded the earth onto trains of 10 cars each, each car holding 10 cubic yards, which were brought within reach of the drag-line bucket on a railroad track built along the river bed. The earth was hauled to low places near the edges of the city, where it was used in building up the ground, thus making valuable property out of what had before been nothing but a city dump. One area, nine blocks long and several hundred feet wide, was raised in this way. The material was also used in building levees along the river banks. The levees are 8 feet, or more, wide on top, have side slopes of 2 feet on the horizontal to 1 foot on the vertical, and are so high that, according to calculations, the greatest possible future flood will fall 3 feet short of their tops. The work was commenced in the summer of 1918 and is being completed this season.

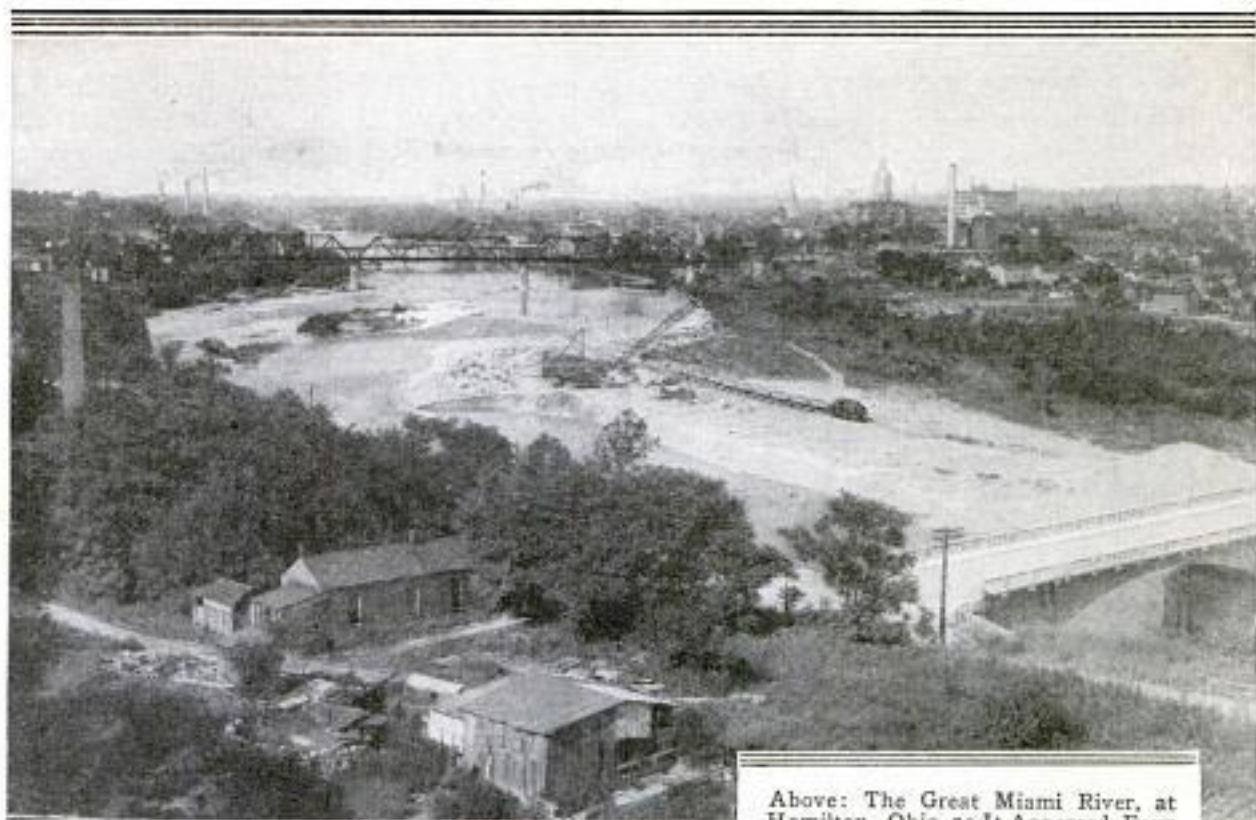

Above: The Great Miami River, at Hamilton, Ohio, as It Appeared Four Years Ago with the Channel Partially Blocked by Sand Bars, Bushes, and Detritus of All Kinds. Below: As It Appears Today with Smooth, Gradually Sloping Banks Protected by Flexible Concrete-Block Mattresses below the Water Line and by Tough Mats of Sod Above. The Excavated Material was Used for Filling Lowlands in the City



9349

232

*Edw. Moran & Hebergall,  
Denver, Colo.*

**POPULAR MECHANICS**

**SPIRAL STEM SIMPLIFIES OIL AND GAS-WELL DRILLING**

Marking a radical departure, a stem for drilling oil and gas wells has been

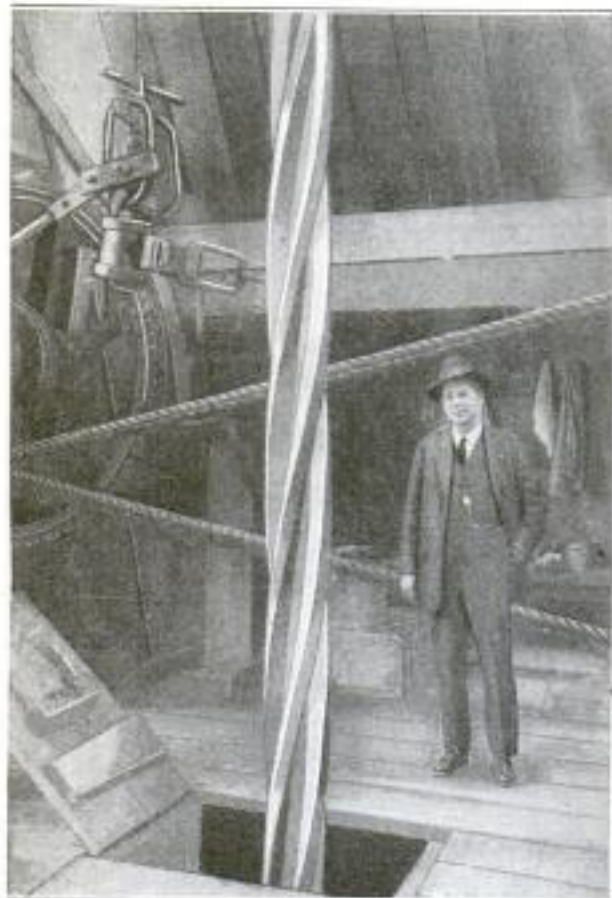

Drill Stem Made in the Form of a Fluted Spiral, Which is Said to Have Many Advantages for Drilling Oil and Gas Wells

made in the form of a fluted spiral instead of the usual cylindrical form. Some of the advantages claimed for the new design

are that it tends to prevent the drilling of crooked holes, keeps the mud and cuttings at the bottom of the hole mixed, smooths the walls of the hole, prevents caving, and greatly simplifies the job of "fishing" for lost or broken tools.

9426

**HOTEL FURNISHES FREE TAXI FOR LUNCHEON GUESTS**

As an incentive for guests to patronize its noonday luncheon, a southern hotel has adopted unusual service for their convenience. During the dull summer season it furnishes a special luncheon, offering a choice of 20 dishes, with all tips eliminated, and in addition gives the guest free taxi service to and from his place of business and the hotel. The total charge for luncheon and taxi service is only one dollar per person.

*L. E. Clabney, c/o J. H. et Tom  
New Orleans*

**TRAPPER'S ROADSIDE MARKET**

**MONOPOLIZES PROFITS**

At least one trapper has developed a method whereby he eliminates the tanner and the middleman, and keeps all the profits of the trade in his own hands. He does his trapping in the winter, tans the skins, dresses them, makes them into coats, rugs, and other articles, which he retails during the remainder of the year from an open-air roadside market. His stand is situated near Upland, Calif., on the foothill highway between Los Angeles and San Bernardino, where thousands of motorists pass every day. The exceptionally low price at which he can sell his goods makes them very attractive.

9204



Roadside Fur Market Where a Trapper, after Doing His Own Tanning and Manufacturing, Retailers His Fur Goods Direct to the Consumer: When the Fur Business Is Dull He Adds to His Stock Other Goods, Such as Fresh Fruit and Indian Rugs

*W. A. Osburn, Los Angeles, Calif.*

Copyrighted material

9306 Auto-Safe Storage Co  
 608 W. Fifth St.  
 POPULAR MECHANICS  
 Kansas City, Mo.

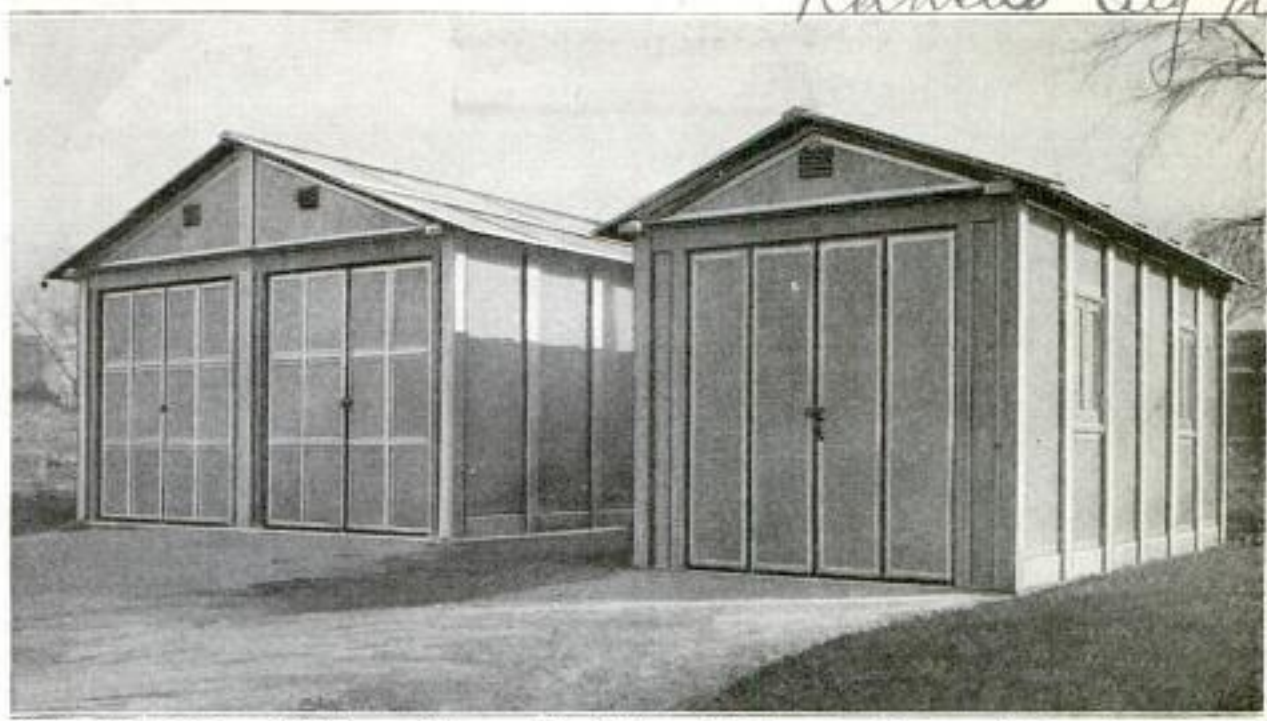

Single and Double Portable Concrete Garages: The Walls and Rafters Are of Precast Units, and the Roof is Covered with Concrete Slabs. The Doors Are Concrete Slabs in Steel Frames, to Which the Hinges are Attached. No Mortar is Used

9306

**PORTABLE CONCRETE GARAGE  
 VERY EASY TO ASSEMBLE**

A concrete garage, so portable that it can be delivered anywhere on an ordinary truck, and which can be set up ready for use in a day's time, has been developed by a Kansas City manufacturer. The walls are made entirely of precast units, and the rafters are also precast. The roof and doors consist of concrete slabs, those for the doors being cast in special steel molds consisting partly of frames to which hinges are attached. The concrete window sash are glazed with wired glass. There is no mortar used, and the building can be taken apart as easily as it is put together.

9390

**EQUIP TRAVELING MOTOR CAR  
 WITH MANY CONVENIENCES**

A man in a western city has just completed a car that has many of the conveniences of home. This is a traveling car built on a small automobile chassis. The interior of the car is leather-upholstered throughout, has a folding bed, chemical toilet, table, oil stove, electric lights, mirrors, and medicine cabinet, all in addition to a workbench equipped with an electrically driven sewing machine, which will be used by the owner in making and repairing automobile tops as he and his wife travel from town to town. The sewing-machine motor is ingeniously connected with the motor of

Emb. Arthur W. Monroe,  
 Montrose, Colo.

the auto so that the power is furnished by the running automobile engine. Ample storage room is provided in the car.

9358

**GRAPEVINE ROOTS PLANTED  
 WITH ELECTRIC DRILL**

Planting the roots of grapevines in holes made with an electric drill, describes the original manner in which a western grower set out his vineyard. The apparatus used consisted of an ordinary 5/8-horsepower motor drill, fitted with a special long-shanked 3-inch auger, or bit. A long extension cord, reaching from a transformer connected to an electrical transmission line on the adjacent road, served to convey the necessary power. Usually a slow and tiresome operation, the planting is said to have been considerably lightened by the new method.



Drilling Holes in the Ground with an Electric Motor for the Purpose of Planting the Roots of Grapevines: The Extension Cord Reaches to the Side of the Vineyard

Chicago Pneumatic Tool Co. 6 E. 49 St. New York.  
 U.S. Electric Tool Co. 2496 W. St. Cincinnati, Ohio.  
 made by

Ed L. Davis,

234

Plan's Mag.

POPULAR MECHANICS

Schenectady, N.Y.

### SIMPLIFIED RADIATOR VALVE REQUIRES NO PACKING

For all types of steam, hot-water, and vacuum systems, a radiator valve that has no stuffing box or packing, and that is opened or closed by simply raising or lowering a handle, is now on the market. When the valve is in its usual position at the base of the radiator, its construction eliminates even the necessity of stooping, for the valve can be opened or closed as easily with the toe as with the hand.

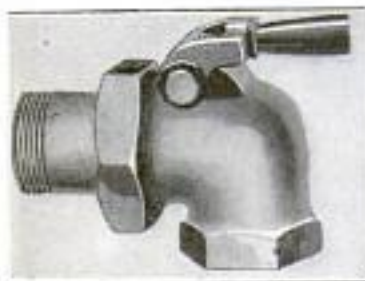

its usual position at the base of the radiator, its construction eliminates even the necessity of stooping, for the valve can be opened or closed as easily with the toe as with the hand.

### TRUCKS IN TANDEM FORMATION DELIVERED BY ONE DRIVER

Inaugurated as a means of reducing shipping expenses in delivering its product to distributors throughout the state, the system adopted by a California motor-truck company has proved satisfactory. When ready to be sent to the dealers, the trucks are arranged in tandem, the front of the second machine resting on the rear of the first, and the front of the third resting on the rear of the second, thus raising the front wheels of the latter cars off the ground. In this strange-appearing formation, the trucks are delivered by one driver, at a cost said to be less than one-fourth of the regular freight rates, in addition to which a saving of three days in time is effected.

Sold by: Martin Frank  
109 Spruce St.  
Buffalo, N.Y.

tion, the trucks are delivered by one driver, at a cost said to be less than one-fourth of the regular freight rates, in addition to which a saving of three days in time is effected.

### TWO ELECTRIC LAMPS IN ONE WITH DOUBLE FILAMENT

Two lamps in one is a designation properly applied to a patented electric lamp that has two independent filaments, and that burns only one of these filaments at a time. On the socket end of the lamp is a small cap, and when one filament burns out, the removal of this cap puts the other filament into service. The incandescent ends of the two filaments are in the form of rings, one above the other, and the removal of the cap shifts the current from one to the other. The bulb contains a gas that prevents its discoloration.

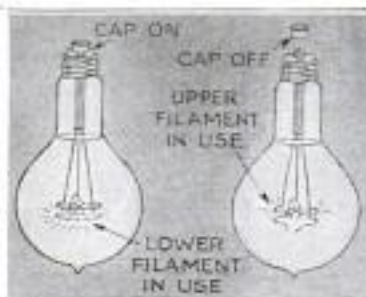

other, and the removal of the cap shifts the current from one to the other. The bulb contains a gas that prevents its discoloration.

As a special feature on one of the Chicago & Alton night trains leaving Chicago for St. Louis, there is one car, designated as a "stag" sleeper, that is reserved for men only.

White - Lite Electric Co  
Infr. 368  
New York

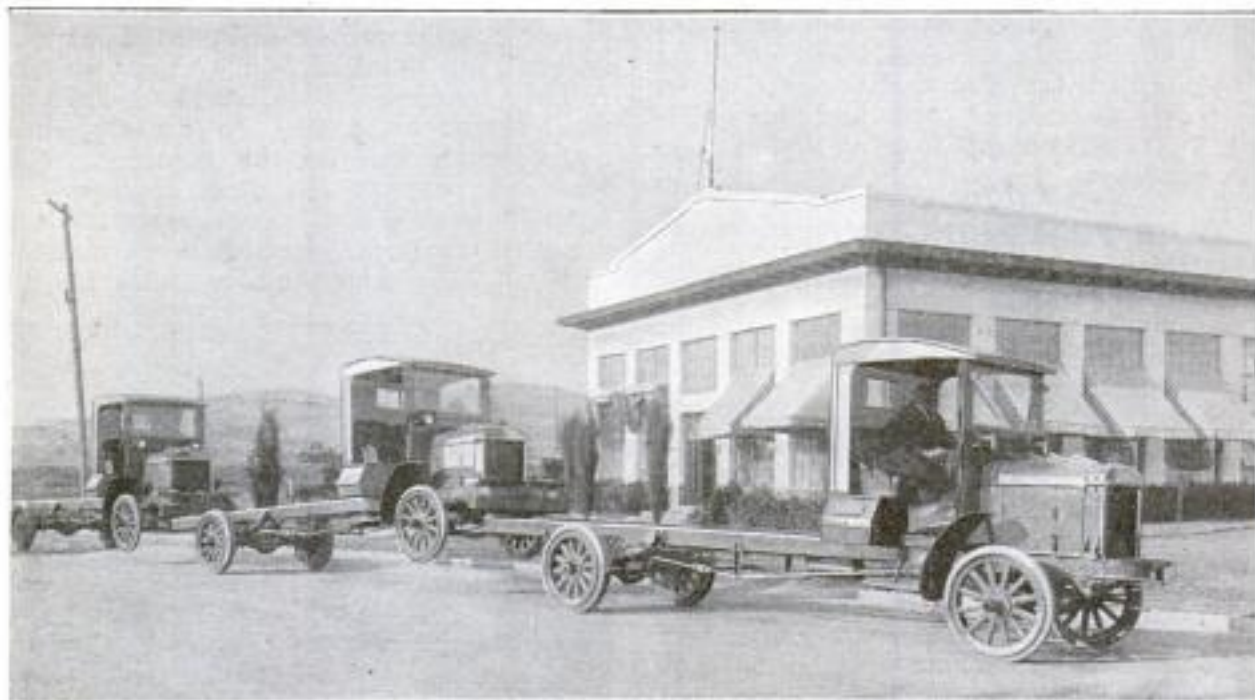

Motor Trucks Arranged in Tandem Formation, with the Front Wheels of the Second and Third Machines Elevated from the Ground and Resting on the Rear of the Car Ahead, the Whole being Driven by One Man

Haged Motors Co, Oakland, Calif.



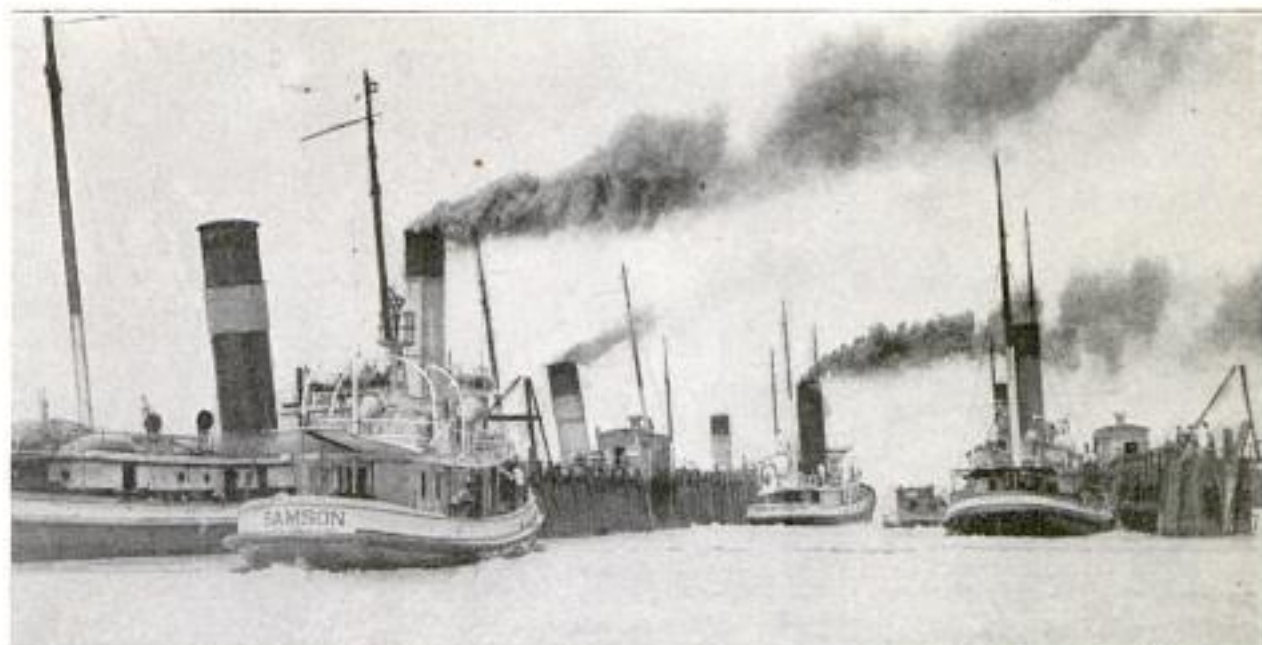

When the Big Drydock Broke Away from Its Moorings near New Orleans, Louisiana, and Floated down the Mississippi River, It Took 11 Tugs to Capture It and Tow It to a Mooring Place

### 9334 **HUGE DRYDOCK BREAKS AWAY ON MISSISSIPPI RIVER**

An eddy in the swift current of the Mississippi River struck the large drydock of one of the ship-repairing plants at New Orleans, La., recently, just as the big steamer "Nyanza" was lashed into place, breaking four 2 $\frac{3}{4}$ -inch anchor chains simultaneously and swinging the dock outward and down stream. The captain of the "Nyanza" reversed his engines, which brought the drydock out into midstream, avoiding a collision with two vessels at the wharf, about 100 yards below.

Once the drydock was well out in the current, the lashings were slipped, and the ship slid out of the dock. A general alarm had by this time brought tugs from all parts of the harbor. The two tugs first to arrive succeeded in getting the dock sufficiently under control to steer it and slacken its speed. It passed within 10 feet of one vessel and barely grazed another. Altogether, 11 tugs were used in stopping the drydock and towing it to a mooring place, more than two miles below the point where it broke away.

### 8969 **MACHINE HUNG ON ITS CHAIN TO OPERATE A HAND HOIST**

Every user of a hand hoist will be interested in a recently patented electrically driven machine that may be suspended in the bight of the operating chain. It operates a hoist at about four times hand speed and, unlike the hand, it never gets

tired. The machine consists of a grooved sheave with a rubber tread, driven by a  $\frac{3}{4}$ -horsepower motor through worm gearing, inclosed in a cast-iron housing. The rubber tread fits any size and pitch of

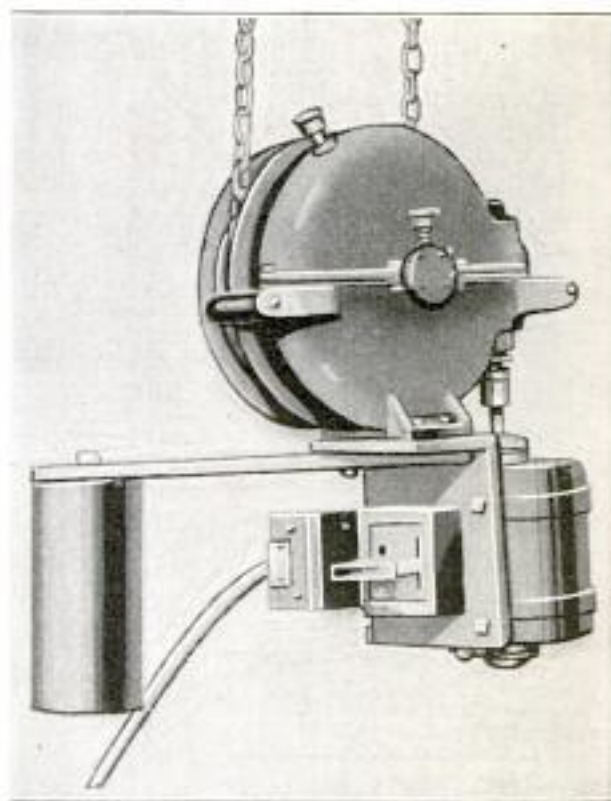

Machine That can be Suspended in the Bight of the Chain of Any Hand Hoist, to Operate It Electrically: The Motor Runs in Either Direction

operating chain. The machine is counter-balanced so that it hangs with its center of gravity in the plane of the operating chain.

new Jersey Foundry & Machine Co.  
90 West 5th St. New York City  
Copyrighted material

9351  
 H. H. Roach, 1439 Syndicate  
 Trust Bldg., St. Louis, Mo.  
**MOVIE CAMERA RECORDS VITAL FACTS  
 IN RAIL DEMONSTRATION**

BY GEORGE F. PAUL 900 Ellsworth Bldg  
 Chicago

**T**HE remarkable possibilities of moving-picture photography in technical

stresses in the rail that correspond to the different distortions.

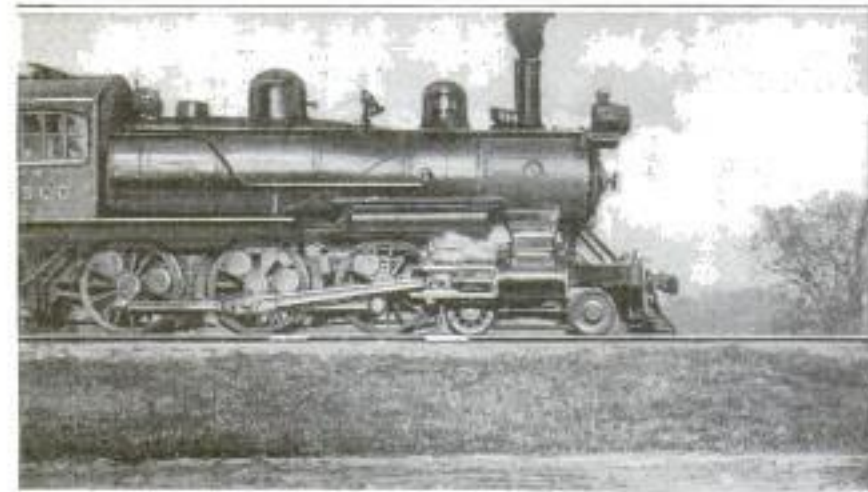

With a moving-picture camera that takes 800 pictures per second—and such cameras are now available—this means that one photograph can be taken for every 1.32 inches of forward movement of a train traveling at the average rate of 60 miles per hour, or a mile a minute. The camera

When the Standing Locomotive Begins to Move, the Distortion of the Rails under the Load is Represented by the Curve at the Right, the Vertical Distances Measuring the Amount

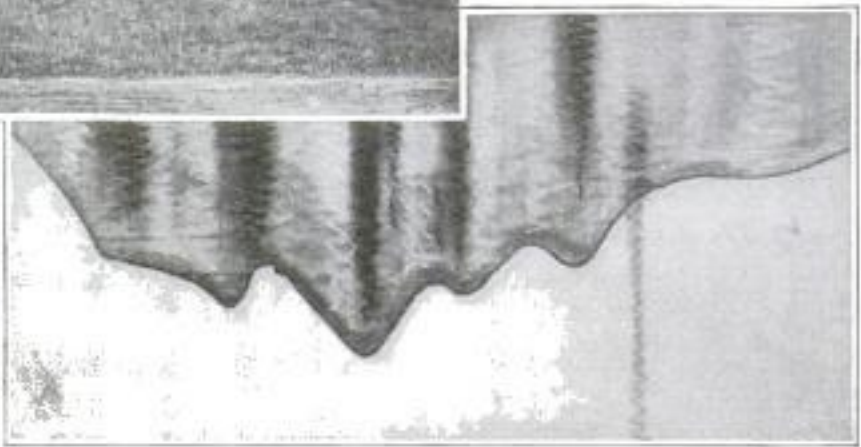

research work have been demonstrated in a series of tests to determine how much a rail is depressed when a locomotive trav-

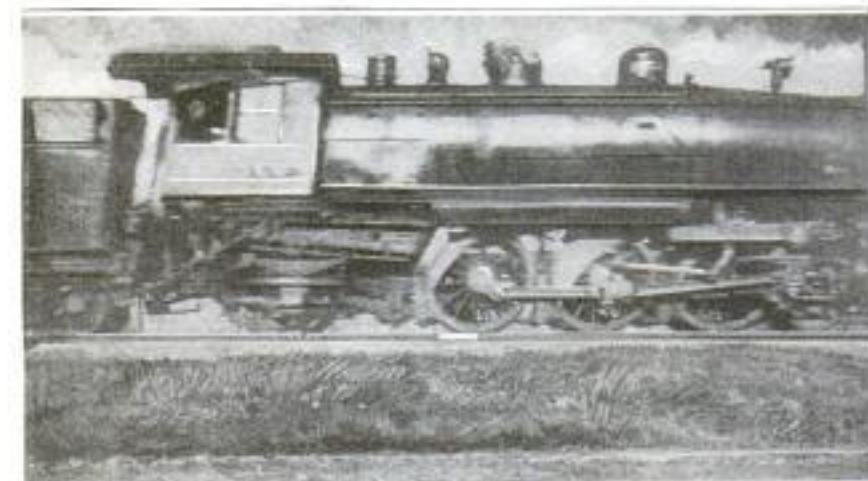

can thus register all the rail distortions in the section of track under observation.

By this means positive knowledge can be obtained on the following important points:

What work the ballast is doing; how much the ties are reacting; what

Here the Engine is Passing the Instrument at a Speed of 55 Miles per Hour, and the Curve at the Right Shows How the Speed Increases the Distortion of the Rails

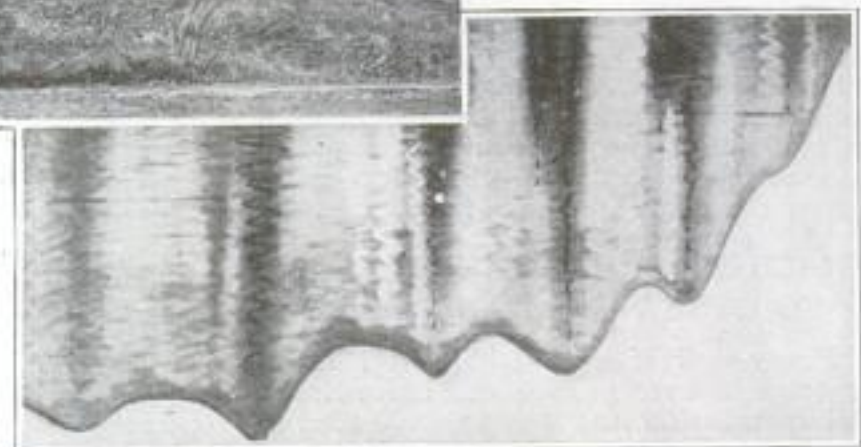

els over it at varying speeds. The photographs are enlarged so that the amount of distortion under the different wheels of a locomotive can be readily measured. Then, the observer can compute the

are the points of greatest stress; what the stress is at the rail joints; what the rail

stress is at any point or at any position of the load, and whether the equalizers are properly installed to distribute the load, as intended, over the drivewheels of the locomotive.

The same method can be used to advantage in making records of deflection of bridges under a moving load. It is also of great value in the laboratory.

As examples of its application may be mentioned two tests made recently on the

St. Louis-San Francisco Railroad. In the first instance, a light passenger locomotive was photographed just as it was starting. The maximum stress in the rail was then found to be 61,390 pounds per square inch. Photographs were also taken on the same track when a heavy passenger locomotive was speeding over the rails at the rate of 55 miles per hour. The maximum stress in the rails under these conditions was 36,810 pounds per square inch.

7278

POTATOES PICKED, CLEANED, AND SACKED AS DUG

A very simple machine has been developed for picking, cleaning, and sacking potatoes in one operation. It can be attached to the rear of any standard chain digger, from which the potatoes are received upon a cleaning apron, as fast as they are dug. This apron revolves in an upward direction, carrying the vines and weeds over the top, while the potatoes are rolled to the sides into elevators, by means of worms. The elevators carry them to a second apron, where they roll to the center and into the sacks. The rolling of the potatoes over the two slatted aprons removes the dirt, vines, and weeds.

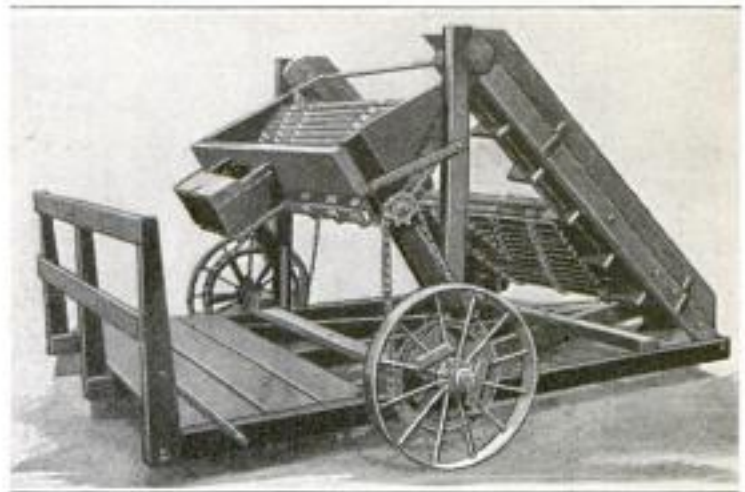

Potato Picker, Cleaner, and Sacker Attached to the Rear of a Standard Chain Digger: The Potatoes are Seen on the Upper Apron

9279 *Chas. Arlo E. Rice, Amboy, Maine.*

INSPECTION OF GEAR TEETH BY ENLARGED PROJECTION

In studying the form of the tooth of a spur gear by placing it in front of the

objective of a microscope, when a powerful light is concentrated on the object, a shadow or image of the gear tooth may be projected on a screen, but by the old method this will appear blurred and indistinct. If the point of a needle be placed against the side of a gear tooth, a sharp image of the whole needle will be shown on the chart, and therefore the needle point will indicate clearly one point on the tooth. If several needles, side by side in one plane, are placed so that each point rests on the gear tooth, the series of sharply defined needle points seen on the screen may be joined by a line that will be the correct outline of the tooth. The magnified image of the gear tooth to be studied is thrown onto a mirror placed at a suitable distance, and from there is reflected back to a ground-glass screen that is located near the operator's position.



Projection of the Magnified Image of a Gear Tooth onto a Mirror, from Which It is Reflected Back to the Ground-Glass Screen on Which the Operator is Drawing Its Outline

*Jones + Lamson Machine Co  
Springfield, Vt.*

9280 238  
Cmt. J. B. Holdcroft,  
1485 Fort St. Water Works  
Victoria, B. C., Canada

## POPULAR MECHANICS

### WELDED-STEEL OVERFLOW PIPE TWO THOUSAND FEET LONG

A steel pipe in one piece, nearly 2,000 feet long and 27 inches in diameter, has



This Steel Overflow Pipe, Welded after being Placed in Position, was Buried in the Ground to Reduce the Effects of Temperature Changes

recently been constructed to serve as an overflow for a reservoir which supplies Victoria, B. C., with water. A great deal of trouble had been given by the periodical overflow of this reservoir, as farm lands below it were either inundated or so waterlogged that it was impossible to seed them in the spring. So it was decided to build this outlet, part of which was to be a concrete-lined canal, and the remaining portion made of pipe.

What form the pipe should take, the engineers left an open question, only specifying, in asking for bids on the pipe, that after installation it should be subjected to what, for an overflow, is an exceedingly severe test—that is, that the lower end of the pipe should be closed and its entire length filled with water, and that under these conditions it should be perfectly tight. A further stipulation was that if a steel pipe was to be used, the joints and seams should have a strength at least 90 per cent of that of the steel body.

As a rule, in a pipe line of this length provision has to be made for expansion and contraction due to the changes in temperature. But in this case the pipe was to be placed underground (where temperature fluctuations are much less) so as not to interfere with traffic or work on the surface, and it was considered safe to dispense with the expansion joints. So it was decided to fabricate the pipe in one piece, not by riveting the plates together, but by welding.

The pipe was made in sections, 20 feet long, at the factory, the plates being rolled to shape and joined by welding. These sections were shipped to the site of the overflow, and were there brought together and held firmly by a clamp of special pattern which allowed a portion of the joints to be welded while the clamp was still tightly screwed up. The lower portion of each joint was welded from the inside, a man creeping in from the open end, carrying the torch and the gas hose. Then, after removing the clamp, the upper portion of the joint was completed until the whole pipe was finished, the welded



The 20-Foot Lengths of Pipe were Drawn Together and Securely Held by This Clamp While the Welding was being Done with Gas Torches

joints making such a homogeneous connection that the pipe from end to end forms one continuous cylinder of steel.

☐ A prune sirup has been developed, made from prunes classed as small or seconds, which is claimed to be the equal of maple sirup, and capable of being mixed with glucose.



A Suitcase Outfit for Demonstrating Lighting Principles and Advantages of Different-Style Lamps: All the Material Shown can be Packed in the Case When Moving On to the Next Customer

9330 *Electric*  
**LIGHTING PRINCIPLES SHOWN WITH SUITCASE OUTFIT**

To enable salesmen to demonstrate to prospective customers the many advantages of electric light and the various kinds of lighting equipment, a compact outfit has been assembled which fits into a case only slightly larger than the ordinary suitcase. Sockets are provided along the top of the case into which the different styles of incandescent lamps may be screwed for demonstration. Into one side of the case has been fitted a miniature display window, by means of which the salesman can show how the different lighting principles are applied.

9193  
**SAFETY STOP AUTOMATICALLY ACTS AS BELT SHIFTER**

A safety stop for use as a belt shifter in connection with automatic machines, so as to stop them in case of any defect or breakage of the work, and that can be operated by current from either a battery, a generator, or a lighting circuit, has recently been placed on the market. The device is wired in series with a tungsten lamp having an open circuit that is

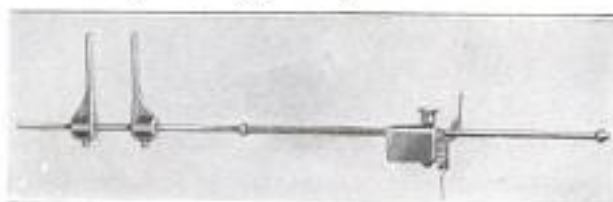

Safety Stop on a Belt-Shifter Rod: Current to the Stop Releases a Latch, and Action of the Coiled Spring Shifts the Belt to a Loose Pulley

closed when the shifter is caused to operate, and therefore lights the lamp, which acts as a signal. A latch in the stop holds a notched belt-shifter rod in running position, and when a current is caused by any defect in the work, the latch is released and a coiled spring on the rod shifts the belt to a loose pulley.

9291  
**AUTOMOBILE EXHAUST USED FOR COOKING PURPOSES**

Utilizing the hot exhaust from an automobile engine for cooking, is possible

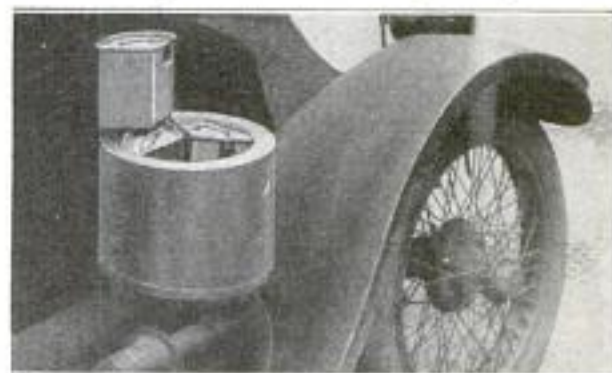

Cooking Utensil That Utilizes the Automobile Exhaust, the Heat of Which Circulates around the Three Receptacles or Compartments

with an appliance having two cylindrical casings, one within the other in such a manner that there is a space between them. Into this space is introduced the exhaust, the heat of which is sufficient to prepare various foods when they are placed in containers that are specially shaped to fit the contour of the casing, thus making cooking both convenient and economical.

The Atlantic Co.  
452 Classon Av.  
Brooklyn, N.Y.

Wm. E. R.  
Pendleton,  
Invt., Chla.

Cont. d van E. Houck,

240

City Engineer

POPULAR MECHANICS

Dayton Ohio

### EMPTYING RESERVOIR ACTS LIKE GIANT BATHTUB

9339

Most people are familiar with the whirling motion of the water that takes place over the drain in a bathtub, or in any



"Vortex Whirl," 25 Feet in Diameter, at the Germantown Dam near Dayton, Ohio, during a Recent Spring Freshet

emptying vessel for that matter, just before the bottom of the vessel is reached. However, it is not often that one sees a whirl several feet in diameter. The accompanying view, taken at the upstream end of the conduits at the Germantown dam, one of the recently completed Dayton flood-prevention dams, during an April freshet, shows a whirl approximately 25 feet in diameter. The central portion of the whirl, the shaded portion, was fully 5 feet wide. The tops of the two conduits, which are each 9 feet high and 13 feet wide, lie 7 feet below the surface of the water. At the time the photograph was taken there were some 9,000 cubic feet of water per second, or about 4,000,000 gallons per minute, flowing out of the reservoir.

It will be noticed that the water is whirling in a clockwise direction. Theoretically, the effect of the earth's rotation would cause it to whirl in a counter-clockwise direction in the northern hemisphere and in a clockwise direction in the southern hemisphere. However, the effect of the earth's rotation is so slight that it is frequently counteracted by a puff of wind, a twig floating on the surface, or by

some other minor influence of like nature. These "vortex whirls," as they are scientifically termed, occur when the height of the water above the center of the orifice is less than about three diameters of the orifice. When the height becomes greater they disappear, leaving the surface smooth, as it is in the other portions of the picture.

### PHOTOGRAPHIC PLATES MADE OF GELATIN ON PAPER

Photographic plates made of glass are fragile and heavy, and those made of celluloid film have other objectionable features. These are avoided, it is claimed, in plates that are now being made of paper. The sensitized gelatin is attached by an adhesive to a thin sheet of varnished paper, which gives it stiffness, and it may be used with any plate holder. The plate is slid into a three-sided frame that fits the slots in the plate holder. One desirable effect of the paper backing is to prevent "halation," caused in other plates by intense light or overexposure. After exposure, the plate is developed in the usual way, and although it is not transparent, the developed picture can be seen by reflection. When developed, the plate is well washed, and afterward, while still wet, it is plunged into a "tanning" bath, which has the effect, after the plate has been well dried, of allowing the paper to be easily separated from the film, which is then ready for printing.

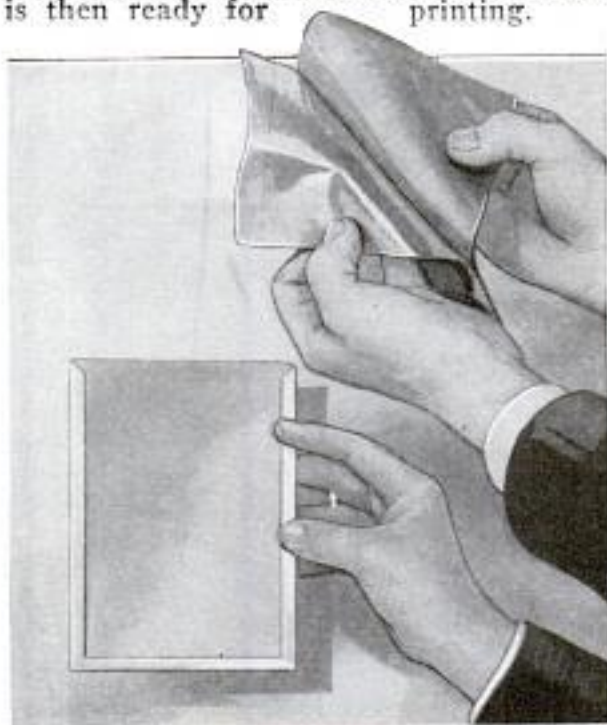

Gelatin-Film Plate Ready for the Camera: Above, the Paper is being Separated from the Gelatin Film, Which is Then Ready for Printing

Sold by: M. Bauchet,  
no. 1, Rue Aubert, Paris,  
France.

**CAMPING OUTFIT IS COMPACT AND COLLAPSIBLE**



Collapsible Camping Outfit Erected without the Walls, Showing Table, Bed, and Benches

The Small Box Carried on the Running Board Contains the Entire Collapsible Camping Outfit

Containing equipment enough for a small cottage, a camping outfit that is collapsible and folds compactly into a box carried on the running board of a car, is now being manufactured by a Chicago concern. It consists of six uprights and the same number of horizontals made of oak and fastened together with malleable-iron castings, the whole being covered with easily attached canvas, and yields nearly 60 square feet of floor space. Comfortable



Camping Outfit with Walls in Place, Showing the Roomy Interior: Two of the Large Screened Windows can be Seen at the Rear

headroom is provided throughout the interior, which will accommodate a 36 by 55-inch table, two benches seating six persons, and the stretching of a specially designed full-size bed. Eight large screened windows furnish sufficient light and air, and at the same time prevent the entrance of flies and mosquitoes. The total weight of the equipment is 150 pounds, and it can be erected or taken down in a few minutes by but one person.

9247

**CATCHES BIG HALIBUT WITH WOODEN HOOK**

Fishing in the waters surrounding Prince of Wales Island, Alaska, recently, one of the natives captured a giant halibut that measured a little more than 8 feet long and 4 feet wide. An old-fashioned native wooden hook was used in making the catch, and after the fish had been killed, it was loaded into a small row-boat and towed ashore by a gasoline launch, the weight of the fish being sufficient to swamp the small boat. The Alaskan natives show great ingenuity in fashioning fishing hooks of wood and ivory, and are very successful in their use.



Above: The Big Fish and the Native Fisherman Who Captured It. Right: The Fish and the Boat in Which It was Loaded and Towed Ashore

Com. Daniel Nelson  
 Kasaaan, Alaska

242

9361

POPULAR MECHANICS

SCALE QUICKLY SHOWS EXACT WEIGHT ON VISIBLE DIAL

Because the question of exact weight enters so largely into commercial business, the problem of making a scale that

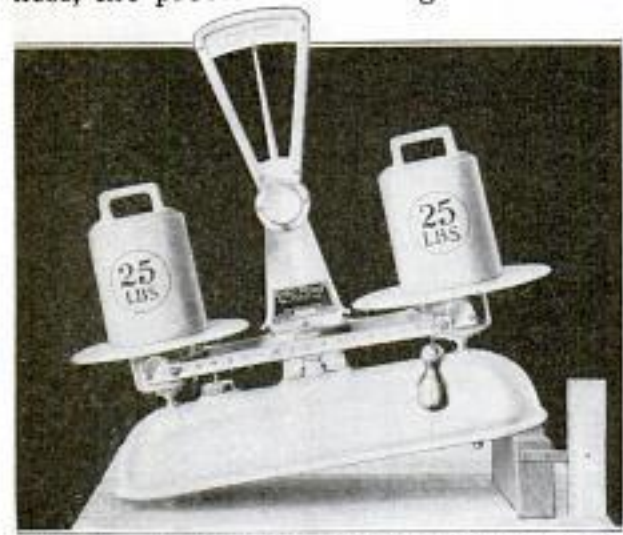

This Demonstration Shows Strikingly That the Scale will Remain in Balance Even When Much Out of Level

is accurate and dependable under adverse conditions presents a tempting field for inventors. A scale has now been designed that is claimed to give an exact weight very rapidly and under all conditions. Standard weights are used, and the material being weighed is placed in the opposite pan. A visible indicator tells at a glance the under or overweight. Being out of level or subject to vibrations or shocks does not affect the accuracy of the scale.

NARROW ESCAPE OF TWO CARS FROM FALLING OAK TREE

9357

That a miss is as good as a mile is seldom so strikingly demonstrated as in an incident that happened recently on the public-school grounds of Tavares, Fla., when an oak tree fell with a crash, and



Position of the Trunk of an Oak That Fell Accidentally between the Two Automobiles, Parked Only 28 Inches Apart, without Touching Them

landed between two automobiles that were parked only 28 inches apart. The trunk of the tree was 17 inches in diameter, and it almost touched the front wheel of one car, and as it lay between the cars, somewhat bowed, it came within 4 inches of the other car. The bottom branches just cleared the rear of the cars, which thus remained completely uninjured. The most skillful of woodmen could not have felled the tree with such precision if he had tried to do purposely what happened accidentally.

9276

ARTIFICIAL KNEE CONTROL IS PRACTICALLY SELF-LOCKING

For the benefit of persons who have had the misfortune to lose a leg above the knee, a new knee control for artificial limbs has been devised which is claimed to be a big improvement over older forms. As the wearer's body passes over the ball of the foot the suspender cords lift the foot and flex the leg at the knee joint. As the movement continues, the leg is straightened, practically locking the joint before the weight comes on it. The new

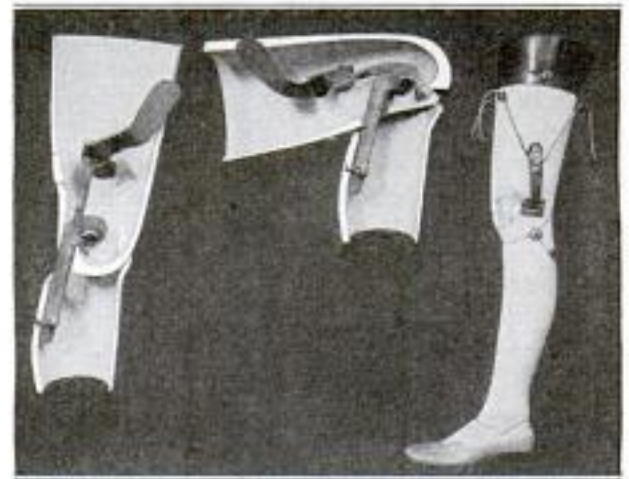

The Cut-Away Sections Show the Leg in Locked Position When Standing and Sitting. The Full View Shows How the Suspender Cords are Attached

control gives a more natural step and does not tire the stump, as the weight is carried from the shoulders or waist.

Research by the Bureau of Mines has developed a simple test for the determination of the quantity of carbon monoxide present in the blood of persons suffering from this form of poisoning. The apparatus used is simple and inexpensive; the accuracy of the results is well within the required limits; the test can be made in 8 to 10 minutes, and no great skill or special training is necessary to make it.

Cont. of Ft. Le Bush, Lake County Chamber of Commerce Tavares, Florida



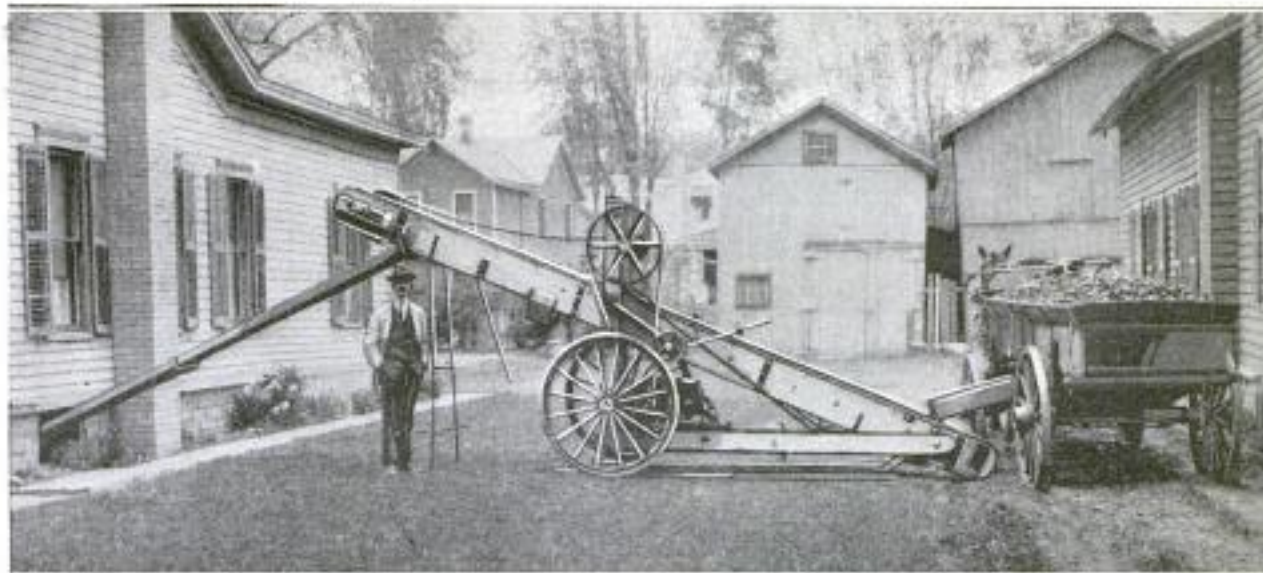

Delivery of Coal, without Damage to a Lawn or Flower Beds, by a Portable Conveyor Driven by a Gasoline Engine: The Coal can be Conveyed in This Manner across a Width of 60 Feet. During Transportation the Conveyor is Hitched to the Back of the Wagon

9315

**PORTABLE COAL CONVEYORS  
AVOID DAMAGE TO LAWNS**

To overcome the difficulty of delivering coal to a house when the cellar window is adjacent to a lawn or flower beds liable to damage, a New York inventor has developed a portable coal conveyor. It is mounted on a pair of wheels near its center, and slopes down to the ground beside the wagon, from which the coal is delivered into it by a chute. The coal is carried to its raised end by scoops on a belt that is driven by a gasoline engine, and is then delivered through an adjustable chute that slopes down to the cellar window. It is drawn from place to place by the wagon, and can be set up in a few minutes.

9307

**LARGEST SCHOOL BUILDING  
ON SINGLE-FLOOR PLAN**

Because of the ever-present danger of fire, the construction of school buildings on the single-floor plan is becoming increasingly popular, and there is now nearing completion the largest building of its kind in the world. Situated at Fort Wayne, Ind., the building will house 1,500 students, and the plan also includes a stadium for athletic games.



This Detailed Model of the Largest School Building in the World Built on the Single-Floor Plan, Shows How the Project will Appear When Completed Ready for Fall Attendance. The Building will House Approximately 1,500 Students

Cont. Frank H. Williams  
1920 Spuy Ken Ave. Fort Wayne Ind.

**GEAR-DRIVE SOCKET WRENCH  
9424 IS EFFICIENT TOOL**

Automobile owners may now avail themselves of a socket wrench having a ratchet-gear drive, with which the mean places, ordinarily difficult of access on a car, can be easily reached. Six standard-size sockets and an extension bar are fur-

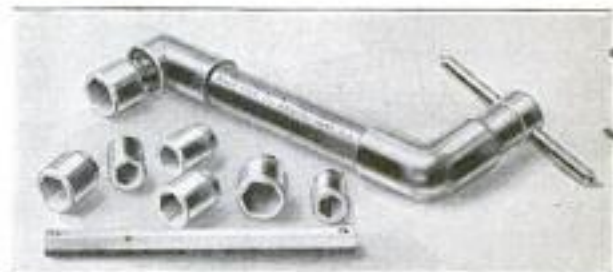

Gear-Drive Socket Wrench and Six Standard-Size Sockets, the Latter Made for Either Square or Hexagon Nuts

nished with the tool, and it is claimed that these will fit approximately 90 per cent of all the nuts, bolts, and capscrews used on automotive machinery which are now being made in this country.

King Tool Co., Asbury, N.J.

Capt. H. E. Thomas,  
911 Blunckley Ave.

244

POPULAR  
MECHANICS  
Portland Oregon  
HISTORICAL ROCK FORMATION  
MADE NAVIGATION AID

"Pillar Rock," a strange formation appearing some 20 miles above the mouth of the Columbia River, between the

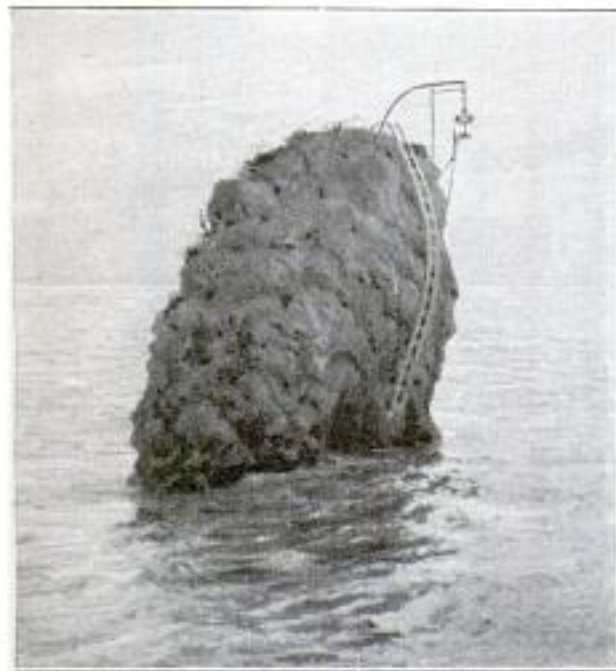

Historical Rock Which is Now Utilized as a Navigation Aid, Showing the Ladder Leading to the Beacon at the Top

states of Washington and Oregon, has lately been made an aid to navigation. This rock, which rises 20 feet above the water, has always been an object of historic interest because it was mentioned by the discoverer of Columbia River and referred to under that name by the early explorers. Now, however, it serves a practical use, since a red beacon has been placed on its top to guide the mariners in following the channel of the river.

### AUTOMATIC PISTOL COMBINED WITH HAND FLASHLIGHT

As a device to discourage burglars, a newly invented flashlight pistol should prove quite effective. The pistol barrel is placed along a tubular flashlight, and



This Combined Flashlight and Automatic Pistol can Fire Six .22-Caliber Shots

Army + Navy Journal

6/3/22

MECHANICS

six shots of .22 caliber can be fired. The pistol is automatic, and the trigger is conveniently placed on the side of the tube opposite the barrel.

### SUBMARINE "S-51" COMPLETES ITS TEST SUCCESSFULLY

The submarine "S-51" has successfully completed a 52-hour continuous-running test on Long Island Sound. It is one of four double-hull navy-designed boats having many new features not found in other S-class submarines, and which are under construction at Bridgeport, Conn. It is 248 feet long, and has a submerging-valve control by means of which the turn of a single lever causes 300 to 400 tons of water to flow into the diving tanks in less than 60 seconds. Submarines of this type are equipped with four 21-inch torpedo tubes in the bow, and one in the stern.

### IMPROVED WARNING SIGNAL FOR AUTOMOBILES

The ordinary signal on the rear of an automobile when it flashes "Stop," nine times out of

ten means go slowly rather than stop. Therefore, motorists have acquired the habit of translating the visible "Stop" into an intended "Slow." An improved signal is now manufactured which makes this misunderstanding impossible, for it has both words on the signal. When either the clutch or the brake pedal is operated, the signal flashes "Slow" in green, and when both pedals are operated together, the word "Stop" is flashed in red.



The Bureau of Public Roads, Washington, D. C., is to conduct investigations seeking to devise methods of treatment to make sands containing organic matter suitable for use in making concrete. Persons are invited to send samples of sand in which the presence of organic matter is suspected.

Tel. Rate. Auto Specialties  
Co. 2160 Superior Ave.  
Cleveland, Ohio.

Dr. S. P. Cottrell  
65 Greer Ave. Buffalo, N.Y. 307

Copyrighted material

9353 International Newsreel Corp  
New York City

AIR VIEW OF TWO GREAT NATIONAL MONUMENTS

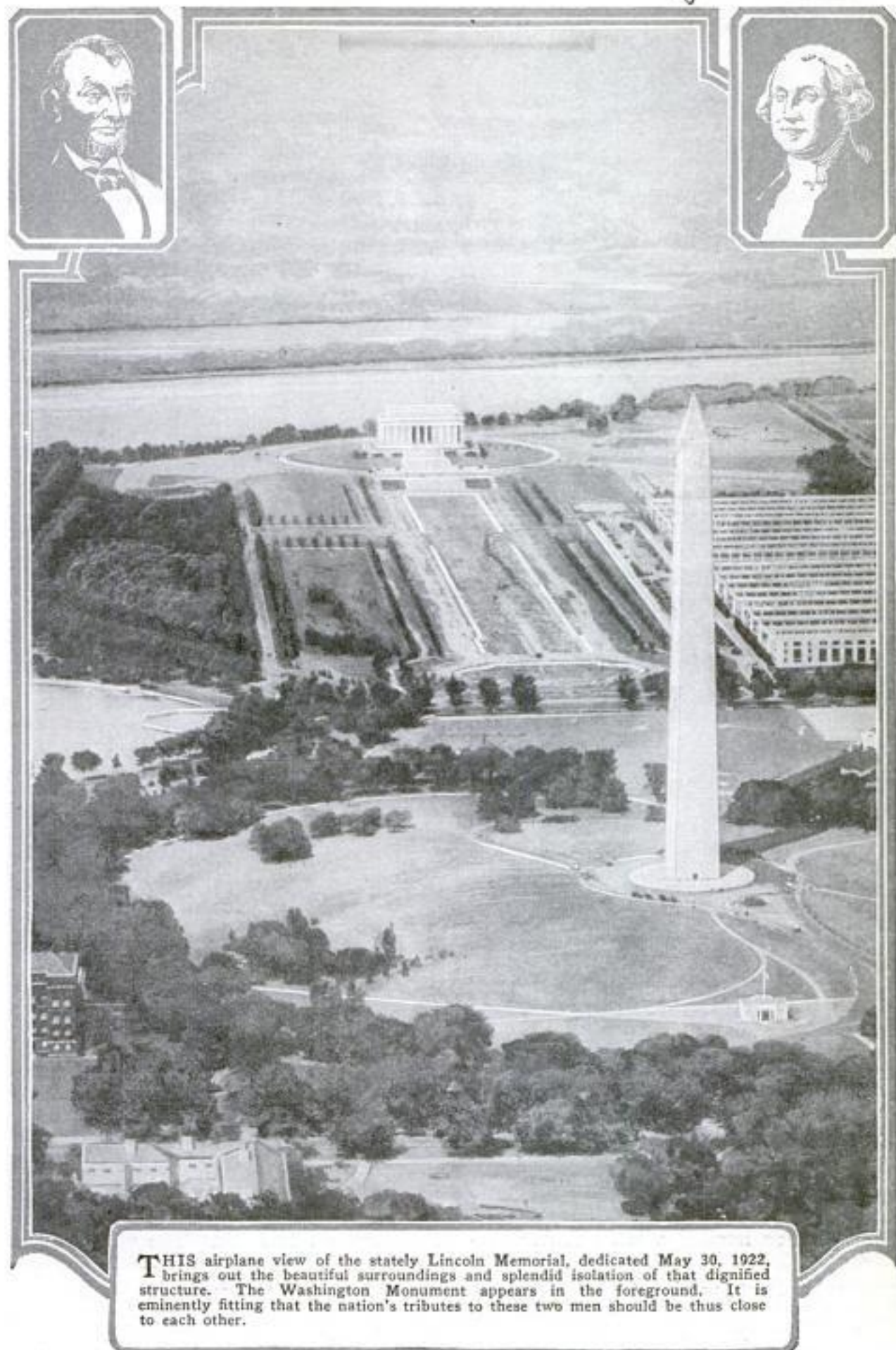

**T**HIS airplane view of the stately Lincoln Memorial, dedicated May 30, 1922, brings out the beautiful surroundings and splendid isolation of that dignified structure. The Washington Monument appears in the foreground. It is eminently fitting that the nation's tributes to these two men should be thus close to each other.

Cont.  
9374  
246

Silbert Gordon  
Post. & Intelligencer  
POPULAR MECHANICS  
Seattle, Wash.

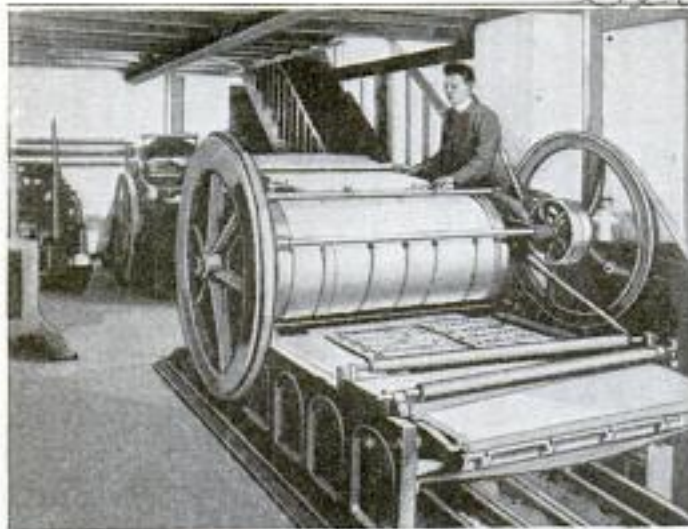

Above: This Is the Press Used for Printing the Chinese Newspaper Published in Seattle, Washington. Ordinary Newsprint is Used, and the Printing is Done in a Glaring Shade of Red Ink. Right: Setting the Type for the Chinese Newspaper. In the Ordinary Typesetter's Font There Are Some 6,000 to 7,000 Characters Used, Each One Denoting a Single Word

9346 <sup>Laundry</sup> ELECTRIC FLATIRON IS MADE IN COMPLETE SECTIONS

Feeling that there was a demand for an electric iron that could be varied in weight, an inventor has developed one

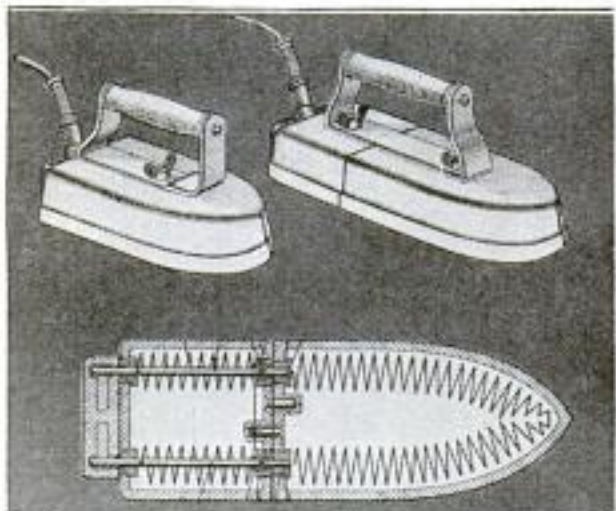

An Electric Iron Made in Sections, Each of Which Is a Complete Unit, by Means of Which the Weight may be Varied to Suit the Work

made in sections, each of which is a complete unit with heating element, sole and pressure plates, and terminal pins. For ironing delicate work, such as laces, only one section is used, weighing about 3 pounds. For heavier work another section is added and a larger handle is attached, the weight in this case being about 6 pounds. For heavier work, as in tailor shops, more sections may be added as desired.

Frank B. Widmayer  
65 W. 95th St.  
New York City

9374 TYPESETTING IS A BIG TASK ON CHINESE NEWSPAPER

For the benefit of the Chinese residents of this country, a Chinese newspaper is being printed in Seattle, Wash. The paper is printed in the reddest of ink on ordinary newsprint. The job of setting type for this paper is a man's-size task, as there are some 40,000 written words in the Chinese language, each represented by a single character. To complicate matters, a certain word may have several different meanings, depending on the words used with it. However, in the ordinary typesetter's font there are only some 6,000 to 7,000 characters that are regularly used.

9480 A "UNIVERSITY CITY"

Progress is being made in France with a scheme for bringing together in peaceful scholastic rivalry successive generations of all nations, especially the allies who fought side by side on the battlefields of the western front. Considerable sums of money have been subscribed to promote an institution to be known as "University City," which will be built on the site of a portion of the dismantled fortifications of Paris. The university is to be international, and already applications for sites for colleges have been made by the United States, Great Britain, Canada, Belgium, the Scandinavian countries, China, and Indo-China.

London Times Weekly  
5/11/22  
Copyrighted material

9146 Elm Lee Garage,  
San Francisco, Calif

## GASOLINE TANK HANDY FOR GARAGE REPAIR WORK

Handy for use in garages is a tank for draining the gasoline from an automobile tank, when repairs are necessary, and for replacing the gasoline in the gasoline tank of the car, when the repairs are completed. The tank is mounted on small rubber-tired wheels, and is flat and low, so that it can be pushed under the car tank for draining the gasoline directly into it at one

end. At the other end is a hand pump with a hose that can be connected to the

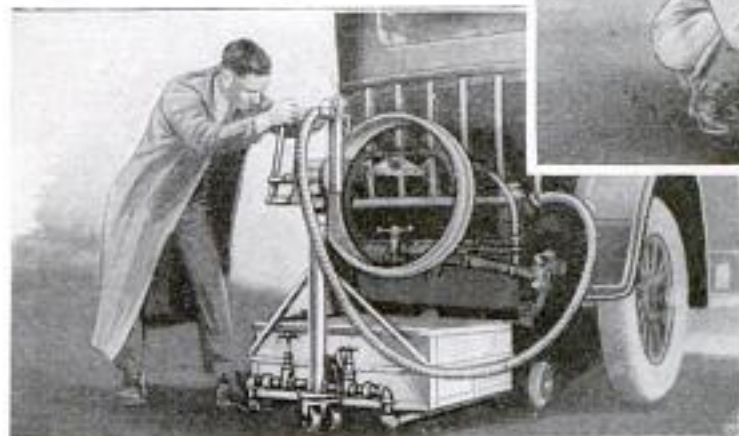

Pumping the Gasoline from the Portable Tank Back into the Gasoline Tank of the Car, When the Repair Work is Finished

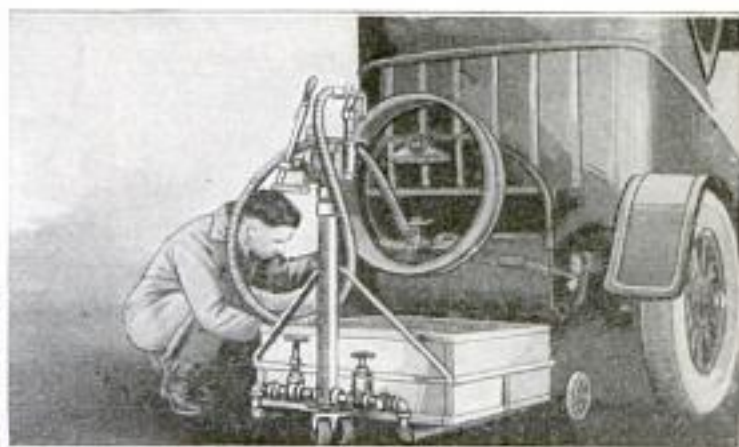

The Portable Tank is Shown under the Gasoline Tank of a Car, the Contents of Which are being Drained into a Compartment of the Portable Tank So That Necessary Repairs may be Made

car tank, into which the gasoline can then be pumped back. Besides being used in connection with repair work the portable tank is handy at any time for replenishing car tanks.

9289

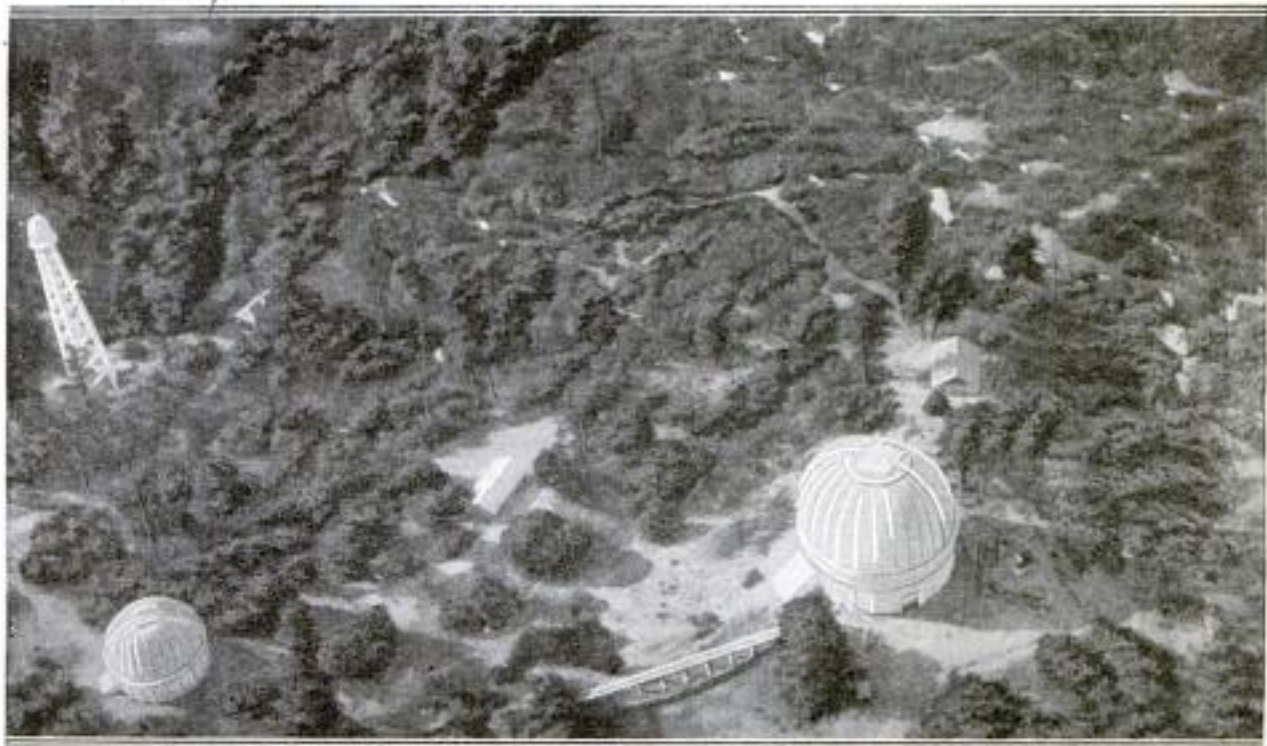

### AERIAL PHOTOGRAPH OF MOUNT WILSON OBSERVATORY

THE great solar observatory at the summit of Mount Wilson, California, was recently photographed from an airplane for the first time. The great dome that contains the famous 100-inch reflecting telescope, stands out very conspicuously in the beautiful panoramic view of its rugged surroundings. The great reflecting telescope of the Mount Wilson observatory is conceded by astronomers to be the most perfect yet designed for modern research. The elevation of the famous observatory being over 5,000 feet above sea level makes its situation, on account of the resulting clearness of the atmosphere at all times of the year, very favorable for all kinds of astronomical work.

International Newsreel Corp.  
New York City

248  
9380

### "WALKING CHAIR" FOR INVALID IS BETTER THAN CRUTCHES

Any person who has been forced to use crutches temporarily, will welcome an im-



For Use in Place of Crutches, This "Walking Chair" Provides Greater Comfort and Security

proved device for taking their place, which can be properly called a "walking chair." The chair is provided with a spring seat and has padded, adjustable shoulder supports. There are also hand grips that can be moved to suit the stature and comfort of the user. The frame of the chair is carried on four rubber-tired wheels, the rear pair being used for guiding.

### ORNAMENTAL CHURCH WINDOW IS WAR MEMORIAL

Commemoration of those of the parish who served in the late war, has been strikingly effected by St. Paul's Anglican Church in Toronto, Can. A window, 18 feet high by 4½ feet wide, and containing 700 fragments of glass gathered from the former battle areas, has been placed in the structure. These fragments, representing in number the parishioners who were engaged in war service, are souvenirs from the ruins of historic cathedrals and public

Christian Science Monitor  
6/3/22

buildings on the once shell-torn Belgian, French, and Italian fronts. The inclusion in the window of the hundreds of pieces of glass of all shapes, sizes, and colors was naturally an arduous task, but the completed work has been pronounced by experts to be a thing of beauty aside from its memorial value.

### NEW ICE-HOISTING CARRIAGE WITH AUTOMATIC ACTION

Hoisting cakes of ice from frozen rivers and lakes up into storage houses has been facilitated by a new roller carriage introduced by a Massachusetts man. With this innovation, 16 cakes can be elevated at each trip, and the carrier is heavy enough to roll back down the slide by its own weight, thus doing away with the old method of dragging it down by hand. When the carriage reaches the bottom of the chute and encounters the first block of ice, a pair of steel arms, or tongs, automatically rise and remain lifted until the last cake is passed, at which point they drop into the proper position for elevating the frozen product, without adjustment

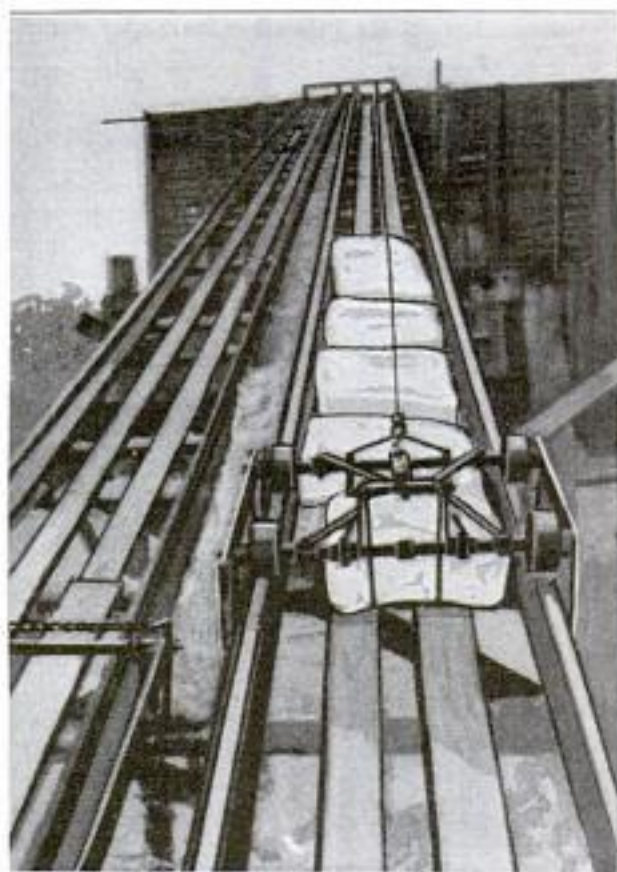

Automatic Hoisting Carriage Shown Part of the Way up the Chute and Elevating Several Cakes of Ice into the Storage House

by the men, after the ice has been brought to the bottom of the chute.

Geo. W. Wall  
Plymouth, Mass.

## BREAKING FARM HORSES STILL BIG BUSINESS

BY FLORENCE L. CLARK

*Mc Esregor, Iowa.*

NUMEROUS as are tractors on American farms, the major part of the nation's crop is still produced by horse power, and in the opinion of many who are making a close study of the relative merits of tractor and horse in farm work, the horse is going to have a place on the farm, if not permanently, at least for some time to come. Best results can be obtained, they believe, by using both tractor and horses. So, while learning how to handle the tractor, farmers are still up against the same old job of breaking in horses.

An Iowa farmer has worked out a method of breaking the big draft-horse colt with a rope, which many of his brother farmers are finding the easiest and simplest way yet known to establish mastery, and to teach the young horse how to obey and work.

His method appeals to them because it is quick and easy, and also humane. Just a rope and "Whoa" does the work. The rope is fastened to the bridle, then arranged so that it passes through a loop on either side below the neck, and

The colt is rigged up in this contrivance, and taken out. As soon as he becomes unruly, the man at the end of the rope says "Whoa" sharply, and as he



The Horse Docilely Permits the Trainer to Mount after But a Short Interval of Teaching with the Rope Harness. Note the Rope on the Forelegs of the Animal

says it, pulls the rope. The horse is brought to his knees, helpless. It hurts him only a little, but he doesn't enjoy it, and his sense of helplessness teaches him he has a master. Just a few "whoas," followed by the pull, teach even the most high-spirited colts the lesson that when they hear "Whoa," it is time to stop and stand still.

An advantage of this kind of breaking in, is that the horse never forgets that he must stop instantly when he hears the familiar "Whoa." This proves a prime factor of safety in emergencies—much safer than if a driver has to depend upon pulling on the lines.

¶ In India the amount of seeds produced for making the various kinds of seed oils runs close to 5,000,000 tons annually. Aside from the castor seed, for making castor oil, there are mowrah seed used for making food products, soap, and

candles; the poppy seed used in the manufacture of salad oil and in the painting industry, and rapeseed used as a drying oil for paints and for the manufacture of margarine.

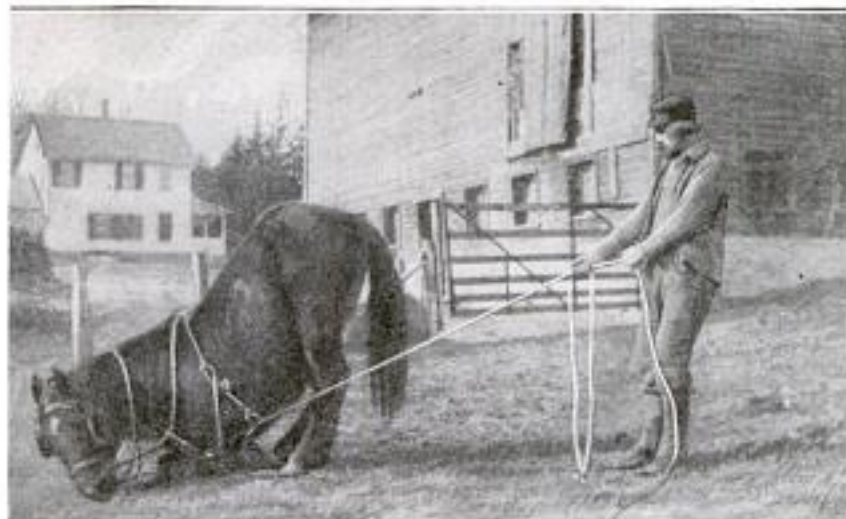

Bringing the Horse to His Knees by Means of a Jerk on the Simple Rope Harness, and Thus Quickly Teaching the Young Animal to Obey the Commands of the Trainer

down the forelegs, where it is attached to leather bands on either foot. Another rope is fastened to this harness, so that a pull on it draws the legs backward.

9393 Mrs. Harry Katz Lake Hopatcong, N.J.

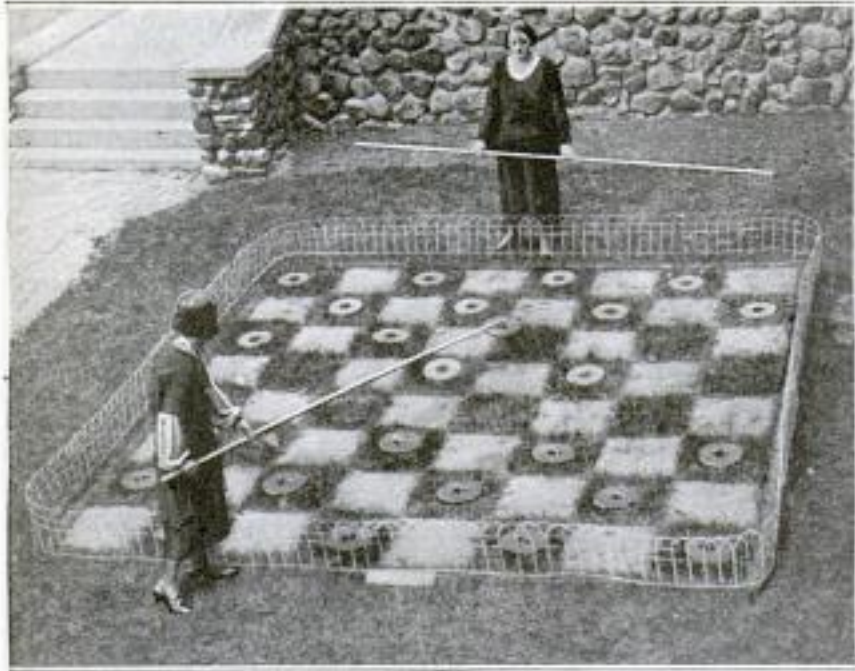

**SQUARES OF GRASS USED IN "LAWN CHECKERS"**

Checkers, that staid old game usually pondered over in the quiet corners of the home, has lately been introduced as an outdoor novelty by a New Jersey inventor. The "board" consists of a specially prepared lawn, the regulation number of "white squares" being made by removing sections of sod, while the "black" are designated by the remaining grass. Disks with holes in their centers are used as the "men," these being manipulated by means of long poles in the hands of the players.

Section of Ordinary Yard Marked Off, and "Lawn Checkers" being Enjoyed by Two Players Who Use the Long Poles to Move the Disks over the Board While Standing at Opposite Sides of It

COPYRIGHT, UNDERWOOD & UNDERWOOD

**SEPARATE WATER BASIN FOR HOUSEHOLD SUPPLY**

Because the demand for water for lawn sprinkling and household purposes during certain hours of the day put too heavy a burden on the supply wells, the city of Dayton, Ohio, is constructing a special storage reservoir to take care of this de-

mand. The site chosen is at an elevation, and the excess water during the day will be pumped into the reservoir, from which it will be available by gravity flow. The reservoir will be of concrete construction, poured from a modern distributing system.

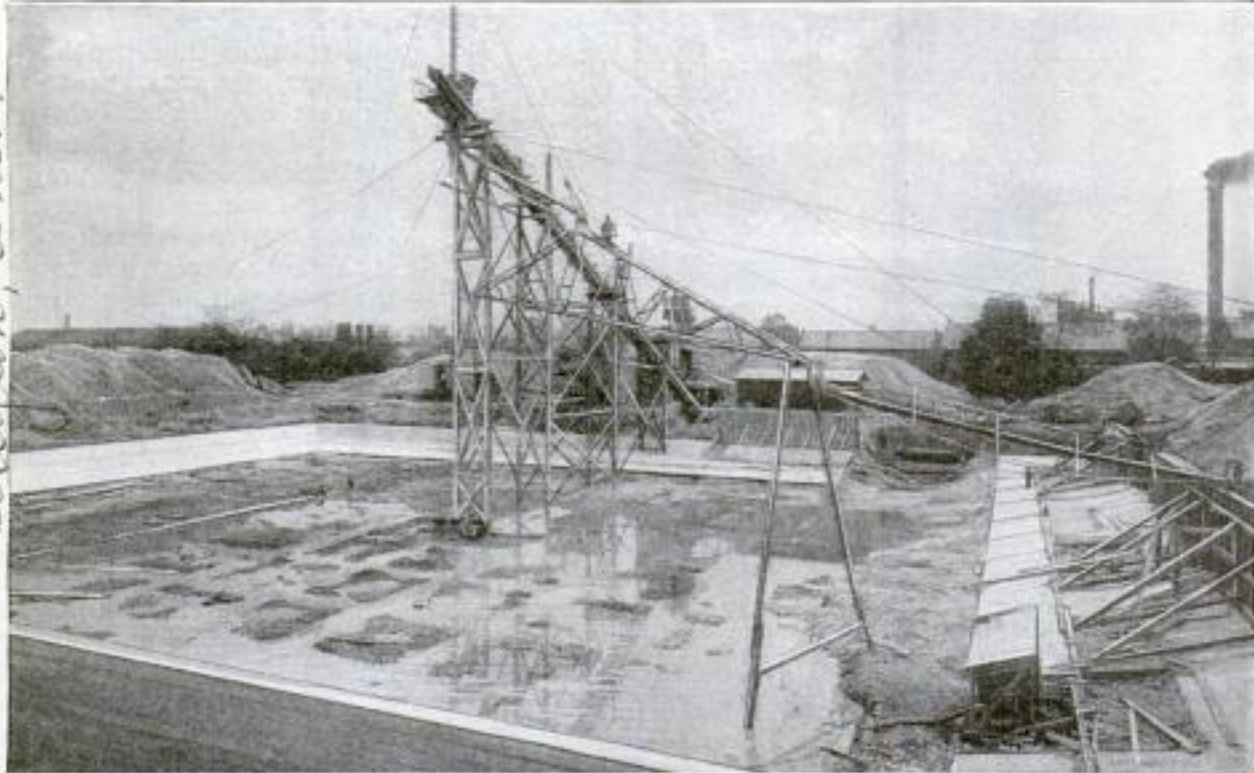

Building the Separate Water Reservoir, at Dayton, Ohio, for Household and Sprinkling Supply: The Distributing System, Used in Pouring the Concrete, is Flexible, and All Material is Handled from a Central Tower

Eslen M. Wiley, Contractor

Copyrighted material

Cont. C. E. Nesbitt 315 Sherd St. Arcade Dayton, Ohio. 9204



9359 Built at Leith, England.  
 Com. 7 rank B. Howe, 412 Mason Opera  
 House, Los Angeles, Calif. 251

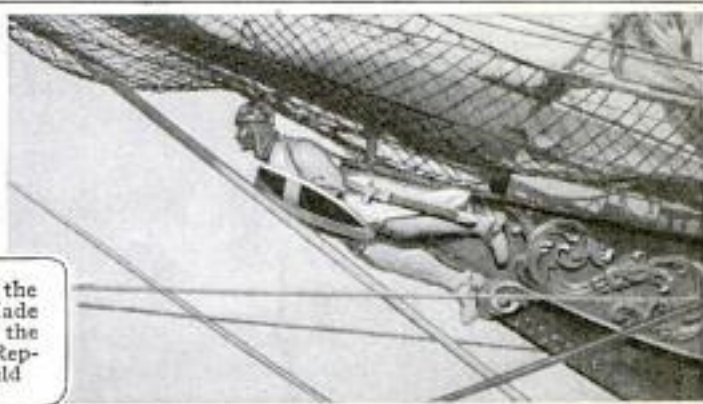
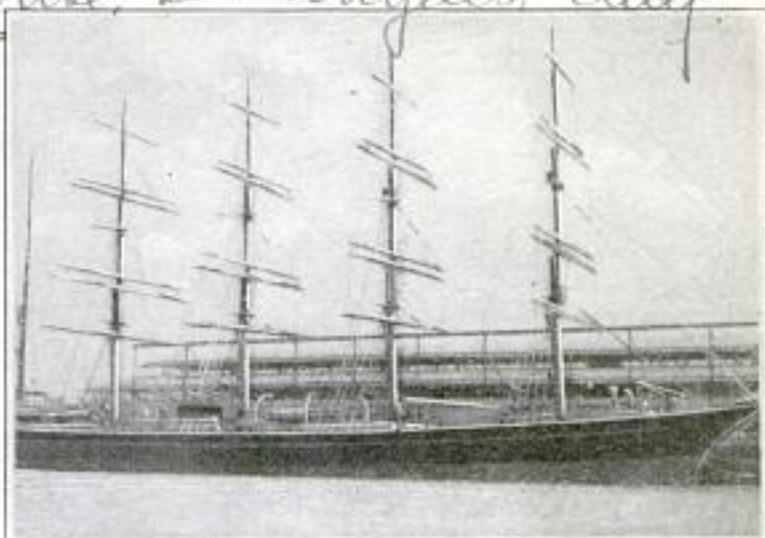

The Two Views Above Convey Some Idea of the Size of the "Köbenhavn," if Comparison is Made with the Figures of the Men Standing on the Dock. Right: The Figurehead on the Bow Represents a Viking Carrying the National Shield

*Boat*  
**SAILING BARK WILL COMPETE WITH OCEAN STEAMSHIPS**

9359 That the sailing vessel will not disappear as an ocean freight carrier, in spite of the competition of steamers and motorships, is presaged by the arrival here of the Danish bark "Köbenhavn" on its maiden trip around the world. Hailed as the largest bark-rigged sailing vessel afloat, this ship is 432 feet long and spreads 50,000 square feet of canvas. The ship is of steel construction, including the five masts, and the lines conform very closely to those of the earlier sailing vessels. Even the figurehead on the bow is not lacking. 9236 *Aeroswitches*

**MAKE REVERSIBLE PROPELLER FOR DIRIGIBLE BALLOON**

With particular application to dirigible airships of the rigid or semirigid type, but also adaptable to airplanes, a propeller has been designed in which the pitch of the blades may be altered or reversed while in motion. The power of the engine is used to effect the changes in pitch, and the position of the blades is graphically shown on the instrument board. Control is by means of a push button, and

the operating mechanism is locked except during changes or adjustment of pitch. As the position of the blades is changed, an automatic throttle governs the speed

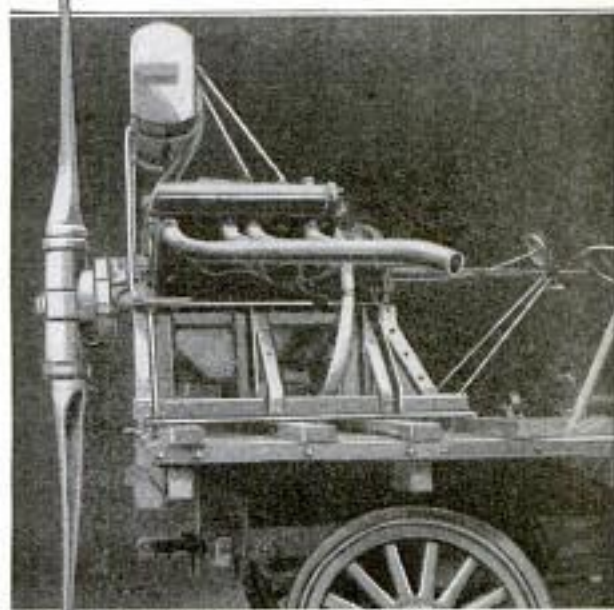

An Air Propeller in Which the Pitch of the Blades may be Altered or Reversed While in Motion by Using the Power of the Engine

of the engine to prevent racing or stalling, but this throttle is at all times subject to manual control.

*Inv. Spencer Heath, President, American Propeller & Mfg. Co. Baltimore, Md.*  
 Copyrighted material

*Alves, Opticians, 513  
Chase St. St. Louis, Mo.*

252  
9251

## POPULAR MECHANICS

### SANITARY SPRAYING SYSTEM FOR OPTICIAN'S COUNTER

A very thorough sanitation system for use on an optician's counter consists of



Antiseptic and Cleansing Sprays That are Used on an Optician's Counter, the Former for Sterilizing the Optician's Hands, and the Latter for Cleaning the Customer's Glasses

a polished white-enameled box in which are two spraying bottles, one containing an antiseptic, and the other a cleansing mixture. Each bottle is provided with a nozzle

that can be connected by a hose to a pipe line that runs the entire length of the counter, and that in its turn is connected to a tank containing a supply of air, compressed to 50 pounds by an automatic pump in the basement. Each optician at the counter has one of these boxes at his right hand, and before he handles a customer's glasses, he first sprays his hands with the antiseptic, dries them on a clean towel, and when he has finished his work, uses the cleanser for polishing the lenses. The same hose is used for both bottles, and is readily removable from one to the other.

### 9320 MACHINE FORMS AND PRINTS SHIPPING CASES QUICKLY

The greatly increased demand for fiber shipping containers has led to the design of a machine for forming and printing the stock automatically in one operation. A sheet of board is fed into one end of the machine, and as it passes through, both ends are neatly trimmed, the slots are cut, and the folding creases made. It is cut away at the two corners for the staple flap, and the label is printed, in two colors if desired. When the sheets come from the machine they are ready to be wire-stitched, to form cases. Only one attendant is required.

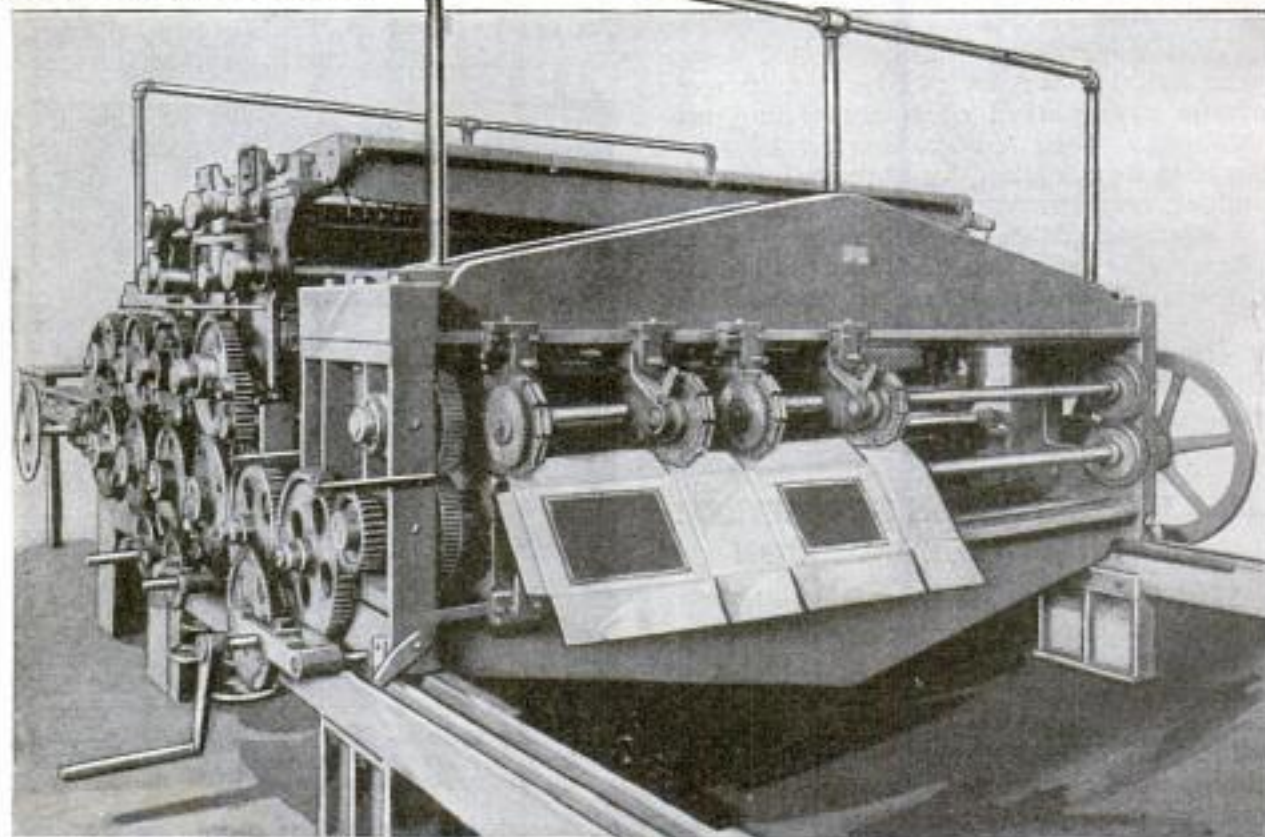

A Machine for Making Fiber Containers, Which Trims Both Ends of the Sheet; Slots and Creases It Both Ways; Cuts Out for the Staple Flap at Two Corners, and Prints the Label, All in One Operation

*George W. Swift Jr. Inc.  
Bordentown, N.J.*

## HEADER CURB ALONG STREET-CAR TRACK PROTECTS PAVEMENT

By HARLAN H. EDWARDS, *City Engineer*

*Ill. Wille, C. E.*

IN many cities the maintenance of pavement along car tracks has been a source of trouble for years. The tracks were laid years ago with light steel rails on small ties spaced too far apart and using very little ballast. The passage of every car caused the track to move up and down in a sort of wave motion, gradually working the adjacent pavement upward. This movement, of course, was also transmitted to the pavement over and adjoining the ties, with the result that the bricks or blocks were pushed up, forming a very rough surface that was rather dangerous to passing vehicles.

The condition, however, is not confined to the car track, but spreads out into the pavement for a distance of several feet beyond the ties. Many cities, therefore, are adopting the use of the header curb, which is simply a little wall along the car tracks, to confine the danger to the point of origin, thus making, in effect, three separate sections of the pavement.

This header curb is composed either of concrete; of a combination of concrete with a steel-angle paving guard; of creosoted wood block, or of granite, and is usually 6 inches thick and from 18 to 24 inches deep, bringing the base of the curb well below the bottom of the track structure. The concrete header curb is usually built integral with concrete pavements, and is of the

same composition. The combination of the concrete header curb with the steel paving

guard has found its greatest use on streets having asphalt or brick pavements adjoining the car track, although this type of curb is suitable for any kind of pavement. It is concealed from view (the top of the steel angle being below the surface of the pavement), yet functions continually. The wood-block and granite

curb, of course, is of use in connection with pavements of these two types, inasmuch as this curb extends to the surface of the pavement and forms a part of the latter.

The header curb also serves several other purposes. It acts as a wall or fence, keeping within bounds the street-railway company's maintenance gangs. Often these workmen are found tearing up a section of the pavement 6 or 8 feet from the rails in order to remove a defective tie without tak-

ing up one of the rails. The pavement is seldom replaced in a satisfactory condition, but is left rough and uneven, a danger to public travel and a detriment to the rest of the pavement. The curb affords an additional protection to the pavement on each side of the track, in that it acts as a retaining wall, holding solidly in place the city's pavement and foundation whenever the car company chooses to take up and relay its track and ballast. This is a very important function, for in track-re-



An Example of the Excellent Condition of the Pavement Where the Header Curb is Used to Localize the Movement Caused by the Street Cars

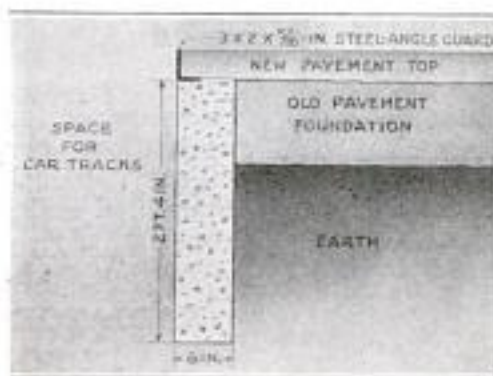

The Concrete Header Curb Is Usually Six Inches Thick and Extends 18 to 24 Inches below the Pavement



This Shows How the Header Curbs Act as Retaining Walls and Boundary Marks When Maintenance Work is being Performed on the Street-Car Tracks

placement operations the track and ballast are frequently entirely removed, leaving for a time an open trench in the street.

In case of heavy rains, the sides of this trench may cave in, leaving the pavement to the side undermined. Again, the new ballast may not be thoroughly compacted, leaving space for the earth walls to work inward under heavy traffic and cause the pavement above to sink.

It is seen, therefore, that this acts as a hidden watchman. It is on guard day and night, year in and year out, protecting the city's and the property owner's pavement from damages due to careless workmanship and indifference in the construction and maintenance of adjoining street-railway tracks. Its cost is not high—in fact, it is one of the cheapest forms of pavement insurance obtainable, to say nothing of cutting down the repair bills of vehicles using the street.

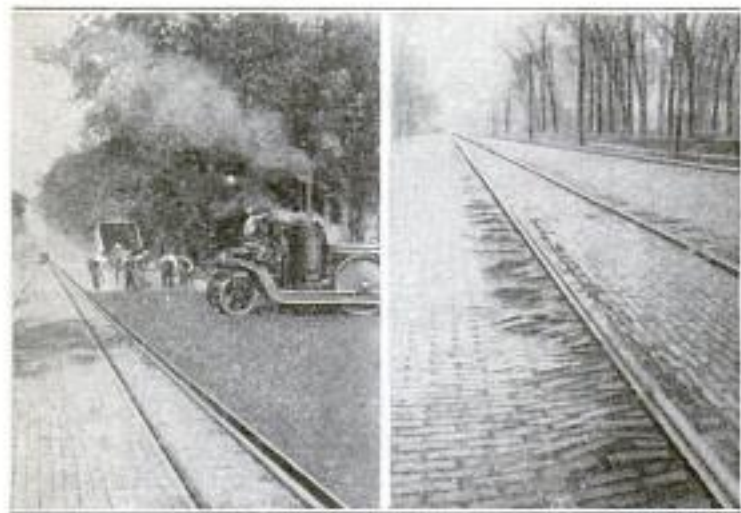

Left: Showing How the Finished Pavement Appears When the Header Curb is Used, the Roadway being Paved with Asphalt and the Car Tracks with Brick. Right: Notice How the Bricks have Worked Up Where the Header Curb is Not Used

9411

**COMBINE MANY DRAFT GAUGES INTO ONE INSTRUMENT**

In the operation of the modern steam plant, accurate draft readings under the

Bailey Meter Co. E. 46th at Euclid Cleveland Ohio

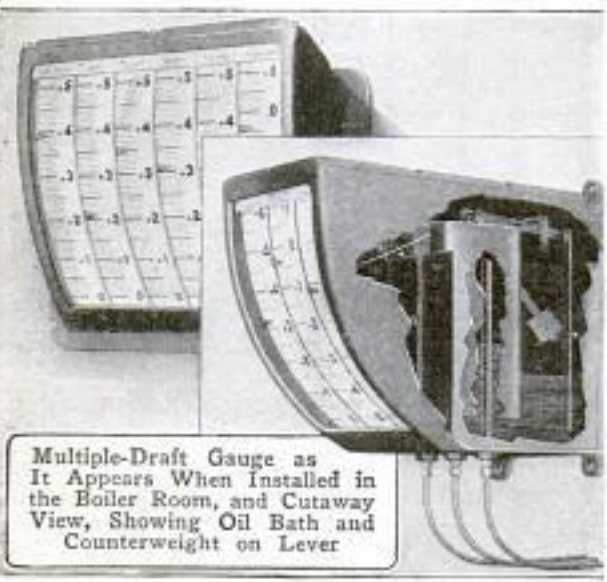

Multiple-Draft Gauge as It Appears When Installed in the Boiler Room, and Cutaway View, Showing Oil Bath and Counterweight on Lever

boiler and at various points in the gas passages are of extreme importance. By the use of a new draft indicator it is now possible to show on one centrally located instrument the amount of draft at many widely separated points. From two to twelve individual pointers and scales can be combined in one gauge. The pointers have a 10-inch travel along the arc of an illuminated scale. The operating levers are supported on knife-edges, to reduce friction, and are supplied with

counterweights for varying ranges of draft. The gauge may also be adapted for other purposes, such as reading steam pressure, or for indicating the number of revolutions per minute of moving machinery, using, in these cases, partially magnified scales for indications over narrow limits.

9385

**RADIATOR CONDENSER MADE IN FORM OF A STILL**

An automobile radiator condenser, designed to prevent overheating of the motor during daily trips up the arid slope of a 6,000-foot

California mountain, is built after the pattern of a still. A polished metal retort is connected to the radiator top, and leads into a coiled tube, the farther end of which is also connected to the radiator top. When the water in the radiator boils, steam enters the retort and passes into the coil, where it is condensed and returned as comparatively cool water to the radiator.



*dr. Clyde Linthicum Escondido, Calif.*



A Form of the Well-Known Chinese Pump Used on the Rice Fields of China for Conveying Water from One Field That is Well Irrigated to Another That Needs More Irrigation: The Hand Crank That Operates This Chinese Pump is Seen near the Right Hand of the Chinaman

## ORIENTAL RICE-FARM LABOR BECOMING HARDER

By LAWRENCE WILLIAM PEDROSE

*Henckley Bldg  
Seattle Wash*

RICE ranks with wheat and rye as one of the world's greatest food resources. Of Indian origin, it spread to China and Japan and then to the western world. It is today the staff of life to hundreds of millions of people, and is familiar to the palate of as many millions more. Contrary to popular belief, rice is not used universally as a food in the Far East. Since early colonial times America has been a large importer of rice, and today is comparatively the largest consumer of this grain.

Rice-growing in Japan and China is an interesting industry. It has shown little improvement in method of cultivation, however. In these countries it is planted, cultivated, and harvested in the same manner as in medieval times, the only change being caused by the fact that increased population has driven the rice farmer higher and higher above the lowlands and made the problem of irrigation more difficult.

The natural field for rice is a swamp where there is a plentiful supply of water.



Panoramic View of an Irrigated Rice Field as It Appears When the Grain, after having been Sown Broadcast and Allowed to Sprout, has been Carefully Transplanted



Typical Little Settlement of Oriental Farmers: The Roofs are All Thatched with Rice Straw. Preparations are being Made for the Erection of a New Hut, and the Roof Trusses can be Seen in the Right Foreground

But in recent years the cultivation of rice on hillsides and plateaus, hundreds of feet above the rivers and streams which irrigate them, is common. And in the Orient this irrigating is done by the laborious hand process, because there is no available pasture land to support horses, oxen, or other beasts of burden.

Rice cultivation necessitates regular flooding of the fields, and to provide the essential water, the hillside and plateau farmer builds terraces. Water is pumped, or carried, to the first terrace above the source of supply, and from there raised in turn to the terraces above. To the plateaus the water is carried in buckets and conveyed from field to field by crude mechanical devices operated by hand—for human labor is still the cheapest kind of power.

The whole rice-growing area of China is no larger, perhaps, than two American states, yet it supplies most of the world with rice. This is made pos-

sible by intensive cultivation, the development to its highest productivity of every foot of soil worked.

Many ingenious devices have been put in use by the Oriental rice grower to assist him in watering his fields. Buckets are used extensively in Japan, but the Chinese have a sort of conveyor equipped with paddles which run in a trough and are operated by a hand crank. The irrigation method of rice cultivation excels in that control of the water supply is always in the hands of the farmers.

Rice is sown broadcast in a deeply hoed field, and quickly sprouts. When two or three weeks old, a large portion of the growing plants is transplanted. Weeding also requires much labor. Fertilizer is carried on the backs of the farm workers, men and women, and carefully distributed by hand.

The straw from the harvested rice is utilized for many purposes, but principally as a thatch for covering houses.

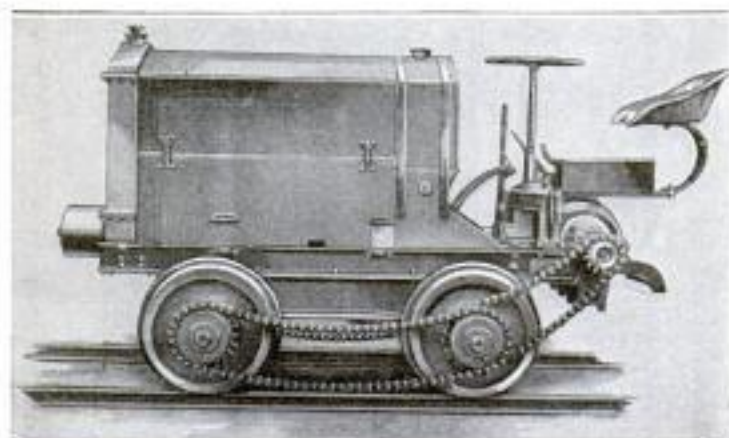

Small Tractor Converted into a Locomotive to Run on a Narrow-Gauge Track in the Roadless Hills of Peru

### SMALL TRACTOR IS CHANGED INTO LOCOMOTIVE

For use in the hills of Peru, where there are no roads, a small tractor has been converted into a locomotive to run on a narrow-gauge track. The tractor is mounted on small flanged railroad wheels, which are driven by a system of sprockets and chains in connection with the transmission of the tractor power plant. It hauls trains of small trailer cars.

Cleveland Tractor Co., Cleveland Ohio.

### SOLVING THE TREE PROBLEM FOR CITY DWELLERS

St. Louis has solved its tree problem. Seven years ago, when the city's forestry department took a census of the number of trees planted on sidewalks and along the thoroughfares of the city, there were only 92,000 trees. Now, there are approximately 1,000,000, according to the figures of the department, including, of course, the trees planted in the parks and playgrounds.

The department plants, trims, and protects the trees from the ravages of decay, insects, and the like. All trees are sold at cost, to the householder or other purchaser. The retail price is \$4 a tree, which includes the cost of the tree itself, shipping charges, planting, trimming, and also the care of it for three years. If a tree dies in that time, another is supplied at the same price. In the course of its activities, the department has discovered that trees will thrive in one section of the city that will die in another. This is caused by sulphur fumes from the soft coal used so plentifully by factories in certain sections of all industrial cities. The most popular trees are the American sycamores, while others extensively used are European sycamores and poplars. The survey made by the department shows that all trees along the streets have a uniformity unknown before the advent of its work; that the maple cannot grow where there is not plenty of ground space around it; but that sycamores will thrive in very narrow planting space.

The forestry department has a force of 24 to 30 men. On rainy days, when they cannot plant trees, the men chop down dead trees, and also do tree surgery. All holes in trees are filled with concrete. So skillfully is this done that often one cannot tell where the tree was operated upon.

### SHOWMAN'S MOTOR-BUS HOME IS VERY ELABORATE

When a traveling showman of England adopted a motor bus as a means of moving from town to town, he had a special



The Motor-Bus Home Adopted by a Traveling Showman of England Is Remarkable for Its Elaborate Interior Carvings and Decorations. The Stairway Is Detachable

body built on a truck chassis, and furnished it much as one would a stationary home. There are a living room and a bedroom, both completely furnished, the living room even containing a piano. Much solid mahogany was used in the construction, and the carvings and decorations are quite elaborate.

Advantage is being taken of the effect of contrasting colors by a manufacturer of egg cartons. It has been found that if the inside of the carton is colored blue the eggs will appear much whiter than they do against uncolored cardboard.

Cmd } C. W. Isseiger Powell + Suller Sts  
 1929 } San Francisco, Calif.  
 Keystone View Co New York City

**HAZARDS OF THE LIFE-SAVER**



Lifeboats are Made Unsinkable by being Constructed with Water-Tight Air Compartments Fore and Aft, So That, If the Boat is Capsized, Though It may Turn Upside Down, It will Never Sink. Here is Seen a Pacific Coastguard Crew Righting an Unsinkable Lifeboat That has been Upset. They are Doing It as Part of Their Practice Drill. One Oar can be Seen Secured to the Thwarts. Others may Be Afloat in the Water

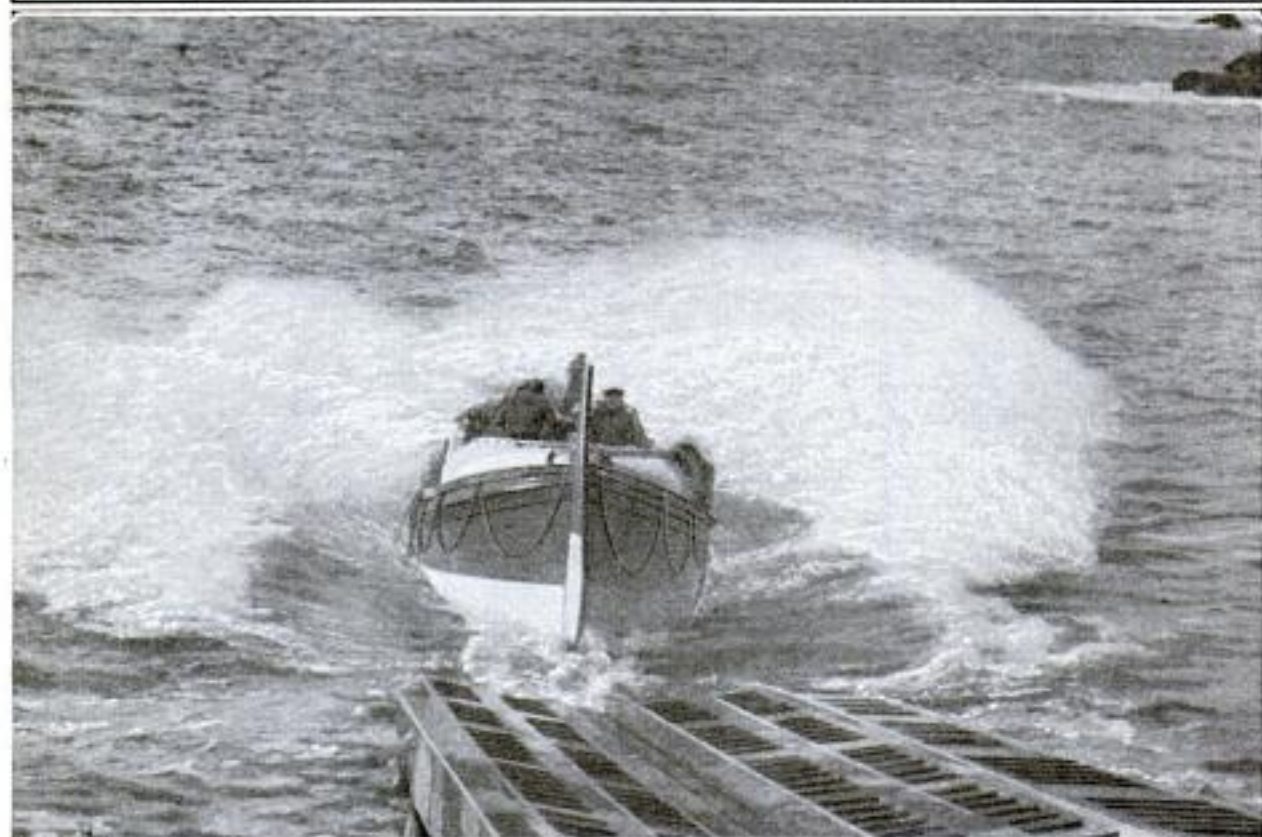

New Motor Lifeboat Taking the Water for a Cruise at Lizard Point, at the Extreme Western End of the South Coast of England, Where a Very Efficient Lifeboat Service Is Essential: On an Average, Over 100 Lives a Year are Saved by the Lizard Point Crews



AND INCIDENTS OF HIS WORK



Members of the United States Volunteer Life-Saving Corps Practicing the Various Methods of Saving Drowning Men and Women: Left, the Life-Saver is Keeping the Drowning Woman Afloat by Grasping One of Her Upraised Wrists While He Keeps Her at Arm's Length; Right, Swimming In with a Girl Who Is Already Unconscious and need Not be Kept at a Distance



Below: Breaking the Frenzied Embrace of a Drowning Man; This Is Always the Greatest Peril That a Life-Saver Encounters



Here Is the Crew of a Boat That has Capsized—It can be Seen Faintly under Water. The Boat is in the Grasp of the Members of the Crew, Who Appear to be Enjoying the Task of Swimming Ashore with It

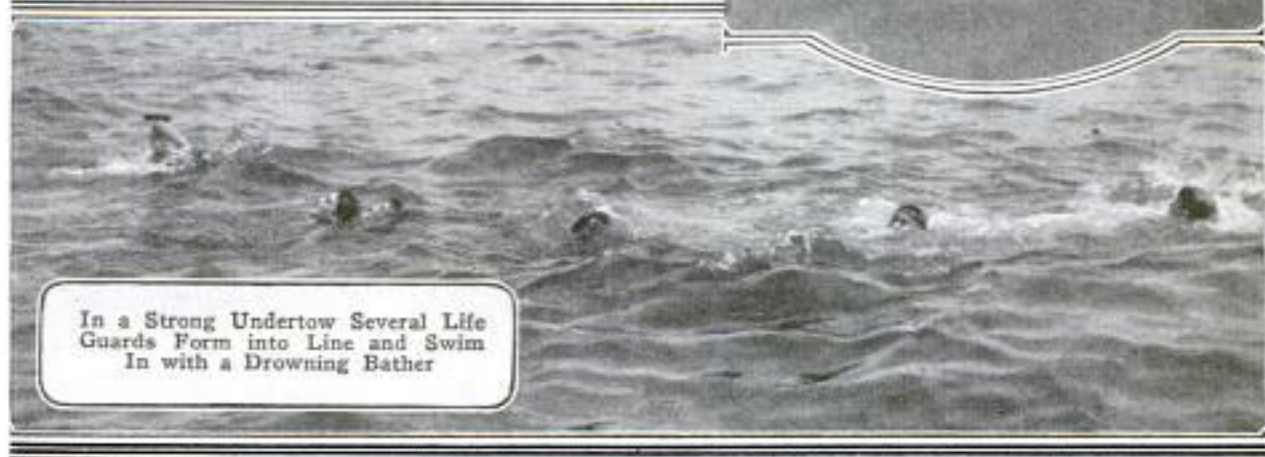

In a Strong Undertow Several Life Guards Form into Line and Swim In with a Drowning Bather

Haynes Shock Absorber Co.  
1023 Washington Ave. S.

260  
9254

POPULAR MECHANICS  
Minneapolis, Minn.

**AUTO SHOCK ABSORBER WORKS  
ON LEVER PRINCIPLE**

To iron some of the rough spots out of the road, a shock absorber and rebound

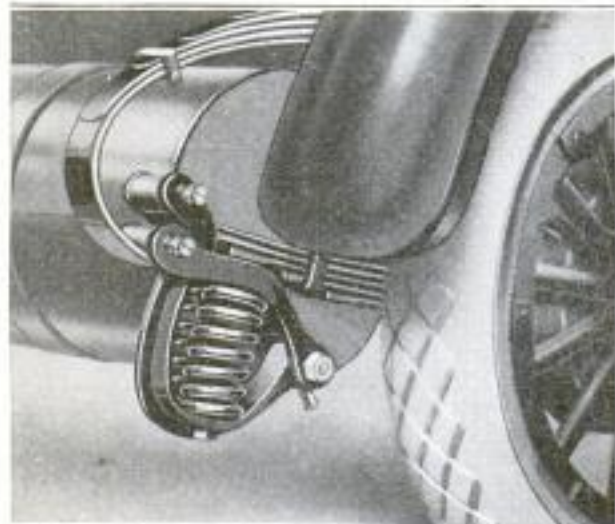

This Shock Absorber and Rebound Snubber Has Two Levers with a Coiled Spring between Them Which Acts as a Fulcrum

snubber has been devised which works on the hinged-lever principle, with a coiled spring between the levers. Although it replaces the spring shackle, it adds only one additional joint to the suspension.

**COMBINED CENTER-LOCATING  
PUNCH AND SCRIBER**

Locating centers on jigs, dies, and other work, can be done more quickly and precisely with a new combined punch and scriber, than by the ordinary button method. The device may be mounted on the cutting arbor of a milling machine so that the punch is either perpendicular or horizontal. The punch point is hardened

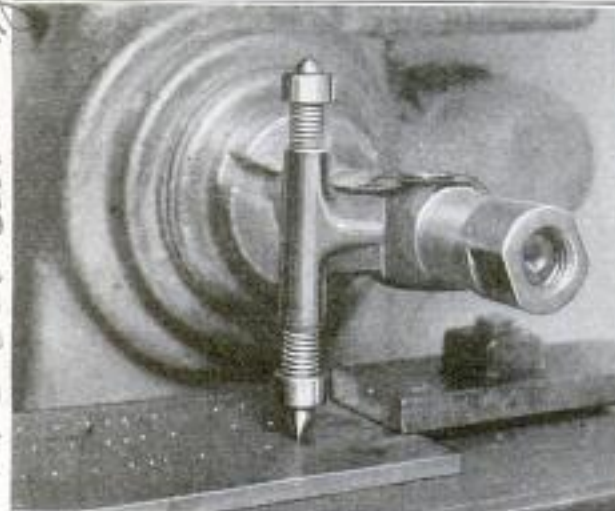

and ground, and is adjustable to the work by means of springs and collars on its shank, above and below its bracketed bearing. On top of the punch is a rounded head, and by tapping this lightly with a hammer, the work is prick-marked. Other centers can be conveniently marked by taking the first center as a reference, and using the adjusting screws, or dividing head, of the milling machine. The punch point can also be used as a scriber.

9294

**FOLDING SCISSORS IN CASE  
OF PENCIL SIZE**

Scissors with folding handles so that they may be carried in a case no larger than an ordinary flat pencil, are a novelty lately introduced in England. Good steel is furnished in the blades, and it is possible to obtain either solid-gold or ster-

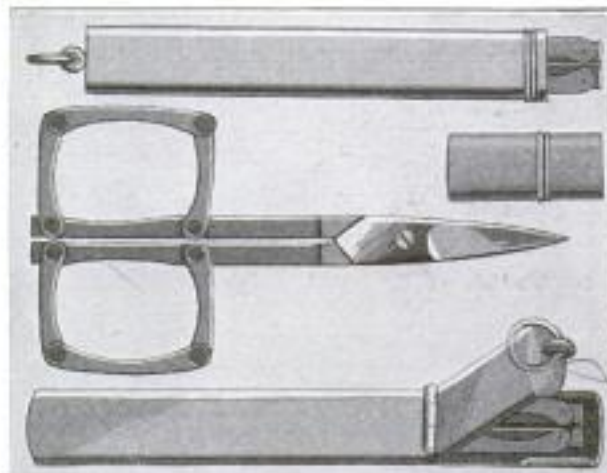

Top: Folding Scissors Inside of Case. Center: Scissors Ready for Use. Below: Another Style of Case

ling-silver cases, which are fitted with small rings for attachment to a watch chain.

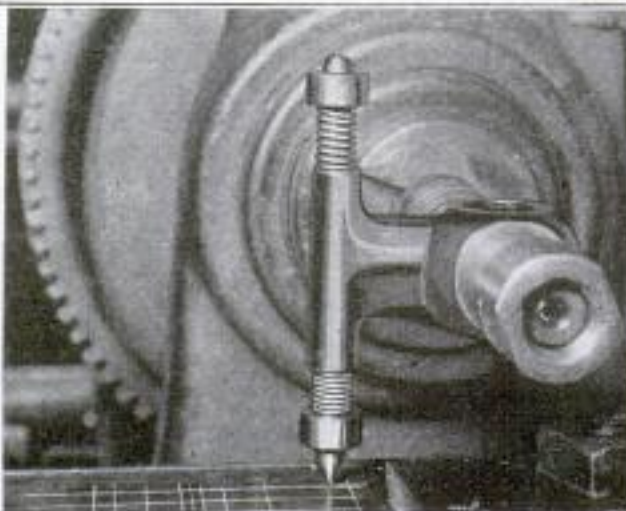

Center-Locating Punch Mounted on the Cutting Arbor of a Milling Machine: When Used as a Punch, the Work is Prick-Marked, as Shown at the Left. At the Right the Punch is Shown Scribing Lines

Mr. Bernard F. Johnson, N.Y.  
3476 Boulevard, Jersey City

Sold by J. E. Vickery, 1177 Broadway, St. Louis, Mo. U.S. England

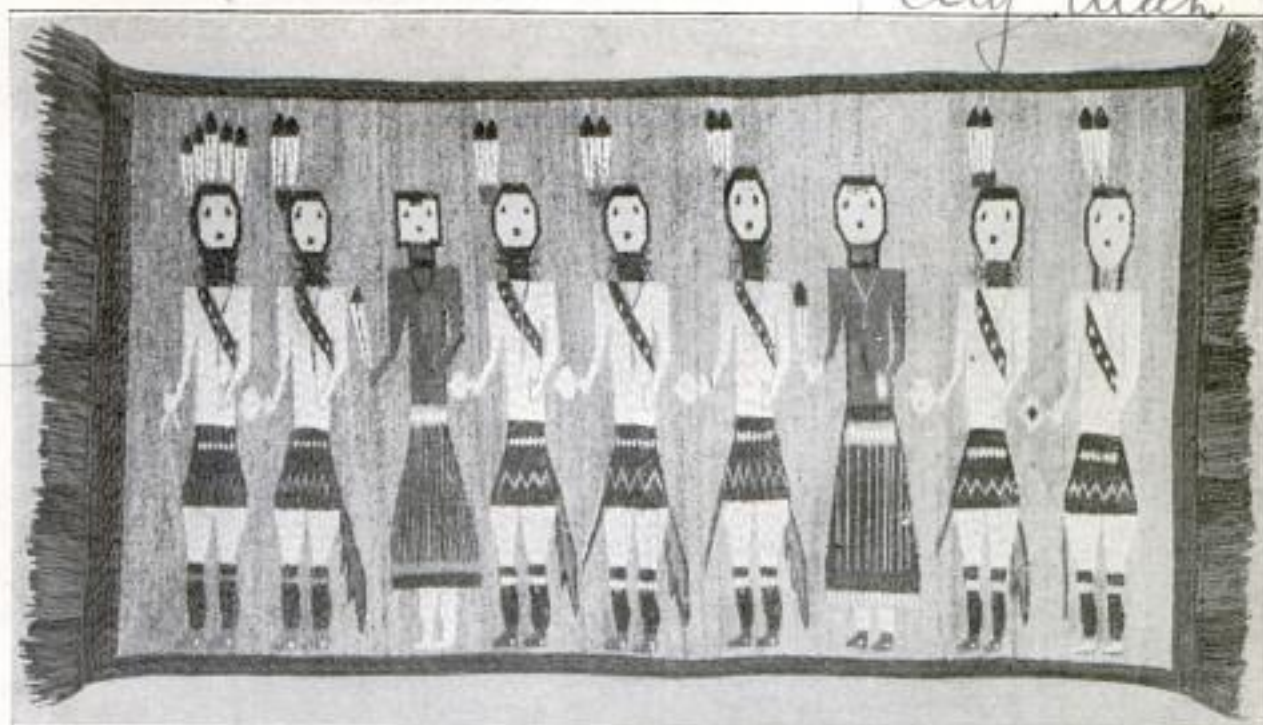

The Pattern of This Navajo Blanket Represents the "Yebitsai Dancers" Shown by the Three Figures in the Center. Other Figures Represent the Tribal Chief, the Medicine Man, and the Daughters of the Rainbow

## BLANKET REPRESENTS STRANGE TRIBAL LEGEND

From the Navajo country, embracing the adjoining corners of Utah, Colorado, Arizona, and New Mexico, there has recently been smuggled one of the rarest patterns of Indian blankets that has been permitted to fall into the hands of white men. The pattern is known as the "Yebitsai dancers" and involves a tribal tradition about which the Navajos are decidedly uncommunicative. The word "smuggled" is used advisedly, for the blanket was removed with extreme secrecy, inasmuch as knowledge by the Indians of its removal probably would have resulted in unpleasantness, to say the least.

The men who procured the blanket brought with it a legend, which is intensely interesting, although it appears to be far from complete. According to this legend the blanket was woven in great secrecy for a chief of the tribe from a pattern painted in the sand by a tribal medicine man. It is a blanket of good will, good wishes, happiness, and prosperity, and will bring blessings to those in whose keeping it may fall. But should the chieftain for whom it was woven dispose of it, then misery will be his lot and the lot of the tribe, the blessings falling to the new owner.

The legend identifies to some degree all the figures in the pattern but one, the second from the right. The first figure

on the left represents the tribal chief and is identified by the five eagle feathers which adorn his head. Next comes the medicine man bearing the rattle of power and potent charm. The two figures clothed in skirts represent the Daughters of the Rainbow, and are indicative of beauty, joy, and long life. Between them and in their keeping are the Yebitsai dancers, representing three virgins of exceptional grace and beauty. It is their part to propitiate the Great Spirit, bring joy and mirth, and to amuse the Evil Spirit so that his influence may not be felt by the tribe. On the extreme right is the tribal crier, or court jester as it were, upon whom also falls the task of providing merriment and chasing away gloom. The one unidentified figure is to the left of the jester.

Collectors of Indian curios who have inspected the blanket assert that they have never seen another of the same pattern, although it has been understood that one of a similar type was obtained some years ago and sent to the Smithsonian Institution.

Popular Mechanics Magazine does not publish the name of maker or seller of any device described in its pages, but this information is kept on file and will be furnished free by addressing our Bureau of Information.

6569

**SECTIONAL WHEEL CHUCK FOR FACE GRINDING**

A sectional wheel chuck for face grinding has recently been placed on the market. The wheel is composed of 12 segments, held in place by wedges between them, each alternate wedge being adjustable, while the others are rigidly fastened. In other respects the sectional chuck is similar to the solid-ring wheel. The advantages of the sectional wheel are that the opening between the segments permits freer cutting and cooler grinding, and that, in wide-area work, there is a smaller area of contact. These wheels are for use on heavy-duty face-grinding machines. It is said that their cost is less than half that of ring wheels. The segments are as durable as the ring wheels.

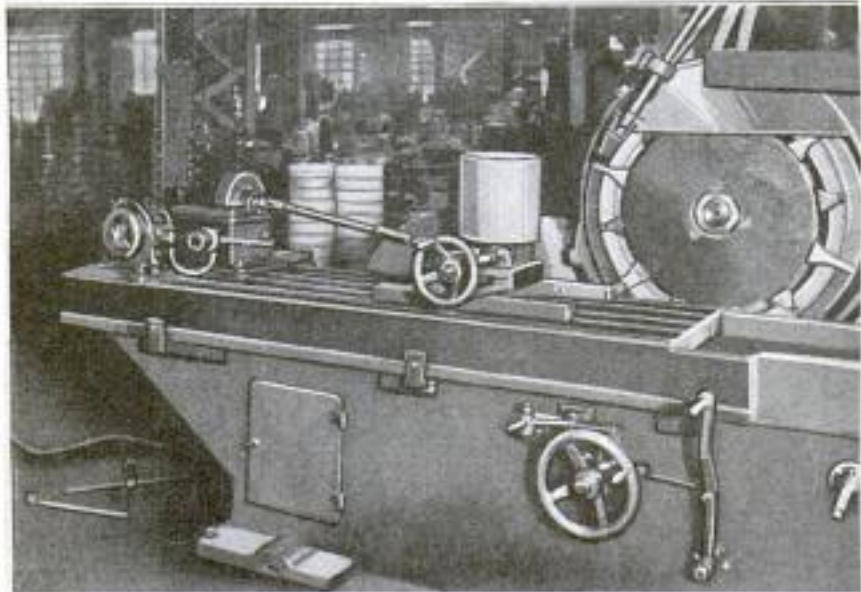

Sectional Wheel Chuck for Use on Heavy-Duty Face-Grinding Machines: The Segments are Held in Place and Adjusted by Wedges between Them

The wheel is composed of 12 segments, held in place by wedges between them, each alternate wedge being adjustable, while the others are rigidly fastened. In other respects the sectional chuck is similar to the solid-ring wheel. The advantages of the sectional wheel are that the opening between the segments permits freer cutting and cooler grinding, and that, in wide-area work, there is a smaller area of contact. These wheels are for use on heavy-duty face-grinding machines. It is said that their cost is less than half that of ring wheels. The segments are as durable as the ring wheels.

9119

**SIMPLE WEED EXTERMINATOR BUILT BY RAILROAD**

Extermination of the weeds growing along their right of ways costs the different railroad companies an average total of \$50,000,000 every year. Clearing these tracks of all growths is usually accomplished with the aid of chemicals, this method having been demonstrated as the one most efficient. With a simple outfit built by a railroad company, the chemical solution is carried

in regular tank cars, from which piping leads to the spraying apparatus on a flat car at the rear of the train. Here, with the spray nozzles placed so that the solution is evenly distributed over a space as wide as the length of the ties, it is possible to apply the treatment to 100 miles of single track each day, thus effectually ridding the right of way of this most obnoxious vegetation.



Top: Weed Exterminator in Operation along the Right of Way. Lower Left: Section of Track Overgrown with Weeds before being Treated. Lower Right: Portion of Track with Weeds Exterminated

Gleade Mfg. Co., 135 Hoboken Ave.  
 Jersey City, N. J.

9317 Cmt. F. W. Warner,  
to The Electrical Times, Sardinia

POPULAR MECHANICS

263

House, Kingsway,  
London, W.C. 2,  
England.

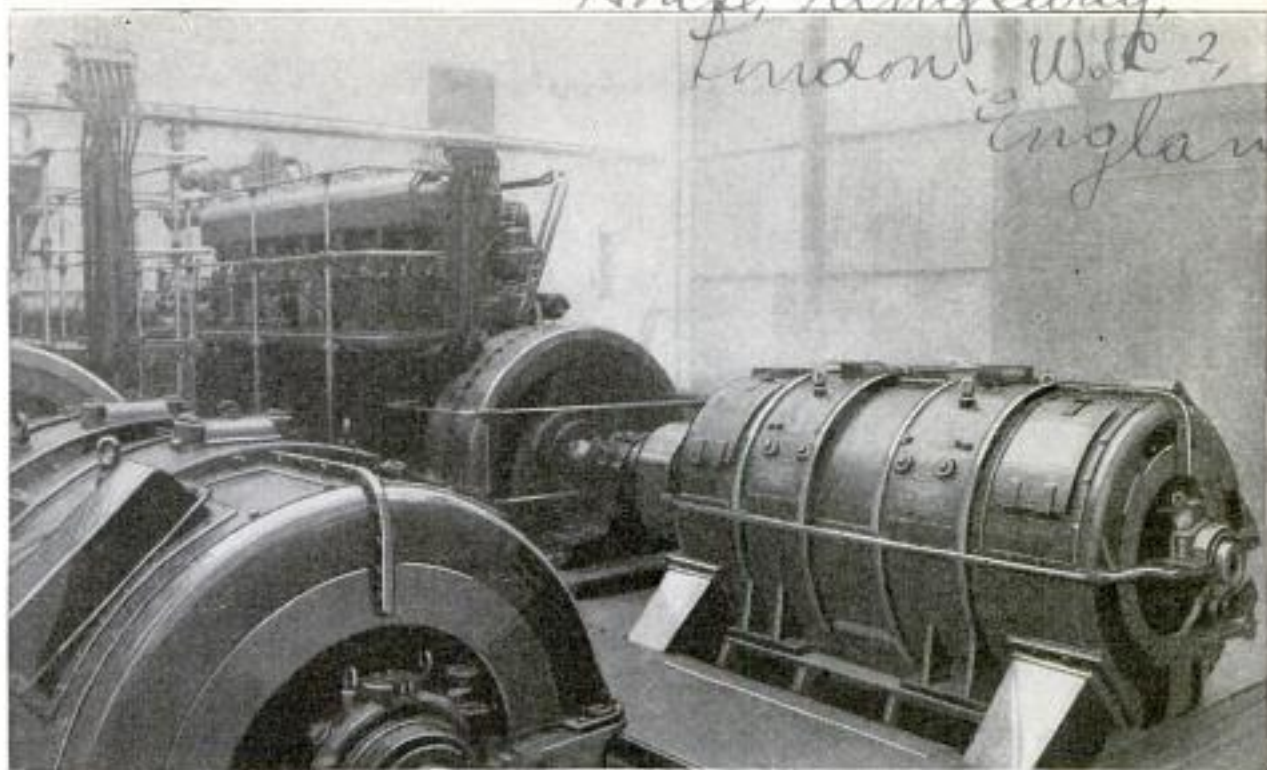

One of Six Generating Sets, Consisting of Diesel Engines, Dynamos, and Air Bottles, for Compressing the Air for the Engines That were Taken from Surrendered German Submarines and Installed in Power Houses at Southend-on-Sea, England

9315  
**GERMAN SUBMARINE ENGINES  
DRIVE ENGLISH LIGHT PLANT**

Late in 1914, the British government commandeered for war purposes five new Diesel-engine driven generating sets ordered by the town council of Southend-on-Sea. This left the town short of a plant to supply its electricity consumers. At the end of the war, the demand for electricity increased largely, and the difficulty could not be overcome by ordering new machinery, as none was then available. In this awkward situation the town's electrical engineer bethought him of the generating sets that had been employed to drive the surrendered German submarine boats. He arranged on behalf of the council to purchase six of these complete Diesel engines, with dynamos and air bottles for compressing the air for the engines. These generating sets, having been altered to make them suited for operation on land, have now been installed, two each in two substations and two in the main power station.

residences. The tile is first cast in concrete that is tinted some neutral shade by mixing pigment with the cement. While this is still more or less plastic, broken fragments of brightly colored rock, such as flint, agate, or quartz, are thrust into it, allowing the jagged edges to protrude



Decorative Tile Made of Neutral-Tinted Concrete, into Which, While Plastic, Fragments of Flint, Agate, or Quartz are Thrust, Leaving the Edges Protruding

9225  
**DESIGN OF DECORATIVE TILE  
RESEMBLES "JAZZ" IN MUSIC**

Of the nature of "futurism" in painting, and "jazz" in music, a new style of decorative tile is now being made in the West, and has already been used in some

somewhat above the surface of the cement. Finally, specially prepared stains are applied to the surface in various colors and patterns that harmonize with the general design. Bright blues, greens, reds, and yellow are used lavishly, and the effect is decidedly novel.

Architect - A. H. Leach  
1006 Hibernian Bldg. - Los Angeles  
Calif.

9250

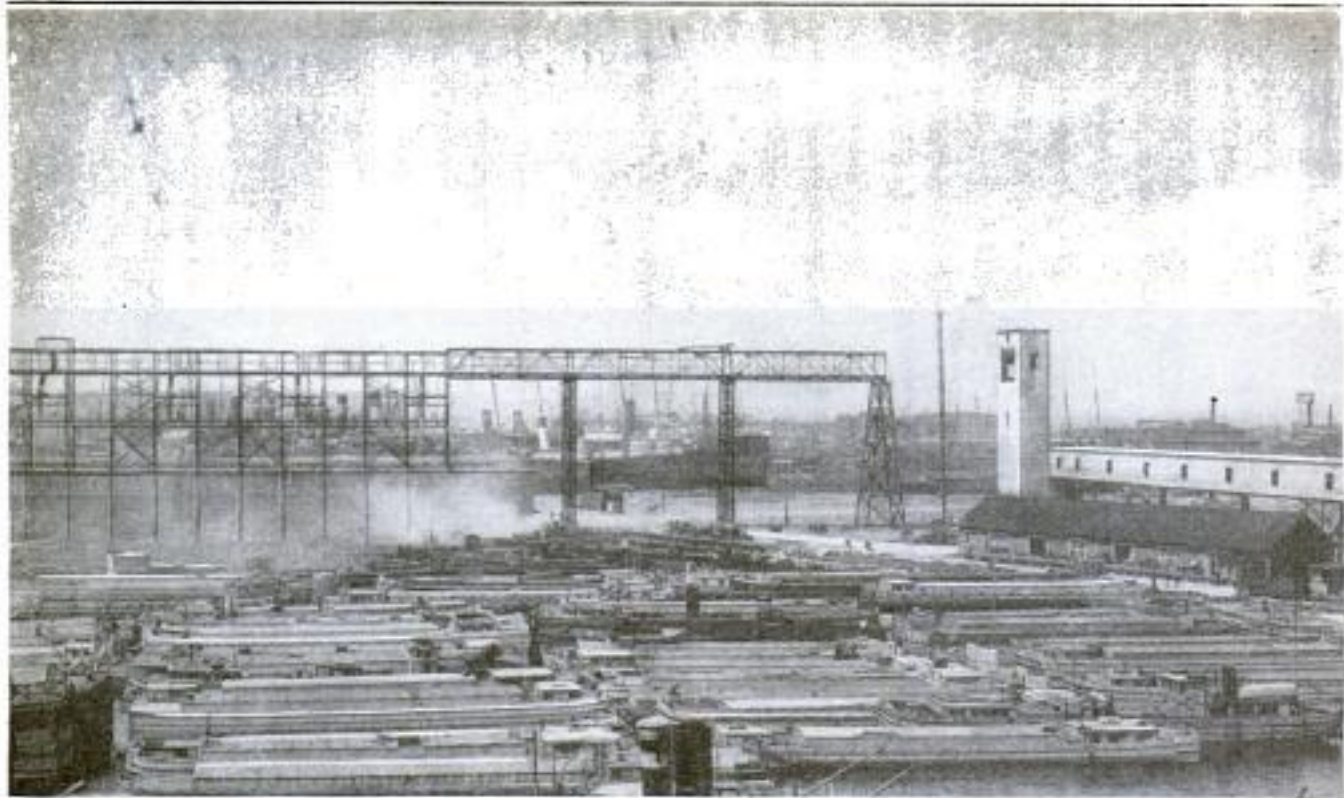

A Panoramic View of the Gowanus Bay Terminal of the New York State Barge Canal: The Terminal Basin at the Portion of the Overhead Conveying System Appears at the Far Side of the Basin. The Adjacent to the Henry Street Slip, Where the

## THE WORLD'S LARGEST CANAL TERMINAL

9250

BY GORDON P. GLEASON

*Madison Place  
Albany N.Y.*

WHILE we often hear it said that "whatever is the biggest is not necessarily the best," this does not apply to the New York State Barge Canal Terminal at Gowanus Bay, for this aid to traffic is not only the biggest canal terminal

in the world, but is admittedly the best. This is due to the fact that it is provided with all improved devices for the handling of water-borne freight, including conveyor systems of the most modern and efficient type, as well as a concrete grain

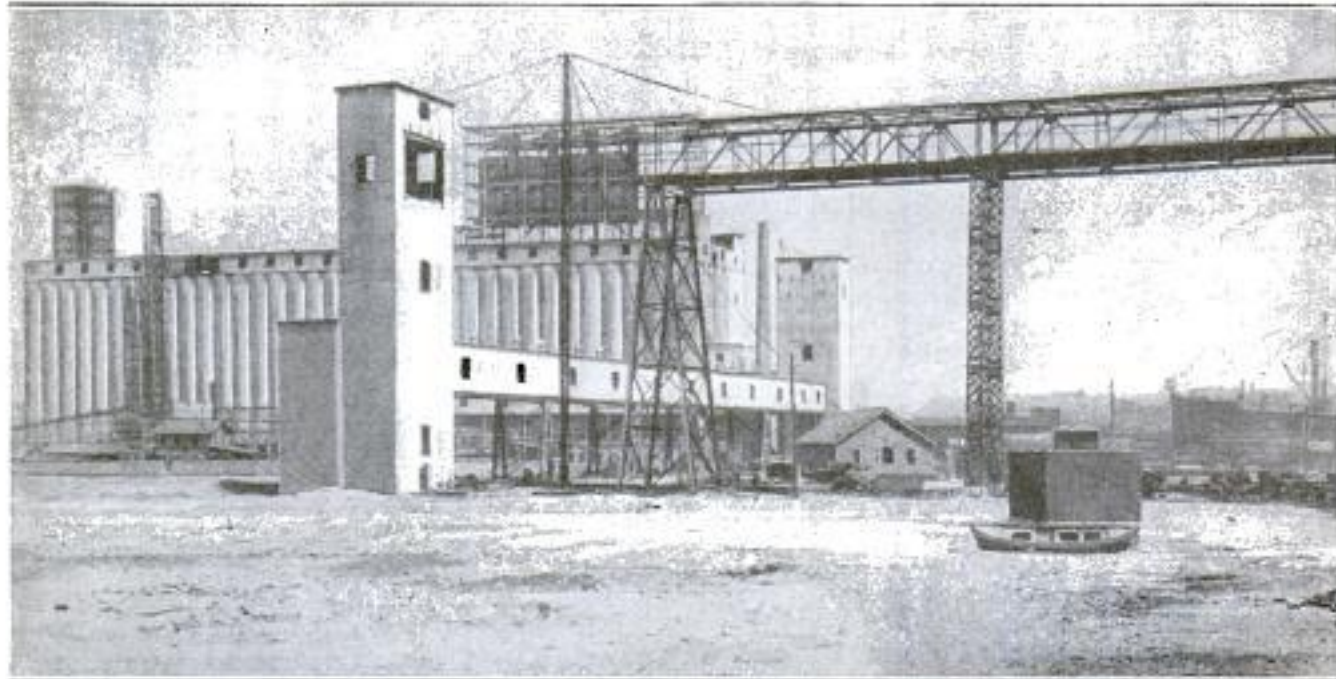

The Gowanus Bay Terminal from the Land Side: The Elevator, Shown at the Left, Covers a Ground Area of 70 Feet in Diameter. Elaborate Unloading and Conveying Machinery has been Installed, and referred to the Storage Bins, or Conveyed Directly to Ocean-

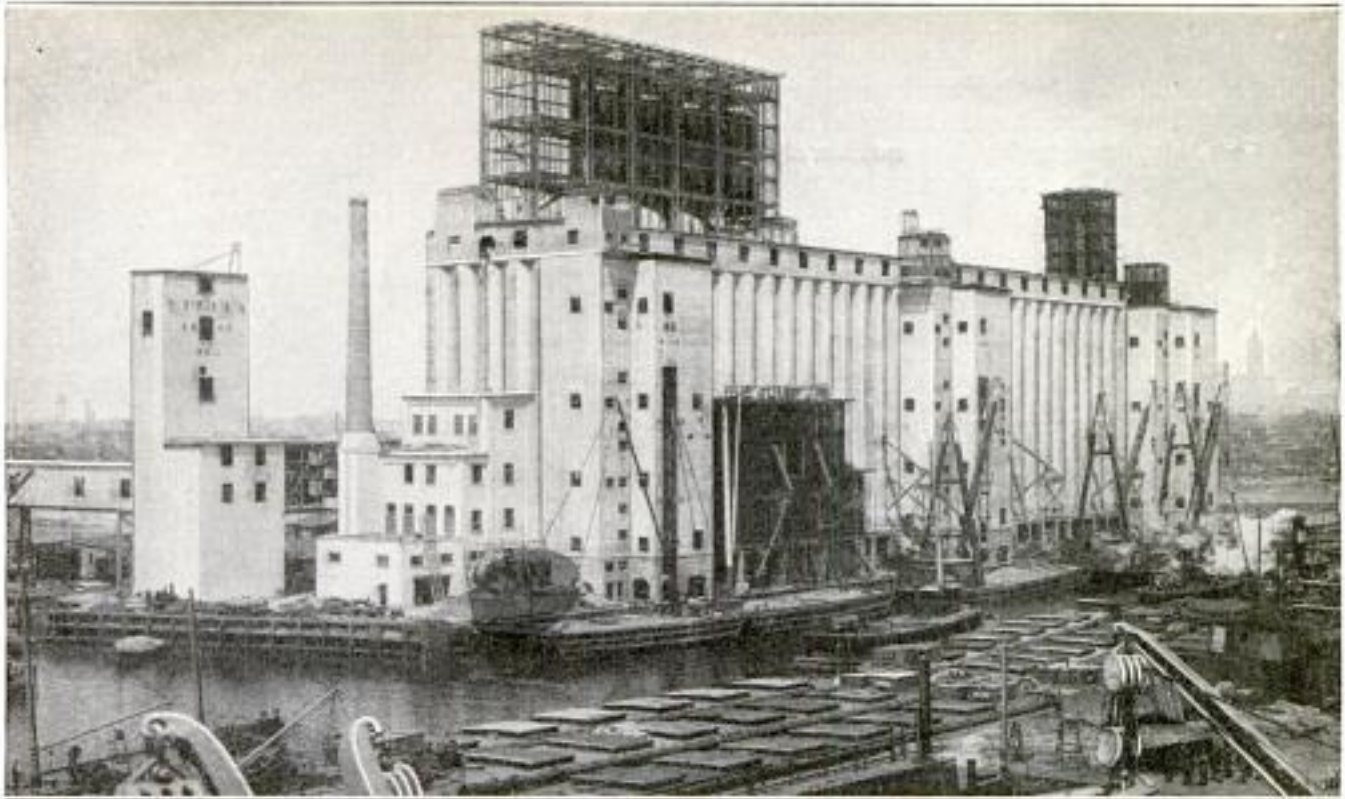

Left Has a Minimum Depth of 12 Feet of Water and will Accommodate More than 200 Modern Canal Barges. A Grain Elevator, at the Right, Has a Capacity of 2,000,000 Bushels. It is Located Water Is Deep Enough for Ocean-Going Vessels

elevator with a capacity of 2,000,000 bushels.

Early in 1909, the canal officials of the state of New York foresaw the necessity of equipping the barge canal with freight depots, or terminals as they are called by the traffic man. As a result, a special commission was appointed which, after a thorough study of water terminals in this country and Europe, reported to the state

legislature, recommending that the new waterway be equipped with such facilities. In 1911, the sum of \$19,800,000 was set aside for the construction and equipment of more than 55 barge-canal terminals. These were to be located at all important cities and villages along the line of the new waterway, while it was planned to make at least one of these terminals, in New York harbor, an important point for

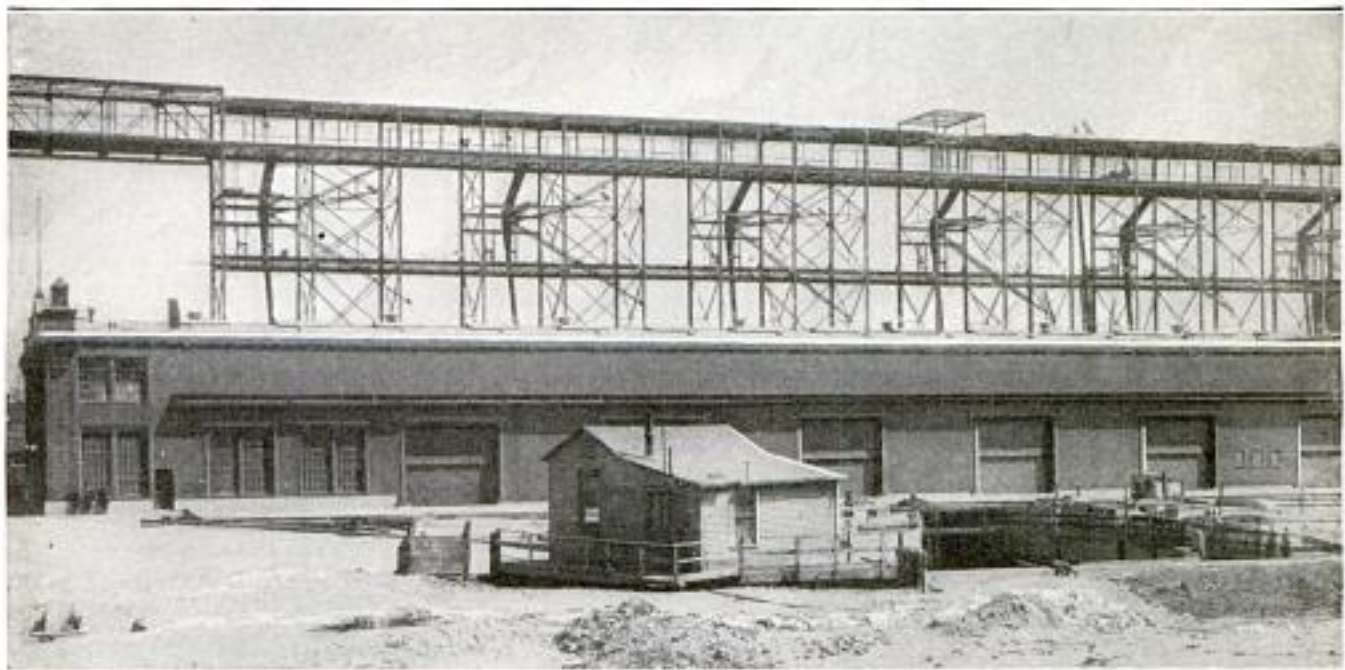

by 429 Feet, and Is of the Latest and Most Approved Design. There Are 54 Circular Bins, 95 Feet High and 20 Grain Unloaded from the Barges can be Weighed, Cleaned, Dried, Reweighed, and Trans-Going Vessels, with a Minimum of Expense and Handling

the interchange of both canal and ocean freights. The site thus selected was Gowanus Bay, and today the new waterway is adequately provided with these

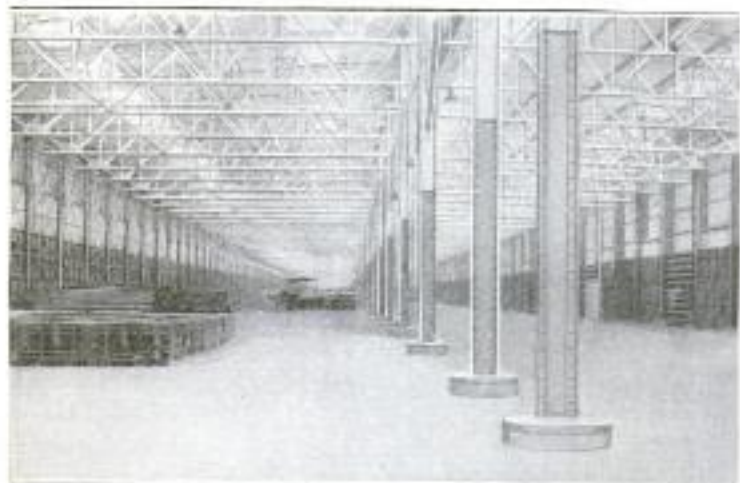

This Steel Transit Shed Affords Ample Space for the Transfer of Package Freight, Both Incoming and Outgoing

freight stations, and work is being completed at this point.

This terminal is worthy of particular note for several reasons. The site is located at the foot of Henry Street,

Brooklyn, and is in the very heart of the shipping district. The land back of the bulkhead wall, which is 1,037 feet in length, covers a ground area of 30 acres, while there is 2,491 feet of deep water immediately adjacent to the so-called Henry Street slip which runs up from the terminal basin proper. In addition to this, a pier, 1,200 feet in length and 150 feet wide, extends into the terminal basin, a 35-foot depth of water being provided alongside this for the accommodation of deep-draft ocean vessels. The terminal basin itself has a minimum depth of 12 feet and will accommodate over 200 modern canal barges, each with a dead-weight cargo capacity of 650 tons, while several ocean vessels can be accommodated alongside the pier at the same time.

Aside from the fact that the Gowanus Bay terminal will accommodate both ocean and canal carriers, thereby making possible a direct exchange of freight without the necessity of employing lighters and

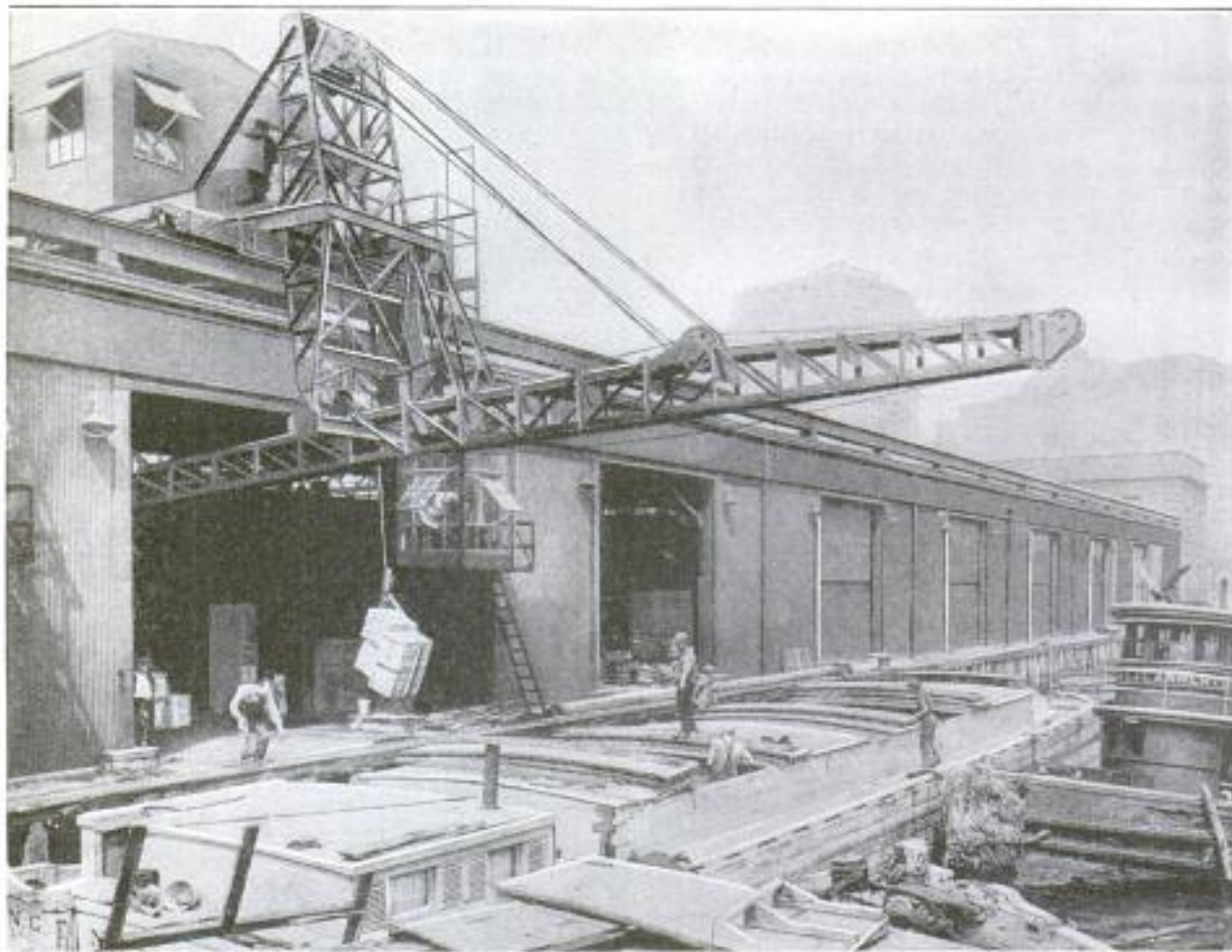

This Special Type of Straight-Line Conveyor Crane is to be Installed on the Steel Transit Shed, and will be Used for Handling Package Freight to and from the Barges



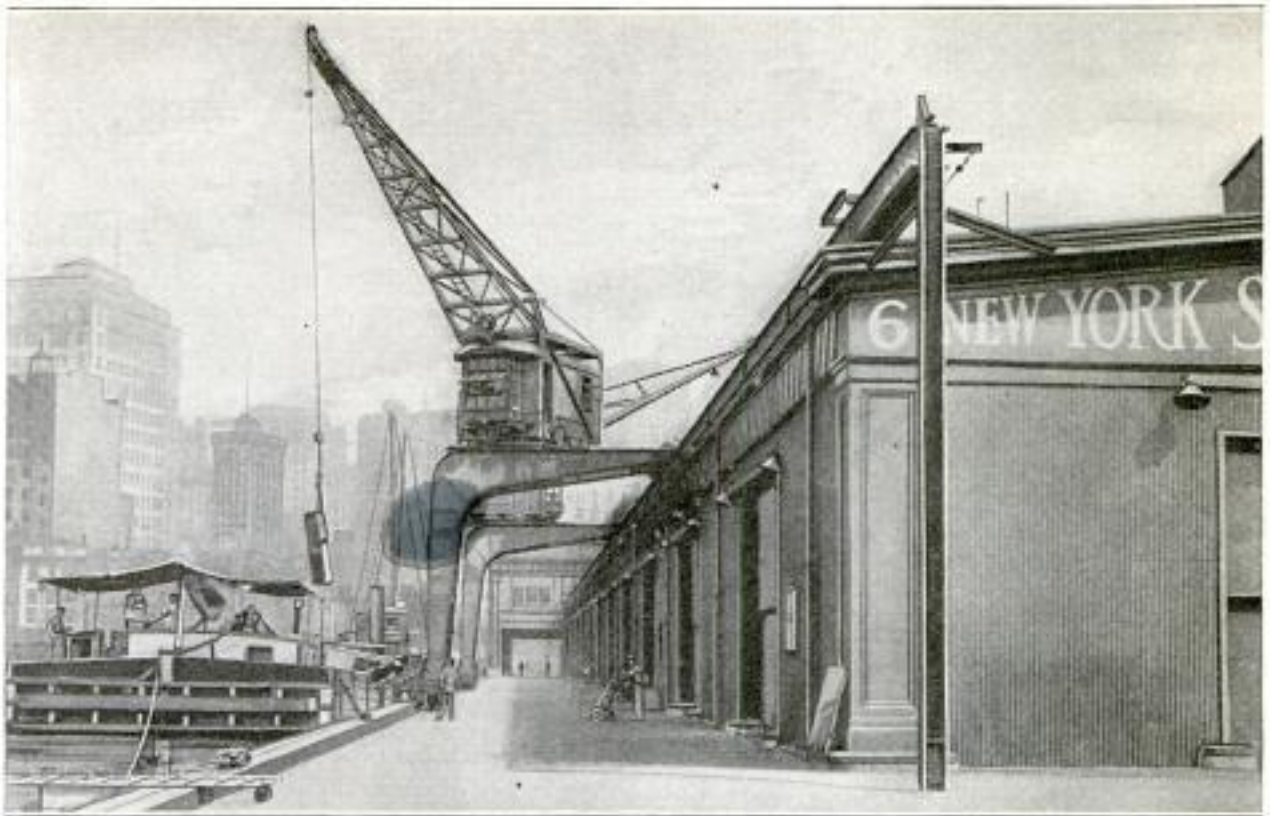

These Semiportal Revolving Jib Cranes are Installed at the Barge Canal Terminal in New York City. Similar Cranes will be Used at the Gowanus Bay Terminal. They Are of Heavy-Duty Type, and are So Constructed That They do Not Block the Loading Platform

other equipment to effect such transfers, the terminal excels in the wide variety of freight-handling devices that have been or will be installed. In this connection the most important structure is the grain elevator which is to be opened this year. This structure covers a ground area of 70 by 429 feet and is located in close proximity to the Henry Street slip. Its construction marks a distinct departure in New York's terminal policy, which has, heretofore, been to provide the terminals with a wide variety of mechanical equipment for the handling of general canal cargoes, leaving the installation of specialized structures, such as coal and ore trestles, oil-pumping stations, storage tanks, grain elevators, etc., to private industry, which builds and operates such structures on its own terminal sites. However, the fact that grain constitutes one of the most important items in the list of canal-borne freights, coupled with the further truth that there is no elevator with sufficient capacity to handle such freights in New York harbor, led the state to take the initiative, and it was determined to construct the elevator as a public enterprise.

The building is of the very latest and most approved design. It has a receiving capacity, for each shipping leg, of upward of 25,000 bushels per hour and a discharg-

ing capacity of between 45,000 and 50,000 bushels. It is so arranged that the grain may be transferred from the barges into storage bins of the elevator proper or loaded direct into the holds of waiting cargo vessels, a conveyor system being provided for this purpose.

As the barge fleets discharge their grain, this will be weighed by a series of scales located in the main cupola of the building. From here it will be conveyed to cleaning and drying devices, after which it is reweighed and transferred into one of the 54 circular concrete storage bins, each of which is 95 feet high and 20 feet in diameter. In the event that the grain is to move from the barge to the ocean vessel, it will first be weighed and cleaned, as in the case of storage grain, but instead of going into the bins, it will be diverted to the conveyor system and carried by this to the pier, where it will be loaded into the hold of the carrier by means of a series of spouts.

In addition to the elevator, the site is, at present, equipped with a steel freight or transit shed, 1,180 feet long and 106 feet wide, which extends along the pier, as well as a wooden warehouse for the temporary storage of freights arriving in canal carriers. This latter structure is located near the bulkhead wall and adjacent to the grain elevator.

9250

The mechanical equipment of this terminal is also very different from that found on the other sites. When fully completed, it will consist of electrically driven heavy-duty derricks, shipping masts, straight-line roof cranes, traveling semiportal revolving jib cranes, tiering machines, portal conveyors, overhead conveyor systems in and on top of the transit shed, as well as miscellaneous equipment consisting of electric-battery trucks, trailers, hand trucks, etc. Plans have also been considered for the installation of a so-called bridge crane, which will operate on rails located one on each side of the slips, thereby greatly facilitating the removal of heavy items of freight from the holds of the barges.

In planning and developing this terminal, State Engineer Frank M. Williams, of New York, has given the matter his personal study and has called into consultation engineers who are familiar with every phase of water transportation. In addition to this, the traffic authorities of various industries, barge operators, and others, as well as a committee of experts appointed by the New York Produce Exchange, have been consulted. The result is that practically every phase of the canal-terminal problem has been thoroughly considered, and the plans made for the development of the site are such that, when it is fully equipped, it will not only meet all barge-canal requirements, but will afford an example in terminal construction which is certain to serve as a model for similar developments throughout the world.

How important terminals are to the future of our inland waterways may best be judged by the fact that, out of the total water-transportation charge, approximately three-quarters represent the handling or terminal cost. Experience on the Great Lakes and abroad shows that properly constructed and equipped docks, wharfs and piers will cut this charge in half. In the case of the Gowanus Bay development this reduction in costs will be very marked. The present canal rate on grain between Lake Erie and New York City is 6 cents a bushel as compared with a rail rate of 8½ cents a bushel. Prior to the war, the canal rate averaged approximately 4 cents a bushel. This included the elevator charge at Buffalo, canal transportation from this city to New York, insurance on the cargo, eight days' free storage in the barge at the seaboard port, and the elevating charge. Canal operators now agree that, with the completion of the new elevator, the present grain rate will drop to a point almost as low as that maintained prior to the war. They further assert that, once the waterway is provided with the barges which are required to enable it to move its capacity of 20,000,000 tons per season, this rate will be lowered to a point below that offered at any time in the history of the canal system.

This tremendous reduction in the grain rate is reflected in other freights as well, and is entirely due to the fact that the mechanical devices and storage facilities provided make it easy to transfer cargoes, thereby permitting a quick turn-about of the carrier, which is released for duty and can start on its return trip. This is illustrated by the fact that, whereas it formerly took the canal barges anywhere from five to ten or more days to effect a transfer of freight in the port of New York, it now takes them only from one to four days to accomplish this, despite the fact that the terminal is not, as yet, fully equipped.

treme compactness that it is no bigger than a safety-match box, weighs only 3 ounces, and yet develops over half a horsepower, was an outstanding feature of a recent model exposition at Dublin, Ireland. The motor is double-acting, with two opposed cylinders of ¾-inch bore and stroke, and runs on compressed air at 100 to 300 pounds' pressure. With the 100-pound pressure at 3,000 revolutions per minute, it develops .6 horsepower. It is so perfectly balanced that at this speed the vibration is imperceptible. It has a rotary valve for air distribution. The motor has neither piston nor connecting rods, the crankshaft rotating in a slot in the end of each piston.

1/0 Henry L. Mc Hally, 7 Vernon Terrace, Rathgar, Dublin Ireland.

9356

**DOUBLE-CYLINDER AIR MOTOR  
SMALLER THAN A MATCH BOX**

An air motor, on the order of those used in pneumatic tools, but of such ex-

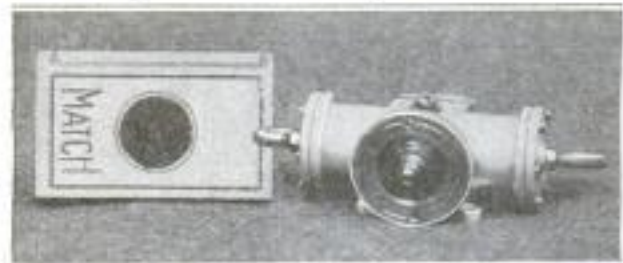

An Air Motor, No Larger than a Safety-Match Box, That with 100 Pounds' Pressure, at 3,000 Revolutions per Minute, Develops .6 Horsepower

It is so perfectly balanced that at this speed the vibration is imperceptible. It has a rotary valve for air distribution. The motor has neither piston nor connecting rods, the crankshaft rotating in a slot in the end of each piston.

Wm. J. A. Armstrong, Vice-President The Dublin Society of Model & Experimental Engineers Dublin Ireland

**MACHINE TIME CALCULATED ON SPECIAL SLIDERULE**

A machine-time calculator on the slide-rule principle will be found useful in computing quickly and accurately all kinds of machine-shop operations of either rotating or reciprocating work. Inclosed in an aluminum case, provided with the necessary reading slots, is a rotating cylinder that carries tables indicating revolutions made per minute for diameters from 1/4 inch to 10 feet at speeds from 10 to 70 feet per minute. The cutting speeds are etched on the aluminum case just above the slot. This can be read for any given piece of work, and then, by means of a sliderule of special design, attached to the base of the instrument, the time required to complete the work can be calculated.

9098

**GRASS-CUTTING MACHINE WITH THREE MOWERS**

Three mowers are incorporated in a grass-cutting machine of recent introduction, which has a speed of 15 miles per hour and an independent clutch in each front wheel. The outfit is also steered by

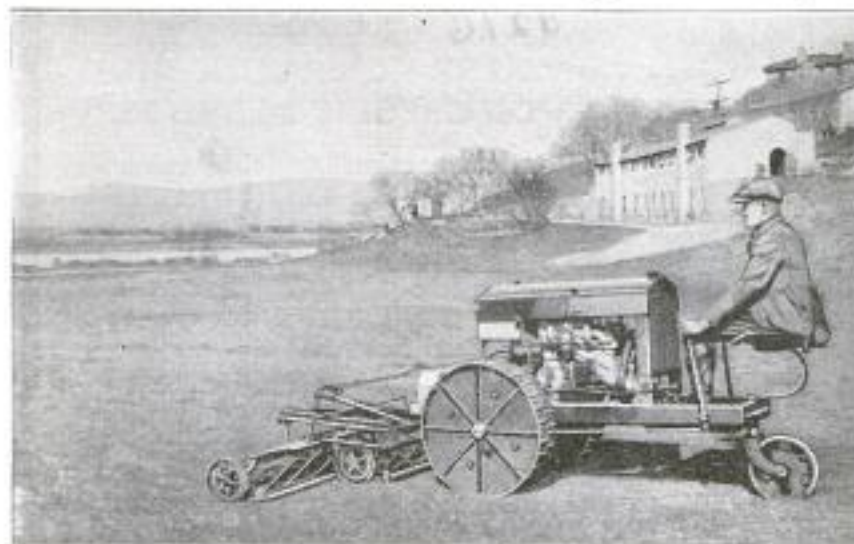

Grass-Cutting Machine with Three Mowers Shown in Operation: A Clutch is Incorporated in Each Front Wheel, of Which the Controlling Handle is Seen

the front wheels and can be turned around in a very short radius, this being accomplished by lifting the mowers off the ground.

Haray Mfg. Co.  
Los Angeles, Calif.

**TRUCK CAB OF LUMBER FIRM**

**9220 IS MINIATURE HOUSE**

Home-building advertising by a lumber firm in a Maine city, includes the con-



Motor Truck of Enterprising Maine Lumber Concern: The Cab was Constructed like a Miniature House for Home-Building Advertising Purposes

struction of a miniature house, in place of the usual cab, on one of its delivery trucks. Correct in every detail, having a roof of patent shingles and clapboarded sides, the suggestive model is said to have considerably increased the business of the company.

9176

**ANCIENT RELICS UNEARTHED IN MOUND NEAR ST. LOUIS**

Three cemeteries, 52 skeletons, 23 funeral urns, and other objects representative of prehistoric residents of the neighborhood of St. Louis, Mo., have been unearthed in the Cahokia mounds by Professor Moorehead, of the University of Illinois. These discoveries substantiate the theory that the mounds are of human construction, and are not natural formations. This is further confirmed by the discovery of an altar at the base of one mound, as it is known that it was the custom of the prehistoric residents of the Mississippi Valley to cover their altars, when they had no further use for them, with mounds of great height. The professor stated that evidence of an effort to smelt lead was found in one mound.

H. G. Jones

Copyrighted material 4/22/22

G. W. White Co. 47 Lincoln St. Lewiston, Maine.

Capt. Herbert Anderson,  
Box 76, Princeton, Minn.

Southeastern Sales  
Co., 203 Trust Bldg  
Charlotte, N.C.

270  
8859

POPULAR MECHANICS

LARGE SWEDISH COPPER COIN  
ANCIENT CURRENCY RELIC

Dated 1734, a copper coin, 10 inches square and weighing 6 3/4 pounds, is owned by Andrew Sjöblom, of Princeton, Minn., who became the possessor of the copper piece when a boy in Sweden. The strange old coin had a true value, on a silver basis, of the present-day U. S. dollar, but of course had a much higher purchasing power. This money was in use during the latter part of the 17th and the earlier part of the 18th centuries, partly to aid the native copper-mining industry and partly on account of the prevailing scarcity of precious metals. A similar coin, but weighing no less than 31 pounds, was illustrated in the August, 1914, issue of this magazine.



by Andrew Sjöblom, of Princeton, Minn., who became the possessor of the copper piece when a boy in Sweden. The strange old coin had a true value, on a silver basis, of the present-day U. S. dollar, but of course had a much higher purchasing power. This

money was in use during the latter part of the 17th and the earlier part of the 18th centuries, partly to aid the native copper-mining industry and partly on account of the prevailing scarcity of precious metals. A similar coin, but weighing no less than 31 pounds, was illustrated in the August, 1914, issue of this magazine.

AMPLIFYING TRANSFORMER IS  
GOOD FOR BROAD RANGE

9319

Of simple and compact design, a radio-frequency amplifying transformer has been developed for use on short wave lengths, which is claimed to be sensitive not only at one or two frequencies, but to be uniformly sensitive over a broad range of wave lengths. An iron or steel core is used in the transformer, the proper length having been determined. It is impractical to use a regenerative circuit in conjunction with amplifiers adapted to this design of transformer.

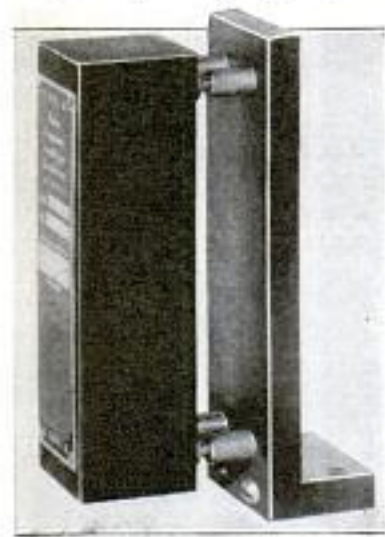

proper length having been determined. It is impractical to use a regenerative circuit in conjunction with amplifiers adapted to this design of transformer.

Radio Instrument Co.  
Washington, D.C.

ALUMINUM SOLDER APPLIED  
WITHOUT USING A FLUX

Aluminum can be soldered without the use of a flux by means of a special aluminum solder that can be handled in the same manner as ordinary half-and-half solder. It can be applied with an ordinary soldering iron, and without a flux. In this manner any kind of joint can be made on castings, sheet aluminum, and of brass or copper to aluminum. If well tinned, the joint will be durable.

DEVICE PREVENTS TRACTORS  
FROM TURNING BACKWARD

For use on any differential-drive tractor to prevent it from turning over backward and endangering the life or limb of the driver, a new safety device, now being manufactured, is attachable to the crankcase. It operates electrically, and when the tractor, in rearing backward, reaches an angle of about 30°, it cuts off the motor, and by releasing the clutch, the tractor returns to its normal position.

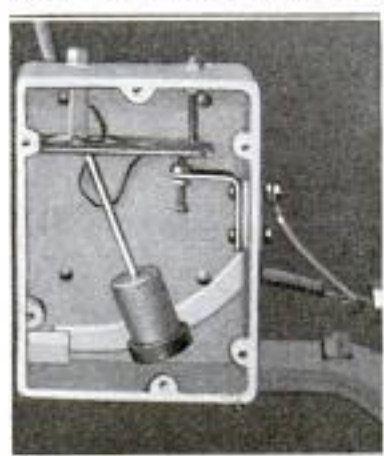

angle of about 30°, it cuts off the motor, and by releasing the clutch, the tractor returns to its normal position.

WATER-SEPARATING FILTER  
ON GASOLINE FEED PIPE

For connection to the tube leading from the gasoline tank of an automobile to the carburetor, a filter has been designed that, by means of chemically treated cloth, separates the water from the gasoline, leaving the former in the tank, and allowing only pure gasoline to reach the carburetor. The water can be drained from the tank through a petcock that is provided for the purpose.

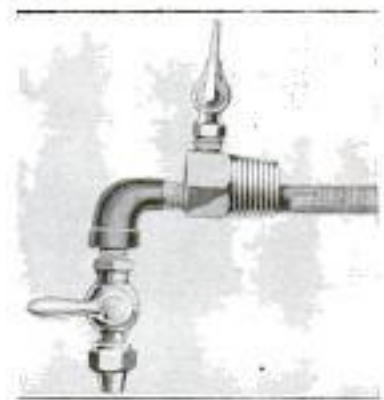

pure gasoline to reach the carburetor. The water can be drained from the tank through a petcock that is provided for the purpose.

W. H. A. Hills, Pres.  
Bousman Mfg. Co.  
Grand Rapids, Mich.

Great Western Smelting & Refining Co.  
3101 N Broadway St  
Denver, Colo

Copyrighted material

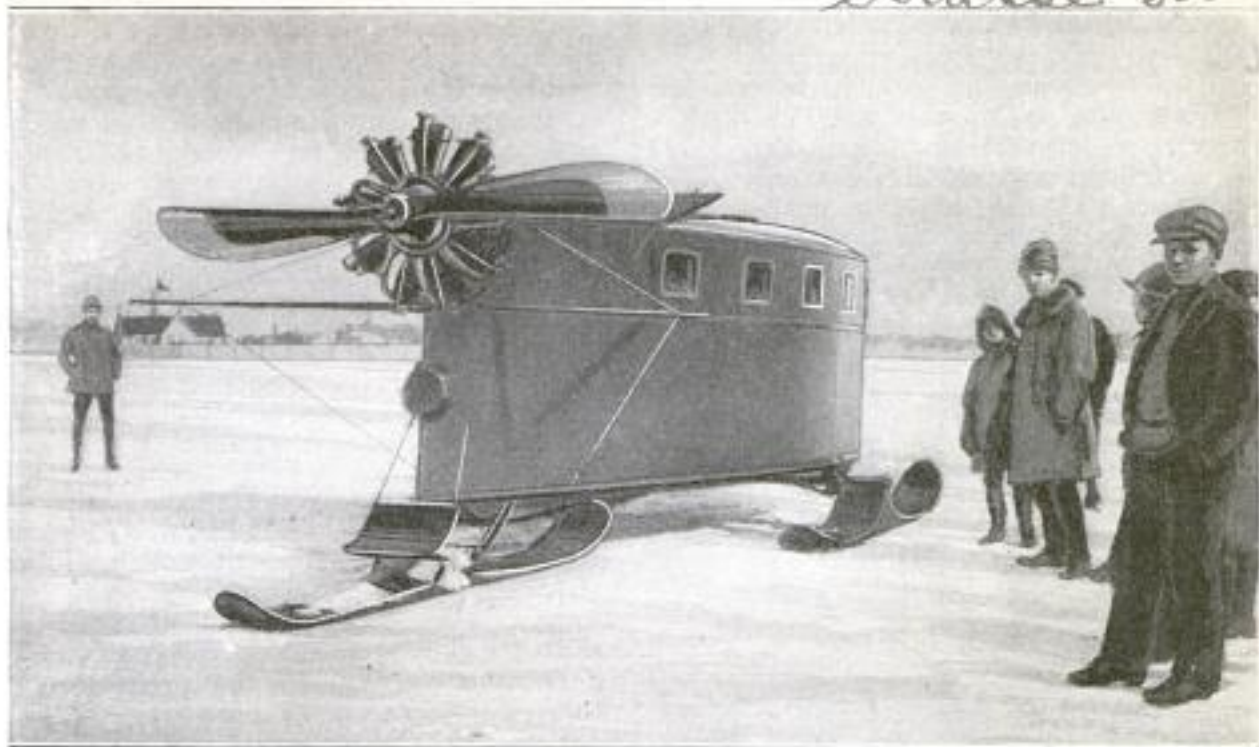

AIR-PROPELLED ICE BOAT WITH MOTOR-BUS BODY

AIR-PROPELLED ice boats of various kinds have been built in this country, and elsewhere, for some time, but seldom on such a large and elaborate scale as the one shown above, which carries passengers between Helsingfors and Sveaborg, in Finland. Supported on three runners, two in the rear and one in front for steering, its body resembles that of a large motor bus, being entirely inclosed, and accommodating 20 persons. Its propeller is of regular airplane type.

9156

SELF-PROPELLING PLOW WITH ROTATING SHARES

In general construction something like a gang plow, but self-propelling and with rotary shares, a newly patented plow is now being demonstrated in Iowa. A rigid frame, from which four rotary shares are adjustably suspended, and with a steering wheel in front and a driving wheel in the rear, supports the power plant, consisting of a 40-horsepower gasoline engine and



Rear View of Self-Propelling Gang Plow, Showing Furrows It Turns Up with Its Four Rotary Shares



Side View of the Plow in Operation on Stubble, with Three of Its Rotary Shares Visible: With a Single Operator Handling the Machine, as Shown, It will Plow 15 Acres in 10 Hours

its usual equipment. The four rotating shares are chain-driven and are shaped so that they turn up the earth in furrows and pulverize it for a width of 4 feet. It can be set to plow 10 inches deep and forms a seed bed the whole of that depth.

Chas. Jay Van Vranken  
 Waverport, Iowa

*d. no. F. J. Forsythe*  
*368, Marion, Kans.*  
 POPULAR MECHANICS

272

**AUTO-SIGNAL DEVICE USEFUL BOTH DAY AND NIGHT**

Combining a license bracket with a regulation taillight, together with a floodlight and semaphore, a rear-signal device has been patented that seems to cover

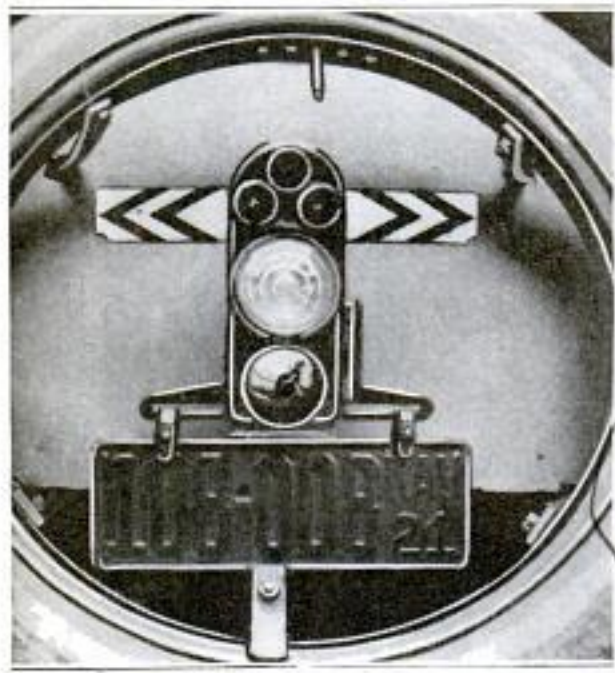

A Rear-Signal Device in Which the Semaphore Arms Operate in Connection with the Signal Lights, a Floodlight being Provided for Use When Backing Up

all requirements. The black and white semaphore arms operate in connection with the lights, making the signal efficient either day or night. The full control of the signal is by a simple switch located on the steering column.

**THREE INSTRUMENTS IN ONE HANDY FOR DRAFTSMEN**

Handy for the draftsman is a combination instrument that can be used as a protractor, a compass, a rule for all angles, and in a small way as a T-square. In line with the rule and with the zero point of the protractor, is an adjustable pivot point. On the rule is a slide that

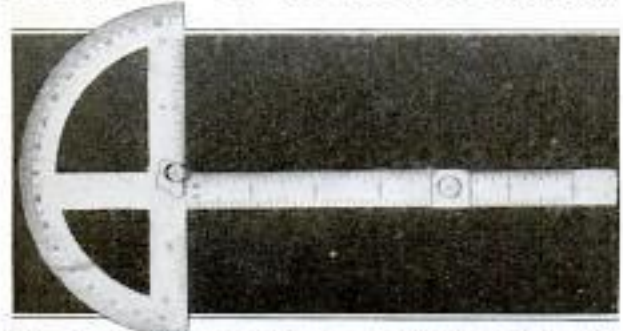

Drawing Instrument That can be Used as Protractor, Compass, or Rule: The Pivot Point is Adjustable, and the Pencil Point Fits in a Loop on the Slide

*The Golden Compass Co., Elkhart, Ind.*

**MECHANICS**

can be clamped at any point on the rule, and that has a loop in which the pencil point can be inserted for using the instrument to describe circles or arcs. On one side the rule is graded to 32nds of an inch, and on the other side to 10ths. The protractor is graduated to half degrees.

*9404*

**FOREIGN TRADE COMMITTEES PUBLISH SALES BOOK**

An attractive booklet has recently been published by the Foreign Trade Committees of the Bureau of Foreign and Domestic Commerce, outlining the scope and activities of the bureau in advancing the export sales of American-made automotive equipment and accessories. The bureau is not an academic institution but a practical commercial organization with a definite purpose in the promotion of foreign commerce. Information will be gathered concerning sales opportunities in foreign countries, and assistance will be given manufacturers in matters pertaining to international sales.

*Gordon Lee, Chief, Automotive Division.*

**TWO KEYS FOR SAFETY LOCK OF LATEST DESIGN**

Two keys are used in operating a safety lock of the latest design, which is claimed to be proof against burglars and other intruders. Opening this lock is such a complicated operation, that even should an undesirable party obtain possession of the keys, it would be a difficult task to effect an entrance without knowledge of the proper method of inserting and turning them.

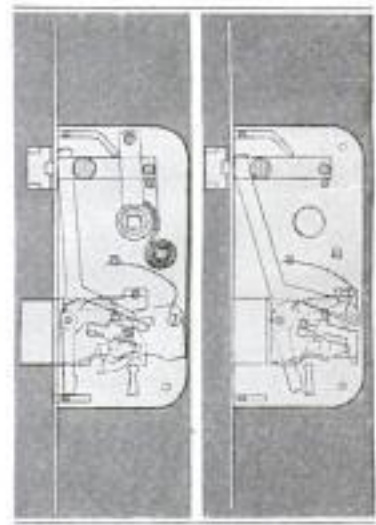

The Popular Mechanics' Bureau of Information offers its free service to all readers of our magazine. Names and addresses of manufacturers and dealers in articles described, and any other details in our possession, will be promptly furnished by addressing the Bureau.

*Letter*  
*Carl E. A. Werner, sold*  
*Foreign Patents Exchange*  
*2804, Wabasha Bldg.*  
*21 E. Van Buren, Chicago*



This Family Group of African Elephants Appears in the American Museum of Natural History in New York City and Is Remarkable for the Wonderfully Lifelike Posing and Mounting of the Great Animals

### LARGEST AFRICAN-ELEPHANT 9143 FAMILY GROUP

Mounting small animals is comparatively easy, and even the larger fur-covered creatures are not so difficult to "stuff," but the huge size and the wrinkled hide of the elephant tax the skill of the taxidermist. The American Museum of Natural History in New York City has just completed the largest family group of African elephants in the world. The framework alone is a work of mechanical perfection, while the outer sculpture covering carried every tiny wrinkle before the skin was glued to it. This remarkable group is to be a part of the vast African Hall that will be dedicated as a memorial to Theodore Roosevelt. Colonel Roosevelt brought down one of the cows during his African hunting trip, and his son, Kermit, bagged the baby elephant. The baby is about the size of a domestic cow, but it looks like a pigmy as it peeps out from between the huge forms of the foremost bull and cow.

Immediately to the left of this largest elephant family group is the new mounting of a two-horned African rhinoceros and calf, while at the right stands one of the largest bull rhinoceroses ever shot. A column prevents the inclusion of the entire elephant and rhinoceros group in the same photograph. These specimens are now exhibited in a temporary loca-

tion, but when the Roosevelt memorial wing of the museum is completed they will be transferred to African Hall. Grouped with many other varieties of African wild life, they will then face the figure of "Bwana Tumbo," as the natives of Africa called Theodore Roosevelt.

### FOLDING CHAIR OF METAL 9163 STRONG AND NEAT

A metal folding chair, the frame of which is constructed of steel tubing, has lately been placed on the market by an eastern manufacturer. The article folds compactly, is practically indestructible, light in weight, and absolutely sanitary, besides possessing an easily detachable seat.



Recent findings by the Bureau of Mines seem to justify the conclusion that the value of oil shales may be determined by microscopic examination.

The Metal Folding  
Chair Co., Princeton  
N.J.

## CIVIC FEATURES THAT PROMOTE THE COMFORT

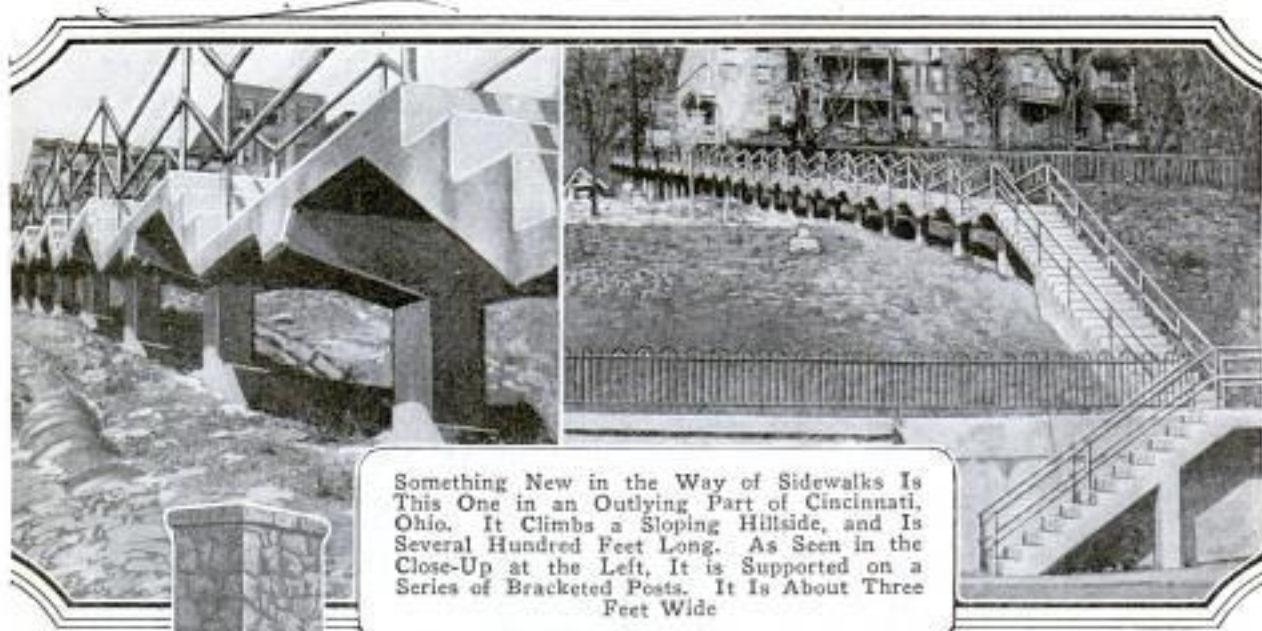

Something New in the Way of Sidewalks Is This One in an Outlying Part of Cincinnati, Ohio. It Climbs a Sloping Hillside, and Is Several Hundred Feet Long. As Seen in the Close-Up at the Left, It Is Supported on a Series of Bracketed Posts. It Is About Three Feet Wide

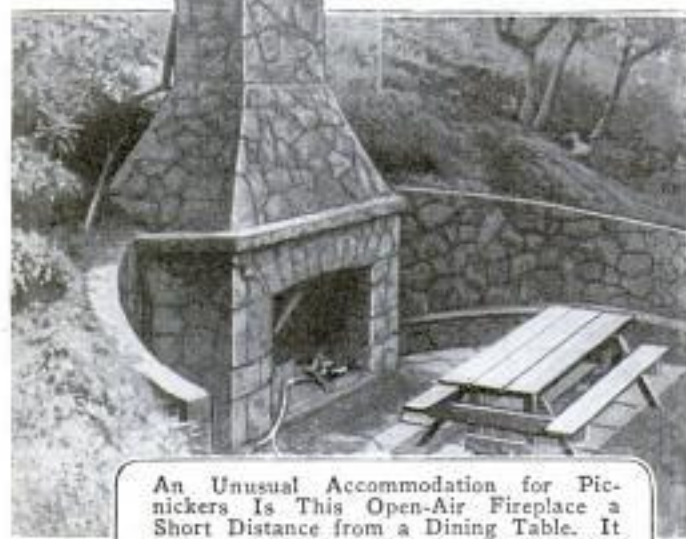

An Unusual Accommodation for Picnickers Is This Open-Air Fireplace a Short Distance from a Dining Table. It Is at the John Garbur Picnic Grounds, Owned by the City of Berkeley, California



Safety-First Signals Built on Both Sides of a Dangerous Railroad Approach West of Norfolk, Nebraska: The Bases are Formed of Stones Painted White. In Their Centers are Installed the Crossing Signals

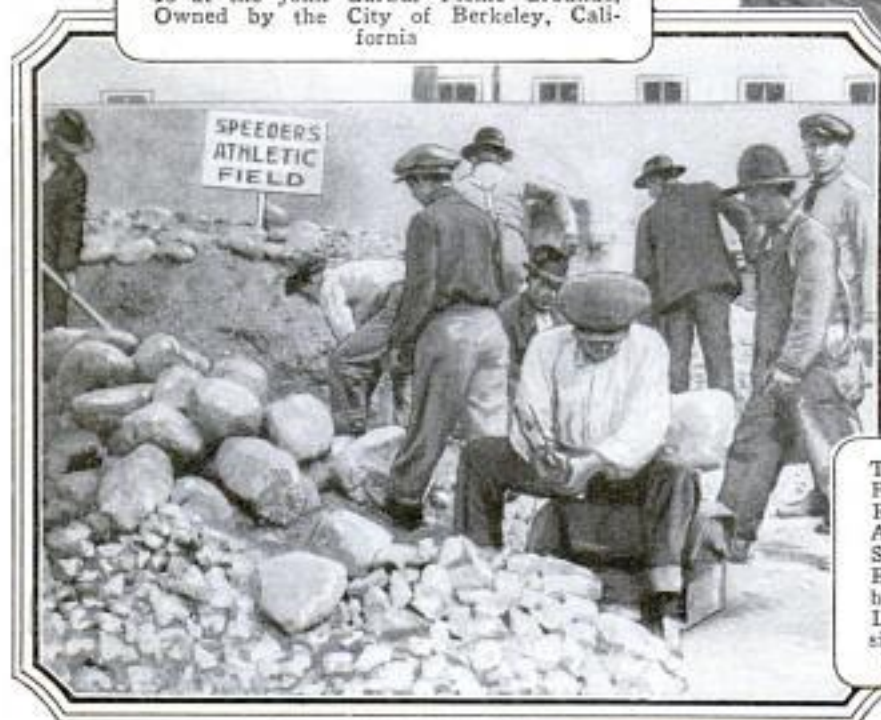

The Sign, "Speeders Athletic Field," Aptly Describes This Rock Pile. For It Is There to Afford Convicted Exceeders of Speed Limits an Opportunity to Exercise Their Love of Swiftness by Reducing the Big Stones to Little Ones as Rapidly as Possible. This Is How Los Angeles Handles Traffic-Law Violators



## AND ENJOYMENT OF VISITORS AND RESIDENTS



Clubhouses on the Susquehanna River, near Wrightsville, Pennsylvania, Built upon a Stone Wall That Is the Remains of an Abutment of an Old Disused Canal: The Location Affords the Club Members an Expansive View of the Beautiful River Scenery. It Is Safe as Well as Secluded

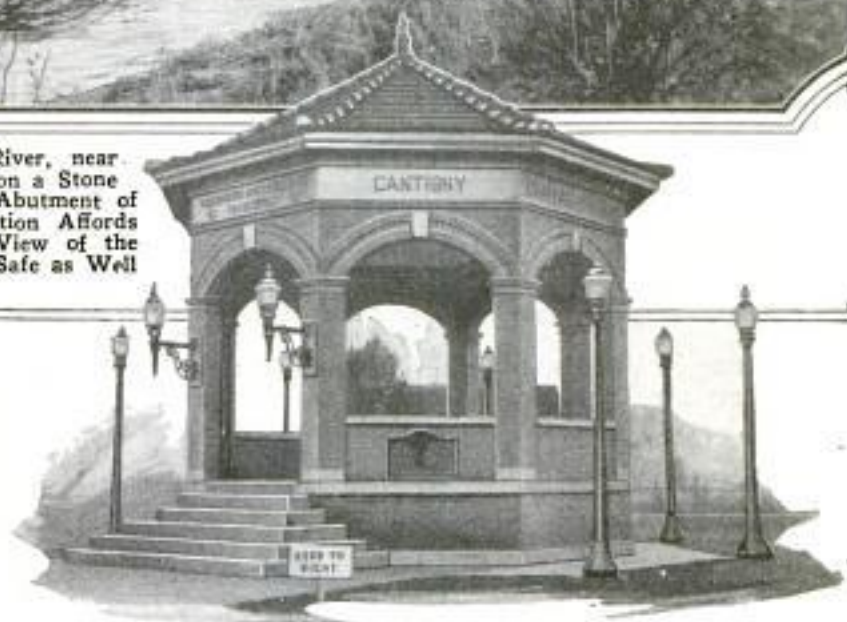

This Quite Imposing Memorial Band Stand is Erected in the Little Town of Spillville, Iowa, with a Population of Only 315, Mostly Bohemians. The Memorial Is in Honor of the Local Veterans of the War, Whose Names are Inscribed on Bronze Tablets

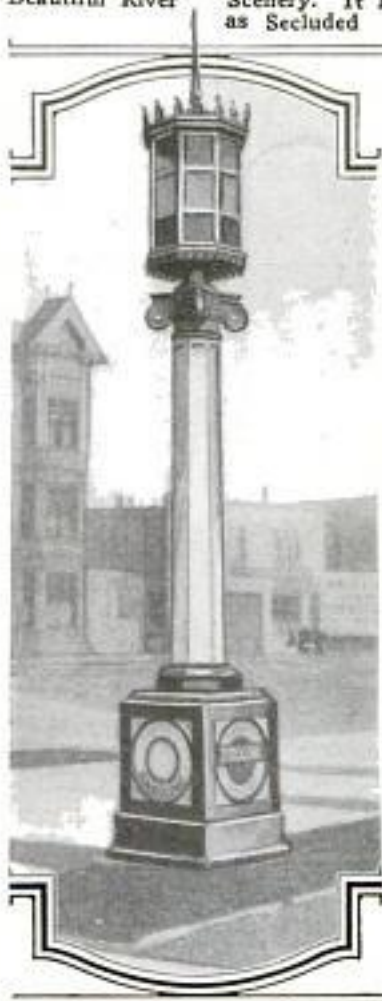

One of Three New Signal Lights in San Francisco, California: They Have a National Color Scheme of Red on the Base, White on the Shaft, and Blue for the Lamp, Followed Also by the Lights, Which Flash Consecutively the Same Colors



These 12 Police Operators are Seated at One of the Largest Private Telephone Exchanges in the World. It Belongs to the Police Department of New York, and Is in Charge of Captain Cooper, Seen Standing. Police Officers are Selected Who Possess the Qualifications Necessary for This Exacting Work. The Messages Received Are in Connection with Fires, Accidents, Crimes, and Similar Matters

The Hall, Writer Co.  
New York City (1881)

Cmb. Horace B. Newton  
1112 Humboldt St  
Santa Rosa, Calif.

276  
9290

POPULAR MECHANICS

EARLY TYPEWRITER RADICALLY DIFFERENT FROM MODERN TYPE

A person watching the flying fingers of a speedy typist would see very little re-

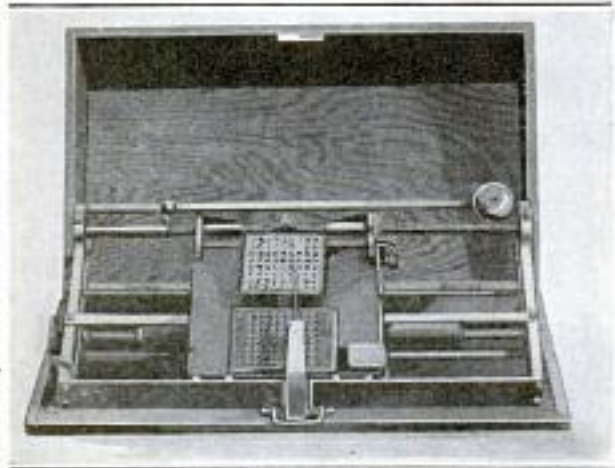

This Typewriter, Built in 1881, Prints the Letters by Pressing a Plunger through a Perforated Keyboard

semblance in the machine she uses to one of the strange typewriting machines built in 1881. In the old machine the keyboard

consisted of a perforated plate, and a sheet above showed the characters represented by the different holes. By moving a pointer to the different letters, the proper character was registered, and the imprint was made by pressing a handle. The bell for indicating the end of the lines was similar to the one of today.

PIPE LAID UNDER A STREET WITHOUT EXCAVATION

A construction engineer in Santa Rosa, Calif., has installed a 3-inch iron pipe below a paved street without in any way disturbing the pavement. The pipe had to be laid from a building on one side to the other side of the street, a distance of 52 feet. A concrete pier was built in the building, and was used as an abutment for a 15-ton jack with which the pipe was forced through the ground. It was to serve as a conduit for an electric cable, and was directed so as to emerge at the desired point, from which a vertical extension of the pipe carried the cable to three large transformers overhead.

Cmb. J. H. Czapfeney, Rutland, Vt.  
52 Center St.

August Burgess & Co.  
Pacific Electric

8962

APPARATUS WHICH MUST BE HANDLED OR WATCHED BY THE PILOT.

- 1 ALTIMETER
- 2 AIR ADJUSTMENT FOR ALTITUDE
- 3 CLOCK
- 4 TACHOMETER
- 5 AIR PRESSURE GAGE
- 6 PRIMING LEVER
- 7 AIR SPEED INDICATOR
- 8 RADIATOR TEMPERATURE GAGE
- 9 AIR CONTROL VALVE
- 10 IGNITION CURRENT GAGE
- 11 OIL PRESSURE GAGE
- 12 COMPASS
- 13 RADIO TELEPHONE TRANSMITTER
- 14 SWITCH CONTROLLING RIGHT IGNITION
- 15 SWITCH CONTROLLING LEFT IGNITION
- 16 RADIO RECEIVING TUNER
- 17 RADIO AMPLIFYING SWITCH
- 18 HAND AIR PUMP
- 19 GAS CONTROL FOR DIFFERENT TANKS
- 20 RADIO TUNING CONDENSER
- 21 RADIO TRANSMIT-RECEIVE SWITCH
- 22 OIL PUMP FOR SYNCHRONIZING GEAR
- 23 RUDDER BAR
- 24 RADIO RECEIVING HELMET
- 25 THROTTLE
- 26 RADIATOR SHUTTER LEVER
- 27 SPARK LEVER
- 28 TRIGGER FOR MACHINE GUNS
- 29 CONTROL STICK
- 30 HAND WHEEL STABILIZER ADJUSTMENT
- 31 ELECTRIC HEATING & LIGHTING CONTROL

NOT SHOWN: 32 TURN INDICATOR 33 OXYGEN CONTROLS 34 INCLINOMETER 35 MAP CASE  
36 TELEGRAPH KEY 37 BOMB RELEASE 38 CAMERA CONTROL 39 PARACHUTE RELEASE  
40 RADIO DIRECTION FINDER

COCKPIT OF MODERN AIRPLANE IS MASS OF INSTRUMENTS AND CONTROLS

THE glance into the cockpit of a modern airplane afforded by the above view, with its explanatory notations, serves to visualize the change that has taken place in the art of aerial navigation since the early days when the pilot sat on the open frame of the machine with a control lever in each hand and a small engine throttle lever near his side.

Cmb. Jno W. Keen, Bureau of Navigation  
Navy Dept. Washington, D.C.

Copyrighted material

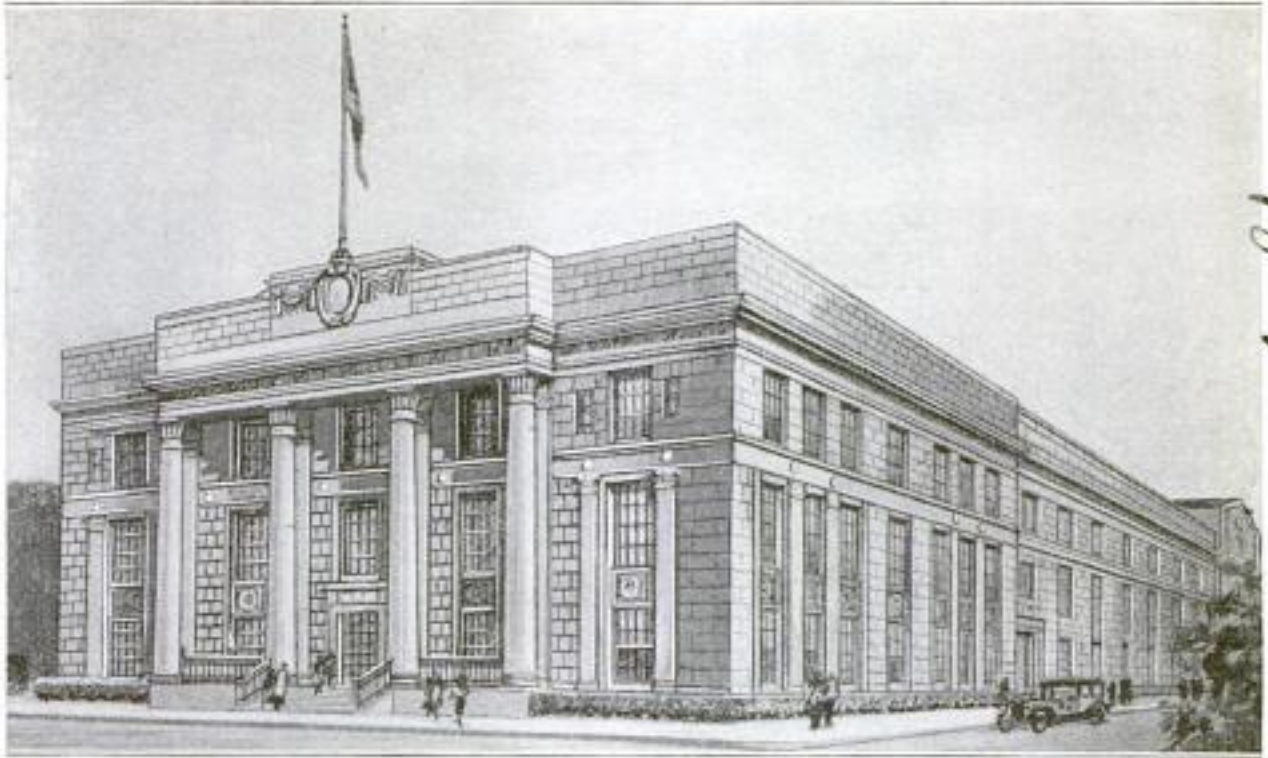

Approved Design for the First Memorial Hall in Illinois Dedicated to Veterans of the Late War, to be Built at Bloomington: In the Building, Which will Cost About \$150,000, There will Be Accommodations for Veterans of the Late War, the Spanish War, and Also of the Civil War

9314  
**MEMORIAL HALL TO BE BUILT AT BLOOMINGTON, ILLINOIS**

With national and state officers of the American Legion and other patriotic organizations in attendance, the corner stone of the first Memorial Hall in Illinois to be dedicated to the veterans of the late war, was laid at Bloomington, May 27. The building, which will cost about \$150,000, is a gift from John McBarnes, a wealthy retired farmer, the site having been presented by the county of McLean. The memorial hall will contain a large auditorium for public meetings, besides rooms for the veterans of the late war, of the Spanish War, as well as those of the Civil War. There will also be a museum of war relics that have up to the present been kept in the courthouse. It is expected that the building will be ready for occupancy about the end of the year.

9360  
**SIGNIFICANT WORD ADOPTED FOR ELECTRIC FIXTURE**

Properly designating electric fixtures or appliances of the movable type such as table and floor lamps, etc., has hitherto been rather confusing to some people. To remedy this, the Illuminating Engineering Society of England has adopted the term "luminaire"—a descriptive word from the French—as being the most significant, in this connection, that could be used.

9277  
**NEW WATER-LEVEL INDICATOR FOR AUTOMOBILE RADIATOR**

A water-level indicator has recently been designed as an attachment to the radiator of a well-known low-priced automobile. The attachment also serves as a quick-filling device, as a condenser, and as an overheat indicator, the last, because it is open at the top, so that if the water in the radiator boils, steam issuing therefrom will attract the attention of the driver. The attachment is in the form of a tubular ring, with a funnel above it that is screened but not closed. Inside the ring is a ball at the end of a rod which extends into the radiator and is connected to a float that rises and falls with the water, thus indicating its level.

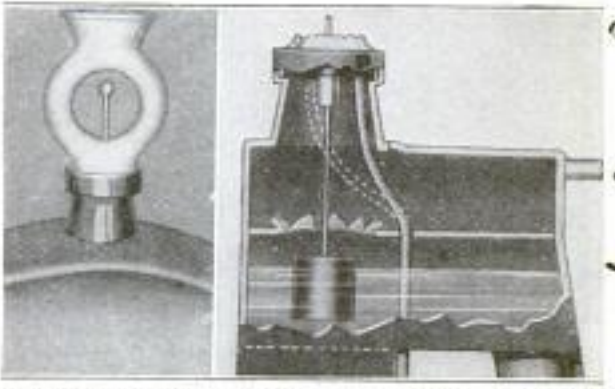

Left: Front View of Indicator and Filler. The Small Ball on Top of Rod Shows Water Level by Means of Float Seen in Sectional View of Radiator at Right

Taylor machinery Co. 78 Battery March St. Boston, Mass.

mechanical engineering  
 5/22/22

9299

# SOME NOVEL AND LITTLE-KNOWN ACCESSORIES



An All-China Coffee-pot Which Has Removable and Double Dripping Plates



This Emergency Rain Cape is Made of Waterproof Material, of Sufficient Size to Cover Any Hat, and can be Used Several Times



Toothbrush with Separate Part for Cleaning the Rear Side of the Teeth

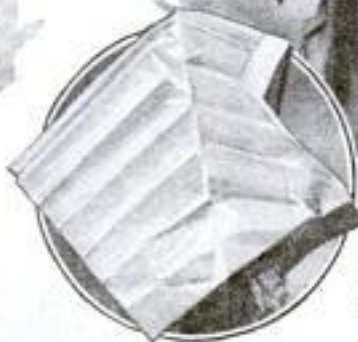

A Combined Brush and Steel Scraper Fitted on a White-Enamelled Handle: It is a Handy Cleaner for All Kinds of Pots and Pans



Traveling Bag of Black Seal Leather with Side Compartment That Opens without Disturbing the Other Contents



This Davenport for Summer Use Has Removable Cushion Covers and Also an Adjustable Headrest for Convenience When Used for Sleeping

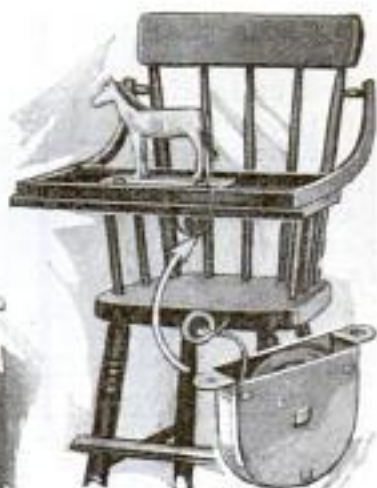

This Toy Holder, Fastened to Baby's Chair, Saves the Tired Mother Many Steps in Picking Up Playthings, and Also Amuses the Child

Anyone wishing further information on devices described in the editorial pages can

# INTENDED FOR THE HOME AND ITS MEMBERS

Combination Holder for Toothbrushes and Collapsible Tube of Paste Which Makes a Convenient Accessory for the Bathroom

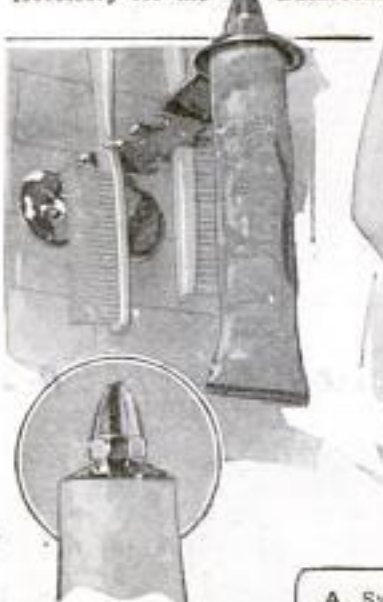

This Water Motor Fits Any Faucet and Has Attachments for Beating Eggs, Grinding Knives, Washing Bottles, and Buffing Silver



A Swimming Belt Which is So Constructed That It will Not Bulge under the Arms, Thus Giving the Maximum Freedom of Movement



This Electric Stove for Making Toast and Coffee, and Frying Eggs or Bacon, Has an Adjustable Top



This Frying Pan Turns Eggs by Simply Giving It a Sharp Jerk



A Crumb Tray with Half-Curled Edges and a Small Roller That Gathers the Crumbs into the Tray, as It is Pushed over the Table

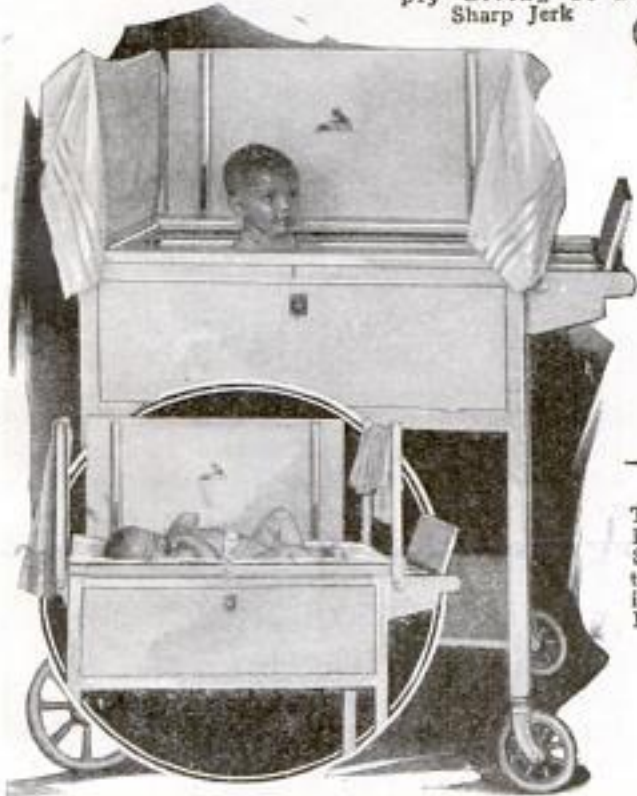

Bath and Dressing Cabinet for Infants: It is Mounted on Wheels, and Has a Removable Enamelled Tub, a Disappearing Dressing Table, and a Safety Belt; Its Height Is Another Convenience

This Simple Support Prevents Soft Hats from Sagging or Kinking at the Front and Rear. It is Made of Celluloid and Fits inside the Sweat-band



obtain it by addressing Bureau of Information, Popular Mechanics Magazine, Chicago.

T  
Br  
To  
Al  
Ha  
Tr  
Cl  
St  
Wa  
Fr  
El  
Ly

Acme Oil & Drilling Co. Inc.  
404 Milam St.

280  
9153

Shreveport, La.  
**POPULAR MECHANICS**  
**OIL-WELL DRILL BIT DRILLS**  
**HOLE AND TAKES A CORE**

The belief that often, in drilling oil wells, promising oil formations are passed through without being known, has led an inventor in the Louisiana field to develop a drill bit which not only drills the hole but saves a core sample at the same time. In operation it is much like the usual rotary rig or fishtail bit, but a central chamber, furnished with individual cutters and a relief valve, preserves a core sample of the pierced strata. These core samples may be brought to the surface and examined, and will give much more information about the geological formations than the cuttings from the ordinary drills.

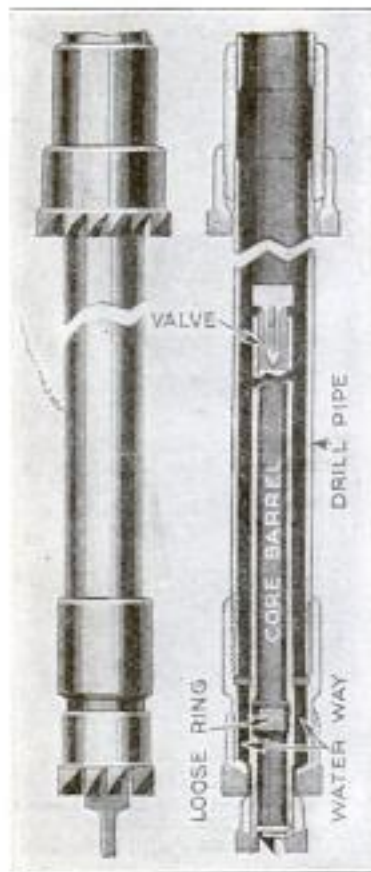

formation about the geological formations than the cuttings from the ordinary drills.

9234 **HANDY DEVICE SECURES HATS**  
**TO INSIDE OF AUTO TOP**

It would seem that new accessories are constantly being devised for the comfort and convenience of the motorist. As an example of this, a patent has recently been granted on a holder for ladies' or men's hats to be attached to the inside of the auto top. The device is extremely simple, consisting of self-winding drums to which cords are attached. When the cords are stretched taut, the brim of the hat is supported by them, but no pressure is

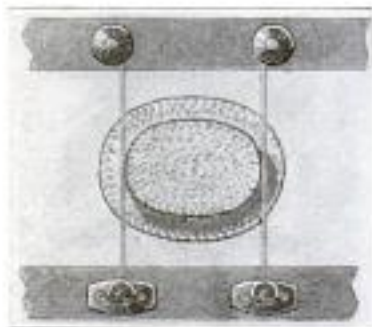

extremely simple, consisting of self-winding drums to which cords are attached. When the cords are stretched taut, the brim of the hat is supported by them, but no pressure is

Chas. Wm. Neyland & Sons,  
10 W. E. Neyland - Sons,  
Isiah, Texas.

exerted on the crown of the hat. The device does not interfere with the operation of the folding top.

9376 Railroad  
**TURNTABLE FOR LOCOMOTIVES**  
**THAT IS 100 FEET LONG**

For the powerful mountain locomotives now being placed in service, a giant turntable, 100 feet long, that is electrically operated, has been installed by the Southern Pacific Company, at Ashland, Ore. It is equipped with the latest safety devices, and weighs 91½ tons. This huge turntable cost about \$50,000, and its erection in only a few minutes more than 10 hours established a record for such an installation.

N.Y. Times 5/22/22 p. 2  
9233 **ELECTRIC INCUBATOR TURNS**  
**ALL EGGS AT ONE TIME**

The increasing use of electricity in rural districts has led to the development of an electric incubator in which the work of turning the eggs is reduced to a minimum. The incubator is a divided metal cylinder with the woven-wire trays, in which the eggs are carried, supported on a central tube. The cylinder itself is hung by a bail pivoted at the center of gravity. When the eggs are to be turned, it is only necessary to reverse the position of the cylinder by turning it on the pivots of the bail. Electric heating coils are located at each end of the case, and the heat is regulated by thermostatic valves.

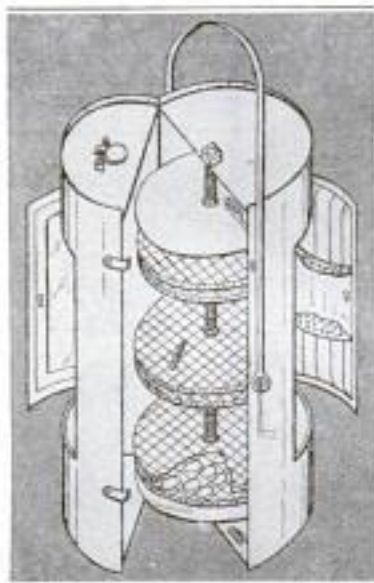

of gravity. When the eggs are to be turned, it is only necessary to reverse the position of the cylinder by turning it on the pivots of the bail. Electric heating coils are located at each end of the case, and the heat is regulated by thermostatic valves.

of gravity. When the eggs are to be turned, it is only necessary to reverse the position of the cylinder by turning it on the pivots of the bail. Electric heating coils are located at each end of the case, and the heat is regulated by thermostatic valves.

Chas. B. Johnston,  
A. C. Johnston, Ant. Canada  
9135 **PEA AND SOY-BEAN THRESHER**  
**USED WITH GRAIN BINDER**

For use as an attachment for a grain binder, a pea and soy-bean thresher has been demonstrated successfully in Missouri. The head of the binder is removed, and the pea and bean thresher is so constructed that it can be put in its place.

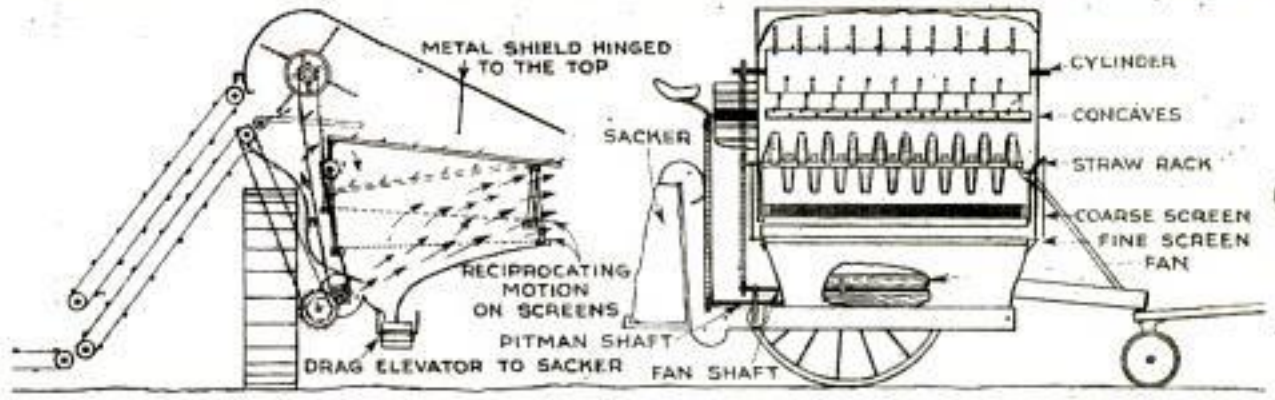

Transverse Section at Left and Longitudinal Section at Right of the Pea and Soy-Bean Thresher: The Straw is Delivered from the Cylinder at Top to the Straw Rack Below, Thence to the Coarse Screen and Fine Screen Consecutively. Arrows Indicate Direction of Air Blast from Fan

The peas or beans are delivered to a cylinder under a metal shield at top of the attachment. This cylinder is rotated by a sprocket and chain in connection with another sprocket on the fan shaft at the bottom of the attachment. From this cylinder the peas or beans are delivered to a straw rack or shaker, where they are screened. They then fall onto a reciprocating coarse screen, and from that onto a fine screen. Below this is a fan which sends an air blast upward through the screens and completes the cleaning process. The peas or beans are finally collected in an elevator which delivers them into a sack fastened onto the rear frame of the binder.

**STEEL-WIRE FILLERS USED  
 9261 IN METAL BROOM**

Cleaning the floors of bakeries, markets, etc., or scraping structural iron before painting, can be efficiently accomplished with a metal broom having steel-wire fillers. Sixteen of these highly tempered fillers, which may be replaced as units at small expense, are bolted between two metal plates. As the article can be frequently sterilized, it is easily kept in a sanitary condition.



**NEW BRIDGE INCREASES TONE  
 OF STRINGED INSTRUMENTS**

To increase the tone of all kinds of stringed musical instruments, a bridge has been invented in England, and is now being sold in this country, that in appearance is much the same as any other bridge, but that has



in each foot of the bridge a sound chamber. Instead of being solid, as in the ordinary bridge, the feet are hollowed out and perfectly balanced. It is said that this bridge produces greater resonance and hence gives a fuller tone to the instrument upon which it is placed.

When you want anything and do not know where to get it, write Bureau of Information, Popular Mechanics, Chicago.

**DENTAL MACHINE CASTS GOLD  
 UNDER AIR PRESSURE**

In making gold castings for dental work, great care must be taken to be sure that the molten gold reaches all parts of the mold. A machine has now been devised in which air is pumped into a cylinder to any desired pressure and held until the gold is in a molten state; a release valve then diverts this air into the casting space, forcing the gold into all parts of the mold and insuring solid castings.



*Am. Jesse L. Jones Co. 5 Byron Ave. East Haven, Conn.*

*Aluma's Casting Machine Co. Worcester 7 S. Crapley St. Worcester, Mass. 26 Southbridge St. Worcester, Mass. 1165 Michigan Ave. Detroit, Mich.*

*American Agent Jones Bridge Co. Far Hills, N.J.*

9091

*Stonell's Mfg Co  
Rochester, N.Y.  
Attach*

**EXPANSION-RELIEVING CENTER FOR LATHE HEADSTOCKS**

The pressure on lathe centers due to expansion of the work by heat is very great, and causes excessive wear on the tailstock center, heavy side wear on the headstock, slippage of drive belts, or buckling of work with a small diameter. All these disadvantages are avoided in a new center for lathe headstocks that automatically releases the force of expansion by withdrawing into its sleeve as far as the work expands. This movement is limited by a stop pin. At the end of the center is a spring device which is adjustable, to equalize the cutting pressure so that the only pressure released is that due to expansion of the work.



**ELECTRIC COFFEE PERCOLATOR THAT IS SELF-POURING**

A self-pouring electric coffee percolator is now in use in France. The outside wall of the percolator is composed of material that produces heat by resistance to an electric current conducted to it by wires. Inside this is placed a cylindrical water container which has a valve in its closed top. Above this is a perforated ground-coffee container that fits the inside wall of the upper part of the percolator, and that has, just below it and completely surrounding it, a narrow gutterlike channel

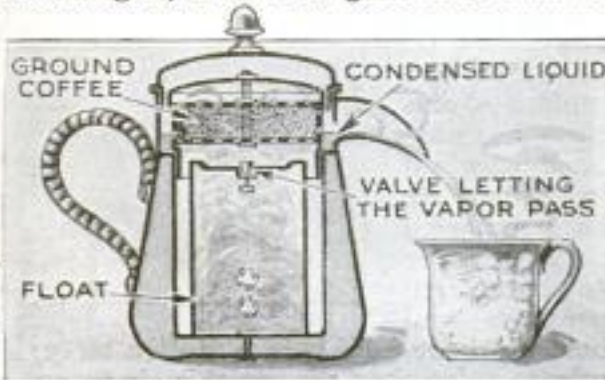

Self-Pouring Electric Coffee Percolator: The Water in the Float Boils, Opens the Valve, Passes to the Coffee, Condenses, and is Conducted to the Spout

that communicates directly with the percolator spout. When heat is produced by turning on the current, the water boils, the steam raises the valve in the top of the container, penetrates the ground coffee, and condenses. The liquid is then conducted directly to the spout, and runs out into a cup placed below it, and will continue running until the electric current is switched off.

**GAS-ENGINE VALVES CLEANED WITHOUT REMOVING THEM**

A gasoline-engine valve may be cleaned of carbon deposits by attaching to its stem a notched disk, which in connection with a ratchet handle designed for the purpose, enables the operator to give the valve a turning motion on its seat. It is necessary, of course, first to adjust the engine so that the valve is closed. The notched disks may be left permanently on all the valve stems of the motor, and only one ratchet handle is necessary for turning the disks.



*The Burno Products Co. Allentown, Pa.*  
**HYDRANTS MADE CONSPICUOUS BY PAINTING THEM YELLOW**

After several experiments it has been found by the officials of the water bureau of Philadelphia that the most suitable color for painting fire hydrants is yellow, instead of the dark green or brown which was formerly used. With the latter colors, it was found that, on account of their low visibility in certain weather conditions, there was an average of one hydrant broken every day by collision with automobiles or other vehicles. The yellow paint makes the hydrants so much more conspicuous in all kinds of weather that they are not only more readily avoided by motorists, but also more easily seen by firemen.

Our Bureau of Information is for your benefit. Use it as often as you please.

*Copyrighted material  
Cmt. J. H. Mc Carren of Pen  
& Pencil Club, 1026 Walnut St  
Philadelphia, Pa.*

*Mme. Monique Chabot, Paris  
15, Rue de Berny, France*



9399

Master-Strip Mfg. Co  
Austin, Texas.  
POPULAR MECHANICS

283

### SPECIAL COVERING PREVENTS BELT FROM SLIPPING

Instead of using some form of belt dressing to prevent a belt from slipping on a pulley, a patented covering for the

off saw, a 12-inch jointer, a tenoner, an upright hollow-chisel mortiser and borer, and a reversible-spindle shaper and sander—eight machines in one. The whole forms a unit in connection with a table on a rigid metal frame, and should

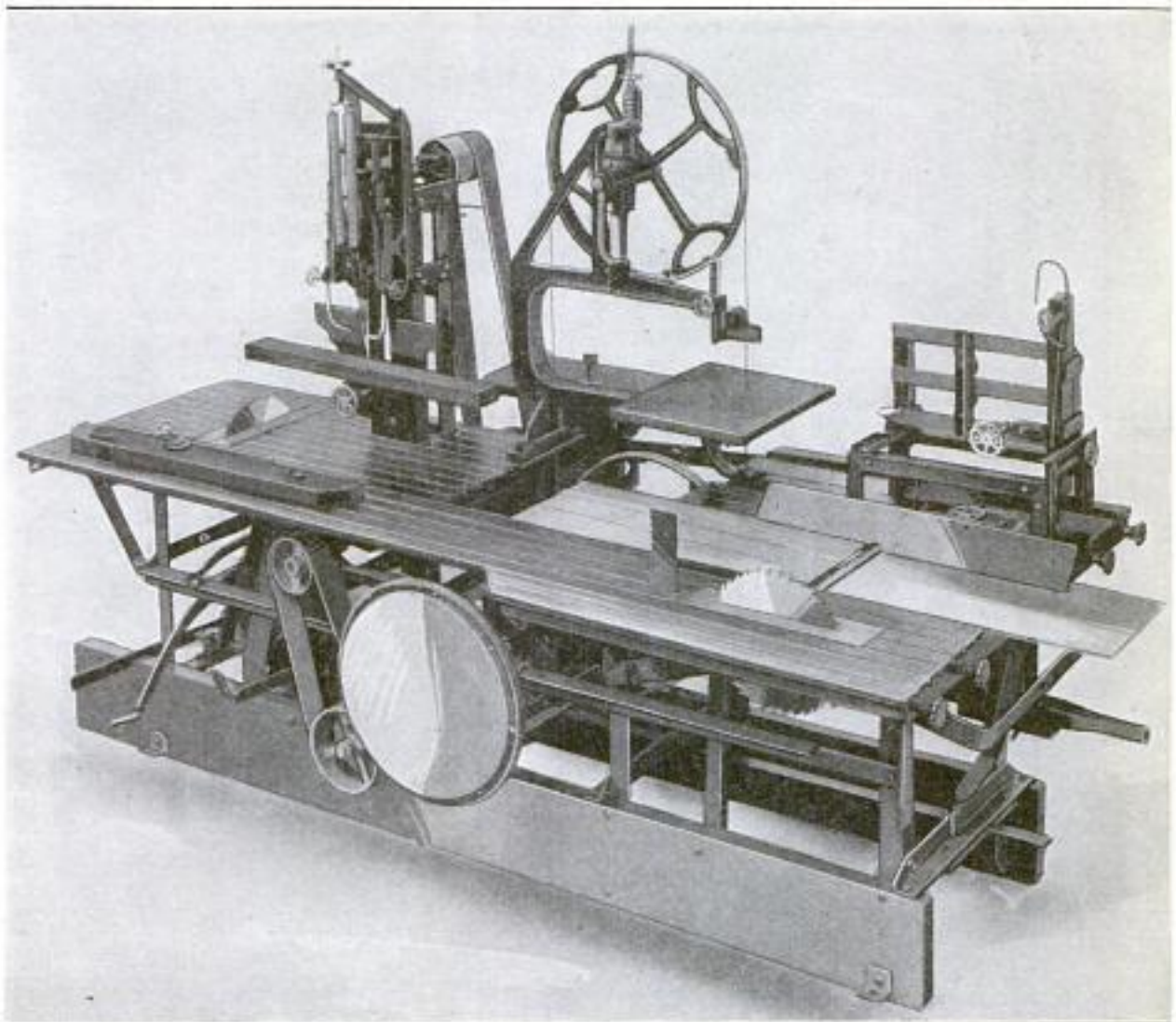

Eight Machines in One, Including Circular Rip and Crosscut Saws, a Band Saw, a Swing Cut-Off Saw, a 12-Inch Jointer, a Tenoner, an Upright Hollow-Chisel Mortiser and Borer, and a Reversible-Spindle Shaper and Sander

pulley is now on the market. The pulley is coated with a special kind of cement, and an open-web fabric is then pressed on, the cement working up through the openings in the web. Where conditions are suited to this form of covering, satisfactory results have been attained.

### EIGHT MACHINES COMBINED IN WOODWORKING OUTFIT

What might be called almost a whole woodworking plant in one machine is being made by a manufacturer in Ohio. This multifarious machine has in combination a circular rip saw, a circular crosscut saw, a hand saw, a swing cut-

be very useful in any kind of wood-working shop. *Windsor*

### WATERPROOF CLOTH PRODUCED 9395 FOR ROLLER SHADES

Should a new cloth be generally adopted for roller curtains, it will not be necessary for the housewife to send the shades out to be cleaned when they become soiled. The new cloth may be cleaned with soap and water, and grease stains removed without damage to the fabric. The special treatment given this shade cloth not only renders it waterproof, but also makes it more durable as regards cracking or sagging.

Park's Real Bearing  
Machine Co.  
Knowlton & Feig  
Cincinnati

Sontine Waterproof  
Shade Cloth Co.  
229 E. 41st. New York City

## CHILDREN'S PICTURE-STORY DEPARTMENT

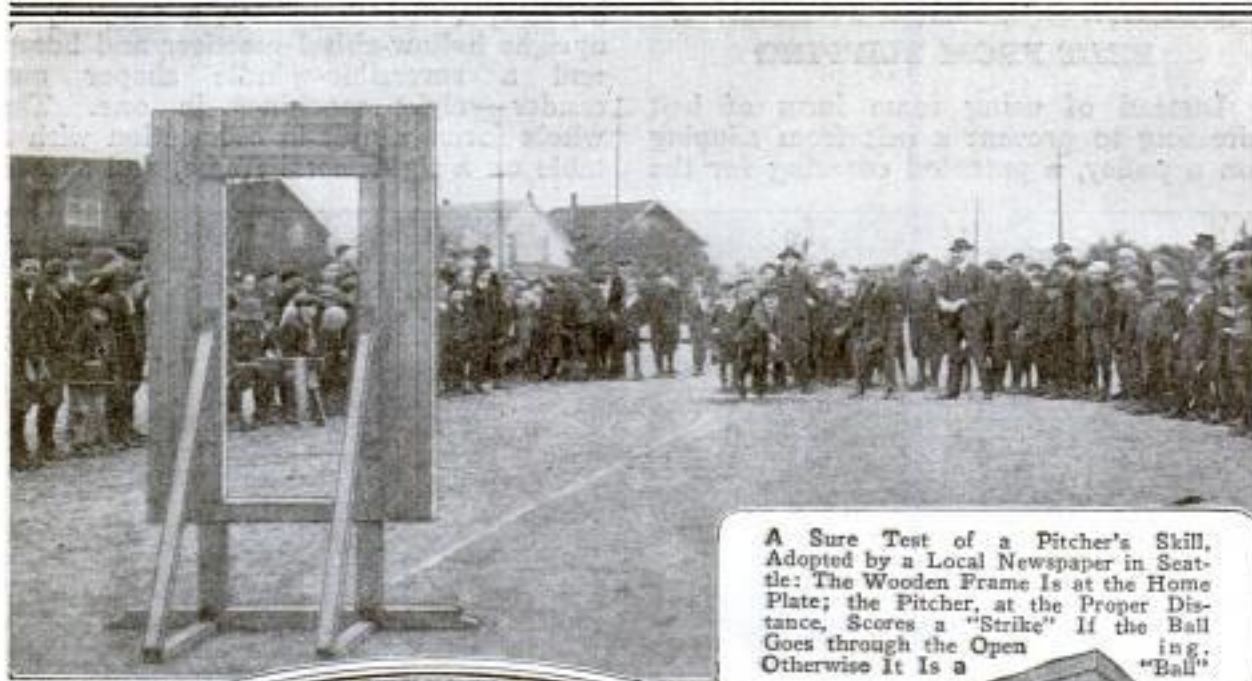

A Sure Test of a Pitcher's Skill, Adopted by a Local Newspaper in Seattle: The Wooden Frame Is at the Home Plate; the Pitcher, at the Proper Distance, Scores a "Strike" If the Ball Goes through the Opening. Otherwise It Is a "Ball."

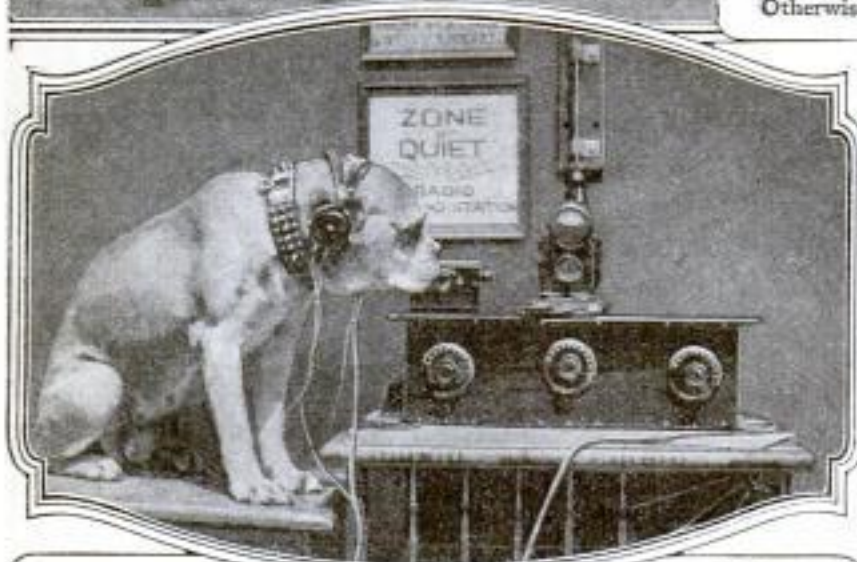

In the Present Even Dogs are Taking an Active Part. Here Is English Bulldog—with Telephone on His Ears—Listening In at a Receiving Set. This Canine Fan the Music as Long as It Lasts

Radio Rage One—an Listen-Enjoys



A Porch or Lawn Playhouse for Children Up to Five or Six Years Old: The Little Table Is Convertible, and the Seats can be Arranged to Form a Bed



There Are Lots of Ways in Which Athletic Boys can Have "a Barrel of Fun," but Never So Truthfully as in This Case. The Barrel Rolls Freely on the Horizontal Pipe, Which is Supported by the Uprights in Concrete Foundations

# Child MODERN ACTIVITIES AND INTERESTS

Sto

Pla

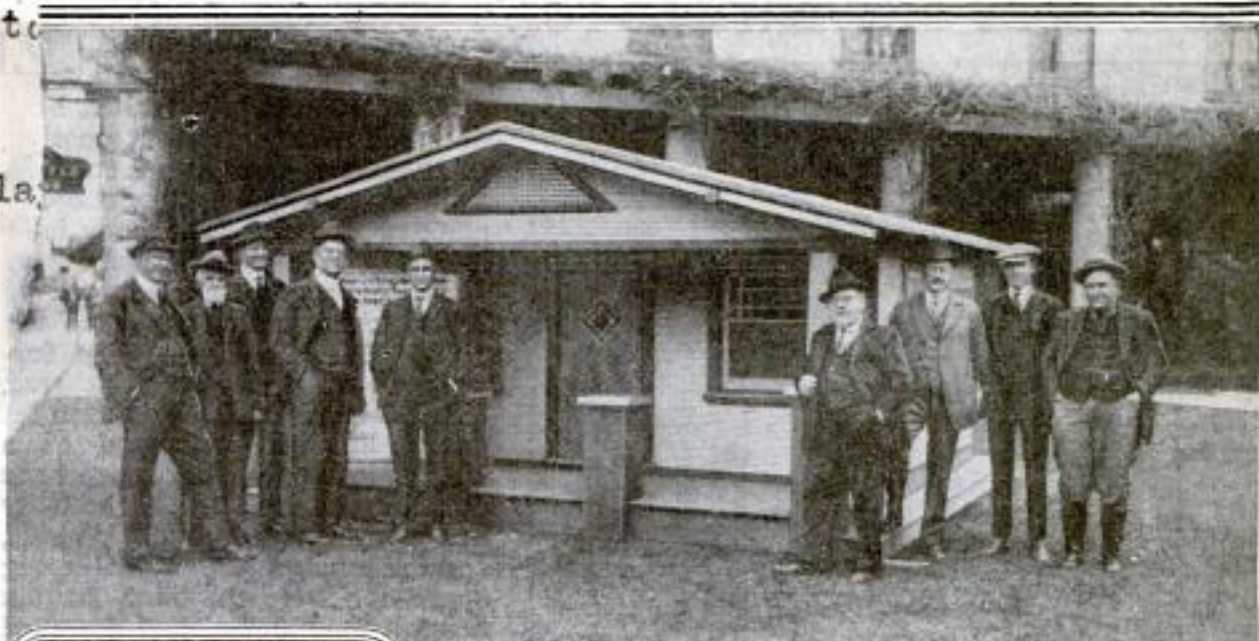

Story Rings for Children: They will Remind the Kiddies of Some of Their Favorite Nursery Rimes, Such as the Little Pig That Went to Market, and the Like

This Little Bungalow was Offered by Material Men and Carpenters of Merced, California, as a Prize for the Best Essay on the Subject, "Why My Parents should Own Their Home." It was Won by Zilpha Razzdale, an 11-Year-Old Girl



At a Contest Recently Conducted by the "Just for Boys Department" of the Newark Evening News, This Model Won the First Prize of the Motorboats. It is Made from Packing Cases

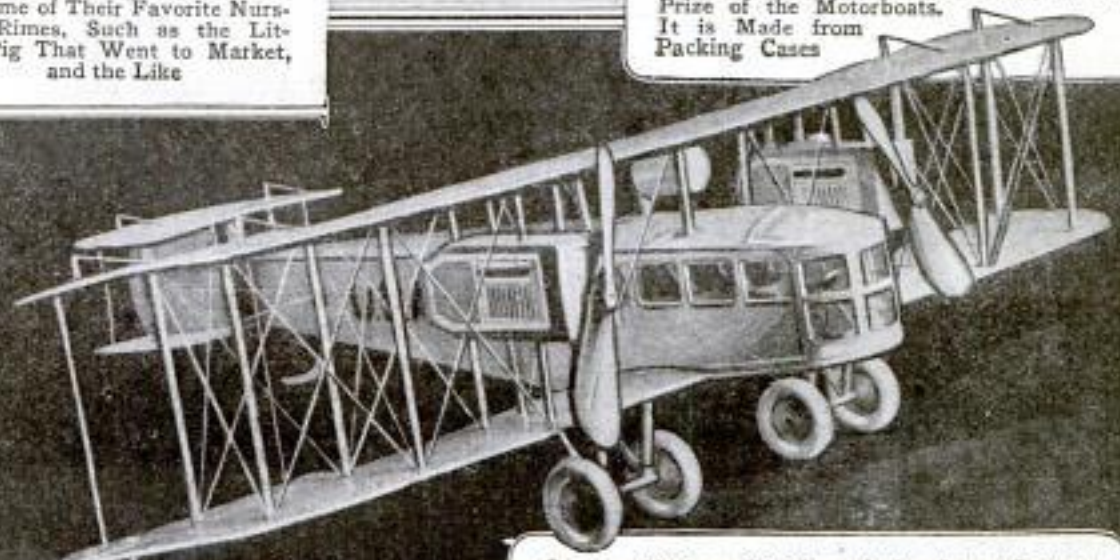

In the Airplane Division of the Same Contest, This Model Won the First Prize. With the Exception of the Wheels, the Propellers, the Steering Gear, and the Wires, the Model is Built Entirely of Cardboard. Its Wings Are Four Feet, and Its Body Three Feet Long

9245 Inland Automobile Co  
223 W. Morris St.

286

POPULAR MECHANICS

*Indianapolis, Ind*

**AUTO BODY CONVERTIBLE FOR TRUCK OR CAMPING**

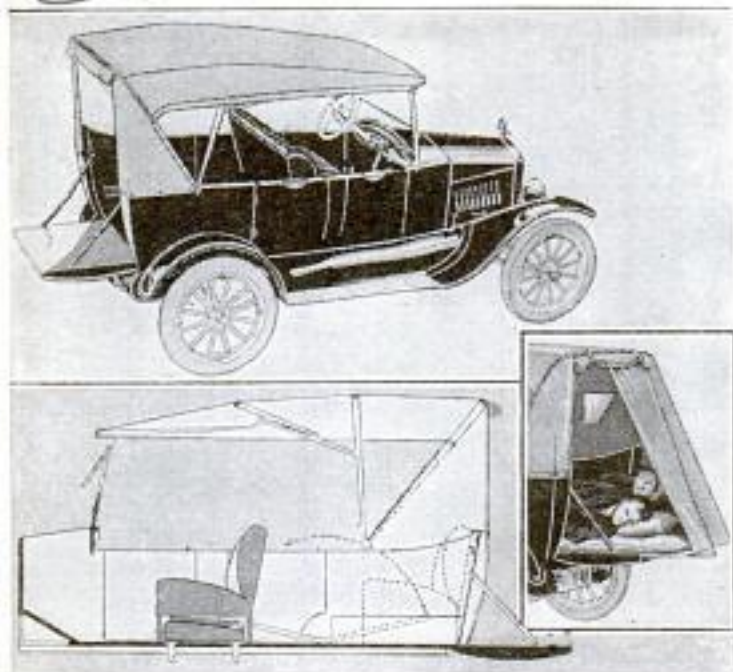

Above: When This Convertible Auto Body is Used as a Delivery Truck, the Back is Let Down and the Back Seat Moved Forward. Below: The Diagram Shows How This is Done. Insert Shows How Body is Used for Camping

For a well-known small automobile, a special body has been designed which makes it possible to convert the car into a truck or a sleeping compartment for cross-country touring. The body is 14 inches longer than the standard body, and the front seat can be folded over and dropped to the floor. The rear seat swings forward to fit over the front seat. The back of the body is then let down, like the tailboard of a wagon, leaving a clear space back of the seat. As a truck, the body has a capacity of 1,000 pounds, and for tourists, provides sleeping space for two, the rear curtain being rolled down and fastened to furnish protection from rain.

Names and addresses of manufacturers of articles described in this magazine will be furnished free by our Information Bureau.

**ECONOMICAL OVERALLS MADE FOR REVERSIBLE WEAR**

Overalls which can be reversed—front and rear—have been invented and should prove popular with laborers and workmen of all trades. These overalls are cut

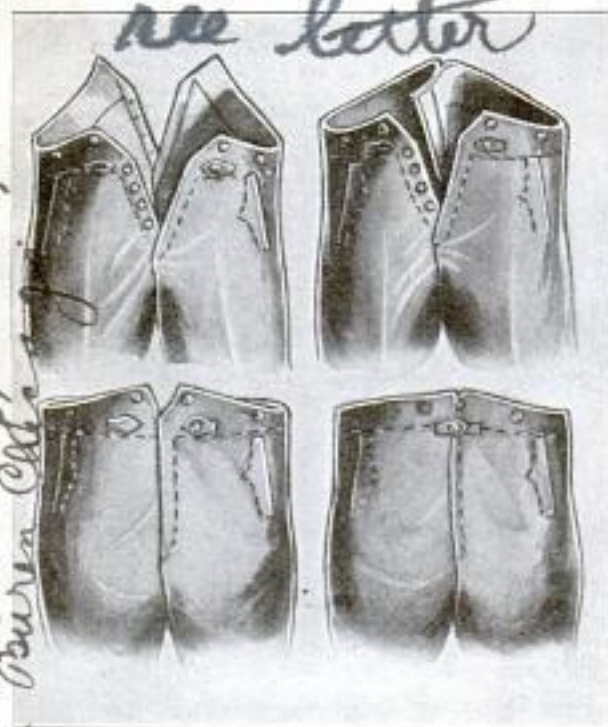

Reversible Overalls, Showing How They are Cut on Straight Lines and the Arrangement of Buttons and Pockets for Double Wear

on comparatively straight lines, with minor details of buttons, belt loops, etc., so arranged that when the seat or knees become torn or worn, it is a small matter to turn them around. Thus the life of the garment is approximately doubled, representing a great economy to the wearer.

**COPPER-STEEL SHINGLE NAILS ARE RUST-RESISTING**

The peculiar properties possessed by steel to which a small amount of copper has been added, has led to the manufacture of a shingle nail that is said to have a life equal to that of the shingle itself. The nails are not only made from copper-alloyed steel but are galvanized by hot-dipping in a solution of molten zinc. By an improvement in the process, it has been found possible to produce a practically smooth galvanized nail that can be held in the mouth without danger of causing canker sores. An instance has come to light recently, in which nails which had been in service on a shingle roof for 52 years and were still in remarkably good condition, were found, upon analysis, to have been made from an iron containing considerable quantities of copper. The roof in question was three-quarters pitch, which drains very rapidly.

Shingle Branch, West Coast Lumbermen's Association, Seattle, Wash. Circular 555

*Emb. E. H. Werner Foreign Letter Patent Exchange, Chicago, Charles Bldg. 21 E. Van Buren St.*

*208 La Salle, Chicago*



Information as to where to obtain any specified materials or parts for making objects described in the following pages may be had, on request, from our Bureau of Information.—Editor.

## Two Practical Garage Conveniences

By J. S. HAGANS

**E**ITHER or both of the devices illustrated will be found as serviceable in any garage and repair shop as they are in the large establishment in which they were photographed.

One of them is used for lifting engines from their chassis. It consists of nothing more than a length of steel rod and two old spark-plug shells. The cores are removed from the spark plugs, leaving only the metal shells, which are slipped over the ends of the rods so that their threaded ends will be on the outside.

tween two of the spark-plug holes in the cylinder-head casting of the engine to be removed. In use, two of the spark plugs are removed from adjoining cylinders of the engine, and the loose shells on the lifting device are screwed into the holes.

The engine can then be lifted out in the manner shown.

A portable hoist or dolly, built of wood throughout and mounted on ball-bearing casters, such as the one shown, will find a variety of uses around any garage or shop where repair work is

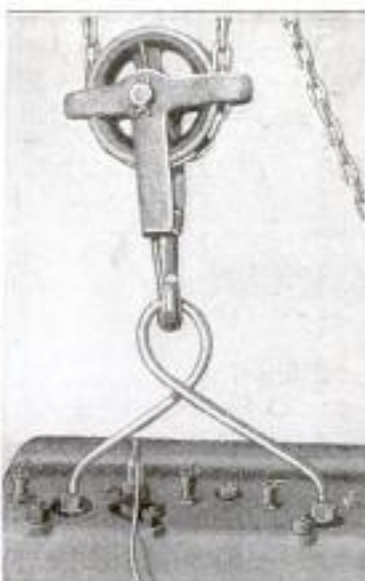

Left: A Portable Hoist, Built from Timbers and Mounted on Ball-Bearing Casters. Center: An Engine Puller Made from Two Spark-Plug Shells and a Piece of Steel Rod. Right: Both Devices Shown in Use for Lifting an Engine from Its Position on the Chassis

After the shells are in place on the rod, the ends of the latter are riveted over to prevent the loosely fitting metal parts from slipping off. Either before or after the attachment of the spark-plug shells, the rod is bent to the form shown, to make an eye into which the hook of the chain block is inserted. The distance between the ends of the device should correspond as closely as possible to that be-

done, as it is cheap to build, and can be easily moved from one part of the shop to another. Four-by-fours are used for making the triangular end supports, while a piece of 4 by 6-in. stuff should be used for the horizontal crosspiece. All parts are rigidly bolted together, and the legs are fastened to the bottom crosspieces with angle plates. The whole dolly is built wide and high enough to clear the sides

and top of a car. An eyebolt is provided in the center of the top crosspiece for the attachment of the usual chain blocks. The value of such a device in the shop is not fully appreciated until it becomes necessary to lift an engine, or elevate the front or rear of the chassis for the re-

moval or insertion of springs, shackle bolts, and other parts. With the dolly, work of this kind can be done by a workman single-handed, so that time and money are saved for the busy repair shop, and the work is delivered to the customer quicker.

### Stretching Tracing Cloth Properly

Many draftsmen, amateur or otherwise, seem unable to acquire the ability of stretching tracing cloth properly on their

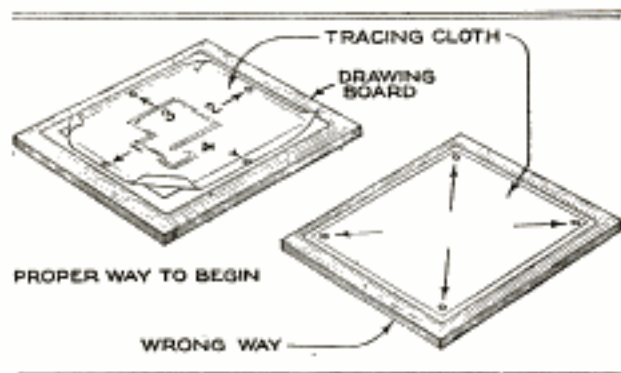

Inserting the Thumbtacks as Illustrated, Instead of at the Corners, the Draftsman can Smooth Out a Piece of Tracing Cloth So That It will Lie Perfectly Flat and Smooth

drawing boards. In the first position illustrated the thumbtacks are placed at the center of the edges and not at the corners. By inserting the thumbtacks in this manner, the cloth is left free at the corners so that it is a very simple matter afterward to stretch the cloth toward each corner and fasten it in a manner that will make it lie perfectly flat and smooth.

### A Piloted Taper Reamer

Having to ream out a number of taper holes accurately, the taper reamer shown in the drawing was devised and used with satisfactory results, by grinding the pilot on the same centers as the flutes. The work was prepared by first drilling the hole and hand-reaming with a straight reamer. Then the pilot was lapped down to a close sliding fit in the hole, after which the taper-reaming operation was performed. The result was a job having the taper hole absolutely square and without chatter marks. Also, the time of production was reduced by about one-third.—W. Burr Bennett, Honesdale, Pa.

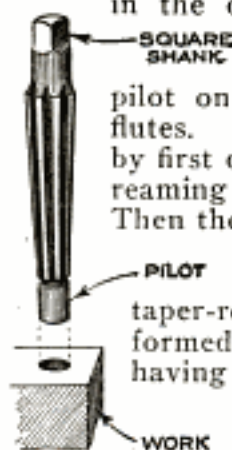

### Dissolving Slide for Stereopticon

A simple but effective dissolving shutter, that can be used by moving-picture and stereopticon operators for changing from one slide to another, is shown in the drawing. Two sheet-metal blades, having V-shaped notches cut out of their inner edges, slide in grooves in a wooden frame. Each slide is connected to a pivoted lever by a short connecting arm so that movement of the lever is communicated to the blades, opening or closing them. Such a shutter can also be used on an enlarging lantern. If it is desired to obtain a true dissolving effect on a double stereopticon, two shutters can be used, one in front of each lens or at each projection port, but some connection must be made between the shutters so that both can be operated at the same time from a single lever. One of the shutters, in this case, should open while the other is closing.—H. Hughes, Henrietta, Tex.

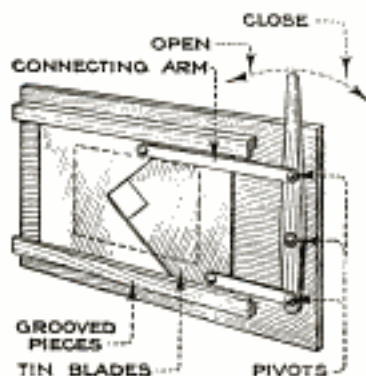

used, one in front of each lens or at each projection port, but some connection must be made between the shutters so that both can be operated at the same time from a single lever. One of the shutters, in this case, should open while the other is closing.—H. Hughes, Henrietta, Tex.

### A Simple Boring Gauge

The drawing shows a gauge that is very useful on boring work, as it is cheaply made, accurate, and worn parts are easily renewed. A piece of tubing is cut a little shorter than the diameter of the hole to be bored, and both ends of it are turned over to retain the balls with which it is filled. One end of the tubing is slotted so that the balls can be sprung in or out. As steel balls are made to limits of .0001 in., the possible error will be very small.

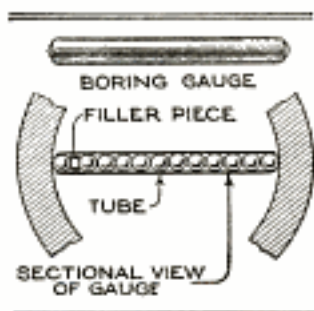

If the gauge is a long one, greater accuracy can be obtained by carefully selecting the balls, calipering each before using. Of course, such a gauge will ordinarily measure in dimensions that are multiples of the diameter of one ball, but, by using a filler piece in the manner shown, other sizes can be measured as well.

### Spring Dog for Small Lathe

Two things are done by the type of lathe dog illustrated. The work is held in close contact with the live center, and it is revolved by the faceplate. The dog spring is made of stiff sheet metal, and is permanently bent so as to bring the ends closer to the faceplate than the center, although they must be drawn toward the faceplate by the machine screws; for this reason the ends of the spring are slotted. The work is held in a collar which is fastened to the center of the spring with two screws. The hole in the collar is machined with a "V," to provide a three-point bearing for the work when the setscrew is tightened.

In using this dog, the clamp or collar is so adjusted that, when the work is on the live center, the slotted ends of the spring

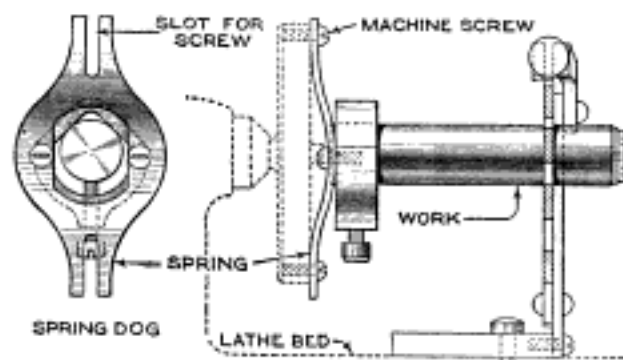

A Spring Lathe Dog for Light Work That Holds Work Close to the Live Center: It Is Convenient for Work One End of Which is Held in the Steady Rest

will be a sufficient distance from the faceplate to provide the necessary pressure against the center when the screws are tightened, drawing the ends into contact with the faceplate. A dog of this type is particularly useful when working on a job one end of which is held on the live center and the other in a steady rest, for centering or other operations.—H. E. Balfour, Ottawa, Can.

☐ In starting a trial cut on a milling machine, feed the work toward the cutter slowly; this will prevent the tool from digging into the work, which might loosen the setting, break teeth from the cutter, or spring the arbor.

### A Double-Point Soldering Bit

The tinsmith and electrician will appreciate the advantages of the double-point bit illustrated, especially when working on

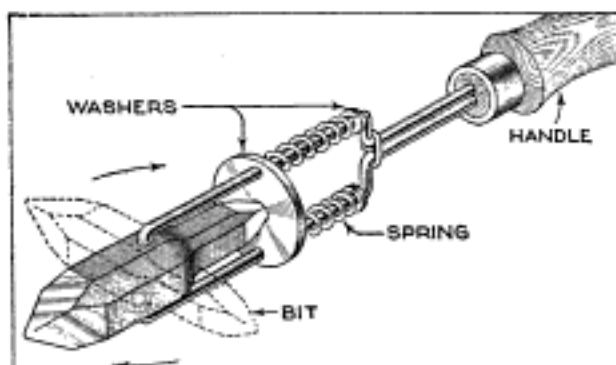

A Double-Point Soldering Copper for Tinsmiths and Electricians: This Saves Carrying Two Bits, and One Bit Is Kept Warm While the Other Is in Use

jobs that require continual changing from a light to a heavy bit. A large copper bit is removed from its shank, heated, a small bit point forged on the shank end as shown, and a hole drilled through the body to take the ends of a new shank. This shank is made of  $\frac{1}{4}$ -in. rod, bent as indicated, and fitted with springs on each arm, small washers being placed behind the springs, on the handle end of the arms. A large washer, drilled to fit the arms, and with a hole in its center in which the bit points will fit, is then slipped on, and the ends of the arms bent and sprung into the hole in the copper body. The springs and washer hold the bit firmly in position, and when it is desired to change from one point to another, it is only necessary to push the washer back. This allows the bit to be revolved; the washer is then released, locking the bit again.

### Removing Outer Ball Race

The outer ball race, or cup, in the front wheel of the light automobile is easily

forced from its seat with a length of an old rear-axle spindle from the same make of car. The axle is just the right size to bear against the inner edge of the cup, which is forced out by striking the outer end of the shaft with a hammer.

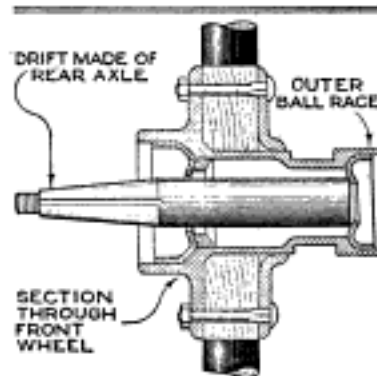

### Catcher for Japan Clover Seed

While intended primarily for catching the seeds of Lespedeza or Japan clover, the device illustrated can be used with similar results in the harvesting of common clover. The attachment is very simple, and consists of a sheet-metal pan,

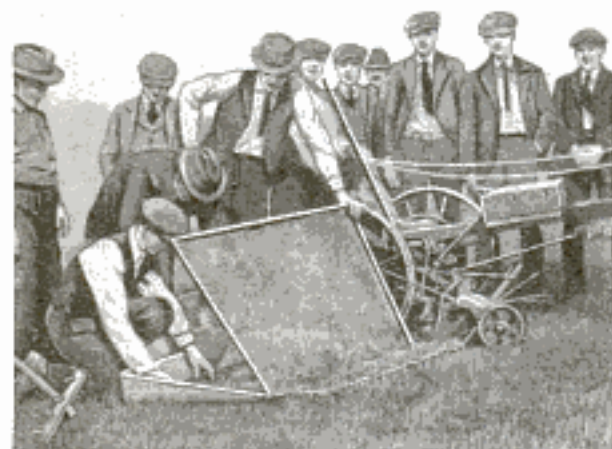

An Attachment for the Mowing Machine for Catching the Seeds of Plants That are Harvested at Maturity or That Scatter Easily

the sides of which are tapered; the pan is covered with a screen with mesh large enough to allow the seed to fall through it. The catcher is mounted on the mowing machine, just behind the mower bar. An extra man is required to keep the plants raked off the catcher, but the expense of this item is overcome by the value of the seed obtained.—Bessie Staller, Memphis, Tenn.

### Setting a Countersinking Tool

When numbers of different-sized screw holes are to be countersunk, the device illustrated is a real timesaver as well as a means of preventing unsightly holes. Whether a countersink has an adjusting sleeve, or whether it is set by the machine stop, it is necessary to use the cut-and-try method

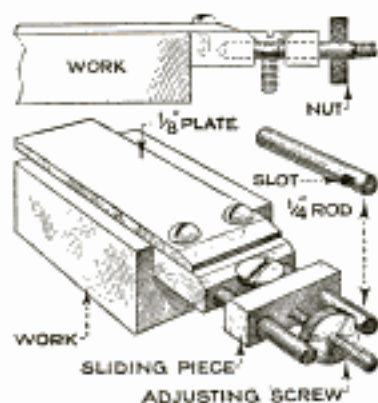

for the first hole or two, and naturally it is not uncommon to see work with a poor appearance, caused by one or two deep countersinks. To make the gauge illustrated, obtain a long piece of  $\frac{1}{8}$ -in. flat steel, and fasten it to a short piece of

$\frac{3}{8}$ -in. stock with two screws; then bevel off one corner at the same angle as the screw heads. Two  $\frac{1}{4}$ -in. pins are driven into one end of the  $\frac{3}{8}$ -in. piece, and sliding on these is another piece of  $\frac{3}{8}$ -in. stock, beveled on the upper and inner edge to correspond with the angle on the head of the screw. The center of the sliding piece is tapped for a  $\frac{1}{4}$ -in. stud that carries a knurled nut, the outer diameter of which fits easily in two shallow slots filed or milled near the ends of the pins. When in use, the device is laid on the work and held down by one hand, and the screw to be used is dropped between the beveled edges. The nut is then turned until the screw lies flush with the surface of the  $\frac{3}{8}$ -in. pieces; it is then removed, the countersinking tool is brought down, and the stop set. It will be apparent that in this manner the tool will be set to its correct depth at once without any preliminary cuts.

### Auxiliary Bushings for Toolmaker's Buttons

When boring jigs, buttons are used to locate the holes; if they are very close together, trouble is encountered when indicating them to ascertain whether they run true, or, in the case of a milling machine, to find whether the spindle is in perfect alignment with the bushing. To overcome this difficulty, an auxiliary bushing should be made, with one side ground away in the manner shown. It is absolutely necessary that this bushing should be a wringing fit on the button, so that it will run true, and that there may be no danger of shifting until the work has been trued up.

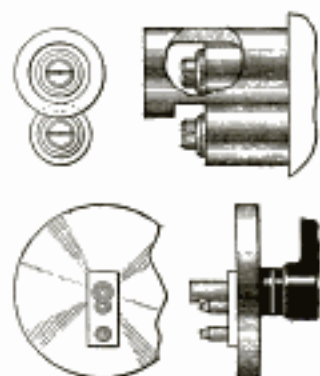

### Winch Improved from Lathe

Our shop was a new one and was built with a runway for a traveling crane, but no appropriation had been made for a crane, so one was designed and built in the shop. It was not an elaborate affair, but certainly substantial, so much so that when the time came to set it on its runway, there was no machinery in the plant capable of lifting it in place. We had



already installed a 30-in. heavy-duty lathe, which was bolted to a concrete base. I was finishing, on this lathe, a casting that resembled the "niggerhead" or capstan of a hoisting crab. This suggested an idea, which was acted upon at once. A snatch block was fastened opposite the lathe, the tail rope of the hoisting tackle passed through the block and around the casting, which was held by the chuck and a bell tailstock center. One man took care of the tail rope, another guided the crane into place with a hand line, and a third operated the lathe. This improvised winch landed the crane in place in a few minutes without a jar.—Thos. B. Norris, Birmingham, Ala.

### Drill for Use in Small Space

On a repair job, several holes were to be drilled in a space so small that it was impossible to use either a portable electric drill, or any ratchet drill that was available. As immediate action was imperative, the drill shown in the drawing was used. A short drill of the proper size—in this case  $\frac{23}{64}$  in.—was obtained, a portion cut off the shank, and the shank squared to fit a small ratchet-wrench socket. A hole was drilled and tapped in the end of the shank for a  $\frac{1}{4}$ -in. setscrew, the head of which was turned to form a center. The drill was turned by means of the ratchet wrench, and the feed obtained by unscrewing the setscrew, as with the ordinary ratchet drill.—M. L. Lowrey, Livermore, Calif.

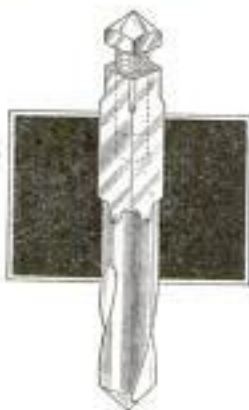

### Grain Soaker for Swine

A considerable economy is effected by soaking grain fed to swine so that it is softened, because, otherwise, a considerable part of the ration of hard grain passes through the animal without having been digested.

The illustration shows a device built by a farmer from two discarded steel wheels from a hayrake. The hydrant was run up to the proper height for the purpose. Then, one of the wheels was laid flat on the ground and the space between the rim and hub filled with cement. After the cement had hardened, a larger pipe

was slipped over the hydrant pipe to serve as a support for the cement-filled wheel; then this was placed over the water pipe also. The space between the rim and hub of the second wheel was filled with wood,



A Device for Soaking Grain Used as Swine Feed: It is Attached to the Yard Pump

and it was placed on the water pipe so that it would just clear the grain-filled containers placed on the circular cement table underneath; this arrangement prevents poultry from scattering the grain and keeps the sun from causing rapid fermentation. One section of the covering on the upper wheel is hinged to make a door, as shown, which forms a convenient opening for filling the baskets of grain with water from the hydrant.

### Extension "Hand" for Stores

For removing articles from the display window or high shelves of a store with-

out considerable inconvenience, some device to increase the salesman's reach is necessary, and this is provided in the "hand" illustrated. At the extreme end of the square wooden handle, two pieces of thin oak are fastened, to form jaws; these are connected to a lever, pivoted in a slot cut in the handle, by means of a cord. To grip an article, the jaws are placed around it and the lever is pulled to tighten them.—Howard Fowler, Rogers, Ark.

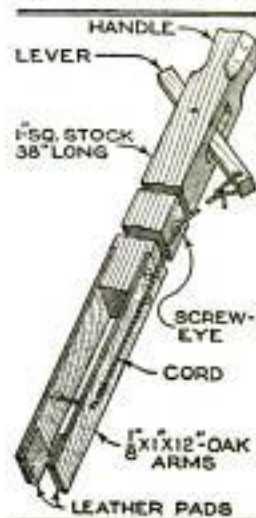

Ⓢ Double riveting is from 16 to 20 per cent stronger than single riveting.

### Electric Sand and Soil Sifter

Two pecks of soil a minute is the record of the homemade electric sifter used in the greenhouse of an agricultural col-

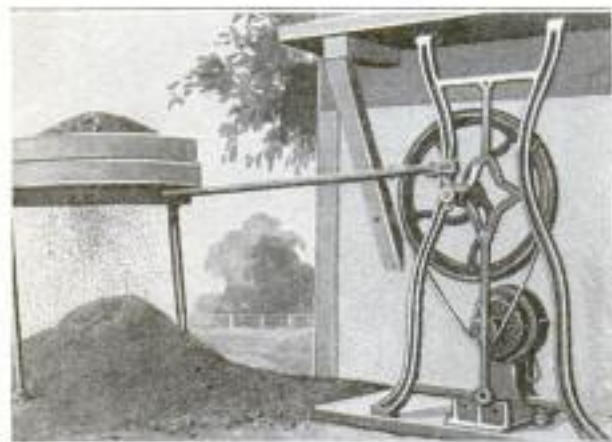

Soil and Sand are Sifted at the Rate of Half a Bushel per Minute in the Greenhouse of an Agricultural College with This Machine

lege. The device was made by one of the students from an electric motor and part of an old sewing-machine stand, together with a few miscellaneous parts, as shown. In making the machine, the ordinary soil sifter is bolted in an iron hoop that is supported on two legs, fastened to pivots bolted to the floor in such a manner that a back-and-forth movement of the sieve is permitted. The motor is bolted directly beneath the crank wheel, and drives it by an ordinary round belt. The shaking motion is transmitted to the sieve by a connecting rod made of pipe, one end of which is fastened to the crankpin and the other to the sieve.—Clementine Paddford, New York City.

### Holding Round Work in a Vise

A handy kink that will be found useful in many cases, when cylindrical work must be clamped in an ordinary bench

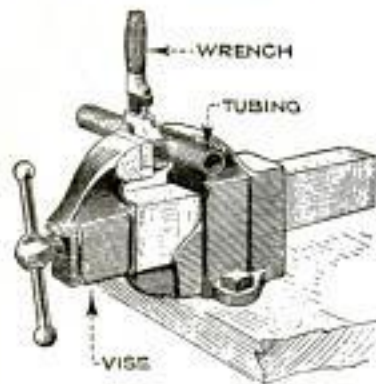

position shown, and the stock will be held as securely as in a pipe vise.—Floyd D. Elmore, Bethesda, Md.

### Marking Celluloid with Type Slug

Draftsmen, particularly those who work in large drawing rooms, find it very convenient, if not necessary, to mark their celluloid instruments with their name or other identifying mark. This is commonly done with the point of a knife blade or other pointed instrument. A better method, which gives excellent results, is to use a linotype slug set with one's name, which can be obtained from almost any print shop at little or no cost. A good size of type for the purpose is known as 14-point. Cut the slug with a hacksaw along the dotted line so that it will be easier to

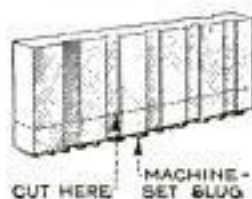

manipulate it in the process. Lay the celluloid article to be marked on a flat surface, and place the slug on it. Now press a hot iron on the upper edge of the slug, watching carefully and removing the iron when the type face begins to sink into the celluloid. The result is a very attractive and finished mark. The impressed characters can be filled with some dark pigment, such as jewelers' wax or enamel.

### Adjustable Centers for Laying Out

Previous to turning or drilling cored castings, the circles and divisions are usually laid out from a center block—

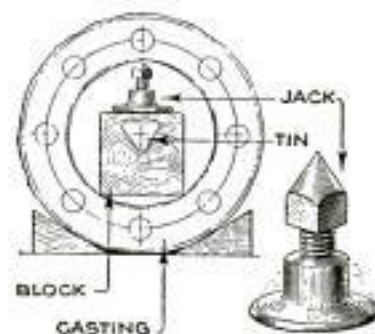

generally a block of wood cut to the length of the cored space and driven into the hole—a small piece of copper or tin being tacked to the wood to

carry the center mark. As a means of saving time in layout work, this individual fitting of wooden blocks should be avoided, and the method shown in the drawing used instead. A block of wood that will enter the hole of the casting loosely is seated solidly against the side, a small jack screw on the opposite side of the block serving to hold the block firmly against the work. The same blocks can be used repeatedly, and the time necessary to wedge them in place and remove them is much less than that required for the older method.

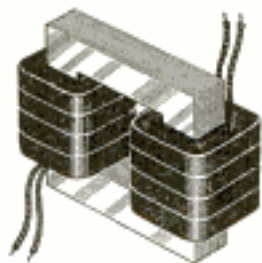

# SMALL SINGLE-PHASE TRANSFORMERS

By H. H. PARKER

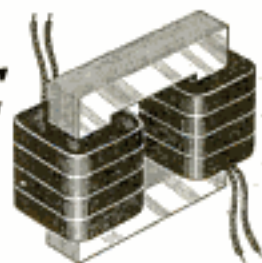

[This article was written in response to a large number of requests from our readers. The author, we think, has handled the subject as clearly and simply as it can be done, and the article should form a valuable addition to the shopman's files.—Editor.]

A **HOMEMADE** transformer, operating from the alternating-current house or shop-lighting circuit, can be put to a large variety of uses, such as Christmas-tree lighting, lighting low-voltage lamps for decorative effects or night lights, operating toy motors or electric railroads, ringing doorbells in place of dry cells, heating soldering or lead-burning apparatus, and so forth. These devices require a low or stepped-down voltage; transformers are also made to step up the voltage; these are suitable for radio or high-frequency work, but are not considered in this article. A small step-down transformer is not hard to build, once the principles of operation are understood, and few tools are needed, but the amateur electrician's main difficulty consists in obtaining data to start the design; he wants to know the size of core to use, the size and quantity of wire for the primary and secondary coils. Just how to obtain the desired secondary voltage is another stumbling block.

The method of working out the design as described here is mainly a cut-and-try, with little mathematics, but the amateur, with the aid of the accompanying tables, ought to be able to work out a satisfactory and fairly efficient transformer. At the start, however, he should understand that a transformer will work only on

alternating current; if attached to a direct-current circuit not only would there be no secondary current produced, but the primary winding would probably burn out. Though most house circuits are 110-volt 60-cycle, data are also furnished for a frequency of 25 cycles. To wind a primary for 220 volts, double the number of turns listed for 110 volts are used, but a wire having half the area, or half the

number of circular mils, as shown by one of the tables, must be selected.

To illustrate the simplest type of transformer, imagine a closed iron ring, or core, with two separate coils of insulated wire wound around the ring; they can be either superimposed, one upon the other, or placed on opposite halves of the ring, but in both cases must be insulated electrically. One of the coils is connected to a source of alternating current, thus causing a succession of impulses to be sent through the coil, first in one direction and then in

the other. One impulse tends to magnetize the core; the succeeding one magnetizes it again, but with opposite polarity; thus the magnetism in the core is being continually built up, broken down, and built up in the opposite direction. This means that the number of lines of force through the iron continually changes, building up to their maximum number, dying down to nothing, and then building up again with opposite polarity. A well-known fact is that

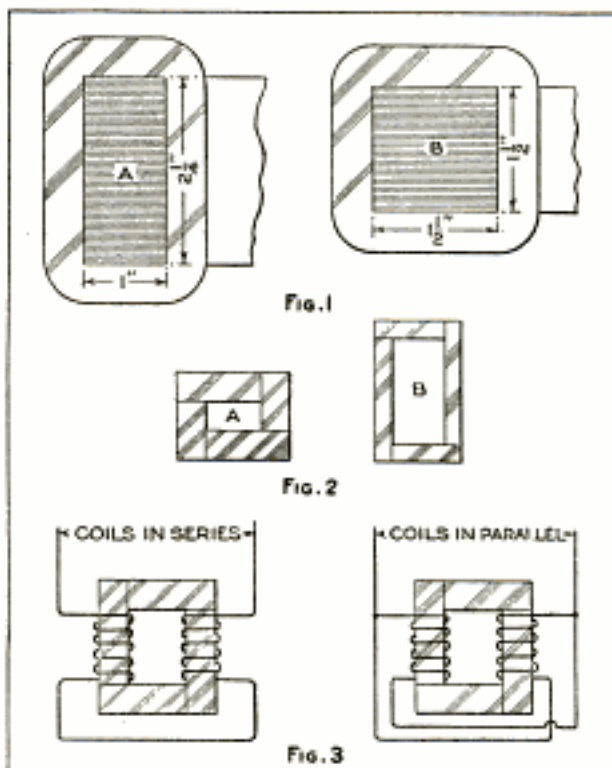

Fig. 1 Shows How Core Shape Influences Length of Wire Necessary; Fig. 2, Poor Core Designs; Fig. 3, How Coils are Connected in Series and in Parallel

a change in the number of lines of force in a magnetic circuit will induce an electric current in any coil of wire surrounding the magnet; hence currents will be set up or induced in the second coil, and as the core changes its polarity at every alternation of the energizing current, the induced, or secondary, current will be alternating like that in the primary, though the two coils are insulated from each other and have no connection electrically.

The amount of electrical energy obtained from the secondary coil, however, can never quite equal that sent into the primary. What causes this loss? In the first place, it takes work to magnetize, demagnetize, and reverse the magnetism in the iron core many times a second, and, especially if the core is of solid iron, much energy is lost through heating the core. Never attempt to construct a transformer core of solid iron; all cores used in alternating-current work must be built up of thin iron or steel sheets, or "laminated"; this is to break up the mass of the core and prevent the formation of stray or eddy currents within the core, which cause a big rise in temperature. In fact, a solid-iron core would cause the windings quickly to burn out. Even with the best laminated core, there will still be a certain core or iron loss, and a copper loss due to the heating of the windings and the self-inductive effect of the alternating current. We will assume these losses to total from 5 to 10 per cent for a small transformer.

The coil connected to the alternating-current supply is always called the primary, and the one furnishing the induced current the secondary, no matter what the voltage ratio is. Assuming the primary circuit to be closed, but the secondary disconnected, or on open circuit, only a very small current will flow through the primary coil, the few watts that are consumed being used up in magnetizing the core. This can be observed experimentally by putting a low-voltage lamp in series with the primary of a small transformer, and leaving the secondary circuit open. Now suppose that a light load is put on the secondary, such as a couple of low-voltage lamps or a high-resistance coil. This load will draw a small secondary current, with a slight increase of the current through the primary. Then, as the secondary load is increased, as by putting more lamps in the circuit, the primary current will increase with the secondary, until, assuming that the secondary terminals are directly connected

so as to form a "dead short," an enormous amperage might be drawn from the secondary and a corresponding current through the primary, resulting in the blowing of fuses, or the burning out of the transformer. Thus we see that there is automatic regulation between the amperes flowing through the two windings, and that they increase and decrease in proportion, which should dispose of the question often asked: "How many amperes can be obtained from the secondary winding?" This depends altogether upon the character of the load connected to the secondary. There is a type of commercial transformer known as the constant-current transformer, in which the amperage is kept practically constant at varying loads, but this kind is not considered here.

The voltage of the secondary, on the other hand, can be assumed to remain practically constant as long as the primary voltage does not change. This brings up another of the common inquiries: "How much wire is required to give a certain secondary voltage?" The secondary voltage depends absolutely upon the ratio between the *number of turns* in the primary and secondary coils, and is proportional to the number of turns. If a transformer has 1,000 turns in the primary and the primary voltage is 100, then with a secondary of 1,000 turns the voltage will be 100 also; with 500 turns, one-half of 100, or 50 volts; with 250 turns, one-quarter, or 25 volts, and so on. The formula is:

$$\frac{\text{No. turns primary}}{\text{Primary voltage}} = \frac{\text{No. turns secondary}}{\text{Sec. voltage}}$$

To change to a different secondary voltage, it is only necessary to alter the number of turns of wire in the secondary coil according to the above proportion; no change is made in primary winding or core.

Assuming that it is desired to design a small single-phase transformer to operate on an alternating-current circuit of known voltage and frequency, there is a fundamental formula that will enable one to start the work:

$$N = (E \times 100,000,000) \div (4.44 \times F \times B \times A),$$

in which

- N = Number of turns of wire in primary coil, (unknown).
- E = Primary voltage, (known).
- F = Frequency of current, (known).
- B = Number of magnetic lines of force (flux) through the laminated core of transformer, (assumed).
- A = Cross-sectional area of transformer core, (unknown).

B varies with the different core material used; with ordinary sheet iron or "stove" iron, often used by amateurs, 40,000 lines

per square inch may be assumed; with transformer iron or silicon steel, if a definite figure cannot be obtained from the makers of the steel, 60,000 may be assumed. We are now left with two unknown quantities, N and A, and the usual method is to assume a value for A and then calculate N. The larger the core cross section A, the fewer the number of primary turns required, but the larger and heavier the core; reducing A means a lighter core but more wire, so the thing to do is to strike a happy medium; if a quantity of suitable wire is at hand, but the core iron has to be bought, the amateur can well afford to reduce the size of the core for the sake of economy, and vice versa. For instance, the core of a 500-watt transformer, 1½ in. square, will contain 13 lb. of iron, which may cost \$4.10, assuming a certain market value; 770 ft. of No. 14 copper wire would be needed for the primary winding, costing \$7.40, making a total cost of iron and copper of \$11.50. If the core is made 2 in. square, 20 lb. of iron, costing \$5.50, will be used; but 440 ft. of No. 14 wire will now be required, at \$4.12, the total cost thus being \$9.62. The smaller core, however, is lighter and better proportioned, so the prospective builder will have to figure out the most suitable combination for his purpose. As a guide, the core proportions given in the accompanying tables can be followed, being modified where necessary. A core need not be square, but this shape requires a minimum length of wire for the same number of turns (see Fig. 1, B); a wide narrow core, while of the same cross-sectional area, as in Fig. 1, A, will take more wire for each turn, resulting in a considerable increase in weight, length, resistance, and cost of the wire. A core should not be too heavy and stocky nor too long and thin, as in Fig. 2, unless some special purpose, as in the magnetic-leakage type of core, requires a sacrifice of efficiency. For the same number of primary turns, a lower frequency means a larger core, as can be seen by comparing the dimensions of the 60 and 25-cycle cores in the table. Having set a value for A, leaving but one unknown quantity N in the fundamental formula, the number of primary turns N can now be found by substituting the known values.

To simplify matters, the actual laying out of a 500-watt transformer, adapted to amateur design and construction, will be described; one of any other capacity may be worked out by substituting values and referring to the tables. Suppose the volt-

age E of the supply mains is 110, and the frequency F 60. Allowing a 10-per-cent core and copper loss for an amateur-built transformer, the total primary wattage would have to be 500 plus 10 per cent, or 550. To find the actual primary current

COPPER-WIRE TABLE

GAUGE B.&S.	DIA. BARE IN.	DIA. S.C.C. IN.	DIA. D.C.C. IN.	FT. PER LB. S.C.C.	FT. PER LB. D.C.C.	AREA, CIR. MILS.
10	0.1019	0.108	0.112	30.6	30.5	10,350
11	0.0907	0.097	0.101			8,234
12	0.0808	0.087	0.091	50	48	6,530
13	0.0719	0.078	0.082			5,178
14	0.0641	0.070	0.074	84	77	4,107
15	0.0570	0.063	0.067			3,257
16	0.0508	0.056	0.059	125	125	2,583
17	0.0452	0.050	0.053			2,048
18	0.0403	0.045	0.048	200	200	1,624
19	0.0359	0.040	0.044			1,288
20	0.0319	0.036	0.040	311	461	1,022
21	0.0284	0.032	0.036			810
22	0.0253	0.029	0.033	491	745	642

ENAMELED WIRE

GAUGE, B.&S.	FT. PER LB.	TURNS PER INCH		
		ENAMEL	S.C.E.	D.C.E.
12	50		12	11
14	79		15	13
16	126		18	17
18	200		22	21
20	319	29	25	25
22	507	36	31	30

S.C.E.—SINGLE COTT. AND ENAMEL.  
D.C.E.—DOUBLE " " " "

This Table will Be of Assistance in Selecting the Proper Size of Wire to Use in the Transformer

in a circuit of this kind, we cannot use Ohm's law, but must consider the power factor; this can be assumed at about 85 per cent for a small-transformer primary. First find the current as though the circuit were direct current, dividing the watts by the volts, or 550 divided by 110, or 5 amp. But the actual current will be more than this; divide the 5 by .85, the power factor, the result being 5.88, or nearly 6 amp., which will be the full-load primary current. Use will be made of this a little later.

A well-proportioned core, if made of stove iron—usually easiest obtained by the home worker—would have a cross section of 1½ by 1½ in., or 2¼ sq. in.; this will be A in the formula, while B is assumed as 40,000 lines per square inch. The number of primary turns N can now be calculated by substituting in the fundamental formula:

$$N = (110 \times 100,000,000) \div (4.44 \times 60 \times 40,000 \times 2.25) = 460 \text{ turns}$$

If silicon steel or transformer iron is available, a smaller and lighter core can be made, using 460 primary turns as above. This can be seen by calculating A from the fundamental formula, using 460 for N, and 60,000 instead of 40,000 for B; A is then found to be about 1½ sq. in.

SINGLE-PHASE TRANSFORMER DATA, 50 TO 1000 VOLT-AMPERE CAPACITY

VOLT-AMPERE CAPACITY	60-CYCLE CORE												PRIMARY WINDING											
	STOVE IRON				SILICON STEEL				110 VOLTS, 60 OR 25-CYCLE				220 VOLTS											
	LEG SHEETS	YOKE SHEETS	THICKNESS IN., COM. APPROX.	WEIGHT IN LB.	CROSS SECT. SQ. IN.	LEG SHEETS	YOKE SHEETS	THICKNESS IN., COM. APPROX.	WEIGHT IN LB.	TOTAL WT. LB. APPROX.	TOTAL LENGTH FT. APPROX.	TURN PER LAYER	LAYERS PER LEG	TOTAL TURNS	SIZE WIRE B. & S.									
50	1 X 3 1/4	1 X 2 1/2	* 1	2.9	.75	2 X 2 1/2	2 X 2	† 1	1.8	1000	2 1/4	580	50	10	2000	25								
100	1 X 3 1/2	1 X 2 3/4	1	3.1	.75	2 X 3	2 X 2 1/2	1	2.2	1000	2	580	50	10	2000	23								
200	1 1/2 X 3 1/2	1 X 3 1/4	1 1/8	3.8	.75	2 X 3	2 X 2 3/4	1	2.4	920	3	580	46	10	1840	21								
300	1 1/2 X 3 1/2	1 1/2 X 4	1 1/8	9.4	1.37	1 X 4 1/2	1 X 3 1/2	1 1/8	5.6	500	14	292	50	5	1000	17								
500	2.25 X 3 1/2	1 1/2 X 4	1 1/2	10.7	1.54	1 1/2 X 5	1 1/2 X 3 1/2	1 1/2	6.6	480	4	325	46	5	920	17								
800	2.6 X 3 1/2	1 1/2 X 4 1/2	1 1/2	13.3	1.72	1 1/2 X 5 1/2	1 1/2 X 4	1 1/2	8.0	440	8	640	50	8	4400	14								
1000	4.0 X 3 1/2	2 X 5	2	23.0	2.62	1 1/2 X 6	1 1/2 X 4 1/2	1 1/2	13.7	270	6	450	54	5	4400	14								
BELL RINGER	.37 X 2 1/2	2 X 1 1/4	1/2	.8				SAME		2200	34	1/2	100	22	4400	38								
<b>25-CYCLE CORE</b>																								
50	1 1/2 X 4 1/4	1 1/2 X 3 1/2	1 1/8	9.7	1.75	1 1/2 X 3 1/2	1 1/2 X 3	1 1/8	5.9	18	36	54	73	91	136	180	290							
100	1 1/2 X 4 1/4	1 1/2 X 3 3/4	1 1/8	10.3	1.75	1 1/2 X 4	1 1/2 X 3 1/2	1 1/8	6.3	18	36	54	73	91	136	180	290							
200	1 1/2 X 4 1/4	1 1/2 X 4 1/4	1 1/8	10.9	1.75	1 1/2 X 4 1/4	1 1/2 X 3 3/4	1 1/8	6.9	33	50	67	83	125	167	259	417							
300	2 X 6 1/2	2 X 5 1/2	2 1/4	27.6	3.3	1 1/2 X 5 1/2	1 1/2 X 4 1/2	2	16.9	18	27	37	45	68	91	145	230							
500	2 X 7	2 X 5 1/2	2 1/2	33.1	3.6	1 1/2 X 6	1 1/2 X 4 1/2	2 1/8	18.9	17	25	33	42	64	84	113	210							
800	2 1/2 X 7 1/4	2 1/2 X 6	2 1/2	42.0	4.1	2 X 6 1/2	2 X 5	2 1/8	23.1	22	29	31	55	73	116	162	218							
1000	3 1/2 X 8	2 1/2 X 6 1/2	3 1/8	66.7	6.1	2 1/2 X 7	2 1/2 X 5 1/2	2 1/8	38.1															
BELL RINGER	.75 X 2 1/2	2 X 1 1/4	1	.8	.6	2 X 2 1/2	2 X 1 1/2	1	1.1	NO.25 B.&S.	TAP AT 100,200,300 TURNS	APPROX. 3.5 & 7 VOLTS	15 V. 18 #14 WIRES IN PARALLEL 18 SECTIONS OF 6 TURNS PER LAYER, 8 LAYERS											

\* - STOVE-IRON CORE {0.25} REQUIRES ABOUT 35 SHEETS TO INCH WHEN COMPRESSED  
 † - SILICON STEEL {0.14}

\*\* - 400 TURNS ON EACH LEG AND LESS IN PARALLEL, 2 NO.14 WIRES IN PARALLEL  
 \*\*\* - CONNECT PRIMARY COILS IN SERIES FOR 220 VOLTS

TO OBTAIN TWICE THE VOLT-AMPERE CAPACITY & TWICE PRIMARY VOLTAGE: DOUBLE THE CROSS-SECTIONAL AREA OF CORE, KEEPING SAME NO. PRIMARY TURNS, AND SAME WIRE SIZE. TO OBTAIN TWICE THE VOLT-AMPERE CAPACITY BUT SAME PRIMARY VOLTAGE, DOUBLE THE CROSS-SECTIONAL AREA OF CORE, & USE WIRE OF TWICE THE AREA, BUT SAME NO. OF TURNS. SIZE OF SECONDARY WIRE DEPENDS UPON MAXIMUM CURRENT TO BE CARRIED AT LOWEST VOLTAGE TAP, AND MUST BE CHOSEN FOR EACH INDIVIDUAL CASE. SEVERAL SMALLER WIRES IN PARALLEL ARE PREFERABLE TO ONE HEAVY WIRE OF THE SAME TOTAL AREA, WHICH WOULD BE STIFF AND DIFFICULT TO WIND.

Winding Data, Formulae, and Winding Suggestions for the Design of Small Transformers for Use on Both 25 and 60-Cycle Alternating Current: It should be Borne in Mind That the Table is Intended to Serve Only as a Guide, and Some Experimental Calculation Is Necessary before Deciding Definitely on Any Size of Core or Winding

instead of  $2\frac{1}{4}$  sq. in., and a core 1 in. wide and  $1\frac{1}{2}$  in. thick, or  $1\frac{1}{4}$  in. square, would suffice. Or, if the core is kept the same size as when stove iron was used, or  $2\frac{1}{4}$  sq. in., a smaller number of turns, 306, can be put on, as found by substituting 60,000 for 40,000.

Before going farther, the proper size of the primary wire must be determined. The actual full-load current was found to be 5.88 or practically 6 amp., and a wire must be chosen of such diameter or cross-sectional area that this current can be carried without overheating. A home-made transformer is generally operated intermittently and not for long periods, so that a smaller wire can be safely used than if an all-day full-load current is carried. The builder must decide upon the operating conditions and choose his wire accordingly. Copper-wire areas are expressed in circular mils, and it is customary to allow 1,000 circular mils per ampere for continual full-load running. Six amperes will, therefore, call for a wire having an area of 6,000 circular mils; referring to the table, No. 12 wire is seen to be suitable, as it has an area of 6,530 mils, but for intermittent service, No. 14, 4,107 mils, can safely be used.

Next draw out a full-size outline of the proposed core. One 7 in. high and 6 in. wide, with sheets  $1\frac{1}{2}$  in. wide, may be tried; this will give a "window," or inner winding space, 4 in. long, and the actual coils should be about  $\frac{1}{4}$  in. shorter than this. The window will be 3 in. wide, but the core may be made narrower if the calculated thicknesses of the coils will allow it. Assume that each layer will have 50 turns of No. 14 d. c. c. copper magnet wire; the table gives the diameter of this wire as .074 in. This multiplied by 50 gives 3.7 in., which will be the length of the coil, and be within the limits of the winding space. Now to find the number of layers. Half the primary turns, or 230, will be wound on each leg, and 230 divided by 50 gives 4.6 layers. This means that the layers will not come out even, and while this would not be a great objection, there is a possibility that, with a little juggling of turns and layers, a better combination may be found.

Trying 46 turns to the layer, the length of the coil will be 46 multiplied by .074, or 3.4 in.; this will leave a  $\frac{1}{4}$ -in. space on each side of the coil, and the core might be shortened  $\frac{1}{4}$  in. to suit. Dividing 230 by 46 gives an even 5, so that 5 layers, of 46 turns to the layer, will be decided upon. Five layers of No. 14 wire will be at least  $5 \times .074$ , or 3.7 in. thick,

and, allowing for insulation, and the springing of the wire while being wound,  $\frac{1}{2}$  in. is none too great for the space occupied by the coil in the inner winding space of the core.

As for the secondary winding, suppose a stepped-down voltage of 12 is desired, with a primary voltage of 110 and 460 primary turns. *The number of secondary turns* is found from the proportional formula:

$$460 : \text{Sec. turns} = 110 : 12, \text{ or } 50 \text{ secondary turns.}$$

The secondary output at full load being 500 watts at 12 volts, the secondary full-load current will be about 500 divided by 12, or 42 amperes, requiring a wire having a cross section of about 42,000 circular mils. This would mean a very heavy wire, even for intermittent service, impossible to wind satisfactorily in a small space, so we will use the same size wire as used in the primary, or No. 14 d. c. c., but wound in several sections which will all be connected in parallel, as indicated in Fig. 3, giving the same result as though the large wire had been used. Eight No. 14 wires in parallel will have a total area of 32,856 mils, sufficient for intermittent operation. This would correspond to a single No. 5 wire, .182 in., or nearly .2 in., in diameter. There will be four sections, each of 50 turns, on each leg; if made with 10 turns per layer, four sections would occupy 3 in. of winding space; five layers will be wound on each section. If each section is wound separately, the four will occupy about the same length of winding space as the primary coil. The total thickness of each primary coil, with the superimposed secondary sections, will be  $10 \times .074$  in. or  $\frac{7}{4}$  in. for the wire alone, there being five layers in both primary and secondary. Allowing for insulation of core and windings and the springing of the wire turns, at least 1 in. should be allowed for the total thickness of the coils on each leg; or to be on the safe side, make the window in the core  $2\frac{1}{2}$  in. wide. The core sheets being  $1\frac{1}{2}$  in. wide, this would make the yoke sheets  $1\frac{1}{2}$  in. wide and 4 in. long, and since  $\frac{1}{4}$  in. was taken from the original leg-sheet length, these will now be  $1\frac{1}{2}$  in. wide and  $5\frac{1}{4}$  in. long; and the outer dimensions of the core, as built, will therefore be  $6\frac{3}{4}$  in. high,  $5\frac{1}{2}$  in. wide, and  $1\frac{1}{2}$  in. thick.

If several taps are taken from the secondary winding, to furnish different voltages, it will be seen that the heaviest full-load current will be taken from the winding furnishing the lowest voltage, and the size wire suitable for such cur-

rent may be chosen for this section and used throughout, or the remaining sections can be wound with small wire, as determined by the full-load current to be drawn from each tap. A wire sufficient to carry 10 amp. at 50 volts, for instance, would be too small for the 50 amp. that could be drawn, at full load, from a 10-volt winding tapped from the secondary coil; a 20-volt tap could carry 25 amp. The 10-volt section could be wound with eight No. 14 wires in parallel; part of this coil would, of course, carry the current going through the 20-volt tap, but the remainder could be wound with four No. 14 wires in parallel, while the number of turns necessary to make up the 50-volt

winding could be made up of two No. 14 wires in parallel. The use of No. 14 wire is, of course, not essential, as long as the total area is correct, but this size is easy to obtain, and fairly easy to wind on a small core.

As actual constructional details of small-transformer building are not to be taken up in this article, practically all the fundamental points of design have been described, and, with the assistance of the tables for guidance—there is nothing hard and fast about the data given—the amateur should be able, with a little good judgment and common sense, to build a small transformer suited to any of his needs.

### Saving Seed from Barn Chaff

Thousands of dollars' worth of clover and timothy seed are lost every year in handling it as food for stock. When the

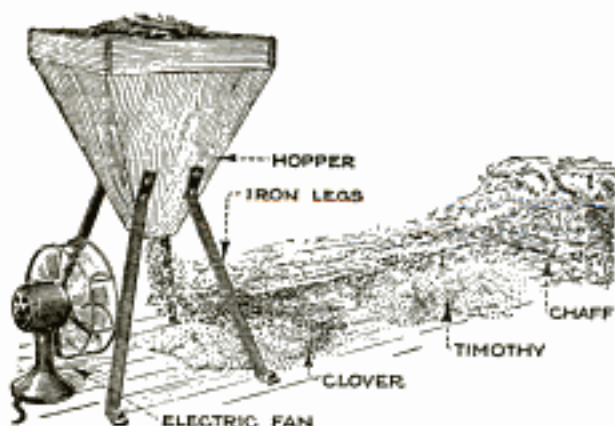

Saving the Timothy and Clover Seed from the Waste of the Hay Loft: This Is Only One of the Uses to Which the Fan can be Put on the Farm

hay is taken from the loft, quantities of chaff or sweepings are left; this is used for bedding, destroyed, or thrown away, and the seed contained in the refuse is wasted. Much of this could be saved with a fanning mill, but in the absence of such equipment, an electric fan, driven by the farm electric plant, will answer.

A small wooden hopper, set on iron legs, is made as shown. After a quantity of sweepings have accumulated, a space in the driveway is swept clean, and the apparatus set up as illustrated. When the fan is turned on, the chaff is fed into the hopper, and it sifts down into the air blast, which separates the refuse in the manner shown, according to the weight of chaff and seeds.

☛ When broaching cast iron, use soda and water as a lubricant.

### Template for Laying Out Keyways

In machining a number of small rocker arms, it was required that the keyway be placed exactly on the center line of the two holes. As there was no great quantity of these to run, an expensive jig for laying out the keyways was out of the question, so the template illustrated was used for accurately locating the grooves. A piece of  $\frac{1}{8}$ -in. flat steel was used to make the template. The center distances were accurately laid out on this, and the position of the pins located. The pins were  $\frac{1}{8}$  in. in diameter, and when pressed in, projected  $\frac{1}{8}$  in. on each side of the plate. These pins were placed so that the edge of the plate was parallel to the center line of the rocker arm, at a distance of half the width of the keyway from it. By placing the template over the rocker arm and rocking it until the lowest position is found, one side of the keyseat may be scribed, then by turning the plate over and repeating the operation on the opposite side of the holes, the other side of the groove is marked.

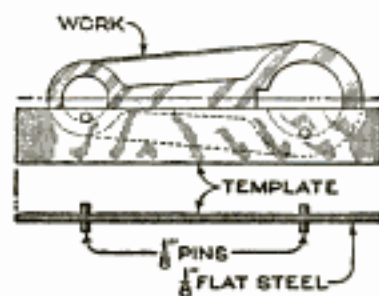

### Salvaging Interior Woodwork

In the wrecking, remodeling, and altering of buildings, it is sometimes imperative or expedient to save the inside finish, such as casings, baseboards, molding, or other trim, for use again. Efforts to draw the nails generally result in marred surfaces, as the puttied nail



heads cause the surrounding wood to splinter, leaving an ugly wound that is difficult for the painter to conceal entirely. To overcome this, I have found that, by placing the piece to be salvaged with the nail head resting on a block of soft wood and striking the point of the nail a sharp blow with the hammer, the nail will, in most cases, be driven through the piece without marring it. The block of wood underneath the nail heads acts as a die, allowing the nail to punch out the putty neatly. The same hole can be used when nailing the piece up again and can be finished by the painter to look like new work.—Francis Wilkin, Pittsburgh, Pa.

### Repairing Spokes in Tractor Wheels

While attempting to back my tractor into position for belting to a corn sheller, the clutch refused to disengage, and before the machine could be stopped, it had backed into a near-by stump, with the result that

three spokes in one of the drivewheels were broken. The wheels were of the type using round steel spokes cast into the hub, so that it was impracticable to replace them. In order to repair the broken spokes, an

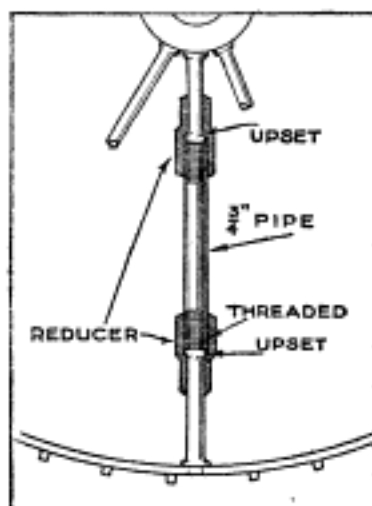

8-in. section was cut from each, and a  $\frac{3}{4}$  to  $\frac{1}{2}$ -in. pipe reducer was slipped over each of the broken ends of the spoke, after reaming the threads from the smaller ends of the reducers. The ends of the spokes were then heated with a blowtorch and upset so as to form a head for holding the reducers. After the ends of each spoke had been thus prepared, a piece of  $\frac{3}{4}$ -in. pipe was cut an inch longer than the distance between the reducers when they were pulled up snugly against the upset heads. The pipe section was then inserted between the reducers and each of them was screwed onto the threaded ends of the pipe by hand, after which two pipe wrenches were used to draw the reducers up until the proper tension had been obtained in the spoke.—G. G. McVicker, North Bend, Neb.

### Shims Cut from Old Gaskets

When replacing some connecting-rod caps, a shortage of shims started a search for suitable material from which to cut

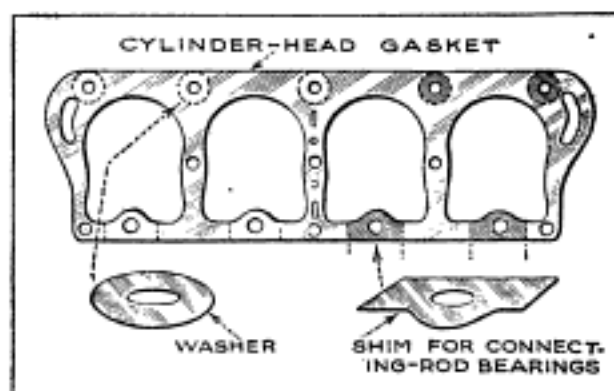

Shims and Washers for a Variety of Purposes can be Cut from Around the Stud Holes of a Discarded Copper-and-Asbestos Cylinder-Head Gasket

them. An old copper-and-asbestos cylinder-head gasket, which had been replaced by a new one, was the only available material. Pieces cut from around the bolt holes of the gasket provided satisfactory shims and washers, as the punched holes were suitable for the cap bolts and the edges matched up well with the connecting-rod caps. A pair of tin snips was found to be the best tool to use in cutting.—G. A. Luers, Washington, D. C.

### A Novel Planer Clamp

The drawing shows a very useful form of planer clamp. The 60° "tooth" of the clamping member is on a higher plane than the axis of the bolt, and this member is made of tool steel, while the body part is made of gray iron. When the elevator screw is

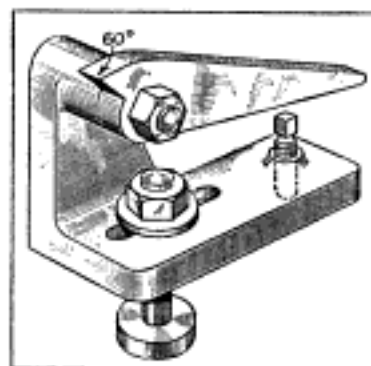

raised, a downward and inward pressure is exerted on the work. When used on work having finished surfaces, a block of soft metal is placed between the tooth and the work. Clamps of this sort should be used in pairs, so that a clamp on one side of the work will be directly opposite the one on the other side, and the slot in the base should be long enough to allow the clamp to be bolted to the planer table in almost any position.—Ralph Hanenkratt, Northville, N. Y.

### Wrench Made from a Coil Spring

A special coil spring, together with a screwdriver, form a wrench that is very handy for driving thin tubes, polished

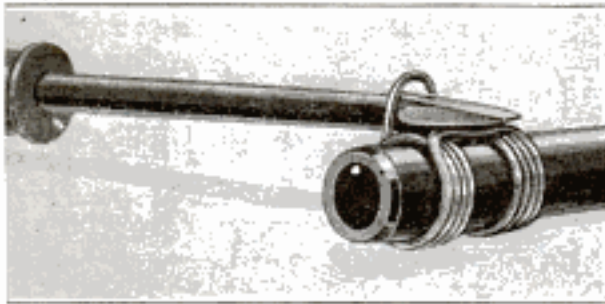

For screwing up thin tubing, the application of a coil spring and screwdriver in place of a pipe wrench will be found an ideal method.

studs, or other work of a similar character, into place. It is not, of course, in cases of this kind desirable to use a pipe wrench, which would mar or dent the surface, and for this reason the coil-spring wrench is ideal because it grips evenly all around. The shape of the spring is clearly shown; three or four coils formed on either side of a loop, the screwdriver being inserted in the latter and pressing on the ends of the spring. The spring is made a good fit for the work, so that when the screwdriver is inserted in the loop and pressure applied, the spring coils will contract and grip the work tightly. The same idea can be used when space is so limited that a complete revolution of the wrench cannot be made, as the spring slips easily in the reverse direction and tightens immediately on the forward thrust.

### On Cleaning Tracings with Gasoline

Gasoline is generally used for the cleaning of tracing-cloth drawings, and some trouble is occasionally encountered in getting good blueprints from tracings so cleaned. By experiment it has been found that, where powdered soapstone or talc has been used to rub off the surface of the tracing cloth before inking in the lines, the ink seems to be held in suspension, so that when the work is cleaned as described, the lines become quite faint. A large number of draftsmen refuse to use prepared powders for this purpose on account of their gritty and unpleasant feeling. Common chalk, however, has been found to overcome both of these objections, and allows the ink to make a permanent line that is unaffected by cleaning with gasoline.

### Protecting Wood-Plane Cutters

A few short lengths of a discarded inner tube are valuable articles in a kit of woodworking tools. By snapping one over each plane, so that the edge of the iron is entirely covered, there is slight possibility of a damaged cutting edge resulting from contact with other tools.

### Lathe Spindle Made from Pin Vise

A small attachment that can be applied to a sewing machine for work on small pins and similar operations is made from an ordinary

pin vise, supported on bearings and driven by a small pulley. A simple casting is required to furnish a bearing for the handle of the vise, and the pulley,

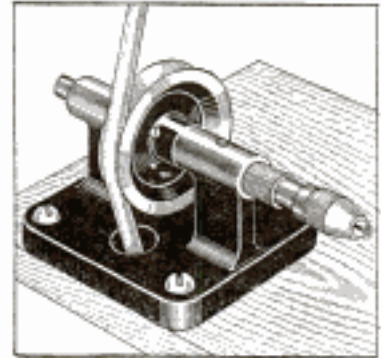

placed between the bearings, prevents the tool from coming loose. A setscrew is used for fastening the pulley to the handle of the vise. In use, the chuck can be turned so that the work can be done from either side.

### A Soft-Metal Anvil

The mechanic frequently needs a soft yet firm surface against which to hold polished or plated work without danger

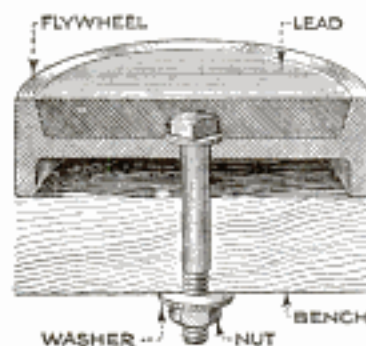

of marring it. A convenient bench anvil of this sort may be made from an old automobile flywheel. The flywheel is fastened to the bench by a bolt passing through the bench top, the head of the bolt being on top, so that the fixture can be removed from the bench when necessary. The anvil is completed by filling the hollow upper surface of the wheel with melted lead, flush with the rim. When the surface of the anvil becomes too much battered, the lead can be removed, remelted, and poured back again.

### Using Old Water Colors

Those who have occasion to use water colors will have observed how hard and dry they become if stored in a dry place, making it very difficult to dissolve them. This condition can be remedied by making a small humidior from a can with a tightly fitting cover, placing a piece of damp blotting paper in the bottom, and the pans of color on top of this. Close the cover, and in 24 hours the colors will have regained their original moist condition, and will dissolve readily.

### Magnifying Runner for Slide Rules

Practically every engineer saves time by using a slide rule to aid him in his calculating, but when very accurate work is

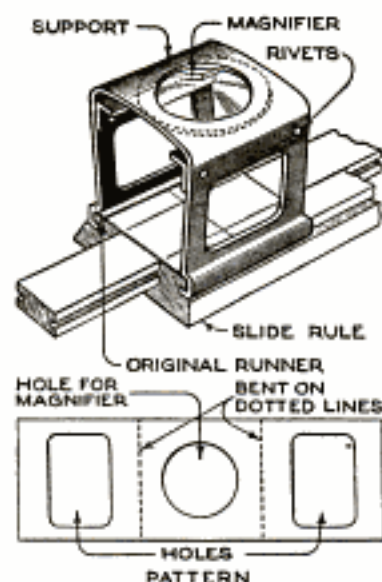

required the ordinary slide rule often is useless, as, for example, when four places of decimals are required, and the rule gives only a three-place result. However, by fitting a magnifier to the rule in the manner shown in the drawing, a fourth place can easily be obtained.

A suitable magnifying lens having been obtained from an optician, an aluminum or sheet-brass frame is made to hold it, as shown. The lens opening in the top of the frame is made about  $\frac{3}{8}$  in. less in diameter than the lens, which is supported by clips riveted to the frame. After the correct focal distance from the magnifier to the scale has been determined, the ends of the support are bent to fit over the ordinary runner. Two rectangular openings must be cut in the sides of the support to admit light and make the reading easier. The great advantage of such a magnifier is that the original runner of the rule need not be altered, but can be used, either without the magnifier, for rough work, or with it, for more accurate calculations, the magnifier being slipped on without disturbing the adjustment of the slide or runner.—C. A. Oldroyd, Barrow-in-Furness, Eng.

### Tumbler Made from Keg

A small manufacturing plant uses the homemade tumbler shown in the illustration for all the work that a small

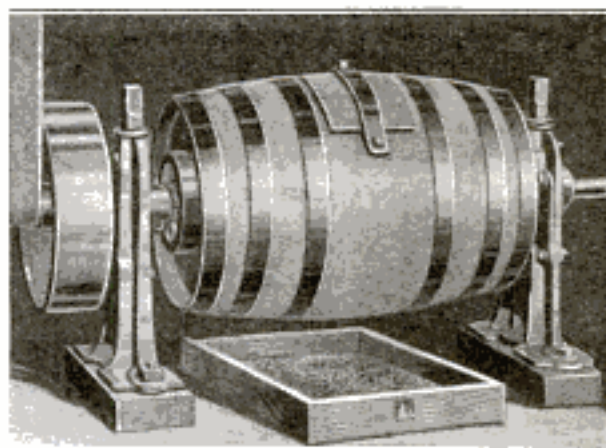

A Simple and Cheap Tumbling Barrel, Made from a Wine Keg: The Barrel is Supported on Small Shaft Hangers, Bolted to a Bench

machine of this type can handle. Simplicity and economy as well as small size being essential, a small wine keg is used. The driving and bearing shafts are attached to flanges bolted to the heads of the keg. The bearings are small shaft hangers. A door is cut in the bilge for filling and discharging.

### A Rapid Screw-Slotting Fixture

The drawing illustrates a simple but effective fixture for use when cutting the slots in screwheads. This clamp will hold 12 screws while a saw cuts the slots. The V-blocks will accommodate several different sizes, and blocks of various sizes can be made to fit the same fixture, as the

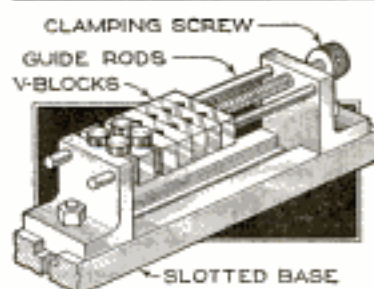

bolt shown at the left can be loosened, the V-blocks slid off the guides, and others substituted. The V-blocks and guides are, of course, hardened to withstand wear. The clamping screw can be varied in size and enlarged to meet conditions. To insure that the screws are properly held between the V-blocks, the holes through which the guides pass must be a loose fit; this allows the blocks to adjust themselves to the inequalities of the individual screws and to hold them steady without crushing the threads.

### A Homemade Piston Vise

When work is to be done on automobile pistons, some method of holding them firmly without danger of injury must be

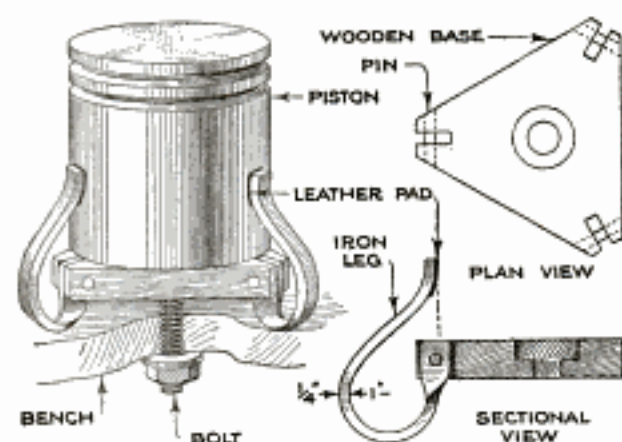

A Simple Clamp for Holding Pistons Securely, and without Danger of Distorting or Scratching Them

used. The drawing shows a piston vise that can be easily assembled by the average worker. The device consists of a wooden base having three pivoted clamps made of  $\frac{1}{4}$ -in. machine steel, bent to the form shown and pinned in slots cut in the corners of the triangular base, so as to allow free movement. The upper end of each leg has a piece of leather riveted to it, to prevent scratching of the pistons. A hole is drilled and counterbored in the center of the base to take a bolt that passes through the workbench.

In use, the nut carried on the bolt on the underside of the bench is drawn up, which causes a downward pull on the wooden base. The clamps are so formed that this pressure will cause the lower ends to spread apart, and make the upper ends close in against the piston. The shape of the legs also gives them a certain amount of spring, which prevents injury to the piston due to excessive pressure.—R. H. Kasper, Philadelphia, Pa.

### Fire Extinguisher Carried by Watchman

A watchman is employed mainly to guard against thieves and fire, and, while he is usually provided with a gun or other weapon of defense against the former, if he discovers a fire, valuable time is generally lost while he runs for help, or a fire extinguisher. Were he prepared to deal with it at once, the fire might easily be extinguished. For this purpose it is well that the watchman should be supplied with a suitable holster in which he can carry one of the small handpump type of fire extinguishers. It is simple to

use, and in this manner a small blaze, that may grow into a fire of dangerous proportions while the watchman runs to summon help and give an alarm, can be put out at once. The holster can be made of leather, in the form of a cylinder, with one or two metal rings fastened to the edge, so that a shoulder strap can be attached with snap hooks. If desired, the holster can be made close-fitting, so that by making an opening in the bottom for the nozzle, it can be operated without removing it from the holster.

### Starting Small Brads

Difficulty is usually experienced in starting small brads into hardwood. To overcome this trouble and prevent the slender



nails from bending, a tool similar to the one shown can be used to advantage. Take a 3-in. length of  $\frac{3}{8}$ -in. steel rod, drill a hole in one end,  $\frac{3}{16}$  in. less than the length of the brad, and a little larger in diameter. Cut a slot, the thickness of the nail head, at right angles to the hole, then shape the end as indicated. To start the brad into the wood the nail is inserted in the position shown and held with one finger, the hammer being used on the other end of the holder.—C. R. Jones, Chicago, Ill.

### Cleaning Threads with Beveled Bolt

Every mechanic will appreciate the advantage of a beveled bolt of the type shown for removing dirt from the threads of a stud hole or nut, when a tap of the proper size is not handy. The motor mechanic, who, after replacing a cylinder head, finds the bolt hole obstructed by a burr, the gasket, or dirt, can use the beveled bolt to clear away the obstruction, so as to get the regular bolt started without loosening all the other bolts again. In cases where the threads have been more or less mutilated, it will help considerably if the tool is casehardened.—G. A. Luers, Washington, District of Columbia.

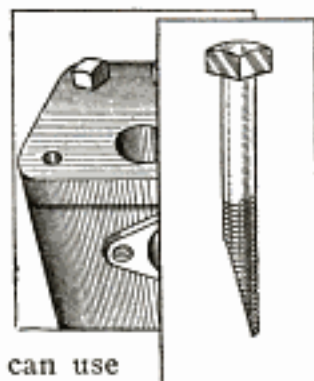

# A Homemade Bench Punch

By CLIFFORD A. BUTTERWORTH

**M**ADE chiefly of wood, the bench punch described in this article is a useful piece of equipment for the small shop. The cost of the materials is small, even though it is necessary to have the few metal parts needed made by a blacksmith or machinist. The compound-leverage principle used in the construction produces a total leverage of 20 to 1, so that metal up to No. 16 gauge can be handled.

The levers and their supports are best made of ash, although any other hardwood can be used. The base is  $1\frac{1}{2}$  in. thick, and two blocks are formed as shown and fastened to it from the underside, with screws. The long wooden piece that forms the punch guide is then bolted down

bushings. The outer support of the hand-lever fulcrum bolt is bolted to a block fastened to the base, another block,  $1\frac{3}{8}$  in. thick, being placed between the lever and guide. The punch holder is made from a piece of  $\frac{3}{4}$ -in. cold-rolled steel rod and is 6 in. long; a  $\frac{3}{8}$ -in. hole,  $1\frac{1}{2}$  in. deep, is drilled in the lower end to take the punch, and the holder is fitted with a setscrew. It is connected to the lever by two small links, of  $\frac{1}{8}$  by  $\frac{3}{4}$ -in. iron, slotted at the upper end. The hole in which the punch works may be lined with babbitt, fitted with a brass bushing, or left plain. A piece of metal is fastened to the underside of the lever to prevent wear. The punches are made of  $\frac{3}{8}$ -in.

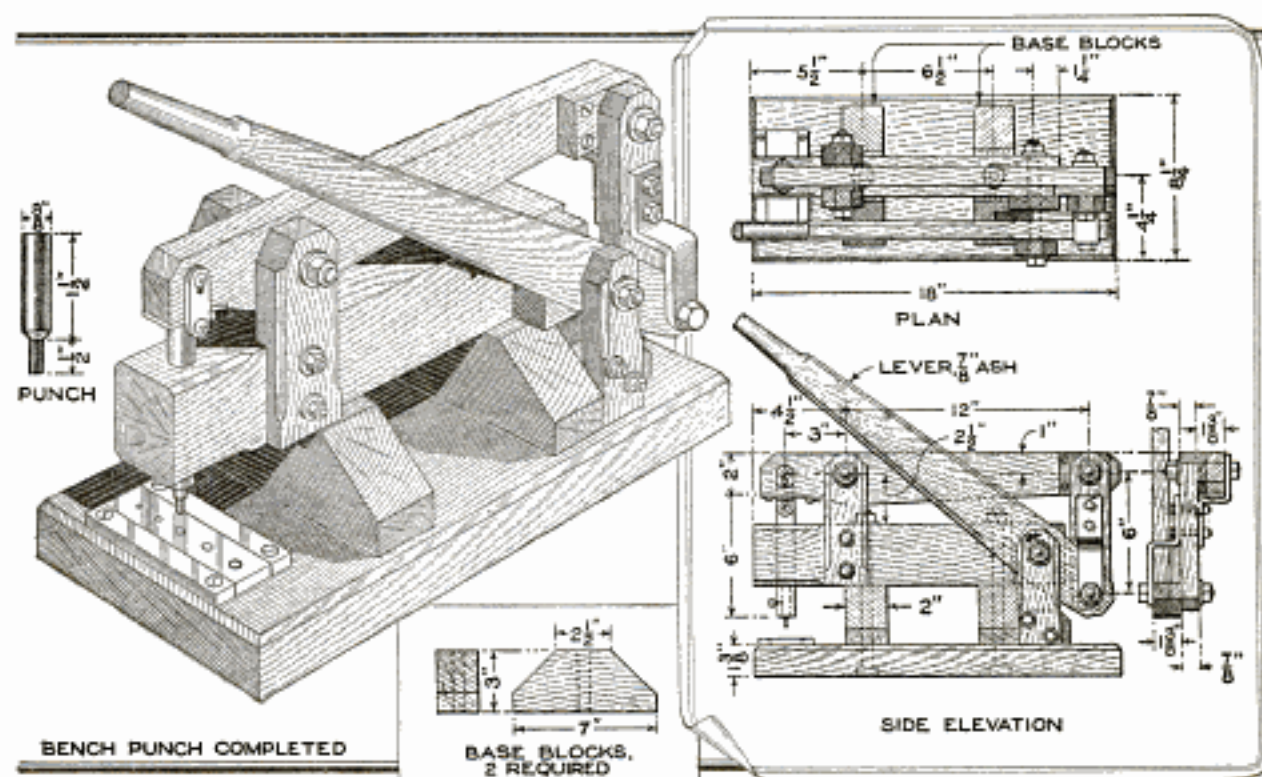

An Easily Made Bench Punch That will Prove of Much Use in the Small Shop: All Heavy Parts are Made of Hardwood, Little Metal Work Being Necessary

with  $\frac{1}{2}$ -in. bolts, the nuts fitting into recesses in the base. The two lever supports near the front are set in so as to be  $1\frac{1}{8}$  in. apart. The supports are made of  $\frac{7}{8}$ -in. stock. The length of the hand lever from end to fulcrum is 19 in., and from fulcrum to link bolt,  $3\frac{1}{2}$  in. Both levers are 3 in. wide at the fulcrum; they work on  $\frac{1}{2}$ -in. bolts, and are fitted with short lengths of brass tubing for bushings. At the back end they are fitted with blocks,  $\frac{1}{2}$  in. thick, to bring them into alignment with the connecting link. The link is made of ash, 2 in. wide, and the two iron brackets of  $\frac{1}{4}$  by  $1\frac{1}{4}$ -in. stock. The bolts fit in the levers tightly, and the link is fitted with

tool steel and hardened. The die is a piece of  $\frac{3}{8}$  by  $1\frac{1}{2}$ -in. tool steel, 5 in. long, with five holes ranging from  $\frac{1}{8}$  to  $\frac{3}{8}$  in. in diameter drilled along the center line,  $\frac{3}{4}$  in. apart; it fits between two pieces of  $\frac{3}{8}$  by  $\frac{3}{4}$ -in. iron screwed to the base.

## Thread-Cutting Compound

A compound for lubricating thread-cutting dies and chasers, that works equally well on all kinds of steel, is made by adding four tablespoonfuls of gum camphor and one tablespoonful of sulphur to each half pint of a half-and-half mixture of lard oil and turpentine.

### A Homemade Farm Winch

All parts of the powerful winch illustrated were picked up around the farm where it was built, with the exception of

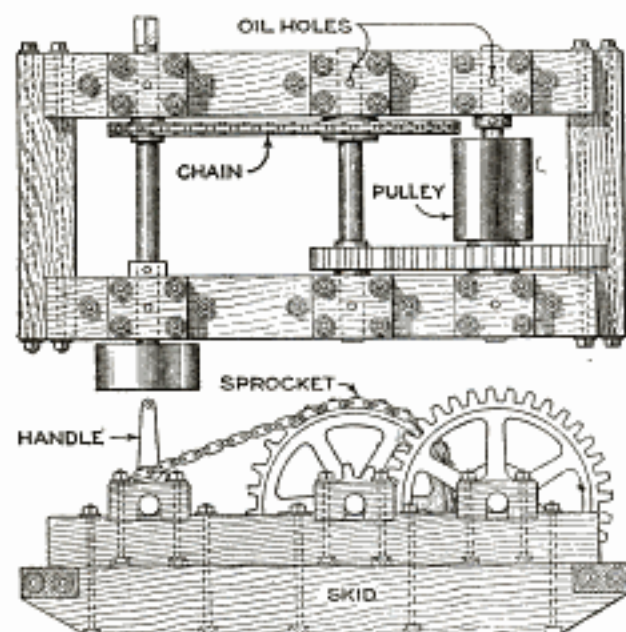

A Powerful Winch, Made from Parts of Old Farm Implements, Provides a Handy Tool for Pulling Stumps, Hoisting Hay, and Similar Work

a few bolts, which were bought from the village junk dealer. All the gears, sprockets, and chains were parts of an old manure spreader, the shafts being cut off to the proper length. The skid beams were made from 10 by 12-in. oak timbers that had been washed ashore on the lake front. The top beams were 8 by 10-in. hemlock. Holes were drilled for bolts, and the wooden parts firmly bolted together with  $\frac{3}{4}$ -in. bolts. All the bearing-cap bolts were drilled in the upper hemlock timbers, and the bolts inserted head down, for ease in removing the caps when necessary. The bearing caps were made from 4 by 10 by 10-in. hardwood blocks, grooved to fit the shafts. The winding drum was made from an old pulley, 9 in. in diameter and 10 in. long, while the driving pulley was 12 in. in diameter with a 5-in. face. The opposite end of the pulley shaft was squared for a crank, so that the machine could be operated by either hand or power. The farmer uses this device for such work as hoisting hay, pulling stumps, dragging logs, and pulling his boat out of the water for the winter. When power is used, the drive pulley is belted to the tractor.

☞ Sand that can be pulverized, that soils the hands, or smells, will not make good concrete.

### Drill Used as Lathe Arbor

The drawing shows how the job of turning 20 spools,  $\frac{1}{2}$  in. in diameter,  $1\frac{3}{4}$  in. long, and having a  $\frac{9}{16}$ -in. hole through the center, was done by a foreign workman. Seven pine blocks,  $1\frac{3}{4}$  in. square by  $6\frac{1}{8}$  in. long, were first cut, and a deep center made in them with a centerpunch, after which a  $\frac{9}{16}$ -in. drill was placed in the turning lathe. One of the blocks was drilled about two-thirds of the way through the center. The lathe was then stopped, and the lips of the drill were forced

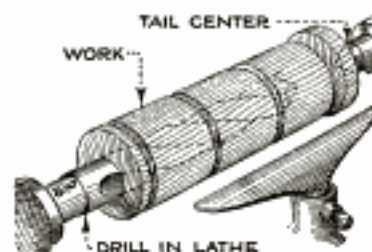

into the bottom of the hole, after which the turning was done, the drill being used as an arbor. The pieces were then grooved on the parting lines, and the hole in the center drilled through, the pieces being afterward separated with a handsaw. Two things must be kept in mind to make a success of this idea. Never attempt to force the point of the drill into the wood while the lathe is running, and follow up the work with the tail center when drilling the hole, otherwise it will not come true in the center of the turned work.—M. E. Duggan, Kenosha, Wisconsin.

### Polishing Bored Holes

When holes of medium diameter are finished by boring and no reamer is available for the size bored, a finish can be given the work by running emery cloth up and down the bore a few times. To keep the bore accurate, however, it is necessary to apply an even pressure on the abrasive. In the case of a short hole, this can be done by wrapping the emery cloth around a piece of wood, but if this

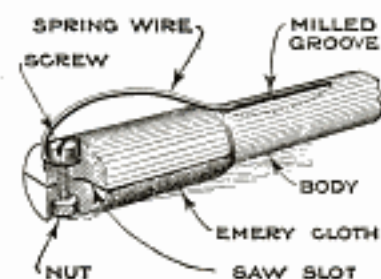

method is used in a longer hole, pressure will be applied at the front of the hole, and little, if any, at the back. The drawing

shows an improved method of polishing a long hole with the certainty of having the pressure evenly distributed all the

way. A piece of round stock is slit down the middle, and at right angles to the slit, near the end, is drilled through, and counterbored on both sides for a screw and nut. One end of a piece of spring wire is bent into an eye to fit underneath the head of the screw, the opposite end of the spring resting in a groove milled in the shank.

Emery cloth is wrapped around the lower half of the split portion, and the screw, with the wire in position as in the drawing, is dropped into place and tightened. When entering the tool into the bore the spring is pressed down with the thumb until the emery cloth is inside; it is then released, providing the necessary pressure; the operator has only to move the tool back and forth in the hole.—Harry Moore, Montreal, Can.

### Automatic Gas Lighter for Typesetting Machines

To permit the gas under the metal pot of a typesetting machine to be turned out at night, in order to save fuel, and also to prevent the loss of time that would be caused by waiting for the metal to melt again in the morning, the automatic lighter illustrated can be used to turn on

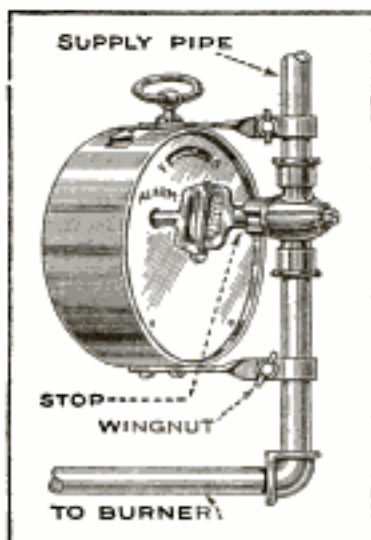

the gas at any predetermined time. A substantial alarm clock has a slotted key fitted to the alarm-winding stem to fit over the cock in the gas-supply pipe. Then the clock is mounted on the pipe by means of two iron clamps. Small bolts and wingnuts are provided so that the clock can be swung out of the way when it is not in use, or for winding. A small pilot light must be placed near the burner so that the gas will light when the cock is opened. An ordinary gaslight pilot can be adapted to the purpose, as the adjusting screw will permit it to be turned off during the time the machine is in use. The pilot light, of course, must be cut in from the "live" side of the gas-supply pipe; that is, from the part of the pipe above the cock.

### Jig for Drilling Ball Handles

To drill a ball-shaped handle similar to the type shown in the drawing is no easy

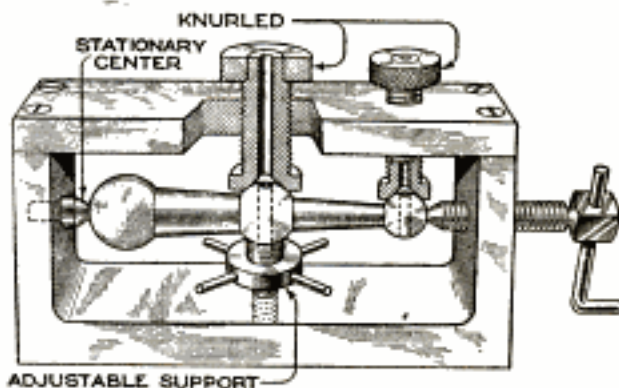

Holes in Ball Handles are Accurately Drilled When the Work is Held in a Jig of the Type Illustrated

matter, unless it is held in some kind of jig, a simple type of which is illustrated.

The ball ends of the handle bear against centers, one of which is stationary and the other adjustable, and as the center holes are generally left in such handles before the final operation, this method of holding the work insures that the holes will be at right angles to the axis. An adjustable support underneath the center of the handle removes the thrust almost entirely from the centers. The drill bushings are threaded into the jig casting, and are provided with knurled heads to make them adjustable for balls of different diameters. The bottoms of the bushings conform to the radii of the balls.

### Making Fillet Tools

The very best kind of a fillet tool can be made from two steel balls, taken from old ball bearings, and a piece of steel rod. Select the size of bearing balls desired and anneal them, preferably in the flame of

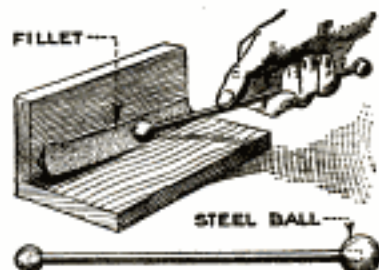

a blowtorch. Allow the heated ball to cool gradually, then drill a hole halfway through each ball; this can be done easily by making a center mark with a punch and holding the ball under the drill in a pair of pipe pliers. The hole should be a drive fit for the steel rod. A different-sized ball is driven onto the opposite end of the rod, producing a tool that can be used on fillets of two different radii.—Glen W. Noble, Jesup, Ia.

### Preventing Leakage through Pump Lubricators

Sometimes a mysterious leak in an automobile, marine, or stationary engine,

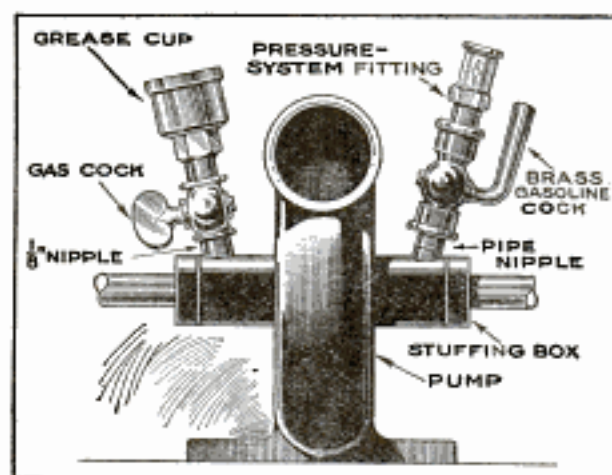

A Simple Remedy for Preventing Loss of the Cooling Water from the Radiator of an Automobile through the Grease Cups on the Pump Bearings

or any machine equipped with a rotary or centrifugal pump, may finally be traced to the grease cups, or other lubricators, supplying the pump shaft. Water will even force its way through the outer threads of a screw cup holding heavy grease, as has often been noticed in the case of small marine engines. Recently an automobile, of popular make, lost considerable water from its radiator, and this was finally traced to the grease nipples on the pump-shaft bearings, the stuffing box and connections being tight.

One sure way to overcome a leak of this character is to place a small cock or valve between the bearing and lubricator, when the lubrication is intermittent, as is usually the case with grease, so that the water cannot back through. A brass gasoline cock, preferably having female ends, may be used, and an old key cock from a discarded gas fixture will also answer. When the grease cup is to be screwed down, or the grease gun applied, the cock is opened, and closed when the greasing is completed. A pressure-system fitting may be fitted, as shown, on the right-hand side of the pump.

### A Handy Tool for Farmers

It is quite impossible for the average farmer to have all the tools he could use at hand at all times. The repairman at his shop has this advantage, and when work is taken to him or he is called on some job, he has just the tools needed to make a good repair quickly.

A pair of bolt clippers, although not a common tool in the farmer's kit, is one of the best timesavers when repairs are to be made. One does not hesitate to use a new bolt or new nuts when time is the main thing to save, but usually the time required to remove the old bolt is many times greater than that required to replace it with a new one. In such cases, the bolt clippers will cut the old bolt or the nut, if not too large, in a second. They will also hold the round head of a carriage bolt while the nut is being removed, when a wrench or pliers will not even grip it. There are several sizes of bolt clippers made, but the No. 2 is recommended as the best for all-around work. The larger ones are too heavy to carry and too unhandy to get into small places.

In emergency cases, when a horse gets tangled in a barbed-wire fence, or when a rod or bar has to be cut to release a person or beast after some accident, the clippers are the surest and most rapid tool to have at hand. The clippers can be used in places where a cold chisel or hacksaw could not, and, where light castings are in danger of being broken by pounding, they are safer.

### Movable Bench for Repair Pit

A desirable feature for the repair pits of automobile garages, and other shops where such pits are commonly used, as

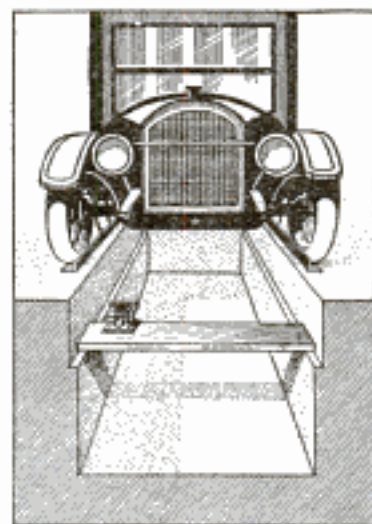

in car barns, is a strong plank that can be used either as a workbench or seat for the workman. As such pits are uniformly made in concrete forms, it is a very simple matter to provide the necessary projections, as shown. Apart from affording a comfortable working position, there will be no necessity to climb out of the pit to reach a vise.

☞ To catch the sparks and emery dust when grinding in the lathe, place a small pan of water under the wheel.





## Building a Sectional Flat-Bottom Rowboat

By F. ST. BOULANGER

**A** NOVEL form of flat-bottom rowboat that has been found very handy on hunting and fishing trips is shown in the illustrations. The boat is made in two sections, and may be transported easily on a light auto; another desirable feature is that, if two men have crossed a stream and one desires to return before the other, he can disconnect and use one section for

in. by 15 ft., for cleats, to be of spruce, the lumber surfaced on all sides; one box of No. 8 flat-head screws,  $1\frac{1}{2}$  in. long; 2 lb. of shingle nails, and twelve  $2\frac{1}{2}$ -in. stove bolts with washers.

Having obtained these materials, the construction is begun by cutting six cleats from the  $1\frac{1}{2}$  by  $1\frac{1}{2}$ -in. stock. Both center cleats are the same length; the end

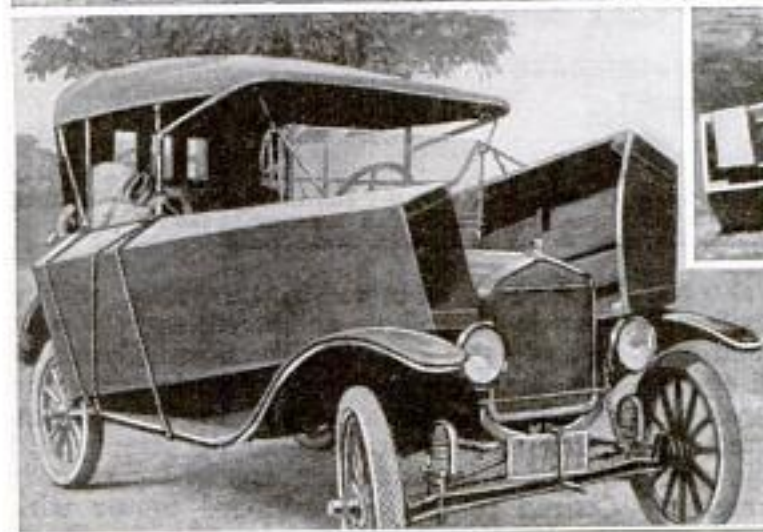
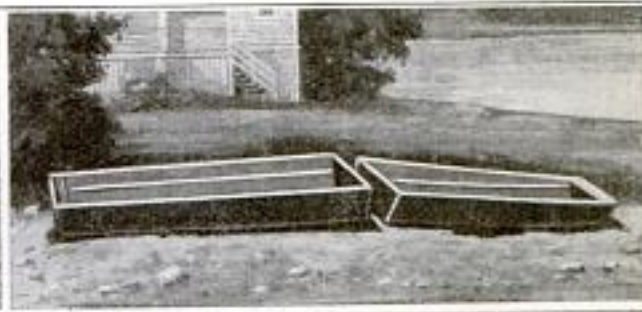
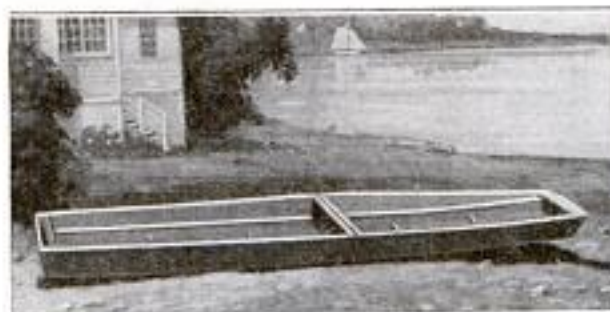

Above: The Boat Sections Shown Fastened Together and Separate. Below: Right, the Sections Nested for Transportation, and Left, Lashed to the Running Board of an Automobile

his purpose, leaving the other section for his partner.

The materials necessary for the construction of the boat are: two boards,  $\frac{5}{8}$  by 12 in. by 16 ft., for the bottom; two pieces,  $\frac{1}{2}$  by 12 in. by 16 ft., for the sides; one board, 1 by 12 in. by 7 ft., for the ends and centers; two boards,  $\frac{1}{2}$  by 5 in. by 16 ft., for footboards, all of cypress; 30 ft. of screen-door molding, for seat rail; one piece,  $1\frac{1}{2}$  by 3 in. by 6 ft., for end braces and cleats; one piece,  $1\frac{1}{2}$  by  $1\frac{1}{2}$

cleats are cut from the  $1\frac{1}{2}$  by 3-in. material. Care must be taken that these pieces fit exactly, otherwise the flare will not be correct, and the cleats will not fit the sides of the boat, when finished. Next, take the two boards that are to form the bottom, lay them edge to edge, insert a 1-in. strip of tar paper that has been well coated with roofing cement in the joint, and clamp together; this forms the rough outline of the boat bottom. Then take the two center cleats and nail them in position loosely, with a tar-paper gasket between the planks and cleats. The cleats are nailed so that their inner

edges are  $2\frac{1}{4}$  in. apart. When properly set, turn over the planks and screw the bottom to the cleats with four or more screws to each cleat. The remaining cleats and the end braces are applied in

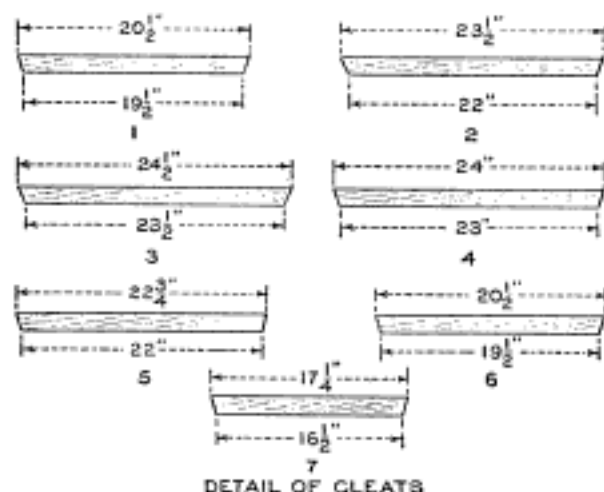

DETAIL OF CLEATS

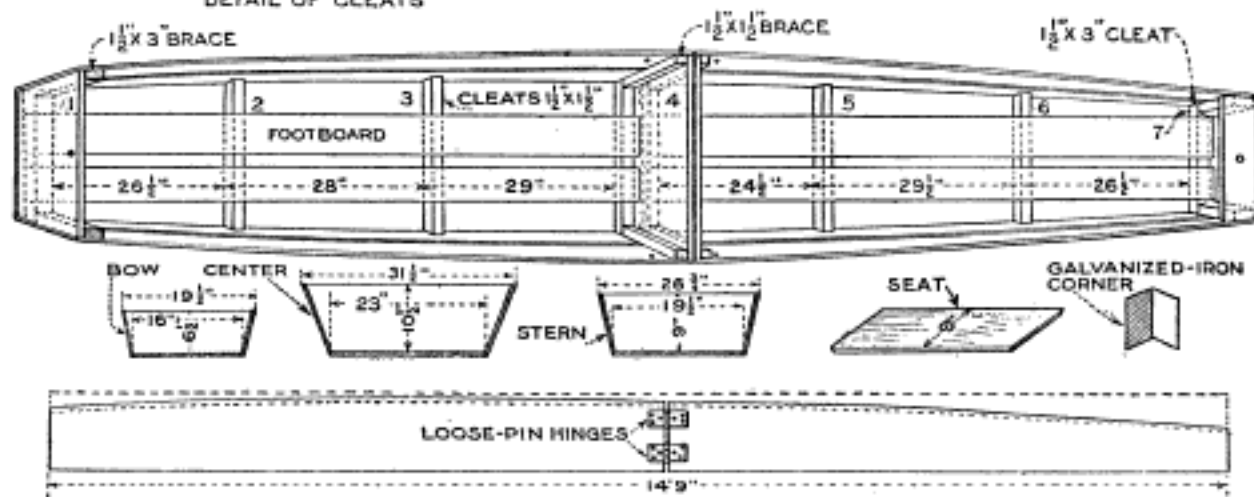

Dimensions and Structural Detail for Building the Two-Section Rowboat, the Halves of Which can be Used Independently by Two Individuals: The Halves of the Boat are Secured Together at the Middle by Means of Loose-Pin Hinges, Fastened to the Sides with Stove Bolts

the same manner, in the positions shown in the drawing. After all the cleats have been set, the planks must be trimmed off at the sides and ends, with a bevel equal to that of the cleat ends. Having done this, the bottom of the boat is finished.

The next step is to cut the ends and centerboards as shown in the drawing, fastening them securely with screws to the proper cleats and braces. Then take one of the boards intended for the sides and tack it so that the upper edge will be flush with the top of the end and center pieces. To accomplish this, it will be necessary to bend the bottom of the boat, thus obtaining the proper curve. The process is repeated on the opposite side, and the boat now begins to take shape. While the boat is thus loosely fastened together, cut the center corner braces from the  $1\frac{1}{2}$  by  $1\frac{1}{2}$ -in. stock, and the end

braces from the  $1\frac{1}{2}$  by 3-in., and fit them as shown. After all the braces are in place, knock off the sideboards and cut gaskets of tar paper to fit every joint, then reassemble the boat piece by piece, tacking the tar-paper gaskets, well coated with roofing cement, in each joint. In the final assembling of the boat it is best to use screws wherever possible, and to space the nails and screws not more than  $2\frac{1}{2}$  in. apart. After the final assembling, trim off the waste of the sideboards to fit the boat bottom. Then heat a quantity of roof cement, and, while it is hot, run it into all cracks to insure a water-tight craft. When this is done, fit the bow board, and the molding that forms the seat rail; the latter should be at least 5 in. from the top of the sides. The footboards may next be laid; these are not essential, but make the boat stronger.

Nail the galvanized-iron corners on the outside of the bow and stern, and the boat is ready to be cut into sections. Carefully saw between the centerboards until the two halves are separated, fit the hinges, using stove bolts instead of screws, and the boat is ready for use. In case it is desired to use an outboard motor with the boat, a 2-in. stern board should be used.

### Removing Paint from the Hands

It is not advisable to use turpentine or gasoline in removing paint from the hands, but, by oiling thoroughly with linseed oil, or, in fact, with any fatty oil, and then thoroughly washing with soap, the paint may be removed, provided the stains have not been allowed to become entirely dry and hard.

### A Rat Alarm

In places where it is absolutely necessary to keep rats and mice away, it is sometimes more desirable to be apprised of their presence than to keep traps and poisons constantly set for the pests. A simple device that will effectively indicate their presence can be made by mounting some screweyes, about  $\frac{1}{4}$  in. from the floor, along the baseboard, then to a height of several feet up the wall, fastening a string to one of these and threading it through the others to a weight which the string is just able to support. The string should be previously boiled in beeswax or paraffin, to which a small quantity of cream cheese has been added. This prevents the string from rotting and serves as a permanent and alluring scent. Rats, on entering, will almost immediately chew the taut string and cause the weight to fall, thus giving an indication of their presence.

### Tool for Adjusting Auto Brakes

Those who have undertaken the adjustment of the external, or service, brake of an automobile, by tugging and pulling at the adjusting wingnut between the spokes of the wheel, will welcome anything that will make the work less exasperating. The tool shown is made from a piece of pipe of sufficient diameter to fit over the body of the wingnut, and about 15 in. long, or as long as required. The end of

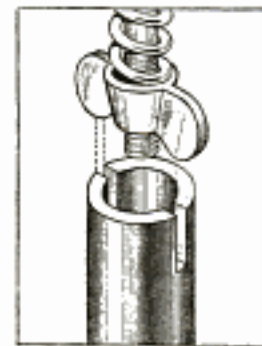

the pipe is slotted to fit over the wings of the nut. A pipe wrench applied to the lower end of the pipe, or a tommy put through holes drilled in it, will run the thumbnut up or down as fast as required.

### A Toy Farm Tractor

Driven by rubber bands, but in a manner entirely different from that in which model airplanes are operated, the toy tractor illustrated will furnish interesting work for the amateur maker. Most of the wooden parts are of  $\frac{1}{4}$ -in. whitewood, with the exception of the rear wheels, which are made of  $\frac{1}{2}$ -in. stuff. The front wheels are made from slices sawed from a curtain pole; tin disks are fastened on both sides at the center of all wheels, for

bearings. The axles are lengths of soft-iron wire, the ends of which are flattened; the rear axle is also flattened near one end for a part of its length, to prevent the drive disk from turning. Heavy tin is

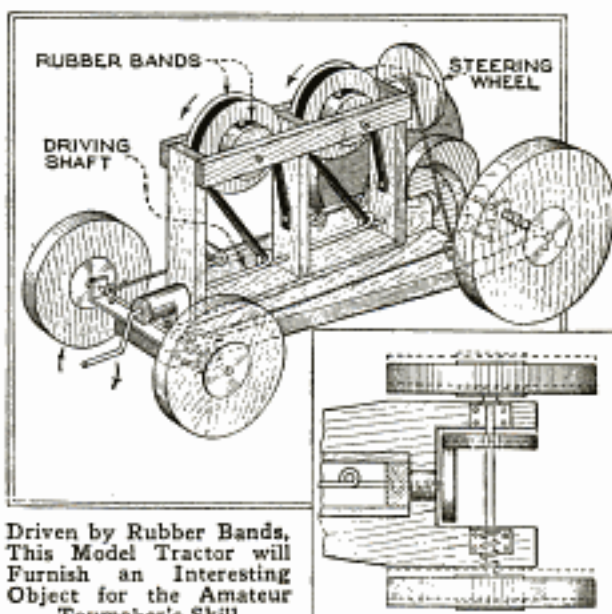

used for the axle bearings. The power from the rubber-band motor is transmitted to the rear wheels by means of friction disks, and a small compression-coil spring is placed between the wheel and axle bearing on the side opposite the drive disk, to keep the friction disks in contact. This arrangement also serves as a clutch, allowing the drive disk to run free while the motor is being wound; this is done by pushing the rear axle to the position indicated by the dotted lines in the lower detail. A steering wheel is mounted at the rear of the engine frame, and turns the front wheels by means of a cord fastened to the ends of the pivoted front-axle bearing. In building up the motor, two small disks are fastened to larger ones with small nails, and a short rubber band attached to each small disk and to the frame upright, as shown. A longer rubber band has one end fastened to each of the larger disks, and the other end is fastened to eyes formed on the drive shaft. The disks are then mounted in the motor frame, as shown. After bending the eyes in the driving shaft, it is important that the wire on either side be straightened accurately. The winding band should be nearly  $\frac{1}{16}$  in. thick,  $\frac{1}{8}$  in. wide, and long enough to reach once around the large pulley, and should be used single. The short band should be about twice as strong as the former, or it may be of the same size and double.—Donald W. Clark, Buffalo, N. Y.

### Oiling Auto Springs through a Tube

The owner of an automobile can provide a simple means for oiling the springs to avoid crawling underneath the car. A

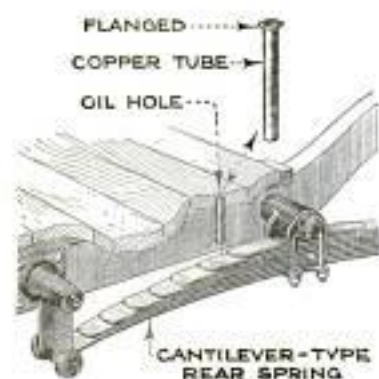

small hole is drilled through the floor of the car, and a short copper tube inserted to carry the lubricant to the springs. With this attachment, it is only necessary to pour

### Mail Box That is Always Locked

oil from the spout of an oil can into the tube. The copper tube should be a snug fit in the hole, and the upper end should be flanged to prevent it slipping through.

Always locked, yet always open so that mail matter can be placed in it, the rural mail box illustrated prevents unauthorized persons from tampering with the contents. It is necessary to raise the cover to place a letter or parcel inside the box; when the cover is closed the mail is dropped into the box and can only be removed by the person having the key to the lock. The self-locking feature is a

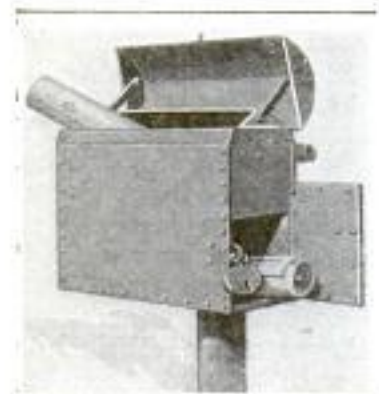

revolving cylinder, one side of which is open; this cylinder is connected to the cover of the box by a short link at each end. The cylinder is supported inside the sheet-metal box by a bolt or rivet at each end, and is so arranged that, when the cover is lifted, the open side will be brought to the top of the box, ready for the reception of mail matter. When the cover is closed, the cylinder turns so that the opening is downward, allowing its contents to fall into the box underneath.—A. C. Brundage, La Crosse, Wis.

☛ Newspapers, reduced to pulp, make a good filling for cracks in poultry houses.

### "Towing" without a Towrope

Being out in a car that had stalled and refused to start again, the driver hailed a passing car for a tow home. Neither car was provided with a towrope or chain of any kind. However, the disabled car was carrying an extra tire in the rear and the other car was fitted with a bumper; this suggested the idea of pushing the broken-down car, the bumper of the one car pressing against the spare tire of the other.—Louis Latour, Plattsburg, N. Y.

### Music-Rack Attachment Holds Instrument

Amateur and professional musicians often desire a suitable support on which to place their instruments during intermissions.

Such a support is afforded by the device illustrated, which will hold either clarinet or violin, although by modifying the idea, it may be made to hold any instrument. The forks are made of  $\frac{3}{16}$ -in. mild-steel rod. The clamp is made of steel,  $\frac{3}{4}$  in. wide, and the hooks are welded to it on opposite sides. The completed holder clamps around the standard of the music rack, and is easily and quickly detached.—Edwin Kilburn, Spring Valley, Minn.

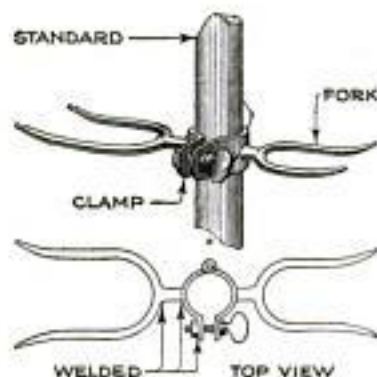

### Positives Direct from the Camera

Generally, the development of a sensitized plate or film in a camera results in a negative image, the parts exposed to light being darkened. For many experimental purposes, or when the finished picture is wanted in a hurry, it is sometimes of great advantage to be able to make positives in one operation. This can be accomplished by the employment of a simple "reversing" solution, in the process of development. This solution is prepared from 30 gr. of potassium permanganate, 3 dr. of sulphuric acid, and 35 oz. of water.

The negative should be developed in the usual developer, but held somewhat longer than usual, and until it is rather

dark. It is next placed into the reversing solution and allowed to remain for three minutes. It should then be returned to the original developer, and the tray carried into the open daylight or under strong artificial light. The reversing solution "eats" away the parts of the image originally blackened in the developer, and the second development, with the sensitive surface exposed to light, blackens the remaining parts of the image, or those not exposed to light in the camera, resulting in a positive image. When the second development has been carried to the proper depth, the sensitized material, plate, paper, or film, is washed and dried, no fixing being necessary.

By substituting bromide paper, cut to the proper size, for the plates or films used in the camera, direct positives can be obtained on paper. The paper will require about five times as long exposure as a plate or film, and the resulting picture will be reversed, as when an object is viewed in a mirror. If the finished positive is too dark, it indicates that the exposure was too short, and vice versa—a point that must be remembered if the first attempts are not perfect; the reversal of the image requires also a reversal of judgment as to the causes of any imperfection.

### Siphon Supports and Float

In drawing off the clear liquid or solution from settled or precipitated material

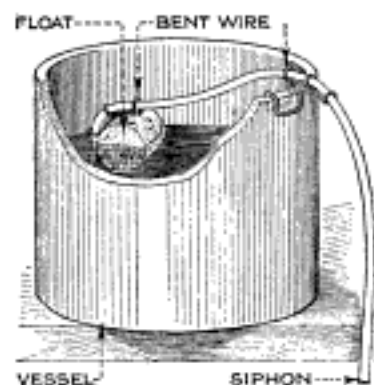

at the bottom of the container with a siphon, considerable care is necessary to prevent the siphon from choking, as well as to keep any of the sediment from being siphoned over. The drawing shows how both these aims can be accomplished by means of two simple holders, made of stiff wire. One of the holders fits over the edge of the vessel, and prevents the siphon from bending at a sharp angle and stopping the flow. The other is fastened to a tin-can or cork float; the end of the siphon is slipped through the holder, and adjusted so that it cannot reach the sediment at the bottom of the container.—David A. Glushak, Washington, D. C.

### Small Envelopes from Large Ones

When there is no other size of envelope at hand but one of the large "legal" size, and the inclosure is small, an envelope to fit the latter can be made by cutting down the big envelope. The operation is simple and consists in sticking down the flap, and cutting the envelope in two, so that one end will be a little larger than the size necessary. Then a flap is cut, folded over the cut end, and pasted, as in the drawing.

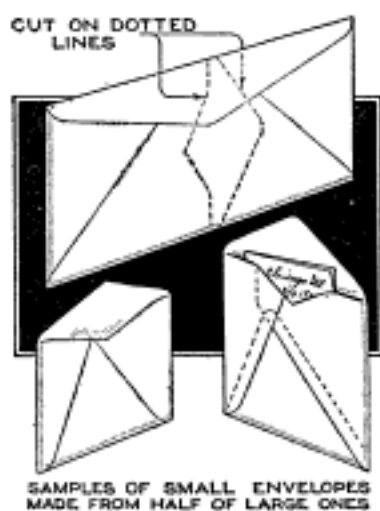

### Dandelion Destroyer

A lawn or yard thickly studded with dandelions presents a discouraging prospect at any time, but particularly when the owner considers digging them out. However, to a certain extent, the spread of the weeds can be controlled by preventing the blossoms from going to seed. The implement shown in the drawing, when pulled across a dandelion-infested lawn before the blossoms ripen, pulls off the flower heads, and thus effectively prevents self-seeding. A 12 by 16-in. piece of heavy galvanized iron, bent as shown, is toothed on one edge, the teeth being 1 in. apart and 1 in. deep. A piece of iron bar is riveted to the sheet iron so that it can be fastened to a handle and used in the same manner as a rake.—Jesse L. Blickenstaff, N. Manchester, Ind.

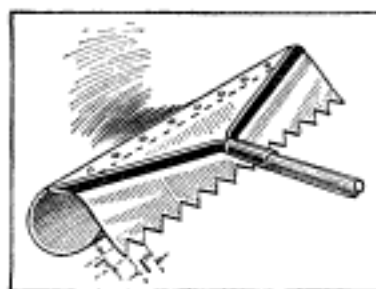

☛ A small piece of friction tape, or adhesive plaster, used to hold coins sent through the mail, will prevent them from breaking through the envelope and becoming lost. The coin is placed on a sheet of paper, the tape or plaster stuck over it, and the paper folded as usual.

### Portable Phonograph for Schools

A four-room school has a phonograph that is used at different periods during the day in the several rooms, and, until the

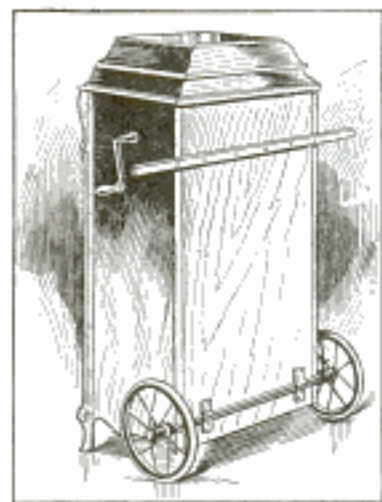

arrangement shown was provided, it was something of a nuisance to be obliged to move the heavy instrument several times each day. Two rubber-tired wheels from a baby carriage were mounted on a 1/2-in. shaft and fastened just above the rear legs, which were then cut off. A suitable handlebar was fastened across the back at a convenient height, so that to move the instrument from one room to another, it is only necessary to tip it back until the weight rests on the wheels.—D. R. Van Horn, College View, Neb.

### A Ring-and-Peg Puzzle

A short piece of board is provided with 10 short wooden pegs, and eight wooden disks are drilled through the center to fit



over the pegs easily; four of the disks are white and the others are either made of dark wood, or painted black. When the block and disks have been made, the latter are placed on the first eight pegs, white disks alternately with black, the last two pegs being left vacant. The object of the puzzle is to get the four white and four black disks grouped together without leaving any pegs vacant, except two at either end. The disks must be moved two at a time and the rearrangement made in four moves, two disks at a time.

The upper drawing shows the arrangement of the disks at the commencement of the puzzle and the center one shows how the disks should appear at the con-

clusion. The secret of the puzzle is as follows: Move the disks B and C to the vacant pegs I and J; E and F to B and C; H and I to E and F, and A and B to H and I; this gives the necessary transposition, and the disks can be returned to their original positions by reversing the movements.

### Insulator for Wireless Antenna

Neat and efficient insulators for amateur wireless aerials can be made from the

hard rubber obtained from discarded storage-battery cells, which can be obtained from any battery-repair shop for nothing. The rubber can easily be cut with a hacksaw, or it may

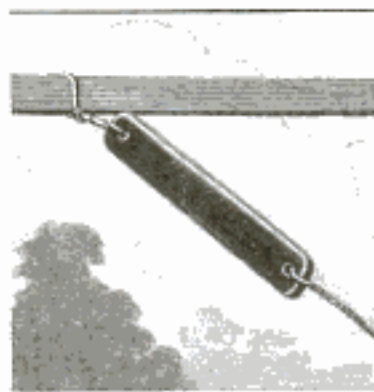

be cut by heating in boiling water for a few minutes until it is soft enough to be worked with a pocketknife, the rough edges being dressed down smooth with a coarse file. A hole is drilled in each end for the antenna wire and guy. The cheapness of an insulator of this type recommends it for small aerials, in the absence of the molded type most commonly used.—Werner J. Baumeister, Cambridge, Massachusetts.

### Protecting Identification Cards

Cards that are used continually, such as passes, and lodge and club-membership cards, should be kept clean and presentable. A very simple case for such cards can be made from an old photographic film, after the emulsion has been cleaned off in hot water. A strip of the thin,

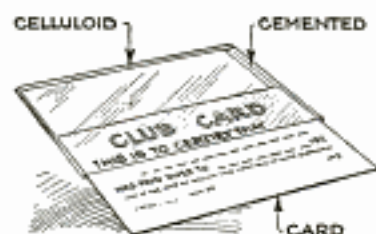

transparent celluloid thus obtained is bent around both sides of the card, and about 1/4 in. on each edge is folded over

and cemented with collodion, pressure being applied while the cement is drying. With a case of this kind, both front and back of the card are open to view, while protected against wear and dirt.



## HONEYCOMB COILS FOR SHORT-WAVE RECEIVER

By F. L. BRITTIN

SOONER or later, the builder of the short-wave receiver with two-step amplifier, described in the June and July issues, will wish to add honeycomb coils to the set, to enable it to be tuned to long waves. These coils can be very cheaply added to a cabinet already built. If the reader has not yet started on the construction of the set, the detector, amplifier, and honeycomb coils can be incorporated in one panel and cabinet, or, if

bottom of the tuner cabinet, inside the latter. This is for the purpose of bringing the ground connection up to the little aerial and ground switch in the upper right-hand corner of the panel, beside the switch mentioned before. In the wiring diagram, Fig. 4, this switch is shown near the A-battery, on the left, below the primary coil; the two inner switches represent the eight-pole anticapacity switch. When this little double-pole, double-throw switch is thrown up, the aerial and ground are put into the honeycomb-coil circuit, and when thrown down, the aerial is connected to the short-wave tuner through post Aer. 1, on the panel at the rear of the cabinet. A flexible lead is run from this post to a variable condenser of the external or table type; this condenser is connected to the short-wave tuner aerial post. Two variable condensers, of the panel-mounting type, are used in the honeycomb-coil circuit; one is placed at the right-hand side of the upper cabinet, for the primary coil, and is connected to the series-parallel, or primary-condenser, switch on the side

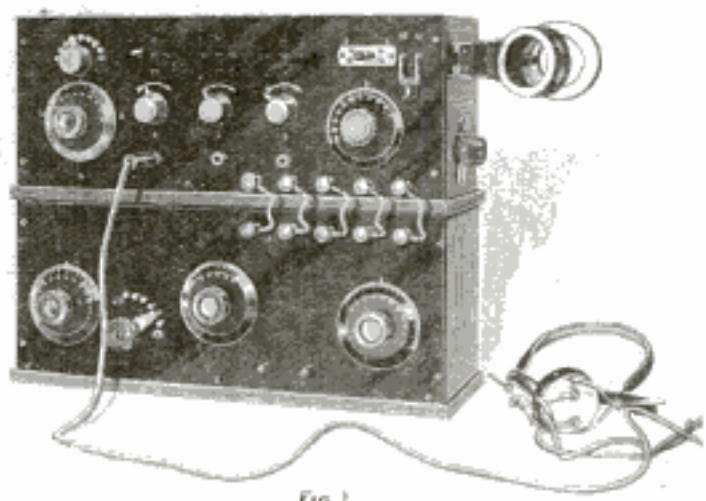
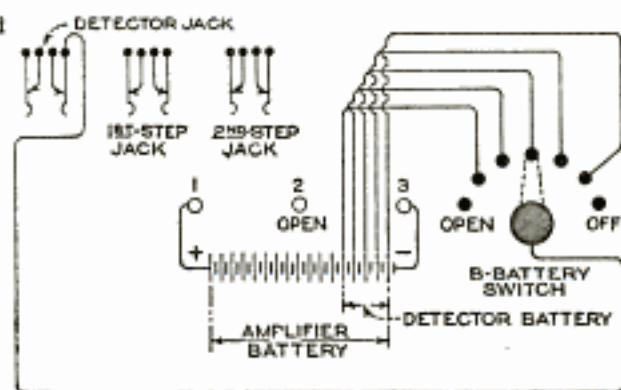

Fig. 1

Front View of Complete Instrument, Showing Coils and Switch Mounted on Side Panel

just starting on the amplifier unit, the coil mountings can be placed on the amplifier panel. Still another way, and the one described herein, is to place them, together with a series-parallel switch, on a panel mounted on the side of the upper cabinet, as shown in Fig. 1. This shows an instrument in which the detector and amplifier are built in one cabinet, with a single panel. Fig. 6 shows panel templates for this instrument, giving the proper position of all holes. The square hole in the upper right-hand corner is for an anticapacity switch.

In the wiring diagram, in the June number, it will be remembered, post 3 on the tuner panel was connected to post 1, but in the July number, the post 3 was left open; now that honeycomb coils are to be added, post 3 is used again, a lead being run from it to the ground post on the



CONNECTIONS FOR POSITIVE-TAPPED B-BATTERY

Fig. 2

If Negative-Tapped B-Batteries Are Not Obtainable, the Connections are Made in the Manner Shown in This Illustration

panel, the other condenser being mounted at the left-hand side of the upper cabinet, and connected across the secondary coil. The aerial is connected to post Aer. 2, on the rear panel. Binding posts for the A-battery, loud talker, and B-battery are

also mounted on this panel. Post 3 on this panel has no external connection, the lead to the switch lever on the B-battery running inside the cabinet. This binding post may

switch beside it, is all that is necessary to change the instrument from long to short-wave reception, and vice versa. Honeycomb coils may be obtained for

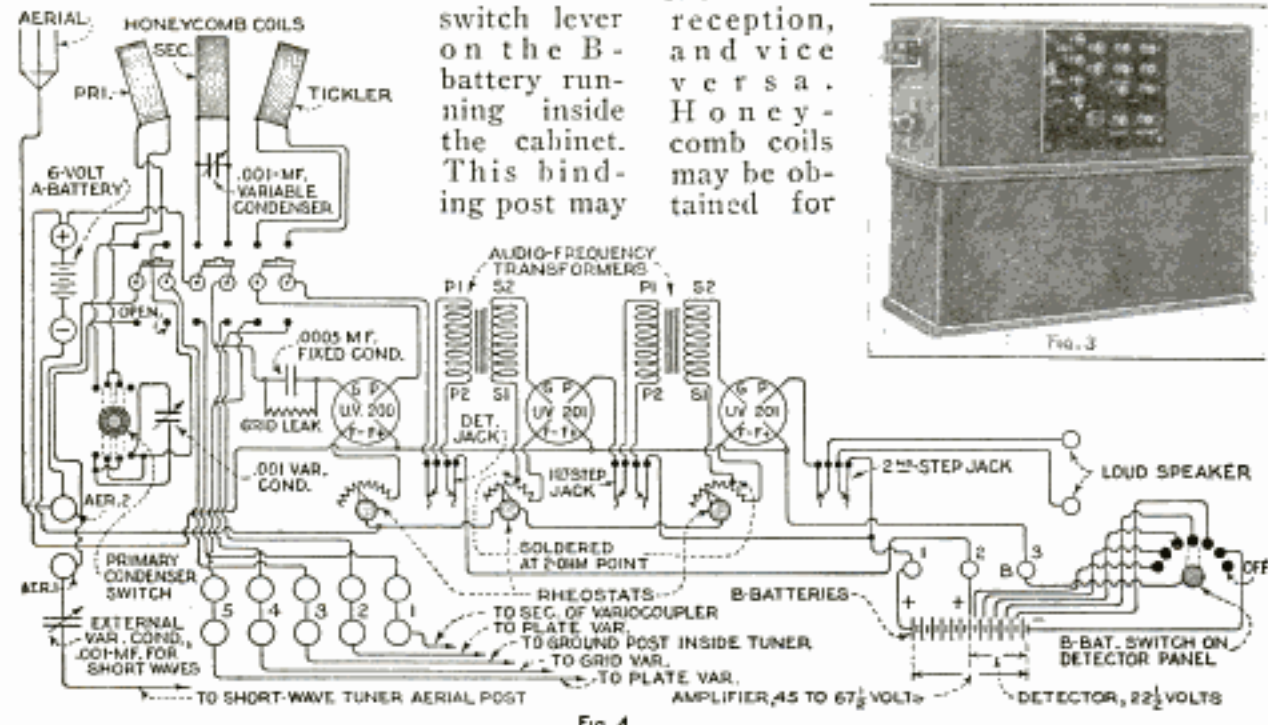
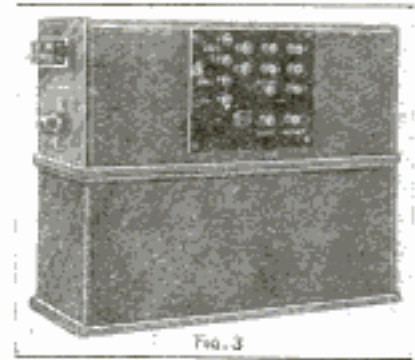
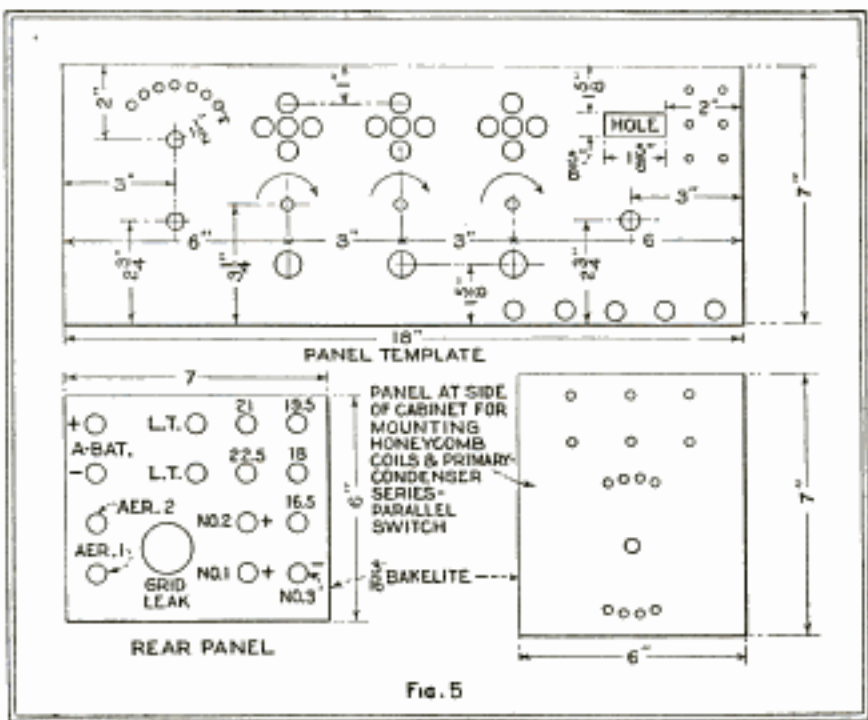

Fig. 3.—Back View of Complete Tuner, Amplifier, and Honeycomb-Coil Set, Showing Binding-Post Panel.  
 Fig. 4.—Wiring Diagram: Note Carefully the Connections of the Honeycomb Coils to the Anticapacity and Aerial Switches

be omitted, if a negative-tapped B-battery, as shown in Fig. 4, is used, the lead being taken direct from the switch lever to the positive side of the A-battery. If a positive-tapped B-battery is used, however, post 3 has an external connection to the negative side of the B-battery, and post 2 is left open, the lead running from the detector jack to post 2 being changed to the switch lever of the B-battery. These positive-tapped batteries usually have only five taps, so the end point on the switch is left open, as shown in Fig. 2. A round-type grid leak is placed on the rear panel, in addition to the binding posts.

all bands of wave lengths, and, with the proper coils, this instrument may be tuned to wave lengths of from 150 to 20,000 meters, receiving both arc and spark stations.



Panel Templates: The Positions of All Holes should be Laid Out on Cardboard, and the Cardboard Used to Mark the Panels

An eight-pole, double-throw switch, of the anticapacity type, is mounted in the upper left-hand corner of the panel; this switch, marked "S" on one side, for short waves, and "L" on the other, for long waves, together with the double-pole, double-throw

The cabinet used for this instrument is the same size as the tuner cabinet de-



scribed in the June issue; a part of the right end is cut out to fit the coil-and-switch panel, and a part of the back, for the binding-post panel. The audio-frequency transformers are placed behind the variable condensers, and the tube sockets immediately behind the jacks.

When making this instrument, check the

wiring carefully against the wiring diagram, at every step, and solder all connections thoroughly, using resin-core solder, when sure that they are correct. Do not run wires parallel with each other, where it can be avoided. All wiring is No. 18 tinned-copper, spaghetti tubing being used for insulation.

### Safety Dog Leash for Auto

A simple device that may save the life of a highly prized dog when riding in the auto, consists of a large screweye or staple fastened in the top center of the seat back. The leash should have a snap on each end, and be just long enough to permit the animal to sit or lie comfortably when one end is snapped to the collar and the other to the screweye, but not so long that it can jump or fall out of the car. This leash also makes it unnecessary for the driver or passenger of the car to give a part of his attention to restraining an active pet.—Mrs. K. J. Unwin, Worcester, Mass.

### Air Release for Inner Tubes

While it is possible to remove the valve fittings from the valve stem of an inner tube, to let the air escape when it is necessary to remove

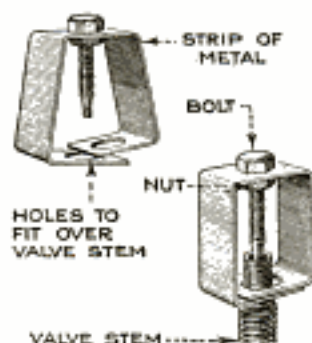

a tire, or to deflate the tube after locating a small leak, the rubber packing is frequently mutilated in so doing. Aside from the time required to remove and replace the small parts, there is the additional

possibility of losing them that makes the practice undesirable. A simple air release for the valve stem, which can be slipped over the valve in a second, is shown in the drawing. This little convenience is made from a strip of sheet metal with a hole in each end and a small bolt and nut secured to the center. The tip of the bolt is filed down to enter the valve stem, and the spring ends hold it in place, the valve being held open until the device is removed.

☞ A teapot makes a convenient receptacle for melted paraffin when canning fruits and vegetables.

### Extension Lawn-Mower Handle

It is quite difficult to mow the grass on steeply slanting terraces, and for this work an extension handle for the lawn mower will be found a great help. Two pieces of hardwood of about the same dimensions as the mower handle are fastened to the latter with bolts, as shown. A handle is fastened to the extremity of the longer piece and the upper end of the brace is slotted to make the attachment adjustable for work on different slopes. By means of this extension the mower can be pushed down the terrace and pulled up easily by the operator, while working on the level ground above.—F. C. Davis, St. Joseph, Mo.

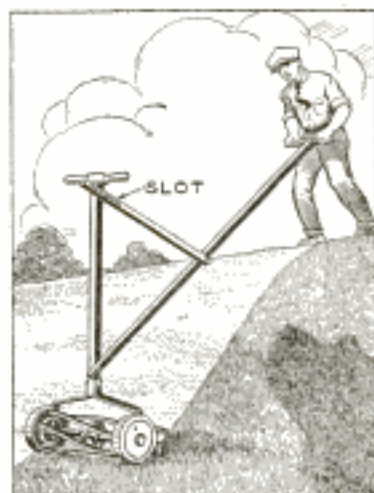

A handle is fastened to the extremity of the longer piece and the upper end of the brace is slotted to make the attachment adjustable for work on different slopes. By means of this extension the mower can be pushed down the terrace and pulled up easily by the operator, while working on the level ground above.—F. C. Davis, St. Joseph, Mo.

### Clothes Hook for Bedstead

Many modern bedsteads of brass and iron afford no convenient projections for hanging the clothes overnight as the old-fashioned wooden four-poster did. To the mind of many people this is a drawback, but it can be overcome by the use of clamps such as shown in the drawing. These can be made in a few minutes in the home workshop from single pieces of light flat iron. A small bolt is used to clamp the hook to the bedpost.

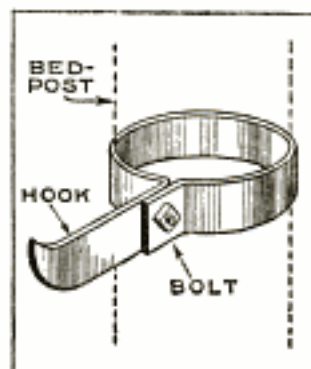

### Flower-Bed Borders from Auto Rims

The photograph shows the novel and not unattractive result made possible by using old automobile tire rims as the



Novel and Attractive Arrangement of Flower Beds Formed by Planting Flowers and Plants inside the Circle Formed by Old Automobile Tires and Rims

borders for flower beds. Not only can the rims be used in this manner, but old tires will also serve the purpose. The rims or tires are first painted white, the space within them filled with earth, and the flowers or plants set inside the circle thus formed.—F. J. Hiscock, Cody, Wyo.

### Preventing Vibration of Headlight Bulbs

The bulbs of automobile headlights often fit rather loosely in their sockets. This gives rise to vibration when the engine is running, and is not only annoying to the pedestrian meeting a car carrying

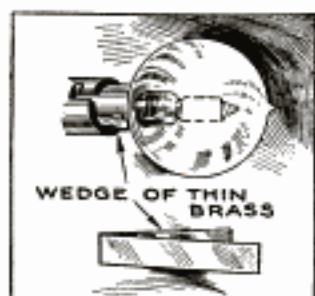

such flickering lights at night, but shortens the life of the bulb filaments. To overcome the trouble, a wedge of thin spring brass can be slipped between the lamp base and its socket. The wedge is made by doubling the brass strip, as shown, and filing the doubled end to form a sharp edge; the wedge is laid against the lamp base, and the two pushed into the socket together.—L. B. Robbins, Harwich, Mass.

### Tightening Loose Pipe Stems

When a hard-rubber pipe stem becomes loose in the pipe, it can be expanded easily to make a good fit. It is only necessary to immerse the loose end of the stem in boiling water for a few minutes

to soften it. Then, a nail, or piece of wire a trifle larger than the bore of the stem, is inserted into the bore while the rubber is still soft, and allowed to remain until it has hardened again. If the stem has been expanded too much, it can be dressed down to a good fit with sandpaper or with a fine file.—Wm. J. Volk, Woodhaven, N. Y.

### A Hanger for Clothing

Sometimes it is necessary that clothing be hung in a room where no wardrobe or closet room is provided.

Placing hangers on the wall is usually out of the question, as it mars the plaster, but if there is a picture molding around the room, a hanger like the one illustrated can be used to advantage. It is

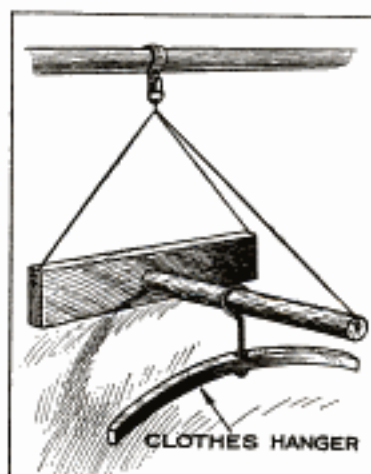

made from two short pieces of wood, one preferably being round, as shown, fastened together at right angles. Three wires, one from each end of the wooden pieces, unite at the same point and are fastened to a ring. The hanger is then suspended from the molding by a picture hook. The clothes, on hangers, are hung from the projecting piece.

### Stretching Curtains without a Frame

One can dry lace curtains, without using expensive and cumbersome curtain

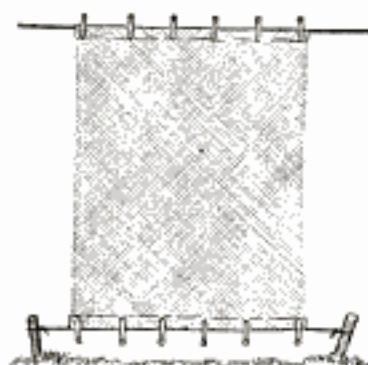

stretchers, by means of the simple arrangement illustrated. As shown in the drawing, one edge of the curtain is pinned to the regular clothesline, while the other edge is similarly fastened to another line, parallel with the first, and fastened to pegs driven into the ground.—R. E. Deering, Clements, Kan.

### Cutting Lawns in Dry Weather

In dry weather, it is sometimes advisable to allow the grass to remain a little longer than the mower will ordinarily cut, when the cutter has been elevated as high as possible by adjusting the roller. If the lawn is large, the strain of pushing down on the handle soon becomes exhausting. To relieve this strain, I obtained three pieces of old belting, 2 in. wide, and tacked these around the roller, one on each end and one in the center.—Jas. C. Bailey, Indianapolis, Ind.

### A Handy Mirror for the Camp

A handy mirror that will add to the pleasure and convenience of camping can easily be made from almost any ordinary mirror provided with a metal back or a wooden frame. Two spring-wire members are fastened to the top and bottom of the mirror, so that it can be attached to a tree, tent pole, or other vertical support, or set at an angle on the table. In the case of a wooden-framed mirror, the pointed wires can be attached with small staples driven into the frame, while with a metal-backed mirror or one having a metal frame, small strips of tin must be soldered to it to hold the hooks.—Doris Johnson, Rockford, Ill.

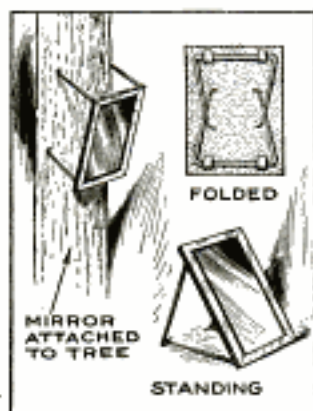

### Litter Rake Made from a Pitchfork

When a rake is needed, either on the farm, for removing litter, or in the factory, for pulling out chips from underneath machines, the implement illustrated will be found serviceable. It can be made from any ordinary wide fork. The

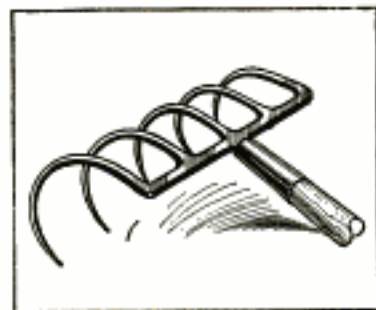

tines are heated and bent over in a curve so that all the points will be in line.—Louis Schneider, Clinton, Mo.

### An Adjustable Seesaw

The usual form of a children's seesaw—a plank placed on a buck—provides no adjustment for the unequal weight of chil-

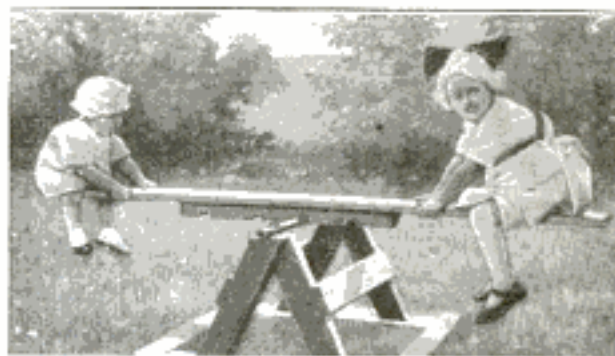

This Adjustable Seesaw Makes It Possible to Establish a Balance When It is Used by Children of Unequal Weight

dren of different ages. This defect is readily overcome, as in the seesaw or teeter board illustrated. On the underside of the plank, a series of blocks or a notched board is placed so that the distance from the buck to the ends of the board can be varied as necessary. The board is supported on a piece of pipe across the top of a simple horse.—E. E. Johnson, Inglewood, Calif.

### Mounting Rowboat Motor in a Canoe

Placing a rowboat motor in a canoe is a problem that many have been compelled to give up, but it can be done in a workmanlike manner by setting a wooden box or well into the craft, in the manner shown, and attaching the engine to the edge. The box itself must be water-tight, and the joint between it and the bottom of the hull must also be made water-tight by calking or other means. The top of the box should be nearly as high as the sides of the canoe and should be well braced to insure rigidity. Such an arrangement becomes a permanent fixture, but does not prevent the canoe from being used without the engine.

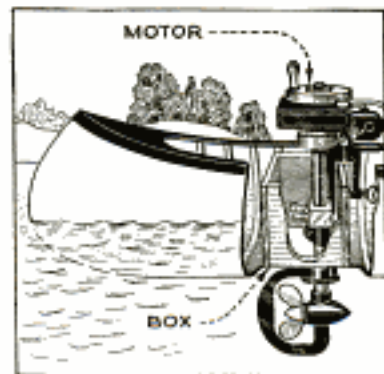

☛ A piece of rubber matting underneath the rugs on polished hardwood floors will prevent them from slipping.

### Attaching an Electric Motor to a Hand-Power Washer

An ordinary hand-power washing machine of the type shown can be easily ar-

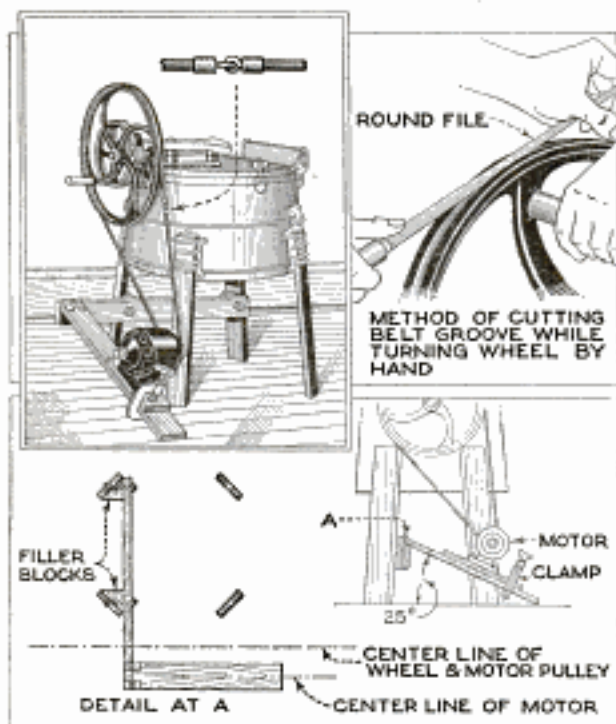

A Hand-Power Washing Machine Modernized by the Addition of an Electric Motor: The Motor can be Removed and Used for Other Work

anged for electrical drive, practically the only expense being the purchase of the motor and belt. The washing machine is not altered in any way that would prevent it from being operated by hand in case it should be necessary.

A board is fastened to two legs of the machine in the position indicated; it is possible that triangular filler blocks will have to be used between the board and the legs, as illustrated in the detail drawing, in order to make a solid job. Another board, the motor base, is connected to the end of the stationary horizontal board by a pair of hinges. The motor is mounted on a wooden block and clamped to the hinged board as shown, so that the motor pulley and the washing-machine hand-wheel are in line. A round belt is used for driving the washer, and consequently the handwheel must be grooved; this is done by holding a round file against the rim of the wheel as it is revolved by hand. When clothes are to be put into the machine or taken out of it, the hinged motor base is raised and the belt removed. By mounting the motor on a block and clamping it to the washing machine in this manner, it can be removed instantly and used for other purposes.

### Garden Hose as Substitute for a Spray Pump

The use of a garden hose for spraying is especially suited for trees, vines, and shrubs within reach of the hose. The spraying mixture is poured into the hose, which is then attached to the faucet, and the water turned on to force the mixture out through the spray nozzle in a fine mist.

To fill the hose, the nozzle should be opened to let out the air as the solution is poured in through a funnel at the faucet end, the nozzle end, of course, being elevated, so that the liquid cannot run out. When the hose is filled, the nozzle is closed and the hose screwed onto the faucet. Fifty feet of hose will hold about a gallon of the spray solution. When all is ready, the water is turned on slightly, not full force, and the nozzle is partly opened; this forces the solution out through the nozzle. The color of the spray will indicate the moment when the clear water has entirely displaced the solution. Before refilling the hose with the spray mixture, the water must be drained from the hose.—James T. Ford, Hollywood, Calif.

### Partitions for Catalog Files

In places where a large collection of manufacturers' catalogs are kept on file for reference, on shelves, as is the general practice, the whole lot falls over at an angle when one or more of the volumes are removed.

A good way to prevent catalogs, or even books, shelved in this manner, from falling over, and yet preserve the alphabetical arrangement, is to make removable upright partitions. Such partitions are easily made by fastening pieces of sheet metal at right angles to blocks of wood of the proper size, the ends of the metal sheets being held down by the weight of the catalogs, and the filing letters stenciled or marked with gummed letters on the edges of the blocks.—P. A. Daschke, Astoria, N. Y.

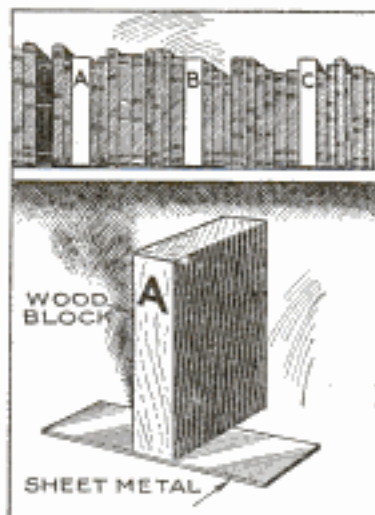

# BUILDING A WIND WAGON

By J. SUTTER



A WIND wagon, that can be built by almost any amateur mechanic, is shown in the accompanying illustrations. When powered with a motorcycle engine running at 1,000 r.p.m., it is capable of developing a speed of from 45 to 50 miles an hour, and will climb a hill with a 20-per-cent grade with ease; steeper ones can be climbed if a little start can be obtained before attacking the slope.

The construction of the frame should be undertaken first. As shown in Fig. 2, this consists of two 1 1/4-in. angle irons, placed in the form of a triangle. The front axle is a piece of 2 by 3-in. hardwood, cut as shown in Fig. 3, and is bolted to the ends of the

angle irons. A motorcycle front-wheel fork is connected to the rear end of the frame, as in Fig. 8, by short lengths of angle iron. As the connections for different makes of motorcycle forks may vary somewhat, this connection has merely been indicated in the drawing; it is necessary, however, that the fork be mounted so that it may swing, as the rear wheel is used for steering. A guide, made of 3/8-in. pipe, or flat iron, is bolted across the frame, as shown in Fig. 8, on which the fork slides. A motorcycle rear wheel is slung in the fork, and fitted with a mudguard, as shown.

Motorcycle front wheels are used for

the front of the wagon, and are fastened to the axle by means of pieces of 1/2 by 2-in. flat iron, bent L-shape, and with the longer leg bolted to the underside of the axle, as shown in Fig. 3.

The engine frame is next built up. This is made of 1 1/4-in. angle iron, bolted to the front axle, and connected by tie-rods, as

in Fig. 3. The engine is a two-cylinder motorcycle engine; it is braced by a 3/8-in. pipe, which also serves as the outside wheel brace, on each side, and by another brace running to the top of the steering pillar, shown in Fig. 5. The inside wheel braces are bolted to the outside braces at one end, and to the wheels at the other end.

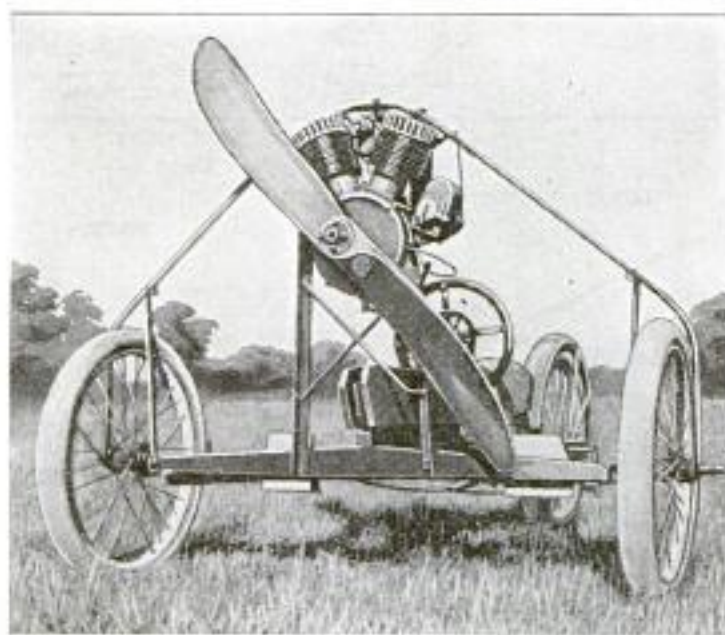

Front View of the Completed Wagon: The Propeller Guard has been Removed

The seat frame consists of a 1 1/4 by 3-in. board, bolted, at its front end, to the axle, and at its rear, to a 1 by 2 1/2-in. crosspiece bolted to the frame; this is clearly shown in Fig. 5.

A pipe flange is fastened to the top of the seat frame with wood screws; then a short piece of pipe, with a tee on one end, is screwed into it, being tightened until the run of the tee is parallel with the seat frame. A pipe, long enough to reach to the transmission case of the engine, is screwed into the front end of the tee, and the front end fastened to the transmission case by means of a bolt, made in the form of an "L," put through a hole drilled in

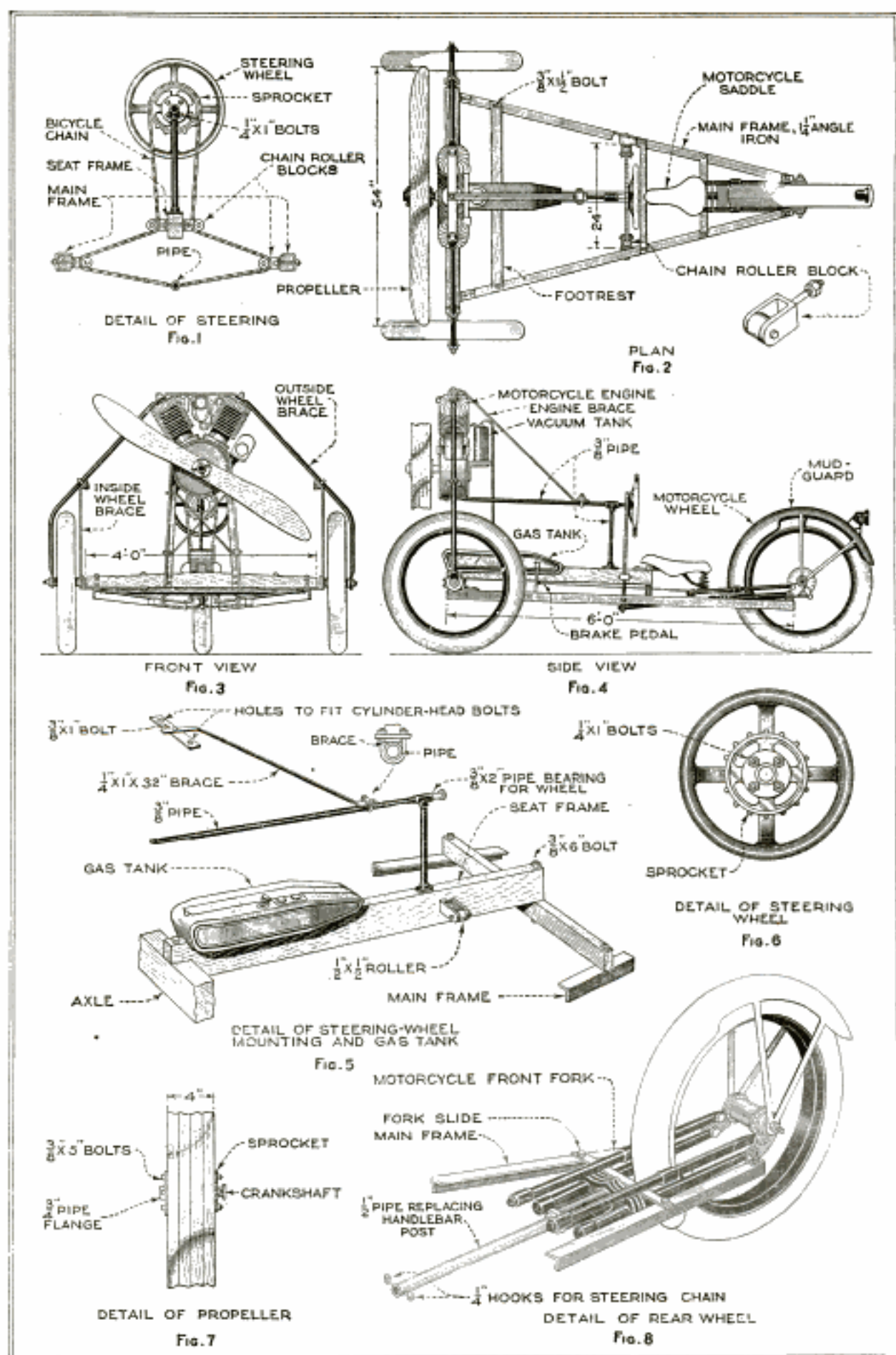

Complete Plans and Details of the Wind Wagon: Some Modification of Fig. 8 may be Found Necessary, to Suit the Particular Type of Wheel Employed, and This Also Applies to the Mounting of the Gas Tank Shown in Fig. 5, and to the Fastening of the Seat to the Seat Frame, Fig. 4. The Remaining Details in the Drawing may be Followed Exactly

the end of the pipe, and through one of the holes in the side of the case. A short piece of pipe is screwed into the other side of the tee to serve as a bearing for the steering wheel. When the steering wheel is in place, the proper length of this pipe can be marked, the pipe cut, a thread or two cut on the end, and a pipe nut fitted to hold the steering wheel. A regular automobile steering wheel, with a large bicycle-chain sprocket bolted to it, as shown in Fig. 6, is placed on the bearing, a chain run over the sprocket, through the four roller blocks, a detailed view of which is given in Fig. 2, and the ends attached to  $\frac{1}{4}$ -in. hooks in the end of the  $\frac{1}{2}$ -in. pipe that replaces the handlebar in the rear fork. The arrangement of the steering mechanism is clearly shown in Fig. 1.

The regular brake in the hub of the rear wheel is connected, by means of a  $\frac{1}{4}$ -in. iron rod, to a bicycle pedal, mounted on the seat frame, as shown in Fig. 4. A footrest, made of 1-in. board, is bolted across the frame, in the most convenient position, as shown in Fig. 2, and a motorcycle saddle bolted to the seat frame, as in Fig. 4. A backrest, while

not essential, can be added if desired. An automobile vacuum tank draws the gasoline from a motorcycle fuel tank fastened to the seat frame. This arrangement is shown in Fig. 4, but it may be modified by mounting a small tank directly on the engine, if desired, or if a vacuum tank cannot be obtained. The throttle and spark levers are bolted on the brace that runs from the steering post to the engine, and are connected to the carburetor and timer by  $\frac{3}{16}$ -in. wire.

The propeller is  $4\frac{1}{2}$  ft. in diameter, with a pitch of 4 ft. It is made of spruce or pine boards glued together, and is 4 by 6 in. in section before carving. It is bolted directly to the crankshaft sprocket, as shown in Fig. 7, a pipe flange being used on the outside of the hub.

A propeller guard, made of wire netting, reinforced by rolling the edges around a steel rod, is mounted on the front, and bolted to the outside wheel braces and to the engine. This is not shown in the drawings, but should not be omitted when building the machine.

The engine is started by turning the propeller in the same manner as an airplane engine is started.

### Edging Tool for Lawns

Much time is usually consumed in trimming or edging a lawn or grass plot with the shears, or in digging a neat little trench along the walk, and it is somewhat disappointing to see how quickly the trench fills up and the edge of the plot becomes ragged again.

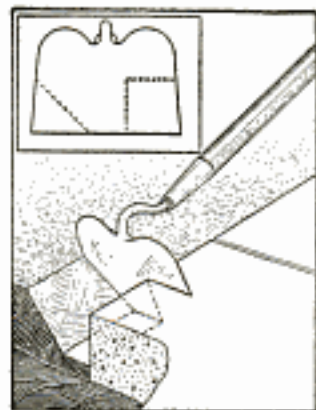

A tool that will form a neat trench when the soil is loose, as when the lawn is first dug and seeded, and will aid in keeping the trench, once formed, clear and

straight, is shown in the illustration. A hoe, which may be an old one, is cut as indicated by the dotted lines. In use, the vertical and horizontal faces of the tool are pressed against the walk as the hoe is pulled along, so that a uniform width and depth are obtained along the trench. The use of this tool once or twice a week will insure that much-desired neat appearance of the lawn edges.—S. E. Gibbs, Corydon, Ia.

### Attachment for Paper Holders

A piece of iron with two small clips with which to fasten it over the ends of the cutter of a paper-roll holder, such as forms a part of the fixtures of every store and shipping room, is an improvement that will be appreciated by wrappers and shipping clerks. A piece of flat iron, the same length as the cutter, has a spring-steel clip fastened to each end, the device being attached to the cutter on the holder, in the manner shown. The end of the roll is passed between the cutter and the attachment, thus keeping the paper from sticking to the roll, and making it easier to get at the end of the roll when a piece is to be torn off.—Vernon Brooks, Pittsburgh, Pennsylvania.

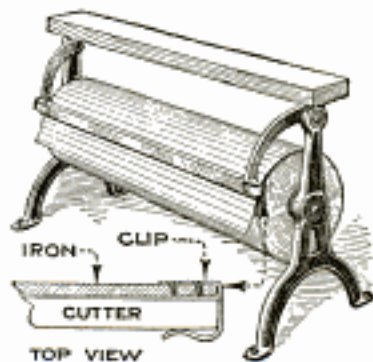

☛ Chamois skin may be cleaned by soaking in soda and water, and then in soap-suds.

### Hanging Rugs and Carpets on the Clothesline

No matter what method is used to beat the dust out of a large-size rug or carpet,

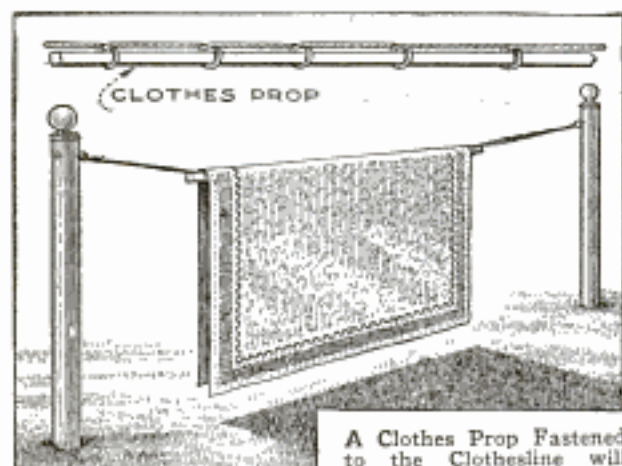

A Clothes Prop Fastened to the Clothesline will Prevent a Large Rug or Other Floor Covering from Wrinkling and Sliding Down toward the Middle of the Rope

it is advisable, if not necessary, to hang it on a line, not only to allow the dust and dirt to fall to the ground, but to allow the sun and air to exercise their cleansing action. Regardless of how taut the line is drawn, the carpet or rug will always wrinkle and sag down more or less; this can be prevented by taking one of the clothes props and fastening it to the line by a series of single hitches, in the manner illustrated.—John L. Dougheny, Toledo, Ohio.

### Connecting Burglar Alarm to the Lighting Circuit

Burglar alarms for either stores or residences can be advantageously wired in circuit with the electric-lighting circuit

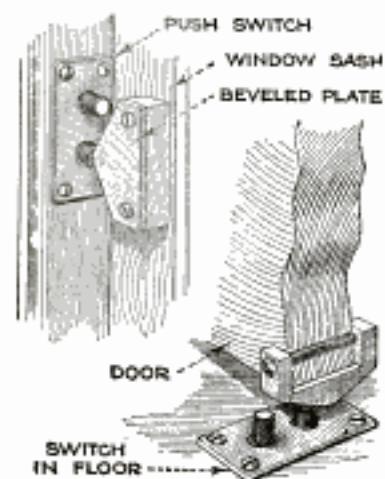

of the place, so that separate batteries can be dispensed with, and while the wires of a battery circuit can be easily detected and cut, a burglar will usually hesitate at cutting 110-volt wire. Of course, by this method it is

necessary to have all switches and alarm appliances wound for the voltage of the lighting circuit, but the alarm circuit can

be taken through a bell-ringing transformer. The drawing shows how the familiar push-button light switch can be fitted to doors and windows, so that if they are opened the circuit will be closed and an alarm given. In the case of a window, the switch is mounted in the casing and the operating block is fastened to the lower sash. In the case of a door, the switch is arranged at the top or bottom.

### Re-Serving a Fishing Rod

A method of re-serving a fishing rod that has some advantages over the usual process is shown in the drawing. A little

over half of the serving is wound on in the usual manner, the end of the thread being laid along the rod, and the serving wrapped over it. A very fine needle is then

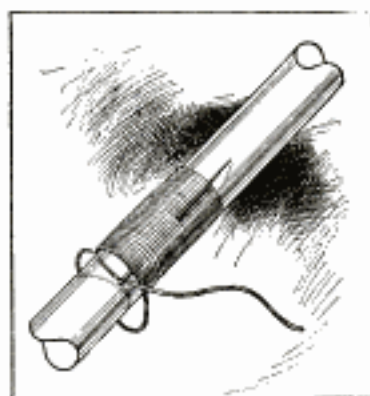

laid down on the rod and the serving continued over it. The other end of the thread is passed through the eye of the needle, and the latter pulled out; a mere touch of vaseline on the needle will cause it to pull through easily; if it sticks, however, it can be grasped in a pair of flat-nosed pliers, and pulled through.—Robt. Page Lincoln, Minneapolis, Minn.

### Holder for the Typewriter Eraser

Like many other typists I frequently misplaced my circular typewriter eraser. By the use of a twisted-wire paper clip,

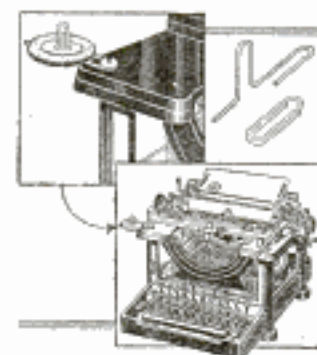

made into a holder, however, the eraser is always at hand. The clip is bent to the shape illustrated and is secured to the machine underneath the head of a convenient screw on the frame of the machine. The perpendicular U-shaped part is squeezed

together to make an easy fit through the eyelet in the center of the eraser.—L. H. Unglesby, Baton Rouge, La.



### Repairing Leaking Water Tanks

Rust often eats holes through galvanized-iron range boilers used for heating the domestic water supply. Many owners and users of such apparatus do not know that a leak in such a tank or boiler can be stopped without shutting off the water by driving a tapered wooden plug into the hole as a temporary repair. The wood from which the plug is made should be dry; after it is inserted, it will absorb water and swell, so that it will stick tightly. A small hole may be drilled into the thick end of the plug, and a smaller plug driven into this hole, to press the larger plug even more tightly against the edge of the orifice.—James E. Noble, Toronto, Can.

### Telephone Pad Holder and Desk

A useful pad holder, of particular convenience when used in connection with a wall-type telephone, is easily made. Two pieces of white pine are used, one a little larger than the other. The center is cut

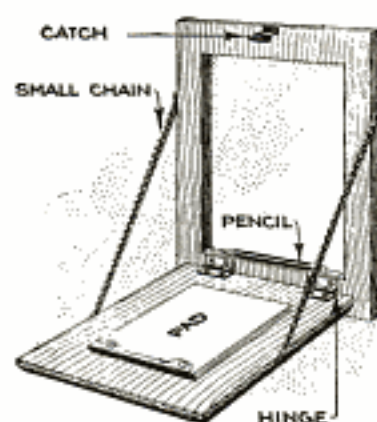

out of the larger piece so as to leave a margin of about  $1\frac{1}{2}$  in. on each side; this is to allow room for the pad and pencil when the holder is closed up. The smaller block is used for the cover and pad holder, and the edges of this piece are neatly beveled. Two small hinges are used at the bottom of the cover, which is held in the proper position for writing, when opened, by short lengths of chain. A catch at the top keeps the cover in place when the pad is not in use.—C. R. Jones, Chicago, Ill.

### Making Small Hinges

Small hinges for various purposes can quite often be made from larger ones by cutting off the superfluous parts, and drilling and countersinking new holes for the screws, as suggested by the examples shown in the upper left-hand corner of the illustration, the dotted lines indicating the parts cut away.

A simple hinge for poultry coops, rab-

bit hutches, and similar uses can be made from a piece of strong wire or iron rod and a few staples. The wire is bent into the shape of a "U," and the ends arc-bent at right angles, the bottom staples

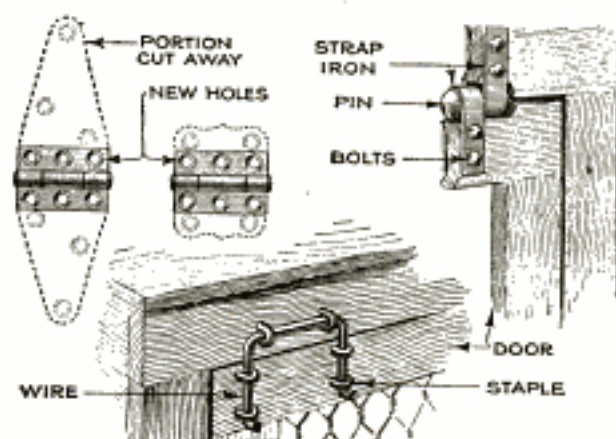

Small Hinges for Cabinet Work, Light Doors, Windows, Poultry Coops, and Rabbit Hutches

on the door resting on the projections thus formed. Staples are used for attaching the hinge to the frame, as shown.

A very strong, though simple hinge of the thief-proof type is made from two U-shaped pieces of flat iron, one of which is fastened to the frame and the other to the door or window on which it is used. A pin of the proper length and diameter is put in place, the grooves for the reception of the pin and hinge ends are cut in the woodwork, and the hinge is fastened with carriage bolts. The nuts of the bolts should, of course, be placed inside.

### Aid in Driving on Dark Roads

As an aid to the motorist in driving along dark roads, and in preventing the accidents that are a result of crowding too close to the ditch to allow another car to pass, a small mirror mounted in the manner indicated will prove of much value.

A small plane rear-view mirror, such as is obtainable at practically any auto-supply store, is clamped tightly to the headlight brace, in such a manner that part of the light from the right headlight will be reflected at right angles to the car, illuminating the side of the road.

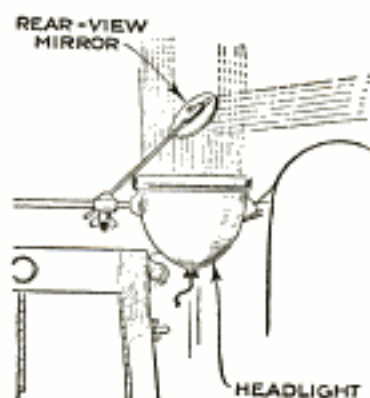

### Enlarging Maps and Drawings Quickly

During a recent campaign, it was necessary for a Sunday school to copy, for display on the walls of the headquarters, a



Maps and Other Drawings can be Greatly Enlarged and the Outlines Marked with a Crayon by Projecting an Image of the Small Original through the Lens of a Postcard Projector

map of a certain territory. The map was made at a minimum of expense and trouble by projecting the image of a small map through a postcard projector onto a piece of muslin stretched on the wall. The outline of the map and its various divisions were quickly and accurately sketched on the muslin with a crayon.

### Remover for Split Rims

An easily made implement for applying and removing tires, which is equally

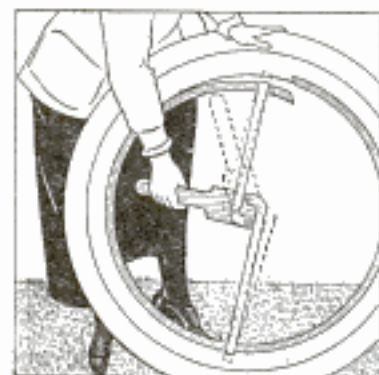

valuable in the tool box and in the garage, consists, as indicated in the drawing, of but three pieces.

The two arms are made of steel, and are forged with a short hook on the outer ends, to enter between the rim and bead of the tire. The inner ends are bent at right angles and pivoted, off center, to a wooden lever.

When the handle is raised a little above the horizontal, the device is positively locked. The rim can be expanded by placing the ends against the inside of the rim and operating the lever.

### Removing Sickle Sections

To remove worn or broken sickle sections from a mower bar, rest the bar on an anvil, or other solid support, with the broken section vertical and against the side of the anvil. Strike the top of the section two or three heavy blows; this will shear off the rivets without distorting the mower bar.

### Portable-Typewriter Stand Made from Camera Tripod

A camera tripod, of the heavy type used by professional photographers, makes an excellent typewriter stand, particularly for the light portable models that are so popular. Cut a board of the size it is desired to make the base, and in its center drill a shallow hole; force into the hole a nut that will fit

on the screw in the tripod head. The tripod screw will probably be somewhat longer than the thickness of the nut, so that a smaller hole must be drilled clear through the board to make room for the end of the screw. This board can be fastened to the tripod in the same manner



as the camera, to form a table for the typewriter; the side of the board into which the nut is sunk must be uppermost when in use. In case the legs of the tripod should prove too long for convenient writing, they can be spread out rather far, and prevented from slipping by using three short pieces of light chain extending from one leg to the other.—C. L. Meller, Fargo, N. D.

### Rubber Tires for the Wheelbarrow

A piece of garden hose will serve as a rubber tire for a wheelbarrow. Split a sufficiently long piece of hose in half, and fasten one of the halves to the rim of the wheel with wires.—J. Stumpf, Mt. McGregor, N. Y.

### Suitcase Made into Motor Picnic Kit

A suitcase can be made into a motor picnic kit without in the least preventing it from being used for its intended purpose. A piece of thin, tough wood, or a piece of wallboard, just large enough to fit snugly inside the top, is covered with denim or similar material, and suitable straps and pockets for holding the spoons, forks, plates and similar articles are sewed or tacked on, as shown. Glove

snap fasteners, if they can be obtained, should be used for securing the straps. Strips of light wood are fitted into the body of the case to form compartments

of the proper size for vacuum bottles, food boxes, drinking cups, and other articles, an individual compartment being provided for each. These partition strips are all fastened together, but not to the

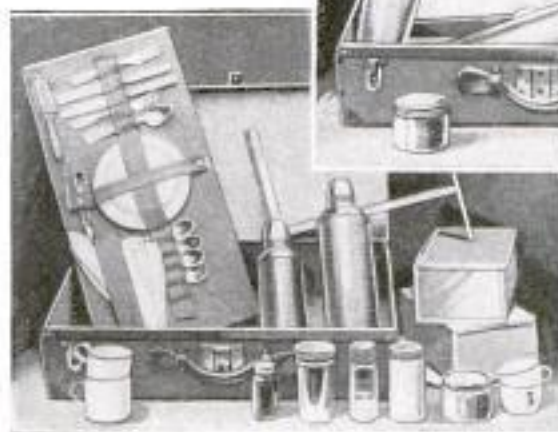

A Motor Picnic Kit in a Suitcase: Places are Provided for Dishes and Food Containers, and Everything can be Easily Removed

suitcase, so that they can be removed as a unit and the several strips prevented from becoming mislaid or lost. In this manner, the "legitimate" use of the suitcase is not interfered with, as everything can be easily removed. Such a lunch kit

is carried just as any other suitcase when on the car, on the running board or trunk rack, due care being taken, of course, to see that the contents of the kit are kept "right side up."

By using a

suitcase made of vulcanized fiber, and making the partitions and other fittings permanent, an outfit is obtained which is very strong

and practically indestructible. Genuine vulcanized fiber is very tough, and cannot easily be scratched and marred as can the ordinary leather case.—Walter C. Harris, Brooklyn, N. Y.

### "Spark Intensifiers"

Much has been said both for and against the so-called "spark intensifiers" as used in connection with automobile spark plugs. Very few can explain the principle upon which they operate, although many know that by their use the ignition of some engines is improved.

Spark intensifiers are designed to cause a carbonized plug to fire in spite of its fouled condition. They contain a gap which is from  $\frac{1}{32}$  to  $\frac{1}{16}$  in. wide, and are attached to the spark plug in such a way that the spark must jump both the gap in the intensifier and the gap in the spark plug, as these gaps are in series.

In order to jump the gap in the spark plug a potential of about 5,000 volts is required, but before this value is reached, a carbonized plug begins to let current leak from the coil, which lowers the voltage to such an extent that a pressure of 5,000 volts may not be attained, in which case there is no spark at the plug gap. The action of the

spark in the intensifier, however, stops this preliminary leakage because it disconnects the spark-plug wire from the carbonized plug. The high-tension current is then dammed up until it finally breaks down the gap in the intensifier, and the current comes with such a rush that it cannot all leak through the soot and some must therefore jump the spark gap, thus producing a spark at a plug that would not otherwise fire.

In experiments made with the intensifier it has been found that, with oil-pumping engines, they may be used to advantage, but no benefit can be said to be derived from their use on an engine free from spark-plug trouble. Furthermore, there is a possibility that their continual use may result in harm; for example, if the gap is widened either by becoming jarred out of adjustment or burning away, the voltage may build up to a point where injury to the coil insulation would result. This, of course, could only occur to coils that are not provided with safety spark gaps.

### Reel for Developing Roll Films

For the amateur photographer who has only an occasional roll of film to develop and who dislikes the tiresome ordinary

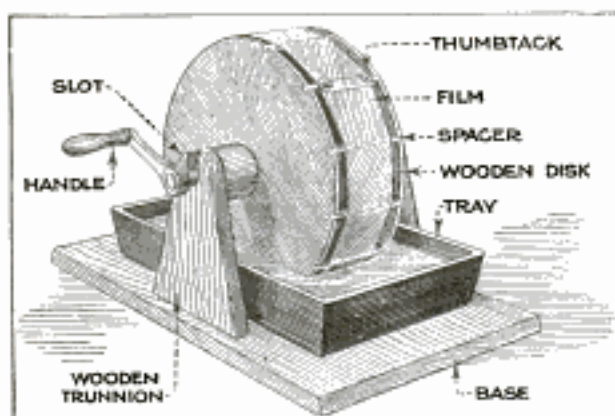

Developing Roll Films by Attaching Them to an Easily Made Drum, Which is Revolved in a Tray of Developing Solution Placed Underneath

method of dipping the strip from side to side, the developing device illustrated is particularly intended. The device consists of a wooden cylinder that is mounted on suitable supports and revolved by a crank. The drum is made of two wooden disks, of the proper diameter, which are held the right distance apart by short strips of wood; these also form a support for the film, which is attached to one of the cross-pieces with thumbtacks. The drum is mounted so that it can be revolved in a tray of developer placed underneath. In developing a film by this method, the dull or sensitized side, should be uppermost. The paper backing should be removed from the film, as in developing by hand, and the wheel should be turned slowly.

### Novel Spark-Plug Terminals

A pair of snap cuff links can be used to make a spark-plug terminal that may be disconnected instantly. The halves of the links are separated, and one part is soldered to the terminal of the ignition cable.

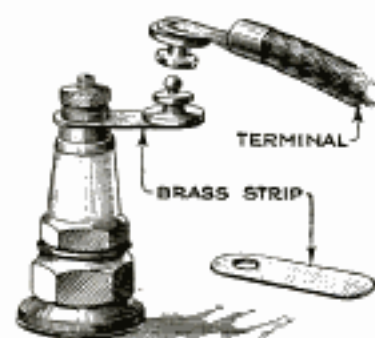

Then a small strip of stiff brass, about 2 in. long and  $\frac{3}{4}$  in. wide, is cut, and a  $\frac{3}{16}$ -in. hole drilled in one end. The other half of the cuff link is soldered to the opposite end of the strip. Slip the hole

over the brass spark-plug screw, screw down the nut, and the connection is complete when the button on the cable is snapped in place. By lightly twisting the blade of a screwdriver between the halves of the links, the connection can be instantly separated.

### Driving Auto with One Foot

A stonemason had one of his feet so badly injured by a stone falling on it that he was unable to drive his car, until the pedals had been arranged as in the drawing, so that but one foot was needed to control the clutch and brakes. A piece of flat iron, long enough to extend across to the clutch pedal, was bolted to the brake pedal. With this arrangement the clutch is automatically disengaged as soon as the pressure is applied to the brake pedal, but the clutch may still be disengaged without applying the brake. It may be found necessary, in some cases, to make an offset in the iron strip, between the two pedals, owing to differences in the length of travel of the two pedals.—H. C. Rowell, Hudson, N. H.

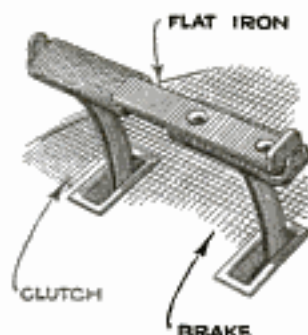

### Funnel Prevents Air Binding

When liquids are poured into a vessel through a funnel the fluid displaces the air in the vessel and compresses it, so that

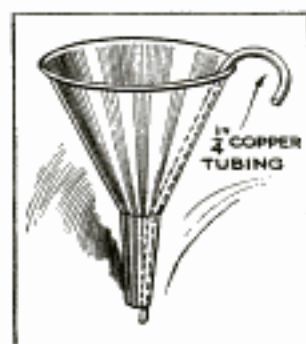

it must find an outlet before more of the fluid can enter; this is the cause of bubbling in the funnel, which sometimes causes more or less of a mess. The trouble can be overcome by soldering a piece of  $\frac{1}{4}$ -in. copper tubing inside the funnel so that the ends of the tubing extend beyond the spout and edge, the end projecting above the edge being bent over to form a handle. This arrangement allows the confined air to escape through the tubing and lets the liquid flow into the vessel in a steady stream.—John H. Schalek, Pittsburgh, Pa.

# PRIZE OFFERS AND ANNOUNCEMENTS

## THE AMERICAN LEGION OFFERS PRIZES FOR BEST ESSAYS ON AMERICANISM

The American Legion plans to hold annually an essay contest for the purpose of inciting in school children a desire for higher education, and for promoting patriotic research. This year, for the best essay by boys or girls between the ages of 12 and 18 on "How the American Legion can Best Serve the Nation," three cash prizes are offered of \$750, \$500, and \$250, respectively. Prizes will also be awarded in each state. The contest closes Aug. 1, 1922. Address: The American Legion, National Americanism Commission, Indianapolis, Ind.

## PRIZE OF 100 BOOKS TO BE AWARDED FOR BEST ESSAY ABOUT PASTEUR

In anticipation of the centenary of the birth of Pasteur, the great French chemist, which occurs next December, a prize of 100 books on scientific subjects will be awarded to the writer in French of the best essay on "Les Titres de Pasteur à la Reconnaissance Humaine" (Pasteur's Claims to the Gratitude of Humanity). To be eligible, the writer of the essay must be a member of one of the groups of the Fédération de l'Alliance Française. The essays must be mailed before Sept. 1, 1922, to the office of the federation, 32 Nassau Street, New York City.

## PRIZES OFFERED TO BOYS AND GIRLS FOR BEST BACK-YARD RAILROADS

For the best photos of toy railroads built by boys or girls in a back yard or a vacant lot, 23 cash prizes are offered, ranging from \$25 to \$2 each. The photos must be sent, with descriptions of how the railroad was built, before Sept. 15, 1922, to American Flyer Mfg. Co., 2219-39 South Halsted St., Chicago, Ill.

## FOR A NOVEL BY AN AMERICAN AUTHOR AN ATTRACTIVE PRIZE IS OFFERED

A prize of \$2,000 for a novel written by an American citizen, who has not published a novel prior to Aug. 1, 1914, is offered by Harper & Brothers. Manuscripts must be mailed before March 1, 1923. Address: Harper & Brothers, New York City.

## SEVERAL EXAMINATIONS FOR POSITIONS BY U. S. CIVIL SERVICE COMMISSION

The U. S. Civil Service Commission announces the following open competitive examinations:

For illustrations assistants in the Forest Products Laboratory, Madison, Wis., at \$1,500 to \$2,100 a year; receipt of applications closes July 18, 1922. For junior engineers and deck officers, U. S. Coast and Geodetic Survey, at an entrance salary of \$2,000 a year; to be held Aug. 9 and 10, and Oct. 4 and 5, 1922. For junior engineers, Bureau of Standards, at \$1,200 to \$1,500 a year; to be held Aug. 23, 1922. In all cases appointees will be allowed the bonus granted by congress of \$20 a month.

All desirous of competing should at once apply for form 1312, in the case of vacancies for junior en-

gineers, and in the other case for form 2118, stating title of the examination, to the Civil Service Commission, Washington, D. C., or to the secretary of the U. S. Civil Service Board in the applicant's locality.

## THE CHICAGO TRIBUNE OFFERS \$100,000 IN PRIZES FOR BUILDING DESIGNS

In commemoration of its 75th birthday, The Chicago Tribune offers \$100,000 in prizes for designs for a building to be erected on North Michigan Avenue. The contest is international. Architects desiring complete information are advised to write to Robert R. McCormick or Joseph M. Patterson, The Chicago Tribune.

## FOR BEST POEM ON A BIRD OR FLOWER A PRIZE OF \$25 IS OFFERED

A prize of \$25 is offered for the best unpublished poem, of not more than 20 lines, having for its subject a bird or flower. The offer is made by Dr. Mary McKibben, through the Bookfellow of Chicago. The contest closes Aug. 1, 1922. Address, Harper Prize Contest, The Order of Bookfellow, 4917 Blackstone Avenue, Chicago, Ill.

## HOMEMADE RADIO OUTFIT DESCRIBED IN GOVERNMENT CIRCULAR

The construction of a very simple homemade radio-receiving outfit is fully described in circular No. 120 of the Bureau of Standards. The equipment is for radio communication on wave lengths between 600 and 800 meters between stations within 50 miles of each other. A copy of the circular may be obtained by sending five cents to the Superintendent of Documents, Government Printing Office, Washington, D. C.

## CONFERENCES TO BE HELD AT HONOLULU BY THE PAN-PACIFIC UNION

Under the auspices of the Pan-Pacific Union, a commercial conference, to be attended by representatives of all the races and peoples of the Pacific, will be held at Honolulu, next October. This is the fourth of a series of conferences called by the union, the other three representing, respectively, scientists, educators, and journalists. The most valuable result of these conferences will be the promotion of international friendship that will develop cooperation.

## CONTESTS PREVIOUSLY ANNOUNCED

Medals, Diplomas, and Money Awards: Announced August issue, 1921; awards offered by the Franklin Institute.

For Service to City of Philadelphia: Prize \$10,000; announced September issue, 1921; awarded each year by Edward Bok, former editor of The Ladies' Home Journal.

One Million Francs for Best Motor: Announced January issue, 1922; closes June 1, 1923; address, Aero Club of France, Paris.

Man-Propelled Airplane: Prize 20,000 francs; announced April issue, 1922; closes September 13; ad-

(Continued on page 328)

## BLUEPRINTS

We often receive requests from readers who want blueprints of certain devices, machines, or instruments described in our pages. We do not supply blueprints, as we do not feel that they would be of any service to the reader. We take great pride in making our drawings as complete and clear as possible, and no more information could be obtained from a blueprint than from the drawings in the magazine. One gentleman said that he would like to have a blueprint "so that he could measure directly from it." This should never be done; with a machine where even a  $\frac{1}{16}$ -in. error will make a difference in the final result, the practice of scaling off measurements is especially pernicious. Blueprints never come out exactly to scale, and if all dimensions are clearly marked, as they should be, where is the necessity for measuring?

If we thought that blueprints would be of any assistance to our readers we would gladly supply them free, but we do not, and we take this opportunity of impressing upon those of our readers who think that white marks on a blue ground are, by some mysterious process, more reliable than black marks on a white ground, the fact that this idea is a totally erroneous one.—Editor.

dress, Maison Peugeot, 80 Rue Danton, Levallois-Perret (Seine), France.

**Best Lists of Uses of Shoe Polishes:** Prizes, \$500, \$300, \$200, 10 of \$25 each, 20 of \$15 each, 50 of \$5 each, 50 of \$2 each, and 100 of \$1 each; announced April, 1922; closes Aug. 31, 1922; address, F. F. Dalley Company of New York, 277 Military Road, Buffalo, N. Y.

**Annual Commercial Airplane Contest for "Italy's Great Trophy":** announced, July issue, 1922; address, Aero Club of Italy.

**For Best Lists of Uses for "Sanlo":** Prizes, \$50,

\$25, \$10, and three of \$5 each; announced June issue, 1922; closes Aug. 31, 1922; address, Contest Department, The Parker Sanlo Co., Inc., Rochester, N. Y.

**Research Thesis by a Woman:** Prize \$1,000; announced October issue, 1921; awarded annually; address: Dr. Lillian Welsh, Goucher College, Baltimore, Md.

**Ideas for New Occupations for Shut-Ins:** Prizes, \$100, \$50, and \$25; announced July issue, 1922; closes Nov. 1, 1922; address, Prize Editor, Popular Mechanics Magazine, 6 North Michigan Ave., Chicago.

In answering prize offers please mention Popular Mechanics Magazine

### A SALE OF REPAIRS

The farmer gazed with heavy frown  
Upon his mower broken down,  
Then hastened to the nearest town  
To buy repair.  
He told the dealer of his woe,  
And how much hay he had to mow,  
But not a number did he know—  
Nor seem to care.

"The part I want," he wisely said,  
"Is hollowed out and painted red.  
I had the number in my head—  
But I forget.  
It holds the thing-um-bob in place  
About an inch from that long brace  
That fastens to the big main base,  
And keeps it set.

"You surely know just what I mean,  
It broke before on this machine,  
The what-you-call-ums it's between  
And just behind,  
The thing that moves along like that  
About as big as that old hat  
Would be if you could smash it flat,  
I think you'll find."

[The above—from a Canadian weekly—was sent in by a trader who was unable to name the paper from which it was clipped.]

9367

The dealer sighed and shook his head,  
"I don't know what you mean," he said,  
"We'll have to search the extra shed,  
So come along.  
If you would only tax your brain  
So that the number you'd retain  
Or bring the old part in 'tis plain  
You'd not go wrong."

From end to end he searched the bins  
Clawed over castings, bolts and pins,  
And skinned his fingers and his shins—  
It made him cuss.  
But still he searched with sinking heart,  
(He'd seen two customers depart)  
And in the last bin found the part—  
'Twas ever thus.

"That's it," the farmer cried with glee,  
"I thought 'twas number thirty-three.  
Now what's the price of that to me?  
Great jumping frogs!  
Not forty cents? An awful rate  
For a thing that hasn't got no weight.  
Oh, well, just put it on the slate,  
Till I thresh my hogs."

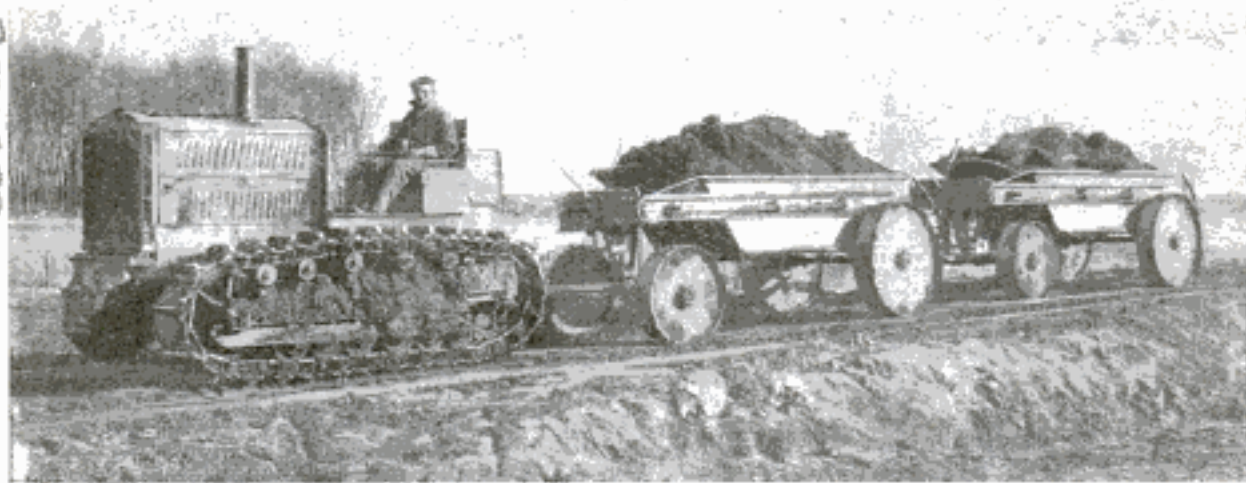

### USE OVERSIZE DUMP WAGONS FOR ROAD-BUILDING WORK

THE advent of the tractor and steam shovel as factors in road-building operations has brought, as a natural consequence, a change in the size of the dump wagons used for hauling the material excavated. Approximating in size small freight cars, dump wagons are now being manufactured that carry 6 cubic yards of dirt a trip, and are hauled two in a train by a powerful tractor. The wagons are of steel construction and are equipped with broad steel tires, to prevent them from sinking too deeply in the soft earth.

IN accordance with the editorial policy of this magazine never to accept compensation in any form for what appears in our reading pages, and also to avoid all appearance of doing so, we are obliged to omit the name of the maker or the seller of any article described. This information, however, is kept on file and will be furnished free, by addressing Bureau of Information, Popular Mechanics Magazine, Chicago. [Editor.]

La Plant Choate with Cedar Blafids, Iowa



## 1,820,000 Telephones Moved

In the telephone business every day is "moving day". Telephone subscribers are probably the most stable and permanent portion of our population; yet during the past year one telephone out of every seven in the Bell System was moved from one place of residence or business to another at some time during the year.

The amount of material and labor, and the extent of plant changes involved in "station movement" are indicated by the fact that this item of service cost the Bell System more than \$15,000,000 in 1921.

To most people, the connecting or disconnecting of a telephone seems a simple operation of installing or removing the instrument. As a matter

of fact, in every case it necessitates changes in the cables and wires overhead or underground. It also necessitates changes in central office wires and switchboard connections; in subscribers' accounts and directory listings; and frequently requires new "drop" lines from open wires or cables.

The problems of station movement are among the large problems of the telephone service. Because of the double operation of disconnecting and re-connecting, the work involved is often twice as great as in the case of new subscribers. With nearly 2,000,000 changes a year, it is only by the most expert management of plant facilities that Bell service is enabled to follow the subscriber wherever he goes.

" BELL SYSTEM "

AMERICAN TELEPHONE AND TELEGRAPH COMPANY  
AND ASSOCIATED COMPANIES

*One Policy, One System, Universal Service, and all directed toward Better Service*





## No Money Down Sent on Approval

Our determination to this year double our sales of the world famous *Santa Fe Special* and *Bunn Special Watches* prompts this matchless offer.

While other watch dealers are raising their prices, asking you for larger monthly payments, and making payment terms harder for you to meet, we are offering you our new model *Santa Fe Special*, and the famous *Bunn Special*, no advance in price, no money down, easier terms and smaller monthly payments. We realize the war is over and in order to double our business we **MUST** give you pre-war inducements, better prices, easier terms, and smaller payments.

## LOOK **Santa Fe Special** AND **Bunn Special Watches**

Without one penny of advance payment let us place in your hands to see, to examine, to inspect, to admire, to approve a real masterpiece in watch creation.

### Page Twelve of Our Watch Book is of Special Interest to You!

Ask for our Watch Book free—then select the watch you would like to see, either the famous *Santa Fe Special* or the 6 position *Bunn Special*, and let us explain our easy payment plan and send the watch, express prepaid, for you to examine. No money down.

**REMEMBER** No money down—easy payments buys a master timepiece—a 21 Jewel guaranteed for a lifetime at about half the price you pay for a similar watch of other makes. No money down—a wonderful offer.

**Santa Fe Watch Company**  
86 Thomas Bldg. Topeka, Kans.

Santa Fe Watch Co., 86 Thomas Bldg., Topeka, Kans.

Please send prepaid and without obligation your Watch Book free, explaining your "No Money Down" Offer on the *Santa Fe Special Watch*.

Name .....

Address .....

State .....





# Your Home Is Within Your Reach When You Buy From Us

## NOW is the time to build your Harris Home!

And here is a mighty organization of thirty great departments ready to serve you. Managed by expert material buyers, designers and practical builders. We have vast stocks bought at huge quantity price savings which are now at your command. Our sole aim and purpose is

*To help you get a home that will prove entirely satisfactory at a price that will mean a substantial saving in actual dollars of your money.*

The combined efforts of these great departments in experimenting and testing materials and methods of construction have produced for you a **GUARANTEED** home, expert machine cut, bundled and marked—the last word in building economy.

### Not One Penny in Advance

So sure are we of the super-excellence of our material and our **GUARANTEED** Ready-Cut System that we will ship you any **HARRIS HOME** without the payment of one cent down. Our Plan Book explains our liberal terms fully.

### FREE Plan Book

The latest edition is waiting for you, contains our **FREE PLAN OFFER** and photographic reproductions, with floor plans and specifications of 100 beautiful homes. Mail coupon today.

### Building Material of All Kinds

For over a quarter of a century, thrifty wise buyers have realized that here is the "open door" to real economy, whether it be a brand new home or material for improvements or repairs. Our big stocks of brand new building material, all purchased in tremendous quantities at savings that are passed along to you are ready for quick and complete shipments.

### "PRESTO-UP" Patented Bolt-together Buildings!

The wonder buildings of the age. Guaranteed buildings, for quick industrial housing. Individual Homes, etc., extra strong, practical and suitable for all year 'round habitation in any climate. 50 different plans. They come to you in easily handled sections—painted and stained, ready to bolt together and move in.

### Plumbing and Heating!

Hot water and heating systems, warm air heating plants, pipeless furnaces and plumbing material of every kind—the product of America's leading makers. Our mammoth plumbing stock offers unlimited possibilities for you to save money. Our heating plants are guaranteed to heat your home in any weather with big fuel economy. Mail the coupon for our Plumbing and Heating Book and get the benefit of our Expert Engineering Service.

Department NM-7

**HARRIS BROTHERS CO.**  
1349-1525 W. 35th St., CHICAGO

**FREE BOOK  
of Plans**

**HARRIS BROTHERS CO.**  
Dept. NM-7, Chicago

These books are **FREE** and sent post paid. Mark an "X" in the squares to indicate which ones you wish.

- |  |   |
|--|---|
| <input type="checkbox"/> Harris Home Book of Plans | <input type="checkbox"/> Book of "Presto-up" Houses and Garages |
| <input type="checkbox"/> Building Material Catalog | <input type="checkbox"/> Plumbing and Heating Book              |

Name.....

Address.....

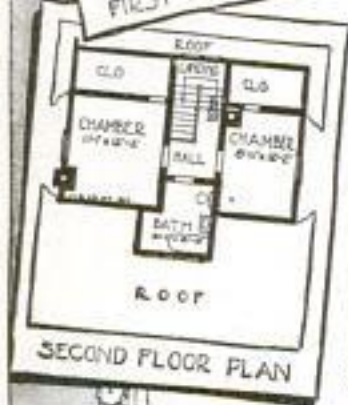
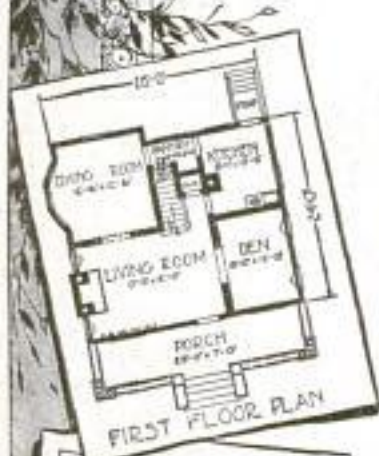

Micrometer  
Caliper  
with Ratchet Stop  
No. 2 R  
Price, \$13.50



**“You can't fool a skilled machinist about tools,” says Mr. Punch.**

Take this Ratchet Micrometer, for instance.

See how conveniently the ratchet is located. It can be operated with the same hand that holds the instrument, so your other hand is free to hold the work you're doing. The workmanship, accuracy, quality, of Goodell-Pratt Micrometers are known and appreciated by most users of high-grade tools.

You can tell they're good by their feel as well as by their looks.

Why, men, if you could see with your own eyes the exacting precautions taken to insure all Goodell-Pratt Tools coming up to the 100% standard set for them, you would say the same as thousands and thousands of other good workmen say.

GODELL-PRATT COMPANY, Greenfield, Mass., U.S.A.

*Toolsmiths*

The Ratchet, by always applying an equal amount of pressure, enables more uniform and accurate measurements to be taken.



Be sure to write for your copy of "Tools for the Toolmaker."

**GODELL-PRATT**  
1500 GOOD TOOLS

# Big Money for Ambitious Men

Seldom has such an opportunity been offered to ambitious men as we present in the agency for the Vacuette, the wonderful *non-electric* vacuum cleaner which is literally sweeping its way across the country, being sold by thousands thru salesmen who are making incomes such as few of them dreamed were possible.

Already more than 200,000 Vacuettes have been placed in American homes and every wheel in our factory is humming, every employee is kept busy, every department is running to full capacity to keep up with the flood of orders our representatives are sending in.

The Vacuette has opened a field for money making so big that ambitious men are even leaving good jobs to grasp the chance which it offers. Any man who will look into this proposition will see that here is a business where the limit is taken off, where any man can get all that is coming to him, where he can actually make big money and be independent.

## Vacuette

### Non-Electric Vacuum Cleaner

*As Efficient as an Electric—as Easy to Operate as a Carpet Sweeper*

We can place a few more active, ambitious men (also women) in choice territory to demonstrate and sell the Vacuette in homes. No experience necessary as the Vacuette *actually sells itself*. Women who see how marvelously it cleans rugs and carpets will not do without it. The Vacuette representative is welcomed in every home, for not only is this the work saver which women have been looking for—but our great national advertising campaigns have made it known everywhere.

### No Electricity

The Vacuette is the latest, greatest invention in vacuum cleaners. It operates from its own self-contained mechanism.

It requires *no electricity*. It has no cords, plugs, or other cumbersome attachments. It cleans rugs and carpets as perfectly as the best electric cleaner and costs only about half. The simplest, most efficient mechanical vacuum cleaner ever made. It is just what every housewife has been wanting, looking for, expecting. Our salesmen don't have to argue—they simply show the Vacuette and the sale is made.

Decide right now at least to investigate. Tell us to send you all the facts—ask us to prove that this is the greatest proposition ever offered. Then you can make your final decision.

*Men who started with no experience are making money. This may also be your big chance.*

**Send the Coupon**

Don't delay or you may lose the chance. Write for the facts about this sensational offer.

**The Scott & Fetzer Company.**

West 114th St. and Locust Ave., Dept. 18, Cleveland, Ohio

Without obligation please send full information about your big-money proposition for salesmen.

Name .....

Address .....





**WHETHER** an apprentice in the School of Experience, or a student in the finest Technical College in the country, no man graduates without an appreciation of good tools. Industrial developments have led to new theories and new practices but the dependable accuracy of Starrett Precision Tools is still an axiom in both machine shop and classroom.

*Send for Catalog No. 22 "A. P." and the Supplement showing the newest Starrett Tools*

### THE L. S. STARRETT COMPANY

*The World's Greatest Toolmakers  
Manufacturers of Machine Tools and  
ATHOL, MASS.*



*Heavy one-inch micrometer Caliper No. 238. Designed to stand up under hard usage—exceptionally practical for lathe or milling machine work.*

# Starrett Tools



42-163

Thousands of miles must be reeled off by the test tires on this special rough-running machine. All to prove the long life of your sturdy, strong Vitalics.

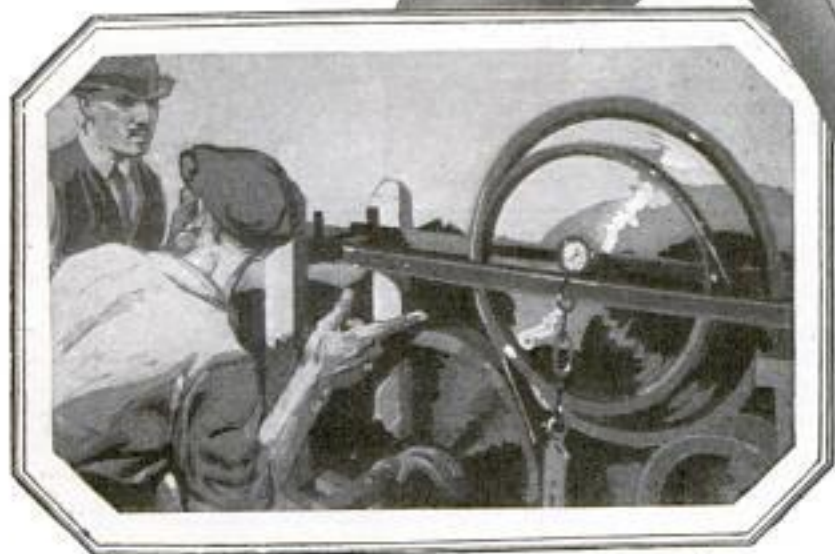

## Many tests must prove them "tougher than elephant hide"

**I**MAGINE examining every single inch of the great rolls of strong 14 $\frac{1}{4}$  ounce fabric for thin threads and flaws! Think of the work testing every shipment of rubber and all other materials to prove they are up to Vitalic Standard!

Even after your fine, sturdy Vitalics are finished, many other critical tests must be given them

to make sure they will deliver full mileage of trouble-free service. Every Vitalic Tire that leaves the factory must measure up to the Vitalic high standard of quality.

No wonder the makers of such good bicycles as Black Beauty, Columbia, Dayton, Emblem, Excelsior, Indian, Iver-Johnson, Pierce and Yale use Vitalics on their better grade wheels.



Send for this booklet. It tells you just how Vitalics are built and tested

CONTINENTAL RUBBER WORKS  
1934 LIBERTY STREET ERIE, PA.

# VITALIC

TRADE MARK REGISTERED

# Bicycle Tires



TRADE MARK  
"Tougher than  
elephant hide"

## YOU CAN LETTER LIKE THIS WITH THE LILLY LETTEROGRAPH.

FOR MECHANICAL, ELECTRICAL AND ARCHITECTURAL ENGINEERS AND DRAFTSMEN,

AND OTHER PROFESSIONAL MEN AND STUDENTS.

THE ALPHABET CAN BE EXECUTED IN LESS THAN 1½ MINUTES. Used by Leading Technical Schools and Engineering Corporations.

No. 1 OUTFIT—1 LETTEROGRAPH,  
2 PENS, COPIES AND INSTRUCTIONS  
(4 SIZES OF LETTERS) \$ 3.50

No. 2 OUTFIT—2 LETTERGRAPHS,  
3 PENS, COPIES AND INSTRUCTIONS  
(6 SIZES OF LETTERS) \$ 6.50

DURO METAL PRODUCTS Co. 360 E. GRAND AVE., CHICAGO, ILL.  
(LETTERED WITH THE LETTEROGRAPH)

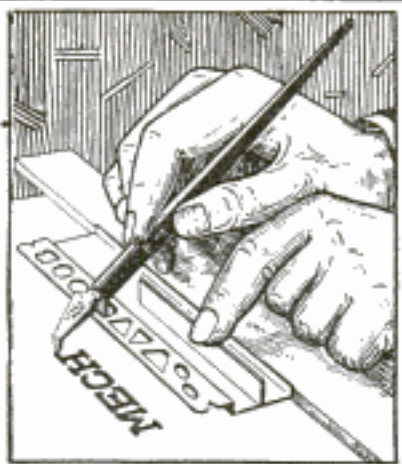

## Handy Power for Your Home Work Shop



**Runs 10 Hours on One Gallon of Gasoline**  
Full half horse-power, yet weighs only 40 pounds. Pick up, carry where needed and belt up in a few minutes. Small, compact, only 11 x 14 in. Use for running lathe, drill, grinder, buffer, saw—any small machine. Don't confuse with cheap 2-cycle or bothersome water-cooled 4-cycle engines.



## "Fullpower" 1/4 Cycle Engine

**Air Cooled—Can't Overheat**

Equipped with magneto and easy-pull starter. Best construction—built like high-grade auto-engine. Conforms to Underwriters' specifications—safe anywhere. Thoroughly dependable. Made and guaranteed by one of America's largest and oldest makers of automotive components.

**Send Only \$10 with Order**

Balance \$36.50 on delivery, anywhere in the U. S. Your money back if you don't consider it the biggest engine value you ever saw. Send \$10 draft or money-order—now—we ship same day order is received. Descriptive circular free.

**Briggs & Stratton Co.**

1033 Louis Avenue Milwaukee, Wis.

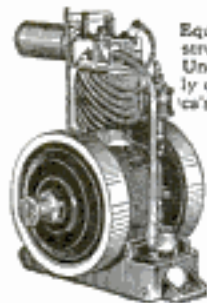

## DISTRIBUTORS WANTED FOR

### Prest-Air Tire Inflator and Fire Extinguisher

Does two jobs well—Inflates tires without pumping Extinguishes fires instantly

Prest-Air is a small cylinder 6"x2". Its expansive content is the same as used in soda fountains to make sodas and is called carbonic gas. It is HARMLESS—good for rubber. DOES NOT DETERIORATE. Inflates 5 to 7 tires from flat with one charge. HAS A TIRE GAUGE that tells pressure in tire also tells pressure in cylinder. In addition to Prest-Air being such an excellent tire inflator, it is also a most effective fire extinguisher. Fire cannot burn in the presence of carbonic gas. Sells for \$0.50 retail \$0.75. Passes U. S. Government tests. It is an amazing product. Several choice territories open for capable experienced distributors, who are in good financial shape. National advertising and strong backing from factory.

PREST-AIR COMPANY 1107 Stroh Building Detroit, Michigan

## It's Easy to Build Things with a JUNIOR BENCH SAW



Does Rippling, mitering, grooving, rabbeting, tenoning, sanding, grinding and many other operations with ease and accuracy. Top 10" by 12". Saws 1 1/2" stock. Driven by 1/4 or 1-3 h.p. motor. Portable. Runs from any light socket. All metal construction. Extremely accurate. Descriptive circular tells many things of interest to workers in wood, fiber, bakelite and soft metals.

Junior Bench Saw only, with guides and one 6" saw blade..... \$28.75

Price complete with 1/4 h.p. Ball Bearing Motor \$60. Ball Bearing Motors are used exclusively on Bolex Machines—another indication of their high quality. Cheaper than any more durable and serviceable.

Ask about our Bench Jointers, 14" Bench Band Saws, larger motor drives Bench Saws, Bench Drills and 1/4 and 1-3 h.p. Ball Bearing Motors

W. & J. BOICE, 114 23rd Street, TOLEDO, OHIO

## Moore Push-Pins

Glass Heads—Steel Points

### Moore Push-less Hangers

To hang up things

Ask your dealer to show them

Sold Everywhere 10¢ per packet

Moore Push-Pin Co.

Wayne Junction Philadelphia

## A NEW KEY CUTTING MACHINE

### The American Duplex

Ready set to cut Square, Angular or Round Slots.

For particulars address

AMERICAN SHARPENING MACHINE COMPANY

Dept. 6, 184 W. Washington Street, Chicago

## RADIO For Everybody

Make Radio a profession instead of a plaything. You can earn big money as a Radio-trician. Learn by mail, in spare time, how to design, construct, install, repair, maintain, operate, sell and demonstrate complete radio outfits. Write for free 32-page catalog describing our course entitled, "How to Learn Radio at Home."

National Radio Institute, Dept. 1192, Washington, D. C.

## Bam-Bee-A Real Baseball

Played on any table anywhere. Ask your dealer, or write

The Bam-Bee-A Sales Co., Dept. 642 Toledo, Ohio

Hand Forged Razor Steel Blades, No. 57



A GENUINE \$2 KNIFE FOR \$1.18 POSTPAID

## Direct at Factory Prices

This \$2 KNIFE \$1.18 Postpaid

Hand Forged Razor Steel Blades

Handy shaped B i n d e makes this knife best for mechanics, sportsmen and farmers; light but strong; re-sharpened easily. Stag handle. German silver finish; blades file tested, hand forged from razor steel and warranted.

Sample \$1.18 3 for \$3.00 Postpaid.

Send for our 100-page List and "HOW TO USE A RAZOR" FREE

MAHER & GROSH CO., 106 A St., Toledo, Ohio



## A good battery costs the least

**T**HOUGH Westinghouse Batteries are "oversize" and in every way looked upon as the ultimate in battery engineering, they are not relatively high in price. But their biggest economy is in the performance you get—in the extra capacity, longer life, and in the satisfaction derived from knowing you've a battery that is *dependable*.

WESTINGHOUSE UNION BATTERY CO., Swissvale, Pa.

# WESTINGHOUSE BATTERIES



### THE AJAX EYELET FASTENER BINDS AND INSERTS AJAX EYELETS IN PAPER, CARDBOARD, LEATHER OR CLOTH

It Saves Time by Punching the Hole, Feeding the Eyelet and Clinching It in One Operation.

Drop the eyelets into the magazine and go right ahead. Order from your stationer or direct.



PRICE WITH 1500 AJAX EYELETS. \$10.00 DELIVERED IN U. S. A.

Write for our catalogue of office tools

**MACHINE APPLIANCE CORPORATION**

351-353 Jay St.

Spec. Dept.

Brooklyn, N. Y.

Cooking  
Lighting  
Heating

## GAS For Country and Suburban Homes

An extremely practical and highly efficient individual plant for furnishing cooking, lighting and heating gas for country and suburban homes at an unusually low cost. Does away with old style, inconvenient and uncomfortable coal, wood and oil stoves. Makes homes modern. Provides easy and convenient method of heating for laundry and bath. Easily installed, simple and easy to operate and absolutely safe. Fully guaranteed. Hundreds of satisfied users. Lasts a life time.

### Distributors Wanted

—men of sound, sensible business experience, capable of earning \$10,000 or more yearly, and who can develop and train salesmen. Must be financially able to handle distribution and sale of plants and accessories, backed by strong national advertising and extensive co-operation from factory. Right man should make \$10,000 to \$20,000 yearly. Several choice territories still open. Write—no wire—today.

**Suburban Gas Co.,** 7882 Marrow St., Detroit, Mich.



You Can Ride Rings Around  
the Other Fellows When You're  
on One of Those Speedy

## Dayton Bicycles

You will get the "jump" on them every time—and hold the lead too—so little effort is needed to keep the Dayton spinning along.

That's why champion racers ride it—and why the big hope of most boys is to have one of these fast, smooth-running bikes.

Every single unit of the Dayton is made in our own immense factory—the surest way of producing a bicycle that will prove up 100% in service.

If that's the sort of a bicycle you want—speedy, enduring, good looking, easy riding—get a Dayton. Be the best mounted boy in your town.

Our new booklet "How to Choose a Bicycle" will tell you many things you ought to know. Write for your copy now. Use the coupon.

Cycle Division  
**The Davis Sewing  
Machine Company**  
Dayton  
Ohio



**FILL IN—CUT OUT—MAIL TODAY**  
The Davis Sewing Machine Co., Dayton, Ohio.  
Please send me, without obligation, your booklet  
No. 25, "How to Choose a Bicycle," and the  
1922 Dayton Catalog.  
Name.....  
Address.....  
Air.....

## Men With Autos Wanted



to introduce and take orders for our **NEW PROCESS STORAGE BATTERY**. Plates cannot sulphate or buckle. No expert attention required.

One-half cup water every 3 months. Made for autos, radios, lighting outfits and all other battery purposes.

### Guaranteed 2 Years

The biggest money maker and greatest business builder ever known. Write today for our exclusive proposition and low wholesale prices.

**HARSHA BATTERY CO.** Dept. 10.  
21 East Van Buren St. CHICAGO



## PAUL REVERE BICYCLE

A sturdy dependable Bicycle—all workmanship and parts absolutely guaranteed for five years. 7 models to choose from. 12 months to pay. Express charges prepaid. Beautiful Catalog free. Agents wanted.

**MYEROW BROS.**  
258-260 COLUMBUS AVE.  
BOSTON, MASS.

## THE SHAW MOTOR ATTACHMENT Makes Your Bike a Motorcycle

A high grade 2½ H. P. Motor attachment quickly clamped to any bike frame. Speed 4 to 40 miles an hour. 90 to 125 miles per gallon of gas.

**Special Low Price Now!** Write today for Complete Description and Special Low Prices on SHAW Motor Attachments and the Shaw Complete Motorbicycle.  
**SHAW MFG. CO., Dept. 37, GALESBURG, KANS.**



## SEND for the INTERNATIONAL CATALOG

Factory to Consumer direct—Our net price list of auto bodies and body supplies at Wholesale Prices.

FOR FORD, CHEVROLET, DODGE, MAXWELL AND OVERLAND FOUR—PRICES FROM \$27.85 UP  
International Body Works 914 W. Ohio Street, Dept. 7 Chicago, Ill.



## AUTO DRIVERS

Can make big money in spare time or devote entire time to introducing and taking orders for our

### IMPROVED CORD TIRES

Highest quality. Sensational prices. Big profits. Permanent business. Write today for catalog and agent's special offer.

**LANGAN & PHILLIPS**  
Dept. 104 CHICAGO





# REX—

A 1" BROWN & SHARPE MICROMETER AT A LOW PRICE

## \$6.25

This high grade precision instrument retains the high degree of accuracy of all Brown & Sharpe Micrometers—there can be but one Brown & Sharpe standard of accuracy—the highest.

Note these features in the Rex Micrometer: The frame of I-section to give strength with lightness, and the deep opening to afford large measuring capacity. Note also the decimal equivalents on the thimble.

Learn about the new Rex line of high grade measuring instruments, at a low price, in 24 sizes, measuring from 0 to 24".

Write today for circular describing complete line.

**Brown & Sharpe Mfg. Co.**  
Providence, R. I., U. S. A.

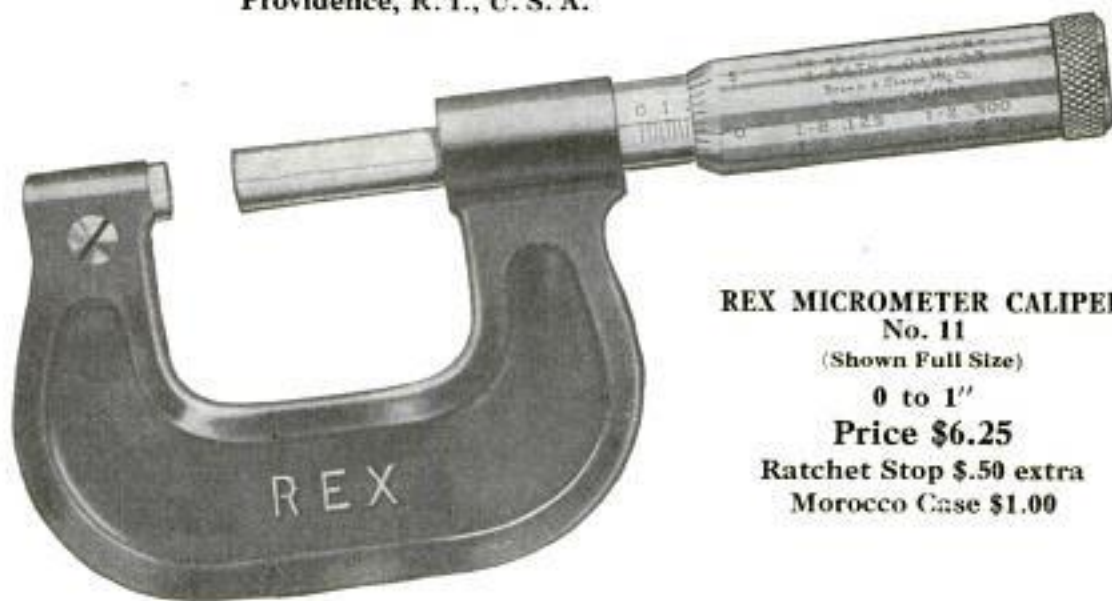

**REX MICROMETER CALIPER**  
No. 11

(Shown Full Size)

0 to 1"

Price \$6.25

Ratchet Stop \$.50 extra

Morocco Case \$1.00

### Be A Floor Surfacing Contractor

New overcrowded field. Contractors prefer to subcontract floor surfacing to American Universal Contractors. Machine does work of 6 men. Works quickly, easily. We set you up in business of your own, furnish office forms, advertisements, etc.

**Make \$5,000 to \$15,000 or More—Yearly**

Prepare for big building boom. Make new floors perfect, old floors like new. Every floor a prospect. Big money in old floors. No town too small. Dealership often pays for machines first month with profit besides. Get full information.

**THE AMERICAN FLOOR SURFACING MACHINE CO.**

523 So. St. Clair St.

Teled. O., U. S. A.



### A PERFECT POLISH WITH CLEAN HANDS



**KAXO**  
SHOE BRUSH

**POLISH, DAUBER and BRUSH** combined in one convenient article. Polish is in a tube enclosed in metal case on top of brush, and when tube is used up, new ones may be obtained at leading stores everywhere, 25 cents. Buy of your dealer or order direct, stating whether black, tan, mahogany or white is desired. Fine opportunity for agents.

Postpaid anywhere \$1.25  
Address Sales Dept.

Everett & Barron Co., Providence, R.I.

## DIAMONDS

### Here at 60% of Market Price

This snappy perfectly cut diamond 7/8—3/32 ct. at \$52.50 among bargains in recent list. Many other big values in our lists. Buy HERE! Prices based on loan values, not market values. This 75 year old diamond banking firm has thousands of unpaid loans and other bargains. Must sell NOW.

**Why Pay Full Prices**  
Any diamond sent for absolutely free examination at our risk. No obligation. No cost to you.

**Send for Latest List**  
Describes Diamond Bargains in detail, gives guaranteed loan values. Explains unlimited exchange privilege. Write for list today. Send NOW.

**JOS. DeROY & SONS** 1985 DeRoy Building  
Only Opposite Post Office Pittsburgh, Pa.

# Roofing Book FREE

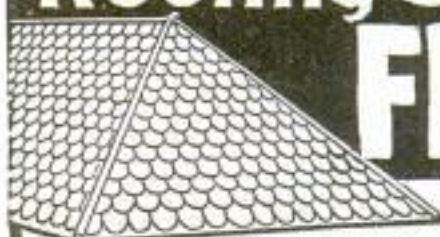

## World's Best Roofing at Factory Price

Don't buy Roofing of any kind until you get our big Free Roofing Book, describing full line of Edwards Famous "Tightcoats" Galvanized Roofings, Sidings and Ceilings, and our lowest factory prices. Then see for yourself how much we save you by selling direct and saving you all in-between dealers' profits.

## EDWARDS Metal Shingles

Absolutely rust proof. By our patented "Tightcoats" process, edges as well as sides of metal sheets are heavily coated with zinc—not a space the size of a pin point exposed to weather. Fire and lightning proof. Outlasts three ordinary roofs. Forever wind and weather proof. Need no repairs—and all roofing expense. Patent INTERLOCKING DEVICE makes water tight seams—all nail heads covered—no chance for rust or leaks.

### EDWARDS Galvanizing Test

Edwards "Tightcoats" Galvanized Roofing can be bent, twisted or struck by lightning, and the galvanizing will not crack or flake. Bend it or hammer it—you can't loosen or peel the galvanizing. No other galvanized roofing can withstand this test.

### Low Priced Garages

Wide variety of styles, all sizes of Portable Fireproof Metal Garages. Lowest prices ever made. Postal brings Big Garage Catalog free.

Write Today for free samples and proof that we can save you a lot of money on any kind of roofing siding or ceiling you may need. Ask for Roofing Book No. 100.

**THE EDWARDS MFG. CO.,**  
800-850 Pike St., Cincinnati, O.



**FREE**  
Samples &  
Roofing Book

## FORD and CHEVROLET SPEED BODIES

Dealers:  
Write for Accessory Catalogue

MAKE DRIVING  
A PLEASURE



Equip your old Ford or Chevrolet Chassis with one of our new distinctively modern bodies. Up-to-date Roadster, Touring and Speedster designs. Ford bodies as low as \$29.50 and up. Territory open for live wire dealers and agents. Make real profits.

Buy Direct from Factory  
**FEDERAL MOTOR SUPPLY CO., Inc.**  
1424 S. Blue Island Ave. Chicago  
CANADIAN DISTRIBUTORS  
Federal Auto Body Co., Toronto, Ont.; Campbellton, N. B.

## Banish Ford Lighting Troubles

Put an end to costly burned wires; flickering lamps and loose connections.

"Union" Fuse Block protects entire wiring system. When there is a ground, a fuse simply blows, which can be replaced for a few cents. And you can quickly locate the trouble.

Permits use of standard lamps for both bright and dim lights, instead of high-priced double-filament type.

Easy to install. Sent postpaid for \$1.50 if not at your dealers. Money back if not satisfactory. Write for booklet.

**CHICAGO FUSE MFG. CO.**  
1503 W. 15th St., Chicago, Ill.  
Eastern Branch: New York

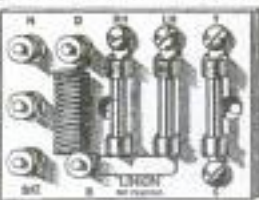

**2 TIRES FOR \$11.95**

**FREE TUBE WITH EACH TIRE**

### SENSATIONAL CUT IN STANDARD TIRE PRICES!

Two used tires for less than the usual cost of one, and a free inner tube with each tire! No double treads or seamed tires. Our big volume means best tire values. Act now and cut your tire cost in two. Thousands of steady customers are getting full mileage out of these tires and you, too, can get **8,000 MILES**.

You can see the mileage in our tires. Order and prove it—but order now! This is a special lot selected for record-breaking sale. Supply limited and going double quick.

#### NOTE THE BARGAIN PRICES ON TWO TIRES OF SAME SIZE

Size	1 Tire	2 Tires	Size	1 Tire	2 Tires
30 x 3	\$ 7.25	\$11.95	32 x 4 1/2	\$13.45	\$21.45
30 x 3 1/2	8.25	13.95	33 x 4 1/2	13.95	22.45
32 x 3 1/2	9.45	15.45	34 x 4 1/2	14.45	23.45
31 x 4	10.65	16.90	35 x 4 1/2	14.95	24.90
32 x 4	11.85	19.75	36 x 4 1/2	15.45	25.45
33 x 4	12.45	20.90	33 x 5	15.65	25.95
34 x 4	13.25	21.95	35 x 5	15.90	26.45
36 x 4	14.35	23.95	37 x 5	16.45	26.95

SEND NO MONEY! Shipments C.O.D. express or parcel post. Examining tires on arrival and if not fully satisfied return same at our expense and your money will be promptly refunded. State whether straight side or clincher. DON'T DELAY! ORDER NOW!

ALBANY TIRE & RUBBER COMPANY  
2721 Roosevelt Road Dept. 164H Chicago, Illinois

## Rider Agents Wanted

Select from the 44 styles, colors and sizes of Ranger Bicycles. Ride and exhibit sample Ranger and make money. Delivered free, express prepaid, on approval. Factory-to-Rider prices save \$10 to \$25.

12 Months to Pay on any Ranger if desired. Boys and girls easily save the small monthly payments. Parents often advance first payment.

Best quality, at factory prices, express prepaid. Lamps, wheels and equipment, low prices. Send No Money, do business direct with makers.

**Mead Cycle Company**  
Dept. F716 Chicago



## FORDS RUN 34 MILES

on Gallon of Gasoline



Wonderful new carburetor. Guaranteed to reduce gasoline bills from one-half to one-third and increase power of motors from 30 to 50%. Start easy in coldest weather.

Sent on 30 DAYS' TRIAL

Fits any car. Attach yourself. Fords make as high as 34 miles to gallon. Other cars show proportionate saving. Send make of car and take advantage of our special 30-day trial offer. Agents Wanted.

**AIR FRICTION CARBURETOR CO.**  
3380 Madison Street Dayton, Ohio

## AUTO OWNERS Make Big Money



Earn big money in your spare time introducing our splendid tires in your community. By our plan you can start a permanent, profitable tire business of your own. **Harrison Hand Made Tires** are positively guaranteed **10,000 miles**, made by skilled workmen from finest materials. Easily sold at our low prices. Shipped on approval prepaid. No capital or experience necessary. Sample section **FREE**.

### WRITE FOR SPECIAL OFFER

Our agency plan and confidential low prices to user agents sent you without obligation. Write today.

**Harrison Tire & Rubber Co.**  
230 Indiana St. - Hammond, Ind.

## Easy to Play Easy to Pay



### Saxophone Book Free

Tells when to use Saxophone singly, in sextettes or in regular band; how to play from cello parts in orchestra and many other things you would like to know.

(34)

In big demand for orchestra dance music. The portrait above is of Donald Clark, Soloist with the famous Paul Whiteman's Orchestra.

**Free Trial** You may order any Buescher Instrument without paying one cent in advance, and try it six days in your own home, without obligation. If perfectly satisfied, pay for it on easy payments to suit your convenience. Mention the instrument interested in and a complete catalog will be mailed free.

## Buescher Band Instrument Co.

Makers of Everything in Band and Orchestra Instruments  
2534 Buescher Block, Elkhart, Indiana



## Agents

LARGE MANUFACTURER OF SHIRTS  
L wants Agents to sell complete line of shirts direct to wearer. Exclusive patterns. Big values. No capital or experience required. Write for free samples.

MADISON SHIRT MILLS  
307 Broadway New York, N. Y.

## RADIO For Everybody

Make Radio a profession instead of a plaything. You can earn big money as a Radio-trician. Learn by mail, in spare time, how to design, construct, install, repair, maintain, operate, sell and demonstrate complete radio outfits. Write for free 32-page catalog describing our course entitled, "How to Learn Radio at Home."

National Radio Institute, Dept. 1192, Washington, D. C.

## HAWAIIAN IM. DIAMONDS



No. 8018  
Special price \$2.98

The Greatest Discovery the World Has Ever Known

Just to advertise times in those im. diamonds we will send you one of these 14K gold 1. rings, postage paid. When it arrives pay postman \$2.98 C.O.D. charge to cover cost etc. Only 10,000 rings given away. Money refunded if you can tell it from a genuine diamond. Read size of rings.

KRAUTH & REED  
Dept. C  
Masonic Temple Chicago



No. 8011  
Special price \$2.98

## Try This Typewriter 5 Days FREE



\$3.00 Down — Balance \$5.00 Monthly  
Any standard make. Perfectly rebuilt. Guaranteed satisfaction or your money back. Save \$25 to \$60. Pay while you earn. Try 5 days at our expense. Send postcard for special bargain prices. Save fully 1/3 to 1/2. Do it NOW!

WYNN TYPEWRITER EXCHANGE, 12 Bellvue Bldg., Kansas City, Mo.



## This Plier Is Guaranteed to outlast and outcut any plier made

Neverslip Pliers not only wear longer but they cut better because their cutting blades are made from special high carbon crucible steel.

Moreover, these cutting blades are renewable. Should they become accidentally nicked or broken they can be quickly and easily replaced with a brand new pair—same as a safety razor.

That is why you can cut nails, heavy wire, soft metal or insulation cleanly and quickly with Neverslip Pliers.

Your plain sense of economy ought to tell you that it's worth a special trip to your Hardware Dealers for a pair. If your dealer hasn't Neverslip Pliers in stock, send us his name and we'll see that you are supplied. Write for leaflet.

THE NEVERSLIP WORKS  
New Brunswick New Jersey

## NEVERSLIP side cutting pliers

Neverslip Pliers are furnished in six, seven and eight inch sizes.

If you use pliers you ought to read this interesting leaflet. It's mailed free upon request.

Please Mention Popular Mechanics

# Tune to B-D-X-X

Panel your Radio Set on XX BAKELITE-DILECTO for positively permanent insulation and utterly eliminated vibration. Far better than hard rubber or marble, hence used for years by U. S. Navy and Signal Corps. Tests highest in every particular. Astounding Dielectric and tensile strength (proved constant 5.2). Proof against water, heat or mild acids.

*Absolutely unequaled for*

## Radio Panels and Wireless Insulations

BAKELITE DILECTO Grade XX—everlasting BLACK—comes in sheets 38x38. Any live dealer can get it for you. Any machine shop can mortise it, drill it, and cut it to the size you want. WRITE US DIRECT and we'll tell you where to get it CUT TO SIZE. Insist on BAKELITE DILECTO for your Radio Panel for efficiency's sake—and because it will make your outfit look like a million dollars!

### The Continental Fibre Company of NEWARK, DELAWARE

New York—233 Broadway, Rochester—85 Plymouth Ave., S., Chicago—332 S. Michigan Ave., Pittsburgh—301 Fifth Ave., San Francisco—75 Fremont St., Los Angeles—411 S. Main St., Seattle—1927 First Ave., S.

# bakelite-dilecto



## RenuLife Ozone Generator

Purifying ozone and the healing balm of pine needles can be breathed in your own home. A trip to a change of climate for the relief of hay-fever, rose-fever, asthma or catarrh is unnecessary—use this scientific instrument.

For rheumatism, neuritis and blood, nerve and skin disorders use the RenuLife Violet Ray Generator.

Write for information and interesting book. It's free.

RenuLife Electric Co.,  
148 Newberry Bldg., Detroit.  
(In Canada: Pitt St., E.,  
Windsor, Ont.)

Gentlemen: Please send me  
information regarding:

RenuLife Ozone Generator  
RenuLife Violet Ray

Name .....

Address .....



## SAY!

Thousands have; why don't you improve your financial condition? Operate a **Kingery Popcorn Popper**, Peanut Roaster or Popcorn Fritter Outfit. 70 cents profit on every dollar. Many styles and sizes. Popping 40 quarts to 12 bushels per hour. Roasting 12 quarts to 5 bushels. Prices \$40 to \$550. Liberal terms. Catalog free.

**KINGERY MFG. CO., Est. 1881**  
Dept. 242 CINCINNATI, OHIO



## Agents: \$50 a Week

For your spare time. Men or women selling guaranteed hosiery. Must wear 12 months or replaced free—all styles, colors and fancy stripes, including silk hose.

**Sell for Less Than Store Prices**

Often sell dozen pair to one family. Every man or woman, young or old, can make big money selling this quality line. Write for samples.

**THOMAS MFG. CO.**

H-3048 Dayton, Ohio



## RAISE BELGIAN HARES

New Zealand Reds - Flemish Giants - American Blues.

**BIG PROFITS, WE PAY \$1.50 TO \$8 EACH.**

Also Cavies, Mink, Skunk, Fox, Muskrat, Etc.

Easily raised anywhere. 32-

page Catalog and Contract **FREE!**

Illustrated book "COMMON SENSE RABBIT

RAISING," quarterly journal, and copy of

America's leading small stock magazine, all for 10 cents. Address

**Outdoor Enterprise Co., 1005 S. E. Blvd., KANSAS CITY, MO.**

## TYPEWRITERS

We Save You 50%

**FREE TRIAL—EASY TERMS**

Your choice of all STANDARD MAKES.

UNDERWOOD, ROYAL, SILENT L. C.

SMITH, Self-starting REMINGTON, etc.

Rebuilt by the Famous "Young Process."

Guaranteed good as new. Lowest cash prices.

Time payments or rentals with special pur-

chase privileges. Largest stock in U. S.

Write for special prices and terms—

**YOUNG TYPEWRITER CO., Dept. 358 CHICAGO**





Send  
today for  
this free  
booklet.

## Own a Corona!

Increase your income

**T**HIS wonderful little 6½ pound folding typewriter pays for itself in time it saves and work it turns out. Fold it up—take it with you—typewrite anywhere.

# CORONA

The Personal Writing Machine

REG. U. S. PAT. OFF.

Corona Type-writer Co., Inc.,  
108 Main St.,  
Groton, N. Y.



## NOW TIME TO START

**BIG DEMAND. HIGH PRICES BEING PAID**  
An uncrowded occupation. Exceptional opportunities for live men and women. Raised at home. Only small space needed. Small expenditures will start you in a practical money-making enterprise, big profits. Booklet telling all free. Write  
**Nat'l Spawn Co., Dept. 12, Brighton, Mass.**

A Baseball Jersey

## Be the First in Your Club



School, City or Town, to wear this pure, all wool sweater, double collar and cuffs. Your choice in colors. This jersey was selected by 10,000 of my customers for last season. Your chum will recommend it. Send for my big illustrated catalogue. Write me and learn my offer for your club's order. Popular Prices. Best Grade Sporting Goods—Baseball, Basketball, Tennis, Golf, Football, etc.  
**WRITE ME NOW**

Jack Shannon Co., Dept. 46, 111 So. Dearborn St., Chicago



## If You Can Tell it from a GENUINE DIAMOND Send it back

To prove our blue-white MEXICAN DIAMOND cannot be told from a GENUINE DIAMOND and has same DAZZLING RAINBOW FIRE, we will send a selected 1 carat gem in ladies Solitaire Ring, (Cat. price \$5.50) for Half Price to introduce, \$2.63, or in Gents Heavy Tooth Belcher Ring (Cat. Price \$5.50) for \$3.25. Our finest 1 1/2 carat Gold Filled earrings, GUARANTEED 20 YEARS, SEND NO MONEY. Just mail postcard or this ad. Size Size. We will mail at once. When ring arrives deposit \$2.63 for Ladies ring or \$3.25 for Gents with postman. If not pleased return in 2 days for money back less handling charges. Write for Free catalog. Agents Wanted.

MEXICAN DIAMOND IMPORTING CO., Dept. ET, Las Cruces, N. Mex.  
(Exclusive controllers Mexican Diamonds)

# 21 Jewel Burlington



Adjusted to the Second 21 Ruby and Sapphire Jewels  
Adjusted to Temperature 25 Year Gold Strata Case  
Adjusted to Isochronism Your Choice of Dials  
Adjusted to Positions (Including Montgomery B. R. Dial)  
New Ideas in Thin Cases

# Only \$1.00 Down

Only One Dollar Down will buy this masterpiece of watch manufacture. The balance you are allowed to pay in small, easy, monthly payments. The Burlington—a 21-Jewel Watch—is sold to you at a price much lower than that of other high-grade watches. Besides, you have the selection of the finest thin model designs and latest styles in watch cases. Don't delay! Write for the FREE Watch Book and our SPECIAL OFFER today.

# Write While This Special Offer Lasts

Get the Burlington Watch Book by sending this coupon. Find out about this great special offer which is being made for only a limited time. You will know a great deal more about watch buying when you read this book. You will be able to "steer clear" of the over-priced watches which are no better. Remember, the Burlington is sent to you for only One Dollar down, balance in small monthly payments. Send the coupon for watch book and our special offer TODAY! Do not delay one minute!

## Burlington Watch Company

Dept. C135, 19th St. & Marshall Blvd., Chicago  
Canadian Address: 62 Albert St., Winnipeg, Manitoba

Please send me (without obligations and prepaid) your free book on watches with full explanation of your \$1.00 down offer on the Burlington Watch.

Name \_\_\_\_\_

Address \_\_\_\_\_

Please Mention Popular Mechanics

# Enders

## SAFETY RAZOR

*"Just like  
wiping your  
face with  
a towel"*



Perfectly  
Simple  
Simply  
Perfect

ENDERS SELLS FOR \$1.00 with six blades of the best quality Swedish-base steel. Packed in black Keratol box, velvet lined. Extra blades, package of 5—35 cents. IN CANADA—Razor, \$1.50; blades, 50 cents.

*For Sale by all Up-to-Date  
Dealers Everywhere*

ENDERS SALES COMPANY  
105-111 West 40th Street, New York

*The Enders*  
TRADE MARK  
PAT. MAY 2, 1926

Please Mention Popular Mechanics

# DEAF?

**"I Now Hear Clearly"  
You, Too, Can Hear!**

500,000 satisfied users have testified to the wonderful results obtained from the "Acousticon." We therefore feel perfectly safe in urging every deaf person, without a penny of expense and entirely at our risk, to accept the



**1922 ACOUSTICON**  
For 10 Days' FREE TRIAL  
*No Deposit—No Expense*

Just write saying that you are hard of hearing and will try the "Acousticon." The trial will not cost you one cent, for we even pay delivery charges.

**WARNING!** There is no good reason why every one should not make as liberal a trial offer as we do, so do not send money for any instrument for the deaf until you have tried it.

The "Acousticon" has improvements and patented features which cannot be duplicated, so no matter what you have tried in the past send for your free trial of the "Acousticon" today and convince yourself—you alone to decide.

**DICTOGRAPH PRODUCTS CORP.**  
1307 Candler Bldg. 220 W. 42 St., N. Y. City

**MILLIONS OF MEN** will eventually delight in use of this invention, is our prediction. Is as revolutionary as perfection of the safety razor. For only 50 cents, postpaid, we will send you the wonderful WIZ strop-  
per for safety blades.

With the WIZ anyone can perfectly strop any safety blade in 20 to 30 seconds. 30 to 300 or more delightful shaves from a single blade, one user to date has had 480 shaves from same blade and declares blade good as new. The WIZ is vest-pocket size, nickel finish, will last for years. No strap-strop used. A sharp blade in a jiffy, any time, any place. Saves you many dollars. Sold only on ten days' trial money back guarantee. Order one from us today. Add 10 cents if you remit by check. Dealers wanted.

**GORDON SPECIALTY WORKS**  
BOX 709, STATION C. LOS ANGELES, CALIF.

**HOME LOVERS' BARGAIN BOOK FREE**

*Showing Over 10,000 Furniture Bargains*  
All selections loaned free for a month. Take a year to pay if satisfied, paying little by little almost as you please.  
**SPIEGEL, MAY, STERN CO., 1108 W. 35th St., Chicago**

## Getting Back on time

Easy—if you have any one of the nine styles of Taylor Compasses. They take you back via the shortest route in the quickest time.

*Your dealer has them  
and will quote prices.*

### TAYLOR COMPASSES



*Taylor Instrument Companies*  
ROCHESTER, N. Y.  
Distributors of Taylor Compasses for Every Purpose



### Travel with Comfort and Economy

You will not only enjoy the water trip but will save money by traveling on D & C Steamers which make daily trips between Detroit and Buffalo; Detroit and Cleveland on Eastern Time.

**Detroit and Buffalo**  
Lv. Detroit 5:30 p. m.  
Arr. Buffalo 8:30 a. m.  
Lv. Buffalo 6:00 p. m.  
Arr. Detroit 9:00 a. m.  
Fare — \$6.00 one way;  
\$11.50 round trip.

**Detroit and Cleveland**  
Lv. each city 11:00 p. m.  
Arr. each city 6:15 a. m.  
(Daylight trips during  
July and August)  
Fare — \$3.60 one way;  
\$6.50 round trip.

Berths, \$1.80 up; Staterooms, \$4.20 up;  
Parlor, \$7.20 up

Direct rail connections made at Detroit, Buffalo and Cleveland for all sections of the country. Rail tickets accepted and automobiles carried (15 to 25% reduction in rate this year.) Gas must be removed. Wireless aboard.

For reservations and further information address E. G. Stoddard, Gen. Pass. and Ticket Agt., Detroit, Mich.

**Detroit & Cleveland Navigation Co.**

A. A. Schantz,  
Pres. & Gen. Mgr.

Jas. T. McMillan,  
Vice-Pres.



### NEW SINGLE PHASE A. C. MOTORS

$\frac{1}{4}$  H. P.—110  
volt, 60 cycle,  
1725 speed, com-  
plete with cord,  
plug and groov-  
ed pulley, \$13.00



$\frac{1}{2}$  H.P. 547.00  
 $\frac{3}{4}$  H.P. 58.00  
1 H.P. 62.00  
 $1\frac{1}{2}$  H.P. 76.00  
2 H.P. 85.00  
3 H.P. 108.00  
Include pulley  
and base.

ONE YEAR GUARANTEE

$\frac{1}{2}$  H.P. and larger, 110/220 volt Rep. Ind. Type  
Satisfaction guaranteed or money refunded  
Illustrated Catalog of Motors and Supplies FREE  
HYRE ELECTRIC CO., 615-H So. Dearborn St., Chicago

**SEND  
5 CENTS**

and get our 48 p. catalogue of **IDEAL Model  
Aeroplanes, Parts and Supplies.** Tells how  
to build Aeroplanes that fly like real ones.  
**IDEAL AEROPLANE & SUPPLY CO.**  
159 Wooster St., cor. W. Houston New York City



### PLUMBING & HEATING

Buy Direct—Save 50%

**\$66.95 Complete Bathroom  
Outfit \$66.95**

Send NOW for our FREE Catalog "A" of  
Wholesale prices

Satisfaction Guaranteed

**LAMPLOUGH BEAUMONT COMPANY**  
99 So. Portland Ave. Brooklyn, N. Y.



*"Mary, that hot lunch from my  
Icy-Hot makes a new man of me!"*

**I**CY-HOTS are making over millions of men,  
giving them new "pep" and energy for their  
work. A hot meal at noon gives a man a new  
start on the day. You don't feel fatigue so  
quickly.

An Icy-Hot Lunch Kit pays for itself many  
times over in better lunches, better health  
and easier work days.

Get an Icy-Hot Lunch Kit and enjoy good  
hot dinners at work each day. Have delicious  
hot coffee, or chocolate, or rich hot soups,  
prepared at home. The Icy-Hot Lunch Kit also  
keeps lunch fresh and clean—no more dried  
out sandwiches, or dusty food. Icy-Hot all-  
metal construction is absolutely dust-proof.



Be sure you get a guaranteed Icy-  
Hot. Look for the name on the bot-  
tom. Sold by reliable hardware, drug,  
and department stores everywhere.  
Send coupon for catalog of Icy-Hots  
for all purposes.

THE ICY-HOT BOTTLE CO.  
193 W. Second St., Cincinnati, O.

## ICY-HOT VACUUM PRODUCTS

Made in America, of American Material, by Amer-  
ican Labor, Built for Lifetime Service

The Icy-Hot Bottle Co.  
193 W. Second St., Cincinnati, Ohio  
Please send complete catalog of Icy-Hot products.

Name \_\_\_\_\_  
Street and No. \_\_\_\_\_ State \_\_\_\_\_  
P. O. \_\_\_\_\_

**KEEP CONTENTS HOT 24 HOURS: COLD 3 DAYS**

Please Mention Popular Mechanics

**DIAMONDS-WATCHES**  
CASH or CREDIT  
**LOFTIS**  
BROS. & CO. EST'D 1890

**GENUINE DIAMONDS GUARANTEED**  
**PRICES GREATLY REDUCED**

We invite comparisons. You will be convinced that you can do better with LOFTIS. Our IMMENSE BUYING POWER for our Chain of Stores and our large Mail Order House enables us to make lower prices than small concerns. Liberty Bonds accepted at par.

**SEND FOR FREE CATALOG**  
Everything explained. Over 2,000 illustrations of Diamond-set Jewelry, Pearls, Watches, etc. An article sent prepaid for Free Examination. Satisfaction guaranteed or money refunded.

The handsome articles shown are selected from our "All Best Sellers." Diamonds are excellent, blue white, perfect cut. Mountings are all Solid Gold. Furnished at prices given, up to any price you wish. Order by Number.

**DIAMOND RINGS:** 1-White Gold, \$150. 2-White Gold, or Green Gold, with White Gold prongs, \$75. 3-White Gold, \$75. 10-White Gold, or Green Gold, with Diamond set in White Gold, \$27.50. 11-Yellow Gold, Diamond set in White Gold, \$150. 6-WEDDING RING: Platinum, \$25; Green or Yellow Gold, \$15. 7-WATCH: 17-J, gold filled, guaranteed 25 years, \$27.50. 12-WRIST WATCH: White Gold, 15-J., \$50; 17-J., \$45. Credit Terms: One-fifth down, balance divided into equal payments within eight months.

**LOFTIS**  
BROS. & CO. EST'D 1890  
108 N. State Street, Chicago, Illinois  
Stores in Leading Cities

**Pepsodent**  
REG. U.S. PAT. OFF.  
The New-Day Dentifrice

**SEND NO MONEY**  
Try this Portable  
Typewriter 10 Days  
**FREE**



**10 Months to Pay**

Now you can buy famous, 9-pound National Typewriter direct from the factory, after 10 days' trial—absolutely free. You be the judge. Then we give you

**10 MONTHS TO PAY**

Same machine as used by thousands of doctors, lawyers, bankers, salesmen, students, writers and business men in 31 countries. Every feature of best, standard size machines. 28 keys.

84 characters. Brand new—not a rebuilt typewriter. Neat, compact carrying case free with every machine. Send today for our 10 Days' Free Trial offer and 10 Months' Easy Payment Plan.

**NATIONAL TYPEWRITER CO.**  
Dept. 7H. Fond du Lac, Wis.

**WINDOW SIGNS**

**AGENTS** \$60-\$200 a week. Free Samples GOLD SIGN LETTERS for store fronts and office windows.

Anyone can put them on. No experience necessary. Big demand. LIBERAL OFFER TO GENERAL AGENTS.

**METALLIC LETTER CO., 433B, N. Clark St., CHICAGO**

**A NEW WAY TO GET YOUR CLOTHES ABSOLUTELY FREE**

and Make Big Money during your spare time—something different, better, bigger, more liberal than any offer ever made. Lower prices—better clothes—bigger cash profits—express or postage paid on everything.

**DOUBLE PAY**

Free Clothes and Cash Profits Besides. You can easily earn \$50.00 cash, extra, every week during your spare time, taking orders for our made-to-measure clothes. We don't ask you to use your cash profits for your own clothes. That's not our way of doing business. Ours is a new and better plan.

Fifty-six stylish, real cloth samples—FREE colored (fashion plates); inside wholesale prices—everything FREE. Just drop us a line today and we will send complete outfit FREE.

**SPENCER MEAD CO. H-245 Chicago**



**AGENTS: \$8 a Day**



Selling concentrated, non-alcoholic food flavors. Always fresh. Put up in collapsible tubes. Ten times the strength of bottled flavors. Guaranteed under U. S. pure food laws. All flavors. Sells in every home. Used every day. Not sold in stores. Big demand. Big repeater. 100% profit.

**MEN OR WOMEN**

can make big money. Hard sold over \$300 in one month. You will find this a big, easy seller and a sure repeater. Must satisfy customers or money back. Write for territory and sample outfit. Get a big line of customers. Get repeat orders every month and have a steady income. Write quick.

**AMERICAN PRODUCTS CO., 6539 American Bldg., Cincinnati, Ohio**

**RADIO For Everybody**

Make Radio a profession instead of a plaything. You can earn big money as a Radio-trician. Learn by mail, in spare time, how to design, construct, install, repair, maintain, operate, sell and demonstrate complete radio outfits. Write for free 32-page catalog describing our course entitled, "How to Learn Radio at Home."

**National Radio Institute, Dept. 1192, Washington, D. C.**

The Prophylactic  
Tooth Brush  
Ask your druggist for "the brush in the yellow box"—he knows



## Different from all others—the NEW BENJAMIN

### AIR RIFLE

Made on a different principle from all other Air-Rifles. The Benjamin is really a strong air-pump used to compress the air in the air chamber to any degree of power desired. From one to six strokes of the pump give all the force necessary. Each additional stroke gives increased power. The Benjamin works on the same principle as all air-drills and air-hammers—with this difference:

You control the shooting force as you desire. Look at this block of hardwood. It shows how Benjamin power is regulated as you wish.

You can't have accidents with a Benjamin. It's safe, always, because you control the power. The Benjamin never loses shooting force, and has no springs to get out of order or shake your aim. Write us for an interesting folder about this wonderful air-gun.

For sale by all dealers.  
Price \$5.00.

BENJAMIN  
AIR-RIFLE & MFG. CO.  
615 N. Broadway, St. Louis, Mo.

Ask your dealer for demonstration.

Pacific-Coast  
Representatives:  
Stuart & Otis  
228 Wilcox  
Bldg., Los  
Angeles,  
Cal.

## Are You All Primed?

We can supply you with Masonic books of reference, study, history, etc. Also fine aprons, regalia, novelties, jewelry and supplies.

Send for Free Catalogue X

**REDDING & CO.**  
Publishers and Manufacturers

Dept. D 200 Fifth Avenue, New York

## GET A RAZO!

This unique Razor-blade pocket knife is the handiest, safest general utility knife. Uses an old Gillette blade. Artists, writers, draftsmen, tailors, dressmakers, office men, women, school children all need RAZO. Send 25c for yours today. Great money maker for agents.

**RAZO NOVELTY CO.**  
23 E. Van Buren St. Chicago

## Do Your PRINTING

Cards, circulars, labels, tags, book, menus, paper, press, \$12. Larger \$35. Job Press \$150 up. Save money. Print for others. **BIG PROFITS.** All easy, rates sent. Write factory TODAY for price catalog. TYPE, cards, paper. **THE PRESS CO. D-37, MERIDEN, CONN.**

## Rabbit Book FREE

Illustrated. Facts about the easy, profitable home industry—growing domestic hares for meat, fur, fancy. Little space—cheap equipment. Big demand. We buy all you raise at \$7 to \$18 per pair. Turn your spare time into cash. Book free—write now.

**STANDARD FOOD & FUR ASS'N**  
407B Broadway New York City

WURLITZER  
200 YEARS OF MUSICAL INSTRUMENT MAKING

# On Trial

## Send for New Book On Musical Instruments **No Charge**

EVERY known instrument illustrated, many in full colors. All details and complete descriptions. A veritable musical encyclopedia—absolutely free!

You may now have any musical instrument for a week's trial in your home at our risk. No obligation to buy. Return the instrument at our expense at the end of a week if you decide not to keep it. The trial will not cost you a penny.

## Monthly Payments

A few cents a day will pay. Special combination offers in complete musical outfits—velvet lined case, all accessories, self-instructor, etc., all at direct factory price—everything you need at practically the cost of the instrument alone.

Wurlitzer instruments are known all over the world for artistic quality. Used by the greatest musicians, bands and orchestras. Wurlitzer has made the finest musical instruments for over 200 years.

**Write Today.** Wurlitzer has stores in over thirty cities. But no matter where you live, Wurlitzer is no farther than your nearest mail box. Send coupon today.

**THE RUDOLPH WURLITZER CO., Dept. C177**  
117 E. 4th Street, Cincinnati 120 W. 42nd Street, New York  
300 W. Jackson Blvd., Chicago 250 Stockton St., San Francisco  
Send me your new catalog with illustrations in color and full descriptions of all musical instruments, also details of the Wurlitzer Free Trial Easy Payment Plan. No obligation.

Name.....

Address.....

(State musical instrument in which you are interested.)

Copyright 1922, The Rudolph Wurlitzer Co.

Please Mention Popular Mechanics

## Why Aren't You Satisfied?

Put yourself in the place of the boss. Would you pay your help as much as you pay yourself? Would you let them come down any hour they wanted to in the morning—go home any time they wanted at night? You know that you wouldn't. You would set definite hours for your help and insist that they be adhered to. And—the lion's share of the profit is yours you would say because you established the business—you are the boss.

You would positively do these things if you had a business of your own. Why then expect the man you work for to do different? But you want to get ahead—you are not satisfied. Are you in earnest? Do you really and truly want a business of your own—to be your own boss—to get the major portion of the profit?

Wright's Big-City Store-At-Your-Door offers you the very opportunity you seek. A complete retail clothing store that is yours without investment. Everything that men and boys wear—conveniently arranged—cleverly displayed. It is YOUR complete retail clothing store. The money you make from it is all YOURS—all clear—all "gravy". And you will make big money. 1484 men who have grasped this opportunity are making from \$3000.00 to \$5000.00 a year and are their own boss. 610 others have taken up this work in their spare time and are adding \$20.00 to \$35.00 a week to their income. Good character—a good name—and the willingness to work. That's all you need. We supply everything else. Have you the necessary requirements? Write us today for full details. An extremely interesting booklet "A Wright Business of Your Own" will also be sent you.

**WRIGHT & CO. Dept. C155 CHICAGO, ILL.**  
CONGRESS, THROOP & HARRISON STREETS



## Dry Cleaners—Men and Women EARN \$200— \$500 a MONTH

Everybody wants Clothes and Furnishings cleaned, and disinfected against moths, disease germs, vermin, etc. Let us start you in a profitable business in your own home anywhere. You need our process anyhow for your own clothes; no expensive apparatus required. Supplies on sale everywhere. Experience and capital unnecessary.

### 30 Days' Trial—Send No Money

Economy Educator Corp., Dept. 201  
1664 Broadway, New York

Mail This Coupon or  
a Written Request.

Send me your wonderful Dry Cleaning Method complete, with full instructions, on 30 days' trial. Also enclose FREE 30 MONEY-MAKING PLANS, personal efficiency secrets for business and social success, etc. I will pay the postman \$1.80 plus postage on delivery and will keep them 30 days. If they are not as advertised, I will then return them and you are to refund my money in full immediately. I agree to pay you \$2 royalty EACH MONTH I EARN \$200 OR MORE by your method and instructions.

Name.....

Address.....

## DIAMONDS

10 MONTHS TO PAY 1/2 CARAT \$99<sup>00</sup>

**CASH VALUE \$165. 30 DAYS TRIAL**

Genuine blue-white perfect cut diamonds now sold direct to you by DIAMOND IMPORTERS at wholesale prices on credit at 40% discount. 18Kt. solid, white, goldring included free.  $\frac{1}{4}$  carat only \$49.00;  $\frac{1}{2}$  carat \$147.00; 1 carat \$195.00. If satisfied: pay  $\frac{1}{2}$  down and balance in 10 monthly payments. We guarantee to please you or refund your money. Order direct from this ad, or write for 128-page bargain catalog of other jewelry \$1,000,000 and 48 years' experience back our guarantee

**B. GUTER & SONS**  
172 NASSAU STREET  
DN. 370, NEW YORK

## "SOMETHING NEW UNDER THE SUN"

Send  
No  
Money



Send us your name and address and we will forward by parcel post a 4 inch POCKET or EMBROIDERY scissors for 50c C. O. D. Made from TOOL STEEL, just patented. Guaranteed satisfaction or money refunded.

AGENTS WANTED to sell complete line of EMBROIDERY SCISSORS and HOUSEHOLD SHEARS. 100% profit  
**THE W. F. CONCANNON SHEAR CO., Inc., Milford, Conn.**

## Electric Fireless Cooker

Gives every facility of electric range plus every advantage of fireless cooker at less cost than a good oil stove.

### Automatic Rapid Electric Cooker New Invention Revolutionizes Cooking

Saves 50% to 75% fuel cost

Bakes, roasts, boils, steams, fries, toasts. Needs no watching. Shuts electricity off automatically. Attaches to any electric socket. No special wiring. Write for FREE Home Science Cook Book, 30-day FREE trial offer and direct factory prices.

**WM. CAMPBELL CO.**

Dept. 64  
Georgetown, Ont.

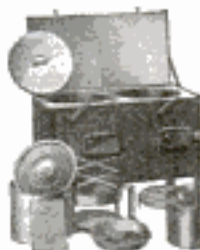

## "Lighting Fixtures"

READY TO HANG

(Direct from Manufacturers)

Completely wired, including glassware. New designs. Send for catalogue No 24. Send for DEALERS' proposition.

**ERIE FIXTURE SUPPLY CO.**  
STA. A. ERIE, PA.



## Beautiful HOUSES \$900 and BUNGALOWS

CAN BE BUILT FOR AND UP  
This and many others in my new book, Building Plans for Modern Homes, will save you hundreds of dollars. One of the most complete and comprehensive books of plans ever published by any architect. New edition just off the press. Nearly 100 floor plans and photographs of bungalows, Colonial homes, etc., costing from \$200 up; gives sizes and cost to build.



**FREDERICK H. GOWING**  
ARCHITECT

Sent postpaid for \$2.00

101 Tremont St., BOSTON, MASS.

## The WONDERFUL

### ERICKSON PATENT LEG

Will not  
chafe,  
overheat,  
nor draw  
end of  
stump.



ERICKSON ARTIFICIAL LIMB CO., 38 Wash. Av. N., Minneapolis, Minn.

### "BOW LEGS and KNOCK-KNEES" UNSIGHTLY

SEND FOR BOOKLET SHOWING PHOTOS OF MEN WITH AND WITHOUT THE PERFECT LEG FORMS

**PERFECT SALES CO.**  
140 N. Mayfield Ave., Dept. 5, Chicago, Ill.



## "Best" Hand Lantern



A powerful portable lamp, giving a 300 candle power pure white light. Just what the farmer, dairyman, stockman, etc., needs. Safe—Reliable—Economical—Absolutely Rain, Storm and Bug proof. Burns either gasoline or kerosene. Light in weight. Agents wanted. Big Profits. Write for Catalog.

ADOPTED BY THE U. S. GOVERNMENT  
**The Best Light Co., 324 E. 5th St., Canton, O.**

# SAVE HALF - INSTALL YOUR OWN PLUMBING AND HEATING BY OUR NEW EASY METHOD

## Send for Our Big Handy-Man Plumbing and Heating Encyclopedia

It shows and explains our NEW EASY METHOD—how to save skilled labor, unnecessary material and heavy work. Any handy man can do the installing with our simplified systems and working plans. OUR NEW EASY METHOD saves much cutting, threading, time and material. Even if you are a plumber the big saving by using our products and NEW EASY METHOD will surprise you.

## Big Book Saves Labor and Material

Every builder, mechanic, farmer, etc., needs this BIG INSTRUCTIVE PLUMBING AND HEATING ENCYCLOPEDIA. Besides being our wholesale catalog, it contains hundreds of floor plans, elevations, diagrams and installing sketches from the simplest to the most difficult systems, showing our EASY METHOD of installing your own plumbing or heating, gives hundreds of mechanical rules, links, receipts, short cuts, etc., how to lay out plumbing and heating, estimate costs, repair leaks, etc. It shows and describes over 10,000 FACTORY FITTED plumbing and heating fixtures and supplies with wholesale prices; helps you to select the best plumbing outfit, or heating plant, to meet your needs. Any handy man can do the installing with the aid of OUR HANDY-MAN PLUMBING AND HEATING ENCYCLOPEDIA.



## Our Factory Fitted Plumbing and Heating

BATHROOM OUTFITS, TOILETS, LAVATORIES, BATH TUBS, SINKS, LAUNDRY TUBS, WATER SUPPLY SYSTEMS, WATER HEATERS, PUMPS, PIPELESS AND WARM AIR FURNACES, HOT WATER AND STEAM PLANTS, PIPE, FITTINGS, VALVES, etc. All outfits factory fitted for the handy man, with beauty, durability and EASE OF INSTALLATION built through and through.

SEND 25c FOR YOUR COPY TODAY

COUPON

**HARDIN-LAVIN CO.** 50 YEARS AT 4547-57 COTTAGE GROVE AVE., CHICAGO

Enclosed find 25c. Please send me your HANDY-MAN PLUMBING AND HEATING ENCYCLOPEDIA with wholesale discounts, and mail me your monthly bulletin, "Service." 25c to be refunded to me with my first order.

Name \_\_\_\_\_

Street and No. \_\_\_\_\_

City \_\_\_\_\_

State \_\_\_\_\_



Only \$15 Down

Play Well in 4 Weeks



—Eight Months to Pay

Latest C Melody Saxophone Outfit complete, only \$95—lowest price ever quoted. Sent on 5 days' trial. If satisfied, pay only \$10 a month for 8 months. No interest to pay—no extra. Outfit includes finest nickel trimmed and richly lined Case, Instruction Book, Album of Popular Saxophone Solos, Music Lyre, Carrying Strap, Mouthpiece and three fine Reeds.

**"Masterbilt" Saxophones**  
Highest quality, built in perfect tune, assembled and tested by experts. Has all latest key improvements, light, quick action and beautiful finish. Order direct from this advertisement or write for Free Catalog Folder today.  
The Saxophone Shop, 427 S. Wabash Ave., Chicago  
Largest Exclusive Dealers in Saxophone Supplies in the World

Puts this ELGIN WATCH In Your Hands

No Red Tape, No Waiting

Simply send \$2.00 and receive watch. Full seven Jeweled Elgin in stylish Octagon Case. This model, guaranteed 20 years.

30 DAYS FREE TRIAL

Send only \$2.00 and watch comes charges paid. Carry for 30 days and if not satisfactory your deposit is returned. Pay balance \$2 a month for 10 months. Price only \$22.00. Send for FREE ROYAL BARGAIN BULLETIN, addressing Dept. 401.

ROYAL DIAMOND & WATCH CO.  
35 Maiden Lane, New York



EASIER TO PUT UP  
CAN'T SLIP

EASIER TO TAKE DOWN  
CAN'T SAG

## CRIMP GRIP CLOTHES LINE FASTENER

A simple, time-saving device for wash day. A rope holder for Tennis Ropes, Tents, Sail Boats, etc. Simple to put up. A WONDERFUL SELLER. Any man, woman, boy or girl can make big wages selling Crimp Grip Clothes Line Fasteners. The value of time saved by the use of Crimp Grip Rope Holders, pays for them in a short time.

Send no money with order, one pair sent C. O. D., parcel post—price 50c. Agents wanted, write for particulars

CRIMP GRIP COMPANY

BELVIDERE, ILLINOIS



# REDUCED PRICES

## JUNE 1, 1922

# SOUTH BEND LATHES

	Standard Change Gear	Quick Change Gear		Standard Change Gear	Quick Change Gear
9'x3' Lathe	\$150.00	\$189.00	16'x 8' Lathe	\$385.00	\$436.00
11'x4' Lathe	194.00	233.00	18'x10' Lathe	591.00	649.00
13'x5' Lathe	259.00	301.00	21'x12' Lathe	831.00	905.00
15'x6' Lathe	320.00	367.00	24'x14' Lathe	1129.00	1218.00

64-page Catalog No. 76 for 1922 sent free to any address

ESTABLISHED 1906

**SOUTH BEND LATHE WORKS**

625 E. Madison St.

**SOUTH BEND, IND.**

**How to Run a Lathe:**—New 80-page book, Revised Edition No. 24, for 10 cents postpaid, silver or stamps.

**SAVE MONEY ON GUARANTEED MOTORS**

**Buy Direct from Headquarters**

Save from 25% to 40% on standard makes of new and rebuilt motors. Get the proper size and type of motor to suit your exact needs—and get it fully guaranteed by a motor merchandising house backed with 20 years of dependable service direct to users. Write today for catalog No. 70. It quotes prices on motors of every size and type.

Electrical Equipment Bought, Repaired or Exchanged.

**THE FUERST-FRIEDMAN COMPANY**

CLEVELAND

"Reliability Built In."

OHIO



THE CRESCENT MACHINE CO., 83 Columbia Street, Leetonia, Ohio

It is the well known quality of CRESCENT machines that justifies you in selecting one of them each time you have need for wood working machinery. The CRESCENT line is better than ever and will always give you satisfaction in every particular. Ask today for catalog of hand saws, saw tables, jointers, shapers, planers, borers, planers and matchers, swing saws, disk grinder, cut off table, hollow chisel mortiser, variety wood worker, Universal wood workers.



Can't lose it! A shackle securely fastens Keen Kutter quality and satisfaction to your chain! Be one of the multitude attached to Keen Kutter pocket knives.



Simmons Hardware Company

**KEEN KUTTER**

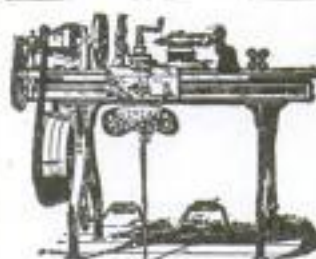

**LATHES**

9 to 18-inch Swing

List price \$165 and up according to size. When ready to buy send for Lathe Catalog and prices.

**W. F. & John Barnes Co.**

100 Ruby Street, ROCKFORD, ILL.



**Only \$2<sup>00</sup> Puts This Handsome Watch In Your Pocket**

Seize this chance—get a Watch that you can rely upon every second of the day. Make sure that **YOUR TIME IS ALWAYS EXACT.** New thin models, 12-size Elgin, in handsome gold-filled case, guaranteed for 20 years.

**Knife and Chain Free**

Send us only \$2.00. Together with the famous Elgin, we will send you absolutely FREE, a handsome, gold-filled knife and chain. Then send us \$1.30 EACH MONTH until the total price of the Watch, \$14.98, has been paid. No advance over cash dealer's price. **NO DELAY—NO RED TAPE—EVERYTHING STRICTLY CONFIDENTIAL.**

Free de luxe Catalog—send for it! Amazing values in Watches, Diamonds, and Jewelry. Address **Dept. 532-N.**

**CAPITAL, \$1,000,000**

**L. W. SWEET, Inc., 1650-1660 Broadway, New York**



## All You Need to solder Aluminum



A Clean Soldering Iron and a Bar of  
**EVERSTICK**  
Aluminum Solder

No Flux Necessary

Price \$2.50 a Pound—Delivered. Trial  
Bar 50 Cents, Postpaid

Order TODAY From

GREAT WESTERN SMELTING & REFINING CO.  
3100 N. Broadway St. Louis, U. S. A.

## WIRELESS OPERATORS

—Amateur and Professional—need

**SOLDERALL—25c** per tube  
and TORCH, \$1.50

Pat. Oct. 2, 1911



A Paste That Turns Into Metal When Heated  
A match will do it, but best results can be  
obtained by using our new improved torch.  
Requires no acid or soldering iron. Joins or  
repairs wires, metal or metalware. Sold by  
Hardware and Electrical Stores, or sent by  
us postpaid.

**SOLDERALL CO., Dept. P**  
129 Sussex Avenue NEWARK, N. J.  
Dealers Send for Quantity Prices  
Beware of Imitations with Similar Names

## THE WORLD FAMOUS Alvan Clark Telescope

We are now able to supply these wonderful  
instruments for terrestrial and astronomical  
observations. Cut shows new type 3' port-  
able terrestrial. Light weight—compact—  
easily carried anywhere—highest quality  
throughout. Circular and prices on request.

**THE ALVAN CLARK & SONS CORP.**  
Makers of the famous "Yecker" and "Lick" Telescopes  
55 Henry St. Cambridge, Mass.



## SQUAB BOOK FREE

Squabs are selling at the highest prices ever  
known. Breed them and make money. Write  
at once for free book, prices, etc.

Firmoth Rock Sem Co. 634 Howard St., Melrose Highlands, Mass



The Midget "FIVE-IN-ONE" Slide  
Rule is a combination Mannheim, Log-  
Log, Add and Subtract, Polyphase and  
Binary Slide Rule. It will instantly add,  
subtract, multiply and divide any combina-  
tion involving whole numbers, fractions, decimals  
and mixed numbers. Gives every possible root and  
power of every quantity. The graduations are  
printed on metal, coated with white celluloid and  
are gross and waterproof. While it is the most  
versatile calculator ever invented, its operation is  
simple and easily understood. Diameter 4 inches.  
Price with 16-page Instruction Book, \$1.50.  
Leatherette carrying case 50c extra. Cash on  
order. Your money back if you are not satisfied.  
**GILSON SLIDE RULE CO., Niles, Mich.**

## TOOL CHESTS

for Machinists & Toolmakers  
Every tool arranged in order. No  
up-to-date mechanic should be with-  
out one. A Gerstner Case costs no  
more than some tools, and will last  
a lifetime. Catalog free.

*Gerstner & Sons*

717 Columbia Street DAYTON, OHIO



"Red Devil" Rapid Boring Auger Bits are  
33 1/2%, easier boring, have 10% greater clearance,  
and bore with or against the grain of any wood.  
Style 2400—10/16 in., shown here, 75c.

## Red Devil Pliers

REG. U.S. PAT. OFF.



A "RED DEVIL"  
Plier is some-  
thing more than  
a piece of metal given  
a certain shape. If it  
is worth using at all, it is  
because someone knew  
how best to select the steel  
for the particular purpose,  
how to forge it, how to  
temper it, how to finish it.

It is because "Red Devil"  
Pliers are made by men  
who do know these things,  
that they have become  
universally accepted as

## Good Tools for Good Work

"Red Devil" Slip Joint Plier No. 924—  
an all-around tool for the home, office,  
car and garage. Size 6 1/2 inches. **50c**  
From dealers or us, - - - -

Mechanics' tool booklet free

"RED DEVIL" TOOLS—AMERICAN MADE

**SMITH & HEMENWAY CO., Inc.**

Manufacturers of "Red Devil" Tools  
260 Broadway, New York, N. Y.

"Red Devil" Glass Cutters—the glaziers' stand-  
ard tools of the world. "It's all in the wheel."  
Made in 40 styles. No. 024 shown here, 20c.



Please Mention Popular Mechanics

## Do Your Own Lathe Work

**I**T WILL pay inventors, experimenters and owners of small shops to own the MONARCH Junior 9 inch Engine Lathe. You can do all of your own lathe work and do it exactly as you want it done.

This wonderful little lathe is so simple and trouble proof that even a beginner can soon turn out finished work.

Small, sturdy and compact, it is the ideal lathe for the home or small work shop. Economically operated, has

automatic safety devices and is fully equipped.

It will do all small work that any other lathe will do and do it with 1/1000 of an inch accuracy.

Write today for Free Catalog and full information about the Monarch Junior Lathe.

Monarch  
Junior  
9-inch  
Engine  
Lathe

**\$225**

With Bench  
Legs

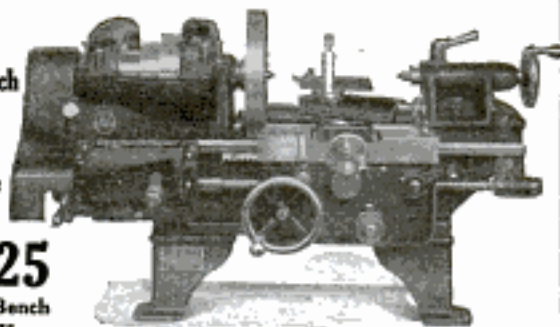

**THE MONARCH MACHINE TOOL CO.**  
400 Oak Street - - - Sidney, O.

*Monarch Lathes are built up to 30 inches swing*

## DISTRIBUTORS WANTED!



Big money for you in equipping every Fordson Tractor in your territory with Steel Crawler. A wonderful attachment that increases tractor's power, and doubles its usefulness. Sells wherever a Fordson owner sees it. Be the first in your

neighborhood to get our money-making proposition.

Address Box 2

**POPULAR MECHANICS MAGAZINE, Chicago, Ill.**

## DIAMONDS

FOR A FEW CENTS  
A DAY

**\$150 a Week**  
SEND NO MONEY  
Looks like  
**\$350 Solitaire**  
NO. 177C  
only **\$59.50**  
We Trust You

Don't send a single penny. Ten days Free Trial. When the ring comes examine it—if you are not convinced it is the Greatest Bargain in America, send it back at our expense. Only if pleased, send \$1.50 weekly—at the rate of a few cents a day. This Bargain Cluster Ring with 7 Blue-White Perfect Cut Diamonds can be yours. **FREE** No red tape. No risk.

Send today. It pictures thousands of bargains. Address Dept. 177C.

Million Dollar Bargain Book **FREE**

**J.M. LYON & CO.**  
2-4 Maiden Lane N.Y.



**F**OR any old odd job, any old time, you can't beat Bernards. Pliers with square jaws—meet like a vise. With cutting blades that slice through metal like a knife through cheese. At hardware dealers.

MADE IN SEVEN SIZES

Send for illustrated Plier Booklet M.



**BERNARD  
PLIERS**

Wm. SCHOLLHORN CO.  
NEW HAVEN, CONN.



PARALLEL JAWS

OUTSIDE CUTTER

## For Uses Requiring Hard Solder— Briggs' Silver Solder

1 oz. Tape—5 ft. long, 3/4 in. wide, 3/1000 in. thick, in non-waste, metal box, **\$1.25**

**J. Briggs & Sons Co., Mfrs.**  
67 Clifford St. Providence, R. I.

## Interlox

QUICK AND ACCURATE  
INSIDE  
MEASUREMENTS!



USE IT for all measuring—inside or out. The only interlocking, sliding Rule—Ideal for Carpenters, Mechanics, Engineers, Electricians, etc. If not at dealer's, send his name and 20¢ per ft. for rule sent prepaid (any length, from 2 to 5 ft.).  
**MASTER RULE MFG. CO., INC.** (FORMERLY DAHL MFG. CO.)  
841-43 E. 136th St., NEW YORK CITY  
Dealers and Agents: Write for Liberal Proposition

## MYERS WONDERFUL SEWING AWL

Tools in Handle



A complete repair shop in itself. Sews anything heavy or light, leather, shoes, harness, buggy tops, canvas, belts, etc. **\$1.00 Postpaid.**  
**C. A. MYERS COMPANY,** 6339 Woodlawn Ave., Chicago, Ill.

## BURN YOUR NAME ON TOOLS

WITH  
**ARKOGRAF**

Protect your tools from theft. Write your name, engrave any design on metal with electricity as easily as writing on paper with pen or pencil. Complete outfit \$3.50, prepaid anywhere. Interesting descriptive circular free. Write today. Agents Wanted. **Arkograf Pen Company**  
695 Capitol Ave. Portland, Oregon

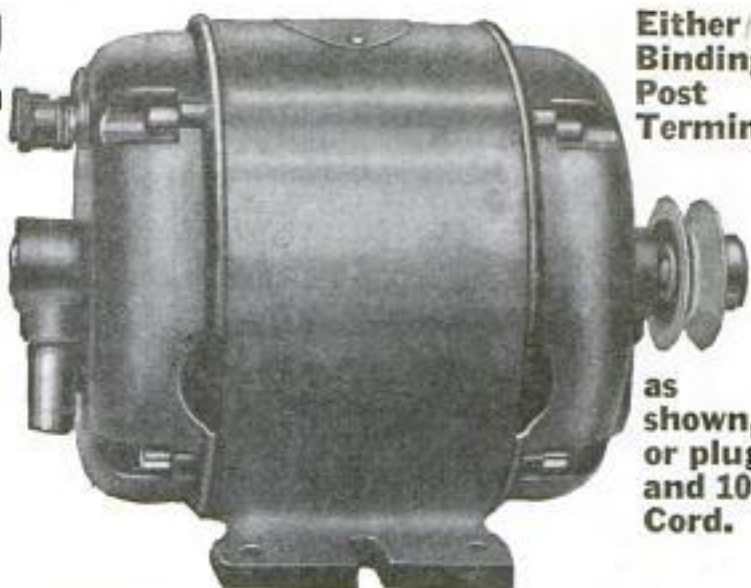

**BARGAIN!****1/4 H. P.****Guaranteed  
MOTOR****Split-phase, A. C. 110 volt,  
60 cycle, 1740 R. P. M.****\$13.50****Either/  
Binding-  
Post  
Terminal****as  
shown,  
or plug  
and 10 ft.  
Cord.**

Also **GRINDER and BUFFER**, operated by above motor. **\$25.00**  
Has 6 inch abrasive wheel and 7 inch Buff. Speed 1740 r.p.m.  
—with base, switch, cord and plug

Send Cash with order, as these low prices permit of no bookkeeping or collection expense. You run no risk, as motors are fully guaranteed by the maker for 1 year, a serially-numbered **Guarantee Service Tag** being wired to each motor before it leaves the factory. Any motor found defective within one year will be taken back and full credit allowed (f.o.b. Chicago) or replaced with new motor.

**RADIO** Also ask for prices on motors, generators, and Motor Generator Sets for Radio Service.**NORTHWESTERN ELECTRIC CO.**  
408 So. Hoyne Ave. Chicago**DRIVE 100 TACKS AND SAVE \$25.00**

Ford Roadster Top Recovering \$5.20, Touring \$6.95, with beveled plate glass lights, Touring \$9.95. Chevrolet, Dodge or Maxwell Roadster \$10.45, Touring \$13.95. All other 5 passenger cars \$16.50, with plate glass lights. Gypsy Side Back Curtain like cut, Ford \$2. Other cars \$3 extra. Ford regular side curtains \$5.95 up. Other cars \$11.50 up. Ford Best Side, Roadster \$3.15, Touring \$4.25, or tailored, Touring \$9.50. Other cars \$4 to \$5. Ford Combs \$5.75. All goods same as car tires, use quality the best and guaranteed to fit. Printed instructions given how to apply. Send for samples. Prices above include delivery at your door.

AUTO EQUIPMENT CO., 32 Canal Street,

Cincinnati, Ohio

**Only \$45.00 For This Job Complete**

Save exorbitant freight rates and one-half original cost by buying Ford Speedster Bodies knocked-down. Simple, complete instructions furnished, all parts cut to exact fit. Any one can assemble this job. Complete with hood, radiator shell, instrument board, upholstery, metal parts, wood parts, bolts, screws, etc. Flat radiator shell furnished made up. Designed low with lack of wind resistance. Price set up \$80, further particulars on request.

The Central Auto Supply Co., Eng. Dep. 120, Louisville, Ky.

**12 Months to Pay**

You can easily earn or save money for the small payments. Parents often advance first payment to help buy a **RANGER** bicycle. Choice of 44 styles, colors and sizes. **FACTORY-TO-RIDER** prices. **DELIVERED FREE** express prepaid on approval for **30 DAYS' TRIAL**, actual free riding test. Tires best quality, at factory prices, express prepaid. Lamps, wheels, and equipment, low prices. Send No Money.

**Mead Cycle Company**  
Dept. F108 Chicago

Write today for free Ranger Catalog, factory prices and marvelous easy payment terms

**MOTORCYCLES****RELIABLE STANDARD MAKES that you can DEPEND on.**

Enjoy the glorious experience of going wherever you like—whenever you like. The price is within your means—35% to 50% less than others. These machines are slightly used, thoroughly overhauled or rebuilt. Send for catalogue.

MYEROW BROS.,  
258 Columbus Ave., Boston, Mass.

**Auto Supplies**  
Knowing **HOW** to buy is merely knowing **WHERE**  
This is Chicago's Great Wholesale House.  
**AUTO SUPPLIES AND MOTOR PARTS**  
**WHOLESALE ONLY**  
Dealers send today for this big money-saving book

**AXTELL AUTO ACCESSORIES COMPANY**  
1574 A South Michigan Avenue  
CHICAGO

**MOTORCYCLE BARGAINS****Save 25% to 65%**

on Slightly used and Rebuilt Motorcycles, Side Cars, Johnson Motor Wheels, Evans Power Cycles, Bicycles. Send for Free Bargain Bulletin and Money Saving Message, listing hundreds of Bargains in used, rebuilt and new machines, supplies, accessories, etc.

AMERICAN MOTOR CYCLE CO. CHICAGO  
Dept. #14 2047 W. Chicago Avenue.**Add \$5 a Day to Your Profits WITH A TORIT ACETYLENE TORCH NO. 13**

For radiator repairing, general soldering, light brazing, heating, battery recharging, etc. Produces instant hot flame, works rapidly. Furnished with 4 different tips and soldering copper, enabling you to do a wider range of work.

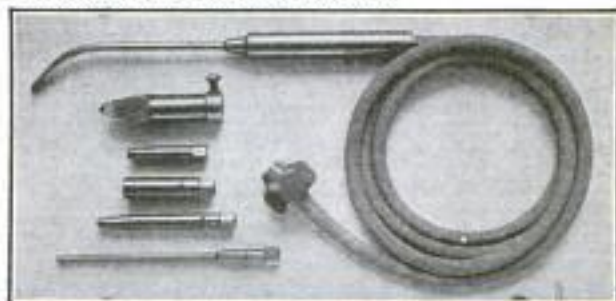
**USES ACETYLENE GAS ONLY**

A splendid use for discarded auto acetylene tanks. Many owners melt the Torch No. 13 pay for itself in a single day. Torch with 4 different tips, soldering copper, 5 ft. tubing and connection for auto acetylene tank.....\$7.50

**ORDER TODAY FROM YOUR JOBBER, OR**  
St. Paul Welding & Mfg. Co., 177 W. 3rd St., St. Paul, Minn.

# FEDERAL

BICYCLE TIRES



The satisfaction you will get from a set of strong, sturdy, long-wearing Federals, will make you want no other.



Cord Non-Skid

The "Big Six" Quality Line

THE FEDERAL RUBBER CO. OF ILLINOIS, Cudahy, Wis.



## EQUIP YOUR TIRE REPAIR SHOP WITH AN OUTFIT

that is the very latest invention—Adjustable Cavity Tire Mould. Wedge-shaped cavities instead of straight side cavities. Can use sand bags equally as well as air bags for pressure medium. Will cure more tires per day than two moulds of other makes with same number of cavities. Will cure Two 3 1/2", or Three 4" or

Two 4 1/2" Tires at one time and without a reducing shell. No. 3 Mould is Bloc type and comprises complete shop equipment. No. 10 is shipped set up ready to operate—takes up but little room and includes tools and moulds to operate a complete high-class repair shop. A small amount of cash will place this equipment in your shop. Easy payment plan if desired. High-grade equipment—popular price. Write for descriptive booklet and price list.

F. M. DUNCAN COMPANY  
341-49 East Ohio St., Chicago, U. S. A.

## Harley-Davidson

World's Champion Motorcycle

Rebuilt and Guaranteed  
1915, three speed twin electric \$125; 1916, \$135; 1917, \$150; 1918, \$165; 1919, \$180; 1920, \$200. Shipped on approval. Catalog free, describing Harley-Davidsons, Excelsiors, Indians, Smith Motors at \$40 and upwards. Liberty Bonds taken at full face value. Letters of recommendation from hundreds of satisfied customers. Ref.: Banks and Harley-Davidson Motor Co. Rapid service on 1912 to 1923 Harley-Davidson parts. 100 page PARTS catalog B, 25 cents. Stamps or coin.

WISCONSIN CYCLE SALES COMPANY

726 NATIONAL AVENUE MILWAUKEE, WIS. Oldest and Largest Dealers in the Northwest. "Milwaukee—World's Largest Motorcycle Center"



## Jimmy's Diary Saturday July 22

"Connor's cottage caught fire. Dad jumped on my bike to go for help. After it was all over he sed, 'Jimmy, a funny thing happened—Thought sure I had a punktur. Heard the tire go s-s-s-s-z and then stop. Didn't go fat after all! I told him there was Neverleak Tire Fluid in that tire. It stops punkturs and leaks instandy. I always use it in my tires.'"  
"Dad sed, 'Wise boy. I always sed you had a good head.'"  
Treat your tires with Neverleak. Positively stops leaks, and makes tires wear longer. 25c a tube at all dealers.

FREE—Send for handy Neverleak Pencil Clip. In attractive colors, holds pencil firmly in place.

BUFFALO SPECIALTY CO.  
104 Ellicott St. Buffalo, N. Y.



# NEVERLEAK TIRE FLUID

"HEALS PUNCTURES ON THE RUN."

## We Pay \$8 a Day

taking orders for Insyde Tyres—inner armor for automobile tires. Positively prevents punctures and blowouts. Guaranteed to give double tire mileage.

We Want 2000 Representatives

Easy to get orders. Every auto owner a prospect. Old worn-out casings will give three to five thousand miles more service. Use over and over again. Demand enormous. Write quick and get started.

AMERICAN ACCESSORIES CO., B-1876, Cincinnati, O.

## MAKE YOUR FORD INTO THIS SPORT CAR \$ ONLY 6.40

Other types down to \$1.50. Famous size 48. Red-Pol life-size patterns and simple instructions show all details. You can easily convert your Ford into this fast, easy Sport Car as hundreds have done with a few dollars worth of material from the hardware store. No need to lay up the car. The "PAL" with coolest disc wheel patterns, Pressed Metal Streamline Rear only \$6.40 delivered. Built low, rides wonderfully easy. Order NOW while we can take a good delivery. Send for coin for illustrated prospectus of Sport Bodies, "Jules" Tops and "Goose" Windshields. Kuempel Co., 94 Kuempel Bldg., Guttentberg, Iowa



## FOR CAMP & SUMMER WEAR

- Best quality, lowest prices. Our money back guarantee covers all purchases.
- Army Shelter Tents.....\$1.50
  - Folding Shelter Tent Poles......25
  - ic Khaki Trousers.....2.25
  - ic Khaki Shirts......95
  - ic Camp Cooking Grates......30
  - ic Folding Mess Pans......25
  - ic Athletic Shirts......50
  - ic Army Folding Coats.....4.00
  - ic Army O. D. Wool Blankets.....2.75

Army tents all sizes and 5000 other articles for camps or outings. Send 10c for big catalog 112

RUSSELL'S, INC.  
245 W. 42d Street New York  
Formerly Army & Navy Store Co.





# PATENTS TRADE-MARKS AND COPYRIGHTS

## OUR OFFER—Free Opinion as to Patentable Nature

Before disclosing an invention, the inventor should write for our blank form "Record of Invention." This should be signed and witnessed and if returned to us together with model or sketch and description of the invention, we will give our opinion as to its patentable nature.

## Our Three Books Mailed FREE to Inventors



OUR ILLUSTRATED GUIDE BOOK

### HOW TO OBTAIN A PATENT

Contains full instructions regarding Patents, Trade-Marks, Foreign Patents, Our Methods, Terms, and 100 Mechanical Movements illustrated and described; Articles on Patent Practice and Procedure, and Law Points for inventors.

### OUR TRADE MARK BOOK

Shows the value and necessity of trade-mark protection and gives information regarding unfair competition.

### OUR FOREIGN PATENT BOOK

We have direct agencies in all the principal foreign countries and secure foreign patents in the shortest possible time and at the lowest cost. Write for our illustrated Guide Book on Foreign Patents, sent free to any address.

### LIST OF PATENT BUYERS SENT FREE

Containing unsolicited letters from manufacturers and others who are constantly writing us regarding the purchase or leasing of meritorious patents. We endeavor to assist our clients in the commercial development of their inventions.

### Specialization—Our Staff

The field of invention is so vast that it is impossible for any one man to become an expert in all the different classes of invention. For this reason Victor J. Evans & Co. employ a number of patent lawyers and mechanical experts who have been selected for their special knowledge and ability in certain lines of invention. Each case is placed in charge of experts in the classes to which the invention relates.

### THE VALUE OF YOUR PATENT

will depend much upon the skill and care with which your case is prepared and prosecuted in the United States Patent Office. That every case entrusted to us receives our best efforts, and that our work is done consistently, skillfully, and thoroughly is evidenced by the many unsolicited letters of commendation that we receive constantly from our clients. We will furnish upon request lists of clients from any State in the Union for whom we have secured patents.

### Our New York, Philadelphia, Pittsburgh, Chicago and San Francisco Offices

Owing to the growth of our business we have established for the benefit of our clients Branch Offices in New York City, Philadelphia, Pa., Pittsburgh, Pa., Chicago, Ill., and San Francisco, Cal. These branch offices being located in these large commercial cities together with our Main Office located near the U. S. Patent Office, in Washington, enables us to more promptly handle the business of our clients, particularly as the branch offices are in constant touch with the Main Office and fully equipped to handle patent business in all its branches.

**Highest References—Prompt Attention—Reasonable Terms**

---FREE COUPON---

## VICTOR J. EVANS & CO., Patent Attorneys

NEW YORK OFFICES  
1007 Woolworth Building

CHICAGO OFFICES  
1114 Tacoma Building

PHILADELPHIA OFFICES  
714-715 Liberty Bldg.

PITTSBURGH OFFICES  
514 Empire Building

SAN FRANCISCO OFFICES  
Hobart Building

MAIN OFFICES: 765 9<sup>TH</sup> STREET, N.W., WASHINGTON, D. C.

Gentlemen: Please send me FREE OF CHARGE your books as described above.

Name.....Address.....



# PATENTS

**I**F YOU HAVE AN INVENTION which you wish to patent you can write fully and freely to Munn & Co., for advice in regard to the best way of obtaining protection. Please send sketches or a model of your invention and a description of the device, explaining its operation.

All communications are strictly confidential. Our vast practice, extending over a period of seventy-seven years, enables us in many cases to advise in regard to patentability without any expense to the client. Our Hand-Book on Patents is sent free on request. This explains our methods, terms, etc., in regard to **Patents, Trade Marks, Foreign Patents, etc.**

If you are a reader of the  
**SCIENTIFIC  
AMERICAN**

you are probably aware of the fact that it has a special appeal to the inventor. Each issue contains a description of a large number of recently patented inventions. Pending patent legislation as well as the most recent rulings of the Patent Office and the courts are considered in its columns.

## MUNN & CO.

SOLICITORS OF PATENTS

672 Woolworth Bldg., NEW YORK  
Scientific American Bldg., WASHINGTON, D. C.  
801 A Tower Bldg., - - CHICAGO, ILL.  
611 Hanna Bldg., - CLEVELAND, OHIO  
582 Market St. SAN FRANCISCO, CALIF.

Please Mention Popular Mechanics

# RADIO

and other Electrical Inventions  
patented

MASON, FENWICK & LAWRENCE

Patent Lawyers

Washington, D. C.

Established 1861

We have with us four late members of the examining corps of the United States Patent Office.

Other offices: New York, Chicago, Denver, Seattle

Trade marks registered in United States and foreign countries

# PATENTS

TRADE-MARKS

COPYRIGHTS

Send for our free book of patent information.

**Beale & Park** 802 F St., Washington, D. C.  
16 S. Broad St., Philadelphia, Pa.



# PATENTS

Send us sketch or model for patentability opinion and exact cost of patent. Our book "How to Obtain a Patent." Sent Free on request. It tells how to apply for Patents, Trade Marks, Foreign Patents, Copyrights, etc.; gives information on Patent Procedure; tells what every inventor should know. Thousands of Inventors, who are our clients, are our references.

**Chandlee & Chandlee, 25 Years Experience.**  
422 7th St. Washington, D. C.

# PATENTS and TRADE-MARKS

As one of the oldest patent firms in America, and representing a clientele extending to all parts of the country, we afford inventors and Manufacturers, at lowest consistent charges, a service noted for efficiency and results, evidenced by many well-known Patents and Trade-Marks of extraordinary value.

Lacey & Lacey, 646 F St. Washington, D.C.

ESTABLISHED 1869

Our book Patent Sense - Free

# PATENTS Secured

Prompt service. Avoid dangerous delays. Send for our "Record of Invention" form and Free Book telling How to Obtain a Patent. Send sketch or model for examination. Preliminary advice without charge. Highest references. Write TODAY. J. L. Jackson & Co., 327 Ouray Bldg., Washington, D. C.

# RADIO For Everybody

Make Radio a profession instead of a plaything. You can earn big money as a Radio-trician. Learn by mail, in spare time, how to design, construct, install, repair, maintain, operate, sell and demonstrate complete radio outfits. Write for free 32-page catalog describing our course entitled, "How to Learn Radio at Home."

National Radio Institute, Dept. 1192, Washington, D. C.



# GEARS ALL KINDS SMALL

The most accurate made and prices reasonable. We carry a complete line of gears in stock for immediate shipment. Can also quote on special gears of all kinds. Send us your inquiries.

WRITE FOR CATALOGUE.

CHICAGO STOCK GEAR WORKS  
105-109 S. Jefferson St., CHICAGO

# PATENTS

Booklet Free

Highest References

Promptness Assured

Best Results

Send drawing or model for preliminary examination

**ALL BUSINESS GIVEN PROMPT AND PROPER ATTENTION**

**WATSON E. COLEMAN, Patent Lawyer, 624 F St., Washington, D. C.**

## PATENTS

### To the Man with an Idea

I offer a comprehensive, experienced, efficient service for his prompt, legal protection and the development of his proposition.

Send sketch, or model and description, for advice as to cost, search through prior United States patents, etc. Preliminary advice gladly furnished without charge.

My experience and familiarity with various arts frequently enable me to accurately advise clients as to probable patentability before they go to any expense.

*Booklet of valuable information and form for properly disclosing your idea free on request. Write today.*

**Richard B. Owen, Patent Lawyer**

9-303 Owen Building, Washington, D.C.  
2276-E Woolworth Bldg., New York City

### Can You

think of a simple, practical idea that will fill one of the many requests we have on file for new inventions? It may mean a fortune for you. Thousands of things are needed **right now**. Your brains can help. Send today for our great new book—

**"Inventions and Trade-Marks, Their Protection and Exploitation"**

and learn more about making money from ideas than you ever knew before. It tells many things that are wanted, too.

**A postal will do—  
It is free**

### We Help Our Clients

without charge, to get the dollars out of their ideas—having facilities none others possess. Advice free. Don't delay—get the book at once.

**American Industries, Inc.**  
200 Patent Dept.  
WASHINGTON, D. C.

### Patents Advertised For Sale Free

in Invention and Manufacturing Supplement

Published for the man with an idea. Send for free sample copy. One year's subscription, 50c.

## PATENTS If You Have an Invention and Desire to Learn How to Secure a Patent

Send for our Guide Book, **HOW TO GET A PATENT**, sent Free on request. Tells our terms, methods, etc. Send model or sketch and description of your invention and we will give our opinion as to its patentable nature.

**RANDOLPH & CO.**  
600 F St., N.W., Washington, D.C.

NAME.....

STREET.....

CITY.....STATE.....

## PATENTS PROMPTLY PROCURED TRADEMARKS REGISTERED

Send disclosure of invention, design, or trademark for actual search of U. S. Patents and novelty report. Validity and infringement investigations. Patent and trademark suits prosecuted and defended anywhere in the United States. Discriminating clients appreciate my efficient service. No literature will be sent you as this is a professional service, *individual* and *Personal*. Specific information and advice given regarding each individual case. Specialize in prosecution of pending cases that have been previously rejected by the Patent Office. Specialize also in unfair competition litigation before the Federal Trade Commission.

**George P. Kimmel, Master of Patent Law**  
53-K Loan & Trust Bldg., Washington, D. C.

## U.S. PATENTS



**SEND FOR  
THIS FORM  
DON'T LOSE YOUR RIGHTS  
TO PATENT PROTECTION**

Before disclosing your invention to anyone send for blank form "EVIDENCE OF CONCEPTION" to be signed and witnessed. A sample form together with printed instructions will show you just how to work up your evidence and establish the same before filing application for patent. As registered patent attorneys we represent hundreds of inventors all over the United States and Canada in the advancement of inventions. Our schedule of fees will be found reasonable. The form "Evidence of Conception," sample, instructions relating to obtaining of patents and schedule of fees sent upon request. Ask for them—a post card will do.

PATENTS AND TRADE MARKS

**LANCASTER & ALLWINE**

204 Ouray Bldg. Washington, D. C.  
Originators of forms "Evidence of Conception."

## PATENTS

**C. L. PARKER**  
Formerly Member Examining  
Corps, U. S. Patent Office  
**PATENT LAWYER**  
MCGILL BLDG.  
WASHINGTON, D. C.

Patents, Trade Marks, Copyrights, Patent Litigation

Handbook for Inventors, "Protecting, Exploiting  
and Selling Inventions," sent free upon request.

Please Mention Popular Mechanics



**PROTECT  
YOUR  
RIGHTS**

WRITE TODAY FOR FREE BOOK ABOUT PATENTS and "RECORD OF INVENTION" for establishing evidence of conception. The book tells how to proceed, the usual cost of obtaining a patent, and contains good sound practical advice every inventor should know. "RECORD OF INVENTION" should be filled out, signed and witnessed before you disclose invention to anyone. Send rough sketch or model and description for free report upon patentable nature and cost to Patent, etc. **Prompt, personal service.** Reasonable fees. Partial payment plan. Preliminary advice without charge.

**J. REANEY KELLY**  
**PATENT LAWYER**

612-COLUMBIAN BLDG. WASHINGTON, D.C.

**INVENTORS** AIDED. Ideas developed. Experimental Machinery Built. Individual Service.  
**RICHARDSON & ROGERS, 7 ALBEE, WASHINGTON**  
Practice in all Courts.  
**TRADE-MARKS. We seek the valid PATENTS**

## PATENTS

Inventors should write for our "Evidence of Disclosure" form. It's Free. Avoid Dangerous Delays. Send sketch or model of your invention for examination and advice. Ask for Free Book "How to Obtain a Patent." Highest references. Write to-day.

**Merton-Roberts & Co., 184 Mather Bldg., Washington, D.C.**

# YOU CAN MAKE \$18 DAILY PROFIT

With Our Great Introductory Offer  
Giving These \$1.25 Dress-Making Shears **FREE**



With each sale of our wonderful 11 piece Toilet Article Assortment for only \$1.75. TOTAL STORE VALUE \$4.60

**\$18.00 a Day PROFIT on only TWENTY Sales**



Lucky 11 Toilet Set—Retail Value \$3.35!

## MY! HOW THEY SELL!

You get the attention with the free Shears. Walter Harris sold 800 boxes in six weeks. Profit over \$100 a week. You can do this too.

**Act Now!** Sell like hot cakes year round. A baby could sell Lucky 11. Don't wait a minute. Save time. Send \$1.75 for complete outfit including display case. At least write for circulars explaining our unique plans, including 30 other packages. **ACT NOW!**

E. M. DAVIS CO., Dept. 2358, CHICAGO, ILL.

away  
from home

the antiseptic germicidal liniment in one container is easiest to carry; dependable for a greater variety of emergencies; safe and pleasant to use and provides against the host's lack of necessary preparations. \$1.25 at druggists or postpaid. Liberal trial bottle, postpaid, 30c.

W. F. YOUNG, Inc.  
147 Temple Street  
Springfield, Mass.



**Absorbine, Jr.**  
THE ANTISEPTIC LINIMENT

## ANY BOY CAN BUILD THIS 20" CAT BOAT

with our complete Construction Set.

"Everything but the paint"  
**\$5.00**

We have other boats, engines, boilers, etc.

Catalog Free

The H. E. Boucher Mfg. Co.  
154 Lafayette St., New York



## Pay Nothing

An amazing new offer—wear this GENUINE DIAMOND for a week at our expense—absolutely no risk to you—deposit nothing—**READ EVERY WORD OF THIS OFFER:**

Send No Money

Pay No C. O. D.

### Mail the Free Trial Coupon Below

Just send the coupon below—do not enclose a penny—and we will send you on approval at our expense your choice of these diamond rings. The ring illustrated above is the most beautiful hand engraved solid gold ladies' ring you ever saw, set with a fine, large, genuine blue-white diamond. Pay nothing when it arrives. Merely accept the ring and wear it for a week, at our expense. After a week decide. If you return the ring, that ends the matter. You have risked nothing. But if you keep the ring, send us only \$3.75 a month until you have paid the amazingly low price of \$38.75 for this regular \$50 value. The ring is an elaborate pierced model in solid 14K green gold with hand engraved white gold top. A striking new model. The diamond is a beauty—extra brilliant, blue white, perfectly cut—a remarkably big value.



Men's extra massive 14K solid gold fluted ring with 18K hand cut white gold top set with extra fine perfectly cut blue-white genuine diamond. Extra Big Value. Now \$38.75—\$3.75 a month. Send no money. Pay no C. O. D. A week's trial absolutely FREE. Mail coupon now.

Just mail the Free Trial coupon below. Be sure to enclose finger size. **SEND NO MONEY—pay nothing on arrival.**

Harold Lachman Co., Dept. C177204 S. Peoria St., Chicago

Send me absolutely free and prepaid, for a week's trial, the genuine diamond ring checked below. I am to pay nothing when it arrives. After one week I will either return the ring by registered mail and that ends the matter, or I will send you \$3.75 each month until \$38.75 has been paid. Title remains with you until fully paid. **I ENCLOSE MY FINGER SIZE.**

Ladies' Ring No. A4350

Men's Ring No. A4450

Name.....

Address.....

Age..... Occupation.....

Copyright 1925, Harold Lachman Co.

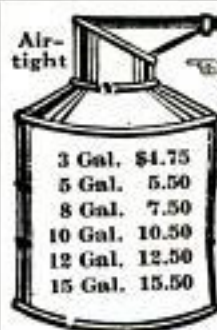

## COPPER CANS

Air-tight Screw Top.

FOR GASOLINE AND HOME USE

Postage & Insurance 50c extra. Chicago & West 75c Extra.

Prices on large and special made cans by request.

These cans furnished with 1/2 or 3/4 in. unions.

Deposit Required on All C. O. D. Orders.

Catalogue free on request

**NATIONAL CAN CO.**

1826 A J. Ridge Avenue

PHILADELPHIA, PA.



## "Stop those back fence concerts"

THE yowls of a prowling Tommy are as mere love-songs beside the ear-splitting howls of a perturbed radio set (and you'll be surprised how often one gets perturbed without the calming influence of the proper Amplifying Transformer).

Most any transformer can amplify sound, but it will also amplify the stray fields which produce howling and distortion. It takes the Acme Amplifying Transformer with its specially constructed iron core and coil to put an end to the "back-fence" concerts. Only when you add the Acme do you get the realistic tone and volume so markedly absent in the ordinary radio receiving set.

The Acme Radio Frequency Transformer greatly increases the range of any receiving set, either vacuum tube or crystal detector type. The Acme Audio Frequency Transformer produces not only volume, but reality of tone. It is indispensable to the satisfactory operation of loud speaking devices. The combination of one or more stages of Acme Radio and Audio Frequency Transformers assures the maximum of range, of volume and of reality in tone.

The Acme Apparatus Company, pioneer radio engineers and manufacturers, have perfected not only Radio and Audio Frequency Transformers as well as other receiver units and sets, but are recognized as the foremost manufacturers of Transmitting Apparatus for amateur purposes. Sold only at the best radio stores. The Acme Apparatus Company, Cambridge, Mass., U. S. A. New York Sales Office, 1270 Broadway.

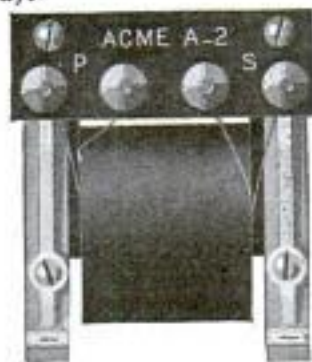

Type A-2 Acme Amplifying Transformer  
Price \$5 (East of Rocky Mts.)

# ACME

for amplification

## LATEST IN RADIO Sweeney's Line of Radio Supplies

Personal service, information and instruction for all radio users together with immediate supply of the most complete and very latest equipment. Keep in touch with newest scientific development by getting our catalog. Among new items: See the Variometer for \$5.50 and Varicooper \$5.00; designed by electrical engineers and finished by instrument maker. Sweeney Battery, 80 Ampere hour, made of hard rubber, (can't leak) \$22.00. Variable condensers \$3.75. Phone condensers 35 cents; Grid condensers and leaks 50 cents.

SWEENEY RECEIVING SET—5 tube receiver (two stages of radio frequency amplification) detector and two stages of audio frequency amplification. Wave length 175 to 1000 meters. This is a wonderful set; price \$150. SEND 15c for illustrated instruction book, hook-up diagrams and complete catalog. Lowest prices and latest radio developments.

Write Dept. B

**Sweeney**  
RADIO & ELECTRICAL CO.  
UNION STATION PLAZA, KANSAS CITY, MO.



### TIRRO

THE IDEAL MENDING TAPE

At Drug Stores

BAUER & BLACK, 2500 DEARBORN ST., CHICAGO

## RADIO For Everybody

Make Radio a profession instead of a plaything. You can earn big money as a Radio-trician. Learn by mail, in spare time, how to design, construct, install, repair, maintain, operate, sell and demonstrate complete radio outfits. Write for free 32-page catalog describing our course entitled, "How to Learn Radio at Home."

National Radio Institute, Dept. 1192, Washington, D. C.

### THE BOOK YOU HAVE BEEN WAITING FOR

Gilbert Radio Telephone and  
Broadcasting - 35c postpaid

The A. C. Gilbert Company, 312 Blatchley Ave., New Haven, Conn.

## MOVIES EVERYBODY!

Write for free catalogue of  
Machines and Film.

Machines \$6.00 to \$25.00. Film 35c per foot  
PARAMOUNT MFG. CO., Dept. M, Box 1171, Boston, Mass.

## Big ENGINE Sale

Prices Smashed Again!

Famous OTTAWA Engines back to 1914 prices! New Improved Models. Better built for long, hard service. Direct-From-Factory Sales Plan saves you \$15 to \$150. Big surplus over rated H-P. Built in largest, most modern engine factory. Prices way down on all sizes.

OTTAWA 90 Days Trial

1922 MODEL ENGINES

stationary, portable or saw rig; gasoline or kerosene. Easy to start—may be operated. Guaranteed for 10 years. Cash, or Easy Payments. Write Today for book "How to Know Better Engines." Send at once while Sale is on.

Ottawa Mfg. Co. 533-F King St. Ottawa, Kans.

2	H-P	\$38.50
2½	H-P	45.57
3½	H-P	54.50
4	H-P	75.95
5	H-P	97.50
7	H-P	115.15
10-12-16-22	H-P	at Proportionally Low Prices





## The end of the lightning bugaboo

**A** BLINDING flash—a deafening crash—not your house—but close. Your radio set can be ruined by the high induced charges set up in your antenna wire unless protected by a Radisco Lightning Arrester.

Put an end to this lightning bugaboo. The Radisco side tracks these induced charges without injury to your set. Small, inexpensive, weather-proof. \$3 at your dealers or RADIO DISTRIBUTING CO., NEWARK, N. J.

Write for catalog of radio supplies

# RADISCO LIGHTNING ARRESTER

### THIS WONDERFUL INVENTION



converts any ordinary cook stove into a gas stove. OXO-GAS is made from kerosene and air. Cheaper, cleaner and more efficient than coal. Responsible distributors wanted.

**GLORIA LIGHT COMPANY**  
114 N. May St. Chicago, Ill.

### BIG MONEY MAKERS for AGENTS



**SHOCK-PROOF LAMP**, the new unbreakable mill type lamp, is fast replacing the old style. Stronger and gives many times the downward light. As its name implies, it is **SHOCK PROOF**; stands jostle and sudden knocks so prevalent in GARAGES, FACTORIES, MILLS, SHIP YARDS, STEAMSHIPS, MINES—you, even in the HOMES. Lasts longer and is sold for less money. Big money-saver.



**FREE** Send for our AGENTS PLAN and Booklets; fully explain how easy it is to sell SHOCK PROOF lamps. Every GARAGE, FACTORY, MILL, RAILROAD YARD, STORE and HOME is looking for just this chance to get a better lamp for less money and it is a **BIG MONEY MAKER**. AGENTS everywhere are "cash-in-in." This is YOUR opportunity. Don't let it get by. Grab it.

**SEND FOR OUR AGENTS PLAN TODAY**  
**EXCLUSIVE TERRITORY** given to agents who qualify. Now is the time to get your share of **BIG MONEY** and **EXCLUSIVE TERRITORY**. GET THE AGENTS PLAN TODAY. IT COSTS YOU NOTHING.

**MIDWEST LAMP CO., 143 W. Austin Ave., CHICAGO**

# Machine-Shop Men can now Cash In On Radio

*Practical hints in free book tell just how to profit big from nation-wide craze. Big new money-making field opened to machinists everywhere.*

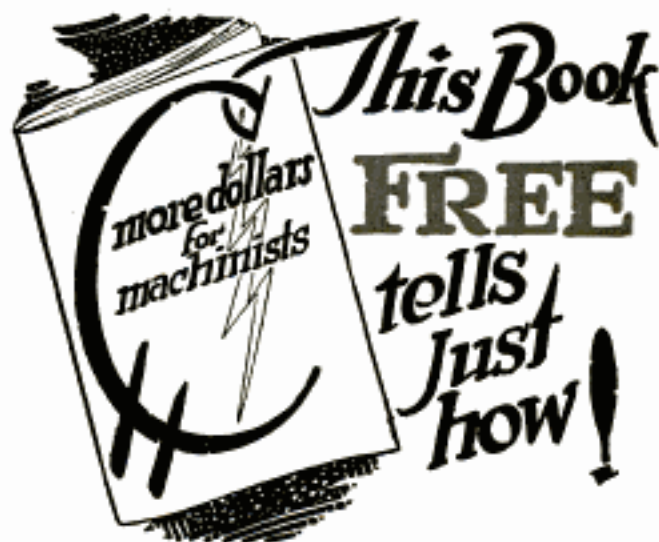

### Huge Demand for Radio Panels

Every real radio-fan insists today upon one certain material for panelling his outfit; and cutting that material to dimensions is as profitable and practical a job as any machine-shop can ever make money doing. The makers of that material, wanting reputable machine-shops to cash in on this proper preference of radio enthusiasts, have prepared a handy little book which gives the machinist all the particulars he wants to open up for him this immensely profitable new field. A copy is yours for the asking.

### Wonderful Money-Maker for Machinists

This supremely demanded material comes in sheets 38x38 inches, is miles ahead of every other known substance for panelling and insulating radio installations, and can be readily machined by any decently-equipped machine-shop. The difficulty the machinist will have will be in taking care promptly of the orders that will be forced upon him; and that, though it sounds almost too good to be true, is absolutely a **FACT**. The free book tells all about it, giving every fact the machine-shop man wants to know; and there is not one cent to pay for a copy of it, if you are legitimately a machinist with a plant fit for ordinary work. Send for your copy today, ride the wave of radio development to your own profit, and understand that you commit yourself to nothing whatever by asking for a copy. Ask **The Continental Fibre Company**, Newark, Delaware.



## listen to radio through your phonograph

Ekko connects your head phones with the tone arm of your phonograph, and transmits Concerts and Programs through the sound box.

The best Loud Speaker you can use—utilizes the scientific design of the phonograph sound box, produces a mellow, pure tone. If your dealer does not yet carry Ekko, use the coupon—send \$3 and we will mail one immediately, post paid. Money back if not satisfied. Mention the make of your phonograph.

THE EKKO CO., 911 Harris Trust Bldg., Chicago  
Enclosed \$3.00. Please send me one Ekko Radio phonograph adapter. My money back if not satisfactory. My phonograph is a \_\_\_\_\_

Name \_\_\_\_\_

Address \_\_\_\_\_



**RADIO**  
HEAD SETS, JACKS, PLUGS,  
MICROPHONES  
Manufacturers  
*American Electric*  
COMPANY  
State and 64th Sts., Chicago, Ill.

### WRIST WATCH AND 2 FINE STRAPS

30 DAYS' FREE TRIAL



Luminous Dial and Hands \$4.95

10 DAYS' FREE TRIAL

Nickel Case  
7 Jewel Lever

UNBREAKABLE  
GLASS  
VALUE \$15.00

This elegant men's Wrist Watch was never sold for less than \$15.00. The sturdily-built, high-grade lever movement will keep accurate time. Has luminous dial and hands to show time in the dark. You can have it in nickel or gun metal case, 7 Jewels \$4.95; 10 Jewels \$5.75; Sterling silver \$8.95.

Extra thin Model Gents' Watch, Nickel, High-grade 7 Jewel lever movement, \$4.95 or guaranteed 10 year gold filled \$7.50. Free: Fine gold filled Waldemar chain.

**SATISFACTION GUARANTEED  
OR MONEY REFUNDED**

We bring you any of these watches with a written guarantee to you, pay balance to postman on arrival. If you are not entirely pleased after 10 days' trial, return watch and we will explain it or refund your money. Write us today. Illustrated Watch Booklet Mailed Free.

Uneda Watch Co., Dept. MP  
217 Eighth Ave., New York City

Please Mention Popular Mechanics

# RADIO

## Equipment

### Big FREE Catalogue



THIS FREE catalogue tells you the kind of a Wireless Telephone to own, so that you receive in your own home all the latest news, music, church services, lectures—everything broadcasted throughout the United States.

Every home will soon have a wireless telephone outfit. We now offer complete outfits from \$15 up.

Everyone interested in radio should see our low prices on parts and accessories. Write for this book. Learn about the miracle invention of the age. Easy to install, as simple to operate as a regular telephone.

One copy of this booklet is yours, FREE.  
Write for your copy.

Address Dept. R-6

**Montgomery Ward & Co.**

Kansas City

Chicago

St. Paul

## Electric Motors below cost

Big manufacturer of electrical equipment canceled his order after we had them all made. Strictly high grade, entirely new motors. Chance of lifetime to get motor to run sewing, washing, broing machine; compressor, bench lathe, drill press, etc. Write for circular.



**REYNOLDS**  
ELECTRIC COMPANY  
2610 West Congress St., Chicago

Washing Machine Size  
Guaranteed to Satisfy  
**\$10**

SELF-FILLING

INK PENCIL

"INDEPENDENT"

Meets all requirements. Self-filling, non-leakable, safety cap. Attached clip. Smooth writing gold style point.

Guaranteed Improved Fountain Pen. Eliminates fatigue. Promotes efficiency. Writes uniform. A business necessity.

\$2 By Mail

Your Name in Gold—25 Cents Extra

AGENTS WANTED

J. C. ULLRICH & CO., 161 Washington St., New York

**Salesmen** Sell our wonderful tailored to order \$29.50 virgin wool suits and o'coats direct to wearer—all one price—\$20 less than store prices. You keep deposit. Everything guaranteed. Big watch outfit free; protected territory for hustlers.  
J. B. SIMPSON, Inc., Dept. 125, 831 W. Adams St., Chicago

## Build Your Own PHONOGRAPH

IT'S EASY WITH OUR HELP

A few hours' interesting work saves over half and gives you a machine to suit your ideas. We furnish motors, tone arms, case material, blue prints and full instructions. Plays any record. Make fine profit building phonographs for your friends.

Write today for our **FREE** Blue print offer.

**AGENTS** wanted for Choraleon Phonographs.

CHORALEON PHONOGRAPH CO.  
822 1st St., Elkhart, Ind.



SAVE  
OVER  
HALF





**World Batteries**  
FOR  
**RADIO OR AUTOMOBILE**  
**SAVE YOU 50%**

Buy direct from factory. Pay only one profit. Highest quality made.—lowest prices.

**WRITTEN TWO-YEAR GUARANTEE****AUTOMOBILE PRICES**

**6 Volt, 11 Plate - \$13.00**  
Ford, Chev., Mich., Hup.,  
Grant, Egin, Vels, Saxon,  
**6 Volt, 13 Plate - 15.00**  
Overland, Buick, Reo, Paige,  
Hudson, Nash, Stude, and Dort.  
**12 Volt, 7 Plate - 20.00**  
Maxwell, Dodge, Regal, Frank,  
Brusco, and Crown-Elkhart.  
Give year and model of car.

We defy price competition. A glance at the prices below will convince you that the World Battery is the best buy on the market. Batteries shipped immediately. Express C. O. D. Begin now to get 100% battery service at one-half cost. Mail your order today.

**RADIO PRICES**

6 Volt, 40 Amps.	-	-	\$ 8.50
6 " 60 "	"	"	10.00
6 " 80 "	"	"	13.00
6 " 100 "	"	"	15.00

**WORLD BATTERY CO.,** 1219 S. Wabash Ave.  
Dept. F., Chicago, Ill.



*Model 1-8D DRILL*

**A Powerful, Lightweight Drill**

**D**OES the work better, quicker and easier. Ideal for drilling in hard-to-reach, out-of-the-way places. Simple to operate—economical to buy. Special, interchangeable attachments make it capable of performing many jobs besides drilling. Grinds valves, removes carbon, buffs, etc.

*Write for complete specifications and interesting booklet*

**WISCONSIN ELECTRIC CO.**  
RACINE, WISCONSIN  
Dept. D

**DUMORE**  
Geared  
**ELECTRIC DRILLS**

**-Car Owners Wanted!!-**  
**To sell and introduce the World's Best Automobile Tires**

Great Exclusive processes that enable us to guarantee these Wonderful Tires for 12,500 MILES AGAINST: **RUT-WEAR RIM CUTS—STONE BRUISES and BLOWOUTS!**

An Agent wanted in each community to introduce these wonderful Tires at amazingly low prices.

**FREE TIRES FOR YOUR OWN CAR!**

Write for our Free Sensational Introductory Offer to one Agent in each locality.

Dept. 109  
**INTERNATIONAL RUBBER CORP.**  
Grand Rapids, Michigan



**REBUILT**  
**Indian Motorcycles**  
AT EXTREMELY ATTRACTIVE PRICES

Write for list containing detailed description and prices.

The GEO. L. MINER CO. 136 CLINTON AVE., SO.  
21 Years in Business in Rochester, N. Y.

**Over \$200 Profit Weekly Above Expenses**

All over the U. S. and Canada, we are establishing vulcanizing service stations. We instruct you and furnish the most modern methods and equipment—

**THE ANDERSON**  
Known the World Over

We have 34 schools in U. S. and 4 in Canada. One is near you. School credits you \$5 per day while you learn vulcanizing if you buy Anderson equipment for your station. Small capital. Big profits.

Write for full particulars TODAY.

**THE ANDERSON STEAM VULCANIZER CO.**  
Manufacturers of Modern Tire Repair Equipment  
103 Williams Bldg. Indianapolis, U. S. A.



**C-G SPARK PLUGS**

Send no money. This set of plugs sent to any address C. O. D., Parcel Post prepaid.

**For Tractors, Trucks and High Powered Cars**

A SPARK PLUG which will operate efficiently on any grade of fuel in tractor, truck or passenger car. It has been developed out of more than fifteen years' experience.

C. G. Spark Plugs are designed especially to meet the requirements of the Ford Motor. Equip with a complete set of four of these high grade plugs—and your Spark Plug troubles will be over.

We guarantee C. G. Spark Plugs to give satisfaction and we will replace with new goods any C. G. Plug returned to us at Belvidere, Illinois, together with twenty-five cents per plug to pay postage, packing, etc.

Under this guarantee, you can return the entire set of plugs to us each year and have a new set for only one dollar.

Price per set of four, **\$2.40 per set, postage paid**

Dealers, write for our special offer to dealers

When ordering, give name and model of your car.

**MFG. BY CRIMP GRIP CO., Belvidere, Ill., U. S. A.**



# FROST - FONES

The Ideal Receivers for

use with Home Radio Sets



2000 Ohm Set No. 162. \$5.00  
3000 Ohm Set No. 163.. \$6.00

## FROST PLUGS

Small, neat and perfectly finished. Specially designed for Radio Panel Work. Interchangeable with other standard makes.

## FROST JACKS

Nickel plated and highly buffed finish throughout. Sturdy construction. Perfect spring adjustment, gripping contact of springs on tip and sleeve of plug.

Write, wire or phone your nearest Dealer or Jobber

# HERBERT H. FROST

National Factory Distributors to the Electrical-Radio Jobber

154 W. Lake St. CHICAGO, ILL.



# Pullman

Sleeper can be made of your car. Auto beds, stoves, tents, camp equipment. Dep. 8. P VANDERPOOL CO., Springfield, Ohio.



## AUTO BATTERIES ONE-HALF PRICE

FOR ALL CARS. 2-YEAR WRITTEN GUARANTEE. Direct from big responsible Co. Batteries brand new, fully charged, ready to put in car. SAVE ONE-HALF. Don't buy any battery until you receive our BIG FREE ILLUSTRATED CIRCULAR describing ROYAL BATTERIES. Write, give year and model of your car. K-E Battery Co., 646 N. Michigan Ave., Dept. 132, Chicago

# PRIDE—PLEASURE—PROFIT

Ford-speed Bodies 3 New Models

16 Valve Heads Speed Differential Gears



Underlung Fixtures 4-Speed Transmission Crankshaft Counterbalance Designed for discriminating purchaser whose taste demands class. Owners of FORDSPEED cars derive pride, pleasure and profit. TO INTRODUCE our new models, we offer a wonderful proposition. BIG opportunity for rider agents.

Specials for this month	Price
Underlung Fixtures.....	\$15.00 \$9.95
3-1/2 Chrome Nickel Gears.....	12.50 7.95
2 1/2 Chrome Nickel Gears.....	15.00 8.95
Speed & Power Camshaft.....	17.50 9.95
Steel Wheel Discs (8).....	12.00 8.95

Pat'ns of Motion of Money Back Guarantee: Terms 50% with order, balance upon delivery C. A. FORD SPEED & POWER EQUIPMENT MANUFACTURERS 280 West 54th St., New York Cable Address "Fordspeed"

# AUTO DRIVERS Garage and Electric Men WANTED



to introduce and sell the newest invention in **AUTOMOBILE and RADIO STORAGE BATTERIES.** Cannot be injured by over-charging or discharging, evaporation or standing. Will not sulphate and

plates will not buckle. **30 days free trial.**

## Guaranteed Two Years

Requires no expert attention. Made for every kind of storage battery service. Lowest prices, and biggest profits. Write today for the best money-making proposition you have ever seen. **WILLIAMS RADIO BATTERY CO.** Dept. 103 Philadelphia, Pa.

## 10c. CHARGES RADIO & AUTO BATTERIES

FROM A LAMP SOCKET AT HOME OR BUSINESS WITH AN F-F BATTERY BOOSTER, which is a FULL WAVE



Magnetic Rectifier for 105-125 volt 60 cycle A.C. Leave Battery just as it is in Your Car. Snap Clamps onto Battery Terminals. Turn Switch & Battery will be charged in 100 Minutes. **AMMETER** Eliminates ALL QUERR WORK. A Complete Portable Automatic Charging Unit, with Infusible Carbon Rectifying Brushes, which Charge Uninterrupted. No Skill is Required. A Fully Charged Battery Starts Car & Truck Quick, thus fewer Expenses. Replacement Storage Batteries must be bought, when Kept Fully Charged. So It Comes Less to Buy a Booster than to be without one. Do Not Think Your Battery is dead and worn out simply because it will not start Your Car. Buy a BOOSTER. Fill it with Life and Hear Engine Spin. These Pioneer FULL WAVE Automatic Chargers Save You Money & Last a Lifetime. **REDUCED PRICES:** Type G charges "A" 6 volt Battery at 8 amperes \$15 Type B charges Radio "B" Batteries up to 100 volts \$15 Type A-B charges Both "A & B" Radio Batteries \$20 Type I2 charges 12 volt Battery at 5 amperes \$15 Type I04 charges 6 volt Battery at 12 amperes \$24 Type I012 charges 12 volt Battery at 7 amperes \$24

**CHARGES AUTOS & RADIO** Type I020 is a Combination of Types I04 & I012 \$30 The Larger Types are recommended for heavy Batteries, or where time is limited. Shipping Weights Catalogue with AMMETER BATTERY CLIPS, is to be Purchased from Your Dealer or Mail Check for Prompt Express Shipment. If for P. P. Mail add Postage & Insurance Charges. Or ORDER us to forward TYPE desired C.O.D. For Dependable, Economical GROUP CHARGING, WRITE for FREE Descriptive 17 Battery, 8 Amperes, FULL WAVE AUTOMATIC RECTIFIER Bulletin 24-A. ORDER Now or WRITE Immediately for FREE Descriptive BOOSTER Bulletin 24. **THE FRANCE MFG. CO., CLEVELAND, OHIO, U. S. A.** Canadian Representatives: Battery Service & Sales Co., Hamilton, Ontario, Canada.

## For FORD CARS Any Year, Any Model Genuine HEINZE-SPRINGFIELD \$49.75 Starting and Lighting System

Limited supply—latest improved type! Price includes Ammeter, Dash and Tail lights, Switch Lock and new high-grade battery of standard make. Quick, sure start—bright, steady lights. Easily attached to any Ford. Order direct from this ad or write for literature.

The Service Products Co., Dept. 9, - Springfield, Ohio

## \$1,487.35 RETURNS IN 60 DAYS

Make \$25 daily from Box Ball Alleys. Clean business. Small expense. Quick returns. Installed in spare space anywhere. Full particulars by return mail showing amazing profit possibilities. Write now. **AMERICAN BOX BALL COMPANY** 102 Van Buren Street Indianapolis, Indiana

# MOTOR REPAIR BOOK FREE

SMOOTH-ON REPAIR BOOK



Why spend dollars, when you can make perfect Automobile and Household repairs quickly and easily with SMOOTH-ON IRON CEMENT No. 1 at a few cents expense? Write for this book and learn how—it's Free. Smooth-On No. 1 is sold in 6oz., 1 lb., and 5 lb. tins. Hardware and Auto Supply Stores. **SMOOTH-ON MFG. CO.** Dept. 37H Jersey City, N. J.

# SMOOTH-ON IRON CEMENT No. 1 For Motor and Household Repairs

**CONN**

Highest Honors at World Expositions

Easy to play; beautiful in tone.

WORLD'S LARGEST MANUFACTURERS OF HIGH GRADE BAND AND ORCHESTRA INSTRUMENTS

**FREE TRIAL** Easy Payments. Any band or orchestra instrument. Conn supremacy is based on quality. Ask for details on **important new improvements.** Write now.

**C. G. CONN, Ltd.** 831 Conn Bldg., Elkhart, Ind.



## AUTO OWNERS WANTED



To introduce the best automobile tires in the world. Made under our new and exclusive **Internal Hydraulic Expansion Process** that eliminates **Blow-out—Stone-Bruise—Rim-Cut** and enables us to sell our tires under a

### 10,000 Mile Guarantee

We want an agent in every community to use and introduce these wonderful tires at our astonishingly low prices to all motor car owners. Write for booklet describing this new process and explaining our amazing introductory offer to owner agents.

**Hydro-United Tire Co.**

Dept. 100—Chicago San Francisco Pittsboro, Pa.



Dependable  
**Champions**  
For Every Engine Everywhere

Ask your dealer to sell you a full set

## CUSTOM TAILOR MADE

To fit your individual car  
Made in our custom shops after your order is received. We ship ordinarily in 2 or 3 days. Perfect fit guaranteed when correct name, year and model of car is given. You can easily apply it yourself. We furnish instructions and all necessary tacks, welts and fasteners. Our catalog No. 10, with samples, is free for the asking.

**LIBERTY TOP & TIRE CO., Dept. E-7, Cincinnati, O.**

**\$4.40 and up**  
Parcels Post Paid

Send No Money  
Wear 10 Days FREE

### PUT IT BESIDE A DIAMOND

These beautiful Gilodite Gems match genuine diamonds in every way—same glitter, flash and dancing play of living rainbow rays. **SEND NO MONEY**—just your name, address and tell us which ring to send (No. 1—Ladies', No. 2—Men's). When it arrives deposit amount shown with your postman. Printed price is all you pay. **WEAR TEN DAYS FREE.** If you or your friends can tell it from a genuine diamond, send it back and your money will be immediately refunded. You don't risk a single penny. These genuine Gilodite Gems are about one carat size set in latest mountings of 14-k Gold S.—guaranteed 20 years. Send strip of paper for ring size. Write today—NOW.

**GILODITE CO.** Dept. 10 Nashville, Tenn.

# You can get cool



These hot evenings if you have an

## Indian Motorcycle

Breeze through the country. Come back rested and refreshed.

Easy to buy on the partial payment plan.

Easy and extremely economical to operate. 60 to 70 miles to the gallon.

## New Low Prices Partial Payment Plan

Ask any INDIAN dealer for a demonstration. Write for free literature.

Address Dept. 37

**Hendee Manufacturing Co.**  
Largest Motorcycle Manufacturer in the World

Springfield, Mass.

U. S. A.

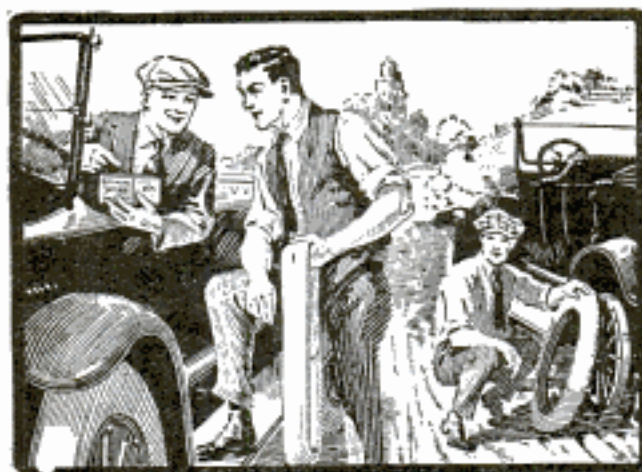

## Try My Shaler!

No tool-kit is complete without a Shaler 5-Minute Vulcanizer. It is a necessity and the greatest convenience ever offered to the motorist. Why take chances with cold patches when you can make a heat-vulcanized repair that will "stick"—even outlast the tube—in five minutes?

The Shaler 5-Minute Vulcanizer is easy to use—you need only a match. Always ready—never bothered by wind or storm. Cannot injure or burn the tube. No gasoline—no danger of fire.

Get a Shaler 5-Minute Vulcanizer from your dealer. It will soon pay for itself by the saving in time, trouble and tire repair bills.

**\$1.50 at All Auto Supply Stores**

*Slightly Higher in Canada and West of the Rockies*

The outfit includes the vulcanizer, 12 Patch-&-Heat Units (6 round for punctures and 6 oblong for cuts)—ready to use—with complete instructions. Extra Patch-&-Heat Units 75 cents a dozen.

**C. A. SHALER CO.**

2007 Fourth St. Waupun, Wis.



## PERFECT Ford CONTROL with a Stoner Footthrottle



When you step on a **STONER FOOTTHROTTLE**, the smooth response lends an ease and confidence that makes your driving a real pleasure. Can be installed by anyone in a "jiffy." No drilling or boring necessary, as the pedal slips thru the finger-hole in the lower toe-board. A mechanically perfect, beautiful device. Fits all models. Illustrated folder sent **FREE** on request.

If your dealer can't supply you mail \$1.50 today and your **FOOTTHROTTLE** will promptly be sent. This is a special introductory price. Satisfaction absolutely guaranteed or money refunded.

*Special Proposition for Dealers*

**STONER EQUIPMENT CO.** 326 W. MADISON STREET CHICAGO, ILL.

**Agents \$75.00 Weekly**

Amazing new seller. **JIFFY-JEANS** (not an overall) protects clothes while working around auto, shop, or home. On and off in 5 seconds. Cannot streak dirt or mud from shoes to clothes when putting on. Kept firmly in place by flexible steel bands. Will not wrinkle clothes. Made of high-grade Ducking. One size fits everyone. Easily laundered.

**150% PROFIT**

Sells like hot cakes. Just show and sale is made. Nothing else like it. Low price. Make \$75.00 weekly easily. Write today for liberal Agency Proposition.

**JIFFY-JEANS, 5650 W. Lake St., Dept. 12, Chicago, Ill.**

**Mounted on Wheel Easy To Move**

**15-Year Guarantee Cash or Terms**

**Try for 30 Days**

**Ottawa \$69**

New Log Saw just built. Saws 8-in. logs as well as 6-foot logs. Start or stop saw—engine runs on. Use Four-cylinder Engine for other work. Shipped from factory or nearest of nine branch houses. Write for full particulars today.

**OTTAWA MFG. CO. 1741-E Wood St., Ottawa, Kansas.**

**AGENTS** make \$10 to \$20 daily taking orders for new auto invention that removes carbon, stops oil pumping and saves 25% on gasoline. Sells on sight to every car owner on our money back guarantee. Everybody can afford it at \$2.00. You make 100% profit. Write for free sample booklet.

**Warren Mfg. Co. 278 Gray Bldg. Kansas City, Mo.**

## THE HANDIEST TOOL in the WORLD

**OLSON MAGAZINE SCREW DRIVER**

Patent on-hand Box Full Length, 8 Inches

Large enough to hang a door. Small enough to fit a belt. Three blades, one and a half, guaranteed. Fit any common screw and makes holes. Ask your hardware store or send \$1.25, prepaid.

**Olson Manufacturing Company 82 Commercial St., Worcester, Mass.**

## MAKE BIG PROFITS CHARGING BATTERIES \$20 Brings You an HB Charger

Balance on long easy terms, more than paid for by your big monthly profits. No expense for repairs or renewals. Sizes for 8, 10, 16 or 32 batteries. Write us about HB Air Compressors, Motors, Generators, etc. All big money-makers for you. HB uses clear \$1.50 to \$200—you can, too! Write today.

**HOBERT BROTHERS COMPANY**  
Box M 88 Troy, Ohio



# If You're Vacation Wise



—you and your pal and a Harley-Davidson are all set for the best outing you ever had. Over the hills you go, with the cares of "the job" forgotten! Speed past the hot, dusty tourists on the crowded main-roads, or take the short cut to hidden lakes and camping grounds.

You don't spend most of your vacation money for car fare, when you ride a motorcycle. Fifty miles for a dollar—gas, oil, tires and all—is the Harley-Davidson's average. And think of the fun you can have—the economical week-end trips you can take this Summer and Fall—with this speedy, dependable, comfortable mount to breeze you there and back again!

Your local dealer will gladly give you a free demonstration. Ask him about the reduced prices and the improvements on 1923 models, and his easy payment plan. Or write us for new literature.

Opportunity for dealers in unassigned Territories. Address Desk A-2

**HARLEY-DAVIDSON MOTOR CO.**  
Milwaukee, Wisconsin

## Harley-Davidson

World's Champion Motorcycle

### A REAL BOAT FOR REAL FISHERMEN



## The MOTO-ROW \$250

MAKE your vacation a real outing by owning a Moto-Row. Here is the greatest boat value ever offered—a combination power and row boat of ideal design and construction for fishing, hunting and pleasure purposes at less cost than an outboard makeshift. Built of selected airplane grade, copper riveted, and equipped with a dependable 2-H.P. motor protected from weather and theft beneath the stern deck, the Moto-Row offers you something distinctly new and practical. Dimensions 16 by 4 ft., speed 7 M.P.H., capacity six persons. Supplied with reinforced skeg which permits backing without injury to propeller. Salt water equipment \$25 extra. Built by Sidney McLeath, Marine City, Michigan. Write for illustrated catalog.

**BELLE ISLE BOAT & ENGINE COMPANY**

DEPT. 1

Builders of Belle Isle Boat

DETROIT, MICHIGAN

## Reel 'em In with a "Buddy"

The Fisherman's Pal

A regular, honest-to-goodness, high grade, smooth running, quadruple windster

**FISHING REEL for only \$2.65**

Regular \$4.00 value

Suitable for casting or still fishing. Made of brass, all nickel plated, with cone bearings carefully machined and adjusted. Has both click and drag with 60 yard spool. Runs like a high priced reel. Don't lose the big fellows. Get a "Buddy"—add fun and fun to every trip. Mailed postpaid anywhere in the U.S. on receipt of price.

Send today. Money Back if not satisfied.

**BUDDY REEL CO.** Dept. 1000 Toledo, Ohio

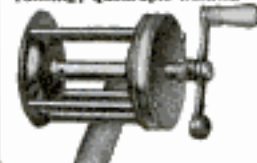

## MOTORCYCLES

### ONE YEAR TO PAY

Know the joy of owning—for business or pleasure—a HARLEY-DAVIDSON, EXCELSIOR, HENDERSON, INDIAN, CLEVELAND, or any other standard make; thoroughly rebuilt in our own factory.

Write for Free Bargain Bulletin and Easy Payment Plan

**HAVERFORD CYCLE COMPANY**  
America's Largest Cycle House  
Established 26 Years  
503 Market St., Philadelphia, Pa. Dept. P. M.

## RADIO TEXT BOOK

# 10c

Complete 50c instruction book for 10c on how to make and operate crystal and vacuum tube Radio receiving sets. Wonderful information, makes you understand radio. With every order we send FREE our complete Catalog of Radio parts and equipment. Buy direct from factory and save money. Both text book and catalog mailed postpaid on receipt of 10c.

Dept. P, Clearcut Radio, 1817 First National Bank Bldg., Detroit, Mich.

50¢  
Detroit, Mich.  
RADIO  
10¢

# IVER JOHNSON

## The SAFE Revolver

### \$20 Brings YOU AN HB BATTERY CHARGER

Pay balance out of your profits on long easy terms. Biggest season just starting. Get these revolvers. Sizes for 8, 10, 16 or 22 batteries. Hold on money-back guarantee. Write today for information.

**HOBART BROS. CO., Box M 82, TROY, OHIO**



## DIAMONDS, WATCHES ON CREDIT

YOU SHOULD HAVE THE JAMES BERGMAN JEWELRY BOOK IN YOUR HOME. It is full of many bargains. Diamonds, Watches, Jewelry, Toilet Articles, etc. Select any article desired, have it sent to you, all charges prepaid. If satisfactory, send one-fifth of purchase price and keep it, balance in TEN monthly payments. No interest charged. No security required. Write Today for Big Free Catalogue No. 5. It tells JAMES BERGMAN 37-39 MAIDEN LANE, Est. 1896, NEW YORK CITY about Our Low Prices and binding guarantee.

411  
\$3.50  
\$4.00



**Every Good Musician Praises the KING**

FOR more than a quarter century King Brass Instruments have been built to the specifications of world-famous musicians. Every King Instrument has the latest improvements — is built by an expert — and is thoroughly tested in our sound-laboratory before being shipped. That's why Every Good Musician Praises the King.

**Perfect Instruments Easiest to Play**

Whether you are just learning to play or are a finished musician you will find these wonderful King Saxophones, Trombones, Trumpets, and Horns easier to play than any other make. The wonderful tone-quality of the King is admired by everyone.

It's easy to own a King Instrument. They are sent on trial, and sold on easy payments. By buying from the factory you save all the middleman's profits.

**Get Price List of Used Instruments**

We now have on hand a large stock of used instruments of other makes, rebuilt and refinished to look like new. They are sold for cash at very low prices. Ask for our list of used instruments, also for our catalog of new factory guaranteed Kings — Mailed no charge.

**The H. N. White Company**  
5238 Superior Avenue :: Cleveland, Ohio

**"KING" BAND INSTRUMENTS**



## TYPEWRITER SENSATION!

Free Trial—Use as You Pay

Send us only \$4.00 a month until the low total price of \$48.85 is paid, and the machine is yours.

This is absolutely the most generous typewriter offer ever made. Do not rent a machine when you can pay \$4.00 a month and own one. Cash price \$44.00, just a little less than half its original price.

**(STANDARD) SMITH Model No. 6**  
**(VISIBLE)**

Perfect machines, Standard size, Keyboard of Universal arrangement, writing 84 characters—used in teaching the touch system. The entire line of writing completely visible at all times, has the tabulator, the two-color ribbon, the back spacer, in fact every late style feature and modern operating convenience. Comes to you with everything complete; tools, cover, operating book and instructions—nothing extra to buy. **You cannot imagine the perfection of this beautiful reconstructed typewriter until you have seen it. We have sold thousands of these perfect late style machines and every one of these thousands of satisfied customers had this beautiful, strictly up-to-date machine on five days' free trial before deciding to buy it.** We will send it to you F. O. B. Chicago for five days' free trial. It will sell itself, but if you are not satisfied that this is the greatest typewriter you ever saw, you can return it at our expense. You won't want to return it after you try it, for you cannot equal this wonderful value anywhere.

**SEND NO MONEY Put In Your Order Now** **\$4.85 AFTER TRIAL**

When the typewriter arrives deposit with the express agent \$4.85 and take the machine for five days' trial. If you are convinced that it is the best typewriter you ever saw keep it and send us \$4.00 a month until our bargain price of \$48.85 is paid. If you don't want it, return it to the express agent, receive your \$4.85 and return the machine. We will pay the return express charges. This machine is guaranteed just as if you paid \$100.00 for it. It is standard. These typewriters are samples the manufacturer had at their branch offices throughout United States and have never been used except for demonstration purpose. Just like new but at extremely low price. **The supply at this price is limited, the price will probably be raised when next advertisement appears, so don't delay. Fill in the coupon to-day—the typewriter will be shipped promptly.** There is no red tape. We employ no solicitors—no collectors—no chattel mortgage. It is simply understood that we retain title to the machine until full \$48.85 is paid. You cannot lose. It is the greatest typewriter opportunity you will ever have. **Do not send us one cent. Get the coupon in the mails to-day—sure.**

SMITH TYPEWRITER SALES CO., 288, 218 N. Wells St., Chicago, Ill.

SMITH TYPEWRITER SALES CO., 288, 218 N. Wells St., Chicago, Ill. Ship me the Standard Visible Smith Model No. 6, F. O. B. Chicago, as described in this advertisement. I will pay you \$4.00 monthly as rent until the \$44.00 balance of the Special \$48.85 sale price is paid. The title to remain in you until fully paid for. It is understood that I have five days in which to examine and try the typewriter. If I choose not to keep it I will carefully repack it and return it to the express agent. It is understood that you give the standard guarantee.

Name .....

Street Address .....

City .....

State .....

Occupation or Business .....

## Jewel 22 in. Band Saw \$75

Here's the machine for your shop at a moderate price. Strongly constructed to last a lifetime. Angle-steel frame, electric welded. Build on your own bench-top to suit your special needs. Roomy table with tilting adjustment for sawing bevels. Band saw has 22 in. swing cutting to center of 44 in. circle. Hand-wheel tension regulator. Will take material up to 7 in. thick.

Price with  $\frac{3}{8}$  in. band saw, \$75.

Send for complete catalog of Parks machines

**THE PARKS BALL BEARING MACHINE CO.**  
1500-1540 Knowlton Street CINCINNATI, OHIO  
Canadian Factory, 200 Notre Dame East, Montreal



48

**PARKS**  
WOODWORKING MACHINES

# CAILLE MOTORS

for Rowboats

**\$75<sup>00</sup> Up**

There is a Caille Motor for any boat and for any purpose—and for any purse.

Caille 5-Speed Motor is highest grade—most flexible rowboat motor made. It has two speeds ahead, two in reverse, and a neutral or idling position. Furnished with a real mechanical starter.



Caille Liberty Drive will run a boat anywhere a boat will float. Tilts automatically to pass over shoals and sunken obstructions. Goes through weeds like an eel.

CAILLE PERFECTION MOTOR CO.  
6210-50 Second Blvd. DETROIT, MICH.

The Versatile  
**HAMMOND**  
Folding Portable  
Typewriter

MULTIPLEX HAMMOND'S  
Instantly changeable type  
Many styles, many languages  
Just Turn the knob to change

Hammond Typewriter Corp., 569A East 69th Street  
New York City, N. Y., U. S. A.

**YOU CAN OVERCOME WEAKNESS and ILL-HEALTH**

This big, valuable book sent without obligating you in any way. Learn how to treat yourself for ailments caused by disordered nerves, impoverished blood or poor circulation. Build up cells and tissues to healthy activity, banish aches and pains and eradicate poisons.

Merely send request for **FREE BOOK**.

**J. S. CAPE, 810 W. Park Pl., Detroit, Mich.**



**Make \$150 to \$300 MONTHLY CHARGING BATTERIES**

\$20 brings HB Battery Charger. Balance easy monthly terms. No repairs or renewals. Sizes for 8, 10, 16 or 22 batteries. Write us to recommend size for you.

**HOBERT BROS. CO., Box M 21, TROY, OHIO**

**RADIO WIRE SHIPPED PROMPTLY--OVER 50 TONS IN STOCK**

Size	Enamel			Single Cotton			Single Silk		
	1 lb.	1/4 lb.	1/8 lb.	1 lb.	1/4 lb.	1/8 lb.	1 lb.	1/4 lb.	1/8 lb.
22	.48	.28	.16	.95	.52	.30	.95	.51	.28
24	.55	.31	.18	1.05	.57	.32	1.07	.57	.31
26	.60	.34	.19	1.21	.65	.36	1.19	.63	.34
28	.64	.36	.20	1.36	.73	.40	1.44	.76	.40
30	.68	.38	.20	1.70	.89	.48	1.89	.98	.51

Send 5 cents to cover postage on our New Perpetual Catalog. No stamps accepted

**I. R. NELSON CO., Bond St., Newark, N. J.** | Broadcasting Station W-A-A-M

**Ingersoll**

"SENSIBLE WATCHES"

**YANKEE**

**\$1.50**



THE world's most popular watch—more than fifty millions sold. Sturdy, reasonable, reliable, good-looking, it carries a sound guarantee.

The Yankee Radiolite is the same watch equipped for telling time in the dark. \$2.50.

The Ingersoll Waterbury is the stylish 12-size. Four jewels, \$4.00. With Radiolite figures and hands. \$5.00.

**Ingersoll Watch Co., Inc.**

Owned by the Waterbury Clock Company, world's largest manufacturers of watches and clocks

NEW YORK CHICAGO  
SAN FRANCISCO



YANKEE  
RADIOLITE  
\$2.50



WATERBURY  
RADIOLITE  
\$5.00

Treat yourself at home

# Vi-Rex

## VIOLET RAYS

Used successfully for the treatment of

Asthma	Falling Hair	Neuralgia
Boils	Hay Fever	Paralysis
Blackheads	Headache	Pimples
Catarrh	Insomnia	Rheumatism
Colds	Lumbago	Skin Diseases
Eczema	Nervousness	Sore Throat

and other ailments

Complete Outfit **\$12<sup>50</sup>**



If you have less than perfect health you are sub-normal! If you will take the advice of thousands of leading medical men and famous beauty specialists, you will revitalize and tone up the muscles, nerves and tissues of your body through VI-REX VIOLET RAY treatments. VIOLET RAY TREATMENTS will preserve or restore for you these choicest gifts of Nature.

### Free Trial

Because the VI-REX is the most scientific, most effective and best built machine made, we know that it will give you the MAXIMUM RESULTS obtainable from the use of VIOLET RAYS. In ten days you will be thoroughly convinced. Make this experiment ENTIRELY AT OUR RISK, we will give you a full 10-days free trial of our machine on request.

Wonderful book  
**FREE**

Learn why your vitality is low, why you have pains, aches and ills! Remarkable book just published contains charts of nervous system, organic locations, and describes beneficial results of VI-REX VIOLET RAY TREATMENTS. Clip this coupon and mail it today.

**Vi-Rex Electric Co.**

326 W. Madison St.

Dept. 28

Chicago,  
Ill.

VI-REX ELECTRIC CO., 326 W. Madison St., Dept. 28, Chicago, Ill.  
Please send me without any cost or obligation your free book describing your VI-REX Violet Ray outfits, and details of your free trial offer.

Name.....  
Address.....  
City.....  
State.....



### SAFEGUARD

your expensive tools. Keep them secure, safe from rust, theft, loss and damage in a

### UNION TOOL CHEST

There is a place for every tool. You can check up at any time and know instantly whether any tool is missing. Ask your dealer or write us for illustrated literature describing more than fifty patterns and sizes.

UNION TOOL CHEST CO.  
22 Mill St. Rochester, N. Y.



## CAMERAS

Over a Hundred Styles and Sizes  
Send for new illustrated catalog showing latest reduced prices. It's Free.

10 days' trial given

SENECA CAMERA MFG. COMPANY  
300 Central Avenue Rochester, N. Y.



### \$20 STARTS YOUR BATTERY CHARGING BUSINESS

Lost any terms on balance, quickly paid from your big monthly battery charging profits. HB uses clear \$1.50 to \$3.00 per month. HB Charger is easy for 8, 10, 16 or 32 batteries. Write for recommendations as to outfit best suited to your requirements. Start your battery business NOW—no experience needed. BIG PROFITS easily made. HOBART BROS. CO., Box M 83, TROY, OHIO

## Oh, You Skinny!



Strongfort  
The Perfect Man

Why stay thin as a rail? You don't have to! And you don't have to go through life with a chest that the tailor gives you; with legs you can hardly stand on. And what about that stomach that flinches every time you try a square meal? Are you a pill-feeder?

Do you expect Health and Strength in tablet form—through pills, potions and other exploited piffle?

You can't do it; it can't be done. The only way to be well is to build up your body—all of it, through Nature's methods—not by pampering the stomach. It is not fate that is making you a failure; it's that poor emaciated body of yours; your half sickness shows plain in your face and the world loves healthy people. So be HEALTHY—STRONG—VITAL. That's living. Mark the ailments on the free consultation coupon upon which you wish special confidential information and send with a 10c piece (one dime) to help pay postage on my Special Talk on Thinness and my book "Promotion and Conservation of Health, Strength and Mental Energy." Don't put it off—send for my free book Right Now—TODAY.

### LIONEL STRONGFORT

Physical and Health Specialist

Dept. 931

Newark, New Jersey

### FREE CONSULTATION COUPON

Absolutely Confidential

Mr. Lionel Strongfort, Dept. 931, Newark, N. J.—Please send me your book, "PROMOTION AND CONSERVATION OF HEALTH, STRENGTH AND MENTAL ENERGY," for postage on which I enclose a 10c piece (one dime). Send me special information on subjects marked (X) below, without obligation, also on those I may write on extra line below:

.. Colds	.. Increased	.. Poor Memory
.. Catarrh	.. Height	.. Rheumatism
.. Asthma	.. Pimples	.. Falling Hair
.. Hay Fever	.. Blackheads	.. Weak Eyes
.. Obesity	.. Insomnia	.. Gastritis
.. Headache	.. Short Wind	.. Heart Weakness
.. Thinness	.. Flat Feet	.. Poor Circulation
.. Rupture	.. Stomach	.. Skin Disorders
.. Lumbago	.. Disorders	.. Despondency
.. Neuritis	.. Constipation	.. Round Shoulders
.. Neuralgia	.. Biliousness	.. Lung Troubles
.. Flat Chest	.. Torpid Liver	.. Stoop Shoulders
.. Deformity	.. Indigestion	.. Muscular
.. (Describe)	.. Nervousness	.. Development
		.. Great Strength

Mention other ailment here.....

Name.....

Age..... Occupation.....

Street.....

City..... State.....



# \$375.75 IN ONE DAY WITH THIS GREAT MACHINE

Cash Business  
Easy, Fascinating

Good times coming back. Conditions growing better. Make and sell Crispettes with this machine. Profits enormous. Demand phenomenal. Chances for quick success bright. It's the business for you.

## Many are Successful

Many men making thousands. Ira Shook says: "Started with nothing, now have \$12,000. Took in \$375.75 in one day!" Kellogg writes: "Am \$700 ahead in two weeks!" Gibbs reports: \$50.00 profit the first night. Erwin's boy averages \$35.00 every Saturday afternoon. Master's letter states: "and sold \$40.00 in four hours." Turner did so well that he was

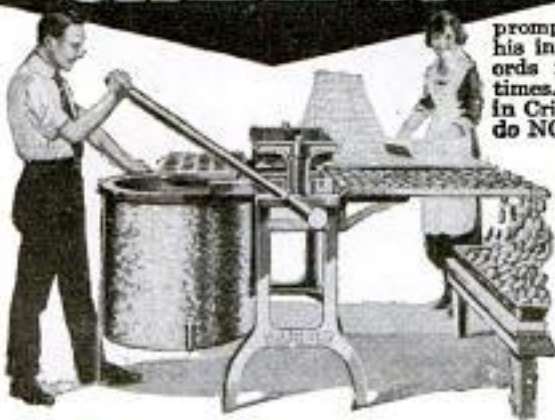

promptly offered \$700 profit above his investment to sell. All these records made during recent unsettled times. There is money—lots of money—in Crispettes. Think what you can do NOW! Splendid opportunities galore—parks, fairs, carnivals, concessions, crowded streets. Big possibilities wholesaling to stores, candy stands, etc. Start right in your town. Good location not even necessary.

## Success! Anywhere!

Set machine up in own home. Wholesale from your kitchen. Nothing to stop you. Little capital starts you. Experience not necessary. I furnish everything. Raw materials plentiful and

cheap. Nothing like Crispettes. A delicious confection made from secret formula. People never get enough. Always come back

## One-thousand Dollars Monthly Possible

Be first in your town to start. Send coupon—get my help. Learn the facts of this great business. Learn how others have succeeded. Read their letters. See pictures of their stores and stands. Find out all about my liberal proposition. Coupon brings complete details. Puts big 32-page fully illustrated book in your hands. Tells all you want to know. Shows how you can find your place. How you can get on road to quick success. It's FREE! Mail coupon NOW!

**LONG EAKINS COMPANY**

828 High Street

Springfield, Ohio

**LONG EAKINS CO.**  
828 High Street  
Springfield, Ohio

Please send me full particulars of the Crispetto business.

Name.....

Address.....

## AUTO SUPPLIES and BEAUTIFUL BODIES at WHOLESALE PRICES

Big Free Catalog

AUTO SUPPLIES FOR ALL CARS

Know the latest prices before you buy. Send for our illustrated price list. Every page is filled with bargains. We buy for cash—and sell for cash.

Save Money on Special Bodies

We carry a complete line of "Fidelity" Bodies for Ford and Chevrolet "490" at Bargain Prices; \$29.95 and up.



Send for Catalog P. It shows over 3000 bargains in repair parts, tops, radiators and general accessories for Fords and other cars. All guaranteed standard quality.

Fidelity Bodies \$29.95 and up for Fords and Chevrolet "490"

**NEMCO BARGAIN SUPPLY HOUSE**  
1017 W. Jackson Blvd. Chicago, Ill.

## FORD

## CHEVROLET OWNERS

True Amount of Oil Right Before Your Eyes!

## CARTER OIL GAUGE

Accurately records oil in crankcase and operates perfectly under all conditions. No moving parts, cocks, or floats to get out of order. Neat, compact, nickel-plated gauge, screws onto instrument board or dash. True oil level in crankcase recorded right before you. Connecting air tube with special elbow attached screws in place of lower petcock. Gauge indicates plainly level of oil at all times. If your dealer can't supply, use coupon—money back if not satisfied.

### JOBBER AND DEALERS

Write for discounts, sales helps and copies of letters from satisfied users.

—Use This Coupon For Order—  
**CARTER MOTOR ACCESSORIES, Inc.,**  
386 Pearl St., Buffalo, N. Y.

Enclosed find (check) (money order) for \$..... Ship prepaid.....(no. or doz.)  
Carter Oil Gauge—Ford Type.....(no. or doz.)  
Carter Oil Gauge—Chevrolet Type.....

Name.....

Street.....

City.....

Dealer's Name.....

(If coupon is used by Dealer, shipment will be sent C. O. D. with free advertising literature; free demonstrator stand shipped with order for 1 dozen or more.)

From Popular Mechanics



Only \$3.00





## Tobacco Is Hurting You

Look at the facts square in the face, Mr. Tobacco User. You may think tobacco is not hurting you.

That is because you haven't as yet, perhaps, felt the effects of the nicotine poison in YOUR system. For you know that nicotine, as absorbed into the system through smoking and chewing tobacco, is a slow working poison. Slow, yes—but sure.

Tobacco is lowering your efficiency. It slows a man down. Makes it harder for you to concentrate your mind on your work. You haven't near the amount of "pep" and energy you would have if you stopped using it. There's many a man twice as old as you in years who's twice as young in energy, simply because he lets tobacco alone.

Some day you will realize to what an alarming extent tobacco has undermined your system.

When your hands begin to tremble—  
and your appetite begins to fail—  
and your heart seems to "skip a beat" now and then—  
and slight exertion makes you short of breath—  
then you have a right to suspect that  
**TOBACCO** is getting the upper hand.

Any well-informed doctor will tell you that these are only a few of many symptoms of tobacco poisoning.

And YOU know that the use of tobacco in any form is an expensive, utterly useless habit. You know you ought to quit.

## Tobacco Habit Banished Let Us Help You

It doesn't make a particle of difference whether you've been a user of tobacco for a single month or 50 years, or how much you use, or in what form you use it—whether you smoke cigars, cigarettes, pipe, chew plug or fine cut or use snuff—**Tobacco Redeemer** will positively remove all craving for tobacco in any form in a very few days. Not the slightest shock to the nervous system. Your tobacco craving will usually begin to decrease after the very first dose—there's no long waiting for results.

**Tobacco Redeemer** contains no habit-forming drugs of any kind and is marvelously quick, scientific and thoroughly reliable.

It is in no sense a substitute for tobacco. After finishing the treatment you have absolutely no desire to use tobacco again or to continue the use of the remedy. It helps to quiet the nerves and make you feel better in every way.

### Results Guaranteed

A single trial will convince you. Our legal-binding, money-back guarantee goes with each full treatment. We will refund every cent you pay for the treatment if after taking it according to the easy-to-follow directions, it should fail to banish the tobacco habit completely.

### SEND Coupon for Free Proof

Let us send you our free booklet on the deadly effects of tobacco, together with testimonial letters from men all over the country telling how they have been absolutely freed from the tobacco habit by this simple home treatment. You could not ask for stronger proof that **Tobacco Redeemer** will free you from the habit than the evidence we will gladly send on request. Just mail the coupon—or a postal will do.

**NEWELL PHARMACAL CO.**  
Dept. 300 St. Louis, Mo.



## Free Book Coupon

**NEWELL PHARMACAL CO.**

Dept. 300

St. Louis, Mo.

Please send, without obligating me in any way, your free booklet regarding the tobacco habit and proof that **Tobacco Redeemer** will positively free me from the tobacco habit or my money will be refunded.

Name .....

Street and No. ....

Town..... State.....

# One Man and This Machine Can Earn \$500 a Month



**FIVE** hundred dollars month is low estimate. Many make more. Gibbard, Mich., had amazing record of \$60,000.00 last year! Others had wonderful successes. My new Tire Surgery machine did the trick!

**HAYWOOD'S  
TIRE SURGERY**

is the new and better tire repair method. You can learn in two weeks. I'll teach you. I'll furnish you with one of these new, compact Tire Surgery outfits. Will place you on direct road to fortune and financial independence. Your determination to succeed and this wonderful machine is all you need.

## Experience Not Necessary

To start is the thing! Haywood's easy Tire Surgery method and Haywood's "One Man" machine will do the rest. Will make money for you—lots of it—from very beginning. Charlie Evans of Indiana, carpenter, past middle age, knew nothing of tires less than year ago. He bought a Haywood machine. Learned Tire Surgery. Now is earning more than \$100 week!

## Opportunity Never Better

Seven million car owners in country. Most of them must economize. Can't buy new tires. Must make old tires do. They can tinker with their auto, but can't mend tires. This work will swamp present Tire Surgery stations. Many more needed in every section of United States.

## I Can Place 500 Men in Good Locations Right Now!

It's a proposition you can handle. Cash in on this great economic wave that is sweeping old tires into repair shops instead of junk piles. Etzrodt of Pennsylvania averages \$30,000 in this business. Blair of Ohio does more than \$100 daily with small Tire Surgery shop. Oldham of Illinois reports recent earnings of \$2300 in four months. And so on. These men acted. They had no experience. Possessed very little capital. Enjoyed no advantages you haven't got.

**M. HAYWOOD, Pres.**

**HAYWOOD TIRE & EQUIPMENT CO.**  
980 Capitol Avenue Indianapolis, Ind.

## \$6000.00 Year Easy

Haywood's Tire Surgery is so successful—so profitable—because it is thoroughly efficient. Look at the machine. See how compact and complete it is. Whole plant can be placed in space eight feet square. Observe its convenience—how one man can easily watch every detail from steam plant to vulcanizing without turning head. Look at its capacity—think of the dollars it will pour into your pockets in one single day. Its operation is so simple any man can do perfect work without long experience or apprenticeship.

## Fill Out Coupon Now!

I have ready to mail you, the day I get your request, a fascinating book which tells all about tires. How to repair them by the Haywood method of Tire Surgery. How to start in business. How to build up trade. What to charge. You needn't write a letter. Just tear out the coupon right now. Fill it in and mail. Within 48 to 72 hours you can have the whole proposition before you. It's a case of walking right into \$3000 to \$5000 a year. Use the coupon below.

## Send for Free Book

**M. HAYWOOD, Pres.**  
**HAYWOOD TIRE & EQUIPMENT CO.**  
980 Capitol Ave., Indianapolis, Ind.

Dear Sir: Please send me by return mail your free book on the new Haywood Tire Surgery method and the details of this profitable business.

Name.....

Address.....

# TRIMM RADIO

Professional

3000 Ohms

Head Set



## FREE 5 DAYS TRIAL

Expressly designed and refined for Radio work; built by technical experts of long experience in producing high-grade microphones. 3,000 Ohms; unlimited range. Cases and caps made entirely of Phenol compound; free from sulphur and other corrosive and odorous gases; accurately molded; warp-proof. Head band of new, improved pattern insures perfect comfort. TRY IT FREE, AT OUR RISK, WHILE THIS OFFER LASTS.

**Your Money Back** If not absolutely satisfied after 5 days' trial, send it back and your money will be promptly refunded. Special introductory price, only \$10.00. Order through your dealer or direct from us. We prepay charges and ship C. O. D. Write for descriptive folder with valuable information.

TRIMM RADIO MFG. CO.

DEPT. 10, 24 S. CLINTON STREET

CHICAGO

## MAKE YOUR OWN RADIO SET

Prices Slashed!



Buy direct from the factory. Satisfaction guaranteed or money refunded. Every part carefully tested and inspected by radio experts.

This is your opportunity to make your own, efficient radio receiving set at small cost. Send full payment with order, or if you prefer, you may send deposit, and pay balance C. O. D., and we will ship any of the following radio parts at the bargain prices quoted:

	Regular Price	Special Price
Variometers .....	\$5.00	\$3.00
Vario Couplers .....	5.00	3.00
Transformers .....	5.00	3.00
23 Plate Condensers .....	3.00	2.25
43 Plate Condensers .....	4.50	2.75
Vacuum Tube Sockets .....	1.00	.65
Dials and Knobs .....	1.00	.65

**FREE** Wiring diagram and blue print with every order. This special bargain price offer is for a limited time only. Act at once! Remember—we guarantee satisfaction or refund your money. Circular mailed on request.

**METRO ELECTRIC CO.**  
1422-1438 RANDOLPH ST. CHICAGO



### Favorites at the Beach

**B**BETTER bathing beaches are quickly reached when your rowboat or canoe is Evinrude-powered. A breezy trip over the water, with this husky little motor to do your oar-work, fills you with "pep" after your dip in the lake. Every summer outing—fishing, camping, picnicking—is far more sport when there's an Evinrude in the party.

There are two Evinrude models to select from—the famous Standard, and the newer Lightweight, a remarkably portable motor weighing only 50 pounds. See these Evinrudes at your hardware or sporting goods dealer's. Or write for free catalog.

**EVINRUDE MOTOR CO.**

711 Evinrude Bldg. Milwaukee, Wis.

#### Distributors:

69 Cortlandt St., New York, N. Y.

780 Commonwealth Avenue

Boston, Mass.

119 Broadway

Oakland, Cal.

211 Morrison St. Portland, Ore.

## EVINRUDE

DETACHABLE MOTOR FOR WATERCRAFT

### Your Own Stationery \$1

100 Noteheads and 100 Envelopes of fine quality printed with your name and address. Thousands of satisfied customers. Simply send dollar bill with your name and address plainly written. ECONOMY PTG. CO., 37 Work Drive, AKRON, O.

### Makes Gasoline 100% Efficient

No matter how old or new your car is, a set of Turbulators will reduce carbon and increase efficiency. Install in 10 minutes—no special tools. At your dealer or write us—Eteen days trial.

The Turbulator Corporation, Dept. M, 2625 So. Michigan Ave., Chicago, Ill.

Our BUREAU OF INFORMATION will answer all questions regarding articles appearing in this magazine. Address Bureau of Information, Popular Mechanics Magazine, Chicago.

### RADIO FOR THE AMATEUR

Building, Installing and Operating Stations for Radio Communication are presented in convenient form in **Practical Amateur Wireless Stations**

An experience book containing the best suggestions of thirty-three experimenters compiled by the editor of Wireless Age.

It blazes a clear-cut trail to the practical achievement of an amateur wireless station.

Where a method is described, it is one which the author of the chapter has worked out and tried himself; and the same is true whether dealing with a single piece of apparatus or a complete station.

136 Pages—115 Illustrations  
Size 6x9. Price 75c postpaid

Popular Mechanics Book Dept.  
6 N. Michigan Ave. Chicago



# \$215 In One Day

**Salesmen Reporting Biggest Sales They Ever Made on Amazing New Invention Everyone Wants**

**H**ERE'S an amazing new invention that is banishing forever the mess, dirt and drudgery of coal and wood fires—saving housewives from roasting kitchens in Summer, giving ready heat in uncertain Fall weather and three times the heat of coal in Winter. Set it in any fire-box of any coal range. Presto! In one minute you have an actual gas stove. Then just the turn of a valve gives as much or little heat as needed.

## No Experience Needed for Big Money

Besides its other points the Oliver burns 95% air and 5% oil, the cheapest fuel there is. With everybody raving about the price of coal and the probable shortage, sales of Oliver Burners are breaking all records. You don't need to be a high powered salesman to make money on a proposition like this. The Oliver's amazing features sell it for you.

Now you know why W. H. Drew of Michigan made \$85.00 in one day; why L. Zueher of Ohio made \$21.50 in three hours; why A. M. Russell of Connecticut has averaged \$660.00 for the last 6 months; why one order sent by P. M. Ford of Iowa gave him a profit of \$646.25.

## Quick Sales—Big Profits

Every agent we appoint makes big money. You, can too. We have a number of definite territories which we are ready to dispose of to those who act quickly.

## Coupon Brings Full Offer

Mail this coupon now for our offer. We are not making any extravagant claims about this. We don't have to. We want to give you the facts. Writing will not obligate you in any way. But hurry. Send the coupon at once if you want to get in on this big money, whirlwind all-season seller.

**OLIVER OIL-GAS BURNER & MACHINE CO.**  
2014-T Oliver Bldg. ST. LOUIS, MO.

## A Long Looked For Invention The VIRZI

**"TONE PRODUCER"** A device installed in the violin, piano and all other stringed instruments, it renders the **tone free, more mellow and brilliant** than any other existing in the world. It is recommended and used by Kreisler, Heffetz, Casals, Betti and many other of the greatest artists. Write **J. & J. Virzi Bros., No. 587 Fifth Avenue, New York City** for booklet. *Sole owners and distributors.*



**Michigan Marine Motors \$115**  
*Repairs at any Ford Garage*

**MORE** power, greater dependability, less weight, longer life, easier repairs, and lower cost—six salient points which make the Michigan Marine Motor the logical power equipment for your boat. Parts and repair service available at any Ford garage in the world. Here is a feature of outstanding importance—a feature that you cannot afford to overlook.

Michigan Marine Motor develops 4 h.p., weighs only 125 lbs., is of 4 cycle type, and is fully guaranteed for one year. It is especially designed for use in launchers, tenders, fishing boats, and all similar craft requiring a full-powered motor of unending dependability.

Motor equipped with Bosch Magneto and impulse coupling, \$20 extra. Built by Michigan Marine Motor Co. Write for special dealer offer.

**BELLE ISLE BOAT & ENGINE CO.**  
Builders Belle Isle Boats.  
Dept. 1, Detroit, Michigan

**ONE-HAND-Y ELECTRIC DRILL**

For quick, accurate and easy drilling in wood or metal, the One-Hand-Y Electric Drill is unsurpassed. It is a compact, serviceable electric drill for light work and saves time and labor.

Write direct to  
**Knight Engineering & Sales Company**  
30 W. Walton Place, Chicago

## Salesmen are Making Fortunes

"Am making \$1000 per month. I have made big money before but did not expect so much. Your Burner is just the thing."  
J. Carnegie, S. D.

"Am sending today for 7 Oliver's. This is one day's orders (\$85 profit). Selling like beer in a dry town."  
W. H. Drew, Mich.

"Send following weekly hereafter: 10 No. 1; 8 No. 2; 4 No. 5." Berger's Weekly Profit on order, \$258.50.  
R. Berger, Ont.

"I made \$43 last night selling Oliver Burners."  
N. B., Chelan, Wash.



F. W. Bentley of Phila., says: "Ye Gods—some seller! I made \$215 today!"

**Oliver Oil-Gas Burner & Machine Co.,**  
2014-T Oliver Bldg., St. Louis, Mo.

Please send me full facts about how I can make big money representing you in my territory. Also your plan, if I wish to make big money in my spare time.

Name .....

Address .....

City.....State.....

## Let the CROWN Fuel Saver put you on the business map

Establish a permanent business where steady work brings big profits. Become an exclusive distributor for CROWN Fuel Saver. Thousands in use. Easily sold because it saves at least one-fifth of the fuel. Every furnace and boiler owner a prospect.

**We advertise the CROWN in your local paper**

We back you with strong selling literature. We tell you how to sell the CROWN and help you do it. One \$35.00 sale a day means \$450 per month net profit.

Don't delay. Profitable fall business just beginning. Some extra good territory open. Write or wire for exclusive distributor proposition. This puts you under no obligation. Do it now.

**CFSCO, 15 N. 10th St., Richmond, Indiana**

Price, \$12.40 Net  
Weight, 3 lbs.  
Capacity, 1/4"

**ONE-HAND-Y ELECTRIC DRILL**

Westinghouse Universal Motor  
210 W. Seventh Street, Los Angeles



# BIG CUT

## On WITTE Engines

2 to 30  
H-P.

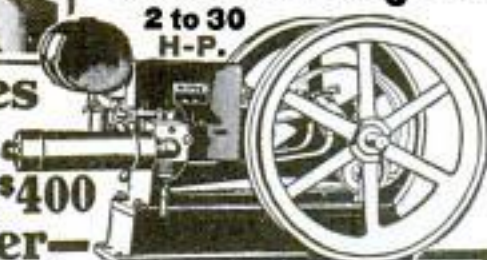

**Prices  
Now  
\$20 to \$400  
Lower—**

**THE next change will likely be higher. Tell me what size or style engine you need Now—2, 3, 4, 6, 8, 12, 16, 22 or 30 H-P.—Kerosene or Gasoline—Stationary, Portable or Saw Rig—and I will quote you a price, today, that will save you money.**

**Big Catalog FREE!**

Tells all about WITTE Engines, shows how they are made, where made and why they are better. Also how I can sell them direct from factory at such low prices—Cash or Easy Terms. Let's figure it over. ED. H. WITTE, Pres.

**WITTE ENGINE WORKS**

1743 Oakland Avenue, KANSAS CITY, MO.  
1743 Empire Building, PITTSBURGH, PA.

# BALBA *bouquet* perfume



Get Our Money-Making Agency Offer  
**Balba Sales Machines**  
Make \$200 to \$1000 Monthly

This new plan of selling high quality perfume has taken the country by storm! Men everywhere are jumping at the opportunity to get into this big money-making field. See page 171 of March Popular Mechanics.

**Over 500 Cities Already Taken**

Remember the first who qualify get the exclusive sales rights. We do the local newspaper and national advertising. Get full particulars NOW.

**BALBA CORPORATION of AMERICA, Inc.**  
Dept. 44, Adams and Jackson Sts.  
TOLEDO, OHIO, U. S. A.

## Copper Steam Boiler

Latest improved Solid Copper High Pressure Steam Cooker—Complete and Perfect in every detail. Cannot explode. Absolutely steam tight. Note the safety features, steam gauge, safety valve and special 1/2 inch steam outlet valve. Made of absolutely purest heavy copper throughout. No solder inside. Can screw is large enough for hand—easily cleaned. Has a thousand uses. You pay no more for this heavy solid copper pressure boiler than for those made of cheap metals.

### World's Lowest Prices

2 gal. ....	\$ 7.50	10 gal. ....	\$17.50	STEAM CLOCK	1/2 INCH
4 gal. ....	10.00	15 gal. ....	20.00	SAFETY VALVE	STEAM
6 gal. ....	12.50	20 gal. ....	25.00	STEAM TIGHT	OUTLET
8 gal. ....	15.00	30 gal. ....	35.00	SCREW	
		50 gal. ....	\$50.00		

**Send Only \$1**

Order any size boiler at the price shown. Just tell us the size you want. Enclose \$1. The Boiler will be shipped at once without red tape or delay. Pay the balance when Boiler is delivered. Also made in wash-boiler shapes—12, 15, 20, 25, 35 gallon sizes. Price \$1 per gallon.

**General Products Co.**  
Dept. 43 C  
1827 W. Lake St., Chicago



## KEROSENE

Make **BIG Money** Men and Women Wanted to Sell



### PERFECTO

**Kerosene Iron**

No experience necessary. Big profits selling this wonderful self-heating satisfaction guaranteed iron. Easy to operate and demonstrate. Sells itself. Use Kerosene (Coal Oil) or Gasoline with same satisfactory results. Absolutely safe, no smoke or odor. Get facts in detail and let us tell you how to obtain Free Sample and start you in a big paying business. Sample cost FREE to Agents.

Perfecto S&I Iron Factory, Dept. 28, 126 So. Clinton St., Chicago, Ill.

## TIRE Agents Wanted

An auto owner in each locality to use and introduce

**Mellinger EXTRA-PLY and CORD Tires**

Make big money part or full time. No capital or experience needed. Sample Sections furnished. **GUARANTEED**

**8,000 and 10,000 Miles (No Seconds)**

Hand made. Finest materials. Shipped prepaid on approval.

**FREE Tires for Your Car** to one user in each locality for taking a few orders. Be first to write quick for Special Agents Offer and Low Wholesale Prices.

**MELLINGER TIRE & RUBBER CO.**

310 North Oak Street Kansas City, Mo.



## Battery Charging Pays \$1500 to \$3000 a Year

An HB Battery Charger will be your biggest money-maker. Profits biggest when other lines slowest. No experience needed—anyone can operate. An HB Outfit charges batteries for 4c to 12c each. Customer pays 75c to \$2.00. Figure that profit. HB Charging Service brings new customers, builds trade.

**\$20 Brings You an HB Battery Charger**

Balance, easy monthly terms, more than carried by your profits. Write us for information. Ask about HB Automatic Air Compressors, Tire Buffers, Motors, Lighting Generators, Stock-keeping Cabinets, etc. Also HB Constant Potential Charging Set for established battery shops. Charges batteries perfectly in 8 hours. All big money-makers for you. Sold on easy terms. Write today.

**HOBART BROTHERS CO., Box M8, Troy, Ohio**



**Small Cash Payment—Balance Easy Terms**



# LEARN A TRADE

## AND GET A GUARANTEED JOB

If you are mechanically inclined write me today—don't bother about a letter—just a postcard will do—or clip and mail the coupon.

So confident am I of the practical automotive, tractor and Radio training that is offered you in this Million Dollar Trade School, that if you will agree to take the necessary preliminary work, I will agree to employ you upon graduation. This position requires not only automotive training but radio training as well. But to equip you for this work I will give you a free course in radio.

Furthermore, I need you NOW. And to make it possible to get the right sort of men I will pay your railway fare to Kansas City.

I want Sweeney Trained men to act as my salesmen and representatives to sell radio sets, storage batteries, accessories, etc.—to run garages, tire shops in 5000 places where I am opening sales branches.

If you are mechanically inclined and want an assured position as branch manager, write me today for sample contract. I will make this offer only to those who are sufficiently in earnest and sufficiently energetic to write me at once. Naturally, I will only employ Sweeney trained men.

### The Sweeney System

famous the world over, can be had only in the Sweeney School. Trains men to be mechanics by practical work. You learn by doing—no books—you do the actual work. The course takes only 8 weeks. No place in the world can you get so much real instruction—so much actual value, for so little money. Over 46,000 graduates. Write me today—don't put it off—I've got some information that will open your eyes—but you must take the first step—Write for my Big Free Book.

### Good Jobs for You

With your radio experience here you can go back home and install receiving sets or sell them. You can make sets for yourself. You can run a garage. You learn to make a good \$25 Ford battery for \$7.00. You learn how to weld a broken crank case. You learn how to make a real 4000 mile tire from old casing and rubber. You can be a chauffeur or truck driver. You can be an auto mechanic—a repair man in a shop or factory. Learn about stationary engines. Learn tractor work. Be a demonstrator or salesman. Hundreds of good jobs open to Sweeney trained men. Even before he finished his course Runsey was grabbed by the American Radiator Co. at \$150 a month as an expert welder.

With inexpensive receiving set you can get daily service from the Sweeney station. Sweeney students are furnished with the very latest and most powerful radio equipment.

**FREE** I will gladly send my 72-page illustrated catalogue FREE. Also a copy of the Sweeney School News, a most interesting monthly school paper published here. You will enjoy them.

Read the worthwhile stories of men like yourself who came to Sweeney's and found success. Read how Frank Powell and Harry Wilson built up a \$20,000 business in about two years after graduating. Read how Elbert A. Pease built up a \$25,000 yearly garage business. These stories and others are told by the Sweeney students. Also I want you to learn how my students enjoy themselves after work in the swimming pool, club and reading rooms, etc. No colored students accepted.

### Pick the Job You Like

Chauffeurs	\$90 to \$150
Truck Driver	\$125
Tire Vulcanizers	
	\$100 to \$200
Welders	\$140 to \$200
Battery Men	\$150 to \$200
Auto Mechanics	
	\$6 to \$10 a day
Auto Electrician	\$225
Tractor Engineer	\$10 a day
Garage Mgr.	\$150 to \$400
Demonstrator and Salesman	\$150 to \$500

### Free Radio

Come to the Sweeney Auto School and learn Radio work without a cent's extra charge. Receive messages—learn to build and install Radio sets—get agencies and sell sets—receive messages from all over the world—all this is now part of the regular eight weeks' course without advance in tuition.

### Great Broadcasting Station

Aerials 325 feet above the ground send Sweeney news, concerts, weather and market reports to the U. S. Station cost \$20,000 to erect. Call is W.H.B. Wave length 360 and 485 meters. A 500 watts W.E. set provides the power for this great station.

MAIL COUPON NOW

LEARN A TRADE  
**Sweeney**  
 SCHOOL OF AUTO-TRACTOR-AVTATION  
 1049 SWEENEY BLDG. KANSAS CITY, MO.



EMORY J. SWEENEY  
 President

1049 Sweeney Bldg.  
 Kansas City, Mo.

Please send me free without any obligation on my part, your 72-page catalog and your Sweeney School News. Tell me of the opportunities in the Auto and Tractor Business.

Name.....

P. O. .... State.....

# ATKINS

SILVER STEEL SAWS

Introducing  
Improved  
Universal  
No.  
93



**A Saw  
Made To  
Do All Work  
Better and Easier**

Every user of tools will be interested in this new saw—different and better than any other—designed by the famous experts of the great Atkins saw factory.

Different—because its tooth edge is made with three alternate sections for cross-cutting, ripping and mitering. Better—because it's made of "Silver Steel" and will do every class of work quicker and easier and hold its edge longer.

At last—it is the saw of saws. No kit of tools is complete without it. If your dealer cannot show it to you, write for our circular describing it and we will arrange to supply you. But before you invest a cent in saws—know Atkins Number "93"—the saw that's made for you.

**"Have YOU Read  
Saw Sense"?**

We'll mail you this useful book without charge—besides describing the better Atkins Saws and their savings in every wood or metal cutting operation, it is full of helpful facts on caring for saws and interesting facts on construction work. Just send your name and address and the use you make of a saw to—



**E. C. ATKINS & CO., Inc.**  
Makers of "Silver Steel"  
Saws and Tools

Dept. P

Indianapolis, Ind.

# WITTE

LOG SAW  
\$75<sup>00</sup>

New Price for  
Short Time Only

F. O. B. Pittsburgh \$80

F.O.B.  
K. C.



**Our  
Biggest  
and Best Log Saw**

DIRECT  
To YOU

Look! See What You Get—Big Surplus Power 4-cycle engine—weight over axle (not on handles)—two-wheel truck—easy to move. Direct geared (no chains or belt). Lever controlled clutch—Arm swing motion. We have only one Log Saw—our biggest and best (at advertised price). Why pay \$50 more for any saw. Order direct from this ad. Lifetime guarantee—Cash or terms—Immediate Shipment. Tree Saw at small extra cost. Catalog Free.

**WITTE ENGINE WORKS**

1748 Oakland Avenue,  
1748 Empire Building,

KANSAS CITY, MO.  
PITTSBURGH, PA.



**CATALOG No. 22  
IS READY**

Small Steam and Gasoline Engines, 1/8 H. P. up. Pumps, gears, model makers' supplies. Sent postpaid (2 dimes preferred) or 20c stamps.

Modern Engine & Supply Co.  
334 Meadbrook Bldg., Chicago



**5 Master Keys**

Only keys of their kind in existence. Open and test thousands of different locks. Tell you instantly if your door or padlocks are burglar proof. Serve in emergencies, too. Thousands of sets in daily use. Novel key chain FREE with each set. Send only \$1 today. Agents wanted. Mention if interested when ordering. **MASTER KEY CO.,** 132 Manhattan Block, MILWAUKEE, WIS.



You'll Like

**Nu-Way**  
or  
**EXCELLO**  
RUBBERLESS  
SUSPENDERS

Year's wear guaranteed. No rubber. Phosphor Bronze Springs give the stretch. Comfortable. Easy on buttons. If your dealer hasn't them, send direct, giving dealer's name. 50c and 75c pair.

Nu-Way Stretch  
Suspender Co., Mfrs.  
Adrian, Mich.





# Win \$5,000



19-year-old Samie Koss, Hochmensch, N.J., who won \$5000 in last Reefer Contest.



Mrs. B. R. Young of Girard, Pa., is another winner of a \$5000 contest prize.



Each  
**Won \$5,000**  
 Will you win this time?



**Big Picture FREE On Request**

#### OBSERVE THESE RULES

- 1—Any one excluding our employees and their relatives may enter this contest. There is no entrance fee of any kind.
- 2—All word lists must be received through the mail by E. J. Reefer, 9th & Spruce Sts., Philadelphia, Pa., and envelopes must be postmarked by post office closing time, November 15, 1922.
- 3—Contestants who have sent lists or orders before November 15th will be qualified for the higher prizes provided orders for Yeast are received through the mail, postmarked on or before November 30th.
- 4—Only English words will be counted. Obscure, hyphenated or compound words will not be counted. Only the singular or the plural of a word will be used, but both singular and plural will not count. Each article or object can be given only one name. Single words made up of two separate words or objects, such as teaspoon, teaspoon, or heading will not count. Webster's International Dictionary will be the final authority. Where several synonyms are equally applicable to an object shown in the picture, a person submitting any one of such synonyms will be given credit for one word only.
- 5—The largest list of words which correctly name visible objects beginning with the letter "R" will receive first prize, and so on down the list of 105 prizes. The winning list will be made up from among the words submitted by the contestants, and not controlled by any predetermined list of words selected by the judges as being the "correct" or "master" list.
- 6—For each wrong word a percentage will be deducted from the total number of correct words.
- 7—Two or more people may co-operate in answering the puzzle. However, only

one prize will be given to any one household or any one group.

8—If a contestant sends us more than one list under an assumed name or pseudonym, then all lists of such contestant will be disqualified.

9—You must use only one side of paper. You must number each page and object in a consecutive rotation. Your full name and address must be written on each page in the upper right hand corner. It will aid the judges materially if you will arrange your words alphabetically, and if you will use paper size about 6 in. by 9 in. Failure to do so, however, will not count against you, nor will neatness or handwriting affect your score. Typewritten your list, if possible. An enlarged picture will be furnished free upon request.

10—The final decision will be made by three judges entirely independent of and having no connection whatever with the E. J. Reefer Company. They will judge the answers submitted and award the prizes at the end of the contest. Each participant entering this contest agrees to accept the decision of the judges as final and conclusive, without argument or question. All answers will receive full consideration, whether or not merchandise is purchased. At the close of the contest, when all lists have been graded, the list winning first prize and the names of the prize winners will be published, and a copy of such list and prize winners' names and addresses will be sent upon request to any participant who sends us a self-addressed, stamped envelope.

11—An additional prize of not over \$500 (or proportion, as specified above, will be awarded.

12—In case of ties for any prize offered, each tying contestant will receive full amount of the prize so tied for.

**Can You Find More Than 15 or 20 Words in This Picture Beginning with Letter "R"?**

There is Road, Rake, Rope. How many more can you find? Write them down and send them in. See how easy it is!

**Costs Nothing to Try!**

Just send in your list of "R" words. If the judges decide your list is the largest which correctly names the visible objects beginning with "R" they will award you first prize.

**Win the \$5000**

You don't have to buy anything to win a prize in this contest. If you have bought nothing, first prize is \$50. If you send \$1 for Yeast, and win first prize, you get \$750. If you send \$2, first prize is \$1500. But if you send \$5 for 5 packages of Reefer's Yeast, and your list is judged best, you win \$5000. Which do you want, \$50 or \$5000?

	If no Reefer's Yeast Tablets are ordered	If one \$1 pkg. Reefer's Yeast Tablets is ordered	If two \$1 pkgs. Reefer's Yeast Tablets are ordered	If five \$1 pkgs. Reefer's Yeast Tablets are ordered
<b>\$11,500 in Prizes</b>				
1st prize	\$50	\$750	\$1500	\$5000
2nd prize	35	375	750	2500
3rd prize	25	200	400	1250
4th prize	25	125	250	600
5th prize	25	75	150	400
6th to 55th prizes, each	2	4	8	25
56th to 105th prizes, each	1	2	4	10

**\$600 Extra!** Your word list may be mailed any time up to Nov. 15, but for every day before Nov. 15, that your Yeast order is received, a special prize of \$10 for each day (not exceeding \$600) will be added to any first prize you win.

## Yeast Tablets

A wonderful scientific tablet, combining all three natural vitamins. Helps build up vitality, strength, endurance. Try this way to bring back the freshness of youth—the natural complexion all women long for. Try Reefer's Vimogen—and also quality for the \$6000.

No goods bought in this contest are subjected to exchange, refund or approval.

**E. J. Reefer, Dept. C177**  
 9th and Spruce Sts. Philadelphia, Pa.

# FREE-Book On Home Beautifying

S. C. JOHNSON & SON, Dept. P.A.8,  
Racine, Wis. (Canadian Factory—Brantford)

Please send me, free and postpaid, your  
book on Home Beautifying and Wood Fin-  
ishing. One of the best painters here is

.....  
His Address.....

.....My Name

.....My Address

This book explains how inex-  
pensive soft woods may be  
finished so they are as beauti-  
ful and artistic as hard wood.  
Tells what materials to use  
and how to use them. In-  
cludes color charts—gives cov-  
ering capacities, etc. It is the  
work of experts beautifully il-  
lustrated in color. Fill out  
and mail this coupon for a  
free copy.



## JOHNSON'S WOOD DYE

**W**ITH Johnson's Wood Dye inexpensive soft woods, such as pine, cypress, fir, etc., may be finished so they are as beautiful and artistic as hard-wood. Johnson's Wood Dye is very easy to apply—it goes on easily and quickly, without a lap or a streak. It penetrates deeply, bringing out the beauty of the grain without raising it—dries in four hours and does not rub off or smudge. Made in 14 beautiful shades which can be easily lightened, darkened and intermixed. Color chart in book.

**S. C. JOHNSON & SON, Dept. P.A.8, Racine, Wis.**

*"The Wood Finishing Authorities"*

(Canadian Factory—Brantford)

ANNOUNCING  
*The New*  
**OLIVER**



**SPEEDSTER**

Our latest and finest model, No. 11

Now, in our 27th year, we introduce a new-day perfection in typewriters, a super-typewriter, one with an ancestry of 1,000,000 Olivers. It embodies many advancements, countless refinements. It is the climax of years of development.

We want everyone who is planning to buy a typewriter to become acquainted with this remarkable Oliver Speedster. Note our offer below. To see it, to operate it, brings a new appreciation of the ultimate.

The Oliver Speedster discards many old ideas, many limitations. It brings dozens of improvements which you will appreciate quickly. To own an Oliver Speedster—years ahead in design—means a new satisfaction.

No one can now afford to buy any typewriter without first investigating this advanced and wonderful Oliver, the finest, the most durable, the quietest model we've ever built.

**SAVE \$35**

While we retain all the fundamental and proven features which have brought such fame to earlier models, and while we bring improvements not to be found elsewhere, we do not revert to the customary \$100 price.

The New Oliver Speedster, worth \$100 if any typewriter is, is sold from factory-to-you, at \$65, saving you the \$35 that it formerly cost to sell an Oliver.

Our policy, since 1917, has been to produce the finest typewriter possible at the lowest cost. We have eliminated extravagant, roundabout selling plans, and substituted the popular factory-to-you plan. The Oliver sells itself. It must prove that it is the finest, regardless of price.

**FREE TRIAL**

We ship the new Oliver Speedster to you for five days' free trial. That is the best way for you to become acquainted with its advancements. Use it as if it were your own. Note its superiorities. Compare it. See what the numerous improvement offer.

Then if you agree that it out-classes any typewriter on the market, and want to buy it, send us only \$4 after trial, then \$4 per month. If you do not want to keep it, ship it back at our expense.

This free trial does not obligate you to buy. It is part of our new plan. You are the sole judge. The coupon brings the Oliver, or further information. Check which you desire.

**The Oliver Typewriter Company**  
 109B Oliver Typewriter Building  
 Chicago, Ill.



**THE OLIVER TYPEWRITER COMPANY**  
 109B Oliver Typewriter Bldg., Chicago, Ill.

Ship me a new Oliver No. 11 Typewriter for five days free inspection. If I keep it I will pay \$65 as follows: \$4 at the end of trial period and then at the rate of \$4 per month. The title to remain in you until fully paid for. If I make cash settlement at end of trial period I am to deduct ten per cent and remit to you \$55.50. If I decide not to keep it, I will ship it back at your expense at the end of five days.

My shipping point is \_\_\_\_\_

Do not send a machine until I order it. Mail me your book—"The High Cost of Typewriters—The Reason and the Remedy," the Speedster catalog and further information.

Name \_\_\_\_\_

Street Address \_\_\_\_\_

City \_\_\_\_\_ State \_\_\_\_\_

Occupation or Business \_\_\_\_\_

Express  
Prepaid  
Anywhere  
in the U.S.

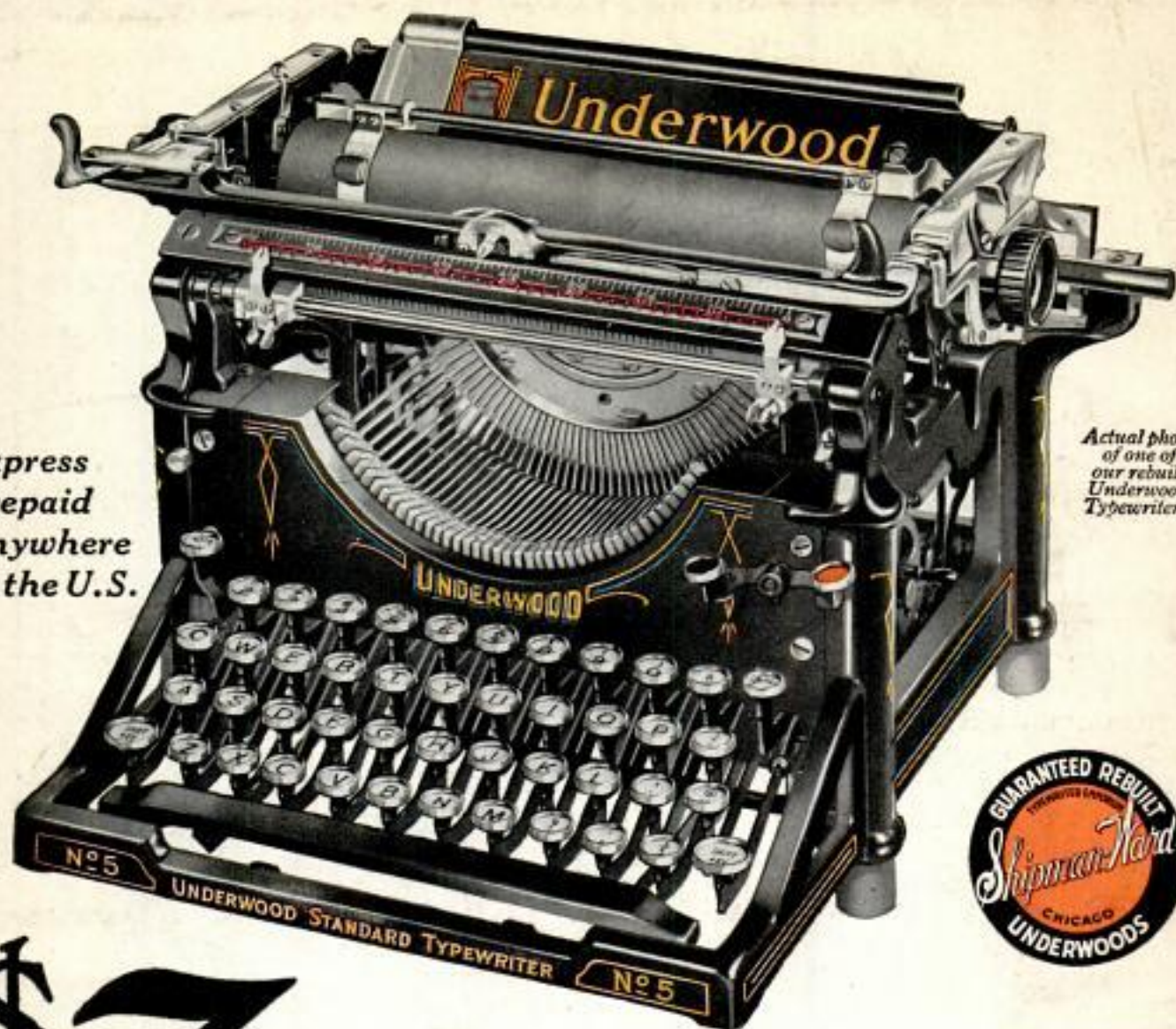

Actual photo  
of one of  
our rebuilt  
Underwood  
Typewriters.



**\$3**  
**DOWN**

# And It's Yours

## Standard Underwood

Rebuilt like new. Every typewriter is factory rebuilt by typewriter experts. New enamel—new nickeling—new lettering—new platen—new key rings—new parts wherever needed—making it impossible for you to tell it from a brand new Underwood. An up-to-date machine with two color ribbon, back spacer, stencil device, automatic ribbon reverse, tabulator, etc. In addition, we furnish FREE, waterproof cover and a special Touch Typewriter Instruction Book. You can learn to operate the Underwood in one day.

## From factory to you

Yes, only \$3 brings you this genuine Rebuilt Standard Visible Writing Underwood direct from our factory, and then only small monthly payments while you are using it makes it yours; or, if convenient pay cash. Either way, there is a big, very much worth-while saving, too. Genuine new Under-

wood parts wherever the wear comes—genuine standard four row, single shift keyboard—thoroughly tested—guaranteed for 5 years.

## \$3 Puts It in Your Home

You don't even have to scrimp and save to pay cash. Instead, you pay only a little each month in amounts so conveniently small that you will hardly

notice them, while all the time you are paying, you will be enjoying the use of and the profits from the machine.

## 10 Days' Free Trial

Remember, you don't even have to buy the machine until you get it and have used it on 10 days' free trial so that you can see for yourself how new it is and how well it writes. You must be satisfied or else the entire transaction will not cost you a single penny.

Typewriter Emporium  
**Shipman-Ward Mfg. Co.**

C-212 Shipman Bldg., Montrose and  
Ravenswood Aves., Chicago, Ill.

**FREE TRIAL COUPON**

**Use Coupon**

## Shipman-Ward Mfg. Co.

C-212 Shipman Bldg., Montrose and Ravenswood Avenues, Chicago, Ill. Send by return mail Bargain Offer No. C-212 of a Standard Visible Writing Underwood. This is not an order and does not obligate me to buy.

Name.....

Street or  
R. F. D. No.....

Post  
Office..... State.....

Now is the time when every dollar saved counts. Let us save you many dollars. Don't delay. Get this wonderful easy payment bargain offer now, so you can send for and be sure of getting your Underwood at a big saving—and our easy terms or for cash.

**Act Now—  
Send Coupon Today!**



All shipments made direct to you from our big modern factory (shown above)—the largest typewriter rebuilding plant in the world.