

POPULAR MECHANICS MAGAZINE

WRITTEN SO YOU CAN UNDERSTAND IT

REG'D TRADE MARK, GREAT BRITAIN, No. 410426

REG. U. S. PAT. OFF.



SEE PAGE 84

Learn Auto and Tractor Trade Fill a Job Like This!

A Raise of \$150 a Month

*How 8 Weeks' Scientific Practice With Tools
Lifted Me From a Laborer's \$12.50 a Week
To a Foremanship at \$2,400.00 a Year*

**A TRUE STORY—By Louis Beimer
MARLIN, TEXAS**

At the age of 20 years I was drawing \$12.50 a week—laborer's pay.

At the age of 24 I am a foreman and my salary is \$2,400.00 a year.

But it didn't take me four years to make the jump. I qualified for the advancement *by only eight weeks' scientific practice with tools.* Then, in two quick steps, I reached my present position.

Those eight weeks were spent in one of Henry J. Rahe's big auto and tractor schools. I earned \$50 a month before I went there. On my return home, I went to work for \$150 a month and in a very short time was made foreman at \$200 a month—a total salary increase of \$150 a month, due entirely to Rahe training.

If you want to get ahead QUICKLY, take the quick, easy, thorough course at a Rahe School.—Louis Beimer.



Louis Beimer

who says Rahe training put him on "Easy Street" in two months.

Wayne Russell, 20 years old, of Waldo, Ark., says Rahe training multiplied his pay by TEN. "I earned \$1.50 a day before," he writes. "My salary is now \$15.00 an hour."

W. W. Peace, another Rahe graduate, writes of getting \$250 a month and expenses operating a tractor in the oil fields.

Emanuel Rushfeldt, Vulcan, Alberta, says, "Earning \$10 a day. Formerly earned \$50 a month; 20 years old."

Thousands of Rahe-trained experts make success reports like these.

I'll Pay Your Railroad Fare

To CHICAGO or CINCINNATI

I'm going to start hundreds of men to QUICK success in the next few weeks, just as I started Beimer. Be one of them and travel FREE to my nearest school. I'll pay your railroad fare to my school nearest your home, no matter what part of the country you live in.

Special Course for High School Students

Limited Classes now forming for June 12, 19 and 26, July 3 and 10.
Write NOW for SPECIAL LOW RATES.

Be a Specialist! Get out of the grind—out of the army of unskilled job hunters! My easy, practical course in motor-maintenance engineering will make you an expert—a specialist—in just a few weeks!

A Job Is Waiting For You!

This is a BIG year in the motor business. Thousands of Rahe-trained specialists are needed. It's YOUR big opportunity. Let me prove it! Write me today.—

Be Sure to Address My Nearest School

Dept. 892 **Rahe Auto & Tractor Schools**

CHICAGO
Michigan and Ontario

CINCINNATI
Ninth and Walnut

Thousands of Men Needed; \$3,000 to \$10,000 a Year!

More than 40,000 men have taken the "Rahe Way" to success. Thousands more are needed now. I never knew a better time to start. Calls for Rahe-trained men come from all parts of the country.

Quick, Easy Training

No "book-learning" required—just easy, scientific practice with tools on engines, cars, tractors. Master instructors tell you the "hows" and "whys." I furnish everything. And in just a few weeks you'll be ready for BIG MONEY.

FREE My big illustrated book, details of free fare and low tuition and proof of what Rahe training will do for YOU. Write for them now—a card will do.

Henry J. Rahe

Victrola homes are happiest



The Victrola is the one instrument that presents in the home the best music of every kind and description in the tones of actual reality. The genius, the power, the beauty of every voice and every instrument—the diverse gifts possessed by the foremost artists of this generation. Their Victor Records played on the Victrola—a combination that is essential to perfect results — duplicate in the home the public triumphs of these great artists.

Victrolas in great variety—\$25 to \$1500.



"HIS MASTER'S VOICE"

Victrola

REG. U. S. PAT. OFF

Important: Look for these trade-marks. Under the lid. On the label.

Victor Talking Machine Company

Camden, New Jersey

FOR USES WHICH INVITE DECAY,
YOU SHOULD SPECIFY, AND INSIST ON
"ALL-HEART" WOOD. IT WILL PAY YOU.

Buy your Cypress by the Cypress Arrow.



Look for this on every board or bundle offered as Cypress. It identifies the TIDE-WATER product, the true "Wood Eternal."

AND SPECIFY
"ALL-HEART"



NEW
ONE

The Cypress "Pergola-Garage"

Why should a garage be homely? This one isn't. — (Is it?)
The man driving out is the owner. He is well satisfied with the fact that he has enhanced the beauty of his grounds at the same time that he has protected his car.

The picture shows how *your* garage may look if you will allow us to send you, with our compliments, and with no obligation at all, the

Complete Working Drawings (on sheet 24 x 36 inches) including full specifications—enough for any good carpenter to build from. Perhaps you enjoy such work yourself. If so, you can't go wrong.

It might even be possible to remodel your present garage on these lines. If you do so, of course you will know what kind of lumber to buy. "If you build of Cypress you build but once." You know "the Wood Eternal" is the champion pergola lumber—does not tend to shrink, swell or warp like so many woods—takes paint and stain beautifully, but *does not need either*, except for looks—lasts and lasts and lasts without them. (See U. S. Govt. Rept., reprinted in full in Vol. 1, Cypress Pocket Library. Just mention that you'd like this book, also.)

This Pergola-Garage is AN 'ADDED SUPPLEMENT

to the 13th big reprint of **VOLUME 28** of that home-lovers' guide, counselor and impartial friend, the famous Cypress Pocket Library. It's FREE. Will you write?

When planning a Pergola, Mansion, Bungalow, pasture-fence or sleeping porch, remember, "With CYPRESS you BUILD BUT ONCE"



Let our "ALL-ROUND HELPS DEPARTMENT" help YOU MORE. Our entire resources are at your service with Reliable Counsel.

SOUTHERN CYPRESS MANUFACTURERS' ASS'N.

1219 Poydras Building, New Orleans, La., or 1219 Graham Building, Jacksonville, Fla.



INSIST ON TRADE-MARKED CYPRESS AT YOUR LOCAL LUMBER DEALER'S. IF HE HASN'T IT, LET US KNOW IMMEDIATELY.

Transformer - 821. Popular Mechanics Magazine

6 N. Michigan Avenue, Chicago, U. S. A.

H. H. WINDSOR, Editor

London: Hachette & Co.,
16-17, King William Street, Charing Cross, W. C. 2

Paris: Hachette & Co.,
111 Rue Reaumur

Melbourne, Australia,
The Australasian News Co.

ISSUED MONTHLY

SUBSCRIPTION:

SINGLE COPY, 25 CENTS

In United States, and its possessions, Cuba, Mexico, and Canada, per year, postpaid - \$3.00

To all other countries in the Postal Union 3.50

All subscriptions are discontinued at expiration. Please examine the date printed on your wrapper.

Entered as Second Class Matter Sept. 15, 1903, at the Post Office at Chicago, Illinois, under Act of March 3rd, 1879.
Entered as Second Class Matter at the Post Office Department, Canada.

Published monthly by POPULAR MECHANICS CO. Copyright, 1922, by H. H. Windsor. Copyright in Australia.

Vol. 37

Contents for June, 1922

No. 6

Air Compressor and Hoist on One Support.....	922
Air Compressor, Overheated, Stopped by Fusible Plug	868
Air Moisture Eliminators of Demountable Type....	929
Airplane, French Design, Has Lower Wing Larger Than Top	919
Airplane, Goliath, Controlled with Automatic Pilot...	857
Airplane, New Spad, for European Air Lines.....	890
Airplane Service, Commercial, Starts in California...	870
Airplane, Small, Is New Customer for Gasoline-Filling Station	843
Airplane, Wrecked, Portuguese Airman Halted by...	840
Airplanes, Two London-Paris Air-Route, Colide and Fall	869
Airship Service to India and Australia Proposed....	848
Airships, German, to be Manufactured Here.....	918
Airships, New Noninflammable Gas Produced for....	906
Alcohol as a By-Product of a Mexican Plant.....	934
Apple Storage House Has Good Ventilation.....	938
Automobile Armrest Easily Attached to Side of Door...	938
Automobile Boat Tested on River Rhone.....	891
Automobile Elaborately Equipped for Camp and Outing Use	862
Automobile, Racing, Three-Mile-a-Minute Mark Reached by	844
Automobile Serving Table Stands on Running Board...	858
Automobile, Specially Built, Employed for Sleeping...	928
Automobile, Specially Designed, for Transporting Canines to the Chase.....	887
Automobile Speedometer Changed to Make Soil Surveys	874
Automobile Tail Lamp Designed for Protection.....	919
Automobile Timer, Improved, Has Only Two Wires...	871
Automobile Tires, Corrugated Rubber Tubes for....	869
Automobile Wheels, Tire Ropes Replace Chains on...	891
Automobile Whistle Plays Any Tune at Any Pitch...	822
Automobile Windshield Cleaner Wipes Upper Half...	934
Automobiles, Pliant Metal Spring Cover for.....	933
Automobiles, Watch Carrier for, is Handy Accessory	932
Ax, Steam Operated, for Chopping Redwood	905
Banio Resonator Amplifies Its Volume Snappily....	932
Bank, Home Savings, Combined with Desk Watch...	890
Barracks, Army, Runaway Truck Demolishes.....	885
Bearing Bushings, Swedging Tool Renews without Displacement	933
Bed Making Contest for Hotel Chambermaids.....	858
Bed, Tourists' Folding, Fits Rear Auto Seat.....	870
Belt Guide, New Type, for Use with Long Belts....	879
Belt, New Type Leather, to Prevent Slipping.....	880
Bootleggers, Bold, Life Saving Belt Adopted by....	829
Bootlegger's Trick Can for Swindling Customers....	903
Bridge, New Steel, to Cross Columbia River.....	833
Caliper Has Scriber for Marking Centers.....	932
Camera Attachment, Simple, for Stereoscopic Views...	865
Camera, Jewelers', Makes Exact Size Pictures....	894
Canning Wastes, Experimental Purification of....	823
Cañon Walls Serve as Poles for Transmission Wires	820
Capitol, Old Washington, Given to Woman's Party...	858
Car Dump, Automatic, Newly Designed.....	917
Carburetors, Auto, Air Stabilizing Attachment for...	895
Cattle, Blooded, Identified by Means of Nose Print...	915
Children's Pages	926
Church Building, Abandoned, Utilized as a Garage...	886
Church, Shreveport, Has Many Unusual Features, by Archie Richardson	866

Civic Features	926
Clock, Unusual Hand-Carved, Made Entirely of Wood	844
Coal, Flotation Process Adapted for Cleaning.....	916
Coal, Low-Grade, to Produce Electric Power with...	830
Coin Collecting Appliance Fashioned Like Scoop....	900
Colors, Harmony of, Tested by Revolving Disk.....	900
Comment and Review, by H. H. Windsor.....	845
Community Center at Isolated Power Plant, by Charles W. Geiger	889
Concrete Span, Huge, Fire Causes Fall of.....	908
Concrete, Tower Tests Waterproofing Material for...	913
Container, New, for Sending Tokens of Friendship...	868
Conveyor, Automatic Aerial, for Shingle Bolts....	890
Copper, Oxidized, Process for the Recovery of.....	902
Corn Borer, Insect, to Investigate Migration of....	908
Cotton, Blue, Now Bleached to Increase Its Value...	864
Cotton Seed Treated for Elimination of Diseases...	884
Cotton Warehouses, Models Show Best Type of....	892
Crossing Markers, White Cement Blocks for.....	885
Crystal Palace Tower Tanks, Preserving from Rust...	904
Date Harvesting Requires Both Skill and Agility...	924
Dehorner, Improved, Cuts Both Horns at Once.....	933
Department Store, Self-Government Practiced by...	933
Dictaphone Records, Loud-Speaking Reproducer for...	871
Ditching Machine Does Work of Many Men.....	873
Dome, Large, New Method of Painting Interior of...	869
Drydock, Canadian, Work on Ordered Abandoned...	872
Dumping Car, Monorail, Now in Use in Germany...	910
Dyes, Germ Killing, Experiments in Production of...	834
Egg Carrier, Cardboard, for Shipping.....	862
Electric Fan, Spherical, Throws Air Radially.....	918
Electric Furnace, Self Adjusting Electrodes in....	897
Electric Lighting Project for French Villages.....	894
Electricity—High-Tension Direct-Current Power from House Circuits, by H. A. Lane.....	821
Elephant Has Wooden Leg as Added Attraction.....	868
Engines, Oil and Air-Cooled, Developed in England...	925
Evaporator Tubes Arranged in Diagonal Lines.....	888
Ferryboat, Large, Terrific Boiler Explosion on....	855
Floor Oils, Test Darkening Effects of.....	830
Flue Hole Stops, Fireproof, Invisible on Wallpaper...	917
Fly Traps, Sanitary Paper, Made Ornamental.....	862
Garage and Cottage Combined for Touring Motorists...	918
Garage, Basement, for Office Building Tenants....	921
Gas Burner Is Adjustable for Any Pressure.....	894
Gas Main "Sweat" Collected from Drip Wells....	897
Gas, Natural, Wild Wells Cause Great Loss of....	916
Gas System, High Pressure, to Solve Fuel Problem...	818
Glass, Unbreakable, Now Produced.....	924
Glider Flight, Remarkable, in Switzerland.....	819
Harrow Plows and Pulverizes in One Operation....	861
Headlight Shield, Auto, Aids Driving at Night....	894
Heater, Wall-Pocket Gas, Set Flush in Wall.....	892
Heaters, Odd Departure in, Used in Switzerland...	837
Horse, Artificial Nose Placed in Neck of.....	935
Hotel, New Chicago, to Have Five Bungalows on Roof	914
House Number on Curb to Guide Motorists.....	906
Household Devices	930
Hydroelectric Station, New, in Valencia, Spain....	848
Hydroglider, Japanese, Built Like an Airplane...	907
Iron Foundry to be Erected on South Georgia Island	919
Irrigation and Water Power Development to Restore the Holy Land, by Lewis R. Freeman.....	849

[Continued on Page 4]

This One



BN9F-CY7-8RQX

aterial

[Contents—Continued]

Jack, Automobile, Combined with Rim Contractor.....	911
Jumping Stunt, Spectacular, Ends in Death.....	904
Kitchens, Steel, for Conserving Space.....	934
Knife, Electrically Heated, Aids Battery Men.....	836
Kudzu, Forage Plant and Soil Builder, by C. E. Pleas	909
Labels, Metal, for Salutation in Letters.....	848
Ladder Has Auxiliary Legs to Prevent Accidents.....	912
Lathe, Center Drive, Resembles Two Machines.....	901
Leather, Rubber Solution Removes Stains from.....	906
Library, Free Public, "Walking Books" Advertise.....	847
Library, New, being Erected at Louvain.....	820
Lighthouse Floats Five Miles Down a River.....	843
Lighting Effects, Unusual, Produced in Church.....	823
Locomotive, Double Drive, with Boiler in Center.....	820
Locomotive Explodes with Unusual Violence.....	907
Locomotives, Strange Type, in Himalaya Mountains.....	883
Logging Truck Runs on Wire Covered Track.....	817
Mail, Recalled, Romance of the, by Grace Orb.....	883
Memorandum Pad, Convenient Desk, Keeps Paper Clean.....	935
Memorial, Booker T. Washington, Unveiling of.....	847
Memorial, Robert E. Peary, Typifies Arctic Exploits.....	824
Mill, Century Old Stump, Still Grinds Grain.....	826
Mine, Model Visualizes Inside Workings of.....	829
Mines, Wet Drills Reduce Dustiness of.....	826
Miter Scribing Instrument for Irregular Surfaces.....	880
Monument Unveiled in Paris to Victims of Bombardment.....	880
Mosque, Only Mohammedan in Western World.....	891
Motion Picture Camera, "Direct-Positive" Home.....	824
Motion Picture Films to Show Events of American History.....	882
Motion Pictures Made Audible by Use of Phonograph.....	870
Motion Pictures, Talking, Made with Aid of Radio.....	859
Motion Pictures to Illustrate Einstein Theory.....	892
Motor Busses on Rails to Replace Street Cars.....	855
Mountains of Burma, Expedition to Investigate.....	827
"No Man's Land" at Rheims Contains 600 Houses.....	825
Nonmagnetic Force, New Attractive, Discovered.....	915
North Pole Flight, Amundsen to Attempt, by Lawrence Wm. Pedrose.....	875
Oil Development Predicted for South America.....	882
Oil Gusher Damages Residential Part of City.....	887
Oil Production Lessened by Delay in Drilling.....	890
Oil Wells, Obstructed, Machine for Cleaning.....	895
Operation, Flashlights Used by Doctor to Complete.....	823
Orange Grove, Propellers Circulate Air to Heat.....	902
Paper, Mulching, Prevents Weed Growth.....	830
Pecan Trees, Culture of, to be Tried in China.....	898
Pencils, Rubber Grip for, Prevents Slipping.....	890
Phonograph Sound Box with Perforated Disks.....	918
Phonograph, Special, Sends Concerts by Radio.....	848
Pianos, Grand, Three Sectional Top Lid for.....	830
Pile Driver, Tiny, Drives Pipes at Pole Base.....	902
Pipe Bowl, Two-Piece, Smoke Takes Spiral Course in.....	929
Plow, Tractor-Drawn Brush, for Land Clearing.....	864
Power Shovel, Novel, Gas Engine Drives.....	832
Press, Foot, Ordinary Seal Hand Press Made into.....	871
Radiators, Cloth Covers for, Keep Walls Clean.....	892
Railroad—Brake Rods, Automatic Slack Adjuster for.....	891
Railroad Cars, Wooden, Have Longer Life Than Steel.....	920
Railroad Crossing, Two Span, of River in Washington.....	824
Railroad Diner, English, Electrically Equipped.....	856
Refrigeration Plant, House, Simple and Noiseless.....	823
River Currents, Erratic, New Means of Controlling.....	831
Road Building, Concrete, Float Bridge Aids.....	882
Road Roller, Three Wheel, Has Engine at Rear.....	905
Roofing Materials Tested in "Exposure Parks".....	923
Roofing, Roll-Changing Machine Used in Making.....	911
Rugs, Paper Tubes for Shipping.....	905
Ruins of Colophon, Excavations will be Made at.....	934
Saw, Portable Bench, Cuts Miters at Any Angle.....	833
Saw, Shaping, Does Complicated Shaper Work.....	894
Sawdust Converted into Cattle Food by Chemical Process.....	863
Screwdriver, Adjustable Handle.....	908
Settlers, Wisconsin's Novel Method of Attracting.....	878
Ships, Copper-Sheathed, Menace Iron Vessels.....	917
Signal Device, Protection, Fires Ten Shots.....	818
Silo Top Made with Hinged Segments.....	919
Stack Puller to Replace Block and Tackle.....	890
Soap Bubbles Made to Study Explosion of Gases.....	910
Solder Iron, Self Heating, without Valve or Pump.....	857
Soldering Iron and Blowtorch Combined.....	895
Stage Scenes, Rapid Method of Changing in Berlin.....	910
Street Drain and Manhole in Combination Inlet.....	858
Street Washer, Motor, London's Midnight.....	861
Stump Removing Machine Leaves Only Chips.....	879
Surveying Test Drill Holes an Interesting Process.....	912
Swimming Buoy for Nonswimmers Made in Animal Form.....	879
Table Top, Inlaid, Thousands of Pieces Used for.....	915
Tax Computing Machine Has Chart for Any Tax Rate.....	863
Telephone Cable, New, Laid across Irish Channel.....	829
Telephone Service Measured Like Electric Light.....	833
Tile Ditcher Does Work of Many Men.....	913
Timber Preservative, Copper Sulphate Water Is.....	850
Tires, Worn-Out Auto, Used to Build Fence.....	891
Tool Set, Quick Change, Has Detachable Bits.....	920
Totem Poles "Copyright Law" of Northwest Indians, by Francis Dickie.....	898
Tractor, Powerful Steam, Has Two Engines.....	857
Tractor Route, Sixty Mile Beach Used as.....	896
Tractor Snowplow, Combined, Cleans City Streets.....	915
Tractor, Track Treads Give Greater Pulling Power to.....	918
Tractors, Five, Reduce Farming to Single Operation.....	901
Tree, Historic Pine, Lived 1,200 Years.....	914
Trees Grow from Stone Bags Used as Flood Protection.....	872
Trout Sorted into Sizes by Roller Sieve.....	900
Truck, Elevating Platform, Has Gasoline Motor.....	882
Truck, Motor, Elevating End Gate Attached to.....	877
Truck, Two Purpose Factory, Has Four Lifting Legs.....	939
Turbine Plant, Gigantic, Designed.....	834
Valve, Automatic Ball, of Extreme Simplicity.....	881
Vending Machine, Miniature Pistol Range Is.....	922
Ventilation of Machinery Increases Efficiency.....	958
Wallpaper, Electric Steam Machine for Removing.....	903
Warships, U. S. Navy, Scrapping, by H. G. Layton.....	835
Water, Surplus, Gravelly Soil Used to Store.....	920
Watercycle, Life Saving, Folds into Small Space.....	827
Waves, Novel Attempt to Utilize Energy of.....	828
Welding Machine, Arc, Uses Alternating Current.....	848
Wireless Apparatus, Four Sets of Headphones on.....	834
Wireless Apparatus to Make Mountain Climbing Safer.....	818
Wireless Equipment Installed on Railroad Trains.....	842
Wireless Generator, Single Blade Propeller Drives.....	895
Wireless Messages Received on Phonograph Records.....	920
Wireless Outfit Combined with Aviator's Oxygen Helmet.....	880
Wireless Reproducing Apparatus, New, Aids Radio Reception.....	827
Wireless Telephone Broadcasting over Light Wires.....	831
Wireless Telephone Customers, Prospective, Listen While They Shop.....	916

SHOP NOTES

Acetylene as a Primer for Cold Engines.....	950
Bell Center, Improved.....	941
Belt Shifter, Automatic, for Grinder.....	942
Belts, Emery, Prolonging the Life of.....	946
Belts, Flesh or Grain Side for.....	948
Block, Adjustable, for Hacksaw Vise.....	953
Calipers, Scale Attachment for Setting.....	940
Carriage Bolt Holder, Improvised.....	947
Clutch Shifter Made to Stay "Put".....	955
Concrete Walls, Preventing Sweating of.....	941
Core Boxes, Hacksaws as Facing for.....	942
Corn, Sweet, How to Plant.....	954
Drawing Board Drawer, Keeping in Place.....	955
Drawings, Trimming with a Knife.....	952
Dynamite, Some Ingenious Uses for.....	954
Engine Testing at the Muffler.....	933
Gas Controller, Automatic, How to Make.....	930
Gaskets, Cylinder Head, Locating.....	942
Gauge, Depth, Scale Used as.....	949
Gauges, Small Thread, Protecting.....	952
Hasp, Preventing from Breaking.....	953
Hay, Stacking by Gravity.....	948
Holes, Grinding Straight.....	963
Ink, Testing for Acid.....	952
Jug Clamp, Quickly Operated.....	943
Knurl Holder Fits Lathe Toolholder.....	942
Lawn Mower, Sharpening with Power.....	940
Magneto and Generator Testing Base.....	950
Nails Prevented from Splitting Thin Wood.....	956
Nonmagnetic Materials, Holding on Magnetic Chuck.....	947
Nuts, Rounded Edge, Tightening.....	953
Oilcan, Increasing the Reach of.....	947
Pistons, Jack Prevents Distortion of.....	951
Potato Planter Made from Old Corn Planter.....	956
Punch and Die, Simple, How to Make.....	952
Riveting Kink.....	951
Saw Filing Kink.....	941
Screw Hooks, Driving Quickly.....	947
Scribing Long Straight Lines.....	951

[Contents Continued on Page 6]

DRAKE'S PRACTICAL MECHANICAL BOOKS

THEY WILL RAISE YOUR PAY— ORDER ON 5-DAY TRIAL

The books listed below will perfect you in your chosen trade — pave the way to the big positions. Written in non-technical language—easy to read and understand. **Every book covers its subject completely. An entire course of instruction condensed into one volume.** Your choice sent postpaid — you benefit 5 days — money refunded in full if not entirely satisfactory. Order direct from this page.



Automobile Books

- Automobile Ignition, by ManlyLeatherette \$2.00
 Automobile Starting and Lighting, by Manly.....Leatherette \$2.00
 Brookes' Automobile Handbook.....Leatherette \$2.00
 Ford Motor Car, Truck and Tractor, by Manly.....Cloth \$1.50
 Starting and Lighting Troubles, Remedies and Repairs, by ManlyLeatherette \$3.00
 Automobile Battery, Care and Repair, by Manly.....Leatherette \$2.00
 Automobile Catechism and Repair Manual.....Leatherette \$1.50
 Tires and Vulcanizing, by TuffordCloth \$2.00
 Gas and Oil Engine Handbook.....Cloth \$1.50
 Automobile Upkeep and Care, by Manly.....Cloth \$1.50
 Motorcycle Handbook, by Manly.....Cloth \$1.50

Shop Practice Books

- Sheet Metal Workers' Manual.....Leatherette \$3.00
 Oxy-Acetylene Welding and Cutting.....Leatherette \$1.75
 Sound Welds.....Cloth \$2.00
 Slide Rule and Logarithmic Tables.....Leatherette \$2.00

- Handbook for Millwrights.....Cloth \$2.00
 Modern Blacksmithing.....Cloth \$1.25
 Machine Shop Practice.....Cloth \$2.00
 Mechanical Drawing and Machine Design.....Cloth \$2.00
 Pattern Making.....Cloth \$1.50

Carpentry Books

- Cloth Binding
 Modern Carpentry, 2 vols.....\$3.00
 The Steel Square, 2 vols.....\$3.00
 Wooden Boat and Shipbuilding.....\$1.50
 Modern Estimator.....\$1.50
 Timber Framing.....\$2.00
 Builder's Architectural Drawing.....\$2.00
 Concrete.....\$1.50
 Practical Bungalows.....\$1.00
 Low Cost Homes.....\$1.00
 Roof Framing.....\$1.50
 Stair Building and Hand Railing.....\$1.50

Electrical Books

- Practical Applied Electricity.....\$2.00
 Alternating Current.....\$1.50
 Electric Motor Control Systems.....\$1.50
 Wiring Diagrams and Descriptions.....\$1.50
 Electrical Tables and Data.....\$1.50
 Armature and Magnet Winding.....\$1.50
 Modern Electrical Construction.....\$1.50
 Modern Electric Illumination.....\$1.50
 Electricians' Operating and Testing.....\$1.50
 Motion Picture Operation.....\$1.50
 Drake's Electrical Dictionary.....\$1.50
 Electric Motors, D. & A.....\$1.50
 Electrical Measurements and Meter Testing.....\$1.50
 Drake's Telephone Handbook.....\$1.50
 Modern American Telephony.....\$2.00
 Easy Electrical Experiments.....Cloth \$1.25
 Wireless Telegraph and Telephone Handbook.....Cloth \$1.25
 Telegraphy Self-Taught.....Cloth \$1.25

Steam Engineering

- Swingle's Handbook for Steam Engineers and Electricians.....Leatherette \$4.00
 Examination Questions and Answers for Marine and Stationary Engineers.....Leatherette \$2.00

- Steam Boilers.....Leatherette \$2.00
 Swingle's Catechism of Steam, Gas and Electrical Engineering.....Leatherette \$1.50

Painting Books

- Scene Painting and Bulletin Art.....Cloth \$4.00
 A Show at Sho' Cards.....Cloth \$4.00
 Sign Painting.....Cloth \$4.00
 Strong's Book of Designs.....Leatherette \$4.00
 Strong's Art of Show Card Writing.....Cloth \$4.00
 Signist's Alphabets.....Cloth \$1.50
 Modern Painter's Cyclopedia.....Cloth \$2.00
 Automobile Painting.....Cloth \$1.50
 Estimates, Costs and Profits, Painting and Decorating.....Cloth \$1.50
 New Hardwood Finishing.....Cloth \$1.50
 The Amateur Artist.....Cloth \$1.50
 New Stencils.....Cloth \$1.25

Farm Books

- Farm Mechanics.....Cloth \$1.25
 Farm Buildings.....Cloth \$1.25
 Farm Engines.....Cloth \$1.25
 Traction Farming.....Cloth \$1.50

Business and Reference Books

- Better Business Letters.....Leatherette \$1.50
 Better Business English.....Leatherette \$1.50
 Better Advertising.....Leatherette \$1.50
 Finger Prints Simplified.....Cloth \$2.00
 Practical Bricklaying.....Cloth \$1.25
 Practical Instruction for Detectives.....Cloth \$1.00
 Practical Plumbing.....Cloth \$1.50
 Hot Water Heating.....Cloth \$1.50
 Elementary Chemistry.....Cloth \$1.50
 Courses in Civil Service.....Cloth \$1.50
 Cyclopedia of Recipes.....Cloth \$1.50
 American Star Speaker.....Cloth \$1.50

Modern Languages

- By Prof. P. S. Allen, U. of Chicago
 French without a Teacher.....Cloth \$1.25
 Spanish without a Teacher.....Cloth \$1.25
 German without a Teacher.....Cloth \$1.25
 Everyday French.....\$1.25
 Everyday Spanish.....\$1.25

ORDER DIRECT FROM THIS PAGE—ON OUR MONEY-BACK PLAN

The books listed above are only a few of the many in our catalogue, which you will receive promptly after filling out and mailing us the attached coupon. For quick action order direct from this page—cross name of each book wanted and send in with price quoted. We prepay postage and send the books on our money-back plan.

FREDERICK J. DRAKE & CO.

PUBLISHERS

1008 Michigan Ave., Chicago

Drake Books Are For Sale at All Book Stores

FREDERICK J. DRAKE & CO.
1008 Michigan Avenue
Chicago, Ill.

GENTLEMEN:—Please send me free, postage paid, your illustrated catalogue which lists and describes over 100 Practical Mechanical Books for Home Study.

My name is

and my address

Mail Coupon For Free Catalogue
Your Guide to Home Study

DON'T SWEAT OVER A KITCHEN STOVE!

No excuse any more for fussing and fuming over a hot kitchen stove in summer time! No need of keeping a hot fire going all day just to do a little cooking. Amazing new invention does away with this dirt, muss, and kitchen drudgery.

Amazing Invention

Gives plenty heat when you want heat. You turn it off instantly when you don't want heat. Cheaper—Burns 95% air 5% oil. Saves money, time, labor, health. No fires to make, no ashes, dirt, smoke, odor, chopping, shoveling, carrying dirty coal or wood.



Quick Heat On or Off at Turn of Valve

Don't let your coal-and-wood stove turn your kitchen into a roasting-room. Wonderful invention—Oliver Oil-Gas Burner gives quick heat at turn of valve. Fits in fire box without adjustment.



Note how simply it works. Absolutely safe. Lasts lifetime. Fine all seasons. No roasting Summer kitchen. Ready heat in chilly Fall and Spring. 3 times more heat in Winter.

FREE BOOK telling all about the "New Kind of Heat," sent free. Also amazingly low introductory-price offer including 30-Day Trial. Write today.

OLIVER OIL GAS BURNER & MACHINE CO., 2014-F Pine St., St. Louis, Mo.
Oldest, Largest Manufacturers of Oil-Gas Burners in the World.

AGENTS Oliver agents earn as high as \$500 a month—\$25 a day spare time is easy. Exclusive territory. Big all-season seller. Write for Special Offer.



Hotels Need Trained Executives

Nation-wide demand for trained men and women in all departments of hotels, clubs and apartment houses. Uncrowded field; fine living, quick advancement in the big hotels of the United States—now America's Fourth Largest Industry. Statistics show that **ONE IN EVERY TEN HOTELS WILL HAVE AN OPENING FOR A MANAGER THIS YEAR.** Thousands of other positions also open to those who qualify through training.

The Lewis School guarantees to give you the valuable knowledge that it has taken some of the most successful hotel men years to obtain—men who are now making \$5,000 to \$10,000 a year. All of your training will be under the personal direction of Clifford Lewis—a hotel expert of national reputation. A few spare-time hours a week given to the simple, clear lessons of the course will open the way to a good position, a fine living and a handsome salary. The training will in no way interfere with your present activities.

Send today for **FREE BOOK**, "Your Big Opportunity." Don't wait a minute—you may lose the opportunity of a lifetime. Mail the coupon **NOW.** Your whole future may depend on it. **Founded 1916.**

LEWIS HOTEL TRAINING SCHOOL
 Clifford Lewis, Pres.
 Room 319
 Washington, D. C.

Free Coupon
LEWIS HOTEL TRAINING SCHOOL

Room 319
 Washington, D. C.
 Send me without obligation the **FREE BOOK** "Your Big Opportunity."

Name.....
 Please Print Name
 Street.....
 City..... State.....

[Contents—Continued from Page 4]

Skid for Use on Steps.....	941
Soap, Soft, Handy Container for.....	941
Springs, Cutting after Winding.....	943
Square, Center Punch Attachment for.....	943
Switch, Knife, Guard Plate for.....	943
Tailstock Handle, Lever for.....	948
Tap Holder, Novel, for the Drilling Machine.....	955
Tractor, Some Unusual Jobs for the.....	944
Tree Surgery, Certain Features of, Patented.....	940
Type Cases for Holding Small Parts.....	952
Water Tank, Raising 25 Feet.....	948
Windless Holds Hay on Truck.....	956

AMATEUR MECHANICS

Automobile Mudhooks Made from Hinges.....	969
Automobile Theft Alarm, Improvised.....	974
Automobile Trouble Lamp Mounted on Clothespin.....	970
Axle Repair, Emergency.....	976
Bags Quickly Placed over Clothing.....	958
Berry Picking Made Easy.....	962
Binders, Filing Papers in.....	978
Bird Bath of Simple Design.....	970
Boat Rudder for Shallow Water.....	978
Box Lid, Secret, How to Make.....	962
Brush Hook Made from a Shovel.....	978
Bureau, "Built In," Saves Space.....	960
Climbing Irons, Improvised.....	961
Corn, How to Plant.....	978
Door, Padlocked, Opened from Either Side.....	958
Eaves Gutter, Repairing.....	976
Faucet Guard for Dishwashing.....	972
Faucet, Hose, Preventing the Use of.....	971
Fish Bait, Unusual, for Salt Water Fish.....	970
Flower Vases, Rustic.....	977
Foot Scraper, Simple, How to Make.....	960
Furniture, Skate Aids in Moving.....	973
Gaskets, Cork Auto, Carrier for.....	973
Gun Locks, Repairing.....	971
Hoe, Garden, Double Action.....	969
Hoe, Guard Prevents Dulling of.....	973
Horse, Kiddie, How to Make.....	968
Hose Connections, Garden, Washers for.....	977
Key Guide for the Back Door.....	973
Lawn Mower Handle, Strong, How to Make.....	974
Lawn Sprinkler, Simple.....	968
Lens Hood Made from Drinking Cup.....	960
Lenses, the F-Numbers of.....	974
Linoleum Makes Sanitary Poultry House Floor.....	977
Lumber, Yellow Poplar, Drying.....	972
Medicine Dropper Kept Handy on the Bottle.....	960
Motor, Small, Simple Mounting for.....	974
Motorcycle Delivery Truck, How to Make.....	957
Paint Pails, Opening.....	961
Parachutes, Toy, Release for.....	963
Pen, Portable, for Chicks.....	969
Piano Rolls, Player, Repairing.....	969
Pictures, Framed, How to Hang.....	961
Poppies, Growing Oriental.....	960
Prints Judged for Good Sepia Tones.....	961
Rubber Stopper Used as Spring.....	972
Screen Door Fastenings, Permanent.....	972
Screen Wire, Pulling Taut.....	976
Seeder, Simple, How to Make.....	971
Shelf, Bedstead, for the Sick Room.....	971
Shoes, Tan, Restoring Color to.....	962
Sod, Cutting around Trees.....	974
Sod, How to Lay Properly.....	958
Soldering Blowpipe, Homemade.....	958
Steam Boiler, Small, Electrically Heated.....	975
Swimming under Water.....	972
Swing, Airplane, How to Make.....	959
Tent Peg, Improved.....	970
Trapping Rodents without Bait.....	977
Tray, Improvised Developing.....	977
Trellis, Indoor, Made from Chain.....	978
Typewriter Ribbons, Restoring.....	969
Vacuum Cleaner, Cooling Breezes from.....	970
Windows, Center Pivoted, Screening.....	978
Wireless Telephone Receiver, Short Wave.....	963

LAW STUDY AT HOME

Become a lawyer. Legally trained men win high positions and big success in business and public life. Greater opportunities now than ever before. Lawyers earn \$3,000 to \$10,000 Annually.

We guide you step by step. You can train at home during spare time. Let us send you records and letters from LaSalle students admitted to the bar in various states. Money refunded according to our Guarantee Plan if dissatisfied. Degree of LL.B. conferred. Thousands of successful students enrolled. Low cost, easy terms. We furnish all text material, including fourteen-volume Law Library. Get our valuable 100-page "Law Guide" and "Evidence" books FREE. Send for them—NOW.

LaSalle Extension University, Dept. 664L, Chicago, Ill.

Let These Guides

Solve Your Problems



Electricity at your finger ends

HAWKINS ELECTRICAL GUIDES IN TEN VOLUMES

3500 PAGES

4700 PICTURES

\$1 A VOLUME

\$1 A MONTH

Send No Money—Send Only This Coupon

Know the facts in Electricity. They mean more money and better position for you. Hawkins Guides tell you all you need to know about Electricity. Every important electrical subject covered so you can understand it. Easy to study and apply. A complete, practical working course, in 10 volumes. Books are pocket size; flexible covers. Order a set today to look over.

LEARN ALL ABOUT

Magnetism—Induction—Experiments—Dynamoes—Electric Machinery—Motors—Armatures—Armature Windings—Installing of Dynamoes—Electrical Instrument Testing—Practical Management of Dynamoes and Motors—Distribution Systems—Wiring—Wiring Diagrams—Sign Flashers—Storage Batteries—Principles of Alternating Currents and Alternators—Alternating Current Motors—Transformers—Converters—Rectifiers—Alternating Current Systems—Circuit Breakers—Measuring Instruments—Switchboards—Wiring—Power Stations—Installing—Telephone—Telegraph—Wireless—Bells—Lighting—Railways. Also many Modern Practical Applications of Electricity and Ready Reference Index of the ten numbers.

SHIPPED FREE

Not a cent to pay until you see the books. No obligation to buy unless you are satisfied. Send Coupon now—today—and get this great help library and see if it is not worth \$100 to you—you pay \$1.00 a month for ten months or return it.

THEO. AUDEL & CO.,
72 Fifth Ave., New York City

Please submit me for free examination, HAWKINS ELECTRICAL GUIDE, (Price \$1 a number). Ship at once prepaid, the 10 numbers. If satisfactory, I agree to send you \$1 within seven days and to further mail you \$1 each month until paid.

Name.....

Occupation.....

Employed by.....

Home Address.....

Reference.....

PM JUNE 15

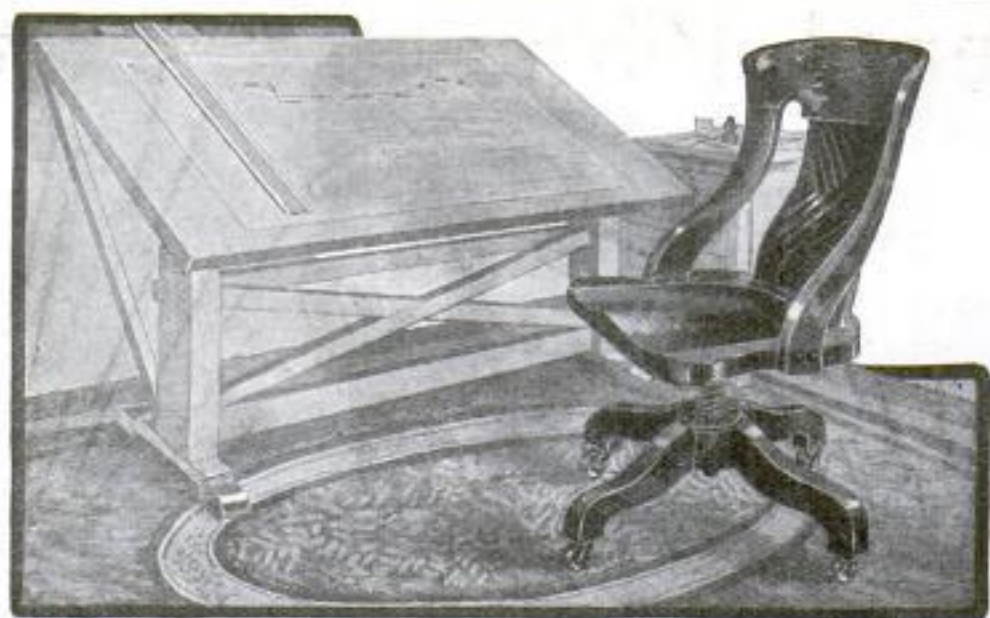

Wanted—

72,000 Men at \$3600 Per Year to Fill Vacant Draftsmen's Chairs

Write to me today if you want to sit in one of the many vacant chairs like this—if you want a splendid position as a skilled draftsman at \$3600 a year. Now is the time to get ready for the big building boom everywhere.

Closest estimates fix the number of men who will be needed every month during 1922 at 9000. Write to me and I will tell you how I make you a first-class, big money-earning draftsman in a very few months—in plenty of time so that you will be ready.

Many a man who has written to me now earns \$3600 or more. The draftsman's training they got from me gave them the power to command this price. There will be no obligations on you if you send me your name. Now, more than at any other time it is your duty to find out now I can train you personally to fill a position as a high grade draftsman. This chair is yours if you want to fill it.

Will you accept the opportunity?

I Guarantee to Train You Until You Are Placed in a Position Paying from \$250 to \$300 per Month

No other man or institution can imitate my method. I teach you personally. I give you private instruction. I make you see how I made a success as a draftsman. For 20 years I have been doing the highest paid expert drafting work as chief draftsman.

So the instruction you get from me is practical. That

is the kind of instruction you need to hold one of the big paying positions. I know what the big firms demand. Remember, I train you until you are actually placed in a position paying from \$250 to \$300 per month.

So write to me today. Do not put this opportunity off. Positions are open right now—this very minute.



FREE!

\$25.00 Drafting Outfit

Here is the high-grade drafting outfit which I give you without one cent of expense to you. Every instrument of the highest quality. Everything you need. Packed in a handsome plush lined case. Just the kind I use myself.

Chief Draftsman Dobe, 4001 Broadway, Dept. A135, Chicago, Ill.



Chief Draftsman Dobe

4001 Broadway, Dept. A135, Chicago, Ill.

Without any obligation whatsoever, please mail your book, "Successful Draftsmanship," and full particulars of your liberal "Personal Instruction" offer to a few students.

Name _____

Address _____

Earn Money While Learning

I even give you an opportunity to begin earning money as soon as you enroll as one of my personal and private students. This enables some men who might not be able to begin this practical training now to pay their way as they go along. Write for this plan today, if you are a man dreaming of a big successful future.

Mail Coupon Today

There are no obligations in sending your name and address to me on this free coupon. Send it today. I will mail you at once absolutely free and prepaid my new book, "Successful Draftsmanship." It will tell you why so many men are needed right now and it will tell you how to earn money while learning. So send the coupon now.

I Teach Piano a Funny Way

So People Told Me When I First Started in 1891. But now, after over twenty-five years of steady growth, I have far more students than were ever before taught by one man. I am able to make them successful players of the piano or organ in *quarter the usual time at quarter the usual cost.*

To persons who have not previously heard of my method, this may seem a pretty bold statement.



But I will gladly convince you of its accuracy by referring you to my graduates in any part of the world. There isn't a State in the Union that doesn't contain many players of the piano or organ who obtained their training from me *by mail.*

Investigate by writing for my 64-page free booklet, "How to Learn Piano or Organ."

My way of teaching piano or organ is *entirely different* from all others. Out of every four hours of study, one hour is spent *entirely away from the keyboard*, learning something about Harmony and The Laws of Music. This is an awful shock to most teachers of the "old school" who still think that learning piano is solely a problem of "finger gymnastics." When you *do* go to the keyboard, you accomplish *twice as much* because you *understand what you are doing.* Within four lessons I enable you to play an interesting piece not only in the original key, but in all other keys as well.

I make use of every possible scientific help—many of which are *entirely unknown* to the average teacher. My patented invention, the COLOROTONE, sweeps away playing difficulties that have troubled students for generations. By its use, Transposition—usually a "nightmare" to students—becomes easy and fascinating. With my fifth lesson I introduce another important and exclusive invention, QUINN-DEX. Quinn-Dex is a simple, hand-operated moving-picture device, which enables you to see, right before your eyes, every movement of my hands at the keyboard. You actually see the fin-



DR. QUINN AT HIS PIANO

From the Famous Sketch by Schneider, Exhibited at the St. Louis Exposition

gers move. Instead of having to reproduce your teacher's finger movements from MEMORY—which cannot always be accurate—you have the correct models before you during every minute of practice. The COLOROTONE and QUINN-DEX save you months and years of wasted effort. They can be obtained *only from me*, and there is nothing else, anywhere, even remotely like them.

In all *essential* ways you are in closer touch with me than if you were studying by the oral method—yet my lessons cost you only 43 cents each—and they include all the many recent developments in scientific teaching. For the student of moderate means, this method of studying is *far superior* to all others; and even for the wealthiest student, there is nothing *better* at any price.

You may be certain that your progress is at all times in accord with the best musical thought of the present day, and this makes all the difference in the world.

My course is endorsed by musicians who would not recommend any course that did not maintain the highest musical standards. It is for beginners or experienced players, old or young. You advance as rapidly or as slowly as you wish. All necessary music is supplied without extra charge. A diploma is granted. Write today, without cost or obligation, for 64-page free booklet, "How to Learn Piano or Organ."



FREE BOOK COUPON

QUINN CONSERVATORY, Studio PM 46,
598 Columbia Road, Boston, 25, Mass.

Please send me, without cost or obligation, your free booklet, "How to Learn Piano or Organ," and full particulars of your Course and special reduced Tuition Offer.

Name.....

Address.....

**Marcus Lucius Quinn
Conservatory of Music**

Studio PM 46

598 COLUMBIA ROAD, BOSTON, 25, MASS.

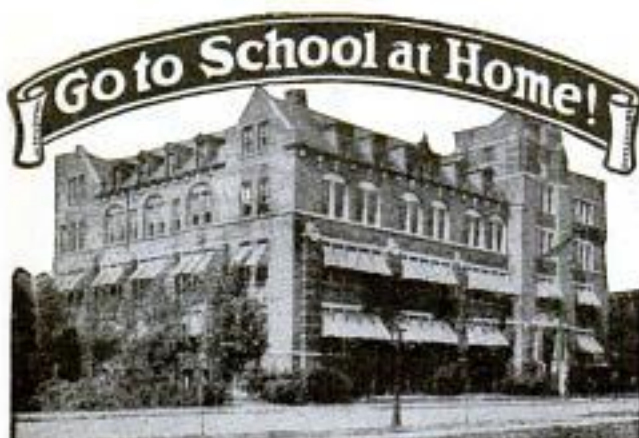

High School Course in Two Years!

You Want to Earn Big Money!

And you will not be satisfied unless you earn steady promotion. But are you prepared for the job ahead of you? Do you measure up to the standard that insures success? For a more responsible position a fairly good education is necessary. To write a sensible business letter, to prepare estimates, to figure cost and to compute interest, you must have a certain amount of preparation. All this you must be able to do before you will earn promotion.

Many business houses hire no men whose general knowledge is not equal to a high school course. Why? Because big business refuses to burden itself with men who are barred from promotion by the lack of elementary education.

Can You Qualify for a Better Position?

We have a plan whereby you can. We can give you a complete but simplified high school course in two years, giving you all the essentials that form the foundation of practical business. It will prepare you to hold your own where competition is keen and exacting. Do not doubt your ability, but make up your mind to it and you will soon have the requirements that will bring you success and big money. **YOU CAN DO IT.**

Let us show you how to get on the road to success. It will not cost you a single working hour. We are so sure of being able to help you that we will cheerfully return to you, at the end of ten lessons, every cent you sent us if you are not absolutely satisfied. What fairer offer can we make you? Write today. It costs you nothing but a stamp.

AMERICAN SCHOOL

Dept. H-A74, Drexel Ave. and 58th St., Chicago

AMERICAN SCHOOL

AMERICAN SCHOOL

Dept. H-A74 Drexel Ave. and 58th St., Chicago

Explain how I can qualify for position checked:

...Architect \$5,000 to \$15,000	...Lawyer \$5,000 to \$15,000
...Building Contractor \$5,000 to \$10,000	...Mechanical Engineer \$4,000 to \$10,000
...Automobile Engineer \$4,000 to \$10,000	...Shop Superintendent \$4,000 to \$7,000
...Automobile Repairman \$3,500 to \$4,000	...Employment Manager \$4,000 to \$10,000
...Civil Engineer \$5,000 to \$15,000	...Steam Engineer \$2,000 to \$4,000
...Structural Engineer \$4,000 to \$10,000	...Fireman's Course \$2,000 to \$4,000
...Business Manager \$5,000 to \$15,000	...Sanitary Engineer \$2,000 to \$5,000
...Certified Public Accountant \$7,000 to \$15,000	...Telephone Engineer \$2,500 to \$5,000
...Accountant and Auditor \$2,500 to \$7,000	...Telegraph Engineer \$2,500 to \$5,000
...Draftsman and Designer \$2,500 to \$4,000	...High School Graduate in two years
...Electrical Engineer \$4,000 to \$10,000	...Fire Insurance Expert \$3,000 to \$10,000
...General Education In one year.	

Name..... Address.....

LEARN BY DOING

Every phase of all branches of

ELECTRICITY

Taught by Actual Practice

In America's foremost and oldest institution for trade training.

**No Books Used
Individual Instruction
Start Any Day**

A SPECIAL and SEPARATE Course in Ignition, Auto Lighting and STARTER Systems. Write for FREE 64-page catalog.

THE
NEW YORK ELECTRICAL SCHOOL
44 West 17th Street NEW YORK CITY

WRITE NOW FOR Dyke's FREE Booklet

NEW IDEA OF TEACHING BY MAIL tells how you can learn at home—spare time—and become an Auto Expert on repairing and electrical systems.

WITH DYKE'S WORKING MODELS CHARTS, MANIFOLD, ETC.

OPPORTUNITIES IN AUTO BUSINESS THE AUTOMOBILE BUSINESS

DYKE'S SCHOOL OF MOTORING, Box 300 Granite Bldg., St. Louis, Mo.

A department of the Firm: A. L. Dyke, Publisher, Original and only system of its kind. Endorsed by leading motor authorities of the world.

Music Lessons

UNDER MASTER TEACHERS

At Home

Complete Conservatory Course by Mail

Wonderful home study music lessons under great American and European teachers. Endorsed by Paderewski, Master teachers guide and coach you. Lessons a marvel of simplicity and completeness, featuring courses you are interested in: Violin, Piano, Harmony, Voice, Public School Music, FREE CATALOG. SEND for it NOW!

University Extension Conservatory, 621 Siegel-Myers Bldg., Chicago

FREE Lesson in Drafting

Send for our free lesson which shows how easily you can master Drafting by the Chicago "Tech" Method and prepare for a high salaried job. You get this training in spare time by mail under the direction of our experts. The fees are moderate, the terms easy.

Find out about this now. The lesson is free and we send our catalog with it. Write today.

Chicago Technical College, 630 Chicago "Tech" Bldg., Chicago, Ill.

AVIATION Information FREE

Send us your name and address for full information regarding the Aviation and Airplane business. Find out about the many great opportunities now open and how we prepare you at home, during spare time, to qualify. Our new book "Opportunities in the Airplane Industry" also sent free if you answer at once.

AMERICAN SCHOOL OF AVIATION
Dept. 119-A 3601 Michigan Ave. CHICAGO

Do You Want A Bigger Salary?

It doesn't matter what you are Today or what you were Yesterday. Tomorrow is your bright, clear day of Opportunity. Nothing can keep you *down* if you really make up your mind to go *up*.

Maybe you've gotten a bad start. Perhaps you haven't had a decent raise in years. Or perhaps you are among those thousands who have had their wages cut—or have been thrown out of a job. But you aren't going to curl up and quit, are you? Right now, when trained men are in such demand, you've the best chance you ever had to get out of the rut and do something worth while.

But you're "too old to start over," you say. Nonsense! When some of the big men of this country were your age, they weren't earning half what you are getting today. But they didn't quit. They worked! They studied! They learned to do some one thing well.

At 35, Henry Ford was working in the mechanical department of the Edison Electric Light & Power Company. At 38, John R. Patterson, who founded the National Cash Register Company, was the proprietor of a small and none too successful country store. At 25, George Eastman, president of the Eastman Kodak Company, was a bookkeeper in a savings bank. At 22, Edison was a roaming telegraph operator—out of a job—too poor, when he arrived in New York, to buy his own breakfast!

Forget what you are today and decide on what you want to be. No man has failed until he admits it to himself. And no *real* man ever admits it. Why, man, in just one hour a day—in the spare time you will never miss—you can fit yourself for a better job and a bigger salary.

What Do You Want To Be?

An Automotive Engineer? The vice-president in charge of engineering of the Packard Motor Car Company is an I. C. S. student. A Ship Builder? The world's greatest ship builder is an I. C. S. student. An Architect? The Equitable Building in New York, and many others were built by I. C. S. students. An Engineer? An I. C. S.-trained engineer has just written to us that his income has been increased to \$25,000 a year.

Do you want to advance in Business? In Advertising? In Salesmanship? Many of the country's foremost Advertising and Sales Managers have won success through I. C. S. training.

Accounting? Commercial Law? All over America, bookkeepers, accountants, office managers, private secretaries, are reaping the rewards of time invested in I. C. S. training in these subjects.

Do these positions sound too good for you? Are you afraid to take the same chance these men took—and get the opportunity to make good as they did? They were in worse jobs than yours. Some of them had no schooling beyond a few grammar grades. But they forgot about what they were—and they thought about what they wanted to be.

Get out of the rut, and get out today. You've got it in you to make good in a big way, if you will only learn to do some one thing well.

Your Chance Is Here!

No matter where you live, the I. C. S. will come to you. No matter what your handicaps, or how small your means, we have a plan to meet your circumstances. No matter how limited your previous education, the simply-written, wonderfully-illustrated I. C. S. lessons make it easy to learn. No matter what career you choose, some one of the 300 I. C. S. courses will surely suit your needs.

When everything has been made easy for you—when one hour a day spent with the I. C. S. in the quiet of your own home will bring you a bigger income, more comforts, more pleasures, all that success means, can you afford to let another single priceless hour of spare time go to waste?

This is all we ask: Without cost, without obligating yourself in any way, put it up to us to prove how we can help you. Just mark and mail this coupon.

----- TEAR OUT HERE -----
INTERNATIONAL CORRESPONDENCE SCHOOLS
BOX 5639-C
SCRANTON, PA.

Without cost or obligation, please explain how I can qualify for the position, or in the subject before which I have marked an X:

- | | |
|---|--|
| <input type="checkbox"/> ELEC. ENGINEER | <input type="checkbox"/> BUSINESS MANAGEMENT |
| <input type="checkbox"/> Electric Lighting & Railways | <input type="checkbox"/> SALESMANSHIP |
| <input type="checkbox"/> Electric Wiring | <input type="checkbox"/> ADVERTISING |
| <input type="checkbox"/> Telegraph Engineer | <input type="checkbox"/> Show Card & Sign Ptg. |
| <input type="checkbox"/> Telephone Work | <input type="checkbox"/> Railroad Positions |
| <input type="checkbox"/> MECHANICAL ENGINEER | <input type="checkbox"/> ILLUSTRATING |
| <input type="checkbox"/> Mechanical Draftsman | <input type="checkbox"/> Cartooning |
| <input type="checkbox"/> Machine Shop Practice | <input type="checkbox"/> Private Secretary |
| <input type="checkbox"/> Toolmaker | <input type="checkbox"/> Business Correspondent |
| <input type="checkbox"/> Gas Engine Operating | <input type="checkbox"/> BOOKKEEPER |
| <input type="checkbox"/> CIVIL ENGINEER | <input type="checkbox"/> Stenographer & Typist |
| <input type="checkbox"/> Surveying and Mapping | <input type="checkbox"/> Certified Public Accountant |
| <input type="checkbox"/> MINE FOREMAN or ENGR | <input type="checkbox"/> TRAFFIC MANAGER |
| <input type="checkbox"/> STATIONARY ENGINEER | <input type="checkbox"/> Cost Accountant |
| <input type="checkbox"/> Marine Engineer | <input type="checkbox"/> GOOD ENGLISH |
| <input type="checkbox"/> ARCHITECT | <input type="checkbox"/> Common School Subjects |
| <input type="checkbox"/> Contractor and Builder | <input type="checkbox"/> CIVIL SERVICE |
| <input type="checkbox"/> Architectural Draftsman | <input type="checkbox"/> Railway Mail Clerk |
| <input type="checkbox"/> Concrete Builder | <input type="checkbox"/> AUTOMOBILES |
| <input type="checkbox"/> Structural Engineer | <input type="checkbox"/> Mathematics |
| <input type="checkbox"/> PLUMBING & HEATING | <input type="checkbox"/> Navigation |
| <input type="checkbox"/> Sheet Metal Worker | <input type="checkbox"/> AGRICULTURE |
| <input type="checkbox"/> Textile Overseer or Supt. | <input type="checkbox"/> Poultry Raising <input type="checkbox"/> French |
| <input type="checkbox"/> CHEMIST | <input type="checkbox"/> Airplane Engines <input type="checkbox"/> Spanish |
| <input type="checkbox"/> Pharmacy | <input type="checkbox"/> WIRELESS <input type="checkbox"/> Banking |

Name.....

Street..... 2-1-22
and No.....

City..... State.....

Occupation.....

Persons residing in Canada should send this coupon to the International Correspondence Schools Canadian, Limited, Montreal, Canada.

Do You Like to Draw?

Here Is a Simple, Easy Way
to Draw a Comic Face

TRY IT



Make a square with pencil, then add to it with pencil as shown in the small squares above. Erase all pencil guide lines after the drawing is completed.

We will not give you any "grand prize," if you draw this picture. Nor will we claim to make you "rich in a week." But if you are anxious to develop your talent with a **successful cartoonist**, so you can **make money**, send a copy of this picture with six cents in stamps for portfolio of cartoons and sample lesson plate, and let us explain more in detail. Some of the **most successful cartoonists** are former students of this school. It is not hard to learn to draw originals when you are shown how in a practical way.



THE W. L. EVANS SCHOOL OF CARTOONING

"The School That Has the Reputation"

821 Leader Bldg.

CLEVELAND, OHIO



PROF. HENRY DICKSON
foremost authority on Memory
Training and Principal
Dickson Memory School

SEND NO MONEY

Just a postcard. I will send you my new, complete, revised course in **CHARACTER READING—PSYCHO-ANALYSIS**

for five days' free examination. Most lucid, practical instruction on this subject. 50 years' experience put into this course. Shows you how to read character—to "size others up," to

KNOW YOURSELF

Eight persons out of every ten are in the wrong job, **are you?** For what are you best fitted? Can you overcome your weak points? Are you easily discouraged? Are you getting on?

BE MASTER OF YOUR DESTINY

Instead of its victim! Overcome your failings, dominate circumstance. **Get the job you want at the salary that's right!**

THROUGH MY CHARACTER READING COURSE

secrets are revealed that took me a life-time to penetrate. Your hidden powers are developed, your influence made vital, you find what type of persons to cultivate as friends, what type to avoid, **what type you should marry.**

ON APPROVAL

This lavishly illustrated Course, with photographs, diagrams and charts, showing types, characteristic and composite, with their traits; the significance of profile contour, the concave, convex and plain, and **PERSONAL SELF-MEASURING EFFICIENCY CHART ANALYZING YOUR OWN CHARACTER**, all this sent for 5 days' examination free. If not satisfied, simply return it to me. When, however, you realize that the Course can be a turning point in your career, then remit \$2.00 which pays for the Course **IN FULL** (no extra charges of any kind) and secures also personal instruction privileges and an analysis of your own character **FREE**. Address

PROF. HENRY DICKSON

1041-K Chicago Ave.

Evanston, Ill.

Complete Vacuum Tube Radio Set **FREE**

With **PROFESSIONAL COURSE**

BEST Theory, Instruments, Text Books, Service
Also Complete Course for Amateurs
Send for Free Booklet

NEW YORK WIRELESS INSTITUTE

258 Broadway, New York

Dept. 700



Wonderful, new device, guides your hand; corrects your writing in few days. Big improvement in three hours. No failures. **Complete outline FREE**. Write C. J. O'Connell, D-34, St. Louis, Mo.

TRI STATE COLLEGE OF ENGINEERING

Makes you a Civil, Mechanical, Electrical or Chemical Engineer in two years, 48 weeks each. No entrance examinations. High School Diploma not required. Compact courses made up of essentials only. Expenses low. For catalog address

100 "M" STREET, ANGOLA, IND.

40,000 Opportunities in Hotels

Nation wide demand for high smarted men and women; past experience unnecessary; we train you by mail and put you in touch with big opportunities. Big pay, fine living, interesting work, quick advancement; permanent. Write for Free Book, "Your Big Opportunity"

LEWIS HOTEL TRAINING SCHOOL, Room 328, Washington, D. C.

PIANO JAZZ

By note or ear. With or without music. Short Course. Adult beginners taught by mail. No teacher required. Self-Instruction Course for Advanced Pianists. Learn 67 styles of Bass, 180 Syncopated Effects, Blue Harmony, Oriental, Chime, Movie and Cafe Jazz, Trick Endings, Clever Breaks, Space Fillers, Sax Sturs, Triple Bass, Wicked Harmony, Blue Obligato, and 247 other Subjects, including Ear Playing, 110 pages of **REAL JAZZ**, 25,000 words. A Postal brings our **FREE** Special Offer. **Waterman Piano School, 259 Superba Theatre Bldg., Los Angeles, Calif.**

"Big men are only little men given a fair chance to grow."—J. Ogden Armour

Introduces Band-Saw to Box-Car —Wins \$6,000 Job!

"Lucky chap!"—that's what they're saying about John Erie.

Just a short time ago Erie was tied to a humdrum job in the general offices of the "Continental." Now he sits at a big mahogany desk and swings a \$6,000 position. Here's the story, true in all particulars except the names.

One of the "leaders" in the Continental line was a band-saw. The outfit weighed only 780 pounds, but it was a rangy affair, too big to get thru the door of a box-car; it had to be shipped on a flat-car.

Strange, but it had never seemed to occur to anyone to find out whether it would be *cheaper* to ship the machine in a box-car—or whether the design of the machine could be *changed* in some simple way so as to permit of such shipment.

But it occurred to John Erie.

Erie, you see, was studying Traffic Management in his spare time, and he had learned that when shipped on a flat-car—according to the classifications of the Interstate Commerce Commission—the band-saw had to be figured as weighing a minimum of 4,000 pounds—*more than five times its actual weight!*

Erie recommended that the frame be cast in parts and bolted together. Thus it could be readily "knocked down" and loaded thru a box-car door.

The change was made—it saved his company \$6,000 a month—and John Erie stepped into the job of Traffic Manager, at a salary to start of \$6,000 a year.

Business Needs Competent Traffic Managers—Pays Them Well

Just an unusual opportunity, you say—with Erie on the job to take advantage of it.

Don't you believe it!

Millions of dollars, literally millions, are being wasted every year by the big shippers, just for lack of really competent traffic managers.

We know of a former rate clerk, for example—a LaSalle-trained traffic man—who recovered for one of the big packers more than \$200,000 in cash, simply by proving a correct rate of \$1.53 a hundredweight on certain shipments as against the rate of \$1.60 which the company had been paying.

Men who can effect such savings are in *demand*. Large industrial concerns, railroads, chambers of commerce and boards of trade are actively bidding for their services. Such men command big incomes. Salaries of \$5,000, \$7,500, \$10,000 and up are not unusual. The rate-clerk just referred to promptly won advancement. He is now traffic manager for the largest cement company in the world.

Train by the Problem Method

Why content yourself with the slender earnings of the routine man, when right in your own home by the LaSalle Problem Method you can quickly prove your title to the big mahogany desk?

Under the Problem Method you will work to all purposes side by side with trained traffic men, handle the very problems met daily by the traffic directors of the railroads and by the big shippers. They will answer every question you ask, make every point clear, direct your training every step of the way. You will cover, under their instruction, the entire field of traffic, including the organization and administration of a traffic department, freight classification, rates, claims, law of carriers, procedure before the Interstate Commerce Commission, express service and rates, ocean traffic and trade—even to the point of working with the actual forms, agreements and contracts in everyday use.



Just a short time ago he was tied to a humdrum job—out in the general office. Now he sits at a big mahogany desk and swings a \$6,000 position.

Send for "Skillful Traffic Management"

No need to urge you to act—not if you're real executive timber. You know that the thing to do is to get the facts. They are contained in an interesting booklet, "Skillful Traffic Management." The coupon will bring this to you without obligation, together with details of our convenient payment plan; also your copy of that inspiring book, "Ten Years' Promotion in One." "Get this book," said a prominent Chicago executive, "even if you have to pay five dollars for it." We will send it *free*.

Mark—Sign—Mail the coupon—NOW.

INQUIRY COUPON

LaSalle Extension University
Dept. 664-TR Chicago, Ill.

Please send me catalog and full information regarding the course and service I have marked with an X below. Also a copy of your book, "Ten Years' Promotion in One," all without obligation to me.

Traffic Management—
 Foreign and Domestic:

Training for position as Railroad or Industrial Traffic Manager, etc.

Other LaSalle Training Courses

LaSalle is the largest business training institution in the world. It offers training for every important business need. If more interested in any of these courses, check here:

- | | |
|--|--|
| <input type="checkbox"/> Business Management | <input type="checkbox"/> Banking and Finance |
| <input type="checkbox"/> Salesmanship | <input type="checkbox"/> Modern Foremanship and Production Methods |
| <input type="checkbox"/> Higher Accountancy | <input type="checkbox"/> Personnel and Employment Management |
| <input type="checkbox"/> Railway Accounting and Station Management | <input type="checkbox"/> Expert Bookkeeping |
| <input type="checkbox"/> Law—Degree of LL. B. | <input type="checkbox"/> Business English |
| <input type="checkbox"/> Commercial Law | <input type="checkbox"/> Commercial Spanish |
| <input type="checkbox"/> Industrial Management Efficiency | <input type="checkbox"/> Effective Speaking |
| <input type="checkbox"/> Modern Business Correspondence and Practice | <input type="checkbox"/> C. F. A. Coaching |

Name

Present Position

Address

LaSalle Extension University

The Largest Business Training Institution in the World

I Have 5000

For Sweeney Trained Men



E. J. SWEENEY

**Sweeney
Trains You
To Fill
Positions
Like These**

Chauffeurs	\$90. to 150.
Truck driver	\$125.
Tire Vulcanizer	\$100 to 200.
Welders	\$140. to 200.
Battery Man	\$150. to 200.
Auto Mechanic	\$6. to 10. a day
Auto Electrician	\$225.
Tractor Engineer	\$10 a day
Garage Manager	\$150 to 400
Demonstrator and Salesmen	\$150 to 500.



So confident am I of the practical training that is offered you in this Million Dollar trade school that if you will agree to take the necessary preliminary work, I will agree to employ you upon graduation.

This position requires not only automotive training, but radio training as well. But to equip you for this work I will give you a free course in radio.

Furthermore—I need you NOW, and to make it possible to get the right sort of men I WILL PAY YOUR RAILWAY FARE TO KANSAS CITY.

I Want Sweeney Trained Men

to act as my salesmen and representatives to sell radio sets, storage batteries, accessories, etc.—to open garages, tire shops in 5000 places where I am opening sales branches.

If you are mechanically inclined and want an assured position write me today for a sample contract.

I will make this offer only to those who are sufficiently in earnest and sufficiently energetic to write me at once. Naturally, I will employ only Sweeney trained men.

You Must Apply Now

If you are ready for PROFIT-ABLE EMPLOYMENT after eight weeks' training write me today.

Do not delay—for this opportunity may not occur again. For when these jobs are filled I cannot offer such employment agreement any longer.

For fifteen years I have trained young men mechanically inclined. This is the first time I have been able to GUARANTEE A JOB. And I can only guarantee a certain number. But you can be one of those who take training UNDER MY GUARANTEE OF EMPLOYMENT IF YOU ACT NOW.

Please do not apply unless you are willing to take eight weeks' course of training.

LEARN A TRADE
Sweeney
SCHOOL OF AUTO-TRACTOR-AVIATION
1023 SWEENEY BLDG. KANSAS CITY, MO.

Learn Radio Free

Jobs Open Now

BRANCH MANAGERS WANTED!

You have heard of RADIO? Do you know about the new business that is taking the world by storm? Do you realize the opportunities in this business? What it means to handle and install radio sets? To act as salesmen. Why, one man last week got orders for over \$2,000 worth of radio supplies—everybody wants to hear the voices in the air. Let me tell you about the opportunities in RADIO. Remember my RADIO COURSE IS FREE. Not a cent extra charge.

Probably you have read my advertising before. But this is a special offer. I want 5000 go-getters. Give yourself a real training. If you will qualify I WILL HIRE YOU. If you are in earnest write me today.

I Pay Your Railroad Fare This training takes in NOT ONLY the Sweeney System of Practical Instruction which was endorsed by the Government during the War in turning out over 5000 auto mechanics, and which has put 46000 men into the auto business in civil life, but INCLUDES without a cent's extra cost the new FREE RADIO INSTRUCTION and my new offer to PAY YOUR RAILWAY FARE to Kansas City no matter where you live.

Get My Big Free Catalog

FREE The first step is to send me the coupon or write a postcard for my 72-page illustrated catalog. It tells all about this Million Dollar trade school. It tells how to equip yourself for a real job. It tells how thousands of men just like you, without any special knowledge but simply a liking for mechanics, MADE A LIFETIME SUCCESS as a result of this simple training. I don't care how old you are. I don't care how small your education, for I teach with TOOLS NOT BOOKS. It tells also about this new radio business. How to make money. How to make your own sets. It tells about the school and our big swimming pool and how students enjoy themselves while learning. It gives you in the own words of hundreds of men just what they learned here and what they have done since graduating. And my special offer. This is not in the catalog. But I have big plans. I need 5000 salesmen and representatives to handle Sweeney batteries and radio supplies. I want managers for branch offices. I will hire you if you are in earnest and will qualify. And if you write me now I will send you SAMPLE CONTRACT. And if you are willing to go to work I WILL PAY YOUR RAILWAY FARE to Kansas City. Write me NOW.

EMORY J. SWEENEY,
President.

LEARN A TRADE

Now is the time for you to learn a trade. I teach men to be successful auto mechanics. Can you make a tire? Can you weld a broken crank case? Can you build a battery? Can you repair an automobile? Can you go anywhere in the U. S. and get a job in a garage, repair shop, auto agency, tire shop, welding concern? Can you get a job as a driver or chauffeur?

This FREE Book
Tells You
Everything

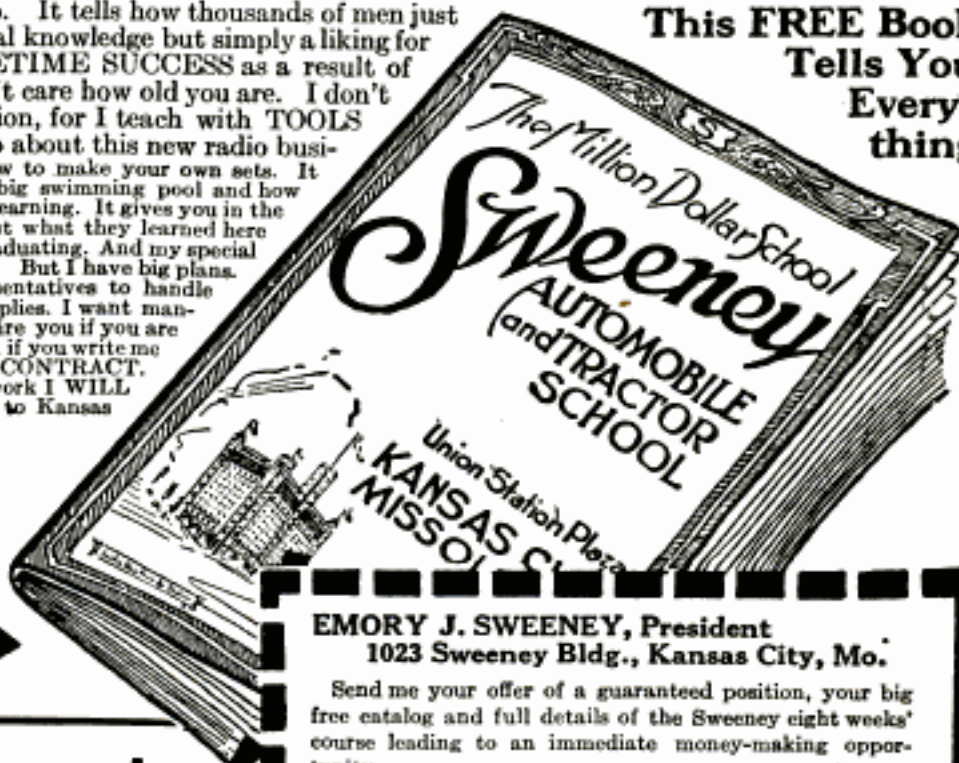

EMORY J. SWEENEY, President
1023 Sweeney Bldg., Kansas City, Mo.

Send me your offer of a guaranteed position, your big free catalog and full details of the Sweeney eight weeks' course leading to an immediate money-making opportunity.

Name

Address

**For Big Offer and
Catalog Mail this
Coupon Today**

NO COLORED STUDENTS ACCEPTED



FREE!

This Ad-Writer's Wonderful Working Outfit

Yes, FREE to you, a complete Ad-Writer's Working Outfit! Not a penny to pay. You get this superb outfit as a FREE gift on our sensational new offer. We want to interest 5,000 more men in the great profession of ad-writing. The "field" needs more good men and needs them badly. We want to interest 5,000 men quickly in the opportunity—hence this amazing free offer. The 5,000 ad-writer's outfits will go fast. Immediate action is necessary if you want one free. Mail coupon today for full details.

\$200-A-Week Ad-Writers Use The Same Tools These are real ad-writers' "tools"—the very same kind used by the men who are getting \$100, \$200, \$300 a week. There's inspiration in handling these instruments. You work at your best. "Just the thing," say successful ad-writers, "to start ad-men off right."

LEARN TO WRITE ADVERTISEMENTS

All These Articles FREE

- 1 Drawing Board
- 1 T Square
- 1 Triangle
- 2 Drawing Pencils
- 1 Double Line Ruling Pen
- 1 Single Line Ruling Pen
- 1-2 Golden Thumb Tacks
- 20 Sheets of Drawing Paper
- 1 Ad Rule
- 1 Slider
- 1 Compass
- 50 Envelopes (Self-Addressed)
- 50 Sheets of Paper
- 1 Eraser
- 1 Bottle Higgins India Ink
- 1 Bottle Red Ink
- 1 Bottle Library Paste
- 1 Straightline Rule
- 1 Fr. 8 In. Shears
- And other useful Articles

Ad-writing is the best paying profession in the world. Statistics prove it. One ad-writer, formerly a bookkeeper makes over \$1,000 a week. Another, an ex-shophand, earns over \$200 a week. Scores step right into Ad-writing from other lines. No special "gift" required—just common sense plus some training. Let Page-Davis experts train you—by mail. Learn in your spare time how to lay out and write ads that "ring the bell."

Now! Mail the coupon for our FREE Ad-writer's working outfit offer.

Don't delay—thousands will speak for one of these outfits. Only 5,000 to be given free. Get the coupon in the mails today. It brings also full information on the famous Page-Davis Courses in ad-writing—postpaid and free. No obligation. ACT NOW.

Page-Davis School
Dept. A-18
CHICAGO, ILL.

Name

Street and Number

City.....State.....

Free Coupon
Page-Davis School
Dept. A-18
CHICAGO, ILLINOIS

I want an Ad-writer's working outfit free. Give me the details of this offer and also particulars of your course in Ad-writing. This places me under no obligation.

Please Mention Popular Mechanics

Want a Better Job?

Study YOURSELF—and promotion, more money and steady employment are certain. We help you "find" yourself in the field where you fit best. We analyze you and assist you with our **free employment service.** Ask for the free booklet "Self-Appraisal" and learn how you can insure advancement and a better job.

Vocational Service Corporation
Dept. (61) 116 S. Michigan Ave., Chicago

BRUSHES and SUPPLIES FOR SIGN and SHOW CARD WRITERS

Largest sign shops and studios use BLUE HANDLE BRAND brushes and supplies. The PIONEER line. Established 1909. Recognized Quality—Tremendous purchasing power, and long years of practical experience, permit us to offer the highest quality supplies at the lowest prices. Theo. Cosack Co., of Indianapolis, writes: "We offer you the highest recommendation for your goods." Write for our new 1922 catalogue. It's FREE! DETROIT SCHOOL OF LETTERING, 1186 D. S. of L. Bldg. SUPPLY DEPT., Detroit, Mich., U. S. A.



Theo. J. Cosack
President

BIG PROFITS FROM POULTRY

We Teach You How; Easily Learned at Home; our guaranteed methods make success certain; write for free booklets "How to Raise Poultry for Profit" and "Absolute Evidence." Free.

The National Poultry Institute, Inc., Dept. 312, Marden Bldg., Washington, D.C.

WORK While Learning Electricity

—GET OUR FREE OFFER

S & H Electrical Works Dept. F 1, 308 S. Green St. CHICAGO

LEARN WATCHMAKING and ENGRAVING

Earn while learning. Most practical watch school. Individual instructions. Graduates in great demand. Book free. Chicago School of Watchmaking, Dept. 20, 4340 Lincoln Ave., Chicago

STATEMENT OF THE OWNERSHIP, MANAGEMENT, CIRCULATION, ETC., REQUIRED BY THE ACT OF CONGRESS OF AUGUST 24, 1912, of Popular Mechanics Magazine, published Monthly at Chicago, Ill., for April 1st, 1922.

State of Illinois, County of Cook, ss.
Before me, a notary public in and for the state and county aforesaid, personally appeared H. H. Windsor, who having been duly sworn according to law, deposes and says that he is the editor and business manager of the Popular Mechanics Magazine and that the following is, to the best of his knowledge and belief, a true statement of the ownership, management, etc., of the aforesaid publication for the date shown in the above caption, required by the Act of August 24, 1912, embodied in section 443, Postal Laws and Regulations, printed on the reverse of this form, to wit: 1. That the names and addresses of the publisher, editor, managing editor, and business manager are: Publisher, Popular Mechanics Co., 6 No. Michigan Ave., Chicago, Ill., Editor, H. H. Windsor, 6 No. Michigan Ave., Chicago, Ill., Managing Editor, J. E. Poshody, 6 No. Michigan Ave., Chicago, Ill., Business Manager, H. H. Windsor, 6 No. Michigan Ave., Chicago, Ill. 2. That the owners are (Give names and addresses of individual owners, or, if a corporation give its name and the names and addresses of stockholders owning or holding 1 per cent or more of the total amount of stock): H. H. Windsor, 6 No. Michigan Ave., Chicago, Ill., L. B. Windsor, 6 No. Michigan Ave., Chicago, Ill., First Trust and Savings Bank, Trustee for H. H. Windsor, Jr., Chicago, Ill. 3. That the known bondholders, mortgagees, and other security holders owning or holding 1 per cent or more of total amount of bonds, mortgages or other securities are (If there are none so state): None. 4. That the two paragraphs next above, giving the names of the owners, stockholders and security holders, if any, contain not only the list of stockholders and security holders as they appear upon the books of the company, but also, in cases where the stockholder or security holder appears upon the books of the company as trustee or in any other fiduciary relation, the name of the person or corporation for whom such trustee is acting, is given; also that the said two paragraphs contain statements embracing within their full knowledge and belief as to the circumstances and conditions under which stockholders and security holders who do not appear upon the books of the company as trustees, hold stock and securities in a capacity other than that of a bona fide owner; and this affiant has no reason to believe that any other person, partnership, or corporation has any interest direct or indirect in the said stock, bonds or other securities than as so stated by him.

H. H. WINDSOR, Editor.
Sworn to and subscribed before me this 27th day of March, 1922.
J. GRAHAM,
Notary Public

[My commission expires June 17, 1924.]

You Might Call It Luck

*If Only One Man Had Jumped
to Such Amazing Earnings*

-but Hundreds Have Done It!

WHEN a man steps from a \$50 a month job as a farmhand to a position that paid him \$1,000 the very first month—was it luck?

When another man leaves a job on the Capitol Police Force at a salary of less than \$1,000 a year and then in six weeks earns \$1,800—is that luck?

Probably the friends of Charles Berry of Winterset, Iowa, and of J. P. Overstreet of Denison, Texas—the two men mentioned above—call them lucky. But then there is F. Wynn of Portland, Ore., an ex-service man who earned \$554.37 in one week—and George W. Kearns of Oklahoma City, whose earnings went from \$60 a month to \$524 in two weeks. And C. W. Campbell of Greensburg, Pa., who quit a clerking job on the railroad to earn \$1,562 in thirty days.

There is nothing exceptional about these men. They live in all parts of the country—they had been engaged in all kinds of work. Many had been clerks, bookkeepers, mechanics. Some had already achieved successful places in the business world.

No Limit to the Opportunities

And then in one swift stroke, they found themselves making more money than they had ever dreamed possible. The grind of routine work—the constant struggle to obtain even a slight increase in earnings—the discouraging drudgery of blind-alley jobs—all this was left behind for careers of immediate and brilliant success. And great as are their earnings today, they are looking forward to increasing them constantly—in fact, there is no limit to the amounts they may earn—only their own efforts can determine that.



"I had never earned more than \$60 a month. Last week I cleared \$306 and this week \$218."—Geo. W. Kearns, Oklahoma City.

in the Selling end of business. Salesmen are the very life blood of any concern—upon them depends the amount of profits made.

And for the men who are in the "Star" class—who are Masters of Salesmanship—there is practically no limit to their earnings.

And that is how the men whose pictures you see and hundreds of others like them, found the way to their present magnificent incomes. They are all Master Salesmen now!

The Back-Bone of Business

And there is. In the first place they discovered a vital fact about business.

They discovered that the big money is

New Way to Enter This Field

Yet previously they had no idea of becoming Salesmen—many didn't even think it possible to do so. But they learned of an amazingly easy way by which any man can quickly become a Master Salesman—and in his spare time at home!

Secrets Only Master Salesmen Know

Salesmanship is not a natural gift—it is an art and science that is open to any man. There are fundamental rules and principles that anyone can put into practice—there are Secrets of Selling that put any man who knows them into the "Star" class.

The proof of this is in the wonderful success achieved by men who, without any previous Selling experience, have suddenly become Master Salesmen thru the National Salesmen's Training Association. Step by step—in their spare time at home—they were taken through every phase of Salesmanship. Every underlying principle of sales strategy was made as simple as A-B-C. Thru the National Demonstration Method every form of Sales problem is solved.



"The very first month I earned \$1,000. I was formerly a farmhand."—Charles Berry, Winterset, Iowa.



"After ten years in the railway mail service I decided to make a change. . . My earnings during the past thirty days were more than \$1,000."—W. Hurtle, Chicago, Ill.

Startling Proof Sent Free

Whether or not you have ever thought of becoming a Salesman, you should examine the facts about the tremendous possibilities for big earnings in this fascinating field. Read the extraordinary stories of others and see how easily you can do what they are doing. The PROOF is so overwhelming that it may mean the turning point in your life, as it has in so many others. Simply mail the coupon below. It will bring you by mail the whole wonderful story, and in addition a great Book "Modern Salesmanship" and full particulars about the remarkable system of Salesmanship Training and Free Employment Service of the N. S. T. A.

Right now—tear off the coupon and mail it today. It costs you nothing to do this—it obligates you in no way.

National Salesmen's Training Association

Dept. 12-G

CHICAGO, ILL.

NATIONAL SALESMEN'S TRAINING ASSOCIATION

Dept. 12-G, Chicago, Ill.

Please mail me Free Proof that I can become a Master Salesman and qualify for a big money position. Also send your illustrated Book "Modern Salesmanship" and particulars of membership in your association and its Free Employment Service. This is all free of cost or obligation.

Name.....

Address.....

City..... State.....

Age..... Occupation.....

LEARN CARTOONING

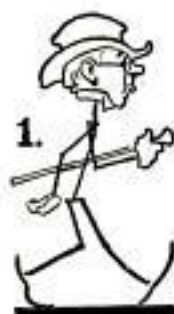

If you like to draw, develop your ability and quickly raise your income

Hundreds of others who had the same ambition have become successful cartoonists through the Landon Picture Chart Method of teaching cartooning. They are now **earning from \$75 to \$400 and more per week.**

The Landon Course of Cartooning with the famous Landon Picture Charts teaches you how to make **original** drawings. As your eye follows sketch after sketch on these charts, you learn just how and where to start a drawing and place each line in completing it.

You can learn during your spare time, at home—and a personal criticism service on each lesson corrects mistakes which you may make.

Celebrated cartoonists and educators everywhere pronounce **Landon Picture Charts** as the greatest achievement in the teaching of drawing. No other plan gives you such a thorough understanding of the fundamentals of drawing—none develops originality so rapidly.

The opportunities in cartoon work were never so great as at present.

Write today for sample Landon Picture Chart, long list of successful Landon students and full information showing the possibilities for you. Please state your age.

The Landon School

338 National Bldg.

Cleveland, Ohio

Learn to Write

I Teach by Mail

I CAN make a good penman of you at your home during spare time, no matter where you live or how poorly you now write. My simplified system has shown thousands of others the way to good penmanship during the past twenty years—it can and will do the same for YOU!

Beautifully Illustrated Book

"How to Become a Good Penman" FREE!

It contains general information, with testimonials and beautiful specimens of penmanship showing what others have accomplished by the Tamblin System. (Your name elegantly written on a card if you enclose stamp for postage.) WRITE TODAY. Address

F. W. TAMBLIN
618 Ridge Bldg., Kansas City, Mo., U. S. A.

F. W. Tamblin

How to Box 40c

By Terry McGovern, James J. Corbett, J. Gardner Smith, M. D., Arthur P. Keeley and Gus E. Keeley.

How to Box to Win, How to Build Muscle, How to Punch the Bag and How to Stand, Walk or Run.

This interesting book written by experts is known also as "The Book of Health and Strength." It will greatly assist everyone in keeping fit, in putting them in condition to master a strenuous undertaking either physical or mental.

62 illustrations. Size 4 1/2 x 7 1/2 in. Paper copy . 135 pages.

SHREWSBURY PUBLISHING CO.
5525 West Lake Street, Chicago, Ill.

RAG JAZZ PIANO, SAXOPHONE, or TENOR BANJO in 20 lessons. Christensen Schools in most cities or Learn by Mail. Write for Booklet, or money-making teacher's opportunity.

AXEL CHRISTENSEN, 16 E. Jackson, Chicago, Ill.

WANTED!
U. S. RAILWAY
MAIL
CLERKS

\$135 to \$190
MONTH

Hundreds Needed
MEN—BOYS
OVER 17

FRANKLIN INSTITUTE
Dept. D178, Rochester, N. Y.
Kindly send me, by return mail, free information telling how I can quickly get into the U. S. Gov't service as Railway Mail Clerk (\$1600 to \$2300 a year) or as City Mail Carrier or Post Office Clerk (\$1400 to \$1800 a year).

Name
Address



Become a Radio-trician

Learn at home the greatest profession of to-day and the future. Become a master of radio installation, operation, maintenance, repair, mechanics, design, inspection, salesmanship and invention.

THE world is aflame with Radio. Never before in the history of the country has an industry leaped to the forefront as rapidly as this great, new science. Hundreds of thousands of radio receiving sets are in operation—tens of thousands of sending stations will be erected—and this enormous craze is permanent. Even to-day manufacturers are months behind their orders! Improvements are being made every day which must increase the demand for radio equipment to even *greater* proportions than now.

Men of foresight, men of vision know what this means. Never before has there been such an opportunity. Radio-tricians are needed to-day everywhere. More and more will be needed as the demand for radio installation, radio operation, radio maintenance, radio repair, radio salesmanship becomes greater and greater.

Wherever you go, there are hundreds of radio sets to be installed—wherever you go, thousands upon thousands of dollars worth of radio equipment is being sold—wherever you go, there are radio sets to repair; and if you seek adventure, there are radio sending stations calling to you from ships and land stations all over the world.

The Pioneer School

The National Radio Institute has a record of over 8,000 students. It is the pioneer school. It teaches every phase of radio from the ground up. It teaches by means of actual practice, actual assembling of a radio outfit, actual operation of radio equipment. It teaches by problem and principle so that National Radio-tricians are in demand everywhere.

Here is a profession which is paying enormous earnings to men all over the country to-day—a profession that will make hundreds of men wealthy—a profession far more lucrative than that of any other technical or mechanical employment you can secure.

What will you do?

The world is aflame with radio. What are you going to do to "cash in" on the demand for men, for equipment, for experience? Are you going to sit idly by wondering what it is all about, or are you going to make the most of this, the greatest opportunity presented to men of ambition in 50 years.

Write at once for the complete catalogue to the National Radio Institute. This is the turning point in your life. Upon your decision *this instant* may depend your entire future. Mail the coupon, or write a letter **NOW—for your own sake!**

NATIONAL RADIO INSTITUTE, Radio Headquarters

Dept. 1085

Washington, D. C.

Copyright 1921, National Radio Institute

NATIONAL RADIO INSTITUTE, Radio Headquarters
Dept. 1085, Washington, D. C.

Please send me your book telling how I can become a Radio-trician through your Home Study Course, in my spare time.

Name.....

Address..... City..... State.....

BOYS



Learn Drafting

DRRAFTING offers exceptional opportunities to boys and young men because drafting itself not only commands good pay, but it is the first step towards success in Mechanical or Structural Engineering or Architecture. And drafting is just the kind of work a boy likes to do. There is an easy, delightful way by which you can learn right at home in spare time. For 30 years the International Correspondence Schools have been giving boys just the training they need for success in Drafting and more than 300 other subjects.

Let the I. C. S. help you. Choose the work you like best in the coupon, then mark and mail it. This doesn't obligate you in the least, but it will bring you the information that will start you on a successful career. This is your chance. Mark and mail this coupon now.

----- TEAR OUT HERE -----

International Correspondence Schools
Box 5643-C, Scranton, Penna.

Without cost or obligation, please send me complete information about the subject which I have checked below:

- | | |
|---------------------------------------|---|
| <input type="checkbox"/> DRAFTING | <input type="checkbox"/> BUSINESS |
| <input type="checkbox"/> CARTOONING | <input type="checkbox"/> CIVIL SERVICE |
| <input type="checkbox"/> AUTOMOBILES | <input type="checkbox"/> PHARMACY |
| <input type="checkbox"/> CHEMISTRY | <input type="checkbox"/> ARCHITECT |
| <input type="checkbox"/> ADVERTISING | <input type="checkbox"/> BOOKKEEPER |
| <input type="checkbox"/> SALESMANSHIP | <input type="checkbox"/> GOOD ENGLISH |
| <input type="checkbox"/> ELECTRICITY | <input type="checkbox"/> WIRELESS |
| <input type="checkbox"/> ACCOUNTING | <input type="checkbox"/> CIVIL ENGINEER |
| <input type="checkbox"/> SURVEYING | <input type="checkbox"/> AIRPLANE ENGINES |

Name.....

Address.....

Occupation.....

Persons residing in Canada should send this coupon to the International Correspondence Schools Canadian, Limited, Montreal, Canada

Please Mention Popular Mechanics

WANTED! RAILWAY MAIL CLERKS

You won't get fired or laid off if you work for Uncle Sam. When everybody else is worrying about his job or looking for work, the U. S. Civil Service Employee is earning good, steady pay in a pleasant occupation of his own selection.

**\$1600 TO \$2300
A YEAR GUARANTEED**

Let me train you to pass the U. S. Civil Service Examination with **HIGH RATING** so you can get a position **QUICKEST**—at \$1600 to \$2300 guaranteed. I have trained **THOUSANDS**, and I guarantee you a position, or money back.

GET MY FREE BOOK

I was Civil Service Secretary Examiner for 8 years and **KNOW** how to qualify you in your spare time. My free book explains everything. Be sure to write postal for it **NOW**. Get into the Railway Mail, Post Office, Rural Carrier, Departmental, Internal Revenue, Immigration, Custom House or Postmaster Services right away and stop worrying about money or jobs! Write me now.

Arthur R. Patterson, Principal, Patterson Civil Service School, 85 Wisner Bldg., Rochester, N. Y.



HOW TO BECOME A PROFESSIONAL PHOTOGRAPHER

Earning \$35 to \$125 a Week

An interesting illustrated booklet (free) on choosing a vocation, the exceptional opportunities Photography offers you and how to avail yourself of these advantages.

Motion Picture—Commercial—Portraiture

Three to six months' Practical course. Modern equipment. Day or evening classes. Easy terms. Call or write for Catalog No. 49.

N. Y. INSTITUTE OF PHOTOGRAPHY
NEW YORK CHICAGO BROOKLYN
141 W. 36th St. 630 So. Wabash Ave. 505 State St.

\$5,000 SALARIES

are often paid to traffic managers. Numberless traffic positions pay \$2,500 to \$5,000 per year. Millions of dollars are wasted annually because of ignorance of cheaper ways to ship. You can be a traffic expert—step losses—make big money for yourself. Thousands of men now needed.

Learn at Home—Book Free

Actual Practice Method will quickly make you a Certified Traffic Manager. You can very soon qualify for a splendid traffic position. Write quick for big new illustrated book describing this wonderful training in detail. Write today. Address

American Commerce Association Dept. 106, 4043 Drexel Blvd. CHICAGO, ILL.

STAMMER

If you stammer attend no stammering school till you get my large **FREE** book entitled "STAMMERING, Its Origin and the Advanced Natural Method of Cure," bound in cloth and stamped in pure gold. Ask for special literature and a **FREE** copy of "The Natural Speech Magazine." Largest, best equipped and most successful school in the world for the cure of stammering, stuttering, etc. No sing-song or time beat. Write today. The North-Western School, 2317 Grand Ave., Milwaukee, Wis.

Genuine
\$20.00
Imported

Will Be
Given
To You
VIOLIN FREE

Help me introduce this beautiful Violin in your district. Be first to show how easy it is to play with help of three new inventions and my scientific instructions. You can play it in one week.

10,000 Students Found Violin Playing Easy to Learn

You can learn as easily as others. Surprise your friends. My three new inventions make it very easy. Have been teaching 40 years. Write your name and address on bottom of page and send for free violin offer and three new violin inventions.

PROF. A. HINCHCLIFFE, 233 Broadway
Woolworth Bldg. Dept. 50-6 NEW YORK

FREE RAILROAD FARE

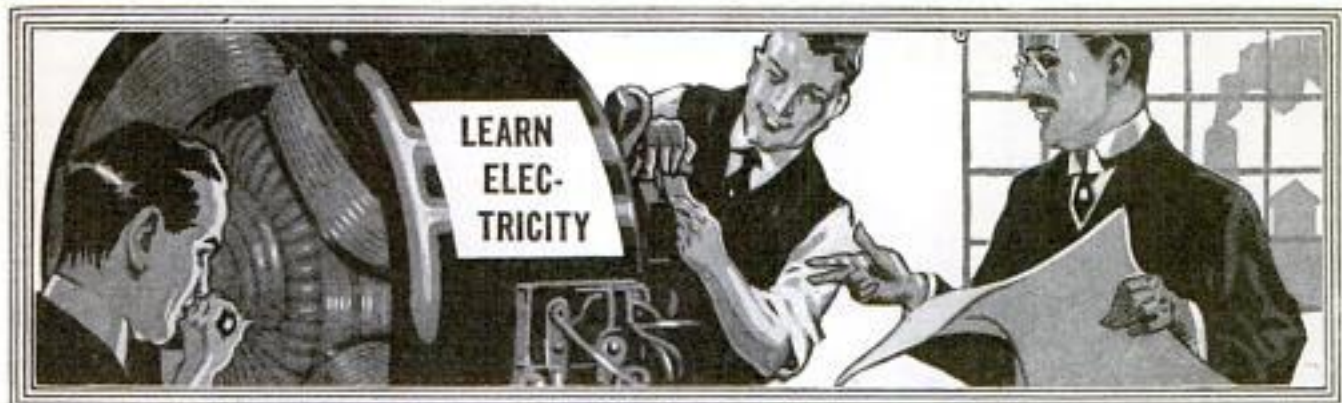

LEARN IN THE GREAT SHOPS OF EARN
 IN 3½ MONTHS **COYNE!** \$150 to \$400
 MONTHS A MONTH

Make this the most profitable and enjoyable summer of your life. Come to Chicago, the greatest summer resort city in the country on beautiful Lake Michigan, and the greatest electrical center in the world. We will pay your railroad fare from any place in the United States. See the country at our expense. And at the same time become a skilled electrical expert in the great shops of Coyne.

EARN WHILE YOU LEARN

Our Employment Department helps place students in jobs to earn a part or all of their expenses while studying. No charge for this service. Hundreds have worked their way through. The catalog explains fully.

Learn in 3½ Months

No books or useless theory. You are trained on \$100,000 worth of electrical equipment. Everything from door bells to power plants. You work on motors, generators, house-wiring, autos, batteries, radio, switchboards, power plants—everything to make you an expert ready to step right into a position paying from \$15 to \$100 a week. Learn electricity in the electrical center of the world. Here you see the mighty power plants, the great electrical manufacturers and marvelous electrical sign displays. You truly live with electricity in Chicago.

Coyne Training is Complete

The whole world of electricity is open to the Coyne trained man. He is trained completely. He can make big money as Power Plant Operator, Superintendent, Telephone man, Construction worker, auto, truck or tractor electrician, battery man, radio expert or he can go into business for himself as electrical contractor, dealer, auto ignition or battery expert and make from \$3,000 to \$20,000 a year. Hundreds of our graduates today are making big money and you can do the same if you grasp this opportunity—act now. Send for full particulars today.

Great Summer Resort City

Chicago, situated on beautiful Lake Michigan, is the Nation's summer playground. Marvelous boulevards, beautiful parks, bathing beaches, soaks, lake trips, amusement parks. Coyne is near the lake and bathing beach. Chicago's daylight saving time gives you a chance to enjoy these things by daylight.

One of
 Chicago's
 Many
 Big
 Pleasure
 Boats



Radio Course FREE

Besides paying your railroad fare we include with your regular course

- (1) A complete course in auto, truck and tractor electricity and storage batteries. Greatest outlay of auto electrical and battery equipment in the country.
 - (2) Complete training in Business Management—trains you thoroughly to run a business of your own.
 - (3) Course in Radio—the marvel of the age. Constructing, installing and operating—build your own set.
- Every student is given a life scholarship—he can stay as long as he likes and return whenever he likes.

Greatest Offer Ever Made

This is the greatest offer ever made by a school and it is for a limited time. Our departments may soon be filled and the offer withdrawn.

SEND COUPON NOW Don't delay a minute—send that coupon in **right now** for our big free catalog and full particulars of this wonderful offer.

B. W. COOKE, President
COYNE TRADE & ENGINEERING SCHOOL

Dept. 16
 39-51 E. Illinois Street
 CHICAGO, ILL.

COUPON

B. W. COOKE, Pres.
COYNE TRADE & ENGINEERING SCHOOL
 Dept. 16, 39-51 E. Illinois St.
 Chicago, Ill.

Dear Sir:—Please send me free your big catalog and full particulars of your special offer of free railroad fare and 3 extra courses.

Name.....

Address.....



\$100.00 a Week

He Doubled His Pay

and now enjoys the comforts and pleasures of a real income

Why not double your pay? Thousands of our students have done it and thousands more will do it. You can be one of them. Do not think for a moment that it is luck or pull which brings success and real money—far from it. It is preparing for the big opportunity and knowing what to do when the right time comes that does it. The men who have made successes for themselves were ready when their main chance came. Your main chance, too, will come. Are you ready for it?

Remember the Empty Lot?

The older fellows were playing ball and you were watching, wondering if you would ever get a chance to play. You knew if you only got a chance you would show them. Sure enough, one day they hollered, "Come on, kid, grab a bat!" Your chance at the pill had come. That is the way with life. Your chance at the pill will come, but, if you want to stay on the team, you will have to deliver the goods—and that you can do only if you are prepared. The big money and the permanent job go to the man "who knows."

You Can be the Man "Who Knows"

We will show you how. Without loss to you of a single working hour, we can show you a sure way to success and big pay. A large number of men in each of the positions listed are enjoying their salaries because of our help. We want to help you. Make a check on the coupon against the job you want and we will help you get it. Write or print your name on the coupon and send it in today.

AMERICAN SCHOOL

Dept. G-A74 Drexel Ave. and 58th St., Chicago

AMERICAN SCHOOL

Dept. G-A74 Drexel Ave. and 58th St., Chicago

Send me full information on how the PROMOTION PLAN will help me win promotion in the job checked.

- | | |
|------------------------------|----------------------------|
|Architect |Lawyer |
|Building Contractor |Machine Shop Practice |
|Automobile Engineer |Photoplay Writer |
|Automobile Repairman |Mechanical Engineer |
|Civil Engineer |Shop Superintendent |
|Structural Engineer |Employment Manager |
|Business Manager |Steam Engineer |
|Cert. Public Accountant |Foremanship |
|Accountant and Auditor |Sanitary Engineer |
|Bookkeeper |Surveyor (& Mapping) |
|Draftsman and Designer |Telephone Engineer |
|Electrical Engineer |Telegraph Engineer |
|Electric Light & Power |High School Graduate |
|General Education |Fire Insurance Expert |

Name

Address

Please Mention Popular Mechanics

WE TEACH COMMERCIAL ART

Properly Trained Artists Earn \$100 a week and up. Meyer Both College—a Department of the Meyer Both Company—offers you a different and practical training. If you like to draw, develop your talent. Study this practical course—taught by the largest and most widely known Commercial Art Organization in the field with 20 years' success—which each year produces and sells to advertisers in the United States and Canada over ten thousand commercial drawings. Who else could give you so wide an experience? Commercial Art is a business necessity—the demand for commercial artists is greater every year. It's a highly paid, intensely interesting profession, equally open to both men and women. Home study instruction. Get facts before you enroll in any school. Get our special booklet, "Your Opportunity"—for half the cost of mailing—4c in stamps.

**MEYER BOTH COLLEGE
OF COMMERCIAL ART**
Michigan Ave. at 29th St.
Dept. 15 CHICAGO, ILL.

Free to Writers!



A WONDERFUL BOOK—read about it! Tells how easily Stories and Plays are conceived, written, perfected, sold. How many who don't DREAM they can write, suddenly find it out. How the Scenario Kings and the Story Queens live and work. How bright men and women, without any special experience, learn to their own amazement that their simplest ideas may furnish brilliant plots for Plays and Stories. How one's own imagination may provide an endless gold-mine of ideas that bring Happy Success and Handsome Cash Royalties. How new writers get their names into print. How to tell if you ARE a writer. How to develop your "story fancy," weave clever word-pictures and unique, thrilling, realistic plots. How your friends may be your worst judges. How to avoid discouragement and the pitfalls of Failure. How to win! This surprising book is absolutely free. No charge. No obligation. Your copy is waiting for you. Write for it now. Just address

AUTHORS' PRESS, Dept. 51 AUBURN, NEW YORK

**Taxidermy
Book
FREE.**



**Stuff Beautiful
Birds.** Learn by mail to stuff and mount

all kinds of birds, animals, fish and game heads, make rugs, tan skins. Mount your own specimens and make money preserving for others. Men, women and boys learn easily and quickly. Success guaranteed or no tuition. Write today for our wonderful FREE book "How to Learn to Mount Birds and Animals. N.W. School of Taxidermy, A177 Elwood Bldg., Omaha, Neb.

Write Today.

STAMMERERS

For 55 years we have successfully corrected stammering by our simple and natural course of individual lessons. Attend no school until you have read our free booklet, "How To Stop Stammering."
SAMUEL A. ROBBINS, Director.
Boston Stammerers' Institute
245 Huntington Ave. Boston 17, Mass.

BE A JAZZ MUSIC MASTER



PLAY BY EAR

Play popular song hits perfectly by ear. Hum the tune, play it by ear. No tedious ding-dong daily practice—just twenty brief, entertaining lessons which you can master in no time. Send for the free book. It tells how to start if you want musical ability at which friends will marvel.
Niagara School of Music
Dept. 462, Niagara Falls, N.Y.

Send for this Free Book

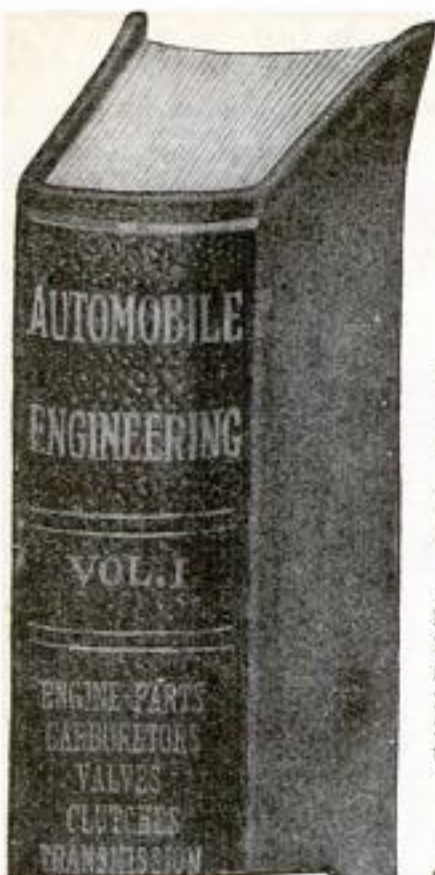

Price Reduced

Down goes the price on these famous Auto Books. We have induced our printers and binders to cut the price they charge us. We pass this saving on to our customers.

Mail Coupon Now For FREE Trial

NAME	POSITION	SALARY
John	AUTOMOBILE ENGINEER	\$125 A WEEK
	REPAIR MAN	\$50 A WEEK
	CHAUFFEUR	\$30 A WEEK



Put Your Name On This Pay-Roll

Men like you are wanted for big-pay positions in the fascinating field of automobile engineering. We have made it easy for you to fit yourself for one of these positions. You don't have to go to school. You don't have to serve an apprenticeship. Fifteen automobile engineers and specialists have compiled a spare time reading course that will equip you to be an automobile expert without taking any time from your present work.

AUTO BOOKS 6 Volumes Shipped Free

Now ready for you—an up-to-the-minute six-volume library on Automobile Engineering, covering the construction, care and repair of pleasure cars, motor trucks and motorcycles. Brimming over with advanced information on Lighting Systems, Garage Design and Equipment, Welding and other repair methods. Contains everything that a mechanic or an engineer or a motorcyclist or the owner or prospective owner of a motor car ought to know. Written in simple language that anybody can understand. Tastefully bound in American Morocco flexible covers, gold stamped, 2,650 pages and 2,100 illustrations, tables and explanatory diagrams. A library that cost thousands of dollars to compile, but that comes to you free for 7 days' examination.

Only 10c a Day

Not a cent to pay in advance. First you see the books in your own home or shop. Just mail coupon and pay express charges when books arrive. You can read them and study them for seven whole days before you decide whether you want to keep them or not. If you like the books send only \$2.80 in seven days and \$3 a month until the special introductory price of \$24.80 has been paid. (Regular price \$45.00.) Along with the set goes a year's consulting membership in the American Technical Society. (Regular price \$12.) This great bargain offer must soon be withdrawn.

PARTIAL LIST OF CONTENTS

- More than 190 Blue Prints of Wiring Diagrams
- Explosion Motors
- Welding
- Motor Construction and Repair
- Carburetors and Settings
- Valves, Cooling
- Lubrication
- Fly-Wheels
- Clutch
- Transmission
- Final Drive
- Steering Frames
- Tires
- Vulcanizing
- Ignition
- Starting and Lighting Systems
- Shop Kinks
- Commercial Garage Design and Equipment
- Electrics
- Storage Batteries
- Car and Repair
- Motorcycles
- Commercial Trucks
- Glossary



Mail The Coupon For These Books

Send No Money Now

Don't take our word for it. See the books without cost. There is so much profit in this offer for you, that we urge you to waste not a moment in sending for the books. Put the coupon in the mails today. Send no money—just the coupon.

Please send me the 6-volume set, Automobile Engineering, for 7 days' examination shipping charges collect. If I decide to buy, I will send \$2.80 within 7 days and the balance of \$3.00 a month until \$24.80 has been paid. Then you send me a receipt showing that the \$45.00 set of books and the \$12 Consulting Membership are mine and fully paid for. If I think I can get along without the books after the seven days' trial I will return them at your expense.

American Technical Society, Dept. A-19-A CHICAGO, ILL.

Name.....
Address.....
Reference.....

Dept. A-19-A

American Technical Society

Chicago, Illinois

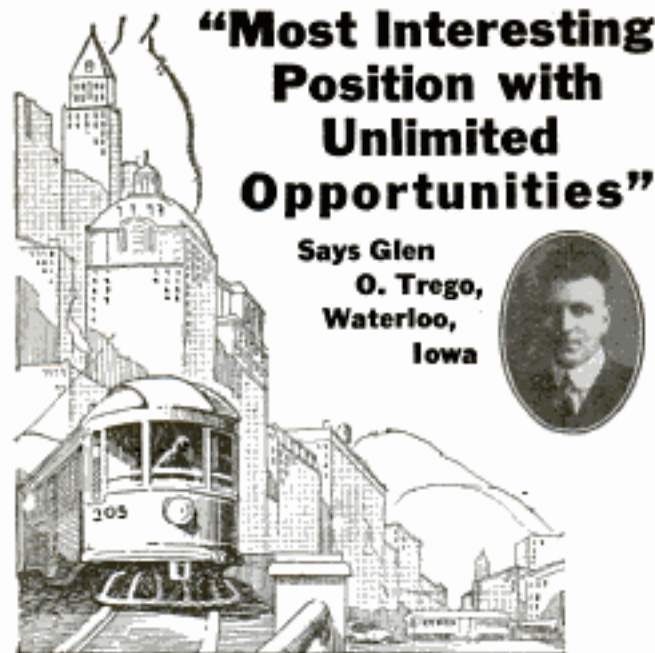

"Most Interesting Position with Unlimited Opportunities"

Says Glen
O. Trego,
Waterloo,
Iowa



BE A RAILWAY TRAFFIC INSPECTOR

Earn Up to \$250 Per Mo.
Position GUARANTEED

Hundreds of openings for trained Railway Traffic Inspectors. Any average man can qualify. Steady, pleasant, outdoor work; travel or remain near home. Something new every day.

Splendid Opportunities

Start at \$110 per month, expenses paid, after 3 mos. spare-time study at home. Advancement rapid with experience. Earn up to \$250.00 and \$300.00 per month. Many splendid opportunities thru contact with big railway officials.

Read What G. C. Trego Says:

"Having completed your course in traffic inspection about nine months ago and received a position within a few days thereafter, I now feel it my duty to express my gratitude to you for the help which was extended me after I began work. And that was far more than I expected.

"I find railway traffic inspection to be the most interesting position with unlimited opportunities that any man could look for. I find that being a railway traffic inspector does not only enable a man to receive higher positions in railways, but it also verses one so he is more capable of conducting any kind of business which may be chosen for the future.

"I must admit that the price paid for the course of traffic inspection is the best investment I made."

YOU TAKE NO RISK

If position is not obtained for you, enrollment fee is refunded without question. You have nothing to lose! Send coupon for full details and booklet No. D-585.

STANDARD BUSINESS TRAINING INST.
BUFFALO, N. Y.

Standard Business Training Inst.,
Buffalo, N. Y.

Send me, entirely free, Booklet No. D-585, giving full particulars about course in Railway Traffic Inspection.

Name

Street

City

PLAYA SAW



You can produce most wonderful, soft, sweet music from any common carpenter's saw with a violin bow or soft hammer. **If you know how.** No musical ability required—you need not know one note from another.

Easy to Learn in 3 Weeks

I ABSOLUTELY GUARANTEE to teach you to play popular music within three weeks. I will give you all the secrets and tricks I have learned in my ten years' success as a saw musician—secrets never before revealed and unknown to other musical entertainers. Very little practice required—it's all in knowing how. I furnish a specially tempered Musical Saw and complete course of instructions.

Send today for complete free information
"How to Play a Saw."

C. J. MUSSEHL - - - 312 MACK BLDG., FT. ATKINSON, WIS.

"Learn to Draw in One Evening

"—just as I did. I made actual pictures in an hour after my course arrived. Charles Lederer's wonderful method of drawing, as he calls it, makes drawing almost as easy as writing. Before long, I was holding down a well-paid position as a newspaper artist."

Complete Course Sent FREE

Just mail letter or post card to Lederer's publishers. Address them as "Independent Corporation, Dept. D-456, 319 Sixth Ave., New York." Say "Without obligation on my part send me the Lederer Complete Art Course for five days' free examination." Examine this course. See how easily you can become an artist almost "while you wait." Then, if you decide to keep this wonderful short-cut to a new, dignified, well-paid profession, all you have to do is to mail them only \$3.00 in full payment. There will be no further charges. If you do not wish to keep this course just re-mail it to them within 5 days. You do not risk a penny. But act quickly. Better mail letter today.



NAVIGATION TAUGHT BY MAIL

Hundreds of Ship Officers needed in Merchant Marine and Navy. Salaries up to \$412 monthly and living expenses. You can qualify through Captain Warren Shepard's Home Study Course on Navigation. Chance of a lifetime to see the world as a ship's officer at a big salary. Write for free Book, "Your Future is on the Seven Seas."

World Technical Institute, Dept. 100A, Fuller Building, Jersey City, N. J.

HIGHER EDUCATION

HOME
STUDY

Courses in English, Spanish, Mathematics, Chemistry, Drawing, Education, Business and in 35 other subjects are given by correspondence. Begin any time.

The University of Chicago

30th Year

Division 4, Chicago, Ill.

LEARN MOTOR MECHANICS

Our Big Shop Standard methods prepare you for the best paying jobs—make you a real mechanic. Test and Trouble work alone is worth tuition. Completely equipped shops. Get full information.

Write for Big Free Book

IOWA STATE AUTO & TRACTOR SCHOOL

"The Quality School" 739 Nebraska St., Sioux City, Iowa

RADIO FOR THE BEGINNER

An up-to-the-minute book in plain language presenting the principles of radio, the vacuum tube, radio tuning, and helpful suggestions for the Beginner. Handy pocket size, substantially bound. Price \$1.00. Address:

ALFRED FOWLER

18 Board of Trade

Kansas City, Missouri

Latest photograph
of
Earle E. Liederman
Taken
February, 1922

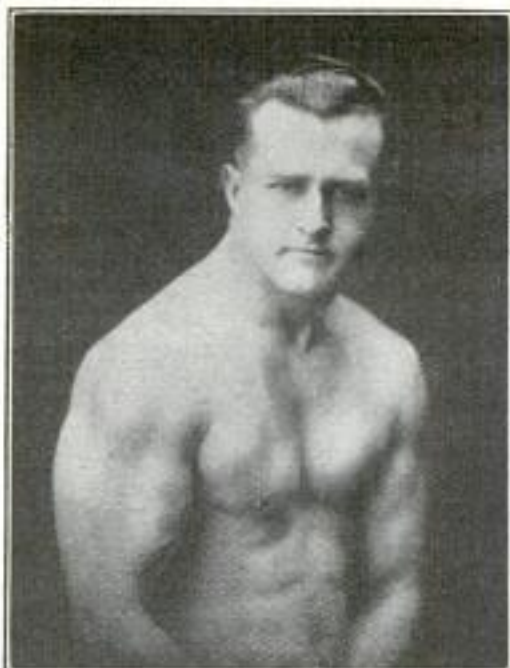

How Do You Look in a Bathing Suit?

Are you proud or ashamed of your appearance? Do you often long to hide your skinny arms or legs, your flat chest or your narrow shoulders? Perhaps you are one of those with a stout abdomen, which not only hinders you in your every effort, but is most unpleasing in the eyes of others. Are you satisfied to go through another summer just as you are today? Or do you have that longing for big, broad shoulders, massive, muscular arms, well shaped legs and a deep powerful chest? These are the possessions we long for as we step out on the beach. For at this time we are judged by our physical appearance. It is now up to you as to whether others will admire you or scorn you.

Why All This Muscle?

With massive muscles come mighty strength, powerful personality, tireless energy. You will also possess internal organs which function properly thus causing your entire being to fairly thrill with life and vitality at all time.

A Real Strong Man

You can be one. Now is the time to start. You can completely change your physical appearance before the summer is over. You can fill out your chest, broaden your shoulders and develop arms to be justly proud of. And with it you will attain the vim and pep that

EARLE E. LIEDERMAN
Dept. 2006, 305 Broadway, New York

only a real live blooded athlete knows. Those who now look at you and smile will envy you for your physical charms. They will look up to you and respect you. Get busy then, for time flies. Summer will soon be here. What impression are you going to make? Decide right now that this dominant physique will be yours.

Send for My New Book

"Muscular Development"

It contains 26 full page photographs of myself and some of the athletes I have trained. This book is bound to interest you and thrill you. It will be an inspiration to you. There is not another book like it on the market. I want every man and boy who reads this page to send for a copy. *It is absolutely free.* Remember, this does not obligate you in any way. I want you to have it, so it's yours to keep. All I ask you to cover is the cost of wrapping and postage—10 cents. Now, do not delay one minute. This may be the turning point of your entire life. Tear off the coupon and mail at once while it is on your mind.

EARLE E. LIEDERMAN

Dept. 2006, 305 Broadway, New York City

Dear Sir:—I enclose herewith 10 cents, for which you are to send me, without any obligation on my part whatever, a copy of your latest book, "Muscular Development." Please write or print plainly.

Name.....

Address.....

City.....State.....

Make Your ENGLISH Win for You!

You are sized up every day by the way you speak and write. The words you use, the way you use them, how you spell them, your punctuation, your grammar—all of these tell your story more plainly than anything else you do. And it is a story open to all. An unusual command of language enables you to present your ideas, in speech or on paper, clearly, forcefully, convincingly.

Sherwin Cody's Wonderful New 100% Method Self-Correcting!



SHERWIN CODY

A simple method has been invented by which you can acquire a command of the English language from the ground up. Sherwin Cody, perhaps the best known teacher of practical English, after twenty years of research and study, has perfected an invention which places the ability to talk and write with correctness and force within reach of every one with ordinary intelligence. Sherwin Cody was amazed to discover that the average person in school or in business is only 61% efficient in the vital points of English grammar. That is because the methods of teaching English in school left you only a hazy idea of the subject—they did not stick in your mind. But Sherwin Cody's new invention upsets all old standards of teaching English. His students secured more improvement in five weeks than had previously been obtained by other pupils in two years. Only 15 minutes a day of spare time with "100% Self-Correcting Method" will, within a very short time, give you an easy command of language.

15 MINUTES A DAY PERFECTS YOUR ENGLISH

Mr. Cody was granted a patent on his unique device, and now places it at your disposal. It overcomes the only weak point in instruction by mail. It actually takes the place of an instructor at your elbow. It assigns you lessons in Expression, Spelling, Punctuation, Grammar, Reading and Conversation, corrects them for you, and anticipates your questions. It even grades your papers and assigns you your class percentage till you reach the 100% mark. Yet so simple are the lessons that only 15 minutes a day are required, and each minute is fascinatingly interesting.

New Book Free If you feel your lack of language power, if you are ever embarrassed by mistakes in grammar, spelling, or punctuation, if you cannot command the exact words to express your ideas, this booklet will be a revelation to you. Merely mail the coupon and it will be sent by return mail. Learn how Sherwin Cody's new invention makes command of language easy to gain in 15 minutes of your daily spare time. Mail this coupon or a postal AT ONCE.

Sherwin Cody School of English

56 Searle Building ROCHESTER, NEW YORK

SHERWIN CODY SCHOOL OF ENGLISH
56 Searle Building, Rochester, New York

Please send me at once your Free Book "How to Speak and Write Masterly English."

Name

Address

City State



Learn Photography

Good-paying positions in the best studios of the country await men and women who prepare themselves now. For 28 years we have successfully taught

Photography, Photo-Engraving and Three-Color Work

Our graduates earn \$35 to \$100 a week. We assist them to secure these positions. Now is the time to fit yourself for an advanced position at better pay. Terms easy; living inexpensive. Largest and best school of its kind. Write for catalog today.

ILLINOIS COLLEGE OF PHOTOGRAPHY
Box P. 999 Wabash Ave. Effingham, Illinois

Earn \$35-\$125 a Wk



Your Opportunity in MECHANICAL DENTISTRY

Ambitious men of all ages can rise above small salaried positions into this profession of unlimited possibilities.

Taught by actual practice—day or evening. Three months' course. Modern laboratories. No previous knowledge or experience required. No charge for tools or equipment. The men we train are in demand. Established 30 years. Catalog free.

Address your inquiry to Dept. 2

BODEE SCHOOLS OF MECHANICAL DENTISTRY

NEW YORK
136 W. 52 ST.

PHILADELPHIA
15 1/2 and Walnut Sts.

BROOKLYN
15 Flatbush Ave.

EARN MONEY AT HOME

LEARN Show Card Writing by our new, simple Directograph system and earn money in your spare time at home. No canvassing or soliciting. We guarantee to supply work and pay you cash for the work you do. Write for full particulars and free booklet.

WEST-ANGUS SHOW CARD SERVICE
76 Colborne Building Toronto, Can.

LAW In Your Spare Time at Home for BUSINESS or PROFESSION

Degree of LL.B. Conferred. Only institution which gives same course by Correspondence through Lecture System as was given for years at resident classes of this college. We coach you free to pass the Bar Examination. Complete 1921, 13-volume library. Easy terms. Organized 1910. Low enrollment fee. Write for free book.
Hamilton College of Law, 431 S. Dearborn St., Dept. 66, Chicago



SHORTHAND IN ONE MONTH

Boyd—the Wonderful, New, Easy System. Writers hold World's record. 100 to 150 words a minute in 30 days guaranteed. New Principles—dictation first week. Best for Court Reporting and Secretaries. Also Typewriting, Bookkeeping and Commercial Law. Send today for Catalog and Money-Back Guarantee.
CHICAGO HOME STUDY SCHOOLS, 802 Resper Block, Chicago, Ill.



Write for my FREE BOOK, "HOW TO BECOME AN EXPERT PENMAN." It contains specimens and tells how others became expert writers. Your name written on a card if you enclose stamp.
T. M. TEVIS, Box 25K, CHILLICOTHE, MO.

You Can Play the Hawaiian Guitar Just Like the Hawaiians!

Because Our Native Hawaiian Instructors Will Help You

OUR STUDENTS SAY

Blaine, Wash., March 8-22
First Hawaiian Conservatory of Music,
Chas. F. Holland,
Dear Sir:

I received my Guitar in good condition and am now on my ninth lesson. I am having no trouble at all, and must say that I am more than pleased with the course and the simplicity of it. Any person who will just half try will surely succeed. I have never studied music of any kind. Consequently did not know one note from another and thus far I have committed all my lessons to memory. I am in a way handicapped by the loss of the index finger of the right hand but by little practice I find no great difficulty in playing or picking the different changes as I say any person who lose all of their fingers with a little practice should experience little or no difficulty by your wonderful method. I will be pleased to recommend your course to my friends. Very respectfully,
B. R. SOUTH, Class No. KI-12,033.

San Quentin, Calif., Jan. 15-22
First Hawaiian Conservatory of Music,
903 Woolworth Building, City,
Dear Sir:

Lessons 18 and 19 came last evening and I was pleased to see that they are beginning to get hard, or at least a little bit more to learn in them. I have a great deal of spare time to put in on the Guitar and I enjoy it. Your course is the simplest and most interesting I have ever tried to learn. I am getting along fine and can play every lesson up to the last one and I can readily see that when I have finished with all of the lessons I will be able to play most anything and play it good. I am, in appreciation,
Yours truly, J. E. FERGUSON.

P. S. If at any time you wish to use my name as a reference for your course you may do so, as I think that any one who takes it up will derive a great benefit from it and never regret it.

Our improved method of teaching is so **simple, plain and easy** that you begin on a piece with your first lesson. **In half an hour you can play it.** Thousands of successful students prove this to be true.

ONLY 4 MOTIONS We have reduced the necessary motions you learn to only four, and you acquire these in a very few minutes. Then it is only a matter of a little practice to acquire the weird, fascinating, tremolos, staccatos, slurs and other effects that make this instrument so delightful. **The Hawaiian Guitar plays any kind of music**, both the melody and the accompaniment.

FREE Just think of it. 52 lessons on this wonderful guitar. You get a beautiful large sized **Genuine Hawaiian Guitar absolutely free as soon as you enroll for the lessons.** All the necessary picks, the steel playing bar and **52 pieces of music are included without cost to you.**

Special Arrangements for Lessons if You Have Your Own Guitar

Play Any Music

In half an hour after you get the free Hawaiian Guitar and the first lesson, you can play **Hawaiian Melodies.**

In a very short time after a little practice you can play **any kind of music** as well as Hawaiian, both the melody and accompaniment.

[TEAR OUT COUPON]



Tear Off and Mail Today

First Hawaiian Conservatory of Music, Inc.
233 Broadway (Woolworth Bldg.), New York City

Please send me full information about your 52 easy lessons and FREE GUITAR OFFER.

NAME.....

ADDRESS.....

TOWN..... STATE.....

Print name and address clearly. P.M. 6

Learn Autos and Tractors



Wonderful opportunities constantly offered trained men; we train you thoroughly to start your own business or make good money as motor expert, driver, shop foreman, etc.

7,000 Graduates making good. Catalog Free

Cleveland Automobile School, 1814 E. 24th St., Cleveland, O.

TIME IS MONEY ROPP'S CALCULATOR



Saves Both. Shows prices, quantities, weights, etc., of familiar commodities in any business.

Desk Size, - - \$1.50
Pocket size, leatherette, - 1.00
Pocket size, cloth, paper, .35
Postage free anywhere

WELLS & EDWARDS
852 George St. Chicago, Ill.
Send for free book catalog

"THERE'S MONEY IN IT"

AT HOME LEARN TELEGRAPHY AT HOME MORSE AND WIRELESS

TEACH YOURSELF

In half usual time, at trifling cost, with the wonderful Automatic Transmitter **THE OMNIGRAPH.** Sends unlimited Morse or Continental messages, at any speed, just as an expert operator would. Adopted by U. S. Government, and leading Universities, Colleges and Telegraph Schools. 3 styles. Catalog free.

OMNIGRAPH MFG. CO.

16-22 Hudson St., NEW YORK

Learn Watchwork, Jewelrywork and Engraving.

A fine trade commanding a good salary, and your services are always in demand. Address HOROLOGICAL, Dept. P, Bradley Institute, Peoria, Ill., for our latest catalog.

WHY not spend Spring, Summer and Fall gathering butterflies, insects? I buy hundreds of kinds for collections. Some worth \$1 to \$7 each. Simple outdoor work with my instructions, pictures, price list. Get posted now. Send 25c (NOT STAMPS) for my Illustrated Prospectus. Mr. Simbar, Dealer in Insects, Dept. 6, Green Park, Calif.



WANTED

Railway Mail Clerks
\$1600 to \$2300 Year

MEN-BOYS OVER 16
SHOULD WRITE IMMEDIATELY

Steady work. No layoffs. Paid Vacations

Common education sufficient.
Send coupon today-SURE



RAILWAY MAIL CLERKS

FRANKLIN INSTITUTE, Dept. D177, Rochester, N. Y.

Sirs: Send me without charge, (1) sample Railway Mail Clerk Examination questions; (2) Schedule showing place; in all coming U. S. Government examinations; (3) list of many government jobs now obtainable.

Name.....

Address.....

How I Earn \$15 to \$25

a Week at Home
in my Spare Time
By Wm. S. Coulthard



I needed money. I had a lot of time on my hands in the evenings, Saturday afternoons, etc.—for I had no hobby—and besides my expenses had been mounting fast—so you will see the receptive mood I was in when I saw your little ad, "MAKE MONEY AT HOME."

I sent for your free booklet. I read it.

Your plan looked good to me—your guarantee so liberal—and on investigation I found you were reliable, so I accepted your offer. If others could make money by your plan, I could.

That was less than a year ago.

Now I am earning \$15.00 to \$25.00 a week, each week, writing show cards in my spare time. In addition to this, I still hold my regular job, and my salary has been increased there, too. I believe my spare time work has made me better satisfied with life, and so I'm doing my regular work better.

I have been offered positions writing show cards, but I am not interested, as my present position is perfectly satisfactory, but I certainly am glad I enrolled in your school—my spare time money is exceedingly attractive. Besides, I find show card writing an interesting occupation that fills in those evening hours that used to drag so. In fact, it is really a hobby now with me—and a profitable one, as you can well imagine. Only last week I received a check from your school for \$70.00 for work done over the last three weeks. Of course, you'd have paid me regularly each week if I'd bothered about it, but I was too busy to tell you the amount of work I'd finished.

There are times, however, that I feel show card writing by your simple method is almost too good a thing—that's when I have so many orders ahead that I cannot see my way clear to finish them—and have to turn down work.

Your system of supplying work to your students has certainly helped me, but sometimes you send too much—I'm only working at it in my spare time, you know. Please note this, and don't try to overload me too much.

By the way, I think you'll be interested to know that previous to enrolling in your school I had never tried my hand at any work of this nature.

I'm glad to thank you for what you've done for me—and you can certainly use my name and tell prospective students, for I feel I'll be doing any one a real good turn if I can help them get started in this profitable work.

Yours sincerely,

WM. S. COULTHARD.

NOTE:—The above is the story of Mr. Coulthard. It tells of facts, for Show Card Writing offers a marvelous opportunity to both men and women, either for spare time or full time work. What Mr. Coulthard has done and is doing, you can do. Colbran, Dusenberry, Wendt, Blade, Poulson, Charles, Wright, Babineau and many other men have proved it. Mrs. Litherdale, Mrs. Lush, Mrs. Le Moine and dozens of housewives have added to the family income in this way. Girls like Misses MacDonald, Clegg, Bordreau and Hoyle are but a few of those who have bettered their positions in this pleasant way. All these owe their success to the American Show Card School method of training—the old established school which has trained hundreds to make money in SHOW CARDS. The American Show Card School will gladly send you full particulars if you but send your name and address to them.

Use this
Coupon.

TEAR OFF HERE AND MAIL TO-DAY:

Name..... (Print your name plainly)

Address..... (In full)

State.....

American
Show Card
School

2030 Ryrie Bldg.
Toronto, Can.

Send me your Free Booklet on Show Card Writing, and show me how I can make money at home—without canvassing or soliciting. It is understood that this places no order or obligation of any kind.

BE AN ARTIST

We can teach you **DRAWING** in your own home during your spare time.

Our 18 years of successful teaching prove our ability. 30 Courses in Commercial and Illustrative Drawing. Teachers Normal and Applied Art. Endorsed by high art authorities. Students trained by members of our Faculty are filling high-salaried positions. Artist's Outfit FREE to Enrolled Students. Write today for Art Year Book.

OUR HANDSOME ART YEAR BOOK FREE TO YOU!

SCHOOL OF APPLIED ART

APPLIED ART BLDG. No. 2 BATTLE CREEK MICH.

Keystone Institute

Automotive Course

A splendid opportunity to learn the automobile business by comprehensive instruction and actual practice. Your success assured after finishing our course, whether as mechanic, salesman, or garage owner. Complete equipment, expert instructors, every modern facility for a thorough knowledge in this ever-growing field. Day and night courses. Write for full information to The Vice-President,

133 N. Fourth Street, Reading, Pa.

ELECTRICAL ENGINEERING

men with training are in demand. For more than a quarter of a century this school has been training men of ambition and limited time, for the electrical industries. Condensed course in Electrical Engineering enables graduates to secure good positions and promotions. Theoretical and practical Electricity, Mathematics, Steam and Gas Engines, Mechanical Drawing. Students construct dynamos, install wiring and test electrical machinery. Course with diploma, complete.



Thoroughly equipped fireproof dormitories, dining hall, laboratories, shops. Over 3000 men trained.

Write for catalog. 30th year begins Sept. 27, 1922.

BLISS ELECTRICAL SCHOOL

404 TAKOMA AVENUE, WASHINGTON, D. C.

LEARN WATCH REPAIRING

Be a watchmaker—you can learn this profitable trade by correspondence in a few weeks in your own home by the DeSelms Chart System. After you complete the course you will know a watch from A to Z. You will know just what the matter is and how to repair one. When you graduate you will be a practical watchmaker and repairer and competent to fill any position. Positional for our graduates.

Ask for our Free Book. I'll explain our system and terms

THE DeSELMS WATCH SCHOOL
23 Perry Street ATTICA, INDIANA



STAMMER NO MORE

Kill the fear of stammering. Re-education the key. The widely famed Hatfield Method fully outlined in an accurate, dependable, worth-while book—"HOW TO STOP STAMMERING." It has inspired thousands. Free copy today.

THE HATFIELD INSTITUTE, 109 N. Dearborn, Chicago, Ill.

BECOME AN EXPERT ACCOUNTANT

Executive Accountants command big salaries. Thousands of firms need them. Only 3600 Certified Public Accountants in U. S. Many are earning \$1,000 to \$10,000 a year. We train you thereby by mail in spare time for C. P. A. examinations or executive accounting positions. Knowledge of bookkeeping unnecessary to begin. The course is under the personal supervision of William B. Carlenholm, Jr., C. P. A., former Comptroller and Instructor, University of Illinois; also former Director of the Illinois Society of C. P. A.'s, and of the National Association of Cost Accountants. He is assisted by a large staff of C. P. A.'s, including members of the American Institute of Accountants. Low tuition fee—easy terms. Write now for information. LaSalle Extension University, Dept. 664-H Chicago. The Largest Business Training Institution in the World



If He Had Passed It Up

He Would Still be a Laborer at \$2 a Day. No Money, Nothing Ahead but Hard Work, Longer Hours—and Regrets. But He Didn't Pass It Up

He decided to learn Mechanical Drawing. He buckled down to work with the Columbia School of Drafting. When he had a quiet half hour to spend he spent it—as a wise man spends money—to get full returns.

MADE \$275 EXTRA IN 3 DAYS. He recently received \$275 for one drawing that only took him three days to draw.

NOW HOW ABOUT YOU? Are you working up hill or down? Count the money in your pay envelope next pay day. You'll find the answer there.

MAKE \$35 TO \$100.00 A WEEK. We will train you to be an expert Draftsman in your spare time at home by mail. There's lots of room for you if you act now.

PROMOTION IS QUICK. WE'LL QUALIFY YOU for a high-salaried position in the drafting field and keep you in touch with openings for Draftsmen in the big machine shops, industrial plants and United States Government departments. Men who start as

Draftsmen are often advanced to Chief Draftsmen, Chief Engineers, Production Managers and so on.

GET THE RIGHT TRAINING. Mr. Claffin, the founder and director, stands personally in back of the Columbia School of Drafting. You spend no time in long-winded theories—useless and expensive to you. You start on actual drawing work the day you receive your first lesson.

YOU NEED NO PREVIOUS TRAINING. The course is easy to understand and easy to follow. Many students are qualified even before they complete the course.

SUCCESS CALLS MEN OF ACTION ONLY. If you are a man of action clip the coupon now and show that you are a man of action. Keep right on top of this opportunity to make real money. Don't go looking for a pair of scissors. Tear the coupon off and mail it right now. We have a special offer for those who reply promptly. Get started now.

What We Give You

PRACTICAL PROBLEMS. You are carefully coached in practical Drafting work.

WE HELP YOU GET A JOB. We help you get a position as a practical Draftsman as soon as you are qualified.

PERSONAL INSTRUCTION AND SUPERVISION THROUGHOUT THE COURSE. You receive the personal instruction and help of Roy C. Claffin, president of the Columbia School of Drafting and a practical Draftsman of many years' experience.

DRAFTSMAN'S EQUIPMENT. We furnish you with a full set of Drawing Equipment and Drafting Instruments as shown in the picture below when you enroll. You keep both sets on completing the course.

CONSULTATION PRIVILEGES. You are free to write us at any time for advice and suggestions regarding your success.

DIPLOMA. The diploma we give you on completing the course attests to your proficiency as a Draftsman. It is an "entering wedge" to success.

FREE SUBSCRIPTION TO DRAFTSMAN'S PUBLICATION, "THE COMPASS." You are given free a subscription to our helpful, inspiring publication, "The Compass."



**Drafting
Outfit
Free**

FREE We give you free with our course this professional Drafting outfit. It is yours to keep when you complete the course.

U. S. Civil Service Commission Needs DRAFTSMEN

The following are a few of the many positions open in Government Departments from time to time. The salaries are starting salaries, subject to increase. Practically all of them carry a bonus of \$240 a year additional.

Architectural Designer..... \$4,000
Chief Draftsman (Aeronautical) Naval Aircraft Factory, per day.. 15.04
Aeronautical Draftsman—Field Service of Navy Department, \$5.20 per day to \$12 per day.

FREE BOOK

Send in this coupon today. Immediately on receipt of it we will send you our book, "Your Future in Drafting," which tells you all about our new method of teaching Mechanical Drawing and gives full details of our special offer to those who reply promptly.

THE COLUMBIA SCHOOL OF DRAFTING

Roy C. Claffin, President

Dept. 1755, 14th and T Sts., N. W., Washington, D. C.

Free Book Coupon

COLUMBIA SCHOOL OF DRAFTING,
 Dept. 1755, 14th and T Sts., N. W., Washington, D. C.

Enter my name for a free subscription to "The Compass" and also send me without charge your illustrated book on Drafting, telling me how I can secure your complete Home Study Course and your help in securing a position as Draftsman.

Name.....

Address.....

City..... State.....



"Look At Him Today!"

"Six years ago he started in here just as you are doing. Now he's General Manager and makes more in a day than he used to make in a week. The first week he was here he began to train for the job ahead by studying in spare time with the International Correspondence Schools. Inside of six months he got his first promotion. You've got the same chance he had, young man. Follow his example. Take up some I. C. S. course right away. What you are six years from now is entirely up to you."

This is the story of thousands of successful men. They did their work well, and in spare time, with I. C. S. help, trained themselves for advancement. That's the thing for you to do. Whatever your chosen work may be, there is an I. C. S. Course that will prepare you right at home for a better position with bigger pay.

More than 130,000 men are getting ready for promotion right now in the I. C. S. way. Let us tell you what we are doing for them and what we can do for you. The way to find out is easy. Just mark and mail this coupon.

----- TEAR OUT HERE -----

INTERNATIONAL CORRESPONDENCE SCHOOLS
BOX 5641-C SCRANTON, PA.

Without cost or obligation, please explain how I can qualify for the position, or in the subject before which I have marked an X:

- | | |
|---|--|
| <input type="checkbox"/> ELEC. ENGINEER | <input type="checkbox"/> BUSINESS MANAGEM'T |
| <input type="checkbox"/> Electric Lighting & Railways | <input type="checkbox"/> SALESMANSHIP |
| <input type="checkbox"/> Electric Wiring | <input type="checkbox"/> ADVERTISING |
| <input type="checkbox"/> Telegraph Engineer | <input type="checkbox"/> Show Card & Sign Ptg. |
| <input type="checkbox"/> Telephone Work | <input type="checkbox"/> Railroad Positions |
| <input type="checkbox"/> MECHANICAL ENGINEER | <input type="checkbox"/> ILLUSTRATING |
| <input type="checkbox"/> Mechanical Draftsman | <input type="checkbox"/> Cartooning |
| <input type="checkbox"/> Machine Shop Practice | <input type="checkbox"/> Private Secretary |
| <input type="checkbox"/> Toolmaker | <input type="checkbox"/> Business Correspondent |
| <input type="checkbox"/> Gas Engine Operating | <input type="checkbox"/> BOOKKEEPER |
| <input type="checkbox"/> CIVIL ENGINEER | <input type="checkbox"/> Stenographer & Typist |
| <input type="checkbox"/> Surveying and Mapping | <input type="checkbox"/> Certified Public Accountant |
| <input type="checkbox"/> MINE FOREMAN or ENGR | <input type="checkbox"/> TRAFFIC MANAGER |
| <input type="checkbox"/> STATIONARY ENGINEER | <input type="checkbox"/> Cost Accountant |
| <input type="checkbox"/> Marine Engineer | <input type="checkbox"/> GOOD ENGLISH |
| <input type="checkbox"/> ARCHITECT | <input type="checkbox"/> Common School Subjects |
| <input type="checkbox"/> Contractor and Builder | <input type="checkbox"/> CIVIL SERVICE |
| <input type="checkbox"/> Architectural Draftsman | <input type="checkbox"/> Railway Mail Clerk |
| <input type="checkbox"/> Concrete Builder | <input type="checkbox"/> AUTOMOBILES |
| <input type="checkbox"/> Structural Engineer | <input type="checkbox"/> Mathematics |
| <input type="checkbox"/> PLUMBING & HEATING | <input type="checkbox"/> Navigation |
| <input type="checkbox"/> Sheet Metal Worker | <input type="checkbox"/> AGRICULTURE |
| <input type="checkbox"/> Textile Overseer or Supt. | <input type="checkbox"/> Poultry Raising <input type="checkbox"/> French |
| <input type="checkbox"/> CHEMIST | <input type="checkbox"/> Airplane Engines <input type="checkbox"/> Spanish |
| <input type="checkbox"/> Pharmacy | <input type="checkbox"/> WIRELESS <input type="checkbox"/> Banking |

Name.....

Street and No..... 2-1-22

City..... State.....

Occupation.....

Persons residing in Canada should send this coupon to the International Correspondence Schools Canadian, Limited, Montreal, Canada.

Please Mention Popular Mechanics



THE PRACTICAL Automobile, Wagon, House and Sign Painter

By W. F. White

Postpaid, \$1.00

This book is written for the man who wishes to paint his automobile, or his home, or wagon. It will tell the inexperienced just how to do it, and it will tell him how to mix paints. It also contains many painters' recipes and trade secrets of great value. Bound in Cloth—157 pages—Size 5 x 7 1/2.

Postpaid \$1.00

SHREWSBURY PUBLISHING CO.
5525 West Lake Street Chicago, Illinois

LEARN PIANO TUNING

MAKING TRIALS
OF TRUE TONE

By
TUNE-A-
PHONE



We furnish our accurate teaching device with tools, Action Model, lessons, and analysis of business advertising which makes you a master of the tuner's art. Diploma given graduates. 18 years' experience in teaching the most independent and lucrative profession by correspondence. SIMPLER and BETTER than oral instruction. Write today for FREE booklet and guarantee plan.

NILES BRYANT SCHOOL OF PIANO TUNING
22 Bryant Bldg. Augusta, Mich.

MUSIC LESSONS FREE



IN YOUR
OWN
HOME

You can read Music like this quickly
Piano, Organ, Violin, Mandolin, Guitar, Banjo, etc.
Beginners or advanced players. One lesson weekly. Illustrations make everything plain. Only expense about 3c per day to cover cost of postage and music used. Write for FREE booklet which explains everything in full.
AMERICAN SCHOOL OF MUSIC, 51 Lakeside Building, CHICAGO

LEARN WATCH REPAIRING



You can learn by our modern and original system of instruction every part of the Watch Repairing Trade at home as good or better than at a shop. You can earn money while learning and secure a well paying position or start in business after completing our course of instruction. Good watch repairers are always in demand and earn from \$20 to \$70 per week. For particulars apply to the WISCONSIN SCHOOL OF WATCH REPAIRING 166 Mason St., MILWAUKEE, WIS.

LEARN AUTOMOTIVE ENGINEERING

A business for "live wires." There is a constant demand for trained Repairmen, Chauffeurs, Truck Drivers, Demonstrators, Automobile Salesmen, Garage Managers, etc.

COURSES \$25 AND UP

Positions secured for all competent graduates without charge. Diplomas granted. Write for free booklet.

GREER COLLEGE OF AUTOMOTIVE ENGINEERING
2024 Wabash Ave., Dept. 16 Chicago, Illinois

Learn Chemistry at HOME

Chemistry offers the greatest opportunities to-day of any profession. If you want to know how you can learn chemistry at home, in your spare time, write to one of the foremost authorities on Chemistry, Dr. T. O'Connor Sloane, care Chemical Institute of New York, Home Extension Division 6, 140-P Liberty St., New York City. Dr. Sloane will send you full information FREE, by return mail.

Draftsman's Complete Outfit

FREE



Everything Used by Expert Draftsmen Given You Absolutely FREE

Outfit includes "professional" complete set of fine drawing instruments with double set of compasses and dividers all in velvet lined case. Drawing board, T square, two triangles, protractor, universal curve, triangular, standard scale, water-proof ink, pens, pencils and all accessories—furnished you free in this expert's complete outfit.

Draftsmen Make \$225.00 to \$500.00 a Month

There is a tremendous demand for trained draftsmen. Now is the time to start. Draftsmen get good pay from the start and can work up to \$500 a month **and more**. Draftsmen are needed everywhere. Once you are trained you can choose your own business and work in any part of the country you please. Coyne training makes everything easy for you. Coyne student, L.T. Dubendorf, writes: "Immediately after completing Coyne course I went to work for Armour & Co. Work was easy for me. Five months later I accepted a position in New York at a large increase in salary."

3 Months' Course at

School You can qualify as an expert draftsman by 3 months' intensive training at the school in Chicago. Living

cheap. Possibilities of earning way while studying. If you go a far to come to school instead of the "Home Study" course, check coupon and send it for complete information.



B. W. Cooke

President

COYNE

HOME STUDY DEPT.

TRADE & ENGINEERING SCHOOLS

Recognized Producer of Successful Men

39-51 E. Illinois St., Dept. A177, Chicago, Ill.

Easy to Learn at Home from Great School Known all over the World

The Coyne Home Study course guarantees to train you. Remember, the Coyne Trade and Engineering Schools are recognized by educators all over the world. Students come from all over the **world** to get Coyne training. Why? Because of the Coyne school's long established, tremendous reputation for successful teaching by its great staff of experts. Coyne is not a "one man" school, but a great educational institution, 22 years old, an acknowledged leader and originator. Coyne originated the "Learn by Doing" method now endorsed by educators everywhere. Coyne has graduated thousands of successful, prosperous men all over the world. You can't make a mistake if you write for the Coyne free book. Coyne students say every minute of the course was enjoyable. Some students took **good positions three months before their course was finished.**

Send for FREE Book

Mail this coupon for our interesting book, "Drafting, the Foundation of Industry," sent you free. It explains all about the Coyne home study method and shows you how to become a draftsman in the quickest and easiest way. You want to know all about this great institution. Don't put it off. Send for this book now. It's absolutely free, no obligation. It contains the most valuable information you will ever get in your life. Send the coupon now.

Check Coupon Below and Mail Now!

**Coyne Trade and Engineering Schools,
Department A177 39-51 E. Illinois St., Chicago, Ill.**

Dear Sirs:—Please send me, absolutely free, without obligation, your book, "Drafting, the Foundation of Industry," also full information about the Course in Drafting. (Check which course you prefer.)

Home Study Course School Course

Name

Address

City.....State.....

YOU Too, Can Learn to Boss This Job

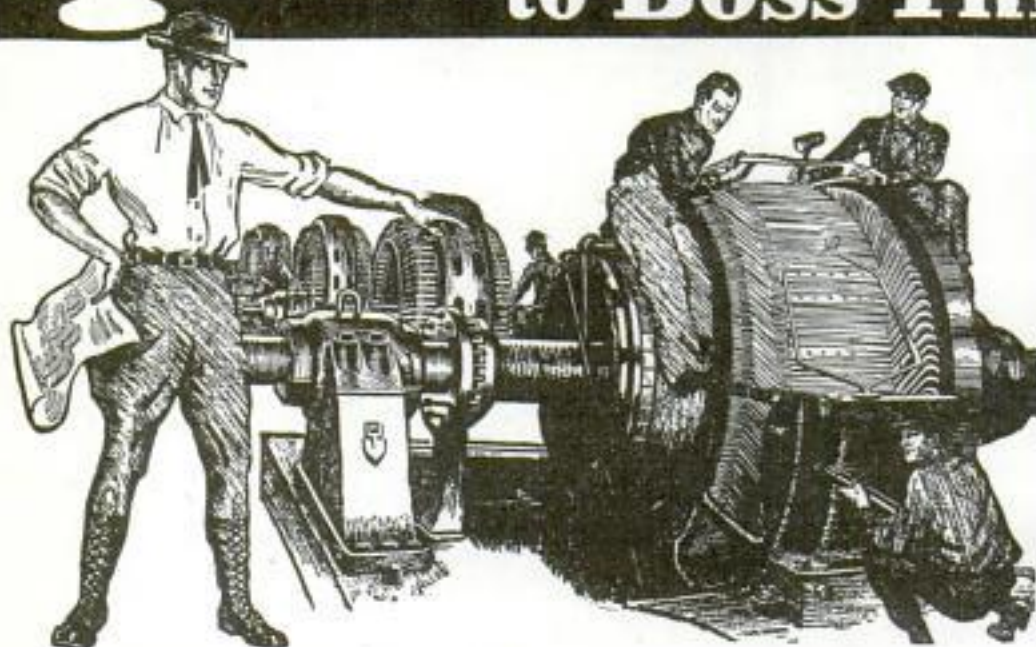

EXTRA SPECIAL!

Radio Course FREE

An up-to-the-minute Home Study Course—the latest wireless developments—given free to all who enroll for my great Electrical Course **NOW**. Two courses for the price of one. Mail coupon for full particulars.

“Electrical Experts” Earn \$12 to \$30 a Day Be an Electrical Expert

Today even the ordinary electrician—the “screw-driver” kind—is making money—big money. But it's the trained man—the man who knows the whys and wherefores of Electricity—the “Electrical Expert” who is picked out to “boss” ordinary electricians—to boss the big jobs—the jobs that pay **\$3,500 to \$10,000 a Year**. Get in line for one of these “Big Jobs” by enrolling now for my easily-learned, quickly-grasped, right-up-to-the-minute Spare Time Home Study Course in Practical Electricity.

Age or Lack of Experience No Drawback

You don't have to be a College Man; you don't have to be a High School Graduate. My Course in Electricity is the most simple, thorough and successful in existence, and offers every man, regardless of age, education or previous experience, the chance to become, in a very short time, an “Electrical Expert,” able to make from \$70 to \$200 a week.

I Give You a Real Training

As Chief Engineer of the Chicago Engineering Works, I know exactly the kind of training a man needs to enable him to get and hold good positions, and to earn big pay. I not only know, but I give you that training—I will train you as I have trained thousands of other men who, today, are holding splendid electrical positions, or are in business for themselves as Electrical Contractors.

FREE ELECTRICAL Working Outfit

With me you do PRACTICAL work—at HOME. You start right in after the first few lessons to WORK AT YOUR PROFESSION in a practical way. For this you need apparatus, and I give it to you ABSOLUTELY FREE. For a limited period, besides making a slashing cut in the cost of my tuition, I will GIVE each new student ABSOLUTELY FREE OF COST, a complete Electrical Working Outfit, consisting of Voltmeter, Ammeter, Electric Motor, Bells, Wire Gauge, Wire for Wiring, Tools, etc., for home and construction work.

But You Must Act Today

This offer is positively limited, and may shortly be withdrawn. Fill in and send me the coupon, or drop me a post-card, giving me your full name and address, and receive full particulars of this great offer. But do it NOW—TODAY—before it is too late.

L. L. COOKE, Chief Engineer

CHICAGO ENGINEERING WORKS

Dept. 1-A, 2150 Lawrence Avenue, Chicago, Ill.

L. L. Cooke,
Chief Engineer
Chicago Engineering Works

Dept. 1-A, 2150 Lawrence Ave., Chicago, Ill.

Dear Sir:—Send at once Sample Lessons, your Big Book, and full particulars of your Free Outfit and the two Home Study Courses—all fully prepaid, without obligation on my part.

Name

Address

What's YOUR Future?

Today you are earning \$20 to \$30 a week. In the same six days as an Electrical Expert, you can make from \$70 to \$200, and make it easier—not work half so hard.

Then why remain in the “small pay” game—in a line of work that offers—No Big Promotion—No Big Income—No Big Future?

Fit yourself for a Big Job.

Your Success Is Guaranteed

So sure am I that you can learn electricity—so sure am I after studying with me, you too get in the “big money” class in electrical work, that I will guarantee under Bond to return every single penny paid me in tuition if, when you have finished my Course you are not satisfied it was the best investment you ever made.

The “Cooke” Trained Man is the “Big Pay” Man

CLASSIFIED ADVERTISEMENTS

WORLD'S BEST WANT AD MEDIUM

Advertisements in this section, 25 cents per word, each insertion, minimum 10 words, payable in advance. To be inserted under proper classification in July issue, copy should be in our office May 25th.

AUTOMOBILE SUPPLIES

AUTOMOBILE Parts, guaranteed new, for all cars. Save money; get parts direct at wholesale. We ship immediately from stock, transmission and differential gears, bearings, shafts, gaskets, flywheel gear rings, pistons, rings and other parts for any car. When necessary we make gear-special from old samples. Get our wholesale prices today. Wire or write us when you need parts in a hurry. State make of car, model and parts wanted. We refund your money, including transportation charges, if parts are unsatisfactory. Mechanics Gear Works, 3708 North Halsted Street, Chicago, Ill.

AMERICAN Garage & Auto Dealer publishes each month interesting and helpful suggestions and information on sales, merchandising, advertising, business management, accounting, welding, cutting, brazing, practical and progressive hints for office and shop for "small-town" automotive dealers, garagemen, repairmen, mechanics. Subscription price \$1.00 per year. Sample copy on request. American Garage & Auto Dealer, 1904 Lake View Bldg., Chicago.

AUTOLOG! Only accessory on the market for keeping monthly record of gas, oil and mileage per gallon. Clamps on steering wheel. No larger than a watch. Price, \$2.00. Satisfaction guaranteed or money back. Autolog Company, Dept. P, 1032 So. Grand Ave., Los Angeles, Calif.

AUTO Parts—Save 25-90%. New gears, axles, bearings, springs, radiators, magneto—4,000 models. Bankrupt supplies, retopping outfits. Brightman Auto Exchange, 321 Windsor Ave., Hartford, Conn. Largest in the East.

AUTO PARTS: Case, Overland, Paige, Studebaker, Ford, Maxwell; also starters and generators. Motor Service Co., 715 No. Spring, St. Louis, Mo.

AUTO Top Roof Covers easy to put on. You drive 100 tanks and save \$15 to \$40. Ford Roadster \$5.20, Touring \$6.95 and \$9.95. Chevrolet, Dodge or Maxwell \$13.95. All other cars \$16.50 with plate glass lights. Ford regular side Curtains, \$5.95 up. For other cars \$11.50 up. Ford Seat Slips, Roadster \$3.15, Touring \$6.25, or tailored, Roadster \$6.20, Touring \$9.90, other cars \$4 to \$32. Ford Cushions \$5.95. All goods same as car manufacturers use and guaranteed to fit. Printed instructions given how to apply. Send for samples. Prices delivered at your door. Equipment Co., 30 Canal, Cincinnati, Ohio.

AUTO PARTS for any car. We save you 10 to 90% and ship same day order is received. We have gears, shafts, bearings, springs, pistons, pins, rings and bushings, cylinder head gaskets, top slip roofs, clutch leathers, radiators, coils, magnetos, Atwater Kent, Connecticut, Delco and Remy ignition systems and parts. When you want auto parts, write us giving make, model and parts wanted. We have it, will get it, or it is not made. Guarantee to please you or will refund your money. Auto Tire and Parts Co., 501 Broadway, Cape Girardeau, Mo.

95 PER CENT Saved on Auto Parts. We save you up to 95 per cent on slightly used gears, axles, bearings, springs or motor parts for every make or model car, or we furnish new parts at savings up to 50 per cent; send for our prices or order direct from this ad; all parts guaranteed to give complete satisfaction or your money refunded in full. Our reference: Parkers State Bank of Kansas City. Brown Auto Wrecking Co., 1593 East 18th St., Kansas City, Mo.

AIR Compressor with Tank and Hose \$50. With Motor \$72.50. Suitable for private or public garage, tire shop, painting or cleaning. Also Motor in the Head Buffer. Home size \$18.50, Shop size \$25. Garage size \$100. Battery charging outfit, home or garage size \$14. Send for our large 100-page catalogue, describing all kinds of Air Compressors, Vulcanizers, Garage and Battery outfits. Equipment Co., 21 Canal St., Cincinnati, Ohio.

AGENTS Wanted. Colpin Magneto Re-Charger charges any magnet, charges Ford Cars, Trucks and Tractors without removing parts, all from A. C. light socket; guaranteed to do perfect work or money refunded. \$32.50 with order, balance \$5.00 per month for five months. Liberal discounts. Magnetizer Manufacturing Co., 150 W. Florence Ave., Los Angeles, Calif.

GARAGE, Repair or Harnessmen: Write now for complete proposition that enables you to quickly and profitably make new or repair old flat belts for cars, trucks, tractors or small shop machinery. See our ad, on page 159. Lakewood Fabric Belting & Mfg. Co., 1518 W. 117th St., Lakewood, Ohio.

AUTOMOBILE Owners, Garagemen, Mechanics, Repairmen, send for free copy of our current issue. It contains helpful, instructive information on overhauling, ignition troubles, wiring, carburetors, storage batteries, etc. Over 140 pages, illustrated. Send for free copy today. Automobile Digest, 505 Butler Bldg., Cincinnati.

PROTECT Your Rights. Write for "Record of Invention," which contains forms to establish evidence of conception of your invention. Prompt personal service. Preliminary advice without charge. J. Beane Kelly, 612-G, Columbian Bldg., Washington, D. C.

PRONTO Series Gap Mica Spark Plugs. Guaranteed life of motor. Positively shoots through oil. 100% Government Air Mail Service test. Real dealers and distributors write. Pronto Mfg. Co., Omaha, Nebr.

SELL the new R. & C. Pedal for Fords. Positive neutral without guesswork. Eliminates use of emergency lever. Send for literature. Burnham-Cote Co., Holyoke, Mass.

LEARN Automobile Painting, Retrimming Business at home. No previous experience required. Profitable work everywhere. Worth many times the cost. Auto-finishing Co., Sheboygan, Wisconsin.

RUST-I-CIDE Chemically Kills Rust. Automobiles; Body, Fenders, Rims, Springs. Bottle postpaid 35c. Sales Agents' opportunity here. The Rusticide Co., Cleveland, Ohio.

AREND Piston Rings—Patented Sept. 27, 1921. Adjustable. Send for circular and price list. John Arend, Mankato, Minn.

AUTO Parts, Tires, Tools, Factory-made Pistons, Pins, Rings, National Accessories Co., Box 404, Detroit.

SALESMEN—Motor Oils, Blake Oil Co., 94 Ives Street, Waterbury, Conn.

"HOW To Sell Patents" free. Patent News, F. Washington, D. C.

MAGNETO Charger, Guaranteed; Free Trial. Reliable. 426 Mary St., Utica, N. Y.

SAVING fuel and oil, stopping oil pumping, decreasing carbon deposits is accomplished by Zelec, the zinc-coated piston ring; price 45c each; coated by special process. If your dealer doesn't handle, order of Zelec Piston Ring Division, Zelnicker, St. Louis. Distributors wanted.

STORAGE Battery Charging Earns Unusual Profits, using HB Chargers. \$29 starts. Balance payments. Hobartsons, Troy, Ohio.

FREE Inner Tubes, Veteran's War Patent. Photographer, National Home, Ohio.

AUTO Motors Supplies; Buick—Michigan—Stoddard-Dayton—E. M. F.—Cadillac—Overland—Continental and Buda Motors. All types, \$50.00 each and up. New Dixie Magnetos \$20.00. Splitdorf High Tension Magnetos \$10.00. Kellogg Pumps \$3.50. Auto-Lite generators, new, \$10.00. Air Gauges 65c. Remy Ignition Coils, new, \$3.00. Electric and gas headlamps, coils, distributor heads, air compressors, etc. Write for catalog. Motor Sales Dept. 15, West End, Pittsburgh, Pa.

VULCANIZING and Repairing is a paying business. Forty million tires need repairing every day. Make big profits in tire repair. Easy to learn. Instructions free. No hard times, Always busy. Get into this moneymaking business quick! Plants \$200 up. Write for free catalog. Equipment Co., 1 Canal, Cincinnati, Ohio.

AUTO Owner Tire Agent wanted each locality to use and take orders for hand-made Mellinger extra ply and cord tires; guaranteed by bond for 8,000 and 10,000 miles (no seconds); shipped prepaid on approval; get your tires free; no capital or experience required; make \$100 to \$200 weekly. Write for wholesale prices and sample section. Mellinger Tire Co., 929-K Oak, Kansas City, Mo.

AIR Compressors—Genuine Brunner Compressors, new, on very attractive terms; send post card. Brunner Mfg. Co., Dept. A, Utica, N. Y.

AUTOMATIC Compressors, Grinders, Battery Chargers, Motors. Unusually easy terms. Write us your needs. Hobarts, Troy, Ohio.

ELECTRIC Service and Battery Stations send your jobber's name for booklet entitled "The Testing and Repairing of Automotive Electrical Equipment as a Profitable Business." Electric Machine Corporation, Indianapolis, Ind.

AUTOMOBILES

"AUTOMOTIVE Service Monthly," a pocket-size trade paper containing the best reading matter on modern practice in service work that it is possible to secure and a review of the articles on service and repairing now appearing in all the motor papers. Every foreman or superintendent should read every issue to keep posted up to date on his job. \$1.00 a year. Send order and will bill up with first number, or send cash with order and a useful small tool souvenir will be included. F. M. Dampman, 98 Park Place, New York.

AUTOMOBILE Owners, Garagemen, Mechanics, Repairmen, send for free copy of our current issue. It contains helpful, instructive information on overhauling, ignition troubles, wiring, carburetors, storage batteries, etc. Over 140 pages, illustrated. Send for free copy today. Automobile Digest, 505 Butler Bldg., Cincinnati.

DYKE'S Automobile Encyclopedia contains the greatest array of automobile facts ever published in one volume. Several separate books containing the same information would cost in the neighborhood of \$21.00. New, enlarged edition, 963 pp., 3362 illus. Cloth \$8.46. American-Morocco, \$7.96 postpaid. Popular Mechanics, Book Dept., 6 N. Michigan Ave., Chicago.

STUDEBAKER Four-cylinder seven-passenger touring, like new, \$440; accept \$200 cash, balance twelve monthly notes. Miss Kay, 409 East 163rd St., New York City, N. Y.

AUTOMOBILE Repairman's Helper. In Two Vols. An excellent new work that gives every operation required to adjust or repair the troubles likely to be found in all standard cars. Vol. 1, Repairshop Practice, Passenger Cars, Trucks, 535 pp., 417 figs. Price \$3. Vol. 2, General Shop Practice, Passenger Cars, Parts and Accessories, 528 pp., 428 figs. Price \$3. Popular Mechanics Book Dept., 6 N. Michigan Ave., Chicago.

PATENTS—Write for our free illustrated Guide Book and Evidence of Conception Blank. Send model or sketch and description of your invention and we will give our opinion of its patentable nature. Highest references. Prompt service. Reasonable terms. Victor J. Evans & Co., 185 Ninth, Washington, D. C.

FOR FORD OWNERS

FORD Owners. Stop your Ford from Chattering by installing Bredar's Ball Shim. Price \$1.50. Write for information and Agency proposition. Nic Bredar's Son Mfg. Co., Rock Island, Ill.

FORD Car Repair Book sent free. This complete, well illustrated, valuable book explains in a simple way the Causes and Cures of Overheating; Repairing Ford Timer; Curing Piston Ring Troubles; Carburetor Adjustments and Repairs; Connecting Rods; Transmission Troubles; Care and Repair of Rear Axle; Stopping Axle Grease Leaks; also covers practically every other phase of Ford Car Repairing. Send 25c coin for three months' trial subscription and get the valuable repair book free. Ford Owner and Dealer Magazine, 518 Montgomery Bldg., Milwaukee, Wis.

SPECIAL Offer. Ford and Fordson Owners! 100% Saving! Factory to User. \$1.25 brings postpaid 4 Genuine Blue Flame Spark Plugs, 10 for \$2.50. Money back if not satisfied. Crimp Grip Company, Belvidere, Ill. Dept. P.

WONDERFUL Mayer Carburetors. More mileage; easier starting. Sold everywhere since 1910. Former price \$18.50. Our price while they last, \$7.75. Send no money. Just name, address, and state if car has self-starter. Pay postman on arrival. Order today. Jaffe Radiator Co., 741 W. Van Buren St., Chicago.

FORD Sport Model Fenders. Something new and very classy. Ask for complete description. Star Supply Co., Lima, Ohio.

FORD Speeders 70 to 80 miles per hour. One dollar tells you how. D. L. McCreezy, Florence, Colo.

KEEP Cool. Breeze brackets make the windshield adjustable. Prepaid \$5. Agents. Address. Buckstaff Breeze Bracket Co., Lincoln, Neb.

FORD Magnets Recharged in Five Minutes without removing any parts from car. Secret exposed. Anyone can do it with materials you already have. Nothing extra to buy. Fully charged magnet removes cause of ignition troubles, gives easy starting, bright lights, more power, saves gas. Complete simple instructions and wiring diagram 50c coin or money order. The Auto Electrician, Box 261, Middletown, N.Y.

YOU don't have to get under or raise the hood. U-See-It shows exact amount of oil from the driver's seat day or night. Built like time-tried gauges in the big cars. Endorsed by experts. Nicely finished, strong, durable; special patented features, easily installed. Absolute money-back guarantee. Postpaid in U. S. \$4.75. Oil-O-Meter Mfg. Co., 420 Sycamore St., Evansville, Ind.

EXCLUSIVE territory open now. Nothing placed on market in recent years improves driving a Ford car as our Duplex Gear-Control. A permanent utility. Will outwear the car. Hobbs gear in neutral or low. Makes hill-climbing a pleasure instead of hard work. Retails for \$6.00. For particulars address Morris & Burns, 278 Twelfth Street, Oakland, Calif.

PROTECT Your Motor; save time, money, clothes and temper with our superior, water-proofed, detachable belts for Fords. Regular price 50c each. Six belts sent postpaid for \$1.25. State model when ordering. Money refunded if not entirely satisfied. See our adv. on page 150. Lakewood Fabric Belting & Mfg. Co., 1518 W. 117th St., Lakewood, Ohio.

INVESTIGATE—Ford Owners, Dealers and Salesmen: We have a Ford low-speed and neutral lock for all model Ford Cars and Trucks. Eliminates the necessity of holding low-speed pedal down. Retail price \$3.00. Good proposition for dealers. Huck Low Speeder Company, Virginia, Ill.

CYCLO "Modified Vapor" System is the only all-year hot-spot manifold automatically regulated without moving parts. Big gas saving. Cyclo Manifold Co., South High St., Akron, Ohio.

THE B. & C. Pedal for Fords. Eliminates use of emergency lever and finds neutral for you. Salesman wanted. Send for literature. Burnham-Cote Co., Holyoke, Mass.

CONVERT Ford into 1½-ton truck. Complete auxiliary springs \$20. Unwin, 305 Broadway, New York, N. Y.

SPEEDSTER Fans: Don't fail to see "Red-1-Kut" ad. Page 141.

LACEY Patent Sense. See page 158.

JULES Oil Circulator stops any Ford from pumping oil, doubles oil mileage. Guaranteed. \$4.00 each. Special introductory price, \$2.00. C. O. D. Money back if dissatisfied. Electric Machine Corporation, Indianapolis, Ind.

FORD Owner: Should you lose your Ignition Key, "don't get stuck on the road"; be prepared. Learn the secret of running your car without the ignition key. Full instruction for a dollar bill. Fred Brewer, 129 Park Place, Brooklyn, N. Y.

"READ" Ball-Bearing Clutch Screw doesn't drag, it rolls. Makes Hand Brake Operate Easily. 20c (coin). Address "Read," 78 Kingston Ave., Brooklyn, N. Y.

SIMPLEX Starter \$29.09. Easily sold. American-Simplex Co., Anderson, Ind.

MOTORCYCLES, BICYCLES AND SUPPLIES

EXCELSIOR. Henderson parts; new or used—parts lists, 10c. Expert repairing. Excelsior Motor Supply Co., 100 N. 12th St. Leech, Mo.

BREECHEs. puttees at exceptionally low prices. Write for Bargain Bulletin. Union Merchandise Co., 100 Summit St., Toledo, Ohio.

BARGAINS in 1919-1921 Twin Indians. Harleys. G. L. Claggett, Barnesville, Md.

HARLEY-DAVIDSON, electric, 3 speed, fully equipped, \$135.00; also other makes. Write for our bargain list and our easy-payment plan. Lavin Motor Supply Co., 1932 N. Napa St., Philadelphia, Pa.

SHAW Motorcycle, Super H Model, 2-inch tire, chain drive, new, never used, in original crate: \$110. Roy Bates, Janesville, Wis.

BUILD own sidecar, trailer. Wheels 28x3, with ball bearings, \$6. All parts cheap. Unwin, 305 Broadway, New York, N. Y.

BARGAINS in used motorcycles, new and used motor wheels. Lists free. Seeber-Hofbeins, Buffalo, New York.

WHY buy a used motorcycle? A new Cleveland costs only \$185. See page 139.

POWERPLUS Indian twin, fine condition, \$75. Geo. Laatch, Altamont, Ill.

BALTIMORE Police Indians, '20 model Elec. Equipped, \$160.00; '21 Model, Elec. Equipped, \$210.00; 22" Truss Frame Bicycles, \$23.00. Howard A. French, Baltimore, Md.

SEND for big list of slightly used motorcycles on our easy payment plan. Howard Cycle Co., 152 N. Broad St., Trenton, N. J.

USED parts for all motorcycles cheap. State wants. Schock Cycle Co., 1922 Westlake, Seattle, Wash.

USED and new parts, Indian, Excelsior, Harley, Reading, Thor, Henderson, Yale. Get our price lists. Kingshighway Cycle Co., 1166 North Kingshighway, St. Louis, Mo.

DON'T buy a Bicycle Motor Attachment until you get our catalogue and prices. Shaw Mfg. Co., Dept. 27, Galesburg, Kan.

NEW motorcycles have been reduced 10%. Our prices have been reduced 35%. Send for big bargain list of rebuilt motorcycles. Western Supplies Co., 359 Hayutin Bldg., Denver, Colo.

USED motorcycles, new and used parts; write us. Mahowald Cycle Co., Mankato, Minn.

BOYS, build your own cycle car! Send 25c for building plans and list of parts. We can supply motor with clutch and all parts at low prices. Shaw Mfg. Co., Car Dept., Galesburg, Kan.

MOTORCYCLE Cylinders reground, fitted with new piston rings, \$6.00. Guaranteed. Muncie Piston Co., Muncie, Ind.

AVIATION

NEW Standard 3-seater plane, 100 h. p. motor, full set of instruments, ready to fly; immense bargain at \$975. Aero Exchange, 88 Park Row, New York, N. Y.

THIS is Your Chance of a lifetime to become an Airplane Expert. Write Leslie Coombs, Chief Engineer, Central Airplane Works, 3254 Lincoln Avenue, Chicago.

HEATH propellers represent the most efficient method of aerial drive. Each propeller individually designed for the particular work to be done, as laid out by America's oldest aeronautical Engineers. Propeller catalog 4c. Heath Airplane Co., Chicago, Ill.

A WONDERFUL opportunity to learn to fly by our new method, includes three hours' instruction in the air and one month intensive shop course, complete at \$100.00. Heath Airplane Co., Chicago, Ill.

FOR June we offer the greatest bargains in the history of aviation. Dope \$1.65; turnbuckles, all sizes 25c; aero cloth 39c yd.; shock absorber 5c ft.; Curtiss or Gnome motors \$200.00; new propellers \$18.00; clevis pins 2c; steel tubing 5c ft.; airplane sheet steel 5c lb.; other wonderful bargains. Get free sale sheet. Heath Airplane Co., Chicago, Ill.

AERIAL propeller attachment for boats. Blue Print only, 75c. Aeronautical Supplies Bulletin, 4c. Ostergaard Aircraft Works, 1289 North Narragansett, Chicago.

BIGGEST best catalogue Model Aeroplanes, Parts and Supplies; 5c postpaid. Ideal Aeroplane Co., 67½ West Houston, New York.

INVENTORS desiring patents should write for our Free Illustrated Guide Book and Evidence of Conception Blank. Send model or sketch for our opinion of its patentable nature. Highest references. Prompt service. Reasonable terms. Victor J. Evans & Co., 187 Ninth, Washington, D. C.

WELDING

WELDING Encyclopedia—A complete instruction book on all welding processes: oxy-acetylene, electric arc, electric resistance and thermit. Welding of all weldable metals fully discussed. 325 pp. 375 illus. The accumulated experience of the welding brains of America is yours for \$5. Money back if not satisfied. Popular Mechanics Book Dept., 6 N. Michigan Ave., Chicago.

MOTOR Grinder and Tire Buffer, Automatic Compressors, Battery Chargers, Motors. Unusually Easy Payments. Write us. Hobart's, Troy, Ohio.

BOOKS AND PERIODICALS

STUDY Human Nature, know people, make more money. Send 10 cents for "Personal Power," a little book that points the way. Address, Progress League, C-31 Union Square, New York, N. Y.

"36 ACCOUNTING Problems Solved by C. P. A." Cloth bound, loose leaf, new, original, up-to-date, valuable. Prepaid, \$1.00. Walhamore Company, Lafayette Bldg., Philadelphia, Pa.

BOOK on boxing and home exercises, by Jack Malone, 25c. Progressive Publishers, St. Paul, Minn.

1,600,000 INDUSTRIAL Facts, Calculations, Receipts, Processes, and Trade Secrets for every business are contained in the 1916 page book "Moore's Universal Assistant and Complete Mechanic," 500 engravings, cloth. Price \$2 postpaid. Popular Mechanics Book Dept., 6 N. Michigan Ave., Chicago.

PROFESSIONALS—Palmsistry and Dictionary \$1. Original Master Key \$5. Catalogue 2c. Sovereign Company, 160 Sycamore St., Buffalo.

BOOKS, All kinds. Lists. Higene's, A2241 Post Street, San Francisco, Calif.

OUR new catalogue listing over five hundred carefully selected practical books under eighty different subject groupings will be sent free upon request. Popular Mechanics Book Dept., 6 N. Michigan Ave., Chicago.

CONCENTRATION. Learn how to keep your mind upon one subject despite interruptions. Wonderful possibilities through psychology of thought control. Book 50c. Another book, "How to Conquer Fear," shows how to avoid worry, doubt, nervousness; gain contentment, 50c. Both \$1. Satisfaction or money back. Centre Publishing Co., 108 W. 34th Street, ZB, New York, N. Y.

AGENTS—Big profit selling our up-to-date Radio books. Write for agents' proposition. Norman W. Henley Publishing Co., 2 West 45th St., New York.

ELECTRICITY Taught by experts; earn while you learn at home; electrical book and proof lessons free; your success guaranteed and position secured. Chicago Engineering Works, Dept. 51A, 2144 Lawrence Ave., Chicago.

TOY maker book, 64 pages, illustrated. Postpaid 10c. Western Puzzle Works, St. Paul, Minn.

LATEST Magic—Professor Hoffman, world-famed authority. New stunts, card tricks, sleight of hand. Handsomely bound, illustrated, \$2.15 postpaid. Spon & Chamberlain, 120 P. M. Liberty Street, New York.

ANY book you want at cut-rate prices. Don't buy until you see our bargain list. Send postal for free copy. Midwest Book House, Dept. 20, 53 West Washington St., Chicago.

THIRTY-FIVE Cent Electrical and Mechanical Books. Fully illustrated. Other popular subjects. Send for list. Spon & Chamberlain, 120 P. M. Liberty St., New York.

AMBITIOUS Writers send today for Free copy America's leading magazine for writers of photoplays, stories, poems, songs. Instructive, helpful. Writer's Digest, 603 Butler Building, Cincinnati, Ohio.

LIGHTNING Cartoonist's Book, Secrets, Tricks, \$1.00, Christmas, 2925 Euclid, Kansas City, Mo.

PLANS for Poultry Houses. All styles. 150 illustrations; secret of getting winter eggs, and copy of "The Pull Egg Basket." Send 25 cents. Inland Poultry Journal, Dept. 74, Indianapolis, Ind.

INDUSTRIAL Alcohol. Wright's book everybody wants. Full directions for making with drawings of necessary apparatus. \$2.50 postpaid. Spon & Chamberlain, 120 P. M. Liberty Street, New York, N. Y.

INSTRUCTION Book (for shop use) on vulcanizing auto tire, boots and shoes, \$1.00. Equipment Co., 3 Canal, Cincinnati, O.

PICTURES, POSTCARDS & NOVELTIES

MEMBERSHIP and dozen girl beauties, 25c. Bureau, 233, Champaign, Ill.

SURPRISE Friends. Tour Rocky Mountains while staying home. Ten magnificent views 30 cents. Return for mailing. Great fun. Hadler, 4085 So. Broadway, Denver, Colo.

TRUE-BLUERS everywhere. Exchange posts. Organized 1908. Membership: Year, \$1; half, 50c; quarter, 25c. Hundreds listings, 10c. Ed. Ericson, 622, Elroy, Wis.

JOIN Live Postcard club: Sample paper, list, catalog, 10c. Harvey Teeple, Decatur, Ind.

"BOLIVIAN Lucky Beans," something original; each bean everlasting, natural, brilliant, scarlet and black; for earrings, brooches, watch chains, rings, bangles, etc., \$2.50 per dozen. Address, Weeds, Chacabuco 430, Valparaiso, Chile, South America.

YOUR portrait copied on a handkerchief \$1.50; silk, \$2.00. Acme Service, 733 Central Ave., Los Angeles, Calif.

GAMES AND ENTERTAINMENTS

VENTRILOQUISM taught almost anyone at home. Small cost. Send 2c stamp today for particulars and proof. George W. Smith, Room M-287, 125 N. Jefferson Ave., Peoria, Illinois.

PUZZLES, perplexing peg, figure eight wire, three-way wood, interurban trolley, difficult crescent, 25c each, \$1 all. Address, Puzzle King, Evans City, Pa.

MAGIC disappearing coin trick and Magic Catalog, 25c. Western Magic Co., Box 606, Station C, Los Angeles, Calif.

SNEEZE powder, greatest fun maker on earth. Bottle, 10c. C. Fenner, 2401 Jefferson, Louisville, Ky.

ENTERTAINING Books, Puzzles, Tricks, Jokes. Catalog free. Anderco, 4047 North Whipple, Chicago.

"MARGO" Psycho-Sphere. The greatest little novelty out. Everybody wants one. Descriptive Circular free. James T. Herr, Desk C, 2919 W. North Ave., Baltimore, Md.

67 TRICKS, 400 Jokes, Riddles, Toasts, Fortune Telling Secrets, Funny Readings and big catalog, 10c. Ideal Book Shop, 5501NC, North Robey, Chicago.

MAGIC Trick Cards and Illustrated Catalog, 10c. T. V. Youngblood, 16 Grove, Charlotte, N. C.

REDUCED Prices! Tricks, Jokes, Novelties. Catalog 6c. Lyle Douglas, Station A, Dallas, Texas.

\$7000 STOCK Magical Goods. Catalogues 15c. Address, Gilmagico, Morgan Park, Ill.

TRICKS, Puzzles, jokes, magical apparatus, plays, stage supplies, mind-reading acts, and sensational escapes. 140-page illustrated professional catalogue, 10c. Oaks Magical Co., Dept. 548, Oshkosh, Wis.

200 KINDS iron, wood and wire puzzles. Leader and illustrated list 10c. Western Puzzle Works, St. Paul, Minn.

MAGIC—Tricks, Books and Supplies. For Amateurs as well as the great professionals. Anyone can learn through our instructions. Feature Acts in Mind Reading, Spiritualism, Rope Ties, etc. Large Illustrated Professional Catalog, 10c. Chicago Magic Co., Dept. B, 140 S. Dearborn St., Chicago, Ill.

250 MAGIC Tricks 25c. Big Catalog 2c. Harvey Teeple, Decatur, Ind.

STAMP COLLECTING

START a Stamp Collection—65 different stamps from 65 different foreign countries, including Africa, Asia, Australia, Europe, West Indies, etc. Our pamphlet which tells "How to make a collection properly," and price list of albums, packets and sets, all for only 16 cents. Queen City Stamp Co., Room 36, 604 Race St., Cincinnati, O.

EXCHANGE Postage Stamps with Friends in every country. Membership, 25 cents. International Stamp Club, 4002 Brooklyn Ave., Seattle, Wash., U. S. A.

LIBERAL Offer: 500 mixed U. S., 1,000 hinges, 100 diff. foreign, Bargain Stamp paper 6 months for 25c. Weatherby, Medina, Ohio.

PACKET 1,000 different Stamps (Fine). While they last, \$2.80. (Approvals.) W. Leppert, P. O. Box 438, Far Rockaway, N. Y.

STAMP News of the world. Send for current issue, 15c. "The Albemarle Stamp Collector," published monthly, Bethlehem, Penna.

BEST one-cent approvals in America. F. P. Hand, 1117 So. 60th St., Philadelphia, Pa.

MOROCCO, 42 different, catalog \$3.00, 60c. Groves, 3 East Crescent, Botherham, England.

PACKET Desirable Stamps to Approval Applicants. Goldstein, Burdette Ave., Cincinnati, Ohio.

STAMPS—50 different Jamaica, Venezuela, etc., only 7c; 100 all diff., 10c; 1000 all diff., \$2.50; 1000 diff., U. S., 25c; 1000 Hinges, 10c; 50 per cent approvals with every order. List free. I buy stamps. Write L. B. Dorer, Dept. A, Longmont, Colo.

UNITED STATES Columbian Issue 1c-10c, 8 var. 25c. Postpaid. New United States Price List free on request. Midwest approvals contain honest value stamps. Write today for a selection. Address, Midwest Stamp Company, Kemper Building, Kansas City, Mo.

115 DIFFERENT Foreign Stamps, including Zambesia, Zanzibar, Argentina, Georgia, Herzegovina, Holkar, Liechtenstein, Madagascar, Mozambique, Newfoundland, Roumania, Montenegro, Ukraina, Venezuela, 20c. Liberty, 3974 Arsenal, St. Louis, Mo.

FREE! Finest Perforation Gauge with beautiful price list. Ask for approvals. Address, Allen Sears, Dept. P, 220 Lathrop Building, Kansas City, Mo.

25 FOREIGN Stamps, cat. from 3c to 20c each, total at least \$1.50, for 40c. Mrs. Louise Kellogg, W. Hartford, Conn.

FREE! 30 Different Unused French Colonials to applicants for approvals who send 2c postage. Nickles, 122 Florida Ave., Washington, D. C.

1,000 HINGES and 25 U. S. free with approval request and 10 cents. St. Elmo Stamp Co., 4501 N. Ashland Ave., Chicago.

CHINESE Famine Set, also 50 different French Colonials, for 25c. Jacob Fischer, 1539 North Lawler, Chicago.

FREE. 100 different stamps to applicants for approvals sending 2c. Richard P. Lamprecht, Valparaiso, Ind.

1,000 HINGES 7c to applicants for net priced approvals. Excel, 939A Webster Ave., Chicago.

FREE. 7 beautiful French Colonials to new approval applicants. Frank Hadler, Plainfield, N. J.

1, 1½ AND 2c Approvals. Weld Stamp Company, 1 Weld St., New Bedford, Mass.

BRITISH Colonies, 50 different 20c. Browne, 111 Willow, Wollaston, Mass.

50 DIFFERENT Wars 10c. F. Buffham, Lake Ave., Racine, Wis.

\$1.00 WORTH of Stamps for 10c. Hull, Station H, New York.

150 NICE Stamps 3c. No approvals. Alvin Johnson, Hawarden, Iowa.

1,500 DIFFERENT stamps \$5.00; 1,000, \$2.50; 500, 75c; 300, 45c. Fred Onken, 630 79th street, Brooklyn.

FREE—New Europe, 20 diff., to applicants for my ¼, ½, 1, and 2c approvals; also the higher-priced stamps at 50% discnt. Send reference and receive extra premium. Chas. T. Egner, 1335 Pike St., Philadelphia, Pa.

FREE, 25 U. S. stamps with 60% approvals to reliable parties, 100 different U. S. 25c. C. Seidenberg, Merton, Wis.

FRENCH Colonies Free—Beautiful Picture set, including Native Chiefs, Tigers, Pictorials, 2c Postage. Empire Stamp Company, Toronto, Canada.

100 DIFFERENT Stamps and Perforation Gauge for 10 cents. I. Sonnee, 675 Ivy St., St. Paul, Minn.

3 NYASSA Giraffe stamps free to approval applicants. Wilmar Edgar, Cherokee, Iowa.

200 STAMPS and subscription Stamp Magazine 15c. Harvey Teeple, Decatur, Ind.

STAMPS, 50 Varieties, Africa, Brazil, Peru, Cuba, Mexico, etc., 10c. 50 different U. S., 25c; 1,000 mixed, 40c; 1,000 hinges, 10c. List free. C. Stegman, 5948 Cote Brillante, St. Louis, Mo.

SWEDISH Stamps free. Approvals 3c postage. F. Seebeck, 1957 Toronto St., Regina, Canada.

100 FOREIGN Stamps sent free. Cornish Company, Schenectady, N. Y.

STAMPS Free—War Stamps, Surcharged, Unused, Pictorials, British, French Colonials 2c postage. Midland Stamp Co., Toronto, Canada.

158 GENUINE Foreign Stamps—Mexico War Issues, Venezuela, Salvador and India Service, Guatemala, China, etc., only 10c. Finest approval sheets, 50 to 60%. Agents Wanted. Big 72-p. Lists Free. We Buy Stamps. Estab. 20 yrs. Hussman Stamp Co., Dept. 54, St. Louis, Mo.

LIKE Triangular Stamps? To introduce our Sudden Service Approvals we'll send triangular Plume, set China ships, large \$1.90 United States revenue, also packet 50c foreign, millimetre scale, perforation gauge, ruler and bargain lists for only 9c! Fennell Stamp Company, Dept. F, Fullerton Bldg., St. Louis, Mo.

FREE! Sectional Loose Leaf Postage Stamp Album at the rate of 8 pages each month given with subscription to our monthly Journal. Send two-cent stamp for prospectus. United Stamp Co., 140 S. Dearborn St., Chicago, Ill.

BIG Variety Packet Foreign Stamps free for 2c postage. Gray Stamp Co., Station E., Toronto, Canada.

STAMPS sent on approval at 70% discount. Reference required. Emory Renoll, Hanover, Pa.

STAMPS Free—Ask for money-saving approvals. John P. Borresen, Cedar Falls, Ia.

24 VARIETIES Cuban stamps, 10 cents. List of 6,000 low-priced stamps free. Address, Chambers Stamp Co., 111P, Nassau St., New York City, N. Y.

105 CHINA, etc., stamp dictionary, list, 2c. Album (500 illustrations), 3c. Ballard, Sta. A, Boston.

55 ALL Different Stamps, including China, Japan, French Colonies, etc., given to applicants for our high-grade approval selections. Send references and 2c stamp to the Edgewood Stamp Co., Dept. H, Milford, Conn.

20 UNUSED stamps free. All different. Postage, 2c. Fisk Stamps, Toledo, Ohio.

PACKET of 23 stamps, no two countries alike. Packet hinges. Set of \$1 and \$2 U.S. Rev., all for 5c. Mention paper. Miami Stamp Co., Toledo, Ohio.

STAMPS, 20 unused, all different, free. Postage 2c. Mention paper. Quaker Stamp Co., Toledo, O.

FREE 10 different Scandinavian, millimetre scale, gauge, book, lists, etc., to all sending 10c for 57 different Stamp, Ceylon, Guatemala, etc. 200 different, 25c; 300 different, 60c; 100 different U. S., 25c. Hawk-eye Stamp Co., Cedar Rapids, 39, Ia.

100 DIFFERENT from 30 different countries, 5c. Lufbery, Yalesville, Conn.

RARE COINS

SEND for this now—Civil War Cent—historically interesting, and large 50 page illustrated coin catalog for only ten cents. This offer is just to get acquainted. You'll be surprised how pleasant and profitable you'll find coin collecting. Start now. H. Max Mehl, Numismatist, Mehl Bldg., Dept. K—, Fort Worth Texas. Largest rare coin establishment in the United States.

WILL Pay Fifty Dollars Cash for nickel of 1913 with Liberty Head. Watch your change. We pay cash premiums for all rare coins. Send 4c for Coin Circular. Numismatic Bank, Dept. H, Fort Worth, Texas.

CALIFORNIA gold, $\frac{3}{4}$ size, 27c. $\frac{3}{8}$ size, 53c. 3c piece and catalogue, 10c. Address Norman Shultz, Colorado Springs, Colo.

HALF Dollar Size California Gold, 52c; Flying Eagle Cent, 1st, 10c. Holco, Anawan, Ill.

CALIFORNIA Gold, Quarter size and Columbia nickel coin only 30c. Italy 20 cents and catalog 10c. Homer Shultz, King City, Mo.

OLD coins, large Spring selling catalogue of coins for sale, free. Catalogue quoting prices paid for coins, ten cents. William Hessein, 101B Tremont St., Boston, Mass.

\$2 TO \$500 Each paid for hundreds of old coins. Keep all old money. Send 10 cents for Illustrated Coin Value Book. 436. Guaranteed Prices. It may mean your Fortune. Address Clarke Coin Company, Ave. 2, Le Roy, N. Y.

FOR BOYS

BOYS, get ready for the Fourth. Make powder for colored lights, green, pink, red, blue, yellow, white; also invisible ink. Receipts each 20c, or all for \$1. Edahl, 2834 Van Buren, Chicago.

500,000 YOUNG hares wanted this year from club members only. Join National Club now, \$1. Get \$20 paid Giants free. We buy young. Send stamp. Bulletin Board, Box 88, Elkhart, Ind.

BOYS!—You who like gripping, thrilling stories of achievement will want to read "Victories of the Engineer," a book that tells in a way you can understand it how the great feats in railroad engineering, building great bridges, ships, dams, canals, harbors, tunnels, mining, etc., have been accomplished. By A. Williams, 487 pp. 259 illus. Price \$2 postpaid. Popular Mechanics Book Dept., 6 N. Michigan Ave., Chicago.

PLAY mouth-organ. It's easy. Complete instructor, 25c. Instructors for violin, piano, tenor banjo, ocarina, ukulele, or drums, 25c. G. Elsen, Bowling Green, Ohio.

INEXPERIENCED, I built radiophone following simplified diagrammed instructions. Just out. \$1. Box 263, Los Angeles, Calif.

ELECTRICITY Taught by experts; earn while you learn at home; electrical book and proof lessons free; your success guaranteed and position secured. Chicago Engineering Works, Dept. 51A, 2144 Lawrence Ave., Chicago.

BOYS, Get flying model aeroplane free. Write to Acro Shop, 3050 Hurliout Ave., Detroit, Mich.

CAMERAS AND PHOTO SUPPLIES

KODAK Pictures! Professional finishing for amateurs. Lowest prices—Prompt service. Your films are entitled to good workmanship. We guarantee it. Developing—Printing—Enlarging—Copying—Coloring—Framing—Mounts and Folders. Free valuable booklet on photography and price list with your first order. Any size roll developed 10c. Six $2\frac{3}{4} \times 3\frac{3}{4}$ prints 22c. Six $3\frac{3}{4} \times 5\frac{3}{4}$ prints 30c. Beautiful 8x10 enlargement mounted 65c. Mail your films and be sure of good pictures. Photographic Institute, Dept. M, Wedgeway Building, Schenectady, N. Y.

JUST Published—Our new complete 123-page catalog and bargain book of new and used cameras and supplies. Our goods are guaranteed finest quality obtainable. We have thousands of satisfied customers. Write at once for this bargain bulletin, just hot from the press. Address Central Camera Co., 124 S. Wabash Ave., Dept. E 58, Chicago, Ill.

ONE roll film developed and six prints made for twenty cents. Expert workmanship at ordinary prices. Pioneer Studio, Vinton, Iowa.

PHOTO Mounts for Amateurs. We are the only manufacturers selling direct to amateurs exclusively. Therefore, all Mounts and Folders purchased from us are of unexcelled quality and artistic perfection, at a price most pleasing to you. Send stamps, five cents, for sample and prices. (State Brown or Gray.) We know your decision will be an order. I. P. C.—Universal Corporation, 270-276 Hudson Ave., Albany, N. Y.

KODAK Finishing. Not the cheap way, but the most reliable. Our Quality Work insures best prints from every negative. Get particulars and List of Prizes. Send us your orders. Moon Photo Service, 21-A, LaCrosse, Wis.

SEND your next Roll Film and 20c or six Film Negatives, one hand-tinted free. Address, Ax-U-Lyk-M, Dept. C, Bristol, Va.

EXPERT Photo Finishing, any size roll, 10c prints, 3 for 10c. Frank C. Miller, 1110 Franklin St., Cedar Falls, Iowa.

LUSTRE Prints—Best yet. Sample roll finish, 25c. Mounting corners free. Reed Studio, Norton, Kan.

DEVELOPING 10c. Prints 5c cash with order. No stamps. Address, Harry Nicholson, Photographer, Castleton, N. Y.

8x10 KODAK enlargement, beautifully colored, \$1.00. Kodakin, 287 Bellevue Place, Milwaukee, Wis.

4x5 CAMERA \$7.50; other bargains. List free. Dusso, 25 Mulberry, New York City, N. Y.

GLOSSY Prints three cents. Rolls developed seven cents. MacFarlane's Studio, 4150 Hamilton, Cincinnati, Ohio.

OLD Tintypes, Daguerreotypes or Faded Pictures of loved ones can be restored so as to produce beautiful enlargements and perfect likenesses under our new process. Individual pictures may also be produced out of groups. Satisfactory results guaranteed. Prompt work. Roanoke Photo Finishing Co., 512 Bell Ave., Roanoke, Virginia.

BIG Money Saved on Photographic Lenses and Apparatus—goods exchanged; repairing done. Ralph J. Golsen, 1128 Argyle St., Chicago, Dept. P.

BASS Camera Bargains are known the world over. Write your needs. Largest stock of Graflex, Kodaks and Motion Picture Cameras in the world. Bass Camera Company, Mail Order Division, Chicago, Ill.

KODAK films developed and finished with attractive margin designs 25c. Something new. New England Photo Service, Box 1202, Boston, Mass.

HAVE You a Camera? Write for Free sample of our big magazine, showing how to make better pictures and earn money. American Photography, 790 Camera House, Boston, 17, Mass.

MOTION PICTURES

EARN \$75 to \$125 a week. Learn Motion Picture Camera operating. Wonderful opportunities in taking educational, commercial and amusement pictures. Our short course prepares you thoroughly and quickly at home. Free catalog. American Institute of Cinematography, Inc., Dept. 2, Steinway Hall Bldg., Chicago, Ill.

AMERICA'S Greatest Fortunes have been made in the Moving Picture Business. Small investment needed. We furnish complete theatre equipment. Easy payments. Openings everywhere. Catalog free. Monarch Theatre Supply Co., Dept. F, 724 So. Wabash Ave., Chicago, Ill.

MOVIE Camera, 200-foot F. 3.5 lens, \$85. Tripod with panorama and tilt, \$25. Cinematograph motor-driven projector, \$75. 2,000 reels of films, \$3 to \$5 reel. Ray, 326 5th Avenue, New York.

WE buy used portable suitcase and professional moving-picture machines. Highest prices paid. What have you for sale? Monarch Theatre Supply, 724 So. Wabash Ave., Chicago, Ill.

MOTION-PICTURE machine and film ready to run; in fine condition; only \$100. Address Box 38, Sioux Falls, So. Dak.

FILMS cheap. Home projectors, \$30-\$50. Professional projectors \$250. Address Movie Sales, High Ridge, Mo.

MOVIE Cameras, \$20. Drawing, Illustrating, Stereoscopic, \$15. Catalog. Hetz, 302 E. 23d, New York.

TWO Movie Cameras, first-class condition. Joseph Dorothy, 517 West 148th, New York City.

\$25.00 PROFIT nightly. Small capital starts you. No experience needed. Our machines are used and endorsed by government institutions. Catalog free. Atlas Moving Picture Company, 482 Morton Bldg., Chicago.

JUST Out! Send for one at once! The Complete Cinema Hand Book. A complete course in motion-picture making from raw film to the projected image. 508 pages crammed full of authoritative information. Postpaid to any part of the world on receipt of \$3.00. Everything in Motion Picture Apparatus. Cameras from \$20.00 to \$1500.00. Write for information to the Motion Picture Headquarters of the World. Bass Camera Company, Dept. 114, 100 No. Dearborn St., Chicago, Ill.

BIG Profit Nightly—Moving Picture Business—small capital starts you, easily accomplished. Teach you—furnish everything. Ralph J. Golsen, 1128 Argyle St., Chicago, Dept. M.

CLEARANCE Sale—500 reels high-grade film. Two to six reel subjects Famous Movie stars. Special \$3.50 per reel only while they last. Stock up now. List free. Monarch Theatre Supply Co., Union and Fourth, Memphis, Tenn.

BUY direct from Manufacturers—New or rebuilt Moving Picture Machines for Homes, Schools, Lodges, Churches, Traveling Shows and Theatres. Mazda—Arc or Gas complete outfits—Film and Supplies. Dept. X, Monarch Theatre Supply Co., Memphis, Tenn.

FILMS for Toy and Professional Machines. All famous movie stars, \$3.00 per reel and up. Machine bargains also. Write for big list free. Monarch Theatre Supply Co., Dept. P. M., 724 S. Wabash Ave., Chicago, Ill.

FILMS For Sale—\$2.50 per Reel up. Address Queen Feature Service, Birmingham, Ala.

MAKE money writing photoplays; details free to beginners. No correspondence course. Producers League, 230 Wainwright, St. Louis.

FREE to Writers—A wonderful little book of money-making hints, suggestions, ideas; the A B C of successful story and play writing. Absolutely Free. Just address Authors Press, Dept. 12, Auburn, New York.

SCENERY TO RENT

SETTINGS for Opera, Plays, Minstrels, Flush Drops. Catalog. Amelia Grain, Philadelphia.

EDUCATIONAL AND INSTRUCTION

MECHANICAL Drafting and Tool Designing taught by mail. Students trained in latest drafting room and machine shop practice. Complete outfit of instruments furnished. J. A. Harding, 76 Brighton Ave., Highland Park, Mich.

PATENT Drafting. Complete instruction book teaching this artistic, high salaried business for 50 cts. Patent Drafting Syndicate, Box 858, Schenectady, N. Y.

BOOKKEEPING self-taught in a week with "Dukes' Columar Bookkeeping." Price, \$4. Newton A. Dukes, E-13 Fox Street Station, New York.

DOUBLE Entry Bookkeeping mastered in 60 hours with 8 keys; guaranteed; Diplomas. International Bookkeeping Institute, Dept. 8, Springfield, Mo.

PENMANSHIP—Improve your handwriting! \$1 monthly. Prince, Station H, New York.

WHAT'S Your Future? Develop winning personality, be popular. Higher business positions, social acquaintances, and larger earning capacity. Success depends largely on personality, no matter what business you are in or have studied. It's a wonderful thing. Free literature. Write today. Personal Service Bureau, Box 235, West Palm Beach, Fla.

LEARN to design patterns for men's clothing. Always in demand. Lesson 1, one dollar. Start today. Cheapest course of its kind. Box 187, Baltimore, Md.

ROPP'S Calculator and Short-Cut Arithmetic shows the answer as quickly as a watch shows the time to all problems likely to occur in office, store, shop, bank, farm or factory. Price, pocket size, paper 35 cents; cloth, 50 cents; leatherette, \$1; desk size, cloth, \$1.50 postpaid. Popular Mechanics Book Dept., 6 N. Michigan Ave., Chicago.

LEARN advertisement writing. Home employment evenings. Sell your "copy" by mail. Dime brings Preliminary Lesson. Williams, 74 Cortlandt Street, New York, N. Y.

PROFITABLE results from practical personal instruction in drafting. Write Box 127, Bangor, Maine.

"**WHAT** to Invent For Profit" free. Patent News, N. Washington, D. C.

HAVE a business of your own; the most fascinating, best paying business-profession in the World, a foot correctionist; easy terms for training you at home in a few weeks, a new protected system that has enabled men and women to rise in one step to greater earnings than they ever thought possible; no capital required or goods to buy, no agency or soliciting. Address, Stephenson Laboratory, 1 Back Bay, Boston, Mass.

ARTIFICIAL Marble, sanitary flooring instructions, ornamental casting, concrete plaster, papier-mache decorations, garden furniture, statuary. Rubber-moulds, Electrometallurgy, particulars and 200 illustrations free. Chris Mahler, Box 122, Huntington, N. Y.

STUDY Bacteriology—become a laboratory expert. Course interesting, can be mastered in few months at home or in school. Good paying positions open. Degree granted our graduates. School 13 years old. Send for Announcement, American College of Bacteriology, 2923 S. Michigan Ave., Chicago, Ill.

SUCCEED: Home Shorthand, \$2.50. Send money order. We are responsible. Byrne Publishing Company, Tyler, Texas.

WANTED: Information exchanged about commercial uses for air compressors. Address Engineering Dept., Brunner Mfg. Co., Utica, N. Y.

AMBITIOUS writers—send today for free copy America's leading magazine for writers of photoplays, stories, poems, songs; instructive, helpful. Writers Digest, 708 Butler Bldg., Cincinnati.

WRITE articles, stories, news, in spare time for newspapers and magazines. Big pay. Copyright book free. Press Syndicate, 552, St. Louis, Mo.

DOUBLE Entry Bookkeeping mastered in 60 hours with 8 keys; guaranteed; Diplomas. International Bookkeeping Institute, Dept. 8, Springfield, Mo.

THE most profitable Art as well as the easiest to learn. Sign Painting and Show card Writing. Complete course \$2.50. Hall's Sign Shop, Franklin Square, Worcester, Mass., Dept. A.

INVENTORS—Write for our illustrated guide book and Evidence of Conception Blank. Send model or sketch and description for free opinion of its patentable nature. Highest references. Prompt attention. Reasonable terms. Victor J. Evans & Co., 167 Ninth, Washington, D. C.

WORLD-ROMIC System, Masterkey to All Languages, Six Textbooks, \$1.75. French Chart, 37c; Spanish, 37c. Pronunciation—Tables, 70 languages, 30c each language. Languages Publishing Company, 8 West 40th Street, New York.

TELEGRAPHY

TELEGRAPHY—Morse and Wireless—taught at home in half usual time and at trifling cost. Omnigraph Automatic Transmitter will send, on Sounder or Buzzer, unlimited messages, any speed, just as expert operator would. Adopted by U. S. Govt. and used by leading Universities, Colleges, Technical and Telegraph Schools throughout U. S. Catalog free. Omnigraph Mfg. Co., 18 Hudson St., New York.

TELEGRAPHY (both Morse and Wireless) and Railway Accounting taught quickly. Big salaries. Great opportunities. Oldest and largest school; established 46 years. All expenses low—can earn large part. Catalog free. Dodge's Institute, H St., Valparaiso, Ind.

WIRELESS

BROADCASTED music and news received over ordinary telephone. Operation as a telephone not affected. Send 25c for complete instructions and blue prints. Earl Barnes, Elec. Engr., 6207 Linden Ave., Seattle, Wash.

WIRELESS telephone—complete receiving outfit. Full instructions. Best and cheapest on market. Frank Taylor Mfg. Co., Norwood, Ohio.

RADIO OUTFITS AND SUPPLIES

THE Home Radio—How to make and use it. At last! A simple explanation of the making and use of a home radio outfit. Every step in construction is carefully directed and illustrated with numerous working diagrams. Bound in cloth. Postpaid for 75c. "Broadcasting Guide," 25c. Radio Educational Service, 290 5th Ave., R-416, New York City.

BUILD Radio Sets. We supply parts or complete units. Catalog 15 cents. Easily understood assembly drawings. Crystal Detector Set, Non-regenerative Receiver, Regenerative Receiver, 2-Step Amplifier, 25 cents each. All five \$1.00. No stamps accepted. Hatfield Airfone Company, Dept. D, Owego, N. Y.

"**PHOENIX** Radio Apparatus." Within an hour after receiving your set you can tune-in on concerts, press reports, etc., over unheard of distances. Write for literature. Phoenix Radio & Parts Co., 119 West 4th St., Cincinnati, Ohio.

CRYSTAL Set that gets radio concerts. Build it right, boys. Plans and full instructions for building at small cost, high-grade, fine adjustable Crystal Receiving Set, fifty cents postpaid. Dept. 27-R, Shaw Mfg. Co., Galesburg, Kans.

STORAGE batteries for automobiles and radio. Buy direct from manufacturer and save money. Prices on request. Radio supplies. Dealers wanted. General Battery Service Station, 921 Washington Blvd., Chicago.

"**RADIO** for Beginner"—gives fundamental facts necessary for successful operation of receiving outfit, presupposes no knowledge by reader. Best book on market. Send \$1. Frank Taylor, Norwood, Ohio.

JOIN Radiohelpers. Members exchange hints; Questions-Answers, Practical Advice Bulletins. Those without sets, build one. New, simplified method free to newcomers. Membership, \$2. Radiohelpers, Box 263, Los Angeles, Calif.

DO you know anyone who is not interested in radio outfits and equipment? In 11 days we received 393 inquiries concerning radio outfits—and every mail brings many others. These inquiries, in most cases, could be converted into actual orders, so you see what you are missing by not advertising in this column. Send us your copy and remittance for our July issue, forms for which close May 25th. Get the business! J. Roy McCrellan, Manager Classified Advertising, Popular Mechanics Magazine, Chicago.

RADIO Special: 6-volt storage battery, 40 amp., \$12.00; 60 amp., \$14.00. Shipped fully charged. W. & G. Tufts, Manufacturers, 238 Newbury St., Boston, Mass.

WRITE for catalog showing complete line of Elmco Shielded Radio Apparatus, tuners, detectors, amplifiers, transformers and sockets. Electric Machine Corporation, Indianapolis, Ind.

WRITE for literature on Simplex Radiophone Concert Receivers. T. & H. Radio Company, Anthony, Kan.

RADIO Manufacturing—Parts, complete units, any quantity, high-class workmanship, prompt service; send samples or drawings for lowest quotations. Address Vogtley Bros., 828 Metropolitan Avenue, Brooklyn, N. Y.

RADIO Cabinets: We build special cabinets and cases to order. Tell us what you want, and get our price. National Cabinet Co., Dept. R-1, Dayton, Ohio.

BUILD your own Radio Receiver for \$5.00 and hear the concerts nightly. Our Blueprint No. 119 explains all. Price, \$1.00. Experimenters' Service, 45 Pinehurst Ave., New York, N. Y.

RADIO for the Amateur—Building, Installing, Operating Stations for Radio Communication treated simply in "Practical Amateur Wireless Stations," a 136-page book compiled by Editor of Wireless. Age. 115 illus. and diag. Size 6 x 9 in. Price, 75c ppd. Popular Mechanics Book Dept., 6 N. Michigan Ave., Chicago.

RADIO Receiving Set. Easily made. Construction blue print, 25 cents. Two-car garage plan, 25 cents. The Plan Co., 4413 Lillibridge, Detroit, Mich.

RADIO Supplies, all kinds. We specialize on variometers at \$4.50, variocouplers, \$3.75 each, immediate delivery, postpaid. General Radio Supply Co., 5055 Broadway, Chicago.

RADIO—Simple, complete blueprints and illustrated instructions for home manufacture and operation. Stamped addressed envelope and 25c coin. Cottrell, Box 259, Chicago.

CRYSTAL Set that gets radio concerts. Complete with instructions for installing and operating. \$25.00. Shaw Mfg. Co., Galesburg, Kans.

RADIO Receiving Sets and Parts. Send 50c for large catalogue with hook-up plans. Ray, 326 5th Avenue, New York.

NEW Radio Books—Construction of Radiophone and Telegraph Receivers for Beginners, 75c. How to Make Commercial Type Radio Apparatus, 75c. A B C of Vacuum Tubes Used in Radio Reception, \$1. Prices postpaid. Popular Mechanics Book Dept., 6 N. Michigan Ave., Chicago.

RADIO Apparatus and Supplies. Standard makes. Quick delivery. Universal Radio Co., 20 East Jackson Blvd., Chicago, Ill.

RADIOPHONE, \$11.00 will construct receiving station. Complete plans and instructions, 60c. Nelson, 213 East Lafayette, Baltimore, Md.

MAKE \$60 weekly with Radio advertising. Plans, 30 cents. Address today! H. Vogt, Sioux Falls, So. Dak.

THE Best in Radio. Write for circular. Howard Lindsey, Sacandaga, N. Y.

RADIOPHONE wiring diagram. Send 25 cents. Dunphy, 52 Bramhall St., Portland, Maine.

TRADE SCHOOLS

MAKE money writing for newspapers, \$2.00 to \$10.000 yearly; good pay for spare-time work. Experience unnecessary. Men and women needed everywhere; editorial, reporting, special articles, stories, sports writing, local correspondence, etc. Special privileges, press pass, etc. Qualify quickly in spare time at home under veteran newspaper men. Fascinating book free. Explains everything. Write today. Newspaper Training Assn., Dept. 26, New York City, N. Y.

BUSINESS OPPORTUNITIES

ZERO Pie (ice cream in chocolate shell). Anyone can make it. Any kitchen has complete equipment. Secret formula and complete instructions sent for only \$2.00. You can make profits at once. Big sales, picnics, parties, soda fountains, etc. Start a paying business today. Zero Pie Co., 313 26th Ave., Milwaukee, Wis.

\$3,000 TO \$6,000 Yearly. Want it? Others are making it. Send check or money order today for our invaluable books "How to Sell Real Estate," \$3.00—and "How to Conduct Real Estate and Insurance Business," \$1.50. Absolute satisfaction guaranteed. Free catalogs. Realty Book Co., Dept. 52, Cleveland, Ohio.

THE new concrete street and railroad tie, patent 1,399,123, patented Dec. 6, 1921, for sale—\$1,000 and 5% royalty; safer than any railroad tie at the present time. Pete Jarnowski, Lombard, Ill.

GET into the specialty manufacturing business. Amazing profits. We will send you free book explaining our system. Write immediately. A wonderful opportunity awaits you. National Scientific Laboratories, 624 Main, Richmond, Va.

BE Independent, establish profitable safety-razor sharpening business. Small investment—no experience—sure success. Agents wanted every county, demonstrate, sell machines. Odell Mfg. Co., 428 Boyd, Los Angeles, Calif.

ATTENTION: Enormous profits—manufacture "Frozen Feast," ice cream in a sealed chocolate shell. 10c bar, costs 2c. We furnish everything. Frozen Feast Co., 211 6th St., Racine, Wis.

LEARN a trade. Painting signs, name plates, gold letter making. Our patterns do the work. Outfit absolutely free. Address Thomas Clark, 505 Line Ave., Ellwood City, Pa.

MOVIES: With the one in your locality you can operate a good paying practical business without capital or experience. Address "Goss," Box 59, Canaan, N. H.

START Profitable Mail Order Business at Home. We teach you by successful method. Particulars free. Walhamore Company, Mail Order Dept., Lafayette Bldg., Philadelphia, Pa.

ADVERTISE—25 words in 20 big Sunday papers \$10. Sales letters built free by experts. Cope Agency, 233, Champaign, Ill.

PATENTS—If you have a patent to sell or lease, send particulars to Supply & Demand, 1819 Broadway, New York, N. Y.

GOOD income in spare time writing news, stories, articles, letters, advertisements, photoplays; experience unnecessary; details free. Dickinson, Oklahoma, Okla.

HOW only \$10 down starts anywhere profitable Branch Mfg. Business. Request details. Address P. O. Box 425, Chicago, Ill.

LATEST Book on Patents. Send your idea for search of U. S. Records. H. L. Woodward, 712 9th, Washington.

EXCLUSIVE distributors for chemical compounds. Mechanical. Splendid re-actors. Samples \$2.00 Refund made. Volcano Manufacturing Co., Los Angeles, Calif.

SAMPLE ¼ pound of rubber bands 20c, with business proposition. Martin Co., Loeb Bldg., Portland, Ore.

MONEY in mail-order business. Names of 50 supply houses 10c. Pennell Company, Covington, Ky.

\$1,000 STARTS you assembling motorcycle, automobile trailers. 200% profit. Unwin, 305 Broadway, New York.

BECOME a Battery Manufacturer. Write for particulars to Lavender Battery Mfg. Co., Webster City, Iowa.

20,000 FORMULAS—money makers. 530 pages \$1.10. "Ideal," 5501-F North Robey, Chicago.

SELL Cigars; territory assigned; large commissions. Address Graham, 27 Warren, New York, N. Y.

ADVERTISE. 30 words 100 magazines, \$1.50. Pennell Company, Covington, Ky.

"WHAT To Invent for Profit" free. Patent News-C, Washington, D. C.

"HOW To Sell Patents" free. Patent News-H, Washington, D. C.

PRESSED paper novelties; fans, lampshades, garlands, flowers, bells and other flat folding decorations and novelties. Paper and hand-presses, for cutting and assembling, furnished manufacturers and home-workers. No experience necessary. We buy these goods all year and place large orders for same. Big demand throughout the United States and in other countries. Liberal profits and very easily handled, owing to light weight. Write for information only if you mean strictly business. Tissue Paper Novelty Works, 1685 Southern Boulevard, New York.

MEN Wanted to earn \$3,000 to \$10,000 a year. Prepare quickly and easily through our amazing system for profitable and permanent business reclaiming waste paper for largest manufacturers in country. Boys do the work—you simply direct. Practically no investment necessary—a few dollars will start you. Simply send name for big free opportunity book—a post card will do. Write The Traub System, 303 Traub Bldg., Kansas City, Mo.

\$5,000 TO \$10,000 a year. Agents and crew managers who own Fords get into new and unlimited field. Great demand, indispensable Ford necessity. Endorsed by oil stations, garages, expert mechanics, and users as only practical, satisfactory device of its kind. Quick sales, big profits, no competition. We furnish selling plan. Require small investment and eight hours' work daily. Otto Mfg. Co., 420 Sycamore St., Evansville, Ind.

PATENTS—Trademarks. Before disclosing an invention, the inventor should write for my blank form "Evidence of Conception." This should be signed, witnessed and returned to me with sketch or model, upon receipt of which I will promptly render opinion as to patentable nature and send booklet on Patents. Highest references. Prompt attention. Reasonable terms. Clarence B. O'Brien, Registered Patent Lawyer, Seventh Floor, Southern Bldg., Washington, D. C.

ENTER a new business. Earn \$3,000 to \$6,000 yearly in professional fees making and fitting a foot specialty, openings everywhere, with all the trade you can attend to; easily learned by anyone at home in a few weeks, at small expense; no further capital required, no goods to buy, job hunting, soliciting or agency. Address Stephenson Laboratory, 11 Back Bay, Boston, Mass.

SALESMAN-PARTNER with \$500.00 for ½ interest to open real estate office in live location. Experience not necessary, but must be a salesman, and willing to work. This proposition will earn \$10,000.00 to \$20,000.00 a year. References exchanged. My reference First National Bank, Chicago. Give age, experience, and reference in first letter. D. E. M., 9th Floor, 78 E. Madison, Chicago.

PATENTS Procured—Trade Marks Registered. A comprehensive, experienced, prompt service for the protection and development of your ideas. Preliminary advice gladly furnished without charge. Booklet of information and form for disclosing idea free on request. Richard B. Owen, 26 Owen Building, Washington, D. C., or 2276-H, Woolworth Bldg., New York.

ATTENTION!! Go into business for yourself. Establish and operate New System real estate; business brokerage, and Insurance Agency in your community. Office at home; earn \$5,000 year. Representatives wanted everywhere; send stamp for booklet. Hayes Realty Association, Cincinnati, Ohio.

"BUSINESS Opportunities," an unusual book filled with practical productive money-making plans to fit the needs of every person. \$1.00 prepaid. Particulars free. Send today! Sell Rite Mfg. Co., 799 Military Ave., Dept. A, Detroit, Mich.

PROTECT Your Rights. Write for Record of Invention which contains form to establish evidence of conception of your invention. Prompt personal service. Preliminary advice without charge. J. Reaney Kelly, 612 G, Columbian Bldg., Washington, D. C.

CAPITAL to invest. Will buy outright or underwrite any meritorious stock. Form companies, develop your business, finance your patent. Save money. Address Statistical Office, Box 617, Schenectady, N. Y.

START manufacturing imitation Meer-schaum pipes. An expert can't tell it from a genuine. Send \$2 money order for details. Address G. Hielscher, 111 W. Main St., Seattle, Wash.

668 WAYS to make money—2,716 formulas in "Encyclopedia Business Opportunities," 3 volumes; price, \$3; yours for \$1. Order at once. Ideal Book Shop, 5501-VF North Robey, Chicago.

CASH business if interested in conducting your own profitable business, capital \$125 to \$1,000. Call or write for free booklet. Paul Kaye, 149 Broadway, New York, N. Y.

\$30 A WEEK evenings; I made it with small mail order business. Booklet for stamp tells how. Sample and plan 25c. Al W. Scott, Cohoes, N. Y.

WANTED, local representative; successful plan appeals to all theater managers. Nets you \$35 weekly. Theatre Bulletin Co., 622 Washington Building, Los Angeles, Calif.

OPEN hat and clothes cleaning parlor at home. Big profits. Particulars free. Byron, Box 27, Sta. I, New York, N. Y.

SPECIALTY-Proprietary manufacturing—small capital; re-orders; unlimited field; large profits. The Thaly Co., Dept. 29, Washington, D. C.

MAKE money with your camera. Information free. Send stamp. Lancaster, 409B Wright-Cullender Building, Los Angeles, Calif.

"MONEY-MAKERS for Live Wires," Free. Box 562, Fort Smith, Ark.

NO money needed if you are responsible or have excellent reputation; big commissions; prefer men calling on power plants, railways, large factories. You can make plenty of money if you are right; have a real article. We are nationally known and highly rated in Dun's and Bradstreet's. Manufacturers, 1000 Kingsland Ave., St. Louis.

DOLLARS yearly in your backyard. No Mushroom dope. Particulars free. Metz, 313 East 39th, New York, N. Y.

SELL or finance your business or invention. Write Box 474, Cleveland, Ohio.

BECOME Master Dealer—Learn Secrets Real Estate Success. Be Independent. Big Profits Either Sex. Special Offer Free. Stephens System, 618 Wysox, Muncie, Ind.

GOOD money easily earned at home, spare time silvering mirrors; no capital. Free instructive book tells how. Patterson & Co., Brooksville, Ky.

IF you have about \$1,000 and capable of organizing sales force, to sell article needed by every merchant, wholesaler and retailer, which should net you \$10,000 profits first year, write Sales Director, 326 Reaper Block, Chicago.

I MADE \$30 a week home. French bread-making, 15 years' experience; free booklet tells. Ashbrook, 67, Marengo, O.

BE Independent. We teach by mail how to manufacture unexcelled Toilet Preparations. Earn while you learn. Results guaranteed. Particulars Free. School of Cosmetics, Box K, Omaha, Nebr.

FREE—Formula Catalog, S. & H. Laboratories, Boylston Building, Chicago.

LEARN the collection business. Good income, quick results. Interesting booklet, "Skillful Collecting," free. National Collectors Assn., Long St., Newark, O.

START a Paying Business of Your Own. Be a business man. Any location. 8,000 new Tire Vulcanizing and Repair Stations needed. Business always good. Are you ambitious? \$200 will start you. Write at once. Wonderful opportunity. Equipment Co., 11 Canal, Cincinnati, Ohio.

MARBLE mixing instructions, covering wood or cement flooring ½ inch thick, fire-proof, waterproof, low cost, sanitary, all colors. Particulars, 200 illustrations free. Chris Mahler, Box 122, Huntington, N. Y.

LET Me Show you how to make real money. Absolutely new proposition and new products. Materials cost \$2.00, sell for \$15.00. One man sold a thousand dollars' worth in a week. Exclusive manufacturing and sales rights to one man in each territory. Write today for booklet 5, Crouch, Chemist, 309 Broadway, New York.

SILVERING Mirrors! My exclusive French Tartaric method opens enormously profitable business. Booklet free. H. Barstow, 514 23d Street, Oakland, Calif.

MAIL Order Business is your opportunity. Brenner's Famous Handbooks teach how to start small, grow big. Sell merchandise, service, ideas; enormous profits. Spare time to begin. Get complete set, 11 books, \$3.00, and be posted. Brenner, 335 Walnut, Philadelphia. Descriptive Catalog and big batch interesting mail order information, 25c. None free.

\$100,000 CORPORATION wants capable man; open office; manage sales for High Class New Device. Every Home a Prospect. Big money-making possibilities for the right man. Opening in every city. Cost \$2.00, retails \$5.00. \$500 to \$2,000 necessary to finance exclusive agency. Scott Corporation, 82 W. Washington, Desk G, Chicago.

EXCEPTIONAL Opportunity for Sales Manager capable of handling state distribution. Marvelous new Adding Machine. Retails \$15. Work equals \$550 machine. Tremendous possibilities. Unlimited profits. Write quick for details. Lightning Calculator Co., Dept. B, Grand Rapids, Mich.

RESPONSIBLE Corporation wants general sales managers to open branch office, manage salesmen. \$500 to \$5,000 necessary; expenses allowed to Baltimore if you qualify. Address Manager, 603 N. Eutaw St., Baltimore, Md.

CLEAN Wallpaper and Window Shades this winter and spring. Big demand. Take large contracts. We show you how. C. Swanson & Sons, Mankato, Minn.

THIS May Be Your Opportunity. A large, modern Middle Western manufacturing institution will consider proposals from inventors and small manufacturers, with a view of manufacturing on royalty basis or of buying outright. Small brass products preferred, but any high-grade proposition will be considered. Address P. O. Box 426 Kokomo, Ind.

WE Start You in Business, furnishing everything; men and women. \$30.00 to \$100.00 weekly operating our "New System Specialty Candy Factories" anywhere. Opportunity lifetime; booklet free. W. Hillier Ragsdale, Drawer 4, East Orange, N. J.

"SCHEMER Magazine," Alliance Ohio, prints big profit schemes; one subscriber making \$25,000 from three; another \$10,000 from one. Try your luck. Year, only \$1.00; three months, 25c.

CHEMICAL Expert will furnish Formulas and Trade Secrets. All lines. Lists Free. W. L. Cummings, Ph.D., 223 Gordon Ave., Syracuse, N. Y.

ELECTRICITY Taught by experts; earn while you learn at home; electrical book and proof lessons free; your success guaranteed and position secured. Chicago Engineering Works, Dept. 51A, 2144 Lawrence Ave., Chicago.

CHEMISTRY

CHEMICAL Analysis, Chemical and Industrial formulas. Burson Chemical Laboratory, 227 West 4th, Ottumwa, Iowa.

CHEMICAL and bacteriological examinations guaranteed accurate. Formulas, processes. Write me about your chemical problems. List free. J. F. Mazur, M. B., 937 W. 20 St., Lorain, Ohio.

FORMULAS AND TRADE SECRETS

500 FORMULAS, 20c. Luminous paint—Resilvering Mirrors—Renewing dry batteries—Mechanics' Soap—Gas Tonic—Carbon remover. Puncture Plugger, 20c each. Entire collection, 50c. Ideal Book Shop, 5501FF, North Robey, Chicago.

"500 THINGS to Sell by Mail!" A valuable up-to-date compilation of fast selling suggestions, plans and methods. Prepaid, \$1.00. Walhamore Company, Lafayette Bldg., Philadelphia, Pa.

1,000,000 FORMULAS, Trade Secrets, for Every Business, \$2.00. Ideal Book Shop, 5501FF, North Robey, Chicago.

FORMULAS—Catalogue free. "Clover," 5501FF, North Robey, Chicago.

SOMETHING New. Will cut glass any thickness, any desired shape and design. Unlike a glass cutter this cuts right through as like cutting paper with shears. No machinery or chemicals needed. Very simple, valuable to glaziers, etc. Secret, \$1.00. L. J. Richards, 866 Main St., Fitchburg, Mass.

AN opportunity to obtain a real valuable money-making formula for polishing autos and furniture. This is not a 25-cent or dollar formula proposition. Send 75 cents for test sample. A. Dreiling, 3055 Salmon St., Philadelphia, Pa.

LUMINOUS Paint. Genuine formula sent on receipt of 50c. Money making painting gas and electric light chains, hangers, push buttons, clock-dials, statues, etc. L. J. Richards, 866 Main St., Fitchburg, Mass.

550 RARE Formulas for 25c (coin). We can furnish any formula wanted for 50c. Allen's Enterprises, 1227 Milwaukee Ave., Chicago, Ill.

ABSOLUTE Money Getters!—New catalog of novel, startling propositions free; postal will do. Fitzgerald Laboratory, Box 49-B, Stapleton, N. Y.

MY Surprise Collection, six big money-making formulas, 25c (no stamps). H. Rennacker, 358 Cherry, Meadville, Penna.

500 SUCCESSFUL money-making formulas and trade secrets for 50c. Postpaid. Rudolph Bergard, Rollag, Minn.

1,000,000 FORMULAS and recipes—1016 pages, \$2.00. Englewood Book Shop, 7021A, South Winchester, Chicago.

ABSOLUTELY any formula. Satisfaction guaranteed. Price, \$1.00. Robert Tyler, 526 Park, Newton, Mass.

FORMULAS worth buying. Literature free. Hager Supply, 509 28th Ave. So., Nashville, Tenn.

10,000 SELECTED scientific, chemical, technological and practical recipes and processes including hundreds of so-called trade secrets for every business alphabetically arranged in one large volume of 800 pages. Price, \$4 postpaid. Popular Mechanics Book Dept., 6 N. Michigan Ave., Chicago.

FREE—Twelve Processes. Enclose 2c postage. Signs, 52 Lerant, San Francisco, Calif.

FORMULA catalog free. C. A. Lutz, Apartment 464, York, Pennsylvania.

REMARKABLE Discovery!—Positively removes tattoos, coal marks, moles; safe, sure, simple process. Original since 1918. Formula \$1.00. Harding Co., 142 Dearborn St., Philadelphia.

FORMULAS of the better sort. Write for our free catalog. National Scientific Laboratories, 624 Main, Richmond, Va.

FREE—Formula Catalog. S. & H. Laboratories, Boylston Building, Chicago.

AGENTS WANTED

AGENTS, Men or Women, full or spare time, earn \$25.00 to \$100.00 a week and be your own boss representing the Ho-Ro-Co Mfg. Co., manufacturers of the wonderful Ho-Ro-Co Tonic, the great blood purifier and system builder; some profit-maker. Ho-Ro-Co Medicated Skin and Scalp Soap for the baby, toilet, bath, skin and scalp; a repeater. Over 100 other fast-selling specialties, toilet preparations, perfumes, flavoring extracts, spices, medicinal preparations and household specialties. Every item a fast seller and a big profit-maker. Don't fail to ask for our free sample case offer. We furnish advertising matter and samples free of charge. Ho-Ro-Co representatives are successful. Write today. Ho-Ro-Co Mfg. Co., 154 Locust St., St. Louis, Mo.

WHIRLWIND money-maker for agents—sample free. Sell powdered Hanslick, an absolutely new, non-competitive, and unbeatable hand cleanser. Removes grease, grime, ink, paint, etc., without slightest injury to skin. Its use spreads like wildfire. Cheaper than all others. Sells in cans (or bulk with dispensers) to garages, autoists, mechanics, factory and office folks, to housewives, hardware stores and to auto supply houses. Huge quantities used weekly by mercantile houses. (Names on request.) Big repeat business assured. Exclusive agencies, crews working for you, fast sales, splendid profits and a permanent business for hustlers. Live ones can clean up \$500 a month. Send 2c stamp for postage on Free sample. Complete sales plan goes with it. Write quick to Solar Products Company, 124 W. Lake St., Chicago, Ill.

\$50-\$100 WEEKLY—Whirlwind Seller. Klean-Bite. New Washing Compound. Women crazy about it. 300% profit. Premiums for customers. Distributing Samples Free. Write Quick. Besterer Products Co., 1941-K6, Irving Park, Chicago.

WHY work for others? Make and sell your own goods. We show you how. Enormous profits. Write quick for free book explaining everything. National Scientific Laboratories, 624 Main, Richmond, Va.

AGENTS—Send for sample "Fretnot"—the washday wonder. Be convinced you can do a whirlwind business. You can clear at least \$20 to \$100 weekly, according to spare or whole time. You don't have to talk; if she doesn't buy at sight, leave sample; she will be looking for you long before you are able to make the rounds again. Samples furnished free. Premiums for your customers. Exclusive territory guaranteed to agents who can produce. Credits given. Don't call. P. M. Motter & Sons, 20 E. Jackson Blvd., Chicago.

WOULD \$18 an hour interest you? Clarke made this selling amazing windshield cleaner; for autoists, motormen, engineers; works like magic; one rub keeps glass clear 24 hours; cleans entire windshield; works while you drive; chemical-felt sheds water like a duck's back; snappy metal holder fits pocket; guaranteed year; sells \$1; Street sold 2,000 few days; amazing details free. Security Mfg. Co., Dept. 622, Toledo, Ohio.

SALES Agents, Men or women, \$30 a month. Steady employment. Take orders for Jennings New Guaranteed Hosiery for men, women, children. Written guarantee with each pair to wear and give satisfaction or new hose free. All styles. Finest silk hose. Low priced. Write for complete line of samples. Big money for spare time. Jennings Mfg. Co., Dept. 368, Dayton, O.

AGENTS—Earn \$50 to \$100 a week selling Marquette Tire Tool. Simple demonstration sells it. Removes tires in a jiffy. Every owner wants it. Thousands in use. Exclusive territory going fast. Agent's sample \$1.25, retails at \$2.50. Write for full particulars or send \$1.25 for sample and particulars. Marquette Mfg. Co., Dept. A, 218 S. Wabasha Ave., St. Paul, Minn.

AGENTS—Sell articles which repeat and on which you can build up a permanent business. You can do it with "Zanol" Products, a high-class line of Soaps, Perfumes, Flavors, Coffee, Tea, Baking Powder and other Pure Food Products and Household Necessities. Write today for New Money-Making Plan. American Products Co., 5886 American Bldg., Cincinnati, Ohio.

DISTRICT Managers—Big profits. Men capable of organizing and managing crews of lady solicitors, can easily clear \$50.00 to \$100.00 per week with the B. & G. Protector, the original and best protector on the market. Every woman needs and buys it. Two grades. B. & G. Rubber Co., Dept. 155, 618 Penn Avenue, Pittsburgh, Pa.

AGENTS—We pay \$9 a day taking orders for Insyde Tyres. Best and easiest seller ever put on the market. Guaranteed to give double tire mileage. Any tire. No punctures or blowouts. Every auto owner buys on account of low price. Enormous demand. Write quick for agency. American Accessories Co., B-678, Cincinnati, Ohio.

TERRITORY Salesmen—First popular price Fire Extinguisher ever made. Every home, garage and office can be sold. \$30 a week can be made. No capital or experience necessary. You take orders, we deliver and collect—pay you daily. Write for territory. Thurston Mfg. Co., 278 Poe St., Dayton, Ohio.

AGENTS Wanted—Brand new article with wonderful sales possibilities. Applicants must be big enough to handle County rights on exclusive basis. Our contract assures you a permanent and substantial business. Sample fifty cents. Money refunded if we do not connect. Dept. 21, Bethlehem Utilities Co., Bethlehem, Pa.

AGENTS, \$8 a day. Take orders for Blue Ribbon Cutlery Set. Stainless steel. Aluminum handle. Guaranteed. We deliver and collect. Pay you daily. Big demand. Easy to take orders. No capital needed. Write for sample outfit. Parker Mfg. Co., 375 Awl St., Dayton, Ohio.

LIBERAL Commissions for Selling Advertising Thermometers made by the world's largest manufacturers of thermometers. Profitable proposition for energetic men. Liberal commissions. Write, giving past employment and references. Only a few more men needed. T. B. Dix, Taylor Instrument Companies, Rochester, N. Y.

MIAMI, Florida: The World's fastest growing city. Wealth, Climate, Tuckerman & Square.

\$100 REWARD will be paid to the first person who proves that the Keystone Economizer fails to save 25% to 50% of any car's ordinary gasoline consumption and entirely eliminate carbon. This is a bona fide offer. The Keystone Economizer is a real gasoline saver which has made good. Results Guaranteed. More mileage, more power, less cost. Fits any car. Easily attached. Saves its cost in a month. \$4 post-paid. Splendid offer for factory representatives, agents and salesmen. Write or wire for particulars to Keystone Economizer Co., Stock Exchange Bldg., Los Angeles, Calif.

AGENTS, Salesmen—Get distributing contract for "Lightnin' Gloss," new refinisher for automobiles. No polishing or rubbing. Dries dustless 30 minutes. Permanent gloss. Wonderful seller. Retail \$1.50. Get busy. Big profits. Makes old cars new. Address: Lightnin' Gloss Co., Wichita Falls, Texas.

AGENTS—\$50 a week taking orders for guaranteed hosiery for men, women and children. Must wear 12 months or replaced free. All styles and finest line of silk hose. Write for sample outfit. Thomas Mfg. Co., Class 282, Dayton, Ohio.

AGENTS—\$100 Weekly. New invention for all automobiles. You're backed by reliable concern in business for over five years. Products positively guaranteed. Honesty, Quality, Service, our motto. If you're sincere, write at once. Ovee Mfg. Co., Dept. 180, Louisville, Ky.

"THE Mucilage Fountain Pen"—Carry in pocket with your fountain pen. No sticky fingers. Lasts lifetime. Never dry. Handy office or home. Sample 50c U. S. stamps. Agents wanted. Liberal terms. Jax Co., Box 292 Steger, Ill., U. S. A.

SELL CurManCo—Two Changeable Signs in One. Every storekeeper buys two and three at 200% profit to you. Nothing like it. You will want nothing better to sell this year. Currier Manufacturing Company, 29 Minneapolis, Minn.

PORTRAIT Agents—Earn big money selling our Photo Medallions. Everybody buys. You charge \$3.00; make \$2.40 each sale. \$10 daily easy. Big variety designs. 4-day service. Perry Photo Novelty Corporation, Section 16, 369 Bowers, New York.

STARTLING Agents Proposition—\$100 weekly selling Rolly's Washday Wonder, New Chemical Dirt Solvent. Harmless. Cleans without rubbing. Enormous profits. Repeat orders assured. Experience unnecessary. Territory going fast. Samples free. Rolly Chemical Co., Al, Hastings, Neb.

BIG Money—Broken arms, cranking accidents prevented by Non-Kick Device for Fords. Burnett sold 144 in two weeks; made \$216. Write for particulars—exclusive territory. Non-Kick Co., 717 Central, Kansas City, Mo.

AGENTS—Cost \$5—Your Profit \$89.50. transfer monograms on autos, trunks, bags, furniture, etc. No experience, no license. Write for free samples. Globe Monogram Co., Inc., Dept. P, 244 Market St., Newark, N. J.

TEMPERED Copper? 80% Copper Chisel, Cuts Steel. Unaffected by Heat. Big Seller. Send 25c for Agent's Sample and Full Particulars. Wm. J. Eberle, A. M. & M. Bank Bldg., Milwaukee, Wis.

AGENTS Coining Money selling Universal Gas Saver for every gas stove. Wonderful device. Cuts gas bills in half. Big profits. Write quick. B. C. Moore, Gas Saver Co., Topeka, Kansas.

SOMETHING Big—Dime puts you on our mailing list one year. You receive latest money-making opportunities, propositions, from manufacturers and supply houses everywhere. Kentucky Agency, Covington, Ky.

AGENTS and Distributors wanted to sell our Radio-Gaslighters. 25-cent sellers, \$9.00 per gross. Universal demand. Write for proof. Ignition Products Company, Inc., 12 Union Square, New York.

CAPS made to order. Latest styles. The newest agents' idea out. Undersell stores. \$10.00 daily easy. Armstrong Cap Factory, 210 Superior Ave., Dept. 70, Cleveland, O.

YOUR Opportunity—Big money. Sell our Brushes. Best quality. Lowest prices. Wonderful variety. Homes, Offices, Hospitals, Apartments, Garages, Large Users. Write Springfield Brush Works, Springfield, Mass.

WHY work for others? Make and sell your own goods. We show you how. Enormous profits. Write quick for free book explaining everything. National Scientific Laboratories, 624 Main, Richmond, Va.

TEN Dollars daily easy selling Kleenall. Washes clothes without rubbing. 300 per cent profit. Sale first order guaranteed. Free samples. Quality Products Co., Altoona, Pa.

AGENTS—Buy direct from manufacturer quickest sellers at lowest wholesale prices. Big profits. Unquestionably best proposition ever offered. Write today. National (27), Woodhaven, N. Y.

300% PROFIT. Snap Laundry Crystals. The modern washing wonder. Bigger and better. Exclusive territory. Sample and particulars free. Snap Products, Dept. X, Rochester, N. Y.

300% PROFIT selling Gas and Cigar Lighters. Lights without matches or friction. Sample 25c, Pocket Size. Rapid Mfg. Co., 10 E. 14th St., New York, N. Y.

AGENTS Wanted to sell the latest self-selling novelties. Territories for live ones. Sample 10c. Dept. A, R-D-K Novelties Co., 1429 Lexington Ave., New York.

\$15.00 DAILY Easy selling the New Amheroid Unbreakable Combs; kind you can hit with a hammer; write for wholesale prices. Oliver Gandy, Crisfield, Md.

AGENTS—Mason sold 18 Comet Sprayers and Autowashers one Saturday. Profits \$2.50 each. Particulars free. Established 30 years. Rusler Co., Johnstown, Ohio, Dept. D.

AGENTS—German Barber Razors. World's best make. Money back guarantee. Dozen \$14.00. Single sample \$1.50. Money order. Address Berg Co., Times Building, New York, N. Y.

A BUSINESS of Your Own—Make sparkling glass name plates, numbers, checkerboards, medallions, signs; big illustrated book free. E. Palmer, 511 Wooster, Ohio.

80% PROFIT—Every Home, Store, Office and Garage Needs. Easily carried, quickly sold. Free sample. Address Chapman Company, 839 Dwight Bldg., Kansas City, Mo.

200 PER Cent Profit selling "Shyn-cloth." Makes all metals look like new, quickly. We guarantee sales. North Texas Supply House, Weatherford, Texas.

MOST Wonderful Seller. 96c profit every dollar. No stock to carry. License unnecessary. Sample free. Mission, 2421-MP, Smith, Detroit.

CHEVROLET Anti-rattler for gear shift lever. Sells on sight. Send 25c for sample. Proticco, 873 Hoover St., Los Angeles, Calif.

CALIFORNIA Rosebuds selling like hot cakes. Agents coining money; new stuff. Big profits. Catalog free. Mission, 2421-PM, Smith, Detroit.

SHOP Agents—Live men to distribute our Machinists' Tools. Good commission. Perdue Tool Mfg. Co., 526 16th Ave., Milwaukee, Wis.

AGENTS Wanted to sell the only and latest real pocket pencil Sharpener. Sample mailed 25c. Fred Voegt, West Frankfort, Ill.

COUNTY Distributors wanted throughout country for Household necessity. 100% profit. Sing Chemical Co., P. O. Box 1151, Indianapolis, Ind.

AGENTS—Everywhere. Fifty thousand men to sell every housewife and laundry in the United States the newest "Labor Saving Laundry Device." Nothing like it in the world; easily demonstrated; sells on sight; Money Back Guarantee. Big Commission and bonus. Exclusive territory. Mail \$1 for sample and particulars. Barrett Iron Stand Company, 1340 Broadway, New York.

AGENTS—Sell Real Solid, 99% pure and seamless Aluminum Ware. Put up in sets or single pieces. Big money for the hustler. Aluminum ware is a repeater and builds you a business. We have several other money-making lines for agents. Write for circulars. H. C. Aluminum Co., Frederickburg, O.

AGENTS—Don't overlook our proposition on page 146. C. B. Haven Co.

\$31 YOUR Clear Profit With Only \$1.50. Selling Pure Gold Leaf Monograms for Automobiles, Trunks, Bags—Window and Wagon Letters. Applied Instantly. No experience necessary. No. 1 Outfit brings you \$32.50—Cost only \$1.50—You make \$31.00 profit. Get Colored Catalog. Full Particulars, Free Samples (36 Designs). "Hurry." Nulife Auto-Aid Corporation, Hartford, Conn.

TAILORING agents wanted to sell guaranteed tailor-made suits and overcoats. We ship free prepaid, large traveling sample outfit, 250 all-wool fabrics at \$15.00 and up for guaranteed suit or overcoat. Write today for fall and winter samples. Jay Rose & Co., 411 S. Wells St., Chicago, Dept. 560P.

IMMEDIATE Commissions—no investment—no delivering—no collecting. Pay-day every day. Profits larger than usual. That's our proposition No. 1. For the agent that buys to resell—our proposition No. 2 would instantly appeal. 100% profit and Free Goods. High grade guaranteed aluminum cooking utensil specialties and staples. Our Free Goods Offer is unusually interesting. We maintain a 24-hour shipping schedule. Exclusive territories granted and protected. Get yours before it's too late. Perfection Aluminum Mfg. Co., Desk A., Lemont, Ill.

AGENTS: The kitchen, not the front porch, is where sales are made. The Martin Plan takes you right in. It secures and holds the housewife's attention; makes every call count. A splendid proposition itself, but helps introduce your regular line if you carry one. Novel, original, profitable. Complete plan and sample of fast seller only 20 cents. Stamps will do. Money-back guarantee. Address The Martin Agency, 214 West 34th St., New York City, N. Y.

AGENTS calling on motorists and garages make \$100.00 weekly selling original Tire-Doh. 12 years the leading repair for auto tires. No heat—no tools—repairs punctures permanently in 2 minutes at cost of 2 cents. Send 40 cents for big \$1.00 outfit. Money refunded if not satisfied. Write at once for full particulars. Atlas Auto Supply Co., 652 W. Austin Ave., Chicago.

AGENTS to demonstrate and sell to car owners. Nationally advertised auto polish that removes that dull gray film, restores the factory lustre, and leaves a glass-hard, dust-proof surface. Thousands of instances prove quick sales result from demonstrations, and steady growth of profits from repeat business. For free testing sample and details, address C. S. Manfg. Co., 502 N. Whittier, St. Louis, Mo.

AGENTS: Make \$75.00 a week selling our strictly All-Wool made-to-measure suits at \$28.50. You collect profits in advance and keep them. We supply finest selling outfit in America. Many exclusive money-making features. Tailoring, raincoat and side-line men, part or full time, get in touch with us immediately. Address Dept. 161, Goodwear, Inc., 843 W. Adams St., Chicago.

LARGE profits selling Spee Dee. The marvelous hand cleaner. Washes hands without water—no grit, acid or lye. Every motorist and mechanic, garage and factory buys on sight. Quick repeat orders roll up your profits. Send 20c to cover postage on big 27 ounce can. Write for particulars at once. States Chemical Co., 652 W. Austin Ave., Chicago.

AGENTS—To sell universal vise attachments that have exclusive features and used by plumbers, steamfitters, automobile garages and manufacturing plants. Affords big profits. Fully guaranteed and very easily sold. Samples, advertising matters, and territory free to live agents. Address the Universal Equalizer Company, 8 E. Pearl St., Cincinnati, O.

MEN and Women are now making big money with our new proposition selling high-grade line. Everybody uses it. Wide selection. Continuous repeater. New fast-selling "leaders" that are in big demand. Quick sales and splendid profits. Write today. The Pioneer Soap Co., 35 St. Paul Ave., Dayton, Ohio.

\$5 TO \$15 daily introducing new style guaranteed hosiery; must wear or replace free; no capital or experience required; just show samples; write orders. Your pay in advance; we deliver and collect; elegant outfit furnished, all colors and grades, including silks. Mac-O-Choo Mills Co., Desk 106, Cincinnati, Ohio.

BE our part time shoe agent in your locality. Pleasant work, good earnings. Sell from our catalog to wearer. We send shoe book with your name on front cover direct to your customers. For particulars address Tanners Shoe Mfg. Co., 116 South St., Boston, Mass., Dept. 15.

MAKE \$50 Daily. Something New! 400% profit. All business, professional men need it. Sells \$5. Costs \$1. Brooms, Texas, sold 20 first day, profit \$80. Big weekly repeater. Sells quickly. Experience unnecessary. Write today for territory wanted. Sample outfit free. Federal Association, 71-K Asylum St., Hartford, Conn.

BIG Money Makers. Large factory offers you big profits on 150 fast sellers. Toilet gift sets, flavoring extracts, remedies, soaps bring you \$8.00 to \$25.00 daily. House of Illinois makes \$4.00 an hour. Sample outfit free to workers. Lincoln Chemical Works, Dept. 155, 2956 No. Leavitt, Chicago.

SELL Muntmend for tires and tubes—cost 2c. Repair; surpasses vulcanizing, saves 500%. Every auto and accessory dealer buys. Profits amazing. Shaw made \$21 first day. Hart \$155 first week. Particulars and free sample. The Colonial Rubber Co., Dept. 85, Philadelphia, Pa.

AGENTS—Make 200% profit selling only device for cleaning Carpet Sweeper and Vacuum Cleaner brushes, mops, etc. Sell every housewife. Exclusive selling rights to live wires. Sample, 25c. Den-Wal Sales Co., Dept. C, 189 Market St., Newark, N. J.

FORD Driver Agents—New, patented, Thermo-Vaporizer. Installed three minutes. Wonderful results instantly. No dissatisfied users. Sells Five Dollars. Lasts lifetime. No adjustments. Money-back guarantee. Endorsed by leading Engineers-Motor Manufacturers. T. B. Funk Co., Indianapolis, Ind.

A DISCOVERY destined to revolutionize Tire Industry. Only practical air-filled puncture-sealing inner tube. Fully guaranteed. Autoists buy on sight. One sale sells another, \$100 weekly. Experience or capital unnecessary. A. Wenstone, 3025 Indiana Ave., Chicago.

PICTURE men ask how to get your prints at cost. Our plan is easy. United Print Co., Sta. D., Chicago, Ill.

PORTRAIT Agents—\$50,000 is what "Picture Man Friedman" made canvassing. Free circular "Profits in Portraits" tell how. 24-hour service prints, finished portraits, frames. Samples free. "Picture Man Friedman," Dept. 8, 127 N. Dearborn St., Chicago.

MANUFACTURE something new with our guaranteed solid metal outfit; makes article 7½x3 costing 1c, sells 10-25c, outdoor and indoor, like wildfire; price \$7.50 with instructions; sample 25c. New Jersey Specialty Co., 16 Bergen Sta., Jersey City, N. J.

PORTRAIT Agents—\$50,000 I made canvassing. Free circular "Profits in Portraits" explains how. 24-hour Service Prints, Portraits, Frames. I finance you, guarantee delivery. Samples free. Write today. Friedman's Studio, Dept. 8, 127 N. Dearborn, Chicago.

AGENTS—Men and Women—We start you in a permanent business without any investment. Whole or spare time. Big line, easy sales everywhere. Handsome profits. No experience necessary. Write now. National Mfg. Co., B-33 West Hoboken, N. J.

LIVE Agents Wanted. New device, designed to fill a known demand. Sells for \$2.50. Agents get \$1.00 commission on all sales and resales. Sells on sight. M. & S. Mfg. Co., Box 934, Hartford, Conn.

AGENTS—\$5 to \$10 daily selling Snow Dust Washing Compound. Washes clothes without rubbing. Women wild about it. Big repeater. Free samples boost sales. Exclusive territory. 300% profit. Sample free. Norman E. Conrad, Wahash, Ind.

THE only practical auto-cover on the market. Covers or uncovers your car instantly. Unlimited possibilities. No competition. Dealers and public garages everywhere interested. State territory wanted in first letter. Beard Manufacturing Co., Hardinsburg, Ky.

PROTECT Your Rights. Write for Record of Invention which contains form to establish evidence of conception of your invention. Prompt personal service. Preliminary advice without charge. J. Reaney Kelly, 612 G. Columbian Bldg., Washington, D. C.

PORTRAIT crews get our rock bottom prices on finishing. Service Art Sta. D., Chicago, Ill.

PROFITABLE side line for salesmen calling on banks and financial houses. Several states still open. Give particulars of lines now selling and itinerary. Mercury Bronze & Embossing Co., 126 West Third Street, Los Angeles, Calif.

EASY Money—\$18 daily—Something new. "Simplex" Ironing Board Covers. Remarkable invention every woman buys on sight. New agent sold 100 first two days (profit \$75.00). Write quick, W. J. Lynch, Springfield, Ill.

AGENTS: Make \$50 to \$100 weekly selling our rebuilt typewriters. All standard makes \$15.00 up. Guarantee five years. One month free trial. Send for agents' proposition. Typewriter Exchange, Wholesale Dept., Fordham, N. Y.

AGENTS: See our display advertisement on page 128 in this magazine, then write us immediately. Wide awake agents need no other line. Address, Sales Dept., The Kaxo Company, Cambridge, 39, Mass.

AMBITIOUS Agents are coining money manufacturing and selling Orange Blossom Shampoo. Please particular customers; repeat orders assured. Materials obtainable anywhere. Machinery unnecessary. Interesting booklet free. Address Norman M. Ort, East San Diego, Calif.

CHAFFIN Polishing Cloth cleans without scratching. 25c seller, 150% profit, \$10 daily easy. Every housewife buys one to three. Free sample demonstrator. Chaffin Products Co., 5511 Euclid Ave., Cleveland, Ohio.

WONDERFUL, Fast Seller; new auto service makes tools, etc., accessible without removing cushion. Retaila \$2.00. Agent's sample, \$1.00. Act quick for territory. E. C. Whiting, 204 Washington St., Boston, Mass.

AGENTS—Investigate. Big money taking orders. Guaranteed Electric Hot Plate. We deliver and collect. Pay you daily, full or spare time. Lenz Specialty Co., Box 3, Highland Park, Detroit, Mich.

AGENTS—Build substantial business selling article that steadily increases and repeats. Territory being rapidly assigned. Write for particulars today. The Zeta Company, Inc., Dept. 18, 1819 Broadway, New York City, N. Y.

AGENTS: Something new, Wireless guaranteed umbrellas. Adjust new top in minute. Handles collapse to fit suit-case. Other features. Popular prices. Free sample. Parker Mfg. Co., 278 Dixie St., Dayton, Ohio.

SALES Agents for exclusive county representation on Dico spark plugs. Hustlers make \$60.00 and better weekly. Every car and tractor use a prospect. Write quick. Dayton Ignition Co., Dayton, Ohio.

ALUMINUM Brush Agents. Aladdin Polish for aluminum and other metals; highly profitable side line. 30c-\$1.00 sizes for homes and public places. Sample, 4c. Address Texply Co., Somerville, N. J.

MEN'S shirts. Easy to sell. Big demand everywhere. Make \$15.00 daily. Undersell stores. Complete line. Free samples to workers. Chicago Shirt Co., 9 So. Clinton, Factory 205, Chicago.

TAILORING Agents Wanted—Make \$50.00 to \$100.00 and more per week, selling our wonderful all wool one price line. Suits sell for \$29.50. None higher. Retail stores ask at least \$50.00 for the same quality. Also strong line of featherweight fabrics to sell at \$16.75 per suit. You collect your profits at once. We ship C. O. D. to customer for balance. We furnish beautiful 6x9 swatch outfit and powerful co-operation. Hustlers write at once. Salesmanager J. B. Simpson, Inc., Dept. A-112, 831 West Adams Street, Chicago, Ill.

WANTED—Men to sell Lawn Mower Sharpener. Sample \$2.00. Simplex Sharpener Co., Dept. A, 819 Goodwin Street, Peoria, Ill.

WANTED. Representatives in every county to sell the Statyte. Every chair owner a prospect. Exclusive territory. Liberal commission. Sample 50 cts. Address Foss-Fischer Mfg. Co., Coldwater, Ohio.

TWO Real Money Makers. Self-threading needles. Needle books cost 5c, sell at 15c. Send for samples. Atlas Needle Works, Box 1888, Madison Sq. Sta., New York, N. Y.

SALESMEN: \$100.00 and commission to sell guaranteed cord and fabric tires direct from factory at lowest prices. Gooddeck Tire Company, 1100 South Michigan Avenue, Chicago, Ill.

WIRE twisted sanitary Brushes-Mops, Dusters, Automobile Brushes, etc., are the leaders in specialties. Restricted territory for live wires. Steelset Brush Co., 487 Broadway, N. Y. City.

VINOBAR Co., 536 Washington St., San Francisco, Calif., sole manufacturers. Exceptional proposition. Food beverage. Exclusive territories. New invention. Different, unusually attractive, repeater. Sample, \$1. Big profits.

AGENTS: Big profit selling our up-to-date Radio books. Write for agents' proposition. Norman W. Henley Publishing Co., 2 West 45th St., New York.

SALESMEN can sell our tools to every hotel, because they pay for themselves first time used. Address J., 1040 Georgia St., Los Angeles, Calif.

WANTED: Experienced agent to organize crews to sell standard automobile equipment. Big money to right man. Paul G. Towseley, Ashton Bldg., Grand Rapids, Mich.

SOFT Drink Extracts, Non-alcoholic flavorings, Toilet Preparations, best agents' proposition for men or women selling housewares direct. Fletcher Production Company, 415 E. 60th, Chicago.

PURE 23-karat gold leaf and many other styles of entirely new window sign letters. Boston Window Lettering System, 210 Dover St., Boston, Mass.

AGENTS—We are glad you saw this ad. Wonderful seller, sample of actual size, 25c. Don't miss answering this ad. Rovin, 801 Breitmeyer Bldg., Detroit, Mich.

SOLD man-to-man. \$40,000 formula. Imported horse-hide razor sharpener. Show sample, sale sure. Neat case. County rights. Success insured. Habanix Company, Toledo.

AGENTS Wanted—Salary or commission for demonstrating and selling our Marred Can Opener and other specialties. Staples Mfg. Co., Box 289, Mt. Vernon, Ind.

TWENTY good propositions for wide-awake agents. There is one to suit you. Particulars free. The Lawrence Products Company, Dept. M, Beaver Dam, Wis.

START Little Mail Order Business anywhere. Home employment evenings. Everything furnished. Stamp brings instructive booklet. E. Pier, 72 Cortlandt Street, New York, N. Y.

FISHER Safety Steering Device "Makes a Ford Drive like a Packard." Agents wanted every county. Good money. Fisher Sales Co., Lincoln, Nebr.

EARN \$10 daily silvering mirrors, plating and refinishing metalware, autos, chandeliers, bedsteads. Outfits furnished. E. DeCle Laboratories, 286 Fifth Avenue, New York, N. Y.

AGENTS: Make \$1 hour, selling useful 15c article. Every housewife buys. Big commission. Jerome Mfg. Co., 25 East 99th Street, New York.

QUICK Seller—New auto accessory. Fits any car. 60c retail. Agents' delight. Indispensable Products Co., 1757 N. Whitely St., Chicago, Ill.

AGENTS—Just out "No-Sag" attachment for screen doors. Big profits, sample 25c. Mfg. by Anderson & Co., North Easton, Mass.

WORLD'S Fastest Selling Auto Accessory! County Distributors wanted; write today. G. L. W. Spring Oiler Co., San Diego, Calif.

AGENTS: Lowest-Priced Gold-Leaf Window Letters. Free Samples. Address Liberty Letter Co., 77 Chapel St., New Haven, Conn.

AGENTS sell used clothing; make \$10.00 to \$25.00 day easily. New wholesale method. Crosby Co., 609 Division, Chicago.

"BLADEKNIFE" means genuine pocket knife from any discarded blade. Sample twenty cents. Address, L. L. Martin, Paterson, N. J.

AGENTS, sell new Neutral pedal for Fords. Big seller. For literature, write Burnham-Cote Co., Holyoke, Mass.

17c PROFIT on 25c sale. Two new fast sellers. ABC Manufacturing Co., Box 1715B, Washington, D. C.

THE Agent's Guide—Tells where to buy almost everything. Copy 10c. Wilson Publishing Co., 1406 Broadway, New York.

SHEEP wool pollshers, cleaners, dusters, 100% profit. Home, commercial, auto use. Remington Duster Co., East Boston, Mass.

\$30.75 PROFIT on \$2.50 outfit; gold initials for automobiles, etc. Write National, Station D, Brooklyn, N. Y.

AGENTS Wanted—Big money in selling artificial flowers. Lotus Manufacturing Co., 1734 N. Halsted St., Chicago.

SELL Ladies' Art Embroidery Needles. Sample 50 cents. Eugene Marquis, 5200 North Keystone, Indianapolis, Ind.

BIG Profits, Fast sales. Every housewife buys. Polishing cloths. Pease Supply Company, Keene, N. H.

AGENTS, \$100 weekly with latest invention. Raymonds Manufacturing Co., 31 East 132nd St., New York.

AGENTS—Don't overlook our proposition on page 146. C. B. Haven Co.

GOOD prices paid for butterflies, insects. See Sinclair's Display Advertisement, page 27.

AGENTS—Don't overlook our proposition on page 146. C. B. Haven Co.

WHY work for others? Make and sell your own goods. We show you how. Enormous profits. Write quick for free book explaining everything. National Scientific Laboratories, 624 Main, Richmond, Va.

NEW Garter, Patent Pending. Free sample. Art Co., 513 North Dearborn, Chicago.

"HOW to Sell Patents" free. Patent News-O, Washington, D. C.

MANUFACTURERS Agents—District Managers—Crew Managers—Get immediately our proposition. Mother Goose Wringer Mop—New, Patented, Perfect. Saves the back—Housewife stands erect to do all scrubbing—Hands never touch the water. Retail \$1.50. More than 100% profit. Sample prepaid \$1.00. We had to double size of factory last year to handle the order. You can make a small fortune. The Alline Company, 6523 Euclid Avenue, Cleveland, Ohio.

AGENTS—Enormous profits selling Genuine Gold Leaf sign letters. Guaranteed not to fade. Establish a permanent business or travel. Anybody can do it. Free samples. Guarantee Sign Service, A 430 South California Ave., Chicago.

AGENTS—Easy, quick sales. \$60 to \$100 weekly. Valuable free premium to every customer. You write orders. We deliver and collect. Commissions daily. No capital or experience. Wonderful new solid aluminum handle, big cutlery set, sells itself. Best year-round proposition. Sample outfit free. Also free Ford car offer. New Era Mfg. Co., 803 Madison St., Dept. 21, Chicago.

EVERPLAY Phonograph Needle plays 27,000 times. Better tone and reproduction. Pressures records. Fits all phonographs like ordinary needle. Not a jewel. Point renewed as used from 9 inches of soft special alloy wire coiled within the needle. Saves \$40. Retail \$1.00. No dealers to buck. Big profits. Everplay, 1 McKay Bldg., San Francisco, Calif.

AGENTS: We want agents to sell our Guaranteed Batteries for Automobile Starting and Lighting; our Batteries are right in quality and price. (Ford size sells for \$16.00.) We will furnish you instructions for installing, and pay you a good commission. Box 96, Defiance, Ohio.

MOTOR Ignition Amplifier—A Wonder Invention! Gives new power to an old motor and more power to the new. Sell to garages, accessory dealers and users. Quick action, big money and satisfaction. Write for prices and literature. Motor Ignition Corporation, Mfgs., Albany, N. Y.

BIG Profits Selling New \$3.50 Automatic Adding Machine. Absolutely accurate. Fully guaranteed. Quick sales. Ten daily easy. No competition. Pocket size. Business people everywhere positive customers. Thousands being sold. Tremendous demand. Here's a high-grade money-maker. Bassett Co., 1458-D, Hollywood Ave., Chicago.

HIGH-GRADE agents for entirely new accessory for any automobile. Makes night driving safe. Can carry in pocket; every car owner buys. Fits any make. Men who can stand big profits and stay on job. Ray Auto Filter Company, Marion, Ind.

AGENTS coining money with our women's household aprons and other rubberized goods; children's aprons, pinafores and sun-bonnets, utility bags, etc. Best goods made at least prices. Write for catalog 11. The Schafuse Corporation, 466 Broome St., New York, N. Y.

SALES Representative wanted every county to give all or spare time. Position worth \$1,200 to \$3,000 yearly. No previous experience or capital necessary. Write for full particulars. A. A. Silver-Chamberlin Co., Clayton, N. J.

SELL Menso Sticite Patches for tires and tubes. Every Auto Owner and Dealer buys. Appoint Sub-Agents. Exclusive territory. Sales Plan and Free Sample. Menso Products Co., 533 Rosedale, Pittsburgh, Pa.

SIGNS for stores and offices. Entirely new. \$50 week easily made. Chicago Sign System, F150 W. Austin Ave., Chicago.

WANTED—Agents and Salesmen to handle Europe's Famous Wonder Glass, the newly imported Prism "Binoculetta." For theatre, hunting, yachting, races, touring, aviation, etc. This is the smallest and of its size the most powerful Glass in the world. Can be carried in vest pocket or ladies' bag. Retail at \$25.00. Confidential wholesale price to agents \$12.50. Send money with order to George Mayerle Optical Co., General Importers, established 1894, 960 Market St., San Francisco, Calif. (Send for catalog.)

3 IN 1 Bags, \$5 per dozen. Sells for \$1.25 each. Send 50c for sample. Write for catalog of 100 sure sellers. Economy Sales Co., Dept. X, Boston, Mass.

CABBAGE Cutter, 5 knives, slices 20 vegetables, like aluminum, don't rust, never dulls, 20,000 users Cincinnati alone, endorsed by Good Housekeeping Institute. Sample 48c. Meyer Co., Orland Ave., Cincinnati, Ohio.

AGENTS—Sell Our Marvel Can Opener. Make \$4 on every \$2 invested. Our tip—your opportunity. Write us now. Staples Mfg. Co., Mt. Vernon, Ind.

SELLS like hot cakes; big profits; new ironing wax; perfumes clothes with lasting violet perfume. Working outfit 10c. Yankee Manufacturers, 280 Atlantic Ave., Brooklyn, N. Y.

LATEST, niftiest, simplest folding automobile and camping stool ever devised. Sells also like wildfire at parades, public gatherings, etc. 100% profit. Mincke, Alhambra, Calif.

AGENTS Make \$1.50 on every shirt order from manufacturer direct to wearer. Menzies Shirt Co., 3863 3rd Ave., New York City.

\$10 DAILY Easy with my specialty. 500% profit. K. Home, 1957 Warren, Chicago.

"GLARESCOPE"—New auto accessory. Just out, nothing else like it on the market; \$15.00 to \$20.00 daily easy; retail at \$2.00. Write for exclusive proposition. American Reflector Co., Hammond, Ind.

AGENTS—Unusual opportunity. Handsome profit to live agents. Every autoist convinced by demonstration. Write today for attractive proposition. Address Blasdel Products Co., 4319 McPherson Ave., St. Louis, Mo.

EXTRACT Men: Sell Vanilla, Lemon and Orange in bulk at one-half price. Wonderful goods. Profit 200%. Address Trask, Manufacturer, Temple, Maine.

\$25.00 REWARD paid for any Corn Great Christopher Positive Corn Cure cannot remove. Also good for Warts, Bunions, Moles and Callouses. Price 35c. Particulars free. Reliable Specialty Corporation, Buffalo, N. Y.

AGENTS make \$50.00 weekly selling Yankee Wringer Mop; sample free. Scheff Co., 2248 North Ave., Chicago.

AGENTS: Men and women, in spare or full time, make big money selling household necessity. Every home a prospect. Quick sales, big profit. Territory open. Write for particulars. Judd & Leland Manufacturing Company, Box 21, Clifton Springs, N. Y.

AGENTS—Sell Patented Cigar Lighters and Cigar-Case Moisteners, Big Profits. Start making money at once. Write for circulars, cuts and sales plan. Drake Mfg. Co., Dept. M., Milwaukee, Wis.

MEN or Women—Enormous Profits selling Duo Guaranteed Products. Easy Sales at every house. All or spare time. Big repeaters. Write Quick. Duo Co., Dept. Y-1, Attica, N. Y.

SELL Pudding Powders—Delicious dessert. Fast sellers; quick repeaters; big profit. Send for terms and sample. C. H. Stuart Co., 75 Broadway, Newark, New York.

AGENTS—Sell Electric Body Batteries for Nervous Diseases and Rheumatism. Nealeigh & Co., Indianapolis, Ind.

EVERYBODY uses Extracts. Sell Duo Double Strength Extracts. Complete line necessities. Big repeaters. Write today. Duo Co., Dept. E-1, Attica, N. Y.

AT Last—World's Greatest Adding Machine. Almost human. Retail \$15; week equals \$300 machine. \$500 monthly easily made, demonstrating to stores, offices, garages, factories. Simple, easy; adds, subtracts, multiplies, divides, automatically. Speedy, accurate, durable, handsome. Five year guarantee. Tremendous demand; amazing profits. Liberal trial offer. Protected territory. Write quick. Lightning Calculator Corp., Dept. F, Smith Bldg., Grand Rapids, Mich.

AGENTS Sell Neverfail Iron Rust and Stain Remover. Huge profits. Big line. Sample. Write today. Sanford Deal Co., Inc., Newark, N. Y., Dept. 6.

AGENTS—Advertising Pencils, ready sellers, excellent sideline. Write for proposition. North American Pencil Works, 310 So. Canal St., Chicago.

AGENTS—\$60-\$200 a week. Free Samples. Gold Sign letters anyone can put on store windows. Liberal offer to general agents. Metallic Letter Co., 431-C N. Clark St., Chicago.

GALLAGHER made \$356.00 in one week selling guaranteed Collection Systems, used by all business men. Sayers Mfg., 2815 Sheffield Ave., Chicago, Ill.

BIG profits. Sell Plate Glass Wind Deflectors, Rear View Mirrors, Aluminum Foot Scrapers and 20 nationally advertised accessories. Car owners, Dealers, Garages buy one to gross. Write quick for illustrated catalog and agency prices. Rapid Sales Corporation, 11-D Grand Rapids, Michigan.

POLISHING Cloth—great seller—big profit. Get our proposition. Newton & Co., 19 Main St., Newark, N. Y.

FREE Sample "Rain Shield Wiper," Retail \$1.00—Costs You 25 Cents (300% Profit). Every Autoist Buys Quickly. No Cloth. No Paste. No Mechanical Attachment. (1) Rub keeps Windshields clear 48 Hours against Rain, Snow Storms. Invention Just Out. Prevents Accidents. (Williams makes \$12 Hour.) Experience Unnecessary. Wonderful Pocket Sideline. Write Quick for Your Free Sample. Nu-Life (B) Corporation, Hartford, Conn.

100% PROFIT selling our felt rugs to homes, hotels, offices, etc. Everybody buys. We are manufacturers, not jobbers. Prices defy competition. \$75 week easy. Newark Felt Rug Company, 56-C Bergen Street, Newark, N. J.

SOFT Drinks In Powder; ten kinds. Just add cold water and sugar; no trouble. Fine for the home, picnics, parties, dances, etc. Many make \$10 to \$50 day. Ten-glass package, best drink you ever tasted, and particulars 10c postpaid. Morrissey Company, 4403-11 Madison St., Chicago.

AGENTS: 1922's Greatest Sensation. 11-piece toilet article set selling like blazes at \$1.75 with \$1.00 dressmaker's shears free to each customer. Line up with Davis for 1922. E. M. Davis Co., Dept. 506, Chicago.

PLYMOUTH Bags. We are selling this popular bag in green, black, blue and brown leatherette, cretonne lined. \$6-\$8.50-\$7.20 and \$10 per dozen. Sample 65c prepaid. Write for free samples of material. E. Condon, Mfg., 12 Pearl St., Boston, Mass.

LIVE Agents make \$10 Day selling Eureka Strainer and Splash Preventor for every water faucet. Takes on sight. Widely advertised and known. Get details today. A. B. Seed Filter Company, 73 Franklin, New York.

MAKE 600% Profit, Free Samples, Lowest priced Gold window letters for stores, offices. Anybody can do it. Large demand. Exclusive territory. Big future. Sideline. Acme Letter Co., 2800-D, Congress, Chicago.

SELFOLITE—Agents, Streetmen—Selfolite lights any fire while user sleeps, or any time. Performs surprising stunts. Newly patented. Sample 25c, postpaid; money back. Particulars. Kaytwo Mfg. Co., C195 Station A, Boston, Mass.

AGENTS: Big Profits. Genuine Gold Leaf Window Letters anyone can put up. Scripts and 57 varieties. Chicago Agency Co., 842 Altgeld St., Chicago.

\$1,000 PER man per county. Get yours. Inexperienced men pulling down star salesmen's profits. Write for proof: How farmers, ministers, clerks—men in all walks of life—made big money in whole or spare time. You can do it. Amazing proposition—wanted everywhere. Exclusive territory—no sales limit. A hot or cold running water bath equipment for any home at only \$7.50. Self-heating. No plumbing nor water works required. Investigate. Terms. Send no money. Write letter or postal today. Allen Mfg. Co., 654 Allen Bldg., Toledo, Ohio.

PORTRAIT Agents—A new portrait, something entirely different. Write for particulars, also catalogue and price list. Fidelity Portrait Company, Dept. 100, 3047 Harrison St., Chicago, Ill.

WHY work for others? Make and sell your own goods. We show you how. Enormous profits. Write quick for free book explaining everything. National Scientific Laboratories, 624 Main, Richmond, Va.

AGENTS—Big Profits. Gold Sign letters easily applied, samples free. Liberal offer to General Agents. Dept. C, Interstate Sign, 2820 No. Halsted St., Chicago.

EARN Big Money Fast applying Lithogram Initials to automobile doors. Every owner buys. \$1.35 Profit on each sale. Full particulars mailed. Address, Lithogram Company, 17-S East Orange, N. J.

YOU can make \$12,000 a year selling well-known, standard, advertised make of hand-drawn chemical fire engines, motor fire apparatus, extinguishers, hose, and complete line of fire-fighting sundries. We have several openings in good territories. Other men are making \$1,000 a month in territories not so good as we now offer. Address Ajax Fire Engine Works, Bush Terminal Bldg., 10, Brooklyn, N. Y.

AGENTS Make \$10 a day selling Presur-own Trousers presser and creaser. Connolly, 55 Vesey St., New York.

AGENTS wanted to sell "Havana Treat" 5c cigars to smokers and stores. Havana Treat Cigar Co., Utica, N. Y.

GOOD income, spare time, refinishing chandeliers, brass beds, automobiles, etc., by new method; producing amazing results; every household possible customer; experience unnecessary; simple plan of manufacturing at home starts you in big money-making business. Write for free samples, showing finishes, etc. Gunmetal Finish Co., Ave. H, Decatur, Ill.

GOLD Leaf Sign Letters; make and sell; profits exceed 1,000%; immense demand; particulars free. Johnston Co., Quincy, Ill.

AGENTS—Texas Remedies 200%. Address In'tl. Remedy Co., 1331 Franklin, St. Louis, Mo.

EASY, pleasant work for Mechanics, Shop Men, Clerks, during spare hours; will add many dollars to their salaries. Also want persons who can give full time. Big wages assured. Novelty Cutlery Co., 67 Bar St., Canton, O.

IF you need good live agents—fellows who can get the business—ask me how others are doing it. I'll gladly render the necessary assistance. J. Roy McClellan, Mgr. Classified Advertising, Popular Mechanics Magazine, Chicago.

FREE—Formula Catalog. S. & H. Laboratories, Boylston Building, Chicago.

AGENTS make 140% profit. Iridium (luminous) crucifix shines in the dark. Sells for \$2.00. Costs 84c. Complete line religious articles, crucifixes, bulbs, switch plates, house numbers and match boxes. Novel! Ornamental! Useful! Every home a prospect. Big sales. Get free demonstrating outfit. The Pioneer Corporation, 1259 W. 63d St., Chicago, Ill.

AMERICO Booster auxiliary water carburetor makes autos burn water. Eliminates carbon. Low cost; liberal profits; details free. Americo Co., Dept. 178, Cincinnati, Ohio.

ANY man handy with paint brush can start new mechanical business on nearly nothing; needed everywhere; nearly all profit; experience not required. John Braceland, 1457 So. Ninth, Philadelphia, Pa.

SELL Necessities. Everybody needs and buys the "Business Guide." Bryant cleared \$806.00 in July. Send for sample. It's free. Nichols Co., Box 4-B, Naperville, Ill.

AGENTS make 500% profit handling Auto Monograms, New Pictures, Window Letters, Transfer Flags, Novelty Signs, Catalog Free. Write Hinton Co., Star City, Ind.

PORTRAIT Agents, who want good work and prompt service and who desire to purchase their frames at factory prices, should write us at once for catalog and price list. W. G. Hannan Co., Dept. A-4, 57 E. 18th St., Chicago, Ill.

AGENTS—New patented curtain rod, necessity in every home; big profit; 4 to 10 sales at every house. Write for free sample. Home Curtain Rod Co., Providence, R. I.

LARGE shirt manufacturer wants Agents to sell complete line of shirts direct to wearer. Exclusive patterns. Big values. Free samples. Madison Mills, 503 Broadway, New York.

AGENTS—Clever Invention! Inkspoon makes every pen a fountain pen. Fast office seller; big profit, demand increasing everywhere. Exclusive territory offered. Sample free. H. Marul Company, Tribune Bldg., New York, N. Y.

AGENTS: Big Money Monogramming By Transfer Method. Catalogue Showing Over 50 Styles and Particulars Free. Motorists' Accessories Co., Mansfield, Ohio.

\$200 WEEKLY. Free samples. Sell gold sign letters to stores, offices. No experience. Big future guaranteed. Can travel. Exclusive territory. Become our general agent. Acme Letter Co., 2840D Congress, Chicago.

MAKE \$25 to \$50 Week representing Clows' Famous Philadelphia Hosiery, direct from mill—for men, women, children. Every pair guaranteed. Prices that win. Free book "How to Start" tells the story. George Clows Company, Desk 31, Philadelphia, Pa.

YOU can letter Automobiles, Doors, Trunks etc., without any previous experience by Transfer Process. Make \$27.50 on \$2.50 Outfit. Auto Monogram Supply Co., 16 Green St., Newark, N. J.

BEST Proposition on Earth. Kitchen Specialty Every Woman Wants. Nothing like it in existence. 200% profit. Best Novelty Mfg. Co., Dept. C, 160 N. Wells, Chicago.

WE Start You Without a Dollar. Soaps, Extracts, Perfumes, Toilet Goods. Experience unnecessary. Carnation Co., 201 Olive, St. Louis.

AGENTS and portrait men. Crew managers. We give you more for your money. Better and quicker service. Lowest prices on frames and glass. Rejects credited. Catalog free. The Pioneer Corporation, 1259-A West 63rd St., Chicago.

AGENTS—Stamping names on Pocket Key Protectors; sample check with your name and address, 25c. Stamping Outfits, Emblem Checks, Check Fobs, Name Plates. Hart Mfg. Co., Desk 2, 303 Degraw St., Brooklyn, N. Y.

YOU can be your own boss with our Key Check outfit. Good for \$5 a day stamping names on pocket key checks, fobs, etc. Sample check with your name and address, 20 cents. Pease Die Works, Dept. M, Winchester, N. H.

PATENTS—Write for our free illustrated guide book and Evidence of Conception Blank. Send sketch or model for our opinion of its patentable nature free. Highest references. Prompt attention. Reasonable terms. Victor J. Evans & Co., 143 Ninth, Washington, D. C.

PORTRAIT Agents: Our goods will make you big profits. Delivery guaranteed. Rejects credited. Prompt shipments. Send for latest catalog and prices. Adam J. Kroll & Co., 602 Blue Island Ave., Chicago, Ill.

DICHINOLINDIMETHYLSULPHATE. It's a Chemical. Miller's The Chemist supplies Latest Manufacturers' Formulas for Food, Beverage, Household, Automobile, Summer Specialties in all lines. Grape-ola New Beverage with the Kick. Stamp brings Lists. Valuable information to start a business paying Fifty to Five Hundred Dollars weekly with small investment. Miller, Chemist, Tampa, Florida.

WANTED—Tailoring Sales Agent—Make big money from very start—\$40.00 to \$75.00 weekly. Largest made-to-measure tailoring house, furnishing an equipment of five hundred woolsens, wants you to take orders. Satisfaction guaranteed. Biggest merchants in many towns have started with our line. If you want to establish yourself permanently in business and make big money write for full particulars, giving your experience as salesman or tailor's sales agent. H. F. Foster, Sales Manager, Lock Box 483, Chicago.

AGENTS—Best seller; Jem Rubber Repair for tires and tubes; supersedes vulcanization at saving of over 800%; put it on cold, vulcanizes itself in two minutes, and is guaranteed to last the life of the tire or tube. Sells to every auto owner and accessory dealer. For particulars how to make big money and free sample, address Amazon Rubber Co., Amazon Bldg., Philadelphia, Pa., Dept. 505.

AGENTS—If you are making less than \$300 a month our proposition on Sentinel Burglar Alarms for windows and doors will interest you. Many agents earn \$20 daily. Brand new inventions. No wires, batteries or nails. Instantly attached to any door or window. Handsomely nickel plated. Sell on sight. No competition. Provides cheap burglar insurance. Big money makers. Write today for extremely liberal terms to agents. Sentinel Alarm Co., 140 S. Dearborn St., Chicago, Ill.

AGENTS: Big profits. Best and cheapest window letters made. Easily applied. Dime brings five samples. Particulars free. Stairite Co., 1115 Second Ave., New York.

MAKE \$2 an Hour. Article that removes iron rust, grass, medicine, fruit, mildew stains. Cleans Panama and Straw Hats. Bleaches clothes. Sells Every home. Write for free demonstrating outfit and start taking orders at once. Christy, 81A Union, Newark, N. Y.

AGENTS: Big Returns, fast office sellers; particulars and samples free. One Dip Pen Co., 2 Daily Record, Baltimore, Md.

AGENTS make a dollar an hour. Sell Mendets, a patent patch for instantly mending leaks in all utensils. Sample package free. Collette Mfg. Co., Dept. 404-B, Amsterdam, N. Y.

BIG money and Fast Sales. Every owner buys Gold Initials for his auto. You charge \$1.50; make \$1.35. Ten orders a day easy. Write for particulars and free samples. American Monogram Co., Dept. 40, East Orange, N. J.

OUR Ex-Cel Luminous Crucifix shines brilliantly in the dark. Churches, hospitals and individuals are only waiting for a demonstration before buying. Agents make handsome profits. W. G. Hannan Co., Dept. B, 57 E. 18th St., Chicago.

HIGH-GRADE SALESMEN WANTED

SALESMEN can earn \$5.00 a day selling our line of Calendars, Fans, Pencils, Whistles, Yard Sticks, Blotters, Fly Swatters, Signs and other Novelties. Liberal commission. Sells entire year. Fine side lines. Local and traveling agencies. Live capable men can build up a big local trade or a big business in a wide territory. One of the finest lines on the road. Only one case to carry. High-grade salesmen can make \$5,000 a year. Address Model Calendar Co., Dept. 226, South Bend, Ind.

ONLY one policy a day means \$130 per month profit; same on renewals. Policy pays \$5,000 death; \$25 weekly benefit for injury or sickness. Premium \$10 yearly. Full or spare time. Easy seller. Write quick for territory. Underwriters, Dept. K-30, Newark, N. J.

HAVING sold 150,000 of a household appliance in New England we now offer direct salesmen and district managers in other territory equal opportunity to earn from \$2,500 to \$5,000 yearly. The Reeves Company, 65 Broad Street, Milford, Conn.

TO a Few Salesmen—real producers—a live manufacturer offers a proposition of exceptional merit. Plenty of opportunity to develop and advance. Get your application in at once. Auburn Brush Co., Box 315, Lynn, Mass.

MAKE big money selling new, self-adjusting Robert Wrench. Most wonderful tool on market. Sells for \$1.85. You make almost 100% on each. No free samples. Robert Wrench Co., 71-C Murray St., New York.

SALESMEN—Sell Zim's Peerless Collection System (108 letters). Professional and business men need it. Has special, exclusive features. Sell \$7.50. Costs you \$2.00. Creditors' Association, 812 McKnight Bldg., Minneapolis, Minn.

SIX Live Patented auto accessories: Oil gauge, windshield cleaners, hose clamp, etc. No investment. Big commissions. Address Sales Mgr., 42, 8th St., Omaha, Nebr.

CALIFORNIA Roseheads selling like hot cakes. Agents coining money. Absolutely new. Big profits. Catalog free. Mission, 2421-SP, Smith, Detroit.

SALESMEN sell "Ratskyl," our non-poisonous Rat and Mouse Exterminator. Wonderful new discovery. Ready for use, no mixing, no bait required. Harmless to man, poultry, cat, dog and other animals. Rodents die outside premises. No odor. Call on hotels, restaurants, bakeries, groceries, department stores, mills, etc. Good salary and commission. Empire Specialties Co., 1549 N. Wells, Dept. 391, Chicago, Ill.

SALES district managers wanted for Dominant Polish, the new wonder that is being adopted everywhere. If you have small capital we can make you a remarkable offer, one that will put dollars in your pockets while you are making cents now. Exclusive territory granted. Dominant Products Co., 163 South St., New York City, N. Y.

SALESMEN—\$200 to \$500 monthly easily earned demonstrating wonderful Two-pound Desk Adding Machine. Sells for only \$15. Equals work of costly machines, speedy, accurate, fully guaranteed, big demand, stores, offices, garages; enormous profits. Experience unnecessary. It sells itself. Write quick for trial offer. Address, Pangborn Adding Machine Co., Desk 606, Grand Rapids, Mich.

SALESMEN to sell new invention of popular-priced combination fire and burglar alarm; can be handled as side line by cigar, hardware, drug, candy salesmen and others; big profits, wonderful opportunity for good workers, territories limited, nationally advertised. Send 25c for sample and particulars at once. Frank's Products, 702 Broadway, New York City.

MAKE \$50 Daily. Something New, 400% Profit. All business, professional men need it. Sells \$5. Costs \$1. Brooks, Texas, sold 20 first day, profit \$80. Big weekly repeater. Sells quickly. Experience unnecessary. Write today for territory wanted. Sample outfit free. Federal Association, 71-D Asylum St., Hartford, Conn.

EASY to sell Groceries, Paints, Automobile Oils, Roofing, Stock Food to consumers from samples, no capital or experience necessary; steady, profitable work. Commissions advanced. Satisfaction guaranteed. 59 years in business. Write for full particulars. Lovern & Browne Co., Wholesale Grocers, 1775 S. State Street, Chicago, Ill.

A FIRST-CLASS Side-line Salesman can obtain a most desirable arrangement. We are established manufacturers selling a specialty to banks. Samples light and compact. Address, Continental Banking-Supply Co., Mexico, Mo.

SALESMEN—Find out about "Smack," the new soft drink flavor. No competition. There's nothing else like it. Exclusive territory. Big profits. Write today. Pitkin & Co., 399 Commercial Bldg., Newark, New York.

SALESMEN—If you want \$6,000 this year, write me. Strong line for retail stores. Nationally advertised. Liberal weekly advance to producers. W. Morgan, Mgr., 1920 Euclid, Cleveland, Ohio, Dept. 290.

CREW Managers, Distributors: Fast-selling \$4.69 household necessity. No capital required. Protected territory. We deliver and collect. Attractive sales plan. Address, Eastern Keenware Co., Franklinville, N. Y.

SELL patented necktie holder, 25 cents; five for one dollar. Gross: six dollars. Standard Metal Stamping Works, 224 Centre, New York.

SOMETHING New, a Necessity. All business and professional men need it. Sells \$7.50, costs you \$1.40. Big repeater. Sample free. Merchants Ass'n., Minneapolis, Minn.

LET'S Go! We produce, you sell "Lyn-Lens" shade everywhere electric lights are used. Unusual moneymaker. Write, Lyons, Wilburton, Okla.

SALESMEN, Sell B. & C. Pedal for Fords. Write for particulars. Burnham-Cote Co., Holyoke, Mass.

MAKE \$50 to \$100 per week selling direct to wearer our \$20, \$24, \$28 line of Virgin wool made-to-measure Suits and Top Coats. You get your profit the minute sale is closed; experience not necessary. We teach you how and furnish everything to do business with; no extra charges for double breasted or fancy coats, extra sizes or skeleton linings. House of Campbell, Campbell Building, 456 South State St., Chicago, Ill.

SALESMEN: Sell State pocket maps, showing auto roads, to advertisers and dealers. Easy to sell. Get our splendid offer. Standard Map Company, 127 W. Ohio St., Chicago.

BEST Seller: Jem Rubber Repair for tires and tubes; supercedes vulcanization at saving of over 800%; put it on cold, vulcanizes itself in two minutes, guaranteed to last life of tire or tube; sells to every auto owner and accessory dealer. Get particulars how to make big money and free sample. Amazon Rubber Co., Philadelphia, Pa., Dept. 510.

ASKO—Salesmen to sell Auto Acc. as side line; can carry sample in vest pocket; sells on sight. Big comm. Write for sample. Allen Specialty Co., 3721 West Lake St., Chicago.

"OUTOSITE," aluminum hip suspenders, 50c. Shirt down, pants up. Enormous seller. Woods, 501 North Seventh, St. Louis.

SELL Advertising Pencils. Big Commissions. Quick Sellers. Write for Proposition. Keystone Pencil Works, Altoona, Pa.

57 MILES per gallon made with new patented gasoline Vaporizer. Write for particulars. Vaporizer Co., Pukwana, S. Dak.

EVERYBODY Eats Every Day. You can handle Sugar, Flour, Canned Goods, Dried Fruit, Coffee, and entire line of groceries, as well as Paints, Roofing, Aluminum Ware and Automobile Oils, with no rent to pay; no money invested; take large orders from samples. Goods are guaranteed and proven quality. Selling experience not necessary. Steady, profitable work for "workers." Address Hitchcock-Hill Co., Dept. 200, Chicago, Ill. Reference: Any Bank or Express Co.

\$300 PER month and bonus guaranteed salesmen successfully demonstrating wonderful new adding machine. Retail \$15.00. Work equals \$350 machine. Genuine opportunity. Full time or side-line. Lightning Calculator Co., Dept. G, Grand Rapids, Mich.

AGENTS—\$60-\$200 a week. Free samples. Gold sign letters anyone can put on store windows. Liberal offer to general agents. Metallic Letter Co., 431-E N. Clark St., Chicago.

LIVE Wire Distributors and Dealers everywhere make money selling Seal-Fast inner-tube repair kits because of the unequalled efficiency and our aggressive and helpful sales promotion and advertising co-operation. Write Sales Manager for particulars. Robert M. Bowes Co., Indianapolis, Ind.

HELP WANTED

\$5-\$10 HOURLY during spare or full time laying Stanco Marbleized Flooring. No experience necessary. Indestructible, noiseless, waterproof. Most substantial and ornamental interior flooring for homes, public buildings, etc. All colors, easily prepared and applied. One job brings many. Enormous profit. Field unlimited. Formula, complete instructions and sure selling plan. \$3. Stanco Products, 2412-F, Ogden Ave., Chicago.

WHAT is it worth to you? Distributor—District Manager—Salesmen or Agent—to have the agency for best line of Rubber Specialties on the market? Hot Water Bottles, Bathing Caps, Combination Shopping Bags, Pure Rubber and Rubberized Aprons, Rubber Gloves, and forty other fast-selling articles needed in every home. Profits range from 100 to 150 per cent. Write R. & G. Rubber Mfg. Co., 618 Penn Ave., Pittsburgh, Pa., Dept. 156.

GOVERNMENT positions. Men, women, 18, over. Wanted for railway mail, post-office, other government positions. Examination soon. Salary \$1400-\$1800 year. Experience not required. Particulars free. Write Columbia School of Civil Service, 411 Pope Bldg., Washington, D. C.

\$100 MADE in one week by young man in small town without capital or expense in local advertising business. Why can't you do likewise? Free book tells how. S. Myer, 211 7th St., Louisville, Ky.

DISTRIBUTOR or sales agency to represent line of sanitary brushes sold direct to home. Oldest concern, excellent proposition with exclusive territory. Large commissions. Wire Grip, 29 Mercer St., New York, N. Y.

WOMEN wanted: Become costume designers. \$140 month. Learn while earning. Sample lesson free. Franklin Institute, Dept. D-585, Rochester, N. Y.

\$35 WEEK. Learn while earning. Boys—men. Become automobile experts. Write Franklin Institute, Dept. D-461, Rochester, N. Y.

FIREMEN, brakemen, baggagemen, sleeping car, train porters (colored). \$140-\$200. Experience unnecessary. 810 Railway Bureau, East St. Louis, Ill.

START Silvering Mirrors, Auto Headlights, Tableware, etc. Plans free. Clarence Sprinkle, Dept. 28, Marion, Ind.

LEARN Plating—Automobile Painting—Refinishing. Plans Free. Norman Borick, 127 Carroll St., Akron, Ohio.

MEN—Boys over 17. Become U. S. Government Railway Mail Clerks. Big opportunity. Commence \$135 month. Quick, sure raise to \$195. Pleasant work traveling constantly. Every second week off—with pay. No layoffs. Common education sufficient. Pull unnecessary. Write immediately for free list Government positions open. Franklin Institute, Dept. E-3, Rochester, N. Y.

EARN Money at Home; We Pay You \$15 to \$50 weekly during spare time. No experience necessary writing show cards. We instruct by correspondence, and keep you in steady work. Sho-Rite Sign System, Dept. 276, 5439 Field Ave., Detroit, Mich.

STRICTLY Homework. We buy your product. Materials obtainable anywhere; no canvassing nor experience; 255 propositions, plans, samples, formulas, 25c; details dime; money back. Co-operative Club, Augusta, Maine.

WANTED—Men to learn motion picture machine operating. Positions secured. Salary \$50 weekly; small tuition in easy payments. Write today. Box 88, Sioux Falls, South Dakota.

EARN \$10 daily silvering mirrors, plating and refinishing metalware, autos, chandeliers, bedsteads. Outfits furnished. E. Decie Laboratories, 284 Fifth Avenue, New York, N. Y.

MEN—Boys. Become Railway Mail Clerks. \$135 month. Write immediately. Franklin Institute, Dept. E-21, Rochester, New York.

START Little Mail Order Business anywhere. Home employment evenings. Everything furnished. Stamp brings Instructive Booklet. H. Pier, 72 Cortlandt Street, New York, N. Y.

GOVERNMENT needs Railway Mail Clerks, \$133 to \$192 month. Write for free specimen questions. Columbus Institute, E2, Columbus, Ohio.

WANTED—Men—Boys over 17. Become Railway Mail Clerks. Commence \$133 month. Common education sufficient. List positions free. Write immediately. Franklin Institute, Dept. E-21, Rochester, N. Y.

GOOD prices paid for butterflies, insects. See Sinclair's Display Advertisement, page 27.

\$135 MONTH. Become Railway Mail Clerks. Big opportunity. List positions free. Write immediately. Franklin Institute, Dept. E-21, Rochester, N. Y.

MANY Ways to Make Money. 25c. W. D. Browning, Memphis, Tenn.

"WHAT to Invent for Profit" free. Patent News-B, Washington, D. C.

U. S. GOVERNMENT Jobs. Men—Women, \$92 to \$190 month. List positions open. free. Write immediately. Franklin Institute, Dept. E21, Rochester, N. Y.

SALESMEN—Become Independent. Own your business; experience unnecessary; selling our \$7,500 Accidental Death, \$50 Accident, \$25 Sick Weekly Benefits; \$12.50 yearly; other amounts proportionate. Guaranteed steady income from renewals. \$250,000 deposited Insurance Department. Registration Dept. A, Newark, N. J.

SIGN Letter Agents and Painters: 500% Profit. Gold and Silver Sign Letters for Stores and Office Windows. Anyone can put on. Big demand. Free Samples. Metallic Letter Co., 431D N. Clark St., Chicago.

FINGER Print Lesson based on Henry System included with Detective Course. Particulars free. Write, American System, 1968 Broadway, New York.

WANTED—Men, women over 18 for United States Government positions. Good pay; lifetime jobs. Experience unnecessary. Write for full information. Chicago Civil Service College, Dept. A, Kesner Building, Chicago.

ALL men—women over 17, willing to accept Government Positions \$135 (Traveling or Stationary), write Mr. Oament, 101 St. Louis, Mo.

SILVERING mirrors, French plate taught. Easy to learn. Immense profits. Plans free. Wear Mirror Works, Excelsior Springs, Mo.

UNITED States Government Wants Men. Excellent positions at attractive salaries. Railway Mail Clerk Examination soon. Let our expert (former United States Civil Service Examiner) prepare you for this and other fine positions. Write today for free catalog P.M. Paterson Civil Service School, Rochester, N. Y.

BE a Railway Traffic Inspector! \$110 to \$250 monthly; expenses paid after 3 months' spare-time study. Splendid opportunities. Position guaranteed or money refunded. Write for free booklet CM-46, Stand. Business Training Inst., Buffalo, N. Y.

STORIES, poems, plays, etc., are wanted for publication. Good ideas bring big money. Submit manuscripts or write Literary Bureau, 522, Hannibal, Mo.

START a Paying Business of Your Own. Be a business man. Any location. 8,000 new Tire Vulcanizing and Repair Stations needed. Business always good. Are you ambitious? \$100 will start you. Write at once. Wonderful opportunity. Equipment Co., 175 Canal, Cincinnati, Ohio.

WRITE Articles, stories, news, in spare time for newspapers and magazines. Big pay. Copyright book free. Press Syndicate, 853, St. Louis, Mo.

MAKE money writing Photo-plays; details free to beginners. No correspondence course. Producers' League, 230 Wainwright, St. Louis.

INVENTORS desiring to secure patents should write for our book, "How to Get Your Patent," tells our terms and methods. Send sketch for our opinion of its patentable nature. Randolph & Co., Patent Attorneys, 620 F, Washington, D. C.

OUR genuine gold window sign letters are an excellent money-making proposition for handy men. Slann Sign System, St. Antoine St., Detroit, Mich.

FOR ADVERTISERS

THOUSANDS maintain New York addresses. Why? How to increase your advertising results. Free. D. C. Way, 42 Broadway, New York.

FIFTY genuine photo postals from any photo or product, \$2.00; 500, \$12.00; Samples, 10c. Address Barbeau, Oswego, N. Y.

25 WORDS in 50 weekly and Sunday newspapers \$5. Cope Agency, 238, Campaign, Ill.

INCH display 100 magazines, \$4.00; three times, \$8.00. Pennell Company, Covington, Ky.

ADVERTISE your ad in 100 magazines for 5c per word. Sample copy 10c. Harley Snell, 1621 State Ave., Cincinnati, Ohio.

YOUR 30-word advertisement in 75 magazines \$1.50. Riley Publishers, 1833 S. 50th Court, Cicero, Ill.

JACOBUS Copy Pulls Business. Jacobus Advertising Service, Irvington, N. J.

COMMERCIAL Engraving and Printing, the most practical and complete book on engraving, printing and allied subjects ever published. Over 800 pages and 1500 illustrations presenting over 3500 distinct ideas on 35 separate subjects. Cloth, price \$15.00 prepaid. We highly recommend this book. Popular Mechanics Book Dept., 6 N. Michigan Ave., Chicago.

ADVERTISE in 24 Big Sunday Newspapers, 25 words \$15.00. Catalog listing 1,000 leading Dailies, Weeklies, Magazines, 4c stamps. Union Advertising, Baltimore Bldg., Chicago.

INCH Display Advertisement 161 Magazines Thrice \$15. Year \$50. Page \$100. Wood's Popular Services, Atlantic City, N. J.

MAILING LISTS

100 AGENTS' names \$2.00. Send for list of classifications. Pennell Company, Covington, Ky.

EVERY county 2,075 Nebraska farmers, \$3.00. Joston's Service, Box 769, Omaha, Neb.

TYPEWRITERS AND SUPPLIES

TYPEWRITERS. All Makes. Save one-half. Thoroughly Rebuilt in our factory by the famous "Young Process." Fully guaranteed. Free trial. We handle all standard makes. Cash or sold on easy terms. Write for Catalog. Young Typewriter Co., Dept. 320, Chicago, Ill.

UNDERWOOD Typewriters at far less than manufacturer's price; rebuilt, all worn parts replaced, guaranteed good as new. Cash, installment payments. Write for Catalogue A-151. Typewriter Emporium, estab. 1892, Montrose and Ravenswood Ave., Chicago, Ill.

ALL Makes, \$100 used typewriters, \$6 up. Free trial. Write for illustrated Bargain List 287. Northwestern Typewriter Exchange, 320 Goethe Street, Chicago.

TYPEWRITERS, all makes, \$15.00 up. Guarantee five years. One month's free trial. Special proposition to agents. Typewriter Manufacture Exchange, Fordham, New York.

INFORMATION

RELIABLE information furnished on any subject or money refunded, 75c. Co-Operative Service, Times Plaza, Box 364, Brooklyn, N. Y.

BUSINESS SERVICE

SALES Managers: Exclusive state territories. Finger print check and signature protector. Positive identification. Cannot duplicate or alter. Attractive proposition. Address Chesney Finger Print Protector, Lincoln Inn Court, Cincinnati, Ohio.

RELIABLE information. Authority on organizations, individuals, ratings; where buy or sell; personal calls; business represented; contracts handled promptly; \$1. Cottrell Service, P. O. Box 259, Chicago.

SOUTH Carolina, Rock Hill, Collections, Legal Business. J. H. Foster.

INCORPORATE. Our lawyers do the work, saving you time, annoyance and money in incorporating under the most liberal laws of Arizona. Laws and forms free. Southwestern Securities & Investment Co., Box D488, Phoenix, Ariz.

DUPLICATORS AND DEVICES

YOU can make 50 to 100 copies of a letter, notice, etc., on three cents' worth of Hoyer Quality Compound. Write for free catalog and samples. The Hoyer Duplicator Co., 162 N. Wells St., Chicago.

WANT a "Modern" Duplicator to print Typewritten or Pen Written Letters, Drawings, Lessons, Music, Bids, Menus, Maps, Specifications or anything in one or more colors! Prints two a minute, \$2.25 up. Special sale on; 30 Days Free Trial. Booklet Free. J. E. Durkin-Reeves Co., Pittsburgh, Pa.

ADDING MACHINES

NEW \$3.50 Automatic Adding Machine. Adds, Subtracts, Multiplies. Absolutely accurate. Capacity 9999,999.99 Fully guaranteed. 75,000 pleased users. Makes adding easy, positive, quick. Eliminates Mistakes. Saves Time. Postpaid, \$3.50. Bassett Co., 1458-C, Hollywood Ave., Chicago.

FREE Trial, Marvelous new Adding Machine. Adds, Subtracts, Multiplies, Divides, automatically. Work equals \$350.00 machine. Price only \$15.00. Speedy, durable, handsome. Five-year guarantee. Used by largest corporations. Write today for catalog and free trial offer. Lightning Calculator Co., Dept. E, Grand Rapids, Mich.

PRINTING, ENGRAVING AND MULTIGRAPHING

250 GOOD Bond Letterheads or Envelopes printed and mailed \$1.50, or 1,000 for \$4.50. Address Hatton Printing Co., Hatton, N. Dak.

150 NOTEHEADS, 100 white Envelopes printed and mailed \$1.00. Samples printing free. "Sun Co.," Mohawk, New York.

500 LETTERHEADS and 500 Envelopes \$4.65, 20 lb. bond paper. Samples, Wellman Printing Co., Huntington, West Va.

1,000 HAMMERMILL Letterheads or Envelopes \$4.00. Full Line Samples Free. Quality Printshop, Marietta, Ohio.

1000 FULL-SIZE Hammerrmill Bond Letterheads \$3.65. Postpaid. Other stationery in proportion. Business building Multigraph letters cheap. Samples free. Charles B. Hatfield, Box 353, Oswego, N. Y.

5000 5 1/2 x 8 1/4 CIRCULARS, \$8.50; 5 1/2 x 6 1/2, \$4.50; 8 1/2 x 5 1/2, \$4.50. Attractive colored paper. Samples. Hargain List. Good's Printery, Harrisonburg, Va.

PERFECT Printing. Everything reasonable. 1000 bond letterheads \$4.75. Samples free. Address, Lewis Stationery Co., Troy, New York.

200 HAMMERMILL Bond Letterheads, Envelopes, Billheads or Business Cards, \$1.00 postpaid. Race Printing Company, Hudson, N. Y.

ELEGANT Calling Cards, 33% commission. Agents, sample 25, your name, 25c. Good's Printery, Harrisonburg, Va.

GET our samples before ordering elsewhere. "Adverpress," Station C, Milwaukee.

MERCHANTS: Lowest prices on Highest Quality Advertising Pencils. Sample with your Ad. on imprinted in Gold, 10 cents. S. Musial & Co., 422 Walnut St., Yonkers, N. Y.

PRINTING Presses, Type, Supplies. No Junk. Catalog Free. Lawrence, 1426 South St. Francis, Wichita, Kan.

100 BOND Letterheads—100 Envelopes to match; embossed \$2.00. Samples. Wolf Advertising Service, Danville, Ill.

WE print anything. Circulars, stationery, Catalogs, Samples. Commercial Press, Batavia, Ohio.

100 BOND Letterheads, 100 Envelopes \$1.35. Others reasonable. Economic Press, Leonia, N. J.

REDUCED prices for better printing. 1,000 Bond letter-heads, \$5.00; 1,000 good envelopes, \$4.25; 1,000 four-page folders, 3 1/2 x 6 1/2 inches, \$12.00. Catalogues, circulars, booklets our specialty. All printing at reduced prices. Samples free. Pantus, 525 S. Dearborn St., Chicago.

QUANTITY Users save 30%. Wolf Roll Labels, Sta. E, Philadelphia.

PRE-USED Printing Presses, Type and supplies. List for stamp. Popular Bargains, Richland, Pa.

EMBOSSED business, personal stationery. Samples, stamp. Daniels Co., Pittston, Pa.

1,000 LETTERHEADS or Envelopes. \$3.00, sent prepaid. Samples Free. Monitor Press, Morrisville, Pa.

PRINTING Outfits—Presses, type supplies, type novelties. Send stamp for catalogue. Model Press, York, Penna.

RAZORS AND BLADES

BLADES resharpened; one edge, 2c; double, 3c. Ervin Mikkelsen, Wakonda, S. D.

BLADES Resharpened 2c single edge, 3c double. Guaranteed service. Standard Safety Razor Corporation, Pittsburgh, Pa.

BLADES, resharpened, one edge 2c; double 3c. New York Edge Co., Glen Cove, N. Y.

FOR MEN

WHY Men Are Old at Forty. Men, if depressed, if backache, sciatica or tender feet annoy you, if nerves are gone, if your sleep is disturbed, send for a simple drugless treatment that cannot interfere with your work or doctor's care. If you are suffering you will bless this book. Write now before you forget. The Electro-Thermal Co., 2128 Main St., Steubenville, Ohio.

I WANT to send Free to every chronic pipe smoker in the country a good, big, generous sample package of my pure, sun-cured, nature-flavored Old Green River Pipe Tobacco. No money to pay. If you are a tobacco crank, all the better. Try the pure stuff. No syrup, flavoring or dope. After you try it free, I'll show you how to cut your smoke bill one-half and get more pipe joy. Just send name and address, and say whether you want mild, medium or strong. Pete Moberly, Box 820, Owensboro, Ky.

TOBACCO

HOMESPUN Smoking Tobacco, mild and mellow—10 lbs. \$1.50; 20 lbs. \$2.75; delivery guaranteed. We furnish free recipe for preparing. Smoking Tobacco Exchange, Sedalia, Ky.

PURE Red Leaf Tobacco, quality guaranteed. Best chewing, 4 lbs. \$1.25, 10 lbs. \$3.10. Mild smoking, 4 lbs. \$1.00, 10 lbs. \$2.10, delivered. O. D. Collier, Agent, Martin, Tenn. "Collier is absolutely honest and reliable." Martin Bank, Raymer, Cashier.

GUNS, SPORTING GOODS, ETC.

BASEBALL Players, use Hollman's Glove Pep. It's great. Softens the leather, makes the ball stick, breaks in new gloves quickly; 2 sizes, 50c and \$1. Send Paul Hollman Company, 6029 St. Lawrence Ave., Chicago, Ill.

GUNS and Pistols of any make repaired. Bradley & Son, Savannah, Ga.

FISHING TACKLE

FISHERMEN, Attention! Don't dig for worms. Wormite brings them out. Something new. No trouble. Sample ten cents in coin. Address, United Supply Bureau, Elizabeth, N. J.

BOATS AND LAUNCHES

16'-ROWBOAT. 12½'-Rowboat. 12'-Folding Rowboat. Easily made. Construction blueprints 30c each. Wee-Sho-U Co., West Market, Detroit, Mich.

PALMER four-cycle motor for Rowboats, Yacht Tenders. Price \$88.00. Also two and four-cycle to seventy-five horsepower. Catalogue free. Palmer Bros., Cos Cob, Conn.

"HOW to make your boat leakproof." Send for booklets. L. W. Ferdinand & Co., 152 Kneeland St., Boston, Mass.

OPTICAL GOODS

ULTRALEN'S Microscope. Patents pending. Model with magnification gradually variable from 2,500 to 62,500 times, \$1.00. Others from 100 to 250,000 times. Something new. Circular P-7 free. Address, Specialty Mfg. Co., Milton, Pa.

DIAMONDS, WATCHES AND JEWELRY

CHINESE Lucky Rings, said by the Chinese to bring good luck to wearer, genuine silver plated, come in ladies' and gentlemen's styles, adjustable, will fit any finger. Price postpaid in plush-lined ring box, 50c. (no stamps.) William H. McClure, 1257 South Jefferson, Saginaw, Mich.

ANTIQUES AND RELICS

WORLD War Relics collected from Europe's Battlefields. Catalog 10c. War Photos, actual warfare, 275 diff. \$5. Sample set 14 views 25c. Lieut. Welsh, 50 Fort-greene, Brooklyn, N. Y.

GENUINE Indian Baskets and Wampum. Wholesale catalog. Gilham, Kelseyville, Cal.

FOR THE HOME

MAKE Inexpensive Iceless Refrigerator. Blueprint 35c. Wil'iam Quemore, Camden, New Jersey.

PHONOGRAPHS AND RECORDS

BUILD a genuine Choralion phonograph and save over half. Big profit building and selling. We furnish motors, tone-arms, full instructions and all necessary parts. Send for catalog and free blueprint offer. Choralion Phonograph Co., 622 11th St., Elkhart, Ind.

BUILD your own phonographs. We can supply you with motors, tone arms and all accessories at wholesale prices. Write for catalogue AX. Pleasing Sound Phonograph Co., 204 East 113th Street, New York, N. Y.

BUILD your own phonograph. Write for our parts catalog. American Phonograph Co., 3515 North Crawford, Chicago.

SUPERIOR Phonograph parts make real musical instruments. Prices low. Superior Phonographs Co., Erie, Pa.

WONDERFUL Bargains in Phonograph Cabinets. Hunter Factory, McHenry, Ill.

BUILD your phonograph. Quality Phonographs. Highest quality spring and electric Motors, Tone Arms, Reproducers, Amplifiers, Case Material and Accessories. Free Blue Prints and Building Instructions. Big saving. Wonderful results. New catalog mailed for ten cents. Hoosier Manufacturing & Supply Co., Phonograph Supply Department, 313 Baldwin Block, Indianapolis, Ind.

MUSIC AND MUSICAL INSTRUMENTS

"I WONDER Why You Hang Around." Biggest novelty song hit going. Only 15c per copy. Eastern Music Co., North Adams, Mass.

SONG Writers—Have wonderful proposition for poem or melody writers. Ray Hibeler, D110, 4040 Dickens Av., Chicago.

"MUSIC Composed" to words. Bauer Bros. (formerly of Sousa's Band), Oshkosh, Wis.

MAIL old gold, unused postage, war and thrift stamps, Liberty bonds, silver, platinum, diamonds, jewelry, watches, false teeth, magnets points, etc., new or broken. Cash immediately. Held ten days, returned if unsatisfactory. Ohio Smelting Co., 205 Lennox Building, Cleveland, Ohio.

RAG Jazz Piano, Saxophone, or Tenor Banjo in 20 lessons. Christensen Schools in most cities, or Learn by Mail. Write for Booklet, or money-making teacher's opportunity. Axel Christensen, 16 E. Jackson, Chicago, Ill.

WE Buy, Sell and Exchange 65-note player rolls. Standard Music Co., 183 North Wabash Ave., Chicago, Ill.

MUSIC—Composed, arranged, orchestrated. Best service at "knockout" prices. Paul Jeffries, Michigan, Arctic, Atlantic City, N. J.

VIOLINS—Deep, Mellow, Soulful—on credit. Easy terms for wonderful instrument. Get details today. Gustav F. Henning, Box 2043, Denver, Colo.

CORNETISTS—Trombonists—Saxophonists—Clarinetists. Send for "Free Pointers." Name instrument. Virtuoso School, Buffalo, New York.

WRITE Songs. Big money and reputation. Write for information. J. Gordon Pub. Co., 291 N. Hoyne Ave., Chicago.

I WANT song poems. Casper Nathan, Garrick Theatre Building, Chicago.

PATENT ATTORNEYS

PATENTS—"How to Obtain a Patent" is the name of a book which every inventor should have. It will be sent free upon request, and will tell you what you want to know about patents. It contains the whole story. It describes the different parts of the application and explains in simple language the prosecution before the Patent Office. It tells about joint applications, releases, agreements, assignments, licenses, interferences, infringements, process patents, design patents, trade-marks, and prints and labels. If you are interested in patents either as an inventor, manufacturer or owner of a patent you will enjoy reading this book which was written by a lawyer who has had twenty-five years' experience in patent matters. If you have an invention and will send us a sketch, model or photograph of it we will promptly make a search of the Patent Office records and advise you whether or not, in our opinion, your invention is patentable, our charge for the service being \$5.00. We feel that our experience of twenty-five years has fitted us to render prompt and efficient service which will merit your confidence. Write today. Talbert & Talbert, 463 Talbert Building, Washington, D. C.

PATENTS promptly procured. Personal, careful and efficient service. Highest references. Moderate fees. Send sketch or model for actual search and advice. George P. Kimmel, Master of Patent Law, 54-J, Loan and Trust Bldg., Washington, D. C.

WOODWARD, New Book. Send your sketch. H. L. Woodward, 714 9th, Washington.

PATENT, Trade-mark and Copyright specialist. Prompt, personal efficient service. Advice on request. M. E. Jones, Lawyer, 509B 7th St., Washington, D. C.

PATENTS. Booklet free. Highest references. Best results. Promptness assured. Send model or drawing for preliminary examination. Watson E. Coleman, Patent Lawyer, 624 F Street, Washington, D. C.

ROBB, Robb & Hill offer a strictly professional service to manufacturers and inventors in patenting inventions and registering trade-marks, a service which is the result of 20 years' experience. Write for free booklet and names of prominent manufacturers and inventors represented by us. Send sketch for preliminary advice. 811 McLachlen Bldg., Washington, D. C.; 1348 Hanna Bldg., Cleveland, Ohio.

PATENTS—Trademarks—Write for our free illustrated guide book and Evidence of Conception Blank. Send model or sketch and description and we will give our opinion of its patentable nature free. Highest references. Prompt attention. Reasonable terms. Victor J. Evans & Co., 106 Ninth, Washington, D. C.

INVENTORS! Send sketch or model of your invention for opinion concerning patentable nature and exact cost of applying for patent. Book, "How to Obtain a Patent," sent free. Gives information on patent procedure and tells what every inventor should know. Established twenty-eight years. Chandee & Chandee, 426 Seventh St., Washington, D. C.

PATENTS—Herbert Jenner, patent attorney and mechanical expert, 622 F St., Washington, D. C. I report if a patent can be had and its exact cost. Send for circular.

PATENTS—Trademark, copyright; folder free; results procured. Write Metzger, Washington D. C.

PATENT your invention. But note: a patent is no better than its claim. Be sure your patent is as good as your invention. Patent claims skillfully drafted by Lamb & Co., Patent Attorneys, 1419 G Street, Washington, D. C.

PATENTS, Trademarks. Before disclosing an invention, the inventor should write for my blank form Evidence of Conception. This should be signed, witnessed and returned to me with sketch or model, upon receipt of which I will promptly render opinion as to patentable nature and send booklet on Patents. Highest references. Prompt attention. Reasonable terms. Clarence B. O'Brien, Registered Patent Lawyer, Seventh Floor, Southern Bldg., Washington, D. C.

PATENTS Procured, Trademarks Registered. A comprehensive, experienced, prompt service for the protection and development of your ideas. Preliminary advice gladly furnished without charge. Booklet of information and forms for disclosing idea free on request. Richard B. Owen, 30 Owen Bldg., Washington, D. C., or 2276-B, Woolworth Bldg., New York.

PATENTS, Trademarks. Thirty-five years' experience. Send model or sketch for opinion as to patentability. Free "Invention Guide." Highest references and personal attention assure best results. Franklin H. Hough, 522 Washington Loan & Trust Bldg., Washington, D. C.

PATENTS—Prompt, personal efficient service by an attorney-at-law, skilled in all branches of Patent Practice. Over 12 years' actual experience; full information upon request. B. P. Fishburne, 331 McGill Bldg., Washington, D. C.

PROTECT Your Rights. Write for Record of Invention which contains form to establish evidence of conception of your invention. Prompt personal service. Preliminary advice without charge. J. Reaney Kelly, 612G, Columbian Bldg., Washington, D. C.

PATENTS, Trademarks, Designs and Copyrights. Registered firm of attorneys-at-law. Careful, prompt, personal service assured. Moderate fees. Full information free upon request. Gross & Collings, 606 Ouray Bldg., Washington, D. C.

PATENTS Secured. Co-operative personal service. Send sketch or model for search of U. S. patents and patentability opinion. Moderate fees, payable in installments. Trademarks. Eugene Stevens, Jr., Barrister Bldg., Washington, D. C.

PATENTS and Trademarks obtained. Prompt service. Write for our new book on patents. Established in 1889. D. Swift & Co., 369 7th St., Washington, D. C.

PATENT applications filed on partial payment plan. Trademarks, copyrights, etc. Milo B. Stevens & Co., 685 F St., Washington; 352 Mononock Bldg., Chicago. Established 1861.

PATENTS. Have you an idea to patent? Write for "Inventors Record" and instructions for its use. Terms and advice sent immediately upon request. Address, Wm. H. Mulligan, 134 Woodward Bldg., Washington, D. C.

INVENTORS—Send for form "Evidence of Conception" to be signed and witnessed. Form, fee schedule, information free. Lancaster & Allwine, 221 Ouray Bldg., Washington, D. C.

INVENTORS Aided. Ideas developed. We seek the valid patents, Richardson & Rogers, 7 Albee Building, Washington. Experimental machinery built. Practice in all courts.

COMPLETE patent applications \$15. To buy or sell patents write Patent News-G, Washington, D. C. Only Inventors' newspaper. Yearly \$2. Copy 20c.

MONROE MILLER, Ouray Building, Washington, D. C., patent attorney, mechanical and electrical expert. Best quality of work and results. Moderate charges.

"INVENTORS' Guide," free on request; gives very valuable information and advice. Write Frank Ledermann, 21 Park Row, New York, N. Y.

FOR INVENTORS

PATENTS. If you have an invention which you wish to patent you can write fully and freely to Munn & Co. for advice in regard to the best way of obtaining protection. Please send sketches or a model of your invention and a description of the device, explaining its operation. All communications are strictly confidential. Our vast practice, extending over a period of seventy years, enables us in many cases to advise in regard to patentability without expense to the client. Our Hand-Book on Patents is sent free on request. This explains our methods, terms, etc., in regard to Patents, Trade Marks, Foreign Patents, etc. "Scientific American" contains Patent Office Notes. Decisions of interest to inventors, and particulars of recently patented inventions. Munn & Co., Solicitors of Patents, 523 Woolworth Bldg., New York; Scientific American Bldg., Washington, D. C.; 801 A Tower Bldg., Chicago, Ill.; 611 Hanna Bldg., Cleveland, Ohio; Hobart Bldg., 582 Market St., San Francisco, Calif.

PATENTS—"How to Obtain a Patent" is the name of a book which every inventor should have. It will be sent free upon request, and will tell you what you want to know about patents. It contains the whole story. It describes the different parts of the application and explains in simple language the prosecution before the Patent Office. It tells about joint applications, interferences, infringements, process patents, design patents, trade-marks, and prints and labels. If you are interested in patents either as an inventor, manufacturer or owner of a patent you will enjoy reading this book which was written by a lawyer who has had twenty-five years' experience in patent matters. If you have an invention and will send us a sketch, model, or photograph of it we will promptly make a search of the Patent Office records and advise you whether or not, in our opinion, your invention is patentable, our charge for the service being \$5.00. We feel that our experience of twenty-five years has fitted us to render prompt and efficient service which will merit your confidence. Write today. Talbert & Talbert, 464 Talbert Building, Washington, D. C.

PATENTS Secured. Prompt service. Avoid dangerous delays. Send for our "Record of Invention" form and Free Book telling How to Obtain a Patent. Send sketch or model for examination. Preliminary advice without charge. Highest References. Write today. J. L. Jackson & Co., 244 Ouray Bldg., Washington, D. C.

INVENTORS. Send sketch or model of invention for advice. Write for Evidence of Disclosure form and Book on Patents. Free. Prompt Service. Merton-Roberts & Company, 182 Mather Building, Washington, D. C.

LATEST Book on Patents. H. J. Woodward, 711 9th, Washington. Send your idea.

PATENTS, Trademarks. Before disclosing an invention, the inventor should write for my blank form Evidence of Conception. This should be signed, witnessed and returned to me with sketch or model, upon receipt of which I will promptly render opinion as to patentable nature and send booklet on Patents. Highest references. Prompt attention. Reasonable terms. Clarence B. O'Brien, Registered Patent Lawyer, Seventh Floor, Southern Bldg., Washington, D. C.

PATENTS Procured, Trademarks Registered. A comprehensive, experienced, prompt service for the protection and development of your ideas. Preliminary advice gladly furnished without charge. Booklet of information and forms for disclosing idea free on request. Richard B. Owen, 30 Owen Bldg., Washington, D. C., or 2276-B, Woolworth Bldg., New York.

INVENTORS and Manufacturers. For developing your invention, designing and constructing Automatic Machinery, Labor-saving Devices for all purposes, Coin-Controlled Beverage and Food-Dispensing Machines, Consult John Frick, Mechanical Engineer, 1640 N. Park Ave., Philadelphia, Pa.

PATENTS Obtained. Complete application \$15. "Patent News Plan" saves money. Patent News-E, Washington, D. C.

GET your own patent. Complete instructions \$1. Cutting Sons, Campbell, Calif.

INVENTORS: We sell patents on commission. Patent Co., Peterson, Iowa.

900 MECHANICAL Movements and 50 Perpetual Motions illustrated and explained in my book, *Inventor's Universal Educator*, 5th Edition—Tells how to procure and sell patents. Government and other costs. Covers the matter from A to Z—160 pages—Elegantly bound. Contains noted decisions of U. S. Supreme and State Courts on Patent cases. Mechanical Movements greatly assist inventors—suggest new ideas that might prove of great aid in perfecting inventions. Tells how to select an Attorney. Has valuable information regarding Patent Sharks, Selling Agents and promoters. Price, \$2. Postage free everywhere. Fred G. Dieterich, 621 Ouray Bldg., Washington, D. C.

PROTECT Your Rights. Write for Record of Invention which contains form to establish evidence of conception of your invention. Prompt personal service. Preliminary advice without charge. J. Reaney Kelly, 612 G, Columbian Bldg., Washington, D. C.

PATENTS. Have you an idea to patent? Write for "Inventors Record" and instructions for its use. Terms and advice sent immediately upon request. Address, Wm. H. Mulligan, 135 Woodward Bldg., Washington, D. C.

INVENTORS, if you have an idea, before spending unnecessary money for a patent, write Inventors & Engineers Consulting Co., P. O. Box 344, Washington, D. C.

INVENTIONS. If you have one we may develop and make it for you. Special facilities, confidential service, square deal. Castonguay Engineers, Thompsonville, Conn.

"INVENTOR'S Guide," free on request; gives very valuable information and advice. Write Frank Ledermann, 21 Park Row, New York, N. Y.

MODEL Making and experimental work; Modern Shop; expert workmen. Manufacturing. Lamson Model and Experimental Works, 625 W. Jackson, Chicago.

I SELL Patents. Established 1900. Address, Charles A. Scott, 775PM Garson Avenue, Rochester, N. Y.

PATENTS. Write for free illustrated guide book. Send model or sketch and description for free opinion of its patentable nature. Highest references. Prompt attention. Reasonable terms. Victor J. Evans & Co., 157 Ninth, Washington, D. C.

HAVE You an Invention? If so, write for our free book, "How to Get Your Patent," tells our terms and methods. Send model or sketch for our opinion of its patentable nature. Randolph & Co., Dept. 144, Washington, D. C.

MODELS—Developing your idea, mfg. same is my specialty. Why experiment? Write me and get facts. Henry Backer & Co., 904 Evans, Cincinnati, O.

PATENTS FOR SALE

PATENTS secured. Prompt service. Avoid dangerous delays. Send for our "Record of Invention" form and Free Book telling How to Obtain a Patent. Send sketch or model for examination. Preliminary advice without charge. Highest references. Write today. J. L. Jackson & Co., 242 Ouray Bldg., Washington, D. C.

ANTI-SLIPPING Sandal or Gaiter—13,474-1; Coat Fasteners—13,508-1; Adjustable Skirt Hanger—13,561-1; Anti-Skid or Traction Chain for Wheels—13,711-1; Jack for Journal Boxes—13,211-1. Talbert & Talbert, Talbert Bldg., Washington, D. C.

AUTO Signal, visible all directions, advance of danger, manually operated, illuminated, disappearing; right, left, slow, stop; fits any vehicle. All year seller. Advertises itself. F. A. Cox, 27 West Ohio St., Chicago.

INVENTORS. Send sketch or model of invention for advice. Write for Evidence of Disclosure form and Book on Patents. Free. Prompt Service. Merton-Roberts & Company, 181 Mather Building, Washington, D. C.

CASH or Royalty: Auto safety adjustable headlight focusing device with mechanism operating from dashboard. Patent pending. Simmons, Forbes & Smith, Box 595, Rocky Mount, N. C.

PATENT upon Sectional Boat. Very meritorious and practical device. Will sell outright or on royalty. Write: S. Zgliczynski, Patterson Station, Box 11, Baltimore, Md.

AN Automatic newspaper dispensing device; have a perfect working model; outright, royalty, or partner. M. A. Kelley, 4222 Calumet Ave., Chicago.

7 PATENTS: Land Roller, Chicken Feeder, Cement Block Machine, Mixer, Post Mold and Staple Fastener. W. L. Koller, Kearney, Nebr.

DON'T miss this big profit: three new much needed articles. U. S., Canadian, outright or royalty. Address Alex Nager, Livonia, N. Y.

ROTATABLE elbow-shaped chimney cow, positioned by the wind; prevents down draughts. Best offer accepted, Will McCullough, Salem, Mo.

NEW Book. Send sketch of your idea for proper advice. H. L. Woodward, 713 9th, Washington.

NEW cheap household necessity for daily use. Frank Beckman, 534 N. 22nd Street, East St. Louis, Ill.

PATENT 1,355,582. Music-stand leaf turner. Reasonable offer takes it. Particulars. J. O. Gemsey, Montevideo, Minn.

OUTRIGHT or Royalty: Cushion handle scissors. Patent pending. Write L. C. Warren, Como, Miss.

DON'T buy or manufacture without book by H. L. Woodward, 701 9th, Washington.

SEVEN Inventions. Sale or royalty. Unke Sales Co., Nevada, Mo.

OUTRIGHT or Royalty—Resilient wheel for automobiles and trucks. All metallic wheel, outside of the rubber fabric tire. No punctures, blowouts; no air. Strong, light, cheap to manufacture. Patent pending. J. E. McRoberts, Box 131, Parma, Idaho.

FOR Sale—U. S. and German patents on Egg Separator, issued 1913. Write for drawings and specifications. Sell cheap for cash. Address today! Grant S. Martin, Lock Box 144, Ann Arbor, Mich.

PATENT: Tool that every carpenter must use. If you want to manufacture and market a practical self-selling tool, here is your opportunity. Hancil Cordrey, Chula Vista, Calif.

FOR Sale—State or outright: New, sensational merry-go-round; horses jump hurdles and the like. Patent applied for. P. Burrow, 131 South Ave. 19th, Los Angeles, Calif.

ANTI-THEFT device for automobiles. Has been tested for over a year. Manufactured cheaply. Best offer. Address George A. Harris, Terre Haute, Ind. R. E. C.

MANUFACTURING, 3c, sells 25c—wire, 15c, sells 50c—sheet metal. Demand unlimited; blessing to every farmer. Health falling—must sell both. Fredrick Becklund, Detroit, Minnesota.

OUTRIGHT or Royalty—Adjustable ladder avoids danger of tipping on sloping or level ground; very practical. Martin Enke, 1346 East 23th St., Oakland, Calif.

PATENT for sale, portable sheet-metal water gate for irrigation; simple, practical, and effective. For details, write A. O. Edwards, Box 952, El Centro, Calif.

PATENT 1,151,573, handkerchief cooling device for fever and headaches; made of metal; no competition. Make offer. J. Dolgonas, 1529 N. Washenaw Ave., Chicago, Ill.

IMMENSE fortune to be made on two new electrical devices. Patents pending. For full particulars, address Nicholas Feines, 277 Grant St., Buffalo, N. Y.

FOR Sale or Royalty, adjustable knee support, applicable to all guitars for Hawaiian Steel Guitar playing. C. A. Ullman, 1980 Estrella Ave., Los Angeles, Calif.

FOR Sale—United States Patented Traffic Signal for automobiles; visible all directions. H. Pope, 169 Ahrens St., Kitchener, Ontario, Canada.

PATENT: Ford and Chevrolet tank cap, without threads or spring; sale or royalty. C. W. Arnason, Balaton, Minn.

PATENTS For Sale: To sell, buy or obtain patents write Patent News—P, Washington, D. C.

ICE-CREAM Bar application: new idea; real money-maker; excellent proposition for promoter. Holco, Annawan, Ill.

RECENT Issue, stamped metal specialty; cheap; big market. John Becker, Mackinaw, Ill.

CASH Safety lubricator filling plug. P. S. Smith, Box 595, Rocky Mount, N. C.

OUTRIGHT: Pat. No. 1,128,871. Better investigate. Chas. Holik, Sparks, Okla.

7 PATENTS, land roller, chicken feeder, cement block, machine mixer, post mold and staple fastener. W. L. Koller, Kearney, Nebr.

YOU have a worth-while patent, haven't you? Why don't you tell our two million readers about it? Most of them are specially interested in patents and new inventions. Ask me to tell you how other inventors successfully sold their patents. J. Roy McClellan, Manager, Classified Advertising, Popular Mechanics Magazine, Chicago, Ill.

FOR Sale: Handy and economical match scratcher. Can be pinned on inside of garment. Cash or royalty. Big seller. E. L. Hane, 3346 Warner, Chicago, Ill.

PATENT 1,392,165 on Tube Brushes, for sale. J. Bergesen, Sr., 261 E. 31st, Brooklyn, New York.

PATENTED cattle dehornor for sale outright, royalty or partnership. Make offer. Van Amber, 7326 Princeton Ave., Chicago.

MODELS AND MODEL SUPPLIES

MODELS and Patterns made. Light manufacturing. Address H. W. Hathorn, Mason City, Iowa.

WE make working models for inventors and do experimental work and carry a complete stock of brass gears and model supplies. Send for catalogue. The Pierce Model Works, Tinley Park, Ill.

INVENTORS—Write for our free illustrated guide book and Evidence of Conception Blank. Highest references. Prompt attention. Reasonable Terms. Victor J. Evans & Co., 165 Ninth, Washington, D. C.

PUNCH Press work, tool and die making, model and special machine work wanted. Completely equipped with new machinery of the latest type. Prompt delivery, reasonable prices guaranteed. Quality Hardware & Machine Co., 6154-56 N. Clark St., Chicago.

MODEL making and experimental work; Modern Shop expert workmen. Manufacturing. Lamson Model and Experimental Works, 625 W. Jackson, Chicago.

FOR MANUFACTURERS

ATTENTION, Mfr.: Poultry Fumigator. New invention; sell reasonable. Andrew Woudema, De Motte, Ind.

MODEL making and experimental work; Modern Shop expert workmen. Manufacturing. Lamson Model and Experimental Works, 625 W. Jackson, Chicago.

PATENT Rights—Worth \$25,000 to any Specialty Manufacturer. Address all inquiries to L. J. Aldridge, Victor, N. Y.

WANTED—Metal Stamping and Model work taken on contract basis. We are ideally located and equipped to develop patents. Meyers Company, Box 262, Bedford, Ind.

EXPERT Drafting and Engineering Service. Designs furnished. Rates reasonable. Polishak Engineering Company, Clintonville, Wisconsin.

MANUFACTURING

LET us be your machine shop! We build models and will do your manufacturing. Victor Eng. Co., 2524 W. Chicago Avenue, Chicago.

PATENTED Articles, Models, Brass Work, Machine Construction; Dies Made. Baum's Metal Specialties, Kansas City, Mo.

STANDARD Metal Stamping Works, Tools, Dies, Patents. 224 Centre, New York.

POWER Users—Have you considered the economy and advisability of changing from steam to gas producer operation? Our authentic book "Power Gas and the Gas Producer," written by a recognized authority on this subject will enable you to judge intelligently. Price, \$1. postpaid. Popular Mechanics Book Dept., 6 N. Michigan Ave., Chicago.

METAL Specialties, Dies, Tools, Patent Articles, made for Canadian market. Tools & Stampings, Limited, Toronto, Canada.

MODEL Making and experimental work; Modern Shop expert workmen. Manufacturing. Lamson Model and Experimental Works, 625 W. Jackson, Chicago.

EXPERIMENTS developed, dies, models and manufacturing, machine designing. Estimates and information promptly given. Address Schroer Bros. Machine Works, 512 East 25th Street, Kansas City, Mo.

METAL Specialties. If of metal, we can make it for you. Complete equipment. Western Die & Stampings Works, 721 Fulton St., Chicago, Ill.

IF you want dies and metal stampings, write us. Lyons Machine Works, Lyons, Ia.

SPECIAL Devices and Machinery developed and built at reasonable rates. Jigs and fixtures designed and built for interchangeable and economical manufacturing. Punches and dies made for all kinds of metal stamping. Machine work to order. Simplex Tool Company, Woonsocket, R. I.

WIRE Goods, all kinds made to order. Cooley Mfg. Co., 524-530 N. Western Ave., Chicago.

LET us be your factory! Write today. Logan Machine Company, 222 South Clinton Street, Chicago, Illinois.

DRAWING INSTRUMENTS

BARGAIN price, 5½" Compass Drawing Set, with pen and pencil attachments and lengthening bar. Bow Spacer, Bow Pencil, Bow Pen, 2 Buling Pens, Box for Leads. Cloth pocket-book case, velvet lines, complete. Send for particulars. Kolesch & Co., 138 B Fulton Street, New York.

SURVEYING INSTRUMENTS

THE Golden Combination; complete drawing outfit in one instrument. Used by Students, Civil Engineers, Abstractors, Draftsmen, Architects, etc. Write for free trial. Golden Compass Co., Elkhart, Ind.

NEW and used surveying instruments direct from factory. Satisfaction guaranteed or money refunded. Wisler, 619 Broadway, St. Louis.

MACHINERY, TOOLS AND SUPPLIES

MACHINISTS, Attention! Why not save half on that new tool case? Buy my blue-prints containing cross-sections, elevations, cabinet projection, and detail drawings of every part; bill of material and instructions for latest type standard size suitcase style tool case. Five large blue-prints, price, \$1.00. No stamps. H. R. Davis, 969 E. 15th St., Davenport, Iowa.

FOR Sale, 24" x 10" Engine Lathe, Taper Attachment, Screw-cutting, all change gears. Price \$250.00. Gallagher Bros., Uhrichville, Ohio.

PULLEYS, Grooved and Motor, Reducing Gears, Light Transmission Machinery. Send for catalog. Winfield H. Smith, Buffalo, N. Y.

ONE 16x6 Engine lathe, \$200.00; one Kempsmith universal milling machine, \$175.00; one 24-inch drill press, \$185.00; one straighten arbor press, \$30.00; quantity of chucks, small tool. Standard Machine Tool Co., Columbus, O.

CONCRETE Mixers, 3-ft. capacity, \$39.00; with 1½ horsepower engine and magneto, \$85.00. Circular free. Address McCarthy Brothers, Fort Washington, Wis.

LAG your pulleys without rivets. Better than leather. 29 years' success, 10 sq. ft. prepaid, \$4. W. S. Raymond, Niles, Mich.

CONCRETE Building Block Machines and Molds. Catalogue free. Concrete Machine Co., 303 South Third St., St. Louis, Mo.

WANTED: Information about new air compressors. Write for free manual. Engineers Dept., Brunner Mfg. Co., Utica, N. Y.

12-TOOL Handy Set, made of best steel. The most useful and practical tool on the market. Postpaid \$1.25. National Specialties, 32M Union Sq., New York City.

OTHERS have successfully sold their machinery through our columns—so can you. Ask me for proof. J. Roy McClellan, Manager, Classified Advertising, Popular Mechanics Magazine, Chicago.

ENGINES, MOTORS AND DYNAMOS

FOR Sale—New footpower, thirty dollars. One-fourth horsepower direct current motor and rheostat, thirty-five dollars. Write Theodore Carlson, Kellerville, Pa.

\$12.50 WILL purchase a new 1/4 h. p. 60-cycle a. c. motor. Get one while they last. Lewmco, Belleville, Ill.

IMPROVED Robertson-Thompson Steam Engine Indicator with reducing wheel, three way cock, etc., complete, price \$45.00, practically new. Wissler, 629 North Broadway, St. Louis.

AUTOMOBILE Owners, Garagemen, Mechanics, Repairmen, send for free copy of our current issue. It contains helpful, instructive information on overhauling, ignition troubles, wiring, carburetors, storage batteries, etc. Over 140 pages, illustrated. Send for free copy today. Automobile Digest, 507 Butler Bldg., Cincinnati.

SPECIAL Garage Motors: Manufactured by the General Electric Co. 1 H. P., \$78.50; 2 H. P., \$110.00; 3 H. P., \$128.50; 5 H. P., \$166.50. All sizes, both single and Poly-phase Motors, for immediate delivery. Special charging generators, all voltages. Write for catalog. Motor Sales Dept. 15, West End, Pittsburgh, Pa.

ELECTRIC Motors, 500 Heavy Duty 1/4 H. P. motor, General Electric and other standard makes, 110 Volt, 60 Cycle, Single Phase. New, original packages, guaranteed perfect. \$18.99 to \$22.00. Pennsylvania Motor Exchange, Lancaster, Pa.

ALTERNATING and direct current motor bargains. New and rebuilt. All guaranteed for one year. Special prices. Get our price list before buying. Motors exchanged and repaired. Hyre Electric Co., 633-8M South Dearborn St., Chicago.

ELECTRICAL

WASHING Machines, Universal, Portable and Butterfly, \$30.00 and \$65.00; Electric Irons, 5 and 8 lb., \$2.50 and \$3.15; Electric Motors, \$9.00 and up; Dry Cells and Flashlight Batteries, 30c and 10c; Nitrogen, Tungsten Lamps, Fans, etc., at extremely low prices. Agents with capital wanted. All material standard, new, guaranteed. Send for complete lists. We buy your surplus stock. J. Strauss & Blum, 254 W. 41st St., New York.

ELECTRICITY For 10c Per Hour. Motoco Auto Generator. Operates on any make automobile. Produces electricity for Moving Picture Machines, Theatres, Schools, Churches, Homes, Etc. Write for free particulars. Monarch Theatre Supply Co., Dept. AG 724 South Wabash Ave., Chicago.

POWER Attachments for Ice Cream Freezers, \$7.50. Can be attached to any hand freezer. Gives the right reduction between motor and freezer. Winfield H. Smith, Buffalo, N. Y.

1/4 H. P. ELECTRIC Motors, Repulsion Induction. Standard make, 110-220 volts, 60 cycle, single phase, 1725 R. P. M. Price \$17.50 each F. O. B. Chicago, cash with order. Write us your requirements in electric motors, as we have other bargains. Unit Electric Sales Co., 29 East Jackson Blvd., Chicago, Ill.

BARGAIN—New 1/6 horse Wagner, single phase, sixty cycle motors, worth \$21.00 at factory; our price \$12.50 each, cash with order. Gregory Electric Co., 1601 South Lincoln St., Chicago.

RENEW Dry Batteries. 3 guaranteed processes 20c. "Ideal," 5501 North Robey, Chicago.

ELECTRICITY Taught by experts; earn while you learn at home; electrical book and proof lessons free; your success guaranteed and position secured. Chicago Engineering Works, Dept. 31A, 2144 Lawrence Ave., Chicago.

ELECTRIC motors and supplies, including sockets, wire conduit, cleats, lugs, rosettes, switches. New revised wholesale prices. Illustrated Catalog free. Hyre Electric Co., 633-GH, South Dearborn St., Chicago.

PAYMENTS easy monthly brings Electric Motors. Any size. Hobartmotors, Troy, Ohio.

FOR MECHANICS

INVENTORS. Send sketch or model of invention for advice. Write for Evidence of Disclosure form and Book on Patents. Free. Prompt Service. Merton-Roberts & Company, 183 Mather Building, Washington, D. C.

ALUMINUM Solder that will stand the test. Send 50c for sample (no personal checks). Formula \$5.00. John Brackman, 727 South Oakley Blvd., Chicago, Ill.

IF you have an idea to patent, write for free book, "Patent Advice," and full instructions for proceeding. Address Wm. H. Mulligan, 133 Woodward Bldg., Washington, D. C.

SHOP Notes Volume 17 contains 102 practical articles such as Half-ton Traveling Crane, Boring Machine, Toggle Press, Gas-Fired Forge, Oil-Gas Generator, Movable Table for Drill Press, etc., 224 pp. 496 ill. 50 cents postpaid. Popular Mechanics Book Dept., 6 N. Michigan Ave., Chicago.

PATENTS—Write for our free illustrated guide book and Evidence of Conception Blank. Send model for sketch and description of the invention for our opinion of its patentable nature free. Highest references. Prompt attention. Reasonable terms. Victor J. Evans & Co., 184 Ninth, Washington, D. C.

BLACKSMITHS

BLACKSMITHS. Farmers, Inventors, Here's what you've been looking for. New, powerful Iron Bender. Bar iron constructed. Bends any shape. Capacity 1/2" x 3" cold; 1 1/2" dia. hot. Price \$7.00 or if you prefer to make one yourself will send working drawings for fifty cents. A. Hoesfeld, 815 E. Center St., Rochester, Minn.

BLACKSMITHS. Listen: Any Handy man can make more money doing hard jobs easy. Forging and welding solid, with Toy's Modern Methods of Blacksmithing. Hardening and tempering to a standard with colored tempering charts. All for one dollar. Samples Free. W. M. Toy, Sidney, O.

FOR THE SHOP

SHOP Notes for 1922—Bench Lathe, Electric Soldering Outfit, Jib Crane, Pump Troubles, Road Roller, Bench Grinder, Bench Miller, are among the 653 articles in this new volume. 224 pp. 50 cents postpaid. Popular Mechanics Book Dept., 6 N. Michigan Ave., Chicago.

FOR SALE—MISCELLANEOUS

PARCEL Mail Boxes, steel, rustproofed, \$4.00. 17x17x14. Motivepower, Cleveland, Ohio.

AIR Compressor with Tank and Hose, \$50. With Motor, \$72.50. Suitable for private or public Garage. Tire Shop, Painting or Cleaning, also Motor in the Head Buffer. Home size, \$18.50. Shop size, \$25. Garage size, \$106. Battery Charging outfit, Home or Garage size, \$14. 6 Tools in one, Forge, Vise, Anvil, Pipe Vise, Drill Press, Emery Grinder, \$25.00. Send for our large 100-page catalogue, describing all kinds of Air Compressors, Vulcanizers, Garage and Battery Outfits Equipment Co., 167 Canal, Cincinnati, Ohio.

15-CENT repainted Golf Balls \$1.75 dozen; also better grades. 3,000 New Golf Clubs, Bags and Balls, best makes, at special prices. Ladies' and Gents' right and left-hand clubs. All Guaranteed. Send for free price list. Money refunded. Free delivery on every \$10.00 purchase. Well's Curiosity Shop, 20 South Second St., Philadelphia, Pa.

BRAND new auto hosiery knitter, 3-in-1, with 10 lbs. yarn; cost \$100.00. Make offer. Big money maker, Adam Bortner, Batavia, Ill.

REVOLUTIONARY Scientific Achievement. Price 30c. Presto cloth polishes copper, silver, and all tarnished metals. Address I. Rose, 1352 Clinton Ave., Bronx, N. Y.

ADDRESSOGRAPHIC. Letter Folders, Multigraphs, Envelope Sealers, Duplicators, less than half price. Guaranteed. Pruitt Co., 112-B N. La Salle, Chicago.

LUMINOUS Paint, Bottle 20c. Laboratories H. Box 316, Portland, Ore.

REAL ESTATE AND FARM LANDS

GOOD Farm Lands: 20, 40, 80-acre tracts near bustling city in Michigan. \$15 to \$35 per acre; only \$10 to \$50 down and \$10 to \$20 per month. Investigate this opportunity. Write today for Free booklet giving full information. Swigart Land Co., P-1259, First National Bank Building, Chicago.

\$700 GETS 240-Acre Farm, with Horses, Poultry, 13 Cows and Calves, Tools; on improved road; 10-room house overlooking lake, garage. Only \$3,850 with \$700 down. Page 21 Free Catalog. Strout Farm Agency, 150-P, Nassau St., New York City, N. Y.

OKLAHOMA Farms. Write for information. Board of Commerce, Shawnee, Okla.

\$5.00 DOWN, \$5.00 monthly; 20 acres unimproved fruit, stock, poultry, woodland; \$100; Ozarks. Fishing, hunting, trapping. Address, Alfred Zimmerman, 1890 N. Fifth, Kansas City, Kansas.

ATTENTION! "Get Acquainted." Cash for your property. Farm, Hotel, or Retail Store, no matter where located; confidential service. Hayes' Business Agency, Cincinnati, Ohio.

I WANT Farms for cash buyers; will deal with owners only. R. A. McNowa, 312 Wilkinson Bldg., Omaha, Neb.

FLORIDA Oranges are most profitable as well as most delicious. Grow your own in a land of sunshine, away from winter blizzards and coal bills. Money you'll not miss will buy you land for a grove in a high, rolling, lake-jewelled land of many golden groves. If you mean business, write today for Book of Facts and Photos. Lake County Land Owners' Association, 95 Arbor Avenue, Fruitland Park, Fla.

FREE Government Lands—Our official 112 page book, "Vacant Government Lands," lists and describes every acre in every county in U. S.; tells location, place to apply, how secured Free; 1922 diagrams and tables, new laws, lists, etc.; price 50 cents postpaid. Webb Publishing Co., Dept. 71, St. Paul, Minn.

MINNESOTA good wild land, part timber, splendid location, \$13.50 per acre. Address P. Fones, New Richmond, Wis.

SELL your property quickly for cash, no matter where located. Don't pay big commissions. Particulars free. Real Estate Salesmen Co., Desk B, Lincoln, Neb.

WANTED—MISCELLANEOUS

CASH Paid. Mail us your discarded jewelry, gold crowns and bridges, watches, diamonds, silver, platinum, War Savings Stamps and old false teeth. Highest prices paid. Money sent by return mail. Packages held 4 to 12 days and returned at our expense if our offer is refused. United States Smelting Works (The Old Reliable), Dept. 71, Chicago, Ill.

DOGS, BIRDS, POULTRY AND PETS

FOR Sale—Registered Scotch Collie Pups, guaranteed. Crossbred English Bloodhound and Foxhound Pups, guaranteed. Write Charles Reasbeck, Vankleek Hill, Ontario.

AIREDALE and Boston Puppies for sale. Ripon Kennels, Ripon, Wis.

SILVERBLACK Foxes \$300. Skunks \$10. Time payments. Booklet dime. Arthur Schumacher, Lockland, O.

WHITE Mice, \$1.15 pair, prepaid; great pets. Frank Wyss, 2033 Arapahoe, Denver, Colo.

DOG Owners' Text Book Free. An expert guide for dog owners on proper training, feeding and care of dogs. Sent free with three months subscription to Sportsman's Digest. Send 25 cents (coin or stamps) today. Sportsman's Digest, 307 Butler Bldg., Cincinnati, O.

BARGAINS: Collies, Airedales, Bulldogs, Rabbits, Pigeons, Canaries, Parrots. Catalog. Breeders Exchange, Minneapolis, Minn.

BELGIAN HARES, GUINEA PIGS, ETC.

BELGIAN Hares. A very interesting and instructive book on raising Belgian Hares and other rabbits. It tells how to select the stock, how to make the hutches and pens, how, when and what to feed them, how to prepare for the young, weaning, marketing, killing, their ailments and everything the beginner should know. Price 25c; worth double. Rabbit Culture, Fredericksburg, O.

RABBIT Folks. Write for big spring bargain list and literature. All breeds. Grandview Rabbit Farm, 3114 Hamilton, El Paso, Tex.

BREED Squabs. Book free. E. Rice, Melrose Highlands, 77, Massachusetts.

RAISE guinea pigs. Pay better than poultry or rabbits; easy to raise; little space required. We guarantee market. Particulars and booklet how to raise free. Cavies Distributing Co., 3102 Grand Ave., Kansas City, Mo.

PERSONAL

OPPORTUNITY Calls You. Success awaits you. Join the Thought, Force, Health, Success Association. Secure seven wonderful lessons which positively teach you the laws of Concentration, Success, Memory, Will Power, Influencing Others, Read People at Sight, Self-Control, Banishing Fear. Procure these Remarkable Formulas. Develop the power God gave you, make good use of it. Write for information today. Hancil Cordrey, Box 175, Chula Vista, Calif.

GRAPHOLOGIC study of character. For trial study send 25c and handwriting of yourself or anyone whose character may interest you. Address Amad. Fayo, Box 140, Station G. New York City, N. Y.

CIGARETTE habit positively cured or money back. Scientific method—no drugs. State number of cigarettes used daily, enclosing one dollar. Address The Antitobacco System, 503 Hensen Street, Camden, N. J.

BE Wise! Be Cheerful! Be Prosperous! New way plan brings wonderful results. Valuable pointers and your personality revealed for 10c and birthdate. Thomson-Heywood, Dept. 985, Chronicle Bldg., San Francisco, Calif.

YOUR Horoscope covering full year for 35c. Includes an extensive reading, valuable daily guide, large pictorial chart and special forecasts for each month. Scientific, complete. Try it! Money back if dissatisfied. Give birthdate. Address, H. Daniels, Flatbush Sta., Box 32, Brooklyn, N. Y.

YOUR Horoscope—Life revelation showing your character, talents, suitable occupation. Scientific and accurate. Send birth date, 10c. The Astrolite Company, Sharpsburg, Pa.

TOBACCO Kills Manly Vigor—Quit easily. Cigarettes, chewing, smoking, snuff, conquered or no charge. Small sum if satisfactory. Stops craving; harmless. Full treatment on trial. Perkins Co., 31A, Hastings, Nebr.

FREE—Stop using tobacco. We will give free information how to conquer habit easily and permanently. Results guaranteed. Anti-Tobacco League, Box K, Omaha, Nebr.

TOBACCO or Snuff Habit cured or no pay. \$1.00 if cured. Remedy sent on trial. Superba Co., TP., Baltimore, Md.

MISCELLANEOUS

PORTABLE Playhouse. Use indoors or outdoors. Thousands building. Plans and instructions 25c coin. E. Kubler, Clifford Ave., Springfield, La. L., N. Y.

MYSTERIOUS Mathematical Cards. Sample pack 30c. Dollar's worth fun. Miller Sales Company, Box 228, Lexington, Ky.

ART Metal Workers—You will find our book "Metal Work and Etching" a complete manual on making book ends, desk sets, pad corners, paper knives, letter openers, stationery racks, rocking blotters, desk calendars, arts and crafts jewelry, etc., 95 pp. illus. Price 50 cents postpaid. Popular Mechanics Book Dept., 6 N. Michigan Ave., Chicago.

GOOD prices paid for butterflies, insects. See Sinclair's Display Advertisement, page 27.

LOCKSMITHS: Send \$1.00 for valuable chart for cutting tumbler padlock keys. Globe System, 278 Washington St., Newark, N. J.

LOCKSMITHING from A to Z—500 tricks of the locksmith trade, \$1.50—money back if dissatisfied. H. Routson, 3406 Andover St., Oakland, Cal.

CUTS anybody can make. Simple, cheap process. \$1. Specimens, particulars. 20 stamp. M. Day, Windfall, Ind.

SAVE incorporating expenses and excess profit taxes and avoid personal liability by organizing your company on the Common Law Plan under a Declaration of Trust. Anyone, anywhere, can fill in Demaree Standard Forms, issue shares and begin doing business same day. Pamphlet B-53 free. C. S. Demaree, Legal Blank Printer, 613 Walnut, Kansas City, Mo.

ARTIFICIAL Eyes, \$3. Booklet free. Denver Optic, 559 Barclay, Denver, Colo.

WANTED!

\$1,000 REWARD

CONVICT 6138, escaped from the State Penitentiary; Name, Charles Condray; Age, 37; Height, 5 ft. 8 in.; Weight, 141 pounds; Hair, light brown; Eyes, gray.

Easy enough to identify him from his photograph and this description, you may say—but, Condray took the name of "Brown"; dyed his hair, darkened his skin, grew a mustache, put on weight and walked with a stoop.

Yet he was captured and identified so positively that he knew the game was up and returned to the penitentiary without extradition. A Finger Print Expert made this identification and secured the reward.

MORE TRAINED EXPERTS NEEDED NOW!

There is a big chance for you in this uncrowded, fascinating profession. State, City, and Private Bureaus being established and expanded constantly. Trained men in great demand. Many earn \$3000 to \$10,000 yearly.

LEARN AT HOME IN SPARE TIME

Common school education, common sense and ambition, the only requirements. Many of the country's greatest experts learned their profession in this great school. A few hours' spare time a week soon fits you for a fine position as a Finger Print Expert.

UNIVERSITY OF APPLIED SCIENCE

1920 Sunnyside Avenue,
Dept. A135, Chicago, Ill.

Gentlemen:—Without any obligation whatsoever, send me your new, fully illustrated FREE Book on Finger Prints and your offer of a FREE course in Secret Service Intelligence and the Free Professional Finger Print Outfit.

Name.....

Address.....

Present.....

Occupation..... Age.....

FREE! for a limited time. A professional Finger Print Outfit—a course in Secret Service Intelligence. Also a complete book on Finger Prints sent at once if you will mail this coupon. Write today.

UNIVERSITY OF APPLIED SCIENCE
1920 Sunnyside Ave.
Dept. A135
CHICAGO, ILL.



A Better Job Now!

Why take small pay from uncertain jobs? Why be buffeted around from this to that, and not know whether you are going to have a job tomorrow or not? You can change all that. Learn a trade. Know autos—how to repair them and take advantage of the countless opportunities to make big money. Pave the way for a business of your own—a business that can make you independent for life. You can do it with a few weeks' training at the Michigan State Auto School—the great auto-trade school in the heart of the industry.

Be a Trained Man—Successful!

Fellows just like you step out and make great successes. Trained men wanted all the time—everywhere! More than 10,500,000 autos, trucks and tractors in use. All need service and repairing. 50 million tires, millions of batteries to be kept in commission. More men needed for good jobs. More garages—more electric service stations—more tire-repair shops—welding shops—battery stations needed. This means amazing opportunities for the men who start now. Fit yourself to win a good job, or to start a business of your own. Very small capital is needed. You are right on the threshold of big money if you decide now to make this your business.

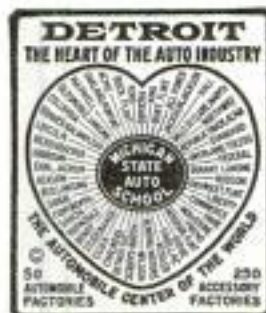

Come to the Auto Center

Learn Autos in a Few Weeks by Factory-Endorsed Methods

Come to Detroit. Here is where autos are made. Come to the Michigan State Auto School where you get first-hand experience and knowledge. Great auto factories endorse and recommend M. S. A. S. training. *The Cadillac Motor Co.* says: "We believe you have the best and most complete school of its kind." *The Hudson Motor Co.* says: "The best equipped and most efficient school in America." You can learn the business thoroughly on latest equipment. You visit the great Detroit auto-plants. Get first-hand knowledge and a quality-training that means certain success, if you do your part.

Get All Facts—Mail Coupon Today!

Decide now to grasp this opportunity. If you like autos—and are mechanically inclined—there are big-money jobs—a business of opportunities waiting for you. Classes always open. Your enrollment includes Life-Membership with privilege to come back at any time to brush up on the latest equipment, and get new money-making ideas. Investigate! Let us show you what we can do for you. Mail the coupon for big illustrated catalog.

Colored Students Not Solicited

MICHIGAN STATE AUTOMOBILE SCHOOL

A. G. ZELLER, President
306 Auto Bldg. 3729 Woodward Ave.
DETROIT, MICHIGAN

FREE

CATALOG
MICHIGAN STATE
AUTO SCHOOL

Mail Coupon To Day

MICHIGAN STATE AUTO SCHOOL
306 Auto Bldg., Detroit, Mich.

Gentlemen:—Send FREE and without obligation, your illustrated catalog, and Auto School News, giving complete information and showing the opportunities and advantages of a Factory Endorsed Detroit-Training to make the most money.

Name

Street or R. F. D.

City State

The Factory Endorsed School



"I Knew You'd Make Good"

"I ALWAYS felt you had it in you to get ahead. But for a time I was afraid your natural ability would be wasted because you had never trained yourself to do any one thing well. Yes, I was afraid you would always be 'a jack of all trades and master of none.'"

"But the minute you decided to study in your spare time I knew you'd make good. You seemed more ambitious—more cheerful—more confident of the future. And I knew that your employers couldn't help but notice the difference in your work."

"Think what this last promotion means! More money—more comforts—more of everything worth while. Tom, those hours you spent on that I. C. S. course were the best investment you ever made."

HOW about you? Are you always going to work for a small salary? Are you going to waste your natural ability all your life? Or are you going to get ahead in a big way? It all depends on what you do with your spare time.

Opportunity knocks—this time in the form of that familiar I. C. S. coupon. It may seem like a little thing, but it has been the means of bringing better jobs and bigger salaries to thousands of men.

Mark and mail it today and without obligation or a penny of cost, learn what the I. C. S. can do for you.

----- TEAR OUT HERE -----

INTERNATIONAL CORRESPONDENCE SCHOOLS
BOX 5640-C SCRANTON, PA.

Without cost or obligation, please explain how I can qualify for the position, or in the subject before which I have marked an X:

- | | |
|---|--|
| <input type="checkbox"/> ELEC. ENGINEER | <input type="checkbox"/> BUSINESS MANAGEMENT |
| <input type="checkbox"/> Electric Lighting & Railways | <input type="checkbox"/> SALESMANSHIP |
| <input type="checkbox"/> Electric Wiring | <input type="checkbox"/> ADVERTISING |
| <input type="checkbox"/> Telegraph Engineer | <input type="checkbox"/> Show Card & Sign Ptg. |
| <input type="checkbox"/> Telephone Work | <input type="checkbox"/> Railroad Positions |
| <input type="checkbox"/> MECHANICAL ENGINEER | <input type="checkbox"/> ILLUSTRATING |
| <input type="checkbox"/> Mechanical Draftsman | <input type="checkbox"/> Cartooning |
| <input type="checkbox"/> Machine Shop Practice | <input type="checkbox"/> Private Secretary |
| <input type="checkbox"/> Toolmaker | <input type="checkbox"/> Business Correspondent |
| <input type="checkbox"/> Gas Engine Operating | <input type="checkbox"/> BOOKKEEPER |
| <input type="checkbox"/> CIVIL ENGINEER | <input type="checkbox"/> Stenographer & Typist |
| <input type="checkbox"/> Surveying and Mapping | <input type="checkbox"/> Certified Public Accountant |
| <input type="checkbox"/> MINE FOREMAN or ENGR | <input type="checkbox"/> TRAFFIC MANAGER |
| <input type="checkbox"/> STATIONARY ENGINEER | <input type="checkbox"/> Cost Accountant |
| <input type="checkbox"/> Marine Engineer | <input type="checkbox"/> GOOD ENGLISH |
| <input type="checkbox"/> ARCHITECT | <input type="checkbox"/> Common School Subjects |
| <input type="checkbox"/> Contractor and Builder | <input type="checkbox"/> CIVIL SERVICE |
| <input type="checkbox"/> Architectural Draftsman | <input type="checkbox"/> Railway Mail Clerk |
| <input type="checkbox"/> Concrete Builder | <input type="checkbox"/> AUTOMOBILES |
| <input type="checkbox"/> Structural Engineer | <input type="checkbox"/> Mathematics |
| <input type="checkbox"/> PLUMBING & HEATING | <input type="checkbox"/> Navigation |
| <input type="checkbox"/> Sheet Metal Worker | <input type="checkbox"/> AGRICULTURE |
| <input type="checkbox"/> Textile Overseer or Supt. | <input type="checkbox"/> Poultry Raising <input type="checkbox"/> French |
| <input type="checkbox"/> CHEMIST | <input type="checkbox"/> Airplane Engines <input type="checkbox"/> Spanish |
| <input type="checkbox"/> Pharmacy | <input type="checkbox"/> WIRELESS <input type="checkbox"/> Banking |

Name.....

Street and No. 2-1-22

City..... State.....

Occupation.....

Persons residing in Canada should send this coupon to the International Correspondence Schools Canadian, Limited, Montreal, Canada.



New Simplified Method of Learning Drawing

Amazing shortcut method now teaches you Illustrating, Cartooning, and Designing in half usual time. You learn at home in spare time, yet your work receives the personal criticism of one of America's foremost Artists. No matter what your previous experience or education has been, this method qualifies you for the fascinating, high-salaried profession—Commercial Art.

FREE BOOK

Write today for our handsomely illustrated Free Booklet, which tells you how at the cost of but a few cents a day you can learn to draw pictures that bring you from \$50 to over \$500. Read about the big demand for Artists by Newspapers, Magazines, Department Stores, Advertising Agencies, and Business Concerns—about the amazing success of our students. Special short time offer of Complete Artist's Outfit Free to new students. Write for Free Booklet and details of this offer. Mail card today. Address

Washington School of Art, Inc.
1849 Marden Bldg., Washington, D. C.

CRYSTAL RADIO SET, \$4.75

Complete in Cabinet as shown.



Head Telephone and Antenna, \$5.00 extra.
Satisfaction guaranteed or Money Refunded.

CORONA RADIO CORPORATION
265 Canal Street, New York

"HOW I BEAT THE GAME"

The Inspiring Story of how one poorly paid garage mechanic won success, his own business and a big income. Tells how you can increase your salary from 100 to 500%. Send for it today FREE.

Ambu Engineering Institute
Dept. 16-A 2632 Prairie Ave., Chicago, Ill.



TWO GREAT FUN MAKERS

The dog head is made of metal, with rubber bulb. When you squeeze bulb the dog barks and it's a wise dog that can tell the difference from the real thing. The cat is worked the same way, only the sound is produced by a bellows within each. This cat's meow will fool any cat or your friends. Both are small enough to be concealed in the pocket. Thousands of these have been sold in Chicago.

The Two Sent Postpaid For Only 25 Cents

THE FLASUM CO., Dept. 31, 3137 MONROE ST., CHICAGO, ILL.

Learn Sign Lettering in 20 Hours!

Using our New Method Patented Mechanical Device—no stencils. Have a business of your own earning from \$2,000 to \$6,000 a year lettering store windows, show cards, signs, roofs, walls, fences, and signs of all kinds. Students can have established business doing finest of work in thirty days. We guide you step by step. Absolute satisfaction guaranteed.

Write today. Details free
AMERICAN SCHOOL OF LETTERING
Dept. M Omaha, Nebraska

YOUR CHOICE FREE

\$20 *Violin, Mandolin, Guitar,
Ukulele, Hawaiian Guitar,
Banjo or Banjo Mandolin,
Tenor Banjo or Cornet,
Banjo Ukulele.*

Actually given away, absolutely free, to first pupils in each locality. Last year we gave away thousands of high-grade musical instruments on this sensational offer, now repeated for YOUR benefit.

We have the most wonderful new system of teaching NOTE music by mail. Take your choice of any of these magnificent instruments absolutely free and learn to play by this easy to learn method. Can have you playing standard note music in 4 lessons. A very small charge for lessons—just a few cents a week—your only expense. Your success guaranteed. Pay nothing if you fail to learn; you take no risk. Complete outfit free with every instrument. Don't wait a minute, but mail the coupon NOW.

To Advertise Our Copyrighted Course

Our plan is, \$2.00 monthly for lessons. No charge for instrument. Ukulele and banjo ukulele given free with 20 lessons at 50c a lesson. Tenor banjo, banjo and Hawaiian Guitar given free with 32 lessons at 50c a lesson. Violin, mandolin, guitar and banjo mandolin given free with 56 lessons, 43½c a lesson. Cornet free with 56 lessons at 50c a lesson. Lessons are mailed one each week. Fill out the coupon and enclose \$2.00 and you will get an instrument you will be proud to own. At end of one week if you are not delighted with instrument and lessons, send outfit back and we will refund your money.

Do not delay, but mail the coupon today, before it is too late. Be sure to state whether you want a free Violin, Mandolin, Guitar, Ukulele, Hawaiian Guitar, Banjo, Banjo Mandolin, Tenor Banjo or Cornet. We guarantee any one of these instruments positively worth \$20 or more.

FREE INSTRUMENT COUPON

Slingerland's Correspondence School of
Music, Inc., 1815 Orchard Street,
Chicago, Illinois

Please send me one.....free,
(Name of instrument)

I am enclosing \$2.00 for first month's lessons, but if I am not satisfied at end of one week's trial, I will return outfit and my \$2.00 is to be returned to me or, I will pay \$2.00 monthly until lessons are paid for. Deduct 15% when full amount comes with order.

Name

St.....R. F. D.....

CityState



Health! Energy! Strength!

At last there is a quick and inexpensive way to physical power—glowing health—pulsing vitality. Electricity in its most scientific form for the human system! A Violet Ray of tremendous curative nature. Not a Vibrator—not a massaging device. A penetrating RAY of ENERGY that heals and invigorates. Endorsed by every doctor, physical culture and beauty expert.

*A remarkable book on
health and beauty via*

Vi-Rex Violet Rays

Sent to you
FREE

We have just published a remarkable book for free distribution. This book explains in detail the manifold uses of Violet Rays in treating almost every known human ailment. This book also contains charts and diagrams of the nervous system, and organic locations, and fully describes just how the Violet Ray works its many seeming miracles, written in a simple style—devoid of all technical language.



10-day free trial will prove all we claim

Use Violet Rays in the privacy of your home. Day by day you will see the difference in your physical fitness—the condition of your sinews and muscles. WE WANT

YOU TO BENEFIT by this great modern invention and offer you our book on perfect health and a ten day trial of the Vi-Rex machine FREE. Write for the book and details of the free trial offer TODAY.



Vi-Rex Electric Co.
Dept. 26, 326 W. Madison St.
CHICAGO

Deformities of the Back



Greatly benefited or entirely cured by the Philo Burt Method.

The 45,000 cases successfully treated in our experience of over 20 years is absolute proof of this statement.

No matter how serious your deformity, no matter what treatments you have tried, think of the thousands of sufferers this method has made well and happy. We will prove the value of the Philo Burt Method in your own case.

The Philo Burt Appliance on 30 Days' Trial

Since you run no risk there is no reason why you should not accept our offer at once.

The photographs here show how light, cool, elastic and easily adjustable the Philo Burt Appliance is—how different from the old torturing plaster, leather or steel jackets. To weakened or deformed spines it brings almost immediate relief even in the most serious cases. You owe it to yourself to investigate it thoroughly. The price is within reach of all.

Send for our Free Book today and describe the nature and condition of your trouble as fully as possible so we can give you definite information.

PHILO BURT CO.

53-17 Odd Fellows Bldg., Jamestown, N. Y.



TOBACCO USER

Can you quit tobacco? If not, do you know why? Do you know its effect on mental and physical efficiency? These and other questions answered in booklet written by one who has treated thousands for the tobacco habit. Free for the asking. Write

DR. T. H. TRINWITH, Black Bldg., LOS ANGELES, CALIF.

NO JOKE TO BE DEAF

—Every Deaf Person Knows That I make myself hear, after being deaf for 25 years, with these Artificial Ear Drums. I wear them day and night. They are perfectly comfortable. No one sees them. Write me and I will tell you a true story, how I got deaf and how I make you hear.



Medicated Ear Drum

Pat. Nov. 8, 1906

Address
GEO. P. WAY, Artificial Ear Drum Co. (Inc.)
80 Adelaide St., Detroit, Mich.

Don't Wear a Truss

Brooks' Appliance, the modern scientific invention, the wonderful new discovery that relieves rupture, will be sent on trial. No obnoxious springs or pads.



MR. C. E. BROOKS

Brooks' Rupture Appliance

Has automatic Air Cushions. Binds and draws the broken parts together as you would a broken limb. No salves. No lies. Durable, cheap. Sent on trial to prove it. Protected by U. S. patents. Catalog and measure blanks mailed free. Send name and address today.

BROOKS APPLIANCE CO., 126C State St., Marshall, Mich.

CONQUER Your Weaknesses



LIONEL STRONGFORT
Dr. Sargent, of Harvard, declared that "Strongfort is unquestionably the finest specimen of physical development ever seen."

Master yourself—correct your physical defects—banish the ailments that make your life an existence of misery and regret—throw off the shackles of Catarrh, Constipation, Indigestion, Dyspepsia, Bad Blood, Rupture, Rheumatism, Weak Heart, Vital Depletion, Weak Lungs, Anemia, Nervousness, Poor Memory, Fear, Bad Habits, etc., and the numerous other results of neglecting your body and violating natural law (see Consultation Coupon). Show them that you can and will be a healthy, vigorous man with a real man's ambition, spirit and endurance—the powerful man that Creation and Civilization demand you to become.

Get Rid of Your Handicaps

Build up your body and brain and get the joy out of life. You can't be successful, popular or wanted in the home, in business, in society—anywhere, without the health, and strength and vigor of a real man. People you come in contact with instinctively analyze your physical and mental condition. If you are not vigorous and magnetic—if you lack power, endurance and vitality, everybody will know it. You know how these things affect you when you see them in other people. You know that nobody has the least bit of respect for a weakling. They can't have confidence in a man that may end up any moment on the scrap heap of worn out and useless humanity. You wouldn't have much respect for a business associate who was groggy with Constipation, yellow with Biliousness, weak, anemic and handicapped with Rupture, Flat Feet, Weak Back or some other physical defect—you wouldn't have confidence in a man whose bad living habits showed clearly in his face and bleary eyes—you wouldn't want to do business with or associate with an irritable, grouchy person with frayed nerves and a wretched, unreasonable temper. Now look at yourself with the same eyes. Are you guilty of these physical and mental defects? Do you not recognize the many faults and weaknesses that have often robbed you of success in business, preference in society and cheated you out of the priceless benefits of real friendship and companionship? Judge yourself without favor—then get busy to root out the elements of failure and make yourself a real man.

Win Back Your Vigor and Vitality

Let me help you as I have thousands of others. Accept my hand in friendship as you would a brother's and I will show you Nature's Way back to Health and Happiness. I'll teach you how to get rid of the ailments and physical defects that are ruining your body and brain. I'll build you up **externally** and **internally**, by the same scientific methods that won for me the World's award as the finest specimen of physical and health attainment. I have dedicated my life to the task of rescuing sick, ailing humanity from the bog of Weakness and Poor Health and thousands of my pupils gladly testify to the wonderful effectiveness of my methods. You can apply these scientific principles with the same satisfactory and permanent results. I want to help you—I can rebuild and restore you with

STRONGFORTISM

The Modern Science of Health Promotion

The Principles of **Strongfortism** are based on my discovery—that **internal muscular harmony and strength** is the Key to lasting, abundant Health and Vitality. The Heart, Lungs, Stomach, Bowels, and other vital organs function thru virtue of the contracting power of the muscles contained in their structures. Circulation, Digestion, Assimilation and Elimination are largely the result of **internal muscular action**. The Strongfort Methods go to the very cause of all ailments and weaknesses and by scientifically strengthening and developing the **important internal muscles**, provide 100% results when all other methods disappoint.

Once you accept **Strongfortism**, you enter a new life. The results are immediate and positively thrilling. You feel the rich blood racing thru your body—you feel new strength and power developing in every organ and structure—you acquire new poise and a magnetic personality. You can't fail with Strongfortism. I guarantee it.

My Methods Are Beyond Physical Culture

Do not confuse the Science of Strongfortism with gymnastic or ordinary physical culture Courses. I am not merely a developer of bulging muscles—I am far more than that for I have devised a real science thru which weak, ailing men are restored to the Glory of Perfect Health—to the Summit of Health, Happiness and Success, without the use of dope and drugs, lifting and stretching machines, unnatural deep-breathing, starvation, diets, nerve-racking routines or other foolish fads and fancies. From start to finish Strongfortism is practical, sensible and scientific, and planned to suit the pupil's individual needs.

Get My Book—It's Free

The truth about the scientific application of natural law is contained in my wonderfully interesting book, "**Promotion and Conservation of Health, Strength and Mental Energy.**" It will tell you frankly and plainly how you can banish your ailments and build up 100 per cent Health, Strength and Vitality. It's absolutely free. Mark the subjects on the free consultation coupon on which you want **special confidential information**, write additional subjects on extra line and send with 10c to help pay postage, etc. I'll do the rest. Send for my free book **Right Now—TODAY.**

LIONEL STRONGFORT

Physical and Health Specialist
Dept. 848

Founded 1895
NEWARK, N. J.

FREE CONSULTATION COUPON

Mr. Lionel Strongfort, Dept. 848, Newark, N. J.—Please send me your book, "**PROMOTION AND CONSERVATION OF HEALTH, STRENGTH AND MENTAL ENERGY,**" for postage of which I enclose a 10c piece (one dime). I have marked (X) before the subject in which I am interested. Also on those I may write on extra line below.

- | | | |
|-------------------------|-------------------------|-------------------------|
| .. Colds | .. Increased Height | .. Poor Memory |
| .. Catarrh | .. Pimples | .. Rheumatism |
| .. Asthma | .. Blackheads | .. Falling Hair |
| .. Hay Fever | .. Insomnia | .. Weak Eyes |
| .. Obesity | .. Short Wind | .. Gastritis |
| .. Headache | .. Flat Feet | .. Heart Weakness |
| .. Thinness | .. Stomach Disorders | .. Poor Circulation |
| .. Rupture | .. Constipation | .. Skin Disorders |
| .. Lumbago | .. Biliousness | .. Dependency |
| .. Neuritis | .. Torpid Liver | .. Round Shoulders |
| .. Neuralgia | .. Indigestion | .. Lung Troubles |
| .. Flat Chest | .. Nervousness | .. Stoop Shoulders |
| .. Deformity (Describe) | .. Weaknesses (Specify) | .. Muscular Development |
| .. Neurasthenia | | .. Great Strength |
| .. Diabetes | | |

..... Mention other ailments here.

Name

Age..... Occupation

Street

City..... State

Improve Your Figure

**Control Your Nerves—Enjoy Life
Be Free from Nagging Pains and Ailments**

How? Correct your posture and strengthen your muscles and nerves by using for a little while this gentle, easy, natural support. Nearly 200,000 have done it with the wonderful

Natural Body Brace

Overcomes weakness and organic ailments of women and men. Brings restful relief, comfort, ability to do things, health and strength.

Develops Erect, Graceful Figure

Does away with the strain and pain of standing and walking; replaces and supports misplaced internal organs; reduces enlarged abdomen; straightens and strengthens the back; corrects stooping shoulders; develops lungs, chest and bust; relieves backache, curvatures, nervousness, ruptures, constipation, after effects of Flu. Comfortable—easy to wear.



KEEP YOURSELF FIT

EVERY MAN with heavy abdomen, rupture, stooping shoulders, backache, shattered nerves, or other spinal trouble, should wear my brace.

Wear it 30 Days Free at Our Expense

Write me in confidence today, stating your condition and desires. I will answer quickly and send illustrated booklet, measurement blank and our very liberal proposition.

HOWARD C. RASH, Pres. Natural Body Brace Co.
223 Rash Building, Salina, Kansas

I Make Strong Men



That is my business. I make no other claims. But what I promise, I fulfill. I will increase your arm one full inch in 30 days and your chest in proportion. In three months I will make you a finished strong man. Are you interested? Read my book "Physical Perfection." It tells you how. All I ask is 10 cents to cover postage and wrapping. Don't put it off. Send today.

Arthur L. Hyson
100 Laegden Bldg. New York City

Clear-Tone FOR PIMPLES

Your skin can be quickly cleared of Pimples, Blackheads, Acne Eruptions on the face or body, Enlarged Pores, Oily or Shiny Skin. \$1,000.00 Cold Cash says I can clear your skin of the above blemishes. **WRITE TODAY** for my FREE Booklet—"A Clear-Tone Skin"—telling how I cured myself after being afflicted for fifteen years.

E. S. GIVENS, 129 Chemical Bldg., Kansas City, Mo.

STOP USING A TRUSS

Do Away With Steel And Rubber Bands

FREE TRIAL

STUART'S ADHESIVE PLAPAO-PAD

TRADE MARK

PAT'D APRIL 6 1909

Inner surface is made adhesive to secure the PLAPAO-PAD firmly to the body, keeping the PLAPAO continually applied and the pad from slipping. No straps, buckles or springs attached. Soft as velvet—easy to apply.

It's the Non-Slipping, yet Non-Rigid Pad and What is Within It That Counts

FREE to 5,000 Truss Sufferers

To the extent of 5,000 sufferers who may apply I will send, ABSOLUTELY FREE, a sufficient quantity of the Plapao to positively convince them that this is the only logical, common-sense way of treating rupture. Plapao is a highly astringent medication placed within the Plapao-Pad and being absorbed through the skin, creates a wonderful feeling of relief and at the same time tends to strengthen the weakened muscles and thus permanently close the rupture opening. The process of recovery is natural, so you'll have no use for a truss—you can throw it away forever! Old and young have testified under oath that the Plapao-Pads cured their rupture—many of them long-standing, aggravated cases—without delay from work. Patent allowed in U. S. and foreign countries. Awarded Gold Medal at Rome and Grand Prix at Paris.

Send No Money—for a sufficient quantity of the Plapao is sent without charge to enable you to give it a thorough test; you pay nothing for this trial now or ever. Write for it and full information today. Address: Plapao Laboratories, Block 1427 St. Louis, Mo.

Buchstein's Fibre Limb

is soothing to your stump—strong, cool, neat, light. Easy payments. Braces for all deformities.

D. BUCHSTEIN CO.
113 6th St. S., MINNEAPOLIS, MINN.

Send for Catalog Today



Deafness

For over 25 years Perfect Hearing has been restored in nearly every condition of deafness by the use of our "Little Wireless Phones for the Ears."

The Wilson Common-Sense Ear Drums effectively replace what is lacking or defective in the natural ear drums; require no medicine; are simple little devices easily fitted into the ears, where they are invisible. Soft, safe and comfortable to wear.

Write today for FREE book, explaining the causes of DEAFNESS, and giving experience of hundreds whose hearing has been happily restored.

WILSON EAR DRUM CO., Incorporated
829 Inter-Southern Bldg. LOUISVILLE, KY.

NO MORE BALD HEADS



WHEN our VACUUM CAP is used a few minutes daily. We accept no pay until you have tried the Cap 30 days and are satisfied. The Vacuum Cap is an appliance that draws the blood to the Hair Roots and starts a new healthy crop of hair. It stops Dandruff, stops the hair from falling out.

Bought by Doctors and men who know that it is the only reasonable HAIR GROWER known to science. No Drugs Used. Write for application blank, testimonials, and booklet on "HAIR," sent sealed in plain envelope, FREE.

THE MODERN VACUUM CAP CO.
Y 559 BARCLAY, DENVER, COLO.

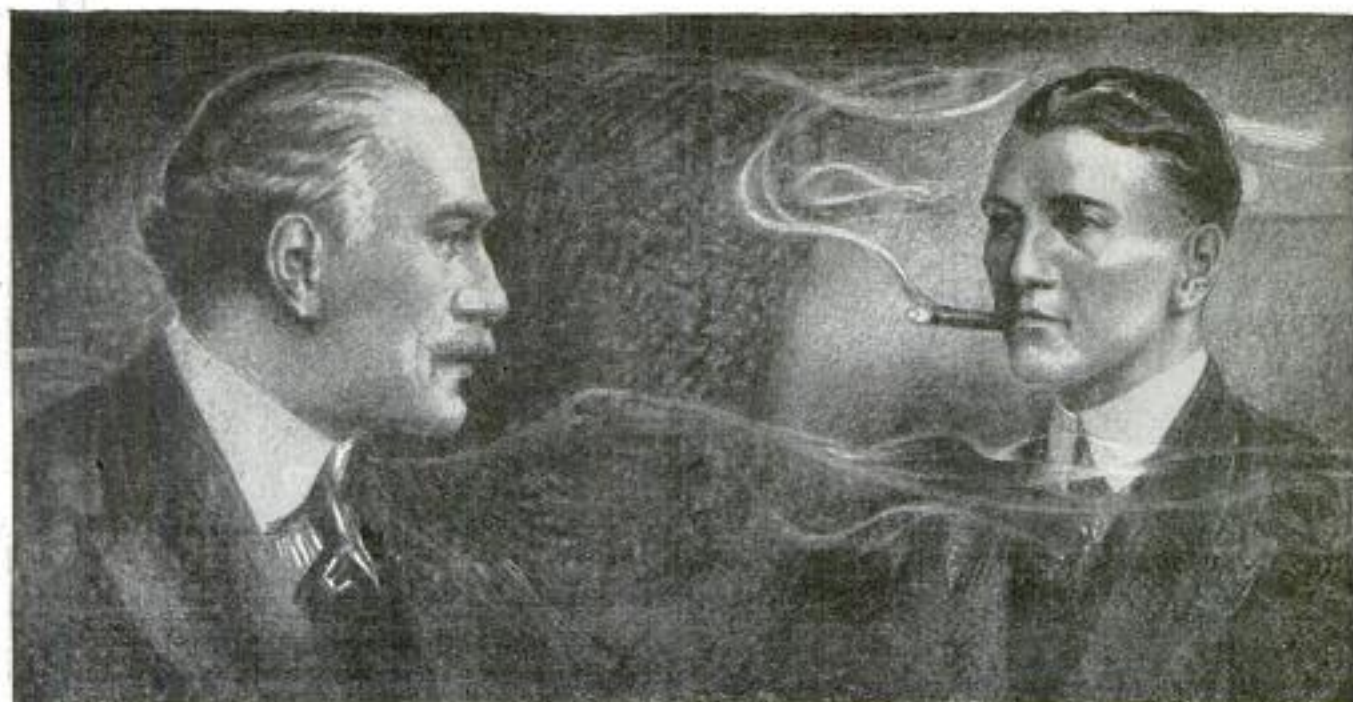

Tobacco Is Hurting You

Look at the facts square in the face, Mr. Tobacco User. You may think tobacco is not hurting you.

That is because you haven't as yet, perhaps, felt the effects of the nicotine poison in YOUR system. For you know that nicotine, as absorbed into the system through smoking and chewing tobacco, is a slow working poison. Slow, yes—but sure.

Tobacco is lowering your efficiency. It slows a man down. Makes it harder for you to concentrate your mind on your work. You haven't near the amount of "pep" and energy you would have if you stopped using it. There's many a man twice as old as you in years who's twice as young in energy, simply because he lets tobacco alone.

Some day you will realize to what an alarming extent tobacco has undermined your system.

When your hands begin to tremble—
and your appetite begins to fail—
and your heart seems to "skip a beat" now and then—
and slight exertion makes you short of breath—
then you have a right to suspect that
TOBACCO is getting the upper hand.

Any well-informed doctor will tell you that these are only a few of many symptoms of tobacco poisoning.

And YOU know that the use of tobacco in any form is an expensive, utterly useless habit. You know you ought to quit.

Tobacco Habit Banished Let Us Help You

It doesn't make a particle of difference whether you've been a user of tobacco for a single month or 50 years, or how much you use, or in what form you use it—whether you smoke cigars, cigarettes, pipe, chew plug or fine cut or use snuff—Tobacco Redeemer will positively remove all craving for tobacco in any form in a very few days. Not the slightest shock to the nervous system. Your tobacco craving will usually begin to decrease after the very first dose—there's no long waiting for results.

Tobacco Redeemer contains no habit-forming drugs of any kind and is marvelously quick, scientific and thoroughly reliable.

It is in no sense a substitute for tobacco. After finishing the treatment you have absolutely no desire to use tobacco again or to continue the use of the remedy. It helps to quiet the nerves and make you feel better in every way.

Results Guaranteed A single trial will convince you. Our legal-binding, money-back guarantee goes with each full treatment. We will refund every cent you pay for the treatment if after taking it according to the easy-to-follow directions, it should fail to banish the tobacco habit completely.

SEND Coupon for Free Proof Let us send you our free booklet on the deadly effects of tobacco, together with testimonial letters from men all over the country telling how they have been absolutely freed from the tobacco habit by this simple home treatment. You could not ask for stronger proof that Tobacco Redeemer will free you from the habit than the evidence we will gladly send on request. Just mail the coupon—or a postal will do.

NEWELL PHARMACAL CO.

Dept. 300

St. Louis, Mo.



Free Book Coupon

NEWELL PHARMACAL CO.

Dept. 300

St. Louis, Mo.

Please send, without obligating me in any way, your free booklet regarding the tobacco habit and proof that Tobacco Redeemer will positively free me from the tobacco habit or my money will be refunded.

Name

Street and No.

Town..... State.....



\$95 An Hour!

"Every hour I spent on my I. C. S. Course has been worth \$95 to me! My position, my \$5,000 a year income, my home, my family's happiness—I owe it all to my spare time training with the International Correspondence Schools!"

Every mail brings letters from some of the two million I. C. S. students telling of promotions or increases in salary as the rewards of spare time study.

What are you doing with the hours after supper? Can you afford to let them slip by unimproved when you can easily make them mean so much? One hour a day spent with the I. C. S. will prepare you for the position you want in the work you like best. Yes, it will! Put it up to us to prove it. Mark and mail this coupon now!

----- TEAR OUT HERE -----
INTERNATIONAL CORRESPONDENCE SCHOOLS
 BOX 5642-C SCRANTON, PA.

Without cost or obligation, please explain how I can qualify for the position, or in the subject before which I have marked an X:

- | | |
|--|--|
| <input type="checkbox"/> ELEC. ENGINEER | <input type="checkbox"/> BUSINESS MANAGEMENT |
| <input type="checkbox"/> Electric Lighting & Railways | <input type="checkbox"/> SALESMANSHIP |
| <input type="checkbox"/> Electric Wiring | <input type="checkbox"/> ADVERTISING |
| <input type="checkbox"/> Telegraph Engineer | <input type="checkbox"/> Show Card & Sign Ptg. |
| <input type="checkbox"/> Telephone Work | <input type="checkbox"/> Railroad Positions |
| <input type="checkbox"/> MECHANICAL ENGINEER | <input type="checkbox"/> ILLUSTRATING |
| <input type="checkbox"/> Mechanical Draftsman | <input type="checkbox"/> Cartooning |
| <input type="checkbox"/> Machine Shop Practice | <input type="checkbox"/> Private Secretary |
| <input type="checkbox"/> Toolmaker | <input type="checkbox"/> Business Correspondent |
| <input type="checkbox"/> Gas Engine Operating | <input type="checkbox"/> BOOKKEEPER |
| <input type="checkbox"/> CIVIL ENGINEER | <input type="checkbox"/> Stenographer & Typist |
| <input type="checkbox"/> Surveying and Mapping | <input type="checkbox"/> Certified Public Accountant |
| <input type="checkbox"/> MINE FOREMAN or ENG'R | <input type="checkbox"/> TRAFFIC MANAGER |
| <input type="checkbox"/> STATIONARY ENGINEER | <input type="checkbox"/> Cost Accountant |
| <input type="checkbox"/> Marine Engineer | <input type="checkbox"/> GOOD ENGLISH |
| <input type="checkbox"/> ARCHITECT | <input type="checkbox"/> Common School Subjects |
| <input type="checkbox"/> Contractor and Builder | <input type="checkbox"/> CIVIL SERVICE |
| <input type="checkbox"/> Architectural Draftsman | <input type="checkbox"/> Railway Mail Clerk |
| <input type="checkbox"/> Concrete Builder | <input type="checkbox"/> AUTOMOBILES |
| <input type="checkbox"/> Structural Engineer | <input type="checkbox"/> Mathematics |
| <input type="checkbox"/> PLUMBING & HEATING | <input type="checkbox"/> Navigation |
| <input type="checkbox"/> Sheet Metal Worker | <input type="checkbox"/> AGRICULTURE |
| <input type="checkbox"/> Textile Overseer or Supt. | <input type="checkbox"/> Poultry Raising <input type="checkbox"/> French |
| <input type="checkbox"/> CHEMIST | <input type="checkbox"/> Airplane Engines <input type="checkbox"/> Spanish |
| <input type="checkbox"/> Pharmacy | <input type="checkbox"/> WIRELESS <input type="checkbox"/> Banking |

Name.....

Street.....
 and No. 2-1-22

City..... State.....

Occupation.....

Persons residing in Canada should send this coupon to the International Correspondence Schools Canadian, Limited, Montreal, Canada.



has enabled John G. Anderson, Aurora, Ill., to keep on the payroll since his right arm was amputated some years ago. The reproduction (from an actual photograph) shows Mr. Anderson at work on an intricate machine using his Carnes Artificial Arm.

INCONSPICUOUS - SERVICEABLE

The Best Substitute for the Natural Arm.

To see him on the street you would not realize that his right arm was artificial. Wearers of this wonderful arm find that it practically takes the place of the natural arm. With it you can dress yourself, use knife and fork, carry grips, write, pick up large and small objects—in fact, do practically everything that was possible before. Even though the amputation be at the shoulder, the CARNES ARTIFICIAL ARM bends at the elbow and wrist, and the fingers open and close as desired.

WONDERFUL BOOK SENT FREE Every armless man or woman should write today for the wonderful illustrated 150 page book showing with actual photographs what can be done with this invention. Write today to

CARNES ARTIFICIAL LIMB CO.
 205 CARNES BUILDING KANSAS CITY, MO.

\$150 to \$400 a Month for YOU

As an Expert Auto Mechanic



EASY TO LEARN HOW

In 6 to 8 Weeks' Time

Come down to Washington—the Nation's Capital. Drop in at the American Motor Schools. Go all thru our big new \$250,000 building. Watch the young men who are learning, by actual practice, every detail of auto construction and repair, auto electricity, battery building, vulcanizing, tire repairing, and welding. Lots of these fellows will soon own their own garages

and be making from \$5,000 to \$10,000 a year. Many of them will soon be holding down good jobs paying from \$150 to \$400 a month.

You too can get your start towards success in the Auto business with the help of the American Motor Schools.

FREE CATALOGUE

Fill in and send the following coupon and we will send you free our illustrated catalogue telling about your opportunity in the auto business and how we will help you to make good. By acting promptly you can save \$50. Mail the coupon NOW.

American Motor Schools, Inc.,
 Dept. 257 16th & You Sts. Washington, D. C.

-----Send the Coupon-----

The American Motor Schools, Inc.,
 16th & You Sts., N. W.,
 Dept. 257, Washington, D. C.

Please send me, free of charge, illustrated catalogue and information regarding your Auto Mechanics Course.

Name.....

Address.....

City..... State.....



LEARN MUSIC AT HOME!

Piano, Organ, Violin, Cornet, Guitar, Banjo, Mandolin, Harp, Cello, Trombone, Flute, Clarinet, Ukulele, Saxophone, Piccolo, Sight Singing, Harmony and Composition, Hawaiian Steel Guitar, Tenor Banjo, Automatic Finger Control, Drums and Traps.

No longer need the ability to play be shut out of your life. Just mail coupon or postal today for our new Free Book. Let us tell you how you can easily, quickly, thoroughly learn to play your favorite musical instrument by note in your own home, without a teacher, by our New Improved Home Study Method. Different, easier than private teacher way—no tiresome, dry exercise—no inconvenience, no trick

music, no "numbers," yet simple, wonderful, amazingly easy for even a mere child.

Amazing Offer

We want to have ONE PUPIL IN EACH LOCALITY AT ONCE to help advertise our wonderful easy system of teaching music. FOR A LIMITED TIME we therefore offer our marvelous lessons at practically no cost—charges amounting merely to about the cost of sheet music, postage, etc. Beginners or advanced pupils. Get all the proofs, facts, letters from pupils. AMAZING FREE OFFER and fascinating New Book just issued.

SUCCESS

"Since I've been taking your lessons I've made over \$200 with my violin. Your lessons surely are fine."—Melvin Freeland, Macopin, N. J.

"When I started with you I knew nothing about the Cornet or music, but now I can play almost any piece of music."—Kasson Swan, Denmark, Col. Co., Nova Scotia.

"I want to extend the heartiest approval of your Piano Course. It has done more for me than years of other lessons."—Moxie N. Lewis, 319 Jefferson, Neosho, Mo.

"The folks at home are delighted to hear me play the Organ so well. You have a wonderful system of teaching music."—M. F. Allard, Carquet, N. B.

WRITE! This is your opportunity. Write today for free book and full particulars. Send postcard or letter. Please write name and address very plainly.

U. S. SCHOOL OF MUSIC

76 Brunswick Bldg., New York

U. S. SCHOOL OF MUSIC 76 Brunswick Bldg., New York City

Please send me your free book, "Music Lessons in Your Own Home," and particulars of your special offer. I am interested in the following course:

(Name of Instrument or Course)

Name..... (Please write plainly.)

Address.....

City.....State.....

BIG PAYING HOTEL JOBS OPEN

to trained men and women; we train you by mail; get 20 years' hotel experience in few months; earn \$3,000 to \$10,000 a year; fine living; work is fascinatingly interesting; quick advancement. Send for FREE BOOK today!

LEWIS HOTEL TRAINING SCHOOL, Room 329, Washington, D. C.



"BECOME A LIGHTNING TRICK CARTOONIST"

MAKE MONEY CHALK TALKING. SEND \$1.00 FOR SHARP PROGRAM OF TRICK DRAWINGS WITH INSTRUCTIONS BY A PROFESSIONAL CARTOONIST. SATISFACTION GUARANTEED. CIRCULAR FREE. BALDA ART SERVICE, Q1, OSHKOSH, WIS.

\$100 a WEEK for DRAWING

How would you like to make \$100 a week as a commercial artist? If you like to draw, you are indeed fortunate—well-trained artists are always at a premium. They readily earn \$75, \$100, \$150 a week, and even more, and beginners with practical ability soon command \$50 a week.

LEARN QUICKLY AT HOME IN YOUR SPARE TIME

Develop your talent—put your natural ability to its best use. The Federal "Master" Course, endorsed by high authorities, teaches you by mail in your spare time. No experience needed, each step is clearly explained.

You receive individual personal criticisms on all your lessons.

Send for "Your Future," a splendid book showing work of Federal Students, telling all about this remarkable course, and pointing out opportunities that will surprise you. If you are in earnest and 16 years old or more, write today for this free book, kindly stating your age.

FEDERAL SCHOOL OF COMMERCIAL DESIGNING, 677 Federal Schools Bldg., Minneapolis, Minn.

WANTED RAILWAY MAIL CLERKS \$1600 to \$2300 Year

MEN—BOYS OVER 14 SHOULD

SEND COUPON IMMEDIATELY

Steady Work No Layoffs Paid Vacations

Common education sufficient

Send coupon today—SURE



Franklin Institute, Dept. D176, Rochester, N. Y.

Slrs: Send me, without charge, (1) sample Railway Mail Clerk Examination Questions; (2) schedule showing places of all coming U. S. Government examinations; (3) list of many Government jobs now obtainable.

Name.....

Address.....

If you really want to be a BIGGER MAN



Ask for a free copy of this booklet



It is a frank, man-to-man discussion of personal development that we are glad to send every ambitious young man. It does not paint any "blue-sky dreams" that you cannot realize, but it tells how we are helping thousands of young men to make the most of their study hours. We will also give you the "Six Reasons" why you should select the United Y. M. C. A. Schools to help you to qualify for greater responsibility, more congenial or letter-paying work, and larger manhood. Our friendly counsel is free.

Tear Out and Send This Slip

United Y. M. C. A. Schools' Correspondence Courses,

or positions for which they afford training:

Accountants	Electrical Engineer	
Advertising Man	Factory Management	
Agricultural Courses	Farm Management	
Architect	Foreign Languages	
Auto Mechanic	High School Subjects	Salesman
Banking	Foremanship	Secretarial
Better Letters	Highway Engineering	Shorthand and Type-writing
Bookkeeper	Machine-Shop Practice	Steam Engineer
Building Construction	Leadership Courses	Structural Drafting
Business English	Locomotive Operator	Surveyor
Business Law	Mathematical Courses	Tool Designing
Business Organization	Mechanical Engineer	Tractors and Farm Machinery
Civil Engineer	Plumber	Traffic Management
Civil Service	Poultry Husbandry	Use of the Slide Rule
Concrete Engineer	Radio Operator	Are You an ex-Serviceman?
Dairy Farming	Radio Engineer	
Draftsman	Railroad Engineering	
Electrician		



United Y.M.C.A. Schools
375 Lexington Ave.
New York City.

Without obligating me, please advise regarding the

..... course.

Age and Occupation.....

Name.....

Full Address.....

2-36

(Please write plainly)

Be an Artist

Comics, Cartoons, Commercial, Newspaper and Magazine Illustrating, Postal Order Portraits and Fashioning. Earn money; become famous. Our simple method quickly develops your talent in spare time. By Mail or Local Classes. Write for terms and list of successful students. ASSOCIATED ART STUDIOS 87-B Flatiron Building NEW YORK



THIRTY-FIVE EASY LESSONS IN RADIO 50c

A systematic course of elementary principles written in a simple and concise lesson course, easily understood. Thousands have taken up Radio for entertainment and are operating their own amateur sets.

This book embodies all the principles and application of everyday radio for the home and in business. Paper cover.

Price postpaid 50c

SHREWSBURY PUBLISHING CO.
5525 West Lake Street Chicago, Ill.

SELL US YOUR SPARE TIME

You can earn money writing show cards in your own home. No canvassing—A pleasant, profitable profession easily and quickly learnt by our new simple graphic block system—Artistic ability not necessary—We teach you how, and supply you with work—Distance no object. Full particulars and booklet free.

Wilson Methods, Ltd., Dept. M, 64 Richmond East, Toronto, Canada.

GO TO HIGH SCHOOL AT HOME



Study at home in spare time, with the world's largest correspondence school. Your choice of any four of the following subjects: Grammar, Composition, American Literature, English Literature, History, Physiology, Geography, Physics, Geology, Zoology, Biology, Astronomy, Chemistry, Economics, Algebra, Plane Geometry, Solid Geometry, Trigonometry. Write today. International Correspondence Schools, Box 5647-C, Scranton, Pa.

ELECTRICITY LEARN AT HOME

Send for catalog which tells how Burgess Home Training enables men and boys to get good jobs and keep them. Burgess Electrical School, Dept. P-6, 744 E. 42nd St., Chicago



Big Money

Made by agents selling our wonderful Facial Soap, Perfumes, Toilet Articles, Spices, Extracts, etc. Free cake of soap and agents' terms mailed to any address.

LACASSIAN CO. Dept. 455 ST. LOUIS, MO.

LOOK 50c Look



Wonderful Instrument. Greatest thing yet. Nine separate articles in one. Everybody delighted with it. Odd, curious and interesting. Lots of pleasure as well as very useful. It is a double Microscope for examining the wonders of nature. It is also an Opera Glass, a Stereoscope, a Burning Lens, a Reading Glass, a Telescope, a Compass, a Pocket Mirror, and a Laryngoscope—for examining eyes, ear, nose and throat. It is worth all the cost to locate even one painful cinder in the eye. Folds flat and fits the pocket. Something great—you need one. Don't miss it. Sent by mail, with 300 page Novelty Catalog, ONLY 50c or 3 for \$1.25.

THOMSON SMITH & CO., Dept. B40 3774 N. Halsted St., CHICAGO

Whatever Your Question;—be it the pronunciation of Bolsheviki, the spelling of a puzzling word, the location of Murman Coast—the meaning of blighty, ace, lank, ukulele, etc., this Supreme Authority—

WEBSTER'S NEW INTERNATIONAL DICTIONARY

contains an accurate, final answer 400,000 Words, 2700 Pages, 6000 Illustrations. Regular and India-Paper Editions. G. & C. MERRIAM CO., Springfield, Mass.

Write for specimen pages, prices, etc. and FREE Pocket Maps per Popular Mechanics



Why Miss Half the Fun in Life?



BE POPULAR—Learn to dance well! Arthur Murray, America's greatest dancing teacher, has invented a remarkable new easy method which enables anyone to learn all the newest dances at home—in a few hours—at very little cost!

No music or partner needed. *Success positively guaranteed!* "60,000 learned dancing by mail."

FREE DANCING LESSON—To prove you can learn easily and quickly, Arthur Murray will send you a lesson absolutely free. Also, the Secret of Leading, How to Gain Confidence and other dancing helps, in plain cover. For mailing, send 10c. Act now and be a good dancer soon.

Arthur Murray, Studio 253
100 Fifth Avenue New York

CHEMISTRY



Good salaries await trained men. No work is more interesting—no other profession offers greater opportunity for advancement. You can learn quickly and easily at home—in an hour a day of the spare time that now goes to waste. Write today for full particulars. International Correspondence Schools, Box 5645-C, Scranton, Penna.

New Gum Vending Machine Makes You \$10 to \$20 a Day

Pays Rent for Store Owner

Install one in your store or any public place and get this easy profit. Requires no attention. Always works. Machine's profits pay the rent. Write us about rebuilt penny and nickel machines. Finished like new. In excellent running order. Pay their cost in 10 days.

Write or wire today for full particulars. \$25 down payment. Balance C. O. D. Mints \$30 per case—2,000 5-cent packages. Single boxes, 100 5-cent packages, \$2.50.

SILVER KING NOVELTY CO.
400 Williams Bldg. Indianapolis, Ind.



Wrestling Book FREE

Be an expert wrestler. Learn at home by mail. Wonderful lessons prepared by world champions Farmer Burns and Frank Gotch. Free book tells you how. Secret holds, blocks and tricks revealed. Don't delay. Be strong, healthy. Handle big men with ease. Write for free book. State your age. Farmer Burns, A177 Range Building, Omaha, Neb.

MURDER WILL OUT Police Dept., factories, banks, industries adopt latest print method of identification to find originals. **BE A FINGER PRINT EXPERT.** Train at home in spare time. Write for FREE reports telling uses of finger prints and how to learn this profitable profession. POSTAGE GUARANTEED. U. S. SCHOOL OF FINGER PRINTS, Room 93A, 7003 N. Clark St., Chicago, Ill.

TOBACCO

OR SNUFF HABIT CURED OR NO PAY \$1.00 IF SUCCESSFUL

No matter whether used in pipe, cigarettes, cigars, chewed, or used in the form of snuff. Superba Tobacco Remedy contains nothing injurious, no dope, poisons, or habit forming drugs. **SENT ON TRIAL GUARANTEED.** Costs nothing if results are not satisfactory. **WRITE FOR FULL TREATMENT TODAY.** SUPERBA CO. M-19 Baltimore, Md



A Bigger Job—and You're the Man

Are you hunting a bigger job, or does the bigger job hunt you? Why waste priceless years at routine work, when you can acquire in a comparatively few months the specialized knowledge that big firms pay big money for? Literally thousands of men have doubled and tripled their incomes by home-study business training under the LaSalle Problem Method. Let us show you how you can do just as well or better. The coupon will bring you complete information, together with details of our convenient-payment plan; also your free copy of a remarkable book—"Ten Years' Promotion in One." Make your start toward that bigger job today.

Coupon

LaSalle Extension University

Dept. 664-R Chicago, Ill.

Please send me catalog and full information regarding the course and service I have marked with an X below. Also a copy of your book, "Ten Years' Promotion in One," all without obligation to me.



- Business Management:** Training for Official, Managerial, Sales, and Executive positions.
- Salesmanship—Principles and Practice:** Training for Sales and Advertising Executives, Solicitors, Sales Promotion Managers, Salesmen, Manufacturers' Agents and all those engaged in retail, wholesale or specialty selling.
- Higher Accountancy:** Training for positions as Auditor, Comptroller, Certified Public Accountant, Cost Accountant, etc.
- Traffic Management—Foreign and Domestic:** Training for positions as Railroad and Industrial Traffic Manager, etc.
- Railway Accounting and Station Management:** Training for Railway Auditors, Comptrollers, Accountants, Clerks, Station Agents, Members of Railway and Public Utilities Commissions, etc.
- Industrial Management Efficiency:** For Executives, Managers, Office and Shop Employees and those desiring practical training in industrial management principles and practice.
- Modern Business Correspondence and Practice:** Training for Sales and Collection Correspondents; Sales Promotion Managers; Credit and Office Managers; Correspondence Supervisors, Secretaries, etc.
- Banking and Finance:** Training for executive positions in Banks and Financial Institutions.
- Modern Foremanship and Production Methods:** Training in the direction and handling of industrial forces—for Executives, Managers, Superintendents, Contractors, Foremen, Subforemen, etc.
- Personnel and Employment Management:** Training for Employers, Employment Managers, Executives, Industrial Engineers.
- Law:** Training for Bar: Commercial Law. LL. B. Degree. Effective Speaking.
- Expert Bookkeeping.** C. P. A. Coaching.
- Business English.** Commercial Spanish

Name.....

Present Position

Address

Please Mention Popular Mechanics

HOMEMADE **RADIO** APPARATUS

is the title of a new book
soon to be published by

Popular Mechanics Magazine

Popular Mechanics Magazine is famous for its clear constructional articles and the publisher takes pride in being able to present a Radio book of the very highest standard, so clear that anyone, no matter how slight his knowledge of radio, can, by following the simple directions, build a first-class outfit.

This book will cover thoroughly the construction of radio apparatus from the simplest crystal receiver up to the most advanced radio-telephone transmitter, completely illustrated by drawings and photos, and, to the last detail,

“Written So You Can Understand It”

The theory of radio transmission and reception will be touched on very briefly, as the purpose of the book is to describe, step by step, the actual construction of the apparatus and all auxiliaries.

There will be ten complete articles on increasingly efficient sets, 5 receiving and 5 transmitting; the cost of materials for making will range from \$10 to \$100. The instruments described could not be purchased for several times the cost of construction.

In addition, there will be a number of shorter articles, describing the making of condensers, high-speed keys, and detectors, operating suggestions, symbols, code, extracts from laws governing radio, etc.

About 180 Pages with over 100 Illustrations, including many Full Page Drawings. Attractive Cloth Binding.

"RADIO TELEPHONY FOR AMATEURS"

By **STUART BALLANTINE**
Formerly Expert Radio Aid U. S. N.

is the book that tells the how and why of radio telephony. Written so you can understand it fully. The biggest help to the amateur operator. 200 pages, freely illustrated.

\$1.50 net, by mail \$1.65
Send for your copy

DAVID McKAY COMPANY, Philadelphia

ANY BOY CAN BUILD THIS 20" CAT BOAT



with our complete Construction Set.

"Everything but the paint"
\$5.00

We have other boats, engines, boilers, etc.

Catalog Free

The H. E. Boucher Mfg. Co.
154 Lafayette St., New York



DO YOUR OWN ELECTRICAL WORK AND WORK FOR OTHERS IN YOUR SPARE TIME

Anyone with the aid of *Electrical Kinks* can do wiring and repairing of door bells, burglar alarms, garages, electric irons, vacuum cleaners, washing machines, table lamps, etc., in fact most anything electrical used in the home. The book has 131 pages, 75 illustrations and the cost is **ONLY \$1.00, postpaid**. Send the money today—you may need the book tomorrow.

HOME BOOK CO., 338 Arcade Bldg., Cleveland, Ohio

Our Scientific Method will stop that

STAMMER!

Send for free 200 page book. It tells how to permanently stop stammering or stuttering in a few weeks' time. A natural guaranteed method.

The Lewis School for Stammerers
32 Lewis Bldg., 71-77 Adelaide St., Detroit, Mich.

LEARN WATCHMAKING

and become independent. Good-paying positions secured. Easy to learn. Send for FREE CATALOG.

ST. LOUIS WATCHMAKING SCHOOL, Dept. 5, ST. LOUIS, MO

The Dying Pig



The most ingenious novelty yet conceived. Made of rubber, and you have only to blow it up and at a

the pig on his feet, when he begins to squeal as he slowly collapses and finally lies down and dies in the most natural manner. You can blow him up as often as desired, and each time he will go through the same performance to the great amusement and delight of your friends.

Price 15 cents; 3 for 40 cents; one dozen \$1.35, mailed postpaid.

Johnson Smith & Co., 324 N. Halsted Street, Dept. 40, Chicago

Popular Watch Charms



Very pretty little curiosities and decidedly novel. Fitted with Magnifying Lenses that enlarge the pictures to a very surprising degree; in fact, it seems almost incredible that a clear picture could be possible in such a small compass, and how sharp and distinct they show up when you look through. Come in assorted views—Actress, views of Panama Canal, Lord's Prayer in type, etc.

Price 15c; 3 for 40c; \$1.35 doz.

Why haven't you clipped this coupon?

IT takes but a moment to mark the career of your choice, sign your name, clip out and mail the coupon printed below.

Yet that simple act has started more than two million men and women toward success.

In city, town and country all over the world, men are living contented lives in happy, prosperous homes—because they clipped this coupon.

In every line of business and industry, in shops, stores, offices, factories, in mines and on railroads, men are holding important positions and receiving splendid salaries—because they clipped this coupon.

You too can have the position you want in the work you like best, a salary that will give you and your family the home, the comforts, the little luxuries you would like them to have. No matter what your age, your occupation, your education, or your means—you can do it!

All we want is a chance to prove it. That's fair, isn't it? Then mark and mail this coupon. There's no obligation and not a penny of cost. It's a little thing that takes but a moment, but it is the most important thing you can do today. Do it now!

----- TEAR OUT HERE -----

INTERNATIONAL CORRESPONDENCE SCHOOLS BOX 5644-C SCRANTON, PA.

Without cost or obligation, please explain how I can qualify for the position, or in the subject before which I have marked an X:

- | | |
|---|--|
| <input type="checkbox"/> ELEC. ENGINEER | <input type="checkbox"/> BUSINESS MANAGEMENT |
| <input type="checkbox"/> Electric Lighting & Railways | <input type="checkbox"/> SALESMANSHIP |
| <input type="checkbox"/> Electric Wiring | <input type="checkbox"/> ADVERTISING |
| <input type="checkbox"/> Telegraph Engineer | <input type="checkbox"/> Show Card & Sign Ptg. |
| <input type="checkbox"/> Telephone Work | <input type="checkbox"/> Railroad Positions |
| <input type="checkbox"/> MECHANICAL ENGINEER | <input type="checkbox"/> ILLUSTRATING |
| <input type="checkbox"/> Mechanical Draftsman | <input type="checkbox"/> Cartooning |
| <input type="checkbox"/> Machine Shop Practice | <input type="checkbox"/> Private Secretary |
| <input type="checkbox"/> Toolmaker | <input type="checkbox"/> Business Correspondent |
| <input type="checkbox"/> Gas Engine Operating | <input type="checkbox"/> BOOKKEEPER |
| <input type="checkbox"/> CIVIL ENGINEER | <input type="checkbox"/> Stenographer & Typist |
| <input type="checkbox"/> Surveying and Mapping | <input type="checkbox"/> Certified Public Accountant |
| <input type="checkbox"/> MINE FOREMAN or ENGR | <input type="checkbox"/> TRAFFIC MANAGER |
| <input type="checkbox"/> STATIONARY ENGINEER | <input type="checkbox"/> Cost Accountant |
| <input type="checkbox"/> Marine Engineer | <input type="checkbox"/> GOOD ENGLISH |
| <input type="checkbox"/> ARCHITECT | <input type="checkbox"/> Common School Subjects |
| <input type="checkbox"/> Contractor and Builder | <input type="checkbox"/> CIVIL SERVICE |
| <input type="checkbox"/> Architectural Draftsman | <input type="checkbox"/> Railway Mail Clerk |
| <input type="checkbox"/> Concrete Builder | <input type="checkbox"/> AUTOMOBILES |
| <input type="checkbox"/> Structural Engineer | <input type="checkbox"/> Mathematics |
| <input type="checkbox"/> PLUMBING & HEATING | <input type="checkbox"/> Navigation |
| <input type="checkbox"/> Sheet Metal Worker | <input type="checkbox"/> AGRICULTURE |
| <input type="checkbox"/> Textile Overseer or Supt. | <input type="checkbox"/> Poultry Raising <input type="checkbox"/> French |
| <input type="checkbox"/> CHEMIST | <input type="checkbox"/> Airplane Engines <input type="checkbox"/> Spanish |
| <input type="checkbox"/> Pharmacy | <input type="checkbox"/> WIRELESS <input type="checkbox"/> Banking |

Name.....

Street.....

City..... State.....

Occupation.....

Persons residing in Canada should send this coupon to the International Correspondence Schools Canadian, Limited, Montreal, Canada.

THE SCIENTIFICALLY BUILT WATCH

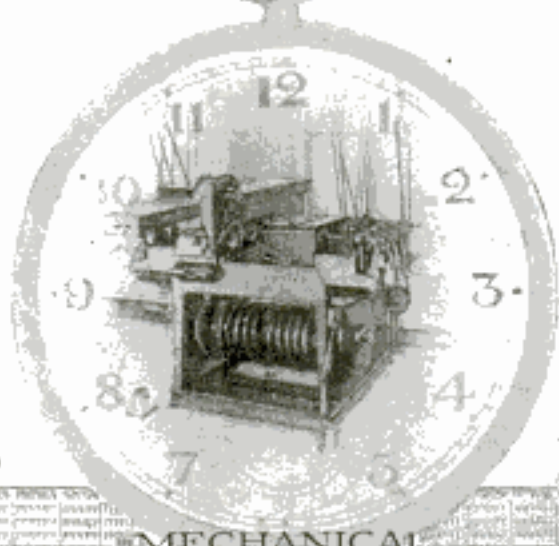

MECHANICAL

PERFECTION



Jewel Bearings

FROM the application of the first wheel to mechanics, the elimination of friction, through the development of bearings, was one of the greatest problems confronting man.

Years ago watchmakers discovered that diamonds, rubies and sapphires being the hardest known materials were the best from which to make the bearings for the revolving parts of a watch.

For nearly three-quarters of a century Waltham has been inventing and perfecting machines for building and locating these most important parts.

The machine illustrated is the perfected result of the study and development related to this very important factor.

Nowhere else in the world can you find such a machine. Created and built at the Waltham factory, it performs a task day after day undreamed of, except by Waltham genius. This machine locates one bearing (or jewel) with the other so accurately that friction, the greatest enemy of good time-keeping, becomes a minor consideration in Waltham Watch construction.

When you own a Waltham Watch, the mechanical perfection of its parts insures you accurate time and the lowest possible up-keep cost of any watch made today.

This is one more reason why the Waltham Watch leads everywhere in true watch value. Buy a Waltham Watch and enjoy the pride you will have in its exclusive qualities of service and dependability.

Write for a valuable booklet that is a liberal "watch" education. Sent free upon request. The Waltham Watch Company, Waltham, Mass.



Colonial Series No. 1420
Raised Gold Figure Dial, Solid Gold Case
Catalogue No. 116. \$85.00

Makers of the famous Waltham air-friction quality Speedometers
and Automobile Time-pieces used on the world's leading cars

WALTHAM

THE WORLD'S WATCH OVER TIME

Where you see this sign they sell Waltham Watches

GIFTS THAT LAST

Popular Mechanics Magazine

REGISTERED IN U. S. PATENT OFFICE

WRITTEN SO YOU CAN UNDERSTAND IT

Vol. 37

JUNE, 1922

No. 6

8776

When the Brakes Are of First Importance

IN THE WEST, logging camps are mostly situated in the hills, and the heavy loads of logs have to be hauled out, always downhill. Often that helps to make the hauling easy, but sometimes the grades are so steep that it makes it too easy—so easy that it entails difficulty. Indeed, in these instances the term hauling is a misnomer, for that implies pulling the load, and the operation actually consists in pushing against the load instead of pulling it. Two and a half miles of specially constructed track is used at one western logging camp for transporting heavy loads on a large motor truck down

a very steep grade. The truck is six-wheeled, and has powerful brakes on its four rear wheels. These brakes are controlled exclusively by one man, while another takes care of the driving and steering.

The wooden track has a continuous serpentine wire cable fastened to it so that it keeps the wheels from slipping when the brakes are on, and helps the traction in going upgrade. Along the center of the track, and between the car wheels, are two wooden guides that help the driver to keep the truck from leaving the track.



Specially Constructed Track for Hauling Heavy Loads on a Truck down a Very Steep Grade: Two Operators Are Necessary, the One on the Right Having Exclusive Control of the Brakes on the Rear Wheels. The Driving and Steering are Done Entirely by the Other Man

Cont H. E. Thomas, 911 Commercial Ave
Portland, Oregon. 817
Copyrighted Material

Com. Harold H. Blanchard
Tuckahoe, N.Y.

PROTECTION-SIGNAL DEVICE
FIRES TEN SHOTS

HIGH-PRESSURE GAS SYSTEMS
TO SOLVE FUEL PROBLEM

As a protection against burglary or theft, an alarm signal has been devised which is adaptable to many uses. In size, it is only a little larger than a big watch, which it resembles. It is loaded with 10 blank cartridges which are fired by a fuse on the inside of the device. In case of danger it is only necessary to release a safety catch on the face of the device and drop or throw the signal, keeping hold of the finger ring, from which the alarm is released when flung. This action ignites

In the interest of economy and as the first step toward the solution of the fuel problem, engineers are now seriously considering the plan of converting the coal at the mines into gas which would be distributed through pipe lines to distant cities. Under this plan, large gas plants would be erected at the mines, and the gas would be piped under high pressure to the cities, where it would be used for nearly all purposes where coal is now employed, such as steam and heating plants. At reduced pressure, it would be introduced into the service mains for household uses.

Under present conditions, it costs more to transport and distribute a ton of coal than the coal itself costs at the mine, and the saving of these charges should be sufficient to defray the costs of installation and upkeep of the gas plants and pipe lines. The value of the by-products recovered during the distillation of the coal would form an important source of revenue which would go far toward reducing the cost of gas. The secondary economies resulting from the use of this clean fuel would be beyond calculation. Better economy of the heat contained in the fuel would be manifest immediately, while the abolishment of the smoke nuisance in the cities would effect savings in innumerable ways.

Long-distance transmission of electricity over wires and the transportation of oil for great distances through pipe lines now are common practice, so, while the distribution of high-pressure gas may at first appear as a radical departure, it is, in fact, but

a logical step in the interest of economy and convenience.

RADIO APPARATUS WILL MAKE
MOUNTAIN CLIMBING SAFER

A French engineer, after years of study, has succeeded in constructing radio apparatus capable of withstanding the severe atmospheric changes of high altitudes that would break ordinary instruments. It is proposed that mountain-climbing parties in the vicinity of Mont Blanc be supplied with small wireless outfits with which to summon aid in case of necessity.

Christian Science
Monitor

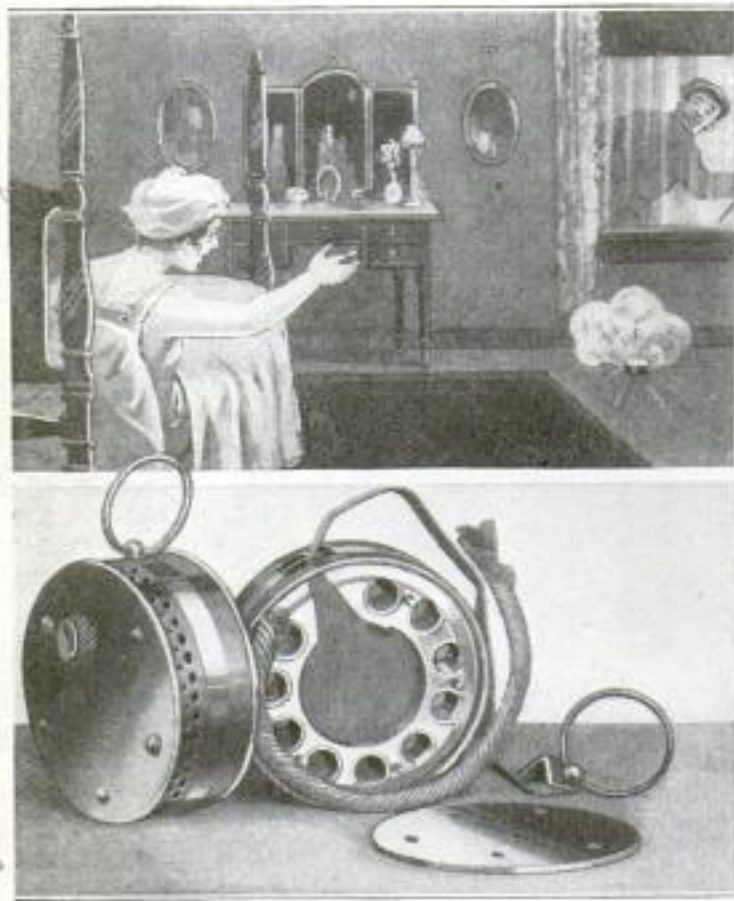

By Pulling the Finger Ring of This Alarm Signal, the Fuse is Ignited, and This Causes 10 Blank Cartridges to be Fired in Rapid Succession

the fuse, which in turn fires the 10 shots in succession. The device can be attached to windows or doors to act as a burglar alarm or fastened to a parked automobile, and may also be carried in the pocket to be used as a distress signal in case of holdup. After being fired, the case may be returned to the manufacturer for inspection and reloading.

Announcement was recently made that the government of Brazil had officially changed the name of the River of Doubt, discovered by Theodore Roosevelt, to the Roosevelt River.

Blaine - Thompson Co
74th National Bldg.
The
river put on
market

8792

8792

Engineering

Blaine - Thompson Co
74th National Bldg.

The
river put on
market

8000
Gymnasium

REMARKABLE GLIDER FLIGHT IN SWITZERLAND



Above: The Motorless Glider in Flight over the Snow-Covered Hills. On This Flight the Glider Was in the Air for 40 Seconds and Attained a Height of More than 150 Feet in Its 600-Yard Flight. Right: About to Take Off for a Flight. This Machine Appears to Be Much Smaller than Those being Used for Gliding Flight in Germany. It is Patterned Much after the Standard Airplanes, the Construction, However, Being Much Lighter. The Glider is Launched by Moving Forward against the Wind from the Top of a Small Hill



COPYRIGHT, UNDERWOOD & UNDERWOOD

CAÑON WALLS SERVE AS POLES FOR TRANSMISSION WIRES

With a right of way that runs through solid rock, the Denver and Rio Grande Railway finds that in certain cañons it is

Braced steel brackets driven into the walls of the cañon serve to carry the wires. To reach these, it is necessary to use hanging ladders which are made of 2 by 4-in. pieces held by heavy cables. The railway, in many places, has to divide its right of way with a stream.



Placing the Wires on Steel Brackets Set in the Wall was Found to Be the Most Practical Method of Carrying the Wires through This Narrow Cañon

more practicable to use the sides of walls than to try to set poles along the tracks.

NEW LIBRARY AT LOUVAIN NOW BEING ERECTED

The library of the University of Louvain, that was destroyed by the Germans during their march through Belgium in 1914, is to be replaced by a building which is a gift by the people of the United States to the Belgian people. The new structure, the contract for which is already let to a New York concern, will cost more than \$1,000,000, and will be in the style of the Flemish Renaissance, surmounted by a tower 375 ft. high, with a main building 220 ft. long and 150 ft. wide. In the tower is to be a belfry, and a carillon, or chimes, that will play the national airs of all the allied nations. The corner stone of the building was laid with appropriate international ceremonies, July 28, last year.

DOUBLE-DRIVE LOCOMOTIVE WITH BOILER IN CENTER

Very unusual in design, at least as far as this country is concerned, is a locomotive built in England for use in South Africa. The object of the design is to obtain the greatest possible power for any given weight allowance. A very even distribution of the weight over the axles is obtained by placing the boiler between two driving systems, which are in connection with a tender at each end. The boiler itself is like that of any other locomotive, and at its fire-box end is the cab. This construction provides room for a very large boiler with great steam-producing capacity.

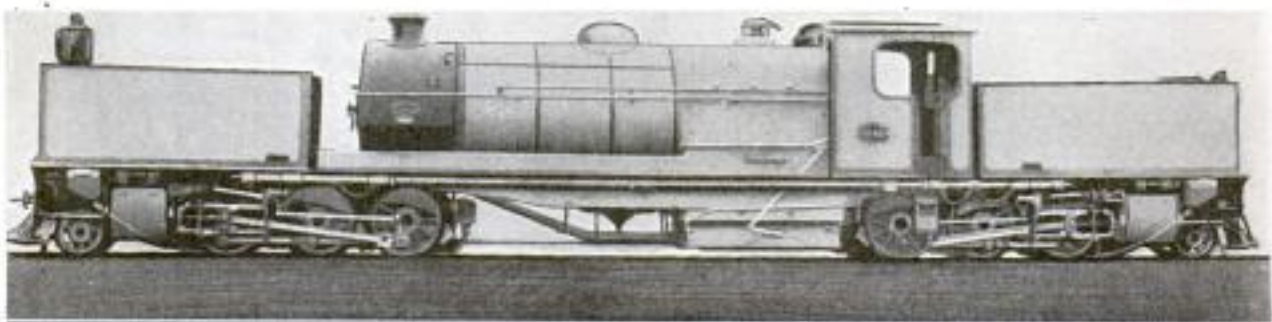

Locomotive with Tender and Driving System at Each End, Designed to Accommodate a Large Boiler with Great Steam-Producing Capacity in Proportion to the Total Weight: It was Built in England for Use in Natal, South Africa

*Reyer, Peacock & Co. Ltd
Manchester, England*

*8917
Cmt. Chas. A. Soddard, 5626 Clivington
Place, Los Angeles, Calif.*

8929

8968

7359 C. H. Hulbert, 7010 N. Ashland
 Ave. Chicago, Ill. Not in J. U.

5/20/25

Signal wire to
 menomic, Mich.



HIGH-TENSION DIRECT-CURRENT POWER FROM HOUSE CIRCUITS

New Machine Changes 110-Volt Alternating Current to 10,000-Volt Direct Current—Inexpensive Wireless Sending Sets for Amateurs Is Probable Result

By H. A. LANE.

RESEARCH, study, and practice during the history of electricity have resulted in the present-day usefulness of this wonderful and invisible force or energy. The mere pushing of a button to illuminate a home, and the throwing of a switch to put huge machines into operation, were considered marvelous when first introduced, but are quite commonplace now. Today one of the most absorbing problems confronting the minds of those engaged in the electrical industry, is the development of wireless telephony and telegraphy. Numerous broadcasting stations enable reproductions of the voices of noted speakers and singers, and also musical scores, to be heard within the family circle for the benefit and entertainment of all who care to listen. To enjoy the concerts, speeches, etc., which compose the "current events" of the radio world, all that is needed is the possession of a receiving set with the ordinary simple wiring for an aerial. Should the amateur, however, desire to do any sending or broadcasting, he must first install costly and more complicated equipment, such as motor-generator sets, large batteries, vacuum tubes, filaments, or similar apparatus found in the usual sending stations. This entails a considerable outlay of money, and is a drawback to persons who are not supplied with sufficient funds to carry out their ideas of an experimental nature. To these experimenters and amateurs, great pos-

sibilities have been opened up by an invention of C. H. Hulbert, of Chicago.

This man, whose typical and sound maxim is, "Thinking about anything is all right, but if you want results, you must work it out," has patiently persevered in his theory since 1907. At that time, when employed by the government in the Philippine Islands as an expert electrician, he conceived the idea of producing high-voltage direct current from a low-voltage alternating source. In short, rectification was his constant thought. Those familiar with alternating current know the characteristics of the sine wave, and its deviation from "zero" to "maximum," on one side of a given line, and then the reversion back to zero again, from which the curve extends to a maximum on the other side of the line. The progression from one maximum to the other constitutes a cycle, frequency, or revolution.

This cycle, therefore, consists of two actual deviations from the center, or zero, both of equal strength, but in opposite directions. Therefore, if an alternating current has 60 complete cycles per minute, which is the common lighting voltage used in homes, and an interrupter, or spark gap, is employed in the circuit and operates 60 times per minute, it can be readily seen that during the periods when the gap is closed, an even flow of 60 half cycles will ensue, producing a direct current.

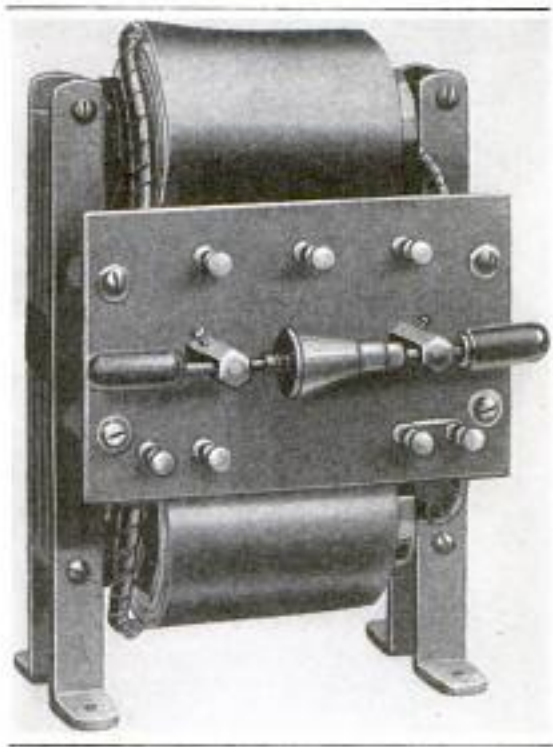

"Transrectifier" Which Changes the Ordinary House-Circuit Current to High-Voltage Alternating Current, and Then Rectifies It to Direct Current

Info. Hulbert Electric Co. 7010 N. Ashland Blvd. Chicago, Ill. 75.00

Acting upon this theory, Hulbert tirelessly pursued his experiments, trying various windings, or coils, and experimenting with different voltages. Although having left the employ of the government and embarked in mining ventures on the islands, the hard-working genius gradually became convinced that electrical research was his real field. In July, 1921, he decided to come back to the States and completely develop his idea. The results speak for themselves. His vision has been rewarded with the production of an instrument that performs, at one operation, the astonishing feat of transforming low-voltage alternating current to a high-voltage direct one.

By connecting the apparatus to an ordinary 110-volt, 60-cycle alternating-current lighting circuit, it is possible to obtain 10,000-volt direct current at 30 milliamperes, thus yielding 300 watts of power. In addition to attaining this remarkable result, there are no rotary or vibrating parts to get out of order, no jars to break, no cells to overheat, no fragile and expensive vacuum tubes to replace, and no filaments to burn out or depreciate.

Especially appealing to the experimenter is the great durability of the machine, it being practically impossible to burn out the windings, if but the usual

care is taken. The apparent economy of the apparatus will aid many chemical and physical-research laboratories in colleges, schools, and factories, which have been forced to omit laboratory work requiring high-potential direct current, simply through the lack of necessary financial means. Continuous-wave telegraphy will also be greatly reduced in cost by the invention.

Other uses to which the Hulbert machine can be put are X-ray photography, smoke precipitation, the testing of high-tension insulating materials, as well as many practical adaptations in the industrial and scientific world, where the methods now in vogue are expensive and inefficient by comparison.

Wireless operators who have examined the apparatus realize the possibilities of a new method of selective sending, while power engineers are impressed with the production of high-voltage direct current. X-ray experts are astonished to learn that alternating current could be transformed and rectified to any desired potential and wave form of direct current. The united opinion of those who have witnessed demonstrations

of the machine is that a great field of usefulness awaits the practical application of this noteworthy invention, but that, as yet, its real worth cannot be estimated.

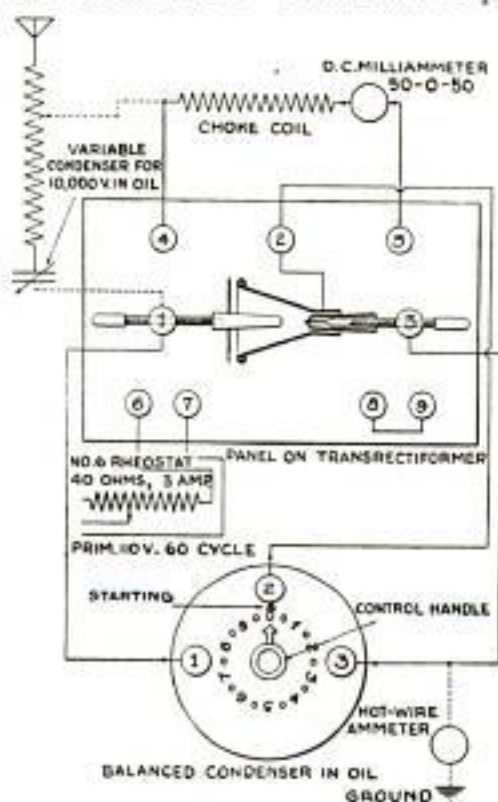

Wiring Diagram of Transrectifier Which Illustrates the Different Connections

P.C.C. 117

AUTOMOBILE WHISTLE PLAYS ANY TUNE AT ANY PITCH

Any tune can be played by any autoist, musically educated or otherwise, on a novel kind of auto accessory in the form of a whistle that is under the hood, and is operated by a handle near the steering wheel. The pressure necessary to blow the whistle is supplied by the exhaust gases from the motor, and the volume, as well as the pitch, of the sound is under perfect control by means of the operating handle. Already, it is stated, a great number of these whistles have been installed on automobiles.

Any Kind of Tune, Soft or Loud, can be Played on This Whistle under the Hood, Which is Controlled, as Shown, by a Handle near the Steering Wheel

Ferris & Mfg. Co.
 2052 E. St.,
 Lincoln, Neb.

Ferris & Mfg. Co.
 2052 E. St.,
 Lincoln, Neb.

Copyrighted material

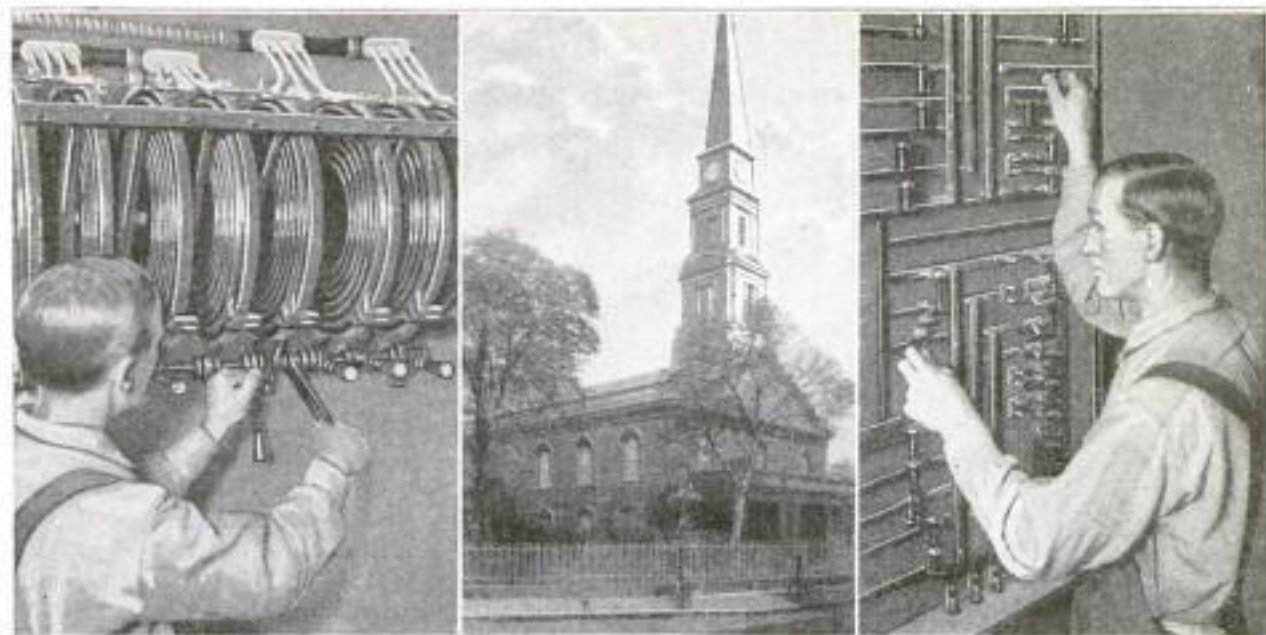

PHOTOS BY WILLIAMS SERVICE

Left: Part of Electrical Equipment Known as Dimmers, Which are Used to Vary the Brilliancy of the Lights. Center: St. Mark's Church in New York City. Right: Portion of Elaborate Switchboard Which has been Installed in the Church to Produce Unusual Lighting Effects

8842

UNUSUAL LIGHTING EFFECTS PRODUCED IN CHURCH

Lighting effects, vastly different from those ordinarily used in churches, have been produced in St. Mark's Church, New York City. The Rev. William Norman Guthrie, rector, conceived the idea of delivering "prismatic sermons," meaning the use of varicolored lights in synchronism with the sermon. Realization of this unusual undertaking required rather elaborate electrical equipment. Fixtures, having lamps of red, blue, green, and amber color, were uniformly distributed throughout the interior, each lamp being so wired that either of the various tints, or a diffusion of two or more of them, could be obtained from the switchboard. Clear lamps and spotlights, with special shields that conceal them from the congregation, are also installed in sufficient numbers to provide proper illumination for reading purposes. Favorable comment on the innovation has been plentiful, and it is thought that the same, or a similar, course will be followed in other places of worship.

8830

HOME REFRIGERATION PLANT SIMPLE AND NOISELESS

Refrigeration, as a home process, has been made simple and automatic by the introduction of an ice machine which operates on the ammonia-absorption principle. This method results in the drawing out of the heat in the refrigerator, and

creates a perfectly dry, cold atmosphere. No moving parts are incorporated in the apparatus, which consequently functions without any noise and needs practically no attention or care. The outfit, which requires city-gas and water connections,

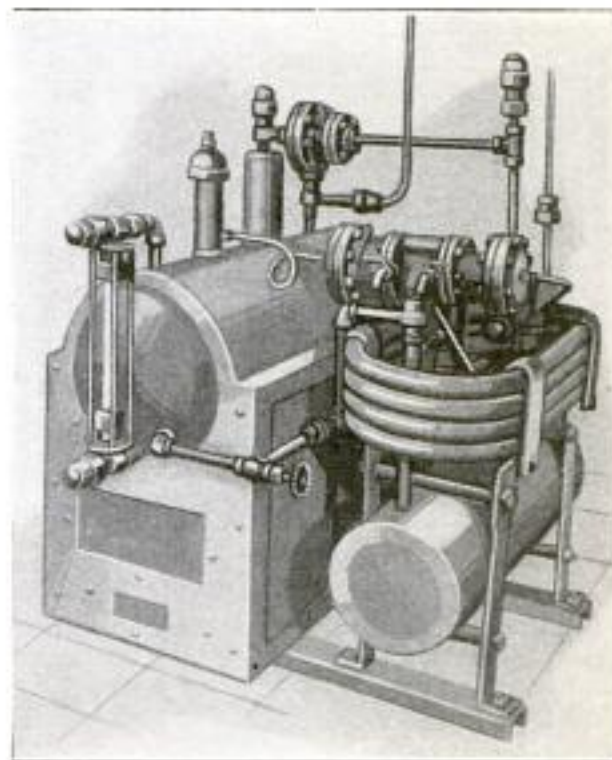

Simple and Noiseless Home Refrigeration Plant, Showing Generator-Absorber, Condenser Coils, and Outgoing and Return Pipes

and an outlet through a drainpipe, is claimed to be less expensive in operation than the cost of ice in maintaining the same temperature.

Common Sense Ice Machine Co. 1844 W. 4th St. Chicago
 Copyrighted material

MEMORIAL TO ROBERT E. PEARY TYPIFIES ARCTIC EXPLOITS

A monument has been erected at the Arlington National Cemetery in memory

of the late Rear Admiral Robert E. Peary, discoverer of the north pole, and was unveiled April 6, the 13th anniversary of his achievement. The monument is fashioned from a design of the explorer's own sug-

gestion. It is in the form of a large globe with the terrestrial continents and islands embossed on it, and in proper axial position with the north pole, represented by an embossed star. This globe rests on a solid granite base, upon which are suitable inscriptions. The actual unveiling of the monument was done by the late admiral's daughter, who was born in the arctic regions during one of the polar expeditions, and was known as the "Snow Baby." The ceremonies were under the auspices of the National Geographic Society, and were participated in by President Harding, the secretary of the navy, and other high officials.



Granite Memorial to Rear Admiral Peary in Arlington Cemetery, Unveiled April 6, the Thirteenth Anniversary of His Discovery of the North Pole: It Is a Reproduction of the Earth, with the North Pole Shown by an Embossed Star

"DIRECT-POSITIVE" HOME-MOVIE CAMERA

AN interesting development arising out of the invention of the so-called "direct-positive" photographic paper is the direct-positive motion-picture camera. This camera, in operation and appearance, resembles the ordinary one, but instead of the celluloid negative film, it uses the new paper, which eliminates printing and makes it possible to show the pictures within three minutes after the exposure has been made. The camera also offers a ready means of satisfying the curiosity of thousands of potential movie stars—not to mention the millions of "fans"—who are anxious to see how they themselves "register."

To show the subject in continuous motion, the "film" is punched and cut into separate pictures by a special device, and the cut pictures inserted into a booklet provided for the purpose. By running the booked pictures between the thumb and index finger, the illusion of motion is produced, as in the almost-forgotten Edison "mutoscopes" of the early nineties. The machine utilizes perforated paper of the same width as the regular motion-picture film. However, it is not

restricted to the use of perforated paper; an additional device incorporated in the camera enables the operator to use plain paper at will, which, in many cases, is a desirable advantage.

Under ordinary operating conditions, six exposures per foot of paper are made. As the machine holds a roll containing 200 ft., about 1,200 pictures are possible before it becomes necessary to reload. The camera weighs 10 lb.; measures 6 by 7 by 12 in., and is equipped with a high-grade lens. A counting device connected to the crank handle registers the number of exposures made, each revolution of the crank handle causing one exposure.

The photographic medium is a specially prepared bromide paper, requiring one minute for developing and two minutes for fixing and toning. It has a remarkably high speed, rivaling that of a good grade of fast dry plate. Two fully timed exposures per second are possible even with the scant illumination furnished by a 500-watt lamp. Of course, with the illumination produced by high-actinic lights, or under daylight, much higher speeds are possible.

The Positive Corporation of America
246 7th St. and 11th St. N.W.
2016

8906

The Positype Corporation of America
246 4th Ave. New York City

Filmless motion portraits Corporation, 101 W. 42nd St. New York City

This is the camera for taking moving pictures at home on strips of "Direct-Positive" paper. Each revolution of the handle causes one exposure to be made, and two fully timed exposures per second are possible. A counting device registers the number of exposures made.

The finished pictures can be bound in a case, and when allowed to slip rapidly under the finger, will give the appearance of the subject in motion.

Above: The camera case open, showing the unexposed roll of paper above and the finished pictures below. Left: The perforating device.

Positype Corporation of America
45 W. 57th St. New York
Copyrighted material

Service & Iron Supply Co. Bureau of Mines
 30 E. Wabash St. Serial # 2339
 826 POPULAR MECHANICS
 8954 March 1922
 887 | *Detroit Mich*
ELECTRICALLY HEATED KNIFE
AIDS BATTERY MEN
supplies

Storage-battery, tear-down, and reassembly work has been facilitated by the introduction of a knife having an electrical-

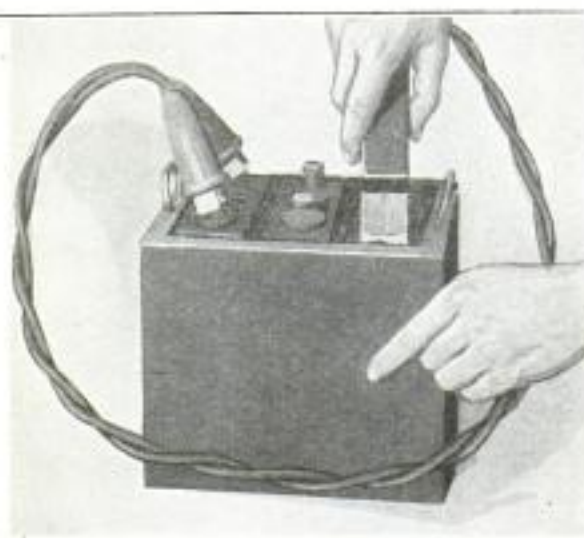

A Special Electrical-Heating Element in the Knife Makes It an Easy Matter to Remove the Sealing Compound from Storage Batteries

heating element in the blade, which is fastened in a heavy handle. Attached to the handle are rubber-covered wires terminating in clips for connection to any six-volt cell, which quickly heats the appliance for the removal of sealing compound or the resealing of batteries.

Investigation by the Bureau of Mines has shown definitely that the so-called wet drills, used in mining, aid materially in reducing the dustiness of the air in drilling places. It has been found, however, that if not operating properly, or if out of repair, the wet drills may throw into the air a mist or fog laden with minute mineral particles which is almost as dangerous, when breathed, as dry dust. Also, if water, or compressed air and water, under excessive pressure, is forced through the drill, this mineral-laden fog is produced. But even at their worst, the wet drills produce more healthful conditions than the dry drills.

8926 **CENTURY-OLD STUMP MILL**
STILL GRINDS GRAIN

After more than a century of usefulness, an old-fashioned stump mill in South Boston, Ind., is still grinding grain today. The burrs, or stones for the mill, were brought over to this country from France, 117 years ago, and were placed in position by the great-grandfather of the present owner. Horsepower is used to operate the grinding mechanism, and 20 minutes are required to grind a bushel of wheat, or three minutes for the same amount of coarse feed.



This Old-Fashioned Burr Mill is Still being Used Today, Although It Is More than 100 Years Old. Horses Walking around the Circular Path Furnish the Power

8926
 Comb. George F. Paul, 900 Ellsworth
 Chicago
 Copyrighted material

Evansville, Wis

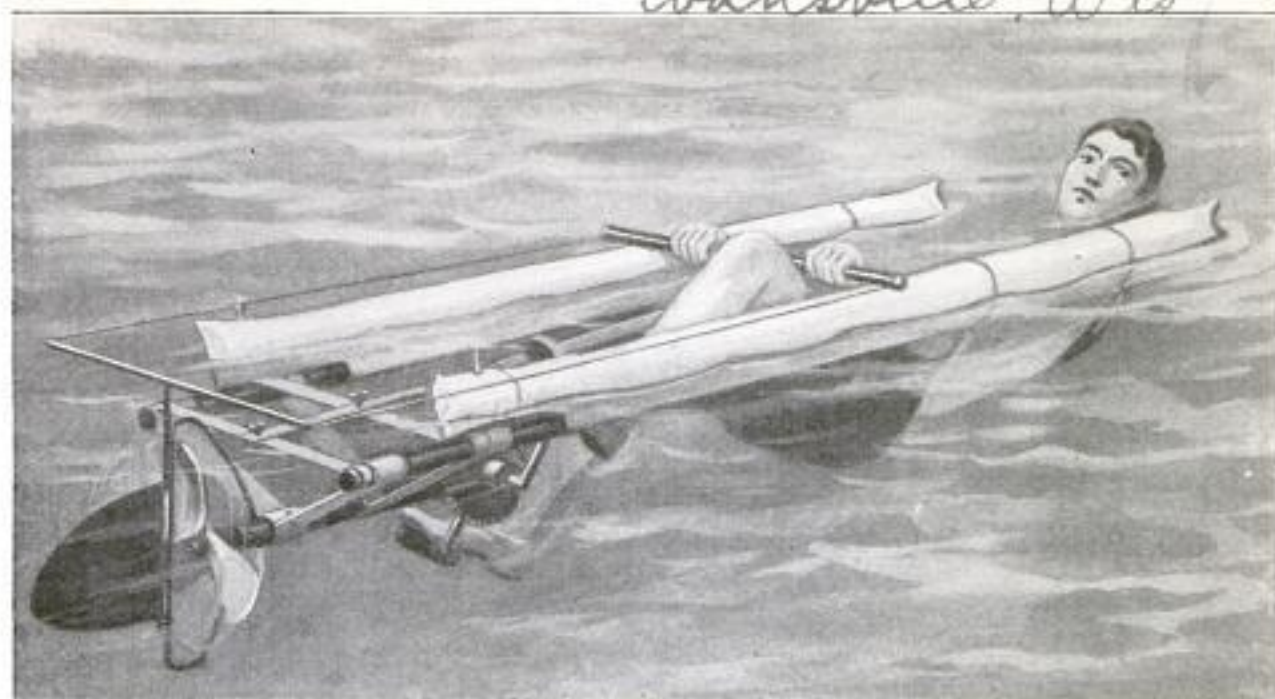

In Using This Watercycle, the Bather Lies Partly in the Water and Turns the Pedals with His Feet, and the Gear-Driven Propeller Sends the Craft Ahead at Good Speed. The Entire Machine Weighs Only 20 Pounds

8722

A LIFE-SAVING WATERCYCLE FOLDS INTO SMALL SPACE

A watercycle has been invented by a Wisconsin man which can be used for life-saving purposes or as a pleasure craft for bathers. The frame is made of aluminum tubing and is of knockdown construction, held together by thumbscrews. Buoyancy is supplied by two air-inflated tubes, in balloon-cloth cases, which slip over the side tubes of the frame. The watercycle is forced through the water by a gear-driven propeller which is operated by bicycle pedals, the machine being steered by a rudder and handlebar. A "lazyback" is supplied when the cycle is to be used as a pleasure craft. The different parts of the machine are adjustable to suit persons of different build, and when dismantled, can be folded and packed in an ordinary suitcase. The complete machine weighs only 20 lb., and when used by a life-saver should develop a much greater speed than the fastest swimmer.

8948

EXPEDITION TO INVESTIGATE MOUNTAINS OF BURMA

With the object of investigating some features in the mountain structure of northwestern Yunnan, and western Szechwan, an expedition, consisting of scientists of the university of Glasgow, Scotland, is on its way to Burma. The district is one of special geological and biological

Science 4/14/22

interest. It includes mountain ranges that are believed to be a prolongation of the Himalayas, and that contain peaks of from 20,000 to 25,000 ft. in height. Zoological and botanical collections will be offered to the British Museum of Natural History, and to the India Museum, Calcutta.

NEW REPRODUCING APPARATUS AIDS RADIO RECEPTION

8888

Wireless enthusiasts now have available a new regenerative receiver and a reproducing apparatus, which will greatly aid in the reception of broadcast radio communications. The receiver has a condenser with two capacities brought out to separate binding posts, the lower capacity being used for wave lengths up to 350 meters, while the higher capacity is used from this point up to 500 meters. The sound-chamber arrangement possesses a special metal diaphragm, which is said to yield the finest quality of reproduction.



Wardhouse
Electric & Eng. Co.
East Pittsburgh, Pa.

Emb. S. Swerton, Huber, Oregon.

8269

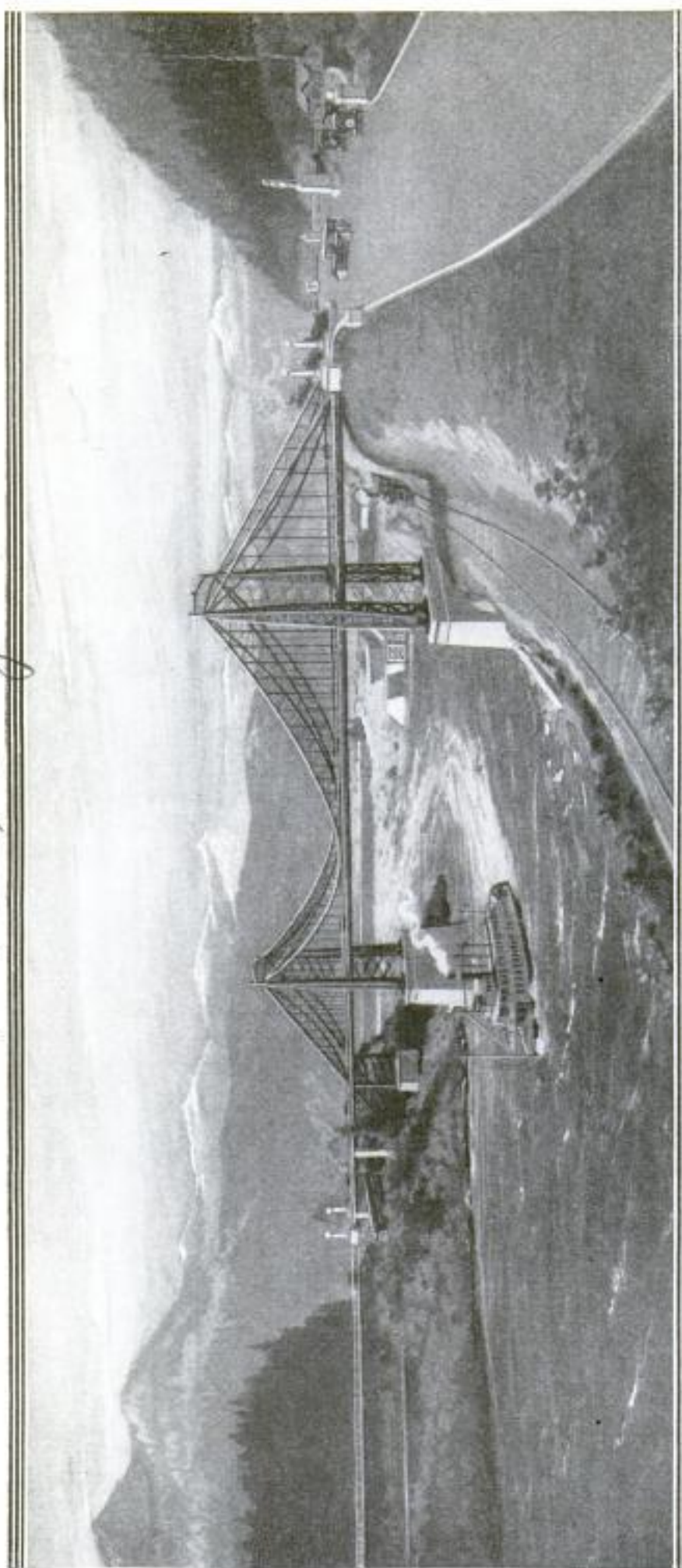

MODERN STEEL STRUCTURE AT SITE OF LEGENDARY "BRIDGE OF THE GODS," ACROSS COLUMBIA RIVER

AT CASCADES, on the Columbia River, about 50 miles east of Portland, Ore., according to Indian legend, the river was spanned, before the days of the palefaces, by a natural bridge in the form of a rock arch, which they called the "Bridge of the Gods." Something that the Indians did displeased the gods, who, in their wrath, destroyed the bridge. Once more at this site the river is to be spanned by a bridge, to be completed by the fall of 1923, built by white men, independently of the red men's gods, and likely to be more permanent than its legendary predecessor. In the design of the bridge an attempt has been made to have it harmonize with the stately mountain scenery that surrounds it, but not at any sacrifice of structural efficiency. In this respect it is somewhat novel, for though in appearance it will be altogether like a suspension bridge, it combines with the suspension principle that of the arch, the 705-ft. main span being in effect an inverted arch truss, built entirely of standard structural-steel shapes. The roadway clearance of this great span is 150 ft. The two pairs of steel towers supporting the main spans rise 240 ft. above their foundations, and are braced transversely by an elaborate system of crossbracing, and longitudinally by the back stays, which are trusses that connect the main spans with the abutment anchorage. These are very massive, and built of concrete with steel grillage. There will be 1,200 tons of steel in the bridge, and 5,000 cu. yd. of concrete in its piers and abutments.

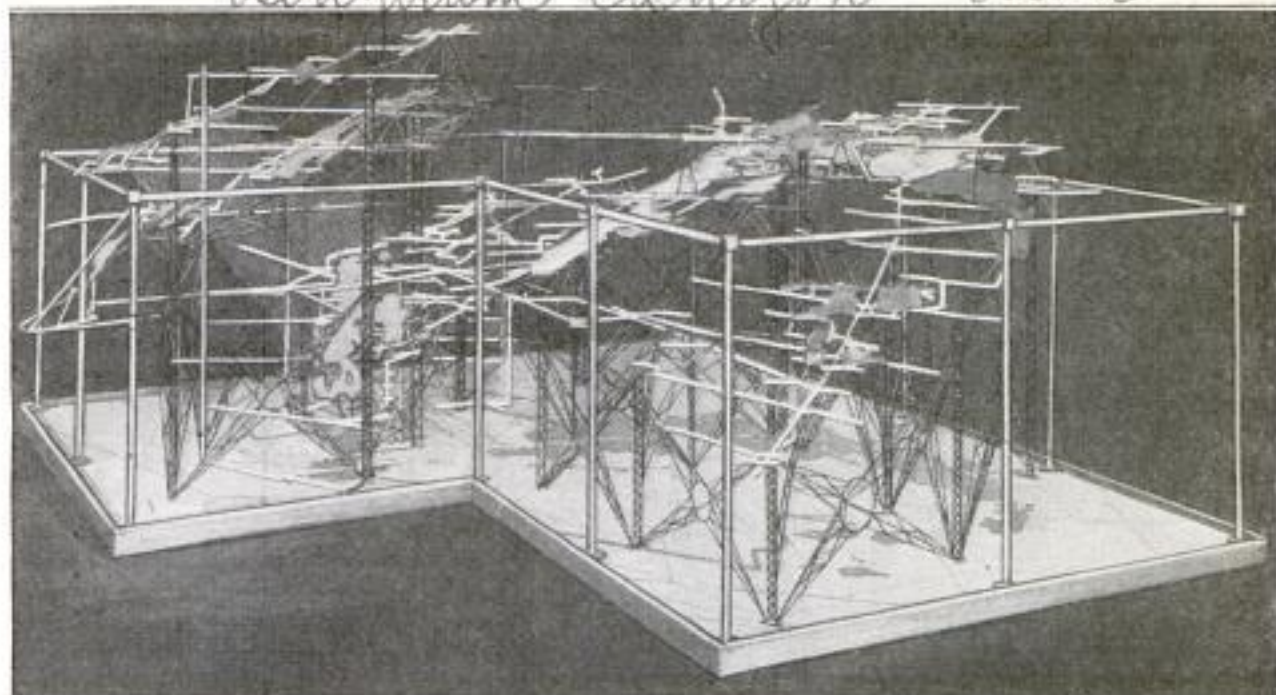

This Model of the Underground Workings of Two Mines Shows How the Drifts, Tunnels, and Shafts, as Well as the Stopes, or Rooms from Which the Ore has been Taken, would Appear If All of the Surrounding Ground were Taken Away

INSIDE WORKINGS OF A MINE VISUALIZED BY A MODEL

In a recent lawsuit between mining companies in Utah, a model of the mine properties involved was constructed and used as an exhibit in order to show the inside workings of the mines. These mine workings form a very complicated network of rooms and hallways, sometimes extending to great depths, and the model shows in three dimensions the different openings and their relation to each other. The tunnels, raises, and shafts are made of brass rods, bent, cut, and soldered precisely to scale. The stopes, or rooms from which the ore has been extracted, are made of wood. The model is mounted on a board, showing a map of the mines as they appear horizontally.

NEW TELEPHONE CABLE LAID ACROSS IRISH CHANNEL

A new cable, 25 $\frac{1}{2}$ miles long, has been laid from Port Mora, Scotland, to Port Patrick, Donaghadee, Ireland, which will greatly improve telephonic communication between those two countries. If the new cable is found to be satisfactory, trunk circuits will be provided between Glasgow and Belfast by joining up the land lines. The new cable contains four copper wires, insulated by balata, which provide two so-called "physical" circuits. A third circuit will be obtained by the system known as superposing, forming a so-

called "phantom" circuit, which is equivalent to a third trunk channel that operates without interfering with conversations carried on over the two physical circuits.

LIFE-SAVING BELT ADOPTED - BY BOLD BOOTLEGGERS

Recent raids by prohibition authorities in Milwaukee, Wis., have furnished another proof that the ways of the bootlegger are devious. In one of these raids, the chief prize consisted of a life-saving belt, the interior of which was designed to hold liquor, instead of the old-fashioned cork compositions. In use, the belt was hung by straps from the shoulders, resting just under the armpits, so that by pressure of the arms the vender could force the liquid through a faucet affixed at the top.



Engineering 3/31/22

3rd Victor Rubin
90 The Milwaukee
Journal, Milwaukee, Wis.

Certain-Seed Paper
Product Co. Boatmen

Electrician 3/24/22

834 POPULAR MECHANICS

Rank Old St. Louis Mo

STRIPS OF MULCHING PAPER TO PRODUCE ELECTRIC POWER WITH LOW-GRADE COAL

PREVENT WEED GROWTH

Wedding would become a lost art if the use of mulching paper could be applied

8950 The problem of the utilization of low-grade coals and lignites is one of utmost importance to Australia.



These Pineapple Plants are Growing through Slits Cut in the Strips of Mulching Paper, Which Prevent the Growth of Weeds

plied to all gardens as successfully as it is in growing pineapples. In this case the strips of paper are rolled out where it is desired to plant, and slits are cut in the paper through which the pineapple suckers are planted. Nothing more is needed until harvest time, as the paper strips prevent the growth of weeds, and conserve the moisture. This method has been introduced in the Philippines, where it has increased the yield of pineapples, according to good authorities.

Recent investigations on low-grade coals, containing about 50 per cent of water in the raw state, show that their fuel value can be much improved by heat treatment below 400°C. (750°F.). A patented apparatus has been designed for drying and heat-treating the low-grade fuels in a continuous process, using only the sensible heat in the burnt gases passing from the boiler. This process is now being tested in a commercial way, and, if successful, will be used for the generation of electric power. It is claimed that by the use of this new process nine boilers will give the same steam output as would be obtained from 12 boilers fired with the untreated fuel.

895 THREE-SECTIONAL TOP LID FITS ANY GRAND PIANO

A patent three-section top lid for grand pianos, which can be fitted to any make of instrument and entirely does away with the projecting point of the lid at the curved corner of the instrument, has been brought out by one of the largest piano makers in England. The new lid is much neater in appearance than the conventional one. When folded back, it leaves the top of the piano almost entirely clear, and objects on each side of the front of the piano top, such as lamps or candlesticks, are left undisturbed by it.

TESTS OF DARKENING EFFECTS OF VARIOUS FLOOR OILS

Under the direction of the Department of Agriculture, investigations extending over a period of six months have been made regarding the comparative darkening effects of various floor oils. Three types of mixtures were tested, in an occupied apartment, upon pine floors which were very old and dark from many coatings of shellac and varnish, and it was found that a floor oil consisting of one part of boiled linseed oil to three parts of turpentine was the most satisfactory. This oil had a cleansing effect, retained a high gloss, and did not darken to any extent the floor, to which it was applied with a mop.

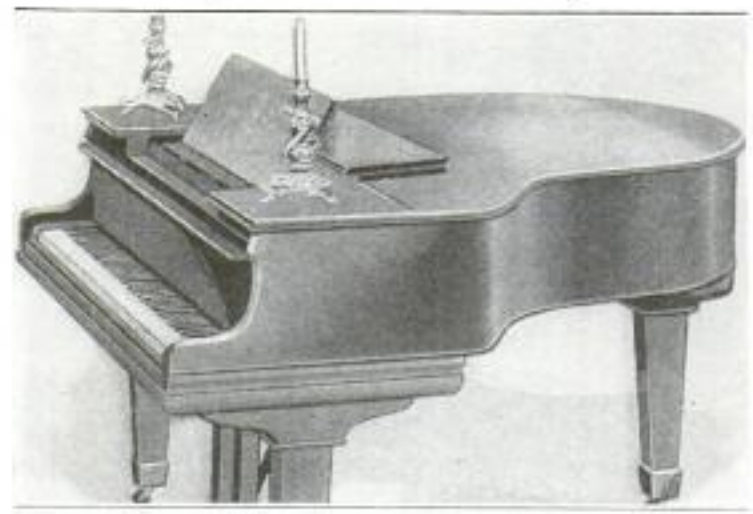

Three-Section Top Lid for Grand Pianos, Now in Use in England: When Folded Back, as Shown, It Is Very Compact with No Projecting Point at the Curved Middle of the Right-Hand Side of the Instrument

It is stated that on nearly 9,000 farms in New Zealand some form of electric milking machine is used.

Sold by: Archibald Ramsden Cecilian House, 65, Whitehall London, England.

Vertical text on the left margin: Mrs. R. Chillerburgh, Dec 34 61, Paraffine & Wood, San Francisco Calif.

D. R. Winters, 702 Electric Hotel Bank
Osleg.Washington,
D.C.

RADIOTELEPHONE BROADCASTING OVER LIGHT WIRES

RECENTLY Major General Squier announced a new and remarkable development, of his invention, in the art of broadcasting wireless telephone news and concerts. This is an outgrowth of "wired wireless," and a demonstration was held in the signal-corp headquarters where the usual receiving instrument was attached to the electric-lighting wires instead of to an antenna. To install the receiving apparatus, it is only necessary to remove a light bulb from its socket and attach a cord similar to those used for attaching a vacuum cleaner or electric iron. The broadcasting station is connected with the lighting circuit through a lamp receiver, and the wireless impulses travel over the circuit in much the same manner as is the case in using wired wireless over the telephone circuit. This method of broadcasting brings to every home where electric lights are used, the concerts and news that have previously been broadcast in the air. It is not necessary to erect an antenna; simply remove a light bulb and plug in the receiving set, and radio news is immediately available. No headpieces are required, as any of the regular loud-speaking instruments can be used. The further development of this idea should do much to relieve the present congestion of the air.

NEW MEANS OF CONTROLLING ERRATIC RIVER CURRENTS

At last, after 3½ years of experimentation, a means has been devised for controlling the treacherous currents of western rivers. The method applied consists in driving a number of concrete piles, about 35 ft. apart, into the river bed and anchoring to the top of each six 1-in. to 1¼-in. cables, about 100 ft. long. The other ends of these cables are spread out fanlike, and are connected to the stump ends of hundreds of cut trees, the interlacing boughs of which fill up any part of the river from bed to surface. The sand held in suspension by the running water

is gradually deposited among the tree branches, forming in time a solid sand bar, and making possible the diversion of the stream in any direction desired. Thorough tests have been made on the Platte River, in Nebraska, and from the results of these tests it is believed that this new method of controlling a river current will be of incalculable value in reclamation work, and in protecting river banks.

Investigation is being urged as to the advisability of the creation of a United States Aeronautical Academy, to hold the same relation to the air service that West Point does to the army and Annapolis to the navy.

Christian Science
Monitor 3/11/22

DESIGN WALL-POCKET HEATER SET FLUSH IN WALL

To meet the demand for a small auxiliary heating unit with which to remove the chill from the bathroom, or other



small room, a wall-pocket gas heater has been designed which sits flush with the wall and occupies no floor space. It can be set into the wall in the space between the studdings, and because of its insulated construction, does not constitute a fire hazard. It burns with a yellow flame, and no air mixer is used, which prevents the possibility of back-firing. The reflecting back is arranged to direct the heat toward the floor from where it rises.

ONE GASOLINE ENGINE DRIVES NOVEL POWER SHOVEL

It has long been recognized that, to meet certain conditions, a gasoline-driven power shovel would have advantages over machines using other forms of power.

Many attempts have been made, patterned mostly after the steam shovel, to adapt gasoline power to this type of machine, but all of them have been open to criticism. Now, however, a new type of gasoline power shovel has been placed on the market which is a radical departure from the accepted designs.

In this machine, which has successfully passed its preliminary trials, all power is supplied from one slow-speed gasoline engine, and there are no motors, engines, or clutches on the boom. The application of the power for digging is most ingenious, all operations being controlled through two cables. At the knee of the boom is a shaft carrying two pinions and a drum of larger diameter. Two racks on the lower side of the dipper arm engage the pinions, while the two operating lines are fastened to the drum. One of these lines passes over a sheave near the top of the boom and then to the winding drums, while the other line passes to a sheave near the dipper, and thence, over the end of the boom, to the drums.

The dipper can be put through any motions possible with the steam shovel, even to the shaking of the dipper to free it of sticky material. The boom may be raised or lowered in the usual manner, while the swing is controlled by a separate clutch. The shovel is mounted on tractor treads and is self-propelled.

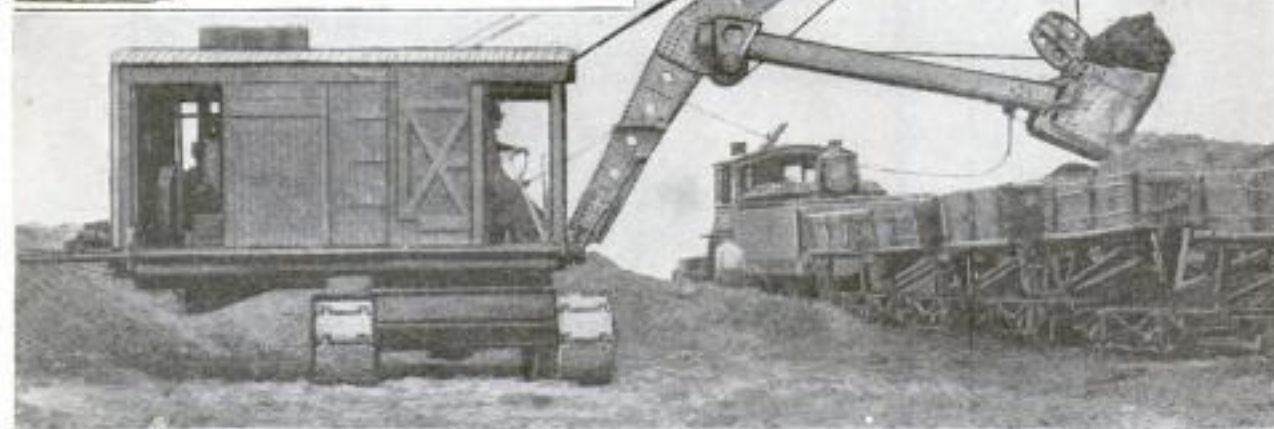
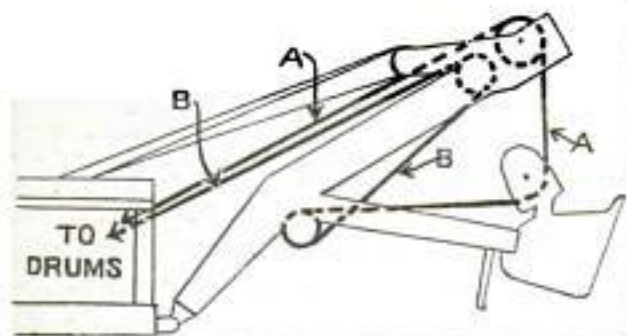

Gasoline-Driven Power Shovel Actuated by One Engine: The Dipper is Thrust into Digging Position by Holding Line A and Hauling on B, and Raised by Holding B and Hauling on A. Any Combination of These Motions may be Effected

The Bucyrus Co., South Milwaukee

Copyrighted material

8973 Cnr. Frank. C. Hoig,
914 Second Ave. Seattle, Wash.



Electrical Equipment Which is Installed at the Central Office to Operate the Measured Telephone-Service System: The Two Duplicate Time Clocks are Seen Above and the Pole-Changing Switches Below, Together with Meters, Knife Switches, Fuses, and Other Necessary Apparatus

PHONE SERVICE MEASURED LIKE ELECTRIC LIGHT

THE first metered telephone service in the world is now given in Everett, Wash., where about 6,000 subscribers are paying for just the amount of talking they do. The new rates, which are now on trial under orders of the Washington State Board of Public Works, are based on the time consumed in actual talking over the telephone, as gas, electricity, and water are metered. Under this system the service company asserts that it is possible to reduce the cost to 85 per cent of its subscribers and increase the capacity of its plant by 2,000 telephones without adding to the exchanges.

These changes are made possible through the development of a device known as a

"telechronometer," which accurately measures the length of time each telephone is used by the calling party. Incoming calls are not registered. For more than a year the telechronometers have been tested, and last December they were ordered placed on all telephones in the Everett system. Just recently the work was completed, and the change made from a flat-rate basis to a "pay-for-what-you-use" system. The ceremony of throwing the switch that turned the current into the new system was witnessed by a large number of engineers, public-utility officials, mayors, councilmen, and others, from the Pacific Northwest.

Among other advantages of the telechronometer, the company



Measured-Service Equipment Which is Installed at the Subscriber's Home or Place of Business, Showing the Recording Meter above the Telephone

claims that it will discourage and probably eliminate "listening in" on party lines, as it will cost the eavesdropper money to take down his receiver and gather the neighborhood gossip; unnecessary and frivolous conversations will be reduced to a minimum, and the use of ten, eight, six, and four-party lines will be increased, because there will be less traffic on the lines.

Tests made with the telechronometer while the system was still on a flat-rate basis showed that 50 per cent of the subscribers used 78 per cent of the service at a cost of .64 cent per "telechrone," which is the term used for one minute of conversation. The other 50 per cent used only 22 per cent of the service at a cost of 2.27 cents a telechrone. Yet all paid the same flat rate for a similar class of service.

Telephone service is now given for as little as \$1 a month, which entitles the subscriber to 60 telechrones a month. If he uses more than that amount he pays one cent a telechrone for it. Single-party business telephones that formerly cost \$6 a month are now \$5.25 a month, which entitles the subscriber to 600 telechrones, or almost 24 minutes of conversation, each business day.

The telechronometer is a little device located close to each telephone and registers the time consumed by the calling party, after "central" has made the con-

nection. Registration is stopped the instant the receiver is replaced on the hook. No influence outside the control of the subscriber can cause registration.

The inventor describes the telechronometer as a train of gears that controls the dial pointers which register in tens, hundreds, and thousands. Movement of the meter is caused by a polarized relay, which operates as follows: When a subscriber removes his receiver from the phone and the operator has made the desired connection, current flows from the central battery to the telephone transmitter and the telechronometer begins to register, and when the receiver is hung up, the current is reversed and the meter stops registering. Thus the pointers on the dial measure the exact time of the conversation.

The apparatus at the central office consists of a duplicate pole-changing switch, each set being controlled by a standard time clock. The unit of time movement of the pole-changing switches for local service is 15 seconds, and the meter dials register one unit for every four current changes from the central pole changer.

The two big clocks located in the central office of the Everett system are guaranteed to operate with no more than 10 seconds of variation in 24 hours. Any defect in the meter would only cause it not to register, and the telephone company is willing to take this chance.

FOUR SETS OF HEADPHONES ON RADIO APPARATUS

Four sets of headphones, or receivers, can be attached to a new article of radio equipment which has recently made its appearance. The appliance is placed on a table, or stand, and an ordinary receiver



Radio Apparatus Placed in Center of Table So That Four Persons can Listen to the Broadcasting.

held tightly on top of it by means of an elastic band. Rubber extension tubes are then affixed to its base, and an assembled quartet can "listen in" to the broadcasting.

9015

EXPERIMENTS IN PRODUCTION OF GERM-KILLING DYES

Great strides are being made, in England, in the production of various dye-stuffs that are poisonous to some particular disease germ without being in any way injurious either to human beings or to any others. Proof that success is being achieved in this direction is demonstrated by the fact that at sewage works where the disposal of the sewage depends upon bacterial action, it is now possible by the use of a specific dyestuff to kill other microorganisms which are destructive of the purifying germs without injuring the latter. Similarly dyes have been produced which pick out and destroy disease germs in the blood.

London Times Weekly

4/7/22

Copyrighted material

8924
Hippell Mfg Co
831 North Pittsburgh Pa

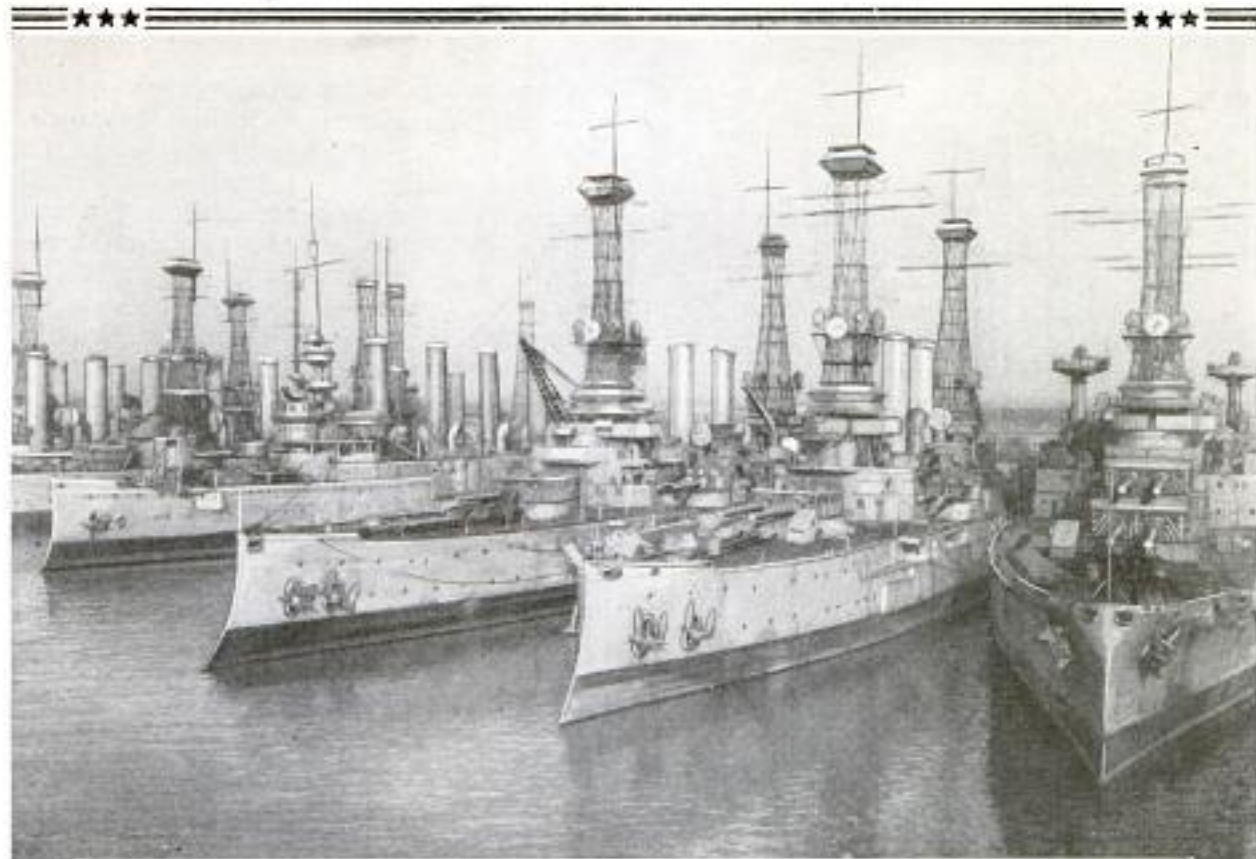

SCRAPPING THE WARSHIPS OF THE U.S. NAVY

By H. G. Layton

COPYRIGHT,
HENRY A. HITNER'S SONS CO.

Order 7949 Philadelphia, Pa

ALL the glamour, romance, and best traditions of the United States Navy are bound up in the dismantling and scrapping of the many units purchased by the Henry A. Hitner's Sons Co., of Philadelphia, and now being junked at its huge yards there on the Delaware River. From the old and tiny "A-1 Plunger" submarine, one of the world's first successful undersea boats, to the monitor "Monterey," built in 1887, and on through the list to the former queen of the navy, the battleship "Wisconsin," all functioned in the creation of history's second most powerful naval force.

The Limitation of Armament Conference at Washington restricted a completed or under-construction naval program of the United States from approximately 1,370,000 tons to 525,000 tons. This necessitated the scrapping or sale by the government of 845,000 tons of all types of its maritime defense to maintain the 525,000-ton first-line naval-strength ratio accepted by the United States as a signatory to the terms of the naval-limitation treaty.

The sale of this huge tonnage total from our naval list has created a new

industry and thrown upon the market for purchase by the highest bidder hundreds of completely equipped fighting craft. The number runs into the hundreds, as it takes a great many mixed-caliber battleships of the 12,500-ton "Missouri" type and "Eagle" boats of 500 tons to balance capital ships, completed or under construction, of the 35,000-ton battle cruiser or predreadnaught types represented by the 33,190-ton "Tennessee."

This new industry may be best presented by the methods employed at the Hitner yard when it bid successfully for a navy whose total tonnage and fighting strength exceeded that of the United States in 1910, or of Italy at the beginning of the World War.

Here, tied to the long docks and groaning protest as they strain at their hawsers, are the battleships "Maine," "Missouri," and "Wisconsin," for example, and, picking at random from the others, the once proud first-class cruiser "Columbia," and coast-guard battleship "Number Four," formerly the "Iowa"; the monitors "Ozark," "Monterey," and "Tonopah," and the destroyers, Eagle

89 86
836

boats, and other craft that are just numbers.

Powerful oxyacetylene torches wielded by masked and hooded gnomes are cutting through the 11-in. nickel-steel turret armor of the "Maine," while a giant 125-ton crane is snaking out of its barbets one of the mighty 12-in. 40-caliber rifled guns that once maintained the principles of this federated republic.

Farther along the yard, the little sub with its paper-thickness shell is being

armament conference. Creature of the brain of J. P. Holland—Robert Fulton of the submarine—the early trials of the "A-1" were the subject of almost as much ridicule and scoffing as marked the first efforts of Fulton on the Hudson River, but the basic principles of the "A-1" are found incorporated, though modernized, in the "S-41," built nearly 25 years later.

Nothing can destroy the place in the history of maritime armament which these old fighting craft hold, or efface from the

proud record of our navy the part which they played in its upbuilding, yet one feels a little tightening of the throat when he witnesses a huge piece of side armor go creaking aloft to be dropped upon a pile of scrap; or sees the oxyacetylene torches cutting up the 12-in. rifles for junk.

But the process of converting our one-time defenses into peaceful uses must go inevitably forward. The armor is thrown into open-hearth furnaces, and emerges as one of the most valuable by-products of this big scrapping job. Its alloy content of nickel steel makes it adaptable to many peaceful uses, particularly in the automobile industry, into

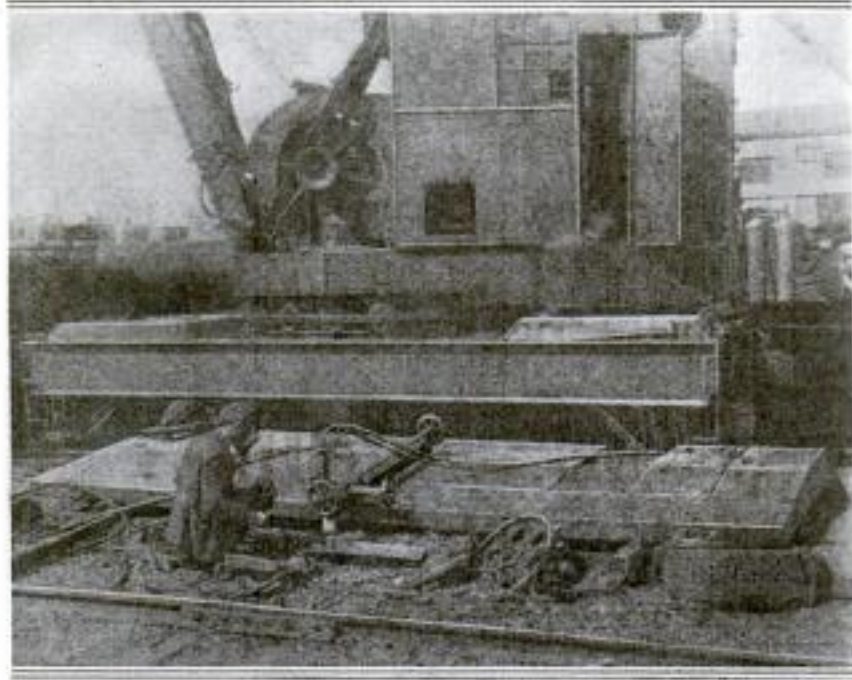

Strip of the Waterline Belt of Hull-Armor Plate, Weighing 25 Tons, being Cut with an Acetylene Torch into 25-Foot Lengths for Open-Hearth Furnace Billets

ripped apart with chisels to the accompaniment of the Gatling-gun-like staccato of compressed-air hammers. The obsolete monitor "Monterey," modernized edition of Ericsson's gallant "Monitor," with its surface-flush deck, built, 35 years ago, by the Union Iron Works of San Francisco, is rapidly being converted into open-hearth billets, but its 10 and 12-in. rifles still grin menacingly through the turrets of its squatty superstructure, as they did in the early nineties when the "Monterey" was the most powerful battle craft afloat, and as a coast-guard unit was held by naval experts to be invincible. From it grew the double-turreted, 16-in., 25-mile range, super-rifled capital dreadnaughts of the "California," "Arizona," "Pennsylvania," and "Tennessee" types, for whom it dies that they may live.

The little "A-1 Plunger" was the grandfather of the modern submarine cruiser "S-41" of proved success, that has eliminated it from the future navies of the world as "commerce destroyer" by the dis-

ticularly in the automobile industry, into which most of it will find its way. Gray-iron foundries will purchase the small scrap resulting from the crumbling, by huge stone pile drivers with a 100-ton impact, of the almost human machinery which operated gun turrets, ammunition hoists, and refrigerating systems. After being treated in combination with low-grade iron ore, it will be recreated into engine beds, and frames of harvesting and other agricultural machinery. The most precious junk of all is the copper, gun metal, navy brass, manganese, bronze, lead, zinc, and navy compositions, which are sorted into their different grades and sold to metal dealers, and in some instances, as with the equipment from the "Maine," will take form in new ship castings, steam pumps, and propellers.

Complete destruction is not necessary in the case of all the craft. The hulls of some of the torpedo boats will undergo a transformation to adapt them to peaceful pursuits. This has already been done



COPYRIGHT, UNDERWOOD & UNDERWOOD

Huge Blackboard in the Office of the Chief of Naval Operations, on Which the Daily Movements and Locations of Every Ship in the Navy are Recorded

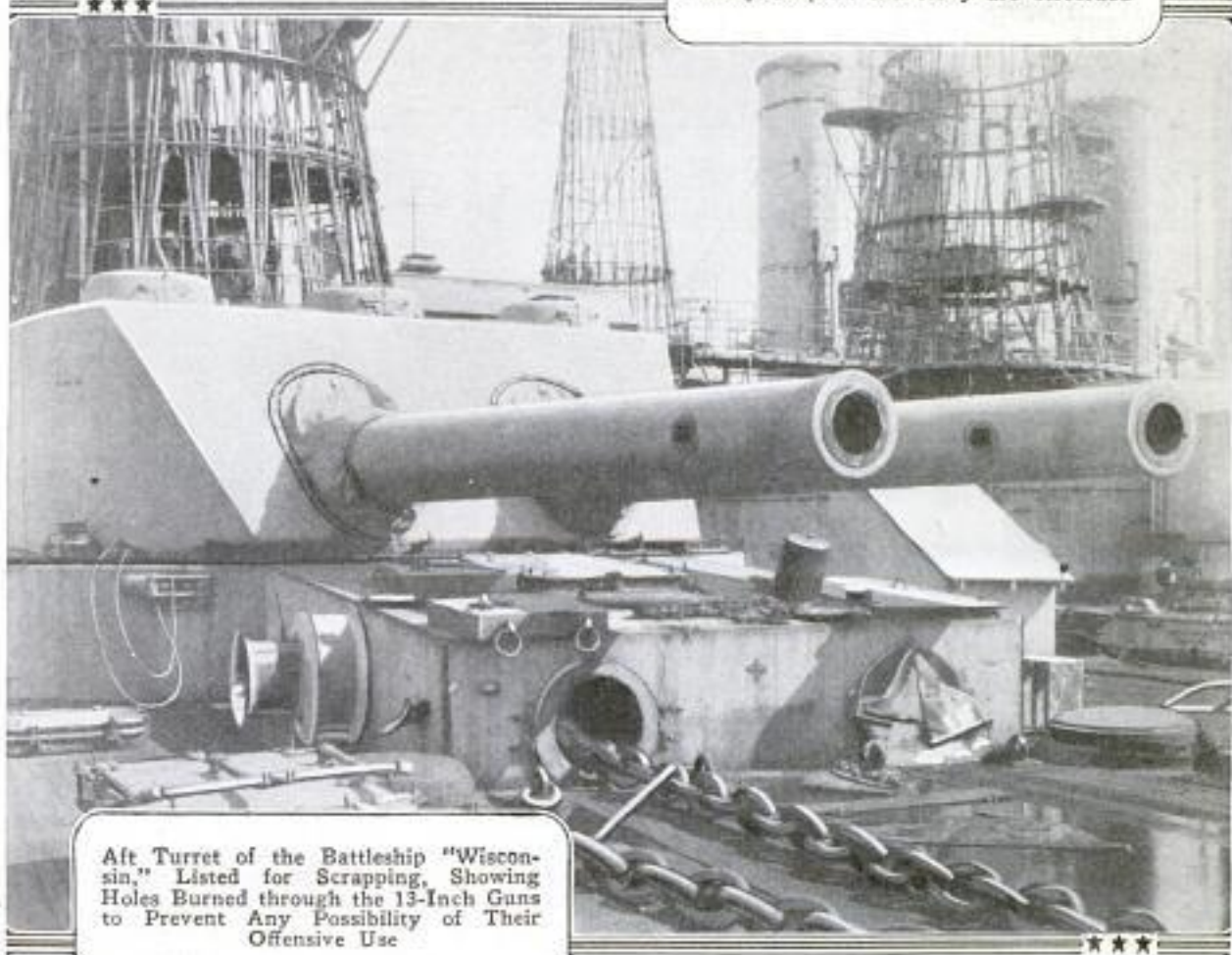

Aft Turret of the Battleship "Wisconsin," Listed for Scrapping, Showing Holes Burned through the 13-Inch Guns to Prevent Any Possibility of Their Offensive Use

COPYRIGHT, HENRY A. MITCHELL'S SONS CO.

with the destroyers "Truxton," "Worden," and "Whipple," which will ply

vices. Destroyer armor is light, and huge 10-ton "crocodile" shears cut it into pieces that are remelted and rolled into various shapes adapted to structural steel, rails, and sheet plate.

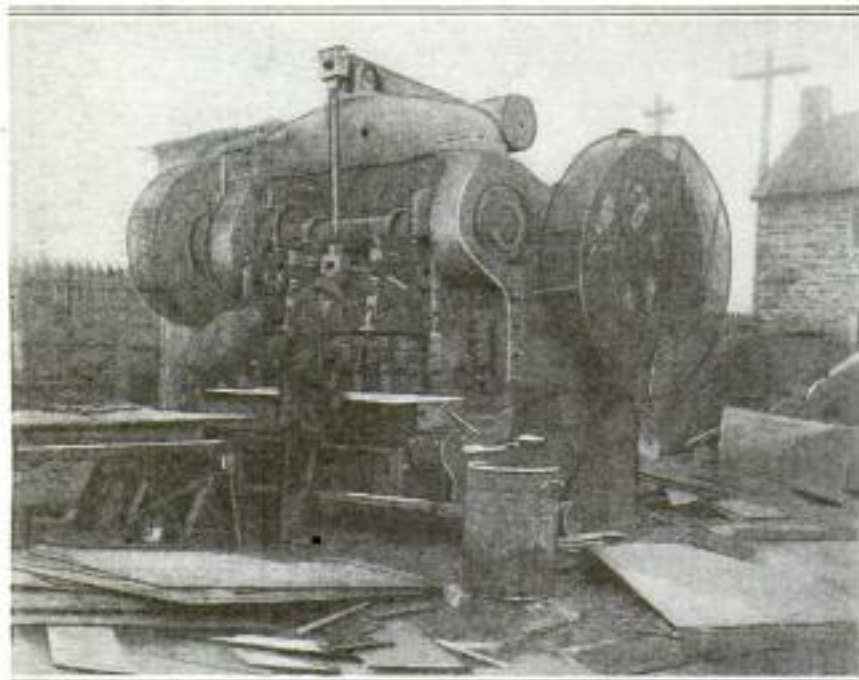
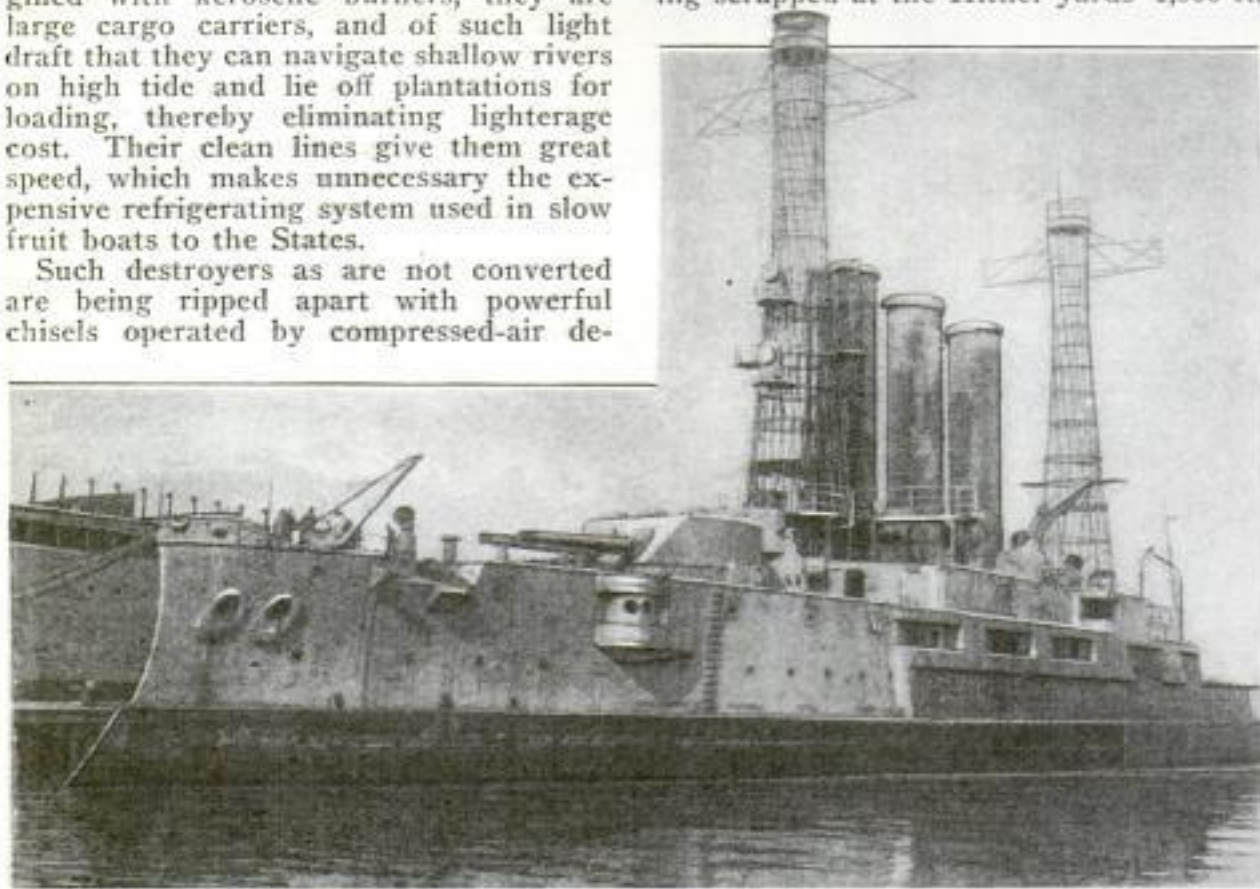

PHOTO COPYRIGHT, HENRY A. HITNER'S SONS CO.
Torpedo-Boat Destroyer Bulkheads being Sheared into Standard Sizes for Use as Ordinary Structural Plates in Any Kind of Construction Work in Connection with Peaceful Industries

between the United States and Central America, carrying cargoes of fruit. Engineered with kerosene burners, they are large cargo carriers, and of such light draft that they can navigate shallow rivers on high tide and lie off plantations for loading, thereby eliminating lighterage cost. Their clean lines give them great speed, which makes unnecessary the expensive refrigerating system used in slow fruit boats to the States.

Such destroyers as are not converted are being ripped apart with powerful chisels operated by compressed-air de-

war craft that now lie at anchor in the Delaware River or already in process of being scrapped at the Hitner yards' 1,000-ft.



View of the Battleship "Maine," Tied Up in the Huge Yards of Henry A. Hitner's Sons Company, of Philadelphia, Ready to be Scrapped: It can be Seen That Part of the Waterline Belt of the 11-Inch Hull Armor has Already been Removed

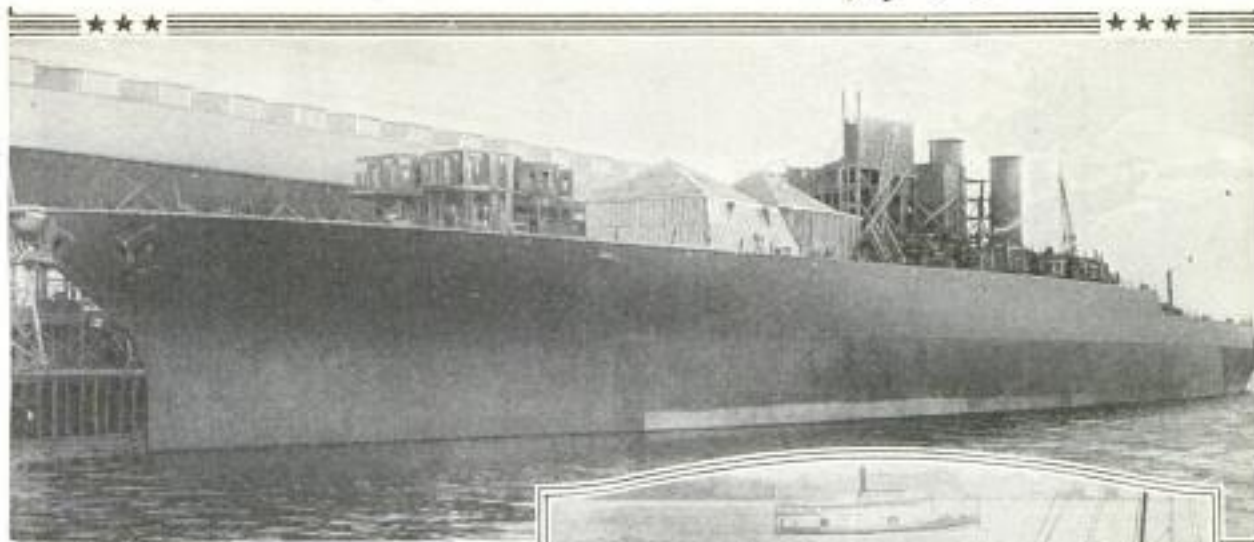

Above: Superdreadnaught "Washington," to be Scrapped Although Nearly Three Parts Completed. It was to have been Armed with Eight 16-Inch Guns in Its Main Battery, and Fourteen 5-Inch in Its Secondary Battery. Its Estimated Cost Was \$20,000,000

Upper Right: In Another Part of the Henry A. Hitner's Sons Company's Yard Is This Partially Dismantled Torpedo-Boat Destroyer

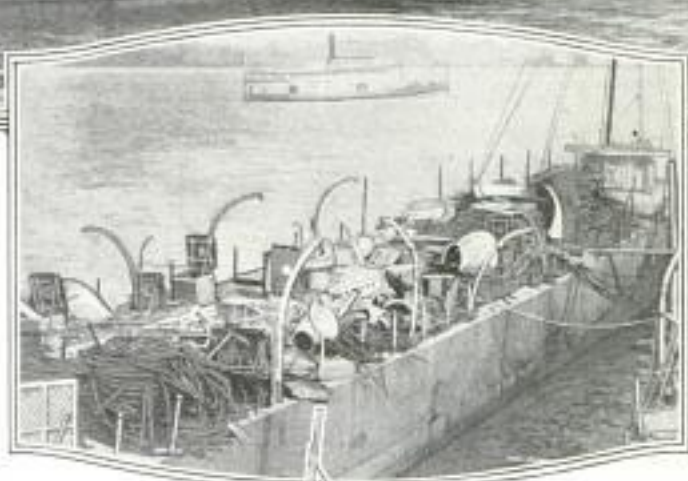

Lower Right: The Holland "A-1 Plunger," Known as the Grandfather of the Submarine. This Product of the Brain of J. P. Holland—Inventor of the Submarine—Was the Precursor of the Modern Undersea Warship, Such as is Exemplified in the Powerful Submarine Cruiser "S-41"



Below: Modernized Forms of the Famous Ericsson "Monitor," the First Armored, Turreted Battleship Ever Built. These Two Coast-Defense Monitors are being Made Ready to be Dismantled

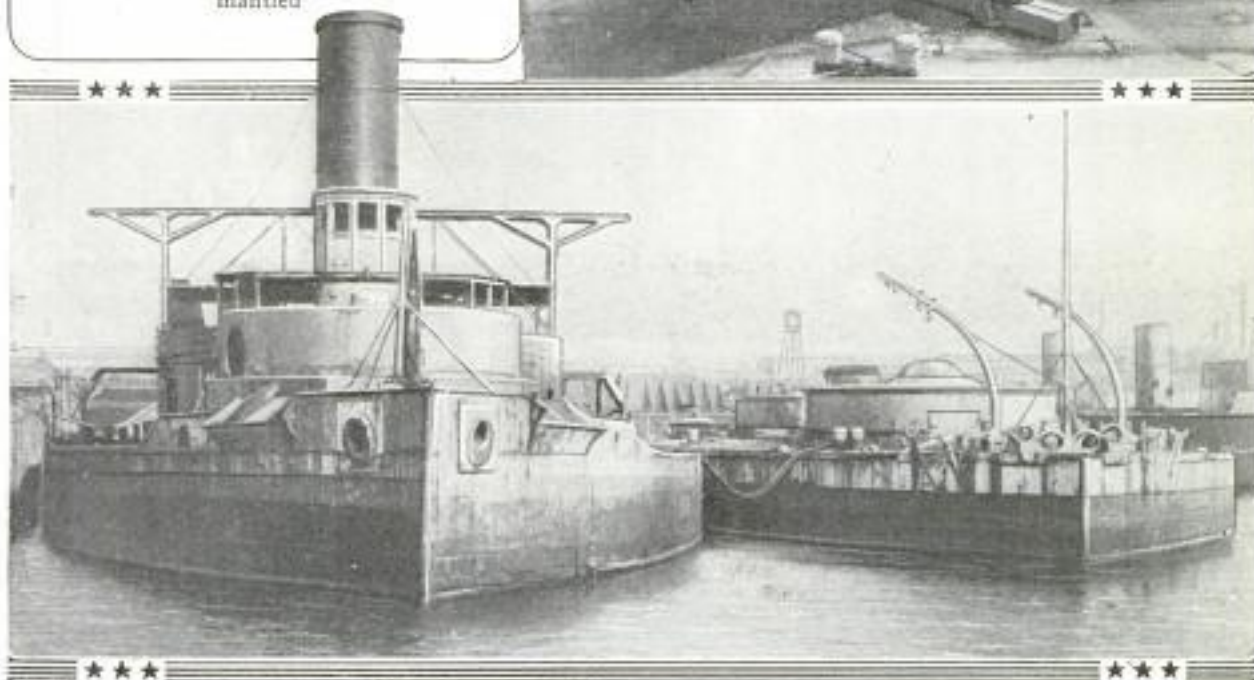

8986

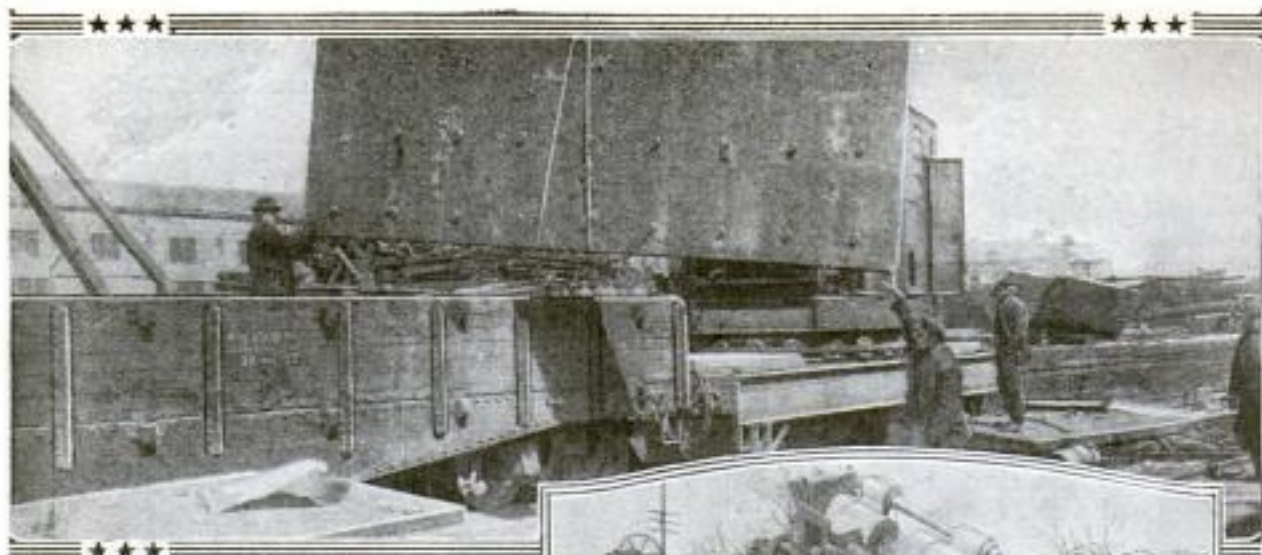

Above: A 40-Ton Plate of 14-Inch Hull Armor being Swung by a Crane from a Freight Car to the Ground in the Henry A. Hitner's Sons Company's Yard on the Delaware River, Philadelphia



Upper Right: Pile of Power Compressors Ready to be Scrapped with an Oxyacetylene Torch, Which will Cut Them into Billets for the Open-Hearth Furnace

Lower Right: Crocodile Shear Cutting Up a Plate of Protective Deck Chrome-Nickel Steel Armor from a Scrapped Torpedo-Boat Destroyer. This Valuable Alloy is Adapted to Many Peaceful Uses, Particularly in the Automobile Industry



Below: Pile of Battleship Boiler Tubes in Another Part of the Yard Ready to be Broken Up and Then Thrown into the Furnace to be Formed into Billets



PHOTO COPYRIGHT, HENRY A. HITNER'S SONS CO.

waterfront, include, in addition to those already mentioned, the cruisers "Detroit" and "Raleigh"; the destroyers "Stewart," "Bainbridge," "Perry," "Barry," "Dale," "Paul Jones," "Hull," "Lawrence," "Smith," and "Decatur"; the monitors "Canonicus," "Mahopic," "Catskill," "Jason," "Ajax," "Nachant," "Puritan," and "Miantonomah," as well as Eagle boats, submarine chasers, mine sweepers, and submarines.

Junking of ships on a scale of such magnitude as this has probably

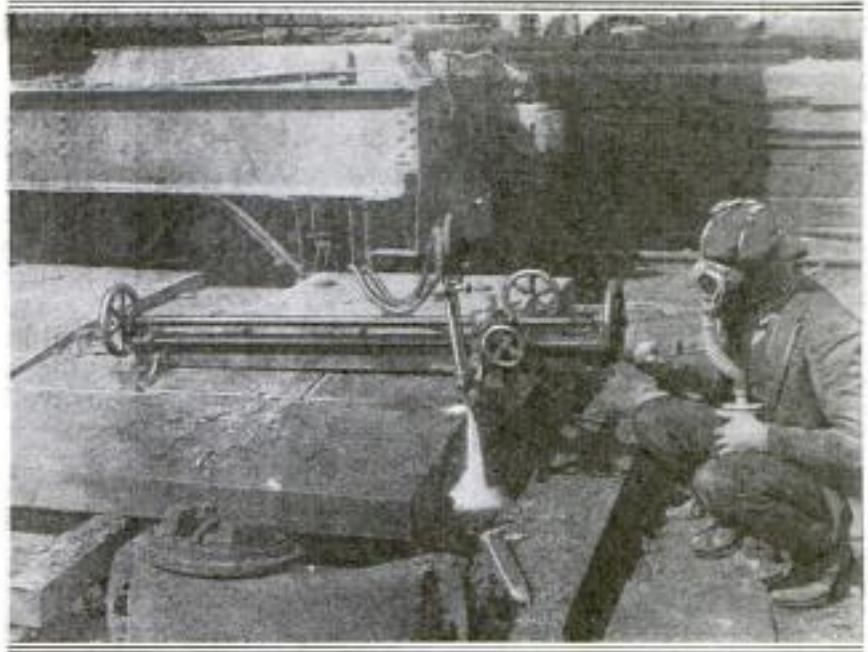

PHOTOS COPYRIGHT, HENRY A. HIRSCH'S SONS CO.

Above: Close-Up of a 25-Ton Strip of 11-Inch Waterline Armor Plate from the Hull of a Battleship being Cut into 25-Foot Billets with an Acetylene Torch. Left: Interior of the Hull of the Torpedo-Boat Destroyer "Worden," being Converted into a Fruit Freighter to Trade between This Country and the West Indies

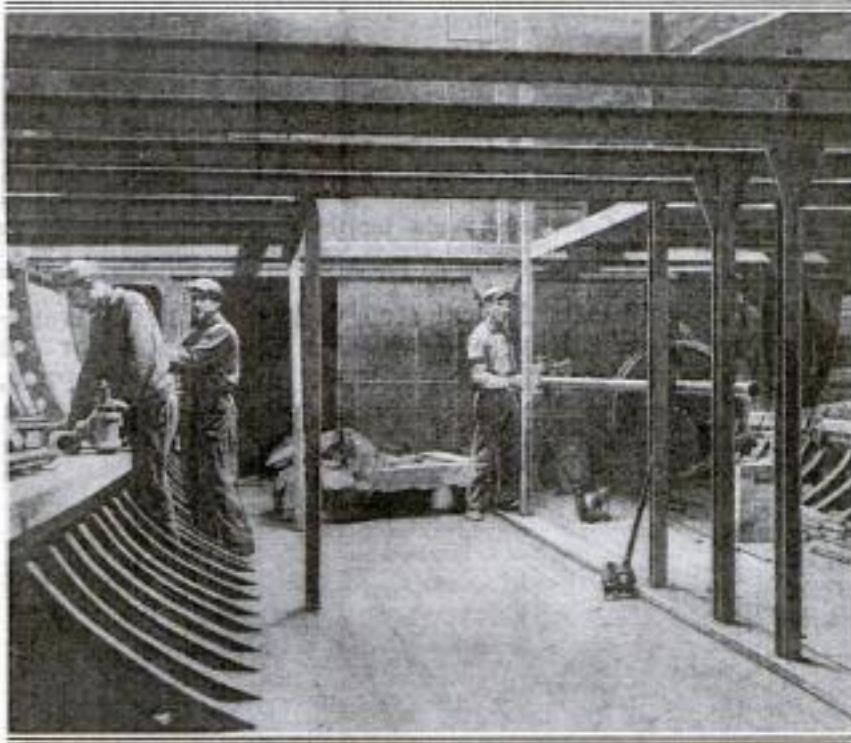

never before been undertaken at any one yard in the world, and certainly not here, although this yard has for 30 years specialized in that business.

¶ The trunk telephone between Sydney and Melbourne, Australia, has been duplicated by superimposing a duplex telegraph circuit upon each of the circuit wires. The new cable is 580 miles long.

PORTUGUESE AIRMAN HALTED BY WRECKED AIRPLANE

In an attempt to make a transatlantic flight from Lisbon, Portugal, to Pernambuco, Brazil, two Portuguese naval airmen, after covering more than three-quarters of the journey, were forced to stop at St. Paul's Rocks because of the wrecking of their seaplane. The start was made on March 30, from Lisbon, and the route followed was to the Canary Islands, thence to Cape Verde Islands, and to St. Paul's Rocks, where the flight stopped on

April 18. St. Paul's Rocks are only about 500 miles from Pernambuco, the goal of the airmen, so one may judge how near they came to succeeding in their venture. They used only a small type of naval seaplane equipped with a 360-hp. engine and having a fuel capacity for only 18 hours' flying. This is the first attempt to fly the Atlantic from east to west in a seaplane, and while they fell short of their goal, the distance covered speaks volumes for the ability of the men and the reliability of their machine, as no extensive patrol was maintained to guide the airmen.

n. y. Times

*3/21-3/22
Chicago Tribune*

RADIO EQUIPMENT INSTALLED ON RAILROAD TRAINS



Radiophone Equipment Installed in a Buffet Car on the Lackawanna Railroad being Tested Prior to Its Regular Use on the Trains

using six wires, and the other road two, with the entire set being grounded through the axles to the rails. Although activities along this line have hitherto been more or less of an experimental nature, it is thought that the success achieved by these companies will induce other railways to provide similar amusement for the traveling public; also, that the



Specially Constructed Aerial for the Radiophone Equipment on the Lackawanna Railroad Buffet Car being Connected on Top of the Train before Making an Experimental Trip with the Apparatus

Radiophone equipment has been installed on trains of two railroads in this country, namely, the Lackawanna, and the Chicago, Milwaukee, and St. Paul. Both these companies have converted buffet cars into virtual receiving stations, wherein the passengers can don headpieces and listen to the various broadcasting. Or, if the headpieces are not desirable, the occupants may be entertained by means of a loudspeaking horn, which is also connected in the circuit. The coaches are surmounted by special aerials running the length of the cars, and are of different construction, the Lackawanna

next logical step will be to install transmitting apparatus on these trains for the further convenience of the passengers,



Radiophone Installation on the Chicago, Milwaukee, and St. Paul Railroad

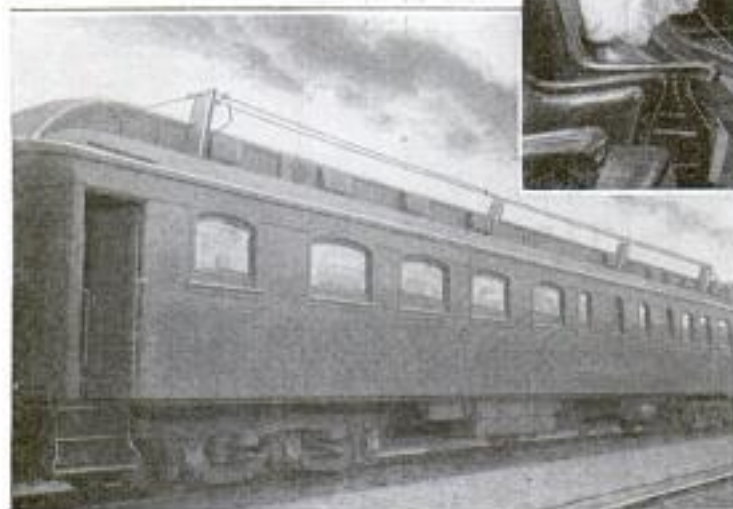

Aerial of Radiophone Equipment on Top of the Chicago, Milwaukee, and St. Paul Railroad's Buffet Car, Showing How Two Wires are Carried on Two-Foot Posts, the Full Length of the Car

who will then be enabled to send messages while en route.

Wattle wood and the spent bark from the wattle-extract mills, are to be used in the manufacture of wrapping paper, according to the announced plans of a company in Natal, South Africa.



LIGHTHOUSE FLOATS FIVE MILES DOWN A RIVER

Keystone View New York City

e have
advise
uilt b
uilt t
air Ser
machine
product

HOUSES in cities—even large ones—have often been moved from place to place, and now the same thing has happened to a lighthouse of quite respectable proportions. The structure is 55 ft. high, and weighs 80 tons. It was put aboard a large scow at its original site on the Niagara River, and was then towed five miles along the river to Grand Island, where it was put ashore. The inhabitants along the river front rubbed their eyes to see if they were awake, when they saw the well-known lighthouse floating majestically along the river.

8968

Argentine Military



A NEW CUSTOMER FOR THE GASOLINE-FILLING STATION

International Newsreel

THIS little airplane has been designed in the search for a small machine that would be within the reach of all enthusiasts. It weighs only 500 lb., and is small enough to be kept in the garage. The claim is made that it can be manufactured for less than the price of a small automobile. Its flying speed is 100 miles per hour, and it is so small that it can land on, or take off from, a space no wider than the ordinary city street.

The Engineer

9012

4/17/22

**UNUSUAL HAND-CARVED CLOCK
MADE ENTIRELY OF WOOD**

A remarkable clock has just been completed by an ironworker of Peoria, Ill., in which all of the parts, even the shafts

**ELECTRIC-LIGHTING PROJECT
FOR FRENCH VILLAGES**

Shell-torn districts of northern France are being repopulated by returning natives, and these have made use of the miscellaneous electrical equipment left there by the different armies. Generators, driven by gasoline engines, have been put in use, and the cellars of ruined buildings, or the poorest wooden huts, are furnished with light and power. So great have been the benefits derived from these small and crude outfits, that the ministers of agriculture, finance, interior, and of the public works, have obtained the approval of the president for the establishment of an inter-ministerial commission. This commission will draw up a program for the distribution of electrical power in the rural communities and also endeavor to find a way for the proper financing of the project.

89/18
Maker - Louis Heyden,
Peoria, Ill.

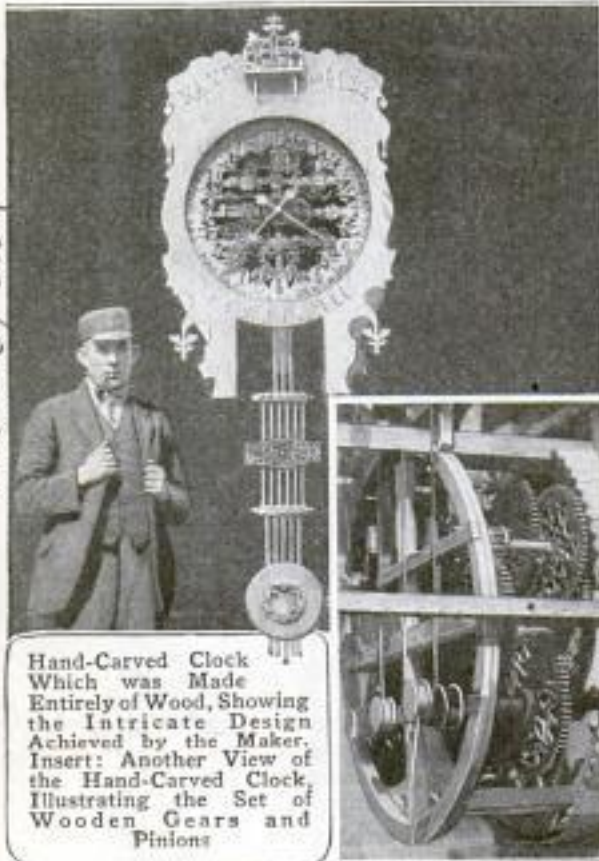

Hand-Carved Clock Which was Made Entirely of Wood, Showing the Intricate Design Achieved by the Maker. Insert: Another View of the Hand-Carved Clock, Illustrating the Set of Wooden Gears and Pinions

COPYRIGHT, INTERNATIONAL

and fretworked gears, are carved by hand from solid pieces of wood. It has taken three years to make the clock, which not only tells time but also gives the day and month, weather prospects, and other information. However, its worth as a timepiece will depend on how the gears and pinions withstand climatic changes.

8932
**THREE-MILE-A-MINUTE MARK
REACHED BY RACING CAR**

On Thursday, April 6, over the Daytona beach course, Florida, the coveted speed mark of three miles a minute was reached by Sig Haugdahl driving a specially designed racing car. The official time for the measured mile, recorded electrically, was 19.97 seconds, which corresponds to a speed of 180.27 miles per hour. The previous record made on this same course was 24 miles per hour less than the new mark. The car used by Haugdahl was powered by a 250-hp. aluminum hydro-plane motor, weighing only 610 lb. The body of the car is only 20 in. wide and is streamlined. Even the axles and all exposed bolts and nuts have received the same careful treatment.

Auto

Ent. J. Malone, Aragon Hotel, Atlanta, Ga.

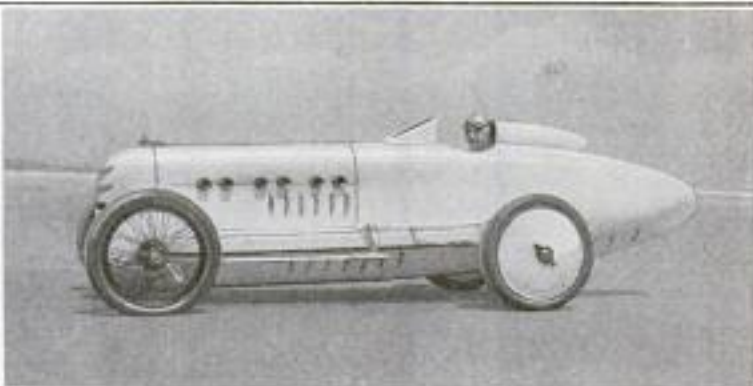
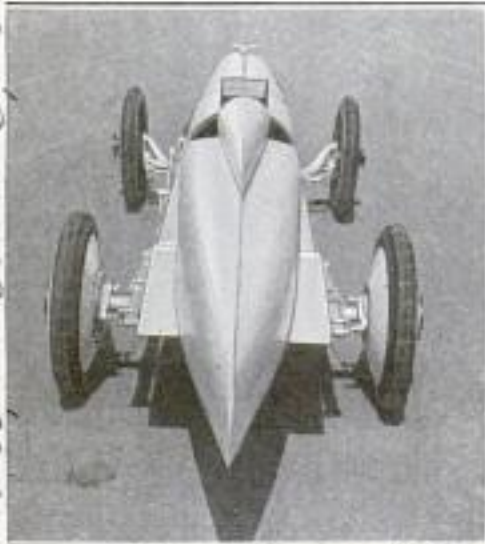

Left: Rear View of the Specially Designed Motor Car Which Traveled at the Rate of 180.27 Miles per Hour, Showing the Unusual Lines of the Body. Right: Side View, Showing the Driver at the Wheel, and Displaying the Peculiar Bullet-like Streamline Design

Owner - Sig Haugdahl. Car built to order.
Wisconsin Special. Copyrighted material

COMMENT AND REVIEW

[These pages were printed April 25, 1922.]

JACKSONVILLE, Fla., has an active Association of Commerce, that does things well, but its members are even more proud of the Junior Association of Commerce, largely, but not exclusively, composed of young men who are sons of members of the parent body. These budding captains of industry last month scored a tremendous success in a "Made in Jacksonville" week. The event opened with a mammoth street parade, composed entirely of exhibits of things made in their own city. The largest auditorium in the city was packed with exhibits and crowded all week. In addition to local residents and the thousands of winter tourists in town, large delegations attended from down state, for the event was advertised widely in a very attractive, and therefore effective, way.

Enterprising Junior A. of C.

The few old men doubters who failed to realize the tremendous power of organized young men changed to enthusiastic boosters the first day, for the way the boys carried the enterprise over the top was something inspiring.

What these young men—most of whom are under 25—accomplished, is a demonstration of wonderful possibilities to the young men in other cities, and an example well worth following throughout the country. The Jacksonville juniors, who conceived and carried out the idea entirely on their own initiative, proved their mettle in a big success, both financial and otherwise, and their first effort has already become an annual event. If the seniors have already preempted the "made here" week elsewhere, there are other equally good things waiting development. 'Attaboy!



THE Portuguese have always been daring navigators, and still stand among the best sailors in the world. The attempted flight of two of them from Portugal to Brazil has been watched with interest from day to day by the entire world, which, within a few hours, knows of their departure or arrival at each station. It is to be hoped the wrecking of their seaplane at St. Paul's Rocks will not seriously delay the completion of their journey, for which a new plane is reported under way from Portugal.

Trans- Ocean Flights

In several countries, plans are under way for an airplane circumnavigation of the earth, and it is not unlikely the present year may witness at least the attempt to do so. The Pacific Ocean, of course, presents the longest "leg" of the trip, but even these severe conditions are not likely to delay the effort very long, nor discourage these intrepid trail blazers of the air. Deserts and other wildernesses of the earth are already being explored by airmen, who are discovering routes and means of entrance which have hitherto baffled caravans and horsemen. Before many years, the secrets of jungles and mountain fastnesses, which thus far nature has guarded so jealously, will be an open book and familiar to children in grammar-school grades.



THE province of the magician in these days is to amuse and entertain by an appeal to both the eye and mind. No longer is he an individual feared for the evil influence he was once supposed to exert. On the contrary, magic is one of the finest types of entertainment we have. To perfect himself requires the patient, unsparing practice of a lifetime, and the place of high regard and affection which the magician may attain was notably manifested a few weeks ago when Keller passed on into that greater mystery than any even he had known.

Magicians Deserve Protection

A mystery is something we cannot understand; with an explanation, the mystery vanishes and the subject of it immediately loses its interest and attraction. On several occasions, in our effort to bring to our readers the earliest information on all subjects, this magazine has explained and illustrated just how certain unusually baffling major mysteries were performed. These stories were acquired in what seemed a perfectly honorable way, having come in from paid contributors. We are so elated at getting these "scoops" that it never occurred to our editorial department that what we expected our readers would regard as enterprise, in reality was a most unfair and unjust thing to do. Not until Harry Houdini, president of the Society of American Ma-

gicians—1,000 strong—explained the matter, did we realize what an "exposure" meant to the performer. A major mystery is the product of the brain of some magician, to the perfection of which he often works for years, and in some cases has expended thousands of dollars in experimenting and building one set of costly apparatus after another. And when it is finally a success, and he hopes to receive the reward he so fully deserves, there is no possible way in which he can protect himself. The act cannot be copyrighted; neither, like an invention, can it be patented. To do so would involve a minute description of how it is done. He is therefore helpless to protect himself except by an appeal to the fair-mindedness of publishers to refrain from tearing down in one short article that which he has worked so long and hard to produce, and on which he must depend for the financial return to which he is entitled. The case is a most unusual one, for which we recall no parallel.

This magazine has already published its decision to refrain hereafter from describing how such mystery acts are produced, and we feel sure our readers will not only approve our decision, but join with us in the hope that all publishers will adopt the same policy; for whatever satisfaction the reader may obtain from this knowledge cannot compare with the interest and pleasure he would otherwise have enjoyed in witnessing a clever and scientific performance.



BOSTON, be it said to her great credit, finds time in these whirlwind days to recall and suitably observe many of the anniversaries of great historical importance in the annals of our country. We would all be better Americans did we more frequently follow this example. The recent anniversary of the ever-thrilling ride of Paul Revere and William Dawes was observed by exercises in Faneuil Hall and on the Boston Common, and the ride itself was reenacted.

*The Days
of '76
and Now*

It is impossible to refrain from contrasting this event of 147 years ago with the facilities of today. Then, the breathless, hard-riding horseman was the only quick and certain means of communication. Today, either the telephone, telegraph, automobile, motorcycle, airplane, or wireless would transmit the alarm in a period of time ranging from a few seconds to, at most, 15 minutes, although the splendid spirit of patriotism in which the farmers responded then could not be excelled by anything which modern invention has yet provided, or ever will.



THAT the taxes which go into the government treasury are being paid in very large part by the comparatively few, is plainly set forth in figures compiled by the New York Globe, which claims that fifteen to twenty million persons failed properly to report their incomes in 1921. It estimates the amount which should have been reported, and was not, at the staggering figure of \$46,000,000,000 during the past five years. Of nearly six and one-half million farmers—owners and renters—less than six per cent reported an income of over \$2,000 in the year 1919, which was by no means a bad year agriculturally. Among the wage earners the percentage was only one-eighth of one per cent. The investigation showed very little disposition on the part of the rich to evade proper returns. Doubtless thousands of the smaller taxpayers failed to report through sheer inability to make out the income-tax report, which baffles even the best lawyers.

*A Few
Pay the
Taxes*

The present system, a relic of war times, is atrocious and should be changed to one which people generally can understand.

H. H. WINDSOR



8979



UNVEILING OF MEMORIAL TO BOOKER T. WASHINGTON

244

A MEMORIAL to Booker T. Washington has been erected at the Tuskegee Institute, and was recently unveiled by Alvin J. Neely, president of the Tuskegee Alumni Association. During the ceremony he presented a gift of \$75,000 from the association to the institute.

9034

ODD DEPARTURE IN HEATERS USED IN SWITZERLAND

8940

"WALKING BOOKS" ADVERTISE FREE PUBLIC LIBRARY

Engineering
Feb 12/3

"Linear heating" is a term used by Swiss engineers and defines the method employed by them to obtain heat by means of electrical resistance. Instead of utilizing the coil of wire so commonly seen in this country in heating elements, they stretch the wire, tape, or band, in a straight line between the terminals. These conductors are then incased in iron pipes, or flexible coverings, and carried through the rooms, offices, or workshops, in much the same manner as hot-water pipes.

The librarian of Stockton, Calif., recently hit upon a clever idea for increasing the popularity of the public library. A display sign, 4 by 2 ft. by 15 in., was made in the form of a book and was carried about town by a boy who walked inside the sign. Messages to the public, describing features of the library, were printed on the sides, back, and inside "pages" of the book, which bore imprinted on it the name "Anne Othority" as its author.



This "Walking Book" Made of Sign Cloth Tacked on a Light Frame, is Carried about Town by a Boy, and Acquaints the People with the Attractive Features of the Free Public Library

Chas. Allen H. Wright
San Diego, Calif.

Mfrs. Seneca Electric Welder Co, Seneca, Kans.

The Engineer 4/7/22

848

POPULAR MECHANICS

8945

ARC-WELDING MACHINE USES ALTERNATING CURRENT

Welding, usually accomplished heretofore by the oxyacetylene method, or by the use of bulky direct-current outfits, can now be done with an alternating-current

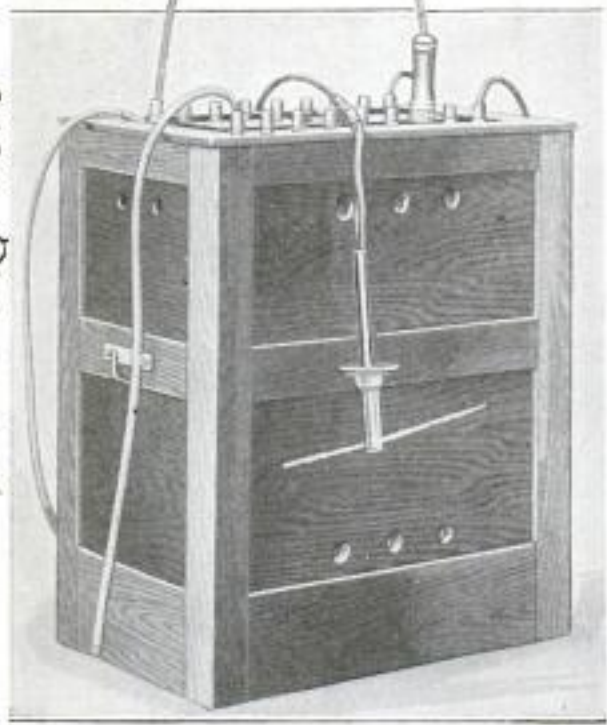

Arc-Welding Machine Which Uses Alternating Current, Showing the Contacts on Top for Obtaining the Different Controls That Yield Extreme Flexibility of Heat Range

machine. This contrivance, the invention of three Kansas men, has incorporated in it an effective heat control, enabling 14 different temperatures, which are obtained by the stepping-down process, or in other words, with an induction coil. Voltages ranging from 100 to 110 are maintained, while the amperage is reduced from 170 to 30. Thus the practical value of the apparatus is apparent—that of producing heat at a workable point without affecting the voltage—and almost any kind of welding can be performed, owing to the extreme flexibility of heat range.

ENGLAND-INDIA AND AUSTRALIA AIRSHIP SERVICE PROPOSED

Plans are now being considered for the formation of a company to establish an airship service between England, India, and Australia. It is proposed to have a biweekly service to India, with a weekly extension to Australia, the service to be increased as necessity demands. The aim

of the company would be a mail and passenger schedule of 5 1/2 days to Bombay, while the present trip takes 17 days. The time to Australia would be 11 1/2 days as against four to five weeks now required for the trip. The company would require no capital investment by the government, only a guarantee of interest.

NEW HYDROELECTRIC STATION IN VALENCIA, SPAIN

The second most important hydroelectric company in Spain has completed the construction of its station at Dos Aguas, which is the junction of the rivers Jucar and Gabriel, in the province of Valencia. When completed, the station will furnish 100,000 hp., and will greatly assist in supplementing the present inadequate power and light service of Madrid.

SPECIAL PHONOGRAPH SENDS CONCERTS BY RADIO

The fact that it is not always possible to employ expert musical talent for broadcasting wireless-telephone concerts has led to the development of a special phonograph for transmitting music. The tone chamber is larger than that of the ordinary phonograph and is supported on three posts which rest on a sound box similar to the body of a guitar. It is claimed that this machine is not only louder than the regular phonograph, but produces its tones more clearly and free from foreign vibrations.

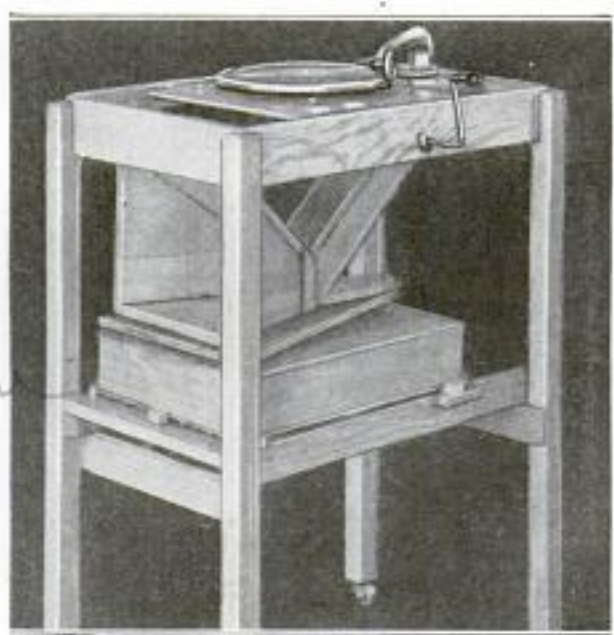

This Phonograph for Transmitting Wireless Music Has a Special Tone Chamber Resting on a Sound Box, and Produces Exceptionally Loud, Clear Tones, Free from Interfering Vibrations

Mr. Wm. O. Erbes, 4813 - 72nd St., S.W., Portland, Oregon.

London Times Weekly 4/7/22
2014 and George J. Brummelt, Earl Brummelt, Seneca, Neb.

Copyrighted material

MEDITERRANEAN-DEAD SEA TUNNEL TO RESTORE THE HOLY LAND

By Lewis R. Freeman



The "Well of the Apostles": It is from such sources as this that the present water supply of Palestine is obtained. The primitive method of dipping water from the well in jars is still in vogue here.

WITH the Jews to the ends of the earth deeply stirred by the fulfillment of prophecies which lead them to believe that the hour of the founding of their New Zion is about to strike, and with many of them actually planning a return to the land of their forefathers, the question of the potential ability of that land to support a greatly increased population at once arises. The political division called Syria, roughly comprising a 200-mile-wide strip of the country at the end of the Mediterranean, had an area of 130,050 square miles and an estimated population of 3,326,160. Approximately one-third of this area was included in Palestine proper, and rather less than one-fourth of the population. Can a semi-desert region of this kind, which was hardly more than self-supporting at its best, give sustenance to a population of five or ten times the 700,000 souls that eked out a precarious existence there before the war? If not, the movement of any great number of people to Palestine, no matter by what motives impelled, would bring about an upsetting of the economic balance that could not but result in a great addition to the world's burden of suffering.

While it is probable that the Biblical description of Canaan as a "land flowing with milk and honey" was largely due to the impression of a number of rich oases made upon the minds of a people who had journeyed long over barren sands, yet it is far from being today the barren desert that it seems to the casual visitor. As a matter of fact, Palestine, which is in about the same latitude as southern California, has soil, topography, and climate strikingly similar to those of this most fruitful region of North America. Rich and fairly well watered coastal slopes, and deeply indented arid interior valleys, are common to both regions. In the matter of rainfall, Palestine, with its annual precipitation of from 20 to 25 in., is at a distinct advantage over southern California, which does not average much over 16 in. Probably this difference in rainfall is about offset by the fact that California, with higher and better forested mountains, has far better natural storage areas than Palestine.

There is no possible doubt that the Palestine of Biblical days, with a rainfall not greatly in excess of that of the present time, supported an almost exclusively agricultural population of many millions.

As there was nothing of the character of modern irrigation works at that time, this must have been made possible by the fact that the country was well covered with trees, so that the rainfall, which now rushes off in savage floods with the accompaniment of heavy erosive action, was stored in the earth. If almost complete deforestation was not brought about during the centuries of incessant warfare of earlier times, it must have come shortly after Turkish control was established. In no region long under the Star and Crescent have the trees survived in more than occasional groves and patches. Even Greece was almost completely denuded of its forests during the years it was governed by the Porte.

Nevertheless, although Palestine is a man-made rather than a natural desert, the problem of its reclamation is a more difficult one than that of many great areas—like the Imperial Valley, in California, for instance—which had never before known irrigation or cultivation. This is because there is no great river from which water can be diverted by a gravity flow, nor yet any readily available power which can be used in pumping. Neither coal nor oil are produced sufficiently close at hand to make their use in pumping plants economically feasible, and the absence of perennial streams of sufficient gradient and volume precludes the possibility of hydroelectric power in that manner.

Yet it is because some kind of power is indispensable to any extensive reclamation in Palestine, that these normally prohibitive limitations have not been allowed to bar completely the door of the future. One source of power, though a hitherto untried one, still remains—the sea. I do not mean tidal power, for the Mediterranean is practically tideless; but rather the utilization of the difference in elevation between the surface of the great Middle Sea and that of the deeply sunk valley of the Jordan. As the Dead Sea is almost 1,300 ft. lower than the Mediterranean, and as the supply of water from the latter is inexhaustible, it follows that the principal problem in connection with

such a project will be an engineering one—the construction of the necessary works at a reasonable cost. Given the power that can undoubtedly be developed through such an installation, the restoration of Palestine to a productiveness that will support a population of many millions may be reckoned as an absolute certainty.

There are several extensive areas in the world that are below the level of the sea—notably in the western Sahara and the Colorado Desert of our own Southwest—but none where such a project as has now been put forward in Palestine could be advanced seriously. Yet, this boldest of modern engineering projects, unexampled



This Old Donkey-Driven Grist Mill at Beirut-Jibrin will Be Only a Curious Relic When the Dead Sea Hydroelectric Project Makes Electric Power Available

though it is, is quite simple in its basic conceptions. A 37-mile tunnel through comparatively soft rock, a turbine installation to develop tens of thousands of horsepower, a transmission line to a great pumping plant 60 miles away, a couple of main canals to carry the lifted water, and the usual system of laterals and ditches—construct these at a cost that will not leave too heavy an interest charge against the land reclaimed, and Palestine can be made to provide "milk and honey," to say nothing of grain and fruit and sugar, for a population vastly in

excess of that ruled over even by King Solomon. Without it, any attempt to found a New Zion through greatly augmenting the present population of Palestine would be almost certain to result in failure, if not in disaster.

No one with the least interest in hydroelectric development can ever have visited Palestine without remarking the power possibilities latent in the proximity of the Mediterranean to the Dead Sea depression, but the fact that the Turk was in control of the country put even a tentative study of the engineering side of such a project out of the question. The first time I ever heard it mentioned was in 1912, when a French engineer with whom I had crossed from Bagdad to Aleppo, pointed out the comparatively slight "divide" our train had surmounted in passing from the depression of the

Jordan, below the Sea of Galilee, to the level of the Mediterranean at Haifa. He said he had often discussed with his colleagues of the DeMorgan archaeological mission the excavation of a tunnel and canal that would carry water from the Mediterranean to some point above the lower Jordan Valley, where a fall of a thousand feet or more could be obtained for a hydroelectric installation. He was of the opinion that most of the canal could be made an open cut, but that highly expensive aqueducts might be needed in maintaining the level across the deep *wadies* draining to the lower Jordan. The power generated, he said, could be distributed all over Palestine and used for pumping from wells now laboriously dipped from by buckets, and, if the thing were done in a big way, it might also be used for raising the water of the Sea of Galilee to the level of the fertile plains of Esdraelon and Kishon, and perhaps on to the broad, rich plain of Sharon. "However," he concluded, "no money could ever be found for such a project as long as the country is under Turkish rule; so why waste time talking about it?"

It was doubtless the fact that the blighting rule of the Turk in Palestine is over for good and all, that encouraged the eminent Norwegian engineer, Albert Hjorth, to make a detailed study on the



The "Well of Jacob," One of the Many Perennial Wells with Which Palestine is Plentifully Supplied: Irrigation Canals will Bring Water to This Country Where Water is Now Carried in Jars from Wells. In Localities Which cannot be Reached by Canals, Water will be Pumped from the Wells

ground for a project of the character suggested by my French companion. As Mr. Hjorth's plan calls for a tunnel from the Mediterranean directly under Jerusalem, I take it that his surveys have proved that such a bore would be preferable to the more or less open, but much longer, canal from a point near Haifa.



This View of a Section of the Damascus-Beirut Railway Gives an Idea of the Barren Aspect of the Country through Which It Passes. It is Proposed to Electrify This Road with Power Generated by Water Flowing from a Spring

Doubtless the first thing an engineer would investigate in studying power development and irrigation for Palestine is the possibility of turning to advantage the fall of the Jordan between the foot of the Sea of Galilee and the head of the Dead Sea. As the latter is 1,292 ft. below sea level and the former 682 ft., the Jordan will be seen to have a fall of 610 ft. in its sinuous course of 185 miles. As the river is very winding, a canal of something like 60 miles in length would suffice to carry water to a point above the head of the Dead Sea. Unfortunately, the valley of the Jordan itself is so restricted that the comparatively small area of land commanded by such a canal, if built for irrigation purposes only, would not warrant the expense of its construction. On the other hand, if built as a supply canal to a

soft limestones and marls. As this is the easiest kind of excavating, it is hoped that the tunnel, in spite of its unprecedented length, would not involve much more time in its construction than the short bores of Simplon and St. Gothard.

The size and the gradient of the tunnel are points that will be governed by the magnitude of the reclamation project—the area to which water will be pumped and distributed. Obviously, the greater the fall of the tunnel, the swifter the flow; and the swifter the flow, the smaller the diameter of the bore needed to provide a given quantity of water. Also, the greater the fall, the greater the head that will have to be sacrificed at the Dead Sea end. Thus, a fall of $2\frac{1}{2}$ ft. to the mile would make a total drop in the 37 miles of $92\frac{1}{2}$ ft., leaving an efficient head of about 1,200 ft. In practice, doubtless it will be found most economical to give the bore a much greater fall, allowing the increased volume of water to compensate for loss of head. Just where the most economical mean will be established will depend upon the power demand.

Perhaps the first point upon which an engineer would seek assurance in considering a project of this kind is the extent to which the rise of the basin into which water is discharged from the power plant would affect the efficient head. As the Dead Sea has no outlet, this, offhand, might seem



Construction Work Progressing on the Hydroelectric Power Flume Which will Carry Water from a Well That is Traditionally Believed to have Sprung from a Footprint of Abraham

to impose a serious limitation upon the amount of water turned into it. Fortunately, in this instance, the difficulty is one which provides its own remedy. Practically all of the water that flows to the Dead Sea is brought by the Jordan. But as the Sea of Galilee is but a collecting basin for the Jordan, any water pumped from the former for irrigation would reduce by just so much the flow of the latter into the Dead Sea. As it is probable that more water would be taken from the Sea of Galilee by pumping than would be added to the Dead Sea from the spillways of the hydroelectric plant, it follows that a fall rather than a rise in the surface of the latter is likely to take place. If this was considerable, it would, of course, mean that in time there would be a gain

power plant, the diversion from the Sea of Galilee would be so considerable that not enough water would be left to pump to the rich plains above. I do not find this project mentioned in the Hjorth report, but I set down these limiting considerations here because, offhand, the idea of a gravity diversion for both power and irrigation from the Sea of Galilee seems not unfeasible.

The tunnel would leave the Mediterranean in the vicinity of Jaffa, long the port of Jerusalem, and said to be built upon the cliffs where Andromeda, chained up to be devoured by a sea monster, was rescued by Perseus. It would strike at once into a chalk deposit of the upper cretaceous era, and its whole course, it is believed, would be through comparatively

to impose a serious limitation upon the amount of water turned into it. Fortunately, in this instance, the difficulty is one which provides its own remedy. Practically all of the water that flows to the Dead Sea is brought by the Jordan. But as the Sea of Galilee is but a collecting basin for the Jordan, any water pumped from the former for irrigation would reduce by just so much the flow of the latter into the Dead Sea. As it is probable that more water would be taken from the Sea of Galilee by pumping than would be added to the Dead Sea from the spillways of the hydroelectric plant, it follows that a fall rather than a rise in the surface of the latter is likely to take place. If this was considerable, it would, of course, mean that in time there would be a gain

rather than a loss in efficient head, but even disregarding any reduction of the flow of the Jordan, Hjorth figures that the evaporation from the furnacelike heat beating upon the Dead Sea would just about take care of the additional salt water flowing into it. It is estimated that the Dead Sea receives on an average of 6,500,000 tons of water a day, all of which (except its mineral content) is removed through evaporation. For one of his tunnels, Hjorth estimates a flow of 20 tons per second, or about 1,750,000 tons per day. For a short time this would have the effect of raising the level of the Dead Sea a foot or more a year. But with increase of surface would come increase of evaporation, and Hjorth figures that when the present 4,000 square miles of the sea would be increased to 4,800, the heat of the sun would suck up an amount equal to the whole additional flow, and that no further rise would take place. In any event, the danger of loss of head from a filling up of the Dead Sea is not one that need to be reckoned with.

The Sea of Galilee is the principal collecting basin for the waters of the lower Jordan. It is 13 miles long, with its greatest width $7\frac{1}{2}$ miles. Its depth varies from 140 to 160 ft. Although its surface is 682 ft. below sea level, its waters are fresh, clear, and not heavily impregnated with minerals. They are not only free from alkaline or other salts that would

render them dangerous for irrigation, but are even drinkable, being used by the inhabitants of Tiberias and the other villages upon the banks of the lake. The main stream of the Jordan heads upon Mount Hermon, at an altitude of 1,705 ft. Besides the Sea of Galilee, its only other important collecting basin is the Lake of Huleh, 7 ft. above sea level.

There are no accurate figures available on the discharge of the Sea of Galilee to the Jordan, but this is known to be sufficient for the irrigation of some hundreds of thousands of acres of land. Should it prove desirable to increase the mean an-

nual flow, however, this can be readily effected by a dam at the foot of the lake to hold up the flood discharge of the rainy winter months and widen the storage area. Still further increase of water supply could be brought about by diverting the very considerable flow of the Yarmuk, which now empties into the Jordan some miles below the outlet of the Sea of Galilee, into the lake itself. Some further storage could also be effected by a dam at the Lake of Huleh.

Hjorth's plan calls for two main canals at suitable levels, roughly paralleling the general course of the Jordan. These

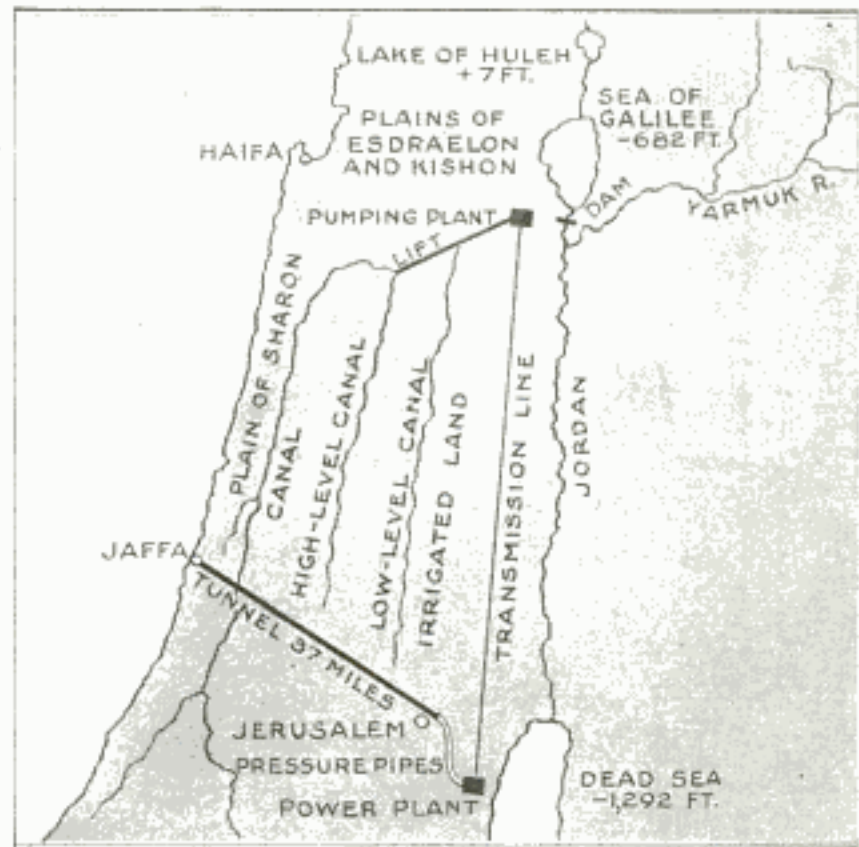

This Map Shows the Proposed Location of the Tunnel for Carrying Water to the Power-Generating Station, and the Location of the Transmission Line, Pumping Plant, and the Three Levels of Irrigation Canals. The Figures under the Names of the Bodies of Water Indicate Their Situation above or below Sea Level

would be supplied from the great pumping plant at the foot of the lake, and from them laterals would run to carry water to all of the extremely rich land in the valley of the Jordan. This has never been accurately surveyed, but it is known to run to many thousands of acres. A third and much larger canal at a higher elevation would start at an altitude somewhat above sea level and run to the southwest. This would carry water to the tens of thousands of thirsty acres of the magnificent Plain of Esdraelon, and the equally rich if somewhat less extensive area of Kishon nearer the Mediterranean. The final and

culminating step, in the event the installation at the Dead Sea is made large enough to generate the necessary pumping power, would be to carry this canal to a point from which the great Plain of Sharon—the ancient granary of the He-

wadies and plains in the south and west of the country that cannot hope to be brought within any extensions of the Sea of Galilee project. Some of the best paying crops in California, Algeria, and India are raised by water pumped from wells under conditions no more favorable than those which should obtain in Palestine for this kind of farming.

Other uses to which Hjorth suggests putting the power from his Dead Sea plant are the production of fertilizer with nitrogen from the air, the exploitation of the vast deposits of asphalt, and for extensive works for the manufacture of salt from the sea water discharged at the spillways. All of these projects would dovetail effectively with the general scheme of restoration. In no place in the world have lands been tilled longer than in Palestine.



The Principal Fall in a Stream Coming from a Spring: Electric Power is Generated from This Fall, and is at Present Utilized to Operate Street Cars, and Light the City of Damascus

brews, Greeks, and Romans—could be commanded.

The details of the project do not appear to have been worked out to a point where more than an approximation of the acreage reclaimable has been arrived at, and this, of course, varies greatly according to the areas the water is carried to. If the plains of Esdraclon and Sharon are included in the scheme, this might well run to several hundred thousand acres. The water available from the Jordan drainage area is the limiting consideration, as the generation of enough power for pumping is merely dependent upon the size of the tunnel from the Mediterranean.

Scarcely less important in the long run than the Sea of Galilee project in restoring Palestine to fruitfulness, will be the utilization of a part of the power from the Dead Sea hydroelectric plant for pumping from wells. A land with so many perennial springs and wells as this can hardly fail to be underlaid with inexhaustible reservoirs of water that can be tapped by deep boring. There has never been an attempt to develop artesian water in Palestine, although the formation is such that it is more than probable that flowing wells would be brought in at no very considerable depth. But with cheap power, even good pumping wells would make possible the irrigation of many rich

Cropped to the point of exhaustion as certain areas are, the cheap and convenient fertilizer from the nitrate plant would be of the greatest help in bringing them back to full fruitfulness once water is available. The exploitation of the asphalt deposits, besides being an important industry in itself, may, as in Trinidad, bring the discovery of oil in its wake; and nothing could more effectively supplement cheap electrical power in Palestine than cheap fuel.

The advantages offered for the cheap and expeditious manufacture of salt promise to be more favorable than those enjoyed by any other spot in the world. The plan is to construct a horizontal canal which would take the brine discharged from the turbines and distribute it in a thin film over the broad expanses of sun-baked rocks bordering the Dead Sea. Evaporation would be almost as fast as in an oven. The residue could be collected for refinement as often as the incrustation on the rocks demands.

A comprehensive system of reforestation, carried out concurrently with the construction of the power and irrigation works, would in time act to conserve the by no means inconsiderable rainfall of the country, and ultimately make it possible to raise crops by irrigation from the augmented flow of streams long dry.

8810

How Wheel Drive Auto Co,
 Clantonville, Wis.

POPULAR MECHANICS

Motor 855

MOTOR BUSES ON RAILS REPLACE STREET CARS

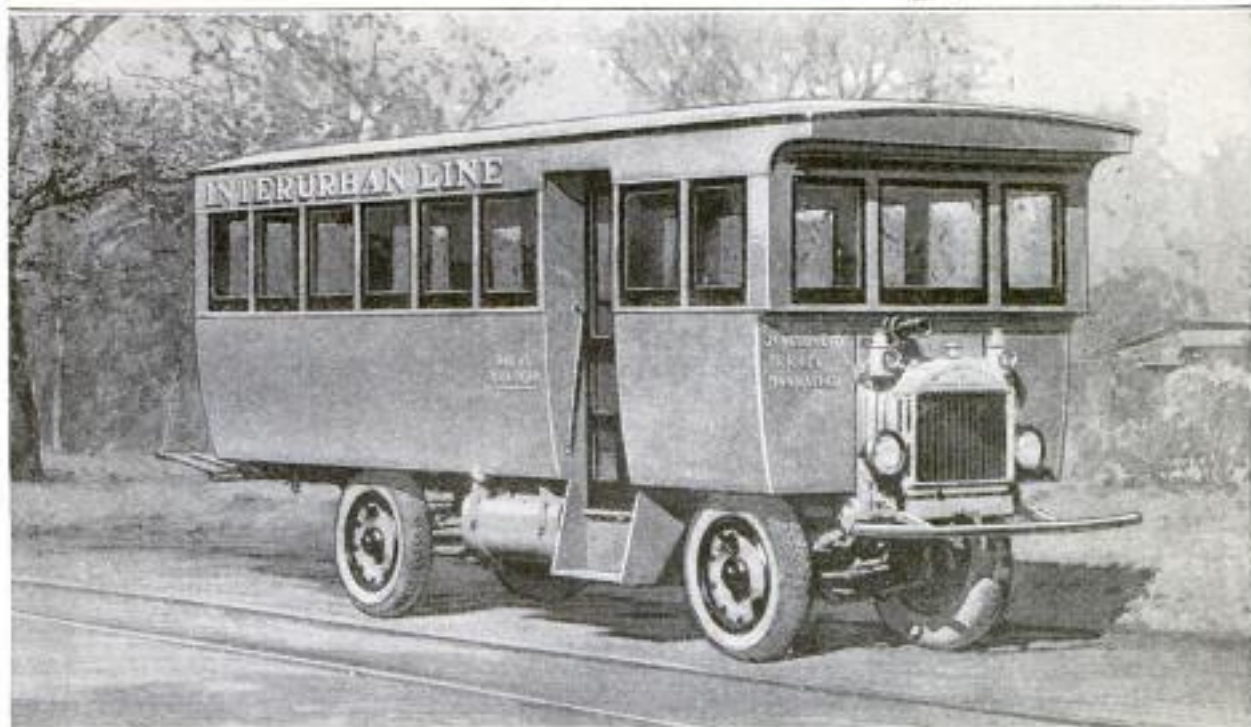

This Bus is Operated by the Street-Car Company on the Highway and is Used as a Feeder for the Interurban Line. It Runs on Schedule Time and Makes Connections with the Buses That Use the Rails

When the "jitneys" and motor busses first made their appearance, the street-car companies were their most bitter critics, but now they have adopted them for their own use as a means of reducing costs and furnishing better service. At Manhattan, Kan., they are used not only for interurban service but on the city streets as well. Special bodies were fitted on standard truck chassis, and steel wheels were substituted for the wooden wheels

and rubber tires. The cars operate on schedule time and have given complete satisfaction, both to the company and to passengers. The cars drive on all four wheels and negotiate heavy grades with ease, even under adverse weather conditions, while, because of their lighter weight, the maintenance costs for cars and track are considerably reduced. They are said to operate more quietly than the street cars formerly used.

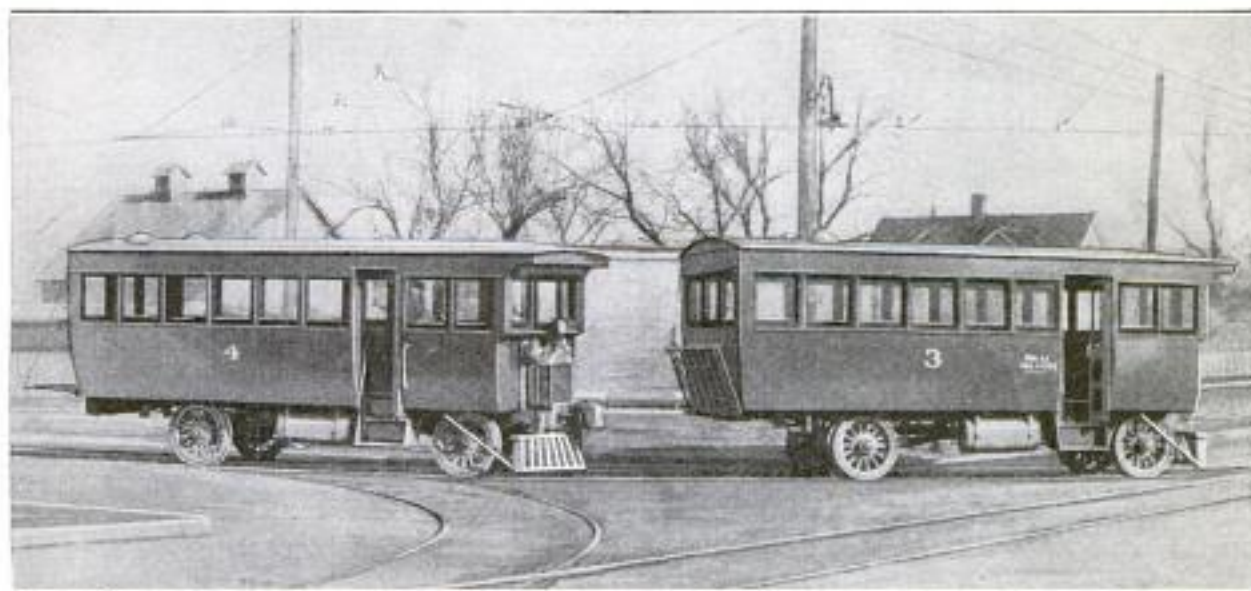

These Motor Buses Operate on the Street-Railway Lines and Replace the Electric Cars. The Special Bodies were Built on Standard Chassis, and Flanged Steel Wheels Replace the Wooden Wheels and Rubber Tires

8855 Emb. F. W. Warner. /o The Electrical Times. London, U.C. 2, England
Sardinia. House, Kingway, London, U.C. 2, England

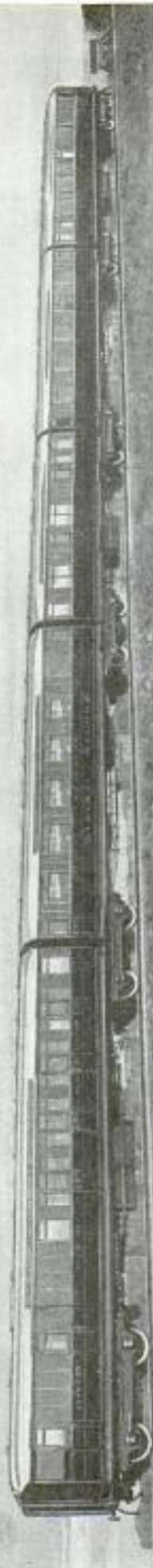

car
**DINER ON ENGLISH RAILROAD
ELECTRICALLY EQUIPPED**

INAUGURATING a new departure, the Great Northern Railway Co., in England, has equipped the kitchen of one of its dining cars with electrical cooking apparatus. Power for the apparatus is furnished by two generators, which are belt-driven from the axles of the trucks, each having a rating of 6 kw. In the kitchen, across one end, is the main cooking range and roasting oven, with a steaming oven above it, while over the latter, a grill and a hot-water tank are located. A boiling range having four hot plates, two 10-gal. boiling pans for vegetables, and a fish fryer, are also included in the installation, which has yielded such satisfactory results that the company is seriously considering similar equipment for other trains. The train has five cars mounted upon but six trucks, instead of the usual two trucks per coach. This method of suspension is said greatly to improve riding conditions, besides reducing weight, running expenses, and the initial cost of the equipment. Of these enumerated advantages, the most important, from the standpoint of the passenger, is the improvement in the riding. It is a well-known fact that the most comfortable part of a car is the center portion, and in these trains, there is no overhang of the cars beyond the trucks, as the ends are carried on a common truck center.

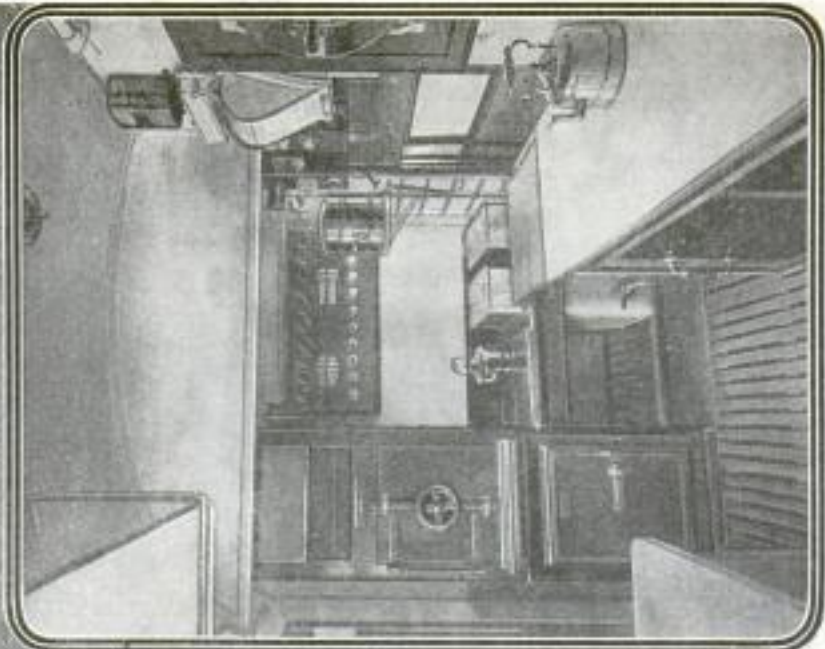
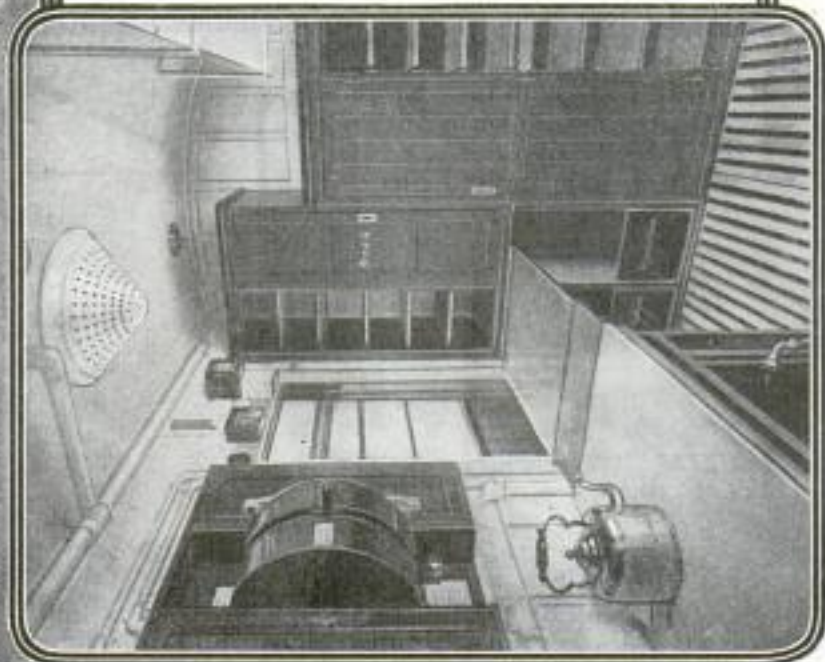

natured alcohol in a very handy self-heating soldering iron now on the market. Inside its handle is a tube, the lower part of which is the reservoir for the alcohol, while the upper part is filled with asbestos

8974 4/17/22 POPULAR CONTROL "GOLIATH" AIRPLANE WITH AUTOMATIC PILOT

That the automatic stabilizer is destined to play an important part in controlling an airplane when flying through fog, is forecast by a recent test carried out in France. A Farman "Goliath" airplane, equipped with the same form of stabilizer that was used in making a flight across the English Channel some time ago, rose from the flying field through 4,500 ft. of dense fog into clear air above. After making several turns at this altitude, the engines were throttled down and the automatic stabilizer brought the airplane down in safety to within 150 ft. of the ground without help from the pilot.

8807 SELF-HEATING SOLDER IRON WITHOUT VALVE OR PUMP

Combined blowtorches and soldering irons, the latter being therefore self-heating, have been made in various forms, but seldom without a pump to obtain air pressure. A pumpless and valveless blowtorch is made possible by the use of de-



Above: Combined Blowtorch and Soldering Iron. Below: Handle Cut Away to Show Construction. Right: Solder-Melting Pot



packing. Just above the handle is a priming cup in which a small quantity of alcohol is burned, furnishing enough heat to generate gas under constant pressure in the handle. This gas blows through a pinhole into the burner part of the tool, onto the end of which is screwed the soldering point. Once started, the process is continuous until all the alcohol is consumed.

8893

POWERFUL STEAM TRACTOR HAS TWO ENGINES

Two engines are built on a powerful oil-burning steam tractor, which has been designed for universal use, although considered especially adapted for the lumber industry. During the summer, two ordinary steel wheels in front and two track-laying wheels at the rear are used, while in the winter the front wheels are exchanged for sled runners. The implement is rated at a load capacity of 10 tons, has a speed of six miles

an hour, weighs 8 1/2 tons, and its wheel-base is 126 in. The two engines develop 30 hp. each, and are mounted, one on either side, midway between the front and rear of the machine.

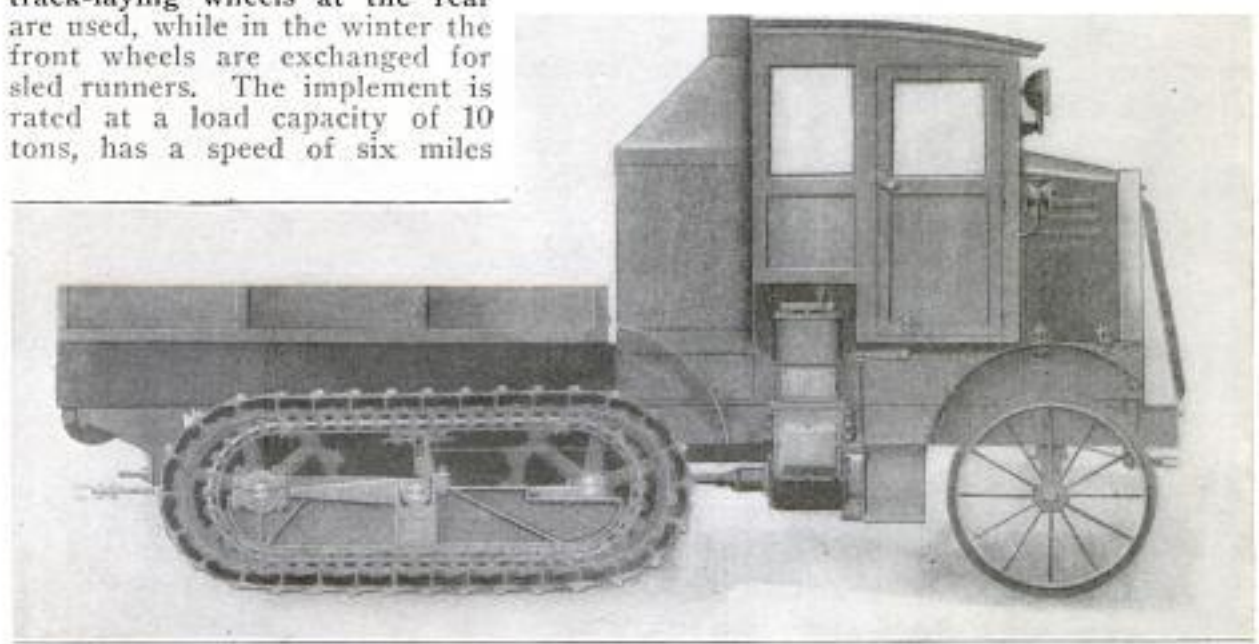

Steam Tractor Which is Equipped with Two Engines, One on Each Side, and Which was Specially Designed for Use in the Lumber Industry of the North: In the Winter, the Two Front Wheels are Replaced with Sled Runners

Phoenix Mfg Co., Eau Claire Wis.

8788
Access

POPULAR

Christian Science
Monitor 4/12/22
8956

**AUTO SERVING TABLE STANDS
ON RUNNING BOARD**

Placed on the running board of any automobile, a new serving table can be quickly set up for the convenience of the



COPYRIGHT, UNDERWOOD & UNDERWOOD
This Gives an Idea of the Convenience of the New Auto Serving Table Which, When Not in Use, can be Folded and Occupies Little Space in the Car

hungry motorist. Lunches or refreshments can also be served on it at picnics or outings, and when not in use the table can be compactly folded so that it occupies very little space in the car. The construction is simple, and such that the table can be adapted to different cars.

**OLD CAPITOL AT WASHINGTON
GIVEN TO WOMAN'S PARTY**

Standing on a terrace, surrounded by huge shade trees, and within distant view of the great dome of the present Capitol, at Washington, is the old Capitol, in which President Monroe was inaugurated in 1817, and where congress sat from 1815 to 1819. The old Capitol has been divided into three houses, and these are to be remodeled into one great mansion immediately following its rededication, on May 21, with much elaborate ceremony, to the use of the National Woman's Party. This has been made possible through the generosity of a member, who gave the \$146,000 necessary for the purchase and reconstruction of the building. With the dedication of their new national headquarters the formal inauguration of the Woman's Party will be celebrated.

8902

**PRIZE CONTEST IN BED MAKING
FOR HOTEL CHAMBERMAIDS**

Of new efficiency contests there seems to be no end. Introduced at a fashionable California hotel for the amusement of winter tourists, the chambermaids' bed-making competition apparently takes first place for novelty. Lining up eight beds on the lawn of the hotel, the maids started at a given signal to make the beds assigned to them. Prizes were given not only for speed, but for the best-appearing bed, the neatest bed, the most securely tucked bed, and for a number of other points of perfection. A cup was later awarded the best of the bed makers, and she was declared California's champion in that event.



Left: The Novel Bed-Making Contest in Progress, with the Eight Beds of the Contestants Lined Up on the Lawn of the Hotel. Right: Awarding the Cup to the Champion Bed Maker; Prizes were Given Also to Some of the Other Competitors

Cont. Frank B. Howe, 4112 Mason
Opera House Bldg Los Angeles
Calif.

August Bryson, Chicago

Copyrighted material



COPYRIGHT, ROTHACKER FILM CO.

"Talking Pictures" in the Making: In the Center Is the Noted Actor, Frank Bacon, Delivering a Speech. At the Left Are the Camera Man, Promoter, and Director, While at the Right Is a Stenographer Who is Taking Down the Words of Bacon So That He can Later Repeat the Identically Same Speech.

8837 "TALKING PICTURES" MADE WITH AID OF RADIO

"Talking pictures" have been demonstrated as a practical possibility by Chicago men, who adopted the synchronization of radio and the motion-picture machine as the basis for their experiments. An ordinary picture is first enacted, then duplicates of this film are made and distributed to numerous theaters. The actors and actresses now repair to a radio-broadcasting station, where the original picture is thrown on a screen before them. As the story unfolds on the screen, the assembled cast again speak their parts, simultaneously with the action of the film. The projection machine in the station controls the starting and the operating speed of the machines in the theaters, so that, as the voices are broadcast, the different audiences are entertained with a synchronous blending of both action and sound, all of which makes the picture seem almost lifelike.

8972 MANHOLE AND STREET DRAIN IN COMBINATION INLET

Combining a manhole cover and a street drain in one casting, is the result attained by a recent invention. The drain is installed in a bed of concrete, with the top of the drain hole on a level with the top of the curb. The cover is fitted securely into the manhole opening with a bar, which locks it in place.



"Radio with your shine," is the motto of a western bootblack who has installed a radiophone, together with a large sound magnifier, in his stand. Customers dropping in for the daily polish are entertained with broadcast concerts and news from a radius of 4,000 miles.

East Dubuque Foundry Co. Dubuque, Iowa.

Dr. W. Water Is. Hill The Engineer
4135 N. Kenneth Ave

860

3/31/22

8714 Chicago MITER-SCRIBING INSTRUMENT FOR IRREGULAR SURFACES

An ingenious patented device makes it as easy to scribe a miter on a surface with irregular and curved contours as

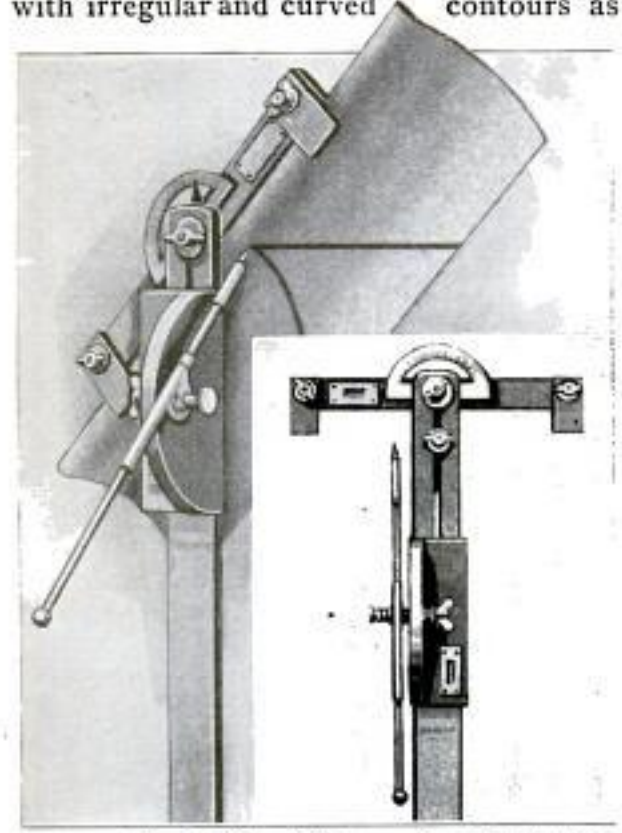

Instrument for Scribing Miters on Irregular Surfaces, Such as a Gutter or Eaves Trough: It can Also be Used for Laying Out Slopes at Any Required Angle

on a flat surface. The instrument will be particularly useful to tanners, and fitters of eaves troughs, and for scribing miters on gutters. It will also be useful to woodworkers, particularly to cabinet and pattern makers. In addition to scribing miters, the instrument can, of course, like any other of its type, be used for laying out slopes at any required angle, or as a simple straightedge.

8944 COPPER-SULPHATE WATER IS TIMBER PRESERVATIVE

In some of the western mines the water that is pumped from the mine contains a considerable amount of copper sulphate, and experiments have shown that this acts as a preservative in protecting the mine timbers against decay. Timbers which have been allowed to soak in this mine water for two or three weeks, sometimes outlast three sets of untreated timbers.

8854

AUTOMATIC AERIAL CONVEYOR FOR SHINGLE BOLTS

Among the cedars of a mountainous locality in British Columbia, the engineers, in connection with a shingle mill, have built an ingenious conveyor for the shingle bolts, or bundles, that is entirely automatic. The conveyor has a length of three-fourths of a mile, and there is a difference of 900 ft. in elevation between the heading where the bolts are loaded onto carriers and the terminal where they are automatically dumped on a platform, for reloading in railroad cars. Between these two points are stretched aerial cables, on which the carriers run with trolleys. The loaded carrier is automatically locked to the haul-back cable, and in descending, its accumulated momentum is sufficient to return an unloaded ascending carrier, and also to run a small electric-lighting plant.

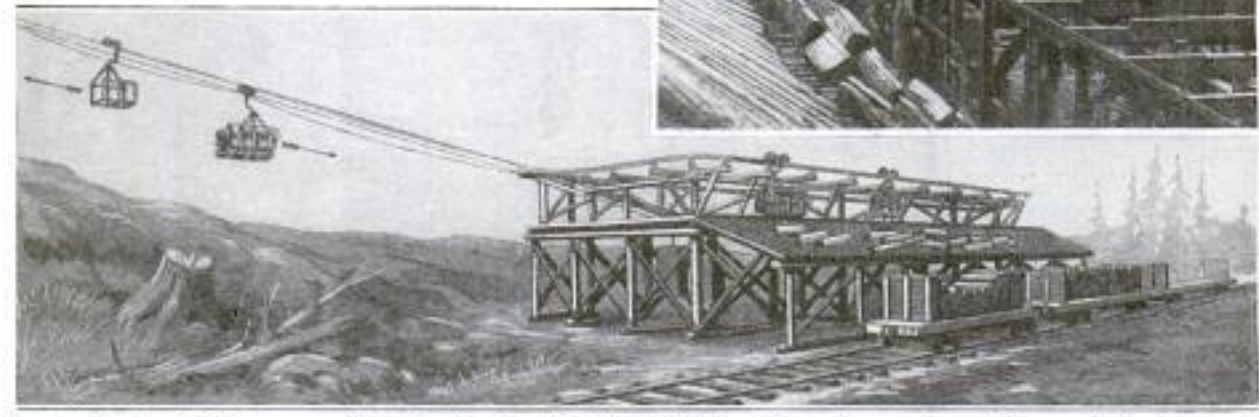

Automatic Aerial Conveyor with a Carrier Loaded with Shingle Bolts, Shown Descending and, by Force of Gravity, Driving Upward an Unloaded Carrier, as Indicated by Arrows: In Foreground Is the Dumping Platform for Reloading onto Railroad Cars. Insert Shows a Loaded Carrier Leaving the Heading

Ent. Henry C. Copeland, 106 Winch Bldg, Vancouver, B.C., Canada

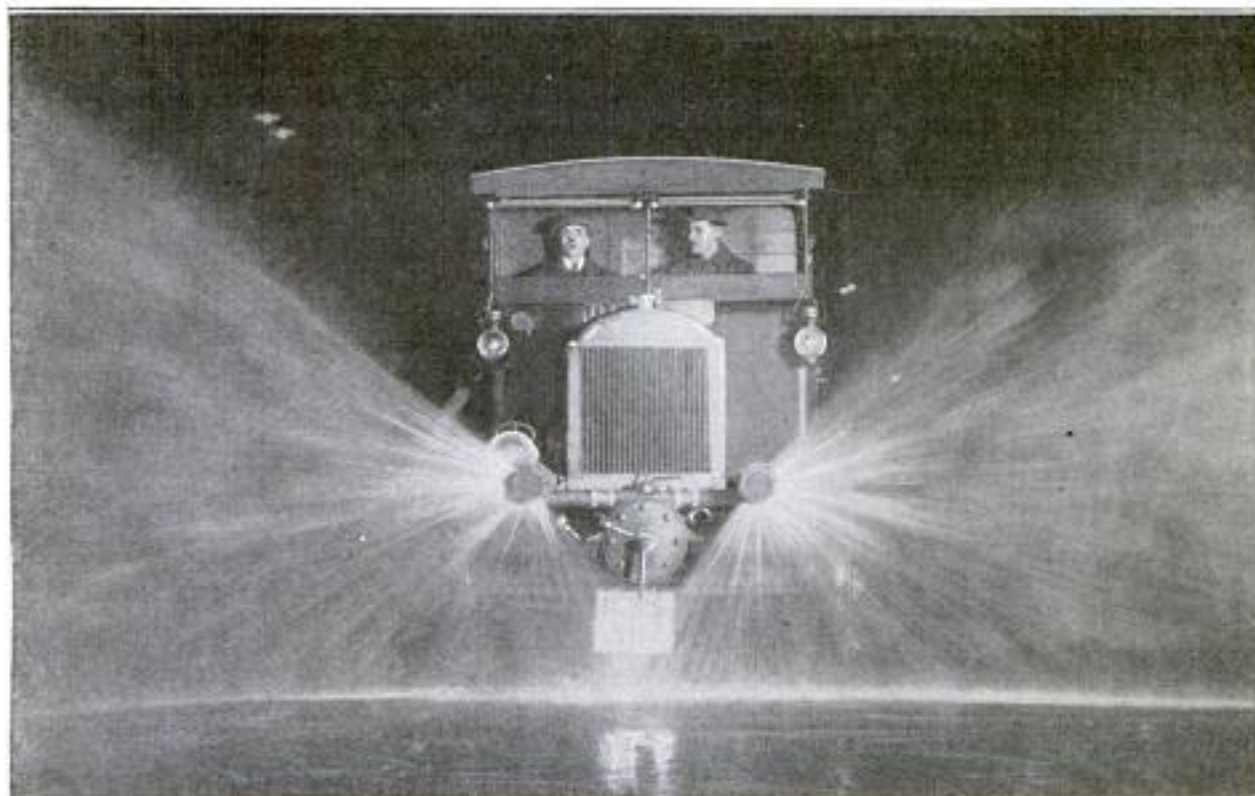

LONDON'S MIGHTY MIDNIGHT MOTOR STREET WASHER

U. S. U.

FOR many years, every night as the clock strikes twelve, every street in the West End of London, England, has been flooded and scoured with water. Formerly this was done with hose and sprinklers. Now it is being done with a motor street washer that has sprinklers mounted on the front of the powerful car, which throw the water in great streams to a distance of from 25 to 50 ft. The machine can be used also as a first-aid fire engine, as it will throw a jet of 175 gal. at 100-lb. pressure. The illustration—a night view—shows the machine operating as a street washer.

7865

Sketch 3/22/22 P. 484

MACHINE PLOWS AND HARROWS SOIL IN ONE OPERATION

A harrow is now being manufactured which, the makers claim, does the work of the ordinary plow and the disk harrow in one operation. In place of disks it has knives, which cut and pulverize the soil to a depth of six or seven inches. These knives are shaped like boat propellers, which gives a rolling effect and leaves the ground well plowed but smooth and even on the surface, so that a single trip with the machine over a field will give sufficient preparation for seeding.

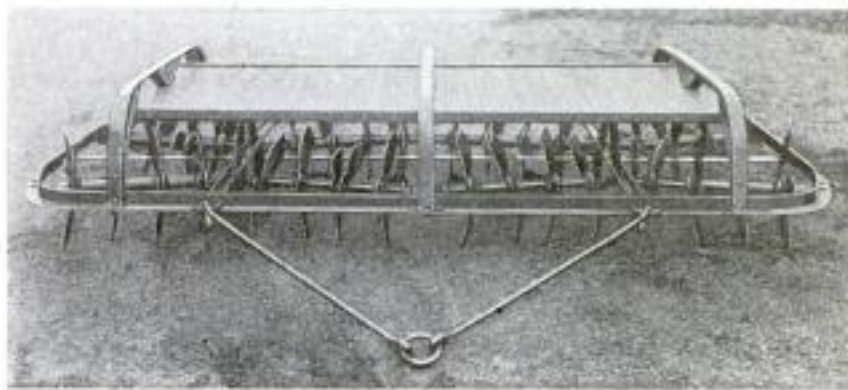
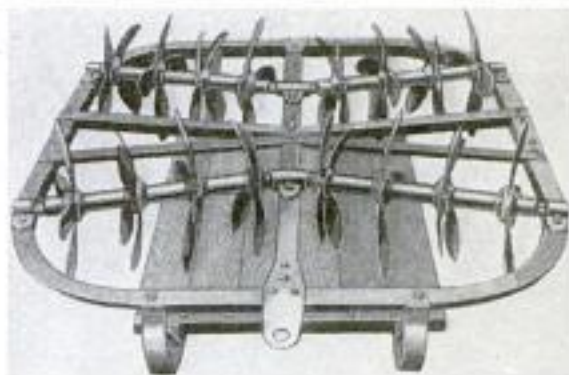

Above: Bottom View of the Harrow Resting on Its Skids, Ready to be Moved to the Next Field. Below: In Operation, the Propeller-Shaped Blades Cut and Turn the Soil, and Leave a Smooth Surface

According to recent announcement, the Japanese are producing, from the inner bark of the mitsumata plant, a good grade of vegetable leather which is said to be almost as tough as the so-called French kid.

No record of maker.
Cook Arthur Hallam

*Wm. H. C. Sawyer
Jacksonville Terminal Co.*

862 POPULAR MECHANICS
8798 Jacksonville, Fla.
**CARRIER FOR SHIPPING EGGS
STANDS ROUGH HANDLING**

Because of the enormous loss occasioned in shipping eggs, the problem of a

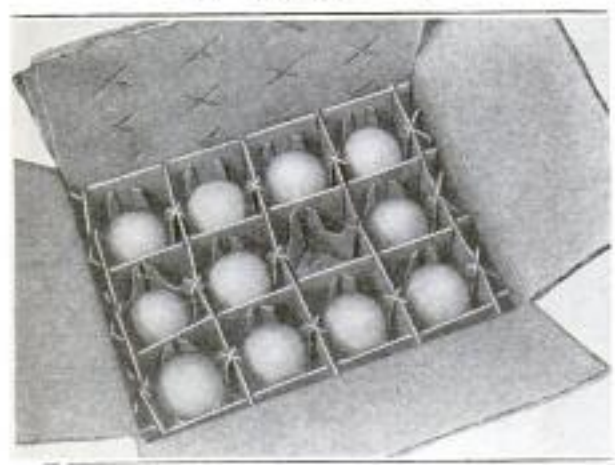

In This Egg Carrier, the Diagonal Strips of Cardboard inside the Rectangular Openings Form Flexible, Individual Protecting Pockets for the Eggs

design of an efficient carrier is a fertile field for research. As hens do not work to any standard, the carrier must have a certain amount of flexibility, and yet be rigid enough to protect the fragile contents. In a recently patented carrier, diagonal strips of cardboard, placed inside the usual rectangular openings, hold the eggs in individual pockets which are protected from the shocks received in shipment.

8905 **AUTO ELABORATELY EQUIPPED
FOR CAMP AND OUTING USE**

Elaborate equipment has been installed in a motor-car camping outfit designed and built for a Philadelphia man. The body of the car has wide doors fitted with locks, and all the windows are operated

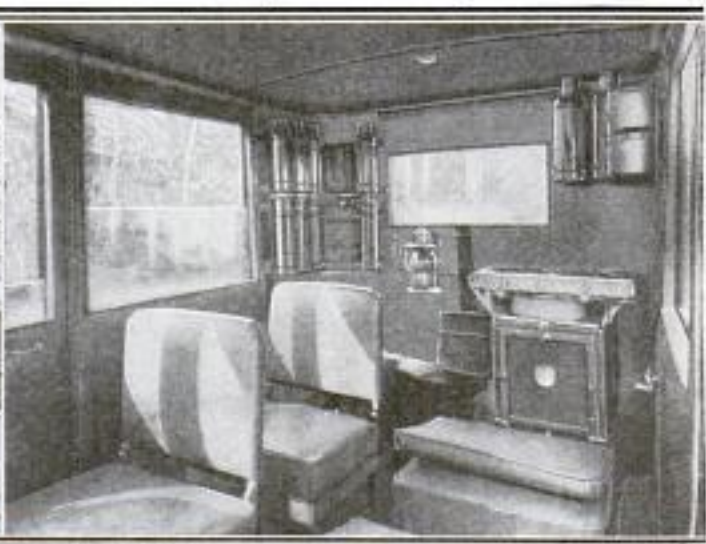

Motor-Car Camping Outfit: Left, Exterior of the Specially Designed Machine, Showing the Wide Doors and Numerous Windows, Right, Interior, Showing Cookstove, Vacuum Bottles and Jars, and Other Equipment

*Huxley Huber Auto Body Co., Philadelphia
40th + Mt. Vernon Sts., Pa.*

by a mechanical locking arrangement. The interior is finished in gray art leather, and has folding, or removable, seats for day use, while at night four canvas hammocks can be swung. Inside the machine, at the rear, is a marine-type cookstove with burnished sheet-aluminum paneling around it, and which has a copper fuel tank. Numerous shelves, brackets, and compartments are provided for lantern, vacuum bottles and jars, sugar, spice, tea, and coffee containers, and other outing necessities.

8743 **SANITARY PAPER FLY TRAPS
MADE ORNAMENTAL**

Sanitary on account of its effectiveness, and not unsightly, is a newly patented paper fly trap.

It is collapsible on a dished base so that it is convenient for storage or shipment. It is made of decorative paper, and it expands into a cage, ornamentally shaped, with a conical top of lighter color than the bottom, so as to attract the flies upward. The flies enter the trap through small openings at the base, whither they are attracted by tempting food. The trap may be suspended from the top or stood upon its base.



*J. H. Shelly
Sanitary Fly Trap & Paper Co.
3235 Franklin Blvd. & Acornmonte Calif*

864 21

POPULAR

8951

SALUTATIONS IN LETTERS WITH METAL LABELS

BLUE COTTON NOW BLEACHED TO INCREASE ITS VALUE

A very snappy salutation in connection with a letter is conveyed by means of a thin metal label, 1 in. square, with the word "Greetings" embossed on it in bright gold letters. This is attached to one corner of the paper, and is held there by two small triangular catches bent against it.

The greeting is good all the year round, and is used by business concerns to take the chill off formal letters.



Cotton growers and manufacturers will be interested to learn that a method has been discovered whereby the bleaching of blue-bender, blue-Texas, or blue-stain cotton, is a practical possibility. The redemption of this product, heretofore cheapened because of its color, is expected to prove a boon to planters all over the world.

As a means of visualizing the methods of manufacture of American machinery and products, and their use, motion-picture films are to be made by the Bureau of Commerce in coöperation with the Bureau of Mines. The films will be distributed in this country and abroad.

8765

TRACTOR-DRAWN BRUSH PLOW FOR LAND CLEARING

Breaking down and burying dense brush growths under the furrow slice may seem impossible, but this feat is successfully performed by a recently invented brush plow, which is drawn by a power-

growing brush, and small trees up to 15 ft. in height and 3 to 4 in. in diameter, covering the whole with earth. Land-clearing experts, judging from lately conducted tests, expect that the new plow will revolutionize present-day methods. Undoubtedly, it will greatly speed up the work of clearing brush-covered land, and prove invaluable to settlers engaged in this labor. The development of the brush plow is the last step in the mechanical clearing of cut-over land.

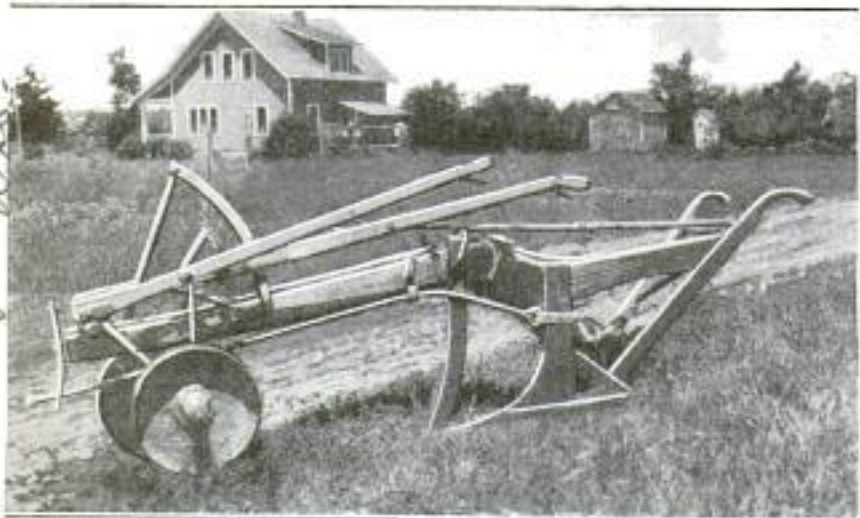

The High-Arched Beam of This Original Brush Plow was Hewn from the Trunk of an Oak and Reinforced with Iron Bands

ful tractor. The plow has an arched beam that increases the clearance from the ground 8 in. over that of the ordinary implement, and enables it to bury in the furrow standing brush of any size that the tractor is able to override. It is claimed that the outfit will actually break down



The Tractor-Drawn Brush Plow in Operation: Because of the Extra-Large Clearance in the Throat, the Brush Plow can Turn Under Any Standing Growth That the Tractor Is Able to Override

L. F. Wrammes + Sons, Allentown, Pa.
Mrs. Frank Conrath, Ladysmith, U.S.A.

Com. Robt. P. Thompson, Jr.
815 Wall St.
Port Huron, Mich.

Dr. William Prucha
1132 - 8th St
865
8828 San Diego, Calif.

POPULAR MECHANICS

8902 TERRIFIC BOILER EXPLOSION ON LARGE FERRYBOAT

SIMPLE CAMERA ATTACHMENT FOR STEREOSCOPIC VIEWS

The boiler of a ferryboat that plied between Port Huron, Mich., and Sarnia,

The amateur photographer who has taken pictures and later been disappointed



Wreck of the Ferryboat After Its Boiler Exploded: In the Background Is the House upon Which the Shell of the Boiler Landed

Ont., burst with terrific force on March 26, last, while the boat was lying in the Black River. The shell of the boiler was hurled 100 ft., and landed on a house, which was completely destroyed, the red-hot coal in the fire box igniting the neighboring houses, and causing much damage. The hull of the ferryboat was torn to pieces, and the fireman and engineer were buried in the wreckage. Two deckhands were hurled 25 ft. to their death, and besides these four men killed, there were 17 persons injured.



View of the Shattered Hull of the Ferryboat Lying in the Black River, Michigan, Showing How Completely It was Wrecked When Its Boiler Exploded

by the flat appearance of the prints, can now arrange to take stereoscopic views with his regular camera. A simple attachment can be fitted on the tripod which holds the camera in correct positions for

Aeromantics 2112910
DRIVE RADIO GENERATOR WITH SINGLE-BLADE PROPELLER

In the effort to eliminate head resistance and produce a clearer and more constant tone for radio transmission from airplanes, a generator driven by a single-blade propeller has been tested. This generator is carried on a special mounting on the side of the fuselage, and preliminary trials indicate that better



results may be had with this style than with the older styles of generators.

Com. John W. Keane
Bureau of Navigation,
Navy Dept., Washington,
D.C.



This Simple Attachment, Fastened on the Tripod, Makes It Possible to Take Stereoscopic Views with the Regular Camera

taking the two views of the object necessary for producing stereoscopic pictures.

Recently a musical program, played on a phonograph at the Canadian wireless station at High River, Alta., was heard by a station on Maui Island 100 miles from Honolulu, or about 2,800 miles from the sending station.

8947

SHREVEPORT CHURCH HAS MANY UNUSUAL FEATURES

By ARCHIE RICHARDSON, *254 Stoner Ave Shreveport La.*

A RADIO broadcasting station with a coast-to-coast radius and a 10-story tower are novel features of the First Baptist Church of Shreveport, La., erected at a cost of \$500,000, and used for the first time Sunday, April 9. The structure, uniting a main building of four

carillon of 13 bells, and the connecting rooms of the main building provide for a Sunday school of 3,000. A roof garden has accommodations for 1,000, and will be used for regular services, concerts, and social meetings in the summer. There is also a banquet room that seats 500 at two

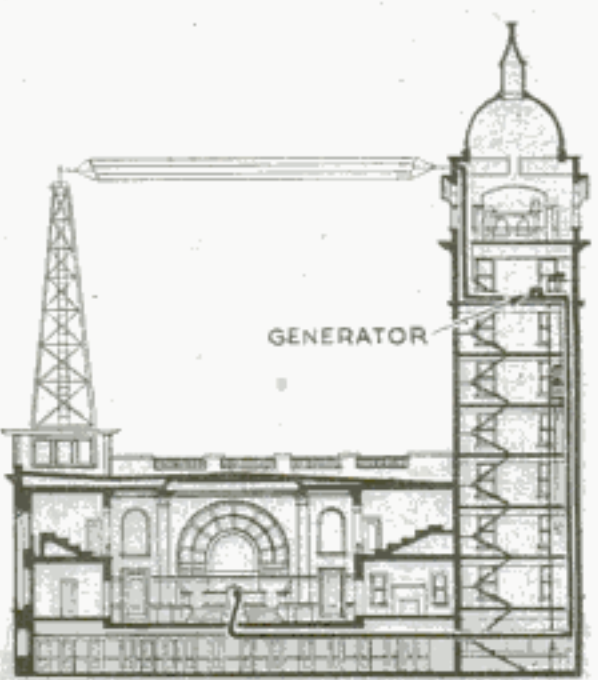
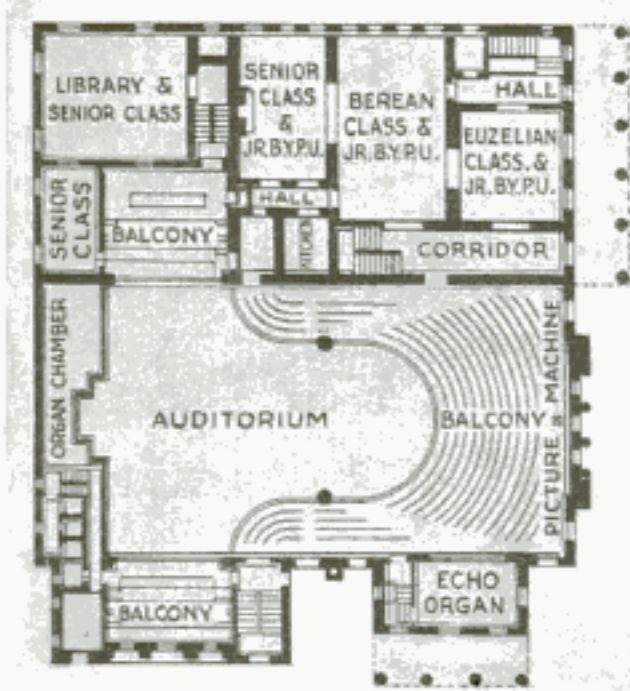

Third-Floor Plan of Church Building, Showing Arrangement of Special Rooms for Classes, and Auditorium with a Seating Capacity of 2,500 to 3,000 Persons

floors and the 10-story tower, contains 51,000 sq. ft. of floor space, and accommodates 7,000 persons.

The main auditorium has a seating capacity of 2,500 to 3,000, and is equipped with a four-manual organ, with echo set, and chime connection for special music features. Even the deaf are provided for in this church, for a so-called acousticon has been installed in the pulpit and connected with the pews by concealed wires. The tower, on the ninth floor of which is installed a

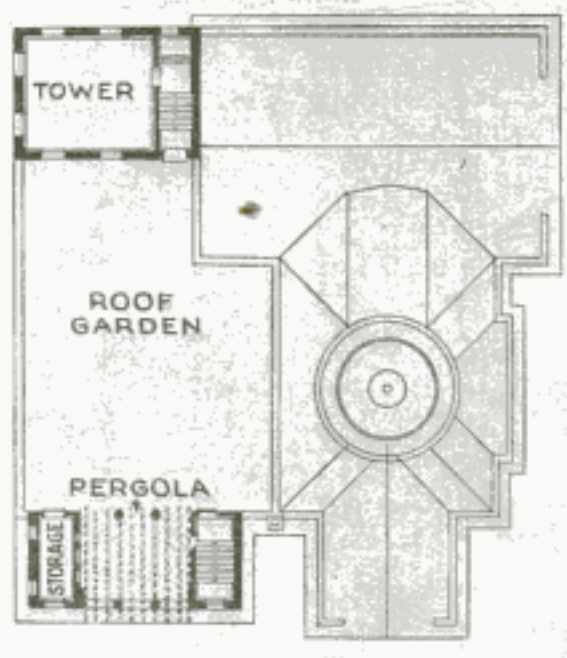

This Roof Garden, with a Seating Capacity of 1,000 Persons, will be Used in Summer for Concerts and Social Meetings

Section through the Church Building, Showing Wires Leading from the Pulpit to the Radio Generator on the Eighth Floor of the Tower and Thence to the Antenna

tables, and a nursery in the basement is provided with sand piles and, under supervision, cares for children of mothers who are attending services, or who are occupied during the week. The dining rooms of the church furnish noon lunches to several hundred working girls daily, besides serving banquets several times a week.

Situated almost in the heart of Shreveport's business district, the tower dominates the city's skyline.



Above: This Church in Shreveport, Louisiana, is Four Stories High, with a 10-Story Tower, Seen in the Center Background. Below: Close-Up of the Tower; a Wireless Antenna will Reach from This Tower to a Steel Tower to be Erected at the Right, and will be Used for Broadcasting Sermons to Smaller Churches in the Surrounding Country

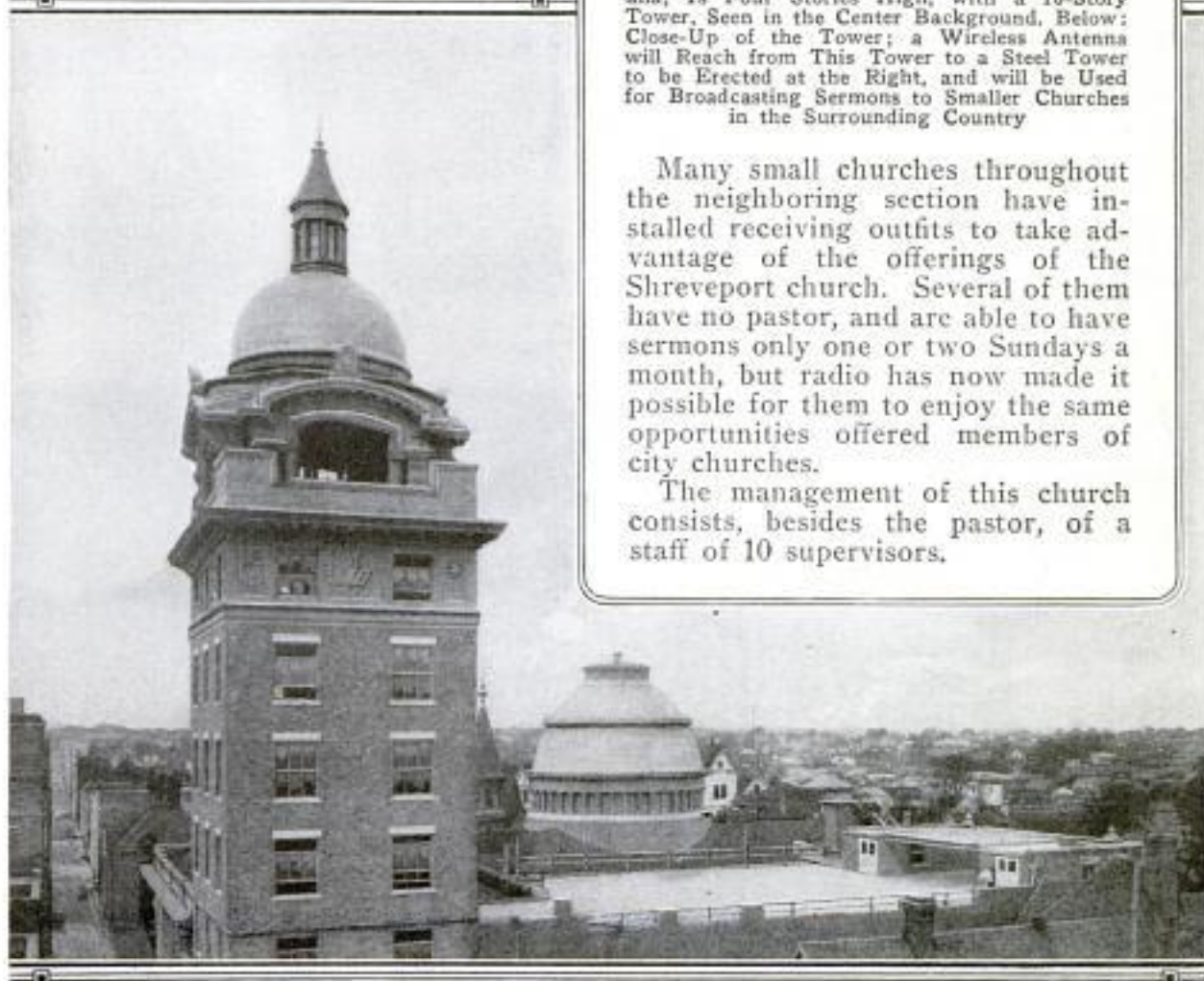

Many small churches throughout the neighboring section have installed receiving outfits to take advantage of the offerings of the Shreveport church. Several of them have no pastor, and are able to have sermons only one or two Sundays a month, but radio has now made it possible for them to enjoy the same opportunities offered members of city churches.

The management of this church consists, besides the pastor, of a staff of 10 supervisors.

Cml. Felix J. Koch
325 Hearne Ave.
868
Avon, Cincinnati, Ohio

Cml. E. H. Bernhardt
Engl. Bernhardt & Co.
Buffalo, N. Y.

Barnes Circus
Frank H. Jones, 9009
15 Row St. Astoria, Ore.

POPULAR MECHANICS
WOODEN LEG FOR ELEPHANT
AS ADDED ATTRACTION

An elephant having a wooden leg would be a rare and curious sight, at least so



Wooden Leg Which is Fastened to the "Knee" of the Elephant in Preparation for the Gaze of Curiosity Seekers

thought the proprietor of a small circus, recently, when he had a peg constructed for one of these huge animals. The peg, solidly fashioned of 4-in. oak, has a metal cap at the top for the insertion of the elephant's "knee." With this makeshift limb—only worn during the day—the behemoth hobbles around, much to the wonderment of the spectators, and the resultant free advertising incidentally yields lucrative financial returns to the owner.

lack of ventilation shows scarcely noticeable effects in short periods of observation or tests, in the long run they may become very injurious. Therefore, extensive studies are often made, taking into consideration even such things as the direction of rotation of all moving parts of the machine, with a view of designing and arranging types of blowers that will properly ventilate the machine.

OVERHEATED AIR COMPRESSOR STOPPED BY FUSIBLE PLUG

Fusible plugs are being used in South Africa to protect air compressors, and pipe lines in connection with them, from excessive heat in the air, with accompanying formation of dangerous pressures. When the plug fuses it releases by means of a valve the overheated air from the mains, and at the same time acts on another valve that shuts off the steam supply to the compressor engine. To restart the compressor, a new fusible plug is inserted, and the valves are resealed. Compressed-air systems in South Africa are likely to suffer from overheating on account of the almost constant high atmospheric temperatures.

The Engineer 10/14/21

NEAT CONTAINER FOR SENDING TOKENS OF FRIENDSHIP

Instead of sending candy and flowers in separate packages, it is now possible to combine these tokens of affection in one attractive package. A container has been devised with space at the top for candy, an individual flower holder and water compartment in the center, and a division

VENTILATION OF MACHINERY INCREASES EFFICIENCY

Investigations covering many different kinds of machines, especially electrical machinery, have shown conclusively that machines need constant ventilation to render them more efficient. Rotating machinery, or machines which have a large number of smaller working parts, such as printing machinery, textile, paper, and grinding machinery, and practically all electrical units, need moving air about them to carry away fine dusts and fumes that, sooner or later, raise havoc with the moving parts of the machine. Excess heat and static charges of electricity are practically eliminated by currents of moving air, particularly if the air is properly conditioned, or moistened, before being passed over and about the machine. While

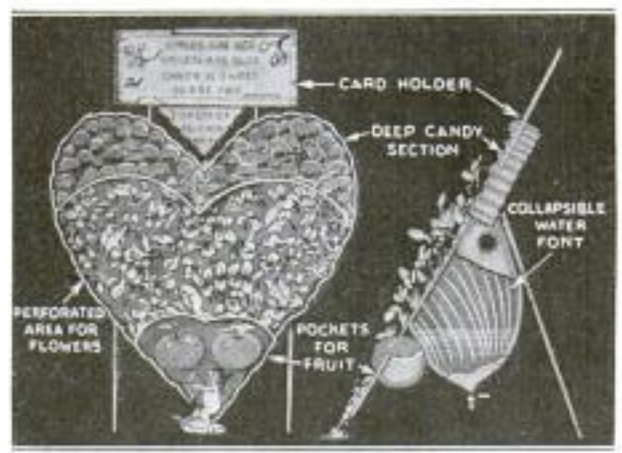

This Novel Gift Holder Provides Spaces for Candy and Fruit, and a Flower Holder with Water Container Below

for fruit at the bottom. A card at the top, bearing an appropriate sentiment, completes the assembly.

M. V. Bauer, 2443
18th St. N. W.
Washington, D. C.

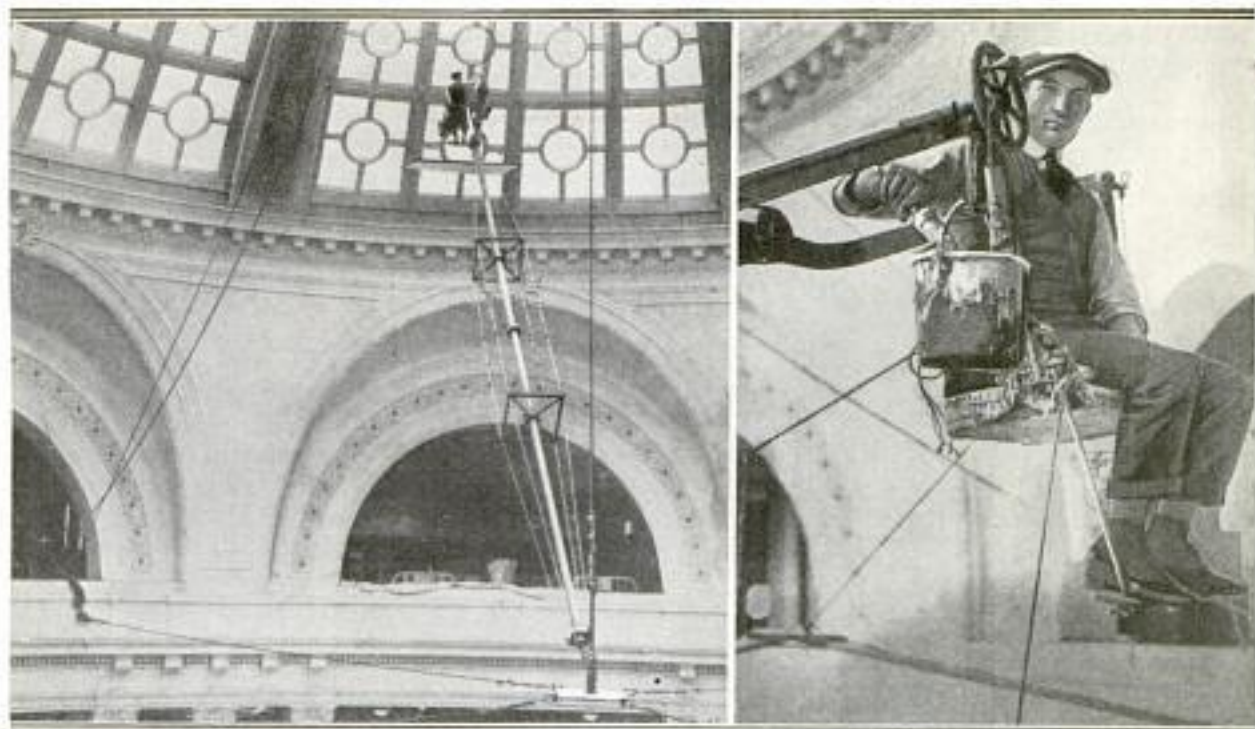

Scaffold for Painting the Large Dome in a San Francisco Department Store: At the Left It is Suspended with Its Boom That can be Swung Around, Raised or Lowered, and Lengthened or Shortened. At the Right Is a Close-Up of the Painter's Seat

8920.
**CLEVER METHOD OF PAINTING
 INTERIOR OF LARGE DOME**

Over the main part of one of San Francisco's biggest department stores is a large dome, and the building superintendent of the store has devised a very ingenious scaffold to facilitate the painting and cleaning of it. Suspended from the center of the peak to about the level of the bottom of the dome is a steel cable, which is rigidly braced by four guy ropes. Pivoted at the bottom of this cable is a long derrick boom, from the end of which is slung a comfortable seat for the painter. This boom can be swung around the dome, raised or lowered, and lengthened or shortened, so that any part of the face of the dome is easily accessible.

Aeronautics—Accident
**TWO LONDON-PARIS AIR-ROUTE
 PLANES COLLIDE AND FALL**

On April 7, two airplanes flying in passenger service between London and Paris, collided in mid-air about 70 miles north of Paris and fell in flames, with a loss of six lives—three passengers, two pilots, and a mechanic. The crash was due primarily to the fog, as the pilots were unable to see each other until too late to avoid collision. The planes were flying at an elevation of about 400 ft. when the crash occurred. This air route has been in operation since 1919, and has been re-

markably free from accidents, considering the large number of passengers carried, as this is only the second fatal accident. The other occurred when a plane, in taking off, struck a tree.

8941
**CORRUGATED RUBBER TUBES
 FOR AUTOMOBILE TIRES**

Corrugated red-rubber tubes for automobile tires are the latest addition to the field of motoring, and are the offering of a New York inventor. The purpose of the corrugations is to prevent overheating, sticking, and pinching of the tube within the tire. The innovation is also claimed

Corrugated Red-Rubber Tube Inflated and Ready for Use in a Tire: Insert Shows a Cross Section of the Corrugated Tube, Displaying the Thickness of the Rubber



to aid the vulcanizing process, and to increase the life and elasticity of the rubber.

*Corrugated Rubber Corp.
 25 W 43 rd St
 Poughkeepsie, N. Y.*

*Cml. Chas. W. Isinger,
Powell & Sutter
San Francisco Calif*

*The Electrical Review
3/24/22*

POPULAR MECHANICS

**COMMERCIAL FLYING SERVICE
STARTS IN CALIFORNIA**

**USE OF PHONOGRAPH TO MAKE
MOVING PICTURES AUDIBLE**

8970
A passenger air route has been established between Los Angeles and San Francisco

8978
The use of the phonograph in connection with moving pictures to make the actor's speech audible has been tried for some time, but never with very satisfactory results. A demonstration was recently given in England of a newly invented apparatus which electrically synchronizes the lip movements of the actors on the screen with the sounds emitted by the phonograph. That part of the problem was solved perfectly, but there still remained the characteristic defects of the phonograph, such as the scraping of the needle, and occasional harshness or indistinctness of the voice. These defects were enhanced by the amplifier horns, which were indispensable in spreading the sound over a large auditorium. If these shortcomings can be remedied, and clearness of enunciation, together with tonal volume, can be obtained, the perfect synchronization of the new apparatus should make audible moving pictures a practical success.

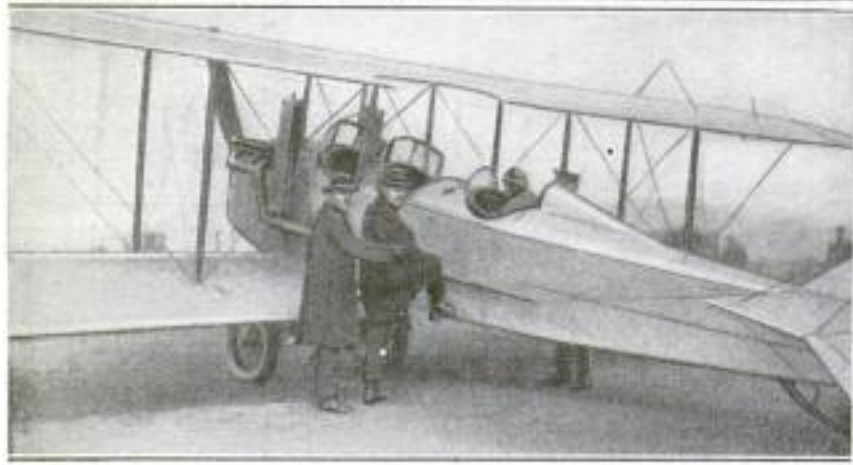

Above: Five of the Airplanes That Made the Flight When the Service was Inaugurated. Below: A Close-Up of One of the Planes That Carries Four Passengers and Pilot

Francisco, Calif., and two regular trips will be made each day. Flying time between the two cities will be five hours, with a stop at some central point for luncheon and rest. The single-trip fare is \$50, and the distance approximately 400 miles.

Ⓢ A portable radiographic installation has been set up on Flores Island, near Montevideo, Uruguay. It is to replace the submarine telegraph which has hitherto connected the island with the mainland.

with tonal volume, can be obtained, the perfect synchronization of the new apparatus should make audible moving pictures a practical success.

8760
**FOLDING BED FOR TOURISTS
FITS REAR AUTO SEAT**

When touring by automobile, it is essential that all available space should be utilized to the greatest possible advantage. With this in view, a bed has been constructed which, when folded,

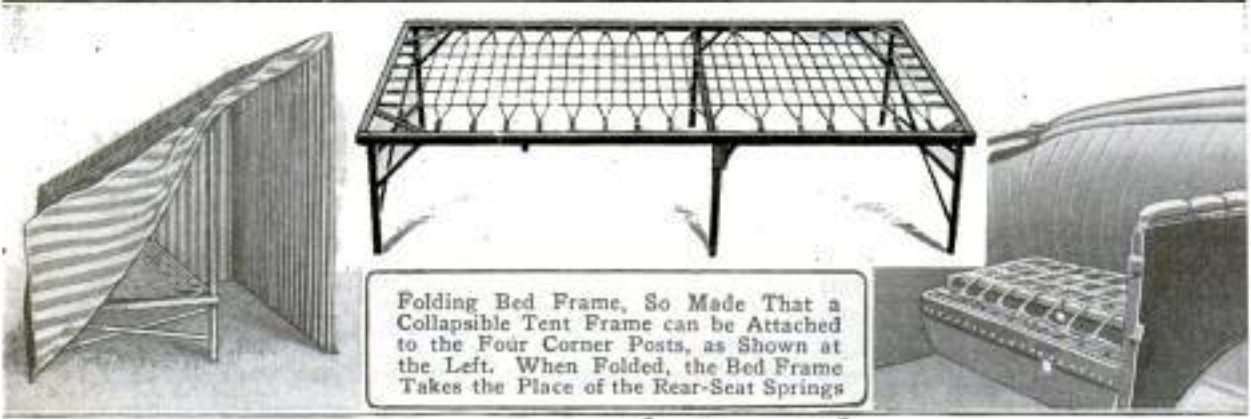

Folding Bed Frame, So Made That a Collapsible Tent Frame can be Attached to the Four Corner Posts, as Shown at the Left. When Folded, the Bed Frame Takes the Place of the Rear-Seat Springs

*Spiro's 301 Market St.
San Francisco Calif*

Chicago

takes the place of the springs in the rear seat, while the mattress and bedding can be used as a cushion. When the bed frame is extended for sleeping, a folding tent frame can be attached to the four corner posts of the bed, making a serviceable shelter in case of rain. In this way the tourist is assured of a comfortable bed at night, and also makes good use of the space in the rear seat by day.

8883

Access

IMPROVED AUTOMOBILE TIMER HAS ONLY TWO WIRES

On a certain popular light automobile the standard timer in connection with the motor has four wires, two of which, being next to the fan belt, are soon damaged by it. In order to avoid this, a new timer has been brought out that has only two wires on the side that is away from the belt. Another improvement in this new timer is extreme simplicity, there being only one moving part. Furthermore, the contact maker revolves with the camshaft. The revolving and stationary contacts are made of copper, and the

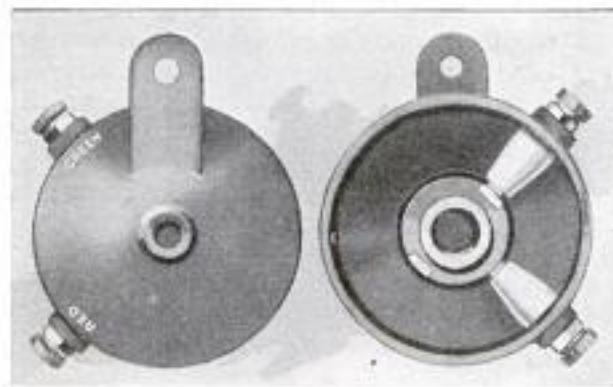

Outside and Inside Views of New Timer with Only Two Wires, to Replace, on a Popular Light Automobile, the Standard Timer Which Has Four Wires, Two of Which are Easily Damaged by the Fan Belt

brush holders are of brass. All these parts are inclosed in a bakelite case that is perfectly nonconducting, and is rust and moisture-proof.

8938

LOUD-SPEAKING REPRODUCER FOR DICTAPHONE RECORDS

A new dictaphone reproducer has been invented, which is claimed to be far superior to present instruments of its class. In place of the usual sound box, there is a small device containing an armature held between the poles of a magnet, and the grooves in the record impart the vibrations to this armature and set up electric currents, as in the

ordinary dynamo. The volume of sound can be altered by shifting a small lever, and increased to such a degree, it is



This Dictaphone Reproducer Makes It Possible to Secure a More Accurate Control of the Volume of Sound

claimed, that head receivers are not necessary. This tone-control feature has special appeal where many persons dictate on the same cylinder.

8782

ORDINARY SEAL HAND PRESS MADE INTO FOOT PRESS

Converting ordinary hand presses of any size, such as are used to emboss corporate seals on stock certificates, bonds, or other documents, into a foot press, has been made possible by an eastern inventor. With his machine, this is accomplished without drilling any holes, removing the dies, or in any way altering the hand presses which are quickly inserted, or taken from the outfit to be replaced with a different seal. The apparatus is of rugged and simple construction and requires but little more than one square foot of floor space.



Dr. Paul Leo, Elizabeth, N.J.

*Dr. Edward J. Jones,
3997 Dumaine St.
New Orleans, La.*

Cmt. J. B. Holdcroft,
1485 7th St

872
Victoria, B. C., Canada

8939
MECHANICS

WORK ON CANADIAN DRYDOCK ORDERED ABANDONED

It is not often that a work of the magnitude of the drydock which was being built at Esquimalt, B. C., by the Canadian government, is abandoned in an incomplete condition. Work had been in progress on this contract for over a year and more than \$1,125,000 had been spent, when peremptory notice was received from the authorities by the contractors, ordering immediate cessation of work. Although rumors had been afloat for some time that a temporary shut-down might be ordered, pending an investigation by the new government as to the advisability and necessity of this work, the order to quit came as a complete surprise to all parties concerned, couched as it was in such terms as to leave the inference that abandonment was intended.

In the 12 months since construction commenced, 160,000 cu. yd. of rock were excavated, and over 100,000 cu. yd. of material dredged from the approaches to the dock site. Several large timber cribs, intended for portions of the permanent work, were also constructed and in process of receiving their filling of concrete, preparatory to being sunk into position.

As to the cause of the abandonment order, nothing definite is known, although it is thought that the outcome of the disarmament conference at Washington, together with the Japanese treaty arrangements, probably have a good deal to do with it. Esquimalt has for many years been the most important British naval station on the Pacific coast.

9008

TREES GROW FROM STONE BAGS USED AS FLOOD PROTECTION

In protecting the embankment of a railroad in Chile that was in danger of being washed away by flooded streams, wire bags filled with cobblestones and small boulders were used extensively. In placing the stones in the heavy, galvanized-wire bags, many willow sticks were forced in among the meshes of the wire. The bags were placed end to end along the river's edge for several miles. Some time later it was observed that the willow sticks had taken root among the rocks and were growing rapidly. Accumulating sediment from the river aided the growth until finally a most desirable hedge of young willow trees still further aided in keeping the waters of the river from encroaching on the roadbed.



General View of the Uncompleted Drydock at Esquimalt, British Columbia, Work on Which was Stopped by the Government: The Dock was to have Been 1,100 Feet Long and 110 Feet Wide

Cmt. Frank H. Jones, 15 Rowe St.
Auburndale, Mass.

8747

W. H. Jordan Co. 1st Calumet
Trust Savings Bank Bldg
East Chicago, Ind.



Wing-Type Ditcher at Work on a Railroad: The Wing or Scraper Attached to the Heavy Car, Which is Moved by a Locomotive on the Track, is Adjusted to Give the Desired Section to the Ditch at the Side of the Roadbed. The Wing Cuts the Soil and Shoves It Ahead

DITCHING MACHINE DOES WORK OF MANY MEN

IN the great work of extending and maintaining America's railway systems, the ditching machine plays a prominent part. Recent improvements have made the present-day ditching machine a wonder worker in changing the appearance of a railroad's right of way. When it is considered that a modern machine can do as much work in a day as a gang of 200 section hands, it is apparent that such a machine must represent real construction economy.

The wing type of railway ditcher has been developed from the old-type spreader car. A heavy car is equipped with a scraper blade, or wing, that is shaped to conform to the standard section of the ditch and roadbed shoulder. This blade cuts the soil and shoves it ahead until it can be thrown clear of the roadbed. A larger type of machine has wings on both sides and can thus clean the two ditches at the same time.

In operating the machine, it is often necessary to make three or four runs through the cut, depending on the nature of the soil. On the last run, a steel template is

used on the bottom of the wing to finish the roadbed shoulder, ditch, and side slope to standard form. When working under average conditions, a machine should move about 400 cu. yd. of material in a day and finish almost a mile of ditch.

A heavy locomotive is required for this work. It is run at a speed of four to eight miles per hour, varying according to the quantity and nature of the material



Last Run of Ditcher being Made with Steel Template on the Bottom of the Wing to Finish the Roadbed Shoulder, the Ditch, and the Side Slope to Standard Form

to be handled and the condition of the track. When the second wing is used, much back haul is eliminated. With both

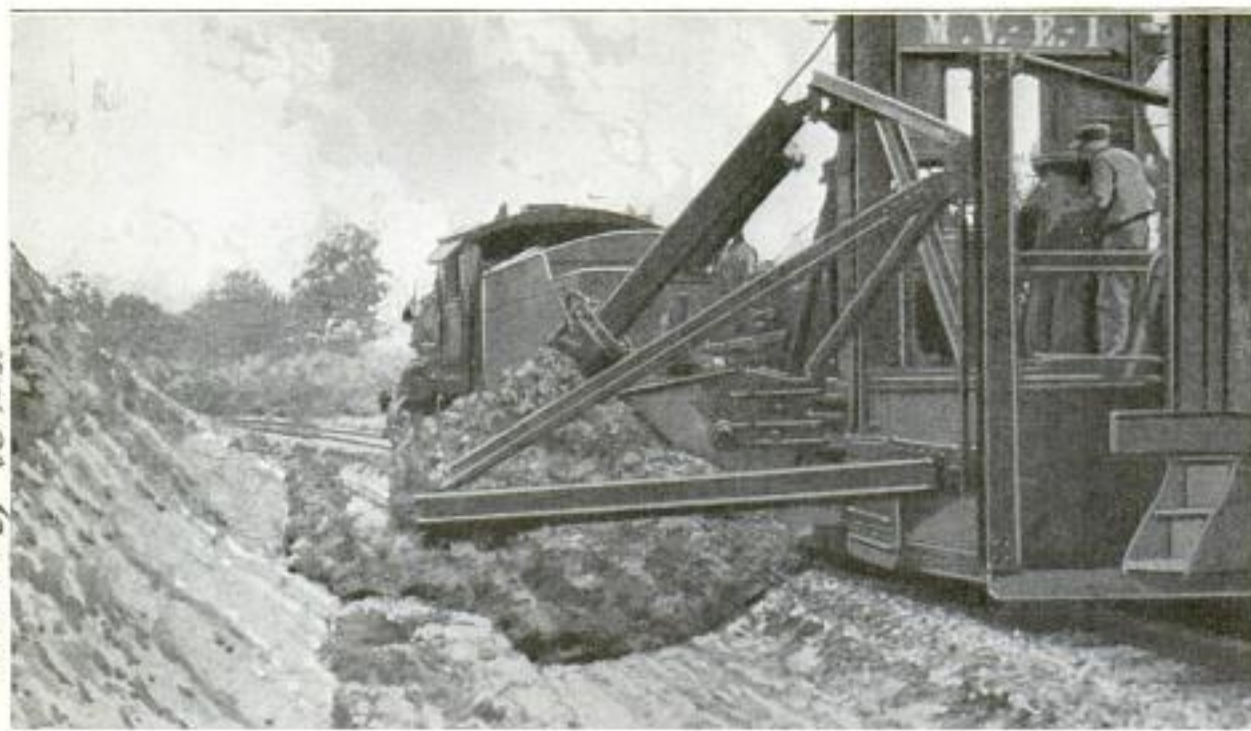

Another View of the Wing-Type Ditcher Making the First Cut in the Process of Forming the Ditch and Roadbed Shoulder: The Steel Frame Supports the Air Cylinder That Operates the Wing, Which Is 15 Feet Long and 5 Feet Deep

Wings in operation, the outfit is so balanced that a higher speed is possible. To operate this outfit, only one or two men are needed in addition to the regular crew.

The car is fitted with cast-steel cutting shoes that clear the track of obstructing

material. An upright steel cross frame supports the vertical air cylinders used for operating the main wings. The wing measures 15 ft. in length and 5 ft. in depth. For transportation, the wings are folded compactly against the car.

AUTO SPEEDOMETER CHANGED TO MAKE SOIL SURVEYS

In making the traverse surveys necessary for the production of soil maps to a scale of 1 in. to the mile, which are

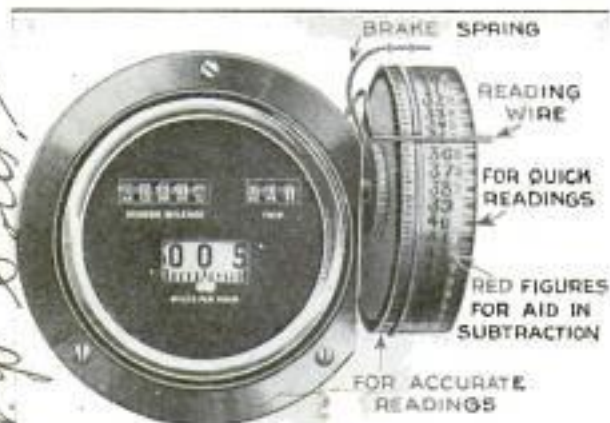

Standard Automobile Speedometer Changed to Make Possible Measurements in Hundredths of a Mile, Registered on the Large Dial Attached to the Trip Setter of the Speedometer

being made everywhere by the U. S. Bureau of Soils, measurements were taken in the past by the use of the com-

mon odometer attached to the front wheel of a buggy. Now that the buggy has been replaced by the automobile, the odometer has been replaced by the speedometer. As this instrument in its standard form records only .1 mile, changes had to be made to make readings possible to .01 mile. The speed and season-mileage registers are left unchanged. In connection with the trip-mileage register, the trip setter that extends from the side of the speedometer head is changed so that it is permanently connected to the trip-mileage gears. On the shaft of the setter is then screwed, and locked with a nut, a large dial with a scale on its circumference graduated to suit the required readings.

It has been found that copper salts added to casein glues greatly increase their resistance to moisture and also make them more durable when exposed to the action of molds and fungi. Glues containing little lime are specially improved by the addition of copper, which does not shorten the life, or period of workability, of the glue, as much as an addition of more lime would.

AMUNDSEN TO ATTEMPT NORTH POLE FLIGHT

By Lawrence W. Pedrose

Hinchley Bldg.
Seattle, Wash.

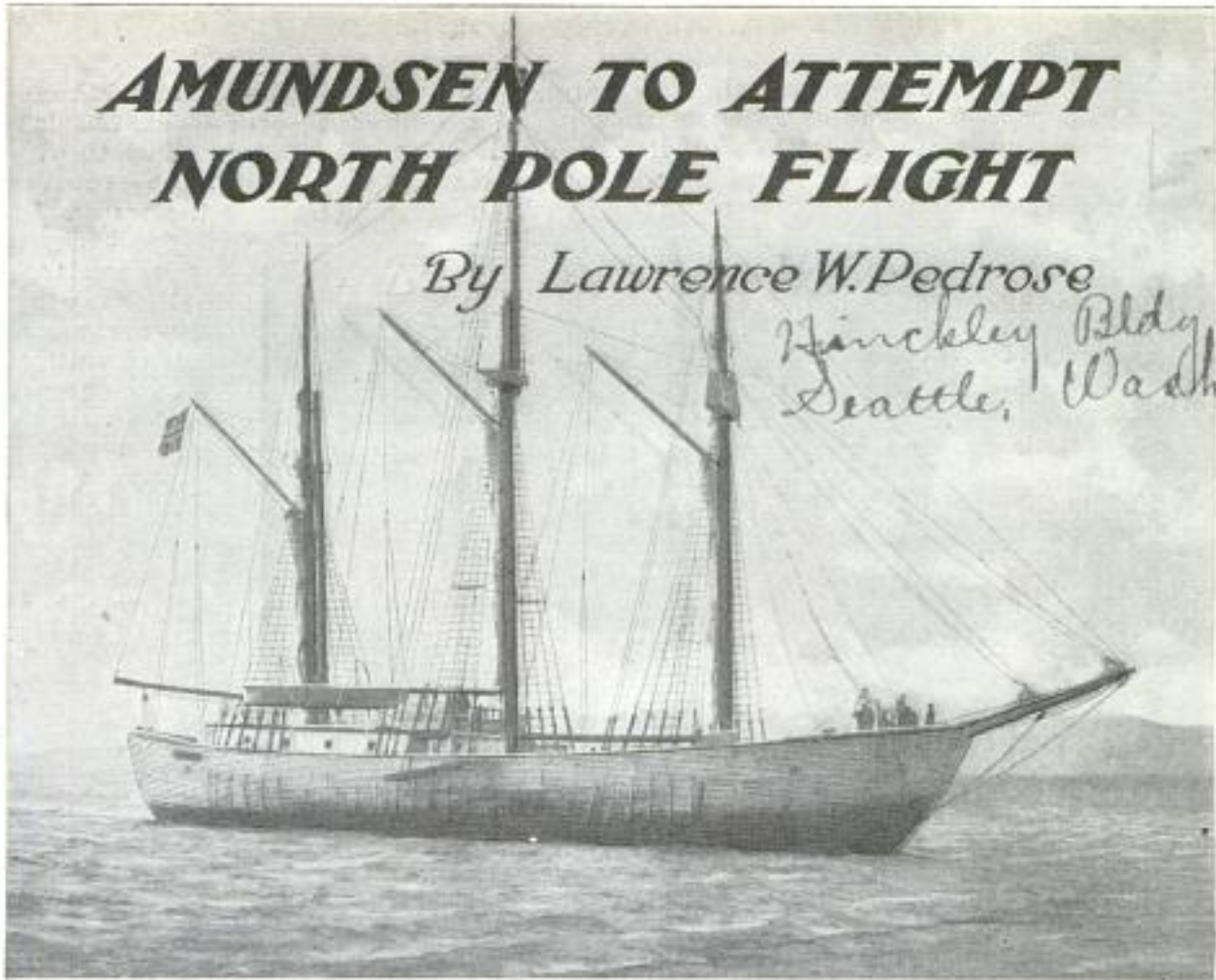

The Three-Masted Schooner "Maud," Leaving Puget Sound on Its Second Trip to the Arctic Regions, in Command of Captain Roald Amundsen and with a Picked Crew: The Intention Is to Enter the Ice Floes before Winter, and after being Frozen In, to Drift with Them across the North Pole

OUTFITTED and provisioned for a seven-year cruise, the power schooner "Maud" left Puget Sound early this month with Capt. Roald Amundsen, discoverer of the South Pole and conqueror of the Northwest Passage, and a crew of picked men, who will make a second attempt to drift across the polar basin in the vicinity of the North Pole. The "Maud" carries with it two airplanes, one of which is to be utilized, if necessary, for the final dash to the pole and return.

Captain Amundsen is a Norwegian scientist and explorer. He is 50 years old. He reached the South Pole in 1910-11. Financed by the government and King Haakon VII of Norway, Captain Amundsen left Christiania in July, 1918, and entered the Arctic through Bering Strait in the fall of the same year, intending to freeze in with the icepack and drift across the polar sea. However, the vagrant ice floes moved to the west, then east-

ward instead of to the north, and the "Maud" lost its propeller near Cape Serge, Siberia, in October, 1921. Short of supplies, Captain Amundsen returned to Nome, Alaska, and from there came to the United States.

At Seattle the famous exploring ship of Commodore Peary, the "Roosevelt," was chartered to succor the "Maud." The "Roosevelt" reached the "Maud" and towed it to St. Lawrence Island, where there was no ice to impede its progress, and it sailed under its own canvas to Seattle, 2,500 miles southward. As the "Maud" is flat-bottomed, without a keel, the feat is considered without parallel in Pacific marine annals.

Returning to Norway, Captain Amundsen perfected plans to continue his search for the North Pole. There he procured the services of a Norwegian-army flight officer to pilot the airplane, an all-steel JL-6 plane, obtained in New York,



Captain Roald Amundsen, Who Expects to Take the "Maud" to the North Pole

8803 826

which held the endurance record, having made a nonstop flight of 2,400 miles a few months previously. Because of its bulk, the machine was to be flown across the American continent before being dismantled and stowed away in the "Maud." Unfortunately, it was wrecked on the trip, but this did not alter Amundsen's plans, and the large plane carried will be able to take the whole crew out of the Arctic, should the ship be crushed in the ice.

Another modern invention, with which the ship will be equipped, is a long-range radiophone outfit, and it is not beyond the bounds of possibility that this Arctic voyage, far from being the lonesome venture of earlier explorers, will be relieved by frequent exchange of news or other information with the centers of civilization.

frozen into the polar icepack, thus making impossible a repetition of the last mishap. When the ship is ready to proceed under its own power, the propeller will be lowered again into the water.

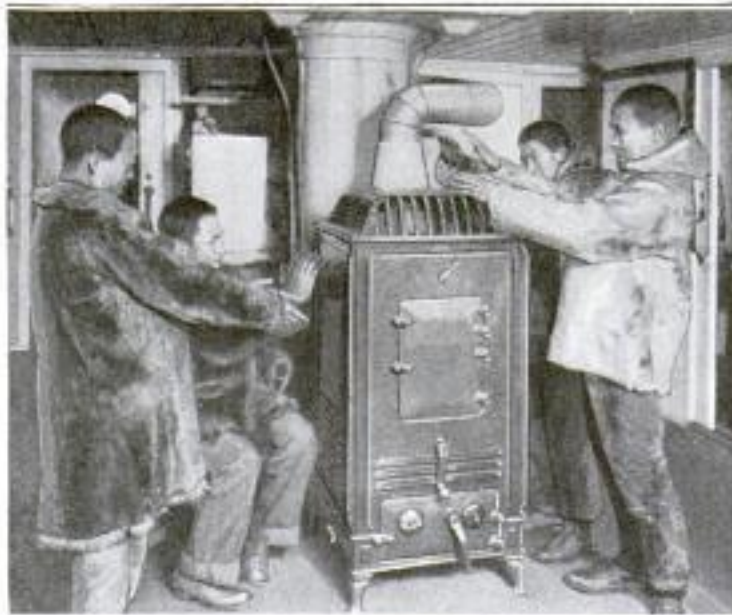

Comfortable Living Quarters on the "Maud," and Four of the Siberian Eskimo Sailors Warming Their Hands at One of the Heating Stoves with Which the Ship is Equipped

It is believed by scientists that the polar icepack, vast as a continent, is carried across the North Pole from the Pacific to the Atlantic and back again in cycles of three to five years. Many ships lost in the ice on the Pacific side of the Arctic have been disgorged by the floes, years later, on the Atlantic side.

Arctic via Nome, in time to nose into the eternal ice floes when the winter freeze begins. Once in the grip of the floes, the explorers will have nothing to do but drift, make observations, and gather magnetic and meteorological data. New lands

may be discovered and claimed, and it is possible rich mineral deposits will be found. These will accrue to the kingdom of Norway, under whose flag the "Maud" sails.

The personnel of the party will comprise eleven men: Captain Amundsen, commander; Capt. Oskar Wisting, personal friend of the explorer and his companion on the South Pole trip; Dr. H. V. Sverdrup, eminent Norwegian scientist; the pilot of the plane, and a crew of seven Siberian Eskimo sailors, who have remained with the "Maud" since the last unsuccessful attempt to reach the pole.



Part of the Crew of the "Maud," with Doctor H. V. Sverdrup and Captain Oskar Wisting in the Center, Scientist and Navigator Respectively, Who have Accompanied Captain Amundsen on His Various Explorations

The "Maud" has been fitted with a device for lifting its propeller when it is

enough to last seven years are carried, Captain Amundsen believes his ship will

emerge in the Atlantic Ocean within three to five years. It is expected the ship will reach a point nearest the pole in the early spring of 1924. With the "Maud" as a base for operations, the big plane will then be brought into use for the final dash to the North Pole, while the other plane, a Curtiss Oriole type, christened the "Kristina" before it was delivered to the explorer at Curtiss Field, on April 6, will be used for scouting purposes and other incidental service. It is equipped with an electric self-starter, can stay in the air seven hours, and like its mother ship will fly the Norwegian colors.

8880



COPYRIGHT, UNDERWOOD & UNDERWOOD

Christening of the "Kristina," at the Curtiss Field: In the Foreground, Left to Right, Are the Pilot, Lieutenant Omdahl; the Sponsor, Miss Lily Raynor, and the Explorer Himself

Access

ELEVATING END GATE ATTACHED TO MOTOR TRUCK.

The appearance on the market of a new elevating end gate for motor trucks should come as welcome news, not only to the driver who has to load the truck, but also to the merchant who is anxious to speed up deliveries and reduce costs. The elevator is attached to the rear of the truck and the

elevating gears are driven from the engine shaft, a simple shifting of a convenient lever raising or lowering the end gate. Should the truck be stuck in the

mud, the elevating screws may be used as jacks to lift the truck until skids can be placed under the wheels or the depressions filled in.

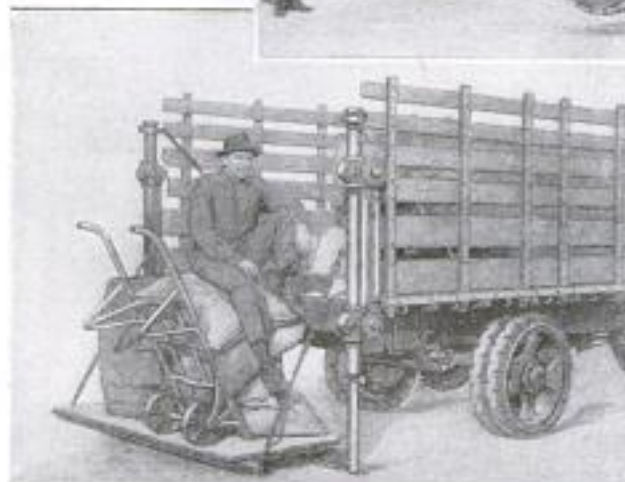

This Elevating End Gate Takes Much of the Labor Out of Truck Loading. The Hand Truck is Run onto Gate When in the Low Position, and by Shifting a Lever, Gears on the Engine Shaft are Thrown In and the Gate and Load Raised

*2 amw mfg Co
San Bernardino, Calif.*

893 WISCONSIN'S NOVEL METHOD
OF ATTRACTING SETTLERS

Wisconsin's method of adding to the population and wealth of the state is distinguished by absolute originality, and what is better, by unparalleled success. Like all states, not to mention Canada, where immigration is desired, Wisconsin uses printed pamphlets describing the attractive features of the state, but it uses these only as a secondary feature—the



Reduced Reproduction of a Large Chart, Showing by Dots the Locations of the 5,280 Families Who have Settled in Upper Wisconsin Since the War, as a Result of the Immigration Bureau's Work

primary feature of its method of attracting new residents, and of retaining them after settlement, being an entirely personal appeal, an appeal from man to man, from the director of immigration directly to the prospective settler, and a supervision of his interests after his arrival in the state.

This method can be best illustrated by describing a typical example. In reply to a bureau of immigration classified advertisement, there came an inquiry from a man in Iowa. In reply to this went a long personal letter from the director of the bureau, interpreting an accompanying pamphlet on "Farm Making in Upper Wisconsin," and pointing out the use of an inclosed "certificate of inquiry" to be presented to any person or firm from whom the prospective settler might purchase land. This certificate is a protection to the land purchaser, and it warns the land salesman that the Wisconsin Bureau of Immigration intends to keep in touch with the purchaser during the

whole transaction. • Thus is the immigrant in a large measure protected from falling into the hands of unscrupulous land agents, and should he nevertheless do so, he could appeal to the bureau to have his wrongs righted.

The first inquiry from the man in Iowa was followed rapidly by another, asking for a soil map of a particular county. This was sent to him, accompanied by a pamphlet on the subject, and another personal letter from the director of immigration, fully explaining the soil map and describing the characteristics of that county.

After that came several "follow-ups," all personal letters from the director with the object of maintaining the interest of the man in Iowa, and offering service by men who are experts in their respective lines of work. These letters make the prospective settler better able to avoid mistakes in purchasing and selecting land. Every branch of the Wisconsin farming industry is described, from land clearing to potato growing, with special pamphlets on each subject.

Then came the final punch, a short note with an intimate touch—so intimate that it even mentioned how irresistibly it made the director's stenographer smile at the very idea that the man in Iowa wouldn't realize how splendidly he could make good if he would come to Wisconsin. It was explained that every member of the department felt the same way about it as the stenographer, and the man in Iowa was asked kindly to "just write a note on the back of this sheet and return it to us in the inclosed stamped envelope."

The reply came within a week—not from Iowa, but from Wisconsin. That last note had converted the prospective into an actual settler.

The result of this kind of work has been that, since the war, 5,280 families have located in northern Wisconsin to develop farm homes. Two large charts have been made, one covered with dots representing new families located on the land during the last three years, and the other showing, with similar dots, each new family that has been directly assisted by the immigration bureau. The second chart has nearly as many dots as the first.

Corrosion of the iron apparatus used in the process of manufacturing sal ammoniac, can be prevented by allowing the solution to flow over pieces of calcium carbonate. Complete neutrality of the solution is said to be obtained by this method, which has recently been patented in Great Britain.

8904

S. L. Hurd, 2603 Canal St

POPULAR MECHANICS

New Orleans, La. 879

MACHINE LEAVES ONLY CHIPS IN PLACE OF STUMPS



When the Tractor Wheels Force This Machine Ahead, the Rapidly Revolving Cutter Arms Reduce the Stump to Chips in a Short Time, and Leave Only a Moderately Large Hole in the Ground, as Shown at the Left

The problem of removing stumps has been attacked from many angles, including burning, dynamiting, and the use of many forms of stump pullers. Now another machine has made its appearance which is a radical departure from the usual designs. At first sight it looks like

a wind wagon or a machine for testing airplane propellers, but in place of the propeller is a rapidly revolving four-blade cutter, which, when forced ahead by the tractor, reduces a stump to chips in a very short time. The engine furnishes all necessary power for traction and cutting.

8976

NEW FORM OF GUIDE FOR USE WITH LONG BELTS

In driving farm machinery, such as a thresher or sheller, from the drive pulley of a tractor, it is often difficult to place the two pulleys exactly in line. In order to prevent the belt from slipping off the pulley, a guide has been devised with flanged, conical rollers, which hold the belt in place but do not fray the edges as a stationary guide would.



to prevent the belt from slipping off the pulley, a guide has been devised with flanged, conical rollers, which hold the belt in place but do not fray the edges as a stationary guide would.

9031

ANCIENT MOUNTAIN HIGHWAY BECOMES MODERN RAILWAY

The most important of the old Norwegian highways crosses the Dovre, the most famous of all Norway's mountains, and for more than a thousand years was the main route between north and south. Now, in place of this mountain highway is a first-class state railway, which, although only 100 miles long, it required 10 years to build. The fact that only 10 miles a year could be built will be under-

stood when it is learned that 23 tunnels had to be constructed with a total length of about five miles, and altogether 20 bridges had to be built. Moreover, the railway had to cross a 3,335-ft. summit,

8875

SUPPORT FOR NONSWIMMERS MADE IN ANIMAL FORM

On the order of the inner tube of a tire, much used by nonswimmers to make floating and deep-water bathing safer and more enjoyable, a buoyant contrivance of a more elaborate character has been devised, that has the appearance of an exaggerated duck, or other amphibious animal. This improved float, or buoy, is not blown up like the tire tube, but is made of waterproof material filled with a very light packing. It surrounds the body of the bather, like the tire tube, but is much larger and has a duck's or other animal's head in front.



E. A. Levingburg New York
302 Fifth Ave

The Avery Co. Peoria, Ill.

Christian Science Monitor 4/18/22

Christ J. M. Harris Newark N. J.

Cmd. J. A. Winters
702 Electric National

880 896 4 Bank Bldg, Washington, D. C.
POPULAR MECHANICS

**RADIO OUTFIT COMBINED WITH
AIRMAN'S OXYGEN HELMET**

The use of the oxygen helmet has become a necessity when attempting record altitude flights because of the rarefied air



This is the type of suit which must be worn when flying at extremely high altitudes. The new oxygen helmet will also contain a wireless sending and receiving set

at the upper levels. The army air service has now designed an oxygen helmet in combination with a sending and receiving set for wireless-telephone messages, so that the airman may keep in communication with the ground station, no matter at what altitude he may be flying. The radio generator will also furnish current for the electric-heating elements contained in the airman's protective suit.

**NEW TYPE OF LEATHER BELT
TO PREVENT SLIPPING**

A type of leather belt that will not slip on a pulley has been invented in France. It is of oak-tanned leather and has riveted on the under, or pulley, side strips of chrome leather. The manufactured sizes are from 1 in. to 16 in. wide, with the chrome strips 3/16 in. wide by 5/32 in. thick, and a 3/16-in. space between strips. The rivet attachment consists of a single line of brass rivets, 2 in. apart, in each chrome strip. It is claimed that the combination

of oak-tanned and chrome leather gives the ideal of tensile strength in the former and efficient adhesion in the latter. In the ordinary belt the presence of air between pulley and belt is a cause of slipping; in the new form of belt any such air is squeezed into the spaces between the strips. Comparative tests with an ordinary belt and one of the new type, each 3 in. wide by 1/4 in. thick, showed the coefficient of friction of the latter to be greater than that of the older style.

8930
**MONUMENT UNVEILED IN PARIS
TO VICTIMS OF BOMBARDMENT**

It will be remembered that on Good Friday, four years ago, the church of St. Gervais, in Paris, was struck by a shell from the famous German long-range gun, located 75 miles away. A large congregation was in the midst of its devotions, and 91 persons were killed and 150 injured. On the fourth anniversary of this sad event the archbishop of Paris unveiled a monument in the restored church, erected to the memory of the victims.



Monument Erected in the Church of St. Gervais, Paris, to the Memory of the Victims of the German Bombardment, Good Friday, 1918

Designed to meet the peculiarities of the roads and local conditions, the first Japanese automobile has a wheelbase of 84 in. and a weight of 850 pounds.

International News and Corporation.

Cmd. G. J. Cone
8 Arch St. Flushing 9013

TEST AMPHIBIOUS MOTOR CAR ON RIVER RHONE



Paddles, Forming Part of the Four Wheels, Furnish Means for Propelling the Car in the Water



The Amphibious Car is Here Approaching the Bank of the Stream after Traveling on the Water



Two Float Tanks Supply Buoyancy for the Car When in the Water, and the Wheels are Drawn Up by a Special Arrangement So the Paddles will Be at the Proper Depth

Another new motor car which will travel equally well on land or water, the product of an inventor of Lyons, France, has proved successful in preliminary trials which have been held.

It was first tested on a canal in the neighborhood of the great silk center, and with 10 passengers on board developed a speed of 7½ miles per hour against the current. Before this preliminary trial it was driven along the road from the inventor's garage and after the trip made its way home with perfect ease.

A more exacting test has now been carried out on the swift-flowing river Rhône. Entering the water on the quay side, by way of one of the inclined planes used as

landing stages for small craft, the car was easily steered in face of a rapid current, and thus, traveling now on the road, now on the river, about 15 miles were covered during the tests.

Indeed, so successful was this second test that the inventor announced that he intended shortly to take his amphibious car to Calais by road and there try to cross the Channel to Dover. Propulsion in water is obtained by paddles, forming part of the four wheels, which are raised by a special mechanism when the car is floated. In this way the paddles are at the right level. This test car is fitted with a 14-hp. motor. Two float tanks support it when in the water.

8557

NEW AUTOMATIC BALL VALVE OF EXTREME SIMPLICITY

Consisting of only two parts, a noiseless automatic ball valve, the invention of a veteran journeyman plumber, is the essence of simplicity. The valve is in the form of a spindle, threaded into a socket so that when the floating ball in connection with the spindle is in the required position, the valve has moved onto a valve seat in the socket, automatically closing it. The thread has a large pitch, and the least movement of the ball reopens the valve. It is made of brass, and has little to get out of order.

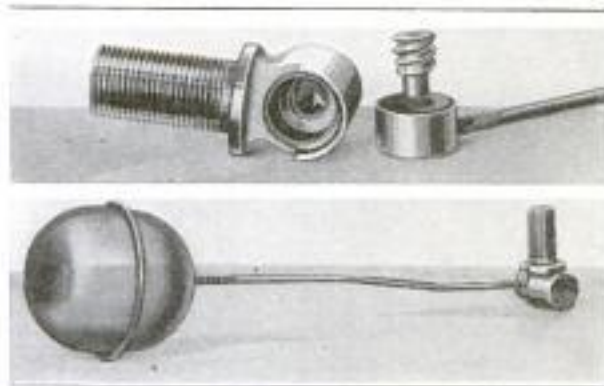

Simple Automatic Ball Valve Seen Assembled Below, and Disassembled Above, on an Enlarged Scale, Showing the Only Two Parts of Which It Consists—a Spindle and Socket

H. L. Kanter

Lash. Kanter Mfg. Co.
1408 S Union Ave.

Chicago Copyrighted material

FLOAT BRIDGE LATEST AID FOR ROAD BUILDING **EVENTS OF AMERICAN HISTORY TO BE SHOWN IN FILMS**

8718

Supplementing the work of the "finishing machine," a float bridge—the latest item of equipment for the construction of

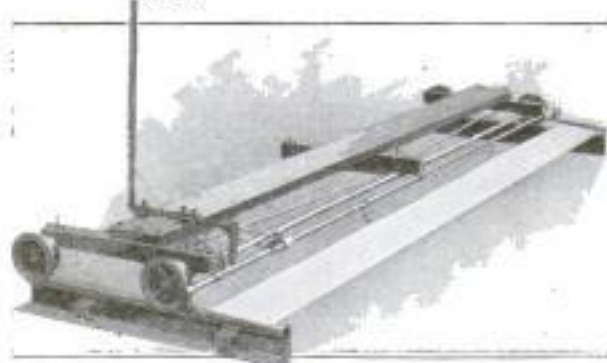

Combined Float and Bridge for Finishing Concrete Roads: The Smoothing Belt is Operated by the Lever Fastened to the Bridge, Which is Mounted on Wheels

concrete roads—has recently been developed by a Cleveland company. The essentials of the apparatus are a combined belt float and substantial bridge extending across the pavement, all of which can be easily handled by one man. A lever moves the smoothing belt back and forth over the soft surface of the work and at the same time automatically advances the machine with each stroke. It is claimed that after the concrete has been struck off, tamped, and surfaced, the use of the float bridge prevents the appearance of "hair cracks" in the finished product.

That the study of American history may be made something besides the mere drudgery of memorizing names and dates, is presaged by the announcement that many of the more important events are to be made the subjects for motion-picture films. More than one hundred reels are to be made under the auspices of Yale University, and every effort will be made to have all details authentic.

ELEVATING-PLATFORM TRUCK HAS GASOLINE MOTOR

Elevating a platform, 26 in. wide by 54 in. long, with a load of 4,000 lb., from a minimum of 11 in. to a maximum of 16 in. from the floor in eight seconds, is possible with a new gasoline-driven truck. The lifting mechanism is operated by hydraulic pressure derived from a 15-hp. 4-cyl. tractor engine, which is mounted at the rear in a closed compartment containing the transmission, governor, vacuum tank, radiator, etc. The machine has a forward and reverse speed of six miles per hour, will climb a 10-percent grade fully loaded, and has a brake-lever pedal so arranged that the removal of foot pressure automatically causes it to stop. High-grade roller and ball bearings are used in the running mechanism.

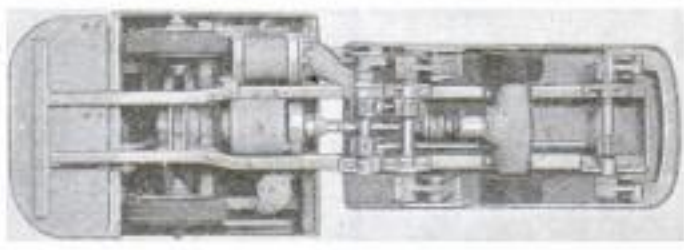

Elevating-Platform Truck being Used in a Machine Shop for the Purpose of Transporting Heavy Bins Containing Miscellaneous Unfinished Parts from One Department to Another: The Control Levers, Gasoline Tank, and Siren Horn can be Plainly Seen in Front of the Operator. The Insert Gives a Bottom View of the Elevating-Platform Truck and Shows the Lifting Mechanism Which is Actuated by Hydraulic Pressure Derived from the Engine

The ROMANCE of the RECALLED MAIL



By Grace Orb, 106 North
St. W. Lafayette Blvd.

DID you know that there is a department in Uncle Sam's postal service whose business it is to "snatch back" letters for the sender—letters which, if delivered, would entail all kinds of undesirable consequences, every possible phase of human tragedy or comedy? On the quick action and accuracy of the employes in this department oftentimes hinges not only hundreds of thousands of dollars, but even human life itself. Thirty thousand such cases were handled by the Chicago office during last year.

A man, holding a high position with an eastern corporation was going from New York to San Francisco. He stopped off in Chicago in order that he might get some special-delivery mail which was to meet him there. This mail was coming from the West, and on its receipt at this point hinged a \$2,000,000 contract and the decision as to whether he should go straight on to San Francisco or return at once to New York; should he fail to receive it, not only the contract would be seriously jeopardized, but he would be left in a quandary as to his next move. On his arrival he went to the hotel and asked for his mail, and was told by the clerk, "Yes, we did have some mail for you, but we have just sent it back to the post office. You know our instruction was to hold mail for you 24 hours and then forward to Kansas City. Sorry; it has not been gone half an hour." By some unlucky chance his mail had arrived 24 hours ahead of him. And he dared not miss those letters! He went at once to the postmaster, and with the assistance of the hotel authorities, explained his dilemma, proved his identity and ownership of the mail, and it was rescued for

him just as it was about to be placed in a bag bound for Kansas City. The man was saved and all was well; but the margin of safety was exceedingly narrow.

Another instance: A young man (well groomed, but evidently much disturbed in mind) came into this department of the service one day; gave his name as John S., and wanted to get back a letter addressed to Miss Mary Blank; said he had put a "wrong inclosure" in this letter, and it was extremely important that it be corrected. He gave proof of his ownership of the letter and it was given back to him on the reason given by him—"wrong inclosure." But, being wise in human lore, the employe knew that John had probably (in a fit of anger or jealousy) written a nasty letter to Miss Blank (perhaps breaking his engagement to her) and mailed the letter immediately; a little later he came to, regretted the letter, and wanted to get it back.

Many, many times in the course of a year this kind of situation arises, and the postal service turns omnipotent and holds up the consequences of the letter written on the impulse of the moment.

A large manufacturer was sending out price lists to his outlying representatives; some 20,000 of these letters had just been placed in bags and sent to the down-town post office. A wire came in that market prices had gone up. If those letters should be delivered, he would be the loser by thousands of dollars. There was quick action, the regular forms were resorted to, and with strenuous effort the letters were intercepted before they left the city office.

Of the many reasons given for the recall of mail, that of "wrong inclosure" predominates; and these words are a convenient symbol for the letter written in



"John had probably (in a fit of anger or jealousy) written a nasty letter to Miss Blank . . . a little later he came to and wanted to get the letter back."

8804

haste, or for the changes necessitated by the fluctuations of the market. Practically 90 per cent of the requests for the recall of mail come from the railroads, and nearly all are local recalls. Telegraph recalls average only about one per day in the Chicago office.

However, the law makes provision for the recall of mail anywhere (with the exception of mail sent to Great Britain or its colonies, to which reference will be made later), whether it be before it leaves the post office of the sender, en route on train or ship, or in a foreign country. Application is made by the sender to the local postmaster for a recall, giving the reason for such, and he wires either the railway clerk or the postmaster of the addressee (at the expense of the sender, who also deposits a sufficient sum of money to cover return telegram or cablegram, as the case may be). The letter is returned, the sender calls for it, and leaves a receipt which is kept on file. A foreign recall is handled through the second assistant postmaster-general.

This course of procedure applies generally except to Great Britain and its colonies. Here the law considers the letter which is once posted to be from that time on the property of the addressee. The United States takes the other view; namely, that a letter is the property of the sender until it has been placed in the possession of the addressee. Hence the whole procedure rests upon the sender's establishing his ownership of the mail to be recalled. While this law proves a mighty boon to many an anxious indi-

vidual, it is easily evident that the exercise of the greatest possible care is necessary, or the wrong piece of mail may be given back, or given to the wrong person, or to one who is desirous of using it for some illegitimate purpose. Nevertheless the romance clustering around this particular department of the postal service is exceedingly interesting and offers almost as varied an appeal as does the human equation itself.



"The local postmaster wires either the railway clerk or the postmaster of the addressee (at the expense of the sender, who also deposits a sufficient sum of money to cover return telegram or cablegram, as the case may be)."

vidual, it is easily evident that the exercise of the greatest possible care is necessary, or the wrong piece of mail may be given back, or given to the wrong person, or to one who is desirous of using it for some illegitimate purpose. Nevertheless the romance clustering around this particular department of the postal service is exceedingly interesting and offers almost as varied an appeal as does the human equation itself.

8910
**GIGANTIC
 TURBINE
 PLANT
 DESIGNED**

A German professor has prepared a design of a super-power station in which the units will be of 160,000 kva. each, or almost three times as large as the largest turbo-generators that have so far been constructed. The turbines are designed as double-flow machines, with steam admission in the center and exhaust at both ends. The weight of each unit will be about 600 tons, of which the rotor represents nearly 222 tons. Each station will have six units, one being held in reserve. One hundred boilers of 10,750-sq.-ft. heating surface each, will be required, and the cooling water necessary could be supplied only by a large river. The station would consume 50,000 tons of coal per week, which would be handled in trainloads from the mines and dumped into bunkers at the station, to be fed into the boilers by bucket conveyors. It would be transported from storage by overhead railroads. Five of these super-power stations would be able to supply the total power demand of Germany.



"The letter is returned, the sender calls for it, and leaves a receipt which is kept on file."

Sup. *James Trade*
 3/18/22 *Registered material*

Balboa Canal zone

runaway truck
RUNAWAY TRUCK DEMOLISHES ARMY BARRACKS

WHILE delivering coal with a truck in the Panama Canal Zone, the driver attempted to back the machine against a coal shed, which was located on the lower side of a road leading up a hill, and lost control of the vehicle. Breaking through the light guard rail at the edge of the highway, the heavy truck plunged down the incline and crashed into a large building being used as an army barracks. The impact was so great that the building collapsed, as shown in the accompanying photograph, burying beneath the debris a soldier, who was the sole occupant and who received but slight injuries from the unusual accident.

5526

trial
WHITE CEMENT BLOCKS FOR CROSSING MARKERS

A new method of outlining the limits of street crossings, which does away with the necessity of painting the lines on the pavement once or twice a year, has been adopted by the city of Portland, Ore. White cement blocks, 6 in. in cross sections and 2 ft. long, are set into the pavement with their edges flush with it. They are slightly crowned on the top side so that they project about 1 in. above the surface at their centers. Each street intersection requires 56 of the blocks to outline the four crossing limits, there being seven of them placed on each side of each crossing. Hydraulic cement, mixed with a solution rich in celluloid, is used in making the

blocks. The latter ingredient has the effect of producing a very hard, tough, durable, glasslike finish which, it is thought, will withstand heavy traffic.



Hydraulic-Cement Blocks are Used to Mark Street Crossings in Portland, Oregon. Being Exceptionally Smooth, Hard, and Tough, They are Expected to Last Several Years, Thus Eliminating the Yearly Painting Job.

Bureau of Public Works, Portland, Oregon.
Commissioner - A. L. Barber

EVAPORATOR TUBES ARRANGED
 IN DIAGONAL LINES

A new type of evaporator has been designed which appears to combine the advantages of the older styles in which

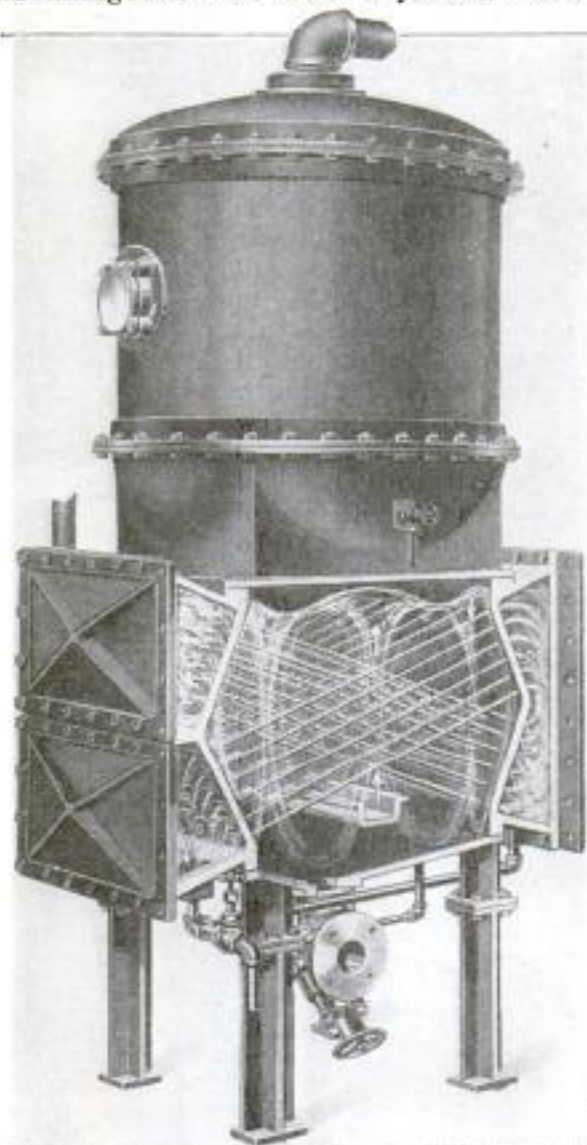

In This Evaporator the Steam Passes Downward through One Bank of Tubes and Returns through the Other Bank. The Liquid being Evaporated is Introduced in the Shallow Pan beneath the Tubes

the tubes were arranged either vertically or horizontally. In this new evaporator the tubes are placed in banks along diagonal lines, and the construction is such that the steam passes down through one set of tubes and returns through the other set. By this method of placement it is possible to use tubes of smaller diameter, which are claimed to be more efficient for the transfer of heat. Also, the water condensed from the steam flows by gravity in the same direction that the steam is traveling. The liquid to be evaporated is introduced in the center below the two banks of tubes.

PROCESS FOR ELIMINATING
 DISEASES IN COTTON

Boll rot and other fungus diseases of cotton may be eliminated by a process which is the result of many experiments, extending over a period of two years, made at the University of South Carolina. The cotton seed is first dried and heated to a temperature of about 212° F. It is then subjected to a treatment by sulphuric acid, which removes the lint and kills all fungi, particularly the boll rot. It was found during the experiments that a very large proportion of the seed treated was perfectly sterilized by the sulphuric acid alone, without previous heating. Seed treated in this manner was found to sprout much more rapidly than untreated seed.

Columbia, S.C.

ABANDONED CHURCH BUILDING
 UTILIZED AS A GARAGE

An abandoned church building in Washington, D. C., has been converted into one of the most commodious and serviceable garages in the city. The old wooden floor was replaced by one of concrete, and part of the steeple was torn down, the remainder serving as support for a large water tank. The garage accommodates the numerous milk wagons con-



Between the Limbs of the Trees can be Seen the Front of a New Garage in an Old Abandoned Church Building. Part of the Old Steeple is Replaced by a New Water Tank

nected with the largest dairy in Washington. The front exterior of the building was repaired and finished so that it looked like a new stone building.

Carl A. H. Stacy
 National Press Club
 Washington, D. C.



Screened-In Body Which is Built on an Automobile Chassis and Which is Used to Transport the Hounds to the Starting Point of the Hunt: The Fox Horns and Other Necessities of the Hunt are Seen on the Top of the Conveyance

8707
**"HOUND WAGON" TRANSPORTS
 CANINES TO THE CHASE**

Yelping and eager for the sport, fox hounds belonging to a southern estate are hauled to the chase in a specially designed "hound wagon." This consists of a double-decked, screened-in body built on the chassis of a small automobile, on top of which are carried the fox horns and other necessities of the hunt.

It is announced that Tufts College, Medford, Mass., is to commence giving a series of lectures by radiophone under the auspices of the faculty. The lectures will be broadcast twice a week.

8857
**RESIDENTIAL PART OF CITY
 DAMAGED BY OIL GUSHER**

Before the discovery of oil, Signal Hill was one of the most beautiful residential sections of Long Beach, Calif., and many of the finest homes were located there. Now, however, it looks like an oil field which has strayed into town by mistake. Recently one of the oil companies operating there brought in a well which proved to be a gusher, and the entire section was drenched with a spray of black oil which ruined trees and gardens and caused untold damage to houses and furnishings. The oil spray was carried in some cases a distance of three miles from the oil well.



Left: This Gives Some Idea of the Appearance of the Trees after being Drenched with the Spray of Black Oil from the Gushing Oil Well. Right: Before the Discovery of Oil, This Was One of the Most Beautiful Residences in Long Beach, but It Is Now the Office of One of the Oil Companies

Cent Mary St. Los Angeles
 944 E. California St.
 Pasadena, Calif.

Pacific Gas + Electric Co.
San Francisco Calif.
COMMUNITY CENTER AT ISOLATED POWER PLANT

By CHARLES W. GEIGER

Press Club
Powell + Sutter St. San Francisco

8669

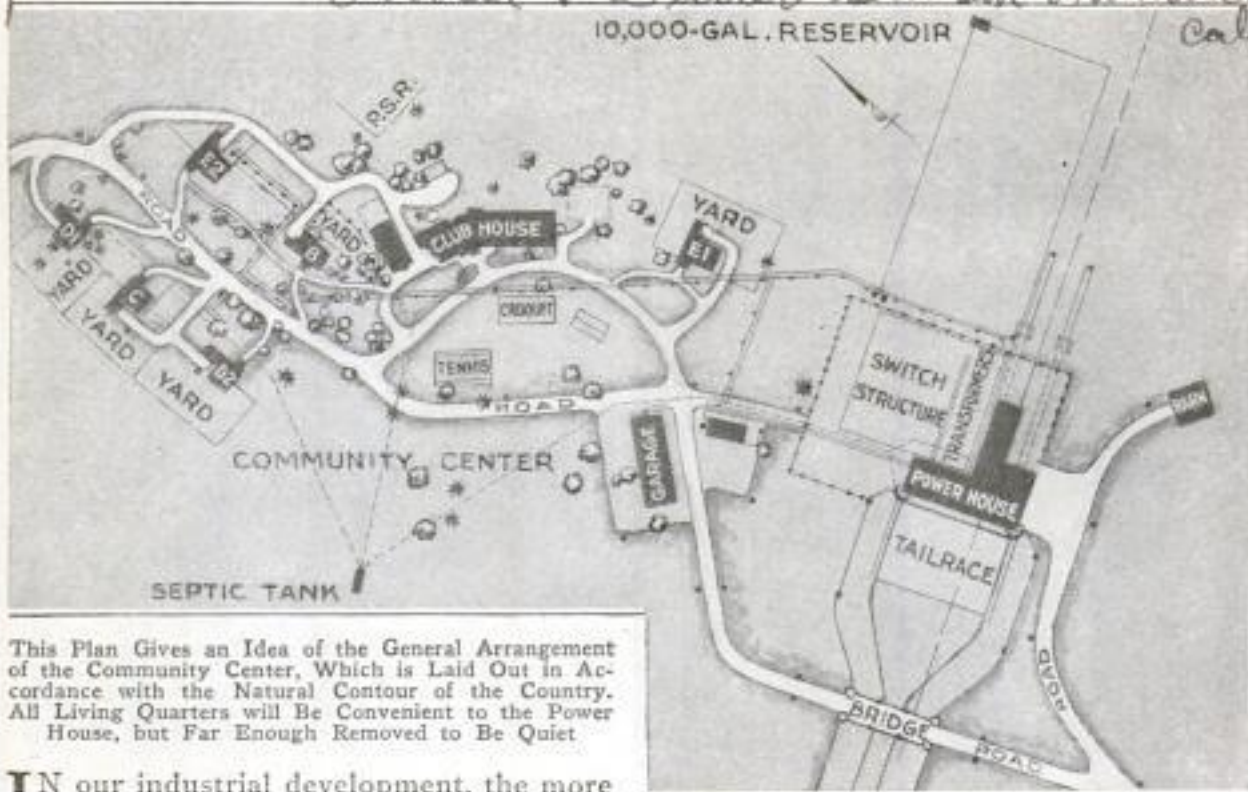

This Plan Gives an Idea of the General Arrangement of the Community Center, Which is Laid Out in Accordance with the Natural Contour of the Country. All Living Quarters will Be Convenient to the Power House, but Far Enough Removed to Be Quiet

IN our industrial development, the more progressive companies have given increased attention to the physical and mental welfare of their workers, not entirely from altruistic motives, but because they realized that the mental attitude of the individual had a direct bearing on the quality of his service. A cheerful, contented worker brings to his task a

tractive surroundings and comfortable accommodations has been realized by one of the power companies on the Pacific coast, and has found expression in the community-center development at one of its power plants. The station is located in the high mountains among beautiful surroundings, but will have one great drawback—isolation. The company has sought to overcome this by the creation of the community center, where all the conveniences of the modern city will be available. There will be attractive cottages for the married men and their families, and a spacious clubhouse for social gatherings, with one wing given to rooms for the single men and visitors. The plan has been carefully laid out, and

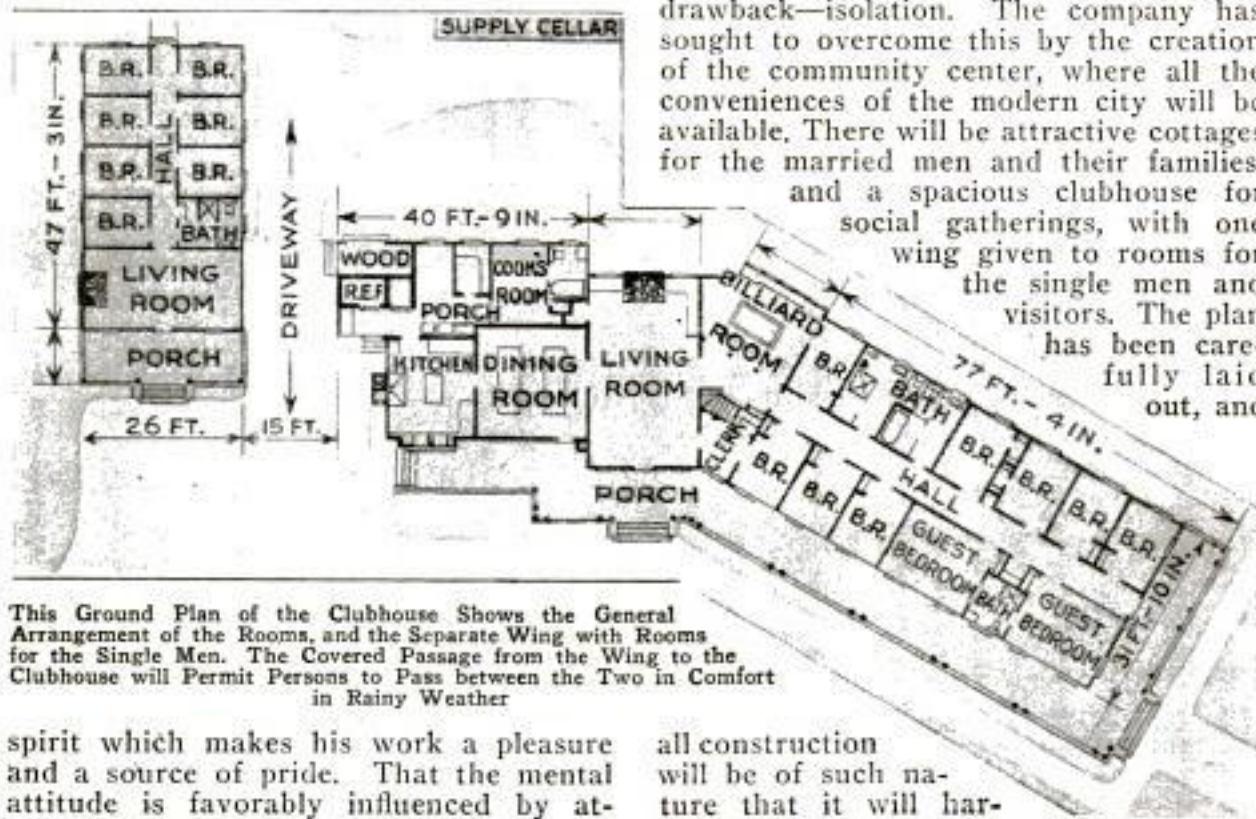

This Ground Plan of the Clubhouse Shows the General Arrangement of the Rooms, and the Separate Wing with Rooms for the Single Men. The Covered Passage from the Wing to the Clubhouse will Permit Persons to Pass between the Two in Comfort in Rainy Weather

spirit which makes his work a pleasure and a source of pride. That the mental attitude is favorably influenced by at-

all construction will be of such nature that it will har-

Pit River Plant No. 1.



This View of Three of the Cottages Exemplifies the Care That has been Used in Designing Them So That They should Have an Individual Appearance. Right: The Power House with Its Beautiful Surroundings

monize with the surroundings. Native rock will be used for the foundations, and different combinations of rustic exterior coverings will be used, so that each home will have an individuality of its own.

In order to impress the points being brought out in a safety campaign, the Bureau of Mines is making arrangements with a number of producing oil companies in California to make moving-picture films of the petroleum industry.

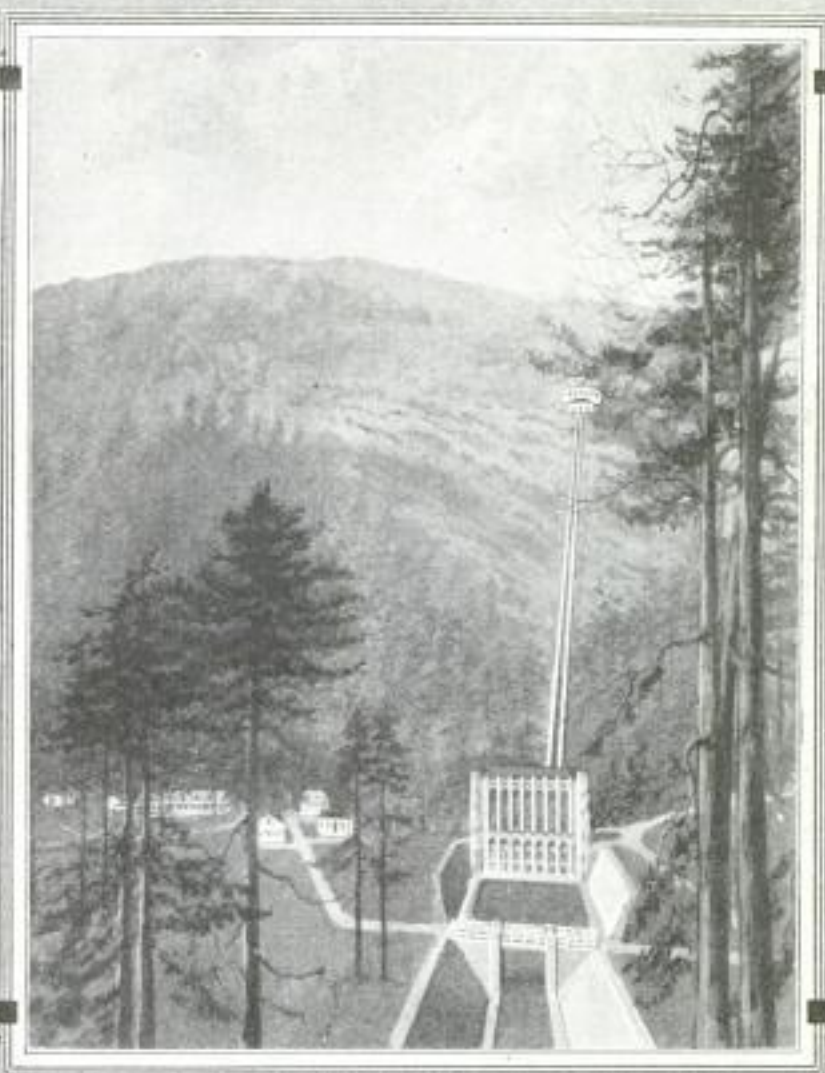

This View of the Clubhouse Gives an Idea of the Way in Which It will Blend with the Surroundings. The Foundation will Be of Native Rock, and the Exterior of Rustic Design. The Separate Wing will Contain Rooms for Single Men

890
8758
**SLACK PULLER TO REPLACE
BLOCK AND TACKLE**

For pulling the slack out of guy wires, or for any similar work, to much better advantage than with the customary block and tackle, a special slack puller has recently been placed on the market. Instead of requiring the work of several men, as is often necessary with the block and tackle, this puller can always be operated by one man. The pulling power is obtained by a pair of bevel gears that operate a bronze nut in connection with a long threaded rod, at the end of which is a strong drop-forged hook. The gearing is driven with a ratchet crank, which gives one man plenty of power for any ordinary wires.



and tackle, a special slack puller has recently been placed on the market. Instead of requiring the work of several men, as is often necessary with the block and tackle, this puller can always be operated by one man. The pulling power is obtained by a pair of bevel gears that operate a bronze nut in connection with a long threaded rod, at the end of which is a strong drop-forged hook. The gearing is driven with a ratchet crank, which gives one man plenty of power for any ordinary wires.

The gearing is driven with a ratchet crank, which gives one man plenty of power for any ordinary wires.

8815
**RUBBER GRIP FOR PENCILS
PREVENTS SLIPPING**

Adaptable to various sizes of pencils or penholders, a soft-rubber sleeve has been invented to eliminate the constant slipping down of the fingers when writing. The sleeve, or tube, has longitudinal slits



Left: Rubber Grip for Pencils, Showing How the Ends are Twisted and Pushed Together. Right: Rubber Grip before being Twisted

cut in it, which permit the regulation of the tube to any desired finger position.

This is accomplished by twisting the solid ends of the appliance and pushing them toward one another, after being placed on the pencil or pen.

8886
**OIL PRODUCTION IS LESSENER
BY DELAY IN DRILLING**

Recent investigations by the Bureau of Mines have shown that a delay in drilling into an oil formation after it has been opened may cause a loss up to 50 per cent in the ultimate amount of oil produced from a well. When a well penetrates the oil formation, the oil is forced out by the pressure of the gas included in and associated with the oil. This gas pressure may cause the oil to move through the deep layers from surrounding territory and be forced or pumped out of a well on adjoining property. This explains in some cases why the first well drilled in a new field may have a much larger production of oil than wells drilled at a later time.

8786
**COMBINE HOME SAVINGS BANK
WITH NEAT DESK WATCH**

There is no doubt that the home savings banks have been the means of inducing people to save their money, but, unfortunately, in some cases the little banks have been put away and forgotten. Now, however, one type of these metal banks has been combined with a watch to form an attractive desk clock, and this is an assurance that the bank will be kept where it will be always ready to receive any spare change. The bank has a capacity of \$12 to \$14 in the various coins, in addition to which there is a slot for the insertion of paper money.



At a recent wireless-receiving contest the championship was won by a young man from Chile, and a new speed record was established when he received 49 1/2 words per minute sent in continental code by wireless.

Stronghart Co.
Wabach + 6th
Chicago

Mr. J. McQuigan
Chicago, Ill.

Copyrighted material

ONLY MOHAMMEDAN MOSQUE IN WESTERN WORLD

For the first time in history a Mohammedan mosque has been erected in the western hemisphere. Although there are many thousands of Moslems in America, most of whom observe their religious customs as far as possible, they have never had until recently any mosque or house of worship in the new world. Now, however, a building has been completed in Highland Park, a suburb of Detroit, which is typically Turkish in design, having two minarets, one on each front corner and a small tower of similar design in the center of the roof, these three towers all bearing the star and crescent. The auditorium is so arranged that, in accordance with the ordinances of their faith, the

worshippers will face Mecca when they perform their daily prayers.



Mohammedan Mosque in Highland Park, near Detroit, Showing the Towers Adorned with the Star and Crescent: Although There Are Thousands of Moslems in America, This Is the First Mosque Ever Built in the Western Hemisphere

8738

AUTOMATIC SLACK ADJUSTER FOR BRAKE RODS

For use on railroad cars, an automatic slack adjuster for brake rods has recently been placed on the

and on the wheels of the car, for which, without this device, the only remedy is to send the car to the repair shop. The slack adjuster is attached to the brake rod of the car truck, and has a small hose connection to the main air-brake cylinder through a port 3 in. from the cylinder's end. When shoe wear causes the piston in this cylinder to travel beyond this port, compressed air is admitted automatically to the small cylinder of the slack adjuster, where it moves forward a pawl that engages a ratchet on the brake rod in such a manner that, when it is returned by the action of a spring in connection with it, the proper adjustment is made to cause the shoe to act again.

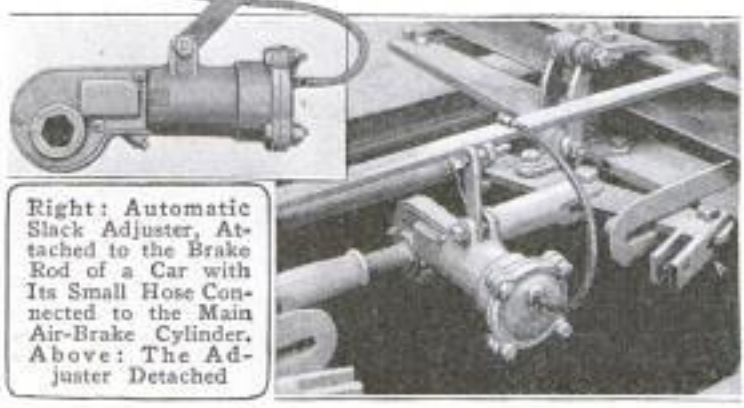

Right: Automatic Slack Adjuster, Attached to the Brake Rod of a Car with Its Small Hose Connected to the Main Air-Brake Cylinder. Above: The Adjuster Detached

market. It automatically adjusts the rods in connection with the brakes, so as to compensate for wear on the brake shoes

8857

TIRE ROPES REPLACE CHAINS ON MOTOR-CAR WHEELS

Armored tire ropes, as substitutes for the commonly seen chains, have been produced by an Ohio man, for use on any motor car when it is difficult to obtain good traction. The covering of armor extends over the width of the tire, and a wedge clip is employed to keep the rope from shifting. When the armor becomes worn on one side, it is an easy matter to twist the rope so that another part of the armor will be exposed to wear.

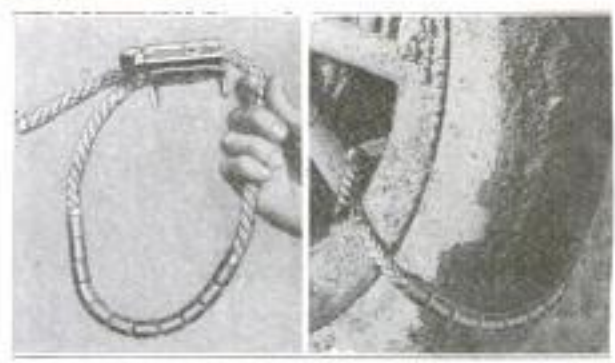

At the Left is Seen the Armored Tire Rope, Showing the Wedge Clip That Keeps It from Shifting. The Manner of Attaching the Rope to the Wheel and Tire is Shown at the Right

Matthews Co., Port Clinton Ohio

The J. S. Brill Co. 42 mg + Woodland Philadelphia, Pa.

Cml. Frank O. Howe, 412 Mason Opera House
Bldg., Los Angeles, Calif.
POPULAR MECHANICS

899
7681

MOVING PICTURES TO ILLUSTRATE EINSTEIN THEORY

Scientist Helmar A. Whitton
Studios Louis B. Mayes, Los Angeles, Calif.



AN ATTEMPT is being made to visualize by means of the movies Professor Einstein's much-discussed theory of relativity. Already many feet of film have been made in this attempt to picture the intricate principles involved in the theory in such a manner that anybody can understand them. In doing this, all the tricks of the movie camera—such as double exposures, lap dissolves, matting out, high and low speeds—have been resorted to. Demonstrations of this kind in connection with the astral universe will be given in an interesting manner by the use of the objects shown in the accompanying pictures, in which the small ball in the upper left-hand picture

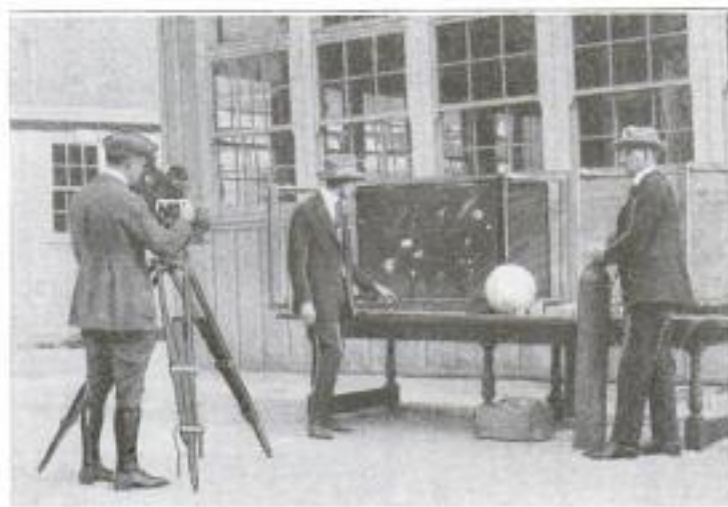

is a miniature reproduction of the earth. This will be used in combination with the reproduction of the nocturnal heavens shown in the upper right-hand picture. In this the stars and planets are made of colored glass, and can be manipulated as desired. With these objects, the process of making a film is shown in the lower picture. Another part of the film will be devoted to the application of the principles to occurrences of everyday life, so that they will convey concrete ideas to minds that are old or young, simple or complex.

This will be done by means of pictures of adventures of an extraordinary nature that might happen to human beings by a strict application of these principles.

8884

MODELS SHOW BEST TYPES OF COTTON WAREHOUSES

Model fireproof cotton warehouses that pay for themselves in a few years out of savings in insurance rates alone, have recently been designed by the Department

of Agriculture. These warehouses combine utility with every known fire-protective device. They range from one-story buildings with wooden walls that can be

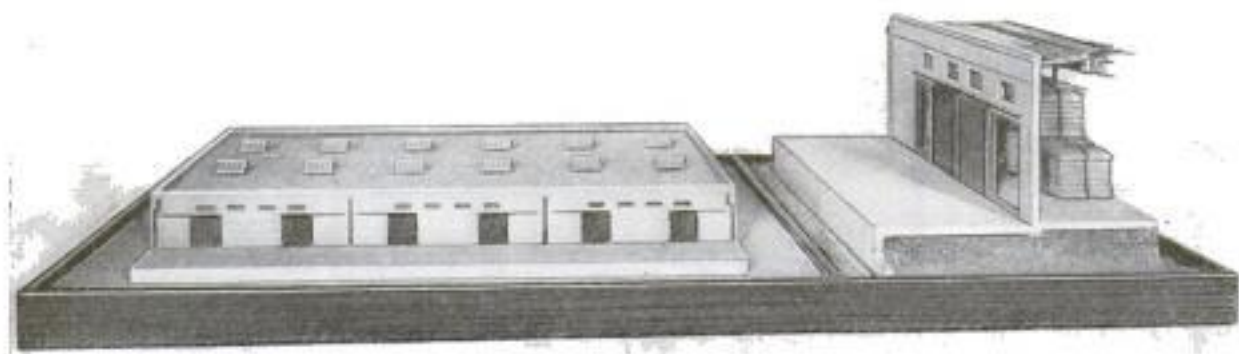

This Model of a One-Story Cotton Warehouse of Reinforced Concrete Exemplifies the Best Features in Fireproof Construction. The Section at the Right Shows Automatic Fire Doors and Concrete Loading Platform

Cml. C. Moran, 3825-13th St. N.W.,
Washington, D.C.

Copyrighted material

knocked down in case of fire, to four-story reinforced-concrete buildings that are practically indestructible.

One model is a one-story three-section brick structure with concrete foundation and loading platforms. Continuous fire-brick walls, 18 in. thick, separate the sections, and extend 18 in. above the roof to prevent the spread of fire from one compartment to another. Additional sections can be added as the business may require. The roof is graveled, and spark-proof. There are automatic sprinkler systems throughout. Double doors at front and back provide continuous passageways for trucking through the building, and

bale is automatically disengaged at the proper floor. To lower the cotton, a circular or straight chute is provided. One-story buildings of this type can also be constructed.

Of the 3,000 cotton warehouses in the

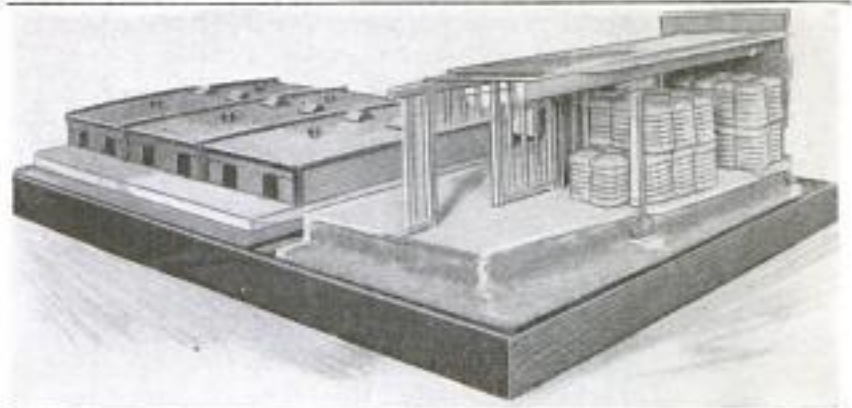

This Model Shows the Proper Construction When Wood is Used, the Warehouse being Built in Sections, with Walls That can be Knocked Down in Case of Fire, to Aid the Firemen in Reaching the Flames

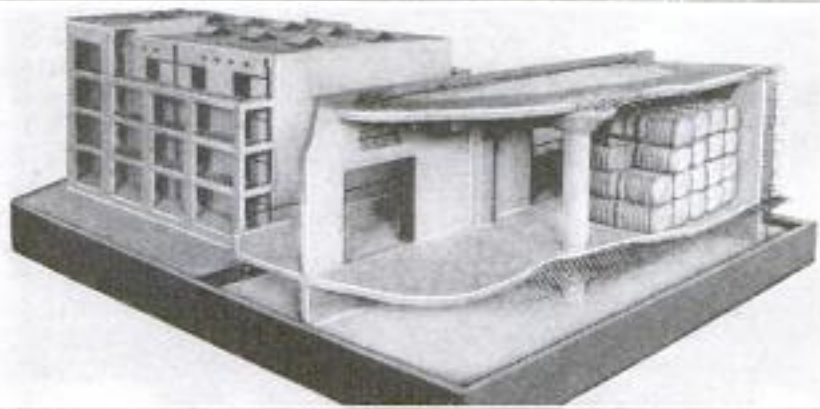

This Is a Model of a Four-Story Cotton Warehouse of Reinforced Concrete and is Equipped with Fire Doors between Sections, Which Close Automatically When a Certain Fixed Temperature is Reached

light is admitted through skylights, and through windows over the doors.

A reinforced-concrete building in four stories is the most improved type of cotton warehouse known. Spread of fire in the building is prevented by automatic doors which close when the heat reaches 160° F. These doors are controlled by chains with one or two links of soft metal that melts at this temperature. Concrete platforms are provided on each floor for trucking and sorting the bales, a chain elevator being used to raise the bales to the various platforms. Hooks on the chain catch the axle of the truck carrying the cotton, and the

story fireproof building would pay for the structure within five years.

Recent statistics show that one-tenth of the lead produced in the United States is used in the telephone industry.



This Model Shows the Proper Construction for a One-Story Warehouse When Brick is Used. It is Built in Sections, with 18-Inch Firewalls between Them, Which Extend 18 Inches above the Roof

Burke + James Inc.
 240 E. Ontario St.
 894
 8752 Chicago

The Wiley Day
 2909 N. 24th St.
 Omaha, Neb

POPULAR MECHANICS

EXACT-SIZE PICTURES MADE WITH JEWELERS CAMERA

Jewelers will appreciate the introduction of a camera that will photograph any article up to 5 by 7 in., yielding a reproduction which is exact to size and the finest detail. The appliance, which hangs on the wall by hinges, is 40 in. high, 10 in. wide, and 7 3/4 in. deep, and has an adjustable table on which objects to be photographed are placed and automatically focused by means of a lever at one side of the framework, thus enabling any person to operate the camera.

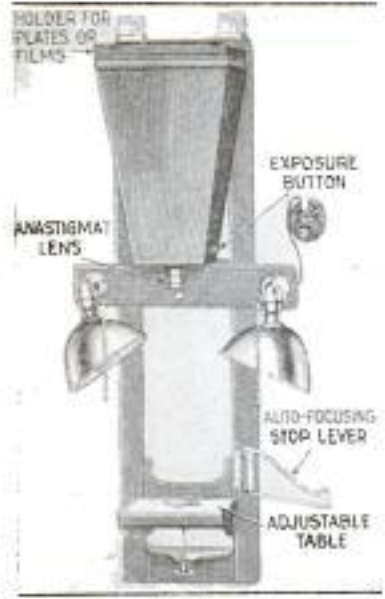

nating all vibration and chatter. The blade is mechanically lifted from the work on the noncutting stroke with a uniform lift on every stroke. There is a uniform feed pressure through the entire cut, and this is regulated automatically by the resistance in the material being cut. The speed can be regulated to suit all classes of material. The machine has various fixtures for angle-cutting operations, and for cross-feeding. It is driven with an individual motor. The outstanding advantages of the machine are the great saving of stock in many jobs, as compared with similar work done on a shaper, and a corresponding saving of time.

8546

CAR-HEADLIGHT IMPROVEMENT AIDS DRIVING AT NIGHT

Night driving over country roads has been greatly aided by the introduction of a headlight improvement which can be easily and quickly mounted on any car. The accessory reflects the light so that the road ahead, the wheels, the ditches at the side, and any oncoming machine are seen simultaneously. Glare is prevented from showing above a 42-in. height, there-

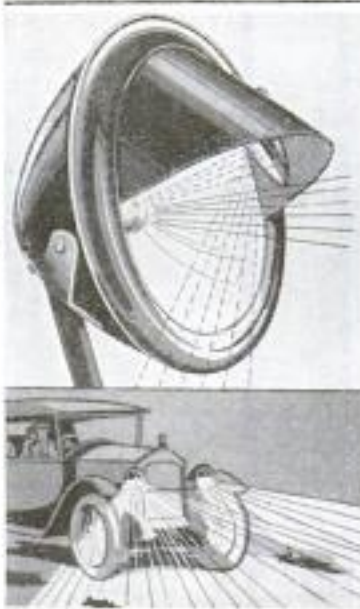

by eliminating the blinding of an approaching motorist and reducing the possibility of an accident which often results from a careless use of the "bright lights."

8647 COMPLICATED SHAPER WORK DONE WITH SHAPING SAW

Work similar to that done on a shaper or a milling machine, is now being done with a machine tool that does all its cutting with a saw blade like that used in a hack saw. This is carried centrally in a four-sided frame that enables the blade to be put under proper tension, elimi-

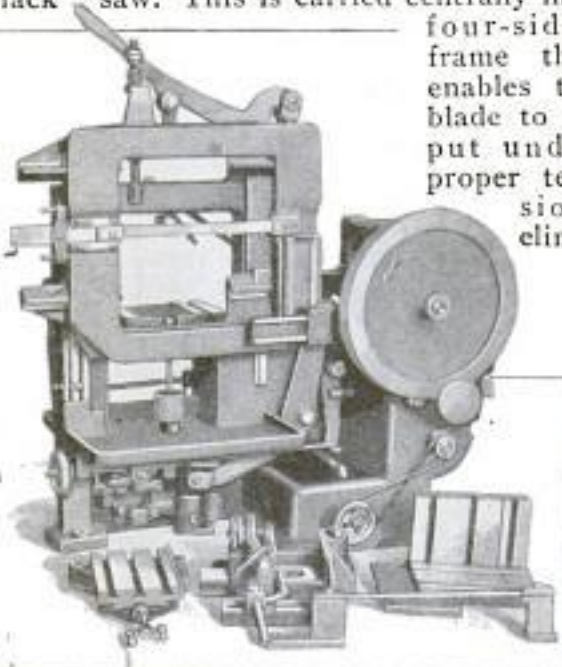

At the Left is Shown the Saw with Which Work Similar to That Done on a Shaper, or a Milling Machine, can be Accomplished. At the Right are Seen Specimens of Numerous Kinds of Work Completed with the Shaping Saw

Peerless Machine Co., Wis.
 Racine

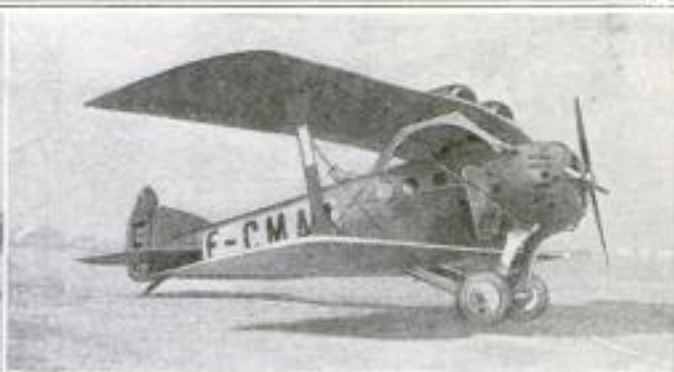
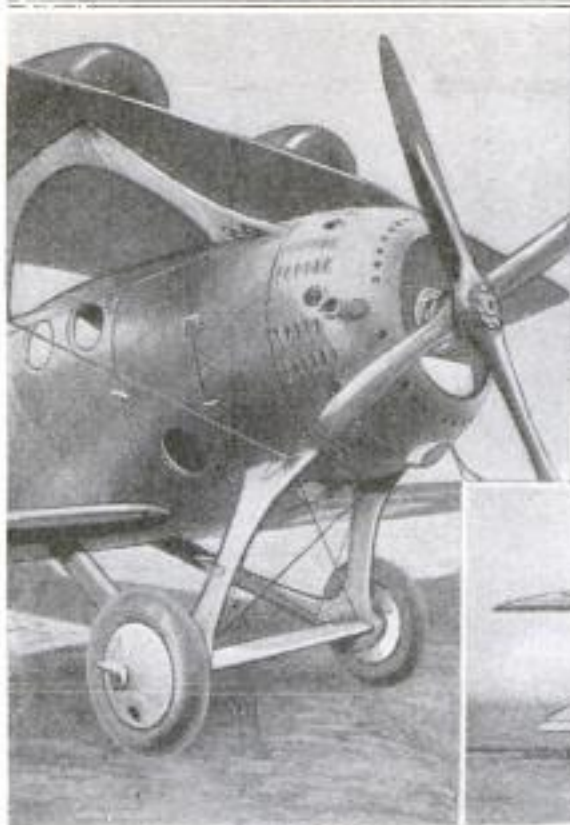

This Five-Passenger Spad-Herbemont Plane is Flying on Many of the European Air Routes, and is Powered by a 250-Horsepower Engine, Driving a Four-Blade Propeller



PHOTO COPYRIGHT, W. P. B.

NEW SPAD-HERBEMONT PLANE FOR EUROPEAN AIR LINES

A new Spad airplane of remarkably clean lines has recently made its appearance on many of the European air routes. The passenger cabin, entirely inclosed and accommodating five persons comfortably, is situated between the wings and just back of the engine compartment. The pilot's cockpit is located farther back in the fuselage. Power is furnished by one 250-hp. motor, and the plane carries sufficient fuel for a flight of 6½ hours with five passengers. The flying speed is about 110 miles per hour, with a motor speed of only 1,450 revolutions per minute.

AIR-STABILIZING ATTACHMENT FOR AUTO CARBURETORS

Complete combustion of the fuel in an automobile engine, under all varying conditions of atmospheric temperature and density, requires some mechanical means of stabilizing the air so that it carries always the same proportion of oxygen. An air stabilizer has been constructed for this purpose that can be connected to any carburetor. The air passing in on all sides of the cylindrical device is first dry-filtered by an outside screen, from which it passes through six humidifying screens that are kept constantly moistened by

capillary attraction from a bowl of water below them. The supply of water in the bowl is maintained from a tank bracketed to the dash under the hood. Thus the temperature and condition of the air that

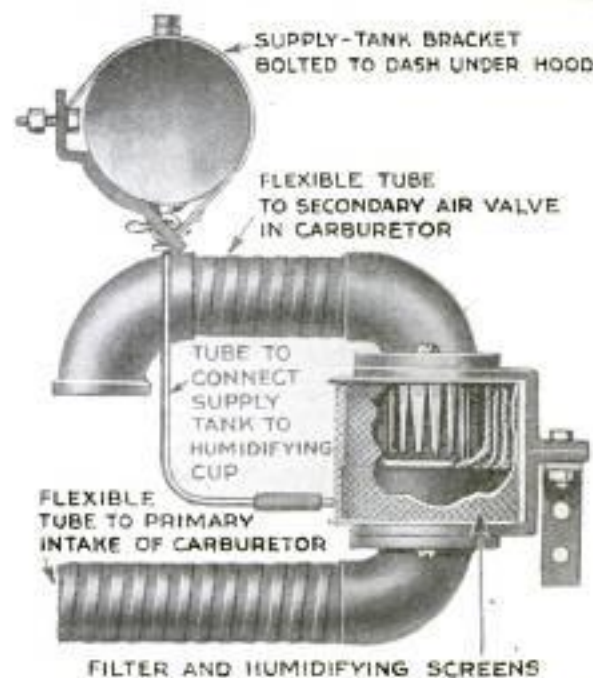

Air Stabilizer for Connection to Carburetors, Fully Explained by Notations: Outside Filter is Cut Away to Show Humidifying Screens and Internal Construction

passes to the carburetor are kept uniform under all atmospheric conditions.

Lasco Corporation, P.O. Box 678
Niagara Falls, N.Y.

Spad, 5 Rue du Val d'Or, Colons de St Quentin Cloud, France

Cmt. Hogg + Ford, 4/6 Union League
Blag. Los Angeles, Calif.
POPULAR MECHANICS

SIXTY-MILE BEACH USED AS TRACTOR ROUTE



Above: One of the Machines Using the Beach as a Tractor Highway. At Low Tide the Hard-Packed Sand Makes an Ideal Road for the Tractors. Left: Map of the Coast, with the 60-Mile Beach Heavily Shaded

Along the California seacoast, extending from Capistrano south to Morena, there is a piece of level coastal plain, some 60 miles in length and about five miles wide, which is given over almost completely to the growing of navy beans. The bean farms are of vast acreage, and tractors are used almost exclusively for cultivation. A paved motor highway runs north and south through the entire length of this bean country, but the tractor men are forbidden to use this highway because of the damage they inflict to the pavement if they do not go to the trouble of removing the cleats from the bull wheels of their vehicles. Obviously, the exclusion of the tractors from the highway inflicted a serious handicap upon the farmers in getting from one field to another, and from farm to farm, with their ponderous vehicles. The difficulty, was

made all the worse by the fact that most of the farmers do not own the tractors, but let their work to several different firms doing business in the tractor cultivation of lands.

For several years the farmers have struggled along, getting their tractors from farm to farm as best they could. For the most part the tractors have been loaded onto motor trucks, and thus transported with the expenditure of considerable labor and money. Recently, however, the problem of tractor transportation from farm to farm vanished with the discovery, by one of the tractor men, that the hard sand along the seashore at low tide offers a convenient tractor highway up and down the entire length of the bean country. The tractors may drop down onto the seashore from almost any farm in the 60-mile stretch, and once there, at low tide they have an easy route to any other farm in the system, without any physical or legal difficulties.

8885
**THE CULTURE OF PECAN TREES
TO BE TRIED IN CHINA**

Encouraged by the success of the pecan growers on the western coast of the United States, an attempt is to be made to introduce the culture of pecan trees in China. The College of Agriculture of the University of Nanking is distributing seed nuts at a nominal price to farmers or persons who are interested. Planting and culture directions are also furnished.

Sort Bureau Economic Information
88 Tung An men Ja Chich
Peking, China

Copyrighted material

8711

Com. J. Benjamin Faucett
482 Parkside Ave
Brooklyn N.Y. 897

POPULAR MECHANICS

COLLECTING GAS-MAIN "SWEAT"
FROM DRIP WELLS

Soon after gas leaves the holder it begins to "sweat." The cooler walls of the mains cause a condensation of gas moisture that must have an outlet or the underground pipes will quickly fill with this liquid. For this reason gas mains must be laid with sufficient fall to drain the accumulating condensation into drip wells located at certain points in the system. These wells, or siphons, as they are sometimes called, have varying capacities, some of them in the largest city mains holding several hundred gallons. They are usually constructed in the form of a huge drum, having a gas-main outlet on opposite sides and another smaller standpipe leading to the manhole in the street above, so that the drip water can be pumped out. The wells must have considerable excess capacity, as the quantity of water often varies many gallons during the course of a day. Underground temperature may increase or decrease the flow without any apparent change in street-surface weather conditions.

The deepest and largest drip well in Brooklyn, N. Y., situated near the southeast entrance to Prospect Park, is

8716

ELECTRODES SELF-ADJUSTING
IN ELECTRIC FURNACE

Self-adjusting electrodes are the feature of a new electric furnace, and these are counterweighted so that the lower ends

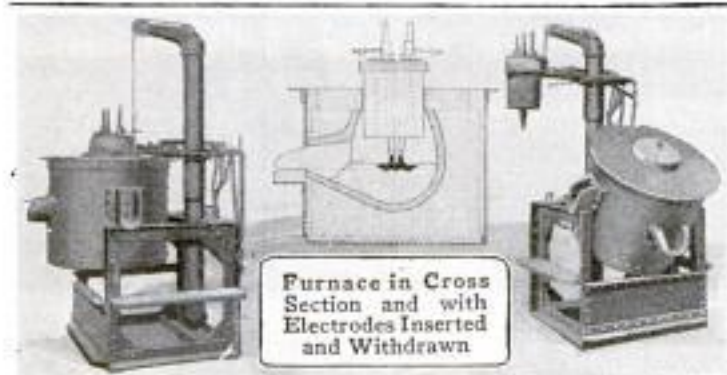

Furnace in Cross Section and with Electrodes Inserted and Withdrawn

40 ft. below the street, and often yields 200 gal., or more, at each daily pumping. Formerly, the pumping of all the drip water was done by hand, but the motor of a 788-gal. tank wagon now does this



Hand-Pumping the Drip Water from One of the Drip Wells into a Bucket, from Which the Water is Pumped by a Motor into a Tank Truck: The Insert Shows a Cross Section of the Drip Well

work for all except this deepest well. Its drip water must be hand-pumped, as the motor pump has not enough pressure. The greenish-yellow fluid pours into a bucket, from which it is sucked by the motor pump. Drip water smells strongly of gas and is extensively used in the making of high explosives, such as trinitrotoluene.

swing together in contact when the current is off. The counterweights can be regulated so as to draw any predetermined amount of current desired from a three-phase line. When the power is switched on, the electrical repulsion and the formation of gases between the carbons immediately force them apart a distance proportionate to the strength of the current. Should the power be reduced, the carbons are automatically drawn closer to each other, which prevents the breaking of the heating arc. Thus the outfit may be operated as either a "direct-arc" or as an "indirect-arc" furnace, depending on the kind of metal to be melted.

The Deep-Arc Furnace Co.,
Indianapolis, Ind.

Copyrighted material

"COPYRIGHT LAW" OF NORTHWEST INDIANS

Strict Rules—in Effect a Copyright Law, Although Inspired by a Different Motive—Protect the Totem Poles of Individual Clans against Imitation

BY FRANCIS DICKIE, *Heriot Bay, B. C. Canada*

8860
THAT a "copyright law," very similar to that in force among the civilized nations of the world, existed among the primitive Indians of northern British Columbia and Alaska long before the white man came, is a remarkable fact which the correspondent of Popular Mechanics discovered recently while traveling through the northern wilderness region of British Columbia in company with William Beynon, of the Canadian ethnological research. Mr. Beynon is one of the greatest living authorities on the native peoples of this region. The copyright law's existence is in connection with the totem poles, those symbols of totemism which are peculiar to northern British Columbia and Alaska; in fact in no other place in the world did primitive men make representation of totem designs in any manner nearly resembling the immense cedar poles of the northern part of North America. The strange thing is that though much has been written of totem poles, and some pictures of them shown, the existence of copyright has been entirely overlooked. In fact, the meaning of these poles, and the strange ceremonies attaching to them, have never been made known to the general reading public.

Herewith is given for the first time the story of how these primitive peoples of North America instituted a copyright law along exactly the same lines as followed by the white men today.

To be the owner of a totem pole was a sign of social position, rank, wealth, and power. Every native above the slave class aspired to raise one some day. In the erection of the pole a great amount of wealth had to be lavished; the more wealth lavished, the greater the owner's standing in the community. The reader, noting the accompanying photographs, will see how some are much plainer than

others. But from the fact that one pole has less carving work done upon it, it must not be inferred that the plainer pole cost less in ceremony. Sometimes a very plain pole represents a greater outlay than a very extensively carved one.

When a native decided he would have a totem pole, he and his family, and sometimes, in the case of a great chief, the whole clan, set about gathering wealth to meet the occasion. These preparations usually began a year in advance; in some cases so long a time as three years was spent in preliminaries. While this was going on, the prospective owner called in the artist of the tribe, a man of a

distinctive class whose wages were very high. To the artist the prospective owner related all the traditions of each figure and crest he wished carved. The artist then started to work, spending sometimes months on the intricate designs necessary. His work was made highly difficult because he must not in any way duplicate any carving already in existence in the region. This rule was very rigidly enforced, marking the first workings of the copyright law in North America. When the artist had completed his labors, the prospective owner next called the song composer, and to him in turn related the traditions connected with the various figures. The appointed com-

poser went away in solitude and created themes and words to suit the various carvings. When his composing was completed he returned, and the prospective owner called in the singers of his house, varying in number from ten to a hundred. The composer at once began rehearsal with these men and women and continued till they were thoroughly trained. The songs became the property of the owner of the pole; the composer did not receive royalty.



COPYRIGHT, MR. BEYNON
The Haida Tribe of the Prince of Wales Archipelago, Alaska, Had a "Copyright" on This Design of Totem Pole, Featured by the Very Unusual Addition of a Canoe

Shortly before the day on which the pole was to be erected, the owner sent out messengers summoning near-by tribes. When these were assembled before his house, the owner intrusted to some tribe he particularly wished to honor, the raising of the pole. When this had been set in the ground, the owner related at great length and with considerable oratorical vigor the tradition attaching to each figure and crest carved on the pole, going into great details of his family history to demonstrate his right to carvings, and further declaring them his particular property. This constituted the registering of copyright. This done, all the gathered people were invited into the owner's house and seated according to rank. Then began the really expensive part of the ceremony, the presenting of gifts gathered in the last year or more. In days before the white man came, these consisted mostly of furs, sometimes rare foods and canoes. In recent times, the gifts have been white man's blankets and money. In making this great display, a native would impoverish not only himself, but sometimes his family, and

even clan. At the conclusion of the gift giving, great quantities of food were handed around. The eating concluded, the singers then related the history of the pole and its owner's rights to the various designs in use upon it, in which words and music they were so thoroughly drilled by the composer. They also declared the owner's sole right to these songs.

Thus the totem pole was erected among the Tsimshian, Haida, and Tlingit Indians of British Columbia and

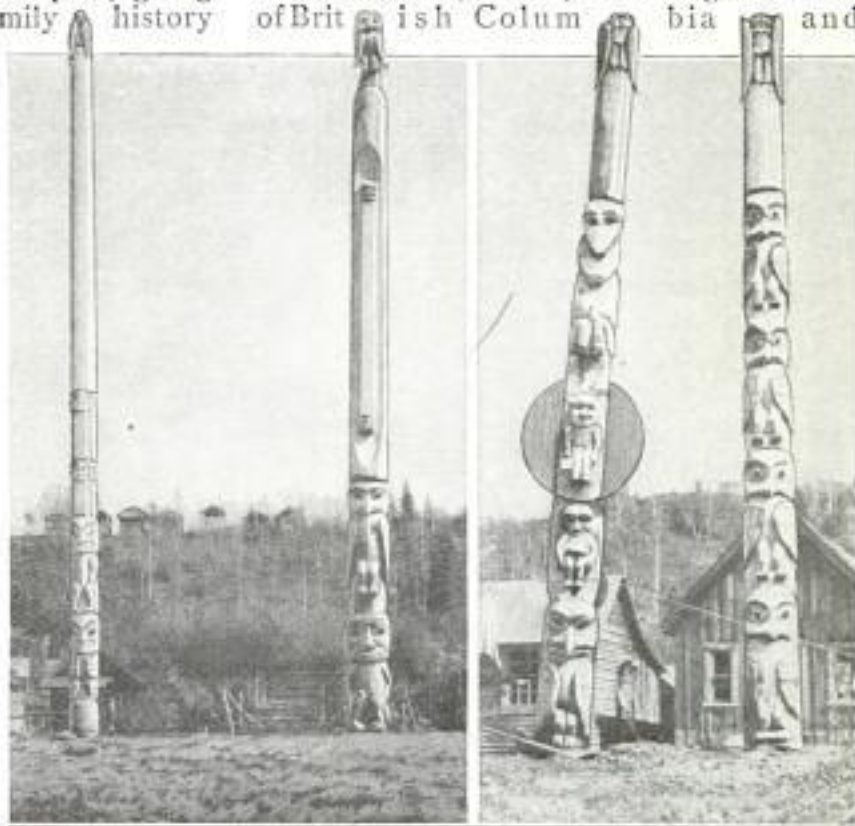
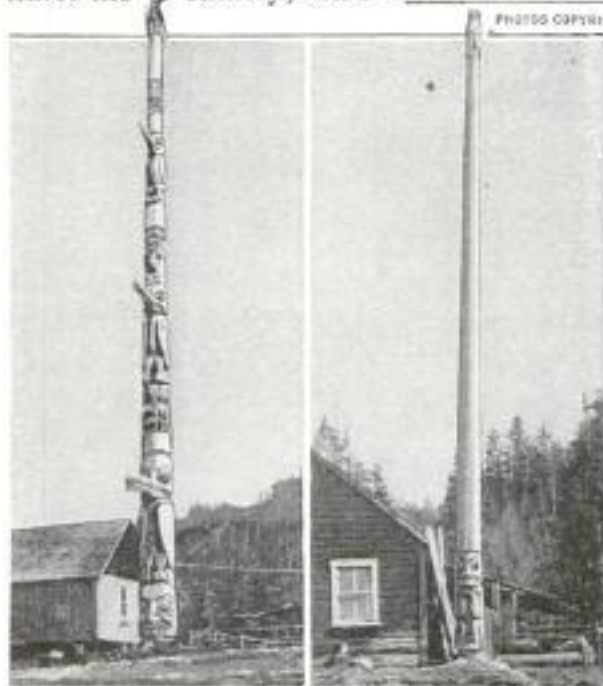

PHOTO COPYRIGHT, W. H. BERNER

These Four Poles, Executed by Various Clans of the Tsimshian Tribe, While Showing the General Characteristics of Totemism, Well Illustrate the Individualism That the Stringent Copyright Rules Entorced



Left: Another Tsimshian Pole. Right: The Tlingit Tribe is Represented by This Simple Design

Alaska for hundreds of years before the white man came, and copyright declared upon totem-pole designs and songs.

The past tense has been used throughout, for though an odd totem pole may still be raised among some of the very primitive tribes, the custom has practically passed, through the natives' intercourse with the white man. In fact, the Canadian government has stopped the natives impoverishing themselves by such ceremonials, which have been commonly known among white men as "potlatches," though their significance has been entirely lost upon the egotistical white man, for the most part too contemptuous of the native to inquire closely into his doings.

So, soon the Indians who first introduced the law of copyright will cease to need it.

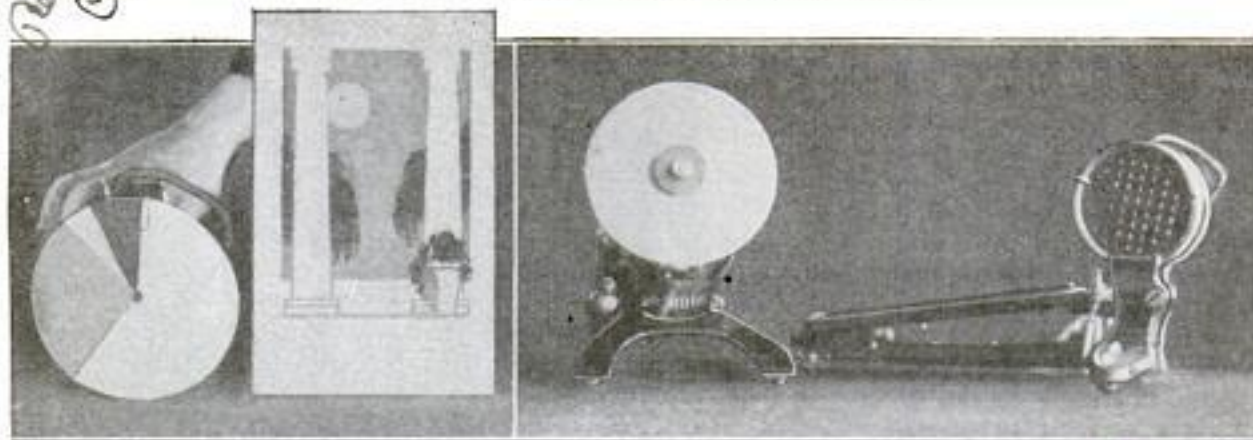

Left: A Magazine Cover and a Color-Harmony Testing Disk, on Which the Colors are Arranged in the Same Proportion as They are Used on the Cover. The Disk is Then Placed on the Machine and Revolved Rapidly, and the Resulting Color Determines if a Proper Harmony Exists. Right: The Revolving Disk and Control

8813 **TROUT SORTED INTO SIZES BY ROLLER "SIEVE"**

Trout will automatically sort themselves into different sizes at the fish-hatchery



pools, if a lately invented roller "sieve" is installed. The outfit consists of a boxlike structure, in one side of which are fitted numerous tubular brass rollers. When the sieve is placed in a trout pool, the fish, following their instinct to swim upstream, always attempt

to get through the rollers. With the boxes set in various locations in the pool, connected by channels through which a current of water is flowing, it is said that in 48 hours the trout will have sorted themselves into their several sizes.

8769 **HARMONY OF COLORS TESTED BY REVOLVING DISK**

It is a well-known fact that a pleasing harmony of colors attracts the eye much as musical harmony pleases the ear. In order to test the harmony of color combinations, a machine has been devised with which a colored disk is revolved rapidly so as to cause the colors to merge, and this visual mixing of the colors gives the same result to the eye as would the actual

mixing of the colored inks themselves. When a disk made up of the proper areas of harmonizing colors is revolved, a pleasing shade of gray develops. If this pleasing gray does not develop, it shows that a wrong combination of colors has been used, and that the color scheme is not attractive to the visual sense.

8822 **COIN-COLLECTING APPLIANCE FASHIONED LIKE SCOOP**

A new coin-collecting appliance has recently appeared on the streets of Boston, Mass., and was invented by a



man of that city. The outfit is made of tin fashioned in the shape of a large scoop, open at the top, in which the passers-by are asked to toss pennies, or larger coins, for the benefit of disabled soldiers.

□ The development of an electrochemical process for the manufac-

ture of metallic calcium and of 97.5-percent caustic soda, free from chloride of soda, has recently been announced. The new process is claimed to be much cheaper than those now in use. Further information may be obtained from the fuel division of the Department of Commerce and Labor.

900 Redlands Calif.
Mr. Franklin Strathmore Paper Co. MITCHELL, MASS.
8769
8822
8813
418 Bldg Union League Bldg
8769
8822
8813

Mr. E. Fred Cullen
c/o Educator Cracker Co.
Boston, Mass.
 Copyrighted material

**MACHINE WITH CENTER DRIVE
 LIKE TWO LATHES IN ONE**

A new type of lathe with the headstock and drive at the center, and a tailstock at each end of the machine, is now on the market. The headstock is very short, and carries a chuck at each end of the spindle, which is of cast iron and hollow. It is driven by a motor attached to the rear side of the lathe bed, and controlled by a treadle at the front of the machine. There are two carriages arranged to receive special magazine toolholders and with automatic-feed devices. They will op-

erate simultaneously at each end of a piece of work. The machine is specially adapted for turning shafts, such as axles, where no work is to be done at the center portion, but similar work at each end.

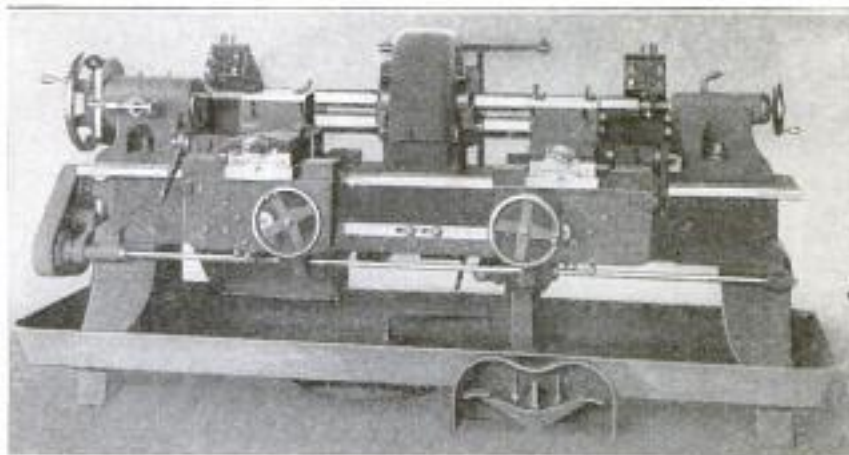

Front View of Center-Drive Lathe, Specially Designed for Turning Both Ends of Any Kind of Car Axles: Its Central Headstock Is Very Short

8850

WORN-OUT AUTOMOBILE TIRES USED TO BUILD FENCE

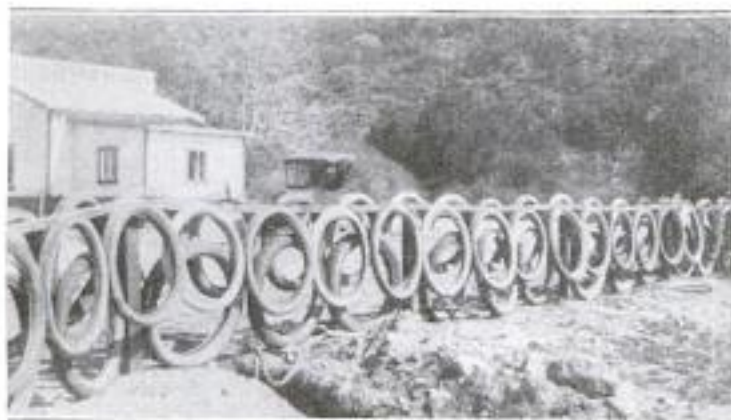

Fence Constructed of All Sizes and Makes of Discarded Automobile Tires Which have been Nailed to the Wooden Railing. Nearly 300 Tires, Whose Original Value has been Estimated at More than \$6,000, Form This Strange Fence

8812

Worn-out automobile tires have been used in the construction of a strange-appearing fence around an oil-service station in one of the western states. This station is situated in a rather remote locality, and as touring motorists purchased new tires, they usually gave the old ones to the service man. Instead of selling them for junk, the service man constructed a fence having 4 by 4-in. posts and a 2 by 3-in. railing, into which spikes were driven to support the hundreds of discarded tires of all sizes and makes.

cont. Albert Marfelle, 716 S. Louise St. Selendale, Calif.

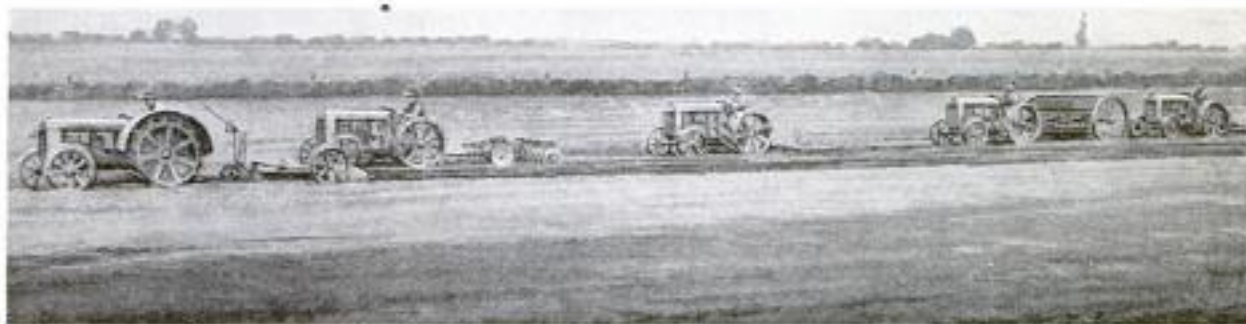

FIVE TRACTORS REDUCE FARMING TO A SINGLE OPERATION

EMPLOYING five tractors for only a few days in the spring, a western rancher performs at one time all the operations of spring planting on a 1,500-acre farm. The first tractor pulls a gangplow which turns the earth; the second draws a disk harrow, and the third pulls a spiked cultivator which finishes the preparation of the soil. The fourth tractor draws a seeding machine, while the fifth tractor, bringing up the rear of the procession, pulls a drag for covering the seed.

cont. Haggard Ford, 416 Union League
 Club, Los Angeles, Calif.

8923

**TINY PILE DRIVER DRIVES
PIPES AT POLE BASE**

Much of the labor and 90 per cent of the time required to drive ground pipes at the base of poles along electric trans-

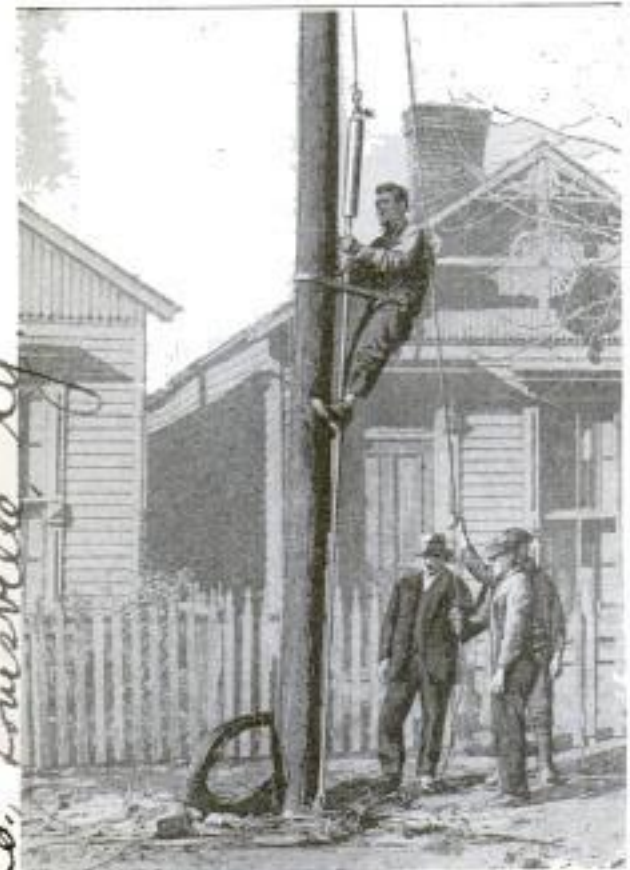

Miniature Pile Driver, Illustrating the Method Employed by Linemen in Driving Ground Pipes Instead of Using the Sledge Hammer

mission lines have been eliminated through the invention of a portable pile driver. It trims down the old working time of two hours to 10 or 15 minutes, depending on the nature of the soil in which the work is done. The old method was slow, clumsy, and exhausting. The workman was supported by climbers and a safety belt, and while thus held in position, he had to swing a heavy sledge. Often, because of his failure to strike a square blow, the pipe was bent or mashed. The new device consists of a piece of lineshaft, about 3 in. in diameter and 18 in. long. It is attached to a steel guide rod that will enter a 1-in. pipe without rubbing. At the other end, an eyebolt allows a rope to run through a pulley, suspended from the crossarm, to the ground man. The latter, by pulling down on the rope and releasing it, drives the pipe from 6 in. to 12 in. at each stroke. The new method protects the worker and keeps the pipe and pole in better condition.

Chas. George Miller Supt. Electric Construction, Louisville, Ky.

8912

**PROCESS FOR THE RECOVERY
OF OXIDIZED COPPER**

A patent has been granted on a process for the recovery of copper from oxidized ores in which the basic reactions are between the copper, metallic iron, and a little free acid. The finely crushed ore is heated to about 70° C. (150° F.) in agitating tanks containing finely ground metallic iron and a small amount of ferrous sulphate. The copper is precipitated as a cement copper, and can be recovered either by washing or by flotation. The process is a regenerative one, it being necessary only to add metallic iron with each new charge.

8806

**PROPELLERS CIRCULATE AIR
TO HEAT ORANGE GROVE**

Saving the citrus fruit from damaging frosts is the aim of a California inventor who has produced a huge fan, or propeller, which is mounted on a 20-ft. tower. An electric motor is installed to drive the propeller blades, which are so constructed that they draw the warmer air from above, and circulate it throughout the grove. In extremely cold weather, large heaters will be placed under each fan, and it is claimed that four towers of this description are sufficient to serve a 10-acre orange grove.



Large Propellers, or Fans, are Mounted on High Towers for the Purpose of Saving the Citrus Fruit from Damaging Frosts

Chas. H. Q. Maas
547 E. 10 St.
Ontario, Calif.
Copyrighted material

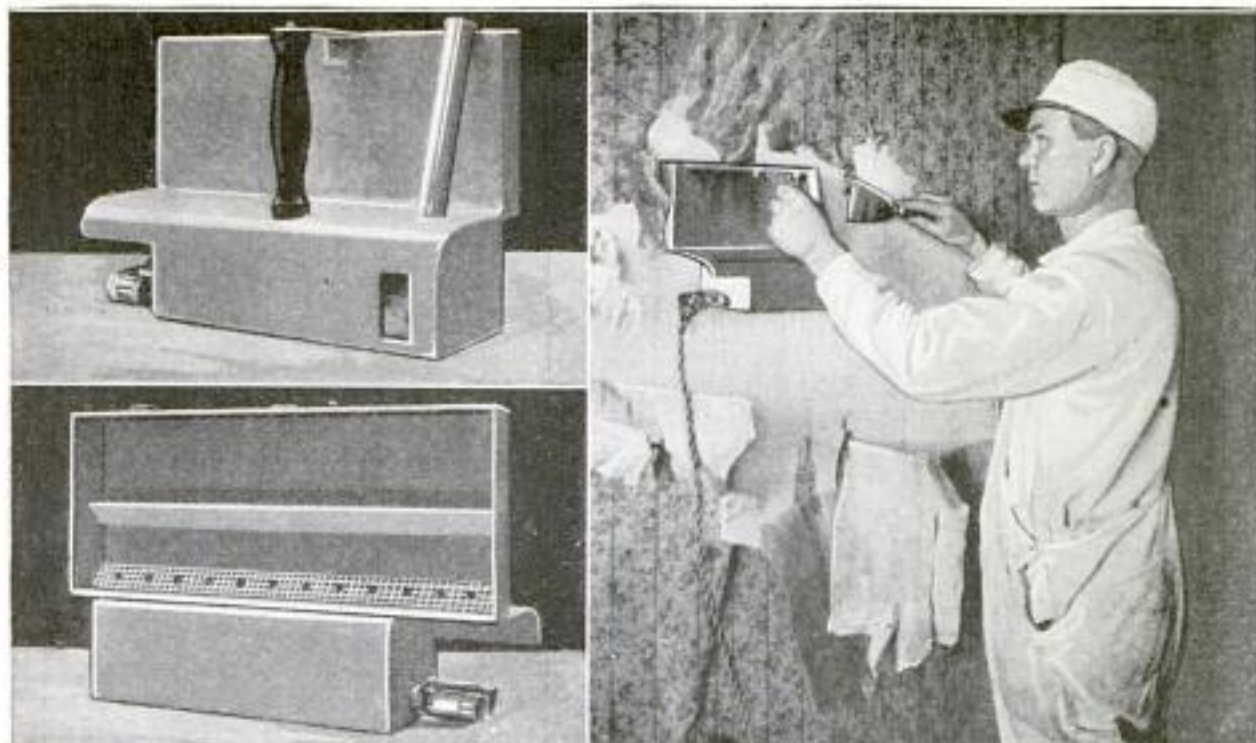

Left: The Back and Front Views of the Machine Give a Good Idea of the Heating Space and the Steaming Compartment. Right: In Operation the Tank is Filled with Water, and the Cord is Attached to Any Light Socket. The Resultant Steam Quickly Loosens the Paper, Thus Facilitating Its Removal

AN ELECTRIC STEAM MACHINE FOR REMOVING WALLPAPER

The tedious task of removing wallpaper can be made a comparatively simple operation by the use of a recently invented machine. This little device weighs only 3 lb., is easily portable, and operates from any electric-light socket. It is equipped with an electric heating element to generate the steam, which penetrates and loosens the wallpaper, making its removal a simple matter. It operates equally well on the walls or ceiling, and because of its construction is not a fire hazard, the temperature never being higher than the boiling point of water.

BOOTLEGGERS USE TRICK CAN FOR SWINDLING CUSTOMERS

At Newark, N. J., the weights and measures officials seized 42 short-measure 5-gal. cans which were apparently designed to perpetrate a profitable bootlegging fraud. A small chamber of about a quart's capacity was provided just below the screw-top opening, which was to be filled with liquor, the remainder of the can being filled with water. The customers were allowed to draw from the can a sample of the excellent liquor placed in the small cavity, and gain the impression that the can contained 5 gal. of it. This they would pay for, later to

find that they had been defrauded. Evidently the perpetrators trusted that the illegal nature of the purchase would restrain the victims from advertising the nature or existence of the swindle.



Five-Gallon Can with Sides Cut Away to Show the Arrangement Devised for Swindling Purchasers of Liquor: The Small Cavity Just below the Screw Top was Filled with Whisky, the Remainder of the Can Containing Water

Cont. C. A. (Briggs)
 1521 Oak St. N.W.
 Washington, D.C.

8755 Cml. Harle Jims
Howard. Ohio.

904

POPULAR MECHANICS

SPECTACULAR JUMPING STUNT FINALLY ENDS IN DEATH

Spectacular jumps, or dives, from a small platform placed at the top of an 80-ft. ladder into a net below, was the

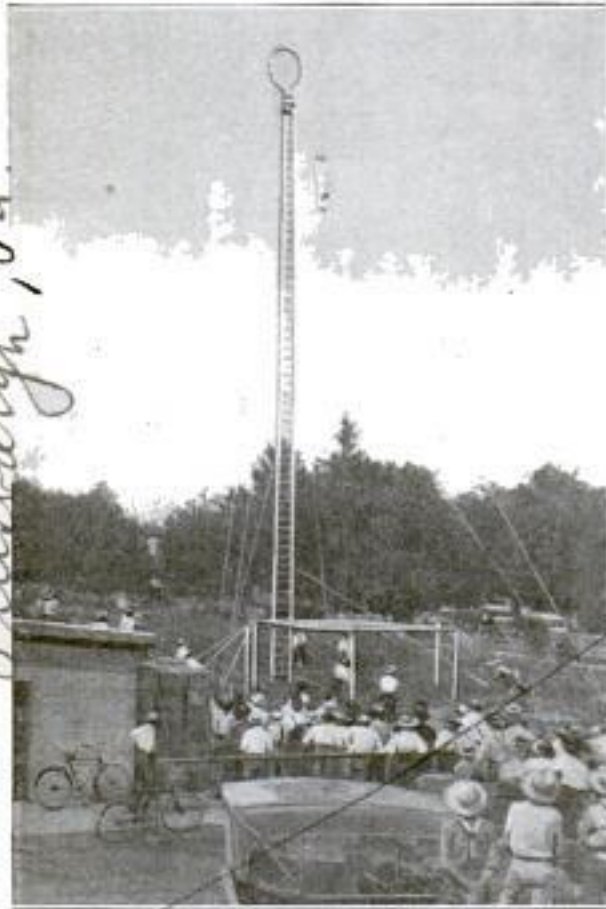

Spectacular Jumper Shown in Mid-Air Just After He has Dived from the Small Platform at the Top of the 80-Foot Ladder

chosen occupation of a father and three sons in different parts of the country. Advertised as the main attraction at county fairs and exhibits, these men pursued their hazardous calling until finally each, through slight miscalculation, failed to land in the net and was instantly killed.

PRESERVING CRYSTAL PALACE TOWER TANKS FROM RUST

Everyone who has seen the world-renowned Crystal Palace, near London, Eng., which was, 70 years ago, the first structure ever built for an international exhibition, will remember the great crystal towers that flank either end of the main building. Each of these high towers, built entirely of glass in what looks like a very slender iron frame, carries at its top a wrought-iron tank, 47 ft. in diameter and 38 ft. deep, with a capacity of 250,000 gal. of water, which is the source of sup-

ply for fire hydrants, for blowing the great organ in the palace, and for the extensive fountain system in the palace grounds. Recent examination showed that the long-continued process of rusting had reduced the thickness of the tank walls from 25 to 30 per cent. On account of this dangerous weakening of the tank plates, it is now proposed to reduce the water pressure within them by reducing their depth. This would be simple enough if it were not for the fact that a weight equal to the weight of the tanks when filled with water is needed as stabilizers for the towers that are so large in proportion to their small weight. Therefore the difficulty is to be overcome by filling a large part of each tank with cement, which will reduce the water pressure in the tank while maintaining the pressure at the points of delivery due to the water head.

GAS BURNER IS ADJUSTABLE FOR ANY PRESSURE

High gas bills are caused chiefly by the gas burner being more than 1 1/4 in. from the cooking utensil, according to recent investigations made by the Department of Agriculture, the Bureau of Standards, the Bureau of Mines, and the Ohio State University. As a remedy for this condition, a burner has been produced that can be adjusted to give the correct

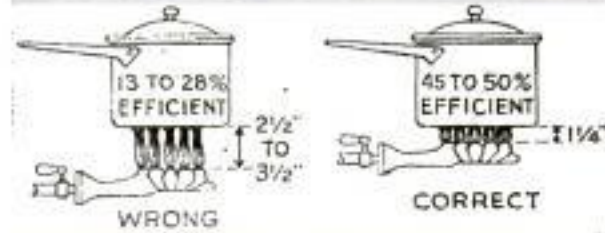
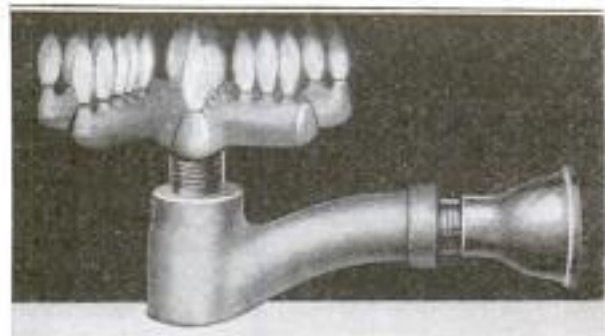

At the Top is Seen the Adjustable Gas Burner Which can be Screwed Up or Down, to Reach the Correct Position Shown Below

height of flame, by being screwed either up or down, in accordance with the pressure, and which can be fitted easily to any gas range now on the market in a short time and with but slight cost.

878
Cml. Cameron Brown. 214 Wood St. Pittsburgh, Pa.

878
Cml. Leonard Smith 83 Crofton Road Camberwell, London England

PACK RUGS IN PAPER TUBES FOR SAFE SHIPMENT

Packing rugs in paper tubes so that they will be kept clean and protected from injury during shipment, is the method employed by a western concern. The tubes are of a suitable diameter, in length equal to the width of the rug being shipped, and made in two sections. Either of the sections can easily be removed by the dealer for display purposes, and then be replaced for delivery or reshipment.

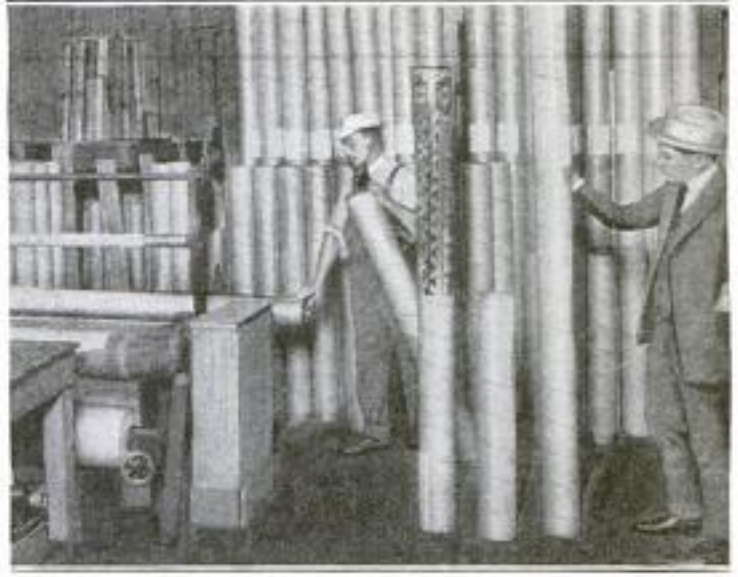

Paper Tubes in Which Rugs are Packed for Safe Shipment: One Section of the Tube can be Removed for Display Purposes

■ A British concern has succeeded in producing a paint pigment of white oxide of antimony which has none of the unsatisfactory features of paints formerly made with this compound. Paint made with it is said to be nonpoisonous.

8932

THREE-WHEEL ROAD ROLLER HAS ENGINE AT REAR

A new design in gasoline-driven road rollers, while it is unconventional, produces a machine of exceptionally short wheelbase, capable of turning in a small radius, which is a very desirable thing in machines of this character.

The roller is controlled much in the manner of an automobile, and the driving wheels are equipped with a differential which can be locked with a pin in case it is necessary. The

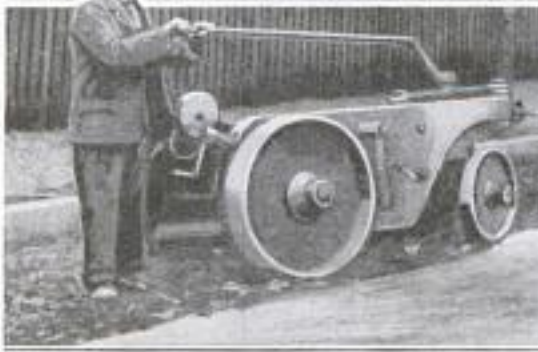
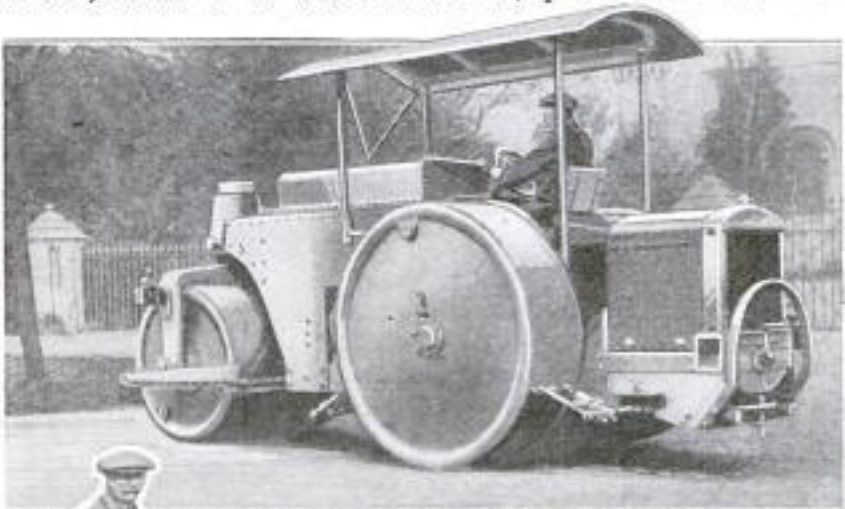

Above: By Placing the Engine at the Rear of This Three-Wheeled Gasoline Road Roller, the Wheelbase is Greatly Reduced, with a Consequent Increase of Flexibility. Below: Drawing a Scarifier. The Short Turning Radius Makes This Roller Particularly Useful for Road Work

duces a machine of exceptionally short wheelbase by placing the engine at the rear. This feature makes a very engine, transmission, and control are mounted on a subframe which is carried on three-point suspension.

Mfr. Beardford + Perkins, Ltd. Peterborough, England

770 information on tractors

Used by - The Paraffine Co. Inc. 24 Series
 San Francisco Calif. 3/17/22 P20
 906 POPULAR MECHANICS Bureau of Chemistry
 8819 8793

EMPLOY STEAM-OPERATED AX FOR CHOPPING REDWOOD

Because of its fire and acid-resisting qualities, redwood bark is a desirable material for use in the manufacture of



This Steam Ax Operates like a Steam Hammer, and is Equipped with a Four-Bladed Bit for Chopping Redwood Bark to be Used in the Manufacture of Roofing Material.

felt for roofing material, but it must be reduced to small pieces before going to the pulp machines. As a first step in the operation, one company uses a steam-operated ax for chopping the large slabs of bark as they are received. The steam ax is patterned after the familiar steam hammer, but is equipped with a four-bladed bit for cutting. A heavy shield and screen protect the operator.

NEW NONINFLAMMABLE GAS PRODUCED FOR AIRSHIPS

Announcement has recently been made of the production of a new lifting gas for airships which is claimed to be non-inflammable and nonexplosive, and to have a lifting power almost equal to pure hydrogen. The gas is made by an electrolytic process, and it is said that it can be produced at a much lower cost than an equal quantity of helium gas produced at the Fort Worth helium plant.

Aerial Age Weekly 3/24/22 P911

Mr. The International Transportation Co. 716 S. Los Angeles, Calif.

STAINS ON LEATHER REMOVED BY SOLUTION OF RUBBER

New methods for the removal of stains from leather goods have been developed by the Bureau of Chemistry of the Department of Agriculture. For the removal of grease spots of any kind from any leather article, the best method has been found to be to coat the leather with a thick solution of rubber, in which the solvent evaporates rapidly. When almost dry, this coating peels off quickly and removes the grease stains with it. In exceptional cases it may be necessary to repeat the operation several times. The solution recommended is composed of unvulcanized Para or Ceylon rubber in the proportion of one part to ten, by weight, of carbon bisulphide. The fumes of this solvent are very inflammable and poisonous, and it is, therefore, essential to work at a distance from fire, and where the ventilation is good. Just before applying the solution, the leather should be made slightly wet to prevent too strong adhesion.

SHOW HOUSE NUMBER ON CURB TO GUIDE MOTORISTS

No longer will the motorist driving in a strange neighborhood be compelled to peer along from house to house searching for the number, if a system devised by a western man is adopted. With a set of stencils he marks the house-number on the curb in figures that are plainly visible from a passing automobile, lamp-black and oil being used for the marking.



France has decided to sell her government-owned railroads, as the operation under government ownership has not proved entirely successful.

Copyrighted material
 Mr. Albert Warple 716 S. Island Ave. Escondido, Calif.

8882 Cont. of L. Kahn, Triy State
 Editor The Commercial Appeal
 POPULAR MECHANICS 907
 Memphis, Tenn

LOCOMOTIVE EXPLODES WITH UNUSUAL VIOLENCE



Top of the Cab Blown 25 Feet across the Track, When the Locomotive Boiler Exploded with Great Violence While on the Track

The Locomotive Boiler That was Blown Clear of the Frame and Hurlled to a Distance of 100 Feet, is Shown Where It Landed



Locomotive Frame and Part of the Smoke Box That Remained Standing on the Track After the Boiler Exploded: The Engineer was Killed and the Fireman Injured

While standing on a siding at Egypt, Miss., the boiler of a Mobile & Ohio locomotive recently blew up, killing the engineer, injuring three other men, and wrecking the locomotive in a most sensational manner. The boiler itself was blown clear of the frame to a

distance of 100 ft. The top of the cab was blown 25 ft. across the track. The locomotive frame and running gear, with part of the smoke box, remained on the track. The force of the explosion was so great that windows were broken two miles away.

8866

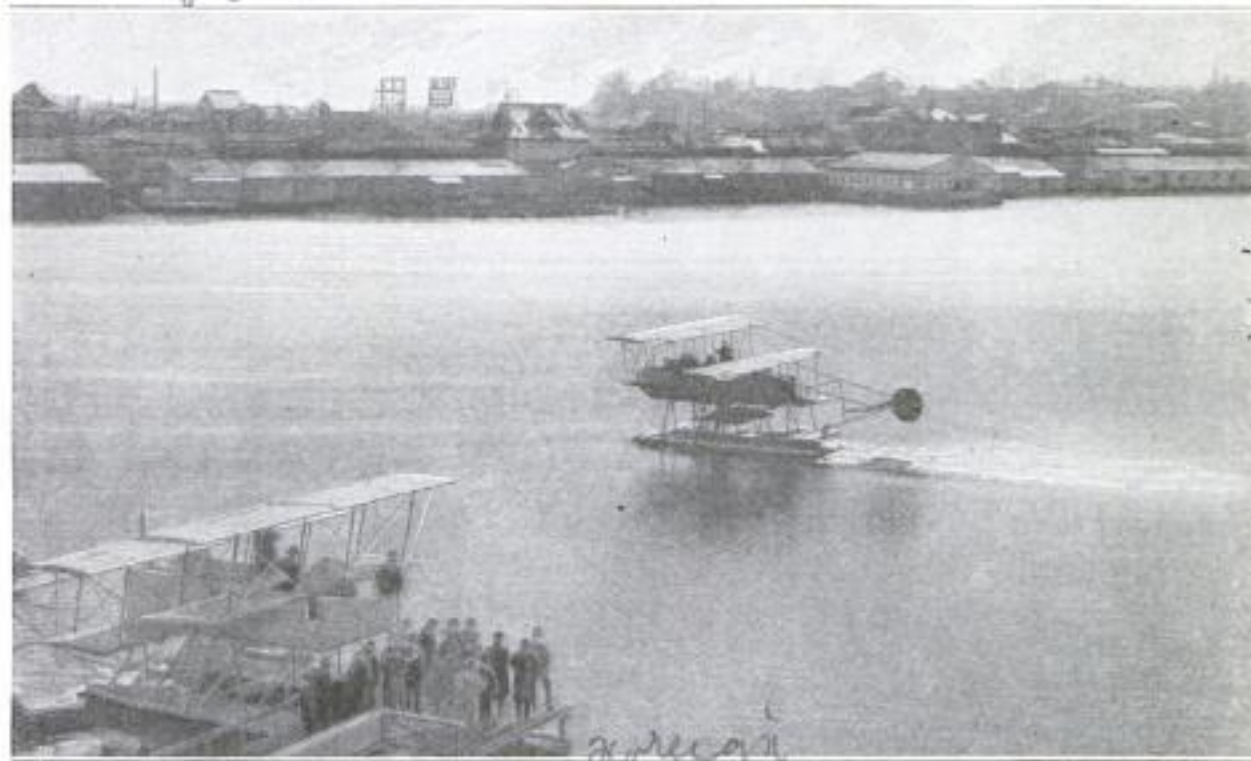

JAPANESE HYDROGLIDER IS BUILT LIKE AN AIRPLANE

AN amusement device has made its appearance in Japan which gives nearly all the thrills of flying but with the element of danger practically removed. It consists essentially of a tandem biplane carried on a float and propelled by an airplane motor. It has a seating capacity of about 20 persons, and instead of rising from the water, it glides over the surface at a fair speed.

Cont. Mr. Sakata, 05 Chome, Tidmachi Kojimachi-ku, Tokyo, Japan.

Alvora January, 1923-56 Feb. 1923-243
 December, 1922-837
 Oct. 1921-585

Carl Hjalmer Lyndquist
713 Sunset Blvd.

POPULAR MECHANICS

Los Angeles, Calif

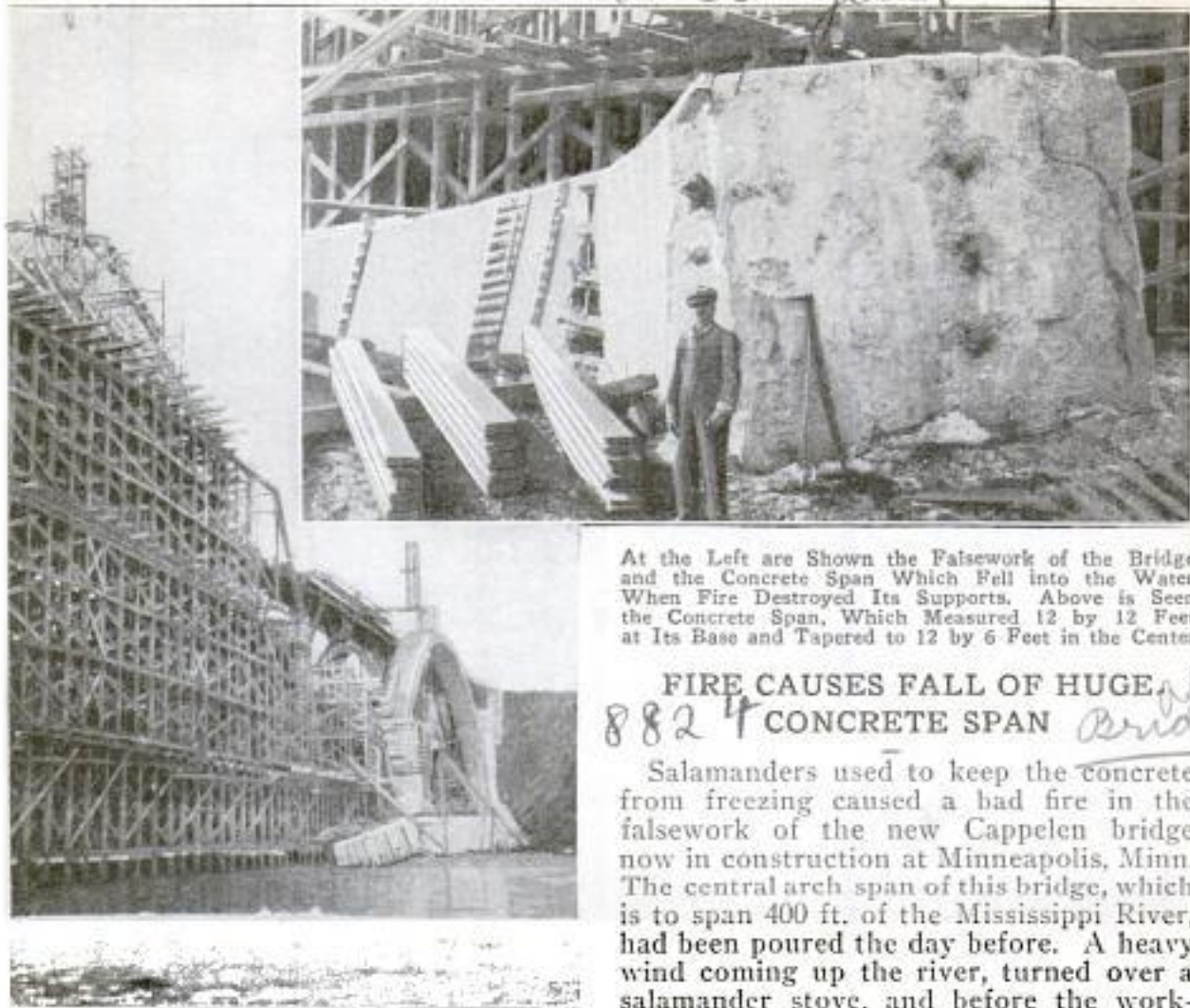

At the Left are Shown the Falsework of the Bridge and the Concrete Span Which Fell into the Water When Fire Destroyed Its Supports. Above is Seen the Concrete Span, Which Measured 12 by 12 Feet at Its Base and Tapered to 12 by 6 Feet in the Center

FIRE CAUSES FALL OF HUGE 882' CONCRETE SPAN

Salamanders used to keep the concrete from freezing caused a bad fire in the falsework of the new Cappelen bridge now in construction at Minneapolis, Minn. The central arch span of this bridge, which is to span 400 ft. of the Mississippi River, had been poured the day before. A heavy wind coming up the river, turned over a salamander stove, and before the workmen could guard against it, a fire had been started in the scaffolding and surrounding canvas. Firemen rushed to the scene, but difficulties in reaching the flame prevented its immediate extinction. Nearly half of the 400-ft. arch was torn loose from the piers, and fell when the falsework was burned from under it.

The damage done is to be repaired immediately, but no more chances are being taken on another such accident in the future. A fire hose has been placed ready for service at a moment's notice.

TO INVESTIGATE MIGRATION OF INSECT CORN BORER

Because that insect pest, the European corn borer, has made its appearance in a narrow strip extending practically the entire length of Lake Erie, investigation is to be made to determine if the moths of this insect fly across the lake. If permission can be obtained, observers will be stationed at the lighthouses along the American shore, in the belief that the moths will be attracted by the lights.

SCREWDRIVER WITH HANDLE THAT IS ADJUSTABLE

Carpenters and mechanics will find useful a new screwdriver that is double-acting.

It can be used like any ordinary straight-bit screwdriver, or by pressing a catch with the thumb or finger, the handle can be turned at right angles to the bit, enabling the operator to apply much more force, and thus do work with

one hand that, with the old-fashioned tool, would require two hands, and possibly the help of a wrench besides.



8626
Logan Machine & Mfg Co
223 S. Clinton St.
Chicago

Dept. of Agriculture Bull.
Clip Sheet # 197
Copyrighted material

KUDZU PRICES FOR 1922-1923

Note Well the Following Terms and Conditions:

THESE PRICES SUPERSEDE ALL FORMER QUOTATIONS AND ARE SUBJECT TO PRIOR SALE, STRIKES, FIRES, FLOODS OR WRECKS OR ACCIDENTS BEYOND OUR CONTROL.

SAFE DELIVERY GUARANTEED ANYWHERE IN THE U.S. But we cannot control conditions beyond that, and will not be responsible for results, and ANY CLAIM FOR FAILURE TO ARRIVE IN GOOD CONDITION MUST BE MADE WITHIN TEN DAYS OF RECEIPT OF PLANTS.

CASH IN FULL is required on all orders for less than 1000 plants. On larger amounts, 25% with order and balance C. O. D., if desired.

As we have never been able to supply the demand, first orders received with the cash will be given first consideration. Order early to make sure of plants and we will reserve them for you until planting time in your locality. Very early Spring best.

FOR ORNAMENTAL PURPOSES and where quick results are of greatest importance, we recommend selecting size No. 3 or No. 4.

Orders Not Accepted for Less than \$1.00: USE OUR ORDER BLANKS AND DON'T FORGET TO SIGN YOUR NAME AND ADDRESS PLAINLY AS WE ARE NOT GOOD AT SOLVING PUZZLES.

PRICES

NO. 1. 15 STRONG PLANTS, POSTPAID.....	\$1.50
NO. 1. 100 STRONG PLANTS, EXPRESS COLLECT.....	\$6.00
NO. 1. 1000 " " " " " ".....	\$40.00
NO. 2. 15 LARGER SIZE PLANTS, POST PAID.....	\$2.00
NO. 2. 100 " " " " " " EXPRESS COLLECT.....	\$10.00
NO. 2. 1000 " " " " " " " " " ".....	\$90.00
NO. 3. 15 EXTRA LARGE PLANTS " " " ".....	\$2.50
NO. 3. 100 " " " " " " " " " ".....	\$15.00
NO. 4. 2 VERY LARGE SPECIMEN PLANTS BY EXPRESS.....	\$1.00

SPECIAL RATE on lots of 10,000 or more.

WE DO NOT SHIP 500 at thousand rate nor 50 at one hundred rate.

TO ALL FOREIGN COUNTRIES, we ship by PREPAID PARCEL POST, for which the PRICES ARE 50% ADDITIONAL to the above list, cash in full. Remit Postal Money Order or New York Exchange.

REMEMBER

That we were the FIRST TO DISCOVER KUDZU AS A FORAGE PLANT IN AMERICA.

That there are many varieties of KUDZU, but only ONE worthy of culture for forage purposes.

That our plants are the TRUE FORAGE VARIETY, field-grown, self-rooted and self-inoculated, and should not be classed with the small, uninoculated Northern out-house plants, nor the undersized, inferior plants put out by some at a lower price in order to get business.

That few people or concerns know how to properly dig, handle and pack Kudzu plants for shipment to insure safe arrival in best growing condition, especially over long distances.

That our many years of costly experimenting and investigation have pre-eminently fitted us to give BETTER PLANTS and BETTER SERVICE than anyone else and that cheap plants are dear at any price.

PLANT KUDZU (from the right source) AND HAVE A GOLD MINE ON YOUR FARM.

C. E. PLEAS PLANT CO.

CHIPLEY, FLA., U. S. A.

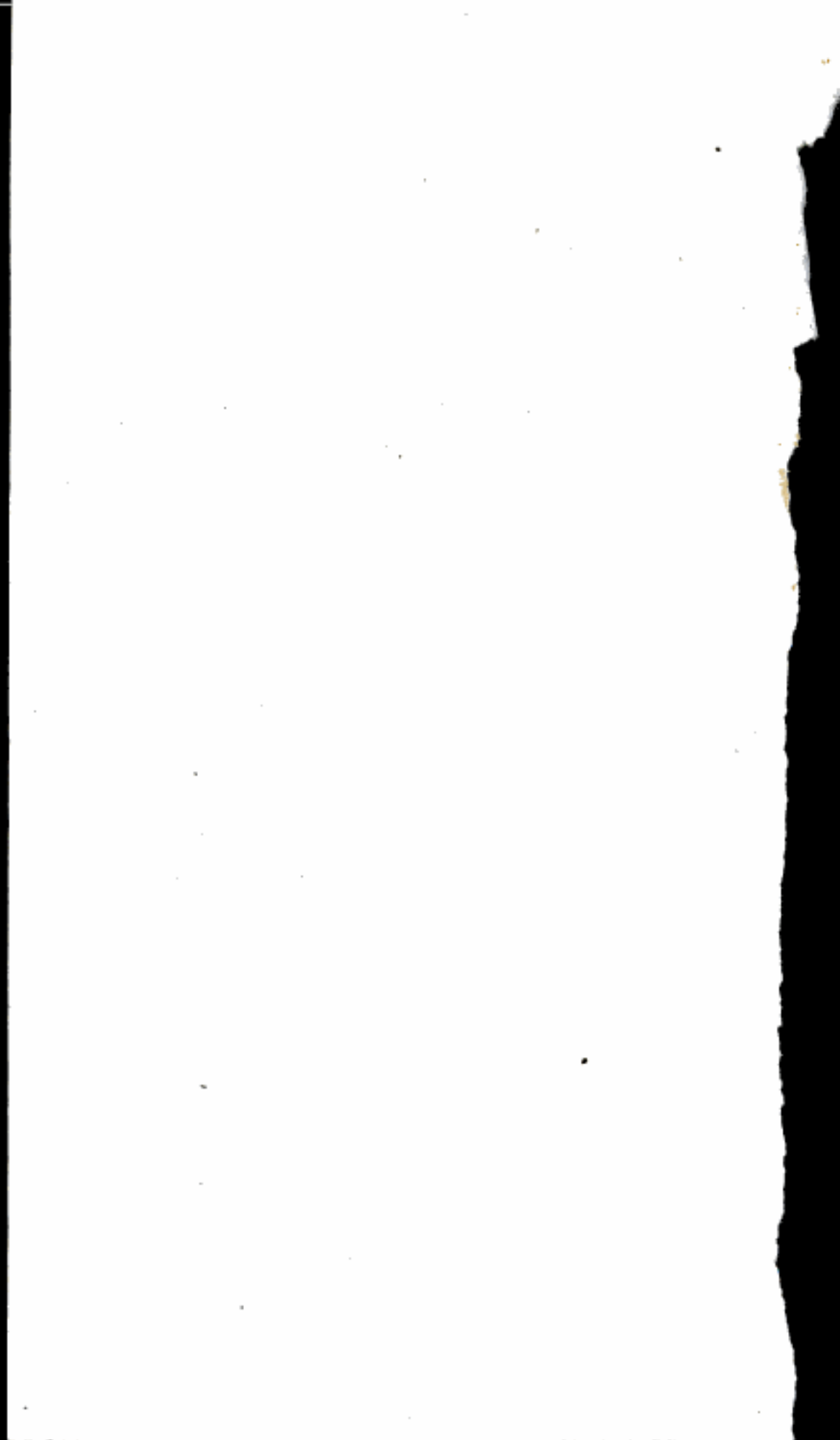

2801

KUDZU, FORAGE PLANT AND SOIL BUILDER

By C. E. PLEAS, *Islen Arden Farm, Chipley, La.*

AN ARTICLE on kudzu, the remarkable forage plant which promises so much to North American agriculture, appeared in the July, 1919, issue of this magazine. It attracted widespread attention and was received with such eagerness that, departing from our customary policy, we are again covering the subject with an article written by Mr. C. E. Pleas, the man responsible for bringing the plant to the attention of the public and the recognition of the farming industry.—Editor.

RANKING high among the forage plants, kudzu might properly be called a typical American crop, not because it originated in America, but because it seems adapted to all well-drained soils in the United States, from coast to coast, and from the Gulf to northern Maine. No other fodder, hay, or pasture plant is adapted to such a wide range of territory, nor able to adjust itself to such a variety of conditions.

It is a perennial legume of most marvelous growth and hardiness, able to withstand the coldest as well as the hottest temperatures found in the United States. It does not require liming or heavy fertilization, nor is its growth restricted to some particular soil or climatic condition. Like other leguminous plants, it carries nitrogen-absorbing bacteria on its roots, making artificial inoculation unnecessary. It may be planted in poor, rocky, hilly, stumpy, or worn-out fields and still make a reasonable return in hay or pasture. It

may be cut as hay at any time of the season regardless of the weather, as a shower of rain does not ruin it. And it is most palatable to all farm animals, and has a feeding value equal to the best wheat bran, containing an average 17.63 per cent protein.

While kudzu is a perennial that trails on the ground, rooting at the joints, it is in no sense a pest, but can be easily kept in bounds or killed. It never spreads from seeds or underground runners, nor will a root sprout when cut off a few inches below the crown.

Under very favorable conditions, some remarkable yields of hay have been made, but under normal conditions kudzu should yield, in two cuttings a year, from four to six tons per acre. It cuts easily and does not drag ahead of the mower blade. It cures the quickest and brightest of any known legume hay.

As a soil builder or reclaimer, it probably has no equal. It has immense roots



This Shows How the Roots Start from the Joints of the Vine with the Nitrogen-Gathering Nodules Appearing on the Roots



A Field of Kudzu Growing Waist-High: This Hardy Plant Needs No Cultivation, and Is a Soil Builder Because of Its Ability to Extract Nitrogen from the Air and Add This Essential Element to the Soil

6996 Cont. D. D. Winters
702 District National
Bank, Washington, D. C.

that penetrate deeply into the subsoil, and through the medium of the bacteria on its roots has the power of extracting nitrogen from the air and adding this essential element to the soil. Yields of 40 to 50 bushels of corn are not unusual following kudzu.

8787
**MONORAIL DUMPING PUSH-CAR
NOW IN USE IN GERMANY**

For use on farms, as well as in industrial enterprises, a small single-rail dumping car has been constructed in Germany.

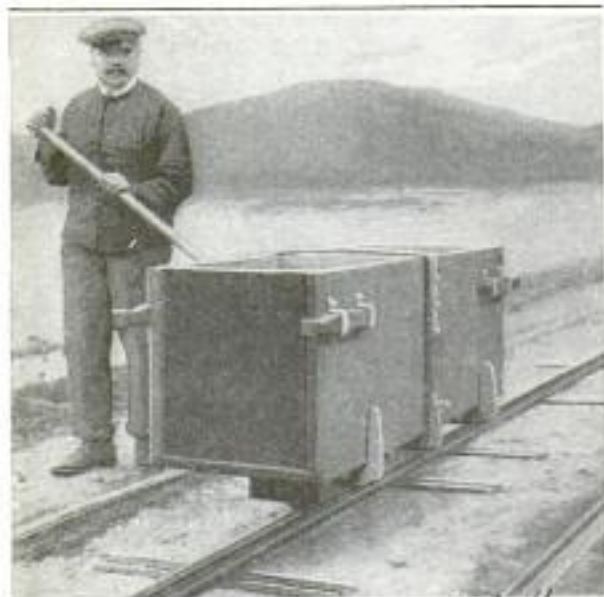

Monorail Push-Car Used in Germany: It is Pushed, and Also Dumped and Righted with the Pole Attached to One Side of It. It can be Slung on or off the Rail

A long pole attached to one of the four sides of the body of the car is used for pushing it, and also for dumping and righting it. The body is supported on small flanged wheels that travel on the single rail. It is also provided with a sling for lifting or removing.

8925
**RAPID METHOD OF CHANGING
SCENES ON BERLIN STAGE**

There has recently been completed in Berlin a series of experiments in theater craft that, it is predicted, will revolutionize the ordinary methods of scene shifting. The time and labor involved by these methods of changing scenery are completely avoided by placing on the main stage a number of smaller ones, each with a complete setting of scenery required by the different acts. These smaller stages are mounted on rails so that they can be wheeled back, one after another, leaving only the required setting in view of the audience.

**SOAP BUBBLES USED TO STUDY
EXPLOSION OF GASES**

Everyone who buys gasoline for his automobile has a direct concern in the efficiency of engines, the study of which is being assisted by soap bubbles. These are now being used at the Bureau of Standards in determining the rate of propagation of flame in combustible mixtures of gases. Strangely enough, for years there has been sought a means whereby explosions could be studied under constant pressure free from complicating circumstances, but it was just recently pointed out at this institution that soap bubbles afford in ideal fashion just what is wanted.

In these experiments a bubble, about 8 or 10 in. in diameter, is blown with the gaseous mixture around a special form of spark gap, adjusted to its center. This is set up behind a screen containing a narrow horizontal slit on a level with the center of the bubble, and upon which is focused a camera. The film of the camera is set in motion in a direction at right angles to the slit, and a spark is passed through the gap, causing the bubble to explode. The progressive ignition of the gas appears through the slit as a line of light beginning at the spark gap and extending in both directions along the slit, and as the film is moving while this is going on, the resultant image on it takes the shape of a wedge, the exact form of which gives the data desired. Contrary to the results obtained under other conditions, the velocity of propagation in mixtures so far investigated is uniform,

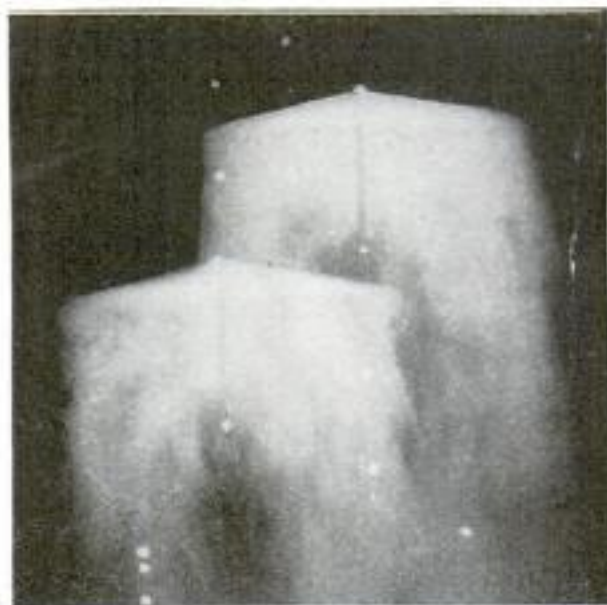

Photographic Record of Two Soap-Bubble Explosions Viewed behind Slit: The Straight Sides of the Wedge Indicate That the Explosion is Propagated Uniformly

Christina S. Savel
Monitor 4/4/22

8968 The Paraffine Co, Inc

POPULAR MECHANICS - San Francisco, Calif. 911

USE ROLL-CHANGING MACHINE IN MAKING ROOFING

The base of many prepared roofings is felt which is treated with various substances to render it water and weatherproof. This felt is received at the manufacturing plant in large rolls, called "jumbo"

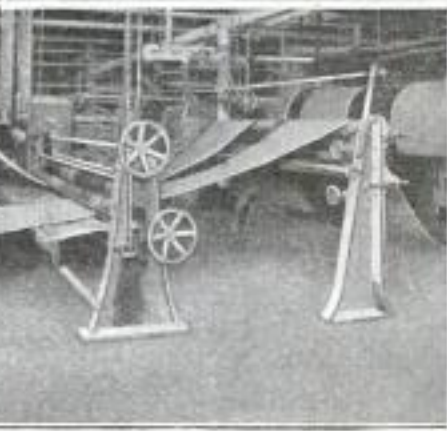
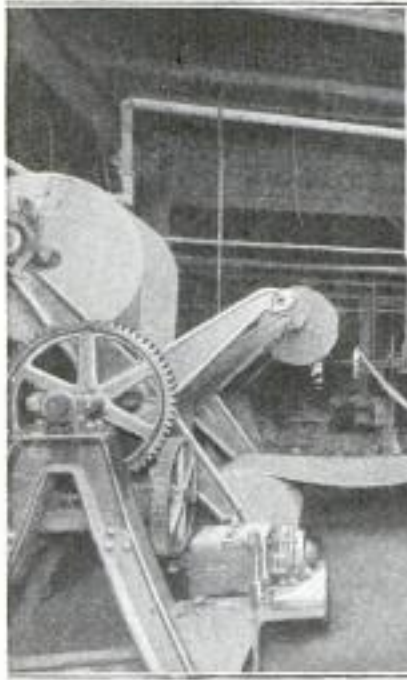
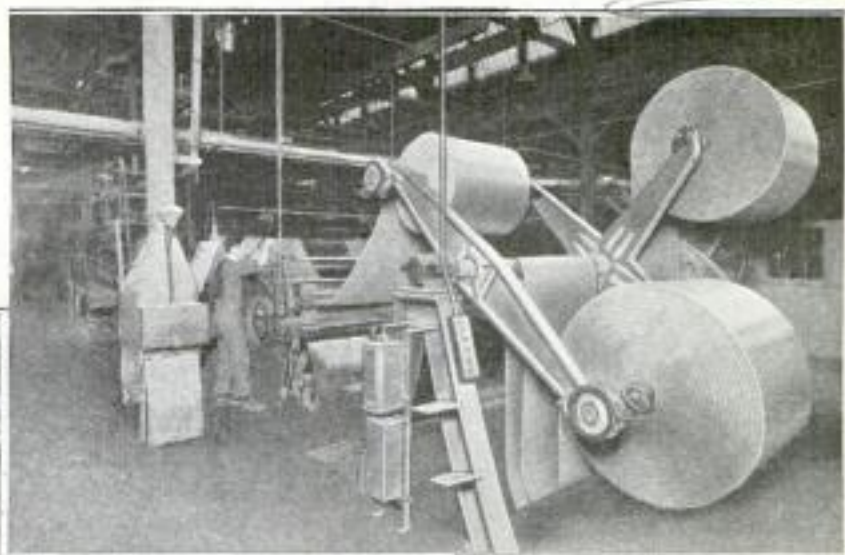

A Fresh Roll of Felt has Just been Placed in the Holder, and as the Upper Roll is Exhausted, the Holder is Revolved to Make the New Roll Available

ess should be continuous, so the rolls are carried on large spiders in such a way that as one roll is unwound another can be started through the tanks without stopping the machinery. The holder is so arranged that the new roll can be moved into position without being lifted from the floor, and the roll holder can be

The Roll of Felt Going to the Treatment Tanks is Nearly Exhausted, and the Roll Holder has been Revolved to Bring the New Roll into Position, Where It can be Started without Stopping the Balance of the Machinery, as It is Desirable to Have the Process Continuous

rolls, which are unwound, and the strip of felt is passed through the treatment tanks. It is very desirable that this proc-

revolved when needed without interfering with the operation of the rest of the process.

8946

TIRE REPAIR WITH COMBINED JACK AND RIM CONTRACTOR

For the motorist, a handy tool that serves two purposes is a combined jack and rim contractor to facilitate the removal of a tire for repairs. The jack is of the gear-operated screw type, the operating gear in connection with the hand lever being engaged by a double pawl, allowing the jack to be used for pushing when it is lifting the car, and for pulling when it is contracting the wheel rim. At the base of the jack are two pivoted arms with braces that slide in a rack on each side of the jack, so that these arms can be extended horizontally to support the jack when lifting the car, or at an angle of about 45°, so that their ends can be hooked over the wheel rim

when used as a contractor. At the end of the jack is also a hook which engages the top of the rim and pulls it downward.

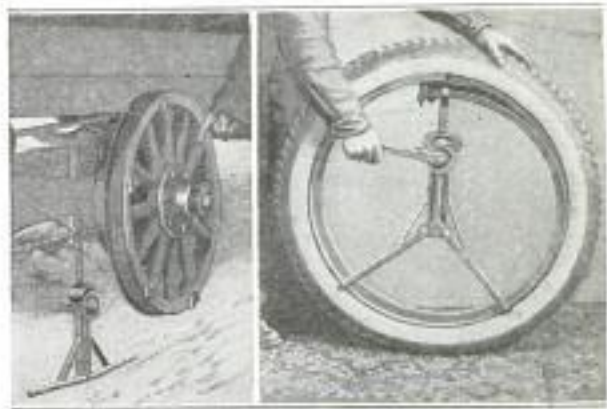

Combined Jack and Rim Contractor, Shown at Left in Use as a Jack, and at Right as a Rim Contractor, to Facilitate Tire Removal for Repair Work

L. W. Fred C. Rhode, Fairview, Illinois
Copyrighted material
Mowh

*Chas. W. Martin F. Enke
1346 E. 28th St.*

874 ⁹¹² *Oakland Calif.*

POPULAR MECHANICS

LADDER HAS AUXILIARY LEGS TO PREVENT ACCIDENTS

Accidents may be prevented by the use of an adjustable ladder fitted with auxiliary legs for the purpose of assuring a firm support on ground that is not level. The legs, of which there are three, are fas-



Ladder with One Side off the Ground, but Firmly Supported by the Auxiliary Legs and the Rear Leg

Above, the Ladder is Set Up on Uneven Ground, and Below, It is Folded for Carrying

tened to the ladder body, one on each side at the base and the other at the top, and the former can be adjusted along the sides as desired, being held firmly in place by a sliding spring-pawl arrangement. For carrying, the legs are folded.

and drill rods, though the fact is, the whirling of the drill rods and their knocking against the walls of the drill holes, tend to lift the drill point so that the drill hole curves upward; the nearer the horizontal, the greater the rise per unit of distance, ordinarily.

"Surveying" the drill hole is the determination of the exact direction and position of the drill hole at all points, whether to right or left, or above or below the line projected from the starting point of the drill hole. To do this apparently impossible job of measuring, it is only necessary to fill a long slender glass tube or bottle with hot water, containing a small amount of melted paraffin and also a floating spirit level, with a compass needle attached, the spirit level being so adjusted as to float in liquid with the bubble in a central position. This bottle, by means of a bail or attachment, is let down on a measuring line, and brought to a stop at certain intervals, usually not less than 5 or 10 ft. Here it is held quietly until the paraffin sets by falling temperature. On being hauled to the surface, it is easy to bring the spirit level to a level position,

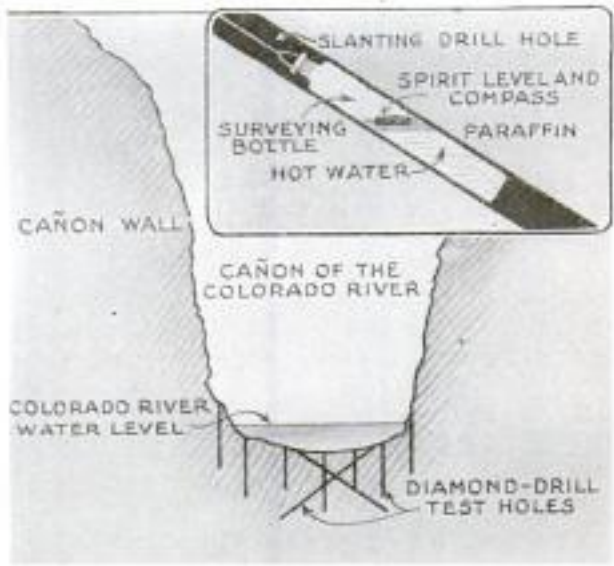

Diagram of Slanting Drill Holes Which were Made to Test the Rock for a Dam Site: Insert Shows Method of Surveying Holes

"SURVEYING" TEST DRILL HOLES AN INTERESTING PROCESS

In examining the structure of a rocky crevice in a proposed dam site on the Colorado River, in northwestern Arizona just recently, engineers made the usual test drill holes in the bottom to a depth of from 50 to 100 ft. Desiring to check the theory that the stream crevice or cañon itself might be a fault line, slanting drill holes were made, in both directions, athwart the stream, to a sufficient depth to intercept the fault escarpment beneath the water, if any were present.

At first thought, it might be assumed that such drill holes would sag, and curve downward with the weight of the drills

and the compass, compared with a free compass, into the magnetic path, and obtain the angle of the hole at that point, from both base lines, vertical and horizontal. This is repeated for the entire length of the hole, and its exact position charted.

Write our Bureau of Information, if you wish to know who makes or sells any article described in this magazine. Send no postage; the service is free.

*53 55
Encl. J. Cecil Altar
1103 Boston Blvd.
Spelt Lake City*

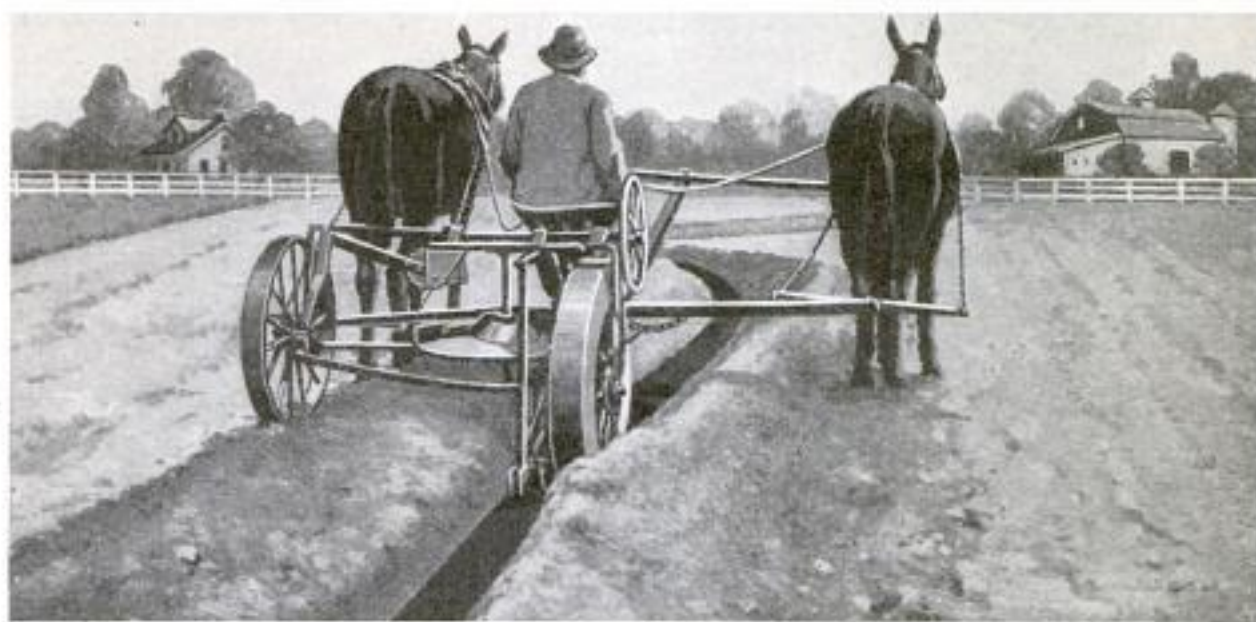

Ditcher in Operation, Showing How the Machine Throws Half the Dirt on Each Side of the Ditch When Operated in Alternate Directions: The Ditcher can be Used with Equal Effectiveness on Either Level Land or on Any Hillside Where a Team or Tractor can be Driven

8693
**HILLSIDE AND TILE DITCHER
 DOES WORK OF MANY MEN**

Digging ditches for the laying of tile can be rapidly accomplished with a new implement which will dig a trench 30 in. deep and any desired width, requiring only one man to operate it. A specially designed share cuts the dirt and throws it into a bull wheel which is equipped with container compartments, or pockets. These pockets carry the dirt upward and deposit it upon a horizontal throw-off table, which is revolved by gears connected with the bull wheel. The outfit has a leveling arrangement that keeps the bull wheel and cutting tool vertical at all times, regardless of the depth of the ditch or the slope of the ground.

8767
**TOWER TESTS WATERPROOFING
 MATERIAL FOR CONCRETE**

While concrete is ordinarily thought of as a solid, impervious material, there are, in fact, many small openings in it through which water can find its way, and this makes it unsuitable where a waterproof structure is required. This has led to a search for some substance which can be mixed with the concrete to fill these tiny openings and make the concrete waterproof. One company doing this experimental work has constructed a water tower in five vertical sections, two of which are made of ordinary concrete and

the other three of mixtures containing some form of waterproofing material. By filling the tower with water, the effect the different materials have in preventing the water from finding its way through the concrete can be studied.

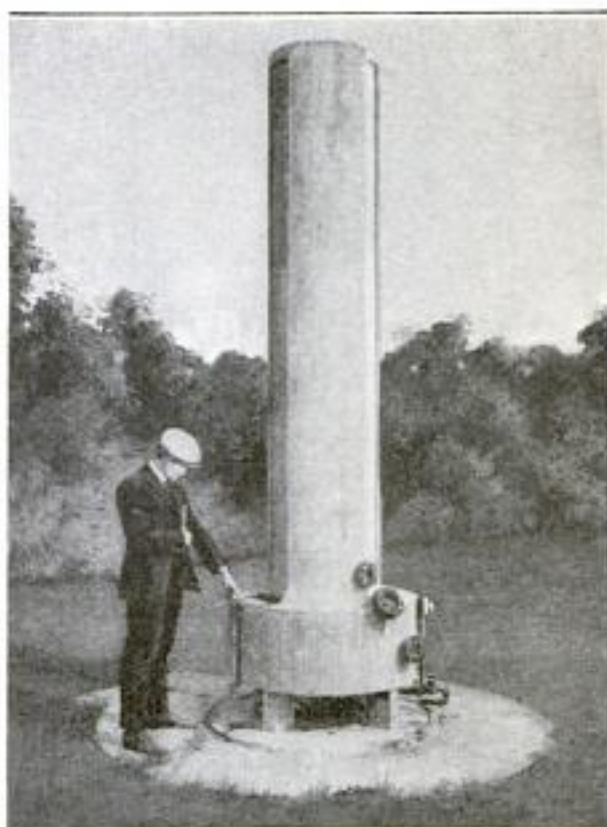

While the Water in the Tower Seeped through the Untreated Concrete, the Waterproofed Sections Showed No Sign of Moisture on the Outer Surface

Paraffine Companies, Inc.
 San Francisco, Calif.

8749
914

Com. George F. Paul, 300 Ellsworth Bldg., Chicago

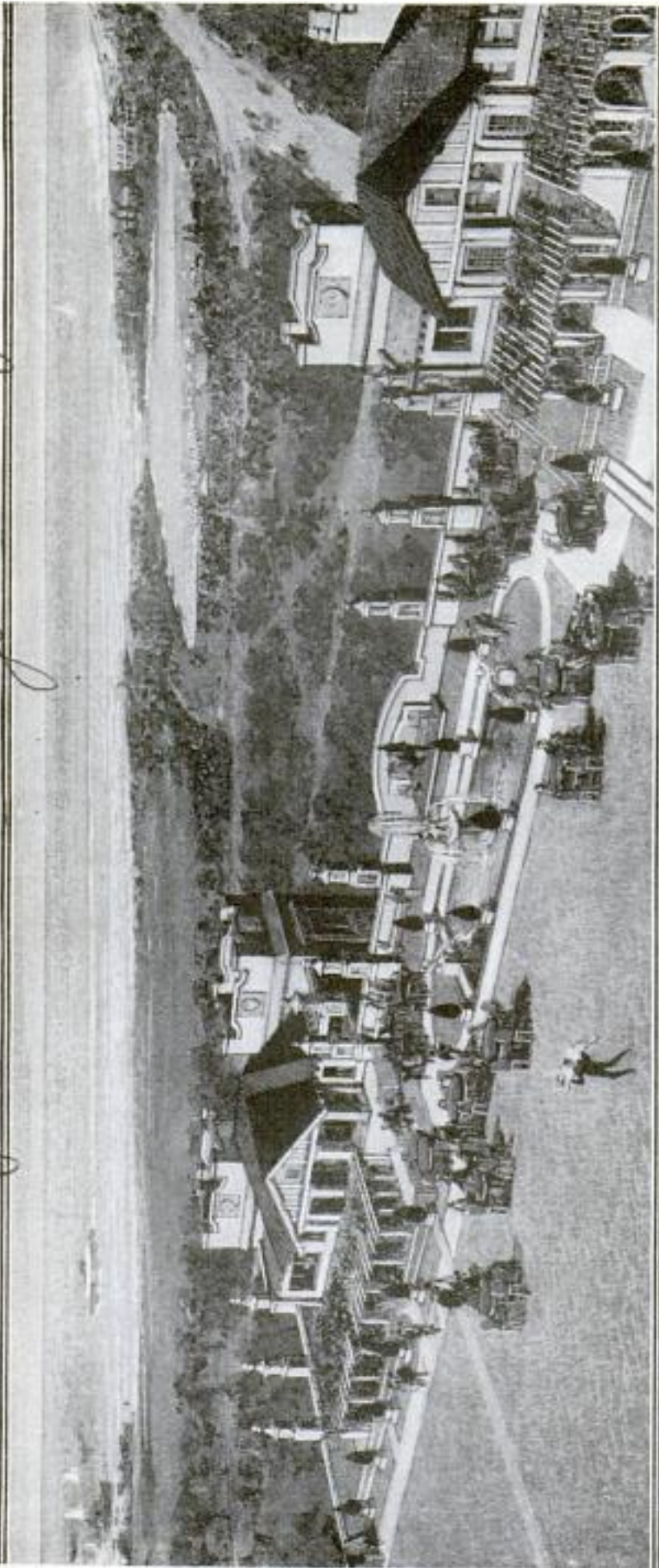

Roof of Proposed Chicago Hotel, Showing Two of the Five Bungalows Which will be Placed on the Top of the Structure, According to the Present Plans of the Builders: The Hotel will be Located Where the Occupants of the Bungalows can Have an Uninterrupted View of Lincoln Park, Lake Shore Drive, and Lake Michigan

NEW CHICAGO HOTEL WILL HAVE FIVE BUNGALOWS ON ROOF

Five bungalows, pergolas with climbing vines, sunken gardens, fountains, handball and tennis courts, will change to a scene of great activity and beauty the top of a new hotel which is to be built in Chicago during the summer of this year. These bungalows will have many special electrical features that will make them highly attractive and convenient. The unobstructed views from the windows will furnish an added charm to these ultramodern homes, commanding a vista of Lake Shore Drive with its parks and water front. It will form a noteworthy addition to the list of new Chicago hotels.

8778
HISTORIC PINE TREE LIVED 1,200 YEARS

Twelve hundred years was the age of a historic old pine tree which grew on the edge of Lake Biwa, in Japan, and which recently died. Being famous in song and legend, the tree was visited by thousands of pilgrims every year, and was the center of time-honored religious ceremonies. The ancient pine was of the low spreading variety, attaining a height of only 30 ft., but having a spread of 163 ft. from east to west, and 154 ft. from north to south. Another tree, 350 years old, will succeed to the near-worship which was formerly bestowed on the dead pine.

The World
1/15/22

Christian Science
Monitor 4/3/22

Esash Stall & Co
Chester, Pa 815

8913
BLOODED CATTLE IDENTIFIED BY MEANS OF NOSE PRINT 8756
COMBINED TRACTOR-SNOWPLOW CLEANS CITY STREETS

Nose prints of cattle are the latest means of identification used to determine the authenticity of any claim that an animal has a blooded pedigree. This method of identifying cattle was adopted by a University of Minnesota professor, who thus utilized a variation of the familiar Bertillon system employed by the police in cataloguing humans by finger prints. Since the inauguration of the system a few months ago, some 500 prints have been taken, and the closest examination has failed to reveal a duplication among the different breeds. Neither has there been found any change in the design as the animal grows older, so that a print attached to a registration certificate, at once identifies and prevents the substitution of inferior cattle.

Added proof of the versatility of the modern tractor is given in the production of a snowplow attachment,



Combined Tractor-Snowplow in Operation, Showing the Method of Attaching the Plow to the Front of the Tractor, and Also How It is Weighted

8679
THOUSANDS OF PIECES USED FOR INLAID TABLE TOP

An Idaho man has recently completed an inlaid table top, on which he spent two years' time in making the 12,215 pieces in its construction. Assembling the many parts was accomplished in seven days, and the finished product includes a checkerboard, at which game the patient worker will no doubt now spend his idle hours.

which is manufactured by a Pennsylvania company. The arrangement is fastened to the front of the implement and heavy weights are placed on it, after which good results are obtained in clearing the sidewalks and streets of blockading snowdrifts. 8921

DISCOVERS NEW ATTRACTIVE NONMAGNETIC FORCE

A statement has recently been made that a German scientist has discovered a new attractive force which is nonmagnetic, and yet which causes attraction between, not only iron, but also all other metals and even minerals. It is believed that it will find immediate application in wireless telegraphy and telephony, as the energy requirement is from 300 to 500 times less than that of ordinary electromagnets for the same purpose. It is also claimed that this discovery will make possible a speed of 2,000 letters per minute in telegraphic writing.



Inlaid Checkerboard-Table Top, Constructed of Many Thousand Pieces by an Idaho Man: The Design Attained is Quite Intricate and Testifies to the Patience of the Maker

maker - R. N. Aldenburg
Moscow, Idaho

There has been installed at the University of Indiana complete equipment for the analysis of oil shales.

Dr. Erich S. Huth
Gesellschaft für Fern-
telegraphische Arbeiten

Patent - Wall, Berlin, 226,19,
4/5
Berthstr

Cml. George F. Paul

James. Picayune

8730 900 POPULAR MECHANICS 1/15/22
8897

PROSPECTIVE RADIO CUSTOMERS LISTEN WHILE THEY SHOP

GREAT LOSS OF NATURAL GAS CAUSED BY "WILD" WELLS

The widespread interest in wireless-telephone outfits is intensified by the methods used by a specialty shop in Chicago

It is estimated that five "wild" gas wells in one field in Louisiana alone are allowing 30,000,000 cu. ft. of natural gas to escape daily, and steps are now being taken by the State Department of Conservation to curb this waste.



The Prospective Customers are Furnished with Receivers So They can Listen to the Wireless Messages and Discuss with the Salesmen the Merits of the Different Receiving Sets being Shown

Brooklyn. Here the salesmen and the customers are alike supplied with receivers, and they can thus pick the messages from the air and discuss the possibilities of this new feature of modern life. In this practical manner the prospective customer is brought immediately into touch with the magic of the air, and is elated with the simplicity of it all.

The wells went wild owing to faulty drilling methods in use a few years ago, as the casing was not cemented and the gas blew out between the joints and caused a crater to form around the casing. At present some of these craters are as much as 250 to 300 ft. in diameter and are filled with mud and water. The gas escaping through this mixture gives the craters the appearance of boiling caldrons, and the roar can be heard a half mile away. In one case the derrick and drilling tools disappeared in the crater.

TRACK TREADS GIVE TRACTOR GREATER PULLING POWER

A new attachment designed to give the small tractor greater bearing area and increased pulling power, replaces the round wheels with two large sprockets. Outside of each sprocket is a cast-steel arm which projects forward and downward, carrying at its front end a smaller idler wheel. A track tread passes around the sprocket and idler wheel, giving the tractor increased bearing area.

FLOTATION PROCESS ADAPTED FOR CLEANING COAL

Recent investigations by the Bureau of Mines have shown that the flotation process which is so successfully used in the concentration of metallic ores can be used for cleaning many American coals of part of their ash and refuse content. Experiments on coals from the state of Washington showed that this process would eliminate much ash which was not removed by washing in jigs. The investigation did not cover the commercial phase of the problem, and the success of this method will depend on the cost as compared with the present cost of putting clean coal on the market. The problem of cleaning coal becomes more important as the present coal areas are mined out and higher-ash coals come into use.

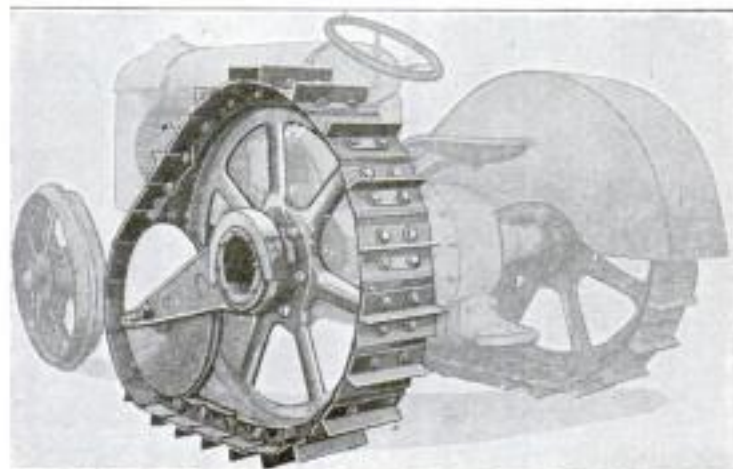

The Large Sprockets Replace the Round Wheels, and the Track Tread Increases the Bearing Area on the Ground

Schmeiser Mfg. Co.
Laris Calif.

material

8493

~~Cont. Allen P. Childs, Box 73,~~

Station E, Kansas City, Mo

Myr. Ammiston Electric Steel Corp. Ammiston, Ala.

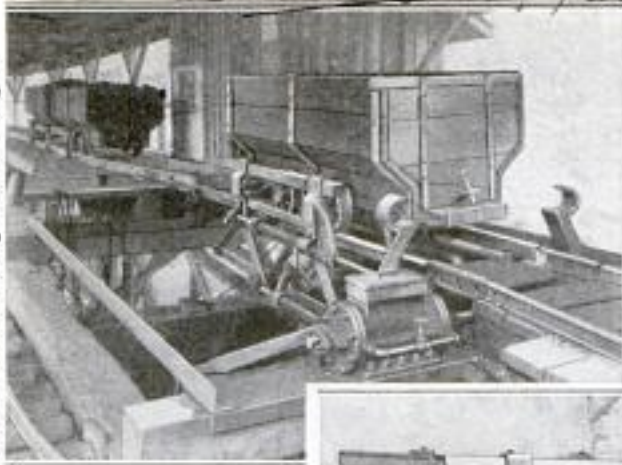

Above: Automatic Car Dump, Showing an Empty Car Which has Just been Elevated to the Track by the Weight of Another Loaded Car being Dumped. In Front of the Car is a Compression Cylinder Which Brings the Dump to Rest

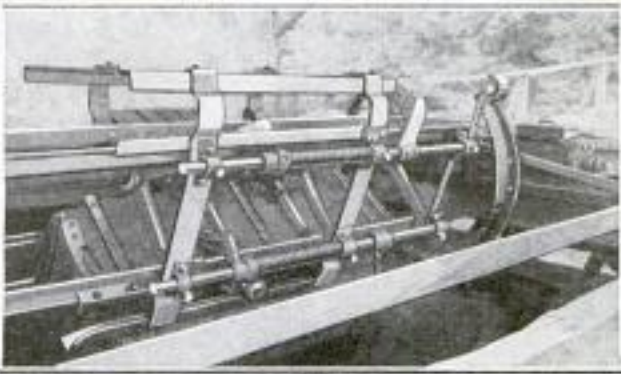

Above: Automatic Car Dump, Illustrating the Manner of Dumping the Cars. The Loaded Car on the Left is being Dumped by Gravity and at the Same Time Elevates the Empty Car on the Right to the Track. Left: The Dumping Mechanism

NEWLY DESIGNED CAR DUMP WORKS AUTOMATICALLY

An automatic car dump with several interesting features has been constructed recently by a southern concern. In operation, a loaded car runs on the dump where a trip lever is struck, this action bringing a steel bar in front of the car wheel and stopping it in the proper place. At the same time a latch is released and the dumping mechanism operates. The loaded car is dumped on one side of the track, the weight of this bringing up an empty, previously dumped car on the opposite side. When the empty car reaches a normal position on the track, its similar steel holding bar is released, and the empty car runs off the mechanism to make way for another loaded one. It is claimed that the apparatus can be adjusted so as to allow the handling of 10 cars every minute.

FIREPROOF FLUE-HOLE STOPS INVISIBLE ON WALL PAPER

Fires in buildings have often been caused by papering over a flue hole in a wall without proper protection, and to afford this protection there is now being made an invisible fireproof flue stop. It fits within the flue hole flush with the wall, so that when papered, the surface is

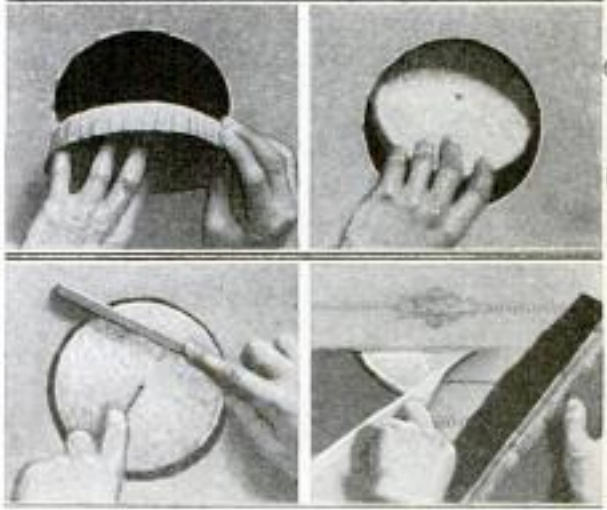

Above: Fireproof Flue-Hole Stop being Placed in Hole. Below: Left, in Place Ready for Wall Paper; Right, being Covered with Wall Paper

COPPER-SHEATHED SHIPS MENACE IRON VESSELS

When a ship sheathed with copper is moored nearer than 200 yd. from an iron ship the action of the salt water upon the iron and copper generates an electrical current which produces electrolysis in the iron hull and destroys it. As a result of this, one of the regulations of the Navy Department is that no ship having a copper sheathing shall be placed inside of 200 yd. of an unsheathed iron ship.

Cont. Sam E. Conner
31 Orange St.
Leicester, Maine

Jones, Cambridge, d. d.
d.w. Q. M.

cm. Walter C. Harris

H. M. Jones

918
8936 1588 E. 19th St

MECHANICS 3/11/22 P. 17

2.50
Copyright
G. M. Jones

COZY APARTMENTS PROVIDED FOR TOURING MOTORISTS

COMPANY WILL MANUFACTURE GERMAN AIRSHIPS HERE

Touring motorists who follow a southern route will find in many towns, on the

An American company has recently acquired the patent and manufacturing



Type of Combined Cottage-Garage, of Which Many have been Built along the Highways in Florida Towns, to Provide Shelter and Comfort for the Numerous Motorists Touring in the Sunny South

way to Florida, automobile camps which are equipped with unusual conveniences for the transient occupants. One type of a combined cottage-garage has been evolved with ample space for two cars below, and comfortable living quarters above for two families. Outside stairways lead up into these cozy apartments, which are provided with gas, electric lights, and running water.

rights for the Schuetten-Lanz type of rigid airships, and two new passenger ships are to be designed for this company. Part of the material for their construction will be fabricated in Germany and part in this country, where the ships will be assembled. That much of the hazard of aerial travel will be eliminated is forecast by the announcement of the company that it will use helium gas for inflating the airships, which are to be used in commercial service between New York and Chicago. The establishment of other routes will depend on the success of the initial venture. The company expects to have the first two airships in operation by next year.

Touring

8776
PHONOGRAPHIC SOUND BOX WITH PERFORATED DISKS

Anything that eliminates sound waves that are disturbing to those produced by the action of the record itself, in phonographic devices, will naturally improve the reproduction of instrumental and vocal music. This is said to be done in a patented phonographic

2585
SPHERICAL ELECTRIC FAN THROWS AIR RADIALLY

Unlike the ordinary electric fan, a fan, spherical in form, recently patented, is so designed that it throws the air radially from it in every direction. This is made possible by a construction of the fan blades so that the air is drawn in from above and below the fan, and then thrown out again in a radial



stream of the width of the blades. Thus, the fan could be placed in the center of a room, and cool all parts of it equally at the level of the fan.



sound box of the usual shape having the usual vibratory diaphragm at one end, and between that and the outlet a series of disks with registering openings, gradually decreasing in number toward the outlet, so that the sound waves are not affected by the sound box itself.

Whenever you find that you wish to know more about any article in the magazine, write our Bureau of Information.

cm. Fred C. Howe
428 S Broadway
Los Angeles, Calif.

cm. W. C. Kayner
103 S 6th St
Reading, Pa.

Copyrighted material



Above: In This French Airplane, of Unusual Appearance, the Lower Wing Has a Span Greater than the Upper Wing, This Design being Adopted to Equalize the Stresses in the Wings. Right: The Wings are Set Much Farther Back on the Fuselage than Is the Case with Airplanes of Conventional Design



8770 *more*
**AIRPLANE OF FRENCH DESIGN
 HAS UNUSUAL FEATURES**

Designed originally as a bombing machine, but capable of being converted for commercial use, a new French airplane departs from the usual practice which has been followed in biplane construction. In this machine the lower wing is of greater span than the upper one, this construction being adopted in order to obtain a more uniform distribution of the stresses in the wings, and to permit the use of wing spars of the same size for both wings. Another remarkable feature is that the wings seem to be placed very far back on the fuselage as compared with other airplanes.

8763 *3,000*
**NEW DESIGN PROTECTS AUTO
 TAIL LAMP FROM DAMAGE**

To prevent the annoyance of broken tail lamps, an English concern has designed a lamp of unusually heavy construction. The body is formed of two heavy aluminum castings, and the red glass is mounted between rubber washers held in place by a coil spring. A



white light is provided on each side, one to illuminate the license plate, and one to show the road when the car is moving in reverse. The heavy casting protecting the red glass is held by four cap screws.

*motor, esadgets, Ltd
 45, London St
 Chertsey, England.*

8603 *5*
**INGENIOUS SILO TOP MADE
 WITH HINGED SEGMENTS**

Quite an ingenious silo top is in use on a farm in Ontario, Can. It is made of a number of triangular segments of metal-covered wood, each connected pivotally to the circular top of the silo with two strap hinges. These segments are so shaped that when turned down horizontally they overlap sufficiently to form a close-fitting weatherproof

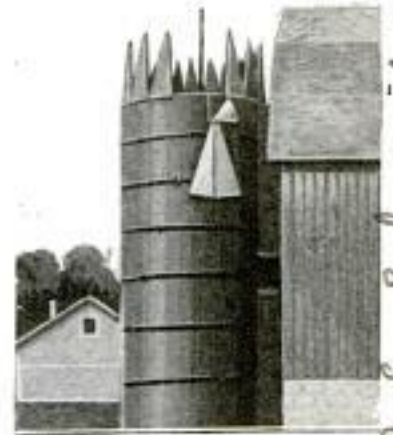

top. When raised vertically, they are surrounded with wire netting so that the contents of the silo can be piled several feet above the top, leaving the silo completely filled after settlement.

8849
**IRON FOUNDRY TO BE ERECTED
 ON SOUTH GEORGIA ISLAND**

Although usually thought of as a barren waste of snow and ice, it is interesting to note that the equipment for a small iron foundry has been shipped to the island of South Georgia—that remote spot where Sir Ernest Shackleton was buried. It is to be used for making repair castings for the whaling station at that point or for ships which call at the island three or four times a year. This will be a great convenience for vessels, as this island is 2,000 miles from civilization.

*The Engineer
 2/20/12* material

*Dr. J. E. Schneider R.O. #5,
 Ryburn, Ontario, Canada*

WIRELESS MESSAGES RECEIVED ON PHONOGRAPH RECORDS

In the new wireless station at Lyons, France, two systems of receiving high-speed messages will be employed. One is



These Phonographs Run at Much Higher Speed than the Regular Machines, and are Used in Receiving High-Speed Radio Messages Which are Recorded and Preserved on the Extra-Heavy Disks

the method of making a photographic record on a strip of sensitized paper, and in the other method the message is taken on a special high-speed phonograph. After the message has been recorded on the extra-heavy disk, the latter is placed in a machine running at much slower speed, and can then be transcribed by an operator. The reverse of this system can also be used in transmitting messages at speeds up to 150 words per minute.

WOODEN RAILROAD CARS HAVE 846 LONGER LIFE THAN STEEL

Recent investigations by one of the large car-building companies have brought out the remarkable fact that wooden cars have a longer life than steel cars. The company claims that many steel cars less than 10 years old have had to be rebuilt, principally because of the corrosion of the roof, and even, in cases, of the principal beams of the car. The conclusions are contrary to the general belief that has been held by engineers in the past.

☐ Flying recently near Copenhagen, Denmark, a Rumpler airplane used kerosene as fuel instead of gasoline. A special carburetor was used and the operation was entirely successful, the only noticeable difference being a decrease of 100 r.p.m. in the speed of the engine.

USE AREAS OF GRAVELLY SOIL TO STORE SURPLUS WATER

Because the rainfall of California is confined to a few months in the winter, the conservation of water for irrigation purposes during the dry season is of prime importance. Where suitable sites exist, this is accomplished by building dams to impound the surplus water, which is drawn off later as required. Where there are no suitable reservoir sites, it has been found that much of the surplus water can be conserved by spreading it over areas of gravelly soil where the streams emerge from the mountains. By this practice the underground formations hold this water until it can be recovered by pumping during the dry season. The method is now practiced on about a dozen streams in southern California, and has been found quite effective.

QUICK-CHANGE SET OF TOOLS HAS DETACHABLE BITS

Instead of the bulky set of chisels and punches, there is now available a compact set in which the different bits can be inserted as desired in a single handle. Seventeen tools are supplied in the set,

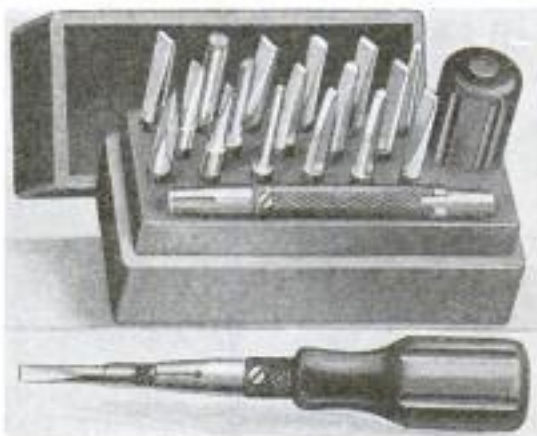

This Set of Percussion Tools Has Separate Bits Which can be Inserted in the Steel Handle. A Screw-driver Handle is Also Included

and it is claimed that, as a percussion tool, each is as rigid under the hammer as the ordinary solid forged tool.

*Winters & Haas
2823 Wilcox St.
Chicago*

*Emb. Francis B. Mammey, Paris
12 Boulevard Arago, Paris
France
Nat. Lumber Bull. 3/5/22*

Journal of Mechanics

8814 Cont. Hogg & Ford, 416 Union League Bldg. Los Angeles Calif.

POPULAR MECHANICS

921

BASEMENT GARAGE FOR OFFICE-BUILDING TENANTS

No American motorist who has driven in the busy district of any big city has failed to realize the seriousness of the parking problem which the tremendous popularity of the motor car has created in recent years. Streets, laid out before motor vehicles were dreamed of, prove utterly inadequate for accommodating the cars which the public would like to park in the business district. That some solution must



Entrance to the Underground Garage: Broad, Easy-Sloping Ramps Lead to the Two Floors below Ground Providing Space for Nearly 200 Cars. The Garage Is Directly under the Open Parking Space

The Space at the Left of This Recently Erected Los Angeles Office Building is Reserved as a Parking Space for the Cars of Clients and Patrons of Tenants of the Building. Cars may be Parked Here Free of Charge for One Hour

sands of persons, a large number of whom use motor cars. Not only has provision been made for tenants of the building, but for patrons of these tenants as well, thereby giving occupants of this big structure a decided advantage over those in other buildings.

be found at an early date is manifest. Of peculiar interest, therefore, is the practical solution which has been worked out by the management of a new office building in Los Angeles housing thou-

In the construction of this skyscraper an underground garage was built at the rear of the lot and adjoining the office building. This fireproof storage space accommodates nearly 200 cars and is



Underground Parking Space, Where Tenants of the Building may Store Their Cars during the Day: The Construction Is of Concrete, and Fire Protection is Afforded by a Sprinkler System. Windows Opening into a Well along One Side Furnish Part of the Illumination

reached from the street by broad ramps. Stalls in the garage rent for \$20 per month. Here a moderate temperature obtains at all times, and a car and its contents are safe from exposure to the elements, and also from thieves.

The ground area immediately above the garage has been made into a fenced-in parking place for the free use of patrons of the building tenants. Outsiders who have business in the building may drive in here and park their cars. Each one is given a numbered claim check, which

must receive the signature of the tenant in the building who has been called on. Countersigned thus, it is presented to the attendant in the parking place, and the car owner drives off without paying any parking fee. There is one limitation to this regulation, namely: that a person using the space longer than one hour at a time, must pay at the rate of 25 cents for each additional hour or fraction thereof.

This is one of the first, if not the first, buildings in America to work out the parking problem in the manner described. Both features—the underground garage and the free parking place for tenants' patrons—are considerations which give this new building a decided advantage over older structures. In the short time since this building was completed it has been found that prospective tenants consider these arrangements for automobiles a decided advantage which is worth dollars and cents to them. There is every reason to believe that the additional investment will prove a profitable one.



The Parking Space is Protected by a Fence Which Prevents Unauthorized Persons Making Use of It Either for Storage Space or as a Passageway between Adjoining Streets

AIR COMPRESSOR AND HOIST ON ONE SUPPORT

A very compact combination of an air compressor and hoist, the whole built as a unit, is a novel installation that will be particularly useful in all kinds of steel-erection work. The power is furnished by a 15-hp. gasoline engine, which drives the hoist by gears, and the water-cooled air compressor by belting. The compressor has sufficient capacity for driving a riveting hammer, or for calking, drilling, or reaming. The hoist is equipped with a drum that holds 700 ft. of $\frac{1}{2}$ -in. cable, and that has a "nigger-head" at each end for handling scaffolding, etc. Both hoist and compressor are equipped with friction clutches, allowing the operation of either independently. The whole outfit is rigidly mounted on a frame made of channel steel.

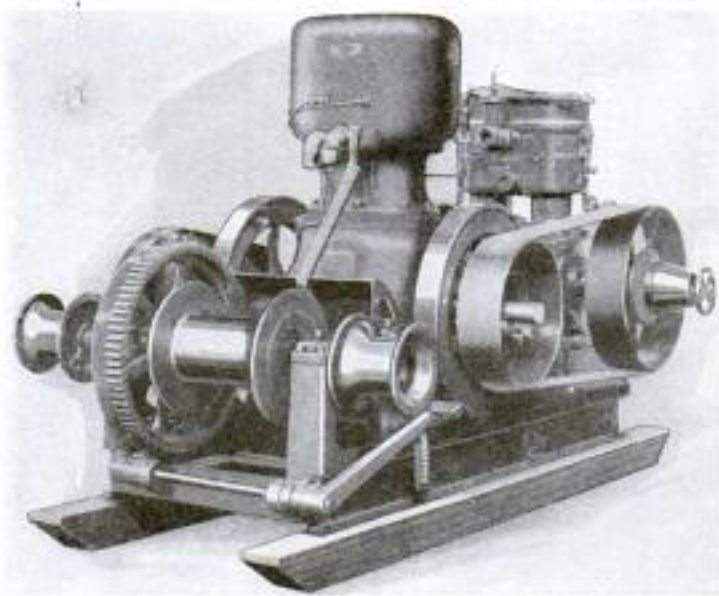

Combination Power-Driven Hoist and Air Compressor: The Gasoline Engine at the Center Drives the Hoist with Gears, and the Compressor with Belting. The Whole is Rigidly Mounted on the Steel-Channel Frame

5535
 Ward Engine Co. Hanging
 Mech.

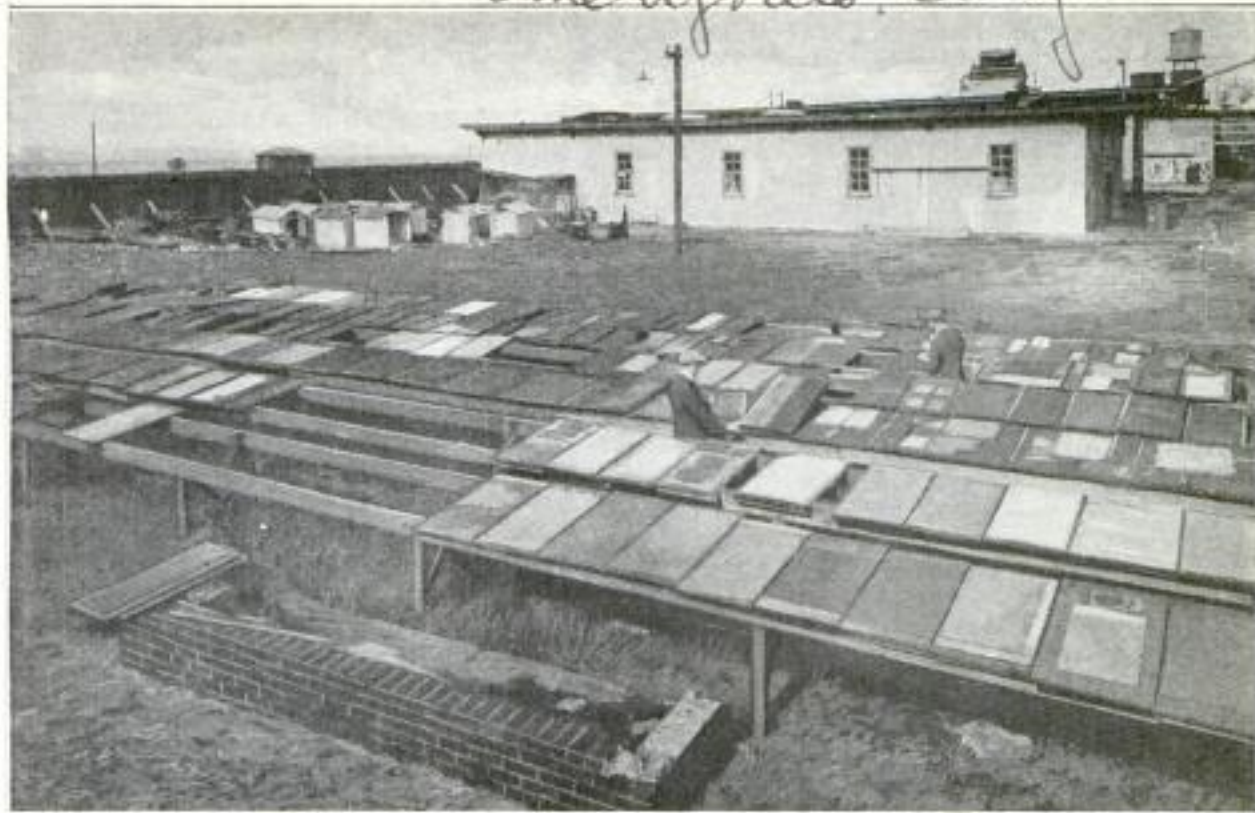

In "Exposure Parks" like This, Located in Different Parts of the World, Samples of Roofing are Laid Out and Exposed to the Weather, and Their Condition Noted after Months or Years

8766
**TESTING ROOFING MATERIALS
 IN "EXPOSURE PARKS"**

In order to test the wearing qualities of various kinds of roofing materials, one company has established what it calls "exposure parks." Here the samples of roofing are exposed to the elements and their condition noted from time to time and a record kept. These parks have been established at various places for the purpose of studying the weather-resisting qualities in different climates. In this way the manufacturer is able to advise his customers which roofing is best suited to withstand certain climatic conditions.

8826 —
**FLASHLIGHTS USED BY DOCTOR
 TO COMPLETE OPERATION**

While an operation was being performed on a patient at the County Hospital in Urbana, Ohio, the electric lights were suddenly extinguished by a lineman who was repairing some wires in the vicinity. The surgeon in charge of the case, with rare presence of mind, immediately called for pocket flashlights, of which eight were obtained. With these serving for illumination, the operation was successfully completed, and announcement made that the patient would undoubtedly recover.

Com. Bert A. Lecters
 L. B. 295
 Springfield, Ohio.

8745 **MINIATURE PISTOL RANGE
 IS VENDING MACHINE**

Shooting pennies from a pistol, at targets in which are holes for bull's-eyes, is the principle of a vending machine manufactured by a Wisconsin novelty company. A penny is inserted in the spring gun, careful aim taken, and with the pulling of the trigger, the penny is shot at the target. When a bull's-eye is made, the "sharpshooter" is rewarded with a piece of candy, gum, etc., which is automatically released by the impact of the coin.

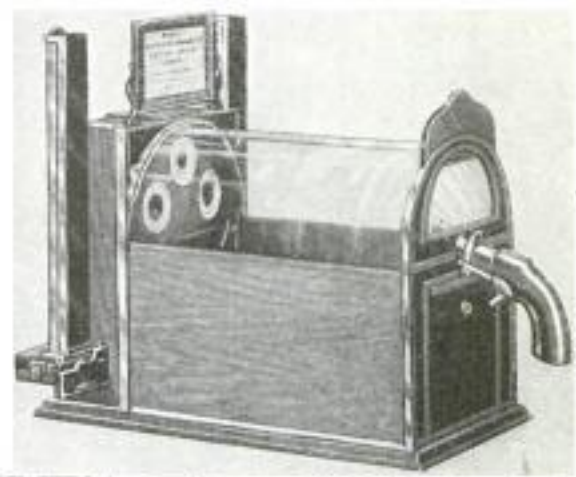

Miniature Pistol Range, Showing the Holes Which are Used as Bull's-Eyes at the Left, and the Pistol at the Right End

Wisconsin Novelty Co. Wis.
 Kankakee

Association of Date
 Importers, 46 Cedar St
 New York City
 POPULAR
 HARVESTING DATES REQUIRES
 BOTH SKILL AND AGILITY

Inv. Mr. Horak, Ingr.
 Kavalir Glass Factory
 Sazava, Bohemia.
 NOW SUCCEED IN PRODUCING
 UNBREAKABLE GLASS

8805

8925

As dates grow in large bunches at the tops of trees which reach a height of 40 to 60 ft., it is quite a feat to harvest them,



This Arab Workman Makes Use of a Rope Loop around the Trunk of the Tree to Assist Him in Climbing after the Dates When They are to be Harvested

but the Arab workman becomes very adept at the task. He passes a loop of rope around the tree trunk and works his way up by leaning back against the rope and climbing with his bare feet on the knobby surface of the trunk. The bunches of dates, often weighing as much as 15 lb., are cut off with a sharp knife and lowered to the ground on a rope.

According to recent reports, a Bohemian inventor, after 13 years of research, has succeeded in producing unbreakable glass. At a recent demonstration, it is said, plates and vessels of the material remained whole when thrown to the ground from a height of 12 ft. Meat was roasted on a thin glass plate over an open fire at a temperature of 750°F. Tin was melted in a glass pot, and nails were driven in a piece of hardwood, using a piece of glass for a hammer. A thin glass tumbler was heated in a stove to such a temperature that wood placed in it was charred to ashes. The glass not only stood the heat, but even remained unbroken when plunged into cold water while still in an overheated condition. The carborundum stones used for cutting ordinary glass cannot be used on the unbreakable glass, as even a diamond sometimes fails to cut it, due to its extreme toughness.

8701

TWO-SPAN RAILWAY CROSSING OF RIVER IN WASHINGTON

In connection with the power development of the Skagit River in Washington, as part of a 26-mile railroad, the river is crossed at Devil's Elbow by a bridge with two deck spans formed of Howe trusses, one span being 100 ft. and the other 150 ft. The pier between them was built upon a large natural boulder, that very much simplified its construction. The curved approaches are on trestle bents. The bridge has a headway clearance of 80 ft., and has already withstood the highest water experienced in 10 years.



Two-Span Railroad Bridge, at Devil's Elbow, on the Skagit River in Washington. Showing, at Left, the Huge Natural Boulder That Supports the Pier between the Two Spans: The Approaches, One of Which is Shown to the Right, Are Ordinary Trestle Bents, and the Spans are Formed of Howe Trusses

Built by City of Seattle

Carl Aaron Evans, Power Camp
 Rockport, Wash

of the glass.

7963 Oil Restoring
 Reamer Co. 915 Walnut
 Kansas City, Mo.
POPULAR MECHANICS
MACHINE FOR CLEANING
OBSTRUCTED OIL WELLS

Oil wells in which the flow of oil has been obstructed by the accumulation of sand at the bottom of the well, can be cleaned by a machine that has recently been developed. To the bottom of the tubing that is used for pumping the oil is screwed a cutting bit that is about 2½ ft. long, and that is split in two longitudinally. Each half is pivoted at its upper end, so that when the tube is rotated, they swing outwardly, and as they cut away the sand, gradually assume a nearly horizontal position. When fully extended, they clean out the sand to a diameter of about 5 ft. The tube is rotated

by bevel gearing in connection with a driving pulley on a suitable stand at the top of the well. This may be driven by a belt from the drilling outfit at about 90 revolutions per minute.

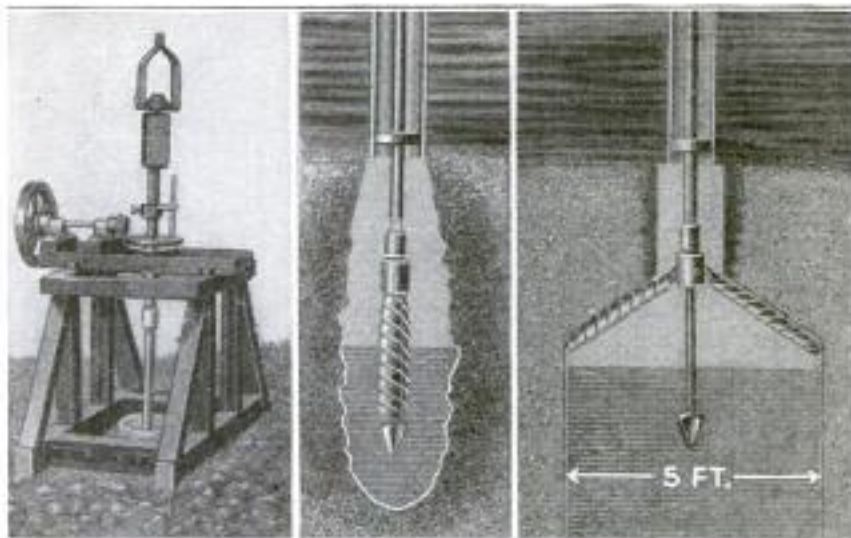

Left: Driving Mechanism at Top of Well for Rotating the Cutting Bit at the Bottom, as Seen at Center. When Rotated, This Opens Out to a Nearly Horizontal Position, as Seen at the Right, Cutting Sandy Obstructions Away to a Diameter of Five Feet

8764
OIL AND AIR-COOLED MOTORS
DEVELOPED IN ENGLAND

As the result of tests made during the war at the air-craft factory at Farnborough, Eng., it was demonstrated that in air-cooled internal-combustion engines as much as 40 to 47 per cent of the cooling was, under certain conditions, done by the crankcase. The result has been the design of a so-called oil-cooled engine, in which the crankcase has been greatly enlarged so as to almost completely envelop the cylinders. Single-cylinder, double-opposed and V-shaped four-cylinder motors designed on this principle have been applied to motorcycles and to automobiles with very satisfactory results. They have proved to be as quiet-running and as dependable as the best water-cooled engines, being very slightly affected by variations in atmospheric conditions. These engines are not entirely dependent upon the cooling action of the lubricating oil contained in

the large crankcase, for around the latter are air passages through which a blast is circulated by fan blades on the fly-wheel, mounted on the crankshaft in front of the engine. The protruding cylinder

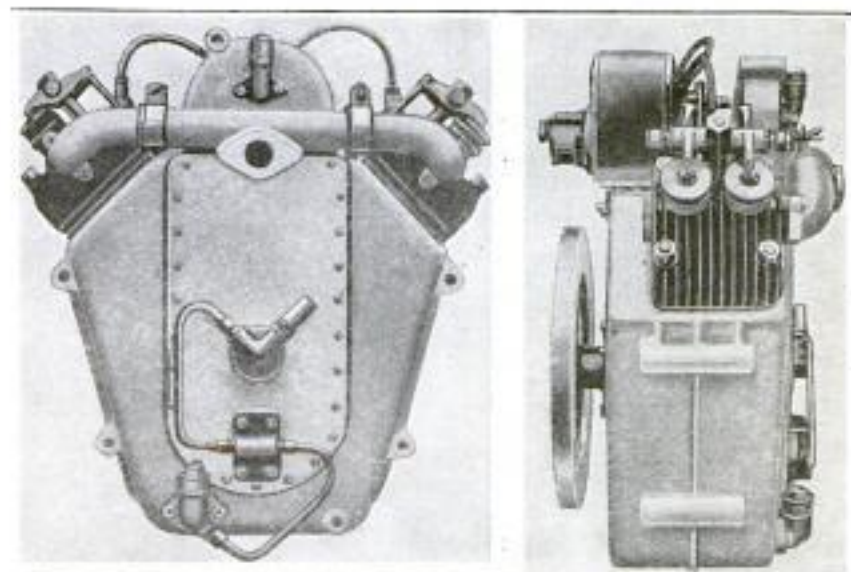

V-Shaped Four-Cylinder Oil-Cooled Motor of English Design: The Side View, at Left, Shows the Intake Side with Enlarged Crankcase for Cooling with Oil. The End View, at the Right, Shows the Overhead Valves

heads are provided with cooling fins that are also reached by this air blast.

At a recent automobile show a team of three men took down a truck motor in the remarkable time of 14 minutes.

Inv. Mr. Bradshaw
 90, Jermyn St.
 London, W.1, England.

8797
CIVIC FEATURES THAT PROMOTE THE COMFORT

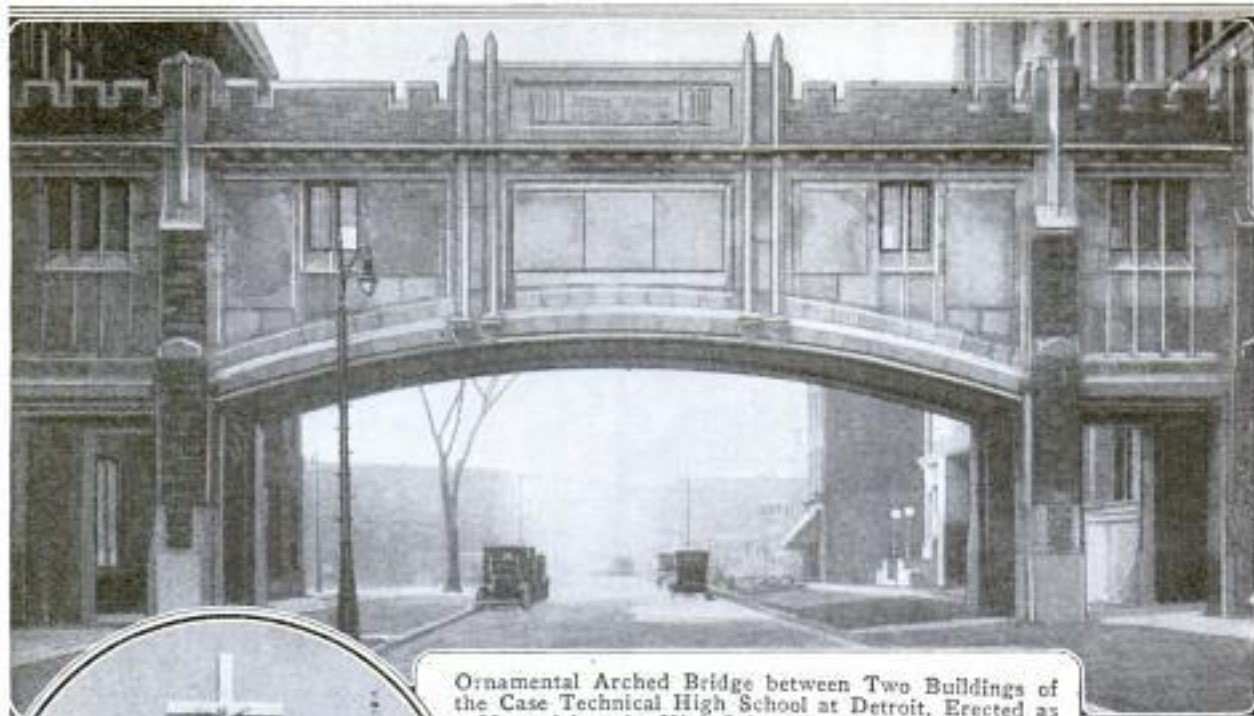

Ornamental Arched Bridge between Two Buildings of the Case Technical High School at Detroit. Erected as a Memorial to the High-School Boys Who Saw Service in France: For Each High School of the City There Is a Bronze Tablet Inscribed with the Names of the School Veterans



Wayside Shrine on a Wisconsin State Trunk Highway in Portage County: Inside the Structure Is a Statue of the Virgin Mary with the Infant Jesus in Her Arms

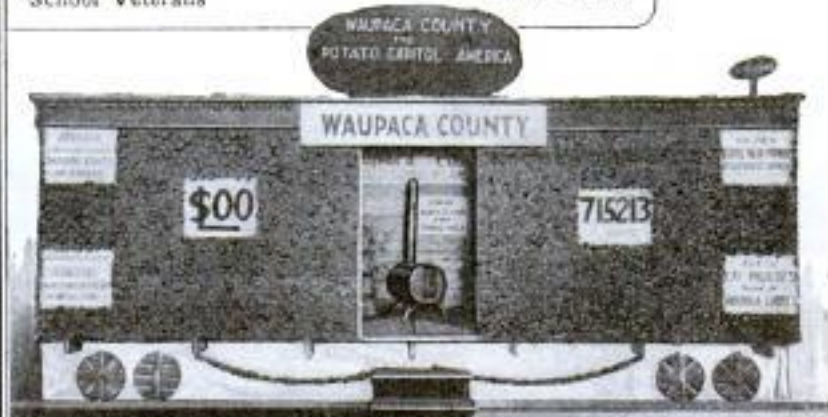

Photo of a Booth at the Recent Wisconsin Markets Exhibit Held at Milwaukee, Being a Representation of a Box Car Ornamented on the Outside with Potatoes



Students in the Practical Mechanics Department of a Consolidated School at Goodrich, Michigan, Who Built This Bus, as Indicated by the Sign on It

AND ENJOYMENT OF VISITORS AND RESIDENTS



Spring at the Hermitage, Tennessee, Old Home of President Andrew Jackson, Now Supplying Water for the Confederate Soldiers' Home



Trolley Poles at Stop Corners in Detroit were Formerly Striped with White Paint. Aluminum Paint is Now Used and is Found More Readily Visible at Night



Attractive Road Sign Erected in New Jersey and Located Six Miles from Cape May, on the New State Highway Leading from Atlantic City, New York, and Philadelphia: It is 12 Feet High, 40 Feet Long, and is Illuminated at Night by Eight Powerful Lights; the Lighthouse Is More than a Picture, for It Has Two Revolving Lights, One White and the Other Red



Near the Town of Dundas, Ontario, Stands an Old Long-Abandoned Cemetery. It is Now being Converted into a Park, and the Tombstones are being Collected for Preservation

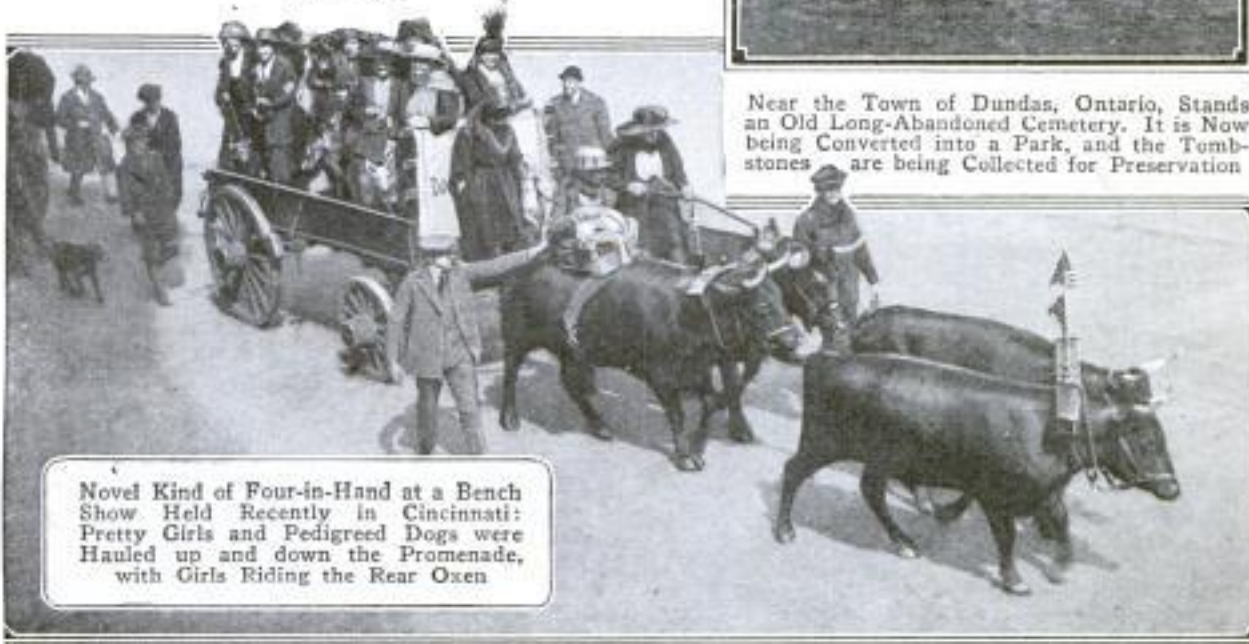

Novel Kind of Four-in-Hand at a Bench Show Held Recently in Cincinnati: Pretty Girls and Pedigreed Dogs were Hauled up and down the Promenade, with Girls Riding the Rear Oxen

The Fleet Agency
 152 Fleet St E.C. 4
 8699 London England

N.Y. Times
 3/23/22
 P. 17

POPULAR MECHANICS
 SPECIALLY BUILT MOTOR CAR
 EMPLOYED FOR SLEEPING
 8795 OF CANNING WASTES
 EXPERIMENTAL PURIFICATION

Auto
 Trans.

Employing an automobile for sleeping purposes is possible with a machine now

Tests made by the U. S. Public Health Service have proved that the waste liquids

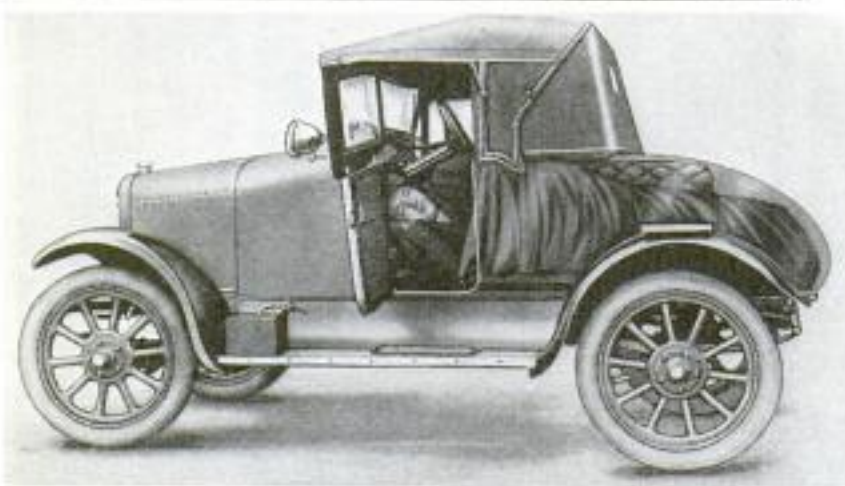

Specially Built Motor Car, Showing How It was Designed for Quick Conversion into a Sleeping Compartment When being Used for Touring Purposes

found on the English market. The car, a small runabout or roadster model, has a removable seat and back. These are so arranged that the occupant lies in a comfortable position, his head near the dashboard and feet extending to the rear of the vehicle, thus allowing him to obtain rest while touring.

The separated solids were disposed of in shallow beds of sand and cinders. The liquid from the settling tanks was filtered first through a bed of coarse cinders and then through sand, after which it was found that fish could live in it for six weeks. There were no objectionable odors in connection with this work.

6921

NOVEL ATTEMPT TO UTILIZE ENERGY OF WAVES

A new attempt to utilize the energy generated by wave action is interesting

because of its novelty. A track, 75 ft. long, set at an angle of about 30° with the ocean surface, has been constructed at Ocean Beach, Calif. A weighted car runs on the track, but cannot leave it. The front of the car presents a broad surface at right angles to the track. A cable, attached to each end of the car, runs over a drum at the upper end of the track, and over a submerged pulley at the lower end. The waves striking the car, drive it up the track, and when the waves recede, the car returns by gravity. In this manner the car is given a reciprocating motion, which, transmitted through the drum, can be used to drive a pump or other machinery.

Emb. Arthur W. Reed
 800 E. St. San Diego, Calif.

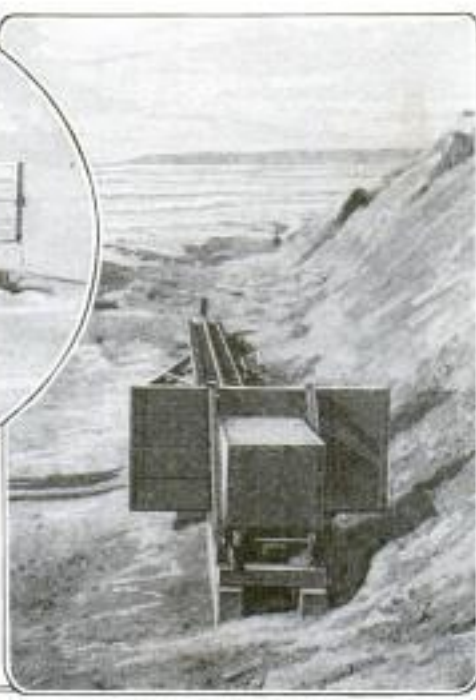
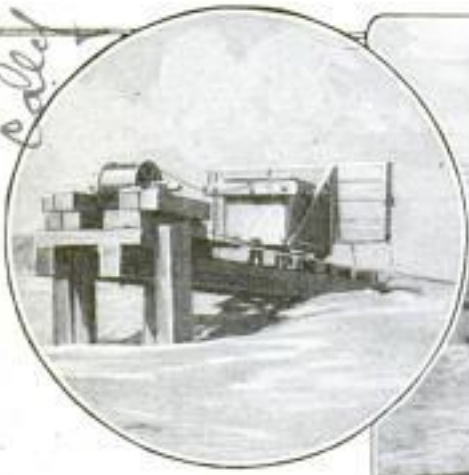

Above: The Drum at the Head of the Track, with the Cable Passing around It from the Car. At the Right: The Car at the Upper End of the Track, Showing the Surface against Which the Waves Strike

8706 cont Louis A. Condensing Bldg.
 305 3rd St. Rdg. Rockford Ill.
 POPULAR MECHANICS 929

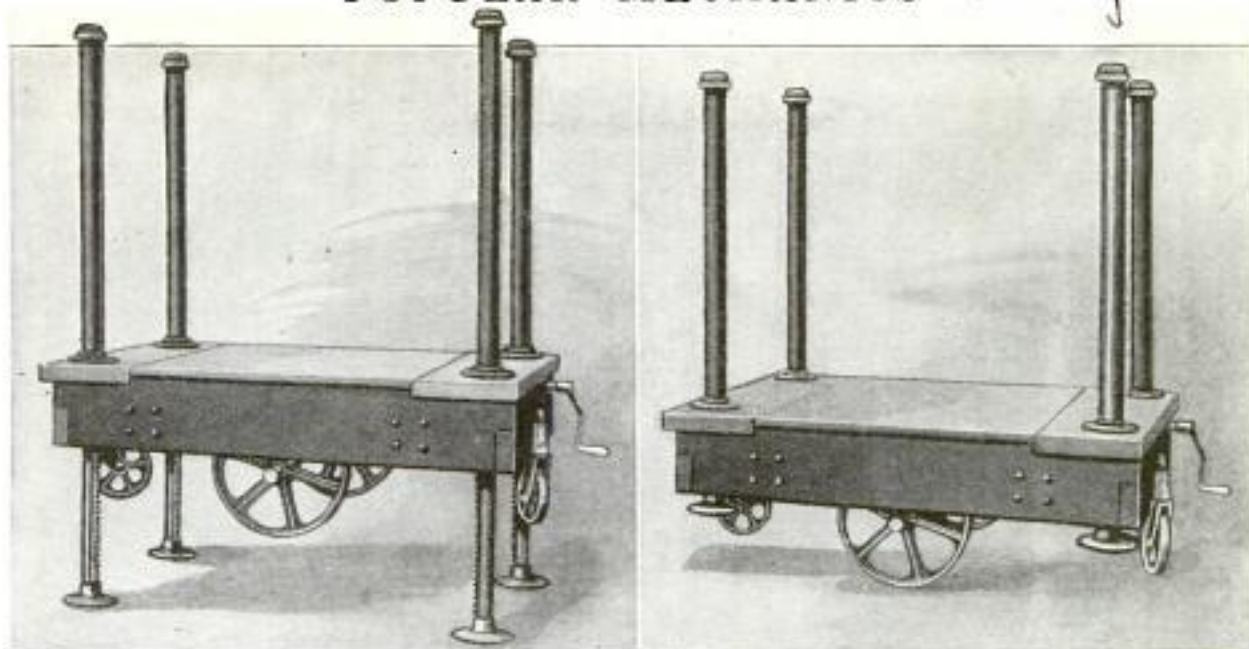

Left: By Turning the Crank at the End of the Truck, a Worm Gear and Pinion Cause the Legs to Extend, Raising the Truck Body High Enough So It may be Used as a Workbench. Right: When Used as a Truck the Extension Legs are Lifted Clear of the Ground

TWO-PURPOSE FACTORY TRUCK HAS FOUR LIFTING LEGS

AIR-MOISTURE ELIMINATORS OF DEMOUNTABLE TYPE

A factory truck with a capacity up to 2,000 lb. has been devised along rather unusual lines. At each corner it is equipped with an extension leg, and by turning a handle, the truck body can be raised to form a workbench or to assist in transferring the load to an auto truck or car. The lifting mechanism is self-locking at any point. 8.381

Eliminator plates, used for the elimination of moisture in the process of washing air, are now being manufactured so

SMOKE TAKES SPIRAL COURSE IN TWO-PIECE PIPE BOWL

With the object of producing a dry, clean smoke, a new pipe has been devised which consists of an inner bowl screwed into an outer shell. The threads are so formed that the smoke follows a spiral path in passing from the bowl to the stem. The bowl may be removed for cleaning.

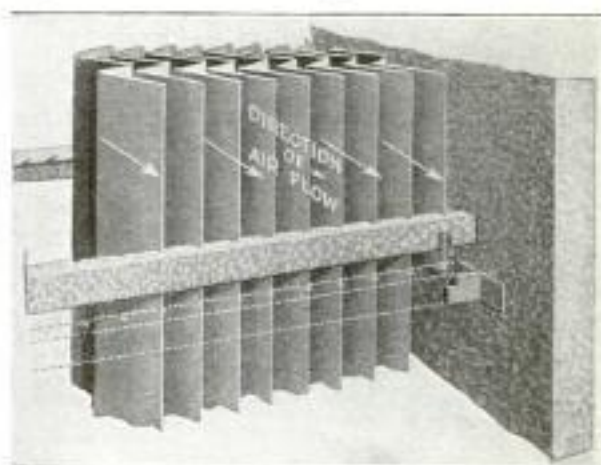

Eliminator Plates of Air-Washing Process Shown Placed in the Angle-Iron Frames, Which are Slipped into Brackets Riveted to Air-Washer Casing

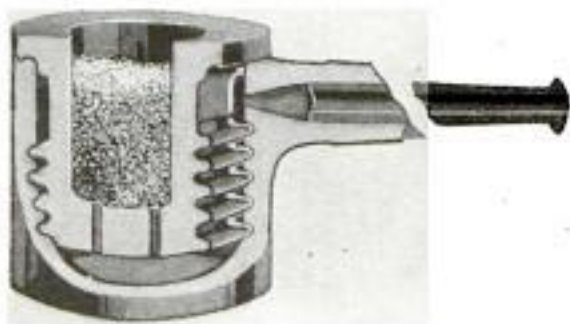

The Smoke is Drawn Down into the Bottom Chamber and Then Up along the Spiral Thread to the Stem

path in passing from the bowl to the stem. The bowl may be removed for cleaning.

that they may be installed or taken down with a minimum expenditure of labor. Angle-iron frames, provided with slots in which the plates are placed and rigidly held, are slipped into a bracket that is riveted to the side of the air-washer casing. This method of construction supplies an effective means for cleaning, painting, or making repairs, as the entire set of plates, or any unit thereof, can be removed or replaced with ease and facility, thereby reducing the possibility of corrosion, and extending the life of the plates.

Lynn Mfg Co.
 5931 S. Kedzie Ave.
 Chicago

Carrier Air Conditioning Co. of America
 Buffalo, N. Y.

8660

SOME NOVEL AND LITTLE-KNOWN ACCESSORIES



An Air-Purifying and Deodorizing Attachment for Electric Fans Which Circulates an Agreeably Perfumed Germicide



This Dish Scraper Has a Rubber Blade Which Easily and Quickly Scrapes Dishes and Utensils of Any Size and Shape, Thus Saving Water, Soap, and Towels



A Refrigerator Basket Which is Built Something like the Ordinary Vacuum Bottle So That It Retains Either a High or Low Temperature as Desired, Making It an Ideal Basket to Use for Picnics



Fixture Switch That can be Attached to Any Canopy, Ceiling Fan, Wall Bracket, or Other Electric Fixture in the Home

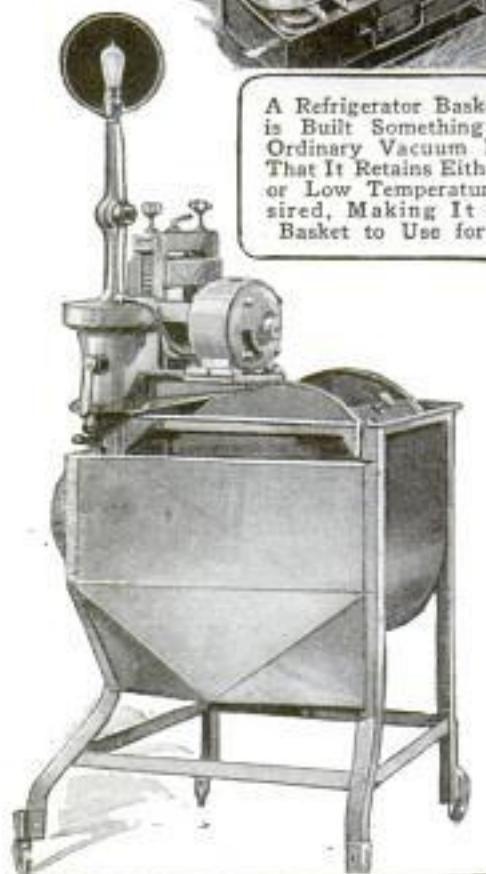

An Electric Washing Machine Which Has a Light Mounted on a Vertical Arm to Illuminate the Dark Places of the Laundry: The Lamp is So Wired That It is Independent of the Motor

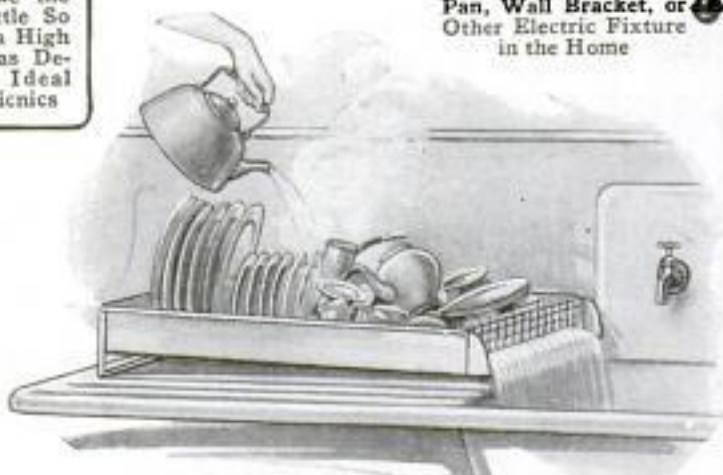

This Dish Drainer Runs the Water off the Dishes Directly into the Sink. It is Elevated at one End, While the Other Hangs over the Edge of the Sink



A Cuff Holder That Enables the Wearer to Adjust the Cuff on the Forearm or above the Elbow, Making It Possible to Wash the Hands or Perform Other Work without Soiling the Cuffs

INTENDED FOR THE HOME AND ITS MEMBERS



This Combination Can Opener and Bottle-Cap Lifter Has an Aluminum Nonrusting Handle and a Crucible-Steel Cutting Edge



An Electric Washer Pump Which Empties Water from the Sink or Tub at a Rate of Eight Gallons a Minute



The Use of This Small Heater, Which Burns Alcohol, Keeps a Room Comfortable on Chilly Days



A Vanity Pillow That Opens like a Bag and Contains a Mirror, Powder, Rouge, and Other Make-Up Necessities



A New Rotary Fruit and Vegetable Press That Saves Much Time in Crushing Fruit for Ices, or Vegetables for Soup



This Sanitary Dish Washer will Automatically Soap, Wash, Rinse, and Sterilize the Dishes, Glasses, and Silverware



Bathroom Toilet Cabinet with Storage Compartments for All Necessary Toilet Articles, a Dressing-Table Top, Bevel-Glass Mirror, Clean-Towel Drawer, and a Hamper for Soiled Linen



A Swing for the Baby, Which Folds Compactly and Is Easily Carried When Going on an Outing



Combination Knife and Tape Measure Which Has a Blade of Good Steel and an 18-Inch Tape Measure

W
V
A
F

Isalli Sales Co
110 W. 42 nd St.

8570

POPULAR
New York City

**BANJO RESONATOR AMPLIFIES
ITS VOLUME SNAPPILY**

A resonator, or sound amplifier, that can be attached to any banjo, greatly increases its volume and gives a sharp, snappy quality to the tone. It consists of a polished brass cover that fits on the back of the banjo flush with its outside rim. On the cross-bar of the instrument, at its center,



there is clamped a threaded tube, one end of which is soldered to the center of the brass cover. The resonator is made to fit 10, 11, or 12-in. instruments, and can be attached or removed instantly without injuring the instrument in any way.

**WATCH CARRIER FOR AUTOS
IS HANDY ACCESSORY**

Autoists making long trips in a machine that has no clock permanently installed in it, can have the advantage of this convenience by the use of a watch carrier. This accessory consists of linen-covered steel wire, which is bent in such a manner as to securely hold a 16 or 18-size timepiece. Fastened to the dashboard, the watch is visible from any seat.



**OIL DEVELOPMENT PREDICTED
FOR SOUTH AMERICA**

Predicting a great oil development in South America, Dr. David White, of the U. S. Geological Survey, has stated that that continent is richer in petroleum resources, in comparison with the area, than any other, with the possible exception of North America. This expert also claims that 13,000,000,000 of the estimated 60,000,000,000 bbl. of the world's total supply, lies under the surface there, waiting for some one to place it on the market.

N.Y. Times 3/5/22
P. 12

Dr. Neville P. Mowatt
Maurant Hotel
Flint, Mich.

Geologists have evidence of high-grade petroleum deposits, and in numerous regions the conditions are such as to warrant the belief that oil would be found by exploration and drilling.

**CLOTH COVERS ON RADIATORS
KEEP ROOM WALLS CLEAN**

As a cover for steam radiators a very simple device has been found to protect the walls and ceiling of a room from being disfigured by the dust that always rises with the heated air from any radiator. The cover is made of coarse cloth, preferably of a dark-gray color, cut in one piece to fit exactly the top of the radiator, with two end and sidepieces, a few inches wide, all neatly sewn together. The cover is removed from the radiator several times a week, and is cleaned by shaking.



**NEW CALIPER HAS SCRIBER
FOR MARKING CENTERS**

On an ordinary outside caliper there has been pivotally connected to its legs, and on its central axis, a short tubular sleeve, in such a manner that however its legs are opened, the sleeve remains always on this central line. Sliding through this sleeve, and extending through the pivoted apex of the caliper, is a rod that at its other end has a hardened point like a scriber. A helical spring on this rod tends to hold the jaws of the caliper tight on any piece of work that it straddles, and a little pressure on top of the rod with the hand that is adjusting the caliper will cause the point on the other end of the rod to mark or scribe the exact center of the piece of work.

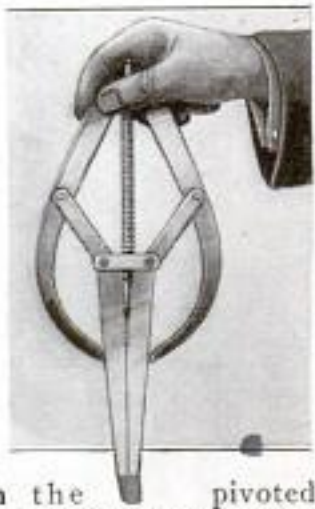

Dr. William H. Harris
Laurium, Mich.

8629
Mr. George B. Pendcock, N.H.
W. Burleigh

**SELF-GOVERNMENT PRACTICED
 BY DEPARTMENT STORE**

One of the large department stores of Boston has successfully tried a form of self-government patterned much on the order of the U. S. government. Employees elect members of the House by ballot. Department executives form the Senate. Four high executives form the cabinet, and the president of the company is the chief executive. Under this plan, the employees practically regulate their own working conditions, and the system has led to a valuable exchange of ideas, the founding of welfare organizations, and a substantial increase in the store's business.

**PLIANT-METAL SPRING COVER
 FOR AUTOS AND TRUCKS**

To keep all dirt, sand, and moisture from automobile and truck springs, and to maintain them in a constant state of perfect lubrication, a metal cover is being manufactured that can be made to fit any spring, and can be enameled to match the color of the car. The cover is a continuous, flexible-metal sleeve, that yields to any deflection of the spring, and yet re-

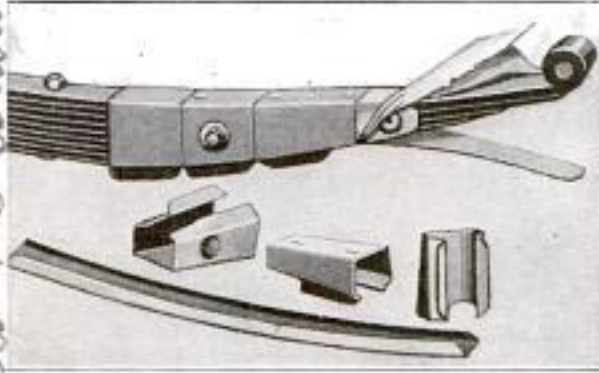

Three Sections of Flexible-Metal Spring Cover, Shown Assembled Above and Disassembled Below: When Completed, Similar Sections Extend the Whole Length of the Spring

mains at all times grease-tight. It is filled with graphite grease, which is forced in through a fitting provided for that purpose, and which gets between the leaves of the spring.

**PORTABLE BENCH SAW CUTS
 MITERS AT ANY ANGLE**

In a new portable bench saw, a motor and a circular saw are mounted on a frame that swivels in either direction, permitting both right-angled and oblique cuts to be made. The machine is provided with a revolving table that is graduated on its outer edge. This table fits

into, and revolves in, a circular base, on the side of which is a locking device. Above the table is a bar used as a gauge for holding the work, so that after the

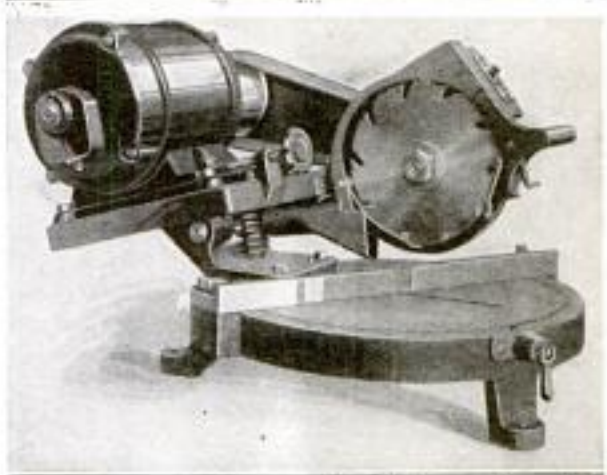

Portable Bench Saw for Cutting Miters on Any Kind of Wooden Fittings: The Handle in Front of the Base Is for Locking the Table at Any Required Angle

table is revolved and locked at the desired angle, any bevel or miter can be cut quickly and accurately. On the housing of the saw is a control handle, and near it a simple switch, so that a finger of the same hand that depresses the saw into the work, starts and stops the motor with the switch.

**IMPROVED DEHORNER REMOVES
 BOTH HORNS AT ONCE**

For dehorning cows or calves, an instrument that, it is claimed, will remove both horns in 30 seconds, is certainly an improvement over old methods of sawing still in common practice. The dehorner comprises stationary and pivoted cutting blades which engage the horns, and by the operation of a crank handle these cutting blades are moved so that the horns are cut from the animal. There are two pairs of cutting blades, which are adjustable laterally to fit any pair of horns, both of which are thus removed simultaneously.

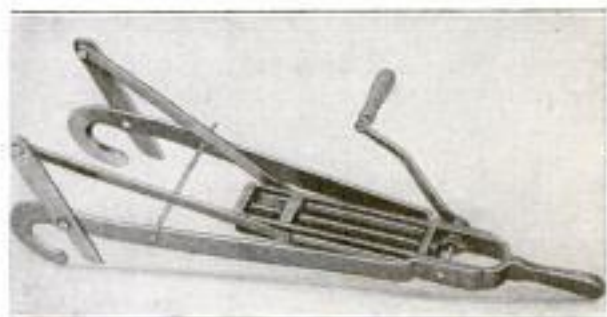

Two Views of Dehorner That Removes Both Horns at Once from an Animal

C. M. Crawford
 Apex of Illinois
 367 S. Wabash Chicago

H. Van Amber
 7036 Gale Ave. Chicago

The Tannery Works
 Grand Rapids, Mich

Beick Corporation
934 Brockton, Mass.

Emb. E. Delafond
Apartado Corred. 1288.
8780 Mexico City
ALCOHOL AS A BY-PRODUCT
OF A MEXICAN PLANT

**STEEL KITCHENS PROVE AID
IN CONSERVING SPACE**

Conservation of space is an important problem in the construction of the modern apartment building, and a kitchen



Steel Kitchen with Refrigerator and Shelves at the Left, Three-Burner Gas Range in the Center, and Sink at the Right

consisting of two steel cabinets, 18 in. deep, 30 in. wide, and 82 in. high, has greatly aided in this effort. One cabinet contains a three-burner gas range having a broiler burner in a large oven, and the other houses a refrigerator of 50-lb. ice capacity and possesses spacious food compartments. Numerous drawers for cutlery, pans, etc., and shelves for dishes are provided, in addition to a standard 18 by 24-in. sink with special drain shelves, which is mounted beside the cabinets. When not in use, the kitchen can be shut off from the remainder of the living quarters by large wooden doors which match the interior trimming of the room.

In Mexico, a plant known as the maguey, which is a species of the agave, or American aloe, has for a long time been utilized for the manufacture of sisal hemp. Up to the present the sap contained in the plant has been wasted, but it is now contemplated to utilize this also for the production of industrial alcohol. The plant grows very extensively in many parts of Mexico, and it is calculated that without any further cultivation, there could now be produced annually many million gallons of alcohol. The promoters of the enterprise in Mexico base their estimate of the value of the industry to Mexico on the fact that the alcohol would be a valuable fuel for internal-combustion engines, especially of the gasoline type, which fuel it could easily replace at a very great reduction in price. The intention is to utilize the fiber of the plant for making sisal hemp, leaving a residue suitable for making paper, and thus the alcohol would be entirely a by-product of inexhaustible quantities that could be sold at a very low price.

8691
UPPER HALF OF WINDSHIELD
WIPED BY NEW CLEANER

**UPPER HALF OF WINDSHIELD
WIPED BY NEW CLEANER**

Realizing that the usual type of windshield cleaner gives the automobile driver a very limited range of vision, a new cleaner has been devised which wipes the entire upper half of the windshield glass. The wiper arm is attached to a piston in a tube which extends across the full width of the top. This tube is connected

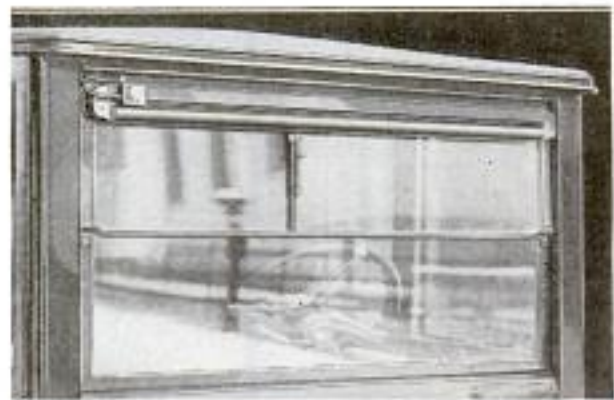

This Wiper Cleans the Entire Upper Half of the Windshield and is Actuated by the Suction in the Intake Manifold of the Engine

Motor Car Specialties
Co., Boston, Mass. Copyrighted material

Chicago agent - 175 W. Jackson Blvd. Chicago

Proctor's as: Mexico, Yucatan, Guatemala, Yucatan, Mexico

**EXCAVATIONS WILL BE MADE
AT RUINS OF COLOPHON**

A particularly promising site for excavations is that of the ancient city of Colophon, in Asia Minor, that flourished about 800 B. C. Permission has been granted by the Greek government to the American school of classical study at Athens to make excavations there, and under the permit the school will do this work in collaboration with the Fogg Museum of Fine Arts of Harvard University. Colophon was one of the twelve cities of ancient Ionia.

Chicago Journal
2/5/22

to the intake manifold of the engine, and the vacuum at this point causes the piston to move in the tube. An ingenious system of valves causes the suction to be applied to the other side of the piston when it reaches the end of its stroke.

8649
COMBINED SOLDERING IRON AND BLOWTORCH

A combination gasoline blowtorch and self-heating soldering iron which can be used as the latter when combined, or as the former when the soldering point is removed from it, is now on the market. The part of the device that forms the handle, when used as a soldering iron, is a barrel 1½ in. in diameter, and about 10 in. long, in which is the air pump and the gasoline container, and at the end of this is the blowtorch nozzle, with a removable soldering point, against which all the

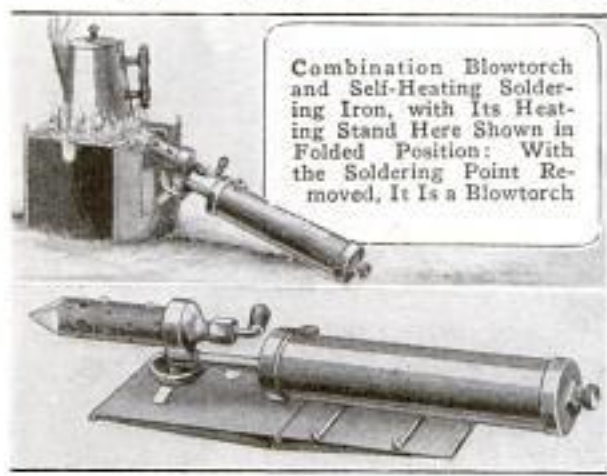

flame in the torch is directed. A heavy cotton wick assures the flow of gasoline regardless of the position in which the torch is held. A folding heating stand is supplied with the torch.

8777
"NO MAN'S LAND" AT RHEIMS CONTAINS 600 HOUSES

"No man's land" in the outskirts of Rheims, France, has had 600 houses constructed on it during the last year, in which 4,000 persons will live. The new buildings are erected between the forts of Nogent-l'Abesse and Berru, and are equipped with every modern improvement, including nurseries for infants and playgrounds for children.

It is announced that the recently completed government railroad from Seward to Fairbanks, Alaska, has been officially named "The Alaska Railroad."

CONVENIENT DESK MEMO PAD KEEPS PAPER CLEAN

One of the latest devices in office equipment is a memorandum pad for the desk which is so built that the paper, while



This Convenient Desk Accessory Contains a Roll of Memorandum Paper Which is Protected from Dirt but Always Ready for Use

readily available, is always kept clean. A roll of paper is carried in the holder, and a slight pressure on the top of the case enables the user to grasp the end of the strip, which can be drawn out and detached with one hand.

8637
ARTIFICIAL "NOSE" PLACED IN NECK OF HORSE

Deprived of natural breathing facilities through an accident several years ago, a horse in Cincinnati, Ohio, has been provided with an artificial "nose."



The apparatus consists of a silver tube, which is inserted in the neck of the animal, connecting with the windpipe. A fine-meshed screen in the tube prevents the entrance of any foreign matter that might shut off the air supply, and the horse has been driven as usual since the operation, with no apparent ill effects, although its daily appearance on the city streets never fails to arouse interested comment.

U.S. Tribune
 (Chicago Tribune 2/27/22)

Max Memo Pad Co. Chicago
 6253 Kimbark Ave.
 Cincinnati, Ohio
 Cnd. J. A. Schuydt
 3557 St. Charles



Equally Entertaining and Instructive, the Most Popular Scientific Instrument of the Day is the Radiophone, the Interest in Which is Spreading So Rapidly That It Looks as If before Long No Well-Furnished Home will be Thought Complete without One. In Many Schools There Are Now Regular Classes in Radio Instruction Such as the One Shown Above, Which is at the Lane Technical High School, in Chicago. The Instructor Has No Difficulty in Holding the Attention of the Students

Snow in Southern California Transported from the Mountain Tops and Dumped onto a Green Lawn for the Kiddies to Enjoy Snowballing. Right: A Rabbit up a Tree, Although Rabbits cannot Climb. The Little Hill behind the Tree Was So Close to It That Bunnie could Hop Easily from One to the Other



Village of Plymouth Modeled by Sixth-Grade Pupils: Houses are Made of Twigs, with Strips of Bark for Roofs, All in a Trayful of Sand

OF MODERN ACTIVITIES AND INTERESTS



A Real Live Alice in Wonderland, For It Is Alice Hastings being Carried by Natives through the Wilds of the Belgian Congo: She Was the Youngest Member—Only Six Years Old—of a Party of Americans Who were There Hunting Gorillas



A Brood of Ducklings Who Lost Their Real Mother, and Now Have as Foster-mother a Hen Whose Only Trouble Is How to Take Care of Her Brood without Getting Wet



An Overland Canoe Makes the Kiddie Driver Independent of the Water and Free from Its Dangers. It Is Self-Propelling, and will Carry 200 Pounds

Slingshot Made of Polished Aluminum—Very Light and Smooth, Therefore Easier to Handle Than the Old Ones of This Type



Automatic
Columbia, D.C.
Cutler Co.

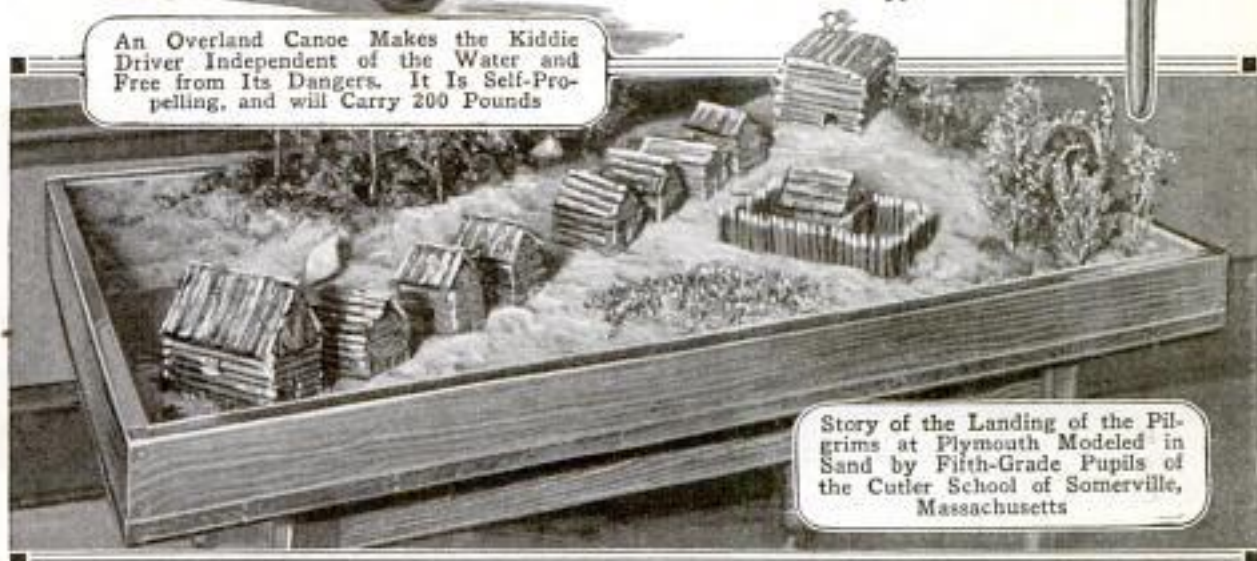

Story of the Landing of the Pilgrims at Plymouth Modeled in Sand by Fifth-Grade Pupils of the Cutler School of Somerville, Massachusetts

W. R. Ames Co.
604 Mission St. San Francisco, Calif.
nfr.

American Bushing
 & Wedge Co. 436 N. James
 938
 7611 Bldg Jacksonville

POPULAR MECHANICS

BEARING BUSHINGS RENEWED
 WITHOUT DISPLACEMENT

In order to eliminate the necessity of replacing the bushing when a bearing becomes loose from wear, a swedging tool

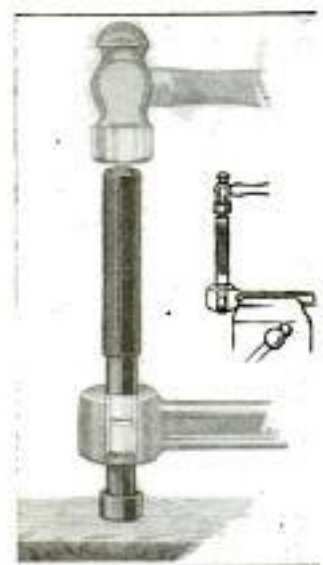

has been devised that will reduce the bore of a bushing as the result of a few strokes from a hammer. The tool consists of two parts, each of which has an end small enough to fit inside the bushing, with a shoulder that fits over the end of the bushing, and inside the hole in which the bushing is set. One of these parts is short, and rests on

any support below the bushing under treatment, and the other part is long, and is above the bushing. Blows from a hammer on its upper end shorten the bushing slightly, and cause it to swell, thus reducing the bore as much as required.

STORAGE HOUSE FOR APPLES
 HAS GOOD VENTILATION

Apples or other perishable commodities can be kept for a long period of time without danger of decay, in a storage house which was especially designed for the apple industry of the Northwest. The

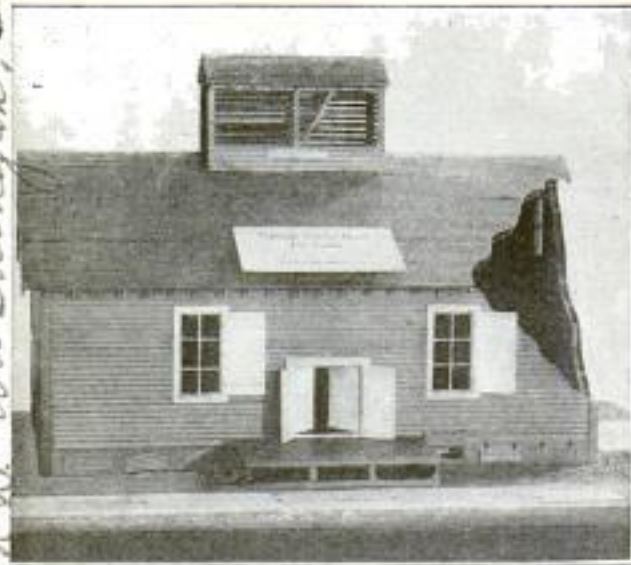

walls, floor, and ceiling of the building are insulated with sawdust, mill shavings, commercial cork, or mineral wool. The doors are also insulated, while the windows have two thicknesses of glass, and have insulated shutters. Every 10 ft. along the bottom of the sides and ends, are 18 by 24-in. openings, or vents, and inside the structure is a false floor with the boards laid 1 1/2 in. apart and built just above the openings around the base. Topping the whole is a cupola in which are numerous vents, and which has a damper placed where it joins the ceiling. At night, in warm weather, all the vents are opened, and the warm air inside the house escapes through the cupola, thus providing free circulation of cool air, which aids in preserving the fruit.

ARMREST EASILY ATTACHED
 -ON DOOR OF SMALL CAR

Automobile owners now may avail themselves of an armrest which can easily be attached to



attached to the door of the machine, thus adding comfort to the trip. The appliance has two U-shaped brackets that

fit over the door top near the wheel, and the rest is padded and may be covered to match the interior of the car.

When you want anything and do not know where to get it, write Bureau of Information, Popular Mechanics, Chicago.

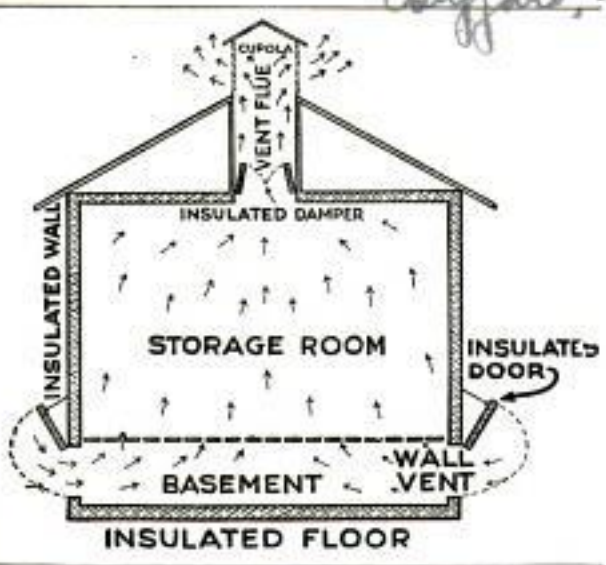

Left: Apple-Storage House, Showing Insulated Doors, Shutters, and Cross Section of Walls. In the Base of the Building are Seen Numerous Vents. Right: Ventilation Plan of House, Showing How Air is Circulated

End. C. Morgan, 3825-13th St. S.E.
 Wash. D.C.



Supply of Gas Automatically Controlled

By CURTIS RALSTON

THE gas controller shown is a device which, owing to its cheapness and simplicity, may be used for many purposes where it is necessary to regulate the flow of natural or artificial gas used for heating.

The controller, or regulator, working in connection with an ordinary expansion thermostat, opens the gas valve whenever the temperature falls to a predetermined point, and when the temperature has risen to the desired maximum the valve is automatically closed, except for a sufficient flow of gas to supply a "pilot" light. Since the power for opening and closing the valve is supplied by one or two dry cells, it is of great importance to cut off the flow of electric current as soon as the work is done and thus prevent waste of power; how this is done is clearly shown.

The thermostat may be made at home, if desired, but the purchased article will generally be found more satisfactory. When the thermostat gets warm, its expanding member curves downward, closing a circuit through the electromagnetic solenoid at the right, which then pulls down into it the iron rod forming the core, thus closing the gas valve. As the valve completes its rotation, it breaks the circuit through the closing coil and closes another circuit through the opening coil at the left, thus preparing the

valve-opening coil to work as soon as its thermostatic contact closes. The whole operation takes place at a single "click" and occupies but the fraction of a second, and the amount of energy taken from the battery is so small that a single pair of cells will last for a long time. The electromagnets are of the "shell" type, each being covered by two iron pipe caps, which are connected by a nipple. The coils are wound around a hollow core of iron pipe which has a diameter sufficient to accommodate the solid movable cores. A hole is drilled through the center of the upper pipe caps to permit insertion of the cores. Bell wire is used for the coil windings, and the greater the number of turns the greater will be the "pull" exerted on the cores; also, more current will be required to operate the device. The magnetic circuit is thus mostly all iron, which produces a very powerful type of magnet. When

the controller is set up, the first adjustment to make is for the flow of gas for the pilot burner, and this is done by a screw in the bottom of the valve-closing magnet. The two thin-brass contact springs, which make contact with the segments on the fiber or hard-rubber valve disk, should then be adjusted to give a positive break, late enough so that rotation of the valve is complete.

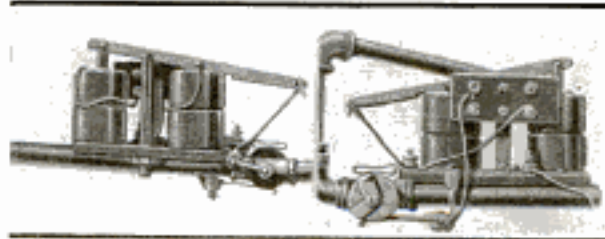
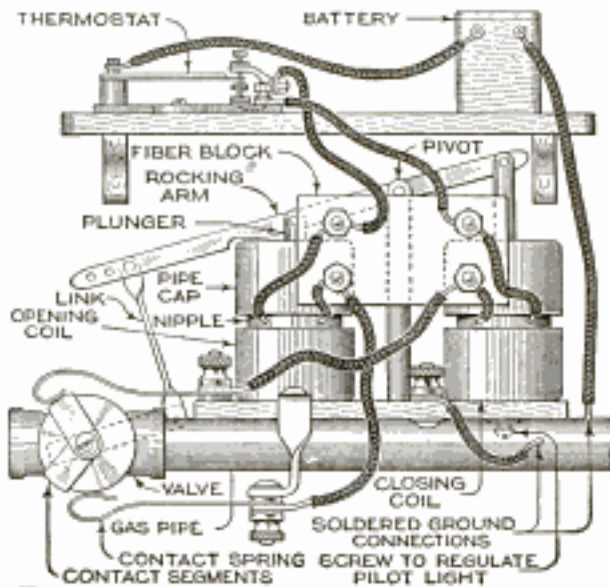

Above: Constructional Features and System of Wiring for Connecting the Thermostat, Battery, and Electromagnets to the Levers. Below: Photographs of the Regulator, Giving Front and Rear Views of the Device

Certain Features of Tree Surgery Patented

While it is no infringement of an inventor's right for a publisher to tell how a patented article is made, it is, of course, an infringement for any one actually to make the article for the use of himself, or others, without permit from the owner of the patent. For that reason this magazine never publishes in this department a description of how to make anything it knows to be patented. On page 283 of the February, 1922, issue, we published an article entitled, "How to Save De-

cayed Trees," being a description of how to perform divers operations of tree surgery. It now appears that patent No. 890,868, issued in 1908, and patent No. 958,478, issued in 1910, and now owned by the Davey Tree Expert Company, of Kent, Ohio, cover particularly the filling of a cavity in a tree with concrete in sections, and the provision of a water channel at the edge of the cavity, as described in our article. Our readers are hereby cautioned *not to use* the above features of the described process without having first secured consent or license from the Davey Tree Expert Company, Kent, Ohio.

Sharpening the Lawn Mower

The photograph illustrates a method by which lawn mowers are easily sharpened in a few minutes. The apparatus required

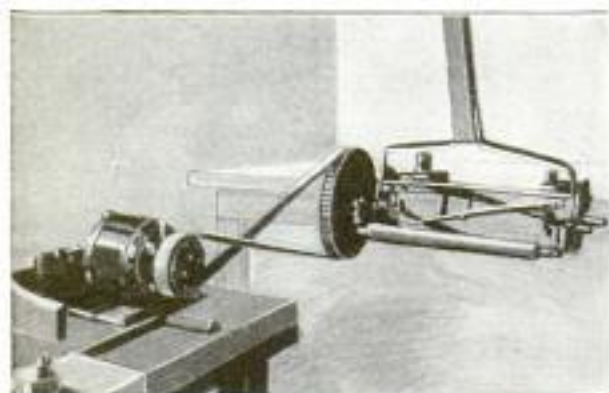

By Revolving the Cutter Reel of a Dull Lawn Mower in a Direction Opposite to That in Which It Runs When Mowing the Lawn, and Feeding an Abrasive Compound onto the Blades, They are Rapidly Given a Keen Cutting Edge

includes an electric motor; a large wooden pulley to fit the end of the cutter shaft; two clamps, a belt, and some oil and emery powder.

The mower is clamped rigidly by the crossbar, the wheels and pinions are removed, and the wooden pulley is fitted to the end of the shaft. The proper speed for the mower shaft to turn is about 300 r.p.m., and with the motor running at about 1,750 or 2,000 revolutions, the wooden pulley should be about six times the diameter of the motor pulley. The mower shaft must turn in the opposite direction to that in which it revolves when cutting grass. After the motor is started, a little oil and emery is fed onto the cutter edges and the horizontal knife at the bottom of the mower as well; they are then allowed to grind each other to a sharp edge by running the motor from 5 to 20 minutes. Ordinarily, the motor will have to be stopped at intervals and the

knife set a trifle closer to the cutters by means of the adjusting screws. The adjustment must not be made too tight or the motor may be overworked, and besides, the emery cuts better when the adjustment is little, if any, tighter than is proper for operating the mower.

Scale Attachment for Setting Calipers

Much work is spoiled as a result of wrongly or inaccurately set calipers. The usual method of setting inside calipers, by holding the end of the scale against a flat surface, is very deceptive, because if the scale is not exactly at right angles to the end surface, the calipers will be a little over or under the required dimension. Furthermore, as all ordinary calipers have rounded points it is no easy matter to see when the setting is correct.

The drawing shows a simple little attachment that makes the setting of calipers easy and accurate. It is made in three parts, consisting of a stationary endpiece into which a piece of $\frac{1}{8}$ -in. steel wire is tightly driven, and a sliding block.

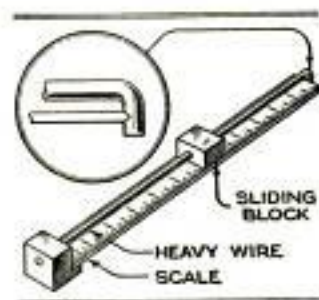

The wire is bent over at its outer end, and a "V" is filed so that the scale makes a snug sliding fit in the attachment, the opposite end of the scale resting against the endpiece. When using, the sliding block is moved to the required dimension as indicated by the scale, where it is held by the thumb until the calipers are set. When setting outside calipers, the legs are, of course, set against the outside of the endpiece and sliding block, the latter being located on the scale accordingly.

Preventing "Sweating" of Concrete

Much trouble is caused by the "sweating" of concrete walls on the inside; this is usually caused by faulty construction, as concrete walls, like masonry, should be built with a dead-air space between the wall and the interior plaster. Many types of concrete walls provide for hollow spaces within the walls, but, in addition to this, the interior plaster should be furred out so as to leave a continuous dead-air space between it and the concrete. In the case of barns, as cattle give off a large amount of moisture, some adequate system of ventilation is also very desirable.

An Improved Bell Center

Almost every mechanic is familiar with the usual type of bell center used in machine shops for marking the centers on rough round stock; this cannot be satisfactorily used on square stock. The bell center illustrated, however, can be used on either square or round stock with equal facility and satisfaction. As will be observed from the drawing, this center has four equally spaced arms radiating from the body at an angle of 30°. When in use, these arms rest upon the edges of the square-stock

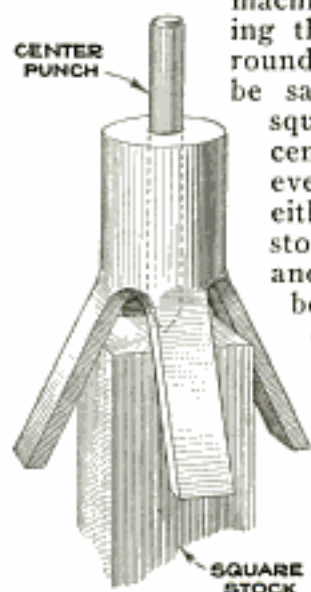

face, insuring a more accurately located center than can be obtained by the use of the ordinary type, as this would rest on the corners, which generally have a heavy burr on them that throws the center off.—Chas. Homewood, Ontario, California.

A Saw-Filing Kink

When filing a saw, swab the teeth with a solution of copper sulphate (bluestone or blue vitriol) and water. This will deposit a thin coating of copper on the metal, and when the first set of teeth are filed, the unfiled teeth will show up very distinctly. This idea will be found a great help, especially where the light is poor.—F. L. Schneider, Palmer, Mass.

Handy Container for Soft Soap

A useful and economical method of holding soft soap, prepared hand cleaner, or left-over pieces of soap in the shop or

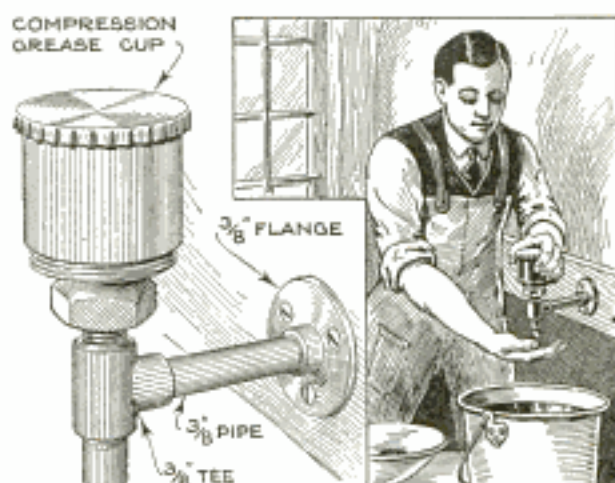

Soft Soap, Hand-Cleaning Compounds, and Fragments of Soap Contained in a Large-Sized Grease Cup are Economically Kept and Used in the Shop or Garage

garage, is to place the soap or cleaner in a large-sized compression grease cup. The grease cup is screwed into a tee, and is fastened to the wall or woodwork by means of a short length of pipe and a pipe flange in the manner shown. The outer end of the horizontal pipe is plugged to prevent the soap from running into it. In use, one hand is held underneath the tee while the other is used to screw down the cap, which forces the soap out through the bottom.—Herbert A. Strickler, Buffalo, N. Y.

Skid for Use on Steps

In a large public building, where pianos and other heavy furniture are frequently moved over a short flight of steps, the plank skid shown in the drawing has proved very useful. Triangular blocks, attached to the underside of the plank, rest upon the stair treads, the number of blocks depending upon the length of the skid; one for every other step will generally be found sufficient. The undersides of the blocks are covered with rubber or felt to prevent scratching the steps. When not in use, the skid can be pushed to one side, where it will not interfere with the use of the stairs.

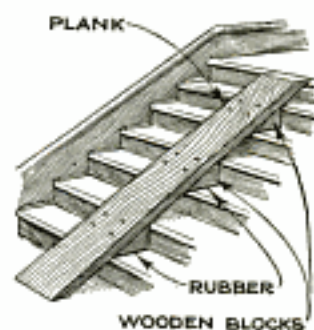

Automatic Belt Shifter for Grinder

Practically every shop experiences trouble because the workmen forget to stop the grinding wheel after they have

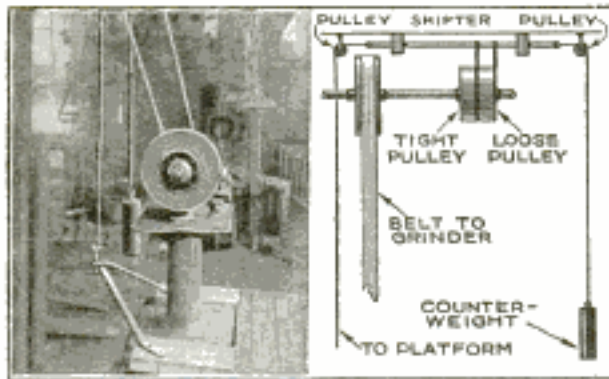

When the Workman Steps on the Platform, the Belt is Shifted from the Loose Pulley and the Grinding Wheel Started. When the Man's Weight is Removed, a Counterweight Pulls the Belt Back onto the Loose Pulley, Stopping the Machine

used it. In order to make certain that this would not occur in a small machine shop, the arrangement illustrated was installed, and worked with success.

A platform, surrounding three sides of the machine, is elevated at the end nearest the machine, and connected to one end of the shifter rod so that, as soon as the workman steps on the platform, the belt is shifted over onto the tight pulley and the wheel begins to revolve. When the weight of the man is removed from the platform, a counterweight attached to the opposite end of the shifter rod pulls the belt back over to the loose pulley, stopping the machine. This arrangement not only saves a lot of the men's time, but prevents accidents and saves power, as the grinder is running only when in use.—Ethan Viall, Barboursville, Ky.

Hacksaw as Facing for Core Boxes

The cores from a half-core box were quite satisfactory while the box was new, but as the face of the core box was unprotected, the constant rubbing of the strickle, or strike board, soon wore down the face of the box so that the two half cores, when pasted together, formed an oval, instead of a round core. The core box was repaired and faced with tin, but this was soon cut through. It was then suggested that worn-out hacksaw blades be nailed to the edges of the box. The suggestion was acted upon, and since then there has been little or no wear on the core box as the hardened saw blades provide protection for the wooden edges.—M. E. Duggan, Kenosha, Wis.

Locating Cylinder-Head Gaskets

The difficulty experienced when the cylinder-head gasket shifts while the head is being placed in position on an automobile engine, can be avoided by the use of two simple locating studs. These consist of two cylinder-head bolts with the heads sawed off and slots sawed across their upper ends to facilitate removal with a screwdriver. The studs are inserted in diagonally opposite holes in the cylinder block, the gasket is placed over them, and the head put in position; when the bolts are inserted, they will coincide with the corresponding holes in the gasket, the studs, of course, being unscrewed when the head is in place.

Knurl Holder Fits Toolholder

A quantity of small brass thumbscrews were to have their heads knurled while the stems were held in a universal chuck. It was necessary to chuck the screws with the heads close to the chuck jaws, to prevent bending, and a regular toolpost knurling tool was found to strike against the jaws, besides being too heavy for the work. A hand-rest knurling tool, on the other hand, was not altogether satisfactory, and the difficulty was finally overcome by mounting the small knurl taken from the hand-holder in a specially made bracket, fitting into the $\frac{5}{16}$ -in. square hole in an offset toolholder.

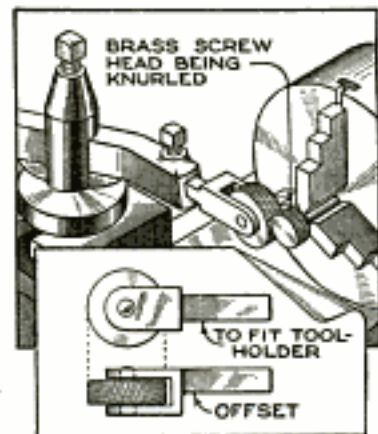

The bracket can be removed for use in a straight holder also, or in one offset in the opposite direction. While only one knurling wheel was used, the result on the small brass-screw heads was entirely satisfactory. The bracket was made of tool steel, for toughness, and the arms through which the knurl shaft passed were as thin as possible, consistent with strength, in order to allow the knurl to be used close to the chuck jaws. The square stem was offset to allow further clearance for the toolholder shank; by reversing the bracket, this offset can be made to come on the other side for use on work located close to the tailstock.

Cutting Springs after Winding

When making a heavy wire spring in the machine shop, it is generally coiled on a mandrel held between the centers of a lathe. After the spring has been wound to the desired length, it is a good plan to turn the lathe spindle backward a few turns before cutting off the wire. This relieves the strain on the spring, and makes it safe to cut the wire with a hacksaw or pliers without danger of having the end of the wire fly back.

Quickly Operated Jig Clamp

A quickly operated jig clamp is shown in the drawing. The clamp is made with

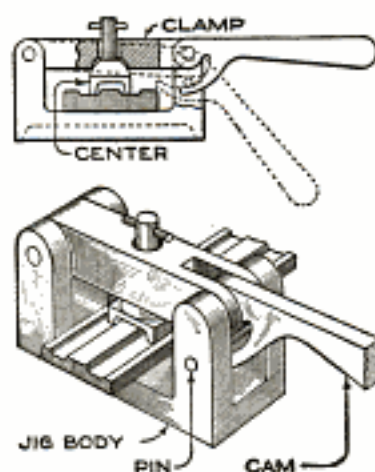

four lugs, one at each corner, with the swinging leaf pivoted between two of them, the actual clamping being done by means of the cam-and-pin arrangement shown in the sectional diagram. In order to be sure of accuracy,

the work is held by a floating foot, or center. A pin, driven through a hole in the top of the center shank, prevents it from falling out, and the center is ball-shaped so that it can adapt itself to the surface irregularities of the work.—J. H. Moore, Toronto, Can.

Center-Punch Attachment for Square

The attachment illustrated will be found a timesaver when laying out work. By setting the index mark on the attachment to a graduation on the square blade, any desired distance from the edge of the work can be prick-punched instantly; for greater accuracy, a pair of calipers, or an inside micrometer, can be used in setting.

The base of the device, which is made of tool steel, is machined with a shoulder that fits against one edge of the square blade; a slotted extension opposite this shoulder carries a cam or eccentric that locks the attachment in place. The slot, and the construction of the cam stud, enable the attachment to be used on blades of varying widths. The punch is carried in a sleeve, forced into a hole in the

shouldered end of the base; in line with the punch point, an index mark is cut on the base, and the edge of the slotted extension is milled or ground exactly in

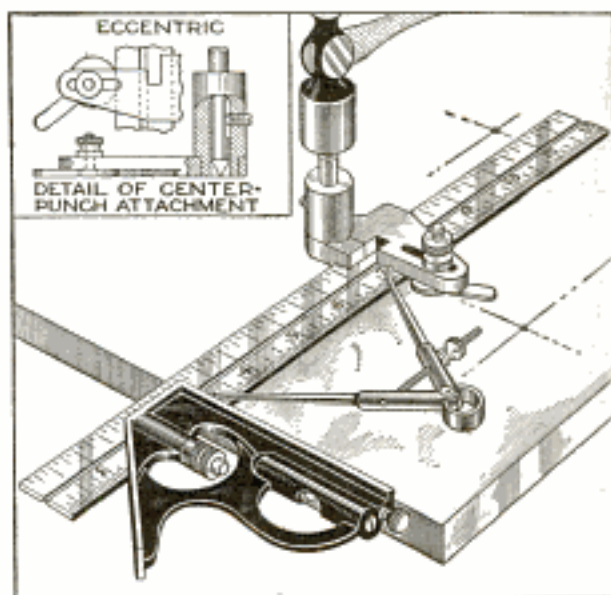

A Center-Punch Attachment for the Combination Square That will be Found Very Useful on the Laying-Out Bench

line with the punch point also. A flat, filed on one side of the punch, and a small setscrew in the sleeve, prevent the punch from dropping out.

Guard Plate for Knife Switch

An unprotected knife switch is a real menace to the lives of those who work around it, especially if the switch is carrying a heavy current. If it is not possible to use the safety switches that are now accepted as standard, the exposed knife switch can be made practically safe by applying an insulating cover that will prevent accidental contact with the switch.

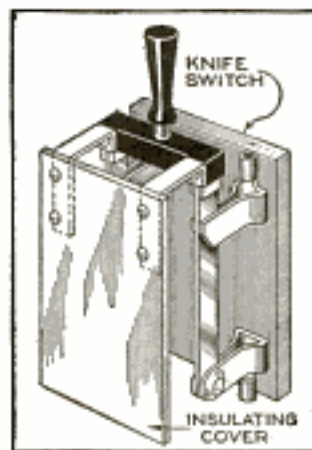

The drawing shows a method in use at one plant. Here a piece of sheet fiber, or other insulating material, is attached to the switch by metal brackets. The insulating material completely covers the switch blades so that in opening or closing the switch, the operator cannot come into contact with anything but the handle.—Clementine Paddleford, New York City.



SOME UNUSUAL JOBS FOR THE TRACTOR

By GEO. G. McVICKER

MANY farmers seem to be laboring under the impression that a tractor is only useful for drawing plows and other implements, and, when fitted with a power pulley, for driving a thresher or a circular saw. There are many other jobs around the farm, however, for which the tractor could be used with a consequent saving in time and labor. A few such jobs are here described.

The foundations of many barns and other farm buildings extend but a few feet below the surface of the ground, and very often the foundation walls will settle away from the building, due sometimes to undermining by rats, sometimes to heaving of the ground by frost. When this happens, only a small portion of the wall supports the building. I found this to be the case with one of my barns after the frost had loosened the ground. Rather than employ a mason to relay the wall, section by section, I decided to try using the tractor to push it back into place. This was accomplished as shown in Fig. 1. A 3 by 12-in. plank, as long as the wall, was placed with its broad face against the latter. I then attached a 4 by 6-in. timber to the drawbar of the tractor by means of a chain, allowing the timber to extend forward between the wheels and protrude several feet ahead of the tractor. I toenailed this timber to the 12-in. plank, started the tractor, and, allowing the clutch to slip slightly, moved slowly forward in low gear. The foundation was thus pushed into position and held firmly until I had tamped earth solidly underneath it. I did this job alone in a little over an hour; with jacks or crowbars it would have taken several men much longer. It might be necessary, in some cases, to relieve the foundation of the weight of the building side, but this could easily be done by using levers.

A jack is a tool seldom found on the farm, and when a small building is to be lifted, either for repairs to the foundation, or for making the foundation higher, or for placing rollers and skids under it, preparatory to moving it to a new location, crowbars are the tools commonly used. This method requires two or three men,

and makes a tiresome and time-consuming job. The building can be lifted, one side at a time, by using the tractor; this demands but little preparation and no materials that cannot be found on the average farm. The first step is to spike or bolt a 2 by 6 or a 2 by 8-in. timber to one side of the building, at a suitable height above the ground. The tractor is backed to within about 6 ft. of the building, and a 4 by 6-in. timber is cut to such a length that it will reach from a point on the tractor frame just above the drive axle to the timber attached to the building wall. When this timber has been set so that it will stand a good push without slipping, the clutch of the tractor is slowly engaged, and the tractor, in reverse gear, moves back until it is against the building, as shown in Fig. 2. This action provides a powerful lifting effect, and raises the building as steadily and easily as a number of jacks. When the building is lifted, the tractor will hold it until blocking or skids can be placed in position, and then, by driving the tractor slowly forward, the building is allowed to settle on the blocks. The opposite side is lifted in the same manner, and if the building must be raised still higher, the operation is repeated, moving the timbers on the building lower, or using a longer lifting timber. This is a safe and practical method, and the work can, if necessary, be done by one man.

Removing rocks from a field to be seeded appears to be an ever-waiting job for the farmer in localities where the ground is very stony, and many are inclined to farm around the larger ones because of the work involved in moving them. With the aid of the tractor, however, rocks too large to be otherwise moved, without first breaking them, are easily loaded on a sled, hauled to the rock pile or stone fence, and unloaded, without any hand lifting at all being necessary.

The sled used is no different from any common stone sled, except that a steel pulley is attached to the front end, as shown in Fig. 3. The only other piece of equipment necessary is a length of $\frac{7}{16}$ or $\frac{1}{2}$ -in. steel cable, one end of which is fas-

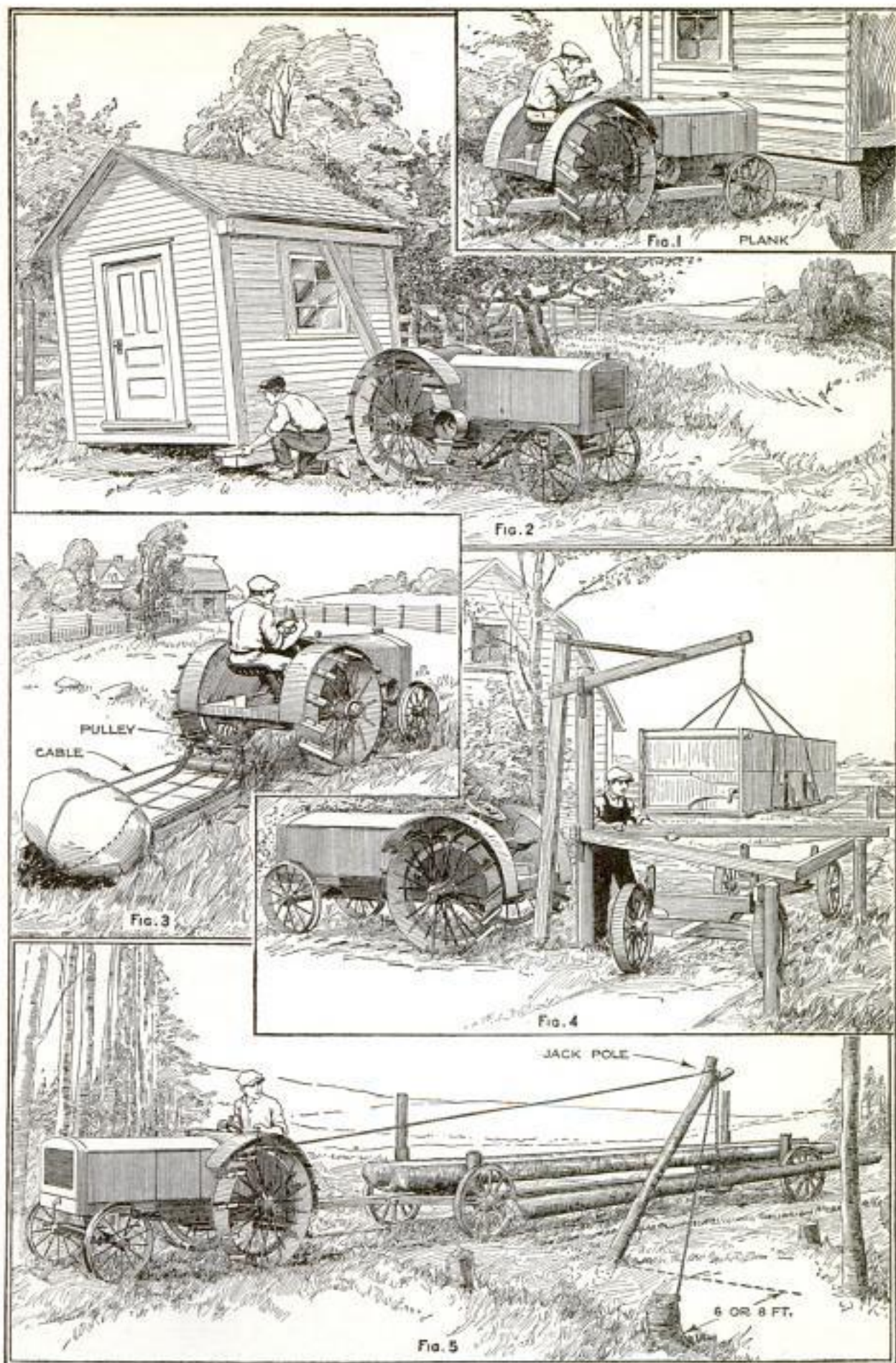

Fig. 1 Shows the Tractor Replacing a Foundation Wall; Fig. 2, Lifting a Building for Foundation Work, or Preparatory to Moving; Fig. 3, Loading, Hauling, and Dumping Heavy Rocks; Fig. 4, Removing a Heavy Wagon Box by the Aid of a Simple Device, and Fig. 5, Loading Felled Trees with a Minimum of Exertion

tened permanently to the front end of the sled, while the other is provided with a hook that will go into the eye of the tractor drawbar.

A hole is poked underneath the stone with a long curved bar, and the cable worked through it. The end is then passed under the pulley, and hooked to the drawbar. As the tractor is driven ahead, the cable rolls the stone up onto the sled, the backward pull on the sled holding it in place until the cable rolls the stone forward against the pulley. The sled will then start to move forward, and without having to stop, the journey can be continued to the rock pile. When this has been reached, the cable is unhooked, run over the top of the pulley, and hooked to the drawbar again. The tractor is then started, the cable rolls the rock from the sled, and then pulls the sled on over the rock, without stopping the tractor, as it is driven back.

I can, if necessary, lift a wagon box on or off the running gear by the exercise of "brute force and ignorance," but I don't like to do it, and I won't, so long as my tractor is at hand. I have a device rigged up, by the use of which so little time and manual exertion are required that it is a pleasure to watch it work.

I set one 4 by 6-in. post, 10 ft. long, 2½ ft. in the ground. At the top of this post, I pivoted a crossarm made of 2 by 8-in. timber, 9 ft. long, the pivot being a ¾-in. bolt, and the pivot hole bored 18 in. from one end. The bolt passes through the upright post on one side, the other end being held by a piece of flat iron, bent and attached to the post as shown in Fig. 4. To the short end of the 2 by 8-in. piece I bolted a 7-ft. length of 2 by 6-in. lumber, bracing the two as shown, with two pieces of flat iron. It will be seen that, when the wagon is on the gear and the crossarm is just at the top of the box, the upright arm is standing at an angle to the main post. Two loops of rope are placed around the box and over the crossarm, and the tractor is then backed against the upright lever arm. This raises the box clear of the running gear, which is then drawn from beneath, the cross supports shown in the illustration are placed in the brackets, and the box is lowered. One man does the whole job.

Loading the trees felled for the winter's fuel, or for a lumber supply, before hauling them to the saw, is easily a two-man job as ordinarily undertaken, and involves some heavy lifting. By using the method shown in Fig. 5, one man can do the

work if necessary, and all manual lifting is eliminated. The necessary implements are a rope, ⅝ or ¾ in. in diameter, 50 ft. long, a piece of the same rope about 10 ft. long, a chain long enough to reach around the largest of the logs, and a jack pole, as illustrated, 10 ft. long.

Drive alongside the log to be lifted, about 3 ft. to one side. Wrap one end of the long rope around one of the mud lugs near the top of the tractor drive-wheel, at the rear, and, at a point on the rope near the center of the log to be lifted, take a half hitch around one of the forks on the jack pole. The jack pole is set in a shallow hole, to prevent slipping, at the outside of the log, and inclined at an angle of 45°. The other end of the long rope is fastened to a stump, or a stake driven in the ground, about 6 or 8 ft. ahead of, and to the outside of, the jack pole, as shown. The log is attached to the jack pole with the short rope and chain; then, with one hand holding the end of the rope that is hitched around the mud log, slowly engage the clutch. As the tractor moves forward the rope will be wound on the drivewheel (the tractor should be steered so that it will), and the log is lifted. As soon as this happens, the jack pole begins to swing in, as the part of the rope between the pole and tractor is always taut, while that between pole and stump begins to slacken as soon as the log is lifted. As the forward movement continues, the jack pole is pulled in farther until the log is dropped in the center of the wagon.

The placing of the jack pole, wagon, and stake demands a little bit of judgment, but after a few trials, the correct relative distances can be estimated with considerable accuracy, and the work will proceed with dispatch.

Several other unusual chores for the tractor have come to my attention, such as using it as a snowplow, by attaching a V-shaped frame covered with boards to the front axle, and for heavy hoisting, by attaching the end of the falls of a block and tackle to the drawbar, then driving the tractor forward; these are but a few of the many that will occur to the wide-awake reader.

Prolonging the Life of Emery Belts

The life of emery belts can be considerably extended by treating them with paraffin wax. The wax is applied to the surface of the moving belt, or may be put on when the belt is idle. After applying the wax, it will be observed that

only the cutting edges of the abrasive grains are visible, the voids between the grit particles being filled with wax. This is the secret of the extra-long wear. As any chips or metal dust cut from the work are forced into the wax, the emery is free to cut instead of clogging and breaking off. This method is especially useful in brass and aluminum work, as this material has a tendency to fill in more than harder metals. However, when the belt has finally filled up and become smooth, it may be made to look like new by using a file card to clean out the accumulated cuttings, after which another coating of wax is applied.—S. S. Sutherland, Detroit, Mich.

Increasing the Oilcan's Reach

By the simple expedient of making a small collar, having a tapered hole, to fit over the spout of an oilcan, and attaching a suitable length of stiff wire to the collar, the range of the oilcan may be considerably increased. The wire, preferably of copper, is soldered into a hole in the collar. In use, the collar, with its attached wire, is slipped over the spout of the oilcan; the oil follows the wire and makes it possible to direct the lubricant into otherwise inaccessible places. The attachment can be put on or taken off the spout in a second.

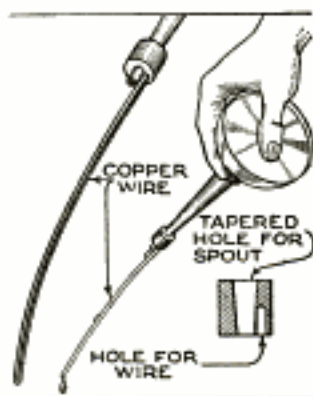

Driving Screw Hooks Quickly

The manual-training class of a high school, in carrying out a project that required a gross of screw hooks to be inserted into boards, found the job very tedious, until the tool shown in the drawing was made. It was made from a stove bolt having a shank that would fit into the chuck of a spiral screwdriver, a flat being filed on the end of the shank to correspond with that on the screwdriver bits. The slot in the bolt head fits over the screw hooks, and inserting them then became a very simple matter.—N. E. Studebaker, Houston, Tex.

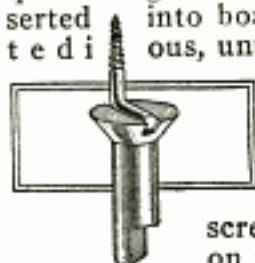

A Carriage-Bolt Holder

Carriage builders, automobile-body workers, and others who have frequent occasions to remove carriage bolts, are familiar with the tendency of the bolt to turn with the nut. As the head of the bolt is round, it is not always an easy matter to get a grip on it that will hold without damage to the adjacent woodwork. The simple tool illustrated has been used for a number of years by a man of long experience in work of this character; it should be made of the best tool steel and tempered as hard as a screw-plate die. The teeth are beveled, and the bevel must be on the upper side.—C. S. Simmons, Cache, Okla.



Holding Nonmagnetic Materials on Magnetic Chuck

In surface grinding brass, or other nonmagnetic parts, considerable trouble is experienced if the grinding machine is equipped with a magnetic chuck. In order to do the work, either the vise or special planer clamps must be used, that is, if the work is flat, as in the drawing. Such flat work, however, having plane surfaces, can be held on the magnetic chuck by using two steel plates of the kind illustrated, one on each side of the work, with a support behind them. The plates should be of such a width that, when placed between support and work, they will lie at a small angle to the surface of the chuck. The edges of the plates are beveled, and the beveled edges are placed as shown; when the current is turned on, the plates are pulled tightly against the work, clamping it to the chuck.—John Homewood, Ontario, Calif.

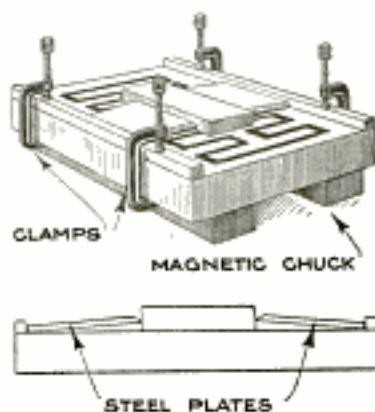

Stacking Hay by Gravity

A western rancher raises alfalfa in summer on the plateau above a swiftly running river, which never freezes. His home and feed lots are located in the river valley below. It was not long until he encountered trouble in hauling the



A Western Rancher's Method of Stacking Hay by Gravity: His Crop is Raised on the High Land, Whence It is Shot down a 400-Foot Chute to His Feed Lot in the River Bottom

hay down to the river bottom, and he proceeded to eliminate the necessity of hauling, as well as much labor, by building a chute from the hayfield above to the feed lot. The chute is about 400 ft. long, about 8 ft. wide, and has a semi-circular cross section. Throughout most of its length the chute rests on the earth. The lower end, being elevated so as to form a stack, is carried on a timber frame.

From 50 to 75 tons of hay are shot down the slide each season, and a load can be put down in the same time as required to put it on a stack below, as a stacker is also used at the top to move the hay from the wagon and drop it onto the chute.

Flesh or Grain Side for Belts

Many discussions have taken place in the past as to whether the grain or the flesh side of a leather belt should be run next the pulley. Definite data were entirely lacking, however, until a series of tests, covering a period of more than two months, and using five 4-in. single-ply belts, made by various makers, each belt

being 30 ft. long, were made at Cornell University. All five belts were thoroughly run in before the tests, and every effort was made to reduce the possibility of error to a minimum.

The method of testing was to take horsepower readings from the belts, when running on each side, the power being increased gradually until four per cent slip was reached. The results indicate clearly that the grain side is undoubtedly the best for power transmission, the flesh side transmitting, under shop conditions, on an average only about 50 to 60 per cent as much horsepower as the grain side. Under a higher tension than is usually found in the shop, however, the flesh side shows a higher efficiency than this; under very favorable conditions, as high as the grain side. The tests show that there is a distinct advantage to be gained by running a belt with the grain side next the pulley.

Lever for Tailstock Handle

When drilling large holes in the lathe, extra leverage on the handwheel of the tailstock spindle makes the work easier for the operator.

The attachment illustrated forms a handy way of getting the extra pressure against the drill point, as it is quick-acting and need not be removed from the handwheel in order to clear the lathe bed. The lever is made from two pieces of cold-rolled steel, one of

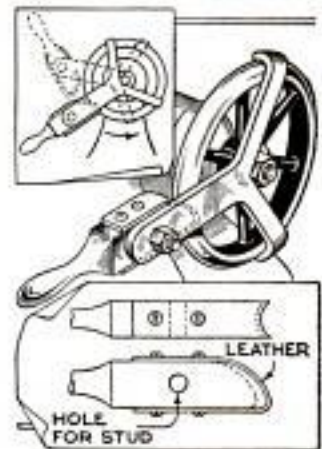

$\frac{1}{2}$ by $1\frac{1}{2}$ -in. flat stock, which is forged to form the forked section, and the handle, made of stock to suit the width of the wheel. The ends of the fork are bent over to conform to the contour of the wheel, while the handle is turned at one end to form a good grip, and drilled near the other for the stud that holds it to the fork. The end of the handle is filed to the same radius as the wheel, and a piece of soft leather is passed around this end and held in place with screws. Downward pressure on the handle causes it to grip the wheel tightly, and apply the necessary pressure. When the lathe bed is reached, a quick upward movement releases the wheel and enables the operator to take a new grip.

Raising a Water Tank 25 Feet

As a rule, when increased height is required for a water tank, the old one is scrapped and a new one erected, or if the condition of the old tank warrants, it is dismantled and then rebuilt on a new support; both of these methods involve the expenditure of considerable time and money.

The photographs illustrate a method by which a 60-ton tank was elevated a distance of 25 ft., and new sections built into the steel tank support, without disturbing the tank. A wooden support was built around the base of the tank, the corner members of which were 14 in. square and 40 ft. long, while the rest of the framework and the braces were made from 8-in. timber. Two heavy chain falls were fastened to the crosspieces, at opposite corners, and cable tackles and winches were attached to the other two corners. The cables were then fastened to each corner of the tank supports. Six guy wires were attached to the bottom of the water tank

proper, to prevent it from falling or moving under the influence of the wind. Each of the guys was provided with a tackle block, and as the tank was raised, the guys were slacked away, while keeping them tight enough to hold the structure steady.

When the tank had been raised the proper distance, the new ironwork section was slipped into the gap and joined to the bottom of the old steel frame. The new sec-



Left: Raising a 60-Ton Water Tank a Distance of 25 Feet by Building a New Section into the Old Steel Frame. Right:

During the Lifting, the Tank was Stayed by Six Guys Fastened underneath the Tank. As the Tank was Lifted, the Guys were Lengthened

tion measures 24 ft. square, and the tank now stands 100 ft. in the air.—W. K. Crosson, Detroit, Mich.

Testing Engines at the Muffler

Many present-day automobiles are built without muffler cut-outs, and with such effective mufflers that it is difficult to tell, from the exhaust, when the engine is missing explosions. In a noisy shop the exhaust can hardly be heard at all if the throttle is nearly closed. Under such conditions, a strip of tin can be used to determine when the engine is "hitting" on all cylinders.

This strip, which should be about 12 in. long and 4 in. wide, is held by one end in the fingers, so that the opposite end rests over the exhaust-pipe opening. The rhythmic striking of this tin strip on the pipe indicates perfect operation. A pause, or "miss," in the stroke is noticed when explosions are missed, regardless of how slowly the engine is operating. By this means, adjustments may be made on the spot without the necessity of a road trial.

Scale Used as Depth Gauge

Mechanics and others who frequently have occasion to measure the depth of small openings such as countersunk holes, short slots, and the like, will find the scale altered as illustrated very convenient, because, as a rule, the width of the ordinary machinist's scale is too great to permit the taking of such measurements.

To convert the ordinary 6-in. pocket scale into a combination scale and depth gauge, it is only necessary to grind away one side of it for a short distance from the end, reducing the width of the scale so that it can be used in the smallest opening encountered.—P. A. Daschke, Astoria, N. Y.

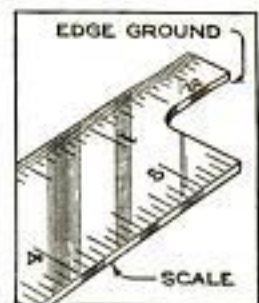

Magneto and Generator-Testing Base

By J. V. ROMIG

NO electrical-appliance repair shop, or even garage, is complete in its magneto and generator department unless it

is shaped with a boss, and, when drilled and tapped, is used as a nut for the adjusting screw; this piece is fastened to the

angle members by small $\frac{1}{4}$ -in. round-head screws.

The adjusting screw is made of steel, and is fitted with a knurled handwheel, 3 or 4 in. in diameter. The clamp that holds the electrical units down on the base is built up of $\frac{3}{8}$ by 2-in. flat-bar stock, riveted together, with $\frac{11}{16}$ -in. spacers between the two sides.

One end of the clamp slips under the tightening nut in a longitudinal direction while the other swings radially, making a handy and quick-acting clamp. By notching it out in the center, as shown, it will hold the units under test tightly and squarely, and prevent them from slipping around. Holes are drilled in the feet, and the device is bolted to the bench in line with the motor. The motor

switch should be mounted underneath the bench, to prevent it from being damaged by accident.

Acetylene gas is more easily ignited than a mixture of gasoline vapor and air, especially at low temperatures; with some motors, if reasonable care is exercised, no accident is likely to occur, but with others, especially with those having heavy flywheels, representing considerable inertia, it is highly probable that the cylinder head or some other part of the combustion chamber will give way before the flywheel has turned sufficiently to remove the pressure, by permitting the piston to

switch should be mounted underneath the bench, to prevent it from being damaged by accident.

Acetylene gas is more easily ignited than a mixture of gasoline vapor and air, especially at low temperatures; with some motors, if reasonable care is exercised, no accident is likely to occur, but with others, especially with those having heavy flywheels, representing considerable inertia, it is highly probable that the cylinder head or some other part of the combustion chamber will give way before the flywheel has turned sufficiently to remove the pressure, by permitting the piston to

switch should be mounted underneath the bench, to prevent it from being damaged by accident.

Acetylene gas is more easily ignited than a mixture of gasoline vapor and air, especially at low temperatures; with some motors, if reasonable care is exercised, no accident is likely to occur, but with others, especially with those having heavy flywheels, representing considerable inertia, it is highly probable that the cylinder head or some other part of the combustion chamber will give way before the flywheel has turned sufficiently to remove the pressure, by permitting the piston to

switch should be mounted underneath the bench, to prevent it from being damaged by accident.

Acetylene gas is more easily ignited than a mixture of gasoline vapor and air, especially at low temperatures; with some motors, if reasonable care is exercised, no accident is likely to occur, but with others, especially with those having heavy flywheels, representing considerable inertia, it is highly probable that the cylinder head or some other part of the combustion chamber will give way before the flywheel has turned sufficiently to remove the pressure, by permitting the piston to

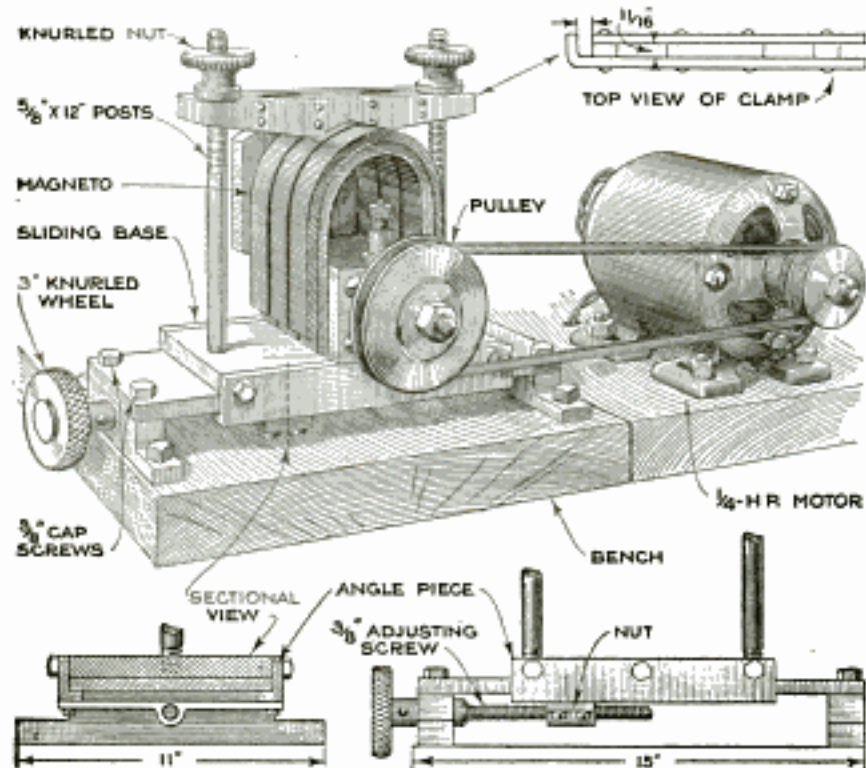

When Testing Magneto and Generator Units, Some Sort of Test Stand is Required to Hold the Piece Securely If It is to be Tested under Service Conditions. The Device Illustrated Eliminates Vibration While under Load

has a testing stand or base on which to clamp the repaired units and test them under actual running conditions. In the device illustrated, the generators, starting motors, or magnetos are held rigidly, and a $\frac{1}{4}$ -hp. electric motor is large enough to drive nearly all ordinary types of generators and magnetos. The magneto or generator is placed on the sliding base of the tester, the pulley adjusted in line with the driving pulley on the motor, and the clamp tightened. By moving the base away from the motor, which is done by turning the adjusting wheel on the front of the device, the proper belt tension is secured for driving the unit under test.

Cold-rolled steel is the best material for building the base, a piece $\frac{1}{2}$ by 7 by 15 in. being used for the bed. This is bolted to two pieces of 1 by 2-in. stock, shaped as shown, to form the feet of the tester. The sliding base proper is made from a piece $\frac{3}{4}$ in. thick by 7 in. wide and 10 in. long. This piece is fitted with angle members on its sides, to make a carriage that will slide on the bed, and is also drilled and tapped for the two upright standards, which have a short thread on their lower ends. A flat piece of brass,

switch should be mounted underneath the bench, to prevent it from being damaged by accident.

Acetylene as a Primer for Cold Engines

There is no question but that acetylene gas is very effective when used to start cold or balky internal-combustion engines, but in the opinion of many engineers of wide experience, such use is very dangerous. The explosion of acetylene gas is so much more violent than that of gasoline or kerosene vapor, for which the engines are designed, that there is considerable likelihood of blowing off the cylinder head or breaking the piston.

Acetylene gas is more easily ignited than a mixture of gasoline vapor and air, especially at low temperatures; with some motors, if reasonable care is exercised, no accident is likely to occur, but with others, especially with those having heavy flywheels, representing considerable inertia, it is highly probable that the cylinder head or some other part of the combustion chamber will give way before the flywheel has turned sufficiently to remove the pressure, by permitting the piston to

move on the downward stroke. This is also largely true of ether used as a primer without dilution.

The use of an open flame in the air intake of an internal-combustion engine, as an aid to starting in cold weather, is seldom recommended, strange to say, yet this is very effective, offers no danger to the operator and practically none to the machine.

Jack Prevents Distortion of Pistons

The illustration shows a device used to avoid the danger of springing pistons out of shape when new pin bushings are to be fitted. It consists of a round steel body, the smaller diameter being threaded, and the head having a recess cut in it to allow the bushings to project the proper amount through the boss without coming into contact with the jack. The threaded shank is fitted with a hexagon nut, the outer face of which is recessed in the same manner as the head on the opposite end.

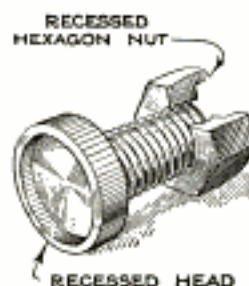

To use the jack, it is placed between the pin bosses, screwed tightly against them, and the bushings are inserted, after which the nut is slacked far enough to allow the device to be removed.—Edwin Kilburn, Spring Valley, Minn.

A Riveting Kink

In cases where a stud is being turned in the lathe for insertion into any part to which it is to be riveted, the work of riveting can be greatly facilitated, and a more permanent fastening obtained by means of a simple dodge. This consists in cutting a concave spot in the end, as shown in the drawing; the resulting ridge is quickly upset with the ball peen of the machinist's hammer, and considerable time is saved, as the ridge turns over quickly under the hammer blows and provides a substantial head.—G. A. Luers, Washington, D. C.

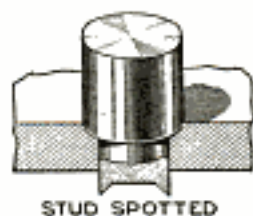

Scribing Long Straight Lines

When a long straight line is to be scribed on a metal surface, and no full-length straightedge is available, a close approximation can be reached, with careful work, by means of a fine steel wire,

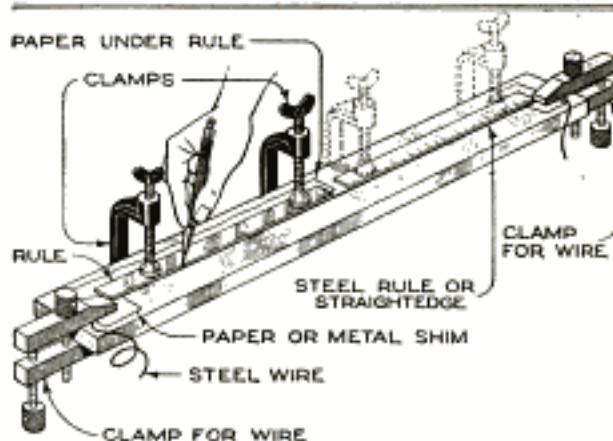

When a Long Straight Line is to be Scribed and a Single Straightedge of Sufficient Length Is Unavailable, an Approximately Exact Line can be Drawn by Aligning Two or More Straightedges

tightly stretched, and clamped to each end of the work. In the drawing, a steel bar is shown, as a simple example, which requires a line scribed down its length. The wire used is preferably steel piano wire, although iron or copper wire can be made to serve. There must be no kinks or bends in the wire, and to help remove such as are not noticeable, clamp one end of the wire in a vise and stretch it by hand as much as the material will stand without actual rupture; then do not allow it to become bent before using. Stretch the wire as tightly as possible upon the work and clamp the ends; if the scribed line is to extend to the ends of the work, carry the wire down over and clamp it at some other point. Make sure the wire does not touch the work enough to be thrown out of true, though it should lie as closely as possible to the surface. Shim up under the ends with paper or thin metal if necessary. Then procure two or more steel rules or straightedges and clamp them along so that their edges just touch but do not move the wire. Use a magnifying glass in setting them, if accuracy requires it. After the straightedges are aligned and clamped, with thin paper under them as a safeguard against slippage, remove the wire and scribe a line against their edges.

Small protruding points in the bottom of the box that retains the oilstone, will prevent it from slipping when it is used on the bench.

Protecting Small Thread Gauges

Thread gauges of the smaller sizes used around the shop very frequently have their usefulness impaired by the numerous knocks

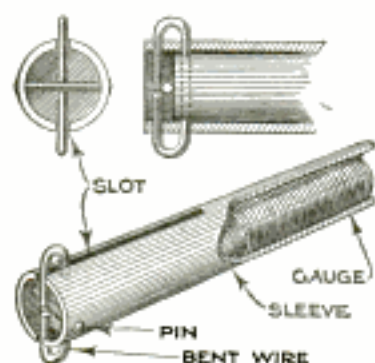

they receive in the course of the day's work. Often, too, vibration will jar the gauge off the bench, or some heavy tool will be dropped on it

by the careless or busy mechanic. Accurate thread gauges are expensive to make, and are well worth protecting; for this purpose the device shown in the drawing will be found simple and effective. A sleeve is made to fit the largest diameter of the gauge, and long enough to cover its entire length. A slot is cut in the sleeve for about half its length, and at right angles to this, near the slotted end, a hole is drilled, and a pin driven in. The gauge shank is then drilled, close to the end, a drive fit for a $\frac{3}{32}$ -in. wire, after which it is inserted in the sleeve, and a piece of the wire is driven in. The ends of the wire are bent over the end of the shank in the manner shown, and adjusted until the ends will just spring over the pin in the sleeve. When in use, the gauge is pushed forward by grasping the bent wire, and when not in use, it is pushed back into the sleeve until the ends of the wire snap over the pin.

Type Cases to Hold Small Parts

Every workshop has as a part of its stock or equipment an assortment of small screws, nuts, bolts, and similar small articles, which are difficult to store and classify. To keep these things in order and within reach when wanted, requires a number of small compartments or containers.

One of the best ways of sorting and keeping in order such a stock of small articles is to use printers' type cases. The case is a drawer about 32 in. long, 16 in. wide, and $1\frac{3}{8}$ in. deep. It is divided into small compartments by wooden partition strips. A "double" case has 49 compartments or "boxes," 2 in. square, on each side, or a total of 98 divisions. A "triple" case has three lots of boxes, $1\frac{1}{4}$ by 2 in., or a total of 147 compartments. Several other

arrangements of the partitions and divisions can be obtained. The boxes or compartments give room for but a few of each of the pieces and parts, but they provide a rather complete stock in a very small space, where they are always kept in order and ready for use.

Old type cases can be obtained at bargain prices from print shops and supply houses, or new ones, together with stands for holding them, if a number are to be used, can be obtained from type foundries. Such a case, mounted as a drawer, underneath a bench, will quickly prove its value.—James W. Cottrell, Hamonton, N. J.

A Simple Punch and Die

A die for experimental work, which is simple and economical of construction, is shown in the drawing. The die is made of casehardened machine steel, and is screwed and doweled to a cast-iron stripper.

The shape of the die is scribed off onto the stripper, which is then machined out to fit the punch. The punch should be made a good fit in the stripper, as it serves as a guide for the former.

The punch is made sufficiently long to permit a rubber washer or sleeve to be slipped over it; this sleeve rests on top of the stripper plate. A hole is drilled near the top of the punch for a pin which holds a steel washer in place against the rubber. The rubber sleeve is compressed when the blank is being punched out, and is strong enough to pull the punch from the stock. Such a die can be operated in a vise or arbor press.

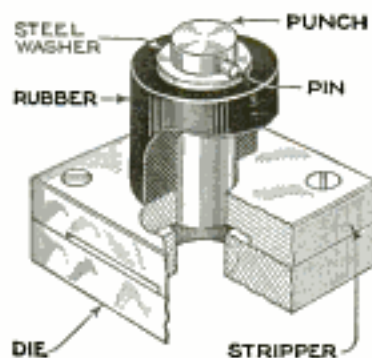

Testing Ink for Acid

A simple method of testing ink, or other fluids, for the presence of acid, consists in dropping some of the liquid under suspicion into a solution of washing, or baking, soda. If the ink is acid, the resulting reaction between the acid and the alkali will cause foam to appear. Blue litmus paper can also be used; this turns to a red or pinkish tint when brought into contact with an acid.

Tightening Nuts with Rounded Edges

When repairing the car, it often happens that nuts which are to be removed from some awkward location have been "chewed up" to such an extent that the edges have become rounded, and it is difficult to grip them properly. A socket wrench will usually slip around over such a nut without moving it, especially if the wrench itself is a little worn. One car owner, who does his own repairing, finds that by placing a piece of fairly heavy cloth over the nut, and then forcing the socket wrench over this, nuts in this condition can be loosened or tightened easily.—A. E. Swanson, Los Angeles, California.

Trimming Drawings with a Knife

When trimming drawings with a pocketknife, using the T-square as a straightedge or guide for the blade, it often happens that the blade of the T-square is damaged. To prevent this, yet insure that the drawing will be cut in a straight line, a narrow slot can be cut in a triangle through which the point of the knife blade is inserted.

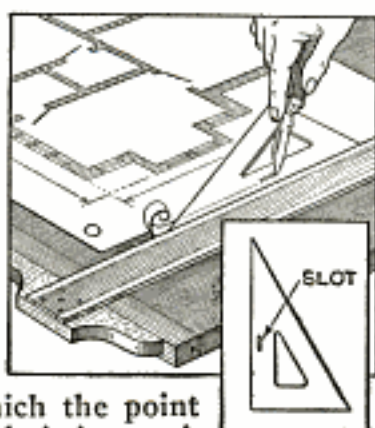

In trimming a drawing, the T-square is placed so that the slot in the triangle will fall on the trim line; it is then only necessary to insert the knife blade and draw it to the right, the triangle sliding easily along the edge of the T-square.—A. K. Harrison, Chicago, Ill.

Grinding Holes Straight

A simple visual method of testing holes for straightness, while grinding, is as follows: When the wheel is in to the full depth of the hole being ground, feed it to the opposite side until it just touches the wall. Then withdraw it from the hole and note the sparking. If the sparks are heavier near the front of the hole, the diameter is smaller at that point. When the grinding wheel is moved over to the opposite side and the sparking is the same throughout the bore as the wheel is withdrawn, the hole is straight.

Preventing Hasp from Breaking

When a padlock hasp becomes jammed between the door and its frame, it is not uncommon that the hasp is broken or pulled from its fastenings. Naturally, if the hasp could be kept out of the way, this would not happen. The arrangement illustrated not only keeps the hasp from between the door and frame but does it automatically. A hole is drilled in the hasp at the point shown, and a bicycle spoke is run through it and fastened to the door frame with staples, so that it can just slide. Owing to the tendency of the springy wire to straighten itself, the hasp will be thrown back automatically as soon as the lock is removed.

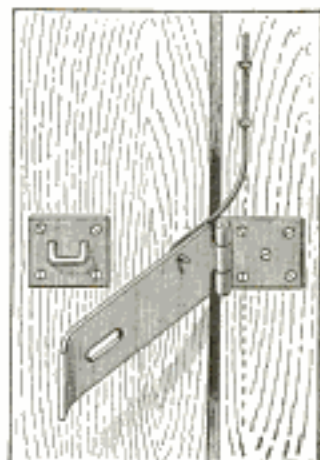

Adjustable Block for Hacksaw Vise

The movable jaw of a hacksaw vise is made to swivel on a stud or screw in order to get a firm grip on rough work, that is, in consequence, probably of unequal width. This, however, is the cause of a great loss in time when it is desired to hold short pieces of work which may be less than half the length of the vise jaws. It is impossible to hold such pieces securely without packing up the other end of the jaws to the same width as the work to be held.

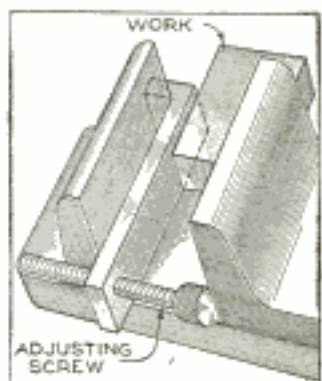

The attachment shown in the drawing will be found much handier than the usual array of nuts, washers, broken saw blades, etc., generally used. The fixture is clearly illustrated, and is simply a piece of flat stock bent over at one end and tapped at the opposite end, as close to the vise as possible, for a knurled screw. The work is held between the attachment and the movable jaw, gripped tightly, and the screw tightened against the opposite end of the jaw.

Some Ingenious Uses for Dynamite

By J. L. BALL

IT requires an emergency job to sharpen the wits of the mechanic to a keen edge; this is especially true around mines, where crude methods are sometimes required to get results, and some of these

deep, were drilled in the hub at two opposite points, and a V-shaped notch was chipped from the hole to the outer edge of the hub. It required a half stick of dynamite, fired separately on each side of



Left: A Sheave Wheel from the Headframe of a Coal Tipple, Removed without Injury to the Shaft. Center: The Effect of Two Charges of Explosive on the Sheave Hub. Right: Blasting Out a Tight Key

methods are as unusual as they are effective. It was necessary to replace some sheave wheels because the rims had become badly worn by the hoisting cable. These sheaves, or bull wheels, are in the headframe of the tippie, and should one of them fail from any cause, the damage would be considerable on account of the heavy weight of the steel cages and the loaded pit cars.

The new sheaves were exact duplicates of the old ones, and it was planned to use the old shafts, to avoid the necessity of fitting new journal boxes. After every known method had been used, without success, in the attempt to remove the old shafts, it was suggested that dynamite be used to burst or crack the hubs. The wheel was blocked up, 1-in. holes, 6 in.

the shaft, to crack the hub, the shaft not being injured in the least. The left and center illustrations show the sheave before and after firing the charge.

The teeth of a large solid gear wheel of a clay-grinding machine were so badly worn that it was necessary to replace it with a split gear. The position of the gear, however, was such that it

required considerable work to get at the key. A very small piece of 40-per-cent dynamite was placed in the keyway of the shaft and fired, driving the key out quickly. It will be well to remember that but a small quantity of explosive is required to do this work, and experiments should be made to determine this quantity, in order to avoid injuring the shaft and bearing.

In another case two cracked spokes made it necessary to remove a 6-ft. fly-wheel from a high-speed steam engine. The key was quickly removed by placing a small piece of dynamite behind the head of the key, as shown in the right-hand illustration, the end of the key being supported by a stout bar, to prevent its being bent downward.

Planting Sweet Corn

That sweet corn planted in June gives the best quality of corn is the contention of many expert gardeners, who maintain that the very highest quality is not obtained by earlier planting.

Sweet corn sown in the early part of May will produce a crop for the table in the latter part of July or early August, just when the summer is usually hottest. In these sizzling days the corn ripens so rapidly that only a portion of it can be picked at top quality. However, smaller early plantings, with the heavier plantings in June, will bring out the bulk of the crop during the last of August and early in September, when the weather is not so hot, so that the corn will ripen more slowly, and its quality remain at

its best for a longer time. Corn is likely to remain longer in the "dough" stage in cooler weather, and be available for the table over a longer period. Plantings of corn 10 days apart until the end of June, provided the first was planted early in May, will give a crop succession from the last of July until well into September.

Corn planted in June gets a faster start because of the warmer weather, and grows more rapidly than that planted earlier, the young plants developing under ideal temperature conditions, which is also another reason why June corn is likely to have finer ears and be of better quality.

When the corn has reached a height of about a foot, a light sprinkling of nitrate of soda is of great benefit. Avoid

getting the nitrate upon the leaves of the plants, and rake it lightly into the soil. When the corn is from 2 to 3 ft. high, some of the balanced fertilizers, or bone meal, can be sprinkled lightly and hoed in; that is usually all that is necessary to produce a good crop. These extra applications will not be necessary if the soil is good, is rich to start with, and has been manured, but if there is any doubt about it, or in the absence of common manure, they will insure a good crop.

Making a Clutch Shifter Stay "Put"

A manufacturing concern had trouble in making the clutch on the countershaft of a bolt cutter stay in the forward, reverse, or neutral positions, until the device illustrated was installed by one of the foremen. Two pieces of $\frac{3}{8}$ by $1\frac{1}{4}$ -in. steel were welded together at right angles to make a T-shaped piece, the horizontal member of which is screwed to one of the overhead timbers. The other member

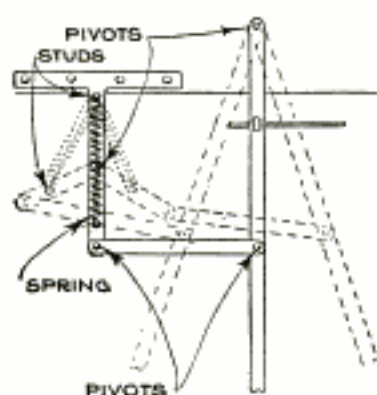

extends down, parallel to the shifter lever when the latter is in neutral. To the end of the vertical member of the T a short length of the same stock is pivoted, making a link that is free to swing to either side of its stationary support. Another link connects the shifter lever to the end of the pivoted arm in the manner shown. A coil spring is hooked over a stud riveted into the upper link near the lower pivot stud and over another located near the angle of the T. When the shifter lever is perpendicular, the link and spring are perpendicular also, and the lever has no tendency to move in either direction, but when the lever is thrown either to the right or left, the spring shortens and holds the clutch firmly. — Ralph Hanenkratt, Northville, New York.

☐ The hole in which a broach is to be started should be drilled or bored. Using a broach in a cored hole soon impairs its accuracy. The face of the work that rests against the faceplate must be true with the bore, otherwise accurate work is impossible.

Novel Tap Holder for the Drilling Machine

Very often it is found necessary to re-tap large batches of nuts, which, for some reason, are too small. The holder shown is very convenient for securing and driving a tap quickly without any tightening

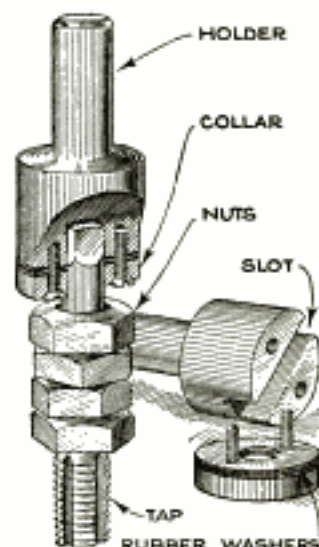

device, thus enabling the operator to insert and withdraw the machine is running. The shank of the holder is turned to fit the drill chuck, while a slot, the width of the square on the tap, is cut across the front end. A collar is made, of the same diameter as the holder, and fastened to the latter by two screws.

Between the collar and holder two rubber washers are placed. With the nuts held suitably on the drill-press table, the tap is pushed up in the holder. The rubber washers, being a wringing fit on the tap shank, will grip the tap sufficiently to keep it from falling, while the slot, of course, receives the square end of the tap shank and drives it. As many nuts as the tap shank will hold are tapped before the tap is pulled out and the nuts taken off.

Keeping the Drawing-Board Drawer in Place

Draftsmen and artists using drawing boards of the type with a drawer on the underside, sometimes forget the presence of the drawer and tilt the board, dumping pencils and other materials onto the floor because the drawer slides out. In order to overcome this objection, and keep the drawer in its proper place on the drawing board, a paper clip is bent in the manner shown, thumbtacks being used to fasten the wire to the side of the drawer and the drawer slide respectively.

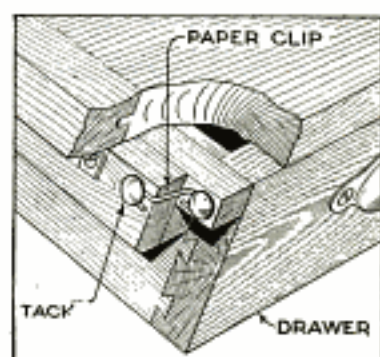

and keep the drawer in its proper place on the drawing board, a paper clip is bent in the manner shown, thumbtacks being used to fasten the wire to the side of the drawer and the drawer slide respectively.

Potato Planter Made from Old Corn Planter

The owner of the old corn planter shown in the photograph saved consider-

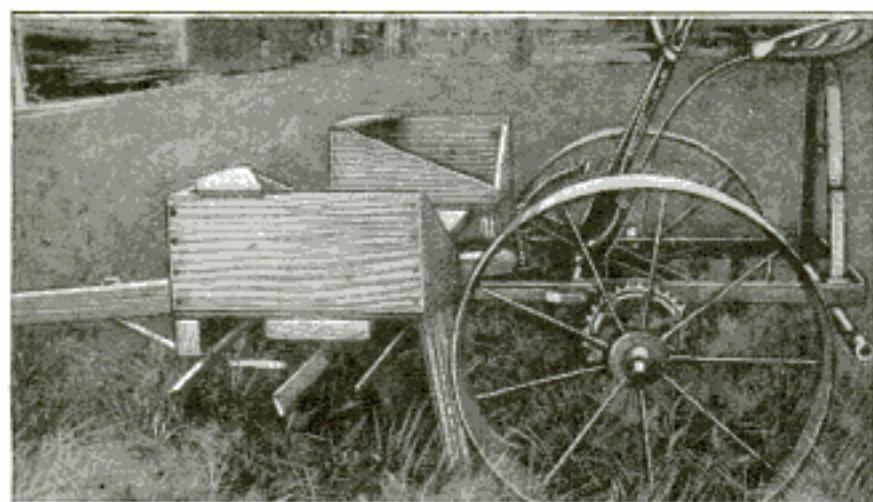

An Old Corn Planter That was Made Over into a Serviceable and Efficient Potato Planter: The Seed-Potato Cuttings are Placed in the Wooden Boxes and Dropped through a Spout into the Furrows

able money when he conceived the idea of making it over into a potato planter. The seed-corn boxes were removed, and

in their place two wooden boxes of the same size were attached. A hole was made through the bottom of each box, at the inside corner, and a length of galvanized-iron spouting was run down to within 3 in. of the bottom of each shoe. In using the planter, one man sits between the boxes and another drives. A peck or more of potatoes is placed in each box, and the cut potatoes are dropped through the holes in the boxes into the furrows. The ground should be prepared for planting by using a corn lister, which ridges the ground, leaving furrows between the ridges. After the potatoes have been planted, they are covered by driving a harrow over the ground. This method is much quicker than planting by hand, and when large tracts are to be seeded, there is considerable saving.

Windlass Holds Hay on Truck

With the introduction of fast motor-truck transportation into the business of farming, there came a demand for some

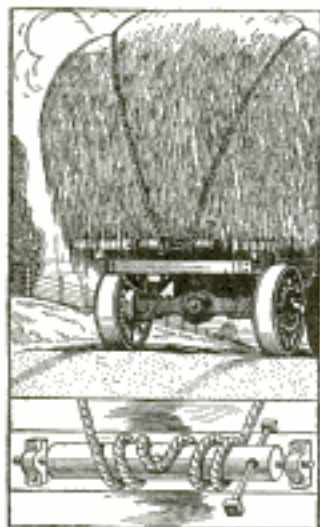

means of securing loose hay in a manner that would make fast delivery safe. The solution comes in the form of a windlass. With this arrangement, the ends of a rope are fastened to the forward corners of the truck body, the loop is passed over the top of the load, and down to the rear frame, where it is wound around a windlass; this draws up the rope tightly. The windlass consists of a roller, in the center of which a pin is driven to hold the loop of the rope. The roller is mounted in brackets on the rear of the truck bed, with sufficient distance between the roller and truck to clear the rope. The windlass is turned by a rod, passed through a hole in the roller, and when the load has been tightened, the

rod is allowed to bear against the frame so that it prevents the windlass from unwinding, but is still immediately ready for use. This last feature is one of considerable importance, since the hay will often settle, after a short distance over rough or bumpy roads, to such a degree that the rope will have to be drawn tight again, before further progress, without danger of spilling the load, can be made.—Roy A. Houston, S. Charleston, Ohio.

To Prevent Nails from Splitting Thin Wood

Having to nail a number of narrow strips, I found that the brads, as ordinarily used, would split them. Accordingly the points of the brads were flattened out or cut to a chisel-like point. By driving the nails with the chisel end at right angles to the grain not a strip was split. Of course, a bradawl would have answered the same purpose, but, even had there been one handy, it would have been a tedious job to punch a hole for each brad. Where the grain of the lower piece is at right angles to that of the top one, and is in danger of splitting, the nail is driven through the first piece as described, then given a quarter turn with a pair of pliers and driven home. This idea has been used on 20-penny nails with success.



A Motorcycle Delivery Truck

By J. R. KOONTZ

FOR several years we have had in use on our farm what one might call a "speed truck," one for quick delivery, where the weight of the load is not over 300 lb. It is very handy and useful, and there are hundreds of old motorcycles that have been discarded, not because of mechanical imperfections, but because of

make of the cycle used, but in general will not have to be very different from those shown in the illustration. Stake sockets are bolted to the sides of the platform. These are made of flat iron, bent to hold the stakes on the side racks, which have strips nailed to each end to form grooves into which the end members

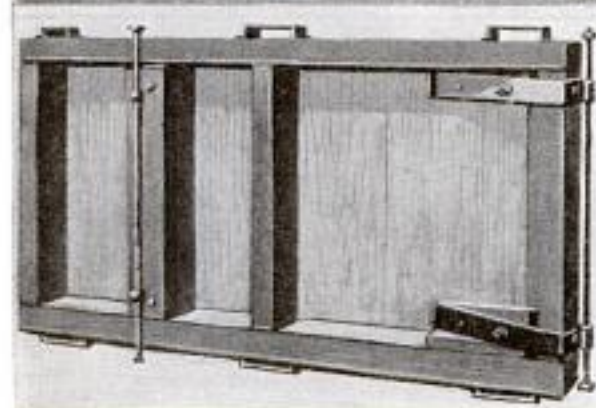
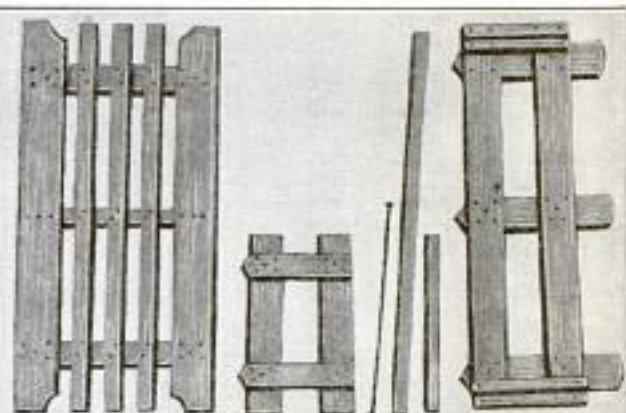

Upper Left: A Hurry-Up Trip from Town with a Load of Binder Twine. Lower Right: A Load of Two Barrels of Oil for the Farm Power Appliances. Lower Left: Construction of the Platform Frame and Arrangement of the Body Irons. Upper Right: Side and End Members of the Rack Body. The Part at the Left is a Cover for the Body

their shabby appearance, that are just the thing for such a truck.

If the motorcycle is equipped with a sidecar, so much the better. Remove the sidecar from the frame or springs and build the platform shown to take its place. This is built up of a framework of 2 by 4-in. lumber, covered with 1-in. boards. The necessary iron fittings for attaching the platform to the sidecar frame and motorcycle will vary somewhat with the

of the rack body fit. Two iron rods, threaded at each end and provided with nuts and washers, will be needed to hold the sides securely against the ends. The narrow strips shown in the upper right-hand illustration are used to make the openings in the rack smaller, for hauling chickens, and a cover for use in the same connection is also shown. A detachable seat can be made for carrying a passenger when necessary.

A truck thus made can be used with profit on any farm, as a gallon of fuel will go twice as far in it as in any other truck that can be made or used; it is especially handy for hauling milk to the station, but there are innumerable other uses for it.

Homemade Soldering Blowpipe

It is possible to convert the burner part of a "junior" incandescent-gas lamp into a soldering torch that will eliminate

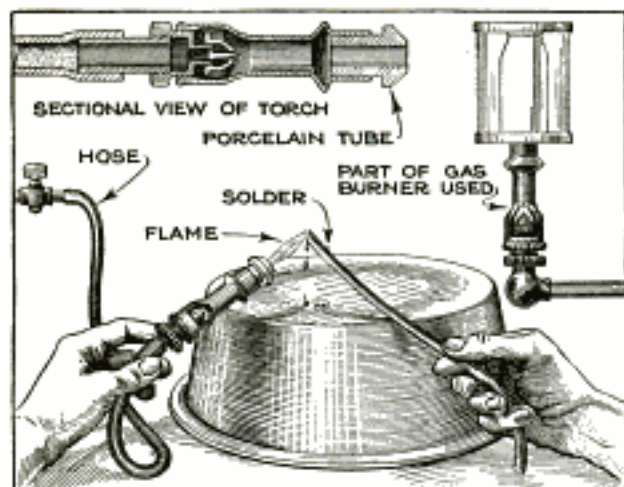

By Using the Burner from a Small Type of Incandescent-Gas Light, a Simple Soldering Torch can be Made. The Burner can Still be Used for Its Original Purpose

the necessity of using a soldering iron, except possibly for smoothing off the work.

A short length of pipe is screwed into the bottom end of the burner for attachment to the gas hose, and a 1-in. length of porcelain-tube insulator is inserted into the upper end, to form a nozzle. The porcelain-tube insulator can be obtained from any electrician, and is the kind used to insulate electric wires passing through woodwork. All that remains is to connect the burner to the gas supply with a length of rubber hose, and adjust the supply of fuel at the mixer.—Herbert A. Strickler, Buffalo, N. Y.

How to Lay Sod Properly

Sod obtained on open land, as, for example, from close-cropped pasture, is the best for lawns. Such sod is exposed to the heat, and, being able to withstand drought, will naturally flourish under the excellent treatment it gets when removed, reset, and given water and every attention. If a drought should occur, this sod is better able to adjust itself to conditions than that taken from cool, sheltered places, where the grass is tender, and more apt to suffer from exposure to the

heat of the sun. The average sod is laid down dry, on a dry surface, and then watered on top; this being so, it is a wonder that more lawns do not die before they can be brought into good condition. It sometimes takes two or three weeks of constant watering and attention to get sod laid in this manner started, while, if some attention were given the matter in the beginning, no trouble would be experienced. A good idea is to bring in the sod in the afternoon before the day it is to be laid. Prepare the lawn for laying by working it up; then sprinkle it moderately. Now arrange the sod in about the place it is to be grown, grass side down. After laying the sod in this manner, sprinkle it. Allow it to remain in this condition overnight, and start turning it early in the morning. Sod treated in this manner will take root and grow at once.

Bags Quickly Placed over Clothing

A commercial dyer and cleaner uses a device that may be of use to others in the same line of business, and that will

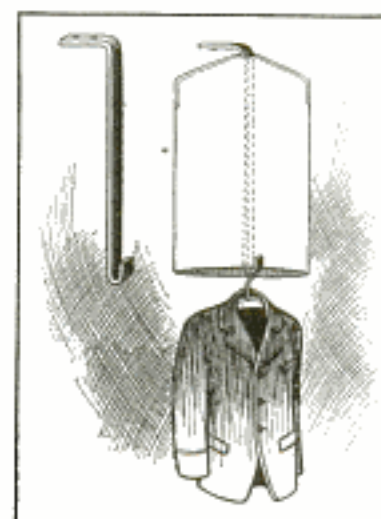

also be appreciated in homes where the spare clothing and heavy winter garments are kept in moth-proof bags in the clothes closet.

The device consists of a long hook, made of flat iron, which is suspended from the ceiling at a convenient height above the wrapper's head. The bag is slipped up until its lower edge rests on the hook, then the clothes hanger, bearing the coat or other garment, is hung on the hook and the bag slipped down over it. The whole operation requires less time than the telling of it; the desirable features of the device will be apparent to anyone who has struggled with a long moth-proof bag.

☛When a car is driven in rain or snow and the headlights are fogged, point the spotlight directly on the engine hood. This makes it easy for other drivers to see the machine, so that accidents are prevented.

Portable Pen for Chicks

Growing chickens require green food if they are to thrive to the profit of the owner, and this is best provided when they have free range over a large field or lawn. Such freedom is not usually possible in the town or city, but movable pens can be made to keep the chicks under proper restraint. Such a coop, that adapts itself to surface irregularities and that can be easily rolled up and moved from place to place, is made from ordinary lath and wire.

A number of laths are cut in half, and wire is interlaced at the top and bottom to hold them together, two strands at the top and two at the bottom. At intervals, a somewhat longer stake, with the point sharpened for insertion into the ground, is provided. The pen can easily be set up in the form of a square or circle by bringing the ends together and driving the stakes into the earth.—G. E. Hendrickson, Argyle, Wis.

Padlocked Door Opened from Either Side

A plumber occupies half of a jeweler's store as a showroom and has his shop in the basement, driving into it through an alley in the rear. There is also a stairway into the basement from the first floor. When the plumber was in the store and wanted to take his truck out, it was necessary for him to walk a considerable distance to get to the rear of the building

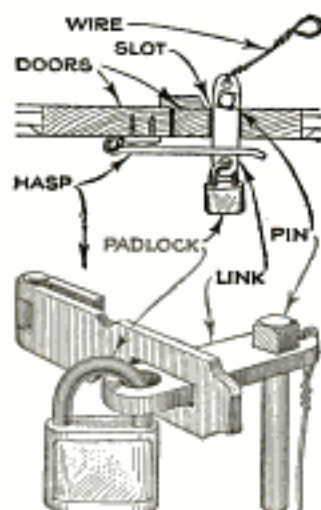

and unlock the padlocked door. In order to make it possible to open the rear basement door from the inside, the arrangement shown in the drawing was used. A piece of flat iron, drilled at each end to accommodate the padlock and a long bolt, passes through the eye of the hasp and through a slot cut in the door. The padlock is fastened through the outside hole and the bolt is slipped through the hole of the link which projects inside the door. A short piece of wire is used to pull the link through the slot, when closing the door from the inside.—S. A. Asquith, Los Angeles, Calif.

An Airplane Swing

Much more thrilling and nearer to flying itself than the sensation obtained from riding in an ordinary rope swing is

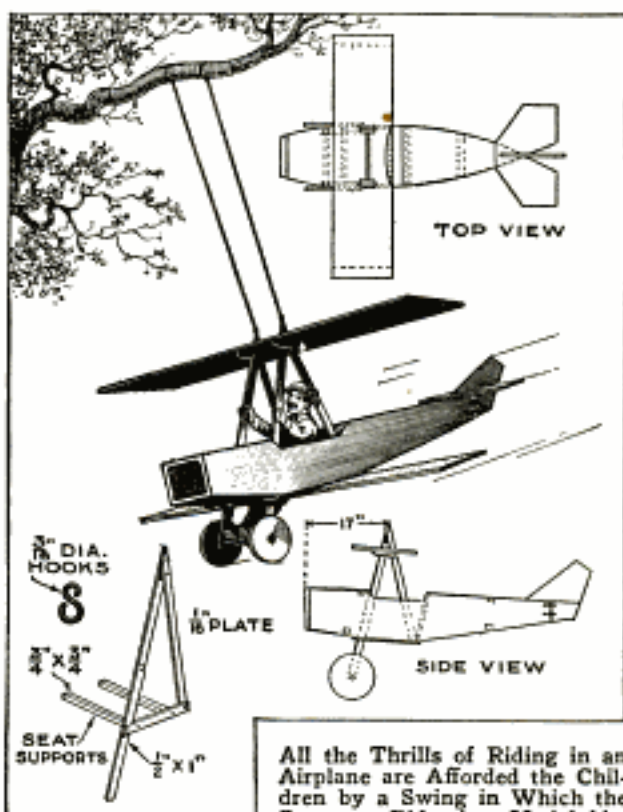

plane Body Made from Light Wood and Wallboard, Suspended by Wire Rope

the experience of sailing through an arc in a dummy airplane that is proof against side-slipping, tailspins, and similar mishaps.

An airplane swing can easily be assembled, and will furnish endless amusement for the children. The triangular hangers are made of $\frac{1}{2}$ by 1-in. stock, put together as shown, and the rest of the body is made of wooden strips, covered with wallboard. The ends of the hangers are bolted to a triangular steel plate, which has a hole drilled through its upper end for the accommodation of a hook. The planes are made of single sheets of wallboard, nailed to the woodwork, a segment being cut out of the rear edge of the upper wing to allow the occupant to get in and out easily.

No control stick is needed, as there are no movable surfaces, and the rider can hold on to the front members of the hangers, or an extra crossbar may be put between the members for that purpose. Bolts, with nuts and washers, should be used for joining the parts wherever possible, because, owing to the strain, the pieces would pull apart in a short time if held together with nails. The swing should

be suspended, preferably, by wire ropes, in any good spot where there is plenty of clearance for the body, and at a convenient height to enable the occupant of the swing to get in or out easily.—Donald W. Clark, Buffalo, N. Y.

Saving Room Space

Considerable space can be saved in a room in some instances if the bureau is quite literally "built in," something after the

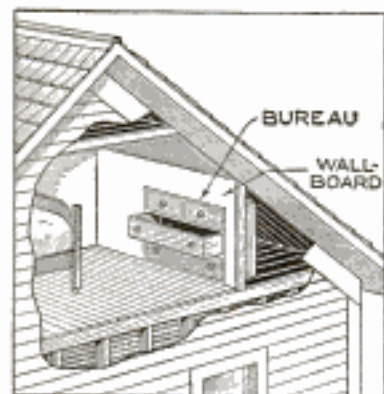

idea suggested in the drawing. This is particularly applicable when partitioning off attic space into rooms, as there is always a great deal of unoccupied space in the angle

formed by the partition, joists, and rafters. This makes a much more attractive and sanitary room than where no partition is employed, as the partition may be decorated, and the room is easily kept clean; it is almost impossible, without a vacuum cleaner, to remove all the dust from the angles of the usual attic room.—L. S. Sterling, Delanco, N. J.

Keeping the Medicine Dropper Handy

The medicine dropper is needed only seldom in most families, but when it is needed, it should be right at hand; to

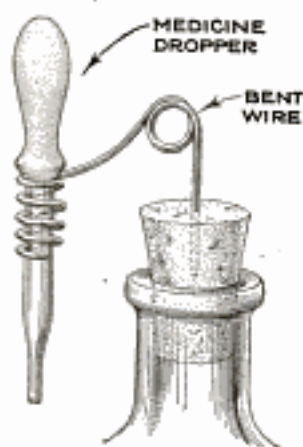

insure this, the simple little device shown in the drawing can be made in a few minutes. Make a coil of spring-brass wire, giving the main portion about four turns, then bend up a single loop and bend the end of the wire downward, to make a straight, vertical

stem. This end should be filed to a sharp point, which can be stuck into the cork in the bottle. Kept in this manner, the dropper is always "on the job."—L. B. Robbins, Harwich, Mass.

Lens Hood Made from Drinking Cup

The amateur photographer is usually advised, when taking pictures with the lens pointing more or less directly toward the sun or other source of light, to use a lens hood, or cap. The reason for this is to prevent the light from striking the lens directly and causing overexposed spots resulting from the reflection of light. A lens shield of some sort is also frequently necessary when photographing scenes of sunlit snow and water, where reflected light is apt to strike the lens.

An excellent lens shade that collapses into a small space can easily be made from one of the familiar collapsible aluminum drinking cups, such as can be obtained for a few cents at almost any variety store. An opening is cut into the bottom of the cup just large enough to fit snugly over the lens mounting. The inside of the cup should be painted with some dead-black finish to avoid possible reflection.

A Good Foot Scraper

Ordinary types of foot scrapers fail in one thing: The bottom of the shoe can be cleaned on them, but the upper part of the toe, and the sides of the shoe cannot.

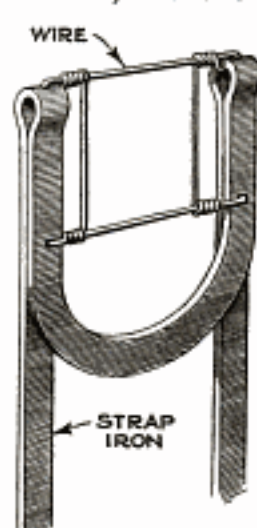

With the scraper shown, every part of the foot can be reached.

A long piece of flat-iron bar is bent into a deep U-shape, the legs being spaced about 10 in. apart. The closed end is turned back in the manner indicated, and the projecting ends are either thrust into the ground or fastened to the side of the steps. Holes are drilled as shown, to permit a section of woven-wire fence to be fastened in the top of the U. This square of wire acts as the scraper by means of which every part of the shoe can be cleaned.

Growing Oriental Poppies

The oriental poppy is the showiest and largest-flowered of all hardy perennials, with its great scarlet or orange cups above a mass of thistlelike foliage; in late May or June it is the sensation of the flower garden. A single packet of seeds

will provide more plants than any one garden can ordinarily accommodate. They should be moved in August, as they are very hard to transplant, and invariably lose their leaves after removal, but these are not dead, and will appear again. It is best to sow the seed where the plants are to remain, rather than to transplant, and thin the seedlings out to about 2 ft. apart. This poppy entirely disappears after its blooming season, so that its location should be marked to prevent the roots from being destroyed by hoeing. It makes a growth of leaves in the fall so that its presence then can readily be determined.

Opening Paint Pails

The drawing illustrates an excellent way to open paint pails that are not fitted with friction tops.

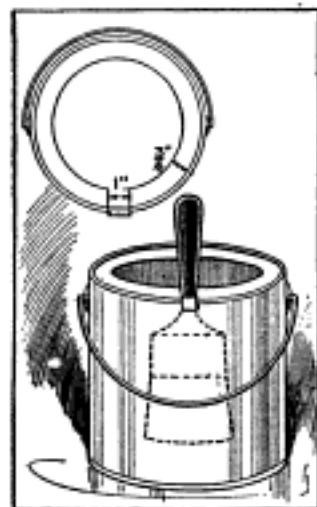

The center is cut out all around, about $\frac{3}{4}$ in. from the edge of the can; this leaves a strip of metal that may be left flat, or bent slightly upward, and that prevents the contents from splashing over the edge of the container. Two slits are cut in this strip, about an inch apart, and the metal between

Judging Prints for Good Sepia Tones

is bent back, thus forming a convenient holder for the paintbrush. When the pail is not in use, it is best to cover it with a piece of cardboard, as this generally fits better and keeps out more air than a tin lid.—Chas. Homewood, Ontario, Calif.

When photographic prints are to be toned sepia, it is necessary that a pure black tone is obtained in the original development, in order that the prints, after redeveloping, may have the desired rich reddish-brown color. An effective way to judge whether any black and white print can be toned to a good sepia color is to view it by the light from a mercury-vapor light. If the black is not pure, it will have a grayish-black tone under this light, but, on the other hand, if it appears as a pure black it will produce a good sepia tone.—Chas. I. Reid, Dayton, Ohio.

Improvised Climbing Irons

When a large flag became fouled around three of the flagstaff guy wires, the only way it could be untangled was for some one to climb the pole. To meet the situation the man undertaking the job built the pole-climbing irons shown in the drawing from $\frac{5}{16}$ by $1\frac{1}{2}$ by $1\frac{3}{4}$ -in. iron. Straps, $1\frac{3}{4}$ in.

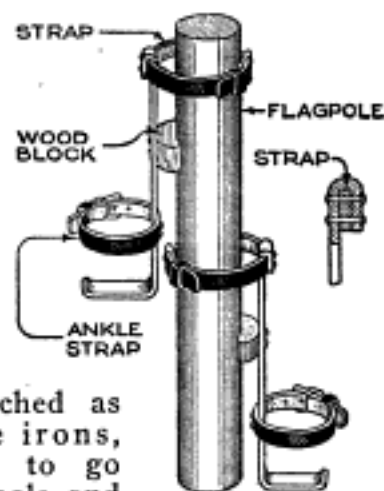

wide and attached as shown to the irons, were provided to go round the flagpole and the ankles of the climber, the buckles being placed on the outside so that they could be tightened during the ascent. A block of wood, curved on the underside to conform to the contour of the pole, is riveted just a little above the center of each iron. In use these wooden blocks operate as fulcrums when the wearer's weight is applied, causing the strap to grip the pole tightly.—Maurice Staller, Fowler, Ind.

Hanging Framed Pictures

When making a very light picture frame, 3 ft. 6 in. long by 12 in. high, and suspending it in the usual manner, the weight of the

glass was found to create a strain on the lower part of the frame, and to exert a tendency to force the frame apart at the lower corners. To overcome this trouble, the picture

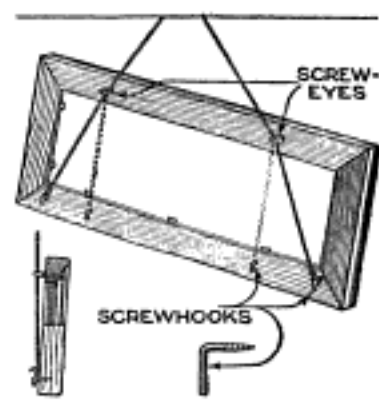

frame was suspended as shown in the drawing, so that the whole weight of the frame was supported by the lower member. Two screwhooks are screwed into this member of the frame, and the wire or cord is passed through screweyes in the upper part. The supporting wire can also be arranged as shown by the dotted lines.

Helps for the Berry Picker

The harvesting of berries, and other small fruits, can not only be speeded up to an appreciable degree by the use of

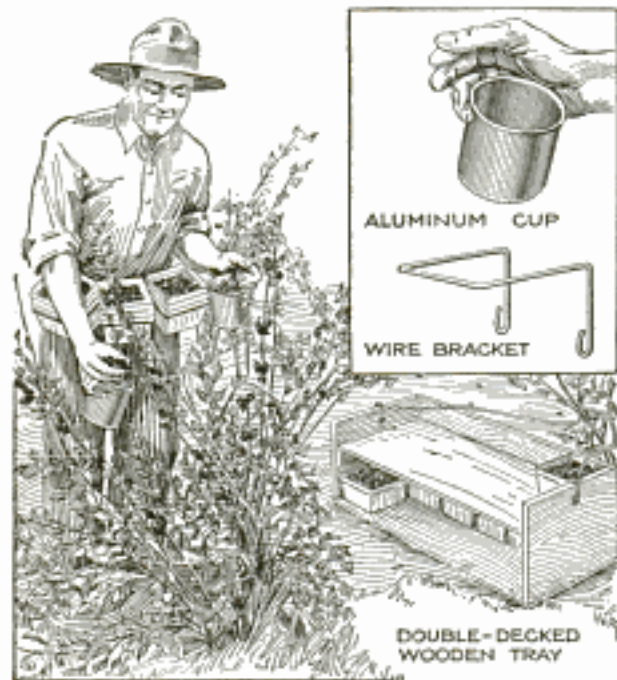

Conveniences for the Berry Picker That Eliminate a Considerable Amount of Lost Motion, Making It Possible to Harvest More Fruit with Less Exertion

the simple ideas illustrated, but the work may also be made easier. Three wire brackets, of the type shown, are slipped behind the picker's belt and serve to carry several nested boxes; this makes it possible for the picker to carry several empty boxes so that the fruit can be sorted while picking. As the baskets are filled they are removed and left on the ground, and later collected in the double-decked tray, which is carried suspended from the neck. When picking, an aluminum drinking cup may be held in each hand so that the thumb and first two fingers are free to pick the berries and drop them into the cup, thus saving time by the elimination of much waste motion.—G. M. Beerbower, Tarrytown, N. Y.

Restoring Color to Tan Shoes

It often happens that tan and brown-colored shoes, after considerable polishing and wear, take on the appearance of black. When this happens, the shoes can be made to show some of their original color by removing all the old polish. This is done by rubbing them with a gasoline-soaked cloth. After allowing the gasoline to evaporate completely, the shoes are polished in the usual way.—A. C. Cole, Chicago, Ill.

Releaser for Parachutes

It is a simple matter to attach a parachute to a kite and release it after the kite is in the air. The simplest method is to soak a piece of loosely woven string in a saturated solution of saltpeter and let it dry. This prepared string is used as a slow-burning fuse. The parachute is attached to the kite or kite string with a length of the prepared string, in such a manner that when the latter is burned up, the parachute will be released. Similarly, the shutter of a camera can be opened, by arranging the trip lever so that it will be pulled by a rubber band when the string burns down.—E. J. Bachman, Fullerton, Pa.

A Secret Box Lid

A simple secret box lid, that is proof against being opened by anyone who does not know the secret, is made by pivoting the lid, near

one end, by means of two nails driven through the sides of the box into the edges of the cover. A hole is drilled in the middle of the opposite end of the lid to take a spring and a nail from which the point and head have been cut.

When the lid is closed, the nail is pushed into a hole drilled in the end of the box, locking it securely. To open the box, it is necessary to push the bolt out of the hole in the box by inserting a heavy pin through a small hole, which leads from the outside to the nail socket, and by pressing down on the short end of the lid. The lid can be given the appearance of being solidly nailed by using shortened nails, and some other side may be made to appear as the cover. A shortened nail can be pushed into the small hole leading to the bolt, and, when in position, will conceal this perfectly. Some kind of mark should be made on the head of this nail, to distinguish it from the corresponding one on the opposite end.—Frank Presnell, Chillicothe, Ohio.

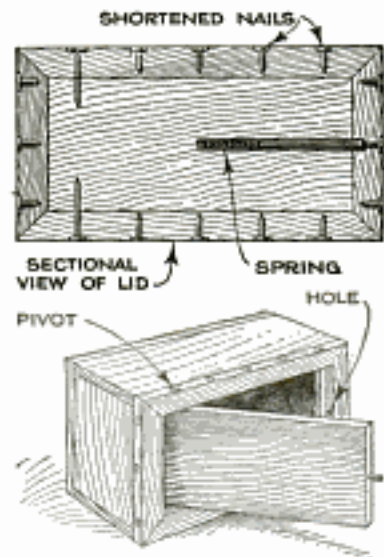



A SHORT-WAVE RADIO-TELEPHONE RECEIVER

By F. L. BRITTIN

THE radio-telephone receiver described in this article is of high efficiency, is very easy to build, and can be made for about one-third the cost of similar instruments now on the market. It has a normal telephone receiving range of about 300 miles, although under exceptional conditions up to 400 miles can be reached; telegraph messages can be heard over a distance of 1,500 miles. Its

full-page drawing, thus allowing easy access to the circuit, and also permitting the builder to add one or two steps of amplification at any time and inclose the whole unit in one cabinet. The full-page illustration shows complete rear views of the tuner and detector, and also a front elevation of the completed instrument. It will be seen that the binding posts marked from 1 to 5 are placed on each panel so that,

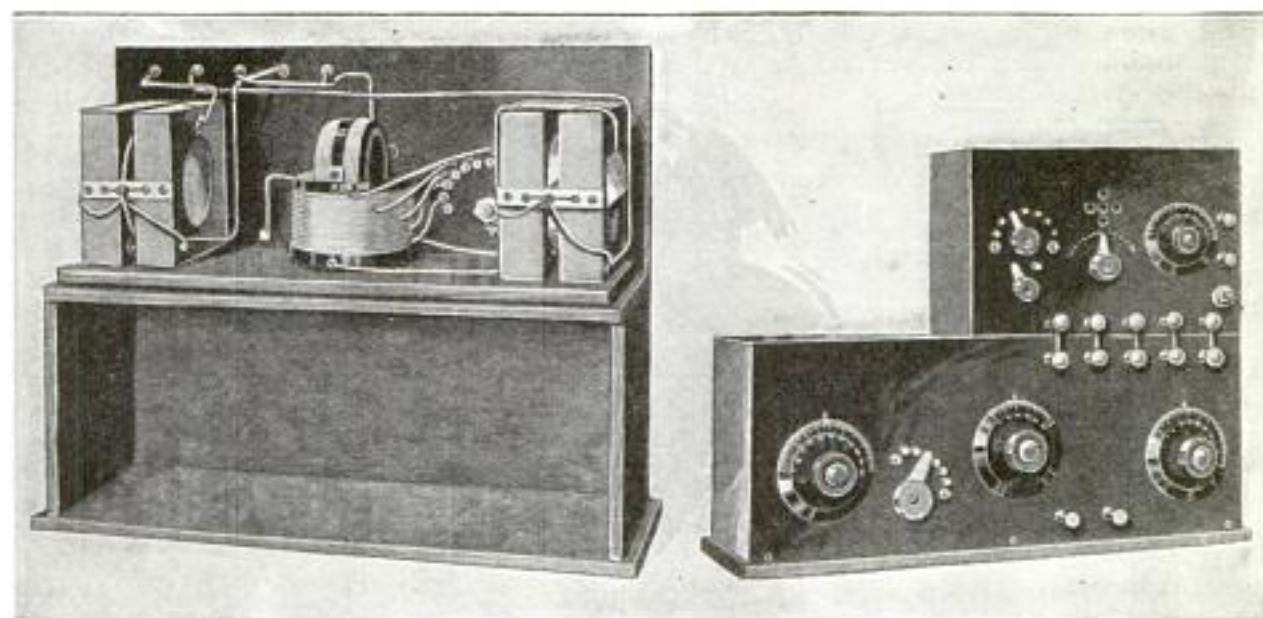

Left: Rear View of Tuner, with Its Cabinet; Right: Complete Instrument. Note How the Binding Posts on Each Unit are Connected by Insulated Jumpers. The Use of a Cabinet for the Detector Is Optional

wave-length range is from 150 to 400 meters, thus making it possible to receive the market reports, news items, children's-hour stories, and concerts now being broadcast from many points over the country by government and commercial stations. A broadcasting station at Pittsburgh, and the radiophone stations at Madison, Wis., have been heard in Chicago with this instrument, using but one tube. With two steps of amplification, it is possible to use a loud talker, enabling speech and music to be heard clearly throughout a large room.

The completed instrument is in two parts, a lower cabinet, containing the tuning instrument, and a smaller one mounted on top, containing the detector unit. The latter need not be placed in a cabinet, but may be mounted as shown in the

when the instrument is assembled, post No. 1 on the detector is directly over post No. 1 on the tuner, and the others in corresponding positions. The panels for both units are of $\frac{3}{16}$ -in. bakelite; that for the tuner is 18 in. long by 7 in. wide, and the detector panel 10 in. long by 7 in. wide. Templates for both these panels are shown in the full-page illustration also; the full-size outline of the panels, together with the location of the various holes, should be laid out on a piece of cardboard, the cardboard cut to size, the holes drilled in the proper positions, and the templates used to mark the panels.

The plate and grid variometers and the variocoupler are built up from knocked-down parts, obtainable from any radio-supply house. These parts may be had with or without windings. Those who

wish to wind their own coils and mount their own units should secure the necessary unwound forms, two stationary forms, measuring $1\frac{1}{4}$ by $4\frac{3}{4}$ in. square, and a rotor ball, 4 in. in diameter by 3 in. thick, being necessary for each variometer, and a rotor ball and bakelite tube for the variocoupler. Each stationary form, or stator half, is hollowed out to take the stationary windings, in such a manner as to allow the rotor ball, with its windings, to be revolved inside the stator without touching the stationary coils, although they must be as close together as possible. The distance between the rotor and stator coils can be adjusted by means of the metal-strip bearings shown on each variometer. Each stationary coil of the variometer is composed of 30 turns of No. 20 single cotton-covered magnet wire. These windings are first wound on a ball form, supplied with the variometers; the coil seat in the stator half is coated with shellac, and the ball form carrying the winding is then forced against the seat and clamped or weighted; when the shellac has dried, the ball form may be withdrawn, leaving the coils in place. These coils are wound clockwise and are joined together between the halves of the stator, near the rear, as shown in the rear view of the tuner panel, and also in the winding detail and connections of the variometers. The outside lead of one coil is brought out to a screw on the side of the stator, the outside lead of the other coil being soldered to a corner of the rear bearing strip connecting the stator halves. The rotor coils are wound with 54 turns of No. 20 single cotton-covered magnet wire, 27 turns on each side of the ball. These coils are wound counterclockwise, the connections between the windings being made on the inside of the ball, as indicated in the winding detail, and the wire passed to the inside of the ball through small holes drilled for that purpose. The outside leads are threaded through small holes running from the edges of the ball to the center, and are then soldered to flexible leads. The rear shaft of the rotor is $2\frac{1}{8}$ in. long, is made of $\frac{1}{4}$ -in. rod, either brass

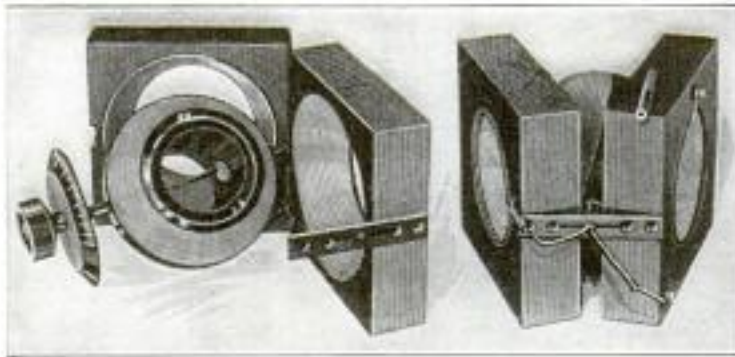

Variometer Wound and Partly Assembled: The Right-Hand View Shows How the Rotor Leads are Brought through the Rear Shaft. One of the Tubular Shafts is Shown on Top of the Stator

or iron, threaded for $1\frac{1}{8}$ in., and has a $\frac{1}{8}$ -in. hole drilled through it, along its axis. A hole a little smaller than the diameter of the shaft is drilled through the ball, the shaft screwed into the hole tightly, and locked with a nut on the inside of the ball. The front shaft is a piece of $\frac{1}{4}$ -in. brass or iron rod, threaded for half its length, and screwed into a hole directly opposite the tubular shaft. One of the flexible leads of the rotor coils is inserted into small rubber or "spaghetti" tubing and both leads brought through the rear shaft, one being soldered to the bearing strip, and the other led to the bottom screw on the stator. These flexible leads are made of small "litzen-draht" wire; this is easily obtainable. Both variometers are built and wound exactly alike. The variocoupler is also made up of two separate units, the primary being wound on a bakelite tube, $2\frac{1}{2}$ in. high and $3\frac{1}{2}$ in. outside diameter, with a wall thickness of $\frac{1}{16}$ in.; 37 turns of No. 20 single cotton-covered magnet wire are wound on this tube, and six taps are taken off, beginning with the first turn at the bottom,

and spacing the taps equally to the top turn; the taps should be staggered, as shown in the rear view of the tuner panel, carefully soldered, and be led to the contact points on the primary switch on the panel. The lever of this switch is connected to the ground post, and the top end of the coil to the aerial post. The end of the first turn, at the bottom, is passed through a hole drilled in the tube, and clinched to hold the winding firmly. The top turn of the primary winding is clinched in the same manner, before being led to the binding post. The secondary is wound on a rotor ball similar to that used for the variometer, but $3\frac{1}{8}$ in. in diameter and $1\frac{3}{4}$ in. wide. Each coil is composed of 16 turns of No. 26 single cotton-covered magnet wire, the coils being wound so that the current will flow in the same direction in each; the connection between the coils is made in the same way as on the variometer balls, but one of the outside leads of the rotor winding is connected to the front shaft,

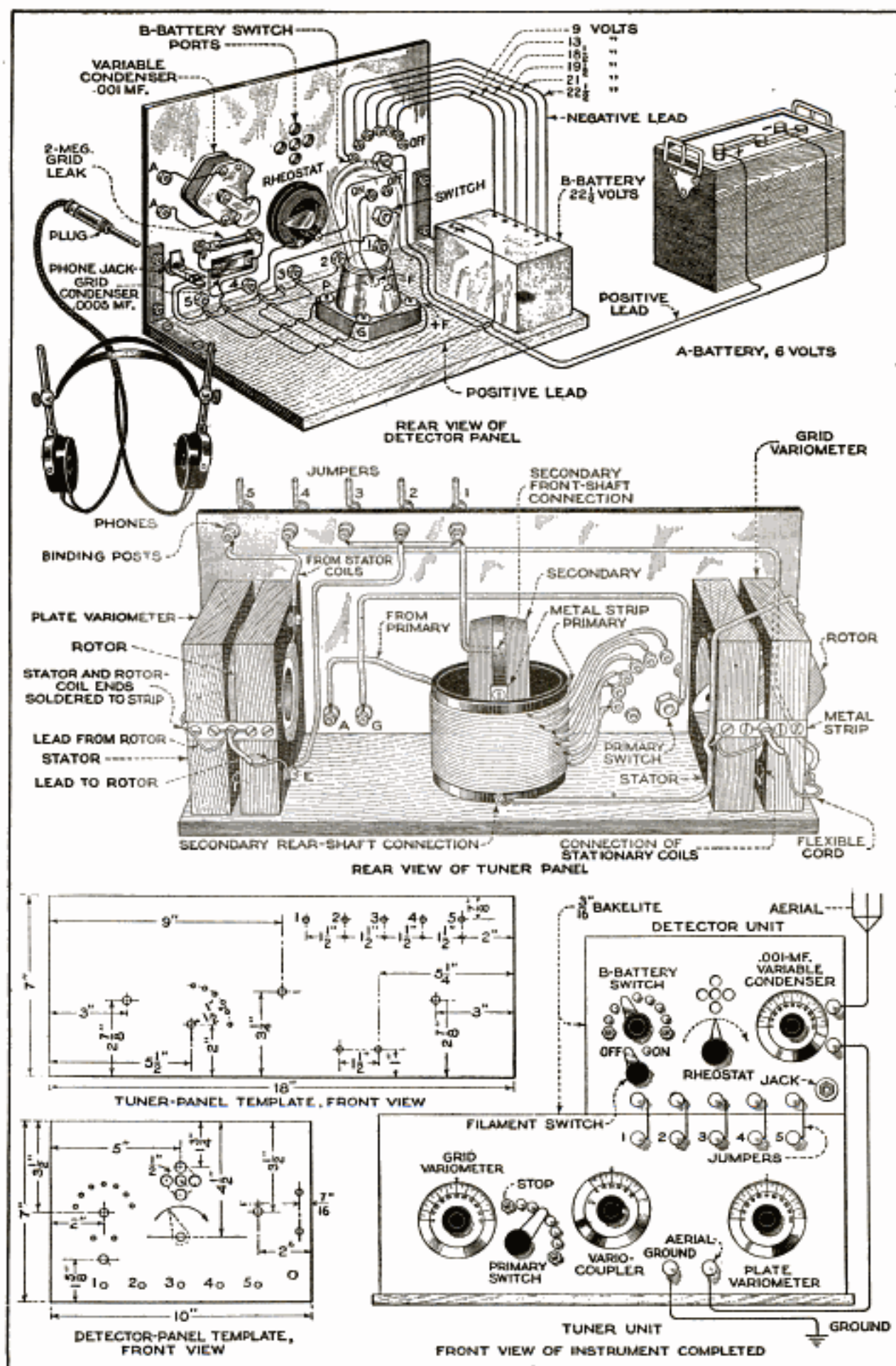

Rear View of Detector and Tuner Units, Layout of Panel Templates, and Front Elevation of Complete Instrument: The Design Is Such That a One or Two-Step Amplifier may be Added at Any Time, Using the Same Tuner and Detector. The Amplifier should be Built to Fit on Top of the Tuner Cabinet, beside the Detector

inside of the ball, and the other to the rear shaft. These shafts are $\frac{1}{4}$ by 2 in. for the front shaft, and $\frac{1}{4}$ by $1\frac{1}{2}$ in. for the rear shaft. The shafts are supported by bearings, in the form of metal strips, $\frac{1}{16}$ by $\frac{1}{2}$ by 3 in., drilled for the shaft, placed upright in the primary tube at the front and rear, and secured to it by small machine screws at top and bottom; the holes for the shafts should be drilled of such a size that the secondary coil will not rotate too freely, and the front and rear shafts should be connected to the bearings by soldered "pigtales" made of flexible litzendraht wire, to insure a good

nections are made with No. 18 tinned-copper wire, covered with spaghetti tubing, although any good insulated wire of this size will do. All connections in the circuit must be thoroughly soldered. When the units have been mounted, the tuner unit is complete, with the exception of the variometer dials, which read to 100° , and the variocoupler dial, which reads to 50 degrees.

At the top of the full-page illustration may be seen the full details and connections of the detector unit. The panel is mounted on a wood base, measuring $\frac{3}{8}$ by $6\frac{1}{4}$ by 10 in., and is held in an upright

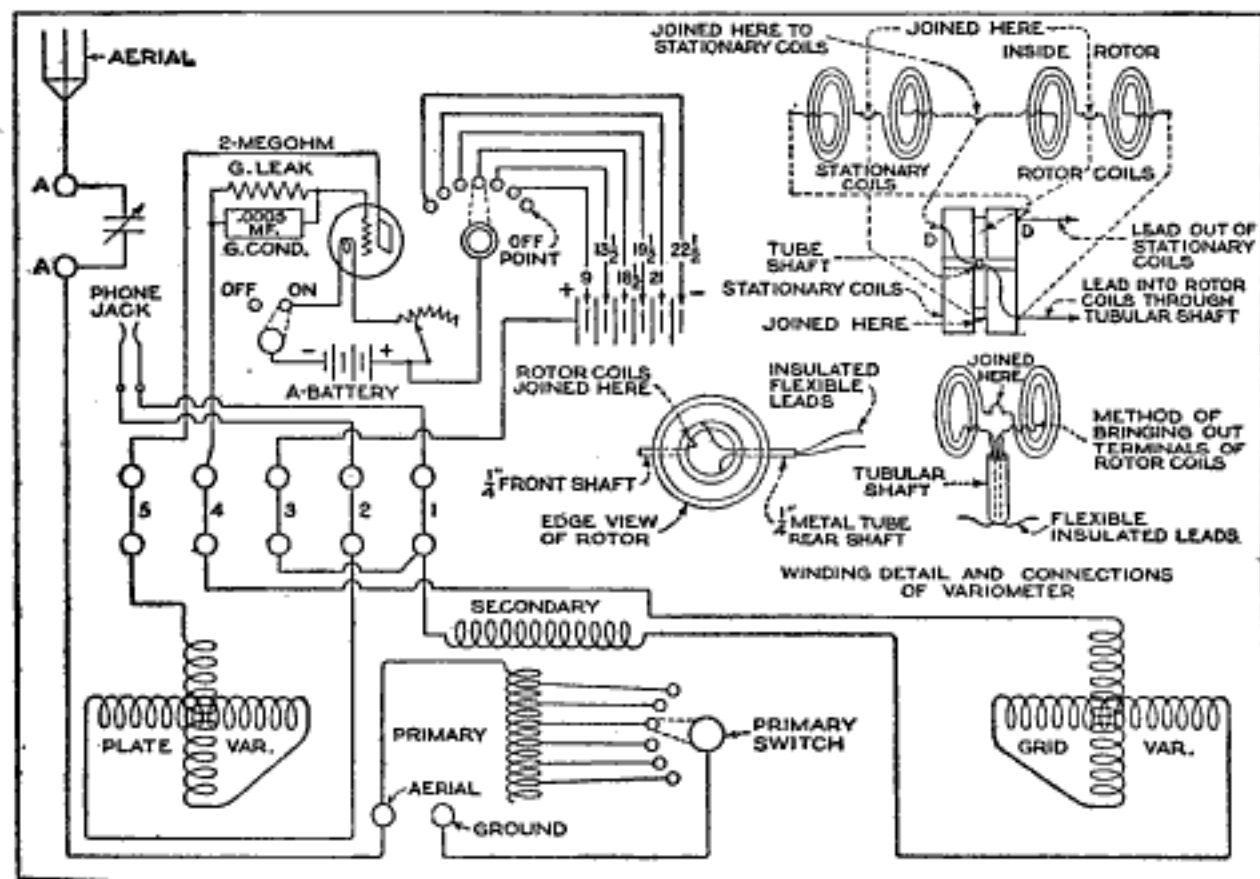

Complete Circuit Diagram and Connection Details of the Variometers: The Latter Show the Connections Only, and No Attempt has been Made to Show the Direction of the Coil Windings

electrical connection. A lead from the front bearing is connected to post No. 1 on the panel, and a lead taken from the bottom of the rear bearing is connected to the screw that also carries the lead from the stationary coil of the grid variometer. The cabinet for the tuner unit is made of basswood, or other easily worked wood. The dimensions are as follows: for the sides, $\frac{3}{8}$ by $6\frac{1}{2}$ by $6\frac{1}{2}$ in.; for the top, $\frac{3}{8}$ by $6\frac{1}{2}$ by $17\frac{5}{8}$ in.; the base, $\frac{1}{2}$ by $6\frac{3}{4}$ by $18\frac{1}{2}$ in., and for the back $\frac{3}{8}$ by $6\frac{7}{8}$ by $17\frac{5}{8}$ inches.

The tuner circuit is very clearly illustrated in the rear view of the tuner panel as well as in the circuit diagram. All con-

nections are made with No. 18 tinned-copper wire, covered with spaghetti tubing, although any good insulated wire of this size will do. All connections in the circuit must be thoroughly soldered. When the units have been mounted, the tuner unit is complete, with the exception of the variometer dials, which read to 100° , and the variocoupler dial, which reads to 50 degrees. At the top of the full-page illustration may be seen the full details and connections of the detector unit. The panel is mounted on a wood base, measuring $\frac{3}{8}$ by $6\frac{1}{4}$ by 10 in., and is held in an upright

tial. The A-battery is an ordinary six-volt 40 ampere-hour auto lighting battery; four dry cells may be used here, but the storage battery is recommended as it is more economical. If the builder wishes to make his own fixed or grid condenser, it may be made of two sheets of tinfoil, measuring 2 by 2 in., mounted alternately with three sheets of mica, measuring $2\frac{1}{4}$ by $2\frac{1}{4}$ in. These, however, can be purchased in the market for about 35 cents. The grid leak is of 2 megohms' resistance, is of standard make, and is connected around the grid condenser as shown in the drawing. The variable condenser mounted just above the grid leak is also of standard make, arranged for panel mounting; it has 43 plates, and a capacity of .001 mf. This condenser is connected to the binding posts marked A. A lead from the lower binding post A goes to the aerial post on the tuner unit, and that from the upper post A to the aerial proper, as shown in the circuit diagram. The phone jack is of the ordinary one-way type, and binding posts can be used here instead of the plug and jack, if desired. The on-and-off switch is used for cutting out the filament current when the set is not in use. The switch lever on the B-battery switch should also be kept on the off point when not using the instrument. This circuit is also wired with No. 18 wire and all connections soldered. The B-battery can be placed on the base of the detector unit, as shown in the drawing, and the A-battery placed underneath the operator's table, the leads being brought up to binding posts arranged at the rear of the panel or base, as desired. The phones used are of standard make and should be of 2,000 ohms' resistance.

The aerial used with this instrument is No. 14 bare copper wire, it should be at least 75 ft. long, and should be strung up 30 ft. from the ground, insulated at each end by porcelain cleats or standard aerial insulators, and brought down to the receiving instrument through a standard 100-ampere grounding switch, placed on the exterior of the building. The lead from the aerial is connected to the middle clip on the switch. The upper post marked A on the detector or panel is connected to the upper switch clip by No. 14 insulated wire, and the lower clip is connected by a lead made of No. 4 insulated wire to a 6 or 7-ft. iron rod driven into the ground on the outside of the building. All connections must be carefully soldered. The No. 14 wire lead running to the instrument from the grounding switch should be led into the house

through a porcelain tube. When installed in this manner, and the grounding-switch lever is thrown down when the set is not in use, the installation conforms to all the requirements of the fire-insurance underwriters; the aerial acts as a lightning rod, and is a protection rather than a source of danger to the building. It is advisable to place the instrument as near the aerial lead as possible. The ground lead from the instrument is connected to a near-by water pipe, steam or hot-water radiator pipe, or to a ground rod in the basement; connections to a pipe may be made by filing the pipe bright, and soldering the end of the lead to a ground clamp, which can be obtained at any electrical-supply store. It is a good plan to connect a switch between the A-battery and the detector panel, so that the battery can be cut out when not in use, as some one unfamiliar with the set may forget to turn the panel switch off.

To operate the set, place the phones on the head, push in the phone plug, see that all resistance is in on the rheostat, put the switches on the "on" points, and it will be noted that the filament in the tube is lit; turn the B-battery switch up to the $18\frac{1}{2}$ -volt contact point, and then turn the rheostat until a hiss is heard in the phones. Turn the rheostat back until the hiss just disappears; this is the operating point of the tube. In some cases it is necessary to use the whole $22\frac{1}{2}$ volts on the tube, but this can only be determined by trial. Signals, on some wave length, will now probably be heard, if so, adjust the variable condenser until they are at their loudest.

The primary switch of the variocoupler is so constructed that, when turned from left to right, the instrument tunes from 150 to 400 meters. The secondary is adjusted by means of the knob and dial on the panel. Some variometers work better when turned to the right, some when turned to the left, depending upon the characteristics of the set, so the final adjustment of the dials on the panels will depend upon this. The dials should be so placed on the shaft that the zero points will stand at the index marks on the panel when the rotors are vertical.

If one is tuning to 360 meters—the wave length of the broadcasting stations—it will probably be found that nearly all of the primary of the variocoupler will be in the circuit, and that the dials of the variometers have been turned through an arc of about 80° . These adjustments take a little practice and patience, but the operator will soon find the knack. The

cost of building this instrument, as similar sets are marketed, without batteries, phones, aerial, or detector tube, is about \$27.60 at current prices. The total cost, including aerial wire and insulators, grounding switch, batteries, phones, and

tube, is about \$45, using four dry cells for the A-battery. If a storage battery is desired, a good 6-volt 40 ampere-hour battery can be had as low as \$11. These prices are for first-class materials, which are necessary for good results.

MATERIAL LIST

- | | |
|---|---|
| <ul style="list-style-type: none"> 1 piece of wood, $\frac{3}{8}$ by $6\frac{1}{4}$ by 10 in. 1 bakelite panel, $\frac{3}{16}$ by 7 by 10 in. 1 bakelite panel, $\frac{3}{16}$ by 7 by 18 in. 1 piece of wood, $\frac{1}{2}$ by $6\frac{3}{4}$ by $18\frac{1}{2}$ in. 1 piece of wood, $\frac{3}{4}$ by $6\frac{3}{4}$ by $17\frac{3}{4}$ in. 1 piece of wood, $\frac{3}{4}$ by $6\frac{1}{2}$ by $17\frac{3}{4}$ in. 2 pieces of wood, $\frac{3}{8}$ by $6\frac{1}{2}$ by $6\frac{1}{2}$ in. 1 pair phones, 2,000 ohms' resistance. 1 variocoupler complete, knocked down, with or without windings. 2 variometers complete, knocked down, with or without windings. 2 variometer dials, reading 0 to 100. 1 variocoupler dial, reading 0 to 50. 1 V.T. socket. 1 V.T. detector tube, soft. 1 battery rheostat for filament control. 1 standard 100-ampere grounding switch. | <ul style="list-style-type: none"> 1 .001-mf. variable condenser, complete with dial (panel-mounting type). 1 .0005-mf. grid condenser. 1 standard 2-megohm grid leak. 1 phone jack, one-way type, open circuit. 1 phone plug. 15 contact points. 3 switch levers. 14 binding posts (preferably with black-rubber knobs). 1 22½-volt B-battery unit, tapped-off type. 1 6-volt A-battery, storage battery preferred. 6 switch stops. 15 nickelplated round-head wood screws, 1 in. long. 4 flat-head screws, $1\frac{1}{2}$ in. long, for attaching sides of cabinet to base. No. 18 insulated copper wire for circuit. No. 14 bare copper wire for aerial. |
|---|---|

Making a "Kiddie Horse"

A toy for the amusement of the children, that costs little or nothing, and that is practically indestructible, can be

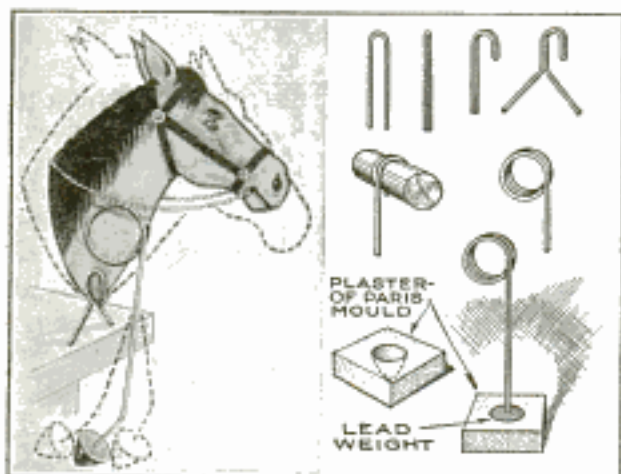

A Simple Toy for the Children is Pivoted on the Edge of a Mantel or Table. Once Set in Motion, the Figure will Continue to Rock for Several Minutes

made from a piece of cardboard, some pieces of wire, and a small piece of lead. A horse's head or other figure is painted on stiff cardboard, and then cut out, although a suitable picture pasted on cardboard and cut out, will answer as well. The cardboard figure is balanced on the edge of a mantelpiece or table by the "legs," or pivot, formed from wire. A somewhat longer piece of wire is bent at one end to clip over the card in the manner of a paper clip, and a lead weight is cast onto the opposite end, in the following manner: A cavity is made in a block of plaster of Paris, or wood, and after the

end of the wire is inserted, the opening is filled with melted lead. The pivot and weight are fastened to the horse's head in the manner illustrated. A slight push will serve to start the head wagging, and it will be several minutes before the figure comes to rest.—Adolph F. Lonk, Chicago, Illinois.

A Simple Lawn Sprinkler

Funds not being available for the purchase of whirling lawn sprinklers, the custodian of a public building overcame the lack by making sprinklers of his own that were effective and practically costless. A standard of wire was made, and the nozzle end of the hose was fastened to the perpendicular part of the standard. An 18-in. length of $\frac{3}{8}$ -in. flexible rubber hose was wired over the end of the nozzle and the water turned on. In operation, the pressure of the water seeking escape through the narrow aperture of the nozzle and hose, causes the latter to thrash about, scattering water in all directions.

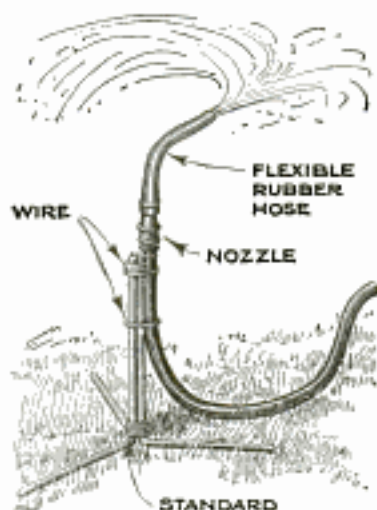

Restoring Typewriter Ribbons

Typewriter ribbons that have been used to such an extent that they produce only a weak impression, can be given additional life by a simple method. Remove the ribbon and spool from the machine, and holding it in one hand, saturate it with alcohol or gasoline. Then pull the free end of the ribbon, while holding the spool tightly, thus causing the coils to compress and force the solvent through the ribbon. The ribbon is then placed in a warm place for about 12 hours, or until thoroughly dry.—Werner W. Baumeister, Cambridge, Massachusetts.

Repairing Player-Piano Rolls

At certain places on player-piano rolls the roll has a tendency to buckle or move slightly to one side, this being specially noticeable on rolls that have been used for some time. This is due to the fact that there are a large number of holes at that point or that the holes are so placed as to weaken the paper. Continued use of the rolls aggravates this condition as the paper becomes soft and warm. A

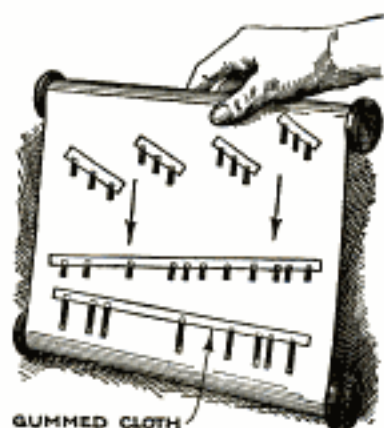

good way to prevent this is to paste a piece of gummed cloth on the roll, keeping as close as possible to the holes without covering them. In some cases this is impossible, owing to the position of the holes. Then, a portion of the holes may be covered, taking care always to cover the back end of the openings, that is, the portion of the holes which is last to pass over the tracker board. The leading end of the holes should never be covered as that will cause the notes to be played slightly late, and to cover the center of the holes will cause two short notes to be played instead of a single long one. By covering the back end of the holes, the notes are merely shortened a trifle; this will not be found objectionable, and, in fact, may even be desirable in some cases, as the music becomes more "snappy." The gummed cloth should be placed on the side of the paper that shows while in operation.—R. H. Kasper, Philadelphia, Pa.

A Double-Action Garden Hoe

By cutting out a portion from the center of the blade of a hoe and pointing the projection on each side, an ordinary hoe is converted into a tool that permits cultivating on



A Fork-Shaped Hoe, Made from the Standard Garden Hoe, Makes It Possible to Save Time by Working on Both Sides of a Row of Seedlings at the Same Time

both sides of a row of seedlings at the same time, thus minimizing the time and effort used.

The blade is cut along the dotted lines, as shown in the drawing, with a cold chisel, and the rough edges are afterward smoothed down by filing or grinding. The implement is used as illustrated, and will be found quite effective for cutting small weeds and loosening up the soil around the roots of the plants.—Gregor H. Glitzke, Kansas City, Mo.

Auto Mudhooks Made from Hinges

Strap hinges of a familiar type can be made into very satisfactory mudhooks for the extrication of a car from mud or sand. However, the hinges should be of rather large size, for they must be bent, as shown in the drawing, so that the ends are in a line inside the

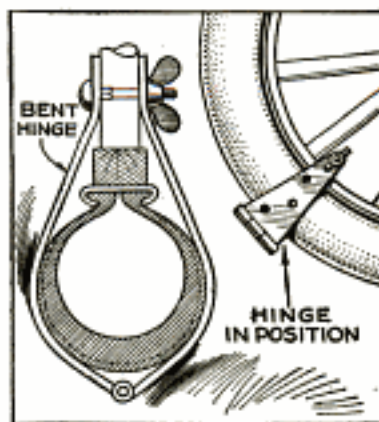

wheel rim. The mudhook thus formed is clamped to the wheel by a bolt and wingnut.

A Bird Bath of Simple Design

No garden can be considered quite complete without a bird bath of some sort, and it need not be an elaborate or expensive affair of concrete or stone to attract the birds, who are more appreciative of the water than of the container.

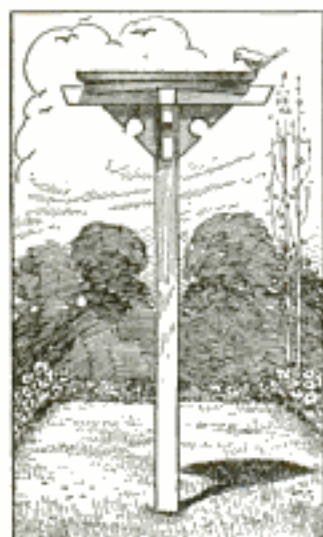

The drawing shows a simple design for a bird bath that can be executed at minimum expense of time and cost of material. A suitable length of 2

by 2-in. stock is used for the upright support, which is driven into the ground. An earthenware dish, such as flowerpots are set in, preferably one about 16 in. in diameter and about 2 in. deep, is used as a container for the water. Four horizontal arms, each 1 ft. long and 1½ in. square, are fastened to the sides of the support to bear the dish. These arms are mortised, to make an opening into which the dish is inserted and which prevents it from being accidentally pushed off. Simple brackets underneath the projecting supports can be used to add to the appearance and solidity of the completed bath.—Leo Rosasco, Indianapolis, Ind.

Trouble Lamp Mounted on a Clothespin

An arrangement by means of which an inexpensive dash lamp can be made into a convenient trouble lamp, that occupies little space in the tool box, requires nothing more than a spring clothespin.

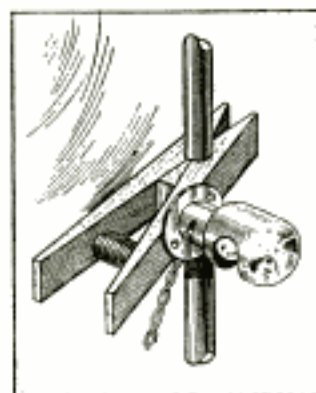

The lamp socket is fastened to the clothespin and provided with a suitable extension cord and plug.

The use of the clothespin permits the lamp to be clipped to many parts of the car, and thus both hands are left free.—J. G. Brown, Evanson, Ill.

Unusual Fish Bait

A Pacific-coast fisherman has devised an original and successful method of catching salt-water fish. A wide-mouthed, clear-glass bottle is used after the bottom has been removed. A cork, to which a pair of hooks is attached to hold the minnows that constitute the bait, is fitted into the mouth of the bottle. Wire rings around the bottle at two places have a series of hooks attached to them, the rings being held the proper distance apart by wires which terminate in a loop over the cork; the entire bait is attached to the line with a swivel to prevent twisting.

With the bottom of the bottle removed the weight is diminished when it is being pulled out, and although the bait is quite effective, due to the transparency of the glass, the fish is prevented from getting anything but a hook on the outside of the bottle.—C. C. Wagner, Redondo Beach, Calif.

An Improved Tent Peg

Many different ideas have been applied to making a tent peg that will not pull out of the ground, but the one illustrated has the merit of using the cheap and easily obtained wooden pegs with a simple attachment that prevents them from being pulled out by accident.

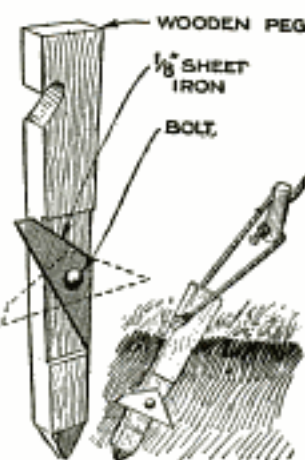

A mortise is cut on one side of the peg to accommodate a triangular piece of sheet iron, pivoted to swing freely. The pegs are driven in the usual manner, but when any undue strain comes on the tent ropes, the sheet-iron piece assumes the position indicated by the dotted lines and locks it as securely as the character of the soil will permit.

Cooling Breezes from the Vacuum Cleaner

The ordinary suction cleaner can be used to cool the temperature of a room without alteration of any sort. Simply place the cleaner over one of the hot-air registers and remove the dust bag. Be sure that the fresh-air intake pipe from

the outside of the furnace is open. If there are no furnace registers, the same effect can be obtained by setting the cleaner near a door or window. In either case see that the nozzle of the machine is raised slightly from the floor so as to allow free suction of air. When the current is turned on, a strong blast of air will be delivered through the dust-bag opening.—Chas. J. LeCompte, St. Louis, Missouri.

Repairing Gun Locks

After a double-barreled shotgun has been used for a long time, trouble is often experienced in keeping the hammers

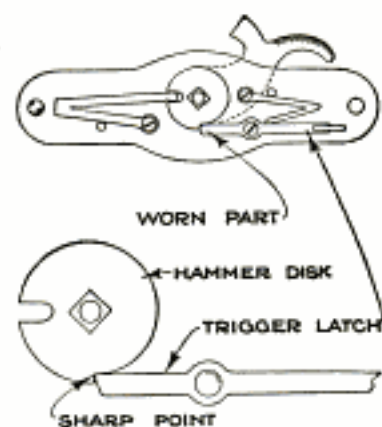

cocked—they occasionally snap off apparently without cause, and make the use of the gun exceedingly dangerous. This trouble is caused by the wearing of the point of the trigger latch, as shown in the drawing. An accumulation of dirt in the notch of the hammer disk will also prevent the latch from getting a good hold. The remedy for both troubles is simple. Remove the side plate of the gun, take off the trigger latch, and with a fine file bevel off the end of the latch, removing as little metal as possible. After cleaning out the notch in the disk and giving it a light coat of vaseline, the lock is reassembled.

Preventing Use of Hose Faucet

Many persons try to prevent meddling with hose faucets by removing the little T-head keys by which they are turned. This kink almost always results in the stem of the faucet being rounded off by the application of pliers and other tools.

A more effective preventive, and one that is free from this drawback, is the application of a $\frac{3}{4}$ -in. pipe cap over the threaded end. The cap can easily be screwed on with a pair of pliers, or even by hand, to prevent the meddling of children. This is also an excellent method of stopping dripping faucets until new washers can be fitted.—Doncaster G. Humm, Phoenix, Ariz.

Bedstead Shelf for the Sick Room

The days in a sick room are monotonous and soon make the patient nervous and fretful; a note of cheerfulness and variety, however, may be introduced by making a shelf to hook over the foot of the bed, on which fresh flowers, pictures, or other articles can be placed. The same shelf can be used with any style of bedstead, whether of wood or metal. Two iron hooks and a narrow board are the only parts required. Articles suggestive of the patient's condition, such as medicine bottles and the like, should not be placed on this shelf, but kept out of sight as much as possible.—Robert H. Neill, Ottawa, Ohio.



A Simple Seeder

When dropping seed in the corn hills, or planting the pumpkin or the melon patch, the stooping that is necessary in order to drop the seeds in the proper place makes the job somewhat fatiguing. So, to make such work easier as well as simpler, the seeder in the drawing was devised.

A piece of thin tubing, about $\frac{3}{4}$ in. in diameter and 4 ft. long, was split at each end for several inches, and the split portions flattened out; one end was bent around a piece of an old broom handle; the opposite end was sharpened, and about 3 in. from the point, a short piece of light angle iron was riveted to the back to serve as a foot step for forcing the tool into the earth. As this step is in a fixed position, the seeds can be planted to a uniform depth.

To operate this seeder, it is forced into the ground, and the seeds are dropped through the opening at the top and fall into the cavity made by pushing the tool forward. By placing the foot in front of the blade, as it is withdrawn from the earth, the seeds are held and covered.

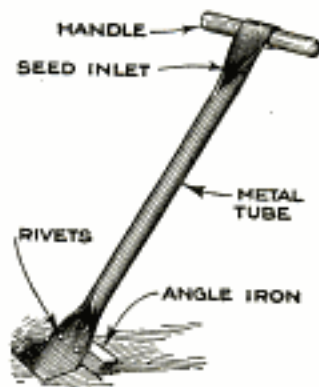

Permanent Screen-Door Fastenings

The necessity of using larger screws or plugging worn screw holes every year, when the screen doors are put up, can be

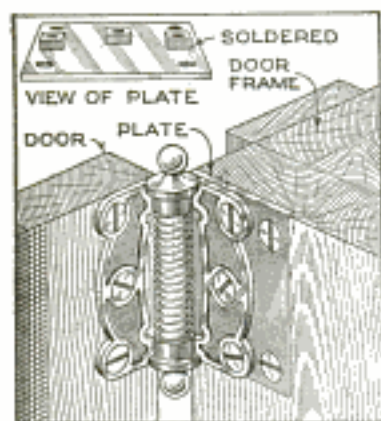

overcome by adopting the idea illustrated. A small iron plate is fastened to the door frame with four screws; this is a permanent fixture. Before fastening the plate in position, holes are drilled through it which coincide with those of the hinge. On the reverse side of the plate, and exactly over the holes, nuts are soldered. Flat-head screws are then run through the holes in the hinge of the screen door to take the place of the ordinary wood screws. The wood underneath the nuts is countersunk with a drill so that the plate will come flush with the door frame.

Faucet Guard for Dishwashing

Part of a rubber ball was used by a householder to prevent dishes from being nicked and broken by contact with the faucet, while washing them in the sink. The ball was cut in two, and a hole, a little smaller than the diameter of the faucet spout, cut in



the cup thus formed. The cup was then forced over the faucet in the manner shown, and held in place by adhesive tape.—Truman R. Hart, Ashtabula, Ohio.

Swimming under Water

The following instructions, when carefully followed, will enable any normal person, who can swim, practically to double the length of time he can remain under the water. The usual method of nearly all swimmers is to take the deepest

breath possible before plunging; they generally swim in a haphazard way, and come to the top just as soon as they think they are getting out of breath.

To break one's own record, one should observe the following rules: First, take several deep breaths, and then blow every particle of air out of the lungs, instantly draw in a full, deep breath, and then dive, going down deeper than usual; second, take regular strokes, about one a second, and always try to go one stroke farther than in the last dive. By counting the number of strokes taken under the water, the swimmer's confidence is wonderfully increased, and he also is able accurately to judge his location at all times.

The ability of a person to remain under water can be tested on land by practicing the above method and timing himself with a watch. This is the method used by most professional swimmers.—Carroll Pfeeger, Milton, Pa.

Rubber Stopper Used as Spring

A small punch, used for punching holes in the leaves of a loose-leaf ledger, was repaired in a simple manner when the spring that returned the plunger became broken. In order to make the punch serviceable until a new spring could be obtained, a rubber stopper was used. A hole, a little larger in diameter than the punch, was drilled through the center of the stopper and the latter inserted into the tool opening in place of the spring. Then, after a washer had been placed underneath the head of the punch, it was inserted through the hole in the stopper. When the plunger was forced down, it was automatically restored to position as soon as the pressure had been released.—Dale R. Van Horn, College View, Neb.



Drying Yellow Poplar

Yellow poplar lumber, fresh from the saw, can be dried quickly and the danger of staining reduced to a minimum by piling the boards on end. The object of this is to permit the moisture to drain off freely and improve the circulation of air around the boards. Lumber dried in this manner will be bright and clean, and can be shipped after a few weeks.

Planting Corn

It is much better to plant four rows of sweet corn 5 ft. long side by side than it is to plant one row 20 ft. long with as many plants. The former method will produce more and better corn than the latter, because there will be a better distribution of the fertilizing pollen, as, the rows being closer together, the wind will carry it between the rows. In a long single row, the greater portion of the pollen will be blown away without falling upon the silk to fertilize it and produce the corn. Each silk fertilized means more kernels of corn on the cob, and failure of proper fertilization causes bare spots upon them.

Guard Prevents Dulling of Hoe

Gardeners, amateur and professional, often damage or ruin the edge of their nicely sharpened hoe by striking a concealed rock.

In order to prevent this, at least to a great extent, the guard illustrated may be used with good effect. It consists simply of three narrow blades, attached to the face of the hoe, with the points extending about $\frac{1}{2}$ in. beyond the edge of the implement.

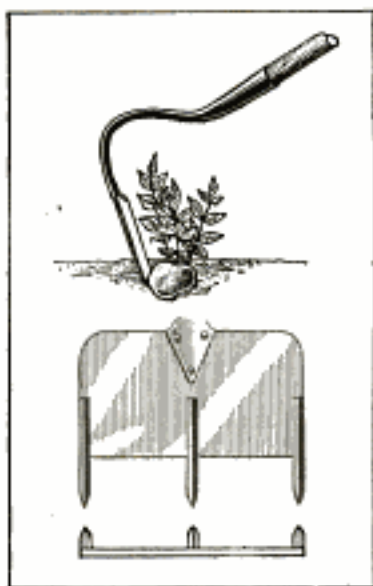

The blades are made of stock heavier than the hoe, and the end and faces are sharpened. If large stones are encountered, the points of the blades take the bump, and even though they become dull, they do not prevent the hoe from entering the ground easily. To make a smooth job, the blades should be welded to the hoe.

Skate Aids in Moving Furniture

Having occasion to move a heavy display table from one end of the store to the other, a distance of about 70 ft., without help, I placed a roller skate under each of the legs at one end, and thus rolled the table along to its new position easily.—H. B. Nissly, Sioux Falls, S. D.

A Carrier for Cork Auto Gaskets

The flimsy cork gaskets used underneath the various cover plates and about every detachable part of an automobile engine, are difficult to handle without breaking, which makes them practically unfit for use. To minimize the danger of breakage, and consequent loss, a serviceable but simple carrier can be made that not only protects the gaskets but keeps them always visible, so that the mechanic can select any one of them without delay. This carrier is made from the back curtain of an old automobile top, containing a square or rectangular celluloid light. The material is sewed over the light to form an envelope, into which one or more sets of the gaskets can be placed, and as the carrier can be dropped and otherwise mishandled with small risk of damage to its contents, the saving will rapidly pay for the trouble involved in making it.



Key Guide for the Back Door

By means of the key guide shown in the drawing, one can locate the keyhole in the darkest night as easily as during the day. The entire device is made from sheet metal. Four strips, each about 1 in. wide, are formed into a flared frame and soldered over a square opening cut out of a flat strip of the same material; this should be a trifle wider than the guide proper. In use, the attachment is fastened to the door with two screws, so

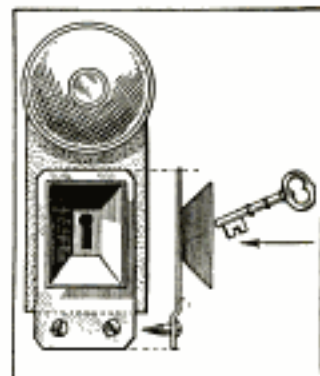

that the keyhole comes in the center of the square hole. As the key is inserted into the guide, the tapering sides cause it to be directed toward the keyhole.

Cutting Sod around Trees

To cut the sod from around the trunks of trees, and at the same time form a circle,



is a little more difficult than is generally realized. However, by the method shown in the drawing it is possible to describe a circle and cut the sod at the same time. A loop of rope is tied around the tree and the spade is inserted into the opposite end. A circle of any desired diameter

may be obtained by increasing or diminishing the radius, represented by the length of the loop of rope.—Doris Johnson, Rockford, Ill.

A Strong Mower Handle

In the rare cases that the handle of a lawn mower becomes broken, another, as strong and serviceable as the original,

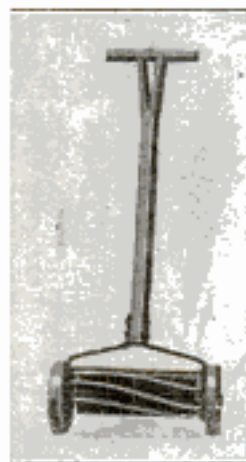

can easily be made from a strip of oak of the same dimensions. The new handle is split down its center for about 14 in. at one end, and a $\frac{1}{4}$ -in. bolt is inserted into a drilled hole about an inch below the bottom of the cut, and tightened, to prevent the piece from splitting. The split end is then steamed and the outer ends bent about 4 in. apart. A tenon on each of the bent parts is fitted into a corresponding mortise in the handle, which is made from a 14-in. piece of the same stock as the handle.

An Auto-Theft Alarm

State laws and municipal ordinances, in most cases, make it practically impossible to lock an automobile so that it is immovable, by chaining the wheels or locking the brakes. However, the use of alarms is not prohibited, and it is consequently possible to wire the horn of the car in such a manner that it will

begin to blow as soon as the engine is started, and continue to do so as long as it is operating. This is accomplished by mounting a concealed switch underneath the cowl, which must be opened when the engine is started, and running a wire from the generator to the horn; this does not interfere with the usual operation of the horn from the button on the steering wheel. Consequently, with the engine stopped and the switch closed, the horn will commence to blow as soon as the generator begins to operate.

Simple Mounting for Small Motor

When using a small electric-battery motor for different experiments in the amateur's laboratory, it is generally found that the units,

when connected in the usual manner, are awkward to move about. To combine the two, the motor is mounted on the top of the dry cell

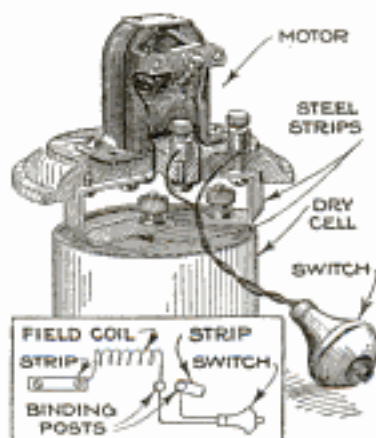

by means of two steel, brass, or copper strips, attached to the underside of the motor base, bent as shown, and clamped to the binding posts of the battery. A switch of the type illustrated, or of any other type desired, is connected to the binding posts on the base of the motor, so that the latter can be started and stopped as desired.—W. A. Saul, Cambridge, Mass.

The F-Numbers of Lenses

The F-numbers of photographic lenses, such as F/7.5 and F/6.3, etc., indicate the working aperture of the lens at which good definition is to be had, and hence the speed of the lens. The numbers themselves indicate the quotient resulting from division of the focal length by the diameter of the largest diaphragm opening. Thus, F/7.5 means that the diameter of the diaphragm opening is contained in the focal length 7.5 times; also, it may be seen that the smaller the number of any particular lens the larger the corresponding working aperture and the shorter the necessary exposure.

A Small Electrically Heated Steam Boiler

By A. N. CAPRON

A GREAT many amateur mechanics have frequent need of some apparatus that will supply steam under light pressure for the operation of model engines, turbines, and such incidental work as opening storage batteries; and it is for just such purposes that the electrically heated boiler shown in the drawing was designed.

First, an earthenware bottle, or jug, of the size required is obtained; this is cut off about $3\frac{1}{2}$ in. from the base, the operation being easiest performed on an emery grinder. Two pieces of hard carbon are required, which are drilled and formed to the dimensions shown in the drawing, the bottom of the larger piece being cut away,

the studs must be drilled through the bottom. This is accomplished by first chipping off the glaze and drilling the holes with a twist drill kept moistened with turpentine. The holes having been drilled, a boiler is made from sheet brass, copper, or iron to correspond with the dimensions of the earthenware jar, as shown in the drawing, with a horizontal support for the jar to rest upon.

This latter piece, which forms the top of the fire box, is drilled to give ample clearance for the studs and should be free from contact with them, as indicated. To prevent any possibility of the water or steam working its way between the earthenware jar and the boiler shell and

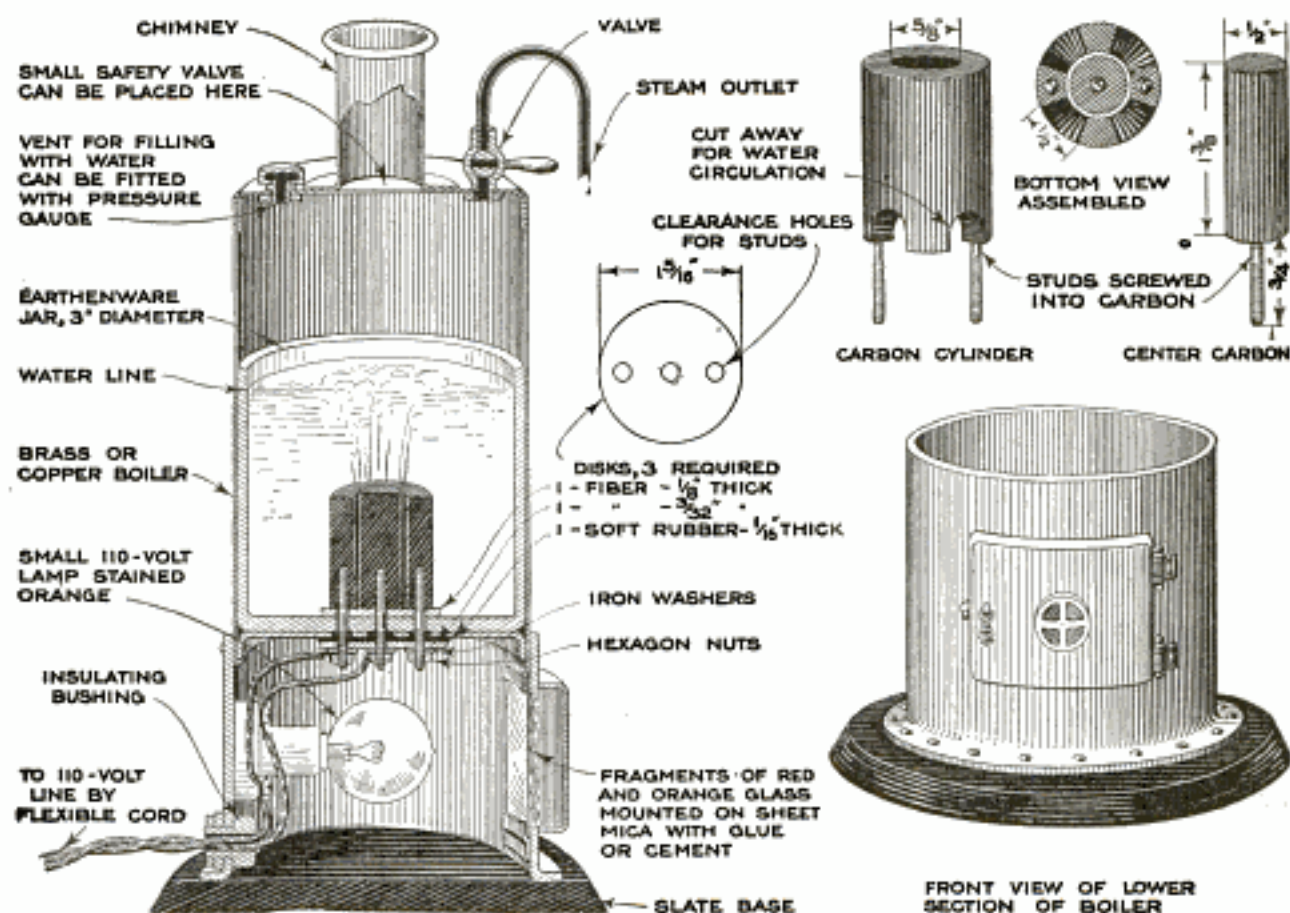

An Electrically Heated Steam Generator for the Amateur Mechanic's Laboratory Which will Supply Sufficient Steam for the Operation of Experimental Engines, without Fire Danger

as indicated, to permit free circulation of water around and through the heating element. Both carbon pieces are drilled to take brass studs which may be made by threading short lengths of $\frac{3}{32}$ -in. brass rod; these are screwed into the holes drilled for them, or they may be held by means of small metal pins.

The carbon heating elements are to be assembled together in the bottom of the earthenware cup so that there is $\frac{1}{16}$ in. between them, and holes to accommodate

out at the bottom, the seam should be silver-soldered, after the shell has been riveted in place, although brazing would be better. The heating element is then placed in position and insulated from the metal boiler with fiber disks, as indicated, a similar disk of soft rubber being used to prevent escape of steam or water. The top of the boiler is equipped with a steam valve, and the other necessary fittings, including a vent for filling the boiler, are brazed or riveted to the boiler shell. It

will be impossible to rivet this piece in place unless it is concaved or "dished," with a flange around the edge for the rivets. To simulate the appearance of fire underneath the boiler a colored miniature lamp may be mounted in the fire box as indicated, or by placing the light behind a fire door that has openings covered with red and orange glass.

The efficiency of such a boiler is quite

Brush Hook Made from a Shovel

The brush hook shown in the drawing has been successfully used for cutting away brush, in clearing land along fence

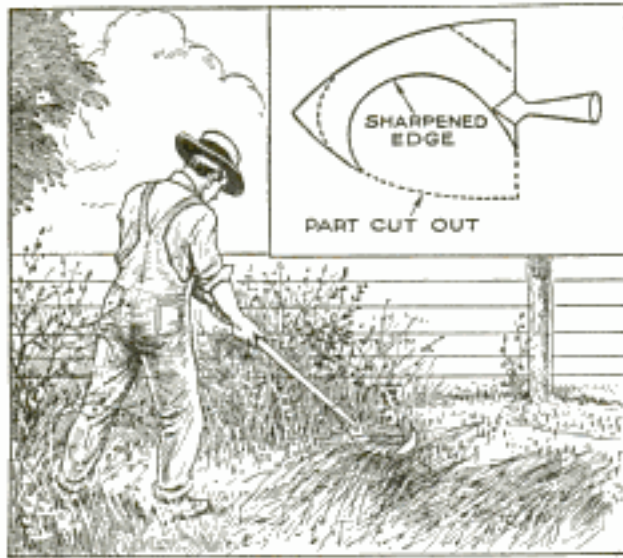

A Brush Hook Made from a Round-Nose Shovel That for Many Purposes Is Superior to the Ordinary Hook

lines, and similar work; it is made from a shovel of the round-nose type. The blade is cut away along the dotted lines, and the resulting sickle is sharpened. For many purposes a hook of this character will be found superior to the ordinary brush hook, as a better blow can be struck and the sickle-shaped blade makes it possible to handle several small shoots at the same time.—G. P. Melrose, Kamloops, B. C., Can.

Emergency Axle Repair

An automobile tourist saved the trouble and expense of being towed to the nearest garage, when one of the rear hubs of his machine became broken. He removed the hub from the wheel so that the end of the axle shaft was exposed. A pipe wrench was put on so as to grip the shaft, and the handle was tied to one of the spokes in the wheel, thus holding the wheel on and causing it to revolve with the axle.—S. S. Spence, Kearney, Neb.

high; the water enters through the four open spaces in the bottom of the outer carbon and is heated as it ascends through the annular opening of the heating element. The water is heated to the boiling point by its own resistance to the passage of current through it. The fire danger that attends the usual alcohol lamp is eliminated, and if the boiler goes dry, the current is automatically shut off.

Repairing Eaves Troughs

Holes that are rusted through the eaves troughs of a building can be mended in a simple manner with ordinary cement, sand, and a little wire screen. A piece of the screen, a little larger than the hole to be cemented, is placed inside the trough to serve as a bond and reinforcement. This is coated with concrete made from equal parts of Portland cement and sand. This idea has also been applied to mending the chipped corners of greenhouse windows, in positions where the holes were difficult to reach from the outside, and the repair was found to be much better than putty; the rich concrete made a perfectly water-tight joint between the glass and the wood, which was thoroughly wetted before applying the concrete.—Ansley Hitz, Chicago, Ill.

Pulling Screen Wire Taut

Having to renew the screening on several large porch screens, I was at a loss to determine how the new screen wire could be drawn taut across the frames. In looking through the toolbox, I found an old carpet stretcher which was tried out and found to answer the purpose in an ideal manner. To use the stretcher, the screen is fastened along one edge of the frame and the carpet stretcher inserted in the mesh on the opposite edge, drawing the screen wire taut. The stretcher was found to be particularly effective on the large frames, where it would have been practically impossible to stretch the wire evenly by any other method.—Harry G. Schultz, Teaneck, N. J.

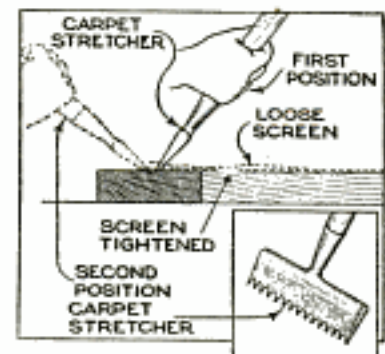

Trapping Rodents without Bait

By setting a spring rat or mousetrap in the usual manner, and placing it so that its trigger end will butt against the wall, it will be found that the animals may be caught without bait. The reason for this is that they usually run along the wall, and across the trap, and as soon as they strike the trigger, the trap is sprung. This method is particularly applicable in a room where there is so much other food that bait would not entice the rodents.—Thos. A. Dickinson, Youngstown, Ohio.

Rustic Flower Vases

A simple and effective flower container for the summer cottage or porch is made from a short length of a tree branch. The



bark gives a rustic appearance to the vase, and a variety of effects are obtainable by judicious selection, the white bark of the birch being the most conspicuous. The container may be made of any diameter by using a section of the desired size, from which the interior has been gouged or drilled out. A "liner," which is what florists call

a container for water in such vases, may be provided by inserting a can, or other receptacle, into the hollow center.

Washers for Garden-Hose Connections

Having to use several lengths of garden hose connected together, it was found that much of the pressure at the nozzle was lost because the water escaped through the washerless connections. Looking about for something from which to make washers, it was found that the cork lining of the ordinary crown bottle cap just fitted into the usual hose coupling. The cork centers were removed from the caps, placed in the hose couplings, and the centers trimmed out with a sharp penknife. When connected together again, with the washers in the connections, leaking at the joints was entirely overcome.—C. E. Diehl, Mammoth, Utah.

Improvised Developing Tray

When a plate or two must be developed in a hurry, away from the dark room and its conveniences, a tray that will be suffi-

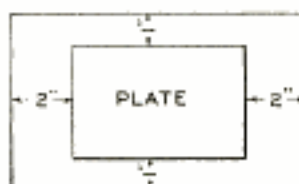

SHEET CUT TO SIZE

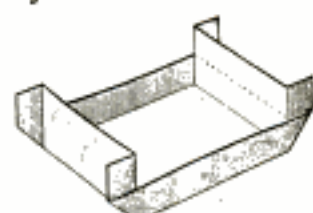

1ST OPERATION



2ND OPERATION

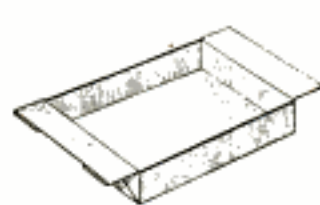

COMPLETED TRAY

When the Photographer Is Away from the Dark Room He can Develop His Plates in an Emergency Tray Made from a Sheet of Stout Paper, Waterproofing It with Paraffin

ciently satisfactory for emergency purposes can be made in a few minutes from a sheet of stiff paper.

The sheet of paper to be used is measured so as to be 1 in. wider at the sides and 2 in. longer at each end than the plate. For example, if the tray is to hold a 5 by 7-in. plate, the paper should be not less than 7 by 11 in. Fold up the sides and ends as illustrated in the first operation. The second operation consists in turning the projecting ears back, and the third, turning the ends down to complete the tray. If convenient, the tray should be dipped in melted paraffin and allowed to cool, or a lump of the wax can be placed in the bottom of the tray and melted by gently heating over a stove or lamp. Do not use denatured alcohol or similar solvents in the waxed tray, as it will dissolve the paraffin and create trouble.—John H. Curtis, Philadelphia, Pa.

Sanitary Poultry-House Floor

The owner of a flock of chickens, on moving from one house to another, found that a piece of linoleum would not fit any of the rooms in the new home. This was trimmed to the dimensions of the chicken house and laid on the floor, producing a smooth, even surface and stopping up the numerous cracks in the board floor. The floor is kept covered with several inches of litter, and the linoleum has been found to make a durable, sanitary, and draft-proof floor.—Paul H. Reuss, Kalamazoo, Mich.

Boat Rudder for Shoal Water

In fitting a small rowboat with a sail, a removable rudder was desired, but, as this boat was to be used in shallow and

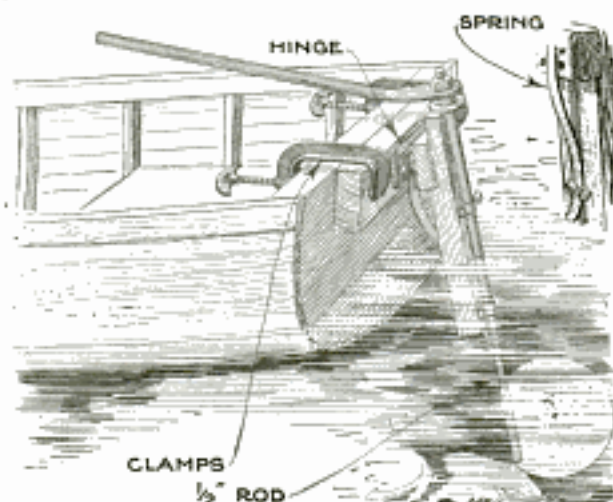

A Rudder for Use in Shallow and Weedy Waters That Swings Out of the Way When an Obstruction is Encountered: Two Ordinary Clamps are Used to Hold the Device to the Transom of the Boat

weedy water, the rudder as well as the leeboards had to be fitted so as to swing out of the way when an obstruction was encountered; this was accomplished in the manner illustrated.

The rudder blade, made of sheet metal, is riveted in a slot cut in the end of a $\frac{1}{2}$ -in. iron rod, the upper end of which is threaded and fitted with a tiller made of iron pipe. A piece of wood, about half as long as the $\frac{1}{2}$ -in. rod, is fastened at right angles to a small block, and the two joined to a third piece by means of a stout butt hinge, as shown, a piece of spring steel about 8 in. long being screwed underneath the hinge leaf fastened to the horizontal strip. The other end of the spring slides on the vertical stick, between guides formed by driving in a round-head screw on each side. The rudder is strapped to the vertical wooden member so as to swing freely, and prevented from dropping by a machine screw bearing against one of the straps; the horizontal member is fastened to the stern of the boat by means of two iron clamps as in the drawing.

A rudder of this type swings back when it strikes an obstruction, and as soon as this has been passed, the spring pulls the rudder back into place.—Walter E. Burton, Kenmore, Ohio.

☐ Silver-white or white lead, with yellow lake or Dutch pink, and a little lemon-chrome yellow, will give a very rich shade of olive-drab or amber color.

Filing Papers in Binders

Where office records were kept in post binders, it had been customary to indicate the contents by a label pasted on the top cover. Binders were then stored on shelves in stacks or rows, in which positions the labels were concealed, and considerable time was lost in locating the particular volume wanted. The only other space available for a label or an inscription was the bound end, which was too rough for writing or pasting. The uneven edges were cut down to an even surface with coarse sandpaper, followed by No. 0 sandpaper, the surface thus produced making it possible to write the title of the contents on it with a broad shading pen and ordinary ink. Under this plan, it became as easy to select any binder as to select a book by its title.—Waldemar Landry, Sr., Baton Rouge, La.

Screening Center-Pivoted Windows

One of the most perplexing problems, to many, is to put fly screens over a window that is pivoted at the center instead of sliding.

The difficulty may be overcome in the manner illustrated. The screen is made in two sections, each half the width of the window. One section is placed on the outside and the other on the inside, as shown, and a strip of felt or rubber, cut from an old inner tube, is tacked to the screen frames in such a manner that they will always bear against the window and close the opening.—J. R. Linton, Sioux City, Ia.

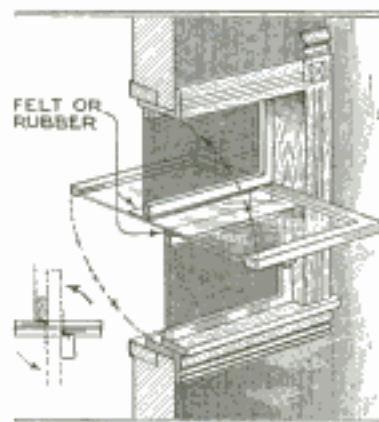

Indoor Trellis Made from Chain

An attractive trellis for a climbing asparagus fern can be made of brass picture chain. A chain is fastened to each side of the wooden pail in which the plant is growing, by a small hook, the other ends of the chains being looped over the curtain rod at the top of the window. Crosspieces of the chain are used to form a ladder effect.—Jo Walker Humphrey, Kirksville, Mo.

PRIZE OFFERS AND ANNOUNCEMENTS

8799

PRIZE OF \$1,000 OFFERED FOR A POEM ON "SPIRIT OF TRANSPORTATION"

To inspire workers in the office or in the machine shop of the automotive industry with a consciousness of the unseen romance connected with their humdrum work, last year 12 paintings, by different artists, visualizing "The Spirit of Transportation," were entered in a contest for a prize of \$1,000, offered by the Clark Equipment Company of Buchanan, Mich. This year the same company is offering the same amount for the best poem on the same subject. The theme of the poem must show the influence of the motor car and truck upon civilization, and it will bear the same title as the pictures: "The Spirit of Transportation."

The conditions are: All poems must be typewritten on one side of the paper and must be original. Poems may refer to the paintings, or may be confined to the general theme. Poems submitted must be accompanied by an assignment of copyright, and if postage is inclosed will be returned at the close of the contest. The prize will be awarded by a board of judges, and their decision will be final. The competition closes June 30, 1922. For full details and registration blank, address Clark Equipment Company, Buchanan, Mich.

8885

ANNOUNCEMENT OF THE FOURTH ANNUAL RACES AT PIKES PEAK, COLORADO

Autoists will be interested in the announcement that the fourth annual Pikes Peak hill-climbing races, the biggest competition of the kind in the United States, will be held this year September 4. The Pikes Peak is the highest automobile highway in the world, and these races are the most spectacular contests of the racing season. To the car making the best time, regardless of class or event in which it is entered, is awarded the Penrose Trophy, in addition to the cash-prize money. The cash prizes total \$2,100. The course is 12 miles 2,200 ft. in length, and cars can run abreast or pass each other with safety. There are three events; for A. A. A., class-C cars with piston displacement of 183 cu. in. or less; for the same class cars with piston displacement of 183 to 300 cu. in., and for A. A. A., class-D cars with a piston displacement of over 300 cu. in. Address: The Chamber of Commerce, Colorado Springs, Colo.

HIGHLY EFFICIENT MUSICAL SERVICE REGARDED AS CIVIC ACHIEVEMENT

By the terms of the Edward Bok award, \$10,000, with a gold medal, is given annually to the person who has been judged to have performed the most noteworthy civic achievement for Philadelphia. The first bestowal of the award, this year, was for a form of service that is not commonly associated with the idea of civic achievement. It was given to Dr. Leopold Stokowski, conductor of the supremely fine orchestra that has made Philadelphia famous throughout the musical world. He has done other work of value to the community, particularly in making music available to people of modest means and small opportunity. He has, on his own account, offered an annual prize to meritorious local musicians. He has, wherever possible, cooperated with local artists and musicians, and with the public-school authorities in the encouragement of music. Thus, it is evident that his work was appropriately characterized as civic achievement.

THE SECOND NATIONAL CONFERENCE IN INTERESTS OF STATE PARKS

The second national conference on state parks, which has been called in the interests of state-park development by John B. Payne, chairman of the conference, will be held at the Bear Mountain Inn, Palisades Interstate Park, New York, May 22-25, 1922. The first national conference was held in Des Moines, Ia., in January, 1921, and since that time a great deal has been done in this work. The importance of a national development of state parks cannot be overemphasized.

These parks, when well developed, produce revenue, stimulate travel to and through the state, preserve the beautiful native scenery and historic spots, and are in every way of benefit to the state. One of the features of these parks undoubtedly will be the establishment of free public camps, which have been so popular in the national parks. Two days of the conference will be devoted to business sessions, while the remainder of the time will be utilized by trips of inspection through the Palisades Interstate Park, West Point, a new state highway around Storm King, the New York Zoological Park, and the Bronx River Parkway. This will give the delegates an excellent opportunity to see the splendid state-park development in that part of the country.

INDIANA LITTLE THEATER SOCIETY OFFERS PRIZES FOR FOUR PLAYS

The Little Theater Society of Indiana offers prizes amounting to \$100 for four plays, and also a production by the Little Theater of the plays selected, and their publication in book form. Plays submitted must be original and unproduced works by residents of Indiana. In form, length, and construction they must be of the one-act type. No author may submit more than four plays. Preference will be given to plays dealing with present-day life and local conditions. Besides the prize money, the authors of the plays selected will receive one-half of all royalties derived from their subsequent use, and from their publication. All plays must be typewritten, and must be mailed before June 1, 1922, to Mrs. William O. Bates, President of the Little Theater Society, 756 Middle Drive, Woodruff Place, Indianapolis, Ind., from whom further particulars may be obtained.

NATIONAL FOREIGN-TRADE CONVENTION WILL INCREASE AMERICAN EXPORTS

In connection with the ninth National Foreign-Trade Convention, held at Philadelphia, Pa., early in May, a series of nine brief articles on "The ABC of Foreign Trade" was widely circulated. The object was to point out how closely related is prosperity in the United States to the volume of its foreign trade. The main theme of the convention was financing and expanding foreign trade. It was shown that domestic consumption alone cannot dispose of the full production of American industry, and that the surplus must be sold abroad. This surplus is generally admitted to be about 20 per cent in manufactured goods, but besides that, there are certain raw materials of which the surplus is very much greater. It is estimated that nearly 50 per cent of the cotton and fully 25 per cent of the wheat produced in this country have to find a foreign market, and it is obvious how much the southern states in the one case, and the northern states in the other, must be affected by the failure to find a market for any portion of this great surplus. It should be realized that the difference between good times and bad times in the United States is the difference between ample foreign markets and a lack of them.

EXAMINATIONS IN THE AIR SERVICE TO APPOINT FLYING CADETS

Examinations are now being held in the air service for the appointment of flying cadets. Both enlisted men and civilians are eligible. At the time of application, candidates must be unmarried male citizens, between the ages of 20 and 27 years. They must be high-school graduates, or possess an equivalent education. They must be of excellent character, and sound in physique.

The base pay of flying cadets is \$75 a month, with a ration allowance not exceeding \$1 a day. Other allowances, such as clothing and equipment, are the same as those of a private in the air service. The term of enlistment is three years, but may be shortened by an earlier successful completion of the prescribed course, when the cadets will be commis-

Christian Science Monitor
3/18/22
O'Connell Cross
Washington, D. C.
Maj. H. M. Dickman, Air Service
Chief Information Division
War Dept. Office of Chief of Air Service
Washington, D. C.

Address: Director of Publicity, 9th National Walnut, Philadelphia, Pa.
Foreign Trade Convention, 12th St.

sioned second lieutenants in the Air Service Officers' Reserve Corps.

Examining boards are located at the various flying stations in the United States and its dependencies, and applicants from civil life will be required to pay all expenses incident to their appearance before the boards.

The next class for cadets in airplane service is scheduled to commence about July 1, and for balloon and airship service about September 25, this year. Other information and application blanks can be obtained by addressing the War Department, Office of the Chief of Air Service, Washington, D. C.

8928
**TRIENNIAL COMPETITION FOR PRIZE
 FOR BEST WORK ON ELECTRICITY**

The triennial contest for the prize known as the George Montefiore Foundation, which was won last year by Dr. J. B. Whitehead, of the Johns Hopkins University, is again announced by the Association des Ingénieurs Electriciens Sortis de l'Institut Electrotechnique Montefiore, of which L. Calmeau, Rue Saint-Gilles 51, Liège, Belgium, is general secretary. This prize, amounting to 21,000 francs (normally \$4,200), is awarded for the best original work in French or English upon the scientific advance of electricity and its technical applications. Though known as the competition of 1920, the next award will be made in 1923, and works may be submitted up to April 30 of that year.

8933
**PRIZE OF \$100 FOR THE BEST POEM BY
 ANY COLLEGE UNDERGRADUATE**

Through the Poetry Association of America, Witter Bynner, its president, offers a prize of \$100 for the best poem, or group of poems, not exceeding 200 lines in length, written by an undergraduate of any college or university in the United States. No limit is placed upon the number of entries by any one person, and previous publication does not disqualify. On each page of the manuscript must be written the name and address of the contestant, and the mark "P. S. Contest." The contest closes May 15, 1922. Poems should be addressed to Haniel Long, 5559 Beeler Street, East End, Pittsburgh, Pa.

8935
**PRIZE-ESSAY CONTESTS TO ENCOURAGE
 TEMPERANCE STUDY IN SCHOOLS**

Temperance study in the public schools is being encouraged through the National W. C. T. U. by the offer of prizes for essays on the subject. The essay writing forms a part of the class work in the schools, which is promoted by a local superintendent, in each state, of the Scientific Temperance Department of the National W. C. T. U. A leaflet is issued containing a full list of the subjects and rules for the prize-essay contests, which can be obtained by addressing either the state superintendent or the Department of Scientific Instruction, National W. C. T. U., Evans-
 ton, Ill.

8900
**TWO PRIZES OFFERED FOR THE BEST
 HUMAN SPINES IN NORTH AMERICA**

For the two best human spines in North America, cash prizes to the amount of \$1,500 are offered by the National League for the Prevention of Spinal Curvature, an osteopathic organization. Women over 18 years of age may compete for a prize of \$1,000, and girls or boys under 12 years for one of \$500. The contestants for the prizes must be examined in each instance by a graduate of osteopathy, who has received his degree from one of the associated colleges under the American Osteopathic Association. The contest closes May 25, 1922, and the prizes will be awarded June 15. Address, Dr. Nathaniel W. Boyd, 126 East Washington Lane, Germantown, Philadelphia, Pennsylvania.

8995
**FOR BEST NAME FOR RECKLESS DRIVERS
 CASH PRIZE OF \$25 IS OFFERED**

It is desired to find an appropriate name, or epithet, to apply to the motor driver who disregards the traffic signal, drives on the wrong side of the street, tries to "shave" another vehicle too closely, and who through his carelessness and recklessness endangers the lives of all, but particularly of children. For the best name denouncing an offender of this kind, a cash prize of \$25 will be paid by the American Automobile Association. The name must be submitted not later than May 15, 1922, and the prize will be awarded May 29. Address, A. A. Association, 1108 Sixteenth Street, N. W., Washington, D. C.

8994
**PRIZES FOR BEST SYSTEM OF MANAGE-
 MENT OF HOUSEHOLD EXPENSES**

To encourage economy and good accounting methods in the management of the household, which is best done by the adoption of a budget system, as fully explained in a little volume entitled, "Menter Plan of Home Budget," the publishers offer \$5,000 in cash prizes. For the most complete budget record on the Menter plan for a period of at least six months, ending Dec. 31, 1922, a first prize of \$500 is offered. Besides this, \$4,500 will be distributed in \$25 awards to 180 of the best records sent in. Address, The Menter Company, 467A Seventh Ave., New York City,

8942
 For the best lists of household uses of a cleansing cream, called "Sanlo," the manufacturers offer a first prize of \$50; a second of \$25; a third of \$10, and three others of \$5 each. The prizes will be awarded by the officers of the company and its advertising department. The contest closes Aug. 31, 1922. Address, Contest Department, The Parker Sanlo Co., Inc., Rochester, New York.

CONTESTS PREVIOUSLY ANNOUNCED

Medals, Diplomas, and Money Awards: Announced August issue, 1921; awards offered by the Franklin Institute.

For Service to City of Philadelphia: Prize \$10,000; announced September issue, 1921; awarded each year by Edward Bok, former editor of The Ladies' Home Journal.

One Million Francs for Best Motor: Announced January issue, 1922; closes June 1, 1923; address, Aero Club of France, Paris.

Best Slogan Describing Razor: Prize \$500; announced January issue, 1922; closes June 30; address, Durham Duplex Razor Co., 190 Baldwin Ave., Jersey City, N. J.

American-History Essays: Prizes, \$3,000 for professors, \$2,000 for specialists, \$1,000 for school-teachers, \$1,000 for students, and \$500 for undergraduates in U. S. colleges; announced March issue, 1922; closes May 31. Address, Knights of Columbus Historical Commission, K. of C. Bldg., 199 Massachusetts Ave., Boston, Mass.

Best Setting of a Song: Prize \$100; announced April issue, 1922; closes July 1; address, D. A. Clipping, 617-18 Kimball Building, Chicago, Ill.

Man-Propelled Airplane: Prize 20,000 francs; announced April issue, 1922; closes September 13; address, Maison Peugeot, 80 Rue Danton, Levallois-Perret (Seine), France.

Posters to Incite Kindness to Animals: Prizes, \$25, \$15, and \$10 for each of eight groups; announced May issue, 1922; closes May 20; address, Poster Department, American Humane Association, Humane Society Bldg., Albany, N. Y.

Essays to Incite Kindness to Animals: Prizes, \$25, \$15, and \$10; announced May issue, 1922; closes May 20; address, Essay Contest Department, American Humane Association, Humane Society Bldg., Albany, N. Y.

IN accordance with the editorial policy of this magazine never to accept compensation in any form for what appears in our reading pages, and also to avoid all appearance of doing so, we are obliged to omit the name of the maker or the seller of any article described. This information, however, is kept on file and will be furnished free, by addressing Bureau of Information, Popular Mechanics Magazine, Chicago. [Editor.]

BUILT FOR HARD WORK

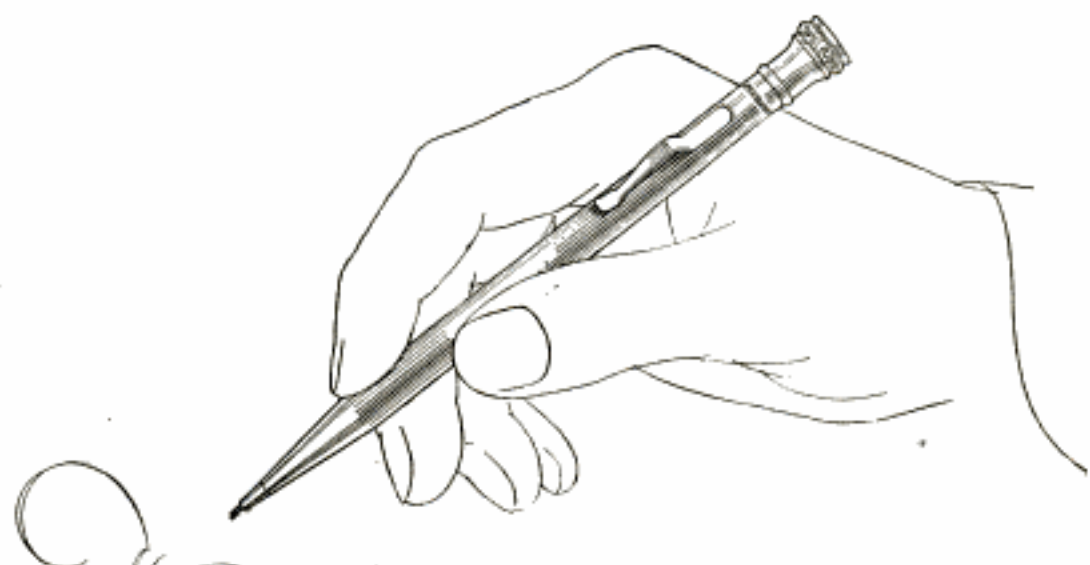

The Pace Maker must be made of sturdy stuff. By its ability for work, EVERSARP holds its leadership. Day after day, its lead is driven to constant sharpness, writing thousands of words, smoothly and steadily. A minute for reloading and the work goes on.

Every part of EVERSARP is made with precision. The exclusive patented tip is gauged to the thousandth of an inch. It holds the lead firmly. No other pencil has ever been made like EVERSARP; no other pencil can be like EVERSARP.

Put EVERSARP on your working force. With no wasteful whittling, no loss of time, it is a positive economy. Styles for pocket, chain or woman's purse, in gold, silver and enamel, 65c to \$65.

Made in U. S. A. by THE WAHL CO., CHICAGO. Canadian Factory, The Wahl Co., Ltd., Toronto

EVERSHARP

Reg. U. S. Pat. Off.

EXCLUSIVE EVERSARP TIP



THE SUPREME POINT OF EFFICIENT WRITING
LEAD HELD FIRMLY, CANNOT SLIP NOR Wobble

BEAUTIFUL DESIGNS



CHISED FINISH, ENGRAVED, OR ENGINE-TURNED.
EQUIPPED WITH SPECIAL EVERSARP HOLD-FAST CLIP

AUTOMATIC LEAD INDEX

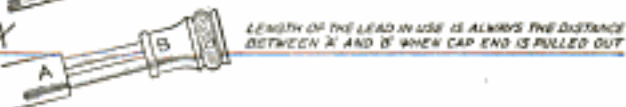

LENGTH OF THE LEAD IN USE IS ALWAYS THE DISTANCE
BETWEEN A AND B WHEN CAP END IS PULLED OUT

HOLDS 6 TO 12 LEADS



SOLD COMPLETELY LOADED. EXTRA LEAD IN
THE RED-TOPPED BOX, IS* EVERYWHERE

HANDY ERASER UNDER THE CAP



NEW ERASER FREE WITH
EVERY BOX OF EVERSARP LEADS

SCIENTIFICALLY BALANCED



FOR SMOOTH AND
TIRELESS WRITING



Guardians of the Circuits

The telephone at your elbow seems so simple an instrument, it does its work so quietly and quickly, that it is difficult to realize the vast and complex equipment, the delicate and manifold adjustments, the ceaseless human care "behind the scenes" in the central offices.

Behind the scenes is the terminal of all the underground and overhead lines on the streets and highways. Here are the cable vaults; the great steel frames containing the thousands of separate wires and fuses for the subscribers' lines; the dynamos and storage batteries; the giant switchboards through which your telephone is connected with the other thirteen million telephones in the Bell System.

And here, in charge of this equip-

ment, are the guardians of the circuits—the wire chief and his assistants—master electricians and experts in telephony. Their first duty is the *prevention* of "trouble." By day and by night they are constantly testing the central office equipment, the overhead and underground lines, the subscribers' individual wires. And when, from some cause beyond control, "trouble" does occur, nine times out of ten it is repaired before the telephone subscriber suffers the slightest inconvenience.

It is the skill of the men behind the scenes, together with scientific development and construction, efficient maintenance and operation, which make it possible for you to rely upon the telephone day and night.

" BELL SYSTEM "

AMERICAN TELEPHONE AND TELEGRAPH COMPANY
AND ASSOCIATED COMPANIES

One Policy, One System, Universal Service, and all directed toward Better Service





“Topkis taught me value”

“I’D like to have the money I’ve wasted because I was afraid to buy an athletic union suit priced as low as a dollar. I cheerfully gave up double, year after year.

“I didn’t know Topkis then.

“Finally, a salesman in Johnson’s shop argued me into trying Topkis. He landed me as a life-time customer.

“My dollar never before brought me as much quality and value. Loose, airy fit that lets my skin breathe. No skimpiness; no bagginess; no pinch; no pull.

“Wear? That’s where Topkis shines. Keeps its size, too.”

Topkis Athletic Union Suits are made of best nainsook and other high-grade fabrics. Pre-shrunk—full size guaranteed. Be sure you get your correct size—38 if you wear a 38 coat, and so on.

No good dealer will ask more than a dollar for the Topkis Men’s Union Suit—although many will tell you it’s worth more.

Men’s Union Suits, \$1.00.

Men’s Shirts and Drawers, 75c per garment. 75c for Boys’ Union Suits, Girls’ Bloomer Union Suits, and Children’s Waist Union Suits.

TOPKIS BROTHERS COMPANY, Wilmington, Delaware

General Sales Offices: 350 Broadway, New York City

Ask for TOPKIS Underwear.
Look for the Topkis label.

Write for free illustrated booklet and
learn what’s what about underwear.

TOPKIS

Athletic Underwear

IVER JOHNSON BICYCLES

Keep Fit

After a few weeks of bicycle riding you'll eat better, sleep better, feel better, and work better.

An Iver Johnson Bicycle so combines natural exercise with pleasure as to make the exercise enjoyable rather than tiresome.

The truss-bridge frame, seamless tubing of nickel steel, drop-forged parts, two-piece crank set—these are some of the features that guarantee the strength, speed and durability of every Iver Johnson Bicycle. The oldest firm in America making bicycles continuously.

Write at once for free bicycle catalog "B 4." Firearms catalog "A 4" also sent on request.

IVER JOHNSON'S ARMS & CYCLE WORKS
4 River Street, Fitchburg, Mass.

New York Office: 99 Chambers Street

San Francisco Office: 717 Market Street

Chicago Office: 108 West Lake Street



Ask your dealer to show you an Iver Johnson Champion single barre! shotgun. Accurate, dependable, moderately priced.



Keep an Iver Johnson revolver in the home for self-protection. It's accident-proof—you can "Hammer the Hammer." Quick, accurate, safe.





Champions

For Every Engine Everywhere

**Cost
You
Less —**



Champion Regular now 75¢
Champion X now 60¢

**Your Dealer has Champions
and can tell you why
You should buy a full set. .**

CHAMPION SPARK PLUG CO.

Toledo, Ohio.

No Money Down!

Our determination to this year double our sales of the world famous Santa Fe Special and Bunn Special Watches prompts this matchless offer.



Santa Fe Special

NEWEST DESIGNS 21 Jewel MONTGOMERY DIAL

Look

Adjusted to Positions
Adjusted to Temperature
Adjusted to Isochronism
Adjusted to the Second
Thin Model All Sizes

While other watch dealers are raising their prices, asking you for larger monthly payments, and making payment terms harder for you to meet, we are offering you our new model Santa Fe Special, no advance in price, no money down, easier terms and smaller monthly payments. WE realize the war is over and in order to double our business we **MUST** give you pre-war inducements, better prices, easier terms and smaller payments.

Without one penny of advance payment let us place in your hands to see, to examine, to inspect, to admire, to approve, a real masterpiece in watch creation.

A watch which passes the most rigid inspection and measures up to the exacting requirements of the great Santa Fe Railway System, and other great American Trunk lines.

Page twelve of our Watch Book is of Special Interest to you

Ask for our Watch Book Free—then select the Watch you would like to see, either the famous Santa Fe Special or the 6-position Bunn Special, and let us explain our easy payment plan and send the watch express prepaid for you to examine. No Money Down.

REMEMBER—no money down—easy payments buys a master time-piece—a 21-Jewel guaranteed for a lifetime at about half the price you pay for a similar watch of other makes. No money down—a wonderful offer.

SANTA FE WATCH CO.
66 Thomas Bldg., Topeka, Kans.

Please send prepaid and without obligation your Watch Book free, explaining your "No Money Down" Offer on the Santa Fe Special Watch.

Name.....

Address.....

State.....

Santa Fe Watch Co.

66 Thomas Bldg. Topeka, Kans.

41 Cash Prizes will be Given Away

First Prize

\$500

Big Shipman-Ward 30th Anniversary Contest Open to Every Reader of This Publication. No Purchase Necessary. No Obligation!—

Here's an amazing offer! A contest that's different from anything you ever heard of before! It means real money for you. And there's no obligation, purchase, lottery, guessing, fees, or payments of any kind! We are giving \$1,500 away, and anybody in the U.S., except our employees, is eligible!

THE PRIZES

FIRST PRIZE	• • •	\$500.00
Second	• • •	250.00
Third	• • •	100.00
Fourth	• • •	50.00
Fifth	• • •	50.00
Sixth	• • •	50.00
Seventh	• • •	25.00
Eighth	• • •	25.00
Ninth	• • •	25.00
Tenth	• • •	25.00
Eleventh	• • •	25.00
Twelfth	• • •	25.00
Thirteenth	• • •	25.00
Fourteenth	• • •	25.00
Fifteenth	• • •	25.00
Sixteenth	• • •	25.00
Seventeenth to forty-first	• • •	25.00

TWENTY-FIVE \$10.00 PRIZES

We make this big contest offer in celebration of our thirtieth business birthday. Since 1892 this company has been in business in Chicago, and boasts over 337,000 enthusiastic customers. It isn't necessary to own a Shipman-Ward Rebuilt in order to compete in the big profit-sharing contest. Any reader of this paper, excepting our employees, is eligible. Just sign the coupon to the right, and get the full details now.

Our contest plan is so simple that anyone has a good chance of winning. Don't delay, get your chance to win hundreds of dollars in cash absolutely FREE. Just sign the coupon and mail it as soon as possible. That's all—and you're under no obligation. So tear out the coupon now!



This is a photograph of the Shipman-Ward Plant. The big Anniversary contest marks the 30th year of this company in Chicago. In this plant are manufactured the famous Shipman-Ward Rebuilt Underwoods.

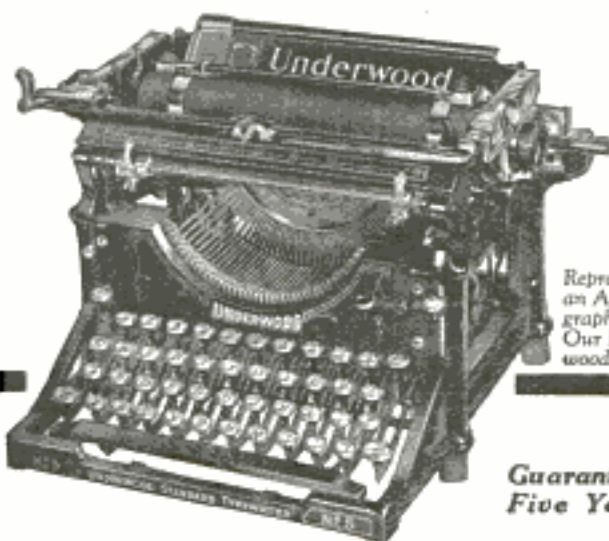

Reproduced from an Actual Photograph of One of Our Rebuilt Underwoods.

Guaranteed Five Years

\$3 Puts It In Your Home

Yes, that's just what we mean. This genuine Shipman-Ward Rebuilt Underwood sent to you for ten days' free trial. Put it in your home by paying \$3 down—we'll refund that \$3 and pay transportation charges both ways if you don't want to keep the Underwood. See for yourself—compare our Underwood with any other typewriter, any make, at any price. If you decide to keep it, you can pay on easy monthly payments—little more than rental.

Less Than Factory Price

Just think of it! Less than the factory price of a new Underwood and yet it's impossible to tell a Shipman-Ward Rebuilt from a brand new machine in appearance, durability or quality of

work. The same three full-size models being made and sold by The Underwood Company today—the same up-to-date features! Two-color ribbon, back-spacer, stencil device, automatic ribbon reverse, tabulator, etc. And the famous Underwood feature—absolutely visible writing—the entire line of typewriting is visible at all times. Standard 4-row single shift keyboard.

Easy Payments

Remember, it doesn't cost you a penny to try the machine. Then, you may pay cash at a substantial discount, or monthly payments so small that you will never miss them. Either way you get the world's standard typewriter at a big cash saving to you. Get all the facts now—mail the coupon today.

Typewriter Emporium SHIPMAN-WARD MFG. CO

"The Rebuilders of the Underwood"

Also Manufacturers of

THE LIGHTNING COIN CHANGER

Est 1892 A212 Shipman Bldg. Ravenswood and Montrose Aves. Chicago

Mail It Now!



Act Today!

SHIPMAN-WARD MFG. CO.
A212 Shipman Bldg., Ravenswood & Montrose
Avenues, Chicago.

(PLEASE MARK WITH A CROSS)

- Please send full particulars about your Thirtieth Anniversary Contest.
- Also send me your beautiful Catalog and tell me how I can get a Shipman-Ward Underwood for \$3 down. This does not obligate me to buy.

Name _____

Street or R. F. D. _____

Post Office _____ State _____



Automobilists and Motor Mechanics

Starrett



Thickness Gage No. 71

Contains six leaves particularly adapted for adjusting motor tappets. Also useful for gaging slots. The six leaves have, respectively thickness of .0015, .002, .003, .004, .006 and .015. Auto mechanics have been looking for this tool.

who know Starrett Tools prefer them for their superior quality, more efficient design, greater durability and dependable precision. When they buy Starrett Tools they know they're getting value for every penny spent. Illustrations and complete descriptions of the entire Starrett line of fine tools are given in the Starrett Catalog No. 22A and special Supplement of new tools. Copies free on request.

THE L. S. STARRETT CO.
The World's Greatest Toolmakers
Manufacturers of Hacksaws Unexcelled
ATHOL, MASS.



Starrett



T-Handle Tap
Wrench No. 93

An extremely handy tool for holding practically all small tools to be turned by hand. New clamp construction insures firm grip on tool. Heat treated jaws guarantee durability.



Use Starrett Tools



Your Home Is Within Your Reach When You Buy From Us

NOW is the time to build your Harris Home!

And here is a mighty organization of thirty great departments ready to serve you. Managed by expert material buyers, designers and practical builders. We have vast stocks bought at huge quantity price savings which are now at your command. Our sole aim and purpose is

To help you get a home that will prove entirely satisfactory at a price that will mean a substantial saving in actual dollars of your money.

The combined efforts of these great departments in experimenting and testing materials and methods of construction have produced for you a **GUARANTEED** home, expert machine cut, bundled and marked—the last word in building economy.

Not One Penny in Advance

So sure are we of the super-excellence of our material and our **GUARANTEED** Ready-Cut System that we will ship you any **HARRIS HOME** without the payment of one cent down. Our Plan Book explains our liberal terms fully.

FREE Plan Book

The latest edition is waiting for you, contains our **FREE PLAN OFFER** and photographic reproductions, with floor plans and specifications of 100 beautiful homes. Mail coupon today.

Building Material of All Kinds

For over a quarter of a century, thrifty wise buyers have realized that here is the "open door" to real economy, whether it be a brand new home or material for improvements or repairs. Our big stocks of brand new building material, all purchased in tremendous quantities at savings that are passed along to you are ready for quick and complete shipments.

"PRESTO-UP" Patented Bolt-together Buildings!

The wonder buildings of the age. Guaranteed buildings, for quick industrial housing. Individual Homes, etc., extra strong, practical and suitable for all year 'round habitation in any climate, 50 different plans. They come to you in easily handled sections—painted and stained, ready to bolt together and move in.

Plumbing and Heating!

Hot water and heating systems, warm air heating plants, pipeless furnaces and plumbing material of every kind—the product of America's leading makers. Our mammoth plumbing stock offers unlimited possibilities for you to save money. Our heating plants are guaranteed to heat your home in any weather with big fuel economy. Mail the coupon for our Plumbing and Heating Book and get the benefit of our Expert Engineering Service.

Department NM-7

HARRIS BROTHERS CO.
1349-1525 W. 35th St., CHICAGO

**FREE BOOK
of Plans**

HARRIS BROTHERS CO.
Dept. NM-7, Chicago

These books are **FREE** and sent post paid. Mark an "X" in the squares to indicate which ones you wish.

- Harris Home Book of Plans Book of "Presto-up" Houses and Garages
 Building Material Catalog Plumbing and Heating Book

Name.....

Address.....

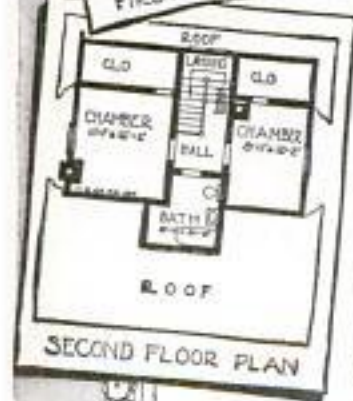



\$4 Down Brings This BRAND-NEW 4 TYPEWRITER

Pay the balance in small monthly payments. We will ship the typewriter to you for ten days' free trial.

The Annell is Standard in size, appearance, construction and mechanical operation, with an action so smooth and a touch so responsive as to be a source of constant pleasure to the experienced operator, and making the progress of the novice immeasurably easier. It turns out beautiful work. The type is clear, clean-cut, hard; the alignment and spacing are utterly perfect. The speed is unlimited; no operator can crowd the Annell. Extremely simple in construction, it is trouble-proof, sturdy, and will last a business lifetime. It embodies the ideas and experience of mechanical geniuses who have been making typewriters and typewriter improvements for generations.

Every Operating Feature

The Annell has every late-style feature and modern operating convenience — each letter completely visible as written (together with all the previous writing), Back Spacer, Tabulator, Two-Color Ribbon, Right- and Left-Hand Shift Key, Shift Lock, Margin Release, Adjustable Line Spacing, Adjustable Margin Stops, Paper Release, Automatic Line Spacer on Carriage Return, Adjustable Paper Fingers, etc., also the 42-key, 84-character Universal Keyboard. Rubber cover and all extras shipped with each machine.

Big Saving—Over a Year to Pay

We are the only company selling a Standard 42-key, 4-Row, Brand-New Typewriter direct to the user by mail at practically the wholesale price of other high-grade typewriters. Our remarkably low price and monthly payment plan enable you to buy a brand-new typewriter easily and conveniently—over a year to pay.

Fully Guaranteed

We protect you with an ironclad guarantee against any flaw in material or workmanship.

No Risk—10-Day Free Trial

We will prove its high-grade quality by sending the Annell to you for ten days' trial. Use it on any of your work. If not satisfactory, return the machine to us. We will refund the express charges and any money you have paid, and the trial will cost you nothing. You are the only judge. Could anything be fairer?

Send for Information, or Send the Coupon

Send coupon or a postal today for full information about the greatest of all typewriter offers. Don't miss it. Act now.

ANNELL TYPEWRITER CO.

629 No. 230 East Ohio Street, Chicago

NOT AN ORDER - MAIL TODAY

ANNELL TYPEWRITER CO.
629 No. 230 East Ohio Street, Chicago.
Send me complete information about your wonderful typewriter offer. This places me under no obligation.

Please Mention Popular Mechanics

Ingersoll Watches



The Utmost in Value

MORE than merely low price sets Ingersoll apart from every other watch. There are other low-priced watches.

Ingersoll watches are reliable, sturdy, honestly good-looking, as well as sold for so little money. Your dealer will show you the complete line.

Announcement

By an arrangement completed on March 31st, the Ingersoll assets were purchased by the Waterbury Clock Company. Thus Ingersolls are now marketed directly by the manufacturers, who have made Ingersolls from the beginning.

Waterbury Clock Company

Factories: Waterbury, Conn.

Sales Offices

New York San Francisco
137 Centre St. 360 Fremont St.

Chicago
215 W. Randolph St.

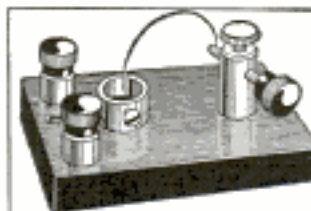

RADIO DETECTORS

Size 3 1/4 x 2". An improved detector of real merit. Nickel-plated posts. Fibre base.

Price 75 cents, postpaid

Dealers get our prices on Panel Switches and Binding Posts.

SYMPHER MANUFACTURING COMPANY
Dept. M TOLEDO, OHIO

SAVE HALF - INSTALL YOUR OWN PLUMBING AND HEATING BY OUR NEW EASY METHOD

Send for Our Big Handy-Man Plumbing and Heating Encyclopedia

It shows and explains our NEW EASY METHOD—how to save skilled labor, unnecessary material and heavy work. Any handy man can do the installing with our simplified systems and working plans. OUR NEW EASY METHOD saves much cutting, threading, time and material. Even if you are a plumber the big saving by using our products and NEW EASY METHOD will surprise you.

Big Book Saves Labor and Material

Every builder, mechanic, farmer, etc., needs this BIG INSTRUCTIVE PLUMBING AND HEATING ENCYCLOPEDIA. Besides being our wholesale catalog, it contains hundreds of floor plans, elevations, diagrams and installing sketches from the simplest to the most difficult systems, showing our EASY METHOD of installing your own plumbing or heating, gives hundreds of mechanical rules, kinks, receipts, short cuts, etc., how to lay out plumbing and heating, estimate costs, repair leaks, etc. It shows and describes over 10,000 FACTORY FITTED plumbing and heating fixtures and supplies with wholesale prices; helps you to select the best plumbing outfit, or heating plant, to meet your needs. Any handy man can do the installing with the aid of OUR HANDY-MAN PLUMBING AND HEATING ENCYCLOPEDIA.

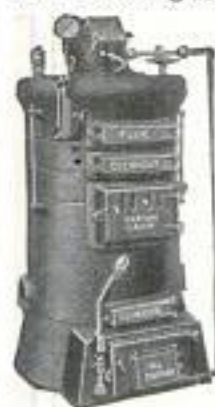

Our Factory Fitted Plumbing and Heating

BATHROOM OUTFITS, TOILETS, LAVATORIES, BATH TUBS, SINKS, LAUNDRY TUBS, WATER SUPPLY SYSTEMS, WATER HEATERS, PUMPS, PIPELESS AND WARM AIR FURNACES, HOT WATER AND STEAM PLANTS, PIPE, FITTINGS, VALVES, etc. All outfits factory fitted for the handy man, with beauty, durability and EASE OF INSTALLATION built through and through.

SEND 25c FOR YOUR COPY TODAY

COUPON

HARDIN-LAVIN CO. 50 YEARS AT 4547-57 COTTAGE GROVE AVE., CHICAGO

Enclosed find 25c. Please send me your HANDY-MAN PLUMBING AND HEATING ENCYCLOPEDIA with wholesale discounts, and mail me your monthly bulletin, "Service." 25c to be refunded to me with my first order.

Name _____

Street
and No. _____

City _____

State _____

Make it a Real vacation!



OVER the hills to vacation land—
with care left far behind! Fifty miles or five hundred, good roads or bad, just say where you want to go and a Harley-Davidson will take you there—comfortably, swiftly, economically.

Miles are but pleasant minutes—distant lakes, streams and camping grounds are but a jaunt away when you ride a Harley-Davidson. With your pal and a week's provisions in the roomy sidecar, you're off for the time of your life—a vacation you'll never forget!

And you don't spend most of your vacation money for carfare when you ride a Harley-Davidson. 50 miles for a dollar—gas, oil, tires and all. That's all it costs! Ask your dealer for a free demonstration and his easy payment plan. Or write us for illustrated literature.

HARLEY-DAVIDSON MOTOR CO.
Milwaukee, Wisconsin

Attractive dealer proposition for unassigned territories. Address Desk A-2

Harley-Davidson

World's Champion Motorcycle



That noon whistle means "Icy-Hots!"

EAT a piping hot dinner from your Icy-Hot Lunch Kit — feel good all day!

An Icy-Hot Lunch Kit keeps your dinner fresh and tasty, and your coffee piping hot and full of flavor. This summer have refreshing lemonade or other iced drinks icy-cold in your Icy-Hot on the hottest day.

Dinner from an Icy-Hot tastes just as good as at the dinner table at home. The Icy-Hot Lunch Kit is all-metal, dust-proof, moisture-proof, and is built for lifetime service.

Icy-Hots are always on the job keeping hot things piping hot twenty-four hours or cold things icy-cold three days. Get an Icy-Hot Lunch Kit today and enjoy a regular hot dinner when the noon whistle blows tomorrow!



Look for name Icy-Hot on bottom. Sold by reliable dealers everywhere. Send for illustrated catalog.

THE ICY-HOT BOTTLE CO.
192 W. Second St., Cincinnati, O.

ICY-HOT

VACUUM PRODUCTS

Made in America, of American Material, by American Labor. Built for Lifetime Service

The Icy-Hot Bottle Co.
192 W. Second St., Cincinnati, Ohio
Please send complete catalog of Icy-Hot products.

Name.....
Street and Number..... State.....
P. O.....

KEEP CONTENTS HOT 24 HOURS! COLD 3 DAYS.

Please Mention Popular Mechanics

HERE IT IS

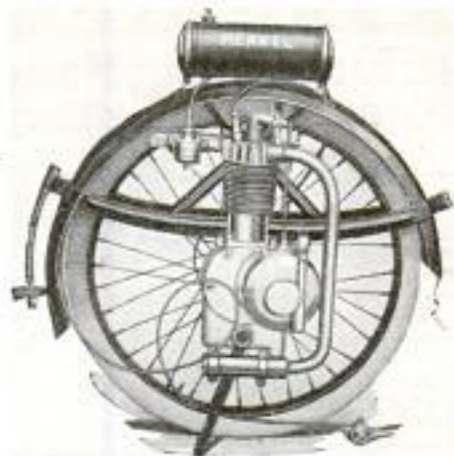

THE MERKEL MOTOR WHEEL

A self-contained power unit to convert the bicycle into a motor driven machine, can be fitted in place of the rear wheel of any standard bicycle.



The final answer to the transportation question.

No skill or special tools required to install it.

It is equipped with a clutch, thus permitting motor to run when you stop your bicycle in heavy traffic.

All working parts automatically oiled.

The Merkel Motor Wheel is not a TOY or Make-shift. IT'S A PRACTICAL POWER PLANT. Designed to meet the long felt desire of the Bicycle rider.

POWER—Enough to master all hills on the highways.

SPEED—Sufficient for safe riding.

Simplicity of operation, any Lady or Gentleman, Girl or Boy owning a Bicycle can operate it.

ECONOMY—No other Motor vehicle in the World can be operated as cheaply as the Merkel Motor Wheel, **FOUR MILES for ONE CENT.**

SATISFACTION—More than you have had with your bicycle, because it will speedily take you there and back without exertion on your part.

Price \$85, F.O.B. Springfield, Mass.

Send for Merkel Catalogue

If there is not a dealer in your town selling Merkel Motor Wheels, write us—we want agents everywhere

HENDEE MANUFACTURING CO.

MERKEL MOTOR WHEEL DEPT.

SPRINGFIELD, MASS., U. S. A.



The power you may never need

WESTINGHOUSE ATTENTION. Get acquainted with this superior service created by Westinghouse. It is for YOUR battery, no matter what make it is. 1800 Westinghouse Service Stations.

WESTINGHOUSE RADIO BATTERIES

eliminate all battery trouble in radio sets. "A" and "B" types.

THOUGH you may never have occasion to draw upon the reserve power of your Westinghouse Battery, the mental serenity you derive from knowing it is there is priceless.

Westinghouse Batteries carry the name, reputation and guarantee of the world-recognized sponsors of the air brake, automatic railway signals and other appliances for safety in transportation. They are not only rugged in construction, vigorous and resourceful in action, but are built "oversize." Their extra plate area—running as high as 25 per cent in common sizes—means larger capacity, longer life, *greater dependability*. Truly this is the kind of battery you have been looking for!

One quality battery—the best Westinghouse can build!
WESTINGHOUSE UNION BATTERY CO., Swissvale, Pa.

WESTINGHOUSE BATTERIES



Only \$15 Down

Play Well in 4 Weeks

—Eight Months to Pay

Latest C Melody Saxophone Outfit complete, only \$65—lowest price ever quoted. Sent on 5 days' trial. If satisfied, pay only \$10 a month for 8 months. No interest to pay—no extras. Outfit includes finest nickel trimmed and richly lined Case, Instruction Book, Album of Popular Saxophone Solos, Music Lays, Carrying Strap, Mouthpiece and three Fine Reeds.

"Masterbilt" Saxophones

Highest quality, built in perfect tune, assembled and tested by experts. Has all latest key improvements, light, quick action and beautiful finish. Order direct from this advertisement or write for Free Catalog Folder today.

The Saxophone Shop, 427 S. Wabash Ave., Chicago
Largest Exclusive Dealers in Saxophone Supplies in the World.

DIAMONDS

For a Few Cents a Day

Diamond bargains—128 pages of them. The greatest Diamond book ever published sent free for your name and address. Your choice of millions of dollars worth of diamonds sent upon request. No money down. Terms as low as a few cents a day. 8 per cent yearly increase in value guaranteed. Extra 5 per cent bonus may be earned.

Write Today for 128-page book, thousands of bargains. No obligations. Write NOW to Dept. A177.

J. M. LYON & CO. 1 Maiden Lane, New York, N. Y.

Enders

SAFETY RAZOR

*"Just like
wiping your
face with
a towel"*



Perfectly
Simple
Simply
Perfect

ENDERS SELLS FOR \$1.00 with six blades of the best quality Swedish-base steel. Packed in black Keratol box, velvet lined. Extra blades, package of 5—35 cents. IN CANADA—Razor, \$1.50; blades, 50 cents.

For Sale by all Up-to-Date Dealers Everywhere

ENDERS SALES COMPANY
105-111 West 40th Street, New York



CIGARETTE EJECTOR

"Just Press the Button"!

\$1.50

and up it comes! Latest in "smoke" cases. Keeps cigarettes perfect, prevents crushing. Works every time, smoothly, noiselessly. Every smoker wants one. Mailed to you for \$1.50 if not at your dealer's.



AGENTS making big money. Sells easily from \$1.50 to \$16.00. Write quick for exclusive territory. Dealers, get big retail offer.

THE LYONS MFG. CO., Dept. M. P.
342 YORK STREET, NEW HAVEN, CONN.

\$3 Cash Buys Typewriter



Balance Only \$5 Monthly

Have 35 to 60% on all Standard makes—Underwood, Royal, Remington, etc. Every machine thoroughly rebuilt and **GUARANTEED**. Try 5 days at our expense before you buy.

WRITE at once for Free Descriptive Circular and Special Low Prices.

**5
DAYS
FREE
TRIAL**

WYNN TYPEWRITER EXCHANGE 11 Reliance Bldg.
Kansas City, Mo.

JUST WHAT YOU WANT!

The NON-SKID Ink Stand



"stays put"
Cannot move, slide or stray from where you place it. A cork insert at bottom does the trick. Made of iron. Will hold any regular size desk ink bottle. Lasts a lifetime. Heavy enough to be used as a paper weight. Mailed day your order is received.

35c

ROLESCH & CO., Sole Mfrs.
Est. 1883 128-A Fulton St., New York Postpaid

A Baseball Jersey



Be the First in Your Club

School, City or Town, to wear this pure, all wool sweater, double collar and cuffs. Your choice in colors. This jersey was selected by 10,000 of my customers for last season. Your chum will recommend it. Send for my big illustrated catalogue. Write me and learn my offer for your club's order. Popular Prices. Best Grade Sporting Goods—Baseball, Basketball, Tennis, Golf, Football, etc.

WRITE ME NOW

Jack Shannon Co., Dept. 46, 111 So. Dearborn St., Chicago

A PERFECT POLISH WITH CLEAN HANDS



**KAXO
SHOE BRUSH**

POLISH, DAUBER and BRUSH combined in one convenient article. Polish is in a tube enclosed in metal case on top of brush, and when tube is used up, new ones may be obtained at leading stores everywhere, 25 cents. Buy of your dealer or order direct, stating whether black, tan, mahogany or white is desired. Fine opportunity for agents.

Postpaid anywhere \$1.25

Address Sales Dept.
The Kaxo Co., Cambridge, (39) Mass.

HAWAIIAN IM. DIAMONDS



No. 8018
Special price **\$2.98**

The Greatest Discovery the World Has Ever Known

Just to advertise these famous IM. diamonds we will send you one of these 14k gold 1. rings, postage paid. When it arrives pay postman \$2.98 C.O.D., charges to cover cost, etc. Only 10,000 rings given away. Money refunded if you can tell it from a genuine diamond. Read size of finger.

KRAUTH & REED

Dept. C
Masonic Temple Chicago



No. 8011
Special price **\$2.98**



—APPEARANCE

THE appearance of Brown & Sharpe Machinists' Tools is in keeping with their superior accuracy and dependability. It reflects the careful workmanship which produces them.

Add this micrometer to your kit. Its splendid finish will be a continual source of pride. The thorough reliability of this accurate measuring instrument will give you the confidence to carry through the most difficult tasks with sureness and speed.

Your dealer will gladly show you this tool. Ask him for our No. 28 Catalog or write us direct.

BROWN & SHARPE MFG. CO.

PROVIDENCE, R. I., U. S. A.

BROWN & SHARPE MACHINISTS' TOOLS

The First Precision Tools in America

The Best Precision Tools Today



Moore Push-Pins
Glass Heads—Steel Points
Moore Push-less Hangers
To hang up things
Ask your dealer to show them
Sold Everywhere **10¢** per packet
Moore Push-Pin Co.
Wayne Junction Philadelphia



Send for a Complete Catalogue of
MASONIC BOOKS
Jewelry and Goods
REDDING & CO.
Publishers and Manufacturers
Dept. P 200 Fifth Avenue, New York

You'll Get
A Year's Wear or more
when you buy

Nu-Way
or
EXCELLO
RUBBERLESS
SUSPENDERS

No rubber to rot. Phosphor Bronze Springs give the stretch. Ask Your Dealer for Nu-Way Suspenders, Garters and Hose Supporters. If he hasn't them, send direct, giving dealer's name. Every pair guaranteed.
Nu-Way Stretch Suspenders Co., Mfrs., Adrian, Mich.



LOFTIS BROS. & CO. Established 1858

DIAMONDS WATCHES CASH or CREDIT



"SYLVIA" Diamond Ring
Blue white, radiant, perfect cut Diamond. The ring is 18-K Solid White Gold, carved and pierced. Extra special at \$100. Credit terms at **\$2.50 A WEEK**
Others at \$75, \$150, \$200 up.

Genuine Diamonds GUARANTEED
Our Diamonds are distinctive in fiery brilliancy, blue white, perfect cut. Sent prepaid for your Free Examination, on Charge Account.

Send for Free Catalog
Everything explained. Over 2,000 illustrations of Diamond-set Jewelry, Pearls, Watches, Wrist Watches, Mesh Bags, Silverware.



Wrist Watch \$2.25 A Month
Cushion Shape Gold filled, guaranteed 20 years. 15 Jewels, warranted. Ribbon bracelet with gold filled clasp. Special \$21

PRICES ARE DOWN
Our immense buying power for our Chain of Stores in leading cities and our large Mail Order House enables us to make lower prices than small concerns. We invite comparisons. You will be convinced that you can do better with LOFTIS. Money back if not fully satisfied. **LIBERTY BONDS ACCEPTED AT PAR.**



Wedding Ring
All Platinum \$25 Gold Wedding Rings, \$10 up.

Octagon, Tannase, Cushion and other shapes, in White Gold, as low as \$30
Every woman wants a Wrist Watch. Every high school girl should have one. Every wage-earning girl needs one. Open a charge account with LOFTIS. Any price you wish.

The beautiful Ring and Wrist Watch illustrated are only a few of a multitude of bargains shown in our large Catalog. Equivalent Diamonds from \$25 up. Send for Catalog Today. Don't Delay.

THE OLD RELIABLE ORIGINAL CREDIT JEWELERS
DEPT A-894
105 N. State Street, Chicago, Ill.
Stores in Leading Cities

SELF-FILLING INK PENCIL "INDEPENDENT"



Meets all requirements. Self-filling, non-leakable, safety cap. Attached clip. Smooth writing gold Style point.

Guaranteed Improved Fountain Pen. Eliminates fatigue. Promotes efficiency. Writes uniform. A Business necessity. \$2 By Mail

Your Name in Gold—35 Cents Extra
AGENTS WANTED
J. C. ULLRICH & CO., 161 Washington St., New York

HOME LOVERS' BARGAIN BOOK FREE

Showing Over 10,000 Furniture Bargains
All selections loaned free for a month. Take a year to pay if satisfied, paying little by little almost as you please.
SPiegel, MAY, STERN CO., 1198 W. 35th St., Chicago

SEND NO MONEY



Try this Portable Typewriter 10 Days **FREE**

Now you can buy famous, 9-pound National Typewriter direct from the factory, after 10 days' trial—absolutely free. You be the judge. Then we give you

10 MONTHS TO PAY
Same machine as used by thousands of doctors, lawyers, bankers, salesmen, students, writers and business men in 31 countries. Every feature of best, standard size machines, 28 keys.

84 characters. Brand new—not a rebuilt typewriter. Neat, compact carrying case free with every machine. Send today for our 10 Days' Free Trial offer and 10 Months' Easy Payment Plan.

NATIONAL TYPEWRITER CO.
Dept. 7F. Fond du Lac, Wis.

Special—to introduce my PAR-AMOUNT SHIRTS



All New York is wearing Par-Amount Shirts—has for years. I have ten Par-Amount Men's Shops in New York City. I have just decided to make it possible for you outside of New York City to wear the same latest patterns and materials that my customers get at my stores. Don't be satisfied with season-old patterns, warehouse merchandise, or shirts cut skimped to meet a price.

I can offer beautifully made, perfectly finished shirts of Genuine Reps—wonderful corded material that outwears two or three ordinary shirts. Nothing skimped—big comfortable coat style shirts, the roomiest made. Non-fraying neck-bands, box center plait, selected pearl buttons, buttoned sleeve facings, felled seams, guaranteed fast colors. For a limited time only **\$1.65, two for \$3.00.**

Send No Money Pay postman price plus postage.
This price is possible only because I have storefront and clerk-hire on these orders.
Plain white or pencil, medium or wide stripes in blue, green, tan, or lavender, on a snow-white background. Sizes 13-12 to 18; any sleeve length. Remember—I personally select and guarantee your purchase, it's a quality proposition. Money back if not delighted.



A. J. George PAR-AMOUNT SHIRT SHOPS
General Offices
155 East 57th St., New York

AGENTS \$6 A DAY

taking orders for Non-Alcoholic Food Flavors. Every variety. Put up in collapsible tubes. Always fresh. Three times the strength of bottled flavors. Not sold in stores. Fast repeaters. Big income every day.



Men and Women
devoting full time can make \$6 to \$9 a day. Big money for spare time. Largest concern of its kind in the world. Over two million dollars worth of orders taken last year by our Representatives for Zanol Pure Food Products, Toilet Preparations, Soaps, Laundry and Cleaning Specialties and Household Supplies. Every article guaranteed. Write for Sample Outfit and Money Making Proposition.

American Products Co.
6677 AMERICAN BUILDING CINCINNATI, OHIO

"BOW LEGS and KNOCK-KNEES" UNSIGHTLY

SEND FOR BOOKLET SHOWING PHOTOS OF MEN WITH AND WITHOUT THE PERFECT LEG FORMS
PERFECT SALES CO.
140 N. Mayfield Ave., Dept. S, Chicago, Ill.



AGENTS \$60-\$200 a week. Free Samples **GOLD SIGN LETTERS** for store fronts and office windows. Anyone can put them on. No experience necessary. Big demand. LIBERAL OFFER TO GENERAL AGENTS.
METALLIC LETTER CO., 433B, N. Clark St., CHICAGO

W. L. DOUGLAS

FOR MEN AND WOMEN

\$7.00 & \$8.00 SHOES

ALSO MANY STYLES AT \$5.00 & \$6.00

YOU CAN ALWAYS
SAVE MONEY BY WEARING
W. L. DOUGLAS SHOES
SOLD DIRECT FROM FACTORY
TO YOU AT ONE PROFIT

W. L. DOUGLAS PRODUCT IS GUARANTEED
BY MORE THAN FORTY YEARS
EXPERIENCE IN MAKING FINE SHOES

They are made of the best and finest leathers, by skilled shoemakers, all working to make the best shoes for the price that money can buy. The quality is unsurpassed. Only by examining them can you appreciate their wonderful value. Shoes of equal quality cannot be bought elsewhere at anywhere near our prices.

Our \$7.00 and \$8.00 shoes are exceptionally good values. W. L. Douglas shoes are put into all of our 108 stores at factory cost. We do not make one cent of profit until the shoes are sold to you. It is worth dollars for you to remember that when you buy shoes at our stores **YOU PAY ONLY ONE PROFIT.**

No matter where you live, shoe dealers can supply you with W. L. Douglas shoes. They cost no more in San Francisco than they do in New York. Insist upon having W. L. Douglas shoes with the name and retail price stamped on the sole. Do not take a substitute and pay extra profits. Order direct from the factory and save money.



BOYS' SHOES
\$4.00 & \$4.50

W. L. Douglas name and portrait is the best known shoe Trade Mark in the world. It stands for the highest standard of quality at the lowest possible cost.

The intrinsic value of a Trade Mark lies in giving to the consumer the equivalent of the price paid for the goods.

Catalog Free.

W. L. Douglas
President

W. L. Douglas Shoe Co.,
128 Spark St., Brockton, Mass.



STAMPING THE RETAIL PRICE
AT THE FACTORY

THE STAMPED PRICE
IS YOUR PROTECTION
AGAINST
UNREASONABLE PROFITS



AT SEVEN
YEARS OF
AGE

MOVIES-BOYS! GIRLS! GROWN-UPS!

Write to-day for free Catalogue of our
MOVIE MACHINES

REAL MOVIES FOR THE HOME
Wonderful Models \$6.00 to \$25.00, with film
PARAMOUNT MFG. CO., Dept. M
Box 1371 Boston, Mass.



We Pay \$9 a Day

Taking orders for Music Chest.
A marvelous invention. Does
more than machines costing ten
times its price. Easily carried
with you anywhere.

BIG OPPORTUNITY

for any man working spare time or full
time. Easy to take orders on
account of low price. Biggest propo-
sition ever offered to our Special
Representatives. Write for demonstrat-
ing sample, terms and territory.

THOMAS MFG. CO. Chest 448, Dayton, Ohio



SEND 5 CENTS

and get our 48 p. catalogue of **IDEAL Model**
Aeroplanes, Parts and Supplies. Tells how
to build Aeroplanes that fly like real ones.
IDEAL AEROPLANE & SUPPLY CO.
159 Wooster St., cor. W. Houston New York City

The
Prophy-lactic

is the

**ONE Tooth Brush in universal
use today—everywhere**

DIAMONDS — ON CREDIT

**Free Book of
DIAMOND BARGAINS**

Send for the most complete catalog of Diamonds and Jewelry ever published, showing exquisite gifts of every description—every article a rare bargain.

Anything you select will be sent for FREE examination and approval. If satisfied, pay only one-fifth purchase price—balance in 10 months. Send TODAY for catalog No. 62-L.



SWEET Engagement Ring set with perfectly cut, blue-white Diamond.
Price \$45
Terms: \$9 Down, \$3.60 a Month. Solitaires from \$25 to \$1000

"THE HOUSE OF QUALITY"
L.W. SWEET INC.
1650-1660 BROADWAY, NEW YORK

FOR CAMP and Summer Wear

Best quality, lowest prices. Our money back guarantee covers all purchases.

Army Shelter Tents	\$3.00
Khaki Riding Breeches	3.00
Khaki Trousers	2.50
Flannel Shirts	3.00
Khaki Shirts	1.50
Camp Cooking Grates30
Folding Mess Pans25
Athletic Shirts75
Army Folding Cots	4.00
Army O. D. Wool Blankets	2.75

Army tents of all sizes and 5000 other articles for camps or outings.

RUSSELL'S, Inc., 245 W. 42nd St., New York
Formerly Army & Navy Store Co.

Catalog 112
Free on
Request



Get JENKINS' Big FREE LOW PRICES Catalog sent on request

on complete line of high grade nationally known band and orchestra instruments before buying. Big FREE catalog sent on request. Easy payment plan—PLAY WHILE YOU PAY. FREE lesson certificate with each instrument.

Musicians Earn Big Pay. Learn to play from Jenkins' Band and Orchestra Books. First violin or cornet parts FREE. Our 44 years in business is your guarantee of reliable service. Post card brings BIG FREE CATALOG.

J. W. JENKINS SONS' MUSIC CO.
910 Jenkins Bldg. Kansas City, Mo.



DEAF?

**Ask for Proof
that you can
Hear!**



For fifteen years we have been urging every deaf person to try the Acousticon for ten days, absolutely free of cost or obligation—this because we are confident that our constant and expert effort has succeeded in keeping it more efficient than any other device. We again urge you to accept the

1922 ACOUSTICON

For 10 Days' FREE TRIAL
No Deposit—No Expense

If you learn of another hearing device which claims equal efficiency, ask for the same free trial which we offer and compare the two in your own home. We will be very happy to have you choose the one which suits you best and return the other. Let no one convince you but yourself.

DICTOGRAPH PRODUCTS CORP.
1307 Candler Bldg. 220 W. 42nd St., New York City

NEW Self-Heating IRON



AGENTS MAKE \$12 A DAY

New scientific development makes ironing remarkably easy. No wires or attachments—all self contained. Gives clean, quick heat, easily regulated. Costs one cent for 3 hour's use. Saves steps. Cuts ironing time in half.

Sells fast. Mrs. Wagner, Ohio, sold 25 in few hours spare time. Moyer, Pa., made \$164.00 in one week. You can do as well. No experience necessary. Work all or spare time. You simply take orders, we deliver by parcel post and do collecting. Commissions paid same day you take orders. Send for Catalog and FREE OUTFIT OFFER. Write today.

AKRON LAMP CO. 35 Iron St., Akron, O.

40,000 Opportunities in Hotels

Nation wide demand for high salaried men and women; past experience unnecessary; we train you by mail and put you in touch with big opportunities. Big pay, fine living, interesting work, quick advancement; permanent. Write for Free Book, "Your Big Opportunity."

LEWIS HOTEL TRAINING SCHOOL, Room 328, Washington, D. C.

Build Your Own PHONOGRAPH

IT'S EASY WITH OUR HELP

A few hours' interesting work saves over half and gives you a machine to suit your ideas. We furnish motors, tone arms, case material, blue prints and full instructions. Plays any record. Make fine profit building phonographs for your friends.

Write today for our **FREE** Blue print offer.

AGENTS wanted for Choraleon Phonographs.

CHORALEON PHONOGRAPH CO.
622 1st St., Elkhart, Ind.



SAVE
OVER
HALF



Send today for this free booklet.

Own a Corona!

Increase your income

THIS wonderful little 6½ pound folding typewriter pays for itself in time it saves and work it turns out. Fold it up—take it with you—typewrite anywhere.

CORONA

The Personal Writing Machine

REG. U. S. PAT. OFF.

Corona Typewriter Co., Inc.,
108 Main St.,
Groton, N. Y.



Pepsodent PAT. OFF.
REG. U. S.
The New-Day Dentifrice

\$7.50 a Day FREE AUTO OFFER

Men and women to distribute samples and take orders in city and farm homes. We show you how to make \$7.50 a day and secure Auto by our plan. No experience necessary. Write quick.



GET THIS FREE CAR

THE JIFFY SOAP PRODUCTS CO., Dept. 1, Dayton, Ohio

MADE-TO-MEASURE 197



Express or Postage Prepaid
Guaranteed for 2 years solid wear or your money cheerfully refunded. These pants are a "Wonder-Value" worth \$8.50 sent to you for \$1.97 as a sample of fine tailoring.

AGENTS WANTED

EARN \$50.00 a week in your spare time. No experience necessary. Write today for our

BIG FREE OUTFIT

with dozens of the newest styles and attractive woolen samples to choose from. Everything sent FREE.
WASHINGTON TAILORING CO.,
Dept. P-345, Chicago, Illinois



FREE

Trial strip of Tirro. Mail coupon below.

Stop that leak this new way



To mend leaky hose; the neck of a water bottle; broken crockery; torn sheet music; to wrap a golf club; to insulate wires; to seal preserving jars—use Tirro, the new waterproofed mending tape.



Bauer & Black—specialists in tapes for 28 years—make it. Extra strong, extra sticky. Clings to glass, metal, rubber, paper, china.



Mends some things temporarily, others permanently. The Handy Andy of the home and garage. You can color it to match the article mended. Try it. "Wonderful!" you'll say.



Three Sizes: Small, 15c; Medium, 25c; Large, 50c
At Drug Stores

PM 6-22

Tirro

MAIL THIS For Free Strip

BAUER & BLACK,
2500 Dearborn St., Chicago.

Mail me a strip of Tirro.

Name

Address

City.....State.....

Please Mention Popular Mechanics

only **\$1**

Puts this **Genuine Diamond CLUSTER RING ON YOUR FINGER**

looks like **1½** carat stone



There is no red tape about this phenomenal offer and we are positive you will be entirely satisfied with this wonderful gem. It's true, a \$1,000 will put this beautiful ring on your finger. It has seven perfect cut genuine diamonds.

Looks like 1½ carat

Compare this gem with a 1.2 carat diamond and you will see that it resembles a \$700 solitaire. The perfectly cut, 7 sparkling, brilliant stones are set in solid platinum not just Placium Top which gives it added beauty. Send us a dollar bill with your name and address and we will ship this wonderful bargain to you by return mail.

Wear it 30 DAYS FREE

If not satisfied after 30 days, return and we will refund your money. Never in history has such a phenomenal offer been made. An excellent return of \$1 per week or \$4 per month until \$48.50 is paid. Try to buy this cluster for less than \$86. You will never see us offer a real bargain. This is one of our best bargains illustrated in our Free catalogue. Rush your order today to Dept. AC50.

James Bergman
37 Maiden Lane N.Y.

Guarantee
You must be absolutely satisfied or money back.

Different from all others—the NEW BENJAMIN

AIR RIFLE

Made on a different principle from all other Air-Rifles.

The Benjamin is really a strong air-pump used to compress the air in the air chamber to any degree of power desired. From one to six strokes of the pump give all the force necessary. Each additional stroke gives increased power. The Benjamin works on the same principle as all air-drills and air-hammers—with this difference:

You control the shooting force as you desire. Look at this block of hardwood. It shows how Benjamin power is regulated as you wish.

You can't have accidents with a Benjamin. It's safe, always, because you control the power. The Benjamin never loses shooting force, and has no springs to get out of order or shake your aim. Write us for an interesting folder about this wonderful air-gun.

For sale by all dealers. Price \$5.00.

Ask your dealer for demonstration.

BENJAMIN AIR-RIFLE & MFG. CO.
615 N. Broadway, St. Louis, Mo.

Pacific-Coast Representatives:
Stuart & Otto
220 Wilcox Bldg., Los Angeles, Cal.





Kingery

New 1922 Prices

Make Big Money!



Get Started NOW

OWN YOUR BUSINESS

Kingery Pop Corn Poppers and Peanut Roasters are proving the business salvation of thousands of men. You need but little capital and your dividends are enormous—1.0c profit on every dollar.

Adaptable for outdoor use, shows, drug stores, fruit stores, general stores, confectioners, news dealers—for any one who wants to make big money with least expense of time, effort or capital.

Write for new 1922 catalog showing FULL line for any location or any business. Over a hundred styles. Most reasonable prices and terms.

THE KINGERY MFG. CO.

Established 1876

Dept. 242

Cincinnati, Ohio

Do Your PRINTING

Cards, circulars, labels, tags, book, menus, paper, Press, \$12. Larger \$35. Job Press \$150 up. Save money. Print for others, BIG PROFITS. All easy, rules sent. Write factory TODAY for press catalog, TYPE, cards, paper. **THE PRESS CO. D-37, MERIDEN, CONN.**



"Lighting Fixtures"

READY TO HANG
(Direct from Manufacturers)
Completely wired, including glassware. New designs. Send for catalogue No 24. Send for DEALERS' proposition.

ERIE FIXTURE SUPPLY CO.
STA. A. ERIE, PA.



FREE SPORTSMAN'S CATALOGUE

Quality Goods at Lowest Prices

Write today for your FREE copy of this complete Sporting Goods Catalogue. Buy by mail and save money. Every price is cut, every article is absolutely guaranteed. Your money back if you are not satisfied.

It shows fishing rods—split bamboo, as low as \$1.35; reels at all prices; guaranteed 12 lb. test casting lines at 48c; 12 ft. steel boats \$28.65; auto tents 7 x 7 ft. \$7.65; tents 8 or 9 ft. for \$14.45; also bathing suits, skates, athletic goods, camp clothes—everything for the out-of-doors, of standard quality at a big saving.

Write today for this complete Sporting and Athletic Catalogue
Address: Dept. G-10

Montgomery Ward & Co.
St. Paul Chicago Kansas City



AN INCOME FOR LIFE

Do you want it? Then send for this free book. It shows you how the man and woman of average means can buy outright, with two years to pay, high-grade listed and dividend paying securities such as U. S. Steel, Westinghouse, Western Union, etc. This interesting book explains in detail how—

1. You can buy five times as much with your available cash.
2. You can take immediate advantage of present low prices of high-grade securities.
3. You get all dividends and market increases from date of purchase.
4. You have two years to pay through this new monthly payment plan.
5. You are absolutely protected against fluctuations and are guaranteed against call for additional funds.

You can start "An Income for Life" by small monthly payments which you will never miss. The business man or woman, farmer, teacher, mechanic, in fact every one who is thinking of his future and will lay aside \$10, \$15, \$25 a month or more can take advantage of the present opportunity to secure high-grade securities at bargain prices and start building "An Income for Life." Don't fail to write for this valuable book today—it's more than worth while. It means "AN INCOME FOR LIFE."



GET THIS BOOK
FREE

Investment Securities Co.
Suite 430 Moffat Bldg., Detroit, Mich.

"Best" Hand Lantern



A powerful portable lamp, giving a 300 candle power pure white light. Just what the farmer, dairyman, stockman, etc., needs. Safe—Reliable—Economical—Absolutely Rain, Storm and Bug proof. Burns either gasoline or kerosene. Light in weight. Agents wanted. Big Profits. Write for Catalog.

ADOPTED BY THE U. S. GOVERNMENT
The Best Light Co., 324 E. 5th St., Canton, O.

Beautiful HOUSES \$900 and BUNGALOWS

CAN BE BUILT FOR AND UP
This and many others in my new book, Building Plans for Modern Homes, will save you hundreds of dollars. One of the most complete and comprehensive books of plans ever published by any architect. New edition just off the press. Nearly 600 floor plans and photographs of bungalows, Colonial houses, etc., costing from \$200 up; gives sizes and cost to build.



FREDERICK H. GOWING
ARCHITECT
101 Tremont St., BOSTON, MASS.

Sent postpaid for \$2.00



WAKE UP!

Make \$15 to \$25 a Day!

Wanted at once—150 live salesmen for "Quicklit" Lamps and Lanterns. Only hustlers need apply. \$90 to \$150 a week for the right men. Greatest lamps and lanterns ever designed. Burn kerosene or gasoline. Brightest, cleanest, cheapest light!

300 Candle Power of Light at a Cost of 1-8c Per Hour!

"Quicklit" Lamps and Lanterns can be lit with ordinary match like city gas. Only lamps made with automatic cleaning nozzle—wonderful feature!
QUICK! Write for particulars of our proposition to "live" men and big earnings. All free and postpaid. Mail a postal today.

The Nagel-Chase Manufacturing Co.
308-309 Erie Street, Chicago, Ill.

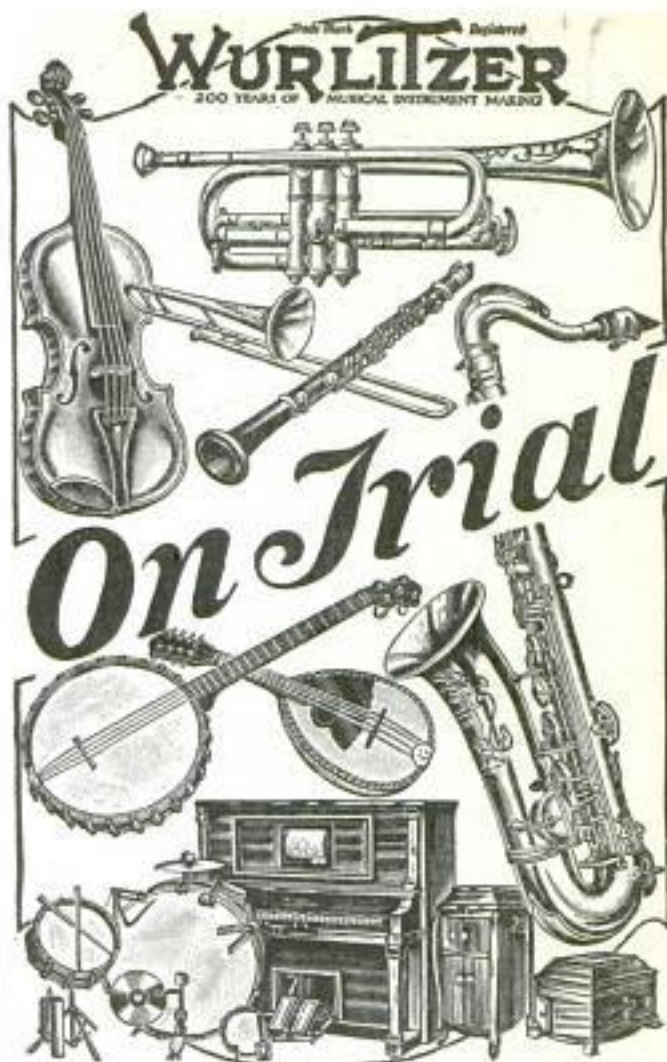

Send for New Book On Musical Instruments **No Charge**

EVERY known instrument illustrated, many in full colors. All details and complete descriptions. A veritable musical encyclopedia—*absolutely free!*

You may now have any musical instrument for a week's trial in your home at our risk. No obligation to buy. Return the instrument at our expense at the end of a week if you decide not to keep it. The trial will not cost you a penny.

Monthly Payments

A few cents a day will pay. Special combination offers in complete musical outfits—velvet lined case, all accessories, self-instructor, etc., all at direct factory price—everything you need at practically the cost of the instrument alone.

Wurlitzer instruments are known all over the world for artistic quality. Used by the greatest musicians, bands and orchestras. Wurlitzer has made the finest musical instruments for over 200 years.

Write Today. Wurlitzer has stores in over thirty cities. But no matter where you live, Wurlitzer is no farther than your nearest mail box. Send coupon today.

THE RUDOLPH WURLITZER CO., Dept. A177
117 E. 4th Street, Cincinnati 120 W. 42nd Street, New York
700 W. Jackson Blvd., Chicago 250 Stockton St., San Francisco

Send me your new catalog with illustrations in color and full descriptions of all musical instruments, also details of the Wurlitzer Free Trial Essay Payment Plan. No obligation.

Name _____
Address _____

(State musical instrument in which you are interested.)

Copyright 1922, The Rudolph Wurlitzer Co.

Please Mention Popular Mechanics

Easy and Economical

BUILD your wireless station, on the ABC sectional system. Start with just the first UNIT—(a complete receiving outfit in itself.) Whenever you wish, add other ABC UNITS—just like a sectional bookcase—without discarding a thing!

Ask your radio or electrical dealer about this exclusive feature of ABC UNITS.

JEWETT MFG. CORP.

Canadian Pacific Building
New York



Standardized Radio
ABC UNITS
Sectional Receiving

for wireless telephone

WITTE

2 H-P.
Pulls
2 3/4

\$39.95
F. O. B.
K. C.

From
Pittsburgh
\$44.95

All other
sizes
Lower

Write
for big
FREE Catalog

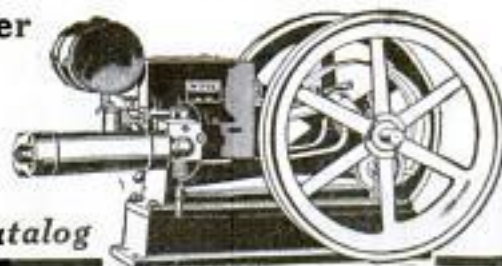

Direct From Factory

WITTE factory price direct saves you money. New quotations are from \$20 to \$400 less than they were last year. All sizes and styles cut in proportion, including Log Saws—Tree Saws—Portable Cutoff Saws and Stationary Buzz Saws.

Lifetime Guarantee Specify what you want and we will send catalog and lowest price—CASH or EASY TERMS, as you wish.

WITTE ENGINE WORKS

1744 Oakland Avenue, Kansas City, Mo.
1744 Empire Building, Pittsburgh, Pa.

RADIO
Equipment
Big FREE Catalogue



THIS FREE catalogue tells you the kind of a Wireless Telephone to own, so that you receive in your own home all the latest news, music, church services, lectures—everything broadcasted throughout the United States.

Every home will soon have a wireless telephone outfit. We now offer complete outfits from \$15 up.

Everyone interested in radio should see our low prices on parts and accessories. Write for this book. Learn about the miracle invention of the age. Easy to install, as simple to operate as a regular telephone.

One copy of this booklet is yours, FREE.
Write for your copy.

Address Dept. R-6

Montgomery Ward & Co.

Kansas City Chicago St. Paul

HIGH GRADE WIRELESS

Head Receivers, Microphones, Keys,
Jacks, Plugs, Etc.

Manufactured by

American Electric

COMPANY

STATE AND 64TH STS. CHICAGO, U. S. A.

TYPEWRITERS
We Save You 50%
FREE TRIAL—EASY TERMS

Your choice of all STANDARD MAKES, UNDERWOOD, ROYAL, SILENT L. C. SMITH, Self-starting REMINGTON, etc. Rebuilt by the Famous Young Process. Guaranteed good as new. Lowest cash prices. Time payments or rentals with special purchase privileges. Largest stock in U. S. Write for special prices and terms.

YOUNG TYPEWRITER CO., Dept. 356 CHICAGO

RADIO DETECTOR

Labels: GALENA PATENT NICKEL DETECTOR CUP AND BINDING POST, SLIDING HARD RUBBER KNOB, NICKEL HOLDER AND BINDING POST, SOLID COMPOSITION BASE.

This is the smallest and lowest priced detector on the market. It does a variety of things as well and better than many \$5.00 detectors. Has composition base; all metal parts nickel plated; furnished complete with galena crystal. Study illustration and notice new features. Note particularly patent nickel detector cup and binding post. Size 1 1/4 x 1 1/4 x 1 inch. Sent prepaid anywhere. Price complete **50c**

If you build your own radio set you must have the RARCO catalog containing 185 illustrations and 50 vacuum tube connection diagrams—the greatest collection published in any catalog. Catalog contains the greatest assortment of parts and raw materials in U. S. Send 15c in stamps or coin for this catalog. "Name Has It."

RADIO SPECIALTY COMPANY, 98 E Park Place, N. Y. City

To get the most from your
Radio Set use "A" and "B"

WESTINGHOUSE

RADIO

W BATTERIES W

The Westinghouse "A" is made exclusively for radio. Its heavy plate and separator insure long life. It furnishes just the type of strong, steady, constant current of low voltage that radio reception needs. It will stand continuous use without growing "tired."

The Westinghouse "B" is the best answer yet found for "B" battery problems. With occasional recharging it will be constantly full of energy, and will last indefinitely.

It is noiseless, clarifies the signals, does not polarize. Its adjustable contact gives adjustable voltage by which you can take the howl out of your vacuum tube.

Don't let inefficient batteries spoil your radio pleasure. Get Westinghouse "A" and "B" from your radio dealer or the nearest Westinghouse Battery Service Station.

"The best Westinghouse can build."

WESTINGHOUSE UNION BATTERY CO.
Swissvale, Pa.

How to Get Rid of Moles



A simple, safe home treatment—
15 years' success in my practice.
Moles (Also BIG Growths) Dry Up.

Ask for Free Booklet of Full Particulars

WM. DAVIS, M. D.

124-5 Grove Ave., Woodbridge, N. J.

DEAFNESS IS MISERY



I know because I was Deaf and had Head Noises for over 30 years. My invisible Antiseptic Ear Drums restored my hearing and stopped Head Noises, and will do it for you. They are Tiny Megaphones. Cannot be seen when worn. Effective when Deafness is caused by Catarrh or by Perforated, Partially or Wholly Destroyed Natural Drums. Easy to put in, easy to take out. Are "Unseen comforts." Inexpensive. Write for Booklet and my sworn statement of how I recovered my hearing.

A. O. LEONARD, Suite 226, 70 5th Avenue, New York City



Set
in
Solid Gold

Set
in
Solid Gold

Send Us Your Name and We'll
Send You a Lachnite

DON'T send a penny. Just say: "Send me a Lachnite mounted in a solid gold ring on 10 day's free trial." We will mail it prepaid right to your home. When it comes merely deposit \$4.75 with the postman and wear the ring for 10 full days. If you, or any of your friends can tell it from a diamond, send it back and we will return your deposit. But if you decide to buy it—send us \$2.50 a month until \$19.75 has been paid.

Write Today Send your name now. Tell us which of these solid gold rings you wish (ladies' or men's). Be sure to send your finger size.
Harold Lachman Co., 394 So. Peoria St., Dept. A177, Chicago

21 Jewel Burlington



Adjusted to the Second 21 Ruby and Sapphire Jewels
Adjusted to Temperature 25 Year Gold Strata Case
Adjusted to Isochronism Your Choice of Dials
Adjusted to Positions (Including Montgomery R. K. Dial)
New Ideas in Thin Cases

Only \$1.00 Down

Only One Dollar Down will buy this masterpiece of watch manufacture. The balance you are allowed to pay in small, easy, monthly payments. The Burlington—a 21-Jewel Watch—is sold to you at a price much lower than that of other high-grade watches. Besides, you have the selection of the finest thin model designs and latest styles in watch cases. Don't delay! Write for the FREE Watch Book and our SPECIAL OFFER today.

Write While This Special Offer Lasts

Get the Burlington Watch Book by sending this coupon. Find out about this great special offer which is being made for only a limited time. You will know a great deal more about watch buying when you read this book. You will be able to "steer clear" of the over-priced watches which are no better. Remember, the Burlington is sent to you for only One Dollar down, balance in small monthly payments. Send the coupon for watch book and our special offer TODAY! Do not delay one minute!

Burlington Watch Company

Dept. A135, 19th St. & Marshall Blvd., Chicago
Canadian Address: 62 Albert St., Winnipeg, Manitoba

Please send me (without obligations and prepaid) your free book on watches with full explanation of your \$1.00 down offer on the Burlington Watch.

Name _____

Address _____

Please Mention Popular Mechanics

Exploring—1922 Style!

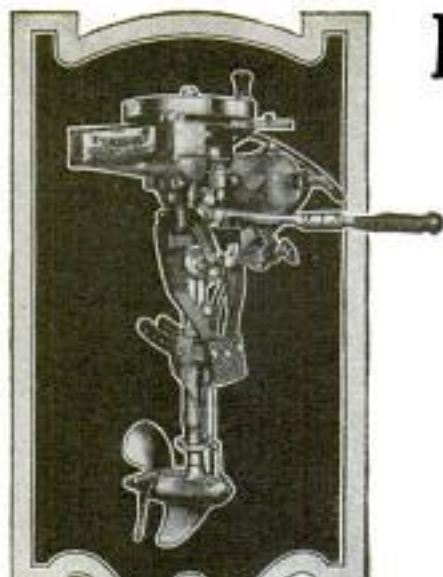

Prospecting strange waterways—seeking new fishing grounds and camping places—seasons at the waterside offer scores of added joys when there is an Evinrude in the family.

Just a twirl of the flywheel and away you go. Swiftly, too, for only heavy, built-in engines equal Evinrude's famous power and speed.

Two Evinrude models—the Standard, for rugged, year 'round service; or the sportsman's Lightweight, weighing only 50 pounds complete—are on display at your sporting goods and hardware dealers.

See them, or write for free catalog describing the Built-in-Flywheel Magneto, Tilt-up Attachment and other Evinrude features.

EVINRUDE MOTOR CO.

679 Evinrude Bldg.

Milwaukee, Wis.

Distributors:

69 Cortlandt St., New York, N. Y.

440 Market St., San Francisco, Calif.

780 Commonwealth Ave., Boston, Mass.

211 Morrison St., Portland, Ore.

EVINRUDE Standard and Lightweight
DETACHABLE MOTORS FOR WATERCRAFT



Evinrude Outings No. 3—Hunting the wild water lily

"Old Town Canoes"

SO steady that it rides rough water with ease—so light, that it answers every pressure of the paddle—so strongly built, that it lasts for years—that's an "Old Town Canoe." \$54 up from dealer or factory. "Old Towns" are the lowest-priced canoes. New 1922 catalog shows all models in colors. Free. Write for it.

OLD TOWN CANOE CO.

1266 Middle Street

Old Town, Maine, U. S. A.



Makes Good beyond Your Hopes

because it is built on sound engineering principles all through.

Play Safe in Buying a Row-Boat Motor you can't afford to take any chances. No matter what style of motor you require, there is a

Wisconsin Detachable Row Boat Motor



that will suit you. For six years this standard little motor has been making GOOD under all conditions—in the hands of thousands of users. And so wonder, when you examine its mechanical construction. It has a number of exclusive features that you should know about. Write for catalog TO-DAY.

WISCONSIN MACHINERY & MFG. CO.
19 Minor Street, Milwaukee, Wis.



Catch Fish, Eels, Rabbits, Skunk, Weasel, Mink, Muskrats etc., in large numbers, with our new, folding, galvanized Steel Wire Traps. They catch them like a fly-trap catches flies. Made in all sizes. Strong and durable. Write for Descriptive Price List, and our Free booklet on best bait known for attracting all kinds of fish.
J. F. GREGORY, Dept. 24, LEBANON, MO.

Send for
Free Catalog
of Money Saving
Bargains

Bargains in Firearms, shot guns, fishing tackle and other sporting items await those who send for this big, beautifully illustrated free catalog. Enjoy exceptionally low prices. Write now for your free copy.
Paramount Trading Company
Dept. 2087
34 West 28th St., New York

Bargains in Sporting Goods

START NOW—SAVE 2/3 COST



Build Your Own Boat
LOWEST PRICED and BEST BOATS in the World Built by BROOKS SYSTEM
Brooks K. D. Outfits make Boat Building a pleasure. You can easily and quickly assemble your own boat by using our simple method. Let us furnish you at trifling cost our instructions, Full Sized Patterns, a K. D. Outfit with parts already shaped and fitted, or build your a Completed Boat. Brooks Models are speedy, staunch and seaworthy. Thousands of satisfied patrons. Get our prices before building, they are lower than ever before.

Send 10 cents for BIG catalog to get information for BOAT buyers.

Brooks, Oldest Established Boat Builders

BROOKS MANUFACTURING COMPANY

Address Cat. Dept.

Saginaw, Mich.

"Fishing Tackle that's
Fit for Fishing"

FOR THE BASS SEASON



"Abbey" Hard Braided Silk
Casting Line

Steel gray in color, smooth, firm and free from imperfections. One of our best lines for bass, pickerel or muscallonge. Fifty yards on spool, two connected.

Nos.....	F	G	H
Tested strength, lbs.....	28	23	18
Retail at, per spool.....	\$3.85	3.50	3.25

Ask your dealer for the famous Abbey & Imbrie tackle. Catalog on receipt of 10 cents

Established 1820 **ABBIE & IMBRIE**
This is Our 102d Year
Division of Baker, Murray & Imbrie
97 Chambers St. New York

VITALIC Bicycle Tires

TRADE MARK REGISTERED
Tougher Than Elephant Hide

MOTORCYCLE BARGAINS

Save 25% to 65%

on Slightly used and Rebuilt Motorcycles, Side Cars, Johnson Motor Wheels, Evans Power Cycles, Bicycles. Send for Free Bargain Bulletin and Money Saving Message, listing hundreds of Bargains in used, rebuilt and new machines, supplies, accessories, etc.

AMERICAN MOTOR CYCLE CO.,
Dept. 614 2047 W. Chicago Avenue, CHICAGO



Only \$45.00 For This Job Complete

Have exorbitant freight rates and one-half original cost by buying Ford Speedster Bodies knocked-down. Simple, complete instructions furnished, all parts cut to exact fit. Any one can assemble this job. Complete with hood, radiator shell, instrument board, upholstery, metal parts, wood parts, bolts screws, etc. Flat radiator shell furnished made up. Designed low with lack of wind resistance. Price set up \$90, further particulars on request.

The Central Auto Supply Co., Eng. Dep. 120, Louisville, Ky.



Not Paper Patterns
All Parts Complete



Racine Wis

America's Finest Canoe

Because it's built that way

Write for Complete Catalog

RACINE BOAT COMPANY
Dept. 61 Racine Wisconsin



Jimmy's Diary

Saturday
June 3rd

"Our Boy Scout troop on 16 mile bicycle ride today. Frank Norton got a puncture. I had tube of Neverleak Tire Fluid in my first aid kit. Squeezed Neverleak in his tire and stopt the leak instantly." Neverleak has saved many a delay. It's the old favorite—guaranteed satisfactory or money back. 25c a tube at all bicycle and repair shops.

FREE—Send for handy Neverleak Pencil Clip.
In attractive colors, holds pencil firmly in place.

BUFFALO SPECIALTY CO.
102 Ellicott St. Buffalo, N. Y.



NEVERLEAK TIRE FLUID

"HEALS PUNCTURES ON THE RUN."

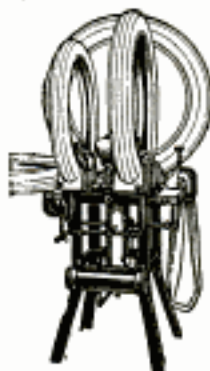

Over \$200 Profit Weekly Above Expenses

All over the U. S. and Canada, we are establishing vulcanizing service stations. We instruct you and furnish the most modern methods and equipment—

THE ANDERSON Known the World Over

We have 34 schools in U. S. and 4 in Canada. One is near you. School pays you \$5 per day while learning to operate the station which you start in your town or elsewhere on small capital. Write for full particulars TODAY.

THE ANDERSON STEAM VULCANIZER CO.

Manufacturers of Modern Tire Repair Equipment
103 Williams Bldg. Indianapolis, U. S. A.

MOTOR CYCLE

Cleveland

PRICE \$185

**THE MOTORCYCLE FOR
TODAY'S DEMANDS**

LOW PRICE. Cleveland is the lowest-priced, real motorcycle. Economy. Cleveland goes 75 miles to the gallon of gas—15,000 miles on one set of tires. Strength. Cleveland uses Mo-lyb-den-um steel. Safety. Low saddle, perfect balance, light weight. Write for catalog "M." If not sold in your city, recommend a dealer.

75 miles to the gallon

Cleveland Motorcycle Manufacturing Company
Cleveland U.S.A.

7th Year
WORM DRIVE

HIS INSPIRATION



They met after years of separation. As boys they had attended the same school. One, was a leader in everything worth-while. He could out run, out swim, and out ride any boy in his class. The other was of sluggish mind—because he didn't develop an active body. He was none too fond of the great out of doors and the sturdy sports of boyhood.

Years passed—they met accidentally on a busy thoroughfare in a large city. A sad but wonderful contrast. Each had developed true to boyhood form.

One was the picture of robust manhood and healthful happiness—a leader in business—a leader of men—a success. Over the desk in this successful man's private office was a little framed photograph, showing him as a boy—during his school days—mounted upon a Dayton bicycle—flashing across the finishing tape a WINNER. This picture had been his inspiration for years.

Dayton Bicycles

"Leaders Since Your Dad was a Boy"

have been the selection of winners since your Dad was a boy. Made complete in our own enormous factory; manufactured by men who have given their brain power for years in assuring every Dayton bicycle owner that his is "a bicycle for champions." These men are working for you.

Do this right away: Get our new booklet—"How to Choose a Bicycle." It will be sent free and postage paid if you will use the attached coupon. This booklet tells a lot about bicycles in general, and the Dayton in particular. Write for it NOW. Use the coupon.

Cycle Division

The Davis Sewing Machine Co., Dayton, O.

FILL IN—CUT OUT—MAIL TODAY

The Davis Sewing Machine Co., Dayton, O.

Please send me, without obligation, your booklet No. 28, "How to Choose a Bicycle" and the 1922 Dayton Catalog.

Name.....

St. and No.

City and State.....

Age.....

2 TIRES FOR \$11.95

FREE TUBE WITH EACH TIRE

SENSATIONAL CUT IN STANDARD TIRE PRICES!

Two used tires for less than the usual cost of one, and a free inner tube with each tire! No double treads or scored tires. Our big volume means best tire values. Act now and cut your tire cost in two. Thousands of steady customers are getting **8,000 MILES** from these tires and you, too, can get

You can see the mileage in our tires. Order and prove it—but order now! This is a special lot selected for record-breaking sale. Supply limited and going double quick.

NOTE THE BARGAIN PRICES ON TWO TIRES OF SAME SIZE

Size	1 Tire	2 Tires	Size	1 Tire	2 Tires
30 x 3	7.25	\$11.95	32 x 4 1/2	\$13.45	\$21.45
30 x 3 1/2	8.25	13.95	33 x 4 1/2	13.95	22.45
32 x 3 1/2	9.45	15.45	34 x 4 1/2	14.45	23.45
31 x 4	10.65	16.90	35 x 4 1/2	14.95	24.90
32 x 4	11.85	19.75	36 x 4 1/2	15.45	25.45
33 x 4	12.45	20.90	33 x 5	15.65	25.95
34 x 4	13.25	21.95	35 x 5	15.90	26.45
36 x 4	14.95	25.95	37 x 5	16.45	26.95

SEND NO MONEY! Shipments C.O.D. express or parcel post. Examine tires on arrival and if not fully satisfied return same at our expense and your money will be promptly refunded. State whether straight side or clincher. **DON'T DELAY! ORDER NOW!**

ALBANY TIRE & RUBBER COMPANY
2721 Roosevelt Road Dept. 164F Chicago, Illinois

"JIFFY CAP"

Make Full Time Money Selling a 100% Ford Necessity—Not Just an Accessory!

Every Ford owner is a "gold" prospect because he avoids the disagreeable five minutes of weary, greasy struggling with gritty or crossed threads that he spends in filling his gas tank. The Jiffy Cap brings smiles to his face as you demonstrate it, and his hand is in his pocket before you finish talking. This article sells for \$1.25.

Write today for our attractive selling plan. A sample will cost you \$1.00.

CHICAGO AUTO SPECIALTY CO.
1349 Bauwau St. Chicago, Ill.

DRIVE 100 TACKS AND SAVE \$25.00

Ford Roadster Top Recovering \$5.00, Topping \$6.65, with celluloid lights in back curtain. With beveled plate glass lights, Ford Roadster \$8.20, Topping \$9.85, Chevrolet, Dodge or Maxwell Roadster \$10.45, Topping \$12.35. All other 5 passenger cars \$10.00, with plate glass lights. Grey Side Back Curtain like cut, Ford \$2. Other cars \$3 extra. Ford Side Curtains that open with doors, Roadster \$10, Topping \$16. Ford regular Side Curtains, Roadster \$6.20, Topping \$8.90. Other cars \$11.50 up. Ford Seat Slips, Roadster \$3.15, Topping \$6.25, or tailored, Roadster \$6.20, Topping \$9.90. Other cars \$4 to \$12. Ford Cushions \$5.75. All goods as car makes, use and guaranteed in Ill. Printed instructions given how to apply. Give model and year of your car. Read 15 with code, and will ship C.O.D., or send for samples. Prices above include War Tax Paid and delivered at your door.

AUTO EQUIPMENT CO., 32 Canal Street, Cincinnati, Ohio

\$45 Buys This Motor Cycle

It's a Harley-Davidson, 16 HP., twin chain drive, magneto and clutch. It has power and can get up and go on the open road at a speed which thrills. This is only one of hundreds of bargains in used motor cycles which you can get. Send for Free Catalog. It tells of his bargains and tremendous values in used motor cycles. Repairs quickly done. Motor cycles exchanged. Send us your machine to be overhauled.



Oliver Cycle and Motor Co., 1045 N. Grand Ave., St. Louis, Mo.

MOTORCYCLES

RELIABLE STANDARD MAKES that you can **DEPEND** on. Enjoy the glorious experience of going wherever you like—whenever you like. The price is within your means—35% to 50% less than others. These machines are slightly used, thoroughly overhauled or rebuilt. Send for catalog.



MYEROW BROS.,
258 Columbus Ave., Boston, Mass.

Roofing Book FREE

World's Best Roofing at Factory Price

Don't buy Roofing of any kind until you get our big Free Roofing Book, describing full line of Edwards Famous "Tightcote" Galvanized Roofings, Sidings and Ceilings, and our lowest factory prices. Then see for yourself how much we save you by selling direct and saving you all in-between dealers' profits.

EDWARDS "REO" Metal Shingles

Absolutely rust proof. By our patented "Tightcote" process, edges as well as sides of metal sheets are heavily coated with zinc—not a space the size of a pin point exposed to weather. Fire and lightning proof. Outlasts three ordinary roofs. Forever wind and weather proof. Need no repairs—end all roofing expense. Patent INTERLOCKING DEVICE makes water tight seams—all nail heads covered—no chance for rust or leaks.

EDWARDS Galvanizing Test

Edwards "Tightcote" Galvanized Roofing can be bent, twisted or struck by lightning, and the galvanizing will not crack or flake. Bend it or hammer it—you can't loosen or peel the galvanizing. No other galvanized roofing can withstand this test.

Low Priced Garages

Wide variety of styles, all sizes of Portable Fireproof Metal Garages. Lowest prices ever made. Postal brings Big Garage Catalog free.

Write Today for free samples and proof that we can save you a lot of money on any kind of roofing siding or ceiling you may need. Ask for Roofing Book No. 150.

THE EDWARDS MFG. CO.,
600-650 Pike St., Cincinnati, O.

FREE
Samples &
Roofing Book

MAKE YOUR FORD INTO SPORT CAR \$ ONLY 6.40

Other types down to \$1.50. Famous size fit. **FREE** life-size patterns and simple instructions show all details. You can easily convert your Ford into this fast, saucy Sport Car as hundreds have done with a few dollars worth of material from the hardware store. No need to lay up the car. The "P.A.S." with conical disc wheel patterns. Pressed Metal Streamline Rear only \$6.40 delivered. Built low, ride wonderfully easy. Order NOW while we can make good delivery. Send 5c coin for illustrated prospectus of Sport Bodies, "Jolly"



\$10.00 A DAY PAID



Weekly to one man in each county taking orders for COFFIELD TIRE PROTECTORS. They prevent punctures, blowouts, stone bruises and fabric breaks. Double tire mileage. Pay for themselves on first tire; used over and over again. Pure live rubber; no metal, no fabric, no friction. Easily applied; no cement or tools required. Nothing like it. Absolute three-year guarantee. Users are boosters. Unlimited demand. Every truck or auto owner a live prospect. No capital required. Checks mailed weekly. Write to

COFFIELD TIRE PROTECTOR CO. 399 Court St., Dayton, Ohio

EARN \$75.00 to \$150.00 A WEEK

By Repairing and Rebuilding TIRES with the greatest Money Making VULCANIZER ever placed on the market. Does Better Work at One Third the usual Cost of Repair. You can guarantee Repair Work to outlast the balance of the tire. Complete Illustrated Instructions with each machine. We teach you how and help you to get started in this big profitable business of tire rebuilding. Complete Outfits \$100.00, \$250.00 and \$350.00. Cash or In Payments. Write today for Circular No. 257.

The Adams-Barre Co.
1248 North High St.
Columbus, Ohio



DELTA ELECTRIC BICYCLE LAMP

To Work!

If YOU go or come from work in darkness—the Delta Electric Bicycle Lamp is just what you need.

Every bicycle should be equipped with this lamp which—with its strong, piercing beam—protects against accidents.

No. 80 solves problem of rear red light—complies with all the laws. Mounts left side front wheel under axle nut. No. 27 mounts on handle bar.

Ask your dealer, or either model sent prepaid for \$2.25 complete (less Battery).

Delta Electric Company

100 DELTA BLOCK MARION, IND.

Standard Makers of Electric Lanterns, Automobile Spotlights, Bicycle Lamps, Flashlights and all kinds of Dry Batteries.

New York San Francisco
Winnipeg



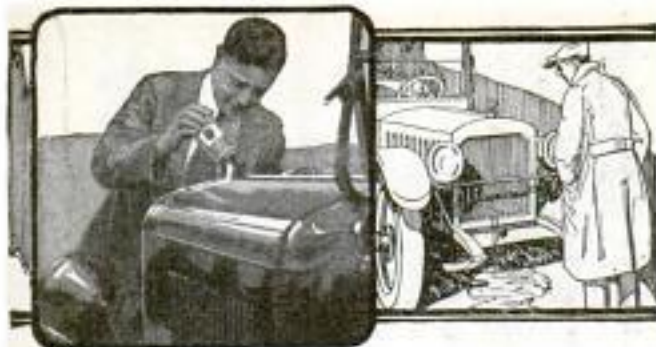

Miracle No. 1

Radiator frozen. Result—steady leak in lower left corner. Couldn't spare car for expensive repairs. Poured

RADIATOR NEVERLEAK

into radiator and completely stopped the leak.

This happened three months ago. Repair solid as ever. Time lost—5 minutes. Cost—75c.

If your dealer hasn't Radiator Neverleak, send 75c for full size can. Guaranteed satisfactory or money back. Carry a can for emergency.

Buffalo Specialty Co.
BUFFALO, N. Y.



Oh Boy! 25 MILES PER HOUR!

is record of our stock car, using our special 1922 motor. Anybody can assemble this car. Send 30 cents for plans, instructions and price list of parts.

SYPPER MFG. CO.
146 Sypher Bldg. TOLEDO, OHIO

LEARN HOW TO GET FREE TIRES FOR YOUR OWN CAR!

1000 more Car Owner Agents wanted at once. Write for full conditions on which full set of famous new process Full Mold Oversize Multiple Weave INTERNATIONAL Tires given FREE to Agents in Exclusive territory! Rock bottom wholesale prices and free wonderful fast selling plan given you right from the start. All tires 8000-mile guaranteed Non-Skids!

AND READ THIS GUARANTEE!

To any person returning an international tire to us accompanied by a sworn affidavit that it did not give service better or equal to any other make of tire it may have been run against, regardless of price, we will replace such tire absolutely free of charge!

INTERNATIONAL TIRES PIRON (No-Rip) TUBES

We need not remind you that this offer of FREE TIRES to live agents, exclusive agency, biggest discounts and ironclad guarantee will get to the required agents almost overnight. Get all the details now! Be in business for yourself! Tie up your own territory with these FREE TIRES and your first order.

DO NOT DELAY—OFFER IS LIMITED! All information as to this great FREE TIRE and AGENCY OFFER sent you free, together with bank references. Write us for them AT ONCE!

Dept. 109 INTERNATIONAL RUBBER CORPORATION, Grand Rapids, Mich.



TWO-YEAR GUARANTEED BATTERIES SAVE 50%



Famous "Royal" Batteries—highest quality made—now selling direct from factory to car owner. You save half. We give written 2-year guarantee—longest on any battery. Big responsible organization backs guarantee. Batteries for any car, tractor or gas engine.

Send no money from this ad. Battery, fully charged, shipped immediately—by express C.O.D. You pay on pick. Our location same for eight years. Reference: Nat'l Bank of the Republic, Dun or Bradstreet.

Free Booklet If you want descriptive matter first, send for free booklet. Gives full details of this superior battery. Get this booklet before you buy any battery. Write today! Give year and model of your car.

K - E BATTERY CO., Dept. 108
646 N. Michigan Blvd., Chicago

Largest Exclusive Mail Order Battery House in America

Members of Chicago Association of Commerce

EARN \$150.00 A WEEK BY YOURSELF with a DUNCAN VULCANIZING PLANT



Includes every tool and vulcanizer for a high-grade repair business. Will handle the work of six men.

We start you in business for as low as \$125.00, balance easy monthly payments, and teach you approved factory methods of tire repair, at home or in one of our own repair shops, FREE; also pay you \$5.00 to \$6.00 per day for the last eight to ten days, when you take the course in one of our repair shop schools, in connection with the purchase of a No. 10 or No. 3 Equipment.

Can you beat this big chance to own your own business upon so small a capital?

The Duncan will cure two or three times as many tires a day as any other mould. It is the only mould made that will operate with sand bags equally as well as with air bag.

F. M. DUNCAN COMPANY

Offices and Factory: 341-349 East Ohio St., Dept. 5, Chicago, U. S. A.

Make Full Time Money

Selling a 100% Auto Necessity—Not Just a Rich Man's Accessory

Every car owner is a "sold" prospect because he realizes his need for an accurate, easy, clean way to save his tires by knowing that they have lost exactly enough air.

You can take his order for this guaranteed money back VISIBLE TIRE TESTER by a simple demonstration. Sample \$2.25. Write today for our attractive selling plan.

Chicago Auto Specialty Co., Inc.



Sells for \$3.00—a fair price

1349 Dearborn St., Chicago, Ill.

BIG PAYING HOTEL JOBS OPEN

to trained men and women; we train you by mail; get 20 years' hotel experience in few months; earn \$3,000 to \$10,000 a year; fine living; work is fascinatingly interesting; quick advancement. Send for FREE BOOK today!

LEWIS HOTEL TRAINING SCHOOL, Room 329, Washington, D. C.

CUSTOM TAILOR MADE To fit your individual car

Made in our custom shops after your order is received.

\$4.40 and up We ship ordinarily in 2 or 3 parcels days. Perfect fit guaranteed Post Paid when correct name, year and model of car is given. You can easily apply it yourself. We furnish instructions and all necessary tools, wets and fasteners. Our catalog No. 10, with samples, is free for the asking.

LIBERTY TOP & TIRE CO., Dept. E-7, Cincinnati, O.

SEND for the INTERNATIONAL CATALOG

Factory to Consumer direct—PAY ONLY ONE PROFIT



Our net price list of auto bodies and body supplies at Wholesale Prices. Save big money by buying Direct from Factory

For Ford and Chevrolet—prices from \$27.85 up
International Body Works 914 W. Ohio Street, Chicago, Ill. Dept. 7



A Torch with Hundreds of Profitable Uses

Torit Acetylene Torch No. 13 PRODUCES A HOT INSTANT FLAME

For radiator and battery repairing, for soldering electrical connections, pots, pans, etc.; for preheating fenders, tempering tools, joining brass tubing, removing rusty bolts and nuts; for light brazing and hundreds of other uses.

A Practical Outfit for Every Mechanic Uses Acetylene Gas Only

Complete with 4 different tips and soldering copper, rubber tubing and tank connection. **\$7.50**

ST. PAUL WELDING & MFG. CO.
177 W. 3rd St. ST. PAUL, MINN.

MOTOR REPAIR BOOK FREE



Why spend dollars, when you can make perfect Automobile and Household repairs quickly and easily with SMOOTH-ON IRON CEMENT No. 1 at a few cents' expense? Write for this book and learn how—It's Free.

Smooth-On is sold in 6 oz., 1 lb., and 5 lb. tins by Hardware and Auto Supply Stores

SMOOTH-ON MFG. CO.
Dept. 37E Jersey City, N. J.

SMOOTH-ON IRON CEMENT No. 1
For Motor and Household Repairs



Make Your Bike a MOTORCYCLE

Make your "foot-power" bike a dependable, easy-running, light-weight motorcycle at small cost. You can do it yourself with the

SHAW MOTOR ATTACHMENT

Compact. Easy to attach. No special tools required. Battery or magneto. Thousands in use. Write at once for free book, prices, terms; also about Shaw Motorbicycle.

Write for
**FREE
BOOK**

SHAW MFG. CO.
Dept. 375
Galesburg, Kans.



95 to 125
Miles per
gallon!

Please Mention Popular Mechanics

Saturday and Sunday Afternoons



What fun to be able to ride wherever you like, in a machine you can afford —an

Indian Motorcycle

60 to 70 miles to the gallon, all upkeep correspondingly low, no garage rent. Comfortable, easy to ride and handle. Cheaper than carfare to ride to work.

Write for literature covering the 1922 models.

Numerous Improvements.

Two brand new models.

Substantial price reductions.

Address Dept. 37

Hendee Manufacturing Company

Largest Motorcycle Manufacturer
in the World

Springfield

Mass.

Eventually on All Fords



Patent Pending

The F-B-Oil-Saver Does All These Things or Money Back

Prevents oil-pumping. Saves 25% to 50% of lubricating oil.

Reduces carbon.

Ends spark plug fouling.

Keeps oil dirt-free.

Reduces wear—improves lubrication.

Saves gasoline.

Stops all oil-leakage.

Sells for **\$1.50**

Dealers and Agents Make \$10—\$30 a Day!

Dealers and agents make wonderful profits selling the F-B-Oil-Saver.

It saves more money for Ford owners than any device ever brought out. Note at left what it does.

A Sure Sale Nearly Every Time

Agents close from 50% to 75% of all prospects talked to. Just put it on a Ford. Show the owner what it does. Only an

instant to demonstrate. No tools, no installation costs.

Hundreds of agents make from \$10 to \$30 a day. No mechanical ability needed. The F-B-Oil-Saver sells itself. Satisfaction or money back guarantee, on every sale. We back you on that. Dealers make big money, too. All Ford owners want this device. Write for our proposition. State whether dealer or agents rights wanted.

Don't wait. Good territory is going fast. Write at once.

PENINSULAR CORPORATION, DETROIT, MICH.

1148 Penobscot Building, Dept. E

Ford Owners

End Lighting Troubles with "Union" Fuse Junction Block

Prevents wires burning from grounds, or lamps flickering due to loose connection. Cuts repair bills. Eliminates fire danger.

Permits use of standard lamps for bright or dim lights instead of high-priced double-filament type. Easy to install. No additional wiring.

Sent postpaid for \$1.50 if not at dealers. Money back if not satisfactory. Write for booklet.

CHICAGO FUSE MFG. CO.

1503 W. 15th St., Chicago

Eastern Branch, New York

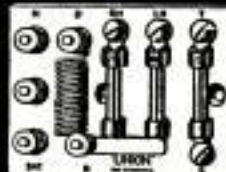

FORD and CHEVROLET SPEED BODIES

Dealers: Write for Accessory Catalogue

MAKE DRIVING A PLEASURE



Equip your old Ford or Chevrolet Chassis with one of our new distinctively modern bodies. Up-to-date Roadster, Touring and Speedster designs. Ford bodies as low as \$29.50 and up. Territory open for live wire dealers and agents. Make real profits.

Buy Direct from Factory

FEDERAL MOTOR SUPPLY CO., Inc.

1424 S. Blue Island Ave.

Chicago

CANADIAN DISTRIBUTORS
Federal Auto Body Co., Toronto, Ont.; Campbellton, N. B.

Small Cash Payment—Balance Easy Terms



\$20 Puts an HB Charger in Your Shop

Balance in easy monthly payments. HB Battery Charging will carry your overhead. No repairs, no renewals, steady, money-making service. Costs you 4c to 12c per battery, customer pays 75c to \$2.00. Quicker, better service with an HB, at lowest cost, means Big Monthly Profits for you. Sold on money-back guarantee. Sizes for 8, 10, 16 or 32 batteries. Let us recommend size to fit your needs. Write today. Ask about HB Air Compressors, Motor Grinders, Tire Buffers, Lighting Generators, Ball Bearing Motors, etc.—all sold on easy payments. Equip your shop to make more money. Write us.

HOBART BROS. CO.

Box M6

TROY, OHIO



Battery Charging Pays \$1500 to \$3000 a Year

Make \$1,000 Easy! From Evening Work

Skidmore of Ohio started last Nov. Has made \$3000 to date! Greatest proposition of century. Grasp it quick! Make \$30 to \$50 a week doing work at home evenings.

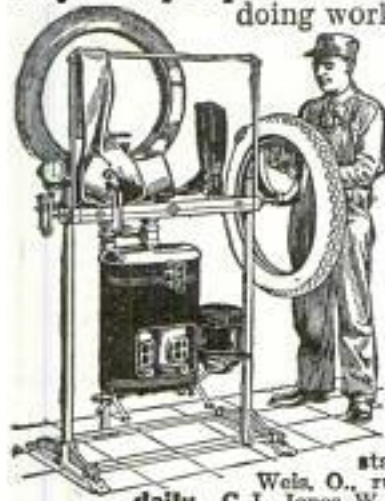

Do Not Quit Your Job

Make big money on side. Turn spare hours into cash with my new home outfit. Vulcanize automobile tires. Mend tubes. Repair gum boots and rubber goods of all kinds. Do thriving neighborhood business. Many men

started economically. L. D.

Wels, O., running better than \$15 daily. C. L. Jones, W. Va., averaging more than

\$47 day during past six weeks, and so on.

Little Money Starts You!

Write me. Get my help. Begin now. Season just opening. Tire repair work galore everywhere. I furnish everything, including machine, tools, clamps, materials and directions. No experience needed. Everything plain and easy. All instructions learned in one evening. Can't go wrong. Marvelous proposition. Wm. Howe, Mo., says: "Biggest little machine I ever saw." Steve Marchand, Texas, writes: "Am having wonderful results with your machine." Others are making extra money—you can too!

Mail Postal To Me, Tonight!

Get full details. It's a proposition you can handle. Place machine anywhere—garage, shed, basement. Has wonderful capacity. Work is easy, pleasant and fascinating. Starts you in big paying business. Puts you on road to independence. Send quick for full information. Address me personally. M. Haywood, Pres.

Haywood Tire & Equipment Co.

974 Capitol Ave.

Indianapolis, Ind.



CORONA CAR Co.

The Sport Car DE LUXE
The Car for Young America
Eighty Miles to the Gallon
A Day's Ride for a Dollar
Half the price of a Flyver
1912 SOUTH WABASH AVE., CHICAGO



SAVE MONEY

Buy your automobile battery direct from factory—highest quality made. You save 50%.

Globe Batteries

For the past two years Globe Batteries have been sold to some of the biggest users of automobile batteries in Chicago. Names of these satisfied users (relisted on request). These same batteries listed below. Save time. Order from this ad. Batteries shipped immediately—express C.O.D.

WRITTEN TWO-YEAR GUARANTEE

6 VOLT 11 PLATE
for Overland, Elgin, Ford, Scripps-Hoath, Grant, Dort, Saxon, Hupmobile, etc.
Usual Cost \$32.00. **Our Price \$12.50**

6 VOLT 13 PLATE
for Oakland, Velle, Nash, Studebaker, Maxwell, Cole, Chevrolet, Mitchell, Buick, Geo. Hudson, Paige, etc. Usual cost \$40.00. **Our Price \$14.50**

12 VOLT 7 PLATE
for Dodge, Maxwell, Crow-Eikhart, Regal, Franklin, Briscoe, etc. Usual Price \$18.00. **Our Price \$12.50**

GLOBE STORAGE BATTERIES FOR RADIO USE

Volts	Amps.	Price	Volts	Amps.	Price
6	20	\$ 8.50	6	60	\$12.50
6	40	10.00	6	80	14.50

Shipped fully charged ready for installation

Begin now to get 100% battery service at half cost, by sending us your order today.

GLOBE BATTERY COMPANY

Dept. P, 1219 S. Wabash Ave.

Chicago, Ill.

Tire Agents Wanted \$4000 A Year



Make Big Money

without risking one cent. I'll start you as I have started so many others in a business of your own. All or part time. The MELLINGER PLAN is revolutionizing the tire business. No capital or experience needed.

I Guarantee Your Profits

Let me prove that you can earn from \$100 to \$400 a month and more. Hundreds, discontented with mere jobs, got this MELLINGER PLAN and today are making big money.

GUARANTEED BY BOND 10,000 MILES



Mellinger Hand Made, over-size Cords and Extra Ply Tires—the finest, most serviceable tires made. I GUARANTEE MILEAGE—some do not. Whether you want CASH or guaranteed mileage for yourself at LOWER WHOLESALE PRICES, write me today. Get my inside figures and discounts. My new low prices amaze everyone. Better tires for less money makes business roll in. One Billion Dollars will be spent for Tires in the next few months. Tires are shipped prepaid on approval.

FREE Master Salesman Kit showing actual sections of tires, fabric, rubber, cord, tubes, etc., in substantial portfolio. Shows secrets of tire construction. Sent free if you're in dead earnest. Tweedie of Maine sells \$1,436.00 in few short weeks; A. M. Amigo, Santurce, P. R., sold \$4,024.00 in 7 months; Hinchelliff, Pa., sells \$1,500 first month. Others do as well.

If You Own a Car, Write Me Quick!

Don't buy anybody's tires until you see these amazing values. I appoint only one agent in each locality. I will make you a surprising offer that will give you a set of tires FREE. Be first in your locality to get my confidential offer. Mail Coupon right now.

GET MY FREE BOOK The most fascinating book you ever read. Wonderfully illustrated. Reveals in detail the remarkable Mellinger Plan that has proven the golden key to thousands, tells all about tires, facts of construction, how tires are sold, explains manufacturers', jobbers', retailers' profits. Don't wait—mail coupon today—Get this big Free book—you never read anything like it. It's free to you—simply send coupon today.

MELLINGER TIRE & RUBBER CO.

1018 Oak St.
Kansas City,
Mo.



B. L. Mellinger, Pres., 1018 Oak St., Kansas City, Mo.

Without obligation, send me your Free Book, details of the Mellinger Plan, and Wholesale Prices and how, without investing any money, I can become your authorized agent.

Name.....

Address.....



A Friend in Need!

Last tube punctured—patches won't stick—you're ready to start home on the rim. Then along comes a helpful friend and shows you how to vulcanize that puncture for good in five minutes. He'll tell you that he wouldn't take ten dollars for the feeling of security his Shaler Vulcanizer gives him and advise you to get one at the next garage or accessory store you pass. You'll do it, and next time the emergency comes you'll thank your lucky star that you were prepared.

Costs Only \$1.50

Slightly higher west of Denver and in Canada

Vulcanizes boots, rubbers, gloves, coats, etc. No gasoline. Each Patch-&-Heat Unit contains its own fuel. A match is all you need.

C. A. SHALER CO.

2005 Fourth St., Waupun, Wis., U. S. A.



**More Mileage
at Less Fuel Cost**



*For Any Car
Any Size—Old or New*

THE foremost item to consider in the upkeep of your car, is fuel consumption. Are you getting every ounce of energy from the gas you buy? There is a way—the New Stromberg Carburetor makes a slave of the gas—gets a "full day's work" from every drop—makes a gallon go farther. It means actual economy through the saving of fuel.

THE make of your car—its age or condition cannot alter the fact that a substantial saving, a noticeable increase in efficiency of operation and additional power is evident where the Stromberg is installed.

Made by
STROMBERG MOTOR DEVICES CO.
Dept. 614
64 East 25th Street
Chicago, Ill.



**New STROMBERG Does it!
CARBURETOR**

**ADVANCE DOOR LOCKING HANDLES
for FORD Closed Cars**



Installed quickly by anyone. They fit in place of original handles. Ford owners delighted with them. Left handle locks automatically, right handle locks with key. Fully guaranteed. Agents: Beautiful sample pair furnished with full particulars. \$3.50 U. S., \$4.50 Canada. Check, money order or C. O. D.
**C. B. HAVEN CO., P. O. Box 1292
Detroit, Mich., or Windsor, Ont.**

**Men With Autos
Wanted**



to introduce and take orders for our **NEW PROCESS STORAGE BATTERY**. Plates cannot sulphate or buckle. No expert attention required.

One-half cup water every 3 months. Made for autos, radios, lighting outfits and all other battery purposes.

Guaranteed 2 Years

The biggest money maker and greatest business builder ever known. Write today for our exclusive proposition and low wholesale prices.

HARSHA BATTERY CO.
21 East Van Buren St.

Dept. 16.
CHICAGO

Please Mention Popular Mechanics

\$2 Brings This Genuine **DIAMOND RING** for 10 Days **FREE TRIAL**

Set in Platinum
Most Sensational Ring Offer Ever Made

Think of it—seven brilliant steel blue genuine diamonds massed by a secret process in a setting of solid platinum set so closely together that only close inspection will distinguish it from a Solitaire valued at \$350.00. Shank of ring is 14 kt. solid gold.

Resembles \$350.00 Solitaire

TEN DAYS' FREE TRIAL

You take no chance—if it is not satisfactory at the end of ten days, or if you can duplicate this genuine diamond ring in any jewelry store for less than \$45.00, your deposit will be refunded to you.

SEND ONLY \$2.00
and the ring goes to you in a handsome gift box, charges paid. A legal guarantee bond as to quality and value accompanies each ring. After ten-day trial pay balance \$4.65 a month for ten months. Price only \$48.50.

Free Royal Bargain Bulletin. Illustrates and describes over 500 special offers in Diamonds, Watches and Jewelry which we are making this month from our \$2,000,000 stock. Address Dept. 541.

ROYAL DIAMOND & WATCH CO.
35-37-39 Maiden Lane - New York
(L. 67-1000-1000)

FORDS RUN 34 MILES on Gallon of Gasoline



Wonderful new carburetor. Guaranteed to reduce gasoline bills from one-half to one-third and increase power of motors from 30 to 50%. Start easy in coldest weather.

Sent on 30 DAYS' TRIAL

Fits any car. Attach yourself. Fords make as high as 34 miles to gallon. Other cars show proportionate saving. Send make of car and take advantage of our special 30-day trial offer. **Agents Wanted.**

AIR FRICTION CARBURETOR CO.
3380 Madison Street Dayton, Ohio

VACCU-FILTER Filters 50 Times Faster than Funnel

For filtering, purifying, clarifying and removing impurities from water—medicine and ALL beverages. VACCU-FILTER nickel plated, guaranteed not to tarnish, \$8.00 complete. (Plain brass \$6.00 complete). Send check or money order 5-day trial—money-back guarantee.

Agents, dealers, jobbers, write for proposition

VACCU-FILTER SALES CO., Inc.
134 West 32nd St. Dept. P New York City

RAISE BELGIAN HARES
New Zealand Reds—Flemish Giants—American Blues—BIG PROFITS, NEAR \$1.50 TO \$3 EACH. Also Cavies, Mink, Skunk, Fox, Muskrat, Etc. Easily raised anywhere. **FREE!** Free Catalog and Contract. Illustrated book "COMMON SENSE RABBIT RAISING," quarterly journal, and copy of America's leading small stock magazine, all for 10 cents. Address **Outdoor Enterprise Co., 1006 G. E. BLDG., KANSAS CITY, MO.**

feels good

and does good. Puts pep in jaded muscles. Athletic trainers recommend it for rub-downs. An antiseptic too, for cuts, scratches, skin abrasions, etc. Excellent for mouth and throat. Few drops suffice. \$1.25 at drug-gists or postpaid.

Liberal trial bottle, postpaid.

10c. **W. F. YOUNG, Inc.**
147 Temple St.
Springfield, Mass.

Absorbine, Jr.
THE ANTISEPTIC LINIMENT

HOMCHARGE YOUR BATTERY for A Nickel

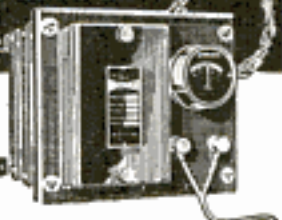

No muss, trouble, dirt—no moving of batteries—loss of time—no effort on your part—no technical or professional knowledge needed.

The Homcharger

successfully meets all charging conditions, and is the only rectifier combining the following essential Homcharging features:

1. Self polarizing. Correct battery either way and it will always charge. No danger of reverse charging, ruined battery or burnt out Rectifier.
2. No delicate bulbs to break or burn out. Only one moving and two wearing parts. These are replaceable as a unit, after thousands of hours use, at small cost. Cannot be injured by rough handling.
3. Operation stops and consumption of current ceases immediately upon disconnecting battery.
4. The only charger costing less than \$100.00 that will fully charge a battery over night. Gives battery a taper charge—exactly as recommended by battery manufacturers. Guaranteed not to harm your battery even though left connected indefinitely.
5. Highest efficiency of any three or six cell charger made.
6. No danger of fire. Approved by the Underwriters.

Attention, Motorists

Will charge your auto battery as well as radio battery. Send for Bulletin No. 58 for further information.

For sale by all radio, electrical and accessory dealers, or shipped express **\$18.50** prepaid for purchase price. . . . \$20.00 West of the Rockies.

THE AUTOMATIC ELECTRICAL DEVICES CO.

129 West Third St. Cincinnati, Ohio

Branch Offices—New York, Chicago, Pittsburgh, Los Angeles, New Orleans, Detroit, Toronto, Philadelphia, Baltimore, Dallas



Largest Manufacturers of Rectifiers in the World

Please Mention Popular Mechanics



Hundreds of Auto Repair Shops and Garages are making big money with the Weldene Scored Cylinder Outfit. Get your share of these handsome profits. ACT TODAY or the other shop in your neighborhood will beat you to it.

MAKE \$10 Per HOUR

With a Weldene Scored Cylinder Outfit you can make and guarantee perfect repairs on Scored Cylinders without dismantling. Broken Motor Blocks, Water Jackets, Aluminum Crank Cases, Fenders, etc., can be repaired without dismantling or preheating by the Weldene Process. No Acetylene. Any mechanic can do it.

PROVE IT BY OUR 10 DAYS FREE TRIAL

Order a Weldene Scored Cylinder Outfit

Try it on Scored Cylinders and be convinced. After ten days, if you are not perfectly satisfied that it will make big money for you—that it is all we say it is—send it back and we will refund your money and transportation charges.

The price of the WELDENE SCORED CYLINDER OUTFIT is only \$20.00. It is patented and there is no other process like it. Hundreds in use in repair shops, auto factories, etc. Positive guarantee. Use on your first repair job will pay for it. ORDER TODAY. Or send for free circular. THE WELDENE COMPANY DEPT. A, 5 W. MADISON STREET, CHICAGO, ILL.

MAKE ICE CREAM BARS

Chocolate-covered ice cream bars are the biggest dime seller of this age. Seven cents profit for you, if you make your own. It's easy, the Jack Frost way.



Complete Outfit \$37.50

Includes everything for coating, wrapping and selling. Full sales rights; no royalty to pay. Get into this profitable business now.

FREE Write at once for pictures and description of the big Jack Frost outfit; address Dept. 1.

JACK FROST CO., 630 S. Wabash Ave., Chicago

\$1 A Month

Buys this world-famous Elgin Watch—the watch you can rely upon every second of the day. It is a new, thin, open-face dust-proof model, 12 size movement. Handsome gold-filled case, guaranteed for 20 years.

Only \$13.98—no advance over the standard Cash price—our amazingly low credit terms only \$2.98 upon receipt and \$1 a month for 11 months. Buy it now!



De Luxe Catalog Free

Contains the most wonderful assortment of Watches, Diamonds and other jewelry. Send for your copy today. Address Dept. 532-L.

Capital, \$1,000,000

"The House of Quality"

L. W. SWEET, INC.
1650-1660 Broadway New York



Auto Owners Save 1/2 SEND NO MONEY

24 MONTHS GUARANTEE

30 DAYS FREE TRIAL

Mail this ad, your name and address. Send no money. We will send you our fully guaranteed JAXON STANDARD auto battery direct from the factory. Be convinced that there are no better batteries at any price. If you are not entirely satisfied after 30 days, return the battery to us. We will refund you the cost plus transportation charges.

Never before has such an offer been made on the highest standard batteries. Jaxon Standard Batteries are made for all cars and shipped fully charged—ready to use. Easy to install. Order today from this ad. Be sure to give model and year of your car. Shipped C. O. D., subject to inspection. You can't go wrong. 24 months' guarantee and 30 days' free trial fully protects you.

Ford—\$13.50 Chevrolet 490—\$13.50 Oakland 20-21—\$13.50
Eggs—\$13.50 Oldsmobile 20-22—\$18.50 18-19—\$13.50
Overland 17-21—\$13.50 Studebaker 15-21—\$15.50 Hudson—\$15.50
Plymouth—\$15.50 Nash 15-21—\$13.50 Dodge 15-21—\$18.50
Write for quotations on cars not listed. Also Radio Batteries and Supplies.
JACKSON BATTERY CO., Dept. A, 1124 Jackson Blvd., Chicago, Ill.



Use Insyde Tyres

in your old casings and get from three to five thousand miles more service.



Positively Prevent Punctures

and blowouts. Give double tire mileage. Any tire—old or new. Can be used over and over again. Low priced. We want men in every county as special representatives to take orders for this big money saver. Write for particulars.

AMERICAN ACCESSORIES CO. B-2076 CINCINNATI, OHIO

Summer Sale OTTAWA LOG SAWS

NOW, get a Log Saw at a big saving. Save more wood—easier to use. 10-Year Guarantee. Shipped from nearest to you of five branch houses. Get FREE BOOK and Special Cut Prices. Write today.

\$64.50
AND UP
L. O. S. Ottawa
OTTAWA MFG. CO., 1741H Wood St., Ottawa, Kas.



FOIL BURGLARS

Make sure your home or buildings aren't next to be robbed. Thousands of dollars and precious valuables lost yearly because most locks are worthless and offer no protection. Test your locks with this wonderful set of Master Keys—5 keys in all, and each one different. Have proved their power to open thousands of different locks and showed hundreds that their homes and property really weren't protected. Endorsed and used by real estate men, bankers, firemen, detectives, policemen, hotel owners, etc. Novel key chain FREE. Send only \$1 today. Money back if not satisfied.



THESE DO IT!

MASTER KEY CO.

121 Manhattan Block Milwaukee, Wis.

$\frac{1}{2}$ H. P.
110 Volt



\$13⁵⁰

AN AMAZING VALUE

Study the specifications of this Motor—Make comparisons—You will not find its equal at anything near our price

It is built for long service. The size, $9 \times 6 \frac{1}{2} \times 6 \frac{1}{2}$ and the weight, 28 lbs., show it isn't in the cheap bargain class. It's a Wagner motor, fully guaranteed, R. P. M., 1725; 60 cycle—1 phase. Has pulley, cord and plug. Shipping weight, 36 lbs.

A real motor—runs your drill press, small lathe, washing or other household machinery; radio equipment, milking machine, pump, etc.

\$13.50 Send cash with order or we will ship C. O. D. if you prefer

THE F. BISSELL CO.

812-822 Lafayette St. Toledo, Ohio
Wholesalers of everything electrical

STICK THIS ON A POSTCARD

Union Tool Chest Co., 22 Mill St., Rochester, N. Y.

Mail me the free booklet that describes completely Union Tool Chests, including new zinc covered line, for machinists, tool makers, carpenters, electricians, plumbers, repairmen, conductors, house and general use. No obligation on my part.

Name.....

Address.....

It's Easy to Build Things with a Boice Pony Bench Machine

Six Machines in One

Does the hundred-and-one things so often desired, with a speed and accuracy that is amazing and at a cost that is ridiculously low.

Especially adapted for cutting all kinds of wood, Shaws materials, and soft metals up to $\frac{1}{4}$ " thick. It will make easy such different operations as cutting-off, ripping, mitring, rabbetting, grooving, cutting tenons, etc. Special attachments simply polishing, buffing, grinding, sanding and drilling.

Ideally suited for use in Private Shops, Manual Training Schools, Cabinet and Pattern Makers' Shops, Furniture Repair Shops, Print Shops, Contractors' Shops, etc. Easily driven by $\frac{1}{4}$ H. P. Motor.

1-rod or 4" and 8" grinding wheels, 6" swan, 3" and 8" sand discs, and 3/8" chisel. All metal construction. Height 10". Weight 21 lbs. Top 10" x 12"; easily elevated or removed. Ready to mount on separate base with motor.

Price of Machine, complete with special equipment, Motor and Base extra. \$37.85

Sold on Money Back Guarantee. Write for Circular.

Also ask about our Bench Joiners, Bench Band Saws, Disc Sanders, larger Motor Driven Bench Saws, and $\frac{1}{4}$ and 1-3 H. P. Ball-Bearing Motors.



W. & J. Boice, 114 23d St., Toledo, O.

WITTE

LOG SAW

New Price for Short Time Only

\$65⁰⁰

F. O. B. Pittsburgh \$70

F. O. B. K. C.



Our Biggest and Best Log Saw

DIRECT To YOU

Look! See What You Get—Big Surplus Power 4-cycle engine—weight over axle (not on handles)—two-wheel truck—easy to move. Direct geared (no chains or belt). Lever controlled clutch—Arm swing motion. We have only one Log Saw—our biggest and best (at advertised price). Why pay \$50 more for any saw. Order direct from this ad. Lifetime guarantee—Cash or terms—Immediate Shipment. Tree Saw at small extra cost. Catalog Free.

WITTE ENGINE WORKS

1748 Oakland Avenue,
1748 Empire Building,

KANSAS CITY, MO.
PITTSBURGH, PA.

MYERS WONDERFUL SEWING AWL

Tools in Handle



A complete repair shop in itself. Sews anything heavy or light, leather, shoes, harness, buggy tops, canvas, belts, etc. \$1.00 Postpaid.
C. A. MYERS COMPANY, 639 Woodlawn Ave., Chicago, Ill.

BURN YOUR NAME ON TOOLS

WITH **ARKOGRAF**

Protect your tools from theft. Write any name, engrave any design on metal with electricity as easily as writing on paper with pen or pencil. Complete outfit \$1.50, prepaid anywhere. Interesting descriptive circular free. Write today. Agents Wanted. Arkograf Pen Company 695 Capitol Ave. Portland, Oregon



THE HANDIEST TOOL in the WORLD



OLSON MAGAZINE SCREW DRIVER

Large enough to bang a door. Small enough to fit a bell. Three blades, one awl, guaranteed. Fits any common screw and makes holes. Ask your hardware store or send \$1.25, prepaid.

Olson Manufacturing Company 52 Commercial St., Worcester, Mass.

One Man Can Move 300 to 800 Bushels of Grain An Hour With the

LIBERTY GRAIN BLOWER

Elevate, clean and grade your grain in one operation. A powerful fan does all the work. Only one moving part. No buckets, chains or gears to get out of order. No inside scooping necessary. One man can move it. Assembled or taken down in five minutes. Costs only half as much as old style elevators. Pays for itself in a few days.

FREE! Send name today for FREE Booklet describing the Liberty Grain Blower and special 1923 price offer.

Midwest Steel Products Co., 448 American Bank Bldg., Kansas City, Mo.

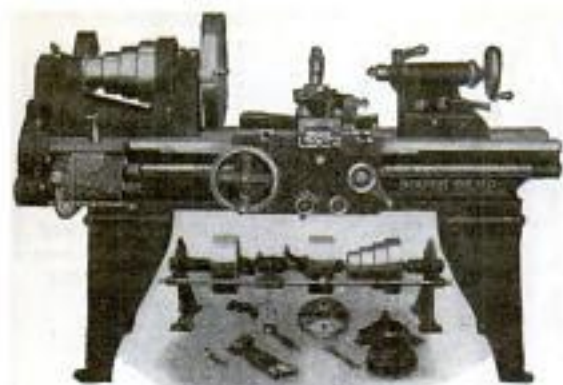

REDUCED PRICES

Back to Normalcy -- 20% Further Reduction

SOUTH BEND LATHES

	Standard Change Gear	Quick Change Gear		Standard Change Gear	Quick Change Gear
9'x3' Lathe	\$176.00	\$216.00	16'x 8' Lathe	\$452.00	\$512.00
11'x4' Lathe	228.00	273.00	18'x10' Lathe	656.00	721.00
13'x5' Lathe	304.00	354.00	21'x12' Lathe	848.00	923.00
15'x6' Lathe	376.00	431.00	24'x14' Lathe	1140.00	1230.00

64-page Catalog No. 73 for 1922 sent free to any address

ESTABLISHED 1906

SOUTH BEND LATHE WORKS

625 E. Madison St.

SOUTH BEND, IND.

How to Run a Lathe An 80-page book, postpaid to any address for ten cents, silver or stamps accepted.

PARKS

New Rapid Upright Hollow Chisel Mor- tising and Boring Machine

\$90

Do better work—quicker—with this Parks. Makes mortises of any size and kind, up to 6 in. deep. Adjustable bed plate tilting to angle of 45 degrees; can be raised and lowered to take work up to 12 in. thick. Takes hollow-chisel bits from $\frac{1}{4}$ to $\frac{3}{8}$ in. and boring bits with $\frac{1}{2}$ in. shank from $\frac{1}{4}$ to 2 in. Operates with 1 to 1 $\frac{1}{2}$ H.P. Frame construction is 2 in. angle steel, joints electric welded—the best you can get. 10-year guaranty, 30-day trial.



Send for catalog

THE PARKS BALL BEARING MACHINE CO.

1500-1540 Knoolton Street

CINCINNATI, OHIO

Canadian Factory, 200 Notre Dame East, Montreal

57

PARKS

WOODWORKING MACHINES

LAKWOOD FAN BELT FASTENERS



MAKE or repair your own flat belts for Autos, Trucks, Tractors, Electric Washers and small Shop Machinery with Lakewood Quick attachable Fasteners. Two sizes— $\frac{1}{2}$ in. and 1 in.; used alone and in combinations handle eight widths flat belting. Simply square up ends, rivet half of fastener to each end, slot together and go. Belt can be removed from pulleys instantly, but can't open in driving. Complete Fastener with rivets, 15c per set; 2 for 25c; 6 for 60c; or 12 sets in neat slide box for \$1.00. Specify size wanted. Sent postpaid same day order received. Fine proposition

Also for V-Type Belts for Garage, Repairmen, and Dealers.
LAKWOOD FABRIC BELTING & MFG. CO.
1518 W. 117th St., Lakewood, Ohio



It is the well known quality of **CRESCENT** machines that justifies you in selecting one of them each time you have need for wood working machinery. The **CRESCENT** line is better than ever and will always give you satisfaction in every particular. Ask today for catalog of hand saws, saw tables, jointers, shapers, planers, borers, planers and matchers, spring saws, disk grinder, cut off table, hollow chisel mortiser, variety wood worker, Universal wood workers.

THE CRESCENT MACHINE CO., 93 Columbia Street, Leetonia, Ohio

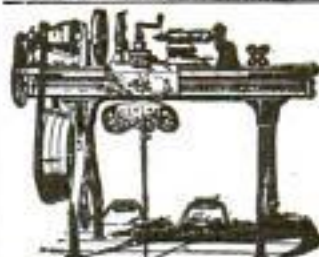

LATHES

9 to 18-inch Swing

List price \$165 and up according to size. When ready to buy send for Lathe Catalog and prices.

W. F. & John Barnes Co.

100 Ruby Street, ROCKFORD, ILL.



MOTOR BARGAIN

$\frac{1}{4}$ hp. A. C., Fan-Cooled **\$13⁵⁰**
Split phase 110 volt, 60 cycle

Rated $\frac{3}{8}$ hp, but tested at the factory for 50% overload. Motor weighs 24 lbs. bare—not a toy, but a sturdy high-power, electric motor, suitable for operating bench lathes and drill presses, grinders, radio sets, washing machinery, churns, cream separators, big ventilating fans and the like. Operates at 1740 rpm.

Guaranteed for 1 year Every motor shipped has wired to it the manufacturer's **GUARANTEED SERVICE TAG**, which entitles the purchaser to a new motor should any defects develop within a year, also to expert advice at any time during the life of the motor.

Same motor with Grinder and Buff—6 inch motor wheel and 7 inch buff, complete with cord and plug **\$25.00**

NORTHWESTERN ELECTRIC CO., 408 So. Hoyne Ave., **CHICAGO**

ONE-HAND-Y ELECTRIC DRILL



Weight
3 lbs.

Capacity
1/4 in.

Westinghouse
Universal Motor
Guaranteed

Knight Engineering & Sales Co.

30 West Walton Place,
Chicago, Ill.

210 W. Seventh Street,
Los Angeles, Calif.

"GET BUSY"
MAKE SCREENS WITH
DIAMOND PRESSED STEEL CORNERS

No mortises, mitres, screws or tacks required. Unbreakable screen, hinges attached, made in a few minutes. Big profits making screens to order. Sample set by mail, 50c postpaid.

DIAMOND HARDWARE MFG. CO.
224 FOURTH AVE., PITTSBURGH, PA.



TOOL CHESTS

for Machinists & Toolmakers
Every tool arranged in order. No up-to-date mechanic should be without one. A Gerstner Case costs no more than some tools, and will last a lifetime. Catalog free.

Gerstner & Sons

717 Columbia Street DAYTON, OHIO

WIRELESS OPERATORS

—Amateur and Professional—need

SOLDERALL—25c per tube

Pat. Oct. 3, 1911

and TORCH, \$1.50



A Paste That Turns Into Metal When Heated
A match will do it, but best results can be obtained by using our new improved torch. Requires no acid or soldering iron. Joins or repairs wires, metal or metalware. Sold by Hardware and Electrical Stores, or sent by us postpaid.

SOLDERALL CO., Dept. P

129 Sussex Avenue NEWARK, N. J.

Dealers Send for Quantity Prices

Beware of Imitations with Similar Names



ATKINS

AAA
ATKINS SAWS
in the SHOP
METAL CUTTING SAWS

Send for this ~ FREE BOOK

Get this big free book that gives all kinds of valuable hints and information on shop practices. Tells you how to increase production and how to get more service from your metal cutting saws. Gives full information on selecting the proper saw to fit the job. Besides this, the book is chock full of other valuable time and money saving suggestions. Learn about the Atkins "Non-Breakable" Hack Saw Blade which cuts faster and easier without breakage. When you send for your book, if you enclose 10c and tell us your work, we'll send you a sample of either 8 or 9 inch blade.

26% Added Service

Atkins KWIK-KUT power hack saw machines use 76% of the blade at every stroke and cut cleaner and faster. Other machines use just 50%. Think what this extra 26% means in a year! "The Saw in the Shop" gives you full details.

It makes no difference for what purpose you use saws, wood or metal. Send for one or more books—"Atkins Metal Saws," "Atkins Hack Saw Chart," "Atkins Metal Cutting Machines," etc. Tell us what use you make of saws. Fill in the coupon NOW!

E. C. Atkins & Co., Inc.

Dept. P, Indianapolis, Ind.

I am interested in saws for

Please send "The Saw in the Shop" and other booklets to

Name

Address

Please Mention Popular Mechanics

Copyrighted material

It Will Pay You to Own A MONARCH JUNIOR Lathe

"The Biggest Little Lathe Built"

There are hundreds of things made of metal or wood, for the shop, automobile and home, that you can make with a MONARCH JUNIOR lathe.

This sturdy dependable small engine lathe, guaranteed to do work with 1/1000 of an inch accuracy, was especially designed for inventors, experimenters and small shop owners who need a lathe of their own.

The Greatest Achievement in Lathe Building
MONARCH JUNIOR \$225 With Bench
9 in. Engine Lathe Legs

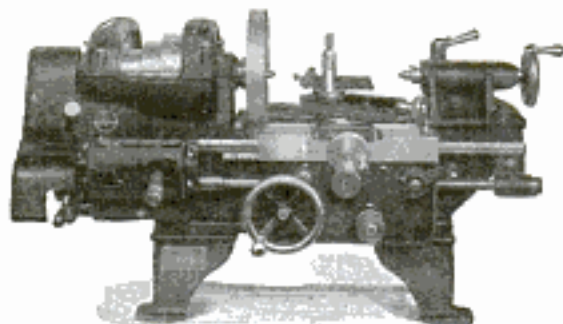

It is easy to learn to operate the MONARCH JUNIOR and even beginners can't jam it. It is equipped in every detail same as the big MONARCH and is guaranteed to do all small work that any other lathe will do.

You can find room for a MONARCH JUNIOR practically anywhere in a small shop or work-room in your home. Write today for catalog and full information about this remarkable—low priced engine lathe.

THE MONARCH MACHINE TOOL CO.
403 Oak Street, - - - Sidney, O.

QUICK!—GET YOURS NOW!



Only
\$6.98
WAS
\$12.00

LEARN DRAWING Here is your only chance to get one of these splendid mechanical drawing outfits—at our special price. Instruments are made of genuine solid German Silver and fine steel, and come in a handsome velvet lined case—4 x 8 1/2 inches, closed. Experts consider these instruments among the highest grade made.

FREE Until further notice we will include with each set of instruments—**A Practical Course in Mechanical Drawing.** This course in mechanical drawing is most simple, thorough and successful in existence, and offers every man, regardless of age, education or previous experience, the chance to become a successful draftsman in a short time and make up to \$100 per week.

SEND NO MONEY Just send us your name and address and pay \$6.98 on arrival of instruments and **Free Course.** Instruments fully guaranteed or money back. This offer is limited—no order now. **Free particulars mailed on request.**

NATIONAL INSTRUMENT CO., 4784 North Hamilton Ave., Chicago, Ill.

SAMSON No. 1 HAND PUNCH

Handles interchangeable. Punches and Dies as Illustrated

Maximum punching capacity 3/8" thru 20 gauge untempered metal. Will also Perforate Paper, Card-board, Leather, etc., up to 1/4" thickness. A Powerful Punch of general utility, made of Drop Forge Steel. Throat 1 3/8" deep.



PRICE,
with complete
set of Punches
and Dies, Post-
paid in U. S. A.

\$5.00

THE MACHINE APPLIANCE CORPORATION
351 Jay Street, BROOKLYN, N. Y.



GET out and get under
with your trusty Bernards. Trouble over quick. Grip and Cut do the trick. The only pliers that grip like a vise and cut like a cleaver. Hardware dealers.

MADE IN SEVEN SIZES

Send for illustrated Plier Booklet M



PARALLEL JAWS

**BERNARD
PLIERS**
Wm. SCHOLLHORN CO.
NEW HAVEN, CONN.



OUTSIDE CUTTER

NEW SINGLE PHASE A. C. MOTORS

1/4 H. P.—110
volt, 60 cycle,
1725 speed, com-
plete with cord,
plug and groov-
ed pulley, \$13.00



1/4	H. P.	\$47.00
1/2	H. P.	58.00
1	H. P.	62.00
1 1/2	H. P.	76.00
2	H. P.	89.00
3	H. P.	108.00

Include pulley
and base.

ONE YEAR GUARANTEE

1/4 H.P. and larger, 110/220 volt Rep. Ind. Type
Satisfaction guaranteed or money refunded
Illustrated Catalog of Motors and Supplies FREE
HYRE ELECTRIC CO., 615-H So. Dearborn St., Chicago

GOODSELL-PRATT 1500 GOOD TOOLS



The Midget "FIVE-IN-ONE" Slide Rule is a combination Mannheim, Log-Log, Add and Subtract, Polyphase and Binary Slide Rule. It will instantly add, subtract, multiply and divide any combination involving whole numbers, fractions, decimals and mixed numbers. Gives every possible root and power of every quantity. The graduations are printed on metal, coated with white celluloid and are grease and waterproof. While it is the most versatile calculator ever invented, its operation is simple and easily understood. Diameter 4 inches. Price with 16-page Instruction Book, \$1.50. Leatherette carrying case 50c extra. Catalog free. Your money back if you are not satisfied.
GILSON SLIDE RULE CO., Niles, Mich.

Interlox

MASTER SLIDE RULE

QUICK AND ACCURATE
INSIDE
MEASUREMENTS!

Exact Inside Measurements
to Smallest Fraction of Inch

USE IT for all measuring—inside or out. The only interlocking, sliding rule. Ideal for Carpenters, Mechanics, Engineers, Electricians, etc. If not at dealer's, send his name and 25c per ft. for rule sent prepaid (any length, from 2 to 8 ft.).

MASTER RULE MFG. CO., INC. (FORMERLY DAHL MFG. CO.)
841-43 E. 136th St., NEW YORK CITY
Dealers and Agents: Write for Liberal Proposition

WINDOW SIGN LETTERS

LARGE PROFITS

194

**EDWARD GOLDSMITH
DELICATESSEN
AND
GROCERY**

CIGARS & TOBACCO **GOODS DELIVERED**

SAMPLES FREE

AGENTS AND SALESMEN

AGENTS WANTED

AGENTS WANTED

SELL For \$15.30

COST YOU \$3.80

\$75.00 to \$150.00 a week. Lowest price gold and silver sign letters for stores, offices, automobiles, etc. Large demand everywhere. Anybody can do it. Exclusive territory or travel all over while you earn. Write for free samples and catalog. ACME LETTER CO., 2806 X Congress St., Chicago

BLANK CARTRIDGE PISTOL



**PRICE
\$1.00**

Well made and effective; modelled on latest type of Revolver; appearance alone is enough to scare a burglar. When loaded it may be as effective as a real revolver without danger to life. Does not shoot real bullets but takes standard .22 Cal. Blank Cartridges, obtainable everywhere. A Great Protection Against Burglars, Tramps and Dogs. You can have it being about without the danger attached to other revolvers. **PRICE \$1.00** Postpaid. Blank Cartridges .22 Cal., shipped express, 50c per 100. **JOHNSON SMITH & CO., Dept. 840, 3224 N. Halsted St., CHICAGO**

MONEY IN MUSHROOMS

NOW TIME TO START

BIG DEMAND. HIGH PRICES BEING PAID

An uncrowded occupation. Exceptional opportunities for live men and women. Raised at home. Only small space needed. Small expenditure will start you in a practical money-making enterprise. Big profits. Booklet telling all free. Write **Nat'l Spawn Co., Dept. 12, Waban, Mass.**

SEND NO MONEY

If You Can Tell it from a GENUINE DIAMOND Send it back

To prove our blue-white MEXICAN DIAMOND cannot be told from a GENUINE DIAMOND and has same DAZZLING RAINBOW FIRE, we will send a selected 1 carat gem in ladies Solitaire Ring. (Cat. Price \$6.25) for Mail Price to introduce, \$2.63, or in Gentle Heavy Tooth Reicher Ring (Cat. Price \$1.60) for \$1.28. Our finest 12k Gold Filled mountings. GUARANTEED 20 YEARS. **SEND NO MONEY.** Just mail postcard or this ad, State Size. We will mail at once. When ring arrives deposit \$2.63 for Ladies ring or \$1.28 for Gents with postman. If not pleased return in 7 days for money back less handling charges. Write for Free catalog. **Agents Wanted.**

MEXICAN DIAMOND IMPORTING CO., Dept. ET, Las Cruces, N. Mex.
(Exclusive controllers Mexican Diamonds)



"Red Devil" Pliers made in 100 styles—one for every need. Known and used the world over. Style 1024—6½ inch shown here, \$1.10.

The Handles Give You a Firm Grip



THE new style extra broad handles fit your hand like a glove. Dentyne knurling gives a firm grip. No bruised knuckles—no pinching—no exasperation from trying to do good work with poor tools.

Red Devil Slip Joint Plier

Has a multitude of practical uses. Once you've used it, you'll never do without it. Forged of tool steel, for strength and backbone.

"Red Devil" Pliers have stood the test for over a quarter century. Used by skilled mechanics the world over. Ask the man who knows tools.

"Red Devil" Slip Joint Plier No. 1226—7 inch, shown here, bonded for 2 years' hard service. Price \$1.20, from dealers or us.

"Red Devil" Tools—American made Mechanics' tool booklet free

SMITH & HEMENWAY CO., Inc.

Manufacturers of "Red Devil" Tools
260 Broadway, New York, N. Y.

"Red Devil" Glass Cutters—the glaziers' standard tools of the world. "It's all in the wheel." Made in 40 styles. No. 024 shown here, 20c.



Please Mention Popular Mechanics

YOU CAN MAKE \$18 DAILY PROFIT

With Our Great Introductory Offer
Giving These \$1.25 Dress-Making Shears **FREE**



With each sale of our wonderful 11 piece Toilet Article Assortment for only \$1.75. TOTAL STORE VALUE \$4.60

\$18.00 a Day PROFIT on only TWENTY Sales



Lucky 11 Toilet Set—Retail Value \$3.35!

MY! HOW THEY SELL!

You get the attention with the free Shears. Walter Harris sold 800 boxes in six weeks. Profit over \$100 a week. You can do this too.

Act Now! Sell like hot cakes year round. A baby could sell Lucky 11. Don't wait a minute. Save time. Send \$1.75 for complete outfit including display case. At least write for circulars explaining our unique plans, including 30 other packages. **ACT NOW!**

E. M. DAVIS CO., Dept. 2356, CHICAGO, ILL.



\$5 Brings this Violin Outfit

Four small monthly payments complete balance. Special Lyon & Healy Student Outfit—includes excellent violin, fanned-lined Kant-Krak case, bow, japanned music stand, tuning pipe, rosin, extra set of strings. Full or three-quarter size. Remarkable value; only limited number at this low price of \$25.85; order today—NOW! Full guarantee—money back if wanted.

LYON & HEALY

60-69 Jackson Blvd. Chicago

AGENTS—A. I. D. FOR YOU



With the new A. I. D. Package Sealer. Sell every store—everywhere—new—efficient—saves time and money—all will buy. Send \$5.00 for sample and agency offer.

A. I. D. Inc., 1352 Beacon St., Boston, 47, Mass.

DIAMONDS

10 MONTHS TO PAY 1/2 CARAT \$99.00

CASH VALUE \$165. 30 DAYS TRIAL

Genuine blue-white perfect cut diamonds now sold direct to you by DIAMOND IMPORTERS at wholesale prices on credit at 40% discount. 18Kt solid, white, gold ring included free. 1/2 carat only \$49.00; 3/4 carat \$147.00; 1 carat \$195.00. If satisfied, pay 1/3 down and balance in 10 monthly payments. We guarantee to please you or refund your money. Order direct from this ad. or write for 128-page bargain catalog of other jewelry \$1,000,000 and 43 years' experience back our guarantee.

B. GUTTER & SONS 172 NASSAU STREET
Dist. 360, NEW YORK

SAVE MONEY ON GUARANTEED MOTORS

Buy Direct from Headquarters

Save from 25% to 40% on standard makes of new and rebuilt motors. Get the proper size and type of motor to suit your exact needs—and get it fully guaranteed by a motor merchandising house backed with 20 years of dependable service direct to users. Write today for catalog No. 70. It quotes prices on motors of every size and type.

Electrical Equipment Bought, Repaired or Exchanged.

THE FUERST-FRIEDMAN COMPANY

"Reliability Built In."

CLEVELAND

OHIO

The HAMMOND

Folding Portable Typewriter

MULTIPLEX HAMMOND'S
Instantly changeable type
Many styles, many languages
Just Turn the Knob to change

Hammond Typewriter Corp., 560A East 69th Street
New York, N. Y., U. S. A.

SALESMEN: Here It Is



Fastest operating and lowest priced Fire Extinguisher made. Patented. Plays 12 streams. Smothers the blaze, be it gasoline or wood, or any other burning substance or fluid.

Money Back if Not Satisfied

We want men in every county. No capital or experience necessary. All you do is take orders. We deliver and collect. Pay you every day. Fell of Detroit made \$90 first week. Write for sample and territory.

Thurston Mfg. Co. F. E. 178 Dayton, Ohio

LUMINOUS PAINT

Make Your Watches, Clocks, Etc., Visible by Night

The very latest discovery in the scientific world. Hitherto, practically unobtainable except at an exorbitant price, we have at last succeeded in producing this remarkable LUMINOUS PAINT, which applied to the surface of any article, emits rays of white light, rendering it perfectly visible in the dark. **THE DARKER THE NIGHT, THE MORE DRILLIANT IT SHINES.** Quite simple to use. Any one—you can do it. A little applied to the dial of your watch or clock will enable you to tell the time by night. You can coat the push buttons or switch plates of your electric lights, match boxes, and innumerable other articles; make your own Luminous Crucifixes, Luminous Flowers, etc. Small bottle, price 25c. Larger sizes, 50c and \$1 postpaid.

Johnson Smith & Co., 2214 N. Halsted St., Dept. 44, Chicago

Big Engine Sale

Prices Smashed on OTTAWA Engines. Only sold direct from factory. 3 months' trial. Easy Terms. Write for Engine BOOK and Sale Prices Today.

	<p>2 H-P \$38.50</p> <p>3 1/2 H-P \$54.50</p> <p>4 H-P \$75.95</p> <p>5, 7, 10, 12, 16, 22 H-P, at Low Prices</p> <p>POWER LOG SAW \$64.50</p>
--	---

OTTAWA MFG. CO.
531 D King St., Ottawa, Kan.

PATENTS TRADE-MARKS AND COPYRIGHTS

OUR OFFER—Free Opinion as to Patentable Nature

Before disclosing an invention, the inventor should write for our blank form "Record of Invention." This should be signed and witnessed and if returned to us together with model or sketch and description of the invention, we will give our opinion as to its patentable nature.

Our Three Books Mailed FREE to Inventors

OUR ILLUSTRATED GUIDE BOOK

HOW TO OBTAIN A PATENT

Contains full instructions regarding Patents, Trade-Marks, Foreign Patents, Our Methods, Terms, and 100 Mechanical Movements illustrated and described; Articles on Patent Practice and Procedure, and Law Points for inventors.

OUR TRADE MARK BOOK

Shows the value and necessity of trade-mark protection and gives information regarding unfair competition.

OUR FOREIGN PATENT BOOK

We have direct agencies in all the principal foreign countries and secure foreign patents in the shortest possible time and at the lowest cost. Write for our illustrated Guide Book on Foreign Patents, sent free to any address.

LIST OF PATENT BUYERS SENT FREE

Containing unsolicited letters from manufacturers and others who are constantly writing us regarding the purchase or leasing of meritorious patents. We endeavor to assist our clients in the commercial development of their inventions.

Specialization—Our Staff

The field of invention is so vast that it is impossible for any one man to become an expert in all the different classes of invention. For this reason Victor J. Evans & Co. employ a number of patent lawyers and mechanical experts who have been selected for their special knowledge and ability in certain lines of invention. Each case is placed in charge of experts in the classes to which the invention relates.

THE VALUE OF YOUR PATENT

will depend much upon the skill and care with which your case is prepared and prosecuted in the United States Patent Office. That every case intrusted to us receives our best efforts, and that our work is done consistently, skillfully, and thoroughly is evidenced by the many unsolicited letters of commendation that we receive constantly from our clients. We will furnish upon request lists of clients from any State in the Union for whom we have secured patents.

Our New York, Philadelphia, Pittsburgh, Chicago and San Francisco Offices

Owing to the growth of our business we have established for the benefit of our clients Branch Offices in New York City, Philadelphia, Pa., Pittsburgh, Pa., Chicago, Ill., and San Francisco, Cal. These branch offices being located in these large commercial cities together with our Main Office located near the U. S. Patent Office, in Washington, enables us to more promptly handle the business of our clients, particularly as the branch offices are in constant touch with the Main Office and fully equipped to handle patent business in all its branches.

Highest References—Prompt Attention—Reasonable Terms

---FREE COUPON---

VICTOR J. EVANS & CO., Patent Attorneys

NEW YORK OFFICES
1007 Woolworth Building

CHICAGO OFFICES
1114 Tacoma Building

PHILADELPHIA OFFICES
714-715 Liberty Bldg.

PITTSBURGH OFFICES
514 Empire Building

SAN FRANCISCO OFFICES
Hobart Building

MAIN OFFICES: 765 9TH STREET, N.W., WASHINGTON, D. C.

Gentlemen: Please send me FREE OF CHARGE your books as described above.

Name Address



PATENTS

IF YOU HAVE AN INVENTION which you wish to patent you can write fully and freely to Munn & Co., for advice in regard to the best way of obtaining protection. Please send sketches or a model of your invention and a description of the device, explaining its operation.

All communications are strictly confidential. Our vast practice, extending over a period of seventy years, enables us in many cases to advise in regard to patentability without any expense to the client. Our Handbook on Patents is sent free on request. This explains our methods, terms, etc., in regard to **Patents, Trade Marks, Foreign Patents, etc.**

If you are a reader of the **SCIENTIFIC AMERICAN**

you are probably aware of the fact that it has a special appeal to the inventor. Each issue contains a description of a large number of recently patented inventions. Pending patent legislation as well as the most recent rulings of the Patent Office and the courts are considered in its columns.

MUNN & CO.

SOLICITORS OF PATENTS

672 Woolworth Bldg., NEW YORK

Scientific American Bldg., WASHINGTON, D. C.

801 A Tower Bldg., - - CHICAGO, ILL.

611 Hanna Bldg., - CLEVELAND, OHIO

582 Market St. SAN FRANCISCO, CALIF.

Can You

think of a simple, practical idea that will fill one of the many requests we have on file for new inventions? It may mean a fortune for you. Thousands of things are needed **right now**. Your brains can help. Send today for our great new book—

"Inventions and Trade-Marks, Their Protection and Exploitation" and learn more about making money from ideas than you ever knew before. It tells many things that are wanted, too.

**A postal will do—
It is free**

We Help Our Clients

without charge, to get the dollars out of their ideas—having facilities none others possess. Advice free. Don't delay—get the book at once.

American Industries, Inc.
200 Patent Dept.
WASHINGTON, D. C.

Patents Advertised For Sale Free

in *Invention and Manufacturing Supplement*

Published for the man with an idea. Send for free sample copy. One year's subscription, 50c.

U.S. PATENTS



DON'T LOSE YOUR RIGHTS TO PATENT PROTECTION

Before disclosing your invention to anyone send for blank form "EVIDENCE OF CONCEPTION" to be signed and witnessed. A sample form together with printed instructions will show you just how to work up your evidence and establish the same before filing application for patent. As registered patent attorneys we represent hundreds of inventors all over the United States and Canada in the advancement of inventions. Our schedule of fees will be found reasonable. The form "Evidence of Conception," sample, instructions relating to obtaining of patents and schedule of fees sent upon request. Ask for them—a post card will do.

PATENTS AND TRADE MARKS

LANCASTER & ALLWINE

204 Ouray Bldg.

Washington, D. C.

Originators of forms "Evidence of Conception."

PATENTS

Booklet Free Highest References Promptness Assured Best Results
Send drawing or model for preliminary examination

ALL BUSINESS GIVEN PROMPT AND PROPER ATTENTION

WATSON E. COLEMAN, Patent Lawyer, 624 F St., Washington, D. C.



WRITE TODAY FOR FREE BOOK ABOUT PATENTS and "RECORD OF INVENTION" for establishing evidence of conception. The book tells how to proceed, the usual cost of obtaining a patent, and contains good sound practical advice every inventor should know. "RECORD OF INVENTION" should be filled out, signed and witnessed before you disclose invention to anyone. Send rough sketch or model and description for free report upon patentable nature and cost to Patent, etc. **Prompt, personal service.** Reasonable fees. Partial payment plan. Preliminary advice without charge.

J. REANEY KELLY
PATENT LAWYER

612-COLUMBIAN BLDG. WASHINGTON, D.C.

PATENTS

To the Man with an Idea

I offer a comprehensive, experienced, efficient service for his prompt, legal protection and the development of his proposition.

Send sketch, or model and description, for advice as to cost, search through prior United States patents, etc. Preliminary advice gladly furnished without charge.

My experience and familiarity with various arts frequently enable me to accurately advise clients as to probable patentability before they go to any expense.

Booklet of valuable information and form for properly disclosing your idea free on request. Write today.

Richard B. Owen, Patent Lawyer
9-303 Owen Building, Washington, D.C.
2276-E Woolworth Bldg., New York City

PATENTS If You Have an Invention and Desire to Learn How to Secure a Patent

Send for our Guide Book, **HOW TO GET A PATENT**, sent Free on request. Tells our terms, methods, etc. Send model or sketch and description of your invention and we will give our opinion as to its patentable nature.

RANDOLPH & CO.
600 F St., N.W., Washington, D. C.

NAME.....

STREET.....

CITY..... STATE.....

PATENTS PROMPTLY PROCURED TRADEMARKS REGISTERED

Send disclosure of invention, design, or trademark for actual search of U. S. Patents and novelty report. Validity and infringement investigations. Patent and trademark suits prosecuted and defended anywhere in the United States. Discriminating clients appreciate my efficient service. No literature will be sent you as this is a professional service, *individual* and *Personal*. Specific information and advice given regarding each individual case. Specialize in prosecution of pending cases that have been previously rejected by the Patent Office. Specialize also in unfair competition litigation before the Federal Trade Commission.

George P. Kimmel, Master of Patent Law
53-I Loan & Trust Bldg., Washington, D. C.



PATENTS

Send us sketch or model for patentability opinion and exact cost of patent. Our book "How to Obtain a Patent," Sent Free on request. It tells how to apply for Patents, Trade Marks, Foreign Patents, Copyrights, etc.; gives information on Patent Procedure; tells what every inventor should know. Thousands of Inventors, who are our clients, are our references.
Chandlee & Chandlee, 25 Years Experience.
422 7th St. Washington, D. C.

PATENTS

TRADE-MARKS COPYRIGHTS

Send for our free book of patent information.

Beale & Park 802 F St., Washington, D. C.
16 S. Broad St., Philadelphia, Pa.

PATENTS

C. L. PARKER
Formerly Member Examining
Corps, U. S. Patent Office
PATENT LAWYER
MCGILL BLDG.
WASHINGTON, D. C.

Patents, Trade Marks, Copyrights, Patent Litigation

Handbook for Inventors, "Protecting, Exploiting and Selling Inventions," sent free upon request.

PATENTS

FREE
PATENT
ADVICE

If you have an idea to patent write for free "PATENT ADVICE" and for form "INVENTOR'S RECORD" which contains full instructions for proceeding - *Personal Service* -

W. H. MULLIGAN, PATENT LAWYER.
202 Woodward Bldg. Washington, D. C.

PATENTS and TRADE-MARKS

As one of the oldest patent firms in America, and representing a clientage extending to all parts of the country, we afford Inventors and Manufacturers, at lowest consistent charges, a service noted for efficiency and results, evidenced by many well known Patents and Trade Marks of extraordinary value.
Lacey & Lacey, 646 F St., Washington, D.C.
ESTABLISHED 1869



GEARS ALL KINDS SMALL

The most accurate made and prices reasonable. We carry a complete line of gears in stock for immediate shipment. Can also quote on special gears of all kinds. Send us your inquiries.
WRITE FOR CATALOGUE.
CHICAGO STOCK GEAR WORKS
105-109 S. Jefferson St., CHICAGO

PATENTS

Inventors should write for our "Evidence of Disclosure" form. It's Free. Avoid Dangerous Delays. Send sketch or model of your invention for examination and advice. Ask for Free Book "How to Obtain a Patent." Highest references. Write to-day.
Merton-Roberts & Co., 184 Mather Bldg., Washington, D.C.

INVENTORS AIDED.

Ideas developed. Experimental Machinery Built. Individual Service.
RICHARDSON & ROGERS, 7 ALBEE, WASHINGTON
Practice in all Courts.
TRADE-MARKS. We seek the valid **PATENTS**



SEND FOR CATALOGUES
Gear and Experimental Parts, 15c
Materials of all Kinds 10c
Model Engine Circulars 5c
COLBURN GEAR & MFG. CO. Successors
5 Woodworth St., Boston 22, Mass.

The WONDERFUL ERICKSON PATENT LEG

Will not chafe, overheat, nor draw end of stump.



ERICKSON ARTIFICIAL LIMB CO., 38 Wash. Av. N., Minneapolis, Minn.

BIG MONEY MAKERS for AGENTS



SHOCK-PROOF LAMP, the new unbreakable mill type lamp, is fast replacing the old style. Stronger and gives many times the downward light. As its name implies it is **SHOCK PROOF**; stands up and resists shocks as prevalent in GARAGES, FACTORIES, MILLS, SHIPYARDS, STEAMSHIPS, MINES—yes, even in the HOMES. Lasts longer and is sold for less money. Big money-maker.



FREE Send for our AGENTS PLAN and Booklets; fully explains how easy it is to sell **SHOCK PROOF** lamps. Every GARAGE, FACTORY, MILL, RAILROAD YARD, STORE and HOME is looking for just this chance to get a better lamp for less money. It's a **BIG MONEY MAKER**. AGENTS everywhere are "cashing-in". This is YOUR opportunity. Don't let it get by. Grab it.

SEND FOR OUR AGENTS PLAN TODAY given to agents who qualify. Now is the time to get your share of **BIG MONEY** and **EXCLUSIVE TERRITORY**. GET THE AGENTS PLAN TODAY. IT COSTS YOU NOTHING.

MIDWEST LAMP CO., 143 W. Austin Ave., CHICAGO

Start Your Own Business

MAKE \$600 to \$5000 A YEAR

Any place, wherever people pass, you can start your own business. Make \$600 to \$5000 a year selling fragrant delicious Butter-Kist Popcorn and Toasted Peanuts; also cones, soft drinks, sandwiches, coffee, gum, etc. The Butter-Kist way makes it easy.

BUTTER-KIST MACHINE and HOUSE The famous Butter-Kist Popcorn Machine and Peanut Toaster is now sold with this specially designed ready-to-set-up, low-cost house. Handsome, convenient, strong proof, takes little space, attracts business. Butter-Kist goods are **proved** money makers. We help you start. Write for new reduced prices, easy terms, today!

HOLCOMB & HOKE MFG. CO.
2026 Van Buren St., Indianapolis, Indiana
World's largest manufacturers of pop corn machines and peanut toasters

PATENTS Secured

Prompt service. Avoid dangerous delays. Send for our "Record of Invention" form and Free Book telling How to Obtain a Patent. Send sketch or model for examination. Preliminary advice without charge. Highest references. Write TODAY. J. L. Jackson & Co., 327 Oursay Bldg., Washington, D. C.

What a Man Should Know

Rejuvenation without "freak" surgery. Have richer blood, lower pressure, boundless energy, perfect digestion—youthfulness. Banish constipation. Lengthen your life—be genuinely happy. Testimonials without number; write for convincing proof.

BYRON TYLER, Food Specialist

308 Gibraltar Bldg. Kansas City, Missouri

Blank Cartridge Pistol FREE

Well made and effective, modeled on the latest type. Revolver does not shoot real bullets, but the appearance alone is enough to scare a burglar. We have loaded it may prove just as effective as a real revolver without danger to life. Does not shoot real bullets, but takes the standard .22 Caliber Blank Cartridges obtainable everywhere. A Great Protection Against Burglars, Tramps and Dogs. You can have it lying about without the danger attached to other revolvers. Advertised extensively by leading firms for a dollar.

REVOLVER STYLE



For a limited time only we are giving these Pistols to secure new subscribers to the **RACINE BULLETIN**, a large monthly illustrated magazine. Every issue crammed full of exciting stories, important items from all over the world, articles on popular science, mystery, music and mirth, money-making wrinkles relating to every trade and manufacture, health hints, tried and tested recipes, gossip about well known persons. Thousands of dollars given away in prizes, not to mention a free \$1,000 Insurance Policy in every issue to each subscriber—all this and lots more combine to make it one of the most interesting magazines published in America. Send ONLY \$1.00 for a three years' subscription to the **Racine Bulletin** and we will send you the Pistol free, and the magazine for three years.

Dept. 839 **THE RACINE BULLETIN** Racine, Wis.

Radio Inventions Needed!

HERE is a new Industry in which millions of dollars have already been invested. Yet it is only in its infancy. There is room for thousands of new inventions. Who will make them? Will you? If you invent a Radio improvement, will you know exactly how to perfect it, patent it, market it? Do you know the habits of thought and the methods of work that produce new ideas?



Let Great Inventors Show You How to Invent

Every man, woman and child is born with inventive faculties. Some develop them to a greater degree than others, and are successful inventors. Invention is an orderly process of the mind, which combines two or more known facts to produce a new fact. Anyone who develops the right mental process can become an inventor. Every successful inventor has this type of mind, developed by constant experience over a period of perhaps many years. Heretofore those who succeeded in the field of invention had to discover all the principles themselves. But, now, just as any student of medicine, law, or engineering can take full advantage of all the recorded experience in these fields of study, so can YOU take the same kind of short cut to the habits of thought, and the methods of work required of successful inventors. A new Course for home study, prepared by R. F. Yates and other inventors, gives you exactly what you need.

Every man, woman and child is born with inventive faculties. Some develop them to a greater degree than others, and are successful inventors. Invention is an orderly process of the mind, which combines two or more known facts to produce a new fact. Anyone who develops the right mental process can become an inventor. Every successful inventor has this type of mind, developed by constant experience over a period of perhaps many years. Heretofore those who succeeded in the field of invention had to discover all the principles themselves. But, now, just as any student of medicine, law, or engineering can take full advantage of all the recorded experience in these fields of study, so can YOU take the same kind of short cut to the habits of thought, and the methods of work required of successful inventors. A new Course for home study, prepared by R. F. Yates and other inventors, gives you exactly what you need.

Little Inventions Win Fortunes

The men who invented the bottle top, the crimped haloin, the vacuum tube for radio, the thin lead automatic pencil, the snap fastener—all these men, perhaps, got their ideas in a flash, and founded their fortunes as a result of a single idea. But in every case their minds operated in accordance with the scientific laws of successful invention. Edison says: "Invention should be taught as a profession." Every inventor realizes the hopelessness of groping in the dark for the habits of thought and methods of work required for successful invention. Trying to invent without knowing the fundamental requirements of invention is like trying to build a bridge without knowing engineering.

Don't Waste Ideas! Every man at some time or other has an idea for something he would like to invent, but his mind doesn't know how to work. He doesn't know what to do about it—doesn't know how to think along inventive lines—and soon someone whose mind is trained along inventive lines invents just the thing you may have thought of.

Write FREE BOOK A wonderful book explaining this wonderful new course in detail has been written and will be sent free to those genuinely interested. This book explains the course in detail, and proves that anyone can become an inventor who trains his mind—it may be the beginning of a fortune for you. If you have ever had an idea for an invention, or if you would like to become a spare-time or professional inventor, and if you would like to know what to invent, send in your name at once on the coupon NOW! Only a limited number of these books are available for free distribution.

Bureau of Inventive Science

46 WISNER BUILDING ROCHESTER, N. Y.

-----COUPON-----

BUREAU OF INVENTIVE SCIENCE

Dept. 46, Wisner Building

Rochester, N. Y.

Please send me your free book, "The Science of Invention."

Name

Address

City

State

BIG MONEY FOR YOU!

\$50—\$200 A Week Easily Possible

For the first time, Mr. Average Man, you are given the opportunity to get into this *immensely profitable* business that has made thousands of operators rich. Let us show you how to be a scale operator! Buy machines from us at wholesale—only a small investment needed. Your money quickly *doubles itself*. No merchandise for you to handle—no time wasted—one hour a month enough at start. Just put scale on location—it does rest.

Scales Are Piling Up Fortunes

Start making yours today. Some scales have earned over \$80 a month. Own only a few and be independent. We make 90% of all coin machines—and we know what scales will do. Our scales are all newest type of construction—best payers. No safer, more profitable investment for you.



FREE! Write for Free Books—"Making Your Fortune With Pennies," "How to Own Your Own Scale Business," "What Harry Williams Did with Five Scales," General Catalog, and *Inside Money-Making Secrets* known only to operators.

AGENTS or Anyone Who Wants to Make Money! If interested in hooking up with the World's Largest Manufacturers of Coin Operated Machines, with no investment on your part, write today. Sell coin machines—fabulous earnings possible. Single machines have earned over \$200 a week. Address Dept. 5B.

Address All Inquiries on Scale Operating to

MILLS NOVELTY COMPANY
JACKSON BLVD. AND GREEN STREET CHICAGO, ILL. Dept. 24

THE BUSINESS FOR YOU!

Make and sell Crispettes, delicious confection. Everybody loves them. Can't get enough. Come again and again for more. Easy to make. I furnish everything. Raw materials plentiful and cheap. Profits enormous.



Quick success possible anywhere—cities, small towns, villages. Amazing market—crowded streets; surging throngs at fairs, carnivals, parks, etc.; wholesale to grocers, bakeries, druggists, and so on. Possibilities unlimited! Need no experience. Little capital starts you on road to phenomenal earnings.

WRITE—GET MY HELP—BEGIN NOW!

Others are making money—lots of it. Letters just received during this year tell of wonderful successes. You can succeed, too. Start is all you need. I'll gladly help you. Furnish everything—complete outfit, materials, secret formula, full directions, wrappers, etc. Send post card for illustrated book of facts. Tells how to start. Explains most successful methods. Gives all information needed. It's free. Write now!

LONG EAKINS COMPANY

628 High Street

Springfield, Ohio

W BUILD YOUR OWN WIRELESS TELEPHONE E

This wonderful invention now within the reach of all. Hear free music, latest news, market reports by radio.

Real pleasure and education for the whole family. Make a "Universal Radiophone" and save \$50. Simple as A-B-C. Uses bulb and 2 amplifiers. Best regenerative hook-up. Receives signals all over U. S. Equals \$150 sets. Blue prints, instructions, list of parts complete to build and operate the famous "Universal Radiophone" Order now today. Cash only; no stamps accepted. Postpaid for 50c. You can't afford to miss this. Thousands sold.

AMERICAN RADIO CO., 27 Warren St., New York, N. Y.

We Want Agents and Distributors

to sell the New Improved Arrow Razor Sharpener. No. 1 Arrow sharpens any kind of Safety Razor Blades. No. 2 Arrow sharpens old-style Open Razors. Each Arrow has two genuine Norton Hones. Easy to operate. Evenly hones both sides of blades. Pocket size, nickel-plated and fully guaranteed. Every man wants an Arrow. Great seller. A live proposition for every Agent.

Special to Our Agents

\$3.50 Puts You in Business

One No. 1 and one No. 2 Arrow sent to you for \$3.50, postage paid, on receipt of Money Order. Very attractive prices in larger quantities. Arrow Razor Sharpener sell to consumer at \$2.50 each. Ask for territory. Mail your order today! Money order, draft, or C. O. D.

WESTERN APPLIANCE CORPORATION
642 Beaubien Street Detroit, Michigan

NEW MOTORS

FOR ALL PURPOSES
STANDARD MANUFACTURERS
PROMPT DELIVERY

ALL SIZES UP TO 5 H.P.

We Specialize In Small Motors & Generators

ALL PHASES AND FREQUENCIES IN STOCK AT ALL TIMES

Largest exclusive Mail Order Small Motor dealers in the world.

CHAS. H. JOHNSTON, Box 13, West End, Pittsburgh, Pa.

WIRELESS, TELEPHONE GENERATORS

500 VOLT - 100 WATT - 3400 R. P. M.

FOR MOUNTING MOTOR GENERATOR SETS.

\$28.50 EACH

WRITE FOR CATALOG



GREEN AUTOMATIC MACHINE



ADD TO YOUR INCOME WITH LITTLE EFFORT \$5 to \$10 A DAY MADE EASY WITH

New Improved Green Automatic Machine

Sharpens, Hones and Straps all kinds of safety razor blades, in one operation, from four to six blades per minute. For both Quality and Quantity, this machine is in a class by itself. There is nothing like it on the market. Let us send you our descriptive literature explaining everything, including the "AMERICAN" Key Cutter—cuts square, angular or round slots.

AMERICAN SHARPENING MACHINE CO. (Inc.), Dept. 6, 114 W. Washington St., CHICAGO



"AMERICAN" Key Cutter

\$2,500 Monthly for Miller with WILLEY UNIVERSAL VULCANIZER



Walter J. Miller invested \$175 in 1919, came to our plant for instructions for three weeks. Since that time he has bought his own home. He is now doing \$2,500 worth of business per month, employing 2 men and making big money.

Sold on Installments

Tire repair business is all cash. Only small investment necessary. There never has been such an opportunity to enter this big money field.

Thousands and thousands of used cars are being bought and used. Most of them have worn tire equipment. They must go to the vulcanizing shop for repairs. GET IT NOW. We give you practical training in our plant and shop or by mail FREE. The machine is self contained, burns coal, wood, kerosene or gas. Economical to operate. Set up in a few minutes. FULLY guaranteed.

WILLEY UNIVERSAL VULCANIZER CO.
26 Willey Building Battle Creek, Mich.

AUTO OWNERS WANTED



To introduce the best automobile tires in the world. Made under our new and exclusive **Internal Hydraulic Expansion Process** that eliminates Blow-out—Stone-Bruise—Rim-Cut and enables us to sell our tires under a

10,000 Mile Guarantee

We want an agent in every community to use and introduce these wonderful tires at our astonishingly low prices to all motor car owners. Write for booklet describing this new process and explaining our amazing introductory offer to owner agents.

Hydro-United Tire Co.

Dept. 100—Chicago San Francisco Pittsburg, Pa.

Auto Supplies

Knowing **HOW** to buy is merely knowing **WHERE**. This is Chicago's Great Wholesale House. **AUTO SUPPLIES AND MOTOR PARTS** WHOLESALE ONLY. Dealers send today for this big money-saving book!

ACCELL AUTO ACCESSORIES COMPANY
307 A South Michigan Avenue
CHICAGO

CAMERAS

Over a Hundred Styles and Sizes. Send for new illustrated catalog showing latest reduced prices. It's Free.

10 days' trial given

SENECA CAMERA MFG. COMPANY
300 Central Avenue Rochester, N. Y.

MOTORCYCLES ONE YEAR TO PAY

Know the joy of owning—for business or pleasure—a HARLEY-DAVIDSON, EXCELSIOR, HENDERSON, INDIAN, CLEVELAND, or any other standard make; thoroughly rebuilt in our own factory.

Write for Free Bargain Bulletin and Easy Payment Plan.

HAVERFORD CYCLE COMPANY
America's Largest Cycle House

Established 26 years
503 Market St., Phila., Pa., Dept. P. M.

Campers! Tourists! Picnickers!



Your outing equipment is not complete without a

Campfire Grub Stake

The handiest article of its kind ever produced. Light, strong, compact and portable. Can be set up anywhere in one minute. Three adjustable racks for skillets, pots and pans, that can instantly be raised, lowered or turned according to direction of wind. Racks stay in position without set-screws or lugs. Guaranteed for life.



On sale wherever Outing Goods are sold. **\$3⁵⁰**
\$4.00 in Canada In U. S.

If your dealer cannot supply you, write us direct, enclosing \$3.50 together with dealer's name, and the Campfire Grub Stake will be sent anywhere in U. S., parcel post paid. Order at once.

CAMPFIRE MFG. CO.

1036-A Boatman's Bank Bldg. St. Louis, Mo.

Which Way?

DON'T take chances—you can know your direction every time if you carry one of the

TAYLOR COMPASSES



Nine Styles. Ask your dealer for prices.

Taylor Instrument Companies
Rochester, N. Y.

There's a *Taylor* Thermometer for Every Purpose.



A REAL BOAT FOR REAL FISHERMEN



The MOTO-ROW \$250

HERE is the ideal all-purpose craft—The Moto-Row—combination power and row boat at a price made possible only by quantity production.

Designed with ample sheer and full flare forward, it is extremely dry in a smashing sea. Constructed of selected airplane spruce, copper riveted, mounting a dependable 2-hp. motor beneath rear deck, protecting it from exposure and theft. The Moto-Row represents a sturdy, convenient boat—without rival for fishing, sporting and vacation purposes. Built by Sidney McLoud, Marine City, Mich.

Moto-Row's reinforced skeg protects the propeller in shallow water and enables the boat to be beached without injury. Six-passenger capacity, 7 M.P.H. Salt water equipment, \$25 extra. Illustrated Catalog on Request.

BELLE ISLE BOAT & ENGINE CO., Dept. I, Detroit, Mich.



Get This Wonderful Ring. If You Can Tell It From a Genuine Diamond Send It Back

These amazing, beautiful CORODITE diamonds positively match genuine diamonds in every way—same glitter, flash and dazzling play of living rainbow fire. They, alone, stand the diamond tests, including the terrific acid test. Even lifetime diamond experts need all their experience to see any difference. Prove this yourself.

Wear a Corodite Diamond 10 DAYS FREE

Make this test. You risk nothing. Wear a genuine Corodite and a diamond side by side on the same finger for 10 days. If you or your friends can tell the difference, return the Corodite. You won't be out a single penny. If you decide to keep the ring, the price printed here is all you pay. No installments. Remember, only Corodites have exactly the same cutting as genuine stones.

- | | |
|--|--------|
| No. 1—Ladies' Tiffany Style 14K Gold S. Ring | \$2.84 |
| No. 2—Gents' Heavy Hecker 14K Gold S. Ring | \$3.48 |
| No. 3—Gents' Massive Hexagon Platinum Finished | \$4.27 |
| No. 4—Ladies' Carved Platinum Finish | \$3.85 |

All stones 1 carat size and the mountings are beauties of the very latest design. Gold or the popular white platinum finish. Unqualified 20-year guarantee. Handsome art-leather velvet-lined case free with each ring.

SEND NO MONEY Keep your money right at home. Just send your name, address and number of ring wanted, and also an 8¢ stamp of paper filling end to eye around finger joint. Your ring will come by return mail. When ring arrives deposit amount shown with postman. If you decide not to keep ring after 10 days' wear, send it back and your money will be immediately returned. Send today.

E. RICHWINE CO.

333 South Dearborn Street, Dept. 38, Chicago, Ill.
We are sole importers of Corodite Gems for the United States

Headache?

Change it to Comfort the RenuLife Way

For the dull, annoying pain of a chronic headache, the sharp recurrent stab of neuralgia or the headache that throbs and pains constantly, RenuLife Violet Ray offers quick relief.

It gives immediate relief, reaches the source of the trouble and remedies the cause. By saturating every cell, nerve and fibre of the body with highly remedial electricity, waste tissues are eliminated and nature is allowed to build up new strength and vigor wherever disease has been.

RenuLife Violet Ray

treatments are pleasant and give no sensation of shock or pain. The youngest child or most feeble invalid can take and enjoy RenuLife Violet Ray. This scientifically approved treatment can be used in your own home whenever needed. It covers a great range of ailments and does its work thoroughly and well. Send coupon today.

RenuLife Electric Company
1106 Newberry Bldg., Detroit, Mich.
Send me without obligation full information on RenuLife Violet Ray and your free book "Health."

Name.....

Address.....



Easy to Play Easy to Pay



BUESCHER

True-Tone SAXOPHONE

Easiest of all wind instruments to play and one of the most beautiful. You can learn the scale in an hour's practice and play popular music in a few

weeks. You can take your place in a band within 90 days, if you so desire. Unrivalled for home entertainment, church, lodge or school.

(34) In big demand for orchestra dance music. The portrait above is of Donald Clark, Soloist with the famous Paul Whiteman's Orchestra.

Free Trial You may order any Buescher Instrument without paying one cent in advance, and try it six days in your own home, without obligation. If perfectly satisfied, pay for it on easy payments to suit your convenience. Mention the instrument interested in and a complete catalog will be mailed free.

Buescher Band Instrument Co.

Makers of Everything in Band and Orchestra Instruments

2534 Buescher Block, Elkhart, Indiana

SQUAB BOOK FREE

Squabs are selling at the highest prices ever known. Breed them and make money. Write at once for free book, prices, etc.

Phonoth Rock Squab Co., 634 Howard St., Melrose Highlands, Mass

Rabbit Book FREE

Illustrated. Facts about the easy, profitable home industry—growing domestic hares for meat, fur, fancy. Little space—cheap equipment. Big demand. We buy all you raise at \$7 to \$18 per pair. Turn your spare time into cash. Book free—write now.

STANDARD FOOD & FUR ASS'N
407B Broadway New York City

THE AJAX EYELET FASTENER BINDS AND INSERTS AJAX EYELETS IN PAPER, CARDBOARD, LEATHER OR CLOTH

It Saves Time by Punching the Hole, Feeding the Eyelet and Clinching It in One Operation.

Drop the eyelets into the magazine and go right ahead. Order from your stationer or direct.

Write for our catalogue of office tools
MACHINE APPLIANCE CORPORATION

351-353 Jay St.

Spec. Dept.

Brooklyn, N. Y.



PRICE WITH 1500 AJAX EYELETS, \$10.00 DELIVERED IN U.S.A.

Make \$200. to \$1000. Profit Monthly

With Balba Perfume Sales Machines

People love perfume. Men, women and children will buy Balba. Its fragrance is soft and lasting and it is easily accessible. Just think. Grown-ups and boys and girls spent \$250,000,000.00 in one year in the United States for perfume, alone, at toilet counters. Consider how much more will be spent when a dime placed in a Balba Sales Machine will bring forth a conveniently sized bottle of rare Balba Bouquet Perfume. Balba Sales Machines, the serve-self idea applied to perfume sales, are popular. One machine holds 144 bottles, and between 3 and 4 people use it daily, with a profit to the owner of \$4.00 per machine per month. 100 machines bring in \$400.00 profit per month and can be easily handled in spare time.

BALBA

Bouquet Perfume

Of rare and lasting quality. Balba Bouquet radiates a fragrance of elegance and refinement about the wearer. Hundreds of regular customers buy from Balba Sales Machines, 5 to 12 bottles of the soft, rich Balba perfume at one time, because they can carry them easily in hand-bag, or pocket.

25c to 50c Value for 10c a Bottle

Because all middlemen's profits are cut out by the serve-self sales plan of Balba Sales Machines, we can manufacture this high quality perfume in large quantities and give 25c to 50c value for 10c a bottle.



Sold Only Through Balba Sales Machines

To give highest quality, and largest quantity at lowest cost in an inexpensive bottle, Balba Bouquet Perfume is sold only through Balba Sales Machines, on the serve-self plan, cutting out all overhead expense. Note the attractively nickel-plated, practically thief-proof, easy to fill, simple to operate; Balba Sales Machines. Weather-proof, used inside or out in small space on wall or counter.

We Want Balba Sales Machines in Every City, Town and Recreation Resort

We have thoroughly proved that Balba Bouquet Perfume is a good seller, it repeats, it makes new users. Balba Sales Machines in good locations show an increasing business, proving that the serve-self plan applied to perfume is a safe, sane, logical selling method. We are offering a tested, proven, big profit, permanent business to a live person (man or woman) in each territory. Instead of territory rights, we sell an allotment of Balba machines in proportion to population. We give the purchaser exclusive rights to sell Balba perfume in that territory. No perfume but Balba is sold like this. Balba is being advertised nationally.

Over 500 Cities Already Taken

Over 500 towns and cities are now under contract. Every mail brings new contracts—Machines are now being shipped in large quantities and being put up daily and National Advertising is being placed—the contracts are going to men of action and vision—thousands of good cities and counties are still open but it will take quick action.

New York, Chicago, Detroit, Cincinnati, Pittsburgh, Buffalo, Des Moines, Los Angeles and Springfield, Mass., are some of the towns taken.

FREE Newspaper Advertising in Your Territory

When you have bought and placed a full allotment of Balba Sales Machines, we will run advertising in your local newspaper, giving locations of all your Balba Sales Machines. This starts people buying Balba from your machines, and the high quality of Balba keeps them buying. We tell you how to place machines and handle them. We are rapidly getting general distribution, and are placing advertising in the National Weeklies and Women's magazines to make perfume users throughout the U. S. want to buy Balba.

Guaranteed 100% Earnings or Money Refunded

Our proposition as well as our perfume is guaranteed. We guarantee 100% earnings on the original machine investment the first year, provided machines are all placed in use and kept filled, or we will refund the original price of the machines and perfume then on hand and take them back.

THE BALBA CORPORATION of AMERICA

Suite 46, Balba Bldg., Toledo, Ohio, U. S. A.

THE BALBA CO. OF CANADA
Leamington, Ont.



WHERE BALBA MACHINES CAN BE PLACED

Theatres	Bath Houses	Silver Shine Parlors
Pool Halls	Factories	Lunch Counters
Depots	Rest Rooms	Skating Rinks
Clubs	Dance Halls	Ticket Offices
Restaurants	Lodge Rooms	Street Car Stoppers
Cafeterias	Carly Shops	Ice Cream Parlors
Drug Stores	Boats	Office Building Lobbies
Cigar Stores	Moving Picture Houses	Passenger Buses
Fruit Stands	Billiard Parlors	Recreation Buildings
Street Cars	Apartment Houses	Waiting Rooms
Elevators	Public Buildings	Hotel Rooms
Trains	Bowling Alleys	Hotel Lobbies
Parks	Interurban Cars	Barber Shops

READ WHAT BALBA SALES MACHINE OWNERS SAY

George Schroder, Ohio, says, "First 100 Balba Sales Machines averaged \$108.50 clear profit first month before advertising was started." Nauman, Michigan, says, "First 50 machines put up, averaged 3 plays daily. This is at the rate of \$108.40 clear profit monthly without advertising."

Send 10c Coin or Stamps

—with name and address for full size bottle of Balba Bouquet Perfume. This offer is open to any one.

Be the first in your territory to make a Fortune in Dimes. Get complete information, literature and sample of Balba. Write today, or better wire us to hold territory until you get our proposition. Read what Balba Bouquet Owners say and send for your allotment now.

NEW INVENTION Ends Tire Troubles

A remarkably simple and inexpensive invention which makes blowouts impossible, eliminates 95% of all punctures and practically does away with all disagreeable tire changing, has been patented by Walter G. Critchlow, Suite 164, No. 716 Madison Street, Chicago. In addition to freedom from the annoyance of punctures and blowouts, users report that they get from 5,000 to 9,000 extra miles wear from their tires. Mr. Critchlow is so proud of his invention that he is making a special 30 day trial offer to every car owner, and also offers \$10.00 reward for any blowout that occurs where his invention is used. He wants one representative in each locality to take care of the tremendous demand that is sure to be created wherever his invention is shown. If you drive a car or want to learn how you can make from \$150.00 to \$350.00 per month send Mr. Critchlow your name and address at once for full particulars, and a good size sample which he will send free of charge.

FORD CAR GIVEN

Solve This Puzzle. Win Fine Prize

15 8 25 15 21
5 5 14 18 25

The figures represent corresponding letters in the alphabet.

8 and so on. The ten figures spell three words. What are the words?
To Men, Women, Boys and Girls

All can share in these EASY-TO-WIN prizes. Send the three words on a slip of paper with your name and address. Besides the Auto I am going to give away Phonographs, Bicycles, Gold Watches, Silverware, etc. and cash rewards. Send your answer. Act quick.
Duane W. Gaylord, 537 S. Dearborn St., Dept. 98, Chicago



Famous Wagner Motors

Brand new A. C. single phase, 60 cy., 110 V., 1750 RPM. motors, complete; 1/4 H. P., \$13.00; 1/2 H. P., \$32.00. Brand new 3-ph., 60 cy., 220 V., 1800 RPM. motors, complete, 5 H. P., \$75.00; 3 H. P., \$60.00; 2 H. P., \$50.00; 1 H. P., \$45.00. New A. C. oscillating fans, 110 V., 60 cy., complete, 12-inch, \$20.00; 16-inch, \$23.00. Order your motors and fans while we have them in stock at these low prices. Our first policy, satisfaction or money back.
CASH MUST ABSOLUTELY ACCOMPANY YOUR ORDER.

General Motor & Machinery Co., 601 W. Adams St., Chicago, Ill.

\$135

America's Lightest weight and lowest priced complete motorcycle

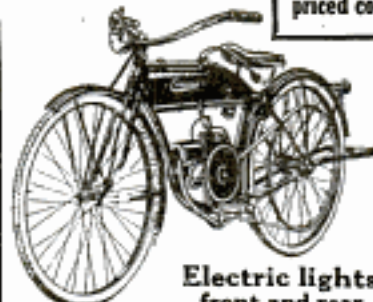

150 Miles to Gallon of Gasoline

Electric lights front and rear

"Beats all"

Low fuel cost Dependable Speedy

Evans

The Evans catalogue, fully describing this wonderful machine, sent upon request

Attractive offer to rider agents in territory not controlled by an Evans dealer

For an economical means of transportation there is no motorcycle like the EVANS. It performs like the heavier, costlier machines—requires no expert mechanical knowledge—is easy to handle—operates swiftly and surely.

Manufactured by

CYCLE MOTOR CORPORATION

Box 1031 - Rochester, N. Y.



Tire User

Car owner agent wanted in every community, to use, introduce and take orders during spare or full time for Harrison Road Made Tires at our low prices, fully GUARANTEED 10,000 MILES (Not second) finest materials used. Shipped on approval prepaid. Capital or experience unnecessary. Sample sections free. Write for local agency offer and get our low factory prices to user agents.
HARRISON TIRE & RUBBER CO.
230 Indiana St., Hammond, Ind.

HEAVY HAND MADE

Attach Your Own Top

Paint your car, too. You can do it in a jiffy. Instructions make it easy and help you save mechanic's bills. Complete new top, back curtain, large can of enamel, for Ford cars, \$9.95. Same outfit for all other cars, \$15.75. Write for samples and Catalogue No. 3.

Special Offer for Dealers

A. E. Schneider Mfg. Co.

4265 Hudson Blvd.

West Hoboken, N. J.



\$140 Weldit Outfit For \$75

In price alone, you cannot find in the open market a welding outfit that resembles a value equal to this "Weldit" under \$140 to \$165. In design, proven efficiency and every detail of actual quality it is not surpassed—we might say **not even approximated at any price.**

Preferred by such representative users as Dodge Bros., Ford Motor Co., Owens Bottle Mch. Co., Studebaker Corp., Timken-Detroit, American Shipbuilding Co., Thompson-Starrett, General Motors Corp., it has stood the severest test of years and is acknowledged to be the **highest development of acetylene welding equipment.** All of our apparatus is inspected and approved by the National Board of Underwriters.

The price of only \$75 is **direct to you from our factory,** backed by our reputation and **absolute guarantee.** No salesman, commissions or dealers' profits, we prefer to do business direct with our customers at our own factory prices. Once you see this equipment you will instantly recognize the great saving and superiority of service this offer represents. **It is a value you cannot afford to pass.** If you need or use acetylene welding.

We suggest that you write today for complete information. Address:

WELDIT ACETYLENE CO., 146 West Larned St., Detroit, Mich.

Factory Prices on Everything for the Welder

Only 357 Motors

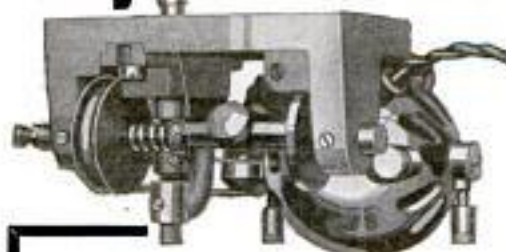

Left at
\$10

Each

Ideal for home-made phonographs, experimental purposes and combination **phonograph-radio** sets.

We have 357 small motors which are greatly under-priced for quick clearance. You will never again equal this low price, when this lot is sold.

They are universal motors, 110 volts, 60 cycle single phase, complete with turntable, cord and socket for immediate use. 1400 R. P. M. Motor has 1" pulley with flange for 3/4" flat belt. Housed in highly polished, nickel-plated shell.

Don't lose out on this remarkable offer. Order your motor today. Tomorrow may be too late. **DO IT NOW!** Price \$10.00 f. o. b. Steger, Illinois.

Industrial Division

Steger & Sons Piano Manufacturing Company
Dept. 90, Steger Building Chicago, Illinois

WANTED TAILORING SALES AGENTS

Make big money from very start—\$75.00 to \$100.00 weekly. Largest made-to-measure tailoring house, furnishing an equipment of five hundred wools, wants you to take orders. Satisfaction guaranteed. Biggest merchants in many towns have started with our line. If you want to establish yourself permanently in business and make big money, write for full particulars, giving your experience as salesman or tailor's sales agent.

P. M. HORN, Sales Manager, Lock Box 483, Chicago

THIS WONDERFUL INVENTION



converts any ordinary cook stove into a gas stove. OXO-GAS is made from kerosene and air. Cheaper, cleaner and more efficient than coal. Responsible distributors wanted.

GLORIA LIGHT COMPANY
114 N. May St. Chicago, Ill.

DIAMONDS

For Graduations, Anniversaries, etc.

Here at 60%
of Market Price

"This absolutely flawless diamond gem 1/2 - 1/16 ct. at \$100 among bargains in recent list. Many other big values in our lists. Buy HERE! Prices based on loan values, not market values. This 75 year old diamond banking firm has thousands of unpaid loans and other bargains. Must sell NOW.

Why Pay Full Prices

Any diamond sent for absolutely free examination at our risk. No obligation. No cost to you.

Send for Latest List

Describes Diamond Bargains in detail, gives guaranteed loan values. Explains unlimited exchange privilege. Write for list today. **Send NOW!**
JOS. DeROY & SONS 1987 DeRoy Building
Only Opposite Post Office Pittsburgh, Pa.

YOU CAN EASILY
MAKE
\$110 per week
PROFIT

\$5720.00 per Year
CLEAR PROFIT
For Yourself!

Millions have been made on the 5c and 10c store idea because these coins are freely spent. Now comes the biggest penny sales idea ever hit upon and electricity has made it possible. A 1c vending machine with new process buttered P-Nuts in plain view. It keeps them toasted; an I serves them HOT. Moreover, it flashes an electric sign all day long saying "Eat 'Em Hot--1c."

Stands Out Like a Light House!

This sensational new type Sparta peanut vending machine absolutely **compels attention**. It gets the pennies by thousands, and serves fresh toasted Buttered P-Nuts so tempting that each customer repeats again and again. We have dozens of letters and affidavits stating that \$30.00 a month is easily made by ONE well placed machine and that **\$5720.00 a year is easily realized**. What you make depends entirely on how many machines you have and where they are located, and remember, a reasonable sum of money puts you in the business right.

WE SHOW YOU HOW!

We give you 50 pounds of our own Buttered P-Nuts **FREE OF CHARGE** with each and every machine. This means you operate without peanut cost for the first 44 days. **Your profits in 44 days will practically pay for each of your machines.** We tell you how to place each machine to best advantage in theatres, clubs, depots, barber shops and many other crackerjack locations. We send you **free**, by return mail, full and complete information on this great Business Offer.

But Remember The Good Territory is Going Fast!

We give every operator A-1 exclusive territory. Consequently this splendid offer necessarily must be limited. Send Coupon below to protect yourself in your territory and get full details without any obligation to you.

SPARTA MANUFACTURING COMPANY
1-3 Iowa Ave., Dept. 2216
Grand Rapids, Michigan

50 Lbs. Peanuts
FREE
to you
NOW!

MAIL TODAY
SPECIAL
FREE OFFER
COUPON

SPARTA MFG. CO.
1-3 Iowa Ave., Dept. 2216
Grand Rapids, Mich.

Gentlemen:—Send without any obligation, full and complete details of your Great Offer on Sparta "Hot Flash" Peanut Vending Machines.

Name.....

Address.....

Territory.....

(Mention approximate territory desired)

Please Mention Popular Mechanics

A MOTOR FOR YOUR BICYCLE



Attach powerful Belt Drive **ROLLAWAY** to your bicycle. **Forget pedals.** Ride in comfort. **ROLLAWAY** gives **positive, dependable power.** Light weight. Runs 100 to 150 miles on gallon gasoline. **Fits any bicycle.** Economical—costs less than one-fifth cent per mile to operate. Shipped complete. Anyone can attach in few minutes. Outfit includes motor, reinforced fork, wheel and guaranteed tire. Hundreds in use. A wonder for **economy and performance.** Price, F.O.B. factory \$35.00. Write for circulars. Adds **joy, speed and comfort** to cycling.

Be Our Salesman!

Buy a demonstrator. Sell. Good commission paid. Write today for our proposition. Address

The Rollaway Motor Co.
621 Shepard Street
Toledo, Ohio

Rollaway

TRADE MARK

Here's your chance to own a real TIRE REPAIR PLANT AT LOW COST

With prices on Western Adjustable and Non-Skid Molds now reduced to a **minimum**—with the mileage guarantee abolished by manufacturers and a contemplated increase in the price of tires—with us giving you complete instructions free either in one of our schools near you, or by our home study course—it's your opportunity to get in the vulcanizing business and clean up!

Prices of the Famous Western Equipment are now even lower than cheap "First Seller" equipment, for an outfit repairing all passenger tires, yet the same higher quality of material, workmanship and design, is maintained. They are the same adjustable molds—the same Non-Skid Retreaders with prices in reach of the man with more ambition than money.

Write us at once for particulars and tell us all about your own desires, ambition and conditions in first letter.

WESTERN RUBBER MOLD COMPANY
315-323 N. CRAWFORD AVE. CHICAGO

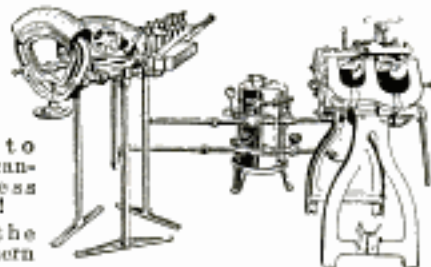

DISTRIBUTORS Wanted

Big Money For **FORD OWNERS**

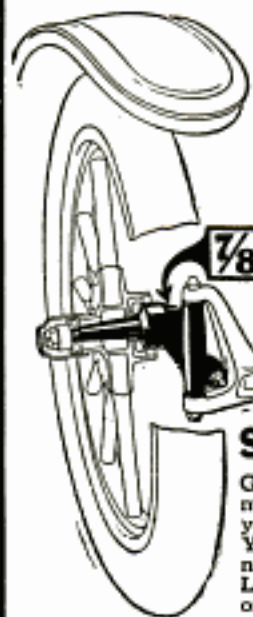

Steer your Ford with one hand at thirty miles an hour over rough roads. Shoot through sand, mud, gravel, in and out of ruts and over car tracks. Your front wheels **CANT** turn and ditch you. Your Ford will stick to the middle of the road like a Packard or a Cadillac if it is equipped with

3/8 INCH OFFSET The Wheel Trails

MOSPICO

SAFETY SPINDLES

Give another driver just five minutes behind your wheel after you put them on your car. You've made a sale. No talking necessary—they sell **themselves.** Liberal profit on every sale. All or part time.

Get Exclusive Contract For Your County

Hundreds of Ford owners within a few miles of you. Most of them will buy after a five minute trial. Make big money wherever you drive your car with these and other fast selling accessories of our manufacture. **WRITE US TODAY.**

Motor Spindle Corp.

16 East Jefferson Avenue
DETROIT, Mich.

**AUTO SUPPLIES
WHOLESALE
3000 BARGAINS**

SEND FOR THIS CATALOG -

it's FREE!

Everything you need in Auto Supplies at Amazingly LOW PRICES.

NEMCO BARGAIN SUPPLY HOUSE
1017 Jackson Boulevard - Chicago, Ill.

GET A RAZO!



This unique Razor-blade pocket knife is the handiest, safest general utility knife. Uses an old Gillette blade. Artists, writers, draftsmen, tailors, dressmakers, office men, women, school children all need **RAZO.** Send 25c for yours today. Great money maker for agents.

RAZO NOVELTY CO.
23 E. Van Buren St. Chicago

Harley-Davidson

World's Champion Motorcycle

PRICES REDUCED ONE HALF Rebuilt and Guaranteed

1915, three speed twin electric \$125; 1916, \$135; 1917, \$150; 1918, \$165; 1919, \$180; 1920, \$200. Shipped on approval. Catalog A free, describing Harley-Davidson, Excelsiors, Indians, Smith Motors at \$40 and upwards. Liberty Bonds taken at full face value. Letters of recommendation from hundreds of satisfied customers. **Boys' Books and Harley-Davidson Motor Co. Rapid service on 1902 to 1922 Harley-Davidson parts.** 106 page PARTS catalog B, 25 cents. Stamps or coin.

WISCONSIN CYCLE SALES COMPANY
726 NATIONAL AVENUE MILWAUKEE, WIS.

Oldest and Largest Dealer in the North-west "Milwaukee—World's Largest Motorcycle Center"





Every Good Musician Praises the KING

FOR more than a quarter century King Brass Instruments have been built to the specifications of world-famous musicians. Every King Instrument has the latest improvements — is built by an expert — and is thoroughly tested in our sound-laboratory before being shipped. That's why Every Good Musician Praises the King.

Perfect Instruments Easiest to Play

Whether you are just learning to play or are a finished musician you will find these wonderful King Saxophones, Trombones, Trumpets, and Horns easier to play than any other make. The wonderful tone-quality of the King is admired by everyone.

It's easy to own a King Instrument. They are sent on trial, and sold on easy payments. By buying from the factory you save all the middleman's profits.

Get Price List of Used Instruments

We now have on hand a large stock of used instruments of other makes, rebuilt and refinished to look like new. They are sold for cash at very low prices. Ask for our list of used instruments, also for our catalog of new factory guaranteed Kings — Mailed no charge.

The H. N. White Company
5238 Superior Avenue :: Cleveland, Ohio

"KING" BAND INSTRUMENTS

Electric Motors below cost \$10

Big manufacturer of electrical equipment canceled his order after we had them all made. Strictly high grade, entirely new motors. Chance of lifetime to get motor to run sewing, washing, ironing machine; compressor, bench lathe, drill press, etc. Write for circular.

REYNOLDS ELECTRIC CO.
2610 West Congress St., Chicago

Washing Machine Size Guaranteed to Satisfy

Be A Floor Surfacing Contractor

New untraveled field. Contractors prefer to submit floor surfacing to American Universal Contractors. Machine does work of 5 men. Works quickly, easily. We set you up in business of your own, furnish office forms, advertising, etc.

Make \$5,000 to \$15,000 or More—Yearly

Prepare for big building boom. Make new floors perfect, old floors like new. Every floor a prospect. Big money in old floors. No town too small. Recorders often pay for machines first month with profit besides. Get full information.

THE AMERICAN FLOOR SURFACING MACHINE CO.
513 So. St. Clair St. Toledo, O., U. S. A.

\$104 PROFIT IN 3 1/2 HOURS

G. A. Barton, Indiana, made that amount-making and selling Candy Floss. Others send in amazing reports: Small, Chicago, says— "Did \$125 business on Sunday." Wendt, Kansas, writes, "Averaged \$128 a day for 3 weeks." Gardner reports, "2,437 sacks of candy sold from 11 a.m. to 10:15 p.m. Big Money in Candy Floss! Ross says: "Cleaned up \$225 in 4 nights in Greenville, Ohio." Candy Floss is a delicious, novelty confection—fluffy, soft as cotton, white as snow, or any color or flavor. Can be made anywhere—in store window, in parks, on street corners, at picnics, summer resorts, base ball games, or wherever crowds gather. Machine easy to operate. Raw materials plentiful and cheap. Send name and address for free illustrated book of facts. Drop postal. Act now! Address

A. T. DIETZ
44 Sayso Bldg. Toledo, Ohio

FREE MY BOOK CANDY SUCCESS

**INTRODUCING—
the Crystal Receiver**



Order by Mail. We Will Ship at Once!

If your dealer or jobber cannot supply you with a Crystal Receiver, write direct. List Price \$18. Murdock or Frost head set \$5.00. Antenna Completion Package, \$5.00. Variometer, unmounted, \$5.00. Send Post Office Money Order with your order.

Radioceptor UNIT



In this—the first of Radioceptor Units—you find a receiver which combines improved electrical efficiency with beautiful mechanical appearance.

A very unusual and exclusive design of variometer forms the tuner—giving greater range of wave length than variometers heretofore designed. Only one adjustment. Continuously variable. No overlapping.

Details of finish include dark mahogany box, highly polished and engraved bakelite panels, buffed nickel parts.

The Crystal Receiver, altho complete in itself, combines with other Radioceptor Units to form a high grade long distance set.

KANSAS CITY RADIO MFG. CO.
605 Grand Avenue Kansas City, Mo.

Jobbers and Dealers—Notice!

Radioceptor Units are sold only through regular trade channels. Write today for our proposition. Stock Radioceptor Units NOW and "cash in" on the popular demand

Please Mention Popular Mechanics



Recharge Your Battery at Home

Charges Both A and B Radio Batteries

Don't be without the use of your Radio Receiving Set while your battery is being recharged. Get a Valley Charger and charge your battery right at home.

Attach the Charger to your home lamp socket—attach the clips to the battery terminals and you will get a quick, tapering charge which just exactly charges your battery, but cannot over-charge or burn it in any way.

Will charge the A 6 volt battery at a 5 ampere rate, and the B 22½ volt battery at the required ½ ampere rate. 45 volt B batteries may be connected in parallel so that they can also be charged.

SATISFACTION GUARANTEED. If your local distributor cannot supply you, write direct to

Valley Electric Company
Department C, St. Louis, Mo.

\$1800
F.O.B. St. Louis



2 RUGS

SEND NO MONEY

TAPESTRY RUGS

Excellent quality. Beautiful Persian Patterns. Attractive colors. Size 54 in. x 27 in. Easy to clean—hard to wear out. \$5 value. Just send name and address. Pay postman \$2.79 and postage on delivery. Still bigger saving on five—\$6.62 and a pair of 8-in. steel household shears FREE.

THE HOME BEAUTIFUL
Dept. 52, 12 W. 40TH ST., NEW YORK

5 Safety Keys \$1.00

Only keys of their kind in existence—open and test thousands of different locks.

Thousands of sets in use among locksmiths, realtors, policemen, detectives, firemen, mechanics, hardware men, travelers, hotel men, etc. Endorsed by all as an invaluable household necessity and convenience in emergencies. Tell you instantly if your locks are burglar proof. Novel chain FREE with keys. Send \$1.00 today. We prepay postage.



MASTER KEY CO., 122 Manhattan Block
Milwaukee, Wis.

CHINESE Good Luck Ring



This Mystic Chinese Symbol of Good Luck, Health, Happiness and Long Life has been looked upon with the deepest reverence by the Chinese for centuries. It is reputed by them to be almost omni-power in its power to bring Good Luck, Riches, Success in Love, Health and Happiness. Amazing stories of good fortune are told by its wearers.

Brings Fanny Brice 'Zigfield Follies' Star, \$2,000.00 in 48 Hours

This famous stage beauty and popular idol says: "Forty-eight hours after I put on my Chinese Good Luck Ring, I received a check for \$2000.00. It was an entirely unexpected present. I call it the best of luck." An actor who had been out of work over a year signed a contract three days after he put his ring on. A mechanic out of work for three months secured a job the next day. The fad of the hour in fashionable New York and Chicago society. Worn by rich and poor alike. Millions sold in the larger cities. Every man, woman and child should have one. Get your Chinese Good Luck Ring at once, or send one to some friend who has been unfortunate.

Send No Money

Don't send a penny. Just your name, address, state whether for lady or gentleman, boy or girl, and give ring size. We will send you a solid Sterling Silver Chinese Good Luck Ring at once by parcel post. When you receive the ring, send us \$1.50 plus a few pennies postage charge. Then wear the ring for ten days and if it does not bring you the best of luck or you are in any way dissatisfied, return the ring to us at end of 5 days and your \$1.50 will be promptly refunded.

CHING LING FOO

Room 1057, 528 So. Clark St.
CHICAGO, ILLINOIS



Please Mention Popular Mechanics



Genuine Bancroft Hollow-ground Razor—with the Everlasting Edge. Direct from manufacturer. Shaves clean. No pulling, scraping or smarting. Makes your face feel fine.

The Genuine BANCROFT

FREE TRIAL

Send No Money. Rush name and Address. Pay postman \$1.75 on arrival. Use razor 10 days. If not satisfactory, money will be returned.

FREE: \$1 HORSE HIDE STROP

For 30 days only we will give a genuine horse-hide double leather strop Free with each razor. A \$4 outfit for \$1.75. Order at once while they last.

BANCROFT RAZOR CORP.

151-A West 19th St. New York

Michigan Marine Motor \$115

Repairs at any Ford Garage



FROM every standpoint—dependability, performance, quick starting, fuel economy, lightness, compactness, and low price—the Michigan Marine Motor stands unapproached.

Here is a 4-hp., 4 cycle, 125-lb motor, fully guaranteed for one year. It rarely requires adjustment and may be repaired at any Ford garage. Admirably adapted for tenders, launches, fishing boats, and other craft requiring a full-powered motor of unfailing reliability. With Bosch Magneto and impulse coupling, \$20 ex. m. Built by Michigan Marine Motor Company.

Special Dealer Opportunity
BELLE ISLE BOAT & ENGINE CO.
Dept. 1, Detroit, Mich.



Make This Test Yourself

Pick up a pair of Neverslip Pliers—moisten a piece of paper between your lips and fit it between the cutting blades. Then grip your hands. Clip! The paper is cut clean as a whistle.

And you can bet your bottom dollar that a plier that stands the paper test will cut anything from a ten penny nail to the softest wire.

Neverslip Pliers cut clean because their cutting edges are made from high carbon crucible steel. But should the blades become accidentally damaged, they may be quickly and easily replaced—for they are renewable and the plier itself will last forever.

That's why Neverslips are guaranteed to outcut and outlast any plier made.

Most hardware dealers sell them.

Write for Leaflet

THE NEVERSLIP WORKS
NEW BRUNSWICK NEW JERSEY

NEVERSLIP

side cutting pliers

Neverslip Pliers are furnished in 6-7 and 8 inch sizes.



Huh! Give up? You fellows can't shoot against me'n *Little Scout*

Ho! Looky there—tore another hole in it. Just 'cause you fellows're bigger'n me don't mean nothin'. Shootin' don't take size.

Aw, don't get sore. You-all could punch holes in the old can, too, if you had one o' those Stevens *Little Scouts*. Come on an' try it once.

Golly, boy! Watch 'at tin can jump. Didn't I tell you? Aint 'at *Little Scout* a bear?

Take a squint through the barrel

Pretty, pretty smooth, eh? You betchal! And you can just store this in the old bean: When a Stevens barrel is rifled, with each motion the cutter removes only the 30th part of a thousandth of an inch. Just jot that down.

I've heard fellows say, "Gee, I'd like to have a rifle, but it costs too much."

Stevens puts a crimp in that bunk. Look at the Stevens prices. That's your answer. Shoot us in a postcard. Simply say, "Send me catalog."

J. STEVENS ARMS COMPANY

Department J253, Chicopee Falls, Mass.

Owned and operated by the Savage Arms Corporation, Executive and Export Offices:
30 Church Street, New York

Retail Price, incl. tax, \$5.40

Stevens "Little Scout." Solid steel barrel, .22 long rifle, .22 long or .22 short rim fire. A real rifle with a real rifle barrel.



The famous Stevens Guarantee

Every firearm turned out by the J. Stevens Arms Co. has attached a tag on which is printed the Stevens guarantee. This tag is your insurance for Stevens quality and workmanship. Read carefully this guarantee.

Stevens

Please Mention Popular Mechanics

Genuine BUSCH Jagdglas \$16²⁵



A five power, extremely serviceable, handsome and well made field glass made by Busch (Germany), needs no introduction, as they are known the world over. These famous glasses up to a short time ago were unobtainable at any price. They are unusually light and compact, made of solid brass, covered with genuine morocco leather and trimmed with hard rubber. Solid leather carrying case and straps.

No. 2509 for \$16.25.

Lomora Prisma Binocular \$25⁰⁰

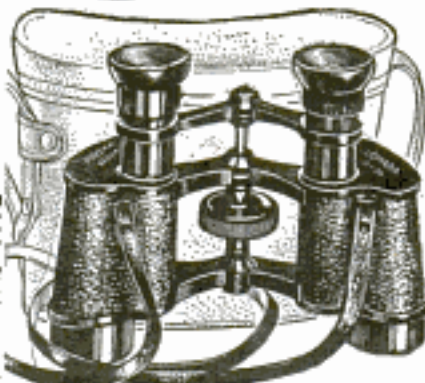

Equipped with central and individual local adjustment, lenses extremely sensitive, can be instantly adjusted to any eye. These binoculars have an unusually long range (825mm). They are handsomely made of solid brass, covered with morocco leather, with shoulder strap and solid leather carrying case and straps. No. 2509 for \$25.00.

All Our Merchandise is Brand New

Order one of these specials now. Supply Limited. Mail Orders promptly filled (Change Prepaid) when accompanied by Money Order or Bank Draft, or if you prefer

SEND NO MONEY

Pay Postman on arrival, our price plus postage. Examine merchandise carefully and if not so represented just return same and get your MONEY BACK without any red tape whatsoever. Bank reference.

Illustrated Catalog No. 9 on Request

EDWARDS IMPORT TRADING CORP.

258 Broadway, Dept. 9, New York City

THE BOOK YOU HAVE BEEN WAITING FOR

Gilbert Radio Telephone and
Broadcasting - 35c postpaid

The A. C. Gilbert Company, 312 Blatchley Ave., New Haven, Conn.

AGENTS WANTED QUICK PROFITS! PERMANENT BUSINESS!

Monstrous proposition offered to agents to handle our Sanitary Aluminous Soap Dispenser. At the same time create a substantial and permanent income. We manufacture a milk powdered soap, highly scented for the machines, costing agents 15c per pound and selling for 50c. Agents establish themselves in permanent business by selling the machines to hotels, office buildings, private homes, and restaurants.

All future orders for soap would be supplied by agents. This soap dispenser means absolute cleanliness. One turn of the handle discharges sufficient for a washing.

Consumers save 500% and avoid using sloppy contaminated unsanitary piece of soap. Don't miss this great opportunity to establish yourself in a business making from \$5,000.00 to \$10,000.00 income per year.

NATIONAL MILLING & CHEMICAL COMPANY, Fox Chase, Phila., Pa.

NERCO (Unitone) Head Phones

A 2200 OHM Head Set for \$8.00

IMMEDIATE DELIVERIES ASSURED

The Nerco "Unitone" Head Phones are designed to give equal tone reproduction through both phones and to receive sounds sharply and clearly. They are correctly and scientifically built for receiving broadcast programs.

Nerco "Unitone" Head Phones have numerous mechanical features:

They are light, stable and have non-rusting diaphragms. They contain guaranteed tungsten magnets.

IMMEDIATE DELIVERY ASSURED

NEWARK ENGINEERING AND TOOL CO., Inc.

476-482 Eighteenth Ave.

Newark - - - N. J.

If your dealer cannot supply you, order
direct from above address

SOMETHING NEW, CATALOG No. 22



New goods, new prices, small boilers, engines, steam and gasoline, 1-5 H. P. up, pumps, castings, blue prints, gears, pulleys, electrical goods, model makers' supplies, materials, 2-4 H. P. Marine engine, 2 1/2 inch sq. model locomotive, etc. Catalog postpaid 20 cents stamps (2 dimes preferred). Refunded first order.

Modern Engine and Supply Co.
53 W. Jackson Blvd. CHICAGO



Be An AUTOMOBILE EXPERT

Big Pay
Study
at
Home

Automobile Experts are always in demand. You don't have to go away to learn either. You can study right at home in your spare time and prepare for a good job at a good salary. Individual instruction. Largest correspondence school in the world. Don't delay. Write today for full details. International Correspondence Schools, Box 5648-C, Scranton, Penna.



Over 30,000 Business and Professional Men, Mothers and Nurses save TIME, MONEY and WORRY over WASTED HOURS spent in barber shops.

The "E-Z" Combination HAIR CUTTER-SAFETY RAZOR makes them independent. CUT YOUR OWN HAIR in ten minutes. Cut the children's hair in less time than it takes to walk to the barber shop. Adjustable for long, short, clipper-effect or pompadour. No practice needed. Any style finished like YOU want. No SPLIT hairs. Cuts wiry, silky, kinky hair. Reversible for ONE-ARM men, right or left-handed persons. EASY BLADES, smoothest you ever had. Two-way SAFETY RAZOR—safe for LADIES—new safety guards blades conform for working under arms, over bumps, hollow spots and behind ears. Life-time durability. Genuine SILVER PLATE, complete with extra blade. Price \$1.50. Price in Canada \$2.00. Try it 10 days—if not satisfied you get YOUR MONEY BACK. Sold through DEALERS or direct by mail upon receipt of price plus like postage. DEALERS WRITE. State Agents Wanted in U. S. and Provinces of Canada. Mention your dealer's name.

J. H. COWAN CO. Dept. 80, M-C Life Bldg., Kansas City, Mo., U.S.A.

COWAN SALES CO. OF CANADA 502 McIntyre Bldg., Winnipeg, Man. Dept. 8, McCullum Bldg., Regina, Sask.

"E.Z." COMBINATION HAIRCUTTER AND SAFETY RAZOR

For
MEN and WOMEN



Make Your Face Show Manhood



Every real man wants the clear, rugged, ruddy face of a real he-man; the healthy, clean skin and alert expression that comes from a vigorous life in the open air. All men want it—all women admire it. You can have it.

STAG

A Man's Cream for a Man's Face—is a true facial invigorator and tonic prepared for men. Two minutes' use brings the red blood tingling to the surface, removes that oily, sallow appearance and leaves the skin clean, clear, firm and with healthy color. It invigorates and hardens the facial muscles and promotes an alert, forceful expression. A sixty-day treatment—with money-back guarantee—will be sent to you for a dollar bill.

Manhood Commands Admiration

Men and women all admire the man whose face shows the clean vigor of perfect health. Stag is made for you men who want to be one of those ruddy, forceful, hard-hitting fellows who are always so popular. Send your name, address and a dollar and it will come to you by return mail—fully guaranteed.

Stag Laboratories 1267 Park Place, West,
Dept. 610 Detroit, Mich.



Radio Build Your Own.

The **BEGINNERS' HANDBOOK** tells how Easy, inexpensive—if you have the **BEGINNERS' HANDBOOK**. Simple language and diagrams, the materials needed, the small cost. Broadcasting stations, wireless code, beginners' dictionary, license information—everything you should know. Send 25c today, coin or money order.

E. J. HENDRICKSON CO.
Dept. 22, 332 East 27th Street, New York



1/4 H. P. Ball Bearing Motor

with cord and plug and grooved or flat face pulley. (New.)
110 Volt 60 cycle A. C. - - \$15.50
32 or 110 Volt D. C. - - 16.90
By parcel post to your door C. O. D.
Motors guaranteed 1 year.
CONVENIENCE MFG. CO.
5901 Maurice Ave. Cleveland, Ohio

Fibre-Lite Limbs

Easy Payments—Do Nature's Work.
AGENTS WANTED who use Artificial Leg. **GOOD PAY.**
FIBRE Fibre Sample. **WORMAN CO.** 252-P HENNEPIN AVE. MINNEAPOLIS. MINN.

WYANDOTTE AUTOMATIC
POP GUN
19 Inches Long

25c Every Boy Wants a Pop Gun. A Big, Strong, Rust-proof Automatic Break Gun. Nothing like it on the market. Wonderful value, price 25c. If your dealer can't supply you send 10c extra for postage.
ALL METAL PRODUCTS CO., WYANDOTTE, MICH.



The
Easiest
Instrument
to Play
Sent to You
ON

FREE TRIAL

Yes, you can have the World famous York Saxophone shipped to you on **10 days' Free Trial**. Play it at home for ten full days. Convince yourself of its superb quality and richness of tone.

And then, if our instrument does not completely sell itself to you simply ship it back to us, and it won't cost you a penny.

Take Your Choice

You can get any one of these fine band instruments made by the House of York on **10 days' Free Trial**. Send the coupon below for beautifully illustrated literature and take your pick of the following:

Saxophones Drums
Clarinets Trombones
Cornets Baritone

Easy Payments

You can pay while learning to play. Make a small payment down and the balance in monthly remittances. We send you everything you need—carrying case and all necessary attachments.

Send Coupon Today

Fill out the Coupon now with your name and address and simply mention the instrument you are interested in and we will send illustrated literature and full details of our Trial Offer and Easy Payment Plan. This literature also tells you how to practice and how to learn to play. **Send Coupon today.**

J. W. YORK & SONS
Dept. 221A
Grand Rapids, Mich.

Mail This Coupon Today

J. W. YORK & SONS,
Dept. 221A, Grand Rapids, Mich.

Gentlemen:—
Kindly mail, without cost to me, your beautifully illustrated literature and details of your Free Trial and Easy Payment Offer.

NAME.....
ADDRESS.....
INSTRUMENT.....
(Mention above the instrument most interested in)

Don't Strangle Your Ford!



The natural wear of the stem ends of the intake and exhaust valves, cam shaft, cam bearings and tappet ends of your Ford engine results in improper timing of the valves, which causes strangling of the motor. New valves of the ordinary type will not help this condition to any appreciable extent. There is only one real remedy—

Pyromite

Tru-Timing Adjustable INTAKE AND EXHAUST VALVES

FOR FORD ENGINES

If your Ford is not developing its full power, put on a set of these valves. They multiply power, quiet the motor, and do away with periodical valve replacement. Pyromite Valves will not warp, pit or corrode.

Learn how to keep your Ford Valves properly timed. Write for our special circular "E".

Steel Products Mfg. Co.
Dept. S. RACINE, WISCONSIN
District Distributors Wanted

"HOW I BEAT THE GAME"

The Inspiring Story of how one poorly paid garage mechanic won success, his own business and a big income. Tells how you can increase your salary from 100 to 500%. Send for it today FREE.

Ambu Engineering Institute
Dept. 16-B 2632 Prairie Ave., Chicago, Ill.



Complete with Ropes and Stakes

\$650

AMERICAN CAMP EQUIPMENT CO.
700 So. Crawford Ave. Chicago, Ill.

LOWEST PRICES IN U. S.

We guarantee you saving on full weight, fine quality tents. You can have a wonderful, healthy, care-free, economical trip with our Moto-Tent. No hotel or garage bills—pays for itself in 2 nights. Up in 5 minutes—no poles needed. Buy direct—our guaranteed profit costs you. \$47.75, \$6.50, 12 lbs., 7x7 ft. \$7.50, 15 lbs. Don't buy till you get our circular.

10c. CHARGES STORAGE BATTERY

FROM A LAMP SOCKET At HOME Or BUSINESS With An F-F BATTERY BOOSTER.



CHARGES AUTOS & RADIO

The Larger Types are recommended for heavy Batteries, or where time is limited. Shipping Weights Complete with AMMETER & BATTERY CLIPS, 12 to 15 Pounds. Mail Check for Prompt Express Shipment. Or if for Parcel Post Shipment add Postage & Insurance charges. Or Order us to forward the Type you desire C. O. D. Dudes New or Write Immediately for FREE Descriptive BULLETIN BULLETIN 24. For GROUP CHARGING write also for Free ROTARY RECTIFIER Bulletin 24-A. It Charges up to 26 Cells Commercially also Rectifies for Wireless High D. C. Voltages. **THE FRANCE MFG. CO., CLEVELAND, OHIO, U. S. A.** Canadian Representative: Battery Service & Sales Co., Hamilton, Ontario, Canada.

RADIO MESSAGE

FORD SPORT BODIES



16 Valve Heads Underlung Fixtures
Speed Differential Gears 4-Speed Transmission
Crankshaft Counterbalance

"YOU CAN BUILD THIS CAR"

and enjoy the pleasure and thrills of motoring. "Ford-Speed" bodies will fit any Ford chassis and convert it into a beautiful car that will give you sport, speed, safety and economy, happy week ends, jolly vacation, boating and fishing trips in "God's Free Country—OUTDOORS." Two and four Passenger Bodies complete Speed & Power Specialties. Good Dealers Proposition. Write for catalog.

Specials for this month:

	Price
Underlung Fixtures	\$15.00 \$8.95
31 Chrome Nickel Gears	12.00 7.95
21 Chrome Nickel Gears	15.00 8.95
Beard & Power Crankshaft	13.50 9.95
Steel Wheel Discs (8)	12.00 8.95

Satisfaction or Money Back Guarantee: Terms 50% with order, balance upon delivery.

L. T. FORD SPEED & POWER EQUIPMENT MANUFACTURERS
280 West 54th St., New York Cable Address "Fordspeed"

SCHICKEL MOTORCYCLE

Economical
Practical
One Man
Transportation
Complete with
Two-Speed Gear
Clutch
Kick Starter
Spring Fork



Every Day Travel for Less than a Penny a Mile

WRITE for CIRCULAR—Mention occupation when writing.
SCHICKEL MOTOR CO., 6908 Garden St., STAMFORD, CONN.

Pullman Sleeper



can be made out of your Sedan or Touring Car. Folds into very small package. Will last for years. Save hotel bills. Live out doors for better health and a good time. \$14.50. Send no money. Pay your postman.

VANDERPOOL CO. Dept. 6. Springfield, Ohio

ENINGER WILL SAVE
BIG MONEY SAVINGS FOR YOU
Used and rebuilt motorcycles, all make and types, \$25 to \$100. Used bicycles, \$5.00; accessories, \$10.00. All machines guaranteed in good working order. New bicycles and motorcycles at Factory prices. You save dealers' profits. Motorcycle and automobile tires too! \$3.00. Complete line of parts and supplies. **Eninger Cycle Co., Rochester, N.Y.**
YOU 25 TO 50 CENTS

AUTOMOBILES

From Maine to California Bush Agents are making money. Mr. E. J. K., in Iowa sold four in two weeks and got a Bush Car Free for his time, freight prepaid. Mr. Van E., in New Jersey made \$400 in two weeks. Mr. K., in Maine, made \$200 in 300 Day. Less fees did this, this spring. No experience required. More agents wanted. Write for details. Address Dept. 9.

BUSH MOTOR COMPANY, BUSH TEMPLE, CHICAGO

\$3.00

Always Accurate—Carter Oil Gauge for Fords and Chevrolet (490 and F.A.). Attaches to Instrument board. Connecting tube runs to elbow which screws to lower petcock. No moving parts. Can't get out of order. Satisfaction guaranteed or money refunded. **Carter Motor Accessories, Inc., 390 Pearl St., Buffalo, N. Y.**



MAKE A MOTOR CYCLE OUT OF YOUR BICYCLE with a STEFFEY MOTOR ATTACHMENT. RELIABLE—ECONOMICAL—EFFICIENT. Easy to attach. Fits any wheel. Send stamp for circulars.
STEFFEY MFG. CO., Dept. P, 5025 Brown St., Phila., Pa.

DIAMONDS WATCHES

One Year to Pay

**Diamond Prices Smashed
to Less Than Cash Prices**

Amazing money-saving prices on
Finest Quality Genuine Diamonds,
Watches and Jewelry. DIAMOND
RINGS \$14.85 and up. Wrist Watches
\$19.65 up. Men's Elgin and Waltham
Watches \$28.75 up.

Get DeLuxe Catalog FREE. Explains
easiest credit Terms and Money Back
Guarantee fully. Examine Diamonds
first if you wish. One whole year to pay.
Use Your Credit. Get this Beautiful Bar-
gain Catalog. NOW!

Klein & Co. 122 W. Madison St.
Dept. B76 Chicago, Ill.
Nearly 1-4 century same location

\$4.50
A Month
payments will
buy this magnifi-
cent hand engrav-
ed "Lady Lorraine"
ring. 14Kt Solid Gold.
Large steel-blue white
perfect cut Diamond
of fiery brilliancy.
Was \$199.00.

**Now Only
\$68.00**

Use Your Credit
No Delay—No Red Tape

RAILWAY MAIL CLERKS



Thousands of appointments yearly.
Permanent positions. Good salaries.
Pleasant work. Generous vacations.
And you can study at home in your
spare time! World's biggest corre-
spondence school. Individual instruc-
tion. Thousands of successful stu-
dents. Write today for full details.
International Correspondence Schools,
Box 5646-C, Scranton, Penna.



**\$4 or \$5 a month
WILL BUY**
A Standard, Guaranteed
TYPEWRITER

With Every Modern Writing Convenience
Write Today for Illustrated Circular
Explaining Try-Before-You-Buy Plan

SMITH TYPEWRITER SALES CO.
(Harry A. Smith) 910-218 No. Wells St., Chicago, Ill.

Mystic Skeleton

A jointed figure
of a skeleton 14 in.
in height, will
dance to music
and perform vari-
ous gyrations and
movements while
the operator may
be some distance
from it.

Serpent's Eggs

Box contains 12 eggs. When
lit with a match, each
one gradually hatches
itself into
a snake
several
feet long
with
curls
and twists about in a most life-
like manner. Price per box, 10c ppd.

JOHNSON SMITH & CO., Dept. 440, 3224 North Halsted Street, CHICAGO



Good Luck Ring

Ornate
and Novel
Design

A VERY striking and uncom-
mon ring. Silver finish, skull and
crossbone design, with two bril-
liant, flashing gems sparkling out of the
eyes. Said by many to bring Good Luck
to the wearer, hence its name, Good Luck
Ring. Very unique ring that you will take
a pride in wearing. **ONLY 25 CENTS.**

**Yankee
VIOLET RAYS**
Only
\$12.50

Positively will give bee-facial treatment for most ordinary ailments and increases
blood circulation, stops disease destroying action and imparts a delightfully
stimulating effect on the whole body.

SEND NO MONEY

Just your name and address, we will send Home Oufit by mail
\$12.50 collect—5 days' free trial. Money back if not satisfactory.

Its Beneficial Effects Have Been Acclaimed by the Foremost Physicians
of the World

The prohibitive prices of other Violet apparatuses ranging from \$35 to \$100
have deprived thousands of the benefits afforded through their use. The Yankee
Violet Ray Oufit will last a lifetime and will pay for itself many times in its
health giving benefits. Write for booklet—IT'S FREE.

Guaranteed to Last a Lifetime With Ordinary Use

YANKEE LABORATORIES, INC.

318 East 43rd Street New York, N. Y.



The Penalty of Dry Driving—

Oil! It's the life blood of your motor. And yet
it's usually the most neglected factor. Scored
cylinders, ruined bearings, broken piston rings
and connecting rods—that's the penalty of **dry
driving**. Don't guess you have enough oil in your
crank case. Know for a certainty. Play safe.
Oil is cheaper than repairs.

The RAJO OIL GAUGE tells you instantly how
much oil you have in your crank case. Just lift
the hood and read the red-tipped wire. Non-clog-
ging and positive in operation. Nothing to get
out of order. Works on same principle as oil
gauges on some of the most expensive cars.
Adapted to Nash and Buick cars as well as Fords.

Send \$3.00 today for your gauge. It may save
you a repair bill to-morrow.

RAJO MOTOR CO. 1377 Racine St. RACINE, WIS.

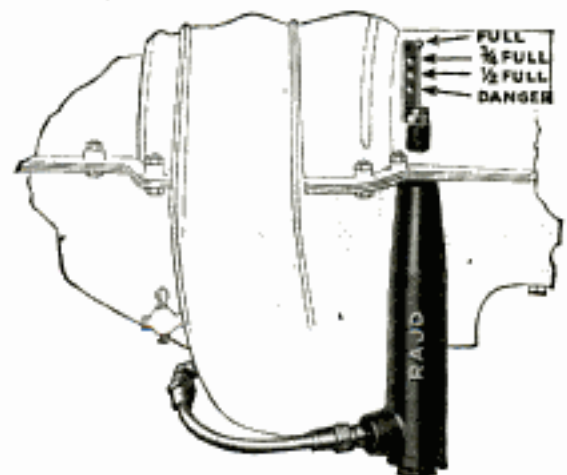

**Absolute
Protection** **\$3.00**

RAJO
OIL GAUGE FOR FORDS

SHOOTS 300 FEET TURNS NIGHT INTO DAY \$25

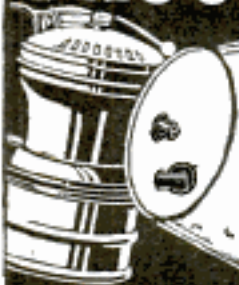

The **AUTO-LITE** is a patented lamp that throws a powerful brilliant light 300 feet. No smoke. No grease. No sparks. Light without matches. Not affected by wind or rain. All you need is carbide and water. Safe, sure and simple to operate.

FOR Camping Hunting Fishing Boating Hiking Auto Tourists Trouble Shooting Way Scouts Night Emergencies

The **AUTO-LITE** is constructed of brass, highly polished nickel finish. Light in weight, yet strong and durable. Small, compact and is only 4 inches high. Can be carried in the hand; hooked on to the front of your hat, in your coat lapel, fastened on to small poles, hung up or stand anywhere. It is indispensable for all purposes where a strong brilliant light is required. Burns 3 1/2 to 4 hours at a cost of one penny.

LIGHTS WITHOUT MATCHES

Universal Lamp Co. 1016 S. Wabash Ave. CHICAGO

ORDER ONE TODAY

Its usefulness, merits and value are beyond description—must be seen to be fully appreciated. **ORDER ONE TODAY.** You can't go wrong. If, for any reason whatever, you don't want to keep it, return it, and your money will be promptly refunded. No questions asked. This guarantee is positively unconditional. Thousands in use, among satisfied owners. **ORDER YOURS TODAY.** Mail check, money order, draft or cash for \$1.25. It will be mailed postpaid the same day your order is received.

DEALERS **AUTO-LITE** lamps carried by all leading Hardware Jobbers. If your jobber cannot supply you, order direct.



Build Your Own Radio At Small Cost

You ought to have your own radio in your home or office to pick up the market reports two or three times a day. That's business. Also to get the ball scores and the evening concert. That's pleasure. We will furnish you the parts and a free book of instructions. We have good stocks at present, but do not delay. There never was such a demand for anything as there now is for radio supplies. Write today for Illustrated Price List.

Northern Radio Supply Corp.

Dealers write for our proposition.

Dept. A, 542-544 West Washington St. CHICAGO, ILL.

BINOCULARS

Special value in highest grade genuine imported **FRENCH CONDE** prismatic binoculars, in fine calf skin case with straps. 8 power; 32 mm. 23 oz. **\$45.80**



Sent on Approval brand new; not war stocks. Over 1000 pairs sold last year. Drop us postcard for illustrated circular.

BARLER & CO. 644-D N. Michigan Ave. CHICAGO

BURN Home Made GAS COAL STOVES



Change your coal or wood stove into a gas stove in 3 minutes. A Child can do it. Burn kerosene Vapor Gas—hotter than coal or wood and costs less. Safe and simple.

FREE TRIAL

Just turn a valve and get even heat instantly. No ashes, no dirt, no smoke, no wood to chop or carry. No fires to build and feed. No fuel wasted. Cooks and bakes better. No damage to stoves. Makes its own gas from common coal oil, cheapest, cleanest fuel. Guaranteed five years. Money back if not satisfied after 30 days trial.

Write for **FREE** folder with proof and **SPECIAL OFFER**
SIMPLEX UTILITIES MFG. CO.
610 Simplex Bldg. 2537 S. State St., Chicago

Bam-Bee-No Real Baseball

Played on any table anywhere. Ask your dealer, or write The Bambeano Sales Co., Dept. 662 Toledo, Ohio

YOU CAN OVERCOME WEAKNESS and ILL-HEALTH

This big, valuable book sent without obligating you in any way. Learn how to treat yourself for ailments caused by disordered nerves, impoverished blood or poor circulation. Build up cells and tissues to healthy activity, banish aches and pains and eradicate poisons.

Merely send request for **FREE BOOK.**
J. S. CAPE, 610 W. Park Pl., Detroit, Mich.

We Guarantee Our Agents \$60 a Week

FOR ONLY 4 ORDERS A DAY
No Delivering—No Collecting—Commissions same day you take orders

AT LAST

A Simple Practical Dependable



FUGO Automatic Fire Extinguisher

Extinguisher for only

\$5

No Experience Needed Our improved instructions guide you—you can't go wrong—a 5 minute demonstration and it's sold. Your neighborhood fire department will recommend it—boost it—push it.

Exclusive Territory Become our licensed agent—employ sub-agents—each one brings you a good profit. You take no risk—you don't invest a penny. We deliver and collect—you receive commission same day you take orders.

THE OHIO INSTRUMENT MFG. CO.
9416 St. Catherine Ave. Cleveland, Ohio

Get Our Plan—TODAY

You don't hear of an invention like this every day—don't delay. Trained agents will jump at this opportunity. Write now for full particulars showing big possibilities for YOU. Sample Fugo Automatic **FREE.**

Increase Your Store Profits \$600 to \$5000 a Year!



Get These Money- Making Butter-Kist Facts!

SEND the coupon now. Learn how to add \$600 to \$5,000 a year profit to your business the Butter-Kist way. How to meet high rents and other expenses—make a big profit in *spite* of conditions. Other merchants are adding \$3 to \$18 a day to cash profits. \$50 to \$460 a month. \$800 to \$5,000 a year. They pay entire overhead expense, including rent, from their amazing profits. This has happened in thousands of cases.



BUTTER-KIST

Popcorn and Peanut Machine

Pops, advertises and sells popcorn. Also sells toasted and salted peanuts. You make 60c profit from each \$1 in sales. Three to four times greater percent of profit than cigar counter or soda fountain. Capacity \$1 to \$9 an hour—\$6 to \$54 in 10-hour day. Wonderful success.



Buy Butter-Kist Goodies

Popcorn, peanuts, etc.—in the trade marked packages. Look for merchants with Butter-Kist Machines. They are good men to know.

SEND COUPON FOR FREE BOOK

IT explains how the Butter-Kist machine occupies only a few feet of waste store space. How its motion stops people; coaxing fragrance makes them buy; toasty flavor brings trade for blocks; stimulates other sales; pays like a little gold mine. It gives new low prices, easy terms, and letters from Butter-Kist owners. Mail coupon now!

Holcomb & Hoke Mfg. Co.
2014 Van Buren St., Indianapolis, Ind.

World's Largest Manufacturers of
Popcorn Machines and Peanut
Toasters

HOLCOMB & HOKE MFG. COMPANY,
2014 Van Buren Street,
Indianapolis, Indiana

Gentlemen: Please send me, without obligation, full particulars in regard to the machine checked.

- Triumph Model Butter-Kist Popcorn Machine.
The latest machine—smaller, lower in price.
- Grand Model Butter-Kist Popcorn Machine.
The large type, recently improved and changed.
- Universal Model Butter-Kist Peanut Toaster.
Sits on counter—operates by electricity.

Name Age

Business How long in business

Address

City

Have you copy of our book, "America's New Industry"?

Have you electricity in your town?

\$3,000 to \$5,000 YEAR!

The Business For YOU!



This is new. Nothing like it. Simply great. Go into **battery building** business. Easy. No mystery about it. Demand enormous. Possibilities astounding.

RIDE TO SUCCESS ON RADIO WAVE

Every receiving outfit uses storage battery. Over six hundred thousand in use today. Increasing at rate of hundred thousand monthly. All must be recharged often. Repairs will be amazing. This field alone offers tremendous opportunities.

EVERY AUTO MUST HAVE BATTERY

Almost ten million cars swarming country. All—even Fords—have batteries. Car owners seeking money-saving bargains. You can quickly learn to build **guaranteed** batteries. Can knock competition sky high and still make big money. This is your chance. Opportunity has knocked. Throw open the door. Drop everything and get busy. Nothing to stop you.

LITTLE MONEY STARTS YOU

We furnish everything needed. Fit you out complete with boxes, plates, terminals, tools, distillers, materials, supplies and directions. Our instruction course plain and simple. You can learn almost over night. No business on earth offers greater chances for success. No business on earth can be started with so little money. Don't wait a minute. Get in on ground floor. It's the coming industry. Demand for storage batteries never better. Market increasing by leaps and bounds.

WRITE QUICK FOR DETAILS

It's a proposition you can handle. Nothing hard about it. Pleasant, fascinating work. We help you to the limit. We have been in business over twelve years. Have put thousands of men into business. We'll do the same for you. Write or wire today.

Haywood Hypower Battery Co.

1363 CAPITOL AVE.

INDIANAPOLIS, IND.

Baby Grand Lathes

Not a Toy---Just Like a Big One

For other metal or wood working—ideal for auto and electric repair shops, pattern and model shops. Because of their simplicity and compactness, we are able to build into each Baby Grand Lathe the same Quality that characterizes the finer types of big lathes—and at a price within the reach of everyone, everywhere.

Put One on Your Bench at Home

Baby Grand Lathes develop talents, make more products and provide a means of enjoying and your ideas right in your home. Do your own work on either metal or wood. **WONDERFUL FOR THE BOY.** They are light, compact and simple to operate, but at the same time so sturdy that the highest quality of work is produced. **Home Training teachers endorse the Baby Grand.** It is a wonderful help to the student. **Best at home.** The lowest priced **GOOD LATHE** ever produced.

6 In. Swing
12 In. Between Centers
20 In. Bed



Write for
Prices and
Details

THE WATSON MFG. CO.
26 Post St., Toledo, Ohio

AGENTS Wanted for open territory; Exclusive agency. Highest quality of Approved Lightning Rod. More than 1,000,000 buildings now protected. Fire Insurance Cost give reductions in rates.

Your Chance to MAKE a real Success

Sell a necessary protective device for every exposed farm structure. Most profitable and easiest to sell. We help you to sell. Goods are perpetually guaranteed. **MONEY**

Write today—before territory is gone and ask for our Booklet "Lightning and Lightning Rods."
ST. LOUIS LIGHTNING ROD CO.
2140 DeKalb St. St. Louis, Mo.

CRYSTAL RADIO SET, \$4.75

Complete in Cabinet as shown.



Head Telephone and Antenna, \$5.00 extra. Satisfaction guaranteed or Money Refunded.

CORONA RADIO CORPORATION

265 Canal Street, New York

MAKE YOUR **wife's or mother's wash tub into a WASHING MACHINE**

It's a child's play to do your week's wash in 5 to 10 minutes—clean and without wear, with the Van Cup Attachment. No electric or water power necessary. Vacuum and suction principle—formerly the Dodge and Zuhl Syracuse "Easy." Sent on 30 days' free trial. Easy monthly payments if desired. Send postal card for how to save work.
BURLINGAME MFG. CO. 622 Sunset Ave., Syracuse, N. Y.

Light Fibre Legs and Arms

636

Dean Bldg.

RAY TRAUTMAN Minneapolis, Minn.

100 SHOTS FOR 1¢

NEW PATENT 500 SHOT revolver shown 2 shots in 2 seconds just pull the trigger. Will shoot 500 times with one loading. Reloads automatically after each shot. Ammunition costs only 5c for a package of 5000 shots. Register pocket model genuine gas metal finish comes loaded ready for 500 shots. Each shot advanced-automatically harmless. Sent postpaid to you for only 77c or 2 for \$1.50, stamps not accepted. Order direct from this ad. Shipment guaranteed in 24 hours.
THE IRVING A. CO., 1636 So. Lawndale Ave., Chicago, Ill.

CROSLEY

Radio Apparatus

is low in price because it is simple in construction

Crosley Radio goods are quality goods. Quantity production is responsible for the reasonable prices of Crosley Radio parts.

CROSLEY Harko Senior Receiver

Pictured Below

This highly efficient tuner and detector will of itself without amplifier bring in from hundreds of miles, concerts loud and clear with head phones alone. The hook-up is Crosley non-regenerative, efficient, yet simple. Do not mistake the low price as an indication of its quality. Detroit, Pittsburgh, Chicago, Newark, etc., are heard regularly in Cincinnati. Pittsburgh is heard constantly in Minnesota and Denver hears Schenectady nightly on this receiver without amplifier. Well built, finely finished in mahogany color.

\$20

\$20 is the price without batteries, head phones or tubes.



If your dealer cannot supply you, write for our complete Radio Apparatus and Radio Parts Catalog and send us his name.

THE CROSLEY MFG. CO.
CINCINNATI Department PM522 OHIO

1
Crosley Rheostat for vacuum and filament control. Thoroughly efficient. Price 60c.

2
Crosley Tap Switches, perfect contacts and constant tension. Special Crosley buss wire connection. Price 40c.

3
Crosley Model B Variable Condenser (.0005 mf capacity), Simpler and better, costs less, \$1.75.

4
Crosley porcelain vacuum tube socket, base or panel mounting, 60c.

5
Crosley Sheltran. Highly efficient. Ratio of 9 to 1. Base area $1\frac{1}{4} \times 2\frac{1}{2}$ ". $2\frac{1}{4}$ " high, \$4.00.

Crosley Parts
better - cost less -
write for catalog

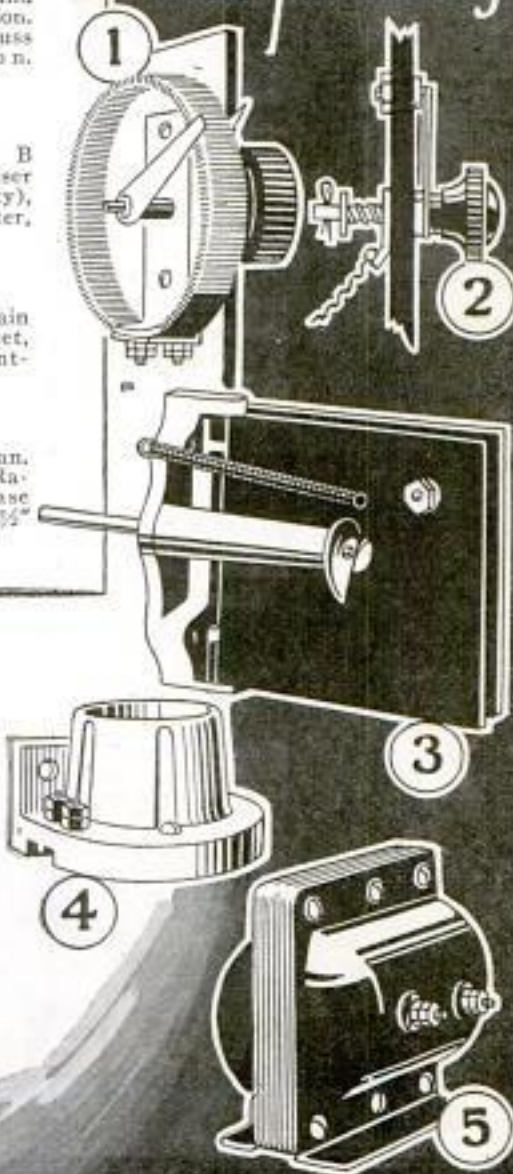

CONN RADIO CONCERTS

from
Ocean to Ocean



Brass Choir
San Francisco Symphony
Orchestra

Pictured here are some of the artists appearing in
Conn Radio Concerts. Above—Frank Westphal's
Rainbow Garden Orchestra, Chicago.

THIRD OF NATIONAL SERIES—Friday Evening, May 19

CONN radio concerts have taken the nation by storm! Our programs of March 17 and April 14 by America's leading dance orchestras and nationally famed soloists have occasioned universal admiration for Conn enterprise.

Isham Jones, Joseph Smith, Frank Westphal, Hal Nichols, D. C. Rosebrook and their orchestras have already played; Benne Henton, Charles Randall, John Leick, Mable Keith Leick and Fred Tait have given solos. More of their calibre are to appear.

Travelers on shipboard 1500 miles from the Atlantic and Pacific coasts, people in Northern Canada and in Central America will enjoy the same music which will be heard throughout the United States May 19.

Think of it—Conn Ltd. is entertaining people by wireless a quarter of the way around the globe

May 19 programs will be broadcasted from:

New York, Station WJZ;	Chicago, Station KYW;	Denver, Station ZAF;
San Francisco, Station KDN;	Pittsburgh, Station KDKA;	Kansas City, Sweeney Station
Detroit, Station WWJ;	New Orleans, Station WAAB;	Seattle, Wash., Station KGB

Conn dealers are entertaining at radiophone concerts. Watch for local announcements.

Write to Conn Ltd. now for new saxophone book; FREE. Tells why the Conn is the world's finest, choice of the famous artists on the radio programs.

631 Conn Building C. G. CONN, LTD. Elkhart, Indiana

Agencies in All Large Cities

Conn New York Co., 233-5-7 W. 47th St.	Conn Chicago Co., 62 E. Van Buren St.
Conn Detroit Co., 243 E. Grand River Ave.	Conn Seattle Co., 1609 Third Ave.
Conn New Orleans Co., 317 Baronne St.	Conn Portland Co., 127 Tenth St. (Oregon)
	Conn Cleveland Co., 1220 Huron Road
	Conn Atlanta Co., Auburn and Ivy Sts.

WORLD'S
LARGEST MANUFACTURERS
OF HIGH GRADE BAND AND
ORCHESTRA INSTRUMENTS



F. W. BENTLEY
of Philadelphia, says:
"Ye Gods—some seller. I
made \$215.00 today."

J. Carnegiey of
S. D., says:

"Am making \$1000 a
month. I have made big
money before, but did not
expect so much. Your
Burner is just the thing."

\$ 215⁰⁰ In One Day

A Whirlwind Summer Seller Agents Are Making Fortunes!

NO wonder this amazing new invention is making fortunes for agents. Everywhere, this new device is doing away with the muss, dirt and drudgery of coal and wood fires—saving housewives from roasting kitchens in Summer. It turns any coal range into a gas stove—in just one minute. Then simply turning a valve instantly gives just as much or as little heat as is needed—only when it is needed. That's why the Oliver Improved Oil-Gas Burner is making fortunes for agents. You don't need experience to get your share. The device sells itself upon sight. Send the coupon today for full particulars.



Turn Fire on and off with a valve

New Invention Ends This Drudgery—Sells Like Wildfire

SUPPOSE you were a housewife who had to sweat and fume and fuss over a hot mussy coal and wood stove in a roasting kitchen in July. You'd jump at the chance to buy a device that turned coal and wood stoves into gas ranges and gave you a cool kitchen all Summer—gave as much heat as you needed in the Winter—and banished forever the drudgery of building fires and emptying ashes.

That's why housewives all over the country are clamoring for this amazing new invention. That's why salesmen are cleaning up on the Oliver Oil-Gas Burner.

It isn't hard to sell a thing that everybody wants. And the Oliver makes an instant hit with everyone because just by the turn of a valve—like a gas stove—it gives instant heat only when it is wanted.

Another thing: The Oliver burns 95% air and 5% oil, the cheapest fuel there is. It is not a mere kerosene wick burner. A new invention turns the oil and air into gas. It is the gas that burns. Now you know why W. H. Drew of Michigan made \$85.00 in one day; why L. Zucher of Ohio made \$21.50 in 3 hours; why R. Burger of Ontario in one week earned \$258.50; why A. M. Russell of Connecticut has averaged \$660.00 for the last 6 months; why one order sent by P. M. Ford of Iowa gave him a profit of \$646.25.

Quick Sales—Big Profits

These men know a good thing when they see it and they know that an invention that makes effective use of the cheapest fuel and at the same time frees women from the drudgery of wood and coal fires,

sweltering Summer kitchens, and the dirt of ashes is the thing they want to tie up to.

No Experience Needed to Make Big Money

You do not need to be a high-powered salesman. The Oliver's amazing features sell it for you. Every agent we appoint makes big money. You, too, can use this secret of making big money easily. We have a number of definite territories which we are ready to dispose of to those who act quickly.

COUPON BRINGS FULL OFFER

Mail this coupon now for our offer. We are not making any extravagant claims about this. We don't have to. We want to give you the facts. Writing will not obligate you in any way. But by acting quickly you will receive our offer in time to get an exclusive territory franchise with private selling rights—if you want it.

But hurry. Send the coupon at once if you want to get in on this big-money, whirlwind Summer seller.

OLIVER OIL-GAS BURNER & MACHINE CO.

2014-R Pine St.

St. Louis, Mo.

Oliver Oil-Gas Burner & Machine Co.
2014-R Pine St., St. Louis, Mo.

Please send me full facts about how I can make big money representing you in my territory. Also your plan if I wish to make big money in my spare time.

Name

Address



Establish a Profitable Business of Your Own

With a small investment you can install our Complete Dry Cleaning Plant which will not only yield you good returns, but will grow into a large establishment. There is a growing and profitable field for anyone

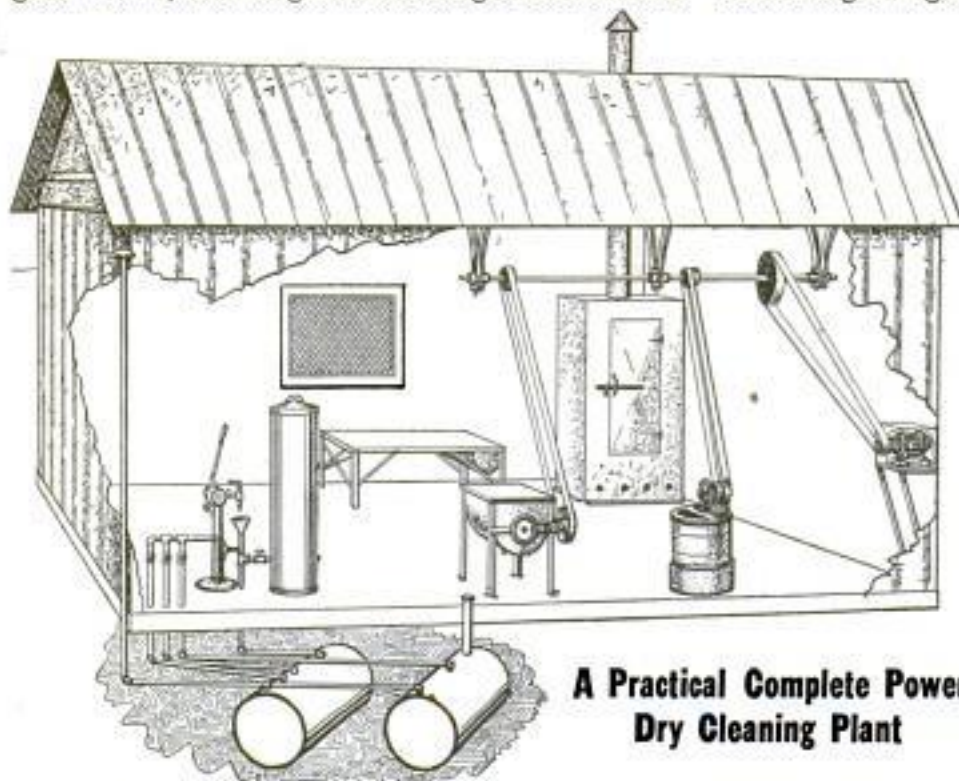

A Practical Complete Power Dry Cleaning Plant

Suit capacity Dry Cleaner, One Six-Suit Capacity Extractor, One 50 Gallon Capacity Gasoline Filter, One Scrub Table, One Six-Suit Capacity Electric Dry Room, and Underground Gasoline Storage System. Price Complete, as per illustration, except pipes leading from tanks. **\$735.00**

Price of Plant complete without the building, \$360.00

in the Dry Cleaning Business and we urge you to avail yourself of this unusual opportunity of installing our Complete Dry Cleaning Plant.

Order our Complete Dry Cleaning Plant at once, or, write us for full information. It is our earnest desire to assist and co-operate with you. Many men have made a success of this business who had absolutely no experience when they first started.

We furnish the inexperienced man with a guide to Dry Cleaning.

Has an Earning Capacity of \$480.00 per Week

One Portable, All-Metal Fire-Proof Building with two windows, one door and gas-tight motor box with outside door and ventilator, a $\frac{3}{4}$ H. P. Motor and Overhead Transmission, One Six-Suit Capacity Electric Dry Room, One 50 Gallon Capacity Gasoline Filter, One Scrub Table, One Six-Suit Capacity Extractor, One 50 Gallon Capacity Gasoline Filter, One Scrub Table, One Six-Suit Capacity Electric Dry Room, and Underground Gasoline Storage System. Price Complete, as per illustration, except pipes leading from tanks. **\$735.00**



The Midget Complete Hand Plant

This is not a toy; it does the same high grade work as machines that cost more money and is designed to start you in the Dry Cleaning Business with the least outlay. This Plant consists of One Four-Suit Capacity Hand Dry Cleaner, One Four Suit

Capacity Hand Extractor, One 25-gallon Capacity Gasoline Filter and One Four-Suit Capacity Electric Dry Room. Price Complete **\$120.00**

TERMS—Send draft or Money Order for $\frac{3}{4}$ the amount with your order. Balance payable upon delivery. Export orders must be accompanied by U. S. Exchange for the full amount. All machinery is shipped F.O.B. factory.

G. R. SCHMIDT WOOLEN COMPANY

The Most Complete Tailors' Supply House

Woolens, Tailors' Trimmings and Supplies, Cleaners' and Dyers' Supplies, Launderers' and Hatters' Supplies

900-902 Washington Avenue, St. Louis, Mo.



LEARN A TRADE

Young man—you want A BETTER JOB—more money—opportunity—success. If you are mechanically inclined write me today—don't bother about a letter—just a postcard will do—or clip and mail the coupon.

I Will Make You an Amazing Offer

If you are interested in mechanical work, if you are interested in automobiles and WILL WORK, this Million Dollar Trade School offers you an opportunity that may never come to you again. Will you PUT EIGHT WEEKS' TIME in this great trade school IF YOU ARE CONVINCED IT MEANS A REAL JOB AND A LIFETIME SUCCESS? Because of the demand for Sweeney trained men I am making now MY BIGGEST AND MOST SURPRISING OFFER—no matter where you live—no matter if you have had no previous experience—no matter how old you are. But I will make this offer ONLY to those who are sufficiently IN EARNEST and SUFFICIENTLY ENERGETIC to write me AT ONCE.

The Sweeney System

famous the world over, can be had only in the Sweeney School. Trains men to be mechanics by practical work. You learn by doing—no books—you do the actual work. The course takes only 8 weeks. No place in the world can you get so much real instruction—so much actual value, for so little money. Over 46,000 graduates. Write me today—don't put it off—I've got some information that will open your eyes—but you must take the first step—Write for my Big Free Book.

Pick the Job

You Like

Chauffeurs	\$90 to \$150
Truck Driver	\$125
Tire Vulcanizers	\$100 to \$200
Welders	\$140 to \$200
Battery Men	\$150 to \$200
Auto Mechanics	\$6 to \$10 a day
Auto Electrician	\$225
Tractor Engineer	\$10 a day
Garage Mgr.	\$150 to \$400
Demonstrator and Salesman	\$150 to \$500

Free Radio

Come to the Sweeney Auto School and learn Radio work without a cent's extra charge. Receive messages—learn to build and install Radio sets—get agencies and sell sets—receive messages from all over the world—all this is now part of the regular eight weeks' course without advance in tuition. Who is the right man to sell and install these simple receiving sets? The garage man or auto mechanic. These sets are cheap and easily made. Learn how to make them.

The Sweeney School is always the leader. That is why I am offering this great new development free.

MAIL COUPON NOW

Good Jobs for You

With your radio experience here you can go back home and install receiving sets or sell them. You can make sets for yourself. You can run a garage. You learn to make a good \$25 Ford battery for \$7.00. You learn how to weld a broken crank case. You learn how to make a real 4000 mile tire from old casing and rubber. You can be a chauffeur or truck driver. You can be an auto mechanic—a repair man in a shop or factory. Learn about stationary engines. Learn tractor work. Be a demonstrator or salesman. Hundreds of good jobs open to Sweeney trained men. Even before he finished his course Runsey was grabbed by the American Radiator Co. at \$150 a month as an expert welder.

FREE

I will gladly send my 72-page illustrated catalogue FREE. Also a copy of the Sweeney School News, a most interesting monthly school paper published here. You will enjoy them. Read the worthwhile stories of men like yourself who came to Sweeney's and found success. Read how Frank Powell and Harry Wilson built up a \$20,000 business in about two years after graduating. Read how Elbert A. Pence built up a \$25,000 yearly garage business. These stories and others are told by the Sweeney students. Also I want you to learn how my students enjoy themselves after work in the swimming pool, club and reading rooms, etc. No colored students accepted.



EMORY J. SWEENEY
President

1024 Sweeney Bldg.
Kansas City, Mo.

Please send me free without any obligation on my part, your 72-page catalog and your Sweeney School News. Tell me of the opportunities in the Auto and Tractor Business.

LEARN A TRADE
Sweeney
SCHOOL OF AUTO-TRACTOR-AVIATION
1024 SWEENEY BLDG. KANSAS CITY, MO.

Name.....

P. O. State.....

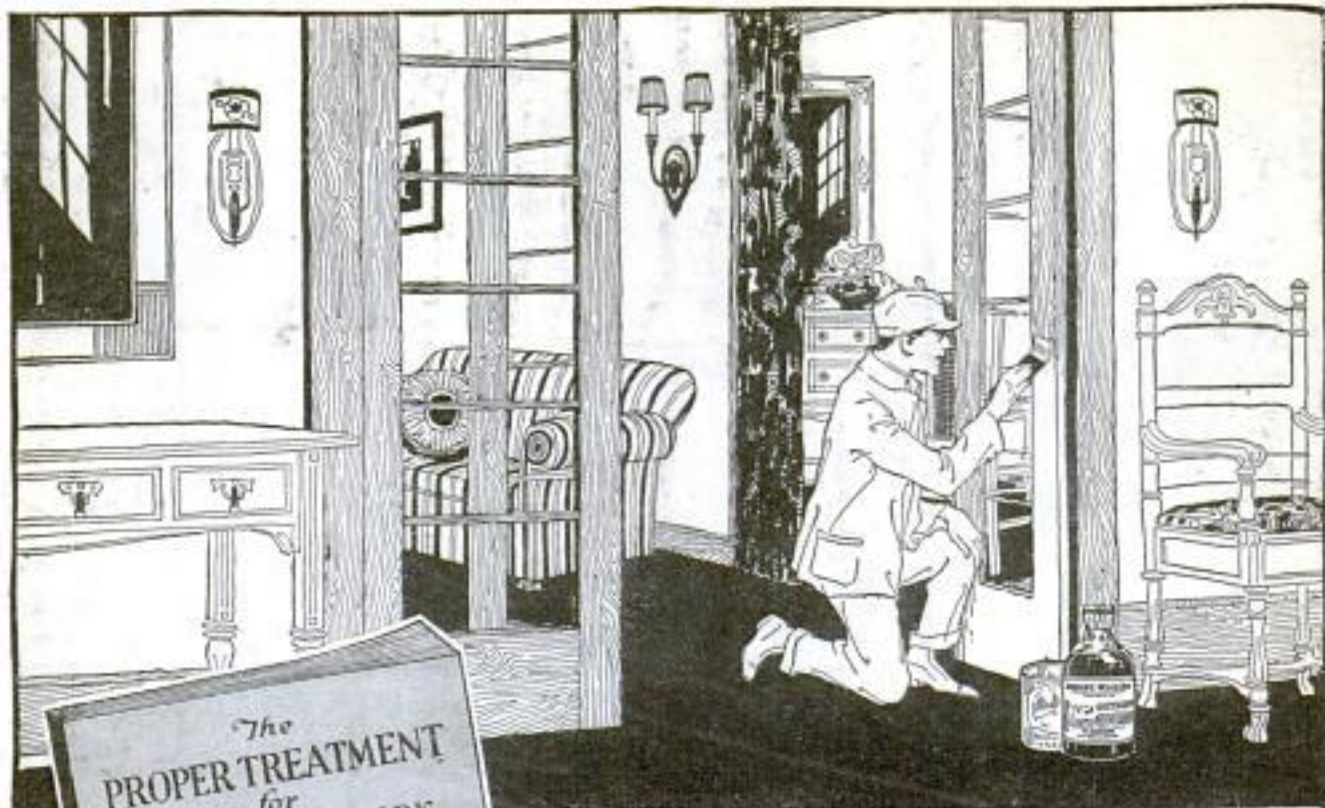

This Beautiful Book on Wood Finishing FREE

GIVES complete instructions for finishing all wood—hard or soft—old or new. Explains just what materials to use and how to apply them. Tells how inexpensive soft woods may be finished so they are as beautiful and artistic as hard wood. This book is the work of experts—illustrated in color. Includes color card—gives covering capacities, etc.

JOHNSON'S WOOD DYE

Use coupon below for a free copy of "The Proper Treatment for Floors, Woodwork and Furniture." It is full of valuable ideas on Wood Finishing and Home Beautifying.

S. C. JOHNSON & SON, Dept. PA6, Racine, Wis.

Please send me, free and postpaid, your instruction Book on Wood Finishing and Home Beautifying.

NAME.....

ADDRESS.....

CITY & STATE.....

Dealer's Name.....

Johnson's Wood Dye is very easy to apply—dries in four hours and does not rub off or smudge. Penetrates deeply, bringing out the beauty of the grain. Made in fourteen popular shades, all of which can be easily lightened or darkened. Color card in book.

S. C. JOHNSON & SON

"The Wood Finishing Authorities"

Dept. PA 6 RACINE, WIS.

Canadian Factory—Brantford

**FREE
TRIAL**

**EASY
TERMS**

**Brand
New!**

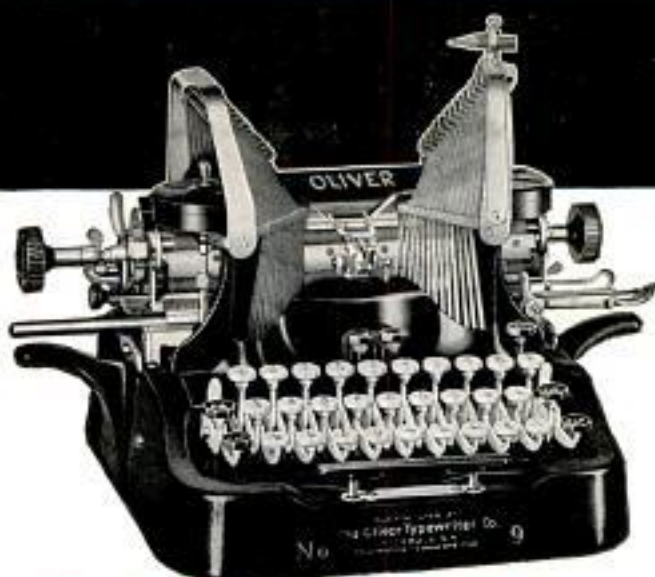

Save Half
On This New
Standard Typewriter

Send No Money!

We Ship You This Wonderful New Oliver Nine on Free Trial!

HERE IS OUR OFFER: The most startling offer ever made by any typewriter manufacturer. *Send no money*—not a single penny down. Just mail us the coupon.

We will ship you absolutely **FREE**, on a **5-DAY TRIAL**, a brand new **OLIVER NINE** typewriter, direct from the factory to your home or office.

You **TRY** it! If you are thoroughly convinced that it is the best typewriter *at any price* that you ever tried, you then pay us a small amount a month—only a few cents a day—and this wonderful typewriter is yours at about half the cost of any other standard typewriter.

SAVE HALF OR MORE

The **OLIVER NINE** is offered to you *today* at an amazingly low price. A few years ago the Oliver sold for \$100, or more, like any other standard machine. We had the same cumbersome, expensive methods of selling through branch offices, agents, salesmen. Then we learned this new day way of selling direct by mail.

Today you get an *improved* **OLIVER NINE**, with many 1922 refinements and improvements—a finer typewriter than we formerly sold for \$100—and you get it at this astonishing new low price—lower than the price of a second-hand typewriter.

950,000 SOLD

Don't make any mistake. This is *not* a second-hand typewriter, but a spick-and-span new **OLIVER NINE**, 1922 model, shipped to you direct from the factory.

This is the identical **OLIVER** used by foremost business concerns like the N. Y. Central Lines, the U. S. Steel Corp., New York Edison

Co., Hart, Schaffner & Marx, Morris & Co., and others of like character. It is the *finest typewriter made at any price!*

You are to be the sole judge of its merits. We will send it to you on **FREE 5-DAY TRIAL** without your sending us a cent. Then—when you have convinced yourself of its merits, its superiorities—you pay a little each month at the present low price.

USE THE COUPON

We might tell you volumes about the merits of the **OLIVER NINE**, its ease of operation, how durable it is, how economical, how noiseless. But we prefer that you learn these facts for yourself by actual test.

All we ask you to do is to fill out and mail the **COUPON**. We will then send you our complete **FREE TRIAL OFFER**, a beautifully illustrated catalog and a startling revelation entitled "The High Cost of Typewriters—The Reason and the Remedy."

You can't afford to overlook this opportunity. A typewriter is today a necessity. An economy as well as a convenience, to everyone. Mail the **COUPON NOW**, before you forget it. Learn how you can save half on a standard **OLIVER** typewriter—new from the factory.

THE OLIVER TYPEWRITER COMPANY
1096 Oliver Typewriter Bldg., Chicago, Ill.

**FREE
TRIAL
OFFER**

The Oliver Typewriter Company
1096 Oliver Typewriter Bldg., Chicago, Ill.

Please send me without the slightest obligation on my part your special free trial offer, illustrated art catalog and the booklet "The High Cost of Typewriters—The Reason and the Remedy."

Name.....

Street.....

City..... State.....

RIDE A RANGER



ALL THE YEAR 'ROUND

30 Days' Free Trial

See for yourself the values found in Ranger bicycles with their complete equipment of accessories and extras. Send to-day for catalog and select the model you prefer. Ride it thirty days, test its speed, sturdy qualities, de luxe equipment and exclusive features. If at the end of thirty days you want to return it for any reason, send it back and you will not be out one cent.

Factory-to-Rider When you buy a Ranger you are dealing direct with the makers at Factory Prices. Your "Ranger" is waiting for you. The breath of Spring is in the air. Write for our catalog to-day. When we get your order your bicycle will leave on a fast express train (all charges prepaid) packed in a waterproof paper lining and enclosed in a strong wooden crate. Safe delivery in perfect condition guaranteed.

12 Months to Pay

If not convenient to pay cash for your "Ranger" bicycle, we will ship it to you at once and arrange with you to accept twelve small monthly payments which will enable you to take advantage of our rock-bottom factory-to-rider cash price with only a slight amount added to cover the cost of extra bookkeeping. Parents frequently advance the initial small payment and energetic boys and girls save and earn the later small monthly payments.

There are 44 styles, colors and sizes in the famous line of **RANGER Bicycles** a model to suit every taste and any pocket book.

5-Year Guaranty

This means we make good trouble arising from any defect in workmanship or material at no cost to you. Our guaranty is a written contract—we are directly responsible for the satisfaction and general performance of your bicycle because we made it.

Every Mead "Ranger" is warranted for five years.

Tires and Equipment

Our big free catalog illustrates and describes parts, equipment and sundries that our more than a million riders may need. All are carefully selected from the leading parts makers of the world, to Save You Money at our Factory Prices.



Get this FREE Catalog

We have a copy all ready for you and it will be sent as soon as we receive the coupon in the lower corner of this page. If you prefer send a postcard—only write your name and address plainly. Turning the pages of the "Ranger" catalog is like walking down the aisles of the largest and greatest of bicycle stores seeing bargains, new ideas and conveniences that you never saw or heard of before.



Send No Money Ask for the big catalog and full particulars of our Factory Prices, marvelous offers and Easy Payment terms. Read especially about our extra \$5.00 FREE Premium set which goes with every "Ranger" bicycle.

Send No Money Ask for the big catalog and full particulars of our Factory Prices, marvelous offers and Easy Payment terms. Read especially about our extra \$5.00 FREE Premium set which goes with every "Ranger" bicycle.

MEAD CYCLE COMPANY

Dept. D-108, Chicago, U. S. A.

Send me the new Ranger Catalogue, factory-to-rider wholesale prices, 30-day Free Trial Offer and Easy Payment Terms.

Name.....

R. F. D. or

Street No.

Town..... State.....

FACTORY DISTRIBUTORS IN 264 CITIES

The nearest city (with a population of 25,000 or more) which I can conveniently visit to select a Mead Ranger is.....

If you have a Special Factory Distributor there, send me letter of introduction to him so I can inspect the Rangers and take delivery from there at Factory prices or on Easy Payment Plan if I prefer.

MEAD CYCLE COMPANY

DEPT. D-108

CHICAGO, U. S. A.

Copyrighted material