

May

25 Cents

POPULAR MECHANICS MAGAZINE

WRITTEN SO YOU CAN UNDERSTAND IT

REG'D TRADE

BRITAIN No. 410426

REG. U. S. PAT. OFF



SEE PAGE 667

A Raise of \$150 a Month

**How 8 Weeks' Scientific Practice With Tools
Lifted Me From a Laborer's \$12.50 a Week
To a Foremanship at \$2,400.00 a Year**

**A TRUE STORY—By Louis Beimer
MARLIN, TEXAS**

At the age of 20 years I was drawing \$12.50 a week—laborer's pay.

At the age of 24 I am a foreman and my salary is \$2,400.00 a year.

But it didn't take me four years to make the jump. I qualified for the advancement *by only eight weeks' scientific practice with tools*. Then, in two quick steps, I reached my present position.

Those eight weeks were spent in one of Henry J. Rahe's big auto and tractor schools. I earned \$50 a month before I went there. On my return home, I went to work for \$150 a month and in a very short time was made foreman at \$200 a month—a total salary increase of \$150 a month, due entirely to Rahe training.

If you want to get ahead QUICKLY, take the quick, easy, thorough course at a Rahe School.—Louis Beimer.



Louis Beimer

who says Rahe training put him on "Easy Street" in two months.

Wayne Russell, 20 years old, of Waldo, Ark., says Rahe training multiplied his pay by TEN. "I earned \$1.50 a day before," he writes. "My salary is now \$1.50 an hour."

W. W. Peace, another Rahe graduate, writes of getting \$250 a month and expenses operating a tractor in the oil fields.

Emanuel Rushfeldt, Vulcan, Alberta, says, "Earning \$10 a day. Formerly earned \$50 a month; 20 years old."

Thousands of Rahe-trained experts make success reports like these.

I'll Pay Your Railroad Fare

To CHICAGO, CINCINNATI or KANSAS CITY

I'm going to start hundreds of men to QUICK success in the next few weeks, just as I started Beimer. Be one of them and travel FREE to my nearest school. I'll pay your railroad fare to my school nearest your home, no matter what part of the country you live in.

Training Fee Reduced Again!

With large schools in three cities, I can now sell a Complete Life Scholarship at the lowest price ever quoted. Your total expense will be less than a good Rahe-trained mechanic earns in three weeks.

Be a Specialist! Get out of the grind—out of the army of unskilled job hunters! My easy, practical course in motor-maintenance engineering will make you an expert—a specialist—in just a few weeks!

A Job Is Waiting For You!

This is a BIG year in the motor business. Thousands of Rahe-trained specialists are needed. It's YOUR big opportunity. Let me prove it! Write me today.—

Be Sure to Address My Nearest School

Dept. 891 **Rahe Auto & Tractor Schools**

CHICAGO
Michigan and Ontario

CINCINNATI
Ninth and Walnut

KANSAS CITY
Twenty-Second and Oak

Thousands of Men Needed; \$3,000 to \$10,000 a Year!

More than 40,000 men have taken the "Rahe Way" to success. Thousands more are needed now. I never knew a better time to start. Calls for Rahe-trained men come from all parts of the country.

Quick, Easy Training

No "book-learning" required—just easy, scientific practice with tools on engines, cars, tractors. Master instructors tell you the "hows" and "whys." I furnish everything. And in just a few weeks you'll be ready for BIG MONEY.

FREE My big illustrated book, details of free fare and low tuition and proof of what Rahe training will do for YOU. Write for them now—a card will do.

Henry J. Rahe

New models that are true musical instruments



Victrola No. 240,
\$115
Mahogany or walnut

Being musical instruments the first requirement is quality of musical performance and in these new models the design is determined by their *musical* requirements. These requirements have been learned through twenty-four years devoted solely to the talking-machine art.



Victrola No. 260,
\$160
Mahogany or walnut



Victrola No. 280,
\$200
Mahogany or walnut
Victrola No. 280, electric, \$265
Mahogany

See and hear these new Victrolas which, while new in design, have all the characteristic tone-quality which has made the Victrola pre-eminent.



Victrola No. 300,
\$250
Victrola No. 300, electric, \$315
Mahogany, oak or walnut



Victrola No. 330,
\$350
Victrola No. 330, electric, \$415
Mahogany



HIS MASTER'S VOICE

Victrola

REG. U. S. PAT. OFF.

Important: Look for these trade-marks. Under the lid. On the label.
Victor Talking Machine Company
Camden, New Jersey

This One



JSPD-JZ1-EUFG

material

Here's a "dandy" Free Text
Book for Home Carpenters

12 WORKING DRAWINGS
 VOL. 36
CYPRESS
 POCKET LIBRARY
 "THE WOOD ETHERAL"

"SHORT CUTS" TO
 GOOD CARPENTRY

"Short Cuts to Good Carpentry"—
 (Vol. 36, Cypress Pocket Library)

48 pages of authoritative instruction (simple, clear and stimulating) fully illustrated and with big Supplement, 24 x 36 in. with detailed Working Drawings that show how to make twelve "hard jobs" easy, safe and economical of both labor and Lumber. Read what "Rural Life," (Rochester, N. Y.) says of

"SHORT CUTS to
 GOOD CARPENTRY"

"It is a guide book for the man or boy who can handle a saw or hammer and wants to know how to use them to the best advantage."

Ten topics pertaining to the house and 4 about barns. Sent free with our compliments.

WE TRUST YOUR
 OWN JUDGMENT
 and SELF-INTEREST to
 INSURE CYPRESS on YOUR job.
 "The Wood Eternal" keeps values going up by keeping the place from running down."

When planning a Mansion, a Bungalow, a Farm, a Sleeping-Porch or just a Fence, remember—
 WITH CYPRESS you BUILD BETTER ONCE. TRY IT.

Let our "ALL ROUND HELPS DEPARTMENT" help YOU. Our resources are at your service with Reliable Counsel,
SOUTHERN CYPRESS MANUFACTURERS' ASSOCIATION
 1219 POYDRAS BLDG., NEW ORLEANS, LA., or 1219 GRAHAM BLDG., JACKSONVILLE, FLA.
 (Please address nearest office)

INSIST ON TRADE-MARKED CYPRESS AT YOUR LOCAL DEALER'S. IF HE HASN'T IT—LET US KNOW



Popular Mechanics Magazine

6 N. Michigan Avenue, Chicago, U. S. A.

H. H. WINDSOR, Editor

London: Hachette & Cie,
16-17, King William Street, Charing Cross, W. C. 2

Paris: Hachette & Cie,
111 Rue Reaumur

Melbourne, Australia,
The Australasian News Co.

ISSUED MONTHLY

SUBSCRIPTION:

SINGLE COPY, 25 CENTS

In United States, and its possessions, Cuba, Mexico, and Canada, per year, postpaid . \$3.00

To all other countries in the Postal Union 3.50

All subscriptions are discontinued at expiration. Please examine the date printed on your wrapper.

Entered as Second Class Matter Sept. 15, 1900, at the Post Office at Chicago, Illinois, under Act of March 3rd, 1879.

Entered as Second Class Matter at the Post Office Department, Canada.

Published monthly by POPULAR MECHANICS CO.

Copyright, 1922, by H. H. Windsor.

Copyright in Australia.

Vol. 37

Contents for May, 1922

No. 5

Airplane Flight, Angle of, Automatically Indicated...	714
Airplanes, Lighthouse for Guiding, by Everett J. Lovett	670
Airship "Roma" Victims, Last Rites for	754
Airships, Dirigible, Great Britain Abandons	694
Aliens to be Deported May be Held Four Months	701
Aluminum Alloys, Investigate Properties of	717
Animal Training Behind the Guard Ropes, by Frank Braden	705
Animals Anaesthetized in Special Chamber	703
Anthills, Skyscraper, South African Ants Build	679
Apples, Oiled Wrappers Stop Formation of Scald on	738
Aqueduct, Wooden Canal, Replaced with Steel	757
Arches, Long Series of, Afford Study in Perspective	684
Asbestos Insulating Mats Have Many Advantages	703
Automobile Ash Receptacle Convenient for Smokers	733
Automobile Bodies, Five, Covered Trucks Carry	713
Automobile Bus, Twenty Passenger, Specially Designed	657
Automobile Danger Sign at Bad Corner	746
Automobile, German, Shaped Like Raindrop	690
Automobile Ignition, Use of Secondary Condenser Improves	748
Automobile Show, First Chinese, Housed in Bamboo Shed	738
Automobile, Special Racing, Has Narrow Body	704
Automobile, Steam, Similar in Form to Gasoline Car	692
Automobile Tire Dust Cap, Threadless	768
Automobile Towing Tongue Steers Automatically	739
Automobile, Tractor Trend, for Travel over Snow	749
Automobile Washer, Handy, Saves Soap and Varnish	765
Automobiles, Disabled, Combined Trailer and Crane for	753
Automobiles, High Class Ignition System for	764
Bacteria in the Mouth is Generally Harmless, Why	771
Banquets, Gas Filled, Toy, Are Fire Menace	682
Banana Industry, Pacific Coast of Guatemala to Have	756
Battleship, Giant, Converted into Floating Crane	686
Bearings, Staggered Roller, for Heavy Duty Service	750
Beehive Gate Passes One Bee at a Time	723
Bells, Church, Demonstrated Over Telephone	716
Bicycle, Thirty Year Old, Has Wood Frame	700
Blueberry Experiments Give Remarkable Results	752
Boat—Fisherman Challenger, Launch Prospective	698
Boats, Eskimos' Whaling, are American Built	721
Bookholder, Simple, Made by Bending Iron Wire	682
Bookmark, Inexpensive, Pasted Inside Cover	760
Bookmark, Neat Practical, Invented by Blind Man	770
Bookblack Stand, Roller Curtain Mounted on	724
Brake, High Power Staff, for Freight and Passenger Cars	736
Bridge, Crude Albanian, Built of Wood	760
Building, Beautiful Fraternal, for Fort Wayne	743
Building Material, To Study Standardization of	752
Building, Two Story Office, Moved by Motor Truck	717
Camel Control, Nevada Legislature Passes Law for	685
Camera, French Plate, Built Like Pistol	750
Children's Pages	729
Citrus Fruit Treatment Makes Icing Unnecessary	704
Coal Recovered from Cinders with Electromagnet	718
Coal Weighed and Unloaded by Large British Crane	759
Concrete Houses, Fireproof, Built Economically	676
Concrete, Moulded, Delicate Decorative Effects in	722
Cotton Made Fireproof by New Process	654

Crankpin Tool, Adjustable, Easy to Operate	771
Crocoiting Tube, Immense, Makes Freak Shipment	674
Crocodiles, Borneo Inhabitants Eat Flesh of	752
Crusher Station and Assay Office, Traveling	678
Cultivator, Motor Vineyard, Operated by One Man	724
Cyclecar, Propeller Driven, Resembles Airplane	759
Cylinder Gauge, Accurate, with Registering Dial	764
Deaf, Partially, New Vacuum Tube Amplifier Aids	704
Derrick, Huge Floating, in Logging Operations	725
Desert Roadway Fenced to Guide Motorists	686
Dishes Standardized to Avoid Breakage, by G. H. Dacy	755
Dog Team Derby, Great American	751
Door Hinge Prevents Fingers from being Mashed	768
Dyes, Two New, Discovered in Coal Tar Products	770
Earthquake, Violent, Under Pacific Ocean Recorded	763
Electric Furnace, Automatic, for Treating Steel Parts	694
Electric Heater, Small, Possesses Many Merits	701
Electric Torch Successful in Underwater Cutting	745
Electric Train, Russian, Exceedingly High-Powered	675
Electric Welder, Alternating Current Used in	679
Engine Lathe, New Automatic, for Quantity Production	699
Engine, Wild, Plunges into Turntable Pit	697
Envelope Moistener Has Tray for Accessories	765
Felt Weaving Loom is Largest Ever Constructed	728
Fire, Chicago, Most Menacing Since the Great Fire	685
Fire Fighting, Wheat Field, in Eastern Washington	668
Fish Market Surveys Made by Bureau of Fisheries	733
Flashboard Machine, Typewriter Student Aided by	696
Floor Covering, Advertising Stunt Tests	739
Floors, Elephants Used for Testing	719
Flowers, Glass Models of, at Harvard University	673
Flue Heading Tool, Rubber Retaining Ring on	757
Forest Service, War Department Supplies Beds to	749
Forests, Dense Red Cedar, in British East Africa	764
Forgeries, Detection of, by Microphotography	754
Foundation Tests, Union Station, Astonishing Results of, by Henry S. White	653
Fountain, Automatic, Serves Self-Mixed Drinks	743
Fruit Peeling Machine Uses Caustic-Soda Vapor	726
Furniture, Short Legged, Caster Cup Levels	768
Gas Meter, Venturi, Largest Built	699
Gauge, Simple, to Measure Oversize in Cylinders	750
Gauge, Snap, Measures Errors in Size Exactly	681
Gears, Internal, Vertical Shaper Modified to Cut	758
Glass, Tinted, for Producing Artificial Daylight	674
Golf Course Sprinkler Has Rubber Rollers	716
Golf, Water, is Latest End of Pleasure Seekers	742
Grader, Gasoline, Cuts Eight Inch Trench	703
Grinding, Safety Code Available Pertaining to	765
Hammer, Soft Face Flogging, Has Mold for Refacing	736
Harvester Thresher, Combined, Motor to Operate	774
Heating, Personal, is Theory of Englishman	725
Hotel, New York Apartment, to House a Church	731
Household Devices	766
Houses, Apartment, to be Wired for Radiotelephones	738
Hydroelectric Power Project, Italian, Uses Old Lake Beds for Storage	712
Incubator Egg Tray, New, Turns All Eggs at Once	714
Inert Gas Used in Canning Various Food Products	720
Inhalation Outfit, Handy, of New Design	726
Island Once Barren Clothed with Vegetation	774
Ivory Carvers of Bering Sea, by G. Dallas Hanna	761
Jack, Automatic, Controlled from Auto Driver's Seat	696

[Continued on Page 4]

[Contents—Continued]

Japanese, American Born, May Own Land.....	736	Street Car Window Wiper, Mechanical, Aids Motor-	764
Jerusalem, Will the Lost Tribes Return to, by Lewis		men.....	764
R. Freeman.....	659	Street Cars, Haitian, Built from American Autos....	727
Knife, Hunter's Skinning, Prevents Cutting Hides...	658	Surveys, Preliminary, New French Device Aids....	758
Lace Sewing Machine Saves Much Labor.....	669	Swimmer, Long Distance, Shark Proof Net Protects	717
Lard Oil Vindicated as a Lubricant.....	689	Table Top, Ornamental, Made of Steel Tubing.....	715
Lawn Mower Grass Carrier Works on New Principle.	714	Tanks Destroy Stills Captured in Raids.....	727
Life Saving Appliance, Projectile Pocket Pistol is....	728	Tapestry, Wonderful, France Prepares, for America.	690
Lightning Bolt, Artificial, Realistically Produced....	691	Tar in Gas, Amount of, Rapid Method Determines..	686
Loom, Automatic and Shuttleless, Made in England..	732	Teakettle, Electric, Has Two Compartments.....	746
Lumber is Transported to Kauai, How.....	729	Theater Roof, Washington, Causes of Failure of....	699
Lumber Truck Ratchet Crank Facilitates Unloading..	758	Thermometer Holder on Bed is Handy and Sanitary	725
Lungs and Blood Studied in the Andes.....	763	Thresher Hailer, Combined, Saves Time and Money	732
Machine Gun, Power Driven, Under Development....	685	Tie Changing Machine, New, Rapid and Economical	695
Mail Box, Glass, Letters Plainly Visible in.....	718	Toboggan, Motor, Travel Snow Covered Roads with	731
Mail Carried by Dog Team in Southern California...	721	Toothbrush, New, Cleans all Surfaces of the Teeth..	731
Mail Terminal, New, Equipped to Handle Big Tonnage	744	Torch Cuts Cast Iron at Deep Depth, by A. M.	
Manganese Mines Developed in Argentina Desert....	720	Hoffmann.....	682
Manikins, Metal, Introduced by Germans.....	657	Tractor and Automobile Make Pioneering Easy....	715
Maps, Aerial, Check Hydrographic Survey by.....	733	Tractor, Small, Gives Double Service.....	721
Memorial, Service Banner, in Geneseo, Illinois.....	693	Tractor, Small, Usable for Various Purposes.....	685
Metals, Polished, Annealed without Tarnishing....	716	Transmission Line to Span Straits of Messina.....	728
Meter Reading Contest for Power Company's Custo-		Trap, New Style, Rats Caught and Drowned in....	738
mers.....	743	Truck, Six Wheel Drive, Pulls Highway Train.....	745
Milk Adulteration, Apparatus Tests Percentage of...	774	Turbine Pumps, High Speed, Placed on Motor Cars	677
Milk, Effervescent, Produced as Carbonated Beverage	760	Typesetting Machine, Practice Chart of Keyboard on	700
Milking Machine Washer, Rapid Sanitary.....	730	Typewriter, Blind and Deaf Cripple Operates.....	673
Moist Radiograms, Scientists Investigate, by L. D.		Viaduct, New, Replaces Old Toll Bridge.....	656
Lotton.....	711	Violin Made of Matches, Toothpicks, and Glue....	695
Motion Pictures, Philadelphia City Council Shown...	673	Wall Papering Machine Holds Paste and Paper....	680
Motor Bus, New Chicago, Nearly Equals Street Car..	680	Warships to be Converted into Breakwater.....	793
Motor Bus, Windshields on Upper Deck of.....	720	Washbowl, Portable Rubber for Travelers.....	690
Motorboat Travels Over Snow Covered Highways....	697	Watch Charm, Land Elevations of Nation Shown in	696
Mountain—Mount Rainier Climbing in Midwinter, by		Weather Chart Used to Save Money When Placing	
Lawrence Wm. Pedros.....	713	Ties.....	688
Mussels on Ship Bottom Capture Small Fish.....	728	Wheat Cleaning Machine Cleans at Time of Threshing	689
Ocean, Employ Echo for Measuring Depth of.....	689	Window Radiator, Electric, Prevents Frost.....	725
Oil Pipe Line, Proposed, for Argentina.....	770	Windows, Frameless, Replaces Ships' Circular Port-	
Oils, New Substance as Catalyst Hardens.....	656	holes.....	700
Oxygen Removed from Water to Prevent Pipe Rust-		Wireless Amplifier, Ordinary Receivers Used with..	736
ing.....	744	Wireless Garter Latest Fad for Radio Fans.....	710
Paper Strength Visualized by Novel Demonstration..	658	Wireless Telephone Constructed in Form of Phono-	
Paving, Brick, Serves Well During Long Period....	759	graph.....	753
Phonograph Motor, Small, Fits Any Instrument....	765	Wood, Artificial Plastic, Like Real Timber.....	771
Phonograph Records, Hang Up Filing Envelopes for	763	Wrench, New Fruit Jar, Gives Firm Grip.....	698
Photographs of Distorted Reflections Snapped from		Wrench, Socket, Adjustable for Various Size Nuts..	752
Roat.....	744		
Pipe Coils Relieve Tension Caused by Expansion...	771		
Pipe Line, 700 Foot, Refuse Conveyed by Suction in	748		
Piston, Improved, Saves Gas and Oil.....	770		
Pistons, Iron, Made Light by Skillful Design.....	680		
Planet Venus, Atmosphere of, Contains no Oxygen..	714		
Platinum, Substitute for, Proves Satisfactory.....	724		
Polcemen, Egyptian, Carry Shields for Protection..	693		
Portrait Lamp, New, Home Photography Aided by..	675		
Potash Indications Found When Drilling for Oil....	735		
Printers' Chase for Locking Forms.....	658		
Printing Press Attachment for Distributing Ink....	718		
Prison, Great Military, off San Francisco Coast....	702		
Pump, Economical Fuel, Fits Any Barrel or Drum..	694		
Radiographs, Flash Timing Arrangement for Making	692		
Range Finder, Huge British, with 22 Mile Range...	684		
Reading Machine, New, Makes Pocket Library Pos-			
sible.....	677		
Reflecting Device Projects Views of Objects.....	716		
Reflector, New, Brilliant Light Obtained with....	688		
Refrigerator Cars Converted for Winter Use.....	769		
Refuse, City, Making an Island from, by Wm. B.			
Goodwin.....	740		
Refuse Container, Durable, Made Ornamental.....	760		
Rice Harvester Collects Grain from Standing Stalks	692		
River, Absolute Control of, with Waterworks Dam..	701		
River Terminals, Municipal, Erected at Nashville...	737		
Road Paving, Average Cost of Various Types of....	674		
Road Repairing Machine Resembles Pile Driver....	763		
Roofing, New Prepared, Old Rags Used in.....	738		
Safety Drill and Tap Chuck Saves Tools.....	748		
Scale, Improved Form of, Weighs Rubber Tires....	732		
Shingles, 500,000, Cut by Mill Daily, by Henry C.			
Copeland.....	734		
Ship, Concrete, Buried to Save Expense.....	747		
Ships, Communication with, from Telephone Booth..	742		
Ship's Course, Instrument Draws, on Chart.....	739		
Ships, Naval, Government Saves Fuel Oil on.....	764		
Signboard, Graphic, Shows Progress of Building...	758		
Smoke Stack, Worn Out Steel, Unusual Means of			
Wrecking.....	719		
Snow Bound Cities Reach Outer World by Radio..	668		
Spinach Pickers Use Boats on Large Chinese			
Marshes.....	678		

SHOP NOTES

Alarm Circuit for Open Fuses.....	794
Arbor Press, Large Capacity.....	775
Belt Pulleys, Silent Chain Sprockets as.....	782
Belt Winding, Thresher, by Power.....	791
Blueprints, Writing White on.....	793
Bolt Cutter, Small.....	787
Boxes, Steel Stock, Rack for.....	792
Calcium Chloride, Dissolving.....	793
Capsules, Veterinary, for Small Parts.....	785
Clamping Work for Drilling.....	781
Cold Chisel, Extension for.....	791
Combination Tool, Handy.....	783
Crane, Improvised.....	776
Diamonds, Wheel Truing, Care of.....	776
Drill for Slate or Marble.....	793
Film Stripping from Cracked Negatives.....	786
Filter, Feed Water.....	785
Floor Layouts, Rubber Stamps for.....	777
Gauge, Automatic, for Machined Work.....	770
Gauge, Simple Internal.....	784
Grinding Troubles Remedied.....	788
Hexagons, Gauge for Milling.....	783
Jig Clamp, Rapid.....	794
Kafr Corn, Header for.....	781
Lathe, Punching in the.....	788
Lathe Used as Milling Machine.....	784
Lawn Mowers, Fixture for Repairing.....	789
Locknut, Simple.....	788
Ornamental Ironwork, Cutting Torch Produces....	787
Painting on Old Walls.....	785
Patterns, Finishing Wooden.....	792
Pipe Cutter, Improving a.....	783
Pine Driving Underground.....	788
Piston Rings, Grinding.....	781
Polishing Wheels, Balancing.....	787
Pump Jack Repaired for Engine Drive.....	782
Punch Made from Letter Press.....	777
Rivets, Shortening, in Quantities.....	780
Rolls, Machine, Guards for.....	781
Rope, Formula for Breaking Strength of.....	789
Scaffold, Substantial Building, without Nailing...	797

DRAKE'S PRACTICAL MECHANICAL BOOKS

THEY WILL RAISE YOUR PAY—

ORDER ON 5-DAY TRIAL

The books listed below will perfect you in your chosen trade — pave the way to the big positions. Written in non-technical language—easy to read and understand. *Every book covers its subject completely. An entire course of instruction condensed into one volume.* Your choice sent postpaid — you benefit 5 days — money refunded in full if not entirely satisfactory. Order direct from this page.



Automobile Books

- Automobile Ignition, by ManlyLeatherette \$2.00
 Automobile Starting and Lighting, by Manly.....Leatherette \$2.00
 Brookes' Automobile Handbook,Leatherette \$2.00
 Ford Motor Car, Truck and Tractor, by Manly.....Cloth \$1.50
 Starting and Lighting Troubles, Remedies and Repairs, by ManlyLeatherette \$3.00
 Automobile Battery, Care and Repair, by Manly.....Leatherette \$2.00
 Automobile Catechism and Repair Manual.....Leatherette \$1.50
 Tires and Vulcanizing, by TuffordCloth \$2.00
 Gas and Oil Engine Handbook,Cloth \$1.50
 Automobile Upkeep and Care, by Manly.....Cloth \$1.50
 Motorcycle Handbook, by ManlyCloth \$1.50

Shop Practice Books

- Sheet Metal Workers' Manual.....Leatherette \$2.00
 Oxy-Acetylene Welding and CuttingLeatherette \$1.75
 Sound WeldsCloth \$2.00
 Slide Rule and Logarithmic TablesLeatherette \$2.00

- Handbook for Millwrights.....Cloth \$2.00
 Modern Blacksmithing.....Cloth \$1.25
 Machine Shop Practice.....Cloth \$2.00
 Mechanical Drawing and Machine DesignCloth \$2.00
 Pattern Making.....Cloth \$1.50

Carpentry Books

- Cloth Binding
 Modern Carpentry, 2 vols.....\$3.00
 The Steel Square, 2 vols.....\$3.00
 Wooden Boat and Shipbuilding.....\$1.50
 Modern Estimator\$1.50
 Timber Framing\$2.00
 Builder's Architectural Drawing.....\$2.00
 Concrete\$1.50
 Practical Bungalows\$1.00
 Low Cost Homes.....\$1.00
 Roof Framing\$1.50
 Stair Building and Hand Railing\$1.50

Electrical Books

- Practical Applied Electricity.....\$2.00
 Alternating Current\$1.50
 Electric Motor Control Systems.....\$1.50
 Wiring Diagrams and Descriptions\$1.50
 Electrical Tables and Data.....\$1.50
 Armature and Magnet Winding.....\$1.50
 Modern Electrical Construction.....\$1.50
 Modern Electric Illumination.....\$1.50
 Electricians' Operating and Testing\$1.50
 Motion Picture Operation.....\$1.50
 Drake's Electrical Dictionary.....\$1.50
 Electric Motors, D. & A.....\$1.50
 Electrical Measurements and Meter Testing\$1.50
 Drake's Telephone Handbook.....\$1.50
 Modern American Telephony.....\$2.00
 Easy Electrical Experiments.....Cloth \$1.25
 Wireless Telegraph and Telephone Handbook.....Cloth \$1.25
 Telegraphy Self-Taught.....Cloth \$1.25

Steam Engineering

- Swingle's Handbook for Steam Engineers and Electricians.....Leatherette \$4.00
 Examination Questions and Answers for Marine and Stationary Engineers.....Leatherette \$2.00

- Steam Boilers.....Leatherette \$2.00
 Swingle's Catechism of Steam, Gas and Electrical EngineeringLeatherette \$1.50

Painting Books

- Scene Painting and Bulletin ArtCloth \$4.00
 A Show at Sho' Cards.....Cloth \$4.00
 Sign PaintingCloth \$4.00
 Strong's Book of Designs.....Leatherette \$4.00
 Strong's Art of Show Card WritingCloth \$4.00
 Signist's Alphabets.....Cloth \$1.50
 Modern Painter's Cyclopedia.....Cloth \$2.00
 Automobile Painting.....Cloth \$1.50
 Estimates, Costs and Profits, Painting and Decorating.....Cloth \$1.50
 New Hardwood Finishing.....Cloth \$1.50
 The Amateur Artist.....Cloth \$1.50
 New StencilsCloth \$1.25

Farm Books

- Farm Mechanics.....Cloth \$1.25
 Farm Buildings.....Cloth \$1.25
 Farm Engines.....Cloth \$1.25
 Traction Farming.....Cloth \$1.50

Business and Reference Books

- Better Business Letters.....Leatherette \$1.50
 Better Business English.....Leatherette \$1.50
 Better Advertising.....Leatherette \$1.50
 Finger Prints Simplified.....Cloth \$2.00
 Practical Bricklaying.....Cloth \$1.25
 Practical Instruction for DetectivesCloth \$1.00
 Practical PlumbingCloth \$1.50
 Hot Water Heating.....Cloth \$1.50
 Elementary Chemistry.....Cloth \$1.50
 Courses in Civil Service.....Cloth \$1.50
 Cyclopedia of Recipes.....Cloth \$1.50
 American Star Speaker.....Cloth \$1.50

Modern Languages

- By Prof. P. S. Allen, U. of Chicago
 French without a Teacher.....Cloth \$1.25
 Spanish without a Teacher.....Cloth \$1.25
 German without a Teacher.....Cloth \$1.25
 Everyday French.....\$1.25
 Everyday Spanish.....\$1.25

ORDER DIRECT FROM THIS PAGE—ON OUR MONEY-BACK PLAN

The books listed above are only a few of the many in our catalogue, which you will receive promptly after filling out and mailing us the attached coupon. For quick action order direct from this page—cross name of each book wanted and send in with price quoted. We prepay postage and send the books on our money-back plan.

FREDERICK J. DRAKE & CO.

PUBLISHERS

1008 Michigan Ave., Chicago

Drake Books Are For Sale at All Book Stores

FREDERICK J. DRAKE & CO.
 1008 Michigan Avenue
 Chicago, Ill.

GENTLEMEN:—Please send me free, postage paid, your illustrated catalogue which lists and describes over 100 Practical Mechanical Books for Home Study.

My name is

and my address

Mail Coupon For Free Catalogue
 Your Guide to Home Study

DON'T SWEAT OVER A KITCHEN STOVE!

No excuse any more for fussing and fuming over a hot kitchen stove in summer time! No need of keeping a hot fire going all day just to do a little cooking. Amazing new invention does away with this dirt, muss, and kitchen drudgery.

Amazing Invention

Gives plenty heat when you want heat. You turn it off instantly when you don't want heat. Cheaper—Burns 95% air 5% oil. Saves money, time, labor, health. No fires to make, no ashes, dirt, smoke, odor, chopping, shoveling, carrying dirty coal or wood.



Quick Heat On or Off at Turn of Valve

Don't let your coal-and-wood stove turn your kitchen into a roasting-room. Wonderful invention—Oliver Oil-Gas Burner gives quick heat at turn of valve. Fits in fire box without adjustment. Note how simply it works. Absolutely safe. Lasts lifetime. Fine all seasons. No roasting Summer kitchen. Ready heat in chilly Fall and Spring. 3 times more heat in Winter.



FREE BOOK telling all about the "New Kind of Heat," sent free. Also amazingly low introductory-price offer including 30-Day Trial. Write today.

OLIVER OIL GAS BURNER & MACHINE CO., 2014-E Pine St., St. Louis, Mo.
Oldest, Largest Manufacturers of Oil-Gas Burners in the World.

AGENTS Oliver agents earn as high as \$500 a month—\$25 a day spare time is easy. Exclusive territory. Big all-season seller. Write for Special Offer.



Hotels Need Trained Executives

Nation-wide demand for trained men and women in all departments of hotels, clubs and apartment houses. Uncrowded field; fine living, quick advancement in the big hotels of the United States—now America's Fourth Largest Industry. Statistics show that **ONE IN EVERY TEN HOTELS WILL HAVE AN OPENING FOR A MANAGER THIS YEAR.** Thousands of other positions are open to those who qualify through training.

The Lewis School guarantees to give you the valuable knowledge that it has taken some of the most successful hotel men years to obtain—men who are now making \$5,000 to \$50,000 a year. All of your training will be under the personal direction of Clifford Lewis—a hotel expert of national reputation. A few spare-time hours a week given to the simple, clear lessons of the course will open the way to a good position, a fine living and a handsome salary. The training will in no way interfere with your present activities.

Send today for **FREE BOOK**, "Your Big Opportunity." Don't wait a minute—you may lose the opportunity of a lifetime. Mail the coupon **NOW.** Your whole future may depend on it. Founded 1916.

**LEWIS HOTEL
TRAINING SCHOOL**
Clifford Lewis, Pres.
Room 319
Washington, D. C.

Free
Coupon
**LEWIS
HOTEL
TRAINING
SCHOOL**

Room 319
Washington, D. C.

Send me without obligation
the **FREE BOOK** "Your Big
Opportunity."

Name.....
Street.....
City..... State.....

[Contents—Continued from Page 4]

Screws, Removing Tight.....	789
Sheet Metal, Cutting with Handsaw.....	782
Sidewalk Construction, Concrete, Faults in.....	778
Straightening Fixture for Spindles.....	786
Support, Adjustable Stock.....	789
Tapered Work, Laying Out.....	794
Tees, Clamp for Welding and Brazing.....	777
Testing Unit, Portable Electric.....	781
Tubing, Thin, Tapped Holes in.....	782
Valves, Overhead, Rocker Lever for.....	781
Wire, Unwrapping in the Lathe.....	780
Wood Silos, Creosoted.....	784
Wrench, Connecting Rod.....	785
Wrench, End, Combination Box and.....	792

AMATEUR MECHANICS

Apron, Novel for Kitchen or Shop.....	799
Automobile Radiators, Condenser for.....	798
Automobile Seat Made Comfortable.....	797
Battery, Auto, as B-Battery.....	808
Beans, Planting Dwarf Varieties of.....	797
Bicycle, Trailer for.....	811
Birds, Feeding Tray for.....	811
Boat, Hauling from One Lake to Another.....	809
Book Ends, Self-Adjusting.....	799
Campfire Irons, Nails Used as.....	800
Concrete Wall Adds to Warmth of House.....	806
Cork, Extracting from Bottle.....	797
Driveway, Vehicle Gate for.....	810
Electric Fan as Window Display.....	808
Engines, Model Gas, Building Hints for.....	812
Fence Post, Facilitating Removal of.....	799
Fruit Trees Protected from Frost.....	812
Fulle's Earth for Clutch and Brake.....	804
Furniture, Lead Doll House, Making.....	809
Fuses, Bridging.....	807
Garden Mulcher, Novel and Effective.....	813
Grass Rugs, Rejuvenating.....	799
Gutters, Brush for Removing Refuse from.....	796
Hornet, Driving from Nest.....	810
Ice Cream Freezer Held Stationary.....	807
Ladders, Rolling, Improvement for.....	804
Lamp Filler, Nonoverflowing.....	797
Lamps, Kerosene, Care of.....	810
Lariat, Throwing the.....	801
Linoleum Kept Fresh.....	806
Milk Bottle Carrier, Handy.....	796
Moth Preventive, Tissue Paper as.....	798
Motorcycle, Using for Power.....	807
Negatives, Clearing Stained.....	807
Plant Transplanting Tool.....	808
Play Pen, Simple, for Children.....	811
Poppies as Cut Flowers.....	806
Price Tag Holders, Simple.....	805
Prints, Glossy Photographic.....	805
Prints, Preventing Discoloration of.....	796
Pump, Homemade, for Shallow Wells.....	800
Razor Strap for Campers.....	804
Reflector, Cheap, for Home Photography.....	812
Rims, Demountable, Holder for.....	804
Screen Wire, Applying.....	798
Silk, Real and Artificial, Testing.....	797
Silver, Cleaning Tarnished.....	799
Soldering Flux Containers.....	800
Sprayer, Potato Plant, How to Make.....	795
Storage Batteries, Repairing.....	814
Terminals, Wire, Made from Eyelets.....	805
Tire Chains for Emergencies.....	813
Trees Protected from Insects.....	805
Varnished Surfaces, Removing Spots from.....	814
Washing Machine Handle, Emergency.....	805
Watch Dial for Standard and Summer Time.....	798
Water Plane, Toy.....	808
Wireless Key, High Speed, How to Make.....	814
Wireless Receiver, Using Several Phones on.....	813
Wool or Silk Goods, Testing.....	811

LAW

STUDY AT HOME

Become a lawyer. Legally trained men win high positions and big success in business and public life. Greater opportunities now than ever before. Lawyers earn **\$3,000 to \$10,000 Annually**. We guide you step by step. You can train at home during spare time. Let us send you records and letters from LaSalle students admitted to the bar in various states. Money refunded according to our Guarantee Plan if dissatisfied. Degree of LL.B. conferred. Thousands of successful students enrolled. Low cost, easy terms. We furnish all text material, including fourteen-volume Law Library. Get our valuable 120-page "Law Guide" and "Evidence" books FREE. Send for them—NOW.

LaSalle Extension University, Dept. 564L, Chicago, Ill.

Let These Guides

Solve Your Problems

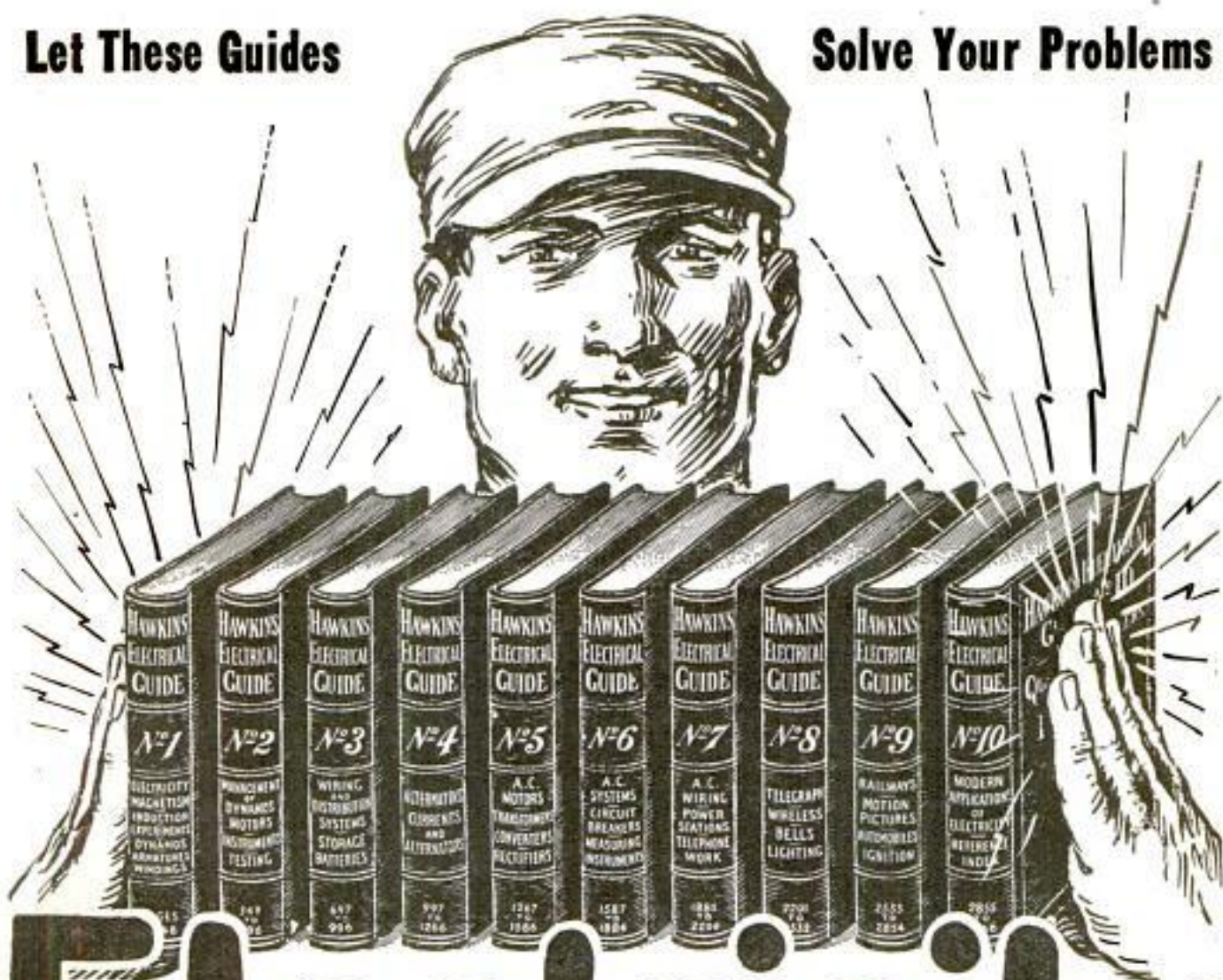

Electricity at your finger ends

HAWKINS ELECTRICAL GUIDES IN TEN VOLUMES

3500 PAGES
4700 PICTURES

\$1 A VOLUME
\$1 A MONTH

Send No Money--Send Only This Coupon

Know the facts in Electricity. They mean more money and better position for you. Hawkins Guides tell you all you need to know about Electricity. Every important electrical subject covered so you can understand it. Easy to study and apply. A complete, practical working course, in 10 volumes. Books are pocket size; flexible covers. Order a set today to look over.

LEARN ALL ABOUT

Magnetism—Induction—Experiments—Dynamoes—Electric Machinery—Motors—Armatures—Armature Windings—Installing of Dynamoes—Electrical Instrument Testing—Practical Management of Dynamoes and Motors—Distribution Systems—Wiring—Wiring Diagrams—Sign Flashers—Storage Batteries—Principles of Alternating Currents and Alternators—Alternating Current Motors—Transformers—Converters—Rectifiers—Alternating Current Systems—Circuit Breakers—Measuring Instruments—Switchboards—Wiring—Power Stations—Installing—Telephone—Telegraph—Wireless—Bells—Lighting—Railways. Also many Modern Practical Applications of Electricity and Ready Reference Index of the ten numbers.

SHIPPED FREE

Not a cent to pay until you see the books. No obligation to buy unless you are satisfied. Send Coupon now—today—and get this great help library and see if it is not worth \$100 to you—you pay \$1.00 a month for ten months or return it.

THEO. AUDEL & CO.,
72 Fifth Ave., New York City

Please submit me for free examination, HAWKINS ELECTRICAL GUIDE, (Price \$1 a number). Ship at once prepaid, the 10 numbers. If satisfactory, I agree to send you \$1 within seven days and to further mail you \$1 each month until paid.

Name

Occupation

Employed by

Home Address

Reference

FBI MAY 22

\$300 a Month Salary \$450 on the Side at Home



Chief Draftsman DOBE

That's the kind of money my drafting students make. Read what this one says:

"As a beginner I am doing fine. Am earning a salary of \$300 per month, besides I made over \$450 at home the last two months, drawing plans for private parties. The practical drafting training you gave me by mail put me where I am in less than six month's study. Thank you for all your personal interest and help you gave me so far."

(Signed) J. B.

(Name and Address upon request.)

I Guarantee

To Train You Until You Are Placed in a Position Paying \$250 to \$300 a Month

Write and I'll tell you how I make you a first-class, big-money-earning draftsman in a very few months! I do this by a method no other man nor institution can imitate. I give you personal training at home by mail. And I mean just what I say. I train you until you are actually placed in a position paying from \$250 to \$300 a month. Six thousand draftsmen are wanted every month. Hurry up and register so you can start earning.

Free \$25 Outfit!

And more—I give you a whole set of drafting tools the minute you become my student. You get every tool you need. A magnificent \$25 set of instruments with which to build your success in draftsmanship.

Take this offer now—while it is open. Remember—the draftsman goes up and up to the fabulous incomes of engineers and architects. And I start you on this road—start you personally and stick by your side until success is yours.



Chief Draftsman Dobe

Dept. 9355, 4001 Broadway, Chicago, Illinois

Without any obligation whatsoever, please mail your book, "Successful Draftsmanship", and full particulars of your liberal "Personal Instruction" offer to few students.

Name.....

Address.....

Post Office..... State.....

Free Book!

Send Coupon TODAY

No matter what plans you have for the future. Get this great book—"Successful Draftsmanship." Find out about the simply marvelous opportunities ahead now. How the world needs draftsmen, engineers, architects and builders. What great salaries and possibilities there are! Send coupon for free book today.

Chief Draftsman Dobe

Dept. 9355, 4001 Broadway Chicago, Ill.

I Teach You Piano in Half Usual Time

To persons who have not previously heard of my method, this may seem a pretty bold statement. But I will gladly convince you of its accuracy by referring you to any number of my graduates in any part of the world.

There isn't a State in the Union that doesn't contain many players of the piano or organ who obtained their training from me **by mail**. I have far more students than were ever before taught by one man. Investigate by writing for my 64-page free booklet, "How to Learn Piano or Organ."

My way of teaching piano or organ is **entirely different** from all others. Out of every four hours of study, one hour is spent **entirely away from the keyboard**, learning something about Harmony and The Laws of Music. This is an awful shock to most teachers of the "old school," who still think that learning piano is solely a problem of "finger gymnastics." When you **do** go to the keyboard, you accomplish **twice as much** because you **understand what you are doing**. Within four lessons I enable you to play an interesting piece not only in the original key, but in other keys as well.

I make use of every possible scientific help—many of which are **entirely unknown** to the average teacher. My patented invention, the **COLOROTONE**, sweeps away playing difficulties that have troubled students for generations. By its use, Transposition—usually a "nightmare" to students—becomes easy and fascinating. With my fifth lesson I introduce another important and exclusive invention, **QUINN-DEX**. Quinn-Dex is a simple, hand-operated moving-picture device, which enables you to see, right before your eyes, every movement of my hands at the keyboard. You actually see the fingers move. Instead of having to reproduce your teacher's finger movements from **MEMORY**—which cannot be always accurate—you have the correct models before you during every minute of practice. The **COLOROTONE** and **QUINN-DEX** save you months and years of wasted effort. They can be obtained only from me, and there is nothing else, anywhere, even remotely like them.

Men and women who have failed by other methods have quickly and easily attained success when studying with me. In all **essential** ways you are in closer touch with me than if you were studying by the oral method—yet my lessons cost you only 43 cents each—and they include all the many recent developments in scientific teaching. For the student of moderate means, this method of studying is **far superior** to all others; and even for the wealthiest student, there is nothing **better** at any price.

You may be certain that your progress is at all times in accord with the best musical thought of the present day, **and this makes all the difference in the world.**

My course is endorsed by distinguished musicians, who would not recommend any course that did not maintain the highest musical standards. It is for beginners, or experienced players, old or young. You advance as rapidly or as slowly as you wish. All necessary music is supplied without extra charge. A diploma is granted. Write today, without cost or obligation, for 64-page free booklet, "How to Learn Piano or Organ."

**MARCUS LUCIUS QUINN
CONSERVATORY OF MUSIC**

Studio PM 45 598 Columbia Road
BOSTON, 25, MASS.



DR. QUINN AT HIS PIANO

From the Famous Sketch by Schneider, Exhibited at the St. Louis Exposition



FREE BOOK



-----**FREE BOOK COUPON**-----

**QUINN CONSERVATORY, Studio PM 45
598 Columbia Road, Boston, 25, Mass.**

Please send me, without cost or obligation, your free booklet, "How to Learn Piano or Organ," and full particulars of your Course and special reduced Tuition Offer.

Name

Address

How to Speak and Write Masterly English

The Art of Making Language Power WIN For You. Sherwin Cody's New Invention Improves Your English in 15 Minutes a Day

DO you write and speak correctly or do errors reveal you and handicap you? Every time you talk, every time you write, you show what you are. When you use the wrong word, when you mispronounce a word, when you misspell a word, when you punctuate incorrectly, when you use flat, ordinary words, you handicap yourself tremendously. Words are the driving, compelling force in business. Ideas can not be expressed except through words. An unusual command of English enables you to present your ideas clearly, forcefully, convincingly.



SHERWIN CODY

A simple method has been invented by which you can acquire a command of the English Language in only 15 minutes a day. Sherwin Cody, one of the best-known teachers of practical English, after twenty years of research and study, has perfected an invention which places the ability to talk and write with correctness and force within the reach of every one with ordinary intelligence.

Self-Correcting Method

Mr. Cody was granted a patent on his unique device, and now he places it at your disposal. You do the lesson given on any particular page, then you see just how Mr. Cody would correct that paper. You mark your errors and check them in the first blank column. Next week you try that page again, on the second unmarked sheet, correct your errors, and check them in the second column. You see at a glance what you have failed to remember, and at the bottom you compare your average with that of average grammar school graduates, high school graduates, and experienced stenographers, until you have reached the 100 per cent. point in spelling, punctuation, grammar, and expression.

And the wonderful thing about Mr. Cody's course is the speed with which these habit-forming practice drills can be carried out. When you write the answers to fifty questions in 15 minutes and correct your work in 5 minutes more, it gives you a good idea of the practical and effective value of this course.

New Booklet FREE

A booklet explaining this course in detail is ready. If you ever feel your lack of language power, if you are ever embarrassed by mistakes in grammar, spelling, or punctuation, if you can not instantly command the exact words with which to express your ideas, this book will prove a revelation to you.

A polished and accurate command of the English language not only gives you the stamp of education, but it wins friends and convinces the world of your power. Many men and women spend years in high school and in college largely to get the key to social and business success. And now a really efficient system of acquiring an unusual command of English is offered to you. Spare-time study—15 minutes a day—in your own home will give you power of language that will be worth more than you can realize.

Write for this new free book, "How to Speak and Write Masterly English." Merely mail the coupon or a letter, or even a postal card. You can never reach your greatest possibilities until you know language. Write today for the free booklet that tells about Mr. Cody's simple invention for making command of language easy.

Sherwin Cody School of English
55 Searle Building Rochester, N. Y.

SHERWIN CODY SCHOOL OF ENGLISH
55 Searle Bldg., Rochester, N. Y.

Please send me your new Free Book, "How to Speak and Write Masterly English."

Name.....

Address.....

City..... State.....



The Practical Gasoline Engine

Revised by Berton Elliot

The constant increase of the use of gas and gasoline engines in this country for power purposes makes this authoritative work most timely. It is a simple and correct guide to the essentials of engine construction, erection and operation under all conditions. What to do and how to do it is told in everyday language. "The Practical Gasoline Engine" should be in the hands of every prospective gas or gasoline engine owner as well as those now operating an engine.

75¢

127 pages, two illustrations. Size 4 1/4 x 6 1/4 inches. Cloth bound. Postpaid.....75c

SHREWSBURY PUBLISHING CO.
5525 West Lake St., Chicago, Ill.

BE AN ARTIST

We can teach you **DRAWING** in your own home during your spare time.

Our 19 years of successful teaching prove our ability. 10 Courses in Commercial and Illustrative Drawing. Teachers Normal and Applied Art. Endorsed by high art authorities. Students trained by members of our Faculty are filling high-salaried positions. Artist's Outfit FREE to Enrolled Students. Write today for Art Year Book.

OUR HANDSOME ART YEAR BOOK "FREE" Book.

SCHOOL OF APPLIED ART

APPLIED ART BLDG. NO. 2 BATTLE CREEK MICH.

LEARN ENGINEERING

Courses, 3 months to 2 years practical-technical training under experts. Not a Trade School, but a practical-technical college teaching electricity, steam, etc., auto-electric, sensitive winding, drafting. Extensive laboratory and shop equipment. Degrees awarded. Day and night sessions. Enroll any time.

FINLAY ENGINEERING COLLEGE
1001 Indiana Avenue Kansas City, Mo.



NAVIGATION TAUGHT BY MAIL

Hundreds of Ship Officers needed in Merchant Marine and Navy. Salaries up to \$412 monthly and living expenses. You can qualify through Captain Warren Sheppard's Home Study Course on Navigation. Chance of a lifetime to see the world as a ship's officer at a big salary. Write for free Book, "Your Future is on the Seven Seas."

World Technical Institute, Dept. 100A, Fuller Building, Jersey City, N. J.



WANTED—Railway Mail Clerks

\$135 to \$190 Month

Hundreds Needed at Once
MEN—BOYS
Over 17

Franklin Institute
Dept. C178, Rochester, N. Y.
Kindly send me, by return mail, free information, telling how I can quickly get into the U. S. Government service as Railway Mail Clerk (\$1600 to \$2300 a year) or as City Mail Carrier or Postoffice Clerk (\$1400 to \$1800 a year).

Name.....
Address.....

If not interested, hand to a friend.



"He Deposits \$500 a Month!"

"SEE that man at the Receiving Teller's window? That's Billy King, Manager for the Browning Company. Every month he comes in and deposits \$500. I've been watching Billy for a long time—take almost as much interest in him as I do in my own boy.

"Three years ago he started at Browning's at \$15 a week. Married, had one child, couldn't save a cent. One day he came in here desperate—wanted to borrow a hundred dollars—wife was sick.

"I said, 'Billy, I'm going to give you something worth more than a loan—some good advice—and if you'll follow it I'll let you have the hundred, too. You don't want to work for \$15 a week all your life, do you?' Of course he didn't. 'Well,' I said, 'there's a way to climb out of your job to something better. Take up a course with the International Correspondence Schools in the work you want to advance in, and put in some of your evenings getting special training. The Schools will do wonders for you—I know, we've got several I. C. S. boys right here in the bank.'

"That very night Billy wrote to Scranton and a few days later he had started studying at home. Why, in a few months he had doubled his salary! Next thing I knew he was put in charge of his department, and two months ago they made him Manager. And he's making real money. Owns his own home, has quite a little property besides, and he's a regular at that window every month. It just shows what a man can do in a little spare time."

Employers are begging for men with ambition, men who really want to get ahead in the world and are willing to prove it by training themselves in spare time to do some one thing well.

Prove that you are that kind of a man! The International Correspondence Schools are ready and anxious to help you prepare for something

better if you'll simply give them the chance. More than two million men and women in the last 30 years have taken the I. C. S. route to more money. Over 130,000 others are getting ready in the same way right now.

Is there any reason why you should let others climb over you when you have the same chance they have? Surely, the least you can do is to find out just what there is in this proposition for you. Here is all we ask: Without cost, without obligating yourself in any way, simply mark and mail this coupon.

----- TEAR OUT HERE -----
INTERNATIONAL CORRESPONDENCE SCHOOLS
 BOX 5631-C SCRANTON, PA.

Without cost or obligation please explain how I can qualify for the position, or in the subject before which I have marked an X:

- | | |
|---|---|
| <input type="checkbox"/> ELEC. ENGINEER | <input type="checkbox"/> BUSINESS MANAGEM'T |
| <input type="checkbox"/> Electric Lighting & Railways | <input type="checkbox"/> SALESMANSHIP |
| <input type="checkbox"/> Electric Wiring | <input type="checkbox"/> ADVERTISING |
| <input type="checkbox"/> Telegraph Engineer | <input type="checkbox"/> Show Card & Sign Ptg. |
| <input type="checkbox"/> Telephone Work | <input type="checkbox"/> Railroad Positions |
| <input type="checkbox"/> MECHANICAL ENGINEER | <input type="checkbox"/> ILLUSTRATING |
| <input type="checkbox"/> Mechanical Draftsman | <input type="checkbox"/> Cartooning |
| <input type="checkbox"/> Machine Shop Practice | <input type="checkbox"/> Private Secretary |
| <input type="checkbox"/> Toolmaker | <input type="checkbox"/> Business Correspondent |
| <input type="checkbox"/> Gas Engine Operating | <input type="checkbox"/> BOOKKEEPER |
| <input type="checkbox"/> CIVIL ENGINEER | <input type="checkbox"/> Stenographer & Typist |
| <input type="checkbox"/> Surveying and Mapping | <input type="checkbox"/> Certified Public Accountant |
| <input type="checkbox"/> MINE FOREMAN or ENGR | <input type="checkbox"/> TRAFFIC MANAGER |
| <input type="checkbox"/> STATIONARY ENGINEER | <input type="checkbox"/> Railway Accountant |
| <input type="checkbox"/> Marine Engineer | <input type="checkbox"/> Commercial Law |
| <input type="checkbox"/> ARCHITECT | <input type="checkbox"/> GOOD ENGLISH |
| <input type="checkbox"/> Contractor and Builder | <input type="checkbox"/> Common School Subjects |
| <input type="checkbox"/> Architectural Draftsman | <input type="checkbox"/> CIVIL SERVICE |
| <input type="checkbox"/> Concrete Builder | <input type="checkbox"/> Railway Mail Clerk |
| <input type="checkbox"/> Structural Engineer | <input type="checkbox"/> AUTOMOBILES |
| <input type="checkbox"/> PLUMBING & HEATING | <input type="checkbox"/> Mathematics |
| <input type="checkbox"/> Sheet Metal Worker | <input type="checkbox"/> Navigation |
| <input type="checkbox"/> Textile Overseer or Supt. | <input type="checkbox"/> AGRICULTURE <input type="checkbox"/> Spanish |
| <input type="checkbox"/> CHEMIST | <input type="checkbox"/> Poultry Raising <input type="checkbox"/> Banking |
| <input type="checkbox"/> Pharmacy | <input type="checkbox"/> Airplane Engines |

Name.....

Street and No..... 1-10-22

City..... State.....

Occupation.....

Persons residing in Canada should send this coupon to the International Correspondence Schools Canadian, Limited, Montreal, Canada.

LEARN CARTOONING



If you like to draw, develop your ability and quickly raise your income

Hundreds of others who had the same ambition have become successful cartoonists through the Landon Picture Chart Method of teaching cartooning. They are now **earning from \$75 to \$400 and more per week.**

The Landon Course of Cartooning with the famous Landon Picture Charts teaches you how to make **original** drawings. As your eye follows sketch after sketch on these charts, you learn just how and where to start a drawing and place each line in completing it.

You can learn during your spare time, at home—and a personal criticism service on each lesson corrects mistakes which you may make.

Celebrated cartoonists and educators everywhere pronounce **Landon Picture Charts** as the greatest achievement in the teaching of drawing. No other plan gives you such a thorough understanding of the fundamentals of drawing—none develops originality so rapidly.

The opportunities in cartoon work were never so great as at present.

Write today for sample Landon Picture Chart, long list of successful Landon students and full information showing the possibilities for you. **Please state your age.**

The Landon School

338 National Bldg.

Cleveland, Ohio

"ELECTRICITY

Taught by a Master Teacher"

is the name of a valuable 56-page booklet which should be in the hands of every man and boy in the United States who is interested in electricity or electrical engineering.

It is **FREE**. Send for your copy today. It tells the facts about the greatest industry on earth, and contains an astounding offer.

DIVISION OF ENGINEERING

World Technical Institute, Jersey City, N. J.

Free to Writers!



A WONDERFUL BOOK—read about it! Tells how easily Stories and Plays are conceived, written, perfected, sold. How many who don't DREAM they can write, suddenly find it out. How the Scenario Kings and the Story Queens live and work. How bright men and women, without any special experience, learn to their own amazement that their simplest Ideas may furnish brilliant plots for Plays and Stories. How one's own Imagination may provide an endless gold-mine of Ideas that bring Happy Success and Handsome Cash Royalties. How new writers get their names into print. How to tell if you ARE a writer. How to develop your "story fancy," weave clever word-pictures and unique, thrilling, realistic plots. How your friends may be your worst judges. How to avoid discouragement and the pitfalls of Failure. **How to win!** This surprising book is absolutely free. No charge. No obligation. Your copy is waiting for you. Write for it now. Just address **AUTHORS' PRESS, Dept. 56 AUBURN, NEW YORK**



HOW TO BECOME A PROFESSIONAL PHOTOGRAPHER

Earning \$35 to \$125 a Week

An interesting illustrated booklet (free) on choosing a vocation, the exceptional opportunities Photography offers you and how to avail yourself of these advantages.

Motion Picture—Commercial—Portraiture

Three to six months' course. Practical instruction. Modern equipment. Day or evening classes. Easy terms. Call or write for Catalog No. 49.

N. Y. INSTITUTE OF PHOTOGRAPHY
141 W. 36th St., N. Y. or 505 State St., Brooklyn

Learn Autos and Tractors



Wonderful opportunities constantly offered trained men; we train you thoroughly to start your own business or make good money as motor expert, driver, shop foreman, etc.

7,000 Graduates making good. Catalog Free

Cleveland Automobile School, 1814 E. 24th St., Cleveland, O.

BRUSHES and SUPPLIES

FOR SIGN and SHOW CARD WRITERS

Largest sign shop and studio use BLUE HANDLE BRAND brushes and supplies. The PIONEER line. Established 1889.

Recognized Quality—Tremendous purchasing power, and long years of practical experience, permit us to offer the highest quality supplies at the lowest prices. Thea Cusack Co., of Indianapolis, writes: "We offer you the highest recommendation for your goods."

Write for our new 1923 catalogue. It's FREE

DETROIT SCHOOL OF LETTERING, 1185 D. S. of L. Bldg. SUPPLY DEPT., Detroit, Mich., U. S. A.



Chas. J. Strong
Founder

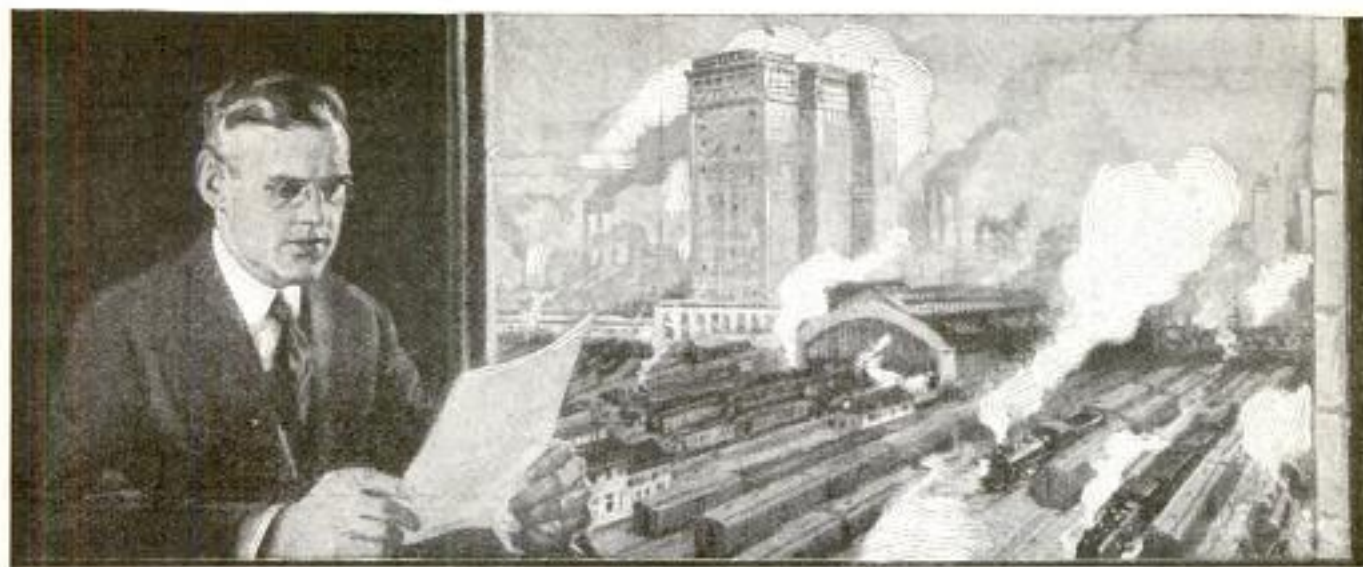

A Real Chance to Command Big Pay!

Competent Traffic Managers Earning \$100 to \$200 a Week

Five hundred thousand business firms in the United States are paying freight charges annually totaling billions of dollars. Fifty thousand concerns pay a freight bill of \$5,000 and over every month.

Once—when business was riding the crest of the wave—these firms could entrust their transportation problems to "second-raters"—shipping clerks who had learned all they knew about traffic at the warehouse.

TODAY—in this era of intense competition upon which business is entering—

WANTED—as never before in the history of American commerce—*trained traffic managers*. To men who are really competent in this field, business firms are gladly paying from \$50.00 to \$200.00 a week.

The Straight Route to Promotion

Here's the way promotions are won in this field of Traffic Management:

A trained traffic man recently pointed the way for a large concern making woodworking machinery to save \$6,000 a month on freight charges simply by making a few changes in construction to permit its bandsaws to be shipped in box cars instead of on flat cars. Result—a salary of \$6,000 a year.

Another LaSalle man—at that time only a rate clerk for one of the big packing companies—discovered by investigation and study that his firm was paying a rate of \$1.60 a hundredweight on certain shipments, as against a rate of \$1.53 to which it was entitled. He recommended the filing of claims with the Interstate Commerce Commission and recovered for his company \$200,000 in cash—\$80,000 of which was refunded by a single railroad company. He is now Traffic Manager for the largest cement company in the world.

Nothing extraordinary about these men. They are simply cashing in on *scientific knowledge*—instead of *haphazard experience*. Big promotions are the logical result.

Swift Advancement by the Problem Method

Here, then, is a field in which the *demand* for competent men vastly exceeds the *supply*—a field that affords every opportunity to *show results*—a field in which you are offered every opportunity to qualify—swiftly, surely—right in your own home—under the direction of a Traffic Advisory Council of 150 nationally-known traffic men, who will train you in the practical traffic methods utilized by the most efficient organizations in America.

Under the LaSalle Problem Method you will work to all purposes side by side with men who are authorities in their field, handle the very problems met daily by the traffic managers of the railroads and by the big shippers. They will answer every question you ask, make every point clear, direct your training every step of the way. You will cover under their instruction the entire field of traffic, including the

organization and administration of a traffic department, freight classification, rates, claims, law of carriers, procedure before the Interstate Commerce Commission, express service and rates, ocean traffic and trade, even to the point of working with the actual forms, agreements and contracts in daily use.

Make Your Start TODAY!

"Big men," says J. Ogden Armour, "are simply small men who have had a chance to grow." Give yourself that chance!

The coupon below will bring you complete information regarding the training you are interested in, together with details of our *convenient-payment plan*. With this information we will send you your free copy of "Ten Years' Promotion in One," a book that has inspired thousands of ambitious men to greater achievement.

Make TODAY your starting point toward big success—by mailing the coupon NOW.

LaSalle Extension University

The Largest Business Training Institution in the World

INQUIRY COUPON

LaSalle Extension University
Dept. 564-TR Chicago, Ill.

Please send me catalog and full information regarding the course and service I have marked with an X below. Also a copy of your book, "Ten Years' Promotion in One," all without obligation to me.

Traffic Management—
 Foreign and Domestic:

Training for positions as Railroad and Industrial Traffic Managers, etc. **Other LaSalle Training Courses**

LaSalle is the largest business training institution in the world. It offers training for every important business need. If more interested in any of these courses, check here:

- | | |
|--|--|
| <input type="checkbox"/> Business Management | <input type="checkbox"/> Banking and Finance |
| <input type="checkbox"/> Higher Accountancy | <input type="checkbox"/> Modern Foremanship and Production Methods |
| <input type="checkbox"/> Railway Accounting and Station Management | <input type="checkbox"/> Personnel and Employment Management |
| <input type="checkbox"/> Law—Degree of LL. B. | <input type="checkbox"/> Expert Bookkeeping |
| <input type="checkbox"/> Commercial Law | <input type="checkbox"/> Business English |
| <input type="checkbox"/> Industrial Management Efficiency | <input type="checkbox"/> Commercial Spanish |
| <input type="checkbox"/> Modern Business Correspondence and Practice | <input type="checkbox"/> Effective Speaking |
| | <input type="checkbox"/> C. P. A. Coaching |

Name

Present Position

Address



\$100.00 a Week

He Doubled His Pay

and now enjoys the comforts and pleasures of a real income

Why not double your pay? Thousands of our students have done it and thousands more will do it. You can be one of them. Do not think for a moment that it is luck or pull which brings success and real money—far from it. It is preparing for the big opportunity and knowing what to do when the right time comes that does it. The men who have made successes for themselves were ready when their main chance came. Your main chance, too, will come. Are you ready for it?

Remember the Empty Lot?

The older fellows were playing ball and you were watching, wondering if you would ever get a chance to play. You know if you only got a chance you would show them. Sure enough, one day they hollered, "Come on, kid, grab a bat!" Your chance at the pill had come. That is the way with life. Your chance at the pill will come, but, if you want to stay on the team, you will have to deliver the goods—and that you can do only if you are prepared. The big money and the permanent job go to the man "who knows."

You Can be the Man "Who Knows"

We will show you how. Without loss to you of a single working hour, we can show you a sure way to success and big pay. A large number of men in each of the positions listed are enjoying their salaries because of our help. We want to help you. Make a check on the coupon against the job you want and we will help you get it. Write or print your name on the coupon and send it in today.

AMERICAN SCHOOL

Dept. G -574, Drexel Ave. and 58th St., Chicago

AMERICAN SCHOOL

Dept. G -574, Drexel Ave. and 58th St., Chicago

Send me full information on how the PROMOTION PLAN will help me win promotion in the job checked.

- | | |
|------------------------------|----------------------------|
|Architect |Lawyer |
|Building Contractor |Machine Shop Practice |
|Automobile Engineer |Photoplay Writer |
|Automobile Repairman |Mechanical Engineer |
|Civil Engineer |Shop Superintendent |
|Structural Engineer |Employment Manager |
|Business Manager |Steam Engineer |
|Cert. Public Accountant |Foremanship |
|Accountant and Auditor |Sanitary Engineer |
|Bookkeeper |Surveyor (& Mapping) |
|Draftsman and Designer |Telephone Engineer |
|Electrical Engineer |Telegraph Engineer |
|Electric Light & Power |High School Graduate |
|General Education |Fire Insurance Expert |

Name

Address

Please Mention Popular Mechanics

LEARN *The* BUSINESS of Advertising



QUICKLY BY MAIL

We guarantee to teach you. It's easy to learn—and easy to get into! Make the start *this week*. This free book tells how.

\$75 to \$100 a Week

—frequently paid beginners. There is *no limit* to opportunities which men and women trained in advertising meet on every hand.

FREE This interesting book on advertising is sent free. Tells just the things you want to know about getting into this fascinating field. Full of facts.

PAGE-DAVIS SCHOOL, Dept. A17, Page Bldg., Chicago

EARN MONEY AT HOME

LEARN Show Card Writing by our new, simple Directograph system and earn money in your spare time at home. No canvassing or soliciting. We guarantee to supply work and pay you cash for the work you do. Write for full particulars and free booklet.

WEST-ANGUS SHOW CARD SERVICE
76 Colborne Building Toronto, Can.

WRITE NOW FOR Dyke's FREE Booklet

NEW IDEA OF TEACHING BY MAIL tells how you can learn at home—spare time—and **Become an Auto Expert** on repairing and electrical systems.

DYKE'S SCHOOL OF MOTORING, Box 300 Granite Bldg., St. Louis, Mo.
A department of the firm: A. J. Dyke, Publisher, Original and only system of this kind. Endorsed by leading motor authorities of the world.

BIG PROFITS FROM POULTRY

We Teach You How; Easily Learned at Home;

our guaranteed methods make success certain; write for free booklets "How to Raise Poultry for Profit" and "Absolute Evidence." Free.

The National Poultry Institute, Inc., Desk 312, Marden Bldg., Washington, D.C.

LAW High-Grade Instruction Prepares You for the Bar—Est. 1892

Standard Text-Books, Approved by Bench and Bar. Graduates practicing in every state. Send today for Free Catalog and Rules for Admission to the Bar.

Chicago Correspondence School of Law
520 Reaper Block Chicago, Ill.

LEARN WATCHMAKING AND ENGRAVING

Earn while learning. Most practical watch school. Individual instructions. Graduates in great demand. Book free. Chicago School of Watchmaking, Dept. 20, State-Lake Bldg., Chicago

\$5,000 SALARIES

are often paid to traffic managers. Numberless traffic positions pay \$2,500 to \$5,000 per year. Millions of dollars are wasted annually because of ignorance of cheaper ways to ship. You can be a traffic expert—stop losses—make big money for yourself. Thousands of men now needed.

Learn at Home—Book Free New home study Actual Practice Method will quickly make you a Certified Traffic Manager. You can very soon qualify for a splendid traffic position. Write quick for big new illustrated book describing this wonderful training in detail. Write today. Address

American Commerce Association Dept. 105, 4043 Drexel Blvd. CHICAGO, ILL.

**FLEXIBLE
BINDING**
**POCKET
SIZE**

ENTIRE SET ONLY \$12

\$1
PER
MONTH



\$10,000. Master Set
AUDEL'S ENGINEERS
and MECHANICS
GUIDES

**THE BOOKS YOU HAVE
BEEN WAITING FOR!**
4750 Pages---8754 Illustrations

Just Completed—Au-del's New Master Set for Engineers and Mechanics!
Every Engineer, Mechanic and Electrical worker will welcome this set as a sure source of advancement and higher pay because of the complete up-to-date information that is thoroughly and easily explained on every branch of Engineering and Electrical practice.
Why a \$10,000 Library? Because it would cost the reader more than \$10,000 together with years of labor and experience to collect, plan, arrange and prepare for his own study and ready reference, the vast fund of knowledge printed in this Master Set.
The entire set costs you only twelve dollars—knowledge and instruction that has cost thousands of dollars and years of time—yours for \$12.00—\$1.00 a month.

Helping Hand
Books that answer
Your Questions



FREE
EXAM-
INATION

Send No Money--Send Only This Coupon

THEO. AUDEL & CO.,
72 Fifth Ave., New York City

Please submit me for free examination, AUDEL'S \$10,000 MASTER SET FOR ENGINEERS AND MECHANICS. Ship at once prepaid, the 8 numbers, total cost \$12.00. If satisfactory, I agree to send you \$1 within seven days and to further mail you \$1 each month until paid.

Name.....
Occupation.....
Employed by.....
Home Address.....
Reference.....

Study This Brief Table of Contents

Theory, Practice and Operation of All Steam Engines, Valve Motion—VALVE SETTING; complete information on ALL engines and pumps—CORLISS ENGINE and the Theory, Construction and Operation of all Steam Engines, including UNIFLOW and POPPET VALVE ENGINES, and LOCOMOBILES—Locomotive-Marine Engines; Turbines; Rotary Engines—the Indicator—Lubrication—PRACTICAL MANAGEMENT, How to use Indicators—GAS, GASOLINE, OIL, SEMI, and FULL DIESEL ENGINES—Aeroplanes and Aviation—HOW TO SELECT AN ENGINE, working instructions, drawings on STEAM ENGINE DESIGN, including rules and formulae, Theory and Construction of ALL Steam Boilers; Heat-Combustion; Fuel and Fine Gas Analysis—CO₂ recorder—Characteristics of Boilers—Materials—Construction of all types of Boilers. (THE LATEST PRACTICE.)—Boiler Construction—Mechanical Stokers—Oil Burners—Setting—Chimneys—Mechanical Draught—HOW TO SELECT A BOILER—Complete instructions and drawings on BOILER DESIGN based on A. S. M. E. BOILER CODE—OPERATION, including installation, FIRING; care and repair of Steam Boilers—Pipes, Fittings and Pipe Fitting—Heating and Ventilation—Refrigeratives—Cooling Towers—Condensers—Distilling Apparatus—Elevators—Cranes and Hoisting Machinery—Ropes and Cables—Splicing—electric wiring in ALL branches; compendium of practical electrical engineering as an aid for engineers and electricians in obtaining a license—57 chapters—ready reference index, covering entire field of Modern Electricity.

REALIZE your BIGGER SELF



Don't dream along, content with one-third or one-half of your mental growth—as many men do. When

Properly Trained

and exercised, your mind will develop as muscle does. Better still, it keeps on growing after you are twenty, thirty, or forty, bringing you the larger responsibility, the more congenial and profitable occupation, and the leadership which come with growth and increasing ability. Keep in mind the man you want to be two years, five years, ten years hence and start NOW to make the picture a reality. You can if you will.

Get Our Friendly Counsel Free We will paint no "blue-sky pictures" that you cannot realize but will deal with you in frank, man-to-man fashion. "If a man intends to do anything at all, your system will bring it out," says one of our Texas students, and a California student writes: "You develop a man's resourcefulness."

Tell us your occupation and your ambition. We will send our booklet "Head and Shoulders Above the Crowd—How to Get There" and tell you the "Six Reasons" why thousands of young men are finding the United Y. M. C. A. Schools' system of correspondence teaching the one that gives "the most service for the least money."

SEND THIS SLIP

United Y. M. C. A. Schools' Correspondence Courses, or Positions for which the Courses Afford Training:

Accountant	Dairy Farming	Radio Operator
Advertising Man	Draftsman	Radio Engineer
Agricultural Courses	Electrician	Railroad Engineering
Architect	Electrical Engineer	Salesman
Auto Mechanic	Factory Management	Secretarial
Banking	Farm Management	Shorthand and Type-writing
Better Letters	Foreign Languages	Steam Engineer
Bookkeeper	Foremanship	Structural Drafting
Building Construction	Highway Engineering	Surveyor
Business English	High School Subjects	Tool Designing
Business Law	Leadership Courses	Tractors and Farm Machinery
Business Organization	Locomotive Operator	Traffic Management
Civil Engineer	Machine-Shop Practice	Use of the Slide Rule
Civil Service	Mechanical Engineer	
Concrete Engineer	Plumber	
	Poultry Husbandry	

UNITED Y. M. C. A. SCHOOLS

Dept. 2MY 375 Lexington Ave., New York City

Without obligating me, please advise regarding

The Course or Position of

Age and Occupation

Name

Full Address

(Please write plainly)

SPANISH LEARNED EASILY AND QUICKLY!

Also FRENCH and ITALIAN

Another language will enable you to make more money—whether you are an employer or employee, professional man or woman, boy or girl. A Few Spare Minutes Can Increase Your Income. Learning a new language by the Rosenthal Language Phone Method, is as easy as learning a new tune. Study when you are in the mood—in the comfort of your own home—on your own phonograph. Soon, you can talk, read and write Spanish, French or Italian.

ROSENTHAL LANGUAGE PHONE METHOD

makes rapid progress possible

Any number of people can learn at the same time—the whole family or groups of friends.

FREE 64-Page Book. It shows how easy, interesting, and profitable it is to learn a foreign language; and explains Dr. Rosenthal's world-famous method of quick study. Also details of **FREE Trial** offer. Send a postal—*to-day*.

FUNK & WAGNALLS COMPANY
549 Hess Building, 354 Fourth Ave., N. Y.



Keystone Institute Automotive Course

A splendid opportunity to learn the automobile business by comprehensive instruction and actual practice. Your success assured after finishing our course, whether as mechanic, salesman, or garage owner. Complete equipment, expert instructors, every modern facility for a thorough knowledge in this ever-growing field. Day and night courses. Write for full information to The Vice-President,

133 N. Fourth Street, Reading, Pa.

ELECTRICAL ENGINEERING

men with training are in demand. For more than a quarter of a century this school has been training men of ambition and limited time, for the electrical industries. Condensed course in Electrical Engineering enables graduates to secure good positions and promotions. Theoretical and practical Electricity, Mathematics, Steam and Gas Engines, Mechanical Drawing. Students construct dynamos, install wiring and test electrical machinery. Course with diploma, complete.



Thoroughly equipped fireproof dormitories, dining hall, laboratories, shops. Over 3000 men trained. Write for catalog. 30th year begins Sept. 27, 1922.

BLISS ELECTRICAL SCHOOL

404 TAKOMA AVENUE, WASHINGTON, D. C.

LEARN AUTOMOTIVE ENGINEERING

A business for "live wires." There is a constant demand for trained Repairmen, Chauffeurs, Truck Drivers, Demonstrators, Automobile Salesmen, Garage Managers, etc.

COURSES \$25 AND UP

Positions secured for all competent graduates without charge. Diplomas granted. Write for free booklet.

GREER COLLEGE OF AUTOMOTIVE ENGINEERING
2024 Wabash Ave., Dept. 15 Chicago, Illinois

MUSIC LESSONS FREE

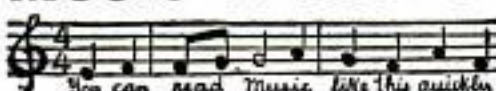

IN YOUR
OWN
HOME

You can read music like this quickly. Piano, Organ, Violin, Mandolin, Guitar, Banjo, etc. Beginners or advanced players. One lesson weekly. Illustrations make everything plain. Only expense about 3¢ per day to cover cost of postage and music used. Write for **FREE** booklet which explains everything in full.

AMERICAN SCHOOL OF MUSIC, 51 Lakeside Building, CHICAGO



SHORTHAND IN ONE MONTH

Boyd—the Wonderful, New, Easy System. Writer, hold World's record. 100 to 150 words a minute in 30 days guaranteed. New Principles—dictation first week. Best for Court Reporting and Secretaries. Also Typewriting, Bookkeeping and Commercial Law. Send today for Catalog and Money-Back Guarantee. **CHICAGO HOME STUDY SCHOOLS, 802 Reaper Block, Chicago, Ill.**

It's a Shame for *You* Not to Earn \$10,000 a Year -When Others Do It So Easily



He Does It

"Last week my earnings amounted to \$554.37; this week will go over \$400."—F. Wynn, Portland, Oregon.

WHEN a farmhand steps from \$50 to \$1,000 a month—when a fireman jumps from \$60 a month to a job paying him \$500 for two weeks' work—when a former railway mail clerk at a yearly salary of \$1,600 changes his job and earns \$1,000 in thirty days—and when hundreds of others quickly jump from small pay to magnificent earnings in the same way—then it's a shame for you not to earn your \$10,000 a year.

There is nothing exceptional about these men. They'd tell you that themselves. Many had been clerks, bookkeepers, mechanics. Some had been policemen, farmhands, firemen. And then in one swift stroke, they found themselves making more money than

they had ever dreamed possible. The grind of routine work—the constant struggle to obtain even a small increase—all this was left behind. Today they know the thrill of independence; they are no longer ruled by an office clock. There is genuine enjoyment in every hour of the day, for their work is filled with real fascination. They have found not only the most interesting, but the best paying branch of all business.

A field that they had never dreamed of as theirs they found to be easy and uncrowded. Earnings that they had always *hoped* to reach were right there in this new field waiting for them. Hundreds have found this new easy way to \$10,000 a year. You can too—let us tell you how.

How You Can Do It Too—

What these men have done, hundreds of others have done, hundreds are doing today, hundreds will do tomorrow. And you may be one of them! For now the same opportunity that put these men into the big money class is open to you.

In the first place they discovered a vital fact about business. They discovered that the big money is in the selling end of business. In the second place they discovered a new and amazingly easy way that will make any man a salesman, no matter what job he held before.

Salesmen are the very life blood of any concern—upon them depends the amount of profits made. No wonder that man for man Salesmen receive the highest pay. For the men who are in the "Star" class—who are Masters of Salesmanship—there is practically no limit to their earnings. Some receive almost fabulous amounts. And that is how these men and hundreds of others

like them have found the way to their present handsome incomes.

They are all Master Salesmen Now!

Yet previously they had no idea of becoming Salesmen. If you had told them success awaited them in the field of Selling, they would have laughed at you. They would have told you that it was absurd to think of it—for they had never sold a dime's worth of goods in their lives! Then they learned of a great organization of top-notch Salesmen and Sales Managers formed for the express purpose of fitting men for the great opportunities in the field of Salesmanship and to help them to positions in the lines that most appeal to them. Step by step—in their spare time at home—this great organization, The National Salesmen's Training Association—took them thru every phase of selling. Then as soon as they were qualified and ready, the Free Employment Service of this Association helped them secure good selling positions. Almost before they realized it they were in the big money class.

FREE BOOK Starts You for YOUR \$10,000-a-Year!

National Salesmen's Training Association
Dept. 12-E, Chicago, Ill.

I simply want to see the facts. Send me FREE your Book on Salesmanship and Proof that I can become a Master Salesman. Also send list of lines with openings for Salesmen.

Name.....

Address.....

City.....

State.....



So Does He

"I had never earned more than \$60 a month. Last week I cleared \$306 and this week \$218."—George W. Kearns, Oklahoma City, Okla.

And He—

"The very first month I earned \$1000. I was formerly a farmhand."—Charles Berry, Whiteset, Iowa.



And He—

"After spending ten years in the railway mail service at salaries ranging from \$900 to \$1600 a year, I decided it was necessary for me to make a change. My earnings during the past thirty days were more than \$1000."—W. Hartle, Chicago.



that you will receive, entirely free, a remarkable illustrated book, "The Knight of the Grip," and the personal stories of men in every part of the country who today are enjoying splendid success and earning five, ten and fifteen times as much money as ever before. Make a start now for your \$10,000 Year. Mail coupon at once to The National Salesmen's Training Association, Dept. 12-E, Chicago, Ill.

Sweeney Says

Young man—you want A BETTER JOB—more money—opportunity—success. If you are mechanically inclined write me today—don't bother about a letter—just a postcard will do—or clip and mail the coupon.



E. J. SWEENEY

**As the Soldier
Looks to West
Point, so the Me-
chanic Looks to
Sweeney's**

PICK THE JOB YOU LIKE

Chauffeurs	\$90. to 150.
Truck driver	\$125.
Tire Vulcanizer	\$100 to 200.
Welders	\$140. to 200.
Battery Man	\$150. to 200.
Auto Mechanic	\$6. to 10. a day
Auto Electrician	\$225.
Tractor Engineer	\$10 a day
Garage Manager	\$150 to 400
Demonstrator and Salesman	\$150 to 500.



I Will Make You An Amazing Offer

If you are interested in mechanical work, if you are interested in automobiles and WILL WORK, this Million Dollar Trade School offers you an opportunity that may never come to you again.

Will you PUT EIGHT WEEKS' TIME in this great trade school IF YOU ARE CONVINCED IT MEANS A REAL JOB AND A LIFETIME SUCCESS?

Because of the demand for Sweeney trained men I am making now MY BIGGEST AND MOST SURPRISING OFFER—no matter where you live—no matter if you have had no previous experience—no matter how old you are.

But I will make this offer ONLY to those who are sufficiently IN EARNEST and SUFFICIENTLY ENERGETIC to write me AT ONCE.

CAN YOU MAKE A BATTERY? Sweeney trained men are battery experts—special work on starting and ignition. Battery service BIG BUSINESS NOW. Learn to make a \$25 Ford battery for \$7.00.

CAN YOU WELD a broken crank case? It's easy by the Sweeney method. Weld holds stronger than original steel or aluminum. Expert welders wanted everywhere. Learn to solder a crank case without taking it down.

TIRES. Can you make a real 4,000 mile tire from old casing and rubber? Sweeney men are TIRE BUILDING EXPERTS. Make and repair them right in our shops.

THE SWEENEY SYSTEM,

famous the world over, can be had only in the Sweeney School. Trains men to be mechanics by practical work. You learn by doing—no books—you do the actual work. The course takes only 8 weeks. No place in the world can you get so much real instruction—so much actual value, for so little money. If you are in earnest, there is a real job looking for you. Write me today—don't put it off—I've got some information that will open your eyes—but you must take the first step—Write for my Big Free Book.

LEARN A TRADE
Sweeney
SCHOOL OF AUTO-TRACTOR-AVIATION
1013 SWEENEY BLDG. KANSAS CITY, MO.

"Learn a Trade"

Can You Fill This \$150 Job?

Even before finishing his course, at Sweeney's, Runsey is grabbed by the American Radiator Co., at \$150 a month for his special skill in soldering. Soldering and welding are just one part of the **Sweeney System of Practical Experience**. Another man has left us to work for 85 cents an hour as a welder. Hadn't finished either, but these big concerns couldn't wait. Practical Experience quickly qualifies men. And employers want Sweeney men—NOW.

Free Radio Learn Radio free at the Sweeney School. My great sending station talks to you anywhere in the U. S. Receive messages—get familiar with radio work—learn to build your own set. All this instruction now part of the regular course without ONE CENT Extra Charge.

S. E. Adair, formerly Chief Engineer of the International Radio Co., is in charge of Radio work and superintendent of Electrical Instruction for the Sweeney School. His assistant, John Schilling, was formerly in charge of the Government school at New London, and is an expert commercial operator. These men are practical men and no better can be found as Radio instructors. With your radio experience here you can go back home and install receiving sets or sell them. You can make sets for yourself.

WHO IS THE RIGHT MAN to have the agency for or make radio receiving sets? To install sets? The garage man or auto mechanic? At the Sweeney School learn how to handle radio work. Get an agency for a \$25 receiving set. The first week you are home you can EARN the whole cost of your school tuition.

Free I will gladly send my 72-page illustrated catalog FREE. Also a free copy of Sweeney School News, a most interesting monthly school paper, published here. You will enjoy

them. Read the worth-while stories of men like yourself who came to Sweeney's and found success. Read how Frank Powell and Harry Wilson built up a \$20,000 business in about two years after graduating. Read how Elbert A. Pence built up a \$25,000 yearly garage business at Clearmont, Mo. These stories and many more are told by the Sweeney students. Also I want you to learn how my students enjoy themselves after work in the swimming pool, the club and reading rooms, etc.

Send today for this free catalog. Get my big, new, special offer. See page after page of mechanical pictures. Read what students say. Note the latest ideas in auto work. Hundreds of illustrations. Learn about the jobs open—the actual present opportunities in the business for Sweeney men. DO IT NOW.

Yours very truly,
EMORY J. SWEENEY,
President.

This FREE Book
Tells You
Every-
thing



Three Points:

1. Learn the Auto Business
2. Learn it at Sweeney's
3. Get the Catalog TODAY

NO COLORED STUDENTS ACCEPTED

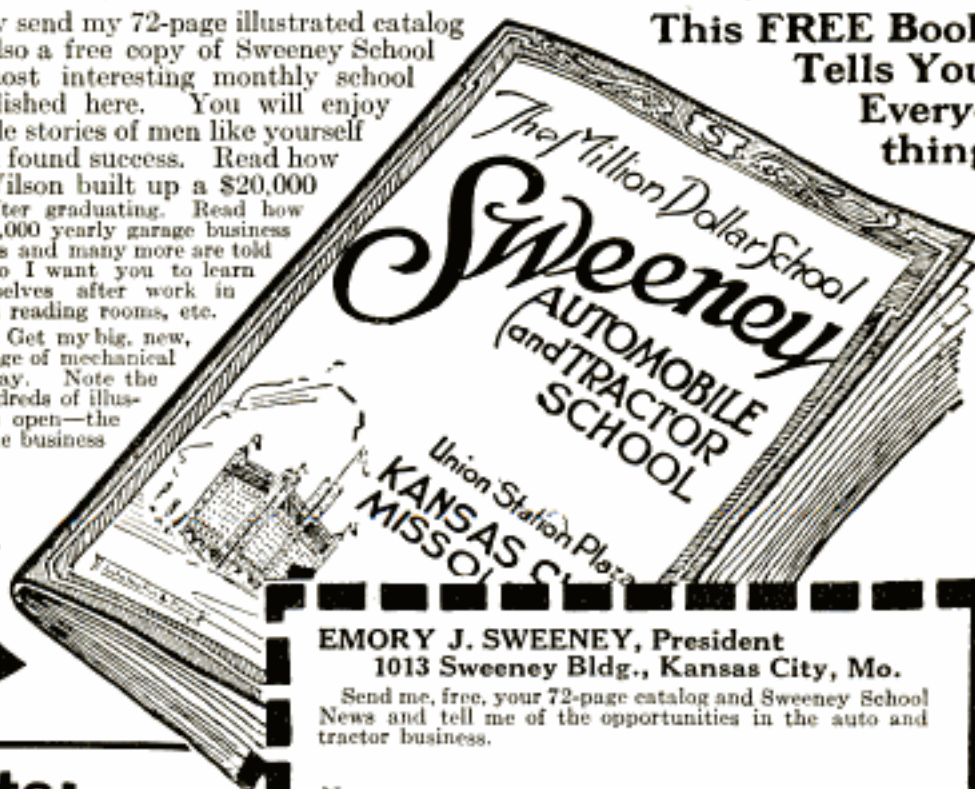

EMORY J. SWEENEY, President
1013 Sweeney Bldg., Kansas City, Mo.

Send me, free, your 72-page catalog and Sweeney School News and tell me of the opportunities in the auto and tractor business.

Name

P. O.

State



"Another \$50 Raise!"

"Why, that's the third increase I've had in a year! It shows what special training will do for a man."

Every mail brings letters from some of the two million students of the International Correspondence Schools, telling of advancements won through spare-time study.

How much longer are you going to wait before taking the step that is bound to bring you more money? Isn't it better to start now than to wait for years and then realize what the delay has cost you?

One hour after supper each night spent with the I. C. S. in your own home will prepare you for the position you want in the work you like best.

Without cost, without obligation, mark and mail this coupon. *Do it right now!*

----- TEAR OUT HERE -----

INTERNATIONAL CORRESPONDENCE SCHOOLS
BOX 5637-C SCRANTON, PA.

Without cost or obligation please explain how I can qualify for the position, or in the subject before which I have marked an X:

- ELEC. ENGINEER
- Electric Lighting & Railways
- Electric Wiring
- Telegraph Engineer
- Telephone Work
- MECHANICAL ENGINEER
- Mechanical Draftsman
- Machine Shop Practice
- Toolmaker
- Gas Engine Operating
- CIVIL ENGINEER
- Surveying and Mapping
- MINE FOREMAN or ENG'R
- STATIONARY ENGINEER
- Marine Engineer
- ARCHITECT
- Contractor and Builder
- Architectural Draftsman
- Concrete Builder
- Structural Engineer
- PLUMBING & HEATING
- Sheet Metal Worker
- Textile Overseer or Supt.
- CHEMIST
- Pharmacy

- BUSINESS MANAGEMENT
- SALESMANSHIP
- ADVERTISING
- Show Card & Sign Ptg.
- Railroad Positions
- ILLUSTRATING
- Cartooning
- Private Secretary
- Business Correspondent
- BOOKKEEPER
- Stenographer & Typist
- Certified Public Accountant
- TRAFFIC MANAGER
- Railway Accountant
- Commercial Law
- GOOD ENGLISH
- Common School Subjects
- CIVIL SERVICE
- Railway Mail Clerk
- AUTOMOBILES
- Mathematics
- Navigation
- AGRICULTURE Spanish
- Poultry Raising Banking
- Airplane Engines

Name.....

Street..... 1-16-22

City..... State.....

Occupation.....

Persons residing in Canada should send this coupon to the International Correspondence Schools Canadian, Limited, Montreal, Canada.

Please Mention Popular Mechanics



CARTOONISTS MAKE BIG MONEY

EVERY time Sid Smith makes a stroke of his pen, millions of people laugh. Every laugh means money for the man who creates it. "Andy" and "Min" earn big money for Sid Smith every day.

Illustrating and cartooning are paying men like Briggs, Smith, Fontaine Fox and J. N. Darling from \$10,000 to \$100,000 a year. You may have ideas that are equally good. Let Federal training develop your talent and give you the skill to put your ideas on paper.

GET THIS FREE BOOK

Write to-day for a free copy of the book, "A Road to Bigger Things." Send 6 cents in stamps to cover postage. It tells of opportunities in the art world and explains the Federal Course of instruction under 60 of America's leading illustrators and cartoonists. **Mention your age.**

Federal Schools, Inc.

503 Federal Schools Building Minneapolis, Minn.

Learn to be a Magician

"The Great Hermann" is a familiar figure to thousands of theater-goers. Baffling performances have delighted audiences from coast to coast. He now tells you how to do dozens of his tricks with cards, coins and handkerchiefs; 158 pages. Paper covers; 4 3/4 by 7 1/4 inches. Postpaid..... 40c

SHREWSBURY PUBLISHING CO.
5525 West Lake Street Chicago, Ill.



Ride A Ranger

The finest bicycle ever built. 44 Styles, colors, sizes; made in our new factory. SAVE \$10 to \$25 by direct from the factory purchase.

Delivered free on approval, express prepaid, for 30 Days' Free Trial. 12 MONTHS TO PAY, if desired.

Best quality at factory prices, express paid. Lamps, wheels, horns, equipment and repairs at unusually low prices. Send No

Money, do business direct with makers.

Mead Cycle Company
Dept. C-106 Chicago

Write today for free Ranger Catalog, factory prices and marvelous easy payment terms



STAMMER NO MORE

Kill the fear of stammering. Re-education the key. The widely famed Hatfield Method fully outlined in an accurate, dependable, worth-while book—"HOW TO STOP STAMMERING." It has inspired thousands. Free copy today.

THE HATFIELD INSTITUTE, 109 N. Dearborn, Chicago, Ill.

LEARN WATCH REPAIRING

Be a watchmaker—you can learn this profitable trade by correspondence in a few weeks in your own home by the DeSelms Chart System. After you complete the course you will know a watch from A to Z. You will know just what the matter is and how to repair one. When you graduate you will be a practical watchmaker and repairer and competent to fill any position. Positions for our graduates.

Ask for our Free Book. It explains our system and terms

THE DeSELMS WATCH SCHOOL
23 Perry Street ATTICA, INDIANA





**YOU CAN DO
THE SAME**

**Read
These
Letters**



"Now the same man is my helper; my pay is bigger than his. He had been in the shop 2 years, but I'm a 'Coyne Man.'"—M. B. K.



"Eight years ago my time card read 'Laborer—\$1.50 a day.' Today my business turnover runs into thousands of dollars."—J. C. M.



"I'm taking care of generators and switchboards at Edison's, earning \$240 a month, thanks to Coyne."—D. O.

Electricity Will Pay You Up to \$400 a Month and More

Only the trained man gets the big pay. Make up your mind right now to be one. Get your training in the best paying of all the professions—Electricity. You can learn Electricity in the Great Shops of Coyne in 3 1-2 months. Then you can go out and command from \$150 to \$400 and more. When you graduate from Coyne in 98 days you can enter any of a dozen or more lines of work—power house operating, telephony, railway signal work, house wiring, electric sign work, motor maintenance, automobile and battery work, street railway service, etc., and earn big money and quick advancement.

EARN WHILE YOU LEARN

You don't need to wait until you have saved up all the money you need to get this Electrical education. Our Welfare Department will help you get a part-time job at which you can earn money to help pay your way.

Auto Electricity Included

If you enroll within a limited time you get the full course in Automobile, Truck and Tractor Electricity without paying a cent above the cost of the Practical Electrical Engineering Course. THIS COURSE CAN BE TAKEN SEPARATELY IF DESIRED; if so desired state so when writing us. This is the finest course in America. The equipment is complete in every detail, and you get your instruction under experts in this branch of electricity. You learn wiring, ignition, lighting and starting systems of all cars, trucks and tractors; you learn how to make and repair batteries; you qualify as an expert auto electrician.

We Train You in Business

We want every one of our graduates to succeed in a big way. If you enroll within a limited

time, we give you, free, a full course in Business Management. You take this course at the same time you take the others. You learn how to manage a business and make money out of it, regardless of whether you work for others or go into business for yourself.

Own Your Own Business

This training, with that in Practical Electrical Engineering, and in Automobile Electricity opens the way to get into a big paying business of your own—as Electrical Contractors, Auto-Electricians, in Garages and Service Stations, as Armature Winders, Electrical Supply Dealers and as Battery Experts—anywhere.

Get Started Now!

Learn Electricity. Make big money. Be somebody. Make good and get real pleasure and satisfaction out of life.

Own your own car and home and be independent. You can do it. It's easy if you get the right start. Filling out the coupon tonight starts you right. If you never do anything you'll never get anywhere. Will you? Write for full particulars. You will want to reserve the right to get the free courses.

**GET YOUR LETTER
OFF TONIGHT!**



B. W. COOKE

PRESIDENT

COYNE
TRADE AND ENGINEERING SCHOOL

Dept. 15, 39-51 E. Illinois Street, Chicago, Ill.

**SEND
COUPON
TODAY**

BENNETT W. COOKE,
President
Coyne Trade and
Engineering Schools
Dept. 15, 39-51 E. Illinois
St., Chicago, Illinois

Gentlemen: Send me your big free catalog with full particulars concerning your Electrical course and how I may secure your course of Auto Truck and Tractor Electricity and the course in Business Management, free. This places me under no obligation whatsoever.

Name.....

Address.....

"THE SAWING QUARTETTE"



American Legion of Wisconsin - Paul Florine Post No 166

Play Music on a Saw

You can play most beautiful music on a common carpenter's saw with a violin bow or soft hammer. No previous musical training necessary. I give you secrets of my ten years' stage experience as a saw musician—secrets never before revealed to the public. After three weeks' lessons, you will be able to play popular songs.

Address: C. J. MUSSEHL, 310 MACK BLDG., FORT ATKINSON, WIS.

Make Big Money

Amaze your friends with this remarkable achievement. Saw musicians are in great demand and earn **big money** playing for entertainments, Clubs, Lodges and Church affairs.

FREE Be first with this novelty in your neighborhood. Send today for **FREE** information on "How to Play a Saw."

"THERE'S MONEY IN IT"

AT HOME

LEARN TELEGRAPHY
MORSE AND WIRELESS

AT HOME



TEACH YOURSELF

in half usual time, at trifling cost, with the wonderful Automatic Transmitter **THE OMNIGRAPH**. Sends unlimited Morse or Continental messages, at any speed, just as an expert operator would. Adopted by U. S. Government, and leading Universities, Colleges and Telegraph Schools. 3 styles. Catalog free.

OMNIGRAPH MFG. CO.

16-22 Hudson St., NEW YORK

STAMMER

If you stammer attend no stammering school; you get my large **FREE** book entitled "STAMMERING, Its Origin and the Advanced Natural Method of Cure," bound in cloth and stamped in pure gold. Ask for special utility rate and a **FREE** copy of "The Natural Speech Magazine." Largest, best equipped and most successful school in the world for the cure of stammering, stuttering, etc. No sing-song or time beat. Write today. The North-Western School, 2317 Grand Ave., Milwaukee, Wis.

SELL US
YOUR SPARE TIME

after enrolling for our course in Show Card Writing. We will train you to write show cards for us. No canvassing or soliciting; we supply you with work; distance no object; will pay you good money for work done.

Wilson Methods, Ltd., Dept. M, 64 E. Richmond, Toronto, Canada

WANTED

Railway Mail Clerks
\$1600 to \$2300 Year
MEN—BOYS OVER 16
SHOULD WRITE IMMEDIATELY

Steady work. No layoffs. Paid Vacations
Common education sufficient.

Send coupon today—**SURE**



MAIL CLERKS

FRANKLIN INSTITUTE, Dept. C177, Rochester, N. Y.

Sirs: Send me without charge, (1) sample Railway Mail Clerk Examination questions; (2) Schedule showing places in all coming U. S. Government examinations; (3) list of many government jobs now obtainable.

Name.....

Address.....

Copyrighted material

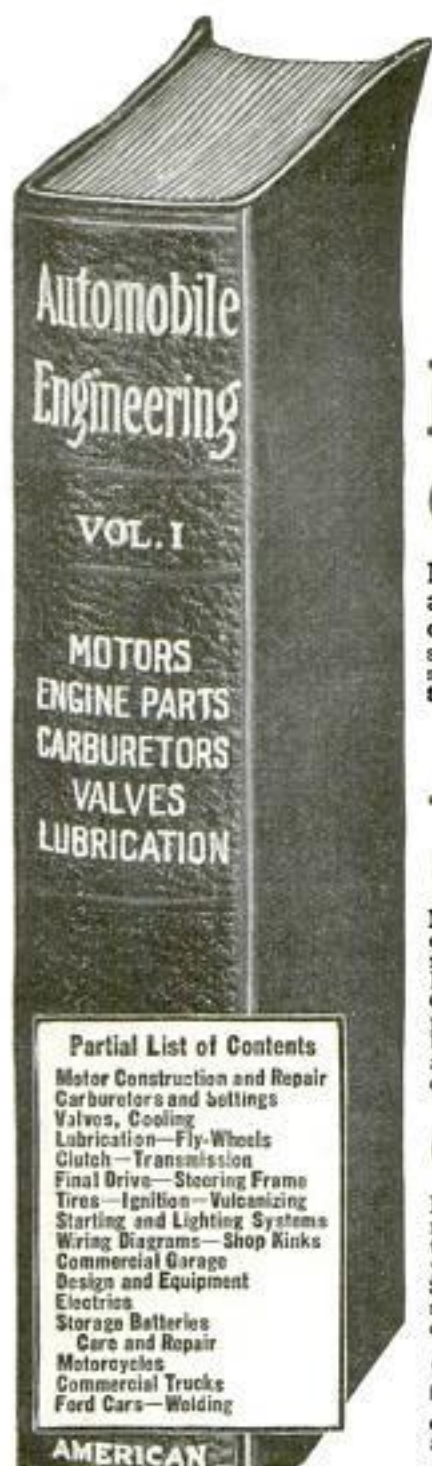

NAME	POSITION	SALARY
John	AUTOMOBILE ENGINEER	\$125 A WEEK
	REPAIR MAN	\$50 A WEEK
	CHAUFFEUR	\$40 A WEEK

Put Your Name On this Pay-Roll

Men like you are wanted for big-pay positions in the fascinating field of automobile engineering. We have made it easy for you to fit yourself for one of these positions. You don't have to go to school. You don't have to serve an apprenticeship. Fifteen automobile engineers and specialists have compiled a spare time reading course that will equip you to be an automobile expert without taking any time from your present work.

AUTO BOOKS 6 Volumes Shipped FREE

Now ready for you—at a big reduction in price—an up-to-the-minute six-volume library on Automobile Engineering, covering construction, care and repair of pleasure cars, motor trucks, tractors and motorcycles. Brimming over with advanced information on Lighting Systems, Garage Design and Equipment, Welding and other repair methods. Contains everything that a mechanic or an engineer or a motorcyclist or the owner or prospective owner of a motor car ought to know. Written in simple language that anybody can understand. Tastefully bound in flexible covers and gold stamped, 2700 pages and 2400 illustrations, tables and wiring diagrams. A library that cost thousands of dollars to compile but that comes to you free for 7 days' examination.

Only 10 Cents a Day

Not a cent to pay in advance. First you see the books in your own home or shop. Just mail coupon and pay express charges when books arrive. You can read them and study them for seven whole days before you decide whether you want to keep them or not. If you like the books send \$2.80 in seven days and \$3.00 a month until the special price of \$24.80 has been paid. (Regular price \$45.00.) Along with the set goes a year's membership in the American Technical Society, including consulting privileges and free employment service.

Send No Money Now

Don't take our word for it. See the books without cost. There is so much profit in this offer for you, that we urge you not to waste a moment in sending for the books. Put the coupon in the mails today. SEND NO MONEY—only the coupon.

American Technical Society
Dept. A-195 Chicago, Illinois

American Technical Society, Dept. A-195, Chicago

Please send me a set of Automobile Engineering books in 6 volumes by express collect, for a week's free use. At the end of a week I will either send the books back at your expense or send you \$2.80 as first payment and \$3.00 each month thereafter until a total of \$24.80 is paid. I understand that I will get a membership in your society, including consulting privileges and free employment service if I purchase the books.

Name

Address

City

State

Reference

Mail The
Coupon For
These Books

Do You Like to Draw?

Here Is a Simple, Easy Way
to Draw a Comic Face

TRY IT

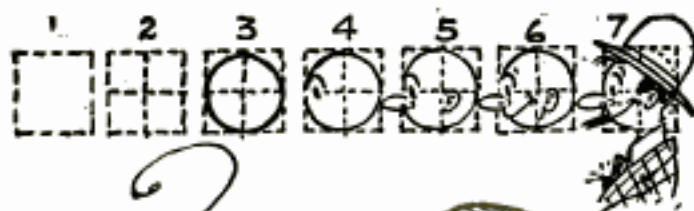

Make a square with pencil, then add to it with pencil as shown in the small squares above. Erase all pencil guide lines after the drawing is completed.

We will not give you any "grand prize," if you draw this picture. Nor will we claim to make you "rich in a week." But if you are anxious to develop your talent with a **successful cartoonist**, so you can **make money**, send a copy of this picture with six cents in stamps for portfolio of cartoons and sample lesson plate, and let us explain more in detail. Some of the **most successful cartoonists** are former students of this school. It is not hard to learn to draw **originals** when you are shown how in a **practical way**.



THE W. L. EVANS SCHOOL OF CARTOONING
"The School That Has the Reputation"
821 Leader Bldg. CLEVELAND, OHIO

WANTED! RAILWAY MAIL CLERKS

You won't get fired or laid off if you work for Uncle Sam. When everybody else is worrying about his job or looking for work, the U. S. Civil Service Employee is earning good, steady pay in a pleasant occupation of his own selection.

**\$1600 TO \$2300
A YEAR GUARANTEED**

Let me train you to pass the U. S. Civil Service Examination with **HIGH RATING** so you can get a position **QUICKEST**—at \$1600 to \$2300 guaranteed. I have trained **THOUSANDS**, and I guarantee you a position, or money back.

GET MY FREE BOOK

I was Civil Service Secretary Examiner for 8 years and **KNOW** how to qualify you in your spare time. My free book explains everything. Be sure to write postal for it **NOW**. Get into the Railway Mail, Post Office, Rural Carrier, Departmental, Internal Revenue, Immigration, Custom House or Postmaster Services right away and stop worrying about money or jobs! Write me now.

Arthur R. Patterson, Principal, Patterson Civil Service School, 85 Wisner Bldg., Rochester, N. Y.



LEARN PIANO TUNING

MAKING TRIALS
OF TRUE TONE

By
**TUNE-A-
PHONE**



We furnish our accurate teaching device with tools, Action Model lessons, and analysis of business advertising which makes you a master of the tuner's art. Diploma given graduates. **18 years' experience** in teaching the most independent and lucrative profession by correspondence. **SIMPLER and BETTER than oral instruction.** Write today for **FREE** booklet and guarantee plan.

NILES BRYANT SCHOOL OF PIANO TUNING
22 Bryant Bldg. Augusta, Mich.

TIME IS MONEY ROPP'S CALCULATOR



Saves Both. Shows prices, quantities, weights, etc., of familiar commodities in any business.

Desk Size, - - \$1.50
Pocket size, leatherette, - 1.00
Pocket size, cloth, .50
paper, .35
Postage free anywhere

WELLS & EDWARDS
852 George St. Chicago, Ill.

Send for free book catalog

TRI STATE COLLEGE OF ENGINEERING

Makes you a Civil, Mechanical, Electrical or Chemical Engineer in two years, 48 weeks each. No entrance examinations. High School Diploma not required. Compact courses made up of essentials only. **Expenses low.** For catalog address

100 "M" STREET, ANGOLA, IND.

"STAMMERING

Its Cause and Cure"

You can be quickly cured if you stammer. Send 10 cents, coin or stamps, for 288 page cloth bound book on Stammering and Stuttering. It tells how I cured myself after Stammering and Stuttering for 20 years. **BENJAMIN N. BOGUE**
740 Bogue Building, 1147 N. Ill. St. Indianapolis

LEARN WATCH REPAIRING



You can learn by our modern and original system of instruction every part of the Watch Repairing Trade at home as good or better than at a shop. You can earn money while learning and secure a well paying position or start in business after completing our course of instruction. Good watch repairers are always in demand and earn from \$50 to \$70 per week. For particulars apply to the **WISCONSIN SCHOOL OF WATCH REPAIRING**
166 Mason St., MILWAUKEE, WIS.

Copyrighted material

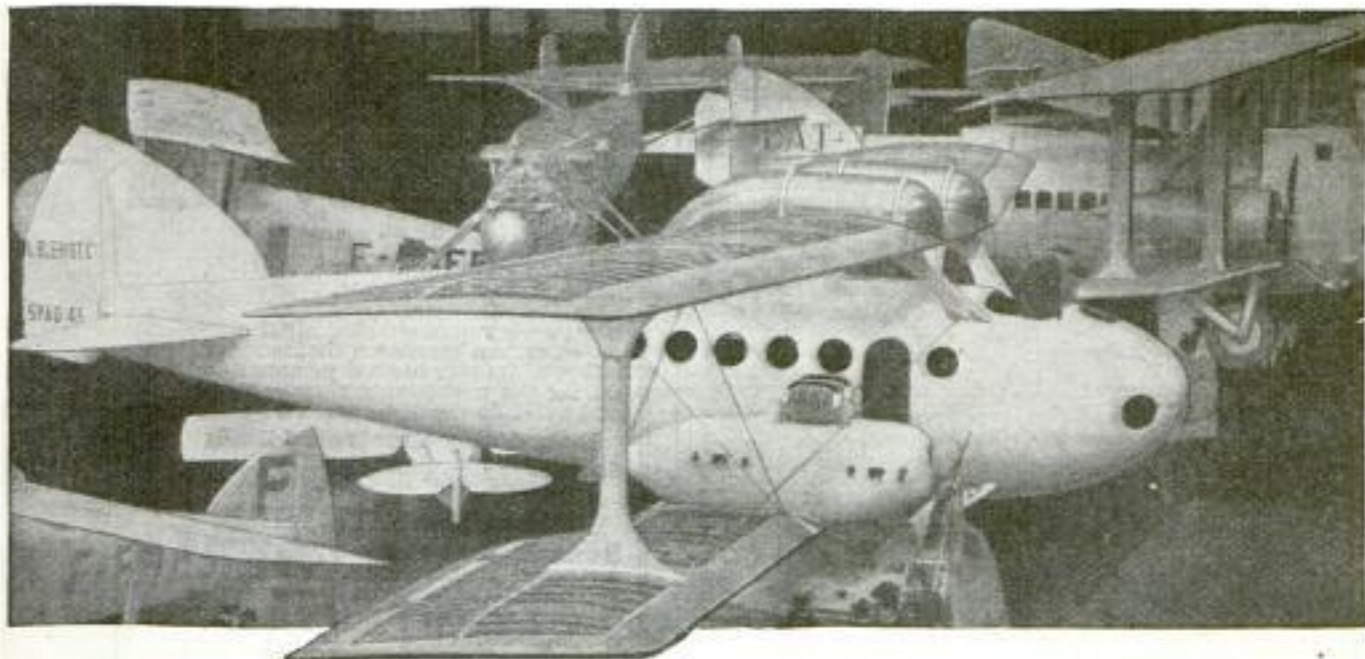

Quick Success in Aviation Fascinating—Daring—Big Paying

To young men of daring, no other field of work offers such a fascination, such high pay, nor such opportunities for quick success as the field of Aviation. As yet, aviation is practically in its infancy. NOW is the time to get in.

Amazing Opportunities in Airplane Industries

In the automobile industry and in the moving picture business hundreds of men got rich by getting in at the start. They made their success before others woke up. Today, these lines offer no greater opportunities than a hundred and one others. BUT AVIATION IS NEW. Get in while the opportunity and pay are big. All over the country there is a clamor for trained men. It is not a question of pay but of getting capable men.

Here Are Real Positions, \$50 to \$150 Per Week

Aeronautical Instructor, Aeronautical Engineer, Aeronautical Contractor, Airplane Repairman, Airplane Mechanician, Airplane Inspector, Airplane Salesman, Airplane Assembler, Airplane Builder.



View in an Airplane Factory

A Sure and Easy Way to Learn Aviation—at Home



A New Job—The Aerial Postman

The study of aviation is almost as fascinating as the actual work. Every lesson is full of interest. That is why it is easy to learn aviation. You do not have to make yourself study—it is like reading an in-

teresting book that tells you things you have always wanted to know. Only one hour each evening will give you the basic training in a surprisingly short time. You need only a common school education.

One of my students, James Powers, Pa., says, "I am indeed surprised that such a valuable Course can be had from such practical men for so little cost."



A New Seven-Passenger Airplane

Personal Instruction by Experienced Men

Men who have had actual experience give you personal attention. They select the lessons, lectures, blueprints and bulletins. They tell you things that are essential in everyday practice. Each lesson is easy to read and understand.

BIG BOOK FREE of Opportunities

Send coupon below for New Book, just out, "Opportunities in the Airplane Industry." It is interesting and instructive. It will show you many things you never knew before about aviation. Due to shortage of paper we could get only a limited supply of these books—send the coupon before they are all gone.

AMERICAN SCHOOL OF AVIATION
3601 Michigan Ave., Dept. 1195, Chicago, Ill.

AMERICAN SCHOOL OF AVIATION
3601 Michigan Ave., Dept. 1195, Chicago, Ill.
Without any obligation, send me your Free Book, "Opportunities in the Airplane Industry," also information about your Course in Practical Aeronautics.

Name.....
Street.....
City..... State.....

Earn Up to \$250 Per Month Position GUARANTEED



BE A RAILWAY TRAFFIC INSPECTOR

Men Wanted!

SPLENDID OPPORTUNITIES for trained Railway Traffic Inspectors. Fascinating new profession; any average man can qualify. Healthful, outdoor work with something new every day. Travel or remain near home.

Start at \$110 per month, expenses paid; advancement rapid with experience. Meet big railway officials. **Earn up to \$250 and \$300 per month, expenses paid.**

YOU TAKE NO RISK

Prepare in 3 months' spare-time study at home. Position is then **GUARANTEED** you, paying at least \$110.00 a month and expenses or your money is refunded. You take no chances; either you are placed in a position as Railway Traffic Inspector or the training costs you nothing.

Many more men are needed than are trained. You can easily qualify. Send for free Booklet No. D-584, giving full particulars.

Send coupon today while you think of it.

STANDARD BUSINESS TRAINING INST. BUFFALO, N. Y.

Standard Business Training Inst.
Buffalo, N. Y.

Send me, entirely free, Booklet No. D-584 giving full particulars about course in Railway Traffic Inspection.

Name.....

Street.....

City.....



Learn to Write

I Teach by Mail

I CAN make a good penman of you at your home during spare time, no matter where you live or how poorly you now write. My simplified system has shown thousands of others the way to good penmanship during the past twenty years — it **can** and **will** do the same for **YOU!**

Beautifully Illustrated Book
"How to Become a Good Penman"

It contains general information, with testimonials and beautiful specimens of penmanship showing what others have accomplished by the Tamblin System. **FREE!**
(Your name elegantly written on a card if you enclose stamp for postage.) **WRITE TODAY.** Address

F. W. TAMBLIN
418 Ridge Bldg., Kansas City, Mo., U. S. A.

F. W. Tamblin

HOW TO PAINT SIGNS AND SHO' CARDS

Our book gives a complete course of instructions, enabling any one to learn to paint good signs. **WHY NOT MAKE YOUR OWN** either for your business or for others?

CONTENTS: Alphabets, Composition, Color Combinations, How to Mix Paints, Show Cards, Window Signs, Banners, Board and Wall Signs, Ready Made Letters, Gilding, Commercial Art and Tricks of the Trade—Contains 100 alphabets and designs. Cloth bound, size 7 x 5 inches, price \$1.00 postpaid.

J. S. Ogilvie Pub. Co., 577 Rose St., New York

WHY not spend Spring, Summer and Fall gathering butterflies, insects? I buy hundreds of kinds for collections. Some worth \$1 to \$7 each. Simple outdoor work with my instructions, pictures, price list. Get posted now. Send 25c (NOT STAMPS) for my Illustrated Prospectus.

Mr. Sinsler, Dealer in Insects, Dept. 8, Ocean Park, Calif.



MINSTRELS

Musical Comedies and Revues with Complete Instructions for Staging. You can put on your own show with our books. Opening Choruses and Finales, Skits and Afterpieces, Monologues, Songs, Vaudeville Acts, How to Stage a Minstrel Show, Wigs, Make-up. Big Catalogue free.

T. S. DENISON & CO., 623 So. Wabash, Dept. 19 CHICAGO



You can Ukulele!

You can easily play quaint, dreamy Hawaiian music or latest songs on the Ukulele. Prof. Harry J. Clarke's latest method enables you now to play the Ukulele in six weeks. We give you a genuine Ukulele absolutely FREE with complete home course of Lessons. Write at once for FREE narrative of Hawaiian music and offer. No obligation! Send now!

The Hawaiian Institute of Music, 390 W. 34th Street, Dept. 2Y, New York City

Copyrighted material

If you were dying to-night

and I offered you something that would give you ten years more to live, would you take it? You'd grab it. Well fellows, I've got it, but don't wait till you're dying or it won't do you a bit of good. It will then be too late. Right now is the time. To-morrow, or any day, some disease will get you and if you have not equipped yourself to fight it off, you're gone. I don't claim to cure disease. I am not a medical doctor, but I'll put you in such condition that the doctor will starve to death waiting for you to take sick. Can you imagine a mosquito trying to bite a brick wall? A fine chance.

A Re-built Man

I like to get the weak ones. I delight in getting hold of a man who has been turned down as hopeless by others. It's easy enough to finish a task that's more than half done. But give me the weak, sickly chap and watch him grow stronger. That's what I like. It's fun to me because I know I can do it and I like to give the other fellow the laugh. I don't just give you a veneer of muscle that looks good to others. I work on you both inside and out. I not only put big, massive arms and legs on you, but I build up those inner muscles that surround your vital organs. The kind that give you real pep and energy, the kind that fire you with ambition and the courage to tackle anything set before you.

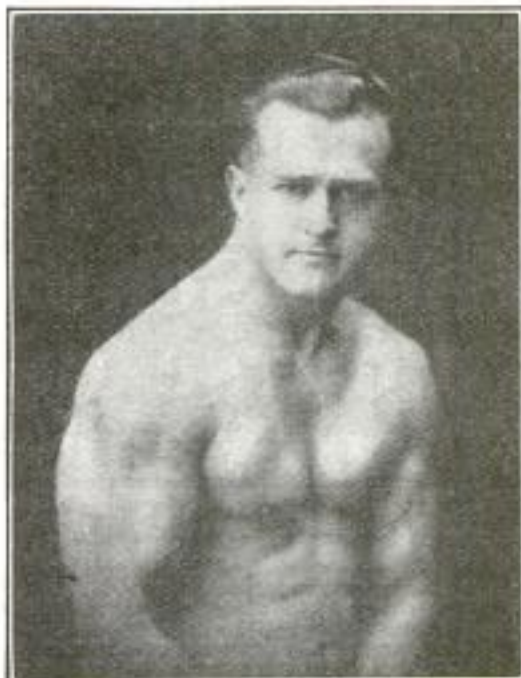

Latest photograph of Earle E. Liederman

All I Ask Is Ninety Days

Who says it takes years to get in shape? Show me the man who makes any such claims and I'll make him eat his words. I'll put one full inch on your arm in just 30 days. Yes, and two full inches on your chest in the same length of time. Meanwhile, I'm putting life and pep into your old back-bone. And from then on, just watch 'em grow. At the end of thirty days you won't know yourself. Your whole body will take on an entirely different appearance. But you've only started. Now comes the real works. I've only built my foundation. I want just 60 days more (90 in all) and you'll make those friends of yours who think they're strong look like something the cat dragged in.

A Real Man

When I'm through with you, you're a real man. The kind that can prove it. You will be able to do things that you had thought impossible. And the beauty of it is you keep on going. Your deep full chest breathes in rich pure air, stimulating your blood and making you just bubble over with vim and vitality. Your huge, square shoulders and your massive muscular arms have that craving for the exercise of a regular he man. You have the flash to your eye and the pep to your step that will make you admired and sought after in both the business and social world.

This is no idle prattle, fellows. If you doubt me, make me prove it. Go ahead. I like it. I have already done this for thousands of others and my records are unchallenged. What I have done for them, I will do for you. Come then, for time flies and every day counts. Let this very day be the beginning of new life to you.

Send for my book

"MUSCULAR DEVELOPMENT"

It is chock full of large size photographs of both myself and my numerous pupils. Also contains a treatise on the human body and what can be done with it. This book is bound to interest you and thrill you. It will be an impetus—an inspiration to every red blooded man. I could easily collect a big price for a book of this kind just as others are now doing, but I want every man and boy who is interested to just send the attached coupon and the book is his **absolutely free**. All I ask you to cover is the price of wrapping and postage—10 cents. Remember this does not obligate you in any way. I want you to have it. So it's yours to keep. Now don't delay one minute—this may be the turning point in your life to-day. So tear off the coupon and mail at once while it is on your mind.

EARLE E. LIEDERMAN
Dept. 2005, 305 Broadway, New York

EARLE E. LIEDERMAN

Dept. 2005, 305 Broadway, N. Y. City

Dear Sir:—I enclose herewith 10 cents for which you are to send me, without any obligation on my part whatever, a copy of your latest book, "Muscular Development." (Please write or print plainly.)

Name.....

Address.....

City..... State.....



High School Course in Two Years!

You Want to Earn Big Money!

And you will not be satisfied unless you earn steady promotion. But are you prepared for the job ahead of you? Do you measure up to the standard that insures success? For a more responsible position a fairly good education is necessary. To write a sensible business letter, to prepare estimates, to figure cost and to compute interest, you must have a certain amount of preparation. All this you must be able to do before you will earn promotion.

Many business houses hire no men whose general knowledge is not equal to a high school course. Why? Because big business refuses to burden itself with men who are barred from promotion by the lack of elementary education.

Can You Qualify for a Better Position?

We have a plan whereby you can. We can give you a complete but simplified high school course in two years, giving you all the essentials that form the foundation of practical business. It will prepare you to hold your own where competition is keen and exacting. Do not doubt your ability, but make up your mind to it and you will soon have the requirements that will bring you success and big money. **YOU CAN DO IT.**

Let us show you how to get on the road to success. It will not cost you a single working hour. We are so sure of being able to help you that we will cheerfully return to you, at the end of ten lessons, every cent you sent us if you are not absolutely satisfied. What fairer offer can we make you? Write today. It costs you nothing but a stamp.

AMERICAN SCHOOL

Dept. H-574, Drexel Ave. and 58th St., Chicago

AMERICAN SCHOOL

AMERICAN SCHOOL
Dept. H-574 Drexel Ave. and 58th St., Chicago

Explain how I can qualify for position checked:

...Architect \$5,000 to \$15,000	...Lawyer \$5,000 to \$15,000
...Building Contractor \$5,000 to \$10,000	...Mechanical Engineer \$4,000 to \$10,000
...Automobile Engineer \$4,000 to \$10,000	...Shop Superintendent \$3,000 to \$7,000
...Automobile Repairman \$2,500 to \$4,000	...Employment Manager \$4,000 to \$10,000
...Civil Engineer \$5,000 to \$15,000	...Steam Engineer \$2,000 to \$4,000
...Structural Engineer \$4,000 to \$10,000	...Foreman's Course \$2,000 to \$4,000
...Business Manager \$5,000 to \$15,000	...Sanitary Engineer \$2,000 to \$5,000
...Certified Public Accountant \$7,000 to \$15,000	...Telephone Engineer \$2,500 to \$5,000
...Accountant and Auditor \$2,500 to \$7,000	...Telegraph Engineer \$2,500 to \$5,000
...Draftsman and Designer \$2,500 to \$4,000	...High School Graduate In two years
...Electrical Engineer \$4,000 to \$10,000	...Fire Insurance Expert \$3,000 to \$10,000
...General Education in one year.	

Name..... Address.....

Practical Electricity with Questions and Answers

By
Cleveland Armature Works and
John C. Lincoln

A standard book on the most interesting subject in the industrial world.

The entire electrical field is well covered in easy to understand language. Contains numerous questions and answers, a dictionary of 1500 electrical terms, 25 valuable tables; also many original ideas. 480 pages—illustrated and cloth bound. Postpaid \$2.00

SHREWSBURY PUBLISHING CO.
5525 West Lake Street Chicago, Illinois



Introductory Price

\$2.00

For students, electricians, engineers, and all those who wish to gain accurate information concerning the designing, operation, and care of dynamos and motors, as well as wiring, batteries, lighting systems and other information. The entire electrical field is well covered in easy to understand language. Contains numerous questions and answers, a dictionary of 1500 electrical terms, 25 valuable tables; also many original ideas. 480 pages—illustrated and cloth bound. Postpaid \$2.00

Earn \$35-\$125 aWk



Your Opportunity in MECHANICAL DENTISTRY

Ambitious men of all ages can rise above small salaried positions into this profession of unlimited possibilities.

Taught by actual practice—day or evening. Three months' course. Modern laboratories. No previous knowledge or experience required. No charge for tools or equipment. The men we train are in demand. Established 30 years. Catalog free.

Address your inquiry to Dept. 2

BODEE SCHOOLS OF MECHANICAL DENTISTRY

NEW YORK
136 W. 52 St.

PHILADELPHIA
15 1/2 and Walnut Sts.

BROOKLYN
15 Flatbush Ave.

LAW In Your Spare Time At Home for BUSINESS or PROFESSION

Degree of LL.B. Conferred. Only Institution which gives same Course by Correspondence through Lecture System as was given for years at resident classes of this college. We coach you free to pass the Bar Examination. Complete 1921, 13-volume library. Easy terms. Organized 1910. Low enrollment fee. Write for free book.

Hamilton College of Law, 431 S. Dearborn St., Dept. 65, Chicago

LEARN MOTOR MECHANICS

Our Big Shop Standard methods prepare you for the best paying jobs—make you a real mechanic. Test and Trouble work alone is worth tuition. Completely equipped shops. Get full information.

Write for Big Free Book

IOWA STATE AUTO & TRACTOR SCHOOL

"The Quality School" 739 Nebraska St., Sioux City, Iowa



Wonderful, new device, guides your hand; corrects your writing in few days. Big improvement in three hours. No failures. Complete outline FREE. Write C. J. Osment, D-34, St. Louis, Mo.

GENUINE \$20.00 VIOLIN Will Be Given To You FREE

Help me introduce this beautiful Violin in your district. Be first to show how easy it is to play with help of three new inventions and my scientific instructions. You can play it in one week.

10,000 Students Found Easy to Learn Violin Playing

You can learn as easily as others. Surprise your friends. My three new inventions make it very easy. Have been teaching 40 years. Write your name and address on bottom of page and send for free violin offer and three new violin inventions.

PROF. A. HINCHCLIFFE, 233 Broadway
Woolworth Bldg. Dept. 5B-5 NEW YORK

\$100 a Week FOR DRAWING

HOW would you like to make \$100 a week as a commercial artist? If you like to draw, you are indeed fortunate—for well-trained artists are **always** at a premium. They readily earn \$75, \$100, \$150 a week, and even more. You will not have to wait for years to get a **good** income, for beginners with **practical** ability soon command \$50 a week.

Learn Quickly at Home in Your Spare Time

Get into this fascinating profession where you can put your natural ability to its best use. Thousands of business firms pay millions of dollars annually for good advertising drawings and designs. Develop your talent—learn the methods and secrets that make your drawings worth **real money**. Without previous training or experience, the Federal Course carries you rapidly forward, each step clearly explained, and gives you **individual personal criticisms**, on all your lessons by men who have themselves made good as commercial artists.

The Federal Course Brings You the Experience of Leading Successful Artists

Leading illustrating companies, designers, artists, and hundreds of successful Federal Students have enthusiastically endorsed Federal Training. You get the advice and experience of men who have produced and sold **hundreds of thousands of dollars' worth of commercial art**—through exclusive lessons contained only in the Federal Course.

Think of having the help of such men as **Franklin Booth**, the wonderful pen-and-ink artist called the "Painter with the Pen"; **Charles E. Chambers**, a leading magazine and story illustrator; **D. J. Lavin**, formerly head of Chicago Tribune Art Dept.; **C. Matlack Price**, a poster authority; **Noysa McMein**, magazine covers; **Charles Livingston Bull**, the animal painter; **Harold Gross**, **Edw. V. Brewer**, **F. E. Shoonover**, **L. V. Carroll**, **Gayle Porter Hoskins** and **N. C. Wyeth**, all illustrators and designers who have made reputations for themselves.

Get this Free Book, "YOUR FUTURE"

Now is the time to investigate! By all means send for this book. It is beautifully illustrated in colors, and tells every detail you need to know about the Federal Course. Shows work of Federal Students, many of whom **earn more than the course costs** while they are studying. The almost unlimited opportunities in this field will surprise you. The Federal Course is aimed at practical results—and **gets** them. If you are ambitious to succeed in commercial art, you cannot afford to be without this book.

It's free for the asking—if you are 16 years of age or more, write for it today.



**Federal School of
Commercial Designing
676 Federal Schools Bldg.
MINNEAPOLIS, MINN.**

Please send me "Your Future," without charge or obligation.

My Age is.....

Name.....

Write your address plainly in margin.

Do You Want A Better Job?

THE only difference between Success and Failure is a matter of training. The big men in business today did not reach their present success through luck or chance.

They got into the work for which they were best fitted—and then trained themselves to know more about their jobs than anyone else. When Opportunity came—as it always comes—these men were ready to grasp it and turn it into fame and dollars.

You have just as good a chance to succeed as these men had—perhaps better! Good positions are always waiting for trained men—positions that you can get if you train yourself to deserve them.

You can secure this training easily and quickly at home through spare-time study with the International Correspondence Schools, just as so many other men have done. The I. C. S. way is the practical way—the fascinating way—the profitable way.

Can you afford to let another priceless hour pass without making your own start toward something better?

Here is all we ask—without obligation or a penny of cost, mark and mail this coupon and learn what the I. C. S. can do for you. It's a little thing that takes only a moment of your time, but it's the most important thing you can do today. Do it now!

TEAR OUT HERE

INTERNATIONAL CORRESPONDENCE SCHOOLS, Box 5636-C, Scranton, Penna.

Without cost or obligation, please explain how I can qualify for the position or in the subject before which I have marked an X in the list below:

- | | | | |
|--|---|---|--|
| <input type="checkbox"/> BUSINESS MANAGEMENT | <input type="checkbox"/> Good English | <input type="checkbox"/> Electrical Engineer | <input type="checkbox"/> Surveying and Mapping |
| <input type="checkbox"/> Advertising | <input type="checkbox"/> Civil Service | <input type="checkbox"/> Electrician | <input type="checkbox"/> Mechanical Engineer |
| <input type="checkbox"/> Salesmanship | <input type="checkbox"/> Railway Mail Clerk | <input type="checkbox"/> Telephone Work | <input type="checkbox"/> Mechanical Draftsman |
| <input type="checkbox"/> Traffic Manager | <input type="checkbox"/> Mathematics | <input type="checkbox"/> Railroad Positions | <input type="checkbox"/> Mining Engineer |
| <input type="checkbox"/> Cert. Public Accountant | <input type="checkbox"/> High School Subjects | <input type="checkbox"/> Architect | <input type="checkbox"/> Agriculture |
| <input type="checkbox"/> Bookkeeper | <input type="checkbox"/> Chemist | <input type="checkbox"/> Contractor and Builder | <input type="checkbox"/> Airplane Engines |
| <input type="checkbox"/> Stenographer | <input type="checkbox"/> Pharmacy | <input type="checkbox"/> Plumbing and Heating | <input type="checkbox"/> Automobiles |
| <input type="checkbox"/> Cartooning | <input type="checkbox"/> French | <input type="checkbox"/> Civil Engineer | <input type="checkbox"/> Wireless |

Name

Address

Occupation

Persons residing in Canada should send this coupon to the International Correspondence Schools Canadian, Limited, Montreal, Canada



Learn Photography

Good-paying positions in the best studios of the country await men and women who prepare themselves now. For 28 years we have successfully taught

Photography, Photo-Engraving and Three-Color Work

Our graduates earn \$38 to \$100 a week. We assist them to secure these positions. Now is the time to fit yourself for an advanced position at better pay. Terms easy; living inexpensive. Largest and best school of its kind. Write for catalog today.

ILLINOIS COLLEGE OF PHOTOGRAPHY
Box P, 999 Wabash Ave. Effingham, Illinois

ELECTRICAL Training Book FREE

Send me your name and address and I will send you my big new Electrical Training Book Free. It will show you how to qualify for high paying jobs in Electricity. Thousands now open. Prepare at home—quickly—during spare time under an Electrical Engineer. Take advantage of this unusual offer—only temporary.

A. W. WICKS, President WICKS ELECTRICAL INSTITUTE
Dept. 1195 3601 Michigan Ave. CHICAGO

Music Lessons

UNDER MASTER TEACHERS

At Home

Any Instrument Write naming course you are interested in: Violin, Cornet, Mandolin, Guitar, Banjo or Reed Organ—and we will send FREE CATALOG. SEND for it NOW!

University Extension Conservatory, 620 Siegel-Myers Bldg., Chicago

Complete Conservatory Course by Mail

Wonderful home study music lessons under great American and European teachers. Endorsed by Paderewski. Master teachers guide and coach you. Lessons a marvel of simplicity and completeness.

WANTED—RAILWAY MAIL CLERKS

\$135 to \$190 a Month for Life

Every second week off with full pay—no "lay offs" because of strikes, poor business, etc.—sure pay—rapid advancement to higher positions. City and country residents stand same chance. Common sense education sufficient—no political influence. Examinations likely in every city very shortly.

CANDIDATES PREPARED FREE

Write for free schedule of coming examination places. Every day's delay means so much less coaching—so write at once.

FRANKLIN INSTITUTE, Dept. C176, Rochester, N. Y.

Mail This Coupon

Write Plainly

Use It Before You Lose It

COUPON

FRANKLIN INSTITUTE, Dept. C176, Rochester, N. Y.

Kindly send me, without any obligation whatever on my part and entirely free of charge, (1) a full description of the position checked below; (2) Sample examination questions; (3) Free copy of copyrighted book "Government Positions and How to Get Them"; (4) A list of U. S. Government Jobs now open; (5) Schedule showing dates and places of all coming examinations.

.. Railway Mail Clerk (\$1600 to \$2300) .. Customs Positions (\$1100 to \$2000)
.. Postoffice Clerk (\$1400 to \$1800) .. Internal Revenue (\$1100 to \$2000)
.. Postoffice Carrier (\$1400 to \$1800) .. Rural Mail Carrier (\$1500 to \$2600)

Name

Address

Draftsman's Complete Outfit

FREE



Everything Used by Expert Draftsmen Given You Absolutely FREE

Outfit includes "professional" complete set of fine drawing instruments with double set of compasses and dividers all in velvet lined case. Drawing board, T square, two triangles, protractor, universal curve, triangular, standard scale, water-proof ink, pens, pencils and all accessories—furnished you free in this expert's complete outfit.

Draftsmen Make \$225.00 to \$500.00 a Month

There is a tremendous demand for trained draftsmen. Now is the time to start. Draftsmen get good pay from the start and can work up to \$500 a month *and more*. Draftsmen are needed everywhere. Once you are trained you can choose your own business and work in any part of the country you please. Coyne training makes everything easy for you. Coyne student, L. T. Dubendorf, writes: "Immediately after completing Coyne course I went to work for Armour & Co. Work was easy for me. Five months later I accepted a position in New York at a large increase in salary."

3 Months' Course at School

You can qualify as an expert draftsman by 3 months' intensive training at the school in Chicago. Living cheap. Possibilities of earning way while studying. If you prefer to come to school instead of the "Home Study" course, check coupon and send it for complete information.



B. W. Cooke

President

COYNE

HOME STUDY DEPT.

TRADE & ENGINEERING SCHOOLS

Recognized Producer of Successful Men

39-51 E. Illinois St., Dept. 1775, Chicago, Ill.

Easy to Learn at Home from Great School Known all over the World

The Coyne Home Study course guarantees to train you. Remember, the Coyne Trade and Engineering Schools are recognized by educators all over the world. Students come from all over the *world* to get Coyne training. Why? Because of the Coyne school's long established, tremendous reputation for successful teaching by its great staff of experts. Coyne is not a "one man" school, but a great educational institution, 22 years old, an acknowledged leader and originator. Coyne originated the "Learn by Doing" method now endorsed by educators everywhere. Coyne has graduated thousands of successful, prosperous men all over the world. You can't make a mistake if you write for the Coyne free book. Coyne students *every* minute of the course was enjoyable. Some students took *good positions three months before their course was finished.*

Send for FREE Book

Mail this coupon for our interesting book, "Drafting, the Foundation of Industry," sent you free. It explains all about the Coyne home study method and shows you how to become a draftsman in the quickest and easiest way. You want to know all about this great institution. Don't put it off. Send for this book now. It's absolutely free, no obligation. It contains the most valuable information you will ever get in your life. Send the coupon now.

Check Coupon Below and Mail Now!

Coyne Trade and Engineering Schools,
Department 1775, 39-51 E. Illinois St., Chicago, Ill.
Dear Sirs:—Please send me, absolutely free, without obligation, your book, "Drafting, the Foundation of Industry," also full information about the Course in Drafting. (Check which course you prefer.)

Home Study Course School Course

Name.....

Address.....

City.....State.....

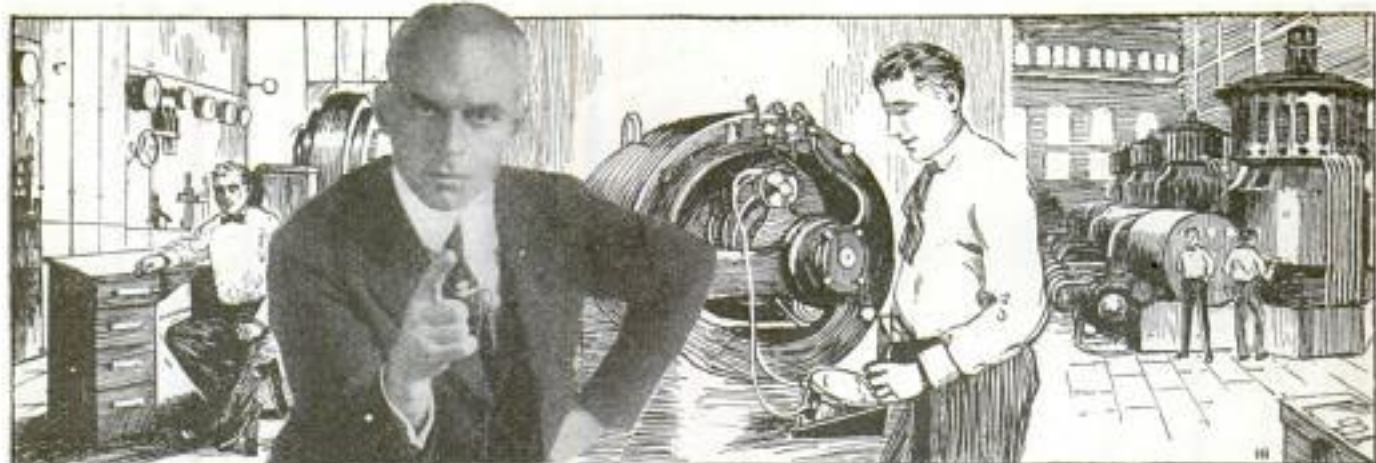

Electricity Needs You

I WILL TRAIN YOU AT HOME

Stop right here. This is YOUR opportunity! Electricity is calling you, and the Electrical Business is in for a tremendous increase. But it needs more trained men—at big pay. By my **Home Study Course in Practical Electricity** I can train you for these positions.

Earn \$70 to \$200 a Week

You've always had a liking for Electricity and a hankering to do electrical jobs. Now is the time to develop that talent; there's big money in it. Even if you don't know anything at all about Electricity you can quickly grasp it by my up-to-date, practical method of teaching. You will find it intensely interesting and highly profitable. I've trained and started hundreds of men in the Electrical Business, men who have made big successes. YOU CAN ALSO

Be a Big Paid ELECTRICAL EXPERT

What are you doing to prepare yourself for a real success? At the rate you are going where will you be in ten years from now? Have you the specialized training that will put you on the road to success? Have you ambition enough to **prepare** for success, and get it?

You have the ambition and I will give you the training, so **get busy**. I am offering you **success** and all that goes with it. Will you take it? I'll make you an **ELECTRICAL EXPERT**. I will train you as you should be trained. I will give you the benefit of my advice and 20 years of engineering experience and help you in every way to the biggest, possible success.

**CHIEF ENGINEER
COOKE**
Chicago Engineering
Works
Dept. 15, 2154 Lawrence Av.
CHICAGO, ILL.

Dear Sir: You may send me entirely free and fully prepaid, a copy of your book, "How to Become an Electrical Expert," and particulars about your **Home Study Course in Electricity**.

Name

Address

City State

Valuable Book Free

My book, "How to Become an Electrical Expert," has started many a man on the way to fortune. I will send a copy, free and prepaid, to every person answering this advertisement.

Act Now! Good intentions never get you anywhere. It is action, alone, that counts. **NOW IS THE TIME TO ACT.**

L. L. COOKE, Chief Engineer

**CHICAGO
ENGINEERING
WORKS**

2154 LAWRENCE AVENUE
Dept. 15 Chicago, U. S. A.

FREE! BIG ELECTRICAL OUTFIT

A fine outfit of Electrical Tools, Instruments, Materials, etc., absolutely FREE to every student. I will also send you FREE and fully prepaid—Proof Lessons to show you how easily you can learn Electricity and enter this splendid profession by my new, revised and original system of Training by Mail.

Radio Course FREE!

Special newly-written Wireless Course worth \$45.00, given away FREE.

Earn Money While Learning

I give you something you can use now. Early in my **Home Study Course** I show you how to begin making money in Electricity, and help you get started. No need to wait until the whole course is completed. Hundreds of students have made several times the cost of their course in spare time work while learning.

CLASSIFIED ADVERTISEMENTS

WORLD'S BEST WANT AD MEDIUM

Advertisements in this section, 25 cents per word, each insertion, minimum 10 words, payable in advance. To be inserted under proper classification in June issue, copy should be in our office April 25th.

AUTOMOBILE SUPPLIES

AUTOMOBILE Parts, guaranteed new, for all cars. Save money; get parts direct at wholesale. We ship immediately from stock, transmission and differential gears, bearings, shafts, gaskets, flywheel gear rings, pistons, rings and other parts for any car. When necessary we make gears special from old samples. Get our wholesale prices today. Wire or write us when you need parts in a hurry. State make of car, model and parts wanted. We refund your money, including transportation charges, if parts are unsatisfactory. Mechanics Gear Works, 3708 North Halsted Street, Chicago, Ill.

SAVING fuel and oil, stopping oil pumping, decreasing carbon deposits is accomplished by Zelco, the zinc-coated piston ring, price 45c each; peened by special process. If your dealer doesn't handle, order of Zelco Piston Ring Division, Zelnicker, St. Louis. Distributors wanted.

ELECTRIC Service and Battery Stations send your jobber's name for booklet entitled "The Testing and Repairing of Automobile Electrical Equipment as a Profitable Business." Electric Machine Corporation, Indianapolis, Ind.

STORAGE Batteries \$3.00 to \$5.00. Build them yourself by a new method. Complete instructions One Dollar. Address Yates Brothers, 3403 W. Washington St., Los Angeles, Calif.

DEALERS, Repairmen: Buy your automobile bulbs at 50% discount. Write or send your order today. Akeley-Steele Co., Aurora, Ill.

EAGLE Wing Radiator Ornament to fit any car \$2.00 postpaid. Simon Supply Company, St. Louis, Mo.

AUTO parts for any car. We save you 10 to 90% and ship same day order is received. Have gears, shafts, bearings, springs, pistons, pins and rings, bushings, cylinder head gaskets, top slip roofs, clutch leathers, radiators, coils, magnetos, Atwater Kent, Connecticut, Delco, and Remy Ignition systems and parts. When you want auto parts write us, giving make, model and parts wanted. We have it, will get it, or it is not made. We guarantee to please you or will refund your money. Auto Tire & Parts Co., 501 Broadway, Cape Girardeau, Mo.

BUY Right, Slightly used auto parts from cars we wreck. Duplicates for almost any make car at 50% to 75% off list. Our regular customers are those who have learned by experience that we sell at lowest prices on market. Satisfaction guaranteed or money refunded. You will save time by sending in your old parts so that we can duplicate them. Auto Parts Supply Company, 1522 Grand Avenue, Kansas City, Mo. "Everything for the Automobile."

DUPLEX Automatic Electric Stop-light warns front and rear; is being installed in preference to all others; has the only foolproof switch on the market. Sample \$2.50. Dealers write for proposition. Duplex Stop Signal Co., Sidney, Ohio.

AIR Compressor with Tank and Hose \$50. With Motor \$72.50. With Paint Sprayer or Dust Cleaner \$84.50. Suitable for private or public Garage, Tire Shop, Painting or Cleaning, also Motor in the Hand Buffer, Home size \$18.50. Shop size \$25. Garage size \$106. Battery Charging Outfit, Home or Garage size \$14. Send time or stamps for our large 100 page catalogue, describing all kinds of Air Compressors, Vulcanizers, Garage and Battery Outfits. Equipment Co., 21 Canal St., Cincinnati, Ohio.

THINK for running board. Outside dimensions 36x16x9. Fits almost all cars. Attached and detached in a moment with thumb screws we furnish. Nicely covered with black imitation leather, with handle and straps and lock. Lined with cloth. Is of size to permit the doors of most cars swinging over it. Price \$9.00 delivered. Circular on request. Discount in quantities. Address Tift, 2 Broadway, New York, N. Y.

THE correct names and addresses of all Garages and Dealers in Omaha (250 in all), only \$1.00. Charles A. Lawrence, 4423 DeCatur St., Omaha, Neb.

SPARK Intensifiers 30c; set of four, \$1.00; Valve grinding tools for any car 35c. Simon Supply Company, 207 No. Seventh, St. Louis, Mo.

MAGNETO Charger, Guaranteed; Free Trial. L. D. Kilbourn, New Hartford, N. Y.

PRISM Binoculars, Tourists' Special, 7 Power Weiss "Alpine" Stereoscopic, Retail price \$55.15, only \$28.00. Brand New, Prepaid. Gordon MacMillan, Desk 27, Box 291, Waukesha, Wis.

STANLEY Automobile Owners enclose stamp for "List." Acme Welded Bolters, Burners, Vaporizers, Superheaters, Engine Gauges, Tubing, Fittings. Everything for your Steamer, "Doc" Paine, Denver, Colo.

PROTECT Your rights. Write for Record of Invention which contains form to establish evidence of conception of your invention. Prompt personal service. Preliminary advice without charge. J. Reaney Kelly, 612-G Columbian Bldg., Washington, D. C.

AREND Piston Rings—patented Sept. 27, 1922. Adjustable. Send for Circular and price list. John Arend, Mankato, Minn.

GARAGE, Repair or Harnessmen: Write now for complete proposition that enables you to quickly and profitably make new or repair old flat belts for cars, trucks, tractors or small shop machinery. See our adv. on page 148. Lakewood Fabric Belting & Mfg. Co., 1518 W. 117th St., Lakewood, Ohio.

IMPROVED Light Alloy pistons, all sizes, finished or semi-finished, lowest prices; get circular. Egge, 7704 S. Main St., Los Angeles, Calif.

95% SAVED on Auto Parts. We save you up to 95 per cent on slightly used gears, axles, bearings, springs or motor parts for every make or model car, or we furnish new parts at savings up to 50%; send for our prices or order direct from this ad; all parts guaranteed to give complete satisfaction or the Packers State Bank of Kansas City will refund your money in full. Brown Auto Wrecking Co., 1893 Holmes, Kansas City, Mo.

FORD and Tractor and Chevrolet Owners: At last a perfect oil gauge. Shows oil on dash. Guaranteed to save enough oil in 90 days to pay for it. Eliminates carbon. Money-back guarantee. Price \$7.50. Liberal discounts to dealers. Simplex Gauge Mfg. Co., 207 Pine St., St. Louis, Mo.

WEEZY, squeaky Springs soon break! Compton foolproof spring oilers prevent breakage! Positively lubricate automatically. Make smooth riding. Watch rust oozing from springs. Send \$4.00 complete set eight oilers; Fords \$2.00. Sample 50c. Quickly attached without drilling. Wholesalers wanted. Box 9, Compton Company, 29 Broadway, New York.

CYLINDERS reground, new pistons and rings fitted. Restores lost power. Write for prices, giving make and model. The Everts Machine Co., Hartford, Conn.

AUTOMATIC Compressors, Grinders, Battery Chargers, Motors. Unusually easy terms. Write us your needs. Hobart's, Troy, Ohio.

STORAGE Battery Charging Earns Unusual Profits, using HB Chargers, \$20 starts. Balance payments. Hobartsons, Troy, Ohio.

AUTO Parts—Slightly used parts from cars we wreck. Duplicates for almost any make car at 50% to 75% off list. New Gears—We are distributors for all standard makes of differential and transmission gears—for any make and model of car. Satisfaction guaranteed or money refunded. Send in your old parts and we will duplicate them. Address Auto Parts Supply Co., "Everything for the Automobile," 1522 Grand Ave., Kansas City, Mo.

AUTO Top Roof Covers easy to put on. You drive 100 ticks and save \$15 to \$40. Ford Roadster \$5.20, Touring \$6.95, with celluloid lights in back curtain. With beveled plate glass lights, Ford Roadster \$8.20, Touring \$9.95, Chevrolet, Dodge or Maxwell Roadster \$10.45; Touring \$13.95. All other 5-passenger cars \$16.50 with plate glass lights. Extra for Gypsy Side Back Curtain like cut, Ford \$2. Other cars \$3. Ford Side Curtains that open with doors. Roadster \$10, Touring \$16, Ford regular Side Curtains, Roadster \$6.50, Touring \$8.99. Other cars \$11.50 up. Ford Seat Slips, Roadster \$3.15, Touring \$6.25, or tailored, Roadster \$6.20, Touring \$9.90, other cars \$4 to \$32. Ford Cushions \$5.75. All goods same as car manufacturers use and guaranteed to fit. Printed instructions given how to apply. Give model and year of your car. Send 1/2 with order and will ship C.O.D., or send dime or stamps for samples. Prices above include War Tax paid and delivered at your door. Equipment Co., 30 Canal, Cincinnati, Ohio.

GARAGEMEN, repairmen, mechanics and dealers will be greatly interested in each issue of American Garage & Auto Dealer, for it features a wide range of important subjects, including vulcanizing, welding, accounting, shop hints, business management, advertising, selling, etc. Here is what a North Dakota garageman writes: "I got one idea from you that will just double my sales in 1922." A Southern dealer says: "Every issue is worth the subscription price—we can't get along without your wonderful magazine." 12 months for \$1.00 anywhere in U. S. (\$1.50 Canada or foreign.) Satisfaction guaranteed or money returned. Mail dollar bill, check or money order. American Garage & Auto Dealer, 1004 Lake View Bldg., Chicago, Ill.

FREE Inner Tubes. Veteran's War Patent. Photographer, National Home, Ohio.

AIR Compressor with Tank and Hose, \$19. Motor for same \$22.50. Equipment Co., 21 Canal, Cincinnati, Ohio.

AUTOMOBILE Owners, Garagemen, Mechanics, Repairmen, send for free copy of our current issue. It contains helpful, instructive information on overhauling, ignition troubles, wiring, carburetors, storage batteries, etc. Over 120 pages, illustrated. Send for free copy today. Automobile Digest, 506 Butler Bldg., Cincinnati.

AUTO Motors Supplies: Buick—Michigan—Stoddard-Dayton—E. M. F.—Cadillac—Overland—Continental and Buda Motors. All types, \$50.00 each and up. New Dixie Magnetos \$20.00. Splittdorf High Tension Magnetos \$10.00. Kellogg Pumps \$3.50. Auto-Lite generators, new, \$10.00. Air Gauges 65c. Remy Ignition Coils, new, \$3.00. Electric and gas headlamps, coils, distributor heads, air compressors, etc. Write for catalog. Motor Sales Dept. 15, West End, Pittsburgh, Pa.

VULCANIZING and Repairing is a paying business. Forty million tires need repairing every day. Make big profits in tire repair. Easy to learn. Instructions free. No hard times. Always busy. Get into this moneymaking business quick! Plants \$200 up. Write for free catalog. Equipment Co., 1 Canal, Cincinnati, Ohio.

AUTO Owner Tire Agent wanted each locality to use and take orders for hand-made Mellinger extra ply and cord tires; guaranteed by bond for 8,000 and 10,000 miles (no seconds); shipped prepaid on approval; get your tires free; no capital or experience required; make \$100 to \$300 weekly. Write for wholesale prices and sample section. Mellinger Tire Co., 929-K Oak, Kansas City, Mo.

AIR Compressors—Genuine Brunner Compressors, new, on very attractive terms; send post card. Brunner Mfg. Co., Dept. A, Utica, N. Y.

BATTERY Stations—Save your broken Battery Jars. Our Hard Rubber Cement makes them good as new; Dollar Bottle; money with order. Address, Cement Works, Peace River, Alberta.

AUTOMOTIVE Wiring Manual—original and only blueprint wiring book—contains more than 800 blueprints covering every make of car and truck since 1912. Over 600 car and truck wiring diagrams; more than 200 internals of generators, etc. Price \$15.00 prepaid. Popular Mechanics Book Dept., 6 N. Michigan Ave., Chicago.

A MOTOR'S Life. Our thousands of customers have been convinced it depends greatly on a clean cooling system. Sample with complete information 50c prepaid. Satisfaction Guaranteed. Agents Wanted. R. G. Kilwing, 3049 Oggood St., Chicago.

AUTOMOBILES

MAGNETO rechargers for all magnetos, \$40.00. Fords charged without removing floor-boards. Alternating current light socket, storage batteries operate. Build yours. Details \$1.00. We sell parts. Benaco, Cartersville, Mo.

DYKE'S Automobile Encyclopedia contains the greatest array of automobile facts ever published in one volume. Several separate books containing the same information would cost in the neighborhood of \$21.00. New, enlarged edition, 968 pp., 3,362 illus., cloth \$4.46—American Morocco, \$7.95 postpaid. Popular Mechanics Book Dept., 6 N. Michigan Ave., Chicago.

PATENTS—Write for our free illustrated Guide Book and Evidence of Conception Blank. Send model or sketch and description of your invention and we will give our opinion of its patentable nature. Highest references. Prompt service. Reasonable terms. Victor J. Evans & Co., 185 Ninth, Washington, D. C.

AUTOMOBILE Owners, Garagemen, Mechanics, Repairmen, send for free copy of our current issue. It contains helpful, instructive information on overhauling, ignition troubles, wiring, carburetors, storage batteries, etc. Over 120 pages, illustrated. Send for free copy today. Automobile Digest, 505 Butler Bldg., Cincinnati.

AUTOMOBILE Repairman's Helper. In Two Vols. An excellent new work that gives every operation required to adjust or repair the troubles likely to be found in all standard cars. Vol. 1—Repairshop Practice—Passenger Cars—Trucks, 525 pp., 417 figs. Price \$3. Vol. 2—General Shop Practice—Passenger Cars—Parts and Accessories, 528 pp., 428 figs. Price \$3. Popular Mechanics Book Dept., 6 N. Michigan Ave., Chicago.

FOR FORD OWNERS

FORD Car Repair Book sent free. This complete, well illustrated, valuable book explains in a simple way the Causes and Cures of Overheating; Repairing Ford Timer; Curing Piston Ring Troubles; Carburetor Adjustments and Repairs; Connecting Rods; Transmission Troubles; Care and Repair of Rear Axle; Stopping Axle Grease Leaks; also covers practically every other phase of Ford Car Repairing. Send 25c coin for three months' trial subscription and get the valuable repair book free. Ford Owner and Dealer Magazine, 517 Montgomery Bldg., Milwaukee, Wis.

JULES Oil Circulator stops any Ford from pumping oil, doubles oil mileage. Guaranteed. \$4.00 each. Special introductory price, \$2.00. C. O. D. Money back if dissatisfied. Electric Machine Corporation, Indianapolis, Ind.

SLEEP luxuriously in your Ford. Eliminate hotel bills. Price \$14.50. Guaranteed. Outers Equipment Co., 812 Mayer Bldg., Milwaukee, Wis.

FORD Magnets Recharged in five minutes without removing any part from car. Secret exposed. Any one can do it. A fully charged magneto will solve half your ignition troubles, give more power, better lights, and save gas. Complete instructions and wiring diagrams 50c coin or money order. The Auto Electrician, Box 261, Middletown, N. Y.

SPEED and Power camshaft, special timed cams extremely accurate; provides additional valve lift, appreciable increase in valve port; adds 20% power, greatly increases speed. Price \$19.50; limited number introductory price \$9.95, cash with order. Now. Satisfaction or Money Back Guarantee. C. S. Pecta Co., 250 West 54th, New York, N. Y.

FORD Owner: Should you lose your Ignition Key, "don't get stuck on the road"; be prepared. Learn the secret of running your car without the ignition key. Full instruction for a dollar bill. Fred Brewer, 129 Park Place, Brooklyn, N. Y.

CYCLO "Modified Vapor" System—most remarkable hot-spot invention, giving long-sought combination of hill-power with big gas-saving. Unusual opportunity for Ford owner agents. Cyclo Manifold Co., South High St., Akron, Ohio.

"READ" Ball-Bearing Clutch Screw doesn't drag, it rolls. Makes Hand Brake Operate Easily, 20c (coin). Address "Read," 78 Kingston Ave., Brooklyn, N. Y.

SLEEP in your Ford. Complete working instructions, illustrated, one dollar. Auto Bed Shop, Lakeview, Ore.

FORD Owners. Stop your Ford from Chattering by installing Brodar's Ball Shim. Price \$1.50. Write for information and Agency proposition. Nic Brodar's Son Mfg. Co., Rock Island, Ill.

PROTECT Your Motor; save time, money, clothes and temper with our superior, water-proofed, detachable belts for Fords. Regular price 50c each. Three belts sent postpaid for \$1.00. State model when ordering. Money refunded if not entirely satisfied. See our adv. on page 148. Lakewood Fabric Belting & Mfg. Co., 1518 W. 117th St., Lakewood, Ohio.

WHEEZY, squeaky springs soon break! Compton foolproof spring oilers prevent breakage! Positively lubricate automatically. Make smooth riding. Actually see rust coming out. Send \$2.00 complete set. No drilling. Quickly attached. Wholesalers wanted. Box 11, Compton Company, 29 Broadway, New York.

SPEEDSTER Fans: Don't fail to see "Red-I-Kut" ad. Page 142.

LACEY Patent Sense. See page 151.

FORD Repairing—New valuable book explains use of all up-to-date tools and shop equipment, describes methods of performing work on all different mechanical parts of car. 250 pp., fully illus. Leatherette. Price \$2.50 postpaid. Popular Mechanics Book Dept., 6 N. Michigan Ave., Chicago.

FORD Touring car tops stretch, become loose and rapidly ruin themselves because the hold-down straps cause too much strain on the covering materials. The Pontiac Windshield Top Supports clamp your top in place same as any other car. Prevents cracked windshields. Affords ideal mounting for mirror or spotlight. Makes your car look neat and trim, and affords clear vision. Made entirely of drop forgings. Beautiful baked enamel and nickel finish. For touring only, 1917 to date. By mail for \$1.75. Satisfaction guaranteed or money refunded. American Forging & Socket Co., Pontiac, Mich.

WANTED, representatives for water circulating pumps; prevent Fords freezing or over-heating under any conditions, 50,000 satisfied users. Retail \$10.50. Demonstration pump factory price. Satisfaction guaranteed or money refunded. Polar Bear Pump Co., Los Angeles, Cal.

SIMPLEX Starter \$20.00. Easily sold. American-Simplex Co., Anderson, Ind.

MOTORCYCLES, BICYCLES AND SUPPLIES

POWER and speed that surprises experts, vibration stopped, cooler motor, less trouble, with Rayday Pistons. Made of a wonderful aluminum alloy of great strength, light weight, long life, especially for motorcycles. Send stamp for folder, "More Power to You," Ray Day Co., Tacoma, Wash.

OUR \$50,000.00 Stock Used Motorcycles. Now on sale at sacrifice prices. Indians, Harleys, Excelsiors, Hendersons, lowest prices in America. Guaranteed and shipped on approval. Send stamp for Big Free List M and New Sales Plan, mailed promptly. Clymer the Motorcycle Man, Denver, Colo.

OUR catalog of supplies for the rider lists two thousand parts you should know about. Motorcycle Equipment Co., Hammondspoint, N. Y.

SPECIAL Offer. Ford and Fordson Owners! 100% Saving! Factory to User. \$1.25 brings postpaid 4 Genuine Blue Flame Spark Plugs, 10 for \$2.50. Money back if not satisfied. Crimp Grip Company, Belvidere, Ill. Dept. P.

THREE 1914 Indian twins \$40. New and used parts. Booz, 121 East Locust, Des Moines, Ia.

GUARANTEED Rebuilt Motorcycles of all makes and models. See page 141.

BRIGGS & STRATTON Motor Wheels, New \$75. Flyers, New \$125. New Tires, Non-Skid \$3; Smooth \$2; Tubes 75c. Seebor & Hofheins, Buffalo, N. Y.

NEW and used Motorcycles, Motorwheels and Bicycles, anything you want at right prices. Write for lists. Seebor & Hofheins, Buffalo, N. Y.

1916 INDIAN \$80. Presto Outfit \$10. Geo. Lantch, Altamont, Ill.

BALTIMORE Police Indians, '20 model Elec. Equipped, \$160.00; '21 Model. Elec. Equipped, \$210.00; '22" Truss Frame Bicycles, \$23.00. Howard A. French, Baltimore, Md.

SEND for big list of slightly used motorcycles on our easy payment plan. Howard Cycle Co., 152 N. Broad St., Trenton, N. J.

BARGAINS in used Harley-Davidson motorcycles. Liberal discount to rider agents. Lister Motorcycle Company, Cleveland, Ohio.

USED parts for all motorcycles cheap. State wants. Schuck Cycle Co., 1922 Westlake, Seattle, Wash.

USED and new parts, Indian, Excelsior, Harley, Reading, Thor, Henderson, Yale. Get our price lists. Kingshighway Cycle Co., 1166 North Kingshighway, St. Louis, Mo.

DON'T buy a Bicycle Motor Attachment until you get our catalogue and prices. Shaw Mfg. Co., Dept. 27, Galesburg, Kan.

NEW motorcycles have been reduced 10%. Our prices have been reduced 35%. Send for big bargain list of rebuilt motorcycles. Western Supplies Co., 359 Hayutin Bldg., Denver, Colo.

USED motorcycles, new and used parts; write us. Mahowald Cycle Co., Mankato, Minn.

BOYS, build your own cycle car! Send 25c for building plans and list of parts. We can supply motor with clutch and all parts at low prices. Shaw Mfg. Co., Car Dept., Galesburg, Kan.

MOTORCYCLE Cylinders reground, fitted with new piston rings, \$6.00. Guaranteed. Muncie Piston Co., Muncie, Ind.

WHY buy a used motorcycle? A new Cleveland costs only \$185. See page 146.

AVIATION

SEND for our large aeronautical supply catalog containing late ideas, 15c. For May we offer the greatest bargains in the history of aviation. Dope \$1.65; turnbuckles, all sizes 25c; aero cloth 39c yd.; shock absorber 5c ft.; Curtiss or Guome motors, \$200.00; new propellers \$18.00; clevis pins 2c; steel tubing 5c ft.; airplane sheet steel 5c lb.; other wonderful bargains. Get free sale sheet. Heath Airplane Co., Chicago, Ill.

NEW Standard Airplanes, less motor, \$800; new and used airplanes, motors, flying-boats; wings \$100 each; JN4D, Canuck Standard; any part for sold airplanes or OX5 motor; OX5 propellers \$15; new OX5 8 cyl. 90 H. P. motors \$150. Largest variety, lowest prices. Floyd Logan, 712 W. Superior, Cleveland, Ohio.

TWO propellers, 5 ft. and 6 ft. diameter \$7.00 and \$8.00. Free description. Melton, 3507 E. 34th, Kansas City, Mo.

TWO Gnome 9-cylinder motors; \$145.00 takes both. Particulars free. Melton, 3507 E. 34th St., Kansas City, Mo.

HEATH propellers represent the most efficient method of aerial drive. Each propeller individually designed for the particular work to be done, as laid out by America's oldest aeronautical engineers. Propeller catalog 4c. Heath Airplane Co., Chicago, Ill.

PROPELLERS for Aeroplanes propulsion. Owing to moving into our new location, we are temporarily discontinuing business. See later issue for new address. Crawford Motor & Aeroplane Mfr., 142 S. Rampart St., New Orleans.

BUILD your plane now! Prepare for flying season, Blueprints \$5. Materials parts, KD planes lowest prices. Circular price list 4c. Huntington Monoplanes Hempstead, N. Y.

FLYING Instruction, \$150.00. Riggins and Motors course included. Expert instructors, modern equipment. Spring class now enrolling. Aviation Engineering Co. Lawrence, Kan.

A WONDERFUL opportunity to learn to fly by our new method, includes three hours' instruction in the air and one month intensive shop course, complete at \$100.00. Heath Airplane Co., Chicago, Ill.

DOPING-Varnish Brushes, \$2.25. Airplane Woods, Fittings, Steel, Everything Aeronautical. Price list 4c. Ostergaard Aircraft Works, 4269 North Narragansett, Chicago.

LEARN to fly for \$100. Best offer yet. Limited. Write Frank J. Oneal, Francisco, Ind.

VERY Small Gasoline Engines for Models, Small Spark Coils, Small Spark Plugs, Weiss Mfg. Co., 323 Washington St., Brooklyn, N. Y.

AVIATION, Motorcycle Magazines. List free! Teep Magazine Agency, Middletown, N. Y.

FOR Sale. A slightly used two cyl. 10 h. p. Aviation Motor. T. B. 473, Harlan, Ia.

INVENTORS desiring patents should write for our Free Illustrated Guide Book and Evidence of Conception Blank. Send model or sketch for our opinion of its patentable nature. Highest references. Prompt service. Reasonable terms. Victor J. Evans & Co., 157 Ninth, Washington, D. C.

BIGGEST, best catalogue Model Aeroplanes, Paris and Supplies; 5c postpaid. Ideal Aeroplanes Co., 67½ West Houston, New York.

WELDING

DON'T scrap aluminum parts. Save with So-Luminum. Great welding solder, stronger than aluminum; perfect substitute for acetylene welding. ¼ time and cost. Use gas torch or soldering iron. No flux required. Booklet on request. Sample bar \$1. Endorsed by United States, England and Japan. So-Luminum Manufacturing Co., 1834 Broadway, New York, N. Y.

ACETYLENE Braising and Soldering Torches, \$2.00. Light welding and lead burning torches, \$7.00. Postage prepaid upon receipt of price. Marshall Mfg. Co., Kansas City, Mo.

WELDING Encyclopedia—A complete instruction book on all welding processes: oxy-acetylene, electric arc, electric resistance and thorium. Welding of all weldable metals fully discussed. 326 pp. 375 ill. The accumulated experience of the welding brains of America is yours for \$5. Money back if not satisfied. Popular Mechanics Book Dept., 6 N. Michigan Ave., Chicago.

MOTOR Grinder and Tire Buffer, Automatic Compressors, Battery Chargers, Motors. Unusually Easy Payments. Write us. Hobart's, Troy, Ohio.

BOOKS AND PERIODICALS

LATEST Magic — Professor Hoffman, world-famed authority. New stunts, card tricks, sleight of hand. Handsomely bound. Illustrated. \$2.15 postpaid. Spon & Chamberlain, 120 P. M. Liberty Street, New York.

"THE Finished Mystery," cloth bound volume, 600 pages, 75 cents. "Millions Now Living Will Never Die," 25 cents. "Can the Living Talk with the Dead?" 25 cents. These books are all on the Bible. Special offer: The three now for 75 cents. B. E. Keith, R. 6, Washington, Ind.

ANY book you want at cut-rate prices. Don't buy until you see our bargain list. Send postal for free copy. Midwest Book House, Dept. 20, 58 West Washington St., Chicago.

TWENTY years of formula gathering. One of the most valuable formula books ever published. Postpaid \$1.00. Address Hager Supply Co., 509 28th Ave. So., Nashville, Tenn.

FOR Sale: How to build beautiful homes at small cost. Read my book on twentieth century building materials. Price one dollar (\$1). Peter de Linde, Zion, Ill.

CONCENTRATION: Learn How to Keep Your Mind Upon One Subject despite interruptions. Wonderful possibilities through psychology of thought control. Book 50c. Another book, "How to Conquer Fear," shows how to avoid worry, doubt, nervousness; gain contentment, 50c. Both \$1. Satisfaction or money back. Centre Publishing Co., 103 W. 34th Street, ZB, New York.

BOOKS—All Kinds—catalogs 20c. We include choice of one of these books: Dreams—Flirtations—Coin Tricks—Gold Fish—Jokes—Boxing—Checkers—Funny Epitaphs—Palmsistry. Address McCarthy, Kellogg, Minn.

BOOKS, All Kinds, Lists. Eugene's, 4241 Post Street, San Francisco, Calif.

HYPNOTISM—Dr. Braid's Wonderful successful method \$1.10. Mesmer's \$5.00 Secret \$1.10. "Auto-Magnetism" banishes disease. Generates magnetic energy. Price \$1.10. All three and \$2.00 coupon for \$3. Self-Culture Society, PMS18, Glendale, Calif.

ELECTRICITY Taught by experts; earn while you learn at home; electrical book and proof lessons free; your success guaranteed and position secured. Chicago Engineering Works, Dept. 315, 2144 Lawrence Ave., Chicago.

THIRTY-FIVE Cent Electrical and Mechanical Books, Fully Illustrated. Other popular subjects. Send for list. Spon & Chamberlain, 120 P. M. Liberty St., New York.

HYPNOTISM controls others—overcomes disease. Wonderful exhibitions possible. Twenty easy lessons \$1.10. "Love's Mysteries Explained" 30c. Science Institute, M.P. 1014, Belmont, Chicago.

25 MAIL Order Magazines and Papers, 100 Circulars, and Catalog of "Money-Making Opportunities" books, 50c. Address Hansen Company, Brookings, S. Dak.

OUR new catalogue listing over five hundred carefully selected practical books under eighty different subject groupings will be sent free upon request. Popular Mechanics Book Dept., 6 N. Michigan Ave., Chicago.

AMBITIOUS Writers send today for Free copy America's leading magazine for writers of photoplays, stories, poems, songs. Instructive, helpful. Writer's Digest, 603 Butler Building, Cincinnati, Ohio.

LIGHTNING Cartoonist's Book, Secrets, Tricks, \$1.00. Christman, 2925 Euclid, Kansas City, Mo.

PLANS for Poultry Houses, All styles, 150 illustrations; secret of getting winter eggs, and copy of "The Full Egg Basket." Send 25 cents. Inland Poultry Journal, Dept. 74, Indianapolis, Ind.

YOU need "Moore's Universal Assistant." All main facts in 200 trades and occupations. 1916 pages. Cloth, \$2.00 postpaid. Wells & Edwards, 852 George St., Chicago.

TOY maker book, 64 pages, illustrated. Postpaid 10c. Western Puzzle Works, St. Paul, Minn.

BRINGING Up Father—Books 1 and 2. Everybody knows the funny cartoons by Geo. McManus. They may be had in book form. One volume for 35 cents or both for 60 cents postpaid. Cartoons Magazine Book Dept., 6 N. Michigan Ave., Chicago.

INDUSTRIAL Alcohol, Wright's book everybody wants. Full directions for making with drawings of necessary apparatus. \$2.50 postpaid. Spon & Chamberlain, 120 P. M. Liberty Street, New York, N. Y.

INSTRUCTION Book (for shop use) on vulcanizing auto tire, boots and shoes, \$1 bill. Equipment Co., 3 Canal, Cincinnati, O.

PICTURES, POSTCARDS AND NOVELTIES

QUAKER post card members everywhere. Yearly membership and list, twenty-five cents. 2445 So. Woodstock Street, Philadelphia.

TRUE-BLUERS everywhere. Exchange postals. Organized 1908. Membership: Year, \$1; half, 50c; quarter, 25c. Hundreds listings, 10c. Ed. Ericson, 522, Elroy, Wis.

JOIN Live Postcard club; Sample paper, list, catalog, 10c. Harvey Teep, Decatur, Ind.

GAMES AND ENTERTAINMENTS

VENTRILOQUISM taught almost anyone at home. Small cost. Send 2c stamp today for particulars and proof. George W. Smith, Room M-286, 125 N. Jefferson Ave., Peoria, Illinois.

JOKER'S Sporting Goods, pocket novelties, tricks, books etc. Send stamp for illustrated catalogue. Address Johnson, Box 423, Scranton, Pa.

MAGIC Tricks—Send 2c stamp for catalogue (professional catalog 25c) book card tricks 25c. Thurston's book, pocket tricks 25c, trick pack cards 50c postpaid. A. P. Felsman, 3234 Harrison, Chicago, Ill.

TRICKS, Puzzles, jokes, magical apparatus, plays, stage supplies, mind-reading acts, and sensational escapes. 169-page illustrated professional catalogue, 10c. Oaks Magical Co., Dept. 548, Oakkosh, Wis.

LOTS of Fun. Snooze powder; greatest fun maker on earth. Bottle 10c. Three for 25c. C. Fenner, 2401 Jefferson, Louisville, Ky.

"MARGO" Psycho-Sphere. Amusing. Entertaining. Mystifying. Descriptive circular free. James T. Herr, Desk C. 2919 W. North Ave., Baltimore, Md.

\$7,000 STOCK magical goods. Catalogues 15c. Address, Gilmaglio, Morgan Park, Ill.

HIGHGRADE Magical Apparatus, Mind-reading, Card Tricks. Sensational Escapes from Handcuffs, Jails and Ropes. Amusement goods of all kinds. Buy direct from manufacturers. Large illustrated catalog free. Write Heaney Magic Company, Berlin, Wis.

TRICKS, Puzzles, jokes, magical apparatus, plays, stage supplies, mind-reading acts, and sensational escapes, 169-page illustrated professional catalogue, 10c. Oaks Magical Co., Dept. 548, Oakkosh, Wis.

250 MAGIC Tricks 25c. Big Catalog 2c. Harvey Teep, Decatur, Ind.

PLAYS, musical comedies, revues, minstrel choruses, blackface skits, vaudeville acts, monologues, dialogues, recitations, entertainments, musical readings, stage handbooks, make-up goods. Big catalog free. T. S. Denison & Co., 623 So. Wabash, Dept. 11, Chicago.

200 KINDS iron, wood and wire puzzles. Leader and illustrated list 10c. Western Puzzle Works, St. Paul, Minn.

MAGIC—Tricks, Books and Supplies. For Amateurs as well as the great professionals. Anyone can learn through our instructions. Feature Acts in Mind Reading, Spiritualism, Rope Ties, etc. Large illustrated Professional Catalog, 10c. Chicago Magic Co., Dept. B, 140 S. Dearborn St., Chicago, Ill.

FREE! "10 select pocket tricks" and illustrated catalog magic tricks, jokes, puzzles and imported novelties at reduced prices. Send today! Lyle Douglas, Station A, Dallas, Texas.

STAMP COLLECTING

SNAPS—150 different stamps, 18c; 60 different United States Stamps, 12c. With each order we give free our price list of sets, packets, albums, etc., and our pamphlet which tells "How to make a collection properly." Queen City Stamp Company, Room 36, 604 Race, Cincinnati, Ohio.

STAMPS—50 different Jamaica, Venezuela, etc. only 7c; 100 all diff., 10c; 1,000 all diff., \$2.50; 100 diff., U. S., 25c; 1,000 Hinges, 10c; 50 percent approvals with every order. List free. I buy Stamps. Write L. B. Dover, Longmont, Colo.

NEWFOUNDLAND Stamps—all issues. Send Want List, and let me quote at prices that cannot be beaten. Rev. E. A. Butler, St. George's, Newfoundland.

FREE—Twenty United States with 60% approvals. Enclose three cents. Illini Stamp Co., 803 West Madison, Chicago.

1,500 DIFFERENT stamps \$5.00; 1,000, \$2.50; 500, 75c; 300, 45c. Fred Onken, 620 79th street, Brooklyn.

BEST one-cent approvals in America. F. P. Hand, 1117 So. 60th St., Philadelphia, Pa.

FALKLAND War Stamp free to all buyers from my approvals. Guest, Box 1042, Dallas, Texas

FREE—World's smallest stamp. To approval applicants. Postage 2c. Cannon, 919 E. 10th, Davenport, Iowa.

RUBBER Stamps—25 cents up; send for catalog. Flint Rubber Stamp Works, Flint, Mich.

STAMPS, 75 different, including India, Japan, etc., 10c. Mogensen, 414 North 14th, Omaha, Neb.

3 TRIANGULARS free with Penny Approvals, References required. Bernard, 1026 Palm, San Luis Obispo, Calif.

50c WORTH of Stamps for Only 2c. Hull, 12 West 101st, New York.

25 DIFFERENT Newfoundland, Egypt, etc. 2c. Harland Burgess, Lima, Ohio.

FREE—New Europe, 20 diff., to applicants for my 1/2, 3/4, 1, and 2c approvals; also the higher-priced stamps at 50% disc. Send reference and receive extra premium. Chas. T. Egner, 1335 Pike St., Philadelphia, Pa.

1,000 AMERICAN Hinges and 100 Different Stamps for 25c. 10 Nyassa Pictorials 12c. 13 Austrian Newspaper Stamps 8c. 12 Austrian Republic 8c. Finest Approval Service. Lists Free. Elwood D. Weber, 812 South Avenue, Plainfield, N. J.

100 DIFFERENT Stamps—Nicaragua, Egypt, Brazil, Chile, Guatemala, Hong-Kong, large pictorial French Colonies, etc. Album with perforation gauge, only 10c. Clarence Gibbs, Tajunga, Calif.

WANTED—We pay high prices for old used postage stamps, also stamp collections. World Stamp Co., Box 2994, Louisville, Ky.

STAMPS, 1,500 different, \$5.45; 1,000, \$2.75; 500, 95c; 200, 50c; 50 African, 25c; 20 Persia, 22c. Michaels, 5602 Prairie, Chicago.

FREE, 25 U. S. stamps with 60% approvals to reliable parties. 100 different U. S. 25c. C. Seidenberg, Merton, Wis.

FRENCH Colonies Free—Beautiful Picture set, including Native Chiefs, Tigers, Pictorials, 2c Postage. Empire Stamp Company, Toronto, Canada.

150 STAMPS, Liberia, Sudan, etc., 10c. Fred Takagi, Box 543, Redwood, Calif.

100 DIFFERENT Stamps and Perforation Gauge for 10 cents. I. Sonnea, 675 Ivy St., St. Paul, Minn.

NEUROPE and fine British Colonials on approval. Free! Fine set India Native States to applicants. Biedell, Schenectady, N. Y.

BELGIUM Olympic Set, also 200 different stamps for 30c. Jacob Fischer, 1539 North Lawler, Chicago.

1,000 DIFFERENT—\$2.75, 1,000 Hinges 9c; (special offer for \$1.00, includes hinges, approval books, sheets, watermark detectors, packets, etc.) Won't appear again. Baumann, 1033 Levick, Philadelphia, Penna.

ZAMBESIA, Holkar, Herzegovina, Ukrainian stamps, menagerie packet, 250 hinges, 10c. Liberty, 3974 Arsenal, St. Louis, Mo.

25 TURKEY 25c, Co-operative Stamp Co., 710 Pelham, St. Paul, Minn.

I BUY Cancelled Stamps and Coins. Price list coin book 10c. Astamp Scott, Cohoes, N. Y.

UNUSED French Colonials, 48 different, 20c. Nickles, 122 Florida Ave., Washington, D. C.

3 NYASSA Giraffe stamps free to approval applicants. Wilmar Edgar, Cherokee, Iowa.

200 STAMPS and subscription Stamp Magazine 15c. Harvey Teeple, Decatur, Ind.

STAMPS, 50 Varieties, Africa, Brazil, Peru, Cuba, Mexico, etc., 10c. 50 different U. S., 25c; 1,000 mixed, 40c; 1,000 hinges, 10c. List free. C. Stegman, 5948 Cote Brillante, St. Louis, Mo.

FIVE CENTS: Japan, two large battleship stamps. Address, Hubert Codwise, Melrose Highlands, Mass.

SWEDISH Stamps free. Approvals 3c postage. F. Seebeck, 1957 Toronto St., Regina, Canada.

100 FOREIGN Stamps sent free. Cornish Company, Schenectady, N. Y.

STAMPS Free—War Stamps, Surcharged, Unused, Pictorials, British, French Colonials 2c postage. Midland Stamp Co., Toronto, Canada.

158 GENUINE Foreign Stamps—Mexico War Issues, Venezuela, Salvador and India Service, Guatemala, China, etc., only 10c. Finest approval sheets, 50 to 60%. Agents Wanted. Big 72-p. Lists Free. We Buy Stamps. Estab. 29 yrs. Hussman Stamp Co., Dept. 54, St. Louis, Mo.

FREE! To applicants for our net approvals, 3 stamps cataloging over \$1.00. Reference necessary. The Stamp Shoppe, 1413 G Street, N. W., Washington, D. C.

FREE, 100 different stamps to applicants for approvals sending 2c. 100 varieties War Stamps 22c. Richard P. Lamprecht, Valparaiso, Ind.

LIKE Triangular Stamps? To introduce our Sudden Service Approvals we'll send triangular Fiume, set China ships, large \$1.00 United States revenue, also packet 50 foreign, millimetre scale, perforation gauge, ruler and bargain lists for only 3c! Fenell Stamp Company, Dept. P, Fullerton Bldg., St. Louis, Mo.

FREE, packet of desirable stamps, exceptional quality, to approval applicants sending satisfactory references. H. Argenbright, Box 352, Staunton, Va.

FREE! Sectional Loose Leaf Postage Stamp Album at the rate of 8 pages each month given with subscription to our monthly Journal. Send two-cent stamp for prospectus. United Stamp Co., 140 S. Dearborn St., Chicago, Ill.

BIG Variety Packet Foreign Stamps free for 2c postage. Gray Stamp Co., Station E., Toronto, Canada.

UNIVERSAL Packet, 100 varieties, all over the world, 10 cents. Covert Stamp, 39 State, Rochester, N. Y.

STAMPS sent on approval at 70% discount. Reference required. Emory Renoll, Hanover, Pa.

STAMPS Free—Ask for money-saving approvals. John P. Borresen, Cedar Falls, Ia.

24 VARIETIES Cuban stamps, 10 cents. List of 6,000 low-priced stamps free. Address Chambers Stamp Co., 111P, Nassau St., New York City, N. Y.

165 CHINA, etc., stamp dictionary, list, 2c. Album (500 illustrations), 3c. Bullard, Sta. A, Boston.

55 ALL Different Stamps, including China, Japan, French Colonies, etc., given to applicants for our high-grade approval selections. Send references and 2c stamp to the Edgewood Stamp Co., Dept. H, Milford, Conn.

20 UNUSED stamps free. All different. Postage, 2c. Fisk Stamps, Toledo, Ohio.

PACKET of 23 stamps, no two countries alike. Packet hinges. Set of \$1 and \$2 U. S. Ref. all for 5c. Mention paper. Miami Stamp Co., Toledo, Ohio.

STAMPS, 20 unused, all different, free. Postage 2c. Mention paper. Quaker Stamp Co., Toledo, O.

FREE 10 different Scandinavian, millimetre scale, gauge, book, lists, etc., to all sending 10c for 57 different Siam, Ceylon, Guatemala, etc. 200 different, 25c; 300 different, 60c; 100 different U. S., 25c. Hawkeye Stamp Co., Cedar Rapids, 39, Ia.

100 DIFFERENT from 30 different countries, 5c. Lufbery, Yalesville, Conn.

RARE COINS

COINS, medals, paper money, stamp collections, guns, swords, pistols, curios, antiques. 1922 Catalogue 4c Stamp. Nagy, 33 South 18th, Philadelphia, Pa.

CENTS worth dollars. Do you know that coin collectors pay up to \$100.00 cash for certain old U. S. Cents, as well as high premiums for all rare coins. We buy all rare coins. Send 4c. Get large coin circular. It may mean much profit to you. Numismatic Bank, Dept. H, Ft. Worth, Texas.

FLYING Eagle Cents are now out of circulation, but you can get one now together with a 50 page Illustrated Coin Catalog by mailing this slip and 10 cents with your name and address. This is "just to get acquainted." Send now, B. Max Mehl, Numismatist, Mehl Bldg., Dept. P, Fort Worth, Texas. Largest Rare Coin Establishment in the United States.

\$2 TO \$500 Each paid for hundreds of old coins. Keep all old money. Send 10 cents for Illustrated Coin Value Book, 4c. Guaranteed Prices. It may mean your Fortune. Address Clarke Coin Company, Ave. 2, Le Roy, N. Y.

WILL sell: Very rare U. S. Treasury Notes and silver pieces; also \$1,800 in old Bank Notes and Confederate Bills. Smith, 112 Smith St., Millville, N. J.

15 COINS 30c a package. Sample Coin Trays 35c each. C. Johnson, P. O. Box 1245, City Hall Station, N. Y. City, N. Y.

SIX old American and foreign coins 25c. Durso, 25 Mulberry, N. Y. City, N. Y.

CALIFORNIA Gold, Quarter size and Columbia nickel coin only 30c. Italy 29 cents and catalog 10c. Homer Shultz, King City, Mo.

OLD coins, large Spring selling catalogue of coins for sale, free. Catalogue quoting prices paid for coins, ten cents. William Hessel, 101B Tremont St., Boston, Mass.

CALIFORNIA gold, Quarter size 27c; 1/2 size, 53c. 3c Piece and catalog, 10c. Norman Shultz, Box 146, Colorado Springs, Colo.

FOR BOYS

EVERY Live Boy makes big money selling automobile watch carrier. List \$1.00. Send \$1.00 for two samples. G. Burrell, Penacook, N. H.

MANUAL Training Outfits and accessories for toy construction. Circular free. Working drawings for making twenty toys only 45c. Address, Woodcraft Shop, 31 South 3rd Ave., Mount Vernon, N. Y.

BOYS!—Build Things. Our three books, The Boy Mechanic, 1, 2, and 3, tells you in a way you can understand how to make such things as Boy's Motor Car, Houseboat, Model Monoplane, Water Toboggan and Slide, Aerial Cableway, Ski Sled, Sailing Canoe, Searchlight, Electric Locomotive, etc. Each book is complete in itself and has 488 pages and upwards of 800 articles and illustrations. Description of each book sent on request. Price \$2.50 per vol. postpaid. Popular Mechanics Book Dept., 6 N. Michigan Ave., Chicago.

BUILD your model boat with our ready fitted set of materials. All difficult work done. Complete parts, except motor to build Mahogany Y-Bottom runabout 30" long \$15.00 including necessary tools. Same outfit 36" long \$20.00. Catalog. Miniature Model Boat & Engine Co., 2027 Magazine St., New Orleans, La.

ELECTRICITY Taught by experts; earn while you learn at home; electrical book and proof lessons free; your success guaranteed and position secured. Chicago Engineering Works, Dept. 515, 2144 Lawrence Ave., Chicago.

BOYS!—You who like gripping, thrilling stories of achievement will want to read "Victories of the Engineer," a book that tells in a way you can understand it how the great feats in railroad engineering, building great bridges, ships, dams, canals, harbors, tunnels, mining, etc., have been accomplished. By A. Williams. 487 pp. 259 illus. Price \$2.00 postpaid. Popular Mechanics Book Dept., 6 N. Michigan Ave., Chicago.

BOYS, Get flying model aeroplane free. Write to Aero Shop, 3050 Huribut Ave., Detroit, Mich.

PLAY mouth-organ. It's easy. Complete instructor, 25c. G. Elsea, Bowling Green, Ohio.

CAMERAS AND PHOTO SUPPLIES

JUST Published—Our new complete 128-page catalog and bargain book of new and used cameras and supplies. Our goods are guaranteed finest quality obtainable. We have thousands of satisfied customers. Write at once for this bargain bulletin, just hot from the press. Address Central Camera Co., 124 S. Wabash Ave., Dept. E 57, Chicago, Ill.

OLD Tintypes, Daguerreotypes or Faded Pictures of loved ones can be restored so as to produce beautiful enlargements and perfect likenesses under our new process. Individual pictures may also be produced out of groups. Satisfactory results guaranteed. Prompt work. Roanoke Photo Finishing Co., 512 Bell Ave., Roanoke, Virginia.

BEAUTIFUL photographic enlargements from your favorite negatives. 6x9—25 cents coin. Address T. Johnson, 1819 East Sergeant, Philadelphia.

DEVELOPING 10c. Prints 5c each with order. No stamps. Address, Harry Nicholson, Photographer, Castleton, N. Y.

CAMERAS, lenses, binoculars, buy, sell, exchange, square deal, lowest prices, good firearms, musical instruments, typewriters taken in trade. National Camera Exchange, 20 Washington Ave., Minneapolis, Minn.

BIG Money Saved on Photographic Lenses and Apparatus—goods exchanged; repairing done. Ralph J. Golsen, 1128 Argyle St., Chicago, Dept. P.

PROJECT Motion-Picture Film with your hand camera; complete instructions and set of films 25c. Film Exchange, F837 Bowery, Akron, O.

KODAK Pictures! Professional finishing for amateurs. Lowest prices—Prompt service. Your films are entitled to good workmanship. We guarantee it. Developing—Printing—Enlarging—Copying—Coloring—Framing—Mounts and Folders. Free valuable booklet on photography and price list with your first order. Any size roll developed 10c. Six 2 1/4 x 3 1/4 prints 22c. Six 3 1/4 x 5 1/2 prints 30c. Beautiful 8x10 enlargement mounted 65c. Mail your films and be sure of good pictures. Photographic Institute, Dept. M, Wedgeway Building, Shenectady, N. Y.

ENLARGEMENT from your favorite negative tinted, 7x11, 65c. Olson Photo Shop, Paxton, Ill.

RWK Photo-Printers give continuous economy and results; made in three sizes, 6 1/2 x 8 1/2, 8x10, and 11x14. Sold to satisfy you. R. W. Kirtledge Co., 824 W. Superior St., Chicago, Ill. Write for particulars.

BASS Camera Bargains are known the world over. Write your needs. Largest stock of Graflex, Kodaks and Motion Picture Cameras in the world. Bass Camera Company, Mail Order Division, Chicago, Ill.

KODAK films developed and finished with attractive margin designs 25c. Something new. New England Photo Service, Box 1202, Boston, Mass.

KODAK Finishing. Not the cheap way, but the most reliable. Our Quality Work insures best prints from every negative. Get particulars and List of Prizes. Or send Trial Order. Moon Photo Service, 21A, LaCrosse, Wis.

HAVE You a Camera? Write for Free sample of our big magazine, showing how to make better pictures and earn money. American Photography, 790 Camera House, Boston, 17, Mass.

MOTION PICTURES

\$35.00 PROFIT nightly. Small capital starts you. No experience needed. Our machines are used and endorsed by government institutions. Catalog free. Atlas Moving Picture Company, 482 Morton Bldg., Chicago.

FILMS—\$2.50—up. New and used Projectors, \$5 to \$250. Address, Movie Sales, High Ridge, Mo.

JUST Out! Send for one at once! The Complete Cinema Hand Book. A complete course in motion-picture making from raw film to the projected image. 508 pages crammed full of authoritative information. Postpaid to any part of the world on receipt of \$3.90. Everything in Motion Picture Apparatus. Cameras from \$20.00 to \$1500.00. Write for information to the Motion Picture Headquarters of the World, Bass Camera Company, Dept. 114, 109 No. Dearborn St., Chicago, Ill.

2,000 REELS Moving Pictures. \$3 up—Drama—Comedy—Educational. Motor-Driven suitcase Projector, \$125. Movie Camera, \$60. Tripod with panorama and tilt, \$30. Developing outfit, \$25. Printer, \$40. Kodak and Photographic bargains. Ray, 326 5th Avenue, New York, N.Y.

BIG Profit Nightly—Moving Picture Business—small capital starts you, easily accomplished. Teach you—furnish everything. Ralph J. Golsen, 1128 Argyle St., Chicago, Dept. M.

MOVIE Film—westerns, comedies, two hundred feet \$1.60. Colman, Mather Building, Washington, D. C.

HOME Projector Films, 1c foot. Trial subjects, 50c and \$1.00. Comedies, travel, news. W. Weir, 226 West 50th, New York City.

CLEARANCE Sale—500 reels high-grade Film. Two to six reel subjects Famous Movie stars. Special \$3.50 per reel only while they last. Stock up now. List free. Monarch Theatre Supply Co., Union and Fourth, Memphis, Tenn.

BUY direct from Manufacturers—New or rebuilt Moving Picture Machines for Homes, Schools, Lodges, Churches, Traveling Shows and Theatres, Masks—Are or Gas complete outfits—Film and Supplies. Dept. X, Monarch Theatre Supply Co., Memphis, Tenn.

MOVIE Film \$1.00 per hundred feet postpaid anywhere in the U. S. A. Address Gamble Bros., Mt. Airy, Philadelphia, Pa.

MOTION picture machines and films. Bargain lists. National Equipment Company, Duluth, Minn.

MOTION Picture Operation. Stage Electrics and Illusions—The only practical handbook and guide published for motion picture operators, theatre electricians and managers. Pocket size, cloth, 393 pp., fully illus. Price \$1.50 postpaid. Popular Mechanics Book Dept., 6 N. Michigan Ave., Chicago.

FILMS for Toy and Professional Machines. All famous movie stars, \$3.00 per reel and up. Machine bargains also. Write for big list free. Monarch Theatre Supply Co., Dept. P. M., 721 S. Wabash Ave., Chicago, Ill.

BIG Clearance sale of films. Westerns, comedies, and features \$3.00 per reel and up. Write for list. Also machines and supplies of all kinds. Monarch Theatre Supply Co., 225 Union Ave., Memphis, Tenn.

BARGAINS in Movie Projectors for homes, schools, churches, roadshows. Films cheap. Address, Werner Brothers, High Ridge, Mo.

MOVIE Cameras, \$20. Drawing, Illustrating, Stereopticon, \$15. Heitz, 302 E. 23d, New York.

FILMS For Sale—\$2.50 per Reel up. Address Queen Feature Service, Birmingham, Ala.

MAKE money writing photoplays; details free to beginners. No correspondence course. Producers League, 230 Wainwright, St. Louis.

FREE to Writers—A wonderful little book of money-making hints, suggestions, ideas; the A B C of successful story and play writing. Absolutely Free. Just address Authors Press, Dept. 12, Auburn, New York.

SCENERY TO RENT

SETTINGS for Opera, Plays, Minstrels, Punch Drops. Catalog, Amelia Grain, Philadelphia.

EDUCATIONAL AND INSTRUCTION

BOOKKEEPING self-taught in a week with "Dukes' Columnar Bookkeeping." Price \$4. Used with standard blank books, Newton A. Dukes, M-13 Fox Street Station, New York City.

LINCOLN-JEFFERSON University. Home study in Academy, College, Theological, Law, Music, Pharmacy, Business and Graduate Schools, leading to degrees. Box W, 61 W. Randolph St., Chicago.

ARCHITECTURAL draughtsmen in demand. Big salary. Easy work. Write for my instruction methods. Designer Evers, Englewood, Denver, Colo.

WORLD-ROMIC System. Masterkey to All Languages. Six Textbooks, \$1.73. French Chart, 37c; Spanish, 37c. Pronunciation—Tables, 79 languages, 30c each language. Languages Publishing Company, 8 West 40th Street, New York.

MATHEMATICAL Short-cuts make for quick, easy figuring—and efficiency. Instructional, entertaining. Send 20c (silver) now. Citrus Company, Los Angeles, Calif.

CUTS made easily. Plate method. \$1. Particulars, stamp. Mac Clark, Ottawa, Kansas.

BOOKKEEPING easily learned. Free particulars. Fred York, 7437 East Jefferson, Detroit, Mich.

STRUCTURAL Drafting and Mathematics taught by mail. Home study courses in Steel Construction, Arithmetic, Algebra, Geometry and Trigonometry. C. Beeman, 94 Brighton, Detroit, Mich.

ROPP'S Calculator and Short-Cut Arithmetic shows the answer as quickly as a watch shows the time to all problems likely to occur in office, store, shop, bank, farm or factory. Price, pocket size, paper 35 cents, cloth 50 cents, leatherette \$1. Desk size, cloth \$1.50 postpaid. Popular Mechanics Book Dept., 6 N. Michigan Ave., Chicago.

STUDY Bacteriology—become a laboratory expert. Course interesting, can be mastered in few months at home or in school. Good paying positions open. Degree granted our graduates. School 13 years old. Send for Announcement. American College of Bacteriology, 2023 S. Michigan Ave., Chicago, Ill.

SUCCEED: Home Shorthand, \$2.50. Send money order. We are responsible. Byrne Publishing Company, Tyler, Texas.

WANTED: Information exchanged about commercial uses for air compressors. Address Engineering Dept., Brunner Mfg. Co., Utica, N. Y.

AMBITIOUS writers—send today for free copy America's leading magazine for writers of photoplays, stories, poems, songs; instructive, helpful. Writers Digest, 708 Butler Bldg., Cincinnati.

PLAY mouth-organ. It's easy. Complete instructor, 25c. Instructors for violin, piano, tenor banjo, ocarina, ukulele, accordion, or drums, 25c. G. Elsea, Bowling Green, Ohio.

THE most profitable Art as well as the easiest to learn. Sign Painting and Show card Writing. Complete course \$2.50. Hall's Sign Shop, Franklin Square, Worcester, Mass., Dept. A.

INVENTORS—Write for our illustrated guide book and Evidence of Conception Blank. Send model or sketch and description for free opinion of its patentable nature. Highest references. Prompt attention. Reasonable terms. Victor J. Evans & Co., 147 Ninth, Washington, D. C.

MATHEMATICS taught by mail. Spare time home study courses in Arithmetic, Geometry, Algebra and Trigonometry. J. A. Harding, 76 Brighton Ave., Highland Park, Mich.

WRITE articles, stories, news, in spare time for newspapers and magazines. Big pay. Copyright book free. Press Syndicate, 552, St. Louis, Mo.

DOUBLE Entry Bookkeeping mastered in 60 hours with 8 keys; guaranteed; Diplomas. International Bookkeeping Institute, Dept. 8, Springfield, Mo.

HAVE a business of your own; the most fascinating, best paying business profession in the World, a foot correctionist; easy terms for training you at home in a few weeks, a new protected system that has enabled men and women to rise in one step to greater earnings than they ever thought possible; no capital required or goods to buy, no agency or soliciting. Address, Stephenson Laboratory, 1 Back Bay, Boston, Mass.

ARTIFICIAL Marble, sanitary flooring instructions, ornamental casting, concrete plaster, parier-mache decorations, garden furniture, statuary, Rubber-moulds, Electro-metallurgy, particulars and 200 illustrations free. Chris Mahler, Box 122, Huntington, N. Y.

TELEGRAPHY

TELEGRAPHY—Morse and Wireless—taught at home in half usual time and at trifling cost, Omnigraph Automatic Transmitter will send, on Sounder or Buzzer, unlimited messages, any speed, just as expert operator would. Adopted by U. S. Govt. and used by leading Universities, Colleges, Technical and Telegraph Schools throughout U. S. Catalog free. Omnigraph Mfg. Co., 18 Hudson St., New York.

TELEGRAPHY (both Morse and Wireless) and Railway Accounting taught quickly. Big salaries. Great opportunities. Oldest and largest school; established 46 years. All expenses low—can earn large part. Catalog free. Dodge's Institute, H St., Valparaiso, Ind.

WIRELESS

WIRELESS telephone; complete receiving outfit. Full instructions. Best and Cheapest on market; also parts to build your own. Write Frank Taylor Mfg. Co., Norwood, Ohio.

RADIO OUTFITS AND SUPPLIES

BUY your Radio parts or sets from us. Instructions for building receiving set \$5.00. Chicago Tool & Engineering Company, 350 Washington Blvd., Chicago, Ill.

RADIO Book—make your own radio receiver; start your own business. Price \$1.00. Agents wanted. H. J. Davis, 200 Ridgewood Ave., Brooklyn, N. Y.

SEND for our free radio bulletin. Important information for you. Ritter Mfg. Co., 325 Washington Street, Brooklyn, N. Y.

RADIO batteries and equipment. Austin Welding Works, 553 W. Quincy, Chicago, Ill.

RADIO—Wireless Telephones, \$15. Radio supplies. Ray, 326 5th Avenue, New York.

DO you know anyone who is not interested in radio outfits and equipment? In 11 days we received 393 inquiries concerning radio outfits—and every mail brings many others. These inquiries, in most cases, could be converted into actual orders, so you see what you are missing by not advertising in this column. Send us your copy and remittance for our June issue, forms for which close April 25th. Get the business. J. Roy McClellan, Manager Classified Advertising, Popular Mechanics Magazine, Chicago.

BUILD Radio Sets. We supply parts or complete units. Catalog 15 cents. Easily understood assembly drawings, Crystal Detector Set, Non-regenerative Receiver, Regenerative Receiver, 2-Stop Amplifier, 25 cents each. All five \$1.00. No stamps accepted. Hatfield Airfone Company, Owego, N. Y.

COMPLETE Receiving Sets with bulb, phones and "B" battery, \$50. Plate batteries 95c. Northern Radio Co., 238 N. Madison, Bay City, Mich.

UP-TO-DATE Radio books—Design Data for Radio Transmitters and Receivers. Simple methods for designing apparatus according to advanced and approved practice. Price 75 cents, postpaid. Radio Hook-Ups—a book of the most advanced circuits of receivers, amplifiers and transmitters for damped and undamped wave work. Price 75 cents, postpaid. Popular Mechanics Book Dept., 6 N. Michigan Ave., Chicago.

BUSINESS OPPORTUNITIES

HERE is your opportunity to make from \$5,000 to \$10,000 a year in your own business, as our District Sales Manager, in large and small cities and rural communities. We manufacture a line of high-grade automobile tires, nationally advertised and sold on a positive guarantee of ten thousand miles. No experience is necessary to act as our District Sales Manager. We show you how to procure business and manage our sales force. We will turn over this established business only to men having a clean past record and who will energetically carry on the work. Many of our most successful branch managers were previously farmers, mechanics, merchants, etc. Because of the distinctiveness of our sales plan, we prefer not to affiliate with tire dealers. An investment is required of \$200, contingent upon later arrangements. In applying, give full information, including your financial status, which will be treated in a confidential manner. Address me personally, A. O. Andrews, Director of Sales, 1921-1929 Indiana Ave., Chicago, Ill.

INCREASE your business through classified advertising. Big returns from little ads. Your 4-line ad (24 words) in this list of leading Sunday papers only \$20. Each additional line (6 words) \$5. Circulation over 3½ million! New York World, Chicago Tribune, Philadelphia Inquirer, Pittsburgh Press, Buffalo Courier, Detroit News, St. Louis Post-Dispatch, Milwaukee Journal, Memphis Commercial Appeal, Cincinnati Enquirer, Denver Post, Indianapolis Star, Des Moines Register, Birmingham News, Kansas City Star. It Pays to use these papers—a trial will prove it. Ads reaching us by Wednesday will be inserted following Sunday. Proof of insertion guaranteed. Send your order now. Sun Agency, Arcade Bldg., St. Louis, Mo.

START a lucrative business of your own. We teach you how to establish and operate a successful collection business, and refer items to you. Capital unnecessary. Practically no competition. Walter Sanford, Nashville, reports \$62,021.94 gross commissions last year. Joseph Cullen, Washington, sends sworn statement showing gross earnings \$8,089.07 for one month. Orin Overholser, Dayton, says, "I averaged nearly \$400.00 net commissions monthly last year. Such earnings bought my home and farm." Start now in spare time. You can succeed like 4,700 others. Write today for New Plan. American Collection Service, 802 Cass Building, Detroit, Mich.

NO money needed if you are responsible or have excellent reputation; big commissions; prefer men calling on power plants, railways, large factories. You can make plenty of money if you are right; have a real article. We are nationally known and highly rated in Dun's and Bradstreet's. Manufacturers, 1600 Kingsland Ave., St. Louis.

WANTED—Silver Fox. We pay \$500 each for fine skins and buy all you raise. Write for free information how to get started. Duffus Silver Fox Store, 21 West 30th, New York, N. Y.

BE Independent—Learn to plate without batteries. Appears like the finest nickel, will last for years. Big demand. Silver quarter for full instructions. Address Southwestern Laboratories, Box 771, Oklahoma City, Okla.

ANYONE who can read and write can start profitable spare-time business without capital or experience. No soliciting. Strictly private. Address Benson, 3722 M St., Philadelphia, Pa.

START a candy kitchen. 100 complete lessons by a practical candy maker. Price \$1.00. Satisfaction guaranteed. Charlie Bowman, 537 South Emporia Ave., Wichita, Kan.

NICKEL Plate automobile accessories, hardware, electrical parts. Big profits. Requires no capital. Simple battery process. Write today. Webster Engineering Co., Webster Groves, Mo.

50c BUYS complete working drawings with instructions for manufacturing dandy household article at home. Address Wm. Hill, 53 Austin St., Rochester, N. Y.

"BUSINESS Booster"—For ambitious men and women—contains many money-making opportunities. Three months 25c coin. Eydman System, St. Louis, Mo.

THIS man in our town is like yourself—He hunted opportunity. With \$5 he bought a workable formula for a salable commodity. In spare time he mixed it in a washboiler at home. Now; his factory is big; he makes 40 products; he is the boss of 340 employees. Imitate him. Let us tell you how. Write today for valuable interesting free particulars. Research Laboratories, 5317 Vine St., Philadelphia, Pa. Established 1916.

SIMPLE, practical invention permits aeroplanes safely to land upon or start from small space like roof of building or deck of ship; United States patent has been allowed and will soon be issued; about \$1,000 needed to obtain patents in foreign countries; to party that will advance \$1,000 I will assign all rights in one country. F. E. Scholfield, Waterford, Conn.

PATENTS—Trademarks. Before disclosing an invention, the inventor should write for my blank form "Evidence of Conception." This should be signed, witnessed and returned to me with sketch or model upon receipt of which I will promptly render opinion as to patentable nature and send booklet on Patents. Highest references. Prompt attention. Reasonable terms. Clarence B. O'Brien, Registered Patent Lawyer, Woodward Building, Washington, D. C.

\$8,000 TO \$8,000 Yearly. Want it? Others are making it. Send check or money order today for our invaluable books "How to Sell Real Estate," \$3.00—and "How to Conduct Real Estate and Insurance Business," \$1.50. Absolute satisfaction guaranteed. Free catalogs. Realty Book Co., Dept. 52, 17546 Archdale Ave., Lakewood, O.

MECHANICS—Wanted reliable mechanics to operate service shop; can earn \$500 per month and up; will give exclusive handling in allotted territories; we have many shops in operation; will cost you \$250 for tools and machinery. We help you build up the business. Call or write A. L. MacKenzie, Mgr., 7 W. Madison St., Chicago.

DOLLARS yearly in your backyard. No Mushroom dogs. Particulars free. Meta, 313 East 89th, New York, N. Y.

MAKE money with your camera. Information for stamp. Lancaster, 409B Wright-Candler Bldg., Los Angeles, Calif.

MONEY in mail-order business. Names of 30 supply houses 10c. Pennell Company, Covington, Ky.

SELL. Finance your business; plan free. P. O. Drawer 474, Cleveland, Ohio.

MAKE Artificial Flowers. Outfit 35c. Particulars Free. Address Box 533, Fort Smith, Ark.

SELL or finance your business or invention. Write Box 474, Cleveland, Ohio.

"MONEY Makers for Live Wires"—Free. Address Box 562, Fort Smith, Ark.

WORK furnished anybody anywhere. Particulars for stamp. Cochran, Graysville, Ohio.

20,000 FORMULAS—money makers. 530 pages. \$1.25. "Ideal," 5591-Y, North Beverly, Chicago.

PAINT: Something new, weatherproof paint, all colors, inside, outside, 25c gallon. No cheap oils or gasoline; use yourself or selling consumers. Immense profits; complete formulas, \$1.00. Mobbs, 629 Stock Exchange Building, Los Angeles, Calif.

PATENT Procured—Trade Marks Registered. A comprehensive, experienced, prompt service for the protection and development of your ideas. Preliminary advice gladly furnished without charge. Booklet of information and form for disclosing idea free on request. Richard B. Owen, 30 Owen Bldg., Washington, D. C., or 2276 B Woodworth Bldg., New York.

PROTECT Your rights. Write for Record of Invention which contains form to establish evidence of conception of your invention. Prompt personal service. Preliminary advice without charge. J. Heaney Kelly, 612 G. Columbian Bldg., Washington, D. C.

SPECIALTY—Proprietary Manufacturing—Small capital; recorders; unlimited field; large profits. The Thaxly Co., Dept. 20, Washington, D. C.

WANTED. local representative; successful plan appeals to all theater managers. Nets you \$35 weekly. Theatre Bulletin Co., 622 Washington Building, Los Angeles, Calif.

ADVERTISE. 28 words 49 country (town) newspapers \$2.00. List for stamp. Pennell, Covington, Ky.

EASY home mouldmaking, and casting methods, for toys, jewelry, novelties, rings.—**Making** (undetectable) artificial silver, gold.—**Silver and Gold Plating**.—**Gilding**.—**Enormous profits** "duplicating" latest novelties in flawless imitation silver, gold, etc. Quickly learned. \$10 starts you. Complete instructions \$2. Gillespie Bain, Ladysmith, B. C., Canada.

YOUR chance in life to own dignified profitable business. We teach you practical real estate, insurance and business brokerage. Earn \$5,000 year, no capital required. Office at home. Representatives wanted everywhere. Stamp for booklet. Hayes Realty Association, Cincinnati, Ohio.

150% PROFIT! Exclusive State rights! Wholesalers able to finance big sales wanted for quick selling Compton Poolproof Spring Oilers. Automatically lubricate springs, stop wheezing, squeaking. Prevent broken springs. \$2,000.00 required. Box 12, Compton Company, 29 Broadway, New York.

We teach you all there is to know about candy making here at the institute or by Correspondence Course. Good income can be made on a moderate investment. The Candy Institute, 876-A Flatbush Ave., Brooklyn, N. Y.

ELECTRICITY Taught by experts; earn while you learn at home; electrical book and proof lessons free; your success guaranteed and position secured. Chicago Engineering Works, Dept. 515, 2144 Lawrence Ave., Chicago.

PROFITABLE Plans Magazine: Contains hundreds of money-making propositions, new ideas, plans, tips, and special articles. Copy 10c. Year, \$1. 3 months, 25c. Bohn Publishing Co., Wilkes-Barre, Pa.

TREMENDOUS profits having others sell Straw Hat Cleaner, Self-threading Needles, etc., for premiums. Free instructions, samples, factory prices. Address Patten Perfume Corporation, 631 "H" Street, Washington, D. C.

\$1,600.00 **MONTHLY** made easily. The greatest business opportunity in years. See our advertisement under "High-Grade Salesmen Wanted." Foster Laboratories.

OPEN Hat and Clothes Cleaning Parlor at home. Big profits. Particulars Free. Byron, Box 27, Station I, New York, N. Y.

"**HOW** and What to Invent for Profit," free. Patent News-C, Washington, D. C.

BECOME Master Dealer—Learn Secrets Real Estate Success. Be Independent. Big Profits Either Sex. Special Offer Free. Stephens System, 618 Wyzor, Muncie, Ind.

MANUFACTURE Extracts, and other necessities. 200% profit; we tell you how. Write White Manufacturing Drug Co., Box 322, Cincinnati, O.

SELL Books by Mail; start spare time, few dollars capital. Particulars free. Jack Pansy, 157-M, East 47th St., New York.

\$3.50 BRINGS 1,000% profit mail order proposition. Pettits, Longdale, Okla.

MAKE Something every auto owner wants. Big profits. Address Howard Lindsey, Sacandaga, N. Y.

LEARN Plating—Automobile Painting—Refinishing. Plans Free. Norman Borick, 427 Carroll St., Akron, Ohio.

HAT Cleaning and Blocking: Some time ago we compiled a book of instructions covering this line of work, which explains both the Simplex Blockless Method of Hat Cleaning and the Simplex Block Method of Hat Cleaning, covering in detail the handling of Felt, Straw and Panama hats, with and without blocks. The book was issued for the benefit of our customers to whom we sold supplies. However, we recently discontinued this particular line and have a limited number of these instruction books still on hand. Former price \$5.00. While supply lasts, \$2.00 per copy, postpaid, including list of supply houses where anything in the line may be purchased. This is an opportunity for you to get into a splendid, profitable business with very little outlay. Send today. E. W. Bender & Co., Dry Cleaners Supplies, Charlotte, N. C.

\$3.50 POCKET Adding Machines. Wonderful seller. Bassett, 1458 E. Hollywood Ave., Chicago.

MAKE Rubber Stamps. We furnish Everything. Big profits. Enormous demand. Write now. Sears, Ashland, Ohio.

COMMERCIAL Engraving and Printing—the most practical and complete book on engraving, printing and allied subjects ever published. Over 800 pages and 1,500 illustrations presenting over 3,500 distinct ideas on 35 separate subjects. Cloth, Price \$15.00 prepaid. We highly recommend this book. Popular Mechanics Book Dept., 6 N. Michigan Ave., Chicago.

GOOD money easily earned at home, spare time silvering mirrors; no capital. Free instructive book tells how. Patterson & Co., Brookville, Ky.

IF you have about \$1,000 and capable of organizing sales force, to sell article needed by every merchant, wholesaler and retailer, which should net you \$10,000 profits first year, write Sales Director, 826 Reaper Block, Chicago.

I MADE \$30 a week home. French bread-making. 15 years' experience; free booklet tells. Ashbrook, 67, Marengo, O.

BE Independent. We teach by mail how to manufacture unexcelled Toilet Preparations. Earn while you learn. Results guaranteed. Particulars Free. School of Cosmetics, Box K, Omaha, Nebr.

FREE—Formula Catalog. S. & H. Laboratories, Boylston Building, Chicago.

LEARN the collection business. Good income, quick results. Interesting booklet, "Skillful Collecting," free. National Collectors Assn., Long St., Newark, O.

MEN Wanted to earn \$3,000 to \$10,000 a year. Prepare quickly and easily through our amazing system for profitable and permanent business reclaiming waste paper for largest manufacturers in country. Boys do the work—you simply direct. Practically no investment necessary—a few dollars will start you. Simply send name for big free opportunity book—a post card will do. Write The Traub System, 303 Traub Bldg., Kansas City, Mo.

MAIL Order Business is your opportunity. Brenner's Famous Handbooks teach how to start small, grow big. Sell merchandise, service, ideas; enormous profits. Spare time to begin. Get complete set, 11 books, \$3.00, and on posted, Brenner, 335 Walnut, Philadelphia. Descriptive Catalog and big batch interesting mail order information. 25c. None free.

\$100,000 CORPORATION wants capable man; open office; manage sales for High Class New Device. Every Home a Prospect. Big money-making possibilities for the right man. Opening in every city. Cost \$2.00, retails \$5.00. \$500 to \$2,000 necessary to finance exclusive agency. Scott Corporation, 82 W. Washington, Desk G, Chicago.

EXCEPTIONAL Opportunity for Sales Manager capable of handling state distribution. Marvelous new Adding Machine. Retails \$15. Work equals \$350 machine. Tremendous possibilities. Unlimited profits. Write quick for details. Lightning Calculator Co., Dept. B, Grand Rapids, Mich.

RESPONSIBLE Corporation wants general sales managers to open branch office, manage salesmen. \$500 to \$5,000 necessary; expenses allowed to Baltimore if you qualify. Address Manager, 603 N. Eutaw St., Baltimore, Md.

CLEAN Wallpaper and Window Shades this winter and spring. Big demand. Take large contracts. We show you how. C. Swanson & Sons, Mankato, Minn.

THIS May Be Your Opportunity. A large, modern Middle Western manufacturing institution will consider proposals from inventors and small manufacturers, with a view of manufacturing on royalty basis or of buying outright. Small brass products preferred, but any high-grade proposition will be considered. Address P. O. Box 426 Kokomo, Ind.

WE Start You in Business, furnishing everything; men and women. \$30.00 to \$100.00 weekly operating our "New System Specialty Candy Factories" anywhere. Opportunity lifetime; booklet free. W. Hillyer Ragsdale, Drawer 4, East Orange, N. J.

"**SCHEMER** Magazine," Alliance Ohio, prints big profit schemes; one subscriber making \$25,000 from three; another \$10,000 from one. Try your luck. Year, only \$1.00; three months, 25c.

START a Paying Business of Your Own. Be a business man. Any location. 8,000 new Tire Vulcanizing and Repair Stations needed. Business always good. Are you ambitious? \$200 will start you. Write at once. Wonderful opportunity. Equipment Co., 11 Canal, Cincinnati, Ohio.

INDEPENDENCE and prosperity await you in the furniture cleaning business. Course \$1.00. Circular free. Send today. Address E. M. Ellis, 110 Riverside Ave., Newark, N. J.

MARBLE mixing instructions, covering wood or cement flooring 1/2 inch thick, fireproof, waterproof, low cost, sanitary, all colors. Particulars, 200 illustrations free. Chris Mahler, Box 122, Huntington, N. Y.

LET Me Show you how to make real money. Absolutely new proposition and new products. Materials cost \$2.00, sell for \$16.00. One man sold a thousand dollars' worth in a week. Exclusive manufacturing and sales rights to one man in each territory. Write today for booklet 5, Crouch, Chemist, 309 Broadway, New York.

SILVERING Mirrors! My exclusive French Tartaric method opens enormously profitable business. Booklet free. H. Barstow, 514 23d Street, Oakland, Calif.

CHEMICAL Expert will furnish Formulas and Trade Secrets. All lines. Lists Free. W. L. Cummings, Ph.D., 228 Gordon Ave., Syracuse, N. Y.

CHEMISTRY

EXPERT Chemical Analysis. Formulas furnished. Reasonable. S. W. Bower, Ph. C., 24 Norway Park, Buffalo, N. Y.

CHEMICAL and bacteriological examinations guaranteed accurate. Formulas, processes. Write me about your chemical problems. List free. J. F. Mazur, M. B., 937 W. 20 St., Lorain, Ohio.

FORMULAS AND TRADE SECRETS

AUTO-TOP Paint, Tobacco Cure, Luminous Paint, Metal-Shine Beads, Sneez Powder, Itch Powder, Wallpaper-Clean, Shade-Clean, Windshield-Clean, Universal-Clean, Washing-Wonder. Each 25c, 3 for 50c, 20 Selected 10c. Chemists, 2845 So. Kedvale, Chicago.

500 FORMULAS, 20c. Luminous paint—Resilvering Mirrors—Renewing dry batteries—Mechanics' Soap—Gas Tonic—Carbon remover. Puncture Plugger, 20c each. Entire collection, 50c. Ideal Book Shop, 5501PE, North Robey, Chicago.

NEWSHINE Auto and Furniture Polish. Second to none; cleans and polishes, leaves dry surface; costs 50c gallon. Formula \$1. Snyder, Box 512, Marshall, Texas.

RICH Gloss Auto and Furniture Polish. Something new, best on market. Low cost to manufacture. Formula \$1. Pank, 31 Cleveland Ave., Nutley, N. J.

ABSOLUTELY any formula. Satisfaction guaranteed, \$1.00. Robert Tyler, 256 Park St., Newton, Mass.

1,000,000 FORMULAS, Trade Secrets, for Every Business, \$2.25. Ideal Book Shop, 5501ME, North Robey, Chicago.

550 RARE Formulas for 25c (coin). We can furnish any formula wanted for 50c. Allen's Enterprises, 1227 Milwaukee Ave., Chicago, Ill.

10,000 SELECTED scientific, chemical technological and practical recipes and processes including hundreds of so-called trade secrets for every business alphabetically arranged in one large volume of 800 pages, Price \$4 postpaid. Popular Mechanics Book Dept. 6 N. Michigan Ave., Chicago.

SPANISH inventor has finally obtained U. S. Patent for new process for plating glass (crystal) without use of heating, Rochelle salt, Ether, Formol or Seignette salt. Cost of plating crystal per square foot, 2c. No machinery, no capital necessary. A man can silver 500 square feet daily. Anyone can make and silver mirrors. Experience unnecessary. Can make \$10 a day at home. Get raw materials in any drug store. Guaranteed 10 years. Copy of formula with instructions for use and permission, 20 pesetas (\$3.00). Express or International money order. Antonio Formoso, Santa Catalina, 12 La Coruna, Spain.

FORMULAS—Catalogue free. "Clover," 5501CE, North Robey, Chicago.

FORMULAS, 20c—Luminous Paint, Paint-Varnish Remover, Gasoline Tonic, Hand-Cleaning Paste, Auto-Furniture Veneer, Battery Renewer, Auto Top Dressing, Polishing Cloth, Cementless Patches, Puncture Plugger, Auto Body Cleaner, Auto See-Clear, Entire Collection \$1.00. Myers, Box 280, Reading, Pa.

REMARKABLE Discovery—Positively removes tattoos, coal marks, moles; safe, sure, simple process. Original since 1918. Formula \$1.00. Harding Co., 142 Dearborn St., Philadelphia.

FORMULAS of the better sort. Write for our free catalog. National Scientific Laboratories, 824 Main, Richmond, Va.

3,000 FORMULAS—400 pages, \$1.00. Catalogue free. Englewood Book Shop, 7021A So. Winchester, Chicago.

FREE—Formula Catalog. S. & H. Laboratories, Hoylton Building, Chicago.

BUSINESS SERVICE

SOUTH Carolina, Rock Hill, Collections, Legal Business. J. H. Foster.

INCORPORATE. Our lawyers do the work, saving you time, annoyance and money in incorporating under the most liberal laws of Arizona. Laws and forms free. Southwestern Securities & Investment Co., Box D488, Phoenix, Ariz.

AGENTS WANTED

WHIRLWIND money-maker for agents—sample free. Sell powdered Hanslick, an absolutely new, non-competitive, and unbeatable hand cleanser. Removes grease, grime, ink, paint, etc., without slightest injury to skin. Its use spreads like wildfire. Cheaper than all others. Sells in cans (or bulk with dispensers) to garages, autoists, mechanics, factory and office folks, to housewives, hardware stores and to auto supply houses. Huge quantities used weekly by mercantile houses. (Names on request.) Big repeat business assured. Exclusive agencies, crews working for you, fast sales, splendid profits and a permanent business for hustlers. Live ones can clean up \$500 a month. Send 2c stamp for postage on Free sample. Complete sales plan goes with it. Write quick to Solar Products Company, 124 W. Lake St., Chicago, Ill.

55% PROFIT: Quick, Easy Seller. Klean-Rite New Washing Compound. Washes clothes without rubbing. Women wild over it. Write quick for Free package and Special Offer. Besterer Products Co., 1941-K5, Irving Park, Chicago.

AGENTS—Salesmen—Dealers. 50c postal order brings Agent's Sample and wonderful offer on newly invented self-selling-vest-pocket magnetic extractor for removing foreign bodies from the eyes. Everybody buys. Gem Cylinder Extractor Co. (a), 9924 Malta St., Chicago.

\$100 REWARD will be paid to the first person who proves that the Keystone Economizer fails to save 25% to 50% of any car's ordinary gasoline consumption and entirely eliminate carbon. This is a bona fide offer. The Keystone Economizer is a real gasoline saver which has made good. Results Guaranteed. More mileage, more power, less cost. Fits any car. Easily attached. Saves its cost in a month. \$4 post-paid. Splendid offer for factory representatives, agents and salesmen. Write or wire for particulars to Keystone Economizer Co., Stock Exchange Bldg., Los Angeles, Calif.

TAILORING Agents Wanted—Make \$50.00 to \$100.00 and more per week, selling our wonderful all wool one price line. Suits sell for \$29.50. None higher. Retail stores ask at least \$50.00 for the same quality. Also strong line of featherweight fabrics to sell at \$16.75 per suit. You collect your profits at once. We ship C. O. D. to customer for balance. We furnish beautiful 6x9 swatch outfit and powerful co-operation. Hustlers write at once. Salesmanager J. B. Simpson, Inc., Dept. A-81, 831 West Adams Street, Chicago, Ill.

AGENTS—Here's a sure winner. We pay \$3 an hour for your spare time taking orders for "Zanol" Pure Food Flavors. Miss Edith Haut made \$34 in one week. Write for sample case. Makes beautiful display. Shows 18 articles of best and fastest sellers of Flavors, Soaps, Perfumes, Toilet Articles, etc. Every woman buys. Big repeaters. Have a steady income. Customer must be satisfied or money back. Send for sample case today. American Products Co., 5725 American Bldg., Cincinnati, Ohio.

AGENTS Wanted—Something New—Fire Fighter sells easily. Makes a spectacular demonstration—car owners, homes, factories, stores practically buy on sight. Our men make \$10 to \$50 a day—exclusive territory. If you wish to establish a business of your own with unlimited possibilities for making big money, write us today. Fyr-Fyter Co., 103 Fyr-Fyter Bldg., Dayton, Ohio.

AGENTS \$8 a day taking orders for In-syde Tyres. Positively prevent punctures and blowouts. Guaranteed double tire mileage. Old worn out casings will give 3 to 5 thousand miles more service. No tools needed. Just slip inside casing before replacing tube. Will not heat or pinch. Katz made over \$500 first month. Biggest thing on the market. Low priced. Write for territory. American Accessories Co., B-1078, Cincinnati, Ohio.

MANUFACTURERS Agents—District Managers—Crew Managers—Get immediately our proposition. Mother Goose Wringer Mop—New, Patented, Perfect. Saves the back—Housewife stands erect to do all scrubbing—Hands never touch the water. Retail \$1.50. More than 100% profit. Sample prepaid \$1.00. We had to double size of factory last year to handle the orders. You can make a small fortune. The Alline Company, 6523 Euclid Avenue, Cleveland, Ohio.

AGENTS—Enormous profits selling Genuine Gold Leaf sign letters. Guaranteed not to fade. Establish a permanent business or travel. Anybody can do it. Free samples. Guarantee Sign Service, A 450 South California Ave., Chicago.

AGENTS—Easy, quick sales. \$60 to \$100 weekly. Valuable free premium to every customer. You write orders. We deliver and collect. Commissions daily. No capital or experience. Wonderful new solid aluminum handle, big cutlery set, sells itself. Best year-round proposition. Sample outfit free. Also free Ford car offer. New Era Mfg. Co., 803 Madison St., Dept. 21, Chicago.

EVERPLAY Phonograph Needle plays 27,000 times. Better tone and reproduction. Preserves records. Fits all phonographs like ordinary needle. Not a jewel. Point renewed as used from 9 inches of soft special alloy wire coiled within the needle. Saves \$40. Retail \$1.00. No dealers to huck. Big profits. Everplay, 1 McKay Bldg., San Francisco, Calif.

WE pay \$7 a day taking orders for Stainless Steel Cutlery Set. Guaranteed. Aluminum handle. We deliver direct to your customer and pay you every day. Big demand. No capital or experience needed. Big money for spare time. Complete outfit to workers. Parker Mfg. Co., 278 Awt St., Dayton, Ohio.

WRITE quick for territory and sample of Joy, newest, most up to date soft drink product out. Nothing like it. Makes delicious refreshing summer drinks for the home, picnics, parties, etc. Agents make \$40 to \$100 a week. Postal will do Arthur N. Christy & Co., 53 Main, Newark, N. Y.

\$5 TO \$15 daily introducing new style guaranteed hosiery; must wear or replace free; no capital or experience required; just show samples; write orders. Your pay in advance; we deliver and collect; elegant outfit furnished, all colors and grades, including silks. Mac-O-Chee Mills Co., Desk 10, Cincinnati, Ohio.

AGENTS—We want agents to sell our Guaranteed Batteries for Automobile Starting and Lighting; our Batteries are right in quality and price. (Ford size sells for \$16.00.) We will furnish you instructions for installing, and pay you a good commission. Box 96, Defiance, Ohio.

MOTOR Ignition Amplifier—A Wonder Invention! Gives new power to an old motor and more power to the new. Sell to garages, accessory dealers and users. Quick action, big money and satisfaction. Write for prices and literature. Motor Ignition Corporation, Mfrs., Albany, N. Y.

BIG Profits Selling New \$3.50 Automatic Adding Machine. Absolutely accurate. Fully guaranteed. Quick sales. Ten daily easy. No competition. Pocket size. Business people everywhere positive customers. Thousands being sold. Tremendous demand. Here's high-grade money-maker. Bassett Co., 1458-D, Hollywood Ave., Chicago.

HIGH-GRADE agents for entirely new accessory for any automobile. Makes night driving safe. Can carry in pocket; every car owner buys. Fits any make. Men who can stand big profits and stay on job. Ray Auto Filter Company, Marton, Ind.

PUT the Allen Day and Night Electric two-way Auto Signal any place on your car and operate it with your left hand on the steering wheel. In the U. S. \$10.00. Agents wanted, Allen, 105 North 6th St., Portland, Ore.

MAKE \$12.00 to \$15.00 daily. Sell Crimp Grip Clothes Line Fasteners. Every housewife a prospect. Over 5,000 satisfied purchasers in one community. 50c brings you one pair and one demonstrator's sample. Money back if not satisfied. Write for particulars. Don't delay. Crimp Grip Company, Belvidere, Ill. Dept. M.

AGENTS coloring money with our women's household aprons and other rubberized goods; children's aprons, pinafores and sun-bonnets, utility bags, etc. Best goods made at least prices. Write for catalog 11. The Schafus Corporation, 466 Broome St., New York, N. Y.

AGENTS—Here's Big Money and Independence. \$2.50 invested nets \$28.25 profit—\$5.00 nets \$83.00. Apply initials to side doors of autos. Every car owner a prospect. Newark Monogram Company, Desk 16, 568 Broad Street, Newark, N. J.

MAKE \$50.00 to \$100.00 and more per week, selling our wonderful all wool one price line. Suits sell for \$29.50. None better. Retail stores ask at least \$50.00 for the same quality. Also strong line of feather-weight fabrics to sell at \$16.75 per suit. You collect your profits at once. We ship C. O. D. to customer for balance. We furnish beautiful 6x9 swatch outfit and powerful co-operation. Hustlers write at once. Salesmanager J. B. Simpson, Inc., Dept. A-58, 831 West Adams Street, Chicago, Ill.

SPECIAL Offer to agents to sell full line of rubber specialties; aprons; baby supplies; drug sundries, etc. We make deliveries and collections. For information write to Everybody's Rubber Supply Co., 220 Third Ave., Pittsburgh, Pa.

PATENTS—Trademarks. Before disclosing an invention, the inventor should write for my blank form "Evidence of Conception." This should be signed, witnessed and returned to me with sketch or model upon receipt of which I will promptly render opinion as to patentable nature and send booklet on Patents. Highest references. Prompt attention. Reasonable terms. Clarence B. O'Brien, Registered Patent Lawyer, Woodward Building, Washington, D. C.

MAKE \$50 Daily. Something New! 400% profit. All business, professional men need it. Sells \$5. Costs \$1. Brooks, Texas, sold 20 first day, profit \$80. Big weekly repeater. Sells quickly. Experience unnecessary. Write today for territory wanted. Sample outfit free. Federal Association, 71-K Asylum St., Hartford, Conn.

\$25 A DAY Easy—Selling remarkable new invention "Simplex Ironing Board Covers." Biggest seller in years. Every woman wants one. New agent sold 100 in two days (profit \$75.00). You may do as well or better. Write quick. Address, W. J. Lynch, Box 718, Springfield, Ill.

SIM'S Shoe Ventilator gives positive relief for sweaty and tender feet. Absolutely new proven article. Easy sales. Agents wanted to buy in dozen lots. Send \$3.50 for sample pair—credited on your first one dozen order. Full particulars. W. B. Sims, 315 Mason St., Portland, Ore.

AGENTS—District agents. Povar, a new polish that varnishes; sells on demonstration to households and automobile owners; big repeater and big profits; exclusive territory for hustlers; exp. unnecessary. Write for city or county rights. American Povar Corp., 530 W. 58th St., New York.

DISTRIBUTORS or Salesmen can make quick commission profits selling live necessary auto accessory to trade or users. Retail \$1.75. Exclusive territory available or can be sold some sections as convenient immediate delivery bidline. Approved Appliances Corp., Box 14, Ann Arbor, Mich.

AUTO-LAVATORY. Keeps Motorists Clean. Invisible, Perfected, Cheap, Necessary. Slickest Device Out. Sells on Sight. Trial Satisfaction Guaranteed. OK. Carbon Gun—Scientifically Removes Carbon. Saves Money and Time. Big Sellers. Agents' Sample, \$1.25. No competition. Emmens Manufacturing Co., Alliance, Ohio.

AGENTS. Knocks the spots out of all fabrics. Great for spring cleaning. Cleans everything. Guaranteed Dry Cleaner. House to house or sell to stores wholesale. Unlimited demand. Send 25c for formula and full instructions. Bright Star Chemical. 1240 Michigan, Chicago.

AGENTS—Men or Women—Build a substantial business selling article that steadily increases and repeats. Sold under money-refund guarantee. Territory being rapidly assigned. Write for particulars today. The Zeeta Company, Inc., Dept. 14, 1819 Broadway, New York City.

AGENTS—Big money, \$8 to \$16 a day. Aluminum handle cutlery set. Brand new. You display and take orders. We deliver and collect. Pay you daily. Sample free. Try it out. Jennings Mfg. Co., Dept. 1668, Dayton, Ohio.

\$72 WEEKLY to start. You sell. We deliver. New beautiful Cocobolo handle cutlery set sells itself to men or women. Five-year guarantee. Sample free. Eastern Keenware Co., Franklinville, N. Y.

SALES Representative wanted every county to give all or spare time. Position worth \$1,200 to \$3,000 yearly. No previous experience or capital necessary. Write for full particulars. A. A. Silver-Chamberlin Co., Clayton, N. J.

GOLD Sign letters for stores and office windows. Photo pillow tops, portraits, frames, sheet pictures, medallions, waterproof aprons, novelties. Samples, catalogue free. Thirty days' credit. James C. Bailey Co., Desk J5, Chicago, Ill.

GOOD Opportunity for Few Reliable Men. Sell advertising thermometers made by the world's largest thermometer makers. Liberal commissions. Sales easy. Write giving experience and references. T. B. Div. Taylor Instrument Companies, Rochester, N. Y.

SELL Mengo Stiletto Patches for tires and tubes. Every Auto Owner and Dealer buys. Appoint Sub-Agents. Exclusive territory. Sales Plan and Free Sample. Mengo Products Co., 533 Rosedale, Pittsburgh, Pa.

3 IN 1 Bags, \$5 per dozen. Sells for \$1.25 each. Send 50c for sample. Write for catalog of 100 sure sellers. Economy Sales Co., Dept. X, Boston, Mass.

CABBAGE Cutter, 5 knives, slices 20 vegetables, like aluminum, don't rust, never dulls, 20,000 users Cincinnati alone, endorsed by Good Housekeeping Institute. Sample 48c. Meyer Co., Orland Ave., Cincinnati, Ohio.

SALESMEN—Agents, sell 15c article, cost 2c; new selling plan; no canvassing or talking required. Plans Free. Sample 15c. H. & E. System, Dept. P1, Lock Box 477, Chicago.

SOMETHING Big. Dime puts you on our mailing list one year. You receive latest money-making opportunities, propositions, from manufacturers and supply houses everywhere. Kentucky Agency, Covington, Ky.

SIDE line men and agents wanted to sell novelties. Tell us what territory you cover. Your references. We do the rest. Bradford & Co., Inc., St. Joseph, Mich.

\$50,000 "PROFITS in Portraits" explains in Free Circular, 24 hour service Prints. Portraits, Frames. Samples Free. Picture Man Friedman, Dept. 8, 127 N. Dearborn, Chicago.

AGENTS, sell newly invented Pie Trimmer and Crimper, 100% profit; sample and particulars 20 cents. Address Don Risk, 1378 W. Cedar Ave., Denver, Colo.

BIG profits, men or women, selling non-competitive Ford Sedan and open-car beds. Saves hotel bills. Outers Equipment Company, 812 Mayer Building, Milwaukee, Wis.

AGENTS—Sell Our Marvel Can Opener. Make \$4 on every \$2 invested. Our tip—your opportunity. Write us now. Staples Mfg. Co., Mt. Vernon, Ind.

SELLS like hot cakes; big profits; new ironing wax; perfumes clothes with lasting violet perfume. Working outfit 10c. Yankee Manufacturers, 380 Atlantic Ave., Brooklyn, N. Y.

LATEST, niftiest, simplest folding automobile and camping stool ever devised. Sells also like wildfire at parades, public gatherings, etc. 100% profit. Minecke, Alhambra, Calif.

A BUSINESS of your own—Make sparkling glass name plates, numbers, checkerboards, medallions, signs; big illustrated book free. E. Palmer, 511 Wooster, O.

AGENTS and Salesmen wanted for a high-grade shoe polish. Write for territory to L. Vorgias, 116 N. Paulina St., Chicago, Ill.

AGENTS Make \$1.50 on every shirt order from manufacturer direct to wearer. Menzies Shirt Co., 3863 3rd Ave., New York City.

WONDERFUL seller! 2,400% profit! Different! Dime brings sample, full details. Refunded on first order. Address Frost, Box 67, San Diego, Calif.

WANTED—Representatives to handle "Success" Products. Used every day in every home. Sales Department, Elms Commercial College, Newark, N. Y.

AGENTS—Wonderfully fascinating pocket novelty just patented; mammoth profits; sample twenty cents. Address L. L. Martin, Paterson, N. J.

POCKETKNIFE with renewable blade. Wonderful seller. Agents wanted everywhere. Sample 25c. Particulars free. Kolar Company, Dallas, Texas.

HART'S Fruit Drink Tablets. Sample ten drinks ten cents coin. E. C. Arehart, Stickney, S. D.

\$10 DAILY Easy with my specialty, 500% profit. K. Home, 1957 Warren, Chicago.

AGENTS—Don't overlook our proposition on page 142. C. B. Haven Co.

PROTECT Your rights. Write for Record of Invention which contains form to establish evidence of conception of your invention. Prompt personal service. Preliminary advice without charge. J. Reaney Kelly, 612 G, Columbian Bldg., Washington, D. C.

\$5,000 IS easily yours in 1922. Greatest Ford Accessory ever invented. Performs \$20 job for \$2. Every Ford owner buys on sight. Exclusive territory. Reserve yours today. Leslie Muter Co., 69th and Vincennes Ave., Chicago.

AGENTS: 100% Profit. King Carbon Remover for automobile engines and King Vapor Flash Gas Saver eagerly bought by auto owners. Write for our special offer. Get started now. Address King-Gates Company, Fort Madison, Ia.

SALES Agents, men or women; Year-round position. No layoffs. Take orders for Jennings new guaranteed hosiery. Must wear and give satisfaction or replaced free. Write for outfit. Jennings Mfg. Co., Dept. 168, Dayton, Ohio.

MEN wanted to work in the metal finishing oxidizing and plating lines. \$12 daily and quick advancement assured. Work is permanent. No capital or experience necessary. Write for particulars. Metallcraft Co., 1135 Broadway (154), New York, N. Y.

AGENTS, Beginners, mail-order men. Valuable tips and inside information free. 300% profit. Also 17 auto specialties. Nite Mail Order & Supply Co., 609 27th St., Denver, Colo.

AGENTS are making fabulous sums selling our gold leaf house numbers and signs, such as: "Deliver Goods in Rear," "Notary Public," "Rooms," etc. Write for particulars. Creed Glass Sign Works, 844 Altgeld St., Chicago.

SOMETHING new in stove and nickel polish; will clean and polish nickel parts and blacken stove in one operation; men and women agents and canvassers wanted. Gabel Brothers, Garnerville, N. Y.

MONEY Made quickly taking orders for portrait medallions. No investment required. No competition. Send for our 1922 illustrated catalogue and details. Puffin & Goldstein, Dept. D, 259 Bowery, New York.

"GLARESCOPE"—New auto accessory, just out, nothing else like it on the market; \$15.00 to \$20.00 daily easy; retails at \$2.00. Write for exclusive proposition, American Reflector Co., Hammond, Ind.

WRITE for particulars. Best article ever offered men. Costs 5c, sells quick for Dollar. \$20 daily, easily made. Knapp, 758 Fifteenth Street, Milwaukee, Wis.

AGENTS—Unusual opportunity. Handsome profit to live agents. Every autoist convinced by demonstration. Write today for attractive proposition. Address Blasdel Products Co., 4319 McPherson Ave., St. Louis, Mo.

SELL Wilson hats from factory to wearer. Extraordinary commission. We deliver and collect. Every man a customer. Address Wilson Hat Works, Dept. P, Montclair, N. J.

WHY not make \$7.25 on each sale? Make more money easier and quicker than ever before. Address Paul G. Towsley, Ashton Bldg., Grand Rapids, Mich.

EARN \$10.00 daily silvering mirrors, plating and refinishing metalware, autos, chandeliers, bedsteads. Outfits furnished. E. Deche Laboratories, 286 Fifth Ave., New York, N. Y.

\$50 WEEKLY selling self-threading needles. Sample terms, etc., 10c. L. Castle Co., Hagerstown, Md.

AGENTS make big profits selling guaranteed Fountain Pens. Details and sample \$2.00. Money refunded if unsatisfactory. Golden Rule Mfg. Co., 135 Maiden Lane, New York.

AGENTS—Men or women. New household article. Make \$5 to \$15 daily. Big repeater. Send at once for particulars. Address National Industries, Elmira, N. Y.

AGENTS—Noxog Ink Powder sells houses, offices, schools, stores. Guaranteed satisfactory. Send 30c for package. Other necessities. Knox Chemical Co., Dept. 5, Rockland, Maine.

AGENTS, Just out! No Sag attachment for screen doors; big profits; sample 25c. Manufactured by Anderson & Co., North Easton, Mass.

RUBBER Belts. Demonstration sells every man. Priced so you undersell stores. Make \$50-\$100 weekly. Sample free to workers. Mathias, 35 So. Dearborn, Chicago.

AGENTS—Don't overlook our proposition on page 142. C. B. Haven Co.

AGENTS make big money, selling Earl's Cutwell Pocket Pencil Sharpener. Sells on sight. Sample 25c, full particulars. B. G. Earl, 56 E. Randolph, Chicago.

SIGNS for stores and offices. Entirely new. \$50 week easily made. Chicago Sign System, 1150 W. Austin Ave., Chicago.

HOME employment evenings. Start little Mail Order business anywhere. Everything furnished. Stamp brings instructive booklet. R. Pier, 72 Cortlandt Street, New York, N. Y.

EXTRACT Men: Sell Vanilla, Lemon and Orange in bulk at one-half price. Wonderful goods. Profit 200%. Address Trusk, Manufacturer, Temple, Maine.

WOULD good durable paints and varnish 40c gallon interest you? Then write today. Dept. 2, Emmelmann Bros. Mfg. Co., Indianapolis, Ind.

AGENTS—The fastest selling and newest known article on earth. Imported Automatic Propeller Hand Ventilator Fan. Thompson, 706 Chestnut, St. Louis.

\$15.00 DAILY, Soliciting, Opening Agencies for Resharpening Blades, or Selling Finest Improved \$1.00 Razor. Standard Safety Razor Corp., Pittsburgh, Pa.

AGENTS—200% Profit handling full line Quick Selling toilet preparations. Write today for catalogue. National Soap Company, 20 E. Lake St., Chicago.

COLLECT Names—Highest prices paid. Instructions 50c. Easterbalm Co., 1827-P Welton, Denver, Colo.

JUST Out! Four quick sellers; samples free. Benedict, 2309 Flora, Dallas, Texas.

SELL—"Tricks of the trades"—Drawing—Lettering, \$1.00. Freeburn, Hicksville, Ohio.

WONDERFUL New Invention Sharpens Razors and Safeties. Free Trial. Schmidt Mfg. Co., Winesburg, Ohio.

MEN Only. Sell New Novelty. Sample 25 cents. Howard Eddy, Meriden, Conn.

RAZORNIFF—Agent's sample 10c. Gits, 5512 Potomac Ave., Chicago, Ill.

\$1 BRINGS Sample and big salary offer. Smok-It, Longdale, Oklahoma.

POSITIVE Repeater. Enormous Profits. Every housewife needs. Sample 10c. Address Utility Co., Popular St., Chippewa Falls, Wis.

AGENTS Plan. make 95% profit. Write Box 191, James City, Pa.

WANTED—Agents and Salesmen to handle Europe's Famous Wonder Glass, the newly imported Prisma "Binoculette." For theatre, hunting, yachting, races, touring, aviation, etc. This is the smallest and of its size the most powerful Glass in the world. Can be carried in vest pocket or ladies' bag. Retail at \$25.00. Confidential wholesale price to agents \$12.50. Send money with order to George Mayerle Optical Co., General Importers, established 1891, 960 Market St., San Francisco, Calif. (Send for catalog.)

SUBSCRIPTION Agents Wanted to sell subscriptions for business magazine. Big book—leader in its field. No turn in. Our men make \$15.00 to \$30.00 a day. Exclusive territory. This is an unusual opportunity to make a permanent and profitable connection with one of the biggest trade-paper publishers in America. Only high-grade men will be considered. Send references and photo, which will be returned if desired. Penton Publishing Co., Cleveland, O.

AGENTS: \$60 a week selling guaranteed hosiery for men, women and children. Must wear 12 months or replaced free. All styles and colors, including finest line of silk hose. Mrs. McClure makes over \$2000 a year. Mrs. Schurman averages \$60 a month working spare time. Geo. Noble made \$35 in one day. Write for sample outfit. Thomas Mfg. Co., Class 562, Dayton, O.

\$40 DAILY can be made selling Marvel Picture Reproducers. They go as fast as you can hand them out after demonstrating in stores, carnivals, etc., or direct to school children. See ad page 148. Send 50c for 3 sample sets and wholesale price list. The Nova Co., Department 2, 326 River St., Chicago.

AGENTS—Don't overlook our proposition on page 142. C. B. Haven Co.

TERRITORY Salesman: First popular price Fire Extinguisher ever made. Retail \$5. Others cost \$15. Every home, office or factory can be sold. One man sold 12,000 in Dayton. Peck cleaning up in Detroit. \$90 a week. No capital. No experience. Territory going fast. Write Thurston Mfg. Co., 178 Foe St., Dayton, Ohio.

STARTLING Agents' proposition—\$100 weekly selling Rolly's Washday Wonder, New Chemical Dirt Solvent, Harmless. Cleans without rubbing. Enormous profits. Repeat orders assured. Experience unnecessary. Territory going fast. Samples going fast. Samples free. Rolly Chemical Co., Al. Hastings, Neb.

PURE twenty-three Karat deep gold leaf, aluminum leaf and many other styles of entirely new window sign letters. Boston Window Lettering System, 210 Dover St., Boston, Mass.

AGENTS—Big money taking orders Suits, Pants, Blankets, Raincoats, direct woolen mill to wearer. Big values. Donahue made \$168.00 first week. Pinocel makes \$200.00 weekly. Complete outfit free. Taylor, Wells & Co., A2740 N. Paulina, Chicago.

AGENTS: See our display advertisement on page 157 in this magazine, then write us immediately. Wide awake agents need no other line. Address, Sales Dept., The Kaxo Company, Cambridge, 39, Mass.

DOZAL—In tubes—cleans and polishes stove and nickel trimming one operation; nothing like it on market; sensational seller and repeater; 150% profit, easily demonstrated, wonderful leader. Address W. B. Williams Co., Montclair, N. J.

\$25.00 REWARD paid for any Corn Great Christopher Positive Corn Cure cannot remove. Also good for Warts, Bunions, Moles and Callouses. Price 35c. Particulars free. Reliable Specialty Corporation, Buffalo, N. Y.

AGENTS. Men or Women, full or spare time, earn \$25.00 to \$100.00 a week and be your own boss representing the Ho-Ro-Co Mfg. Co., manufacturers of the wonderful Ho-Ro-Co Tonic, the great blood purifier and system builder; some profit-maker. Ho-Ro-Co Medicated Skin and Scalp Soap for the baby, toilet, bath, skin and scalp; a repeater. Over 100 other fast-selling specialties, toilet preparations, perfumes, flavoring extracts, spices, medicinal preparations and household specialties. Every item a fast seller and a big profit-maker. Don't fail to ask for our free sample case offer. We furnish advertising matter and samples free of charge. Ho-Ro-Co representatives are successful. Write today. Ho-Ro-Co Mfg. Co., 154 Locust St., St. Louis, Mo.

WONDERFUL Small Article, every man needs. Agent sold 14 one office; profit \$2.45. Carry hundred in pocket. Particulars and 2 samples 25c. Arrow Manufacturing Co., 1629 Lloyd, Milwaukee.

DEPENDABLE Gold Jewelry—Specialties. Beautiful Raylite Diamonds, Rings, Scarf Pins, Soap Links, Stretching Kuff Buttons, at Factory Prices. Very profitable line. Master Jewelers, Sheboygan, Wis.

LEARN modern automobile Refinishing Business Correctly. No Previous Experience Required. Big, unlimited money-making opportunities everywhere. Fred DeWilde, Sheboygan, Wis.

AGENTS: Sell Wolverine Laundry Soap. Big Profits. Monthly bonus to workers. Write quick. Wolverine Soap Co., 314 Water St., Portland, Mich.

NEWEST, fastest-selling household necessity. Agents wiring for gross lots. Sample free for 10c postage. C. Ladwig, 1369 Broadway, New York.

"MILLIONS Will Be Sold." Latest Creation. \$2.00 investment nets \$50.00 three days' work. Dept. 105, 4035 Minnehaha, Minneapolis, Minn.

AGENTS Learn about the profits supplying perfumes to families. Ask Lefler & Co., 753 Walton, St. Louis, Mo.

AGENTS make \$50.00 weekly selling Yankee Wringer Mop; sample free. Schoff Co., 2248 North Ave., Chicago.

AGENTS: We have Sheep Wool polishers, cleaners and dusters. Bennington Duster Co., East Boston, Mass.

AGENTS—\$1,000.00 monthly. See our advertisement under "High-Grade Salesmen Wanted." Foster Laboratories.

FITS any Collar, Samples, etc., 15c. Necktie Form & Holder, Elgin, Ill.

HOW and What to Invent for profit, free. Patent News-A, Washington, D. C.

GOOD prices paid for butterflies, insects. See Sinclair's Display Advertisement, page 28.

AGENTS, salesmen, jobbers, dealers—every poultry owner a customer! Life Preserver—a dependable remedy for white diarrhoea, roup and cholera among poultry. 16 oz. bottle. \$1.00 postpaid. Walter Achard, 4863 Lincoln Ave., Chicago, Ill.

"HOW to Sell Patents" free. Patent News-H, Washington, D. C.

AGENTS. Self-threading needles. Fastest household seller. Sells 15c. Costs 4c. Address Maher Co., Dover, N. J.

MANUFACTURER offers unusual opportunity to experienced crew managers or agents in your home territory. This is an opportunity of a life time for right parties. Product is best seller ever offered and repeat business is simply phenomenal. Tremendous demand already existing with absolutely no competition. If you're making less than \$300.00 monthly—write. All replies considered confidential. State experience and qualifications fully. C. L. Beardsley, Rock Island, Ill.

\$6.00 TO \$12.00 a day. Experience unnecessary with our original plans. Household necessity used in every home. 25c to \$1.50 sale eight out of ten calls. Not sold in stores. Territory going quick. Big concern. Write quick for free sample and plans. The Jiffy Soap Products Co., Dept. 1, Dayton, O.

MAIL Order Business is your opportunity. Brenner's Famous Handbooks teach how to start small, grow big. Sell merchandise, service, ideas; enormous profits. Spare time to begin. Get complete set, 10 books, \$2, and be posted. Brenner, 235A Walnut, Philadelphia. Descriptive Catalogue and big batch interesting mail order information, 25c. None free.

NO Dull Times selling food—people must eat. Federal distributors make big money; \$3,000 yearly and up; no capital or experience needed; guaranteed sales; unsold goods may be returned; your name on packages, build your own business. Free Samples to customers. Repeat orders sure. Exclusive territory. Ask now! Federal Pure Food Co., Dept. 10, Chicago.

AGENTS make \$5.00 per day in spare time introducing Greatest Tire Valve on the market. Stops and prevents leaks. Fits all tires. Rush for particulars. Sample 50c. Stopik Tire Mfg. Co., Buffalo, N. Y.

AGENTS: Men and women, in spare or full time, make big money selling household necessity. Every home a prospect. Quick sales, big profit. Territory open. Write for particulars. Judd & Leland Manufacturing Company, Box 21, Clifton Springs, N. Y.

AGENTS—Sell Patented Cigar Lighters and Cigar-Case Moisteners. Big Profits. Start making money at once. Write for circulars, cuts and sales plan. Drake Mfg. Co., Dept. M., Milwaukee, Wis.

MEN or Women—Enormous Profits selling Duo Guaranteed Products. Easy Sales at every house. All or spare time. Big repeaters. Write Quick, Duo Co., Dept. Y-1, Attica, N. Y.

SELL Pudding Powders—Delicious dessert. Fast sellers; quick repeaters; big profit. Send for terms and sample. C. H. Stuart Co., 75 Broadway, Newark, New York.

WANTED—Responsible man to take Exclusive State Agency and Distributor for Ford Timers. Olof A. Eckra, Kindred, No. Dak.

POLISHING Cloth—great seller—big profit. Get our proposition. Newton & Co., 19 Main St., Newark, N. Y.

AGENTS—Sell Electric Body Batteries for Nervous Diseases and Rheumatism. Nealeigh & Co., Indianapolis, Ind.

EVERYBODY uses Extracts. Sell Duo Double Strength Extracts. Complete line necessities. Big repeaters. Write today. Duo Co., Dept. E-1, Attica, N. Y.

BIGGEST, fastest sellers. Every woman buys Hawkins' High Grade Toilet and Household Necessities on sight. 100% profit. Colonial Chemical Co., 631 Penn Ave., Pittsburgh, Pa.

FREE Sample "Rain Shield Wiper." Retail \$1.00—Costs You 25 Cents (300% Profit). Every Autoist Buys Quickly. No Cloth. No Paste. No Mechanical Attachment. (1) Rub keeps Windshields clear 48 Hours against Rain, Snow Storms. Invention Just Out. Prevents Accidents. (Williams makes \$12 Hour.) Experience Unnecessary. Wonderful Pocket Sideliner. Write Quick for Your Free Sample. Nu-Life (B) Corporation, Hartford, Conn.

AGENTS—Here's big money and independence. \$5 starts your own business. Be independent—our line assures your future prosperity. Jaco Comb Straps are not a novelty but a necessity—a quick seller and big repeater. What others have done you can do. Act now—write for proposition and exclusive territory. 25c brings sample. The Jay Company, Desk 6, Washington, N. J.

100% PROFIT selling our felt rugs to homes, hotels, offices, etc. Everybody buys. We are manufacturers, not jobbers. Prices defy competition. \$75 week easy. Newark Felt Rug Company, 56-C Bergen Street, Newark, N. J.

MIDGET Collapsible Garment Hangers sell fast. Penknife size in beautiful leather case. 100% profit. Sample 35c. Money back if not satisfied. Kalina Company, 384-B Alabama Avenue, Brooklyn, N. Y.

MANUFACTURE Extracts, and other necessities, 200% profit; we tell you how. Write White Manufacturing Drug Co., Box 322, Cincinnati, O.

NEW Garter. Patented pen. No knots, pads, etc. \$1.00 doz.; \$5.50 gross. Art Needle Co., 513 N. Dearborn, Chicago, Ill.

MAKE big money, whole or spare time, selling high grade Pure Aluminum Combination Cooking Utensils with new features that every Housewife wants and can afford. Our unique plans make you welcome and get the business. Exclusive territory—no sales limit. Here's chance to connect with a live one. Unlimited stock—prompt shipments. Apply today—Now. Perfection Aluminum Mfg. Co., Lemont, Ill.

SOFT Drinks In Powder; ten kinds. Just add cold water and sugar; no trouble. Fine for the home, picnics, parties, dances, etc. Many make \$10 to \$50 day. Ten-glass package, best drink you ever tasted, and particularly 10c postpaid. Morrissey Company, 4403-11 Madison St., Chicago.

IMMENSE profits selling rear-end automobile safety stop-lights. Prevents accidents. Costs \$1.35, retails \$5.00. Sample sent C. O. D. with full particulars. National Stoplite Co., 178 W. Randolph, Chicago.

SALESPeople. \$1.00 starts you in business. Costs 15c. Sells for \$1.50. 75c package sent for 4c. Address Texply Co., Somerville, N. J.

AGENTS: 1922's Greatest Sensation. 11-piece toilet article set selling like blazes at \$1.75 with \$1.00 dressmaker's shears free to each customer. Line up with Davis for 1922. E. M. Davis Co., Dept. 504, Chicago.

PLYMOUTH Bags. We are selling this popular bag in green, black, blue and brown leathette, cretonne lined, \$5-\$6.50-\$7.20 and \$10 per dozen. Sample 65c prepaid. Write for free samples of material. E. Condon, Mfg., 12 Pearl St., Boston, Mass.

LIVE Agents make \$10 Day selling Eureka Strainer and Splash Preventor for every water faucet. Takes on sight. Widely advertised and known. Get details today. A. B. Seed Filter Company, 73 Franklin, New York.

MAKE 600% Profit, Free Samples, Lowest priced Gold window letters for stores, offices. Anybody can do it. Large demand. Exclusive territory. Big future. Sideline. Acme Letter Co., 2840-D, Congress, Chicago.

POLMET Polishing Cloth works like magic. Cleans all metals. Gets the attention and money. Fast seller at 25 cents. Sample Free. A. A. Gale Company, 15 Edinboro Street, Boston.

WORLD'S Fastest Agents' Seller. 400% Profit. Needed in every home, office and store. Establish permanent profitable business. Free Sample. Premier Mfg. Co., Detroit, Mich.

\$1.00 SALE means 75 cents profit for you. Wonderful New Automobile Invention. Each Quick Demonstration means Sure Sale. Experience not necessary. Riley made \$108 three days. Stocum made \$10 first hour. Prevents Accidents. Gives Better Service. Carried in Pocket. Mail 25 Cents for \$1.00 sample. (Money Back Instantly.) Write Quick for Sample and Exclusive Territory. (Invention, Box 494), Hartford, Conn.

AT Last—World's Greatest Adding Machine. Almost human. Retails \$15; work equals \$300 machine. \$500 monthly easily made, demonstrating to stores, offices, garages, factories. Simple, easy; adds, subtracts, multiplies, divides, automatically. Speedy, accurate, durable, handsome. Five year guarantee. Tremendous demand; amazing profits. Liberal trial offer. Protected territory. Write quick. Lightning Calculator Corp., Dept. F, Smith Bldg., Grand Rapids, Mich.

AGENTS Sell Neverfail Iron Rust and Stain Remover. Huge profits. Big line. Sample. Write today. Sanford Beal Co., Inc., Newark, N. Y., Dept. 6.

AGENTS—Advertising Pencils, ready sellers, excellent sideline. Write for proposition. North American Pencil Works, 310 So. Canal St., Chicago.

AGENTS—\$60-\$200 a week. Free Samples. Gold Sign letters anyone can put on store windows. Liberal offer to general agents. Metallic Letter Co., 431-C N. Clark St., Chicago.

GALLAGHER made \$336.00 in one week selling guaranteed Collection Systems, used by all business men. Sayers Mfg., 2815 Sheffield Ave., Chicago, Ill.

BIG profits. Sell Plate Glass Wind Deflectors, Rear View Mirrors, Aluminum Foot Scrapers and 20 nationally advertised accessories. Car owners, Dealers, Garages buy one to gross. Write quick for illustrated catalog and agency prices. Rapid Sales Corporation, 11-D Grand Rapids, Michigan.

AGENTS—Big Profits, Gold Sign letters easily applied, samples free. Liberal offer to General Agents. Dept. C, Interstate Sign, 2620 No. Halsted St., Chicago.

EARN Big Money Fast applying Lithogram Initials to automobile doors. Every owner buys. \$1.35 Profit on each sale. Full particulars mailed. Address, Lithogram Company, 17-8 East Orange, N. J.

YOU can make \$12,000 a year selling well-known, standard, advertised make of hand-drawn chemical fire engines, motor fire apparatus, extinguishers, hose, and complete line of fire-fighting sundries. We have several openings in good territories. Other men are making \$1,000 a month in territories not so good as we now offer. Address Ajax Fire Engine Works, Bush Terminal Bldg., 10, Brooklyn, N. Y.

\$1,000 MADE by Wings in six weeks selling Never Fail Razor Sharpener. Purdy made \$40.50 first day. Other inexperienced men cleaning up big money. Applewhite, La., six orders in thirty minutes. Hurry—investigate—exclusive territory. Write today. Never Fail Co., 126 Allen Bldg., Toledo, O.

AGENTS wanted to handle good automobile accessory line. Fine commissions. J. D. Ignition Construction Co., 4724 Lowe Ave., Chicago, Ill.

AGENTS—Big profits selling "Wunrub Polish" for Furniture, Woodwork, Autos, Etc. Cleans and Polishes. Fritch's Laboratories, 6431 Magnolia, Chicago.

WONDERFUL article for direct selling. Address, Sanitary Mfg. Supply, Dept. 5, Akron, Ohio.

SELL Ladies' Art Embroidery Needle. Sample 50 cents. Eugene Marquis, 5200 North Keystone, Indianapolis, Ind.

AGENTS Make \$10 a day selling Pressurized Trouser presser and creaser. Connolly, 55 Vesey St., New York.

AGENTS Wanted, to sell an improved tool that often pays for itself first time used. Address today, J. 1040 Georgia St., Los Angeles, Calif.

\$1,000 PER man per county. Get yours. Inexperienced men pulling down star salesmen's profits. Write for proof: How farmers, ministers, clerks—men in all walks of life—made big money in whole or spare time. You can do it. Amazing proposition—wanted everywhere. Exclusive territory—no sales limit. A hot or cold running water bath equipment for any home at only \$7.50. Self-heating. No plumbing nor water works required. Investigate. Terms. Send no money. Write letter or postal to day. Allen Mfg. Co., 654 Allen Bldg., Toledo, Ohio.

PORTRAIT Agents—A new portrait, something entirely different. Write for particulars, also catalogue and price list. Fidelity Portrait Company, Dept. 100, 3047 Harrison St., Chicago, Ill.

WHY work for others? Make and sell your own goods. We show you how. Enormous profits. Write quick for free book explaining everything. National Scientific Laboratories, 624 Main, Richmond, Va.

AGENTS, we have the finest needle case. You can clear \$50.00 to \$200.00 weekly. Send 10c for sample, sells 25c. Empire Specialties Co., 1519 N. Wells, Dept. 501, Chicago, Ill.

SELFOLITE—Agents, Streetmen—Selfolite lights any fire while user sleeps, or any time. Performs surprising stunts. Newly patented. Sample 25c, postpaid; money back. Particulars. Kaytwo Mfg. Co., C195 Station A, Boston, Mass.

AGENTS: Big Profits. Genuine Gold Leaf Window Letters anyone can put up. Scripts and 57 varieties. Chicago Agency Co., 842 Altgeld St., Chicago.

AGENTS wanted to sell "Havana Treat" 5c cigars to Smokers and Stores. Havana Treat Cigar Co., Utica, N. Y.

BUILD Permanent Business following our Sure Success Plan introducing Guaranteed Hosiery and Underwear from factory to family. Attractive outfit assures quick sales. Large profits. Investigate for yourself. Address C & D Company, 41-B, Grand Rapids, Mich.

GOOD Income, spare time, refinishing chandeliers, brass beds, automobiles, etc., by new method; producing amazing results; every household possible customer; experience unnecessary; simple plan of manufacturing at home starts you in big money-making business. Write for free samples, showing finishes, etc. Gunmetal Finish Co., Ave. H, Decatur, Ill.

COPPER Pots, all sizes; also anything in copper goods desired. Write today for free catalog. Boyer & Co., 609 Reserve Bank Bldg., Omaha, Neb.

GOLD Leaf Sign Letters; make and sell; profits exceed 1,000%; immense demand; particulars free. Johnston Co., Quincy, Ill.

AGENTS—Terve Remedies 200%. Address Int'l. Remedy Co., 1331 Franklin, St. Louis, Mo.

AGENTS—New Invention. Harper's Ten-Use Brush Set and Fibre Broom. It sweeps, washes and dries upstairs windows, scrubs and mops floors and does five other things. Big profits; easy seller. Free trial offer. Harper Brush Works, Dept. X, Fairfield, Iowa.

EASY, pleasant work for Mechanics. Shop Men, Clerks, during spare hours; will add many dollars to their salaries. Also want persons who can give full time. Big wages assured. Novelty Cutlery Co., 67 Bar St., Canton, O.

IF you need good live agents—fellows who can get the business—ask me how others are doing it. I'll gladly render the necessary assistance. J. Roy McClellan, Mgr. Classified Advertising, Popular Mechanics Magazine, Chicago.

BE Successful Agent—Free sample outfit worth \$2.25. "Quality" beauty preparations. Make big money. Extensive line. Established 50 years. Lyuas Co., 214, Logansport, Ind.

FREE—Formula Catalog. S. & H. Laboratories, Boylston Building, Chicago.

AGENTS make 140% profit. Iridium (luminous) crucifix shines in the dark. Sells for \$2.00. Costs 84c. Complete line religious articles, crucifixes, bulbs, switch plates, house numbers and match boxes. Novel! Ornamental! Useful! Every home a prospect. Big sales. Get free demonstrating outfit. The Pioneer Corporation, 1259 W. 63d St., Chicago, Ill.

AMERICO Booster auxiliary water carburetor makes auto burn water. Eliminates carbon. Low cost; liberal profits; details free. Americo Co., Dept. 178, Cincinnati, Ohio.

ANY man handy with paint brush can start new mechanical business on nearly nothing; needed everywhere; nearly all profit; experience not required. John Braceland, 1457 So. Ninth, Philadelphia, Pa.

AGENTS—Clever Invention! Inkspoon makes every pen a fountain pen. Fast office seller; big profit, demand increasing everywhere. Exclusive territory offered. Sample free. H. Marul Company, Tribune Bldg., New York, N. Y.

WRITE for particulars; best article ever offered men; costs 5c, sells quick for dollar; \$15 daily; sworn statement. Beach, 22 Express Bldg., San Diego, Cal.

SELL Necessities. Everybody needs and buys the "Business Guide." Bryant cleared \$800.00 in July. Send for sample. It's free. Nichols Co., Box 4-B, Naperville, Ill.

AGENTS make 500% profit handling Auto Monograms, Snow Pictures, Window Letters, Transfer Flags, Novelty Signs. Catalog Free. Write Hinton Co., Star City, Ind.

PORTRAIT Agents, who want good work and prompt service and who desire to purchase their frames at factory prices, should write us at once for catalog and price list. W. G. Hanson Co., Dept. A-5, 57 E. 18th St., Chicago, Ill.

AGENTS—New patented curtain rod, necessity in every home; big profit; 4 to 19 sales at every house. Write for free sample. Home Curtain Rod Co., Providence, R. I.

LARGE shirt manufacturer wants Agents to sell complete line of shirts direct to wearer. Exclusive patterns. Big values. Free samples. Madison Mills, 503 Broadway, New York.

CALIFORNIA Rosebuds selling like hot cakes. Agents coinng money; new stuff. Big profits. Catalog free. Mission Bead Co., PM-2819, West Pico, Los Angeles.

AGENTS: Big Money Monogramming By Transfer Method. Catalogue Showing Over 50 Styles and Particulars Free. Motorists' Accessories Co., Mansfield, Ohio.

\$200 WEEKLY. Free samples. Sell gold sign letters to stores, offices. No experience. Big future guaranteed. Can travel. Exclusive territory. Become our general agent. Acme Letter Co., 2800D Congress, Chicago.

MAKE \$25 to \$50 Week representing Clows' Famous Philadelphia Hosiery, direct from mill—for men, women, children. Every pair guaranteed. Prices that win. Free book "How to Start" tells the story. George Clows Company, Desk 31, Philadelphia, Pa.

YOU can letter Automobiles, Doors, Trunks etc., without any previous experience by Transfer Process. Make \$27.50 on \$2.50 Outfit. Auto Monogram Supply Co., 16 Green St., Newark, N. J.

BEST Proposition on Earth. Kitchen Specialty Every Woman Wants. Nothing like it in existence. 200% profit. Best Novelty Mfg. Co., Dept. C, 160 N. Wells, Chicago.

WE Start You Without a Dollar. Soaps, Extracts, Perfumes, Toilet Goods. Experience unnecessary. Carnation Co., 201 Olive, St. Louis.

AGENTS and portrait men. Crew managers. We give you more for your money. Better and quicker service. Lowest prices on frames and glass. Refects credited. Catalog free. The Pioneer Corporation, 1259-A West 63rd St., Chicago.

WANTED—Tailoring Sales Agent—Make big money from very start—\$40.00 to \$75.00 weekly. Largest made-to-measure tailoring house, furnishing an equipment of five hundred woolsens, wants you to take orders. Satisfaction guaranteed. Biggest merchants in many towns have started with our line. If you want to establish yourself permanently in business and make big money write for full particulars, giving your experience as salesman or tailor's sales agent. H. F. Foster, Sales Manager, Lock Box 483, Chicago.

MOST Wonderful Seller. 90c profit every dollar. No stock to carry. License unnecessary. Sample free. Mission Bead Co., 1617 Iroia, Los Angeles, Calif.

AGENTS—Best seller: Jem Rubber Repair for tires and tubes; supersedes vulcanization at saving of over 80%; put it on cold, vulcanizes itself in two minutes, and is guaranteed to last the life of the tire or tube. Sells to every auto owner and accessory dealer. For particulars how to make big money and free sample, address Amazon Rubber Co., Amazon Bldg., Philadelphia, Pa., Dept. 505.

AGENTS—If you are making less than \$300 a month our proposition on Sentinel Burglar Alarms for windows and doors will interest you. Many agents earn \$20 daily. Brand new inventions. No wires, batteries or nails. Instantly attached to any door or window. Handsomely nickel plated. Sell on sight. No competition. Provides cheap burglar insurance. Big money makers. Write today for extremely liberal terms to agents. Sentinel Alarm Co., 140 S. Dearborn St., Chicago, Ill.

AGENTS—Stamping names on Pocket Key Protectors; sample check with your name and address, 25c. Stamping Outfits, Emblem Checks, Check Fobs, Name Plates. Hart Mfg. Co., Desk 2, 303 Degraw St., Brooklyn, N. Y.

YOU can be your own boss with our Key Check outfit. Good for \$5 a day stamping names on pocket key checks, fobs, etc. Sample check with your name and address. 20 cents. Pease Die Works, Dept. M, Winchester, N. H.

PATENTS—Write for our free illustrated guide book and Evidence of Conception Blank. Send sketch or model for our opinion of its patentable nature free. Highest references. Prompt attention. Reasonable terms. Victor J. Evans & Co., 163 Ninth, Washington, D. C.

PORTRAIT Agents: Our goods will make you big profits. Delivery guaranteed. Refects credited. Prompt shipments. Send for latest catalog and prices. Adam J. Kroll & Co., 602 Blue Island Ave., Chicago, Ill.

BIG money and Fast Sales. Every owner buys Gold Initials for his auto. You charge \$1.50; make \$1.35. Ten orders a day easy. Write for particulars and free samples. American Monogram Co., Dept. 40, East Orange, N. J.

DICHINOLINDIMETHYLSULPHATE. It's a Chemical Millers The Chemist supplies Latest Manufacturers' Formulas for Food, Beverage, Household, Automobile, Summer Specialties in all lines. Grape-ola New Beverage with the Kick. Stamp brings Lists. Valuable Information to start a business paying Fifty to Five Hundred Dollars weekly with small investment. Miller, Chemist, Tampa, Florida.

AGENTS: Big profits. Best and cheapest window letters made. Easily applied. Dime brings five samples. Particulars free. Stalbrite Co., 1115 Second Ave., New York.

MAKE \$2 an Hour. Article that removes iron rust, grass, medicine, fruit, mildew stains. Cleans Panama and Straw Hats. Bleaches clothes. Sells Every home. Write for free demonstrating outfit and start taking orders at once. Christy, 81A Union, Newark, N. Y.

AGENTS: Big Returns, fast office sellers; particulars and samples free. One Dip Pen Co., 2 Daily Record, Baltimore, Md.

AGENTS make a dollar an hour. Sell Mendets, a patent patch for instantly mending leaks in all utensils. Sample package free. Collette Mfg. Co., Dept. 404-B, Amsterdam, N. Y.

AGENTS: Make \$75.00 a week selling our strictly All-Wool made-to-measure suits at \$26.50. You collect profits in advance and keep them. We supply finest selling outfit in America. Many exclusive money-making features. Tailoring, raincoat and side-line men, part or full time, get in touch with us immediately. Address Dept. 95, Goodwear, Inc., 843 W. Adams St., Chicago.

OUR Ex-Cel Luminous Crucifix shines brilliantly in the dark. Churches, hospitals and individuals are only waiting for a demonstration before buying. Agents make handsome profits. W. G. Hannan Co., Dept. B, 57 E. 18th St., Chicago.

HIGH-GRADE SALESMEN WANTED

MAKE \$50 to \$100 per week selling direct to wearer our \$20, \$24, \$28 line of Virgin wool made-to-measure Suits and Top Coats. You get your profit the minute sale is closed; experience not necessary. We teach you how and furnish everything to do business with; no extra charges for double breasted or fancy coats, extra sizes or skeleton linings. House of Campbell, Campbell Building, 456 South State St., Chicago, Ill.

WANTED—Salesmen experienced in selling books, aluminum, magazines, portraits, office specialties, chautauqua desks and household labor-saving devices. Business expansion creates openings for 800 red-blooded men. Write today for "The North Ridge Way to Better Pay." Give age, education and experience. North Ridge Brush Company, Chicago Avenue, Freeport, Ill.

MAKE \$2.75 profit every sale to car owner. Dealers readily sold in quantities proportionally larger profit. Excellent side line for man with car already covering automobile trade; commission basis. Other men making big money—why not you? Horgan Cavanagh Co., 933-945 W. Washington Blvd., Chicago.

ONLY one policy a day means \$130 per month profit; same on renewals. Policy pays \$5,000 death; \$25 weekly benefit for injury or sickness. Premium \$10 yearly. Full or spare time. Easy seller. Write quick for territory. Underwriters, Dept. K-29, Newark, N. J.

MAKE \$8.00 to \$16.00 per day selling Bradley Universal Signal to car owners. Combined signal parking light and road mirror. Quickly demonstrated, a proven seller. Earn \$4.20 commission each \$12.00 sale. Write Jones Automotive Supply Company, 1403 Hennepin, Minneapolis, Minn.

SALESMEN Wanted in Every Town in the United States to Sell a New Guarantee Fountain Pen. Makes \$10 to \$12 a Day. Send 50c for Sample and Particulars, to Y. Loughlin, 6317 So. Halsted St., Chicago, Ill.

SALESMAN. If you want \$6,000 this year write me. Strong line for retail stores. Nationally advertised. Liberal weekly advance to producers. W. Morgan, Mgr., 1920 Euclid, Cleveland, Ohio, Dept. 290.

SALESMEN to sell to Auto and Electric Supply concerns a complete line of replacement ignition wires for Ford Cars. Sold on commission basis. Address, Grossman Auto Parts Co., White Plains, N. Y.

LEATHER Advertising Specialties, highest quality, lowest prices. Every bank and merchant a prospective buyer. High commissions. Write now to Eastern Leather Specialty Co., 226 Lafayette St., New York, N. Y.

SIX live patented auto accessories: Oil Gauge, Windshield Cleaners, Hose Clamp, etc. No investment. Big commissions. Address Sales Mgr., 32 Sta. C, Omaha, Nebr.

SELL Holmes Tires and Tubes. No capital required. \$100 weekly income. Price sells them, quality gets reorders. Holmes Rubber Co., 1500 W. 15th, Dept. F, Chicago.

SALESMEN wanted for men's shoes sold direct from factory to wearer. Commission one dollar per pair. K-W Shoe Company, Bonhuar Building, Chicago, Ill.

\$5 TO \$15 daily introducing new style guaranteed hosiery; must wear or replace free; no capital or experience required; just show samples, write orders. Your pay in advance; we deliver and collect; elegant outfit furnished; all colors and grades, including silks. Mac-O-Chee Mills Co., Desk 1065, Cincinnati, Ohio.

SELL our men's tailored to measure \$23.50 suits and "Shedrain Dressy Top Coats" direct to wearer. This low price makes numerous sales and big commissions certain. Commissions paid daily. Special Proposition to men writing immediately. Style-Center, Cincinnati.

BIG money selling "Delta" Replacement Parts for Ford Cars to dealers. Product standard. Exclusive territory. Also complete line Radio equipment ready soon. Give references. Delta Products Co., Kresge Bldg., Detroit.

SALESMEN—Sell Zim's Peerless Collection System (108 letters). Professional and business men need it. Has special, exclusive features. Sells \$7.50. Costs you \$2.00. Creditors' Association, 312 McKnight Bldg., Minneapolis, Minn.

SALESMEN, Agents, County Distributors: Sell Schaefer Oilwatch. Most positive oil-gauge for Ford Cars on market. Good commissions. Protected territory. Philip Schaefer & Co., 20 East Jackson Blvd., Chicago.

SIX Live Patented auto accessories: Oil gauge, windshield cleaners, hose clamp, etc. No investment. Big commissions. Address Sales Mgr. 32, Sta. C, Omaha, Nebr.

JOIN Hands with Foster and Success. Twenty quick and easy sales daily will make you over One Thousand Dollars monthly. Present men are doing better than this. Sells to Dealers. No canvassing. District and State Managers can make Thirty Thousand Dollars yearly. Salesmen, side-line men, agents, general agents, crew managers and sales agencies, write or wire for particulars. If you want quick action send \$2.00 for \$9.00 sample. Money back if you want it. Address Foster Laboratories, Dept. 295-P, Eau Claire, Wis.

SALESMEN who travel in Ford cars—Sell the Dual Front Spring System for Fords, a line that has no equal nor competition. Eliminates the front Radius Rod; two front springs and a pair of Shock Absorbers gives the Ford the stability and finished appearance of a high-priced car. Write for plan; will not interfere with your present line. Evans-Cooke Mfg. Corp., 2320 Fairmount Ave., Philadelphia, Pa.

SALESMEN: Sell State pocket maps showing auto roads, to advertisers and dealers. Easy to sell. Get our splendid offer. Standard Map Company, 127 W. Ohio St., Chicago.

AGENTS sell Peck's Soft Metal Rivets for mending any kind pots or pans. 100% profit. Sample free. E. E. Peck Co., Dept. A, Medina, N. Y.

BEST Seller: Jem Rubber Repair for tires and tubes; supersedes vulcanization at saving of over 80%; put it on cold, vulcanizes itself in two minutes, guaranteed to last life of tire or tube; sells to every auto owner and accessory dealer. Get particulars how to make big money and free sample. Amazon Rubber Co., Philadelphia, Pa., Dept. 510.

SELF-ADJUSTING Robert Wrench, most wonderful wrench on market. Grasps pipes, nuts, bolts. Sells for \$1.85. You make 90c on each. Sample 95c. Write Robert Wrench Co., 71-C Murray St., New York.

DISTRICT Sales Managers and Salesmen. Get our proposition selling men's high-grade shoes direct from manufacturer. No collections or deliveries. Commissions daily. Dept. 16, Quick Shoe Co., Brockton, Mass.

SOMETHING New, a necessity. All business and professional men need it. Sells \$7.50, costs you \$2.50. Big repeater. Sample free. Merchants Assn., Minneapolis, Minn.

SPECIALTY Salesmen here's your chance. Want it? Nifty, clever little Cataract Washer cleanses autos quickly. Attaches to Garden Hose. All Brass—can't rust. Won't mar finest varnish. Every car owner a customer. Two Styles No. 1—\$2.50, No. 2—\$1.75. Handsome Profits. Dept. P., Cataract Auto Washer Co., Topeka, Kansas.

ASKO—Salesmen to sell Auto Acc. as side line; can carry sample in vest pocket; sells on sight. Big comm. Write for sample. Allon Specialty Co., 2721 West Lake St., Chicago.

"OUTOSITE," aluminum hip suspenders, 50c. Shirt down, pants up. Enormous seller. Woods, 501 North Seventh, St. Louis.

SELL Advertising Pencils. Big Commissions. Quick Sellers. Write for Proposition. Keystone Pencil Works, Altoona, Pa.

SPECIALTY Salesmen calling on Garages and Accessory Dealers, to handle side line, "Oil King" Piston and Compression Rings. Dygert & Siemers, Chamber of Commerce Building, Los Angeles, California.

57 MILES per gallon made with new patented gasoline Vaporizer. Write for particulars. Vaporizer Co., Pukwana, S. Dak.

EVERYBODY Eats Every Day. You can handle Sugar, Flour, Canned Goods, Dried Fruit, Coffee, and entire line of groceries, as well as Paints, Roofing, Aluminum Ware and Automobile Oils, with no rent to pay; no money invested; take large orders from samples. Goods are guaranteed and proven quality. Selling experience not necessary. Steady, profitable work for "workers." Address Hitchcock-Hill Co., Dept. 200, Chicago, Ill. Reference: Any Bank or Express Co.

SALESMEN can make \$5.00 a day selling our Calendars, Fans, Pencils, Signs, Advertising Novelties, Yard Sticks, Whistles, etc. Liberal terms. Sells entire year. Fine side lines. Local and traveling agencies. Model Calendar Company, Dept. 226, South Bend, Ind.

\$300 PER month and bonus guaranteed salesmen successfully demonstrating wonderful new adding machine. Retail \$15.00. Work equals \$350 machine. Genuine opportunity. Full time or side-line. Lightning Calculator Co., Dept. G, Grand Rapids, Mich.

AGENTS—\$40-\$200 a week. Free samples. Gold sign letters anyone can put on store windows. Liberal offer to general agents. Metallic Letter Co., 431-E N. Clark St., Chicago.

LIVE Wire Distributors and Dealers everywhere make money selling Seal-Fast inner-tube repair kits because of the unequalled efficiency and our aggressive and helpful sales promotion and advertising co-operation. Write Sales Manager for particulars. Robert M. Bowers Co., Indianapolis, Ind.

HELP WANTED

DISTRICT Managers—Big Profits! Men capable of organizing and managing crews of lady solicitors can easily clear \$100 to \$200 per week with the B. & G. Protector, the original and best Protector on the market. Every woman between fifteen and fifty needs and buys it. Two grades, Flesh or White. B. & G. Rubber Co., 618 Penn Avenue, Dept. 147, Pittsburgh, Pa.

DISTRICT Manager: 150,000 sales of a household appliance in New England have paid District Managers upwards of \$3,000 yearly. We are ready to expand. Office work entire or side line. The Reeves Co., 64 Broad Street, Milford, Conn.

SIGN Letter Agents and Painters: 500% Profit. Gold and Silver Sign Letters for Stores and Office Windows. Anyone can put on. Big demand. Free Samples. Metallic Letter Co., 431D N. Clark St., Chicago.

CLERKS—Young men, women, over 17, desiring government positions, \$125 monthly; write for free list of positions now open. Raymond Terry (former Civil Service Examiner), 1504 Continental Bldg., Washington, D. C.

FIREMEN, Brakemen, Baggage-men, Electric Motormen, Conductors, Sleeping Car and Train Porters (colored). Railroads everywhere \$140-\$200. 819 Railway Bureau, East St. Louis, Ill.

FINGER Print Lesson based on Henry System included with Detective Course. Particulars free. Write, American System, 1968 Broadway, New York.

DISTRIBUTORS, District Salesmen, Managers, Agents. Do you know that we make the best Waterproof Aprons and Sanitary Specialties on the market? Sell for less, and your profits are largest. Write now and convince yourself. B. G. Rubber Mfg. Co., 618 Penn Ave., Dept. 148, Pittsburgh, Pa.

\$5 TO \$15 daily introducing new style guaranteed hosiery; must wear or replace free; no capital or experience required; just show samples; write orders. Your pay in advance; we deliver and collect; elegant outfit furnished; all colors and grades, including silks. Mac-O-Chee Mills Co., Desk 1055, Cincinnati, Ohio.

EVERY business needs Bookkeepers. Earn \$25 to \$100 weekly. Learn quickly at home. Easiest system ever produced. Small cost. Particulars free. Write: Winter Accounting School, 412 31st St., Milwaukee, Wis.

LOCOMOTIVE Firemen, beginners, \$150; later \$250 monthly, for railroads nearest their homes, everywhere in United States and Canada. Address Railway Association, Desk M-1, Brooklyn, N. Y.

EARN \$10 daily silvering mirrors, plating and refinishing metalware, autos, chandeliers, bedsteads. Outfits furnished. E. Decie Laboratories, 286 Fifth Avenue, New York.

HOME employment evenings. Start little Mail Order business anywhere. Everything furnished. Stamp brings Instructive Booklet. D. Pier, 72 Cortlandt Street, New York, N. Y.

MEN wanted everywhere. Manage Rumage Sale Stores. Experience unnecessary. Enormous profits. Wholesale headquarters reclaimed clothing. Crosby Co., 609 Division, Chicago.

LADIES: Free Sample 4-point Automatic Rag Rug Embroidery Needle. Take orders. Coin money. Wholesale Supply Co., Valdosta, Ga.

GOVERNMENT needs Railway Mail Clerks, \$135 to \$192 month. Write for free specimen questions. Columbus Institute, E-2, Columbus, Ohio.

SEVERAL hundred men—boys, over 16, wanted immediately to prepare for U.S. Government positions. Railway Mail Clerks, City Mail Carriers, Postoffice Clerks, Customs Clerks, \$110 to \$192 month. Steady work. Short hours. Paid vacation. Common education sufficient. Write immediately for schedule of examinations. Franklin Institute, Dept. D-3, Rochester, N. Y.

\$100 MADE in one week by young man in small town without capital or experience in local advertising business. Why can't you do likewise? Free book tells how. S. Meyer, 211 Seventh St., Louisville, Ky.

\$1,000.00 MONTHLY. See our advertisement under "High-Grade Salesmen Wanted." Foster Laboratories.

WANTED—Railway Mail Clerks, \$133 month. List positions free. Write Franklin Institute, Dept. D-21, Rochester, N. Y.

WANTED—Men, women over 18 for United States Government positions. Good pay; lifetime jobs. Experience unnecessary. Write for full information. Chicago Civil Service College, Dept. A, Kesner Building, Chicago.

GOOD prices paid for butterflies, insects. See Sinclair's Display Advertisement, page 26.

\$5.50 POCKET Adding Machines. Wonderful seller. Bassett, 1458 F Hollywood Ave., Chicago.

YOUNG Men, over 21, fair education, for service and repair work on adding machines. Address, Dalton Adding Machine Co., Cincinnati.

JANITORS: You can make big extra money in your building. Write, J. Brace-land, 1437 So. Ninth, Philadelphia, Pa.

START Silvering Mirrors, Auto Headlights, Tableware, etc. Plans free. Clarence Spink, Dept. 28, Marion, Ind.

RAILWAY Mail Clerks wanted, \$133 month. Men, over 17. List positions free. Write Franklin Institute, Dept. D-21, Rochester, N. Y.

ELECTRICAL Manufacturer offers you a permanent opportunity. We want ambitious men looking for independent future. Write today for particulars to the Allmar Manufacturing Company, Marion, Indiana.

ALL men—women over 17, willing to accept Government Positions \$135 (Traveling or Stationary), write Mr. Ozment, 101 St. Louis, Mo.

SILVERING mirrors, French plate taught. Easy to learn, immense profits. Plans free. Wear Mirror Works, Excelsior Springs, Mo.

BE a Finger Print Expert. Particulars free. National System, 186 E. 79th, New York.

UNITED States Government Wants Men. Excellent positions at attractive salaries. Railway Mail Clerk Examination soon. Let our expert (former United States Civil Service Examiner) prepare you for this and other fine positions. Write today for free catalog P.M. Patterson Civil Service School, Rochester, N. Y.

BE a Railway Traffic Inspector! \$110 to \$250 monthly; expenses paid after 3 months' spare-time study. Splendid opportunities. Position guaranteed or money refunded. Write for free booklet CM-46. Stand. Business Training Inst., Buffalo, N. Y.

MEN, boys over 17, Get Government Jobs, \$92-\$192 month. List positions free. Write immediately. Franklin Institute, Dept. D-21, Rochester, N. Y.

STORIES, poems, plays, etc., are wanted for publication. Good ideas bring big money. Submit manuscripts or write Literary Bureau, 522, Humboldt, Mo.

START a Paying Business of Your Own. Be a business man. Any location. 8,000 new Tire Vulcanizing and Repair Stations needed. Business always good. Are you ambitious? \$100 will start you. Write at once. Wonderful opportunity. Equipment Co., 175 Canal, Cincinnati, Ohio.

WRITE Articles, stories, news, in spare time for newspapers and magazines. Big pay. Copyright book free. Press Syndicate, 553, St. Louis, Mo.

CALIFORNIA Rosebuds selling like hot cakes. Agents coining money. Absolutely new. Big profits. Catalog free. Mission Head Co., SP2819 West Pico, Los Angeles.

SALESMEN—Become Independent. Own your business; experience unnecessary; selling our \$7,500 Accidental Death, 350 Accident, \$25 Sick Weekly Benefits; \$12.50 yearly; other amounts proportionate. Guaranteed steady income from renewals. \$250,000 deposited Insurance Department, Registration Dept. A, Newark, N. J.

MAKE money writing Photo-plays; details free to beginners. No correspondence course. Producers' League, 230 Wainwright, St. Louis.

INVENTORS desiring to secure patents should write for our book, "How to Get Your Patent," tells our terms and methods. Send sketch for our opinion of its patentable nature. Randolph & Co., Patent Attorneys, 620 F, Washington, D. C.

OUR genuine gold window sign letters are an excellent money-making proposition for handy men. Sign Sign System, St. Antonio St., Detroit, Mich.

WANTED: Railway Mail Clerks—\$1,600 to \$2,300. Exams everywhere. Write today for full information. Patterson, Civil Service Expert, Box 4025, Rochester N. Y.

\$133 MONTH Commence. Government Railway Mail Clerks. Men—boys over 17. Steady. Common education sufficient. List positions free. Write immediately. Franklin Institute, Dept. D-21, Rochester, N. Y.

PARTNERS WANTED

WANT Partner to obtain patents on Electric Engine and Automatic Auto Top, both valuable inventions. Will give good interest to party supplying cash for patents. Address Leo Witcus, R. F. D. 2, Taylorville, Ill.

WANTED Partner—To furnish capital for the patenting of a Straight Air, Automatic Pressure Retaining Valve. Address, D. J. Graperine, 432 Green St., Belle Vernon, Pa.

FOR ADVERTISERS

ADVERTISE. 30 words 100 magazines \$1.50. Pennell Company, Covington, Ky.

YOUR 25-word advertisement in 75 magazines \$1.00. Riley, Publisher, 1333 S. 50th Court, Cicero, Ill.

ADVERTISE in 24 Big Sunday Newspapers, 25 words \$15.00. Catalog listing 1,000 leading Dailies, Weeklies, Magazines, 4c stamps, Union Advertising, Baltimore Bldg., Chicago.

ADVERTISE—Your 25-word ad. in 100 magazines for \$1.00. Sample Copy 10c. Harley Snell, 1021 State Ave., Cincinnati, Ohio.

ADVERTISING illustrations, designs, lettering and all kinds commercial drawings made to order by experienced artist. Reasonable. H. A. Grout, 3319 Tejon Street, Denver, Colo.

INCH Display Advertisement 161 Magazines Thrice \$15. Year \$50. Page \$100. Wood's Popular Services, Atlantic City, N. J.

LETTER SPECIALISTS

WHY experiment? \$5.00 and details bring wholesome, human, persuasive sales letters that pull thousands. Try me! Mormark, Garland Building, Los Angeles, Calif.

ATTENTION—Gripping, desire-creating sales letters. So strenuous they have to bring business. Ewald, 209 East 87th, New York.

BIGGEST Pullers on Earth—Jacobus Letters, \$3.50. Jacobus Advertising Service, Irvington, N. J.

MAILING LISTS

PROFITABLE Sales by Mail! Use reliable, authentic lists. 15,000,000 newly compiled classified names. Examples: 5,000 lady canvassers \$25.00; 200,000 wealthy rural mail order buyers, 3,000,000 farmers (by states), \$6.00 thousand. Responsible firm. You'll want more. Martineke Company, Corona, N. Y.

EVERY county, 2,075 Nebraska farmers, \$3.00. Jeston's Service, Box 769, Omaha, Neb.

NAMES of agents our specialty. Send for list. Pennell Company, Covington, Ky.

5,000 WICHITA. County Automobile owners' names. Address, make of car. 1922 Registrations. \$15.00. E. D. Trevathan, 116 7th St., Wichita Falls, Texas.

REAL buyers, 15,000 New York colored people \$25.00. Nelman's Service, 132nd St. and Madison Ave., New York.

1500 YOUNG men's names \$2.50. Fred Bray, Medicine Bow, Wyo.

GUARANTEED List 2,500 Housewives in New Jersey, \$10.00; 200, \$1. Address Bugg-Brooks, 511 Mickle, Camden, N. J.

TYPEWRITERS AND SUPPLIES

UNDERWOOD Typewriters at far less than manufacturer's price; rebuilt, all worn parts replaced, guaranteed good as new. Cash, installment payments. Write for Catalogue 1515. Typewriter Emporium, estab. 1892, Montrose and Ravenswood Ave., Chicago, Ill.

ALL Makes. \$100 used typewriters, \$6 up. Free trial. Write for Bargain List 287. Northwestern Typewriter Exchange, 320 Goethe Street, Chicago.

TYPEWRITERS. All Makes. Save one-half. Thoroughly Rebuilt in our factory by the famous "Young Process." Fully guaranteed. Free Trial. We handle all standard makes. Cash or sold on easy terms. Write for Catalog Young Typewriter Co., Dept. 319, Chicago, Ill.

TYPEWRITERS: All makes \$15.00 up; guaranteed five years; one month free trial; get our list before purchasing. Peekskill Typewriter Exchange, Peekskill, N. Y.

DUPLICATORS AND DEVICES

WANT a "Modern" Duplicator to print Typewritten or Pen Written Letters, Drawings, Lessons, Music, Bids, Menus, Maps, Specifications or anything in one or more colors! Prints two a minute, \$2.25 up. Special sale on: 30 Days Free Trial. Booklet Free. J. E. Durkin-Rooves Co., Pittsburgh, Pa.

"QUICK Process Duplicators." Makes 100 copies in 10 minutes. Remarkable time savers. Thousands in use. Circular Free. Hoyer Duplicator Co., 160-PM, N. Wells St., Chicago.

ADDING MACHINES

NEW \$3.50 Automatic Adding Machine. Adds, Subtracts, Multiplies. Absolutely accurate. Capacity \$999,999.99 Fully guaranteed. 75,000 pleased users. Makes adding easy, positive, quick. Eliminates Mistakes. Saves Time. Postpaid, \$3.50. Bassett Co., 1458-C, Hollywood Ave., Chicago.

FREE Trial. Marvelous new Adding Machine. Adds, Subtracts, Multiplies, Divides, automatically. Work equals \$350.00 machine. Price only \$15.00. Speedy, durable, handsome. Five-year guarantee. Used by largest corporations. Write today for catalogue and free trial offer. Lightning Calculator Co., Dept. E, Grand Rapids, Mich.

PRINTING, ENGRAVING AND MULTIGRAPHING

MERCHANTS: Lowest prices on Highest Quality Advertising Pencils. Sample with your Ad. on imprinted in Gold, 10 cents. S. Musial & Co., 422 Walnut St., Yonkers, N. Y.

150 LETTERHEADS and 150 Envelopes, \$2.00, prepaid. Samples for stamp. Other printing. Jos. Sikora, 2403 S. 62d Ave., Cicero, Ill.

2,000 LETTERHEADS or Envelopes \$6.25, prepaid 3rd zone. Samples Free. Quality Printshop, Marietta, Ohio.

ATTRACTIVE Gummed Labels! Samples Free! Edward Harrison, Printing, Rubber Stamps, Baltimore.

HIGH-GRADE Union printing at the lowest prices consistent with good work. Letterheads and envelopes our specialty. Free samples. Lewis Stationery Company, Troy, N. Y.

PRINTED Stationery—100 Bond Letter Sheets and 50 Envelopes \$1.00. Samples free. Roessler, Rossville, Newark, N. J.

PRINTING Presses, Type, Supplies. No Junk. Catalog Free. Lawrence, 1426 South St. Francis, Wichita, Kan.

SEND 2c for our samples before ordering. "Mailpress," 2818 Congress, Chicago.

STATIONERY! Name and address printed on 100 Bond Letterheads, 100 Bond Envelopes \$1.50 postpaid. Address, Stationery Printing Company, South Bend, Indiana.

100 BOND Letterheads—100 Envelopes to match; embossed \$2.00. Samples. Wolf Advertising Service, Danville, Ill.

50 EACH letterheads, envelopes, cards, \$1. Long, Printer, Ottawa, Kan.

WE print anything. Circulars, stationery, Catalogs, Samples. Commercial Press, Bayta, Ohio.

100 BOND Letterheads, 100 Envelopes \$1.35. Others reasonable. Economic Press, Leonia, N. J.

REDUCED prices for better printing. 1,000 Bond letter-heads, \$8.00; 1,000 good envelopes, \$4.25; 1,000 four-page folders, 3 1/2 x 6 1/2 inches, \$12.00. Catalogues, circulars, booklets our specialty. All printing at reduced prices. Samples free. Pantum, 525 S. Dearborn St., Chicago.

QUANTITY Users save 30%. Wolf Roll Labels, Sta. E, Philadelphia.

PRE-USED Printing Presses, Type and supplies. List for stamp. Popular Bargains, Richland, Pa.

EMBOSSED business, personal stationery. Samples, stamp. Daniels Co., Pittston, Pa.

1,000 LETTERHEADS or Envelopes, \$3.00, sent prepaid. Samples Free. Monitor Press, Morrisville, Pa.

PRINTING Outfits—Presses, type supplies, type novelties. Send stamp for catalogue. Model Press, York, Penna.

250 LETTERHEADS, 250 White Envelopes, printed and mailed, \$3.00. Samples printing free. Write Sun, Mohawk, N. Y.

RAZORS AND BLADES SHARPENED

BLADES Resharpened 3c. any make. Guaranteed Service. Standard Safety Razor Corporation, Pittsburgh, Pa.

BLADES, resharpened, one edge 2c; double 3c. New York Edge Co., Glen Cove, N. Y.

FOR MEN

NEW Novelty of interest to men—makes 'em laugh; get this. Mail 25c (coin). Private Amusement Co., Marshall, Mich.

I WANT to send Free to every chronic pipe smoker in the country a good, big, generous sample package of my pure, sun-cured, nature-flavored Old Green River Pipe Tobacco. No money to pay. If you are a tobacco crank, all the better. Try the pure stuff. No syrup, flavoring or dope. After you try it free, I'll show you how to cut your smoke bill one-half and get more pipe joy. Just send name and address, and say whether you want mild, medium or strong. Pete Moberly, Box 820, Owensboro, Ky.

GUNS, SPORTING GOODS, ETC.

PRISM Binoculars, 7 power Weiss "Alpine" Stereoscopic. Retail price \$55.15, only \$28.00. Brand new. Prepaid. Gordon MacMillan, Desk 17, Box 291, Waukesha, Wis.

SPORTSMEN: Three Guaranteed gun-bunching formulas. Excellent results obtained. Price with complete instructions \$1.00. William J. McNamara, Webster, Mass.

BOATS AND LAUNCHES

PALMER four-cycle motor for Rowboats, Yacht Tenders, Price \$98.00. Also two and four-cycle to seventy-five horsepower. Catalogue free. Palmer Bros., Cos Cob, Conn.

16' ROWBOAT. Easily made. Construction blueprint 30c. Wee-Sho-U Co., West Market, Detroit, Mich.

"HOW to make your boat leakproof." Send for booklets, L. W. Ferdinand & Co., 152 Kneeland St., Boston, Mass.

OPTICAL GOODS

ULTRALENS microscope, magnifies 25,000 times, 75c. Patents pending. Get circular P-6 of other models. Specialty Mfg. Co., Milton, Pa.

DIAMONDS, WATCHES AND JEWELRY

TURKISH Lucky Stones are beautiful. Send \$3.50 and change your luck. Red stamp brings large list cut and uncut stones. Satisfaction guaranteed. Old-Young King Brady Gem Co., 150 W. 99th St., Los Angeles, Calif.

ANTIQUES AND RELICS

FOR Dons—Relics collected from Europe's battlefields; guns, medals, helmets, etc. Catalogue 10c. War Photos, actual battle scenes. Samples 20c. Lieut. Welsh, 50 Ft. Greene Pl., Brooklyn, N. Y.

GENUINE Indian Baskets and Wampum. Wholesale catalog. Gilham, Kelseyville, Cal.

FOR THE HOME

MAKE Inexpensive Iceless Refrigerator. Blueprint 35c. William Quemore, Camden, New Jersey.

PHONOGRAPHS AND RECORDS

BUILD a genuine Choraleon phonograph and save over half. Big profit building and selling. We furnish motors, tone-arms, full instructions and all necessary parts. Send for catalog and free blueprint offer. Choraleon Phonograph Co., 522 11th St., Elkhart, Ind.

STOP wasting money changing needles! Particulars free. Address Gerald Hyde, Fort Atkinson, Wis.

WONDERFUL Bargains in Phonograph Cabinets. Hunter Factory, McHenry, Ill.

NORTHERN phonographs. Play all records. Most wonderful bargain. Price \$10.00 delivered. Northern Supply Company, Milwaukee, Wisconsin.

SUPERIOR Quality Motors, tone outfits, amplifiers, hardware and cabinets make the finest phonographs. Superior Phonoparts Co., Erie, Pa.

BUILD your phonograph. Quality Phonoparts. Highest quality spring and electric Motors, Tone Arms, Reproducers, Amplifiers, Case Material and Accessories. Free Blue Prints and Building Instructions. Big saving. Wonderful results. New catalog mailed for ten cents. Hoosier Manufacturing & Supply Co., Phonograph Supply Department, 313 Baldwin Block, Indianapolis, Ind.

MUSIC AND MUSICAL INSTRUMENTS

SONG Writers—Have you poems or melodies? I have wonderful proposition to offer you. Ray Hibbler, D-110, 4040 Dickson Ave., Chicago.

I WANT song poems. Casper Nathan, Garrick Theatre Building, Chicago.

COMPLETE Solian Harp Building Instructions 10c. William Quemore, Camden, New Jersey.

SEND four-cent stamp for "Secrets of Song Writing." Casper Nathan, 928 Garrick Theatre Building, Chicago.

VIOLINS—Deep, Mellow, Soulful—on credit. Easy terms for wonderful instrument. Get details today. Gustav P. Henning, Box 2043, Denver, Colo.

RAG-JAZZ Piano or Saxophone in 20 lessons. "Christensen" Schools in most cities. See your phone book or write about Mail Course. Teachers wanted. Axel Christensen, 438, 20 E. Jackson Blvd., Chicago.

CORNETISTS—Trombonists—Saxophonists—Clarinetists. Send for "Free Pointers." Name Instrument. Virtuoso School, Buffalo, New York.

WRITE Songs. Big money and reputation. Write for information. J. Gordon Pub. Co., 201 N. Hoyne Ave., Chicago.

PATENT ATTORNEYS

PATENTS—Trademarks. Before disclosing an invention, the inventor should write for my blank form "Evidence of Conception." This should be signed, witnessed and returned to me with sketch or model upon receipt of which I will promptly render opinion as to patentable nature and send booklet on Patents. Highest references. Prompt attention. Reasonable terms. Clarence B. O'Brien, Registered Patent Lawyer, Woodward Building, Washington, D. C.

PATENTS—"How to Obtain a Patent" is the name of a book which every inventor should have. It will be sent free upon request, and will tell you what you want to know about patents. It contains the whole story. It describes the different parts of the application and explains in simple language the prosecution before the Patent Office. It tells about joint applications, releases, agreements, assignments, licenses, interferences, infringements, process patents, design patents, trade-marks, and prints and labels. If you are interested in patents either as an inventor, manufacturer or owner of a patent you will enjoy reading this book which was written by a lawyer who has had twenty-five years' experience in patent matters. If you have an invention and will send us a sketch, model or photograph of it we will promptly make a search of the Patent Office records and advise you whether or not, in our opinion, your invention is patentable, our charge for the service being \$5.00. We feel that our experience of twenty-five years has fitted us to render prompt and efficient service which will merit your confidence. Write today. Talbert & Talbert, 463 Talbert Building, Washington, D. C.

PATENTS. Booklet free. Highest references. Best results. Promptness assured. Send model or drawing for preliminary examination. Watson E. Coleman, Patent Lawyer, 624 F Street, Washington, D. C.

PATENT. Trade-mark and Copyright specialist. Prompt, personal efficient service. Advice on request. M. E. Jones, Lawyer, 509B 7th St., Washington, D. C.

PATENTS promptly procured. Personal, careful and efficient service. Highest references. Moderate fees. Send sketch or model for actual search and advice. George P. Kimmel, Master of Patent Law, 54-H, Loan and Trust Bldg., Washington, D. C.

PATENTS Procured—Trade Marks Registered — A comprehensive, experienced, prompt service for the protection and development of your ideas. Preliminary advice gladly furnished without charge. Booklet of information and form for disclosing ideas free on request. Richard B. Owen, 30 Owen Building, Washington, D. C., or 2276-R Woolworth Bldg., New York.

PATENTS — Trademarks. Thirty-five years' experience. Send model or sketch for opinion as to patentability. Free "Inventors Guide." Highest references and personal attention assure best results. Franklin H. Hough, 522 Washington Loan & Trust Bldg., Washington, D. C.

PATENTS—Prompt, personal efficient service by an attorney-at-law, skilled in all branches of Patent Practice. Over 12 years actual experience; full information upon request. B. P. Fishburne, 331 McGill Bldg., Washington, D. C.

PROTECT your rights. Write for "Record of Invention" which contains form to establish evidence of conception of your invention. Prompt personal service. Preliminary advice without charge. J. Beane Kelly, 612-G Columbian Bldg., Washington, D. C.

PATENTS. Trade Marks, Designs and Copyrights. Registered firm of attorneys-at-law. Careful, prompt personal service assured. Moderate fees. Full information free upon request. Gross & Collins, 606 Ouray Building, Washington, D. C.

PATENTS and Trade-marks obtained. Prompt service. Write for our new book on patents. Established in 1859. D. Swift & Co., 365 7th St., Washington, D. C.

PATENT applications filed on partial payment plan. Trade-marks, copyrights, etc. Milo B. Stevens & Co., 685 F St., Washington; 352 Monadnock Bldg., Chicago, Estab. 1864.

INVENTORS—Send for form "Evidence of Conception" to be signed and witnessed. Form, fee schedule, information free. Lancaster & Allwine, 221 Ouray Building, Washington, D. C.

MONROE MILLER, Ouray Building, Washington, D. C., patent attorney, mechanical and electrical expert. Best quality of work and results. Moderate charges.

FREE Advice on patenting new inventions. Total cost divided, six payments. Sterling Buck, Near Patent Office, Washington, D. C.

PATENTS. Booklet free. Highest references. Best results. Promptness assured. Send model or drawing for preliminary examination. Watson E. Coleman, Patent Lawyer, 624 F Street, Washington, D. C.

ROBB, Robb & Hill offer a strictly professional service to manufacturers and inventors in patenting inventions and registering trade-marks, a service which is the result of 20 years' experience. Write for free booklet and names of prominent manufacturers and inventors represented by us. Send sketch for preliminary advice. 811 McLachlen Bldg., Washington, D. C.; 1348 Hanna Bldg., Cleveland, Ohio.

PATENTS — Trademarks — Write for our free illustrated guide book and Evidence of Conception Blank. Send model or sketch and description and we will give our opinion of its patentable nature free. Highest references. Prompt attention. Reasonable terms. Victor J. Evans & Co., 166 Ninth, Washington, D. C.

INVENTORS! Send sketch or model of your invention for opinion concerning patentable nature and exact cost of applying for patent. Book, "How to Obtain a Patent," sent free. Gives information on patent procedure and tells what every inventor should know. Established twenty-eight years. Chandler & Chandler, 426 Seventh St., Washington, D. C.

PATENTS—Herbert Jenner, patent attorney and mechanical expert, 622 F St., Washington, D. C. I report if a patent can be had and its exact cost. Send for circular.

PATENTS—Trademark, copyright; folder free; results procured. Write Metzger, Washington D. C.

PATENT your invention. But note: a patent is no better than its claims. Be sure your patent is as good as your invention. Patent claims skillfully drafted by Lamb & Co., Patent Attorneys, 1410 G Street, Washington, D. C.

FOR INVENTORS

PATENTS. If you have an invention which you wish to patent you can write fully and freely to Munn & Co. for advice in regard to the best way of obtaining protection. Please send sketches or a model of your invention and a description of the device, explaining its operation. All communications are strictly confidential. Our vast practice, extending over a period of seventy years, enables us in many cases to advise in regard to patentability without expense to the client. Our Hand-Book on Patents is sent free on request. This explains our methods, terms, etc., in regard to Patents, Trade Marks, Foreign Patents, etc. "Scientific American" contains Patent Office Notes. Decisions of interest to inventors, and particulars of recently patented inventions. Munn & Co., Solicitors of Patents, 623 Woolworth Bldg., New York; Scientific American Bldg., Washington, D. C.; 801 A Tower Bldg., Chicago, Ill.; 611 Hanna Bldg., Cleveland, Ohio; Hobart Bldg., 582 Market St., San Francisco, Calif.

PATENTS—"How to Obtain a Patent" is the name of a book which every inventor should have. It will be sent free upon request, and will tell you what you want to know about patents. It contains the whole story. It describes the different parts of the application and explains in simple language the prosecution before the Patent Office. It tells about joint applications, releases, agreements, assignments, licenses, interferences, infringements, process patents, design patents, trade-marks, and prints and labels. If you are interested in patents either as an inventor, manufacturer or owner of a patent you will enjoy reading this book which was written by a lawyer who has had twenty-five years' experience in patent matters. If you have an invention and will send us a sketch, model, or photograph of it we will promptly make a search of the Patent Office records and advise you whether or not, in our opinion, your invention is patentable, our charge for the service being \$5.00. We feel that our experience of twenty-five years has fitted us to render prompt and efficient service which will merit your confidence. Write today. Talbert & Talbert, 463 Talbert Building, Washington, D. C.

PATENTS Secured. Prompt service. Avoid dangerous delays. Send for our "Record of Invention" form and Free Book telling How to Obtain a Patent. Send sketch or model for examination. Preliminary advice without charge. Highest References. Write today. J. L. Jackson & Co., 242 Ouray Bldg., Washington, D. C.

FREE: Preliminary examination of Patent Office records to determine patentability of your invention. Delays have proven a great loss to many inventors. Send sketch or model of your invention at once. Harry E. Coleman, Oriental Bldg., Washington, D. C.

INVENTORS. Send sketch or model of invention for advice. Write for Evidence of Disclosure form and Book on Patents. Free. Prompt Service. Merton-Roberts & Company, 182 Mather Building, Washington, D. C.

MODEL. Making and experimental work; Modern Shop; expert workmen. Manufacturing. Larson Model and Experimental Works, 625 W. Jackson, Chicago.

PATENTS—Trademarks. Before disclosing an invention, the inventor should write for my blank form "Evidence of Conception." This should be signed, witnessed and returned to me with sketch or model upon receipt of which I will promptly render opinion as to patentable nature and send booklet on Patents. Highest references. Prompt attention. Reasonable terms. Clarence B. O'Brien, Registered Patent Lawyer, Woodward Building, Washington, D. C.

PATENT Procured—Trade Marks Registered. A comprehensive, experienced, prompt service for the protection and development of your ideas. Preliminary advice gladly furnished without charge. Booklet of information and forms for disclosing idea free on request. Richard B. Owen, 39 Owen Bldg., Washington, D. C., or 2276-R Woolworth Bldg., New York.

PROTECT Your rights. Write for Record of Invention which contains form to establish evidence of conception of your invention. Prompt personal service. Preliminary advice without charge. J. Reaney Kelly, 612-G Columbian Bldg., Washington, D. C.

900 MECHANICAL Movements and 50 Perpetual Motions illustrated and explained in my book. Inventor's Universal Educator, 5th Edition—Tells how to procure and sell patents. Government and other costs. Covers the matter from A to Z—160 pages—Elegantly bound. Contains noted decisions of U. S. Supreme and State Courts on Patent cases. Mechanical Movements greatly assist inventors—suggest new ideas that might prove of great aid in perfecting inventions. Tells how to select an Attorney. Has valuable information regarding Patent Sharks. Selling Agents and promoters. Price, \$2. Postage free everywhere. Fred G. Dieterich, 621 Ouray Bldg., Washington, D. C.

INVENTORS: Have your invention perfected by expert draughtsmen—Patent, working drawings, free hand illustrating. Send model or sketch for estimate. Address W. H. Rockwell, Oriental Bldg., Washington, D. C.

WHY pay from \$7.50 to \$10.00 a sheet for Official Patent Office Drawings when you can get the same for \$5.00. S. L. Boardman, 932 D St. N. W., Washington, D. C.

GENTLEMAN from Chile going back to his country would be glad to have exclusive sale of inventions of practical use. F. Valdivieso Valdes, 642 Chamber of Commerce Bldg., Los Angeles, Cal.

PATENTS for Sale. Patent applications fully prepared, \$15. To buy or sell patents, write Patent News, G. Washington, D. C. Only inventors' newspaper. Yearly \$2, copy 20c.

MODELS— Developing your idea, mfg. same is my specialty. Why experiment? Write me and get facts. Henry Backer & Co., 904 Evans, Cincinnati, O.

INVENTORS and Manufacturers. For developing your invention, designing and constructing Automatic Machinery, Labor-saving Devices for all purposes, Coin-Controlled Beverage and Food-Dispensing Machines. Consult John Frick, Mechanical Engineer, 609 Stroh Bldg., 28 Adams Ave. W., Detroit, Mich.

I SELL Patents. Established 1900. Address, Charles A. Scott, 773PM Garson Avenue, Rochester, N. Y.

PATENTS. Write for free illustrated guide book. Send model or sketch and description for free opinion of its patentable nature. Highest references. Prompt attention. Reasonable terms. Victor J. Evans & Co., 157 Ninth, Washington, D. C.

HAVE You an Invention? If so, write for our free book, "How to Get Your Patent," tells our terms and methods. Send model or sketch for our opinion of its patentable nature. Randolph & Co., Dept. 144, Washington, D. C.

INVENTORS: The first step toward a patent is a proper search of the pertinent United States records. Send sketch. Horace L. Woodward, Attorney, 700 9th St., Washington. Highest references, reasonable charges.

GET your own patent. Complete instructions \$1. Cuttingsons, Campbell, Calif.

PATENTS FOR SALE

PATENTS Secured. Prompt service. Avoid dangerous delays. Send for our "Record of Invention" form and Free Book telling How to Obtain a Patent. Send sketch or model for examination. Preliminary advice without charge. Highest References. Write Today. J. L. Jackson & Co., 244 Ouray Bldg., Washington, D. C.

AUTO Safety Signal and Direction Indicator; visible all directions, advance of danger; manually operated, illuminated, disappearing. All-year seller; advertises itself. Royalty or sale. Specializer preferred. F. A. Cox, 27 West Ohio St., Chicago.

DRYING Rack for Hot Water Boiler. Slides around Boiler to position required; folds down to surface of boiler when not in use. Address B. Leahy, 395 E. 155th St., New York City.

SELL American Patent outboard reverse and brake for motor boats. A. D. Stewart, General Delivery, Toronto.

INVENTORS. Send sketch or model of invention for advice. Write for Evidence of Disclosure form and Book on Patents. Free. Prompt Service. Merton-Roberts & Company, 181 Mather Building, Washington, D. C.

FOR Sale: Handy and economical match scratcher. Can be pinned on inside of garment. Cash or royalty. Big seller. E. L. Hans, 3346 Warner, Chicago, Ill.

UNIQUE Mail order proposition. American Patent. Outright or Royalty—Combined Pocket Comb and Brush. Universally useful. Tait, 2036 8th Ave. W., Vancouver, British Columbia.

ATTENTION Mfgs. and Railroad Owners: Patented joint for steel rails for Sale. Investigate this today. Address M. L. Cochran, 743 Osage Ave., Kansas City, Kan.

FOR Sale—Cash or Royalty. Just Patented. Hand-rail, Newest Accessory for automobiles; Sure Success. Address Andrew Matthews, 131 Orchard St., Plymouth, Pa.

OUTRIGHT or Royalty. Simple device for Rewinding phonographs automatically, best advantages. Wm. Kappel, 457 38th St., Milwaukee, Wis.

PATENT Steel Derrick and Excavating Machine. Can be made in any blacksmith shop. Address H. J. Hughes, Chillicothe, Mo.

PATENT—Pneumatic inner tube; no down wheel. Sell outright. Make offer. D. Muddell, 4132 Wentworth Ave., Chicago.

ATTENTION, Patent Buyers. For Sale. Latest and Best Ford Transmission Band; Patented Feb'y. 21, 1922. #1,407,385. Guaranteed "Fool proof." Automatic self-locking, detachable lug. Install thro hand hole; reline set in 20 minutes. Cheap to manufacture. Simple. Lug guaranteed to never accidentally detach in Transmission. Has been tested satisfactorily one year in several cars. Sell outright or part cash and royalty. Best offer. Address Leonidas Franklin Crumley, La. Follette, Tenn.

MOST perfect working wrench ever invented. Plain and Pipe styles. Canada and United States rights. Outright or royalty. Working model sent to reliable parties. Full information free. Fred C. Thompson, Happy Camp, California.

PATENT. 1,324,323 Compound Tool, the wrench and plier of them all. Outright or royalty. Edwin J. Searseth, Galeville, Wis., Route 2, Box 22.

AUTOMATIC Auto Jack; tire-saving device whereby a car can be driven on by its own power; fully tested. Particulars. Hy Schrieber, Nashville, Ill.

FOR Sale—Patent on Handy Laundry Cabinet. Inexpensive and quick seller. Broolin & Fortin, 31 Salem St., Salem, Mass.

SALE or Royalty—Patent 1,366,652. Combination auto lunch box and table. Henry Harild, 730 South Maple St., Spokane, Wash.

PATENTED cattle dehorner for sale outright, royalty or partnership. Make offer. Van Amber, 7326 Princeton Ave., Chicago.

A SPRINGLESS Snaphook. Manufactured cheaply. Very strong. \$550.00. Wm. Monroe, Neola, Iowa.

FOR Sale—Adjustable, self-supporting screen-door brace. Royalty. Wm. L. Albee, Topeka, Kan., R. 2.

U. S. PATENT, One Minute to hang washing. Sale or Royalty. R. Barneck, Bismarck, N. D.

PATENT—Combination Slip-joint Plier, and Instant Adjustable Wrench. Emil J. Hanson, Viroqua, Wis.

YOU have a worth-while patent, haven't you? Why don't you tell our two million readers about it? Most of them are especially interested in patents and new inventions. Ask me to tell you how other inventors successfully sold their patents. J. Roy McClellan, Manager, Classified Advertising, Popular Mechanics Magazine, Chicago, Ill.

WANTED, the smartest Railway President or Manufacturer to investigate my Ballasting Machine. Saves 70 laborers. Earns 180% in year. Sell patent to highest bidder. J. Maxwell, 9748 165th St., Edmonton, Alta., Can.

PATENTS, Trade-marks—30 years of confidential service; expert advice, prompt action, reasonable fees. Send for Free Book. Edgar Tate & Co., 245 Broadway, New York; 635 F St. N. W., Washington, D. C.

CASH or Royalty—Doll hands which hold any object. Imagine the impressive advertising. Millions in demand. Berthold, 6 E. Lake St., Chicago, Ill.

SALE or Royalty—Patented Vacuum Milk or Ice Cream Can. F. Crist, 709 Adams Ave., Scranton, Pa.

A DAMPER which removes Soot from Base of Flue and Stove Pipe. Elbert McSpadden, Crawfordsville, Indiana.

PATENT obtained; complete application, \$15. Try "Patent News Plan." Save Money. Patent News-C, Washington, D. C.

MUST Sell patent: Combination Mud Hook and Chain. Best offer takes. Write, Maurice Frank, Anthon, Iowa.

PATENTS for Sale: To sell, buy or obtain patents, address Patent News-P, Washington, D. C.

PATENT for Sale—Foldable screened rocking chair, adapted for porches, country places, hospitals, seashore. Address, Strausky, 200 Greenway, Darby, Pa.

PATENT 1,392,105 on Tube Brushes, for sale. J. Bergesen, Sr., 261 E. 31st, Brooklyn, New York.

PATENT for Sale: Locking and guiding bolt for combined swinging and sliding doors. Several special features. Will pay you to investigate. Genuine bargain. Edward T. Murphy, 14 W. 103d St., New York City.

HAVE you a Patent to Sell? Sell direct to manufacturers. B. M. Beeman, 94 Brighton, Detroit, Mich.

INVENTORS: The first step toward a patent is a proper search of the pertinent United States records. Send sketch. Horace L. Woodward, Attorney, 700 9th St., Washington. Highest references; reasonable charges.

MODELS AND MODEL SUPPLIES

WALTER E. ECKEL, Patterns, Models, Castings—Bronze, Brass, Copper and Aluminum castings. Send your drawings for free estimate, Crozer Bldg., Chester, Pa.

MODEL making and experimental work; Modern Shop expert workmen. Manufacturing, Lamson Model and Experimental Works, 625 W. Jackson, Chicago.

MODELS: We have fully equipped model shop and carry complete line of model supplies. Modern Machine & Pattern Co., Terre Haute, Ind.

WE make working models for inventors and do experimental work and carry a complete stock of brass gears and model supplies. Send for catalogue. The Pierce Model Works, Tinley Park, Ill.

INVENTORS—Write for our free illustrated guide book and Evidence of Conception Blank. Highest references. Prompt attention. Reasonable Terms. Victor J. Evans & Co., 165 Ninth, Washington, D. C.

PUNCH Press work, tool and die making, model and special machine work wanted. Completely equipped with new machinery of the latest type. Prompt delivery, reasonable prices guaranteed. Quality Hardware & Machine Co., 6154-56 N. Clark St., Chicago.

FOR MANUFACTURERS

MODEL making and experimental work; Modern Shop expert workmen. Manufacturing, Lamson Model and Experimental Works, 625 W. Jackson, Chicago.

PATENT Rights—Worth \$25,000 to any Specialty Manufacturer. Address all inquiries to L. J. Aldridge, Victor, N. Y.

WANTED, someone to manufacture by royalty a resilient spoke wheel, very cheap. Box 562, Tarrytown, N. Y.

EXPERT Drafting and Engineering Service. Designs furnished. Rates reasonable. Polisheshek Engineering Company, Clintonville, Wisconsin.

CALIFORNIA, the bright spot of business. Let us represent and sell for you here. Correspondence invited. Morkmark Company, Garland Building, Los Angeles.

WANTED—Metal Stamping and Model work taken on contract basis. We are ideally located and equipped to develop patents. Meyers Company, Box 263, Bedford, Ind.

MANUFACTURING

MODEL Making and experimental work; Modern Shop expert workmen. Manufacturing, Lamson Model and Experimental Works, 625 W. Jackson, Chicago.

EXPERIMENTS developed, dies, models and manufacturing, machine designing. Estimates and information promptly given. Address Schroer Bros. Machine Works, 512 East 25th Street, Kansas City, Mo.

WE design and build special machinery, make models, dies, stamping tools, do general machine work and light manufacturing. Marshall Mfg. Co., Kansas City, Mo.

METAL Specialties, Dies, Tools, Patent Articles, made for Canadian market. Tools & Stampings, Limited, Toronto, Canada.

INVENTIONS developed. Light manufacturing. Write Lynds Wrench Co., Wilburton, Okla.

POWER Users—Have you considered the economy and advisability of changing from steam to gas producer operation? Our authentic book "Power Gas and the Gas Producer" written by a recognized authority on this subject will enable you to judge intelligently. Price \$1 postpaid. Popular Mechanics Book, Dept. 6 N. Michigan Ave., Chicago.

PATTERNS, wood and metal. Models, tools and dies. Brass and Aluminum castings. General machine work. Modern Machine & Pattern Co., Terre Haute, Ind.

EXPERIMENTAL Work, stampings and special machines for any purpose designed and built at reasonable prices. Address Brownstein Manufacturing Co., Engineers and Manufacturers, Ellwood City, Pa.

LET us be your factory! Write today. Logan Machine Company, 222 South Clinton Street, Chicago, Illinois.

MACHINE Work of any kind—Special Devices—Experimental Work—Jigs and Fixtures. Up-to-date Shop. The Advance Tool Co., Canal and Jackson Sts., Cincinnati, Ohio.

METAL Specialties. If of metal, we can make it for you. Complete equipment. Western Die & Stamping Works, 721 Fulton St., Chicago, Ill.

IF you want dies and metal stampings, write us. Lyons Machine Works, Lyons, Ia.

WE have a light modern well equipped machine shop to make your models and to manufacture your article. So, if it is to be made of metal, let us make it for you. Victor Engineering Co., 2524 W. Chicago Ave., Chicago.

SPECIAL Devices and Machinery developed and built at reasonable rates. Jigs and fixtures designed and built for interchangeable and economical manufacturing. Punches and dies made for all kinds of metal stamping. Machine work to order. Simplex Tool Company, Woonsocket, R. I.

WIRE Goods, all kinds made to order. Cooley Mfg. Co., 524-530 N. Western Ave., Chicago.

SURVEYING INSTRUMENTS

THE Golden Combination; complete drawing outfit in one instrument. Used by Students, Civil Engineers, Abstractors, Draftsmen, Architects, etc. Write for free trial. Golden Compass Co., Elkhart, Ind.

NEW and used surveying instruments direct from factory. Satisfaction guaranteed or money refunded. Wissler, 619 Broadway, St. Louis.

MACHINERY, TOOLS AND SUPPLIES

MUST part with my new bench planer 36x10 1/4 x 9, powerful and accurate, \$175.00; Photo. Also Yankee bench drill press, two speeds, automatic feed—brand new, \$15.00. Braun, 1132 Bergen, Brooklyn, N. Y.

12-TOOL Handy Set, made of best steel. The most useful and practical tool on the market. Postpaid \$1.25. National Specialties, 324 Union Sq., New York City.

OTHERS have successfully sold their machinery through our columns—so can you. Ask me for proof. J. Roy McClellan, Manager, Classified Advertising, Popular Mechanics Magazine, Chicago.

CONCRETE Building Block Machines and Molds. Catalogue free. Concrete Machine Co., 112 S. Second St., St. Louis, Mo.

WANTED: Information about new air compressors. Write for free manual, Engineers Dept., Brunner Mfg. Co., Utica, N. Y.

ENGINES, MOTORS AND DYNAMOS

ALTERNATING and direct current motor bargains. New and rebuilt. All guaranteed for one year. Special prices. Get our price list before buying. Motors exchanged and repaired. Hyre Electric Co., 633-RM South Dearborn St., Chicago.

AUTOMOBILE Owners, Garagemen, Mechanics, Repairmen, send for free copy of our current issue. It contains helpful, instructive information on overhauling, ignition troubles, wiring, carburetors, storage batteries, etc. Over 120 pages, illustrated. Send for free copy today. Automobile Digest, 507 Butler Bldg., Cincinnati.

SPECIAL Garage Motors: Manufactured by the General Electric Co. 1 H. P., \$78.50; 2 H. P., \$110.00; 3 H. P., \$128.50; 5 H. P., \$166.50. All sizes, both single and Poly-phase Motors, for immediate delivery. Special charging generators, all voltages. Write for catalog. Motor Sales Dept. 15, West End, Pittsburgh, Pa.

ELECTRIC Motors, 500 Heavy Duty 1/4 H. P. motor, General Electric and other standard makes, 110 Volt, 60 Cycle, Single Phase. New, original packages, guaranteed perfect. \$18.00 to \$22.00. Pennsylvania Motor Exchange, Lancaster, Pa.

ELECTRICAL

STORAGE Batteries for Automobiles and Radio apparatus. Buy direct from manufacturer and save money. Prices on request. General Battery Service Station, 921 Washington Blvd., Chicago.

EVART Bell-ringing transformers. Evart Electric Co., Box 26, Racine Junction Station, Racine, Wis.

NITROGEN Electric Lamps: New, High-Grade, Pear-Shape, 25-40 or 50 Watt each 30c. 60 or 75 Watt each 45c. 100 Watt each 65c. 150 Watt each 90c. 200 Watt \$1.25 each. 300 Watt \$1.90 each. 500 Watt \$3.00 each. Frosted add 5%. Natural Blue add 10%. No order too small. Free Delivery anywhere. We stand breakage. Money-back guarantee. Terms C. O. D. Send for catalog. Kelly Lamp Corporation, 538 So. Ridgeland Ave., Oak Park, Ill.

AUTO Owners: Buy your storage batteries direct. Our batteries are A No. 1. 6 volt, 3 plate, \$12.00; 6 volt, 11 plate, \$18.75; 6 volt, 13 plate, \$23.50; 6 volt, 15 plate, \$29.00; 12 volt, 7 plate, \$36.00. Also radio and farm-lighting batteries. Austin Welding Works, 553 W. Quincy St., Chicago, Ill.

PAYMENTS easy monthly brings Electric Motors. Any size. Hobartmotors, Troy, Ohio.

ELECTRICITY Taught by experts; earn while you learn at home; electrical book and proof lessons free; your success guaranteed and position secured. Chicago Engineering Works, Dept. 515, 2144 Lawrence Ave., Chicago.

ELECTRIC motors and supplies, including sockets, wire conduit, cleats, loom, rosettes, switches. New revised wholesale prices. Illustrated Catalog free. Hyre Electric Co., 633-GH, South Dearborn St., Chicago.

FOR MECHANICS

INVENTORS. Send sketch or model of invention for advice. Write for Evidence of Disclosure form and Book on Patents. Free. Prompt Service. Merton-Roberts & Company, 183 Mather Building, Washington, D. C.

PATENTS—Write for our free illustrated guide book and Evidence of Conception Blank. Send model for sketch and description of the invention for our opinion of its patentable nature free. Highest references. Prompt attention. Reasonable terms. Victor J. Evans & Co., 184 Ninth, Washington, D. C.

FOR THE SHOP

SHOP Notes, Volume 17, contains 702 practical articles such as Half-ton Traveling Crane, Boring Machine, Toggle Press, Gas-Fired Forge, Oil-Gas Generator, Movable Table for Drill Press, etc., 224 pp., 49¢ ill. 50 cents postpaid. Popular Mechanics Book Dept., 6 N. Michigan Ave., Chicago.

SHOP Notes for 1922—Bench Lathe, Electric Soldering Outfit, 1½ lb Crane, Pump Troubles, Road Roller, Bench Grinder, Bench Miller, are among the 655 articles in this new volume. 224 pp. 50 cents postpaid. Popular Mechanics Book Dept., 6 N. Michigan Ave., Chicago.

BLACKSMITHS

BLACKSMITHS, Farmers, Inventors, Here's what you've been looking for. New, powerful Iron Bender, Bar iron constructed. Bends any shape. Capacity ½" x 3" cold; 1½" dia. hot. Price \$7.00 or if you prefer to make one yourself will send working drawings for fifty cents. A. Hossfeld, 815 E. Center St., Rochester, Minn.

BLACKSMITHS, Listen: Any Handy man can make more money doing hard jobs easy. Forging and welding solid, with Toy's Modern Methods of Blacksmithing. Hardening and tempering to a standard with colored tempering charts. All for one dollar. Samples Free. W. M. Toy, Sidney, O.

INFORMATION

PUZZLE Contestants lists of B, C, D, P, and S, words. All words listed possible objects; single list \$1.00; all for \$3.00. Fred I. Conner, 18 Boston Ave., Youngstown, Ohio.

FOR SALE—MISCELLANEOUS

FIXALL Metal—Permanent repair for cylinder heads, crank cases, aluminum-ware, etc. Wonderful for farm, laboratory, household. Needs only blow torch. Satisfaction guaranteed. Large stick \$1.00. Colorado Chemical Products Company, Salida, Colo.

AUTOMATIC pencil, always sharp. Send three dimes. W. Hegel, Box 155, Hoboken, N. J.

GANEMETER Multigraph, first class; Extras, reasonable. Box 307, Eleanor, Pa.

FOR Sale, Bargain, Wayne Five Gallon Gasoline Pump. Good as new. Illuminated Sign, Garage. Hurry if you want these. Standard Garage, Coldwater, Mich.

AIR Compressor with Tank and Hose \$59. With Motor \$72.50. With Paint Sprayer or Dust Cleaner \$84.50. Suitable for private or public Garage, Tire Shop, Painting or Cleaning, also Motor in the head Buffer, Home size \$18.50, Shop size \$25. Garage size \$106. Battery Charging outfit, Home or Garage size \$14. 6 Tools in one, Forge Vise, Anvil, Pipe Vise, Drill Press, Emery Grinder \$25. Send dime or stamps for our large 100 page catalogue, describing all kinds of Air Compressors, Vulcanizers, Garage and Battery Outfits. Equipment Co., 167 Canal, Cincinnati, Ohio.

EXCELLENT, self-filling fountain pen, 25 cents; real bargain. Jersey Supply Company, 99 Second Avenue, Newark, N. J.

\$17.50 GENUINE Carl Zeiss Field, Marine and Aviation Glasses, eight power, adjustable focus and eye pieces, cost \$38.00, with carrying case. Sent C. O. D. subject to examination. Money refunded. We have other Glasses, Binoculars and merchandise. Well's Curiosity Shop, 20 S. 2nd St., Philadelphia, Pa.

ADDRESSOGRAPHS, Letter Folders, Multigraphs, Envelope Sealers, Duplicators, less than half price. Guaranteed. Pruitt Co., 112-B N. La Salle, Chicago.

LUMINOUS Paint, Bottle 20c. Laboratories H, Box 316, Portland, Ore.

FOR SALE OR EXCHANGE

WILL trade twelve-horse marine, two cylinder motor for portable rowboat motor. Address H. Waldorf, Hudson, So. Dak.

REAL ESTATE AND FARM LANDS

FLORIDA Oranges are most profitable as well as most delicious. Grow your own in a land of sunshine, away from winter blizzards and coal bills. Money you'll not miss will buy you land for a grove in a high, rolling, lake-jeweled land of many golden groves. If you mean business, write today for Book of Facts and Photos. Lake County Land Owners' Association, 93 Arbor Avenue, Fruitland Park, Fla.

LANDSEEKERS! Opportunity awaits you on our clay loam lands in Michigan. 20, 40, 80 acre tracts near bustling city. \$15 to \$35 per acre. Very easy terms. Write today for Free booklet giving full information. Swigart Land Company, P-1259, First National Bank Building, Chicago.

\$300 GETS 60-Acre Farm, Furniture, cows, poultry included; 7-room house, barn, all \$950. See page 11 Free Catalog. Strout Farm Agency, Inc., 150 P Nassau St., New York City.

\$5.00 DOWN; \$5.00 monthly; Five acres fruit, poultry, fur farm, Riverfront; Ozarks; \$100; hunting, fishing, trapping. Address Harvey Hubbard, 1973 North Fifth, Kansas City, Kans.

ATTENTION!! "Let's get acquainted." Cash for your property, farm, hotel, retail store or factory. Confidential service. Hayes Business Agency, Cincinnati, Ohio.

IMPROVED Marathon County 80, fine buildings, \$10,000. A Sturm, Stratford, Wis.

FREE Land—Homestead information. Fred Bray, Medicine Bow, Wyo.

FREE Government Lands—Our official 112 page book, "Vacant Government Lands," lists and describes every acre in every county in U. S.; tells location, place to apply, how secured free; 1922 diagrams and tables, new laws, lists, etc.; price 50 cents postpaid. Webb Publishing Co., Dept. 71, St. Paul, Minn.

MINNESOTA good wild land, part timber, splendid location, \$13.50 per acre. Address P. Fonos, New Richmond, Wis.

SELL your property quickly for cash, no matter where located. Don't pay big commissions. Particulars free. Real Estate Salesmen Co., Desk B, Lincoln, Neb.

REAL Estate and Farm Lands. Will take \$135 per acre for quick sale; 15 acres on Boulevard, ready for subdividing. Lots close by selling \$600. Just outside West Egg Harbor, N. J. No better place for poultry or gardening. Richard Wollborg, Halfway, Michigan.

WANTED—MISCELLANEOUS

WANT—Second-hand National Cash Registers in any condition. Agents wanted. National Instrument Company, 4704 North Hamilton Ave., Chicago.

WANTED—Guns, pistols, helmets. War Relics. Kestler, 50 Fort Greene, Brooklyn, N. Y.

WHY not mail us your Old Gold, Silver, Diamonds, Jewelry, War Stamps, Bonds, etc.? Highest prices paid. Satisfaction Guaranteed or goods returned. Won't you try us? Mormark Company, Garland Building, Los Angeles, Calif.

CASH Paid. Mail us your discarded jewelry, gold crowns and bridges, watches, diamonds, silver, platinum, War Savings Stamps and old false teeth. Highest prices paid. Money sent by return mail. Packages held 4 to 12 days and returned at our expense if our offer is refused. United States Smelting Works (The Old Reliable), Dept. 71, Chicago, Ill.

MAIL old gold, unused postage, war and thrift stamps, Liberty Bonds, silver, platinum, diamonds, jewelry, watches, false teeth, magneto points, etc., new or broken. Cash immediately. Held ten days, returned if unsatisfactory. Ohio Smelting Co., 205 Lennox Building, Cleveland, Ohio.

TOBACCO

PURE red leaf tobacco, quality guaranteed. Best chewing, 3 lbs., \$1.00; 10 lbs., \$3.10. Mild smoking, 4 lbs., \$1.00; 10 lbs., \$2.10, postpaid. O. D. Collier, Agent, Martin, Tenn. Collier is absolutely honest and reliable. Martin Bank, Raymer, Cashier.

TOBACCO, Natural Leaf, for mild smoking; 10 lbs. \$1.50; 20 lbs. \$2.75; will furnish free receipt for preparing. Leaf Tobacco Exchange, Mayfield, Ky., Star Route.

DOGS, BIRDS, POULTRY AND PETS

GERMAN Police Dogs, Airedales, Fox-terriers, St. Bernards, Eskimos, Collies, 50 others; state wants; we ship anywhere. American Kennels, Ivyland, Pa.

WE buy Dogs and Puppies, all Breeds; also sell and Exchange Puppies for Poultry. American Kennels, Ivyland, Pa.

BREED Squabs. Book free. E. Rice, Melrose Highlands, 77, Massachusetts.

GREAT Dane Pups—For Danes that have size and intelligence write Collins Kennels, Box 109, Reedsburg, Wis.

FAMOUS Airedales—Championship—Pedigreed pups or grown dogs. Write wants. Lloyd F. Hanson, Dawson, Minn.

BARGAINS: Collies, Airedales, Bulldogs, Rabbits, Pigeons, Canaries, Parrots. Catalog. Breeders Exchange, Minneapolis, Minn.

LIFE Preserver—a dependable remedy for white diarrhoea, roup and cholera among poultry. 16 oz. bottle, \$1.00 postpaid. Agents and Dealers wanted. Walter Achar, 4803 Lincoln Ave., Chicago, Ill.

SILVERBLACK Foxes \$300.00. Booklet dime. Time payments. Arthur Schumacher, Lockland, Ohio.

BELGIAN HARES, GUINEA PIGS, ETC.

RAISE Rabbits for me, 25 to 50c lb, for all you raise. Breeders cheap. Cross, 3845 Easton, St. Louis, Mo.

RAISE guinea pigs. Pay better than poultry or rabbits; easy to raise; little space required. We guarantee market. Particulars and booklet how to raise free. Cavies Distributing Co., 3162 Grand Ave., Kansas City, Mo.

PERSONAL

STOP falling hair; stop itching scalp quickly. Men and women, wonderful home treatment. Will dissolve and eradicate all dandruff. Lubricates any dry scalp. Costs only few cents. Harmless, most reliable. Send 35c coin for complete instructions. Scalp treatments my specialty. Money refunded if not satisfactory. H. Foster, office 3901 Grand Blvd., Chicago.

COMPLETE life reading 35c. Give birthdate. Jay Wambaugh, Goshen, Ind.

BE Wise! Be Cheerful! Be Prosperous! New way plan brings wonderful results. Valuable pointers and your personality revealed for 10c and birthdate. Thomson-Heywood, Dept. 985, Chronicle Bldg., San Francisco, Calif.

78% Of All Auto Repairs Are ELECTRICAL

No Wonder \$75 Jobs
Are Waiting in
This Big New Field



Automotive Electricity!

HERE is a chance to make the biggest money of your life. Hundreds who read this notice will leave the rut and start right out making \$75 to \$150 a week—right from the beginning. Jobs are waiting. In a year—six months—many of them will have their own businesses—be independent—have others working for them—and get incomes from \$5,000 to \$12,000 a year.

Figure it out for yourself. The Automobile business has developed the gasoline motor to the point where it is almost infallible. The trend now is **electrical**. Every week sees another manufacturer announcing some new feature—**always electrical**. And everyone of the twelve million cars in America is filled with complicated electrical units—constantly getting out of order, and defying all efforts of the average garage man to repair them.

HUNDREDS OF JOBS WAITING

So rapidly is this enormous field developing that today 78% of all automobile repairs are **electrical**. And not one out of fifteen garage men can make these repairs. What is the inevitable result? A little handful of automotive electricians swamped with work, making more money than they have time to spend—not even half enough men to fill the enormous demand. Thousands of new electrical service stations needed—thousands of men wanted in stations already established.

BIGGER MONEY THAN EVER BEFORE

Is it any wonder that our graduates start right out in \$75 to \$150 a week jobs? Is it any wonder that they are making money faster than ever before—\$5 for ten minutes work; \$30 a day—\$75 to \$150 a week—EASY!

They do this because when they leave the Ambu Institute they know—positively and surely—every phase of automobile electrical work. As each class

at Ambu is limited to twenty men every man gets individual instruction. And not a lot of theory, either. When a man comes to Ambu he starts work at once—in his overalls. He discovers at once, as has everyone else who ever worked with electricity, that there is no work in the world more fascinating. He learns all fundamentals—the laws that govern electrical work—principles that apply on every make of car. He learns about every type of ignition, every phase of starting, lighting and generating and becomes as familiar with the working of storage batteries as the men who make them. Every bit of this is actual work—not a lot of dry as dust lectures. You learn to work with your hands as well as with your head. When you get through you **KNOW!**

FREE BOOK ON AUTOMOTIVE ELECTRICITY

We can't tell you in this small space all that we want you to know about the course or about the fascinating, pleasant work and the amazing opportunity for making big money right from the start. Send the attached coupon for our catalog, which explains the whole big opportunity in detail. You don't need a bit of experience. As long as you have a common school education and two hands to work with we can make an Automotive Electrician of you in eight weeks. Our employment service helps you get a job at once in any part of the country that you want to go to. Jobs are waiting. Send the coupon quick. The least you can do is to find out—without cost.

AMBU ENGINEERING INSTITUTE

Dept. 15 2632 Prairie Ave., Chicago

AMBU ENGINEERING INSTITUTE,
Dept. 15, 2632 Prairie Ave., Chicago

I want to know more about the opportunity for making big money—quick—that awaits me in the rich new field of Automotive Electricity. Send me free booklet and complete information. I am interested in learning (at Chicago) (at home).

Name.....

Address.....

City.....

PROOF!

"I have earned \$75 to \$100 a week ever since I left school."
N. Blotcher, Chicago

"Before I went to Ambu my salary was \$30 a week. In two weeks I was raised twice to \$60. Now doing even better in my own business."
Wm. Dean, Leominster

"Earning 70% more than ever before. The course at Ambu did it."
S. E. Kilgore, Bostoria

"Believe me, they sure grab you off when you say you've been through Ambu."
J. L. Dally, Rockford

"Have my own shop. Earning four times what I did before I went to Ambu."
Wilfred W. Ludlow

Continued from Page 50

CIGARETTE habit positively cured or money back. Scientific method—no drugs. State number of cigarettes used daily, enclosing one dollar. Address The Antitobacco System, 563 Bensen Street, Camden, N. J.

PLEASANT root, easily, inexpensively, overcomes any tobacco habit. Send address. Franklin Stokes, Mohawk, Fla.

COCONUTS: Did you ever see a coconut in its original shell, just as it grows on the trees of Florida, a real curiosity? Postpaid \$1.00. Otto C. Muecke, Miami, Fla. Conn. Apts.

PARTICULAR people appreciate Bed Dragon Tablets. A high-grade deodorant that eliminates odors caused from perspiration. Makes an elegant foot tonic. \$1.00 per box. Direct Tail-Creo Company, Hamilton, Canada.

HOROSCOPE—complete, 25c. Give birthdate. Hull, Station H, New York.

YOUR Horoscope—Life revelation showing your character, talents, suitable occupation. Scientific and accurate. Send birth date, 10c. The AstroLite Company, Sharpsburg, Pa.

YOUR Horoscope covering full year for 35c. Includes an extensive reading, valuable daily guide, large pictorial chart and special forecasts for each month. Scientific, complete. Try it! Money back if dissatisfied. Give birthdate. Address, H. Daniels, Flatbush Sta., Box 32, Brooklyn, N. Y.

TOBACCO Kills Manly Viper—Quit easily. Cigarettes, chewing, smoking, snuff, conquered or no charge. Small sum if satisfactory. Stops craving; harmless. Full treatment on trial. Perkins Co., 31A, Hastings, Nebr.

DO the Dead Live? Fake mediums exposed 25c postpaid. Bert Walton, 314 Washington Bldg., Seattle, Wash.

ST-STU-T-T-TERING and stammering cured at home. Instructive booklet free. Walter McDonnell, 46 Potomac Bank Bldg., Washington, D. C.

FREE—Stop using tobacco. We will give free information how to conquer habit easily and permanently. Results guaranteed. Anti-Tobacco League, Box K, Omaha, Nebr.

TOBACCO or Snuff Habit cured or no pay. \$1.00 if cured. Remedy sent on trial. Superba Co., TP., Baltimore, Md.

MISCELLANEOUS

AUTO-LAVATORY—Keeps Motorists Clean. Most Needed Invention. Perfect Success. Satisfaction by Trial Guaranteed. O. K. Carbon Gun Scientifically Removes Carbon. Saves you money. Information free. Emmons Mfg. Co., Alliance, Ohio.

CARRY in your pocket or Auto our Medical Case—twelve assorted standards, with directions. We please or return money. Order today; postpaid \$2.50. William Meyer Laboratory, Dearborn, Mich.

WONDER Ink Powder—Great! 30 cents, coin, for sample pint. Money-back guarantee. Address, Nelson, 37 First St., Newark, N. J.

LOCKSMITHS: Send \$1.00 for valuable chart for cutting tumbler padlock keys. Globe System, 278 Washington St., Newark, N. J.

LOCKSMITHING from A to Z—500 tricks of the locksmith trade, \$1.50—money back if dissatisfied. H. Routson, 3406 Andover St., Oakland, Cal.

MAKE big money Opening Safes and Setting Combinations. Wayne Strong, Box 1430, Los Angeles, Cal.

\$1000.00 MONTHLY. See our advertisement under "High-Grade Salesmen Wanted." Foster Laboratories.

GET Posted for Spring. Good prices paid for butterflies, insects. See Sinclair's Display Advertisement, page 26.

CARE of the band saw, electric water heater, modern barn construction, motorcycle trailer, tent house, correcting dynamo troubles, homemade metal fence, auto turntable, are among the hundreds of practical articles in Shop Notes Vol. 13. Price 50 cents postpaid. Popular Mechanics Book Dept., 6 N. Michigan Ave., Chicago.

GRANDFATHER clock works, \$5.00. Build your own case, instructions free; make good profits selling your friends. Clock works with chimes for old or new cases. Write for full particulars. Clock Co., Nicetowne, Philadelphia, Pa.

CUTS anybody can make. Simple, cheap process. \$1. Specimens, particulars. 2c stamp. M. Day, Windfall, Ind.

SAVE incorporating expenses and excess profit taxes and avoid personal liability by organizing your company on the Common Law Plan under a Declaration of Trust. Anyone, anywhere, can fill in Demaree Standard Forms, issue shares and begin doing business same day. Pamphlet B-53 free. C. S. Demaree, Legal Blank Printer, 613 Walnut, Kansas City, Mo.

ARTIFICIAL Eyes, \$3. Booklet free. Denver Optic, 559 Barclay, Denver, Colo.

ART Metal Workers—You will find our book "Metal Work and Etching" a complete manual on making book ends, desk sets, pad corners, paper knives, letter openers, stationery racks, rocking blotters, desk calendars, arts and crafts jewelry, etc., 96 pp. illus. Price 50 cents postpaid. Popular Mechanics Book Dept., 6 N. Michigan Ave., Chicago.

WANTED!

\$1,000 REWARD

CONVICT 6138, escaped from the State Penitentiary; Name, Charles Condray; Age, 37; Height, 5 ft. 8 in.; Weight, 141 pounds; Hair, light brown; Eyes, gray.

Easy enough to identify him from his photograph and this description, you may say—but, Condray took the name of "Brown", dyed his hair, darkened his skin, grew a mustache, put on weight and walked with a stoop.

Yet he was captured and identified so positively that he knew the game was up and returned to the penitentiary without extradition. A Finger Print Expert made this identification and secured the reward.

MORE TRAINED EXPERTS NEEDED NOW!

There is a big chance for you in this uncrowded, fascinating profession. State, City, and Private Bureaus being established and expanded constantly. Trained men in great demand. Many earn \$3000 to \$10,000 yearly.

LEARN AT HOME IN SPARE TIME

Common school education, common sense and ambition, the only requirements. Many of the country's greatest experts learned their profession in this great school. A few hours' spare time a week soon fits you for a fine position as a Finger Print Expert.

UNIVERSITY OF APPLIED SCIENCE
1920 Sunnyside Avenue,
Dept. 1355, Chicago, Ill.

Gentlemen:—Without any obligation whatever, send me your new, fully illustrated FREE Book on Finger Prints and your offer of a FREE course in Secret Service Intelligence and the Free Professional Finger Print Outfit.

Name.....
Address.....
Present Occupation.....

FREE! for a limited time. A professional Finger Print Outfit—a course in Secret Service Intelligence. Also a complete book on Finger Prints sent at once if you will mail this coupon. Write today.

UNIVERSITY OF APPLIED SCIENCE
1920 Sunnyside Ave.
Dept. 1355
CHICAGO, ILL.



A Better Job Now!

Why take small pay from uncertain jobs? Why be buffeted around from this to that, and not know whether you are going to have a job tomorrow or not? You can change all that. Learn a trade. Know autos—how to repair them and take advantage of the countless opportunities to make big money. Pave the way for a business of your own—a business that can make you independent for life. You can do it with a few weeks' training at the Michigan State Auto School—the great auto-trade school in the heart of the industry.

Be a Trained Man—Successful!

Fellows just like you step out and make great successes. Trained men wanted all the time—everywhere! More than 10,500,000 autos, trucks and tractors in use. All need service and repairing. 50 million tires, millions of batteries to be kept in commission. More men needed for good jobs. More garages—more electric service stations—more tire-repair shops—welding shops—battery stations needed. This means amazing opportunities for the men who start now. Fit yourself to win a good job, or to start a business of your own. Very small capital is needed. You are right on the threshold of big money if you decide now to make this your business.



Come to the Auto Center

Learn Autos in a Few Weeks by Factory-Endorsed Methods

Come to Detroit. Here is where autos are made. Come to the Michigan State Auto School where you get first-hand experience and knowledge. Great auto factories endorse and recommend M. S. A. S. training. *The Cadillac Motor Co.* says: "We believe you have the best and most complete school of its kind." *The Hudson Motor Co.* says: "The best equipped and most efficient school in America." You can learn the business thoroughly on latest equipment. You visit the great Detroit auto-plants. Get first-hand knowledge and a quality-training that means certain success, if you do your part.

Get All Facts—Mail Coupon Today!

Decide now to grasp this opportunity. If you like autos—and are mechanically inclined—there are big-money jobs—a business of opportunities waiting for you. Classes always open. Your enrollment includes Life-Membership with privilege to come back at any time to brush up on the latest equipment, and get new money-making ideas. Investigate! Let us show you what we can do for you. Mail the coupon for big illustrated catalog.

Colored Students Not Solicited

MICHIGAN STATE AUTOMOBILE SCHOOL

A. G. ZELLER, President
305 Auto Bldg. 3729 Woodward Ave.
DETROIT, MICHIGAN

FREE

CATALOG
MICHIGAN STATE
AUTO SCHOOL

Mail Coupon To Day

MICHIGAN STATE AUTO SCHOOL
305 Auto Bldg., Detroit, Mich.

Gentlemen:—Send FREE and without obligation, your illustrated catalog, and Auto School News, giving complete information and showing the opportunities and advantages of a Factory Endorsed Detroit-Training to make the most money.

Name

Street or R. F. D.

City State

The Factory Endorsed School



Do You Want to Be A Surveyor?

ARE you fond of outdoor work? Would you like to become a Civil Engineer? Then take up Surveying. It is a profession that not only pays big salaries itself, but it is the stepping stone to something even better. Probably 99 out of every 100 Civil Engineers were surveyors first.

Fill out the coupon below and let us tell you how you can prepare for success in Surveying, Engineering, Drafting, Chemistry, etc., through spare-time study at home with the I. C. S.

----- TEAR OUT HERE -----

INTERNATIONAL CORRESPONDENCE SCHOOLS
Box 5635-C, Scranton, Pa.

Without cost or obligation, please send me complete information about the subjects before which I have placed an X in the list below:

- | | |
|---|--|
| <input type="checkbox"/> SURVEYING | <input type="checkbox"/> ADVERTISING |
| <input type="checkbox"/> DRAFTING | <input type="checkbox"/> Salesmanship |
| <input type="checkbox"/> Mechanical Engineering | <input type="checkbox"/> BOOKKEEPING |
| <input type="checkbox"/> Civil Engineering | <input type="checkbox"/> Civil Service |
| <input type="checkbox"/> ARCHITECTURE | <input type="checkbox"/> Railway Mail Service |
| <input type="checkbox"/> Electrical Engineering | <input type="checkbox"/> Pharmacist |
| <input type="checkbox"/> Stationary Engineering | <input type="checkbox"/> Traffic Manager |
| <input type="checkbox"/> CHEMISTRY | <input type="checkbox"/> Business Management |
| <input type="checkbox"/> Automobiles | <input type="checkbox"/> Certified Public Accountant |
| <input type="checkbox"/> STENOGRAPHY | <input type="checkbox"/> Airplane Engines |
| <input type="checkbox"/> High School Courses | <input type="checkbox"/> Wireless |

Name.....

Address.....

Occupation.....

Persons residing in Canada should send this coupon to the International Correspondence Schools Canadian, Limited, Montreal, Canada.

LEARN BY DOING

Every phase of all branches of

ELECTRICITY

Taught by Actual Practice

In America's foremost and oldest institution for trade training.

No Books Used
Individual Instruction
Start Any Day

A SPECIAL and SEPARATE Course in Ignition, Auto Lighting and STARTER Systems. Write for FREE 64-page catalog.

THE
NEW YORK ELECTRICAL SCHOOL
44 West 17th Street NEW YORK CITY

DRAFTSMEN EARN BIG MONEY YOU CAN TOO

Drafting is the profession of opportunity. It is the foundation of industry. By taking advantage of your spare time, you can prepare yourself in a few months to fill one of the thousands of positions open. We offer the best instruction possible, and you have no difficulty in filling a position, which we help you to secure. It is not necessary for you to have any other training, but a knowledge of simple arithmetic, and the ability to read and write. FOR INFORMATION AND CATALOG WRITE TO

Boston School of Practical Drafting, 1065 Columbus Ave., Boston, Mass.

BE AN EXPERT Penman

FREE Particulars, "How To Become An Expert Penman," and Your Name in Fine Penmanship on two Cards, Different Colors, Embellished, Attractive Designs, ALL FREE. Write Today
T. M. TEVIS, Box 25-K, Chillicothe, Mo.

Learn Watchwork, Jewelrywork and Engraving.

A fine trade commanding a good salary, and your services are always in demand. Address HOROLOGICAL, Dept. P, Bradley Institute, Peoria, Ill., for our latest catalog.



Wrestling Book FREE

Be an expert wrestler. Learn at home by mail. Wonderful lessons prepared by world's champion Farmer Burns and Frank Gotch. Free book tells you how. Secret holds, blocks and tricks revealed. Don't delay. Be strong, healthy. Handle big men with ease. Write for free book. State your age.
Farmer Burns, 1775 Range Building, Omaha, Neb.

5 Master Keys

Only keys of their kind in existence—(patented). Open and test thousands of different locks. Tell you instantly if your door or padlocks are burglar proof. Serve in emergencies, too. Thousands of sets in daily use among detectives, policemen, contractors, locksmiths, firemen, mechanics, travellers, home and hotel owners, etc. Give feeling of security and protection worth many times their cost. Novel key chain FREE with each set. Send only \$1 today.
MASTER KEY CO., 103 MANHATTAN BLK., MILWAUKEE, WIS.



Artist Wanted \$100 a Week



Big Demand Everywhere for Artists!

You can now realize your ambition—become a successful artist—and make \$40, \$50, \$100 or even more every week. The demand for Illustrators, Cartoonists and Commercial Designers is steadily increasing. Never were there such opportunities for trained artists! Magazines, newspapers, advertising agencies, department stores—all are glad to pay real money for artists who can produce pictures with commercial value. You have a big future in this fascinating, pleasant and profitable profession.

Learn at Home This New, Easy Way

Our wonderful new method makes it possible for *anyone* to learn Illustrating, Cartooning, or Commercial Art. Most of our students never touched a drawing pencil before they studied with us, yet hundreds of them are now making splendid incomes. You can do the same. The simplicity of this amazingly simple way will astonish you. No matter what your present ability—no matter whether you think you have "talent" or not—we can teach you to draw—and draw well. You—with a little spare time study at home—and the *personal* instruction of one of America's foremost commercial artists—can easily and quickly qualify for a big paying artist's position.

New Way Makes Success Easy

Our new way simplifies everything. All the tedious "art school drudgery" has been done away with, and in place of months of aimless practice in drawing "plaster casts" you get definite, practical instructions, aiming at a *definite* object—to qualify you to *make money* in the commercial art field as soon as possible. You start drawing with straight lines, then you begin using curves, and before you realize it you are drawing pictures with shading, action and perspective. And you are taught all the "inside secrets"—the "tricks of the trade" that would otherwise take you years to learn. Our Art Director has had years of experience in commercial

art. He knows the kind of pictures that sell and he teaches you how to make them—in the least possible time.

Success of Students

Read what these well-known artists say about our course:

"I heartily recommend the Washington School of Art." Granville Road, New York.

"I shall never cease to be grateful for the foundation your school gave me." Frank Godwin, New York.

"I shall ever feel grateful to you for your valuable criticism and encouragement." H. Bradford, Kensington, Md.

Write for FREE BOOK

An interesting and handsomely illustrated booklet, "How to Become an Artist," has been prepared and will be sent you *without cost*.

Mail this coupon for it. Learn how you can easily become an artist in a few minutes daily spare time. Get also full particulars about our "Free Artist's Outfit" offer. Send the coupon **NOW!**

THE WASHINGTON SCHOOL OF ART, Inc.
Room 1830 Marden Bldg., Washington, D. C.

THE WASHINGTON SCHOOL OF ART, Inc.

Room 1830 Marden Building, Washington, D. C.
Please send me without cost or obligation on my part your free book, "How to Become an Artist."

Name.....

Address.....



Increase Your Pay Within the next few months!

Are you sacrificing the best years of your life to a routine job, in the thought that you must *stand in line* for promotion—that you can advance only at the shuffling pace of the rank and file? The man who depends on *length of service* for advancement rarely gets beyond the information desk.

Why throw away your future in a low-pay job, when you can qualify, in a comparatively few months, for a high-salaried position as a business specialist?

Thousands of men with no better start than you have doubled and tripled their incomes by home-study business training under the LaSalle Problem Method. During a period of only three months, 1,089 members of LaSalle Extension University reported definite salary-increases as a result of training under this remarkable method. *The average increase per man was 56 per cent.*

If "half as much again" would look good to you *within the next twelve months*, and if you have the stamina to do the work, check the training that interests you, sign and mail the coupon NOW. It will bring you full particulars, together with details of our *convenient-payment plan*; also your free copy of "Ten Years' Promotion in One." "Get this book," said a prominent Chicago executive, "even if you have to pay five dollars for it." We will send it *free*.

Make your start toward that bigger job TODAY!

LaSalle Extension University

The Largest Business Training Institution in the World
Dept. 564-R. Chicago, Illinois

Gentlemen: Send without obligation to me information regarding course indicated below:

- | | |
|--|--|
| <input type="checkbox"/> Business Management | <input type="checkbox"/> Modern Business Correspondence and Practice |
| <input type="checkbox"/> Salesmanship | <input type="checkbox"/> Modern Foremanship and Production Methods |
| <input type="checkbox"/> Higher Accountancy | <input type="checkbox"/> Personnel and Employment Management |
| <input type="checkbox"/> Traffic Management | <input type="checkbox"/> Expert Bookkeeping |
| <input type="checkbox"/> Railway Accounting and Station Management | <input type="checkbox"/> Business English |
| <input type="checkbox"/> Law—Degree of LL. B. | <input type="checkbox"/> Commercial Spanish |
| <input type="checkbox"/> Commercial Law | <input type="checkbox"/> Effective Speaking |
| <input type="checkbox"/> Industrial Management Efficiency | <input type="checkbox"/> C. P. A. Coaching |
| <input type="checkbox"/> Banking and Finance | |

Name.....

Present Position.....

Address.....

WE TEACH COMMERCIAL ART

Properly Trained Artists Earn \$100 a week and up. Meyer Both College—a Department of the Meyer Both Company—offers you a different and practical training. If you like to draw, develop your talent. Study this practical course—taught by the largest and most widely known Commercial Art Organization in the field with 20 years' success—which each year produces and sells to advertisers in the United States and Canada over ten thousand commercial drawings. Who else could give you so wide an experience? Commercial Art is a business necessity—the demand for commercial artists is greater every year. It's a highly paid, intensely interesting profession, equally open to both men and women. Home study instruction. Get facts before you enroll in any school. Get our special booklet, "Your Opportunity"—for half the cost of mailing—4c in stamps.

**MEYER BOTH COLLEGE
of COMMERCIAL ART**
Michigan Ave. at 20th St.
Dept. 16 CHICAGO, ILL.

BE A JAZZ MUSIC MASTER

PLAY BY EAR
Play popular song hits perfectly by ear. Hum the tune, play it by ear. No tedious ding-dong daily practice—just twenty brief, entertaining lessons which you can master in no time. Send for the free book. It tells how to start if you want musical ability at which friends will marvel. Niagara School of Music
Dept. 46L, Niagara Falls, N.Y.

Send for this Free Book

Our Scientific Method will stop that

STAMMER!

Send for free 200 page book. It tells how to permanently stop stammering or stuttering in a few weeks' time. A natural guaranteed method.

The Lewis School for Stammerers
32 Lewis Bldg., 71-77 Adelaide St., Detroit, Mich.

Learn Drafting Increase Your Income

Expert Draftsmen earn from \$60 to \$150 a week and are in line for promotion to executive positions. You can become an expert by the Chicago "Tech" Method. Train by mail in spare time and put yourself in the high salaried class.

Free Trial Lesson

Send for Free Lesson which shows how easily you can get this practical training at little cost and on easy terms. Write today.

CHICAGO TECHNICAL COLLEGE
530 CHICAGO "TECH" BLDG., CHICAGO, ILL.

Mystic Skeleton

A jointed figure of a skeleton 14 in. in height, will dance to music and perform various gyrations and movements while the operator may be some distance from it. 10c pd.

Serpent's Eggs

Box contains 12 eggs. When lit with a match, each one gradually hatches itself into a snake several feet long, which curls and twists about in a most life-like manner. Price per box, 10c ppd.



Good Luck Ring

Quiet
and Novel
Design

A VERY striking and uncommon ring. Silver finish, skull and crossbone design, with two brilliant, flashing gems sparkling out of the eyes. Said by many to bring Good Luck to the wearer, hence its name, Good Luck Ring. Very unique ring that you will take a pride in wearing. ONLY 25 CENTS.

JOHNSON SMITH & CO., Dept. 777, 3224 North Halsted Street, CHICAGO



FREE

PROFESSIONAL TONE MUSICAL INSTRUMENTS

and lessons sent on **free** trial. Violin, Tenor Banjo, Hawaiian Guitar, Ukulele, Mandolin, Cornet, Banjo-Mandolin, Banjo-Ukulele, Guitar, Banjo-Guitar, or Banjo. Wonderful new copyrighted system of teaching note music by mail. Four lessons will teach you several pieces. Over 100,000 successful players. Do not miss this free trial offer. Write for booklet. No obligations.

SLINGERLAND SCHOOL OF MUSIC, INC., 1815 ORCHARD ST., DEPT. 104, CHICAGO, ILL.

Cheapest Way to Go

to work or school and recreation is on a Ranger bicycle. You can have your choice of 44 Styles, colors and sizes. **30 DAYS' FREE TRIAL.** Express prepaid. **Factory-to-Rider** Prices save you \$10 to \$25. **12 Months to Pay** if desired. Saved time and care-free easily meets the small payments. Parents often advance first payment.

best quality, at factory prices, express prepaid. Lamps, wheels and equipment, low prices. Send **No Money, do business direct with makers.**

Mead Cycle Company
Dept. C-105 Chicago

Write today for free Ranger Catalog, factory prices and marvelous easy payment terms



Taxidermy Book FREE.



Write Today.

Stuff Beautiful

Birds. Learn by mail to stuff and mount all kinds of birds, animals, fish and game heads, make rugs, tax skins. Mount your own specimens and make money preserving for others. Men, women and boys learn easily and quickly. Success guaranteed or no tuition. Write today for our wonderful **FREE** book "How to Learn to Mount Birds and Animals. N.W. School of Taxidermy, 1775 Elwood Bldg., Omaha, Neb.

Whatever Your Question;—be it the pronunciation of Bolsheviki, the spelling of a puzzling word, the location of Murman Coast—the meaning of blighty, ace, tank, ukulele, etc., this Supreme Authority—

WEBSTER'S NEW INTERNATIONAL DICTIONARY

contains an accurate, final answer. 400,000 Words, 2700 Pages, 6000 Illustrations. Regular and India-Paper Editions. **G. & C. MERRIAM CO., Springfield, Mass.** Write for specimen pages, prices, etc. and **FREE** Pocket Maps per Popular Mechanics



FREE Book on Signaling

Write today for book that tells about opportunities in the profession of Signal Engineering. Men needed. Learn how you can get training that you need to fill the big job. **\$125 to \$300 a Month** The free book gives you just the information you want. Write: **DEPARTMENT OF SIGNALING, Dept. 1355, 1924 Sunnyside Avenue, CHICAGO**

COST ESTIMATING BLUEPRINT READING—DRAFTING

all branches. **EARN \$250 to \$300 a month** as Estimator. Big demand guarantees high salaried position. Get in now. Big pay. Steady work. The only School offering home training in the **NEW MODERN SYSTEM OF ESTIMATING.** Write today for free book.

UNIVERSAL CORRESPONDENCE SCHOOLS
519 New York Life Bldg. Dept. 2C Minneapolis, Minn.

From Poverty To Riches



Walter Michael Barry

I STARTED WITH \$60 and built up a \$100,000.00 Business

When I resigned my U. S. Army commission on July 19, 1919, I discovered that I was dead broke. Uncle Sam handed me a bonus of \$50. I am now the head of a \$100,000.00 corporation and another \$25,000.00 corporation. I am going to make more money than ever and you can help me while learning the secret of my success.

I DON'T CARE WHO OR WHAT YOU ARE—you may be established in a business or profession; at school or college; at skilled or unskilled work—I can help **MEN AND WOMEN** to success, whether they retain their present vocations or apply themselves exclusively to the **NEW OCCUPATIONS** I can indicate to them.

Do you want to make big money in whole or spare time?

I can help you. No! I have not discovered a mysterious, unknown power; it is all so simple that any **MAN, WOMAN, BOY OR GIRL** who can read plain English will understand and appreciate it instantly. It does not require weeks of study.

Let me tell you, without obligation, the amazing story of my success and show you how my plan will benefit you.

WALTER MICHAEL BARRY

ECONOMY EDUCATOR CORP., (Dept. 6)
1664 BROADWAY, NEW YORK, N. Y.



MONEY BACK GUARANTEED IF NOT AS ADVERTISED

ECONOMY EDUCATOR CORP. (Dept. 6)
1664 Broadway, New York, N. Y.

Kindly send me Mr. Barry's story. Enclose copyrighted Economy Plan introducing 30 methods of making and saving money, personal efficiency secrets for business and social success, etc. I realize the expense of postage and preparing this offer, which may prove so profitable to me, and think it fair that I should pay my share. I therefore enclose **ONE DOLLAR** which you guarantee to return to me if this offer is not as advertised. (No personal checks.) If your special introductory offer and the terms which accompany it are satisfactory, I will comply with same. I am to be the sole judge of this.

Name.....
Address.....

FREE COURSE IN DRAFTSMANSHIP

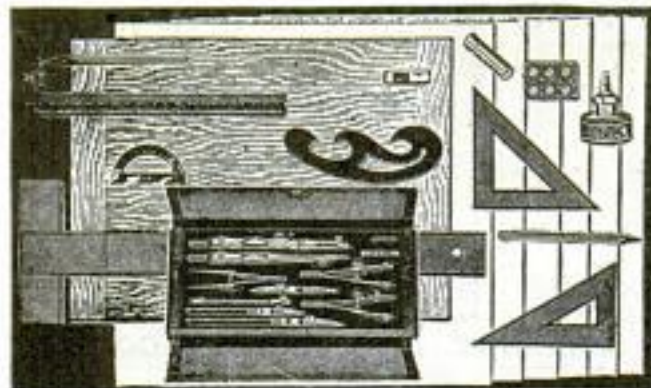

BE A DRAFTSMAN QUICK SUCCESS and MORE MONEY

Salaries \$40 to \$100 per week. Here is your only OPPORTUNITY to get this wonderful HIGH-PRICED, COMPLETE DRAWING OUTFIT, including a FREE, PRACTICAL COURSE IN MECHANICAL DRAWING—AT OUR SPECIAL OFFER.

SEND NO MONEY

We will send this complete HIGH-GRADE splendid Draftsman's Outfit—with a FREE COURSE in Mechanical Drawing—to YOU—anywhere in the United States without any extra charge. This is a remarkable offer, with which you can build your success in DRAFTSMANSHIP. You can put yourself in a class of trained men whose services are always in DEMAND.

EASY TO LEARN AT HOME IN YOUR SPARE TIME and is your one chance to earn the biggest money of your life, and will be one of the most profitable investments you have ever made.

NO EXPERIENCE NECESSARY

The course is most simple, thorough, and successful in existence, and offers every man, regardless of age, education or previous experience, the chance to become a successful draftsman in a short time, and make up to \$100 per week.

REMEMBER

There are more than 5000 men wanted every month—and positions open everywhere—everything used by expert draftsmen given to you—as follows:—

Set large size Professional Draftsman's drawing instruments of Fine Nickel Silver, set into a handsome Velvet Lined pocket book folding case, size 4 by 8½ inches closed—also One Drawing Board 29 by 24½ inches—One 24-inch T Square—One 12-inch Standard scale rule—One Protractor—Supply of drawing paper—Two Triangles—One French Curve—Pencils—Eraser—One bottle waterproof drawing ink—Thumb Tacks—and one enlarged Edition FREE—A PRACTICAL COURSE IN MECHANICAL DRAWING. You cannot make a mistake by taking up drawing.

GUARANTEE YOUR FUTURE—NOW OFFER IS LIMITED—DON'T DELAY—WRITE AT ONCE

Tear Out and Mail Today

NATIONAL INSTRUMENT CO., 4714 North Hamilton Ave., Chicago, Ill., U. S. A.

Mark an X in One of the Squares Below for Offer Desired

Please send me at once—Complete Drafting Outfit—with a FREE COURSE in Mechanical Drawing—for which I am to pay \$11.95 on arrival—with no extras to pay—all guaranteed as represented above.

Please send me more particulars how I can become a successful Draftsman with your Complete Drafting Outfit—and FREE-COURSE OFFER—absolutely FREE.

Name.....

Address.....

(Please write plainly)

5-22

Arthur Murray Invents New Easy Way to Learn to Dance

Quicker, Easier, Costs Less Than Personal Teacher. You Can Learn at Home in Few Hours



Arthur Murray, America's greatest teacher of social dancing, has invented a remarkable new method which enables anyone to learn all the newest ballroom steps at home in one evening, at very little cost. No music or partner needed. So simple even a child can learn quickly. 60,000 have learned to dance by mail. Your own success is guaranteed.

Arthur Murray
Instructor to the
Vaudeville



BE POPULAR!

No longer need you envy those who dance well. By Arthur Murray's amazingly simple method you can learn in a few hours to be an accomplished confident dancer. Surprise your friends by learning to dance all the latest New York steps.

To prove you can learn easily and quickly, Arthur Murray will send you a Fox Trot lesson FREE, which includes the Secret of Leading and How to Gain Confidence. Send 10c for mailing. Write for your lesson today!

Studio 218
ARTHUR MURRAY, 100 Fifth Ave., N. Y.

Learn Sign Lettering in 20 Hours

Using our New Method Patented Mechanical Device—no stencil. Have a business of your own earning from \$2,000 to \$5,000 a year lettering store windows, show cards, barns, roofs, walls, fences, and signs of all kinds. Students can have established business doing lines of work in thirty days. We guide you step by step. Absolute satisfaction guaranteed.

Write today. Details free

Dept. M AMERICAN SCHOOL OF LETTERING Omaha, Nebraska

STOP USING A TRUSS

Do Away With Steel And Rubber Bands

FREE TRIAL



Inner surface is made adhesive to secure the PLAPAO-PAD firmly to the body, keeping the PLAPAO continually applied and the pad from slipping. No straps, buckles or springs attached. Soft as velvet—easy to apply.

It's the Non-Slipping, yet Non-Rigid Pad and What is Within It That Counts

FREE to 5,000 Truss Sufferers

To the extent of 5,000 sufferers who may apply I will send, ABSOLUTELY FREE, a sufficient quantity of the Plapao to positively convince them that this is the only logical, common-sense way of treating rupture. Plapao is a highly astringent medication placed within the Plapao-Pad and being absorbed through the skin, creates a wonderful feeling of relief and at the same time tends to strengthen the weakened muscles and thus permanently close the rupture opening. The process of recovery is natural, so you'll have no use for a truss—you can throw it away forever! Old and young have testified under oath that the Plapao-Pads cured their rupture—many of them long-standing, aggravated cases—without delay from work. Patent allowed in U. S. and foreign countries. Awarded Gold Medal at Rome and Grand Prix at Paris.

Send No Money—for a sufficient quantity of the Plapao is sent without charge to enable you to give it a thorough test; you pay nothing for this trial now or ever. Write for it and full information today. Address Plapao Laboratories, Block 1427 St. Louis, Mo.

You Can Play the Hawaiian Guitar Just Like the Hawaiians!

Because Our Native Hawaiian Instructors Will Help You

OUR STUDENTS SAY

241 E. Sharpshoot St.,
Otn, Phila., November 6, 1921.
First Hawaiian Conservatory of Music.

Dear Sir—
I received my guitar and first lesson and am very much pleased with it, and its fine appearance and tone. I have learned how to tune it and am getting along fine with the lessons, and can hardly wait for my next lesson. Your method is very simple; it is great for all beginners. I must say it is better than personal teaching. Thanking you very much for the enrollment blank. I gave your enrollment blank to my friend and he said he will send it and the money order for ten dollars for your violin course.

Yours truly,
Milton H. Johnson.

October 1st, 1921.
Keebler School,
314 So. Franklin St.,
Chicago, Ill.

First Hawaiian Conservatory of Music,
Inc.

I shall certainly be very glad to recommend your course whenever the chance is mine to do so. Mr. W. R. Johnston has not phoned me yet, and if he does not phone in a day or so, will write him. Am sending a letter to Miss Helen Slavik today which I think may help to secure her enrollment, and I shall be glad at any time to write a personal letter to anyone whom you may suggest.

Your former student,
W. L. Walker.

Vinton, Iowa, 10-7.

Dear Sir—
Received picks and first lesson September 29th. Rave was surprised how much I learned first lesson. Wishing you the best of success with your course, I am
Respectfully yours,
Van Wright,
Mgr. Western Union, Vinton, Ia.

Our improved method of teaching is so **simple, plain and easy** that you begin on a piece with your first lesson. **In half an hour you can play it.** Thousands of successful students prove this to be true.

ONLY 4 MOTIONS necessary motions you learn to only four, and you acquire these in a very few minutes. Then it is only a matter of a little practice to acquire the weird, fascinating, tremolos, staccatos, slurs and other effects that make this instrument so delightful. **The Hawaiian Guitar plays any kind of music,** both the melody and the accompaniment.

FREE Just think of it. 52 lessons on this wonderful guitar. You get a beautiful large sized **Genuine Hawaiian Guitar absolutely free as soon as you enroll for the lessons.** All the necessary picks, the steel playing bar and **52 pieces of music** are included **without cost to you.**

Special Arrangements for Lessons if You Have Your Own Guitar

Play Any Music

In half an hour after you get the free Hawaiian Guitar and the first lesson, you can play **Hawaiian Melodies.**

In a very short time after a little practice you can play any kind of music as well as Hawaiian, both the melody and accompaniment.

[TEAR OUT COUPON]



Tear Off and Mail Today

First Hawaiian Conservatory of Music, Inc.

233 Broadway (Woolworth Bldg.), New York City

Please send me full information about your 52 easy lessons and **FREE GUITAR OFFER.**

NAME.....

ADDRESS.....

TOWN..... STATE.....

Print name and address clearly. P.M.5

How I Earn \$15 to \$25 a Week at Home in my Spare Time

By Wm. S. Coulthard



I needed money. I had a lot of time on my hands in the evenings, Saturday afternoons, etc.—for I had no hobby—and besides my expenses had been mounting fast—so you will see the receptive mood I was in when I saw your little ad, "MAKE MONEY AT HOME."

I sent for your free booklet.

I read it.

Your plan looked good to me—your guarantee so liberal—and on investigation I found you were reliable, so I accepted your offer. If others could make money by your plan, I could.

That was less than a year ago.

Now I am earning \$15.00 to \$25.00 a week, each week, writing show cards in my spare time. In addition to this, I still hold my regular job, and my salary has been increased there, too. I believe my spare time work has made me better satisfied with life, and so I'm doing my regular work better.

I have been offered positions writing show cards, but I am not interested, as my present position is perfectly satisfactory, but I certainly am glad I enrolled in your school—my spare time money is exceedingly attractive. Besides, I find show card writing an interesting occupation that fills in those evening hours that used to drag so. In fact, it is really a hobby now with me—and a profitable one, as you can well imagine. Only last week I received a check from your school for \$70.00 for work done over the last three weeks. Of course, you'd have paid me regularly each week if I'd bothered about it, but I was too busy to tell you the amount of work I'd finished.

There are times, however, that I feel show card writing by your simple method is almost too good a thing—that's when I have so many orders ahead that I cannot see my way clear to finish them—and have to turn down work.

Your system of supplying work to your students has certainly helped me, but sometimes you send too much—I'm only working at it in my spare time, you know. Please note this, and don't try to overload me too much.

By the way, I think you'll be interested to know that previous to enrolling in your school I had never tried my hand at any work of this nature.

I'm glad to thank you for what you've done for me—and you can certainly use my name and tell prospective students, for I feel I'll be doing anyone a real good turn if I can help them get started in this profitable work.

Yours sincerely,
WM. S. COULTHARD.

NOTE:—The above is the story of Mr. Coulthard. It tells of facts, for Show Card Writing offers a marvellous opportunity to both men and women, either for spare time or full time work. What Mr. Coulthard has done and is doing, you can do. Colbran, Dusenberry, Wendt, Blade, Poulson, Charles, Wright, Babineau and many other men have proved it. Mrs. Litherdale, Mrs. Lush, Mrs. Le Moine and dozens of housewives have added to the family income in this way. Girls like Misses MacDonald, Clegg, Berdrea and Hoyle are but a few of those who have bettered their positions in this pleasant way. All these owe their success to the American Show Card School method of training—the old established school which has trained hundreds to make money in SHOW CARDS. The American Show Card School will gladly send you full particulars if you but send your name and address to them.

Use this
Coupon.

Name.....

(Print your name plainly)

Address.....

(In full)

State.....

TEAR OFF HERE AND MAIL TO-DAY. American Show Card School
2030 Ryrie Bldg.
Toronto, Can.

Send me your Free Booklet on Show Card Writing, and show me how I can make money at home—without canvassing or soliciting. It is understood that this places me under no obligation of any kind.

Dr. T. O'Connor Sloane Will Teach You CHEMISTRY Right In Your Own Home



DR. T. O'CONNOR
SLOANE

A. B. A. M. L. D. Ph. D.
Educational Director
Chemical Institute of
New York, formerly
Treasurer American
Chemical Society and
a Practical Commercial
chemist as well as a noted
instructor. Dr. Sloane
personally examines and
corrects the examination
papers of every student.

Good chemists command high salaries. Industrial firms of all kinds pay tempting salaries to get the right men. Salaries of \$10,000 a year are not unusual for Chemists of exceptional abilities. The work of the chemist is especially interesting. If you are fond of experimenting, take up chemistry. If you want to earn more money, the way is open through our Course in Chemistry.

You Can Learn at Home

Dr. Sloane will teach you Chemistry at home in a practical, intensely interesting way. Our Course is remarkably simple. No special education required—if you can read and write plain English, you can thoroughly understand and master every lesson.

Easy Monthly Payments

The price of our course is very low and the tuition includes everything, even the chemistry outfit—there are no extras to buy with our course. You can pay in small monthly amounts as you go along. Our plan places a chemical education within the reach of everyone.

Experimental Equipment Given to Every Student

One special feature of our course is that we give to every student, without additional charge, the physical equipment he will need for his studies, including forty-two pieces of laboratory apparatus and supplies and eighteen different chemicals and reagents. The fitted, heavy wooden box serves as a carrying case, and as a laboratory accessory for performing experiments.

SPECIAL THIRTY-DAY OFFER

In addition we are making a special offer for a short time only. You owe it to yourself to find out about it. Mail the Coupon to-day for free book, "Opportunities for Chemists" and full details of our special 30-day offer. Act immediately before this offer is withdrawn.

CUT HERE

CHEMICAL INSTITUTE OF NEW YORK, Inc.
(Home Ext. Division 5) 149-P, Liberty St., N. Y. City

Without obligation or cost, send me your free book "Opportunities for Chemists" and full particulars about the Experimental Equipment given to every student, and tell me about your plan of payment and special 30-day offer.

Name.....

Address.....

City..... State.....

Be an Artist

Comics, Cartoons, Commercial, Newspaper and Magazine Illustrating, Pastel Crayon Portraits and Fashion. Earn money; become famous. Our simple method quickly develops your talent in spare time. By Mail or Local Classes. Write for terms and list of successful students.

ASSOCIATED ART STUDIOS
87-B Flatiron Building NEW YORK

Gibson Instruments

Mandolin, Mandola, Mando-Cello,
Guitar, Tenor-Banjo, Mandolin-
Banjo, Cello-Banjo, Guitar-
Banjo, Harp-Guitar,
Mando-Bass —



Easy to Play Easy to Pay

Select your Gibson now. You can soon be playing the music of the day. Your friends will be surprised and delightfully entertained. Let us help you organize a Gibson Orchestra in your community. You can increase your popularity, income and pleasure by playing for Concerts, Entertainments, Church Affairs, etc. A small down payment and then \$5 a month will soon pay for a Gibson and will furnish you with wholesome, year-round entertainment. If you have an old instrument, we will make liberal allowance on a Gibson. Write for Free Book, Catalog, Free Trial Offer, information about Wm. Place, Jr. Book and Instrument post-prefer.

GIBSON MANDOLIN-GUITAR COMPANY
1365 Parsons Street Kalamazoo, Mich., U. S. A.

OVER
\$9300
PER WEEK
earned by Burgess-
Trained Man

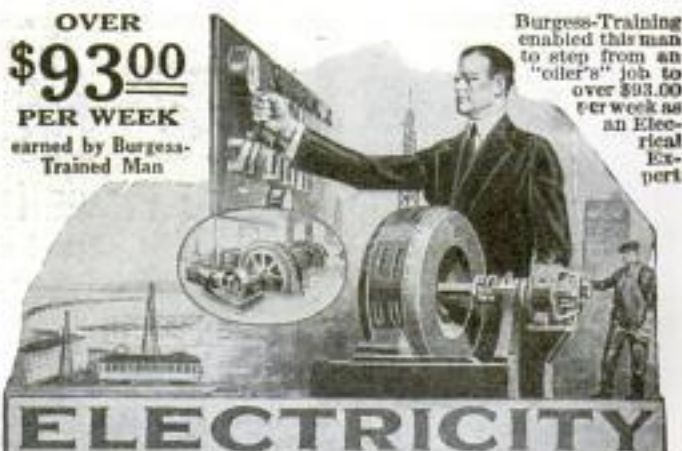

Burgess-Training enabled this man to step from an "odd's" job to over \$93.00 per week as an Electrical Expert

HOME STUDY BURGESS ELECTRICAL COURSE

in simple English—for anyone who can read and write

ENDORSED BY IMPORTANT PLANTS and ELECTRICAL ENGINEERS. A course so good that it does not require free offers or misleading claims to sell it.

Beginners quickly fitted for electrical jobs. All material, tools, etc., for practice work, furnished without extra charge.

Advanced Training for EXPERIENCED MEN

Good, sound, up-to-date, practical information, taught by a practical man. Slide Rule and special lessons on the use of same.

Write today for Special Catalog and tell me whether you are a Beginner or an Experienced Man.

Yorke Burgess, Superintendent

BURGESS ELECTRICAL SCHOOL
744 E. 42nd Street Dept. P-5 Chicago, Ill.
(Canadian Branch, 201 Crawford St., Toronto)

\$150 to \$400 a Month for YOU As an Expert Auto Mechanic



EASY TO LEARN HOW In 6 to 8 Weeks' Time

Come down to Washington—the Nation's Capital. Drop in at the American Motor Schools. Go all thru our big new \$250,000 building. Watch the young men who are learning, by actual practice, every detail of auto construction and repair, auto electricity, battery building, vulcanizing, tire repairing, and welding. Lots of these fellows will soon own their own garages

and be making from \$5,000 to \$10,000 a year. Many of them will soon be holding down good jobs paying from \$150 to \$400 a month.

You too can get your start towards success in the Auto business with the help of the American Motor Schools.

FREE CATALOGUE

Fill in and send the following coupon and we will send you free our illustrated catalogue telling about your opportunity in the auto business and how we will help you to make good. By acting promptly you can save \$50. Mail the coupon NOW.

American Motor Schools, Inc.,
Dept. 254 16th & You Sts. Washington, D. C.

Send the Coupon

The American Motor Schools, Inc.,
16th & You Sts., N. W.,
Dept. 254, Washington, D. C.

Please send me, free of charge, illustrated catalogue and information regarding your Auto Mechanics Course.

Name.....

Address.....

City..... State.....



From "One of the Unemployed" to \$100 a Week

"YES, it's tough to be out of a job." It was the employment manager speaking. "And *there's* a man who knows it, too," he added, pointing to the Chief Draftsman whose office door was open. "A year ago Mr. Macy lost his job as clerk and he found new jobs scarce. He determined then to fit himself for a *real* job.

"Studying the Help Wanted ads opened his eyes to a field where there never seemed to be enough men for the jobs, bad times or good times. He found there was constant demand for skilled Draftsmen, at better salaries for beginners than he'd ever got in any job.

"A Chief Draftsman friend told him how *he* and thousands of other successful Draftsmen had trained themselves for their jobs. They had taken the Home Study Course of the COLUMBIA SCHOOL OF DRAFTING. Mr. Macy wrote for literature and enrolled for the course.

"The secret of a permanent job, with steady advancement, is *specialized training*. Mr. Macy as a clerk a year ago got \$22 a week; as our Chief Draftsman he gets \$100."

COLUMBIA Will Do As Much for You

The answer to every ambitious man's desire to succeed is the COLUMBIA SCHOOL OF DRAFTING. Chief Draftsman Macy got out of the rut of a small-paid job. You can do it, too, the COLUMBIA way. If you have talent, taste, liking or interest in machinery, construction or electricity—you can fit yourself for the well-paid Drafting profession. It opens the way to still bigger-salaried positions as Chief Draftsman, Engineer, Production Manager and other executive ranks.

You need only ordinary intelligence and *ambition* to master the Course. We give practical drafting work *right from the first lesson*. We give you instruction as personal as if you were our only pupil. We furnish you with a complete professional Drafting Outfit. We help you get a job when you've completed the Course. You may be capable of accepting one *before* then. Mail the coupon and convince yourself. Every day's delay robs you of a day's bigger pay. Mail it now.

COLUMBIA SCHOOL OF DRAFTING

Dept. 1743

14th and T Sts.

Washington, D. C.

COLUMBIA SCHOOL OF DRAFTING Dept. 1743, 14th & T Streets, Washington, D. C.

I want to know what sort of a future Drafting offers me. Please send me your free book, "Your Future in Drafting," which also describes your course and tells how you will help me get a position as Draftsman.

Name.....

Address.....

City..... State.....

An Easy, Fascinating Way to Learn CHEMISTRY AT HOME



BECAUSE of conditions which grew out of the war, there never was a time in the history of America when chemists were in such demand as now.

Good salaries await the right men. No work is more interesting—no other profession offers greater opportunities.

For 30 years the International Correspondence Schools have been training men in just your circumstances for success in Chemistry and over 300 other subjects. They will help you prepare right at home for a position in the line of chemical work you like best—or in any other work that appeals to you. Thousands of men have stepped into fine jobs through I. C. S. training.

Let the I. C. S. help you, too. Choose the work you like best in the coupon below, then mark and mail it today. This doesn't obligate you in the least, and it will bring you the full story of what the I. C. S. can do for you.

TEAR OUT HERE

INTERNATIONAL CORRESPONDENCE SCHOOLS
Box 5633-C, Scranton, Penna.

Without cost or obligation, please send me complete information about the subject before which I have placed an X:

- | | |
|---|--|
| <input type="checkbox"/> CHEMISTRY | <input type="checkbox"/> High School Courses |
| <input type="checkbox"/> Pharmacy | <input type="checkbox"/> Advertising |
| <input type="checkbox"/> Mechanical Engineering | <input type="checkbox"/> Salesmanship |
| <input type="checkbox"/> Civil Engineering | <input type="checkbox"/> Bookkeeping |
| <input type="checkbox"/> Architecture | <input type="checkbox"/> Civil Service |
| <input type="checkbox"/> Electrical Engineering | <input type="checkbox"/> Railway Mail Service |
| <input type="checkbox"/> Stationary Engineering | <input type="checkbox"/> Traffic Manager |
| <input type="checkbox"/> Drafting | <input type="checkbox"/> Business Management |
| <input type="checkbox"/> Surveying | <input type="checkbox"/> Certified Public Accountant |
| <input type="checkbox"/> Automobiles | <input type="checkbox"/> Airplane Engines |
| <input type="checkbox"/> Stenography | <input type="checkbox"/> Wireless |

Name.....

Address.....

Occupation.....

YOU CAN MAKE \$18⁰⁰ DAILY

Great Introductory Offer
Giving These \$1.25 **FREE** Dress-Making Shears



With each sale of our wonderful 11-Piece Toilet Article Assortment for only \$1.75. Total store value \$4.60

MY! HOW THEY SELL

You get the interest with the free Shears. Walter Harris sold 800 boxes in 6 weeks. Profit over \$600.00.

ONLY 20 Boxes a Day Means \$18.00 Daily Profit!

ACT NOW! Sells like hot cakes year 'round. A baby could sell "Lucky 11." Don't delay a minute. Write for circulars explaining our unique plans, including 30 other packages. Act Now!

E. M. DAVIS CO., DEPT. 3355, CHICAGO, ILL.



"BECOME A LIGHTNING TRICK CARTOONIST"

MAKE MONEY CHALK TALKING. SEND \$1.00 FOR SNAPPY PROGRAM OF TRICK DRAWINGS WITH INSTRUCTIONS BY A PROFESSIONAL CARTOONIST. SATISFACTION GUARANTEED. CIRCULAR FREE. BALDA ART SERVICE, Q1, OSHKOSH, WIS.

WORK While Learning Electricity

—GET OUR FREE OFFER

S & H Electrical Works Dept. E 1, 308 S. Green St. CHICAGO



FREE "Linene" COLLAR

For trial, a sample of our New Style Copley, if you send 2 cents for postage and state size wanted.

Reversible Collar Co., Dept. U., Boston, Mass.



40,000 Opportunities in Hotels

YOU can have one of these well-paid, pleasant executive positions—40,000 of them in the big hotels of the United States—now America's Fourth Largest Industry. Statistics show that ONE IN EVERY TEN HOTELS WILL HAVE AN OPENING FOR A MANAGER THIS YEAR. Thousands of other positions are also open to those who qualify through training.

The Lewis School guarantees to give you the valuable knowledge that it has taken some of the most successful hotel men years to obtain—men who are now making \$5,000 to \$50,000 a year. All of your training will be under the personal direction of Clifford Lewis—a hotel expert of national reputation. A few spare-time hours a week given to the simple, clear lessons of the course will give you the training for a good position, a fine living, and a handsome salary. The training will in no way interfere with your present work or recreation. Send today for FREE BOOK, "Your Big Opportunity." Don't wait a minute—you may lose the opportunity of a lifetime. Mail the coupon NOW. Your whole future may depend on it.

LEWIS HOTEL TRAINING SCHOOL
Clifford Lewis, Pres. Room 315 Washington, D. C.

FREE COUPON

LEWIS HOTEL TRAINING SCHOOL
Room 315 Washington, D. C.

Send me without obligation the FREE BOOK "Your Big Opportunity."

Name.....

Street.....

City..... State.....

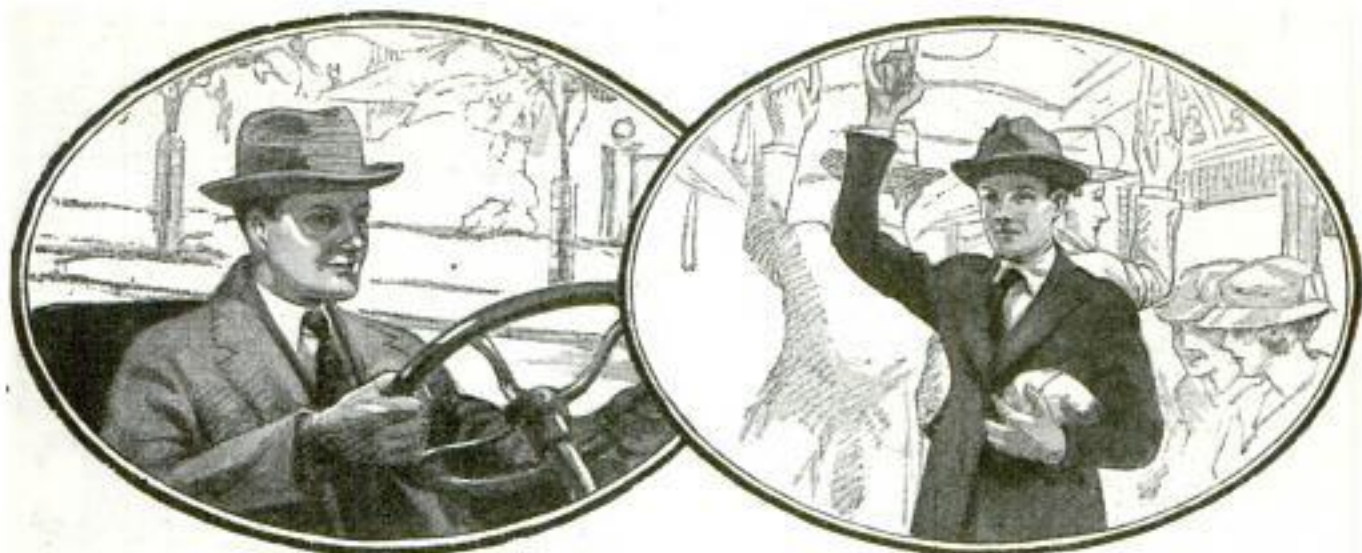

How do *you* ride to work?

Riding to work in a street car is hardly a mark of success. Few of your fellow passengers are really successful men—men who are holding big jobs and drawing big pay. Such men have the means to enjoy the luxuries of life. They are the men who ride comfortably to work in their own automobiles.

You can get into the car-owning class!

Books that help men to earn big money

More than 200,000 ambitious men have won better jobs and bigger pay through the help of these famous books. They are written in simple language and contain thousands of illustrations and diagrams that make difficult points as clear as day.

	Books in set	Old Price	New Price
Automobile Engineering	6	\$45.00	\$24.80
Carpentry and Contracting	6	\$7.50	24.80
Practical Applied Electricity	8	\$0.50	34.80
American Law and Practice	18	\$7.50	49.80
Modern Civil Engineering	9	\$7.50	39.80
Drawing	4	\$0.00	19.80
Steam and Gas Engineering	7	\$5.00	29.80
Fire Prevention and Insurance	4	\$0.00	19.80
Modern Machine Shop Practices	4	\$5.00	29.80
Accountancy and Business Manage- ment	7	\$2.50	29.80
Sanitation, Heating and Ventilation	4	\$0.00	18.80
Telephony and Telegraphy	4	\$0.00	19.80
Employment Management and Safety	7	\$2.50	29.80

We have made it easy for you to get into the big-pay class. One of the sets listed at your left will soon bring you a better job, a bigger income and all the pleasures of life that go with it. You will marvel at the simplicity of these books—the ease with which they explain problems that other men took long years to master. All the knowledge necessary to make rapid progress in your line of work is set down in plain, everyday English.

Sent for FREE TRIAL

Don't send a single penny. Just fill in and mail the coupon. When the books arrive, use them as if they were your very own for an entire week. Put them to every test you can think of. If you aren't convinced they will help you to earn more money, return them at our expense. If you decide to keep them, pay the specially reduced price at the rate of only 10c a day.

American Technical Society

Dept. X-195 Chicago, U. S. A.



Along with every set goes a year's Consulting Membership in the American Technical Society (regular price \$12). Consult our experts without charge.

AMERICAN TECHNICAL SOCIETY

Dept. X-195, Drexel Ave. and 58th St., Chicago, U. S. A.

Please send me set of
for 7 days' FREE examination, shipping charges collect. I will examine the books thoroughly and, if satisfied, will send \$2.80 within 7 days and \$3.00 each month until I have paid the special price \$
If I decide not to keep the books I will write you to have them returned at your expense.

Name

Address

City State

Reference

Please fill in all lines

An Open Letter

Do you recall one of those rare moments in life when the veil is lifted for a moment, when a breath of inspiration comes like a flash, when the future seems to be suddenly illuminated, when you feel a mastery stealing into hands and brain, when you see yourself as you really are, see the things you might do, the things you can do, when forces too deep for expression, too subtle for thought, take possession of you, and then as you look back on the world again, you find it different, something has come into your life—you know not what, but you know it was something very real?

Winning victories is a matter of morale, of consciousness, of mind. Would you bring into your life, more money, get the money consciousness, more power, get the power consciousness, more health, get the health consciousness, more happiness, get the happiness consciousness? Live the spirit of these things until they become yours by right. It will then become impossible to keep them from you. The things of the world are fluid to a power within man by which he rules them.

You need not acquire this power. You already have it. But you want to understand it; you want to use it; you want to control it; you want to impregnate yourself with it; so that you can go forward and carry the world before you.

And what is this world that you would carry before you? It is no dead pile of stones and timber; it is a living thing! It is made up of the beating hearts of humanity and the indescribable harmony of the myriad souls of men, now strong and impregnable, anon weak and vacillating.

It is evident that it requires understanding to work with material of this description; it is not work for the ordinary builder.

If you, too, would go aloft, into the heights, where all that you ever dared to think or hope is but a shadow of the dazzling reality, you may do so. Upon receipt of your name and address, I will send you a copy of a book by Mr. Bernard Guilbert Guernsey, the celebrated New York author and literary critic. It will afford the inspiration which will put you in harmony with all that is best in life, and as you come into harmony with these things, you make them your own, you relate with them, you attract them to you. The book is sent without cost or obligation of any kind, yet many who have received it say that it is by far the most important thing which has ever come into their lives.

CHAS. F. HAANEL, 210 Howard Bldg., St. Louis, Mo.

This Advertisement contains a message of such transcendental importance that no reader of Popular Mechanics, whether man, woman, or child, should fail to answer it.

BE A LABORATORY EXPERT

EARN \$250 TO \$500 A MONTH

Study BACTERIOLOGY, Microbiology and Sanitary Science. Learn these interesting and profitable professions easily and quickly. Enjoy high social standing in your community, and financial independence.



We teach these sciences as well as Urinalysis, Blood Analysis, Detection of Poisons, Blood Stains, Serology, Parasitology, and Waterways Tests quickly and thoroughly. Home Study and Residential Courses. Diplomas and Degrees granted. We help you secure position; many now open.

46 Piece Urinalysis Outfit Free

To every new student who enrolls within next thirty days, we will give this remarkable Urinalysis Outfit, shown here, absolutely free. Outfit consists of 46 piece laboratory glass apparatus and includes beautiful leatherette carrying case 17x7x5 1/2 inches and 17 distinct chemicals and reagents measuring over 30 ounces; enough material to make 25 complete chemical urinalyses. Outfit retails at \$25.00. Write today for free 48-page prospectus and free offer on

Urinalysis Outfit. Act quickly. Offer may be withdrawn any time. Physicians & Surgeons College of Microbiology, 550-C Garfield Ave., Chicago

TRAFFIC

Men Needed Everywhere

Big salaries. "Bankers" hours. Dignified position. Your own boss. Work easily learned in a few weeks at home. Course guaranteed. Satisfaction assured. Graduates coached free for two years after in position. You can't fail. Practical experience in actual traffic office offered graduates. Student R. W. Fish appointed General Traffic Manager after six months' study. His salary to start \$2,000.00. Complete training inexpensive. Make up your mind NOW to get started. Easy terms. Write today and save \$34.00. Act at once.

Interstate Traffic School

25 Traffic Building

Fort Wayne, Ind.

MAKE AND REPAIR YOUR OWN DEVICES

ELECTRIC HEAT

Just Out—For the Journeyman and Experimenter How to Figure and Build Units. Where to Get Real Resistance Wire Without a License. What Materials to Use and How; What not to Use and Why. The results of 5 Years and \$100,000.00 of Electrical Heating Development Exclusively. Learn the Branch of Electricity with the Biggest Future. Handy Pocket Size, Cloth Bound, for Only \$2.00. Postpaid. Money Returned if Not Satisfactory. Send Today. Alexander Swan, 2d., 312 E. Third Street, Los Angeles, California.

STAMMERERS

For 55 years we have successfully corrected stammering by our simple and natural course of individual lessons. Attend no school until you have read our free booklet, "How To Stop Stammering." SAMUEL A. ROBBINS, Director, Boston Stammerers' Institute 246 Huntington Ave. Boston 17, Mass.

12 De Maupassant Stories 10c

239 Book Catalog FREE

Send us your name and address and 10c in coin or stamps and we will send you a book of 12 short stories by De Maupassant and a free 64-page catalog of 239 other wonderful books of history, philosophy, love, mystery, religion, and adventure, which we sell at only 10c each. Haldeman-Julius Co., Dept. 104, Girard, Kans.



FREE LESSONS EXPERT AUTO and MOTOR WORK

Men—Boys, 15 or over, can easily learn Expert Motor and Auto operation and construction during spare moments

IN 10 WEEKS

Auto and Motor Experts frequently earn

\$40 to \$90 a week

Send Coupon Immediately

MAIL AT ONCE TO

Franklin Institute

Dept. C433, Rochester, N. Y.

Kindly send me, absolutely

free, sample lessons in MOTOR AND AUTO OPERATION AND CONSTRUCTION. Tell me also how I can take up this work and earn while learning.

Name.....

Address.....

MAN! Are You 100% Alive!



LIONEL STRONGFORT
Dr. Sargent, of Harvard, declared that "Strongfort is unquestionably the finest specimen of physical development ever seen."

Or are you satisfied to drift along half dead—half alive—always getting on the nerves of those with whom you associate—overlooking half of the beautiful things around you—ashamed to acknowledge that you are a miserable failure—a physical and mental wreck? Then you are indeed only 50% man—a man to be looked down on—despised—discarded.

But perhaps you don't know that you can be restored—that your flagging powers can be revived—that you can "come back."

To you I say—cheer up and confide in me. I will show you how you can be a 100% man and make your life worthwhile.

Don't Be a Chronic Weaking

You haven't been well for a long time. You have been dragging along half sick—miserable—complaining—always a little under the weather. You have been wasting your time and money with drugs, dope and materials opposed to natural law and common sense. You are not better—you are worse and are headed straight for hopeless, useless invalidism. You must stop NOW—look the facts squarely in the face and decide what your future is to be. It is up to you whether you will drag along as you are—a physical weakling—or if you will banish your ailments and be a healthy, worthwhile, vigorous man—a real 100% man.

Restore Your Pep and Power

When you admit that you have physical defects, you have taken the first step towards the accomplishment of real manhood; but you must not stop there. You must see to it that you are completely instructed and directed by one who can prove by his own physical fitness that he is able to really give you the health, strength and vigor you desire. You must go to a man who practices what he preaches. I am that man, as thousands of my pupils have voluntarily testified. I built up my own body and won the world's record as the finest specimen of physical and health attainment. These are the same principles I want to apply to you. I don't care what has caused your present unfitness—I don't care how often other methods have failed, you will find my methods entirely different and resultful. I will rebuild and restore you. I will give you the power, vitality and personality that every real man must have. I will make a real man of you—a 100% man. I will accomplish this in Nature's own way, no drugs or dope. Simple, sensible instructions scientifically applied without the use of fads or fancy methods or expensive apparatus. I guarantee that I will accomplish all I undertake with

STRONGFORTISM

The Modern Science of Health Promotion

This Science which I constructed from twenty-five years' experience as a physical and health specialist will not interfere with your occupation. No matter what your surroundings or conditions are, you can successfully apply these principles in the privacy of your own home and rid yourself of such ailments as Catarrh, Constipation, Indigestion, Rupture, Nervousness, Poor Memory, etc., and the results of neglecting your body. Strongfortism will give you renewed confidence, vitality, ambition and success, and fit you for the joys of life.

Send For My Free Book

The experience and research of a lifetime are contained in my wonderfully instructive book, "Promotion and Conservation of Health, Strength and Mental Energy." It will tell you frankly how you can make yourself over into a vigorous specimen of vital manhood with 100% pep, power and personality. It will show you how to be true to the best that is within you. It is absolutely free. Just check the subjects on the free consultation coupon on which you want special confidential information and send to me with a 10c piece to help pay postage, etc. It is a man-builder—a success maker and a life-saver. Send for my free book **Right Now—TODAY.**

LIONEL STRONGFORT

Physical and Health Specialist

Dept. 808 Founded 1895 Newark, New Jersey

Special Notice:—Lionel Strongfort, the World's Famous Athlete and Physical and Health Specialist, has achieved wonderful results with the Principles of Strongfortism. Thousands of his pupils throughout the world have testified to the benefits gained under his guidance. He enjoys an excellent reputation in his profession and can be depended upon to do exactly as he promises.

ABSOLUTELY CONFIDENTIAL

Mr. Lionel Strongfort, Dept. 808, Newark, N. J.:—Please send me your book, "PROMOTION AND CONSERVATION OF HEALTH, STRENGTH AND MENTAL ENERGY," for postage on which I enclose a 10c piece (one dime). Send me special information on subjects marked (X) below, without obligation.

- | | | |
|-----------------|-----------------|---------------|
| .. Colds | .. Biliousness | .. Great |
| .. Catarrh | .. Torpid Liver | .. Strength |
| .. Hay Fever | .. Indigestion | .. Deformity |
| .. Asthma | .. Nervousness | .. (Describe) |
| .. Obesity | .. Poor Memory | .. Stomach |
| .. Headache | .. Rheumatism | .. Disorders |
| .. Thinness | .. Gastritis | .. Pimples |
| .. Rupture | .. Heart Weak- | .. Blackheads |
| .. Lumbago | .. ness | .. Round |
| .. Neuritis | .. Poor Circu- | .. Shoulders |
| .. Neuralgia | .. lation | .. Lung |
| .. Flat Chest | .. Increased | .. Troubles |
| .. Insomnia | .. Height | .. Muscular |
| .. Bad Blood | .. Dependency | .. Develop- |
| .. Weak Eyes | .. Skin | .. ment |
| .. Short Wind | .. Disorders | .. Weak Back |
| .. Flat Feet | .. Anemia | .. Weaknesses |
| .. Constipation | .. Falling Hair | .. (Specify) |
| .. Neurasthenia | | |



has enabled John G. Anderson, Aurora, Ill., to keep on the payroll since his right arm was amputated some years ago. The reproduction (from an actual photograph) shows Mr. Anderson at work on an intricate machine using his Carnes Artificial Arm.

INCONSPICUOUS - SERVICEABLE

The Best Substitute for the Natural Arm.

To see him on the street you would not realize that his right arm was artificial. Wearers of this wonderful arm find that it practically takes the place of the natural arm. With it you can dress yourself, use knife and fork, carry grips, write, pick up large and small objects—in fact, do practically everything that was possible before. Even though the amputation be at the shoulder, the CARNES ARTIFICIAL ARM bends at the elbow and wrist, and the fingers open and close as desired.

WONDERFUL BOOK SENT FREE Every armless man or woman should write today for the wonderful illustrated 190 page book showing with actual photographs what can be done with this invention. Write today to
CARNES ARTIFICIAL LIMB CO.
 203 CARNES BUILDING KANSAS CITY, MO.



Some
 Say
 because
 Early Man
 walked
 this way--

Men and Women Suffer Today

Some physicians and scientists hold that a large share of the aches and pains of men and women today trace back to a time when our organs were arranged for "walking on all fours." I don't believe it; but I know that God requires of you the best possible care of your body; and I know that countless thousands need the scientific, comfortable, health-giving support of

For
 Boys
 and
 Girls
 Also



The Natural Body Brace

Nearly 200,000 users. Does away with strain and pain of standing and walking. Replaces and supports misplaced internal organs. Reduces enlarged abdomen. Straightens and strengthens the back. Corrects stooping shoulders. Develops lungs, chest and bust. Relieves backache, curvature, nervousness, ruptures, constipation.

Wear It 30 Days at Our Expense

"Wouldn't part with it for \$10,000," writes a user. Overcomes weakness and Organic ailments. Brings restful relief, health, ability to do things. Write me in confidence today for illustrated book, measurement blank and our very liberal proposition.

HOWARD C. RASH, Pres., Natural Body Brace Co.
 223 Rash Building, Salina, Kansas

LATEST and BEST RADIO BOOKS

- Construction of Radiophone and Telegraph Receivers for Beginners.** By M. B. Sleeper. Fully Illus. - Price \$.75
- How to Make Commercial Type Radio Apparatus.** By M. B. Sleeper. Fully Illustrated - - - - Price \$.75
- Construction of New Type Trans-Atlantic Receiving Set.** By M. B. Sleeper. Fully Illustrated - Price \$.75
- Radio Hook-Ups.** By M. B. Sleeper. Price \$.75
- Radio Design Data.** By M. B. Sleeper. Price \$.75
- A B C of Vacuum Tubes Used in Radio Reception.** By E. H. Lewis. Fully Illustrated - - - - Price \$1.00
- Wireless Telegraphy and Telephony Simply Explained.** By A. P. Morgan. 154 Pages (5x7½), 156 Illustrations - - - - - Price \$1.50
- Experimental Wireless Stations.** By P. E. Edelman. 392 Pages; 167 Illustrations Price \$3.00
Above prices postpaid

POPULAR MECHANICS BOOK DEPT.
 6 N. Michigan Ave. CHICAGO

JUST OUT SHOP NOTES FOR 1922

VOLUME XVIII
 224 PAGES — 655 ARTICLES
 465 ILLUSTRATIONS

Six-Inch Bench Lathe—Electric Soldering Outfit—Contractors' Jib Crane—Pump Troubles—Farm or Road Roller—Small Bench Grinder—Small Bench Miller are among the many useful articles in this volume.

PRICE 50 CENTS, POSTPAID

POPULAR MECHANICS BOOK DEPARTMENT
 6 N. MICHIGAN AVE. CHICAGO

Mathematics Made Easy by ROPP'S CALCULATOR AND SHORT-CUT ARITHMETIC

Shows the Answer as Quickly as a Watch shows the Time to all Problems likely to occur in the Office, Store, Shop, Bank, Farm, or Factory.



Over 2,000,000 Sold

Explains and simplifies every principle in Arithmetic, Mechanics, and Mensuration.
 PRICES POSTPAID
 Desk Size...\$1.50
 Leatherette, Pocket Size...\$1.00
 Pocket Size, Cloth...\$0.50
 Pocket Size, Paper...\$0.35

Popular Mechanics Book Dept., 6 N. Michigan Ave., Chicago

Swear Off Tobacco

Tobacco Habit Banished Let Us Help You

Quick Results

Trying to quit the tobacco habit unaided is often a losing fight against heavy odds, and may mean a serious shock to your nervous system. So don't try it! Make the tobacco habit quit you. It will quit you if you will just take **Tobacco Redeemer** according to directions.

It doesn't make a particle of difference whether you've been a user of tobacco for a single month or 50 years, or how much you use, or in what form you use it. Whether you smoke cigars, cigarettes, pipe, chew plug or fine cut or use snuff—**Tobacco Redeemer** will positively remove all craving for tobacco in any form in a few days. Your tobacco craving will usually begin to decrease after the very first dose—there's no long waiting for results.

Tobacco Redeemer contains no habit-forming drugs of any kind and is marvelously quick, scientific and thoroughly reliable.

Not a Substitute

Tobacco Redeemer is in no sense a substitute for tobacco, but is a radical, efficient treatment. After finishing the treatment you have absolutely no desire to use tobacco again or to continue the use of the remedy. It helps to quiet the nerves, and will make you feel better in every way. If you really want to quit the tobacco habit—get rid of it so completely that when you see others using it, it will not awaken the slightest desire in you—you should at once begin a course of **Tobacco Redeemer** treatment for the habit.

Results Absolutely Guaranteed

A single trial will convince the most skeptical. Our legal, binding, money-back guarantee goes with each full treatment. If **Tobacco Redeemer** fails to banish the tobacco habit when taken according to the plain and easy directions, your money will be cheerfully refunded upon demand.

Let Us Send You Convincing Proof

If you are a slave of the tobacco habit and want to find a sure, quick way of quitting "for keeps" you owe it to yourself and to your family to mail the coupon below or send your name and address on a postal and receive our free booklet on the deadly effect of tobacco on the human system, and positive proof that **Tobacco Redeemer** will quickly free you from the habit.

Newell Pharmacal Company
Dept. 300 St. Louis, Mo.



Free Book Coupon

NEWELL PHARMACAL CO.,

Dept. 300

St. Louis, Mo.

Please send, without obligating me in any way, your free booklet regarding the tobacco habit and proof that **Tobacco Redeemer** will positively free me from the tobacco habit or my money will be refunded.

Name.....

Street and No.....

Town..... State.....



Tobacco Tells on
Nervous System



Tobacco Ruins
Digestion



Tobacco Stunts
Boy's Growth



Tobacco Robs
Man of Vitality



Tobacco Steals
from You the
Pleasures, Com-
forts, Luxuries
of Life

I Make Strong Men



That is my business. I make no other claims. But what I promise, I fulfill. I will increase your arm one full inch in 30 days and your chest in proportion. In three months I will make you a finished strong man. Are you interested? Read my book "Physical Perfection." It tells you how. All I ask is 10 cents to cover postage and wrapping. Don't put it off. Send today.

Arthur L. Hyson
100 Langdon Bldg. New York City

Don't Wear a Truss

Brooks' Appliance, the modern scientific invention, the wonderful new discovery that relieves rupture, will be sent on trial. No obnoxious springs or pads.



MR. G. E. BROOKS

Brooks' Rupture Appliance

Has automatic Air Cushions. Binds and draws the broken parts together as you would a broken limb. No salves. No lies. Durable, cheap. Sent on trial to prove it. Protected by U. S. patents. Catalog and measure blanks mailed free. Send name and address today.

BROOKS APPLIANCE CO., 126G State St., Marshall, Mich.

How to Get Rid of Moles



A simple, safe home treatment—15 years' success in my practice. Moles (Also BIG Growths) Dry Up.

Ask for Free Booklet of Full Particulars

WM. DAVIS, M. D.

124-5 Grove Ave., Woodbridge, N. J.

WRITE TODAY for
Our 168-PAGE
FREE BOOK on

Deafness

and learn how Perfect Hearing is now being restored in every condition of deafness or defective hearing. Our "Little Wireless Phones for the Ears" require no medicine, but effectively replace what is lacking or defective in the natural ear drums. They are simple devices, which the wearer easily fits into the ears, where they are invisible. Soft, safe and comfortable.

WILSON EAR DRUM CO., Incorporated
711 Inter-Southern Bldg. LOUISVILLE, KY.

NO MORE BALD HEADS



WHEN our VACUUM CAP is used a few minutes daily. We accept no pay until you have tried the Cap 60 days and are satisfied. The Vacuum Cap is an appliance that draws the blood to the Hair Roots and starts a new healthy crop of hair. It stops Dandruff, stops the hair from falling out.

Bought by Doctors and men who know that it is the only reasonable HAIR GROWER known to science. No Drugs Used. Write for application, blank testimonials, and booklet on "HAIR," sent sealed in plain envelope, FREE.

THE MODERN VACUUM CAP CO.

X 559 BARCLAY, DENVER, COLO.

DYKE'S AUTOMOBILE ENCYCLOPEDIA

Contains the Greatest Array of Automobile Facts Ever Published in One Volume

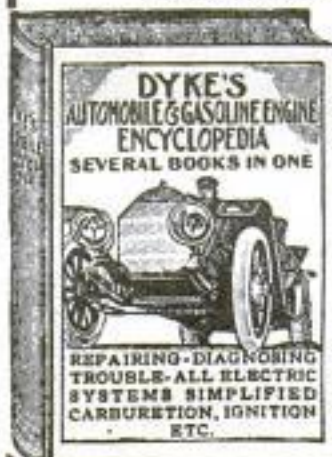

12th edition, revised and enlarged; has 968 pages. Size 6½x9¾ inches. 3362 Illustrations. 6700 Lines of Index.

Will Teach You How to Become:

1. Automobile Repairman
2. Engine Expert
3. Electric "Trouble Shooter"
4. Ignition Expert
5. Tire Repair Expert
6. Storage Battery Expert
7. Carburetor Expert
8. Tractor Expert
9. Truck Expert
10. Automobile Tractor and Truck Operator, Radiator Repairman.

This book fairly oozes information. Facts tumble over each other, there are so many. This practical, useful information is all indexed so that you can put your finger on just what you wish to know. If you were to purchase separate books on the subjects covered the lot would cost about \$21.00.

Dyke's Book { Regular Cloth Binding, \$6.46 prepaid
{ Amer. Morocco Limp, \$7.96 prepaid

You Need It—Order at Once from
POPULAR MECHANICS BOOK DEPT.
6 N. Michigan Ave. Chicago

10,000 Practical Recipes

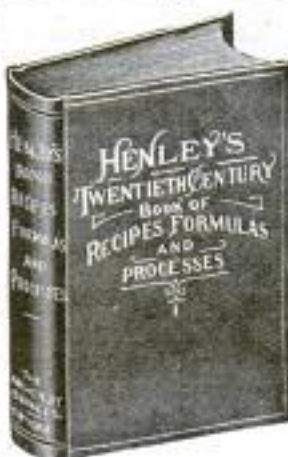

HENLEY'S

Twentieth Century
Book of

Recipes, Formulas and Processes

Edited by

GARDNER D. HISCOX, M. E.

Contains over 10,000 Selected Scientific, Chemical, Technological and Practical Recipes and Processes, including Hundreds of So-Called Trade Secrets for Every Business. This book of 800 pages is the most complete Book of Rec-

ipes ever published, giving thousands of recipes for the manufacture of valuable articles for every-day use. Hints, Helps, Practical Ideas and Secret Processes are revealed within its pages. It covers every branch of the useful arts and tells thousands of ways of making money and is just the book everyone should have at his command. A book to which you may turn with confidence that you will find what you are looking for. A mine of information up-to-date in every respect. Contains an immense number of formulas that everyone ought to have that are not found in any other work.

Price, Cloth Binding, \$4.00

Popular Mechanics Book Dept.
6 N. Michigan Ave., CHICAGO

The Road to Health

Vi-Rex Violet Rays

Treat yourself
at home for—

Asthma
Boils
Blackheads
Catarrh
Colds
Corns
Eczema
Falling Hair
Hay Fever
Headache
Insomnia
Lumbago
Sore Throat
Nervousness
Neuralgia
Paralysis
Pimples
Rheumatism
Skin
Diseases

Learn the secret of beauty, health and happiness!

We have just published a remarkable book for FREE DISTRIBUTION. This book explains in detail the manifold uses of Violet Rays in treating almost every known human ailment. It also contains charts and diagrams of the nervous system, and organic locations, and fully describes just how the Violet Ray works its many seeming miracles, written in a simple style—devoid of all technical language.

Vi-Rex Violet Rays carry life and vim to every cell—



The Violet Ray, as used in the treatment of the body, sends a spray of mild, tiny currents through every part and organ; flowing through each infinitesimal cell, massaging it, invigorating it, and revitalizing it. It leaves no soreness after use, only a delightful sensation of relief. Vi-Rex is *not a vibrator*. It creates cellular massage, the most beneficial electrical treatment known.

Wonderful Book Sent FREE!

10-day Free Trial proves all we claim

Clip this coupon and mail it today! This wonderful free book will be a revelation to you. We will also give you the details of our 10-DAY FREE TRIAL OFFER, which enables you to test the benefits of Vi-Rex Rays free in the privacy of your own home.

Vi-Rex Electric Co.
Dept. 25, 326 W. Madison St.
Chicago

For New York City only, address: 47 W. 34th Street

VI-REX ELECTRIC CO., Dept. 25
326 West Madison Street, Chicago

Please send me, without cost or obligation, your free book describing your Violet Ray Machine, and details of your free trial offer.

Name.....

Address.....

City..... State.....



\$2,500 Reward For the Capture of An Unknown Man

TWICE he had entered the St. Clair Mansion. What was he after? Who? What was in danger? Berteau, the famous detective, had warned St. Clair that the mysterious marauder would come again. And now—a noise in the passage! The creak of an opening door. A shot in the dark! A capture!

Is this wounded stranger the mysterious intruder? Who could tell? Yet Berteau identified the man without hesitation and won the \$2500 reward.

How did he do it? Easy enough for the Finger Print Expert. He is the specialist, the leader, the cream of detectives. Every day's paper tells of their wonderful exploits in solving mysterious crimes and convicting dangerous criminals.

More Trained Men Needed

The demand for trained men by governments, states, cities, detective agencies, corporations, and private bureaus is becoming greater every day. Here is a real opportunity for YOU. Can you imagine a more fascinating line of work than this? Often life and death depend on finger print evidence—and big rewards go to the expert. Many experts earn regularly from \$3,000 to \$10,000 per year.

Learn At Home in Spare Time

And now you can learn the secrets of this science at home in your spare time. Any man with common school education and average ability can become a Finger Print Detective in surprisingly short time.

Free Course in Secret Service

For a limited time we are making a special offer of a Professional Finger Print Outfit, absolutely Free and Free Course in Secret Service Intelligence. Mastery of these two kindred professions will open a brilliant career for you.

Write quickly for fully illustrated free book on Finger Prints which explains this wonderful training in detail. Don't wait until this offer has expired. Mail the coupon now. You may never see this announcement again! You assume no obligation. You have everything to gain and nothing to lose. Write at once. Address

University of Applied Science

Dept. 1355 1920 Sunnyside Avenue, Chicago

UNIVERSITY OF APPLIED SCIENCE
Dept. 1355 1920 Sunnyside Avenue, Chicago, Ill.

Gentlemen:—Without any obligation whatever, send me your new, fully illustrated, FREE book on Finger Prints and your offer of a FREE course in Secret Service Intelligence and the Free Professional Finger Print Outfit.

Name.....

Address.....

Present Occupation..... Age.....

PALATIAL FLORIDA HOME

THE finest estate in that part of Florida, situated amid five acres of orange, grape fruit, sweet bay, palmetto and a large variety of semi-tropical trees and foliage. A water front of 400 feet, with entrance from a Boulevard, in a community of 30,000, affording every modern convenience. House recently completed and never occupied. Has every modern improvement, large sun parlors, sleeping porches and eight bath rooms. Inexhaustible supply of absolutely soft water; steam heat, high, light basement under entire house. This is one of the best built houses in the entire state of Florida. Surf bathing all winter within 5 minutes walk.

For full details, photographs and price, address

E. H. PECK

S. OSGOOD PELL & COMPANY
17 West 44th Street New York City



LUMINOUS PAINT

Make Your Watches, Clocks, Etc., Visible by Night

The very latest discovery in the scientific world. Hitherto, practically unobtainable except at an exorbitant price, we have at last succeeded in producing this remarkable LUMINOUS PAINT, which applied to the surface of any article, emits rays of white light, rendering it perfectly visible in the dark. **THE DARKER THE NIGHT, THE MORE BRILLIANT IT SHINES.** Quite simple to use. Anyone—you can do it. A little applied to the dial of your watch or clock will enable you to tell the time by night. You can coat the push buttons or switch plates of your electric lights, match boxes, and innumerable other articles; make your own Luminous Crosses, Luminous Rosaries, etc. Small bottle, price 25c. Larger sizes, 50c and \$1 postpaid. **Johnson Smith & Co., 3214 N. Halsted St., Dept. 717, Chicago**

The WONDERFUL

ERICKSON PATENT LEG

Will not chafe, overheat, nor draw end of stump.



ERICKSON ARTIFICIAL LIMB CO., 38 Wash. Av. N., Minneapolis, Minn.

STEADY WORK

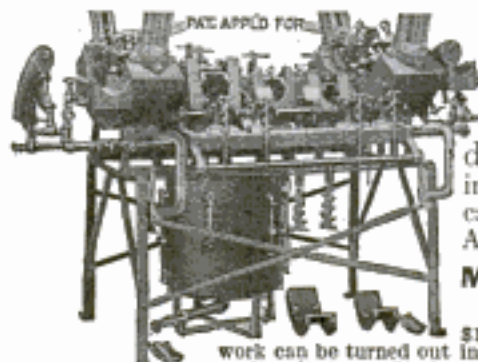

in a fast growing business.

With Vanderpool latest improved Vulcanizer made in America you can

MAKE MORE MONEY

\$100 to \$150 worth of work can be turned out in a day with the five cavity plant—profit about one-half.

VANDERPOOL VULCANIZER CO., Dept. P5, Springfield, Ohio
F. H. Dibb, Agent for the British Isles, 26 Fairfield Rd., Winchester, England

Popular Mechanics Books

EACH one of the following books has been published by Popular Mechanics and is characterized by the same careful editing and authoritative presentation of the subject matter as is the magazine itself. All are unusually good values for the prices asked.

THE BOY MECHANIC—BOOK ONE 480 Pages—700 Articles—800 Illus.	\$2.50
THE BOY MECHANIC—BOOK TWO 480 Pages—1000 Articles—895 Illus.	2.50
THE BOY MECHANIC—BOOK THREE 480 Pages—800 Articles—802 Illus.	2.50
MISSION FURNITURE, HOW TO MAKE IT, PART 1 128 Pages—30 Designs, Illus.	.50
MISSION FURNITURE, HOW TO MAKE IT, PART 2 128 Pages—32 Designs, Illus.	.50
MISSION FURNITURE, HOW TO MAKE IT, PART 3 128 Pages—36 Designs, Illus.	.50
WOOD-WORKING FOR AMATEUR CRAFTSMEN 128 Pages—125 Illus.	.50
ARTS-CRAFTS LAMPS, HOW TO MAKE THEM 96 Pages—16 Designs, Illus.	.50
LAMPS AND SHADES IN METAL AND ART GLASS 128 Pages—18 Designs, Illus.	.50
METAL WORK AND ETCHING 96 Pages—Illus.	.50
ELECTROPLATING 112 Pages—62 Illus.	.50
PRACTICAL COURSE IN MECHANICAL DRAWING 160 Pages—157 Drawings.	.50
HEAT 128 Pages—Illus.	.25
KINGDOM OF DUST 128 Pages—40 Illus.	.50
HOW TO MAKE DEVICES FOR OUTDOOR WINTER SPORTS. 64 Pages—Illus.	.25
SHOP NOTES FOR 1922 224 Pages—655 Articles—465 Illus.	.50
SHOP NOTES SERIES 11 Vols.	5.50
PATTERN MAKING 224 Pages—312 Illus.	1.00
POWER GAS AND THE GAS PRODUCER 192 Pages—Illus.	1.00

Above prices are postpaid.

POPULAR MECHANICS BOOK DEPT.
6 N. Michigan Ave., Chicago

BOOK 3

THE BOY MECHANIC

Uniform in the series with Books 1 and 2, but containing nothing found in either. Tells how to make

Boys' Motor Car
Houseboat
Model Monoplane
Water-Coasting
Toboggan and Slide
Aerial Cableway
Ski Sled
Sailing Canoe
Searchlight
Sail-Rigged Wind
Motor
Miniature Fighting
Tank
Submarine Camera
Electric Locomotive
Model and Track
System
Parlor Cue Alley
Parcel-Delivery Bicycle
Small Castings

and hundreds of equally interesting things.



800 Things a Boy Can Make or Do

Handsomely bound in cloth. Contains 480 pages (7x10 in.), 800 articles, 802 illustrations. Price \$2.50 p.pd.

THE BOY MECHANIC

BOOK ONE

Bound in cloth, 480 pages (7x10 in.), 700 articles, 800 illustrations.

BOOK TWO

Bound in cloth, 480 pages (7x10 in.), 1000 articles, 995 illustrations.

Any one of these volumes sent to any address, postpaid \$1.50.

POPULAR MECHANICS BOOK DEPT.
6 N. Michigan Ave., CHICAGO

I Can Train You For A High Salaried Hotel Job in 20 weeks



The Hotel Business offers wonderful opportunities to the trained man or woman! Now America's **FOURTH LARGEST INDUSTRY**, with thousands of high-salaried positions open to those who qualify through training. Statistics show that **ONE IN EVERY TEN HOTELS WILL HAVE AN OPENING FOR MANAGER THIS YEAR.** The men who will get them will be the **TRAINED** men.

I GUARANTEE TO TEACH YOU in my 50-lesson home-study course on hotel work, all that the leading hotel experts know about the business—men making from \$5,000 to \$50,000 a year! My students successful without slow, laborious "working up." Services of our Placement Bureau **FREE** to all graduates. Big pay, fine living, free meals and apartment, fascinating work—all these may be yours if you will fit yourself for the thousands of opportunities in Hotel Work.

SEND FOR FREE BOOK

20 Years' Experience in 20 Weeks is what this wonderfully complete course gives you. Course prepared and your training under personal direction of Clifford Lewis, Hotel Expert of National Reputation. Endorsed by managers of such hotels as Biltmore, Waldorf-Astoria, Copley-Plaza, New Willard, St. Francis, etc. Interesting **FREE BOOK** explains all. **SEND FOR IT TODAY.**

LEWIS HOTEL TRAINING SCHOOL

Founded 1916

CLIFFORD LEWIS, President

Room 121 Washington, D. C.

LEWIS HOTEL TRAINING SCHOOL

ROOM 323, WASHINGTON, D. C.

Send me without obligation the **FREE BOOK**, "Your Big Opportunity."

Name.....
Please Print Name

Street.....

City.....State.....



Play "JAZZ" on the Saxophone

Become musician so quickly as to astound everyone. Learn by playing real music—instead of tiresome "exercise." You'll soon become the most popular person in your "set."

NEW EASY METHOD

is a revelation. Nothing else like it for thoroughness and rapidity. So simple that young and old find it easy to play with amazing skill. No "trick music"—but actual notes, learned quickly right in your own home.

FREE BOOK

offer this wonderful musical opportunity. Send for it today before copies are exhausted. You'll be astounded, thrilled, fascinated, at this easy, rapid way to become a veritable master of your favorite instrument. Name below the instrument you are particularly interested in.

LEARN TO PLAY ANY INSTRUMENT

Piano	Mandolin
Organ	Drums and
Violin	Traps
Banjo	Harmony and
Clarinet	Composition
Flute	Sight Singing
Harp	Ukulele
Cornet	Piccolo
Cello	Trombone
Guitar	Saxophone
Voice and Speech Culture	Automatic Finger Control

U. S. SCHOOL OF MUSIC, 75 Brunswick Bldg., New York City
Send me your amazing free book "Music Lessons in Your Own Home." This does not put me under any obligation.

NAME.....
(Please Write Plainly)

ADDRESS.....

INSTRUMENT.....

Make \$1000 Easy From Evening Work

Skidmore of Ohio started last Nov. Has made \$3000 to date! Greatest proposition of century. Grasp it quick. Make \$30 to \$50 a week doing work at home evenings.

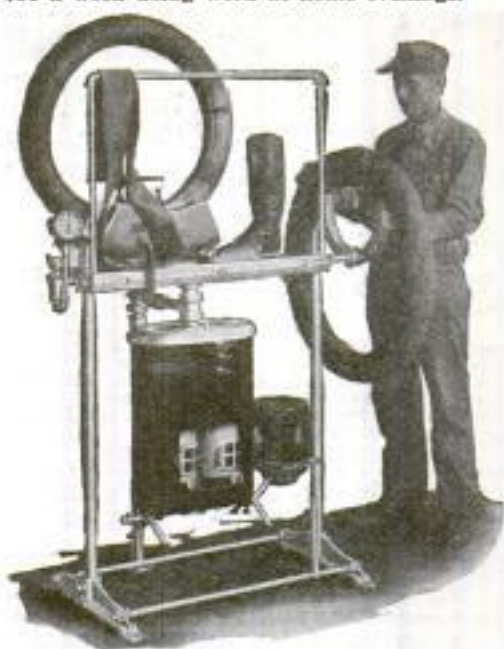

STICK TO YOUR JOB!

Make big money on side. Turn spare hours into cash with my **new home outfit**. Vulcanize automobile tires. Mend tubes. Repair gum boots and rubber goods of all kinds. Do **thriving neighborhood business**. Many men started economically. L. D. Weis, O., running better than **\$15 daily**. C. L. Jones, W. Va., averaged more than **\$47 day** during past six weeks, and so on.

Only Little Money Required to Start!

Write me. Get my help. Begin **now**. Season **just opening**. Tire repair **work galore everywhere**. I furnish **everything**, including machine, tools, clamps, materials and directions. No experience needed. Everything **plain and easy**. All instructions **learned in one evening**. Can't go wrong. Marvelous proposition. Wm. Howe, Mo., says: "Biggest little machine I ever saw." Steve Marchand, Tex., writes: "Am having wonderful results with your machine." Others are making **extra money**—you can too!

Mail Postal To Me, Tonight!

Get full details. It's a proposition you can handle. Place machine anywhere—garage, shed, basement. Has **wonderful capacity**. Work is **easy, pleasant and fascinating**. Starts you in big paying business. Puts you on road to independence. Send quick for full information. Address me personally. M. Haywood, Pres.

Haywood Tire & Equipment Co.

974 Capitol Ave.

Indianapolis, Ind.

Makes Big Money \$118 Per Week

American
**BOX
BALL**

One man reports this return on a single Box Ball alley

American Box Ball is a clean, automatic, portable bowling game, easy to play and extremely fascinating to young and old. No pin boys or help needed. Each alley has an earning capacity of **\$1.50 per hour**. Box ball alleys can be operated in any ordinary store space or under a tent. Many are cleaning up \$100 per week with two single alleys running only a few hours daily. You can do as well.

ACT Write at once for special proposition. Make the Big Money now. Don't wait. Address

AMERICAN BOX BALL COMPANY

2006 Van Buren St., Indianapolis, Ind.



Why Many Men are Old at 40

Perhaps the most common cause is the disturbed condition of an important gland. Even men of iron constitution are not exempt from this amazingly common irregularity. We have for limited distribution, an ethically accurate, educational and interesting

FREE BOOK

Its message may prove of unsuspected value to you. It explains how a disturbed condition of this vital gland may cause sciatica, backache, painful and tender feet, interrupted sleep and other extremely uncomfortable and often serious conditions. It tells of Thermanaid, a simple means by which the essential of a new hygienic principle, done into convenient form corrects this prostate gland condition and its attendant health faults without medicine, massage, or knife. The records of its success for five years is incontrovertible. The book is free. Simply address

THE ELECTRO THERMAL COMPANY
2102 Main St., Steubenville, Ohio



PRACTICAL ELECTRICAL EDUCATION—

in 6 MONTHS. We teach by scientific and original methods the theory and practice of **Electric Light Wiring, Testing, Meter Work, A. C. and D. C. Armature Winding, Transformer, Motor, Generator Repair and Maintenance.** No matter what your education, we guarantee to train you until competent and assist you to secure **profitable employment.** Hundreds of successful graduates and satisfied employers. Write for new ill. Book. Absolutely **FREE** to the earnest knowledge seeker.

SCHOOL OF PRACTICAL ELECTRICITY
P. M. 5, 415 Marshall Street Milwaukee, Wis.

RADIO For Everybody

Don't be satisfied with putting around with Radio. You can **earn big money.** Learn by mail, in spare time, how to design, construct, install, repair, maintain, operate, sell and demonstrate complete radio outfits. Write for our book, "How to Learn Radio at Home" National Radio Institute, Dept. 1955, Washington, D.C.

NO JOKE TO BE DEAF

—Every Deaf Person Knows That I make myself hear, after being deaf for 25 years, with these Artificial Ear Drums. I wear them day and night. They are perfectly comfortable. No one sees them. Write me and I will tell you a true story, how I got deaf and how I make you hear.



Address
GEO. P. WAY, Artificial Ear Drum Co. (Inc.)
80 Adelaide St., Detroit, Mich.

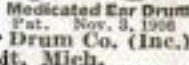

SOMETHING NEW, CATALOG No. 22

New goods, new prices, small boilers, engines, stoves and gasolines, 1-8 H. P. air pumps, castings, blue prints, gears, pulleys, electrical goods, model makers' supplies, materials, 2-4 H. P. Marine engines, 2 1/2 inch gas model locomotive, etc. Catalog postpaid 20 cents stamps (2 dimes preferred). Return first order, Modern Engine and Supply Co. 52 W. Jackson Blvd. CHICAGO

BLANK CARTRIDGE PISTOL

PRICE
\$1.00



Well made and effective; modelled on latest type of Revolver; appearance alone is enough to scare a burglar. When loaded it may be as effective as a real revolver without danger to life. Does not shoot real bullets but takes standard .22 Cal. Blank Cartridges, obtainable everywhere. A Great Protection Against Burglars, Tramps and Dogs. You can have it lying about without the danger attached to other revolvers. PRICE \$1.00 Postpaid. Blank Cartridges .22 Cal., shipped express, 50c per 100. JOHNSON SMITH & CO., Dept. 787, 3224 N. Halsted St., CHICAGO

The Inside of the Wayside

The May issue of **WAYSIDE TALES** contains one of the greatest collections of short stories and serials ever brought together between two covers. See for yourself:

EDEN PHILPOTTS
RANDALL PARISH
WILL LOVINGTON COMFORT
A. N. AND C. M. WILLIAMS
THE PINKERTONS
ALVAH MILTON KERR
KENNETH PERKINS
S. GORDON GURWIT
H. M. HAMILTON
K. R. G. BROWNE, AND
WALLACE WADSWORTH

Romance, Adventure, Mystery, Business, the West, the Northwest, the Orient, the Sea—Life with its passions, its laughter, its tears—Life wherever found has been tapped to afford entertainment for the readers of

Wayside Tales

176 pages of Quality Fiction, with ten additional pages of original humor in prose, verse and drawings, to be obtained by filling out the attached coupon.

WAYSIDE TALES
CHICAGO

Gentlemen: For the enclosed 25 cents, please send me the May issue of your magazine.

Name

Street

Town and State



He Starts at \$5,200 a Year

One hundred dollars a week!—And only a few years ago his weekly wage was less than \$30. Didn't dream he could do it when he first took up the study of Higher Accounting under the LaSalle Problem Method; but he just couldn't *help* getting ahead—so he wrote—because he found it the most interesting thing he ever tackled.

Knew nothing about bookkeeping, but LaSalle quickly gave him the necessary foundation. Then, step by step, he was trained in the practical work of Cost Accounting, Auditing, Business Law, Organization, Management, Finance, Income Tax Procedure—not theoretically, mind you, but by the solving of actual problems lifted bodily from business life. As a result, he sits at a big mahogany desk and commands a salary of \$5,200 a year.

His Chance is Yours!

Typical, this man's experience, of that of thousands of ambitious men who have found their path to success in the LaSalle Problem Method. During three months' time, 1,089 LaSalle members wrote to the University telling of the "raises" they got as a result of their training. *The average increase per man was 36 per cent.*

These men were not unusual; they had no "pull" or "luck;" they got their start by signing just such a little coupon as appears directly below this text. Mark that coupon, sign and mail today—and *get the facts*. Remember, the cost of LaSalle training is small and can be covered in easy monthly payments, if you so desire. *The decision that you make this moment is important. Mail the coupon now.*

LASALLE EXTENSION UNIVERSITY
The Largest Business Training Institution in the World
Dept. 564-HR Chicago, Illinois

Please send me catalog and full information regarding the course and service I have marked with an X below. Also a copy of your book, "Ten Years' Promotion in One."

Higher Accountancy

Training for positions as Auditors, Comptrollers, Certified Public Accountants, Cost Accountants, etc.

Other LaSalle Training Courses

LaSalle is the largest business training institution in the world. It offers training for every important business need. If more interested in any of these courses, check here:

- | | |
|--|--|
| <input type="checkbox"/> Business Management | <input type="checkbox"/> Banking and Finance |
| <input type="checkbox"/> Salesmanship | <input type="checkbox"/> Modern Foremanship and Production Methods |
| <input type="checkbox"/> Traffic Management | <input type="checkbox"/> Personnel and Employment Management |
| <input type="checkbox"/> Railway Accounting and Station Management | <input type="checkbox"/> Expert Bookkeeping |
| <input type="checkbox"/> Law—Degree of LL.B. | <input type="checkbox"/> Business English |
| <input type="checkbox"/> Commercial Law | <input type="checkbox"/> Commercial Spanish |
| <input type="checkbox"/> Industrial Management Efficiency | <input type="checkbox"/> Effective Speaking |
| <input type="checkbox"/> Modern Business Correspondence and Practice | <input type="checkbox"/> C. P. A. Coaching |

Name

Present Position

Address

Please Mention Popular Mechanics

Learn to Earn

Big Money as a Motor Mechanic

Mastery of the finer points in motor mechanics is what pays the really big money. Our course makes you the master of every intricacy of the automobile—valve timing, bearing fitting and scraping, carburetion, all the ignition systems, starting and light, clutches, transmissions, rear axles, front axles, battery, and wiring. All instruction is under personal direction of R. G. Dasbach, known nationally as the "Master Mechanician" who was for two years

Barney Oldfield's Mechanician

and was also speedway mechanic for Dario Resta. Class instruction is followed by practical shop work under a corps of competent assistants with an Advisory Board composed of prominent automobile men. Absolutely the most complete and practical course obtainable. Come to beautiful Denver, the city of health, pure air, mountains and sunshine, for the training that will make you a master mechanic. Write for special summer rates today.

Western Motor Mechanics School
1517 Cheyenne Pl. Denver, Colorado

RADIO For Everybody

Don't be satisfied with puttering around with Radio. You can earn big money. Learn by mail, in spare time, how to design, construct, install, repair, maintain, operate, sell and demonstrate complete radio outfits. Write for our book, "How to Learn Radio at Home" National Radio Institute, Dept. 1065, Washington, D. C.

1¢ FOR 1,000 SHOTS



Shoots and flashes like a real gun. Reload ammunition costs only 1¢ a load and with one loading will shoot and flash 5,000 times. Shoots and loads automatically. No caps, no powder, no smoke, no danger. Within the law. Each gun sent with one loading, 5,000 shots and flashes, for only 35¢, 3 for \$1, postpaid. THE FLASUM CO., DEPT. 41, CHICAGO, ILLINOIS, U. S. A.

BIG PAYING HOTEL JOBS OPEN

to trained men and women; we train you by mail; get 20 years' hotel experience in few months; earn \$3,000 to \$10,000 a year; fine living; work is fascinatingly interesting; quick advancement. Send for FREE BOOK today! LEWIS HOTEL TRAINING SCHOOL, Room 329, Washington, D. C.

Learn Drafting

Individual study at home may be successfully engaged in with the aid of our new enlarged book **A Practical Course in Mechanical Drawing** Cloth. 160 Pages. 157 Drawings. Price, 50¢ Postpaid. POPULAR MECHANICS BOOK DEPT., 78 East Madison St., CHICAGO



\$4 or \$5 a month WILL BUY
A Standard, Guaranteed
TYPEWRITER

With Every Modern Writing Convenience
Write Today for Illustrated Circular
Explaining Try-Before-You-Buy Plan

SMITH TYPEWRITER SALES CO.
(Harry A. Smith) 910-218 No. Wells St., Chicago, Ill.

Moore's Universal Assistant and Complete Mechanic

Contains 1016 Pages, 500 Engravings, and Over 1,000,000 Industrial Facts, Calculations, Receipts, Processes, and Trade Secrets for Every Business!



For Sterling Value, Elegance, and Low Cost, This Work Has No Compeer in the English Language

The Work contains 200,000 items for Gas, Steam, Civil and Mining Engineers, Machinists, Iron Founders, Plumbers, Metallurgists, Assayers, Miners, Builders, Metal and Wood Workers, Manufacturers, etc. Full details (with 500 Engravings) for constructing, operating, and repairing Mill and Steam Machinery of every kind, setting of Valves, Link and Valve Motion, Eccentrics, Indicator Diagrams, Injectors, Steam Boilers, Gauges, Machinists' Tools, Mechanical Movements, Tunnelling, Mining and Rock Drilling Machinery, Wheel Gearing, Gas Meters, Diagrams for Sheet Metal Workers, Views of Noted Buildings, Bridges, Plans of Mills, etc.

FULL INSTRUCTIONS TO ENGINEERS, FIREMEN, BOILER MAKERS, ENGINE AND CAR BUILDERS, ETC. Proportion of Engines, Repairing Locomotive Break-Downs on the Road, Boiler and Steam Pipe Covering, Cements—69 kinds, Bright Polish—4 kinds, Scale Preventives—10 kinds to Clean Waste, Details for Cotton, Woolen, and Fulling Mill Machinery; ditto, for Flour, Oatmeal, Saw, Shingle, Planing, Paper and Wind Mills, Grain Elevators, Sugar, Oil, Marble and Rolling Mills, Blast Furnaces, Gas Works, Water Works, Mill Dams, Water Wheels, Hydraulics, Cotton Presses, Speed of Wheels, Pulleys, Drums, Circular Saws, Woodworking Machinery, Horse Power of Streams, Belts, Strength of Metals, Timber, Building Materials, etc. Seasoning of Timber—12 ways, Growth of Forest Trees, Logging, Cost of Supplies, Stream Driving, Lumber Measurement and Surveyors' Tables, full and complete. Views of Lumbering Scenes, Saw Mills, Saw Filing, etc., etc.

PRICE ONLY \$2.00 POSTPAID

Popular Mechanics Book Dept.

6 N. Michigan Ave., Chicago

Make Your Bike a MOTORCYCLE

Make your "foot-power" bike a dependable, easy-running, light-weight motorcycle at small cost. You can do it yourself with the

SHAW MOTOR ATTACHMENT

Compact. Easy to attach. No special tools required. Battery or magneto. Thousands in use. Write at once for free book, prices, terms; also about Shaw Motorcycle.

Write for
**FREE
Book**

SHAW MFG. CO.
Dept. 375
Galesburg, Kans.



95 to 125
Miles per
gallon!

Make Your Own Wireless

Learn to make your own complete wireless phone. It's easy. We guarantee to teach you. Hear concerts, lectures, latest news, messages, etc., hundreds of miles away. Full course with FREE personal instruction tells you how. Success guaranteed. "How To Make Your Own Wireless" is a course in 8 easy lessons. Any boy can understand it. Prepared for amateurs by a radio expert. Send only \$1.00 for complete course and diagrams. Free personal instruction goes with it.

GELATT INSTITUTE

1935 North Park Ave. Dept. 1 Philadelphia, Pa.

LEARN WATCHMAKING

and become independent. Good-paying positions secured. Easy to learn. Send for FREE CATALOG.

ST. LOUIS WATCHMAKING SCHOOL, Dept. 5, ST. LOUIS, MO

MAKE YOUR FORD INTO THIS SPORT CAR \$ ONLY 6.40

Other types down to \$3.50. Patents sure fit. **Red-Top** life-size patterns and simple instructions show all details. You can easily convert your Ford into this fast, snappy Sport Car as hundreds have done with a few dollars worth of material from the hardware store. No need to lay up the car. The "PAL" with optional disc wheel pattern. Pressed Metal Streamline Rear only \$6.40 delivered. Built low, rides wonderfully easy. Order NOW while we can make good delivery. Send for color illustrated prospectus of Sport Bodies, "Jolly" Tops and "Gone" Windshields. Kaempel Co., 83 Kaempel Bldg., Guttenberg, Iowa



Patents sure fit. Red-Top life-size patterns and simple instructions show all details. You can easily convert your Ford into this fast, snappy Sport Car as hundreds have done with a few dollars worth of material from the hardware store. No need to lay up the car. The "PAL" with optional disc wheel pattern. Pressed Metal Streamline Rear only \$6.40 delivered. Built low, rides wonderfully easy. Order NOW while we can make good delivery. Send for color illustrated prospectus of Sport Bodies, "Jolly" Tops and "Gone" Windshields. Kaempel Co., 83 Kaempel Bldg., Guttenberg, Iowa

Blank Cartridge Pistol FREE

REVOLVER STYLE

Well made and effective; modeled on the latest type. Revolver does not shoot real bullets, but the appearance alone is enough to scare a burglar. When loaded it may prove just as effective as a real revolver without danger to life. Does not shoot real bullets, but takes the standard .32 Caliber Blank Cartridge obtainable everywhere. A Great Protection Against Burglars, Tramps and Dogs. You can have it lying about without the danger attached to other revolvers. Advertised extensively by leading firms for a dollar.



For a limited time only we are giving these Pistols to secure new subscribers to the RACINE BULLETIN, a large monthly illustrated magazine. Every issue crammed full of exciting stories, interesting items from all over the world, articles on popular science, mystery, magic and mirth, money-making wrinkles relating to every trade and manufacture, health hints, tried and tested recipes, gossip about well known persons. Thousands of dollars given away in prizes, not to mention a free \$1,000 Insurance Policy in every issue to each subscriber—all this and lots more combine to make it one of the most interesting magazines published in America. Send ONLY \$1.00 for a three years' subscription to the Racine Bulletin and we will send you the Pistol free, and the magazine for three years.

Dept. 803 THE RACINE BULLETIN Racine, Wis.

Mechanical Engineering



Learn at Home!

EMPLOYERS everywhere are looking for men with mechanical ability. Splendid salaries and rapid advancement are offered those with special training.

There is an easy, delightful way in which you can learn right at home in spare time. For 30 years the International Correspondence Schools have been giving men and women just the training they need for success in mechanical engineering and more than 300 other subjects. Hundreds of thousands have stepped into good positions through I. C. S. help, but never were opportunities so great as now.

Let the I. C. S. help you. Choose the work you like best in the coupon below, then mark and mail it today. This doesn't obligate you in the least and it will bring you information that will start you on a successful career. This is your chance! Don't let it slip by. The most important thing you have to do is to mark and mail this coupon now.

TEAR OUT HERE

INTERNATIONAL CORRESPONDENCE SCHOOLS
BOX 5634-C SCRANTON, PA.

Without cost or obligation please explain how I can qualify for the position, or in the subject before which I have marked an X:

- | | |
|---|---|
| <input type="checkbox"/> ELEC. ENGINEER | <input type="checkbox"/> BUSINESS MANAGER |
| <input type="checkbox"/> Electric Lighting & Railways | <input type="checkbox"/> SALESMANSHIP |
| <input type="checkbox"/> Electric Wiring | <input type="checkbox"/> ADVERTISING |
| <input type="checkbox"/> Telegraph Engineer | <input type="checkbox"/> Show Card & Sign Ptg. |
| <input type="checkbox"/> Telephone Work | <input type="checkbox"/> Railroad Positions |
| <input type="checkbox"/> MECHANICAL ENGINEER | <input type="checkbox"/> ILLUSTRATING |
| <input type="checkbox"/> Mechanical Draftsman | <input type="checkbox"/> Cartoning |
| <input type="checkbox"/> Machine Shop Practice | <input type="checkbox"/> Private Secretary |
| <input type="checkbox"/> Toolmaker | <input type="checkbox"/> Business Correspondent |
| <input type="checkbox"/> Gas Engine Operating | <input type="checkbox"/> BOOKKEEPER |
| <input type="checkbox"/> CIVIL ENGINEER | <input type="checkbox"/> Stenographer & Typist |
| <input type="checkbox"/> Surveying and Mapping | <input type="checkbox"/> Certified Public Accountant |
| <input type="checkbox"/> MINE FOREMAN or ENG'R | <input type="checkbox"/> TRAFFIC MANAGER |
| <input type="checkbox"/> STATIONARY ENGINEER | <input type="checkbox"/> Railway Accountant |
| <input type="checkbox"/> Marine Engineer | <input type="checkbox"/> Commercial Law |
| <input type="checkbox"/> ARCHITECT | <input type="checkbox"/> GOOD ENGLISH |
| <input type="checkbox"/> Contractor and Builder | <input type="checkbox"/> Common School Subjects |
| <input type="checkbox"/> Architectural Draftsman | <input type="checkbox"/> CIVIL SERVICE |
| <input type="checkbox"/> Concrete Builder | <input type="checkbox"/> Railway Mail Clerk |
| <input type="checkbox"/> Structural Engineer | <input type="checkbox"/> AUTOMOBILES |
| <input type="checkbox"/> PLUMBING & HEATING | <input type="checkbox"/> Mathematics |
| <input type="checkbox"/> Sheet Metal Worker | <input type="checkbox"/> Navigation |
| <input type="checkbox"/> Textile Overseer or Supt. | <input type="checkbox"/> AGRICULTURE <input type="checkbox"/> Spanish |
| <input type="checkbox"/> CHEMIST | <input type="checkbox"/> Poultry Raising <input type="checkbox"/> Banking |
| <input type="checkbox"/> Pharmacy | <input type="checkbox"/> Airplane Engines |

Name.....

Street and No.

City..... State.....

Occupation.....

Persons residing in Canada should send this coupon to the International Correspondence Schools Canadian, Limited, Montreal, Canada.

Stop Forgetting



Make Your Mind a File—Not a Pile

Let me show you how to make your mind as forget-proof as a card index file. When you wish to recall a name, place or date, must you grope in vain in a pile of miscellaneous knowledge? Summoned to give facts and figures does your mind become a blank? Be master of your mind's infinite resources—instead of a victim of its disordered details.

KNOWLEDGE IS POWER

and Memory Is the Basis of All Knowledge

I HAVE HELPED THOUSANDS

The Dickson Method of Memory and Mental Training, perfected by 20 years experience, is recognized as the most thorough, efficient of its kind. Highly endorsed—easy to master. Give me 10 minutes a day and I will train your memory so you can classify ideas, names, faces, etc., and recall them instantly. Develop self-control, concentration; overcome bashfulness.

Perfect Your Memory and Command What Salary You Will

Send name and address and I will send you free, my interesting booklet, "How to Remember," and unique, copyrighted Memory Test; also tell you how to secure free of charge my \$3.00 book, "How to Speak in Public."

Prof. Henry Dickson, Principal
DICKSON MEMORY SCHOOL
Dept. 705, 1041 Chicago Ave.
Evanston, Ill.



The Key to Success

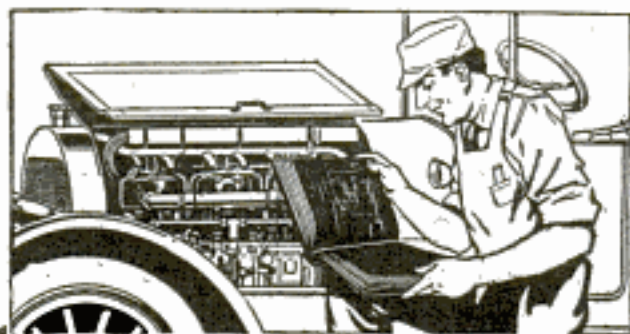

THIS REPAIRMAN HAS NO WIRING WORRIES HAVE YOU?

If so a copy of the Automotive Wiring Manual will enable you to shoot electrical trouble in any car regardless of its strangeness.

The Automotive Wiring Manual

"The Original and Only Blueprint Wiring Book"

contains over 800 clear, sharp new blueprints of car wiring systems, more than 200 interior diagrams of generators, etc. All easily legible in poor light. Securely bound in one substantial volume that prevents loss and damage in the rough-and-tumble of everyday garage service.

Price \$15.00 prepaid

For sale by
POPULAR MECHANICS
BOOK DEPT.
6 N. Michigan Ave.
Chicago



BIG CARTOON COURSE for \$7.00

Carl Anderson's Complete Cartoon Course

My book, "Thirty years of Cartooning" tells how I got started and what I did to make good on the "New York World" and "Life". Large Portfolio of Lessons teaches how to get action and punch in your cartoons and comic strips. Simple and easy to learn. Review of your work by correspondence. Lessons endorsed by former Editor of the NEW YORK WORLD COMIC SECTION, who gives important information and advice for beginners. Send 6 cents for comic strip folder and particulars.

THE CARL ANDERSON SCHOOL, Box 355, Madison, Wis.



I, CHARLES L. H. WAGNER,

Principal of the Wagner School of Sign and Show Card Writing, POSITIVELY GUARANTEE to teach you to become a successful sign and show card writer by my original BLUE PRINT METHOD. ALL I expect from you is application. I have proven this with others, I can do the same for you. Let me tell you how. Write me today for P. M. Booklet of my course.

Wagner-Sprague Correspondence School
131 Columbus Avenue, Boston, Mass.

Listening In?

Fun and profit for you—if you can make things electrical. Radio outfits, reading lamps, electric clocks, toasters, and countless other useful appliances can be constructed by you from materials easily obtainable and with no previous electrical knowledge. Clear directions, fully illustrated, are contained in this new handyman's guidebook.

HOW TO MAKE THINGS ELECTRICAL
Over 400 pages; 4½x7, postpaid, \$2.50

Your money back if you don't keep the book

U. P. C. Book Co., Inc.
Dept. M.
243 W. 39th St., New York



Every Welder Should Have The Welding Encyclopedia

It is America's most complete and authoritative reference and instruction book on welding. It gives you a vast fund of expert knowledge on all forms of welding, conveniently arranged, fully illustrated by drawings and photographs and written in language you can understand. It has the approval of the leading manufacturers in the trade. You need this book in your shop.

326 Pages--375 Illustrations--Clothbound

Edited and Compiled by the Editors of the Welding Engineer with the help of many experts in the welding trade

CONTENTS

Illustrated encyclopedia covering all words, terms and trade names used in welding—Oxy-acetylene Welding—Aluminum, Steel, Cast Iron, Copper, Brass, Bronze, Full instructions for welding each of these metals.—Electric Arc Welding—Electric Resistance Welding, includes Butt, Line, Percussion and Spot Welding—Thermit Welding—Use and Misuse of Oxy-acetylene Equipment—Boiler Welding—Heat Treatment of Steels—Rules and Regulations—Charts and Tables, including temperature color chart—Condensed Catalogs and Buyers' Index.

The Accumulated Experience of the Welding Brains of America
Yours for \$5.00

Absolute Refund Guarantee—If, after having ordered and examined this book, you are not satisfied with same, return it to us and your money will be refunded.

Popular Mechanics Book Dept.
6 N. Michigan Ave. Chicago

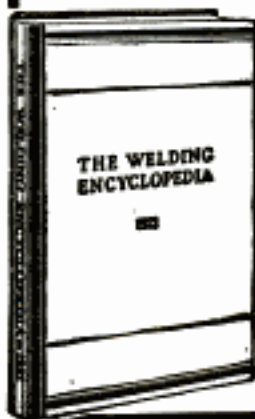

Drawing Outfit

FREE

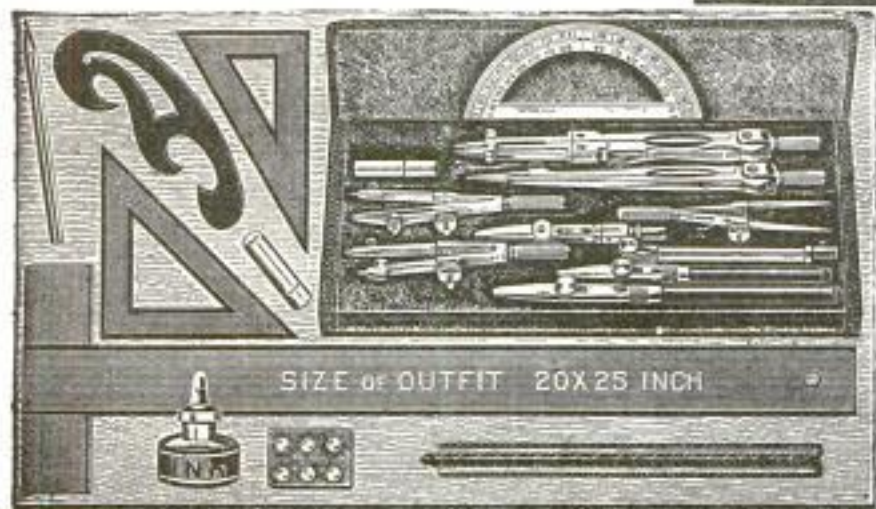

Complete Set of Drawing Instruments Delivered AT ONCE

Yes, I will give you this complete drawing outfit absolutely free. The instruments are in a handsome high class, plush lined folding case. They are regular draftsman's working instruments. Besides I will give you absolutely free, a 20 x 25 inch drawing board, a 24 inch T square, a 12 inch rule, a supply of drawing paper, two triangles, a French curve, pencils, erasers, thumb tacks, etc.

\$3600 a Year *Drafting Salary*

There is an urgent demand for skilled draftsmen. Companies are issuing calls every day for men to fill positions paying \$3600.00 a year. Work is light, pleasant and profitable.

Chief Draftsman *Will Instruct You Personally*



I am Chief Draftsman of a large and well known firm. I have been doing the highest paying expert drafting work for a quarter of a century and I know just the kind of training that is demanded from men who get the big salaries. I train you by giving you actual, practical work, the kind you must be able to do to hold permanent, big paying positions. I give you my individual instruction. If your work is right, I will advance you rapidly. If it is wrong, I will show you where and make you do it right, and do all I can to make you an expert draftsman and designer in a short time.

Write Today Without Fail!

I GUARANTEE
to train you until
you are placed in
a position paying
\$250 to \$300 a
month.

Send Coupon For New Book!

Put your name and address on the coupon or a letter or a post card and send it to me today. I will send you absolutely free and post-paid, my new book "Successful Draftsmanship," and the great special offer that I am now making on which you get the complete Draftsman's Working Outfit **absolutely free**. You assume no obligations of any kind in sending in the coupon. Get in line for a big paying position. Getting the book and full particulars of the special offer is the first step.

Chief Draftsman Dobe
Dept. 1355 4001 Broadway Chicago, Ill.

Chief Draftsman Dobe
Dept. 1355, 4001 Broadway, Chicago, Ill.

Without any obligation on me whatsoever, please, mail your book, "Successful Draftsmanship" and full particulars of your liberal "Personal Instruction" offer to a few students. It is understood that I am obligated in no way whatever.

Name.....

Address.....

Wipe Out Every Rat and Mouse

Amazing New Discovery Quickly Kills Them All. Not a Poison

Rats, Mice, Gophers—in fact all Rodents can now be wiped out easily and quickly from Stores, Warehouses, Elevators, Farm Buildings and Homes. Imperial Virus will do it. This new discovery is a fluid, true Virus. Entirely harmless to humans, poultry, stock, pets, etc.

Infects Rodents only. Greedily eaten on bait. Sets up burning fever. The pests communicate it to others, and all die outside, hunting air and water. Imperial Virus is put up in sealed bottles, thus insuring full strength and potency. Only safe, sanitary method to



overcome these pests. Protect your Poultry, especially Baby Chicks and Egg Hatches.

YOU CAN GET YOURS FREE

Here's how! Send \$1.00 today (currency, M. O., Check, etc.) and we will ship you by return mail, postpaid, two regular, full size (double strength) \$1.00 bottles of Imperial Virus. Use one to rid your place of these pests, and sell the other to a neighbor, thus getting yours free. Special inducements to agents.

If more convenient, send no money, just your name and address to Imperial Laboratories, Dept. 767, 2110 Grand Ave., Kansas City, Mo. Pay postman \$1.00 and few cents postage when two bottles arrive. Guaranteed to do the work to your entire satisfaction within 30 days, or your \$1.00 will be cheerfully refunded.

40,000 Opportunities in Hotels

Nation wide demand for high salaried men and women; past experience unnecessary; we train you by mail and put you in touch with big opportunities. Big pay, fine living, interesting work, quick advancement; permanent. Write for Free Book, "Your Big Opportunity."

LEWIS HOTEL TRAINING SCHOOL, Room 328, Washington, D. C.

If you need a book on some mechanical subject and do not know where to find it, write

POPULAR MECHANICS BOOK DEPARTMENT
6 N. Michigan Ave., Chicago

MODEL MAKING

New 400-page book covering workshop practice, design and construction of models. The work described is real model engineering and not the construction of mere toys. 303 Illustrations. Cloth. Price, \$3.00 Postpaid.

POPULAR MECHANICS BOOK DEPT., 6 N. Michigan Ave., CHICAGO

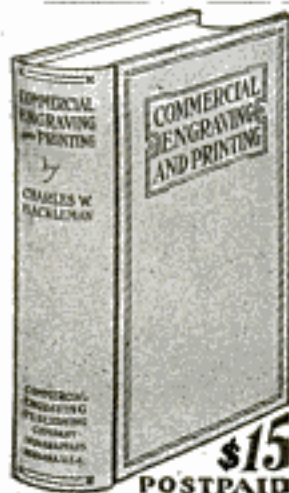

\$15
POSTPAID

FOR THE PRINTING, ENGRAVING AND ALLIED TRADES AND FOR BUSINESS MEN WHO USE THEIR PRODUCTS

COMMERCIAL ENGRAVING and PRINTING

By C. W. HACKLEMAN

is a remarkable new book that will answer any and every question which may arise concerning these subjects. A vast amount of time and thousands of dollars were expended to make this the most practical and complete book on engraving and printing and related lines of work ever published.

Nearly 900 Pages and More Than 1000 Illustrations

Presenting Over 3500 Distinct Ideas on 35 Separate Subjects

OUTLINE OF CONTENTS—Commercial Photography—Proportions—Art Room Accessories—Retouching, Alterations and Grouping of Photographs—Wash Drawing—Line Drawing—Methods of Treatment—Line Etching—Line Color Plates—Halftones—Halftone Color Plates—Combination Plates—General Photo Engraving Information—Duplicate Plates—Wood Engraving—Wax Engraving—Calk Plates—Methods of Mounting—Letterpress Printing—Lithography and Offset Printing—Photogalvanic Process—Copper Plate Engraving and Printing—Steel Plate and Die Engraving, Printing and Embossing—Photogravure—Rotary Photogravure—Printing Inks and Harmony of Colors—Embossing, Stamping and Cutting Dies—Bookbinding—Music Engraving—Poster Making—Paper, Envelopes—Patents, Trademarks and Copyrights—Mailing Lists and Postal Information—Cases and Filing of Plates and Copy—Index.

We highly recommend this book. For real practical help in your work this will be one of the most profitable investments you have ever made.

POPULAR MECHANICS BOOK DEPT., 6 N. Michigan Avenue, CHICAGO

SELECT LIST OF HELPFUL

AUTOMOBILE BOOKS

Dyke's Automobile Encyclopedia Latest edition. Most widely used auto reference book on the market today. Covers every detail of construction, operation and repair. 940 Pages. 3382 Illustrations. Cloth, \$8.46. American Morocco, \$7.98

Automotive Wiring Manual 900 detailed blue prints showing the complete wiring system of all standard autos manufactured since 1912 up to and including this year models. Price, \$15.00

Starting, Lighting and Ignition Systems All the leading systems described and illustrated. Over 200 wiring diagrams. Trouble locating. Making repairs, etc. 800 Pages. 422 Illustrations. Price, \$3.00

The Modern Gasoline Automobile A complete, practical and up-to-date treatise. New enlarged edition. An incomparable reference book for home or school. 1032 Pages. 1000 Illustrations. Price, \$4.00

Automobile Repairing Made Easy Complete directions for making repairs to all parts of the motor car mechanism. Founded on thoroughly practical experience. 1036 Pages. 1000 Engravings. Price, \$4.00

The Model T Ford Car Its construction, operation and repair, including the Fordson Farm Tractor, F. A. Lighting and Starting System, Ford Motor Truck. 410 Pages. 153 Illustrations. Price, \$2.00

Ford Engine Chart Deals with location and correction of engine faults and troubles. Price, 35 cents

Storage Batteries Simplified Tells how to charge, care for and rebuild storage batteries and outlines industrial uses. 208 Pages. Price, \$2.00

The Modern Motor Truck Design, construction, operation and repair. A reference of great value. 800 Pages. 750 Illustrations. Price, \$5.00

Above Prices Postpaid

POPULAR MECHANICS BOOK DEPT.

6 N. MICHIGAN AVE., CHICAGO

The FORD Standard Electrical Equipment

SUBJECTS COVERED:

Ammeter—3 Ammeter Tests—Battery Troubles—Carbon in Engine—Changing Position of Third Brush—Regulation of Charging Current—Circuits—Coils—Commutator—Cutout—Engine Not Running, Lamps Off—Engine Not Running, Lamps On—Engine Running, Lamps Off—Engine or Power Plant Troubles—Generator—Ignition System—Lamps—Lighting and Ignition Switches—Locating Missing Cylinder—Magneto—Special Instruction for Lamp Troubles—Starting Motor—Starting Switch—Starting Troubles—Wiring of Electrical Units.

Price \$2.00 Postpaid

150 Pages—48 Illustrations and Charts. Bound in Leather.

Popular Mechanics Book Dept., 6 N. Michigan Ave., Chicago

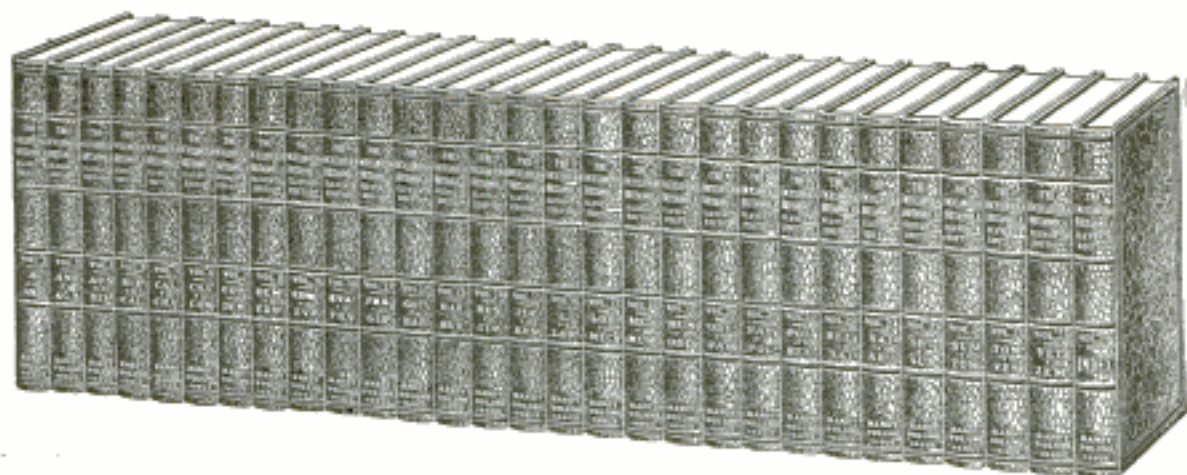

Why Do Men Build Bookshelves in Their Homes?

A FAIR question, isn't it? Why does a man when he builds his own home carefully provide space for bookshelves in his living room, in his library, in the same manner as he builds pantry shelves, closet shelves or shelves in his medicine cabinet? The answer is a simple one. To put books in, of course, as pantry shelves are to put food on, closet shelves to put clothes on and shelves of the medicine cabinet are to put medicine in.

But there's more of an answer to the question. A man puts bookshelves in his home or buys bookcases because he knows that either are as necessary in his home as pantry shelves or closet shelves. He knows that books are as vital a necessity to every man and his home as his food and his clothes and medicine.

The Corner Stone of Every Home Library

In the same manner as a man chooses his food for the good it is going to do his body, and his clothes for their serviceability, he chooses the books to put in these shelves for their ability to feed and strengthen the mind; books that clothe the man and his family with knowledge and give protection against ignorance. He must choose with utmost care to give

his family such books as will be of the most value day in and day out and represent an investment in knowledge from which he and his family can obtain a definite and lasting benefit.

He selects and purchases first the Encyclopaedia Britannica and builds his library around this great work. Why?

Because it furnishes him with information on every conceivable subject written by the world's greatest authorities.

Because it gives to every woman information which she needs to keep posted on the events of this interesting world.

Because it furnishes the children information to satisfy their expanding minds and supplements their school studies.

The Luxury of India Paper

He chooses the Encyclopaedia Britannica because it is well made from the physical standpoint. It is printed on the genuine India paper, which makes the Britannica far more usable than any encyclopaedia ever was before.

Send for the large illustrated booklet describing the Britannica, and giving the attractive prices and terms of payment on which it is sold.

THE ENCYCLOPÆDIA BRITANNICA

SIGN AND MAIL THIS COUPON TODAY.

A Small First Payment Brings You This Complete Set of 29 Volumes, 44,000,000 Words, 30,000 Pages, 15,000 Maps and Illustrations. The Balance Is in Monthly Payments. Send for Free Booklet.

Sears, Roebuck and Co.
CHICAGO

Sears, Roebuck and Co., Chicago, Ill.

Gentlemen: Please send me, free, your illustrated Book No. 18AC, giving full information about the Encyclopaedia Britannica. Also tell me what I will have to pay for a set of the Britannica printed on genuine India paper.

Name

Postoffice

R. F. D.

No. Box

No. No. State

Street

and No.

THE SCIENTIFICALLY BUILT WATCH

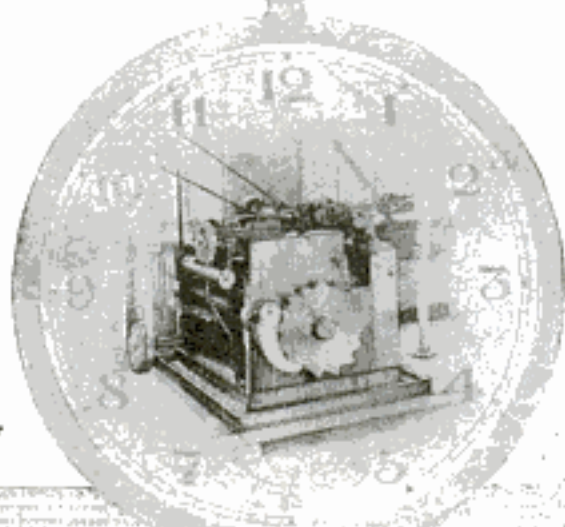

MECHANICAL

PERFECTION



The Escape Wheel

SEVENTY years ago the first "Waltham" inventor gazed upon the big, thick, clumsy contrivance called "a watch"—the "turnip" of our forefathers. His problem then was—how to build machines that would transpose that lump of erratic time-telling mechanism into the slim, accurate, life-long pocket friend which millions of men today call "Waltham."

And do you know that Waltham inventors—Waltham experiment, development and research, are responsible for the remarkable improvements that differentiate the modern watch from the antique timepiece of our ancestors?

Every part of a Waltham watch that was not perfection itself has been perfected by the unusual process of inventing marvelous machinery to perform the job beyond the power of the human hand to accomplish.

Thus, Waltham machinery is responsible for Waltham accuracy—and Waltham mechanical perfection—hidden in this famous movement.

This is the story of the intricate machine (illustrated above) that cuts with unerring precision the escape wheels for every Waltham watch—a machine that cannot be found in any other watch factory in the world.

When you buy a Waltham watch you buy originality and leadership—seventy years of American mechanical genius concentrated to produce a time-telling piece of mechanism that has amazed the world—and its greatest tribute is the American watch industry, every watch of which is built upon the original Waltham plan of "interchangeability of parts."

There are many more valuable reasons why your watch selection should positively be a Waltham.

Write for a valuable booklet that is a liberal "Watch" education. Sent free upon request. The Waltham Watch Company, Waltham, Mass.

Makers of the famous Waltham air-friction quality Speedometers and Automobile Time-pieces used on the world's leading cars



Colonial Series No. 1420
Raised Gold Figure Dial
Catalogue No. 116. \$85.00

WALTHAM

THE WORLD'S WATCH OVER TIME

Where you see this sign they sell Waltham Watches

GIFTS THAT LAST

Popular Mechanics Magazine

REGISTERED IN U. S. PATENT OFFICE

WRITTEN SO YOU CAN UNDERSTAND IT

Vol. 37

MAY, 1922

No. 5

Astonishing Results of Foundation Tests

8542

By HENRY S. WHITE

VERY interesting results have been obtained from the unique tests of the foundation piers and caissons for the new Union Station at Chicago, that were fully described and illustrated in the January issue of this magazine. Since that time the tests have been completed on both piers. On the one with the belled base, having a bearing area of $54\frac{1}{2}$ sq. ft., a load of 970 tons was ap-

plied to the concrete. Thus the remarkable result is shown of a load that was over 13 times the load allowed by the city of Chicago ordinance, with a total settlement at the base of only $1\frac{1}{16}$ inches.

The next test helped to explain this unexpected result, for it proved positively that fully a quarter of the load was car-



End of Tunnel to Unsupported Base of Foundation Pier: Bottom of Pier, at the Man's Hand, had been Pushed Down from Top of Tunnel by Load of 260 Tons.

ried for 10 days continuously, resulting in a total settlement of $1\frac{1}{4}$ in., of which $\frac{1}{2}$ in. was found to be due to the compression of the concrete itself. On the other pier, without a belled base, and with a bottom area of $12\frac{1}{2}$ sq. ft., a load of 1,000 tons was applied continuously for six weeks, with a total settlement of 2 in., of which $\frac{3}{16}$ in. was due to the compression

of the concrete. Thus the remarkable result is shown of a load that was over 13 times the load allowed by the city of Chicago ordinance, with a total settlement at the base of only $1\frac{1}{16}$ inches.

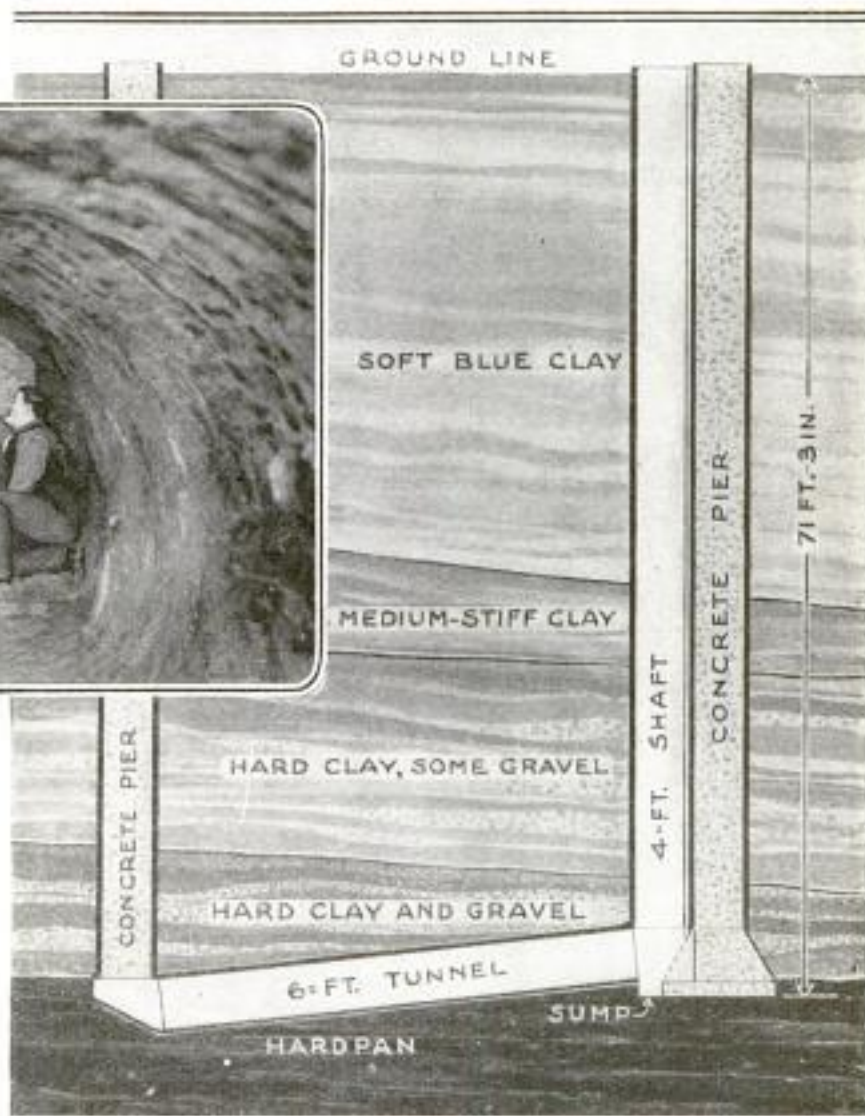

Diagram of Shaft and Tunnel, 45 Feet Long, for Examining Results of Tests on Two Foundation Piers: At Left Is the Pier without Belled Base, on Which Skin-Friction Tests were Made after Removal of the Hardpan

Chicago Union Station Co. Copyrighted Material
City Clerk's Office Chicago

rounding it. A shaft, 4 ft. in diameter, was sunk alongside the pier with the belled base to the bottom of it, and a tunnel, 6 ft. in diameter and 45 ft. long, was driven to the bottom of the other pier. The shaft alongside the first pier furnished opportunity for a thorough examination of the soil, which was found to be partly soft, and partly hard clay and gravel. Under the other pier the hardpan was all dug away, leaving the base entirely unsupported. Loads were then applied, and gradually increased until a load of 260 tons was reached, when for

the first time the unsupported pier began to move. When the pier had been pushed down about 3 ft., the load was taken off. This proves that the resistance from skin friction alone was at least 250 tons, showing by calculation that there was resistance from friction at the rate of 570 lb. per square foot of the pier's surface. This is the first time a test of this kind has been made, and the results are deemed to be of great value. It is hoped by engineers that these demonstrations will convince the city authorities that the present allowable load could safely be doubled.

8521 NEW PROCESS MAKES COTTON FIREPROOF

BALED cotton, which so easily catches fire, or quickly rots when exposed to the weather, is to be largely saved from both huge losses by a new chemical process which is simple to apply at the time the cotton is ginned and does not injure the quality of the cotton.

Anyone who has touched a match to a piece of cotton batten knows how the flame spreads over the surface in a flash. This has led to the adoption of the term "flash fire" in the cotton industry, and is one of the menaces to be guarded against in shipping or storing cotton bales. Another form of fire risk is the so-called "burrowing fire," which refers to the fire which eats its way into the bale. One would think that this fire hazard was a sufficient handicap to be placed upon any industry, but cotton is also subject to another loss, called "country damage," caused by fermentation among the fibers when the bales are stored in contact with the ground or under adverse weather conditions. This country damage spreads into the bale, and may occasion the loss of as much as 80 per cent of the cotton in the bale.

When consideration is given the fact that, with the single exception of corn, cotton is the most valuable of our agricultural products, and far exceeds in value any other exported commodity, the economic importance of any process that will reduce the fire loss and prevent the loss through country damage, can be appreciated.

The process of treatment is extremely simple and has been tested to a point where its commercial value is proved. In treating the gin-baled cotton it is only necessary to roll the bale through an L-shaped vat containing the chemical in such a way that all surfaces are exposed to the liquid. The level of the liquid in

the vat is maintained by a float valve controlling the supply from a storage tank. At least two minutes must be consumed in passing the bale through the vat in order to insure a proper penetration of the chemical solution. When it comes from the vat, the bale is placed on a platform and allowed to drain for two or three days, when it is ready for shipment or storage.

Fire tests on the treated bales show that matches and cigar or cigarette stubs may scorch the surface, or even start local flash fires in some cases, but that, as a general rule, these die out quickly without starting burrowing fires. In the exceptional cases where burrowing fires started, they were easily quenched with water. In one particularly rigid test, the flame from a blowtorch was passed over the surface of a treated bale, and while the surface was scorched, no flash fire or burrowing fire was started.

In addition, several tests showed that treated bales were practically fire-resistant to sparks such as would come from a coal-burning locomotive. This fact alone is of great importance, not only to the cotton industry but to the railroads which transport the crop, for it means that cotton may be shipped on flat cars or in ordinary cars without special precautions being taken, as is now the case. As a consequence, the first-grade spark-proof cars can be released for the movement of other crops.

Many tests have shown that treated bales are practically immune from country damage, even when stored under adverse weather conditions. One test showed that the loss after three years was only 2 lb. on a 500-lb. bale, while with the untreated bales the loss in only a few months may range from 80 lb. to as much as 400 lb. per bale.

Inventor: Mr. Haley

8521 International Cotton
Protecting Co. 14 E Jackson Blvd
Chicago

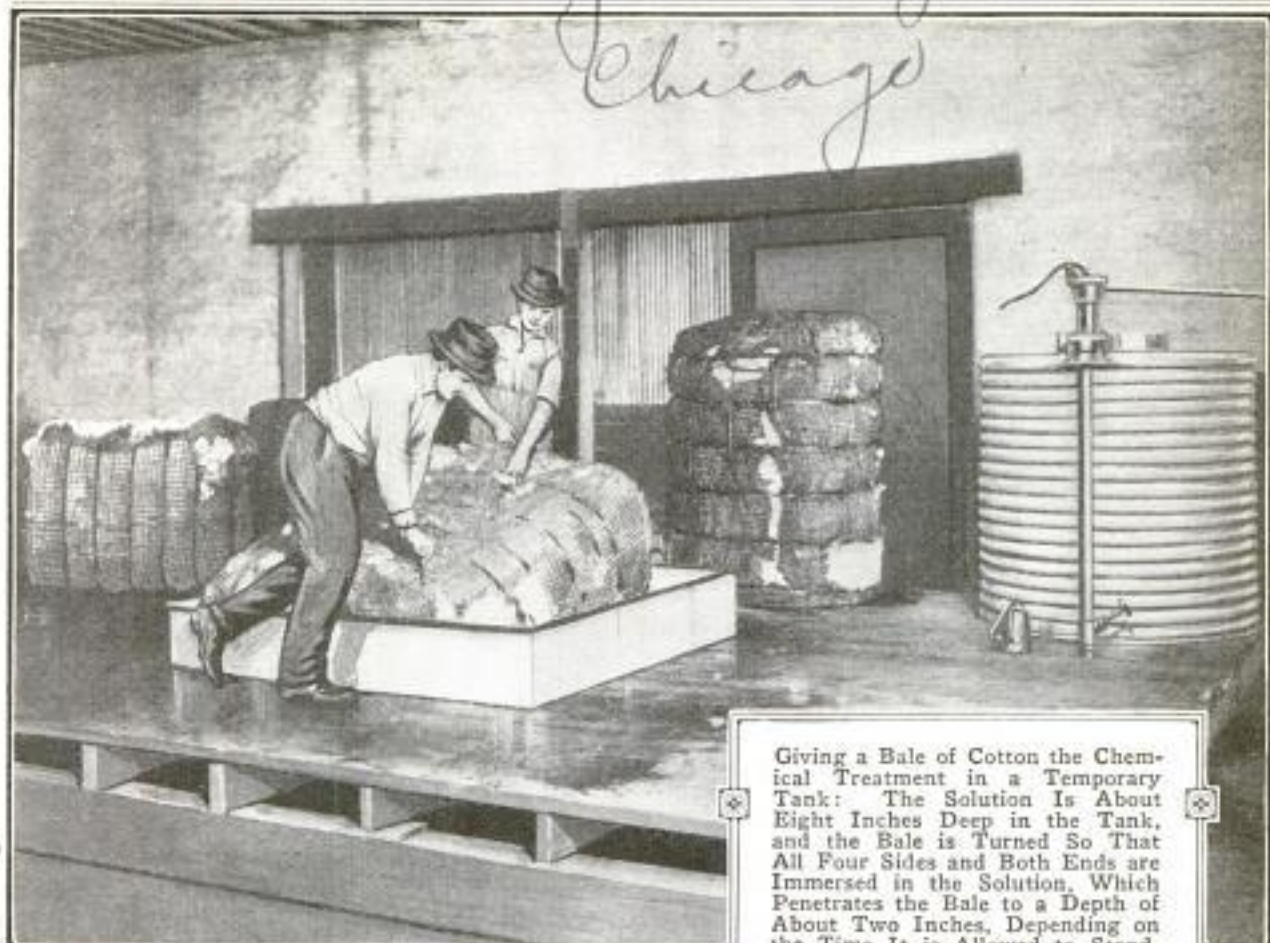

Giving a Bale of Cotton the Chemical Treatment in a Temporary Tank: The Solution is About Eight Inches Deep in the Tank, and the Bale is Turned So That All Four Sides and Both Ends are Immersed in the Solution, Which Penetrates the Bale to a Depth of About Two Inches, Depending on the Time It is Allowed to Stand. It Takes About Two Minutes to Apply the Treatment

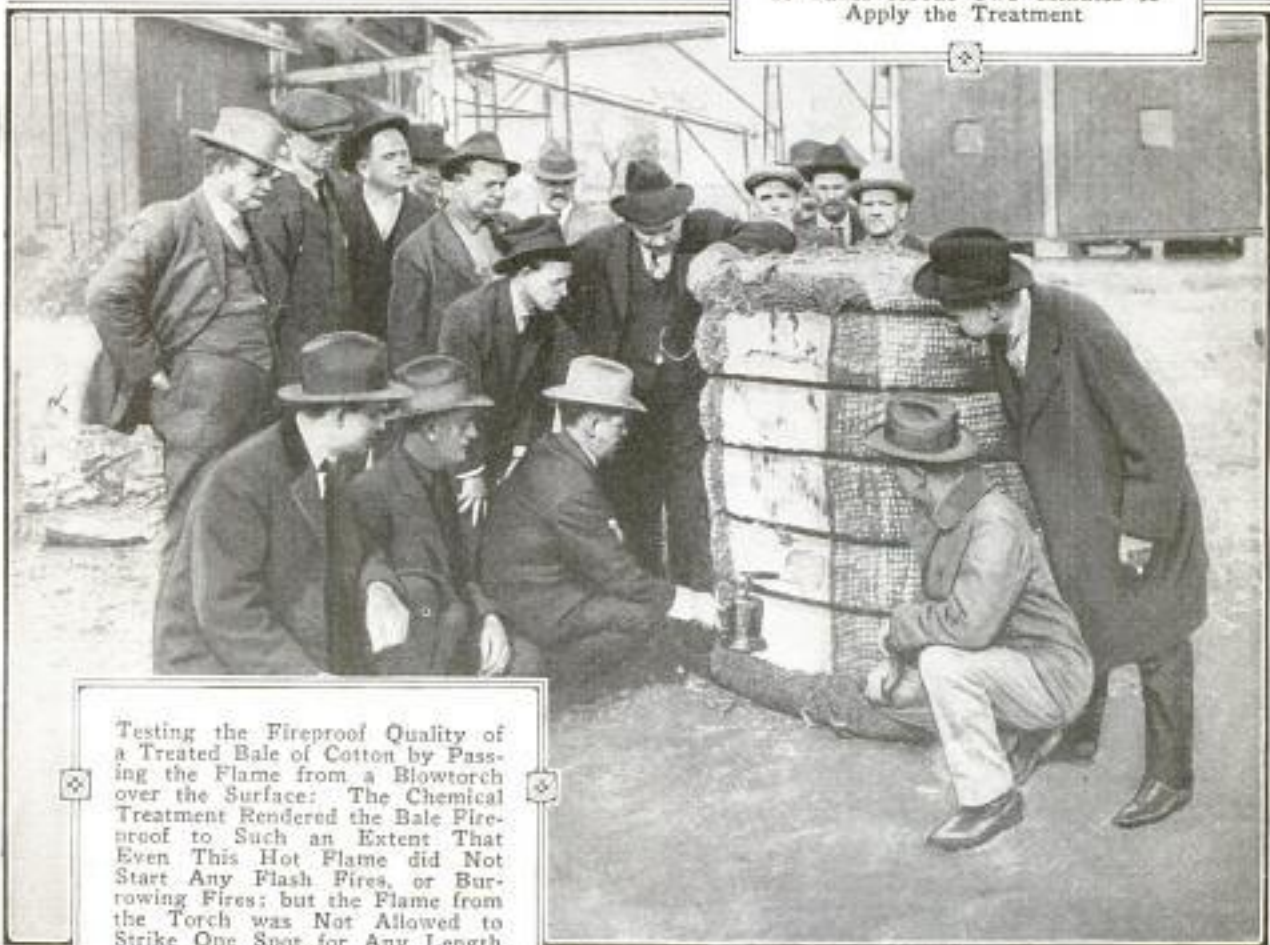

Testing the Fireproof Quality of a Treated Bale of Cotton by Passing the Flame from a Blowtorch over the Surface: The Chemical Treatment Rendered the Bale Fireproof to Such an Extent That Even This Hot Flame did Not Start Any Flash Fires, or Burrowing Fires; but the Flame from the Torch was Not Allowed to Strike One Spot for Any Length of Time

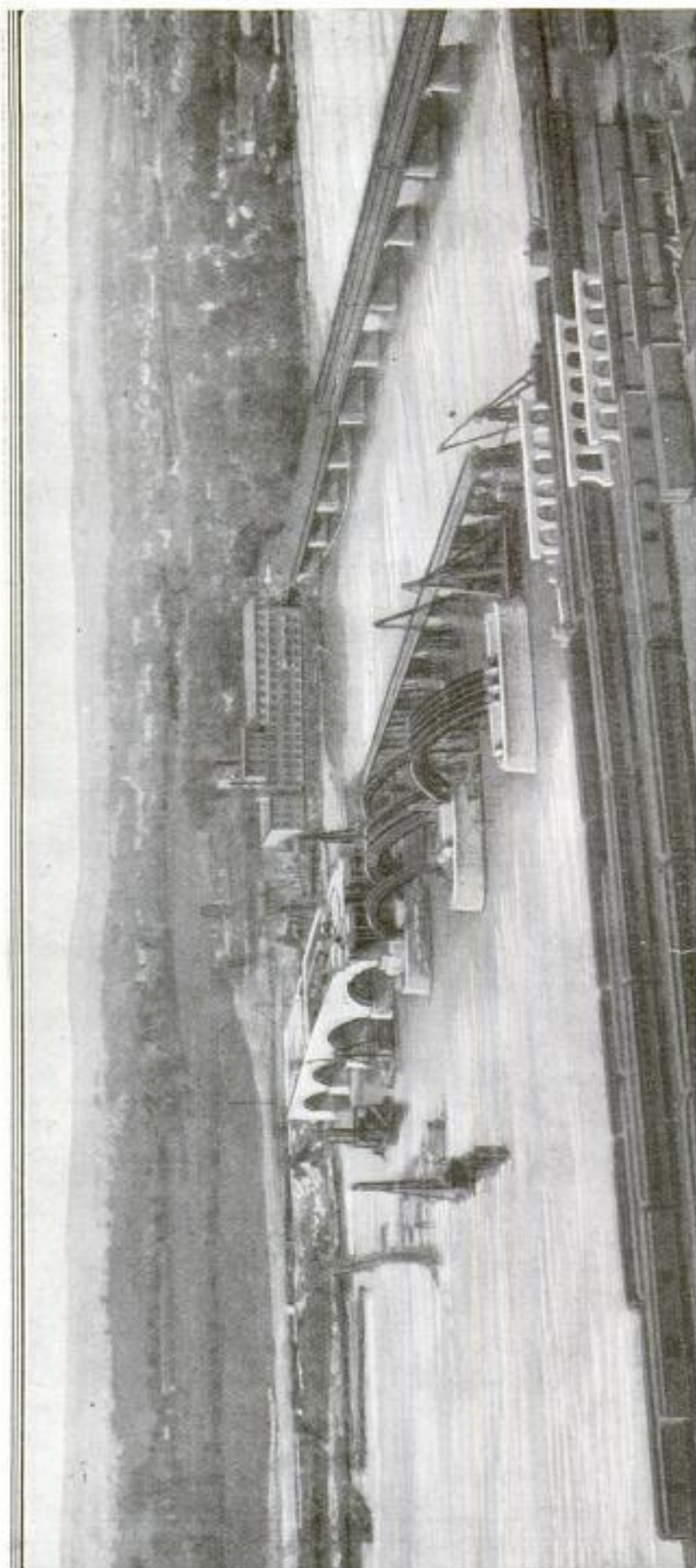

This New Bridge over the Connecticut River at Springfield Is of Modern Steel and Stone Construction and will Take the Place of the Old Bridge to the Right Which has been Condemned as Unsafe for Traffic after having Been in Use, with Few Interruptions, for a Period of 105 Years

NEW VIADUCT REPLACES OLD TOLL BRIDGE

A new bridge is being erected over the Connecticut River at Springfield, Mass., to take the place of the old toll bridge which has been in service since 1816 and is now declared unsafe for traffic. The old bridge is of the two-way, covered type and was constructed of hand-hewn oak timbers held together by hand-wrought iron rods and hardwood pegs. The new bridge is of modern steel and stone construction, and will be 80 ft. wide to allow for car tracks, vehicular and pedestrian traffic. One feature of this bridge is the center span of 172 ft., which is so constructed that it can be replaced by a drawbridge should the river be made navigable for ocean-going boats later.

NEW SUBSTANCE AS CATALYST HARDENS OILS

The process of oil hardening, called hydrogenation, consists in the conversion of oils, which at ordinary temperatures are liquid, into fats which are hard under the same conditions, and depends on the use of a catalyst, which is a substance causing the action but not affected by it. It has been found that a combination of nickel-magnesium silicate gives much better results than any of the catalysts previously used.



German Substitute Manikins. Made of Metal Instead of Wax: At Left is Shown a Seated Manikin Undraped; to the Right of It, Draped. To the Extreme Right Is a Standing One, and to the Left of It, the Same Manikin Draped. The Manikins Revolve on Balls at Their Feet

GERMANS INTRODUCE MANIKINS OF METAL INSTEAD OF WAX

During the war almost every staple in Germany was replaced by an "ersatz"—a substitute—and now it seems that also in peace time certain substitutes have come into use. One notable instance, that is said to be for the purpose of counteracting French influence, is the substitution of metal manikins for the beautiful wax ones so universal, not only in France, but throughout the whole world of fashion. These lay figures are the invention of a famous German sculptor and are made of such light metal that they can easily be carried about. The arms are jointed, and the whole figure rests on a ball upon which it will revolve.

20-PASSENGER AUTO BUS IS SPECIALLY DESIGNED

8450

A new passenger-carrying bus, now undergoing its preliminary trials, has been specially designed for this service. The running boards and floor are placed low for convenience in entering and leaving. Sidesway is eliminated to a great extent by the increased width of the tread, which is 68 in. as against the usual 56 in. The bus is equipped with a 64-hp. motor provided with a governor, and is capable of a maximum speed of 52 miles an hour. The interior appointments have been specially designed for the comfort and convenience of the passengers. The motor and driveshaft are supported on fabric or rubber pads to eliminate vibration.



Left: "The Silver Fox" is Specially Designed for Passenger Service and has the Floor and Running Boards Placed Remarkably Low for the Convenience of Travelers. Above: The Extra-Wide Tread Makes for Easy Riding and Reduces Sidesway

Hagedorn Motors Co., Oakland, Calif.

Capt. Harry Gordon 316 High St. Col. Arthur W. Stevens Box 623, Kearney

658 8518 Holyoke, Mass. POPULAR MECHANICS Nebr.

VISUALIZE PAPER'S STRENGTH BY NOVEL DEMONSTRATION

A rather unusual method was recently employed to demonstrate the strength of a certain kind of paper. A single sheet

almost instantly, like a prairie fire. Thousands of dollars are lost each year from this cause alone. The causes of the fires are various, many of them being incendiary.

So vital is the success of the wheat crop to the welfare of the region that the business men of Colfax, which is located in the heart of the wheat belt, have organized a volunteer fire department to aid the ranchers in saving their crop. The method used by the ranchers is the same as that employed by the earlier settlers in protecting their homes against prairie fires—a plowed strip ahead of the fire. Also a call for help is telephoned to town.

In town, a special signal is sounded on the fire whistle, and autos and volunteer fire fighters flock to the fire station. A pile of gunny sacks that is kept at the station, is soaked with a stream from the hose. The first auto to arrive is given a load of shovels and these wet sacks. Following autos are loaded with men, and they leave in rapid succession for the fire. Usually, by the time help from town arrives, the rancher and his neighbors have the plowed fire line completed and are ready for the men with the wet sacks. The sacks are used to beat out any small fires that start on the opposite side of the plowed strip.

So common are wheat fires during the harvest season that as many as five or six alarms may be turned in during one day.

SKINNING KNIFE FOR HUNTER PREVENTS CUTTING HIDE

Hunters, or other persons who have occasion to skin wild or domestic animals, will appreciate a new knife invented by an eastern man. The knife has a blade with a sharply curved tip which terminates in an oblong knob.



Both edges of the blade are sharpened, and in using, the knob is first inserted between the hide and the flesh. In this position, the knife may be either drawn or pushed without fear of cutting deeper than intended, and without raising the skin with the fingers.

Edw. Osgood Lefebvre Dupont Lake, N.Y.

American Writing Paper Co., Holyoke, Mass.



The Single Sheet of Paper is Supporting a Weight of 769 Pounds. The Young Women Seem to Have Perfect Confidence in Its Ability to Hold

of this paper, no heavier than the usual letter stock, was suspended in a frame carrying a seat on which five young women stood and sat. The total weight supported was 769 lb., which included the weight of the platform.

FIGHTING WHEAT-FIELD FIRES IN EASTERN WASHINGTON

In eastern Washington is an agricultural region, known as the Palouse Country, that is devoted almost entirely to wheat raising. Here one may ride mile after mile through what has been aptly termed, by one writer of fiction, a "desert of wheat." After the crop has been successfully nursed through dry winters, wet springs, and dry summers, comes the time of ripening grain and its danger from fire. When the wheat is about ready to harvest, a fire started in it will spread

866/

WILL THE LOST TRIBES RETURN TO JERUSALEM?

By Lewis R. Freeman

287 E. California
S. Pasadena, Calif

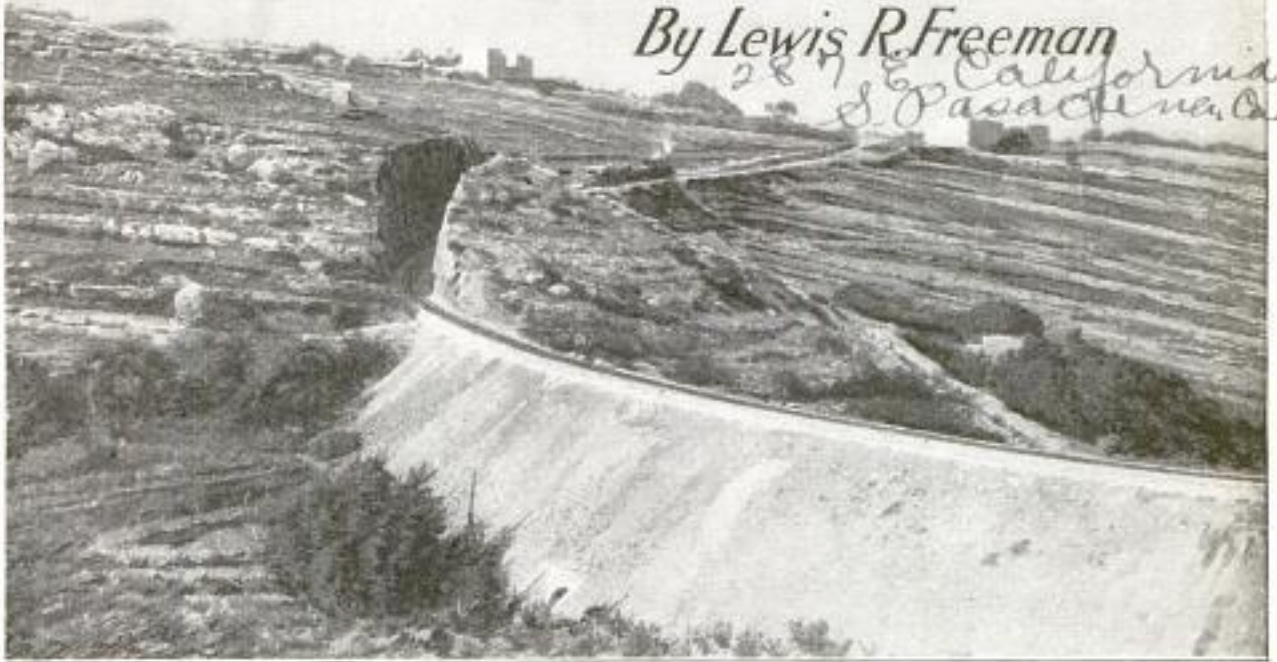

Characteristic View of the French-Built Railroad, near Homs, in Northern Syria, between Reyak and Aleppo: The Road Is an Almost Continuous Succession of Cuts and Fills, Owing to the Peculiar Conformation of the Country

OUT of the "Grapes of Wrath," trodden in the wine vat of the World War, have flowed strange vintages, most of them bitter if not poisonous. One of the few that sparkles with the bright effervescence of promise is that which typifies the release from their centuries of Turkish bondage of the Jews, Armenians, and Arabs, to say nothing of various and sundry odds and ends of lesser peoples who had long suffered virtual strangulation in the grip of the tentacles of the

dying Ottoman octopus. The difficulty of extending succor to the young Armenian republic may mean that it will yet have to face for many years the threat of Turk and Bolshevik; but for the Jews of Palestine—with a strong but liberal British protectorate established, and ultimate autonomy in sight—there is hardly a cloud on the horizon.

And for those who were once called "God's Chosen" the vintage of the war has brought more than freedom—it has



A Group of Pre-War Jewish Colonists in Palestine: They Were, as a Rule, Very Poor and Their Equipment Primitive in the Extreme. Undoubtedly the New Colonization Scheme will Alter All This

brought fulfillment. To the ends of the world Jews are thumbing the pages of Isaiah, Jeremiah, and others once of scant honor in their own country, pointing out how prophecies already come true have opened the way for the fulfillment of others of even greater import, leading up to a virtual renaissance of the race and the establishment of their long-dreamed-of New Jerusalem. I shall discuss here only that covered by two verses from Isaiah. Because the war has made the "highways" referred to a *fait accompli*, that prophecy, with all that its fulfillment

tanks, khans, and caravansaries, marking the windings of a dusty camel and ass-beaten path across the desert. Certainly, not in the farthest-flung vista of his vision could he have seen the glistening tracks, the thundering trains, the crowded station yards that differentiate the modern railway and railway travel from that by the ancient caravan. And yet it is in the railway that the prophecy comes to fulfillment. From thousands of miles beyond the outermost limits of the known world of Isaiah's time it is now possible to reach Jerusalem by rail. The

highway from Egypt to Assyria, via Palestine, is an accomplished fact; but that (save as it fulfills the letter of the prophecy) seems hardly more than a negligible incidental when one learns that the whole of the European railway system, together with great and increasing lengths of those of Africa and Asia, have been brought—almost overnight as it were—in rail connection with Jerusalem. No matter whither, on any one of these three continents, the most restless remnant of any of the lost tribes has wandered, there are few who would have to march for

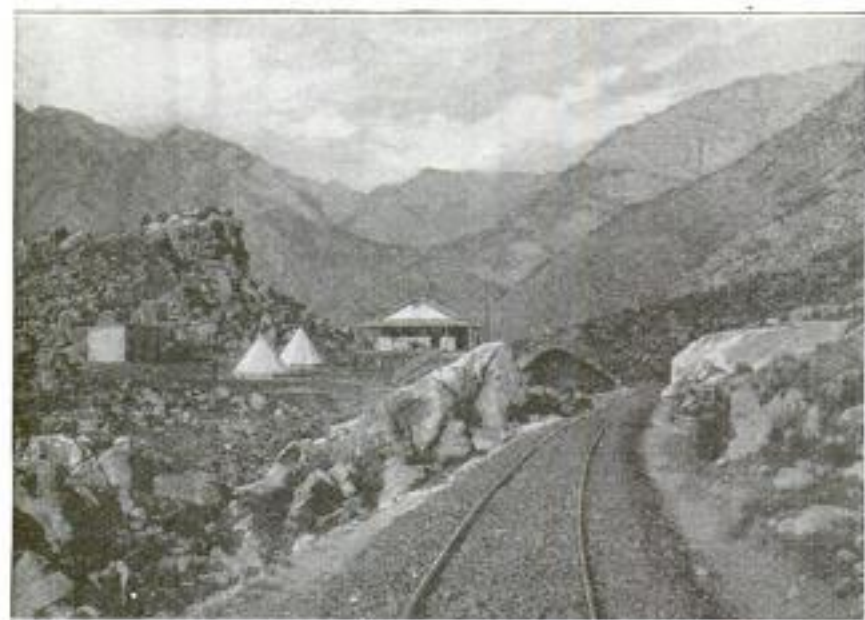

A Section of the Bagdad Railway in Northern Syria: This was Built by the Germans before and during the War, as a Part of Their Ambitious Plan of Connecting Berlin by a Direct Railroad with the Head of the Persian Gulf

seems likely to lead up to, falls fully within the field of a magazine which devotes itself exclusively to accomplished, and accomplishable, facts. Visioning the return of the "Lost Tribes" of Israel, Isaiah wrote (xi:16):

"And there shall be an highway for the remnant of his people, which shall be left, from Assyria; like as it was to Israel in the day that he came up out of the land of Egypt."

And again (xix:23):

"In that day shall there be a highway out of Egypt to Assyria, and the Assyrian shall come into Egypt, and the Egyptian into Assyria, and the Egyptians shall serve with the Assyrians."

Just what a highway connoted to Isaiah, it would be interesting to know. Doubtless, however, clear-seeing as was the great prophet of the redemption, it is not probable that he visualized much more than a long series of wells and

more than a day or two to reach a highway that will lead them back to Israel. To what extent they will bring about the fulfillment of other prophecies by returning, still remains to be seen.

Just how much the war and the pressing transportation needs of the belligerents put forward the establishment of through rail connection between Jerusalem and the world to the east and west and south, it is hard to say. Even had the war not come, so that Palestine and Syria would have remained under Turkish control, it is still conceivable that a roundabout connection with the Bagdad Railway would have been effected in the course of the next eight or ten years. Nevertheless, the facts that the Palestine and Syrian lines were French, though of different gauges, and that the Damascus-Medina line was Turkish, and the Bagdad line German, would have made coöperation to this end very problematical. Still one heard such a connection spoken of frequently in Palestine in the years just

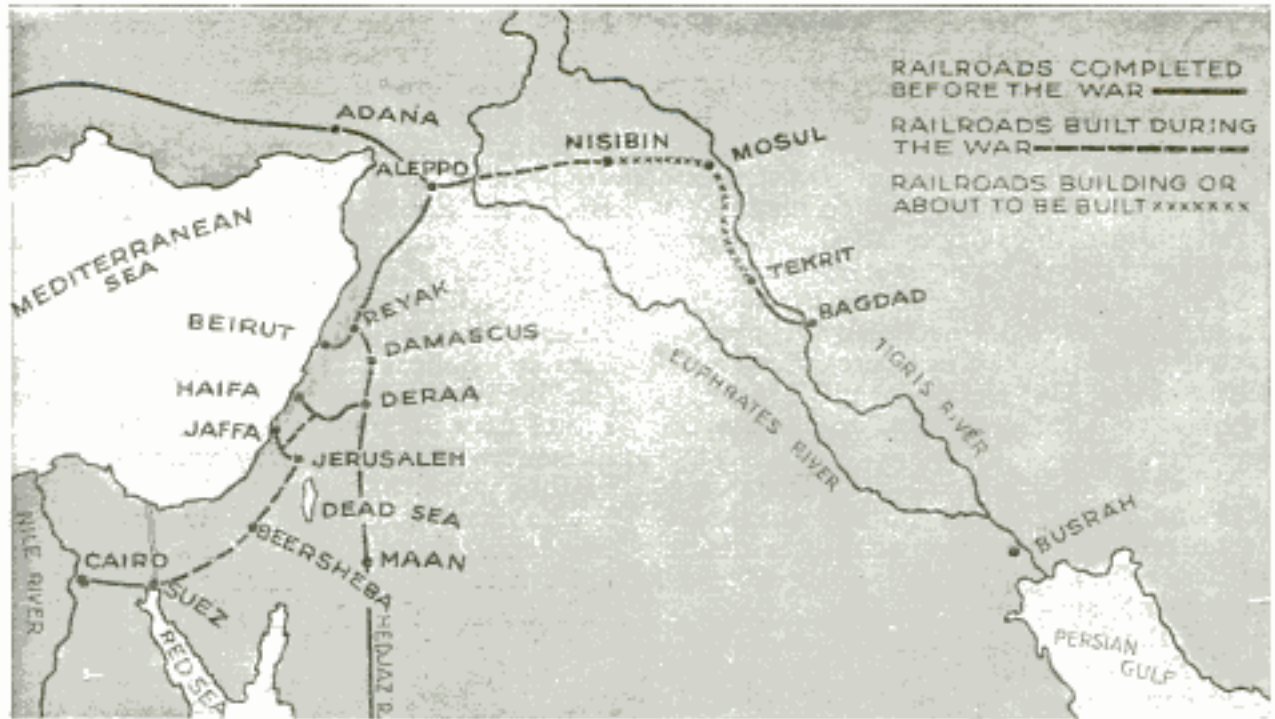

General Map of Palestine, Syria, and Mesopotamia, and Adjacent Territories, Giving an Idea of the Extent to Which the Railways are Developed at Present: It will be Seen That Even Now the Old Prophecy of a "Highway Out of Egypt to Assyria" Is Practically Fulfilled

previous to the war, and perhaps it would eventually have come to pass. A railroad across the barren Sinai Desert to the delta of the Nile, however, I never heard discussed at that time, either in Palestine or Egypt. As the insignificant trade between these two regions was easily handled by the existing steamer service, it is probable that many years would have gone by before Turkey, or even private concessionaires, would have been willing to sink money in what could hardly have been a profitable enterprise. Had not this railway been built as a strategic line then, it seems likely that there could have been no incentive for its construction until Palestine and Syria had fallen from the palsied hand of the "Sick Man" by their own weight. Without the war, this might not have eventuated for several decades. I shall hardly need to add that there is no possibility of the Jews ever having come to their own while Palestine remained under Ottoman control.

A brief survey of the railway situation in Turkey-in-Asia at the outbreak of the war will be necessary to an understanding of what was accomplished during the war, and a consideration of the possibilities this latter development opens up for the age-long Jewish dream of a New Israel in a restored Palestine.

By the middle of 1914, the Bagdad Railway (under construction by German concessionaires as the backbone of their grandiose plan of eastward penetration)

was, save for a number of heavy cuts and tunnels in the Taurus and Amanus mountains, complete from the Bosphorus to the Euphrates. The bridge over the latter, at a point not far from Aleppo, was well under way, and some preliminary work had been done on the eastward extension to Mosul, opposite the site of old Nineveh, on the Tigris. At the opposite end of the survey, working with material brought up the Tigris from the Persian Gulf, the grading had been completed from Bagdad to Samara, 60 miles north of the ancient capital of the caliphs.

In Syria a French-constructed and operated railway ran from Beirut, over the Lebanon Mountains to Reyak, from where one branch ran northeasterly to Homs and Aleppo, and another southeasterly, across the Anti-Lebanon Range, to Damascus. From the latter metropolis the German-built but Turkish-operated Hedjaz Railway ran almost due south, across a bleak and sterile desert, to Medina. This line had been built solely with the idea of handling the pilgrim traffic to Mecca, and Turkish mismanagement had brought it to a hopeless state of disrepair within a year of the time the Ottoman government took over the control. A branch of the Hedjaz line ran from the junction of Deraa, down to the Sea of Galilee and the Jordan—well below sea level—and on to the Mediterranean at Haifa.

6399

In Palestine proper the only railway was the 54-miles-long line, owned and operated by a French company, connecting Jaffa and Jerusalem. On account of its open roadstead, Jaffa was useless as a port for days at a time, which fact had set the Turkish government to planning a connection with Haifa by means of a spur from the Hedjaz branch to Jerusalem. As this would have rendered the French line from Jaffa almost worthless, the concessionaires of the latter were much perturbed over the outlook at the time of my last visit to Jerusalem, just before the war.

When I crossed by caravan from Bagdad and Mosul to Aleppo and the Mediterranean in the summer of 1912, evidences of feverish activity were observable all along the survey of the Bagdad Railway. This could have been nothing, however, to what went on after the war began, and especially after the inauguration of the first British drive up the Tigris toward Bagdad. That route immediately became the main—indeed, the only—artery of communication of the Turko-German defense, and remained so until that defense crumbled away to nothing in the last year of the war. The greatest effort was made in pushing the Taurus and Amanus tunnels, as that part of the Bagdad Railway was also the main line of communications for the operations in Palestine and Syria. Through traffic was opened to Aleppo in 1916, about the middle of the year.

Meantime, construction had been pushed on across northern Mesopotamia from the completed bridge over the Euphrates, and by the end of 1916, Nisibin, halfway to Mosul, had been reached. The next year saw the completion of the grade to Mosul, but the tremendous demand for steel in Germany made it impossible to supply material for rails and bridges. Nisibin remained practically the railhead, as far as transportation was concerned, to the end of the war, and I have not

been able to learn that any active construction has been carried on there since. As this is one of the most unsettled regions of the late Turkish empire in Asia, it is not likely that much work will be done here until the combined Turko-Bolshevik threat to Armenia is removed, the Kurds reduced to subjection, and the peoples of this much-harassed section allowed to resume the ways of peace. As Nisibin, however, lies well within the borders of Biblical Assyria, the prophecy of the highway between that country and Israel may be said to have come to fulfillment when the railway was completed to that point.

The materials on hand in Bagdad at the outbreak of the war sufficed only to build a railway from that city to Tekrit, 20 miles north of Samara, and that strange little Arab town—which received its name from Alexander the Great—was railhead at this end when all of southern Mesopotamia was overrun by the British at the culmination of Maude's masterly campaign. Much grading was found to have been done on the survey north to Mosul,

but rails had not been laid. The closing up of the uncompleted gap of the Bagdad Railway need not be a matter of many months, once the country to the north is pacified and the nations concerned (Great Britain and France) in the establishment of a through line from the Mediterranean to the Persian Gulf find the money for the project.

With the French railway from Beirut reaching both Aleppo and Damascus, all the Germans had to do to establish a through line from the Bosphorus to Arabia (once the Taurus and Amanus tunnels were completed) was to connect the French and the Hedjaz systems at Damascus, and change the former from a meter gauge to standard. Maan, on the Hedjaz Railway, was made the base for the early Turkish operations across the Sinai Desert against the Suez Canal, but no new line was laid to assist in this



Section Boss and His Gang on the Hedjaz Railway: The Ties Used Are of Steel, as No Wood could Stand the Climate. This Railroad Is Turkish-Built, and Mainly Serves the Pilgrim Traffic



The Narrow-Gauge French-Built Line, Climbing the Mountains Back of Damascus: The Grades Are in Some Places Very Steep; Here, for Instance, the Gradient Is Six per Cent, and a Rack System Was Necessary to Secure Traction

ill-advised and ill-fated operation. It was not until it became apparent that the Turks were to be on the defensive rather than the offensive in Palestine, that each belligerent in this theater began work on lines which, when finally united, effected fulfillment of the prophecy of the highway from Egypt to Assyria.

The Germans, after building a line to connect the Haifa branch of the Hedjaz Railway with that from Jerusalem to Jaffa, pushed construction on southward until Beersheba was reached. This was their expiring effort in railway extension in Palestine, and the result of it was that there was a through, if roundabout, line all the way from the Bosphorus to Jerusalem and Beersheba.

When Allenby launched his campaign against the Turks he carried his railway right along with him as he went. It was the sequel to his capture of Beersheba that made possible the welding of the final link in the highway that Isaiah had foretold. Fortunately both lines were standard gauge, so that Allenby's railway

trains were almost upon his heels when he marched into Jerusalem. The final defeat of the Turkish army was so complete that little was done in the way of destroying their railways, and consequently the whistle of the locomotive followed close upon the pursuing cavalry all the way up to Damascus and on to Aleppo. At the latter point Allenby reached the Bagdad Railway.



The "Wailing Place" of the Jews, outside the Old Temple Wall at Jerusalem: The Interior of the Temple had been Converted into a Turkish Mosque, So the Jews could Not Enter

So much for the prophecies that have already been fulfilled. Now what of those which it seems certain are about to come to pass? With Israel once more open to them, and with a highway stretching fair before them, will the Lost Tribes return to realize their New Jerusalem? Of many prophecies in point, one from Jeremiah (xxiii:3) will suffice. In its explicitness of expression it is but typical of what Isaiah, Hosea, Joel, and several other of the prophets, have said on the same subject.

"And I will gather the remnant of my flock out of all countries whither I have driven them, and will bring them again to their folds; and they shall be fruitful and increase."

The Jews are found all over the world at the present day. Speaking very broadly, these may be divided into two classes: the descendants of the tribes which were carried into captivity, or who fled to avoid being carried into captivity; and the descendants of later and more voluntary emigrations. The former movement was in the main toward the east, and occurred previous to 586 B. C., the date of the final destruction of the kingdom of Judah by Nebuchadnezzar; the latter movement has been westward, most of it in the Christian Era. The emigration of European Jews to America is the final wave of this westerly drift.

Students of Biblical history will recall that the union of the twelve Hebrew tribes under the warlike Saul, which was further consolidated under David and Solomon, fell into two parts after the death of the latter. That to the north retained the name of the kingdom of Israel, while that to the south, with its capital in Jerusalem, was called Judah. Israel, after sapping its strength with wars with the princes of Damascus, fell an easy victim to the Assyrians, under Sargon, in 722 B. C. All the inhabitants were carried off to Nineveh, and Assyrian colonists sent to replace them. It was because all trace of the expatriates disappeared that they came to be referred to as the Lost Tribes of Israel.

That the lost tribes were, as history tells us, originally planted in the Tigro-Euphrates Valley is evident even to the veriest tyro of an ethnologist who travels in central Asia today. From the source of the Tigris, near the Black Sea, to its confluence with the Euphrates above the head of the Persian Gulf, the unmistakable Hebraic cast of countenance is encountered in every town and village. In

the larger cities, such as Diarbekr, Mosul, Bagdad, and Busrah, the Jewish quarters are scarcely less extensive than the Musulman. In Mosul and Bagdad, the cities nearest to the respective Assyrian and Babylonian capitals of ancient times, business is today very largely in the hands of men whose ancestry would undoubtedly trace back to captives of Sargon and Nebuchadnezzar. For most of these, it will be but the matter of a short journey by *arabanah* [a sort of prairie schooner used in Asia] to reach the beginning of the highway that will take them all the way back to Jerusalem.

How far fragments of the lost tribes wandered eastward will never be definitely known, but unquestionably far into China, if not all the way to the Pacific. One finds Jews in plenty in the bazaars of Kermanshah and Teheran, and right on east across the ancient cradle of civilization from which their Semitic ancestors came. One sees types that are Jewish ethnologically beyond question in the bazaars of Kashgar, Yarkand, and Samarkand, though their religious observances have often been greatly modified by their environment. Farther east still, one finds valleys that are peopled by tribes of unmistakable Jewish origin. In the mountains along the Chinese border they occur only in scattered villages, and by the time one has penetrated 500 miles toward the heart of the Middle Kingdom, the effect of the Jewish immigration is noticeable only in the narrower and more aquiline faces of a type that is predominately Mongol. Another 50 miles and the Hebraic cast of features has become exceptional, and beyond that one rarely sees it at all.

The numerous Jews one encounters all over Siberia were carried there by a reflux wave of the later westward movement from Palestine. They all came from European Russia, not from the eastward movement of the lost tribes. Russian Jews have always made up a considerable part of the pilgrims to Jerusalem. Once communication with what was formerly the Russian empire is restored, the trans-Siberian trunk will open through rail connection for all the Jews between the Baltic and the Pacific, right through to the Holy Land. These will undoubtedly figure largely among the new colonists in Palestine.

The many migratory movements between Palestine and Egypt since the time of the Exodus were responsible for the presence of numerous Jews in northern Africa, though those of the bazaars of



A Typical Station on the Jaffa-Jerusalem Railroad: This Road Is 54 Miles Long, Built by a French Company, and Forms a Part of the "Highway of Prophecy"

Cairo, Algiers, and Morocco are mostly the result of the later westward drift. For a hundred years, however, explorers have been finding so-called "Black Jews" in many parts of the Sahara, upper Egypt, Abyssinia, and even as far south as the Nyasa lakes. The warlike Masai, who graze their herds over a vast area of the high country about the head of the Nile, are strikingly Hebraic in appearance, though it is difficult to trace anything Judaistic in their religious observances. In any event, should any of the Black Jews of any part of Africa desire to return to their mother country, the fact that the highway of prophecy connects in lower Egypt with the almost completed Cape-to-Cairo trunk offers the opportunity to do so cheaply and expeditiously.

The Jews of present-day Europe are largely the descendants of those carried away in the early Greek and Roman conquests, or who migrated during the later Byzantine empire, or through opportunities arising in connection with the Crusades. Most of these have preserved the ancient religious observances, and it is they, therefore, who have been most assiduous in rereading and reinterpreting the prophecies, and in laying plans for the establishment of a New Zion upon the ruins of the old. To these the completion of the highway to Jerusalem has particular significance; for, with all of Europe in rail connection with Constantinople, the fact that the steel rails lead on without a break from the other side of the Bosphorus right to the foot of Mount Zion means that the next step in fulfillment—the return of the remnants of Israel from all the world—may well be

at hand. To one who knows the Palestine of today, the first question that presents itself in connection with the return of any considerable number of the Jewish race is: "Can that dry and barren country support a population greatly in excess of the comparatively sparse one which lives there now?" The answer would be a most emphatic "No," were it not for the fact that the way appears to be open for reclamation which bids fair to make of this desert country another land of Canaan—a land literally flowing with milk and honey. Of the possibilities of restoring Palestine to fruitfulness through general reclamation, and particularly a project for developing power by utilizing the difference in elevation between the Mediterranean and the Dead Sea, I shall write in a later article.

NEVADA LEGISLATURE PASSES LAW FOR CAMEL CONTROL

Camels roaming at will upon the roads and highways of Nevada seems almost like a fairy tale, but the state legislature, in the year of 1875, evidently recognized it to be a most annoying fact. At any rate, at that time a law was passed which prohibited the straying about of these mild-appearing animals that were considered distinctly out of place by the protesting natives, but which had been introduced for hauling purposes at the Virginia City mines. Whether the statute succeeded in safely tethering them is not known, but it is thought that there is no other place in this country that has legislated in this manner against the unassuming camel.

and. A. A. Stafford
Box 163, Reno, Nevada.

8171
Cmt. Albert Marple, 716 S. Louise St.
Escondido, Calif

666

POPULAR MECHANICS

DESERT ROADWAY FENCED TO GUIDE MOTORISTS



Desert Roadway Which has been Fenced to Prevent Touring Motorists from Straying off the Correct Route of Travel, and Consequently becoming Lost. These Barren Stretches of Sand are Often Encountered When Motorists in Some of the Western States

There are several stretches of road in the deserts of western Arizona and eastern California, where the roadways are constantly being filled with sand blown by the strong winds. In many of these sections fences, consisting of iron posts and chains, are used to keep the motorists to the right path. At the seasons of the year when the winds of the deserts are unusually strong and frequent, this novel method of keeping the traveler from going astray proves valuable.

8491

CONVERT GIANT BATTLESHIP INTO FLOATING CRANE

One of the constructive features in the scrapping of the battleships of the navy is the conversion of the "Kearsarge" into a 250-ton floating crane. When the transformation is completed, the crane will bear very little resemblance to the former fighting unit. The hull will remain, but the giant guns and battle turrets will give way to the great boom and its operating

Jun 1918

machinery. In extended position the crane will have a maximum radius of about 174 ft., with a maximum reach of 101 ft. for a 250-ton load. The total height of lift at the 101-ft. radius will be about 143 ft. The remodeled "Kearsarge" will be used as a service crane and in the dismantling of the battleships which are to be scrapped.

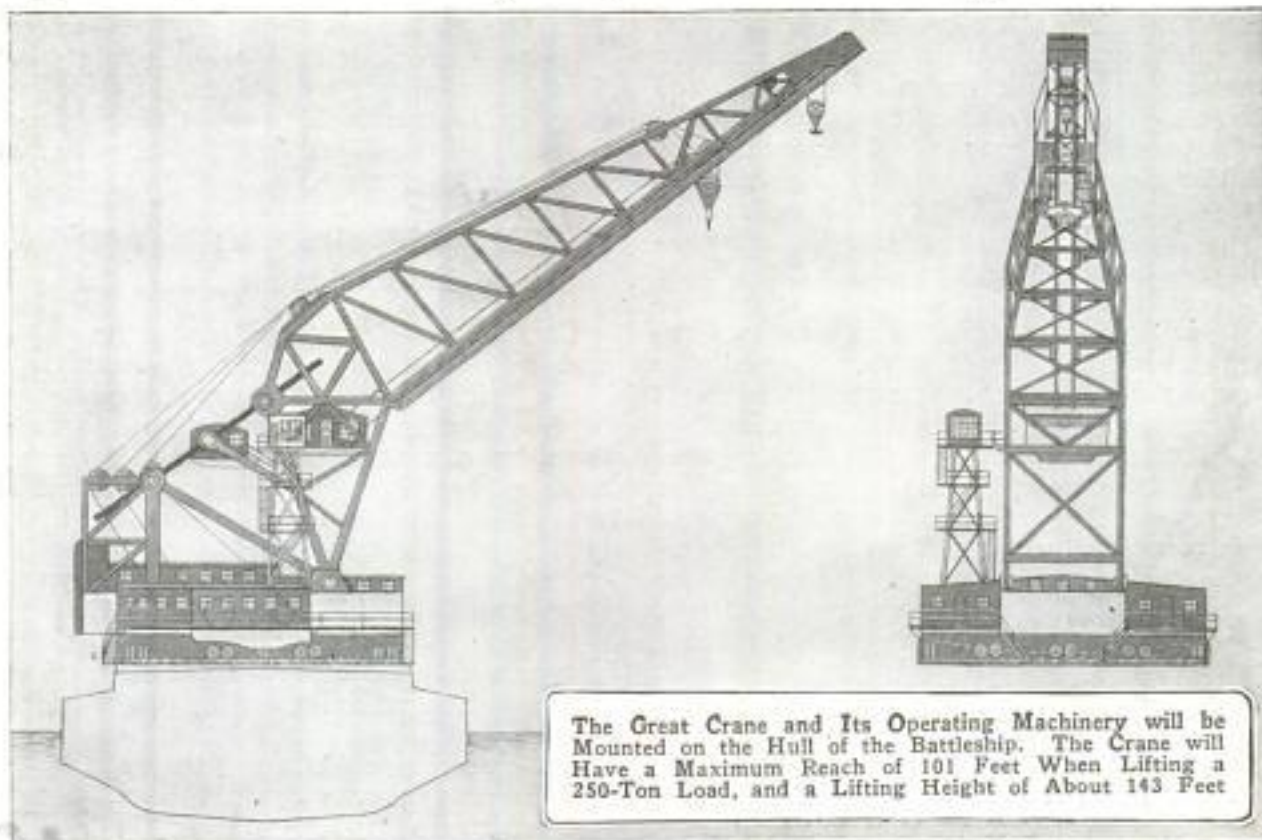

The Great Crane and Its Operating Machinery will be Mounted on the Hull of the Battleship. The Crane will Have a Maximum Reach of 101 Feet When Lifting a 250-Ton Load, and a Lifting Height of About 143 Feet

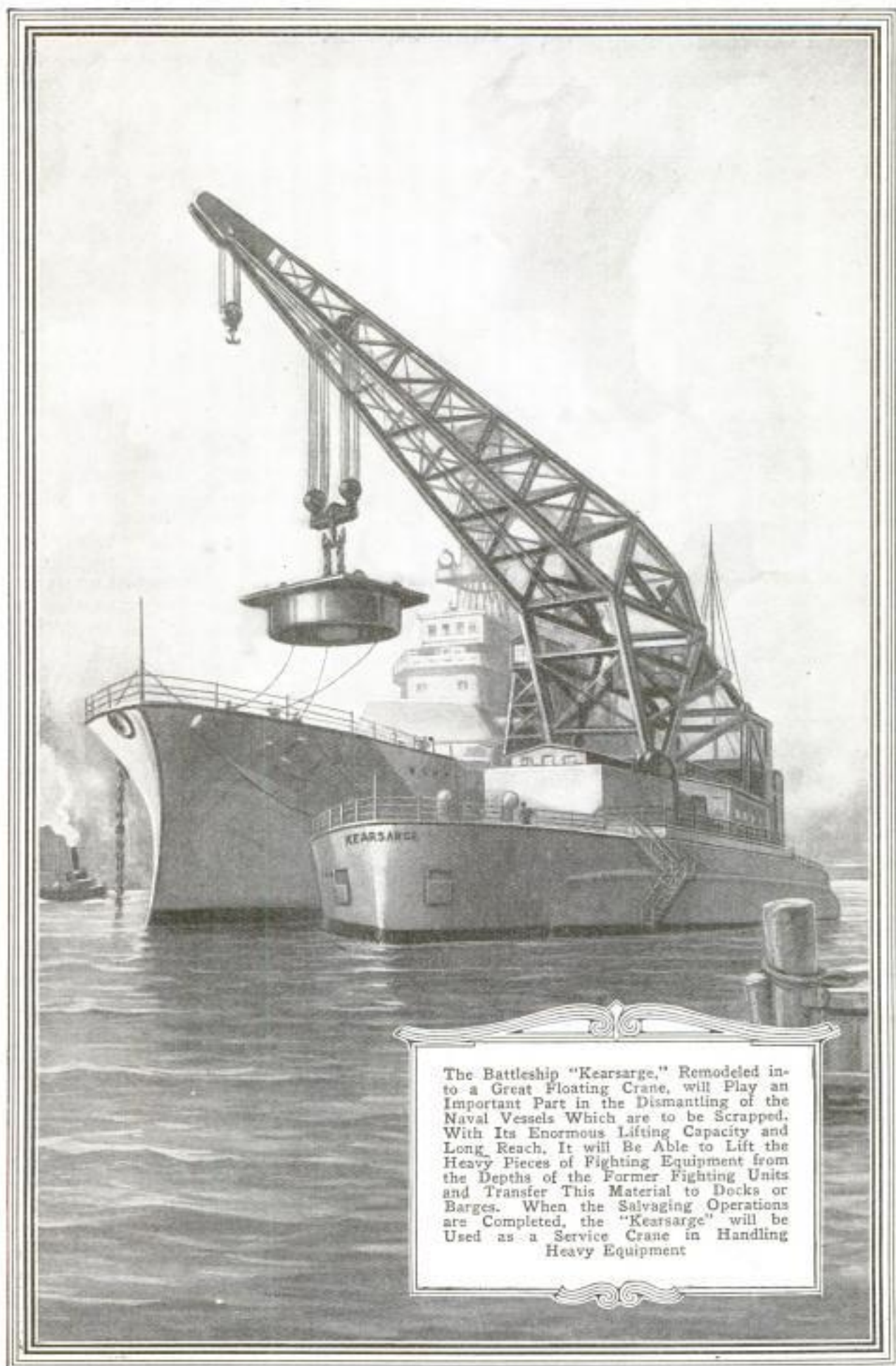

The Battleship "Kearsarge," Remodeled into a Great Floating Crane, will Play an Important Part in the Dismantling of the Naval Vessels Which are to be Scrapped. With Its Enormous Lifting Capacity and Long Reach, It will Be Able to Lift the Heavy Pieces of Fighting Equipment from the Depths of the Former Fighting Units and Transfer This Material to Docks or Barges. When the Salvaging Operations are Completed, the "Kearsarge" will be Used as a Service Crane in Handling Heavy Equipment

Cmd. W. C. Voss, Isenesed, d. ll.

856

**SERVICE-BANNER MEMORIAL
IN GENESEO, ILLINOIS**

A war memorial in the form of a many-sided service banner inscribed with 497 names of the soldiers and sailors of six

townships, has been erected in front of the public library at Geneseo, Ill. In front of each name is a five-pointed star that indicates graphically, by its color and various details, the nature of the man's service, and something of his history.

For instance, a plain gold star denotes "died in service," a star with a small medallion on each point means "died in action," and a star with five plain gold tips denotes "died after discharge." This last item is to be kept up to date, and therefore, eventually every star for discharged men will have the five gold tips. A key to the various stars, 15 in number, is part of the banner. The monument is a substantial structure surmounted with a conical roof bearing a flag-pole. It is brilliantly illuminated with electric lamps, so arranged that all the names can be read at night.



KEY TO SERVICE BANNER	
KE.M.R	★ RED CROSS NURSE
N.B.C.	★ DIED IN PRISON
AMS.J.	★ DIED IN ACTION
AMS.A	★ CITED FOR BRAVERY
H.E.	★ DIED IN SERVICE
N.A.G.	★ WOUNDED IN ACTION
N.H.E.	★ OVER SEAS UNDER 6 MO.
SON.E.G	★ OVER SEAS 6 MONTHS
N.H.L.	★ OVER SEAS 1 YEAR
CH.W.W	★ DIED AFTER DISCHARGE
A.	★ PRISONER OF WAR
M.J.	★ IN AMERICA UNDER 6 MO.
E.	★ IN AMERICA 6 MONTHS
S.B.	★ IN AMERICA 1 YEAR
KE.G.	★ CITED FOR GALLANTRY
S.L.	
TON.H.	

Left: General View of Service-Banner Memorial. Right: Close-Up of Key to Meanings of the Various Stars, 15 in Number, One of Which beside Each Man's Name Denotes, by Its Color and Other Details, the Nature of His Service

8624

Cmd. Victor Rubin, The Milwaukee Journal Milwaukee Wis.

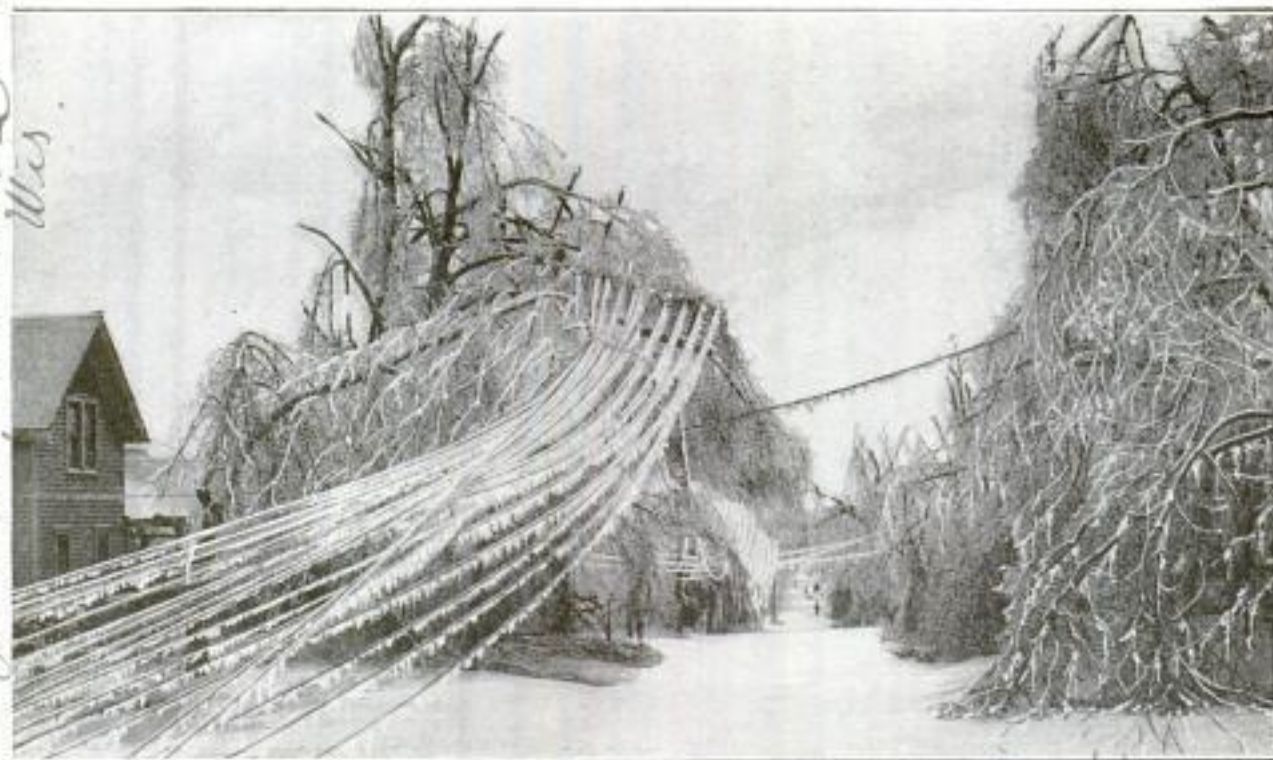

SNOW-BOUND CITIES REACH OUTER WORLD BY RADIO

Application

IN the latter part of February, when the state of Wisconsin was visited by one of the worst snow and sleet storms in recent years, untold damage was done to trees and orchards, and all regular forms of communication were put out of commission. Miles of telephone and telegraph wires and power lines were torn down by the weight of the ice coating. In this emergency, radio stations were brought into service and kept the snow-bound cities in touch with the outer world until normal means of communication were reestablished.

8648

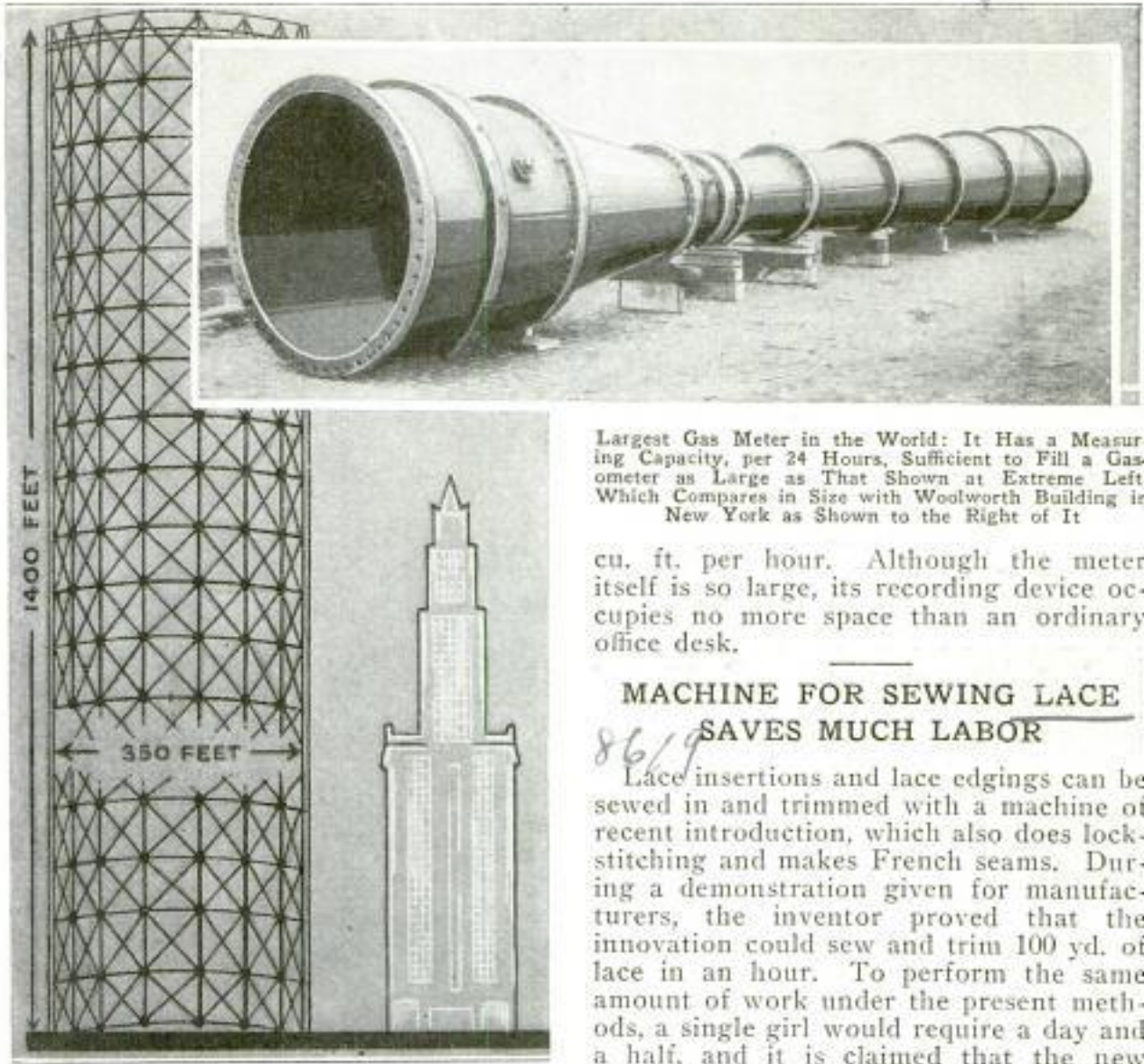

Largest Gas Meter in the World: It Has a Measuring Capacity, per 24 Hours, Sufficient to Fill a Gasometer as Large as That Shown at Extreme Left, Which Compares in Size with Woolworth Building in New York as Shown to the Right of It

cu. ft. per hour. Although the meter itself is so large, its recording device occupies no more space than an ordinary office desk.

**MACHINE FOR SEWING LACE
SAVES MUCH LABOR**

Lace insertions and lace edgings can be sewed in and trimmed with a machine of recent introduction, which also does lock-stitching and makes French seams. During a demonstration given for manufacturers, the inventor proved that the innovation could sew and trim 100 yd. of lace in an hour. To perform the same amount of work under the present methods, a single girl would require a day and a half, and it is claimed that the new machine will consistently produce an average of 12 times the production of one operator.

**LARGEST VENTURI GAS METER
THAT HAS YET BEEN BUILT**

What is said to be the largest gas meter in the world, built upon the principle of the Venturi, which consists of a conical, nozzle-like reducer, followed by a gradual enlargement to the original size in a pipe line, is in use at the Bethlehem Steel Company's plant at Sparrow's Point, Md. It is for the purpose of measuring the combustion gases from the blast furnaces, which formerly were wasted, but which for many years now have been a valuable by-product at all steel-producing plants. The meter is 59 ft. long, and the diameter of the pipe line is 72 in., the Venturi throat diameter being 26 in. It is calculated that the measuring capacity of this huge meter per 24 hours is sufficient to fill a gasometer 350 ft. in diameter and 1,400 ft. high, or about twice the height of the Woolworth building, in New York. The meter's rated capacity is 5,700,000



Operator Using Motor-Driven Lace-Sewing Machine Which Equals the Production of 12 Hand Workers

*Chas. W. B. M. Sharpe
Boston, Mass.*

161 Massachusetts Ave.

8719 American Aero Accumulator Co
 Elizabeth, N.J.
 Barber, Bernard + Turanne,
 Paris, France

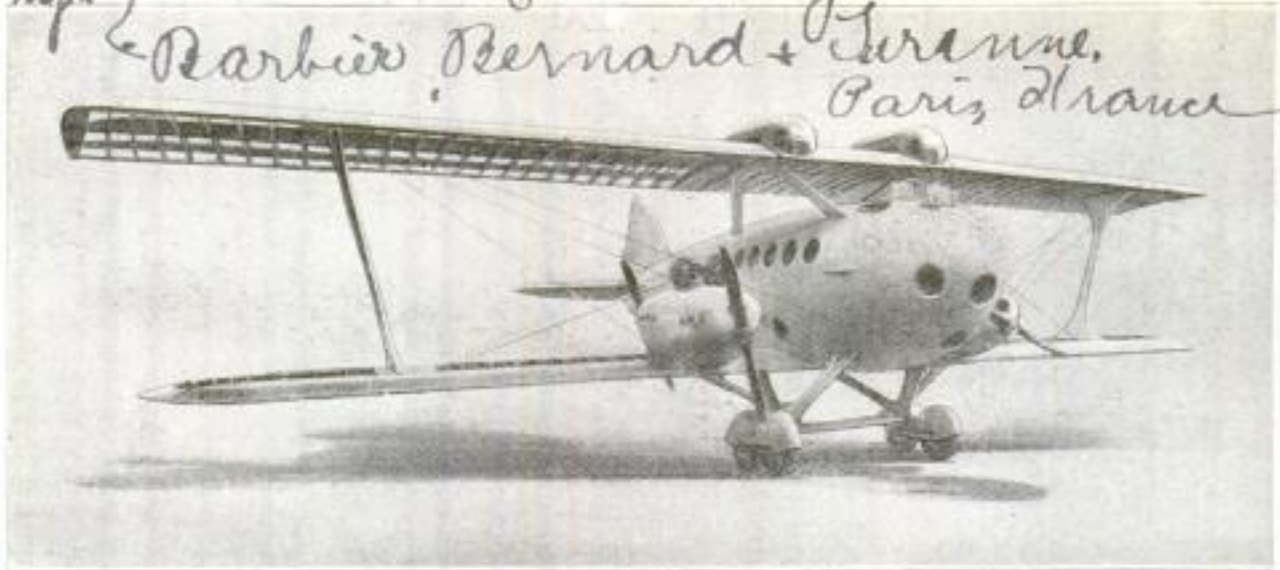

In This Blériot Air Liner of French Construction, Great Attention has been Given to the Question of Wind Resistance. The Four Motors are Carried in Pairs on the Lower Wing and are Included in Streamline Housings

GUIDING THE AIR LINER INTO PORT

By EVERETT J. LOVETT



The Interior of the Liner Resembles a Railroad Parlor Car with Its Comfortable Armchairs and Large Observation Windows

There is no doubt that the history of these longer routes will be only a repetition of the success of the short ones, and that the flying companies feel assured of this, is evidenced by the plans they are making for the safety and comfort of their passengers.

The question of comfort is really of secondary importance and has already been answered in a satisfactory way in the latest limousine planes affording ample space for passengers, and furnished with comfortable armchairs in which one may sit at ease and view, through large ob-

COMMERCIAL aviation, particularly in Europe, is fast approaching a point where it is an accepted mode of travel, and the success of the shorter routes has led to the establishment of lines of international scope. As typical examples of some of the present routes might be mentioned those from London to Copenhagen by way of Amsterdam and Hamburg; from Toulouse, France, to Casablanca, North Africa, by way of Barcelona and Gibraltar, and from Cairo to Bagdad; while some account should be taken of some of the proposed routes, such as the one from Paris to Algiers by way of Italy and Sicily, and the route from Paris to Warsaw by way of Strassburg and Prague.

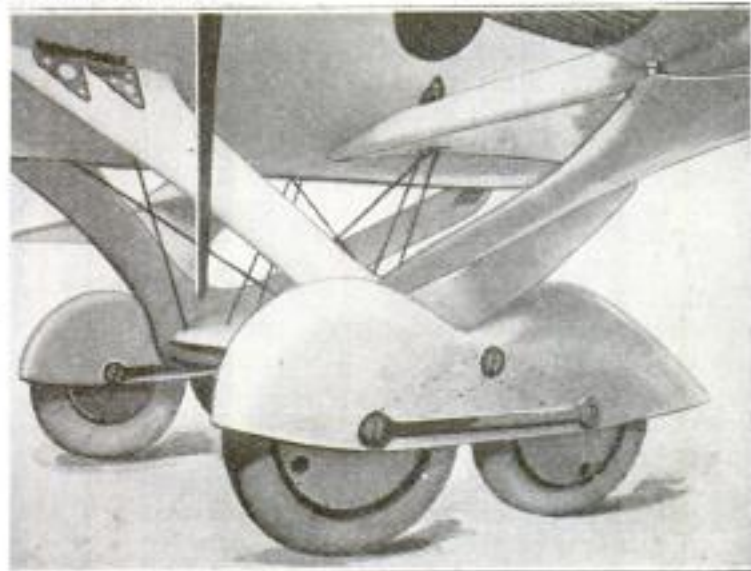

Even the Landing Gear has been Given a Streamlined Housing in the Effort to Reduce Head Resistance to a Minimum. The Struts are Flexibly Hinged to the Fuselage, in Order to Reduce the Shock in Landing

PHOTOS COPYRIGHT, M. BOL

Am. Inquiries E. Belgium, Antwerp, Belgium
 M. Paul, Paris, France. Wide World Photos, New York

8229

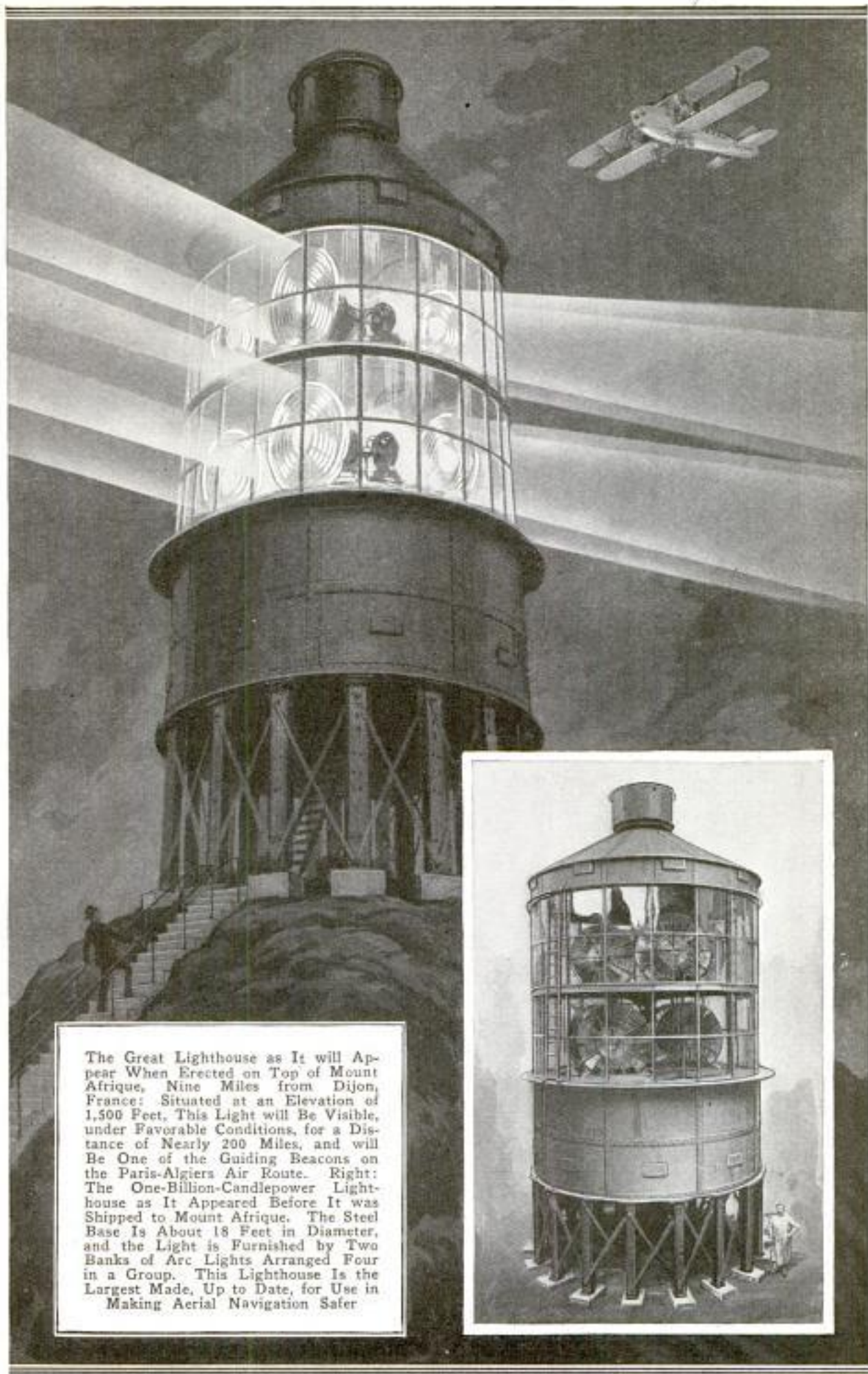

The Great Lighthouse as It will Appear When Erected on Top of Mount Afrique, Nine Miles from Dijon, France: Situated at an Elevation of 1,500 Feet, This Light will Be Visible, under Favorable Conditions, for a Distance of Nearly 200 Miles, and will Be One of the Guiding Beacons on the Paris-Algiers Air Route. Right: The One-Billion-Candlepower Lighthouse as It Appeared Before It was Shipped to Mount Afrique. The Steel Base Is About 18 Feet in Diameter, and the Light is Furnished by Two Banks of Arc Lights Arranged Four in a Group. This Lighthouse Is the Largest Made, Up to Date, for Use in Making Aerial Navigation Safer

servation windows, the varying panorama passing below as the ship speeds on.

As the longer air routes become more popular, as they surely will, there will be more and more necessity of night flying, and the companies are anticipating this by the erection of lighthouses at intervals along the line. Lights of limited intensity and with a visual range of from 20 to 40 miles have been in use on the London-Paris route, but these will be dwarfed by the light that is now being

installed on the top of Mt. Afrique, near Dijon, France. This will be of one billion candlepower and will be visible, it is claimed, at a distance of nearly 200 miles under favorable conditions, and will be one of the guideposts on the international airway between France, Italy, and Algeria. Two groups of arc lights, arranged four in a group, will furnish the illumination for this beacon which has taken more than two years to construct. The lenses and lights are carried in a steel tower, 18 ft. in diameter, which will be solidly supported on concrete foundations at the top of the mountain, 1,500 ft. high, adding materially to the visible range of the light.



One of the Smaller Lighthouses on the London-Paris Route is Equipped with Lenses for Throwing a Horizontal Beam, and Four Reflecting Lights Which Project a Vertical Beam



Guided by such giant beacons, the airman will fly confidently through the darkness to the landing field where is located the traffic-control office. This office is in a tower, from which an unobstructed view may be had in all directions, and is equipped with the latest signaling devices, such as pistol flashlamps and electric flashers. As the airman approaches the landing field, automatic lights will show



Above: The Controller of Traffic Using a Pistol Flashlamp from the Balcony of the Control Tower. Left: From the Inside of the Tower He can Communicate with the Approaching Flier by Wireless Telephone and Give Him Special Information as to Ground Conditions. All Landing and Signal Lights are Controlled from the Tower. Right: Using an Electric Flasher to Communicate with the Airman

Geo. H. Mc Claire
1026 Walnut St.
Philadelphia, Pa.

him the direction and strength of the wind, while the controller of traffic will give him by wireless telephone any special information that he may need for his guidance, such as the amount of fog and

ground mist, and the condition of the landing field itself. In this way he will bring his craft into port with the same certainty as the captain of an ocean liner brings his ship into the harbor.

8726

MOVING PICTURES GAIN GRANT OF IMPROVEMENT FUNDS

Displaying motion pictures or stereopticon views of contemplated civic improvements for the purpose of obtaining necessary appropriations, is the method used by the Department of Public Works of Philadelphia, when the question comes up before the city council. Heretofore, considerable friction has developed among the aldermen relative to the size and need of various requests for funds to start or complete a municipal project, and principally because the council members were not sufficiently familiar with the work. By showing motion, or other, pictures of each prospective undertaking, together with a lecture on the subject, the city engineers hope to create a better understanding and unity among all parties concerned. The plan was inaugurated with an illustrated discussion of proposed improvements of the city's sewage-disposal system.

8731

GLASS MODELS OF FLOWERS AT HARVARD UNIVERSITY

The artist who modeled the famous "glass flowers," now in the Botanical Museum at Harvard University, is at work on a supplementary collection of glass models of grasses and sedges, which will be exhibited at the university on their completion. The collection now illustrates 160 families of flowering plants, and 803 species. Besides these there are more than 3,200 enlarged details. All the specimens were made by Rudolph Blaschka, who has now in his studio in Germany 20 models and 50 enlarged details, which, when transported to Harvard, will complete the collection.

Science 3/16/22

8685

BLIND AND DEAF CRIPPLE OPERATES TYPEWRITER

Terribly handicapped by the loss of both hands, eyes, and hearing, a persever-

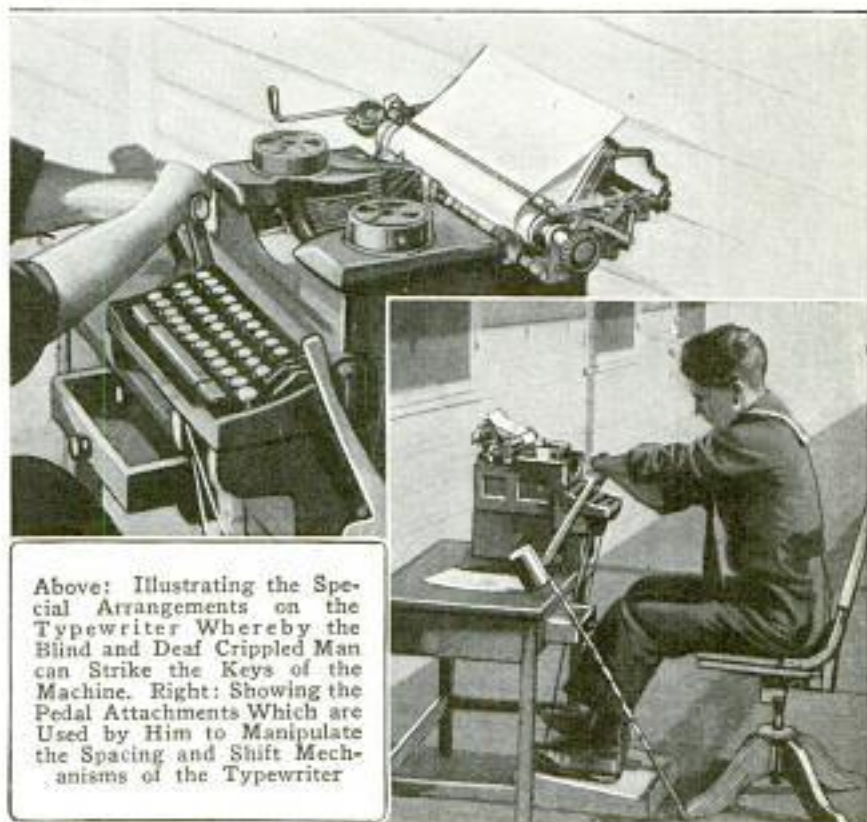

Above: Illustrating the Special Arrangements on the Typewriter Whereby the Blind and Deaf Crippled Man can Strike the Keys of the Machine. Right: Showing the Pedal Attachments Which are Used by Him to Manipulate the Spacing and Shift Mechanisms of the Typewriter

PHOTOS BY GILLIAMS SERVICE

ing ex-service man has overcome seemingly impossible obstacles in learning to operate a typewriter. Special arrangements on the machine enable the maimed man to strike the keys, while pedal attachments are provided so that he can manipulate the spacing and shift mechanisms. Observers have viewed with astonishment the speed and accuracy attained by the young fellow in spite of his disheartening affliction, and marveled at his great perseverance.

Ⓐ motor lifeboat of very unusual proportions and characteristics is to be built for use at New Brighton, Eng. The boat will have a displacement of 60 tons, and a passenger-carrying capacity of over 150. Its equipment will include a line-throwing gun, a searchlight, a life-saving net, with first aid, and also heating appliances in its two cabins.

The Williams Service New York City

Chief
W. J. ...
Charles ...
Birmingham ...
Engineer 3/10/12
12/11

674

8671

8671

IMMENSE CREOSOTING TUBE MAKES FREAK SHIPMENT

Unusual arrangements characterize the method devised for shipping a recently manufactured tie-treating tube, which is 7 ft. in diameter and 144 ft. long. Four flat cars were needed for the shipment, but only the two end cars carried any weight, the center cars acting solely as fillers. The tube was carried on pivoted bolsters which allowed it to swing when the train was rounding a curve, and much care was exercised in selecting a route which was free from very sharp curves. The tube is to be used in creosoting ties which will be run in on cars, after which the door is locked and the tube filled with creosote, which will be forced into the ties by subjecting it to a pressure of from 125 to 200 lb. per square inch for a period of four hours.

TINTED GLASS FOR PRODUCING ARTIFICIAL DAYLIGHT

For very accurate work in matching colored fabrics under artificial light, a new tinted glass has been developed. An ordinary gas-filled electric bulb is used in combination with a disk of this tinted glass and a reflector coated with a suitable blue pigment, and it is found that the light emerging through the disk more closely resembles natural daylight than any previous combination. A strong light, however, is necessary as almost two-thirds of it is absorbed.

AVERAGE COSTS OF VARIOUS TYPES OF ROAD PAVING

The Bureau of Public Roads has recently compiled figures on the average cost per square yard of various types of paving for country roads, over a period of five years, with the following results: sand-clay, 18 cents; gravel, 46 cents; plain and surface-treated macadam, 95 cents; bituminous macadam, \$2.10; bituminous concrete, \$2.50; plain cement concrete, \$2.57; reinforced cement concrete, \$2.74, and brick, \$4.10. These figures cover only the cost of paving, and do not include the cost of grading.

Sept. Agric. Press Clip. #195

Because the sea lions and hair seals play havoc with the fishing industries on the British Columbia coast, the Canadian fisheries department plans to attack the seal rookeries on Queen Charlotte Islands with machine guns.

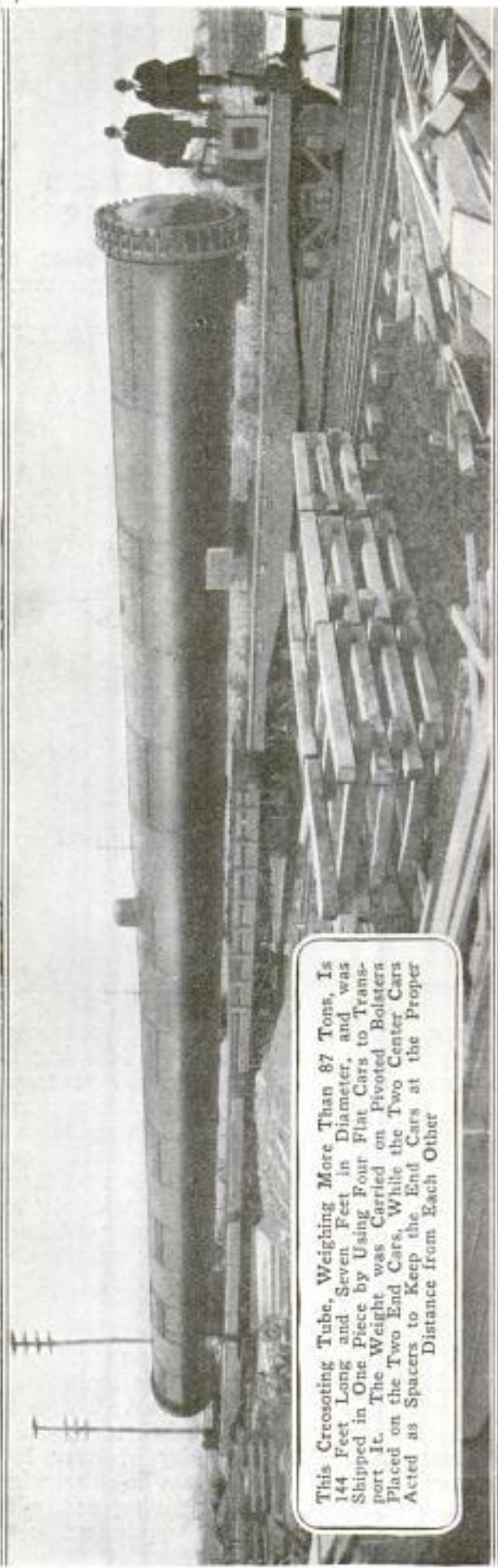

This Creosoting Tube, Weighing More Than 87 Tons, Is 144 Feet Long and Seven Feet in Diameter, and was Shipped in One Piece by Using Four Flat Cars to Transport It. The Weight was Carried on Pivoted Bolsters Placed on the Two End Cars, While the Two Center Cars Acted as Spacers to Keep the End Cars at the Proper Distance from Each Other

COPYRIGHT, N. C. BATES

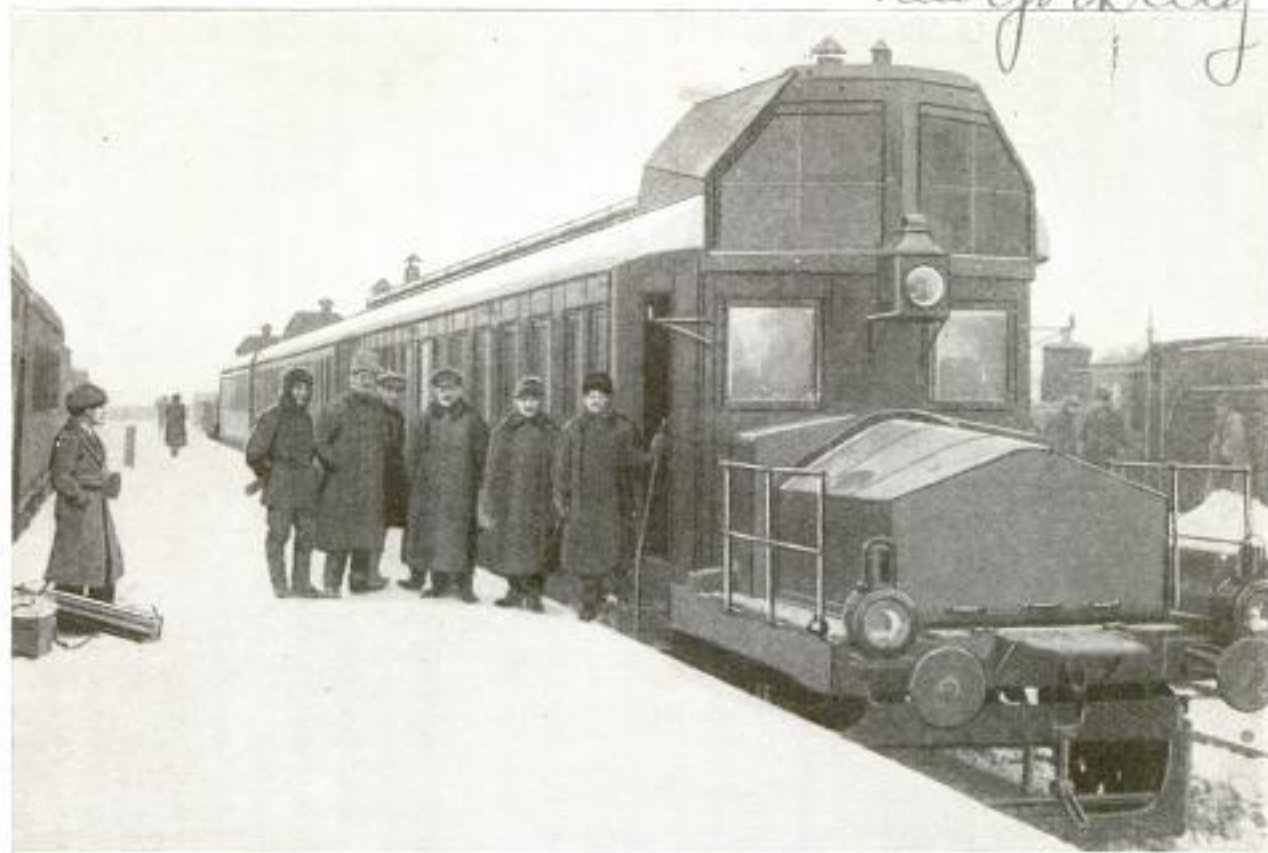

High-Powered Electric Train Now Running between Moscow and Petrograd, in Russia: It is Said to Have 3,000-Horsepower Electric Motors, and to Run the 500 Miles between the Two Cities without Stoppage for Recharging

8686

**EXCEEDINGLY HIGH-POWERED
 RUSSIAN ELECTRIC TRAIN**

Recently a new type of electric railway car has been developed in Russia that is said to equal anything of its kind anywhere. Trains of these cars are now running from Moscow to Petrograd, a distance of 500 miles, without stoppage for recharging. The train is said to be equipped with electric motors of 3,000 hp. The Soviet government aided the inventor in the design and development of these high-powered cars, and all details of their construction are being kept secret.

**HOME PHOTOGRAPHY IS AIDED
 BY NEW PORTRAIT LAMP**

Employing a battery of five 400-watt bulbs, a new portable portrait lamp has been introduced by an Illinois manufacturer, which has great flexibility of operation. The apparatus is constructed in two hinged sections, so arranged that either may be used as a separate unit, and the power of these units may be decreased by unscrewing enough bulbs to meet the requirements of the occasion. In addition, the lamp has special reflectors so that the greatest possible efficiency of

lighting effects is procured, and a diffusing screen is also provided. The entire outfit, not including the stand, weighs 12 lb., and can be packed in a 5 by 12 by 17-in. case for carrying purposes.

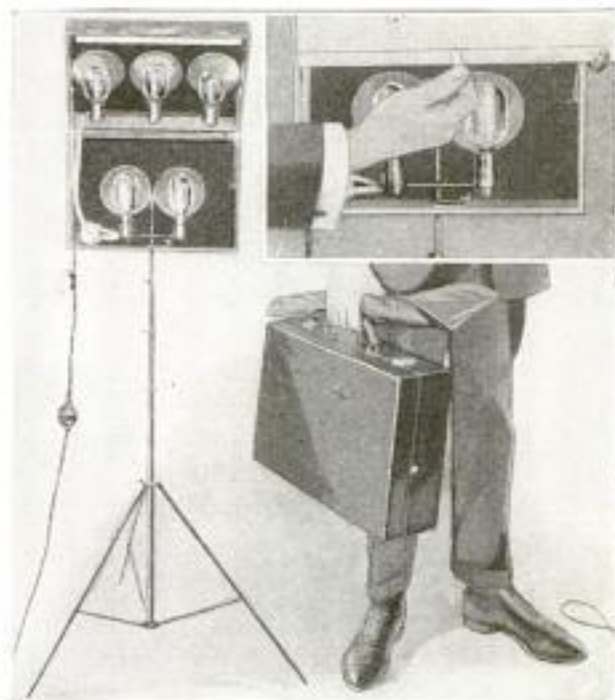

Left: Portrait Lamp and Stand. Upper Right: Pulling Down the Diffusing Screen. Lower Right: Lamp and Stand Packed for Carrying

Info: Halldorson Co., 1772
 Michigan Ave. Chicago

Emb Michigan Blvd. Studio
 3740 Michigan Blvd. Chicago
 Copyrighted material

8682 FIREPROOF CONCRETE HOUSES BUILT ECONOMICALLY

Concrest is the appropriate name given to a village at East Rochester, N. Y., that is being built entirely of monolithic-concrete houses, each being a villa on its own garden site, and with distinctive individual features of design. These houses have a basement and two stories, with seven rooms, besides an attic, and their concrete construction has been so standardized that it is possible to sell them at a profit for \$4,000. A telescoping portable tower, specially designed for this construction, makes it possible, with great economy of labor, to pour one story at a time instead of all three at once. The tower can be raised or lowered to suit each story

height, and the concrete is poured from it at a suitable height. Thus, in pouring the basement, without this tower, every

bucketful of concrete would have to be raised twice as high as is required with the tower at its lowered position.



Monolithic-Concrete House under Construction: Wooden Forms for Upper Story Are in Place, and Concrete is being Poured from the Telescoping Portable Tower with Its Funnel-Shaped Outlet, Which is Raised to Its Full Height

□ The Bureau of Mines is seeking a rapid method for the direct determination of the amount of metallic aluminum in commercial aluminum and its alloys and drosses, and also the determination of aluminum oxide in the light alloys. The problem of oxidation of aluminum will also be studied. These investigations are most timely, as the subject of light alloys is one of much importance.



A Corner in the Village of Concrest, with Three Houses in the Foreground That Are Typical of the Rest: Built of Concrete, the Exteriors Are of Tinted Stucco, and the Roofs of Different Colors

8526

Carl Harold B. Blanchard

Such as in N.Y.



Upper Left: High-Speed Turbine Pump and Other Fire-Fighting Apparatus, Mounted on Ordinary Car. Upper Right: Pump Fitted on Lightweight Engine. Lower Left: Close View of Pump

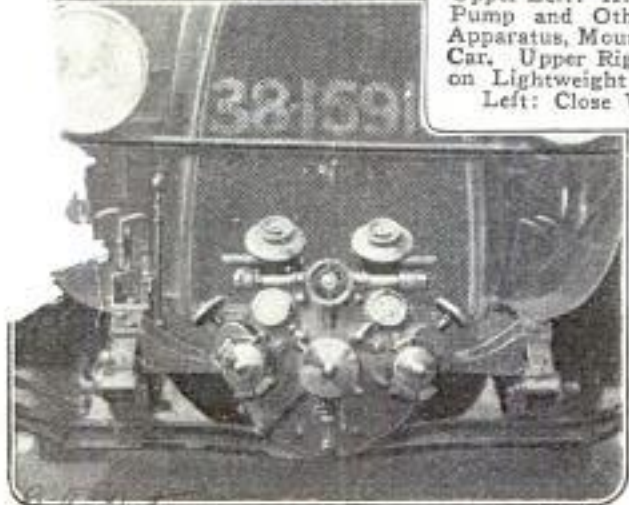

HIGH-SPEED TURBINE PUMPS PLACED ON MOTOR CARS

The transformation of any pleasure car or truck into an effective fire engine is made possible by the installation of a small high-speed turbine pump, which is designed to be mounted just below the radiator, or at the rear of the machine, and be driven direct from the crankshaft. The pump is built in three sizes by an Italian concern, the smallest being suitable for attachment to a 10 or 12-hp. motor; the medium size for a 25 to 30-hp. motor, while the largest size is made for 50-hp. trucks, and these weigh 77, 187, and 322 lb., respectively. The invention should be of particular interest to small communities unable to afford the more expensive fire equipment.

NEW READING MACHINE MAKES POCKET LIBRARY POSSIBLE

With the use of a new reading machine a small library may be carried in the vest pocket, according to the claim of its inventor. The instrument makes legible, through a lens, typewritten matter that has been photographically reduced to ex-

treme tabloid size. The typewritten characters are about .01 of their natural size, and are on a strip of paper that fits in a small aluminum frame, at one end of which is mounted a lens and eyepiece. A small roller attached to the frame is moved by the forefinger, and the paper rolls along so that line after line of the reading matter passes the lens. The instrument is 6 1/4 in. long, 1 7/8 in. wide, 3/4 in. thick, weighs about 5 oz., and is easily carried in the pocket.



Reading Machine That Uses Reading Matter of Extreme Minuteness, as Seen in the Four Columns on Printed Strip in Its Aluminum Frame. Inset: The Inventor Showing How the Instrument is Used

*Dilbertson Corp
100 E 42nd Street
New York*

*Dr. W. H. Davis
New York City*

*Inventor: Clear Admiral
Stoneleigh Court, Bradley D. Hinkle*

8646 Cont. U. W. Allen
678
Copper Mining 1424 Science Ave
Berkeley, Calif.
POPULAR MECHANICS

TRAVELING CRUSHER STATION AND ASSAY OFFICE

As a rule, modern copper-mining operations have to be conducted on a considerable scale, because the high-

tain known as Sacramento Hill is copper-bearing, but most of it ranks as low grade ore, and some is too poor to p



Crusher Station and Assay Office Which Travels by Railroad to the Different Mining Locations Where Samples of Ore are Analyzed and the Results Reported to the Operators

grade deposits, for the most part, have been exhausted. A case in point is found at Bisbee, Ariz., where the moun-

tain known as Sacramento Hill is copper-bearing, but most of it ranks as low grade ore, and some is too poor to p
for treatment by ordinary milling, concentrating, and smelting methods. It requires a close control of operations to grade the ore and reject the waste rock. An accurate knowledge of the copper content is possible only by means of chemical analysis. A prompt decision as to how much copper is contained in an exposed face of rock is often necessary, so a traveling crusher station and assay office has been designed. It can be moved on a railroad track as required. Thus it is possible to crush a sample to powder and analyze it for copper right on the spot, and report the result to the operators without delay.

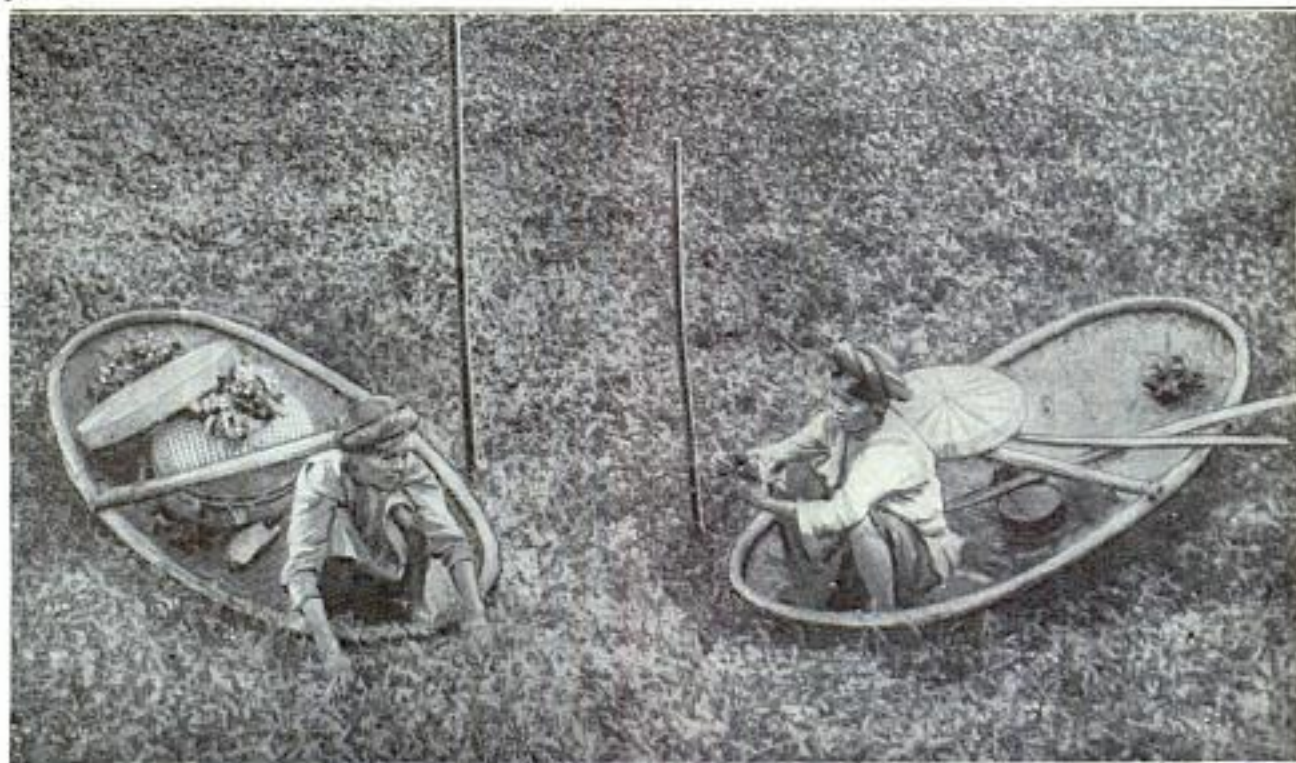

SPINACH PICKERS USE BOATS ON LARGE CHINESE MARSHES

STRANGE methods are employed by the Chinese in the picking of spinach from the large marshes in that country, on which grow vast stretches of this plant. The pickers use small boats of a peculiar shape and construction, two of these being shown in the above photograph. The boats are paddled and pushed around through the thick vegetation until a carefully selected load has been gathered for the market.

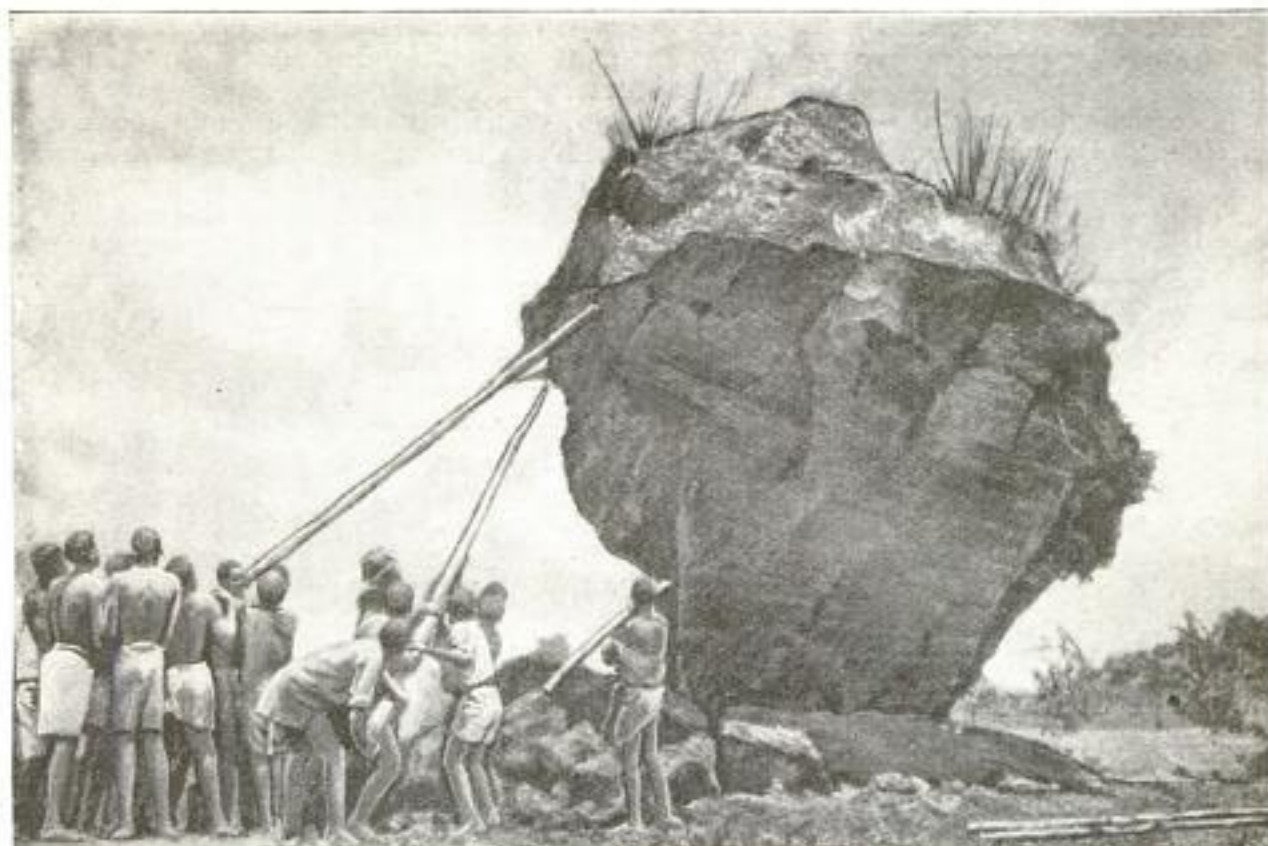

Natives of Rhodesia, Africa, Removing a Mammoth Anthill That Was 25 Feet High, and Was an Obstacle to Cultivation: Anthills of This Kind Are Very Numerous in Rhodesia and the Belgian Congo

SOUTH AFRICAN ANTS BUILD SKYSCRAPER ANTHILLS

Anthills, all over South Africa, but particularly in Rhodesia, are of proportions unknown in America, reaching sometimes a height of 25 ft. or more, and, in spite of the steepness of their sides, covering a very large ground area. They are made of clay, sunbaked to the hardness of bricks, and are the outcome of many years' labor on the part of the industrious ants. Sometimes they are an advantage to the pioneer settlers, often furnishing them with material for making their first homes. At other times they may be an obstacle, preventing the cultivation of the ground they stand on, and then it becomes necessary to remove them. In the case of an anthill 25 ft. high, this is no small task, and may involve as much labor as is required to demolish a fair-sized city building.

8654

ALTERNATING CURRENT USED IN ELECTRIC WELDER

An alternating-current electric welder that does the work as efficiently as with a direct current has been developed by an engineering corporation in Indiana. The welder uses the ordinary city 110-volt current. A patented fusing metal

used in the welding point is the most important feature in connection with this welder, and is said to leave the welded metal just as hard as the original metal in any casting. The welder has been used mostly in repairing scored cylinder walls of automobile engines.

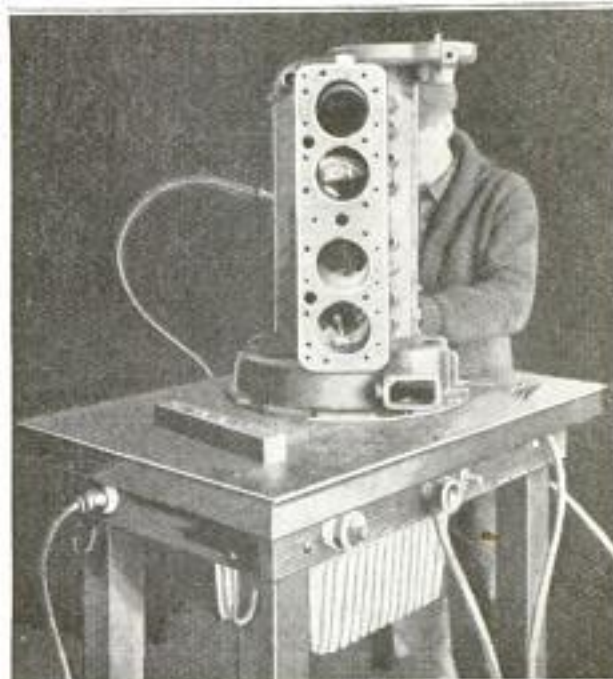

Alternating-Current Welder being Used in Repairing the Badly Scored Cylinder Walls in an Automobile Engine: The Welding Point can be Seen in the Bottom Cylinder

Wainwright

Engineering Corp
Connersville
Ind.

Copyrighted material

7660

IRON PISTONS MADE LIGHT BY SKILLFUL DESIGN

That desirable quality—lightness—is obtained in the pistons of high-speed gasoline engines often by the use of light material, such as aluminum alloys, and sometimes by the use of common cast iron, with the lightness achieved by the scientific construction of the piston.



A good example of the latter is one in which strong reinforcing ribs are cast integral with the piston, radiating from a center reinforcing ring in the head and extending down the full length of the wall. These webs, with their large radiating area, aid materially in dissipating the heat, as well as in strengthening the walls and head, and therefore they add to efficiency as well as lessen vibration, and it is said that they greatly increase gas and oil mileage.

That the motor bus as a means of transportation has met with popular favor, is evidenced by the development that has been made in the busses during the last few years. Recently the first of a new

NEW MOTOR BUS FOR CHICAGO NEARLY EQUALS STREET CAR

That the motor bus as a means of transportation has met with popular favor, is evidenced by the development that has been made in the busses during the last few years. Recently the first of a new

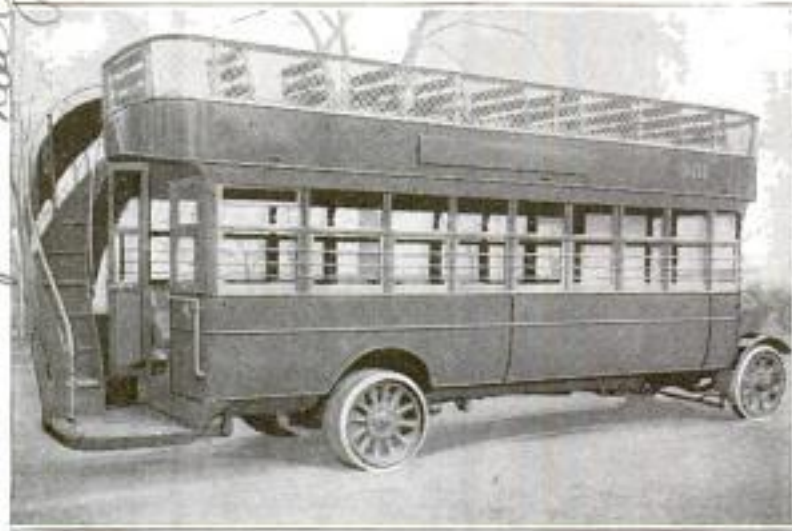

The New Motor Busses Placed in Service in Chicago Are Much Larger Than the Older Ones, Being, in Fact, Almost as Large as Street Cars, Which They Resemble with Their Comfortable Seats and Inclosed Compartment for the Driver. The Entrance Platform at the Rear is Placed Conveniently Low

type has been placed in operation in Chicago which approximates the size and carrying capacity of the ordinary street car. This bus is of the double-deck type and will accommodate more than 60 passengers, is equipped with comfortable seats, and has a separate inclosed compartment for the driver. The open upper deck is reached by an outside stairway.

MACHINE FOR WALL PAPERING HOLDS PASTE AND PAPER

Papering a room is a sticky task for the novice, who usually smears everything within reach with the gummy paste, including his own irate person, and ruins several rolls of paper before the job is completed. A remedy for this has been produced in a machine having containers for the paste and paper, and a pressing or smoothing brush. The machine can be operated with one hand, the paste being automatically applied



to the paper, which is "brushed" as the apparatus is drawn down the wall.

There are more than 1,200 small irrigation and water-supply projects either completed or under construction in Alberta and Saskatchewan, Canada.

International Newsreel Corp 226 William St New York

Dr. W. Stanley Pyle, The Machinery Dept., W. Pa.

8663

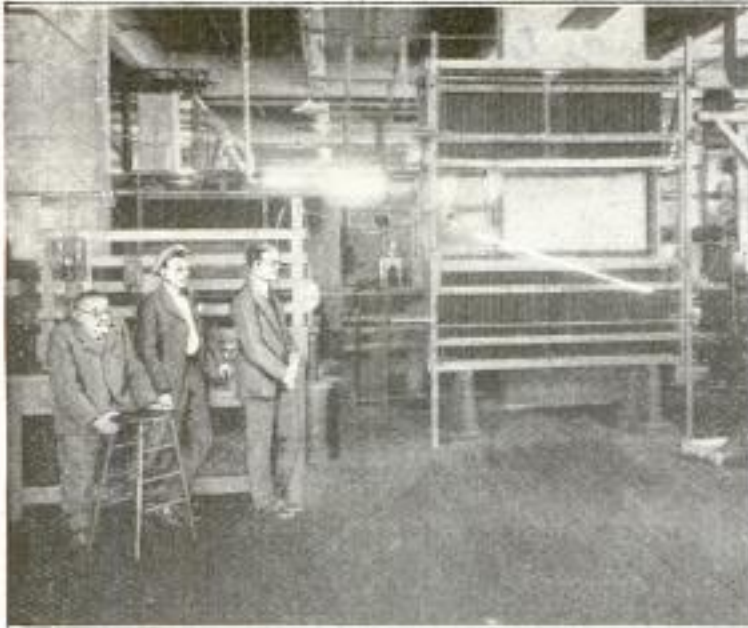

Left: Part of Equipment Used to Produce Artificial Lightning Bolt, Which can be Seen in Front of the Condenser-Generator. Right: Doctor Steinmetz Examining Wood Fragments Shattered by Imitation Lightning

8663
**ARTIFICIAL LIGHTNING BOLT
REALISTICALLY PRODUCED**

Artificial lightning bolts which perform exactly the same as nature's shattering strokes, although on a miniature scale, have been produced by Dr. Charles P. Steinmetz and associate engineers of the General Electric Company. The amount of power expended in each demonstration totaled more than 1,000,000 hp., obtained by the generation of 10,000 amperes at 120,000 volts. The apparatus used consists essentially of a high-voltage condenser of large capacity, in the form of 200 glass plates which are arranged in groups of 50, and in two rows, or banks. Rectified direct current is stored in these condensers, one end representing the thunder cloud in the sky, in which an electric charge is gradually accumulating to its capacity, and the other end corresponding to the earth. When the tension of the stored energy becomes greater than the condenser will hold (120,000 volts, at 10,000 amperes), a flash to the "earth" end results, thus imitating a discharge of lightning to the ground. By placing pieces of wood or other articles in the path of this powerful flash, or discharge, the tearing, explosive effects of genuine lightning were realistically produced.

As a means of protection for women traveling alone. A Canadian Pacific-coast steamship company furnishes each with a small ribbon which indicates by its color to what province she is traveling.

8682
**SNAP GAUGE THAT MEASURES
ERRORS IN SIZE EXACTLY**

A new type of gauge that does the work of a "go" and "no go" snap gauge, but which has a scale graduated to .0001 in. that shows exactly how much a piece of work is over or under the nominal size, is now in use in England. The instrument is shaped like an ordinary snap gauge, and has a movable plunger in one jaw which, through a system of boxed-in levers, operates a pointer on a scale, like the pointer of an ammeter or voltmeter. On a standard piece of work that is of the exact nominal size, the gauge is adjusted so that the pointer is at zero. In



Gauge That Shows, with a Pointer on a Scale Graduated to .0001 Inch, Exactly How Much a Piece of Work Is over or under Size

testing other similar pieces of work, any variation under or over size is then shown on the scale.

Mr. George Pringle
140, Bishop's Road,
Chelmsford, Essex, England

Unable to locate maker

8727

By: ... water

TORCH CUTS CAST IRON IN FIFTY FEET OF WATER

By A. M. HOFFMANN

*114 Stuyvesant Place
New Brighton, Staten Island, N.Y.*

page 745, which had already gone to press before these further interesting details had been received.

Early in February, a dredge accidentally smashed a hole in one of the many 12-ft. sections of which this main is composed. As this pipe line supplies Staten Island with water, it was imperative that service be restored as quickly as possible. This was accomplished in record time by the aid of a gas-electric underwater cutting torch, an American invention promising to have a wide field of usefulness.

WE have become accustomed to the idea of cutting metal under water by burning it, although at first this seemed like an impossibility. Both acetylene and electric torches have been so used for cutting steel plate, but usually at rather shallow depths. Now, by the use of a special electric cutting torch, a wrecking company has been able to cut cast iron—which is much harder to cut by burning than steel—at a depth of 50 ft. under water. Mention of this is also made in an article appearing on

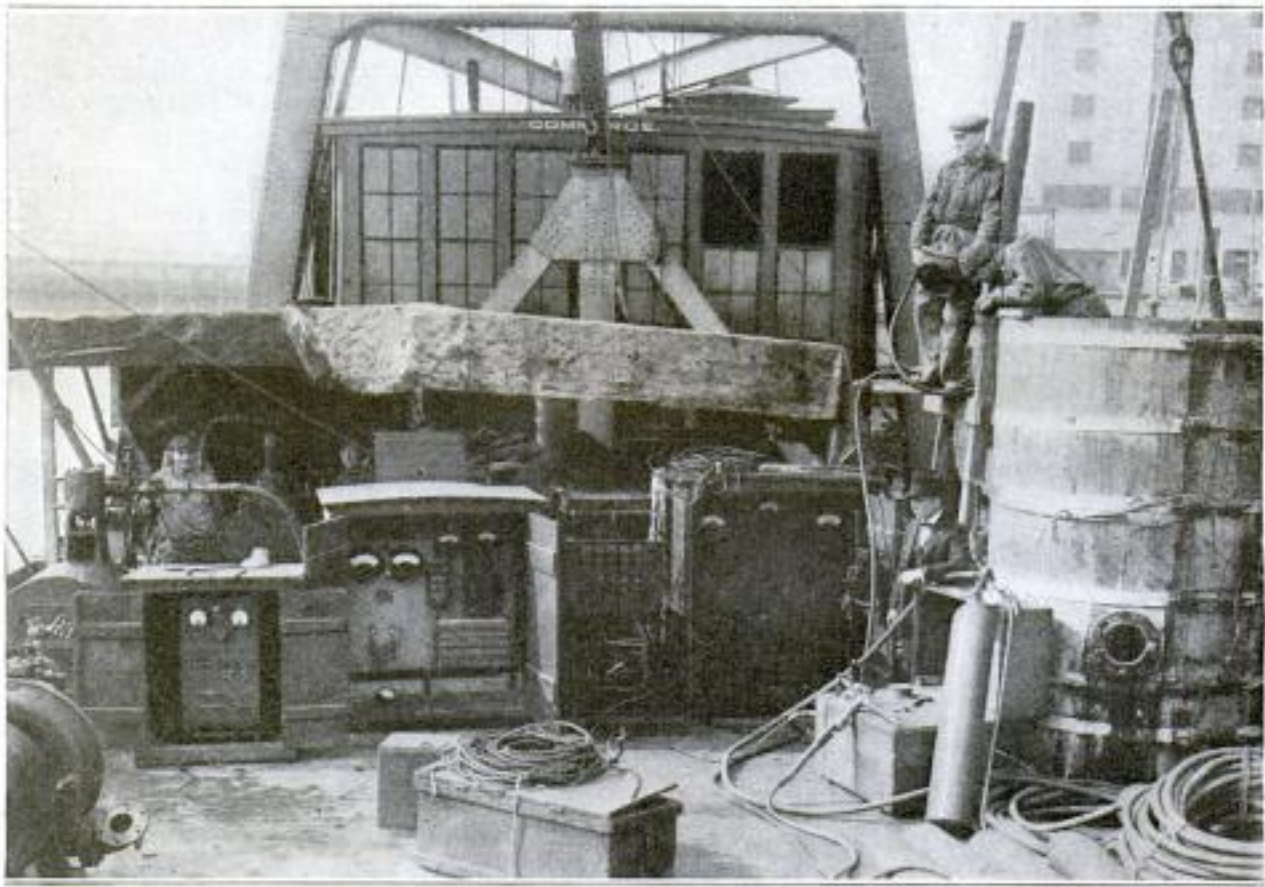

Above: Bringing Up the Broken Length of Pipe Which was Cut Out of Water-Supply Line with the New Type of Submarine Torch. Below: The Assembled Plant Used in Operating the Submarine Torch. The Tank at the Right was Used for Training the Divers for This Work and for Testing the Torch

Used by Merritt & Chapman Derrick &
Wrecking Co., 17 Battery Place,
New York City.

Inventors, Ralph E. Chapman and J. W. Kirk.

State

City

Street

Name

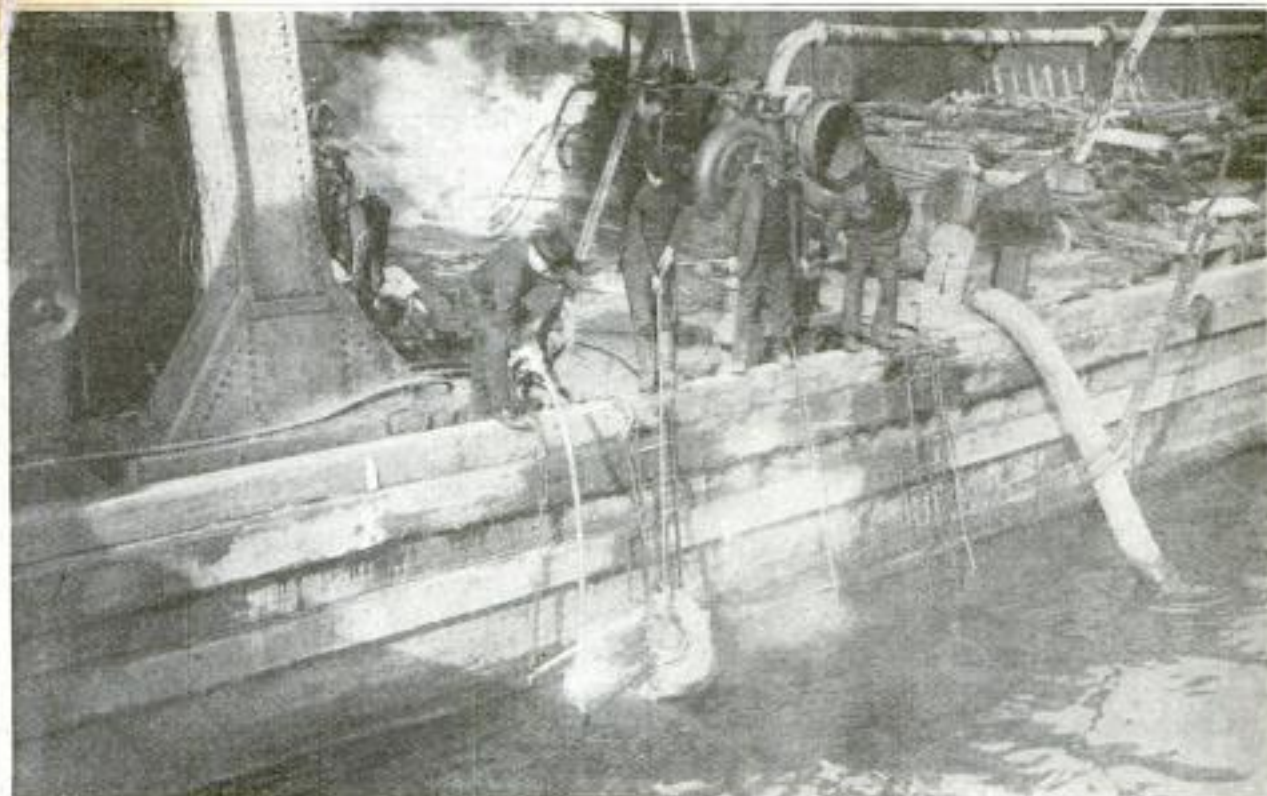

The Diver, without His Helmet, is Demonstrating the Action of the Torch Just below the Surface of the Water. The Gas is Supplied to the Torch through a Flexible Hose Which Also Carries the Electric Wires Furnishing the Current for the Electric Arc with Which the Cutting is Done. The Torch can be Taken under the Water Unlighted and the Gas and Electric Current Turned On When the Diver Is Ready to Begin Cutting

The submarine cutting torch is a very ingenious and simple tool, that first came into use some years ago, and which makes use of the electric arc in conjunction with a gas. The arc is relied upon to do the cutting, while the gas creates a gaseous envelope in which the arc burns. The pressure of this gas is regulated to suit the depth at which the torch is employed. Both the current and the gas are fed from the surface, and the hose that supplies the gas also carries the electric conductor.

On the job, the diver takes the submarine torch down with him unlighted. When he reaches his goal he signals his attendant to turn on the current. In order to make the tool operate, it is only required to hold it a fraction of an inch away from the metal that is to be cut, and instantly the spark jumps the gap and arcking begins. This arc burns away the metal in the same manner as when it is used in the air.

GAS-FILLED TOY BALLOONS DECLARED FIRE MENACE

8862
Toy balloons will no longer be permitted at public gatherings in Detroit,

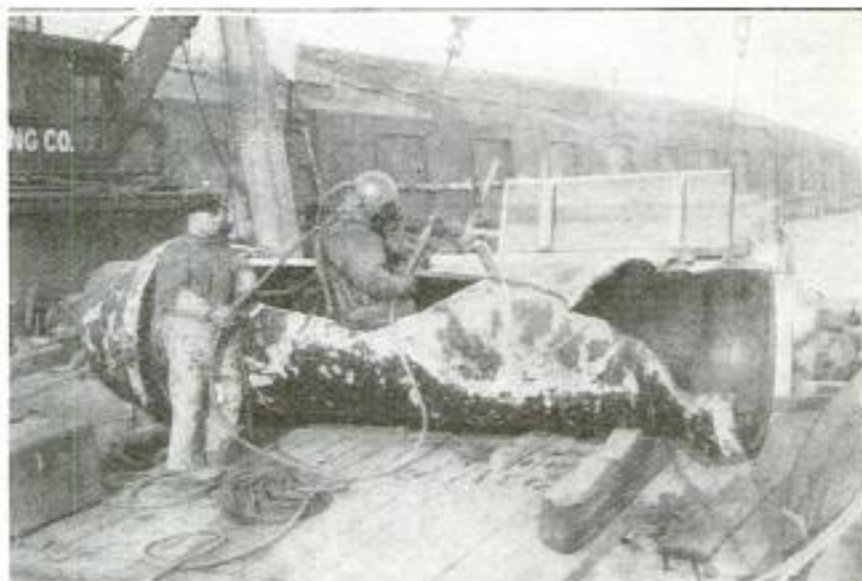

The Broken Pipe on the Dock: The Diver is Showing How the Submarine Torch was Used in Cutting the Pipe at the Bottom of the Harbor, Where the Divers Worked in Two-Hour Shifts Because of the Cold Water

according to the city fire marshal of that place. Severe accidents, and in some cases fires, have resulted from the ignition of hydrogen-filled playthings by a lighted cigar or cigarette.

Detroit News

1/2 8/12 2
Copyrighted material

8698 Built by:
Messrs. Barr & Stroud

684
8715

POPULAR MECHANICS

LONG SERIES OF ARCHES AFFORD STUDY IN PERSPECTIVE

The arcade connecting the new buildings of the recently built Marine Bar-



View from One End of a Series of Arches Forming an Arcade 3,000 Feet Long, Which Shows Perspectively the Other End Converged Almost to a Pin Point

Emb. E. N. Hampton, 4648 Campus Ave
San Diego, Calif.

HUGE BRITISH RANGE FINDER WITH RANGE OF 22 MILES

The largest range finder in the world, over twice the size of any used during the war, has been constructed in England for use in coastal defense. It was designed by the two original inventors of the range finder that has been in use in the British navy for many years, and that consists of a horizontal tube carried on a central frame, which rotates with the tube on a pedestal. In using the range finder, it is necessary to be able to rotate this tube horizontally, and for that purpose, in this huge instrument, there is provided a circular track of large diameter, with the supporting frame as its center, from which radiate connections to trolley wheels that run on the track. At the observing point, beside the pedestal, there are two telescopes in the tube, and in finding the range the observer places his eyes to the eyepieces, and sees a different field with each eye. That presented to the left eye is used as a finder for correctly aligning the instrument. Then the object, as for instance a ship the distance of which is to be found, will be seen with the right eye as two images separated by a thin, black horizontal line. In the case of the ship, these images might be parts of a mast. When the instrument is adjusted so that these two objects assume their proper relative positions, the distance, or range, can be read from a scale provided for the purpose. In this huge range finder the tube is 100 ft. long, and distances up to 22 miles can be measured. In the range finders of the U. S. battleships this tube is 45 ft. long.

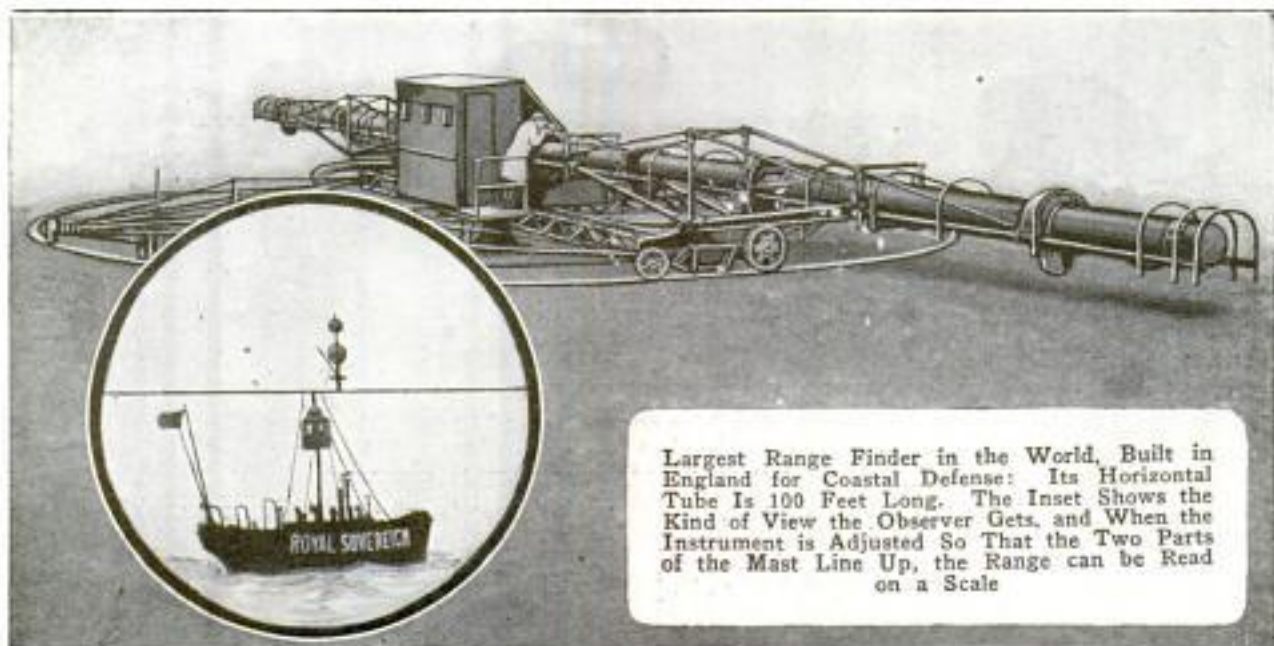

Largest Range Finder in the World, Built in England for Coastal Defense: Its Horizontal Tube Is 100 Feet Long. The Inset Shows the Kind of View the Observer Gets, and When the Instrument is Adjusted So That the Two Parts of the Mast Line Up, the Range can be Read on a Scale

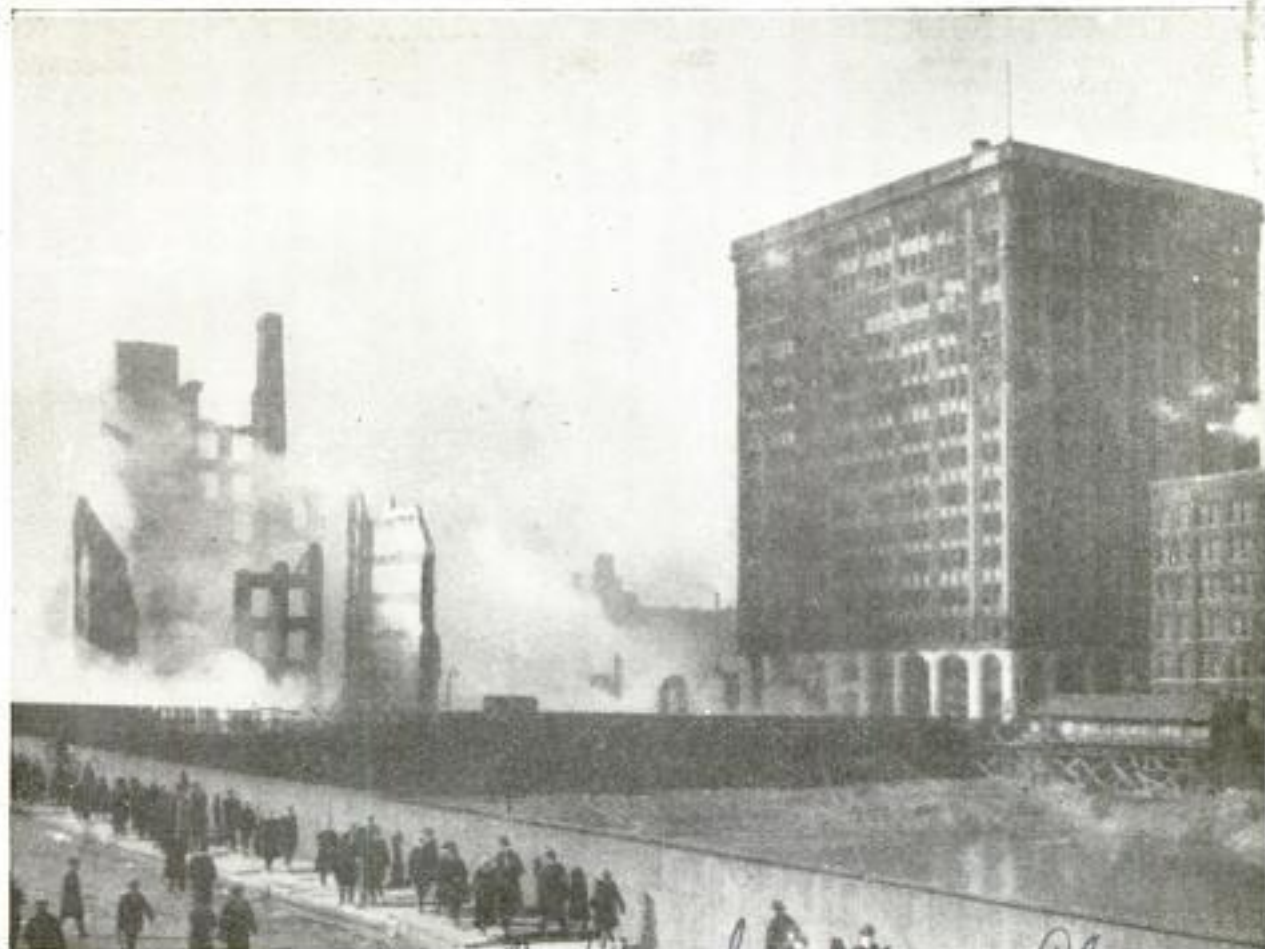

COPYRIGHT, VALLANDE & UNDERWOOD

205 W. Washington, Chicago
MOST MENACING CHICAGO BLAZE SINCE THE GREAT FIRE

WHEN one whole city block and a portion of another in Chicago burned recently, it was characterized as the most menacing conflagration since the great Chicago fire. The 16-story Burlington Building was completely gutted above the eighth floor and was damaged by water below that level, but was probably the means of saving much property situated to the west of it. While severely damaged itself, it acted as a fire wall in preventing the spread of the flames to adjoining property.

8536

SMALL TRACTOR USABLE FOR VARIOUS PURPOSES

Various operations can be performed by a small tractor lately produced by an eastern inventor, the most prominent of these being weeding or hoeing the garden, or pulling a number of lawn mowers. Steering is accomplished with control handles, similar to those of a plow, which extend back to the driver's seat. In turning, one front wheel is thrown out of gear and the other turns the machine, with the stationary wheel as a pivot. Being capable of executing such sharp turns, the outfit is valuable as a garden tractor, or for cutting the grass in an orchard, or on a golf course where trees, bushes, and obstructions of different kinds are found.



Small Tractor Pulling a Number of Lawn Mowers over the Fairway of a Golf Course: The Plowlike Steering Handles Form an Interesting Feature of the Machine

*Ans. George O. Hodge
 Bristol Conn*

8683
Mfg. Steere Engineering Co. Detroit, Mich.
J. W. Steere, U.P.

RAPID METHOD DETERMINES AMOUNT OF TAR IN GAS

When the gas stove fails to operate properly, it may be a sign that some trouble-causing substance has found its way into the mains and service pipes.

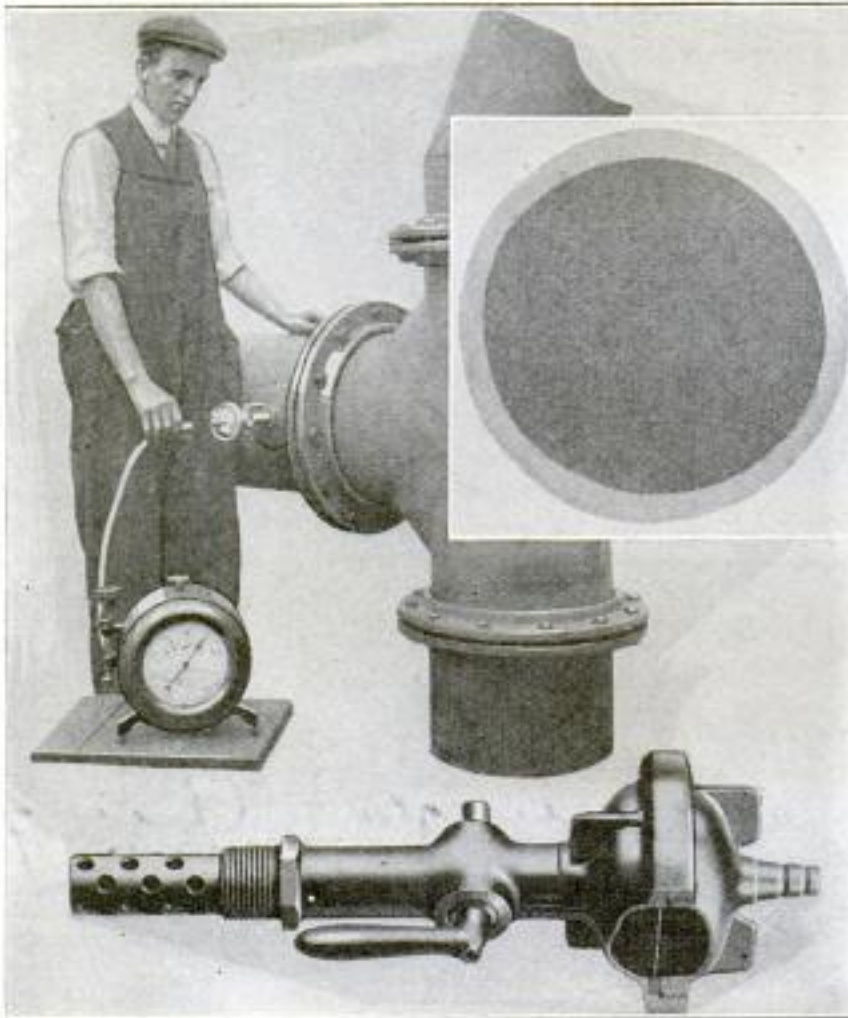

The "Tar Camera," Shown Below, is Screwed into the Gas Main and Connected to the Meter. The Valve is Opened and a Measured Quantity of Gas is Passed Through. The Vapor Stains the Filter Paper, Shown Above, and the Color Records the Amount of Tar in the Gas

One of the most troublesome impurities that the gas companies have to contend with is tar, and skilled chemists are employed to test the gas in an effort to keep this tar out of the mains. In order to provide a simple and rapid means of determining the amount of tar in the gas, an instrument has now been devised which has been nicknamed the "tar camera." By passing a measured quantity of gas through a filter paper it was found that the stain left by the tarry vapors varied with the amount of tar in the gas. By comparing this stain with a set of standard colors, it is a simple matter to determine the amount of tar in the sample of gas tested, and the weight of the material deposited on the paper can be found as a further check. The tar camera, while designed for use in gasworks, can also be used to determine the quantity of moisture or suspended solids in air.

8576
POWER-DRIVEN MACHINE GUN UNDER DEVELOPMENT

8676
Remarkable possibilities are conceivable in connection with a power-driven machine gun, said to have originated in Germany, but which is now being developed in this country. Besides having several advantages over other machine guns, it is, or rather will be when it is fully developed, driven entirely by external power, such as an electric motor, or a gasoline engine. It has a driving shaft in the breech of the gun that operates the firing mechanism, and can be run in either direction, and at very low or very high speed. It does away with troubles due to bad and variable ammunition, and it reduces the amount of gas reaching the breech mechanism. It is fed automatically with ammunition on a cartridge belt

similar to those used commonly in machine guns. In other details it will also resemble existing machine guns, such as its water jacketing of the gun barrel, and it may be mounted on a tripod. Up to the present, it has only been developed for the purpose of demonstrating by hand the operating mechanism. Later on the handwheel, with which it is now driven, will be replaced by a sprocket, which will be driven by a chain from a motor.

Unbreakable glass, which can be heated red-hot and placed in cold water without any perceptible effect, is said to have been produced in Bohemia after years of experiment. Hammers made from the product can be used for ordinary purposes.

Power Driven Machine Gun Corp
New York City

See June, 1922 p. 924

H. J. Hilland Co.,
4411 Beacon St.

688

POPULAR MECHANICS

8655

Chicago
**PRINTERS' CHASE SIMPLIFIES
LOCKING UP FORMS**

Supplies
Time, labor, and material are saved in a newly patented printers' chase, which dispenses with the use of the usual printers' furniture cabinet, and eliminates

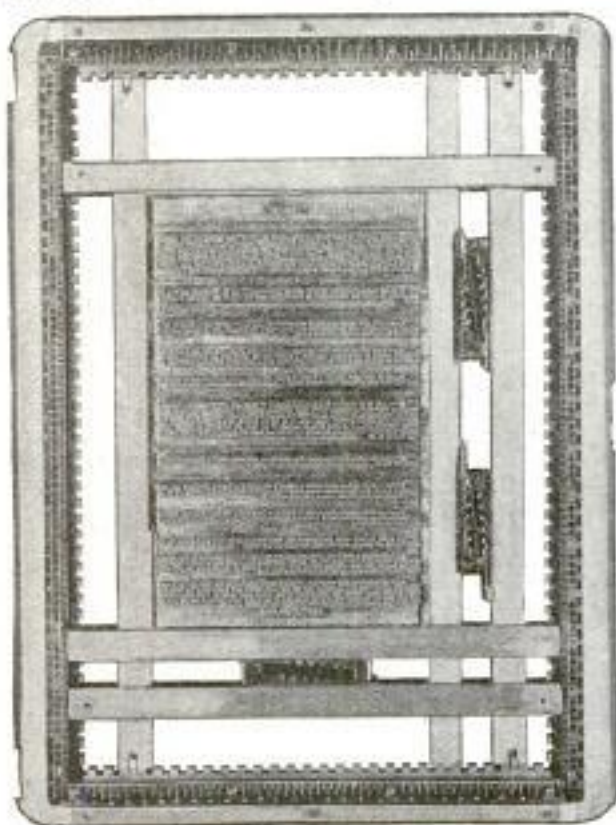

Printers' Chase That, in Locking Up Any Form, Dispenses with the Use of Printers' Furniture: Where the Quoins Are, One Bar is Locked, the Other Loose

roller bearers, as these are fitted onto each end of the chase itself, and can be removed by means of screws. Inside of the four sides of the chase are grooves that accommodate pica notches. In connection with these are bars that stretch from side to side, and end to end, of the chase, and can be moved into any position, and locked there automatically. Some of these bars are double, one being locked and the other loose, so that printers' quoins can be placed between them, and the loose bar be pressed against the type form. These bars are made of nickel-chrome steel and will not bend under severe strain.

8664

**LARD OIL AS A LUBRICANT
VINDICATED BY SCIENCE**

The belief of machinists that lard oil is superior to mineral oils in certain cutting operations, as on a lathe, has been regarded by many as a superstition. Studies of the subject made at the Bureau of Stand-

ards, the results of which have just been announced, show that the machinist is right and that lard oil is distinctly better for many purposes than mineral oil, in fact being well-nigh indispensable in certain cases. The need for lard oil has been previously discredited, as it was thought that the viscosity of the oil determined its behavior with cutting tools, and mineral oils, or mixtures of mineral oils, could be obtained with the same viscosity as lard oil.

It now appears that the lard oil has, aside from viscosity, the important characteristic of adhering more tenaciously to the metal than mineral oils, thereby preventing the tool from seizing the metal of the work, and causing it to drag and tear and make a rough cut. Lard oil is very useful in getting good clean surfaces in cutting soft steel and wrought iron, and also in tapping and threading. However, in hard brittle steel lard oil merely produces a glaze, and turpentine is used with success.

**BRILLIANT LIGHT OBTAINED
8728 WITH NEW REFLECTOR**

Brilliant lighting effects can be obtained with the use of a new reflector having a concave silvered surface containing special indentations, which has recently been introduced in France. These indentations are said to increase greatly the efficiency of any lamp used, which, in public buildings or photographic studios, results in a high illumination at a comparatively low cost in the consumption of the electric current.

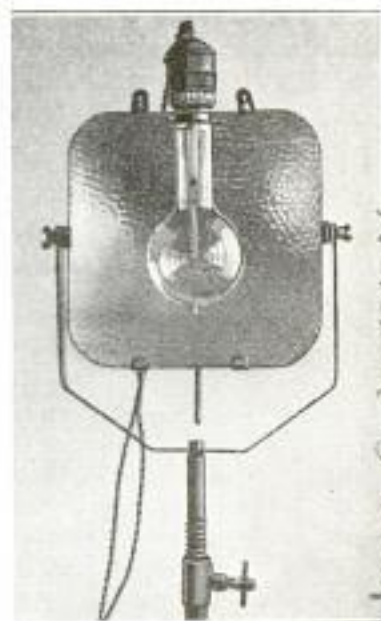

*Com. de l'Association
H. J. Hilland Co.,
Paris, 166 Ave. de
Barrault*

*Mfr. W. J. Bartholomew & Co
40 Leeward St.*

It is reported that concrete ships are now being experimentally built in Germany with the use of a floating iron shell instead of the usual wooden one. It is claimed that the new method is more rapid and less costly.

*Com. C. A. Briggs
1521 Oak St. N.W.*

*Washington
L.C.* Copy London
England

8683

Chas. H. W. Speere, Vice President
 - Speere Engineering Co., Detroit
 Mich

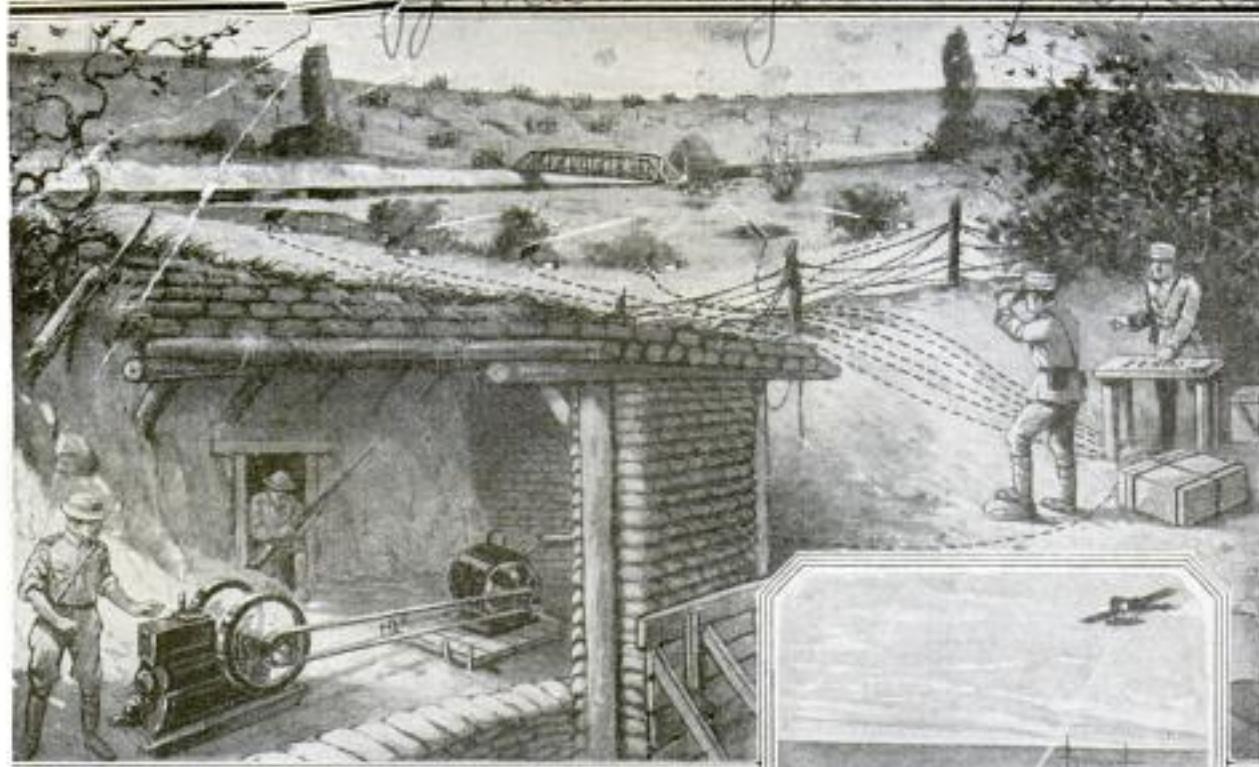

Power-Driven Machine Guns Shown Above Defending a River Crossing against an Assault of the Enemy: Batteries of the Guns in Emplacements are Operated by the Gunners from a Safe Distance in the Rear. Sheltered Power Station in the Foreground is Connected to Operating Base, Which by Wire Connections to the Guns Has Them under Complete Control. To the Right, One of These Guns is Shown on a Battleship's Conning Tower Doing Anti-Aircraft Work. Below: Side Elevation and Bottom View of Operating Gunbreech in Experimental Gun, Built with Handwheel at Rear, Where Driving Sprocket would Be, and Showing Aperture for Cartridge Belt in Front of the Breech. The Water Jacket on the Barrel is Not Shown

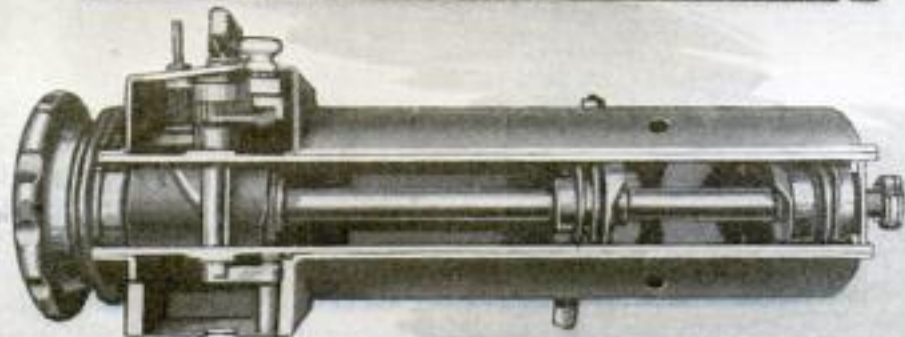
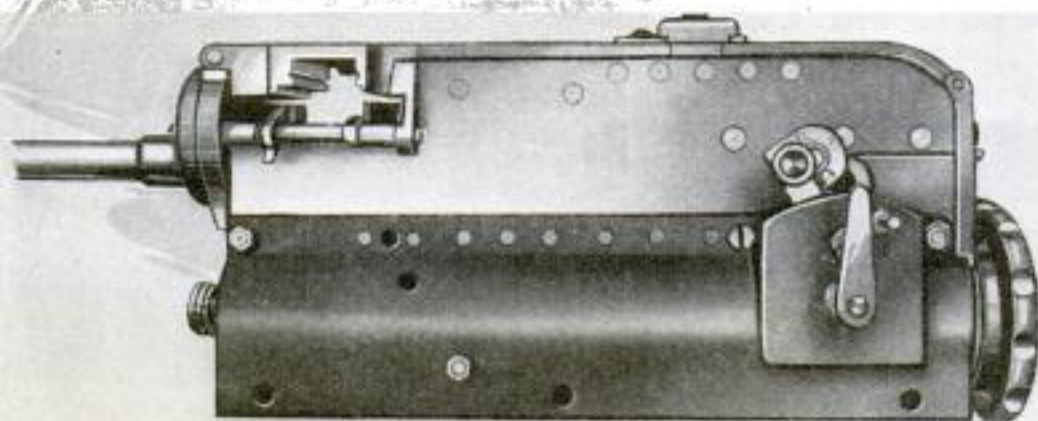
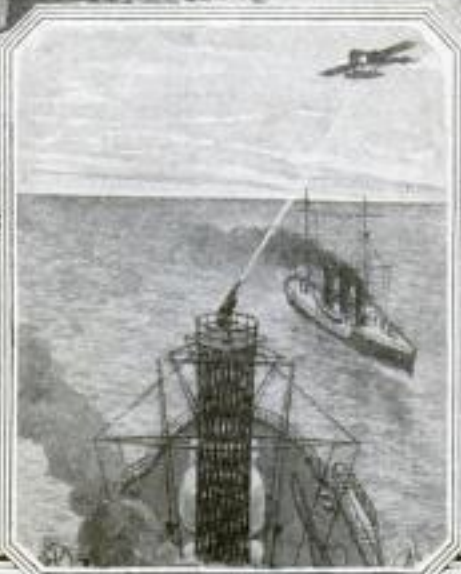

8653

Emb. S. R. Winters
702 District National

POPULAR MECHANICS

Bank Bldg 689
Washington, D.C.

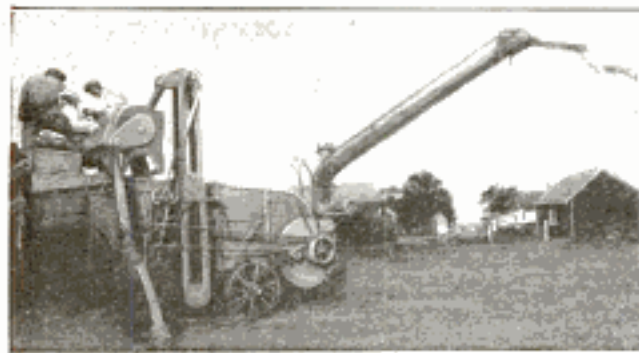

The Wheat-Cleaning Machine Is Light Enough to be Placed on Top of the Threshing Machine, and the Grain is Cleaned Before It is Shipped

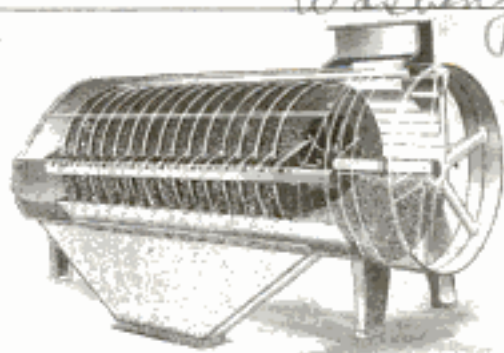

MACHINE WILL CLEAN WHEAT AT TIME OF THRESHING

One source of economic waste has been the contamination of wheat by dirt and the seeds of various weeds and foreign grain, such as wild oats, buckwheat, and many others. Lately a machine has been designed and tested which seems to point to the solution of the problem of cleaning wheat at the time of threshing. It is of simple construction and can be placed on the top of the threshing machine, receiving its power from that source. In operation, the grain is fed into a horizontal cylinder in which are revolving disks provided with undercut pockets of such size that the dirt and foreign seeds are discharged at one point, while the cleaned wheat is discharged at another point. It is claimed that the separation is very satisfactory.

EMPLOY ECHO FOR MEASURING THE DEPTH OF THE OCEAN

The Navy Department has been working on a device for measuring ocean depths by means of reflected sound waves, but as yet has not perfected it to a point where it wishes to give out information regarding it. A recent German device of similar nature has been developed, by means of which depth measurements, accurate to within one foot, can be made even when the ship is moving at full speed. The principle, which has been applied previously, is very simple. A sound is made on the ship, the sound waves travel to the bottom of the ocean and are then reflected back to the ship. Sound travels in water at the rate of about 4,700 ft. per second, so all that is necessary is a suitable sending and receiving instrument with a means of measuring the time it takes for the sound to go and come back. The German apparatus is capable of recording a difference of $\frac{1}{10,000}$ part of

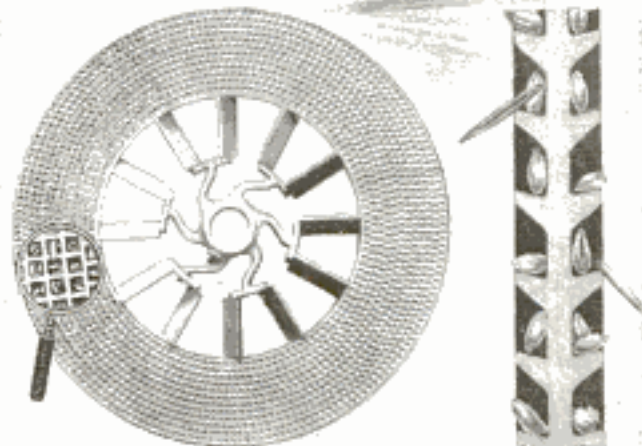

Above: A Phantom View of the Machine, Showing How the Disks Revolve in the Grain. Below: Enlarged View of the Disks, Showing the Arms Which Move the Grain Ahead and Pockets Which Deliver It at the Proper Place

a second. The apparatus is tuned in such a way that the usual noises and vibrations of the ship in motion do not interfere with its operation.

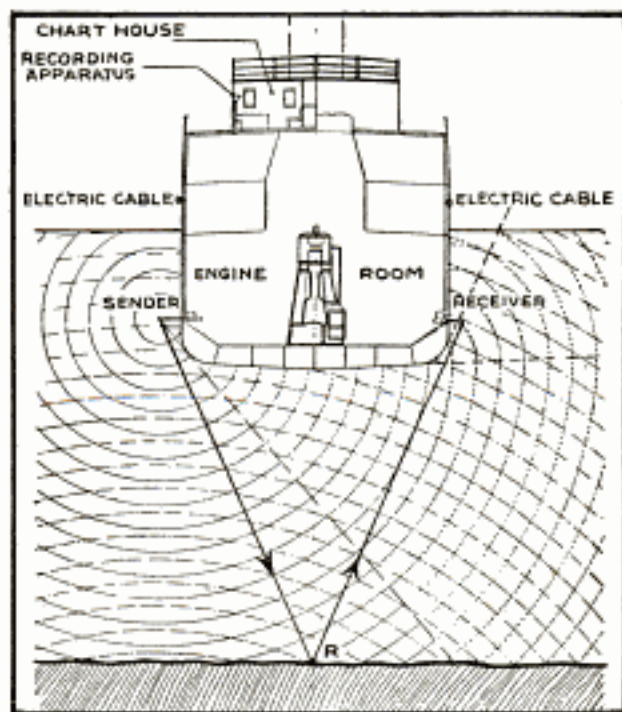

When the Captain Wishes to Take a Sounding, He Causes a Cartridge to be Fired at the Sending Instrument and Notes the Time It Takes for the Sound to Reach the Receiving Instrument. The Interval of Time Required for the Sound to Return Measures the Depth of the Water under the Ship

Emb. Carl. Cornmety, Beumenshal, Hannover
Lindenstr 106, Germany.

Copyrighted material

Chas. H. Winsor
Palmyra, N. J.

Christian Science
Monitor 8/18

**PORTABLE RUBBER WASHBOWL
FOR USE OF TRAVELERS**

Insanitary conditions of hotel wash-
bowls have caused the introduction of a
portable bowl consisting of rubberized
hospital sheeting. The material is pinched

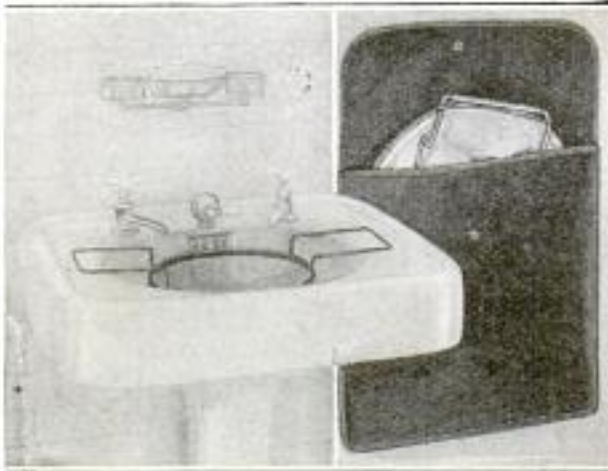

Left: Portable Rubber Washbowl on Hotel Washstand.
Right: Washbowl Folded in Leather Case

between two metal loops, as linen is held
in the rings of an embroidery frame. A
telescopic frame enables the innovation to
be fitted in any ordinary washbowl, and
when not in use, it can be folded in a
small flat leather case.

**FRANCE PREPARES WONDERFUL
TAPESTRY FOR AMERICA**

For the purpose of commemorating
America's entry into the great war and of
further showing her appreciation of the
assistance rendered, France is causing to
be made a great tapestry which is to be
presented to the United States. The tap-
estry shows in large figures the departure
of American soldiers for France, and is
wonderfully complete in details and color-
ing. In making the tapestry, the weavers
are aided by sets of mirrors, one of which
reflects all the details of the large paint-
ing which hangs behind the weavers, while
another enables the workers to watch the
results as the weaving proceeds.

GERMAN AUTOMOBILE SHAPED LIKE A RAINDROP

Radical departures in automobile design
have apparently not yet reached their
limit, judging from a striking example of
novelty presented by a car that caused a
sensation at a re-
cent auto show at
Berlin, Germany.
The principal aim
of the designer was
to construct a car
with streamlines
that would offer the
least possible resis-
tance to the air, and
for that reason a
falling raindrop was
taken as an ideal
model. Everything
in the construction
of the car was made
subsidiary to this,
and incidentally in-
volved many strik-
ing novelties. The
chassis is made of
two wide pieces of
pressed steel, under
part of which there
is a streamlined bot-
tom of thin metal.
The body, in both
the open and limousine types, follows
strictly the raindrop pattern. In both

cases the driver sits in front and the pas-
sengers behind, all the seats being in the
center of the car between the two
axles. The motor is at the back of the
car just in front of
the rear axle, and
consists of six cyl-
inders in three
pairs, arranged ra-
dially, with the cen-
tral pair vertical
and the others at
60°. Normally it de-
velops only 10 hp.—
all that is required
to drive the car as
a result of its slight
air resistance. Be-
hind the motor, in
line with the rear
axle, is the radiat-
or, which is cooled
by a powerful fan.
The center of grav-
ity of the car is
very low, and it
rides quite steadily
with a chauffeur
and two passengers,
even at such a high
speed as 75 miles
per hour, recently
attained on a race
track.

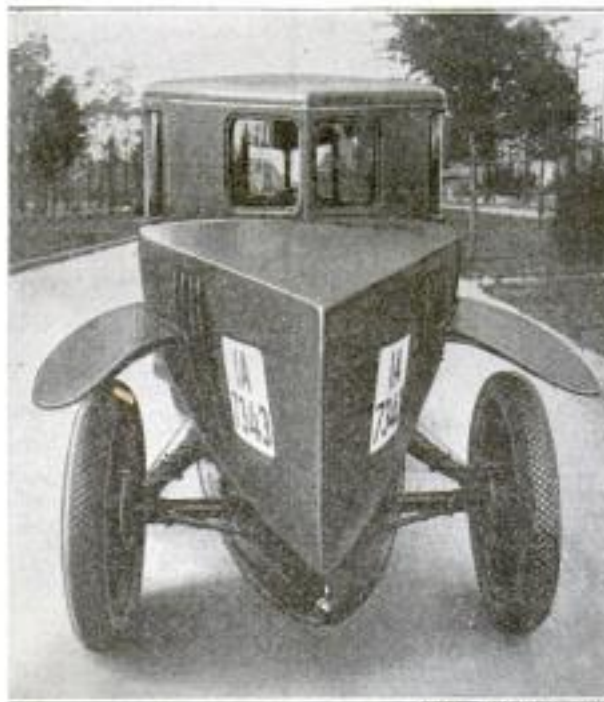

Rear View of Automobile with Ideal Streamlines,
Shaped like a Raindrop; The Motor is Located near
the Rear Axle Where Ventilator Openings are Seen

8696

7766

Handwritten signature

*Dr. Herr Kumpfer
Lehrer*

7766

Mr. The Rumpeler Works
 Berlin-Johannisthal, Germany



Side View of Limousine Type of Automobile Shaped like a Raindrop: The Whole Body Has Streamlines That Offer the Least Possible Resistance to the Air. The Mudguards Are like Rudimentary Wings

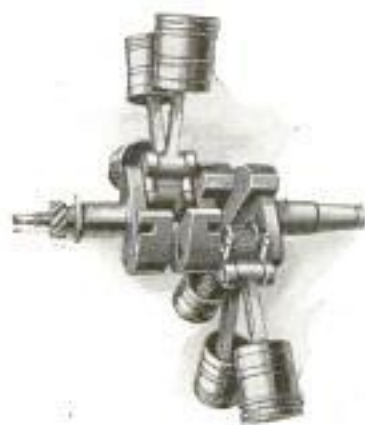

Crankshaft and Pistons of the Six-Cylinder Engine Built with Two Cylinders Vertical, and Two at 60 Degrees on Either Side of Them

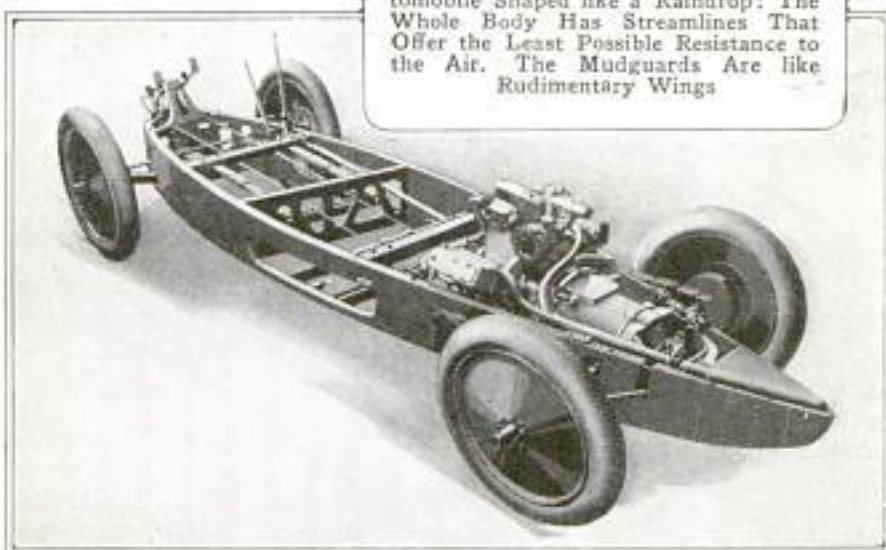

Streamlined Chassis with the Motor and Its Driving Equipment at the Rear Axle, and the Controlling Pedals and Levers Seen at the Front, Where the Driver's Seat is Located

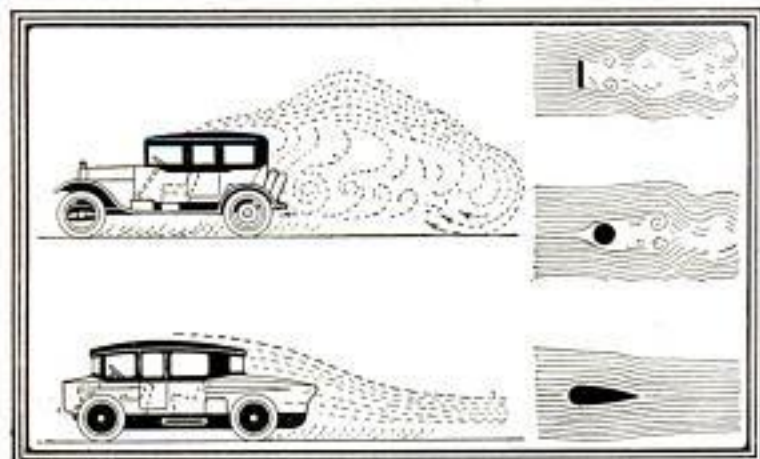

Reaction of the Air to the Ordinary Car, and to the Car Shaped like a Raindrop: The Former, in Upper View, Causes Eddies like the Disk or Ball at Right, While the Latter Disturbs the Air No More than the Raindrop at the Right

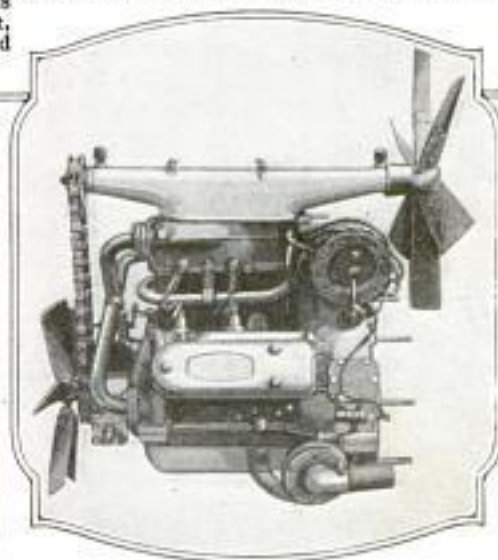

Power Plant of Raindrop Car on Rear Axle with Six-Cylinder Motor at Left and Radiator at Right, Which is Cooled by a Powerful Fan

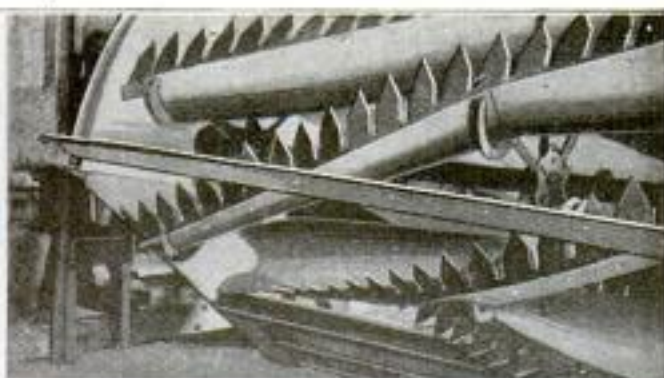

Left: Front View of the Rice-Stripping Machine in Action, Showing How It is Pulled through the Rice Field by a Tractor. Right: Construction of the Stripping Teeth on the Cylinder of the Machine

8092 **FLASH-TIMING ARRANGEMENT FOR MAKING RADIOGRAPHS**

Instantaneous radiographs, or X-ray pictures, can be made with a new flash-

timing apparatus which has a range of from $\frac{1}{40}$ to $\frac{1}{2}$ second. The instrument consists of a hollow cylinder having a weight inside, which makes an electrical contact according to the way a small indicator is placed on the outside scale. After the indicator is adjusted on the scale for the desired time of exposure, the weight is pulled up toward the top of the cylinder,



until at a certain point it is automatically released. As the falling weight passes the indicator, a contact is made which opens a shutter for the exposure, and when the weight strikes the bottom of the cylinder, the shutter is closed.

HARVESTER COLLECTS RICE FROM STANDING STALKS

A rice-stripping machine has been developed that marks a decided advance in the harvesting of rice. This machine strips off the rice while it is standing in the field, leaving the stalk and taking only the grain. This makes unnecessary cutting and threshing, which are the most expensive of the rice-harvesting operations. This stripper is equipped with a cylinder with six bars, on which are

mounted fingers, or teeth, of the proper shape for stripping the rice. Revolving as it moves along, the teeth of the stripper comb the rice from the straw and throw it up over the cylinder in the hood and drop it into a trough.

The grain is then conveyed by an elevator across to a platform, where the elevator empties it into sacks, which are tied, dropped off in piles, and finally picked up and hauled to the granary. This leaves the straw standing in the fields to be plowed under and used as fertilizer for the next year's crop.

This stripper, being mounted on, and attached to, one of the regular harvesting tractors, is able to work successfully in any rice field. When the rice comes from the stripper, it is from 60 to 80 per cent threshed clean off the stem; the other 20 to 40 per cent consists of blades, whole heads, and part heads that have been jerked off with the rice grains still intact. This rice must be carried through some cleaning process to get it ready for the granary or for the market.

8608 **SIMPLE BOOKHOLDER MADE BY BENDING IRON WIRE**

Bending a piece of iron wire to make a simple bookholder is the idea of an Indiana inventor. The holder consists of



a wire with an eye bent in the center for a screw, and with two arms bent at right angles to rest upon the book. The whole arrangement is

screwed to the back of the school-desk upright, and the tension of the wire holds the arms flat against the pages. The device is patented.

Chas. O. B. Sandifer
North Manchester, Ind.

Roentgen Appliance Co
 San Francisco
 909
 C. M. George, D. Paul,
 900 Ellsworth Bldg
 Chicago 648

8700

Coates Steamer & Co. Merchants Bank Bldg. Chicago
8122
Auto

STEAM TOURING CAR SIMILAR IN FORM TO GASOLINE CAR

Past experience with steam cars has shown that, while some would operate as economically, it has been difficult to manufacture them at as low a first cost as equivalent gasoline-engine cars. Built in many respects on the lines of a gasoline car, there is now being constructed a commodious steam touring car which the manufacturers expect to be able to market for about \$1,000. Viewed externally, it is difficult to distinguish it from any ordinary gasoline car. The hood is exactly similar, with what appears to be an ordinary radiator, but is, as a matter of fact, the condenser for the exhaust steam from the engine. Immediately behind this is the boiler, which supplies superheated steam at a pressure of 600 lb. It operates intermittently, its fire box being a mixing chamber for air and kerosene forced into it by motor-driven pumps, and ignited by a spark plug, all of which are on an electric circuit, which is automatically broken when the pressure reaches 600 lb., and closed when it drops below that pressure, or by a switch operated by hand in starting. The engine—of the V-type—located behind the boiler, has three cylinders, one on one side, and two on the other, with poppet valves operated by cams. In combination with the engine is a two-speed and reverse transmission. Power is transmitted to the rear axle by the usual propeller shaft. At the driver's seat are gear-shift and emergency-brake levers, with a service-brake pedal, and another for controlling the steam cut-off. Directly below the steering wheel is the throttle for speed control. The weight of the car fully equipped is 2,250 pounds.

POLICEMEN IN EGYPT CARRY SHIELDS FOR PROTECTION

Broken bottles, stones, etc., are the favorite weapons of rioters in Egypt, and



Left: Egyptian Policeman Ready for Action with Club and Shield. Right: Carrying Shield When Not in Use

to protect the police from these crude barrages, they have been furnished with shields. These are of woven-reed material, and when not employed in warding off flying missiles of a miscellaneous character, are carried on the back by the policemen.

Ghostly materializations of a Danish medium aroused such widespread interest that scientists of Stockholm, Sweden, decided to verify the performances. During a seance, when a "soul" was projected outside of a body, a photograph showed that the filmy emanation was nothing but a piece of chiffon.

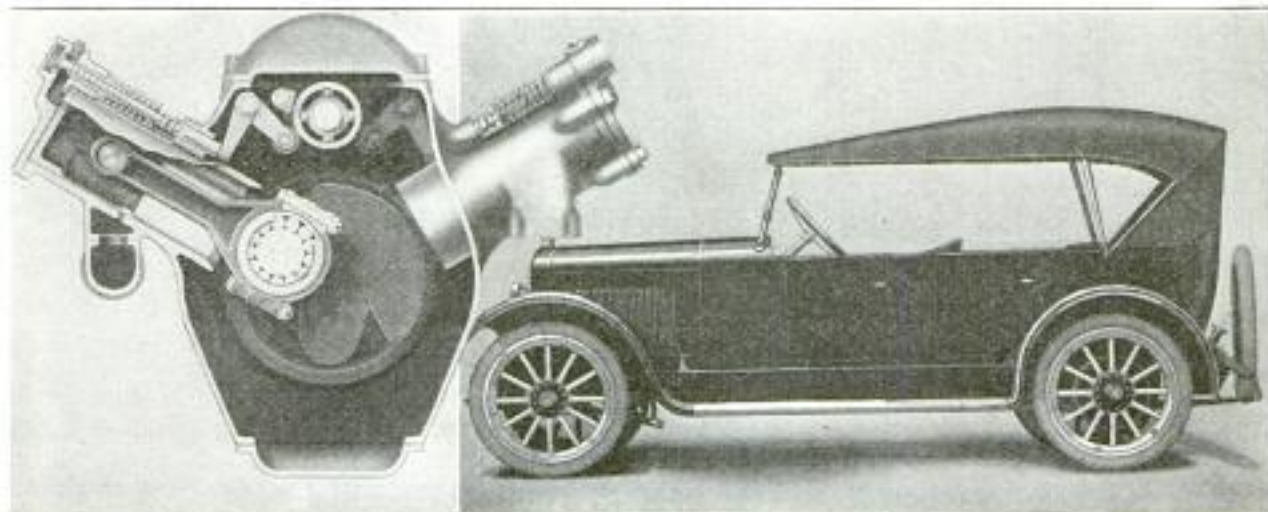

Steam Touring Car That Is Indistinguishable in Appearance from a Gasoline Car, and can be Manufactured Very Economically: What Looks like the Radiator Is the Steam Condenser, and under the Hood, besides the Boiler, Is the Three-Cylinder V-Type Engine, Shown to the Left on an Enlarged Scale

8681

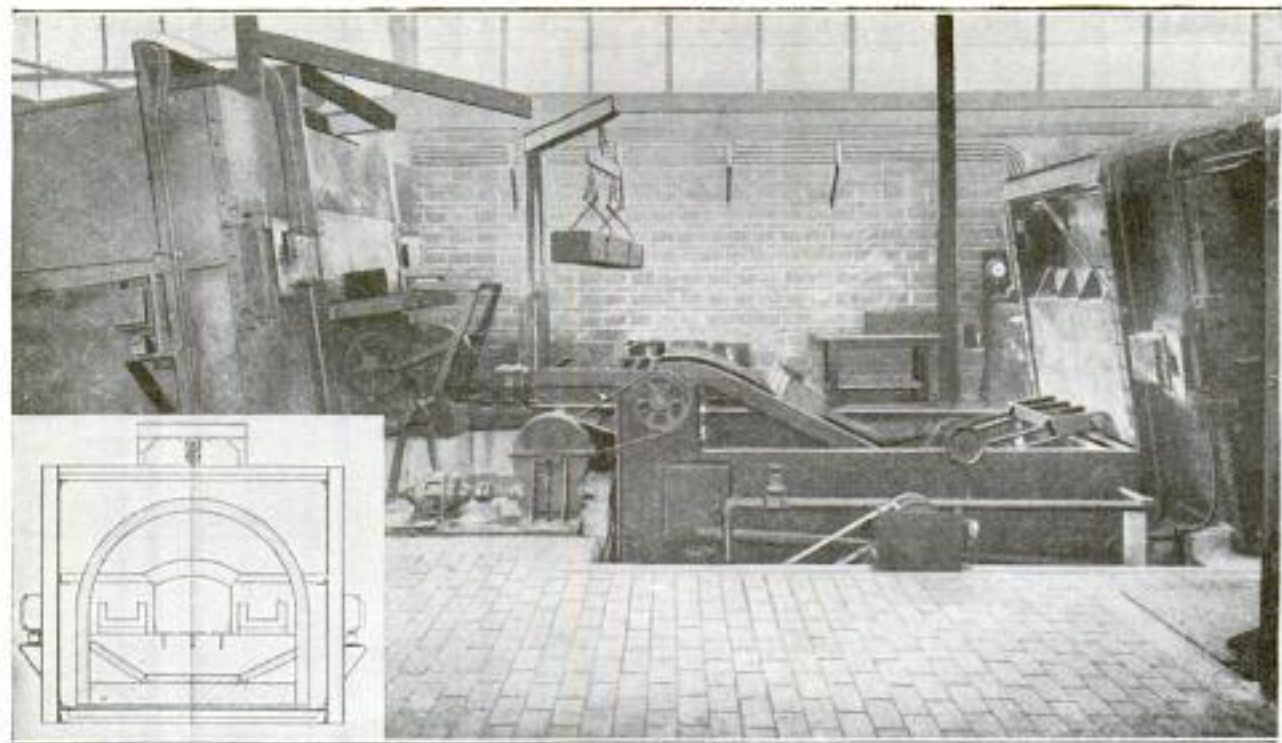

The Steel Parts Go, Automatically, through the Hardening Furnace at the Right, the Quenching Tank, in Center, and the Annealing Furnace at the Left. The Insert Shows the Interior Arrangement of the Furnace

Price Pump Co., Quincy, Ill.

ECONOMICAL FUEL PUMP FITS ANY BARREL OR DRUM

Farmers can have their own miniature filling station if use is made of a pump placed on the market by an Illinois concern. The pump is made entirely of brass, insuring durability, is adjustable to fit any size wooden or steel barrel, or drum, and has a capacity of 5 gal. per minute. Preventing the evaporation or spilling of the fuel, and eliminating all danger when filling the tanks of motor cars or tractors, are additional features of the product.

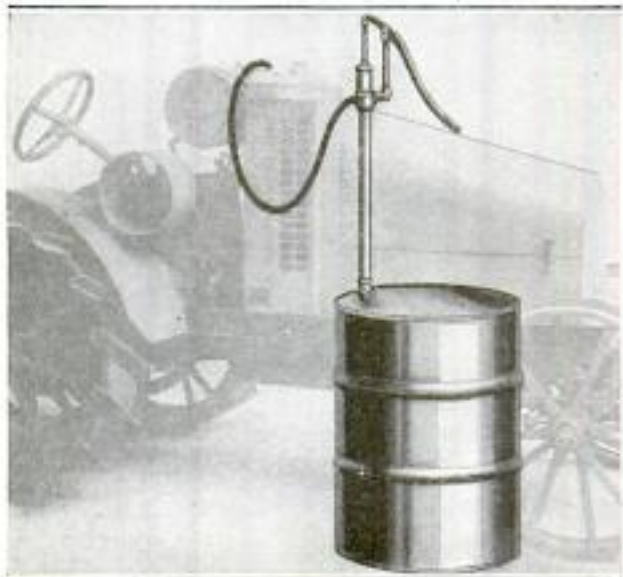

This Fuel Pump Fits Any Steel or Wooden Barrel, and Prevents Waste

AUTOMATIC ELECTRIC FURNACE FOR TREATING STEEL PARTS

It has long been known that the proper heat treatment of steel is a big factor in determining the strength and wearing qualities of the piece treated. This is of particular importance in the automobile industry. Up to date, heat treatment has been practiced in various kinds of furnaces, but always under the supervision of skilled operators equipped with the most delicate instruments for measuring time and temperature. Now, however, an automatic electric furnace, installed at a Michigan automobile plant, has been devised in which the parts to be treated move through the different processes on a predetermined schedule. The parts are loaded in metal baskets and pass through the hardening furnace to the quenching tank, thence to the drawing furnace. The mechanism is set so that the parts undergo each step of the treatment exactly the required period of time.

8740 GREAT BRITAIN NOW ABANDONS DIRIGIBLE AIRSHIPS

It is announced that Great Britain is to scrap her aerial navy, as far as the large dirigibles are concerned. The action is partly the result of the desire for economy and partly because of the disasters to the two great airships, the "ZR-2" and the "Roma," with their consequent loss of

Aeronautical
Michigan
Aerial Age Weekly
Copyrighted material
3/20

Cont. *Margorie A. Ruff*
 8675 120 Langdon St.
 Madison, Wis

POPULAR MECHANICS 695

**VIOLIN MADE OF MATCHES,
 TOOTHPICKS, AND GLUE**

When a person speaks of violin making, it brings to mind thoughts of the finest wood, thoroughly seasoned, and carefully worked to the proper dimen-

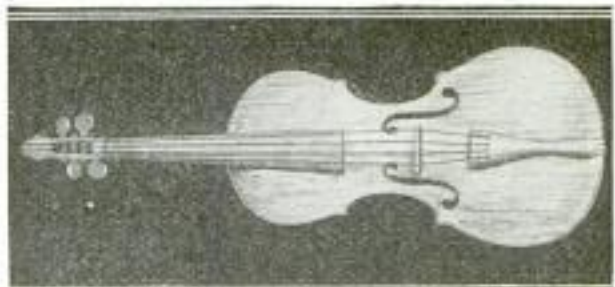

This Violin is Composed of More Than 13,000 Matches and Toothpicks

sions. That this is not a necessity, is shown by a patient worker who has made a violin entirely out of matches and toothpicks glued together and fashioned to the proper thickness. In spite of the unusual material used in its construction, the violin has a soft mellow tone, said by experts to be of good quality and volume. It seems remarkable that a violin constructed in this way should stand the strain and vibration of being played upon.

life. The equipment at the large airship bases is to be dismantled and sold at scrap prices. This action means the abandonment of plans to link up the empire aerially.

**NEW TIE-CHANGING MACHINE
 RAPID AND ECONOMICAL**

Replacing railroad ties reaches a yearly average of more than 10 per cent of the total number in the roadbed, and a machine has been developed that will do this work at a cost of .4 man-hour per tie, instead of the old rate of 1.2 man-hours. In operation, the apparatus is placed across the rails, and a ratchet arrangement with handles works back and forth upon it. Attached to the ratchet is an anchoring chain and also a steel pulling cable, the latter terminating in a special clamp which is fitted over the end of the tie. After the spikes and tieplates have been removed, the clamp is fastened on and the worn-out tie pulled from under the rails without disturbing the roadbed. Where there is but a single track, the new tie can be pulled in without moving the machine, but with a double-tracked right of way, it must be reversed so as to pull the tie in from the "ditch" side.

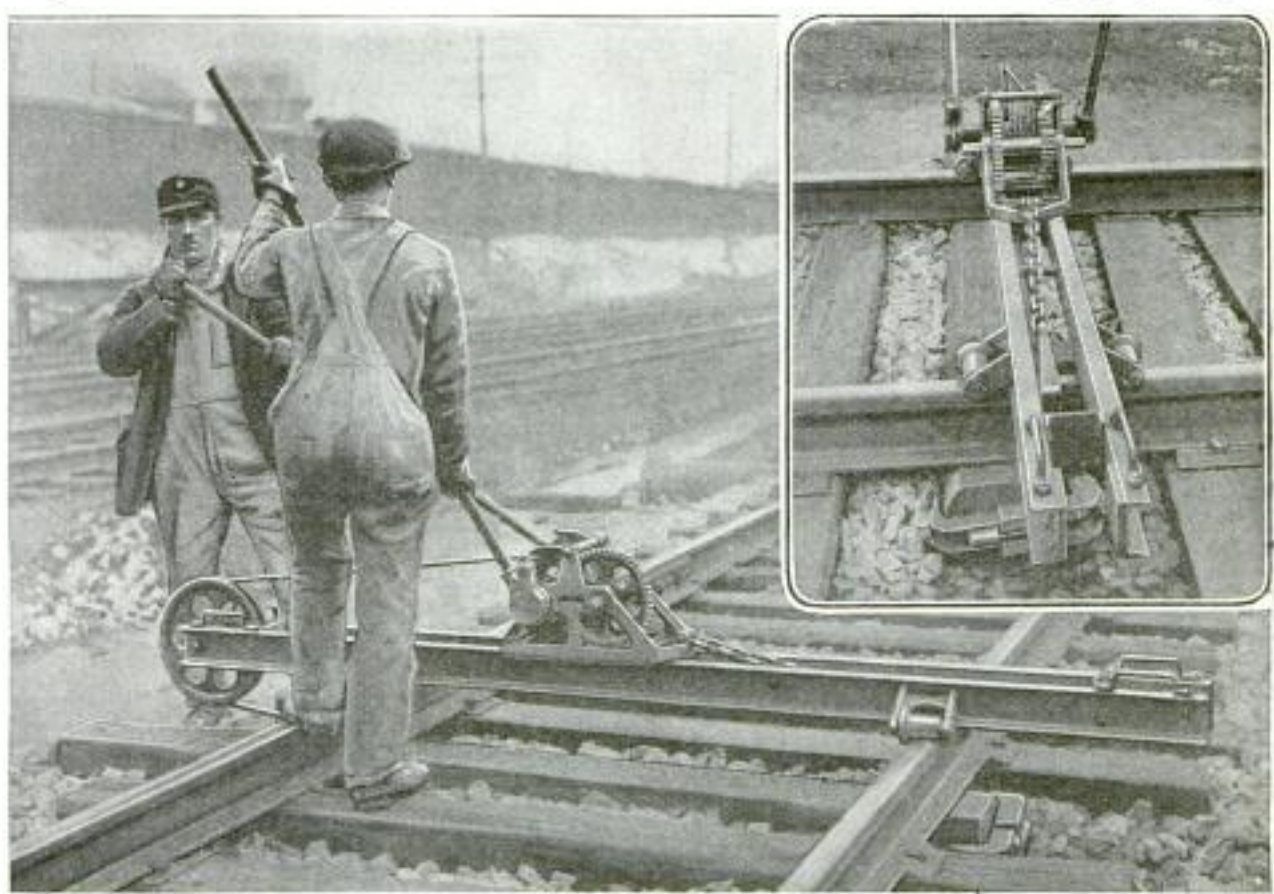

Tie-Changing Machine. Showing the Ratchet Arrangement in the Center, the Pulling Cable at the Left, and the Special Clamp under the Right End of the Frame: The Inset Shows the Anchoring Chain

Owen Pennsylvania Corp
Wilkes-Barre, Pa

The Flashwriter Co

696

Troy N.Y. *attach*

POPULAR MECHANICS

8480
15.00
25.00

TYPEWRITER STUDENTS AIDED BY "FLASHBOARD" MACHINE

Typewriter students have been greatly aided by the introduction of a flash writing machine which furnishes an easy

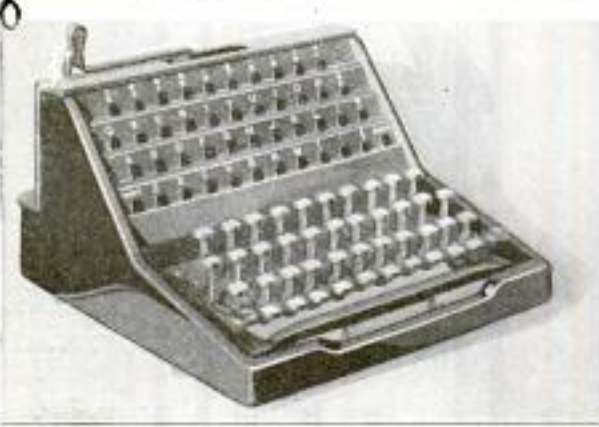

Machine for Typewriter Students, Showing the "Blind" Standard Keyboard Below and the Lettered "Flashboard" at the Top with the Shutters

method of visualizing letters and words on a keyboard. The apparatus has a "blind" keyboard with the standard number of blank keys on it, and in place of the usual set of type, has what is called a "flashboard." This flashboard also is equipped with the standard layout of letters, signs, etc., each having a white spot under it, but which is concealed by a small shutter. When a key is struck, the shutter beneath the corresponding letter or sign is drawn down for an instant, exposing the white spot. The beginner thus forms a mental picture of the positions of the different letters and soon becomes adept in "seeing" entire words, all of which helps in the development of speed.

Access
AUTOMATIC JACK CONTROLLED FROM AUTO DRIVER'S SEAT

With a new device consisting of four jacks permanently attachable to any car



Automatic Jacks Permanently Installed, One at Each Wheel, Operated by Power from the Engine, and Controlled from the Driver's Seat: The Lift Is 5 1/2 Inches



Imp. Automatic Jack
Corp. Federal Reserve
Buildg. Pittsburgh, Pa.

—one adjacent to each of the wheels— an automobile driver can jack up any one or all of the wheels without leaving his seat. The jacks are operated by power from the engine, transmitted either from the flywheel or the pump shaft. Four levers near the driver's seat furnish the means of control. The jacks have a maximum lift of 5 1/2 in., and are powerful enough to lift any load that the car is capable of moving. Tire changing will thus be greatly facilitated, and the jacks will make it easy to take the load of the car off all the tires when not in use, thus greatly adding to their length of life.

8656

LAND ELEVATIONS OF NATION SHOWN IN WATCH CHARM

An unusual watch charm, which is representative of the extremes of land elevations within the continental limits of the United States, has been made by a western man. The charm consists of three pieces of polished stone picked up in California: one from Death Valley, symbolical of the lowest point below sea level; one from Redondo Beach, to represent sea level, and one from the summit of Mt. Whitney, being emblematic of the highest point of land. These are set in a gold mounting which bears an engraved description of the three layers of mineral, the whole serving as a pleasing reminder of the owner's visits to the different localities.



Wm. Audubon
Culver City, Calif.

USE WEATHER CHART TO SAVE MONEY WHEN PLACING TIES.

That rainfall charts may be used as money savers was recently shown by a railroad wishing to place ties it had on hand which had been treated with zinc-chloride preservative. The ties treated with this zinc salt are satisfactory in dry climates, so a map was prepared showing portions of the line where the rainfall was relatively small, and the ties were used at these points, while creosote-treated ties were used at points subject to heavier rainfall.

8724

Railroad Construction

8614
St. Bernard
Pittsburgh, Pa.
Wm. Phelps

Dept. Agriculture
Pres. C. S. Shul
Copyright 1915

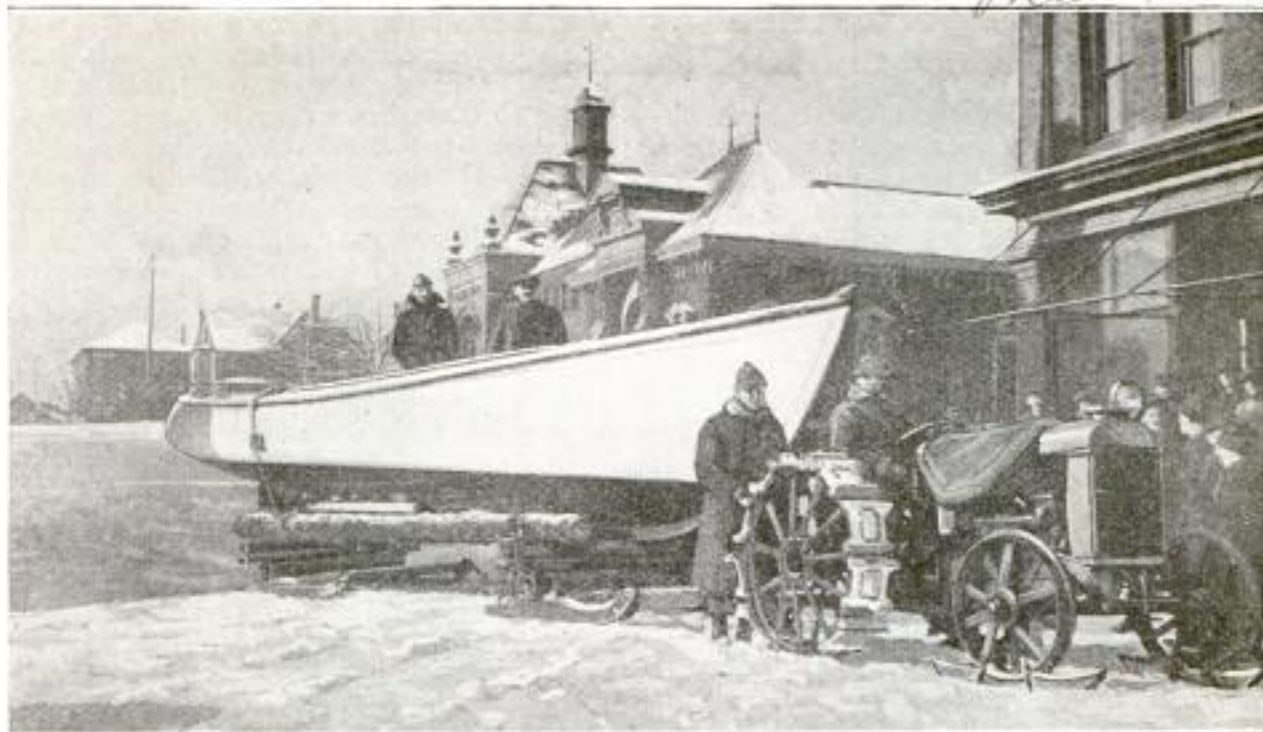

MOTORBOAT TRAVELS OVER SNOW-COVERED HIGHWAYS

BUFFETING through snowdrifts in a motorboat was the strange experience of three men who made a 70-mile trip over the highways to deliver the purchased craft to its owner. The boat, which was ordered built for pleasure purposes on a Maine lake, is 40 ft. long, 8 ft. 6 in. wide, 3 ft. 6 in. deep, has an oak frame with cedar planking, and weighs two tons. Two 24-hp. gasoline engines will drive two propellers, to yield a speed of 18 knots (20¾ miles an hour). In making the journey from the boat works to the buyer, the craft was mounted on ordinary bobsleds and pulled by a one-ton tractor.

8674

Locomotive Journal

WILD ENGINE MAKES PLUNGE INTO TURNTABLE PIT

Running wild, an engine in a roundhouse of the Southern Pacific Railroad steamed out of the building and plunged into the turntable pit, causing \$1,750 damage. Men were working on other engines in the immediate vicinity, when suddenly the large locomotive was seen to move and



Workmen Raising the Runaway Engine upon Blocks Preparatory to Taking It Out of the Turntable Pit: The Damage to the Cab of the Engine can be Plainly Seen



Runaway Engine Shown in Turntable Pit Immediately After It had Made the Disastrous Plunge

gather headway, but with no one visible in the cab. After due investigation, the board of inquiry appointed by the company reported that an unknown person, or persons, had opened the throttle and started the engine on its disastrous journey.

Cont. A. A. Hafford, Reno, Nevada

NEW FRUIT-JAR WRENCH GIVES FIRM GRIP

Anyone who has struggled with an obstinate fruit-jar cover will appreciate a wrench recently devised. The wrench is



so constructed that the harder one pulls on the handle, the tighter the wrench grips the top of the jar, the handle giving sufficient leverage to start the tightest top but, because of the shape of the jaws, there is no danger of spoiling the cover or the jar. The

wrench is made of stamped metal and combines lightness and strength.

CHALLENGER IN FISHING-BOAT RACE IS LAUNCHED

The American fishing schooner "Puritan," prospective challenger for the international trophy won by the Nova Scotian craft "Bluenose" in a contest last fall against the "Elsie" of Gloucester, Mass., was launched on March 15 at Essex, Mass. More than 1,000 persons witnessed the launching, despite the fact that the shipyards in which the schooner was built are in a remote community.

The "Puritan" was christened by Miss Grace Adams, of Malden, who, with Capt. Jeff Thomas, master of the craft, rode into the stream on the vessel. Although after sliding down the ways, the stern of the schooner fetched up against the oppo-

site bank of the narrow Essex River, no damage was done. The craft is financed by the Manta Club, an organization of some 16 Gloucester men, formed to make efforts to put a schooner into the water capable of bringing back the international trophy to the United States.

Following the launching, the "Puritan" was towed to Gloucester, where it will be rigged and fitted out. Then it will leave, under Captain Thomas, for the halibut-fishing grounds for active service until the elimination races off Gloucester next October to pick the American challenger.

In the elimination races the "Puritan" may meet the Boston schooner "Mayflower," which was ruled out of the international contest last fall by the Canadian authorities on the ground that it was more of a yacht than a practical fishing schooner. The "Mayflower" has been actively engaged in the fishing industry for nearly a year, and quite probably will be allowed to enter the elimination contests.

Another schooner, of Boston build, is scheduled to enter the elimination tests. Plans call for its completion the latter part of April. It has been tentatively named "Uncle Sam." A group of Gloucester men arranged for its construction.

The "Puritan" is well within the regulations governing the international trophy competition. Its over-all length is 138 ft., water line 107 ft., beam 25.2 ft., depth of hold 11.91 ft., and draft 14.6 ft. It has a gross tonnage of 149. The construction throughout is that of the ordinary deep-water fishing craft. The bowsprit is 12 ft. outboard. It is approximately 20 tons lighter than the "Mayflower," and from deck to main topmast measures 10 ft. less in height.



Above: After the Launching, the "Puritan" was Towed to a Gloucester Yard, Where It will be Rigged and Fitted Out for Active Service on the Halibut-Fishing Grounds. Right: Miss Grace Adams, Who Christened the Schooner, Rode with Captain Jeff Thomas on the Deck as the Ship Slid down the Ways. Although the Launching Took Place at a Remote Shipyard, More Than 1,000 Persons Witnessed the Ceremony

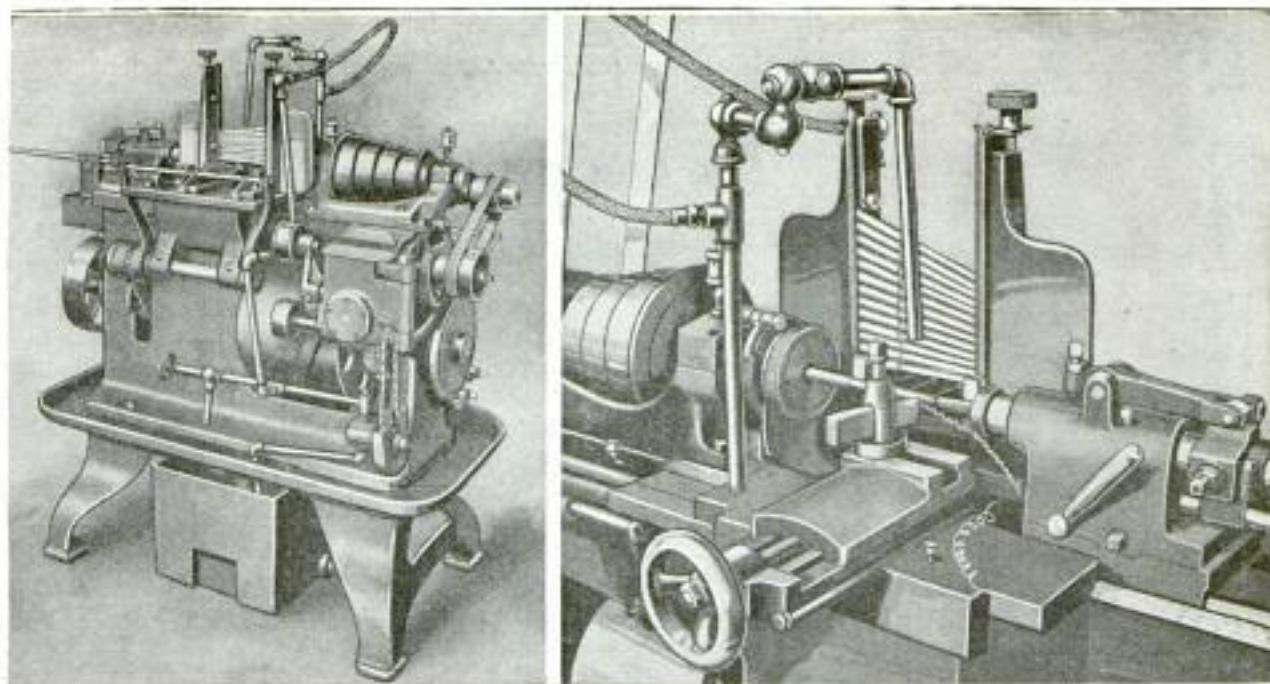

Left: Rear View of Automatic Engine Lathe. Tank below Lathe Holds Supply of Cooling Compound, Which is Conveyed to the Work by Chain-Driven Gear Pump Seen at Right of It. Right: Close-Up, Showing Lathe at Work, with Magazine at Rear Half Filled with Cut Lengths of Bar Stock

7876
**NEW AUTOMATIC ENGINE LATHE
 FOR QUANTITY PRODUCTION**

Engine lathes, entirely automatic in their action, taking the work from a magazine, gripping it and setting it up, and ejecting the finished piece, all without any attention from an operator, are now on the market. The machine is designed for quantity production, handling cut lengths of bar stock or forgings that must be turned on centers. All the operator has to do is to replenish the magazine, and keep the cutting tool in proper condition, and, therefore, he can attend to a number of machines simultaneously. In general, the machine resembles a common engine lathe, but in place of the lead screw is a drum cam for the carriage traverse. This cam has adjustable dogs which may be arranged to produce the required length of cut. In operation the carrier, connected with the magazine, moves forward, presenting the work in alinement with the centers. The tailstock center then moves up and pushes the work between the jaws of the driver, or chuck, and then the carriage moves the tool to the cutting position. At the end of the cut the tailstock spindle is withdrawn, the chuck is opened, and the work dropped out.

☐The Canadian Pacific Railroad is to resume work on its new ocean pier at Vancouver, B. C., which, together with the Ballantyne pier, will provide 10 additional steamship berths.

8734
**CAUSES OF FAILURE OF ROOF
 OF WASHINGTON THEATER**

An investigation of the causes of the failure of the roof of the Knickerbocker theater, in Washington, D. C., when 97 people were killed and 135 injured, has been made by a committee of the Washington chapter of the American Association of Engineers. The committee consisted of N. D. Mitchell, chairman, and W. G. Noll, L. M. Neel, W. A. Slater, and J. A. Cliff. The features of the theater building that most deserve criticism, according to the report of the committee, were nine in number, as follows:

1. Support of main truss on a thin wall lacking solidity and mass.
2. Support of main truss on a skew bearing, combined with lack of stiffness in connection between the end post and lower chord of truss.
3. Failure to anchor trusses and heavy beams into walls.
4. Scant bearings at walls.
5. Insufficient section areas, and inadequate details of truss members.
6. Inadequate column bracing.
7. Absence of lateral support of intermediate panels of a main truss.
8. Absence of diagonal bracing between other trusses.
9. Inadequate strength of roof slab.

The committee expressed the opinion that every one of these nine items required correction to make the building safe, but that the correction of the first three alone would have postponed the failure of the roof. The conclusion drawn by the committee was that the construction of this building violated the building laws of the District of Columbia in many respects.

news of Engineering
 Progress Chicago
 Bulletin # 96

Cml. Chas. A. Isoddard 5626 d. rington Place Los Angeles
 Cml. M. E. Armstrong Austin, Minn.
 POPULAR MECHANICS
 Calif. Journal

THIRTY-YEAR-OLD BICYCLE WITH WOODEN FRAME

8673

At first glance a person would say that there was nothing strange about an old bicycle found in a Los Angeles shop, but



Nine Strips of Hickory Wood were Used in Making This Bicycle Frame, but They are So Skillfully Joined That It Has the Appearance of One Piece

a closer inspection shows that the frame and forks are made entirely of hickory wood. Built 30 years ago when steel frames were very massive, this bicycle weighed 10 lb. less than the standard machine of those days.

PRACTICE CHART OF KEYBOARD ON TYPESETTING MACHINE

8725

So that persons who are studying to become typesetting machine operators may practice at home, a copyrighted chart has been prepared which shows all the characters of the standard keyboard and

the location in which they occur. In use, the chart can be fastened to a board or table top, which should be inclined to form about the same angle as the regular keyboard.

FRAMELESS WINDOW REPLACES SHIP'S CIRCULAR PORTHOLE

A notable feature of the modern passenger ship is the change from the old restricted circular porthole to a square type of window of generous proportions. The improvement is comparable to the change ashore from the old diamond pane to the balanced window sash. But, of course, at sea the ordinary framed window sash will not stand the exposure to spray and rain, where water-tightness is essential, without constant care and attention. For this reason a frameless window has been devised which consists entirely of thick plate glass with well-smoothed edges. The windows are now being installed quite extensively in ships built in England. They are used in all deckhouses, charthouses, and on the bridge. The window is a highly polished sheet of glass, its finished edges sliding in brass guides, thickly lined with felt. A handle is fixed at the top of the window, with which it is raised or lowered. It rests upon a double set of levers, hinged together so as to move in and out, on the well-known lazy-tong principle, the lower end terminating in a spring box in which the springs are so designed as to balance the window in any position. This is all housed in the wooden framing below the window, and at the top of the framing is a small brass handwheel which acts upon the guides so that they hold the window tight against vibration and leakage.

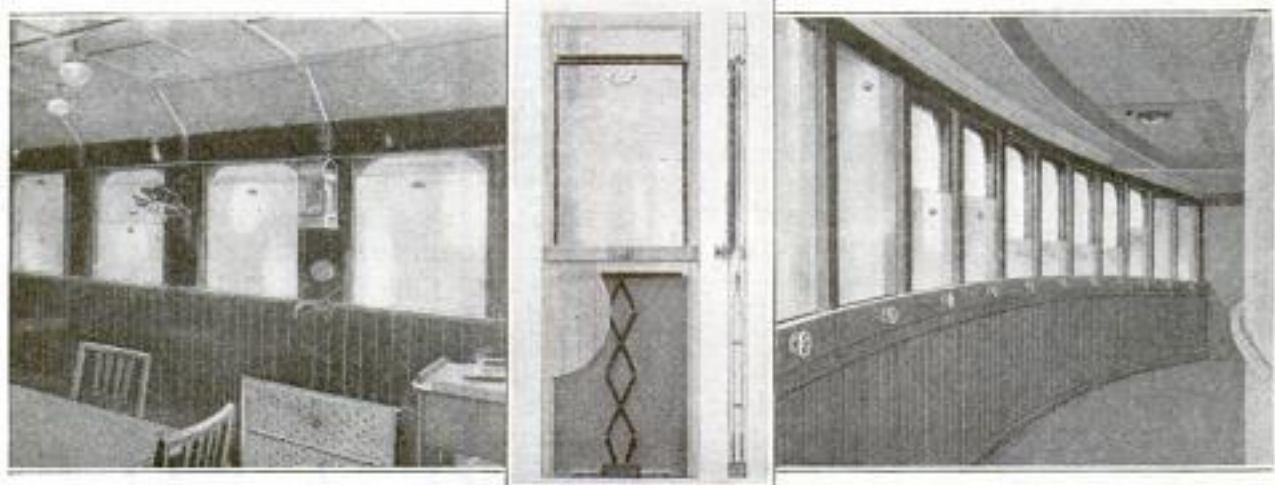

Balanced Frameless Ship Windows. Shown in Two Deckhouses, Illustrating Their Superiority over Old-Fashioned Round Portholes: In the Center Are Sectional Views, Showing Balancing Arrangement on a Double Set of Levers, like Lazy Tong. The Small Handwheel above the Levers Tightens the Window to Prevent Vibration

Becket, Laywell, & Watkinson
 Willisden, London, N. W. England.
 Copyrighted Material

8608

Cont. H. E. Thomas

911 Blunckley Ave.

POPULAR MECHANICS

701

Portland Oregon



Waterworks Project. Showing the Dam Which Controls the River: Beginning at the River Just above the Dam can be seen the Canal That Leads to the Screen House. From the Screen House the Water is Carried through a Narrow Channel Leading to the Pipe Lines

8608
ABSOLUTE CONTROL OF RIVER WITH WATERWORKS DAM

Controlling an entire river has been achieved by engineers of a waterworks project which supplies Portland, Ore., and which was lately completed about 20 miles east of that city. By means of a dam, 30 ft. high, the water is caused to pass through a canal, 30 ft. wide, 10 ft. deep, and 200 ft. in length. This canal has a screen house built upon it for removing gravel, or any other foreign matter, from the water, and leads to a pond from which are laid huge pipe lines to the reservoirs of the city. Besides giving absolute control of the water and eliminating the debris, the undertaking furnishes an additional 30-ft. head on the waterworks system.

8668

ALIENS TO BE DEPORTED MAY BE HELD FOUR MONTHS

According to a decision recently handed down, undesirable aliens to be deported may be held by the authorities only four months. If action is not taken within that time, the alien may obtain his freedom on the grounds of "unlawful imprisonment."

St. Louis Post-Dispatch
 1/3/22

8580
SMALL ELECTRIC APPLIANCE POSSESSES MANY MERITS

Electric Household

Frying eggs, toasting bread, boiling water, or making coffee, and providing better illumination, are several of the uses to which a small electric heater may be put. The appliance weighs but 3 lb., is finished in polished copper or nickel-plate, and has a screw-type element of 615-watt capacity, which can be removed for interchanging with a 15-watt lamp. An adjustable spot-welded guard is furnished with the outfit, so that different articles can be placed at varying distances above the heating element.

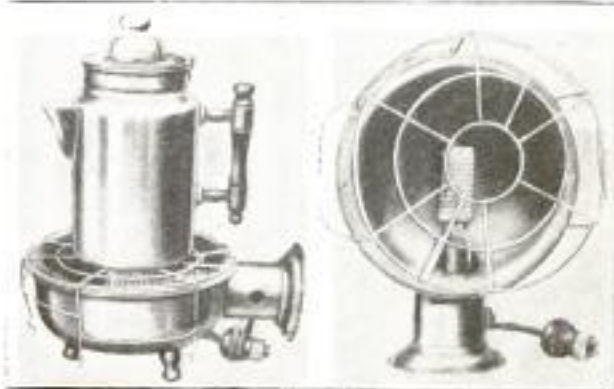

Left: Small Electric Appliance being Used to Heat a Coffee Percolator. Right: Same Appliance being Used as an Ordinary Heater

W. 39 St. New York City
 Copyrighted material

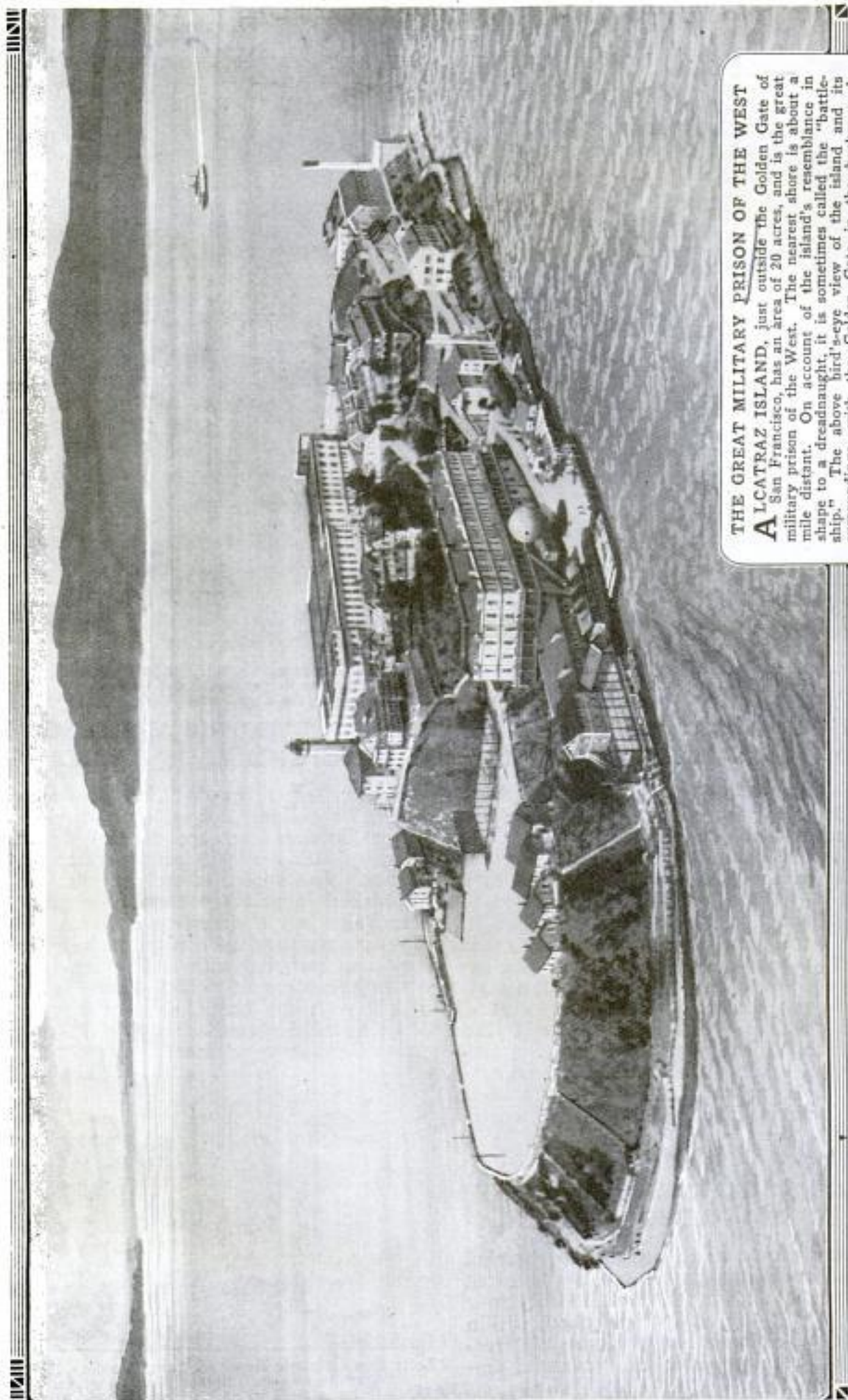

THE GREAT MILITARY PRISON OF THE WEST

ALCATRAZ ISLAND, just outside the Golden Gate of San Francisco, has an area of 20 acres, and is the great military prison of the West. The nearest shore is about a mile distant. On account of the island's resemblance in shape to a dreadnaught, it is sometimes called the "battle-ship." The above bird's-eye view of the island and its surroundings, with the Golden Gate in the background, was photographed from an airplane.

8392 *Emb. William R. Reimcke*
184 1/2 La Salle Ave.

POPULAR MECHANICS

703

**ASBESTOS INSULATING MATS
HAVE MANY ADVANTAGES**

Asbestos mats as insulating coverings for boilers, steam cylinders, turbines, and similar machines, have been used for the last 20 years almost everywhere excepting in the United States, which is somewhat surprising considering their advantages. These mats, made preferably of South African blue asbestos, contain neither wire nor cotton carrier, and have great strength and durability. Their great advantage is the ease and rapidity with which they can be fitted as a cover for an object of very irregular shape, such as a locomotive, in which 10 or 15 strips of matting will do the work

better, and in far less time, than with the ordinary block sections. These mats can be made in very large sizes, indeed in any size desired. The fiber filling possesses great strength and lightness.

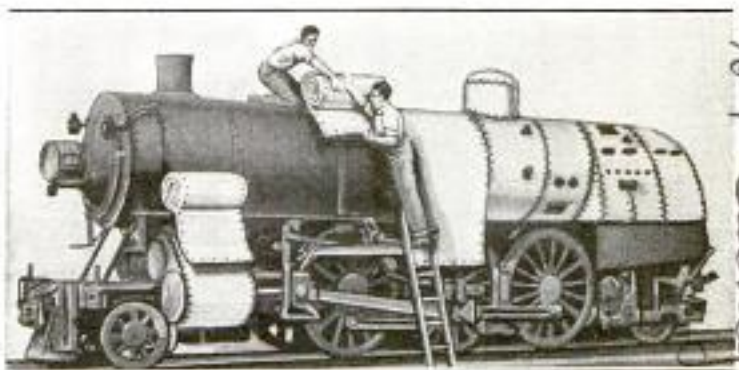

Locomotive, with Its Irregular Surface, being Covered for Insulation with Extremely Flexible Asbestos Mats, Making the Work Easy and Rapid: The Work can be Completed in Much Less Time Than with the Usual Lagging

**ANIMALS ANÆSTHETIZED
IN SPECIAL CHAMBER**



After the Sick Animal is Placed in the Box and the Air-Tight Cover Closed, the Anæsthetic is Forced In by Means of the Bellows

In a well-conducted zoo the animals receive the finest treatment, and, should one of them fall ill, it is examined by medical experts. In case an operation is deemed necessary an anæsthetic is administered in a special chamber designed for the purpose. This is a stout box fitted with an air-tight cover, and with windows at the sides and in the top, through which the condition of the patient may be noted as the anæsthetic is forced in by the bellows until the proper comatose condition is reached.

**GASOLINE GRADER CUTS
EIGHT-INCH TRENCH**

For the use of contractors and highway engineers, a machine has been devised to take the place of some of the pick and shovel gang. It is a motor-driven trench cutter and can be steered to follow a chalk line. At the side of the machine, an eight-blade rotary spiral cutter makes a trench eight inches wide, true to grade, and leaves the bottom of the trench solid. The blades of the cutter are so arranged that only one blade cuts at a time to a depth of about one inch.



Steered along a Chalk Line, This Machine Cuts an Eight-Inch Trench True to Grade and Leaves the Bottom Solid

Emb. Joseph H. Wiley
2800 3/4 Madison Ave. Peoria Ill

Union Asbestos & Sulphur Co.
169 Quinman St. Chicago
224 W. Huron St. Chicago
Edwards & Carr

*Eslobe Phone Mfg Co
Reading, Mass.*

704

POPULAR

MECHANICS *Frank Bley*
8684 Washington St.

**NEW VACUUM-TUBE AMPLIFIER
AID TO PARTIALLY DEAF**

8613

Considerable progress has been made in the development of telephonic hearing aids for the partially deaf, but the limit



Telephonic Hearing Aid Which Employs a Vacuum-Tube Amplifier: Insert Shows the Instrument with the Case Open at the End

had apparently been reached along this line until the new vacuum-tube amplifier was produced. This tube, the result of the efforts of many inventors, consists primarily of a small electric bulb having within it a filament, a spiral wire called a grid, and a metallic plate, all in the order named. An electric current is caused to flow constantly between the filament and the plate in the tube employed in one of the latest hearing instruments. Sound waves striking upon the transmitter of the apparatus, are carried to the grid and greatly amplified by the effect of the current flowing between the filament and the plate, before ultimately reaching the receiver. A rheostat regulates this current in the tube, and correspondingly controls the volume of sound in the receiver, so that the user of this particular instrument is enabled to adjust it so as to conform to his peculiar degree of deafness. The outfit is compactly mounted in a small leather-covered case not unlike the ordinary camera for size, and weighs but 6½ lb., so that it can be carried conveniently on the street, to the church, or theater, as well as proving invaluable in the home. This latest hearing aid is simple of operation and will yield a natural reproduction of voices to persons thus afflicted.

*Cont. S. W. Winters
702 District National*

**TREATMENT FOR CITRUS FRUIT
MAKES ICING UNNECESSARY**

After the grower of citrus fruits has successfully combated adverse weather conditions, blights, and pests, and finally has the ripened fruit ready for market, he still has to face the problem of delivering that fruit to market before it spoils. Under average conditions, this means that the time elapsed from the tree to the consumer should be about 15 days, even when the fruit is precooled and shipped in refrigerator cars. Now, however, this condition may be changed if a new chemical treatment fulfills the claims that are made for it. By this method a chemical emulsion in paraffin is brushed over the fruit as it passes to the packing bins. The chemicals kill all germs and agencies of decay, and then evaporate without leaving taste or odor, while the paraffin seals the fruit air-tight and prevents withering and evaporation. It is claimed that fruit so treated has stood for three months, and when cut, was found to be as firm and juicy as when picked.

8566 _____ *8566*

**SPECIAL RACING AUTO HAS
VERY NARROW BODY**

In the making of automobile-speed records the question of wind resistance is of utmost importance, and special attention is paid to bodies designed to reduce it to a minimum. In one of the modern speed wagons the streamline body is only 20 in. wide and barely provides room for the driver, whose head only is exposed when seated. This car has covered a mile in the remarkable time of 22½ seconds.

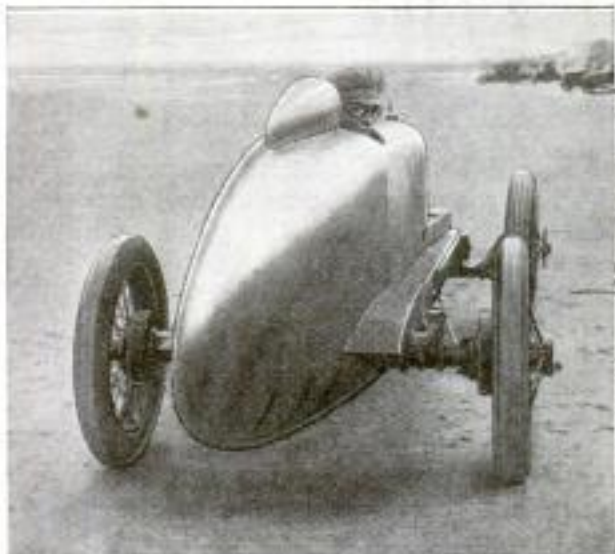

This Modern Speed Buggy Has a Streamline Body Only 20 Inches Wide

*International
Newsreel Corp.*

Vertical text on the right edge of the page, including names like 'Richardson', 'Haworth', 'Carter', 'Ding', 'Haugdahl', 'Wasserman', and 'Hill'.



BEHIND THE MENAGERIE GUARD ROPES

By Frank Braden

*Windsor Cleflox Club
Chicago*



THERE'S a saying in the circus zoo when a new attendant, disregarding the warnings of old-timers, becomes careless while working about the cages. "Here's a new animal trainer," the veterans will remark, as they watch the fresh helper petting a tiger or a leopard. They know that it is only a matter of a few days until the "cat" will lash out with its claws unsheathed and rip the arm of the newcomer. They also know that nothing will teach this type of attendant the alert carefulness necessary in handling wild beasts but an ugly scratching. They can only hope that the man's hurts will be slight. He must have a lesson. He must realize that all animals are dangerous at all times, even if some are more so than others.

One often hears it contemptuously remarked that such and such a beast in an act is "just a mangy, toothless old lion," but often that mangy, toothless old lion, because of its age, is more danger-

ous than its mates in their prime. The old lion is testy, and no matter what its years, it carries a wallop that will break the back of a horse—a wallop backed by ripping claws. Some of the world's foremost trainers, working with the same beasts in acts year after year, have paid for the slight carelessness that familiarity with and affection for their jungle pets have insidiously brought about. At an unexpected diversion—the overturning of a pedestal, for instance—the animals have leaped upon their mentor, but with the element of complete surprise absent, for no real wild-animal expert is caught completely unaware by a beast's leap. The trainer knows one saving fact—the animal must set itself to spring.

Not long ago Louis Roth, one of America's front-rank trainers, was rehearsing a troupe of eight Royal Bengal tigers in the steel-bound circus arena. The beasts were sulky, snarling, spitting as they resisted the forcing with whip and slender bar carried by the trainer. Time and again Roth had driven the animals to their seats on a semicircle of pedestals, only to have them leap to the



"When, to the circus people gazing breathlessly on, it seemed that 'Prince' was in the very act of springing on his trainer, Roth calmly turned his back and swung his snapping whiplash at the other cats."

ground as he turned away. The real battle of wills had attracted a large number of the circus folk to the vicinity of the arena. They stood watching anxiously, for they realized that Roth was in trouble, and that he must conquer or lose control of the finest group of Bengal tigers in the

land. Of all those present, Louis Roth once slipped and fell in the arena when he was "performing" 18 African lions. All the beasts leaped for him at once. Naturally, they struck one another as they met in full flight over his body. Immediately there started the fiercest lion fight in the history of show business—a tremendous battle, with Roth underneath the roaring, ripping, slashing mass of maddened beasts. Attendants, with steel rods, revolvers, and flares, worked like mad, as the trainer, cool even beneath this jungle bedlam, lay perfectly still, waiting a chance to work his way from under the mass of writhing, fighting lions to the door of the great steel cage. Finally, attendants forced the fighting away from Roth, who battled his way out, his clothing ripped into shreds, his body bleeding from 42 cuts.



"He stood between the two largest of the group, with his arms around their necks, their faces pressed against his own. Slowly, irresistibly, the tiger on his right straightened, suddenly to turn and sink his fangs into Roth's right cheek, the long teeth meeting over the trainer's jawbone."

far the least perturbed. He had to win. He knew it, and he forced the issue with the tigers with relentless purpose. Again he drove them to their seats, firing blanks in his revolver, as "Prince," the largest of the group, struck at him blindly, viciously. When, to the circus people gazing breathlessly on, it seemed that "Prince" was in the very act of springing on his trainer, Roth calmly turned his back and swung his snapping whiplash at the other cats. When he finished his work with the animals, Roth was asked how he dared turn his back on "Prince." "He was bluffing!" exclaimed the trainer. "I could tell by his eyes and his muscles that he wasn't set to spring. When a tiger

springs he must get set; he must contract his muscles, measure his distance, switch his tail, as though it were a rudder. The cat does all this in a second, but a good trainer knows, and has time to disconcert the beast with rod, whip, or gun fire."

However, if a number of cats spring together, the trainer is fortunate, indeed, who comes alive through the ordeal. Roth once slipped and fell in the arena when he was "performing" 18 African lions. All the beasts leaped for him at once. Naturally, they struck one another as they met in full flight over his body. Immediately there started the fiercest lion fight in the history of show business—a tremendous battle, with Roth underneath the roaring, ripping, slashing mass of maddened beasts. Attendants, with steel rods, revolvers, and flares, worked like mad, as the trainer, cool even beneath this jungle bedlam, lay perfectly still, waiting a chance to work his way from under the mass of writhing, fighting lions to the door of the great steel cage. Finally, attendants forced the fighting away from Roth, who battled his way out, his clothing ripped into shreds, his body bleeding from 42 cuts.

Another time, Roth was winding up a tiger act with an exhibition of superb confidence in his control. He stood between the two largest of the group, with his arms around their necks, their faces pressed against his own. Slowly, irresistibly, the tiger on his right straightened, suddenly to turn and sink his fangs into Roth's right cheek, the long teeth meeting over the trainer's jawbone. One can imagine the agony of it, but Louis Roth held himself absolutely still. With the smell of the blood reaching the tiger on the left, the slightest movement, reasoned the trainer, meant that beast's turning to crush his shoulder or jaw on that side. With infinite care, with almost imperceptible effort, Roth ever so slowly disengaged the fangs of the first tiger from his face. Then he slowly stepped back—and fainted. Alert, loyal helpers, who had

watched their chance from the door of the arena, rushed in firing blanks, and dragged him to safety. When Roth was able to stand, with his wounds roughly bandaged, he stepped into the arena again and raced the two tigers through a routine of tricks. He did this to maintain his control over them, and it was less than a week before he was again doing his cuddling pose with them, his arms affectionately about their necks.

Naturally, trainers that have worked the same group of wild animals year in and year out, grow more or less fond of their charges, and in spite of their knowledge of the beasts' inherent treachery, become too confident of their ready obedience. There is a celebrated woman trainer—Martha Florine—who worked the same group of tigers for 10 years. Each day she rode in parade in the cage with her animals, sitting in a chair with her feet resting on the neck of the largest of them. While the cage was rolling along in the main street of a western city two years ago, the tigers leaped upon her without warning. They knocked her to the floor of the cage, as the crowds along the curbs screamed in horror. The door to the cage was

locked, and the drivers and parade marshals, who ran to the rescue, could not get in. A man with an elephant hook beat several of the tigers off the unconscious girl, saving her life although she was terribly lacerated, before an ax could be secured in a store and an entrance to the cage effected. She was six months recovering from her wounds, but she is working the same tigers now.

The layman often wonders how the first step in obtaining control of and training wild animals is gone about. Usually the cat animal—lion, tiger, leopard, puma, or jaguar—is "collared," that is, a collar is snapped on its neck, and the beast is held in check by a chain, the end of which is in the hands of attendants outside the steel training arena. The trainer enters the cage in safety and guides the animal to a stool or pedestal, on which he urges it to take position. No animal is beaten into doing the trainer's will, as some suppose. To punish an animal in early teaching is ruinous, and only when it knows what is wanted and refuses, is it touched with a whip. It will be noticed by the close observer of wild-animal acts that no beast is touched with a whiplash while it is on the ground. A surly, combative brute is flicked with the lash or tapped on the nose only when it is on the pedes-

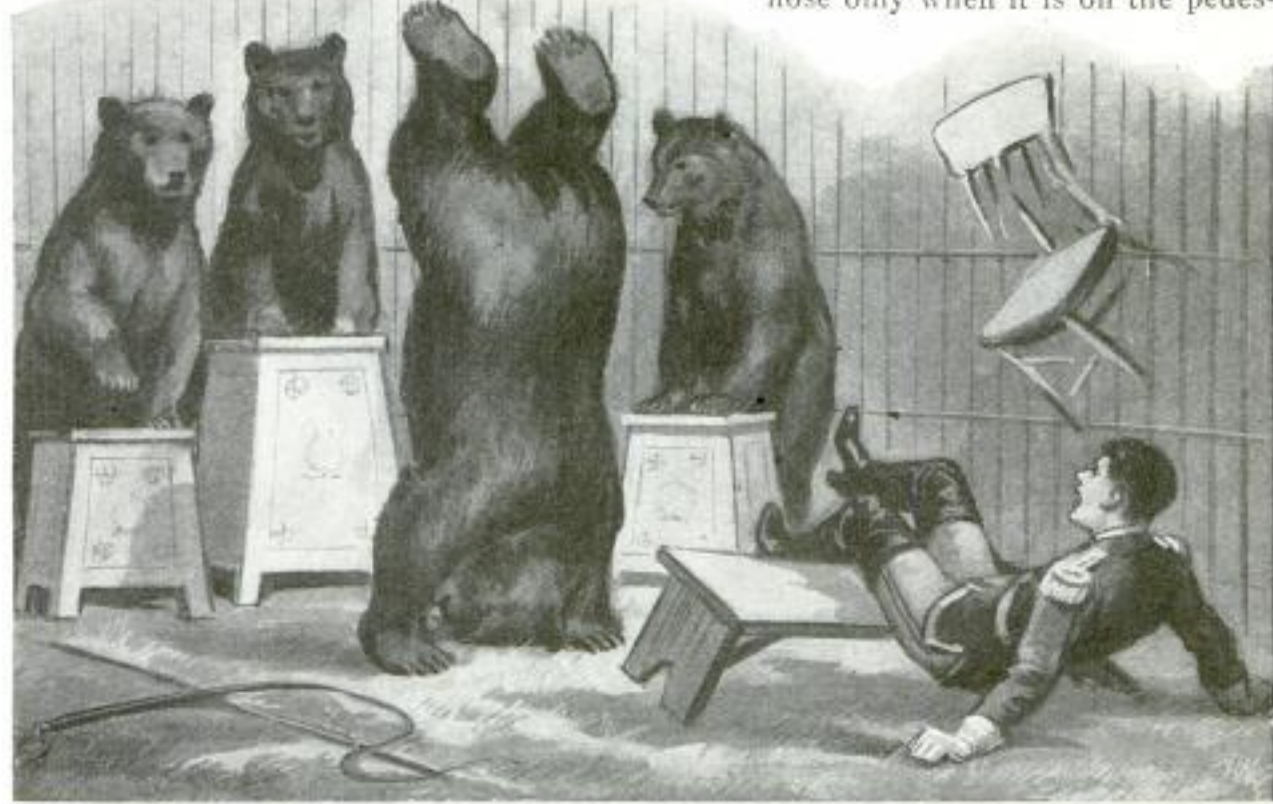

"As the trainer grabbed a rod, the bear sent it spinning and knocked Barry over a bench. . . . The manager, apparently unmoved by Barry's mishap, stood outside yelling: 'Great! Good stuff! Keep it up!' Barry, alternating between justifiable anger at the manager and fright, was astounded to see the bear calmly take position and stand on his head!"

tal. There is a good reason for this. The animal first feels the lash when it is learning to jump on and off the pedestal at the trainer's command. It is then on the chain leash, and if it attempts to spring at its taskmaster, the chain checks it abruptly. Later, when it is unleashed, the

who had had marked success with domestic animals, was prevailed upon by the manager to put the bears through their paces in the center arena. It was in Roseburg, Ore., that Barry, clad in a blue-and-gold suit and patent-leather boots, made his bow from the circle of bears. Everything went splendidly until Barry attempted to make the big bruin stand on his head. He gave the animal the cue for the trick, but the brute had become interested in some green grass that had not been trampled down in the arena. He ignored Barry's cue and nibbled unconcernedly at his find. The young trainer smacked him with his whip. Before Barry could move, the bear had knocked

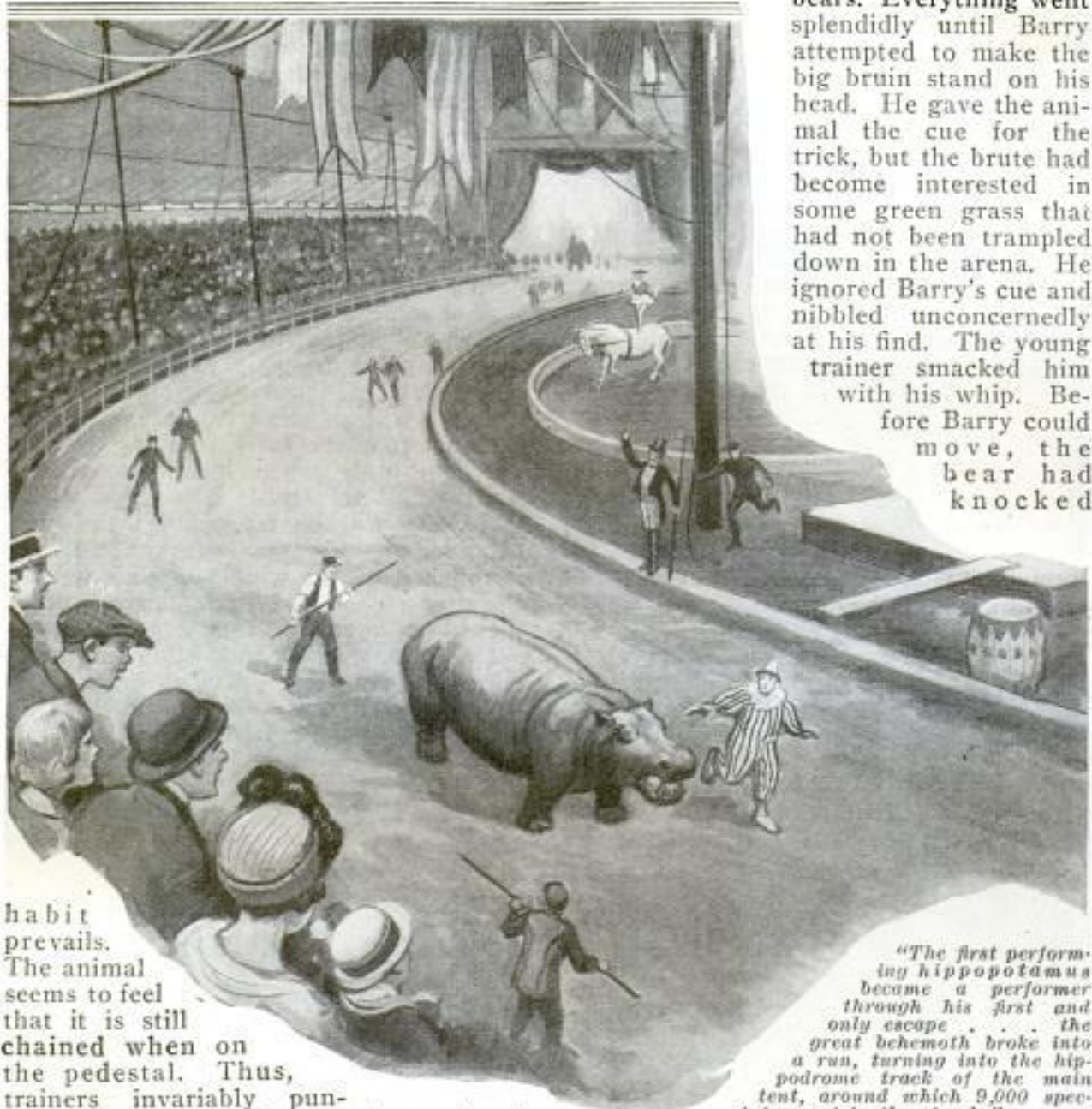

habit prevails. The animal seems to feel that it is still chained when on the pedestal. Thus, trainers invariably punish refusals while the beast is so placed. The danger of a spring is thus minimized. Of course, too much trust cannot be put in this mental trait of the performing cat, as has been shown above in Louis Roth's experiences.

Charles Barry, a leading American trainer, made his debut in a wild animal arena with a troupe of performing bears. Because of the fierceness of one of them—a huge cinnamon—several trainers had failed in presenting the act. Barry, who had shown especial aptitude as an aid and

his whip from his hand. As the trainer grabbed a rod, the bear sent it spinning and knocked Barry over a bench. As he fell, Barry grabbed a chair, but before he could raise it, the bear seized it and threw it against the arena bars. Attendants then pushed the bear back with rods and gun fire, while Barry leaped for his whip and the door. The manager, apparently unmoved by Barry's mishap, stood outside yelling: "Great! Good stuff! Keep it up!" Barry, alternating between jus-

"The first performing hippopotamus became a performer through his first and only escape . . . the great behemoth broke into a run, turning into the hippodrome track of the main tent, around which 9,000 spectators sat in the stands."

tifiable anger at the manager and fright, was astounded to see the bear calmly take position and stand on his head! The young trainer then showed his mettle. He doffed his cap and made his long-delayed bow. As he did so, the bear righted himself and nipped him on the boot. Barry again tapped the brute—viciously and in wild anger—and the bear took another head stand with entire docility. The act was finished without further untoward incident, and Barry worked it with credit throughout the remainder of the season. However, the manager often expressed regret that Barry did not put in the "hippodroming" that featured his maiden effort. "It was the biggest hit I ever saw in a wild-animal arena," he would remark.

Many accidents and escapes of wild animals occur in a circus menagerie, of which audiences in the big top adjoining fortunately know nothing. There is the celebrated case of the first performing hippopotamus, which became a performer through his first and only escape. This animal, which is not vicious, crawled from his tank during an afternoon performance, and was first discovered as he was making his way into the big top. A menageric man attempted to head him off, but the great behemoth broke into a run, turning into the hippodrome track of the main tent, around which 9,000 spectators sat in the stands enjoying the show. True to circus tradition, there was no confusion among the performers or other employes of the circus, but ringmasters and property men raced to head the hippo and turn him back. Now, be it known, a full-grown hippopotamus, huge and awkward as he is, can outrun a fleet-footed man. This hippo astounded the circus employes by breaking into a sprint and circling the track before the audience had the least idea that anything was wrong. Hardly had the announcer bawled his "Keep your seats, good people!" before the hippopotamus completed the circle, turned again into the menagerie, and crashed headlong into the aviary wagon, with the result that tropical birds were flying all over the place in no time. The hippo stopped short and moved over to the elephant lines, where he placidly helped himself to the pachyderms' hay, without

alarming those huge beasts in the least. He was returned to his cage, the birds, with few losses, housed in makeshift cages, and the big show went on without a "bobble." However, the trainers had been shocked into a big idea. They would train the hippopotamus to circle the hip-

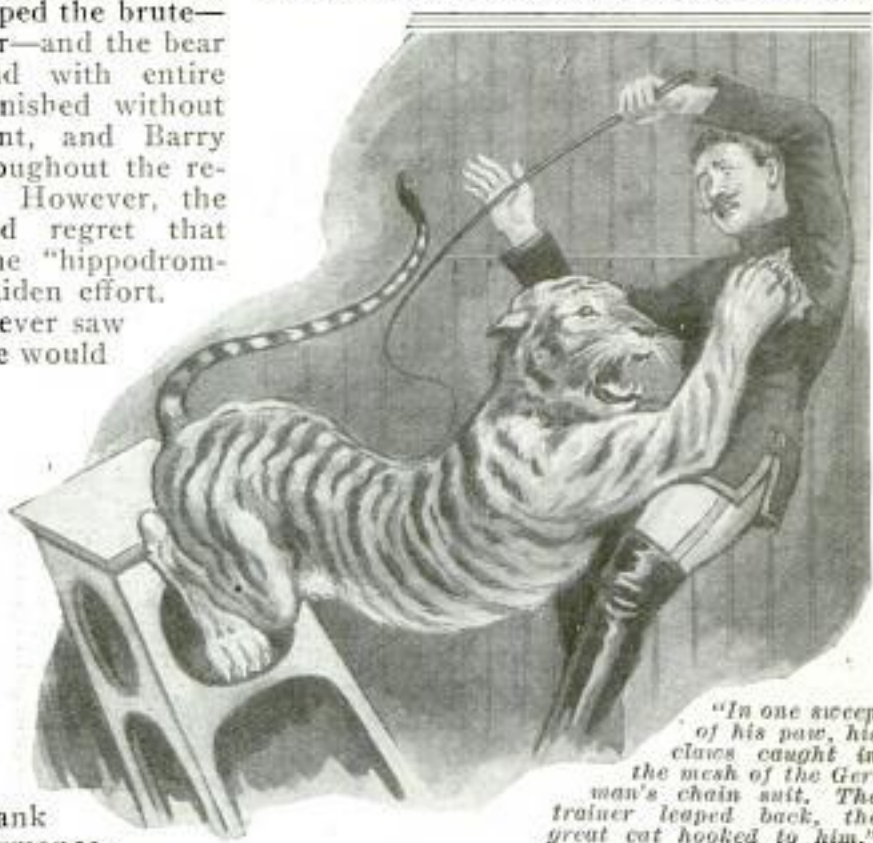

"In one sweep of his paw, his claws caught in the mesh of the German's chain suit. The trainer leaped back, the great cat hooked to him."

podrome track—but under control. This they did the following winter, and only a small whip is now needed to guide the lumbering creature, which, however, is never urged out of a walk. It is a big feature of the show today, but the audience that saw the incident which inspired it, will never forget the speed made by the ponderous, short-legged "blood-sweating behemoth of Holy Writ"—nor will the circus people, for that matter.

The hippopotamus is only dangerous when he charges, and then by reason of his great bulk and through his habit of ramming with his heavy snout. However, his charge is diverted and halted by animal men with whips, who have but to strike him on the head, even tap him, to change his course and slow him up. When the hippo mentioned above circles the track, the attendants keep flicking him with whips on the side of his face toward the audience. This keeps his gaze toward the rings, and should he start to charge, he could easily be halted before any damage, except to circus paraphernalia, perhaps, could result.

There is in the Salt Lake zoo now a

787

lion by the name of "Brutus," a great, splendid specimen of the black-maned African king of beasts. "Brutus" has a record as a "bad" lion. He has slashed and torn many trainers. Because of his magnificent appearance, every effort was made to subdue him. The best trainers in America "worked" him; and they all bear the scars of "The Order of Brutus," as the zoo men termed the group of wild-animal men who were roughed by the mighty cat. Once a great German trainer announced that he had succeeded in working "Brutus" in winter quarters with a polar bear. He took the manager of the circus and a party of friends to the animal barn to view the act. The lion and the polar bear were turned into the arena together. "Brutus" instantly leaped on the bear, killing it. He then literally ate it up, and the combined efforts of the German trainer and his helpers could not separate him from his kill. Some time later Charles Barry entered the steel training cage with "Brutus." The lion wasted no time, leaping 15 feet at the trainer, who managed to dodge. "Brutus'" head struck the steel bars, and he was dazed. Before he could spring again, Barry knocked him out with a bar. The circus manager then gave orders that "Brutus" was through as a performer, and forbade any trainer entering his cage. The animal was shortly afterward sold to the Salt Lake zoo, where he is securely housed—the finest lion on exhibition anywhere in America.

There is the story of one of Bostock's trainers, who volunteered to subdue a "bad" tiger—a Royal Bengal outlaw. The tiger was a great performer, but he had suddenly turned renegade, killing one trainer and injuring several. The Bostock man, a German of large physique, not only offered to subdue the animal but

promised to present him in the first public performance in Leeds, Eng. Now, the trainer had a plan. He purchased for use in the arena a suit of steel mail, woven to fit him under his uniform. However, his pride prevented his telling anyone with the show about the suit, and as he had encountered little trouble in the training cage with the beast, he saw no reason for any confidences afterward in the matter of his armor. The night of the opening in Leeds, he entered the arena and signaled for the attendants to open the runway gate and let in the tiger. Announcements had been made of the brute's ferocity and almost supernatural strength, and a large audience was present to view the thriller. All went well for a while. Encouraged by his success, the German began to "hippodrome" with his charge: that is, he teased the beast into striking at him as the animal sat on the pedestal. The cat was in a fine performing humor, striking and snarling in a semblance of fury. However, in one sweep of his paw, his claws caught in the mesh of the German's chain suit. The trainer leaped back, the great cat hooked to him. Both lost their heads, the tiger bounding, screaming, spitting as it leaped, rolled, and thrashed about, apparently tearing the man into ribbons. Women fainted and men shouted their terror. The cat was unable to extricate his claws, and in the hubbub, the German could not make the helpers understand why they could not drive the tiger from him. At last, a terrific blow on the head stilled the beast, and the claws were extricated from the mesh. The trainer suffered only a few minute scratches, but the audience, which had almost stampeded from the circus building, was convinced it had seen a man eaten alive by a jungle demon.

apparatus Acquire
Hanna

RADIO GARTER LATEST FAD FOR WIRELESS FANS

Feminine wireless fans will be interested in the introduction of a tiny radio set which is made in the shape of, and is worn as, a garter. Wire is coiled around a piece of cardboard, which is covered with silk, and attached to this are two ordinary eyeglass snap chains, one fastened to the foot and furnishing the ground, while the other is affixed to a coil of wire in the hat and forms the aerial. A small bottle containing the necessary crystal, or rectifier, and a receiver complete the apparatus, which has undergone tests and proved practical.



Above: Radio Garter, Showing the Receiver, Crystal, and Snap Chains. Left: Illustrating How the Radio Garter is Worn and the Manner of Using It

8585
Encl. Walter P. Miller, 70 Seattle
v d m. Post-Intelligencer, Seattle, Wash
Copyrighted

Associated Science Authors,
5 Columbus Circle, New York City
SCIENTIST INVESTIGATING "MOTH RADIOGRAMS"

8225

By L. D. LOTTON

MOTHS and some other insects have a very mysterious way of communicating with each other. The female moth may be caged in a scent and soundproof box, and yet she is able to summon the male moth without apparent trouble. Entomologists have been puzzled by this phenomenon for a long time, and it was recently suggested that a system of radio might be used by the insects. Following this suggestion, a New York scientist, L. C. F. Horle, started to investigate the subject. The ingenious apparatus he employed and the results he has achieved, although not conclusive, are highly interesting.

To the layman, the subject may be more or less confusing, since he cannot possibly understand how a living creature could propagate wireless waves. In the firefly we see a creature that is able to send forth visible rays. Scientists now know that the only difference between visible and invisible waves is a matter of wave length. Wireless waves are long, and light waves are short, but they are both of the same nature. If one insect is able to send forth visible waves, why should

not another be able to send forth invisible waves? In order to send wireless waves

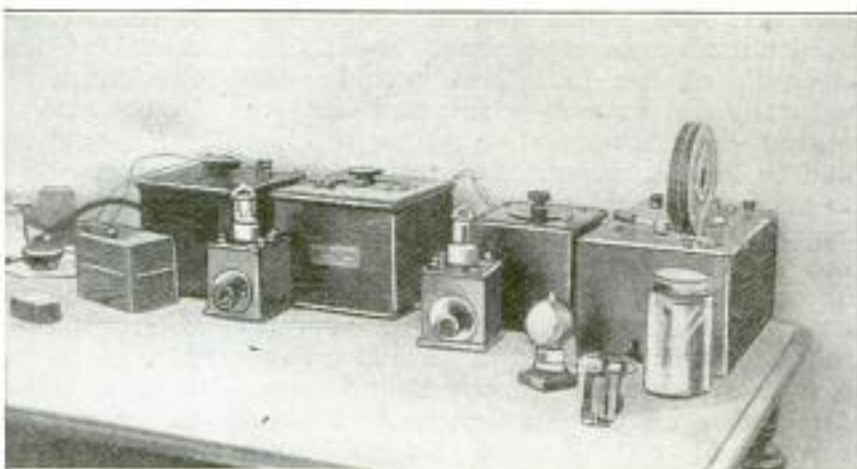

Apparatus Used by Mr. Horle, the New York Scientist, in Investigating the Methods of Communication between Moths, Presumably by Some System Resembling the Propagation of Wireless Waves

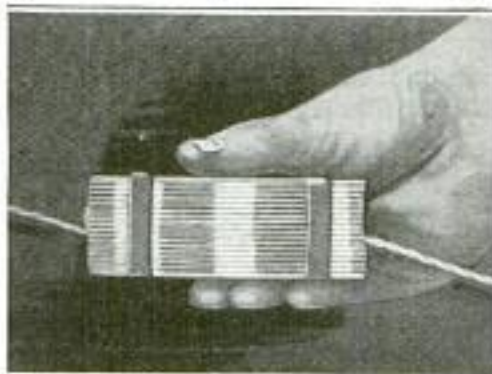

The Sensitive Condenser Microphone Used, Which is Much More Sensitive Than a Telephone Transmitter

from one point to another, we all know that electric power is necessary. We also know that there are certain creatures, like the electric eel, that are able to produce within their own bodies electric currents of very high potential. This proves that a living creature can generate an electric current. In fact, the human heart produces a weak galvanic current at every beat, and this current has been measured.

In watching moths and studying their action, scientists have noticed the peculiar way in which they use their antennæ. When the male is some distance from the female, it will wave its antennæ about first in this direction and then in that, as though it were trying to locate the direction in which a message was coming. After some experimentation in this way, the male will take to its wings and fly off to the female.

The apparatus used by Mr. Horle has been especially developed to respond to very short wave lengths. If the creatures do send wireless waves, they must be

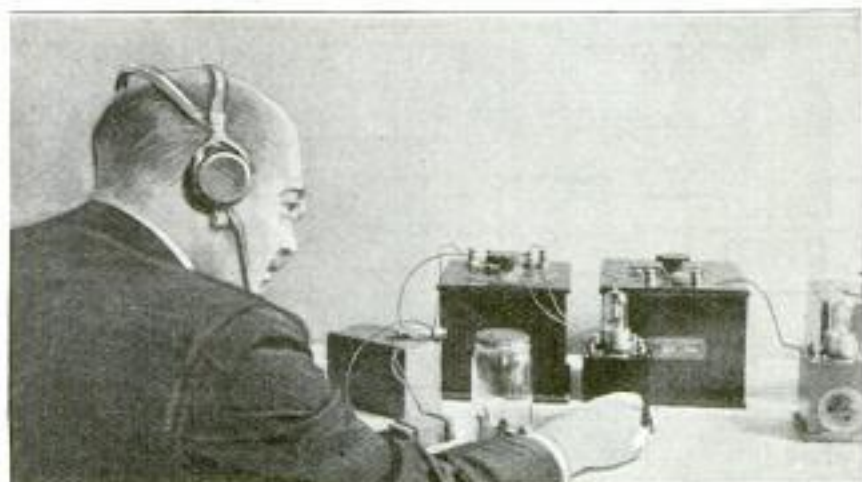

"Listening In" for the Moth Messages: The Female Moth is Imprisoned in the Glass Bottle Seen on the Table. So Far No Conclusive Evidence of the Wireless Nature of These Messages has been Found

Investigated by L. C. F. Horle
New York

of a length that will put them somewhere between those we call heat and the shortest of those that can be called radio. The wave lengths must be short, since the creatures are small and the oscillator used must be correspondingly small. The strength of the radiations would quite naturally not be very great, and for that reason an ultra-sensitive radio receiver had to be assembled. Before he set out to solve the problem by wireless, he first satisfied himself that sound waves were not used. To do this he invented what he calls a "cell microphone," based on a new principle, and used it with a vacuum-tube amplifying device that would greatly increase the volume of any sound waves detected, even though they were beyond perception by the human ear. Although this apparatus was used under the most favorable conditions, no sound was heard that could be identified as insect communication. His radio device, although of great interest to radio technicians, is too involved to be understood in detail by laymen. Since there is no wave meter that will measure the radiation that could be set up by a moth, owing to its smallness, he assembled a receiver which, by successive modulation processes, converted the small wave lengths into those of the usual magnitude. An oscillator of special design was placed in proximity to the insects. The natural frequency of the oscillator was varied to cover a wide range in wave lengths. The small powers produced from the oscillator were allowed

original wave lengths detected were greatly lengthened and the strength of the radio-frequency current produced by them increased to a point where they would be audible. By knowing the electrical constants of the various circuits employed, the length of the original waves detected by the first receiver could be calculated.

An outfit of the nature described above is extremely difficult to handle, owing to the presence of the numerous vacuum tubes. Unless they are carefully watched and regulated, the tubes will set up various noises which would interfere with the reception of moth messages. Although Mr. Horle has not as yet heard anything that could be identified as a message between insects, he believes this means, not absolute failure, but rather that he has not succeeded in getting his apparatus adjusted to a point where it would be sensitive to small radiations of low intensity. Never before has such an outfit been assembled, and it is but natural that considerable experience will be required before results can be expected.

ITALIAN POWER PROJECT USES OLD LAKE BEDS FOR STORAGE

Many interesting conditions are met in the development of hydroelectric power in southern Italy, but one of the most unusual is in the project on the Sila River in Catanzaro. In this mountainous region there were several basins, believed to have been the beds of ancient lakes

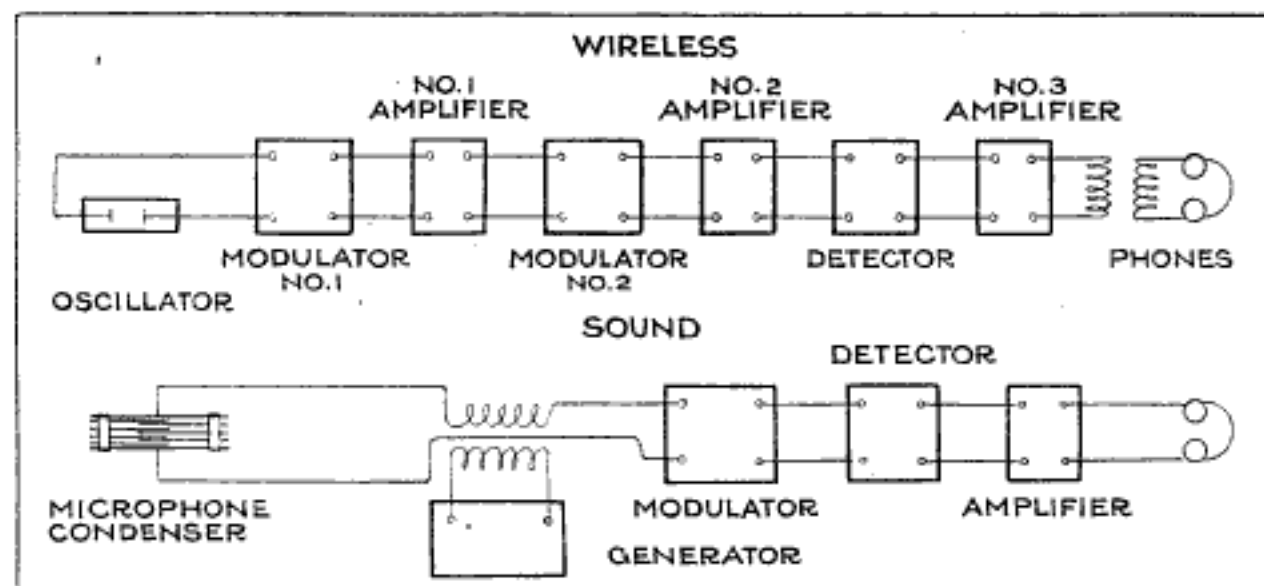

Fully Notated Diagrams of the Apparatus and the Wiring, as Used in Experiments on Sound and Wireless Waves: Lower Diagram Shows the Apparatus Used for Sound Waves, and the Upper One That Used for Wireless Waves

to react upon a radio generator of more nearly usual frequencies. This process was duplicated several times until the

which are now dried up, and these are to be used as storage reservoirs for impounding the water.

The Engineer
Copyright material

8695

CONQUERING MOUNT RAINIER IN MIDWINTER

BY LAWRENCE WILLIAM PEDROSE, *Henckley Blvd.*

Seattle, Wash.

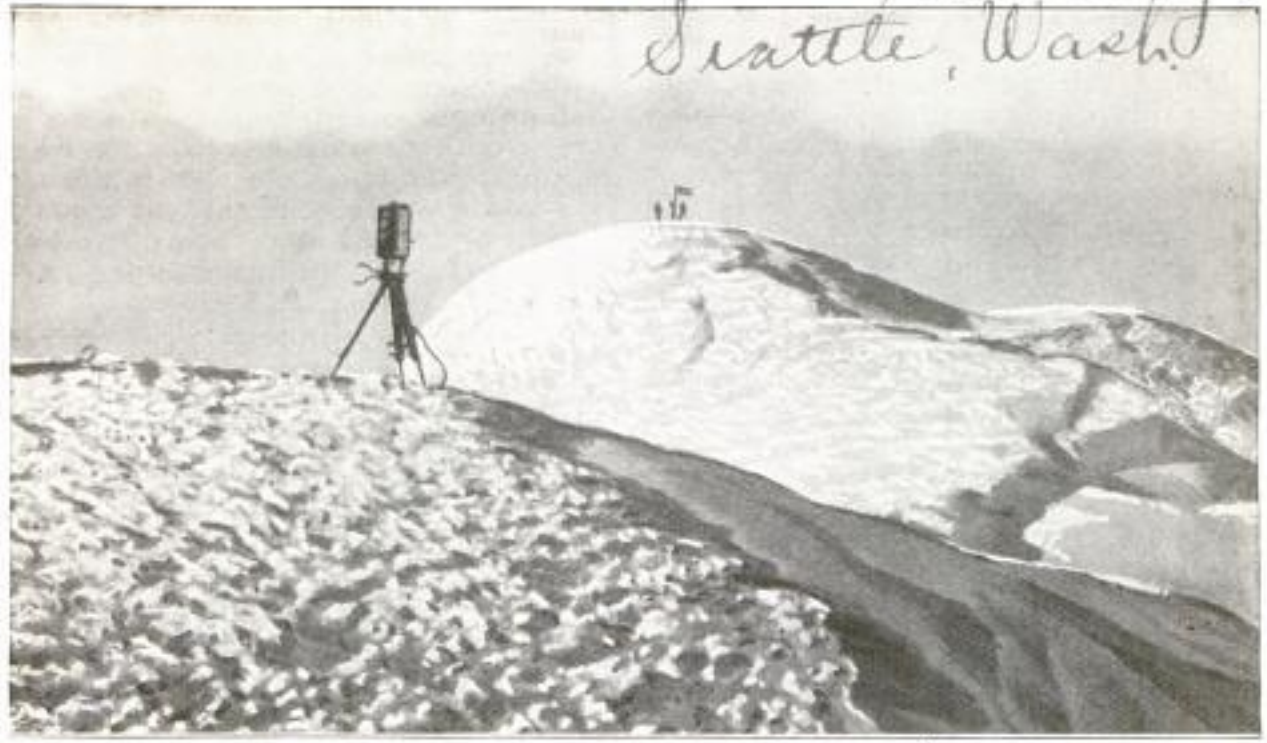

The Summit of Mount Rainier, Conquered for the First Time in Midwinter by a Party of Four Adventurers: The Men are Here Seen Hoisting the American Flag on the Summit, the Climax of a Two Weeks' Struggle with Natural Elements

AFTER a two weeks' contest with storms, four men late in February succeeded in scaling the summit of Mount Rainier, the second highest mountain in the United States. Although in former years many attempts had been made to climb the 14,500-ft. peak in winter, none had been successful.

The climbing party consisted of an American, a Frenchman, and two Swiss. All except the American were experienced alpinists. There was no monetary reward for the climb, and the adventure was undertaken for the sheer love of the thing.

The preliminary work of scaling the

mountain was carried out carefully. Various approaches were reconnoitered, and this precaution took up most of the men's time. The actual scaling of the peak required only five hours, and the return four and one-half hours.

Roped together, 24 ft. apart, with the alpinists in the lead, the men made the dangerous climb, each carrying a pack weighing about 40 lb. At the "Shutes," one of the most hazardous points of the climb, progress was won only by chopping footholds in the ice. At the summit the storm cleared sufficiently for the men to make several remarkable pictures.

Model P545

COVERED TRUCKS HAUL FIVE AUTO BODIES

Long trucks having canvas covers are used to carry all the closed-car bodies from a Detroit factory to an automobile company in Flint, Mich. Each truck, of which there are 10 now in use, is 55 ft. in length, and has a capacity of five bodies. Motorists on the narrow highway find difficulty in passing the long trucks.



Specially Made Motor Trucks Having Long Canvas Covers, Shown en Route on One of Their Daily Trips from the Factory: Each Truck Contains Five Closed-Car Bodies

*Chet Shaper, 90 The Tribune
Flint, Mich*

Cont. Raymond A. Hatcher
103 W. 8th St.
Salem, Ohio

Aeronautics
Accessories
of the
Aircraft

ANGLE OF AIRPLANE'S FLIGHT AUTOMATICALLY INDICATED

Difficulty is experienced by the pilot of an airplane in accurately determining whether he is traveling up, down, or par-

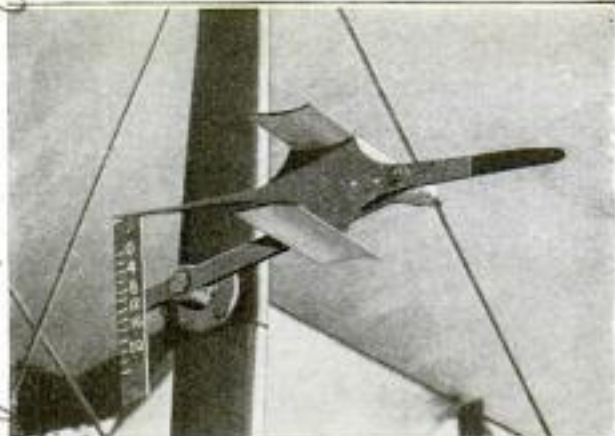

Indicator Fastened to Airplane Strut So the Pilot can Tell at a Glance His Angle of Flight

allel with the earth. The position taken by the plane is termed the angle of attack, meaning the angle at which it is attacking the air, and to determine this an arrangement has been brought out, having a scale which moves with the strut, and a balanced indicator that always maintains a position parallel with the earth. This apparatus is located near the airman, who can easily tell at a glance whether the craft is traveling on an inclined or level course.

LAWN-MOWER GRASS CARRIER WORKS ON NEW PRINCIPLE

An attachment for carrying the grass cut by a lawn mower, which extends no farther back than the old-fashioned can-

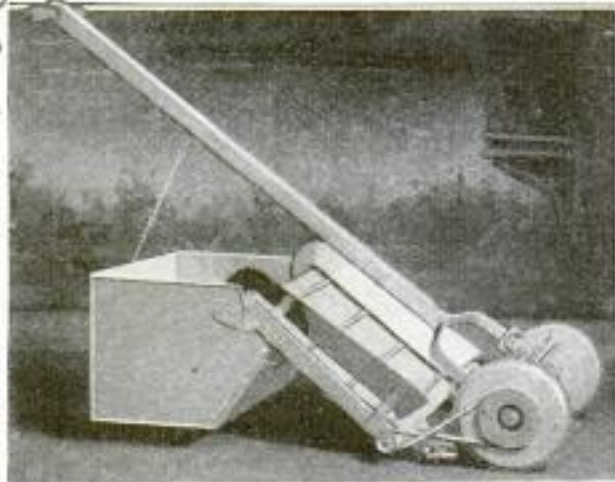

Grass Carrier, Attached to Lawn Mower, Showing the Endless Canvas Belt and the Galvanized-Iron Container

vas basket, has lately been put on the market. The outfit consists of a grass container made of galvanized iron, to which are fastened two wooden rollers and an endless canvas belt. The rollers are driven by a cross belt from the wheel of the mower, and these operate the canvas conveyor, so that the cut grass is constantly carried away from the mower blades and deposited in the large pan.

8589 A NEW INCUBATOR EGG TRAY TURNS ALL EGGS AT ONCE

The present hatching season has marked the introduction of a new type of incubator egg tray which not only adds 25 per cent to the egg-holding capacity of the machine, but also provides a mechanical turning device which turns all the eggs in a few minutes, without removing them from the machine. The eggs are held, pointed end down, in a series of metal cradles which are supported on pivots at both ends. These pivoted ends



In This Incubator Tray the Eggs are Supported in Metal Cradles Which are Pivoted in the Sliding Bars at Their Ends

are carried on a shifting lever which can slide along the side of the tray. By moving the lever, all the eggs are turned in a fraction of the time required by the older method of turning by hand.

8688 ATMOSPHERE OF PLANET VENUS CONTAINS NO OXYGEN

According to spectroscopic studies made at the Mount Wilson Observatory of the light received from Venus, no oxygen-absorption lines are found. This indicates that there is no oxygen or water vapor in the outer atmosphere of Venus, and furthermore that the reflected light of the sun must have penetrated to a considerable depth. It therefore appears necessary to attribute the great brightness of Venus to some other cause than that of high reflective power of water-vapor clouds, and this apparent absence of oxygen must be considered in connection with speculations as to the conditions of the planet.

Cont. C. A. Briggs
1521 Oak St. N.W.
Washington, D.C.

John W. Kraw, Navy Dept.
Bureau of Navigation, Washington D.C.
85104
C. J. Holle, Rushford, Maine

Mr. Converse + Hotel Manager
20 Broad St.
Salem, Ohio

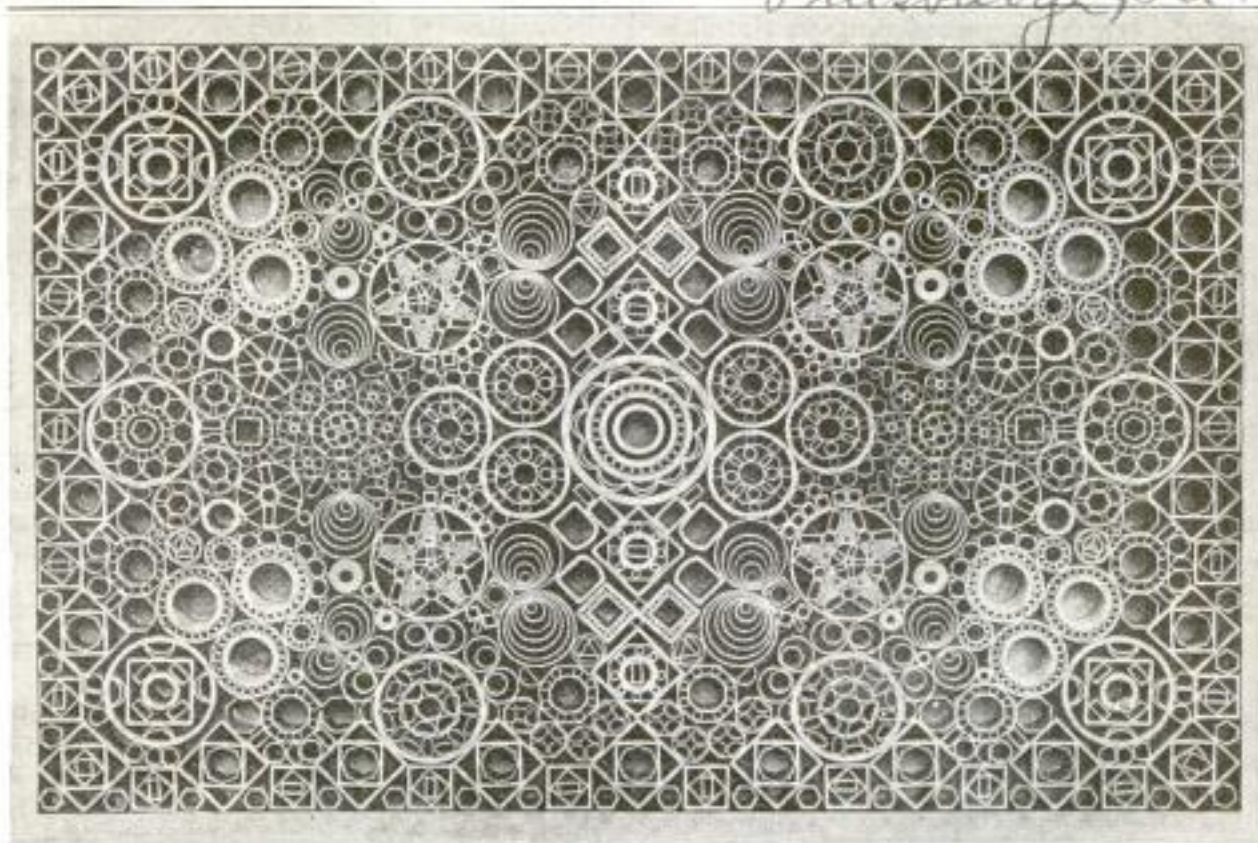

Ornamental Table Top, Showing the Various and Intricate Designs Wrought by the Maker of This Most Unusual Piece of Furniture: The Multitude of Varied Shapes and Sizes Are But the Ends of Seamless-Steel Tubing

8520 ORNAMENTAL TABLE TOP MADE FROM STEEL TUBING

Hundreds of pieces of seamless-steel tubing were used recently in the construction of an ornamental table top, producing a neat and original pattern. As this tubing is made in nearly every conceivable shape and size, the number of designs wrought in the top were limited only by the ingenuity of the maker. Ends of tubes were cut off and these, circles, squares, oblongs, rectangles, ovals, hexagons, crescents, etc., were then imbedded in a soft substance and allowed to "set." After being highly polished and

given a coating of lacquer, this table top is said to be one of the most unusual pieces of furniture ever manufactured.

8503 TRACTOR AND AUTOMOBILE MAKE PIONEERING EASY

Automobiles in place of prairie schooners, and gasoline tractors in place of ox teams, mark the difference between modern and ancient pioneering. After settlement upon the land, the difference is between plowing with a yoke of oxen and a single-share plow at the rate of about an acre a day, and plowing with tractor-hauled gangplows at the rate of

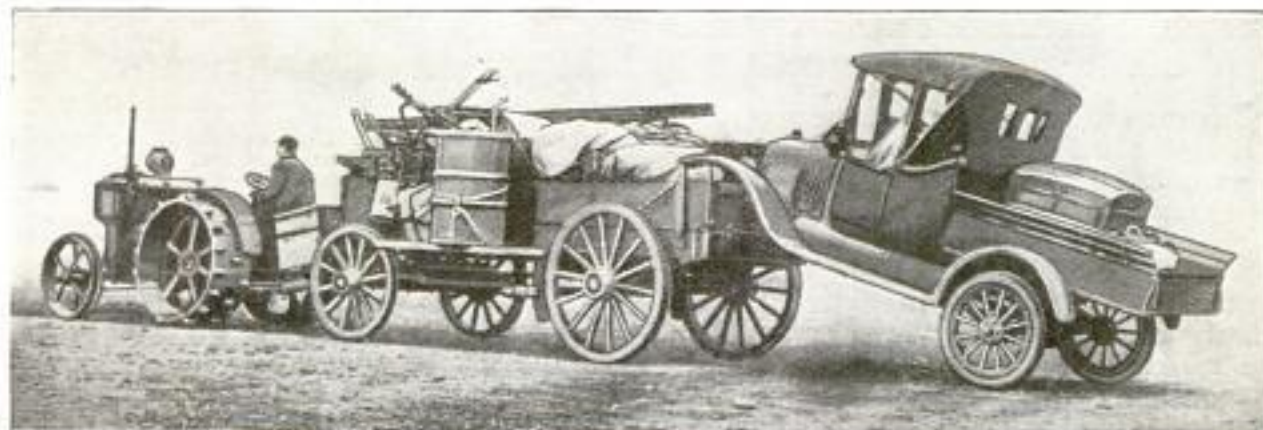

Modern Pioneer Taking a 140-Mile Jaunt on a Tractor Which is Hauling a Load of Four Tons, Including the Indispensable Automobile: Note the Headlight on the Tractor for Night Traveling

Cont. E. & L. Lurgin, 130 Cayman Ave
 Ravine Wis
 Copyrighted material

M.S.A. Journal (Sydney) Jan 15

tens of acres a day, according to the size of the tractor. In a recent instance of modern pioneering, the traveling outfit consisted of a tractor that hauled an ordinary lumber wagon in which were loaded the pioneer's farming and camping outfits, and a gasoline tank. Hitched to this was the inevitable automobile with a truck attachment in the rear, handy for personal baggage. The whole load pulled by the tractor was four tons.

PROJECT VIEWS OF OBJECTS WITH REFLECTING DEVICE

A new form of projection apparatus has been developed abroad which can be

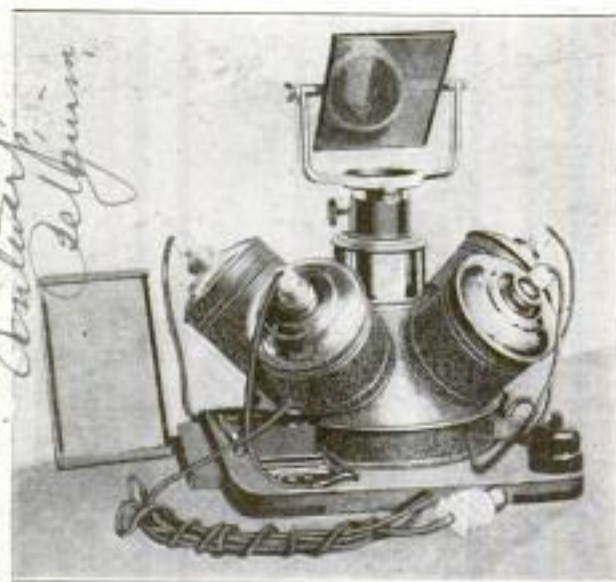

When Placed over Objects, Printed Pages, or Photographs, This Apparatus will Project Views of Them Which can be Thrown onto a Screen

placed directly over the objects, printed pages, or photographs to be shown. Four high-power lights illuminate the object and the view is projected by the lens into the mirror above, which reflects it on the screen.

CHURCH BELLS DEMONSTRATED OVER THE TELEPHONE

An eastern church committee was given the task of selecting a bell, and the chairman called a bell factory by long-distance telephone to arrange for a visit to the plant. While conversing, the tolling of different bells being tested was transmitted so clearly over the wire, that the chairman decided that the selection could be made without going to the factory. Accordingly the entire committee was assembled and each "listened in" on the demonstration, until one of the bells was unanimously chosen.

POLISHED METALS ANNEALED WITHOUT TARNISHING

By covering with a very thin film of boric oxide any polished article that has to be annealed, there will be none of the tarnish which results under ordinary treatment. The coating of boric oxide will resist temperatures up to 1,202° F., which is high enough to protect polished steel from any coloration when it is tempered. The coating is fireproof, does not evaporate, and dissolves any oxidized matter on the surface of the heated metal. It can be applied either as a powder or as a liquid. After annealing, the coating peels off, or may be dissolved in warm water. The process has been patented.

GOLF-COURSE SPRINKLER - HAS RUBBER ROLLERS

Marring the turf of a golf course is always prevented if possible, and one of the latest of these preventives is a rotary sprinkler having rubber rollers, which allow it to be moved freely on the greens and fairways without injuring the soft sod. The sprinkler is 19 in. high, with an arm spread of 28 in., weighs but 14 lb., has connections for either 3/4 or

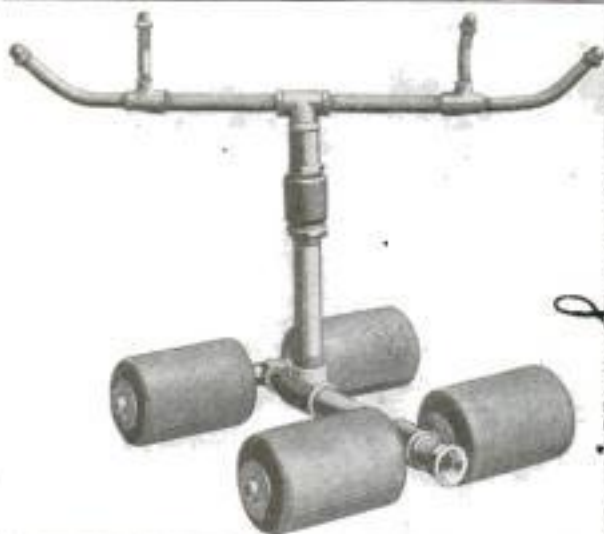

Golf-Course Sprinkler, Showing the Four Rubber Rollers, Hose Connection, and Spread of Sprinkling Arms

1 1/2-in. hose, and has a capacity of 15 gal. per minute over a 70 to 90-ft. area.

Portable altars will be installed in all the passenger steamers of the Cunard Line, according to late reports. During the busy tourist season, one large public room in each section will be set aside for Protestant services and Catholic masses.

8609
Cmd. Maurice E. Pelgrinis
35 Place de la Gare
Antwerp Belgium
Cmd. Floyd Jaffr.
Tray Richard, Shreveport

Mrs. A. Schuster
Charlottenburg Germany
Mr. J. A. Sutcliffe, 1006 1/2 Highland Ave
Los Angeles, Calif

8482 Cont. H. E. Thomas, 911 Blunckley Ave.
 Portland, Oregon
 POPULAR MECHANICS
 Tacoma Ledger 2/12



Motor Truck Moving a 250-Ton Office Building, in Portland, Oregon: The Truck was Blocked, and a Winch, Driven by Its Engine and Mounted Just behind the Seat of the Machine, was Used to Move the Heavy Structure a Little at a Time

TWO-STORY OFFICE BUILDING MOVED BY MOTOR TRUCK 8481 **SHARK-PROOF NET PROTECTS LONG-DISTANCE SWIMMER**

Moving a two-story office building without interrupting the duties of the employes therein, was accomplished recently in Portland, Ore., with the aid of a motor truck. The building is 40 by 80 ft. in size, weighs approximately 250 tons, and was to be relocated at a distance of 600 ft., in addition to being turned completely around. The workmen used a winch mounted on the truck, and driven by its engine, and thus slowly but surely moved the structure to its new location.

TO INVESTIGATE PROPERTIES OF ALUMINUM ALLOYS

Extensive investigations of the properties of light aluminum-alloy castings are being undertaken by the Bureau of Mines, and, when completed, will give exhaustive information on this important subject. The study will not be confined to the physical properties alone, but will deal with the subject of sand castings, die castings, and permanent mold castings. There will also be a discussion of the principal aluminum-alloy systems, such as aluminum copper, aluminum iron, aluminum manganese, aluminum zinc, and others.

U S Bureau of Mines
 Washington, D. C.

How to swim with safety in shark-infested ocean waters was demonstrated recently by a negro in Queensland, Australia, who insisted on swimming from Magnetic Island to Townsville, a distance of five miles, in spite of the sharks, and also of police interdiction. Indeed, it was only on account of the latter that he even deigned to take the precaution of surrounding himself with a floating wooden frame from which was suspended a shark-proof net, 6 ft. deep. The frame and net were towed by a launch, and the negro accomplished his feat without experiencing any interference.



Australian Negro Swimming in Shark-Infested Waters: Suspended from the Floating Frame is a Net, Six Feet Deep, Which was Towed Along as He Swam

Cont. J. U. Clark, c/o Mrs. Turner,
 Bushdock St., North Ward, Townsville
 Queensland, Australia

**PRINTING-PRESS ATTACHMENT
FOR DISTRIBUTING THE INK**

For the production of high-class printing, such as half-tone and color-process

**ELECTROMAGNETIC RECOVERY
OF COAL FROM CINDERS**

In all furnaces to some extent—in some more and in others less—a certain amount

of coal falls into the ashes that is only partly consumed by the fire. Considering the present high cost of coal, especially in Europe, it is not surprising that much interest has been attracted there to the efforts of a German inventor to separate this partly consumed coal from that which is entirely consumed. The method employed is based upon the fact that all coal contains a certain amount of iron pyrites, and that during combustion the iron in this compound becomes converted into an oxide and remains in the cinders. Iron pyrites, such as contained in the unconsumed coal, is not sensitive to magnetic attraction, but the iron oxide in the consumed coal is to a certain extent.

Therefore, if sufficiently powerful magnetic attraction be employed to hold the completely consumed cinders, those only partly consumed will be allowed to escape and can be recovered by a simple separation process.

**LETTER IS PLAINLY VISIBLE
IN GLASS-BODY MAIL BOX**

A very attractive mail box is being made in which the body is of glass. It

can be fastened to the wall or other convenient point, and is so designed that the holding screws cannot be removed when the lid is locked. One advantage of this box is that the contents are always plainly visible. A spring clip is provided for holding papers or envelopes too large for the box.



Deaneath Island Co
Hartford City, Ind.

Weldon's Automatic Reciprocating Printing Ink Equalizer, Delavan, Wis.

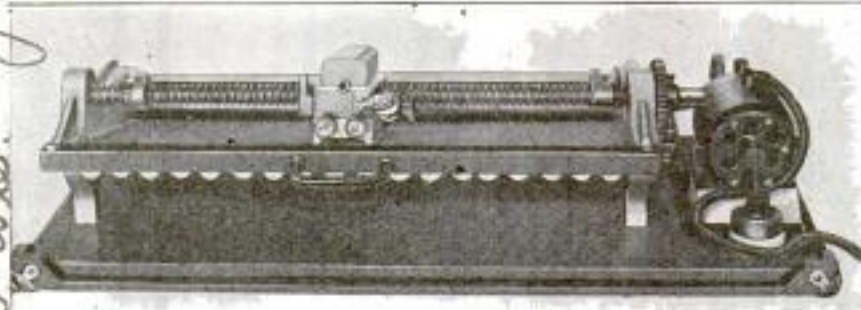

Rear View of the Printing-Press Ink Equalizer, as It Appears When Motor-Driven and with the Inking Knife in Operating Position

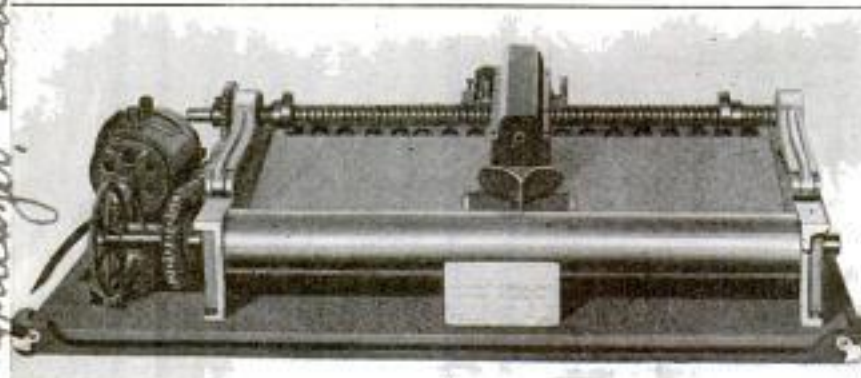

Front View of the Ink Equalizer: The Inking Knife is Automatically Reciprocated by the Threaded Spindle in Connection with It

work, and of any ordinary printing with minimum spoilage, a machine has been designed that, when attached to the press, keeps the ink smooth, soft, and equally distributed. Placed in the fountain it has an adjustable blade that can be raised or lowered to turn any amount of ink desired. When in operation it scrapes the ink loose from the bottom of the fountain, and also plows it against the fountain roller, insuring even distribution on the duct roller. The blade is reciprocated by means of a drive screw which has an adjustment for any-size form. The blade is on a hinged frame which can be raised and moved out of the way when putting ink in the fountain. The attachment can be run by an individual motor or by gears from the press. It eliminates pressroom delay caused by stiff ink.

The Popular Mechanics' Bureau of Information offers its free service to all readers of our magazine. Names and addresses of manufacturers and dealers in articles described, and any other details in our possession, will be promptly furnished by addressing the Bureau.

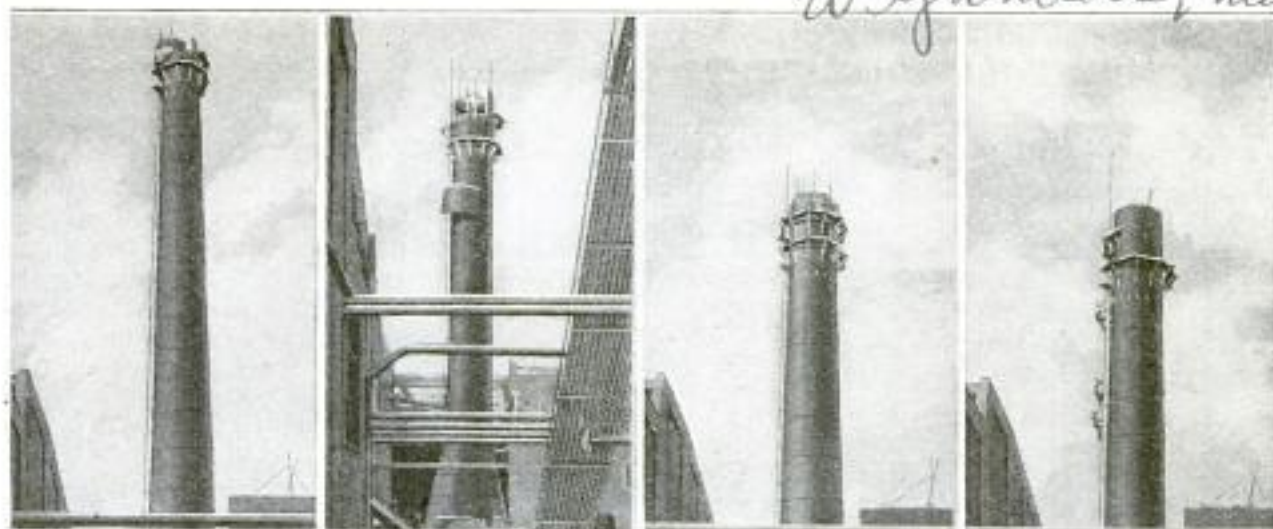

From Left to Right: Beginning at Top to Wreck Old Worn-Out Steel Stack with Movable Platform around It; Wrecking in Progress, Showing One Plate being Lowered outside the Stack; Still Further Progress with Two Platforms in Place; Three Steeplejacks Climbing the Ladder to Platform on Stack

8477
**UNUSUAL MEANS OF WRECKING
WORN-OUT STEEL STACK**

An unusual exploit, done in an unusual manner, was the wreckage recently of a steel stack at an alkali plant in Ford City, Mich. The stack was 180 ft. high, 10 ft. in diameter, and self-supporting. It had been in use for 27 years, and the action of the heat and chemicals in the smoke had pulverized its brick lining, and had eaten away the steel so that the plates buckled and the rivets could be pulled out with the fingers. In wrecking the stack, a scaffold was erected inside it in order to carry a 6 by 6-in. pole. Two 20-in. platforms were placed around the outside of the stack, supported on brackets that were clamped to the stack by a cable tightened with a turnbuckle, thus making them movable. The brick lining on one tier of plates, which were 6 ft. 8 in. wide, was first lowered down the inside

of the stack, and then each plate in that tier was taken off and lowered down the outside of the stack by means of the pole and a winch. The job was completed in six days by three steeplejacks above, and two laborers on the ground, without the slightest mishap.

8479
**ELEPHANTS ACT AS EXPERTS
FOR TESTING FLOORS**

Great confidence was recently placed in the popular tradition that an elephant will refuse to walk upon an unsafe structure. Wishing to determine the strength of his garage floor, a Canton, Ohio, man employed the services of five circus elephants to act as test load. They were led upon the floor and grouped as closely as possible, making a live load of more than 15 tons on the center of the floor—probably the first of this unusual description to be used for such a purpose.

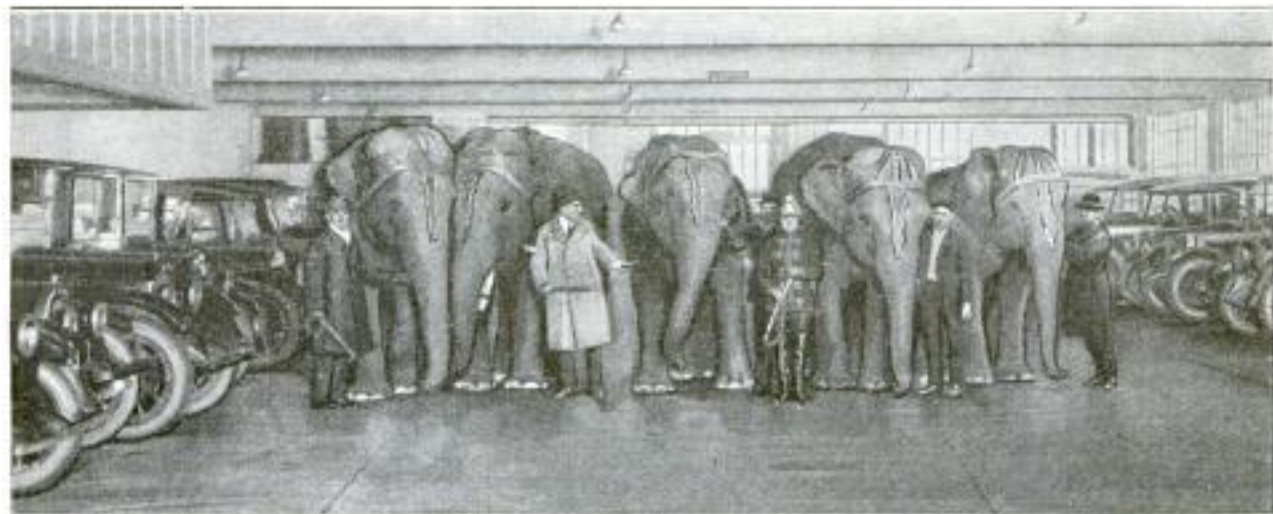

Five Elephants from a Visiting Circus were Employed as "Safety Engineers" in Testing This Garage Floor. Grouped as Closely as Possible, They Represent a Combined Load of More than 15 Tons

8519 720
8519 720
ent. W. K. Crosson,

4429 Townsend Ave
Detroit, Mich

POPULAR MECHANICS

WINDSHIELDS ON UPPER DECK
FOR PASSENGERS' COMFORT

Many motor-bus patrons prefer to ride on the upper deck of the bus but are deterred during the winter months by the



The Big Windshield across the Front and the Individual Shields for Each Seat Make the Upper Deck Comfortable during the Winter Months

chilly winds. This has led a Detroit bus company to install windshields on the upper deck, and they have proved very successful. One big windshield extends across the front of the bus, and each seat is also equipped with an individual shield.

INERT GAS USED IN CANNING
VARIOUS FOOD PRODUCTS

Ninety per cent of the present commercial canned food would be improved, it is claimed, by the complete elimination of the oxygen in the container. This has been known for some time, and various expedients have been adopted, such as venting the cans after heating and sealing while hot, but none has succeeded in removing more than from 50 to 80 per

cent of the oxygen. For some nine years now a much more effective method has been under development, namely the substitution of inert gases for the oxygen. By the use of such a gas, canned coconut has been produced without any loss of flavor whatever. The inert gas used has been carbon dioxide, and an ingenious mechanical method has been developed by which the oxygen is removed by suction from large numbers of cans rapidly, and the vacuum is automatically filled with carbon dioxide. Packers are now considering the possibility of applying the process to many other products.

DEVELOP MANGANESE MINES

8045 IN ARGENTINA DESERT

The United States imports more than 500,000 tons of manganese ore a year. It is principally used by steel mills in the manufacture of the very hard manganese steels, and by glass factories in the manufacture of flint glass. It is also used in making electric dry batteries. Brazil has always been the great source of manganese, while India and Cuba are also important producers. Recently manganese mines have been discovered in Argentina, and an Anglo-Argentine company is developing the industry in that country. The Argentine manganese occurs in a single vein running for about 50 miles through the Santiago desert in the center of the republic. The greatest width of the seam is about 8 ft. The ore is about 75-per-cent pure manganese dioxide, and is claimed to be superior to the Brazilian. The mining is done by native Indians, who are paid an average of one peso per day, or the equivalent of about 33 cents. The ore is brought to the railway, a distance of 90 miles, in two-wheeled carts, carrying a ton and a half of manganese.



Left: The Manganese Vein Runs for Approximately 50 Miles across the Desert. Right: After the Ore is Mined, It is Sorted, Graded, and Sacked by Indian Women and Boys, and is Then Hauled a Distance of 90 Miles, to the Railroad

Chemical Age 8600
2/22
ent. Mrs. George S. Brady, of American Embassy
Charcas 708, Buenos Aires, Argentine

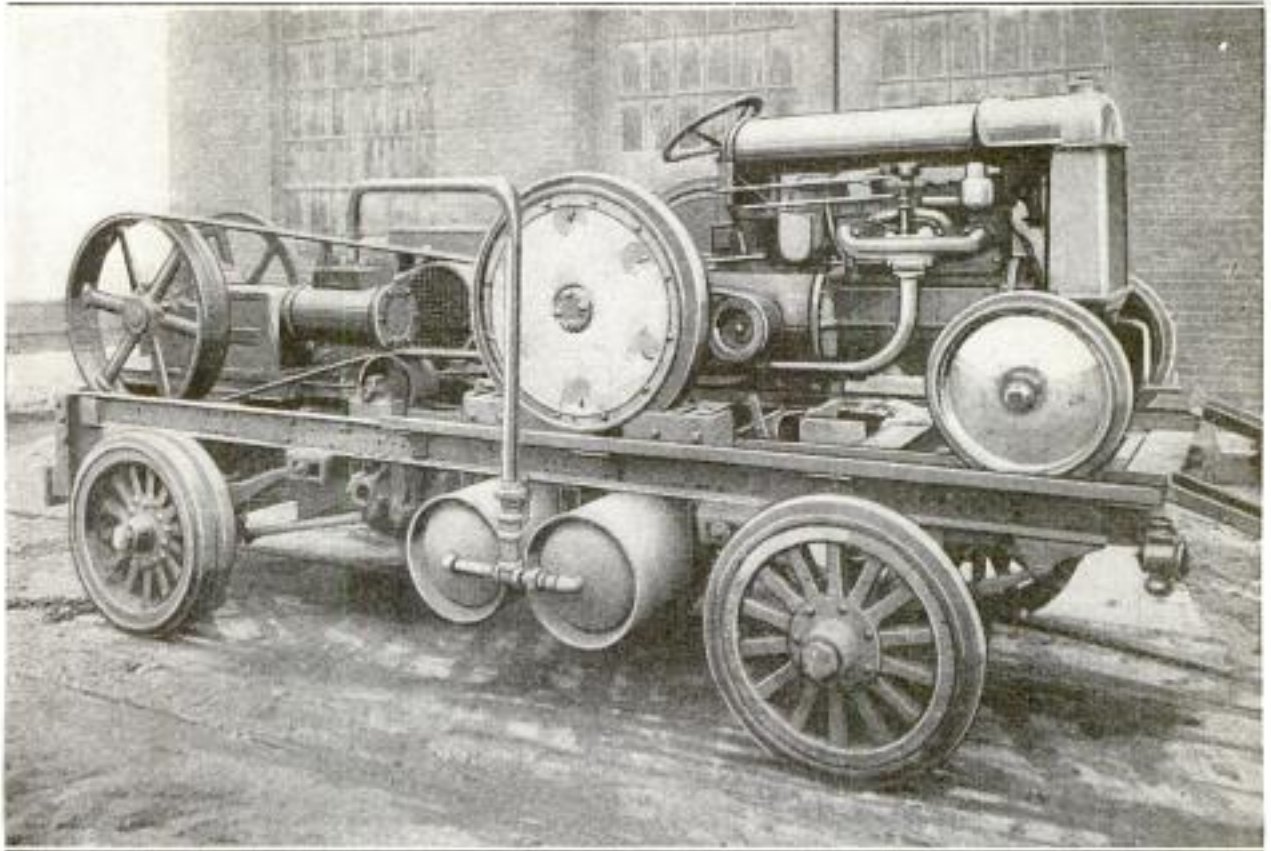

Motor-Truck Chassis with Air Compressor Mounted on the Left End: The Tractor on the Right End of Chassis is Used to Haul the Apparatus from the Garage to the Job, Where It Drives the Air Compressor during the Day, and to Pull the Truck Back to the Garage at Night

Double Use
**DOUBLE SERVICE OBTAINED
 FROM SMALL TRACTOR**

"Killing two birds with one stone" is figuratively done with a small tractor which hauls a concrete-drilling outfit to the job, and then runs up on the chassis of the specially built truck, where it is belted to an air compressor. All day the tractor faithfully chugs away in driving the compressor, and at night it runs down from the chassis and obligingly pulls the apparatus back to the garage.

8596

**MAIL CARRIED BY DOG TEAM
 IN SOUTHERN CALIFORNIA**

On a power-tunnel project in the high mountains of southern California, it was decided to keep the construction work going during the winter from both ends of the tunnel. The road connecting the two ends of the tunnel leads through a pass at an elevation of more than 9,000 ft., and is of course blocked with snow during the winter. In order that mail might be delivered regularly at the farther camp, a team of seven Alaskan dogs is employed, and under favorable conditions can take a load of 500 to 600 lb. over the route.

Engineering News-Record
2/20/22

**ESKIMOS' WHALING BOATS
 ARE AMERICAN-BUILT**

The boats used by the Eskimos of Alaska, as described and elaborately illustrated in "Whale Hunting on the Top of the World," in the February issue, are all American-built. Many of them are built at New Bedford, Mass., and are shipped from there, by way of the Panama Canal, to the Arctic regions. The



Whaling Boats for the Eskimos of Alaska on Their Way to the Steamer Which will Take Them, via the Panama Canal, to the Arctic Regions

boats are not needed in large numbers, and this year's shipment from New Bedford thus far consists of only four boats.

Copyrighted material
557 E. French Ave.
New Bedford, Mass.

6609

Cont. J. A. Brouwer, Pine Wold Park,
Westhampton, N. Y.



"The Castle" Built by the Artist with the Help of One Man: The Structure Is of Brick and Concrete, and was Built in His Spare Time during the Course of Eight Years. There Are Many Examples of Concrete Sculpture in the Building

work

DECORATIVE EFFECTS IN MOLDED CONCRETE

When one speaks of concrete, it conjures up visions of retaining walls, severely plain buildings, and massive bridges, but T. A. Brouwer, of Westhampton, N. Y., has shown that this material is admirably

adapted for artistic work. On his estate, called "Pine-Wold Park," are many examples of his art, in the form of statues, fountains, and the like. In some instances, it seems almost impossible that such delicate figures and designs could have been made of concrete, yet such is the case, and the artist contends that it is a very easy matter to make them.



"The Soul of a Rose:" The Figure of a Butterfly-Woman Bending over a Wild Rose, Molded of Concrete over a Wire-Mesh Frame, Shows the Delicate Effects Produced by This Method

In making a statue, for example, he first makes a frame of light iron pipe, or heavy wire, which conforms to the general lines of the figure and is really the skeleton on which it is molded. Over this frame, a wire-mesh form is molded by hand along the general lines of the figure. This mesh form is made of 1/4-in. galvanized-wire netting and serves as the foundation for the concrete. A mixture of one part cement to two parts sand is used, and is placed and molded by hand. After the general outlines of the figure are formed, the excess material is cut away and the finishing coat of cement is applied with a brush. When this has set, the figure is finished by chipping and working over with a fine chisel.

This method is not limited to statuary but can be applied to decorative effects for buildings, cornices, fireplaces, and also for



Left: A Fountain of Molded Concrete, in Which the Large Shell was Shaped Out of a Single Block as the Material was Setting, the Figure being Built Up on a Frame of Iron Pipe and Wire Mesh. Right: Decorative Pier, Seven Feet High, Cut from a Solid Block. The Bird on Top of the Pier is Molded over a Wire-Mesh Frame

many other purposes. The work can be done very rapidly and the decorative effects are limited only by the skill of the sculptor. The artist has been able to produce various color effects in his work by the proper blending of the material used. Some of his groups of statuary are given a finish similar in appearance to antique bronze, which is very effective against the forest setting in which they appear. Contrasting effects are produced by placing white relief figures or designs against a background of gray or darker color.

8646
**BEEHIVE GATE PASSES
 ONE BEE AT A TIME**

An interesting problem has recently been brought to the attention of the Bureau of Standards by the Bureau of Entomology. In studying the habits of bees they desired to learn the number of bees leaving the hive during the day, so a gate was devised which would permit only one bee to pass at a time, and an arrangement was made whereby the number of bees was counted automatically. The little counting device which is used for registering the number of telephone messages on a given instrument was employed as a recording device. A series of these registers were installed in such a way that the number of bees passing the gate was recorded. As only al-

ternating current was available where the counting was done, it was found necessary to find means of operating the counters on current from rectifiers. Current from batteries could not be used on account of the great number of times the gate would operate during the day, as many as 300-000 exits per day being expected.



Another View of the Fairy Figure Whose Wings Are of Concrete, Modeled and Shaped by Hand, While It Is Still Plastic, over a Frame Made of Stiff Wire

*Bureau of Standards
 Bureau of Entomology.*

8534
724

U. S. Bureau of Mines
Washington
D. C.

POPULAR MECHANICS

ROLLER CURTAIN IS MOUNTED ON BOOTBLACK STAND

Feminine customers showed so much embarrassment while having their shoes shined, that a sympathetic New York



Bootblack Stand with Roller Curtain, Enabling Women Customers to Protect Themselves against Annoyance from Passers-By

bootblack mounted a roller curtain on his stand. Now the wearer of the most abbreviated skirt can pull down the curtain to suit herself, and sit unconcernedly in the elevated chair for a "shine" without being annoyed by the interested glances of the rude passers-by.

8612 SUBSTITUTES FOR PLATINUM PROVE SATISFACTORY

In a search for a substitute for expensive platinum, various alloys have been tried and some have been found satisfactory for different purposes, although no general substitute has been evolved. One combination, known as "palau," resists the activity of most of the reagents, while another, called "rhotanium," is claimed to make a good substitute for electrical-heating units.

8439 MOTOR VINEYARD CULTIVATOR OPERATED BY ONE MAN

As an economizer of time and labor a motor-driven implement has been designed to furnish in one machine a complete equipment for vineyard cultivation. With only one operator, and one operation, it will both harrow the rows and hoe the vines. It can also be used as a tractor for hauling a three-base vineyard plow, and as in the case of ordinary tractors, it can be used as a stationary power plant. Its motor is of the tractor type, with a three-speed selective gear transmission, all mounted on a three-wheeled chassis, and between the front steering wheel, controlled from the driver's seat, and the traction wheels in the rear is a regular disk-harrow equipment, with 12 disks, which is controlled by the operator's feet. Behind the traction wheels is the attachment that hoes the vines. When turning, either of the traction wheels can be left stationary while the other is revolved, causing the cultivator to turn in either direction within a 10-ft. radius.

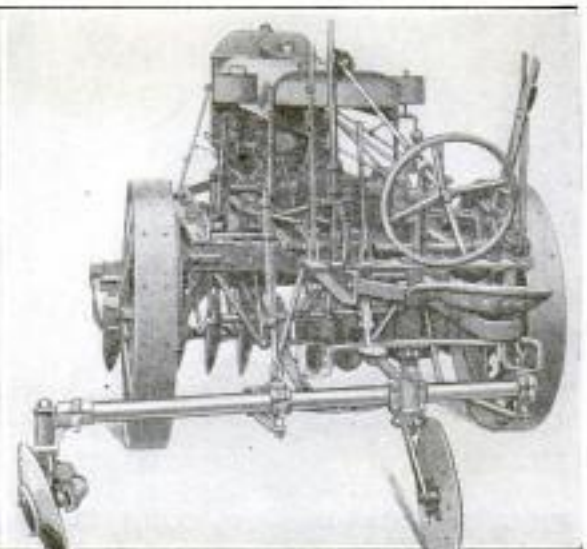
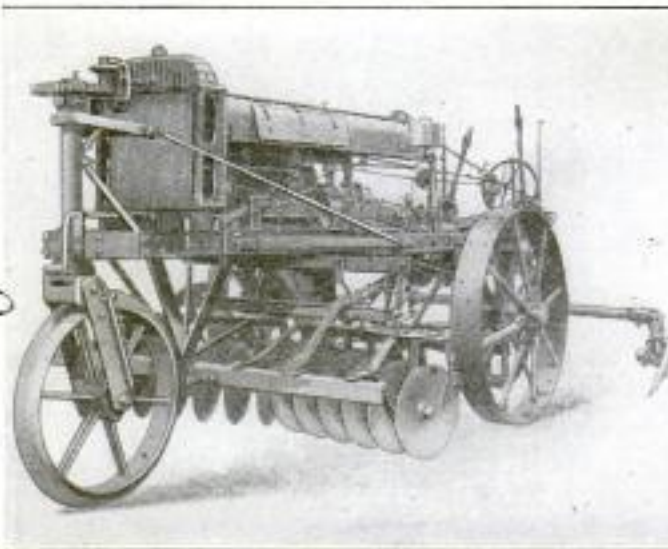

Motor-Driven Vineyard Cultivator, with Self-Adjusting Disk Harrow in Front of Traction Wheels, and Vine Hoe behind Them: The Driver Sits at the Rear, and with the Large Steering Wheel Operates the Front Wheel

Joseph H. Wiley, 2800 1/2 N. Madison Ave.
Peoria, Ill.

Wm. The Avery Co., Peoria, Ill.

Copyrighted material



Above: The Raft and Derrick are Towed from Place to Place by a Tug. Right and Left: Two Views of the "High Lead" Used in Removing the Felled Timber from the Steep Bluffs

THERMOMETER HOLDER ON BED IS HANDY AND SANITARY

8564

Clamping to the bed a small metal holder containing a glass tube, in which

can be inserted the ordinary thermometer, or fever register, of the sick room, is the latest method used in hospitals. Following this procedure, there is slight chance of the thermometer being inter-

changed with that of another patient, or mislaid, thus furnishing a sanitary innovation for the care of the sick.

5476

USE HUGE FLOATING DERRICK IN LOGGING OPERATIONS

Efficient logging of many wooded islands and steep headlands of the British Columbia coast was a problem that long baffled Canadian timbermen. The solution has been found in a floating logging camp, consisting of a pile driver, donkey engine, and derrick, all assembled on one raft which is towed from job to job. The raft is built of huge logs, and is 106 ft. wide and 130 ft. long. The two upright timbers form what is known as a "high lead." Cableways from the high lead into the forest areas provide means of rapid transportation of logs to sea level. The

sticks forming the uprights are each 126 ft. long, 6 ft. in diameter at the base, and 34 in. at the top. A seagoing tug tows the raft to islands and rugged coasts where customary methods are not applicable.

The raft is placed on the beach and anchored with piling, and guy wires are fastened to the shore. The ordinary high-lead system of logging is then used to swing the logs to the shore, where they are piled like so much cordwood, half submerged in water, to form rafts.

8447

ELECTRIC WINDOW RADIATOR IS FROST PREVENTER

Formation of frost on windows can be prevented by the use of an electric radiator, which was designed expressly for this purpose. The appliance consists of a small metal frame extending below the window, mounted on metal supports and containing a heating element. Connected to any light socket, the apparatus gives sufficient heat through its perforated sides to keep the glass clear on the coldest days.

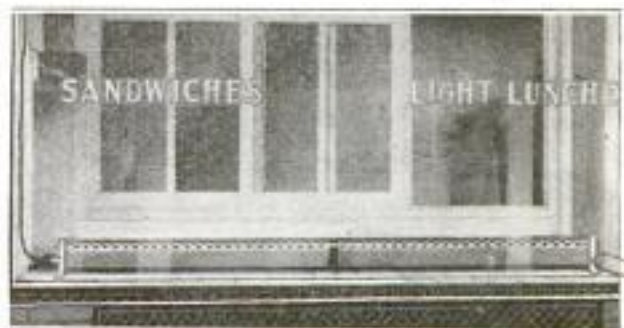

Electric Window Radiator Placed in Position to Prevent Frost from Forming on the Plate Glass

Thornes Bros 386 Broad Ave. New York City

Overland Electric Co 4226 Ogden Ave Chicago

Carl Mel Wharton
590 E. Alder

Carl X-H Hamilton
1507 E. 65th St Chicago

85 53

8111 HANDY INHALATION OUTFIT OF NEW DESIGN

PERSONAL HEATING POSSIBLE IS THEORY OF ENGLISHMAN

Inhalation outfits are numerous, but one of new design consists of a specially constructed mask of rubber, to

Giving as an illustration the pleasing effect produced throughout the body by holding anything warm in the hands, or by immersing the hands in warm water, J. W. Beauchamp, director of the British Electrical Development Association, recently suggested the possibilities of personal heating. According to his theory, in the future, instead of seeking better means of heating the atmosphere within buildings, an effort will be made to heat the bodies of the occupants of these places by individual electric devices, thus leaving the air as fresh as on the outside. The lecturer also thought that science would soon discover a method whereby merely the presence of some small heating medium about the person would provide sufficient heat to make anyone comfortable.

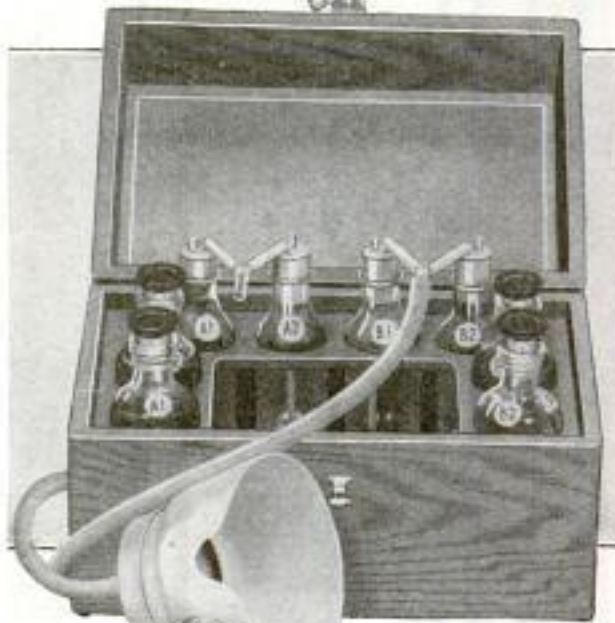

Inhalation Outfit, Showing the Bottles of Liquids to Which is Attached the Rubber Tube Leading to the Special Rubber Mask That is Placed over the Nose

which is attached a tube of the same material. The tube is fastened to bottles containing liquids, which, when inhaled, are transformed into dry gases, and are said to afford relief to the organs of the respiratory tract, when afflicted.

Under the terms of the Leasing Act, royalties of more than \$2,000,000 were paid during the year 1921 for oil and gas produced on government-owned land in the West.

8496 NEW FRUIT-PEELING MACHINE USES CAUSTIC-SODA VAPOR

Fruit canners now have available a new peeling machine which is said to reduce the amount of lye used by half, greatly improve the color and flavor of the product, and effect a saving of approximately 50 cents per ton. With the improved apparatus, the fruit is placed on a conveyor belt, preheated, and then run for about 30 seconds through the vapor of caustic soda, which loosens the peel. Then, without being touched by hands, the fruit passes along between sprays of water which wash the peel off, and which can be carefully regulated according to the condition of the fruit.

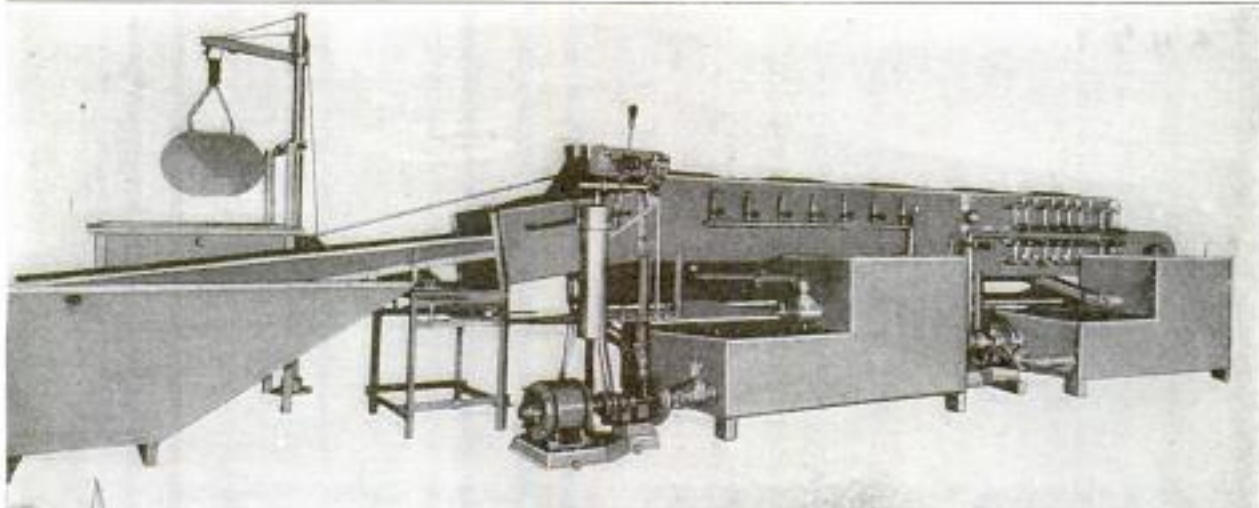

Fruit-Peeling Machine Erected and Ready for Operation in a Canning Plant: The Fruit is Placed on a Conveyor Belt at the Left End, Passes through the Machine without being Touched by Hands, and Emerges at the Right End Thoroughly Peeled and in Readiness for Canning

Hunkley Co, 120 th St Oakland Calif. Copyrighted material

8512 *Enl. J. A. Schmidt*
 355 *St Charles Place,*
 POPULAR MECHANICS 727
Hyde Park, Cincinnati, Ohio.

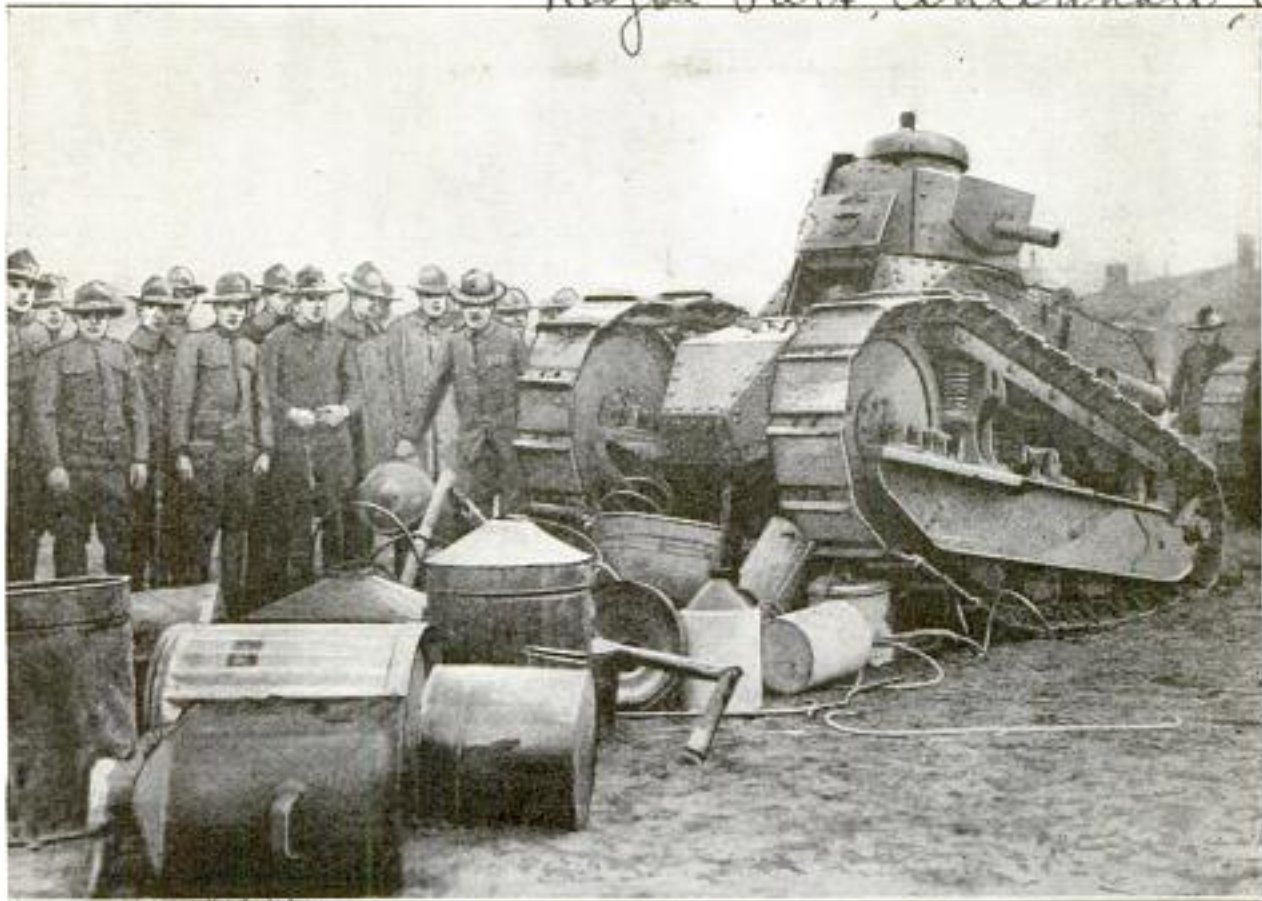

military
TANKS USED TO DESTROY STILLS CAPTURED IN RAIDS

NEW uses are constantly being found for tanks, but one of the most unusual was the reduction of some "moonshine" stills to a condition of junk. During a recent clean-up campaign in Newport, Ky., more than 50 of these illicit stills were taken and were then destroyed by driving two tanks over them. The wreckage was later sold as junk.

7802

motor
HAITIAN STREET CARS BUILT FROM AMERICAN AUTOS

Street cars, built from American automobiles, are being operated in Port au Prince, the capital of Haiti, with great success. The complete chassis, motor, and transmission were used, except that the gearing from the original rear axle to the 32-in. drivewheels was reduced, so that the axle and wheel sprockets are the same size. This greatly increased the available power. The cars weigh 7,250 lb. and can attain a speed of 40 miles an hour. They have proved so successful and economical that the sugar company, which operates all the street cars and railroads of Haiti, contemplates using similar cars to haul sugar, in

place of the old steam locomotives which consumed so much coal.

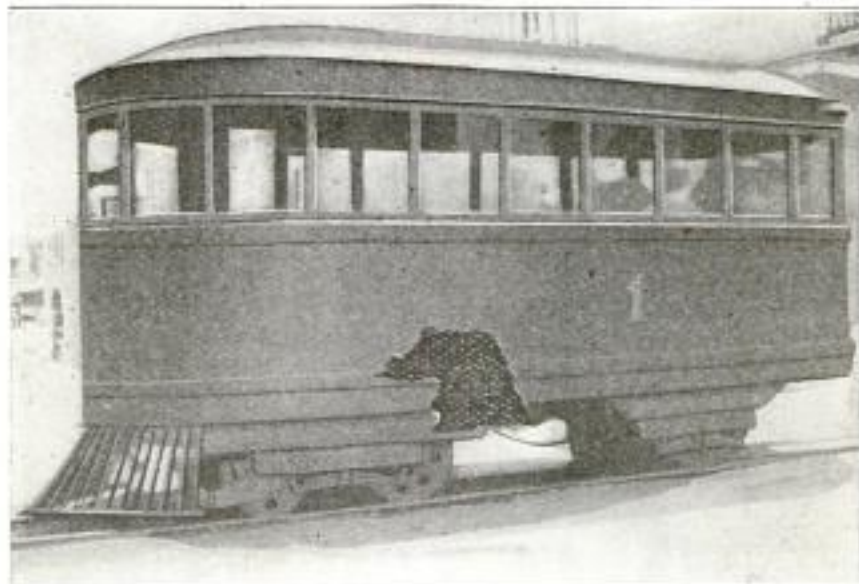

One of the Street Cars, Used in Port au Prince, Haiti, Which were Built from American Automobiles, Using the Complete Chassis and Power Plant: They have Proved a Great Success in Solving the Transportation Problem and may be Adopted Also for Railroad Traffic

Hodge Bros. Motor Car Co. Dept. of Publicity, Detroit, Mich.

PROJECTILE POCKET PISTOL IS LIFE-SAVING APPLIANCE

In case of shipwreck, a few minutes' delay in sending a line to the vessel may

Power
TRANSMISSION LINE TO SPAN STRAITS OF MESSINA

Industrial expansion in Sicily demands the introduction of more electric power, and a 120,000-volt transmission line has been proposed, which will come from Italy by crossing the Straits of Messina. The span would be 3,770 yd., or about 2 1/4 miles, and the cables of nickel or zinc-plated steel, each cable being supported on individual masts. These masts would have to be 900 ft. in height, to provide a 150-ft. clearance for passing ships in the center of the estimated 660-ft. sag. At present the most difficult feature of this huge engineering problem seems to be the construction of strain insulators which will be strong enough to hold the vast weight of the steel cables. However, if this contemplated project can be realized, Sicily will receive approximately 50,000 kw. of power for manufacturing purposes of all kinds.

8389

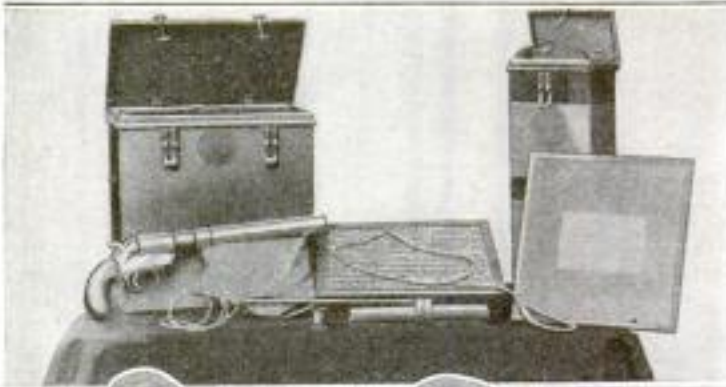

Above: Two Steel Boxes Hold the Complete Outfit. Below: Left, Inserting the Firing Cartridge in the Pistol; Right, Inserting the Self-Propelling Rocket with Line Attached

mean life or death to those on board. A line-throwing rocket pistol has now been devised which, with all equipment, weighs less than 50 lb., and is easily portable. The pistol is fired from the hand. A small cartridge projects the rocket from the barrel of the pistol and ignites the charge in the rocket, which then becomes self-propelling, carrying the line in the direction required. A length of flexible wire connects the line to the rocket.

LARGEST FELT-WEAVING LOOM EVER CONSTRUCTED

A felt loom, said to be the largest of its kind ever constructed, has recently been completed at Worcester, Mass. The loom is for weaving continuous tubular paper-makers' felts, up to a width of 40 ft. The finished machine weighs 18 tons, and will require two freight cars for its shipment.

9621

8584
MUSSELS ON SHIP BOTTOM CAPTURE SMALL FISH

Capturing three fish about the size of sardines was the curious exploit of as many sea mussels, which had attached themselves to the iron bottom of the famous exploration ship, the "Albatross," of the U. S. Bureau of Fisheries. This vessel had lain in San Francisco Bay for some time when it

was decided to condition it for sea duty, but it was found necessary first to put the ship in drydock to clean the hull of the mussels.



On the 30-mile trip to the Mare Island Navy Yard, the vessel must have passed through a school of anchovies, for several of these fish were found entangled on its bottom, and three were held firmly by the head in the shells of the mussels. This curious phenomenon must have been purely accidental, as neither the fish nor the mussels were capable of eating the other.

Christian Science Monitor Cont. Es. Dallas Hanna, Academ. 9 Science, Esolden State Park, San Francisco, Calif.

8/6/22

7780 end A. Is Clutterbuck
Waimoa, Kauai, S. H.

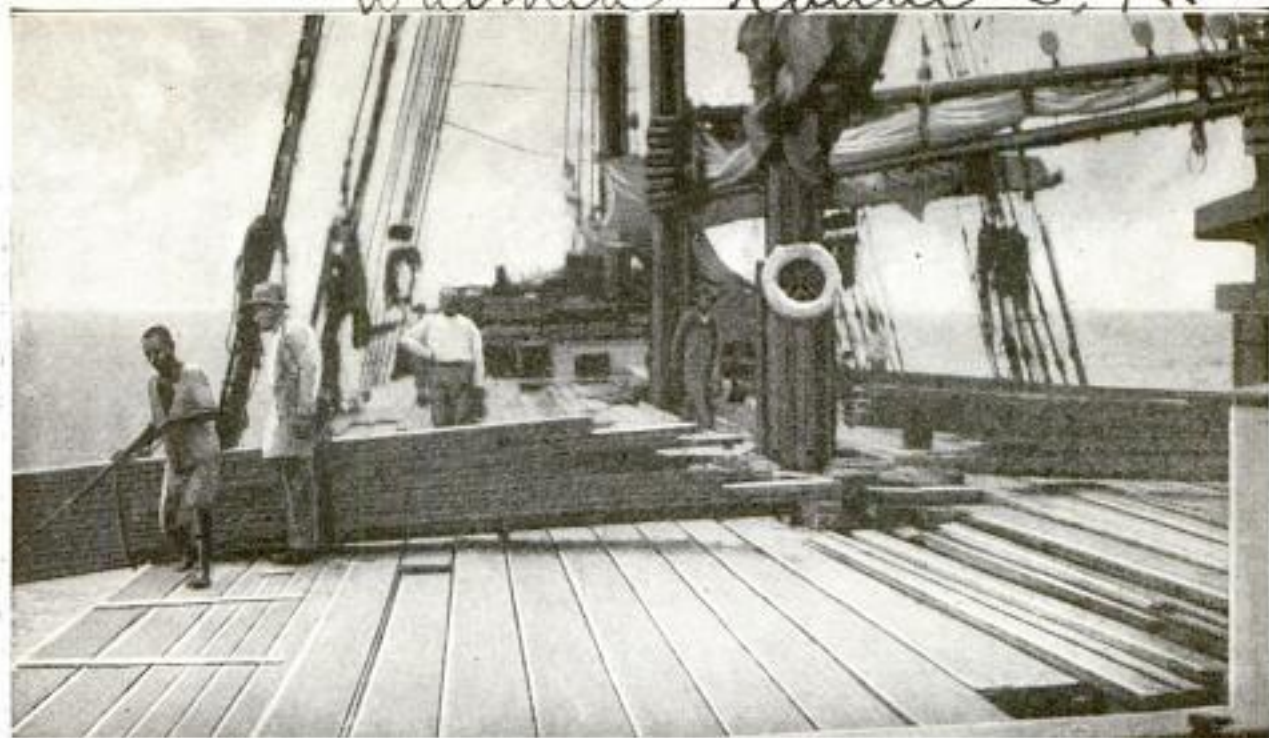

Because of the Danger from Heavy Surf, the Schooner Anchors About a Mile Off Shore, Where the Lumber is Made Up into Rafts. These are Cast Overboard, to be Towed Ashore by a Small Launch Which can Venture Close to the Surf without Fear of being Damaged

HOW KAUAI IN THE MID-PACIFIC GETS ITS LUMBER

THE demand for lumber for building and other purposes in the Hawaiian Islands is enormous, and owing to the fact that neither hard nor soft woods can be produced in commercial quantities, the islands have to depend entirely upon importations. Because of the lack of harbors on the island of Kauai, interesting and somewhat primitive means of landing a cargo have to be resorted to.

The lumber schooner anchors about a mile from shore, beyond

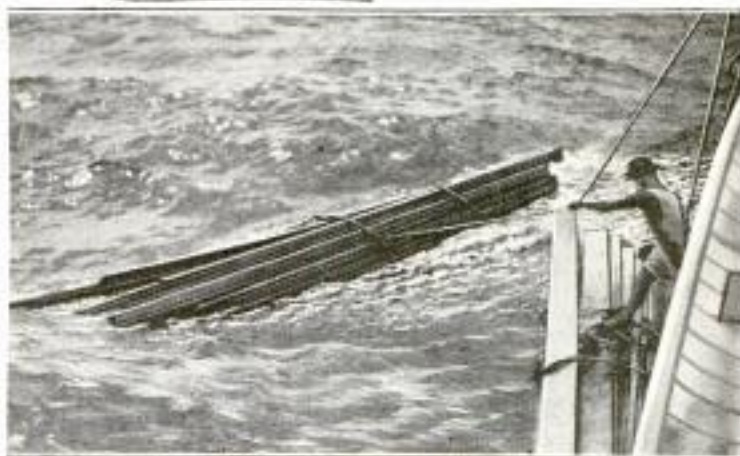

The Rafts are Assembled at the Side of the Schooner Until the Launch is Ready to Start for the Shore

the breakers, and the lumber is made into rafts and jettisoned into the shark-infested ocean. The rafts are secured by the natives and lashed together. They are then "harnessed" over the bows of a motor launch, and the craft proceeds shoreward with its load of about 10,000 board feet. On approaching the shore, the rafts are cast off, and the launch goes astern, while Hawaiians,



The Rafts are Arranged on Both Sides of the Launch Ready for Towing, and a Harness is Passed over the Bow of the Launch in Such a Way That the Rafts can be Cast Off by Reversing the Launch

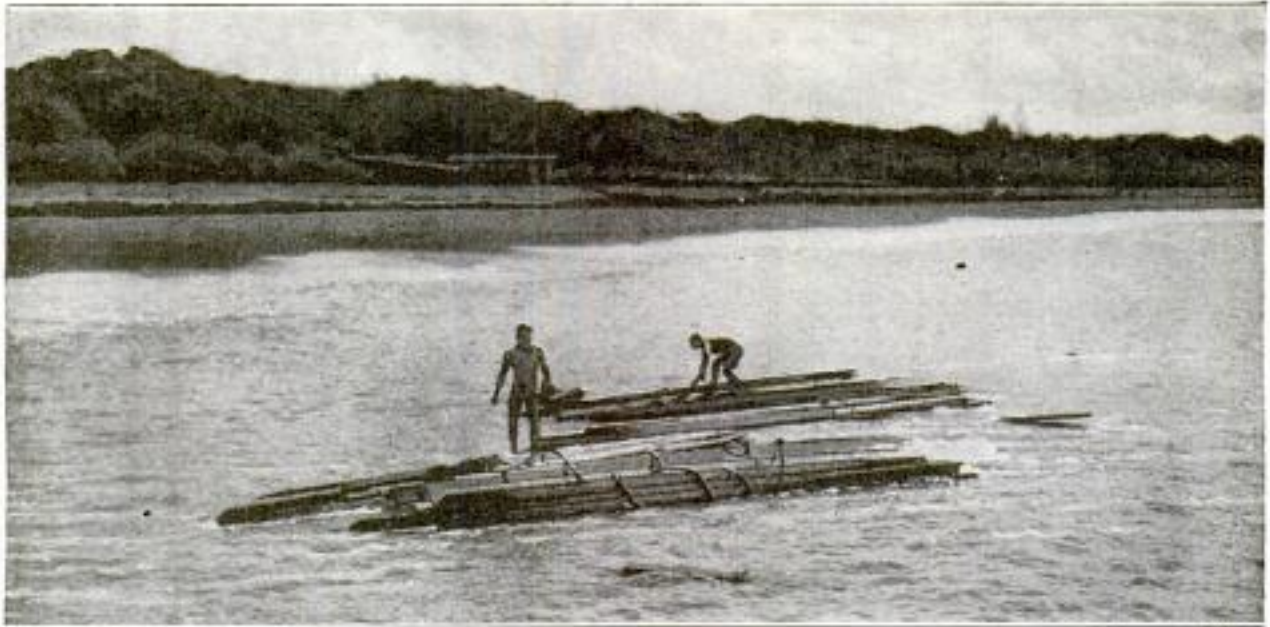

After the Rafts are Cast Off by the Launch, Expert Swimmers Come Out from the Shore and Secure Them to Buoys Until They can be Warped Ashore and the Lumber Hauled Up on the Sandy Beach, Where It is Soon Dried by the Tropical Sunshine

who are notoriously good swimmers, swim from the shore, secure them to buoys, and warp them to the sandy beach. The lumber does not suffer from its im-

mersion, and it is creditably reported that this is the only place in the world where such means of landing a cargo have to be resorted to.

MILKING-MACHINE WASHER IS RAPID AND SANITARY

Milking machines must be washed after every period of use, to prevent their becoming sour and insanitary, and a washer

which does this work rapidly and efficiently has been produced by an eastern manufacturer. The machine consists of four cleaning brushes, two for milk tubes and two for teat cups, the whole being attached to pulleys belted to an electric motor or other source of power. These brushes revolve at a high rate of speed, two revolutions to the right and then two to the left, and are constantly immersed in a container filled with an antiseptic, or sterilizing, solution. It is said that the reversing action of this machine insures a longer life to the brushes than is the case with the usual rotating washers, and that the apparatus is so simple a child can operate it effectively.

Several trial gas installations for cooking in Canal Zone quarters are to be made by the Panama Gas Company. Mains have been laid from Panama and the laying of pipes is now going on.

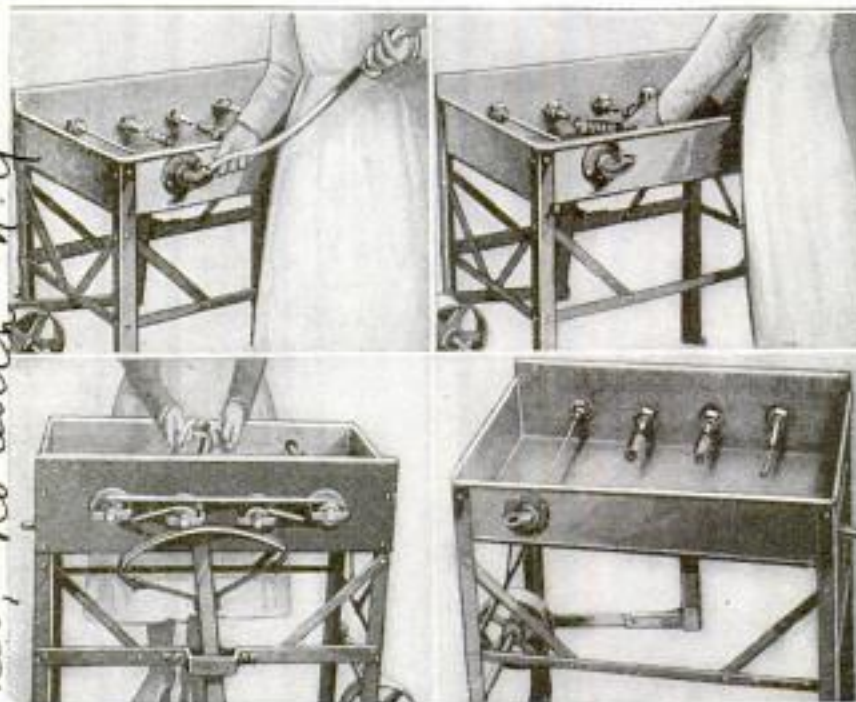

Upper Left: Placing Long Rubber Tube of Milking Machine on Special Brush. Upper Right: Washing Teat Cups. Lower Left: Cleaning Short Rubber Tubes. Lower Right: Four Brushes of Washer, Illustrating the Different Sizes and Shapes Required to Properly Clean the Milker

8429
Sherwood milking machine washer, no record h.t.



Above: A Two-Cylinder Gasoline Engine Furnishes the Power for Driving the Tractor Belts Which are Provided with Wooden Cleats. Right: Passengers and Operator Ride on the Toboggan and the Power Unit Propels It by Pushing from the Rear

TRAVEL SNOW-COVERED ROADS WITH MOTOR TOBOGGAN

A motor toboggan has been invented by a Maine man which is expected to solve most of the transportation problems in localities subject to heavy snowfalls during the winter. The passengers and operator ride on the toboggan, at the rear of which the power plant is fastened by a flexible connection. Power is supplied by a 15-hp. engine which drives the tractor tread, consisting of a rubber belt equipped with metal or wooden lugs. Trials have shown that a speed of 30 miles per hour can be attained. Fuel consumption is at the rate of 45 miles to the gallon of gasoline. The weight of the toboggan, in passing over loose snow, packs it so the treads have a firm grip.

NEW TOOTHBRUSH CLEANS ALL SURFACES OF THE TEETH

In one form or another there have been toothbrushes almost as long as there have been teeth, but hitherto in all forms it has always been necessary to replace them from time to time. Now there is a new form of toothbrush that is almost everlasting, only a small part of it having to be renewed. This renewable part is a small attachment that holds the bristles of the brush in a semicircular ivory frame that is rotatively connected to one end of a metal handle, so that it will move into any position that best suits the form of the teeth. The points of the bristles are semicircular like the frame, and straddle the teeth, cleaning the top and both sides.

8616
NEW YORK APARTMENT HOTEL WILL HOUSE A CHURCH

That the bright lights are not the attraction for all visitors to New York is shown by a recent announcement that an apartment hotel is to be built, in which part of the three first floors will be occupied by a church. The church-hotel will be 17 stories high, with the usual hotel lobby on the first floor. The church will have a separate entrance on the first floor and will occupy most of the space up to the level of the fourth floor. The remaining floors will be arranged for hotel accommodations, divided into suites of not more than four rooms and bath, with single rooms for transients.



Toothbrush with an Everlasting Metal Handle, and a Renewable Semicircular Brush Attachment

W. J. Jones
 3/6/22 Page 2

Bidental Products Co.
 85 Columbia St. Newark, N.J.

Chas. A. H. Emery,
Eslenbrook, Conn.

Commerce Report

8059

POPULAR MECHANICS

8/6/22

AN IMPROVED FORM OF SCALE
WEIGHS RUBBER TIRES

8628

AUTOMATIC AND SHUTTLELESS
LOOM MADE IN ENGLAND

In the manufacture of rubber tires, just sufficient rubber should be supplied to fill the mold, and any excess used results in

A new automatic shuttleless loom, which its English inventor claims will revolutionize the cotton-manufacturing industry, is reported now ready to be placed on the market. It is said that this loom weaves automatically cloth better in appearance by 25 per cent, and with about double the production of existing looms. Two different kinds of yarn, or two different counts, can be put in for effects, and with the attachment of a simple color mechanism, 6 to 10 colors can be put in by the same plain loom. It is also claimed that waste is reduced to practically nothing.

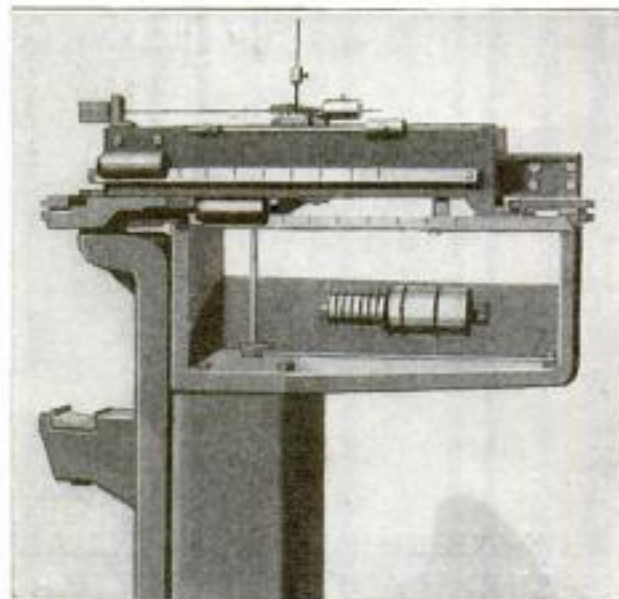

The Short Metal Arm Replaces the Usual Platform and is Used for Weighing Rubber Tires on Their Metal Cores

waste. By weighing the tires on their metal cores before they go to the molds, the exact amount of rubber required can be determined. To do this accurately a scale has been devised which has a short arm projecting from one side, on which the tire is hung and weighed just before going to the mold. The scale is designed to maintain its accuracy under rough usage, and the usual knife-edges are replaced by metallic spring plates.

COMBINED THRESHER-BALER
SAVES TIME AND MONEY

Threshing peas and baling the pea hay in one operation is possible with a machine which has lately been introduced by a Missouri farmer. The implement is placed beside a stack of the hay in the usual manner, the peas are threshed and come out of a spout into waiting sacks, while the hay is carried through the wind stacker and dropped on the baler. The whole is driven by a tractor of 10-18 hp., a belt from an extra pulley on the wind-stacker shaft furnishing the power to operate the baler. With all parts of the outfit placed in a position to reduce the labor of handling to a minimum, it is said that a considerable saving of time and money can be effected, thus making the machine a valuable aid on the farm.



Combined Thresher-Baler, Showing the Manner of Placing the Units to Reduce Labor: At the Extreme Right is Seen the Tractor Belted to the Thresher, While at the Left is Shown the Baler Also Belted to the Thresher

Chas. W. S. Casebolt, Poplar Bluff, Mo.

Photograph of the machine at the Missouri Experiment Station, St. Louis, Mo. + also at the Missouri Experiment Station, St. Louis, Mo.

Copyrighted material

Cml. Wendell M. Whiting,
 Hydrographic Office, Navy Dept.
 POPULAR MECHANICS
 Washington, D.C. 733



OFFICIAL NAVY PHOTO
 Left: The Hydrographic Map is Made by Surveying the Land and Making Soundings of the Water Near By. The Areas of Water of Different Depths are Shown by Different Shadings. Right: The Airplane Photograph of the Same Locality in Which the Areas of Shallow Water Appear of Lighter Shade than the Deep Water. The Photograph is Used to Check the Survey Map and to Discover Changes

8055

**CHECK HYDROGRAPHIC SURVEY
 BY AERIAL PHOTOGRAPHS**

It has recently been demonstrated that aerial photographs can be used as a simple and satisfactory check on hydrographic maps. The map shows the land and the depth of the water around the land, the areas of different depths being represented by different shadings. A photograph of the same locality, taken from an elevation of 5,000 ft., will provide a ready means of checking the data on the map, as the areas covered by shallow water will appear of lighter shade than the deeper water. If radical differences are noted, such as a change of a deep channel, or new shoals appearing, a new survey becomes necessary.

8641

**FISH-MARKET SURVEYS MADE
 BY BUREAU OF FISHERIES**

Surveys of the larger cities of the United States to ascertain their fish distribution and consumption are being made by the Bureau of Fisheries, which issues bulletins on the subject that are of great value to the commercial-fishing industry. A survey has already been made of the Chicago market, and a more recent one of the Twin Cities of St. Paul and Minneapolis. There the fish supply comes

Fishing Gazette
 3/1922

mainly from the Canadian lakes to the north, and from the North Pacific coast. A total of 86 carloads of fish, besides 21 of oysters, weighing 2,841,212 lb., was received in the Twin Cities during the year ended Sept. 30, 1921. These fishery products were handled by 360 firms, of which 11 are in the wholesale business, 5 in the wholesale and retail business, 32 in the retail business handling fish every day, and 312 handling it part of the week.

8396

**AUTOMOBILE ASH RECEPTACLE
 CONVENIENT FOR SMOKERS**

Conveniently mounted on the dash of an automobile for smokers in the front seat, or on any side wall, or other flat surface for those riding in the rear seats, is a new device that acts as an ash receptacle and a cigar and cigarette case holder.



The ash container has a lid that flies open at the touch of a button, and when open has a winged apron that prevents ashes from blowing into the car.

The Hargo. Co. Inc.
 Oshkosh, Wis.

8544

Hunting - Merritt Lumber Co., Ltd.
 Vancouver, B.C., Canada

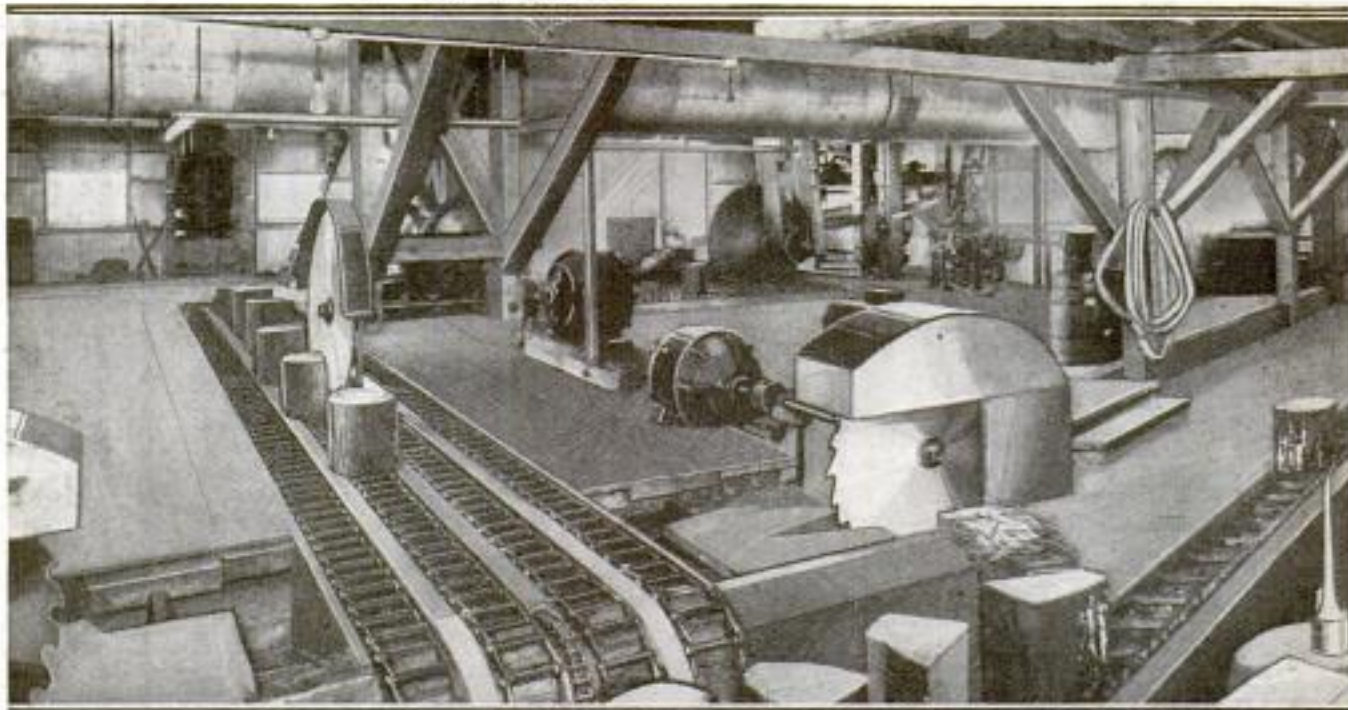

Panoramic View of Shingle Mill: In the Background, About at the Center of the Left-Hand Picture, Is the Log Slip to the Splitting Saws. Near the Knee Bolters at the End of These Conveyors, in the Immediate and Passes the Prepared Log Sections to the 14 Shingle Machines

MILL CUTS 500,000 SHINGLES DAILY

BY HENRY C. COPELAND,

106 Winch Bldg
 Vancouver, B.C.

IT is a far cry from the days when the pioneer went forth with his frow and mallet to split cedar shakes with which to cover his roof, to the shingle mill recently put in operation at Vancouver, B. C., which cuts 500,000 every ten hours.

The cedar logs, ranging all the way from 1½ to 6 ft. in diameter, are floated to the foot of the log slip. There one end of a log is caught by the dogs on an immense endless chain and the log is drawn up the slip, other dogs engaging it as it goes up. If the log is not in the right position as it comes to the end of the slip, there is an overhead canting device which lowers a heavy wire cable and

hook, by means of which the log is turned to place. Just to the right of the end of the log is a swing, circular cut-off saw 7 ft. 2 in. in diameter.

The saw is automatically set to cut 16, 18, or 24-in. lengths from the log; a thrust on a lever, and the saw is forced against the log. If the log is too large for the saw to cut off entirely, another lever is pulled, and an ax comes down and splits off the part sawed, whereupon the canter rolls the log for another cut. This operation is continued until the first length is cut completely free from the log, when the latter is moved ahead for another cut.

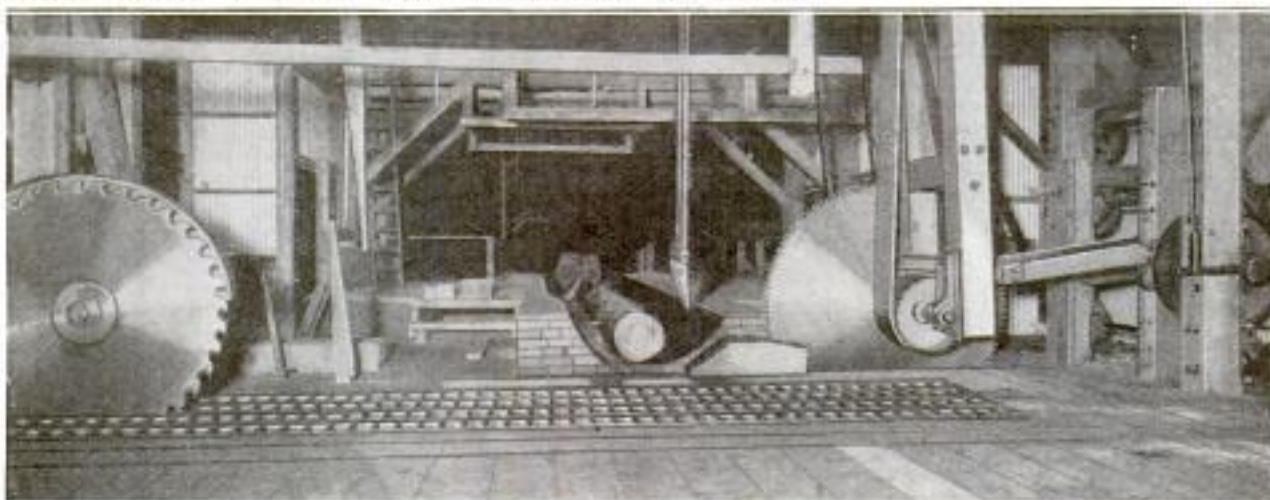

At the Right Is the End of the Log Chute by the Side of the 86-Inch Cut-Off Saw. To the Left of That Are the Steam Ax, the Control Levers, the Log Slip, and the Chain Conveyors, with the First Splitting Saw at the Extreme Left

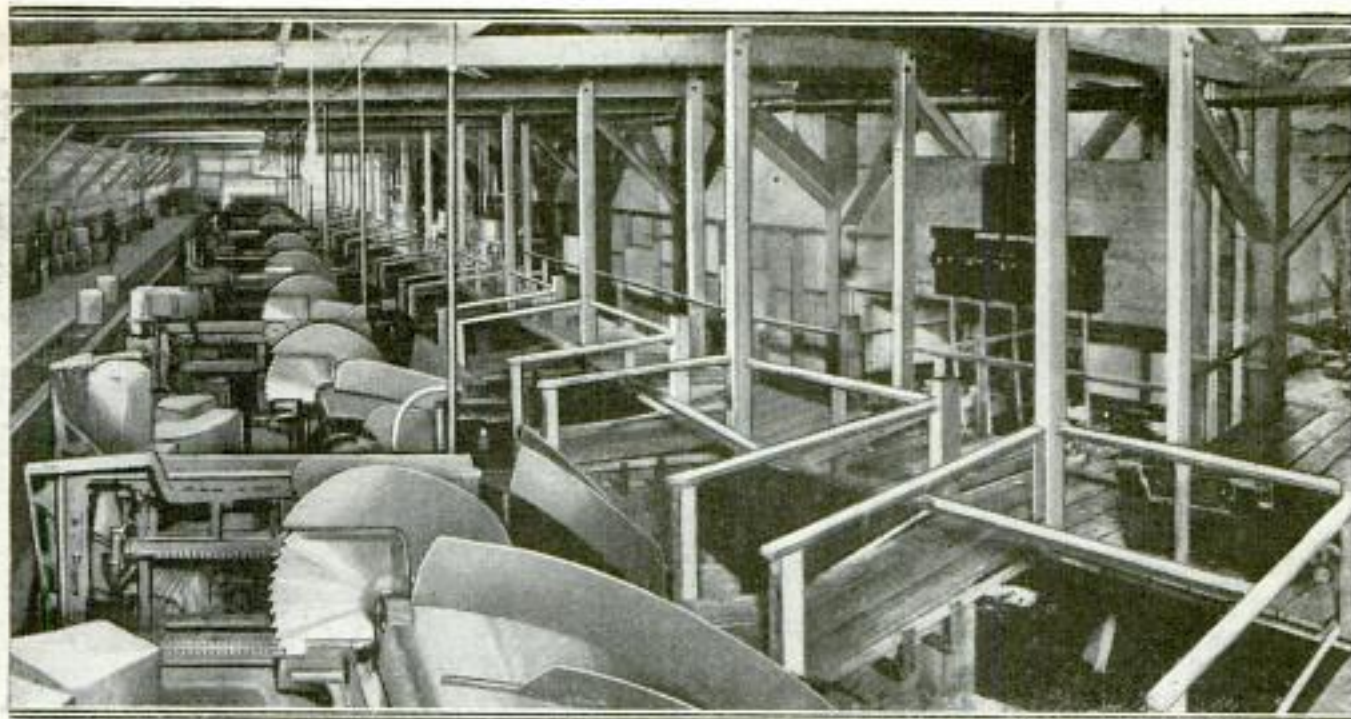

and the 86-Inch Cut-Off Saw. To the Left of This Are the Chain Conveyors in the Floor That Carry the Cut-Off Logs. Foreground, Is Another Conveyor at Right Angles, That Extends the Whole Length of the Mill, to the Right of It. At the Extreme Right Is the Filing Mill

The blocks fall onto a chain conveyor in the floor, and a workman with a pick-iron centers it so that the first splitting saw halves it. As the block arrives at the end of this conveyor, another man switches it onto another conveyor running at right angles to the first.

If the blocks are so large that they need splitting again, they are centered on this conveyor and again split. They next arrive at the knee bolters, where they are trimmed of all bark and rotten spots ready for the shingle sawyers. The knee bolters work in a pit, so that the blocks do not have to be lifted. From the bolters they are placed on the conveyor and passed along to the 14 shingle machines. The conveyors from the cut-off saw to the splitters and then to the knee bolters give more efficiency with three men than was obtainable with 10 under the old system.

The prepared shingle blocks are placed in the grip of the shingle machines and are automatically sawed into shingles. The operator takes the shingles as they fall and "joints" the edges on a small saw in front of him. They are then tossed down the chute to the packer, or "weaver."

As each bundle is packed, it is placed on a gravity conveyor, and by

means of these conveyors and other live conveyors, is carried to the trucks ready for the dry kilns. The trucks go into one side of the kilns and out at the other, then to the repacker and into the car.

8622
**FIND INDICATIONS OF POTASH
 WHEN DRILLING FOR OIL**

While drilling for oil recently in Texas, the drill passed through strata which showed a considerable amount of potash. Unfortunately the samples taken did not give complete information as to the thickness of the deposit. Further investigations are now in progress which may develop new potash areas at a considerable distance from all known Texas deposits.

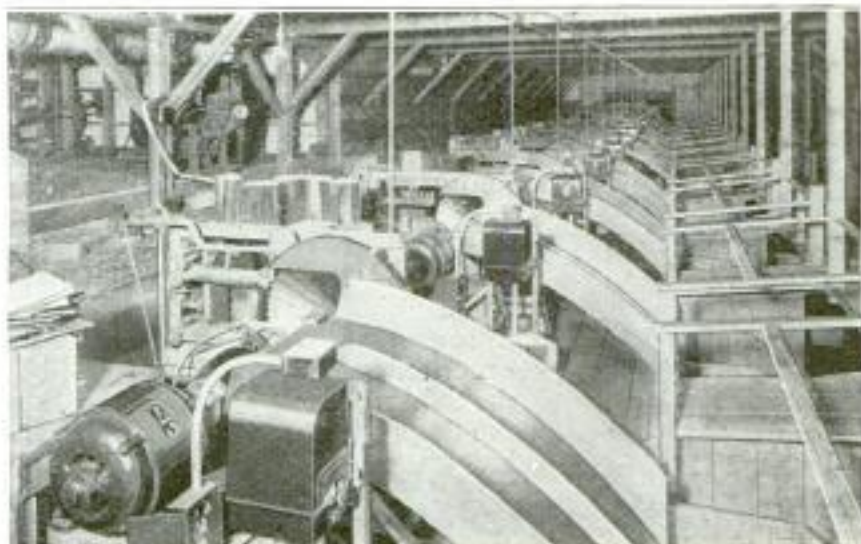

Row of 14 Shingle Machines, Showing the Chutes Down Which the Finished Shingles Slide: The Saw at the Right of the Machine Cuts the Shingles. Each Machine is Driven by Two Motors

*Franklin Institute
 Journal* Copyright 3/1922

Mr. J. Rhamstine
2152 E. Larned St.

Chicago Tribune
3/10/22

736 Detroit POPULAR MECHANICS

ORDINARY RECEIVERS USED WITH NEW AMPLIFIER

Any standard head set may be attached to branches of a new radio amplifier, and held in position by two knurled screws, which are rubber-covered to prevent damage to the receivers. As a rule, persons who buy amplifiers generally have a head set which is thereafter not needed, but with this new loud speaker, the old instruments can be utilized. The sound from the two receivers of matched tone is usually greater and less distorted than when but one is used.



Railroad outfit

FREIGHT AND PASSENGER-CAR HIGH-POWER STAFF BRAKE

For both steam and electric roads, a new type of hand-brake drum is an improvement over the old simple staff hand brake. In place of the plain winding staff is a grooved winding drum. The radius of the drum is large at the upper end, to provide for quick take-up of the brake chain, and tapers down to the lower end. The drum has a winding power about 2 1/2 times that of the plain staff.



Parisians are discussing the erection of a memorial in honor of the dogs employed in the French army, which were killed in service in the late war, being the first nation so to honor these faithful animals.

ing the first nation so to honor these faithful animals.

COURT HOLDS THAT JAPANESE BORN HERE MAY OWN LAND

A decision recently handed down by a California court holds that Japanese born in this country are entitled to own land here. This is the first decision of this kind in California and is based on the Constitution of the United States, which says that all persons born here are citizens. In the case cited, the Japanese father advanced money to his children, who were born here, for the purchase of land. It is hard to say what will be the effect of this decision in California, with its 100,000 Japanese population.

RATS CAUGHT AND DROWNED IN NEW-STYLE TRAP

Catching and drowning rats at the same time is accomplished with a trap of late introduction. The trap is built in the shape of a perpendicular "L," and has a small screened runway through and up which the rodent must crawl to get near the bait. When the rat arrives at the top of the runway and strives to reach the tempting cheese, bacon, or other bait, the animal is precipitated into a galvanized-iron tank filled with water, and drowned.



the runway and strives to reach the tempting cheese, bacon, or other bait, the animal is precipitated into a galvanized-iron tank filled with water, and drowned.

SOFT-FACE FLOGGING HAMMER HAS MOLD FOR REFACING

A soft-face flogging hammer that has a mold in connection with it, so that it can be readily refaced, is now on the market. On its hickory handle the hammer has an iron head, strengthened to stand hard usage, on each end of which is molded a special antimony-lead face, the whole being well balanced and of ample weight. The iron mold that goes with the hammer is so shaped that it will slip over either of the soft ends, and form a mold for pouring molten lead so as to form a new face. It is stated that this can be done in three minutes.

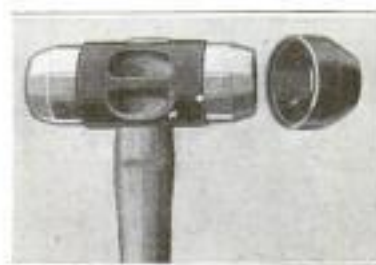

ing the first nation so to honor these faithful animals.

maywood Machine Work
Madison Av. Maywood
Copyrighted material

8461
Cmt. Phil Wall Box 111,
New Bedford, Mass

7575
Ackley Brake & Supply Co.
50 Church St. New York

8448
Cmt. J. R. Jackson
397 Riverside Dr.
Cincinnati, Ohio

8441

cont. B. es. Fields
 c/o The Banner, Nashville,
 Tenn.

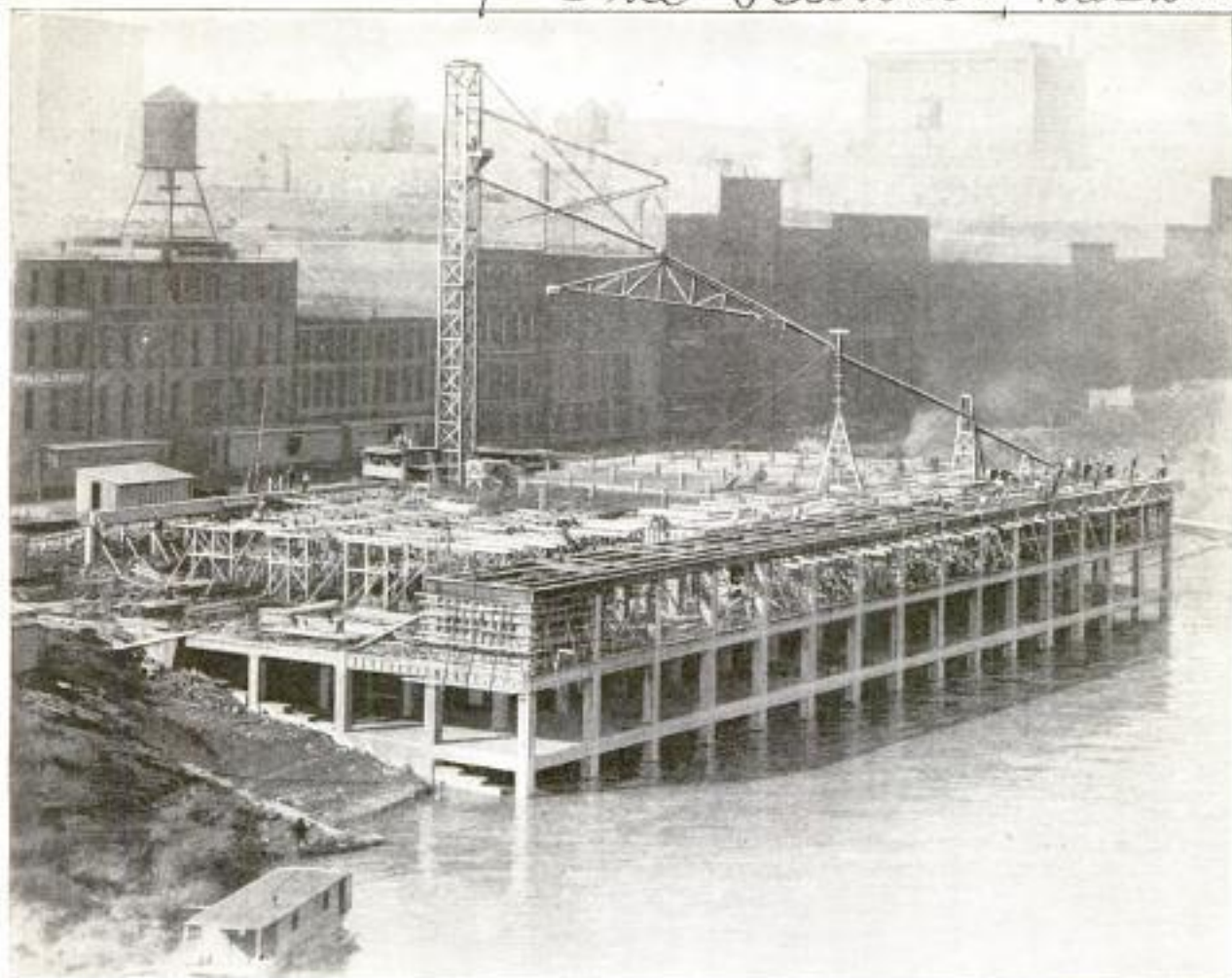

MUNICIPAL RIVER TERMINALS ERECTED AT NASHVILLE

CONSTRUCTION work on the Nashville, Tenn., river terminals, which has been in progress at the municipal wharf since last June, is now nearing completion. Three of the four floors are practically finished, and small quantities of freight have already been stored on them. The terminals are being erected by the city at a cost of nearly \$240,000, and will be of great value to the native shippers and receivers, as well as to the railroads and steamboat companies. Farm products will be the bulk of shipments down the Cumberland River from a hitherto undeveloped part of this state and Kentucky, and transferred through the terminals to the railroads for dispatch to their destinations, or to buyers for local use. Above is seen the municipal terminal during construction, while below is a view of the river terminal in 1862, when steamboats were landing war supplies.

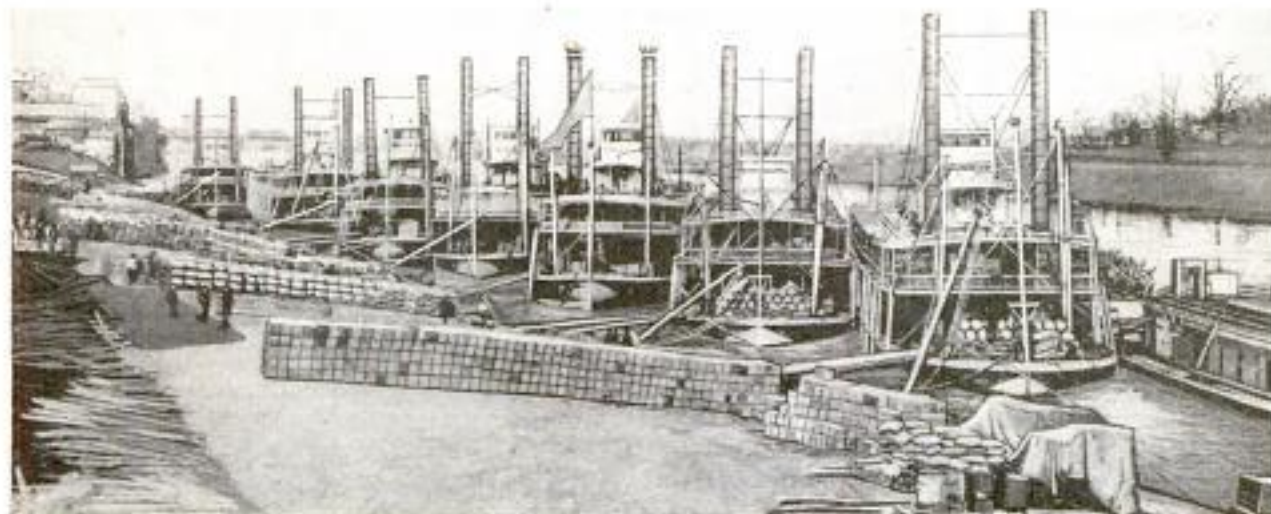

H. Y. James 3/10/22

8642

P. 17 + 26

**FIRST AUTO SHOW IN CHINA
HOUSED IN BAMBOO SHED**

Very characteristically, the first auto show in China was housed in a huge

**TO WIRE APARTMENT HOUSES
FOR RADIOTELEPHONE**

As an indication of the growing popularity of the radiotelephone, a real-estate firm of New York announces that it will wire several apartment houses for this service. The builders say that it will be better for them to erect one aerial for the use of all tenants than to have the tenants erect individual aerials. A building contractor of Philadelphia also announces that buildings being erected by him are to be wired for radiotelephone service as part of the regular equipment.



Top: The Huge Shed during Process of Construction, Showing the Long Bamboo Arches Supported by Slender Uprights of the Same Material. Below: Several of the Exhibition Booths at the Auto Show

shed built entirely of bamboo. Arched bamboo ribs with a very large span were supported at several points by slender bamboo posts. In that respect it was very Chinese, but when completed, with its well-furnished booths filled with American and European cars of the latest models, equipped with conspicuous signs in English, and illuminated with a large number of electric lights, it had very much the appearance of an automobile exposition such as one is accustomed to see in Europe or America.

Tracks of prehistoric animals have been found recently on rocks in Kentucky, between the Kentucky and Cumberland rivers.

**EMPLOY OLD RAGS
IN NEW PREPARED
ROOFING**

That a waste material may become one of the necessary ingredients of a great industry is shown in the manufacture of prepared roofings, as old rags form the basis of the finished roll or shingle. The rags are collected by dealers and shipped to the factory, where they are sorted and reduced to a pulp which is made into a fabric or felt. Hot asphalt is then forced through all the pores of the fabric, and a coating of asphalt is applied on both sides. The wearing surface is then coated with crushed slate, or other stone, which is pressed firmly into the asphalt coating.

**OILED WRAPPERS FOR APPLES
STOP FORMATION OF SCALD**

Scald, which is a transportation and storage disease of apples, is caused by gases given off by the apples themselves, but can be prevented by the use of oiled-paper wrappers. Tests have shown that the wrappers should carry 15 to 20 per cent of oil in order to be effective in preventing the development of scald. These oiled wrappers are not to be confused with wax-paper wrappers.

*Dept. of Agriculture
3/10/22 Cl. Sheet No. 194*

*Mr. C. H. ...
The Rubberoid Co., New York City*

8571

Handwritten notes

Kadel & Herbert

8652

8236 d no. Admiral Villiers, British Navy
 Sold by Sperry Esyroscope Co Ltd.
 London, England.

POPULAR MECHANICS

INSTRUMENT DRAWS ON CHART COURSE OF SHIP'S VOYAGE

For many years there have been in use odometers, or instruments for measuring the distance traveled by vehicles, and now there has been invented in England an odograph, or instrument for drawing to scale on a chart the course traveled by a ship. The instrument consists of a carriage on casters which has a magnetized propelling wheel supported centrally in a revolving frame carrying an index or pointer in the plane of the wheel corresponding to the ship's head. This is first set by hand on the chart to agree with the true course obtained by the ship's compass. After that it always follows any change in direction of the ship's head, and records it on the chart by means of a pencil in a carrier attached to

either side of the carriage. The forward motion of the carriage is at a speed in proportion to the speed of the vessel. The carriage is connected to two rails which extend across the chart to other

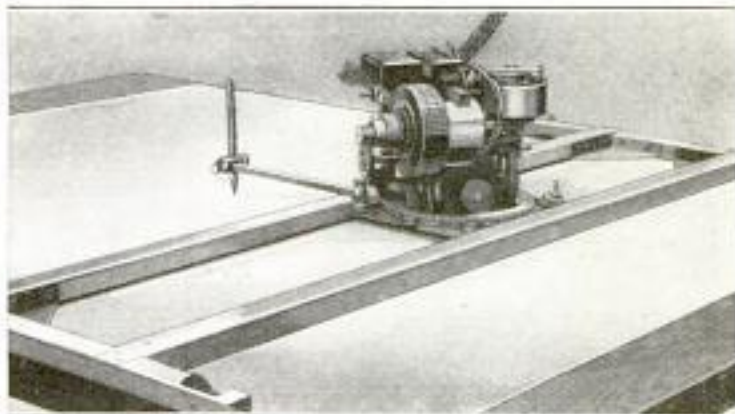

Instrument That Automatically Draws on a Chart Traversed by a Ship at Sea: Everything is Timed and Adjusted So That the Pencil Draws the Vessel's Course Exactly to Scale

rails at right angles to them, one on either side of the table that supports the chart.

8494 Acc

AUTOMOBILE TOWING TONGUE STEERS AUTOMATICALLY

Disabled automobiles, limited in number only by the engine power of the



Automobile Towing Tongue Which Automatically Steers as Many Disabled Machines as the Wrecking Car can Pull Back to the Garage

"wrecking car," may be towed by one driver if a recently invented towing tongue is employed. With these tongues, each machine is controlled by the preceding car, and each will follow the same track on curves of any reasonable degree. As the arrangement consists of jointed flat bar steel, there is no unnecessary jerking when starting or stopping, and no resultant broken fenders, headlights, or other damage from rear-end collisions.

8458

ADVERTISING STUNT TESTS FLOOR COVERING

Not content with subjecting his floor covering to foot traffic by placing a strip of it on the sidewalk, an enterprising merchant placed strips of the same covering in the street, where it was exposed to heavy automobile and wagon traffic. Careful count was kept of the number of vehicles passing over the strips. This, in one case, amounted to 17,000, but the strip showed little evidence of wear.



In Order to Show Its Wearing Qualities, Six Pieces of Floor Covering were Placed in the Path of Traffic at the Intersection of Two Busy Streets

Paraffine Co, d no, San Francisco, Calif

The Towing Tongue Distributing Co.
 1000 Broadway, N.Y.C.

7438

MAKING AN ISLAND FROM CITY REFUSE

By Wm. B. Goodwin, 527 W. 124th St. New York City



Scows, Loaded with New York City Refuse, being Towed up the East River to Riker's Island, Where the Refuse is Dumped in Very Large Quantities: This Island is being Made Ten Times Its Original Size

PROBABLY the most complex and unusual formation which is used for raising crops and for other purposes, is situated in the East River, New York, and known as Riker's Island, or Municipal Farm.

In looking about for a place to dispose of the vast accumulation of waste materials discarded by the thousands of households, the street-cleaning department of New York City decided that if refuse

were placed on this island in sufficient quantities, it would provide a place on which to erect buildings and for raising crops.



Looking East from the River at the Municipal Farm Tower Which is Occupied by an Officer Who Reports Irregularities, and Arrests Anyone Attempting to Bring Narcotics to the Occupants of the Farm

In 1895, the first household refuse was deposited there. Since that time more than 22,500,000 cu. yd. have been added to that plot of ground, which originally consisted of only 60 acres and will eventually be extended to some 600 acres. The material dumped consists of ashes, glass bottles, tin cans, dishes of various sorts, earthenware, beds, mattresses, baby carriages, iron wire, waste paper, wooden boxes — in fact, all household refuse except garbage, which is taken elsewhere.

This refuse is collected from the streets in horse-drawn carts and auto trucks, taken to various docks, dumped directly onto scows, which are towed up the East River to the Municipal Farm and unloaded at two points on the island. It is taken from the scows with steam-operated cranes with dump buckets and placed upon small cars which are easily unloaded by tipping sideways, allowing the con-



Part of Riker's Island, Showing High Hills Formed by Dumping New York City Refuse There, and Clouds of Smoke from Ever-Present Fires

tents to slide off quickly. Thus hand labor is practically eliminated. The distribution of the refuse over the island is done by contractors under the supervision of the street-cleaning department. From this mass of material, things of value, such as money and jewelry, are sometimes picked up by workmen. Thirty per cent of the city's refuse is disposed of here, the remainder going to other places. The top surface of the island is covered with ashes and makes a



Landing Place and Equipment: Watchman at Right of Derrick Reports Presence of Anyone Attempting to Land on Island from Boats



Loaded Cars Leaving Dock: About 50 Such Cars Are in Constant Use for Hauling the Refuse from the Landing Dock to Various Parts of the Island

soil which, in a fairly wet season, produces various vegetables, corn, and other crops. Hogs are also raised on the island, and plans are under way for increasing their number from year to year.

One hundred acres are now under cultivation. In places, the mass of refuse is 60 ft. high and forms an uneven surface, elevations and valleys having been purposely created. Soon after the first load of refuse was placed there, smoke and flames began to appear and have not subsided.

The smoke is carried long distances by the wind, accompanied with a disagreeable odor. No fires are set, but spontaneous combustion causes the flames to burst forth along the embankments where the filling-in work is done.

The Municipal Farm, or older part of the island, is under the supervision of the city's depart-



Embankment of Refuse Used in Building Up Riker's Island: Space to the Left will be Filled to the Level of the Hills Shown on Opposite Page

ment of correction. A number of buildings, dormitories, hospital, jail, and a church have been erected, and at present house 500 drug addicts. These unfor-

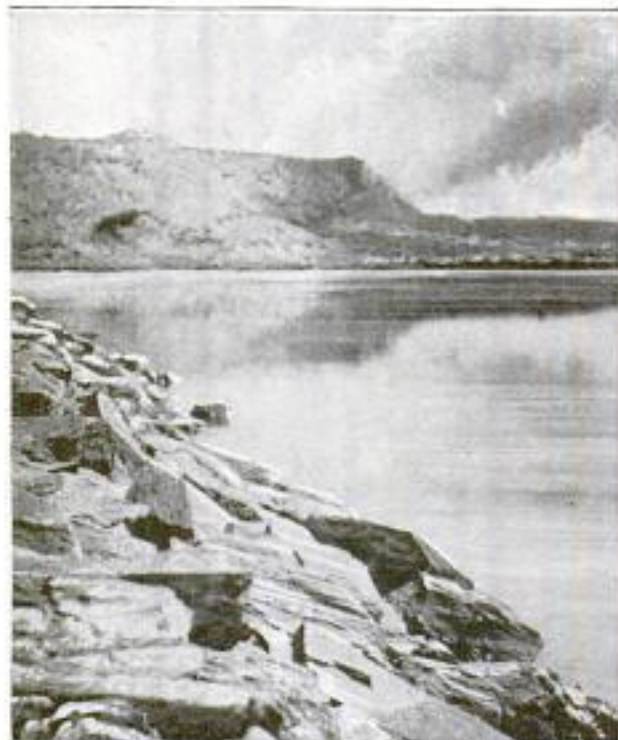

In Foreground, Part of One Embankment; in Background Another; Space between Them will be Filled
 tunates come from the city of New York. After recovery, they are kept working on the farm until the end of their period of commitment.

and then driven over the "fairway" in the direction (if one is fortunate) of the next "hole." The holes consist of markers that are anchored at specified distances apart. After the drive, the caddy paddles to the point where the ball has stopped, the player puts it on the tee again and makes another drive, and thus the game continues. Retaining one's balance in the canoe while driving is an extremely difficult feat, the frequent capsizing of these furnishing an amusing feature of the sport.

8238
COMMUNICATION WITH LINER FROM TELEPHONE BOOTH

Long-distance wireless telephone equipment recently installed on the U. S. Shipping Board liner "America," furnished the means whereby newspapermen were enabled to talk from common telephone booths, to persons on the ship. During the conversation, while the vessel was 370 miles from land, the reporters' voices were carried over the usual wires to a transmitting station and thence by wireless. The incoming messages were wirelessed to a receiving station on shore, and relayed to the New York telephone exchange by ordinary methods. The feat served as a demonstration of long-distance equipment, which, it is predicted, will soon be in general use on ocean liners.

et. AG an rd op th he on, k t
 (An attempt is being made to raise reindeer in the United States on a commercial scale, and a herd of 50 females and 10 males has just arrived from Norway on the way to northern Michigan, as a nucleus for the herd. For many years these animals have been raised in Alaska, but this is the first attempt to acclimate them in any of the states.)

8418
WATER GOLF IS LATEST FAD OF PLEASURE SEEKERS

Water golf, the latest fad of pleasure seekers, is played entirely on the water with the aid of a canoe and a floating tee. The tee, which is tied to the canoe, is placed in the water, the ball upon it,



Left: Playing Water Golf. The Ball is Shown on the Floating Tee. The Player Is Ready to Make a Drive, with the Caddy Anxiously Awaiting Results, Which Not Infrequently Means being Tipped Out of the Canoe. Right: Illustrating How the Floating Tee is Tied to the Canoe

8418
 Capt. Frank B. Howe,
 412 Mason Ave.,
 Los Angeles, Calif.

Unusual
 use

Detroit News 3/1

8591 Cont. Frank H. Williams

1920 Spy Run Ave.

POPULAR MECHANICS

Fort Wayne, Ind. 43

BEAUTIFUL FRATERNAL BUILDING FOR FORT WAYNE

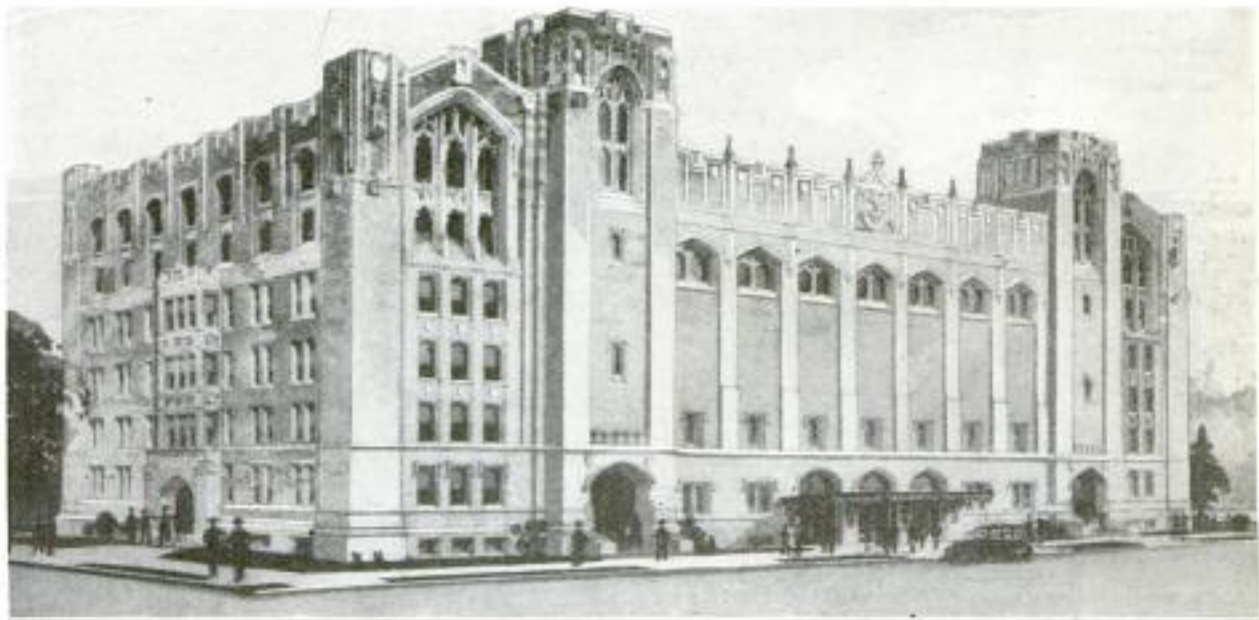

BY combining resources, the fraternal orders of Fort Wayne, Ind., are to erect what will be one of the most costly Masonic homes in America. The building will occupy half of a city block, and will be in fact two buildings joined by a large auditorium for the common use of all Masonic orders housed in the building. The auditorium will have a seating capacity of 4,100 persons, making it one of the largest convention halls in the state.

8561

AUTOMATIC FOUNTAIN SERVES SELF-MIXED DRINKS

Similar in character to the automatic cafeteria where food is dispensed in return for a coin dropped in a slot, is a new automatic sanitary fountain that dispenses drinks in the same way. But it also does a great deal more than that, for it mixes its own drinks, measures them, cools them, and delivers a paper cup with each drink by means of a cup-dispensing system that is said to be entirely novel in design. The fountain has its own electrically operated refrigerating apparatus, and also a filter which purifies the water before it is used in mixing the drinks. It serves three customers at a time, measures and mixes each drink in 12 seconds, and has a capacity of 500 drinks per hour by actual test. All the sirup tanks are porcelain-lined, and the entire dispensing mechanism is silver-plated.



Automatic, Sanitary, Nickel-in-the-Slot Fountain That Mixes Cold Drinks and Serves Them to Three Customers at a Time: Its Own Refrigerating Apparatus can be Seen Below

That the ancient Inca Indian had a knowledge of brass is shown by the analysis of an ax head composed of a mixture of copper and zinc.

And. H.C. Morzani. 723 1/2 Yale Ave. Chicago

Mr. Paul Maurer Magic Fountain Co. 224 N. Sheldon Ave. Chicago

PHOTOGRAPHER IN BOAT SNAPS DISTORTED REFLECTIONS

Photographic studies of water images have been made in the past, usually with the aim of portraying the reflection as an inverted but faithful duplication of the object. The very opposite, however, was the end of experiments carried out recently by one photographer. In every case he attempted to catch the reflection at its instant of greatest distortion. This he

camera at the diverging ripples of the wake he secured pictures of undulating docks, oscillating factory chimneys, and other irregularities often seen but seldom recorded for their own sake.

8192

REMOVE OXYGEN FROM WATER TO PREVENT PIPE RUSTING

In western Australia it is necessary to pump water great distances, and it was found that the formation of rust inside the pipe caused a serious loss in the pumping efficiency. It was suggested that the oxygen dissolved in the water might be the cause of the rapid formation of rust, and the experiment was tried of passing the water through a tower in which a vacuum was maintained. It was found that 90 per cent of the dissolved oxygen could be removed in this manner, and the formation of rust in the pipe was practically stopped, as the remaining oxygen was absorbed in the first

30 miles of pipe. Tests of the water at the end of the pipe showed no oxygen.

8080

EQUIP NEW MAIL TERMINAL TO HANDLE BIG TONNAGE

In the construction of the railway-mail terminal at Chicago, much attention has been given the mechanical equipment which will be necessary to transfer and handle the large tonnage of mail matter which will pass through it daily. The terminal will be capable of handling 3,000 tons of mail each 24 hours, and as one part of its equipment, will have 15 freight elevators. The belt-conveyor equipment is one of the features of the installation, as there will be 65 of these, using a total of seven miles of belting of different widths from 30 to 48 in. They will play an important part in the sorting and transfer of mail sacks and packages. The transfer conveyors on the upper floors will be placed near the ceiling and deliver the mail to spiral chutes leading to the delivery belts on the first floor. This method of placing the belts takes advantage of all the space available and leaves the floor clear for the use of trucks.

Mining & Scientific Press
10/29/21

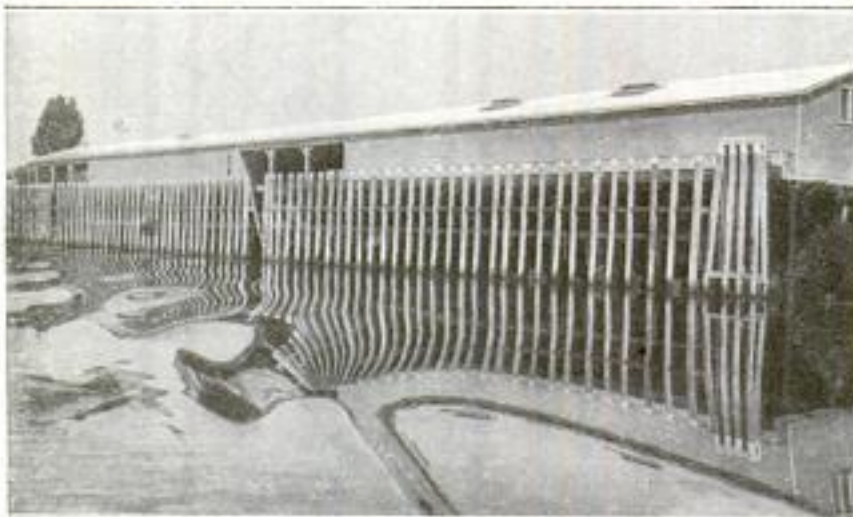

Copyright, I. S. Levin
Photograph Taken from a Boat When the Water was Disturbed by Ripples: If the Upper Half of the Picture were Covered, It would Be Difficult for a Person to Guess What It Showed

did by standing in the stern of a boat which he allowed to drift parallel with and close to the shore. Pointing his



Copyright, I. S. Levin
The Reflection of the Chimney in the Water Makes It Appear as though It were Falling in a Most Peculiar Manner

Ed. L. S. Levin, Carmel, Calif.

ELECTRIC TORCH SUCCESSFUL IN UNDERWATER CUTTING

When a 36-in. cast-iron water-supply pipe was broken recently in New York harbor, a difficult task was presented in the removal of the broken piece. It was decided to try to cut the pipe

One of the latest developments in highway freight transportation is the six-wheel-drive auto truck capable of carrying a 10-ton load and pulling two five-ton

Right: The Highway Train is Coupled Together Much like a Railroad Train, and Air for the Trailer Brakes is Supplied from the Truck through Pipes and Flexible Connections. Center: The Highway Train on a Road Test; the Trailers are So Designed That Their Wheels Follow in the Track of the Truck. Below: The Truck Which Furnishes the Power Drives on All Six Wheels

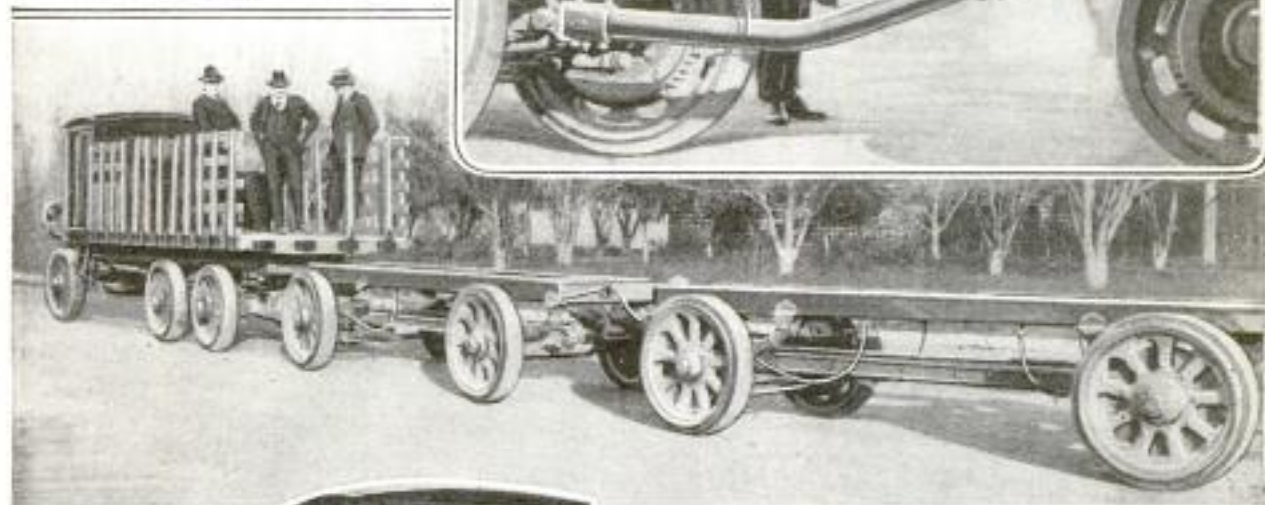
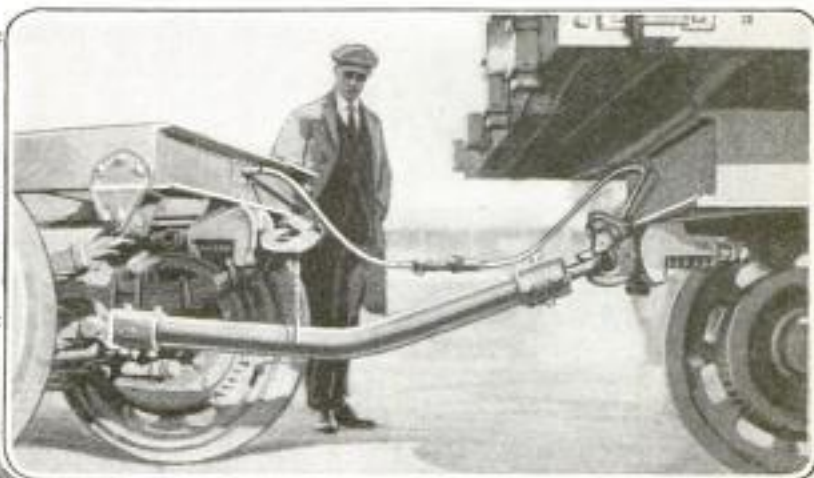

with an electric torch specially designed for underwater cutting. Submarine cutting of steel plates has been done before, but this was the first time that this system was used in cutting cast iron. At the point where the break occurred, the water was 50 ft. deep. Divers were sent down, and the electric torch proved effective, the pipe being cut away in much shorter time than would have been possible with any other known method.

trailers. The truck drives on all six wheels and steers with the two front and two rear wheels. Each wheel of the truck and trailers is equipped with a special hydraulic-pneumatic brake, the brakes on the trailers being arranged to set automatically should the trailer break loose from the train. The trailers are designed so that their wheels will follow in the track of the truck, and are equipped with special antiwabbling devices.

The Columbus Auto Club,
Columbus, Ohio.

Hastie Electric Water
Heater Co.,
Nottingham,
England

746
8593

Small

POPULAR MECHANICS

**DANGER SIGN AT BAD CORNER
SIMULATES REAL AUTO**

Wishing to call the attention of motorists to the curbing at a dangerous street corner, the Columbus, Ohio, Automobile



Club erected a warning sign which was formed like the rear of an automobile. A reflecting danger signal was placed in the center of the "spare wheel," which made the sign efficient at night and much more noticeable than the ordinary warning sign.

**REFUSE CONVEYED BY SUCTION
IN 700-FOOT PIPE LINE**

When recently a lumber company in Ohio built an addition to its plant, situated at a distance of 700 ft., there arose the problem of how to handle the saw-

dust and refuse of both plants efficiently as a unit. The difficulty was overcome by connecting the two plants with a 15-in. pipe line. In connection with this is an air pump which conveys by suction the sawdust and refuse from each plant along the pipe line to a spout that is about 25 ft. above the roof of one of the plants. At this point there is erected on the roof a tank into which, in this way, the refuse is discharged. The tank has a hopper bottom with a discharge pipe leading from it to a point just above a side track for box cars. By this means it is loaded into the cars for shipment. The lumber company thus avoided a threatened increase in its insurance rate of from 20 to 25 per cent, and at the same time does the work more efficiently.

8537

**NEW ELECTRIC TEAKETTLE HAS
TWO COMPARTMENTS**

An electric teakettle has lately been devised which is divided into two compartments.

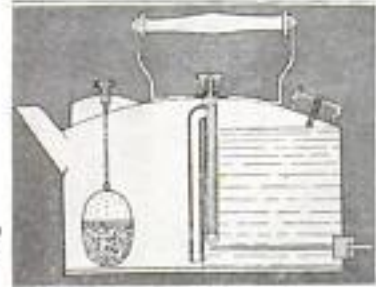

In one compartment an electric element heats the water until it boils; then, by pressing a button at the center of the top, a valve is opened and

the steam pressure is made to force the boiling water into the compartment where the tea ball is hung.

8449

Lumber mill

*Em. L. B. Tichenor
39 7 Grand av. Cincinnati,
Ohio*

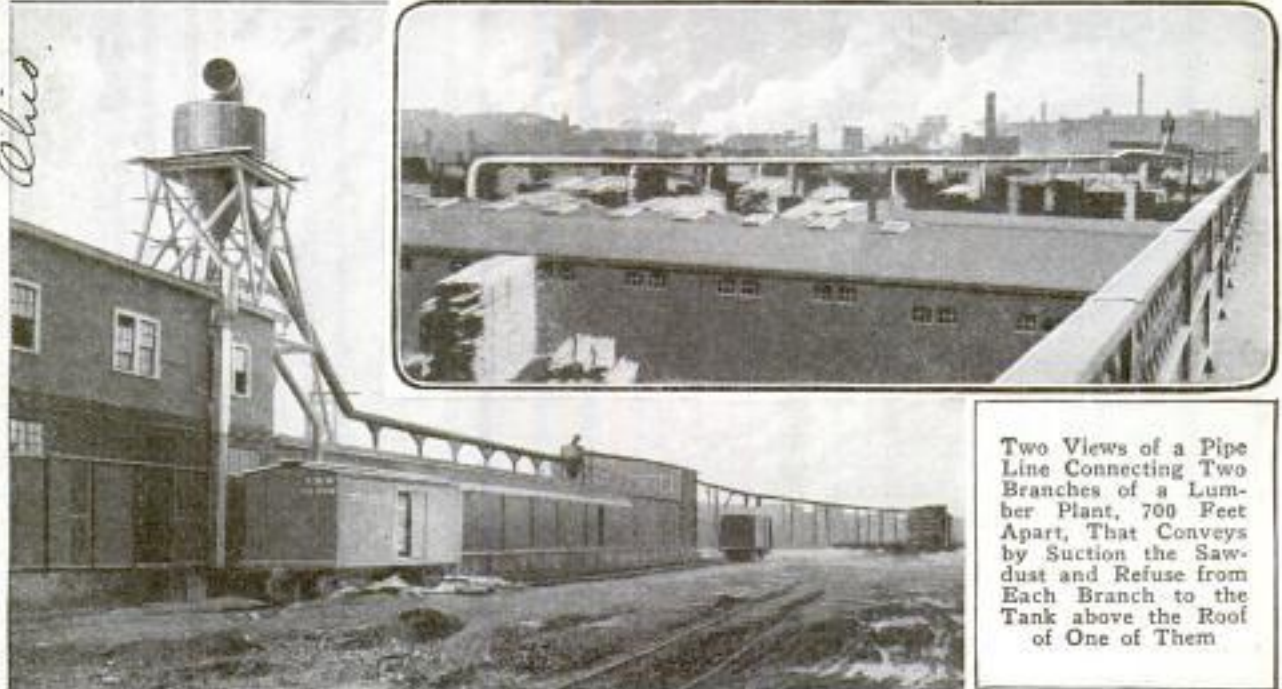

Two Views of a Pipe Line Connecting Two Branches of a Lumber Plant, 700 Feet Apart, That Conveys by Suction the Sawdust and Refuse from Each Branch to the Tank above the Roof of One of Them

8527 Comb Jno. R. Brougher,
Texas City Texas.

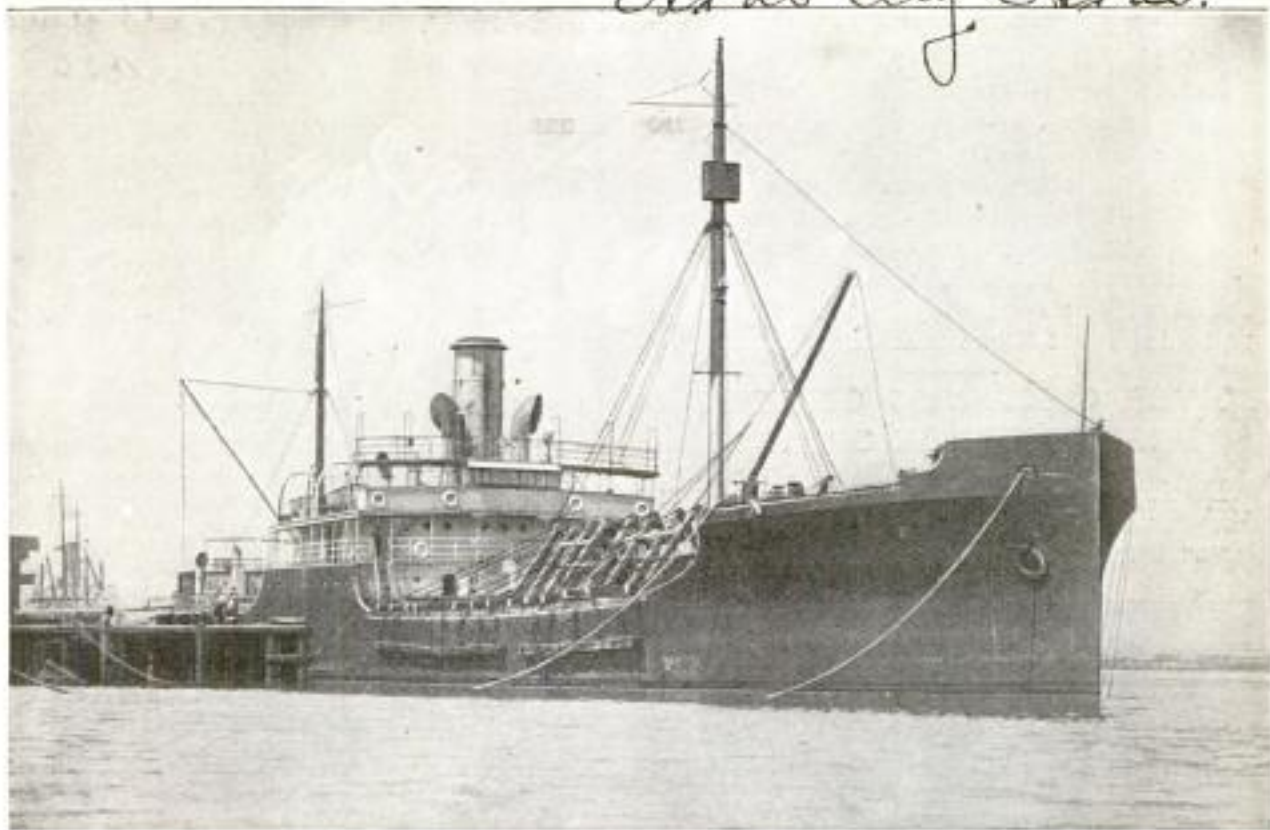

The Wrecked Concrete Tanker "Selma" Tied Up at a Galveston Wharf, after having been Raised by Means of Compressed Air: The Bracing of the Forward Deck Was to Strengthen It So as to Resist the Air Pressure. The Vessel Sank upon the Mud beside the Wharf, and Remained There Nearly a Year

CONCRETE SHIP BURIED TO SAVE EXPENSE

THE use of reinforced concrete as material for building ships was dealt a severe blow recently when the Shipping Board towed the concrete tanker "Selma" from the wharves at Galveston, and literally buried it at considerable expense, to get rid of it and stop wharfage charges.

The vessel, which is reported to have cost nearly \$2,000,000, ran into the rock jetties at Tampico, Mexico, about a year ago, and ripped a big hole in the bottom of the hull. The tanker was raised with compressed air and towed to Galveston. There, shipbuilders decided that it would not be practicable to repair the damage. The rods which reinforced the concrete were projecting through the hull, and it would have been difficult to get the craft in position upon the drydock for repair. So the "Selma" was allowed to sink upon the mud at a wharf where it lay for nearly a year, and wharfage charges of about \$1,500 a month piled up.

The task of getting rid of a steamship, especially one with a big hole in its hull and ready to sink in the nearest deep water, seems simple at first sight. However, the Shipping Board had considerable difficulty in disposing of the "Selma." It was first offered for sale, and nobody wanted it. Then it was proposed that it be towed out and beached near the Galveston jetties, for use as a fishing pier.

The Federal engineering department objected on the ground that the hulk might set in motion currents which would undermine the jetties. The proposal of taking the ship to sea, and allowing it to sink, was abandoned because it was feared that it would sink before it could be towed far enough not to become a menace to navigation.

The ship drew about 24 ft. of water when lifted as high as it was possible, and for that reason the only spots along that section of the coast that it could reach were considered to be navigable waters which must not be obstructed. The gulf is so shallow around Galveston that the vessel could not be brought within a mile of the beach.

The problem was solved by dredging a channel from the deep water of the government channel into Galveston and out into the sand flats at one side of it. This channel was cut 30 ft. deep for 400 ft.; the "Selma" was raised by compressed air, run into this channel, and allowed to settle to the bottom. Its decks and upper works are still above water, and are expected to remain there for a long time. But the currents will soon refill the channel, and the tanker will be lying in sand with only a few feet of water around it. If the vessel is ever desired for use again, it will be necessary to dig it out.

Saveall Tool Co
59 River St.

POPULAR MECHANICS *Waltham Mass.*

It has been suggested that the hulk be used for a shrimp-canning factory, but no definite steps along this line have been taken. All movable machinery was salvaged, but the major portion of the machines on the "Selma" were bedded in the concrete of which it is constructed, and it will be necessary to break the ship up to take out these machines.

POWER COMPANY'S CUSTOMERS READ METER IN CONTEST

During a meter-reading contest conducted for the benefit of its customers, a Harrisburg, Pa., power company discov-

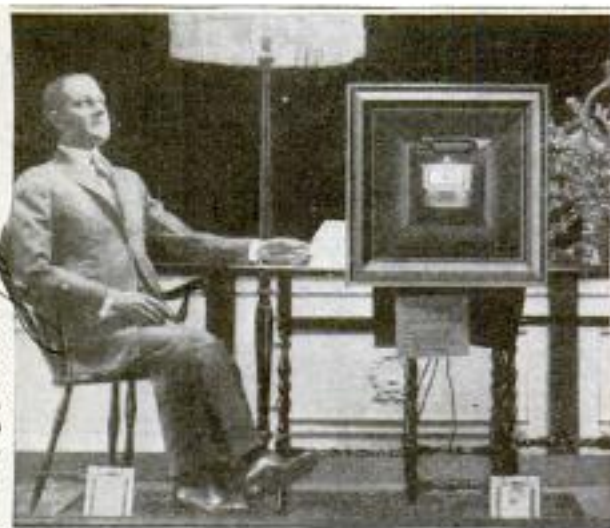

Display Window of Power Company, Showing the Watt-Hour Meter Placed in a Framed and Velvet-Lined Box

ered an amazing lack of understanding relative to the correct reading of the instrument. The meter was placed in a display window of the concern, and cards furnished to those desiring to enter daily records of their conception of the amounts shown on the dials. These cards, together with similar ones marked by regular meter readers employed by the firm, were handed in to clerks who checked and filed them. At the conclusion of the 12-day period, when the several prizes for the best average cards were to be distributed, it was found that but one of the many participants possessed a perfect score.

USE OF SECONDARY CONDENSER IMPROVES AUTO IGNITION

New principles of condenser construction in connection with a high-tension magneto-ignition system for auto engines have been discovered by an experienced engine builder of Detroit. This new con-

denser, made of glass, is absolutely sealed from brush-discharge loss, and is practically indestructible, for it takes 60,000 volts to puncture it. Another departure from the common practice in condenser construction is the use of very thin steel plates in connection with the glass-tube dielectric. After the steel plates are electrically connected, the glass tube is incased in a mahogany box, and the condenser is sealed by pouring over it a cement that has been made specially for this work. It is poured in at a temperature of 250° F., which removes all traces of moisture in the condenser, and eliminates brush-discharge losses. It is used as a high-tension secondary condenser in the high-tension circuit of the ignition system.

SAFETY DRILL AND TAP CHUCK SAVES TOOLS FROM DAMAGE

A friction-drive positive-safety drill and tap chuck, recently patented, has a soft-steel pin which drives the collet, in which the drill or tool is held, and shears off when the cutting tool is overloaded. The collet slips into the chuck when the sleeve is raised, and is held rigid when the sleeve is lowered. In the small end of the collet is an ejector. A light blow on this releases the drill or tool. A hollow screw in the collet prevents the tool from being pulled out or pushed in, and end play of the collet is impossible. As a result of this construction it is impossible to break or burn drills or other tools held

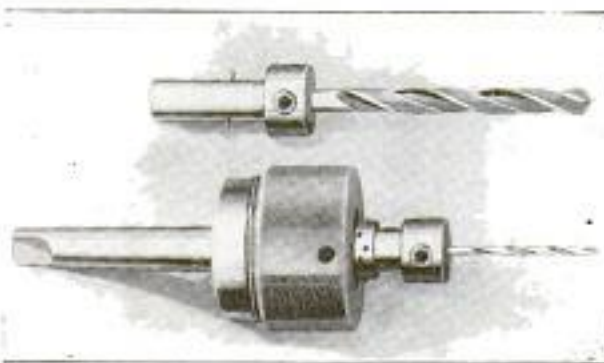

Friction-Drive Positive-Safety Drill and Tap Chuck Are Below. Above, the Collet is Removed, Showing the Soft-Steel Safety Pin That Drives It

in the collet. The tools can be made of carbon steel, and the cost of high-speed steel is, therefore, avoided.

Recent radiotelephone broadcasting by the New York Western Electric Station, using a limited wave length, was heard by a vessel 1,000 miles west of San Francisco.

2708 Mrs. 581 Ave
Emb. George J. Paul, 900 Ellsworth
Chicago
8428

8499 VVO Accellator Price \$5.00

2708 Mrs. 581 Ave
Geo. J. Paul, Los Angeles
Mrs. Saveall

8509

International Newsreel Corp
 no. 206, 4 Rue Richer,
 POPULAR MECHANICS Paris (France) 749

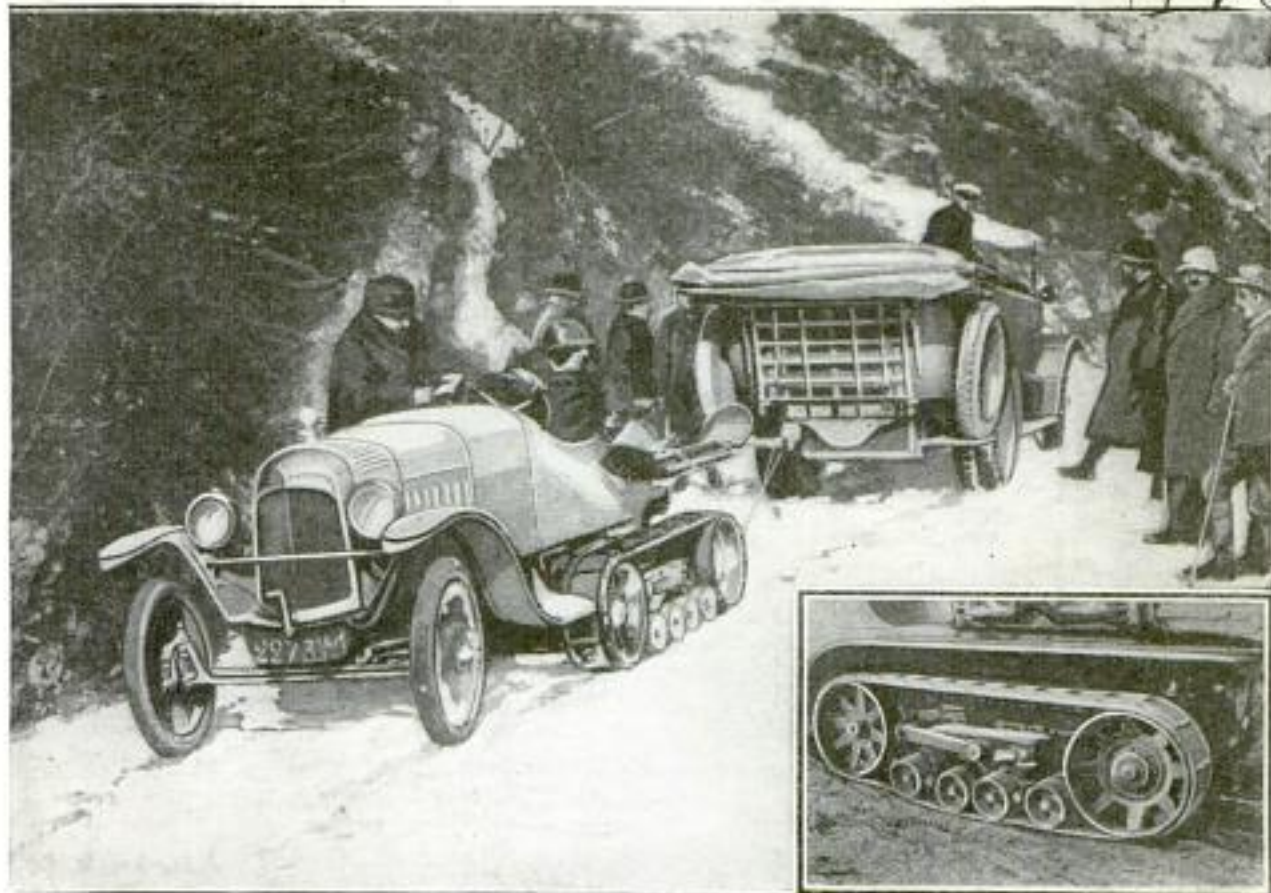

AUTOMOBILE FITTED WITH TRACTOR TREAD FOR TRAVEL OVER SNOW

TRIALS of devices to fit automobiles for travel over snow-covered roads were recently held in France. One of the competitors fitted a tractor tread to his car, consisting of two wheels over which a rubber belt traveled. Four small intermediate wheels helped support the weight of the car and give the belt traction on the snow.

7133 WAR DEPARTMENT SUPPLIES BEDS TO FOREST SERVICE

One of the valuable pieces of work being done by the salvage office of the War Department is providing a supply of beds for the warmth and comfort of forest rangers and volunteers during rests in fighting forest fires. These emergencies require the services of every available man in the region for a task which is extremely taxing. It is essential that during the short periods of rest which are possible, each should have an opportunity to sleep in warmth and comfort. Bed rolls, containing three woolen army blankets and two shelter halves, are now supplied to the fire fighters. The shelter halves form a regular army shelter tent.

The blankets are washed and disinfected at frequent intervals. One bed is apportioned to two men in the summer, while in cold weather each ranger is supplied with a separate unit, and they are carried from one locality to another on mules.



A Pile of Bed Rolls at the Denver, Colorado, Headquarters of the Forest Service, Where 500 Units are being Put in Readiness for Distribution to Camps in the National Forests of Colorado, Wyoming, and South Dakota

Cml. S. C. Winters 702 District, National Bank Bldg. Washington, D. C.

Enl. Maurice E. Pelgrims
35 Place de la Gare

750

POPULAR MECHANICS

Antwerp, Belgium

TINY FRENCH PLATE CAMERA
IS BUILT LIKE A PISTOL

8372
Mr. E. Kraus
Paris, France

A small camera, which might almost be called a watch-charm design, has been introduced by a French firm. In general

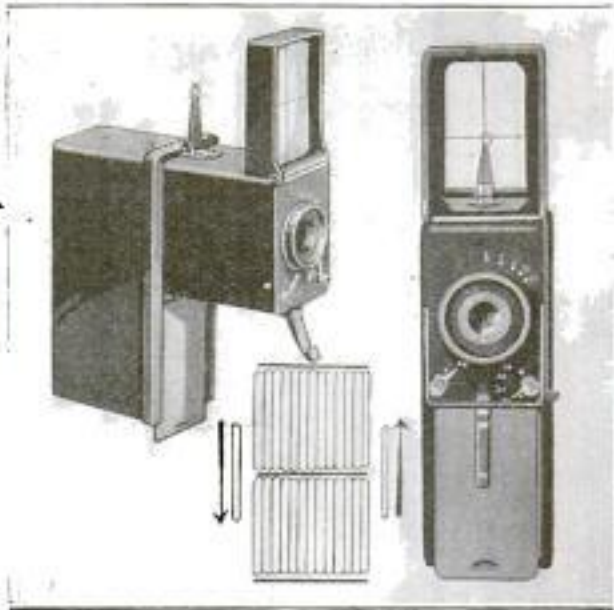

This Extra-Small Plate Camera is Sighted and Snapped like a Pistol. The Diagram Shows the Method of Shifting Exposed Plates in Holder Magazine

appearance it resembles a pistol, and it is pointed and snapped in a similar manner. It carries 48 plates in two compartments, and has an indicator which tells the number exposed. When closed, the range finder folds over to form a protection for the face of the camera, and the trigger snaps up to hold the finder securely. The pictures taken are about $\frac{3}{4}$ by $1\frac{1}{8}$ inch.

STAGGERED ROLLER BEARINGS FOR HEAVY-DUTY SERVICE

8115

Heavy-duty roller bearings are now being made which embody a valuable principle, for there are greatly reduced intervals between the rollers, thus giving

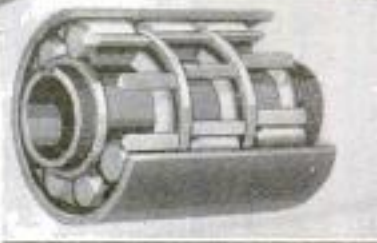

Above: Heavy-Duty Roller Bearing with Outer Race Removed to Show Staggered Rollers. Right: View with Some Rollers Removed to Show Space Rings

a much more continuous radial bearing. This is accomplished by cutting the rollers in sections, spacing them in series longitudinally, and staggering these series with relation to each other. The rollers are mounted in a cage with suitable clearance, and means for retaining them in their staggered positions. Adjustable space rings are mounted on the inner race so as to take care of all end thrust, and also to prevent friction between the ends of the rollers. In general, the inner and outer races are similar to those of conventional bearings.

BRICK PAVING SERVES WELL DURING LONG PERIOD

8598

The first use of building brick for street paving was in Charleston, W. Va., in 1871, and the pavement gave good service for 38 years. Another brick pavement in the same city has been down for 27 years and is still in good condition. One of the first bricks laid in the older pavement has been preserved; it shows a wear of less than one inch during its 38 years of service. *Eng News-Record*

SIMPLE GAUGE TO MEASURE OVERSIZE IN CYLINDERS

For measuring with precision oversizes in cylinders or pistons, a gauge, much simpler and more easily read than the

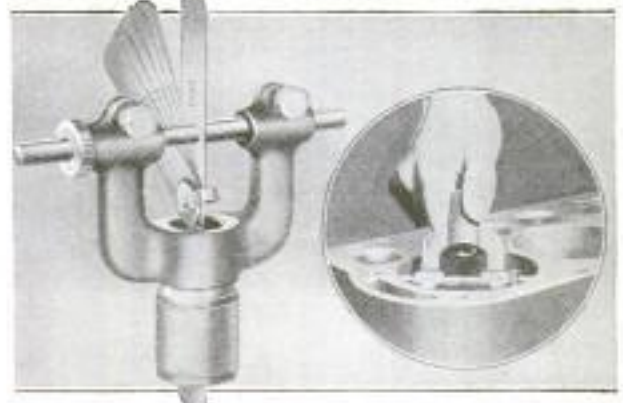

Micro Gauge for Measuring Oversize in Cylinders, Shown with One Blade of a Thickness Gauge between the Pins: Insert Shows the Gauge in Use in a Cylinder

ordinary micrometer, is now on the market. Its pronged arms carry pins, one fixed and the other adjustable, the combined length of which, when together, equals the nominal diameter of the cylinder to be measured. Therefore, any opening between the two pins shows the oversize of the cylinder. This opening is measured with a thickness gauge, of which several are provided, each stamped with its thickness in thousandths of an inch.

Universal Roller Bearing Corp.
Norfolk, Va.

Stevens & Co.
275 Broadway
New York

8541

THE GREAT AMERICAN DOG-TEAM DERBY



Start of the Great American Dog Derby. Held at Ashton, Idaho, February 22, as the First Big Event of the Yellowstone Golden-Anniversary Year: Governor Davis, of Idaho, Was the Official Starter. The Dog Team Shown in the Picture was Driven in the Race by the Only Woman Competitor, Miss Lydia Hutchison. She is Standing beside the Sled, and Evidently Matches Up with Any of Her Male Rivals—in Size, Strength, and Nerve, Not to Mention Clothes. On Her Back Are Two Numbers, One for Herself and the Other Representing "Snaky Gaston," the Famous Dog-Team Driver Who was Lost a Day before the Race



Finish of the Dog Derby, with the Winner, Tud Kent, Shown Dashing across the Line; The Race was Run in a Blinding Blizzard, Which Fortunately Moderated before the Finish. Besides a Valuable Purse, the First Prize Consisted of the Silver Championship Cup

POPULAR MECHANICS

879

INHABITANTS OF BORNEO EAT FLESH OF CROCODILES

BLUEBERRY EXPERIMENTS GIVE REMARKABLE RESULTS

Crocodile meat is considered a delicacy by the natives of Borneo, and when one

Unlike most plants, blueberries thrive only in acid soil and their propagation offers an opportunity for utilizing land otherwise unfit for agriculture or, at best, requiring expensive treatment. For this reason, the Department of Agriculture has been conducting experiments, for the past 10 years, to develop a superior type of berry for cultivation. Most of the work has been done at Whitesbog, N. J., where the combination of sand and peat soil affords ideal experimental conditions. It has been highly successful and hybrids have been developed which are the size of Concord grapes, and in some cases even $\frac{3}{4}$ to $\frac{7}{8}$ in. in diameter, though the wild berries are only about the size of peas. They have also been selected for flavor, juiciness, and firmness. As yet the giant berries have not become available in sufficient quantities for acre planting, though a number of irresponsible dealers have



Slain Crocodile Surrounded by Group of Borneo Natives, Who Consider the Flesh of the Monster a Delicacy, and Permit the Executioner to Carve Out the Liver for His Reward

of the reptiles is slain, there ensues a mad scramble for its flesh, and feasts for those who obtain portions of the carcass. The liver has a flavor which makes it especially desirable to the queer people. It usually is allotted to the man who took the most important part in the slaying of the monster.

berries have not become available in sufficient quantities for acre planting, though a number of irresponsible dealers have

142 W. 23 rd, N.Y.C.

SOCKET WRENCH ADJUSTABLE FOR VARIOUS-SIZED NUTS

Adjustable for use on from $\frac{1}{4}$ to 4-in. nuts, a newly invented socket wrench

consists of a shank with a V-shaped jaw at one end and at right angles to it. On the shank slides a similar V-shaped jaw, with the "V" reversed, that can be held with a setscrew in any adjusted position. Thus the two jaws

are made to grasp hexagon nuts of any size, and the tool can be used as a socket wrench wherever there is nothing to interfere with the radial movement of the shank when turning the nut.

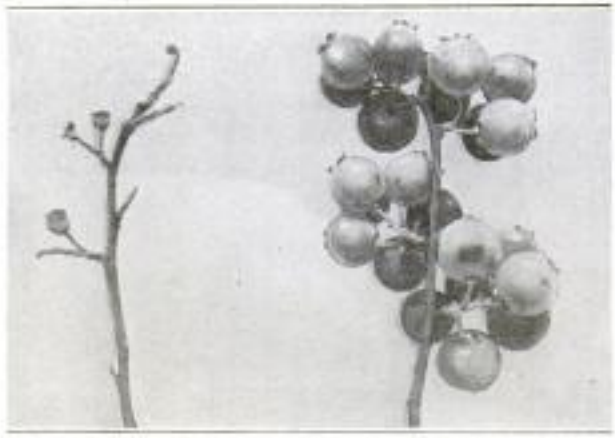

Left: Twig of Blueberry Bush with Berries of Ordinary Size. Right: Twig of the Same Bush Whose Flowers were Pollinated from Another Bush

sold plants, by misleading statements, which have proved a disappointment.

TO STUDY STANDARDIZATION OF BUILDING MATERIAL

As a means of eliminating waste in industry, it is proposed to study the problem of standardization as applied to building materials, with a view of simplifying the types and reducing the number of different sizes of various materials. Items mentioned for study include mill-work, plumbing, heating, hardware, and clay products.

Fabricated Products Chamber of Commerce
 94. S Bulletin

8487
 Eml. Frank J. Herman
 620 Metropolitan Bldg.
 100 Longacre City

Copyrighted material

8560

The World
2/1/22

POPULAR MECHANICS

RECORD VIOLENT EARTHQUAKE
UNDER PACIFIC OCEAN

On January 31, the seismographs all over the country recorded an unusually violent earthquake which was calculated to be at the bottom of the Pacific Ocean, off the coast of Washington or Oregon. At some of the stations the instruments registered more violent disturbances than at the time of the California earthquake of 1906. The disturbance lasted for a little more than three hours, according to the record. It is worthy of note that the San Andreas fault, along which the 1906 earthquake occurred, disappears in a northwesterly direction in the Pacific.

7434

COMBINED TRAILER AND CRANE
HANDLES DISABLED AUTOS

One would hardly expect a practical invention to come from circus clowns, but it is two clowns that have invented a combined auto trailer and crane for handling disabled machines, which promises to prove highly useful. A hinged platform is so mounted on the trailer that a machine may be run onto it. Then, by means of a windlass, the platform is tilted up so that the underside of the car is accessible for repairs. If the car must be taken to a garage, the trailer is hooked to a truck and the whole outfit towed away. A crane attachment, also operated by the windlass crank, can be used to lift the engine out of the machine.

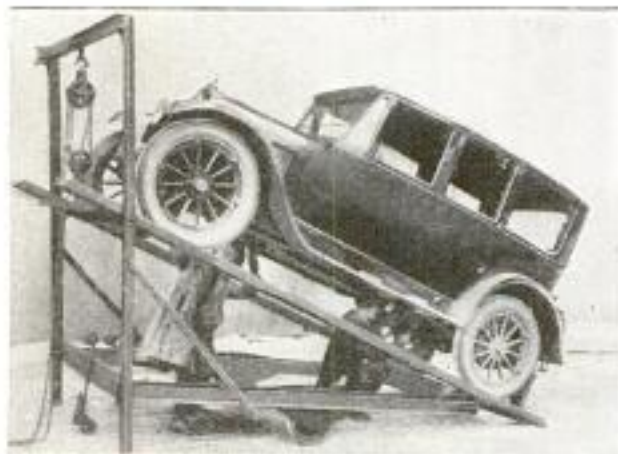

Right: Automobile Trailer being Used to Haul a Disabled Car to the Garage for Extensive Repairs. Above: Elevator or Crane Feature of the Trailer for Making Slight Repairs While on the Road



Wilson & McIsaure Co
1004 Treat Ave.

8437 San Francisco
CONSTRUCT RADIOTELEPHONE
IN FORM OF PHONOGRAPH

At last the radio phonograph has made its appearance. A complete radio receiver, with all controls, is combined in one unit and set in a neat case resembling the present-day phonograph. Two suitable connecting



After Connecting to the Aerial and Ground Wire, the Radio Phonograph is Tuned In by Adjusting the Control Disk

posts are provided for connecting to aerial and ground, the only exterior devices necessary for operating. In the lower part of the cabinet is a storage battery which furnishes power for filaments of the audion bulbs. A rectifier and hydrometer test set are also provided for recharging and testing, so that no detail in the care of the battery is left out. Due to the fact that radio music is now broadcast at all times, it is only necessary to connect aerial and ground and then tune in and enjoy a concert.

The Bureau of Mines is soon to undertake the study of the problem of the preparation of such alloys as that of 50 per cent copper and 50 per cent lead.



A. S. Leake Erecting Co, Bridgeport, Conn.



COPYRIGHT, UNDERWOOD & UNDERWOOD

LAST RITES FOR THE VICTIMS OF THE "ROMA" DISASTER

WHEN the airship "Roma" crashed to the ground, 34 persons were carried to their death. Because many of the bodies had been shipped for burial to homes in distant parts of the country, one body was selected to represent all of the victims. Full honors were accorded this body, and all business activity ceased as the funeral cortège moved from the church to the Casino Grounds, at Newport News, Virginia.

**DETECTION OF FORGERIES
BY MICROPHOTOGRAPHY**

With the help of the microscope and microphotography, it has been possible by means of an exact examination of the ink, and otherwise, to distinguish forged writings from the authentic. But in the case of changes of figures or words in old handwriting by superimposing new pen strokes, it has always been difficult to determine which of the pen strokes preceded the other, and thus to decide positively which was the genuine and which

was the falsification. In doing this by means of microphotography, it has been customary to place the object photographed at right angles to the camera, with results that are not satisfactory. A Frenchman, very well known for his remarkable work in criminal detection, has proved that if the document be placed so that the writing is viewed horizontally, the results are very much more satisfactory than when the document is held at right angles to the camera. His method shows clearly which of two pen strokes, one above the other, was made last.



French Microphotographic Apparatus for Detecting Forgeries: At Left is Shown a Photograph, Taken in the Old Way, of a Figure "1" That was Later Changed to a "4," Which Shows the Horizontal Stroke Apparently below, Whereas It was Actually above, the "1," as Shown Clearly in the Photograph to the Right, Which was Taken by the New Method

*Mr. E. H. Weiss, 80 Boul. Jourdan
Paris (XIe) France.*

*Mr. E. H. Weiss, 80 Boul. Jourdan
Paris (XIe) France.
Lyons, France.
Police Laboratory.*

STANDARDIZING DISHES TO AVOID BREAKAGE

BY G. H. DACY

*National Press Club
Washington, D. C.*

THE dish-juggling and glassware-smashing stunts of "slapstick" comedy are being tried out at the Bureau of Standards laboratories, where dish and glassware-durability tests are now in progress, in order to obtain definite data for the formulation of crockery and glassware specifications which it is expected will be widely adopted. A most novel tumbler tester has been devised which subjects glasses of all classes and types to service wear and rough handling such as they would

be exposed to in active use. This glass-tumbler destroyer consists of a holder in which the different glasses are placed with the bottom side exposed. An iron ball is suspended on a metal rod like a pendulum so that it can be withdrawn different distances and then released and allowed to ram into the bottom of the tumblers. All tumblers which will withstand the impact of a full-swing blow are qualified as satisfactory. The force of the blow delivered in this manner is equivalent to dropping the tumblers from an elevation of four feet upon a concrete floor.

Heretofore, the U. S. Army has been accustomed to purchase hand-made tumblers for use at barracks and messes in all parts of the country. The experts at the Bureau of Standards have ascertained by their extraordi-

nary tests that the machine-made tumblers which cost 50 per cent less, are just as durable and satisfactory for army use

as the more costly glasses previously used. As a result of the investigations now under way, new specifications for army glassware are being drawn up. In addition to the direct jarring tests, many other practical and simple methods of exposing glass and dishware to rapid and effective service tests are followed in these investigations. The crockery is exposed to extremes of heat

and cold similar to the conditions which obtain where automatic dishwashing machines are used. Study is being made of the cobwebs of cracks which occasionally develop in poorly made chinaware, to ascertain the cause and cure for these defects. Glassware is also subjected to

boiling tests in order to determine its suitability to withstand regular and routine sterilization after use.

In addition, strength tests are being conducted relative to the durability and adaptability of different kinds of plate and window glass to various kinds of service. Approximately 5,000 samples of different kinds of plate glass have broken in various strength tests.

As a consequence of these experiments, it is anticipated that shortly the American Institute of Architects will draw up and

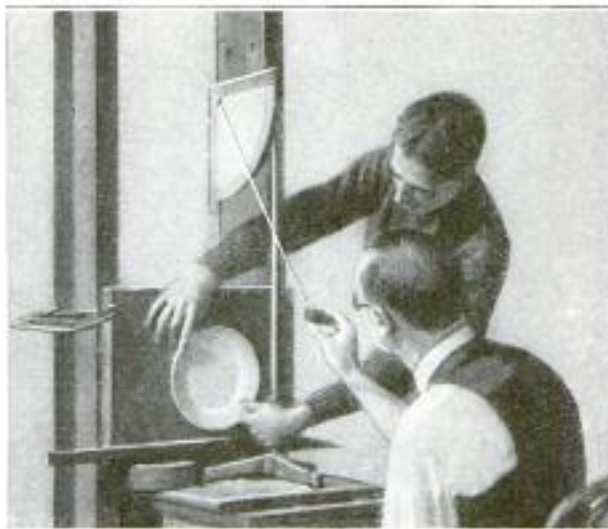

Pendulum Hammer Which is Used to Break Plates Whose Durability is Measured by the Length of the Arc through Which the Pendulum Swings

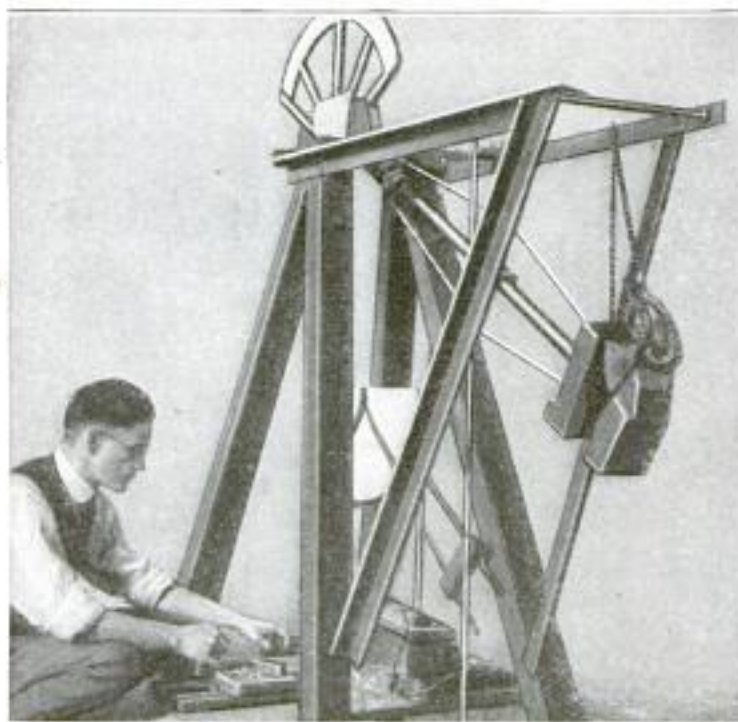

Pendulum Hammer Used to Determine the Breaking Point of Plate Glass, Which is Placed in the Path of the Hammer Whose Swing is Increased Until the Glass Breaks

follow new specifications for plate and window glass. Detailed tests are also being performed with porcelain and enamel-

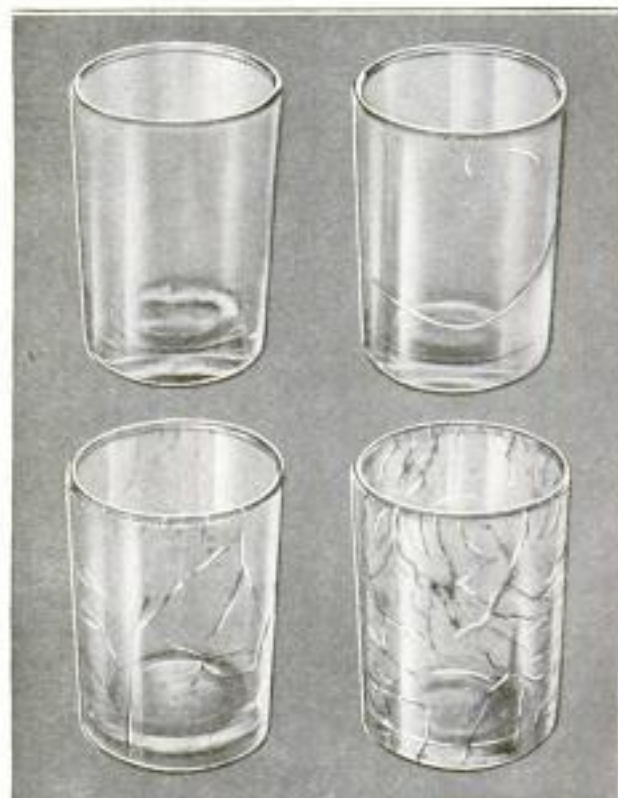

Glasses Which have been Subjected to a Boiling Test of Six to Twelve Hours for the Upper Two, and for the Lower Pair, Which Is of Inferior Quality, of Five to Twelve Hours

ware in order to find out the exact serviceability and durability of these household articles. The fact that the annual dish-breakage bill in a leading Chicago hotel amounts to more than \$50,000, while other prominent hostelries report that their yearly breakages aggregate about 20 per cent of their total supplies, indicates the importance of studying and standardizing glass and dishware and of making these articles stronger and of better materials, so that they will be able to

withstand severe usage longer and more satisfactorily.

Attempts will be made as a result of these investigations to standardize the sizes of plates used and to grade, classify, and mark crockery accurately so that there will be fewer errors made in its manufacture. The Bureau of Standards is urging the potteries and dishware factories to adopt uniform specifications and, as far as possible, to eliminate unpopular styles and sizes of crockery and tumblers. The tests show that American-made dishware and glassware, such as used in the best hotels, are more durable and serviceable than the best of the European dishes. Our hotel china is the best material of its kind on the market.

9575
**PACIFIC COAST OF GUATEMALA
 TO HAVE BANANA INDUSTRY**

For the first time bananas are to be grown on the Pacific coast of Guatemala on a commercial scale. An American corporation, licensed to do business in that country, has acquired a plantation 15 miles west of San José de Guatemala, where it is expected soon to have 2,000 acres planted with bananas. Although the banana industry has reached large development on the Caribbean coast, it has hitherto not been attempted on the Pacific coast, because of a lack of rainfall and transportation facilities. The American corporation intends to employ irrigation, and has completed arrangements for the transportation of the fruit to western ports in the United States.

N.Y. Times 2/28/22 P. 2
 Those wishing further information on anything described in the editorial pages can obtain it by addressing Bureau of Information, Popular Mechanics Magazine, Chicago.

name of company not given

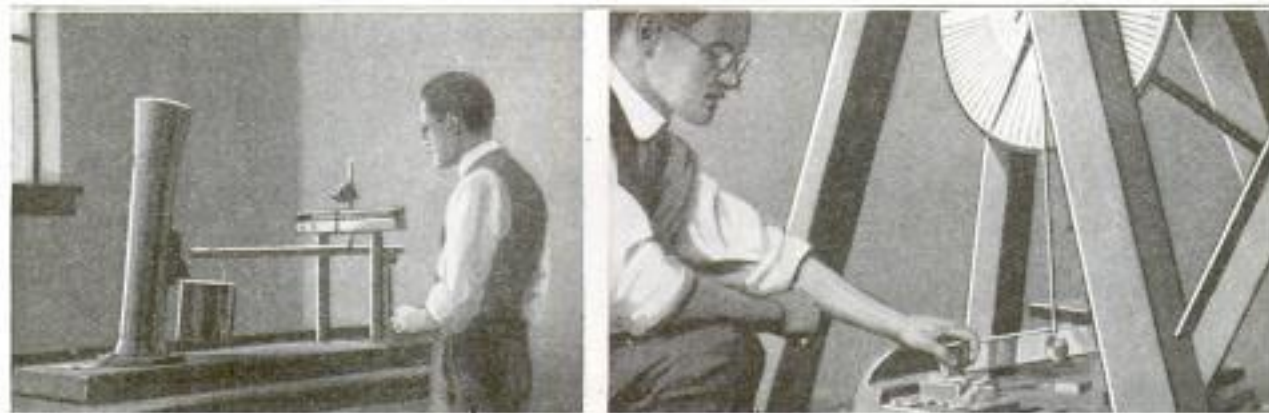

Left: Scale Test for Determining the Durability of Plate Glass. Shot are Loaded into the Pail Until the Glass Breaks under the Weight. Right: Light Pendulum Hammer being Used to Test the Strength and Resistance of Various Kinds of Plate Glass

WOODEN CANAL AQUEDUCT REPLACED WITH STEEL

At the Right can be seen the Aqueduct over the Fox River as it appeared during the Winter Months, with Hanging Icicles Caused by the Water Leaking through the Floors. The Bottom Picture Shows the Leaky Condition of the Floor in the Summer, Thus Plainly Indicating That the Old Structure Was in Great Need of Repairs



At the Lower Left is Shown the Aqueduct with a Temporary Flume Built in It for Carrying Water during the Late Winter So That Ice Companies could Obtain Their Annual Harvest. At the Lower Right is Illustrated the Condition of the Old Floor When the Water was Allowed to Run Out So That Repairs could be Made

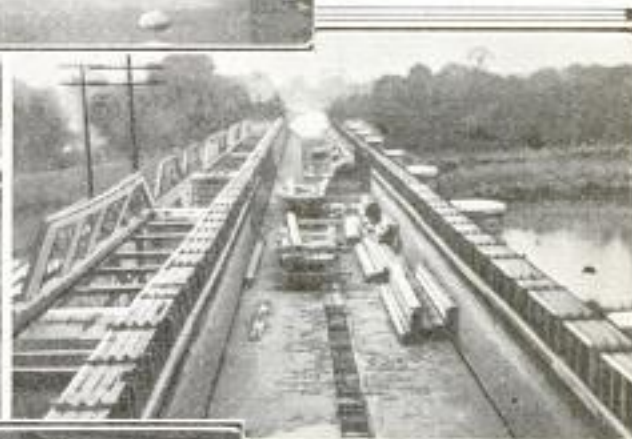
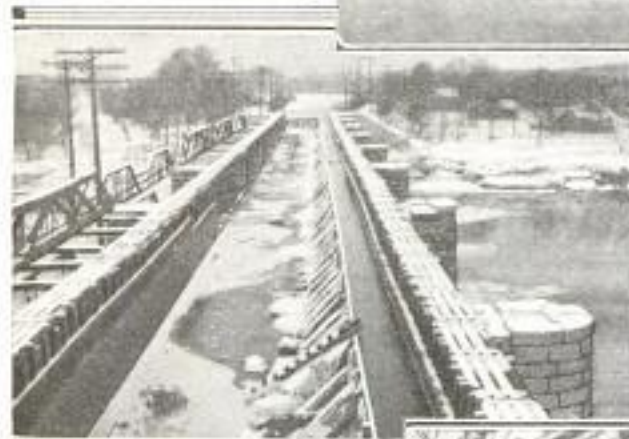

Over the Fox River at Ottawa, Ill., is a large aqueduct which carries the waters of the Hennepin Canal, and which contains eight 57-ft. spans. The original aqueduct was constructed of wood and has had to be repaired very often because of the rapid deterioration of the water-soaked lumber. Last summer the duct was leaking to such an extent that the state proceeded to undertake extensive repairs, but when the water was allowed to run out, the workmen found the entire



structure so weak that it was in danger of collapse at any moment. Consequently bids were solicited for the replacing of the old wooden channel with one of steel, which resulted in the acceptance of a bid for the sum of \$80,000. The work of dismantling has been started, and the building of the new duct is expected to be completed in a short time. Repairs to several of the lock gates will also be necessary before the canal is again ready for use as a waterway.

8083

RUBBER RETAINER EMPLOYED ON FLUE-BEADING TOOL

Boiler flues are beaded to insure a tight fit in the fire box, and an Illinois man has produced a rubber retaining ring, to be placed on the tool used in accomplishing this work, which has been found to be a decided improvement. In operation with an air hammer, there is no possibility of the workman accidentally "shooting" the

beader, or chisel, far into the flue, if the retainer has been previously fitted on it, and the rubber is an aid in turning the tool when it has become heated.



Flue-Beading Tool, Showing the Rubber Retaining Ring Which Prevents the Tool from Going into the Flue

Dr. Carl Bush, 3108 Marshall Ave
Matteson, Ill.

Cont. Maurice E. Pelgrims
 35 Place de la Isare
 758 Antwerp, Belgium

Cont. Cyril E. Lamb
 309 Ballard St.
 Ypsilanti, Mich

POPULAR MECHANICS

8455

PRELIMINARY SURVEYS EASY WITH NEW FRENCH DEVICE

An instrument of French design reduces the work of making preliminary

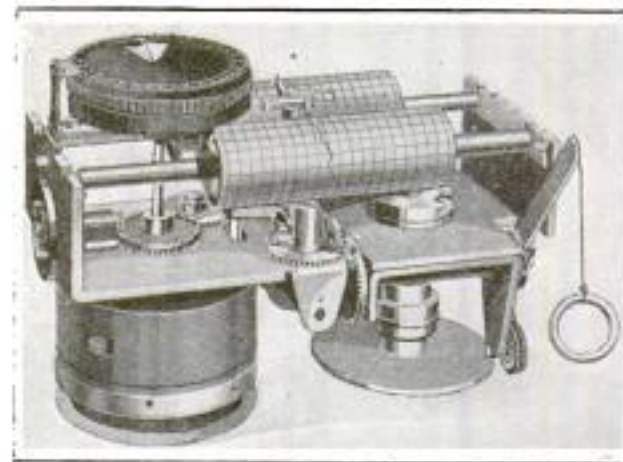

This Portable Instrument for Preliminary Surveys, When Carried by the Surveyor, Records on the Drums the Direction and Elevations of the Course Traveled

surveys quite materially, for it records automatically on two drums the elevation and bearing of the ground covered. In operation, the assistant carries the measuring wire ahead; the surveyor then adjusts the compass to give the direction, and walks toward the assistant. A spring rewinds the wire, and in doing so causes the two drums to revolve, recording the elevations and direction for the distance traveled.

LUMBER-TRUCK RATCHET CRANK FACILITATES UNLOADING

In the ordinary method of loading and unloading lumber by platform rollers on motor trucks, the load is moved backward till it reaches the tipping point, and before the motor truck can be driven for-

ward to draw it from under the load, the crank handle on the roller shaft must be taken off. This is not necessary with a new safety reversible ratchet crank, which can be left on the shaft, and be held in the hand, on account of the action of the ratchet, while the rollers turn rapidly under the falling lumber. This saves time, and prevents any danger of accident from a crank spinning in the air, because of neglect to take it off the shaft at the proper time.

8355

SHOW PROGRESS OF BUILDING WITH GRAPHIC SIGNBOARD

Considerable attention was attracted by a graphic signboard erected on a construction job recently. The board was erected as soon as wrecking operations started on the old building, and as the

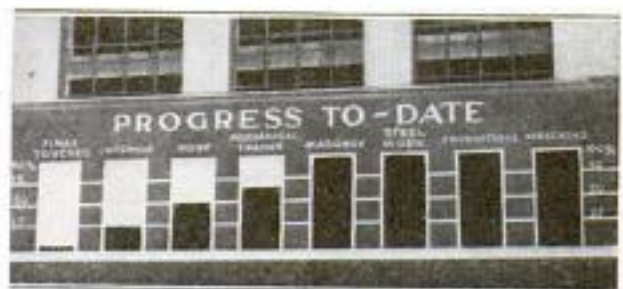

The Graphic Signboard Shows That Four Operations are Completed and the "Final Touches" Just Started

different operations progressed, the white spaces were gradually filled in with red, showing the stage of completion of the various portions of the work.

Blind pedestrians at Denver, Colo., are to be furnished with traffic whistles, by blowing which they may call the traffic officer's attention to their desire of crossing a street.

Washington Machinery & Supply Co. 215 Division St. + 1111 1/2 N. Broadway St. Spokane, Wash.

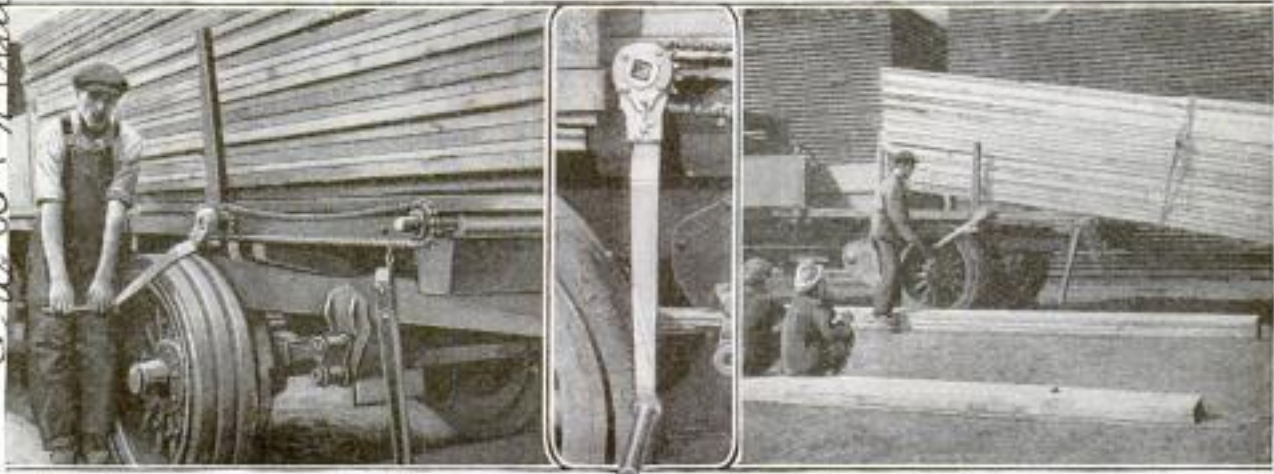

Left: Safety Ratchet Crank being Used on Truckload of Lumber. Center: Close-Up of Safety Ratchet Crank in Place. Right: Operator Seen Holding the Crank While the Lumber is being Unloaded from the Truck. This is Made Possible by the Use of the Ratchet in Connection with the Crank

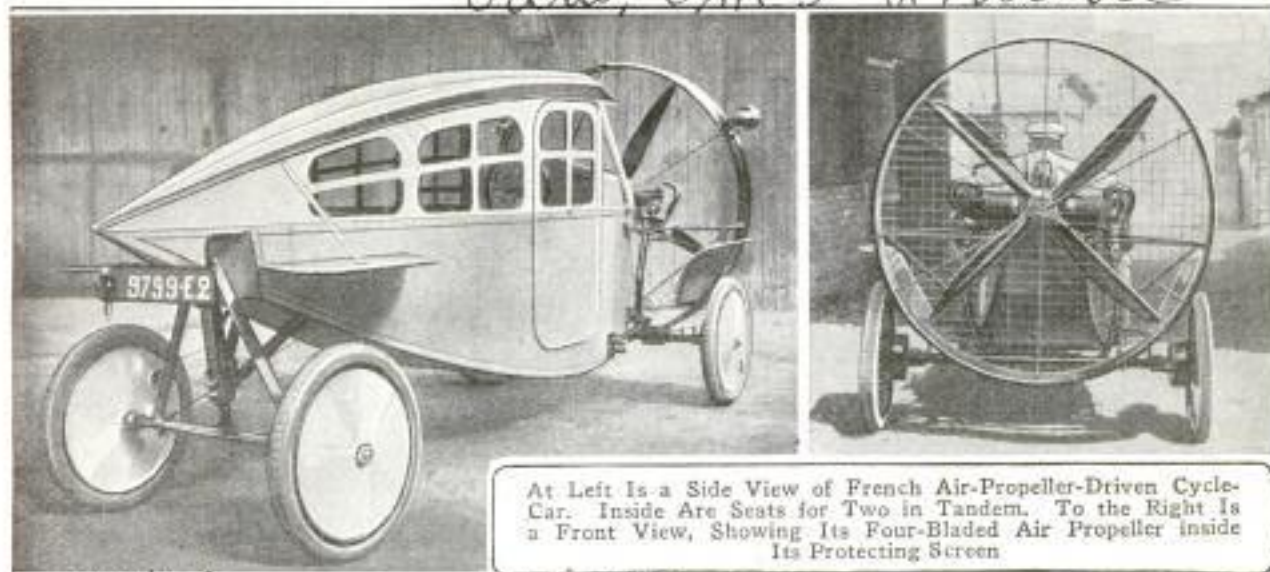

At Left Is a Side View of French Air-Propeller-Driven Cycle-Car. Inside Are Seats for Two in Tandem. To the Right Is a Front View, Showing Its Four-Bladed Air Propeller inside Its Protecting Screen

8379
**PROPELLER-DRIVEN CYCLECAR
 BUILT IN AIRPLANE STYLE**

A novel cyclecar, designed on the lines of an airplane, including its means of propulsion by a large propeller mounted in front of the car, has recently been built in France. It is a four-wheeled car, with the propeller directly in front of the forward wheels, and inclosed in a light circular frame that carries a wire netting as a protection to the propeller. This is direct-connected to an air-cooled rotary engine of the radial-cylinder type. The propeller is either four or six-bladed, the former where high speed is desired, and the latter where high efficiency is preferable to speed. In the body of the car are two seats in tandem. The car does about 30 miles on a gallon of gasoline, and it has traveled from Paris to Bordeaux, about 360 miles, in one day without any trouble. By substituting pontoons for wheels, the car can be converted into a hydroglider.

8602
**VERTICAL SHAPER MODIFIED
 TO CUT INTERNAL GEARS**

Resembling in general appearance and in principle of operation the vertical shaper that was described and illustrated in the November, 1921, issue of Popular Mechanics, is another machine, made by the same manufacturers, that operates with a downstroke instead of with an upstroke like the one described. These two distinct types of the machine have each special advantages for different kinds of work. The downstroke machine is specially adapted for cutting internal gears, internal splines, external cluster gears, and gears in which the teeth termi-

*Stevenson Gear Co
 Indianapolis Ind.*

nate near a shoulder. This work could not be done on the upstroke machine, which is specially adapted to cut plain external gears.

8412
**COAL WEIGHED AND UNLOADED
 BY LARGE BRITISH CRANE**

A British revolving crane for unloading coal cars not only picks up car and all, but weighs the coal at the same time. The car is carried in a horizontal position to the point where it is to be dumped; one end is then raised until the coal is discharged.



This Revolving Crane Picks Up Loaded Coal Cars and Dumps Them Also, Weighing the Coal as It is Discharged

Mitchell Appliance

8443

The Williams Service
32 Union Square
New York City

760

POPULAR MECHANICS



CRUDE ALBANIAN BRIDGE BUILT ENTIRELY OF WOOD

COPYRIGHT, WILLIAMS SERVICE

THIS wooden bridge spans one of the swift streams of Albania and is built entirely of wood, even to the supporting piers in the stream itself. The bridge is more than 40 ft. high, to allow for the passage of river craft. The rustic effect, due to the timber construction, gives the bridge an appearance very different from the usual steel bridges, yet the structural principles involved are the same.

8320

**DURABLE REFUSE CONTAINER
MAY BE MADE ORNAMENTAL**

For keeping streets and grounds free from rubbish, without detracting from the general appearance of the surroundings, an ornamental waste-paper and refuse container has been placed on the market. It is a square-shaped steel can with a self-closing cover, through which is dropped a canvas sack which is the container for refuse thrown into the can. On its four sides are spaces for pictorial advertising posters, and above these for street names.



spaces for pictorial advertising posters, and above these for street names.

**PRODUCE EFFERVESCENT MILK
AS CARBONATED BEVERAGE**

The fact that pure sweet milk is one of the most wholesome and nourishing beverages has led to many attempts to find a method of preserving it. A patent has recently been granted for a process of preservation by which milk is con-

verted into an effervescent beverage which may be kept for long periods, much as is now kept grape juice or ginger ale. The milk is first agitated under vacuum, at a temperature of from 95° to 101° F., for a few minutes to remove foreign flavors, and is then cooled to 40°, carbonated at high pressure, and bottled. It may then be kept for months under proper conditions of temperature, and when used will be found as fresh and wholesome as when first bottled.

8319

**INEXPENSIVE BOOKMARK
PASTED INSIDE COVER**

"Losing the place" because of not having had a bookmark available to place between the pages, need not perplex the reader henceforth, if he but make use of a simple and inexpensive article of this kind. The marker consists of a piece of paper, which is intended to be permanently pasted on the inside of the cover, and which has a flap long enough to be placed anywhere in the book.

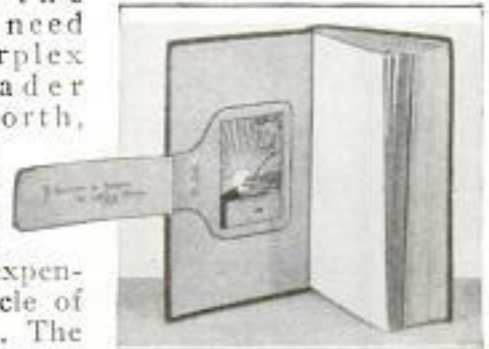

The marker consists of a piece of paper, which is intended to be permanently pasted on the inside of the cover, and which has a flap long enough to be placed anywhere in the book.

Jay Zee Mfg. Co.
Rock Island, Ill.

D.W. Clarke
H. Arnoldi
Manufacturers

Chemical Age
118 & 28th St. New York

The Blaine-Thompson Co.
4th National Bank Bldg.
Cincinnati, Ohio.

THE IVORY CARVERS OF BERING SEA

By G. DALLAS HANNA

Academy of Science, San Francisco, Calif

WINTER life in the frozen North is often supposed by those unfamiliar with it to be as dull as a grounded ice floe. It is pretty generally believed that the long nights are spent around a smoky seal-oil lamp with the streams of conversation frozen solid like the tundra. But this is a mistaken notion and far from true.

Boats are overhauled and put away for the winter; sleds are repaired and winter gear in general is put in shape for the season.

The native villagers of the North have a peculiar philosophy, and volumes have been written about their manners and customs. I, however, shall endeavor to

When the sun sets and does not come back to greet us until late in the forenoon, those are the days when the Northland awakens; then begins the real business of living for the enjoyment of life.

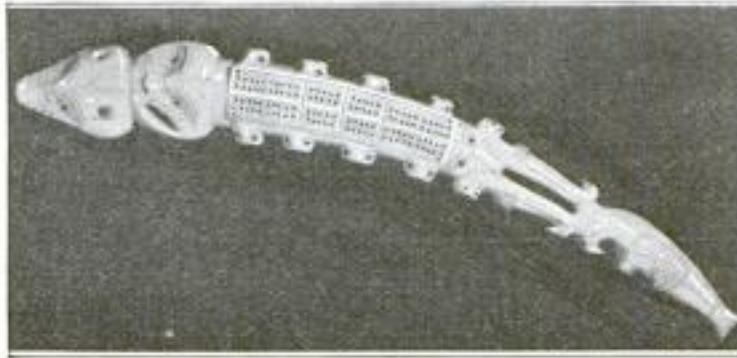

This Very Ornate Cribbage Board was Carved from a Single Walrus Tusk with the Most Primitive Tools

Then the sleigh bells jingle in the twilight and the moonlight; the parties, the dances, the hunts, make one continuous season of pleasure from about November until—well, until the outsiders and their ships begin to appear again in the spring. The awful blizzards of which explorers are so wont to tell, really do not enter into the calculations of resident inhabitants to any large extent. They inspire about as much fear in the heart of an Alaskan as the crossing of a street does to the average city dweller.

The summer season is looked upon as a drudgery by most northerners. It is a necessary evil to be endured only because a living must be earned. Most of the annoyances of life come in the summer; the mosquitoes, the gnats, the flies, and the rains and fogs which are immeasurably more disagreeable than the ice and snow.

tell of a particular class of workers who ply their trade almost entirely in winter. These are the ivory carvers, of whom almost every village can boast one or more.

Before the advent of the white man, the northern natives, the Aleuts, and the Innuits or Eskimos, had to depend upon ivory for the manufacture of certain implements essential to their existence. Knives, spears, arrows, needles, axes, harpoons, and many of the ornaments of person or apparel were made of this material. The white man brought tools of iron which, of course, soon displaced the ivory entirely, so far as utility was concerned. But the tools so superior for other purposes were also found to be far superior for the carving of ivory. Files, knives, saws, and lathes from the great and mysterious "outside"

were incomparable to the flat stones which had formerly been used.

The natives have found that while the ivory is no longer a necessity to them, it can be made into trinkets and ornaments of various kinds that readily sell to summer visitors at good prices. At King Island, a short distance from Nome, almost the entire male population engages in the trade, and at almost every village up and down the coast the work is carried on to a greater or less extent.

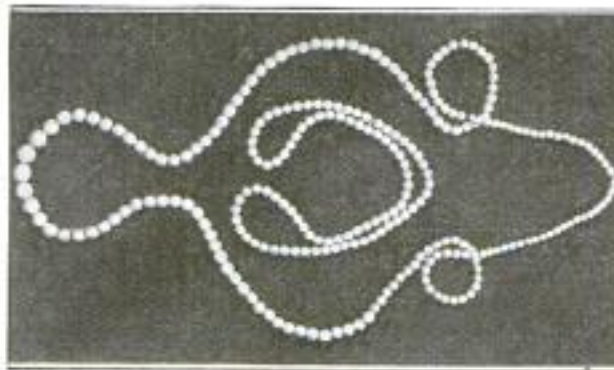

Strings of Beads, Made from the Smaller Pieces of Walrus Ivory, Are the Most Profitable Product of the Carver, Sometimes Bringing as Much as 50 Dollars

Two to four months' work in the summer season ordinarily suffices to provide the average family with sustenance the entire year. Of course, all work does not cease when the snow begins to fall, but that which follows appeals to the people in a most unmistakable manner.

The ivory used in this work comes almost exclusively from the walrus. These

animals are still fairly common in many parts of the North, thanks to the protection which our government has given them. Natives are permitted to kill them for their own use, but the skins cannot be shipped from Alaskan waters. In addition to the tusks of the slain animals, some use is made of those which have been buried in the soil for ages and have become semi-fossilized. These are black or brown with time, and the most highly prized of all ivory. Also, in some places the tusks of the prehistoric mammoth, that long-haired arctic elephant, are used. These tusks are usually called "mastodon ivory" in the North.

The average walrus tusk weighs about 4 lb., and the usable part is an outside shell from $\frac{1}{4}$ to $\frac{1}{2}$ in. thick. The center is occupied by "the core," a hard but more or less bony substance of mottled appearance. The ivory portion is much harder than ordinary elephant ivory and takes a much more brilliant polish, but does not possess the well-known "grain" of elephant ivory.

The ivory carver has four stock articles of trade, for which he always finds a ready sale. These are beads, cribbage boards, napkin rings, and crochet needles. Besides these, a long list of sundry objects, suiting the fancy of the individual workman, could be made. Naturally the workmanship cannot compare with that of some of the Chinese whose feats with elephant ivory are almost unbelievable.

Still, I have seen some paper knives with lacery work which could hardly be improved. And the making of a chain necklace, with tassels on it, of a single piece of ivory, requires patience and skill and a

perfect knowledge of the physical properties of the raw material.

The greatest ingenuity of the native is displayed in the fashioning of his working tools. In one village at the mouth of the Kuskokwim River, the ivory carver's outfit was very simple. He had a sheath knife, an all-purpose implement, which was

called into use almost constantly. A saw he had made of a piece of barrel hoop which he had found on the beach. It mattered little to him if it took a day or a

week to saw off a tusk. He used a bow drill, just as his fathers had done, and for points he had three nails which he prized very highly. With this outfit he was able to do most beautiful pieces, one of which was a cribbage board.

The devising of a lathe is the most difficult of all feats for the native, and some queer contraptions are doing turning duty. As an example may be mentioned one built by Neon Tetoff, a Pribilof islander, for the making of beads. The essential parts are two brass gears salvaged from an old worn-out Russian belfry clock. The larger one is turned by hand, and to the smaller is attached a shaft

with a sort of chuck for holding either the work or the cutting tool.

Ivory beads are about the most profit-



A Young Walrus Whose Tusks Are Not Yet Large Enough to Be Valuable: These Animals are Protected by Game Laws, but may be Killed by the Eskimos for Their Own Use



A Native Carver Cutting Beads with a Simple Lathe Which He has Made from Parts Salvaged from an Old Clock

able of all objects for the native, because the market is not flooded; little material is needed, and they are easily sold at 10 cents each or \$10 per string. In this work two methods are followed. In one the ivory is turned and the cutting tool is held in the hand. The bead is made and polished while turning, then cut off and drilled. In the other method the ivory tusk is sawed into cross sections, the thickness of the diameter of the bead, and then the holes are drilled. The tool is then revolved while the material is held stationary. For this purpose a hemispherical tool is used, which has a guide to fit the hole in the bead. One side is cut at a time, and then the work is reversed

8555

LUNGS AND ARTERIAL BLOOD STUDIED IN THE ANDES

For three months a group of Anglo-American medical investigators studied respiration and blood changes at high altitudes in the Andes, and have now returned to their native countries with some scientific discoveries that may be of value in the treatment of diseases of the heart and lungs. At Cerro de Pasco, Peru, a mining town of 9,000 inhabitants, 14,280 ft. above sea level, a laboratory was established. The subjects for study were divided into three groups—the resident population of engineers who have lived several years at this high altitude, the natives who have been there for generations, and the members of the visiting party. In every case it was found that the arterial blood, instead of being 95 to 100 per cent saturated with oxygen, as it is normally at sea level, was only 80 to 90 per cent saturated at this high altitude. This disproved the theory held by some physiologists that under conditions of oxygen deprivation, the lungs can secrete oxygen to make up for the deficit.

☐The Bureau of Mines is soon to undertake the study of the preparation of phosphor copper by electric smelting direct from phosphate rock.

and the bead released. The truing up and polishing is a separate task. Of course, fairly elaborate shop equipment is required for constructing the tools needed in this latter process, and the beads turned out are superior to those produced by the other method.

Of late years I have seen considerable modern equipment assembled by the ivory carvers. Chisels, bracket saws, hacksaws, breast drills, jewelers' files, etc., are quite common, and once in a while a real foot-power lathe is seen. But while the work turned out is eagerly bought by amateurs, it really does not possess the attractiveness of the pieces made with the crude implements of the past.

ROAD-REPAIRING MACHINE RESEMBLES PILE DRIVER

Resembling a small pile driver in action, an English road-working machine consists of a frame on four wheels, that sup-

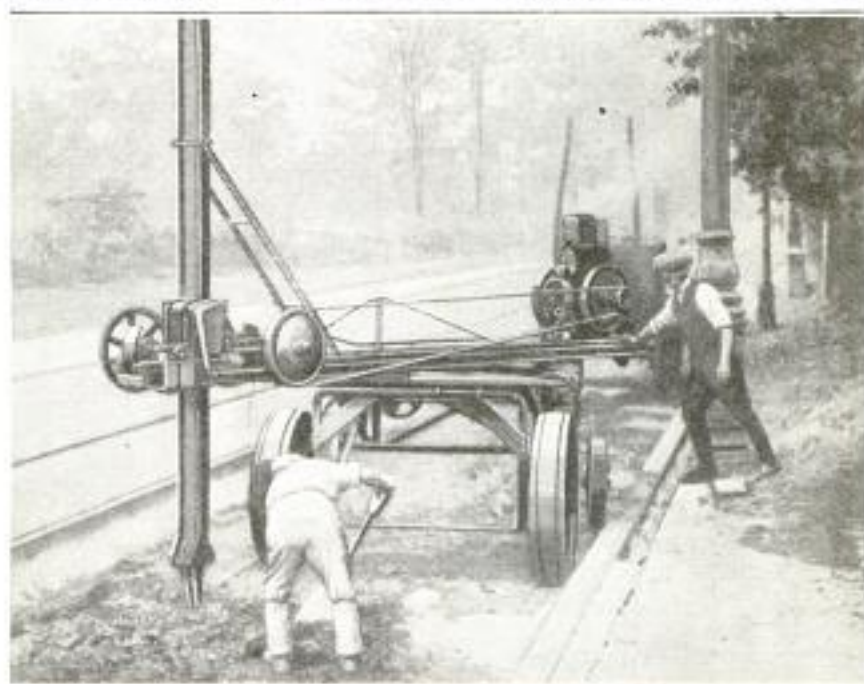

Road-Repairing Machine being Used to Break Up the Surface of the Road: The Cutting Tool and Engine are Mounted on a Swinging Beam Which Permits Operation over a Width of 8½ Feet

ports a swinging beam which carries the tamping or cutting tool and the driving engine. The beam moves horizontally across the work, and the forward movement is obtained by pulling or pushing the entire vehicle. The tamping weight is 150 lb., and 55 blows with a 24-in. stroke can be delivered in one minute. On surface cutting or tamping, the machine will operate over a width of 8½ ft., and is efficient at a depth of 16 ft. when placed beside a 4-ft. trench, or ditch.

Mess. Johnson & Son
Leds, England.

N. U. James 2/26/22 P. 6

Milwaukee Electric
Railway & Light Co.,

761 POPULAR
Milwaukee Wis
MECHANICAL WIPER AN AID
TO STREET-CAR MOTORMAN

8438

Much inconvenience is experienced by motormen when the glass window in front of them becomes obscured in bad



Mechanical Wiper That Enables the Motorman, by Slightly Turning a Handle within His Reach, to Keep the Window in Front of Him Clean in Bad Weather

weather, and consequently on the street cars of Milwaukee a simple mechanical wiper has been adopted. The wiper, in the form of a metal bar carrying a rubber strip, is mounted on the outside front of the car in such a manner that the motorman, by slightly turning a handle that is located inside the car, moves the wiper radially across the glass surface, and cleans a considerable area of the window. This wiper is installed on over 1,000 cars of the Milwaukee system.

ACCURATE CYLINDER GAUGE
WITH REGISTERING DIAL

For the use of garages and small repair shops, a portable cylinder gauge has been developed. The diameter of the cylinder is measured between two contact points and any variations are shown by the pointer on the dial. Five contact points of different lengths are provided, which can be carried in the hollow handle.



When This Gauge is Inserted in a Cylinder, the Diameter is Measured between the Contact Points, and Irregularities are Registered on the Dial

B. C. Ames Co., Waltham, Mass.

London Times Trade &
Eng & Supplement
MECHANICS 2/18/22

DENSE FORESTS OF RED CEDAR
8550 IN BRITISH EAST AFRICA

So greatly is the American production of pencil cedar decreasing that it is predicted that in the near future the only source of supply may be Kenya, in British East Africa. Kenya is a great volcanic mountain, the lower slopes of which are clothed with dense forests of red cedar, said to be the largest in the world. This source of supply is as yet almost untouched. The district can be reached by the Uganda Railway, and if low enough freight rates were provided, there is no doubt that a considerable export trade would soon be developed.

8492

HIGH-CLASS IGNITION SYSTEM
FOR POPULAR LIGHT CAR

A new ignition system has been devised for a well-known small car which can be installed without disturbing the regular wiring, and which, it is claimed, will eliminate most of the troubles caused by faulty ignition.



With this new unit the vibrator points are no longer needed, as one set of breaker points in the timer performs all functions. The condenser of the unit is wired in series with the magneto in such a way that a strong uniform current is always available at the spark plugs even when the engine is running slowly, and this results in much smoother running of the car, which is always desirable.

GOVERNMENT SAVES FUEL OIL
8586 ON NAVAL VESSELS

Economies in fuel-oil consumption aboard ship have been worked out by navy engineers. By changing the fresh-water distilling plants from high pressure to low-pressure double-effect operation and using exhaust steam for power, a saving of approximately nine tons of fuel oil per day was made on the battleships and three tons on the destroyers. At an average cost of \$2.10 per barrel, this represented a daily saving of \$141.75 on the battleships and \$47.25 on the destroyers.

Jno. W. Keaw Bureau
& Navigation, Navy Dept
Washington, D.C.

Milwaukee Engineering
& Tool Co., Milwaukee Wis

8531
clear age
2/23/22

Knapp Mfg. Co.

POPULAR MECHANICS

765

Lebanon N. H.

NEW SAFETY CODE AVAILABLE PERTAINING TO GRINDING

For the use, care, and protection of grinding wheels, a safety code, which has been in the course of preparation for two years, has lately been published. The sponsors of the code are the international association of industrial-accident boards and commissions, and the grinding-wheel manufacturers of the United States and Canada. The new code is said to be a distinct improvement over the others previously issued by the grinding-wheel manufacturers, and contains valuable information which is not to be found in any other publication.

8459

ENVELOPE MOISTENER HAS TRAY FOR ACCESSORIES

Office and bank employes will appreciate a new envelope or finger moistener introduced by an eastern manufacturer, which has a metal base containing several handy trays for rubber bands, pins, clips, etc. The moistening pad is held in a bracket so that either the top or bottom may be used in sealing envelopes, sticking stamps, or counting money. A

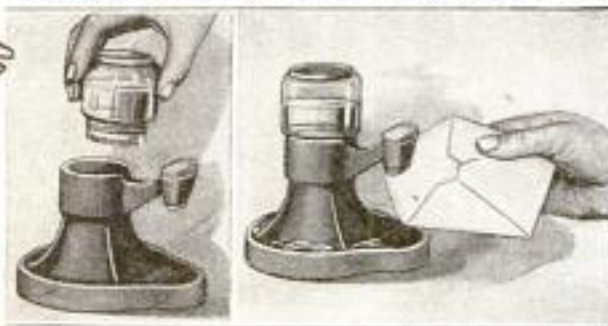

Envelope and Finger Moistener: Left, Replacing Water Container after Filling; Right, Moistening an Envelope Flap

glass reservoir, easily removable for filling, is fitted into the top of the appliance, and the whole arrangement serves as an ornament to any desk.

8311

Access

HANDY AUTOMOBILE WASHER SAVES SOAP AND VARNISH

Specially constructed for use in washing automobiles, a newly invented bucket keeps the soapsuds always clean, and eliminates injury to the varnish on the car caused by undissolved soap, or what is worse, from the sand and gravel that is so often transferred from the dirty car to the water. While it thus saves all the varnish, it is said that it also saves half the soap. Inside a strong galvanized-iron

bucket is a screen and soap container that are raised from the bottom of the bucket so as to leave a space beneath them into which any sand or gravel drains. The

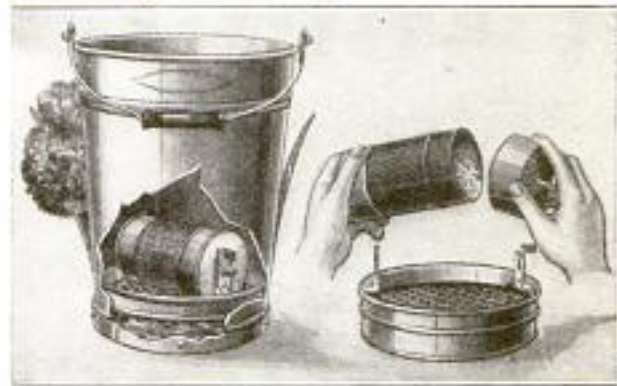

Pail for Washing Automobiles: Left, Partly in Section, Showing Sand Screen and Soap Container; Right, Screen Removed from the Bucket, with Soap Container Open

soap container on top of the sand screen is cylindrical, and perforated so that all the soap must dissolve before it can get into the water. On the outside of the bucket are spring wire holders for sponges, which are thus kept off the floor.

SMALL PHONOGRAPH MOTOR FITS ANY INSTRUMENT

Winding a phonograph is tiresome to most people, and the introduction of a small electric motor, which has been designed to eliminate this work without necessitating any change to the machine, will therefore undoubtedly be appreciated. The apparatus is mounted on a base that permits it to be placed beside the phonograph turntable, which is revolved by a rubber wheel, or pulley, on the motor. The motors are manufactured for either alternating or direct current, at 110 volts, the average operating cost being but five cents per month; they are controlled by the speed regulator on the phonograph, and automatically stop when the record is completed.



At the Upper Left is Seen the Small Motor with Rubber Pulley, or Wheel, While at the Right It is Shown Mounted on the Phonograph

Simplicity Alternating
Corp. New York.

7 furnished by
Pine & Mfg. Co., Chicago, Ill.

Access
New York City
Shelton Electric Co. 16 E. 42nd St. New York City

8500.

SOME NOVEL AND LITTLE-KNOWN ACCESSORIES



This Heater for the Sick Room Has a Small Electric Bulb Placed between Two Perforated Plates. A Fleece or Flannel Cover is Provided and a Heat Regulator is Connected in the Cord



Mop with a Small Wringer on It So That the Dirt and Water can be Squeezed Out: An Adjusting Spring Allows the Wringer Tension to be Set as Desired



A Water-Power Egg Beater That can be Attached to Any Faucet and Also Used for Mixing Small Cakes



Traveling Clothespin Bag Which can be Moved along the Line upon Wire Supports, Thus Keeping the Pins Clean and Saving Much Stooping



On This Wire Screen the Bread or Cake Cools with Air Touching All of Its Sides, Which Eliminates Sogginess



Combination Fork and Spoon Made of Aluminum can be Used like a Pair of Tongs for Lifting Hot Meat, Eggs, and the Like



Collapsible Enameled-Steel Seat for Baby, Which Has Straps for Attaching to Ordinary Chair or to the Seat of an Automobile



This Convenient Bag Has a Removable Compartment Containing the Necessary Toilet Articles Used While Traveling

INTENDED FOR THE HOME AND ITS MEMBERS

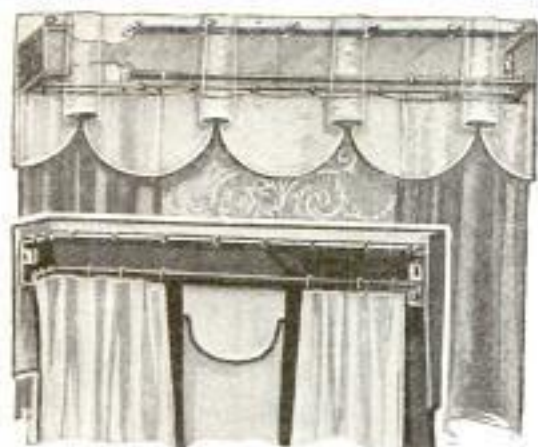

Two Views of a Metal Drapery and Curtain Support Which Allows the Side Draperies, Valance, and Lace Curtain to be Hung Independently

This Polished-Iron Griddle Has a Hollow Base Which Prevents a Gas Flame from Overheating the Center, and Distributes the Heat Evenly



This Electric Cooker Is of Light Construction and Is Especially Valuable in Sick Rooms. Besides the Oven Which is Used to Cook Steaks, Chops, Fish, and the Like, This Appliance Has a Griddle Fastened to One Side and a Hot Plate on the Other



Potato Masher and Beater Made of One Slotted Bar Inserted in a Handle: The Curve in the Mashing Surface Gives Great Strength to the Appliance



Trouser Hanger Which Works on a New Principle, as the Supporting Parts are Placed inside of the Garment and Leave No Mark



This Rolling Pin is Operated with One Hand, Leaving the Other Hand Free to Sprinkle Flour



Clothesline Fastener That Has Three Holes for Mounting Screws and, Due to Its Form of Construction, Makes the Task of Putting Up and Taking Down the Washline an Easy One for the Housewife



Convertible Porch Swing and Hammock Which is So Constructed That the End Members can be Shifted Readily from the Normal Vertical Position to an Inclined or Horizontal Position

Cml. Maurice E. Belgrins
 35 Place de la Gare
 Antwerp Belgium

N.Y. Times

2/17/22

P. 2

Boyle
June 12

83768
 768
 71

POPULAR MECHANICS

**HANG UP PHONOGRAPH RECORDS
 IN FILING ENVELOPES**

A new device for filing phonograph records has been patented in Germany and consists of a heavy paper envelope having a cardboard hanger at the top. The bottom edge of the envelope is also of cardboard so formed as to prevent the record from rolling out. Space is provided for indexing on the lower corner of the envelope, so that the figures are plainly visible when the records are hung in the cabinet.



hope, so that the figures are plainly visible when the records are hung in the cabinet.

**DOOR HINGE SAVES FINGERS
 FROM BEING PINCHED**

Pinched fingers are a common occurrence when children play near a door, and to prevent this painful injury, an inventor has constructed a new door hinge. The invention consists of two bases or plates, which are attached to the door and casing respectively, and integral cylindrical knuckles that have a pivotal connection between the plates. A three-quarter round brass tube is fitted over the corner of the door casing between the hinges and at the ends, thus closing the space which is found upon opening the ordinary door.



When you want anything and do not know where to get it, write Bureau of Information, Popular Mechanics, Chicago.

When you want anything and do not know where to get it, write Bureau of Information, Popular Mechanics, Chicago.

**WARSHIPS TO BE CONVERTED
 INTO A BREAKWATER**

Instead of entirely scrapping 12 of the warships that have to be destroyed in accordance with the terms of the armament conference, recently held at Washington, it is proposed to turn them to profitable use by taking them to Los Angeles, and sinking them so as to form an extension of the San Pedro breakwater. It is claimed that in this way shelter would be provided there for eight additional active battleships.

**ONE-QUARTER TURN REMOVES
 NEW THREADLESS DUST CAP**

Threaded valve caps on automobile tires that have to be removed by a somewhat lengthy process of turning consume time, and are liable to stick. Now there is a threadless dust cap that avoids both these drawbacks. A quarter turn removes both valve and dust cap at once. The cap case is forced by a coiled spring upward against lugs on the base nut, and a quarter turn brings the lugs opposite slots in the cap and releases it.

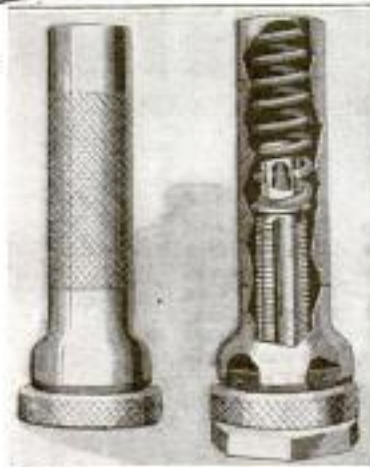

case is forced by a coiled spring upward against lugs on the base nut, and a quarter turn brings the lugs opposite slots in the cap and releases it.

**"SHORT-LEGGED" FURNITURE
 LEVELED BY CASTER CUP**

Furniture having one short leg is a source of constant annoyance in any home, and as a remedy for this common fault, a caster cup has been produced. The cup consists of two parts, each threaded so that the upper part screws on the outside of the lower. The legs of the table, dresser, etc., are placed in the cup-shaped top, and in the event of any side being low, that particular cup is screwed up until the article stands level. The device is equally useful, if the floor is uneven.



Furniture having one short leg is a source of constant annoyance in any home, and as a remedy for this common fault, a caster cup has been produced. The cup consists of two parts, each threaded so that the upper part screws on the outside of the lower. The legs of the table, dresser, etc., are placed in the cup-shaped top, and in the event of any side being low, that particular cup is screwed up until the article stands level. The device is equally useful, if the floor is uneven.

Copyrighted by
 Wm. E. H. Berry, Inventor
 Minneapolis, Minn.

8248

Edw. Frederick J. W. Barrow
 4832 Eddy St. Chicago

Patent Infy. Co., 24 O'Quinn St. Chicago
 San Francisco, Calif.

8040 Cont. C. Moran
 3825-13th St. N.W. Washington
 D.C.

CONVERT REFRIGERATOR CARS FOR WINTER USE

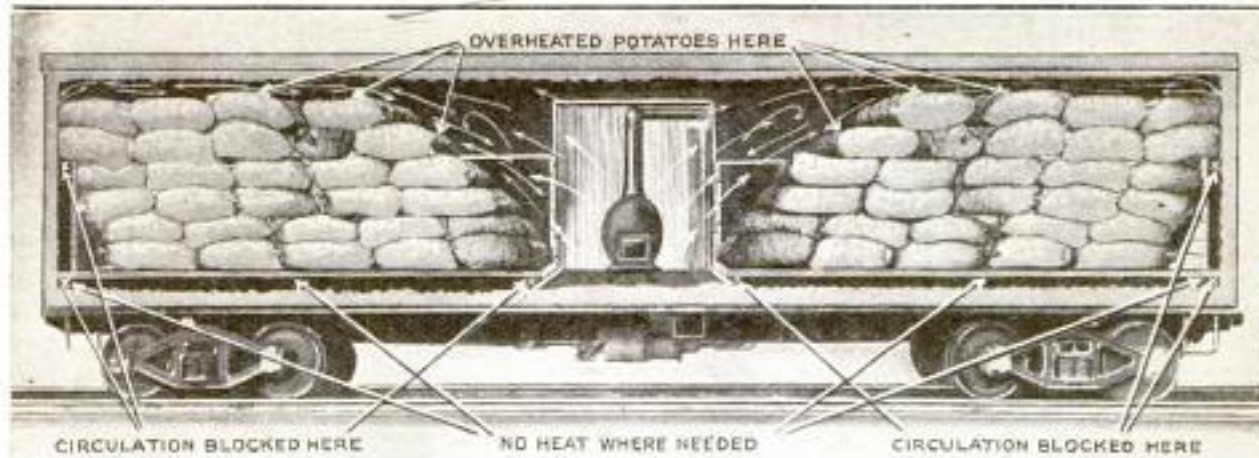

Above: In the Heated Box Car, as Ordinarily Arranged, the Freight near the Stove is Overheated While Other Portions of the Load Freeze

Converting a refrigerator car into a heater car for perishable freight during freezing weather, is a recent accomplishment that makes possible not only the utilization of thousands of refrigerator cars in the winter months, but a saving of the \$2,000,000 of perishable products annually lost on account of freezing while in transit.

The conversion is made simply by providing an uninterrupted passage-

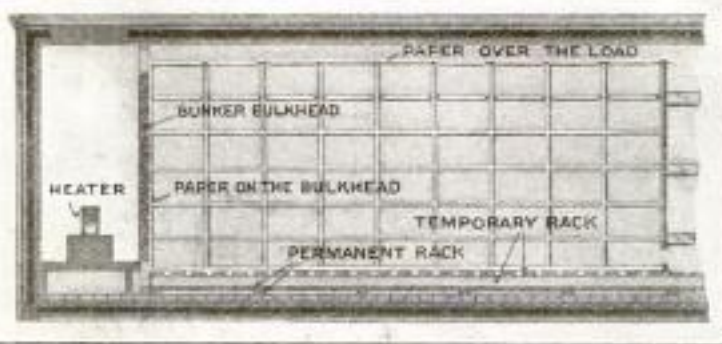

Left: From the Heater, Warm Air is Circulated around the Load. Below, the Lower Tier of Boxes is Spaced to Form Passages

way all around the load in a car, so that a constant and uniform circulation of warm air from a heater in the center of the car can reach all parts of the load. It is merely a recognition of the fundamental principles of the movement of hot and cold air. When the circulation of warm air is obstructed, the produce at the top of the car is overheated, while that at the bottom of the car freezes.

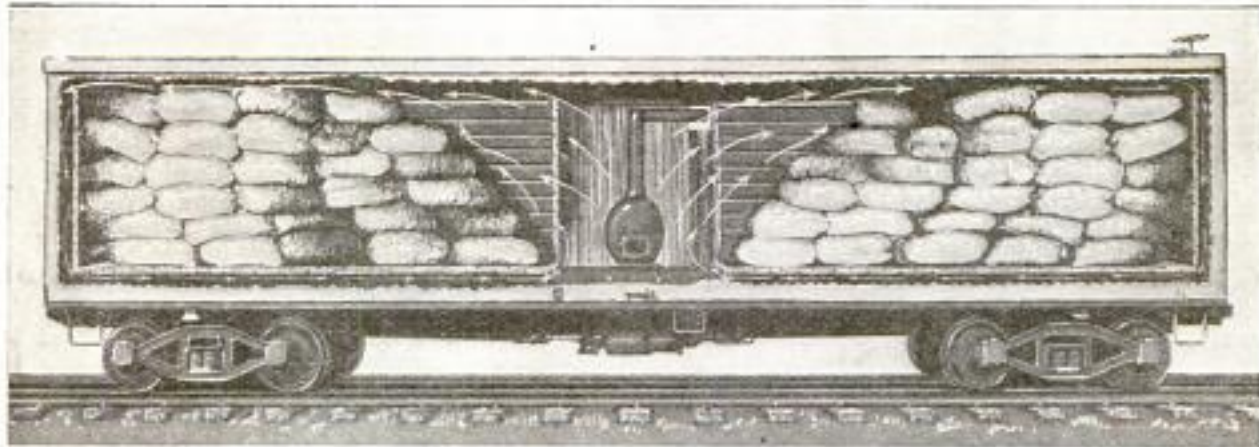
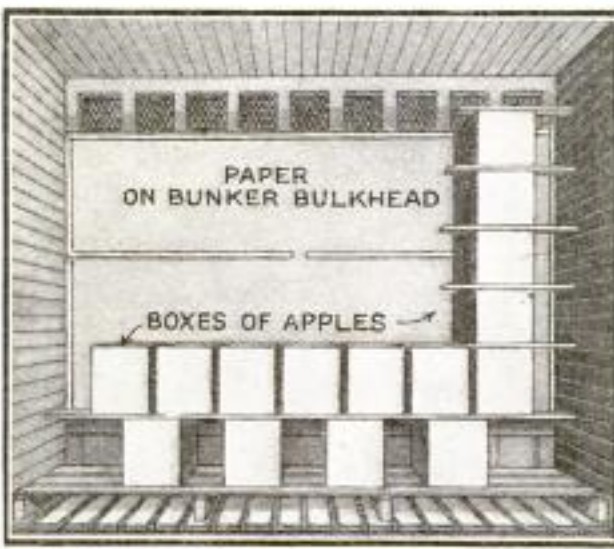

In a Properly Converted Box Car the Protecting Heat from the Stove Rises to the Top of the Car and Circulates around the Load, Returning along the Passage Formed between the Temporary Rack and the Car Floor, Thereby Insuring a Proper Temperature in All Parts of the Lading

To overcome obstructions in the shape of high splashboards at the bottom of the bunkers, and floor racks with transverse supporting strips instead of longitudinal strips, an additional floor rack, with longitudinal stringers not less than four inches high, is placed upon the permanent floor rack. This temporary rack is papered to the center of the car. Open bulkheads are also papered from just below the openings near the ceiling of the car to the top of the first layer of boxes next the bunkers. Bunker bulkheads of the solid type with open spaces at the top and bottom need not be papered.

In loading, the first or bottom layer in the stacks of boxes next to the bunkers consists of only four boxes, spaced so that the bottom boxes in the second stack cannot slip into the spaces between the boxes in the first stack. On top of the

first four boxes two 1 by 6-in. boards are nailed to support the remaining five layers. When the car is fully loaded, paper is placed across the top of the load as far as the bracing in the center of the car, so that warm air from the heater will move to the center of the car before returning to the bunkers. When possible, the ice grates in the bunkers are raised and the heaters placed on the floor of the bunkers, thus providing a lower plane from which the heaters can draw their supply of cold air.

By the use of this system of lining and loading refrigerator cars, adequate control of fruit temperatures can be secured, no matter how low the outside temperature may be. The same principles applied to box cars enable that class of equipment also to be used in heater-car service, with no danger of loss by freezing.

**NEAT, PRACTICAL BOOKMARK
INVENTED BY BLIND MAN**

An eastern man, who is totally blind, has produced a neat and practical bookmark

with a celluloid base, to which is attached a thin strip of isinglass having a small lead weight on the end of it. The base is affixed by means of a V-slit to the top of the back pages, and the strip is then placed

on the page being read. When one page is turned, the weighted strip falls back to the second, so that there is no danger of the reader losing his place if the book is hurriedly closed.

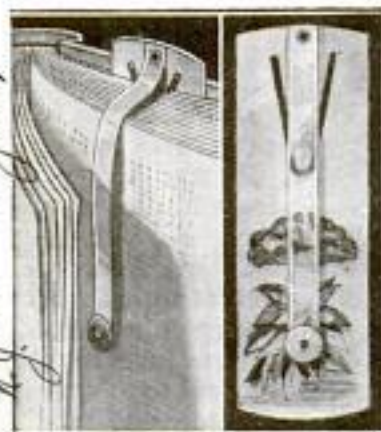

**PROPOSED OIL-PIPE LINE
FOR ARGENTINA**

Feeling that the Comodoro Rivadavia oil fields in Argentina are sufficiently proved to justify the expense, it is now proposed to construct an 8-in. pipe line from the field to Buenos Aires for transporting the oil. The distance will be nearly 850 miles and the carrying capacity of the pipe almost double the actual production of the wells at the present time, but new development may alter this.

London Times Trade & Eng. Supplement
**TWO NEW DYES DISCOVERED
IN COAL-TAR PRODUCTS**

A new chemical reaction which can be employed in making dyestuffs from coal-tar products has been discovered by a Canadian university professor. Two new compounds, one a blue and the other a beautiful shade of rose, have been produced. The professor is now engaged in determining definitely the chemical constitution of these compounds, and in devising methods for their production in quantities suitable for manufacturing purposes.

**PISTON OF IMPROVED DESIGN
— SAVES OIL AND GASOLINE**

Pistons for automobile motors that are guaranteed never to cut or wear the cylinders out of round, and to reduce the gasoline bills from 30 to 50 per cent, and the oil bills from 60 to 80 per cent, have several novel features that are claimed to be the cause of this superiority.



Screwed on the body of the piston are a head and a liner, with an asbestos gasket between them, that keeps the body from becoming heated. These are made of aluminum. Under the head in a groove is a three-piece piston

The International Piston Co., Elyria, Ohio.

8253
Prof. Robert G. Kelly
Newark, N.J.
University of Toronto, Canada

8556
2/18/22
8549

Times Trade & Eng. Signal
2/18/22

19 W. 4th St. Chicago
 19 W. 4th St. New York
 62 Linden Wall St. London, England
 Need of industrial Collodens Ltd. London, England
 Wagoner, 1800 N. 1st St. St. Paul, Minn.
 62 Linden Wall St. London, England

H. A. Lee Tool & Mfg Co.
 310 W. 20th St.
 Kansas City, Mo.

POPULAR MECHANICS
 8396 Mo. Extra mach
ADJUSTABLE CRANKPIN TOOL
EASY TO OPERATE BY HAND

ring, made of special low-friction metal, behind which are asbestos packing and a vanadium-steel spring, which seal the piston-ring groove, and prevent oil and gas-line leakage.

Worn, or out-of-round, crankpins can be trued up with a new hand tool, without removing the motor from the car, in

8515 d.a.m.a 2/8
WHY BACTERIA IN THE MOUTH ARE GENERALLY HARMLESS

It has hitherto been assumed by pathologists that the bacteria which are known to lodge in the cavity of the mouth in seething masses are disease producing, and that they are always present to take advantage of any unfortunate lowering of the powers of resistance in the human body. It has now been demonstrated by a professor at Johns Hopkins University that although the oral cavity has no elaborate system of hairy membranes like the nose and air passages, to rid it of bacteria and foreign particles, nevertheless it does the same thing by a mechanical action of the muscular structures around the mouth that set up suction currents which remove any bacteria or foreign particles from the mouth in from 15 to 30 minutes. These suction currents carry the bacteria uniformly toward the rear of the mouth, without any lateral or forward dissemination, and pass on without lodging on the tonsils or the walls of the pharynx—the pouch that forms the back part of the mouth.

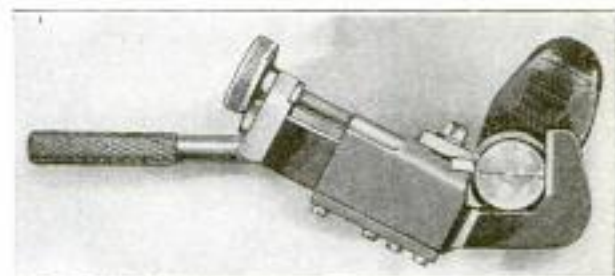

Tool for Truing Up Worn or Out-of-Round Crankpins on Automobile or Stationary Engines without Removing the Crankshaft: The Feed Screw Adjusts the Cutting Blade

the case of an automobile, or when the motor is on the bench, without having to remove the crankshaft. The tool has a jaw which grasps the crankpin, and which on one side has a cutting blade that is always radially opposite to the point of the crankpin on which a hardened back plate on the jaw bears. Extending from the cutting blade is a feed attachment, and the setting of the feed screw in connection with this is the only adjustment necessary.

8552
ARTIFICIAL PLASTIC WOOD JUST LIKE REAL TIMBER

An artificial wood that is so like the real thing that it can be worked with carpenters' tools and finished with a file or sandpaper, is now being produced by an English manufacturing company. The material is known as plastic wood, and at first it has the consistency of a thick paste, and can therefore be molded into any shape. It can then be hardened by exposure to the air, and becomes a tough, solid, waterproof substance. It is expected to be of special use for making patterns for castings. It can also be used for filling in flaws in timber, or openings at joints, and will take paint, stain, or varnish like real wood.

6347
PIPE COILS RELIEVE TENSION CAUSED BY EXPANSION

In long pipe lines for carrying oil the difference in length due to expansion and contraction is a very serious matter and must be compensated for by some means. One of the most simple methods is by forming, at intervals in the line, large

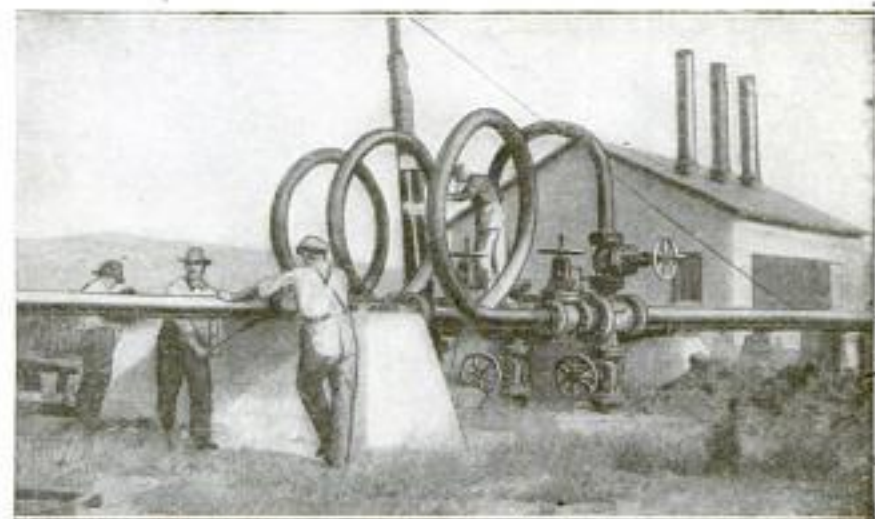

When the Pipe Line Expands on Account of the Heat, the Large Coils Compensate for the Increased Length and Prevent Damage

coils which allow for expansion and contraction without damage to the pipe line.

Times Trader & Eng. Signal
 2/18/22

Copyrighted material

D. S. Levin, Carmel, Calif.
 End.

8501

CHILDREN'S PICTURE-STORY DEPARTMENT



Here Is Decidedly the Sweetest House in the World, or at Least Sweeter than Any Other Unless It is Built as This One is—Entirely Out of Candy. The House, with Its Waterwheel and Its Interesting Surroundings, Is of Homemade-Candy Construction, Built by a Candymaker in Cincinnati, Ohio. It was Exhibited in This Manner in a Show Window

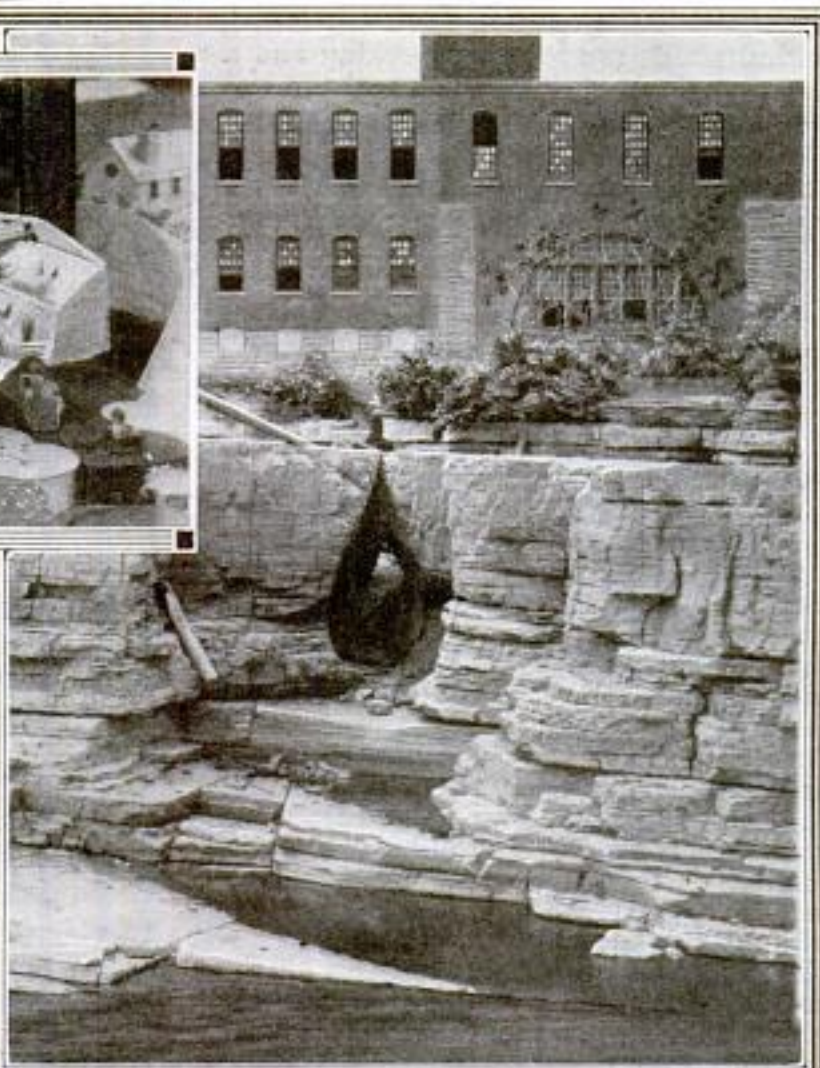

Any Boy or Girl Who has Read—and There cannot Be Many Who have Not—Fenimore Cooper's "Last of the Mohicans" will Remember the Historic "Cooper's Cave" at Glens Falls, New York, Where the Author Himself Hid from the Indians. Here Is the Cave, or Rather the Entrance to It, on the Bank of the Hudson River. From This Pear-Shaped Entrance, Seen in the Center of the Picture, a Winding Staircase Leads to the Cave Itself

I invented by a London engineer exhibited at Horticultural Hall, Westminster London, England



Joy-Riding by the Dozen: This Is Not a Case Where Two Is Company and Three Is a Crowd—Quite the Reverse, the More the Merrier. The Wee Bit of a Traction Engine Is the Work of a London, England, Inventor, Who Recently Caused Quite a Sensation by Appearing on the Streets in This Manner with a Wagon Load of Enthusiastic Youngsters. The Tractor Was on Exhibition at the Horticultural Hall, Westminster

Edw. Ernest W. Rowe, Inc.
 1131 Colorado Springs 8501
 Glenwood Springs, Colo.
OF MODERN ACTIVITIES AND INTERESTS

This Carriage Glides over the Snow in the Same Manner That Speed Wagons Roll over the Ground, by Moving the Handle Back and Forth. It Has a Saddle like a Bicycle, Where the Rider Sits and Grasps the Handlebar with Both Hands

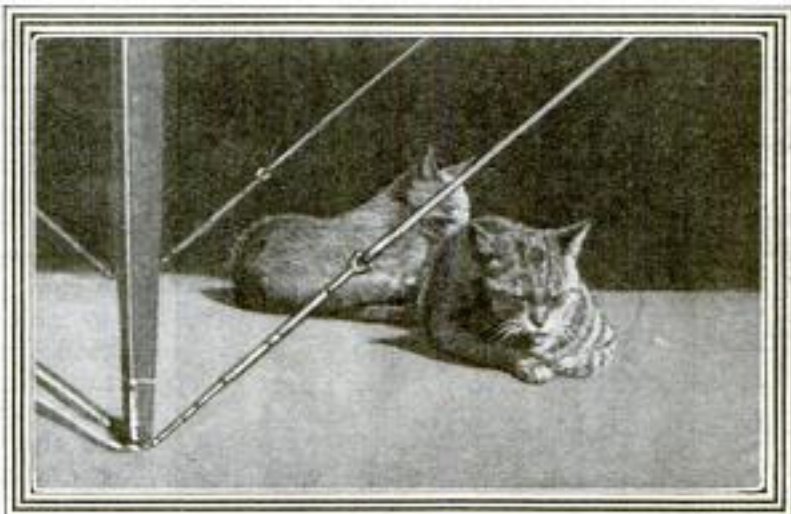

Three Kittens That Are the Petted Mascots of the Air-Mail Hangar at Omaha, Nebraska: Being Bearers of Good Luck, They are Allowed to Go as They Please Anywhere and Anyhow in the Hangar, or over the Airplanes, in Which They have Made Many Flights. The One at the Left, Seated on a Tailplane, is Called "Spark," and Is Yellow—in Color Only, Not in Any Other Sense. The Two at the Right, Called "Contact" and "Tailskid," are Reposing on the Wing of an Airplane



At the Left Is Willetta Huggins, Wisconsin's Blind and Deaf Super-Girl, Chatting with Helen Keller, the World's Most Widely Known Deaf and Blind Woman. In Many Ways They Are Two of a Kind, but Not as Regards Their Methods of Listening. Miss Keller Does It by Holding Her Fingers to the Speaker's Lips, While Miss Huggins Rests Her Finger Tips on the Speaker's Chest

Apparatus sold by: 3rd Ave. - 178th St
Cinner + Arndt, New York City

Julius Hortvet, State
Lairy + Hood Chemical
Laboratory, Old Capitol,
St. Paul, Minn.
POPULAR MECHANICS
APPARATUS THAT TESTS MILK
FOR ADULTERATION

Adulteration of milk is easily determined by the use of an appliance invented by a Minnesota chemist for the purpose of measuring the freezing point of liquids. As the

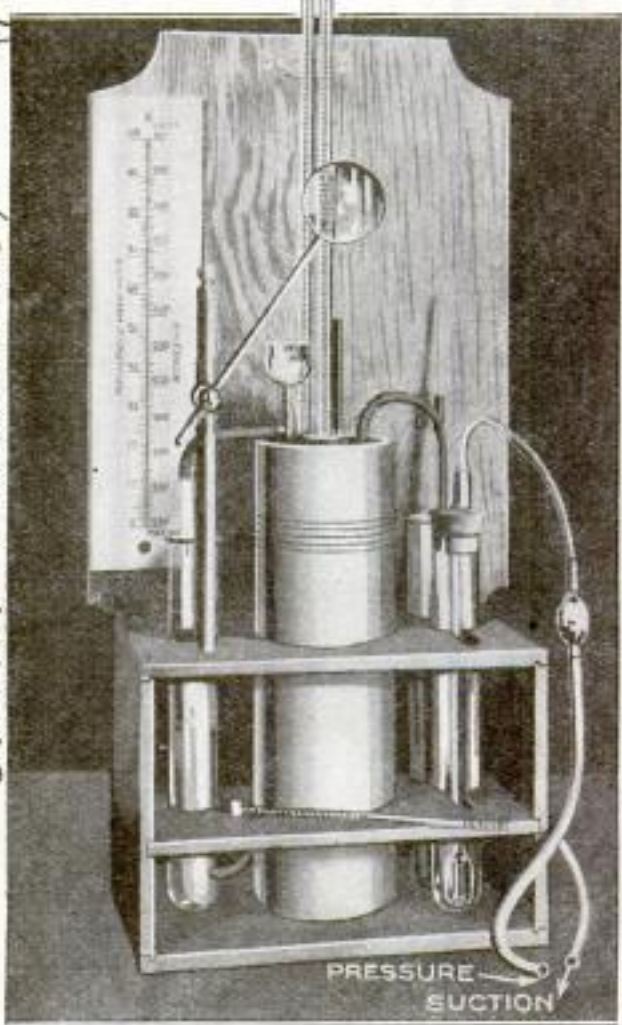

Apparatus for Determining the Percentage of Milk Adulteration, Showing the Thermometers, Test Tubes, and Heat-Retaining Bottle

freezing point of milk is -55° Centigrade (very nearly 1° F.) below that of water, the sample to be tested is placed in a vacuum tube, similar to a heat-retaining bottle, and cooled by means of an air and ether mixture. If the milk freezes before it has been cooled to a temperature of 31° F., the presence of water in excess of the normal is evidenced, and the percentage of additional water can be calculated by means of a properly calibrated scale.

Those wishing further information on anything described in the editorial pages can obtain it by addressing Bureau of Information, Popular Mechanics Magazine, Chicago.

8516 ONCE A BARREN WASTE

The island of Krakatoa, off the west coast of Java, has provided scientists with a natural experimental station for the study of the methods by which islands are supplied with animal and vegetable life. In August, 1883, the island was the scene of one of the most violent volcanic disturbances ever recorded, one result of which was the destruction of all forms of life on the island. Since that time it has been closely watched by scientists who have studied the return of life to the island through natural agencies. A recent expedition disclosed that the island was covered with a dense vegetable growth and that 175 different species of animal life were present.

Chicago Daily News 2/1/22
8425 MOTOR TO OPERATE COMBINED HARVESTER-THRESHER

A power plant to operate a combined harvester-thresher independently of the speed at which the machine is hauled, usually by a tractor, over the ground is a new development. A gasoline engine, with its radiator tank and other equipment, is assembled on a frame that can be separated from the harvester-thresher. The crankshaft of the motor is coupled directly to the cylinder shaft of the thresher, and the other operative parts are driven by chains from the opposite end of the cylinder shaft. The speed with which the machine is operated can be regulated by the motor control.

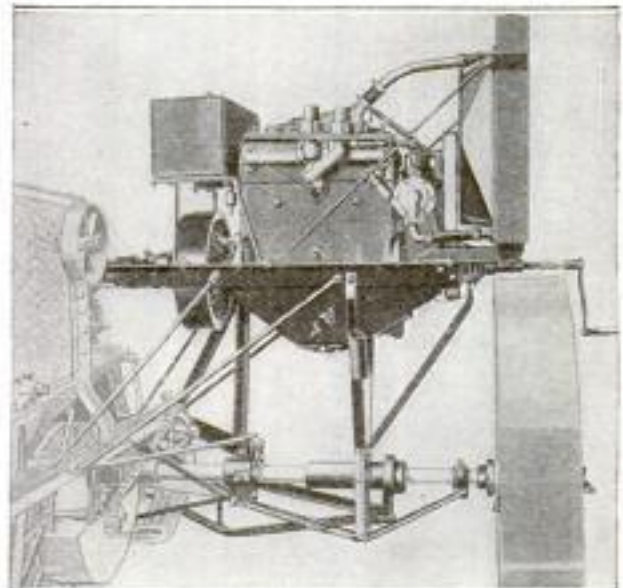

Power Plant That Operates a Combined Harvester-Thresher by Direct Connection to Its Cylinder Shaft, Independently of the Speed at Which It is Hauled over the Ground by a Tractor

Cont. George Es Mellicher
North Bend, Neb.



Information as to where to obtain any specified materials or parts for making objects described in the following pages may be had, on request, from our Bureau of Information.—Editor.

An Arbor Press of Large Capacity

By J. V. ROMIG

EVERY machine shop or garage doing any considerable repair work has an arbor press as part of its equipment. Most of those that I have seen and used, however, have been small, and of very little, if any, use for long work. The press described herein was designed and built by the writer with this in view, and the result is a press of large capacity, adjustable over a wide range, but not too clumsy.

The main member is a length of 3½-in. pipe, which has an outside diameter of 4 in.; it is drilled with a row of ½-in. holes, 2 in. apart, and fitted with a floor flange at each end, the over-all length being the same as the height of the ceiling from the floor. The upper and lower arms are castings, made from simple patterns; the upper arm is bored to fit the rack and gear. The rack and gear are eight-pitch,

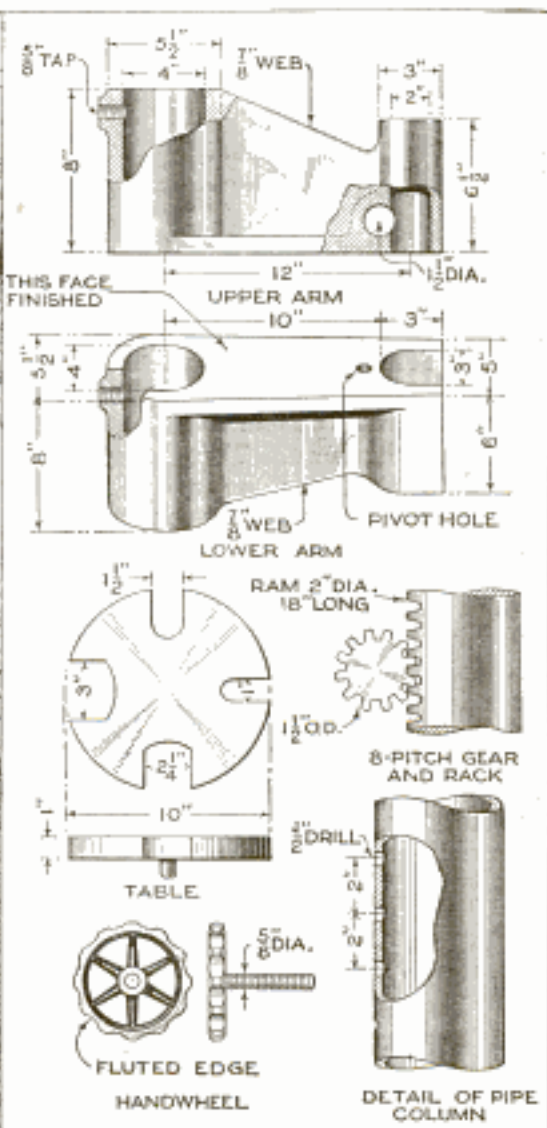
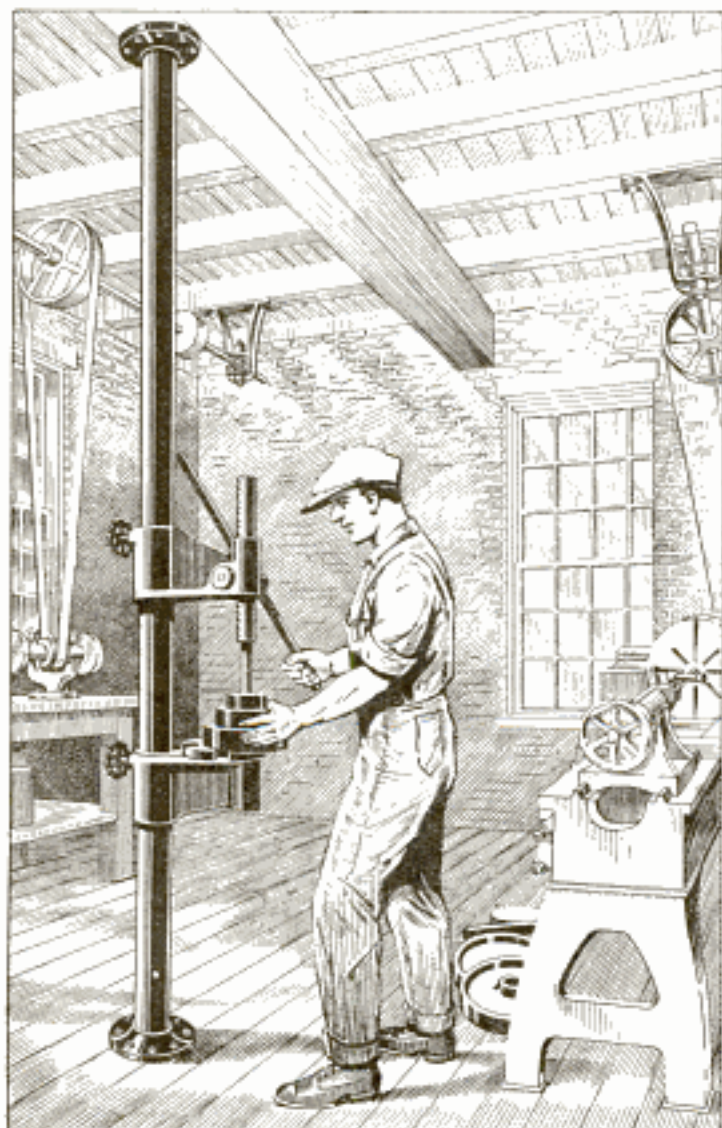

An Arbor Press Suitable for Any Shop or Garage Where a Wide Range of Work is Handled: The Upper and Lower Arms may be Clamped Anywhere on the Column, to Suit the Work or the Operator

and are made and assembled as for any ordinary press. They should be of a good tough grade of steel. The gear may be fitted with a two or four-spoke handle, as desired. Care should be taken, when boring the rack and gear holes, to bore them so that the teeth will mesh correctly. The lower arm is faced on the upper surface, and drilled for the pivot on the table. The table is also a casting, or may be made of steel plate, if a large enough piece is available; it is slotted, as shown, for

work of varying diameters. The clamping screws are made with a pointed end; by means of these, both upper and lower arms can be clamped in the most suitable working positions.

If the height from floor to ceiling is too great for a column, or if overhead cranes are used in the shop, a base of large diameter can be substituted for the lower floor flange, and the pipe column cut off and braced at a height that may be most convenient.

An Improved Crane

In loading some heavy barrels of kerosene, the driver of a truck used a simple method of elevating them to a height

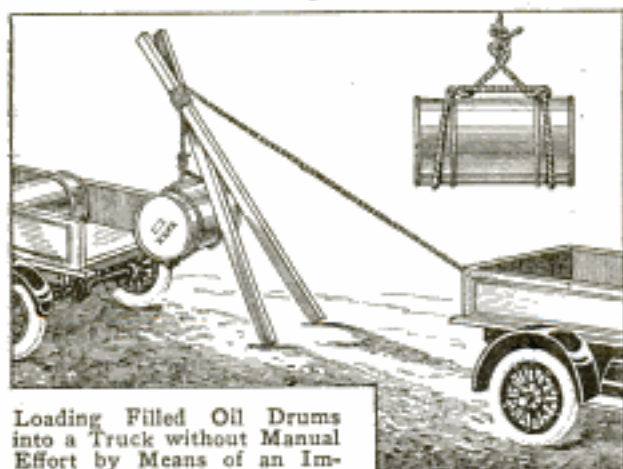

Loading Filled Oil Drums into a Truck without Manual Effort by Means of an Improved Crane: The Same Idea can be Adapted to Other Work Where a Vertical Pull or Lift is Required

where it was possible to back the truck underneath them. Two long sticks were fastened together, near one end, with a rope, and the opposite ends were placed on the ground about 3 ft. apart. A rope was slung around the oil barrel, passed over the crotch of the sticks, and fastened to the rear axle of a second truck. By moving the second truck forward in low gear for a few feet, the barrels were lifted to a corresponding height, when the truck that was to carry them was backed underneath and the load lowered. The same method can be applied to lifting heavy stones, or other work.—G. A. Luers, Washington, D. C.

Care of Wheel-Truing Diamonds

Take only light cuts with the diamond, and as the stone wears, turn the nib in the holder to insure uniform wear; then when the stone wears down to the metal setting, reset the stone so as to expose a new cutting surface. When the diamond is worn down to a small size, reset it in

a holder, and use it in the tool room. Be careful not to jam the diamond into the wheel, and instruct operators not to allow the stone to get any violent knocks, as it is very hard and therefore brittle. Never use a diamond dry, except on small wheels for internal grinding, or on tool or cutter wheels; on large wheels for cylindrical or surface grinding, direct a copious stream of water on the diamond at the point of contact with the wheel.

Work Gauged Automatically

The gauge shown in the drawing will be found applicable to many classes of work and will save the time necessarily required for a separate gauging operation; in addition, it prevents the machine hand from turning out work that is afterward found to be incorrect.

The work shown is a sleeve with beveled ends, the outer diameter being held within limits of plus or minus .01 in. The gauge is made of $\frac{3}{8}$ -in. flat steel, the first operation being to bend it into the form shown, the angle being about 45° . The slots are next milled, the high limit or "go" slot being milled so that the ends, when the gauge is fixed in place, stand in a vertical position, to prevent the work from falling through, back end first, and probably sticking. The low limit or "not go" slot is milled in the bottom portion. It may be as well to say that in cutting the slots, the gauge should be strapped on the table, on its side, and both slots milled with an end mill. The same method is used in grinding the slots to the finished size.

Two holes, drilled and countersunk, ac-

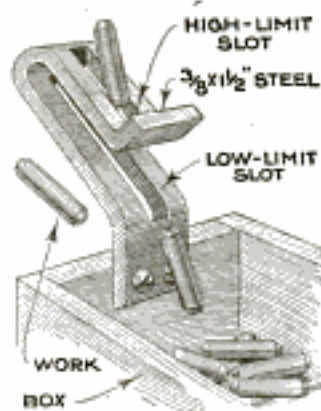

commodate screws that hold the gauge to a wooden box. As the operator cuts off the pieces in a screw machine, he catches them in one hand and places them in the top of the gauge. If the work is below the high-limit size it drops through the slot, and if above the low limit, slides down the slot into the box. If above the high limit, the piece will not drop through the first slot, while if below the low limit, it drops through that slot and onto a piece of tin, where it immediately attracts the operator's attention.

Punch Made from Letter Press

The letter press illustrated was used to good effect in an emergency when it was required to punch $\frac{1}{16}$ -in. cold-rolled stock with holes up to $\frac{1}{2}$ in. in diameter. In drilling the holes in the base of the

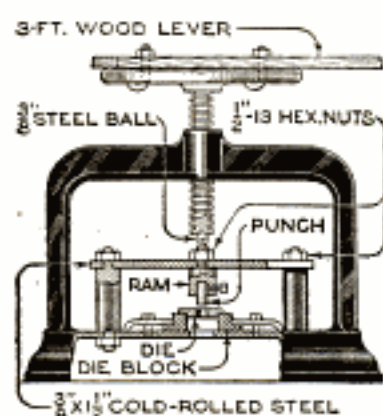

press, the yoke was removed; holes were cut underneath the die and in one side of the bed so that the punchings could be removed. The die is held to the bed by clamps, while the ram is bolted to a

strip of thin steel supported at the proper height at each end. The punch and die being in line with the screw, a cavity is made in the upper end of the ram screw for a steel ball, which furnishes a hardened bearing and reduces the friction. After extensive use, the horizontal piece of steel holding the ram and forming a spring was not permanently bent, as the amount of deflection was not more than $\frac{3}{16}$ in. The extra leverage required to force the punch through the work was obtained by bolting a wooden lever to the handwheel of the letter press.—Dexter W. Allis, Whitman, Mass.

Ⓢ A "circular mil" is a term used in electrical wire measurements and is the area of a circle .001 in. in diameter. The expression "circular inch" is also met with in electrical measurements and is the area of a circle 1 in. in diameter. Hence a circular inch is equal to 1,000,000 circular mils. The circular inch is equal to .7854 sq. in., and a square inch equals 1.2732 circular inches or 1,273,239 circular mils.

Rubber Stamps for Floor Layouts

Frequently, in engineering offices, it is desirable to make preliminary plans in order to show officials or clients a sug-

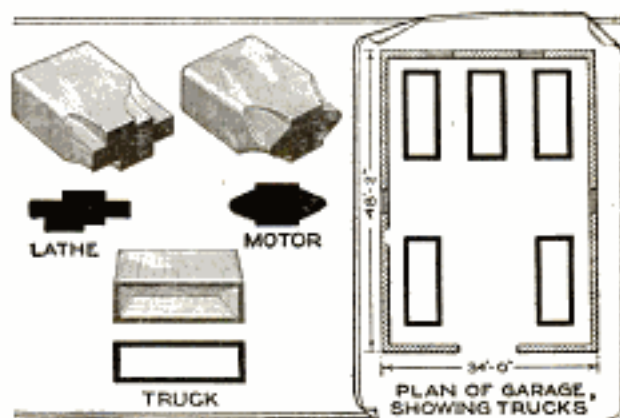

Rubber Stamps Cut from Erasers Prove Useful in Laying Out Floor Plans

gested floor layout. For example, a garage of certain dimensions is proposed; this can be outlined in a few minutes, but then the inevitable question, "How many automobiles will it accommodate?" is asked. An ordinary pencil eraser is cut to represent the space that will be occupied by the car on the scale drawing, and, using it as a rubber stamp, the entire available area may be stamped quickly to show its car capacity. In a similar manner, stamps to indicate electric motors, grinders, planers, or other tools and machines, can be made and used to indicate, on the floor plan of a factory, various arrangements to obtain the greatest economy of space.—Robert W. Shelmire, Chicago, Ill.

Clamp for Welding and Brazing Tees

A clamping tool that consists of an eyebolt, rod, and strap is of special service in holding two sections of pipe together at right angles for welding, soldering, or brazing. All parts of the clamp are generally available, and it is applied to the work as shown in the drawing. This type of clamp is of particular advantage in brazing, where the main requirement is to hold the parts without the least movement until the molten spelter sets, since otherwise the joint is invariably a failure.

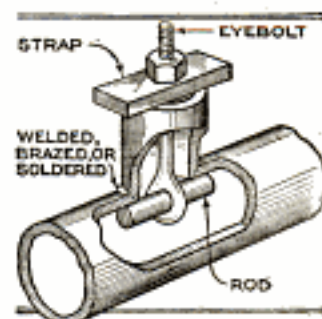



FAULTS IN CONCRETE-SIDEWALK CONSTRUCTION

By A. J. R. CURTIS

111 Washington St
Chicago

ONE of the greatest factors in the tremendously increased use of Portland cement in the last 40 years has been the concrete sidewalk. Although the concrete walk took the country by storm about the time Dewey fought the battle of Manila, and has maintained first place ever since in popular favor, a number of ordinary errors in construction still persist. Some of these mistakes are serious in their consequences, as shown in Fig. 2, endangering life and limb, and causing much needless expense. All, however, are easy to avoid, as the principles involved in laying sidewalks are simple, and the technique easy to acquire.

A concrete sidewalk should be merely a collection of independent concrete slabs, laid one beside another on a firm, well-drained subgrade. In locations where surface water disappears quickly and cannot become trapped under slabs, walks are frequently placed directly on the ground. If the slabs are laid where water is likely to become pocketed under them, either a subgrade, consisting of a 6-in. layer of cinders or gravel, or tile drainage, must be used to prevent possible heaving from frost. Where the walk is placed on an earth fill or elevation, the latter must be thoroughly compacted, and in the case of clay, or other water-bearing soil, the use of a cinder or gravel subgrade under the concrete is a wise precaution. Fills should extend at least 1 ft. beyond the walk on either side and the edges should slope off at an angle of 30° . The finished subgrade should slope toward one side at a pitch of $\frac{1}{8}$ in. to the foot, and the finished walk is usually given a corresponding pitch.

Some of the common mistakes in sidewalk construction are shown in the accompanying illustrations. Failures due to disregard, or ignorance, of the law of expansion and contraction, as illustrated in Figs. 1 and 2, and of proper concreting methods, as in Fig. 6, are the most common. Concrete has an expansion coefficient of about .00001, which means that for every degree Fahrenheit in temperature change a piece of concrete will expand or contract approximately one hundred-thousandth of its length. As a

practical illustration, a sidewalk 100 ft. long has an actual variation in length of about 1.2 in. between the extreme temperatures of zero and 100° F. If this walk were put down when the temperature was at 50° , it might be expected to expand one-half of the above amount if the thermometer reached 100° , and to contract as much from its original length if the temperature reached zero. Expansion in sidewalks may be provided for in ordinary straightaway work by leaving a space of from $\frac{3}{8}$ in. to $\frac{1}{2}$ in. between slabs every 50 feet.

If a long piece of sidewalk is constructed in the summer, without dividing it into separate slabs, the contraction in cold weather will be sufficient to make the walk tear itself apart at one or more places, and the opening thus formed will continue to widen as the sections continue to shrink. The remedy for this, as well as for several other sidewalk difficulties, lies in making the walk a series of disconnected slabs, usually not more than 6 ft. in each surface dimension, no slab to have a greater length than twice the width. Such slabs can take whatever little movement may be required without affecting adjoining slabs. A very effective method of producing a positive division between the slabs is illustrated in Fig. 7, which shows how the slabs are laid alternately.

The need for efficient concreting methods has always been apparent in our sidewalks. Slipshod methods have been due largely to a failure to realize that the sidewalk really constitutes a very exacting use of concrete. The apparent simplicity of the thing invites careless methods. Sidewalk slabs are quite thin for their size, probably averaging less than 4 in. in thickness, exposing large areas to extreme conditions and often hard use without any protection whatever.

In starting to lay the walk, 2 by 4-in. forms are staked firmly to the desired level, the subgrade having been properly leveled, with its surface 4 in. below the grade of the finished walk. Concrete, made of approximately 1 part cement to $2\frac{1}{2}$ parts torpedo sand, and 5 parts of gravel or crushed stone, all pieces of the

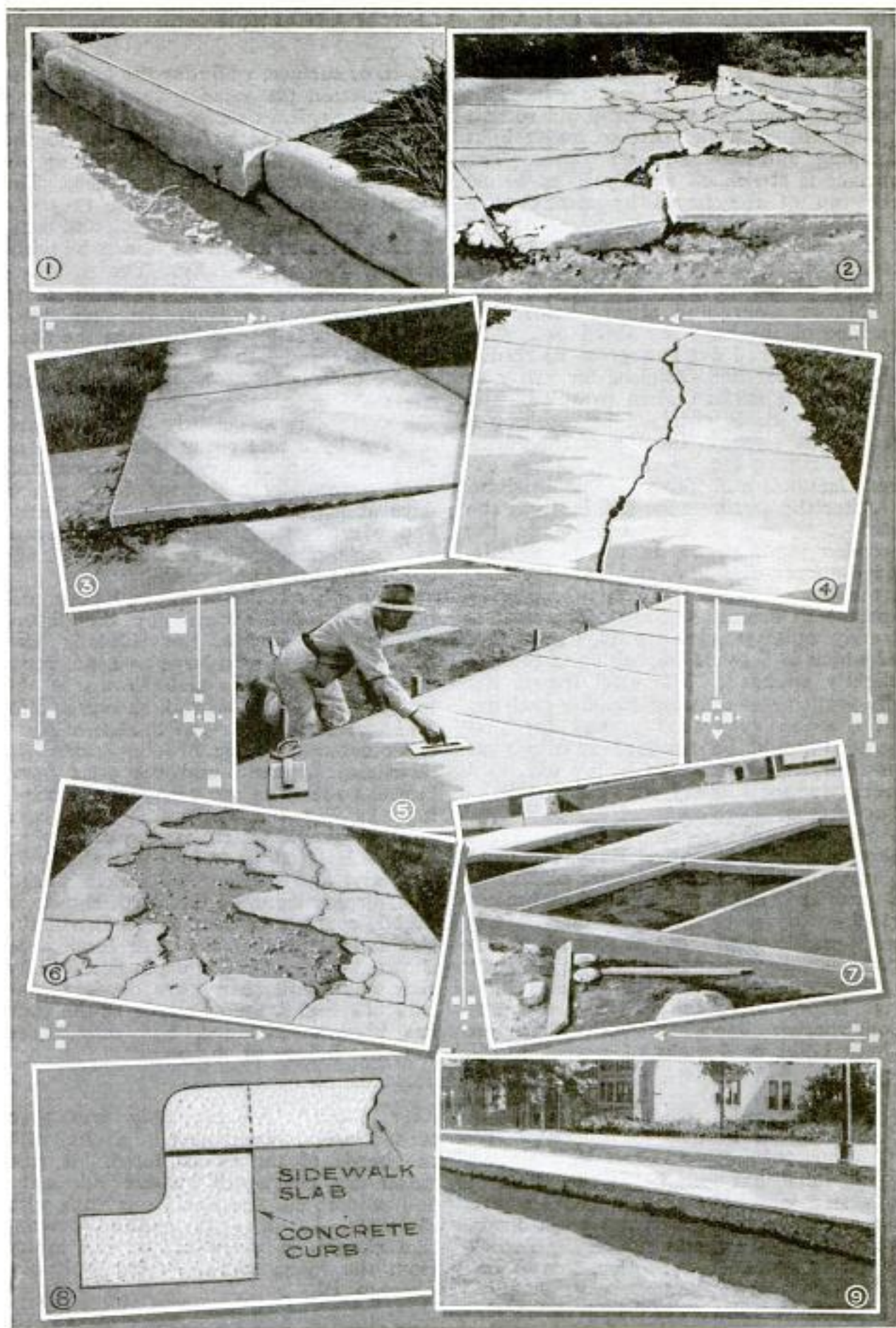

In Figs. 1 and 2 are Shown the Result of Expansion; Fig. 3, a Sidewalk Slab Forced Out of Place by Tree Roots; the Sidewalk in Fig. 4 Failed Because of a Poor Subgrade, While That in Fig. 6 was Made of Weak Concrete, with Dirty Materials, and in Fig. 9 the Subgrade has been Undermined. Fig. 5 Shows the Use of the Trowel, and Fig. 7 the Proper Method of Laying the Walk. Curbs should be Cast as Shown in Fig. 8, to Prevent Their being Pushed Outward by the Expansion of the Walk

latter, above $\frac{1}{4}$ in. in size, is then deposited to a depth of at least $3\frac{1}{4}$ in. This concrete should be sufficiently wet so that water will flush the surface under light tamping, and should be no wetter. The surface is struck off exactly $\frac{3}{4}$ in. below the top of the forms by means of a notched straightedge.

The surfacing course, composed of a mortar made of 1 part cement to 2 parts sand, is placed on the base course, usually within an hour, and always before the surface of the base has dried out. The mortar is mixed wet enough to be readily workable, but not sufficient for water to flush to the surface when troweled. The surface grade is obtained by working a straightedge across the top of the forms with a zigzag motion, removing the excess material and filling the depressions.

After the straightedge has brought the surface to a practically true grade, the wooden float, shown in the lower left-hand corner of Fig. 5, and later the steel trowel, are used to produce a true, even surface of smooth texture. The float is merely a flat wooden trowel, the surface of which is 5 by 15 in., with the corners slightly rounded. The steel trowel has the property of drawing the fine particles to the top very readily, and for that reason should be used as sparingly as possible, as excessive troweling will, as a rule, produce slippery surfaces and hair-line checks.

Single-course sidewalks are made throughout their entire thickness of a single mixture—usually 1 part cement to 2 parts sand and 3 parts gravel or broken stone—and are usually 4 in. thick. It is not possible to produce as smooth a surface as in two-course work, but less material is required, and quite a little less labor. In practice, the two-course construction described above requires about 1 bbl. or 4 sacks of cement for 45

sq. ft. of surface, while for the one-course construction the same quantity produces about 47 sq. ft. of surface. Metal division plates or wooden partitions provide the most convenient means of dividing the forms to produce independent slabs. The metal plates are better because they can be kept in position a few hours, and then, if kept clean and well oiled, can be withdrawn without difficulty. The slabs are frequently laid alternately, as in Fig. 7, to secure positive division. In such cases heavy paper is inserted between the slabs previously and latterly placed.

The walk is by no means finished until the slabs have been cured. As soon as the surface is sufficiently hard to resist damage by a fine spray from a hose or sprinkling can, it should be wetted, and kept continually moist for four or five days at least. Failure to cure properly, and overtroweling, are the chief causes of "dusting," and the former often leads to definite loss in strength.

Some other faults in sidewalk construction are well illustrated by the photographs. In Fig. 3, the sidewalk was placed too close to a large tree, the roots of which raised the slab shown in the foreground. The sidewalk shown in Fig. 6 was a failure because of the use of poor, weak concrete, made of dirty materials, insufficient cement, and the poor bond between the base course and the surfacing. In Fig. 4 is shown the effect of a poor subgrade, which has sunk away on both sides, failing to support the walk properly, and causing a "broken back." The displacement of the curb, shown in Fig. 1, could have been avoided, had the slab been laid over the curb section, as shown in Fig. 8; the expansion of the slab would not then have damaged the curb. In Fig. 9, the subgrade of the walk has been undermined, and may cause eventual failure of the walk.

Shortening Rivets in Quantities

We needed some rivets, $\frac{1}{2}$ in. long and $\frac{1}{8}$ in. thick, but found that the stock of this size was exhausted. There was a large supply of longer rivets on hand, however, and rather than wait for a stock of rivets of the proper size, it was decided to cut down the long ones. A number of $\frac{1}{8}$ -in. holes were drilled in a $\frac{1}{2}$ -in. steel plate, and another and thinner steel plate of the same length and width was also provided. In use, the rivets were inserted in the holes in the drilled plate and the second plate placed over the

rivet heads. The assembly was then turned over and clamped in a vise, with the heads of the rivets down. A cold chisel was sharpened on one side only, and used to cut the rivet ends flush with the plate. In using this method, precaution should be taken to prevent injury from the flying ends.—Frank Jablecnik, Chicago, Ill.

☞The average consumption of coal in steam boilers is 12 lb. per hour per sq. ft. of grate surface; there are 9 sq. ft. of heating surface to each square foot of grate surface.

Rocker Lever for Overhead Valves

Under the above title, on page 158 of our January, 1922, issue, we published a short article describing a tool for removing the tappet rods of an overhead-valve motor. We did not know at the time that this was patented; we have since been informed that it is, and our readers are therefore cautioned against making any tools similar to this.

Clamping Work

Usually one angle plate is applied to clamp work held for drilling or other operations, with the result that, while the work is held square on one face, it may easily tip in the opposite direction. In fact, so readily will the work tip that the workman commonly uses a square to find whether or not it is true. All this takes time, and he has to tap the work with a hammer until he gets it just right. He then gives a final straightening twist to the clamp, and away the work slips again, not much perhaps, but enough to do considerable damage. With the use of two angle plates, all this is avoided, as the faces must be square with each other if the angle plates are square. The one clamp grips slightly lower than the other.

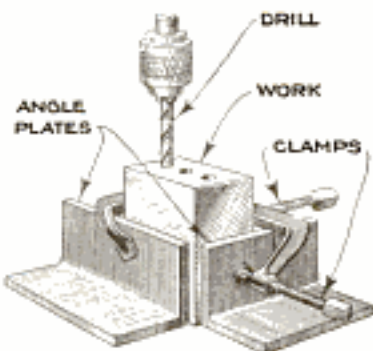

Header for Kafir Corn

One of the best things to use for the blade of a kafir-corn header is an old crosscut or one-man saw. The back of the saw is sharpened by grinding, and the blade is then mounted, back down, between two 2 by 6-in. pieces, these being held a sufficient distance apart by washers, to leave a slot for the blade. Four legs are provided on the ends of the header so that it may be placed over the edge of the wagon box.—R. E. Deering, Clements, Kan.

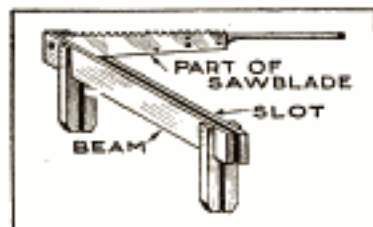

Portable Electric Testing Unit

An electrical testing unit consisting of four dry cells, with one test lamp, and two pointed terminals on flexible leads, is contained in a carrier made from an empty oil can and provided with a handle for carrying.

Two sides of the can are cut off level with the top of the battery and the remaining sides cut as shown. The test lamp is mounted inside, on a wooden block, to prevent breaking. The wooden handle, which can be made from an old broomstick, is fastened to the carrier by a screw at each end. Two holes are drilled through the handle, into which the terminals are inserted to keep them out of the way when the set is not in use, and to prevent short-circuiting of the battery.



Guarding Machine Rolls

Any machine that uses rollers is dangerous, because it is so easy for the operator to get his hand in between the rolls. Generally the distance between the rolls varies according to the work going through them, and this fact in itself makes the problem of protection very difficult.

The drawing shows a simple scheme that has saved many a hand and finger. The two guards not only act as guards but guides as well; they are pivoted on studs, and open or close to suit the thickness of the stock being rolled. The bottom guard is held in an upright position by means of a spring, one end of which is fastened to the guard, while the other is fastened to the body of the machine. Both guards are provided with lugs, on one or both ends, which bear against some part of the machine, and prevent them from coming into contact with the rollers.—J. H. Moore, Toronto, Can.

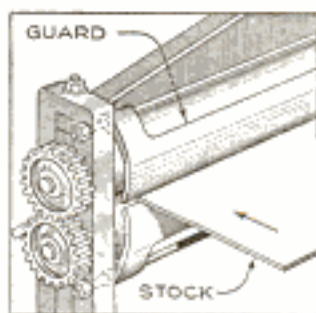

Cutting Sheet Metal with a Handsaw

A simple method of cutting sheet-metal roofing with a handsaw without injury to the latter can be used by carpenters and

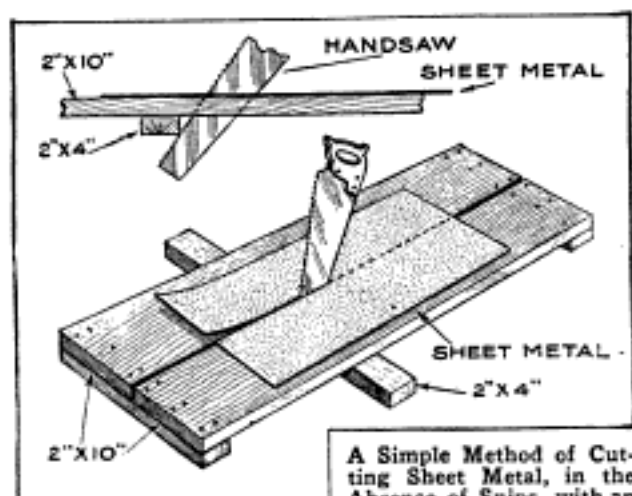

Ordinary Handsaw: The Saw Cuts Cleanly and Quickly, and is Not Injured by the Process

others if a pair of snips is not available. Two planks are supported by horses at each end. A space just wide enough to permit insertion of the saw blade, is left between the planks. To cut the sheet metal, it is laid on the planks, the line along which the cut is to be made being directly over the space between the boards. The back edge of the saw is placed in the space, against the end of the metal. A piece of two by four is then placed against the underside of the planks and the toothed edge of the saw, as shown in the upper drawing. With the saw held in this manner, a backward pull on the handle starts the cut. This operation is repeated until the sheet has been cut across.—Irl R. Hicks, Centralia, Mo.

Tapped Holes in Thin Tubing

In making an overhead irrigation sprinkler, some of the pipes were found too thin to hold threads into which the sprinkler jets could be screwed. The difficulty was overcome by using a center punch to make the holes, and to pull the metal into a long neck, which could then readily be tapped. In this manner the whole of the thin-walled pipe was made to take the sprinkler jets, without the delay that would have been caused in obtaining heavier pipe.—John Gormly, Norristown, Pa.

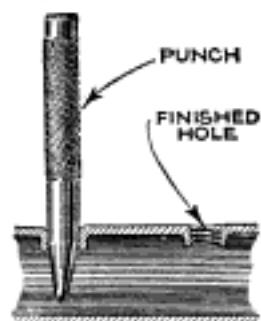

Silent-Chain Sprockets as Belt Pulleys

Small electrical generators for automobile use are almost invariably driven by silent chains running over sprockets. A fact not very generally known is that such a sprocket can be used without alteration to carry a belt when necessary for testing the generator, or even for regular operation on a car in emergency. Many mechanics would suppose that a flat belt would not stay on the sprocket, since it is not crowned like a belt pulley. A test will convince, however, that there is no danger of the belt coming off unless it slips or breaks. The greatest objection to running a belt on a silent-chain sprocket is that it is very hard on the belt and its coupling. The drive should therefore never be used except for a test or when a broken chain, which cannot be immediately replaced, makes the use of the belt necessary.—Curtis Ralston, Chicago, Ill.

Repairing Pump Jack for Engine Drive

A deep-well pump was fitted with a jack geared to a $1\frac{1}{2}$ -hp. engine, pumping water through a $1\frac{1}{4}$ -in. pipe against a 200-ft. head. The jack was of the ordinary commercial type, consisting of a cast-iron yoke through which the pump rod fitted and to which it was clamped, and two hardwood arms, drilled with a series of holes and bearing on crankpins on the gears. The yoke broke in the middle, causing the wooden arms to break also, but without damaging the pump rod, guide, or the cast-iron bearing boxes bolted to the lower ends of the wooden members. As it was thought that a new yoke of the same pattern would soon break also, a new rib consisting of two arms of $1\frac{1}{2}$ by $\frac{1}{2}$ -in. iron was made. The upper ends were bent inward to meet the pump rod, and were bolted to it with a bolt and locknuts, thus eliminating the yoke. The original cast-iron boxes were bolted to the lower ends of the iron arms. When tried out, the arms were found to

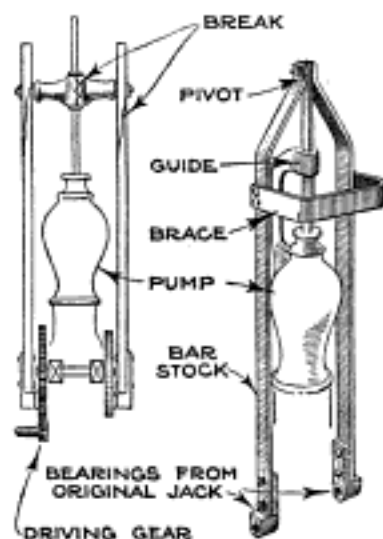

bend outward, and to overcome this, an iron brace of $\frac{1}{2}$ by 2-in. stock was bolted across them. As the thrust on the brace was outward, $\frac{5}{16}$ -in. bolts were found large enough to hold it, although rivets could also have been used. The brace was offset enough to clear the pump-rod guide casting; its corners were forged round instead of square for additional strength.

Gauge for Milling Hexagons

Those who have occasion to mill hexagonal shapes from round stock will find the gauge illustrated a valuable assistant. In order to avoid cutting one side too deeply and thus spoiling the work, it is usual to fall back on the cut-and-try method, whereby it may be necessary to revolve the work in the dividing head several times before a full hexagon is cut.

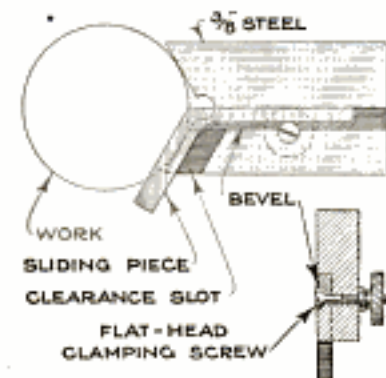

The depth of cut can also, of course, be figured out, but this method is avoided by many on account of the liability of errors creeping into the calculation. The body of the gauge is $\frac{3}{8}$ in. thick, with the end cut to a "V" of 120° , included angle, the center of which is filed away or a hole drilled to admit light. A slot is cut along the length of the body, one side of the slot being exactly in line with the center of the V. Next, a piece is made to slide in the slot with a 30° angle on the end, the angular portion fitting a clearance slot cut in the body. A slight bevel is filed on one side of the sliding piece, and a flat-head screw and knurled nut, used as shown, complete the device. To prevent the screw from turning when the nut is tightened, a flat is filed on the underside of the head, to fit against the bevel on the sliding piece.

To use the gauge, the sliding piece is pushed forward until the corner is in line with the edge of the shaft, as shown. The nut is then tightened, and a line is scribed on the work along the angular part of the sliding piece. This line is then clearly defined with punch marks, and the cutter set to split these in two. The work can then be milled to this depth on six sides, and a perfect hexagon, for the size of stock used, will result.

Handy Combination Tool

A handy combination tool that will find many uses in the hands of the automotive repairman or in the repair shop, is easily

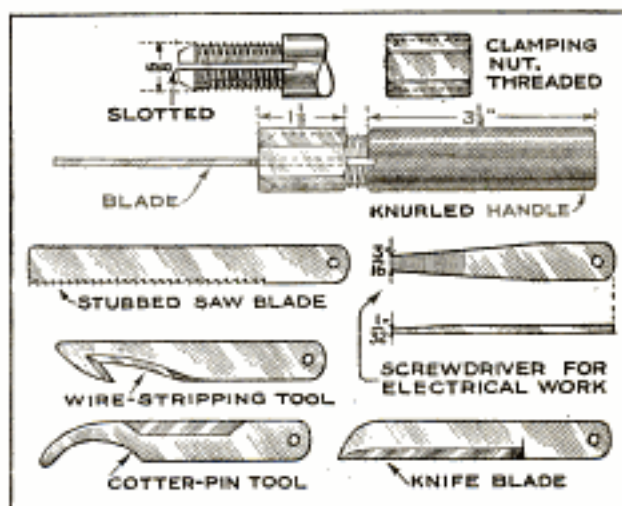

A Handy Toolholder and Outfit of Tools, Made from Pieces of Hacksaw Blades, That will Find Many Uses in the Hands of the Repairman and Auto Owner

made from a piece of round steel, about $\frac{7}{8}$ in. in diameter. One end of the stock is turned, threaded, the end beveled, and slotted to take the tools. A nut, with an interior bevel corresponding to that on the screw, is provided to screw over the threaded portion of the holder, so that, when in place and screwed tight, the tools will be firmly held. A set of tools for use in a holder of the type described may easily be made from pieces of hacksaw blades, a few suggestions being shown in the drawing. These, and others that will suggest themselves, can easily be shaped on a grinding wheel.

Improving the Pipe Cutter

A boiler maker found that boiler tubes cut off at the ends with the revolving-wheel type of pipe cutter cracked when the bead was being turned over. To overcome this difficulty, the movable wheel was removed, and for it a cutter similar to a lathe tool was substituted, with results that were entirely satisfactory. The cutter need not be turned down against the work so hard as is the case when the wheel cutter is used.—Irwin T. Fox, Richmond, Ind.

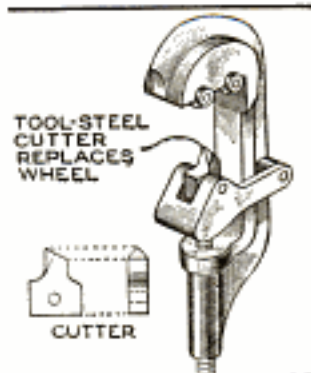

Lathe Used as Milling Machine

With the simple addition of a vertical feed to raise and lower the work, a lathe makes a first-class milling machine. There are various attachments manufactured for this purpose, but all that is necessary

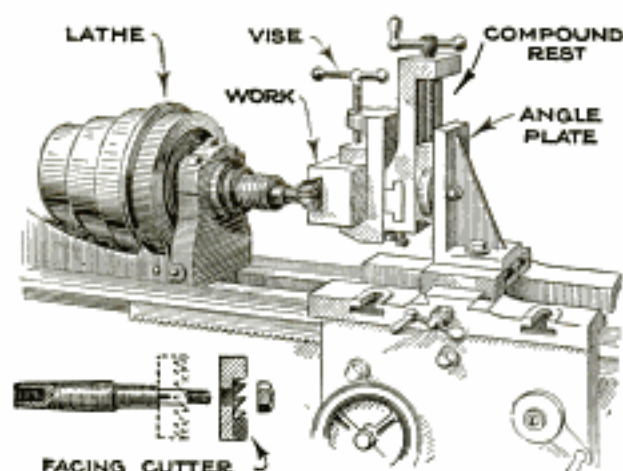

Compound Slide Rest, Mounted on an Angle Plate, Converts the Lathe into a Milling Machine. The Work is Held in a Tool Vise, and Standard Milling Cutters are Mounted on a Taper-Turned Arbor, Fitting into Headstock Spindle

for a small lathe is an angle plate to change the compound slide from the horizontal to the perpendicular. This angle plate, faced on both sides, has holes drilled in it to match the circular groove in the compound swivel. The toolpost slot may be used to hold the work by tapping the casting to receive setscrews. A small tool vise can be clamped to the toolrest, or if a clamping table is preferred, it may be used in the same manner. The attachment is universal, as the plate may be swiveled on the carriage or the compound slide may be swiveled on the plate, to give any desired angle. The cutters are carried on a taper-turned arbor, fitting the lathe spindle. If heavy cutting is to be done, this arbor should be tapped to receive a long stud, passing through the headstock spindle, whereby the arbor can be drawn up tightly. Standard facing, side, or end-milling cutters may be used.—Edwin J. Bachman, Fullerton, Pa.

Creosoted-Wood Silos

Wood-preservation studies have shown that the value of wood silos can be greatly increased by proper treatment with coal-tar creosote. A good creosote treatment will not only increase the durability of the wood, but will reduce the tendency of the staves to shrink when the silo is empty. A creosoted silo cannot be painted afterward; however, it does not need

painting, for the creosote protects the wood, and its color is very pleasing. Highly durable woods, such as heart cypress or redwood, do not need protection against decay so much as the non-durable woods, but a thorough creosote treatment will make the nondurable woods, such as sap pine, last longer than durable species will without treatment.

Contamination of the silage by creosote from the staves need not be feared. This is borne out by experiments and inquiry among the many farmers who have used creosoted silos. In order to be quite sure, it is well to allow the creosoted staves, or the finished silo, to stand a few weeks before filling.

The most thorough creosote treatment can be given by pressure methods. If pressure-treated wood is not available, very good results will be obtained by the hot and cold-bath treatment. If a good penetration of coal-tar creosote is obtained by either of these processes, it is not too much to expect the silo staves to resist decay for from 25 to 30 years.

A Simple Internal Gauge

When used on collars or other work of short length, the adjustable internal gauge illustrated will easily take the place of a number of solid plug gauges. The minimum diameter of the one shown is 1 in., this being the size to which the head is finished. Two $\frac{3}{16}$ -in. holes are first drilled and reamed in the side to take round-ended pins. Next, a quadrant is milled out as shown, and a clamping

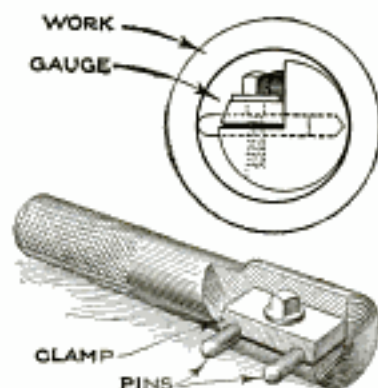

plate, with two grooves to fit over the pins, is made. A hole is drilled and tapped in the gauge, between the two pin holes, and a square-headed collar screw, that passes through a hole in the clamp, completes the assembly. The first pin is used for the low-limit setting, and the second for the high, the pins being set by measuring over all with a micrometer. When setting, it is convenient to have the clamp tightened on the pins just enough to hold them in place; then the micrometer can be brought down to the size required, pushing the pin in at the same time.

Veterinary Capsules for Small Parts

Empty veterinary capsules make excellent receptacles for holding very small parts and pieces in such a manner that the quantity and condition of the contents can be told at any time, as the capsules are transparent, and, unlike glass, practically unbreakable. Used in series, the capsules, which can be obtained in different sizes, can be used to hold beads, paint or bronze colors, pins, tiny buttons, small screws, graphite, or leads. These capsules, being made of gelatin, must not be allowed to become wet. A simple rack for holding such receptacles in either a horizontal or perpendicular position can easily be made.—C. Nye, New York City.

Connecting-Rod Wrench

An offset made on the end of an open-end wrench, as shown in the drawing, will be found of service in removing the cap screw from the wristpin-end of connecting rods.

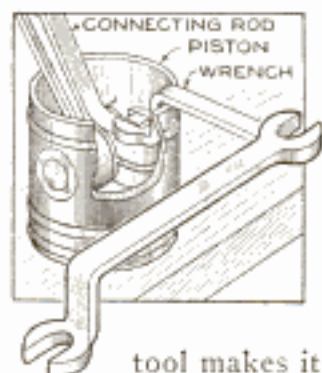

The wrench is bent in such a way that the handle will clear the piston skirt. Working with the hands alone, this tool makes it possible to take out or replace the cap screw without requiring any clamping arrangement to prevent the piston from turning.

A Feed-Water Filter

A rather novel filter, made from Turkish towels and marsh hay, was used in connection with the Dayton river-channel improvement work, for removing sediment from the river water in order to have available at all times an adequate supply of clear water for the steamboat boilers.

The construction of the filter is clearly shown in the drawing. It consists primarily of a long rectangular wooden tank, divided into compartments by partitions, through which the feed water is caused to circulate, entering at one end and leaving at the other and passing through consecutive filters of hay and toweling in the course of its journey. The water enters, yellow or brown with unsettled river mud, and leaves ready to enter the boilers, clear enough to drink.

Five compartments are shown in the drawing, but a greater or smaller number may be used, depending on the amount of sediment to be removed. The compartments are separated by double baffle boards set about 3 in. apart, the water

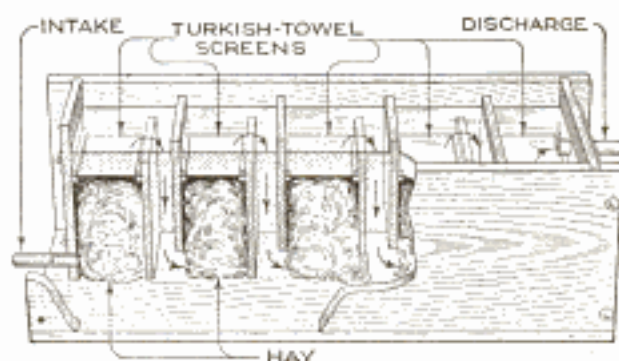

A Simple Filter for Removing Mud from River Water, to Provide Clear Water for Steamboat Boilers, Uses Hay and Turkish Toweling as Filtering Materials

passing, in all cases, over the top of the one nearest the inlet and under the bottom of the next, thus always entering a compartment at the bottom and passing upward through the filter. Each compartment is filled with hay to the level of the cross cleats near the top. Finer screens, made by tacking Turkish toweling onto rectangular frames, are placed on top of the hay and held in place by the cross cleats. The water passing through the compartments, always in an upward direction, leaves its burden of sediment in the hay and under the toweling, thus preventing the rapid clogging of the filter which would result if the water passed downward. With this arrangement, it was necessary to clean the filter only twice a week—a very simple operation, consisting in removing the towels, washing them with a hose and replacing them. It was not found necessary to remove the hay except at long intervals. The simplicity and efficiency of the device, which can easily be built by any carpenter, adapt it to many different situations. It must be remembered, however, that it is for sediment only; lime and other soluble ingredients are, of course, not removed.—Ivan E. Houk, City Engineer, Dayton, Ohio.

Painting on Old Walls

Old walls, especially of kitchens, have a thin layer of grease and smoke upon them that may not be perceptible, but which will prevent paint from adhering properly. Before being repainted, they should be washed thoroughly with soap and water, to which a little ammonia may be added, and finally rinsed with water.

Spindle-Straightening Fixture

Often, in the course of the manufacture of articles of standard design, small shafts or spindles are used; these are

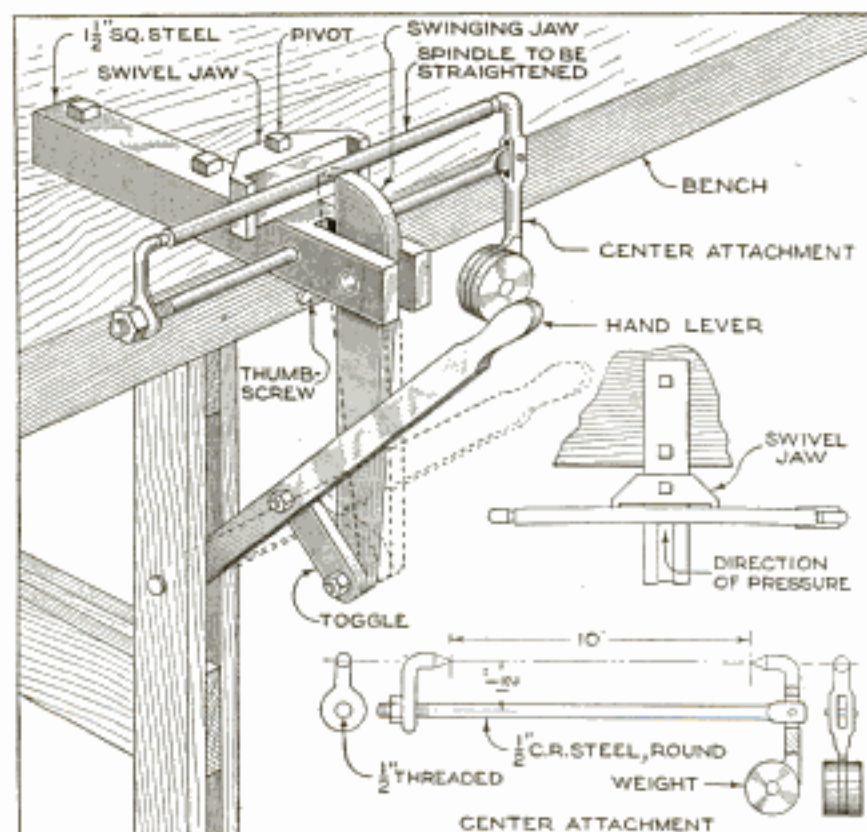

For Straightening Light Shafts or Spindles, in Quantity, a Fixture of This Type Has Much to Commend It. The Centers Holding the Work Are Adjustable Horizontally So That Any Part of the Work can be Reached

usually made from a good grade of tool steel, centered and turned to the form required. After centering a great quantity of such spindles on small turret lathes, it was found, after they had been cut off, that quite a few had been cut from stock that had been slightly bent, and while they would run fairly well at the ends, due to close chucking, the center would run out so badly that they would not clean up on the machining cuts. It was decided that the common method of straightening the stock would be too slow and unprofitable, and the fixture shown in the drawing was made. The body of the device is made of square steel and is bolted to a bench so that the slotted end projects over the edge. A $\frac{1}{2}$ -in. slot, cut in one end, receives a movable swinging jaw. Mounted on the top side of the base is a swivel jaw having two extending lugs, the metal between them having been removed on a shaper; this block is fastened loosely to the base by a $\frac{5}{8}$ -in. capscrew. A $\frac{1}{2}$ -in. hole is drilled and reamed horizontally through the iron base, just behind the slot, to

take the centering attachment upon which the work to be straightened is supported.

The centering attachment is made from a piece of steel rod, which is flattened at one end and threaded at the other. On the threaded end is screwed a stationary center, which is held tightly by a locknut. A swinging center is pivoted to the flat end of the rod, thus permitting quick positioning of the work between the centers. Also, the weighted end of the swinging center keeps it pressed against the end of the work, and keeps the centering fixture normally in a vertical position.

When the operator has placed a spindle between the centers, he will first revolve it with his fingers, and, by sighting, detect the point at which the work runs out. He now brings the high spot toward himself and by pressing down on the toggle handle, exerts pressure against the work, bending it in the opposite direction. The work is again tested, and the operation repeated as may be necessary.

Stripping Films from Cracked Negatives

To strip the film from cracked glass photographic negatives, so that the film can be placed on another piece of glass and prints made from it in the regular manner, the film is first hardened in a three-per-cent solution of chrome alum, washed for five minutes, and then dried. Next, a 20-per-cent solution of white gelatin is made and filtered while hot. A liberal quantity of this is poured over the negative, which has previously been warmed and placed as level as possible. When the gelatin has hardened, the negative is again placed in the chrome-alum solution, washed for five minutes, and placed in denatured alcohol for a half hour, after which it is dried again.

To strip the negative from the glass, use a mixture of 2 oz. water, 1 oz. denatured alcohol, and 1 dr. of commercial hydrofluoric acid. After a few minutes' immersion in this bath the film can be

loosened around the edges with a small stick of wood, cut to a chisel point. When this stage is reached, the negative is transferred to a tray of clean water for a minute or two and then to another; the actual stripping is done in the latter tray, by means of the stick. After removing the film, it is washed in two or three changes of clean water, then laid out smoothly on a ferrotype plate to dry. The fingers should not be allowed to touch the hydrofluoric-acid solution, which is very corrosive and poisonous. Usually it is not advisable to place the film on glass, as there is considerable risk of distortion in drying, but, if necessary, it can be done. A good method is to fix out an unexposed plate, and harden in formalin the layer of clean gelatin left. This is slipped underneath the stripped film while the latter is lying in water. The plate is then raised until the film rests on the glass securely. Finally, it is drained and allowed to dry in contact with the gelatin.

Cutting Torch Produces Ornamental Ironwork

What can be done in the way of producing ornamental hinges from sheet metal

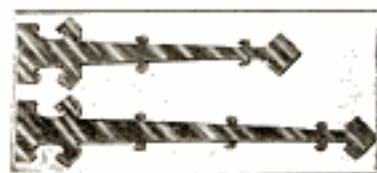

with an oxy-acetylene cutting torch is clearly shown in the photograph. The intense heat developed makes it possible to cut the metal as easily as wood is cut with a band saw. Practically any metal can be worked by this means, the hinges shown having been cut from bronze.—Harold C. Ridgely, New York City.

Balancing Polishing Wheels

It is highly important that polishing wheels be in balance. Balancing ways are made for this special purpose, and the balancing itself is usually done by nailing pieces of sheet lead on the light side of the wheel, until the wheel remains at rest in any position on the ways. It is also important that the wheel run absolutely true. The wheel is not necessarily true, however, even if in balance. By the use of an old file or buff stick, supported by a temporary rest, the wheel can be made to run so that every portion of its circumference will come in contact with the work.

Scaffold That need Not be Fastened to Building

When reshingling or repairing a building, it is quite necessary to have a scaffold to work from, as a ladder does not give the proper freedom of movement or stability for the worker, and, unlike new construction, it is not usually possible to nail blocking to the sides of the house for supports. The drawing shows how a scaffold can be erected



without marring the surface of the building, and yet be substantial enough for all work. A piece of 2 by 4 or 2 by 6-in. stuff is placed at an angle to the building, and as close up under the eaves as possible, as this saves side bracing. Another piece is placed in a vertical position, and crossing the first, and the two are spiked together where they cross. This is done at each end of the building, and in the middle if necessary; then short pieces of similar lumber are nailed across the long pieces to form supports for the staging.

A Small Bolt Cutter

Sawing off the ends of bolts is slow and tedious work, and it is not always possible to use the hacksaw, because space is lacking. The drawing shows a clipper that can be made from two flat files, the arrangement being such that a powerful leverage is obtained. Four 12-in. files are used, their ends being annealed so that they may be drilled and the cutting lips forged. When assembled with bolts or rivets, two ordinary file handles are fitted to the tangs of the files forming the handles. The cutting edges should be tempered to the same hardness as that generally used for lathe tools, that is, to a light-yellow color.

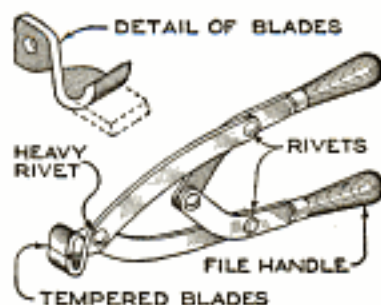

Driving Pipe Underground

It is often possible, when laying iron pipe of small diameter, to drive the pipe through the earth and save the cost and trouble of digging a trench, with the aid of a specially constructed point, something after the style of a well point. One trouble that is common to this method is that the outer end of the pipe must be protected against the blows of the hammer or maul used. Wooden blocks offer slight protection and damage to the threads is likely to result in spite of them. A much better method is to use a steel wedge secured to the pipe by a length of chain in the manner shown. The blows of the hammer on the wedge tighten the chain and afford sufficient grip, and the heaviest blow will not damage the pipe.

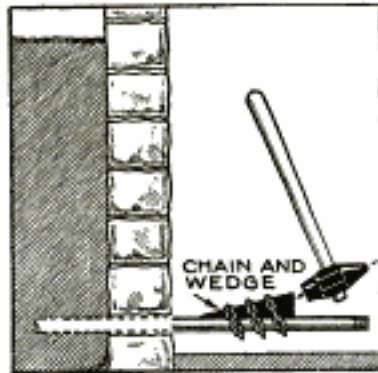

Punching in the Lathe

The drawing shows a rather novel fixture used for cutting cardboard disks in a lathe. There are three main parts, the punchholder, punch, and operating shaft. The holder is made of any convenient size, to the shape shown, the back end fitting in the toolpost. Near the front, a hole is bored to take the milled bar that operates the punch, and tangent to this hole a small hole is drilled from top to bottom. This is counter-bored, the size of the punch to be used, down to the center of the larger hole, and a tapered groove is milled from the front of the holder, on the top face. The punch is made to fit the counterbored hole, as shown, and fitted with a coil spring, washer, and pin, to keep it down on its seat. A narrow slot is

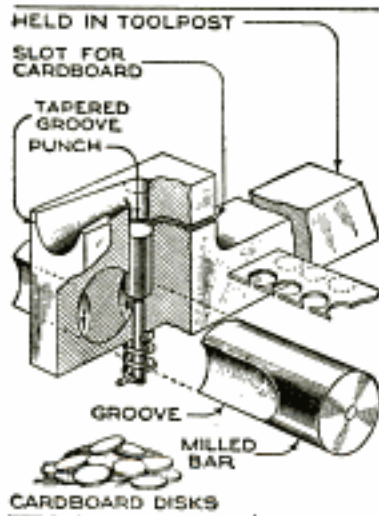

cut in the top of the holder, in the position shown, to take the cardboard from which the disks are cut. The operating shaft is a bar, centered at both ends and having semicircular grooves milled on opposite sides.

In use, the holder is gripped in the toolpost, with the shaft held between centers and driven by a dog. The lathe is run backward, and the stock fed by hand; at each revolution the punch cuts two disks, which are forced out of the hole, and slide down the tapered groove into a box.

A Simple Locknut

The drawing shows one of the simplest forms of locknut, that will stay in place without loosening until forcibly removed with a wrench. A $\frac{3}{16}$ -in. or larger hole, the size varying with the size of the nut used, is drilled through the side of the nut. After the nut has been tightened, a nick is cut across the bolt thread, using a small chisel punch as shown. The

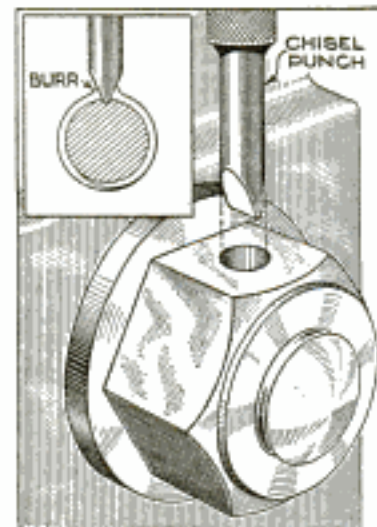

hole serves a double purpose, as it permits insertion of the punch and forms a cavity for the upraised burr, which prevents the nut from turning. Naturally, to be the most effective, the cutting edge of the chisel should be held parallel to the axis of the bolt when raising the burrs.

Grinding Troubles

If the wheel glazes, the work is burned or the wheel cuts slowly, the remedies are, for the first, to use a coarser wheel; for the second, to use a softer wheel, and for the last, to decrease the table speed or increase the feed. If the wheel wears too fast, increase the table speed or decrease the feed; if this has no effect, try either a harder or a finer wheel. For a finish that is too rough use a finer wheel, or, in some cases, an elastic wheel; or, these remedies failing, try a little cutting oil in the grinding solution, if only soda water is being used.

Formula for Breaking Strength of Rope

For three-strand Manila rope with a regular lay, and from $\frac{1}{2}$ to $4\frac{1}{2}$ in. in diameter, the following computation will give the strength of the cordage: The average breaking strength in pounds equals 5,000 multiplied by the diameter of the rope in inches, and the product then multiplied by the diameter in inches increased by one. Thus, in calculating the strength of a 3-in. rope, multiply 5,000 by 3, the diameter in inches, and then multiply the product by 4, which is the diameter of the rope increased by one, the total product being 60,000 lb. This method gives the average maximum weight that the rope will hold, but the working load must, of course, be much less.

Adjustable Stock Support

For a small shop, the handy stock support illustrated will be found much more useful than the usual telescopic arrangement, since it can be used to support bars very close to the floor, as in fitting a shaft to the finished machine, or high up for pipe-threading machines and work in the vise. It is made of $\frac{3}{4}$ by $1\frac{1}{2}$ -in. flat stock. Two pieces of stock form the base.

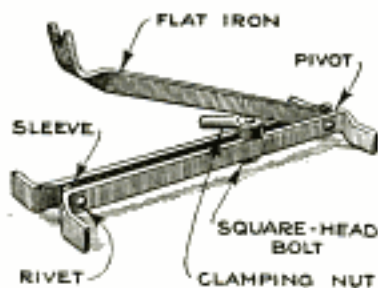

at the ends enough to clear a bolt head, then bent at right angles to form feet. The lever support is twisted at right angles at one end, bent upward a little, and a "V" cut. The opposite end is drilled for the pin on which it pivots, and which, being riveted at both ends, binds the three pieces together; a similar pin, with a sleeve, is used at the other end. An ordinary square-headed $\frac{3}{4}$ -in. bolt slides between the two members forming the base, the top of the square on the bolt being filed a little on the sides to allow it to enter the channel and prevent it from turning. A special clamping nut is shown, which, of course, is convenient, but an ordinary nut will serve the purpose if the cost is to be considered. Made to a length of about 3 ft., this support has a range from that height to 6 in. from the floor. The bars held in this support must be fed or pulled forward so that the pressure is kept on the bolt, that is, away from the pivot.

Fixture for Lawn-Mower Repairs

The drawing shows a fixture that has been in use for several years in a shop making a specialty of lawn-mower repairs. It is made from short lengths of pipe and suitable fittings. The distance between the two half-tees is such that a lawn mower of any width can be placed in the fixture and held firmly. The projecting pipe ends of the fixture fit into holes drilled near the edge of the workbench, so that it can be removed when not in use. The lawn mower is supported in the fixture by the stay rod, as shown, with the handle resting on the floor.—A. W. Zimmerman, Chicago, Ill.

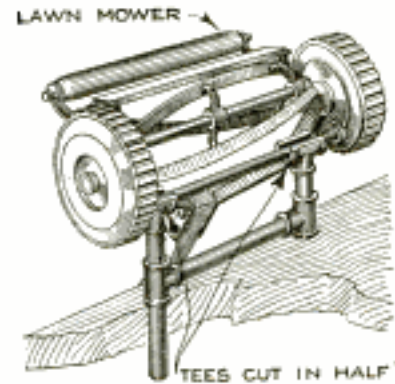

The drawing shows a fixture that has been in use for several years in a shop making a specialty of lawn-mower repairs. It is made from short lengths of pipe and suitable fittings. The distance between the two half-tees is such that a lawn mower of any width can be placed in the fixture and held firmly. The projecting pipe ends of the fixture fit into holes drilled near the edge of the workbench, so that it can be removed when not in use. The lawn mower is supported in the fixture by the stay rod, as shown, with the handle resting on the floor.—A. W. Zimmerman, Chicago, Ill.

Removing Tight Screws

Screws of the slotted-head variety are, at times, very difficult to loosen, especially if they have remained undisturbed for a long time in a damp place. The little tool shown in the drawing will aid in loosening such screws without destroying the slot, as any attempt to hammer them off will do, thus making the job more difficult. A short piece of $\frac{3}{8}$ -in. stock is drilled up the center with a $\frac{1}{16}$ -in. drill, knurled on the outside, and an angular slot, $\frac{3}{8}$ in. wide, and running into the $\frac{1}{16}$ -in. hole, is cut in the side. The driver is made of $\frac{1}{16}$ -in. tool steel, drilled for a $\frac{3}{8}$ -in. pin, which is driven in when the two parts are assembled. With the pin at the bottom of the angular slot, the tool is grasped firmly in one hand and placed in the screw slot. The top is then lightly tapped with a hammer, which, while keeping the blade in the slot, at the same time continually presses it round in a left-hand direction, so as to loosen the screw. Only light taps of the hammer should be used, as heavier blows will not produce the desired effect.

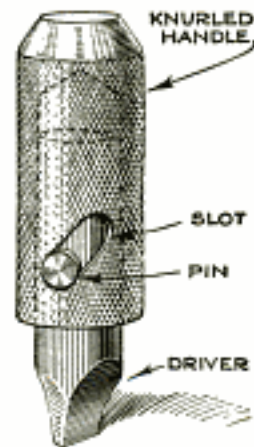

Unwrapping Wire in the Lathe

THERE are occasions when it is necessary to remove the insulation from magnet or annunciator wire, as when triple-covered wire is to be reduced to double, to save winding space, or when the paraffined outer layer of annunciator wire

In use, enough of the wire is stripped by hand to allow the unwrapped portion to be passed through the spindle and attached to the spool at the rear, and the cotton threads are carried through the guide arm and attached to the spool on the tube, the spring being so adjusted as to allow the spool to turn stiffly, yet without pulling the wire badly out of line or breaking the strands. It can be seen that, as the wire is drawn along, the insulation will unwind from it, pass through the guides on the rotating arm and wind itself on the spool. As the rate of winding on the spool will be much less than that at which the strand is unwound from the wire, there will be considerable slippage between the spool, thrust washers, and tube, the

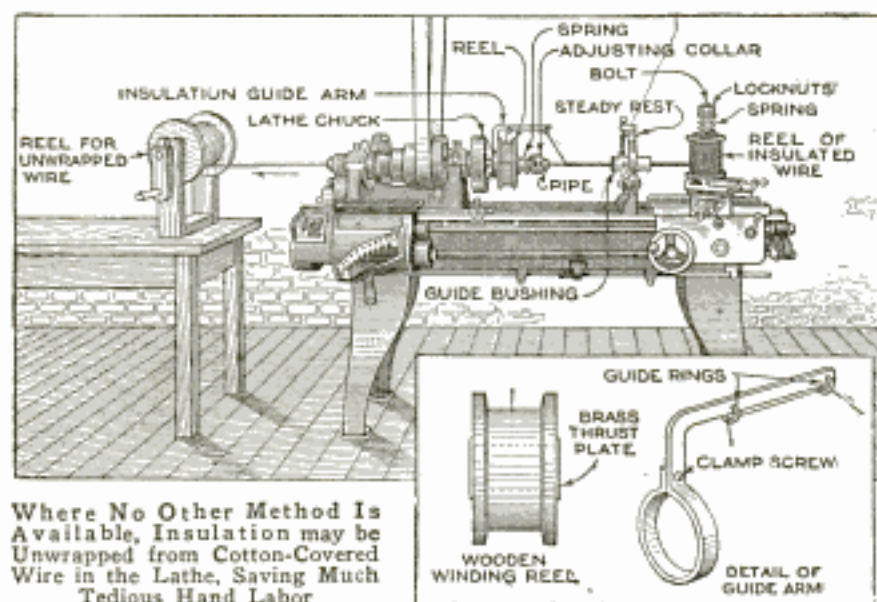

Where No Other Method Is Available, Insulation may be Unwrapped from Cotton-Covered Wire in the Lathe, Saving Much Tedious Hand Labor

is to be removed to convert it into single cotton-covered magnet wire. This is an extremely tedious operation when done by hand, particularly when the wire is of any length.

The drawing illustrates a lathe set-up designed to unwrap the insulation mechanically. The insulated wire is carried on a reel, or spool, held on a bolt clamped to the compound rest. A metal thrust washer, a spring, and two locknuts on the end of the bolt, hold the spool by friction and prevent it from being too easily turned. The wire is carried along above the lathe bed through a sleeve held in the steady rest and through the headstock spindle to another spool, arranged with wooden bearings and a hand crank, and mounted on a bench or stand beyond the lathe. A piece of brass or iron pipe is held in the universal lathe chuck; fastened over the chuck jaws is a clamp made of bar iron having its end turned over at right angles, to form a guide for the insulation stripped from the wire, two guide rings being provided for this purpose. Next, a brass thrust washer or plate is placed on the pipe, and then a hardwood spool, upon which the insulation is wound as it is unwrapped from the wire. Another thrust washer is placed in front of the spool, then a compression spring and an adjustable collar to hold it in place.

spool being pulled around by the insulation. The success of the operation will depend upon the spring adjustment and the rate at which the wire is drawn along. An adjustment that is too loose will prevent the winding of the insulation upon the spool, while one that is too tight will pull the wire out of alignment and possibly break the strand being unwound.

By reversing the process, it is possible to wrap bare wire, but a smooth job would hardly result. For special purposes, however, such as wrapping thermocouple resistance wires with asbestos string, the method should be successful.

For a short lead, the end of the wire could be attached to a bolt clamped to the tool block in place of the spool; then the carriage would be started moving toward the end of the bed, drawing the wire through the headstock spindle and at the same time applying the wrapping. Here a good deal would depend upon giving the carriage the proper rate of feed. Two, three, or more, layers of insulation could be wrapped or unwrapped, but only one at a time, the wire being run back and started through each time another layer was to be worked upon.

☞ To drill horizontal holes accurately with a ratchet drill, make the punch mark deep, and apply sufficient pressure to the drill to prevent its tendency to slip down.

Extension for Cold Chisel

There are times when the only method to loosen a nut with the tools at hand is to set a chisel against one of the corners and strike it with a hammer. However, sometimes nuts are so located that the chisel is not long enough to reach them. In such cases, an extension can easily be made for the chisel by driving a sleeve, of pipe or tubing, over the head of the chisel, and inserting a piece of rod, the size of the chisel shank, into the upper end of the sleeve.

Grinding Piston Rings

In the small jobbing shop there is often a call for special piston rings to fit odd-sized bores of steam and gas-engine cylinders. To get an accurate fit in the ring groove, the sides of the ring must be ground or filed off; this usually difficult job can readily be done on the shop's universal tool grinder.

An angle plate is mounted on the table of the grinder, parallel with the face of a cup wheel, as illustrated. A piece of flat steel is clamped against the angle plate and serves as a stop, against which the outer surface of the ring rotates. The

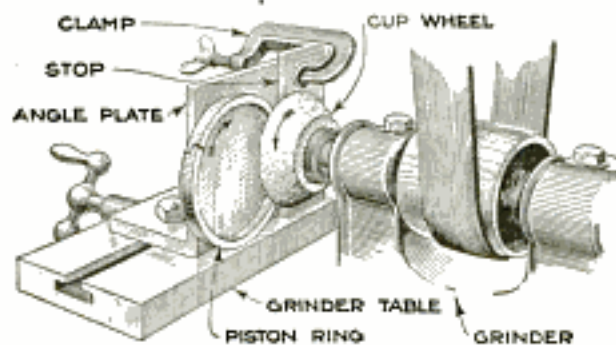

A Simple Method of Grinding Odd-Sized Piston Rings to the Proper Width on a Universal Tool Grinder Solves Another of the Problems of the Jobbing-Shop Mechanic

ring rests and revolves on the table slide. When the rings are cut off the ring "pot" on the lathe, one side is faced carefully and made straight and true. This face is then brought against the vertical face of the angle plate, with the opposite face against the grinding wheel. Rotation of the ring is effected by slowly turning by hand, the wheel producing a pulling effect on the ring in a downward direction. When one side is finished smoothly, the ring is reversed and the opposite side touched up and ground to the exact width of the groove, less about .0015 in. This trick can be applied to many other similar jobs, and, with a little care, good work is easily done.

Winding the Thresher Belt by Power

One of the hard jobs of the thresherman is the winding up of his long drive belt, and a device that reduces the manual

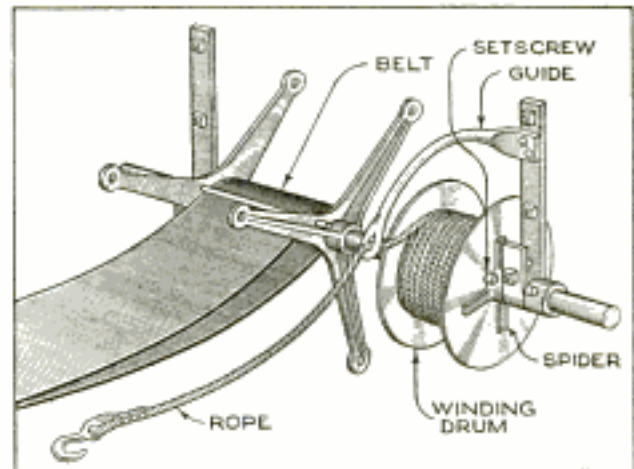

A Simple Attachment for the Grain Separator That Lightens the Labor of the Thresherman by Winding His Long Drive Belt on a Reel—the Tractor Does the Heavy Work

effort required to do this will be appreciated generally.

The arrangement shown in the drawing made it possible for one farmer to use power for the purpose of winding the belt on the reel usually provided for that purpose. A winding drum was made from a section of a maple log and fitted with two 20-in. sheet-metal flanges. This drum was fastened to the shaft on which the reel was fitted by a spider, which was originally the hub from the fan of an old separator. A 60-ft. length of $\frac{1}{2}$ -in. rope, with a loop at one end and a hook at the other, was then prepared. The looped end of the rope was dropped over a pin driven into the face of the drum, so that when the rope had been unwound, it would slip off. An arm, with a hole in the lower end, was attached to the frame of the separator to act as a guide for the rope when rewinding.

To operate the device, the tractor is driven to the separator as for hitching, but only the hook on the rope is attached to the drawbar. The belt is then fastened to the reel and the tractor is driven away. The pull on the rope wound around the drum serves to wind the belt in its place. When the belt is to be unwound again, the rope is attached to the drum and thus, as the belt reels off, the rope is wound up for repeated service.

☿ Mercury boils at 676° F., and at that and higher temperatures it vaporizes rapidly, though mercurial vapors will rise from the metal at a lower temperature.

Rack for Steel Stock Boxes

Every factory uses standard steel stock or "tote" boxes, to carry from one operation to another materials and parts being worked upon in the shops. Usually, there are many different kinds and sizes of parts that must be accommodated, and with a variety of production, it is not advisable

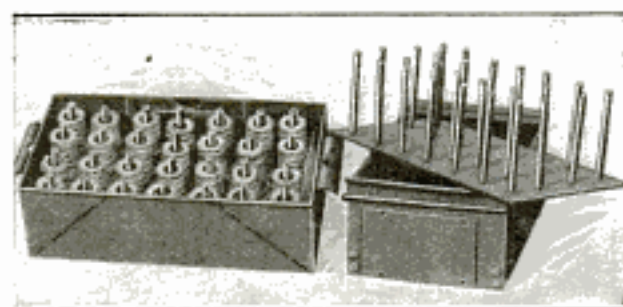

A Rack for Steel Stock Boxes That Makes Possible Rapid Counting of the Parts, and Also Prevents Them from being Damaged

to equip the stock boxes to handle only one particular piece permanently. Flexibility must be secured, and this is accomplished by a large manufacturer of lighting plants as illustrated.

A steel plate, $\frac{1}{4}$ in. thick, is cut enough smaller than the inside dimensions of the steel box so that it will drop in easily. It is drilled with a suitable number of holes, depending upon the number of spindles that is desired in the box. This number will depend on the size of the parts to be placed on the spindles and the clearance necessary between the parts. Enough space should be left between the spindles so that a variety of objects of approximately the same size can be accommodated, without danger of rubbing or damage. The spindles may be iron pipe, of any suitable size, although $\frac{3}{8}$ -in. pipe usually provides sufficient strength. They should be threaded for about $\frac{5}{8}$ in. on one end, and the holes in the plate tapped to suit. After the spindles are screwed into the plate, a pair of thin lock-nuts are screwed on the projecting ends of the spindles and lightly riveted over. This provides a strong, sturdy, adaptable rack that can easily be placed in an empty box. It also allows quick counting, as anyone can tell at a glance if all the spindles are full and how many parts are missing.—Edward H. Tingley, Dayton, Ohio.

¶An arrow cut on the feed pawl of a shaper will save time and confusion, by indicating the direction in which the machine will feed for each position of the pawl.

Finishing Wooden Patterns

In making wooden patterns, the most tedious part of the work is the sandpapering between the several coats of shellac, and, also, applying the beeswax fillet. Little or no sandpapering need be done, yet a high gloss with but one coat of shellac obtained, if the pattern is first completely covered with melted beeswax. This may be applied with a hot iron held against a cake of the wax, which, as it melts can also be guided into the places to be filleted. Care must be taken not to have the iron so hot as to scorch the glue at the joints. Little wooden chisels and round-end tools are used to scrape off the surplus wax and to groove out the fillets, the wax chips being kept brushed away with a small brush. One coat of the varnish will dry with a high gloss, and the pattern will be entirely moisture-proof and ready for the foundry. This method will be found particularly useful with patterns of irregular contour.

Combination Box and End Wrench

A novel and cheaply made wrench, designed for saving time when used on a milling-machine vise, does the work of an open-end wrench and a box wrench. All operators of milling machines know that when the vise is bolted to the table, with the jaws at right angles to the travel of the table, the regular wrench can only be given half a turn at a time, when opening or

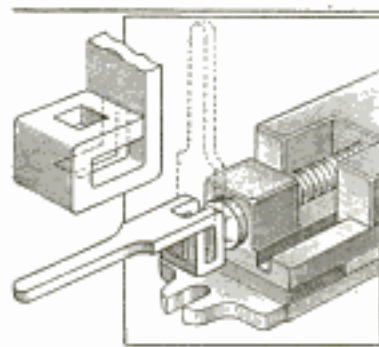

closing the vise, as it strikes the table. To save a little time some use an open-end wrench to bring the jaws up to the work. If special jaws are being used on irregular work, the vise may require several turns of the screw to open or close it.

The wrench illustrated is made from $\frac{3}{16}$ by $1\frac{1}{8}$ -in. stock, forged into the shape shown. The bent-back portion has a square hole in it to fit the square of the vise screw. The front and adjacent side are also slotted to fit the square. The remainder of the stock is finished as desired, to form a handle grip.

When opening or closing the vise, the wrench is used as shown by the solid lines, but when greater pressure is re-

quired to loosen or tighten, the wrench is slipped back until the square hole is off the square on the vise handle; it is then swung around and pushed down until the end of the slot rests on the vise-handle square, and the handle of the wrench is in a perpendicular position, as indicated by the dotted lines. The wrench is then used as an open-end wrench.

Writing White on Blueprints

White ink, water color, or a strong solution of baking soda, are generally used for writing on blueprints when extra details are to be added and it is not desirable to make new prints from the corrected tracing. A fine permanent white line may be made by dissolving a small lump of unslaked lime in water and using this liquid as one would ink. The lime water does not work like whitewash, but, like baking soda, acts on the blue ground chemically.

Drill for Slate or Marble

Tile setters, plumbers, electricians, and others must frequently drill holes through hard, brittle tile, porcelain, or slate at

no slight expenditure of time and broken drills. The drawing illustrates a drill for such work that is particularly effective for use when large holes are to be drilled. The cutting tools, which are made of tool steel, are removable

for sharpening, and can be made for holes of different diameters. The edges are milled off at an angle of about 45°, or enough for good clearance, and the lips are sharpened in about the same manner as an ordinary flat drill, the sides also being sharpened. When a hole is to be drilled with this type of tool, a guide hole is necessary to allow the dust to fall through. Very slow speeds are essential to successful drilling in slate, marble, and similar materials. The drills will not work as well at high speed as at slow speed because of the excessive friction.—Arthur F. Cox, Chicago, Ill.

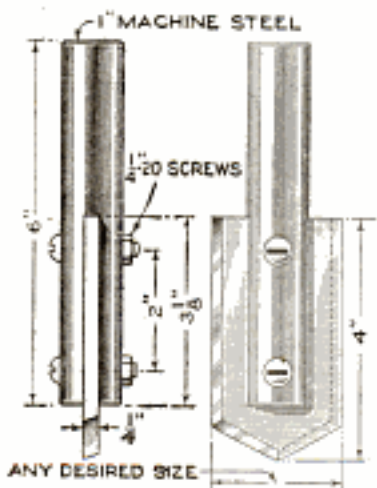

Dissolving Calcium Chloride

When mixing the brine solution for refrigeration plants, calcium chloride is dissolved in water, and many hours of

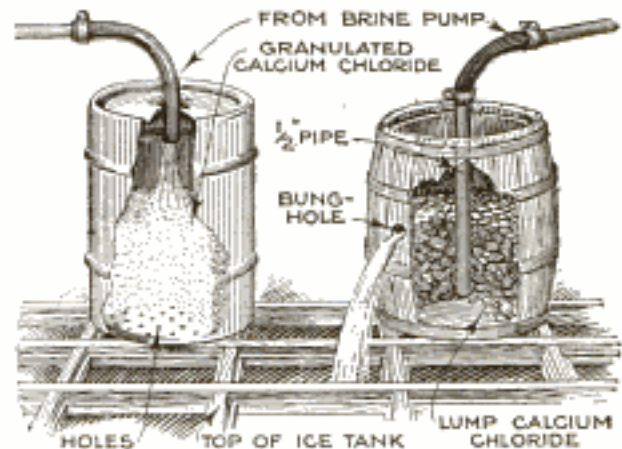

Methods of Dissolving Granular or Lump Calcium, One of the Chemicals Used in the Brine Solutions of Refrigerating Installations, without Manual Labor, the Brine-Circulating Equipment Doing the Work

back-breaking work can be saved if the machinery of the plant is made to do the work mechanically. The usual method of mixing the solution is to stir the chemical in a tub or barrel until dissolved and then dump it into the tank, and repeat.

The drawing shows two systems, depending upon whether the granular or lump chemical is used. If the calcium chloride is granular, punch a number of holes through the bottom of the drum with a chisel and cut an opening in the head large enough for the insertion of a hose. Then roll the drum over on the tank top, remove about six ice cans, and set it up over the opening. Connect with the brine-circulating pump, and run the brine or water through the granulated chemical, which will dissolve in a very short time, leaving the drum empty.

When dissolving the chemical in lump form, take a barrel, set it up over the tank in the same way as before, and connect a length of 1/2-in. pipe to the brine-circulating system; dump in the lump calcium and turn on the brine. The liquid will enter at the bottom of the barrel, and on rising, will pass through the chemical and through the bung-hole into the tank below. In this manner the only manual labor connected with the operation is to fill the barrel occasionally with the undissolved chemical.

Engines running under widely fluctuating loads should be provided with a speed-limiting device which acts independent of the governor. Copyrighted material

Rapid Jig Clamp

Drilling flat plates of square or rectangular shape is a common shop operation, and simple jigs are, as a rule, used to hold the work, more especially if there are any number of pieces of approximately the same size to be drilled. Such jigs generally take the form of a flat plate fitted with bushings for the necessary holes, the work itself being located against flattened pins and held by two screws at

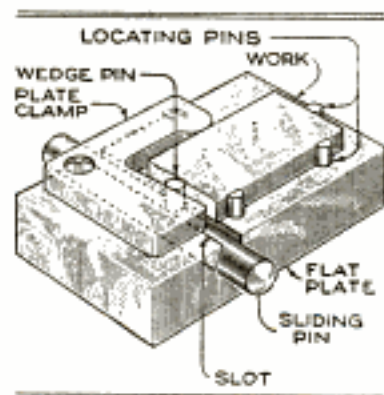

right angles to each other. For work of accurate dimensions, the double-plate clamp shown is much to be preferred to the screws, as the work is gripped or released by a single movement. The clamp is made of flat stock, which should be slightly thinner than the work, cut to the shape shown, and drilled and counterbored for a round-headed screw. Through the side of the jig body a hole is drilled for a sliding pin, which has driven in its center another pin; the latter forming a wedge that slides between the work and the taper side of the clamp. The hole for the sliding pin should be drilled as close to the top as possible and a slot cut through afterward to clear the wedge pin.

In use, the work is laid in place, and the sliding pin is tapped on the end with a light hammer. This forces the wedge pin between the end of the work and the taper of the clamp; this has the effect, as will be seen, of tightening the work from both sides at the same time. A tap on the opposite end of the sliding pin, of course, releases the work.

Laying Out Tapered Work

The work required to lay out tapered work by the methods generally used involves con-

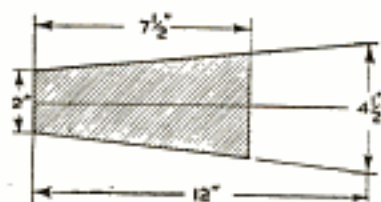

siderable calculation, and an easier method will be appreciated by the draftsman. For example, supposing it is desired to lay out a piece to be turned on the lathe, $7\frac{1}{2}$ in.

long, 2 in. in diameter at the small end, and with a taper of $2\frac{1}{2}$ in. to the foot. Proceed as follows: Lay out the center line, and mark off, on this line, a distance of 12 in. At one end lay off two points, 1 in. on each side of the center line, and erect a perpendicular joining the two points, thus marking the 2-in. diameter. As the taper is $2\frac{1}{2}$ in. per foot, add $2\frac{1}{2}$ to the diameter of the small end, obtaining $4\frac{1}{2}$ in.; then, at the other end of the 12-in. line, lay off $2\frac{1}{4}$ in. on each side. Join these points with the points marking the smaller diameter. From the small end, measure $7\frac{1}{2}$ in. along the center line, and at this point draw a vertical line intersecting the two inclined lines. The length of this line, between the inclined lines, will be the required diameter of the large end of the piece.

Alarm Circuit for Open Fuses

On electric circuits that supply current to draft fans, electric heaters, water sterilizers, and the like, it is important that an attendant should have instant knowledge of trouble in the circuit. Frequently the attendant's station is at a distant part of the plant, and for this reason the circuit shown in the drawing was devised to give an audible alarm when a fuse blows out. Each fuse is bridged by a relay; this may be of almost any type or size, but should have a resistance of 100 ohms or more. The contacts of the two relays are bridged and connected to an ordinary doorbell and dry battery. If desired, a switch may be cut in on the bell circuit to disconnect it when necessary.

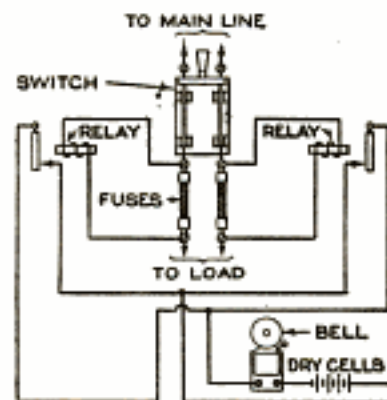

The operation is as follows: Current flows from the main line through the fuses to the load; the relays do not operate, because they are short-circuited by the fuses. Should a fuse go open, the circuit would still be continuous through the relay winding, causing the relay to operate and the alarm to ring. The purpose of the fuse is not defeated, because the resistance of the relay winding will not allow an excessive flow of current.—C. M. Crouch, Minneapolis, Minn.



How to Make a Potato-Plant Sprayer

By GEORGE G. MCVICKER

WHERE acres of potatoes are threatened with destruction by the potato beetle, it is entirely out of the question to combat the insects by the time-honored method of going along the rows and brushing them into a can, or cracking them between two stones, and spraying must be resorted to if the crop is to be saved. If the area planted with potatoes is small, a hand sprayer may be used, but for a large acreage the work is best done by a horse-drawn sprayer.

The homemade sprayer described in this article is made by mounting a suitable container, which may be a steel oil barrel, an old water tank, or something of a similar character, on wheels, and providing it with a pair of shafts, arranged so that the horse will walk between the rows, the wheels straddling the plants. The shafts are thus arranged by placing one shaft on the outside of one wheel and attaching that on the opposite side at an angle. The container is fastened to the frame by iron rods, bent to fit over the container, and threaded at the ends, which are passed through holes drilled in the frame cross members, then drawn up tight by nuts. To maintain the necessary air pressure in the tank for forcing out the spraying solution, a three-cylinder automobile-tire pump is attached to a piece of plank across the front end of the tank; this is held in place by long bolts passing through a similar plank at the rear. The plunger rod, which is fastened to the piston rod of the pump, is made from $\frac{1}{2}$

by 1-in. flat iron, with one end bent at right angles and a hole drilled through it for the piston rod of the pump. In the opposite end of the rod a hole is drilled, and a handle attached so that the pump can be operated by hand, if desired. This plunger may be made of hardwood.

Four projecting lugs are riveted to the wheel on the pump side of the sprayer. These lugs are so arranged as to engage

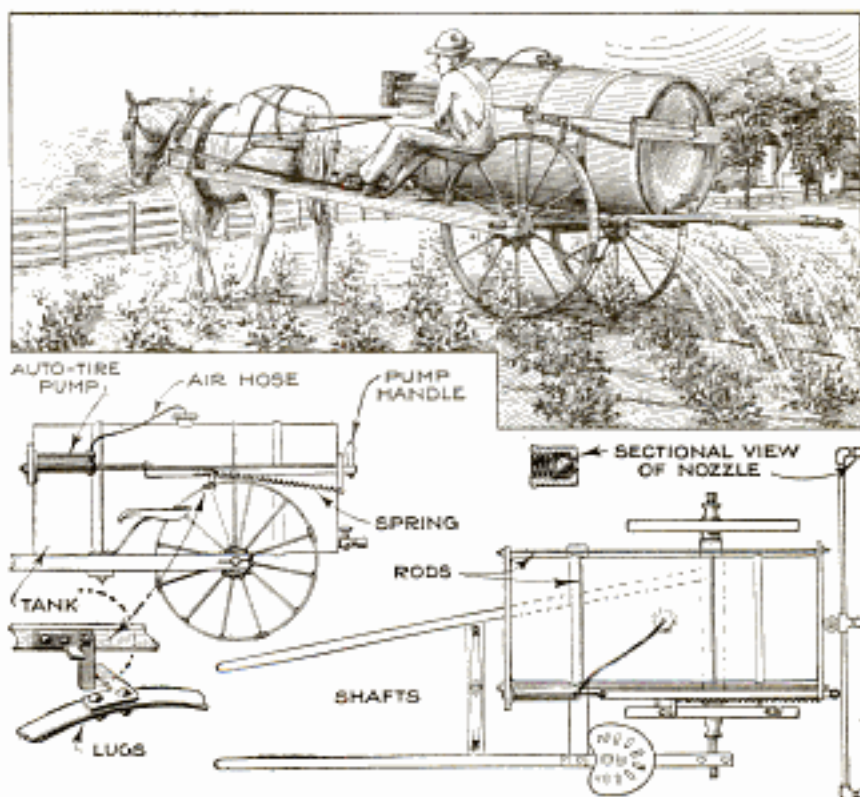

Spraying Potatoes with a Homemade Sprayer, to Protect the Crop from the Ravages of Its Insect Enemies: Air Pressure for Forcing the Spray through the Nozzles is Obtained by Means of a Tire Pump

with a short vertical arm riveted to the plunger rod and push it forward until the lug on the wheel slips off and allows a spring to return the plunger. If it is desired to prevent the pump from working when the device is on the road, the plunger-rod spring can be detached, or the lug on the plunger made as shown in the drawing. To connect the pump to

the tank, a hole is drilled in the cap, large enough for the stem of a tire valve to pass through, and this is held in place by lock-nuts and rubber washers.

The piping and nozzles are made from standard pipe and fittings, and the flow of spraying solution is regulated by a globe valve; separate valves may be added to regulate the flow of individual nozzles. The nozzles are made from ordinary pipe caps, in each of which two

$\frac{1}{16}$ -in. holes are drilled at an angle, as shown in the sectional view. In each cap a $\frac{1}{8}$ -in. brass ball, or a marble of the same size, is placed to make the solution form a spray. A seat for the driver can be mounted on the outboard shaft if this is desired. As the sprayer is jogged about the field, no agitator will be needed, in most cases, to prevent the heavy arsenical poisons commonly used from settling to the bottom.

Brush Removes Refuse from Gutters

When the eaves troughs become filled with leaves, and other litter and refuse, it is quite a task to clean them out. The

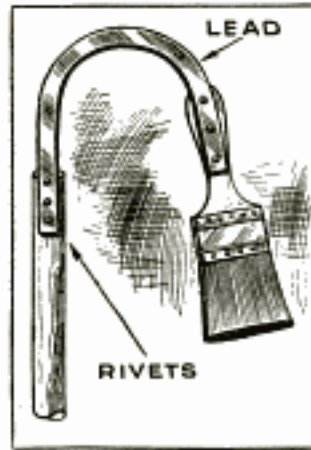

work is usually done by climbing a ladder and cleaning out the gutter for a few feet, then moving the ladder again and again until the work is complete. A simpler and safer method, since no ladder is required, consists in using the device illustrated. An ordinary brush is attached to one

end of a bar of heavy lead or solder, and the opposite end of the bar is fastened to a light pole of the proper length. When this is done, the lead or solder bar is bent so as to allow the brush to sweep the gutter, with the operator standing on the ground. Iron or steel can, of course, be used instead of the lead, if available.

Preventing Discoloration of Prints

Professional photographers rarely, if ever, have trouble with brown spots appearing on the prints in the fixing bath, because the prints are carried into the hypo solution free from developer. This is done by the use of an acetic-acid "check" or "stop" solution, in which the prints are immersed when they are removed from the developer, and before placing them into the hypo. This solution is made by adding commercial acetic acid to clean water, the proportions being immaterial except that enough acid should be used to neutralize completely the developer that remains on the print. The action of this acetic-acid bath is due to one of the most familiar chemical laws, namely, that an acid neutralizes an

alkali and vice versa. The developer is invariably an alkaline solution, while the stop is an acid, and consequently, if the latter is sufficiently strong, the alkaline developer will be neutralized and entirely removed from the print.

It is the introduction of prints into the hypo bath with developer on them that causes the dirty brown spots so frequently seen. Not only this, but unless the prints are completely immersed in the hypo, the exposed portion of the print will continue to develop. Remember that developer has no place in the fixing solution, and it is the oxidized developer in the latter that causes it to turn brown. By using the acetic-acid solution, and mixing up a fresh one from time to time, if a large number of prints are being developed, clean prints will be obtained, and the fixing bath can be used until completely exhausted. The acetic-acid solution is entirely harmless to the prints, and as it is cheap, a clean stop should be used for each batch of prints.

Handy Milk-Bottle Carrier

Milk deliverymen and others who have occasion to carry several bottles at a time will find the carrier shown in the drawing a great convenience and timesaver.

Two pieces of heavy-gauge wire or light iron rod are bent as shown, the horizontal parts being covered with rubber tubing. The joints where the ends of the rods meet are soldered, and the carrier is held together by a rivet at each end. By placing the bottles on the ground and releasing the grip on the handles the bottles are instantly freed.

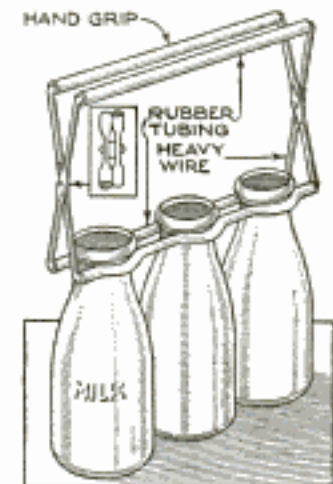

Testing Real and Artificial Silk

Real silk, when burned, smells like burning feathers, while artificial or "fiber" silk has the smell of burning wood. Another way of testing is to place a few threads from the sample into a test tube. The tube is heated and a piece of damp litmus paper held over the open end. If the sample is real silk, the paper will turn blue, but red if it is artificial.

Extracting Cork from Bottle

Corks that have been pushed past the neck inside a bottle or jug can be removed with comparative ease by a simple method. The vessel is filled with rather hot water, which softens the cork a little, and makes



it easier to pull out. Then a large-headed nail, tied on the end of a string, is dropped into the bottle and the cork is maneuvered so that the small end partly enters the neck. The string is then pulled up so that the head of the nail bears against the bottom of the cork and the other end against the side of the vessel. It is now a simple matter to run a corkscrew into the cork, which is then easily extracted.—Arthur Nelson, Chicago, Ill.

Planting Dwarf Varieties of Beans

Dwarf or bush beans are generally the earliest and hardiest. In garden culture they are planted in rows about 18 in. apart, 2 in. deep, and 3 in. apart in the row; in field culture, in drills 2 to 3 ft. apart, so that a horse-drawn cultivator can be used. Until the blossoming period, frequent but shallow cultivation should be given. Seed of the larger varieties should be planted with the eye downward. Two pounds of seed will be sufficient for 100 hills of limas, and 250 to 300 hills of other varieties, and for about 100 ft. of drill; 1 bu. should be planted per acre. Beans should never be worked when they are wet from dew or rain, as this causes rust. Beans can be planted so as to obtain a succession in the crop until within about 60 days of frost.

Nonoverflowing Lamp Filler

A length of brass tubing was fitted to the rear of the oilcan and the joint carefully soldered. The opposite end of the tube was then brought around and securely soldered to the spout in the manner shown, after flattening considerably the circular opening in the tube end. A leather washer was also placed underneath the screw cap to make it air-tight. In using this can, the end of the spout is inserted into the filling hole of the oil reservoir of the lamp or stove for a short distance. As the oil runs out, air enters at the end of the tube, but as soon as the level of the oil rises to the end of the spout, the air supply is cut off and the flow of oil ceases, thus preventing the liquid from overflowing.—Dexter W. Allis, Whitman, Mass.

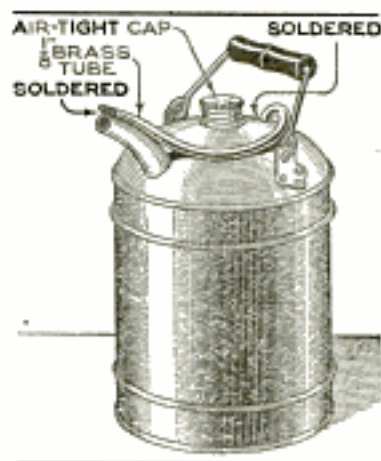

Making Auto Seat More Comfortable

An automobile seat that is nearly flat is not the most comfortable for long hours of steady driving, as the driver slides forward each time the car is stopped or its speed reduced. An upward tilt given to the front edge of the cushion overcomes this to a great extent, and makes riding somewhat less tiring. To tilt the seat, a simple three-sided wooden frame is made and fitted underneath the cushion, as illustrated. The frame can be permanently attached with screws, if it does not interfere with the accessibility of tools or other accessories carried under the cushion.

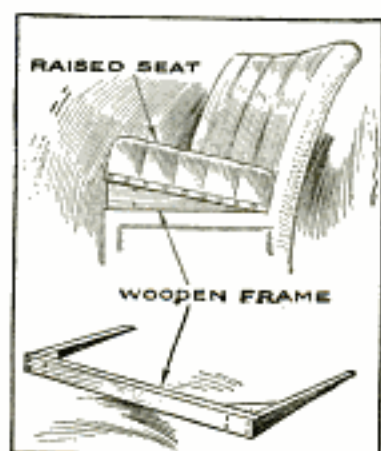

☞ The farm bell will be heard farther if placed on top of the windmill tower.

Condenser for Auto Radiators

The efficiency of alcohol in the radiator of an automobile to prevent the cooling

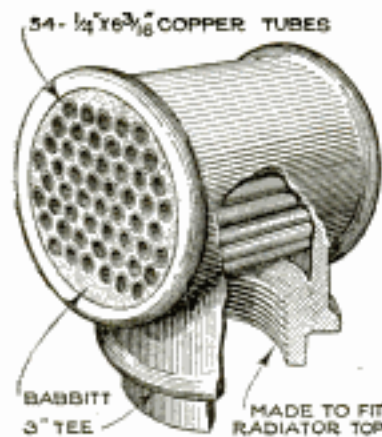

water from freezing, depends entirely upon the quantity of alcohol present in the solution. Alcohol is quite volatile, and when the water becomes heated the alcohol quickly evaporates. However, if

some form of condenser is used, the alcohol, and also more or less of the steam from the water, will be condensed so that the loss will be prevented and the solution retain its cooling and antifreezing properties for a longer time.

The drawing shows such a condenser, made from a 3-in. pipe tee and some copper tubing. Two pasteboard templates, cut to fit into the ends of the tee, were made to hold the ends of the copper tubes in place. Then, melted babbitt was poured into the side opening in the tee, fastening the tubes securely in first one end and then the other. The device is made to fit the radiator-filler pipe, and should be placed pointing toward the front of the car, so that the cold air will pass through the condenser tubes when the car is in motion.—Frank N. Coakley, Buffalo, N. Y.

Standard and Summer Time Shown on the Same Dial

It has been the experience of residents in some communities that neighboring towns have set their time ahead an hour



during the summer months, while their own town did not. Naturally, the confusion under such a system is considerable, as those living in the separate communities must ever bear in mind two different time standards. A commuter found that by setting his watch to agree with the standard time in effect in his suburban town, he was continually being embarrassed by the conflicting daylight-saving time by which he did business in the city. In order to make his watch

indicate both times, he had an extra set of red numerals lettered on the dial of his watch, for the daylight-saving time. These may be printed on small stickers, and stuck to the crystal of the watch, if it is not desirable to letter them directly on the dial.—M. J. Rystrom, Rockford, Ill.

Tissue Paper as a Moth Preventive

A friend of mine keeps a uniform in a small closet, and, happening to be there at a time when the uniform was removed, I noted the absence of the usual moth-balls. Upon asking him about this, I was shown a small quantity of tissue paper scattered around the closet, and also how the moths had eaten a considerable portion of the paper, but had not attacked the clothing. My friend said that he had never known clothes that had been wrapped in tissue paper to be harmed by the insects, as it appeared they preferred the paper to the cloth.—Carl H. Kaufmann, Santa Ana, Calif.

Applying Screen Wire

Drawing up screen wire tightly and evenly on the frame, is usually a rather difficult job, even when considerable care is used.

A very simple method that permits the screen to be drawn up tightly without leaving wrinkles and bulges, involves the use of nothing more complicated than a wooden block of about the

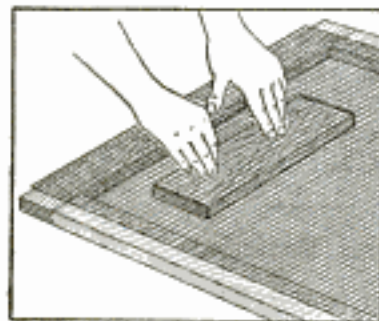

same thickness as the screen frame. One end of the screen is tacked to the frame, and the block is placed inside at the opposite end. The screen is laid down over the block, and, placing the thumbs of both hands on the side of the frame or at the edge, and with the rest of the fingers bearing down on the block, the latter is drawn back, pulling the wire with it. When the proper tension has been obtained, it is held with one hand while a tack is driven with the other; this operation is repeated as necessary until the wire has been applied. The screen should be laid on a table or other flat surface in order to provide a support for the block.

Cleaning Tarnished Silver

Tarnished silver may be cleaned by the so-called electrolytic method as follows: Place in a clean earthenware vessel, or an enamel one in which the enamel is unbroken, a solution of 1 teaspoonful of soda ash, or baking soda, and 1 teaspoonful of common salt, dissolved in 1 qt. of water. A sheet of aluminum or clean zinc is immersed in the solution, and the pieces to be cleaned are placed in contact with this; both the zinc or aluminum plate and the silverware to be cleaned should be completely covered by the solution. Heat nearly to boiling. When the tarnish disappears from the silver, rinse in cold water, and wipe with a soft cloth.

Self-Adjusting Book Ends

A convenient rack for holding the most commonly used books on the desk or

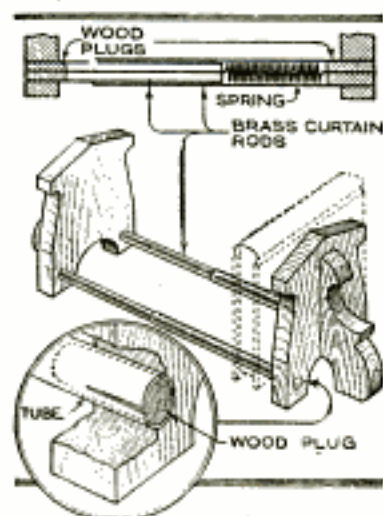

library table can be made from two pieces of hardwood which are cut to form supports or ends; these can be either plain or as ornamental as the taste and wood-working talent of the maker decide. Holes are drilled in each, into which the ends of ordinary telescoping curtain rods are inserted. If there is any difficulty in getting the rods to fit tightly, the ends can be split with a hacksaw and wooden plugs driven in to expand the tubing. A short length of spring, having its ends secured to the opposite blocks inside of each rod, makes the fixture self-adjusting.

Rejuvenating Grass Rugs

Grass rugs are largely used on porches, and for rooms in summer homes, and give an atmosphere of coolness. Whenever such a rug becomes frayed and worn, it can be brightened up, and its life considerably prolonged, by cleaning it thoroughly and applying one or more coats of paint of any desired shade.—H. A. Norrell, Augusta, Ga.

Novel Apron for Kitchen or Shop

It is only necessary to add a few eyelets along the bottom edge of an ordinary apron to increase its convenience very materially for certain classes of work. In use, the eyelets are placed over a corresponding number of small hooks, screwed into the underside of a table or bench, while the apron is tied around



the waist in the usual fashion. The movements of the wearer are not in the least interfered with and she can sit or stand as desired. An apron of this kind will sometimes be found of service in factories and shops; in this case the apron may be fastened to the table or bench semipermanently, so that when the workers leave, it will be necessary only to untie the apron strings.

Facilitating Removal of Fence Posts

In most soils, wooden fence posts last but a few years, and in some localities, under particularly unfavorable conditions, their life is exceedingly short. Where woven-wire fence is used and attached to the posts with staples, a great deal of labor is necessary to pull the staples when a new post must be set, to take the place of one

which has rotted off at the surface. If a piece of wood, about 1 by 3 in., is placed between the fencing and the post, and the staples driven into the strip, which is in turn fastened to the post with about three nails, the whole strip can be removed from the post easily, without in any way disturbing the staples, and without the hazard of breaking one or more strands of wire in attempting to remove them.

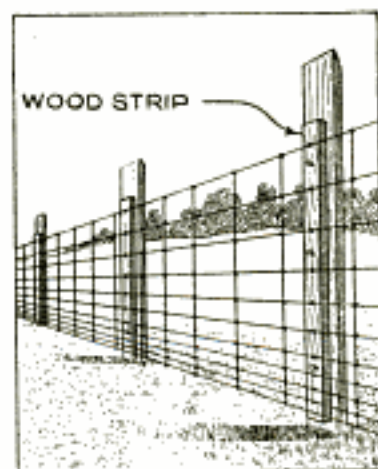

Homemade Pump for Shallow Wells

For pumping water from shallow wells, a simple wooden pump may be made, that costs practically nothing, and that is well worth the time spent in its construction. A square box is made, closed at each

these sides of the box are built the two "cylinders," which are simply square open-top boxes, in height a little more than the stroke of the pump, but less than the depth of the water in the well; in these wooden blocks are fitted closely.

A hole is bored in the center of each block, and a leather flap valve, similar to the ones previously made, fitted to the underside. A hole is also bored in the side of each cylinder opposite the one in the long box. The arrangement of the valves is clearly shown in the insert.

Iron yokes are made and fitted to the blocks, to carry the pump rods, which are also of wood. These rods are pivoted to the pump handle.

One peculiar advantage of a pump of this character is that, owing to the fact that there is no

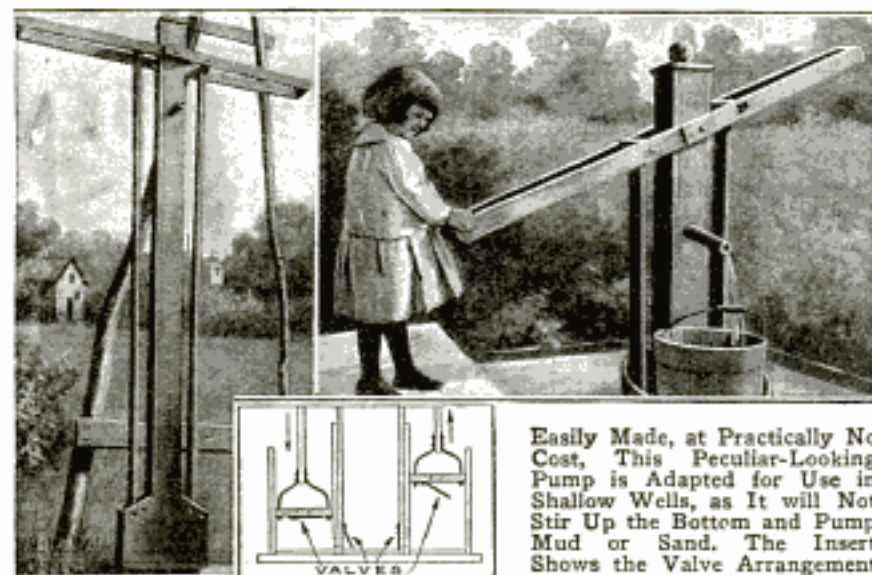

Easily Made, at Practically No Cost, This Peculiar-Looking Pump is Adapted for Use in Shallow Wells, as It will Not Stir Up the Bottom and Pump Mud or Sand. The Insert Shows the Valve Arrangement

end, long enough to reach the bottom of the well, and to project 3 or 4 ft. above the ground. On two opposite sides of this box, at the bottom, holes about 2 in. in diameter are bored, and over these flaps of flexible leather are fitted; these flaps are nailed above the holes, so that they hang downward over the latter. On

suction, the pump does not stir up mud or sand, in spite of the fact that it is set on the bottom of the well. This is so because the water flows over the tops of the cylinders. The water runs from the pump from a 2-in. spout which is placed at right angles to the handle.—Chester C. Cook, Chicago, Ill.

Nails as Campfire Irons

The camper usually finds it difficult to make a pile of stones around his campfire



that will support the cooking utensils and at the same time allow sufficient space for a fire, provided the rocks can be obtained at all. The uncertainty and annoyance of the former method can be overcome by carrying a few 80-penny spikes in the kit. These are merely pushed into the ground and support the cooking utensils without interfering with the fire. Spikes of the size mentioned are about 8 in. long.—Lloyd L. Stewart, Ames, Ia.

Soldering-Flux Containers

For the experimenter using small amounts of flux, there is no better container than one made from an old toothpaste tube. Open the crimped end of the tube with a pocketknife, and, using the blunt end of a pencil, restore the tube as nearly as possible to its original cylindrical shape. Clean out the interior with a toothbrush. Cut a section out of a clean lampwick, and place it in the nozzle of the tube to be used as a spreader and feeder of the flux. Fill the interior of the tube loosely with absorbent cotton; then make up a saturated solution of zinc chloride, by dissolving the chemical in water until no more will dissolve, fill the tube, recrimp the end, and the container is ready for use. A container of this type will operate even more successfully with a paste flux, in which case the cotton filling and the wick in the nozzle will not be needed and are, therefore, omitted.—Werner W. Baumeister, Cambridge, Massachusetts.

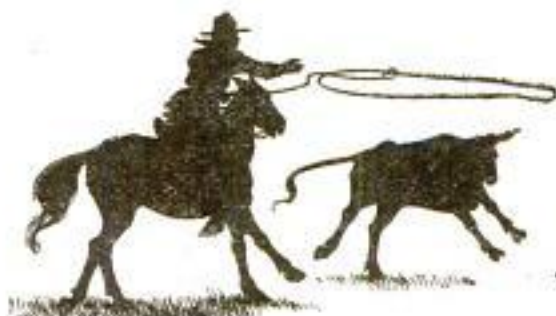

THROWING THE LARIAT

By JOHN F. THORNTON Jr.

WHAT boy, after visiting a "Wild West" show, has not made a noose in a piece of old clothesline and set out to emulate the cowboy? Unless he has had instruction from some one proficient in the use of the lariat, however, it is probable that he has given up the attempt as useless. This is to be regretted, for besides being a typically American sport, lariat throwing is an educator of the eye, and an excellent developer of the muscles of the fingers, wrist, arm, shoulder, back, and legs. There is a good deal of fun in it, also, and it may be a very useful accomplishment. Many a hapless skater or canoeist has been saved by the prompt

called the hondoo (pronounced "ondoo"). Make it a little heavier by winding another piece of wire round its curved end, as shown. The chances are that one will have to try various amounts of wire, after he has begun to practice, until a hondoo has been obtained that will give the best results. Another form of hondoo is a small iron ring, or thimble, such as is used on sails. One end of the "lass rope" is unraveled, and the loose ends brought neatly round the ring from opposite directions, meeting again at the unwound part of the rope. Here they are bound tightly in place along each side of the rope with a piece of fine wire. The lariat is com-

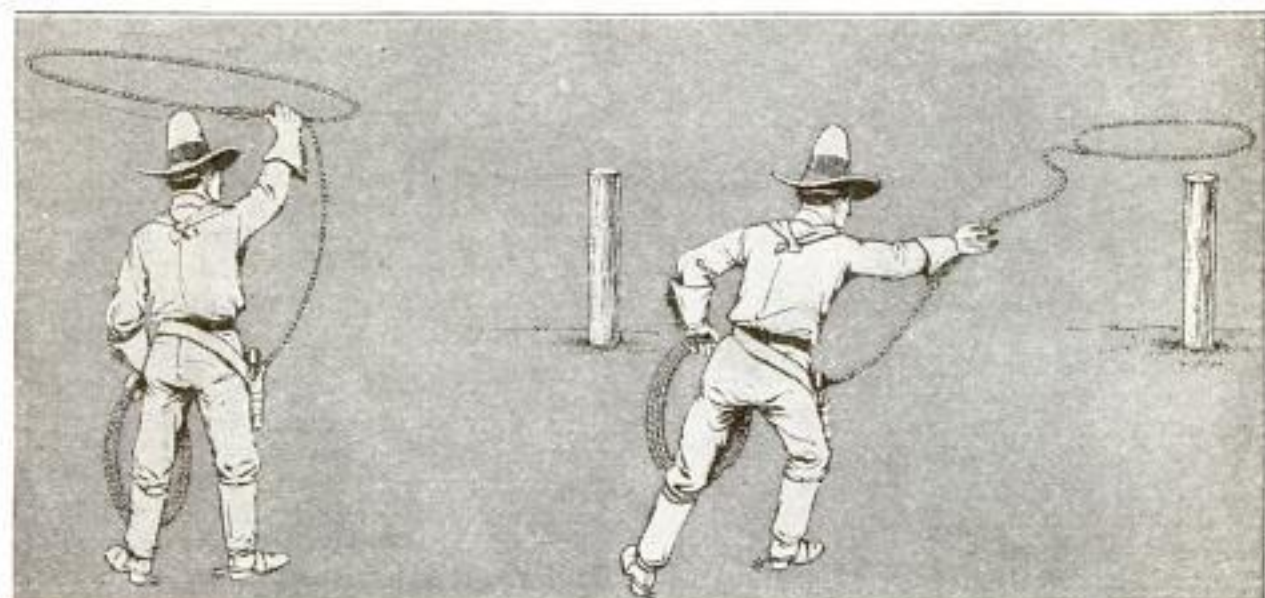

The First Steps in Throwing the Lariat, Showing the Preliminary Swing and the Actual Cast: A Post, or Some Similar Object, is Used as a Target until Proficiency is Attained, When Some Moving Object may be Pressed into Service

action of a spectator who was able to throw a rope with some degree of accuracy and skill.

The very best lariats are made of plaited rawhide. For practice, however, a rope of braided cotton or linen, $\frac{3}{8}$ in. in diameter, will serve. The standard lengths for straight roping—catching objects—are 40 and 50 ft. For fancy swinging, a rope 16 ft. long will do.

Double the rope at a point 5 in. from the end. Bind it by winding both thicknesses for 1 in. with strong, light wire, as shown at the top of the full-page illustration. The loop, or eye, thus formed is

pleted by drawing the other end of the rope through the hondoo, so as to form a running loop, and by knotting the unlooped end, to prevent it from unraveling.

Many lariat experts start with a loop about 1 ft. in diameter, and allow the rope to slip and the noose to grow larger as it is swung. It is best, however, to start practicing the throw with a large loop. Draw the rope through the hondoo until there is a noose 4 or 5 ft. long. Bend the rope back at the hondoo until it lies along one side of the loop. Then grasp both thicknesses with the right hand, at a point about 15 in. from the hondoo.

The little finger should be between the two thicknesses, and the third and fourth fingers round both. The forefinger should cross under one thickness and extend along the underside of the loop rope, as shown in the illustration.

Take position in front of a post. Coil the slack rope in the left hand, so that it will slip off easily, coil by coil; be sure that there are no kinks in the line. Lift the noose over the head, and begin to swing it from right to left. Do not hold the wrist stiffly; imagine that it is an axle and that the loop is a wheel revolving in a horizontal plane over the head. When this movement has been practiced several times, it will be found that a quick, jerky turn of the wrist causes the loop to spread wide open.

It is well to practice this preliminary swing until it can be performed smoothly, before one attempts to make a cast. The proper time to throw the rope is at the moment when the swinging hand comes round from back to front. Step quickly forward, and bring the hand, palm down, forward and to the level of the shoulder. Let the arm stretch to its full length without interrupting the swinging motion, and let the loop go at the post.

The first cast will probably fall far short. But if these instructions have been followed, the noose will sail straight toward the mark without losing its circular form—and that is encouraging. If care is taken to regulate the size of the loop, the length and force of the swing, and the angle of the throw—and if patience and thoroughness in practicing casts are exercised—it will not be long before one becomes fairly expert in this, the first and most important use of the lariat.

The easiest of the cowboy's roping stunts is that of catching a man or animal as he passes at full speed. In roping an animal, the forefoot is always the target, never the head. The open loop is thrown just in front of the moving feet so that the side of the noose nearest the animal is on the ground and the other side is in the air. If the animal keeps moving a second longer, it will step into the noose and become securely caught. In roping animals use a small loop, as they will jump out of a large one. Wait until the steer, cow, or horse has passed, then it will not see the rope coming, and will be unable to dodge. If one is on foot and ropes an animal's head, see to it that the rope is at right angles to the animal; if one is behind it, one will be pulled along by it. One should brace oneself, with the rope held tightly across both

thighs. It is a good idea to wear gloves to avoid any risk of burning the hands.

The "crinoline" is one of the most popular of the fancy lariat tricks. In this stunt the rope appears as a ring, about 5 ft. in diameter, revolving around the body as a center, about waist-high. Prepare for this trick as follows:

Holding the rope as for straight casting, extend the right hand, palm upward, straight out to the side until the arm forms an angle of about 30° with the body. Now, moving the hand rather slowly, describe a horizontal circle in front of the body. When the hand is at the farthest point in front of the body, and the circle is half completed, turn the wrist so that the palm is downward. At the same time drop the loop, but retain a firm grasp on that part of the rope which is held with the little finger, now using all the fingers to hold that part, as shown by the dotted lines in one of the illustrations. Do this without stopping the circular motion of the hand. Continuing to move the hand more or less rapidly in circles, widen the loop into a circle that spins round with a motion that corresponds to that of the hand. If the slack rope is twisted between the thumb and fingers of the left hand in the direction in which the circle is revolving, it can be kept from becoming tangled. One will not, of course, be able to spin the crinoline after ten minutes' practice, but persistent effort will very soon make one proficient.

In spinning the crinoline round the body a loop at least 7 ft. long will be needed. With the right hand grasp the loop as before, but this time about 3 ft. from the hondoo instead of 15 in. With the left hand hold the same side of the loop about 1½ ft. to the left of the part which is held in the right hand. Now, with these few exceptions, take the same position as before, with the left hand just in front of the right trouser's pocket. Such a position will leave part of the loop lying open on the ground to one side.

With a long, swinging, circular motion, bring the right hand up over the head. Use the left hand only to keep the loop open until the right hand has been raised. Then, without stopping the circular motion, drop the loop round the body. Continue to twist the right wrist and there will be a twirling crinoline spinning round the body. Its size can be regulated by the speed with which it is twirled.

A backhand throw is useful when the object is behind one. Hold the rope much as shown in the lower figures. Step back-



The Upper Figures Show the Method of Making the Hondoo and of Holding the Lariat; the Center Ones, the Position for Spinning the "Crinoline" in Front of the Body, the Method of Holding the Noose Before Dropping It over the Body, and the Crinoline Spinning around the Body. The Lower Figures Show the First and Second Positions in Making a Backhand Throw

ward with the right foot, turn facing the object and swing the loop backward and up. A cowpuncher takes care that his horse's head or tail is toward a roped animal. Otherwise he would be dismounted or his saddle would turn. He never ties his lariat to his saddle horn. It is a dangerous practice, for a steer or

even a smaller animal, improperly roped, can throw a horse and man. The real cowboy holds the end of his lariat loosely in his left hand until his animal is caught. Then he takes a couple of quick hitches round his saddle horn that will hold if necessary, or that he can cast loose if occasion demands.

Holder for Demountable Rims

A tight-coopered wooden barrel, such as an old oil barrel, arranged as shown in the drawing, affords a very serviceable

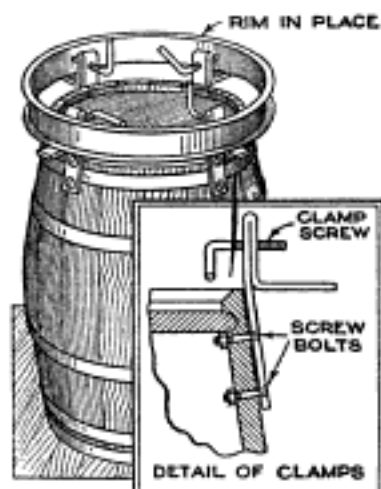

and substantial work-bench for holding demountable rims while applying or removing a tire. Furthermore, the clamp screws serve as a means for expanding a split rim after the tire is in place, and the height of the

barrel enables a convenient working position, as no stooping is required. Four combination brackets and screw clamps, of the type shown, are bolted to the outside of the barrel, the clamp screws being of sufficient length to make the device adjustable to rims of any standard size, and, also, to expand split rims. The brackets are forged from wrought iron. The lower extension on the brackets forms a rest for the rim so that it cannot slip off. When used outdoors, the barrel may be painted and lettered with the firm name, serving as a conspicuous advertisement. By filling the barrel with stones or concrete, it is almost impossible to move the device when working on it.

Fuller's Earth for Clutch and Brake

Fuller's earth can be applied to the clutch and brake linings of an automobile easily and thoroughly by using an ordinary insect-powder gun or bellows. The powder gun can be bought for a few cents and holds enough of the chemical for two or three heavy applications. Fuller's earth, and also talc, are used in the manner described to remedy the slipping of oil-soaked brake and clutch linings.

Razor Strop for Campers

An article that the camper generally leaves hanging on a tree or loses somewhere along the route is his razor strop. A veteran camper has developed an idea that makes it practically impossible to forget or lose the razor strop, by simply fastening it to the inside of his belt. A strip of a used strop, about a foot long, is cut and the ends are riveted to the inner side of the belt. The strop is thus always at hand; it is well protected, and by hooking the belt buckle over a nail or branch is ready for use immediately. There is really nothing lost by narrowing the strop to belt width, and it may be made of any length desired, so long as it does not interfere with the passage of the buckle when the belt is worn.—Robert Page Lincoln, Minneapolis, Minn.

Improvement for Rolling Ladders

The rolling ladders that form a familiar part of the equipment in most stores and factory stockrooms, sometimes have a disagreeable and disconcerting habit of rolling, especially if the person on the ladder happens to lean a little too far to one side. In order to overcome this objection, use has been made of the attachment illustrated, in which the wheels are mounted on the ends of curved arms,



hinged in a bracket made to fit one of the rounds of the ladder. Ordinarily, when there is no weight on the ladder the spring pulls the wheels toward the center and raises the ladder from the floor, but as soon as anyone steps on the ladder, the

tension of the spring is overcome, and the wheels are forced out until the end of the ladder is resting on the floor.—Edwin Schubach, Chicago, Ill.

Protecting Trees from Insects

In summer, when it is desired that no ants, caterpillars, or other crawling insects, should climb the trees, some kind of a barrier is necessary.

The simplest, and one of the cheapest, methods is to place a wide band of cotton batting around the tree at some convenient height, fastening it to the tree with wire. The edges of the batting, protruding from underneath the wire, when fluffed, present an impassable barrier to any type of crawling insect or small animal, the cotton not affording a foothold for the latter.

Simple Price-Tag Holders

For holding display cards, and the like, securely, and in such a manner that they

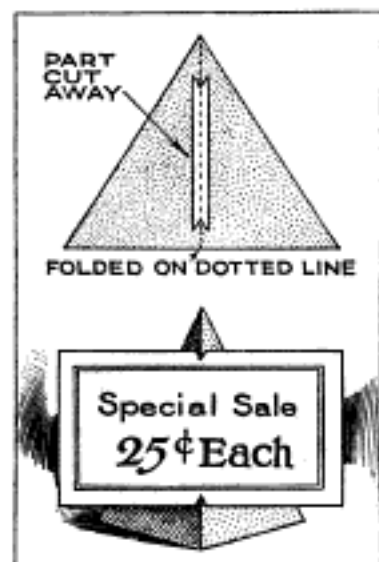

are difficult to upset, a simple holder can be made of stiff paper or cardboard. The stock from which the holder is to be formed is cut into the shape of a triangle which is then folded along its center. A slot is cut out along the center, as shown, and the triangular projections at each end of the slot serve to hold the card in place.—Frank N. Veloz, New York City.

Glossy Photographic Prints

To make photographic prints with the highest possible gloss, the first requirement is that the grade of paper known as "glossy" be used. After they have been printed, developed, fixed, and washed in the usual manner, they are squeegeed face down, on a sheet of plate glass, that has been previously polished with a little French chalk on a cloth. The advantage of glass over the metal ferrotype plates ordinarily used is that one can look through the former to make sure that the entire print is in contact, without air bells between print and glass. However, the enameled ferrotype plates are much lighter and will not break.

Emergency Washing-Machine Handle

Many a housewife using a water-power washing machine is handicapped on wash day by low water pressure or a defective or worn-out motor. Also, it may happen that the water supply has been cut off for repairs to the mains, and there are other emergencies in which the operating handle shown in the drawing will be found of great convenience. On machines of the type using a rotating-vane motor, the attachment of a suitable handle is a simple matter. The knob on top of the dolly shaft is usually held in place by a $\frac{1}{4}$ -in. screw through both shaft and knob; this screw is removed, and a long $\frac{1}{4}$ -in. stud run through the holes. A short section of $\frac{3}{8}$ -in. pipe is then slipped over the stud and clamped tightly in place with nuts and washers.

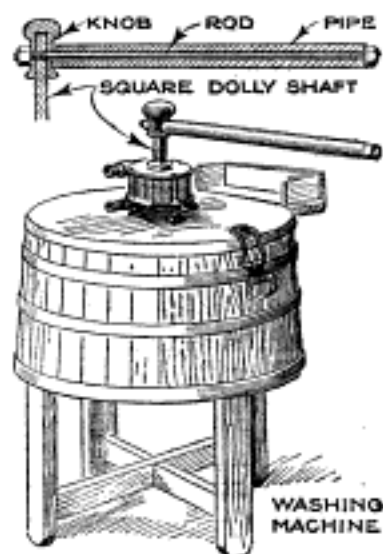

On machines of the type using a rotating-vane motor, the attachment of a suitable handle is a simple matter. The knob on top of the dolly shaft is usually held in place by a $\frac{1}{4}$ -in. screw through both shaft and knob; this screw is removed, and a long $\frac{1}{4}$ -in. stud run through the holes. A short section of $\frac{3}{8}$ -in. pipe is then slipped over the stud and clamped tightly in place with nuts and washers.

Wire Terminals Made from Eyelets

Practical terminals for electric wires that are held on bolt-and-nut binding posts, or for spark plugs, can be made by using the eyelets commonly obtainable at stationery stores for binding papers, and the hand punch used with them. To make such a terminal, the bare end of the wire is looped once around the eyelet, which is then crimped in the hand punch, pressing the metal

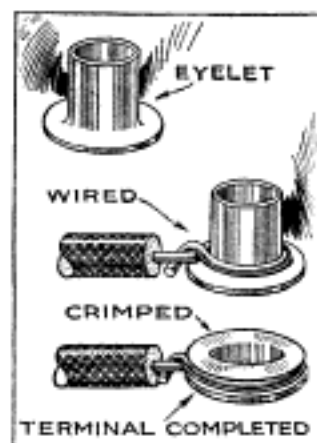

down tightly against the wire and making a terminal that will fit neatly over the screw and give a good contact. If solder is used after crimping, a practically solid metal terminal is obtained that will give a minimum of trouble.

Concrete Wall Adds to Warmth of House

In seeking to modernize a dwelling by giving it the appearance of having a high foundation, the owner tried the experi-



Building a Low Cement Wall around a House to Improve Its Appearance: The Owner has Found That the Floors of the Dwelling Are Now Much Warmer in Winter Than Formerly

ment of applying a 2-in. thickness of solid cement directly over the original foundation and siding. In this way the cost of the improvement was kept at a lower figure than would have been the case had the house been raised and the foundation made higher.

The main precaution taken was to see that there was a firm bond between the foundation and the wooden siding. At first glance it might seem that water would drip down between the concrete and siding, thus starting rot and giving frost a chance to open up cracks. Nails were driven into the siding at the corners of 6-in. squares, with their heads protruding, up to the height of the projected auxiliary wall. The concrete foundation was thoroughly cleaned and given a thin wash of pure cement. Then the forms were made and the concrete poured. A mixture of one part cement to two parts sand was used. The top of the wall fitted underneath the edge of one of the siding boards and was finished by increasing the thickness to 3 in. and sloping it slightly away from the house to run off the water; the corners were reinforced with wire mesh. After the concrete had set for about 24 hours, the forms were removed, and the surface marked off in imitation of brickwork, the lines being cut by running the point of a spike along a straightedge.

Keeping Linoleum Fresh

A mixture of equal parts of oil and turpentine, applied once a week, will keep linoleum looking fresh and clean. Palm oil, used alone, is also good, although not so good as the above mixture.

Poppies as Cut Flowers

Those who have undertaken to use Shirley or silk poppies as cut flowers are familiar with the shower of petals that follows cutting of the blossoms. Florists have a trick of preparing the poppies so that they can be used for cut-flower purposes. The bud of the poppy droops until it is ready to burst the green calyx that covers the flower, when it becomes erect. The flowers should be picked just before they shed this calyx, which is in two parts and splits at the bottom. The right moment for picking is when the calyx has split at the bottom just enough to show the color of the petals within. Cut the poppy at this stage, and gently pick off the green covering, place the crumpled-up bud in water, and the petals will open and will not fall off as they ordinarily do.

Hauling Boats from One Lake to Another

Faced with the alternative of digging a canal, buying two sets of equipment for



Hauling a Boat from One Lake to Another by a Miniature Marine Railway Is the Way a Body of Sportsmen Took to Avoid Digging a Canal to Connect Twin Lakes

use in twin lakes, or continue to carry their outfits from one to the other, a body of sportsmen solved the problem by means of a one-man marine railway.

An incline leads to each lake and a homemade capstan, or windlass, was located at the highest point, so that boats could be pulled up from either side. A single car or cradle, fitted with flanged wheels, runs on tracks laid on the inclines. In operation, the track is rolled into the water, the boat floated into the cradle, and pulled up by means of the windlass. Too rapid progress down the incline on the other side is prevented by means of a rope and snubbing block.—L. J. Ellison, Dubuque, Ia.

Using a Motorcycle for Power

An Illinois farmer uses his motorcycle for running light machinery about his farm, and while not as convenient as a gasoline engine, it can be used where there is not enough work for a heavy engine, as in this case. Of course, the motorcycle engine cannot be run as steadily as a water-cooled engine, but is good for jobs where it can be stopped occasionally and allowed to cool.

The motorcycle is run up onto a wooden framework or platform, and when in use is supported by its stand, at the rear, and by a wooden crosspiece under the frame directly behind the front wheel; this latter is removable and is not inserted until the motorcycle is in place. A pulley shaft, which has a sprocket wheel attached to

it, is mounted on the frame, and after the motorcycle is in place, the chain is removed, shortened slightly, and reconnected around the sprocket on the shaft.

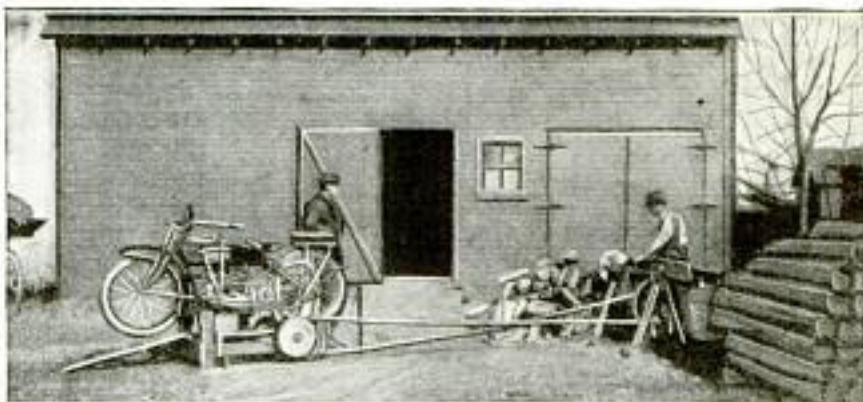

As There Is Not Enough Work to Require a Gasoline Engine, an Illinois Farmer Uses His Motorcycle to Furnish the Necessary Power for Grinding Feed, Cutting Up Firewood, and Other Light Jobs

A good-sized fan, driven by a belt from the shaft, and mounted so as to direct its breeze on the engine, is the simple means employed to prevent the engine from becoming overheated.—Charles Albert, Chicago, Ill.

Bridging Fuses

The fuse is the safety valve of the electrical system, put there for the protection of life and property. If a penny or a piece of wire is inserted when the fuse blows, that protection is removed, and the wires may grow red-hot, and even melt, thereby starting a fire in some concealed place, where it might not be discovered until too late to save the building. If a fuse blows, especially if it blows repeatedly, notify the lighting company; or a reputable electrician, and have any defects corrected. Fuses of standard make only should be used, if the utmost protection is to be given to the system.

Clearing Stained Negatives

About as good a clearing bath as one can use for stained negatives—those that come out of the pyro-developing solution with too much yellow color—is made by dissolving 60 gr. or 1 dr. of powdered alum in 20 oz. of water, and adding 1 dr. of sulphuric acid. Immerse the negatives in this solution for a few minutes, remove, wash, and dry.

Reddish-looking spots with an irregular outline are caused by specks of iron in the water, and they will usually succumb to the sulphuric acid and water solution alone; this may be safely used twice as strong as indicated above.

Subduing the Ice-Cream Freezer

Two simple means of preventing the ice-cream freezer from moving with each revolution of the crank, by holding it to some solid support, are shown in the photograph and drawing. A piece of 1 by 8-in. board is nailed to the bottom of the bucket so that the ends project about 2 in. on either side. The freezer can then be



Two Methods of Holding the Ice-Cream Freezer Stationary: At the Left, a Board on the Bottom of the Freezer Allows It to be Clamped to a Solid Support; Right, the Wooden Frame inside a Laundry Tub

fastened with an ordinary clamp. The drawing at the right shows a frame set into a stationary laundry tub to bring the machine to a convenient height for operating. A movable frame was built to fit into the tub, and a piece of wood across the bottom of the freezer, as in the first example, rests between two cross strips on the frame and prevents the machine from moving.

A Toy Water Plane

The toy water plane shown in the drawing is something of a novelty in the way of model water craft, as the hull only

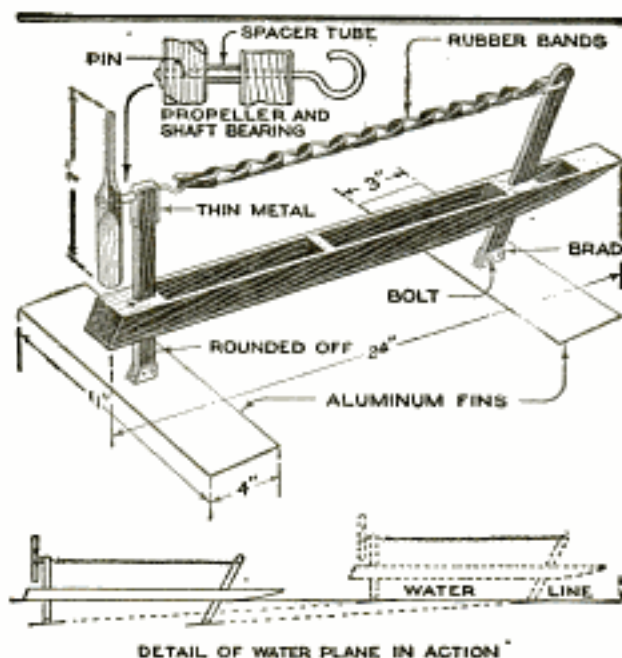

A Toy Water Plane That Rides on the Surface of the Water When Its Propeller is Revolving

rests upon the water when the propeller is not revolving. In traveling at full speed, the hull leaves the water quickly and rides with the fins on the surface of the water, as illustrated.

The sides and bottom of the hull are built up from strips of pine, about $\frac{1}{8}$ in. thick, blocks being used to space the sides the proper distance apart and for the attachment of the wooden supports for the propelling mechanism and fins. The sheet-aluminum planes, or fins, are mounted as shown, so that each is tilted at the same angle. The plane is driven by a model-airplane propeller, which, for a 24-in. water plane, should be about 7 in. long, and the power is derived from a motor made of a number of rubber bands linked together.—Donald W. Clark, Buffalo, N. Y.

Another Use for the Electric Fan

Electric fans of the oscillating type can be made to do double duty, as an advertising feature of a window display. This is done by attaching a circle of wallboard or light wood around the outside of the wire fan guard. Suitable advertising matter is painted on this, or small light articles, such as combs, pocketknives, and the like, can be attached without interfering with the ordinary operation of the fan.

Using Auto Battery as B-Battery

Knowing the inefficiency and weakness of the ordinary radio B-battery, and that the performance of the radio set depends largely upon this battery, an operator devised a method for tapping the 12-volt storage batteries of a truck and car that are housed in a near-by garage. Two sets of wires are run from the radio set to the garage, each set terminating, at the garage end, in a plug that will fit in the dash-lamp socket on the car and truck. The house ends of the wires are connected to the set in place of the B-battery. When the two motors are brought in in the evening, the dash bulbs are removed and the wires plugged in. This arrangement gives a 24-volt B-battery of great power. A rheostat is used to step down the voltage to that found to be the most efficient for the particular type of vacuum tube used. The amount of current drawn from the storage batteries is, of course, restored the next day, when the motors are running.—Philip A. Wall, Bedford, Massachusetts.

A Tool for Transplanting

When transplanting small plants, a simple device made from a tin can and a bit of stiff wire will save considerable work.

One of the ends of a can is melted or cut off square, so as to provide a cutting edge; two holes are punched through the opposite end and a U-shaped piece of wire is inserted, after which the wire ring is attached to the ends, as indicated.

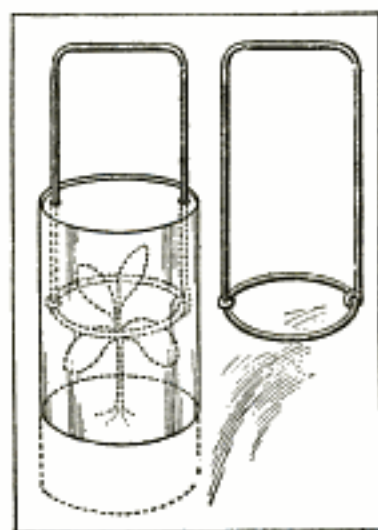

In use, the tool is placed over the plant and the can pushed into the ground for a sufficient depth, the plant and a quantity of earth being withdrawn inside the can when it is pulled from the ground. The plants are transplanted into holes, made in the same manner, by holding the roots and earth surrounding them down with the wire loop with one hand and withdrawing the can with the other.

Making Lead Doll-House Furniture

By E. H. TINGLEY

THE ease with which soft wood may be worked with simple tools, and the low melting temperature of soft lead, make an ideal combination for the boy who desires to produce metal toys. The tools required are a small plane, hammer, chisel, knife, and a ladle for lead. The lead can be obtained from any plumber, by asking for the short pieces of lead pipe to be found in the scrap pile.

For the mold, any soft wood, free from knots, may be used. Blocks, of a size suitable for the toy to be made, are planed square on all faces. The blocks forming each half of the mold should be planed

rated, and the design of the toy to be made drawn on the inner face of each block. Care should be taken that the design on each block will register with the other; that is, that they will come exactly opposite each other when the mold is closed. This may be accomplished by drawing reference lines across the top and ends of the blocks, when clamped together, separating the blocks, and drawing the lines across the faces.

When cutting out the molds, care must be taken to slope the sides of the cuts outward, giving them "draft," as a pattern-maker would say, so as to allow the pieces

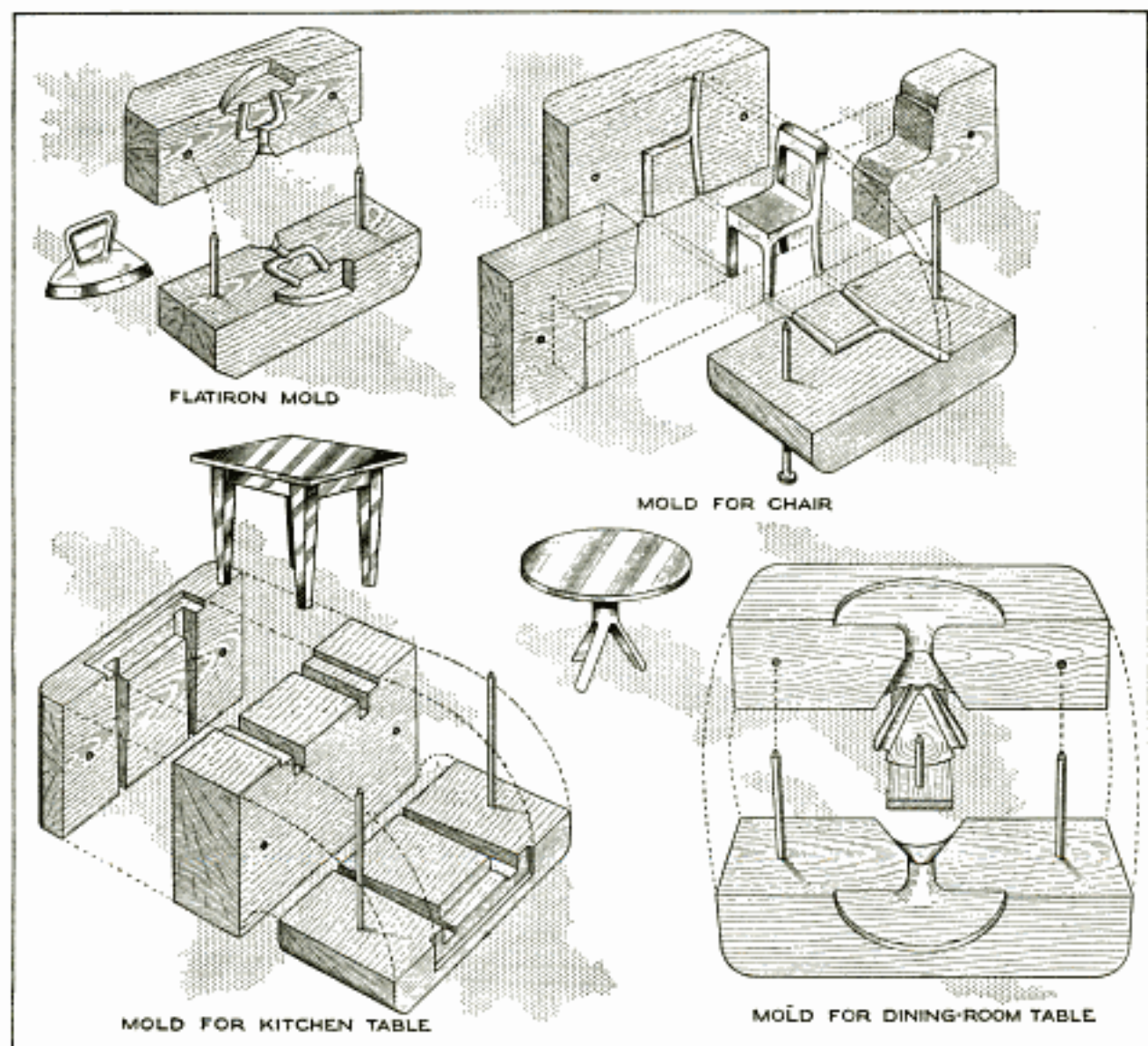

Simple Molds for Making Lead Toys That can be Made by Any Boy with a Few Simple Tools: Scrap Lead Pipe, Obtainable from Any Plumber, Is the Material Used, and, with a Little Care in Making the Molds and Subsequent Trimming, Very Good-Looking Toys are Produced

to the same size, then clamped together, and holes, a little smaller than the diameter of the wire nails used as dowels, drilled clear through both, as shown in the drawings. The blocks are then sepa-

rated, and the design of the toy to be made drawn on the inner face of each block. Care should be taken that the design on each block will register with the other; that is, that they will come exactly opposite each other when the mold is closed. This may be accomplished by drawing reference lines across the top and ends of the blocks, when clamped together, separating the blocks, and drawing the lines across the faces.

When cutting out the molds, care must be taken to slope the sides of the cuts outward, giving them "draft," as a pattern-maker would say, so as to allow the pieces

not remain liquid long enough to run through the leg to the farthest corner of a large top. The parts of the toy must

casting. The molds should be held firmly together and down on the stove lid while pouring. It is necessary that a warm



Molds Used for the Flatiron, Kitchen and Dining-Room Tables and Chair, and Samples of the Toys Cast in Them

be proportioned with this in mind, and the lead kept hot, to secure good castings. The lead can be melted over the gas flame of the kitchen range, and a stove lid, heated fairly hot, used as a base for

metal surface, such as the heated stove lid, be used as a base, else the lead will chill and spoil the work.

Lead remelted too often is not satisfactory for very small toys, as it becomes hard and brittle with repeated melting. The softer the lead, the easier it is to trim with a knife, to produce good-looking toys.

Other toys than those illustrated can be made

by clever boys; dumb-bells, rocking-chairs, water pitchers, tenpins, etc., can be successfully produced. The method of making the molds is clearly shown in the drawings and photograph.

Vehicle Gate for a Driveway

The object shown in the photograph has not the appearance of the conventional gate, yet, set up in the middle of a private driveway, as shown, it prevents the passage of vehicles, but allows unobstructed access to pedestrians.

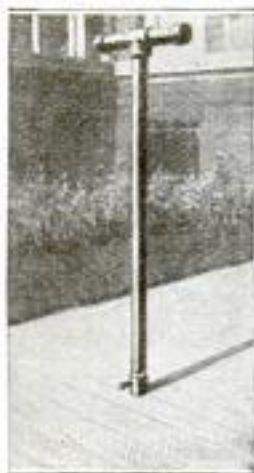

A 4-ft. length of 2-in. pipe, with horizontally projecting arms formed of pipe and fittings, rests in a socket imbedded in the cement driveway. A setscrew holds the "gate" tight. When a vehicle is to pass, the setscrew is loosened, the pipe is lifted out, and replaced when the automobile or carriage has passed.—Curtis Ralston, Chicago, Ill.

Driving Hornets from Nest

Hornets had built a nest in the eaves of a small garage, and their presence being undesirable, various means were tried to evict the potentially dangerous insects. A small plunger-type oil gun was filled with kerosene, and this was squirted onto the nest from a safe distance. The following day the nest had been completely evacuated.

The Care of Kerosene Lamps

Poor light is often caused by the condition of the lamps and wicks. The heavy oils that accumulate in the lamp should be thrown out every month, and the lamp thoroughly cleaned. Water should not be put in the lamp, nor should the wick be permitted to become damp. The lamp should be filled and cleaned, and the charred portion of the wick removed each time before lighting. Oil feeds to the wick better from a full lamp, and there is less danger of gas being formed in the lamp bowl. The wick is the vital part of the lamp, so it should be of good quality, of proper size, and long enough to reach to the bottom of the oil fount. New wicks should be supplied every month or two. They should be dried before the fire and put into the oil while still warm. Wicks clog gradually—clogged wicks make poor light; hence, economy in wicks is poor economy. A smoky flame may be due to a cheap burner, or to an unsuitable chimney. Burner and chimney should be kept clean. Burners may be cleaned by boiling with water to which a little soda has been added. Bad odors are almost always caused by heating and resulting evaporation of the oil on the outside of a dirty lamp or burner.

Kerosene dissolves various substances with which it comes into contact. These dissolved substances clog the wick, and the least water or moisture will make the

oil worthless. Keep the oil can clean and dry. Good oil is sparkingly clear and brilliant.

So-called "safety powders," that are sold under the claim that they make the light brighter or prevent explosions, do not increase either the safety or illuminating power of the oil, and more than likely do positive harm by clogging the wick. They are usually sold with positive instructions to use clean oil, keep the lamp and wick clean, and the oil chamber full. If these instructions are followed, the result is a bright and safe flame, but the same result would be obtained by following the instructions—and throwing the powder away.

A Trailer for the Bicycle

Cultivating a three-acre garden tract six miles from home, the gardener built the bicycle trailer shown in the illustration to carry his tools and produce back and forth. The box body is a large wooden packing case mounted on a pair of stand-

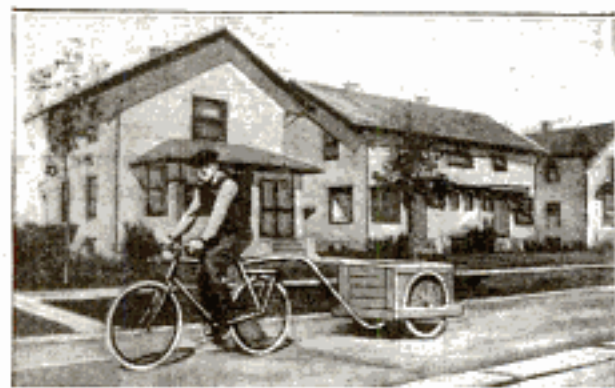

A Bicycle Trailer, Built to Carry the Tools and Produce of an Amateur Gardener over the Six Miles between Home and Garden, has been Found Just as Useful When the Growing Season Is at an End

ard bicycle wheels. A 10-ft. length of pipe forms the connecting link with the cycle. After the growing season had come to a close, the owner used his trailer for hauling chicken feed, groceries, and similar loads.—Uri V. Averitt, Gary, Ind.

Testing Wool or Silk Goods

If a piece of goods that has been sold for all wool or genuine silk is suspected of being mixed with cotton or linen, the truth can be found by boiling a sample of the material in a five-per-cent solution of caustic soda for about five minutes. This treatment will boil out any silk or wool and leave the cotton or linen unchanged, if any is present. By weighing the sample before and after testing, the extent of the adulteration can be found.

A Simple Play Pen

A busy mother desired her baby to play out of doors as much as possible, but at the same time wished to restrain the

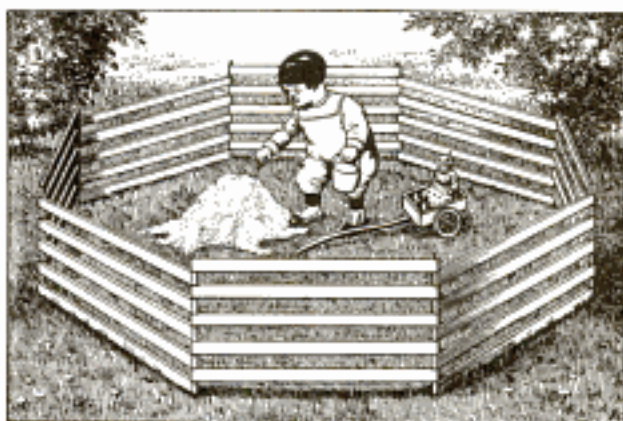

A Simple Form of Inclosure That Restricts the Movements of Its Juvenile Occupant is Made of Fruit and Vegetable Crates of a Familiar Type

movements of the child so that it would not wander off into possible danger. Being unable to keep a constant watch over the child, she evolved the simple form of inclosure illustrated. Certain fruits and vegetables are packed in crates made of a number of strips of wood joined together at the corners by lengths of heavy wire, passed through holes in the ends of the strips. Several of these crates were obtained and dismantled, then linked together at the ends to form a fairly large inclosure, which, when not in use, can be folded to occupy a small space.—Harry G. Schultz, Teaneck, N. J.

Feeding Tray for Birds

At several points about his thickly shrubbed and forested yard, a western business man and nature lover has installed feeding trays for his bird guests that remove them from the danger of cats, dogs, and other molesters. Lengths of pipe are set into the ground, and the galvanized-iron feeding trays are fitted to rods sliding in these. When the tray is to be filled, it is lowered, and when it is to be raised so that the birds may eat in safety, the rod is slid upward and a pin is inserted through a hole in the pipe, underneath the lower end of the rod.—Chas. A. Goddard, Los Angeles, Calif.

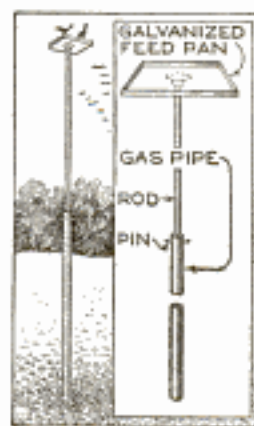

A Cheap Reflector for Home Photography

Good indoor portrait photography is impossible without a reflector, and a good one generally costs more than the aver-

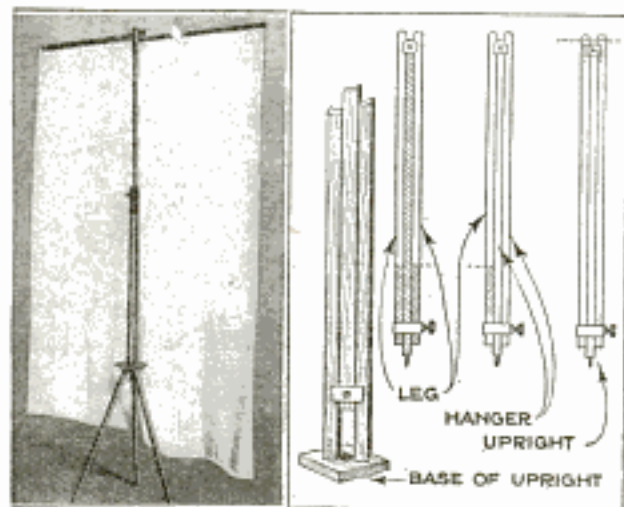

A Reflector and Support That can be Made from an Old Camera Tripod will Equalize the Illumination and Reduce the Violent Contrasts of Light and Shadow

age amateur cares to pay. However, a very serviceable article can be made from the legs of an old camera tripod.

One of the old legs is sawed off to produce three pieces of equal length, about $1\frac{1}{2}$ ft. long, and these are hinged to the tripod head to make a short tripod. The screws that hold these legs should be screwed down tightly so that the legs will stay in the position in which they are placed. The upright is made from another of the tripod legs, and this requires no alteration other than squaring the rounded ends. A square block of wood, about $\frac{1}{2}$ in. thick, is screwed to the ends of this section to form a base. Between the two legs, a tripod socket from an old camera is imbedded in the block. This section, in use, is screwed to the top of the short tripod. For the horizontal hanger, from which the cloth reflector is suspended, the third section of the tripod has a short piece cut out of one of the side members. By loosening the setscrew, the hanger can be extended to about 3 ft. A loop of wire or cord should be fastened near the setscrew for hanging to the upright.

A piece of white cloth, about 3 by 5 ft., is used for the reflector, and a small pocket is sewed into each of the upper corners to slip over the ends of the hanger.

☐ Blotting paper glued to the bottom of bric-à-brac prevents scratching polished mantels and sideboards.

Protecting Fruit Trees from Frost

Much of last year's fruit shortage, especially in the midwest and northern states, was due to the fact that the trees came into blossom earlier than usual, and were damaged by late-spring frosts. The method used by one fruit grower to avoid such a happening is worthy of note. While the ground in his orchard was frozen to a depth of several feet, he hauled the refuse from his barnyard and hayloft out, and spread it upon the ground under the trees, to a depth of 5 or 6 in. When the warm days of early spring followed, bringing neighboring orchards into blossom, his own orchard was as bare as it had been in the depth of winter. The heavy mulch of leaves and straw had held the frost underground, preventing the trees from budding. As soon as he was assured that all danger from frost was past, he removed the protecting mulch, and the trees came into blossom just late enough to miss the frost which destroyed the crops of other growers in his locality.

Hints for the Model Gas-Engine Builder

The maker of model gas engines is generally "up against it" when it comes to making valves in proportion to the size of

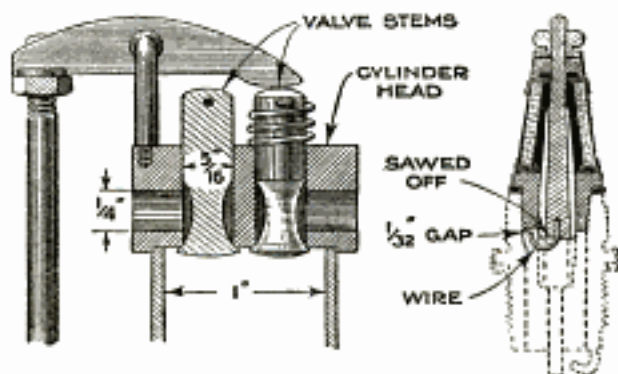

Simple Valves That will Operate Efficiently in a Model Gas Engine, and a Small Spark Plug That can be Made from Any of the Various Types of Separable Plug

the engine; also in trying to buy spark plugs of a corresponding scale on the market. A $\frac{1}{4}$ -in. valve, made in the proportions of the regular ones, would have a stem too thin for practical purposes, and, in addition, would be difficult to turn on the lathe. One way out of the difficulty is shown in the drawing; the valve stem was turned to $\frac{5}{16}$ in., for a 1-in. cylinder, and then cut away back of the head to make a passage for the gases, leaving a strong, durable valve. This makes it easy to machine the cylinder head, as it is only necessary to make seats for the valve

heads. The ports are drilled from the side, as shown.

There are several types of mica spark plugs on the market that are made separable to facilitate cleaning. Part of one of these may be used to make a neat plug for the model. The two parts of the plug are separated, and the long central electrode, or point, is sawed off at the point indicated, then drilled, and a piece of wire driven into the hole; this is bent to form a gap between it and the portion that screws into the cylinder. A gap of $\frac{1}{2}$ in. is sufficient. The miniature cylinder head is then drilled and tapped in the most suitable place to take the spark plug.—Edwin J. Bachman, Fullerton, Pa.

A Novel and Effective Garden Mulcher

Because a garden plot is free of weeds, it does not necessarily follow that it is sufficiently cultivated; if the soil becomes hard, packed by the rain, and baked by the sun, the vegetables or flowers will not thrive. Consequently it is absolutely necessary that the top soil be kept loose if the plants are to develop in the manner they should.

For this purpose a revolving mulcher, made from the cutter reel of a discarded lawn mower, will be found better and easier to operate than a hoe. Make a pair of handles from strong material, and mount the cutter reel across the ends of the handles. Just back of the handles a box is made to hold as many stones or

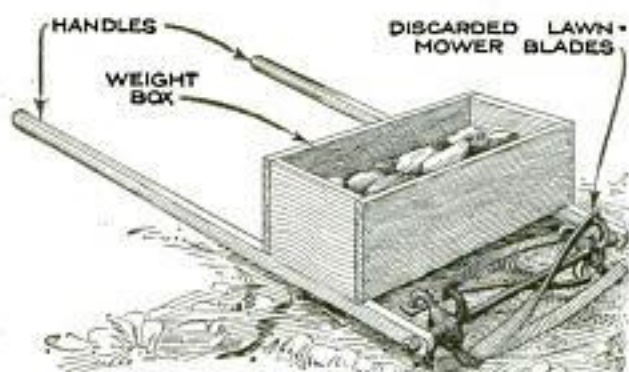

A Garden Mulcher and Weeder That can be Pushed Along between the Rows of Growing Plants is Easily Made from the Revolving Blades of an Old Lawn Mower

other weights as will be necessary to cause the mulcher to cut to the proper depth. In use the tool is pushed or pulled between the rows. The blades will revolve and cut into the soil and, due to arrangement of the cutters, the ground will be loosened and stirred up quite effectively.—G. E. Hendrickson, Argyle, Wisconsin.

Using Several Phones on Radio Receiver

The insistent demands of friends of the radio amateur that he entertain them at an evening of grand opera or musical

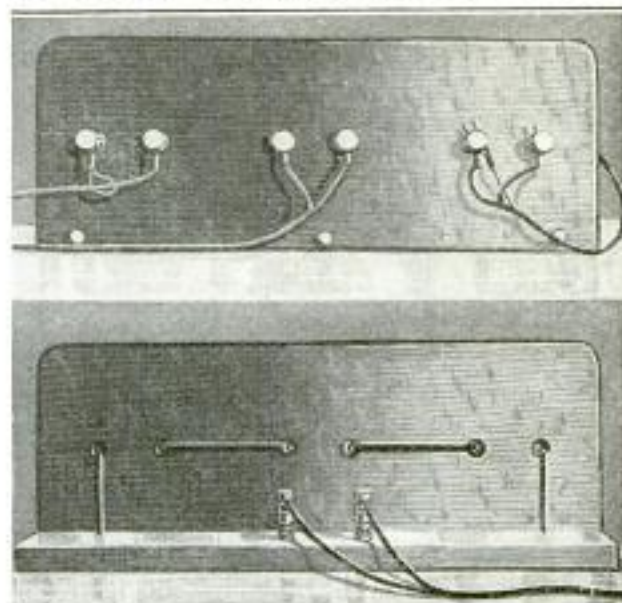

A Device for Connecting Several Sets of Phones to the Radio-Receiving Apparatus, Which is Located in Another Part of the Building, Making It Unnecessary for the Audience to Crowd into the Laboratory

numbers generally present him with somewhat of a problem if he has but a single pair of phone terminals on his cabinet, and no loud-talking device. In the present case the placement of the phones in another room was also something of a problem. In order to connect the three sets of phones used, the device shown in the photograph was made. Two boards, each 18 in. long, and about 6 in. wide, were screwed together at right angles, and three pairs of binding posts were placed on the front and connected in series at the back. The connecting wires were then run underneath the base to the two binding posts at the rear. The lead from the phone terminals of the radio set were then run to the room and connected to the binding posts on the base.—W. J. McGuffage, Chicago, Ill.

Tire Chains for Emergencies

Repair sections for tire chains are obtainable for a few cents each, and these can be attached to the wheel of an automobile by stove bolts or wingnuts, without the necessity of jacking up the car. A few such sections, which should be long enough for their ends to meet when passed around the tire, placed on the rear wheels of the car, will furnish sufficient traction to enable it, in most cases, to be driven out of sand and mud.

How to Make a High-Speed Key

The "bug" or vibrating key has become quite popular with radio amateurs, and can no longer be considered the exclusive

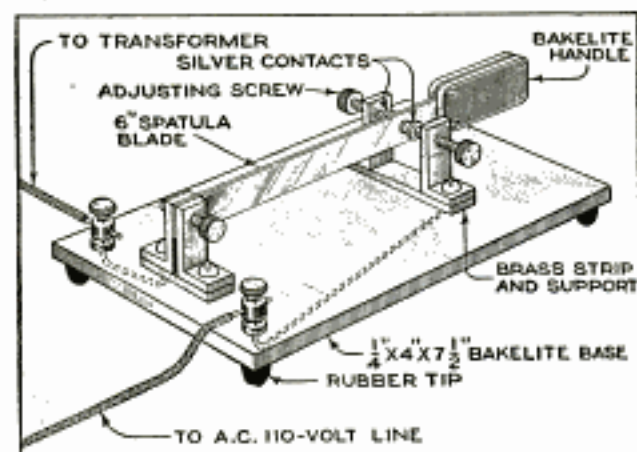

A Vibrator-Type Transmitting Key for the Amateur Radio Operator, Which is Built Up from Easily Obtainable Parts, Makes It Possible to Develop Great Sending Speed

property of the commercial or professional operator. This type of key was first used by wire-telegraph operators to attain great speed, and, as it is easy to build and easy to operate, it is really a great improvement over the old-fashioned type of key. The movement of the key is from side to side instead of up and down, and with a little practice amazing speed in sending can be acquired. However, the operator should exercise some judgment, and not use so great a speed that he cannot transmit correctly.

The base, which is made of $\frac{1}{4}$ -in. bakelite, is supported on rubber feet to permit the wires to be run on the underside, as shown by the dotted lines on the drawing. The vibrator, or blade, can be made from any of various materials, such as a thin, flexible nail file, hacksaw blades, and the like, although an artist's spatula, as shown in the drawing, makes an ideal blade. The original handle of the spatula is removed, and two strips of bakelite are cut to form an insulating handle, which is held together by small machine screws, so placed as not to come into contact with the blade. A $\frac{1}{8}$ -in. hole is drilled near the other end of the blade, which is supported between brackets of the type shown; these are formed from $\frac{1}{8}$ -in. sheet brass, and the blade is securely fastened between them by a screw. Machine screws are used for attaching the brackets to the base. The front brackets, near the handle, are made of the same material and to the same dimensions as those holding the blade at the rear. These brackets are mounted on a brass strip, and each is

provided with a knurled-head screw, as indicated. Coin-silver contacts are soldered to the tips of these screws and to the blade, at the points where it makes contact with the screws.

Adjustments are easily made when the blade is in position, by merely turning the thumbscrews. When the key assembly is completed, one wire is led from the base of the contact-point brackets to one of the binding posts, and another is led from the supporting brackets at the end of the blade to the second binding post. Owing to the fact that the steel blade always tends to straighten itself no switch is needed, because, if the contact points are adjusted to a uniform distance from the blade, it will not come into contact with them when not in use. After the wiring is completed, and the terminals soldered, the key is ready to be connected in series with the supply line leading to the transformer.—F. L. Brittin, Chicago, Ill.

Repairing Storage Batteries

Storage batteries may be repaired without the trouble of removing the jars from the case, and without melting the cross-bars in order to remove a set of plates. A diagonal cut is sawed in the connecting bar, as shown, and the plates of the defective cell are lifted out after the sealing compound has been sufficiently softened.

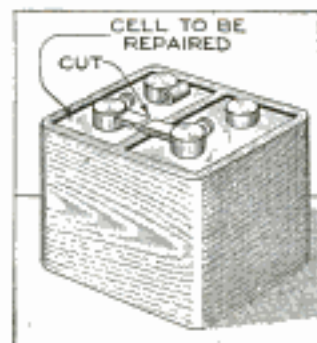

After the plates have been repaired or the separators renewed, the crossbar is carefully soldered together. To facilitate soldering, the ends are pried up slightly and a piece of wood, or a piece of an old separator, is slid under the cut, which is then cleaned, fluxed, bent back into place, and soldered.

Removing Spots from Varnished Surfaces

To remove white spots from a varnished surface, make up, in the proportions given, the following mixture: raw linseed oil, $\frac{1}{2}$ pt.; turpentine, $\frac{1}{2}$ pt., and denatured alcohol, $\frac{1}{2}$ pt. Shake well until thoroughly mixed. Dampen a piece of cheesecloth with this mixture and rub the spots several times, or until they disappear. If tightly corked, the mixture will keep indefinitely.

PRIZE OFFERS

MANY PRIZES FOR POSTERS AND ESSAYS TO INCITE KINDNESS TO ANIMALS

For the best humane posters and essays illustrating the idea of kindness to animals or human beings, numerous cash prizes are offered by the American Humane Association, Albany, N. Y. This is the national contest that succeeds the state contests, similar to the one for Massachusetts, announced last month in this magazine. The national contest is open to everyone, everywhere. It is divided into eight groups, as follows: group 1, for school grades 1-4; group 2, for school grades 5-8; group 3, for high-school grade 9; group 4, for art students, and anyone not in other groups; groups 5 and 6, for any person born before May 20, 1903; groups 7 and 8, for any person born after May 19, 1903. In each group there will be three prizes: first, \$25; second, \$15, and third, \$10. Special prizes of \$10, \$5, and \$3 in groups 6 and 8 will be awarded for the best cartoons with the words "Be Kind to Animals" published in any newspaper or magazine. Three additional prizes, open to all groups, will be awarded for posters or humane essays by pupils in U. S. Indian schools; also a prize of \$25 will be given by the American Society for the Prevention of Cruelty to Animals, New York City, for the best poster suitable for publication by their society, and two other prizes of \$10 and \$5, given by the Pennsylvania Society for the Prevention of Cruelty to Animals for the best posters showing the cruelty of trapping animals for furs.

The rules of the contests are as follows: A competitor may submit any number of posters, maximum size 22 by 28 in. Group number in which poster is entered must appear on front and back of each drawing, with name and address of artist on the back alone. Posters must be sent, wrapped flat, carriage paid, to the Poster Department, American Humane Association, Humane Society Bldg., Albany, N. Y., so as to be received not later than May 20, 1922.

Besides the above prizes, others are offered for essays, to be mailed not later than 6:00 p. m., May 20, to the Association's Essay Contest Department, as follows: three prizes of \$25, \$15, and \$10, given by the San Francisco Society for the Prevention of Cruelty to Animals for the best essays written by Boy Scouts on the protection of animals—open to Boy Scouts everywhere; also \$50, given by the National Association of Audubon Societies, of which \$25 will be awarded to a Campfire Girl and \$25 to a Girl Scout for the best essays on the protection of birds. In these contests, essays must not exceed 800 words in length, and must be signed with the author's name and address.

FOUNDATION TO HELP TOWNS ESTABLISH PLAYGROUNDS

Of interest to every town and city in the country is a new foundation, established in New York by William E. Harmon. The corporation is to be known as the Harmon Foundation, and has for its object the application of sound business principles to many social movements, such as helping towns to establish playgrounds, and in advancing loans to college students through the organization of mutual-aid societies. The foundation will be guided by the principle of helping people to help themselves. For the present the entire time of the staff is being spent in helping towns to establish playgrounds, but later on divisions of vocational guidance, and of counsel to social organizations in financial matters, will be organized.

NEW INDUSTRIAL MACHINERY DIVISION IN DEPARTMENT OF COMMERCE

In the Bureau of Foreign and Domestic Commerce there has been organized the Industrial Machinery Division to provide American manufacturers of machinery with adequate government assistance. The new division will give attention to every kind of machinery in any branch of industry. In order that the division may be thoroughly practical in its work, men who

are qualified engineers and who have sold a great variety of machinery for a number of years in South America and Asia have been placed in charge. The division aims to be of the greatest possible service to American manufacturers and exporters of machinery, and with this object in view, will establish as close contact as possible with these interests. An explanatory pamphlet has been published by the division.

FOUR YEARS' UNIVERSITY SCHOLARSHIP OFFERED HIGH-SCHOOL STUDENTS

For the third consecutive year, a four years' university scholarship is being offered to high-school students to encourage them in the study of highway economics, according to an announcement issued by the Highway and Highway Transport Education Committee. The scholarship is awarded for the best essay on the subject: "How Good Roads are Developing My Community." Essays are not to exceed 700 words in length, and must be in the hands of a high-school teacher or principal not later than May 1. All students of high-school grade, including both public and private schools, are eligible to compete. Essays must be written in proper manuscript form, with the name, school, and home address of the contestant in the upper left-hand corner of the first page.

Complete rules of the contest, a bibliography, suggestions, and other information may be obtained by applying to the Highway and Highway Transport Education Committee, Willard Building, Washington, D. C.

AMERICAN CERAMIC SOCIETY OFFERS AID IN RESEARCH WORK ON GLASS

For the encouragement of research work on glass, the research committee of the Glass Division of the American Ceramic Society offers to supply glass of any desired composition and form, free of charge and without limitation, to investigators in this field. The only obligation put upon the recipient is that of publication of the result of his investigations, preferably in the journal of the American Ceramic Society. Persons interested are requested to address one of the following members of the committee on research: E. C. Sullivan, Corning Glass Works, Corning, N. Y.; E. W. Washburn, University of Illinois, Urbana, Ill.; or R. B. Sosman, Geophysical Laboratory, Washington, D. C.

MANY VALUABLE PRIZES TO BE AWARDED TO FOSTER BETTER-BRED LIVE STOCK

To stimulate the production of better-bred live stock, \$5,000, divided into 35 prizes, is to be awarded at the cattle show to be held in November at the Bourbon Stockyards, Louisville, Ky. Entries will be open to all farmers and breeders of Kentucky, Tennessee, Georgia, and Alabama. There will be fat-cattle, as well as stocker and feeder awards. For the encouragement of boys' and girls' clubs formed for feeding cattle, a special class has been added to the show, in which prizes will be awarded of a value of \$1,500. Anyone desiring more information should write to the Bourbon Stockyards, Louisville, Ky.

PRIZE FOR BEST NAME FOR A MACHINE THAT SAVES WOODWORKING LABOR

For the best name for a new woodworking combination machine that saws, planes, bores, grooves, makes miters, and is handy for all kinds of repair work, a prize of \$100 is offered. The contest is not limited to woodworkers, and everybody is eligible to send in any number of suggestions. The name should be descriptive of the machine, and easy to remember. It must be received by May 1, 1922, written clearly with sender's name and address on any postal card or piece of paper, and addressed to Advertising Department, Hutchinson Manufacturing Co., Norristown, Pennsylvania.

8650
8590
8665
8523
8636
8538
Science 3/10/22
Central Press Clipping Service

Dept. of Commerce Bureau of Foreign & Domestic Commerce Bulletin #35, 2/25/22

Central Press Clipping
Service 2/23/22

Central Press
Clipping Service

816

June

POPULAR MECHANICS

8569

GOOD TASTE IN 'MUSIC' CULTIVATED BY MUSIC-MEMORY CONTESTS

Very popular, and in practice in a large number of schools now, is a form of contest that cultivates good musical taste in the school children and others. It is called a "music-memory contest." The object of these contests is to cultivate an appreciation of good music, and they are promoted by musical and literary clubs in cooperation with the schools. The method of procedure is to select some 30 or 40 classical-music numbers. These are played and sung before the contestants, and interesting information regarding them and their composers is told to the audience, whose business it is to make notes, and memorize it. This continues for about two months, when the examinations begin, to determine which of the contestants recognizes the music, upon its recital, and can give the best account of its origin and its composer.

sities are awarding more valuable prizes than others, and this naturally attracts the "tramp athlete." If all schools and colleges would agree on standard awards, preferably in the form of medals, the tramp athlete would soon be a thing of the past.

CONTESTS PREVIOUSLY ANNOUNCED

Medals, Diplomas, and Money Awards: Announced August issue, 1921; awards offered by the Franklin Institute.

For Service to City of Philadelphia: Prize \$10,000; announced September issue, 1921; awarded in spring or summer of 1922 by Edward Bok, former editor of The Ladies Home Journal.

Model in Clay by Students of Chicago Art Institute: Prizes, \$1,000, \$100, and \$50; announced November issue, 1921; closes April 15, 1922; address, Daily News Office, 15 N. Wells St., Chicago, Ill.

One Million Francs for Best Motor: Announced January issue, 1922; closes June 1, 1923; address, Aero Club of France.

Best Slogan Describing Razor: Prize \$500; announced January issue, 1922; closes June 30; address, Durham Duplex Razor Co., 190 Baldwin Ave., Jersey City, N. J.

American-History Essays: Prizes, \$3,000 for professors, \$2,000 for specialists, \$1,000 for school-teachers, \$1,000 for students, and \$500 for undergraduates in U. S. colleges; announced March issue, 1922; closes May 31. Address, Knights of Columbus Historical Commission, K. of C. Bldg., 199 Massachusetts Ave., Boston, Mass.

Best Setting of a Song: Prize \$100; announced April issue, 1922; closes July 1, 1922; address, D. A. Clippinger, 617-18 Kimball Building, Chicago, Ill.

Man-Propelled Airplane: Prize 20,000 francs; announced April issue, 1922; closes September 13, 1922; address, Maison Peugeot, 80 Rue Danton, Levallois-Perret (Seine), France.

8694

NATIONAL "REPAIR IT NOW" CAMPAIGN DIRECTED AT MOTOR-CAR OWNERS

Aimed at the automobile owner, there is being directed from Chicago a national "Repair It Now" campaign. The object is to impress upon the motorist that repair parts, repair men, and everything connected with repair work are easy to get—now, and that later on they will be difficult to get. Local campaign committees are being organized to promote the campaign by means of advertising, bill-posting, and parades.

Clark-Turner Pastor Los Angeles

STANDARDIZATION OF ATHLETIC AWARDS IN ALL COLLEGES IS ADVOCATED

With the object of eliminating professionalism among college athletes, it is advocated by George L. Rider, athletic director of Washington University, that all awards in any kind of athletics should be standardized. At present some colleges and univer-

8524

In answering prize offers please mention Popular Mechanics Magazine

8584

Radel + Herbert Newdormie
Annual Age Weekly 2/27/22

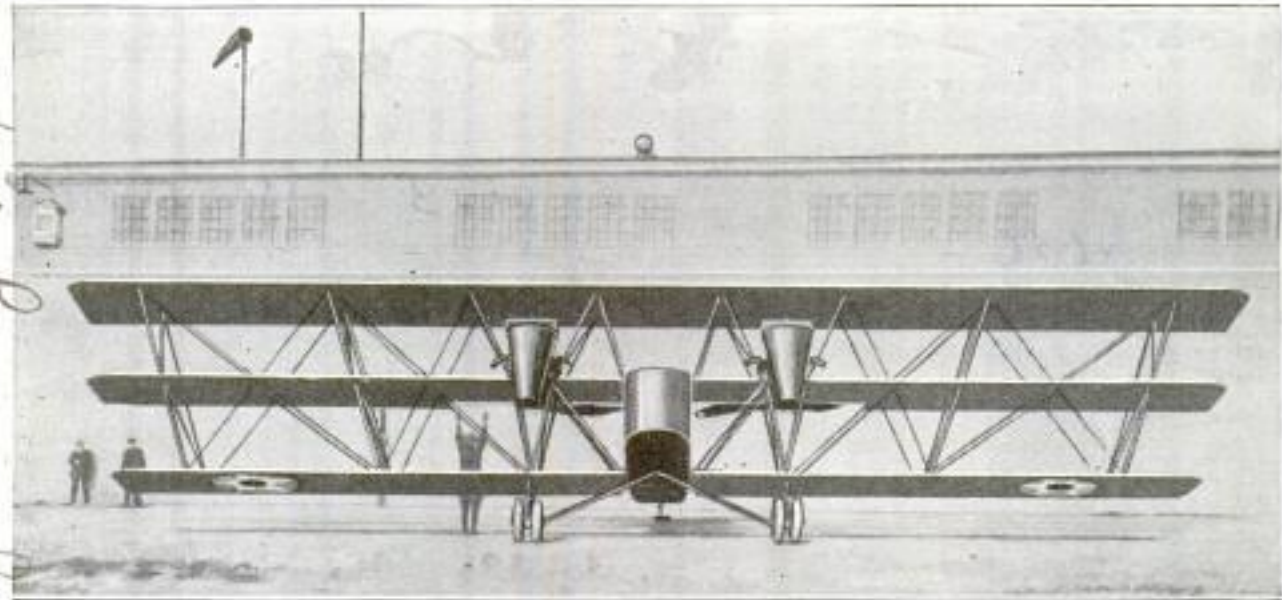

ARMORED TRIPLANE CARRIES ONE CANNON AND SIX MACHINE GUNS

THE latest development in American aviation is this triplane in which all vital parts are protected by armor. As armament it carries a cannon firing a one-pound shell, and has also six machine guns which can be fired in practically all directions. In addition, it carries 10 bombs, and when fully loaded weighs almost five tons. It has a flying speed of 105 miles per hour and a climbing speed of 600 ft. per minute.

IN accordance with the editorial policy of this magazine never to accept compensation in any form for what appears in our reading pages, and also to avoid all appearance of doing so, we are obliged to omit the name of the maker or the seller of any article described. This information, however, is kept on file and will be furnished free, by addressing Bureau of Information, Popular Mechanics Magazine, Chicago. [Editor.]

10 Days'
Free
Trial

Small
Monthly
Payments



\$4 first payment buys this Brand-New Typewriter

Pay the balance in small monthly installments—
We will ship the typewriter to you for ten days' free trial

The Amazing Story

A real need has long existed for a full-size, 4-bank, 42-key, 84-character-keyboard typewriter, with the entire line of writing completely visible, selling for less than \$100.

Annell has been evolved to fill that need; it is the creation of, and is sponsored by, men who know every phase of typewriter manufacturing and typewriter use.

The Annell turns out the most beautiful work that ever came from a writing-machine. The type is clear, clean-cut, hard; the alignment and spacing are utterly perfect. The speed is unlimited, no operator can crowd the Annell. Above all, this Model No. 3A Annell is of extremely simple construction. It is trouble-proof and sturdy; it is free from devices which without adding real writing value complicate the mechanism. It will last a business lifetime.

Every Operating Feature

The Annell has every late style feature and modern operating convenience—each letter completely visible as written (together with all the previous writing), Back Spacer, Tabulator, Two-Color Ribbon, Right and Left Hand Shift Key, Shift Lock, Margin Release, Adjustable Line Spacing, Adjustable Margin Stops, Paper Release, Automatic Line Spacer on Carriage Return, Adjustable Paper Fingers, etc., also the 42-key, 84-character Universal Keyboard. Rubber Cover and all extras shipped with each machine.

The operator of any Universal Keyboard machine can easily change to the Annell because the keyboards have the same relative position of the letters.

The Annell is Standard in size, Standard in appearance, construction and mechanical action—a typewriter that honestly reflects the great lessons learned from years of typewriter experience, with *an action so smooth and a touch so responsive* as to be a source of constant pleasure to the experienced operator, and making the progress of the novice immeasurably easier.

An Immense Saving

Our wonderful machine and remarkably low price are astounding the typewriter world. Never before in the history of the typewriter business has so much real, honest writing value been offered at so low a price. We are the only company selling a Standard 42-Key, 4-Row, Brand-New Typewriter direct to the user by mail at practically the wholesale price of other high-grade typewriters.

Typewriter users who once paid around \$100 for typewriters are now buying the Annell; they appreciate its sturdy day-after-day dependable performance and ease of operation. You can pay more for a typewriter, but you cannot get more writing value at any price than in the Annell. *Absolute reliability, the utmost quality, at a lower price.*

Through this advertisement I want to establish as friendly business relations with you as I possibly can. I want you to realize that it is our earnest effort and intention to give you full honest value for every dollar that you spend with us. That is the only way we can continue to succeed. I have been selling typewriters by mail direct to the user through magazine and direct advertising for over twelve years. During this period I sold over 60,000 typewriters of various makes to all classes of users from the Government down, and I am very proud, indeed, to offer to you our beautiful up-to-date, latest style, brand-new Annell typewriter.

Our business is on the foundation of exceptional value at lowest prices,—and square dealings. We are saving thousands of satisfied customers thousands of dollars by supplying these perfect, latest style, new typewriters at such remarkably low prices.

All our transactions are handled throughout by personal correspondence. You will receive every courtesy and consideration in your dealings with us. I give you my personal assurance that you will receive a remarkable and honest writing value by making your typewriter investment with us. Your response to this offer will have prompt, careful, personal attention. We will be glad to do business with you.

Harry Annell Smith

Over a Year to Pay

Our remarkably low price, together with our convenient monthly payment plan, makes it possible for you to buy a brand-new typewriter easily and without inconvenience—over a year to pay. \$69.00 for this beautiful writing-machine—\$4.00 with your trial order, then \$5.00 monthly in advance. Cash Price, \$64.35—\$4.00 with trial order, \$60.35 after ten days' trial. This \$4.00 deposit and any express charges you have paid will be returned to you if you are not satisfied with the typewriter.

Fully Guaranteed

The Annell is built to watchmaking standards, just so perfectly; from the best of materials money and brains can buy; patterned along proven, standard design; using the best workmanship and the most modern factory equipment obtainable. Yet we absolutely protect you with an iron-clad guarantee against any flaw in the material or workmanship. Annell is built to assure reputation—for leadership.

No Risk—10-Day Free Trial

The high-grade quality of this beautiful machine is even better than we can tell you, or show in pictures; we will prove this to you by sending the machine to you for ten days' trial. You use the machine on any of your work and satisfy yourself that this typewriter will do your work to your complete satisfaction—satisfy yourself that the Annell is the best typewriter value offered today by anybody, regardless of price. If you are not entirely satisfied after trying it thoroughly, return the machine to us. We will refund the express charges and any money you have paid, and the trial will cost you nothing. You are the only judge. Nothing could be more fair.

Send for Information, or Send the Coupon

A postal from you brings free and postpaid all the interesting facts of how you can receive the utmost in writing value, at an immense saving from the usual typewriter prices. Or send the coupon for the typewriter and make the real test.

At present we can make prompt delivery, but our volume of orders is increasing rapidly and will soon tax our factory capacity. Better act now, it does not obligate you. Mail coupon today—don't delay.

ANNELL TYPEWRITER COMPANY
1901 First National Bank Bldg. CHICAGO
TEAR OUT AND MAIL

ANNELL TYPEWRITER Co., 1901 1st Nat. Bank Bldg., Chicago.

Enclosed \$4.00 deposit, as evidence of good faith, Ship me the Annell Typewriter on Ten Days' Free Trial. This does not obligate me in any way to buy the machine.

Name

Address

GIVE REFERENCES ON MARGIN

PM

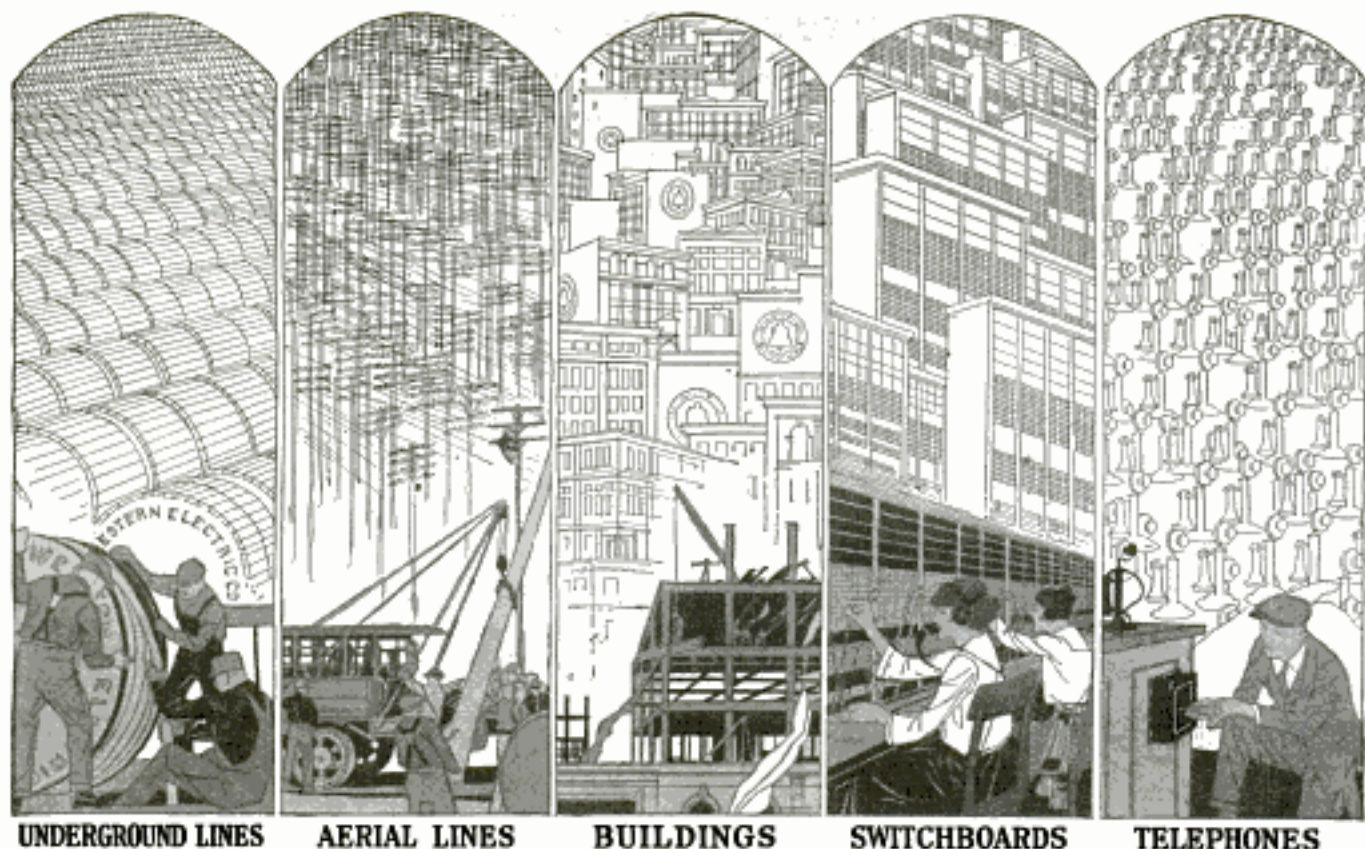

UNDERGROUND LINES

AERIAL LINES

BUILDINGS

SWITCHBOARDS

TELEPHONES

Breaking Construction Records

Since 1920, faced with the greatest demand for service in telephone history, the Bell System has surpassed all previous records for the installation of new telephone equipment. In the last two years more than 1,000,000 additional stations have been added to the system by construction. This is equal to the entire number of telephones in Great Britain.

In 1921 alone, 450,000 new poles were placed—enough to make a telephone line from New York to Hong Kong. The aerial wire put into service in the same year, 835,000 miles in all, is enough to string 60 wires on such a telephone line.

1,875,000 miles of wire, enclosed in 1,500 miles of cable, were added

to underground and submarine lines in 1921. New underground duct totaling 11,000,000 feet was constructed, this representing approximately 300 miles of subway. 69 new central office buildings and important additions were completed or in progress, and new switchboards with a capacity of many thousands of connections were installed.

This equipment added to the Bell System, great though it is in volume and value, represents but a small part of the vast property which enables the telephone on your desk to give the service to which you are accustomed. And to meet the increasing demands for new service, the work of construction goes on.

“ BELL SYSTEM ”

AMERICAN TELEPHONE AND TELEGRAPH COMPANY
AND ASSOCIATED COMPANIES

One Policy, One System, Universal Service, and all directed toward Better Service



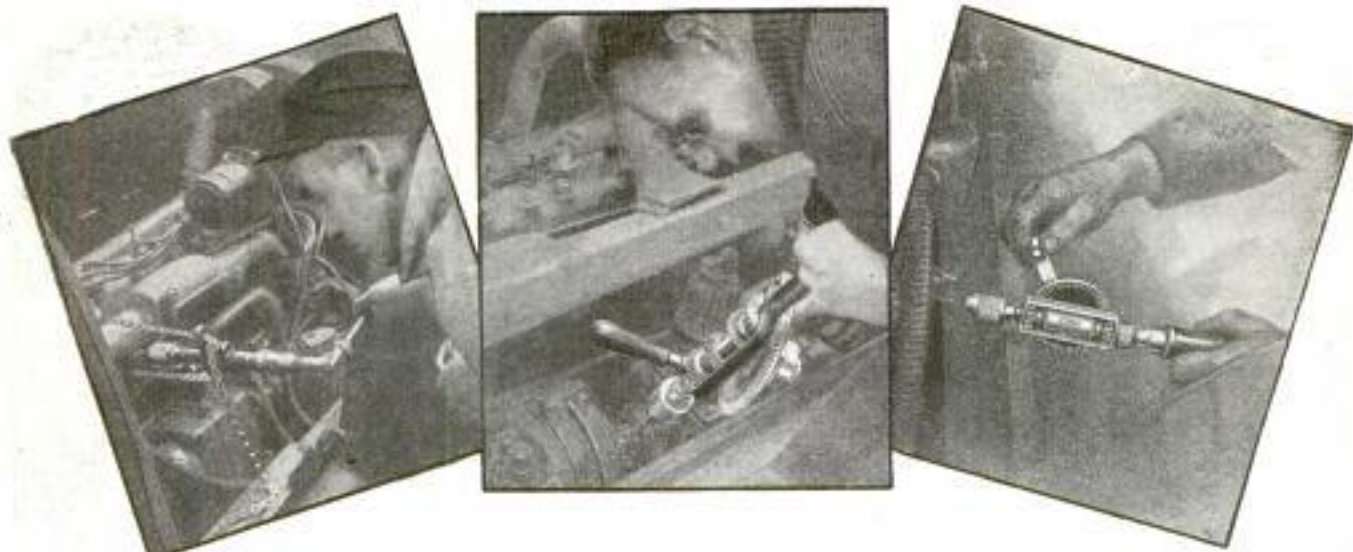

Less labor in drilling when you use the right tools

"Impossible" drilling jobs become simple—all drilling jobs become easier with these ingenious "Yankee" drills. And the work is done quicker and better.

For doing away with hand feeding

"YANKEE" Chain Drill No. 1500

with automatic friction and ratchet feed



All you do is turn brace. Chain is tightened and drill quickly set to the work by "Yankee" Friction Feed; then automatically fed at exactly right pressure by "Yankee" Ratchet Feed. Saves drills. Three-jaw chuck for round shank drills up to $\frac{1}{2}$ in.

For awkward places where other drills won't work

"YANKEE" Ratchet Breast Drill No. 1555

"Yankee" DOUBLE Ratchet keeps drill cutting continuously in places where you can move crank handle only an inch in either direction. Five adjustments; plain drill, left-hand ratchet, right-hand ratchet, DOUBLE Ratchet, gears locked. Speed can be changed without removing drill from work. Length 17 in. Three-jaw chuck for round shank drills up to $\frac{1}{2}$ in.



For small holes in tight quarters

"YANKEE" Ratchet Hand Drill No. 1530

Only 10½ in. long. Weighs only 1¼ pounds. Yet has all five adjustments of big "Yankee" Drills. Holds drills up to $\frac{3}{16}$ in.



Some other "Yankee" Tools

Quick-Return Spiral
Ratchet Screw-drivers
Ratchet Bench Drills
Automatic Push Drills
Ratchet Tap Wrenches

Tool Book FREE

Illustrates and describes all the "Yankee" Tools for saving time and labor.



Dealers everywhere sell "YANKEE" Tools

NORTH BROS. MFG. Co.

Philadelphia

"YANKEE" TOOLS

Make Better mechanics

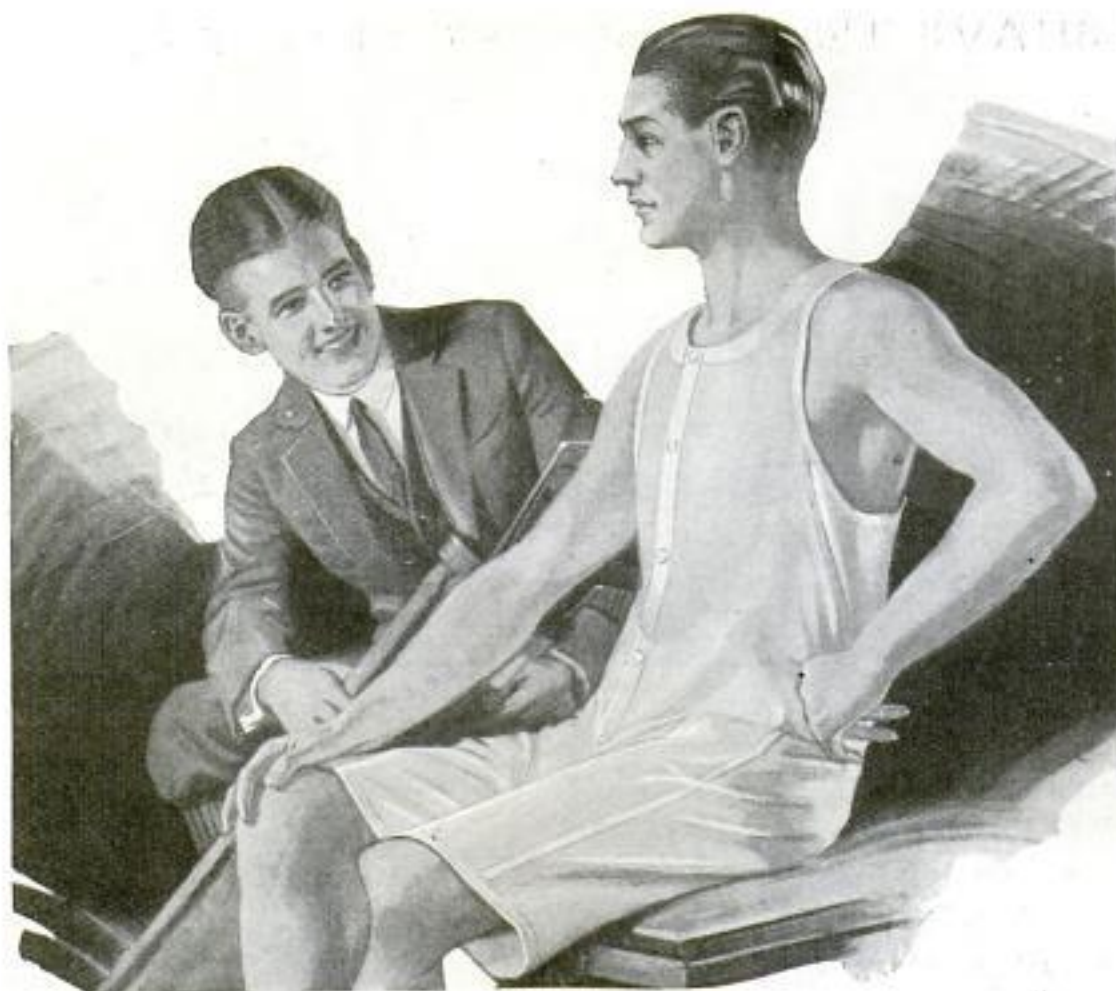

“Comfort—from neck to knee”

WHY didn't somebody make an athletic union suit like Topkis long ago? “Look at the long, wide legs! You can walk all day in Topkis without ever feeling a pinch or a pull. Scarcely touches your body. Big, roomy armholes.

“And listen—Topkis lets your skin breathe. No stuffy feeling.

“Quality? Value? Feel that fabric. Look at the workmanship. Seams firmly stitched; buttons put on to stay. Where could you get anything like it for a dollar except in Topkis?”

Only the best nainsook and other high-grade fabrics are used in Topkis Athletic Underwear. Pre-shrunk—full size guaranteed. But get *your* size—38 if your coat is a 38, and so on.

No good dealer will ask more than a dollar for the Topkis Men's Union Suit—but many will tell you it's *worth* more.

Men's Union Suits, \$1.00.

Men's Shirts and Drawers, 75c per garment. 75c for Boys' Union Suits, Girls' Bloomer Union Suits, and Children's Waist Union Suits.

TOPKIS BROTHERS COMPANY, Wilmington, Delaware

General Sales Offices: 350 Broadway, New York City

Ask for TOPKIS Underwear.
Look for the Topkis label.

Illustrated booklet tells underwear facts
you ought to know. Write for free copy.

TOPKIS
Athletic Underwear

TEN-SHAVE TEST TUBE FREE—SEND THE COUPON

If YOU were inventing a shaving cream—

YOU would decide that your shaving cream would have to meet seven requirements:

- 1 A smooth, quick-spreading cream.
- 2 Instant lather with either hot or cold water—rich, luxurious, soothing.
- 3 Quick, easy beard-softening.
- 4 A shave with one lathering.
- 5 A comfortable, velvety skin after shaving. No delicate outer layer of cuticle or natural oil removed.
- 6 No after irritation or roughness. Just the firm, even texture of perfect skin health.
- 7 A sensible screw top to the tube—big enough to handle with wet fingers and flat enough to stay where you put it.

Three Years of Experiment to Create The Perfect Shaving Cream

No shaving cream you've ever used would satisfy all of these requirements, of course. For more than three years, too, it looked as if our chemists could not compound a shaving cream which would make good on all of them.



But we had a quarter of a century of research and experience with the tenderest skins in the world to guide us. So we kept on trying. Finally we got what we wanted—what you, too, have wanted every time you have tackled your morning shave.

Send Coupon for Free Sample

That's Melba Shaving Cream. We are so sure that it will do everything you ask of a shaving cream, that we are spending a good many thousand dollars to put a ten-shave trial tube into the hands of America's self-shavers. Your tube is waiting for you. Fill out and send the attached coupon. Then "just lather and shave."

MELBA SHAVING CREAM

FREE COUPON

MELBA MFG. CO.
4235 Indiana Ave., Chicago, Ill.

PM

Please send me the free ten-shave trial tube of Melba Shaving Cream.

Print plainly in pencil

Name.....

Street No.....

City.....

State.....

Weaving the giant rolls of strong, flexible fabric which plays so important a part in the high quality of your Vitalic Bicycle Tires.

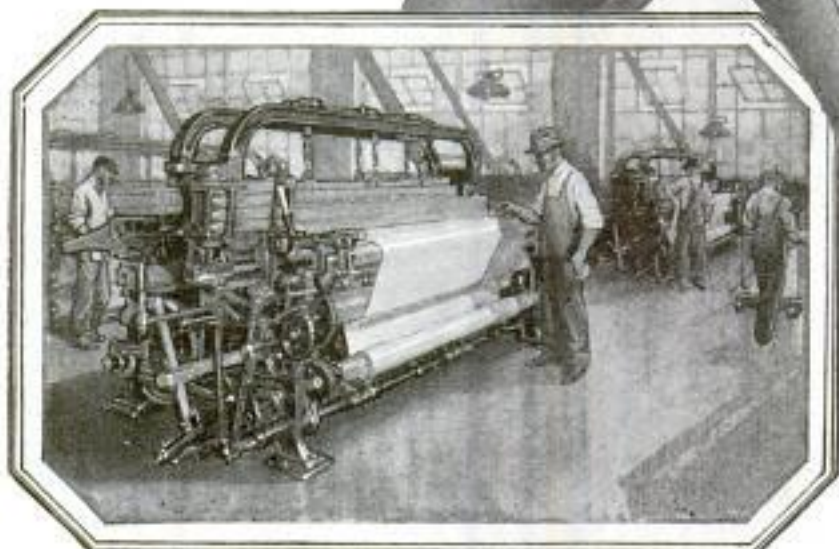

"Tougher than Elephant hide" -because special 14½ ounce fabric

DID you ever see a kite string break? It was caused by too great a strain on a weak spot.

When you spin along on your Vitalic Bicycle Tires, each thread in the strong fabric gets many times the abuse a kite string receives. Yet Vitalic fabric must not break.

Only the very finest fabric can stand such

treatment without being injured. And Vitalics are not only built to withstand the shock, but to absorb it, so it does not reach the rider.

There are good, sound reasons why the makers of such good bicycles as Black Beauty, Columbia, Dayton, Emblem, Excelsior, Indian, Iver-Johnson, Pierce and Yale use Vitalics on their better grade wheels.



Send for this free booklet — and learn all about the special fabric used in your sturdy Vitalics.

CONTINENTAL RUBBER WORKS
1930 Liberty St. Eric, Pa.

VITALIC

TRADE MARK REGISTERED

Bicycle Tires



TRADE MARK

Tougher than elephant hide

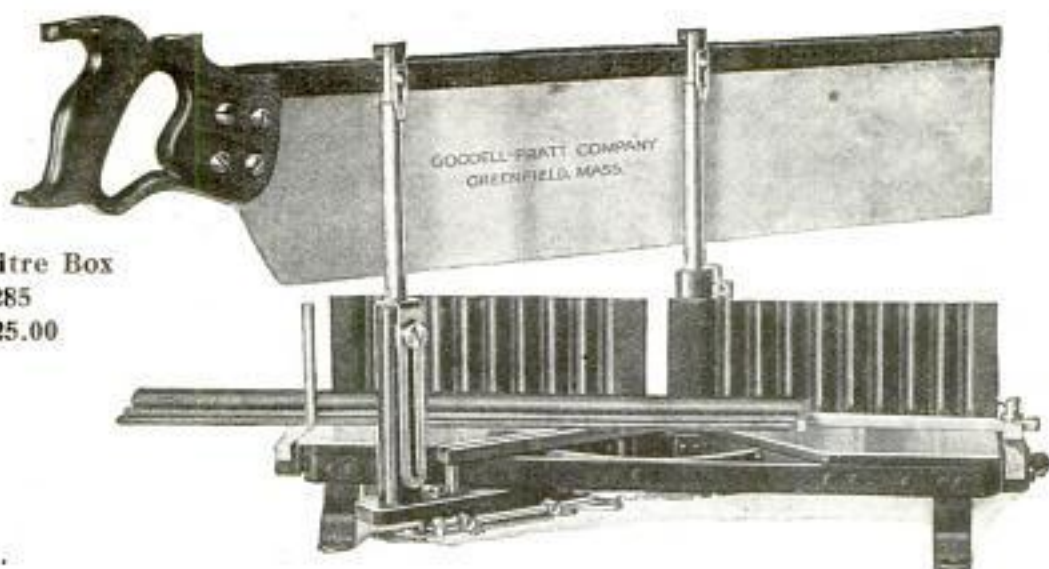

All Steel Mitre Box
No. 1285
Price, \$25.00



Mr. Punch Says: Men, here's a Mitre Box as true as your best friend!

"It lets you make a clean, thin cut at any angle you want. It holds rigid the piece of wood you're working on, and it couldn't splinter it even if it wanted to. When your job's done, the edges are smooth and true."

This Goodell-Pratt All-Steel Mitre Box is trussed like a steel bridge. Saw can be locked at any angle, and is held by a spring that can be released by a slight downward pressure. Stops are easily regulated to permit sawing to any desired depth.

You don't buy tools very often. When you do, you expect them to last a long, long time. That is why it is so well worth your while to remember Goodell-Pratt 1500 Good Tools—it's a name that stands for all that's trustworthy and accurate in tools.

You will find them at those hardware stores where high-grade tools are known and appreciated.

Write for free booklet showing hundreds of different tools for carpenters, mechanics, artisans and home "putters" who take pride in what they can do with their two good hands.

GOODELL-PRATT COMPANY, Greenfield, Mass., U.S.A.

Toolsmiths



GOODELL-PRATT

1500 GOOD TOOLS



The Price You Pay

For dingy film on teeth

Let us show you by a ten-day test how combating film in this new way beautifies the teeth.

Now your teeth are coated with a viscous film. You can feel it with your tongue. It clings to teeth, enters crevices and stays. It forms the basis of fixed cloudy coats.

Keeps teeth dingy

Film absorbs stains, making the teeth look dingy. Film is the basis of tartar. It holds

food substance which ferments and forms acids. It holds the acids in contact with the teeth to cause decay.

Millions of germs breed in it. They, with tartar, are the chief cause of pyorrhea. Thus most tooth troubles are now traced to film. And, despite the tooth brush, they have constantly increased.

Attack it daily

Careful people have this film removed twice yearly by

their dentists. But the need is for a daily film combatant.

Now dental science, after long research, has found two ways to fight film. Able authorities have proved their efficiency. A new-type tooth paste has been perfected to comply with modern requirements. The name is Pepsodent. These two film combatants are embodied in it, to fight the film twice daily.

Two other effects

Pepsodent also multiplies the starch digestant in saliva. That is there to digest starch deposits which otherwise may cling and form acids.

It multiplies the alkalinity of the saliva. That is Nature's neutralizer for acids which cause decay.

Millions employ it

Millions of people now use Pepsodent, largely by dental advice. The results are seen everywhere — in glistening teeth.

Once see its effects and you will adopt it, too. You will always want the whiter, cleaner, safer teeth you see. Make this test and watch the changes that it brings. Cut out the coupon now.

10-Day Tube Free 838

THE PEPSODENT COMPANY,
Dept. 872, 1104 S. Wabash Ave., Chicago, Ill.
Mail 10-Day Tube of Pepsodent to

.....
.....
.....
Only one tube to a family

Pepsodent PAT. OFF.
REG. U.S.

The New-Day Dentifrice

Endorsed by modern authorities and now advised by leading dentists nearly all the world over. All druggists supply the large tubes.



Corona can help you to increase your output and income, just as it has hastened the success of thousands upon thousands of ambitious men and women. Send for the free booklet today.

"Corona has been my helper for nine years!"

"THIS wonderful little typewriter has aided me in my business, increased my income, made school-work easier for my children, been private secretary to my wife — and in nine years of the hardest kind of use *has cost me but thirty-five cents for repairs!*" — W. E. Conklyn, Yonkers, N. Y.

At home, at the office, at school, or on a journey 'round the world, this tireless little "secretary" is always ready to help you turn out more and better work.

The sturdiest of all typewriters

Corona was designed from the beginning as a *portable* typewriter. It is built so strongly and so simply that it practically never gets out of order. And its construction has been proven sound by sixteen years of actual use.

CORONA

The Personal Writing Machine

REG. U. S. PAT. OFF.
CORONA TYPEWRITER CO., Inc.
108 MAIN STREET GROTON, N. Y.

Send for the free booklet

It is full of the actual experiences of men and women whom Corona has helped to success in many lines of endeavor.



Mail this Coupon!
For booklet No. 8. Address
Corona Typewriter Co., Inc., Groton, N.Y.

Name

Address

Fold it up - take it with you - typewrite anywhere

Where seconds count

LOOK 21 Perfect Jewels
Adjusted to Positions
Adjusted to Temperature
Adjusted to Isochronism
Adjusted to the Second
Thin Model All Sizes

Santa Fe Special Watch

Guaranteed to last a lifetime and give satisfactory service. Is NOW being sold at Rock Bottom Prices and on easy payments.

Send for *Free* Watch book and select your watch.

The *ILLINOIS* Famous \$
Santa Fe Special **3.50**
21 JEWEL RAILROAD WATCH **A MONTH**

The Standard Railroad Watch

that is GUARANTEED FOR A LIFETIME OF SATISFACTORY SERVICE. These watches are now in service on practically every railroad in the United States and in every branch of the Army and Naval service. Thousands of them are distributed around the world. Your name or monogram and any emblem you may desire will be engraved in the case to suit your own ideas. Write today for my Free Watch Book—make your selection now. Save One-Third to One-Half the price you pay for a similar watch made by other Manufacturers. Most liberal Offer Ever Made. Our "Direct-to-You" low wholesale terms and Extra Special Distribution Plan is fully explained in the New Santa Fe Special Booklet just off the press. The "Santa Fe Special" Plan means a big saving of money to you and you get the best watch value on the market today. Watch sent for you to see without one penny down.

THE SANTA FE WATCH CO.
56 Thomas Building, Topeka, Kan.

The Home of the Great Santa Fe Railway

A letter, postcard or this coupon will bring My Beautiful Watch Book Free

SANTA FE WATCH CO., 56 Thomas Bldg., Topeka, Kan.

Please send me your New Watch Book with the understanding that this request does not obligate me in any way.

Name.....

Address.....

State.....

Mail
Coupon
Today





Your Home Is Within Your Reach When You Buy From Us

NOW is the time to build your Harris Home!

And here is a mighty organization of thirty great departments ready to serve you. Managed by expert material buyers, designers and practical builders. We have vast stocks bought at huge quantity price savings which are now at your command. Our sole aim and purpose is

To help you get a home that will prove entirely satisfactory at a price that will mean a substantial saving in actual dollars of your money.

The combined efforts of these great departments in experimenting and testing materials and methods of construction have produced for you a **GUARANTEED** home, expert machine cut, bundled and marked—the last word in building economy.

Not One Penny in Advance

So sure are we of the super-excellence of our material and our **GUARANTEED** Ready-Cut System that we will ship you any **HARRIS HOME** without the payment of one cent down. Our Plan Book explains our liberal terms fully.

FREE Plan Book

The latest edition is waiting for you, contains our **FREE PLAN OFFER** and photographic reproductions, with floor plans and specifications of 100 beautiful homes. Mail coupon today.

Building Material of All Kinds

For over a quarter of a century, thirty wise buyers have realized that here is the "open door" to real economy, whether it be a brand new home or material for improvements or repairs. Our big stocks of brand new building material, all purchased in tremendous quantities at savings that are passed along to you are ready for quick and complete shipments.

"PRESTO-UP" Patented Bolt-together Buildings!

The wonder buildings of the age. Guaranteed buildings, for quick industrial housing. Individual Homes, etc., extra strong, practical and suitable for all year "round" habitation in any climate. 50 different plans. They come to you in easily handled sections—painted and stained, ready to bolt together and move in.

Plumbing and Heating!

Hot water and heating systems, warm air heating plants, pipeless furnaces and plumbing material of every kind—the product of America's leading makers. Our mammoth plumbing stock offers unlimited possibilities for you to save money. Our heating plants are guaranteed to heat your home in any weather with big fuel economy. Mail the coupon for our Plumbing and Heating Book and get the benefit of our Expert Engineering Service.

Department NM-7

HARRIS BROTHERS CO.
1349-1525 W. 35th St., CHICAGO

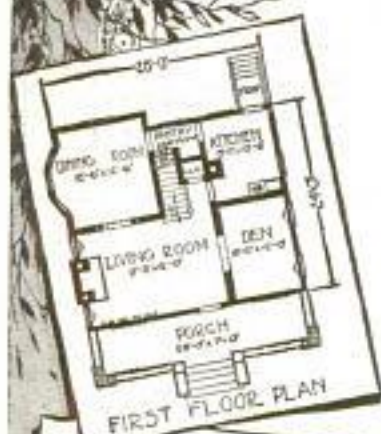

FIRST FLOOR PLAN

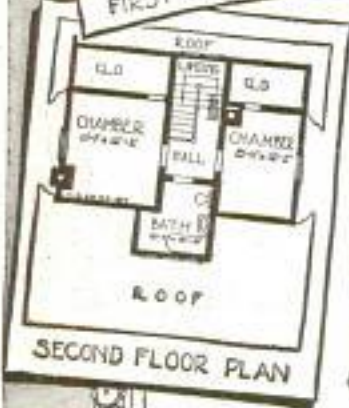

SECOND FLOOR PLAN



**FREE BOOK
of Plans**

HARRIS BROTHERS CO.
Dept. NM-7, Chicago

These books are **FREE** and sent post paid. Mark an "X" in the squares to indicate which ones you wish.

- Harris Home Book of Plans Book of "Presto-up" Houses and Garages
 Building Material Catalog Plumbing and Heating Book

Name.....

Address.....



Evinrude Outings No. 2

Distant fishing grounds are easily reached when your rowboat or canoe is Evinrude-powered.

Fishin' DeLuxe!

THERE'S a new joy to fishing—a new "e-fishency"—when *your* boat is Evinrude-powered. No long, tiresome row to take the edge off the day's sport. You reach the best fishing grounds *early*, and you're fresh and fit when you get there. You've set up your tackle on the way.

With this sturdy little motor to do your oar-work, you can go from weed-bed to weed-bed until luck is with you, without a thought of your distance from camp or cottage.

The Evinrude is now made in two models, Standard and Lightweight. Both motors are the same in design, power and speed. The Lightweight is more portable—due to judicious use of aluminum—it weighs just 50 pounds complete.

See these Evinrude motors at your sporting goods or hardware dealer's. Ask him about the Built-in-flywheel Magneto, Tilt-up Attachment and other Evinrude features. Or write for catalog and new prices (recently cut to pre-war level).

EVINRUDE MOTOR CO.

663 Evinrude Bldg. Milwaukee, Wis.

Distributors:

69 Cortlandt St., New York, N. Y. 440 Market St., San Francisco, Calif.
780 Commonwealth Ave., Boston, Mass. 211 Morrison St., Portland, Ore.

EVINRUDE Standard and
Lightweight
DETACHABLE MOTORS FOR WATERCRAFT

"Old Town Canoes"

"Old Towns" are patterned after real Indian models. They are the lightest, fastest and most durable canoes you can buy—and the lowest priced. An "Old Town Canoe" will float loaded in the shallowest stream. It will carry you wherever there's water. \$54 up from dealer or factory. *New catalog shows all models in colors. Write for it NOW. Free!*

OLD TOWN CANOE CO.
1265 Middle Street
Old Town Maine, U. S. A.



Makes Good beyond Your Hopes

because it is built on sound engineering principles all through.

Play Safe in Buying a Row-Boat Motor you can't afford to take any chances. No matter what style of motor you require, there is a

Wisconsin Detachable Row Boat Motor

that will suit you. For six years this standard little motor has been making **GOOD** under all conditions—in the hands of thousands of users. And no wonder, when you examine its mechanical construction. It has a number of exclusive features that you should know about. Write for catalog **TODAY**.

WISCONSIN MACHINERY & MFG. CO.
19 Minor Street, Milwaukee, Wis.



MAKE MONEY AT HOME

Making beautiful animal toys. We show you how—interesting work. Complete working drawings and instructions, postpaid, \$1.

DEKALB DESIGNING CO.

Toy Dept. 5 Decatur, Ga.

START NOW—SAVE 2/3 COST

Build Your Own Boat

LOWEST PRICED and BEST BOAT'S in the World Built by BROOKS SYSTEM
Brooks K. D. Outfit make Boat Building a pleasure. You can easily and quickly assemble your own boat by using our simple method. Let Us furnish you at trifling cost our instructions, Full Sized Patterns, a K. D. Outfit with parts already shaped and fitted, or build you a Completed Boat. Brooks Models are speedy, smooth and seaworthy. Thousands of satisfied patrons. Get our prices before building. They are lower than ever before.



Send 10 cents for BIG catalog, full of information for BOAT buyers.

Brooks, Oldest Established Boat Builders

BROOKS MANUFACTURING COMPANY

Address Cat. Dept. Saginaw, Mich.



Racine Wis

America's Finest Canoe

Because it's built that way

Write for Complete Catalog

RACINE BOAT COMPANY
Dept. 61 Racine Wisconsin



A Dependable Battery

For the battery now in your car seventeen hundred Westinghouse Service Stations offer you Westinghouse Attention. Get acquainted!



THE man who buys a Westinghouse Battery gives himself the mental tranquillity that comes from knowing his battery is equal to emergency as well as ordinary demands. His assurance is born of the fact that Westinghouse Batteries are "oversize"—as much as 25 per cent in common sizes; are engineered by widely recognized battery minds, constructed of the finest materials, built under the most advanced manufacturing methods, and—*guaranteed by WESTINGHOUSE.*

One quality battery—the best Westinghouse can build!

WESTINGHOUSE UNION BATTERY CO., Swissvale, Pa.

WESTINGHOUSE BATTERIES

DRIVE 100 TACKS AND SAVE \$25.00

Easy to get on. We furnish instructions. We tailor top recovery for all cars, and guarantee them to fit. Ford Roadster, \$5.25, Touring, \$6.95, other cars, \$14.00 to \$15.00, delivered at your door. Side windows that open with doors \$10, \$16, others \$9.50 and up. Seat covers \$3.15 up.

AUTO EQUIPMENT CO., 32 Canal Street East, Cincinnati, Ohio



Write for Catalog and Samples



A.I.D. FOR FORDS

The A. I. D. Airunit pumps a Ford tire in less than 5 minutes.

Aero Fan keeps motor cooler—any one can attach.

A Real Tire Pump—no gears, cams, chains or noise.

Agents Wanted. Send for Circular

A. I. D. Inc.

1362 Beacon St., Boston 47, Mass.

KENNEBEC

CANOES

"Safest to Use"

Because the "Tumble Home" makes them so. The dotted line here is the "Tumble Home" of the ordinary canoe—and the heavy line of the Kennebec.

"Tumble Home" is the bidge of a canoe. You should get our 1922 illustrated book giving the fullest particulars about this wonderful feature of the Kennebec. Mailed to any address, postpaid. KENNEBEC BOAT AND CANOE CO., 22 R.R. Square, Waterville, Me.



WHITING-ADAMS BRUSHES

For Household and Family requirements. Best quality, long wearing, perfect working. Extensive assortment,—every brush needed for home life.

Send for Illustrated Literature

JOHN L. WHITING-J. J. ADAMS CO.
Boston, U. S. A.

Brush Manufacturers for Over 112 Years and the
Largest in the World

Go Into Business for Yourself



Enormous profits can be made by any man, woman or bright boy who will establish one of our "NEW SYSTEM SPECIALTY CANDY FACTORIES" in his or her community. Big openings in cities, towns and villages everywhere. Our original "New System" of candy-making will enable you almost immediately to turn out a large variety of "Specialty Candies"—all big sellers. Wholesale or retail. No previous experience necessary. Only small space required at start. We furnish everything ready for work. Hundreds have become successful. Useful Candy Book FREE

Our Big Candy Book gives all details. It is Free. Write for it at Once.

W. Hillier Ragsdale, Drawer 201 East Orange N.J.

Get JENKINS' Big FREE LOW PRICES Catalog sent on request

on complete line of high grade nationally known band and orchestra instruments before buying. Big FREE catalog sent on request. Easy payment plan—PLAY WHILE YOU PAY. FREE lesson certificate with each instrument.

Musicians Earn Big Pay. Learn to play from Jenkins' Band and Orchestra Books. First violin or cornet parts FREE. Our 44 years in business is your guarantee of reliable service. Post card brings BIG FREE CATALOG.

J. W. JENKINS SONS' MUSIC CO.
910 Jenkins Bldg. Kansas City, Mo.



AN INCOME FOR LIFE

Do you want it? Then send for this free book. It shows you how the man and woman of average means can buy outright, with two years to pay, high-grade listed and dividend paying securities such as U. S. Steel, Westinghouse, Western Union, etc. This interesting book explains in detail how—

1. You can buy five times as much with your available cash.
2. You can take immediate advantage of present low prices of high-grade securities.
3. You get all dividends and market increases from date of purchase.
4. You have two years to pay through this new monthly payment plan.
5. You are absolutely protected against fluctuations and are guaranteed against call for additional funds.

You can start "An Income for Life" by small monthly payments which you will never miss. The business man or woman, farmer, teacher, mechanic, in fact every one who is thinking of his future and will lay aside \$10, \$15, \$25 a month or more can take advantage of the present opportunity to secure high-grade securities at bargain prices and start building "An Income for Life." Don't fail to write for this valuable book today—it's more than worth while. It means "AN INCOME FOR LIFE."

GET THIS BOOK
FREE

Investment Securities Co.
Suite 630 Moffat Bldg., Detroit, Mich.



ASBESTOS

We are miners and shippers of Crude Asbestos in any quantity. We produce all grades at our world-famous BELL ASBESTOS MINES, in Canada. We also card fibres, spin yarns, weave cloths, and make all sorts of Asbestos products.

For anything you want in Asbestos, turn to
KEASBEY & MATTISON COMPANY
Dept. 5-3, AMBLER, PENNA., U. S. A.
Owners of the world's largest Asbestos Mines



Send for a Complete Catalogue of

MASONIC BOOKS

Jewelry and Goods

REDDING & CO.

Publishers and Manufacturers

Dept. P 200 Fifth Avenue, New York

Build and Fly Model Aeroplanes



Build your own Model Aeroplane; make trial flights and learn the principles of Aeroplanes. With IDEAL Scale Drawings and Building and Flying Instructions you can easily build exact 1/4 ft. duplicates of Real Planes. Send now for the Plans for the one you want to build.

Curtiss JN4D-2 Training Plane; DeHavilland Battle Plane; NC-4 Naval Seaplane; Curtiss Military Tractor; Bleriot, Nieuport or Taube Monoplanes; also Cecil Peall Racer; 25c each, postpaid.

Catalogue IDEAL Model Aeroplanes and Supplies, 5c postpaid
IDEAL AEROPANE & SUPPLY CO.
159 Wooster St., cor. W. Houston St. New York City

PLANS AND INSTRUCTIONS 25¢

W. L. DOUGLAS

FOR MEN AND WOMEN

\$7.00 & \$8.00 SHOES

ALSO MANY STYLES AT \$5.00 & \$6.00

YOU CAN ALWAYS
SAVE MONEY BY WEARING
W. L. DOUGLAS SHOES
SOLD DIRECT FROM FACTORY
TO YOU AT ONE PROFIT

WHEN YOU BUY W. L. DOUGLAS SHOES
CONSIDER THE EXTRA QUALITY
YOU RECEIVE FOR THE PRICE PAID

W. L. Douglas shoes are made of the best and finest selected leathers the market affords. We employ the highest paid, skilled shoemakers, all working with an honest determination to make the best shoes for the price that money can buy.

When you need shoes look for a W. L. Douglas store. We own 108 stores located in the principal cities. You will find in our stores many kinds and styles of high class, fine shoes that we believe are better shoe values for the money than you can buy elsewhere.

Our \$7.00 and \$8.00 shoes are exceptionally good values. There is one point we wish to impress upon you that is worth dollars for you to remember. W. L. Douglas shoes are put into all of our stores at factory cost. We do not make one cent of profit until the shoes are sold to you. When you buy shoes at any one of our stores you pay only one small retail profit.

No matter where you live, shoe dealers can supply you with W. L. Douglas shoes. They cost no more in San Francisco than they do in New York. Insist upon having W. L. Douglas shoes with the name and retail price stamped on the sole. Do not take a substitute and pay one or two extra profits. Order direct from the factory and save money.



BOYS'
SHOES
\$4.00 & \$4.50

W. L. Douglas name and portrait is the best known shoe Trade Mark in the world. It stands for the highest standard of quality at the lowest possible cost.

The intrinsic value of a Trade Mark lies in giving to the consumer the equivalent of the price paid for the goods.

Catalog Free.

W. L. Douglas
President
W. L. Douglas Shoe Co.,
128 Spark St., Brockton, Mass.



THE STAMPED PRICE
IS YOUR PROTECTION
AGAINST
UNREASONABLE PROFITS



GREAT INTERCHANGEABLE-TYPE TYPEWRITER
Hammond
MULTIPLEX
A NEW FOLDING MODEL Full Capacity
Write for Free Booklet. Hammond Typewriter Co., 509A East 69th St., New York

Build Your Own PHONOGRAPH

IT'S EASY WITH OUR HELP

A few hours' interesting work saves over half and gives you a machine to suit your ideas. We furnish motors, tone arms, case material, blue prints and full instructions. Plays any record. Make fine profit building phonographs for your friends.

Write today for our **FREE** Blue print offer.

AGENTS wanted for Choraleon Phonographs.

CHORALEON PHONOGRAPH CO.
522 1st St., Elkhart, Ind.



SAVE
OVER
HALF

Please Mention Popular Mechanics

A LATHER THAT SOOTHES

Palmolive Shaving Cream gives a full, creamy lather that makes the beard wax-like. The razor moves smoothly. Palmolive is also a lotion. Contains both Palm and Olive oils. Write for free trial tube. Large size tubes 1 druggists 50c.

THE PALMOLIVE COMPANY Milwaukee, U. S. A.
PALMOLIVE SHAVING CREAM

FREE SPORTSMAN'S CATALOGUE

Quality Goods
at Lowest Prices

Write today for your FREE copy of this complete Sporting Goods Catalogue. Buy by mail and save money. Every price is cut, every article is absolutely guaranteed. Your money back if you are not satisfied.

It shows fishing rods—split bamboo as low as \$1.35; rods at all prices; guaranteed 12 lb. test casting lines at 40c; 13 ft. steel boats \$28.85; auto tents 7 x 7 ft. \$7.65; tents 8 ft. 3 1/2 x 12 for \$14.45; also bathing suits, skates, athletic goods, camp clothes—everything for the out-of-door, of standard quality at a big saving.

Write today for this complete Sporting and Athletic Catalogue

Address: Dept. G-10

Montgomery Ward & Co.
St. Paul Chicago Kansas City

Kingery
POP CORN POPPERS



New
1922
Prices

**Make
Big
Money!**

**Get
Started
NOW**

OWN YOUR BUSINESS

Kingery Pop Corn Poppers and Peanut Roasters are proving the business salvation of thousands of men. You need but little capital and your dividends are enormous—70c profit on every dollar.

Adaptable for outdoor use, shows, drug stores, fruit stores, general stores, confectioners, news dealers—for any one who wants to make big money with least expense of time, effort or capital.

Write for new 1922 catalog showing FULL line for any location or any business. Over a hundred styles. Most reasonable prices and terms.

THE KINGERY MFG. CO.

Established 1876

Dept. 242

Cincinnati, Ohio

Help Wanted

We require the services of an ambitious person to do some special advertising work right in your own locality. The work is pleasant and dignified. Pay is exceptionally large. No previous experience is required, as all that is necessary is a willingness on your part to carry out our instructions. If you are at present employed, we can use your spare time in a way that will not interfere with your present employment—yet pay you well for your time.

If you are making less than \$150 a month, the offer I am going to make will appeal to you. Your spare time will pay you well—your full time will bring you in a handsome income.

It costs nothing to investigate. Write me today and I will send you full particulars by return mail and place before you the facts so that you can decide for yourself.

ALBERT MILLS, General Manager Employment Dept.
6538 American Bldg., CINCINNATI, OHIO



**DIAMONDS
For a Few Cents a Day**

Diamond bargains—128 pages of them. The greatest Diamond book ever published sent free for your name and address. Your choice of millions of dollars worth of diamonds sent upon request. No money down. Terms as low as a few cents a day. 8 per cent yearly increase in value guaranteed. Extra 5 per cent bonus may be earned.

Write Today for 128-page book, thousands of bargains. No obligations. Write NOW to Dept. 1773,
J. M. LYON & CO. 1 Maiden Lane, New York, N. Y.

WINDOW SIGN LETTERS
LARGE PROFITS
194
**EDWARD GOLDSMITH
DELICATESSEN
AND
GROCERY**
CIGARS & GOODS
TOBACCO DELIVERED
SAMPLES FREE
AGENTS AND SALESMEN
\$75.00 to \$150.00 a week. Lowest price gold and silver sign letters for stores, offices, automobiles, etc. Large demand everywhere. Anybody can do it. Exclusive territory or travel all over while you earn. Write for free samples and catalog.
ACME LETTER CO., 2806 X Congress St., Chicago

SELF-FILLING INK PENCIL
"INDEPENDENT"
Meets all requirements. Self-filling, non-leakable, safety cap. Attached clip. Smooth writing gold style point.
Guaranteed Improved Fountain Pen. Eliminates fatigue. Promotes efficiency. Writes uniform. A business necessity.
52¢ By Mail
Your Name in Gold—35 Cents Extra
AGENTS WANTED
J. C. ULLRICH & CO., 161 Washington St., New York

Moore Push-Pins
Glass Heads—Steel Points
Moore Push-less Hangers
To hang up things
Ask your dealer to show them
Sold Everywhere 10¢ per packet
Moore Push-Pin Co.
Wayne Junction Philadelphia

MUSIC LESSONS FREE
IN YOUR OWN HOME
You can read Music like this quickly
Piano, Organ, Violin, Mandolin, Guitar, Banjo, etc.
Beginners or advanced players. One lesson weekly. Illustrations make everything plain. Only expense about 2c per day to cover cost of postage and music used. Write for FREE booklet which explains everything in full.
AMERICAN SCHOOL OF MUSIC, 50 Lakeside Building, CHICAGO

Do Your PRINTING
Cards, circulars, labels, tags, book, menus, paper, Press, \$12. Larger \$15. Job Press \$150 up. Save money. Print for others, **BIG PROFITS**. All easy, rules sent. Write factory TODAY for press catalog, TYPE, cards, paper. **THE PRESS CO. D-37, MERIDEN, CONN.**

GILBERT BOY ENGINEERING The greatest boys' book in years. 128 pages of articles on athletic Training, Football Strategy, Flying, etc., by noted authorities. Chapters on many wonderful sciences. Contains complete catalog of Gilbert Toys. Sent at cost, 25c. Also write for free folder on Gilbert Toys.
A. C. GILBERT CO., 477 Blatchley Ave., New Haven, Conn.

CAMERAS
Over a Hundred Styles and Sizes
Send for new illustrated catalog showing latest reduced prices. It's Free.
10 days' trial given
SENECA CAMERA MFG. COMPANY
300 Central Avenue Rochester, N. Y.

Your Foreman Knows—

WHEN YOUR FOREMAN SEES YOU USING BROWN & SHARPE TOOLS, HE APPRECIATES YOUR CHOICE OF THE TOOLS OF MASTER CRAFTSMEN.

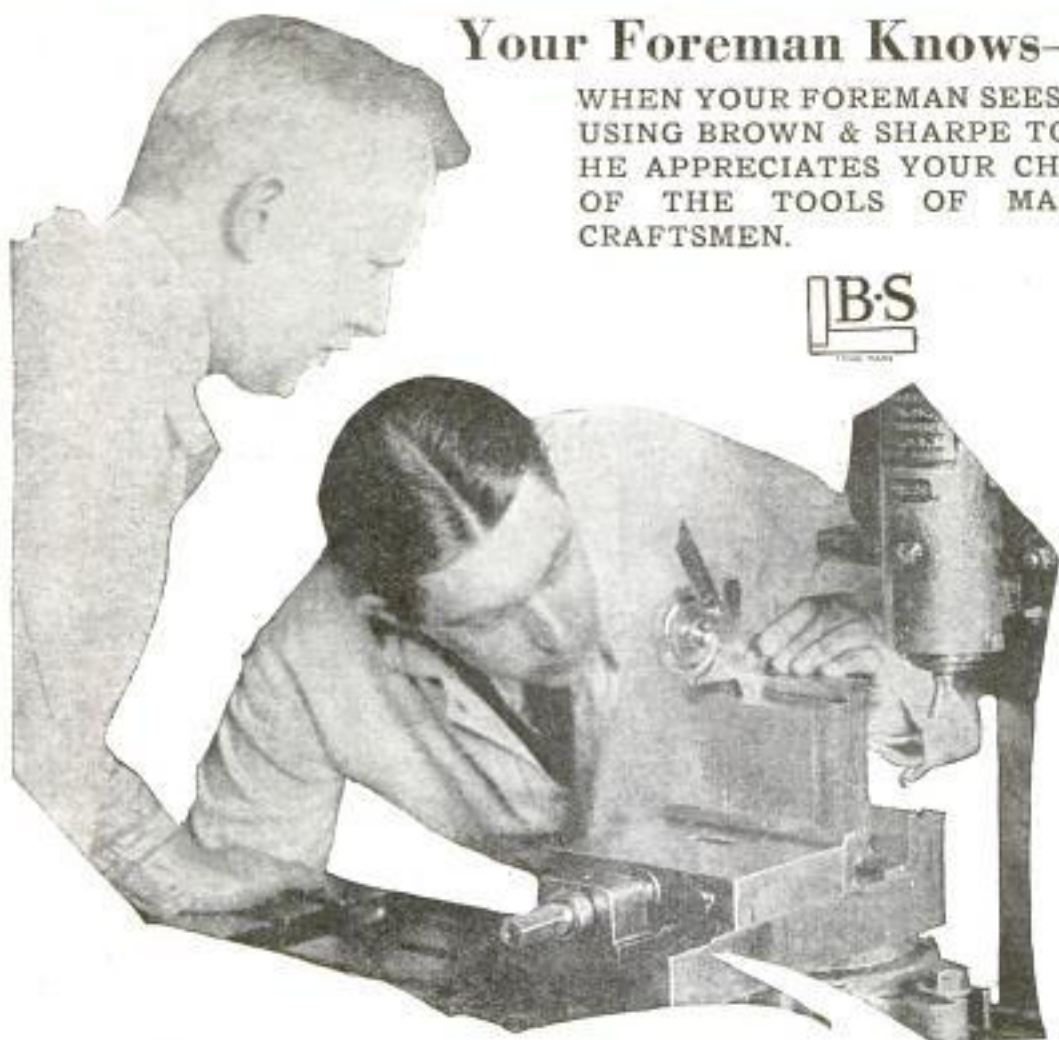
The superiority of Brown & Sharpe Tools is firmly established in the mind of every mechanic, foreman, and manufacturer—your boss knows the difference. He knows they mean better results.

It's natural that he should feel that a man who uses good tools thinks more of himself and his work. Send for Catalog No. 28 showing over 2000 of these superior tools and select your new tools from it.

Let these good tools help you. Write today

BROWN & SHARPE MFG. CO., PROVIDENCE, R. I., U. S. A.

THE FIRST PRECISION TOOLS IN AMERICA WERE BROWN & SHARPE TOOLS. THEY ARE THE BEST TOOLS TODAY

TYPEWRITERS
We Save You 50%
FREE TRIAL—EASY TERMS
Your choice of all STANDARD MAKES, UNDERWOOD, ROYAL, SILENT I. C. SMITH, Self-starting REMINGTON, etc. Rebuilt by the Famous "Young Process." Guaranteed good as new. Lowest cash prices. Time payments or rentals with special purchase privilege. Largest stock in U. S. Write for special prices and terms.
YOUNG TYPEWRITER CO., Dept. 163, CHICAGO



KEYS DUPLICATED
2 FOR 25c
Any Type Key—Send Key with Order
Special rates to clubs and organizations
PHILADELPHIA KEY CO. 170 N. Broad St. PHILADELPHIA



GREEN AUTOMATIC MACHINE



ADD TO YOUR INCOME WITH LITTLE EFFORT
\$5 to \$10 A DAY MADE EASY WITH

New Improved Green Automatic Machine

Sharpens, Hones and Strips all kinds of safety razor blades, in one operation, from four to six blades per minute. For both Quality and Quantity, this machine is in a class by itself. There is nothing like it on the market. Let us send you our descriptive literature explaining everything, including the "AMERICAN" Key Cutter—cuts square, angular or round slots.

AMERICAN SHARPENING MACHINE CO. (Inc.), Dept. 5, 134 W. Washington St., CHICAGO

"AMERICAN"
Key Cutter



1/2 SAVED
BUY DIRECT
GET BIG BOOK



DO YOUR OWN PLUMBING & HEATING AT LOW COST

Send for our big instructive 256-page well-bound **HANDY MAN** Book-Catalog. Every homeowner, contractor, farmer, mechanic, institution, etc., needs it. Shows over 10,000 fixtures and supplies in plumbing and heating at wholesale; how to save skilled labor, hard work and unnecessary material by our new

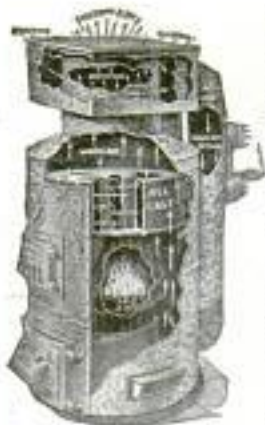

Pipeless Furnace

Cut-To-Fit Method

This wonderful encyclopaedia on plumbing and heating helps you select and install the proper plumbing, water system, hot air, water or steam plant. Besides being our wholesale catalog, it has many practical plans, diagrams, sketches, elevations, handy hints, etc., showing how to do the work this newer easy way. Any handy man with a few tools can do his own installing with the aid of this

Big Handy Man Book

We have spared no effort, and have gone to a **GREAT EXPENSE** to compile this valuable book, and to keep from sending it to uninterested persons, we request 25c, which will be refunded on your first order, or send for our free bulletin.

Write today and save.

HARDIN-LAVIN CO.

50 Years at 4547-4557 Cottage Grove Avenue, CHICAGO

\$500,000 Plants Behind Our Guarantee



Hot Water Boiler

TIRRO

the ideal mending tape of a thousand uses—sticks to anything and stays stuck. For sale at all druggists. A Bauer & Black product.

WINDOW SIGNS



AGENTS

\$60-\$200 a week. Free Samples **GOLD SIGN LETTERS** for store fronts and office windows. Anyone can put them on. No experience necessary. Big demand. LIBERAL OFFER TO GENERAL AGENTS.

METALLIC LETTER CO., 438, N. Clark St., CHICAGO



WAKE UP!

Make \$15 to \$25 a Day!

Wanted at once—150 live salesmen for "Quicklit" Lamps and Lanterns. Only hustlers need apply. \$50 to \$100 a week for the right man. Greatest lamps and lanterns ever designed. Burn kerosene or gasoline. Brightest, cleanest, cheapest light!

300 Candle Power of Light at a Cost of 1-8c Per Hour!

"Quicklit" Lamps and Lanterns can be lit with ordinary match like city gas. Only lamps made with automatic cleaning nozzle—wonderful selling feature!

QUICK! Write for particulars of our proposition to "live" men and big catalog. All free and postpaid. Mail a postal today.

The Nagel-Chase Manufacturing Co.
308-309 Erie Street, Chicago, Ill.

NEW Self-Heating IRON



AGENTS MAKE \$12 A DAY

New scientific development makes ironing remarkably easy. No wires or attachments—all self contained. Gives clean, quick heat, easily regulated. Costs one cent for 3 hour's use. Saves steps. Cuts ironing time in half.

Sells fast. Mrs. Wagner, Ohio, sold 25 in few hours spare time. Meyer, Pa., made \$164.00 in one week. You can do as well. No experience necessary. Work all or spare time. You simply take orders, we deliver by parcel post and do collecting. Commissions paid same day you take orders. Send for Catalog and **FREE** OUTFIT OFFER. Write today.

AKRON LAMP CO. 34 Iron St., Akron, O.



"Lighting Fixtures"

READY TO HANG

(Direct from Manufacturers)

Completely wired, including glassware.

New designs. Send for catalogue No 24.

Send for **DEALERS'** proposition.

ERIE FIXTURE SUPPLY CO.

STA. A.

ERIE, PA.

Beautiful HOUSES \$900 and BUNGALOWS

CAN BE BUILT FOR AND UP

This and many others in my new book, Building Plans for Modern Homes, will save you hundreds of dollars. One of the most complete and comprehensive books of plans ever published by any architect. New edition just off the press. Nearly 500 floor plans and photographs of bungalows, Colonial houses, etc., costing from \$200 up; gives sizes and cost to build.

Sent postpaid for \$2.00



FREDERICK H. GOWING
ARCHITECT

101 Tremont St., BOSTON, MASS



SEND NO MONEY

If You Can Tell it from a GENUINE DIAMOND Send it back

To prove our blue-white **MEXICAN DIAMOND** cannot be told from a **GENUINE DIAMOND** and has same **DAZZLING RAINBOW FIRE**, we will send a selected 1 carat gem in ladies Solitaire Ring. (Cat. price \$5.25) for **Half Price to introduce, \$2.63**, or in **Girls Heavy Tooth Becher Ring** (Cat. Price \$6.50) for **\$3.25**. Our finest 12k Gold Filled mounting. **GUARANTEED 25 YEARS, SEND NO MONEY**. Just mail postcard or this ad. State Size. We will mail at once. When ring arrives deposit \$2.63 for Ladies ring or \$3.25 for Girls with postman. If not pleased return in 2 days for money back less handling charges. Write for Free catalog. **Agents Wanted.**

MEXICAN DIAMOND IMPORTING CO., Dept. ET, Las Cruces, N. Mex.
(Exclusive controllers Mexican Diamonds)



Free Trial

YOU may have any instrument with complete musical outfit, for a week's free trial at home. No obligation to buy. Return it at our expense after trial if you wish. No charge for trial. Outfit includes velvet lined case, self instructor, music and all accessories at factory cost. A tremendous saving.

Convenient Monthly Payments

A few cents a day will pay for instrument and outfit. This offer gives you genuine Wurlitzer instruments, known all over world for artistic quality. Have one now for Free Trial.

Send Coupon for Beautiful New Catalog

Every instrument known illustrated with price, easy terms and free trial blank. Catalog absolutely free. Write today.

The Rudolph Wurlitzer Co., Dept. 1775
 117 East 4th Street, Cincinnati — 700 Jackson Blvd., Chicago
 139 W. 42nd St., New York — 250 Stockton St., San Francisco

Send me your new catalog illustrated in color with full details of Wurlitzer Complete Outfits and free trial and easy payment offer.

Name.....
 Address.....
 (State instrument you are especially interested in)

WURLITZER
 200 YEARS OF MUSICAL INSTRUMENT MAKING
 Cincinnati Chicago
 New York San Francisco
 Copyright 1920, Rudolph Wurlitzer Co.



Big Money

Made by agents selling our wonderful Facial Soap, Perfumes, Toilet Articles, Spices, Extracts, etc. Free cake of soap and agents' terms mailed to any address.

LACASSIAN CO., Dept. 455 ST. LOUIS, MO.

HOME LOVERS' BARGAIN BOOK FREE

Showing Over 10,000 Furniture Bargains
 All selections loaned free for a month. Take a year to pay if satisfied, paying little by little almost as you please.

SPIEGEL, MAY, STERN CO., 1108 W. 35th St., Chicago

HIGH GRADE WIRELESS

Head Receivers, Microphones, Keys, Jacks, Plugs, Etc.

American Electric

COMPANY
 STATE AND 64TH STS. CHICAGO, U. S. A.



RADIO DETECTOR

This is the smallest and lowest priced detector on the market. It does a variety of things as well and better than many \$5.00 detectors. Has composition base; all metal parts nickel plated; furnished complete with galena crystal. Study illustration and notice new features. Note particularly patent nickel detector cup and binding post. Size 1 1/2 x 1 1/4 x 1 inch. Sent prepaid anywhere. Price complete **50c**

If you build your own radio set you must have the RASCO catalog containing 185 illustrations and 50 vacuum tube connection diagrams—the greatest collection published in any catalog. Catalog contains the greatest assortment of parts and raw materials in U. S. Send 15c in stamps or coin for this catalog. "Radio Man II."

RADIO SPECIALTY COMPANY, 98E Park Place, N. Y. City

RADIO

Equipment

Big FREE Catalogue



THIS FREE catalogue tells you the kind of a Wireless Telephone to own, so that you receive in your own home all the latest news, music, church services, lectures—everything broadcasted throughout the United States.

Every home will soon have a wireless telephone outfit. We now offer complete outfits from \$15 up.

Everyone interested in radio should see our low prices on parts and accessories. Write for this book. Learn about the miracle invention of the age. Easy to install, as simple to operate as a regular telephone.

One copy of this booklet is yours, FREE.
 Write for your copy.
 Address Dept. R-6

Montgomery Ward & Co.
 Kansas City Chicago St. Paul



BIG BARGAIN \$25.00

1/4 hp Electric Grinder and Buffer

f. o. b. Chicago

A big-capacity machine weighing 38 lbs. bare or 52 lbs. boxed. Has 6 x 1/2 in. Norton abrasive wheel and 7 x 3/8 in. cotton buff—not the small wheels commonly used on machines of this kind.

Motor is 1/4 hp (not 1/8 or 1/2 usually put onto grinders) totally enclosed and dust proof; 110 or 220 volt A C—60 cycle operating at 1740 rpm—just the right speed for the large diameter wheels, to do best work without danger of burning. Motor is guaranteed for 1 year by the manufacturer.

Motor alone with 1 1/2 in. grooved pulley is offered for \$13.50 or just about half usual price. ship C. O. D., anywhere in the United States, if preferred.

Send cash with order, or we will

OUR PRICES F. O. B. CHICAGO

Complete with AC motor, as described **\$25.00**
 with DC motor, 32 or 110 volt **27.00**
 with DC motor, 220 volt,.... **28.00**
 6 in. wire wheel, extra..... **1.50**

NORTHWESTERN ELECTRIC COMPANY CHICAGO

408 S. Hoyne Ave.



Crane's Handisaw

— a practical little bench saw of surprising capacity for all kinds of light sawing. Completely equipped with adjustable rip guide, combination cut-off and mitre guide, 4 in. saw, and 3-8 in. grooved pulley. Top 6 in. by 9 in. Saw projects 1-4 inch. Cast iron stock easily. Specially designed base encloses saw and provides self-emptying dust chute. Adjustment screw elevates top for grooving. Cuts maximum groove 1-8 inch wide. All parts highly finished. Grease cup lubrication. Easily operated with 1-6 H. P. motor. Adapted for small shops or home use. Speedy and accurate—precision adjusted. Nothing to get out of order. High grade in every respect—Fully guaranteed. Send today. Money back if not satisfied.

Only

\$13.50

Money back guarantee.

Shipping weight 22 lbs.

BOICE BROS., 1505 Boice Bldg., 114 23rd St., Toledo, Ohio



Little Giant Drill Press

Just the thing for small shop and experimental work. Mechanically right and well made. Size 0 to 1/4 in. drill. Weight 22 pounds. Price \$15.00.

Send for circular.

SYPHER MANUFACTURING CO.

Dept. "D"

Toledo, Ohio



Buchstein's Fibre Limb

is soothing to your stump—strong, cool, neat, light. Easy payments. Braces for all deformities.

D. BUCHSTEIN CO.
113 5th St. S., MINNEAPOLIS, MINN.



HB AUTOMATIC AIR COMPRESSOR

\$28 Equips Your Garage

with HB Automatic Air Compressor. Easy monthly terms on balance, easily paid by profits from new customers gained by your better service. \$25 brings HB Tire Buffer and Motor Grinder, another big money-maker for your shop. Balance easy payments. Free trial on money-back guarantee. Write today for complete information. Ask about HB Battery Chargers, Ball Bearing Motors, Lighting Generators, etc. \$20 puts an HB Charger in your shop. You make \$150 to \$300 clear profit every month. Now is the time to start. Write us TODAY.

HOBART BROS. CO. Box M55 TROY, OHIO



HB BUFFER & GRINDER

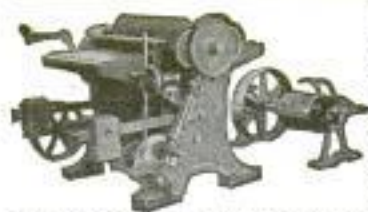

THE CRESCENT MACHINE CO., 93 Columbia Street, Leontonia, Ohio

It is the well known quality of CRESCENT machines that justifies you in selecting one of them each time you have need for wood working machinery. The CRESCENT line is better than ever and will always give you satisfaction in every particular. Ask today for catalog of hand saws, saw tables, jointers, shapers, planes, borers, planers and machines, owing saws, disk grinder, cut off table, hollow chisel mortiser, variety wood worker. Universal wood workers.

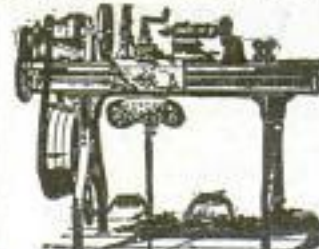

LATHES

9 to 18-inch Swing

List price \$185 and up according to size. When ready to buy send for Lathe Catalog and prices.

W. F. & John Barnes Co.
100 Ruby Street, ROCKFORD, ILL.

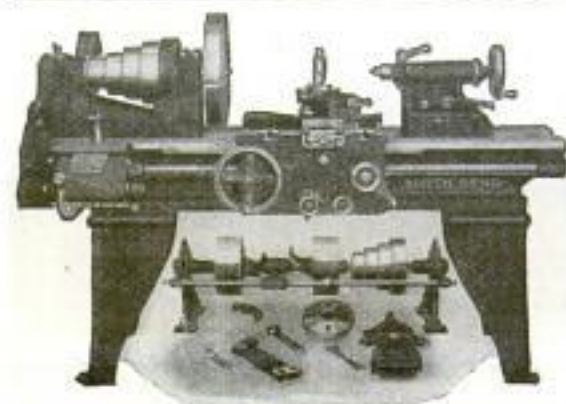

REDUCED PRICES

Back to Normalcy -- 20% Further Reduction
SOUTH BEND LATHES

	Standard Change Gear	Quick Change Gear		Standard Change Gear	Quick Change Gear
9"x3' Lathe	\$176.00	\$216.00	16"x 8' Lathe	\$452.00	\$512.00
11"x4' Lathe	228.00	273.00	18"x10' Lathe	656.00	721.00
13"x5' Lathe	304.00	354.00	21"x12' Lathe	848.00	923.00
15"x6' Lathe	376.00	431.00	24"x14' Lathe	1140.00	1230.00

64-page Catalog No. 73 for 1922 sent free to any address

ESTABLISHED 1906

SOUTH BEND LATHE WORKS
 625 E. Madison St. SOUTH BEND, IND.

How to Run a Lathe An 80-page book, postpaid to any address for ten cents, silver or stamps accepted.

I Made \$1412.63 on the Side

During the Grass Season with your IDEAL Lawnmower Grinder, writes W. F. Kendt.

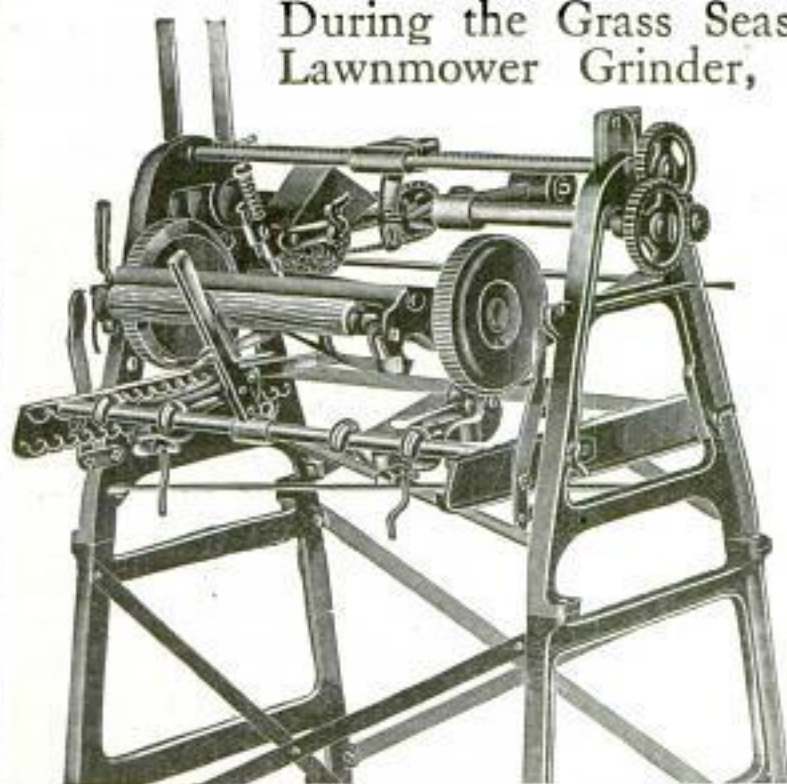

Mr. Kendt lives in Buffalo, and sharpened 790 lawnmowers. Says best investment ever made.

Read What Zeno Says:

Zeno Brandon lives at Middletown, Ohio, and writes:

"I have worked 55 days and made \$820.70. Have made as high as \$38.70 in one day."

WRITE FOR CATALOG

And little booklet, "LET GEORGE SAY IT." It tells the stories of profit as the boys tell it. Mr. Brown bought early, made \$1400 by fall, and built a new shop with the money. Write today.

The Fate-Root-Heath Co.
PLYMOUTH, OHIO

"BOW LEGS and KNOCK-KNEES" UNSIGHTLY

SEND FOR BOOKLET SHOWING PHOTOS OF MEN WITH AND WITHOUT THE PERFECT LEG FORMS
PERFECT SALES CO.
140 N. Mayfield Ave., Dept. S, Chicago, Ill.

Big Engine Sale



Prices Smashed on OTTAWA Engines. Only sold direct from factory. 3 months' trial. Easy Terms. Write for Engine BOOK and Sale Prices Today.

OTTAWA MFG. CO.
531 C King St., Ottawa, Kan.

2 H-P	\$38.50
3 1/2 H-P	\$54.50
5 H-P	\$97.50
7 H-P	\$117.50
10, 12, 16, 22 H-P. at Low Prices	

NEW MOTORS

FOR ALL PURPOSES
STANDARD MANUFACTURERS
PROMPT DELIVERY

ALL SIZES UP TO 5 H.P.

We Specialize In Small Motors & Generators

ALL PHASES AND FREQUENCIES IN STOCK AT ALL TIMES

Largest exclusive Mail Order Small Motor dealers in the world.

CHAS. H. JOHNSTON, Box 113, West End, Pittsburgh, Pa.

WIRELESS, TELEPHONE GENERATORS
500 VOLT - 100 WATT - 3400 R. P. M.
FOR MOUNTING MOTOR GENERATOR SETS.

\$28⁵⁰ EACH

WRITE FOR CATALOG



Send for Your Copy

Everyone interested in lawn maintenance should send for a free copy of this handsome new Moto-Mower book. It will show you how you can keep lawns in condition with only one-fifth of the cutting time and cost required for hand mowing.

It describes our remarkable 24-inch, light weight model, now reduced to only \$175. Also the larger 27-inch model, reduced to \$210.

Extremely simple, durable, and easily operated. Thousands in use in parks, cemeteries, clubs, institutions, and by private estate owners.

Send for copy of the Moto-Mower book today

THE MOTO-MOWER COMPANY
3250 E. Woodbridge Street Detroit, Mich.

WITTE

2 H-P.
Pulls
2 3/4

\$39⁹⁵
F. O. B.
K. C.

From
Pittsburgh
\$44.95

All other
sizes
Lower

Write
for big
FREE Catalog

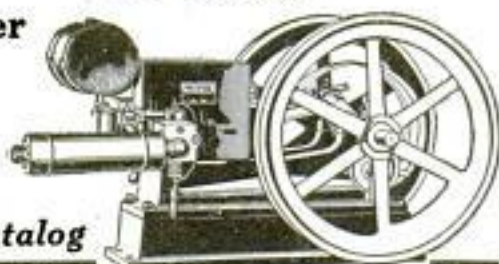

Direct From Factory

WITTE factory price direct saves you money. New quotations are from \$20 to \$400 less than they were last year. All sizes and styles cut in proportion, including Log Saws—Tree Saws—Portable Cutoff Saws and Stationary Buzz Saws.

Lifetime Guarantee Specify what you want and we will send catalog and lowest price—CASH or EASY TERMS, as you wish.

WITTE ENGINE WORKS

1744 Oakland Avenue, Kansas City, Mo.
1744 Empire Building, Pittsburgh, Pa.



SAFEGUARD

your expensive tools. Keep them secure, safe from rust, theft, loss and damage in a

UNION TOOL CHEST

There is a place for every tool. You can check up at any time and know instantly whether any tool is missing. Ask your dealer or write us for illustrated literature describing more than fifty patterns and sizes.

UNION TOOL CHEST CO.
22 Mill St. Rochester, N. Y.

Six Machines in One

Combines bench grinder, polisher, buffer, disc sander, drill and saw for working in wood and soft metals.

A Precision Machine

A high production precision machine especially adapted to the rapid and accurate production of small duplicate parts. Handles 4" and 5" grinding wheels, 6" saws, 6" and 8" sand discs and 3/4" chuck. Saws 1 1/2" wood. Mountable on separate base with motor. Height 10". Weight 31 lbs. Top 10" x 12" easily removed. All metal construction. Easily driven by 1/2 HP. motor. Especially suited for Private Shops, Laboratories, Manual Training Schools, Shipping Dept., Printers, Builders, Cabinet and Pattern Makers, Furniture Repairmen, etc. Machine sold with a Money-Back Guarantee.

We also handle bench jointers, bench band saws, 1/2 and 1/4 HP. Ball-Bearing motors, circular saws, disc sanders, and laser motor driven bench saws.

Write for circular

W. & J. Boice

114 23d St.

Toledo, Ohio



WOODWORKERS! Make Big Money

Put this PARKS in your workshop!



"Four-in-One"—a husky machine for fast, clean work and long service. Steel frame construction. Thousands in use. Four machines in one. Circular rip and cross-cut saw, band saw, jointer, and borer. Guaranteed 10 years. 10 days' free trial.

Many Other
Combination
Woodworkers
LOW PRICES
Send for Catalog

THE PARKS BALL BEARING MACHINE CO.

1500-1540 Knowlton Street, Cincinnati, O.

Canadian Factory: 200 Notre Dame East, Montreal, Canada

PARKS

Light Fibre Legs and Arms

636
Dean Bldg.
RAY TRAUTMAN Minneapolis, Minn.

MYERS WONDERFUL SEWING AWL

Tools in Handle



A complete repair shop in itself. Sews anything heavy or light, leather, shoes, harness, buggy tops, canvas, belts, etc. \$1.00 Postpaid.
C. A. MYERS COMPANY, 6339 Woodlawn Ave., Chicago, Ill.

NEW SINGLE PHASE A. C. MOTORS

1/2 H. P.—110
volt, 60 cycle,
1725 speed, com-
plete with cord,
plug and groov-
ed pulley, \$13.00



3/4 H. P. \$47.00
1 H. P. 58.00
1 1/4 H. P. 62.00
2 H. P. 76.00
3 H. P. 89.00
Include pulley
and base.

ONE YEAR GUARANTEE

3/4 H.P. and larger, 110/220 volt Rep. Ind. Type
Satisfaction guaranteed or money refunded
Illustrated Catalog of Motors and Supplies FREE
HYRE ELECTRIC CO., 615-H So. Dearborn St., Chicago

STASET

Diamond Truer for
Abrasive Wheels

\$5⁰⁰

Half
Actual
Size



diamond-point
wheel-truers.

Genuine diamond keeps abrasive wheels true. Stone guaranteed to remain sharp and in place till completely used up. Send \$5.00 today for one of these guaranteed

Diamond Tool Co., 115 Broadway, New York City

ONE-HAND-Y ELECTRIC DRILL



Weight
3 lbs.

Capacity
 $\frac{1}{4}$ in.

Westinghouse
Universal Motor
Guaranteed

Knight Engineering & Sales Co.

30 West Walton Place,
Chicago, Ill.

210 W. Seventh Street,
Los Angeles, Calif.

BURN YOUR NAME ON TOOLS

WITH
ARKOGRAF

Protect your tools from theft. Write any name, engrave any design on metal with Arkograf as easily as writing on paper with pen or pencil. Complete outfit \$1.50, prepaid anywhere. Interesting descriptive circular free. Write today. Agents Wanted. Arkograf Pen Company 895 Capitol Ave. Portland, Oregon



MAJOR'S CEMENT

Unexcelled for repairing china, glassware, earthenware, furniture, meerschauum, vases, books; for tipping billiard cues, etc. Saves money.

The reliable cement, famous since 1876. Major's Rubber and Leather Cements are good.

All three kinds—20¢ per bottle. At dealers or by mail. MAJOR MANUFACTURING COMPANY, New York

WIRELESS OPERATORS

—Amateur and Professional—need

SOLDERALL—25c per tube

and TORCH, \$1.50



A Paste That Turns Into Metal When Heated
A match will do it, but best results can be obtained by using our new improved torch. Requires no acid or soldering iron. Joins or repairs wires, metal or metalware. Sold by Hardware and Electrical Stores, or sent by us postpaid.

SOLDERALL CO., Dept. P
129 Sussex Avenue NEWARK, N. J.
Dealers Send for Quantity Prices
Beware of Imitations with Similar Names



"Red Devil" Pliers made in 100 styles—one for every need. Known and used the world over. Style 1024—6 $\frac{1}{2}$ inch shown here, \$1.10.

Red Devil

REG. U.S. PAT. OFF.

Slip Joint Plier

the tool you need
in the home



THERE are so many practical uses you can put it to that you'll use it for everything. You will find a pair absolutely indispensable in the household, the office, the workshop or around the car.

"Red Devil" Pliers are made as well as the best materials and expert mechanics can make them. Handles have powerful leverage—fit the hand like a glove—grip as your fingers can't possibly grip—no slipping, no bruised knuckles. Slip joint widens the radius of the jaw action and increases their usefulness.

"Red Devil" Slip Joint Plier No. 1225

—just one of the hundred styles, for all-around handiness. A husky tool with a wire cutter and screw driver. A signed and sealed bond packed with each tool, guaranteeing two years' hard service. Made in 7-inch size—beautifully nickel plated.

At good hardware dealers everywhere
or from us, \$1.30

Mechanics' tool booklet free

SMITH & HEMENWAY CO., Inc.
260 Broadway, New York, N. Y.

"Red Devil" Glass Cutters—the glaziers' standard tools of the world. "It's all in the wheel."
Made in 40 styles. No. 024 shown here, 20c.



Please Mention Popular Mechanics

Copyrighted material

ATKINS

METAL-CUTTING SAWS



Save Time and Money

Atkins' laboratories have discovered the materials and processes of gas-and-oil tempering to make hack saw blades cut faster and easier—*without breakage*. Prove it on your next job. Send us 10c and tell us the cutting you do. We'll send you an 8- or 10-inch blade. If it isn't the best blade you ever used—your money back.

Get This New Book "The Saw in the Shop"

We are just printing a new book full of shop hints—valuable tables—and showing the right saw for every job as well as describing Atkins' Metal Cutting Saws and Machinery. It will save you time, money and material. We'll send it FREE—if you'll fill in the coupon—NOW!

E. C. ATKINS & CO., Inc.
Dept. P, Indianapolis, Ind.

I use saws for.....

Please send "The Saw in the Shop" to

Name.....

Address.....

MONARCH JUNIOR LATHES

"The Biggest Little Lathe Built"

A real engine lathe—small, sturdy, compact, low-cost—guaranteed to do all small work with 1/1000 of inch accuracy. Built with the same care and precision that made **MONARCH ENGINE LATHES** the world's standard of quality and efficiency.

THE MONARCH JUNIOR is ideal for beginners. Occupies small space in your own home or shop. Easy and economical to operate. Simple and trouble-proof, automatic safety features. Fully equipped.

The Greatest Achievement in Lathe Building History

Monarch Junior 9 in. Engine Lathe \$225 With Bench Legs

Full particulars and a Monarch Junior Catalog will be sent you on request.

THE MONARCH MACHINE TOOL CO.
200 Oak Street Sidney, Ohio

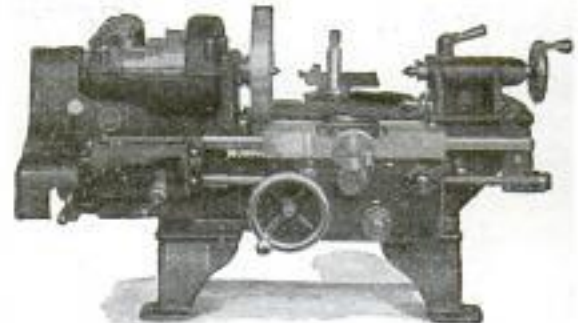

The Midget "FIVE-IN-ONE" Slide Rule is a combination Mannheim, Log-Log, Add and Subtract, Polyphase and Binary Slide Rule. It will instantly add, subtract, multiply and divide any combination involving whole numbers, fractions, decimals and mixed numbers. Gives every possible root and power of every quantity. The graduations are printed on metal, coated with white enamel and are grease and waterproof. While it is the most versatile calculator ever invented, its operation is simple and easily understood. Diameter 4 inches. Price with 16-page instruction book, \$1.50. Leatherette carrying case 50c extra. Catalog free. Your money back if you are not satisfied.

GILSON SLIDE RULE CO., Niles, Mich.



Piliiod General Service Case

Heavy copper-plated over zinc. Brass-plated hardware. Handsome, durable, great for machinists, repair men, motormen, autoists, etc. Will last a lifetime.

FREE—Illustrated folder including tool cases for every purpose.

THE PILLIOD LUMBER CO.

Dept. 1 SWANTON, OHIO



Adjusts Instantly to Any Length

Just slide it out. Gives exact inside or outside diameter. No folding. Accurate, strong, brass trimmed. Any length 2 to 8 feet. If not at dealer's, sent postpaid.

Master Rule Mfg. Co., Inc.
841-43 East 136th Street
NEW YORK CITY

"Interlox"
MASTER SLIDE RULE

THE WORLD FAMOUS Alvan Clark Telescope

We are now able to supply these wonderful instruments for terrestrial and astronomical observations. Cut shows new type 3" portable terrestrial. Light weight—compact—easily carried anywhere—highest quality throughout. Circular and prices on request.

THE ALVAN CLARK & SONS CORP.
Makers of the famous "Yerkes" and "Lick" Telescopes
55 Henry St. Cambridge, Mass.





Get this valuable Book on Better Lawn Care

Every one interested in the care of large, beautiful lawns should have a copy of this book which tells all about Ideal Power Lawn Mowers. It shows many photos of well-known homes, parks, golf clubs, cemeteries, colleges, etc., where the lawns are cared for the "Ideal Way." It tells about the Ideal Junior, a moderate-priced power mower for medium-sized lawns, the 30-inch Ideal Power Lawn Mower for large lawns, and the Ideal Triplex Power Mower for large parks, golf clubs, etc.

Write for this book today—learns how to keep your lawn in better condition at less cost.

IDEAL POWER LAWN MOWER CO.

R. E. OLDS, Chairman

418 Kalamazoo St. Lansing, Mich.

World's Largest Builders of Power Lawn Mowers.

Dealers in all principal cities.

IDEAL Power Lawn Mowers



The Ideal Junior

BINOCULARS

Special value in highest grade genuine imported FRENCH CONDE prismatic binoculars, in fine calf skin case with straps. 8 power; 32 mm. 23 oz.

Sent on Approval brand new; not war stocks. Over 1000 prs. sold last year. Drop us postcard for illustrated circular.

BARLER & CO.
647 N. Michigan Ave.
CHICAGO



The handy-man-around-the-home would be lost without his Bernards. Pliers that grip like a vise and cut like a knife thru butter. Good hardware dealers sell 'em.

MADE IN SEVEN SIZES

Send for illustrated Plier Booklet M



PARALLEL JAWS

BERNARD PLIERS

WM. SCHOLLHORN CO.
NEW HAVEN, CONN.



OUTSIDE CUTTER



TOOL CHESTS

for Machinists & Toolmakers

Every tool arranged in order. No up-to-date mechanic should be without one. A Gerstner Case costs no more than some tools, and will last a lifetime. Catalog free.

Gerstner & Sons

717 Columbia Street DAYTON, OHIO



"GET BUSY" MAKE SCREENS WITH DIAMOND PRESSED STEEL CORNERS

No mortises, mitres, screws or tacks required. Unbreakable screen, fitting attached, made in a few minutes. Big profits making screens to order.

Sample set by mail, 50c postpaid.
DIAMOND HARDWARE MFG. CO.
224 FOURTH AVE., PITTSBURGH, PA.

SAMSON No. 1 HAND PUNCH

Handles interchangeable. Punches and Dies as Illustrated

Maximum punching capacity $\frac{3}{8}$ " thru 20 gauge untempered metal. Will also Perforate Paper, Cardboard, Leather, etc., up to $\frac{1}{4}$ " thickness. A Powerful Punch of general utility, made of Drop Forge Steel. Throat $1\frac{3}{8}$ " deep.



PRICE, Postpaid in U. S. & with 3 extra Punches and Dies, any sizes specified,
\$3.50

THE MACHINE APPLIANCE CORPORATION
351 Jay Street, BROOKLYN, N. Y.

SIZES OF HOLES—PUNCH NO. 1

HAWAIIAN IM. DIAMONDS



No. 2010 Special price \$2.98

The Greatest Discovery the World Has Ever Known

Just to advertise these famous Im. diamonds we will send you one of these 14kt gold 1 ring, postage paid. When it arrives pay postman \$2.98 C.O.D. (change to cover cost, etc.). Only 10,000 rings given away. Money refunded if you can tell it from a genuine diamond. Read size of finger.

KRAUTH & REED

Dept. C Masonic Temple Chicago



No. 2011 Special price \$2.98



The "BEST" LIGHT

Positively the cheapest and strongest light on earth. Used in every country on the globe. Makes and burns its own gas. Casts no shadows. Clean and odorless. Absolutely safe. Over 200 styles, 100 to 2000 Candle Power. Fully Guaranteed. Write for catalog. AGENTS WANTED EVERYWHERE.

THE BEST LIGHT CO., 324 E. 5th St., CANTON, O.

Different from all others—the NEW BENJAMIN



AIR RIFLE

Made on a different principle from all other Air-Rifles.

The Benjamin is really a strong air-pump used to compress the air in the air chamber to any degree of power desired. From one to six strokes of the pump give all the force necessary. Each additional stroke gives increased power. The Benjamin works on the same principle as all air-drills and air-hammers—with this difference

You control the shooting force as you desire. Look at this block of hardwood. It shows how Benjamin power is regulated as you wish.

You can't have accidents with a Benjamin. It's safe, always, because you control the power. The Benjamin never loses shooting force, and has no springs to get out of order or shake your aim. Write us for an interesting folder about this wonderful air-gun.

For sale by all dealers.
Price \$5.00.
BENJAMIN
AIR-RIFLE & MFG. CO.
615 N. Broadway, St. Louis, Mo.

Ask your dealer for demonstration.

Pacific-Coast
Representatives:
Stuart & Otto
229 Wilcox
Bldg., Los
Angeles,
Cal.



DEAF?

Make Us Prove That You Can Hear!



We do not expect those who are hard of hearing to take our word that the Acousticon will make them hear clearly once more—No one's word should be taken for that. We do expect, however, that for their own individual satisfaction, before giving up in discouragement, they will permit us to loan them the

1922 ACOUSTICON

**For 10 Days' FREE TRIAL
No Deposit — No Expense**

500,000 delighted users have given us this permission to their relief and profit. Most of them had tried many other aids and treatments without avail—But the Acousticon has patented features which cannot be duplicated. So disregarding your past experiences, write for your free trial today.

DICTOGRAPH PRODUCTS CORP.
1307 Candler Bldg., 220 W. 42 St., N. Y. City.

Please Mention Popular Mechanics

DIAMONDS WATCHES CASH OF CREDIT

"SYLVIA" Diamond Ring
Blue white, radiant, perfect cut Diamond. The ring is 18-K Solid White Gold, carved and pierced. Extra special at \$100. Credit terms \$2.50 A WEEK
Others at \$75, \$150, \$200 and up.

Genuine Diamonds GUARANTEED
Our Diamonds are distinctive in fiery brilliancy, blue white, perfect cut. Sent prepaid for your Free Examination, on Charge Account.

Send for Free Catalog
Everything explained. Over 2,000 illustrations of Diamond-set Jewelry, Pearls, Watches, Wrist Watches, Mesh Bags, Silverware.

WHIST WATCH \$2.25 A Month

Cushion Shape
Gold filled, guaranteed 20 years. 15 Jewels, warranted. Ribbon bracelet with gold filled clasp. Special \$21

Octagon, Tonnau, Cushion and other shapes, in White Gold, as low as \$30

LOFTIS THE OLD RELIABLE CREDIT JEWELERS
108 N. State St. CHICAGO, ILL.
BROS & CO. 1908
Stores in Leading Cities

Be the First in Your Club

School, City or Town, to wear this pure, all wool sweater, double collar and cuffs. Your choice in colors. This jersey was selected by 10,000 of my customers for last season. Your chum will recommend it. Send for my big illustrated catalogue. Write me and learn my offer for your club's order. Popular Prices. Best Grade Sporting Goods—Baseball, Basketball, Tennis, Golf, Football etc.

WRITE ME NOW

Jack Shannon Co., Dept. 46, 111 So. Dearborn St., Chicago

MONEY IN MUSHROOMS

NOW TIME TO START
BIG DEMAND. HIGH PRICES BEING PAID
An uncrowded occupation. Exceptional opportunities for live men and women. Raised at home. Only small space needed. Small expenditures will give profits. Booklet telling all free. Write Nat'l Spawn Co., Dept. 12, Waban, Mass.

SQUAB BOOK FREE

Squabs are selling at the highest prices ever known. Breed them and make money. Write at once for free book, prices, etc.
Plymouth Rock Squab Co., 634 Howard St., Melrose Highlands, Mass.

RAISE BELGIAN HARES

New Zealand Reds — Flemish Giants — American Blues. BIG PROFITS, WE PAY \$1.50 TO \$8 EACH. Also Cavies, Mink, Skunk, Fox, Minkrat, Etc. Easily raised anywhere. 100% FREE!
Illustrated book "COMMON SENSE RABBIT RAISING", quarterly journal, and copy of America's leading small stock magazine, all for 10 cents. Address Outdoor Enterprise Co., 1009 S. E. BLVD., KANSAS CITY, MO.

THE AJAX EYELET FASTENER

BINDS AND INSERTS AJAX EYELETS IN PAPER, CARDBOARD, LEATHER OR CLOTH

It Saves Time by Punching the Hole, Feeding the Eyelet and Clinching It in One Operation.

Drop the eyelets into the magazine and go right ahead. Order from your stationer or direct.

Write for our catalogue of office tools

MACHINE APPLIANCE CORPORATION

351-353 Jay St. Spec. Dept. Brooklyn, N. Y.

PRICE WITH 1500 AJAX EYELETS. \$10.00 DELIVERED IN U.S.A.



Harley-Davidson

World's Champion Motorcycle

PRICES REDUCED ONE HALF
Rebuilt and Guaranteed

1915, three speed twin electric \$125; 1916, \$135; 1917, \$150; 1918, \$165; 1919, \$180; 1920, \$200. Shipped on approval. Catalog A free, describing Harley-Davidson, Excelsiors, Indians, Smith Motors at \$40 and upwards. Liberty Bonds taken at full face value. Letters of recommendations from hundreds of satisfied customers. Refs.: Banks and Harley-Davidson Motor Co. Rapid service on 1902 to 1922 Harley-Davidson parts. 100 page PARTS catalog B, 25 cents. Stamps or coin.

WISCONSIN CYCLE SALES COMPANY

726 NATIONAL AVENUE

Oldest and Largest
Dealers in the North-
west

MILWAUKEE, WIS.

"Milwaukee—
World's Largest
Motorcycle Center"



START IN BUSINESS



**Make Real Money
on Small Capital**
All over the U. S. and Canada
we are establishing Vulcaniz-
ing Service Stations. Start one
in your town. Make \$10 to \$30
per day on a \$350 investment.
We instruct you and furnish
the **Most Modern Methods
and Equipment**—

THE ANDERSON
Known the World Over
We have 34 Schools in U. S.
and 4 in Canada. One is near
you. School pays you \$5 per
day while learning to operate
your station. Write for full
particulars—**TODAY.**

THE ANDERSON STEAM VULCANIZER CO.

Manufacturers of Modern Tire Repair Equipment,
103 Williams Bldg., Indianapolis, U. S. A.

You Can Save \$40.00

By recovering your old auto top
frame yourself. We make these
recoveries to fit all makes and
models of cars. Any person that
can drive a car can put it on.
We furnish instructions, Roof
and quarters sewed together with
rear curtain, fasteners, welts and tacks. All complete. Give
us the name, year and model number of your car, and we will
send you our catalogue with samples and quote you exact price.
LIBERTY TOP & TIRE CO., Dept. E7, Cincinnati, O.



MOTORCYCLE BARGAINS

Save 25% to 65%

on Slightly used and Rebuilt Motorcycles, Side
Cars, Johnson Motor Wheels, Evans Power
Cycles, Bicycles. Send for **Free Bargain Bulletin** and
Money Saving Message, listing hundreds of Bargains in
used, rebuilt and new machines, supplies, accessories, etc.

AMERICAN MOTOR CYCLE CO., CHICAGO
Dept. 514 2047 W. Chicago Avenue.



Delivered to You Free

for 30 days trial on approval. You can have your
choice of **44 Styles**, colors and sizes of the famous
RANGER Bicycles. Express prepaid. **Factory-to-
Rider** Prices save you \$10 to \$25 on your bicycle.

12 Months to Pay if desired. Many boys and girls
easily save the small monthly pay-
ments. Parents often advance first payment.

Tires best quality, at factory prices, express prepaid.
Lamps, wheels and equipment, low prices. Send
No Money, do business direct with makers.

Mead Cycle Company
Dept. C108 Chicago

Write today for free
Ranger Catalog, fac-
tory prices and marvel-
lous easy payment terms



MOTORCYCLES

RELIABLE STANDARD MAKES that you can **DEPEND ON.**

Enjoy the glorious experience of
going wherever you like—whenever
you like. The price is within your
means—35% to 50% less than oth-
ers. These machines are slightly
used, thoroughly overhauled or rebuilt.
Send for catalogue.

MYEROW BROS.,
258 Columbus Ave., Boston, Mass.

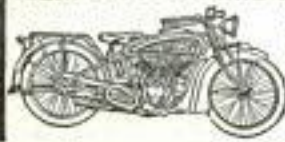

CHAMPION

of the Northwest

Arthur
Lundberg



Lundberg's wonderful victory over a
big field, at Portland, Oregon, where he
captured both the Northwest and Ore-
gon State championship scalps, was won
with a Dayton—the fastest, sturdiest and
most dependable bicycle on the market.

The story of Arthur's success is interesting—it's
a story of rider and bicycle leadership.

That the bicycle of his selection should have
been a Dayton is only natural.

And there are some important reasons why **you**
should own and ride a Dayton.

Dayton Bicycles

"Leaders Since Your Dad Was a Boy"

May we send you (free) a copy of our new art
catalog? Most of all we would like to send you
(also free and postage paid) a copy of a most in-
teresting booklet entitled: "**How to Choose a
Bicycle.**"

This booklet tells a lot about bicycles in general
—bicycle facts that every boy or girl should know
before he or she can safely decide upon a particu-
lar type or make of bike. Send for your free copy of
"How to Choose a Bicycle" at once. Address:

Cycle Division

The Davis Sewing Machine Co., Dayton, O.

FILL IN—CUT OUT—MAIL TODAY

The Davis Sewing Machine Co., Dayton, O.

Please send me, without obligation, your booklet No.
28, "How to Choose a Bicycle" and the 1922 Dayton
Catalog.

Name.....

St. and No.....

City and State.....

Age.....

Please Mention Popular Mechanics

An Easy Way to Make Money



Don't be content to plod along on a small salary. Be independent. Go in the tire repairing business and make \$60 or more a week. One man made \$45 the first day he received his outfit. Others are making \$25 a day and hundreds of wide-awake men are making \$200 to \$500 a month.

No experience needed. We teach you how. Very little capital required. But slight risk, as every car owner in your town is a possible customer. Jobs are plentiful because tires blow out and puncture every day. Business is good the year round.

SHALER Tire Repair Outfit, \$75

Will do as much and as perfect work as the big \$250 to \$500 vulcanizing outfits. A boy can vulcanize perfectly with this simple machine. It's the only vulcanizer that has **Automatic Heat Control**. It must vulcanize just right. It can't undercure or overcure a tire. Requires no watching or regulating. You can learn to do expert tire vulcanizing in half an hour with the Shaler.

WRITE FOR FREE BOOK "HOW TO OPEN A TIRE REPAIR SHOP" and complete Catalog, which gives full information.

WRITE QUICK BEFORE SOME HUSTLER GETS AHEAD OF YOU.

C. A. SHALER CO., 2004 Fourth Street, WAUPUN, WISCONSIN



\$3⁰⁰

The Stromberg Gasoline Filter

EVERY car should be equipped with a Stromberg Gasoline Filter. It cleans the gas—removes all dirt and water—just before it enters carburetor. Eliminates repair bills. Needle valve shuts off flow of gas when sediment chamber is removed for cleaning. Easily attached to vacuum tank, carburetor or gas line—do it yourself. Well made—outlasts car. Prevents theft—it locks car.

Avoids trouble.

State name and model of your car.

Stromberg Motor Devices Co.
Manufacturers of the Stromberg Carburetor

84 E. 25th St. Dept. 514 Chicago

Ford Owners WANTED!

to Show and Sell

GREY GOOSE

SHOCK ABSORBERS



Easiest riding absorber of all time. Easily and quickly attached—only 4 bolts to change—requires no special tools. Put a set on your car. Invite other Ford owners to ride with you. Make sales easily at our price of only \$10 for a complete set of 4. (\$12 in Rocky Mountain States and West.)

We pay liberal commissions. Many of our men are making \$50 to \$150 a week. Sales experience not necessary. Just use your Ford to drive and demonstrate Grey Goose. They almost sell themselves. Order direct from this advertisement. Money back if not satisfied. Write for Free Folder.

Indiana Parts Co., Dept. 195
Richmond, Indiana

ADVANCE DOOR LOCKING HANDLES for FORD Closed Cars



Installed quickly by anyone. They fit in place of original handles. Ford owners delighted with them. Left handle locks automatically, right handle locks with key. Fully guaranteed. Agents: Beautiful sample pair furnished with full particulars. \$3.50 U. S. \$4.50 Canada. Check, money order or C. O. D.

C. B. HAVEN CO., 544 E. Fort St.
Detroit, Mich., or Windsor, Ont.

MAKE YOUR FORD INTO THIS SPORT CAR \$ ONLY 6⁴⁰

Other types down to \$1.50. Famous \$6. **Pal-Pal** life-size patterns and simple instructions show all details. You can easily convert your Ford into his fast, sporty Sport Car as hundreds have done with a few dollars worth of material from the hardware store. No need to lay up the car. The "PAL" with casted disc wheel patterns. Pressed Metal Streamline Rear only \$6.40 delivered. Built low, rides wonderfully easy. Order NOW while we can make good delivery. Send 5c coin for illustrated prospectus a 10-part Double, "Nifty" Top and "Green" Windshield. **Kampel Co., 84 Kampel Bldg., Guttenberg, Iowa**



Small Cash Payment Starts You Making Big Profits Charging Batteries



This Season's Biggest Money-Maker—HB BATTERY CHARGING

Brings new customers, increases profits. \$20 puts an HB Charger in your shop. Profits quickly pay balance on easy terms. Absolute money-back guarantee. No skill or electrical knowledge required. You can clear big profits every month. Sizes for 8, 10, 16 or 32 batteries. Sturdy, dependable, nothing to wear out or break. No expensive repairs or costly renewals. Let us recommend outfit to meet your needs. Get started now at season's opening. Write us your plans. Ask about HB Air Compressors, Motor Grinders, Lighting Generators, Tire Buffers, etc. All big money-makers, sold on easy payments. Complete information sent on request. Write today.

HOBART BROS. CO., BOX M 5, Troy, Ohio

You Can Clear \$150 to \$300 a Month



Champions



**For
Every
Engine
Everywhere**

**Your Dealer has Champions
and can tell you why
you should buy a full set.**

Champion Regulars now 75¢
Champion X now 60¢

CHAMPION SPARK PLUG CO.

Toledo, Ohio

Make Your Ford Ride like a "Six."



Save the expense of shock absorbers. Enjoy real riding comfort—without the vibrations, shocks, squeaks and jars. Install a set of Q. E. D. Spring Oilers on your Ford Car and ride in ease.

Q.E.D. Spring Oilers Oil every leaf of your springs, oil the channel iron of rear spring, prevent rusting, remove any rust that has accumulated, help prevent broken springs, and prevent wear and tear on motor and body.

**No holes to drill
No bolts to disturb
Installed in 3 minutes
Easy to install yourself**

\$2.00 Money Back
complete if Not
delivered Satisfied

You run no risk. Order today. If your dealer cannot supply you, send \$2.00 and set of four will be shipped immediately. Get your car in shape now.

County representatives wanted

PRACTICAL AUTO ACCESSORY CO.
Room 405, 177 N. State St. Chicago

AUTO OWNERS WANTED



To introduce the best automobile tires in the world. Made under our new and exclusive **Internal Hydraulic Expansion Process** that eliminates **Blow-out—Stone-Bruise—Rim-Cut** and enables us to sell our tires under a

10,000 Mile Guarantee

We want an agent in every community to use and introduce these wonderful tires at our astonishingly low prices to all motor car owners. Write for booklet describing this new process and explaining our amazing introductory offer to owner agents.

Hydro-United Tire Co.

Dept. 100—Chicago San Francisco Pittsboro, Pa.

**For Charging Radiophone and
Automobile Batteries
from lamp socket, use**

The Sterling
Portable Rectifier



Individual battery charging at last practical and inexpensive. The Sterling charges a nearly exhausted battery overnight for a few cents. Improved vibrating reed type, simple, effective, and durable. One thumb-screw does all the adjusting. Automatically tapering charge safeguards against over-charging.

Price Complete - - - \$16.00
West of Rocky Mts. - - 17.00

Initial Charging Rate, 6 Volt Battery, 15 Amps. Write for Bulletin giving full information

THE STERLING MANUFACTURING CO.
2836 PROSPECT AVE. CLEVELAND, OHIO

TWO-YEAR GUARANTEED BATTERIES SAVE 50%



Famous "Royal" Batteries—highest quality made—now selling direct from factory to car owner. You save half. We give **written 2-year guarantee**—longest on any battery. Big responsible organization backs guarantee. **Batteries for any car, tractor or gas engine.**

Send no money Save time. Order from this ad. Battery, fully charged, shipped immediately—by express C.O.D. You run no risk. One location same for eight years. References: Nat'l Bank of the Republic, Dan or Broadway.

Free Booklet If you want descriptive literature first, send for free booklet. Give full details of this superior battery. Get this booklet before you buy any battery. Write today! Give year and model of your car.

K - E BATTERY CO., Dept. 107
14 E. Jackson Blvd., Chicago

Largest Exclusive Mail Order Battery House in America
Members of Chicago Association of Commerce

© 1921
SPECIMEN PRICES
Ford-Dort-Chev. \$18.80
Overland-Buick 21.85
Maxwell-Dodge 25.60
Rate 50% saving on all cars

Please Mention Popular Mechanics

Copyrighted material



Be Your Own Top Maker

WE manufacture a complete line of auto fabrics for Ford and all other makes of automobiles. All materials ready to put on. Complete instructions with every purchase.

Schneider's DeLuxe One-Man Top, \$32.50
complete with side curtains for Ford

Our Ford Top Recovering No. 10—Pantasote
guaranteed, which includes two nickel-plated bevel glass windows..... **\$12.50**

Our Ford Top Recovering No. 6— \$6.95
Includes two glass windows.....

Back Curtain with 2 Glass Windows, \$2.50
Slip Covers from \$4.50 up

Send for Samples of Materials and Catalogue No. 3

DEALERS WRITE FOR SPECIAL PROPOSITION

A. E. SCHNEIDER MFG. CO.
4265 Hudson Blvd. WEST HOBOKEN, N. J.

12 Months to Pay

You can easily earn or save money for the small payments. Parents often advance first payment to help buy a **RANGER** bicycle. Choice of 44 styles, colors and sizes. **FACTORY-TO-RIDER** prices. **DELIVERED FREE** express prepaid on approval for **30 DAYS' TRIAL**, actual free riding test.

Tires best quality, at factory prices, express prepaid. Lamps, wheels, and equipment, low prices. **Send No Money.**

Mead Cycle Company
Dept. C108 Chicago

Write today for free Ranger Catalog, factory prices and marvelous easy payment terms



SAVE 75% ON TIRES OR 4 TIRES FOR THE PRICE OF ONE

Most sensational used tire offer. Our special buying advantages and tremendous business throughout the U. S. make this remarkable tire offer possible; every tire rigidly inspected and sold on the fair, square basis of satisfaction; when we say save 75% on your tire bill we mean it.



Size	Tires	Size	Tires	Size	Tires
30x3	\$4.00	32x4	\$9.00	32x3 1/2	\$8.00
30x3 1/2	5.00	33x4	9.00	32x4	9.00
32x3 1/2	6.50	34x4	9.75	33x4	9.50
31x4	7.00	35x4	10.00	34x4	10.00
32x4	7.50	36x4	10.00	34x4 1/2	12.00
33x4	8.00	35x5	11.00	35x4 1/2	12.50
34x4	8.50	37x5	11.00	37x5	14.00

Tire users from coast to coast buy from us regularly. Every one satisfied, including countless Chicago motorists who deal with us personally. They demand the mileage of first class tires and get it at about one-fourth usual cost and so can you.

How to Order: Send \$1.00 deposit for each tire ordered, balance C. O. D., subject to your examination. State whether S. S. or Clincher is desired. **10% DISCOUNT** for full amount with order.

ROYAL TIRE & SUPPLY CO.

1245 S. Michigan Ave.

Dept. P.

Chicago, Ill.

Evans **\$135**

150 Miles to Gallon of Gasoline



LOW FUEL COST
DEPENDABLE
SPEEDY

America's Lightest Weight and Lowest Priced Complete Motorcycle

Join the thousands of motorcycle riders who have chosen the Evans because it costs less to operate, is easier to handle and readily understood even by a boy.

The Evans catalogue, fully describing this wonderful machine, sent upon request

Attractive offer to rider agents in territory not controlled by an Evans dealer

Manufactured by

CYCLE MOTOR CORPORATION

Box 1031 - Rochester, N. Y.



2000 MORE MILES PER TIRE

PULOF
(PULL-OFF)
DUST CAP
SNAPS ON AND OFF INSTANTLY.

It actually takes more time and labor to remove and replace the screw style dust cap than it does to pump up a whole lot of tires. Keep your tires inflated and save thousands of miles.

You can save yourself time, greasy hands and back breaking labor by equipping your car with PULOF.

Agents Here is an accessory that sells fast—write today for our interesting proposition.

CHICAGO AUTO SPECIALTY CO., Inc.
1349 Bauwans St. Chicago, Ill.

PRICE
Set of 4
\$2.50
Retail

10c. CHARGES STORAGE BATTERY

FROM A LAMP SOCKET At HOME Or BUSINESS With An F-F

BATTERY BOOSTER, which is a FULL WAVE Magneto Rectifier for 100-125 volt 60 cycle A. C. Leave Battery Just as it is in Your Car, Snap Charger Clips on Battery Terminals, Turn Switch, & Battery Will be Charged in 1/2 hour or less. No DRAINING whatsoever All Guess Work. A Complete Portable Automatic Charging Unit, with inflexible Carbon Rectifying Brushes, which Charge uninterrupted. No skill Required. A Fully Charged Battery Starts Car & Truck Quick, thus fewer expensive replacement Storage Batteries must be bought, when kept Fully Charged. Do Not Lose to Buy a Booster than to be without one. Do Not Think Your Battery dead and worn out simply because it will not start your car. Buy a Booster. Fill it with Idle and Hear Engine Spin. A BOOSTER SAVES YOU MONEY & Losses & Lifetime.

Bestman Type C charges A 6 volt Battery, 6 amps \$15
Type B charges 2 to 110 volt Radio B Batteries \$15
Radio Type A-B charges Both A & B Batteries \$25
Bassman Type 12 charges 12 volt Battery 5 amps \$15
Type 15A charges 6 volt Battery at 12 amperes \$24
Type 1612 charges 12 volt Battery at 7 amperes \$24
Type 1620 Combination Type C-charger Both 6 & 12 volt Batteries at 12 & 7 amperes... \$30



CHARGING SERVICE

The Larger Types are recommended for heavy Batteries, or where time is limited. Shipping Weights Complete with AMMETER & BATTERY CLIPS, 12 to 15 Pounds. Mail Check for Prompt Express Shipment. Or if for Parcel Post Shipment add Postage & Insurance charges. Or Order us for the Type you desire C. O. D. Order Now or Write Immediately for FREE Descriptive BOOSTER BULLETIN 24. For GROUP CHARGING write also for Free ROTARY RECTIFIER BULLETIN 24-A. In Charge up to 25 Cells Commercially & Rectifier for Wireless High D. C. Voltages. **THE FRANCE MFG. CO., CLEVELAND, OHIO, U. S. A.** Canadian Representatives: Battery Service & Sales Co., Hamilton, Ontario, Canada.

GET FACTORY PRICES
ON GALVANIZED

ROOFING



EDWARDS "REO" Metal Shingles

Absolutely rust-proof—edges as well as ridges. Not the space of a pin point exposed to weather. Also fire and lightning proof. Reduces insurance. Outlast building. Need no repairs—and all roofing expense. Easy to lay—one man can do the work—hammer and nails only tools needed. Lay over old shingles if desired. Patent interlocking device makes water tight seams—all nail heads covered—no rust or leaks possible.

Exclusive "Tightcote" Process
Put all Edwards Galvanized Roofing in a class by itself. Bend, twist, strike it with a hammer as much as you like—you can't loosen or scale off the galvanizing—due to our "TIGHTCOTE" process which practically makes zinc covering a part of the metal sheet. No other galvanized roofing can withstand this test.

FREE Roofing Book Don't buy roofing until you get our big free book, describing Edwards famous "Tightcote"



Roofing, Siding, and Ceilings, and our lowest factory prices. We sell you direct and save you in-between dealers' profits. Write for Roofing Book No. 180.

Low-Priced Garages

Lowest prices on Ready-Made Fire-Proof Steel Garages. Set up any place. Send postal for Garage Book showing styles.



Corrugated



Patent Side Lock
No nail heads in sight or exposed to the weather



Brick Siding



THE EDWARDS MFG. CO.
510-550 Pike St. CINCINNATI, O.

For FORD CARS Any Year, Any Model
Genuine HEINZE-SPRINGFIELD \$49.75
Starting and Lighting System

Limited supply—latest improved type! Price includes Ammeter, Dash and Tail lights, Switch Lock and new high-grade battery of standard make. Quick, sure start—bright, steady lights. Easily attached to any Ford. Order direct from this ad or write for literature.

The Service Products Co., Dept. 9, - Springfield, Ohio

\$45 Buys This Motor Cycle

It's a Harley-Davidson, 16 HP., twin chain drive, magnets and clutch. It has power and can get up and go on the open road, at a speed which thrills. This is only one of hundreds of bargains in used motor cycles which you can get. Send for Free Catalog. It tells of big bargains and tremendous values in used motor cycles. Repairs quickly done. Motor cycles exchanged. Send as your machine to be overhauled.



Oliver Cycle and Motor Co., 1045 N. Grand Ave., St. Louis, Mo.

FORD and CHEVROLET SPEED BODIES

Dealers:
Write for Accessory Catalogs

**MAKE DRIVING
A PLEASURE**



Equip your old Ford or Chevrolet Chassis with one of our new distinctively modern bodies. Up-to-date Roadster, Touring and Speedster designs. Ford bodies as low as \$29.50 and up. Territory open for live wire dealers and agents. Make real profits. Buy Direct from Factory

FEDERAL MOTOR SUPPLY CO., Inc.
1424 S. Blue Island Ave. Chicago
CANADIAN DISTRIBUTORS
Federal Auto Body Co., Toronto, Ont.; Campbellton, N. B.



ESTABLISHED
1820

THIS IS OUR
102d YEAR

"Fishing Tackle that's
Fit for Fishing"

ONE OF 16,400 ITEMS



"Glowbody" Minnow

Crystal body contains tube of permanently luminous material. Looks like wriggling worm as it spirals through water. Attracts bass day or night. Double hook easily detached and single hook substituted if desired. Crystal body protected by wires. Retail at \$1.00.

Ask your dealer for Abbey & Imbrie quality tackle.
Catalog—A Fishing Handbook—on receipt of 10c.

ABBIEY & IMBRIE

Division of Baber, Murray & Imbrie

97 CHAMBERS ST.

NEW YORK

**FORDS RUN 34 MILES
on Gallon of Gasoline**



Wonderful new carburetor. Guaranteed to reduce gasoline bills from one-half to one-third and increase power of motors from 30 to 50%. Start easy in coldest weather.

Sent on 30 DAYS' TRIAL

Fits any car. Attach yourself. Fords make as high as 34 miles to gallon. Other cars show proportionate saving. Send make of car and take advantage of our special 30-day trial offer. Agents Wanted.

AIR FRICTION CARBURETOR CO.

3380 Madison Street

Dayton, Ohio

**Tires With 500 Nail
Holes Leak No Air**

A new puncture-proof inner tube which in actual use was punctured 500 times without showing the loss of any air when tested by a tire gauge has been invented by Paul B. Coats, an electrical engineer of Chicago. It is inflated with air and has the same appearance as the regular inner tube, yet it removes all the necessity of changing tires until the casings are entirely worn out. Cars using these tubes are making from 8,000 to 12,000 miles without removing a tire from the wheel. A wonderful feature of this new tube is that it can be produced and sold at about the same price as the ordinary tube. Mr. Coats has turned over all his rights on his invention to the Milburn Tube Co., 425 W. 47th St., Chicago, who wants to place these tubes in a few cars in every community. They will make a very liberal offer to any one who wishes to try them at the company's risk, until a distributor is appointed for the territory.

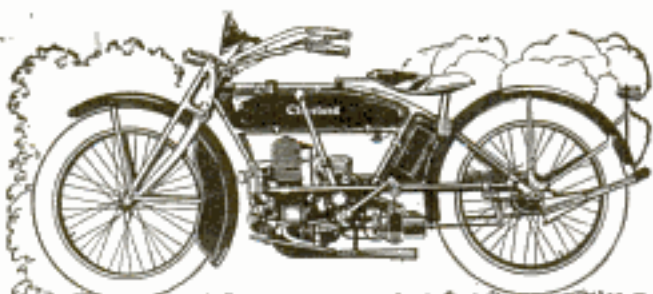

Lowest Price—**\$185**
Lowest Upkeep

of all real motorcycles. Cleveland's \$185 price is half the average motorcycle price. Cleveland travels 75 miles to the gallon of gas—15,000 miles on a set of tires.

America's super steel, Mo-lyb-den-um, gives the Cleveland remarkable sturdiness and durability with light weight.

Low saddle, low center of gravity and light weight make the Cleveland as safe as a bicycle. The Cleveland will give you all the pleasure, comfort and dependability of the big machine at half its cost.

Write now for catalog "M." If there is no Cleveland dealer in your city can you recommend a "live" man to represent us?

CLEVELAND MOTORCYCLE MFG. CO. **7th**
CLEVELAND, U.S.A. **YEAR**



MOTOR CYCLE Cleveland

CAR OWNERS Wanted!

To use and introduce the world's finest, wonderful new process, automobile tires. Massively oversize! Astonishing guarantee! Real wholesale prices to one agent in each community.

INTERNATIONAL TIRES PIRON (No-Rip) TUBES

WRITE for our amazing introductory offer to owner agents

Dept. 109 INTERNATIONAL RUBBER CORPORATION, Grand Rapids, Mich.



DIAMONDS

ONE CARAT \$195⁰⁰

Former retail cash price \$325.

New low prices 40% discount.

3/4 carat \$148.25;

1/2 carat \$97.50;

1/4 carat \$48.75. If satisfied, pay 20% down; balance in 10 monthly payments.

10
MONTHS TO PAY

Genuine sparkling blue-white diamonds now sold direct to you by DIAMOND IMPORTERS on credit at 40% discount. 14 Kt. solid gold ring included free. We guarantee to satisfy you or return your money. **30 DAYS FREE TRIAL!** Order direct from advt. or write for 128-page bargain catalog, sent free. \$1,000,000 and 42 years' experience are back of our guarantees.

B. GUTTER & SONS 172 NASSAU STREET
Div. 367, NEW YORK



Jimmy's Diary Monday, May 8th—"After school hopped on bike and went fishin'. Comin' home had a puncture. S-s-s-s-she went and stopt. Gee, I was lucky. It was in the tire I had put Neverleak Tire Fluid in three weeks before. Didn't lose any air because Neverleak stopt the leak."

A 25c tube of Neverleak saves expensive repairs and makes tires last longer. At all bicycle and repair shops.

FREE—Send for handy Neverleak Pencil Clip. In attractive colors, holds pencil firmly in place.

BUFFALO SPECIALTY CO.
100 Ellicott St. Buffalo, N. Y.



NEVERLEAK TIRE FLUID

"HEALS PUNCTURES ON THE RUN."

MOTORCYCLES

ONE YEAR TO PAY

Know the joy of owning—for business or pleasure—a HARLEY-DAVIDSON, EXCELSIOR, HENDERSON, INDIAN, CLEVELAND, or any other standard make; thoroughly rebuilt in our own factory.

Write for Free Bargain Bulletin and Easy Payment Plan.

HAVERFORD CYCLE COMPANY
America's Largest Cycle House
Established 26 years
503 Market St., Phila., Pa., Dept. P. M.



A-NEW WAY TO GET YOUR CLOTHES ABSOLUTELY FREE

and Make Big Money during your spare time—something different, better, bigger, more liberal than any offer ever made. Lower prices—better clothes—bigger cash profits—express or postage paid on everything.

DOUBLE PAY

Free Clothes and Cash Profits Besides. You can easily earn \$30.00 cash, extra, every week during your spare time, taking orders for our made-to-measure clothes. We don't ask you to use your cash profits for your own clothes. That's not our way of doing business. Ours is a new and better plan.

Fifty-six stylish, real cloth samples—FREE colored fashion plates; inside wholesale prices—everything FREE. Just drop us a line today and we will send complete outfit FREE.

SPENCER MEAD CO. E-245, Chicago





Globe Batteries

SAVE YOU 50%
of THE USUAL COST
and You Get
an Unconditional

WRITTEN TWO-YEAR GUARANTEE

6 VOLT 11 PLATE
for Overland, Elgin, Ford,
Scipps-Booth, Grant, Dort,
Saxon, Hummobile, etc.
Usual Cost \$32.09. **Our Price \$13.00**

6 VOLT 13 PLATE
for Oakland, Vello, Nash,
Studebaker, Maxwell, Cole,
Chevrolet, Mitchell, Buick, Reo,
Hudson, Paige, etc. Usual
cost \$40.00. **Our Price \$15.00**

12 VOLT 7 PLATE
for Dodge, Maxwell, Crown-
Elihart, Regal, Franklin, Bris-
coe, etc. Usual Price \$52.00. **Our Price \$20.00**

GLOBE STORAGE BATTERIES FOR WIRE-LESS USE

Volts	Amps.	Price	Volts	Amps.	Price
6	20	\$7.00	6	40	\$13.00
6	40	9.00	6	80	15.00

Shipped fully charged ready for installation

Begin now to get 100% battery service at half cost, by sending us your order today.

GLOBE BATTERY COMPANY

Dept. P, 1219 S. Wabash Ave. Chicago, Ill.

EARN \$150.00 A WEEK BY YOURSELF with a DUNCAN VULCANIZING PLANT



Includes every tool and vulcanizer for a high-grade repair business. Will handle the work of six men.

We start you in business for as low as \$125.00, balance easy monthly payments, and teach you approved factory methods of tire repair, at home or in one of our own repair shops. FREE; also pay you \$5.00 to \$6.00 per day for the last eight to ten days, when you take the course in one of our repair shop schools, in connection with the purchase of a No. 10 or No. 3 Equipment.

Can you beat this big chance to own your own business upon so small a capital?

The Duncan will cure two or three times as many tires a day as any other mould. It is the only mould made that will operate with sand bags equally as well as with air bag.

F. M. DUNCAN COMPANY

Offices and Factory: 341 East Ohio St., Dept. E, Chicago, U. S. A.

New Gum Vending Machine Makes You \$10 to \$20 a Day

Pays Rent for Store Owner

Install one in your store or any public place and get this easy profit. Requires no attention. Always works. Machine's profits pay the rent. Write us about re-built penny and nickel machines. Finished like new. In excellent running order. Pay their cost in 10 days.

Write or wire today for full particulars. \$25 down payment. Balance C. O. D. Mints \$30 per case—2,000 5 cent packages. Single boxes, 100 5 cent packages, \$2.50.

SILVER KING NOVELTY CO.

410 Williams Bldg. Indianapolis, Ind.



AUTO DRIVERS



Can make big money in spare time or devote entire time to introducing and taking orders for our

IMPROVED CORD TIRES

Highest quality. Sensational prices. Big profits. Permanent business.

Write today for catalog and agent's special offer.

LANGAN & PHILLIPS
Dept. 104 CHICAGO

HERE IT IS



THE MERKEL MOTOR WHEEL

A self-contained power unit to convert the bicycle into a motor driven machine, can be fitted in place of the rear wheel of any standard bicycle.



The final answer to the transportation question.

No skill or special tools required to install it.

It is equipped with a clutch, thus permitting motor to run when you stop your bicycle in heavy traffic.

All working parts automatically oiled.

The Merkel Motor Wheel is not a TOY or Make-shift. IT'S A PRACTICAL POWER PLANT. Designed to meet the long felt desire of the Bicycle rider.

POWER—Enough to master all hills on the highways.

SPEED—Sufficient for safe riding.

Simplicity of operation, any Lady or Gentleman, Girl or Boy owning a Bicycle can operate it.

ECONOMY—No other Motor vehicle in the World can be operated as cheaply as the Merkel Motor Wheel, **FOUR MILES for ONE CENT.**

SATISFACTION—More than you have had with your bicycle, because it will speedily take you there and back without exertion on your part.

Price \$85, F.O.B. Springfield, Mass.

Send for Merkel Catalogue

If there is not a dealer in your town selling Merkel Motor Wheels, write us—we want agents everywhere

HENDEE MANUFACTURING CO.
MERKEL MOTOR WHEEL DEPT.
SPRINGFIELD, MASS., U. S. A.

only **\$1**
 Puts this
 Genuine
Diamond
 CLUSTER RING
 ON YOUR FINGER

There is no red tape about this phenomenal offer and we are positive you will be entirely satisfied with this wonderful gem. It's true, a \$1.00 bill will put this beautiful ring on your finger. It has seven perfect cut genuine diamonds.

Looks like 1½ carat

Compare this gem with a 1.2 carat diamond and you will see that it resembles a \$700 solitaire. The perfectly cut, 7 sparkling, brilliant stones are set in solid platinum not just Platinum Top which gives it added beauty. Send us a dollar bill with your name and address and we will ship this wonderful bargain to you by return mail.

Wear it 30 DAYS FREE

If not satisfied after 30 days, return and we will refund your money. Never in history has such a phenomenal offer been made, on convenient terms of \$1. per week or \$4. per month until \$25.00 is paid. Try to buy this cluster for less than \$25. You will agree we offer a real bargain. This is one of many bargains illustrated in our Free catalogue. Rush your order today to Dept. 140.

James Bergman
 37 Maiden Lane N.Y.

Guarantee
 You must be absolutely satisfied or money back.

HEALTH and ENERGY

Are You 100%

Are you fit—vibrant with health and energy—smooth-skinned and clear eyed?

If not, you should investigate RenuLife Violet Ray.

By eliminating the ills of the body and building up new strength and vitality it leaves you as good as new with clear skin, glowing cheeks and a properly functioning body.

RenuLife Violet Ray can be used right in your home in connection with ordinary electric light current. The treatments are mild and pleasant with absolutely no sense of shock or pain. Treatments can be given the youngest child or most feeble invalid with perfect results.

Don't give up hope—write for RenuLife Violet Ray information—use the coupon.

RenuLife

1105 Newberry Building
 Detroit, Mich.

(In Canada, Pitt St., E. Windsor, Ont.)

Gentlemen: Please send me full information on RenuLife Violet Ray and your free book "Health for All," with no obligation on my part.

Name.....
 Address.....

RenuLife purifies the blood and successfully treats rheumatism, sciatica, neuralgia, bronchial troubles, nervousness, and many other ailments.



Factory Sale

AIR TIGHT

SCREW TOP



Copper Oil Kettles

All made of 16, 18, 20 and 22 gauge best cold rolled heavy solid copper. Non-explosive. All solder outside. 5 inch airtight screw cap. Absolutely guaranteed to be the best and strongest kettle made.

Goods shipped the day order is received. Packed in strong, plain boxes. Above are lowest factory cash prices. Send money order or draft with order.

Catalog of other goods at cut prices FREE, upon request. Price of copper going up. Order now before prices advance. Order at once.

THE HOME MANUFACTURING COMPANY
 Dept. K-126 2650 No. Halsted St., Chicago
 Reference: Cosmopolitan Bank, Chicago, Ill.

MARVEL PICTURE REPRODUCER



Transfers black and colored pictures and designs from newspapers, comics, etc. to paper, silk and linen handkerchiefs, plates, china-ware, etc.

USEFUL AND AMUSING
 Complete set with
 Directions - Send **25c**

THE NOVA CO.
 Dept. 2, 326 River Street Chicago

GET A RAZO!



This unique Razor-blade pocket knife is the handiest, safest general utility knife. Uses an old Gillette blade. Artists, writers, draftsmen, tailors, dressmakers, office men, women, school children all need RAZO. Send 25c for yours today. Great money maker for agents.

RAZO NOVELTY CO.
 23 E. Van Buren St. Chicago

LAKWOOD FAN BELT FASTENERS



MAKE or repair your own flat belts for Autos, Trucks, Tractors, Electric Washers and small Shop Machinery with Lakewood Quick attachable Fasteners. Two sizes— $\frac{1}{2}$ in. and 1 in.; used alone and in combinations handle eight widths flat belting. Simply square up ends, rivet half of fastener to each end, slot together and go. Belt can be removed from pulleys instantly, but can't open in driving. Complete Fastener with rivets, 15c per set; 2 for 25c; 6 for 60c; or 12 sets in neat slide box for \$1.00. Specify size wanted. Sent postpaid same day order received. Fine proposition for Garage, Repairmen, and Dealers.

LAKWOOD FABRIC BELTING & MFG. CO.
 1518 W. 117th St., Lakewood, Ohio

$\frac{1}{4}$ H. P.
110 Volt



\$13⁵⁰

AN AMAZING VALUE

Study the specifications of this Motor—Make comparisons—You will not find its equal at anything near our price

It is built for long service. The size, 9x6 $\frac{1}{2}$ x6 $\frac{1}{2}$ and the weight, 28 lbs., show it isn't in the cheap bargain class. It's a Wagner motor, fully guaranteed, R. P. M., 1725; 60 cycle—1 phase. Has pulley, cord and plug. Shipping weight, 36 lbs.

A real motor—runs your drill press, small lathe, washing or other household machinery; radio equipment, milking machine, pump, etc.

\$13.50 Send cash with order or we will ship C. O. D. if you prefer

THE F. BISSELL CO.

812-822 Lafayette St.

Toledo, Ohio

Wholesalers of everything electrical

Make Full Time Money

Selling a 100% Auto Necessity—
Not Just a Rich Man's Accessory

Every car owner is a "sold" prospect because he realizes his need for an accurate, easy, clean way to save his tires by knowing that they have just exactly enough air.

You can take his order for this guaranteed money back VISIBLE TIRE TESTER by a simple demonstration. Sample \$7.50. Write today for our attractive selling plan.

Chicago Auto Specialty Co., Inc., 1349 Bawens St., Chicago, Ill.



Sells for \$3.00 — a fair price

THE HANDIEST TOOL in the WORLD



OLSON
MAGAZINE
SCREW DRIVER

Large enough to hang a door.
Small enough to fit a bell.

Three blades, oneawl, guaranteed. Fit any common screw and makes holes. Ask your hardware store or send \$1.25, prepaid.

Olson Manufacturing Company
52 Commercial St., Worcester, Mass.

Ask Your Dealer
for

Nu-Way & EXCELLO
RUBBERLESS
SUSPENDERS

Year's Wear Guaranteed

The
Nu-Way Line

Nu-Way and Excello
Suspenders—75¢

Men's Garters—50¢

Ladies' Hosiery—Children's
Hose Supporters—25¢

Ladies' Garter "One-Off"
Hose Supporters—25¢

Always comfortable. No rubber to rot. Phosphor Bronze Springs give the stretch. If your dealer doesn't carry Nu-Ways or Excellos, send direct, giving dealer's name. Accept no substitute.

Nu-Way Stretch Suspender Co.
Mfgs., Adrian, Mich.



Note the renewable cutting blades. There's the reason why Neverslips will outcut and outlast any plier made.

We Guarantee This Plier To outcut and outlast any plier made

Nothing more nor less than high carbon crucible steel cutting edges could make this guarantee possible.

Crucible makes a strong, tough edge that resists wear and remains sharp for a long time. But if you accidentally nick the crucible edge you won't have to throw the plier away.

Neverslip Pliers are made with **renewable** cutting blades—as soon as the edges become worn just replace them with a set of brand new sharp ones. It's done in a jiffy—no bother or trouble.

Neverslips will cut wire or insulation clean and sharp leaving no frayed strings or burred edges.

They're sold by Hardware Dealers, Mill Supply Houses or Electrical Supply Houses nearly everywhere.

THE NEVERSLIP WORKS
NEW BRUNSWICK NEW JERSEY

NEVERSLIP

side cutting pliers

Neverslip Pliers are furnished in 6-7 and 8 inch sizes.



Man-oh-Man watch 'at gun throw 'em in the black

ONE-TWO-THREE-FOUR—Gee! Quick as a wink, and every bloomin' one kerplunk in the bull's-eye, too.

'Course, I got you fellowshiped on shootin', anyway. But on the level, 'taint all me. This Stevens *visible loading* just natch'erly throws 'em hard and straight, any old how. Huh? I'll certainly say it do.

And say, it pumps some sweet, too—crack-crack-crack! 15 shots, just like that, snappy as a triphammer. Get hep, fellow, it's an honest-to-goodness sport shootin' this boy.

Take a squint through the barrel

Pretty, pretty smooth, eh? You betcha! And you can just store this in the old bean: every Stevens barrel is scraped smooth to *less than 1/1000 of an inch*. Just jot that down.

I've heard fellows say, "Gee, I'd like to have a rifle, but it costs too much." Stevens puts a crimp in that bunk. Look at the Stevens prices. That's your answer. Better still, shoot in a postcard. Say, "Send me catalog."

J. STEVENS ARMS COMPANY

Department J256 Chicopee Falls, Mass.

Owned and operated by the Savage Arms Corporation
Executive and Export Offices: 50 Church Street, New York



RETAIL PRICE, inc. tax, \$15.00
Stevens "Visible Loading," .22 Cal. Repeater.

RETAIL PRICE, inc. tax, \$9.85
Stevens "Favorite," 24-in. take-down.

Stevens

Please Mention Popular Mechanics

WITTE

LOG SAW

\$65⁰⁰

F. O. B.
K. C.

New Price for
Short Time Only

F. O. B. Pittsburgh \$70



**Our
Biggest
and Best Log Saw**

DIRECT
TO YOU

Look! See What You Get—Big Surplus Power 4-cycle engine—weight over axle (not on handles)—two-wheel truck—easy to move. Direct geared (no chains or belt). Lever controlled clutch—Arm swing motion. We have only one Log Saw—our biggest and best (at advertised price). Why pay \$50 more for any saw. **Order direct from this ad.** Lifetime guarantee—Cash or terms—Immediate Shipment. Tree Saw at small extra cost. Catalog Free.

WITTE ENGINE WORKS

1748 Oakland Avenue,
1748 Empire Building,

KANSAS CITY, MO.
PITTSBURGH, PA.



Catch Fish, Eels, Rabbits, Skunk, Weasel, Mink, Muskrats etc., in large numbers, with our new, folding, galvanized Steel Wire Traps. They catch them like a fly-trap catches flies. Made in all sizes. Strong and durable. Write for Descriptive Price List, and our Free booklet on best bait known for attracting all kinds of fish.
J. F. GREGORY, Dept. 24, LEBANON, MO.

SEND for the INTERNATIONAL CATALOG

Factory
to Con-
sumer
direct—

**PAY
ONLY
ONE
PROFIT**



Our net price list of auto bodies and body supplies at Wholesale Prices. Save big money by buying Direct from Factory

For Ford and Chevrolet—prices from \$27.85 up
International Body Works 914 W. Ohio Street, Chicago, Ill.
Dept. 7

CIGARETTE EJECTOR

"JUST press the button, that's all." The latest in "smoke" cases. Keeps cigarettes in perfect condition and prevents crushing. Works perfectly every time. Every smoker wants one.



AGENTS—Write for exclusive territory. It's an easy seller from \$1.50 to \$16.00. Agents are making big money. Send \$1.50 for sample of this popular case. Act now—today—before your territory is sold.

THE LYONS MFG. CO., Dept. M. P.
342 YORK STREET, NEW HAVEN, CONN.

SAVE MONEY ON GUARANTEED MOTORS

Fuerst-Friedman MOTORS

Buy Direct from Headquarters



By buying direct from us you save from 25% to 40% on new Columbia motors, and as high as 50% on Fuerst-Friedman rebuilt motors. You save retailer's profit—you save retailer's high sales cost—and you get motors fully guaranteed for one year.

No matter what your motor requirements are, from tiny buffing motors to heavy-duty factory motors, we have a new or rebuilt motor to suit your exact needs. And the cost is from 25% to 50% less than you would pay elsewhere. Send for our free motor catalog—see for yourself the savings you get by buying from us. It tells about our twenty years of successful motor service and the many vast engineering projects we have handled. Ask for Catalog No. 10—the price regulator on new and rebuilt motors.

Electrical Machinery of all kinds promptly repaired or taken in exchange

THE FUERST-FRIEDMAN CO.,
"Reliability Built In"

CLEVELAND OHIO

COLUMBIA MOTORS

MOVIES BOYS GIRLS! GROWN-UPS!

Write to-day for free Catalogue of our **MOVIE MACHINES**

REAL MOVIES FOR THE HOME
Wonderful Models \$6.00 to \$25.00, with film
PARAMOUNT MFG. CO., Dept. M
Box 1371 Boston, O., Mass.



\$5 to \$10 A DAY
MAKING BEAUTIFUL LAMPS, CANDLESTICKS

Book-ends, etc. Profitable spare-time work at home or build a paying business of your own. No experience necessary; anybody can make these quickly-sold art objects. **YOU TAKE NO RISK**—Send \$2.00 for instructions and sample equipment, which will pay for itself many times over. Satisfaction guaranteed or money refunded.

HOME ARTS CO., 76 Beecher Bldg., BUFFALO, N. Y.



Be A Floor Surfacing Contractor

Now uncrowded field. Contractors prefer to sublet floor surfacing to American Universal Contractors. Machine does work of 6 men. Works quickly, easily. We set you up in business of your own, furnish office forms, advertising, etc.

Make \$5,000 to \$15,000 or More—Yearly
Prepare for big building boom. Make new floors perfect, old floors like new. Every floor a prospect. Big money in old floors. No town too small. Beginners often pay for machines first month with profit besides. Get full information.

THE AMERICAN FLOOR SURFACING MACHINE CO.
523 So. St. Clair St. Toledo, O., U. S. A.



Dollars in Hares

We pay \$7.00 to \$18.50 and up a pair and express charges. Big Profits. We supply guaranteed high grade stock at lowest prices and buy all perfect pairs you raise. Use back yard, barn, cellar, attic. Contract and Illustrated Catalog **FREE**.

STANDARD FOOD & FUR ASS'N
407 B Broadway NEW YORK



Where the spot light shows the bullet goes

Thousands of sportsmen have been eagerly awaiting an attachment for gun or rifle which would give:

1. A blinding, piercing spot of light—not a diffused light.
2. Great distance, sufficient for accurate shooting range.
3. A light attachable to the weapon—consequently light in weight and quickly attached or detached.
4. A light ray describing the same course as the flight of the bullet or shot.
5. A dependable instrument, all metal, water proof and sturdily built to withstand rough usage.
6. Long burning power—lasting for months under ordinary night use or many hours steady burning.

And now—finally and actually it is here
—It is Lite-Site

With Lite-Site attached to gun or rifle you can throw the target into flood light prominence and pull the trigger. No aiming—shoot from the hip—from any position—for "Where the spot light shows the bullet goes."

Lite-Site is effective at 400 feet (this distance is guaranteed). By its specially patented clamp it is so attached to the barrel (in 30 seconds) that its light ray is parallel to the bullet's course. When detached, in Lite-Site you have the long-hoped-for hand search light for camp use—for reading in the tent—in the automobile—for any purpose where great brilliancy, distance and long life is needed.

All Lite-Site features are strongly patented—there is nothing like it on the market.

You can focus the head—turn it to a narrow beam, like a big powerful search light or turn it to a diffused light as you will. The Lite-Site battery is a special battery not to be duplicated on the market today. It has longer life, it is individually tested for perfection. It is guaranteed to last months under ordinary use or from 10 to 15 hours steady burning. Lite-Site is completely equipped with extra bulb—a special one—battery and attachment which fits any gun barrel.

You cannot afford to be without Lite-Site. Order it today from your Sporting Goods Dealer. Lite-Site is guaranteed satisfactory or money refunded. If your dealer cannot supply you, order direct from us. Price \$6.00; West of Denver \$6.50; Canada \$7.00 plus duty.

LIGHT SIGHT PRODUCTS CORPORATION
WARREN PENNSYLVANIA

LIGHT SIGHT PRODUCTS CORP., Dept. E, Warren, Pa.
Enclosed is (money order, check) for one Lite-Site complete with all attachments. Provided I am not satisfied, you agree to return my money upon receipt of article.
Name.....
Address (street)..... City.....
Dealer's name and address.....

PATENTS TRADE-MARKS AND COPYRIGHTS

SPECIAL OFFER—Free Opinion as to Patentable Nature

Before disclosing an invention, the inventor should write for our blank form "Evidence of Conception." This should be signed and witnessed and if returned to us together with model or sketch and description of the invention, we will give our opinion as to its patentable nature.

Our Three Books Mailed FREE to Inventors



OUR ILLUSTRATED GUIDE BOOK

HOW TO OBTAIN A PATENT

Contains full instructions regarding Patents, Trade-Marks, Foreign Patents, Our Methods, Terms, and 100 Mechanical Movements illustrated and described; Articles on Patent Practice and Procedure, and Law Points for inventors.

OUR TRADE MARK BOOK

Shows the value and necessity of trade-mark protection and gives information regarding unfair competition.

OUR FOREIGN PATENT BOOK

We have direct agencies in all the principal foreign countries and secure foreign patents in the shortest possible time and at the lowest cost. Write for our illustrated Guide Book on Foreign Patents, sent free to any address.

Specialization—Our Staff

The field of invention is so vast that it is impossible for any one man to become an expert in all the different classes of invention. Only those practically skilled in the class to which the invention relates are capable of rendering efficient service. For this reason Victor J. Evans & Co. employ a number of patent lawyers and mechanical experts who have been selected for their special knowledge and ability in certain lines of invention. Each case is placed in charge of experts in the classes to which the invention relates.

THE VALUE OF YOUR PATENT

will depend much upon the skill and care with which your case is prepared and prosecuted in the United States Patent Office. This work will receive the benefit of skill and experience acquired by a long and successful practice. We spare neither time nor pains to secure the broadest possible patents that the inventions will warrant. That every case intrusted to us receives our best efforts, and that our work is done consistently, skillfully, and thoroughly is evidenced by the many unsolicited letters of commendation that we receive constantly from our clients. We will furnish upon request lists of clients from any State in the Union for whom we have secured patents.

Our New York, Philadelphia, Pittsburgh, Chicago and San Francisco Offices

Owing to the growth of our business we have established for the benefit of our clients Branch Offices in New York City, Philadelphia, Pa., Pittsburgh, Pa., Chicago, Ill., and San Francisco, Cal. These branch offices being located in these large commercial cities together with our Main Office located near the U. S. Patent Office, in Washington, enables us to more promptly handle the business of our clients, particularly as the branch offices are in constant touch with the Main Office and fully equipped to handle patent business in all its branches.

Highest References—Prompt Attention—Reasonable Terms

---FREE COUPON---

VICTOR J. EVANS & CO., Patent Attorneys

NEW YORK OFFICES
1007 Woolworth Building

CHICAGO OFFICES
1114 Tacoma Building

PHILADELPHIA OFFICES
714-715 Liberty Bldg.

PITTSBURGH OFFICES
514 Empire Building

SAN FRANCISCO OFFICES
Hobart Building

MAIN OFFICES: 765 9TH STREET, N.W., WASHINGTON, D. C.
Gentlemen: Please send me FREE OF CHARGE your books as described above.

Name Address



WANTED IDEAS



Inquiries from Manufacturers and Others Who Are Looking
for Good Ideas

PROTECTED BY PATENTS

are constantly being received. Manufacturers are always interested in any new device for which there is a market, which fills a long felt need, which makes production possible at a lower cost, or which will do the work BETTER. Extracts from some of the more recent letters received are printed herewith. There is undoubtedly a great demand today for really worth while inventions.

Your First Step

If you have an idea, send immediately for my blank form "TO RECORD YOUR INVENTION." You should serve your own best interests by filling out and signing this form before you disclose your invention TO ANY ONE. This document will help you determine and establish evidence of invention before filing an application in the U. S. Patent Office. A copy, with full instructions, will be gladly sent free on request.

NEW "SUCCESSFUL PATENTS" SENT FREE

Every man who has an invention, or ever hopes to have one, should send for a copy of my book "SUCCESSFUL PATENTS." It tells what everyone should know about patents, trade-marks, copyrights, etc. It describes my methods, fees and terms, gives information relative to assignment or sale of rights, and instructions in detail. Mail coupon today for a free copy of this book or a post card request will do.

To the Man with an Idea

I offer a comprehensive, experienced, efficient service for his prompt, legal protection, and will endeavor to aid him in the commercial development of his proposition—my service is distinguished by over 12 years' successful practice, and by thousands of satisfied clients and by reasonable fees.

Send sketch, or model, and description, for advice as to cost, opinion as to its patentable nature, etc. Preliminary advice gladly furnished without charge.

-----COUPON-----

RICHARD B. OWEN, Patent Lawyer

Main Office, 9-303 Owen Bldg., Washington, D. C.
Branch Office, 2276-E Woolworth Bldg., New York City.

Please send me, without charge, or other obligation, a copy of your book, "SUCCESSFUL PATENTS," your form "TO RECORD YOUR INVENTION," and information concerning patents, etc.

Name.....Address {

Can You Help?

Here are abstracts from a few recent requests I have received from those who wish to buy, finance or manufacture good inventions. Have you an idea that will fill the bill?

Following is an extract from letter dated July 20, 1921, from a middle western manufacturer whose volume of business last year was approximately \$1,000,000. "If you are in touch with any meritorious proposition seeking manufacturing facilities, in the automotive or some other good field, we shall be glad to have you place us in touch with it. We are willing to consider outright purchase of patents or manufacture upon a royalty basis."

Another request from a large corporation, dated June 27, 1921, follows: "Should you have clients whose inventions are worthy of commercial manufacture and exploitation, we shall be glad to consider the financing of such projects, if they are interesting. In that event, we indicate also that we are identified with two large machinery manufacturing plants located, respectively, in Bridgeport, Ct., and Providence, R. I. These plants, besides having their own foundries, are thoroughly equipped to manufacture anything from a small lathe to a complete automobile. Whether your clients have mechanical inventions or otherwise, we shall be pleased to hear of any proposition requiring financing."

Another letter dated April 28, 1921, from a large corporation whose officers include some of the best known men of the country, says in part: "We are in the market for an invention of merit possessing undoubted economic and commercial value combined with ADEQUATE PATENT PROTECTION."

PATENTS PROMPTLY PROCURED TRADEMARKS REGISTERED

Send disclosure of invention, design, or trademark for actual search of U. S. Patents and novelty report. Validity and infringement investigations. Patent and trademark suits prosecuted and defended anywhere in the United States. Discriminating clients appreciate my efficient service. No literature will be sent you as this is a professional service, *individual* and *personal*. Specific information and advice given regarding each individual case. Specialize in prosecution of pending cases that have been previously rejected by the Patent Office. Specialize also in unfair competition litigation before the Federal Trade Commission.

George P. Kimmel, Master of Patent Law
53-H Loan & Trust Bldg., Washington, D. C.

Can You

think of a simple, practical idea that will fill one of the many requests we have on file for new inventions? It may mean a fortune for you. Thousands of things are needed **right now**. Your brains can help. Send today for our great new book—

"Inventions and Trade-Marks, Their Protection and Exploitation"

and learn more about making money from ideas than you ever knew before. It tells many things that are wanted, too.

**A postal will do—
It is free**

We Help Our Clients

without charge, to get the dollars out of their ideas—having facilities none others possess. Advice free. Don't delay—get the book at once.

American Industries, Inc.
200 Patent Dept.
WASHINGTON, D. C.

**Patents
Advertised
For Sale
Free**

in Invention and Manufacturing Supplement

Published for the man with an idea. Send for free sample copy. One year's subscription, 50c.



PATENTS

Send us sketch or model for patentability opinion and exact cost of patent. Our book "How to Obtain a Patent," Sent Free on request. It tells how to apply for Patents, Trade Marks, Foreign Patents, Copyrights, etc.; gives information on Patent Procedure; tells what every inventor should know. Thousands of inventors, who are our clients, are our references. **Chandlee & Chandlee, 25 Years Experience,** 422 7th St. Washington, D. C.

PATENTS

TRADE-MARKS COPYRIGHTS

Send for our free book of patent information.

Beale & Park 802 F St., Washington, D. C.
16 S. Broad St., Philadelphia, Pa.

PATENTS **C. L. PARKER**
Formerly Member Examining
Corps, U. S. Patent Office
PATENT LAWYER
MCGILL BLDG.
WASHINGTON, D. C.

Patents, Trade Marks, Copyrights, Patent Litigation

Handbook for Inventors. "Protecting, Exploiting and Selling Inventions," sent free upon request.

INVENTORS

who derive largest profits know and heed certain simple but vital facts before applying for

PATENTS

Our book *Patent-Sense*, for Inventors and Manufacturers, gives those facts; free. Write Lacey & Lacey, 646 F St., Washington, D.C.

ESTABLISHED 1869

PATENTS Secured

Prompt service. Avoid dangerous delays. Send for our "Record of Invention" form and Free Book telling How to Obtain a Patent. Send sketch or model for examination. Preliminary advice without charge. Highest references. Write **TO-DAY, J. L. Jackson & Co., 327 Ouray Bldg., Washington, D. C.**



GEARS ALL KINDS SMALL

The most accurate made and prices reasonable. We carry a complete line of gears in stock for immediate shipment. Can also quote on special gears of all kinds. Send us your inquiries. **WRITE FOR CATALOGUE**

CHICAGO STOCK GEAR WORKS
105-109 S. Jefferson St., CHICAGO

PATENTS

Booklet Free

Highest References

Promptness Assured

Best Results

Send drawing or model for preliminary examination

ALL BUSINESS GIVEN PROMPT AND PROPER ATTENTION

WATSON E. COLEMAN, Patent Lawyer, 624 F St., Washington, D. C.

U.S. PATENTS



DON'T LOSE YOUR RIGHTS

TO PATENT PROTECTION

Before disclosing your invention to anyone send for blank form "EVIDENCE OF CONCEPTION" to be signed and witnessed. A sample form together with printed instructions will show you just how to work up your evidence and establish the same before filing application for patent. As registered patent attorneys we represent hundreds of inventors all over the United States and Canada in the advancement of inventions. Our schedule of fees will be found reasonable. The form "Evidence of Conception," sample, instructions relating to obtaining of patents and schedule of fees sent upon request. Ask for them—a post card will do.

PATENTS AND TRADE MARKS



204 Ouray Bldg. Washington, D. C.
Originators of forms "Evidence of Conception."



PROTECT
YOUR
RIGHTS

WRITE TODAY FOR FREE BOOK ABOUT PATENTS and "RECORD OF INVENTION" for establishing evidence of conception. The book tells how to proceed, the usual cost of obtaining a patent, and contains good sound practical advice every inventor should know. "RECORD OF INVENTION" should be filled out, signed and witnessed before you disclose invention to anyone. Send rough sketch or model and description for free report upon patentable nature and cost to Patent, etc. **Prompt, personal service.** Reasonable fees. Partial payment plan. Preliminary advice without charge.

J. REANEY KELLY
PATENT LAWYER

612-COLUMBIAN BLDG. \ WASHINGTON, D.C.

PATENTS If You Have an Invention and Desire to Learn How to Secure a Patent

Send for our Guide Book, **HOW TO GET A PATENT**, sent Free on request. Tells our terms, methods, etc. Send model or sketch and description of your invention and we will give our opinion as to its patentable nature.

RANDOLPH & CO.
600 F St., N.W., Washington, D. C.

NAME.....

STREET.....

CITY.....STATE.....

PATENTS

IF YOU HAVE AN INVENTION which you wish to patent you can write fully and freely to Munn & Co., for advice in regard to the best way of obtaining protection. Please send sketches or a model of your invention and a description of the device, explaining its operation.

All communications are strictly confidential. Our vast practice, extending over a period of seventy years, enables us in many cases to advise in regard to patentability without any expense to the client. Our Handbook on Patents is sent free on request. This explains our methods, terms, etc., in regard to **Patents, Trade Marks, Foreign Patents, etc.**

If you are a reader of the SCIENTIFIC AMERICAN

you are probably aware of the fact that it has a special appeal to the inventor. Each issue contains a description of a large number of recently patented inventions. Pending patent legislation as well as the most recent rulings of the Patent Office and the courts are considered in its columns.

MUNN & CO.

SOLICITORS OF PATENTS

672 Woolworth Bldg., NEW YORK
Scientific American Bldg., WASHINGTON, D. C.
801 A Tower Bldg., - - CHICAGO, ILL.
611 Hanna Bldg., - CLEVELAND, OHIO
582 Market St. SAN FRANCISCO, CALIF.

Inventors

in all cities and many towns in the United States and Canada have secured patents through us. We secure patents in **delayed, neglected, and**

Rejected

cases. Write giving data.

Abraham Lincoln in an Address to Law Students said:

"As a rule, never take your fee in advance, nor any more than a small retainer. When fully paid beforehand, you are more than a common mortal if you can feel the same interest in the case as if something was still in prospect for you, as well as your client; and when you lack interest in the case, the job will very likely lack skill and diligence in the performance."

Engaged in Patent Soliciting exclusively since 1875, we have procured more than 40,000

Patents

Send us a model, drawing or photo with description of invention, remit \$5.00 for search in U. S. Patent Office to find if patentable.

Our booklet on patent protection at home and abroad sent free. Write or come to

C. A. SNOW & CO.

Patent Attorneys Since 1875

710 8th Street, Opp. North Front of U. S. Patent Office
WASHINGTON, D. C.

PATENTS

Inventors should write for our "Evidence of Disclosure" form. It's Free. Avoid Dangerous Delays. Send sketch or model of your invention for examination and advice. Ask for Free Book "How to Obtain a Patent." Highest references. Write to-day.

Merton-Roberts & Co., 184 Mather Bldg., Washington, D.C.

DEAFNESS IS MISERY



I know because I was Deaf and had **Head Noises** for over 30 years. My invisible Antiseptic Ear Drums restored my hearing and stopped **Head Noises**, and will do it for you. They are **Tiny Megaphones**. Cannot be seen when worn. Effective when Deafness is caused by Catarrh or by Perforated, Partially or Wholly Destroyed Natural Drums. Easy to put in, easy to take out. Are "Unseen comforts." Inexpensive. Write for Booklet and my sworn statement of how I recovered my hearing.

A. O. LEONARD, Suite 226, 70 5th Avenue, New York City

Clear-Tone
FOR
PIMPLES

Your skin can be quickly cleared of Pimples, Blackheads, Acne Eruptions on the face or body, Enlarged Pores, Oily or Shiny Skin. \$1,000.00 Cash says I can clear your skin of the above blemishes. **WRITE TODAY** for my FREE Booklet—"A Clear-Tone Skin"—telling how I cured myself after being afflicted for fifteen years.

FREE

E.S. GIVENS, 129 Chemical Bldg., Kansas City, Mo.

Please Mention Popular Mechanics

Send No Money

Ladies' Solitaire Examination Free

This perfectly cut Diamond will be sent free of charge for your complete examination and approval. No money in advance. If satisfied, pay only \$2.00 on arrival, and keep it.

10 MONTHS TO PAY

The balance you send in 10 small monthly payments—only \$2.80 a month. Take advantage of this amazing offer today.

FREE De Lutz Catalog in colors. Write for details of Great Diamond Offer and Book to Dept. 62-K.



Great Inventors Now Teach You How to Invent

How to develop, patent and market your ideas; amazing new course teaches science of invention by mail.

Every man, woman, and child is born with *creative imagination*. Some develop this faculty to a greater degree than others, and those who develop it to the *greatest extent* are successful inventors. Invention is an orderly process of the mind, which combines two or more known facts to produce a new fact. Anyone who develops the right mental process can become an inventor. Every successful inventor has this type of mind, developed by constant experience over a period of perhaps

many years. Heretofore those who succeeded in the field of invention had to discover all the principles themselves. But, now, just as any student of medicine, law, or engineering can take full advantage of all the recorded experience in these fields of study, so can YOU! take the same kind of short cut to the habits of thought, and the methods of work required of successful inventors.

Little Inventions Win Fortunes

Fortunes have been made by men who have thought of a "little" idea in a flash. The man who invented the bottle top, the man who invented the crimped hairpin, the man who invented the thin lead automatic pencil, the man who invented the snap fastener—all these men, perhaps, got their ideas in a flash, and founded their fortunes as a result of a single idea. But in every case their minds operated in accordance with the scientific laws of successful invention.



Raymond Francis Yates
author of the New Course in Inventive Science, in collaboration with 15 other inventors. Mr. Yates is known throughout the country as Editor of scientific magazines, writer of hundreds of articles and inventor of many practical devices and machines.

Edison says: "Invention should be taught as a profession." Every inventor realizes the hopelessness of groping in the dark for the habits of thought and methods of work required for successful invention. Trying to invent without knowing the fundamental requirements of invention is like trying to build a bridge without knowing engineering.

Don't Waste Ideas! Every man at some time or other has an idea for something he would like to invent, but his mind doesn't know how to work. He doesn't know what to do about it—doesn't know how to think along inventive lines—and soon someone whose mind is trained along inventive lines invents just the thing you may have thought of.

WRITE FOR FREE BOOK

A wonderful book explaining this wonderful new course in detail has been written and will be sent free to those genuinely interested. This book explains the course in detail, and proves that anyone can become an inventor who trains his mind—it may be the beginning of a fortune for you. If you have ever had an idea for an invention, or if you would like to become a spare-time or professional inventor, and if you would like to know what to invent, send in your name at once on the coupon **NOW!** Only a limited number of these books are available for free distribution.

**BUREAU OF
INVENTIVE SCIENCE**
Dept. 45, Wisner Bldg.
Rochester, N. Y.

Please send me your free book,
"The Science of Invention."

Name

Address

City

State

Bureau of Inventive Science, 45 Wisner Bldg., Rochester, N. Y.

"THE HOUSE OF QUALITY"
L.W. SWEET INC.
1650-1660 BROADWAY, NEW YORK

Oh Boy! 25 MILES PER HOUR!

is record of our stock car, using our special 1922 motor. Anybody can assemble this car. Send 30 cents for plans, instructions and price list of parts.

SYPPER MFG. CO.
146 Sypper Bldg. TOLEDO, OHIO



A PERFECT POLISH WITH CLEAN HANDS

POLISH, DAUBER and BRUSH combined in one convenient article. Polish is in a tube enclosed in metal case on top of brush, and when tube is used up, new ones may be obtained at leading stores everywhere, 25 cents. Buy of your dealer or order direct, stating whether black, tan, mahogany or white is desired. Free opportunity for agents.

Postpaid anywhere \$1.25
Address Sales Dept.
The Kaxo Co., Cambridge, 139 Mass.

KAXO SHOE BRUSH



SEND FOR CATALOGUES

Gear and Experimental Parts, 15c
Materials of all kinds 10c
Model Engine Circulars 5c

COLBURN GEAR & MFG. CO. Successors
5 Woodworth St., Boston 22, Mass.

SETS OF CASTINGS OF MODEL ENGINES FOR ALL SIZES. GEAR WHEELS & PARTS OF MODELS. **WILSON H. WIGHTMAN & CO.**



TOBACCO

OR SNUFF HABIT CURED OR NO PAY \$1.00 IF SUCCESSFUL

No matter whether used in pipe, cigarettes, cigars, chewed, or used in the form of snuff, Superba Tobacco Remedy contains nothing injurious, no dope, poisons, or habit forming drugs. **SENT ON TRIAL GUARANTEED.** Costs nothing if results are not satisfactory. **WRITE FOR FULL TREATMENT TODAY.** **SUPERBA CO. M-19 Baltimore, Md.**

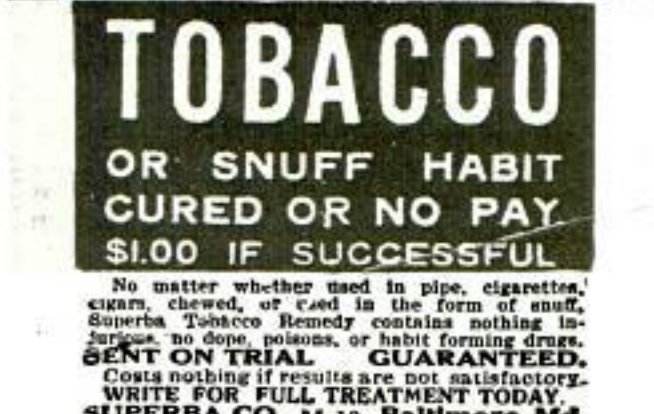

The MILLER LUGGAGE CARRIER

"Most practical Carrier ever built"

PRICE
\$6.00

Gives a Ford Car a Higher Priced Appearance

No fuss or muss to apply—Work can be done in a few minutes

Practical, compact. Serves as all-season running board when closed.



Only carrier on the market for a driver of a Ford carrying miscellaneous grips and bundles.

Extends 9 inches above running board of car.

The MILLER Luggage Carrier is built the correct size for use on any model Ford. It is easy to apply and once on it stays put for a long period of service. Farmers, mechanics, salesmen, tourists, in fact every one carrying loose packages, can free their feet and arms from luggage formerly jammed inside the car by using a MILLER Luggage Carrier for Ford cars.



Showing Miller Luggage Carrier applied to Ford Sedan and closed for service as running board.

Here is a Luggage Carrier for Ford cars with these new points not found in any previous models: strengthens running board, by taking up vibration and adding to rigidity of car; acts as carrier for largest and smallest packages; provides an attractive running board when folded up, with a Battledore Linoleum surface and a neat aluminum bend around the edge.



Showing MILLER Luggage Carrier attached to Ford running board and opened.

Simple and strong in construction—extremely rigid. Delivered ready to put on, with necessary bolts, nuts and washers. Does not break down the edge of the running board. Can't be stolen or lost. PERMITS DOOR TO SWING OPEN FREELY.

Price \$6.00. Big profit for hustlers, especially Ford owners willing to introduce among friends.

THE MILLER CO., Fulton and Lincoln Sts., Chicago, Ill.



A WORLD WAR SOUVENIR for a dollar



THESE finely made, full floating dial compasses, used by the American Expeditionary Forces, are being offered by the War Department at \$1 each as long as they last. All compasses new.

The floating dial, graduated every 5°, has jeweled bearing. North, South, East and West points glow at night. At once, a beautiful pocket compass and a practical surveying instrument.

Or for 50 cents

You can get a floating dial watch compass in beautiful open face brass bronze case. Luminous needle and compass points. All compasses are new.

Buy from Uncle Sam

Send cash or money order, stating number and style of instruments wanted, to

Engineer Supply Officer
General Reserve Depot
Columbus, Ohio

WAR DEPARTMENT

Only \$45.00 For This Job Complete

Save exorbitant freight rates and one-half original cost by buying Ford Speedster Bodies knocked-down. Simple, complete. Instructions furnished, all parts cut to exact fit. Any one can assemble this job.



(Complete with hood, radiator shell, instrument board, upholstery, metal parts, wood parts, bolts screws, etc. Flat radiator shell furnished made up. Designed low with lack of wind resistance. Price set up \$40, further particulars on request.)

Not Paper Patterns

All Parts Complete

The Central Auto Supply Co. Eng. Dep. 120, Louisville, Ky.

Electric Motors below cost

"1-6 H.P. motor received and must say this motor is a wonder."

Jos. B. Sirrianni, Carbondale, Pa.

"Motor received. Much pleased with it. Please ship one more 40 cycle without pulley C. O. D. express."

J. A. Beaudet, Glens Falls, N. Y.

cost
\$10



Washing Machine size

Delivers full 1-6 H.P. with liberal overload capacity. Made for 110 volts, 60 cycle current, 1750 r. p. m. (Also for 25, 30, 40, 50 cycle or 220 volts, if desired, at \$1.00 extra.)

Just the thing to run your washing machine, ironer, dish washer, compressor, bench lathe, blower, fan, drill press, scroll saw or any small machine around house, shop, garage.

THESE ARE WONDERFUL MOTORS

Strictly first grade in all respects, bear our name plate and fully guaranteed. New motor or free repairs if anything goes wrong within one year.

Never Again Prices to Equal This

Several large contracts were cancelled after the motor parts were all made. To turn them into cash we are sacrificing them below cost. Act now. Chance of a life-time. Send cash or order C. O. D. by express.

Net weight 20 pounds. Shipping weight, 26 pounds. Easy means of reversing direction of rotation. 10 ft. cord with 2-piece attachment plug 65c. Pulleys 1 1/4 inch or 2 inch, 50c.

Don't lose out on this chance. Money back quick if you are not more than satisfied.

REYNOLDS ELECTRIC CO. 2610 W. Congress Chicago, Ill.

Used Motorcycles

\$40° and up

Bulletin FREE

ALL MAKES

ASH MOTOR CORPORATION ROCHESTER, N.Y.

Steady Employment

NO LAY OFFS—PAY YOU DAILY

Special Representatives wanted in every State taking orders for Aluminum Handle Cutlery Set.



Written guarantee with each set. Big demand. All you do is take orders. We deliver and collect—pay you daily. Brand new set. Handles made of pure aluminum. Will not hold heat. Can't come apart. Write at once

for proposition to County Representatives. No experience or capital needed.

Jennings Mfg. Co., Delight 626, Dayton, O.

\$2 Brings A Genuine DIAMOND RING For 10 Days FREE TRIAL \$2

Set in Platinum



Resembles
\$350.00
Solitaire

Ladies' Genuine Diamond Ring

Seven brilliant steel blue genuine diamonds massed by a secret process in a setting of solid platinum set so closely together that only close inspection will distinguish it from a solitaire valued at \$350. Shank of ring 14kt solid gold. Price only \$48.00

Most Sensational Ring Offer Ever Made No Red Tape No Delay

Send only \$2.00 and your choice goes to you in a handsome gift box, charges paid. A legal guarantee bond as to quality and value accompanies each ring. After ten-day trial pay balance \$4.65 a month for ten months.

Ten Days' Free Trial

You take no chance—if it is not satisfactory at the end of ten days, or if you can duplicate either of these genuine diamond rings in any jewelry store for less than \$65.00, your deposit will be refunded to you.

Free Royal Bargain Bulletin

Illustrates and describes over 800 special offers in Diamonds, Watches and Jewelry which we are making this month from our \$2,000,000 stock. Address Dept. 537

ROYAL DIAMOND & WATCH CO.
(ESTABLISHED 1895)
35-37-39 Maiden Lane-New York

Set in Platinum



Resembles
\$350.00
Solitaire

14 K

Gentlemen's Genuine Diamond Ring

Seven brilliant steel blue genuine diamonds massed by a secret process in a setting of solid platinum set so closely together that only close inspection will distinguish them from a solitaire valued at \$350.00. Shank of ring is 14 kt. solid gold.

Price only \$55.00

AGENTS: \$54 a Week Taking Orders for New Coal-Oil Burner

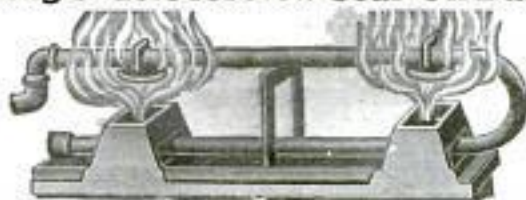

Most perfect burner ever invented. Can't clog up. Burns just like gas. By regulating valve you get as little heat as you want, or you can heat oven to baking point in ten minutes.

BIG SUMMER SELLER Burns coal-oil. One hour for two cents. Easy-piled. Nothing else like it. Not sold in stores. Write quick for agency and sample. No experience or capital needed. You take the orders. We ship by parcel post and do all collecting. Commission paid same day you take orders.

PARKER BURNER CO., 778 Coal St., Dayton, Ohio

RAISE BELGIAN HARES

FLEMISH GIANTS, NEW ZEALAND REDS, ETC., FOR US. **BIG PROFITS.** We furnish guaranteed high grade breeding stock and pay you \$7 to \$19.50 upward per pair and expressage for all you raise.

A Real Money Making Opportunity Easy to raise anywhere, in cellars, back yards, barn, attic, etc. Contract and illustrated catalog **FREE.**

American Hare Breeders Association
100-C Market St., Newark, N. J.



We Pay \$10 a Day

taking orders for Music Chest. Something new. A marvelous invention. Does more than machines costing 20 times its price. Easily carried with you anywhere. Light and well built.

Gratz Made \$394 a Week

JOSEPH earned over \$7285 in 6 months. We paid TED GNAU \$4455 for five months work. Easy to take orders on account of low price. \$8 a day for spare time. Big opportunity for the right men.

Send for terms—free sample

THOMAS MFG. CO., Chest 248, DAYTON, OHIO



SEND NO MONEY

Try this Portable
Typewriter 10 Days
FREE



Now you can buy famous, 9-pound National Typewriter direct from the factory, after 10 days' trial—absolutely free. You be the judge. Then we give you

10 MONTHS TO PAY

Same machine as used by thousands of doctors, lawyers, bankers, salesmen, students, writers and business men in 31 countries. Every feature of best, standard size machines. 28 keys. \$4 characters. Brand new—not a rebuilt typewriter. Neat, compact carrying case free with every machine. Send today for our 10 Days' Free Trial offer and 10 Months' Easy Payment Plan.

NATIONAL TYPEWRITER CO.
Dept. 7E. Fond du Lac, Wis.

10 Months
to Pay

FROM FACTORY TO YOU

GUARANTEED STORAGE BATTERIES

Our new sales plan, selling direct from factory, now enables you to buy famous Bell Storage Batteries less the dealers' and jobbers' commission—saving half.

Bell Batteries are guaranteed to be built with the very finest materials and workmanship—absolutely none better. We positively guarantee them in writing for one and one-half years continuous service. Bank references.

LOOK For Ford, Dort, Chevrolet, Olds, Buick, Oakland, etc. **\$19.50**

Price only.....
Bell Batteries made for all cars, tractors and gas engines with prices now as proportionately low as above. Write for catalog or send \$5.00 and battery will be shipped express C.O.D., subject to your approval. Give name, model and year of your car.

INDEPENDENT BATTERY COMPANY
1937 Grand River Ave. Detroit, Mich.

50%

SAVES

SPECIAL BETHLEHEM SPARK PLUGS

Right from the Government Reserve Supply
(U. S. Government Specifications)



HERE'S a chance for you to purchase Special Bethlehem Spark Plugs at less than jobbers' prices.

Genuine "775" core. Two-piece construction. Porcelains guaranteed not to break with heat. Supplied with 1/8-18 threads—with 1/2 inch or metric. Latest style snap clip screw top. Made throughout of the best material obtainable.

Our Prices

12	@	40c each
25	@	35c each
50	@	30c each
100	@	25c each

Packed in individual boxes.
Usual retail price \$1.00

Terms

Cash with order or C. O. D.
American Express Collect.

W. L. MORRISON
Dealer in Government Supplies
108 MASSACHUSETTS AVE., BOSTON

DISTRIBUTORS Wanted

Big Money For
FORD OWNERS

Steer your Ford with one hand at thirty miles an hour over rough roads. Shoot through sand, mud, gravel, in and out of ruts and over car tracks. Your front wheels CAN'T turn and ditch you. Your Ford will stick to the middle of the road like a Packard or a Cadillac if it is equipped with

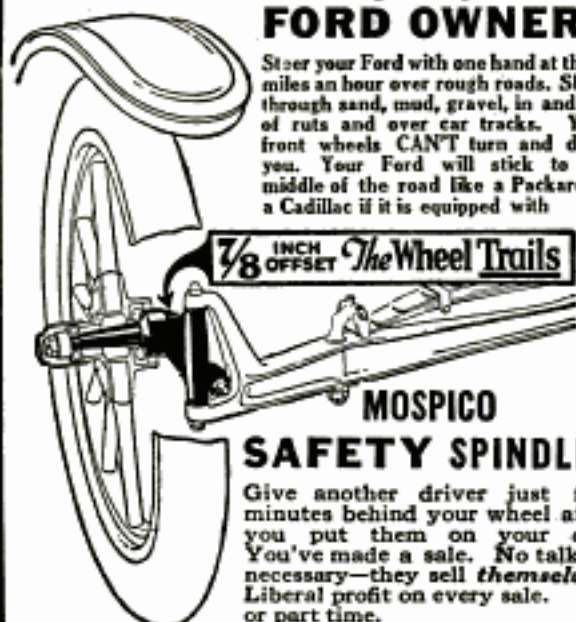

MOSPICO
SAFETY SPINDLES

Give another driver just five minutes behind your wheel after you put them on your car. You've made a sale. No talking necessary—they sell *themselves*. Liberal profit on every sale. All or part time.

Get Exclusive Contract For Your County

Hundreds of Ford owners within a few miles of you. Most of them will buy after a five minute trial. Make big money wherever you drive your car with these and other fast selling accessories of our manufacture. **WRITE US TODAY.**

Motor Spindle Corp. 522 East Jefferson Avenue
DETROIT, Mich.

Tire User

Car owner agent wanted in every community, to use, introduce and take orders during spare or full time for Harrison Hand Made Tires at our low prices, fully GUARANTEED 10,000 MILES (not seconds) Finest materials used. Shipped on approval prepaid. Capital or experience unnecessary. Sample sections free. Write for local agency offer and get our low factory prices to user agents. **HARRISON TIRE & RUBBER CO.** 230 Indiana St., Hammond, Ind.

HEAVY
HAND
MADE

Men With Autos Wanted

to introduce and take orders for our **NEW PROCESS STORAGE BATTERY**. Plates cannot sulphate or buckle. No expert attention required.

One-half cup water every 3 months. Made for autos, radios, lighting outfits and all other battery purposes.

Guaranteed 2 Years

The biggest money maker and greatest business builder ever known. Write today for our exclusive proposition and low wholesale prices.

HARSHA BATTERY CO. Dept. 16.
21 East Van Buren St. CHICAGO

**FOIL BURGLARS**

Make sure your home or buildings aren't next to be robbed. Thousands of dollars and precious valuables lost yearly because most locks are worthless and offer no protection. Test your locks with this wonderful set of Master Keys—5 keys in all, and each one different. Have proved their power to open thousands of different locks and showed hundreds that their homes and property really weren't protected. Endorsed and used by real estate men, bankers, firemen, detectives, policemen, hotel owners, etc. Novel key chain FREE. Send only \$1 today. Money back if not satisfied.



THESE DO IT!

MASTER KEY CO.

104 Manhattan Block Milwaukee, Wis.

**AGENTS SALESMEN**

Now is the time to start in business for yourself. Make \$10 to \$15 daily.

Automobile owners want initials on their cars. You apply them while waiting, charging 25c per letter; three letters on each side of the car, six initial letters in all, for which you charge

the car owner \$1.50, and you make \$1.38 profit. They could not get finer work if they paid \$5.00; then again, no sign painter could give them as nice a job as you could do without experience in 15 minutes. You can sell to individual auto owners, or you can sell to garages and supply stores complete display outfits, like the one illustrated, at big profits.

230 transfer monogram letters in two of our most popular styles, with eight borders to match and complete working outfit only \$5.00. Send money order or certified check. Outfit sent C. O. D. upon receipt of \$1.00 deposit.

TRANSFER MONOGRAM CO., Inc.
Dept. 151, 191 Market Street, Newark, N. J.

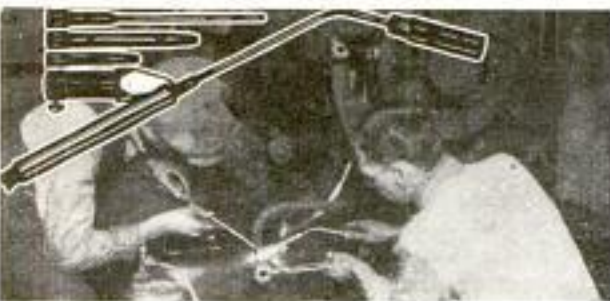

A Torch with Hundreds of Profitable Uses

Torit Acetylene Torch No. 13 PRODUCES A HOT INSTANT FLAME

For radiator and battery repairing, for soldering electrical connections, pots, pans, etc.; for preheating fenders, tempering tools, joining brass tubing, removing rusty bolts and nuts; for light brazing and hundreds of other uses.

A Practical Outfit for Every Mechanic
Uses Acetylene Gas Only

Complete with 4 different tips and soldering copper, rubber tubing and tank connection. **\$7.50**

ST. PAUL WELDING & MFG. CO.
177 W. 3rd St. ST. PAUL, MINN.

SCHICKEL
MOTORCYCLE

Economical
Practical
One Man
Transportation
Complete with
Two-Speed Gear
Clutch
Kick Starter
Spring Fork



THE BEST BUY
ON THE MARKET

Rider Agents
Wanted

WRITE for CIRCULAR—Mention occupation when writing

SCHICKEL MOTOR CO., 6907 Garden St., STAMFORD, CONN.

\$50 a Week EASY AGENTS
Free Sample Offer



You can start a big paying business at once. Don't wait. Get big money. We tell you how—selling the famous E-Z Self-Heating Solder Iron. No experience necessary. Easy to sell. Possibilities great. Every home a prospect. Satisfaction guaranteed. Absolutely safe. Thousands in use.

Write today for proposition.

Enterprise Tool & Metal Works, Dept. 35, 126 So. Clinton St., Chicago

JUST WHAT YOU WANT!
The NON-SKID Ink Stand



Cannot move, slide or stray from where you place it. A cork insert at bottom does the trick. Made of iron. Will hold any regular size desk ink bottle. Lasts a lifetime. Heavy enough to be used as a paper weight. Mailed day your order is received.

35c
KOLESCH & CO., Sole Mfrs.
Est. 1880 138-A Fulton St., New York Postpaid

The Dying Pig



The most laughable novelty yet produced. Made of rubber, and you have only to blow it up and it stands on its feet, when he begins to expand as he slowly collapses and finally lies down and dies in the most natural manner. You can blow him up as often as desired, and each time he will go through the same performance to the great amusement and delight of your friends.

Price 15 cents; 3 for 40 cents; one dozen \$1.35, mailed postpaid.

Johnson Smith & Co., 3124 N. Halsted Street, Dept. 717, Chicago

Popular Watch Charms

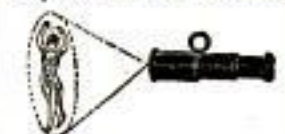

Very pretty little curiosities and decidedly novel. Filled with Magnifying Lenses that enlarge the pictures to a very surprising degree; in fact, it seems almost incredible that a clear picture could be possible in such a small compass, and how sharp and distinct they show up when you look through. Come in assorted views—Actresses, views of Famous Canal, Lord's Prayer in 1799, etc.

Price 15c; 3 for 40c; \$1.35 doz.

This Man Is Sure of His Job



HE saw the handwriting on the wall. Men in his department were being dropped right and left. He might have been the next to go but for a familiar coupon which he saw one day in a magazine. He marked it, and mailed it to Scranton.

Then one day his employer called him in.

"Young man," he said, "I have just received a letter from the International Correspondence Schools telling me you have enrolled and have received a mark of 93 for your first lesson.

"I don't mind saying that this letter has saved your job. I had you on the list of men to be dropped. But I'm going to keep you now. The man who thinks enough of his future to study his job is the kind of a man we want around here."

HOW about you? Are you sitting on the anxious bench wondering if you will be the next to go? Or are you training yourself so that you will not only be sure of your present job but will be ready for the job ahead?

No matter where you live, the I. C. S. will come to you. No matter how limited your previous education, the simply-written, wonderfully-illustrated I. C. S. textbooks make it easy to learn. No matter what career you may choose, some one of the 300 I.C.S. Courses will surely suit your needs.

This is all we ask: Without cost or obligation, put it up to us to prove how we can help you. Just mark and mail this coupon. Today is best.

----- TEAR OUT HERE -----
INTERNATIONAL CORRESPONDENCE SCHOOLS
BOX 5638-C SCRANTON, PA.

Without cost or obligation please explain how I can qualify for the position, or in the subject before which I have marked an X:

- | | |
|---|---|
| <input type="checkbox"/> ELEC. ENGINEER | <input type="checkbox"/> BUSINESS MANAGEMENT |
| <input type="checkbox"/> Electric Lighting & Railways | <input type="checkbox"/> SALESMANSHIP |
| <input type="checkbox"/> Electric Wiring | <input type="checkbox"/> ADVERTISING |
| <input type="checkbox"/> Telegraph Engineer | <input type="checkbox"/> Show Card & Sign Ptg. |
| <input type="checkbox"/> Telephone Work | <input type="checkbox"/> Railroad Positions |
| <input type="checkbox"/> MECHANICAL ENGINEER | <input type="checkbox"/> ILLUSTRATING |
| <input type="checkbox"/> Mechanical Draftsman | <input type="checkbox"/> Cartooning |
| <input type="checkbox"/> Machine Shop Practice | <input type="checkbox"/> Private Secretary |
| <input type="checkbox"/> Toolmaker | <input type="checkbox"/> Business Correspondent |
| <input type="checkbox"/> Gas Engine Operating | <input type="checkbox"/> BOOKKEEPER |
| <input type="checkbox"/> CIVIL ENGINEER | <input type="checkbox"/> Stenographer & Typist |
| <input type="checkbox"/> Surveying and Mapping | <input type="checkbox"/> Certified Public Accountant |
| <input type="checkbox"/> MINE FOREMAN or ENGR | <input type="checkbox"/> TRAFFIC MANAGER |
| <input type="checkbox"/> STATIONARY ENGINEER | <input type="checkbox"/> Railway Accountant |
| <input type="checkbox"/> Marine Engineer | <input type="checkbox"/> Commercial Law |
| <input type="checkbox"/> ARCHITECT | <input type="checkbox"/> GOOD ENGLISH |
| <input type="checkbox"/> Contractor and Builder | <input type="checkbox"/> Common School Subjects |
| <input type="checkbox"/> Architectural Draftsman | <input type="checkbox"/> CIVIL SERVICE |
| <input type="checkbox"/> Concrete Builder | <input type="checkbox"/> Railway Mail Clerk |
| <input type="checkbox"/> Structural Engineer | <input type="checkbox"/> AUTOMOBILES |
| <input type="checkbox"/> PLUMBING & HEATING | <input type="checkbox"/> Mathematics |
| <input type="checkbox"/> Sheet Metal Worker | <input type="checkbox"/> Navigation |
| <input type="checkbox"/> Textile Overseer or Supt. | <input type="checkbox"/> AGRICULTURE <input type="checkbox"/> Spanish |
| <input type="checkbox"/> CHEMIST | <input type="checkbox"/> Poultry Raising <input type="checkbox"/> Banking |
| <input type="checkbox"/> Pharmacy | <input type="checkbox"/> Airplane Engines |

Name.....

Street and No.

City..... State.....

Occupation.....

Persons residing in Canada should send this coupon to the International Correspondence Schools Canadian, Limited, Montreal, Canada.

Where No Car Could Follow

FAR from the monotony of the crowded city—away from the automobile-infested, dusty main-roads—out where the air is cleaner, the grass greener and the picnic places more inviting—why, man, there's a new world waiting to be explored by you, your pal and a Harley-Davidson!

The best vacations, the happiest week-ends, the most successful fishing and hunting trips—all these are yours when you have a motorcycle. And, to all the pleasures and thrills of the "greatest sport in the world," the Harley-Davidson adds **economy**. Fifty miles for a dollar—gas, oil, tires and all—that's all it costs. Think of the fun you can have with a Harley-Davidson at so small a cost this summer!

Your local dealer will give you a **free** demonstration of the Harley-Davidson. Also the reduced prices and an easy payment plan. Or write us for illustrated literature.

Attractive dealer proposition for unassigned territories. Address Desk A-2.

HARLEY-DAVIDSON MOTOR CO.
Milwaukee, Wisconsin

Harley-Davidson

World's Champion Motorcycle

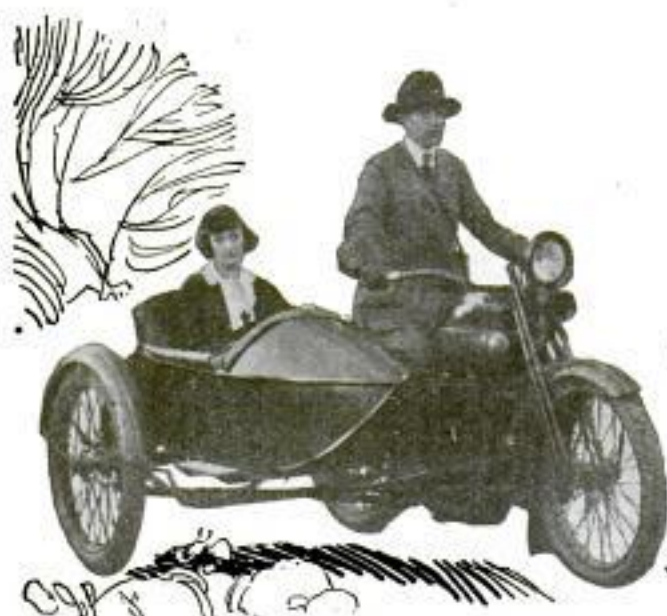

ANY BOY CAN BUILD THIS

20" CAT BOAT

with our complete Construction Set.

"Everything but the paint"

\$5.00

We have other boats, engines, boilers, etc.

Catalog Free

The H. E. Boucher Mfg. Co.
154 Lafayette St., New York



MEN WANTED

to call on garages, stores, factories, schools, hotels, homes, auto owners and demonstrate and take orders for new

Super Fyr-Fyter

Approved by Underwriters, makes spectacular demonstration. Sells easily. Blank made \$59.60 first week. DePries has averaged \$7000 per year for last 3 years. We can train you, without cost, so you can do as well or better. No experience necessary. Write at once for free details showing how you can earn \$2000 to \$10,000 a year.

THE FYR-FYTER COMPANY
63 Fyr-Fyter Bldg. Dayton, Ohio



GOOD-BYE OVERALLS \$1.00 BRINGS THE NOGAR SUIT

Here is the kind of suit you have always wanted—a suit that will withstand the hardest kind of wear in factory or shop and in which you can go and come from work looking neat and presentable. A "dressy" suit that defies wear and water. Perfectly adapted for wear on teams and trucks.

Excellent for hunting, fishing, motoring, etc. For all hard work or outdoor sport you need a NOGAR suit made of special NOGAR cloth that wears like leather. Nine roomy pockets, seams that cannot rip, convertible collar. Send only \$1.00 with order. Pay postman \$8.50 when he delivers your suit (or \$8.75 if you want the patented legging trousers) You take no chances money refunded if unsatisfied.

NOGAR CLOTHING MFG. CO., READING, PENNA.

Chest measurement over vest in.	Coat: Single or double breasted
Length of sleeve under arm in.	Weight Height
Pants waist measure in.	Name
Length of pants in.	Street or P. O. Box
Trousers, Plain, Cuff or Leggings	City State

\$9.50

\$9.75



**Easy to Play
Easy to Pay**

BUESCHER

**True-Tone
SAXOPHONE**

Saxophone Book Free

Tells when to use Saxophones singly, in sextettes or in regular bands; how to play from solo parts in orchestra and many other things you would like to know.



(34) In big demand for orchestra dance music. The portrait above is of Donald Clark, Soloist with the famous Paul Whiteman's Orchestra.

Free Trial You may order any Buescher Instrument without paying one cent in advance, and try it six days in your own home, without obligation. If perfectly satisfied, pay for it on easy payments to suit your convenience. Mention the instrument interested in and a complete catalog will be mailed free.

Buescher Band Instrument Co.

Makers of Everything in Band and Orchestra Instruments
2534 Buescher Block, Elkhart, Indiana

LOOK 50¢ LOOK Wonderful Instrument. Greatest thing yet. Nine separate articles in one. Everybody delighted with it. Odd, curious and interesting. Lots of pleasure as well as very useful. It is a double Microscope for examining the wonders of nature. It is also an Opera Glass, a Stereoscope, a Burning Lens, a Reading Glass, a Telescope, a Compass, a Pocket Mirror, and a Laryngoscope—for examining eye, ear, nose and throat. It is worth all the cost to locate even one painful cinder in the eye. Folds flat and fits the pocket. Something great—you need one. Don't miss it. Sent by mail, with 300 page Novelty Catalog, ONLY 50c or 3 for \$1.25

JOHNSON SMITH & CO., Dept. 787 3224 N. Halsted St., CHICAGO

**DIAMONDS
WATCHES**
One Year to Pay

**Diamond Prices Smashed
to Less Than Cash Prices**

Amazing money-saving prices on finest quality genuine diamonds, watches and jewelry. DIAMOND RINGS \$14.85 and up. Wrist Watches \$19.95 up. Men's Elgin and Waltham Watches \$28.75 up.

Get DeLuxe Catalog FREE. Explains easiest credit Terms and Money Back Guarantee fully. Examine Diamonds first if you wish. One whole year to pay. Use Your Credit. Get this Beautiful Bargain Catalog. NOW!

Klein & Co. 122 W. Madison St. Dept. B75 Chicago, Ill. Nearly 1-4 century same location

\$4.50
A Month
payments will buy this magnificent hand engraved "Lady Lovelace" ring. 18kt Solid Gold. Large brilliant-cut diamond perfect cut diamond of very brilliancy. Was \$100.00.

Now Only \$68.00

Use Your Credit
No Delay—No Red Tape



*A better home
for less money
by the Lewis Method*

YOU can buy the materials for your home at wholesale prices and at the same time save many dollars on labor by the Lewis ready cut method.

For Lewis Homes we furnish lumber logged in our own forests and cut and finished in our own mills. There is a big economy in labor cost because Lewis Homes are cut ready to put together. Weeks of costly time are saved. Yet they are built just as solidly as by old fashioned methods. They comply with all building laws.

The high grade quality of every bit of material is covered by our binding guarantee of satisfaction. In one shipment you receive all the necessary lumber, shingles, nails, paint, hardware, etc. You need pay no money until you inspect the materials.

You know in advance exactly what your Lewis Home will look like. Instead of a mass of blue prints you see an actual photograph of the finished house. And you save the architect's fee. Lewis plans are based on a study of thousands of the most artistic and livable homes throughout the country.

Our Personal Service Bureau will give you information concerning excavation, foundation costs, plastering—every possible item. There will be no extras coming up at the last minute.

Send for 160 page book
"Lewis Homes of Character"

It contains photographs, floor plans and descriptions of 96 homes—colonial or modified colonial designs, bungalows and semi-bungalows, Swiss chalets, Old English half-timbered designs, two family houses, summer cottages, etc. Answers every point you want to know about the Lewis Method of Home Building. 160 pages, 7½x11 inches, fine paper, beautifully bound. Mailed for 25 cents (coin or stamps). Lewis Manufacturing Company, 1254 Michigan Ave., Bay City, Michigan.

LEWIS HOMES

LEWIS MFG. CO., 1254 Michigan Ave., Bay City, Mich.

Enclosed find 25 cents for your book of Lewis Homes.

Name.....

Address.....

City.....State.....

Write name and address plainly. (Note:—If you live anywhere outside of the United States, send \$1.50.)



Patrol \$1.65

Waterbury Watches

MILLIONS of boys are carrying watches of our make. They are made without frills or gold-plate for just this one purpose—to keep good time. They are sturdy and dependable, and will stand all sorts of hard knocks. When you see the watches, you will recognize them as old friends—with new faces.

Waterbury Clock Company

Factories: Waterbury, Conn.

Sales Offices

New York San Francisco
137 Center St. 360 Fremont St.

Chicago

215 W. Randolph St.

Waterbury is famous for clocks, also

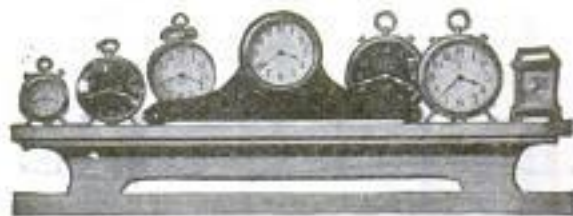

FORD CAR GIVEN

Solve This Puzzle. Win Fine Prize

15	8	95	15	21
8	5	14	18	25

It and so on. The ten figures spell three words. What are the words?

To Men, Women, Boys and Girls

All can share in these EASY-TO-WIN prizes. Send the three words on a slip of paper with your name and address. Besides the Auto I am going to give away Phonographs, Bicycles, Gold Watches, Silverware, etc. and cash rewards. Send your answer. Act quick.
Duane W. Gaylord, 537 S. Dearborn St., Dept. 97, Chicago



Make Your Face Show Manhood



Every real man wants the clear, rugged, ruddy face of a real he-man; the healthy, clean skin and alert expression that comes from a vigorous life in the open air. All men want it—all women admire it. You can have it.

STAG

A Man's Cream for a Man's Face—is a true facial invigorator and tonic prepared for men. Two minutes' use brings the red blood tingling to the surface, removes that oily, sallow appearance and leaves the skin clean, clear, firm and with healthy color. It invigorates and hardens the facial muscles and promotes an alert, forceful expression. A sixty-day treatment—with money-back guarantee—will be sent to you for a dollar bill.

Manhood Commands Admiration

Men and women all admire the man whose face shows the clean vigor of perfect health. Stag is made for you men who want to be one of those ruddy, forceful, hard-hitting fellows who are always so popular. Send your name, address and a dollar and it will come to you by return mail—fully guaranteed.

Stag Laboratories 1267 Park Place, West, Dept. 1005 Detroit, Mich.

DON'T BUY TIRES

And Pay Big Money--Use Insyde Tyres

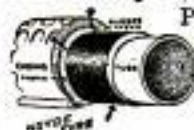

Positively prevent punctures and blow-outs. Give double tire mileage, any tire—old or new. Use over and over again. Old worn-out casings will give three to five thousand miles more service. Car owners save \$50 a year. Over one hundred thousand satisfied customers. Low priced. Special representatives wanted.

AMERICAN ACCESSORIES CO., B-1976, Cincinnati, Ohio

Big Money Making Kisses

D. M. Tree originated and made a fortune with Cream-O-Lasses, delicious Candy Kisses. He will train one person, 18 years or over, in each community, to make and sell them under his advertised trade-mark name—Cream-O-Lasses. Many now making \$10 to \$25 a day clear profit. If interested, just write to D. M. Tree, the Candy Maker, Dept. 202, Kansas City, Mo., for full information and free samples.

From FACTORY TO YOU AT NEW LOW PRICES

Easiest riding, most comfortable wheel built. You'll want it sure when you see the 18 exclusive features of the splendid 1922 model electrically equipped

BLACK BEAUTY

40 Styles

Sold only with our exclusive five year guarantee and six months accident insurance. You can have it right now for a small deposit and only

\$1 A WEEK

New, low, direct factory price saves you big money. Best value ever offered. We pay express charges and ship wheel to you on receipt of order.

ON APPROVAL

Send post card at once for big new color illustrated catalog, large variety of styles, features described—it is

FREE

Haverford Cycle Co., Dept. 375, Philadelphia, Pa.

Copyrighted material

STANDARD
C Melody

SAXOPHONE

NOW
\$64.⁸⁵

Was \$105

By direct-from-factory selling and eliminating all waste we have cut the price to \$64.85, actually less than wholesale! Don't wait—order from this ad. C. O. D. with privilege of inspection.

STANDARD "Professional" Saxophone on 6 Days FREE TRIAL

Express agent will return amount deposited within 6 days if you are not delighted.

Easy to Learn!

You can actually learn to play tunes in an hour! Quickest and easiest of all-instruments to learn, and therefore most popular today!

MAKE EXTRA MONEY!

Saxophone players are in demand all the time and get big money! Here's the easiest way to add to your income.

"A World of Pleasure"

All doors are open to the fellow or girl who can play the Saxophone. You don't know what a good time is until you can play. And the C Melody will be your choice because it's the Saxophone for solos and every other kind of playing.

Illustrated Catalog FREE. Hurry!

Standard Music Co., Dept. 122, P.O. Box 303 Chicago

THE COOKER WITH A THOUSAND USES



Made of extra heavy PURE COPPER. Note the extreme width of pot, which gives an extra large fire space. These pots are packed in PLAIN wooden boxes and shipped same day your order is received. IN ORDERING SEND ONLY \$1.00, BALANCE C.O.D. FREE catalog containing valuable information upon request.

DEVOL & CO.

26 Barker Block
Omaha, Nebr.

DIAMONDS

For Graduations, Anniversaries, etc.

Here at 60%
of Market Price

This absolutely flawless diamond gem 1/2—1/16 ct. at \$100 among bargains in recent list. Many other big values in our lists. Buy HERE! Prices based on loan values, not market values. This 75 year old diamond banking firm has thousands of unpaid loans and other bargains. Must sell NOW.

Why Pay Full Prices

Any diamond sent for absolutely free examination at our risk. No obligation. No cost to you. Send for Latest List

Describes Diamond Bargains in detail, gives guaranteed loan values. Explains unlimited exchange privilege. Write for list today. Send NOW.
JOS. DEROY & SONS 1906 DeRoy Building
Only Opposite Post Office Pittsburgh, Pa

Is Your Brain Hitting on all Six?

All the gas in the world, in the best motor ever made, won't turn a wheel till a spark bursts it into power. Your brain is your motor. Facts about things are the gas. Every boy needs the spark of inspiration to fire his imagination so he will put his facts to work and force himself ahead in the world.

The cracking good stories found every month in

THE AMERICAN BOY

"The Biggest, Brightest, Best Magazine for Boys in All the World"

are a continual chain of sparks that make boys' brains hit on all six all the time. They tell in a mighty human, mighty real and intensely interesting way how men and boys in the work-world use the facts in their heads to get ahead. They show how and why other fellows fail—fellows who had facts, too, but no spark.

What if you had to get gasoline through a forest fire to a stranded airplane? Could you do it? Read "Packing the Gas" in the May AMERICAN BOY, by John Fleming Wilson, and see how three clever kids turned that trick.

That's only a sample. Every issue of THE AMERICAN BOY is full of stories of real life that show boys how to think, think hard for themselves.

Buy the May issue and read the article on Radio, by Armstrong Perry. Straight stuff—and fascinating.

If AMERICAN BOY stories and articles once get their teeth in you, you'll never miss an issue.

At any news-stand, 20c, or subscribe for a year and be sure you'll get every number.

American Boy

The Biggest, Brightest, Best Magazine for Boys in All the World

THE SPRAGUE PUBLISHING CO.
No. 374 American Bldg., Detroit, Mich.

Enclosed find \$2.00, for which send **THREE** AMERICAN BOY for one year, beginning with the current issue, to

Name.....

Address.....

Please Mention Popular Mechanics

*Just like wiping
your face
with a towel*



**In a world
full of
razors
Enders is
unique**

ENDERS sells
for \$1, with six
blades—at all
up-to-date
dealers every-
where. Extra
blades, pack-
age of 5—35c.



ENDERS SALES COMPANY
105-111 West 40th Street, New York

**Imperial
Sanitary
Floor**

Put on like Plaster
Wears like Iron
-waterproof
fireproof
resilient
noiseless
dust-
less

**Base
and Floor
one solid piece**

A composition material easily applied in plastic form over practically any kind of floor. Laid about 5/8 inch thick. Imperial floor does not crack, peel or come loose from foundation. A continuous, fine grained, smooth, non-slipping surface. No crevices to gather grease, dirt, dust, disease germs or moisture.

Ideal Floor for Kitchen, Pantry, Bath Room, Laundry, Porch, Garage, Restaurant, Theatre, Hotel, Factory, Office Building, Railroad Station, Hospital—wherever a beautiful, substantial floor is desired. Several practical colors. Full information and sample FREE of your first and second choice of colors.

Imperial Floor Co., 65-67 East Ave., Rochester, N. Y.

A Success for 15 Years

**MYSTIC EGYPTIAN
LUCK RING**



From ancient Egypt comes the Egyptian Luck Ring with mystic characters and sacred scarab bringing Life, Prosperity and Health to the wearer. Cleopatra is said to have worn one of these rings. Many people wearing them today, claim they bring success to men and admiration to women. **Guaranteed Sterling Silver.** Money back if not pleased. State Ladies' or Gents' Ring. Enclose strip of paper fitting knuckle of ring finger. **Order Quick, Today. Cash \$1.45; C.O.D. \$1.55**

CHALENS SUPPLY HOUSE
7 So. Dearborn St. Dept. 185, Chicago, Ill.

**2 TIRES
FOR
\$11⁹⁵**

**FREE TUBE WITH
EACH TIRE**

SENSATIONAL CUT IN STANDARD TIRE PRICES!

Two used tires for less than the usual cost of one, and a free inner tube with each tire! No double treads or second tires. Our big volume means best tire values. Act now and cut your tire cost in two. Thousands of steady customers are getting full mileage out of these tires and you, too, can get **8,000 MILES**

You can see the mileage in our tires. Order and prove it—but order now! This is a special lot selected for record-breaking sale. Supply limited and going double quick.

NOTE THE BARGAIN PRICES ON TWO TIRES OF SAME SIZE

Size	1 Tire	2 Tires	Size	1 Tire	2 Tires
30 x 3	\$ 7.25	\$11.95	32 x 4 3/8	\$13.45	\$21.45
30 x 3 1/2	8.25	13.95	33 x 4 3/8	13.95	22.45
32 x 3 1/2	9.45	15.45	34 x 4 3/8	14.45	23.45
31 x 4	10.65	16.90	35 x 4 3/8	14.95	24.90
32 x 4	11.85	19.75	36 x 4 3/8	15.45	25.45
33 x 4	12.45	20.90	33 x 5	15.65	25.95
34 x 4	13.25	21.95	35 x 5	15.90	26.45
35 x 4	14.95	25.95	37 x 5	16.45	26.95

SEND NO MONEY! Shipment C.O.D. express or parcel post. Examine tires on arrival and if not fully satisfied return same at our expense and your money will be promptly refunded. State whether straight side or clincher. **DON'T DELAY! ORDER NOW!**

ALBANY TIRE & RUBBER COMPANY
2721 Roosevelt Road Dept. 164E Chicago, Illinois

DELTA

ELECTRIC BICYCLE LAMPS

Spring is here! Now for the balmy jaunts to and from work with a DELTA to whiten the way.

No. 80 solves problem of rear red light—complies with all laws. Mounts left side front wheel under axle nut. No. 27 mounts on handle bar.

Ask your dealer or either model sent prepaid for \$2.25 complete (less Battery).

DELTA ELECTRIC COMPANY.

160 DELTA BLOCK, MARION, IND.



Standard Makers of Electric Lanterns, Automobile Flashlights,
Bicycle Lamps, Flashlights and all kinds of Dry Batteries.

New York Winnipeg San Francisco

THIS WONDERFUL INVENTION



converts any ordinary cook stove into a gas stove. OXO-GAS is made from kerosene and air. Cheaper, cleaner and more efficient than coal. Responsible distributors wanted.

GLORIA LIGHT COMPANY
114 N. May St. Chicago, Ill.

Baby Grand Lathes

Not a Toy---Just Like a Big One

For either metal or wood working—ideal for auto and electric repair shops, pattern and model shops. Because of their simplicity and compactness, we are able to build into each Baby Grand Lathe the same quality that characterizes the finer types of big lathes—and at a price within the reach of everyone, everywhere.

Put One on Your Bench at Home

Baby Grand Lathes develop talents, make more products and provide a means of carrying out your ideas right in your home. Do your own work on either metal or wood. **WONDERFUL FOR THE BOY.**

They are light, compact and simple to operate, but at the same time as sturdy, close the highest quality of work is produced. Manual Training teachers endorse the Baby Grand. It is a wonderful help to the student at home. The lowest priced **GOOD LATHES** ever produced.

Write for
Prices and
Details

6 In.
Swing
12 In.
Between
Centers
20 In.
Bed



THE WATSON MFG. CO.
25 Post St., Toledo, Ohio

Finest Instruments Are Easiest to Play

You cannot learn to play correctly on a cheap, imperfect instrument and expect to achieve success in music. The best teachers will always recommend the finest instruments for their pupils.

King Instruments Now Easy to Own

A quarter century ago the first King Brass Instrument was made to the specifications of a famous artist, and for years thereafter Kings were made and sold only for cash to great musicians. But now, our new easy payment plan makes it possible for anybody to own a King. You can now buy direct from the factory, save middleman's profit, and get a brand new, acoustically perfect, laboratory-tested King Instrument. And, with every new King goes our famous free factory-service and guarantee.

Big Stock of Used Instruments

Thousands of musicians have turned in good instruments as part payment on new and better Kings. These used instruments we sell for cash at very low prices. They are refinished and look like new. Send for our latest complete catalog and list of these bargains before they are gone. Ask for details of easy payment plan on new instruments.

THE H. N. WHITE CO.
5237 Superior Avenue,
Cleveland, Ohio



KING



A Friend in Need

The greatest convenience ever invented for motorists who drive on country roads. It saves time, trouble, cost of new tubes, and repair bills. With the simple Shaler Vulcanizer you can make permanent, heat vulcanized tube repairs in five minutes. Easy to use, and works automatically, without fail, in wind or storm. Cannot burn or injure your tubes. Over a million motorists carry the Shaler for making quick tube repairs.

Simple, compact, handy. Just touch a match to the solid chemical fuel. In five minutes the cut or puncture is repaired—a heat-vulcanized, permanent repair that will not come off, better than any temporary "stuck on" cold patch—stronger than the tube itself.

The Shaler also repairs rubbers, rubber boots, hot water bottles, rubber gloves, coats, etc.

Complete Outfit \$1.50 At All Auto Supply Stores

The outfit includes—the Shaler Vulcanizer, 12 Patch & Heat Units, with complete instructions. Extra Patch & Heat Units 75 cents a dozen. Prices slightly higher west of the Rockies and in Canada.

C. A. SHALER CO.

2016 Fourth St.

Waupun, Wis.



WIRELESS TELEPHONE

BBROADCASTING stations are now in operation at important centers all over the country. You can easily receive these interesting daily programs with an ABC wireless receiving UNIT. ABC UNITS come to you ready-to-operate and complete in every detail. They are built on the sectional system, so that you can increase the range of your station at any time.

Ask your radio or electrical dealer about this and other exclusive features of ABC UNITS. If he cannot supply you, send us his name and address and enclose ten cents, for your copy of our booklet, "How I Put Up a Complete Radio Station in Two Hours." Request Booklet P5.

Jewett Mfg. Corp.
21 E. 40th St., N. Y. C.

ABC UNITS
Standard Model Sectional Receiver

RADIO For Everybody

Don't be satisfied with puttering around with Radio. You can earn big money. Learn by mail, in spare time, how to design, construct, install, repair, maintain, operate, sell and demonstrate complete radio outfits. Write for our book, "How to Learn Radio at Home." National Radio Institute, Dept. 1065, Washington, D.C.

\$3 Cash Buys Typewriter



Balance Only \$5 Monthly
Save 35 to 60% on all Standard makes—Underwood, Royal, Remington, etc. Every machine thoroughly rebuilt and GUARANTEED. Try 5 days at our expense before you buy.

WRITE at once for Free Descriptive Circular and Special Low Prices.

5 DAYS FREE TRIAL

WYNN TYPEWRITER EXCHANGE 11 Reliance Bldg. Kansas City, Mo.

\$104 PROFIT IN 3 1/2 HOURS



G. A. Barton, Indiana, made that amount—making and selling Candy Floss. Others send in amazing reports: Small, Chicago, says— "Did \$125 business on Sunday." Wendel, Kansas, writes, "Averaged \$128 a day for 3 weeks." Gardner reports, "2,437 sacks of candy sold from 11 a.m. to 10:15 p.m. Big Money in Candy Floss! Rees says: "Cleaned up \$225 in 4 nights in Greenville, Ohio." Candy Floss is a delicious, novelty confection—fluffy, soft as cotton, white as snow, or any color or flavor. Can be made anywhere—in store window, in parks, on street corners, at picnics, summer resorts, base ball games, or wherever crowds gather. Machines easy to operate. Raw materials plentiful and cheap. Send name and address for free illustrated book of facts. Drop postal. Act now! Address

FREE MY BOOK "CANDY SUCCESS"

A. T. DIETZ

44 Sayso Bldg.

Toledo, Ohio

Give Your Radio Set
the Advantage of

WESTINGHOUSE

RADIO

BATTERIES

Westinghouse "A" Batteries are especially built for the peculiar requirements of radio work. They deliver a constant, dependable flow of low voltage current at a minimum of cost. Their rigid construction insures long life.

In the Westinghouse "B" battery you have a permanent storage battery for "B" work. It gives a steady, continuous, noiseless service. It lasts indefinitely. When exhausted it is easily recharged. The first cost is the last cost.

Don't lose the complete enjoyment of your radio set by operating under unsatisfactory battery conditions. Get Westinghouse "A" and "B" batteries from your radio dealer or the nearest Westinghouse Service Station.

The best Westinghouse can build.

WESTINGHOUSE UNION BATTERY CO.
Swissvale, Pa.

AGENTS and Housewives

One sale a day makes \$36 weekly. Three sales a day makes \$5000 a year. New invention, sells like wildfire, turns ordinary coal or wood stoves into gas ranges. First user in each neighborhood can get one free. Write today for particulars.

SIMPLEX UTILITIES MFG. CO. QUICK!

2540 S. STATE ST. CHICAGO, ILL.

ORANGEADE

Just Add Cold Water and a little sugar. You will then have the Best Drink You Ever Tasted. Very delicious—refreshing—healthful. Prepared instantly—no trouble, and can be kept on ice for several days if you wish. Five for the House, Parties, Dinners, Parties, Clubs, etc. Big clear profit on Every Dollar at 50 cents. Agents Wanted to sell our Orangeade, Cherry, Lemon, Grape, Lima, Raspberry and Strawberry all in powder. Every home—everyone you meet—is a possible customer. 100 per cent profit to agents. Send dime for ten glass packages, with particulars, postpaid; 7 kinds for 50c, postpaid. Do it NOW.

Make it Yourself

CHAS. T. MORRISSEY & CO. Chicago, Ill.
4411-15 Madison St.



MOTOR REPAIR BOOK FREE



Why spend dollars, when you can make perfect Automobile and Household repairs quickly and easily with SMOOTH-ON IRON CEMENT No. 1 at a few cents' expense? Write for this book and learn how—it's Free.

Smooth-On is sold in 4 oz., 1 lb., and 5 lb. tins by Hardware and Auto Supply Stores.
SMOOTH-ON MFG. CO., Dept. 37E Jersey City, N. J.

SMOOTH-ON IRON CEMENT No. 1
For Motor and Household Repairs



APCO

EQUIPMENT FOR FORDS

helps you keep
your car out of
the repair shop



APCO

Shock Absorber

the best made. Positively protects your Ford from road shocks. Adds 66 inches of resilient coiled spring wire, 1/2 inch in

diameter, to each end of your Ford springs. You can install them yourself. Price \$20.00 for set of four, ready to attach.

You will find APCO Equipment a big help in getting service out of your Ford. Here's the APCO line—not fads but necessities:—

Crank Case Arm. Made from boiler-plate steel, accurately drilled and finished in black. Does a twelve-hour repair job in an hour. Price \$1.00.

Steering Column Brace. Rigidly supports the steering column, preventing rattle which loosens and often breaks the steering column. Made from malleable iron, finished in black. Price \$1.00.

Anti-Rattlers. Used on radius rods and steering rods. Guaranteed to remove all rattles. Made from malleable iron. Price, Radius, 40c each; Steering, 40c pair.

Oil Gauges. Glass gauge is heaviest and largest on the market. Metal gauge shows height of oil by white ball attached to float by wire rod. Price, glass, 40c; metal, 75c.

Horn Buttons. Wheel button attaches to center of steering wheel in place of regular nut. Other type attaches to throttle lever. Price, wheel type, 50c; throttle lever type, \$1.00.

Detachable Transmission Bands. You can do a reline job in 35 minutes with APCO bands. A real time and money saver. Price, \$5.00 for set of three.

Muffler and Cut-out. Made in one casting. Cannot possibly blow out. Price, complete with pedal and all necessary parts, \$5.00.

Connecting Rod Wrench. One-piece ratchet wrench that will work on the fourth connecting rod of the Ford car better than any other wrench made. Steel, drop forged. Price, 75c.

Most dealers carry the complete APCO line. If yours does not, we will ship any accessory prepaid on receipt of price.

APCO MANUFACTURING CO.
1204 Eddy Street PROVIDENCE, R. I.

Please Mention Popular Mechanics

Copyrighted material

Get a Copy of this Book

HOW TO TAKE **VIOLET RAY**
TREATMENTS AT HOME

Are you worrying about your health, or that of any member of your household? Is any member of your family suffering from weakness, nervousness, "run-down" condition, rheumatism or aches or pains of any kind? If so, this book will be of great benefit. It tells in detail how nearly every common disorder can be overcome by simple home methods.

Sent Without Obligation

We want this book to be in every home as a reference book on health. It is the most complete book ever prepared on the home treatment of disease by the Violet Ray method. More than 100 ailments are discussed in simple language, and detailed treatment given for each.

What It Teaches

Do you know that nervous tension can be relieved in ten minutes? Do you know that one Ra-Tone treatment will definitely enrich your blood, add to its oxygen content, increase the number of both red and white corpuscles and combat impurities and poisons? Do you know that aches and pains of all kinds can be relieved?—that the vital internal organs can be invigorated and made to function with the strength of perfect health?

Ra-Tone
VIOLET RAY BUILDS HEALTH
Violet Ray Treatment

is the most highly developed home treatment of its kind available at any price. It is based on years of experience and observation in thousands of cases. The various methods of treatment and the results obtained are described in great detail.

Investigate Proven Results

Ra-Tone Violet Ray Generators are sold on an entirely new basis—that of **results only**. You can read in our book just what has been accomplished in thousands of cases similar to yours—and can expect the same benefits. If you want accurate and reliable information on Ra-Tone treatment—if you want to banish weakness and build perfect health without the use of drugs—this book will teach you how. Send for it **today**.

Ra-Tone Electric Co., 1005 W. Park Place
Detroit, Michigan

Demonstrators and Distributors WANTED

We want an intelligent man or woman in every community to demonstrate Ra-Tone treatment. All or part time. Our unflinching plans will enable you to make a success from the start. You will find this a pleasant, profitable and interesting occupation. Fine opportunities for those qualified as exclusive sales distributors

Please Mention Popular Mechanics

YOU CAN MAKE \$18 DAILY PROFIT

With Our Great Introductory Offer
Giving These \$1.25 Dress-Making Shears **FREE**



With each sale of our wonderful 11 piece Toilet Article Assortment for only \$1.75. TOTAL STORE VALUE \$4.60

\$18.00 a Day PROFIT on only **TWENTY** Sales



Lucky 11 Toilet Set—Retail Value \$3.35!

MY! HOW THEY SELL!

You get the attention with the free Shears. Walter Harris sold 800 boxes in six weeks. Profit over \$100 a week. You can do this too.

Act Now! Sell like hot cakes year round. A baby could sell Lucky 11. Don't wait a minute. Save time. Send \$1.75 for complete outfit including display case. At least write for circulars explaining our unique plans, including 30 other packages. **ACT NOW!**

E. M. DAVIS CO., Dept. 2355, CHICAGO, ILL.

BIG PAYING HOTEL JOBS OPEN

to trained men and women; we train you by mail; get 20 years' hotel experience in few months; earn \$3,000 to \$10,000 a year; fine living; work is fascinatingly interesting; quick advancement. Send for **FREE BOOK** today
LEWIS HOTEL TRAINING SCHOOL, Room 329, Washington, D. C.

GREATEST WONDER

THE ONLY GENUINE INSTRUMENT!
Latest European Invention.
Become Popular. Play this JAZZY FLUTE!
Wonderful fun!
No lessons required. Great entertainment for parties.
15 POPULAR SONGS FREE
SEND NO MONEY. Pay Postman on arrival.
A. ORIOL CO. 15 PARK ROW, N.Y.C.

PLAY IT WITHOUT LEARNING

Ford OWNER Agents Wanted!

In each locality to use and introduce
NON-KICK DEVICE

Prevents Broken Arms—Cranking Accidents.

Make big money, part or full time. Burnett sold 144 in two weeks—made \$216. Big Field—our folder, "How to Make Money With Non-Kick Device," will prove it. Almost 5,000,000 old Fords without starters. 70% 1921 Fords sold without starters, or 875,000 out of 1,250,000.

Try a "Non-Kick" 10 Days at Our Risk

See for yourself how it disengages the clutch, allowing motor to reverse without danger to person who cranks. Thousands of satisfied users. Easy to install; only one nut to remove; slips right on over handle; a child can put it on in two minutes. With a "Non-Kick" on your Ford you will never have a broken arm or cranking accident, with suffering, doctor bills, inconvenience, lost time, etc. Send \$2.50 for sample "Non-Kick" Device (or, we will send it C. O. D. and when it arrives pay postman \$2.50) and if after 10 days trial it isn't as represented get your money back. Be the first in your locality to order—and ask about our attractive exclusive territory offer to agents.

NON-KICK DEVICE COMPANY
778 Central Street Kansas City, Mo.



Flowered Tapestry
Upholstering. Cane-Panel Ends.

William & Mary Style Davenport Sofa-Bed Only 20c A Day

HERE'S a handsome, roomy Sofa for day time use of beautiful design. And for night it becomes in a moment a real comfy, sleep inducing bed. This and nearly 1300 other Furnishings, all shown and described in our big, 128 page FREE Larkin Book of Better Homes. Check first line below for book.

- Furnishings
- Symphonic Pianos
- Symphonic Player Pianos
- Symphonolas

(Check offer interested in)

Music lovers are found in nearly every community praising our Symphonic Pianos, Player Pianos and Symphonolas (those wonderful phonographs with natural tone which play all Records).

**No Money Down—30 Days
Free Trial. 1 to 4 Years Time**

Check above for the book wanted. Send this ad, with full name and address RIGHT NOW.

Desk F P M-522 *Larkin Co Inc.* BUFFALO, N. Y.

Bam-Bee-No

Real Baseball

Played on any table anywhere. Ask your dealer, or write

The Bambeeno Sales Co., Dept. 652
Tolono, Ohio



Now \$1.00 Down

KEEP the New Edison Amberola—Edison's great phonograph with the diamond stylus reproducer—and your choice of records, for only \$1.00. Pay balance at rate of only a few cents a day. Hear it in your own home before you decide. Only \$1.00 down. Seize this opportunity.

Write for Book Get our New Edison Catalog. Your name and address on a post card or letter is enough. Find out about this offer—while this offer lasts.

F. K. BABSON, Edison Phonograph Distributors
19th Street and Marshall Blvd., Dept. 1355 Chicago, Ill.

BOYS



Learn Drafting

DRAFTING offers exceptional opportunities to boys and young men because drafting itself not only commands good pay, but it is the first step towards success in Mechanical or Structural Engineering or Architecture. And drafting is just the kind of work a boy likes to do. There is an easy, delightful way by which you can learn right at home in spare time. For 30 years the International Correspondence Schools have been giving boys just the training they need for success in Drafting and more than 300 other subjects.

Let the I. C. S. help you. Choose the work you like best in the coupon, then mark and mail it. This doesn't obligate you in the least, but it will bring you the information that will start you on a successful career. This is your chance. Mark and mail this coupon now.

----- TEAR OUT HERE -----

International Correspondence Schools
Box 5632-C, Scranton, Penna.

Without cost or obligation, please send me complete information about the subject which I have checked below:

- | | |
|---------------------------------------|---|
| <input type="checkbox"/> DRAFTING | <input type="checkbox"/> BUSINESS |
| <input type="checkbox"/> CARTOONING | <input type="checkbox"/> CIVIL SERVICE |
| <input type="checkbox"/> AUTOMOBILES | <input type="checkbox"/> PHARMACY |
| <input type="checkbox"/> CHEMISTRY | <input type="checkbox"/> ARCHITECT |
| <input type="checkbox"/> ADVERTISING | <input type="checkbox"/> BOOKKEEPER |
| <input type="checkbox"/> SALESMANSHIP | <input type="checkbox"/> GOOD ENGLISH |
| <input type="checkbox"/> ELECTRICITY | <input type="checkbox"/> WIRELESS |
| <input type="checkbox"/> ACCOUNTING | <input type="checkbox"/> CIVIL ENGINEER |
| <input type="checkbox"/> SURVEYING | <input type="checkbox"/> AIRPLANE ENGINES |

Name.....

Address.....

Occupation.....

Persons residing in Canada should send this coupon to the International Correspondence Schools Canadian, Limited, Montreal, Canada

Please Mention Popular Mechanics

Copyrighted material

A MOTOR FOR YOUR BICYCLE



Attach powerful Belt Drive **ROLLAWAY** to your bicycle. **Forget pedals.** Ride in comfort, **ROLLAWAY** gives **positive, dependable power.** Light weight. Runs 100 to 150 miles on gallon gasoline. Fits any bicycle. Economical—costs **less than one-fifth cent per mile** to operate. Shipped complete. Anyone can attach in few minutes. Outfit includes motor, reinforced fork, wheel and guaranteed tire. Hundreds in use. A wonder for **economy and performance.** Price, F.O.B. factory \$65.00. Write for circulars. Adds **joy, speed and comfort** to cycling.

Be Our Salesman!

Buy a demonstrator. Sell. Good commission paid. Write today for our proposition. Address

The Rollaway Motor Co.

521 Shepard Street
Toledo, Ohio

Rollaway

TRADE MARK

The Clark Glare Shield



Men Wanted!

To act as local, district or State agents for this latest auto necessity. Something every auto driver has long wanted, but has been unable to get. The Clark Glare Shield kills glare from approaching headlights—saves the driver from going in the ditch—eliminates road and sun glare—operates with two fingers. Easily attached in a few minutes. Separate styles for closed or open cars. Retail for only \$3.75.

A Bonanza for Agents

This is one accessory that sells on sight. We want hustlers everywhere to sell, either locally or to secure county and state rights. All kinds of sales and advertising helps furnished to workers. Send \$2.75 for a sample pre-paid and mention make and style of car. Look it over, try it yourself and show it to other drivers. Thousands sold in two months—only two returned. Write for proposition today.

THE CLARK PRODUCTS CO.
616 Arcue Bldg. Springfield, Ohio



REWARD!!!

We will refund the cost of a RAD-A-LOK to any car owner or dealer who can prove his motor-meter was stolen when equipped with this thief-proof lock.

\$6 is the price —

RAD-A-LOK positively prevents theft of moto-meters. Easily attached, no key to lose, can't rattle, highly polished and nicked, positively steam and air tight, does away with the hot radiator cap, adds beauty to any car. Sells complete with wings for only \$6.00.

Be the Agent in Your Town

RAD-A-LOKS are selling by the thousands. Think of the car owners in your locality who have had moto-meters stolen. Every garage and automobile dealer will stock a supply. Every car owner will want one. Hundreds of testimonials prove its value. Looks like \$15 value. Act quickly and get our agents' proposition. Send no money unless you want a RAD-A-LOK for your own car. Immediate shipments. Factory co-operation and advertising. Write or wire for guaranteed-profits proposition.

RAD-A-LOK COMPANY

4426 Olcott Avenue, East Chicago, Indiana

RADIO DIARY and INSTRUCTOR \$1.00

Keeps record of interesting "listen-ins." A diary good for a year—start any day. Complete treatise on radio telephony. Brand new—original. Send only \$1.00. Radio dealers write for special proposition.

WM. W. AYRE & COMPANY, Dept. "A," MONTCLAIR, N. J.



SLEEP IN YOUR FORD!

Camp out in any weather—save hotel bills. Two can sleep comfortably in this Folding Ford Bed. Ready for use in 4 minutes—doesn't injure Ford. Sedan or touring car models—\$14.50.

SEND NO MONEY

Live Sales Opportunities. Just pay postman. Money back guarantee. Write or wire. Order from **OUTERS EQUIPMENT CO., 810 Mayer Bldg., Milwaukee, Wis.**

BABE RUTH delights in the sport of Motoring

FORD
SPORT
BODIES

So do you



16
Valve Heads
Speed Differential Gears

Underslung Fixtures
4-Speed Transmission
Crankshaft Counterbalance

Full-line Speed & Power Specialties for the Ford. If you own a Ford rebuild it new. Convert your Ford with a snappy Aero Body as shown above—or with our Champ four model; same lines as above illustration, with additional disappearing seat for two. Ford chassis can be bought cheaply at this time of the year. Dealers equip Fordspeed cars now at low cost and you will be sure to harvest Big Profits in the season. Reductions of 20 to 50 per cent on Fordspeed Products. Write for our catalog and special prices.

Specials for this month	Price	Price
Underslung Fixtures	\$22.00	\$9.95
24:1 Bevel Gears	15.00	9.95
3:1 Bevel Gears	12.50	7.95
Speed & Power Crankshaft	15.00	9.95
For 16 Flat Steel Discs	12.00	8.95

Full line speed & power specialties; write for catalog. Satisfaction or Money Back Guarantee: 100% with order, balance upon delivery.

I. P. FORD SPEED & POWER EQUIPMENT MANUFACTURERS
250 West 54th St., New York Cable Address "Fordspeed"

HOMCHARGE YOUR BATTERY

for A Nickle

The HOMCHARGER

will quickly, efficiently, and safely charge your radio storage battery at a cost of a few cents.

No fuss, trouble, dirt—no moving of batteries—loss of time—no effort on your part—no technical or professional knowledge needed.

Fully automatic—fool proof—self polarizing. The HOMCHARGER is the rectifier you have wanted, and never believed could be made.

All you do is plug into the light current in your home—your HOMCHARGER does everything, and stops when the battery is charged. Fully guaranteed not to injure the battery. Lasts a lifetime.

Price \$18.50 (\$20 West of the Rockies)

Sold by Radio Dealers Everywhere

THE AUTOMATIC ELECTRICAL DEVICES CO.

129 W. 3d ST. CINCINNATI, OHIO

Branch Offices—New York, Chicago, Pittsburgh,
Detroit, New Orleans, Los Angeles, Toronto



Makes Any Stove A Gas Stove

Cuts Fuel Costs in Half

Write today for free descriptive folder telling all about the EVEN HEAT GENERATOR—a simple device that generates gas from kerosene and makes a gas stove out of any cook stove or heater. It's the wonder of the age—the greatest labor saving device ever invented for women.

30 Days Trial—Fits Any Stove

The EVEN HEAT GENERATOR fits any cook stove or heater. You can partition your stove in 5 minutes—no holes to drill—needs only half as much to operate as coal or wood stove. Don't clog—no smoke—no odor. Send for free descriptive folder—learn how you can be relieved of building fires—no more soot—no more dirt. Pays for itself in saved fuel first month—30 days trial. Agents wanted. Write today.

Even Heat Generator Co. (Not Inc.)
Dept. 7 537 S. Dearborn St., Chicago, Ill.

Michigan Marine Motors \$135

Repairs at any Ford Garage



Highly recommended by builders of famous Belle Isle Bearcat. Unequaled for lightness, compactness, dependability, fuel economy and quick starting. Rarely needs adjustment. Specially designed for tenders, launches and fishing boats.

Equipped with genuine Bosch magnets and impulse coupling. Four-SP, 4 cycle, 305 lb. motor fully guaranteed for one year. Special dealer offer.

**BELLE ISLE
BOAT & ENGINE CO.**
DETROIT, MICHIGAN

YOU CAN EASILY MAKE

\$110 per week PROFIT



24 in. high.
Weight 25 lbs.
Toasts 5 lbs. P-
Nuts at once. Hot
on any count-
er; uses ordin-
ary electric
current. Less than
Super de-
spenses
it.

\$5720⁰⁰ per Year CLEAR PROFIT For Yourself!

Millions have been made on the 5c and 10c store idea because these coins are freely spent. Now comes the biggest penny sales idea ever hit upon and electricity has made it possible. A 1c vending machine with new process buttered P-Nuts in plain view. It keeps them toasted; and serves them HOT. Moreover, it flashes an electric sign all day long saying "Eat 'Em Hot--1c."

Stands Out Like a Light House!

This sensational new type Sparta peanut vending machine absolutely compels attention. It gets the pennies by thousands, and serves fresh toasted Buttered P-Nuts so tempting that each customer repeats again and again. We have dozens of letters and affidavits stating that \$30.00 a month is easily made by ONE well placed machine and that \$5720.00 a year is easily realized. What you make depends entirely on how many machines you have and where they are located, and remember, a reasonable sum of money puts you in the business right.

WE SHOW YOU HOW!

We give you 50 pounds of our own Buttered P-Nuts FREE OF CHARGE with each and every machine. This means you operate without peanut cost for the first 44 days. Your profits in 44 days will practically pay for each of your machines. We tell you how to place each machine to best advantage in theatres, clubs, depots, barber shops and many other crackerjack locations. We send you free, by return mail, full and complete information on this great Business Offer.

But Remember The Good Territory is Going Fast!

We give every operator A-1 exclusive territory. Consequently this splendid offer necessarily must be limited. Send Coupon below to protect yourself in your territory and get full details without any obligation to you.

SPARTA MANUFACTURING COMPANY
10-90 Ionia Ave., Dept. 2215
Grand Rapids, Michigan

50 Lbs.
Peanuts

FREE

to you
NOW!

MAIL TODAY

SPECIAL
FREE OFFER
COUPON

SPARTA MFG. CO.
10-90 Ionia Ave., Dept. 2215
Grand Rapids, Mich.

Gentlemen—Send without any obligation, full and complete details of your Great Offer on Sparta "Hot Flash" Peanut Vending Machines.

Name.....

Address.....

Territory.....

(Mention approximate territory desired)

Please Mention Popular Mechanics



RADIO BATTERIES

Your Radio Set is Only as Efficient as Your Battery Is Good

When installing a Radio Set do not neglect the quality of the battery you use. Universal Radio Batteries are built in three types, as shown, all with heavy long life plates and special finish for this kind of work.

Obtain from your dealer—if he can't supply you, order direct from factory. Write for special catalog.

BUILT RIGHT—PRICED RIGHT



TYPE WR

WR - 60 Amp \$15.00
WR - 85 Amp 17.50
WR - 105 Amp 21.00



TYPE RR

RR - 60 Amp \$19.00
RR - 85 Amp 21.00
RR - 105 Amp 25.50



TYPE GR

GR - 16 Amp \$12.75
GR - 60 Amp 18.00

UNIVERSAL BATTERY CO.
3440 So. LaSalle St., Chicago, Ill.

UNIVERSAL
Batteries

BIG MONEY

SHARPENING RAZOR BLADES

Thousands of men with less ability than you are making from \$200 to \$500 a month in the business of sharpening safety razor blades. In big cities and small towns, with a small location on a busy street, the Velvet Edger starts to bring the money in right away. No experience necessary, for you cannot get anything but the finest shaving edges with the Velvet Edger.

Costs Little to Set Up in Business

Why slave for wages, when for the price of an old "flivver" you can set up in a permanent business, which will grow like any other well managed business?

Thousands of men around you are throwing away their blades after a few shaves. YOU can make these blades as good or better than new for them, for half the cost of new blades. Clear profit for you, and you quickly build up a trade with thousands of satisfied customers.

The booklet tells you why the VELVET EDGER turns out better work than any other machine. It shows machines for sharpening 12, 18 and 24 blades at a time. It tells you what others have done. It shows you how to set up in business on a small capital. Write for information to:

F. W. Cochrane Mfg. Co.
5831 S. Vermont
Avenue,
Los Angeles,
Cal.

	Enameled Magnet Wire			Single Cotton Covered Magnet Wire		
	1 lb.	½ lb.	¼ lb.	1 lb.	½ lb.	¼ lb.
No. 22..	\$.48	.28	.16	\$ 1.95	.57	.30
No. 24..	.55	.31	.18	1.05	.65	.32
No. 26..	.60	.34	.19	1.21	.73	.36
No. 28..	.64	.36	.20	1.36	.78	.40
No. 30..	.68	.38	.20	1.70	.89	.48

LITZ WIRE, AERIAL WIRE

From 20c to \$1.25 per 100 ft.

Tubes for Tuning Coils, etc., etc., etc.

REEL EASY PRODUCTS

I. R. NELSON CO., Newark, N. J.

Only \$15 Down

Play Well in 4 Weeks

—Eight Months to Pay

Latest C Melody Saxophone Outfit complete, only \$100—lowest price ever quoted. Sent on 6 days' trial. If satisfied, pay only \$10 a month for 8 months. No interest to pay—no extra. Outfit includes finest nickel trimmed and highly lined Case, Instruction Book, Album of Popular Saxophone Solos, Music Lure, Carrying Strap, Mouthpiece and three fine Reeds.

"Masterbilt" Saxophones

Highest quality, built in perfect tune, assembled and tested by experts. Has all latest key improvements, light, quick action and beautiful finish. Order direct from this advertisement or write for Free Catalog Folder today.

The Saxophone Shop, 427 S. Wabash Ave., Chicago
Largest Exclusive Dealers in Saxophone Supplies in the World

21 Jewel Burlington



Adjusted to the Second 21 Ruby and Sapphire Jewels
Adjusted to Temperature 25 Year Gold Strata Case
Adjusted to Isochronism Your Choice of Dials
Adjusted to Positions (Including Monipomery R. R. Dial)
New Ideas in Thin Cases

Only \$1.00 Down

Only One Dollar Down, will buy this masterpiece of watch manufacture. The balance you are allowed to pay in small, easy monthly payments. A 21-Jewel Watch—is sold to you at a price much lower than that of other high-grade watches. Besides, you have the selection of the finest thin model designs and latest styles in watch cases. Write for FREE Watch Book and our SPECIAL OFFER today.

Write While This Special Offer Lasts

Get the Burlington Watch Book—write today. Find out about this great special offer which is being made for only a limited time. You will know a great deal more about watch buying when you read this book. You will be able to "steer clear" of the overpriced watches which are no better. Write for Watch Book and our special offer TODAY!

Burlington Watch Co., Dept. 1355 19th St. and
Marshall Blvd., Chicago, Ill.

30 Day Sale OTTAWA LOG SAWS

Smashed Now! Prices **\$64.50**
AND UP
F. O. B. OTTAWA
Saws more wood. Falls trees, saws limbs. New Improved Models—shipped from the scenes of 5 branch houses. Guaranteed 10 years. Cash or Easy Terms. Write for Free Book and Sale Prices.
30-Day Trial. OTTAWA MFG. CO., 1741F Wood St., Ottawa, Kan.

FOR CAMP and Summer Wear

Best quality, lowest prices. Our money back guarantee covers all purchases.

Army Shelter Tents.....	\$3.00
Khaki Riding Breeches.....	3.00
Khaki Trousers.....	2.50
Flannel Shirts.....	3.00
Khaki Shirts.....	1.50
Camp Cooking Grates.....	.30
Folding Mess Pans.....	.25
Athletic Shirts.....	.75
Army Folding Cots.....	4.00
Army O. D. Wool Blankets.....	2.75

Army tents of all sizes and 5000 other articles for camps or outings.

RUSSELL'S, Inc., 245 W. 42nd St., New York
Formerly Army & Navy Store Co.

Catalog 112
Free on
Request

RADIO

ANNOUNCEMENT!

Believing in the possibilities of the Radio business, the Sweeney Automobile School has entered into the field, establishing a company known as the

Sweeney Radio and Electrical Company

We handle a complete line of De-Forrest, Fada, Federal, Westinghouse, and Radio Corporation equipment. All parts for building your own sets; also, complete receiving sets. Dealers, write for information.

To give you an idea of the stock we handle, we are listing below only a few of the parts necessary for installation of sets:



Varifometers.....	\$ 5.00
Vario Couplers.....	4.00
Tube Sockets.....	1.00
Rheostats.....	1.00
WE Detector or Amplifier VT-1.....	7.50
Detector Tubes UV-200 or C-300.....	5.00
Amplifying Tubes UV-201 or C-301.....	6.50
POWER TUBES.....	
5 Watt UV-202 or C-302.....	8.00
Kenotrons UV-216.....	7.50
60 Watt UV-203 or C-303.....	30.00
Kenotrons UV-217.....	27.50
Crystal Detector Stands.....	1.25
Phone Condensers .001 MFD.....	.35
Grid Condensers .005 MFD.....	.35
Grid Condensers .00025.....	.35
Grid Leaks .5 1-2 meg Ohm.....	.25
Grid Condenser and Leak.....	.50
Sweeney Radio Battery, 80 amp. 6 volt.....	18.00
(1 year guarantee)	

We can also supply you with the following complete sets:

SWEENEY RD2A RECEIVER , consisting of 1 Radio frequency amplifier, 1 Detector, and 2 Audio frequency amplifiers. Wave Length Range—approx. 175 to 650 meters on average antenna. PRICE COMPLETE.....	\$150.00
WESTINGHOUSE , Aeriola Junior Sets.....	25.00
Aeriola Senior Sets.....	75.00
RC Receiving Sets.....	130.00
FEDERAL , Junior Sets.....	25.00
Detector and 1 step amplifier.....	52.00
KENNEDY , Short Wave Regenerative Tuner.....	85.00
Universal Detector.....	250.00

Write for our combined catalogue and instruction book. This catalogue is published by our Radio Engineers, giving complete information concerning the installation and operation of all different Radio outfits. Price fifteen cents.

When ordering from the above lists, kindly accompany order with money order.

Dealers, write for information

Address Dept. 5

Sweeney

RADIO & ELECTRICAL CO.
5 UNION STATION PLAZA, KANSAS CITY, MO.

Please Mention Popular Mechanics

No Delivering
Commissions
Same Day You
Take Orders

Dependable
Practical
Simple—

Every
Home
Needs
It

\$5



Earn \$60 Weekly

FOR ONLY FOUR ORDERS A DAY

EARNING \$60.00 a week is easy when you sell the Fugo Automatic Fire Extinguisher. Most agents earn more. You can understand how easy it is to sell when you realize that the Fugo sells for \$5.00 while most extinguishers sell for \$15.00 or \$30.00 and are no more efficient or dependable than the Fugo. The Fugo is approved by many of America's most prominent Fire Chiefs. Millions of people want a handy, reliable fire extinguisher for their homes, office, factories, and garages. Agents take orders on every call. Some orders are for 3, 4, or 5 Fugos. There's nothing equal to it as a seller. A 5-minute demonstration and you pocket the order.—No talking. No price argument. No competition. Field unlimited. Customers easily pleased. Sales multiply fast.

Read What New Agents Say

S. B. Kurtz, of Hartsville, Ohio, writes: "I sold eight FUGOS in my first evening's work."

Henry Terp, of Green Bay, Wis., writes: "The FUGO is a superior extinguisher and by far the best seller."

Walter S. Nye, of Oneonta, N. Y., writes: "Ship twenty-four FUGOS immediately. Check enclosed. Have fifty additional orders for later delivery."

Wm. Pierson, of Norfolk, Nebraska, writes: "This is greatest agent's proposition we have ever handled. Wonderful money maker. At rate going now my sales organization will have no trouble selling 25,000 FUGOS the first year."

No Experience Needed

Our proved instructions guide you—you cannot go wrong.—A five minute demonstration and it's sold. Your neighborhood fire department will recommend it. Boost it—push it.

Exclusive Territory

Become our licensed agent, control your own exclusive territory and employ sub-agents. You take no risk—you don't invest a penny. We deliver—you receive commission same day you take orders.

Experienced agents are fast dropping other lines to take up the Fugo proposition.

Write now for full particulars of the real possibilities that you have with the FUGO. Sample FUGO automatic free to every active agent.

The Ohio Instrument Co., 9414 St. Catherine Ave., Cleveland, Ohio

FUGO AUTOMATIC

FIRE EXTINGUISHER

40,000 Opportunities in Hotels

Nation wide demand for high salaried men and women; past experience unnecessary; we train you by mail and put you in touch with big opportunities. Big pay, fine living, interesting work, quick advancement; permanent. Write for Free Book, "Your Big Opportunity."

LEWIS HOTEL TRAINING SCHOOL, Room 328, Washington, D. C.

THE BUSINESS FOR YOU!

Make and sell Crispettes, delicious confection. Everybody loves them. Can't get enough. Come again and again for more. Easy to make. I furnish everything. Raw materials plentiful and cheap. Profits enormous.



Quick success possible anywhere—cities, small towns, villages. Amazing market—crowded streets; surging throngs at fairs, carnivals, parks, etc.; wholesale to grocers, bakeries, druggists, and so on. Possibilities unlimited! Need no experience. Little capital starts you on road to phenomenal earnings.

WRITE—GET MY HELP—BEGIN NOW!

Others are making money—lots of it. Letters just received during this year tell of wonderful successes. You can succeed, too. Start is all you need. I'll gladly help you. Furnish everything—complete outfit, materials, secret formula, full directions, wrappers, etc. Send post card for illustrated book of facts. Tells how to start. Explains most successful methods. Gives all information needed. It's free. Write now!

LONG EAKINS COMPANY

528 High Street

Springfield, Ohio

A REAL BOAT FOR REAL FISHERMEN



The MOTO-ROW \$250

Combination power and row boat, distinctly new all-purpose craft built of selected airplane spruce, copper riveted. Two-hp. motor protected under stern deck. Sheer and full flare insure dryness in smashing sea. Reinforced skeg permits beaching. Dimensions 16x4 ft., speed 7 M. P. H., 6 passengers. Salt water equipment \$25 extra.

Write for Illustrated Catalogue

BELLE ISLE BOAT & ENGINE CO.
DETROIT, MICH.

GUARANTEED UNCONDITIONALLY TWO YEARS

STORAGE BATTERIES



6-Volt 11-Plate	6-Volt 13-Plate	12-Volt 7-Plate
\$12.50	\$14.50	\$18.50

These three types fit 95% of all cars manufactured. When you order from us you deal direct with the manufacturer and get 100% Storage Battery at a saving of 50% on the usual cost.

RICHMOND-SPECIAL FOR WIRELESS 6-Volt, 100-Amp. H., \$12.50

RICHMOND BATTERY CO., Inc.

No. 104 E. BROAD STREET

RICHMOND, VIRGINIA, U. S. A.

Make \$200. to \$1000. Profit Monthly

With Balba Perfume Sales Machines

People love perfume. Men, women and children will buy Balba. Its fragrance is soft and lasting and it is easily accessible. Just think. Grown-ups and boys and girls spent \$250,000,000.00 in one year in the United States for perfume, alone, at toilet counters. Consider how much more will be spent when a dime placed in a Balba Sales Machine will bring forth a conveniently sized bottle of rare Balba Bouquet Perfume. Balba Sales Machines, the serve-self idea applied to perfume sales, are popular. One machine holds 144 bottles, and between 3 and 4 people use it daily, with a profit to the owner of \$4.00 per machine per month. 100 machines bring in \$400.00 profit per month and can be easily handled in spare time.

BALBA

Bouquet Perfume

Of rare and lasting quality, Balba Bouquet radiates a fragrance of elegance and refinement about the wearer. Hundreds of regular customers buy from Balba Sales Machines, 5 to 12 bottles of the soft, rich Balba perfume at one time, because they can carry them easily in hand-bag, or pocket.

25c to 50c Value for 10c a Bottle

Because all middlemen's profits are cut out by the serve-self sales plan of Balba Sales Machines, we can manufacture this high quality perfume in large quantities and give 25c to 50c value for 10c a bottle.



Sold Only Through Balba Sales Machines

To give highest quality, and largest quantity at lowest cost in an inexpensive bottle, Balba Bouquet Perfume is sold only through Balba Sales Machines, on the serve-self plan, cutting out all overhead expense. Note the attractively nickel-plated, practically thief-proof, easy to fill, simple to operate, Balba Sales Machines. Weather-proof, used inside or out in small space on wall or counter.

We Want Balba Sales Machines in Every City, Town and Recreation Resort

We have thoroughly proved that Balba Bouquet Perfume is a good seller, it repeats, it makes new users. Balba Sales Machines in good locations show an increasing business, proving that the serve-self plan applied to perfume is a safe, sane, logical selling method. We are offering a tested, proven, big profit, permanent business to a live person (man or woman) in each territory. Instead of territory rights, we sell an allotment of Balba machines in proportion to population. We give the purchaser exclusive rights to sell Balba perfume in that territory. No perfume but Balba is sold like this. Balba is being advertised Nationally.

Over 500 Cities Already Taken

Over 500 towns and cities are now under contract. Every mail brings new contracts—Machines are now being shipped in large quantities and being put up daily and National Advertising is being placed—the contracts are going to men of action and vision—thousands of good cities and counties are still open but it will take quick action.

Detroit, Cincinnati, Pittsburgh, Buffalo, Des Moines, Los Angeles and Springfield, Mass., are some of the towns taken.

FREE Newspaper Advertising in Your Territory

When you have bought and placed a full allotment of Balba Sales Machines, we will run advertising in your local newspaper, giving locations of all your Balba Sales Machines. This starts people buying Balba from your machines, and the high quality of Balba keeps them buying. We tell you how to place machines and handle them. We are rapidly getting general distribution, and are placing advertising in the National Weeklies and Women's magazines to make perfume users throughout the U. S. want to buy Balba.

Guaranteed 100% Earnings or Money Refunded

Our proposition as well as our perfume is guaranteed. We guarantee 100% earnings on the original machine investment the first year, provided machines are all placed in use and kept filled, or we will refund the original price of the machines and perfume then on hand and take them back.

THE BALBA CORPORATION of AMERICA

Suite 45, Balba Bldg., Toledo, Ohio, U. S. A.

THE BALBA CO. OF CANADA
Leamington, Ont.

WHERE BALBA MACHINES CAN BE PLACED

Theaters	Bath Houses	Shoe Shine Parlors
Pool Halls	Factories	Lunch Counters
Depots	Rest Rooms	Skating Rinks
Clubs	Dance Halls	Ticket Offices
Restaurants	Lodge Rooms	Street Car Shelters
Cafeterias	Candy Shops	Ice Cream Parlors
Drug Stores	Boats	Office Building Lobbies
Cigar Stores	Moving Picture Houses	Passenger Houses
Fruit Stands	Billiard Parlors	Recreation Buildings
Street Cars	Apartment Houses	Waiting Rooms
Elevators	Public Buildings	Hotel Rooms
Trains	Bowling Alleys	Hotel Lobbies
Parked	Interurban Cars	Barber Shops

READ WHAT BALBA SALES MACHINE OWNERS SAY

George Schroder, Ohio, says, "First 100 Balba Sales Machines averaged \$128.50 clear profit first month, before advertising was started." Newman, Michigan, says, "First 50 machines put up, averaged 3 plays daily. This is at the rate of \$168.40 clear profit monthly without advertising."

Send 10c Coin or Stamps

—with name and address for full size bottle of Balba Bouquet Perfume. This offer is open to any one.

Be the first in your territory to make a Fortune in Dimes. Get complete information, literature and sample of Balba. Write today or better wire us to hold territory until you get our proposition. Send what Balba Bouquet Owners say and send for your allotment Now.



Campers! Tourists! Picnickers!

Your outing equipment is not complete without a

Campfire Grub Stake

The handiest article of its kind ever produced. Light, strong, compact and portable. Can be set up anywhere in one minute. Three adjustable racks for skillets, pots and pans, that can instantly be raised, lowered or turned according to direction of wind. Racks stay in position without set-screws or lugs. Guaranteed for life.



On sale wherever Outing Goods are sold. **\$3⁵⁰**
\$4.00 in Canada In U. S.

If your dealer cannot supply you, write us direct, enclosing \$3.50 together with dealer's name, and the Campfire Grub Stake will be sent anywhere in U. S., parcel post paid. Order at once.

CAMPFIRE MFG. CO.

1036-A Boatman's Bank Bldg. St. Louis, Mo.

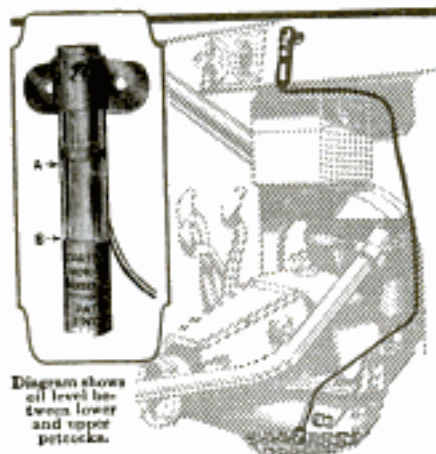

Diagram shows oil level between lower and upper petcocks.

No Oil Passes from Crank Case Thru Tube or Gauge

You Can Easily Install The Accurate

Carter Oil Gauge

FORD TYPE; CHEVROLET TYPE (490 and F. A.)

Simple outfit consisting of special elbow to screw in place of lower petcock; connecting air tube and nickel-plated gauge to screw on dash or instrument board.

Liquid in gauge is controlled by column of air that rises and falls as oil in crank case changes level. When liquid in gauge is at "A" (see cut) the oil in crank case is at upper petcock level; at "B" it is at lower petcock level.

No floats, plungers or moving parts to get out of order; positively accurate in any weather.

Gauge complete packed in attractive carton with instruction sheet, retail price \$3.50 including war tax. Guaranteed satisfaction or money refunded. If your dealer cannot supply, see this coupon and order. Mention name of your supply dealer.

JOHNS AND DEALERS—Write for discounts and sales help.

CARTER MOTOR ACCESSORIES, INC.

386 Pearl Street Buffalo, N. Y.

Cut Off Coupon Here
386 Pearl St.,
Buffalo, N. Y.

Gentlemen:—Enclosed find (Check) (P. O. or Exp. M. O.) for \$..... \$5.00 prepaid
..... Carter Oil Gauge—Ford Type,
..... Carter Oil Gauge—Chevrolet Type

Name..... City.....
Street.....
Write name and address of your dealer in margin.
From Popular Mechanics.

(If this coupon is used by dealer, we will send shipment C. O. D. including a supply of advertising literature; also a demonstrating display outfit with order for one dozen of \$10.00.)

The NELSON Ball Bearing Timer Does away with all Timer Troubles on Fords

The Nelson Timer is guaranteed for 100,000 miles on any Ford



Price \$3⁵⁰

At your Dealer's or postpaid

Countless thousands of Ford owners have demonstrated that the patented Nelson Ball Bearing Timer is positively trouble proof and that it will outwear a Ford car.

The large Nelson Ball Bearing Brush revolves at 1/30 the speed of the ordinary Timer brushes.

Due to the large brush or roller on the Nelson Timer, the contact ring never gets bumpy, the contact seg-

ments never glaze over with oil and the fibre never spreads over the contact segments.

The Nelson Timer insures perfectly timed ignition for the life of the car, for this Timer never requires adjustment and has no delicate parts to break or wear out.

DEALERS ATTENTION—During the past seven months more than 4,000 dealers have taken on the sale of the Nelson Timer. This is a remarkable recommendation not only for the Timer itself but for our selling proposition. The Nelson positively sells on sight.

Write today and ask us to send you sample half dozen C. O. D. at dealer's price.

Nelson Timer Co. 631 East Water St. Milwaukee, Wis.

RADIO For Everybody

Don't be satisfied with putting around with Radio. You can earn big money. Learn by mail, in spare time, how to design, construct, install, repair, maintain, operate, sell and demonstrate complete radio outfits. Write for our book, "How to Learn Radio at Home" National Radio Institute, Dept. 1065, Washington, D.C.

W BUILD YOUR OWN WIRELESS TELEPHONE E

This wonderful invention now within the reach of all Hear free music, latest news, lectures, market reports, broadcasted through the air, day and night, by radio. Afford real pleasure and education to the whole family the year round. Hear New York, Pittsburgh, Chicago and all large cities. Learn "Wireless" operating at home and earn up to \$5000.00 a year. Make a "Universal" long distance set and save \$50.00. Simple as A-B-C. Has wave length range of 170 to 2,500 meters, receives signals from all over U. S., uses bulb and 2 stage amplifier. Guaranteed quartz sets costing \$100.00. Latest book "Wireless in the Home," by celebrated engineer, sent free, if ordered at once. Also prints, instructions, list of parts and prices of each, complete to build and operate, sent by mail, prepaid for only a one dollar bill. Price \$1.00. Order now today. Thousands sold. American Radio Co., 27 Warren St., New York, N. Y.

\$3.50 U. S. SPRINGFIELD RIFLE

Breech Loading
Made by U. S. Government
WILL HIT THE MARK HALF-MILE
45 calibre—41 in. long—7½ lbs.—Cost \$25.00, price \$3.50
These guns have been used but are in first class condition.

Exchangeable shot gun barrel like above cut all complete ready to put on carbine stock in 5 minutes for \$3.00. This gives wonderful combination for all year shooting. No other gun made to equal it. We have 3,000,000 rounds ammunition standard and produced by leading cartridge makers. Our price 45/70 ball cartridges for carbine, \$3.00 hundred. Also loaded No. 8 bird shot cartridges for shot gun, \$3.00 hundred.
W. STOKES KIRK, Dept. 2, 1627 N. 10th St., Philadelphia, Pa.



Yankee VIOLET RAYS



The value of Yankee Violet Rays as a curative agent is without equal—they are the greatest force for health and beauty that science has yet produced; today they are almost as essential to your health and well being as sunshine and fresh air. The stimulating effect of these rays is powerful enough to reach and benefit every part of the body yet so absolutely harmless that babies are treated with it with wonderful results without the slightest shock or pain.

Our Perfect Home Outfit for Bodily Ailments NOW HALF PRICE

This perfect Home Outfit until now sold regularly for \$25. It is a self-contained one-piece machine, simple in construction, easy to operate, nothing to get out of order, and absolutely guaranteed for one year. Works equally well on alternating or direct current; will last a life-time with ordinary use. It includes the Yankee Home Outfit generator, a general applicator, 6 feet of cord, with attachment plug and chart all contained in an elegant imitation leather carrying case.

Formerly \$25
Now Reduced to
\$12.50

Is Your Body Sick or Worn Out?

Is your body sick or worn out by excessive strain? Do you know the use of a Yankee will accomplish more beneficial results than a cabinet full of medicine or a violent course of exercise? Do you also know that in order to destroy or eradicate any disease it is merely necessary to build up the tissue resistance with a Yankee Violet Ray applicator and nature will do the rest?

SEND NO MONEY Sent on 5 days Free Trial

Fill in the coupon at the foot of this page and mail it to-day. The entire amount involved is only \$12.50 and even that does not have to be paid until actual delivery of the outfit has been made. Send no money with your order. Remember, if for any reason you feel that you do not wish to keep it you may return it within 5 days after receipt for a refund of your money. We take all the risk.

SEND FOR
FREE BOOK
YANKEE VIOLET
RAYS



WRITE FOR
YOUR COPY
TODAY

Nothing Better for

Dandruff
Baldness
Falling Hair
Itching Scalp
Soreness of Skin
Massage
Eczema
Obesity
Rheumatism
Lumbago
Gout
Headaches
Weak Eyes
Insomnia
Neuralgia
Grippe
Influenza
Catarrh
Difficult
Breathing
Stomach and
Liver Troubles
Pleurisy
Diabetes
Skin Diseases
Rectal Troubles
Constipation
Nervous Troubles
Hay Fever
Deafness

*These ailments
and hosts of
others respond
like magic to the
disease destroying
influence of
this wonderful
appliance.*

USE THIS COUPON

To YANKEE LABORATORIES, Inc.
318 East 43d Street, New York City, N. Y.

Please send me the Yankee Violet Ray Outfit by mail or express collect—\$12.50. I am to use this outfit for 5 days and if I am not satisfied with it you are to return my money upon your receipt of the outfit in good condition.

Name.....

Address.....

Bausch & Lomb \$22⁵⁰
Prism Binocular



This extra powerful binocular (6x30 m.m.) is equipped with extremely sensitive lenses, affording an unusually clear view of distant objects. Each eye-piece is adjusted individually, thereby suitable to all eyes, also has central adjustment with scale. Made of solid brass, handsomely finished with hard rubber with leather shoulder strap, solid leather carrying case and straps. No. 2409 for \$22.50.

All Our Merchandise is Brand New. Order one of these specials now. Supply Limited. Mail Orders promptly filled (Charges Prepaid) when accompanied by Money Order or Bank Draft, or if you prefer **SEND NO MONEY**, Pay Postman on arrival. Our price plus postage. Examine merchandise carefully and if not as represented just return same and get your **MONEY BACK** without any red tape whatsoever. Bank references.

EDWARDS IMPORT TRADING CORP.

Genuine BUSCH \$16²⁵
Jagdglas



A five power, extremely serviceable, handsome and well made field glass made by Busch (Germany), needs no introduction, as they are known the world over. These famous glasses up to a short time ago were unobtainable at any price. They are unusually light and compact, made of solid brass, covered with genuine morocco leather and trimmed with hard rubber. Solid leather carrying case and straps. No. 2509 for \$16.25.

Lomora Prisma \$25⁰⁰
Binocular



Equipped with central and individual focal adjustment, lenses extremely sensitive; can be instantly adjusted to any eye. These binoculars have an unusually long range (8x24 m.m.). They are handsomely made of solid brass, covered with morocco leather, with shoulder strap and solid leather carrying case and straps. No. 2609 for \$25.00.

Illustrated Catalogue on Request

258 Broadway, Dept. 9, New York City

3000 Bargains

Big Free Catalog
Know the latest prices before you buy. Send for our illustrated price list. Every page is filled with Bargains. We buy for Cash—and Sell for Cash.

AUTO SUPPLIES FOR ALL CARS

Save Money on Special Bodies
We carry a complete line of "Fidelity" Bodies for Ford and Chevrolet "490" at Bargain Prices! \$29.95 and up.

This Book FREE

NEMCO BARGAIN SUPPLY HOUSE
1917 W. Jackson Blvd. Chicago, Ill.

Lowest Prices on BATTERIES
Two-Year Guaranteed
\$14.95



For Fords, Studebaker, Chevrolet, Dort, \$17.70 for Buick, Overland, Essex, Reo, Hudson, Nash, \$21.95 for Maxwell, Dodge. Similar prices for all other cars. The Defiance is one of the highest standard batteries, made by one of the oldest standard battery companies in the world. Sold direct from maker to you without a single extra profit in between.

Defiance Battery at \$14.95 is an excellent (A) radio battery

Send no money. Order direct from these prices home sure to give name, model and year of car, and battery will be sent same day by express C. O. D.

Two-year written guarantee. Highest bank references. Write right now and we will ship right back. Address

DEFIANCE BATTERY COMPANY

Direct Sales Department 12

726 Heuret Building, Chicago

WANTED TAILORING SALES AGENTS

Make big money from very start—\$75.00 to \$100.00 weekly. Largest made-to-measure tailoring house, furnishing an equipment of five hundred wools, wants you to take orders. Satisfaction guaranteed. Biggest merchants in many towns have started with our line. If you want to establish yourself permanently in business and make big money, write for full particulars, giving your experience as salesman or tailor's sales agent.

P. M. HORN, Sales Manager, Lock Box 483, Chicago



A Real Professional Model, Horsehide Fielder's Glove

This glove is a real *professional* model, made by a house which outfits big league teams and well-known college teams. We have been making sporting goods for seventy-five years and selling them *direct to the user*, giving you the middleman's profit you pay in stores. Made of *genuine* pearl horsehide. Leather lined throughout. *Full size* and carefully padded to form a perfect ball pocket. Rawhide laced heel. A *man's* glove—stands the gaff. Send \$3 and if you can buy as good a glove in any store for \$5, return the glove and we will refund your money. Send for catalogue.

HORACE PARTRIDGE CO., Dept. A, 49 Franklin St., Boston, Mass.

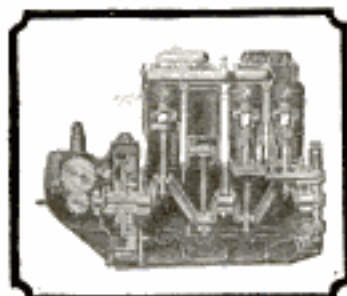

Diagram of the Ace Four Cylinder Motorcycle Engine.

Comfort-Speed-Silence in this Marvelous Motor

MOUNTING steep hills with a silent, steady flow of power—covering great distances with new ease and comfort—the Ace Four Cylinder Motorcycle carries you past the mile posts with lightning-like speed.

The new Ace gives you freedom from troubles and independence for the long tour or the short, quick ride to a nearby destination—in fact a new kind of transportation.

When you mount the flying Ace, you are Master of the highway. Here is a new pick-up-and-go as you worm your way through the most crowded traffic, waiting for a chance to shoot out ahead with the ease of a transcontinental limited. And, off over the hills you may have a slow ambling gait through beautiful countryside as your Ace throttles down in submission.

Don't waste any more days when you ought to be out in the open; don't waste any more time for lack of the surest and speediest transportation. Have a demonstration of the Ace Four Cylinder Motorcycle today.

If you don't know the Ace dealer send for illustrated descriptive catalog and we will refer you to him.

ACE MOTOR CORPORATION
Erie Ave. and Sepviva St., Philadelphia, Pa., U. S. A.

Attractive terms of payment will be arranged for you by Ace Agents. Write us for particulars.

ACE



"E-Z" YOU Most Useful Device on Earth



Over 30,000 Business and Professional Men, Mothers and Nurses save TIME, MONEY and WORRY over WASTED HOURS spent in barber shops. That's why we say YOU.

\$1.00
Price in Canada \$2.00

The "E-Z" Combination HAIR CUTTER-SAFETY RAZOR makes them independent. CUT YOUR OWN HAIR in ten minutes. Adjustable for long, short, clipper-effect, or ponytail. No practice needed. Any style desired like YOU want. No SPLIT hairs. Cuts wavy, silky, kinky hair. Favorable for ONE-AIUM men, right or left handed persons. EASY SHAVES, smoothest you ever had. Two-way SAFETY RAZOR—safe for LADIES—new safety guards blade covers for working under arms, over bumps, hollow spots and behind ears. Barbers and Mothers find it convenient and safe for the child. Lifetime durability. Genuine SILVER PLATE, complete with one extra blade. Three months' service. Sold through DEALERS or direct by mail upon receipt of price plus 10¢ postage. 6 Extra Blades, 50¢. DEALERS WRITE. State Agents Wanted in U. S. and Provinces of Canada. Mention your dealer's name.

J. H. COWAN CO. Dept. 70, K-C Life Bldg., Kansas City, Mo., U. S. A.

COWAN SALES CO. OF CANADA Dept. 7, 1317 Garnet St., Regina, Sask.

FREE TUBE with each tire

New Cords Slashed To \$9.95

GUARANTEED 10,000-Miles

BIG FACTORY SALE—Brand New Strictly Firsts

These strong High Grade Cords made from fresh stock at 50% saving. Absolutely Brand New—firsts, in original wrapper with manufacturer's name and serial number on every tire.

Guaranteed 10,000 Miles

and adjusted at the list prices on a mileage basis. These prices include Tube Free.

Size	Price	Size	Price
30x3	\$ 9.95	32x4 1/2	\$23.99
30x3 1/2	11.75	32x4 1/4	24.10
32x3 1/2	14.40	34x4 1/2	25.99
32x4	15.65	35x4 1/2	26.75
32x4 1/2	16.50	36x4 1/2	26.15
34x4	17.20	35x5	24.75
34x4 1/2	18.95	35x5 1/2	24.99

Send No Money just send your name and address, together with size and number of tires wanted. All tires shipped C. O. D., subject to examination. *Send Today.* We allow a special 5% for full cash with order. Shipments made same day order received.

WEBSTER TIRE CORPORATION

110 S. Dearborn St., Dept. 159, Chicago, Ill.

FOR YOUR NEXT DINNER PARTY PLACE CARDS

Try our set of 12 illustrated and assorted. They will start everybody talking—help you entertain your guests. 50 cents, postpaid. Wayside Tales Book Dept., 6 North Michigan Ave., Chicago.

End Ford Wiring Costs

"Union" Fuse Block puts an end to burned wires—loose connections—blown lamps—flickering lamps. Saves repair bills. Eliminates fire risk. Permits use of standard lamps for both bright and dim lights. Instead of the expensive double filament type.

Anyone can install quickly. No additional wiring.

If not at dealers, Send \$1.50. Money back if not satisfactory. Booklet free.

CHICAGO FUSE MFG. CO.

CHICAGO

NEW YORK

Our BUREAU OF INFORMATION will answer all questions regarding articles appearing in this magazine. Address Bureau of Information, Popular Mechanics Magazine, Chicago.

If you need a book on some mechanical subject and do not know where to find it, write POPULAR MECHANICS BOOK DEPARTMENT 6 N. Michigan Ave., Chicago

MODERN ATLAS

Shows The World As It Is To-day

Contains complete returns of 1920 Census of the United States. Shows all Peace Conference changes. 128 pages of maps in five colors. Size 10 1/4 x 13 1/4 inches. Cloth Binding. Price \$3 Postpaid. Popular Mechanics Book Dept., 6 N. Michigan Ave., Chicago



Only \$2.00 Puts This Handsome Gold Watch In Your Pocket

Seize this chance—get a Watch that you can rely upon every second of the day. Make sure that YOUR TIME IS ALWAYS EXACT. New thin models, 12-size Elgin, in handsome gold-filled case, guaranteed for 30 years.

Knife and Chain Free

Send us only \$2.00. Together with the famous Elgin, we will send you absolutely FREE, a handsome, gold-filled knife and chain. Then send us \$1.50 EACH MONTH until the total price of the Watch, \$14.98, has been paid. NO DELAY—NO RED TAPE—EVERYTHING STRICTLY CONFIDENTIAL.

Free de luxe Catalog—send for it! Amazing values in Watches, Diamonds, and Jewelry. Address Dept. 532-K.

CAPITAL, \$1,000,000

L. W. SWEET, Inc., 1650-1660 Broadway, New York

Copyrighted material

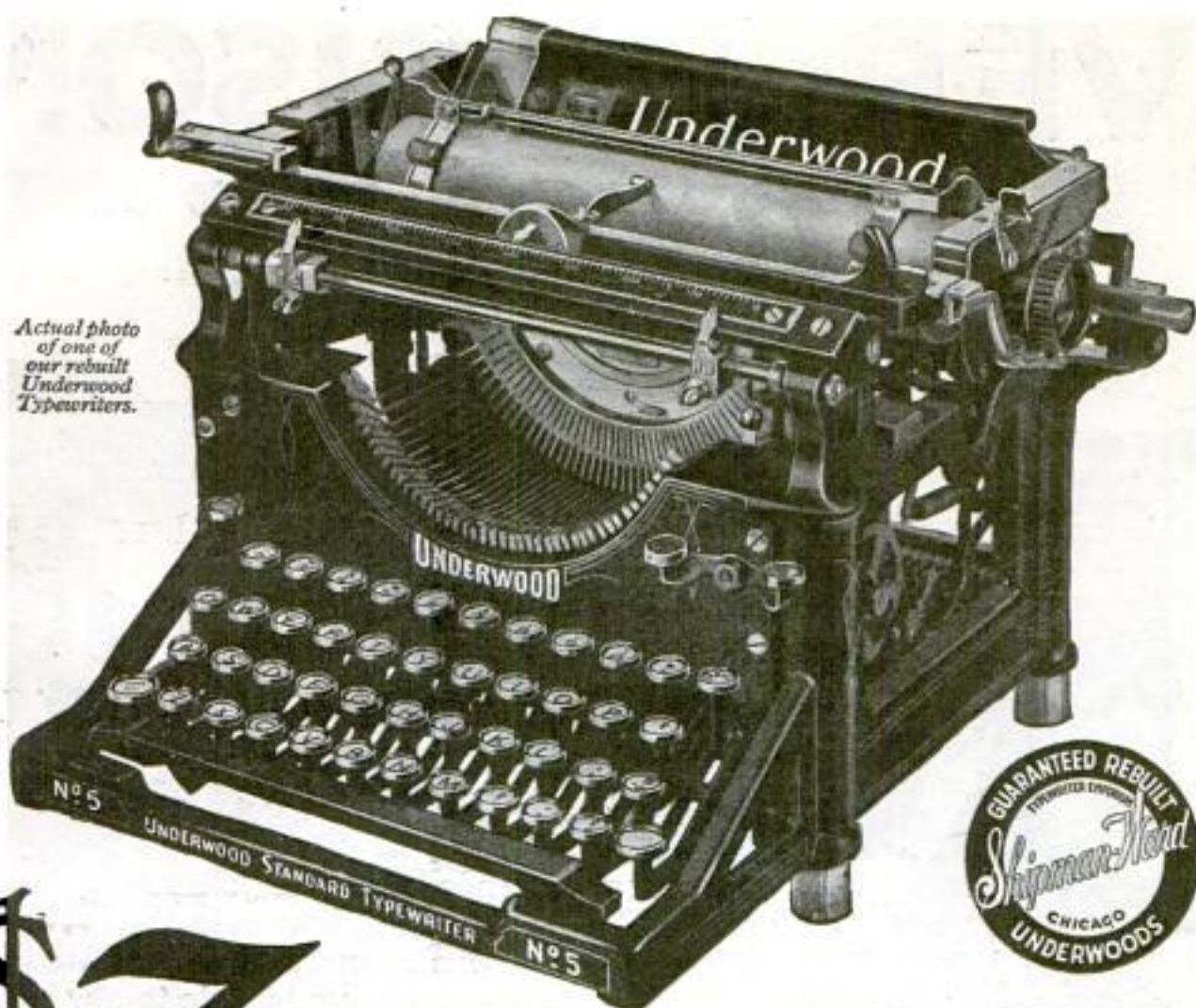

Actual photo
of one of
our rebuilt
Underwood
Typewriters.

\$3
DOWN

And It's Yours

Standard Underwood

Rebuilt like new. Every typewriter is factory rebuilt by typewriter experts. New enamel—new nickeling—new lettering—new platen—new key rings—new parts wherever needed—making it impossible for you to tell it from a brand new Underwood. An up-to-date machine with two-color ribbon, back spacer, stencil device, automatic ribbon reverse, tabulator, etc. In addition, we furnish FREE, waterproof cover and a special Touch Typewriter Instruction Book. You can learn to operate the Underwood in one day.

From factory to you

Yes, only \$3 brings you this genuine Rebuilt Standard Visible Writing Underwood direct from our factory, and then only small monthly payments while you are using it makes it yours; or, if convenient pay cash. Either way, there is a big, very much worth-while saving, too. Genuine new Underwood parts wherever the wear comes

—genuine standard four row, single shift keyboard—thoroughly tested—guaranteed for 5 years.

\$3 Puts It in Your Home

You don't even have to scrimp and save to pay cash. Instead, you pay only a little each month in amounts so conveniently small that you will hardly notice them, while all the time you are paying,

you will be enjoying the use of and the profits from the machine.

10 Days' Free Trial

Remember, you don't even have to buy the machine until you get it and have used it on 10 days' free trial so that you can see for yourself how new it is and how well it writes. You must be satisfied or else the entire transaction will not cost you a single penny.

Typewriter Emporium Shipman-Ward Mfg. Co.

2125 Shipman Bldg., Montrose and Ravenswood Aves., Chicago, Ill.



All shipments made direct to you from our big modern factory (shown above)—the largest typewriter rebuilding plant in the world.

Use Coupon

Now is the time when every dollar saved counts. Let us save you many dollars. Don't delay. Get this wonderful easy payment bargain offer now, so you can send for and be sure of getting your Underwood at a big saving—and our easy terms or for cash.

**Act Now—
Send Coupon Today!**

FREE TRIAL COUPON

Typewriter Emporium Shipman-Ward Mfg. Co.

2125 Shipman Bldg., Montrose and Ravenswood Avenues, Chicago, Illinois

Send by return mail Bargain Offer No. 2125 of a Standard Visible Writing Underwood. This is not an order and does not obligate me to buy.

Name.....

Street or R. F. D. No.....

Post Office.....

IVER JOHNSON BICYCLES

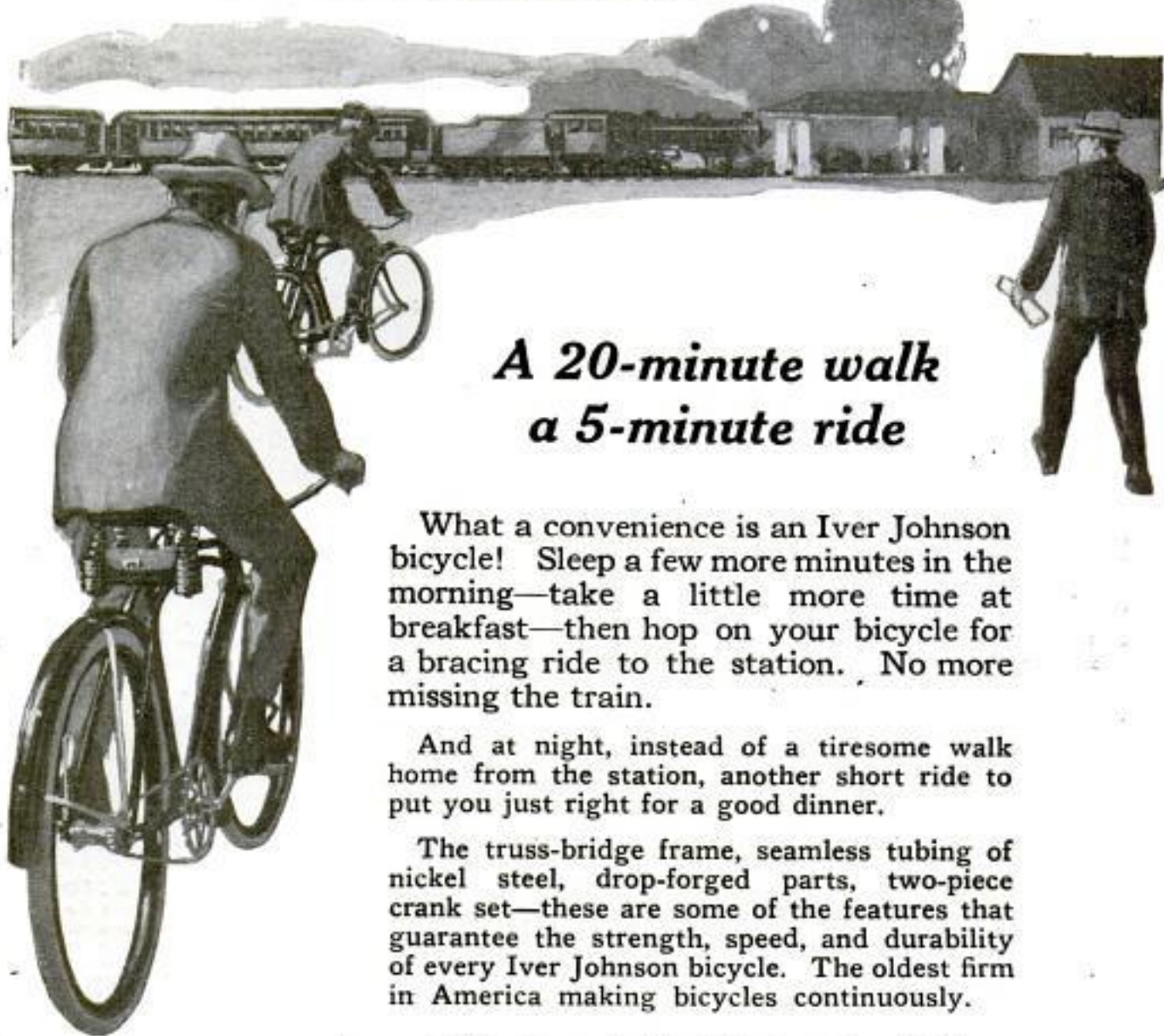

*A 20-minute walk
a 5-minute ride*

What a convenience is an Iver Johnson bicycle! Sleep a few more minutes in the morning—take a little more time at breakfast—then hop on your bicycle for a bracing ride to the station. No more missing the train.

And at night, instead of a tiresome walk home from the station, another short ride to put you just right for a good dinner.

The truss-bridge frame, seamless tubing of nickel steel, drop-forged parts, two-piece crank set—these are some of the features that guarantee the strength, speed, and durability of every Iver Johnson bicycle. The oldest firm in America making bicycles continuously.

Write at once for free Bicycle catalog "B 4."
Firearms catalog "A 4" also sent on request.

IVER JOHNSON'S ARMS & CYCLE WORKS, 4 River Street, Fitchburg, Mass.
New York Office: 99 Chambers St. San Francisco Office: 717 Market St.



Ask your dealer to show you an Iver Johnson Champion single barrel shotgun. Accurate, dependable, moderately priced.



Keep an Iver Johnson revolver in the home for self-protection. It's accident-proof—you can "Hammer the Hammer." Quick, accurate, safe.



The Famous YORK SAXOPHONE

Sent to you
on
**free
trial**

The Easiest
Instrument
to play!

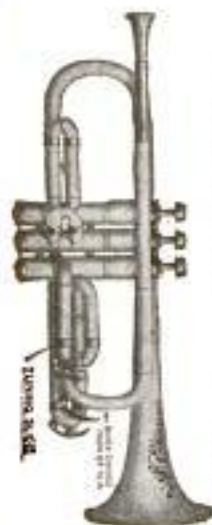

Yes, that is exactly what we mean. You can have the World Famous York Saxophone shipped to you on **10 days' free trial**. Play on it at home to your heart's content for 10 full days. We want you to convince yourself of its superb quality, richness of tone and ease of playing.

And then, if our instrument does not completely sell itself to you, simply ship it back to us at our expense. The trial will not cost you one penny.

TAKE YOUR CHOICE

York makes every instrument used in the band, and for nearly half a century the greatest professional musicians have purchased and endorsed them. You can get **any one** of these good band instruments made by the House of York on **10 days' free trial**. No obligation to buy. Send the coupon below for beautifully illustrated literature and take your pick of the following:

Cornets
Baritones
Clarinets

Trombones
Saxophones
Drums

Trumpets
Altos
Basses

ON EASY PAYMENTS

You can pay while learning to play. Simply make a small payment down, and you can pay the balance in monthly remittances—a splendid opportunity for you to secure a quality instrument at a reasonable price and on easy terms. We send you everything you need, including carrying case and all necessary attachments.

Send this Coupon Now!

Fill out the coupon **now** with your name and address and mention the instrument you are interested in, and we will send you the illustrated literature and the full details of our Free Trial Offer and Easy Payment Plan.

This literature tells you **how to practice and how to learn to play**. It's yours for the asking. **Send the Coupon today.**

J. W. YORK & SONS
Dept. 2215, Grand Rapids, Mich.
(Makers of good Band Instruments since 1882)

FREE COUPON

J. W. YORK & SONS
Dept. 2215
Grand Rapids, Michigan

Gentlemen—Kindly mail, without cost to me, your beautifully illustrated literature on the famous YORK Band Instruments, and the full details of your Free Trial and Easy Payment Offer.

Name.....

Address.....

Instrument.....
(Mention instrument in which you are interested)

Here's Your Chance!

Work for Yourself! Build a Big-Profit Business! Write -OR MAIL COUPON-TODAY

Mr. Albert Mills, President American Products Co.,
6699 American Bldg., Cincinnati, Ohio

Dear Mr. Mills:—

Please send me details of your plan for starting me in business and how I can get a Ford auto.

Name

Address

THERE are thousands of men and women dissatisfied with their lot, tired of the daily grind, long hours, just making a living, who say to themselves—"If I only had a chance, if I could only get a start, I know that I could improve my condition, do more for my family, enjoy life, and lay away something for a rainy day! But, I never had any experience except in my old job, and I have no money to go into business." If you are among these, take courage—I offer you the chance you want—on only one condition—that you are honest, willing to work and determined to stick. If you just have these qualities, the lack of schooling, of experience in business, or of capital, will not stand in your way. The chance I offer you is to become a



Our Own 7-Story Plant—Where Zanol Products Are Made

Direct Factory Representative

for the ZANOL line of "Quality First" Pure Food Products, Toilet Preparations and Household Necessities. These are produced in our own Laboratories and Pure Food Kitchens (see picture at the right). They are known to the housewives of America through our National Advertising in the leading magazines, and are distributed only through our own Direct Representatives. You can build up, as others have done, in a short time, a regular list of customers, who will order over and over again, piling up big profits for you.

NOTE—This is not a get-rich-quick scheme, nor a plan to get you to invest a lot of money. Just a straight-out offer to start you in a business of your own, in which even beginners often make from \$5 to \$10 a day profit. If you are willing to work hard and to stick till you win out—send the coupon or drop me a postal to get full details. I want no money—just your name. Write me Today—Sure.

ALBERT MILLS, President

THE AMERICAN PRODUCTS CO., 6699 American Bldg., Cincinnati, O.

Others Have Done It!

Hundreds of others, by grasping this same opportunity, have reached the road to financial success. I have helped them to create in a few weeks' time, a pleasant, profitable and respectable business, in which they are their own boss and to which they give as much time or as little as circumstances permit. I can tell you of people who, in one or two days, or in a few hours of spare time, have made as much money for themselves as they formerly did by working hard all week. What they have done, you can do, with the help and the backing which I will give you.

Special Free Ford Offer

In addition to the generous profit which you make regularly as the "Zanol" Representative, we give you a Ford automobile absolutely FREE. This offer is the greatest and most liberal ever made by a reliable and responsible concern.



Do We Make Good? Read These!

I have received the Ford Touring Car which you sent me and am much pleased with it. I thank you for your straightforward way of doing business. I won the Ford mostly in spare time as I work three days a week in the shop.

EDGAR BANVILLE,
Mass.

Words cannot express my feelings toward you for the gift of the Ford Car. I will say yours is the most reliable company I ever worked for. They are men of their word. I have been their Representative five years and have built up a good trade.

W. C. FULTON, Ohio.

I want to say that I am certainly pleased with my car, and wish I could see all of your representatives and just tell them how honest you have been with me and how faithful you are in all your undertakings and promises.

BESSIE NOWLIN,
Ky.

IN SCHOOL OR SHOP—this Outfit will Start You Right



In learning to work metals within close limits, here's two good rules for every beginner:

Be sure of your *tools*.

Be sure of your *methods*.

Starrett Tools and the Starrett Book for Machinists' Apprentices will start you out right on both counts.

Copy of Starrett Catalog No. 22-A^m describing and illustrating 2100 fine precision tools—also copy of special Supplement to the Catalog showing latest additions to the Starrett line—sent free on request.

THE L. S. STARRETT CO.

*The World's Greatest Toolmakers
Manufacturers of Hand Saws Unrivaled
ATHOL, MASS.*

Starrett Tool Set, No. 901

Especially designed for use by students and apprentices. A thoroughly practical set of fine tools recommended by instructors and master machinists. See the Starrett Catalog No. 22 for details.



Thousands of Young Men Have Bought this Book 180 pages of easily understood information and special tables invaluable to machinists' apprentices and students. Copy sent postpaid to any address, 75 cents.



Use Starrett Tools

42-307



No wonder salesmen are making fortunes with this amazing invention that saves housewives from roasting kitchens in the Summer. It turns any coal range into a gas stove. Just a turn of the valve instantly gives them as much or as little heat as they need—three times the heat of a coal fire if they want it. That's why the Oliver Improved Oil-Gas Burner is sweeping the country like wildfire! That's why Salesmen are cleaning up on it.



Easy to See Why New Invention Brings Salesmen \$50 a Day

PUT yourself in the position of one of the millions of American housewives who have to sweat and fume and fuss over a hot mussy coal and wood stove in a roasting kitchen in July. Then you'll see why housewives all over the country are clamoring for this amazing new invention! And knowing what such a nation-wide demand means to salesmen or agents you know at once why the men and women who represent the Oliver Oil-Gas Burner are making fortunes.

It isn't hard to sell a thing that everybody wants! You don't have to be a star salesman. You don't have to talk people into a sale. A short, clear-cut demonstration—the sale is made—and the profit's in your pocket.

Salesmen make big profits with the Oliver because it hits the spot at a time when women are looking for and buying every device they can get that will save them labor. The Oliver saves a woman the drudgery of hauling coal and wood, building fires, and cleaning out ashes, at a time when she is looking for just such a labor saver. It makes an immediate hit with her because thru **just a turn of a valve**—just like a gas stove—she gets just as much or as little heat as she wants.

Another thing, the Oliver burns 95% air and 5% oil, the cheapest fuel there is—it really is not a mere kerosene wick-burner. A new invention turns the oil and air into a gas. It is the gas that burns.

Now that you know these things you can understand why agents make profits as shown in their actual letters on this page. There are hundreds of others: W. H. Drew of Michigan made \$85.00 in one day. L. Zucher of Ohio made \$21.50 in three hours. R. Berger of

Ontario earned in one week \$258.50. Big money can easily be made just in spare time. N. Browne of Washington made \$43.00 in one evening.

Oliver Oil-Gas Burner & Machine Co.
2014-Q Pine St., St. Louis, Mo.

Please send me full facts about how I can make big money representing you in my territory. Also your plan if I wish to make big money in my spare time.

Name

Address

A Whirlwind Summer Seller!

Quick Sales--Big Profits

These men know a good thing when they see it and they know that the time is ripe for this new Oliver Improved Oil-Gas Burner. They know that this age of high-priced coal and wood makes it necessary for some substitute. They see ships and locomotives being run by oil, and big buildings being heated by it. And they know that an invention that makes effective use of this cheap fuel for every home and at the same time frees women from the drudgery of wood, coal, sweltering kitchens, and ashes, is the thing they want to tie up to. You, too, can use this secret of big money.

No Experience Needed to Make Big Money

You do not need to be a high-powered salesman. The Oliver's amazing features sell it for you. When people see it they know at once that it is the thing they want. You will realize that this is a proposition that will pay you as big money as it does others. We have a definite number of open territories which we are ready to dispose of to those who act quickly. Every territory allotted is filled with big-money opportunities. And this big money comes easily. Because not only does this invention practically sell itself on sight but our salesmen find that every time they sell one, this one will sell several others as soon as your customer's friends and neighbors see it. And thru our special plan you get credit and commission on all these extra sales that you don't even have to make—commission for every sale in your territory.

COUPON BRINGS FULL OFFER

Mail this coupon now for our offer. We are not making any extravagant claims about this. We do not have to. We believe that your common sense will indicate a good proposition to you when you know about it. We want to give you the facts. Won't you write us? And by doing so quickly you will be allotted an exclusive territory franchise with private selling rights.

The coupon will bring you the facts and will save you writing a letter. But mail the coupon at once.

OLIVER OIL-GAS BURNER & MACHINE CO.

2014-Q Pine St.

St. Louis, Mo.

How Would You Like to Earn \$250 a Week?

"Am making \$1000 a month. I have made big money before, but did not expect so much. Your Burner is just the thing."

J. Carnegie, S. D.

\$660 a Month

"Have averaged \$660 a month for last six months."

A. M. Russell, Conn.



\$215 in One Day

"Ye Gods—some seller! I made \$215 today!"

F. W. Bentley of Philadelphia.

"Here is another order for Burners. I have deducted my profit of \$646.25."

P. M. Ford, Ohio.

LEARN A TRADE



Young man—you want A BETTER JOB—more money—opportunity—success. If you are mechanically inclined write me today—don't bother about a letter—just a postcard will do—or clip and mail the coupon.

I Will Make You an Amazing Offer

If you are interested in mechanical work, if you are interested in automobiles and WILL WORK, this Million Dollar Trade School offers you an opportunity that may never come to you again. Will you PUT EIGHT WEEKS' TIME in this great trade school IF YOU ARE CONVINCED IT MEANS A REAL JOB AND A LIFETIME SUCCESS? Because of the demand for Sweeney trained men I am making now MY BIGGEST AND MOST SURPRISING OFFER—no matter where you live—no matter if you have had no previous experience—no matter how old you are. But I will make this offer ONLY to those who are sufficiently IN EARNEST and SUFFICIENTLY ENERGETIC to write me AT ONCE.

The Sweeney System

famous the world over, can be had only in the Sweeney School. Trains men to be mechanics by practical work. You learn by doing—no books—you do the actual work. The course takes only 8 weeks. No place in the world can you get so much real instruction—so much actual value, for so little money. Over 46,000 graduates. Write me today—don't put it off—I've got some information that will open your eyes—but you must take the first step—Write for my Big Free Book.

Good Jobs for You

You can run a garage. You learn to make a good \$25 Ford battery for \$7.00. You learn how to weld a broken crank case. You learn how to make a real 4000 mile tire from old casing and rubber. You can be a chauffeur or truck driver. You can be an auto mechanic—a repair man in a shop or factory. Learn about stationary engines. Learn tractor work. Be a demonstrator or salesman. Hundreds of good jobs open to Sweeney trained men. Even before he finished his course Runsey was grabbed by the American Radiator Co. at \$150 a month as an expert welder.

FREE

I will gladly send my 72-page illustrated catalogue FREE. Also a copy of the Sweeney School News, a most interesting monthly school paper published here. You will enjoy them. Read the worthwhile stories of men like yourself who came to Sweeney's and found success. Read how Frank Powell and Harry Wilson built up a \$20,000 business in about two years after graduating. Read how Elbert A. Pence built up a \$25,000 yearly garage business. These stories and others are told by the Sweeney students. Also I want you to learn how my students enjoy themselves after work in the swimming pool, club and reading rooms, etc. No colored students accepted.

With your radio experience here you can go back home and install receiving sets or sell them. You can make sets for yourself. You can make sets for \$7.00. You can make sets for \$7.00. You can make sets for \$7.00.

Pick the Job

You Like

Chauffeurs	\$90 to \$150
Truck Driver	\$125
Tire Vulcanizers	\$100 to \$200
Welders	\$140 to \$200
Battery Men	\$150 to \$200
Auto Mechanics	\$6 to \$10 a day
Auto Electrician	\$225
Tractor Engineer	\$10 a day
Garage Mgr.	\$150 to \$400
Demonstrator and Salesman	\$150 to \$500

Free Radio

Come to the Sweeney Auto School and learn Radio work without a cent's extra charge. Receive messages—learn to build and install Radio sets—get agencies and sell sets—receive messages from all over the world—all this is now part of the regular eight weeks' course without advance in tuition. Who is the right man to sell and install these simple receiving sets? The garage man or auto mechanic. These sets are cheap and easily made. Learn how to make them.

The Sweeney School is always the leader. That is why I am offering this great new development free.

MAIL COUPON NOW

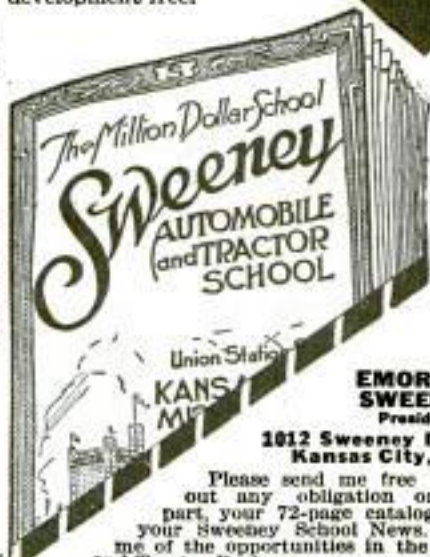

EMORY J. SWEENEY
President

1012 Sweeney Bldg.
Kansas City, Mo.

Please send me free without any obligation on my part, your 72-page catalog and your Sweeney School News. Tell me of the opportunities in the Auto and Tractor Business.

Name.....

P. O. State.....

LEARN A TRADE
Sweeney
SCHOOL OF AUTO-TRACTOR-AVIATION
1012 SWEENEY BLDG. KANSAS CITY, MO.

JOHNSON'S WOOD DYE



How to Finish Woodwork

The finishing of woodwork—old or new, is just a matter of using the proper materials. The Johnson Line of Artistic Wood Finishes is complete—it includes Johnson's Wood Dye, Perfectone Enamel and Undercoat, Varnishes, Prepared Wax, Paste Wood Filler, Crack Filler and everything necessary for woodwork, floors and furniture.

Johnson's Wood Dye is the proper material to use for staining wood—old or new—soft or hard. For the popular enamel finish on either new or old work use Johnson's Perfectone Undercoat and Enamel. Made in White, Ivory and French Gray.

For refinishing old woodwork, floors and furniture in color where you do not care to go to the trouble or expense of removing the old finish, apply one coat of Johnson's Sani-Spar Varnish Stain. Made in four beautiful shades.

This Book on
Home Beautifying

Free!

This book gives complete instructions for finishing all wood—hard or soft, old or new. Tells how inexpensive soft woods may be finished so they are as beautiful and artistic as hardwood. Explains just what materials to use and how to apply them. Includes color card—gives covering capacities, etc. Use coupon.

S. C. Johnson & Son, Dept. PA 5, Racine, Wis.

Please send me, free and postpaid, your Instruction Book on Wood Finishing and Home Beautifying.

NAME.....

ADDRESS.....

CITY & STATE.....

Dealer's Name.....

Are You Building?

If so, you will find our book particularly interesting and useful. It will tell you how to do the work yourself or enable you to talk intelligently on the subject to your architect and contractor. Our Individual Advice Department will give a prompt and expert answer to all questions on interior wood finishing—without cost or obligation.

S. C. JOHNSON & SON, Dept. PA 5, Racine, Wis.
"The Wood Finishing Authorities"
Canadian Factory—Brantford

Was \$100
Now
\$55

FREE TRIAL

No Money in Advance
No Deposit
No Obligation to Buy

Let us send you the Oliver for Free Trial. The coupon brings our latest model, brand new—not second hand.

If you agree that it is the finest typewriter, regardless of price, pay for it at the rate of \$4 per month. We ask no payment in advance. You have over a year to pay. And you'll have the Oliver all that time. There is no need to wait until you have the full amount. No need to consider a second-hand machine.

The free trial does not cost you a penny. For, if after trying the Oliver you wish to return it, we even refund the transportation charges.

Our new plan has been a tremendous success. We are selling more Olivers this way than ever before. Over 950,000 Olivers have been sold! Oliver popularity is increasing daily.

World's Greatest Typewriter Value

For \$55 you now obtain the identical Oliver formerly priced at \$100. It is a finer machine than ever—the price alone is changed. And that because you now deal direct with the Oliver Typewriter Company itself, eliminating unnecessary extravagances in distribution. Had we not adopted this new, simplified way of selling, the Oliver would still be priced at \$100, as it was for many years. But now you save the \$45 by being your own salesman and buying direct from the factory through this advertisement. Thousands have saved money this easy way.

Over 950,000 Olivers in Use

This Oliver is a 20-year development. If any typewriter is worth \$100, it is this splendid model. It is the same machine used by great concerns such as United States Steel Corporation, National Cloak & Suit Company, National City Bank of New York, Diamond Match Company, Morris & Company and others of like prominence. And this machine you now get for \$55, payable at the easy rate of \$4 a month.

Mail the Coupon Now

Remember you need not send any money with the coupon. The coupon alone brings you the Oliver for five days free trial in your own home. If you decide to keep the typewriter you can pay for it on terms so easy that you won't miss the money—only \$4 a month. If you need to have further information before ordering, fill in the coupon for our free catalog. Check the coupon for free trial Oliver or the catalog just as you wish. Clip the coupon now and mail at once.

Canadian Price, \$79

The **OLIVER**
Typewriter Company

1095 Oliver Typewriter Bldg., Chicago, Ill.

Save \$45

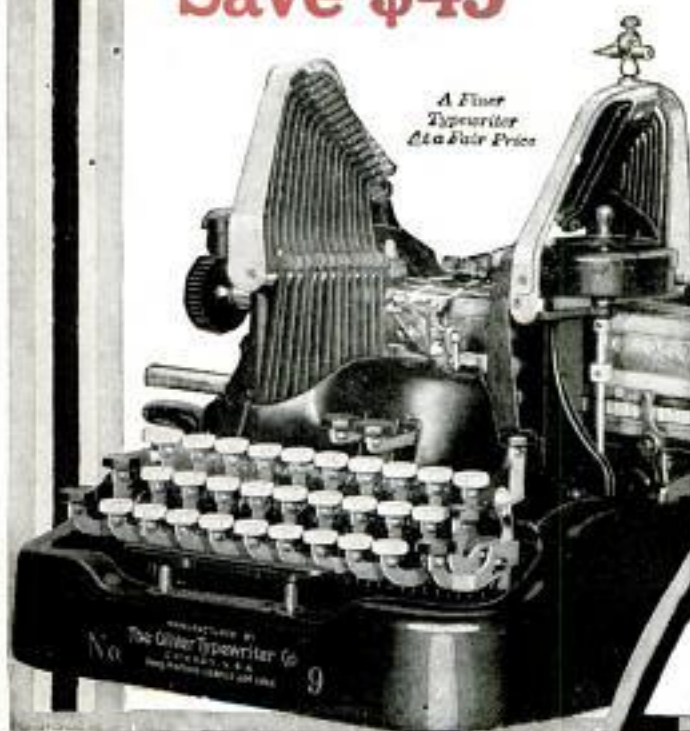

*A Finer
Typewriter
At a Fair Price*

THE OLIVER TYPEWRITER COMPANY
1095 Oliver Typewriter Building, Chicago, Ill.

- Ship me a new Oliver Nine for five days free inspection. If I keep it, I will pay \$55—\$3 after trial, then at the rate of \$4 per month. The title to remain in you until fully paid for. My shipping point is.....
- This does not place me under any obligation to buy. If I choose to return the Oliver, I will ship it back at your expense at the end of 5 days.
- Do not send a machine until I order it.
 Mail me your book—"The High Cost of Typewriters—The Reason and the Remedy." your de luxe catalog and further information.

Name.....

Street Address.....

City..... State.....

Occupation or Business.....

Tire Agents Wanted

Start Money Rolling In by the Amazing Mellinger Plan



Earn and Bank Big Money

without risking one cent. I will start you, as I have started so many others, in a business of your own. Begin all or part time. The Mellinger Plan is revolutionizing the tire business. A positive proven success. Different from anything you ever heard of. No previous experience needed. Tires shipped prepaid on approval. No risk. Save car owners money. Just what millions of tire buyers have been looking for. Piles up profits for Mellinger agents.

I Guarantee Your Profits

LET ME PROVE THAT YOU CAN EARN FROM \$100.00 TO \$400.00 A MONTH. I don't ask you to risk one cent. Make your car an asset, not an expense. I don't care what you have been doing or whether you live in city or country. Storekeepers, garage men, clerks, farmers, young fellows discontented with mere jobs, all sorts of people got this Mellinger Plan and almost overnight made a financial success that changed their whole lives. If you want to know the quickest way to make real money get my **BIG FREE BOOK TODAY.**

One Billion Dollars

will be spent for tires in the next few months. You can dip your hands into this golden flood and take out all the money you need. Whether you want **CASH, CASH, CASH,** or simply want guaranteed mileage tires for yourself at **LOWER** prices, write today. Rubber, cotton, labor, chemicals have all gone down. Get the facts. Buy at wholesale prices. Get the discounts. See how the **MELLINGER PLAN** saves car owners big money. My new low prices amaze everybody. Get my inside figures. Better tires for less money makes business just roll in for Mellinger Agents. There's a **BIG REASON WHY.**

Guaranteed by Bond 10,000 Miles

Mellinger Hand-made, Oversize, Cords and Extra Ply Tires are the finest, most serviceable made. Super-vitalized rubber makes riding easy. New bead construction. My exclusive tread, protected by U. S. Patent No. 69612, gives 10% greater wearing surface. **Absolutely Guaranteed.** I specifically guarantee by legal bond, Mellinger Tires up to 10,000 miles. Ninety-eight leading Manufacturers say: "We do not guarantee mileage." **Mellinger guarantees mileage.**

MADE \$1436

Tweedie, of Maine, sells \$1436.00 in few short weeks; A. M. Amigo, of Santurce, Porto Rico, sold \$4024.00 in seven months; Keighley, of Idaho, says: "I have sold \$900.00 worth of tires since I took the agency and all have given good satisfaction"; Hincheliff, Pitts-town, Pa., sold \$1,500.00 the first month; A. Franklin, Pennsylvania, sells \$600.00 a month.

FREE

This picture shows the **MASTER SALESMAN.** I send this sample Kit absolutely Free. Literally makes them buy. A substantially bound portfolio containing good size samples of fabric, cord, rubber, cross sections cut from tires and pure gum tubes. In 5 Minutes you can demonstrate tire secrets that the average dealer knows nothing about. This Kit was developed by a Mellinger Agent who sells over \$50,000 worth of tires annually. He says: "It's like taking a prospect thru the Factory. The Kit sells the prospect and I take the order." You have everything you need to start right in taking orders. This Star Salesman's Kit is very expensive, but I will gladly send it to you Free if you are in dead earnest.

If You Own a Car!

WRITE ME QUICK. Don't buy anyone's tires until you see these amazing values—see these tires on your own car. **THINK OF IT.** Oversize Cord Tires for less than fabrics used to cost. If there is no authorized Mellinger Agent in your locality, I will want one owner to show and recommend Mellinger Tires. I will ship this magnificent Cord Tire prepaid. For a little of your time and enthusiasm, I will make you a surprising offer that will give you a set of tires **FREE.** Be the first from your locality to get my Confidential offer. Mail the coupon, today—right now; tear it off now. It's your big opportunity. Get this free book that has proven the golden key to thousands. **DON'T MISS IT.**



**MAIL
COUPON
TODAY
FOR BIG
FREE
BOOK!**

**Mr. B. L. Mellinger, Pres.
Mellinger Tire & Rubber Co.,
1045 Oak St., Kansas City, Mo.**

Without obligation, send me details of the Mellinger Plan, Free Book and Wholesale Prices and how, without investing money, I can become your authorized agent.

Name.....

Address.....

B. L. Mellinger, President

MELLINGER TIRE & RUBBER CO.
1045 OAK STREET KANSAS CITY, MO.

References: Any Bank or Trust Co., or Any Publication