

POPULAR MECHANICS MAGAZINE

WRITTEN SO YOU CAN UNDERSTAND IT

REG'D TRADE MARK, GREAT BRITAIN, No. 410426.

REG. U. S. PAT. OFF.

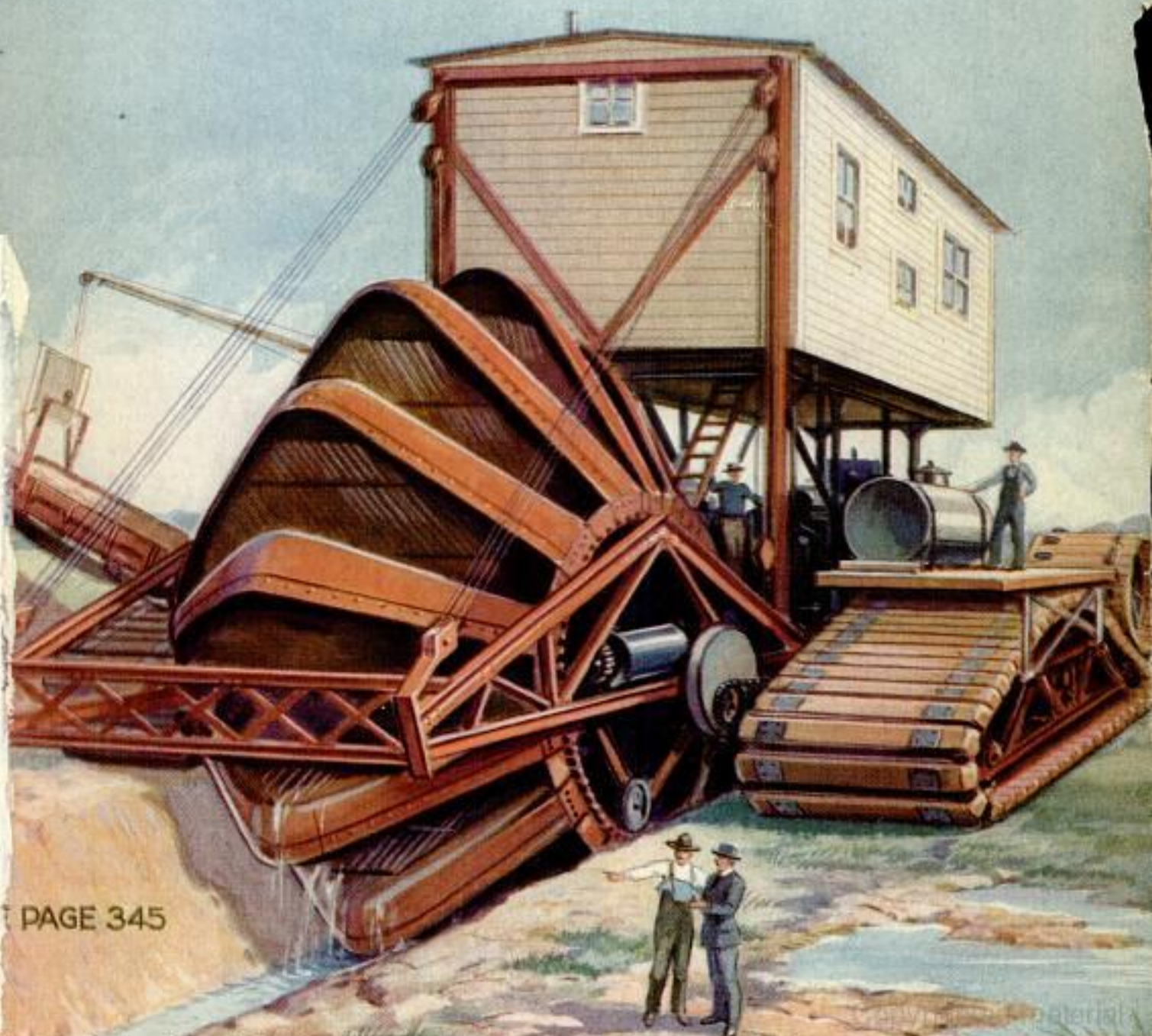

PAGE 345

Motor Secrets That Quickly Put Me On Easy Street

By O. H. Justus

Not so very long ago it looked like I might plod along in the wage rut all my life.

Today I'm living on "Easy Street," and when friends look over my property they say: "Justus, you've been lucky!"

They see a big, busy auto repair shop, new stocks of tires, cars and trucks and scores of cars and customers coming and going. And they wonder how a wage earner could have got hold of such a business.

Well, I didn't do it by "luck," brilliance or somebody else's money. I did it by simply **using** the common sense every man has. And **any** man who wants to can do as well or better.

First, I made up my mind to TRY. Then I saw that the greatest demand for men, best pay and surest future were in keeping our millions of cars, trucks and tractors in repair. But I soon found out that becoming a mechanic by the old "experience" system meant several more years of the grind. I also saw that the men who had learned that way were not getting anywhere, while the good jobs and big money were going to men with special training—men who knew the mechanical secrets of motors. "I don't want to be a grease hound or a second-rate wrench twister," I said to myself. **"I'm going to learn those secrets, too."**

Henry J. Rahe made it possible. Remember his name, because he can do the same for YOU. I read an advertisement about his quick, easy practical course in auto and tractor work in his big shop-schools—**learning with tools, not books**, and from master instructors under Mr. Rahe's personal supervision. Largely out of curiosity, I mailed "the coupon in the corner." And it turned out to be my ticket to "Easy Street."

A few days later I was on my way to one of the Rahe Schools



O. H. Justus and his big agency and repair shops at Parkersburg, W. Va.

which I consider the **ONLY** schools. A few weeks later I was back home, a state graduate—master of all the motor secrets that separate the \$2-a-day laborer from the \$40 to \$100 a week of the **real mechanic**. Easy Rahe training had made me a **free man** for less money than a good Rahe-trained mechanic earns in **three weeks**.

Since then I've never wanted for work an hour. My big pay as a mechanic soon enabled me to open my own shop, which **ALWAYS** has had from a week's to a month's work ahead of it. No job ever has "stuck" me; none of my work has "fallen down." I have employed mechanics who had just "picked up" the trade—almost invariably to my sorrow. But I've never hired a Rahe-trained man who didn't make good. The only trouble was, I couldn't keep them—they **all went into business for themselves**. And, so far as I know, every one of them is now on "Easy Street."

If you want to get somewhere, be your own boss and make some real money, find one of those "coupons in the corner" and send it to Henry Rahe **today**. Then, if you use your wits, it will prove to be **your ticket to "Easy Street,"** too. I'm giving it to you straight. I **KNOW**.

I Want Men! I'll Pay Your Fare to Chicago, Cincinnati or Kansas City

I want to help 500 ambitious men follow Justus to "Easy Street" in the next few months. **YOU**—regardless of your age or education—can get there easier than he did. Today the field is bigger, the demand for Rahe-trained men greater and the pay better. And you can get to my school nearest your home **FREE OF CHARGE!** I'll pay your railroad fare in full to my nearest school, no matter where you live. It's going to be a **BIG** year for Rahe-trained men. Get started early! Just jump on a train for the nearest Rahe school. Every cent of your fare will be refunded the minute you enroll. (Read my 7-day guarantee.)

Master Instructors Wonderful Shops

Every instructor in my three schools is a **MASTER** of his business—trained by me and always under my direction. I keep constantly in touch with each school and see that things are done **RIGHT**. The Rahe shops are really wonderful. They contain **everything** needed to make **YOU**, too, a **MASTER** of this big-money business. You don't need "book learning" to succeed in this business—just a few weeks' pleasant training on actual motors and cars. If you don't want to go into business for yourself, you can make **REAL MONEY** working for others. **Bill Peace, one of my graduates, writes me that he's making \$250 a month and expenses operating a tractor in the**



I've put 40,000 men on "Easy Street." I can and **WILL** do it for you if you'll simply tell me you want to go. Say it **right now**.

HENRY J. RAHE.

oil fields. **THOUSANDS** of Rahe-trained men make reports like this.

Special Money-Saving Price

I've always given as good a course and at as low a price as that made by any reliable school, bar none. Now, with schools in three locations—getting nearer to my prospective students and increasing my capacity—I can reduce my price still further—and **pay your railroad fare** besides! Get my low tuition figures. You'll be pleasantly surprised.

7-Day Guarantee

Try a Rahe School a week. Then, if you don't like it—if you don't believe my methods will make you a competent auto and tractor mechanic—you can withdraw and the 7 days' training will cost you **NOTHING**. No other school offers this guarantee. It's your **INSURANCE** of satisfaction. Don't forget—this will be a **BIG** year for Rahe-trained motor-maintenance engineers—thousands will be needed. Get started **QUICK!** Send the coupon or a post card and find out about the **EASY** Rahe way to "Easy Street."

Do it today.

Yours for quick success,

Henry J. Rahe

Send This Coupon NOW

HENRY J. RAHE, Dept. 2899

Please send me your big illustrated **FREE BOOK** and proof that you can put me on "Easy Street."

Name.....

Street, R. R. or P. O. Box.....

Town..... State.....

Age..... Occupation.....

Address me at my school nearest your home.—H. J. R.

It Costs You Nothing to Get the PROOF

The coupon will bring my big free book, with proof that Rahe training will start you to "Easy Street." No cost—no obligation. Write me **NOW**.

Address the nearest School—Dept. 2899

Rahe Auto & Tractor Schools

CHICAGO Michigan Boul. and Ontario Street
CINCINNATI Ninth and Walnut Streets
KANSAS CITY 22nd and Oak Streets



“My Victor Records shall be my biography”

That was Caruso's characteristic remark when he was once approached regarding his biography.

The one hundred and seventy-eight Victor Records by Caruso, and many records yet to be issued, truly constitute the best autobiography of the world's greatest singer; a unique autobiography which has never been equalled for vividness; an autobiography which is itself alive and which will continue to delight all the succeeding generations.

The Caruso records include fifty-six operatic arias, twenty-three concert ballads, sixteen Neapolitan songs, fifteen love lyrics, twelve sacred numbers, five patriotic selections, and fifty-one concerted numbers, all of which are listed in the Victor Record Catalog. Any dealer in Victor products will gladly give you a copy and play any numbers for you.

Victrola

REG. U.S. PAT. OFF.



“HIS MASTER'S VOICE”

REG. U.S. PAT. OFF.

This trademark and the trademark word “His Master's Voice” identify all our products. Look under the label. Look on the label. VICTOR TALKING MACHINE CO., Camden, N. J.

Victor Talking Machine Company, Camden, N. J.



BDYO-QQP-54ZR

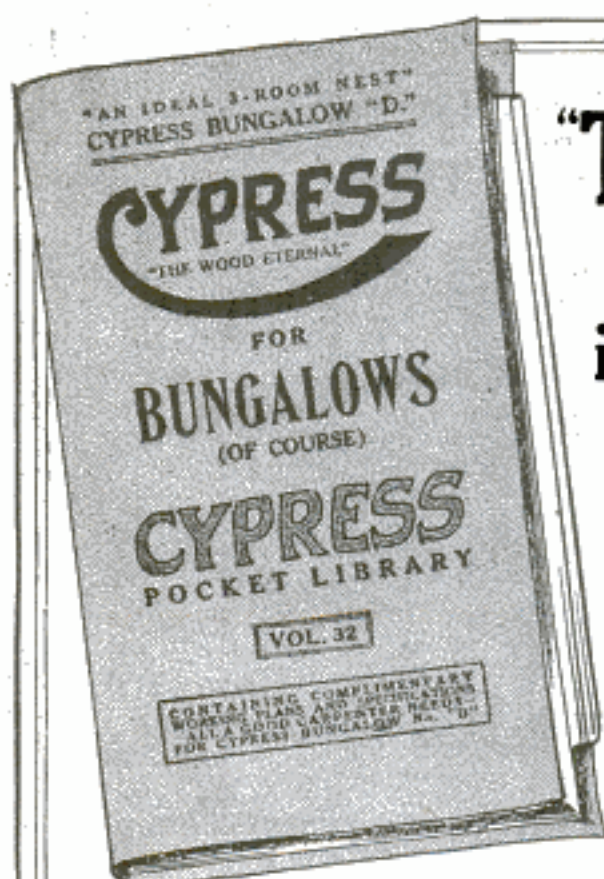

"The Littlest Home"

(and the sweetest little nest ever)

is **Cypress Bungalow "D"**
for which **FREE PLANS** and
complete **Working Drawings**
and **Specifications**

can be had immediately by writing for

Vol. 32 OF THE **Cypress Pocket Library**



3 Sunny Rooms for 2 Happy People { *SO FAR* }

(a joy and a permanent blessing to any one
with even a little piece of ground to put it on.)

Full Working Plans and Specifications Free

if you simply write us for a copy of **Vol. 32**

of the Cypress Pocket Library—that "guide, counselor and
friend of the home-lover"—who also is a good enough
economist to insure himself against the Ravages of Repair
Bills by building of Cypress, "the Wood Eternal," at first.

**AND THEN—THOSE DELIGHTFUL VOLUMES (WITH FREE PLANS)
ON PERGOLAS, SUN-PARLORS, SLEEPING PORCHES,
LITTLE GREENHOUSES, ETC.**

Better write at once for **Vol. 32**—and also ask for **Vol. 1**, which
contains full list of over 40 free volumes of this "Lumber Classic."

Remember—We recommend Cypress Lumber only for uses in which it is best for YOU.

Let our "ALL-ROUND HELPS DEPARTMENT" help YOU. Our entire resources are at your service free
SOUTHERN CYPRESS MANUFACTURERS' ASSN.
1219 POYDRAS BLDG., NEW ORLEANS, LA., or 1219 GRAHAM BLDG., JACKSONVILLE, FLA.

INSIST on **TRADE-MARKED CYPRESS** of YOUR LUMBER DEALER. IF HE HASN'T IT, *Let Us Know*.

Camera Attachment for Slow Motion Pictures 363. Popular Mechanics Magazine

6 N. Michigan Avenue, Chicago, U. S. A.

H. H. WINDSOR, Editor

London: Hachette & Cie,
16-17, King William Street, Charing Cross, W. C. 2

Paris: Hachette & Cie,
111 Rue Reaumur

Melbourne, Australia,
The Australasian News Co.

ISSUED MONTHLY

SUBSCRIPTION:

SINGLE COPY, 25 CENTS

In United States, and its possessions, Cuba, Mexico, and Canada, per year, postpaid - \$8.00

To all other countries in the Postal Union 8.50

All subscriptions are discontinued at expiration. Please examine the date printed on your wrapper.

Entered as Second Class Matter Sept. 15, 1903, at the Post Office at Chicago, Illinois, under Act of March 3rd, 1879.

Entered as Second Class Matter at the Post Office Department, Canada.

Published monthly by POPULAR MECHANICS CO.

Copyright, 1922, by H. H. Windsor.

Copyright in Australia.

Vol. 37

Contents for March, 1922

No. 3

Aeronautics—Aeronautical Chamber of Commerce Organized	429
Air Port, Simplified, No Tumble Bolts in	437
Airplane Engine, Italian, of Diesel Type	344
Airplane Engines, Auxiliary Engine Starts	363
Airplane Engines, Supercharging Compressor for	386
Airplane Stability Demonstrator	328
Airplane, Wind of High Velocity Holds Motionless	359
Alcohol, Denatured, Dangerous Poison	402
Automobiles, Luxurious, for Indian Royalty	421
Bathroom Fixture—Electric Hand Drier Built in Wall	442
Battery Men, New Tool Aids	440
Bed, Baby, for Automobile or House	411
Bell Tones, New American Equal Old European	380
Bells, Confiscated, Shells in Church Tower Replace	446
Blind and Deaf, Conversation Understood between	364
Bricks, Oil Shale By-Product Used for	330
Bridge, Bascule, Rolls Backward in Opening	377
Briquettes, Coal Dust, French Railways Use	378
Brush, Buffing Wheel, Made of Three Materials	425
Buffalo Fur, Substitute for Wool	407
Building, Giant Office, Erected around Two-Story Building, Giant Office, Erected around Building	390
"Bungalette" Camp for Motor Tourists, by John Anson Ford	416
Bus, Pacific Coast, Forty Passengers Capacity of	375
Busses, Big Motor, Tilting Tests Prove Safety of	392
Cables, Submarine, Great Capacity of	362
Camera, Mammoth Electric, Used in Map Making	343
Cards, Bridge Game of Skill, Not Luck, Played with	440
Cash Register, Double, Collection System for	441
Cash Register and Adding Machine	352
Cash Register and Adding Machine	367
Cells, Organic, Reproduced from Inorganic Substance	367
Chair, Invalid's Wheel, New Conveniences for	436
Check Protector, Forgery Prevented by	356
Chemical Action, Testing Under Pressure	346
Chickens Vaccinated Like Human Beings	338
Children's Pages	444
Chute, Coal, Inclosed	354
City Hall, Philadelphia, New Year's Illumination of	370
Civic Features	321
Climate Conditions, Land Values Raised by	353
Coal Mining Machine, Miner Operates, by Everett J. Lovett	337
Coin, Old Swedish, Largest Known	402
Coins, Powder Coated, Thief Trapped with	413
Concrete Blocks, Imitation, Sandpaper Used for	408
Concrete Proportioner, Automatic	387
Cork, Portugal Produces Immense Quantities of	328
Cornet Player Attachment, Fingering Eliminated by	338
Cranberry Bogs, Artificial, in Northwest, by Lawrence William Pedrose	409
Crane Lightweight Portable, Lifts 30 Times Weight	432
Crab, Battleship, President's Turkey Shipped in	414
Crossing, Triple Risk from	433
Dam, Concrete, Foaming Waterfall Appearance of	393
Dam Construction, Mining Methods Applied to	358
Dam, Devil's Gate, Success of	369
Darning Machine, Hand, Works Like Loom	403
Distomate Mine, Valuable, Operated in Oregon	408
Ditcher, Big, Swamps Converted into Farms with	344
Drug Trade, American, Booming in Bombay	340
Electric Power for Seattle from Skagit River Plant	342
Engine, Marine, Has Condenser of Novel Construction	374
Engines, Gasoline, Atomization of Fuel in	436

Fair Leader, Simple, for Guiding Cables	383
Figs, Wheeled Platform for Picking	386
Film Printer, Light Density Control of	360
Fire Call, Uniform, Canadian Communities Adopt	391
Fire Engine, Japanese, Narrow Escape of	372
Fireworks Display for Crown Prince of Japan	374
First-Aid Box Installed in Berlin Street	354
Fish Ladders on River Obstructions in Canada	355
Flight, Endurance, America Sets World Record for	380
Food Mixer, Electric	436
Forest, New National, in Pennsylvania	356
Fur Durability, New Device Measures	428
Furnace, Electric Brass, Has Revolving Mold Table	386
Garage Air Hose, Coin Operated Support for	423
Garage Door, Weight of Car Automatically Opens	364
Garage, Shops on Roof of	404
Gas Sold by Heat Value	390
Gauge, Compression Loss in Motor Cylinders Tested by	430
Grader, Road, Two Graders Abreast Used by	371
Gun, Centrifugal Machine	389
Hair Clipper, Electric, Reciprocating Motor Used in	394
Handbag, Ladies', Flashlight in	351
Heels, Snap-On Rubber, Wearer Attaches	390
Herring, Weir Model, Maine Fisherman Builds	403
Hose, Swivel Joint for	375
Household Devices	438
Houses, Cement, Shooting from Gun, by Cleveland Gaines	361
Houses, Two Made from One	365
Ice, Railroads Use Cutting Machines to Harvest, by F. L. Clark	373
Insulating Material, Synthetic, Italy Develops	377
Jet Industry, Utah Mine Gives Promise of, by Fred-eric Kinney	427
Jinrikisha, Old, Pneumatic Tires Modernize	378
Key Attachment, Locks Safeguarded by	429
Kitchenette, Convenient Features of	414
Knife, Curve Cutting, Scrolls Cut with	326
Lake, Ancient Nevada, Disappearance of	338
Lake Bottom, Grain Raised in, by Fred S. Walker	395
Lamp, Automobile, Nondazzle	443
Lamp, Parking, Unique Design of	342
Lamp-Post, Freak Storm Reproduces	356
Laundry, Bagging Eliminates Marks on	398
Laws, State, Foreign Treaties Overrule	356
Lighting the Mississippi, by Lewis R. Freeman	347
Lightning, Freak, Man Killed and Wife Hurt by	330
Locomotive Pinned to River Bed, Salvaging of	378
Lubricating Device Works with Air Pressure	429
Machine, Articles Distributed into Compartments by	440
Maps, Three Dimensioned Weather, for Airmen	441
Medal, Gold, Defenders of Verdun Commemorated by	326
Metal Oxidation, Aluminum Treatment Prevents	360
Meter, Illumination, Portable and Accurate	346
Meter, Thinning of Crankcase Oil Shown by	380
Meter, Wrist, for Motorists	323
Milker's Stool, Sanitary	308
Mining, Hazardous Occupation, Report Shows	378
Moisture, Device Prevents Damage from	429
Molecule, Model of Magnified	394
Motor Van, Home and Business Establishment	425
Motorcycle, Special Racing, English Rider Designs	403
Moving Picture Film Prepared on Running Train, by Jack A. Bristol	420
Multiplane, French Designed, Strange Appearance of	394

[Continued on Page 4]

Copyrighted material

[Contents—Continued]

Nitrate Plant and Muscle Shoals, Air Views of.....	327	Tractor, Road Grading, Simple and Economical.....	413
Oil Testing Instrument for Auto Engines.....	355	Tractor, "Walking," Used on Plowed Soil.....	350
Organism, Synura, Water Made Distasteful by.....	410	Traffic, New York City, Guided from One Center..	431
Paper Pulp Mill, German, First in Argentina.....	375	Traffic System, American, British Columbia Adopts.	413
Parachute in Two Parts Reduces Shock.....	361	Trains, Heavily Loaded, Air Brake Tests Made on,	
Parade, Safety-First, Animated Statistics Feature of.	392	by George F. Paul.....	331
Peanut Butter, Well Mixed, Machine Dispenses.....	442	"Tree Surgeons," Portable Outfit Aids.....	419
Pen, Ink Reservoir, Redipping Not Necessary with..	437	Trees, Sapling, Holder for Transplanting.....	415
Peppermint Roots, Automatic Machine Plants.....	433	Trucks, Motor, Railroad Uses.....	419
Phonograph, Eight Games Played on.....	397	Tubing, Frame of Large Building Made of.....	422
Photograph, Nature's Mirror Perfectly Portrays.....	372	Tubing, Gas, Metal End Fits Any Hose Connection.	393
Picture, Wooden, Natural Colors of.....	391	Ukulele Peg, Metal, Fits All Types.....	436
Pigeons Substitute for Wireless Messages.....	387	Valve, Safety Relief, for Plumbing.....	432
Piles Driven with Swinging Lead, Breakage Pre-		Vaults, Safety Deposit, Building, by T. Benjamin	
vented by.....	406	Faucett.....	376
Pipe Smoker, Automatic, Tobacco Tested with.....	432	Ventilator Cowls, Ships' Cargoes Preserved by.....	366
Pipe Stem, Steel Wool Strainer Keeps Open.....	402	Vessels, Wrecked, Salvaged without Divers.....	341
Pistol, Twenty Gauge Shot, by Capt. Edward C.		Violin Tones, High and Low, Different Woods Used	
Crossman.....	405	for.....	340
Power Plant, Huge Canadian, Completed at Niagara.	326	Violins, Tone Producer for.....	328
Power Stations, Chicago's, Enormous Capacity of....	394	Vulcanizer, Electric, Merits of.....	400
Press, Power, Prints from Copper or Steel Plates....	342	Water Heater, Electric, Has Hot Water Storage	
Printing Outfit, Type Strung on Wires Used with..	424	Tank.....	356
Printing Telegraph, New Use for.....	440	Water Power Development in Southwestern States..	370
Pump Lined with Rubber, Durability of.....	431	Water Power Expansion in Ohio River Basin.....	386
Pumping Machine for Draining Canals.....	403	Water Tank Heaters, Gas, Electrical Control for....	391
Radiator Truss, Automobile, Cheap Repair with....	433	Weather Bureau Service, Lives and Property Saved	
Radiators, Wall, Adjustable Hanger for.....	404	by.....	326
Radio Change Over Switch, Simple Construction of.	411	Weed Killing and Plowing, Tractor Attachment for..	417
Radio, Lost Shipments Traced with.....	343	Weeds and Insect Life, New Machine Exterminates.	423
Radio Wave Velocity, Demonstration of.....	426	Window Catch, Burglar Proof, Locks Sash at Any	
Radiotelephone, Government Information by.....	382	Point.....	443
Radium Bearing Minerals Found in British Colum-		Wireless Messages, Privacy of.....	393
bia, by Francis Dickie.....	335	Wireless on Interurban Railways.....	362
Railroad, Alaska, Opened from Seward to Fairbanks.	388	Wireless Reports, Amsterdam Stock Exchange Sends	
Railroad System, Morocco, Changed to Normal Gauge	386	Wireless Waves, Air Navigators Guided by, by H.	
Reindeer Acclimatized in Balin Land.....	380	A. Lane.....	329
Rifle Recoil Pad, Military, Severe Tests Passed by..	340	Wood, Myrtle, Popularity Reduces Supply of.....	426
River, Treacherous Mexican, Harnessing.....	384	X-Rays, Soft, from Arcs in Gas Vapors.....	443
Rivet Machine, Tubular, Has Ingenious Feltale.....	353		
Road Sprinkler, Logging Roads Ice Coated with....	430		
Rose Tree, Metal, Produced by Welding Torch.....	378		
Savings System, Thrift Taught by.....	437		
Saw Mounted on Auto, Community's Cordwood Cut			
by.....	411		
Sealing Machine, Electric, Safe and Economical....	418		
Sewage Channel in Big System, Slough Becomes....	413		
Sewing Machine, Slot in Table Facilitates Work on..	443		
Ship, "Quest," Sails from Rio de Janeiro.....	430		
Ship, Weather Beaten, Acetylene Torch Makes.....	380		
"Shoveha penny" Board, New, Game Made Popu-			
lar by.....	383		
Signal, Automobile, Distinctive Lights on.....	340		
Signal, Crossing, New Type of.....	389		
Signal, Stop, Simple and Practical.....	342		
Skating, Roller and Ice, Reservoir Cover Used for..	412		
Ski Jumping in Canada.....	357		
Sled, Motor Coasting, Saves Climbing.....	415		
Steel on Wires, Short Circuit Thaws.....	344		
Smugglers, Clever Dumping Device Used by, by			
Lawrence William Pedrose.....	391		
Snow, Flame Throwing Machine Melts.....	325		
Snow for Skiing, Train Transports.....	363		
Soap Bubbles, Movie Ballet Performs Among.....	339		
Sod Cutting Machine, Lawn Preserved by.....	446		
Sou, Farm, Corrective Applications for Hardening of	432		
Spark Plug, Carbon Proof, Made in France.....	443		
Statue, Wooden, Japanese Carves of Self.....	412		
Steamboat, "Andrew Paddock," Used as Power Plant	405		
Submarines, Condemned, Germans Convert into Tank-			
ships.....	355		
Sunspots Consist of Gases Cooled by Expansion....	414		
Tanks, Steel, More Durable with Fewer Plates.....	431		
Telephone, Wireless, Chinese Mystified by.....	442		
Telescope, Harvard College to Put to Use.....	354		
Temple, Mormon, Straight Line Design of.....	333		
Tennis Courts, Concrete, Permanent Lines on.....	388		
Tennis on "Pogo Sticks" Latest Fad in Sports.....	332		
Tent, Kitchen, for Motor Tourists.....	334		
Thrashing Machine, Giant, Built from Seven Others..	381		
Tickets, Railway, Timesaving Device Speeds Sales of	360		
Tire Pump, Mechanical, Simple Design of.....	383		
Tire Valve Caps, Dust Proof.....	367		
Tires, Pneumatic, Inflated after Six Months.....	366		
Toothbrush Sterilizer, Brush Kept Sanitary with....	440		
Toothpaste Holder, Improved.....	402		
Tractor, Endless Tread, Used as Snowplow.....	393		
Tractor, French, Original Design of.....	401		
Tractor, Hillside, Leveling Attachment on.....	334		
Tractor, Lightweight, Operated by Steam.....	377		

SHOP NOTES

Ball Bearing Puller.....	463
Balls, Check Valve, Lifting.....	459
Blueprint Washer, Improved.....	460
Bolt Circles, Marking.....	450
Bolts, Cylinder Head, Wrench for.....	448
Bench Stop, Adjustable.....	460
Broaches, Lubricating.....	459
Building, Testing for Vibration.....	460
Cabins, Log, Corners for.....	447
Calipers, Firm Joint, Lock for.....	452
Carburetor Leakage, Dirt Cause of.....	455
Cathodes, Silver, Method of Cleaning.....	448
Crankshaft Turning Tool.....	451
Drawings, Large, Cheap Board for.....	456
Fenders, Bent, Presses for Straightening.....	461
Gauge Glasses, Safety Container for.....	449
Generators, Motor, Driving Unit for Banding.....	455
Glass, Soldering Bit Used for Cutting.....	453
Grinder Light and Switch Combined.....	453
Hammer Holder, Belt Loop.....	463
Iron, Rustproofing.....	465
Joints, Brazed, Method Adds Strength to.....	464
Ladder, Long, Truss Stiffens.....	462
Machine Guards, Two Simple.....	454
Magnifying Glass Holder, Artists'.....	465
Matrices, Stereotype, Made from Type Forms.....	463
Milling, Face, Side Milling Cutter Used for.....	451
Motion, Intermittent, Correct Design of Movement	
for.....	452
Motors, Generators, and Transformers, Testing,	
Part II.....	456
Pencils, Drawing, How to Sharpen.....	458
Pins, Long, Slender, Tool for Driving.....	448
Pins, Polishing Ends of.....	461
Planer Tools, Lifter for.....	464
Printing Press, Safety Attachment for.....	455
Pumps, Why They Become Air Bound.....	455
Rack for Storing Sheet Glass.....	451
Razor Blades, Old, Shop Uses for.....	449
Refrigerating System, New, Testing.....	462
Saw, Circular, Spring Guide for.....	464
Scale, Novel, for Machinists.....	463
Springs, Tempered, How to Drill.....	459
Steam, Heating Water with.....	449
Stencils Made from Old Films.....	459
Stickers, Gummed Paper, Rush Orders Indicated by.	449
Tile, Large, Making Smooth Joints in.....	466
Trowel, Special, for Concrete Road Work.....	459
Tumbling Barrel, Automatic Stop for.....	460

DRAKE'S PRACTICAL MECHANICAL BOOKS

THEY WILL RAISE YOUR PAY—

ORDER ON 5-DAY TRIAL

The books listed below will perfect you in your chosen trade — pave the way to the big positions. Written in non-technical language—easy to read and understand. *Every book covers its subject completely. An entire course of instruction condensed into one volume.* Your choice sent postpaid — you benefit 5 days — money refunded in full if not entirely satisfactory. Order direct from this page.



1921
Edition
\$2.00

Automobile Books

- Automobile Ignition, by Manly.....Leatherette \$2.00
Automobile Starting and Lighting, by Manly.....Leatherette \$2.00
Brookes' Automobile Handbook.....Leatherette \$2.00
Ford Motor Car, Truck and Tractor, by Manly.....Cloth \$1.50
Starting and Lighting Troubles, Remedies and Repairs, by Manly.....Leatherette \$3.00
Automobile Battery, Care and Repair, by Manly.....Leatherette \$2.00
Automobile Catechism and Repair Manual.....Leatherette \$1.50
Tires and Vulcanizing, by Tufford.....Cloth \$2.00
Gas and Oil Engine Handbook.....Cloth \$1.50
Automobile Upkeep and Care, by Manly.....Cloth \$1.50
Motorcycle Handbook, by Manly.....Cloth \$1.50

Shop Practice Books

- Sheet Metal Workers' Manual.....Leatherette \$2.00
Oxy-Acetylene Welding and Cutting.....Leatherette \$1.75
Sound Welds.....Cloth \$2.00
Slide Rule and Logarithmic Tables.....Leatherette \$2.00

- Handbook for Millwrights.....Cloth \$2.00
Modern Blacksmithing.....Cloth \$1.25
Machine Shop Practice.....Cloth \$2.00
Mechanical Drawing and Machine Design.....Cloth \$2.00
Pattern Making.....Cloth \$1.50

Carpentry Books

- Cloth Binding
Modern Carpentry, 2 vols.....\$3.00
The Steel Square, 2 vols.....\$3.00
Wooden Boat and Shipbuilding.....\$1.50
Modern Estimator.....\$1.50
Timber Framing.....\$2.00
Builder's Architectural Drawing.....\$2.00
Concrete.....\$1.50
Practical Bungalows.....\$1.00
Low Cost Homes.....\$1.00
Roof Framing.....\$1.50
Stair Building and Hand Railing.....\$1.50

Electrical Books

- Practical Applied Electricity.....\$2.00
Alternating Current.....\$1.50
Electric Motor Control Systems.....\$1.50
Wiring Diagrams and Descriptions.....\$1.50
Electrical Tables and Data.....\$1.50
Armature and Magnet Winding.....\$1.50
Modern Electrical Construction.....\$1.50
Modern Electric Illumination.....\$1.50
Electricians' Operating and Testing.....\$1.50
Motion Picture Operation.....\$1.50
Drake's Electrical Dictionary.....\$1.50
Electric Motors, D. & A.....\$1.50
Electrical Measurements and Meter Testing.....\$1.50
Drake's Telephone Handbook.....\$2.00
Modern American Telephony.....\$2.00
Easy Electrical Experiments.....Cloth \$1.25
Wireless Telegraph and Telephone Handbook.....Cloth \$1.25
Telegraphy Self-Taught.....Cloth \$1.25

Steam Engineering

- Swingle's Handbook for Steam Engineers and Electricians.....Leatherette \$4.00
Examination Questions and Answers for Marine and Stationary Engineers.....Leatherette \$2.00

- Steam Boilers.....Leatherette \$2.00
Swingle's Catechism of Steam, Gas and Electrical Engineering.....Leatherette \$1.50

Painting Books

- Scene Painting and Bulletin Art.....Cloth \$4.00
A Show at Sho' Cards.....Cloth \$4.00
Sign Painting.....Cloth \$4.00
Strong's Book of Designs.....Leatherette \$4.00
Strong's Art of Show Card Writing.....Cloth \$4.00
Signist's Alphabets.....Cloth \$1.50
Modern Painter's Cyclopedia.....Cloth \$2.00
Automobile Painting.....Cloth \$1.50
Estimates, Costs and Profits, Painting and Decorating.....Cloth \$1.50
New Hardwood Finishing.....Cloth \$1.50
The Amateur Artist.....Cloth \$1.50
New Stencils.....Cloth \$1.25

Farm Books

- Farm Mechanics.....Cloth \$1.25
Farm Buildings.....Cloth \$1.25
Farm Engines.....Cloth \$1.25
Traction Farming.....Cloth \$1.50

Business and Reference Books

- Better Business Letters.....Leatherette \$1.50
Better Business English.....Leatherette \$1.50
Better Advertising.....Leatherette \$1.50
Finger Prints Simplified.....Cloth \$2.00
Practical Bricklaying.....Cloth \$1.25
Practical Instruction for Detectives.....Cloth \$1.00
Practical Plumbing.....Cloth \$1.50
Hot Water Heating.....Cloth \$1.50
Elementary Chemistry.....Cloth \$1.50
Courses in Civil Service.....Cloth \$1.50
Cyclopedia of Recipes.....Cloth \$1.50
American Star Speaker.....Cloth \$1.50

Modern Languages

- By Prof. P. S. Allen, U. of Chicago
French without a Teacher.....Cloth \$1.25
Spanish without a Teacher.....Cloth \$1.25
German without a Teacher.....Cloth \$1.25
Everyday French.....\$1.25
Everyday Spanish.....\$1.25

ORDER DIRECT FROM THIS PAGE—ON OUR MONEY-BACK PLAN

The books listed above are only a few of the many in our catalogue, which you will receive promptly after filling out and mailing us the attached coupon. For quick action order direct from this page—cross name of each book wanted and send in with price quoted. We prepay postage and send the books on our money-back plan.

FREDERICK J. DRAKE & CO.
PUBLISHERS

1008 Michigan Ave., Chicago
Drake Books Are For Sale at All Book Stores

FREDERICK J. DRAKE & CO.
1008 Michigan Avenue
Chicago, Ill.

GENTLEMEN:—Please send me free, postage paid, your illustrated catalogue which lists and describes over 100 Practical Mechanical Books for Home Study.

My name is

and my address

Mail Coupon For Free Catalogue
Your Guide to Home Study

NEW KIND OF HEAT!



Try It in Your Stove
30 Days Free
The **OLIVER** Oil-Gas Burner

Keeps home warmer. Three times the heat. Does away with coal and wood—cheaper. Makes your stove or range an oil-gas stove.

No fires to make. No ashes, dirt, smoke, odor, chopping, shoveling, carrying dirty coal or wood. Saves hours of work. Makes your stove heat or bake better, cleaner, quicker. Doesn't change your stove, simply sets in firebox, easily slipped in or out, absolutely safe. Lasts lifetime. Makes its own gas from coal-oil (kerosene) at small cost. Oil is cheap and getting cheaper. Gives even heat instantly, much or little, by simply turning valve. Fits any stove. Saves money, time, labor, health. **BURNS 95% AIR—5% OIL.**



FREE Attractive Book telling all about the "New Kind of Heat," sent you free, postpaid. Also amazingly low introductory-price offer, including 30-Day Trial, if you act quickly. Write today.

OLIVER Oil-Gas Burner & Machine Co.
2014-C Pine Street St. Louis
Oldest, Largest Mfrs. Oil-Gas Burners in World.

AGENTS Oliver Agents earn as high as \$500 a month—\$25 a day spare time is easy. Exclusive territory—real co-operation.

Write for full money-making details. Big season on.

WEALTH, HONOR, RICHES

Do not depend upon opportunity or intellectual brilliancy of any kind, because it is well known that uneducated people often acquire great wealth, while cultured and talented people remain in poverty.

Again, they do not depend upon capital, because many men with capital lose what they have, while others with no capital acquire phenomenal wealth.

Whatever finds a place in human experience is the result of the operation of natural laws, and the determining factors are therefore within your own control.

This may seem "too good to be true," but if you will consider that by the touch of a button or the turn of a lever science has placed almost infinite resources at the disposal of man, it becomes evident that there may be still other laws not generally known which contain even greater possibilities.

We have published a Remarkable little book, giving the conclusions of science concerning these laws, which we will send upon request. If you want to underwrite success on a magnificent scale, send for it.

MASTER-KEY INSTITUTE

210 Howard Bldg.,

St. Louis, Mo.

[Contents—Continued from Page 4]

Valves, Slapping Exhaust, Curing.....	460
Vise, Discarded, Arbor Press Made from.....	465
Vises, Planer, Adjustable.....	462
Wallboard, Beveling Edges of.....	464
Walls, Porous, Size for.....	461
Wick Feed Oiler Made from Grease Cup.....	459
Wood, Sponging before Staining.....	454

AMATEUR MECHANICS

Anchor, Old Propeller Used as.....	479
Automobile Fan Belt, Slipping, Cure for.....	481
Automobile, Mousetrap Prevents Theft of.....	473
Battery Post, Broken, Repair for.....	473
Boat Landings and Docks, Concrete.....	467
Bobsled, Motorcycle Drives.....	474
Bolts, Safety Spring Hanger.....	484
Bottle Caps, "Metal Lath" Made from.....	471
Bottle, Corked, Used as Float.....	485
Brackets for Spare Tire.....	469
Burglar Alarm That Shoots.....	482
Camera, Box, Safety Catch for.....	474
Cards, X-Ray, Pack of.....	485
Cart, Milk, Made from Buggy Shafts.....	472
Checkerboard, Inlaid, How to Make.....	483
Chemical Crusher Made from Spoon.....	470
Coop, Brood, Adjustable Front for.....	472
Cork Extractor Made from Buttonhook.....	474
Court-Plaster, Flexible, Liquid.....	486
Drain Pipes, Forcing Obstruction from.....	471
Electric Light Fuse, "Blow Out" Remedies for.....	472
Films, Cut, Developing Holder for.....	468
Fish, Releasing Hook from Mouth of.....	479
Fishline, Spring Prevents Breaking of.....	485
Flashlight Batteries, Cheap, Satisfactory Use of.....	470
Frog Toy, Jumping.....	485
Funnel, Preventing Tipping of.....	481
Gasoline, Test for Water in.....	482
Gear Puller, Screwjack.....	481
Gears, Worm, for Toy Machinery.....	480
Glasses, Attachment for, Aids Marksman.....	469
Grain Scoop Made from Washboiler.....	469
Gun Barrel, Polishing Bore of.....	472
Headlamp, Auto, Heater Made from.....	471
Hook Pulls Straw from Stack.....	486
Kettle, Copper, Preventing Wear on.....	482
Lamps, Artistic, Vases and Drain Tile Make.....	486
Lamps, Electric, Safe for Heating Purposes.....	474
Negatives, Agitating during Development.....	471
Oilstove Wicks, Emergency.....	479
Poppun, Water.....	469
Rims, Demountable, Stopping Noise in.....	479
Scraper, Improvised, for Hardwood Floors.....	481
Screw Caps, Tight, Removing.....	469
Showcards, "Art" Glass Used as.....	471
Soil Crusher Made from Mower Wheels.....	486
Spring Spreader and Tire Remover Combined.....	484
Stairs, Making Safe for Baby.....	470
Stock at the Manger, Automatic Tie for.....	468
Switch, Dimming, for Electric Incandescent Lamp.....	484
Tanks, Soldering Holes in.....	473
Telephone, Efficient Wireless.....	475
Tires, New, Preventing Theft of.....	470
Violin, Muting.....	479
Wagon Brake, Mountain Type.....	482
Wind Vane, Wooden Sailor.....	473

Earn \$35-\$125 a Wk



Your Opportunity in MECHANICAL DENTISTRY

Ambitious men of all ages can rise above small salaried positions into this profession of unlimited possibilities.

Taught by actual practice—day or evening. Three months' course. Modern laboratories. No previous knowledge or experience required. No charge for tools or equipment. The men we train are in demand. Established 30 years. Catalog free.

Address your inquiry to Dept. 2

BODEE SCHOOLS OF MECHANICAL DENTISTRY

NEW YORK
136 W. 52 St.

PHILADELPHIA
15 1/2 and Walnut Sts.

BROOKLYN
15 Flatbush Ave.

Let These Guides

Solve Your Problems

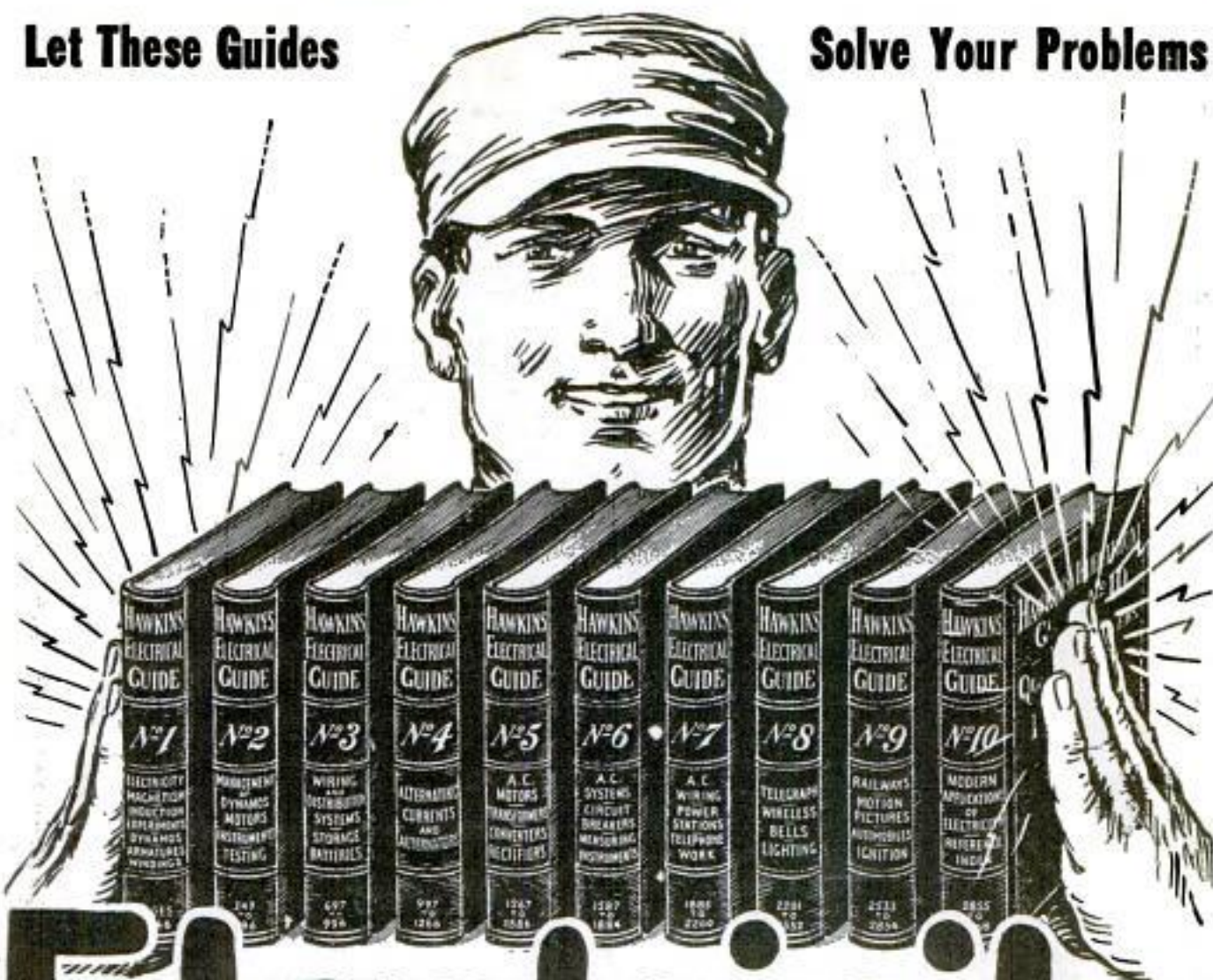

Electricity at your finger ends

HAWKINS ELECTRICAL GUIDES IN TEN VOLUMES

3500 PAGES
4700 PICTURES

\$1 A VOLUME
\$1 A MONTH

Send No Money—Send Only This Coupon

Know the facts in Electricity. They mean more money and better position for you. Hawkins Guides tell you all you need to know about Electricity. Every important electrical subject covered so you can understand it. Easy to study and apply. A complete, practical working course, in 10 volumes. Books are pocket size; flexible covers. Order a set today to look over.

LEARN ALL ABOUT

Magnetism—Induction—Experiments—Dynamoes—Electric Machinery—Motors—Armatures—Armature Windings—Installing of Dynamoes—Electrical Instrument Testing—Practical Management of Dynamoes and Motors—Distribution Systems—Wiring—Wiring Diagrams—Sign Flashers—Storage Batteries—Principles of Alternating Currents and Alternators—Alternating Current Motors—Transformers—Converters—Rectifiers—Alternating Current Systems—Circuit Breakers—Measuring Instruments—Switchboards—Wiring—Power Stations—Installing—Telephone—Telegraph—Wireless—Bells—Lighting—Railways. Also many Modern Practical Applications of Electricity and Ready Reference Index of the ten numbers.

SHIPPED FREE

Not a cent to pay until you see the books. No obligation to buy unless you are satisfied. Send Coupon now—today—and get this great help library and see if it is not worth \$100 to you—you pay \$1.00 a month for ten months or return it.

THEO. AUDEL & CO.,
72 Fifth Ave., New York City

Please submit me for free examination, HAWKINS ELECTRICAL GUIDE, (Price \$1 a number). Ship at once prepaid, the 10 numbers. If satisfactory, I agree to send you \$1 within seven days and to further mail you \$1 each month until paid.

Name

Occupation

Employed by

Home Address

Reference

PM MAR. 22

Drawing Outfit

FREE

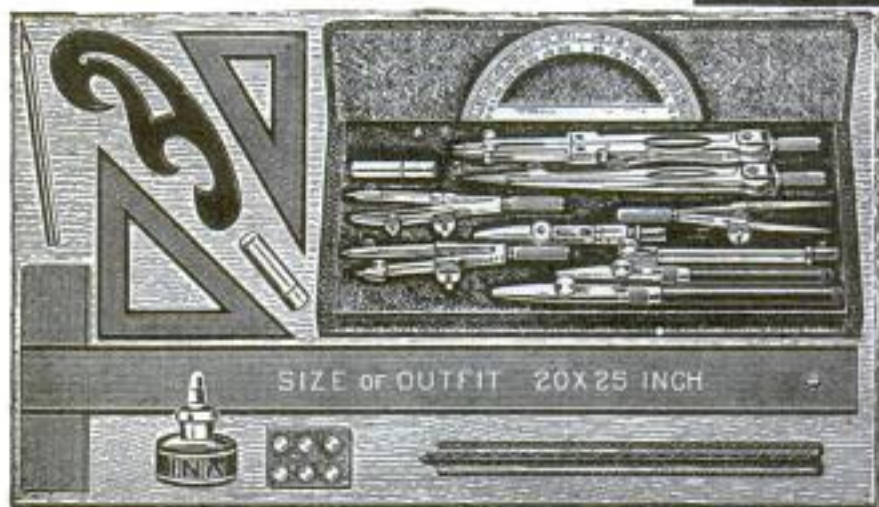

Complete Set of Drawing Instruments Delivered AT ONCE

Yes, I will give you this complete drawing outfit absolutely free. The instruments are in a handsome high class, plush lined folding case. They are regular draftsman's working instruments. Besides I will give you absolutely free, a 20 x 25 inch drawing board, a 24 inch T square, a 12 inch rule, a supply of drawing paper, two triangles, a French curve, pencils, erasers, thumb tacks, etc.

\$3600 a Year *Drafting Salary*

There is an urgent demand for skilled draftsmen. Companies are issuing calls every day for men to fill positions paying \$3600.00 a year. Work is light, pleasant and profitable.

Chief Draftsman *Will Instruct You Personally*



I am Chief Draftsman of a large and well known firm. I have been doing the highest paying expert drafting work for a quarter of a century and I know just the kind of training that is demanded from men who get the big salaries. I train you by giving you actual, practical work, the kind you must be able to do to hold permanent, big paying positions. I give you my individual instruction. If your work is right, I will advance you rapidly. If it is wrong, I will show you where and make you do it right, and do all I can to make you an expert draftsman and designer in a short time.

Write Today Without Fail!

I GUARANTEE
to train you until
you are placed in
a position paying
\$250 to \$300 a
month.

Chief Draftsman Dobe
Dept. 9353, 4001 Broadway, Chicago, Ill.

Without any obligation on me whatsoever, please, mail your book, "Successful Draftsmanship" and full particulars of your liberal "Personal Instruction" offer to a few students. It is understood that I am obligated in no way whatever.

Name.....

Address.....

Send Coupon For New Book!

Put your name and address on the coupon or a letter or a post card and send it to me today. I will send you absolutely free and post-paid, my new book "Successful Draftsmanship," and the great special offer that I am now making on which you get the complete Draftsman's Working Outfit absolutely free. You assume no obligations of any kind in sending in the coupon. Get in line for a big paying position. Getting the book and full particulars of the special offer is the first step.

Chief Draftsman Dobe
Dept. 9353 4001 Broadway Chicago, Ill.

I Teach You Piano In Half Usual Time

To persons who have not previously heard of my method, this may seem a pretty bold statement. But I will gladly convince you of its accuracy by referring you to any number of my graduates in any part of the world.

There isn't a State in the Union that doesn't contain many players of the piano or organ who obtained their training from me by mail. I have far more students than were ever before taught by one man. Investigate by writing for my 64-page free booklet, "How to Learn Piano or Organ."



My way of teaching piano or organ is **entirely different** from all others. Out of every four hours of study, one hour is spent **entirely away from the key-board**, learning something about **Harmony and The Laws of Music**. This is an awful shock to most teachers of the "old school," who still think that learning piano is solely a problem of "finger gymnastics." When you do go to the keyboard you accomplish **twice as much**, because you **understand what you are doing**. Within four lessons I enable you to play an interesting piece not only in the original key, but in all other keys as well.

I make use of every possible scientific help—many of which are **entirely unknown** to the average teacher. My patented invention, the **COLOROTONE**, sweeps away playing difficulties that have troubled students for generations. By its use Transposition—usually a "nightmare" to students—becomes easy and fascinating. With my fifth lesson I introduce another important and exclusive invention, **QUINN-DEX**. Quinn-Dex is a simple, hand operated moving-picture device, which enables you to see, right before your eyes, every movement of my hands at the keyboard. You actually see the fingers move. Instead of having to reproduce your teachers' finger movements from **MEMORY**—which cannot be always accurate—you have the correct models before you during every minute of practice. The **COLOROTONE** and **QUINN-DEX** save you months and years of wasted effort. They can be obtained only from me, and there is nothing else, anywhere, even remotely like them.

Men and women who have failed by other methods have quickly



DR. QUINN AT HIS PIANO

From the Famous Sketch by Schneider, Exhibited at the St. Louis Exposition

and easily attained success when studying with me. In all **essential** ways you are in closer touch with me than if you were studying by the oral method—yet my lessons cost you only 43 cents each—and they include all the many recent developments in scientific teaching. For the student of moderate means this method of studying is **far superior** to all others, and even for the wealthiest students there is nothing **better** at any price.

You may be certain that your progress is at all times in accord with the best musical thought of the present day, and **this makes all the difference in the world**.

My Course is endorsed by distinguished musicians, who would not recommend any course that did not maintain the highest musical standards. It is for beginners or experienced players, old or young. You advance as rapidly or as slowly as you wish. All necessary music is supplied without extra charge. A diploma is granted. Write today, without cost or obligation, for 64-page free booklet, "How to Learn Piano or Organ."



FREE BOOK COUPON

QUINN CONSERVATORY, Studio PM 43,
598 Columbia Road, Boston, 25, Mass.

Please send me, without cost or obligation, your free booklet, "How to Learn Piano or Organ," and full particulars of your Course and special reduced Tuition Offer.

Name.....

Address.....

**Marcus Lucius Quinn
Conservatory of Music**

Studio PM 43

598 COLUMBIA ROAD, BOSTON, 25, MASS.

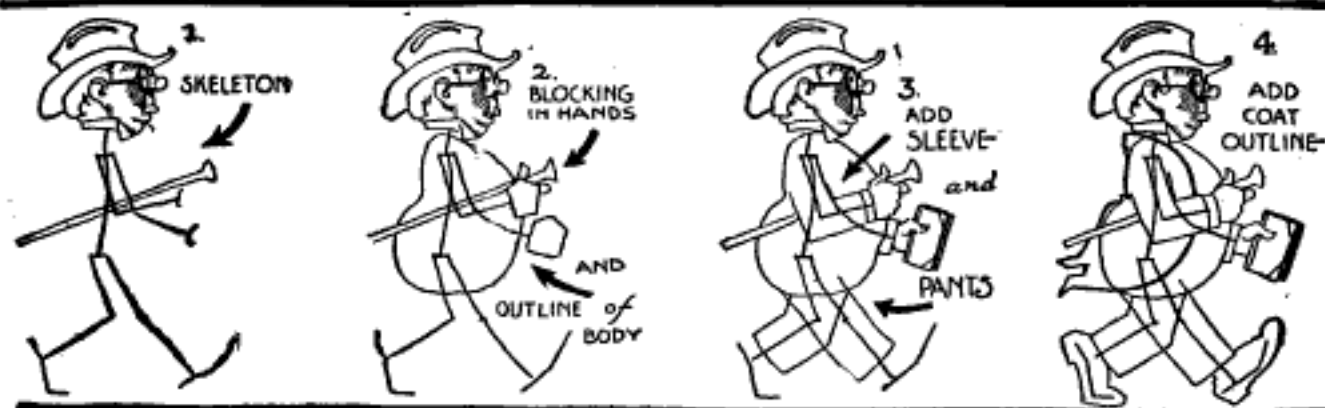

Learn Cartooning Now

THE DEMAND FOR NEW CARTOONISTS has never before been so great. Newspapers want new artists, **trained to do snappy, original work.** That is why they are employing Landon-trained cartoonists.

RESULTS PROVE MERIT. Cartoons by Landon students are appearing daily in hundreds of leading newspapers. If you like to draw, make up your mind **now** to develop your ability and quickly raise your income.

HUNDREDS OF OTHERS have made this decision and through the Landon Course have won life-long success. To-day they are the most successful and best paid of the new generation of newspaper cartoonists.

It's Easy to Learn With Landon Picture Charts

THE SKETCHES ON THIS PAGE show the practical, easy-to-understand method of teaching originated and used exclusively by the Landon School.

EACH LESSON CONTAINS several big Picture Charts, covered with series after series of sketches—clearly explaining how to draw original heads, hands, figures, animals and every subject the cartoonist must understand.

COMPLETE INSTRUCTION ON ORIGINATING cartoon ideas form another exclusive feature of this home-study course. Personal, thorough criticisms guide you at every point.

MAKE PROFITABLE USE OF YOUR SPARE TIME. Write to-day for sample Picture Chart, long list of successful students and information showing possibilities for you. **Please state your age.**

THE LANDON SCHOOL

238 National Bldg.

Cleveland, Ohio

Partial list of newspapers using Cartoons by Landon students

"NEW YORK World"
 "CHICAGO Tribune"
 "PHILADELPHIA Ledger"
 "BOSTON Herald"
 "DETROIT Times"
 "CLEVELAND Plain Dealer"
 "CINCINNATI Post"
 "ST. LOUIS Times"
 "DENVER Rocky Mountain News"
 "ROCHESTER Dem. and Chronicle"
 "ST. PAUL News"
 "SEATTLE Times"
 "LOS ANGELES Express"
 "SIOUX CITY Tribune"
 "NEW ORLEANS Item"
 "ATLANTA Journal"

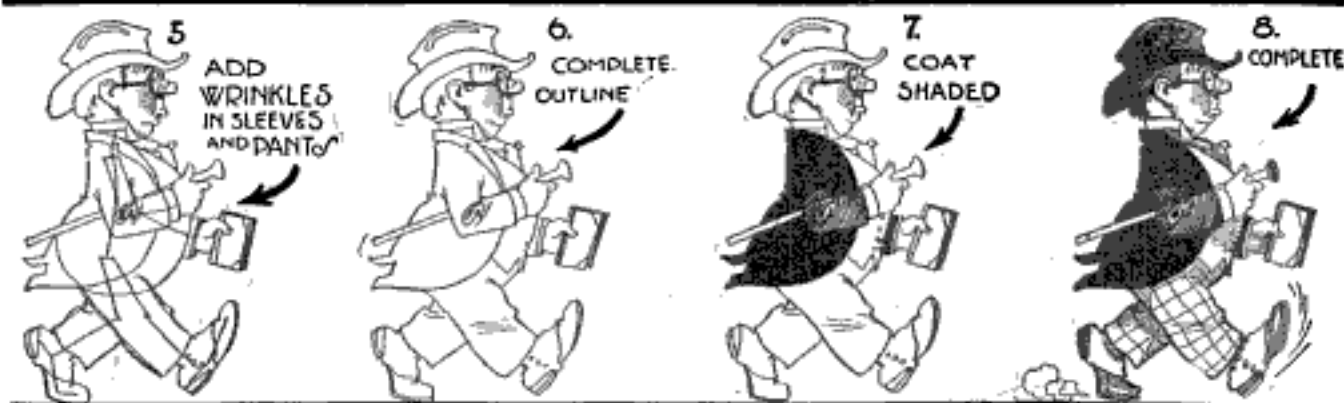

Draftsman's Complete Outfit

FREE



Everything Used by Expert Draftsmen Given You Absolutely FREE

Outfit includes "professional" complete set of fine drawing instruments with double set of compasses and dividers all in velvet lined case. Drawing board, T square, two triangles, protractor, universal curve, triangular, standard scale, water-proof ink, pens, pencils and all accessories—furnished you free in this expert's complete outfit.

Draftsmen Make \$225.00 to \$500.00 a Month

There is a tremendous demand for trained draftsmen. Now is the time to start. Draftsmen get good pay from the start and can work up to \$500 a month *and more*. Draftsmen are needed everywhere. Once you are trained you can choose your own business and work in any part of the country you please. Coyne training makes everything easy for you. Coyne student, L. T. Dubendorf, writes: "Immediately after completing Coyne course I went to work for Armour & Co. Work was easy for me. Five months later I accepted a position in New York at a large increase in salary."

3 Months' Course at School

You can qualify as an expert draftsman by 3 months' intensive training at the school in Chicago. Living cheap. Possibilities of earning way while studying. If you prefer to come to school instead of the "Home Study" course, check coupon and send it for complete information.



B. W. Cooke

President

COYNE

HOME STUDY DEPT.

TRADE & ENGINEERING SCHOOLS

Recognized Producer of Successful Men

39-51 E. Illinois St., Dept. 1773, Chicago, Ill.

Easy to Learn at Home from Great School Known all over the World

The Coyne Home Study course guarantees to train you. Remember, the Coyne Trade and Engineering Schools are recognized by educators all over the world. Students come from all over the *world* to get Coyne training. Why? Because of the Coyne school's long established, tremendous reputation for successful teaching by its great staff of experts. Coyne is not a "one man" school, but a great educational institution, 22 years old, an acknowledged leader and originator. Coyne originated the "Learn by Doing" method now endorsed by educators everywhere. Coyne has graduated thousands of successful, prosperous men all over the world. You can't make a mistake if you write for the Coyne free book. Coyne students say every minute of the course was enjoyable. Some students took *good positions three months before their course was finished.*

Send for FREE Book

Mail this coupon for our interesting book, "Drafting, the Foundation of Industry," sent you free. It explains all about the Coyne home study method and shows you how to become a draftsman in the quickest and easiest way. You want to know all about this great institution. Don't put it off. Send for this book now. It's absolutely free, no obligation. It contains the most valuable information you will ever get in your life. Send the coupon now.

Check Coupon Below and Mail Now!

**Coyne Trade and Engineering Schools,
Department 1773, 39-51 E. Illinois St., Chicago, Ill.**

Dear Sirs:—Please send me, absolutely free, without obligation, your book, "Drafting, the Foundation of Industry," also full information about the Course in Drafting. (Check which course you prefer.)

Home Study Course School Course

Name

Address

City.....State.....



A Big Raise in Salary!

Is Very Easy to Get, If You Go About It in the Right Way

You have often heard of others who have doubled and trebled their salaries in a year's time. You wondered how they did it. Was it a pull? Don't you think it. When a man is hired he gets paid for exactly what he does, there is no sentiment in business. It's preparing for the future and knowing what to do at the right time that doubles and trebles salaries.

Remember When You Were a Kid

and tried to ride a bike for the very first time? You thought that you would never learn and then—all of a sudden you knew how, and said in surprise: "Why it's a cinch if you know how." It's that way with most things, and getting a job with big money is no exception to the rule, if you know how.

We Will Show You How

Without loss to you of a single working hour we can show you a sure way to success and big pay. A large number of men in each of the positions listed are enjoying their salaries because of our help—we want to help you.

Make check on the coupon against the job you want and we will help you to get it. Write or print your name on the coupon and send it in today.

AMERICAN SCHOOL

Dept. G-374; Drexel Ave. and 58th St., Chicago

AMERICAN SCHOOL, Dept. G-374, Drexel Ave. and 58th St., Chicago, U. S. A.

I want job checked — tell me how to get it.

.....Architect.....\$5,000 to \$15,000
Building Contractor.....\$5,000 to \$10,000
Automobile Engineer.....\$4,000 to \$10,000
Automobile Repairman.....\$2,500 to \$4,000
Civil Engineer.....\$5,000 to \$15,000
Structural Engineer.....\$4,000 to \$10,000
Business Manager.....\$5,000 to \$15,000
Certified Public Accountant.....\$7,000 to \$15,000
Accountant and Auditor.....\$2,500 to \$7,000
Draftsman and Designer.....\$2,500 to \$4,000
Electrical Engineer.....\$4,000 to \$10,000
General Education.....In one year

.....Lawyer.....\$5,000 to \$15,000
Mechanical Engineer.....\$4,000 to \$10,000
Shop Superintendent.....\$3,000 to \$7,000
Employment Manager.....\$4,000 to \$10,000
Steam Engineer.....\$2,000 to \$4,000
Foreman's Course.....\$2,000 to \$4,000
Photoplay Writer.....\$2,000 to \$10,000
Sanitary Engineer.....\$2,000 to \$5,000
Telephone Engineer.....\$2,500 to \$5,000
Telegraph Engineer.....\$2,500 to \$5,000
High School Graduate.....In two years
Fire Insurance Expert.....\$3,000 to \$10,000

Name.....Address.....

ENGINEERS

JUST OUT

A \$10,000

MASTER SET

ON LATEST

ENGINEERING



AUDEL'S ENGINEERS & MECHANICS GUIDES \$12 COMPLETE

\$1 4/50 PAGES—8754 ILLUSTRATIONS—POCKET SIZE—FLEXIBLE

Every Engineer, Mechanic and Electrical Worker will welcome this "New Eight Master Set." It will prove to be a sure source of advancement and higher pay. Contain complete, up-to-date information that is thoroughly and easily explained on every branch of Modern Engineering and Electrical Practice. These new Engineers' and Mechanics' Guides answer your problems. They will help you with your daily work.

THESE BOOKS TELL YOU ALL ABOUT—

ALL Steam, UNIFLOW and POPPET VALVE ENGINES, LOCOMOBILES, Locomotive and Marine Engines; Turbines, Rotary Engines—The Indicator—Lubrication—PRACTICAL MANAGEMENT. GAS, GAS ENGINES—Aeroplanes and Aviation—Rules and Formulae. Steam Boilers; Heat-Combustion; Fuel and Flue Gas Analysis—CO₂ Recorders—Boiler Construction; Mechanical Stokers—Oil Burners—Setting—Chimneys—Mechanical Draught—BOILER DESIGN. Pipes, Fittings, Heating and Ventilation—Refrigeration—Cooling Towers—Condensers—Distilling Apparatus—Elevators—Cranes—Ropes and Cables—Splicing—Practical Electrical Engineering, covering entire field of Modern Electricity

SHIPPED TO YOU FREE Not a cent to pay until you see the books. No obligation to pay unless you are satisfied. Send coupon now—today—and get this new Master Set for Engineers and Mechanics and see if it is not worth \$100 to you. Pay only \$1 a month.

SEND NO MONEY—SEND ONLY THIS COUPON

THRO. AUDEL & CO., 72 Fifth Ave., New York City

Please submit this for Free Examination. Audel's New Eight Master Set for Engineers and Mechanics. If satisfactory I agree to send you \$1 with-
in seven days, and to further mail you \$1 each month until \$12 is paid.

Name.....
Occupation.....
Employed by.....
Home Address.....
Reference.....
P. M.
Mar. 20

\$250⁰⁰ in Prizes for Amateur Artists

Do You Like to Draw? Copy this bathing girl, and send us your drawing—perhaps you'll win first prize. This contest is for amateurs only (17 years of age or more), so do not hesitate to enter, even if you haven't had much practice.

1st Prize \$100.00
2nd Prize 50.00

3rd Prize.....\$25.00 5th Prize.....\$10.00
4th Prize..... 15.00 6th to 15th Prizes, ea. 5.00

FREE! Everyone entering a drawing in this contest will receive a beautiful full-color reproduction (suitable for framing) of a painting by a nationally known American illustrator—and also a free test lesson in drawing prepared by the Federal School faculty

If the thing you most long for is to be a real commercial artist, listen! Capable artists readily earn \$50, \$75, \$100, \$150 a week and upwards. Hundreds of ambitious young men and women have found their true work in life—often have quickly doubled and trebled their incomes—through the Federal Home-study Course, recognized by authorities as America's Foremost Course in Commercial Designing. With proper training of your ability, you, too, should succeed. By all means enter this contest—see what you can do.

Rules for Contestants

This contest open only to amateurs, 17 years old or more. Professional commercial artists and Federal students are not eligible.

Note these rules carefully.

1. Make your drawing of girl exactly 4 1/4 inches high, on paper 3 3/4 inches wide by 7 inches high.
2. Use only pencil or pen.
3. No drawings will be returned.
4. Write your name, address, age, and occupation on the back of your drawing.
5. All drawings must be received in Minneapolis by May 1st, 1922.

Drawings will be judged and prizes awarded by Faculty members of the Federal Schools, Inc. All contestants will be notified of the prize winners. Make your drawing of the girl now and send it to

Federal School of Commercial Designing

674 Federal Schools Building
Minneapolis, Minn.



The Trained Motor Mechanic Is Sitting Pretty!



F. D. Hennessy, President

You can be also if you Make Your Start in Motor Mechanics NOW

YOU step into big money when you step into the trained men's class! From then on you have a wide-open future. Thousands of Iowa State graduates, men like you, are now earning \$150 to \$400 a month and up. You can do the same, perhaps better.

Iowa State trained mechanics are always in demand. Here you learn the entire trade with all its many branches, in one course at one price. You put on overalls and learn by doing—everything about the care,

repair and operation of auto, truck, tractor, stationary gas engines and airplane mechanics. No unnecessary lectures. You work with the most modern equipment and motors, including the Liberty Motor.

Learn Big Shop Standards Thoroughly in 7 Weeks

We teach you the modern, practical Big Shop Standard methods. Our test and trouble work alone is worth the price of the entire course. No education or experience required. You work with tools—not books. Life scholarships.

Special Business Course—Your choice of a thorough business training or complete instruction in Bookkeeping and Modern Shop Records and Management as part of regular course.

Y. M. C. A. Membership. Swimming pool, Boxing, Wrestling, Library, etc. No extra charge.

"The
Quality
School"



Big Free Book

tells all about the opportunities in Motor Mechanics and our big shop standards of instruction. Plan now to earn bigger pay—write today.

"The Quality School"



F. D.
HENNESSY,
President and Manager,
IOWA STATE AUTO,
TRACTOR & ELECTRICAL
SCHOOL,

739 Nebraska Street, Sioux City, Iowa.

Please send me your big FREE illustrated book.

Name.....

Address.....

Town..... State.....



LEARN BY DOING

Every phase of all branches of
ELECTRICITY

Taught by Actual Practice

In America's foremost and oldest institution for trade training.

**No Books Used
Individual Instruction
Start Any Day**

A SPECIAL and SEPARATE Course in Ignition, Auto Lighting and STARTER Systems. Write for FREE 64-page catalog.

THE NEW YORK ELECTRICAL SCHOOL
44 West 17th Street. NEW YORK CITY

Learn Photography at HOME

Make \$75.00 a Week on the Side

Establish yourself as a Photographic Expert quickly—during your spare time—under a leading photographer. I'll show you how to start your own business—or command a large salary. Send for my unusual offer—it's only temporary. Act at once. A postal will do. H. Dupont, Pres. INTERNATIONAL STUDIOS
Dept. 37 4451 N. Robey St., Chicago, Ill.



DANCE WELL! Why be a Wallflower?

No need of envying good dancers. Arthur Murray, America's greatest dancing teacher, has invented a new method which enables any one to learn the newest steps in a few hours at home. No music or partner needed. Success positively guaranteed. "60,000 have learned to dance, by mail."

FREE To prove that you can learn easily and quickly, Arthur Murray will send you free of charge, two dancing lessons. To cover postage, handling, etc., send 25c. Write today.

Arthur Murray, Studio 104, 290 Broadway, New York



\$215 In One Day

Bentley of Philadelphia made that. Hundreds making fortunes, too, with **Oliver Oil-Gas Burner**. Heats at turn of valve. No coal or wood. Fits any stove. Burns 95% air, 5% kerosene. 1 minute to demonstrate. Sells big all seasons. No wonder agents clean up.

AGENTS! Write for exclusive territory and Special Offer at once.

Big money in spare time also. **OLIVER OIL-GAS BURNER & MACHINE COMPANY, 2048-O Pine Street, St. Louis, Mo.**



"BECOME A LIGHTNING TRICK CARTOONIST"

MAKE MONEY CHALK TALKING. SEND \$1.00 FOR SHARPLY PROGRAM OF TRICK DRAWINGS WITH INSTRUCTIONS BY A PROFESSIONAL CARTOONIST. SATISFACTION GUARANTEED. CIRCULAR FREE. BALDA ART SERVICE, Q1, OSHKOSH, WIS.

\$5,000 SALARIES

are often paid to traffic managers. Numberless traffic positions pay \$2,500 to \$5,000 per year. Millions of dollars are wasted annually because of ignorance of cheaper ways to ship. You can be a traffic expert—stop losses—make big money for yourself. Thousands of men now needed.

Learn at Home—Book Free

New home study Actual Practice Method will quickly make you a Certified Traffic Manager. You can very soon qualify for a splendid traffic position. Write quick for big new illustrated book describing this wonderful training in detail. Write today. Address

American Commerce Association Dept. 103, 4043 Drexel Blvd. CHICAGO, ILL.



FREE BOOK ON BANKING

Tells of the great opportunities in this attractive profession, and how you can learn by mail in spare time. Send for copy at once. No obligations. EDGAR G. ALCUIN, Pres.

AMERICAN SCHOOL OF FINANCE, 90 McLane Bldg., Columbus, O.

"THERE'S MONEY IN IT"

AT HOME LEARN TELEGRAPHY AT HOME MORSE AND WIRELESS

TEACH YOURSELF in half usual time, at trifling cost, with the wonderful Automatic Transmitter **THE OMNIGRAPH**. Sends unlimited Morse or Continental messages, at any speed, just as an expert operator would. Adopted by U. S. Government, and leading Universities, Colleges and Telegraph Schools. 3 styles. Catalog free.
OMNIGRAPH MFG. CO. 26 D Cortlandt Street; NEW YORK



It's a Shame for *You* Not to Earn \$10,000 a Year

-When Others Do It So Easily



He Does It

"Last week my earnings amounted to \$534.37; this week will go over \$400."—F. Wynn, Portland, Oregon.

WHEN a farmhand steps from \$50 to \$1,000 a month—when a fireman jumps from \$60 a month to a job paying him \$500 for two weeks' work—when a former railway mail clerk at a yearly salary of \$1,600 changes his job and earns \$1,000 in thirty days—and when hundreds of others quickly jump from small pay to magnificent earnings in the same way—then it's a shame for you not to earn your \$10,000 a year.

There is nothing exceptional about these men. They'd tell you that themselves. Many had been clerks, bookkeepers, mechanics. Some had been policemen, farmhands, firemen. And then in one swift stroke, they found themselves making more money than

they had ever dreamed possible. The grind of routine work—the constant struggle to obtain even a small increase—all this was left behind. Today they know the thrill of independence; they are no longer ruled by an office clock. There is genuine enjoyment in every hour of the day, for their work is filled with real fascination. They have found not only the most interesting, but the best paying branch of all business.

A field that they had never dreamed of as theirs they found to be easy and uncrowded. Earnings that they had always hoped to reach were right there in this new field waiting for them. Hundreds have found this new easy way to \$10,000 a year. You can too—let us tell you how.



So Does He

"I had never earned more than \$60 a month. Last week I cleared \$306 and this week \$218."—George W. Kearns, Oklahoma City, Okla.

What these men have done, hundreds of others have done, hundreds are doing today, hundreds will do tomorrow. And you may be one of them! For now the same opportunity that put these men into the big money class is open to you.

In the first place they discovered a vital fact about business. They discovered that the big money is in the selling end of business. In the second place they discovered a new and amazingly easy way that will make any man a salesman, no matter what job he held before.

Salesmen are the very life blood of any concern—upon them depends the amount of profits made. No wonder that man for man Salesmen receive the highest pay. For the men who are in the "Star" class—who are Masters of Salesmanship—there is practically no limit to their earnings. Some receive almost fabulous amounts. And that is how these men and hundreds of others

like them have found the way to their present handsome incomes.

They are all Master Salesmen Now!

Yet previously they had no idea of becoming Salesmen. If you had told them success awaited them in the field of Selling, they would have laughed at you. They would have told you that it was absurd to think of it—for they had never sold a dime's worth of goods in their lives! Then they learned of a great organization of top-notch Salesmen and Sales Managers formed for the express purpose of fitting men for the great opportunities in the field of Salesmanship and to help them to positions in the lines that most appeal to them. Step by step—in their spare time at home—this great organization, The National Salesmen's Training Association—took them thru every phase of selling. Then as soon as they were qualified and ready, the Free Employment Service of this Association helped them secure good selling positions. Almost before they realized it they were in the big money class.

And He—

"The very first month I earned \$1000. I was formerly a farmhand."—Charles Berry, Winter-set, Iowa.



FREE BOOK

The same opportunity that has brought hundreds of others their good fortune is open to you. Whether or not you have ever thought of becoming a Salesman, you should examine the facts about the tremendous possibilities for big earnings in this fascinating field. This will not cost you a penny and places you under no obligation. It simply means

Starts You for YOUR \$10,000-a-Year!

National Salesmen's Training Association
Dept. 12-C, Chicago, Ill.

I simply want to see the facts. Send me FREE your Book on Salesmanship and Proof that I can become a Master Salesman. Also send list of lines with openings for Salesmen.

Name.....

Address.....

City.....

State.....

And He—

"After spending ten years in the railway mail service at salaries ranging from \$900 to \$1800 a year, I decided it was necessary for me to make a change. My earnings during the past thirty days were more than \$1000."—W. Hartle, Chicago.



that you will receive, entirely free, a remarkable illustrated book, "The Knight of the Grip," and the personal stories of men in every part of the country who today are enjoying splendid success and earning five, ten and fifteen times as much money as ever before. Make a start now for your \$10,000 Year. Mail coupon at once to The National Salesmen's Training Association, Dept. 12-C, Chicago, Ill.



The Boy Who Likes Mechanical Things

will find a simply corking fine bunch of ideas and suggestions every month in **THE AMERICAN BOY**.

He can turn to the monthly page "For the Boys to Make" and find descriptions—with illustrations and full instructions of just the things a boy can make in wood.

On the "Novel Inventions and Natural Wonders" page he will find photographs of all sorts of odd and interesting mechanical devices and machines.

The "How to Do It" column gives new and useful little kinks on simple and clever mechanical ways to do things.

He will find practical information and suggestions for his amateur radio work, by Armstrong Perry, a recognized authority on wireless.

The articles on science tell the most curious and fascinating facts about how and why things act.

Reading the splendid fiction stories, he will actually live in factories, engine rooms, radio shacks and inventors' laboratories; learning a surprising lot about the mechanical side of making things go whether they be shops, ships or machines.

A year's subscription to **THE AMERICAN BOY** now costs only \$2.00. Single copies are 20 cents at news-stands. Subscribe for a year or leave a standing order with your news-dealer.

The American Boy
The Largest, Brightest, Best Magazine for Boys in All the World

THE SPRAGUE PUBLISHING CO.
No. 372 American Bldg., Detroit, Mich.

Herewith find \$2.00. Please send **THE AMERICAN BOY** for one year, beginning with the current issue, to

Name.....

Address.....

BE A RAILWAY TRAFFIC INSPECTOR

MEN WANTED! POSITION GUARANTEED
Earn Up to \$250 per Month, Expenses Paid

Big demand for trained men in this fascinating, new profession. Many splendid opportunities thru contact with railway officials. Travel or remain near home. Pleasant, healthful, out-door work.

Start at \$110 per Month

with expenses paid. Prepare in three months' spare-time study at home. Any average man can easily qualify.

POSITION GUARANTEED

If, after completing preparation, we do not secure for you a position paying at least \$110 a month and expenses, we refund your enrollment fee in full. **YOU TAKE NO RISK.** Don't delay—investigate now. Send for free booklet No. D5822 today.

STANDARD BUSINESS TRAINING INST.
BUFFALO, N. Y.



UNCLE SAM WANTS YOU



Get a U. S. Government Job
\$95 to \$195 a Month

Rapid advancement to higher Government Positions. No "Layoffs" because of STRIKES, POOR BUSINESS or THE WHIMS OF SOME PETTY BOSS. **THE POSITION IS YOURS FOR LIFE.** Country residents and city residents stand the same chance for immediate appointment. Common sense education sufficient.

SEND COUPON

Write immediately for full list of many positions now easily obtainable. Don't delay. Every day you lose means the loss of just so much chance of early appointment.

FREE COACHING COUPON

FRANKLIN INSTITUTE,
Dept. A179, Rochester, N. Y.

This coupon, filled out as directed, entitles the sender to free specimen questions; a free copy of our book, "Government Positions and How to Get them;" a list of Government positions now open, and to consideration for Free Coaching for the examination here checked.

.. Railway Mail Clerk (\$1600 to \$2300) .. Postoffice Carrier (\$1400 to \$1800)
.. Bookkeeper (\$1240 to \$1440) .. Rural Mail Carrier (\$ 720 to \$2600)
.. Postoffice Clerk (\$1400 to \$1800) .. Customs Positions (\$1100 to \$2000)

Name.....

Address.....

Use this before you lose it. Write plainly.

How "Modest Jim" Won the \$50 Prize

By WILLIAM LAWRENCE

Author of "The Awakening"

"YES—I remember why they call the Big Boss 'Modest Jim,'" said the Old Timer. "It started way back twenty years ago.

"I was in my third apprentice year when Jim Hadley came to work here—a quiet, bashful boy. His father had died and he was forced to leave grammar school and go to work.

"He was never among the groups of boys dodging the boss or watching the clock nor mixed up in anything that wasn't strictly business. And he never fooled away his time with the bunch after hours, so we left him pretty much to himself. We called him 'Modest Jim.'

"One day Old Man Adams, who owned this outfit in those days, came out into the shop and tacked up a sign over the foreman's desk.

"It seemed that the Old Man and his designer had run into a stone wall or what was Greek to most of us kids those days, and was offering a prize of fifty dollars to anyone who solved the problem. He must have been up against it or he never would have asked our bunch for help.

"About two weeks later, after the rest of us had forgotten all about it, the Old Man rushed out to Jim and fairly pushed five crisp ten dollar bills into his hand. He had solved the problem.

"When the foreman asked him how he did it, he replied, 'Oh, it wasn't anything great. Only a fresh brain on a stale subject.' That's all he ever said about it. But do you know what that boy had been doing? He'd been studying with the International Correspondence Schools in his spare time. No wonder he got ahead!

"And he went right up, and up and up, until today he is the Big Boss. And the rest of us are just about where we started. He's still 'Modest Jim,' but he's earning five times as much as I am.

"Take my advice, lad, and follow along in Jim's footsteps. Don't wait until it's too late to get the special training that is so essential to success."

Employers everywhere are looking for men like "Modest Jim"—men who want to get ahead—who are willing to devote a part of their spare time to training for advancement.

How much longer are you going to wait before taking the step that is bound to bring you a better job and more money?



Isn't it better to make your start now than to wait a year or five years and then wish you had? It certainly is!

No matter where you live, the I. C. S. will come to you. No matter what your handicaps or how small your means, we have a plan to meet your circumstances. No matter how limited your previous education, the simply-written, wonderfully-illustrated I. C. S. lessons make it easy to learn. No matter what career you may choose, some one of the 300 I. C. S. courses will surely suit your needs.

This is all we ask: Without cost, without obligating yourself in any way, put it up to us to prove how we can help you. Just mark and mail this coupon.

TEAR OUT HERE

INTERNATIONAL CORRESPONDENCE SCHOOLS
BOX 5608-C SCRANTON, PA.

Without cost or obligation please explain how I can qualify for the position, or in the subject before which I have marked an X in the list below:

- | | |
|---|---|
| <input type="checkbox"/> ELECTRICAL ENGINEER | <input type="checkbox"/> BUSINESS MANAGEMENT |
| <input type="checkbox"/> Electric Lighting & Railways | <input type="checkbox"/> SALESMANSHIP |
| <input type="checkbox"/> Electric Wiring | <input type="checkbox"/> ADVERTISING |
| <input type="checkbox"/> Telegraph Engineer | <input type="checkbox"/> Show Card & Sign Ptg. |
| <input type="checkbox"/> Telephone Work | <input type="checkbox"/> Railroad Positions |
| <input type="checkbox"/> MECHANICAL ENGINEER | <input type="checkbox"/> ILLUSTRATING |
| <input type="checkbox"/> Mechanical Draftsman | <input type="checkbox"/> Cartooning |
| <input type="checkbox"/> Machine Shop Practice | <input type="checkbox"/> Private Secretary |
| <input type="checkbox"/> Toolmaker | <input type="checkbox"/> Business Correspondent |
| <input type="checkbox"/> Gas Engine Operating | <input type="checkbox"/> BOOKKEEPER |
| <input type="checkbox"/> CIVIL ENGINEER | <input type="checkbox"/> Stenographer & Typist |
| <input type="checkbox"/> Surveying and Mapping | <input type="checkbox"/> Certified Public Accountant |
| <input type="checkbox"/> MINE FOREMAN or ENGR. | <input type="checkbox"/> TRAFFIC MANAGER |
| <input type="checkbox"/> STATIONARY ENGINEER | <input type="checkbox"/> Railway Accountant |
| <input type="checkbox"/> Marine Engineer | <input type="checkbox"/> Commercial Law |
| <input type="checkbox"/> ARCHITECT | <input type="checkbox"/> GOOD ENGLISH |
| <input type="checkbox"/> Contractor and Builder | <input type="checkbox"/> Common School Subjects |
| <input type="checkbox"/> Architectural Draftsman | <input type="checkbox"/> CIVIL SERVICE |
| <input type="checkbox"/> Concrete Builder | <input type="checkbox"/> Railway Mail Clerk |
| <input type="checkbox"/> Structural Engineer | <input type="checkbox"/> AUTOMOBILES |
| <input type="checkbox"/> PLUMBING & HEATING | <input type="checkbox"/> Mathematics |
| <input type="checkbox"/> Sheet Metal Worker | <input type="checkbox"/> Navigation |
| <input type="checkbox"/> Textile Overseer or Supt. | <input type="checkbox"/> AGRICULTURE |
| <input type="checkbox"/> CHEMIST | <input type="checkbox"/> Poultry Raising <input type="checkbox"/> Spanish |
| <input type="checkbox"/> Pharmacy | <input type="checkbox"/> BANKING <input type="checkbox"/> Teacher |

Name.....

Street and No.....

City..... State.....

Occupation.....

Do You Like to Draw?

Here Is a Simple, Easy Way
to Draw a Comic Face

TRY IT



Make a square with pencil, then add to it with pencil as shown in the small squares above. Erase all pencil guide lines after the drawing is completed.

We will not give you any "grand prize," if you draw this picture. Nor will we claim to make you "rich in a week." But if you are anxious to develop your talent with a **successful cartoonist**, so you can **make money**, send a copy of this picture with six cents in stamps for portfolio of cartoons and sample lesson plate, and let us explain more in detail. Some of the **most successful cartoonists** are former students of this school. It is not hard to learn to draw **originals** when you are shown how in a **practical way**.



THE W. L. EVANS SCHOOL OF CARTOONING
"The School That Has the Reputation"
821 Leader Bldg. CLEVELAND, OHIO

GET INTO Advertising!

LEARN BY MAIL

ADVERTISING principles are grasped quickly as we teach them. Our course will open big opportunities for you in the best paying field in the business world. Start now!

Some New Features

Our 27th year; course improved, enlarged, faculty increased for 1922. Students now receive instruction in Modern Business Organization. Complete working outfit free with first lessons.

FREE! This book tells you all about advertising and the course which any advertising man will tell you is the best. Pictures of advertising stars—some of their work in colors—what graduates are doing—prices, terms, etc. **WRITE!**

PAGE-DAVIS SCHOOL
Dept. A-15 Page Bldg. Chicago

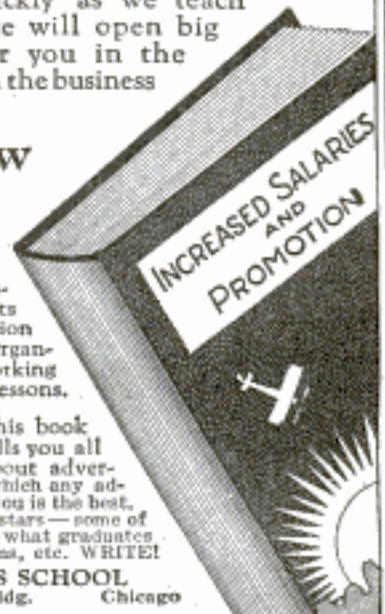

STAMMER

If you stammer attend no stammering school if you get my large FREE book entitled "STAMMERING, Its Origin and the Advanced Natural Method of Cure," bound in cloth and stamped in pure gold. Ask for special: union rate and a FREE copy of "The Natural Speech Magazine." Largest, best equipped and most successful school in the world for the cure of stammering, stuttering, etc. No sing-song or time beat. Write today. The North-Western School, 2317 Grand Ave., Milwaukee, Wis.



WANTED
U. S. RAILWAY MAIL CLERKS
\$1600 to \$2300 Yearly Work 15 days monthly—paid full time. Travel Free. Hotel expense allowance. No experience required. All men and women over 17, should mail coupon below, NOW.

C. J. Ozment, Dept. 111
St. Louis, Mo.

You may send me Free, prepaid, personally prepared instructions how I may quickly secure Railway Mail Clerk and other Government Positions.

NAME _____

ADDRESS _____



Learn In the Great Shops of COYNE

Electricity Will Pay You Up to \$400 a Month and More

Only the trained man gets the big pay. Make your mind right now to be one. Get your training in the best paying of all the professions—Electricity. You can learn Electricity in the Great Shops of Coyne in 3 1-2 months. Then you can go out and command from \$150 to \$400 and more. When you graduate from Coyne in 98 days you can enter any of a dozen or more lines of work—power house operating, telephony, railway signal work, house wiring, electric sign work, motor maintenance, automobile and battery work, street railway service, etc., and earn big money and quick advancement.

YOU CAN DO THE SAME

Read These Letters



"Now the same man is my helper; my pay is bigger than his. He had been in the shop 2 years, but I'm a Coyne Man."—M. E. K.



"Eight years ago my time card read 'Laborer—\$1.50 a day.' Today my business turnover runs into thousands of dollars."—J. C. M.



"I'm taking care of generators and switchboards at Edison's, earning \$240 a month, thanks to Coyne."—D. O.

EARN WHILE YOU LEARN

You don't need to wait until you have saved up all the money you need to get this Electrical education. Our Welfare Department will help you get a part-time job at which you can earn money to help pay your way.

Auto, Truck and Tractor Course Included

If you enroll within a limited time you can get the full course in Automobile, Truck and Tractor Electricity without paying a cent above the cost of the Practical Electrical Engineering Course. **This course can be taken separately if desired** (on another page); if so desired state so when writing us. This is the finest course in America. The equipment is complete in every detail, and you get your instruction under experts in this branch of electricity.

We Train You in Business

We want every one of our graduates to succeed in a big way. If you enroll within a limited time, we give you, free, a full course in Business Management. You take this course at the same time you take the others. You learn how to manage a business and make money out of it, regardless of whether you work for others or go into business for yourself. This training, with that in Practical Electrical Engineering, and in Automobile Electricity opens the way to get into a big paying business of your own—you learn wiring, ignition, lighting and starting systems of all cars, trucks and tractors; you learn how to make and repair batteries. You can, like thousands of our men, earn big money in a business of your own—as Electrical Contractors, Auto-Electricians, in Garages and Service Stations, as Armature Winders, Electrical Supply Dealers and as Battery Experts. The field is nation wide and there is a wonderful opportunity for big earnings.

Get Started Now

Learn Electricity. Make big money. Be somebody. Make good and get real pleasure and satisfaction out of life. Own your own car and home and be independent. You can do it. It's easy if you get the right start. Filling out the coupon tonight starts you right. If you never do anything you'll never get anywhere. Will you? Write for full particulars. You will want to reserve the right to get the free courses. **GET YOUR LETTER OFF TONIGHT!**



B.W. COOKE PRESIDENT

BENNETT W. COOKE, President
Coyne Trade and Engineering Schools
Dept. 13, 39-51 E. Illinois St., Chicago, Illinois

COYNE

TRADE AND ENGINEERING SCHOOL

Dept. 13, 39-51 E. Illinois Street, Chicago, Ill.

SEND COUPON TODAY

Gentlemen! Send me your big free catalog with full particulars concerning your Electrical course and how I may secure your course of Auto Truck and Tractor Electricity and the course in Business Management, free. This places me under no obligation whatsoever. I am interested in

Auto Electricity Course,
 Prac. Electricity and Auto Elec. Course.

Name.....
Address.....



\$95 An Hour!

"Every hour I spent on my I. C. S. Course has been worth \$95 to me! My position, my \$5,000 a year income, my home, my family's happiness—I owe it all to my spare time training with the International Correspondence Schools!"

Every mail brings letters from some of the two million I. C. S. students telling of promotions or increases in salary as the rewards of spare time study.

What are *you* doing with the hours after supper? Can you afford to let them slip by unimproved when you can easily make them mean so much? One hour a day spent with the I. C. S. will prepare you for the position you want in the work you like best. Yes, it will! Put it up to *us* to prove it. Mark and mail this coupon *now!*

TEAR OUT HERE

INTERNATIONAL CORRESPONDENCE SCHOOLS
BOX 5615-C SCRANTON, PA.

Without cost or obligation please explain how I can qualify for the position, or in the subject before which I have marked an X in the list below:

- ELECTRICAL ENGINEER
- Electric Lighting & Railways
- Electric Wiring
- Telegraph Engineer
- Telephone Work
- MECHANICAL ENGINEER
- Mechanical Draftsman
- Machine Shop Practice
- Toolmaker
- Gas Engine Operating
- CIVIL ENGINEER
- Surveying and Mapping
- MINE FOREMAN or ENG'R
- STATIONARY ENGINEER
- Marine Engineer
- ARCHITECT
- Contractor and Builder
- Architectural Draftsman
- Concrete Builder
- Structural Engineer
- PLUMBING & HEATING
- Sheet Metal Worker
- Textile Overseer or Supt.
- CHEMIST
- Pharmacy

- BUSINESS MANAGER
- SALESMANSHIP
- ADVERTISING
- Show Card & Sign Ptg.
- Railroad Positions
- ILLUSTRATING
- Cartooning
- Private Secretary
- Business Correspondent
- BOOKKEEPER
- Stenographer & Typist
- Certified Public Accountant
- TRAFFIC MANAGER
- Railway Accountant
- Commercial Law
- GOOD ENGLISH
- Common School Subjects
- CIVIL SERVICE
- Railway Mail Clerk
- AUTOMOBILES
- Mathematics
- Navigation
- AGRICULTURE
- Poultry Raising
- BANKING
- Spanish Teacher

Name..... 7-1-21

Street and No.....

City..... State.....

Occupation.....

FONTAINE FOX-

Makes More Than
\$200 A DAY



for six drawings a week—more than \$80,000 a year. Briggs, Smith, Darling and many others get immense incomes from simple cartooning and illustrating ideas.

These men and more than 60 others of America's leading illustrators and cartoonists comprise the Federal Staff.

If you have talent for drawing, capitalize your ability. Make it earn big money for you. Be successful by learning drawing from artists who have achieved fame and fortune.

SEND FOR OUR FREE BOOKLET—"A Road to Bigger Things." Read of opportunities in the art world. Learn how you can qualify. Your name, address and age together with 6c in stamps to cover postage, will bring this book.

Federal Schools, Inc.

303 Federal Schools Bldg. Minneapolis, Minnesota



HOW TO BECOME A PROFESSIONAL PHOTOGRAPHER

Earning \$35 to \$125 a Week

An interesting illustrated booklet (free) on choosing a vocation, the exceptional opportunities Photography offers you and how to avail yourself of these advantages.

Motion Picture—Commercial—Portraiture

Three to six months' course. Practical instruction. Modern equipment. Day or evening classes. Easy terms. Call or write for Catalog No. 49.

N. Y. INSTITUTE OF PHOTOGRAPHY
141 W. 36th St., N. Y. or 505 State St., Brooklyn

LEARN WATCH REPAIRING

Be a watchmaker—you can learn this profitable trade by correspondence in a few weeks in your own home by the DeSelms Chart System. After you complete the course you will know a watch from A to Z. You will know just what the matter is and how to repair one. When you graduate you will be a practical watchmaker and repairer and competent to fill any position. Positions for our graduates.

Ask for our Free Book. It explains our system and terms.
THE DeSELMS WATCH SCHOOL
23 Perry Street ATTICA, INDIANA



"STAMMERING Its Cause and Cure"

You can be quickly cured if you stammer. Send 10 cents, coin or stamps, for 288 page cloth bound book on Stammering and Stuttering. It tells how I cured myself after Stammering and Stuttering for 20 years. BENJAMIN N. BOGUE
738 Bogue Building, 1147 N. 111. St. Indianapolis

LAW In Your Spare Time At Home for BUSINESS or PROFESSION

Degree of LL.B., Conferred. Only Institution which gives same Course by Correspondence through Lecture System as was given for years at resident classes of this college. We coach you free to pass the Bar Examination. Complete 1931, 16-volume library. Easy terms. Organized 1919. Low enrollment fee. Write for free book.
Hamilton College of Law, 431 S. Dearborn St., Dept. 63, Chicago



How Would This Man's Pay-Check Look to YOU?

Pay-day!

Out in the main office the clerks have just received their slender envelopes. They thumb the contents quickly. Not hard to count, you know; for not a man in the lot draws more than forty dollars a week.

Meanwhile in his spacious office, Blakeley writes his name on the back of a slip of paper and hands it to his secretary. "Will you please deposit this to my account," says he.

Blakeley's check is sizeable.

"Easy money," says one clerk to another. They recall that only a few months ago Blakeley was working at a desk alongside theirs. That was before he was chosen Manager of the Department.

They forget that for nearly a year Blakeley has been devoting several evenings a week to *specialized business training*.

In his spare time he has been steadily equipping himself for bigger responsibilities—

And now by a law as fundamental and as universal as the law of gravitation, *he has won promotion*.

How You Can Win Promotion

On which side of the partition is *your* desk?

Are you sitting out among the routine clerks while other men, with no greater *natural* ability than you, are moving into private offices of their own, and receiving checks that range from \$100 to \$200 or more a week?

If you *are*, you are blinding yourself to opportunity—

For there absolutely is a swift, short cut to promotion—if you will do the work!

Swift Advancement by the Problem Method

During the past twelve years thousands of LaSalle-trained men have *taken* this quicker route—and have *arrived*. Writes R. A. Warner, of Harrisburg, Pa.

"At the time I enrolled with LaSalle I was operating an addressing machine for a local concern, with absolutely no chance to forge ahead. I decided to take advantage of your course in Business Management and also Higher Accountancy. As a result, this training has taken me from the \$65-a-month class in 1915 to a present earning power (in 1923) of over \$7,000 a year. Without a question, LaSalle Extension University has been the direct cause of my present success."

Other men—and the files of LaSalle Extension University are overflowing with their letters—give equally gratifying accounts of their success thru home-study training under the

LaSalle "Problem Method." Not a day goes by but what many statements such as the following from LaSalle-trained men are brought to light in the morning's mail:

"Three years ago I was occupying a bookkeeper's high stool and drawing \$1,100; today, I am comptroller of a good-sized corporation, with a salary to start of \$4,500."

"Passed the bar examination, with second highest honors in a class of 71."

"Now Service Manager, with 400 per cent increase."

"The Problem Method increased my income \$2,500 a year."

"The most efficient and most rapidly promoted men in our whole organization are LaSalle-trained."

Send the Coupon

Why waste your most productive years while you wait for "experience," in its slow, haphazard way, to provide promotion? You have ambition—and the fixed determination to achieve success. LaSalle has the training that will speed your progress.

Below is a coupon that will bring you full information, show you just how *other* men are winning bigger incomes. With this information we will send you particulars of our *convenient-payment plan*; also your free copy of that inspiring book, "Ten Years' Promotion in One."

Make TODAY your starting point toward big success by marking, signing and mailing the coupon NOW.

LaSalle Extension University

The Largest Business Training Institution in the World

Dept. 364-R Chicago, Ill.

Please send me catalog and full information regarding the course and service I have marked with an X below. Also a copy of your book, "Ten Years' Promotion in One," all without obligation to me.

- | | |
|--|--|
| <input type="checkbox"/> Business Management | <input type="checkbox"/> Modern Business Correspondence and Practice |
| <input type="checkbox"/> Higher Accountancy | <input type="checkbox"/> Modern Foremanship and Production Methods |
| <input type="checkbox"/> Traffic Management—Foreign and Domestic | <input type="checkbox"/> Personnel and Employment Management |
| <input type="checkbox"/> Railway Accounting and Station Management | <input type="checkbox"/> Expert Bookkeeping |
| <input type="checkbox"/> Law—Degree of LL. B. | <input type="checkbox"/> Business English |
| <input type="checkbox"/> Commercial Law | <input type="checkbox"/> Commercial Spanish |
| <input type="checkbox"/> Industrial Management | <input type="checkbox"/> Effective Speaking |
| <input type="checkbox"/> Efficiency | <input type="checkbox"/> C. P. A. Coaching |
| <input type="checkbox"/> Banking and Finance | |



Name

Present Position

Address



GARAGE



MOTOR REPAIRING



ELECTRIC SERVICE



BATTERY

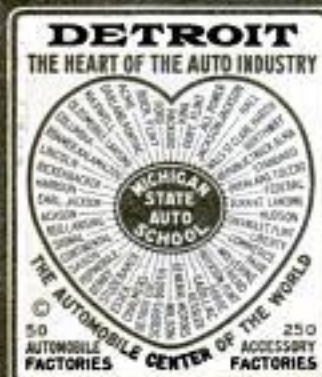

These Jobs Pay A Better

Read What Factories Say:

CADILLAC MOTOR CAR COMPANY

CADILLAC BUILDING CASE AVENUE AT YORK STREET

"We believe you have the best and most complete school of its kind in the country."



BUICK MOTOR COMPANY

"We believe the MICHIGAN STATE AUTO SCHOOL, Detroit, would best meet your requirements, as its course of technical training is most thorough and complete in every detail."

THE STUDEBAKER CORPORATION OF AMERICA

"We do not know of a better automobile school than the MICHIGAN STATE."



HUDSON MOTOR CAR COMPANY

DETROIT, MICH., U.S.A.

"This school is thought very highly of by the automobile men of Detroit, and is considered one of the best equipped and most efficient schools in the country. You will make no mistake in attending the M. S. A. S."

Get into the automobile business to make big money. No limit for trained men. 10 million autos, trucks, tractors now in use. All need repairing, overhauling—millions to be rebuilt. Motorists must economize—make their cars last twice as long. 50 million tires to be re-treaded, put into longer use. Millions of batteries must be replaced. Right now this spells the greatest money-making opportunity in the world for ambitious, red-blooded, "go-getting" men.

No Experience Necessary

Make a start—that's the thing! In a few short weeks, under guaranteed training, you can become a first-class, all-around, practical auto and tractor mechanic, capable of filling a garage job at bigger pay. Or, you can quickly become an Auto Electrician, and double your earnings. You can go into business for yourself—start a garage—electric service station—tire repair shop—battery station—or welding shop. You can sell cars, trucks, tractors, farm-lighting systems or engines. It's a great business—a certain money-making future.

You, Too, Can Succeed!

You have the ambition—you want success. Success is certain if you are willing to work for it. You can have independence—be your own boss—stop the plodding, get into work you like. Earn big money, be prosperous, happy and independent. You can do it just as well, or better, perhaps, than Ed. Wamhof, who writes: "I now have charge of a garage and average \$350 to \$375 a month." Thousands of similar successes. Records seem amazing, but they are only ordinary. It is all done through head and hand training at the M. S. A. S. Decide now to give yourself the training that will pay you big, and establish you in a successful life work.

Come to Detroit--The Auto Center

To the School in the Heart of the Automobile Business

Come to Detroit, to the MICHIGAN STATE AUTO SCHOOL. This is the way to get started right, up the ladder of success. Detroit, the automobile center, in the heart of the industry, is the logical place to learn the auto trade. Here a nickel car fare will take you to the great FORD plants, or the PACKARD, the CADILLAC, the HUDSON,

ESSEX, HUPMOBILE, CHALMERS, PAIGE, STUDEBAKER, MAXWELL, LINCOLN, DODGE, or to more than two hundred and fifty accessory factories—right into the very headquarters of the business—at the fountain head of this great industry. No other place can give you the same opportunity for first-hand knowledge.

MICHIGAN STATE AUTO SCHOOL

"The Detroit Auto School"



WELDING



TRACTOR OPERATING



TIRE REPAIRING



SELLING

\$200 to \$500 a Month

Job Now!

Train Head and Hand! By Factory Endorsed Methods

Who knows better how to teach autos, trucks and tractors than the men who build them? These men know how training should be given to make the most valuable men. The courses of the M. S. A. S. (Detroit's Auto School) are outlined with the assistance of the leaders of the Auto industry and are endorsed by them. Manufacturers here, and everywhere, supply M. S. A. S. with equipment, latest model cars, latest trucks, engines, transmissions, axles, electric equipment, etc.—everything complete to give thorough training. Everything is right up to date—the very last word in automotive training.

Detroit Trained Men Get Best Jobs

The MICHIGAN STATE AUTO SCHOOL is known the world over. Wherever autos are used—Detroit-trained men get the best jobs, highest pay. Auto, truck, and tractor factories employ M. S. A. S. graduates. Leading factories, dealers, service stations, garages, shops, and farms want men who have trained their heads as well as their hands—the M. S. A. S. Detroit-kind.

Learn in a Few Weeks-- Stay as Long as You Like

A thorough training is the thing that fills the pay envelope. You can take a full Automotive Course, or specialize in any one of its money-making branches. You can be an Auto Electrician; a Tire Expert; a Battery Service man; a Chauffeur; a Repair-Man; a Welder; a Machinist; or specialize in motorized farming, with special truck, tractor, or farm electric-lighting and farm engine training.

This 188-Page Catalog **FREE**

Decide NOW that you can make more money. Decide NOW that you will forever discard the old, plodding, low-pay life and make a success! You can do it! It may mean hard work, but hard work is a pleasure when you like it and are making a success. Learn all the interesting facts about this unlimited opportunity. We will send you FREE, without obligation, this 188-page book that tells all about it, and what the M. S. A. S. can do for you. Book is positive proof. Don't fail to get it. Send coupon or post card today.

A. G. ZELLER, Pres. and Gen. Mgr.
303 Auto Bldg., 3729 Woodward Avenue
DETROIT, MICHIGAN



A. G. Zeller
Pres.

Money Back Guarantee

I personally guarantee that a course of training in this school, the Michigan State Auto School, will qualify you for a position as repair man, demonstrator, auto electrician, garage man, automobile dealer, tractor mechanic and operator, chauffeur or farm lighting expert; or refund your money. A similar guarantee is made with all courses. Each course includes Life Membership with privilege of our service without charge at any time.

A. G. ZELLER,
President and General Manager
MICHIGAN STATE
AUTO SCHOOL

Life Scholarship-- Start ANY TIME

Your enrollment entitles you to a life-membership, with privilege of our service any time you want it. Many students come back to brush up on latest automotive ideas and new equipment. It doesn't cost a penny extra. The position of the M. S. A. S. (The Detroit Auto School) in the heart of this industry, insures most thorough, most practical, systematic training, at a cost so low any man, anywhere, can afford it.



Mail Coupon To Day

MICHIGAN STATE AUTO SCHOOL
303 Auto Bldg., Detroit, Mich.

Gentlemen:—Send FREE and without obligation, your 188-page catalog, and Auto School News, giving complete information and showing the opportunities and advantages of a Detroit-Training to make the most money.

Name

Street or R. F. D.

City State



\$1,000 Reward For the Capture of This Man

CONVICT 6138, escaped from the State Penitentiary; Name, Charles Condray; age 37; Height, 5 feet 8 inches; Weight, 141 pounds; Hair, light brown; Eyes, gray.

Easy enough to identify him from his photograph and this description, you may say—but, Condray took the name of "Brown," dyed his hair, darkened his skin, grew a mustache, put on weight and walked with a stoop.

Yet he was captured and identified so positively that he knew the game was up and returned to the penitentiary without extradition. How was it accomplished? Easy enough for the Finger Print Expert. They are the specialists, the leaders, the cream of detectives. Every day's paper tells their wonderful exploits in solving mysterious crimes and convicting dangerous criminals.

More Trained Men Needed

The demand for trained men by governments, states, cities, detective agencies, corporations, and private bureaus is becoming greater every day. Here is a real opportunity for YOU. Can you imagine a more fascinating line of work than this? Often life and death depend on finger print evidence—and big rewards go to the expert. Many experts earn regularly from \$3,000 to \$10,000 per year.

Learn At Home in Spare Time

And now you can learn the secrets of this science at home in your spare time. Any man with common school education and average ability can become a Finger Print Expert in surprisingly short time.

Free Course in Secret Service

For a limited time we are making a special offer of a Professional Finger Print Outfit, absolutely Free and Free Course in Secret Service Intelligence. Mastery of these two kindred professions will open a brilliant career for you.

Write quickly for fully illustrated free book on Finger Prints which explains this wonderful training in detail. Don't wait until this offer has expired. Mail the coupon now. You may never see this announcement again! You assume no obligation. You have everything to gain and nothing to lose. Write at once. Address

University of Applied Science
Dept. 1353 1920 Sunnyside Avenue, Chicago

UNIVERSITY OF APPLIED SCIENCE
Dept. 1353 1920 Sunnyside Avenue, Chicago, Ill.

Gentlemen:—Without any obligation whatever, send me your new, fully illustrated, FREE book on Finger Prints and your offer of a FREE course in Secret Service Intelligence and the Free Professional Finger Print Outfit.

Name.....

Address.....

Present Occupation.....Age.....

Free Course in Draftsmanship

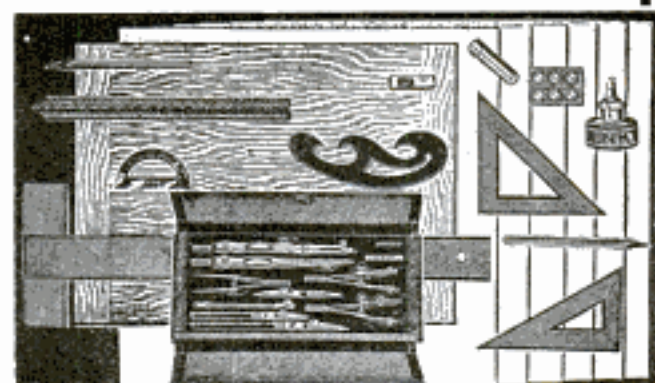

QUICK SUCCESS and MORE MONEY

Salaries up to \$100 per week. Here is your only OPPORTUNITY to get this wonderful, high-priced, Complete Drawing Outfit, including a FREE—PRACTICAL COURSE IN MECHANICAL DRAWING—AT OUR SPECIAL OFFER.

SEND NO MONEY

We ship FREE to any address in U.S., and you pay only \$12.98 on arrival—NO EXTRAS—Write to-day for this remarkable offer, with which you can build your Success in DRAFTSMANSHIP. You can put yourself in a class of Trained Men whose services are always in DEMAND.

EASY TO LEARN AT HOME IN YOUR SPARE TIME
And is your one chance to earn the biggest money of your life, and will be one of the most profitable investments you have ever made. **OUTFIT CONSISTS of—**Set large size Professional Draftsman's drawing instruments, of Five Nickel Silver, and set into a handsome Velvet Lined pocketbook folding case, size 4 by 8 1/2 inches closed—also, One Drawing Board, 20 by 24 1/2 inches—One 24-inch T Square—One 12-inch Standard scale rule—One Protractor—Supply of drawing paper—Two Triangles—One French Curve—Pencil—Eraser—One bottle waterproof drawing ink—Thumb Tacks—and one enlarged Edition FREE—A PRACTICAL COURSE IN MECHANICAL DRAWING. You cannot make a mistake by taking up drawing, so—Guarantee Your Future and Act Now.

OFFER IS LIMITED—FURTHER PARTICULARS FREE
NATIONAL INSTRUMENT COMPANY
4704 North Hamilton Ave., Dept. M. Chicago, Ill.

HOW TO PAINT SIGNS AND SHO' CARDS

Our book gives a complete course of instructions, enabling any one to learn to paint good signs. WHY NOT MAKE YOUR OWN either for your business or for others?

CONTENTS: Alphabets, Composition, Color Combinations, How to Mix Paints, Show Cards, Window Signs, Banners, Board and Wall Signs, Ready Made Letters, Gilding, Commercial Art and Tricks of the Trade—Contains 100 alphabets and designs. Cloth bound, size 7 x 5 inches, price \$1.00 postpaid.

J. S. Ogilvie Pub. Co., 577 Rose St., New York

STAMMER NO MORE

Kill the fear of stammering. Re-education the key. The widely famed Hatfield Method fully outlined in an accurate, dependable, worth-while book—"HOW TO STOP STAMMERING." It has inspired thousands. Free copy today.

THE HATFIELD INSTITUTE, 109 N. Dearborn, Chicago, Ill.

LAW High-Grade Instruction

Prepares You for the Bar—Est. 1892
University Methods, Standard Text-Books, Approved by Bench and Bar, Graduates practicing in every state. Send today for Free Catalog and Rules for Admission to the Bar.

Chicago Correspondence School of Law
620 Reaper Block Chicago, Ill.

LEARN WATCH REPAIRING



You can learn by our modern and original system of instruction every part of the Watch Repairing Trade at home as good or better than at a shop. You can earn money while learning and secure a well paying position or start in business after completing our course of instruction. Good watch repairers are always in demand and earn from \$30 to \$70 per week. For particulars apply to the **WISCONSIN SCHOOL OF WATCH REPAIRING** 106 Mason St., MILWAUKEE, WIS.

Live Ones and Dead Ones

All the dead ones are not holding up tombstones. You find them mingling with the populace in everyday life, shuffling along, void of ambition or the energy to throw out their chest or straighten their round shoulders. They drag their tired feet after them. They are the people we naturally avoid.

The **Live** one, however, shows pep in every step. His head is erect, his chest thrown out, his shoulders back. He radiates the thrill of life within him. People notice him, even turn around and stare at him, for they admire the fire of youth which they themselves lack.

That Is Not All

Imagine the personal joys of such a man. No one can fully realize them until they have acquired them. Beneath those clothes are the powerful muscular arms, the strong back and mighty legs that give confidence, with the feeling that this world was made for him, and he to conquer it. There are thrills in an athlete's life that others never know until they, too, have taken up some scientific system of training under an experienced **LIVE** instructor.

Would You Listen to a Mummy?

If an Egyptian mummy could return to life and teach physical culture, would you listen to him? No! His methods would be 2,000 years old. You desire more modern methods than those of the ancient Egyptian. You want the advanced methods of a **live** up-to-date specialist. Old school methods took three to four years to build up a powerful physique, while I have actually accomplished this in a few months' time. You may become an entirely rebuilt man with a personality that will make you an actual leader of men.

A Doctor Who Takes His Own Medicine

My own body is an excellent example of my methods. An instructor should show results on his own person before teaching others. I am not a "has been," but am now living the best years of my life. If I developed myself from a frail weakling to the athlete I am today, I am sure you will be convinced that there is a lot behind my methods. I DEVELOPED MY OWN ARM FROM 10 to 16½ INCHES, my present measurements. I DEVELOPED MY CHEST FROM 34 to 48 INCHES. I DEVELOPED A 17 INCH NECK FROM A NECK THAT USED TO WEAR A 13 INCH COLLAR.



EARLE E. LIEDERMAN

A Message for You

What I have done for myself, I can do for you if you will put forth a little effort each day and follow my instructions. In my files are thousands of letters from grateful pupils all over the world. If you want the energy and pep that only a real athlete knows, if you want to earn more money by developing a clearer brain from a better supply of blood, if you want to stand out among your associates like all my pupils do, make up your mind today. Turn over a new leaf and become a **LIVE** one. Do not remain a **DEAD** one any longer.

The live ones will send for my booklet—the dead ones will pass this message by. In what class do you belong?

A new edition of my book is just off the press

"MUSCULAR DEVELOPMENT"

It tells the secret. Handsomely illustrated with 26 full-page photographs of myself and some of the world's best athletes whom I have trained. Also contains full particulars of my splendid offer to you. The valuable book and special offer will be sent on receipt of only 10c, stamps or coin, to cover cost of wrapping and mailing.

Don't miss this opportunity. Sit right down now and fill in the coupon. The sooner you get started on the road to health the easier it will be to reach perfect manhood. Don't drag along one day longer—mail the coupon today.

EARLE E. LIEDERMAN

Dept. 2003, 305 Broadway, New York City

EARLE E. LIEDERMAN,

Dept. 2003, 305 Broadway, New York City

Dear Sir:—I enclose herewith 10 cents, for which you are to send me, without any obligation on my part whatever, a copy of your latest book, "Muscular Development." (Please write or print plainly.)

Name.....

Address.....

City..... State.....



FREE
PROFESSIONAL TONE
MUSICAL INSTRUMENTS
and lessons sent on *free* trial. Violin, Tenor Banjo, Hawaiian Guitar, Ukulele, Mandolin, Cornet, Banjo-Mandolin, Banjo-Ukulele, Guitar, Banjo-Guitar, or Banjo. Wonderful new copyrighted system of teaching note music by mail. Four lessons will teach you several pieces. Over 100,000 successful players. Do not miss this free trial offer. Write for booklet. No obligations.

SLINGERLAND SCHOOL OF MUSIC, INC., 1815 ORCHARD ST., DEPT. 104, CHICAGO, ILL.



Hotel Clerks in Big Demand

Hundreds of openings every week in the 20,000 hotels in the United States; salaries up to \$300 per month with the finest of meals, and often your own private room. Front clerks, room clerks, night clerks, mail clerks, key clerks, are always in demand. No unemployment, no "lay-offs" in hotel work. Bright, capable men behind the front office desk are right in line for promotion to Assistant Manager and Manager this year.

You can qualify for one of these pleasant, well-paid positions as hotel clerk, with a few spare-time hours a week given to the simple, easy, clear, lessons of the Lewis School. Special classes now forming for front office training, under the personal direction of Clifford Lewis—a hotel expert of national reputation. The training will in no way interfere with your present activities.

LEWIS HOTEL TRAINING SCHOOL
Room 317
Washington, D. C.

Send us without obligation the FREE BOOK, "Your Big Opportunity."
Send today for FREE BOOK. "Your Big Opportunity." Don't wait a minute—you may lose an opportunity right in your own vicinity. Mail the coupon now. Your whole future may depend on it.

Founded 1916
Lewis Hotel Training School, Room 317, Washington, D. C.

FREE COUPON

Name

Street

City State

Learn DANCING at home

No need of envying good dancers! Arthur Murray, America's greatest teacher of social dancing, has invented a remarkable new easy picture method, which enables anyone to learn all the modern dances at home, in a few hours, at very little cost. Arthur Murray's method is so simple, even a child can learn readily. No music or partner needed. Thousands taught by mail—success guaranteed.

FREE DANCING LESSON To prove you can learn quickly and easily, FREE, a lesson in Fox Trot; also tells the Secret of Leading, How to Gain Confidence and Correct Dancing Position. No obligation. For mailing, send 10c today!

ARTHUR MURRAY, Studio 118, 290 B'way, N. Y.



ELECTRICAL ENGINEERING men with training are in demand. For more than a quarter of a century this school has been training men of ambition and limited time, for the electrical industries. Condensed course in Electrical Engineering enables graduates to secure good positions and promotions. Theoretical and practical Electricity, Mathematics, Steam and Gas Engines, Mechanical Drawing. Students construct dynamos, install wiring and test electrical machinery. Course with diploma, complete.

Thoroughly equipped fireproof dormitories, dining hall, laboratories, shops. Over 3000 men trained.

Write for catalog. 30th year opens Sept. 27, 1922.

BLISS ELECTRICAL SCHOOL
104 TAKOMA AVENUE, WASHINGTON, D. C.



Our Scientific Method will stop that STAMMER!

Send for free 200 page book. It tells how to permanently stop stammering or stuttering in a few weeks' time. A natural guaranteed method.

The Lewis School for Stammerers
32 Lewis Bldg., 71-77 Adelaide St., Detroit, Mich.

WANTED—RAILWAY MAIL CLERKS

\$135 to \$190 a Month for Life
Every second week off with full pay—no "lay offs" because of strikes, poor business, etc.—sure pay—rapid advancement to higher positions. City and country residents stand same chance. Common sense education sufficient—no political influence. Examinations likely in every city very shortly.

CANDIDATES PREPARED FREE
Write for free schedule of Winter and Spring examination places. Every day's delay means so much less coaching—so write at once.

FRANKLIN INSTITUTE, Dept. A178, Rochester, N. Y.

Mail This Coupon
Write Plainly
Use It Before You Lose It

COUPON
FRANKLIN INSTITUTE, Dept. A178, Rochester, N. Y.
Kindly send me, without any obligation whatever on my part and entirely free of charge, (1) a full description of the position checked below; (2) Sample examination questions; (3) Free copy of copyrighted book "Government Positions and How to Get Them"; (4) A list of U. S. Government Jobs now open; (5) Schedule showing dates and places of all coming examinations.

.. Railway Mail Clerk (\$1600 to \$2300) .. Customs Positions (\$1100 to \$2000)
.. Postoffice Clerk (\$1400 to \$1800) .. Internal Revenue (\$1100 to \$2000)
.. Postoffice Carrier (\$1400 to \$1800) .. Stenographer (\$1440 to \$2200)
.. Rural Mail Carrier (\$ 770 to \$2600)

Name

Address



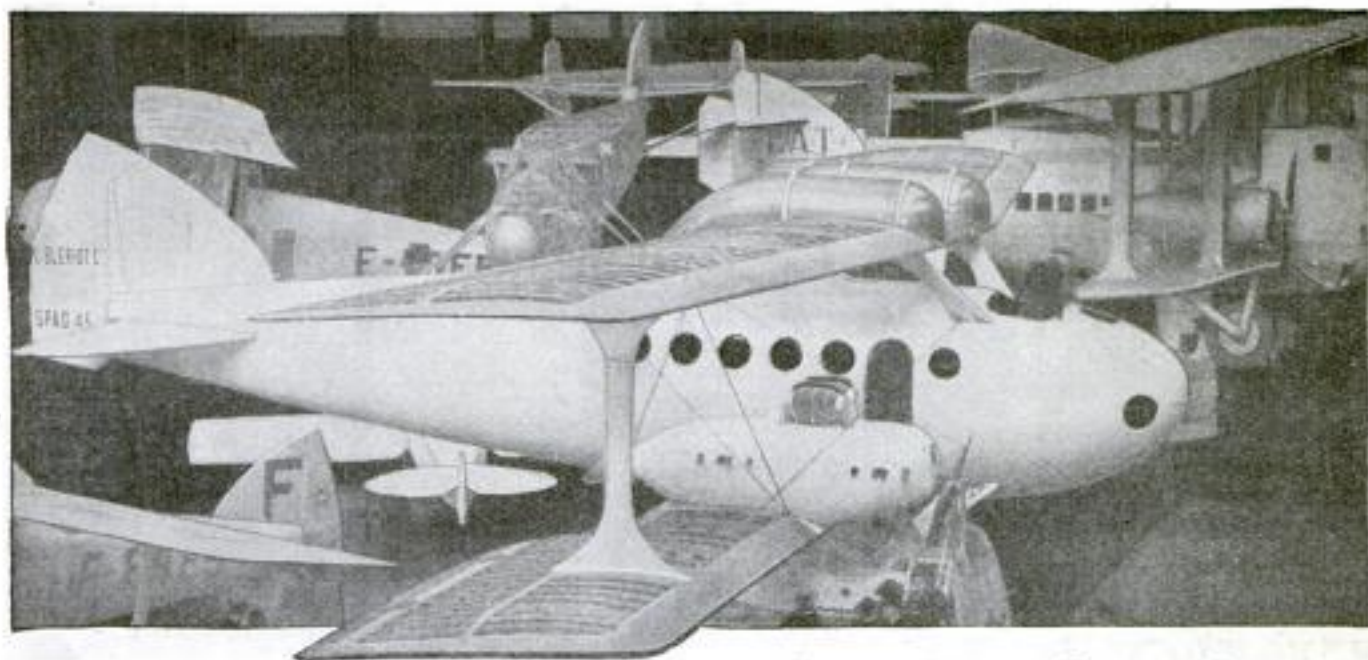

Quick Success in Aviation Fascinating—Daring—Big Paying

To young men of daring, no other field of work offers such a fascination, such high pay, nor such opportunities for quick success as the field of Aviation. As yet, aviation is practically in its infancy. NOW is the time to get in.

Amazing Opportunities in Airplane Industries

In the automobile industry and in the moving picture business hundreds of men got rich by getting in at the start. They made their success before others woke up. Today, these lines offer no greater opportunities than a hundred and one others. BUT AVIATION IS NEW. Get in while the opportunity and pay are big. All over the country there is a clamor for trained men. It is not a question of pay but of getting capable men.

Here Are Real Positions, \$50 to \$150 Per Week

Aeronautical Instructor, Aeronautical Engineer, Aeronautical Contractor, Airplane Repairman, Airplane Mechanician, Airplane Inspector, Airplane Salesman, Airplane Assembler, Airplane Builder.

A Sure and Easy Way to Learn Aviation—at Home



A New Job—The Aerial Postman

The study of aviation is almost as fascinating as the actual work. Every lesson is full of interest. That is why it is easy to learn aviation. You do not have to make yourself study—it is like reading an in-

teresting book that tells you things you have always wanted to know. Only one hour each evening will give you the basic training in a surprisingly short time. You need only a common school education.

One of my students, James Powers, Pa., says, "I am indeed surprised that such a valuable Course can be had from such practical men for so little cost."



A New Seven-Passenger Airplane

Personal Instruction by Experienced Men

Men who have had actual experience give you personal attention. They select the lessons, lectures, blueprints and bulletins. They tell you things that are essential in everyday practice. Each lesson is easy to read and understand.

BIG BOOK FREE of Opportunities

Send coupon below for New Book, just out, "Opportunities in the Airplane Industry." It is interesting and instructive. It will show you many things you never knew before about aviation. Due to shortage of paper we could get only a limited supply of these books—send the coupon before they are all gone.

AMERICAN SCHOOL OF AVIATION
3601 Michigan Ave., Dept. 1193, Chicago, Ill.

AMERICAN SCHOOL OF AVIATION
3601 Michigan Ave., Dept. 1193, Chicago, Ill.

Without any obligation, send me your Free Book, "Opportunities in the Airplane Industry," also information about your Course in Practical Aeronautics.

Name.....

Street.....

City..... State.....

BOYS



Learn

ELECTRICITY

There is a wonderful opportunity right now for boys who like electricity. Boys who are ambitious and will train themselves in spare time can step into positions just as soon as they are ready. Good salaries are offered to start with splendid chances for rapid promotion.

For 30 years the International Correspondence Schools have been training boys for success in electricity and over three hundred other subjects. They will help you prepare right at home for a position in the line of electrical work you like best—or in any other work that appeals to you. Thousands of boys, through I. C. S. training, have stepped into fine jobs, but never were opportunities so great as now.

Let the I. C. S. help you. Choose the work you like best in the coupon below, then mark and mail it today. This doesn't obligate you in the least, and it will bring you information that may start you on a successful career. This is your chance. Don't let it slip by. Mark and mail this coupon now.

TEAR OUT HERE

INTERNATIONAL CORRESPONDENCE SCHOOLS BOX 5613-C SCRANTON, PA.

Without cost or obligation please explain how I can qualify for the position, or in the subject before which I have marked an X in the list below:

- ELECTRICAL ENGINEER
 - Electric Lighting & Railways
 - Electric Wiring
 - Telegraph Engineer
 - Telephone Work
- MECHANICAL ENGINEER
 - Mechanical Draftsman
 - Machine Shop Practice
 - Toolmaker
 - Gas Engine Operating
- CIVIL ENGINEER
 - Surveying and Mapping
 - MINE FOREMAN or ENGR
 - STATIONARY ENGINEER
 - Marine Engineer
- ARCHITECT
 - Contractor and Builder
 - Architectural Draftsman
 - Concrete Builder
 - Structural Engineer
- PLUMBING & HEATING
 - Sheet Metal Worker
 - Textile Overseer or Supt.
- CHEMIST
 - Pharmacy

- BUSINESS MANAGEM'T
 - SALESMANSHIP
 - ADVERTISING
 - Show Card & Sign Ptg.
 - Railroad Positions
- ILLUSTRATING
 - Cartooning
 - Private Secretary
 - Business Correspondent
- BOOKKEEPER
 - Stenographer & Typist
 - Certified Public Accountant
- TRAFFIC MANAGER
 - Railway Accountant
 - Commercial Law
- GOOD ENGLISH
 - Common School Subjects
- CIVIL SERVICE
 - Railway Mail Clerk
- AUTOMOBILES
 - Mathematics
 - Navigation
- AGRICULTURE
 - Poultry Raising
- BANKING
 - Spanish Teacher

Name..... 7-1-21

Street and No.....

City..... State.....

Occupation.....

WE TEACH COMMERCIAL ART

Properly Trained Artists Earn \$100 a week and up. Meyer Both College—a Department of the Meyer Both Company—offers you a different and practical training. If you like to draw, develop your talent. Study this practical course—taught by the largest and most widely known Commercial Art Organization in the field with 20 years' success—which each year produces and sells to advertisers in the United States and Canada over ten thousand commercial drawings. Who else could give you so wide an experience? Commercial Art is a business necessity—the demand for commercial artists is greater every year. It's a highly paid, intensely interesting profession, equally open to both men and women. Home study instruction. Get facts before you enroll in any school. Get our special booklet, "Your Opportunity"—for half the cost of mailing—4c in stamps.

**MEYER BOTH COLLEGE
OF COMMERCIAL ART**
Michigan Ave. at 20th St.
Dept. 16 CHICAGO, ILL.

What 15c Will Bring You

Only 15 cents gives you the **Pathfinder 13 weeks on trial**. The Pathfinder is a cheerful illustrated weekly, published at the nation's center for people everywhere; an independent home paper that tells the story of the world's news in an interesting, understandable way. This splendid national weekly costs but \$1 a year. The Pathfinder is the Ford of the publishing world. Splendid serial and short stories and miscellany. Question Box answers your questions and is a mine of information. Send 15 cents and we will send the Pathfinder on probation 13 weeks. The 15 cents does not repay us, but we are glad to invest in new friends.

THE PATHFINDER, 724 Langdon Sta., WASHINGTON, D. C.

LEARN PIANO TUNING

MAKING TRIALS
OF TRUE TONE

By
TUNE-A-
PHONE



We furnish our accurate teaching device with tools, Action Model, lessons, and analysis of business advertising which makes you a master of the tuner's art. Diploma given graduates. 13 years' experience in teaching the most independent and lucrative profession by correspondence. **SIMPLER and BETTER than oral instruction.** Write today for FREE booklet and guarantee plan.

NILES BRYANT SCHOOL OF PIANO TUNING
22 Bryant Bldg. Augusta, Mich.

SIGNAL
ENGINEERING

\$90 to \$250 a Month
Free Book Tells How



Write today for this big, new Free Book on
SIGNAL ENGINEERING

Railroads need men for this important work. Big positions open throughout U. S. Big Free Book tells all about it—how you get exact training you need. Write—today—now! Dept. Signaling, Room 9353, 1924 Sunnyside Ave., Chgo.

WHY not spend Spring, Summer and Fall gathering butterflies, insects? I buy hundreds of kinds for collections. Some worth \$1 to \$7 each. Simple outdoor work with my instructions, pictures, price list. Get posted now. Send 25c (NOT STAMPS) for my Illustrated Prospectus. Mr. Sinclair, Dealer in Insects, Dept. 6, Orissa Park, Calif.



LEARN ENGINEERING

Courses, 3 months to 2 years practical-technical training under experts. Not a Trade School, but a practical-technical college teaching electricity, steam, gas, auto-electric, apparatus winding, drafting. Estimate laboratory and equip. Degrees awarded. Day and night sessions. Enroll any time.

FINLAY ENGINEERING COLLEGE
1001 Indiana Avenue Kansas City, Mo.

Repair Any Auto or Auto Truck

Examine These NEW AUTO BOOKS FREE

Be an expert auto repair man. You can have the skill that makes every complicated trouble as easy to fix as taking out a spark plug. Learn every detail of all makes of cars and trucks. Know exactly how to find what's wrong and how to make all repairs quickly. These great new Auto Books show you how.

Make Money Repairing Autos

Over 8 million cars are in operation and thousands of men are needed to keep them in good going condition. There are more jobs open than there are good men to fill them. Never before have expert auto repair men been in such great demand and made so much money. Now is your great money-earning opportunity in the auto repair business. Every mechanic, every chauffeur, every car owner needs this great New Library of Automobile Engineering.

Tells About
Explosion Motors, Welding, Motor Construction and Repair, Carburetors and Settings, Valves, Cooling, Lubrication, Flywheels, Clutch, Transmission, Final Drive, Steering, Frames, Tires, Vulcanizing, Ignition, Starting and Lighting Systems, Shop Kinks, Public Garage Design, Equipment and Operation, Electrics, Storage Batteries—Care and Repair, Steam Cars, Motorcycles, Commercial Trucks, Glossary. More than 100 blue prints of Wiring Diagrams.

75c a Week If You Decide to Buy

Let us send you the complete six-volume set of Automobile Engineering for one week's examination. Read the simple directions for repairing every automobile trouble. Six thick volumes, 5½ x 8½ inches, flexibly bound and stamped in gold, 2,650 pages, 2,100 illustrations, wiring diagrams, etc. Everything in plain, every-day language, simple to understand. If you decide to keep them, send only \$2.80 in seven days, and \$8 a month thereafter until the special introductory price of \$24.80 has been paid. The regular price is \$45.00, so you save \$20.20 by acting at once.

Send No Money

Don't send a penny! Your name and address in the coupon brings the six books to you at once for seven days' trial. With each set we give you absolutely free a \$12 Consulting Membership, entitling you to ask our staff of automobile experts as many questions as you wish, a whole year free.

Mail Coupon NOW

American Technical Society
Dept. A-193 Chicago, U. S. A.



Starting and Lighting



Welding

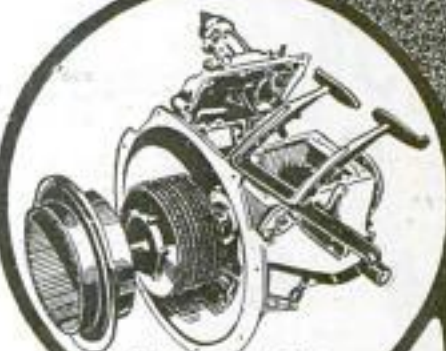

Transmission



Motors

AMERICAN TECHNICAL SOCIETY

Dept. A-193, CHICAGO, U. S. A.

Please send me the six-volume set of Automobile Engineering for seven days' examination, shipping charges collect. If I decide to buy, I will send \$2.80 within seven days and balance at \$5.00 a month until \$24.80 has been paid. Then you will send me a receipt showing that the set of books and the Consulting Membership are mine and fully paid for. If I think I can get along without the books, I will return them, after 7 days, at your expense.

Name.....

Address.....

Reference.....



Get Ready For a Big Pay Job

Be an Electrical Expert

*Earn
\$75 to \$200
a Week*

Men like you are needed right now to fill big paying jobs in the electrical field. There never was a time when opportunities for money making were as good as they are now. Good jobs are open everywhere to men who know "what's what." Electrical experts earn from \$12 to \$30 a day. Even the ordinary electricians get top-notch pay. Why don't you get in on this and get a real man's size job now? With my simplified Electrical Course I can quickly fit you to hold one. Read W. E. Pence's letter below. This is only one of thousands of such letters I have received.

You Can Be a Big Money Maker

I have trained over 20,000 men in electricity—thousands of successful men all over the world attribute their success to my training. I can make you successful, too. In fact, I will guarantee your success. If you will follow my home study course you can become an expert, drawing a fat salary, in the same time it takes you to get a little raise in the work you are doing now.

Age or Lack of Education No Handicap

No matter how old or how young you are, or what education you have, there is a real future for you in electricity. If you can read and write I can put you on the road to success. I can help you to a position that will make people admire you and look up to you.

Cash in on Your Spare Time

Use your spare time to get a better job. Most of us have enough spare time every day to sell a little at about \$10.00 an hour. Sell some to yourself at this price. Watch how quick you will earn the money back if you put the time into study.

Electrical Working Outfit Free

Every man who enrolls for my electrical course gets a big outfit of tools, material and instruments free. This includes an electric motor and other things not usually found in a beginner's outfit. These are the same tools and the same material you will use later in your work. Everything practical and good right from the start.

I Guarantee Your Complete Satisfaction

I am so sure I can make a big pay electrical expert out of you that I guarantee your success. I agree under bond to return every cent you pay me for tuition when you have finished the course, if you are not satisfied that it is the best investment you have ever made. If you don't make good, this million dollar institution will.

Act Right Now

Let me send you my big free book giving details of the opportunities electricity offers you and a sample lesson also free. Mail the coupon and get this at once. Learn how other men "got themselves ready to hold good paying jobs" and how I can help you do the same. This is your big chance—take it.

**Jumps
From \$125
A Month to
\$750 and
Over**

**READ
the Story of
W. E. Pence**



W. E. Pence
in his
working togs

Chehalis, Wash.,
Oct. 9, 1921.

Mr. Cooke:—

When I enrolled with you less than a year ago I was a common mechanic earning \$25 to \$30 a week. Today I am an "Electrical Expert" with a business of my own that gives me a clear profit of over \$750 a month.

I have more work than I can do. The people around Chehalis come to me to fix their starters, generators and ignition troubles because they know that I know how to do it right.

My success, I owe to you, Mr. Cooke. The thorough practical training which you gave me through your Easily-learned Home Study Course in Electricity has made me an independent, highly respected business man in this community. Sincerely yours, W. E. Pence.

L. L. Cooke,
Chief Engineer,
Chicago Engineering
Works, Dept. 13
2150 Lawrence Ave., Chicago, Ill.

Dear Sir: Send at once Sample Lessons, your Big Book, and full particulars of your Free Outfit and Home Study Course—all fully prepaid without obligation on my part.

Name.....

Address.....

L. L. COOKE, Chief Engineer
CHICAGO ENGINEERING
WORKS, Dept. 13
2150 Lawrence
Avenue
CHICAGO

CLASSIFIED ADVERTISEMENTS

WORLD'S BEST WANT AD MEDIUM

Advertisements in this section, 25 cents per word, each insertion, minimum 10 words, payable in advance. To be inserted under proper classification in April issue, copy should be in our office February 25th.

AUTOMOBILE SUPPLIES

AUTO Parts for any car. We save you 10 to 90% and ship same day order is received. Have gears, shafts, bearings, springs, pistons, pins and rings, bushings, cylinder-head gaskets, top slip roofs, clutch leathers, radiators, coils, magnets, Alwater-Kent, Connecticut, Delco, Remy Ignition systems and parts. Radiators for Ford \$14.00, Chevrolet \$22.00. Chevrolet crankshaft \$13.00. Top roof recoverings Ford touring \$6.50, Ford roadster \$5.20. Send forty cents in stamps for one can quick tube repair outfit. Rex All Season Sedan-type tops seven-passenger Nash \$95.00. When you want auto parts write us, giving make model, and parts wanted. We have it, will get it, or it is not made. We guarantee to please you or will refund your money. Auto Tire & Parts Co., 501 Broadway, Cape Girardeau, Mo.

GARAGE, Repair or Harnessmen: Write now for complete proposition that enables you to quickly and profitably make new or repair old flat belts for cars, trucks, tractors or small shop machinery. See our ad on page 137. Lakewood Fabric Belting & Mfg. Co., 1518 W. 117th St., Lakewood, Ohio.

FILLING Station, Exide Batteries, Stock, Equipment, Buildings: live city, state highway. Teach business free. Large profits. Five thousand required. Write Drawer "T." Gregory, S. D.

STORAGE Batteries direct from factory. \$15.00 to \$27.00. Write today, giving make and model of car. Absolute guarantee. Akeley-Steele Co., Aurora, Ill.

CYLINDERS reground, new pistons and rings fitted. Restores lost power. Write for prices, giving make and model. The Everts Machine Co., Hartford, Conn.

AUTO Parts, Rings, Pins, Pistons, etc., direct from Detroit. Write today. National Accessories Co., Box 404, Detroit, Mich.

AUTOMATIC Compressors, Grinders, Battery Chargers, Motors. Unusually easy terms. Write us your needs. Hobart's, Troy, Ohio.

STORAGE Battery Charging Earns Unusual Profits, using HB Chargers. \$20 starts. Balance payments. Hobart's, Troy, Ohio.

AUTO Parts—Slightly used parts from cars we wreck. Duplicates for almost any make car at 50% to 75% off list. New Gears—We are distributors for all standard makes of differential and transmission gears—for any make and model of car. Satisfaction guaranteed or money refunded. Send in your old parts and we will duplicate them. Address Auto Parts Supply Co., "Everything for the Automobile," 1522 Grand Ave., Kansas City, Mo.

AUTO Top Roof Recoverings, easy to put on. You drive 100 tacks and save \$15 to \$40. Ford Roadster \$5.20, Touring \$6.95. Other cars \$14 and \$16, with plate glass curtain lights. Side curtains that open with doors \$10.00 and up; others \$6.50 up. Delivered at your door. Seat covers \$3.10 up. Write for catalog, samples free. Equipment Co., 30 Canal, Cincinnati, Ohio.

AUTOMOBILE owners, mechanics, accessory dealers and jobbers: write for full information on the "Mac" Storage Cell Tester; small, compact and portable for testing storage batteries, retails for \$3.50. Liberal discounts to dealers. Metric Appliance Corporation, 153rd St. and Willow Ave., Bronx, N. Y.

FORD Owners, Chevrolet, Overland: Do your hubs loosen, go on too far, keys wear, wheels wobble? Avoid cost of renewal. Use our improved hub bushing. Quickly applied. Thoroughly tightens. Prepaid, 50 cts each; 5 for \$2. Auto Specialties, 327 Pasadena Ave., Youngstown, O.

AUTOMOBILE License Holder Key Ring. Sample 25 cents. H. Eddy, Meriden, Ct.

STORAGE Battery Plates, Separators, Rubber Jars, "Best Make" Gillette Process, Gillette Battery Corp., 2218 Wabash Ave., Chicago.

AMERICAN Garage & Auto Dealer publishes each month interesting and helpful suggestions and information on sales, merchandising, advertising, business management, accounting, welding, cutting, brazing, practical and progressive hints for office and shop for "small-town" automotive dealers, garagemen, repairmen, mechanics. Subscription price \$1.00 per year. Sample copy on request. American Garage & Auto Dealer, 1804 Lake View Bldg., Chicago.

AUTO Motors Supplies: Buick—Michigan—Stoddard-Dayton—E. M. F.—Cadillac—Overland—Continental and Buick Motors. All types, \$50.00 each and up. New Dixie Magnets \$20.00. Splittorf High Tension Magnets \$10.00. Kellogg Pumps \$3.50. Auto-Lite generators, n.w., \$10.00. Air Gauges 65c. Remy Ignition Coils, new, \$3.00. Electric and gas headlamps, coils, distributor heads, air compressors, etc. Write for catalog. Motor Sales Dept. 15, West End, Pittsburgh, Pa.

AUTOMOBILE Owners, Garagemen, Mechanics, Repairmen, send for free copy of our current issue. It contains helpful, instructive information on overhauling, ignition troubles, wiring, carburetors, storage batteries, etc. Over 120 pages, illustrated. Send for free copy today. Automobile Digest, 506 Butler Bldg., Cincinnati.

VULCANIZING and Repairing is a paying business. Forty million tires need repairing every day. Make big profits in tire repair. Easy to learn. Instructions free. No hard times. Always busy. Get into this money-making business quick! Plants \$200 up. Write for free catalog. Equipment Co., 1 Canal, Cincinnati, Ohio.

AUTO Owner Tire Agent wanted each locality to use and take orders for hand-made Mellinger extra ply and cord tires; guaranteed by bond for 8,000 and 10,000 miles (no seconds); shipped prepaid on approval, get your tires free; no capital or experience required; make \$100 to \$300 weekly. Write for wholesale prices and sample section. Mellinger Tire Co., 929-K Oak, Kansas City, Mo.

PROTECT Your Rights. Write for Record of Invention which contains form to establish evidence of conception of your invention. Prompt personal service. Preliminary advice without charge. J. Reaney Kelly, 612 G, Columbian Bldg., Washington, D. C.

LET us protect your car with a cover. One that will cover or uncover in an instant. A child can operate it. Attractive circular. Beard Manufacturing Co., Hardinsburg, Ky.

MOTOR-Meter Lock; see page 193 February Popular Mechanics. \$3.00 postpaid—discount to dealers. State rights for sale. E. W. Allen, Room 14, Auzerais Bldg., San Jose, Calif.

OWNERS, Garage men, small-town dealers: Make these 17 auto specialties and make money. Free. Nite Mail Order & Supply Co., 609 27th St., Denver, Colo.

STANLEY Automobile Owners: Everything for the steam car. Conservative reductions. Enclose stamp for list serviceable supplies. "Acme" superheaters, vaporizers. All-welded boilers. "Doc" Paine, Denver, Colo.

BE your own Boss. Operate Automobile Refinishing Business. We teach you how. Big money-making opportunities everywhere. No experience necessary. Automobile Finishing Co., Shelosogan, Wis.

STORAGE Batteries \$3.00 to \$5.00. Build them yourself by a new method. Complete instructions One Dollar. Address Yates Brothers, 3463 W. Washington St., Los Angeles, Calif.

IMPROVED Light Alloy pistons, all sizes, finished or semi-finished, lowest prices; get circular. Edge, 7704 S. Main St., Los Angeles, Calif.

FREE Inner Tubes. Veteran's War Patent. Photographer, National Home, Ohio.

AIR Compressor with Tank and Hose, \$49. Motor for same \$22.50. Equipment Co., 21 Canal, Cincinnati, Ohio.

AUTOMOTIVE Wiring Manual—original and only blueprint wiring book—contains more than 800 blueprints covering every make of car and truck since 1912. Over 500 car and truck wiring diagrams; more than 200 internals of generators, etc. Price \$15.99 prepaid. Popular Mechanics Book Dept., 6 N. Michigan Ave., Chicago.

BEST Tire Kink Out—25c. Your money back if not pleased. Gro. M. Loe, Box 44, Mountain Grove, Mo.

AUTOMOBILES

TURNER spring lubricator, fits any car; spreads spring leaves and lubricates in one operation. \$2.50 prepaid. Harry Striker, 232 N. 12th St., Elwood, Ind.

TWENTY thousand miles from each set of tires. Secret, tested four years, for one dollar. Mileage Bureau, R. 3, Vancouver, Wash.

"MORE-PEP" Carbon Remover. Guaranteed. Acidless. \$1.25. It's different. Jess Fulton, Kenton, Ohio.

AUTOMOBILE Repairshop Shortcuts—Over 1500 time and labor saving kinks from more than 1000 of the best Repairshops in the U. S. 256 pp. 1500 figs. Price \$3.50 postpaid. Popular Mechanics Book Dept., 6 N. Michigan Ave., Chicago.

PATENTS—Write for our free illustrated Guide Book and Evidence of Conception Blank. Send model or sketch and description of your invention and we will give our opinion of its patentable nature. Highest references. Prompt service. Reasonable terms. Victor J. Evans & Co., 185 Ninth, Washington, D. C.

AUTO Owners Wanted to use and introduce our new 6,000 and 10,000 Mile Guaranteed Cord and Fabric Tires. Make big money, part or full time. Free Tires for your car. Write quick for special agent's offer and low wholesale prices. It will pay you to answer this little ad, now. Reliable Tire & Rubber Co., 35th St. and Michigan Ave., Dept. 90, Chicago, Ill.

AUTOMOBILE Owners, Garagemen, Mechanics, Repairmen, send for free copy of our current issue. It contains helpful, instructive information on overhauling, ignition troubles, wiring, carburetors, storage batteries, etc. Over 120 pages, illustrated. Send for free copy today. Automobile Digest, 506 Butler Bldg., Cincinnati.

DYKE'S Automobile Encyclopedia contains the greatest array of automobile facts ever published in one volume. Several separate books containing the same information would cost in the neighborhood of \$21.00. New, enlarged edition, 968 pp. 3362 illus. cloth \$6.46; American Morocco, \$7.96 postpaid. Popular Mechanics Book Dept., 6 N. Michigan Ave., Chicago.

TO FORD OWNERS

FORD Car Repair Book sent free. This complete, well illustrated, valuable book explains in a simple way the Causes and Cures of Over-heating; Repairing Ford Timer; Curing Piston Ring Troubles; Carburetor Adjustments and Repairs; Connecting Rods; Transmission Troubles; Care and Repair of Rear Axle; Stopping Axle Grease Leaks; also covers practically every other phase of Ford Car Repairing. Send 25c coin for three months' trial subscription and get the valuable repair book free. Ford Owners' Magazine, 515 Montgomery Bldg., Milwaukee, Wis.

ADJUSTABLE Intake and exhaust valves for Fords increase power. For circular address: Dept. F, Steel Products Mfg. Co., Racine, Wis.

PROTECT Your Motor: save time, money, clothes and temper with our superior, water-proofed, detachable belts for Fords. Regular price 50c each. Three belts sent postpaid for \$1.00. State model when ordering. Money refunded if not entirely satisfied. See our adv. on page 137. Lakewood Fabric Belting & Mfg. Co., 1518 W. 117th St., Lakewood, Ohio.

EVERLASTING hose connection for Fords—no clamps needed. Outlasts your car. Send \$1 for sample set, prepaid. Pyramid Rubber Co., 1300 W. Colfax Ave., Denver, Colo.

FORD Top Roof Recovering. Easy to put on. Drive 100 Tacks and save \$15. Ford Roadster, \$5.20. Touring \$6.95. Ford side curtains that open with doors \$10 and \$15. Others \$4.50 up. Parcel Post Prepaid. Equipment Co., 19 Canal, Cincinnati, Ohio.

A PATTON body on your Ford chassis will give you the best looking car in town. Bodies \$50 and up. Write for free illustrated folder. E. J. Patton Co., 788 Garfield Ave., Aurora, Illinois.

\$25.00 DAILY to Ford Owners. Exclusive contract, complete line, fastest selling accessories made. Let us prove it. Send \$2.00 for all products. Reserve your territory today. Muter Company, Englewood, Ill.

SPEEDSTER Fans: Don't fail to see "Red-I-Kut" ad., page 144.

LACEY Patent Senses. See page 150.

FORD Repairing—New valuable book explains use of all up-to-date tools and shop equipment, describes methods of performing work on all different mechanical parts of car; 250 pp., fully illus. Leatherette. Price \$2.50 postpaid. Popular Mechanics Book Dept., 6 N. Michigan Ave., Chicago.

FORD magnetos recharged in five minutes. Nothing to take apart, secret exposed. Makes easy starting; bright head lights; more power; saves gasoline; satisfaction guaranteed. Complete simple instructions and diagrams \$1.00 prepaid. Send money order or currency today. Magnetizer Manufacturing Co., 146 W. Florence Ave., Dept. 219, Los Angeles, Cal.

FARM with Your Ford. Do 2 days' work in 1. The Adapto-Tractor makes your Ford a tractor and power plant. Guaranteed to be as represented and not to injure your Ford or your money back. Agents wanted. Write for free circular. Geneva Tractor Co., Dept. P. Geneva, O.

MOTORCYCLES, BICYCLES & SUPPLIES

DON'T pay \$60.00 for bicycles when we sell first-class motorcycles for \$75.00. Single tube tires \$1.00, non-skid Ford automobile tires \$5.00. Motorcycle tires \$5.00. Records for Edison Phonographs 15c. Motorcycles, Bicycles, Talking Machines at factory prices. Send stamps for catalogue, Deminger Price Cutter, Rochester, N. Y.

MOTORCYCLE, improved type, just placed on market. One hundred less parts. Weighs only 165 pounds. Simple, dependable, strong, safe. Surprisingly low in price and running expense. Opening for agents in localities where not yet represented. For information, write Schickel Motor Company, Stamford, Conn.

LARGEST stock of new and used motorcycle parts and accessories in the world at your disposal via Uncle Sam's mail. Write for quotations. Motorcycle Parts Mfg. Co., 2030-36 Wabash Ave., Chicago, Ill.

HARLEY-DAVIDSON 1919 Electric, Equipped fine condition. Must sell quick. \$175.00. L. Smith, 445 E. 84th St., New York City.

USED parts for all motorcycles cheap. State wants. Schuck Cycle Co., 1922 Westlake, Seattle, Wash.

WHY buy a used motorcycle? A new Cleveland costs only \$185. See page 138.

HARLEY, electric 3-speed, tandem, \$140; ask for bargain bulletin. Harley cylinder regrinding, also enameling, winter prices. Burnett Motor Sales, Providence, R. I.

1916 INDIAN twin \$90; sidecar \$35. Geo. Laatch, Alamont, Ill.

FOR Sale. Used Bicycles, with Guards and Coaster Brake. Price \$15.00. Examination allowed. \$5.00 with order. Indian Agency, Hudson, N. Y.

\$31.50 AND your Bicycle makes a Motorcycle. Complete motor attachments for bicycles. Full instructions. Guaranteed Bicycle Tires; \$2.10; Electric Lights; \$1.98; Unbreakable Rubber Grips; 49 cents. List Free. Ash Motor Corporation, Dept. J, Rochester, N. Y.

NEW and Used Motorcycles, Bicycles, Motor Wheels, Supplies. Lowest prices. Satisfaction guaranteed. Let us know your wants. Seeber-Hofheims, Buffalo, New York.

GUARANTEED Rebuilt Motorcycles of all makes and models. See page 155.

SIDE cars, motorcycles, magnetos, carburetors, transmissions, engines, air propellers, at bargains (enclose stamp). Expert factory repair service; reasonable; genuine guaranteed parts used. Send work now. Erickson, 8039 Parnell, Chicago.

SEND for big list of slightly used motorcycles and bicycles on our easy payment plan. Howard Cycle Co., 152 N. Broad St., Trenton, N. J.

USED and new parts. Indian, Excelsior, Harley, Reading, Thor, Henderson, Yale. Get our price lists. Kingshighway Cycle Co., 1166 North Kingshighway, St. Louis, Mo.

DON'T buy a Bicycle Motor Attachment until you get our catalogue and prices. Shaw Mfg. Co., Dept. 27, Galesburg, Kan.

NEW motorcycles have been reduced 10%. Our prices have been reduced 35%. Send for big bargain list of rebuilt motorcycles. Western Supplies Co., 359 Hayutin Bldg., Denver, Colo.

USED motorcycles, new and used parts; write us. Mahowald Cycle Co., Mankato, Minn.

INDIAN motorcycles—second-hand at extremely low prices. Howard A. French & Co., Baltimore, Md., and Washington, D. C.

BOYS, build your own cycle car! Send 25c for building plans and list of parts. We can supply motor with clutch and all parts at low prices. Shaw Mfg. Co., Car Dept., Galesburg, Kan.

MOTORCYCLE cylinders reground, fitted with new piston rings, \$8.00. Guaranteed. Muncie Piston Co., Muncie, Ind.

AVIATION

PROPELLERS for Aeroplane propulsion, small propellers for motorcycle-driven snow and ice sleds, road speedsters, and hydroplanes, 4½ feet diameters \$10.00, 6 feet diameters for Fords \$15.00; others in proportion. Overhead countershafting, hub sprocket bearings and thrust, all complete, just right for installing, Ford type \$18.00, motorcycle type \$16.00. Our new ball-bearing countershafting complete for Fords \$18.00; motorcycles \$14.00. Full scale blueprints for building motorcycle snow and ice sleighs 75c. Ford plans \$1.00. Prices of blueprints refunded on purchase of propeller. Crawford Motor and Aeroplane Mfg., 142 South Rampart Street, New Orleans.

FOR March we offer the greatest bargains in the history of aviation. Dope \$1.65; turnbuckles, all sizes, 25c; aero cloth 39c yd.; tachometers \$7.00; altimeters \$12.00; air speed indicators \$12.00; shock absorber 5c ft.; Curtiss or Gnome motors \$200; new propellers \$18.00; clevis pins 2c; wheel covers \$1.25; steel tubing 5c ft. Other wonderful bargains. Get free sale sheet. Heath Airplane Co., Chicago, Ill.

SPORTFORD Tractor Biplane. Knock-down machines sold on \$50 installments. Building plans and instructions only \$2. Motorcycle engine monoplane plans \$1. Aviation Engineering Co., Lawrence, Kan.

DIMINUTIVE rotary gasoline engine for models, blueprints, dollar complete. Castings, small spark plugs, coils. Circular free. Ritter Mfg. Co., 325 Washington Street, Brooklyn, N. Y.

FLYING instruction, \$1.00. Rigging and Motors course included. Expert instructors, modern equipment. Spring class now enrolling. Aviation Engineering Co., Lawrence, Kan.

AIRCRAFT Supplies. Bulletin 4c. Ostergaard Aircraft Works, 4269 N. Narragansett, Chicago.

HEATH propellers represent the most efficient method of aerial drive. Each propeller individually designed for the particular work to be done, as laid out by America's oldest Aeronautical Engineers. Propeller catalog 4c. Heath Airplane Co., Chicago, Ill.

SMALL Lightweight Gasoline Engines, Small Spark Coils, Spark Plugs, etc. Weiss Mfg. Co., 325 Washington St., Brooklyn, N. Y.

SEND for our large aeronautical supply catalog containing late ideas, 15c. Our Ford and Motorcycle Airplane Pamphlets describe the most complete little machines on the market, 4c each. Heath Airplane Co., Chicago, Ill.

BUILD your own Motorcycled Monoplane. Blueprint plan, 25c coin. M. Meyer, R. No. 10, Kalamazoo, Mich.

LEARN to fly, with America's oldest aircraft company. Six hours flying worked in with three months shop training at \$100.00, makes our course the most complete ever offered, and an opportunity long waited for. Enroll at once. Heath Airplane Co., Chicago, Ill.

AVIATION Books, Helmets, Goggles, Jewelry. Blueprints: Motosed, \$1. Standard, De Havilland, "Swallow," Canuck, \$3 ea. Catalogue, 2c. Airplane Novelty Co., 2638 N. Clark, Chicago.

MODEL Aeroplanes that fly. Buy your complete outfit, scale drawings, fittings, compressed air motors and all best model aeroplane supplies from The Wading River Manufacturing Co. Established 1900. Our new 52-page catalog illustrated, 24 latest models and designs. Send 10c for your copy. Wading River Manufacturing Co., 672 A Broadway, Brooklyn, N. Y.

INVENTORS desiring patents should write for our Free Illustrated Guide Book and Evidence of Conception Blank. Send model or sketch for our opinion of its patentable nature. Highest references. Prompt service. Reasonable terms. Victor J. Evans & Co., 187 Ninth, Washington, D. C.

THE American School of Aviation announces a new correspondence course in Mechanics of Aviation. A thorough training in Practical Aeronautics. American School of Aviation, Dept. 1861, 3601 Michigan Ave., Chicago, Ill.

BIGGEST, best catalogue Model Aeroplanes, Parts and Supplies; 5c postpaid. Ideal Aeroplane Co., 67½ West Houston, New York.

WELDING

MOTOR Grinder and Tire Buffer, Automatic Compressors, Battery Chargers, Motors. Unusually Easy Payments. Write us. Hobart's, Troy, Ohio.

WELDING Encyclopedia, just published, is a complete instruction book on all Welding Processes, Oxy-Acetylene, Electric Arc, Electric Resistance and Thermit, Welding of all weldable metals fully discussed. 328 pages, 375 illustrations, clothbound. The accumulated experience of the welding brains of America is yours for \$5. Money back if not satisfied. Popular Mechanics Book Dept., 6 N. Michigan Ave., Chicago.

BOOKS AND PERIODICALS

"500 THINGS to Sell by Mail!" A valuable up-to-date compilation of fast selling suggestions, plans and methods. Prepaid, \$1.00. Walhamore Company, Lafayette Bldg., Philadelphia, Pa.

"26 ACCOUNTING Problems Solved by C. P. A." Cloth bound, loose leaf, new, original, up-to-date, valuable. Prepaid, \$1.00. Walhamore Company, Lafayette Bldg., Philadelphia, Pa.

ATTENTION—For photographs of soldiers killed, wounded and died in world war, \$1.00 per state. S. Mickelson, 601 F St. N. W., Washington, D. C.

THIRTY-FIVE Cent Electrical and Mechanical Books. Fully illustrated. Other popular subjects. Send for list. Spou & Chamberlain, 120 P M Liberty St., New York.

"APPLIED Electricity," 8 volumes, A1 condition, \$25.00. Raymond May, Croff, N. D.

25 FULL Course Lessons, Original Master Key, \$4.75. 21 Personal Magnetism \$1.60. Full Philosophy, Seership, Genuine Mediumship, \$2.10 each. Catalogue 2c. Sovereign Company, 160 Sycamore, Buffalo.

MIND-READING and many other astounding secrets. 290 pages, all for 30c; catalog free. The Midland Company, B 539 East 149th St., New York.

BOOK of Great Secrets—25c. Henry Moody, Box 213, Chicago.

BOOKS, All Kinds, Lists, Hygiene's, A2441 Post Street, San Francisco.

AMBITIOUS writers of Photoplays, Short Stories, songs, poems, newspaper articles, send today for free helpful booklet, "Successful Writing." Writer's Digest, S-603, Butler Bldg., Cincinnati, O.

TOY maker book, 64 pages, illustrated, Postpaid 10c. Western Puzzle Works, St. Paul, Minn.

BRINGING Up Father—Books 1 and 2. Everybody knows the funny cartoons by Geo. McManus. They may be had in book form. One volume for 35 cents or both for 60 cents postpaid. Cartoons Magazine Book Dept., 6 N. Michigan Ave., Chicago.

LATEST Magic—Professor Hoffman, world-famed authority. New stunts, card tricks, sleight of hand. Handsomely bound. Illustrated. \$2.15 postpaid. Spon & Chamberlain, 120 P. M. Liberty Street, New York.

PRACTICAL Books—Mechanical, Electrical, Engineering, many other subjects. Catalogue free. Colonial Book Co., 509 Fifth Ave., Suite 198, New York.

INDUSTRIAL Alcohol. Wright's book everybody wants. Full directions for making with drawings of necessary apparatus. \$2.50 postpaid. Spon & Chamberlain, 120 P. M. Liberty Street, New York, N. Y.

BOOKS, Books, Books. No matter what you want in the realistic book line, I can fill your order. If you cannot find the books you want, send for my list today. Levi Bryant, 4808 Champlain Ave., Chicago, Ill.

INSTRUCTION Book (for shop use) on vulcanizing auto tire, boots and shoes, \$1 bill. Equipment Co., 3 Canal, Cincinnati, O.

PICTURES, POSTCARDS, NOVELTIES

JOIN Live Postcard club: Sample paper, list, catalog, 10c. Harvey Teeple, Decatur, Indiana.

TRUE-BLUERS everywhere. Exchange postals. Organized 1908. Membership: Year, \$1; half, 50c; quarter, 25c. Hundreds listings, 10c. Ed Ericson, 322 Elroy, Wis.

WEST Virginia, "Switzerland of America," 10 beautiful mountain and river "colorviews" 25c. Postal Shop, 837 Sixth, Charleston, West Va.

JOIN active International Card Club: descriptive list in English or German free (Stamp). George Grigoleit, 20 East Jackson Blvd., Chicago, Ill.

25 MAILORDER Magazines and Papers, 25c. Address Hansen Company, Brookings, S. D.

"SEE America First," Sight-seeing tours start continuously. Schedules and rates free. Thirty interesting "colorviews" 25c. Mutual Supply Co., Bradford, Pa.

GAMES AND ENTERTAINMENT

VENTRILOQUISM taught almost anyone at home. Small cost. Send 2c stamp today for particulars and proof. George W. Smith, Room M284, 125 N. Jefferson Ave., Peoria, Illinois.

FUN! Fun! Real joker's sporting goods—pocket novelties. Everybody wants them. Send 2c for illustrated catalogue today. Address Grandfield, 1238 Thorlot Ave., Bronx, New York.

TRICKS, Puzzles, jokes, magical apparatus, plays, stage supplies, mind-reading acts, and sensational escapes. 160-page illustrated professional catalogue, 10c. Oaks Magical Co., Dept. 548, Oshkosh, Wis.

250 MAGIC Tricks, with cards, coins, handkerchief, etc., (simplified and illustrated so that a child can perform them). To introduce illustrated catalogue of tricks and entertaining books, 10c (coin). Allen's Enterprises, 1227 Milwaukee Ave., Chicago, Ill.

\$7,000.00 STOCK magical goods. Catalogues 15c. Address, Gilmaglio, Morgan Park, Ill.

250 MAGIC Tricks, 25c. Big catalog, 2c. Harvey Teeple, Decatur, Indiana.

PLAYS, musical comedies, revues, minstrel choruses, blackface skits, vaudeville acts, monologues, dialog, recitations, entertainments, musical readings, stage handbooks, make-up goods. Big catalog free. T. S. Denison & Co., 623 So. Wabash, Dept. 11, Chicago.

"MARGO," a mystifying novelty that will make them all set up and take notice. Fools the wise ones. Descriptive circular free. James T. Herr, Desk C, 2919 W. North Ave., Baltimore, Md.

AMAZE!—mystify your friends. Big book "250 Magic Tricks"—easy to perform, only 10c. Catalog of Tricks, Jokes, Novelties and Books—stamp. Send today. Henry Moody, Box 213, Chicago.

STINK bombs, Sneeze powder. Greatest fun makers on earth. Per box, 10c. Three boxes only 25c. Address C. Fenner, 2401 Jefferson St., Louisville, Ky.

MYSTIFY your friends. Sealed envelope reading trick explained. Only 25c. Send today! Rippey Magic Shop, 2527 Ocean View, Los Angeles, Calif.

SAWING Lady in Half, Secret 15c. Magic Catalogue free. C. Pentz, Minneapolis.

MYSTERIOUS Wonder Shavings when dropped into water turn into fish, flowers, animals. One dozen in pretty package 15c, three 35c. Excellent for dinner party favors; they create talk. Dozen packages \$1.00. George E. Heinemann, 1424 Rosemont, Chicago.

200 KINDS iron, wood and wire puzzles. Leader and illustrated list 10c. Western Puzzle Works, St. Paul, Minn.

MAGIC—Tricks, Books and Supplies. For Amateurs as well as the great professionals. Anyone can learn through our instructions. Feature Acts in Mind Reading, Spiritualism, Rope Ties, etc. Large illustrated Professional Catalog, 10c. Chicago Magic Co., Dept. B, 140 S. Dearborn St., Chicago, Ill.

FREE! "10 select pocket tricks" and illustrated catalog magic tricks, jokes, puzzles and imported novelties at reduced prices. Send today! Lyle Douglas, Station A, Dallas, Texas.

MAGIC Tricks—Send 2c stamp for catalog (professional catalog 25c) book card tricks 25c. Thurston's book pocket tricks 25c. trick pack cards 50c postpaid. A. P. Felsman, 3234 Harrison, Chicago, Ill.

STAMP COLLECTING

SNAPS—150 different stamps, 18c; 60 different United States Stamps, 12c. With each order we give free our price list of sets, packets, albums, etc., and our pamphlet which tells "How to make a collection properly." Queen City Stamp Company, Room 36, 604 Race, Cincinnati, Ohio.

STAMPS—50 different Jamaica, Venezuela, etc., only 10c; 100 all different, 15c; 1,000 all different, \$4; 100 different U. S., 25c; 1,000 hinges, 10c; 50 per cent approvals with every order. List free. I buy stamps. L. B. Dover, Dept. A, Longmont, Colo.

STAMPS, 50 Varieties, Africa, Brazil, Peru, Cuba, Mexico, etc., 10c; 50 different U. S., 25c; 1,000 mixed, 40c; 1,000 hinges, 10c. List free. C. Stegman, 5948 Cote Brilliante, St. Louis, Mo.

BELGIAN Teacher wants to communicate with Americans to exchange, buy and sell stamps of all nations. Preference private individuals. F. Van Aesch, Turnhout Road, 157 Borgehout (Antwerp), Belgium.

STOP! Here's Bargains—1,000 different, \$2.75; 1,000 hinges, 9c; approvals, 1c, or 6 for 5c; can't be beat! A trial's worth while! Baumann, 1033 Leveck, Philadelphia, Pa.

NYASSA Pictorials, 1921, Ten varieties, unused, 15c. Ask for selection of my one-cent approvals. 100 different French Colonials, 35c. Address G. Ganderberger, East Chatham, N. Y.

WHOLESALE! 150 different Hungary. Worth \$4.78. None damaged. Price \$1.00. Approvals. Free: World's smallest stamp. Postage 2c. Cannon, 918 East 10th, Davenport, Iowa.

FREE—Twenty United States with 60 per cent approvals. Enclose three cents. Illinois Stamp Co., 803 West Madison, Chicago.

BEST one-cent approvals in America. F. P. Hand, 1117 S. 60th St., Philadelphia, Pa.

STAMPS—1,500 different, \$5.45; 1,000, \$2.99; 500, 95c; 200, 20c. Michaels, 6603 Prairie, Chicago.

1,000 DIFFERENT, \$2.80; 500, \$1.00; 300, 45c; 200, 20c. Fred Onken, 630 79th St., Brooklyn, N. Y.

PACKET mixed stamps, 10c; 150 different, 25c. Harvey Teeple, Decatur, Indiana.

FREE—Watermark Detector with lists to approval applicants. Allen Sears, Inc., Dept. P, Kansas City, Mo.

4,000 MIXED (pound), 50c; 1,000 different, \$2.60. Address Lynes, Marlton, N. J.

110 DIFFERENT Foreign stamps, 10 cts. M. Place, Harding, Mass.

STAMPS—50 different Jamaica, Venezuela, etc., only 10c; 100 all diff., 13c; 1,000 all diff., \$4.52; 100 diff., U. S., 25c; 1,000 hinges, 10c; 50 per cent approvals with every order. List free. I buy stamps. Dept. A. L. B. Dover, Longmont, Colo.

158 GENUINE Foreign Stamps—Mexico War Issues, Venezuela, Salvador and India Service, Guatemala, China, etc., only 10c. Finest approval sheets, 50 to 60%. Agents Wanted. Big 72-p. Lists Free. We Buy Stamps. Estab. 29 yrs. Husman Stamp Co., Dept. 54, St. Louis, Mo.

ATTRACTIVE Selections of stamps submitted "on approval" at 50% discount (or more) from catalogue price. Special: Montenegro, 1907, twelve varieties complete set, mint, for 15c. Address B. L. Voorhees, 25 N. Dearborn St., Chicago, Ill.

50 VARIETY packet and 1,000 hinges only 10c to all applicants for approvals, who furnish reference. Address Sioux Stamp Company, Security National Bank Bldg., Sioux Falls, S. D.

WRITE For—15 varieties Austria Jubilee and subscription to Stamp Magazine free. 40 Sweden 15c; 50 Roumania 30c. William Betts, Box 117, Clearfield, Pa.

100 DIFFERENT Stamps—Nicaragua, Egypt, Brazil, Chile, Guatemala, Hong-Kong, large pictorial French Colonies, etc. Album with perforation gauge, only 10c. Clarence Gibbs, Tujunga, Calif.

INTERNATIONAL Package contains 25 fine stamps, \$1.00. None cheap, common. Stamps cat. to \$1.75 each. Approvals 80% discount. International, 50 Ft. Greene Place, Brooklyn, N. Y.

179 GENUINE Foreign Stamps 10c, 15 diff, Mexico 10c, 1,000 Hinges 10c. R. H. Carlton, 346 W. So. Temple, Salt Lake City, Utah.

NYASSA, 10 beautiful varieties 13c; 100 different 12c; 25 French Colonies 12c. Co-operative Stamp Co., 710 Pelham, St. Paul, Minn.

FIUME Triangle steamboat stamp Free with One and Two cent approvals. Hubert Codwise, Melrose Highlands, Mass.

STAMPS Free—War Stamps, Surcharged, Unused, Pictorials, British, French Colonials 2c postage. Midland Stamp Co., Toronto, Canada.

600 DIFFERENT stamps—no trash—\$1.20. Reference necessary for approvals. Mrs. Louise Kellogg, W. Hartford, Conn.

25 U. S. FREE with approvals. Send 3 cents. St. Elmo Stamp Co., 4501 N. Ashland Ave., Chicago.

EXCHANGE Stamps, wholesale, retail, 1/2 cent credit given on approval selection. Dodge, Stacy Bldg., Los Angeles, Cal.

100 DIFFERENT Stamps 10 cents. Perforation Gauge Free. I. Sonnea, 675 Ivy Street, St. Paul, Minn.

TRY money-saving approvals around one-third catalogue. Reference required. John Smoot, McLean, Va.

ALL different, 35 French and British Colonials, 25c. Edgerton, Box 2088, Fresno, Calif.

ABYSSINIA, Nyassa, Thraco Stamps, Menagerie Packet, Hinges, 10c. Liberty, 3974 Arsenal, St. Louis, Mo.

HIGH-GRADE Approvals for Collectors beyond the beginners' class. All countries 1845 to date. Better than usual discounts. Satisfaction certain. References essential. Fred B. Boterberg, 3753 Wilton Ave., Chicago, Ill.

FREE! To applicants for our net approvals, 3 stamps cataloging over \$1.00. Reference necessary. The Stamp Shoppe, 1413 G Street, N. W., Washington, D. C.

FIUME Set—Featuring Post Annumio, also 59 different French Colonials 30c. Jacob Fischer, 1539 North Lawler, Chicago, Ill.

POPULAR unused French Colonials, 43 different, 16c. Nickles, 122 Florida Ave., Washington, D. C.

FREE packet with 50 to 65% approvals. Reference required. C. Buchholz, Norwood, Ohio.

100 DIFFERENT stamps, big value, 12c. Margiuti, City Hall Box 1279, New York.

FREE, 100 different stamps to applicants for approvals sending 2c, 100 varieties War Stamps 22c. Richard P. Lamprecht, Valparaiso, Ind.

50 DIFFERENT foreign, 10c. Alfred Welch, 3906 Reisterstown Rd., Baltimore, Md.

100 DIFFERENT Austria-Hungary 25c. Buckley, 712 Bowen, Dayton, Ohio.

BEST Penny Approvals, New Bedford Stamps Co., New Bedford, Mass.

TWENTY different fine Dutch Indies, 25c. Marvin Allison, Angola, Ind.

COLE'S Approvals will satisfy. Write for selection. W. Jay Cole, 3019 Wallace St., Chicago.

PICTURE stamps, six North Borneo, postage due, 10 cents to applicants for 50% discount approvals. J. G. McIlhenny, 21 Oakridge Avenue, Summit, N. J.

FRENCH Colonies Free—Beautiful Picture set, including Native Chiefs, Tigers, Pictorials, 2c Postage, Empire Stamp Company, Toronto, Canada.

MENAGERIE Packet 15 cents with application for approvals, Bucknam, 63 Court St., Room 1, Boston, Mass.

LIKE Triangular Stamps? To introduce our Sudden Service Approvals we'll send triangular Fiume, set China ships, large \$1.00 United States revenue, also packet 50 foreign, millimetre scale, perforation gauge, ruler and bargain lists for only 2c! Fennell Stamp Company, Dept. P, Fullerton Bldg., St. Louis, Mo.

FREE, packet of desirable stamps, exceptional quality, to approval applicants sending satisfactory references. H. Argenbright, Box 352, Staunton, Va.

STAMPS on approvals, 1/4-cent up, Free premium. Herbert Kelgwin, 31 Walkhill, Middletown, N. Y.

ROYAL approvals—the world's best. Address, Belmont Stamp Co., Box 178, Ocean Grove, N. J.

STAMPS Free—Ask for money-saving approvals. John P. Borresen, Cedar Falls, Ia.

100 STAMPS from 20 different countries, 5c. Lufberry, Yalesville, Conn.

FREE—New Europe, 20 diff., to applicants for my 1/2, 1/4, 1, and 2c approvals; also the higher-priced stamps at 50% disc. Send reference and receive extra premium. Chas. T. Egner, 1335 Pike St., Philadelphia, Pa.

24 VARIETIES Cuban stamps, 10 cents, list of 6,000 low-priced stamps free. Address Chambers Stamp Co., 111P, Nassau St., New York City, N. Y.

FREE! Sectional Loose Leaf Postage Stamp Album at the rate of 8 pages each month given with subscription to our monthly Journal. Send two-cent stamp for prospectus. United Stamp Co., 140 S. Dearborn St., Chicago, Ill.

BIG Variety Packet Foreign Stamps free for 2c postage. Gray Stamp Co., Station E, Toronto, Canada.

UNIVERSAL Packet, 100 varieties, all over the world, 10 cents. Covert Stamp, 39 State, Rochester, N. Y.

STAMPS sent on approval at 70% discount. Reference required. Emory Renoll, Hanover, Pa.

50c WORTH of Stamps for Only 2c. Hull, 12 West 101st, New York.

57 DIFFERENT new and used stamps from Guatemala, Finland, Peru, India, Russia, France, Czechoslovakia, Philippines, etc., perforation gauge, millimetre scale, ruler, price lists to approval applicants. Don't wait. Send now 10c. Leader Stamp Co., Dept. P., St. Louis, Mo.

105 CHINA, etc., stamp dictionary, list, 2c. Album (500 illustrations), 2c. Bullard, Sta. A, Boston.

55 ALL Different Stamps, including China, Japan, French Colonies, etc., given to applicants for our high-grade approval selections. Send references and 2c stamp to the Edgewood Stamp Co., Dept. H, Milford, Conn.

20 UNUSED stamps free. All different. Postage, 2c. Fisk Stamps, Toledo, Ohio.

PACKET of 23 stamps, no two countries alike. Packet hinges. Set of \$1 and \$2 U.S. Rev., all for 5c. Mention paper. Miami Stamp Co., Toledo, Ohio.

STAMPS, 20 unused, all different, free. Postage 2c. Mention paper. Quaker Stamp Co., Toledo, O.

FREE 10 different Scandinavian, millimetre scale, gauge, book, lists, etc., to all sending 10c for 57 different Stam, Ceylon, Guatemala, etc. 200 different, 25c; 300 different, 60c; 100 different U. S., 25c. Hawk-eye Stamp Co., Cedar Rapids, 39, Ia.

RARE COINS

HOW'S this for ten cents? Mail 10c with your name and address, and you'll get a genuine old coin over 100 years old and a 50-page illustrated Coin Catalog. A "just-to-get-acquainted offer." Coin Collecting will prove pleasant and profitable to you. Start now. B. Max Mehl, Numismatist, Mehl Bldg., Dept. P, Fort Worth, Texas. Largest Rare Coin Establishment in the United States.

OLD coins wanted—Have you an odd, or old coin or bill? It may be worth several dollars. Get posted. Send 4c for Coin Circular. May mean much profit to you. Send now. Numismatic Bank, Dept. H, Fort Worth, Texas.

150 OLD coins, all different, \$5.00, 40 Old coins, all different, \$1.00, 29 Large U. S. Cents, \$1.00. Address, Claud Denney, Denison, Texas.

LARGE Catalogue of "Coins for Sale," free. F. Stolteben, 2245 Clifton Ave., Chicago.

COIN over 100 years old, 10c. Durno, 25 Mulberry, N. Y. City.

THREE Large United States Cents 25c. Moore Coin Company, Commerce, Texas.

OLD coins, large Spring selling catalogue of coins for sale, free. Catalogue quoting prices paid for coins, ten cents. William Hesselein, 101B Tremont St., Boston, Mass.

CALIFORNIA gold, Quarter size 27c; 1/2 size, 53c. 3c Piece and catalog, 10c. Norman Shultz, Box 146, Colorado Springs, Colo.

\$2 TO \$500 Each paid for hundreds of old coins. Keep all old money. Send 10 cents for Illustrated Coin Value Book, 4x6. Guaranteed Prices. It may mean your Fortune. Address Clarke Coin Company, Ave. 2, Le Roy, N. Y.

CALIFORNIA Gold, Quarter size and Columbia nickel coin only 30c. Italy 20 cents and catalog 10c. Homer Shultz, King City, Mo.

FOR BOYS

BOYS make money selling toys spare time. Samples 25c and 50c. D. A. Everly, Janesville, Wis.

BOYS—Tricks, Jokes and Puzzles. Get our big catalogue first. Agents Supply House, Dept. PM6, Binnewater, N. Y.

OUTDOOR Winter Sports—New 64-page illustrated book, just out, tells how to make motor driven snow and ice sleds, ice yachts, bobbeds, toboggans, skis, ski gliders, ski sleds, ice gliders, portable fishing shacks, etc., 25 cents postpaid. Popular Mechanics Book Dept., 6 N. Michigan Ave., Chicago.

COMPLETE Movie machines, with films, \$3.00 up. Nite Mail Order & Supply Co., 609 27th St., Denver, Colo.

PLAY mouth-organ. It's easy. Complete instructor, 25c. Ocarina instructor, 25c. G. Elsea, Bowling Green, Ohio.

CAMERAS AND PHOTO SUPPLIES

JUST published—Our new complete 128-page catalog and bargain book of new and used cameras and supplies. Our goods are guaranteed finest quality obtainable. We have thousands of satisfied customers. Write at once for this bargain bulletin, just hot from the press. Address Central Camera Co., 124 S. Wabash Ave., Dept. E55, Chicago, Ill.

AZ-U-LYK-M. Send your next roll film and 20c. We will make six prints, one "hand tinted" free. Az-U-Lyk-M, Bristol, Vt.

KODAKERS—Special Trial Offer—Mail us 20c and one roll Kodak film for development and six prints. Louisville Photo Co., Box 507, Louisville, Ky.

HALF Price Offer: Inca Transparent self-blending photo colors. Instructions. Complete set, postpaid, one dollar. India Co., 16 Lakewood Ave., Buffalo, N. Y.

KODAK films developed and finished with attractive margin designs 25c. Something new. New England Photo Service, Box 1202, Boston, Mass.

100 WORLD War photographs \$2.00. Actual battle scenes, air, land, sea. Samples 15c. Lieut. Welsh, 50 Ft. Greene Place, Brooklyn, N. Y.

SAMPLE enlargement 8x10, 25c. Send film. Kodafin, 387 Bellevue Place, Milwaukee, Wis.

ESTABLISH yourself—at home—as an Expert Photographer and train with R. Dupont, president International Studios, 37C—4451 N. Robey, Chicago.

DEVELOP your plates and films in daylight without tank. Greatest discovery in photography! Chemical makes emulsion light-proof so plates can be developed in white light without risk of fogging. For ordinary plates, Panchromatic, Autochroms! Cheap! Send 25 cents for tube sufficient for hundreds of plates, with instructions. Address, Gougers & Co., Box 284, St. Louis, Mo.

BUY the RWK Photo-Printer for results and economy. It makes photography a pleasure. Size 8 1/2 x 11 1/2, delivered in U. S. A. for \$8.50, complete with bulbs. Prices of 8x10 and 11x14 printers upon request. R. W. Kittredge Co., 824 W. Superior St., Chicago, Ill. Write for information.

KODAK Finishing. Not the cheap way, but the most reliable. Our Quality Work insures best prints from every negative. Get particulars and List of Prices. Or send Trial Order. Moen Photo Service, 21A, LaCrosse, Wis.

EARN \$1,200 to \$10,000 yearly. Travel anywhere. Sell photographs to Newspapers—Magazines—Advertisers. Guaranteed complete course in Kodaking—Five Dollars. Address today, Photographic Institute, Dept. M, Wedgway Building, Schenectady, New York.

MAIL us 20c with any size film for development and six velvet prints. Or send six negatives any size and 20c for six prints. Or send 40c for one 8x10 mounted enlargement. Prompt, perfect service. Roanoke Photo Finishing Co., 209 Bell Ave., Roanoke, Va.

HAVE You a Camera? Write for Free sample of our big magazine, showing how to make better pictures and earn money. American Photography, 790 Camera House, Boston, 17, Mass.

SNAPSHOTS at night! Wonderful invention! Stamp brings information. Cummings, 633 7th Ave., Salt Lake City, Utah.

MOTION PICTURES

MOVIE Arc Generator. Eliminates current bills. Superior projection light. Easy terms. Your engine operates. Hobroco, Troy, Ohio.

FILMS For Sale—\$2.50 per Reel up. Address Queen Feature Service, Birmingham, Ala.

FILMS for Toy Projectors \$1.00 for 100 feet, postpaid. 2,000 reels \$3 to \$10. \$250 new motor-driven suit-case projector \$125. New church and school projector with stereoscopic attachment, \$250. Stereopticon \$35. \$350 used church projector \$175. Movie Cameras reduced. Ray, 326 Fifth Ave., New York.

USED Projectors for school, road show, etc., \$50. New calcium lights \$25. Arnold Werner, High Ridge, Mo.

MOVIE films—Comedies, cowboys, 200 feet \$1.00. Coleman, Mather Building, Washington, D. C.

EARN Money writing photoplays. Plan free. Address Los Angeles Photoplay Company, Los Angeles, Cal.

MOTION Picture Operation, stage electric and illusions—The only practical handbook and guide published for motion picture operators, theatre electricians and managers. Pocket size, cloth, 293 pp., fully illus., price \$1.50 postpaid. Popular Mechanics Book Dept., 6 N. Michigan Ave., Chicago.

NEW \$375.00 Movie Camera. Sacrifice, \$150.00. Stewart Marshall, Rome, Ga.

PORTABLE Professional Moving Picture Machine, for Home, Church or School. Takes Standard Film. Can be operated with Globe from ordinary lamp socket; only \$55.00 cash. Monarch Theatre Supply Co., 228 Union Avenue, Memphis, Tenn.

MAKE money writing photoplays; details free to beginners. No correspondence course. Producers League, 230 Wabwright, St. Louis.

STUDY Cinematography, the science of Motion Pictures. New, Fascinating, Remunerative. Positions pay \$3,000 to \$5,000. Write today for prospectus. American Institute of Cinematography, Dept. 2, Steinway Hall Bldg., Chicago, Ill.

MOVIE Film \$1.00 per hundred feet postpaid anywhere in the U. S. A. Gamble Bros., Mt. Airy, Philadelphia, Pa.

MOTION Picture cameras of all kinds at money-saving prices. Write Bass your needs at once. Bass Motion Camera Company, 109 No. Dearborn St., Chicago, Ill.

FREE to Writers—A wonderful little book of money-making hints, suggestions, ideas; the A B C of successful story and play writing. Absolutely Free. Just address Authors Press, Dept. 12, Auburn, New York.

EDUCATIONAL AND INSTRUCTION

BEGIN Dancing Correctly. Avoid mistakes. Improve wonderfully. New Fashions! Standard, advanced steps, leading, following, music, style; everything taught easily, quickly by mail. Write for interesting particulars. Boyd's, 314C Studio Building, Kansas City, Mo.

LINCOLN-JEFFERSON University. Home study in Academy College, Theological, Law, Music, Pharmacy, Business and Graduate Schools, leading to degrees. Box 239, 64 W. Randolph St., Chicago.

OWN a Kodak? If so, learn Photographic Journalism quickly, by new easy method and earn \$200 monthly. Particulars free. Waltham Institute, Dept. FJ, Philadelphia, Pa.

BOOKKEEPING in a week. Duker, Fox Street Station, New York.

WORLD-ROMIC System, mastery to all languages. Six textbooks, \$1.75. French chart, 37c. Spanish chart, 37c. Speech-organs chart, 37c. Sound-tables, 56 languages, 30c each language: Bohemian, Dutch, American English, British English, Finnish, French, German, Greek, Hungarian, Italian, Japanese, Latin, Norwegian, Portuguese, Sanskrit, Scotch, Spanish, Welsh. Languages Publishing Company, 8 West 40th Street, New York.

FREE—Professional Instruments, outfit and table. Earn big money. Be a draftsman. Practical and complete course in drafting. Costs only few dollars. Easy terms. Write for particulars. Engineering Service Bureau, Dept. 613, 56 E. Randolph St., Chicago, Ill.

MEN and women, know thyself. Send \$1.00 for book; after perusing conscientiously, think not worth \$10 to you, will refund money. Prudhomme Specialty Co., 168 West 124th St., New York.

LEARN Sign painting and Show-card writing. Earn big money. We teach by correspondence. Catalogue free. Address New York School of Lettering, Medina, N. Y.

TEN most interesting and practical chemical experiments, including all chemicals and instructions for same, \$1.00. Technical Chemist, Box 957, Pomeroy, Ohio.

PRINTING—Learn by mail, type-furnished to work and practice. Northwestern Printing School, 4104 Hirsch St., Chicago, Ill.

HAVE a business of your own; the most fascinating, best paying business-profession in the World, a foot correctionist; easy terms for training you at home in a few weeks, a new protected system that has enabled men and women to rise in one step to greater earnings than they ever thought possible; no capital required or goods to buy, no agency or soliciting. Address, Stephenson Laboratory, 1 Back Bay, Boston, Mass.

ARTIFICIAL Marble, sanitary flooring instructions, ornamental casting, concrete plaster, papier-mache decorations, garden furniture, statuary, Rubber-moulds, Electro-metallurgy, particulars and 200 illustrations free. Chris Mahler, Box 122, Huntington, N. Y.

DOUBLE Entry Bookkeeping mastered in 60 hours with 8 keys; guaranteed; Diplomas. International Bookkeeping Institute, Dept. 8, Springfield, Mo.

INVENTORS—Write for our illustrated guide book and Evidence of Conception Blank. Send model or sketch and description for free opinion of its patentable nature. Highest references. Prompt attention. Reasonable terms. Victor J. Evans & Co., 167 Ninth, Washington, D. C.

MATHEMATICS taught by mail. Spare time home study courses in Arithmetic, Geometry, Algebra and Trigonometry. J. A. Harding, 76 Brighton Ave., Highland Park, Mich.

WRITE articles, stories, news, in spare time for newspapers and magazines. Big pay. Copyright book free. Press Syndicate, 552, St. Louis, Mo.

WE teach you all there is to know about candy making here at the Institute or by Correspondence Course. Good income can be made on a moderate investment. The Candy Institute, 876A Flatbush Ave., Brooklyn, N. Y.

TELEGRAPHY

TELEGRAPHY—Morse and Wireless—taught at home in half usual time and at trifling cost. Omnigraph Automatic Transmitter will send, on Sounder or Buzzer, unlimited messages, any speed, just as expert operator would. Adopted by U. S. Govt. and used by leading Universities, Colleges, Technical and Telegraph Schools throughout U. S. Catalog free. Omnigraph Mfg. Co., 26-D Cortlandt St., New York.

TELEGRAPHY (both Morse and Wireless) and Railway Accounting taught quickly. Big salaries. Great opportunities. Oldest and largest school; established 46 years. All expenses low—can earn large part. Catalog free. Dodge's Institute, H St., Valparaiso, Ind.

WIRELESS

PRACTICAL Amateur Wireless Stations—A new, up-to-date book on the construction of wireless outfits. Price 75 cents, postpaid. Popular Mechanics Book Dept., 6 N. Michigan Ave., Chicago.

TRADE SCHOOLS

MECHANICAL Dentistry. Why men are needed now; why you can earn \$35—\$125 weekly or establish a profitable business of your own; how to enter this field of opportunity. Details free. Bodee Schools of Mechanical Dentistry, Department 2A, 136 West 52nd Street, New York (also Brooklyn and Philadelphia).

BUSINESS OPPORTUNITIES

DO You Need Money Capital? Want to start your own business? Get the "Speed System for Securing Cash Capital." Raise \$2,000 to \$5,000 or more as needed, by quick modern business action. We send the complete "Speed System" upon request. Enclose \$1.00 to cover charges, and address Business Service System, Dept. J, Ordway Bldg., Newark, N. J. The Wise Man can act immediately for Business Capital and Control.

MAKE big money manufacturing marble, granite, tile, agate. Cost ten cents per square foot, sell at 75c. Fancy marble face brick, cost \$15, sell \$75 per 1,000. If you want to make several thousand dollars in the next few months, write for full information. Spewer Instruction, Dept. 793, Miami, Fla., Master Cement Worker of the World.

\$100,000 CORPORATION wants capable man; open office; manage sales for High Class New Device. Every Home a Prospect. Big money-making possibilities for the right man. Opening in every city. Cost \$2.00, retails \$5.00. \$500 to \$2,000 necessary to finance exclusive agency. Scott Corporation, 82 W. Washington, Desk G, Chicago.

IF you have about \$1,000 and capable of organizing sales force, to sell article needed by every merchant, wholesaler and retailer, which should net you \$10,000 profits first year, write Sales Director, 828 Reaper Block, Chicago.

STATE rights. Newly patented Safety Pipe Taps. Sell on sight to every pipe smoker. Save tobacco; no sparks, no burns, no fires; fit any pipe. Dozen samples, 50c (cash). Address Sapleo Co., Santa Monica, Calif.

RESPONSIBLE Corporation wants general sales managers to open branch office, manage salesmen. \$500 to \$5,000 necessary; expenses allowed to Baltimore if you qualify. Address Manager, 603 N. Eutaw St., Baltimore, Md.

A BUSINESS for yourself! We furnish everything. Buy Radium Diamonds direct from importer. Enormous profits. Complete selling plans with sample, 50c in stamps. Radium Gem Co., 557 Fifth Ave., Brooklyn, N. Y.

"BUSINESS Booster"—Journal for ambitious men and women—contains hundreds of money-making opportunities. Copy 10c. Three months 25c. Eydman System, Box 647, St. Louis, Mo.

CLEAN Wallpaper and Window Shades this winter and spring. Big demand. Take large contracts. We show you how. C. Swanson & Sons, Mankato, Minn.

START Profitable Mail Order Business at Home. We teach you by successful method. Particulars free. Waltham Company, Mail Order Dept., Lafayette Bldg., Philadelphia, Pa.

START Galvanizing Business—Tire rims, awnings, signs, boat fittings; hundreds of other things exposed to weather. Address Post Box 583, Charleston, S. C.

MANUFACTURE inexpensive dustless ash sifters. Plan 35c. Wm. Quenore, Camden, New Jersey.

\$12.45 FOR a made-to-measure two-piece suit, the biggest bargain offer ever made by any tailoring house. We are out to beat high tailoring prices. Save 50% on your next suit. You can easily earn \$50.00 cash weekly in your spare time by taking orders for our celebrated made-to-measure clothes. Write us today for our beautiful cloth samples and wonderful offer—sent free; postage prepaid. Act quick. The Progress Tailoring Co., Dept. C-144, Chicago, Ill.

PATENTS—Trademarks. Before disclosing an invention, the inventor should write for my blank form "Evidence of Conception." This should be signed, witnessed and returned to me with sketch or model, upon receipt of which I will promptly render opinion as to patentable nature and send booklet on patents. Highest references. Prompt attention. Reasonable terms. Clarence B. O'Brien, Registered Patent Lawyer, Woodward Bldg., Washington, D. C.

HONEST Mail Order Business in infamy. Alive with unlimited possibilities. 500 high-class, workable plans in detail. \$3.00. Many absolutely new. Others proven very successful. Sworn certified guarantee. If you don't enter business we don't want your money. Send 25c for booklet, "Future Fortunes by Mail." Just published. Universal Advertising Service, Box 321, Oklahoma, Okla.

PATENTS Procured—Trade Marks registered. A comprehensive, experienced, prompt service for the protection and development of your ideas. Preliminary advice gladly furnished without charge. Booklet of information and form for disclosing idea free on request. Richard B. Owen, 30 Owen Building, Washington, D. C., or 2276R Woolworth Bldg., New York.

YOUR Chance in life to own dignified profitable business. We teach you practical real estate, insurance and business brokerage. Earn \$5,000 year, no capital required. Office at home. Representatives wanted everywhere. Stamp for booklet. Hayes Realty Association, Cincinnati, O.

MEN Handy with tools, carpenters, painters, weatherstrip men, etc., we teach you in first lesson to make \$200 month up at window and door calking in your own vicinity with our Rawhide Elastic Calking and Glazing Compound; will not crack and fall out. All masonry buildings need it. Saves coal, decorations, etc. Weatherproof Compound Co., 709A Federation Bldg., Chicago.

INVESTORS and traders, forecast your own markets. Don't trust to luck—use method. Amazing new book tells how to make profits, avoid losses. Eye-opening folder free. Master Market Forecaster Co., Dept. A, Topeka, Kan.

PROTECT Your rights. Write for Record of Invention which contains form to establish evidence of conception of your invention. Prompt personal service. Preliminary advice without charge. J. Reaney Kelly, 613 G. Columbian Bldg., Washington, D. C.

MANUFACTURER offers specialty every woman welcomes at big profit to salesperson. Exceptional opportunity for those capable of employing salesladies. Capital unnecessary. American Rubber Products Company, 608 Fifth Avenue, Pittsburgh, Pa.

ROYAL Banner Magazine: Contains hundreds of money-making propositions, new ideas, plans, tips, and special articles. Copy 15c. Year, \$1. 3 months, 25c. Bohm Publishing Co., Wilkes-Barre, Pa.

REAL Money awaits you in cleaning and dyeing business. Big profits. Easy to learn with my course. Particulars free. Byron, Box 27 Sta. I, New York, N. Y.

FORTUNES made manufacturing and selling box lunches. Begin at home. No special training. Small capital. I tell you how. Particulars free. G. Rood, Sacramento, Calif.

PROSPERITY is awaiting you; let our oilproof spark plugs make money for you. Salesman write to Dinger Spark Plug Co., Melina, Wis.

USE your spare time soliciting advertisements. \$1.00 for full instructions, including samples. Community Advertising Co., 1422 East Marquette Road, Chicago.

SPECIALTY—Proprietary Manufacturing—Small capital; repeat orders; unlimited field; large profits. Information free. The Thaxly Co., Dept. 20, Washington, D. C.

SIGNS, Cards, Banners, easily painted with letter patterns, 2 sets \$1. Samples for stamp. Outdoor Adv. Service, Lockport, N. Y.

LEARN Plating, Auto Painting, Refinishing, etc. Steady income, big demand, plans free. Norman Borick, 427 Carroll St., Akron, Ohio.

PARTNER wanted—exploit valuable invention. "Momentum Operated Brakes." Write Coutinho, 150 W. 14th Street, New York, N. Y.

BE independent! \$10 daily silvering mirrors. Complete instructions one dollar. Address, Reliable Sign Co., Sault Ste Marie, Ontario.

MONEY in mail-order business. Names of 30 supply houses 10c. Pennell Company, Covington, Ky.

MAKE Big money opening safes and setting combinations. Wayne Strong, Box 1430, Los Angeles, Cal.

ADVERTISE, 28 words 375 country town newspapers \$8.00. Pennell Company, Covington, Ky.

LEARN Fur dyeing. Formulas guaranteed. Address Rubens, 316 Pulaski St., Brooklyn, N. Y.

RAISE Rabbits. Very interesting and profitable. Read this authoritative book, 20th Century Rabbit Guide. Everything worth knowing about rabbits told by an expert of 15 years' experience. 64 pp., fully illustrated. Price 50 cents postpaid. Popular Mechanics Book Dept., 6 N. Michigan Ave., Chicago.

RESIDENT Manager Wanted who can organize selling crews. \$15.00 a day. Spare time. A permanent connection. Box 441, Chicago.

FOR Sale—Established, profitable garage at Daytona Beach, Florida, with established repair business and large line of accessories. Location in heart of city. Building is two-story fireproof construction, 48x108 ft., with large storage space on second floor, in addition to large and convenient living rooms. Daytona Beach has a summer resort patronage from all parts of the state, making the summer business as good or even better than the winter trade. The business also enjoys a large share of the local patronage in a city which has doubled in population in past 3 years and is growing faster all the time. Address F. J. Jones, Box 168, Daytona, Fla.

START a lucrative business of your own. We teach you how to establish and operate a successful collection business, and refer items to you. Capital unnecessary. Practically no competition. Walter Sanford, Nashville, reports \$92,021.94 gross commissions last year. Joseph Cullen, Washington, sends sworn statement showing gross earnings \$8,439.07 for one month. Orrin Overholser, Dayton, says, "I averaged nearly \$400.00 net commissions monthly last year. Such earnings bought my home and farm." Start now in spare time. You can succeed like 4,700 others. Write today for New Plan. American Collection Service, 802 Cass Building, Detroit, Mich.

PARTNERS wanted to manufacture New Concrete Street and Railroad Ties. This tie will be made and put in place to my idea; it can be made at a price so that any company can use the new tie. This new tie will run with the rail; good chance for a fast growing business. For more detail, write to Pete Jarnowski, 3304 W. Walnut St., Chicago, Ill.

THIS May Be Your Opportunity. A large, modern Middle Western manufacturing institution will consider proposals from inventors and small manufacturers, with a view of manufacturing on royalty basis or of buying outright. Small brass products preferred, but any high-grade proposition will be considered. Address P. O. Box 426 Kokomo, Ind.

WE Start You in Business, furnishing everything; men and women, \$30.00 to \$100.00 weekly operating our "New System Specialty Candy Factories" anywhere. Opportunity lifetime; booklet free. W. Hillyer Ragsdale, Drawer 4, East Orange, N. J.

"SCHEMER Magazine." Alliance Ohio, prints big profit schemes; one subscriber making \$25,000 from three; another \$10,000 from one. Try your luck. Year, only \$1.00; three months, 25c.

PATENTS—Book Free. Send sketch for free opinion of patentable nature. Address Talbert & Talbert, 434 Talbert Bldg., Washington, D. C.

START a Paying Business of Your Own. Be a business man. Any location. 8,000 new Tire Vulcanizing and Repair Stations needed. Business always good. Are you ambitious? \$200 will start you. Write at once. Wonderful opportunity. Equipment Co., 11 Canal, Cincinnati, Ohio.

INDEPENDENCE and prosperity await you in the furniture cleaning business. Course \$1.00. Circular free. Send today. Address E. M. Ellis, 110 Riverside Ave., Newark, N. J.

LEARN nickel plating—the business with a big future. We will send necessary drawings and instructions for \$1.00. No checks nor stamps. Washington Street Auto Supply Company, Brookline, Mass.

YOU can earn big money painting Smoke Stacks, Flag Poles, etc. Book of instructions sent postpaid for \$2.00. S. J. Lee, Publisher, 30 N. LaSalle St., Chicago.

EXCEPTIONAL Opportunity for Sales Manager capable of handling state distribution. Marvelous new Adding Machine. Retail \$15. Work equals \$350 machine. Tremendous possibilities. Unlimited profits. Write quick for details. Lightning Calculator Co., Dept. B, Grand Rapids, Mich.

GET into the specialty manufacturing business. Amazing profits. We will send you free book explaining our system. Write immediately. A wonderful opportunity awaits you. National Scientific Laboratories, 624 Main, Richmond, Va.

MARBLE mixing instructions, covering wood or cement flooring ½ inch thick, fireproof, waterproof, low cost, sanitary, all colors. Particulars, 200 illustrations free. Chris Mahler, Box 122, Huntington, N. Y.

LET Me Show you how to make real money. Absolutely new proposition and new products. Materials cost \$2.00, sell for \$16.00. One man sold a thousand dollars' worth in a week. Exclusive manufacturing and sales rights to one man in each territory. Write today for booklet 5, Crouch, Chemist, 309 Broadway, New York.

SILVERING Mirrors! My exclusive French Tartaric method opens enormously profitable business. Booklet free. H. Barstow, 514 23d Street, Oakland, Calif.

\$3,000 TO \$6,000 Yearly. Want it? Others are making it. Send check or money order today for our invaluable books "How to Sell Real Estate," \$3.00—and "How to Conduct Real Estate and Insurance Business," \$1.50. Absolute satisfaction guaranteed. Free catalogs. Realty Book Co., Dept. 52, Cleveland, O.

CHEMICAL Expert will furnish Formulas and Trade Secrets. All lines. Lists Free. W. L. Cummings, Ph.D., 228 Gordon Ave., Syracuse, N. Y.

MAIL Order Business is your opportunity. Brenner's Famous Handbooks teach how to start small, grow big. Sell merchandise, service, ideas; enormous profits. Spare time to begin. Get complete set, 11 books, \$2.50, and be posted, Brenner, 335 Walnut, Philadelphia. Descriptive Catalog and big batch interesting mail order information, 25c. None free.

ENTER a new business. Earn \$3,000 to \$6,000 yearly in professional fees making and fitting a foot specialty, openings everywhere, with all the trade you can attend to; easily learned by anyone at home in a few weeks, at small expense; no further capital required, no goods to buy, job hunting, soliciting or agency. Address Stephenson Laboratory, 11 Back Bay, Boston, Mass.

GET in business yourself; \$4.00 buys marvelous Keystone Economizer. Easily attached to any make car and saves 25% to 50% present fuel consumption. Satisfaction guaranteed or money refunded. Agents make big money. Address Keystone Economizer Company, 323 Stock Exchange Bldg., Los Angeles, Calif.

I MADE \$30 a week home. French bread-making, 15 years' experience; free booklet tells. Ashbrook, 67, Marengo, O.

BE independent. We teach by mail how to manufacture unexcelled Toilet Preparations. Earn while you learn. Results guaranteed. Particulars Free. School of Cosmetics, Box K, Omaha, Nebr.

DOLLARS yearly in your backyard. No Mushroom dupe. Particulars free. Metz, 313 East 89th, New York, N. Y.

FREE—Formula Catalog, S. & H. Laboratories, Boylston Building, Chicago.

LEARN the collection business. Good income, quick results. Interesting booklet, "Skillful Collecting," free. National Collectors Assn., Long St., Newark, O.

"HOW and What to Invent for Profit," free. Patent News-C, Washington, D. C.

FORMULAS AND TRADE SECRETS

REMARKABLE Discovery—Positively removes Tattoos, Coal Marks, Moles; safe, sure, simple process. Original since 1918. Formula \$1.00. Harding Co., 142 Dearborn St., Philadelphia.

ALUMINUM solder that can't "be beat." No flux used. Send 25c for sample. Formula \$2.00. General Supply Co., 19 Johanna Ave., Freeport, Ill.

START in your town a business which has no competitors. Make plaster-boards-550 starts you. I teach you by mail how to do it. 21 years experience. Only one to a town of 100,000. Rubenack, A 1451 Amsterdam Ave., New York. Ask for circular.

500 FORMULAS, 20c. Luminous paint—Resilvering Mirrors—Renewing dry batteries—Mechanics' Soap—Gas Tonic—Carbon remover. Puncture Plugger, 20c each. Entire collection, 50c. Ideal Book Shop, 5501FC, North Robey, Chicago.

SPIT Fire, Iron Solder, Sugar Substitute, Wall Paper Cleaner, Razor Dressing, Transference; six, 50c, or any one, one silver dime. Cal. Manufacturing Laboratories (any Formula 10 cents), Oxnard, Calif.

FORMULA for making guaranteed grease and paint spot remover. Bigger profits making and selling your own. Formula \$1.00. Geo. Dean, Box 54, Belvidere, Ill.

550 RARE Formulas for 25c (coin). We can furnish any formula wanted for 50c. Allen's Enterprises, 1227 Milwaukee Ave., Chicago, Ill.

OWN a "Little Factory." Manufacture supplies for merchants and agents. Five plus fifty cents. United Laboratories, Batavia, Illinois.

STORAGE Battery Men! Make your own battery plates. \$2.00 for complete secret process. W. L. Thomas, Tama, Iowa.

WELDERS—Make your own fluxes. Send \$1 for formulas. A. Fleming, 2015 S. Grand Ave., Los Angeles.

MAKE and Sell your own products. Formula Catalogue free. C. A. Lutz, Apartment 464, York, Pa.

1,000,000 FORMULAS. Trade Secrets, for Every Business, \$2.25. Ideal Book Shop, 5501MC, North Robey, Chicago.

FORMULAS and Secrets for bluing steel 50c. Mogensen, 414 North 14th, Omaha, Neb.

FORMULAS—Catalogue free "Clover." 5501-CC, North Robey, Chicago.

ABSOLUTELY any formula, \$1.00. Satisfaction guaranteed. Address Robert Tyler, Park St., Newton, Mass.

3,000 FORMULAS—400 pages, \$1.00. Catalogue free. Englewood Book Shop, 7021A So. Winchester, Chicago.

FREE—Formula Catalog. S. & H. Laboratories, Boylston Building, Chicago.

CHEMISTRY

CHEMICAL analysis honestly and correctly done by L. E. Tenney, Colton, N. Y.

AGENTS WANTED

WHIRLWIND money-maker for agents—sample free. Sell powdered Hanslick, an absolutely new, non-competitive, and unbeatable hand cleanser. Removes grease, grime, ink, paint, etc., without slightest injury to skin. Its use spreads like wildfire. Cheaper than all others. Sells in cans (or bulk with dispensers) to garages, autoists, mechanics, factory and office folks, to housewives, hardware stores and to auto supply houses. Huge quantities used weekly by mercantile houses. (Names on request.) Big repeat business assured. Exclusive agencies, crews working for you, fast sales, splendid profits and a permanent business for hustlers. Live ones can clean up \$500 a month. Send 2c stamp for postage on Free sample. Complete sales plan goes with it. Write quick to Solar Products Company, 124 W. Lake St., Chicago, Ill.

350% PROFIT: Quick, Easy Seller. Klean-Rite, New Washing Compound. Washes clothes without rubbing. Women wild over it. Write quick for Free package and Special Offer. Bestever Products Co., 1941-K3, Irving Park, Chicago.

AGENTS Wanted—Something New—Fire Fighter sells easily. Makes a spectacular demonstration—car owners, homes, factories, stores practically buy on sight. Our men make \$10 to \$50 a day—exclusive territory. If you wish to establish a business of your own with unlimited possibilities for making big money, write us today. Fyr-Fyter Co., 163 Fyr-Fyter Bldg., Dayton, Ohio.

START in a permanent business of your own selling guaranteed Hosiery and Underwear direct from mills. No capital or experience is needed; many representatives make \$3,000 to \$5,000 per year. Become our district manager—get others working for you. Write for details to Malloch Knitting Mills, 523 Grant St., Grand Rapids, Mich.

300% PROFIT—Earthquake—Shatters Dirt—The Original Wash Day Wonder. Nature's Mighty Marvel. Nothing else like it. Washes clothes snowy white in a few minutes without Rubbing or Boiling. Removes ink, fruit and blood stains like magic. Saves one-half the soap, time, worry and hard work. Contains no lye, lime, wax or acids—will not injure the finest fabrics. The greatest seller and repeater offered agents in twenty years. Men and women are making \$7.00 to \$14.00 daily. General agents and crew managers up to \$6,000 yearly. Profits guaranteed. Experience unnecessary—new plan makes sales quick and easy. \$6.50 quickly makes you \$60.00. Write quick for free package, proof and coupon worth \$2.00. Foster Laboratories, Box 295P, Eau Claire, Wis.

AGENTS, Men or Women, full or spare time, earn \$25.00 to \$100.00 a week and be your own boss representing the Ho-Ro-Co Mfg. Co., manufacturers of the wonderful Ho-Ro-Co Tonic, the great blood purifier and system builder; some profit-maker. Ho-Ro-Co Medicated Skin and Scalp Soap for the baby, toilet, bath, skin and scalp; a repeater. Over 100 other fast-selling specialties, toilet preparations, perfumes, flavoring extracts, spices, medicinal preparations and household specialties. Every item a fast seller and a big profit-maker. Don't fail to ask for our free sample case offer. We furnish advertising matter and samples free of charge. Ho-Ro-Co representatives are successful. Write today. Ho-Ro-Co Mfg. Co., 154 Locust St., St. Louis, Mo.

AGENTS: Make \$75.00 a week selling our strictly All-Wool made-to-measure suits at \$26.50. You collect profits in advance and keep them. We supply finest selling outfit in America. Many exclusive money-making features. Tailoring, raincoat and side-line men, part or full time, get in touch with us immediately. Address Dept. 483, Goodwear, Inc., 813 W. Adams St., Chicago.

NEW Miracle Motor Gas amazes motorists: 3c worth equals a gallon of gasoline; prevents carbon; engine starts quickly coldest days; increases mileage 15% to 40%. Isom, Idaho, wires. "Ship 500 packages; made \$70 yesterday;" samples free; exclusive territory. 300% profit; get package free money-back offer. Miracle Mfg. Co., Dept. 1340, Toledo, O.

AGENTS—Men or women, \$4 to \$9 a day taking orders for Liberty Raincoats. Made to order in our own factory. Guaranteed. We deliver and collect; pay you daily. Full or spare time. No capital needed. Be sure and write today. Liberty Coat Co., 2580 Liberty Bldg., Dayton, Ohio.

AGENTS: Large profits selling National Automobile Cowl Ventilators and other accessories to dealers, garages or to auto owners direct. Quick sellers, easy to install in any car. Write for our proposition and descriptive matter, don't wait. National Aluminum Co., 1907 Frederick St., Racine, Wis.

BIG Profits Selling New \$3.50 Automatic Adding Machine. Absolutely accurate. Fully guaranteed. Quick sales. Ten daily easy. No competition. Pocket size. Business people everywhere positive customers. Thousands being sold. Tremendous demand. Here's high-grade money-maker. Bassett Co., 1458-B, Hollywood Ave., Chicago.

AGENTS: 1922's Greatest Sensation. 11-piece toilet article set selling like blazes at \$1.75 with \$1.00 dressmaker's shears free to each customer. Line up with Davis for 1922. E. M. Davis Co., Dept. 563, Chicago.

\$5,000.00 IS yours in 1922. Exclusive contracts, complete line, fastest selling auto accessories made. All you need is Pep. We show you how. Secure your territory today. Leslie P. Muter Company, 32 West 69th Street, Chicago, Illinois.

PLYMOUTH Bags. We are selling this popular bag in green, black, blue and brown leatherette, cretonne lined. \$6-\$6.50-\$7.20 and \$10 per dozen. Sample 65c prepaid. Write for free samples of material. E. Condon, Mfg., 12 Pearl St., Boston, Mass.

OUR Ex-Cel Luminous Crucifix shines brilliantly in the dark. Churches, hospitals and individuals are only waiting for a demonstration before buying. Agents make handsome profits. W. G. Hasman Co., Dept. B, 57 E. 18th St., Chicago.

TRIAL Order, two each Household Aprons, Kiddie Aprons, Bibs and Baby Pants, \$2.25 postage prepaid. Sell for double. Splendid line rubberized specialties. Get details, Agents colting money. C. B. Bresler Company, 148 West 23d Street, New York.

LIVE Agents make \$10 Day selling Eureka Strainer and Splash Preventor for every water faucet. Takes on sight. Widely advertised and known. Get details today. A. B. Seed Filter Company, 73 Franklin, New York.

NEW Patented Safety Pipe Taps, fit any pipe. Save tobacco; no sparks, no burns, no fires. Big sellers; every pipe smoker wants it. Sample 10c. Dozen 50c. Address Sapico Co., Santa Monica, Calif.

MOST complete line of easiest selling sanitary Brushes, Dusters and Mops. We pay 50% Commission. Write for territory, selling plan and circular. Wire Grip Brush Corp., 29 Mercer St., New York City, N. Y.

CHAFFIN Polishing cloth cleans without scratching. 25c seller. 150% profit. \$10 daily easy. Every housewife buys one to three. Free sample demonstrator. Chaffin Products Co., 5511 Euclid Ave., Cleveland, Ohio.

MAKE 600% Profit. Free Samples. Lowest priced Gold window letters for stores, offices. Anybody can do it. Large demand. Exclusive territory. Big future. Sideline. Acme Letter Co., 2800-D, Congress, Chicago.

POLMET Polishing Cloth works like magic. Cleans all metals. Gets the attention and money. Fast seller at 25 cents. Sample Free. A. A. Gale Company, 15 Edinboro Street, Boston.

AGENTS make 60 dollars per week selling new Sallie May "Dressup" Aprons. Write and learn how to obtain samples without cost. Moss Apron Co., 68 Searle Bldg., Rochester, N. Y.

AGENTS—Make \$50.00 per week selling our famous \$19.25 made to measure suits—direct to consumer. Free outfits to hustlers. Commonwealth Tailors, Dept. 101, 318 W. Washington, Chicago.

MAKE Money at home making toys. We show you how. Send 50c (no stamps) for complete working drawings and instructions. DeKalb Designing Co., Decatur, Ga.

FREE Sample, quick-selling patented specialty. Get yours now. Also details \$5,000-year golden opportunity. Agents wanted. H. G. Martin, 51 Cliff St., New York City.

WORLD'S Fastest Agents' Seller. 400% Profit. Needed in every home, office and store. Establish permanent profitable business. Free Sample. Premier Mfg. Co., Detroit, Mich.

PRODUCING Tailoring Agents Wanted. men's made to order clothing (Union Made). Beautiful materials—lowest prices. New Spring swatch line ready. Leeds Woolen Mills, Chicago.

A BUSINESS of Your Own—Make sparkling glass name plates, numbers, checkerboards, medallions, signs; big illustrated book free. E. Palmer, 511 Wooster, O.

AGENTS Sell Neverfall Iron Rust and Stain Remover. Huge profits. Big line. Sample. Write today. Sanford Beal Co., Inc., Newark, N. Y., Dept. 6.

HIGH-GRADE agents for entirely new accessory for any automobile. Makes night driving safe. Can carry in pocket; every car owner buys. Fits any make. Men who can stand big profits and stay on job. Ray Auto Filter Company, Marion, Ind.

SEND for pocket tool-chest circular. Tells about remarkable combination tool for the pocket. Hub State Company, 88 Broad Street, Boston, Mass.

AGENTS—\$50 weekly selling EZ-Way Fruit Jar Openers. Every housewife buys. Sample 25c. Standish & Dillenbeck, Mfrs., Binghamton, N. Y.

AGENTS—Advertising Pencils, ready sellers, excellent sideline. Write for proposition. North American Pencil Works, 310 So. Canal St., Chicago.

AGENTS: Wonderful Sellers; easily handled, quickly sold, big profits. Sample 10c, 4 different 25c. Harvey Teeple, Decatur, Indiana.

GET out of the rut and be your own boss by being only one in your locality in introducing direct to the consumer the highest quality line toilet preparations and household specialties sold in America. None better made, regardless of price. Every human being a possible user and positive booster when sold. You double your money. Experience unnecessary. Open to men and women possessing character and ambition. Full or spare time. As evidence of good faith send 50c stamps, receive one of our specialties, with full particulars. You will then be convinced. The Chemists' Company of New York, Box 115, Long Island City, N. Y.

\$12.45 FOB a made-to-measure two-piece suit, the biggest bargain offer ever made by any tailoring house. We are out to beat high tailoring prices. Save 50% on your next suit. You can easily earn \$60.00 cash weekly in your spare time by taking orders for our celebrated made-to-measure clothes. Write us today for our beautiful cloth samples and wonderful offer—sent free, postage prepaid. Act quick. The Progress Tailoring Co., Dept. C-142, Chicago, Ill.

WANTED—Agents and Salesmen to handle Europe's Famous Wonder Glass, the newly imported Prism "Binoculetto." For theatre, hunting, yachting, races, touring, aviation, etc. This is the smallest and of its size the most powerful Glass in the world. Can be carried in vest pocket or ladies' bag. Retail at \$25.00. Confidential wholesale price to agents \$12.50. Send money with order to George Mayerle Optical Co., General Importers, established 1894, 969 Market St., San Francisco, Calif. (Send for catalog.)

\$60.00 WEEKLY during spring. 32 small sales daily will accomplish this. Mystol vanilla flavor is the housewife's favorite. Just think of it. A full half pint of pure, rich, mellow flavor for fifty cents. No conservative woman can resist such a bargain, or will try to. 34 cents profit by our system. Popular for nearly twenty years and the fastest selling food specialty in America. Write Mystol Corp., Geneva Falls, N. Y.

PATENTS—Trademarks. Before disclosing an invention, the inventor should write for my blank form "Evidence of Conception." This should be signed, witnessed and returned to me with sketch or model, upon receipt of which I will promptly render opinion as to patentable nature and send booklet on Patents. Highest references. Prompt attention. Reasonable terms. Clarence B. O'Brien, Registered Patent Lawyer, Woodward Bldg., Washington, D. C.

AGENTS—Sell Necessities like Tea, Coffee, Baking Powder, Flavors, Soaps, Perfumes and other products. Used every day in the year. Repeat over and over again. Every home a customer and regular user. The smart and experienced agents handle this line, why not you? Write today for Money-Making Plan. Don't delay. Territory going fast. American Products Co., 5723 American Bldg., Cincinnati, Ohio.

AGENTS—Make \$50.00 a week and up in tailoring business. Get our big swatch sample outfit—119 powerful fast-selling fabrics to retail at \$23.00—\$27.50—\$34.50—\$37.50 per suit. \$15.00 to \$20.00 cheaper than store prices. You keep \$5.00 deposit on each sale—we deliver and collect balance. Write D. A. Kennedy, Dept. 100, 202 S. Green, Chicago.

AGENTS—Make \$7 to \$14 a day. Brand new Aluminum handle Cutlery Set. You take orders, we deliver and collect. Pay you daily. Full or spare time. No experience necessary. No capital. We need 1500 Sales Agents, men or women, to cover every county in the U. S. Demand enormous. Write quick. Jennings Mfg. Co., Dept. 1868, Dayton, Ohio.

BUICK, originator of valve-in-head motor and founder of the Buick Automobile, wants sales agents to handle the Buick Hi-Power Carburetor—the 100% efficient and economical instrument—immediately commands attention. Agents making \$20 to \$50 day. Write for particulars. David Buick Carburetor Corp., Desk 15, Detroit, Mich.

AT Last—World's Greatest Adding Machine. Almost human. Retail \$15; work equals \$300 machine. \$500 monthly easily made, demonstrating to stores, offices, garages, factories. Simple, easy; adds, subtracts, multiplies, divides, automatically. Speedy, accurate, durable, handsome. Five year guarantee. Tremendous demand; amazing profits. Liberal trial offer. Protected territory. Write quick. Lightning Calculator Corp., Dept. F, Smith Bldg., Grand Rapids, Mich.

AGENTS: Sell full line of guaranteed hosiery for men, women and children. Must wear 12 months or replaced free. All styles, colors and finest line of silk hose. Often take orders for dozen pairs in one family; permanent customers and repeat orders make you steady income. Write for sample outfit. Thomas Mfg. Co., Class 462, Dayton, Ohio.

AGENTS: Here is something you can sell to every housewife. Most useful household article made. Indispensable in every kitchen, restaurants or hotels. Tyler's Ideal Fibre Cutter tenders meat, chops vegetables, shaves ice, cleaves bones, scales fish, all in one. Low price, quick sales, big profit. Address now—M. H. Tyler Mfg. Co., Dept. S-4, Muncie, Ind.

BIG profits in fastest selling article available to agents. Three-in-One Holder is new invention. Sells two for 25c; costs you half that. You can sell a dozen or more to every home, store, office, factory, shop, garage, institution, etc. Tremendous seller because universally useful. Ribbon Steel Products Corporation, 114 Liberty Street, New York, N. Y.

AGENTS: Quick sales, large profits selling insecticides to households and business firms—no guesswork—just find the infested places and it simply sells like blazes. Money-back guarantee. Write now for our liberal proposition.—\$1.35 sample Roach-i-cide for trial to you—60c, postage included. White House Products, 200 North Jefferson Street, Chicago.

TAILORING Agents; wonderful all-wool, one-price line, retails \$29.50 per suit; \$10 to \$20 cheaper than retail prices; you collect profit at once; we ship C. O. D. to customer for balance; exclusive territory; hustlers wanted; none others considered; write fully; state experience. Sales Manager, A-21, 831 West Adams St., Chicago, Ill.

EASY Money—\$20 a day—Something new. "Simplex Ironing Board Covers." Biggest seller in years. Every woman wants one. New agent cleared \$19.50 on Saturday. Another cleared \$6 first hour. Drop dead ones—sell something new and make big money. Write quick. W. J. Lynch, Box 718, Springfield, Ill.

JENSEN sold 3474, Dixon 2025, Harman 700; sell Plate-Too; something new, it's different. Patent pending. Cleans Plates, renews in one operation, wonderful demonstrator. Big repeater. Write for territory before it is too late. Sample \$1.00. Plate-Too Mfg. Co., 614 35 So. Dearborn, Chicago.

AGENTS—\$8 to \$12 a day, taking orders for Music Chest. New invention does more than machine costing 20 times its price. Easily carried with you anywhere. Gratz made \$394 one month. Write for terms and sample. Thomas Mfg. Co., Class 2362, Dayton, Ohio.

SELL Minitmend for tires and tubes—cost 2c. Repair; surpasses vulcanizing, saves 500%. Every auto and accessory dealer buys. Profits amazing. Shaw made \$21 first day. Hart \$155 first week. Particulars and free sample. The Colonial Rubber Co., Dept. 85, Philadelphia, Pa.

AGENTS Wanted for World's best 30x3 1/2 Cord Tire—sells for \$12.50. Write at once, C. D. Hibbs, Ft. Worth, Texas.

BIG profits. Sell Plate Glass Wind Deflectors, Rear View Mirrors, Aluminum Foot Scrapers and 20 nationally advertised accessories. Car owners, Dealers, Garages buy one to gross. Write quick for illustrated catalog and agency prices. Rapid Sales Corporation, 11-D Grand Rapids, Michigan.

AGENTS: Reversible Raincoat. Something new. Latest style. Not sold in stores. Guaranteed Waterproof. Two coats for the price of one. No capital required. We deliver and collect. Write for territory and sample. Thomas Mfg. Co., Class 1462, Dayton, Ohio.

AGENTS: Make \$75.00 per week. Wonderful Instanto Gas Lamp. Lights instantly with a match. Sells to every home. We deliver and collect. Pay you daily. Experience unnecessary. Sample free. Rallen Mfg. Co., Dept. P. M., Baltimore Bldg., Chicago.

PORTRAIT Agents—Earn Big Money selling our Photo Medallions. Everybody buys. You charge \$3.00; make \$2.40 each sale. \$10 daily easy. Big variety designs. 4-day service. Perry Photo Novelty Corporation, Section 16, 369 Bowery, New York.

A VERY profitable business of your own selling our Clean Cutter Can Opener and Acme Universal Kettle Drainer. Wonderful, fast selling, patented necessities demanded in every home. Peninsular Specialty Co., Desk B, 15301 E. Jefferson, Detroit.

BUILD Your Own Business selling our standard products from factory to home at prices that get orders. \$5000 year. Over 150 articles used every day. Write for money-getting plan. Pitkin, 347 Commercial Bldg., Newark, New York.

COMPLETE Line Automobile Necessities that sell to car owners on demonstration. Auto owner agents wanted every county. Make big money. Write today for agent's prices and territory. Crescent Accessories Co., Candler Bldg., New York City, N. Y.

SELL Grito Laundry Tablets. Whirlwind Seller. Big Repeater. Sales guaranteed. Washes dirtiest clothes absolutely without rubbing. Agents coinng money. Send for free sample and particulars today. Grito Soap & Mfg. Co., Dept. 2X, Rochester, N. Y.

PROTECT Your Rights. Write for Record of Invention which contains forms to establish evidence of conception of your invention. Prompt personal service. Preliminary advice without charge. J. Reaney Kelly, 612 G. Columbian Bldg., Washington, D. C.

NEW—Fastest selling specialty on market. Sells everyone on sight, 100% profit. Makes income \$15.00—\$25.00 per day certain and easy. All territory virgin. Safety Blade Handle, 1316 No. American Building, Chicago.

GOLD Sign letters for stores and office windows. Photo pillow 1-gs, portraits, frames, sheet pictures, medallions, waterproof aprons, novelties. Samples, catalogue free. Thirty days' credit. James C. Bailey Co., Desk C3, Chicago, Ill.

BIG Pay. Man or woman of character to distribute religious literature. Chance to make \$600.00 or more. Full or spare time. No capital or experience necessary. Universal Bible House, Dept. H, Philadelphia.

AGENTS, Sell Mengo Sticlite Patches for tires and tubes. Every Auto Owner and Dealer buys. Exclusive territory. Write for free sample and sales plan. Mengo Products Co., 537 Rosedale, Pittsburgh, Pa.

AGENTS See our display advertisement on page 138 in this magazine, then write us immediately. Wide awake agents need no other line. Address, Sales Dept., The Kaxo Company, Cambridge, 39, Mass.

AGENTS—Sell Thompson's Washing Compound—washes clothes instantly without rubbing. Makes washday a pleasure—cleanses everything. Fast Seller—Big Repeater. Write—A. D. Thompson Co., 1103 Union St., Indianapolis, Ind.

AGENTS. Sell Wolverine Laundry Soap; 150 other household necessities. Big line. Big profits. Quick repeaters. Free instruction. Write quick for terms. Wolverine Soap Co., 298 Water St., Portland, Mich.

AGENTS: Start little Mail Order business anywhere. Home employment evenings. Send ten cents for Instruction Booklet and Mail Order Samples. Williams, Department H, 72 Coelndt Street, New York, N. Y.

SOMETHING Big. Dime puts you on our mailing list one year. You receive latest money-making opportunities, propositions, from manufacturers and supply houses everywhere. Kentucky Agency, Covington, Ky.

RAYLITE diamonds, marvelous gem discovery, true diamond color — beautiful guaranteed rings, jewelry, specialties, stretching kuff buttons at factory prices. Big profits. Exclusive territory. Master Jewelers, Sheboygan, Wis.

CANVASSERS—Two real money-makers. Self-threading needles and needle books; coat 5c, sell at 15c. Send for samples. S. Lee, 145 E. 23d St., New York, N. Y.

GASKET Display Boards with Assorted Gaskets for popular autos sell to every repair shop. Easy, profitable sellers, steady repeat. Write for agent's prices and territory. Crescent Accessories Co., 220 West 42nd Street, New York City, N. Y.

AGENTS: New reversible raincoat. Not sold in stores. One side dress coat, other side storm overcoat. Saves \$20. Guaranteed waterproof. Big commission. No capital required. Sample furnished. Parker Mfg. Co., 378 Rue St., Dayton, O.

SEND for our Bargain Bulletins. Hundreds of fast-selling novelties for Agents and Salesmen. Our low prices will surprise you. Circle Sales Co., Dept. 29, Moline, Ill.

EVERY Ford needs our Safety Clutch Control. New Patent. Quick Sales. Small Capital. Low Priced. Circular Free. Sample \$1.00. C. C. Moore, 415 Cuyahoga Bldg., Cleveland, O.

AGENTS. Mail order men: Valuable tips, inside information; also 17 automobile specialties. 300% profit. Particulars. Nite Mail Order & Supply Co., 609 27th St., Denver, Colo.

\$40.00 WEEKLY (whole or part time) selling guaranteed Hose, Waterproof Aprons, Shampoo Caps, Toilet and Sanitary necessities. Credit given. Jas. C. Bailey Co., Dept. M6, Chicago.

SELLS like hot cakes; big profits; new ironing wax; perfumes clothes with lasting violet perfume. Working outfit 10c. Yankee Manufacturers, 380 Atlantic Ave., Brooklyn, N. Y.

GENUINE Oriental Goods, all kinds, direct from the importer. Best agency proposition in U. S. Send for list. McCallister Co., Importers, 570 Phelan Bldg., San Francisco, Calif.

AGENTS: We start you: Paying Mail-order Business: Positive results: Particulars. Samples 25c and name in Agents' Directory Free. Trade Secrets Co., 3923, St. Louis, Mo.

AGENTS. Salesmen: Renshine cleaner, polish. Captivating Auto world, household. Free Sample. 200% profit. Permanent connection. Detroit Renovating Materials Co., 4815 Commonwealth Ave., Detroit, Mich.

OUR no trust signs make the customer pay. Every merchant buys; \$1 for 5. Sample and price 25c. Address, Outdoor Advertising Service, Lockport, N. Y.

AGENTS to sell household necessities. Articles of proven worth. Write for territory and particulars. The 4 Paw Mfg. and Chemical Co., West Allis, Wis.

ATTENTION—Crew Managers: Men and Women earn \$10.00 daily with our absolute ladies' necessity. Sample, particulars free. Toddy Co., 93 Park Place, New York, N. Y.

SELL a necessity. Nimrod work and outing shirts sell when other things don't. Good commission. Nimrod Shirt Company, 1930 Cuyler Ave., Chicago, Ill.

COAST to Coast campaign needs 5,000 agents. Sample and terms dime. Dept. 37, Blossom Hair Net Co., 252 Wallabout St., Brooklyn, N. Y.

GALLAGHER made \$330.00 in one week selling guaranteed Collection Systems, used by all business men. Sayers Mfg., 2815 Sheffield Ave., Chicago, Ill.

SALES Folks: You want a timely product; repeat orders sure; profits aplenty; advancement certain; and a plan that's failure-proof? Then write us! The Robb-Tynan Co., Dept. 3, Bellefontaine, O.

EARN \$10 daily silvering mirrors, plating and refinishing metal ware, autos, chandeliers, bedsteads. Outfits furnished. E. Davis Laboratories, 286 Fifth Ave., New York, N. Y.

AGENTS—See Motor-Meter Lock, page 193 February Popular Mechanics. Sample \$1.50 postpaid. E. W. Allen, Room 14, Auzerais Bldg., San Jose, Calif.

BIG Money Solliciting Blades Resharpener, or Selling Finest Improved \$1.00 Double Edge Razor. Standard Safety Razor Corp., Pittsburgh, Pa.

SALESPEOPLE. \$1.00 starts you in business. Costs 15c. Sells for \$1.50. 75c package sent for 4c. Address Texply Co., Somerville, N. J.

AGENTS, male and female: new line necessities, home, office, auto. Sample 50c postpaid. Address Box 82, East Boston, Mass.

GET Posted for Spring. Good prices paid for butterflies, insects. See Sinclair's Display Advertisement, page 30.

300% PROFIT. Retail \$1.00—You make 75c Profit each sale. 4-8-Razor Co., Hutchinson, Kan.

AGENTS—Read my ad in "For Men" column. Givens, 450 E. 48th St., (A) Chicago, Ill.

SELL Advertising Pencils. Big Commissions. Quick Sellers. Write for Proposition. Keystone Pencil Works, Altoona, Pa.

BEST and absolutely new articles for live men to sell to trade and individuals. Big money. Fast sellers. Better repeaters. Smith, 1317 N. American Bldg., Chicago.

AGENTS—Big Profits, Gold Sign letters easily applied, samples free. Liberal offer to General Agents. Dept. C, Interstate Sign, 2620 No. Halsted St., Chicago.

COMB Cleaners. House to house agents wanted. C. W. Partridge & Co., 334 5th Ave., New York City.

MANUFACTURERS' Sales Agents with live organization. 428 St. James Building. New York City, N. Y.

BIG Profits, quick sales; Selling Crimp Grip Clothes-Line Holder. Agents making \$8.00 to \$20.00 per day. Every housewife a prospect. Send 25 cents (to agents only) for agent's examination sample. Clamps the clothes-line instantly; never lets go until you are ready. Visit your towns twice and sell more the second time than the first. Postage prepaid. References—any Belvidere Bank, Crimp Grip Company, 419 S. State Street, Belvidere, Ill.

MAKE big money, whole or spare time, selling high grade Pure Aluminum combination Cooking Utensils with new features that every Housewife wants and can afford. Our unique plans make you welcome and get the business. Exclusive territory—no sales limit. Here's chance to connect with a live one. Unlimited stock—prompt shipments. General Housewares Co., Lemont, Ill.

EVERY Raincoat Agent should get our proposition at once. If you have never sold raincoats now is the time to start. Any man able to talk is able to sell raincoats. Write for our "profit sharing, collective buying, superior quality" offer. Associated Raincoats Agents, Inc., 4143 North Wells, Chicago.

AGENTS—Your name, address and brand free on toilet preparations, soaps, perfumes, etc., on as small orders as 3 dozen of a kind. Build your own business. Repeat orders sure. Boyer International Co., 940K N. Clark St., Chicago.

AGENTS wanted in every town to sell a first-class Ford Timer direct to the owners. A real money-making proposition for spare time. Write for particulars. P. M. Box N, Norwalk, Conn.

CYCLE "Modified Vapor" system makes Ford run hundred per cent smoother. Wonderful heat control without moving parts. Quickly saves cost. Agent's money maker. Cycle Manifold Co., South High St., Akron, Ohio.

MONEY made quickly taking orders for portrait medallions. No investment required. No competition. Send for our 1922 illustrated catalogue and details. Puddin & Goldstein, Dept. A, 259 Bowery, New York.

AUTO Necessity—Start a business of your own. Very little capital necessary. Write for Proposition to Agents. Leech Accessories, 2713 Vine, Cincinnati, Ohio.

FINEST Hosiery at lowest prices. \$9.00 to \$18.00 profit per day easy. We deliver and collect. Big commissions advanced. Experience unnecessary. Moore Knitting Mills, B208 S. La Salle, Chicago.

HAVE new Violet Ray outfit, perfect in all details, selling for less than half of former prices; only \$7.75 retail. Wonderful opportunity for live agents who know the field. Write today for our proposition. Good profits. Yankee Laboratories, Inc., 305-309 East 43rd St., New York, N. Y.

BEAUTIFUL new map of the United States, showing all transcontinental highways. Profit large. Send for particulars. Standard Map Company, 129 W. Ohio St., Chicago.

EARN Big Money Fast applying Lithogram Initials to automobile doors. Every owner buys. \$1.35 Profit on each sale. Full particulars mailed. Address, Lithogram Company, 17-8 East Orange, N. J.

ONE man wanted in each county to sell direct to user complete line of paint and paint specialties, also Kling-Tite Asbestos Roof Cement, most successful product for waterproofing any type of roof. Big demand in town and country; anyone can sell. Permanent business that will make you \$3,000 or more per year. No capital required. We ship and collect. Commissions advanced. Kling-Tite Products Co., 557 Tacoma Bldg., Chicago.

DOES \$120 weekly interest you? Putnam made this selling Mystic, the amazing vest-pocket windshield cleaner; for autoists, motorists, engineers; works like magic; one rub keeps glass clear 24 hours; cleans entire shield; sheds water like a duck's back; not a cloth or glove but chemical felt, the new discovery; enameled steel mountings; very snappy; fits pocket; guaranteed year; sells \$1. Smooth sold 2,000 in 4 days; big profits; exclusive territory amazing details free. Security Mfg. Co., Dept. 545, Toledo, Ohio.

SELL the popular Universal Ray-Deflector for auto headlights. Notable invention far superior to lenses. Meets legal requirements for glare prevention plus giving full light intensity. Retail \$1.75 per set, ready apply any car. Attractive agents' discount. Big steady business. Write now for territory. Approved Appliances Corporation, Ann Arbor, Mich.

FREE Sample. "Rain Shield Wiper." Every autoist buys quickly. Retail \$1.00—Costs You 25c—(300% Profit). No Mechanical Attachment—No Cloth. One Rub Keeps Windshield Clear 24 Hours against Rain, Snow Storm. Wonderful Side Line—Carried in Pocket. Only 1 Free Sample given away in Your Town. Hurry. Write for Yours. NuLife Auto(D)Aid Corporation, Hartford, Conn.

CABBAGE Cutter, 5 knives, slices 20 vegetables finer than aluminum; never dulls; 18,000 users Cincinnati alone; endorsed by Good Housekeeping Institute. Agent's sample 48c. Meyer Co., Orland Ave., Cincinnati, Ohio.

AGENTS—We want more live demonstrator-agents to demonstrate and take orders for our Ideal Fiber Cutter. We furnish advance advertising matter, folders, etc., and guarantee exclusive territory to producers. High-grade article and big profits. Write immediately for details. M. H. Tyler Mfg. Co., Dept. 83, Muncie, Ind.

\$1,000 MADE by Wingo in six weeks selling Never Fail Razor Sharpener. Purely made \$40.50 first day. Other inexperienced men cleaning up big money. Applewhite, La., six orders in thirty minutes. Hurry—investigate—exclusive territory. Write today. Never Fail Co., 126 Allen Bldg., Toledo, O.

UNDERSELL retailers. Complete line, factory to consumer, shirts. Sure, fast sellers. Price sells them; quality gets repeat orders. \$15 daily easy. Free samples to workers. Chicago Shirt Co., 209 So. Wells St., Room 954, Chicago.

AGENTS—\$60-\$200 a week. Free Samples. Gold Sign letters anyone can put on store windows. Liberal offer to general agents. Metallic Letter Co., 431-C N. Clark St., Chicago.

QUICK Seller. New Improved Midget Collapsible Hangers. Strong—attractive—pocket size in leather case. Everybody wants them. 100% profit. Sample 35c. Write for details. Kalfina Co., 384-B, Alabama Ave., Brooklyn, N. Y.

WHY work for others? Make and sell your own goods. We show you how. Enormous profits. Write quick for free book explaining everything. National Scientific Laboratories, 624 Main, Richmond, Va.

AGENTS, we have the finest needle case. You can clear \$50.00 to \$200.00 weekly. Send 10c for sample, sells 25c. Empire Specialties Co., 1549 N. Wells, Dept. 301, Chicago, Ill.

SELFOLITE—Agents, Streetmen—Selfolite lights any fire while user sleeps, or any time. Performs surprising stunts. Newly patented. Sample 25c, postpaid; money back. Particulars. Kaytwo Mfg. Co., C195 Station A, Boston, Mass.

AGENTS: Big Profits. Genuine Gold Leaf Window Letters anyone can put up. Scripts and 57 varieties. Chicago Agency Co., 842 Altgeld St., Chicago.

AGENTS wanted to sell "Havana Treat" 5c cigars to smokers and stores. Havana Treat Cigar Co., Utica, N. Y.

REPRESENTATIVES: "Success" user in every home. Quick Sales. Big Profits. Address Sales Department, Elms Commercial College, Newark, N. Y.

MAKE \$12.00 daily—wonderful sellers, sample free; write quick, both sexes, steady work. Address Berton Bellis, St. Louis, Mo.

AGENTS—Make 100% profit. Good opportunity for hustlers. Cooper & Co., 141 E. Glenwood, Knoxville, Tenn.

AGENTS Make \$10 a day selling Presur-day Trousers presser and creaser. Connolly, 55 Vesey St., New York.

AGENTS, Canvasers: Enormous profits selling face powder, soaps, other toilet necessities. Permanent repeat business. Highest quality. Lowest prices. National Products, A16 E. 13th St., New York, N. Y.

AGENTS — Wanted — Men or women. Mother Goose Writings Mop is a whirlwind seller. New—Patented—Perfect. Demonstration means sale. Retail \$1.50. More than 100% profit. Sample mailed \$1.00. The Alline Company, 6523 Euclid Avenue, Cleveland, Ohio.

"HOW to Sell Patents" free. Patent News-H, Washington, D. C.

START your Ford in coldest weather, new invention, saves gasoline. Agents, Dealers, Ford Owners, write Jir Specialties Co., Cincinnati, O.

HOW and What to invent for profit. Patent News-A, Washington, D. C.

MAKE \$50 Daily. Something New! 400% profit. All business, professional men need it. Sells \$5. Costs \$1. Brooks, Texas, sold 20 first day, profit \$80. Big weekly repeater. Sells quickly. Experience unnecessary. Write today for territory wanted. Sample outfit free. Federal Association, 71-K Asylum St., Hartford, Conn.

MY "Sureshot" Selling Method Free to Agents. K. Home, 1957 Warren, Chicago.

AGENTS wanted to handle good automobile accessory line. Fine commissions. J. D. Ignition Construction Co., 6721 Lowe Ave., Chicago, Ill.

AGENTS—Big profits selling "Wunrub Polish" for Furniture, Woodwork, Autos, Etc. Cleans and Polishes. Fritch's Laboratories, 6431 Magnolia, Chicago.

WONDERFUL article for direct selling. Address, Sanitary Mfg. Supply, Dept. 5, Akron, Ohio.

YOU can make \$12,000 a year selling well-known, standard, advertised make of hand-drawn chemical fire engines, motor fire apparatus, extinguishers, hose, and complete line of fire-fighting sundries. We have several openings in good territories. Other men are making \$1,000 a month in territories not so good as we now offer. Address Ajax Fire Engine Works, Bush Terminal Bldg., 10, Brooklyn, N. Y.

GENERAL Agents. Something New, Whirlwind seller. "Repeat" washing powder. Washes clothes without rubbing. Women throw away washboards. Big profits. Exclusive territory. Write today, free package. Kittredge Co., 8 Putnam St., Tunkhannock, Pa.

GUARANTEED Brushes: 113 different kinds—household—commercial—auto. Tremendous sellers, everyone a prospect. Permanent business—Steady income. Write or wire Desk 6. Universal Brush Company, 181 Quincy Street, Chicago.

AGENTS! A sale in every home for our beautiful dress goods, silks and general yard goods. Quick sales! Big profits! Large book of 1000 handsome fabric samples. Write today, National Importing & Mfg. Co., Dept. 6X, 573 Broadway, New York, N. Y.

PORTRAIT Agents—\$50,000 is what "Picture Man Friedman" made canvassing. Free circular "Profits in Portraits" tells how. 24-hour service prints, finished portraits, frames. Samples free. "Picture Man Friedman," Dept. 8, 127 N. Dearborn St., Chicago.

AGENTS: Self-threading needles. Every home buys. 175% profit. Sample free. Maher Co., Dover, N. J.

\$1,000 PER man per county. Get yours. Inexperienced men pulling down star salesmen's profits. Write for proof: How farmers, ministers, clerks—men in all walks of life—made big money in whole or spare time. You can do it. Amazing proposition—wanted everywhere. Exclusive territory—no sales limit. A hot or cold running water bath equipment for any home at only \$7.50. Self-heating. No plumbing nor water works required. Investigate. Terms. Send no money. Write letter or postal today. Allen Mfg. Co., 654 Allen Bldg., Toledo, Ohio.

PORTRAIT Agents—A new portrait, something entirely different. Write for particulars, also catalogue and price list. Fidelity Portrait Company, Dept. 100, 3047 Harrison St., Chicago, Ill.

BIG Line—Big Profits—Cold Creams, face powders, perfumes, remedies, spices, extracts, pie fillers, baking powder. Catalog free. Western Laboratories, 1964 Van Buren, Chicago.

BIGGEST, fastest sellers. Every woman buys Hawkins' High Grade Toilet and Household Necessities on sight. 100% profit. Colonial Chemical Co., 631A Penn Ave., Pittsburgh, Pa.

BUILD Permanent Business following our Sure Success Plan introducing Guaranteed Hosiery and Underwear from factory to family. Attractive outfit assures quick sales. Large profits. Investigate for yourself. Address C & D Company, 41-B, Grand Rapids, Mich.

MEN and women make \$100 upwards weekly selling greatest labor and money saving household necessity. Big repeater. Good crew managers' proposition. Free sample and particulars. Holly Co., A-1, Hastings, Neb.

AUTOMOBILE Accidents prevented by new invention; costs distributor \$2.50, delivered; retails at \$7; wonderful self-selling plan. Carl Brown, Manager, Dept. 32, Columbus, Ohio.

WE pay \$200 monthly salary, furnish rig and expenses to all who qualify introducing guaranteed poultry and stock powders. Bigler Company, X368, Springfield, Illinois.

GOOD income, spare time, refinishing chandeliers, brass beds, automobiles, etc., by new method; producing amazing results; every household possible customer; experience unnecessary; simple plan of manufacturing at home starts you in big money-making business. Write for free samples, showing finishes, etc. Gunmetal Finish Co., Ave. H, Decatur, Ill.

COPPER Pots, all sizes; also anything in copper goods desired. Write today for free catalog. Boyer & Co., 609 Reserve Bank Bldg., Omaha, Neb.

O-HELL-O, why didn't I see this before. \$1 an hour selling new product. Removes iron rust, mildew, fruit, ink, medicine and grass stain. Write for free sample and terms today. C. H. Stuart & Co., 24 Broadway, Newark, New York.

AGENTS Wanted, to sell an improved tool that often pays for itself first time used. Address today, J. 1610 Georgia St., Los Angeles, Calif.

GOLD Leaf Sign Letters; make and sell; profits exceed 1,000%; immense demand; particulars free. Johnston Co., Quincy, Ill.

AGENTS—Texas Remedies 200%. Address Int'l. Remedy Co., 1331 Franklin, St. Louis, Mo.

AGENTS! 1921's greatest sensation. 11-piece toilet article set selling like blazes at \$1.75 with \$1.00 dressmaker's shears free to each customer. Get lined up for Christmas rush. E. M. Davis Co., Dept. 506, Chicago.

FASTEST Selling Sanitary Brush Line in America. Huge profit-making opportunity for live workers, with advancement. Other specialties. Get complete details. Act quick. Best season at hand. A. A. Silver-Chamberlain Co., Clayton, N. J.

ANY man handy with paint brush can start new mechanical business on nearly nothing; needed everywhere; nearly all profit; experience not required. John Braceland, 1457 So. Ninth, Philadelphia, Pa.

WONDERFUL Winter Auto Necessity invention. \$1.00 sale means 75 cents profit for you. Experience unnecessary. Absolutely New Specialty. Riley made \$108 three days. Slocum first hour made \$10. Every Automoblist buys after each quick demonstration. Carried in Pocket. Prevents Accidents. Better Service. Reduces Operating and Repair Expenses. Write Quick for Exclusive Territory and Free Sample. Secretary, Box 494, Hartford, Conn.

AGENTS—New Invention, Harper's Ten-Use Brush Set and Fibre Broom. It sweeps, washes and dries upstairs windows, scrubs and mops floors and does five other things. Big profits; easy seller. Free trial offer. Harper Brush Works, Dept. X, Fairfield, Iowa.

EASY, pleasant work for Mechanics, Shop Men, Clerks, during spare hours; will add many dollars to their salaries. Also want persons who can give full time. Big wages assured. Novelty Cutlery Co., 67 Bar St., Canton, O.

IF you need good live agents—fellows who can get the business—ask me how others are doing it. I'll gladly render the necessary assistance. J. Roy McClellan, Mgr. Classified Advertising, Popular Mechanics Magazine, Chicago.

BE Successful Agent—Free sample outfit worth \$2.25. "Quality" beauty preparations. Make big money. Extensive line. Established 50 years. Lynas Co., 216, Logansport, Ind.

AGENTS make 140% profit. Iradium (luminous) crucifix shines in the dark. Sells for \$2.00. Costs 85c. Complete line religious articles, crucifixes, bulbs, switch plates, house numbers and match boxes. Novel! Ornamental! Useful! Every home a prospect. Big sales. Get free demonstrating outfit. The Pioneer Corporation, 1259 W. 63d St., Chicago, Ill.

SELL washing tablets that are different. They work quicker, sell easier and at a greater profit. Get our proposition. Write Newton & Co., 1 Main St., Newark, N. Y.

AGENTS—Clever Invention! Inkspoon makes every pen a fountain pen. Fast office seller; big profit, demand increasing everywhere. Exclusive territory offered. Sample free. H. Marul Company, Tribune Bldg., New York, N. Y.

WRITE for particulars; best article ever offered men; costs 5c, sells quick for dollar; \$15 daily; sworn statement. Besch, 22 Express Bldg., San Diego, Cal.

FREE—Formula Catalog. S. & H. Laboratories, Boylston Building, Chicago.

SELL Necessities. Everybody needs and buys the "Business Guide." Bryant cleared \$500.00 in July. Send for sample. It's free. Nichols Co., Box 4-B, Naperville, Ill.

AGENTS make 500% profit handling Auto Monograms, New Pictures, Window Letters, Transfer Plugs, Novelty Signs. Catalog Free. Write Hinton Co., Star City, Ind.

AGENTS—Steady Income. Large manufacturer of Handkerchiefs and Dress Goods, etc., wishes representative in each locality. Factory to consumer. Big profits, honest goods. Whole or spare time. Credit given. Send for particulars. Freeport Mfg. Co., 59 Main St., Brooklyn, N. Y.

AMERICO Booster auxiliary water carburetor makes autos burn water. Eliminates carbon. Low cost; liberal profits; details free. Americo Co., Dept. 178, Cincinnati, Ohio.

WORLD'S Fastest Selling Auto Accessory! County Distributors wanted; write today. G. L. W. Spring Oiler Co., San Diego, Calif.

PORTRAIT Agents, who want good work and prompt service and who desire to purchase their frames at factory prices, should write us at once for catalog and price list. W. G. Hannan Co., Dept. A-5, 57 E. 18th St., Chicago, Ill.

AGENTS—New patented curtain rod, necessity in every home; big profit; 4 to 10 sales at every house. Write for free sample. Home Curtain Rod Co., Providence, R. I.

LARGE shirt manufacturer wants Agents to sell complete line of shirts direct to wearer. Exclusive patterns. Big values. Free samples. Madison Mills, 503 Broadway, New York.

CALIFORNIA Rosebuds selling like hot cakes. Agents coinng money; new stuff. Big profits. Catalog free. Mission Bead Co., PM-2819, West Pico, Los Angeles.

AGENTS; Big Money Monogramming by Transfer Method. Catalogue Showing Over 50 Styles and Particulars Free. Motorists' Accessories Co., Mansfield, Ohio.

SELL Pudding Powders—Delicious dessert. Fast sellers; quick repeaters; big profit. Send for terms and sample. C. H. Stuart Co., 65 Union, Newark, New York.

AGENTS make one dollar per hour selling "De Luxe Art Panels." Newest thing in art. Men with automobile make forty dollars per day. Tremendous demand. Write for samples and expense money. Consolidated Portrait Co., 225 North Green St., Chicago.

\$200 WEEKLY. Free samples. Sell gold sign letters to stores, offices. No experience. Big future guaranteed. Can travel. Exclusive territory. Become our general agent. Acme Letter Co., 2806D Congress, Chicago.

MAKE \$25 to \$50 Week representing Clows' Famous Philadelphia Hosiery, direct from mill—for men, women, children. Every pair guaranteed. Prices that win. Free book "How to Start" tells the story. George Clows Company, Desk 31, Philadelphia, Pa.

YOU can letter Automobiles, Doors, Trunks etc., without any previous experience by Transfer Process. Make \$27.50 on \$2.50 Outfit. Auto Monogram Supply Co., 16 Green St., Newark, N. J.

BEST Proposition on Earth. Kitchen Specialty Every Woman Wants. Nothing like it in existence. 200% profit. Best Novelty Mfg. Co., Dept. C, 160 N. Wells, Chicago.

WE Start You Without a Dollar. Soaps, Extracts, Perfumes, Toilet Goods. Experience unnecessary. Carnation Co., 201 Olive, St. Louis.

AGENTS and portrait men. Crew managers. We give you more for your money. Better and quicker service. Lowest prices on frames and glass. Rejects credited. Catalog free. The Pioneer Corporation, 1259-A West 63rd St., Chicago.

AGENTS; Big profits. Best and cheapest window letters made. Easily applied. Dime brings five samples. Particulars free. Stairbrite Co., 1115 Second Ave., New York.

PORTRAIT Agents: Our goods will make you big profits. Delivery guaranteed. Rejects credited. Prompt shipments. Send for latest catalog and prices. Adam J. Kroll & Co., 402 Blue Island Ave., Chicago, Ill.

MAKE \$2 an Hour. Article that removes iron rust, grass, medicine, fruit, mildew stains. Cleans Panama and Straw Hats. Bleaches clothes. Sells Every home. Write for free demonstrating outfit and start taking orders at once. Christy, 81A Union, Newark, N. Y.

AGENTS; Big Returns, fast office sellers; particulars and samples free. One Dip Pen Co., 2 Daily Record, Baltimore, Md.

AGENTS make a dollar an hour. Sell Mendets, a patent patch for instantly mending leaks in all utensils. Sample package free. Collette Mfg. Co., Dept. 404-B, Amsterdam, N. Y.

WANTED—Tailoring Sales Agent—Make big money from very start—\$60.00 to \$75.00 weekly. Largest made-to-measure tailoring house, furnishing an equipment of five hundred woolsens, wants you to take orders. Satisfaction guaranteed. Biggest merchants in many towns have started with our line. If you want to establish yourself permanently in business and make big money write for full particulars, giving your experience as salesman or tailor's sales agent. H. F. Foster, Sales Manager, Lock Box 483, Chicago.

MOST Wonderful Seller. 96c profit every dollar. No stock to carry. License unnecessary. Sample free. Mission Bead Co., 1617 Iroka, Los Angeles, Calif.

AGENTS—Best seller; Jem Rubber Repair for tires and tubes; supersedes vulcanization at saving of over 80%; put it on cold, vulcanizes itself in two minutes, and is guaranteed to last the life of the tire or tube. Sells to every auto owner and accessory dealer. For particulars how to make big money and free sample, address Amazon Rubber Co., Amazon Bldg., Philadelphia, Pa., Dept. 505.

AGENTS—If you are making less than \$300 a month our proposition on Sentinel Burglar Alarms for windows and doors will interest you. Many agents earn \$20 daily. Brand new inventions. No wires, batteries or nails. Instantly attached to any door or window. Handsomely nickel plated. Sell on sight. No competition. Provides cheap burglar insurance. Big money makers. Write today for extremely liberal terms to agents. Sentinel Alarm Co., 140 S. Dearborn St., Chicago, Ill.

AGENTS—Stamping names on Pocket Key Protectors; sample Check with your name and address, 25c. Stamping Outfits, Emblem Checks, Check Fobs, Name Plates. Hart Mfg. Co., Desk 2, 303 Degraw St., Brooklyn, N. Y.

YOU can be your own boss with our Key Check outfit. Good for \$5 a day stamping names on pocket key checks, fobs, etc. Sample check with your name and address, 30 cents. Pease Die Works, Dept. M, Winchester, N. H.

PATENTS—Write for our free illustrated guide book and Evidence of Conception Blank. Send sketch or model for our opinion of its patentable nature free. Highest references. Prompt attention. Reasonable terms. Victor J. Evans & Co., 163 Ninth, Washington, D. C.

BIG money and Fast Sales. Every owner buys Gold Initials for his auto. You charge \$1.50; make \$1.35. Ten orders a day easy. Write for particulars and free samples. American Monogram Co., Dept. 40, East Orange, N. J.

DICHINOLINDIMETHYLSULPHATE. It's a Chemical Millers' The Chemist supplies Latest Manufacturers' Formulas for Food, Beverage, Household, Automobile, Summer Specialties in all lines. Grape-ola New Beverage with the Kick. Stamp brings Lists, Valuable Information to start a business paying Fifty to Five Hundred Dollars weekly with small investment. Miller, Chemist, Tampa, Florida.

FASTEST Selling Auto Specialty on market; 500,000 will be sold next six months. Splendid proposition; write quick; \$5.00 brings samples and full details. Write O. B. Herth Mfg. Co., Inc., Hartford, Conn.

SIGN letters for windows at honest prices. Genuine gold leaf, \$50 week easily made. Chicago Sign System F, 150 W. Austin Ave., Chicago.

HIGH-GRADE SALESMEN WANTED

ROOF Cement Salesmen—To sell Roof Cement and other Asbestos products direct to factories, industrial plants and large consumers. If you are now producing business but feel you are not getting sufficient pay for it, here is an opportunity to become associated with a million dollar concern and the pioneer manufacturer of roof cements. Commission basis; full protection on territory. We want only real successful salesmen. Our proposition is worth better than \$10,000 to the right man. Give full information regarding yourself and territory you are now working. Armstrong Paint & Varnish Works (Est. 1854), 5A No. LaSalle St., Chicago.

LEARN the secrets of Star Salesmanship and qualify for \$3,000 to \$10,000 a year as City or Traveling Salesman. Free Employment Service. Send now for free book about our amazing system, also list of lines. National Salesmen's Training Association, Dept. 128-C, Chicago, Ill.

MOTOR Ignition Amplifier—A Wonderful Invention! Gives new power to an old motor and more power to the new. Sell to garages, accessory dealers and users. Quick action, big money and satisfaction. Write for prices and literature. Motor Ignition Corporation, Mrs., Albany, N. Y.

SPECIALTY Salesmen calling on Garages and Accessory Dealers, to handle side line, "Oil King" Piston and Compression Rings. Dygert & Siemers, Chamber of Commerce Building, Los Angeles, California.

GREAT demand everywhere for high grade solid leather specialties. Can you sell the best quality at the lowest price? Write David H. Zell, 532-534 Broadway, New York, N. Y.

ASKO Salesmen to sell Auto Accessory as side line; can carry sample in vest pocket; sells on sight; big commission. Allen Specialty Co., 2721 W. Lake St., Chicago.

SOMETHING new, a necessity. All business and professional men need it. Sells \$7.50, costs you \$2.50. Big repeater. Sample free. Merchants Ass'n, Minneapolis, Minn.

SALESMEN, rare proposition, regular or side line, possesses wonderful selling argument. Meritorious article. Ideal for hardware or lumber trade. Only deal of its kind on the market. Quick seller. \$30 sale, \$10 commission. F. P. Brokamp, 3354 Evergreen Ave., Chicago, Ill.

ARE you the man we are looking for? We want men in this territory to sell the Sprywheel Tractor to gardeners, nurserymen, seed growers, and others intensively cultivating row crops. No rows too close, no plants too high. Intensive cultivation from seedtime to harvest increases yields, and decreases fertilizer expense. You can build up a profitable business selling this little tractor that costs only \$150.00, yet saves the work of four men at the cost of one gallon of gasoline. Write for particulars, H. C. Dodge, Inc., 35 Alger St., Boston, Mass.

BEST Seller; Jem Rubber Repair for tires and tubes; supersedes vulcanization at saving of over 80%; put it on cold, vulcanizes itself in two minutes; guaranteed to last life of tire or tube; sells to every auto owner and accessory dealer. Get particulars how to make big money and free sample. Amazon Rubber Co., Philadelphia, Pa., Dept. 510.

SALESMEN! There are some very attractive territories available for real hustlers on our well known line of high grade shoes for men, sold direct from factory to wearer. Liberal commission. We protect repeat and recommendation orders of men and help you build up a permanent, profitable business. Write for catalog and proposition today. Address Box 274, Stoughton, Mass.

GOOD proposition for state managers selling famous little "Cataract" Auto Washer for cleansing automobiles. Attaches to garden hose—water gushes through mop, keeping it free from grit. Won't mar finest varnish. All brass—can't rust. Sample \$1.50—Profit \$15.00 doz. Cataract Auto Washer Company, Topeka, Kan.

SALESMEN—To sell the Victor, first high-class adding and listing machine at a low price. Reduction to \$100 makes it greatest seller in the business. Sold on small monthly payments if desired. Commission basis. F. B. Willis, 3047 Carroll Ave., Chicago.

BIG Profitable Business of Your Own easily established, selling Pondola Cigars direct to smokers and retailers. Pondola is a winner, on the market 20 years, sells on sight; repeat orders come regularly, assuring steady income. Pondola Cigar Co., Albany, N. Y.

SALESMEN—Just peeped. Oil and moisture-proof automobile lubricating spring-boots. Send \$5.00 for samples. Be first in your territory. Direct to car owner. Proposition worth consideration. H. H. Shelters, Burlington, Vt.

MAKE thousands of dollars selling our exclusive Oriental Pearl Necklaces at importers prices. Enormous demand. Special sales plan mailing circulars. Write quick. McCallister Co., 570 Phelan Bldg., San Francisco, Calif.

SALESMEN—Fastest \$5.00 seller to homes and biggest money-maker ever invented. Saves 1/2 gas, makes cooking better and easier. Stanley Manufacturing Company, 417 So. Campbell, Chicago.

OIL Gauge for Fords. Remarkable new invention. Sells on sight. Big profits easy. Exclusive distributors wanted. Address Sales Mgr., 12, Sta. C., Omaha, Nebr.

FASTEST Seller of the day. Every housewife a prospect for Crimp Grip Clothes-Line Holder. Five minutes will clinch average sale. Agents making \$8.00 to \$20.00 per day. Send \$1.80 for sample carton containing six pair, postage prepaid. Money back if not satisfied. Reference, any Belvidere bank. Crimp Grip Company, 419 S. State Street, Belvidere, Ill.

IF you are a producing tailoring salesman and want exceptional line selling direct to wearer, write Diehl, Kane & Diehl, Dept. 7, Cincinnati, Ohio.

"WEAR-EM-LOOSE" be comfortable! "Outosite" aluminum side suspenders unify shirt and pants; agent's sample set 30c. Woods, 501 North Seventh, St. Louis.

ACCEPT this offer if you want real money. Sweet made \$652 last month. Murphy \$636. Largest company of its kind in America. Your profit \$3 to \$8 per order. We furnish full equipment. All you do is call on our customers and take their orders for famous all-weather coats. Big, permanent proposition. Spare time or full time. No capital required. Write quick for offer that will put you on the road to success. The Comer Mfg. Co., Dept. W-57, Dayton, Ohio.

PREVENT accidents. Wonderful seller. Send \$1 for samples. Highway Automobile Accessories, Portland, Ore.

ONLY one policy a day means \$250 per month profit; same on renewals. Policy pays \$5,000 death; \$25 weekly benefit for injury or sickness. Premium \$10 yearly. Full or spare time. Easy seller. Write quick for territory. Underwriters, Dept. K27, Newark, N. J.

\$5,000 EVERY year. \$2,000 easy in spare time. We share profits with you besides. Sell "Weather Monarch" Raincoats—Ask about "Dual Coat" No. 999. Get your sample raincoat free. Associated Raincoat Agents, Inc., 4414 N. Wells, Chicago.

SALESMEN—Sell State Pocket Maps, showing auto roads, to advertisers and dealers. Easy to sell. Get our splendid offer. Standard Map Company, 127 W. Ohio St., Chicago.

SPECIALTY salesman, sell the sun glare to dealers. Niftiest Auto Visor ever constructed. District and state managers developed from salesmen. Here is your chance! Have you the ability? Address Dept. A, Pugh Lattner Auto Specialty Co., New England Bldg., Topeka, Kans.

SALESMEN can make \$5.00 a day selling our Calendars, Fans, Pencils, Signs, Advertising Novelties, Yard Sticks, Whistles, etc. Liberal terms. Sells entire year. Fine side lines. Local and traveling agencies. Model Calendar Company, Dept. 226, South Bend, Ind.

\$200 PER month and bonus guaranteed salesmen successfully demonstrating wonderful new adding machine. Retail \$15.00. Work equals \$350 machine. Genuine opportunity. Full time or side-line. Lightning Calculator Co., Dept. G, Grand Rapids, Mich.

AGENTS—\$60-\$200 a week. Free samples. Gold sign letters anyone can put on store windows. Liberal offer to general agents. Metallic Letter Co., 431-E N. Clark St., Chicago.

\$200 TO \$400 Weekly. Free Samples. Lowest priced Gold Sign Letters for Stores, Offices. No experience necessary. Large demand. Appoint subagents. Excellent side-line. Acme Letter Co., 2806H Congress, Chicago.

LIVE Wire Distributors and Dealers everywhere make money selling Seal-Fast Inner-tube repair kits because of the unequalled efficiency and our aggressive and helpful sales promotion and advertising cooperation. Write Sales Manager for particulars. Robert M. Bowes Co., Indianapolis, Ind.

WANTED—Salesmen—soaps, greases, oils; old manufacturer. Baum's Castorine Co., Rome, N. Y.

SELLS on Sight—The Perco-Pot—a patented aluminum cooking utensil that cannot burn or boil over. Needs no watching. Food needs no stirring. Cooks thoroughly by percolation. Nationally advertised, already sold direct to thousands of housewives. Most phenomenal seller of the season. Here is a fortune for good salesmen and crew managers. Exclusive territory and liberal assistance. Write Perco Ware Company, Desk 10, Milwaukee, Wis.

\$20.00 A day easily made introducing Rite-Way Auto-Life—The newly perfected paste auto polish; demonstrates in two minutes. Makes old cars look new. Retail for \$1. Every car owner buys. Send \$1 for 2 full size cans, instructions, territory reservation and free sample-case offer. Sheldon Booth & Co., 322 East 41st St., Chicago.

57 MILES per gallon made with new patented gasoline vaporizer. Write for particulars. Vaporizer Co., Pukwana, S. Dak.

SALESMEN for Patented Cigar Lighters and Cigar Case Moisteners. Sell to Cigar Stands everywhere. Thousands in use. Exclusive or side line. Start Now. Drake Mfg. Co., Dept. M, Milwaukee, Wis.

MAKE \$50 Daily. Something New! 400% Profit. All Business, Professional Men Need It. Sells \$5. Costs \$1. Brooks, Texas, sold 20 first day, profit \$50. Big weekly repeater. Sells quickly. Experience unnecessary. Write today for territory wanted. Sample outfit free. Federal Association, 71-D Asylum St., Hartford, Conn.

EVERYBODY Eats Every Day. You can handle Sugar, Flour, Canned Goods, Dried Fruit, Coffee, and entire line of groceries, as well as Paints, Roofing, Aluminum Ware and Automobile Oils, with no rent to pay; no money invested; take large orders from samples. Goods are guaranteed and proven quality. Selling experience not necessary. Steady, profitable work for "workers." Address Hitchcock-Hill Co., Dept. 200, Chicago, Ill. Reference: Any Bank or Express Co.

HELP WANTED

DISTRICT Managers—Big Profits! Men capable of organizing and managing crews of lady solicitors can easily clear \$100 to \$200 per week with the B. & G. Protector, the original and best Protector on the market. Every woman between fifteen and fifty needs and buys it. Two grades, Flesh or White. B. & G. Rubber Co., 618 Penn Avenue, Dept. 129, Pittsburgh, Pa.

DISTRICT Manager: 150,000 sales of a household appliance in New England have paid District Managers upwards of \$3,000 yearly. We are ready to expand. Office work entire or side line. The Reeves Co., 64 Broad Street, Milford, Conn.

YOUNG men, women, over 17, desiring government positions, \$130 monthly, write for free list of positions now open. R. Terry (former Civil Service examiner), address 1504 Continental Bldg., Washington, D. C.

START a pressing, cleaning and dyeing shop; splendid field, excellent profits. We tell you how. Write for booklet. Ben-Vonde System, Dept. C, Charlotte, N. C.

FIREMEN, Brakemen, Baggage-men, Electric Motormen, Conductors, Sleeping car and train Porters (colored). Railroads everywhere. \$140-\$200. 810 Railway Bureau, East St. Louis, Ill.

\$12.45 FOR a made-to-measure two-piece suit, the biggest bargain offer ever made by any tailoring house. We are out to beat high tailoring prices. Save 50% on your next suit. You can easily earn \$60.00 cash weekly in your spare time by taking orders for our celebrated made-to-measure clothes. Write us today for our beautiful cloth samples and wonderful offer—sent free, postage prepaid. Act quick. The Progress Tailoring Co., Dept. C-143, Chicago, Ill.

A BETTER Job now. If you have no trade you can get a good one in a few weeks. Learn the auto business. Repairs—men always needed, get good pay; 10,000,000 autos, trucks, tractors need expert service. You can get in this business in a few weeks. Our free 188-page illustrated catalog gives full particulars. Send name today. Michigan State Auto School, 23 Auto Bldg., Detroit, Mich.

MEN—Women, over 17. Get U. S. Government positions. \$92-\$192 month. Quick sure raise. Steady work. No "layoffs." No strikes. Sure pay. Life positions. Work pleasant. Paid vacation. Common education sufficient. Influence unnecessary. List positions easily obtained free. Write today sure. Prompt action advisable. Franklin Institute, Dept. B3, Rochester, N. Y.

START little mail order business anywhere. Home employment evenings. Send ten cents for instructive booklet and mail order samples. Williams, Department M, 72 Cortlandt Street, New York, N. Y.

BECOME Government Railway Mail Clerks, \$133-\$192 month. Steady. Men—boys, over 17. List Government positions free. Write today sure. Franklin Institute, Dept. B21, Rochester, N. Y.

GOVERNMENT needs Railway Mail Clerks, \$133 to \$192 month. Write for free specimen questions. E-2 Columbus Institute, Columbus, Ohio.

EARN \$10 daily silvering mirrors, plating and refinishing metalware, autos, chandeliers, bedsteads. Outfits furnished. E. Decie Laboratories, 286 Fifth Avenue, New York, N. Y.

GET Government Jobs. \$92-\$192 month. Men—Women. Steady work. List positions free. Write immediately. Franklin Institute, Dept. B21, Rochester, N. Y.

FINGER Print Lesson based on Henry System included with Detective Course. Particulars free. Write George Wagner, 1968 Broadway, New York.

\$133-\$192 MONTH. Become Railway Mail Clerks. List positions free. Write today sure. Franklin Institute, Dept. B21, Rochester, N. Y.

CORRESPONDENCE courses and educational books sold, rented and exchanged. Bargain list free. (Courses bought). Leo Mountain, Pisgah, Ala.

GET Posted for Spring. Good prices paid for butterflies, insects. See Sinclair's Display Advertisement, page 30.

BECOME Railway Mail Clerks, \$133-\$192 month. List positions free. Franklin Institute, Dept. B21, Rochester, N. Y.

MAKE from \$1,000 to \$5,000 per year and share profits besides. No investment or experience necessary. Best season ahead. Free raincoat. Associated Raincoat Agents, Inc., 8444 N. Wells, Chicago, Ill.

STORIES, poems, plays, etc., are wanted for publication. Good ideas bring big money. Submit manuscripts or write Literary Bureau, 522, Hannibal, Mo.

BE a Finger Print Expert. Particulars free. National System, 155 E. 79th, New York.

UNITED States Government Wants Men. Excellent positions at attractive salaries. Railway Mail Clerk Examination soon. Let our expert (former United States Civil Service Examiner) prepare you for this and other fine positions. Write today for free catalog PM, Patterson Civil Service School, Rochester, N. Y.

BE a Railway Traffic Inspector! \$110 to \$250 monthly; expenses paid after 3 months' spare-time study. Splendid opportunities. Position guaranteed or money refunded. Write for free booklet CM-46, Stand. Business Training Inst., Buffalo, N. Y.

GOVERNMENT Wants Railway Mail, Postoffice Clerks, Other positions. Salary \$135 month. Experience unnecessary. Write for information concerning positions and instruction. Columbia School of Civil Service, 411 Pope Bldg., Washington, D. C.

START a Paying Business of Your Own. Be a business man. Any location. 3,000 new Tire Vulcanizing and Repair Stations needed. Business always good. Are you ambitious? \$100 will start you. Write at once. Wonderful opportunity. Equipment Co., 175 Canal, Cincinnati, Ohio.

WRITE Articles, stories, news, in spare time for newspapers and magazines. Big pay. Copyright book free. Press Syndicate, 553, St. Louis, Mo.

GOVERNMENT Clerks Needed soon. (men-women). \$1600-\$2500. Permanent. Few to travel. Write Mr. Osmont, Former U. S. Government Examiner, 101 St. Louis.

SIGN Letter Agents and Painters; 500% Profit Gold and Silver Sign Letters for Stores and Office Windows. Anyone can put on. Big demand. Free samples. Metallic Letter Co., 431D N. Clark St., Chicago.

CALIFORNIA Rosebuds selling like hot cakes. Agents coining money. Absolutely new. Big profits. Catalog free. Mission Head Co., SP2819 West Pico, Los Angeles.

SALESMEN—Become Independent. Own your business; experience unnecessary; selling our \$7,500 Accidental Death, 350 Accident, \$25 Sick Weekly Benefits; \$12.50 yearly; other amounts proportionate. Guaranteed steady income from renewals. \$250,000 deposited Insurance Department, Registration Dept. A, Newark, N. J.

MAKE money writing Photo-plays; details free to beginners. No correspondence course. Producers' League, 230 Wainwright, St. Louis.

INVENTORS desiring to secure patents should write for our book, "How to Get Your Patent," tells our terms and methods. Send sketch for our opinion of its patentable nature. Randolph & Co., Patent Attorneys, 829 F, Washington, D. C.

OUR genuine gold window sign letters are an excellent money-making proposition for handy men. Slann Sign System, St. Antoine St., Detroit, Mich.

WANTED: Railway Mail Clerks—\$1,600 to \$2,300. Exams everywhere. Write today for full information. Patterson, Civil Service Expert, Box 4025, Rochester N. Y.

SITUATIONS WANTED

EX-SERVICE man wishes to tour U. S. and appoint agents—any line. Address, Fred Hubert, Latty, Ohio.

FOR ADVERTISERS

REACH best paid workers in Grand Rapids, Saginaw, Battle Creek and Muskegon through our advertising columns. Two cents a word. Michigan Associated Labor Press, Houseman Building, Grand Rapids, Mich.

ADVERTISEMENTS! Display: inch \$6.50, half \$3.50. Classified: 60 wd. \$1.75, 12 wd. \$8c. Printed, mailed (stamped envelopes) 10,000 homes (selected list). Box 325, Fredonia, N. Y.

SPECIAL!!! Inch display advertisement 161 Magazines Thrice \$15. Year \$50. Wood's Popular Services, Atlantic City.

ADVERTISE. 30 words 100 magazines \$1.50. Pennell Company, Covington, Ky.

COMMERCIAL Engraving and Printing—the most practical and complete book on engraving, printing and allied subjects ever published. Over 800 pages and 1500 illustrations presenting over 3500 distinct ideas on 35 separate subjects. Cloth. Price \$15.00 prepaid. We highly recommend this book. Popular Mechanics Book Dept., 6 N. Michigan Ave., Chicago.

CONSULT us before Advertising. Jacobus Advertising Service, Irvington, New Jersey.

ADVERTISE in 1,000 Corn Belt Weeklies. \$10.00 line. 25 words. 24 big Dailies. \$15.00. Booklet free. Address Union Advertising, Baltimore Bldg., Chicago.

INFORMATION

MUSSEL Shoals, Florence, Alabama; Tennessee River information that you want, we have it for electricians, mechanics, merchants, manufacturers, farmers, laborers. Get posted—only \$1.00. W. L. Sherwood, Florence, Ala.

LETTER SPECIALISTS

LETTERS \$10. Exceptional style. Suggestions free. Morse, 133 W. 103rd., New York.

BUSINESS SERVICE

DRAFTING, all kinds; quick, accurate, confidential. Box 390, Decatur, Ill.

YOUR Business represented here for \$5.00 monthly. Letters forwarded 5c each. Kennedy's, 1906 Broadway, New York.

INCORPORATE. Our lawyers do the work, saving you time, annoyance and money in incorporating under the most liberal laws of Arizona. Laws and forms free. Southwestern Securities & Investment Co., Box D488, Phoenix, Ariz.

MAILING LISTS

ACCURATE printed list of names, addresses, make and model of 480,000 Michigan automobile owners \$75. Special—6,000 Dodge owners \$25. A. W. Campbell, 2233 Lamothe, Detroit.

2000 NEBRASKA Farmers, \$4.00, Jes-ton's Service, Box 749, Omaha, Neb.

LATEST Official List Iowa Auto Dealers—Garages \$3.00 per 1,000. Automobile owners \$1.00 per 1,000. State Supply Co., Cedar Rapids, Iowa.

BIG money compiling mailing lists; experience unnecessary; complete guide and instructions, one dollar. Order today. A. L. Bump, Dwight, Ill.

NAMES of agents and farmers our specialty. Pennell Company, Covington, Ky.

TYPEWRITERS AND SUPPLIES

UNDERWOOD Typewriters at far less than manufacturer's price; rebuilt, all worn parts replaced, guaranteed good as new. Cash, installment payments. Write for Catalogue 1513. Typewriter Emporium, estab. 1892. Montrose and Ravenswood Ave., Chicago, Ill.

\$100 USED typewriters, \$6 up. Guaranteed. Write for Bargain Bulletin No. 90. Mannco, 320 Goethe St., Chicago.

FIVE-DAY Free Trial—Underwoods—Remington—Smith—Royal—Oliver, etc., \$3 deposit, balance small monthly payments. Five-year guarantee; liberal discount for cash. Write for catalogue before buying. See page 55 for our display ad. International Typewriter Exchange, 177 N. State St., Dept. A-5, Chicago.

TYPEWRITERS, \$20.00 up. All makes. Easy payments. Free trial. Payne Company, Rosedale, Kans.

REBUILT Typewriters. All Makes, \$10.00 Up. We sell for cash at prices 20 to 30 per cent lower than installment houses. Every machine fully guaranteed. Send for free descriptive circular. The M. & M. Typewriter Co., 42 N. Wells St., Chicago.

DUPLICATORS AND DEVICES

"MODERN" Duplicators. Business Getters. \$2.25 up. 50 copies from pen, pencil, typewriter. No glue or gelatine. 40-000 in use. Free trial. Need one? Booklet Free. J. E. Durkin-Beeves Co., Pittsburgh, Pa.

"QUICK Process Duplicators." Makes 100 copies in 10 minutes. Remarkable time savers. Thousands in use. Circular Free. Heyer Duplicator Co., 160-PM, N. Wells St., Chicago.

ADDING MACHINES

NEW \$3.50 Automatic Adding Machine. Adds, Subtracts, Multiplies. Absolutely accurate. Capacity \$999,999.99. Fully guaranteed. 75,000 pleased users. Makes adding easy, positive, quick. Eliminates mistakes. Saves Time. Postpaid, \$3.50. Bassett Co., 1458-A, Hollywood Ave., Chicago.

MAKE Calculating Machine that adds, subtracts. Parts, instructions, \$25. James Novelty Co., 421 Bayard Ave., Wilmington, Del.

FREE Trial. Marvelous new Adding Machine. Adds, Subtracts, Multiplies, Divides, automatically. Work equals \$350.00 machine. Price only \$15.00. Speedy, durable, handsome. Five-year guarantee. Used by largest corporations. Write today for catalogue and free trial offer. Lightning Calculator Co., Dept. E, Grand Rapids, Mich.

PRINTING, ENGRAVING AND MULTIGRAPHING

PRINTING. 5000 8x6 inch circulars printed Free. We will print your copy of 150 words or less, using good paper, type and will mail for but \$1.00 per 1,000, making the mailing cost you only \$5.00. The Printing is absolutely Free. This is a Special, and copy with \$5.00 should reach us by return mail. Weber's Press, 5309 Forest, Dept. A-6, Kansas City, Mo.

1,000 HAMMERMILL bond letterheads or envelopes \$4.50. Glick Printing Co., Ridgefarm, Ill.

ADVERTISING Stickers!!! Rubber Stamps!!! Interesting Samples Free!!! Edward Harrison, "Artistic Labels," Baltimore.

CITY Printing at Country Prices. Samples Free. Royal Printers, Sugar Creek, Ohio.

100 ARTISTICALLY process engraved patent book-form cards, \$1.50, business size \$2.00. Elegant case and binding. Agents wanted. Book-Form Card Shop, 3461 Clark St., Chicago.

WE specialize in Ad-Pencils. Sample, with your name on in gold 10c. S. Mustal & Co., 422 Walnut St., Yonkers, N. Y.

100 BOOK-FORM Cards with case, 85 cents; business size, 300 for \$1.75, postpaid. Samples free. Artcraft Printshop, 19 Highland Ave., Elizabeth, N. J.

PERSONAL Stationery, 100 plain envelopes and 200 sheets printed with name and address, \$1.00. High grade stock, good work. Write plainly. Wilson Stationery Co., Dept. 12, Sturgis, Mich.

BOX Gold monogram and gold bordered stationery, 25 calling cards, \$1.10. Use 1 to 3 initials. Artcraft Press, Gary, Ind.

200 HAMMERMILL Bond Letterheads, Envelopes, Billheads, or Business Cards, \$1.00 postpaid. Race Printing Company, Hudson, N. Y.

5000 CIRCULARS 5 1/2 x 8 1/2. 5000 Envelope slips \$5.00. Bargain list—Samples—Free. Good's Printery, Harrisonburg, Va.

225 FINE Bond letterheads, envelopes, billheads, cards, \$1.35 each; combination, \$4.00. Economic Press, Leonia, N. J.

GOOD Printing quick. Gummed labels. Samples free. Pennell-Standard, Covington, Ky.

200 GOOD bond letterheads, printed and mailed, \$1.25, cash with order. Ed. F. Newton, Monticello, Indiana.

250 LETTERHEADS or Envelopes, \$1.50; other printing. Samples, stamp. H. Honey, Paris, Mo.

QUANTITY Users save 30%. Wolf Roll Labels, Sta. E, Philadelphia.

PRE-USED Printing Presses, Type and supplies. List for stamp. Popular Bargains, Richland, Pa.

EMBOSSED business, personal stationery. Samples, stamp. Daniels Co., Pittston, Pa.

1,600 LETTERHEADS or Envelopes, \$3.00, sent prepaid. Samples Free. Monitor Press, Morrisville, Pa.

REDUCED prices for better printing. 1,000 Bond letter-heads, \$5.00; 1,000 good envelopes, \$4.25; 1,000 four-page folders, 3 1/2 x 8 1/2 inches, \$12.00. Catalogues, circulars, booklets our specialty. All printing at reduced prices. Samples free. Fantasy, 525 S. Dearborn St., Chicago.

TWO-COLOR Quality Printing for price of one. Samples. Arrow Print, 3535 Walnut, Waterbury, Conn.

1000 FULL-SIZE Hammermill Bond Letterheads \$3.65. Postpaid. Other stationery in proportion. Business building Multigraph letters cheap. Samples free. Charles B. Hatfield, Box 353, Oswego, N. Y.

250 LETTERHEADS, 250 White Envelopes, printed and mailed, \$3.00. Samples printing free. Write Sun, Mohawk, N. Y.

2,000 LETTERHEADS or Envelopes \$7.50 prepaid 3rd zone. Samples Free. Quality Printery, Marietta, Ohio.

PRINTING Outfits—Presses, type supplies, type novelties. Send stamp for catalogue. Model Press, York, Penna.

FOR MEN

IMPORTED Safety Razors—Uses Gillette blades; not a toy, but a real usable razor. Wonderful imitation of a highly advertised \$5.00 safety razor. Razor complete in classy metal box, 65c. Agents wanted. Given, 450 E. 48th St. (A), Chicago, Ill.

I WANT to send Free to every chronic pipe smoker in the country a good, big, generous sample package of my pure, sun-cured, nature-flavored Old Green River Pipe Tobacco. No money to pay. If you are a tobacco crank, all the better. Try the pure stuff. No syrup, flavoring or dope. After you try it free, I'll show you how to cut your smoke bill one-half and get more pipe joy. Just send name and address, and say whether you want mild, medium or strong. Pete Moberly, Box 820, Owensboro, Ky.

SHAVE with comfort. Flexible Mirror helps wonderfully. Descriptive circular free. Brandaw Company, 971 Atlas Bldg., San Francisco, Calif.

WHY Many Men Are Old at Forty. Men—If depressed, if backache, sciatica or tender feet annoy you—if nerves are gone—if your sleep is disturbed, send for a simple drugless treatment that cannot interfere with your work or doctor's care. If you are suffering you will bless this book. Write now before you forget. The Electro Thermal Company, 2126 Main St., Steubenville, Ohio.

RAZOR AND BLADES SHARPENED

BLADES resharpened 3c, any make. Guaranteed service. Standard Safety Razor Corporation, Pittsburgh, Pa.

GUNS, SPORTING GOODS, ETC.

AUTOMATIC pistols at ridiculously low prices. No. 109, 25-cal., 7-shot automatic, \$9.75. No. 509, 32-cal., Blue-steel Military Model, 10-shot automatic, \$12. Extra magazine free. All goods sold by us are brand new and guaranteed to be absolutely satisfactory after examination or money back. Send no money. Just send your name, address and number of pistol you want. Pay Postman our price and postage on arrival. Send for free catalog. Paramount Trading Company, Dept. 109, 34 West 25th St., New York.

AUTOMATIC Pistols; Mauser, Origes, 25-cal., \$11.50; 32-cal., \$12.50; Remifance, 7-shot 25-cal., \$9.75. Sent C. O. D. Unwin Trading, 305 Broadway, New York.

FREE Blueprint list: homemade boats, traps, etc. Wee-Sho-U Co., West Market, Detroit, Mich.

BOATS AND LAUNCHES

12' ROWBOAT construction plans and instructions, 30c. Address Rancorn Boat Works, 4519 Frankford Ave., Philadelphia, Pa.

16' ROWBOAT—Easily made. Construction blueprint, 30c. Wee-Sho-U Co., West Market, Detroit, Mich.

TURN your boat into a high speed Launch with one of these twelve-cylinder Motors. Displacement 530 cu. in., 32" long, 36" wide, 30" high; 64 h. p. and up, \$985. Can replace standard parts the world over. Triple Block Motor Works, Box 233, Garfield, Wash.

OPTICAL GOODS

ULTRALENS Microscope. Patents pending. Magnifies 25,000 times, 75c. Adjustable power model magnifying up to 100,000 times \$1.50. Others up to 250,000 times. Something new. Circular P-4 free. Specialty Mfg. Co., Milton, Penna.

DIAMONDS, WATCHES AND JEWELRY

"BLACK" Opals. Beautiful colors. Australia's National Gem. Lists free. Worldwide connection. Seward, Optician, Melbourne, Australia.

ANTIQUES AND RELICS

FOR Dens—Relics from Europe's Battlefields. Guns, helmets, medals, etc. Catalogue war photos 10c. Lieut. Welsh, 50 Ft. Greene Pl., Brooklyn, N. Y.

CRYSTALLIZED lead, pyrites of iron, and garnet specimens. Ernest Plage, Silver Cliff, Colo.

PHONOGRAPHS AND RECORDS

BUILD a genuine Choralion phonograph and save over half. Big profit building and selling. We furnish motors, tone-arms, full instructions and all necessary parts. Send for catalog and free blueprint offer. Choralion Phonograph Co., 322 11th St., Elkhart, Ind.

SUPERIOR Quality motors, tone outfits, amplifiers, hardware and cabinets, make the finest phonographs. Superior Phonographs Co., Erie, Pa.

REVIVE Tone on worn Phonograph Records. Formula 50c. Address Record Chemical Co., West Mansfield, Ohio.

BUILD Best Phonographs. Write for parts catalog and free blueprint offer. American Phonograph Co., 3515 North Crawford, Chicago.

BUILD Your Phonograph. "Perfection" high quality spring and electric motors, tone arms, reproducers, wonderful results. Big saving. New catalog and building instructions mailed for ten cents. Hoosier Manufacturing & Supply Co., Phonograph Supply Dept., 313 Baldwin Block, Indianapolis, Ind.

MUSIC AND MUSICAL INSTRUMENTS

RAG-JAZZ Piano or Saxophone in 20 lessons. "Christensen" Schools in most cities. See your phone book or write about Mail Course. Teachers wanted. Axel Christensen, 433, 20 E. Jackson Blvd., Chicago.

LOVE song, most beautiful ever heard, 30c; 4 one dollar, postpaid. Address John Saunders, Publisher, Rockville, Conn.

JOIN our Sheet Music Club and receive latest popular music of all publishers, \$1.00 year plan. Write for details. Sheet Music Club, Suite 703, 1545 Broadway, New York, N. Y.

SONG writers—Have you song poems or melodies? I have very best proposition to offer you. Ray Hibbler, D110, 4040 Dickens Ave., Chicago.

CORNETISTS—Trombonists—Saxophonists—Clarinetists. Send for "Free Pointers." Name instrument. Virtuoso School, Buffalo, New York.

I WANT Song Poems. Casper Nathan, Woods Theatre Bldg., Chicago.

WRITE Songs. Big money and reputation. Write for information. J. Gordon Pub. Co., 291 N. Hoyne Ave., Chicago.

"MUSIC Composed" to words. Bauer Bros. (formerly of Sousa's Band), Oshkosh, Wis.

PATENT ATTORNEYS

PATENTS secured. Prompt service. Avoid dangerous delays. Send for our "Record of Invention" form and Free Book telling How to Obtain a Patent. Send sketch or model for examination. Preliminary advice without charge. Highest references. Write today. J. L. Jackson & Co., 244 Ouray Bldg., Washington, D. C.

PATENTS promptly procured. Personal, careful and efficient service. Highest references. Moderate fees. Send sketch or model for actual search and advice. George P. Kimmel, Master of Patent Law, 54F Loan and Trust Bldg., Washington, D. C.

EDWARD C. SASNETT, patent attorney, former Principal Examiner U. S. Patent Office; former examiner in electrical, optical and mechanical divisions U. S. Patent Office. High-grade personal service. McGill Bldg., Washington, D. C.

INVENTORS—Send sketch or model of invention for advice. Write for Evidence of Disclosure form and Book on Patents, free. Prompt service. Merton-Roberts & Company, 181 Mather Building, Washington, D. C.

PATENTS—Trademark, copyright; folder free; results procured. Write Metzger, Washington D. C.

PATENT, Trade-mark and Copyright specialist. Prompt, personal and efficient service. Advice on request. M. E. Jones, Lawyer, 509B 7th St., Washington, D. C.

PATENTS—Trademarks. Before disclosing an invention, the inventor should write for my blank form "Evidence of Conception." This should be signed, witnessed and returned to me with sketch or model, upon receipt of which I will promptly render opinion as to patentable nature and send booklet on patents. Highest references. Prompt attention. Reasonable terms. Clarence B. O'Brien, Registered Patent Lawyer, Woodward Building, Washington, D. C.

PATENTS Procured—Trade Marks Registered. A comprehensive, experienced, prompt service for the protection and development of your ideas. Preliminary advice gladly furnished without charge. Booklet of information and form for disclosing idea free on request. Richard B. Owen, 39 Owen Bldg., Washington, D. C., or 2276R, Woolworth Bldg., New York.

PATENT your invention. But note: a patent is no better than its claims. Be sure your patent is as good as your invention. Patent claims skillfully drafted by Lamb & Co., Patent Attorneys, 1419 G Street, Washington, D. C.

PATENTS—Trademarks. Thirty-five years' experience. Send model or sketch for opinion as to patentability. Free "Inventors' Guide." Highest references and personal attention assure best results. Franklin H. Hough, 522 Washington Loan & Trust Bldg., Washington, D. C.

PATENT Attorney, H. F. Lowenstein, 8th floor, McLachlen Building, Washington, D. C. Send full description of invention and receive without charge, personal advice on how to proceed in your individual case, and estimate of cost.

PATENTS—Prompt, personal efficient service by an attorney-at-law, skilled in all branches of Patent Practice. Over 12 years' actual experience; full information upon request. B. F. Fishburne, 331 McGill Bldg., Washington, D. C.

PROTECT your rights. Write for "Record of Invention" which contains forms to establish evidence of conception of your invention. Prompt personal service. Preliminary advice without charge. J. Beane Kelly, 612-G, Columbian Bldg., Washington, D. C.

PATENTS, Trade Marks, Designs and Copyrights. Registered firm of attorneys-at-law. Careful, prompt personal service assured. Moderate fees. Full information free upon request. Gross & Collins, 608 Ouray Building, Washington, D. C.

PATENTS and Trade-marks obtained. Prompt service. Write for our new book on patents. Established in 1889. D. Swift & Co., 369 7th St., Washington, D. C.

PATENT Applications filed on partial payment plan. Trade-marks, copyrights, etc. Milo B. Stevens & Co., 685 F St., Washington; 352 Monadnock Bldg., Chicago. Estab. 1864.

INVENTORS—Send for form "Evidence of Conception" to be signed and witnessed. Form, fee schedule, information free. Lancaster and Allwine, 221 Ouray Building, Washington, D. C.

MONROE MILLER, Ouray Building, Washington, D. C., patent attorney, mechanical and electrical expert. Best quality of work and results. Moderate charges.

INVENTORS should write for our book, "How to Obtain a Patent," which contains valuable information which every inventor should have. If you will send us a sketch, model or photograph of your invention we will promptly make search of the Patent Office records and advise you whether or not your invention is in our opinion patentable; our charge for the service being \$5.00. With an experience of over twenty years we feel that we are fitted to render you prompt, efficient service which will merit your confidence. Moderate charges. Write today. Talbert & Talbert, 422 Talbert Bldg., Washington, D. C.

INVENTORS! Send sketch or model of your invention for opinion concerning patentable nature and exact cost of applying for patent. Book, "How to Obtain a Patent," sent free. Gives information on patent procedure and tells what every inventor should know. Established twenty-eight years. Chandler & Chandler, 426 Seventh St., Washington, D. C.

PATENTS—Herbert Jenner, patent attorney and mechanical expert, 622 F St., Washington, D. C. I report if a patent can be had and its exact cost. Send for circular.

PATENTS and Trade-marks obtained. Prompt service. Write for our new book on patents. Established in 1889. D. Swift & Co., 369-7th St., Washington, D. C.

PATENTS. Booklet free. Highest references. Best results. Promptness assured. Send model or drawing for preliminary examination. Watson E. Coleman, Patent Lawyer, 624 F Street, Washington, D. C.

ROBB, Robb & Hill offer a strictly professional service to manufacturers and inventors in patenting inventions and registering trade-marks, a service which is the result of 29 years' experience. Write for free booklet and names of prominent manufacturers and inventors represented by us. Send sketch for preliminary advice. 811 McLachlen Bldg., Washington, D. C.; 1348 Hanna Bldg., Cleveland, Ohio.

PATENTS — Trademarks — Write for our free illustrated guide book and Evidence of Conception Blank. Send model or sketch and description and we will give our opinion of its patentable nature free. Highest references. Prompt attention. Reasonable terms. Victor J. Evans & Co., 166 Ninth, Washington, D. C.

PATENT obtained; complete application, \$15. Try "Patent News Plan." Save Money. Patent News-C, Washington, D. C.

FOR INVENTORS

PATENTS. If you have an invention which you wish to patent you can write fully and freely to Munn & Co. for advice in regard to the best way of obtaining protection. Please send sketches or a model of your invention and a description of the device, explaining its operation. All communications are strictly confidential. Our vast practice, extending over a period of seventy years, enables us in many cases to advise in regard to patentability without expense to the client. Our Hand-Book on Patents is sent free on request. This explains our methods, terms, etc., in regard to Patents, Trade Marks, Foreign Patents, etc. "Scientific American" contains Patent Office Notes, Decisions of interest to inventors, and particulars of recently patented inventions. Munn & Co., Solicitors of Patents, 623 Woolworth Bldg., New York; Scientific American Bldg., Washington, D. C.; 591 A Tower Bldg., Chicago, Ill.; Hobart Bldg., 582 Market St., San Francisco, Calif.

YOUR invention is useless unless you have a practical working model. We develop patents and build models, also the necessary dies, tools and jigs to manufacture the article. Get our ideas, we can help you to make your invention successful. The Ruthman Machinery Co., Dept. 3, Front and Pike Sts., Cincinnati, O.

PATENTS Secured. Prompt service. Avoid dangerous delays. Send for our "Record of Invention" form and Free Book telling How to Obtain a Patent. Send sketch or model for examination. Preliminary advice without charge. Highest references. Write today. J. L. Jackson & Co., 242 Ouray Bldg., Washington, D. C.

WILL arrange to manufacture and sell on liberal royalty basis, patented or patentable inventions pertaining to railroad rolling stock. Any tool, equipment or practice that will cut costs in the manufacture or operation of cars or locomotives, will interest us. Address Charles Lee, Spring Lane, Chestnut Hill, Pa.

INVENTORS—Send sketch or model of invention for advice. Write for Evidence of Disclosure form and Book on Patents, free. Prompt service. Merton-Roberts & Company, 182 Mather Building, Washington, D. C.

MODELS — Developing your idea, mfg. same is my specialty. Why experiment? Write me and get facts. Henry Backer & Co., 994 Evans, Cincinnati, O.

I DEVELOP, improve, and make drawings and blueprints of your idea. \$4 up. H. G. Scholtz, Durand, Mich.

INSTRUCTIONS how to sell your invention without patenting for 25c. Emil Dahlene, Manson, Iowa.

INVENTORS, write for free copy about designing, drawing and blue-printing. Emil T. Dahlene, Manson, Iowa.

PATENTS—Trademarks. Before disclosing an invention, the inventor should write for my blank form "Evidence of Conception." This should be signed, witnessed and returned to me with sketch or model, upon receipt of which I will promptly render opinion as to patentable nature and send booklet on Patents. Highest references. Prompt attention. Reasonable terms. Clarence B. O'Brien, Registered Patent Lawyer, Woodward Bldg., Washington, D. C.

DON'T patent your idea until you know that your invention is mechanically right, practical, and has value. Consult an expert first. I advise on all matters pertaining to inventions and improve inventions. Write for free Disclosure of Conception forms before disclosing your idea to me or anyone. Strictly confidential. E. J. Gibson, Developing Engineer, Box 94, Olean, N. Y.

300 MECHANICAL Movements and 50 Perpetual Motions illustrated and explained in my book, Inventor's Universal Educator, 5th Edition—Tells how to procure and sell patents. Government and other costs. Covers the matter from A to Z—160 pages—Elegantly bound. Contains noted decisions of U. S. Supreme and State Courts on Patent cases. Mechanical Movements greatly assist inventors—suggest new ideas that might prove of great aid in perfecting inventions. Tells how to select an Attorney. Has valuable information regarding Patent Sharks. Selling Agents and promoters. Price, \$2. Postage free everywhere. Fred G. Dieterich, 621 Ouray Bldg., Washington, D. C.

INVENTORS should write us for our book, "How to Obtain a Patent," which clearly sets forth what may be patented and the necessary steps to protect an invention. It describes the procedure in Patent Office and tells about assignments, licenses and trademarks, and gives many useful facts about patents which every inventor should know. Many persons well versed in patent matters have pronounced the book the best of its kind they have ever read. It is written so you can understand it. Copy sent free upon request. Talbert & Talbert, Patent Lawyers, 433 Talbert Bldg., Washington, D. C.

INVENTORS. Well executed drawings and properly prepared specifications are the basic features of protective Patents. I offer twenty years' experience in illustrating inventions. Send Sketch for examination and free advice. W. H. Rockwell, Oriental Building, Washington, D. C.

INVENTIONS Wanted. To make your invention a real success, technical skill must be employed to develop it into a commercial product and business experience to put it on the market. We furnish technical talent, business brains and capital without charge to the inventor. Address Federated Engineers Development Corp., 160 Ogden Avenue, Jersey City, N. J.

PATENTS Procured—Trade-Marks Registered. A comprehensive, experienced, prompt service for the protection and development of your ideas. Preliminary advice gladly furnished without charge. Booklet of information and form for disclosing idea free on request. Richard B. Owen, 39 Owen Bldg., Washington, D. C., or 2276B Woolworth Bldg., New York.

FREE: Preliminary examination of Patent office records to determine patentability of your invention, for a limited time only. Send sketch or model at once and secure the benefit of this generous offer. Address Harry E. Coleman, Oriental Building, Washington, D. C.

PROTECT Your Rights. Write for Record of Invention which contains forms to establish evidence of conception of your invention. Prompt personal service. Preliminary advice without charge. J. Reaney Kelly, 612 G. Columbian Bldg., Washington, D. C.

ENGINEERS and Inventors: Expert and Confidential Service in Machine design, patent office sheets, advertising cuts, labels, trade-marks. Free circular. Bank references. The Engineering Service Co., Canton, Ohio.

INVENTORS: Have your models and experimental work done by experts. Up-to-date equipped special machinery, tools, dies, stampings. Dan Tool Co., 3925 Montrose Ave., Chicago.

INVENTIONS—How to protect, sell, and buy them. A practical and up-to-date guide for inventors and patentees. Price 35 cents postpaid. Popular Mechanics Book Dept., 6 N. Michigan Ave., Chicago.

I SELL Patents. Established 1900. Address, Charles A. Scott, 773PM Garson Avenue, Rochester, N. Y.

"**HOW** and What to Invent for Profit" free. Patent News-N, Washington, D. C.

INVENTORS: The first step toward a patent is a proper search of the pertinent United States records. Send sketch. Horace L. Woodward, Attorney, 700 9th St., Washington. Highest references, reasonable charges.

PATENTS. Write for free illustrated guide book. Send model or sketch and description for free opinion of its patentable nature. Highest references. Prompt attention. Reasonable terms. Victor J. Evans & Co., 157 Ninth, Washington, D. C.

HAVE You an Invention? If so, write for our free book, "How to Get Your Patent," tells our terms and methods. Send model or sketch for our opinion of its patentable nature. Randolph & Co., Dept. 144, Washington, D. C.

"**INVENTOR'S** Guide," free on request; it gives very valuable information and advice. Write Frank Ledermann, 21 Park Row, New York, N. Y.

PATENTS FOR SALE

FOR Sale—Heel Guard and Toe Clips. Prevents slipping on ice or wet streets, and keeps mud off of trousers; also takes place of golf shoes. E. O. Goldsmith, Goldsmith & Sons, Memphis, Tenn.

FOR Sale Outright—Patent 1,393,510. Guard for punch presses and analogous machines; eliminates injury to operator. Many improvements; sure to be success. For details write Michael Dublasky, 412 Edward St., Rockford, Ill.

HANGING Flower Basket, 11,876-1; Musical Toy, 13,216-2; Track Clamps, 13,579-1. Talbert & Talbert, Talbert Bldg., Washington, D. C.

SALE or royalty; U. S. Patent No. 1,367,962, spotlight for open or enclosed cars. Great improvement. Address Lock Box 154, New Era, Mich.

SELF-GREASING lubricating system. Patent pending. Grease car in 30 seconds. For sale on cash or royalty. Particulars, write A. P. Anderson, 920 South Ave., N. S., Pittsburgh, Pa.

MANUFACTURERS, Attention! Inventions for sale. Telescope rib pocket umbrella. Pencil holding pocket. Sash and Door Lock, 118 Fulton St., New York City.

FOR Sale—Self-hooking fish hook; proven success; easily manufactured. Address A. Thorsten, 1121 Flatbush Ave., Brooklyn, N. Y.

PATENT for sale—New patented hand-power posthole digger. Canadian patent. Manufacturers, investigate. Roscoe Benschaw, Strasburg, Ill.

OUTRIGHT or royalty. Nursery or commode chair. Patent pending. C. L. Hopp, 440 Orange St., Newark, N. J.

PATENT for sale—Motor-meter and trouble light combined. Lloyd Thurn, 339 Ohio Ave., Fremont, Ohio.

FOR Sale—Improved household article. Patent No. 1,347,364. T. A. Johnson, 19 Chase St., Lynn, Mass.

VICE, 20th Century, United States and Canadian. J. K. Shinder, Box 193, Kenosha, Wis.

ARTIFICIAL Bait. Cash, Royalty or Partners. This bait looks like a fish. Dives, swims or to use as spinner. Carries fish oil lure. Hooks weedless. Hooks screened from view. Splendid opportunity. Good market indicated. John Frame, Searsport, Maine.

SALE or Royalty, Patent 1,391,731, "Test Indicator." For testing accuracy of intricate and difficult parts of machinery. Has many advantages over other indicators. Address, George Genung, 904 10th Ave., Beaver Falls, Pa.

EXCEPTIONAL opportunity; self-blowing alcohol torch; best offer takes Canadian patent; U. S. patent successfully on the market; watch for the "Duplex" torch; investigate. Address Folgman, 31 Third Street, Brooklyn, N. Y.

FOR Sale—Patent on "Insect attracting and exterminating device." The sale for this device is positively unlimited, for particulars write H. Fred. Rhoads, R.R.1, Winston-Salem, N. C.

PATENT—Cash or royalty. Must sell. Hygienic garter. Positively will not stop circulation. Physicians' endorsements furnished. Universal need. L. G. Warren, Box 35, Westwood, Calif.

PATENT upon "Sectional Boat," perfect for life boats, also pleasure, for sale, cash or royalty. Write, S. Zeligzynski, Patterson Station, P. O. Box No. 11, Baltimore, Md.

RENEWABLE Cartridge type fuse No. 1,367,179 and Quick turn pole truck for farm implements No. 1,385,667. Best offer. George Conrad, Box 55, Stillwater, Minn.

OUTRIGHT or royalty, recent patent Double-Grip Socket Wrench. Address Warren Reist, Williamsville, N. Y.

ON royalty, American and Canadian patents on wonderful little device for keeping bed covers over children and adults. Wm. Dennison, 75 Jones, Columbus, Ohio.

OUTRIGHT: Traveling Mail Carrier used on Rural Routes where patrons live a distance from road. Will sell reasonable. William Borden, Mowrystown, O.

OUTRIGHT or royalty, patent just allowed, best gas saver yet for automobiles. E. C. Angel, 17 East 8th St., Chattanooga, Tenn.

OUTRIGHT or royalty. Patented Spring Leaf Spreader, operates with movement of lever, locks and is adjustable. Harold Schuster, Oconomowoc, Wis.

FOR Sale or Royalty: Patent on Boy's Hand-Car. Patented Household Article, also \$1500 worth of machinery. Horace Leach, Mt. Carmel, Ill.

CANADIAN patent on Adjustable Stilt, now successfully manufactured in United States. Exceptional premium offering. Clare Wetzell, Sterling, Ill.

ROAD Grader or surfacer; best device out. Patent for sale. Address T. C. Bullock, Grand Junction, Colo.

FOR Sale or trade—United States Patent, Helicopter Air Craft. W. E. Morrison, La Fayette, Ind.

FOR Sale, new Improved Riding Wheel Harrow. Cash or Royalty. Address V. Foch, Eugene, Ore.

PATENT Obtained; complete application \$15. Try "Patent News Plan." Save money. Patent News-E, Washington, D. C.

INVENTORS: The first step toward a patent is a proper search of the pertinent United States records. Send sketch. Horace L. Woodward, Attorney, 709 9th St., Washington. Highest references; reasonable charges.

PATENTS for Sale: To sell, buy or obtain patents, address Patent News-P, Washington, D. C.

HAVE you a Patent to sell? Would you like to know what a small classified ad in this column could do for you? Ask me to send you proof of how other inventors sold their patents. J. Roy McClellan, Manager Classified Advertising, Popular Mechanics Magazine, Chicago, Ill.

PATENTED, Inexpensive, effective check protector, ideal advertising specialty. Bargain. R. Home, 1957 Warren, Chicago.

MODELS AND MODEL SUPPLIES

PUNCH Press work, tool and die making, model and special machine work wanted. Completely equipped with new machinery of the latest type. Prompt delivery, reasonable prices guaranteed. Quality Hardware & Machine Co., 6154-56 N. Clark St., Chicago.

MODEL Steam Engines, Boilers, Electric and Steam Boats, Yachts, Model Ship's Fittings and Model Makers' Supplies. Send 20c for new large illustrated catalogue and handbook. Bath Mfg. Co., Dept. D, 5214 Woodland Ave., Philadelphia.

WE make Dies for art castings, hand or machine, to make toys, figures, animals, etc. Send your model, we do the rest. U. S. Art Toy Co., Route 5, Box 272A, North Milwaukee, Wis.

MODEL and experimental work developed; special machinery, tools, dies, designed and built. Twenty-four years' practical experience. Information free. Address Guyer Engineering Co., 1555 Columbus Road, Cleveland, Ohio.

WORKING Models Designed and Built. Inventions Developed. Dies, Tools, Metal Stamping, Manufacturing. Wisconsin Experimental & Model Works, Madison, Wis.

WE make working models for inventors and do experimental work and carry a complete stock of brass gears and model supplies. Send for catalogue. The Pierce Model Works, Tinley Park, Ill.

INVENTORS—Write for our free illustrated guide book and Evidence of Conception Blank. Highest references. Prompt attention. Reasonable Terms. Victor J. Evans & Co., 165 Ninth, Washington, D. C.

TO MANUFACTURERS

CELLULOSE and paper pulp manufacturers, attention—A vast new field for your products. Address P. J. Brewington, Temple, Texas.

WANTED—Metal Stamping and Model work taken on contract basis. We are ideally located and equipped to develop patents. Meyers Company, Box 263, Bedford, Ind.

WANTED—A manufacturer to make Ball-Type Universal Joint. J. E. Fulton, Springfield, Ill.

MANUFACTURING

SPECIAL machinery to order. We do designing, experimental work and manufacturing in quantities of all classes of special machinery for any purpose. Send us your blue prints to figure on. Lamb Co., 1933 Franklin St., Detroit, Mich.

PATTERNS, Wood and Metal, Models, Tools and Dies, Brass and Aluminum Castings. General Machine Work. Write Modern Machine & Pattern Co., Terre Haute, Ind.

A NEW factory well equipped with dies, stampings, forming, heavy pressing, screw machine and wire products, enameling and plating. Contracts of any size handled promptly. Estimates furnished. Metal-Craft Mfg. Company, Inc., 64 W. Randolph, Chicago.

METAL Specialties. If of metal, we can make it for you. Complete equipment, Western Die & Stamping Works, 721 Fulton St., Chicago, Ill.

IF you want dies and metal stampings, write us. Lyons Machine Works, Lyons, Ia.

YOU furnish the idea, we do the rest. Developing, designing and manufacturing. Precision machinery does your work; trained engineers develop your idea into a practical working model, and design the tools or dies for quantity manufacturing. Victor Engineering Co., 2524 W. Chicago Ave., Chicago.

WELL equipped machine shop, pattern shop and foundry is prepared to manufacture any automobile or garage tools or accessories, portions of which are castings, on royalty or other basis. Send us your prints and specifications for estimate. Patented articles preferred. Connersville Foundry Corporation, Connersville, Ind.

SPECIAL Devices and Machinery developed and built at reasonable rates. Jigs and fixtures designed and built for interchangeable and economical manufacturing. Punches and dies made for all kinds of metal stamping. Machine work to order. Simplex Tool Company, Woonsocket, R. I.

METAL Stamping, Dies, Tools, Special Machinery and Machine Parts Remodeled, Designed and Built, Efficiency Increased. Cylinder Grinding, Wisconsin Experimental & Model Works, Madison, Wis.

WIRE Goods, all kinds made to order. Cooley Mfg. Co., 524-530 N. Western Ave., Chicago.

MACHINERY, TOOLS AND SUPPLIES

TUBING—Soft, hard, copper, brass, aluminum—a complete line, connections and unions. Price list on request. Standard Tube & Metal Company, Dept. D, 2412 Ogden Ave., Chicago, Ill.

CARPENTERS and Manufacturers, do you want to know the practical use of the steel square by America's greatest steel square experts. Send \$2.00 for my little book "Noah's Hand-down." This book is intended to be engraved on the steel square for the complete knowledge of the steel square; guaranteed. H. A. Harrison, Box 912, Jamestown, N. Dak.

7" BENCH Lathes, \$3.00. Slide rests, \$8.00. 1/2 H.P. gasoline engines \$17.00. Blue prints, \$1.00. Star Specialty Wks., 1742 W. Park Ave., Chicago.

CONCRETE Building Block Machines and Molds. Catalogue free. Concrete Machine Co., 112 S. Second St., St. Louis, Mo.

OTHERS have successfully sold their machinery through our columns—so can you. Ask me for proof. J. Roy McClellan, Manager, Classified Advertising, Popular Mechanics Magazine, Chicago.

ENGINES, MOTORS AND DYNAMOS

BALL-BEARING motors, automatic compressors, grinders, battery chargers, lighting generators. Unusually easy terms. Write us. Hobart, Troy, Ohio.

BLUE Prints, 2 1/2 in. ga. locomotive \$2.00 per set. 3/4 H. P. Marine Gasoline Engine \$1.00 per set. Other engines, boilers, lathes, etc. Get our new catalog No. 22, sent postpaid, 20c stamps or (2 dimes preferred). Refunded first order. Modern Engine & Supply Co., 53 W. Jackson Blvd., Chicago, Ill.

MOTORS for sale, approximately 1/10 h. p., 10 to 30 volts, direct current, series wound, used but in good condition. Can be used with farm lighting plants and for experimental purposes. Price \$5.50 f. o. b. General Railway Signal Company, Rochester, N. Y.

ALTERNATING and direct current motor bargains. New and rebuilt. All guaranteed for one year. Special prices. Get our price list before buying. Motors exchanged and repaired. Hyre Electric Co., 633-8M South Dearborn St., Chicago.

AUTOMOBILE OWNERS, Garagemen, Mechanics, Repairmen, send for free copy of our current issue. It contains helpful, instructive information on overhauling, ignition troubles, wiring, carburetors, storage batteries, etc. Over 120 pages, illustrated. Send for free copy today. Automobile Digest, 507 Butler Bldg., Cincinnati.

SPECIAL Garage Motors: Manufactured by the General Electric Co. 1 H. P., \$78.50; 2 H. P., \$110.00; 3 H. P., \$128.50; 5 H. P., \$166.50. All sizes, both single and Poly-phase Motors, for immediate delivery. Special charging generators, all voltages. Write for catalog. Motor Sales Dept. 15, West End, Pittsburgh, Pa.

ELECTRIC Motors, 500 Heavy Duty 1/2 H. P. motor, General Electric and other standard makes, 110 Volt, 80 Cycle, Single Phase. New, original packages, guaranteed perfect. \$18.00 to \$22.00. Pennsylvania Motor Exchange, Lancaster, Pa.

ELECTRICAL

WASHING Machines, Electric-Universal, Portable and Butterfly, \$30.00 and \$65.00; Electric Irons, 5 and 8 lb., \$2.50 and \$3.15; Electric Motors, \$10.00 and up; Dry Cells and Flashlight Batteries, 30c and 10c; Nitrogen, Tungsten Lamps, etc., at extremely low prices. Agents with capital wanted. All material standard, new, guaranteed. Send for complete lists. We buy your surplus stock. J. Strauss & Blum, 254 W. 41st St., New York.

1/2 H. P. ELECTRIC Motors, guaranteed for one year. Repulsion Induction, Standard make, 110/220 volts, 60 cycle, single phase, 1725 R. P. M. Price \$13.00 each f. o. b. Chicago. Cash with order. Unit Electric Sales Co., 20 East Jackson Boulevard, Chicago, Ill.

ELECTRIC Fixtures: Buy direct and install them yourself. Send for descriptive Fixture circular and wholesale prices of motors and all electrical supplies. Electric Supply & Plumbing Co., Robinson, Ill.

LIGHTING Fixtures: Build your own. Save one-half. We furnish parts. Catalog free. Troughton Electric Co., Liberal, Mo.

AIR Compressor with Tank and Hose, \$49. Motor for same, \$22.50. Equipment Co., 169 Canal, Cincinnati, Ohio.

EVART Bell-ringing transformers, Evart Electric Co., Box 26, Racine Junction Station, Racine, Wis.

ELECTRIC motors and supplies, including sockets, wire conduit, cleats, looms, rosettes, switches. New revised wholesale prices. Illustrated Catalog free. Hyre Electric Co., 633-GH, South Dearborn St., Chicago.

BATTERY Men: Save Your broken Jars. Our Cement makes good as new. Send One Dollar. Address, Cement Works, Peace River, Alberta.

FOR MECHANICS

INVENTORS—Send sketch or model of invention for advice. Write for Evidence of Disclosure form and Book on Patents, free. Prompt service. Merton-Roberts & Company, 183 Mather Building, Washington, D. C.

STAIR-Builders' Guide, Excellent Treatise on construction of straight flight, platform, cylindrical and elliptical stairs. 256 pp., 358 figs. Cloth. Price \$2.00 postpaid. Popular Mechanics Book Dept., 6 N. Michigan Ave., Chicago.

PATENTS—Write for our free illustrated guide book and Evidence of Conception Blank. Send model for sketch and description of the invention for our opinion of its patentable nature free. Highest references. Prompt attention. Reasonable terms. Victor J. Evans & Co., 184 Ninth, Washington, D. C.

FOR THE SHOP

CARE of the hand saw, electric water heater, modern barn construction, motorcycle trailer, tent house, correcting dynamo troubles, homemade metal fence, auto turntable, are among the hundreds of practical articles in Shop Notes Vol. 13. Price 50 cents postpaid. Popular Mechanics Book Dept., 6 N. Michigan Ave., Chicago.

SHOP Notes for 1922—Bench Lathe, Electric Soldering Outfit, Jib Crane, Pump Troubles, Road Roller, Bench Grinder, Bench Miller, are among the 655 articles in this new volume. 224 pp., 50 cents postpaid. Popular Mechanics Book Dept., 6 N. Michigan Ave., Chicago.

SHOP Notes Volume 17 contains 702 practical articles such as Half-ton traveling Crane, Boring Machine, Toggle Press, Gas-Fired Forge, Oil-Gas Generator, Movable Table for Drill Press, etc., 224 pp., 49¢ plus 50 cents postpaid. Popular Mechanics Book Dept., 6 N. Michigan Ave., Chicago.

CONSULTING ENGINEERS

MANUFACTURING processes, Formulas, Technical Information, Consulting Chemist, Little Falls, N. J.

BLACKSMITHS

BLACKSMITHS, Listen: Any Handy man can make more money doing hard jobs easy. Forging and welding solid, with Toy's Modern Methods of Blacksmithing. Hardening and tempering to a standard with colored tempering charts. All for one dollar. Samples Free. W. M. Toy, Sidney, O.

FOR SALE—MISCELLANEOUS

"CUCKOO" Clocks—Genuine Hand Carved Walnut. Price \$7.00 prepaid. Cut and description free. Gem Novelty Co., Corpus Christi, Texas.

ARMY-NAVY surplus. Tents, Blankets, Clothing, Camping Equipment, Boots, Shoes, Tarpaulins, Slickers. Everything for the farm, house and shop. Astounding bargains. Specify line in which interested. Nathan Frank & Sons, 317 L St., S. W., Washington, D. C.

LUMINOUS Paint—Bottle 20c. Laboratories H. Box 316, Portland, Ore.

AUTO Tire Vulcanizing Molds, Air Compressors, Motors, Battery Charging Outfits. Reduced Prices. Write for catalog. Equipment Co., 167 Canal, Cincinnati, Ohio.

FEATHER Flowers. Fine seller Florists, Poultry Shows, Fairs, etc. Unexcelled for home, office, store. Samples one dollar. Address De Witt Sisters, Battle Creek, Mich.

HEMSTITCHING and pleating attachment works on any sewing machine, easily adjusted. Price \$2.50, with full instructions. Address Oriental Novelty Co., Box 11, Corpus Christi, Texas.

FOR Sale—Furniture; state kind wanted. H. Williams, Reed, Ky.

SLOT machines—will sacrifice them; town closed. Write to W. C. Follin, Charleston, S. C.

\$17.50 Genuine Carl Zeiss Field, Marine and Aviation Glasses, eight power, adjustable focus and eye pieces, cost \$38.00, with carrying case. Sent C. O. D. subject to examination. Money refunded. We have other Glasses, Binoculars and merchandise. Weil's Curiosity Shop, 20 S. 2nd St.

REAL ESTATE AND FARM LANDS

ATTENTION! "Let's get acquainted." Cash for your property, farm, hotel, retail store or factory. Confidential service. Hayes Business Agency, Cincinnati, Ohio.

QUICK—system to sell real estate for cash anywhere; complete plans \$1.00. Realty Publishing Co., Cincinnati, O.

FREE Book of Florida Facts. Own your own orange grove in beautiful Fruitland Park. A few cents a day you now waste will buy it for you. A few dollars a month may provide you with a life income. Schuitzer sold his twenty acre grove here for \$40,000—two thousand an acre. He saw the same opportunity that's offered you and planted a grove. Result—he reaped a small fortune. You have the same chance but you must act now. Write today for Free Book of Actual Photographs, Florida Facts and the interesting story of a Fruitland Park Farm. Learn of crops that help you buy it. Address today, Lake County Land Owners' Association, 93 Sunset Way, Fruitland Park, Florida.

GOOD Farm Lands! 20, 40, 80-acre tracts near bustling city in Michigan, \$15 to \$35 per acre. Very easy terms. Investigate this opportunity. Write today for free booklet, Swigart Land Co., P-1259, First National Bank Bldg., Chicago.

WANT to hear from party having farm for sale. Give particulars and lowest price. John J. Black, 11th St., Chippewa Falls, Wis.

UNUSUAL bargains in Minnesota wild land. Write P. J. Focos, New Richmond, Wis.

OKLAHOMA Farms. Write for free agricultural booklet. Board of Commerce, Shawnee, Okla.

LANDOLOGY, free, special number just out, containing many facts of cloverland in Marinette County, Wisconsin. If for a home or an investment you are thinking of buying good farm lands, where farmers grow rich, send at once for this special number of Landology. It is free on request. Address Skidmore-Rhie Land Co., 506 Skidmore-Rhie Bldg., Marinette, Wis.

SELL your property quickly for cash, no matter where located. Don't pay big commissions. Particulars free. Real Estate Salesmen Co., Desk B, Lincoln, Neb.

WANTED—MISCELLANEOUS

CASH by return Mail for Old Gold, Silver, Platinum, Diamonds, Gold Crowns, Bridges, Magneto Points, Liberty Bonds. Your goods returned if offer refused. Yonover Bros., 1637 Roosevelt Rd., Chicago.

CASH paid used automobiles. Radius three hundred miles Chicago. Write description, lowest price. Warwick, 218 N. Central, Chicago.

WANTED. Songs. With or without music. We sell Songs. Bauer Bros., Oshkosh, Wis.

WANTED—Article which can be sold by large crew of house-to-house canvassers. Give full particulars. Kirkham, 803, 110 W. 40th St., New York, N. Y.

CASH Paid. Mail us your discarded jewelry, gold crowns and bridges, watches, diamonds, silver, platinum, War Savings Stamps and old false teeth. Highest prices paid. Money sent by return mail. Packages held 4 to 12 days and returned at our expense if our offer is refused. United States Smelting Works (The Old Reliable), Dept. 71, Chicago, Ill.

DOGS, BIRDS, POULTRY & PETS

ARE you interested in dogs? Send 25¢ (stamps or coin) today for three months' subscription to Sportsman's Digest. Contains interesting, illustrated stories on dogs, hunting, fishing, etc. Sportsman's Digest, 307 Butler Building, Cincinnati, O.

BABY Chicks, 18c up; Bred-To-Lay, Prepaid guaranteed delivery. Send for circulars. Roy Clark, Dept. P, East Hartford, Conn.

POLICE or Shepherd Dogs and Puppies, pedigreed champion stock, \$50.00 and up. Wolfsburg Police Kennels, Aqueduct, L. I.

BREED Squabs. Book free. E. Rice, Melrose Highlands, 77, Massachusetts.

GREAT Dane Pups—For Danes that have size and intelligence write Collins Kennels, Box 109, Reedsburg, Wis.

"HOUNDS and Hunting"—Regular be-man's magazine of out door life, featuring the Beagle. Sample 20c; \$1.50 a year. Address "Hounds and Hunting," Desk P. M., Decatur, Ill.

BELGIAN HARES, GUINEA PIGS

BLACK or steel-gray Flemish giants, prices and booklet, free. Rabbit & Poultry Farms Co., 609 27th St., Denver, Colo.

RAISE Rabbits for me. 25c to 50c lb. for all you raise. Breeders cheap. Cross, 3845 Easton, St. Louis, Mo.

RAISE guinea pigs. Pay better than poultry or rabbits; easy to raise; little space required. We guarantee market. Particulars and booklet how to raise free. Carver Distributing Co., 3102 Grand Ave., Kansas City, Mo.

TOBACCO

TOBACCO, Natural Leaf, for mild smoking; 10 lbs, \$1.50; 20 lbs, \$2.75; will furnish free receipt for preparing. Leaf Tobacco Exchange, Mayfield, Ky., Star Route.

PERSONAL

FULL Horoscope readings—three questions answered. Birthdate, 50c. Crystal Balls sold. Gazing books \$1. Delnoza, 664 N. 12th, Philadelphia.

COMPLETE life reading 35c. Give birthdate. Jay Wambaugh, Goshen, Ind.

SUCCESS or Failure! Which is your destiny? Scientific information. "Success" pointers and Personality sketch for 10c and birthdate. Thomson-Heywood, Dept. 885, Chronicle Bldg., San Francisco, Calif.

ST-STU-T-T-TERING and stammering cured at home. Instructive booklet free. Walter McDonnell, 46 Potomac Bank Bldg., Washington, D. C.

FREE—Stop using tobacco. We will give free information how to conquer habit easily and permanently. Results guaranteed. Anti-Tobacco League, Box K, Omaha, Nebr.

TOBACCO or Snuff Habit cured or no pay. \$1.00 if cured. Remedy sent on trial. Su-perba Co., TP., Baltimore, Md.

FOR SALE OR EXCHANGE

AMUSEMENT Park, price \$8,000. Want land or diamonds. Black Bros., Brocken-ridge, Texas

SEEDS, PLANTS, TREES, ETC.

WANTED—Everyone interested in garden- ing to write for free copy of our beautiful Seed and Plant Guide. Our new special- ties will interest you. H. W. Buckbee, Rock- ford Seed Farms, Dept. 901, Rockford, Ill.

FURS, WEARING APPAREL, ETC.

FURS, Coats, Scarfs, Muffs, Chokers, etc., made from your raw or tanned furs. Re- modeling and Repairing. Enormous sav- ings. Write for Free Catalog today. Tells everything. Arthur Felber Fur Co., Dept. F343, 25 N. Dearborn St., Chicago, Ill.

SURVEYING INSTRUMENTS

NEW and used surveying instruments di- rect from factory. Satisfaction guaranteed or money refunded. Wissler, 619 Broadway, St. Louis.

MICELLANEOUS

FREE—Very useful and practical article for those mechanically or mathematically inclined. Send name, address, occupation. Engineering Service Bureau, Dept A513, 56 East Randolph St., Chicago.

FIVE Master Keys. Open and test thou- sands of locks. Useful and convenient. \$1.00 brings set and novel chain. Southern Spe- cialty Co., Box 366-A, Birmingham, Ala.

BEST knife in the world for 25c coin. Pocket knife with changeable blade. Uses discarded razor blades. Fred Rutten, 3148 Lowe Ave., Chicago.

SAVE Gas. Gas Jet Heaters that Heat. Last lifetime. \$1.00; \$2.00 postpaid. Meri- torious Articles, Novelties. Address J. Thomas, Box 86, French Lick, Ind.

MOLES, Warts, False Growth removed without knife, blood or pain. "While you wait." 1922 Discovery. Prof. Gregor Kalinskik, Duluth, Minn.

ALMOND Cold Cream in Mentholatum jars, 25c postpaid. Burson Chemical Labora- tory, 227 West Fourth Street, Ottumwa, Ia.

GET Posted for Spring. Good prices paid for butterflies, insects. See Sinclair's Dis- play Advertisement, page 30.

LOCKSMITHS: Send \$1. get valuable chart for cutting tumbler padlock keys. Globe System, 134 Sixth Ave., New York, N. Y.

118-ACRE farm with 10 cows, furniture, etc., included; good house, 60-ft. barn, all \$2,500, part cash. Page 24 free catalog. Strout Farm Agency, 150P, Nassau St., New York City.

CUTS anybody can make. Simple, cheap process. \$1. Specimens, particulars. 2c stamp. M. Day, Windfall, Ind.

LOCKSMITHING from A to Z—500 tricks of the locksmith trade. \$1.50—money back if dissatisfied. H. Routson, 3408 Andover St., Oakland, Cal.

SAVE incorporating expenses and excess profit taxes and avoid personal liability by organizing your company on the Common Law Plan under a Declaration of Trust. Anyone, anywhere, can fill in Demaree Standard Forms, issue shares and begin doing business same day. Pamphlet B-53 free. C. S. Demaree, Legal Blank Printer, 613 Walnut, Kansas City, Mo.

ARTIFICIAL Eyes. \$3. Booklet free. Den- ver Optic, 559 Barclay, Denver, Colo.

FREE BOOK on SIGNAL ENGINEERING

SIGNAL ENGINEERING

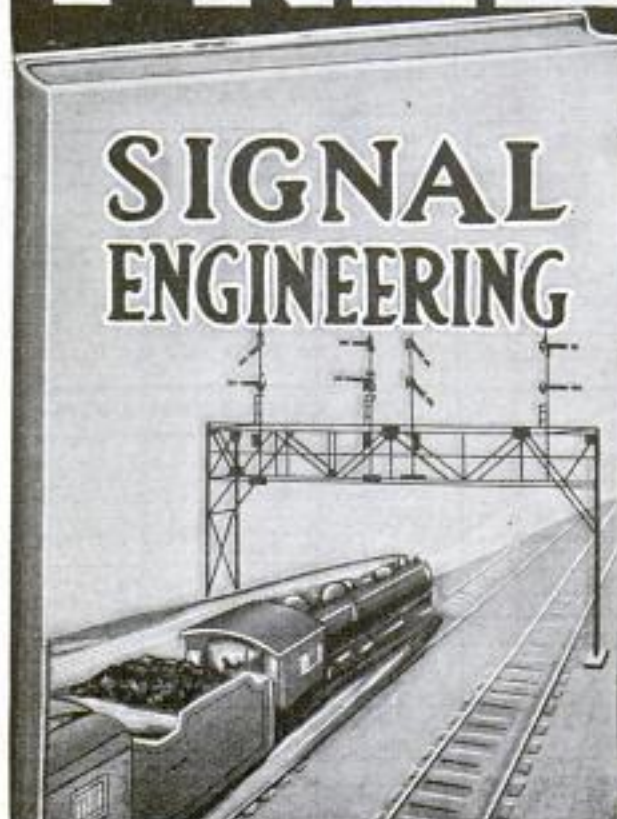

THERE are thousands of miles of railroad that must be equipped with block signal systems. To superintend these installations men are necessary. *Golden opportunities are offered.* Every ambitious man should write for the Free Book on Signal Engineering.

Men Are Needed to Accept High Salaried Positions

Less than one-fourth of the passenger lines in this country are equipped with automatic block signal systems. The day is fast coming when the law will compel railroads to install them. Remarkable opportunities are offered to ambitious men in the profession of Signal Engineering. High salaries are paid. \$250.00 a month is an ordinary salary for a Signal Engineer.

Send the Coupon

Now and get the free book about Signal Engineering. Too, we will tell you how you can get the training that you need in order to become a Signal Engineer. You will be under no obligation by writing for this free book. Do it *Now*.

DEPARTMENT OF SIGNALING
Dept. 8353, 1924 Sunnyside Avenue
CHICAGO

Gentlemen.—Please send me ab- solutely free and prepaid your big new book on Signal Engineering. Also full particulars about your great special free outfit offer. It is distinctly understood that I assume no obligations of any kind.

Department of Signaling

Dept. 8353
1924 Sunnyside
Ave., Chicago

Name.....
Address.....
Age.....Occupation.....

Learn Draftsmanship At Home

A great profession is open to you. No matter where you live or what you are doing, you can become a master Draftsman by spare time study at home. Send the coupon below and get information about this. Learn how other men have risen to big jobs and large salaries through the same Chicago "Tech" courses that you can take. You get the free lesson and catalog which explains everything—just for the asking. Send now—today.

Make Yourself Worth \$60 to \$150 a Week

"We need more expert draftsmen" is the word from thousands of employers. And this means bigger pay than ever before for ready, capable men. Construction work all over the country, postponed during the war, must soon be in full swing. Expanding businesses will need more draftsmen. Factories, architects, electrical plants, contractors, sheet metal works, map publishers, engineering concerns always have paying jobs for thoroughly trained men. This is your chance. Take advantage of the flood tide. Learn Draftsmanship.

FREE TRIAL LESSON

This free test lesson will show you how well qualified you are for Draftsmanship. While other schools ask you to enroll and send money first, we send the free lesson first. Read it, practice the exercises and then decide for yourself whether to take the course or not.

FREE OUTFIT

is included with our Home Study course or credit given if you already have an outfit. These are high grade instruments, drawing board, T square, etc.—same as used by leading draftsmen.



Train Under Experts By the Chicago "Tech" method you are trained by practical men who put you through without waste of time on unnecessary studies. They train you in exactly the methods that they themselves use on important work. They prepare you to stand beside draftsmen who have had years of experience. They give you the very knowledge that is required in men selected for the higher positions.

With this training you become the man wanted—the man who will be pushed ahead because you can do the things that employers want done. Start with a good salary and put yourself in line for quick promotion. If you can't come to Chicago to attend the College, you can get the same training at home by mail, under the same experts who would teach you here. Coupon brings full information on our home study courses.

Other Paying Courses

If you want to take up any other technical study, the coupon gives you a list of our courses. Mark the one you want information on and we will send catalogs. All Chicago "Tech" instruction is given by experts in each particular branch.

Now Big jobs are waiting. You can make more money if you train for it; and Chicago "Tech" instruction will put you in the high salaried class without any needless delay. It makes you thorough—self-confident—expert. In which course are you interested? Mail the coupon now—today!

CHICAGO TECHNICAL COLLEGE

330 Chicago "Tech" Bldg., Chicago, Ill.

Send information on course marked X

- | | |
|---|--|
| <input type="checkbox"/> Machine Drafting | <input type="checkbox"/> Auto. Engineering |
| <input type="checkbox"/> Electrical Drafting | <input type="checkbox"/> Aero. Engineering |
| <input type="checkbox"/> Architectural Drafting | <input type="checkbox"/> Gas Engines |
| <input type="checkbox"/> Structural Drafting | <input type="checkbox"/> Plan Reading—Buildings |
| <input type="checkbox"/> Sheet Metal Drafting | <input type="checkbox"/> Estimating—Buildings |
| <input type="checkbox"/> Topographic Drafting | <input type="checkbox"/> Plan Reading—Machinery |
| <input type="checkbox"/> Surveying | <input type="checkbox"/> Plumbing—Estimating, etc. |
| <input type="checkbox"/> Designing | <input type="checkbox"/> Heating and Ventilating |
| <input type="checkbox"/> Contracting—Buildings | <input type="checkbox"/> Steam Engineering |

Name.....

Address.....

Post Office..... State.....

College or Home Study, state which.....

Free Trial Lesson included when inquiry is for Draftsmanship or Plan Reading.



Don't tell me you never had a chance!

"Four years ago you and I worked at the same bench. I realized that to get ahead I needed special training, and decided to let the International Correspondence Schools help me. I wanted you to do the same, but you said, 'Aw, forget it!' You had the same chance I had, but you turned it down. No, Jim, you can't expect more money until you've trained yourself to handle bigger work."

There are lots of "Jims" in the world—in stores, factories, offices, everywhere. Are you one of them? Wake up! Every time you see an I. C. S. coupon your chance is staring you in the face. Don't turn it down.

Right now over one hundred thousand men are preparing themselves for bigger jobs and better pay through I. C. S. courses.

You can join them and get in line for promotion. Mark and mail this coupon, and find out how.

TEAR OUT HERE

INTERNATIONAL CORRESPONDENCE SCHOOLS
BOX 5609-C SCRANTON, PA.

Without cost or obligation please explain how I can qualify for the position, or in the subject before which I have marked an X in the list below:

- | | |
|---|---|
| <input type="checkbox"/> ELECTRICAL ENGINEER | <input type="checkbox"/> BUSINESS MANAGEMENT |
| <input type="checkbox"/> Electric Lighting & Railways | <input type="checkbox"/> SALESMANSHIP |
| <input type="checkbox"/> Electric Wiring | <input type="checkbox"/> ADVERTISING |
| <input type="checkbox"/> Telegraph Engineer | <input type="checkbox"/> Show Card & Sign Ptg. |
| <input type="checkbox"/> Telephone Work | <input type="checkbox"/> Railroad Positions |
| <input type="checkbox"/> MECHANICAL ENGINEER | <input type="checkbox"/> ILLUSTRATING |
| <input type="checkbox"/> Mechanical Draftsman | <input type="checkbox"/> Cartooning |
| <input type="checkbox"/> Machine Shop Practice | <input type="checkbox"/> Private Secretary |
| <input type="checkbox"/> Toolmaker | <input type="checkbox"/> Business Correspondent |
| <input type="checkbox"/> Gas Engine Operating | <input type="checkbox"/> BOOKKEEPER |
| <input type="checkbox"/> CIVIL ENGINEER | <input type="checkbox"/> Stenographer & Typist |
| <input type="checkbox"/> Surveying and Mapping | <input type="checkbox"/> Certified Public Accountant |
| <input type="checkbox"/> MINE FOREMAN or ENGR. | <input type="checkbox"/> TRAFFIC MANAGER |
| <input type="checkbox"/> STATIONARY ENGINEER | <input type="checkbox"/> Railway Accountant |
| <input type="checkbox"/> Marine Engineer | <input type="checkbox"/> Commercial Law |
| <input type="checkbox"/> ARCHITECT | <input type="checkbox"/> GOOD ENGLISH |
| <input type="checkbox"/> Contractor and Builder | <input type="checkbox"/> Common School Subjects |
| <input type="checkbox"/> Architectural Draftsman | <input type="checkbox"/> CIVIL SERVICE |
| <input type="checkbox"/> Concrete Builder | <input type="checkbox"/> Railway Mail Clerk |
| <input type="checkbox"/> Structural Engineer | <input type="checkbox"/> AUTOMOBILES |
| <input type="checkbox"/> PLUMBING & HEATING | <input type="checkbox"/> Mathematics |
| <input type="checkbox"/> Sheet Metal Worker | <input type="checkbox"/> Navigation |
| <input type="checkbox"/> Textile Overseer or Supt. | <input type="checkbox"/> AGRICULTURE |
| <input type="checkbox"/> CHEMIST | <input type="checkbox"/> Poultry Raising <input type="checkbox"/> Spanish |
| <input type="checkbox"/> Pharmacy | <input type="checkbox"/> BANKING <input type="checkbox"/> Teacher |

Name..... 7-1-21

Street and No.....

City..... State.....

Occupation.....

LEARN SIGN LETTERING IN 20 HOURS

Become independent. Learn a paying profession. Fit yourself in just a few hours to earn \$2000 to \$6000 a year lettering store windows, show cards, walls, fences, barns, and signs of all kinds. We absolutely guarantee quick training results by using our new method patented mechanical device. An improved idea in instruction and sign lettering. Send name and address for free details.

AMERICAN SCHOOL OF LETTERING
DESK P OMAHA, NEB.

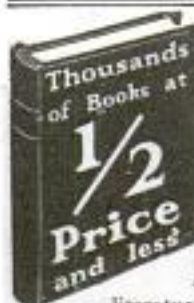

ANY BOOK IN PRINT

Delivered to your door. Standard authors, fine editions, new books, all at biggest savings. Be sure to send postcard for Clarkson's catalog.

FREE Write for our great book catalog.

This catalog is a short course in literature used by some of America's leading universities; 300,000 book lovers buy from it. Free if you write now.
DAVID B. CLARKSON, The Book Broker
387 CLARKSON BUILDING CHICAGO, ILLINOIS

Learn Photography at HOME

Make \$75.00 a Week on the Side

Establish yourself as a Photographic Expert quickly—during your spare time—under a leading photographer. I'll show you how to start your own business—or command a large salary. Send for my special offer—it's only temporary. Act at once. A postal will do. R. Dupont, Pres. INTERNATIONAL STUDIOS
Dept. 371 4451 N. Robey St., Chicago, Ill.



MURDER WILL OUT

Police departments, factories, banks and industries everywhere are adopting the finger print method of identification to locate criminals.

BE A FINGER PRINT EXPERT

You can train yourself at home in spare time. Write for **FREE** reports telling of the uses of finger prints and how you can learn this profitable profession. **Positions guaranteed.**

U. S. SCHOOL OF FINGER PRINTS
ROOM 433, 7003 N. CLARK ST. CHICAGO, ILL.



FREE Particulars, "How To Become An Expert Penman," and Your Name in Fine Penmanship on two Cards, Different Colors, Embellished, Attractive Designs. **ALL FREE.** Write Today
T. M. TEVIE, Box 25-K, Chillicothe, Mo.

MOVING PICTURE MACHINE FREE



This genuine New Model American made Moving Picture machine with film—ALL GIVEN for selling 50 papers. Give us at 5c a paper. Write for them. We send them postpaid. When sold return \$3.00 and we send machine, film and extra premium free of set of admission tickets, postage prepaid.

BLUINE MFG. CO.
554 Mill St.
Concord Junction, Mass.

Be your own Boss Make \$25 to \$100 a week

Let me put you in a pleasant, profitable, independent business of your own.

If you are making less than \$25 a week, I can show you the way to a bigger income at once. By my plan you can build up in a few weeks a profitable business, paying a growing income, in which you'll be your own boss. You can use spare time or all your time, just as you like.

I have put hundreds of men and women on the road to financial success and independence. In all parts of the country you will find my representatives utilizing their spare time to add to their earnings, or, in full time, making more money than they ever did before.

I can do the same thing for you—you don't need any experience. If you've got grit and confidence in yourself, you can make \$25 to \$100 a week in as pleasant an occupation as anybody could wish.

Read below what a few of my representatives are doing:

C. A. Shelton, Missouri, made sales of \$290 last month working two hours a day.

D. F. Shugrue, Mass., sells \$300 worth of goods a month in part time.

Rosenburger, Ill., averages \$870 a month sales in a community of 500 families.

Frank Schoak, New Jersey, writes he sold \$250 worth of Ho-Ro-Co goods in two weeks.

Mrs. Rouse, Georgia, quit school-teaching to sell our products. In two months her sales were over \$600.

Pawling, Massachusetts, writes. "I make \$50 a week and am my own boss."

I will show letters from these representatives to anybody desiring to see them.

With the backing I give you, and the wonderful quality of Ho-Ro-Co Products, all you need is grit and confidence. Repeat orders come easy because our goods satisfy users, every time. H. B. Tenneman of Illinois, says "People call me up—stop me on the street—even write me to bring more goods."

The Quick Selling Ho-Ro-Co Line

includes household specialties, toilet articles, soaps, remedies, and other necessities required by every family. Our agents make thousands of dollars on our two leaders alone. Ho-Ro-Co Tonic and Ho-Ro-Co Skin and Scalp Soap. You can do the same. Why not start now?



Mail this coupon at once—make your start to success,

M. G. ROTH, Pres.

Ho-Ro-Co Mfg. Co.

Established in 1908

155 Locust St.,

St. Louis, Mo.

Hundreds of men and women make from \$25 to \$100 a week without previous experience in selling.

Experience is not necessary. Very few of my most successful representatives had previous experience. Ho-Ro-Co products are so good, so well-known, that it's no task to sell them. Furthermore, I give you the benefit of my years of experience—I show you how to go about this easy, pleasant work with full confidence in your ability to make money.

Get Free Sample Case

Let me tell you how to get a big, well-filled sample case absolutely free—how to show Ho-Ro-Co products to your friends and acquaintances. Then you'll realize how easily you can double or treble your present income.

If you'll send me the coupon below, I'll give you full particulars.



M. G. Roth
President,
Ho-Ro-Co Mfg. Co.

Write your name and address clearly in ink on the coupon.

Mail coupon at once!

M. G. Roth, President,
Ho-Ro-Co Mfg. Co. 155 Locust St. St. Louis Mo.

Send me without obligation, full particulars of your Ho-Ro-Co representative's plan whereby I can increase my income.

Name

St. & No.
or R. F. D.

City

State

Learn to Write

GOOD hand-writing has been truly called the "Bread and butter of a business education." It should be the determination of every body to learn to write at least a good business hand. Good writing is the very foundation of business success.

Easy to Learn By my system you can become a good penman at home, in your own room during spare time. Don't be content with the notion that good penmen "are born" such. Because one's ancestors may have been noted for poor penmanship, is no excuse for him to remain an illegible scribbler. My system is original, unique, and highly successful—the result of 25 years' experience.

Your Spare Time Just your spare moments—that's all I ask. If you follow my instructions you will soon be able to write a beautiful hand that will be a source of pride to yourself and envy to your friends. Notice the improvement shown in Mr. Campbell's writing below.

Leland M. Campbell

"I am astonished at the improvement I've made by means of The Tamblin System in so short time."

LELAND M. CAMPBELL,
Campbelltown, Ohio.

Leland M. Campbell

Mr. Campbell wrote his upper signature July 20, and the lower one November 10—a little less than 4 months apart. Hundreds and hundreds of others in all parts of the world are doing as well with my system.

I have had unbounded success in making poor writers good ones and good writers better penmen than they thought possible.

32
PAGES
HIGHLY
ILLUS-
TRATED.

How to
Become
a
Good Penman

FREE
BOOK
WRITE
FOR IT
TODAY

Penmanship is particularly adapted to correspondence instruction, and I absolutely guarantee satisfactory improvement. Distance no barrier. Ladies taught just as successfully as men.

Don't wait, don't delay, begin now to prepare for that position where good penmanship will be required. Send today for my Free Book, "How to Become a Good Penman," which contains copies and beautiful specimens and tells how others have become good penmen by means of the Tamblin System. Your name will be beautifully written on a card with white ink if you enclose stamp.

F. W. TAMBLYN,
418 Ridge Building,
Kansas City, Mo., U.S.A.

FREE BOOK COUPON

F. W. TAMBLYN, 418 Ridge Bldg., Kansas City, Mo., U.S.A.

I am interested in improving my penmanship. Please send me free your Book "How to Become a Good Penman."

Name.....

Address.....

Sign and mail this today, before you forget it.

Please Mention Popular Mechanics

MECHANICAL DRAWING

Practicing Engineer, Experienced Draftsman and Teacher Will Train You for High Class Position.

High salaries paid Mechanical Draftsmen. Learn by doing practical work at home under personal instruction of expert. Thoro, up-to-date courses by mail. PREPARE NOW FOR BIGGER INCOME. Complete draftsman's outfit included with course.

UNIVERSAL CORRESPONDENCE SCHOOLS
519 New York Life Bldg., Minneapolis, Minn.

Send me without obligation free book on draftsmanship and information concerning course marked below.

- | | |
|---|---|
| <input type="checkbox"/> Mechanical Drawing | <input type="checkbox"/> Architectural Drafting |
| <input type="checkbox"/> Machine Drafting | <input type="checkbox"/> Blueprint Reading and Cost Estimating for Builders and Tradesmen |
| <input type="checkbox"/> Structural Drafting | <input type="checkbox"/> Shop Mathematics |
| <input type="checkbox"/> Topographical Drafting | |
| <input type="checkbox"/> Reinforced Concrete Drafting | |

Name

Address

Send for this AUTOMOBILE HANDBOOK



The most complete book
of its kind ever published

Everything you want to know about an automobile. Packed with practical information that will save you money in operating and repairing your own car or help you to get a job as chauffeur or repair man.

Mail this advertisement—a dollar bill—and your name and address—and this I. C. S. Automobile Handbook will come to you by return mail. You run no risk! Money back if desired!

International Correspondence Schools
Box 5617-C, Scranton, Pa.

301 pages
156
illustrations

ELECTRICAL Training Book FREE

Send me your name and address and I will send you my big new Electrical Training Book Free. It will show you how to qualify for high paying jobs in Electricity. Thousands now open. Prepare at home—quickly—during spare time under an Electrical Engineer. Take advantage of this unusual offer—only temporary.

A. W. WICKS, President WICKS ELECTRICAL INSTITUTE
Dept. 1193 3601 Michigan Ave. CHICAGO

I Teach You to Play the Saxophone



All my students are excellent Saxophone players. Therefore they are much in demand. In twenty easy, comprehensive lessons I will teach you to play the saxophone like a professional. The small cost of my course makes it a good investment. 200 lessons condensed to 20.

EARN BIG MONEY

by being an expert player. My course in saxophone playing is known from coast to coast. Must not be confused with cheap inferior courses. Study at home from the teachings of America's greatest saxophone instructor. Don't delay. Send immediately for particulars.

Newlan School of Music 499 Athenaeum Bldg.
CHICAGO

BRUSHES and SUPPLIES
FOR SIGN and SHOW CARD
WRITERS

Largest sign shops and studios use BLUE HANDLES BRAND brushes and supplies. The FIG-NEER line, Established 1899. Recognized Quality—Tremendous purchasing power, and long years of practical experience, permit us to offer the highest quality supplies at the lowest prices. The Crosby Co., of Indianapolis, writes: "We offer you the highest recommendation for your goods." Write for our new 1922 catalogue. It's FREE.

DETROIT SCHOOL OF LETTERING, 623 D. S. of L. Bldg.
SUPPLY DEPT., Detroit, Mich., U. S. A.



Chas. J. Struss,
Founder

BIGGER AND BETTER THAN EVER!

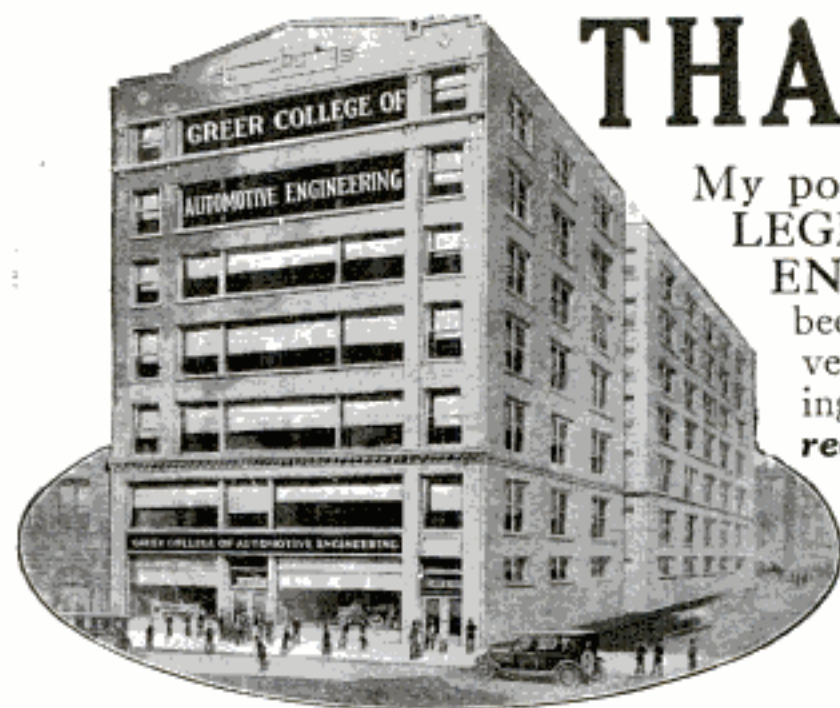

My policy for GREER COLLEGE OF AUTOMOTIVE ENGINEERING has always been to give our students the very best instruction and training possible. We aim to turn out *real* automobile men—**Certified Automotive Engineers.**

And now, in order to give our Students still greater advantages, we have moved into our new building, all of which is used by Greer College for

automotive educational training. In these seven big floors we have much more room, better equipment, better light—finer in every way. Here students study and work on the actual parts of all kinds of cars, under the direction of competent instructors.

BE A "C.A.E." (*Certified Automotive Engineer*)

The prestige enjoyed by Greer graduates is your cue. *A Greer Diploma means something.* Graduate from *Greer College of Automotive Engineering* and be recognized as *"The Man Who Knows."* Greer students who complete the course and earn their diplomas become *Certified Automotive Engineers.*

REAL INSTRUCTION

It is not enough to merely go to some automobile school for a few weeks. You want to go to the College that makes Master Mechanics, real Certified Automotive Engineers. That means, Greer College of Automotive Engineering. Here we always aim to give such instruction and training that Greer graduates will continue to be recognized as the best. Here we prepare you for success. Write for *free* catalog today.

VALUABLE BOOK FREE A new up-to-date edition of my book, *"How to Succeed,"* has just been published. Full of useful and practical information. Worth \$1.00 per copy—yet sent free to anyone interested. Write today.

Orwin Greer

GREER COLLEGE OF AUTOMOTIVE ENGINEERING

2024 Wabash Avenue, Dept. 13, Chicago, Ill.

Please send me free your big book as advertised in the March Popular Mechanics. Am interested in subjects before which I mark X.

Automobiles Vulcanizing
 Tractors Electric Starters
 Batteries Welding

GREER COLLEGE
of Automotive Engineering
2024 So. Wabash Ave., Dept. 13, Chicago,

Name.....

Present Occupation.....

Street or R. F. D.....

City..... State.....



LEARN TO DANCE WELL AT HOME IN DANCING MADE EASY TO LEARN BY ARTHUR MURRAY'S REMARKABLE NEW METHOD—COSTS VERY LITTLE.

FREE DANCING LESSON

Don't miss half the fun in life! Arthur Murray, America's greatest teacher of social dancing, has invented a remarkable new easy method which enables anyone to learn all the newest dances at home—in a few hours—*at very little cost!*

No music or partner needed. "60,000 learned dancing by mail." You, too, can quickly learn. *Success positively guaranteed!*

To prove you can learn easily and quickly, Arthur Murray will send you (in plain wrapper) a lesson absolutely **FREE**. Also, the Secret of Leading, How to Gain Confidence and other dancing helps. For mailing, send 10c. Surprise your friends by becoming a confident, accomplished dancer.

ACT NOW AND BE A GOOD DANCER SOON.

ARTHUR MURRAY SCHOOL OF DANCING, Studio 126, 290 Broadway, N. Y.

HALF-PRICE OFFER ON NOW!



Learn Chemistry at HOME

offers the greatest opportunities to-day of any profession. Chemists earn big money—salaries of \$10,000 to \$15,000 a year are quite common. If you want to know how you can learn chemistry at home, in your spare time, and obtain exactly the same chemical education that you would receive at any college or university, write to one of the foremost authorities on Chemistry, Dr. T. O'Connor Sloane, care Chemical Institute of New York, Home Extension Division 3, 140-P Liberty St., New York City. Dr. Sloane will send you full information **FREE**, by return mail.

MAKE \$1000

Quick, easy profits realized from intensive cultivation of seedling plants in your back yard working spare time. Get plan of Prof. Hood, horticulturist, for making \$800 to \$1200 during spring months.

OUR PLAN—FREE

Get results attained by hundreds of students. Plan explained free for asking. Write.

CONTINENTAL CORRESPONDENCE SCHOOLS OMAHA NEBRASKA



SUN WATCH FREE WITH COMPASS

With it you can tell time by the sun, and every boy should have one. It has compass, sundial, latitude, longitude and variation tables, all in handsome brass case that fits pocket. Given for selling 20 pkgs. Blaine at 15 cts. a pkg. Write today.

BLUINE MFG. CO.
711 Mill St., Concord Junction, Mass.

I Make Strong Men



That is my business. I make no other claims. But what I promise, I fulfill. I will increase your arm one full inch in 30 days and your chest in proportion. In three months I will make you a finished strong man. Are you interested? Read my book "Physical Perfection." It tells you how. All I ask is 10 cents to cover postage and wrapping. Don't put it off. Send today.

Arthur L. Hyson

103 Langdon Bldg. New York City

TOBACCO

OR SNUFF HABIT CURED OR NO PAY \$1.00 IF SUCCESSFUL

No matter whether used in pipe, cigarettes, cigars, chewed, or used in the form of snuff, Superba Tobacco Remedy contains nothing injurious, no dope, poisons, or habit forming drugs. **SENT ON TRIAL GUARANTEED.** Costs nothing if results are not satisfactory. **WRITE FOR FULL TREATMENT TODAY.** **SUPERBA CO. M-19 Baltimore, Md**



THROW YOUR VOICE

Under the table, down in the cellar, into a trunk or any old place. With our **VENTRIL O** which fits into the mouth you can have lots of fun fooling your friends. Also full instructions in the art of **Ventriloquism**, and big book of jokes. Sent by mail for 10 cts. Stamps or coin.



AERIAL AIRSHIP

UP IT GOES!

Climbs in the air by its own power. The propeller spinning automatically at a lively rate. Floats around a

room or outdoors. Lots of fun. By mail 10c.

WONDERFUL WIRELESS TELEGRAPH



Two instruments and 2 Codes in a box. Can Telegraph from room to room or house. Full instructions. By mail 12 cents.

All the Above by Mail for 50c.

STAMPS OR COIN

UNIVERSAL NOVELTY CO.

DEPARTMENT 205 STAMFORD, CONN.

Invisible Ink



Letters written with this ink look like blank paper. Can be brought out plainly by heating over lamp or stove. Bottle in wooden box, 10 cents.

SKULL RING



The eyes in this ring are either Emeralds or Rubies and would scare the timid. Either Roman Gold or Oxidized Silver. 25c by mail.



A Pinning Hold

That Makes An Opponent Helpless

This is one of the greatest of all holds practiced in wrestling. You have your opponent's right arm barred with your left hand and his left arm barred with a leg scissor hold. He is helpless. It is a good hold for self-defense, where you might wish to hold your man under control for some time. Try it on your brother or a friend today and see how completely you have him in your power.

Wrestling Secrets

Revealed by Champions Frank Gotch and Farmer Burns

This picture illustrates only one of thousands of wrestling holds which vary from simple grips to the deadly strangle hold. How would you like to know them all?

This is precisely what you can do! You may learn the regular holds—the blocks and breaks for them—many secret tricks never revealed before—all from two of the greatest world's champions who ever lived—Frank Gotch and Farmer Burns!

Written instructions, telling you exactly what to do, and large clear photographs, showing you exactly how to do it, will make you as much these champions' pupil as if they were by your side.

What Others Say:

"I threw a fellow who was older and weighed 30 pounds more than I did. He could throw me easily before I took your lessons."—Billy Jones, South Dakota

"Your course saved my life. A highwayman tried the 'hold-up' stunt on me with a pistol, but I successfully took the gun away from him with the trick shown in the sixth book of lessons."—D. E. Cox, Alabama.

"I have won everyone of eighteen contests since completing your course. All my opponents were heavier."—J. Misiewicz, New York.

Vigor—Endurance—Bravery!

These lessons will train you speedily to be an athlete, a wrestler, a man! Wrestling breeds quickness, vigor, endurance, bravery—all the manly qualities men defer to and women admire. It develops every muscle in your body. It gives you poise. Be a vigorous, successful, self-reliant! Wrestling will help you. Do not put it off. **Begin Today!**

Free Book!

Send Coupon

The first step is to send the coupon for Farmer Burns' free illustrated wrestling book. It is packed full of information about wrestling and wrestlers. Valuable tricks are shown. A book that every boy should have. You will be under no obligation. The book is free. Just put your name and address in coupon and mail now. Be sure to give age.

Farmer Burns School
1773 Ry. Exchange Bldg., Omaha, Neb.

Farmer Burns School

1773 Railway Exchange Bldg., Omaha, Neb.

Please send at once without any obligation on my part your free book on Scientific Wrestling, Physical Culture, Self Defense and How to Win.

Name.....

Address.....

Age.....

Whatever Your Question;—be it the pronunciation of Bolsheviki, the spelling of a puzzling word, the location of Murman Coast—the meaning of blighty, ace, tank, ukulele, etc., this Supreme Authority—

WEBSTER'S NEW INTERNATIONAL DICTIONARY

contains an accurate, final answer. 400,000 Words. 2700 Pages. 6000 Illustrations. Regular and India-Paper Editions. G. & C. MERRIAM CO., Springfield, Mass. Write for specimen pages, prices, etc., and FREE Pocket Maps per Popular Mechanics



\$1,600 to \$2,300 a Year
Men—Boys—Over 16—
should write at once

Rapid advancement. "No lay-offs." THE POSITION IS YOURS FOR LIFE.

Country residents and city residents stand the same chance. Common-sense education sufficient.

Send coupon today for schedule showing the places and dates of ALL COMING Government examinations. Don't delay. Every boy or man over 16 should send.

FRANKLIN INSTITUTE,
Dept. A177, Rochester, N. Y.

WANTED!



FRANKLIN INSTITUTE (The Pathway to Plenty) Dept. A177, Rochester, N. Y.
This coupon, filled out as directed, entitles the sender to free specimen questions; a copy of our free book "Government Positions and How to Get Them;" a list of Government positions now obtainable, and to consideration for Free Coaching for the examination here checked.

COUPON

.. Railway Mail Clerk (\$1600 to \$2300) .. Postoffice Clerk (\$1400 to \$1800)
.. Postoffice Carrier (\$1400 to \$1800) .. Rural Mail Carrier (\$ 720 to \$2600)

Name.....

Address.....

Use this before you lose it. Write plainly.



BE POPULAR! MAKE MONEY! LEARN MUSIC AT HOME

WHY envy your friends their knowledge of how to play the piano, organ, violin, cornet, or any other musical instrument? Be talented yourself. Make friends. Make money. Teach your children. You yourself can master any musical art right in your own home with the greatest ease.

We have taught thousands how to play their favorite musical instruments easily, quickly and thoroughly without a teacher just by following our New Improved Home Study Method.

We do away with the private teacher. We banish dry, tiresome exercises. We teach you **by note**. No numbers, no tricks, a sound musical education. We make it as fascinating for you to learn as it will be fascinating for you to show your friends what a good musician you are. Our pupils are in demand as entertainers, and some of them have written to us that they are making money through the musical talents they developed by our Home Training Method.

Our free book tells you all about it. Read the letters in it and you will see that what others have done easily, you can also do easily. More than 250,000 men, women and children have learned by our system.

FOR BEGINNERS OR ADVANCED PUPILS

Piano	Harmony
Organ	and
Violin	Composition
Drums and	Sight Singing
Traps	Guitar
Mandolin	Ukulele
Clarinet	Harp
Flute	Cornet
Saxophone	Piccolo
'Cello	Trombone
Hawaiian	Banjo
Guitar	Tenor Banjo
Voice and	Automatic
Speech	Finger
Culture	Control

Mr. David F. Kemp, U. S. School of Music,
73 Brunswick Bldg., New York City.

Please send me your free book, "Music Lessons in Your Own Home," and Particulars of Your Special Offer. I am interested in the following course:

.....
(Name of Instrument or Course)

Name.....
Please Write Plainly

Address.....

City.....State.....

AMAZING OFFER—ACT NOW!

Just mail the coupon now. Because we need one pupil in each locality at once to help us advertise our marvelously easy system of teaching music, we offer for a limited time our lessons at practically no cost—charges about equal to the cost of sheet music, postage, etc. Beginners or advanced pupils.

This offer is too important to hesitate over. Get the proofs, facts, letters from our pupils. Get our fascinating new book just issued, together with our astounding offer. All of these come to you FREE. Just drop us a postal or mail the coupon today.

Instruments supplied when needed, cash or credit

U. S. SCHOOL OF MUSIC
73 Brunswick Bldg. New York

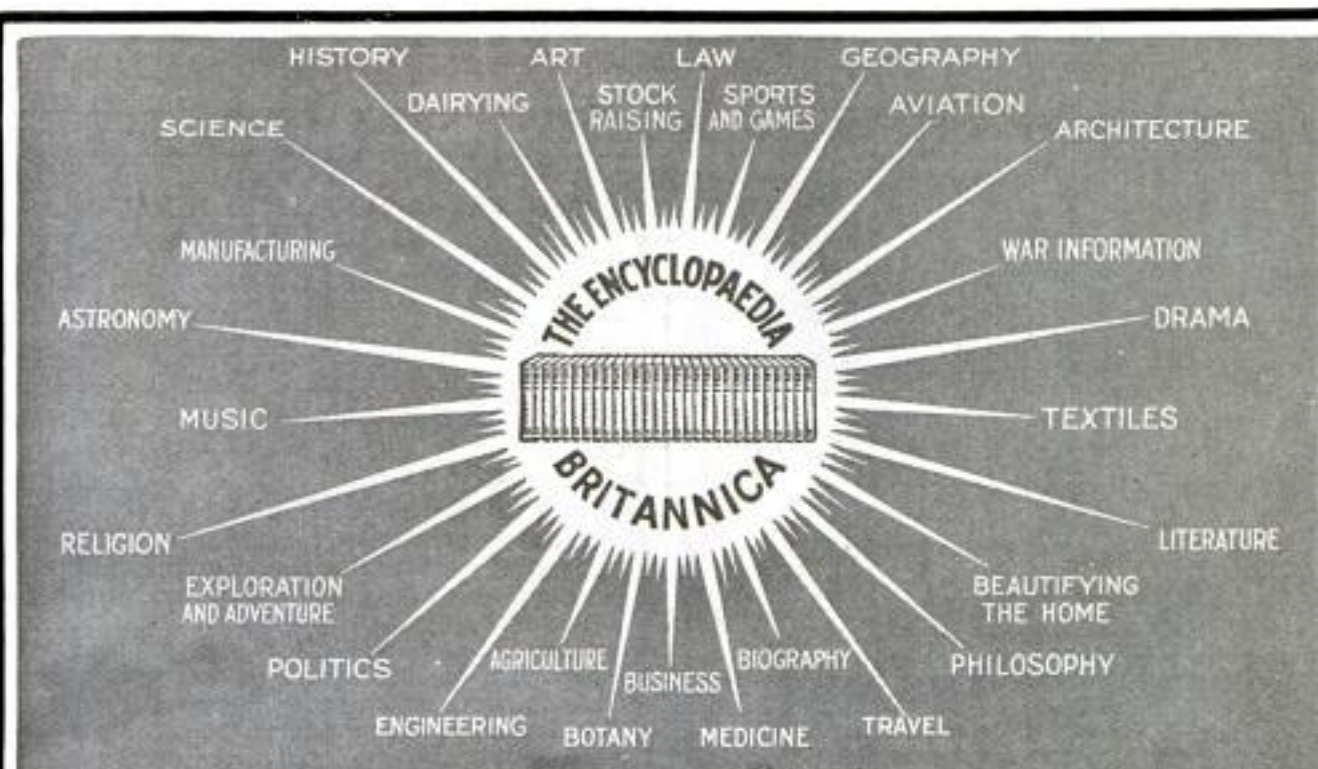

THE ENCYCLOPAEDIA BRITANNICA

Furnishes Accurate Knowledge on Every Subject Under the Sun

The World's Greatest Authority.

THE ENCYCLOPAEDIA BRITANNICA contains probably the best and most reliable information written by the greatest experts on practically every subject known to the human mind. No matter what subject you are interested in, no matter what subject your family or your children are interested in, no matter what subject comes up in your daily papers or your books, you will find that the Britannica gives the most comprehensive information in its 44,000,000 words. Every phase of a subject is covered. Even the smallest, most obscure information is in the Britannica, as well as the articles on the great general subjects.

When you read an article in the Encyclopaedia Britannica you feel confident that the information is reliable, for the Britannica is written by the wisest minds—each a specialist in the particular subject upon which he has furnished an article for the Britannica. These writers are either professors in the great institutions of learning in our country and other countries, or are scientific men and women who, by their superior intelligence and research, have acquired far advanced knowledge of their subjects, or, again, they are the great workers of the world. They write in a clear, concise manner which every member of your family can understand. You will be surprised how interesting and fascinating are the articles in the Britannica, and you will have many hours of profit and pleasure from a set of this great work.

Your Country Needs Your Help in the Solution of Her Post-War Problems.

Shall we retain our high tariff or shall we operate on a free trade basis? Shall we wipe out our enormous national

debt in one or two generations or shall we extend it over a comparatively long period? Shall we adopt universal training or maintain a large standing army? Shall this nation become more autocratic or tend toward Socialism? What will mean the greatest prosperity and happiness to the people?

You, as a citizen of this great nation, in the day of the greatest crisis of its history, should put yourself in a position adequately to answer and pass intelligent judgment on the questions that are so vital to the country and the happiness and welfare of its people.

Give Your Child a Fair Chance.

Who are the men and women in each generation who have stood head and shoulders above their fellow men and who have won the most notable success? They are the men and women who, as children, have educated themselves beyond the station to which they were born. Abraham Lincoln was the best educated lawyer in his town, and he continued throughout his life probably the best posted man of his day, because he read and read. You insist that your child has brains, but you should help that child develop his brains, and give him every advantage possible within your means, so that when he becomes ready to do his work in the world he is not handicapped by lack of education. Education is the path that leads to achievement, to a larger life and to greater success. Put in your child's hands the Encyclopaedia Britannica, the world's storehouse of knowledge, which has been the guide to the education of millions of men and women. It will inspire your child to learn, and it will furnish him with a great teacher on many thousands of subjects.

We Are Offering the Britannica at a Great Bargain

This Complete Set of 29 Volumes, Containing 44,000,000 Words, 30,000 Pages, 15,000 Maps and Illustrations and 41,000 Articles, Sold on Small Monthly Payments. Send Coupon for Prices and Terms of Payment.

Sign and Send This Coupon Today.

Remember, this is an unusual offer of the Britannica printed on genuine India paper. Act today—NOW—by clipping the coupon and sending for the beautifully illustrated book telling all about the Britannica.

Sears, Roebuck and Co.
Chicago, Ill.

Sears, Roebuck and Co., Chicago, Ill.

Gentlemen: Please send me, free, your Illustrated Book No. 182, giving full information about the new Encyclopaedia Britannica. Also tell me what I will have to pay for one of the remaining sets of the Handy Volume issue of the Britannica printed on genuine India paper.

Name

Postoffice

R. F. D. Box

No. State

Street and No.

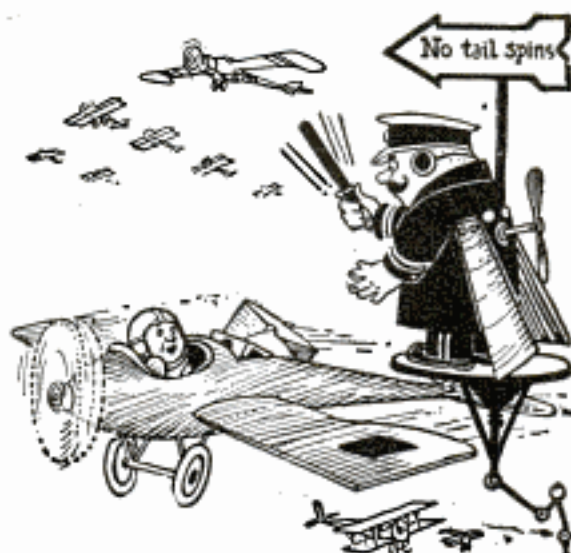

Will They Have Traffic Laws In The Sky?

WILL there be policemen to tell you to "Keep To The Right" or raise a warning finger when you start exceeding the speed limit over New York or San Francisco?

Will there be "AIRPLANE GARAGES" where one may stop for gasoline or repairs?

Will the airplane be used to deliver pins or pianos? Will you step into an airplane jitney and speed down to the office in five minutes, where it now takes 30 or 35?

Who can say? Anything is possible if the airplane continues to develop as it has in the last ten years.

Right now, there are scores of positions open for men who are expert on airplane engines. And every year there will be more.

And right now is the time to get into this business—just as hundreds of men got into the automobile business and the movie business before the rush began.

Best of all, you can learn everything you need to know about airplane engines right in your own home in an hour a day of the spare time that now goes to waste.

All that we ask is this:—Fill out the coupon printed below and mail it to Scranton. This doesn't obligate you in the least—but it will bring you the full story of what the I. C. S. can do for you.

TEAR OUT HERE

INTERNATIONAL CORRESPONDENCE SCHOOLS
Box 5614-C, Scranton, Pa.

Without cost or obligation, please send me complete information about the subject before which I have marked an X in the list below:

- AIRPLANE ENGINES
- Mechanical Engineering
- Civil Engineering
- SURVEYING
- ARCHITECTURE
- Electrical Engineering
- CHEMISTRY
- Stationary Engineering
- Automobiles
- DRAFTING

- ADVERTISING
- Salesmanship
- BOOKKEEPING
- Civil Service
- Railway Mail Clerk
- Traffic Manager
- Business Management
- Cert. Public Accountant
- Stenography
- Good English

Name.....

Address.....

Occupation.....

Persons residing in Canada should send this coupon to the International Correspondence Schools Canadian, Limited, Montreal, Canada.

Please Mention Popular Mechanics

COMMERCE IS SPEED FLYING IS THE ANSWER

LEARN TO FLY

in Chicago with
**RALPH C. DIGGINS SCHOOL
of AERONAUTICS**

Scores of graduates from our flying school are filling big-paying positions. Splendid opportunities for competent pilots are opening everywhere. Your chance is now! Get into this newest, fascinating, best paid profession.

Prepare NOW!

You can prepare now for spring and summer flying classes. Take our home study Special Extension Course, the most modern and practical course ever given, prepared by our experts right on our flying field. This course gives you thorough training in air navigation, flying aeroplanes, motors, instruments, theory of flight, etc. Contains only what you must know to be a successful pilot. Gives you big start over the others in learning to fly a machine when you reach our field.

Easy terms. Write NOW for full information.

**THE RALPH C. DIGGINS SCHOOL
of AERONAUTICS**

Dept. 301, 140 N. Dearborn St., Chicago, Ill.

I Can Train You For A High Salaried Hotel Job in 20 weeks



The Hotel Business offers wonderful opportunities to the trained man or woman! Now America's **FOURTH LARGEST INDUSTRY**, with thousands of high-salaried positions open to those who qualify through training. Statistics show that **ONE IN EVERY TEN HOTELS WILL HAVE AN OPENING FOR MANAGER THIS YEAR**. The men who will get them will be the **TRAINED** men.

I GUARANTEE TO TEACH YOU in my 50-lesson home-study course on hotel work, all that the leading hotel experts know about the business—men making from \$5,000 to \$50,000 a year! My students successful without slow, laborious "working up." Services of our Placement Bureau **FREE** to all graduates. Big pay, fine living, free meals and apartment, fascinating work—all these may be yours if you will fit yourself for the thousands of opportunities in Hotel Work.

SEND FOR FREE BOOK

20 Years' Experience in 20 Weeks is what this wonderfully complete course gives you. Course prepared and your training under personal direction of Clifford Lewis, Hotel Expert of National Reputation. Endorsed by managers of such hotels as Elmhurst, Waldorf-Astoria, Coppley Place, New Willard, St. Francis, etc. Interesting **FREE BOOK** explains all. **SEND FOR IT TODAY.**

LEWIS HOTEL TRAINING SCHOOL

Founded 1916
CLIFFORD LEWIS, President

Room 323 WASHINGTON, D. C.

LEWIS HOTEL TRAINING SCHOOL
ROOM 323, WASHINGTON, D. C.

Send me without obligation the **FREE BOOK**, "Your Big Opportunity."

Name.....

Street.....

City.....State.....

?

Do You Know Yourself?

Do You Know Your Opportunities?

Do You Know How to Use Them?

?

Success Through Vocational Guidance

YOU will win big success through vocational guidance because there is one kind of work or profession that you can do better than any other.

Your experience and natural ability fit you for it. You will make more money in this line than in any other. But to find the right position is often a difficult task. Most men never find their true vocation—that is the reason why there are so many failures.

You have heard lots of talk about "fitting workers to their tasks"—about men who were advised to quit their jobs for something entirely different, and then, in these new jobs, success came their way at once. A few men have by luck or chance found their true vocation. Take for an example John D. Rockefeller. Would he have become the richest man in the world if he had stayed behind the counter of his grocery store? He won success by changing into the oil business. John N. Willys started as a laundryman; he achieved a remarkable success in the automobile business. You can find thousands of like cases where men barely eked out a living—often failed—in one line, and then suddenly won conspicuous success by getting into that line for which they had the talents necessary for success—in a line where their natural talents worked for instead of against them. Where a few men won success by stumbling into their true vocation, you, every normal man, can easily gain Success Through Vocational Guidance.

Your Failures will come without planning—but Your Success is determined by two big factors—knowing what abilities you actually possess and knowing in what line of work or profession to use them so that they will bring the highest price or salary. Thousands are spending time, energy and money in trying to fit themselves for what they guess will bring success. Hard statistics show however that 90% guess wrong, and life passes before they can guess again. Every change of work is a crisis—making changes wisely is the secret of progress. You have in you the qualities necessary for success. It is all a question of putting these talents to the right use. Failures are turned into amazing successes and successes into even greater successes where natural talents and inherent abilities are properly applied.

ANALYZE YOURSELF—find out your strength. Find out what you are best fitted for—then find the market where your peculiar abilities will bring the highest salary. **That means success.** You will find the exact method of doing this in "SUCCESS THROUGH VOCATIONAL GUIDANCE." This great work will come to you on approval, all charges prepaid. Send no money. Merely fill in and mail the coupon. Test it in every way you can think of. Keep it five days. Then if you feel that you can do without it, send it back, and you will owe nothing. But if you realize, as you surely will, that this work will prove to be a tremendous factor in helping you win big success, then remit five dollars in full payment. It costs you nothing to find out just what this great work "SUCCESS THROUGH VOCATIONAL GUIDANCE" is and what it will do for you. So fill in and mail this coupon now while you are thinking about it.

American School Drexel Avenue & 58th Street **Chicago**

Chartered as an Educational Institution 1897

— TEAR OFF HERE —

FREE EXAMINATION COUPON

American School, Dept. V-374, Drexel Ave. & 58th Street, Chicago

You may send me "Success Through Vocational Guidance" on approval, all charges prepaid. I agree to either remit the work to you within 5 days from its receipt, or remit five dollars in full payment.

Name.....

Address.....

SUCCESS comes only when you get in the right line. Many of the following men barely managed to make a living when they started. By changing to another line, for which they had ability, they won success.

NAME	BUSINESS STARTED IN	BUSINESS CHANGED TO
Archbold, John D.	Grocery	Oil
Bell, Alexander G.	Teacher	Telephone
Eastman, George	Insurance	Camera
Gary, Elbert H.	Law	Steel
Guggenheim, Daniel	Lace	Mining
Rosenwald, Julius	Clothing	Mail-Order
Schwab, Chas. M.	Grocery	Steel
Turner, Walter V.	Sheep-Header	Inventor
Vanderbilt, Cornelius	Engineer	Finance
Vanderlip, Frank A.	Machinist	Banking
Willys, John N.	Laundry	Automobile
Wilson, Thomas E.	Railway Clerk	Packer

OVER
\$9300
PER WEEK
earned by Burgess-
Trained Man

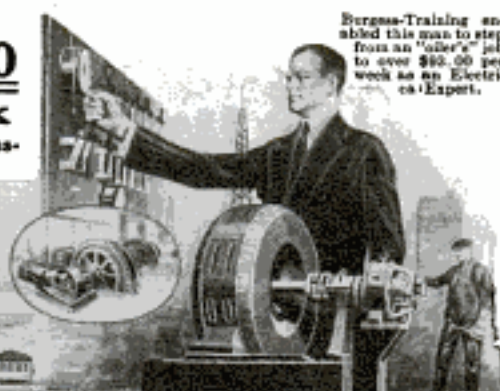

Burgess-Training enabled this man to step from an "offer" job to over \$90.00 per week as an Electrician Expert.

ELECTRICITY

The FOREMOST SCHOOL of its Kind in the World Offers the Way to

Attractive Positions and Large Salaries

for you if you are ambitious and are really earnest in your desire to succeed in electricity. If you are interested in ANY BRANCH of electricity, then you will find that

BURGESS Practical Electrical HOME TRAINING

will help you advance to the position and salary you desire. Hundreds of "Burgess-Trained" men throughout the world are now holding highly paid positions with electrical concerns or making money in their own business. A constant stream of letters tell us of better jobs and bigger pay due entirely to Burgess Home Training in Practical Electricity. Positive proof of the unusual value of Burgess Training is the fact that it is

Endorsed by Important Plants

in the electrical industry, who urge their men to use it. All electrical concerns want better men—the kind of fellows who know more than just one job. That's why "Burgess-Trained" men get the preference. They earn more because they are worth more. In some plants as many as 60 men are Burgess Students. No other course like it. Easy to understand.

Beginners quickly fitted for electrical jobs by the Burgess Simplified Course—known as the easiest and quickest method.

Advanced Training for Experienced Men

that gets right down to the practical, technical knowledge that brings quick, sure advancement to higher positions at better pay. An exclusive copyrighted method.

This course has the enthusiastic approval of electrical engineers and executives of biggest concerns in the world.

Complete Electrical Outfit

including apparatus, tools, material or slide rule supplied with each course without extra charge. Beginners are soon able to earn good money with this outfit. The course alone is worth many times its very reasonable price to anyone electrically inclined. Illustrated Training Course Book sent free on request. This explains fully why the Burgess Method of Home Training is bringing better jobs and better salaries to men and boys all over the world.

BURGESS ELECTRICAL SCHOOL

744 E. 42nd Street Dept. P-3 Chicago, Ill.
Canadian Branch, 201 Crawford Street, Toronto, Can.

SPECIAL Advantages to men and boys who enroll now—fully explained in illustrated book.

*** Use Coupon—check whether beginner or experienced ***

BURGESS ELECTRICAL SCHOOL
744 E. 42nd St., Dept. P-3, Chicago, Ill., or 201 Crawford St., Toronto, Can

Send me your free illustrated training book.

Beginner Experienced.....Years

Name

Address

.....

Quality Fiction

100% entertainment will be found in every one of the 170 pages in the March issue of

Wayside Tales

Look over the following partial list of stories:

- "Brutes" *by Courtney Ryley Cooper*
- "Ultimate Islands" *by Winona Godfrey*
- "The Gift of the Desert" *by Randall Parrish*
- "While the Train Waited" *by Harold dePolo*
- "The Lady from Iloilo" *by Gene Markey*
- "Angela Aircraft, Inc." *by Faith Baldwin*
- "Oh, My Prophetic Soul" *by Vincent Starrett*
- "The Midnight of St. Jean" *by Leslie Gordon Barnard*
- "The Burden of the Sea" *by Henry Holt*

In addition to this superior fiction, we offer a department of original humor never before published—jokes, anecdotes, light verse, and humorous drawings.

Ask your newsdealer, or send 25 cents for a sample copy, using the coupon

WAYSIDE TALES

CHICAGO

Gentlemen: For the enclosed 25 cents, please send me the March issue of your magazine.

Name

Street

Town and State.....

World's Fastest Growing Industry Offers Amazing Opportunities to You!

Wireless Expansion is Sweeping Over the World Like Wild-Fire! Big Opportunities Are Open Now On Land and Sea. You can Share Them and the Amazing Future Offered by this Fascinating Field. Here Is Your Greatest Opportunity for Profit or Pleasure or Both. Learn by Practice at Home.

\$2,400 to \$10,000 A YEAR In WIRELESS NOW EASILY LEARNED AT HOME—IN SPARE TIME

A FASCINATING, big-pay field that you can put your heart into is eagerly calling for you. You can speedily step into a position paying big money and holding a wonderful future. Wireless men get from \$2,400 to \$10,000 a year and big executives get as high as \$25,000 a year.

Do you long to visit every nook and corner of the world? Or would you rather locate in a land station near your home or in another section of the country? Wireless offers you your choice. From the sea comes the call of the U. S. Merchant Marine (operating 30,000 vessels) and of private steamship lines—reaching India, Africa, China and ports in every part of the world. Big opportunities are offered, with the chance to see the whole face of the earth, as an officer with free board and luxurious quarters, and good pay.

From the land, too, comes the call of the new forces that have formed to make Wireless the greatest means of communication in existence. Wireless Corporations, Business Houses, Governments, Railroads, Police Departments, Newspaper Publishers, Banks, Chambers of Commerce, Agricultural Stations, Cities—in every field the expansion of Wireless is sweeping forward. And, now, as never before, is YOUR life-time opportunity to cash in big on the splendid advantages this fascinating field offers you!

Through Remarkable Inventions, furnished to every student—the National Radio Institute makes it easy for anyone to learn Wireless at home; no matter whether or not you know a thing about it or about electricity at the present time. It is not necessary to have any kind of power in your home to use these inventions and neither is it necessary to string any wires or aerials, or make any installations. Just open the box and begin. The inventions become the student's property when the course is completed.

The National Radio Institute was the original and is today the oldest and largest wireless school in America teaching wireless by mail. This Institute is officially recognized by the U. S. Department of Commerce, its diploma is given official credit, its name heads the list of schools recommended by the Shipping Board. Thousands of students have been graduated and have entered this uncrowded field. And in your own home the National Radio Institute will qualify you for a fine Wireless position in a short period during your spare time.

What is Your Interest in Radio?

No matter what field of wireless you are interested in, the National Radio Institute—"Radio Headquarters of the Nation"—can help you.

If you have just purchased a receiving set and want to learn more about it—

If you are tired of listening to music only and want to "plug in" on the thousands of messages sent in wireless code—

If you have an amateur license and want to get a First Class Government license, so that you can hold the big jobs—

Or if you are only a beginner and want to know wireless from the ground up—

In all these cases, you need the National Radio Course, because this one course includes EVERYTHING.

Special Opportunity Now Open

The urgent need for operators prompts us to make a special offer to those who enroll now—you will receive our complete course in Wireless Telegraphy, which is the language of dots and dashes, and in addition, without extra cost, our new course in Wireless Telephony, which is the Wireless of the voice.

The National Radio Institute is located in Washington, the Nation's Capital, where Radio laws, rules, experiments, and regulations are made.

Mail Coupon for FREE Book

It costs you nothing to get our interesting illustrated booklet, "Wireless, the Opportunity of Today." Mail coupon today for this booklet and for full facts about our special Short-Time Offer. Fill out coupon and mail it at once.

National Radio Institute
Dept. 1007 Washington, D. C.
RUSH THIS FREE BOOK COUPON

National Radio Institute
Dept. 1007, Washington, D. C.

Send me your FREE book, "Wireless, the Opportunity of To-day," which explains your Home-Study Course in Wireless Telegraphy and Wireless Telephony and your special Short-Time Offer.

Name.....
Address.....
City.....State.....



From Carpenter's Helper to Electrical Contractor

Here in his own words is the story of A. E. Shreck's rise from a Carpenter's helper at \$18 a week to a business of his own—that pays him \$600.00 and more every month. Read his letter below.

Jumps from \$18 to \$125 a Week

Dec. 21, 1921

Dear Mr. Cooke—
For the first time in my life I am saving an income tax, a fact for which I am greatly indebted to you, as it was your training that put me where I am, in business for myself and—well on the road to Success. I have done a splendid business this year, and feel quite independent. Always have money in the Bank, pay cash for what I get, and ask no odds of any one. My net monthly income is over \$600.00.

That's pretty good for a man of 28, who, before starting with you, was a carpenter's helper, never able to earn more than \$75.00 a month, and broke all the time. So hard up was I at that time that I could hardly scrape together the \$5.00 to send you every month.

Mr. Cooke, I don't want to boast, or flatter you, but thru God's blessing, and your wonderful instruction to back me, I have really made a remarkable success in this business, now employing several men besides myself.

Your student and friend,
A. SHRECK.

Electricity Brings Big Pay

Mr. Shreck's success is only one of thousands of similar cases. Everywhere men are rising out of poor-paying, no future jobs to positions of power and respect as Electrical Experts earning from \$12.00 to \$30.00 a day. You can do it too. The road to real and lasting success is open to you through my simplified Home Study Course.

Let Me Train You at Home

Without losing an hour's time from your present work, I can quickly fit you to hold down one of these big jobs. As Chief Engineer of the Chicago Engineering Works, I know exactly what you need to insure your success. My money-back guarantee protects you.

MAIL Coupon for FREE OUTFIT OFFER and "VITAL FACTS"

I want to prove what I can do for you by sending you my big book of Vital Facts. I want to tell you too about the outfit of tools, instruments and material I give to my students so they can start right out and earn extra money in their spare time. Send the Coupon NOW.

L. L. COOKE, Chief Engineer

CHICAGO ENGINEERING WORKS

Dept. 513, 2150 Lawrence Avenue, Chicago

L. L. COOKE, Chief Engineer, CHICAGO ENGINEERING WORKS
Dept. 513, 2150 Lawrence Avenue, Chicago, Ill.

Dear Sir—Send at once Sample Lessons, your Big Book of "Vital Facts" and full particulars of your Free Outfit and Home Study Course—all fully prepaid without obligation on my part.

Name.....

Address.....

The "Cooke" Trained Man is the "Big Pay" Man

Please Mention Popular Mechanics



The Practical Gasoline Engine

Revised by Berton Elliot

The constant increase of the use of gas and gasoline engines in this country for power purposes makes this authoritative work most timely.

75¢

It is a simple and correct guide to the essentials of engine construction, erection and operation under all conditions. What to do and how to do it is told in everyday language. "The Practical Gasoline Engine" should be in the hands of every prospective gas or gasoline engine owner as well as those now operating an engine.

127 pages, two illustrations. Sizes 4 1/4 x 8 1/4 inches. Cloth bound. Postpaid.....75c

SHREWSBURY PUBLISHING CO.
5525 West Lake St., Chicago, Ill.



Be a Taxidermy Artist

Marvelous FREE Book Sent

You can now learn Taxidermy, the wonderful art of mounting birds, animals, taxonomic skins, etc. Learn at home, by mail. The free book tells how. Mount your own trophies. Decorate home and den. Hunters, trappers, nature lovers, you need taxidermy. Interesting, fascinating, big profits. Join our school. 55,000 students. Success guaranteed. Get our free book without delay. Send right now—today.

N. W. School of Taxidermy, 1773 Elwood Bldg., Omaha, Neb.

NO JOKE TO BE DEAF

—Every Deaf Person Knows That I make myself hear, after being deaf for 25 years, with these Artificial Ear Drums. I wear them day and night. They are perfectly comfortable. No one sees them. Write me and I will tell you a true story, how I got deaf and how I make you hear.



Address
GEO. F. WAY, Artificial Ear Drum Co. (Inc.)
80 Adelaide St., Detroit, Mich.



Medicated Ear Drum
Pat. Nov. 2, 1908

PALATIAL FLORIDA HOME

THE finest estate in that part of Florida, situated amid five acres of orange, grape fruit, sweet bay, palmetto and a large variety of semi-tropical trees and foliage. A water front of 400 feet, with entrance from a Boulevard, in a community of 30,000, affording every modern convenience. House recently completed and never occupied. Has every modern improvement, large sun parlors, sleeping porches and eight bath rooms. Inexhaustible supply of absolutely soft water; steam heat, high, light basement under entire house. This is one of the best built houses in the entire state of Florida. Surf bathing all winter within 5 minutes walk.

For full details, photographs and price, address

E. H. PECK

S. OSGOOD PELL & COMPANY
17 West 44th Street New York City

You Can Play the Hawaiian Guitar Just Like the Hawaiians!

Because Our Native Hawaiian Instructors Will Help You

OUR STUDENTS SAY

341 E. Starbuck St.,
Gen. Phila., November 6, 1921.
First Hawaiian Conservatory of Music.

Dear Sir—
I received my guitar and first lesson and am very much pleased with it, and its fine appearance and tone. I have learned how to tune it and am getting along fine with the lessons, and can hardly wait for my next lesson. Your method is very simple; it is great for all beginners. I must say it is better than personal teaching. Thanking you very much for the enrollment blank. I gave your enrollment blank to my friend and he said he will send it and the money order for ten dollars for your violin course.

Yours truly,
Milton H. Johnson.

October 1st, 1921,
Kosetter School,
214 So. Franklin St.,
Chicago, Ill.

First Hawaiian Conservatory of Music,
Inc.

I shall certainly be very glad to recommend your course whenever the chance is mine to do so. Mr. W. R. Johnson has not phoned me yet, and if he does not phone in a day or so, I will write him. Am sending a letter to Miss Helen Blavik today which I think may help to secure her enrollment, and I shall be glad at any time to write a personal letter to anyone whom you may suggest.

Your former student,
W. L. Walker.

Vinton, Iowa, 10-7

Dear Sir—
Received picks and first lesson September 29th. Sure was surprised how much I learned first lesson. Wishing you the best of success with your course. I am
Respectfully yours,
Van Wright,
Mr. Western Union, Vinton, Ia.

Our improved method of teaching is so **simple, plain and easy** that you begin on a piece with your first lesson. In half an hour you can play it. 10,000 successful students prove this to be true.

ONLY 4 MOTIONS We have reduced the necessary motions you learn to only four, and you acquire these in a very few minutes. Then it is only a matter of a little practice to acquire the weird, fascinating, tremolos, staccatos, slurs and other effects that make this instrument so delightful. **The Hawaiian Guitar plays any kind of music**, both the melody and the accompaniment.

FREE Just think of it. 52 lessons on this wonderful guitar. You get a beautiful large sized genuine Hawaiian Guitar absolutely free as soon as you enroll for the lessons. All the necessary picks, the steel playing bar and 52 pieces of music are included without cost to you.

Special Arrangements for Lessons if You Have Your Own Guitar

Think of the great pleasure you will get from playing fascinating Hawaiian Melodies for your friends. How popular you will be. Surprise your friends. Entertain them. Send the coupon and we'll tell you how to get this wonderful Hawaiian Guitar absolutely free.

[TEAR OUT COUPON]



Tear Off and Mail Today

First Hawaiian Conservatory of Music, Inc.

233 Broadway (Woolworth Bldg.), New York City

Please send me full information about your **FREE HAWAIIAN GUITAR** offer and 52 **FREE** sheets of music.

NAME.....

ADDRESS.....

TOWN..... STATE.....

Print name and address clearly. P.M.3

How I Earn \$15 to \$25 a Week at Home in my Spare Time

By Wm. S. Coulthard



I needed money. I had a lot of time on my hands in the evenings, Saturday afternoons, etc.—for I had no hobby—and besides my expenses had been mounting fast—so you will see the receptive mood I was in when I saw your little ad, "MAKE MONEY AT HOME."

I sent for your free booklet.

I read it.

Your plan looked good to me—your guarantee so liberal—and on investigation I found you were reliable, so I accepted your offer. If others could make money by your plan, I could.

That was less than a year ago.

Now I am earning \$15.00 to \$25.00 a week, each week, writing show cards in my spare time. In addition to this, I still hold my regular job, and my salary has been increased there, too. I believe my spare time work has made me better satisfied with life, and so I'm doing my regular work better.

I have been offered positions writing show cards, but I am not interested, as my present position is perfectly satisfactory, but I certainly am glad I enrolled in your school—my spare time money is exceedingly attractive. Besides, I find show card writing an interesting occupation that fills in those evening hours that used to drag so. In fact, it is really a hobby now with me—and a profitable one, as you can well imagine. Only last week I received a check from your school for \$70.00 for work done over the last three weeks. Of course, you'd have paid me regularly each week if I'd bothered about it, but I was too busy to tell you the amount of work I'd finished.

There are times, however, that I feel show card writing by your simple method is almost too good a thing—that's when I have so many orders ahead that I cannot see my way clear to finish them—and have to turn down work.

Your system of supplying work to your students has certainly helped me, but sometimes you send too much—I'm only working at it in my spare time, you know. Please note this, and don't try to overload me too much.

By the way, I think you'll be interested to know that previous to enrolling in your school I had never tried my hand at any work of this nature.

I'm glad to thank you for what you've done for me—and you can certainly use my name and tell prospective students, for I feel I'll be doing anyone a real good turn if I can help them get started in this profitable work.

Yours sincerely,
WM. S. COULTHARD.

NOTE:—The above is the story of Mr. Coulthard. It tells of facts, for Show Card Writing offers a marvellous opportunity to both men and women, either for spare time or full time work. What Mr. Coulthard has done and is doing, you can do. Colbran, Dusenberry, Wendt, Blade, Poulson, Charles, Wright, Bahneau and many other men have proved it. Mrs. Litherdale, Mrs. Lash, Mrs. Le Moine and dozens of housewives have added to the family income in this way. Girls like Misses MacDonald, Clegg, Bordreau and Hoyle are but a few of those who have bettered their positions in this pleasant way. All these owe their success to the American Show Card School method of training—the old established school which has trained hundreds to make money in SHOW CARDS. The American Show Card School will gladly send you full particulars if you but send your name and address to them.

Use this
Coupon.

Name.....
(Print your name plainly)

Address.....
(In full)

State.....

TEAR OFF HERE AND MAIL TO DAY.
American
Show Card
School
203 Ryrie Bldg.
Toronto, Can.

Send me your Free Booklet on Show Card Writing, and show me how I can make money at home—without carrying or selling. It is understood that this places me under no obligation of any kind.

BLUE PRINT READING

Our new Special Courses for Machinists, Pattern-Makers, Iron-Workers, Blacksmiths, and Building Tradesmen, qualify them by mail to read blueprints and become gang-foremen.

Taught from actual blueprints—easy to learn—no mathematics—no drawing, low prices. Pay-as-you-learn Plan. Write for booklet and free sample blueprint. Dept. F. 134, Industrial Correspondence University, Inc., 1504 Locust St., Philadelphia, Pa.

Makes Big Money \$118 Per Week

One man reports this return on a single Box Ball alley

American Box Ball is a clean, automatic, portable bowling game, easy to play and extremely fascinating to young and old. No pin boys or help needed. Each alley has an earning capacity of \$1.50 per hour. Box ball alleys can be operated in any ordinary store space or under a tent. Many are cleaning up \$100 per week with two single alleys running only a few hours daily. You can do as well.

ACT Write at once for special proposition. Make the Big Money now. Don't wait. Address
AMERICAN BOX BALL COMPANY
970 Van Buren St., Indianapolis, Ind.



FINE OLD VIOLINS

On Easy Payments
30 Days Free Trial



allowed, no matter where you live. If not more than pleased with our values return violin AT OUR EXPENSE—and no harm done. Ability to play the violin brings social and financial success. Get a violin with a rich, mellow tone and it will create in you a desire to master it.

Free! Magnificent Album-Catalog

containing portraits of the world's greatest violinists since Paganini's time, a half-tone of "Stradivarius in His Workshop," and the romantic story of The King of Musical Instruments. A postal brings all to you FREE—no obligations.

CREMONA VIOLIN SHOP
Dept. C41 Chicago

PRACTICAL ELECTRICAL EDUCATION—

In 6 MONTHS. We teach by scientific and original methods the theory and practice of **Electric Light Wiring, Testing, Meter Work, A. C. and D. C. Armature Winding, Transformer, Motor, Generator Repair and Maintenance.** No matter what your education, we guarantee to train you until competent and assist you to secure profitable employment. Hundreds of successful graduates and satisfied employers. Write for new ill. Book. Absolutely FREE to the earnest knowledge seeker.

SCHOOL OF PRACTICAL ELECTRICITY
P. M. 355, 415 Marshall Street Milwaukee, Wis.

PRICELESS SECRETS

"How to convert Worry immediately into Happiness", "How to induce others to do for you as you Desire", and, "How to gain a maximum of iron in the blood, without dieting, drugs, exercise or conscious deep breathing"—these "Secrets Worth Millions" sent to anyone upon receipt of the coupon.

**Alois P. Swoboda, 2601 Berkeley Bldg.,
21 West 44th Street, New York City.**

Send me immediately the Three Priceless Secrets—Secrets Worth Millions—I will gladly hand the mailman three dollars when he delivers them to me. It is understood that my money will be refunded to me by you, without delay or question, if I request it.

Name.....
(Write plainly)

Address.....

City..... State

READ THIS! ACT QUICK!

MAKE MONEY MAKE SHOW CARDS & SIGNS

EARN \$10.00 to \$25.00 DAILY—salary, or have own shop and independence. Easy to learn by our new complete course with individual correspondence instruction. Course includes hand lettered show cards, and large assortment MILLERINE COLORS and BRUSHES FREE. Graduates established in paying sign shop, or good paying "Jobs" await them. WRITE TODAY for illustrated matter, prices and terms.

Empire Pm Art Institute, Inc. 2050 Amsterdam Ave. New York City.

"HOW I BEAT THE GAME"

The Inspiring Story of how one poorly paid garage mechanic won success, his own business and a big income. Tells how you can increase your salary from 100 to 500%. Send for it today FREE.

Ambu Engineering Institute
Dept. 13 2632 Prairie Ave., Chicago, Ill.

Our BUREAU OF INFORMATION will answer all questions regarding articles appearing in this magazine. Address Bureau of Information, Popular Mechanics Magazine, Chicago.

DYKE'S AUTOMOBILE ENCYCLOPEDIA

Will Teach You How to Become:

- (1) An Automobile Repairman.
- (2) Engine Expert.
- (3) Electric Trouble Shooter.
- (4) Ignition Expert.
- (5) Tire Repair Expert.
- (6) Storage Battery Expert.
- (7) Carburetor Expert.
- (8) Tractor Expert.
- (9) Truck Expert.
- (10) Operator and Radiator Repairman.

968 Pages, 6 1/2 x 9 3/4 in.
3,362 Illus.

Price Prepaid, Cloth, \$6.46
American Morocco, \$7.96

POPULAR MECHANICS BOOK DEPT.
6. N. Michigan Ave., Chicago

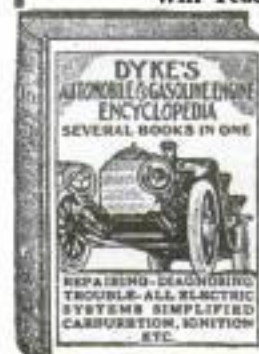

TRAINED MEN WANTED

THOUSANDS of untrained men walk the streets while we are flooded with calls for our graduates at \$150 a month and more. Automobiles must be repaired. No trained motor mechanic has to look for work.

Davenport Automotive Training Guarantees Success. Everyone of our Graduates has had a job waiting for him.

Our post-graduate, lifetime scholarship gives you months of intensive training; and any time in your life you can return without added cost.

**DAVENPORT
AUTOMOTIVE
SCHOOL**

Second and
Warren Sts.,
Davenport,
Iowa

PICK YOUR JOB

We train you to find and fix every trouble an automobile can have by work on live motors and cars. We don't "Mill men through;" we make expert mechanics. Every Davenport Automotive trained man has started at good pay. Many are making \$400.00 a month and more in less than two years.

FREE Write for our forty page, three color catalog, filled with beautiful pictures of automobiles and airplanes; gives full information on how you can learn this business and many interesting stories of the men who are making big money in it; printed in three colors; neatly bound—write for it—FREE.



These Steady Jobs Await You:

Garage Mechanic	\$150 to \$400
Salesman and Demonstrator	\$150 to \$400
Auto Mechanic	\$90.00 to \$100 a day
Auto Electrician	\$225
Tractor Engineer	\$5.00 to \$9.00 a day
Truck Driver	\$125
Chauffeur	\$90 to \$150
Tire Vulcanizer	\$100 to \$200
Battery Man	\$100 to \$200

HOME LOVERS' BARGAIN BOOK FREE

Showing Over 10,000 Furniture Bargains

All selections loaned free for a month. Take a year to pay if satisfied, paying little by little almost as you please.

SPiegel, MAY, STERN CO., 1108 W. 35th St., Chicago

Complete Instruction in Auto Radiator Repairing

The Manual of Automotive Radiator Repair is a complete, practical course in book form. Thoroughly teaches construction, cleaning, soldering with iron and torch, rebuilding and rearing; many other subjects. 185 pages; 120 illustrations; strong flexible binding. **LEARN RADIATOR REPAIRING;** one of **BIGGEST** and **BEST** fields open. Start business of your own. Manual teaches everything needed. Easy to study and apply. Order TODAY. Consultation Service and advice while learning given **FREE** by author. Write **CURFMAN & NULL CO., Maryville, Mo.**



Only
250
CENTS

STUDY OIL

Be a Certified Petroleum Expert

The tremendous growth of the Oil Industry has created as never before a demand for trained men. Every month 4000 new wells drilled; every year 100 new refineries and 6000 miles of new pipeline built. Geologists, drillers, refiners, salesmen, superintendents, are at a premium. Take advantage of this great world-wide need for trained men. New fields in this and foreign countries are constantly discovered.

\$100 a Week to \$100 a Day

This is the opportunity for the ambitious. Get into an industry where many are making millions and where all trained men are liberally rewarded. No matter what your present business or occupation, there is some practical phase of the Oil Industry that you can master and earn big money right from the start. Our practical and easy course will teach you the geology of the oil fields, drilling methods, oil refining and oil salesmanship. Get our free book telling all about this fascinating industry of opportunity. The book costs absolutely nothing. Yours for the asking. Write us today.

PETROLEUM EXTENSION UNIVERSITY,
Department 606, Citizens Trust Building, Fort Wayne, Indiana

21 Jewel Burlington



Adjusted to the Second
Adjusted to Temperature
Adjusted to Isochronism
Adjusted to Positions
21 Ruby and Sapphire Jewels
25 Year Gold Strata Case
Your Choice of Dials
(Including Montgomery H. R. Dial
New Ideas in Thin Cases)

Only \$1.00 Down

Only One Dollar Down will buy this masterpiece of watch manufacture. The balance you are allowed to pay in small, easy, monthly payments. The Burlington—a 21-Jewel Watch—is sold to you at a price much lower than that of other high-grade watches. Besides, you have the selection of the finest thin model designs and latest styles in watch cases. Don't delay! Write for the FREE Watch Book and our SPECIAL OFFER today.

Write *While This Special Offer Lasts*

Get the Burlington Watch Book by sending this coupon. Find out about this great special offer which is being made for only a limited time. You will know a great deal more about watch buying when you read this book. You will be able to "steer clear" of the over-priced watches which are no better. Remember, the Burlington is sent to you for only One Dollar down, balance in small monthly payments. Send the coupon for watch book and our special offer TODAY! Do not delay one minute!

Burlington Watch Company

Dept. 9353, 19th St. & Marshall Blvd., Chicago
Canadian Address: 62 Albert St., Winnipeg, Manitoba

Please send me (without obligations and prepaid) your free book on watches with full explanation of your \$1.00 down offer on the Burlington Watch.

Name _____

Address _____

Please Mention Popular Mechanics

Play
Without
Notes

Be a Master of
JAZZ and RAGTIME

Anyone who can remember a tune can easily and quickly learn to play Jazz, Ragtime and Popular Songs by ear, at a very small cost. New Niagara Method makes piano playing wonderfully simple.

NO matter how little you know about music—even though you "have never touched a piano"—if you can just remember a tune, you can learn to **PLAY BY EAR**. I have perfected an entirely new system. It is so simple, so easy, and shows you so many little tricks of playing that it just comes natural to pick out on the piano any piece that is running through your mind. Even those who could not learn by the old-fashioned method grasp the **NIAGARA** idea readily, and follow through the entire course of twenty lessons quickly.

Play By Ear in 90 Days

No need to devote years to study, in order to learn piano nowadays. Neither is special talent necessary. Every lesson is so easy, so interesting and fascinating that you "can't keep your hands off the piano." Just devote a part of your spare time to it for ninety days and you will be playing and entertaining your friends almost before you realize how this wonderful new accomplishment has been acquired. No tiresome scales, no arpeggios to learn—no do-re-mi, no tiresome practice and meaningless exercises. You learn a bass accompaniment that applies to ANY SONG you play by ear. Once learned you have it for all time and become master of the piano. Experienced and talented musicians are amazed at the rapid progress of Niagara School students and say they cannot understand why this method was not thought of years ago. Yet it has never been used before and is not used by any other teacher or school today.

Be the Popular One in Your Crowd

One who can sit down any time without notes or music, reel off the latest jazz and ragtime song hits that entertain folks—always being the popular one in the crowd, the center of attraction, the life of the party, sought and invited everywhere.

As easily as hundreds of others have learned, so you, too, can learn and profit by it—not only through the pleasure it provides, but also by playing at dances, movies and other entertainments.

Decide to begin now. Just spend a little part of your time with my easy, fascinating lessons, and see how quickly you "catch on" and learn to play. You will be amazed, whether you are a beginner or an advanced student.

Write for my book, "The Niagara Method," describing this wonderful new method of playing by ear. It is sent to you **FREE**.

RONALD G. WRIGHT, Director,

Niagara School of Music, Dept. 426,
Niagara Falls, N. Y.

Clip This Coupon Now

NIAGARA SCHOOL OF MUSIC, Dept. 425 Niagara Falls, N. Y.

Please send me your Free Booklet describing "The Niagara Method." Name.....
Street..... City.....
Age..... Ever taken piano lessons?..... For how long a time?.....

THIS BOOK
FREE



YOU CAN MAKE \$35 to \$100 a WEEK as a "TROUBLE WIZARD"



equipment to give you an opportunity to work on the ignition, carburetor, transmission and timing systems of all the popular makes of cars. You know them—you learn them all not merely by reading or hearing the teacher talk but by repairing them yourself under his personal direction. This one big feature of the American Motor Schools training will quickly help you to a better job in the Auto business than you can get thru any other training.

**We teach YOU
how - in from
6 to 8 weeks in
Washington, the
Nation's Capital**

You Need Not Pay a Cent

until you, yourself, have come down here to Washington and have

YOUR ambition is to become a "trouble wizard" in this great auto repair game—well able to hold down a job or work for yourself anywhere in the country, at \$35 to \$100 a week. All you need is 6 to 8 weeks' TRAINING down here in Washington under the wing of Ed Cooley, our Chief Instructor. Think of it! Only 6 to 8 weeks and you begin drawing big money and building up a "rep" as the "trouble wizard" of your town and paving the way for a future business of your own. But don't choke your ambition by waiting around for something to turn up.

Come Down to Washington — The Nation's Capital

See our new \$250,000 School Building. Make a thorough investigation of our equipment and methods. Watch our students at work.

The big difference between the American Motor Schools and the usual "theory" school might be summed up like this:

The courses you get at the American Motor Schools are not a lot of "talk" about carburetors, magnetos, gears and so forth. No siree. You get into your overalls, down on your hands and knees and take "knocks" and "groans" and other troubles right out of real engines. You don't spend your time on one old "trial horse" motor but on dozens of different standard motors—just as they do in a repair garage.

The American Motor Schools has the complete

conducted a thorough investigation of our method. You can even write your Senator or Congressman about us if you want to.

We have room for a thousand new students. We want these students to talk about us and recommend our School. As a result—we are still offering, but not for long, a rebate of \$50, enough to pay your fare to Washington and leave plenty over to help defray your expense. If you come down NOW, you can save \$50. Write tonight for our Registration Blank.

You know mighty well what the opportunities are in the Auto repair game. Trained mechanics are wanted bad in every town from coast to coast. And you know that this School gives you a thorough practical training in 6 to 8 weeks. The only thing left for you to do now is to CLIP THIS COUPON and send it in. We'll send you complete information by return mail.

AMERICAN MOTOR SCHOOLS, Inc.
Dept. 232 Washington, D. C.

American Motor Schools, Inc.
Dept. 232, 1612-22 U St., N. W.
Washington, D. C.

Without cost or obligation, please send catalogue of information on your Automobile Mechanics Course.

Name.....

Address.....

City.....

State.....Age



Be a Paint Preservative Engineer

Own a Business That Is New, Unlimited, Permanent



Here is a new, unlimited field. Everything must be protected with paint or varnish. It is our purpose to make Paint Preservative Engineers—not chemists—but practical men who know paint and its application from A to Z; men who will be paint authorities in their territory.

Earn \$3,000 First Year; \$5,000 and up, Later

The average county will make \$3,000.00 profit first year by our plan. Graduates make back the original investment first year and own the business. Each year business increases—you are also a distributor for one of America's best paint firms and make a profit on everything sold in the territory. Graduates make money as soon as they open up. \$3,000.00 will earn over 100% in a year because of quick turnovers. You sell home owners, county offices and institutions, schools, factories, farmers, every one. Many counties already have a good business which is turned over to our graduates.

What and How We Teach

Teaching is on basis of both theory and practice. Course takes 4 weeks. Previous experience not necessary. Tuition pays for all but living—you get life membership; you are taught paints and varnishes from A to Z; preservatives of all surfaces; how to remedy and avoid trouble; advertising; selling; accounting; credits; collection; business management. Instructors are successful paint and varnish men.

We Guarantee Location and Factory Connection

To those who graduate and qualify, we guarantee a good, exclusive location and a direct connection with one of the best paint firms in the country, which agrees to locate all our graduates. We can secure exclusive sales privileges to but one in a county. Get full information at once—Write, wire or call.

Reference—Second National Bank, Toledo, Ohio.

PAINT PRESERVATIVE SCHOOL OF AMERICA
DEPT. 23. HOAG STREET, TOLEDO, OHIO, U. S. A.

HISTORY of the WORLD

AT A BARGAIN

We will name our **Special Price** and **easy terms of payment** and mail **free** our 32 beautiful sample pages to all readers interested. A coupon for your convenience is printed at the bottom of this advertisement. Tear off the coupon, write name and address plainly and mail now before you forget it.

\$1
Only
Bring
Books
\$1
Weekly
There-
after



Free
We will mail
free a beauti-
ful 32-page
booklet of
sample pages
to all who
mail us the
coupon.

Six Thousand Years of History

The complete history of all nations and peoples, ancient, medieval and modern. Reading this work will increase your fund of knowledge, improve your mental powers, and increase your earning capacity in any business or occupation. The man or woman who knows history has infinitely better chances of success than the uninformed. "Show me a family of readers," said Napoleon, "and I will show you the people who rule the world." Mail the coupon.

FREE COUPON

WESTERN NEWSPAPER ASSOCIATION (3-22)
140 So. Dearborn St., Chicago, Ill.

Please mail your 32-page free sample booklet of *The History of the World*, containing sample page and photographs of great characters in history, and write me full particulars of your special offer to *Popular Mechanics* readers.

NAME.....
ADDRESS.....



BARKING DOG

GIVEN FREE WITH A YEAR'S SUBSCRIPTION TO THE RACINE BULLETIN, RACINE, WIS.

There is more fun to be had with this BARKING DOG than anything else we know of. Thousands of them are selling in the streets of Chicago every day. Over 100,000 were sold at 25 cents each at the recent Pageant of Progress Exhibition in Chicago. All you have to do is to squeeze the bulb with the hand, and the dog emits a loud bark just like the real thing. Everyone looks around to see where the sound comes from.

THE BARKING DOG AND THE MAGAZINE FOR A WHOLE YEAR, ALL FOR 35 CENTS

For a limited time only we are giving these Barking Dogs to secure new subscribers to the RACINE BULLETIN, a large monthly illustrated magazine. Every issue crammed full of exciting stories, interesting items from all over the world, articles on popular science, mystery, magic and mirth, money-making wrinkles relating to every trade and manufacture, health hints, tried and tested recipes, gossip about well known persons. Thousands of dollars given away in prizes, not to mention a free \$1,000 Insurance Policy in every issue to each subscriber—all this and lots more combine to make it one of the **most interesting magazines published in America.**

Send **ONLY 35 cents** for a year's subscription to the **Racine Bulletin** and we will send you the Barking Dog free, and the magazine for twelve months.

THE RACINE BULLETIN

Dept. 778 RACINE, WIS.

Our BUREAU OF INFORMATION will answer all questions regarding articles appearing in this magazine. Address Bureau of Information, Popular Mechanics Magazine, Chicago.

WARNING

The public is warned not to pay any money intended for subscriptions to Popular Mechanics Magazine to agents of either the "Magazine Service Co., Masonic Temple, Chicago," or the "National Magazine Distributors, Woolworth Bldg., New York City," as there are no such companies at these addresses. Canvassers claiming to be agents of these fake companies are soliciting subscriptions to this magazine, and usually others also, offering a year's subscription at a cut rate of \$2.50 and an Atlas free.

As should be known by this time, Popular Mechanics Magazine employs no solicitors, offers no premiums and never cuts its rates. Any canvasser making the above offers of Popular Mechanics is a fraud, and should be arrested immediately.

Police Departments are requested to telegraph us (collect) of any such arrest, so we can bring legal action at once, and Chiefs of Police are hereby assured of our prosecuting such cases to the limit. The suit we won last year in the United States Court was that no one may legally represent himself as our agent without our consent, and that to solicit subscriptions is the act of an agent. We have no such agents.

Popular Mechanics Co.,
By H. H. Windsor,
President.

Chicago, Dec. 16, 1921.

Swear Off Tobacco

Tobacco Habit Banished Let Us Help You

Quick Results

Trying to quit the tobacco habit unaided is often a losing fight against heavy odds, and may mean a serious shock to your nervous system. So don't try it! Make the tobacco habit quit you. It will quit you if you will just take **Tobacco Redeemer** according to directions.

It doesn't make a particle of difference whether you've been a user of tobacco for a single month or 50 years, or how much you use, or in what form you use it. Whether you smoke cigars, cigarettes, pipe, chew plug or fine cut or use snuff—**Tobacco Redeemer** will positively remove all craving for tobacco in any form in a few days. Your tobacco craving will usually begin to decrease after the very first dose—there's no long waiting for results.

Tobacco Redeemer contains no habit-forming drugs of any kind and is marvelously quick, scientific and thoroughly reliable.

Not a Substitute

Tobacco Redeemer is in no sense a substitute for tobacco, but is a radical, efficient treatment. After finishing the treatment you have absolutely no desire to use tobacco again or to continue the use of the remedy. It helps to quiet the nerves, and will make you feel better in every way. If you really want to quit the tobacco habit—get rid of it so completely that when you see others using it, it will not awaken the slightest desire in you—you should at once begin a course of **Tobacco Redeemer** treatment for the habit.

Results Absolutely Guaranteed

A single trial will convince the most skeptical. Our legal, binding, money-back guarantee goes with each full treatment. If **Tobacco Redeemer** fails to banish the tobacco habit when taken according to the plain and easy directions, your money will be cheerfully refunded upon demand.

Let Us Send You Convincing Proof

If you are a slave of the tobacco habit and want to find a sure, quick way of quitting "for keeps" you owe it to yourself and to your family to mail the coupon below or send your name and address on a postal and receive our free booklet on the deadly effect of tobacco on the human system, and positive proof that **Tobacco Redeemer** will quickly free you from the habit.

Newell Pharmacal Company
Dept. 300 St. Louis, Mo.

Free Book Coupon

NEWELL PHARMACAL CO.,

Dept. 300

St. Louis, Mo.

Please send, without obligating me in any way, your free booklet regarding the tobacco habit and proof that **Tobacco Redeemer** will positively free me from the tobacco habit or my money will be refunded.

Name.....

Street and No.....

Town..... State.....



Tobacco Tells on
Nervous System



Tobacco Ruins
Digestion



Tobacco Stunts
Boy's Growth



Tobacco Robs
Man of Vitality



Tobacco Steals
from You the
Pleasures, Com-
forts, Luxuries
of Life



BOYS



Learn Drafting

DRAFTING offers exceptional opportunities to boys and young men because drafting itself not only commands good pay, but it is the first step towards success in Mechanical or Structural Engineering or Architecture. And drafting is just the kind of work a boy likes to do. There is an easy, delightful way by which you can learn right at home in spare time. For 30 years the International Correspondence Schools have been giving boys just the training they need for success in Drafting and more than 300 other subjects.

Let the I. C. S. help you. Choose the work you like best in the coupon, then mark and mail it. This doesn't obligate you in the least, but it will bring you the information that will start you on a successful career. This is your chance. Mark and mail this coupon now.

----- TEAR OUT HERE -----

International Correspondence Schools
Box 5611-C, Scranton, Penna.

Without cost or obligation, please send me complete information about the subject which I have checked below:

- | | |
|---------------------------------------|---|
| <input type="checkbox"/> DRAFTING | <input type="checkbox"/> BUSINESS |
| <input type="checkbox"/> CARTOONING | <input type="checkbox"/> CIVIL SERVICE |
| <input type="checkbox"/> AUTOMOBILES | <input type="checkbox"/> PHARMACY |
| <input type="checkbox"/> CHEMISTRY | <input type="checkbox"/> ARCHITECT |
| <input type="checkbox"/> ADVERTISING | <input type="checkbox"/> BOOKKEEPER |
| <input type="checkbox"/> SALESMANSHIP | <input type="checkbox"/> GOOD ENGLISH |
| <input type="checkbox"/> ELECTRICITY | <input type="checkbox"/> WIRELESS |
| <input type="checkbox"/> ACCOUNTING | <input type="checkbox"/> CIVIL ENGINEER |
| <input type="checkbox"/> SURVEYING | <input type="checkbox"/> AIRPLANE ENGINES |

Name.....

Address.....

Occupation.....

Persons residing in Canada should send this coupon to the International Correspondence Schools Canadian, Limited, Montreal, Canada

Gibson Instruments

the "Music Pals of the Nation" easily and quickly enable you to play the music of the day. Delight your friends, increase your popularity, income and pleasure by playing for social affairs, concerts, entertainments, etc. Organize a Gibson Orchestra; we help; you receive commission on sales. Small payments, then \$5.00 a month pays for a Gibson; brings you wholesome year-'round entertainment and profit. Gibsons are the recognized world standard. Guaranteed for life.

*Easy to Play
Easy to Pay*



Liberal allowance on old instrument in exchange for a Gibson

Mandolin,
Mandola,
Mando-cello,
Mando-bass,
Guitar,
Harp Guitar,
Mandolin-banjo,
Tenor-banjo,
Cello-banjo,
Guitar-banjo.

Write today for free book, catalog, free trial offer, stating the Gibson you prefer

The Gibson Mandolin-Guitar Co.

1753 Parsons Street
Kalamazoo, Mich.
U. S. A.

WIRELESS

Lessons Loaned Free. Be a Real Expert

We will loan you a set of lessons giving the basic essential facts underlying a PRACTICAL knowledge of wireless—FREE. Keep lessons as long as desired for examination and study without cost or obligation to you.

SEND NO MONEY. Just mail us your name and we will forward lessons at once. On arrival simply pay postman small charge for postage and handling. No charge for use of lessons, now or hereafter. Write at once—while this splendid offer is in force.

S. V. SMITH, Pres.

S. & H. Electrical Works, Dept. C1
310 S. Green St. Chicago, Ill.

Mystic Skeleton

A jointed figure of a skeleton 14 in. in height, will dance to music and perform various gyrations and movements while the operator may be some distance from it. 10c & up.

Serpent's Eggs

Box contains 12 eggs. When lit with a match, each one gradually hatches itself into a snake several feet long, which curls and twists about in a most life-like manner. Price per box, 10c ppd.



Good Luck Ring

Quaint and Novel Design

A VERY striking and uncommon ring. Silver finish, skull and crossbone design, with two brilliant, flashing gems sparkling out of the eyes. Said by many to bring Good Luck to the wearer, hence its name, Good Luck Ring. Very unique ring that you will take a pride in wearing. ONLY 25 CENTS.

JOHNSON SMITH & CO., Dept. 778, 3224 North Halsted Street, CHICAGO

1¢ for 1,000 shots Auto-Repeater

Shoots and flashes, just like a real gun. Reload ammunition costs only one cent for a thousand shots, and with one loading will shoot and flash 5,000 times without reloading.



No Caps
No Powder
No Smoke
No Danger

Within the Law
Sent postpaid for 40c,
or 3 for \$1

The Flaming Co., Dept. 40, 3802 Ellis Ave., Chicago, Ill.



Did YOU Ever Dream of Being a Great Canal Builder --

Like Goethals?



The greatest men are the greatest dreamers. In youth they look years ahead and picture themselves doing the big things that later thrill the admiring world. As boys—they imagine themselves directing the boring of gigantic tunnels underneath towering mountain passes. They see mammoth transoceanic ships—like floating castles—Leviathans—all creatures of their own creative brain. They see great ship canals—channeling through trackless jungles in spite of a thousand obstacles that had threatened failure. All this they see in their youthful dreams. But at last it comes—the great day in which the dream comes true.

MECHANICAL DRAWING outfit and a professional set of highest grade DRAFTING instruments to use throughout the course and after you become a professional draftsman.

At one time, during the construction of the Panama Canal, it was thought that the project would have to be abandoned because of landslides in the Culebra cut. But Goethals, our greatest engineering genius, stuck to his task and WON.

What Happened Between Dream and Success?

Did these men sit back and dream idly? No. No. They had the good judgment to know they must **prepare themselves** for their great chance. They began by determinedly making the first step early in life.

The First Step to Success

One of the first steps to engineering success is DRAFTING—a knowledge of MECHANICAL DRAWING. Goethals—the builder of the Panama Canal learned it. All great engineers and inventors learned it. Edison—John Hays Hammond—Steinmetz—McAdoo—all learned DRAFTING early in their careers.

But in their day no DRAFTING course existed that was not packed with theory and mathematical difficulties. It's different now. To-day the Columbia School of Drafting can teach you DRAFTING in from six to ten months in your spare time at home. Think of it—only 6 to 10 months on a study that can start you to success equal to that of Goethals. You may be the next Goethals. Destiny is **always** calling for such men; but remember this—Destiny calls only men who are prepared.

Columbia Course Is Easy

Hundreds of Columbia graduates are already started, equipped with the first essential of DRAFTING success—expert draftsmanship. These men, without special education, became DRAFTING experts in less than a year and are to-day employed at salaries ranging

From \$35 to \$100 a Week

One of them recently planned and laid out the famous Arlington Memorial Amphitheatre at Washington. Others have done equally well. **You** can do just as well. When you start the course, we'll send you a complete ME-

Help in Finding a Job

We put behind you our Students Employment Bureau in helping you secure a position that will pay well. We have helped hundreds of our graduates and are regularly receiving requests for **more** of our trained draftsmen from some of the country's biggest industrial plants.

Even though Destiny may never call upon you to do the work of a Goethals—yet substantial advancement is always open to you. As you forge ahead from Draftsman to Chief Draftsman and from that to Engineer, to Production and Plant Manager and so on—you keep going on up the salary ladder until your income nets you \$15,000 a year and over. There's really **no** limit to what you can accomplish in this profession. The start is the thing that counts.

Don't say you haven't the education or the talent or the time. You have everything you need—as much and probably more than many of our most successful graduates had. Show that you have the determination to **start** on your career **to-day** by mailing the attached coupon **right now**.

Roy C. Claffin, President

COLUMBIA SCHOOL OF DRAFTING

Dept. 1679

Washington, D. C.

Send For This FREE BOOK "Your Future in Drafting"

which tells in detail how the Columbia Method prepares you for success.

Roy C. Claffin, Pres.
Columbia School of Drafting,
Dept. 1679, Washington, D. C.

I want to make more money. Tell me how Columbia Training will help me; send me your booklet "Your Future in Drafting" and a sample copy of "The Compass."

Name.....

Address.....

City.....State.....Age.....



Now He Knows



UNITED
Y.M.C.A.
SCHOOLS

*His United Y. M. C. A. Course and
the Special Coaching of his Instruc-
tor Supplied Just What he had Lacked*

He is one of our Long Island students, and he writes:

"I had been working at my trade 11 years but had no theoretical knowledge. Now, I am near the end of my Course and last week one of the firms asked me if I cared to take charge of running some of the jobs. Naturally, I said 'Yes.' The Course has done me a world of good."

Personal service is the keynote of the correspondence instruction of the United Y. M. C. A. Schools. Every student has the unlimited attention of a competent, sympathetic instructor who takes an interest in all of the student's problems and special needs—education, business relations, etc. From the choice of a course to the last lesson, this service is unselfish and unflinching.

A Maryland student says: "I cannot understand how, with thousands of students, you can show so much interest in the welfare of each as you have shown in me." An Endicott, N. Y. student writes: "Your lessons contain the exact things needed by the practical man in his daily work."

These letters—which are fair specimens of hundreds we are receiving—show that the "Six Reasons" for preferring the Y. M. C. A. system of correspondence instruction are well founded.

Mark and mail the coupon for these reasons and for details of the course of your choice. We will send you our booklets "Does Education Pay?" and "Head and Shoulders Above the Crowd—How to Get There." Our friendly counsel is free.

UNITED Y. M. C. A. SCHOOLS

Dept. 2-M, 375 Lexington Ave., New York City

I am interested in United Y. M. C. A. Schools' service. Please give free counsel as to the position or home-study course I have marked.

- | | |
|------------------------|---------------------------|
| —Accountant | —Foreign Languages |
| —Advertising Man | —Foremanship |
| —Agricultural Courses | —Freehand Drawing |
| —Applied Psychology | —Highway Engineering |
| —Architect | —Illustrator |
| —Auto Mechanic | —Locomotive Operator |
| —Banking | —Machine-Shop Practice |
| —Better Letters | —Mathematical Courses |
| —Bookkeeper | —Mechanical Engineer |
| —Building Construction | —Plumber |
| —Business English | —Poultry Husbandry |
| —Business Law | —Radio Operator |
| —Business Organization | —Radio Engineer |
| —Chemistry | —Railroad Engineering |
| —Civil Engineer | —Salesman |
| —Civil Service | —Secretarial |
| —Commercial Spanish | —Steam Engineer |
| —Concrete Engineer | —Stenographer |
| —Dairy Farming | —Structural Drafting |
| —Draftsman | —Surveyor |
| —Electrician | —Tool Designing |
| —Electrical Engineer | —Traffic Management |
| —English Courses | —Use of the Slide Rule |
| —Factory Management | —Own-Your-Own-Home Course |
| —Firm Management | |
| —Farm Motor Mechanics | |

Name and Occupation

(Please Write Plainly)

Complete Address

Stop Forgetting

Make Your Mind a File—Not a Pile

Let me show you how to make your mind as forget-proof as a card index file. When you wish to recall a name, place or date, must you grope in vain in a pile of miscellaneous knowledge? Summoned to give facts and figures does your mind become a blank? Be master of your mind's infinite resources—instead of a victim of its disordered details.

KNOWLEDGE IS POWER

and Memory Is the Basis of All Knowledge

I HAVE HELPED THOUSANDS

The Dickson Method of Memory and Mental Training, perfected by 20 years experience, is recognized as the most thoro, efficient of its kind. Highly endorsed—easy to master. Give me 10 minutes a day and I will train your memory so you can classify ideas, names, faces, etc., and recall them instantly. Develop self-control, concentration; overcome bashfulness.

Perfect Your Memory and Command What Salary You Will

Send name and address and I will send you free, my interesting booklet, "How to Remember," and unique, copyrighted Memory Test; also tell you how to secure free of charge my \$3.00 book, "How to Speak in Public."

Prof. Henry Dickson, Principal
DICKSON MEMORY SCHOOL
Dept. 705, 1041 Chicago Ave.
Evanston, Ill.



Stop Forgetting

The Key to Success

LEARN WATCHMAKING AND ENGRAVING



Earn while learning. Most practical watch school. Individual instructions. Graduates in great demand. Book free. Chicago School of Watchmaking, Dept. 20, State-Lake Bldg., Chicago

MUSIC LESSONS FREE



IN YOUR
OWN
HOME

You can read music like this quickly

Piano, Organ, Violin, Mandolin, Guitar, Banjo, etc. Beginners or advanced players. One lesson weekly. Illustrations make everything plain. Only expense about 2c per day to cover cost of postage and music used. Write for FREE booklet which explains everything in full.

AMERICAN SCHOOL OF MUSIC, 51 Lakeside Building, CHICAGO

OH BOYS-GIRLS GREAT SPORT

THROW YOUR VOICE



Into a Barrel, under the Table, Back of a Door, into a TRUNK, DESK, in SCHOOL, Any Old Place. Great FUN fooling the TEACHER, friends, EVERYBODY with Our

CLAXOPHONE

Which Sets on your Tongue Unseen, it NEVER FAILS Anybody Int. Birds, etc. The CLAXOPHONE, with Full Instructions, a Set of SECRET-WRITING TRICKS, (Secret Invs. Ink) a MAGIC-DIAL Trick, (a Great Money maker). ALSO, This Marvelous Novelty—

NEW SCIENTIFIC WONDER

"X-RAY" CURIO



With it you Apparently See thru Clothes. See the bones in your Fingers. Lead in Pensils, etc. No end of fun. WE SEND ALL ABOVE Novelties by prepaid Mail for 3 for 25 cts. A nice Souvenir Free with each 25c order.

3 FOR 25c. BIG FUN

CLAXO TRICK CO., Dept. X-P, NEW HAVEN, CONN.

WE GIVE the BEST and MOST for the MONEY.



Magazine

April

Men's Hats
For Winter Wear

DRAW

PICTURES THAT SELL

Learn at Home

ARTISTS are needed. We cannot train them fast enough to meet the demand.

Men are wanted by newspapers for cartoon work, by large concerns to illustrate their advertising, by publishers to illustrate books. Salaries are higher than ever before.

No Talent Is Needed

Don't be afraid of the word "artist." The old theory that an artist had to be born is exploded. We train you not only to draw, but to draw so that you can **SELL** your pictures. Our course starts you in at the basic principles. You begin by drawing straight lines, then shading, action, perspective follow in order, until you are making drawings that sell for \$100 to \$150. You learn almost without study, once you know the simple principles found in our course—it is so logically arranged.

Personally Instructed

You receive personal instruction. It is just as if a teacher stood at your elbow and guided you. The corrections not only show you how to improve your work,

but why the suggested changes **DO** improve it. Progress is unbelievably rapid. The course covers every angle of commercial art. Many of our students earn Big Money before they complete the course.

Learn in Your Spare Time

A few minutes a day in your own home is all that is necessary. Get into this fascinating game now! Put drudgery and long hours behind you forever. Do the work that never gets tiresome.

New Book and Artist's Outfit FREE

Mail coupon for our valuable book, "How to Become an Artist." It explains our course, reveals secrets of success in commercial art, and shows work done by our students.

Mail Coupon Now

Let us also send you our **FREE OUTFIT** offer.

WASHINGTON SCHOOL OF ART, Inc.
Room 1791 Marden Bldg. WASHINGTON, D. C.
Please send me your free book, "How to Become an Artist" and tell me about your free outfit offer.
Name
State whether Mr., Mrs., or Miss
Address



"I Got the Job!"

"I'm to be Manager of my Department starting Monday. The boss said he had been watching all the men. When he found I had been studying at home with the International Correspondence Schools he knew I had the right stuff in me. Now we can move over to that house on Oakland Avenue and you can have a maid and take things easy. I tell you, Nell, taking that course with the I. C. S. was the best thing I ever did."

Spare-time study with the I. C. S. is winning promotions for thousands of men and bringing happiness to thousands of homes all over the world. In offices, shops, stores, mines, mills and on railroads, I. C. S. trained men are stepping up to big jobs, over the heads of older men, past those whose only qualification is long service.

There is a Job Ahead of YOU

Some man is going to be picked for it. The boss can't take chances. He is going to choose a trained man with sound, practical knowledge of the work.

Get busy right now and put yourself in line for that promotion. You can do it in spare time in your own home through the I. C. S., just as more than two million men have done in the last 30 years, just as more than 130,000 men are doing today.

The first step these men took was to mark and mail this coupon. Make your start the same way—and make it now.

TEAR OUT HERE

INTERNATIONAL CORRESPONDENCE SCHOOLS
BOX 5612-C SCRANTON, PA.

Without cost or obligation please explain how I can qualify for the position, or in the subject before which I have marked an X in the list below:

- | | |
|---|---|
| <input type="checkbox"/> ELECTRICAL ENGINEER | <input type="checkbox"/> BUSINESS MANAGEM'T |
| <input type="checkbox"/> Electric Lighting & Railways | <input type="checkbox"/> SALESMANSHIP |
| <input type="checkbox"/> Electric Wiring | <input type="checkbox"/> ADVERTISING |
| <input type="checkbox"/> Telegraph Engineer | <input type="checkbox"/> Show Card & Sign Ptg. |
| <input type="checkbox"/> Telephone Work | <input type="checkbox"/> Railroad Positions |
| <input type="checkbox"/> MECHANICAL ENGINEER | <input type="checkbox"/> ILLUSTRATING |
| <input type="checkbox"/> Mechanical Draftsman | <input type="checkbox"/> Cartooning |
| <input type="checkbox"/> Machine Shop Practice | <input type="checkbox"/> Private Secretary |
| <input type="checkbox"/> Toolmaker | <input type="checkbox"/> Business Correspondent |
| <input type="checkbox"/> Gas Engine Operating | <input type="checkbox"/> BOOKKEEPER |
| <input type="checkbox"/> CIVIL ENGINEER | <input type="checkbox"/> Stenographer & Typist |
| <input type="checkbox"/> Surveying and Mapping | <input type="checkbox"/> Certified Public Accountant |
| <input type="checkbox"/> MINE FOREMAN or ENG'R | <input type="checkbox"/> TRAFFIC MANAGER |
| <input type="checkbox"/> STATIONARY ENGINEER | <input type="checkbox"/> Railway Accountant |
| <input type="checkbox"/> Marine Engineer | <input type="checkbox"/> Commercial Law |
| <input type="checkbox"/> ARCHITECT | <input type="checkbox"/> GOOD ENGLISH |
| <input type="checkbox"/> Contractor and Builder | <input type="checkbox"/> Common School Subjects |
| <input type="checkbox"/> Architectural Draftsman | <input type="checkbox"/> CIVIL SERVICE |
| <input type="checkbox"/> Concrete Builder | <input type="checkbox"/> Railway Mail Clerk |
| <input type="checkbox"/> Structural Engineer | <input type="checkbox"/> AUTOMOBILES |
| <input type="checkbox"/> PLUMBING & HEATING | <input type="checkbox"/> Mathematics |
| <input type="checkbox"/> Sheet Metal Worker | <input type="checkbox"/> Navigation |
| <input type="checkbox"/> Textile Overseer or Supt. | <input type="checkbox"/> AGRICULTURE |
| <input type="checkbox"/> CHEMIST | <input type="checkbox"/> Poultry Raising <input type="checkbox"/> Spanish |
| <input type="checkbox"/> Pharmacy | <input type="checkbox"/> BANKING <input type="checkbox"/> Teacher |

Name..... 7-1-21

Street and No.....

City..... State.....

Occupation.....

Please Mention Popular Mechanics

BE A RAILWAY TRAFFIC INSPECTOR

POSITION GUARANTEED or Money Refunded!

Earn up to \$250 per Mo., expenses paid, in this fascinating profession. Trained men wanted; splendid opportunities thru contact with big officials. Steady, pleasant, out-door work. Travel or remain near home.

Start at \$110 per Mo., expenses paid. Advancement rapid with experience. Prepare in 3 months' spare-time study at home. Any average man can qualify.



POSITION GUARANTEED or money refunded. You take no risk. High class, confidential work. Write today for Free Booklet No. D5821.

STANDARD BUSINESS
TRAINING INSTITUTE

BUFFALO,
N. Y.



SHORTHAND IN ONE MONTH

Boyd—the Wonderful, New, Easy System. Writers hold World's record. 100 to 150 words a minute in 30 days guaranteed. New Principles—dictation first week. Best for Court Reporting and Secretaries. Also Typewriting, Bookkeeping and Commercial Law. Send today for Catalog and Money-Back Guarantee.

CHICAGO HOME STUDY SCHOOLS, 802 Reaper Block, Chicago, Ill.



NAVIGATION TAUGHT BY MAIL

Hundreds of Ship Officers needed in Merchant Marine and Navy. Salaries up to \$412 monthly and living expenses. You can qualify through Captain Warren Sheppard's Home Study Course on Navigation. Chance of a lifetime to see the world as a ship's officer at a big salary. Write for free Book, "Your Future is on the Seven Seas."

World Technical Institute, Dept. 100A, Fuller Building, Jersey City, N. J.



Wonderful, new device, guides your hand; corrects your writing in few days. Big improvement in three hours. No failures. Complete outline FREE. Write C. J. Orment, D-34, St. Louis, Mo.

Learn to Dance

I CAN TEACH YOU Fox-Trot, One-Step, Two-Step, Waltz and newest "up-to-the-minute" society dances in a few hours—at home—in private by the wonderful

Peak System of Mail Instruction REMARKABLE NEW METHOD. Easy—fascinating. RESULTS GUARANTEED. No music—no partner needed. Thousands taught successfully.

Write me today for my interesting free book! Special low offer if you answer at once.

WILLIAM CHANDLER PEAK, M. B.
Studio 27 4737 Broadway Chicago, Ill.



Which job can you fill?

All these jobs were advertised in a single issue of a Chicago newspaper under "Help Wanted." Which one can you fill? There are good jobs like these with big pay everywhere for men capable of holding them. Why don't you get one? If you haven't the knowledge necessary to make you capable of holding down the best kind of a job, *make up your mind right now to get it.* There is a set of Home Study Books listed below that will quickly fit you to hold any job you want—spare time only is needed.

These books were written by some of the greatest experts in each line. Nothing but plain everyday English is used—thousands of pictures, diagrams and tables help to make everything as simple as A B C. You can't go wrong with these books before you—they explain everything you need to know. Pick out the set you want and see our *free* trial offer below.

Cut Prices on Practical Books

Carpentry and Contracting, 5 vols., 2138 pp., 1000 pictures. Was \$30. Now \$24.80
Civil Engineering, 9 vols., 3900 pp., 3000 pictures. Was \$54.00. Now \$39.80
Fire Prevention and Insurance, 4 vols., 1500 pp., 600 pic. Was \$20. Now \$19.80
Electrical Engineering, 8 vols., 3300 pp., 2600 pictures. Was \$48.00. Now \$29.80
Automobile Engineering, 6 vols., 2600 pp., 2000 pictures. Was \$36.00. Now \$24.80
Machine Shop Practice, 6 vols., 2300 pp., 2500 pictures. Was \$36.00. Now \$24.80

Steam and Gas Engineering, 7 vols., 3300 pp., 2500 pictures. Was \$42. Now \$29.80
Law and Practice (with read'g course) 13 v., 6000 pp., illus. Was \$72. Now \$49.80
Telephony and Telegraphy, 4 vols., 1728 pp., 2000 pictures. Was \$24. Now \$19.80
Sanitation, Heating, Ventilating, 4 vols., 1454 p., 1400 pic. Was \$24.50. Now \$18.80
Accountancy and Bus. Management, 7 v., 2700 p., 2000 pic. Was \$42. Now \$29.80
Drawing, 5 vols., 1578 pp., 1000 pictures, blueprints, etc. Was \$24.00. Now \$19.80

7 DAYS' FREE TRIAL

We'll gladly send you any set of these books you want for seven days' free examination. Don't send us a cent. Just pay the small shipping charges when the books arrive. Examine them carefully. Use them at your work for an entire week. If you feel that the books are not worth more than we ask for them, send them back at our expense. If you keep them, pay only the bargain price on the easy terms explained below.

50c a Week That's all you pay if you keep the books you select. Send \$2.80 within 7 days and the balance of the cut price at the rate of \$2.00 a month (50c a week). Did you ever hear of a more generous offer? Remember, you take no chances—you don't pay us anything if you don't keep the books. *Mail the coupon NOW—before you turn this page.*

AMERICAN TECHNICAL SOCIETY, Dept. X-193, Chicago

Wanted

Office Men

Auditors, Accountants, Office Managers, Credit Men, Cashiers, Bookkeepers and Cost Clerks—\$1,500 to \$7,500 a year.

Factory Men

Electrical and Mechanical Engineers, Factory Managers, Superintendents, Foremen, Designers and Draftsmen—\$1,500 to \$12,000 a year.

Construction Men

Civil and Structural Engineers, Transmitters, Construction Superintendents and Foremen, Estimators, Designers and Draftsmen—\$1,500 to \$10,000 a year.

Trades

Machinists and Toolmakers, Auto Repairers, Electricians, Stationary Engineers, Firemen, Plumbers, Carpenters, Pattern Makers and Telephone Men—\$1,500 to \$3,000 a year.

EXTRA SPECIAL

A consulting membership in this society given FREE with each set of books—regular price of membership is \$12.00.

No Money In Advance

SPECIAL DISCOUNT COUPON

AMERICAN TECHNICAL SOCIETY
Dept. X-193, Chicago, U. S. A.

Please send me set of.....

for 7 DAYS' examination, shipping charges collect. I will examine the books thoroughly, and, if satisfied, will send \$2.80 within 7 days and \$2.00 each month until I have paid the special price of \$..... If I decide not to keep the books I will return them at your expense at the end of one week. Title not to pass to me until the set is fully paid for.

Name.....

Address.....

City.....State.....

Reference.....

Please fill out all lines.

I'LL SHOW YOU HOW TO GET A JOB YOU CAN'T LOSE!

Every newspaper in the country is full of stories about men being thrown out of work. We are facing a period of depression which many say will lead to "soup kitchens and bread lines." Already in New York State tens of thousands of people are idle. "At the present rate," says the Daily News Record, "there will soon be two workers for each job." In Philadelphia in one line of business alone 40,000 employees were dropped. In New England mills and factories have closed or are running on part time. In the South, with cotton selling at low prices, wages are being cut and factories are closing in every section. In Detroit it is reported that the automobile plants laid off 100,000. In Akron the tire companies are running only part of their capacity. In every city in the country, from Coast to Coast, people are working part time, or looking for work or accepting radical reductions in wages.

How Soon Will You Be Out of Work?

Are you going to wait until YOU are out of work before insuring yourself against loss of income—or are you going to get a job NOW that you cannot lose? That kind of a job is—working for Uncle Sam in any of the numerous branches of the Civil Service. According to Federal Law you cannot be fired or laid off for any religious, personal or political reason. Hard times do not affect the government employe. There are no strikes or lockouts. Your pay comes regularly all year round. You can COUNT exactly on what you will get. Increases are rapid in position and salary.

Let Me Train You for a Job With Uncle Sam

Uncle Sam is careful about his employes. You must pass a Civil Service Examination before you are accepted. There are certain things you MUST know. It is my business to PREPARE you for the examination so you can pass successfully. For eight years I was a Civil Service Secretary-Examiner, so I am perhaps the best qualified man in the country to coach you. I guarantee to coach you until you succeed in GETTING A POSITION.

\$1600 to \$2300 a Year

NO STRIKES--NO LAYOFFS--NO LOCKOUTS

Figure your earnings for the past year and if you are an average man you didn't get as much as the average government employe! That is due to strikes, lockouts, slack work, layoffs—none of which can happen to Civil Service employes. They get \$1600 to \$2300 a year to start and they get it. Other positions in the government service pay as high as \$3000 to \$10,000 a year! Hours are easy—eight or less a day. Vacation every year with full pay, work at home or travel, or work in Washington or at Panama Canal.

Get My Free Book

Patterson Civil Service School,

Arthur R. Patterson, Principal

83 Wiener Bldg., Rochester, N. Y.

Please send me your free book about Government positions.

Name

Address

City.....State.....

If you are an American citizen 18 years old or more you are eligible to a Government Civil Service Position, and if you have a common ordinary 4th grade education as a foundation I want you to have a copy of my splendid fully illustrated book telling how I can help you to secure a position with the U. S. Government, in the Railway Mail Post Office, Rural Carrier, Departmental, Internal Revenue, Immigration, Custom House or Postmaster Services. Send in the coupon today or just a postal card.

Arthur R. Patterson, Principal, Patterson Civil Service School
Dept. 83 Wiener Building,
ROCHESTER, N. Y.



Learn Photography

Good-paying positions in the best studios of the country await men and women who prepare themselves now. For 28 years we have successfully taught

Photography, Photo-Engraving and Three-Color Work

Our graduates earn \$35 to \$100 a week. We assist them to secure these positions. Now is the time to fit yourself for an advanced position at better pay. Terms easy; living inexpensive. Largest and best school of its kind. Write for catalog today.

ILLINOIS COLLEGE OF PHOTOGRAPHY
Box P. 999 Wabash Ave. Effingham, Illinois

PLAY MUSIC ON A SAW

You can produce most wonderful, soft, sweet music from any common carpenter's saw with a violin bow or soft hammer, if you know how. No musical ability required—you need not know one note from another.



EASY TO LEARN IN 3 WEEKS

I ABSOLUTELY GUARANTEE to teach you to play popular music within 3 weeks. I will give you all the secrets and tricks I have learned in my 10 years' success as a saw musician—secrets never before revealed and unknown to other musical entertainers. Very little practice required—it's all in knowing how.

MAKE BIG MONEY

Amuse your friends with this remarkable, new form of entertainment. You'll be the most popular person in your crowd. Your services will be in demand at Clubs, Lodges, Church Affairs and Dinners all over your state. Your act will always be the big hit and you will be paid as much money for a few minutes entertaining as most men make in a day.

Send today for complete free information, "How to Play a Saw."

C. J. MUSSEHL, 235 Mack Building, Fort Atkinson, Wis.

WRITE NOW FOR Dyke's FREE Booklet

NEW IDEA OF TEACHING BY MAIL tells how you can learn at home—spare time—and **Become an Auto Expert** on repairing and electrical systems.

DYKE'S SCHOOL OF MOTORING, Box 200 Granite Bldg., St. Louis, Mo.
A department of the Firm: A. L. Dyke, Publisher. Original and only system of its kind. Endorsed by leading motor authorities of the world.

MINSTRELS

Musical Comedies and Revues with Complete Instructions for Staging. You can put on your own show with our books. Opening Choruses and Finales, Skits and Afterpieces, Monologues, Songs, Vandeville Acts, How to Stage a Minstrel Show, Wigs, Make-up. Big Catalogue free. T. S. DENISON & CO., 623 So. Wabash, Dept. 12 CHICAGO

Be an Artist

Comics, Cartoons, Commercial, Newspaper and Magazine Illustrating, Postal Crayon Portraits and Fashions. Earn money; become famous. Our simple method quickly develops your talent in spare time. By Mail or Local Classes. Write for lesson and list of successful students. ASSOCIATED ART STUDIOS 87-B Flatiron Building NEW YORK

LEARN WATCHMAKING

and become independent. Good-paying positions secured. Easy to learn. Send for FREE CATALOG.

ST. LOUIS, WATCHMAKING SCHOOL, Dept. 5, ST. LOUIS, MO



200 Kinds Iron, Wood and Wire PUZZLES

One of our leaders and illustrated folder, postpaid 10 cents. Ask for one difficult if desired. WESTERN PUZZLE WORKS, St. Paul, Minn.

FREE "Linene" COLLAR

For trial, a sample of our New Style Copley, if you send 2 cents for postage and state size wanted. Reversible Collar Co., Dept. 12, Boston, Mass.

Stop Making Mistakes in Speaking *and* Writing

Does your English reveal your lack of education or does it prove that you are a person of culture and refinement? Are you handicapped in your speech and writing or does your command of English rise to meet every occasion and every situation? English is the one weapon you must use every day. Here is how you can improve it almost at once.

As a result of thousands of tests, Sherwin Cody found that the average person is only 61% efficient in the vital points of English. In a five-minute conversation, or in an average one-page letter, from five to fifty errors will appear. It is surprising to see how many experienced stenographers fall down in spelling such common words as "business," "abbreviate," etc. It is astonishing how many business men say "between you and I" instead of "between you and me," and use "who" for "whom," and mispronounce the simplest words. Few people know whether to use one or two "c's" or "m's" or "r's," whether to spell words with "ie" or "ei," and when to use commas in order to make their meaning absolutely clear.

A Remarkable Discovery

Mr. Cody has specialized in English for the past twenty years. But instead of going along in the old way he has applied scientific principles to teaching the correct use of our language. He made tens of thousands of tests of his various devices before inventing his present method. In all his tests he found that the trouble with old methods is that points learned do not stick in the mind. In school you were asked to remember rules, and if you forgot the rules you never could tell what was right and what was wrong. For the past five years, Mr. Cody has worked almost day and night to find a way to replace bad habits in writing and speech with good ones. And as a result of his experience he evolved his wonderful new

Self-Correcting Method

Mr. Cody was granted a patent on his unique device, and now he places it at your disposal. This invention is simple, fascinating, time-saving, and incomparably efficient. You do the lesson given on any page, then you see exactly how Mr. Cody himself would correct it. You mark your errors and check them in the first blank column. Next week you try that page again, on the second unmarked sheet, correct your errors, and check them in the second column. You see at a glance what you have learned and what you have failed to remember, until you have reached the 100% point in spelling, punctuation, grammar, and expression.

Only 15 Minutes a Day

A remarkable advantage of Mr. Cody's course is the speed with which these habit-forming practice

drills can be carried out. You can write the answers to fifty questions in 15 minutes, and correct your work in five minutes more. You waste no time in going over the things you already know. Your efforts are automatically concentrated on the mistakes you are in the habit of making, and through constantly being shown the right way, you soon acquire the correct habit in place of the incorrect habit. There are no rules to remember. There is no tedious copying. There is no heart-breaking drudgery.



Sherwin Cody

New Book Free

Every time you talk, every time you write, you show what you are. Your English reveals you as nothing else can. When you use the wrong word, when you mispronounce a word, when you misspell a word, when you punctuate incorrectly, when you use flat, ordinary words, you handicap yourself. If you feel your lack of language power, if you are ever embarrassed by mistakes, if you cannot command the exact words to express your ideas, our new booklet "How to Speak and Write Masterly English" will prove a revelation to you. Merely mail the coupon, and it will be sent by return mail. Learn how Sherwin Cody's new invention makes command of language easy to gain in 15 minutes a day.

Mail this coupon or a postal AT ONCE

Sherwin Cody School of English

53 Searle Building

Rochester, N. Y.

SHERWIN CODY SCHOOL OF ENGLISH,
53 Searle Building, Rochester, N. Y.

Please send me at once your Free Book, "How to Speak and Write Masterly English."

Mr

Address

City.....State.....



High School Course in Two Years!

You Want to Earn Big Money!

And you will not be satisfied unless you earn steady promotion. But are you prepared for the job ahead of you? Do you measure up to the standard that insures success? For a more responsible position a fairly good education is necessary. To write a sensible business letter, to prepare estimates, to figure cost and to compute interest, you must have a certain amount of preparation. All this you must be able to do before you will earn promotion.

Many business houses hire no men whose general knowledge is not equal to a high school course. Why? Because big business refuses to burden itself with men who are barred from promotion by the lack of elementary education.

Can You Qualify for a Better Position?

We have a plan whereby you can. We can give you a complete but simplified high school course in two years, giving you all the essentials that form the foundation of practical business. It will prepare you to hold your own where competition is keen and exacting. Do not doubt your ability, but make up your mind to it and you will soon have the requirements that will bring you success and big money. YOU CAN DO IT.

Let us show you how to get on the road to success. It will not cost you a single working hour. We are so sure of being able to help you that we will cheerfully return to you, at the end of ten lessons, every cent you sent us if you are not absolutely satisfied. What fairer offer can we make you? Write today. It costs you nothing but a stamp.

AMERICAN SCHOOL

Dept. H-374, Drexel Ave. and 58th St., Chicago

AMERICAN SCHOOL

AMERICAN SCHOOL

Dept. H-374 Drexel Ave. and 58th St., Chicago

Explain how I can qualify for position checked:

...Architect \$5,000 to \$15,000	...Lawyer \$5,000 to \$15,000
...Building Contractor \$5,000 to \$10,000	...Mechanical Engineer \$4,000 to \$10,000
...Automobile Engineer \$4,000 to \$10,000	...Shop Superintendent \$3,000 to \$7,000
...Automobile Repairman \$2,500 to \$4,000	...Employment Manager \$4,000 to \$10,000
...Civil Engineer \$5,000 to \$15,000	...Steam Engineer \$2,000 to \$4,000
...Structural Engineer \$4,000 to \$10,000	...Foreman's Course \$2,000 to \$4,000
...Business Manager \$5,000 to \$15,000	...Sanitary Engineer \$2,000 to \$5,000
...Certified Public Accountant \$7,000 to \$15,000	...Telephone Engineer \$2,500 to \$5,000
...Accountant and Auditor \$2,500 to \$7,000	...Telegraph Engineer \$2,500 to \$5,000
...Draftsman and Designer \$2,500 to \$4,000	...High School Graduate In two years
...Electrical Engineer \$4,000 to \$10,000	...Fire Insurance Expert \$3,000 to \$10,000
...General Education In one year.	

Name..... Address.....

SPANISH LEARNED EASILY AND QUICKLY!

Also FRENCH and ITALIAN

Another language will enable you to make more money—whether you are an employer or employee, professional man or woman, boy or girl.

A Few Spare Minutes Can Increase Your Income
Learning a new language by the Rosenthal Language Phone Method, is as easy as learning a new tune. Study when you are in the mood—in the comfort of your own home—on your own phonograph. Soon, you can talk, read and write Spanish, French or Italian.

ROSENTHAL LANGUAGE PHONE METHOD

makes rapid progress possible

Any number of people can learn at the same time—the whole family or groups of friends.

FREE 64-Page Book. It shows how easy, interesting, and profitable it is to learn a foreign language; and explains Dr. Rosenthal's world-famous method of quick study. Also details of **FREE Trial** offer. Send a postal—**to-day.**

FUNK & WAGNALLS COMPANY
549 Hess Building, 354 Fourth Ave., N. Y.



Free to Writers!



A WONDERFUL BOOK—read about it! Tells how easily Stories and Plays are conceived, written, perfected, sold. How many who don't DREAM they can write, suddenly find it out. How the Scenario Kings and the Story Queens live and work. How bright men and women, without any special experience, learn to their own amazement that their simplest ideas may furnish brilliant plots for Plays and Stories. How one's own imagination may provide an endless gold-mine of ideas that bring Happy Success and Handsome Cash Royalties. How new writers get their names into print. How to tell if you ARE a writer. How to develop your "story fancy," weave clever word-pictures and unique, thrilling, realistic plots. How your friends may be your worst judges. How to avoid discouragement and the pitfalls of Failure. **How to win!** This surprising book is absolutely free. No charge. No obligation. Your copy is waiting for you. Write for it now. Just address **AUTHORS' PRESS, Dept. 330, AUBURN, NEW YORK**

Genuine \$20.00 Imported VIOLIN Will Be Given To You FREE

Help me introduce this beautiful Violin in your district. Be first to show how easy it is to play with help of three new inventions and my scientific instructions. You can play it in one week.

10,000 Students Found Easy to Learn Violin Playing

You can learn as easily as others. Surprise your friends. My three new inventions make it very easy. Have been teaching 40 years. Write your name and address on bottom of page and send for free violin offer and three new violin inventions.

PROF. A. HINCHCLIFFE, 233 Broadway
Woolworth Bldg. Dept. 503 NEW YORK

LEARN JIU-JITSU

Know how to protect yourself and your loved ones against a bully or a ruffian. Muscle and weight are useless before this marvelous science. Anyone can master it easily. Complete instructions in book entitled **JUDO (Improved Jiu-Jitsu)** by Sakujiro Yokoyama, Professor of Jiu-Jitsu in the Kodokwan Gendai athletic university in Japan. 200 pages. Illustrated with 80 actual photos. **Special Reduced Price only \$2.00, Postpaid.** (Same edition originally sold for \$5. Money cheerfully refunded within 5 days if not entirely satisfied.)

RICHARD PRICE MILLER
Dept. B, 120 1/2 So. Broadway Los Angeles, Cal.

Will ship C. O. D. anywhere in U. S. A. if desired.

Learn Watchwork, Jewelrywork and Engraving.

A fine trade commanding a good salary, and your services are always in demand. Address **HOROLOGICAL, Dept. P, Bradley Institute, Peoria, Ill.**, for our latest catalog.

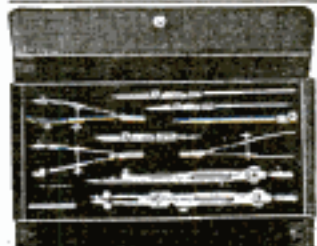

\$29.00 Value Set Mechanical Drawing Instruments

Special Wholesale Price \$6.75 Postpaid

Pocket case 4x8 1/4 inches—velvet lined—Instruments constructed of solid nickel silver and steel—guaranteed. Order now—supply limited. **Free illustrated particulars.**

NATIONAL INSTRUMENT CO.
4704 N. Hamilton Avenue, Chicago, Ill.

Learn AUTO ELECTRICITY



In the Great Shops of **COYNE**

Earn \$45 to \$100 a Week ^{and} More

You can quickly qualify for a good paying job and a successful future in the field of Auto, Truck and Tractor Electricity. A few weeks in the great Shops of Coyne will fit you to fill the positions paying up to \$400 and more a month. Today's big opportunity, almost untouched, lies in the field of the Auto Electrical Expert.

Such men are in demand in every locality—all year round—at big pay. There is an over supply of auto mechanics, but the demand is for men who can locate, analyze, and repair electrical troubles. Most auto troubles are electrical troubles and very few auto mechanics are electrical experts. You can learn this profitable, pleasant profession thoroughly and quickly in the great Shops of Coyne, located in Chicago, the electrical center of the world.

Auto Truck and Tractor Electricity

We train you for the big jobs quickly, through our Learn-By-Doing methods. No books, no unnecessary theory, no wasted time—simply personal instruction, directions, and practice doing the very things you will be paid for later. We save months of time. You learn in a real electrical school on real equipment. Through actual practice you become an expert in Lighting, Starting, Ignition, Testing, Maintenance, Batteries, and Service.

EARN WHILE YOU LEARN

No need to wait until you save the money you need to secure this Automotive Training. Our Employment Department assists ambitious men to secure a job part-time, to enable you to help pay your way. Don't let this hold you back. This is undoubtedly the finest course of its kind in America. Equipment valued at over \$100,000 is used to train you. The equipment is most complete, and you are trained by experts in their line. **This Auto Electrical Course is given separately or can be taken as part of our Course in Practical Electrical Engineering as outlined on page 21 of this magazine.**

We Train You in Business—FREE

By enrolling now you secure FREE a full course in Business Management. You learn how to market your ability. If you work for others it makes your services more valuable; or the Automotive training plus this training in Business Management opens the way to get into a paying business of your own—you can open a Battery Service Station, specialize on Lighting and Starting, manage your own Garage or Service Station or enter any other branch. The field is Nation-wide; now is the time to start.

Don't Delay— Start Now

Think of it! A few weeks after you start you leave here ready to fill a position paying up to \$100 a week! You become somebody; you can make good and enjoy the real comforts of life. You get out of the job hunting class and become a highly paid expert in big demand. You can do it. Start right. Fill out the coupon tonight for full information. You want to reserve that free course in business training, so get that coupon or letter off to us tonight.



B. W. COOKE

PRESIDENT

COYNE
TRADE AND ENGINEERING SCHOOL

Dept. 13A, 39-51 E. Illinois Street, Chicago, Ill.

Bennett W. Cooke,
President
Coyne Trade and
Engineering Schools
Dept. 13A, 39-51 E. Illinois
St., Chicago, Illinois

Gentlemen: Send me your free literature with full particulars concerning your Auto, Truck and Tractor Electricity course and how I may secure the course in Business Management, free. This places me under no obligation whatsoever. I am interested in

- Auto Electricity Course.
 Auto Elec. and Prac. Elec. Course

Name.....

Address.....

**I Can
TRAIN YOU
FOR
BIGGER PAY
In Less Than
2 Months**



40,000 Opportunities in Hotels

YOU can have one of these well-paid, pleasant executive positions—40,000 of them in the big hotels of the United States—now America's Fourth Largest Industry. Statistics show that ONE IN EVERY TEN HOTELS WILL HAVE AN OPENING FOR A MANAGER THIS YEAR. Thousands of other positions are also open to those who qualify through training.

The Lewis School guarantees to give you the valuable knowledge that it has taken some of the most successful hotel men years to obtain—men who are now making \$5,000 to \$50,000 a year. All of your training will be under the personal direction of Clifford Lewis—a hotel expert of national reputation. A few spare-time hours a week given to the simple, clear lessons of the course will give you the training for a good position, a fine living, and a handsome salary. The training will in no way interfere with your present work or recreation.

Send today for FREE BOOK, "Your Big Opportunity." Don't wait a minute—you may lose the opportunity of a lifetime. Mail the coupon NOW. Your whole future may depend on it.

LEWIS HOTEL TRAINING SCHOOL
Clifford Lewis, Pres. Room 315 Washington, D. C.

FREE COUPON

LEWIS HOTEL TRAINING SCHOOL
Room 315 Washington, D. C.

Send me without obligation the FREE BOOK "Your Big Opportunity."

Name.....

Street.....

City.....State.....

MONEY IN POULTRY



Do you know how to MAKE MONEY from poultry? How to get most fall and winter eggs? How to hatch and brood strong, healthy chicks successfully? We can show YOU—Positively. Our officers are nationally known poultry authorities and our course the ONLY poultry correspondence course endorsed by the leading agricultural colleges. Send TODAY for new FREE book, "How to Raise Poultry for Profit."



THE NATIONAL POULTRY INSTITUTE
Dept. 312 Washington, D. C.

Send for This ELECTRICITY HANDBOOK

\$1

238 illustrations
414 pages

HERE'S just the book on Electricity that you need to answer your many questions—to solve your knotty problems, to teach you new kinks, to be your memory for tables, rules, formulae, and other Electrical and Mechanical facts. This "Little Giant" I. C. S. Electrical Engineer's Handbook may be just the thing you need to prepare you for that better job ahead. Note the contents:—

Electricity and Magnetism; Batteries; Circuits; Magnets; Direct and Alternating Currents; Dynamos and Motors; Belts; Shafting; Electroplating; Electrical Measurements; Meters; Arc and Incandescent Lamps; Mercury-Arc Rectifiers; Transformers; Insulation; Electric Cars; Single and Multiple Unit Control; Transmission; Rail Welding; Tables of Wires—Sizes, Capacities, etc.; Mathematical Rules, Formulae, Symbols; Tables of Constants, Weights and Measures; Chemistry; Properties of Metals; Principles of Mechanics.

Just slip a dollar bill into an envelope, and mail it with this advertisement and your name and address to the International Correspondence Schools, Box 5616-C, Scranton, Pa. This 414-page Electricity Handbook will come to you by return mail.

You run no risk! Money back if desired!

A REAL \$20.00 VIOLIN FREE



If you study our new one note at a time violin lessons; simple as A-B-C; Certain as Arithmetic; Over 40 pieces included; Easy to play; Easy to pay; Lessons only cost; Your success and violin guaranteed.

State if you have violin

IMPERIAL MUSIC SCHOOL - 3009 16th Street
Dept. B SAN FRANCISCO-CALIFORNIA

STAMMERERS

For 35 years we have successfully corrected stammering by our simple and natural course of individual lessons. Attend no school until you have read our free booklet. **SAMUEL A. ROBBINS, Director, Boston Stammerers' Inst.** 246 Huntington Ave., Boston 17, Mass.

WANTED Railway Mail Clerks

\$1600 to \$2300

A YEAR

Men—Boys—Over 17—should write at once

Rapid advancement. "No lay-offs." THE POSITION IS YOURS FOR LIFE. Common-sense education sufficient. Political influence NOT REQUIRED.

Write immediately for schedule showing the places and dates of ALL coming Government examinations. Do it to-day.

FRANKLIN INSTITUTE, Dept. A176, Rochester, N. Y.



Hundreds of Railway Mail Clerks Appointed Yearly

FRANKLIN INSTITUTE (The Pathway to Plenty) Dept. A176, Rochester, N. Y. This coupon, filled out as directed, entitles the sender to free specimen questions; a free copy of our book, "Government Positions and How to Get Them"; a list of Government positions now obtainable, and to consideration for Free Coaching for the examination here checked.

COUPON

.. Railway Mail Clerk (\$1600 to \$2300) .. Postoffice Carrier (\$1400 to \$1800)
.. Bookkeeper (\$1340 to \$1800) .. Rural Mail Carrier (\$ 720 to \$2800)
.. Postoffice Clerk (\$1400 to \$1800) .. Customs Positions (\$1100 to \$2000)

Name.....

Address.....

Use this before you see it. Write plainly.



\$10,000 a Year

Because He Knows Law!

Are you *in earnest* when you say you would like to increase your income—qualify for the management of big affairs?

Then there is one thing you should do just as quickly as possible—**STUDY LAW!**

No *guess work* about this, mind you; it's the verdict of the most prominent executives in America—the very men who are naming *other* men for positions paying from \$10,000 to \$50,000 a year.

"What must I do?" asked Leonard Livingstone, when Percy H. Johnston (now President of the great Chemical National Bank of New York) told him that the man who *prepared* would go along with him to bigger responsibilities.

"Study law!" replied Mr. Johnston.
"A good sound knowledge of the law," writes D. P. Kingsley, President of the New York Life Insurance Company, "is becoming more and more necessary. I would advise any man who intends to equip himself for the management of large business interests not to consider his training complete until he has taken a law course."

"Whether I went thru college or not," advises William Maxwell, Vice-President of Thomas A. Edison, Inc., "I should surely study law."

"In looking over the field," writes a prominent Eastern manufacturer, "I find that nearly all the positions commanding a salary of \$10,000 or more are filled by men who have studied law."

Be a Law-Trained Man

Why stand still while other men are steadily preparing for the job you want? *You can train just as well as they!*

Right in the quiet of your own home, under the LaSalle Problem Method, you can study the same cases you would read at the resident universities, master the fundamental principles of law set forth by some of the most eminent authorities in the profession, develop under their direction a sound understanding of business relationships, a power for keen and logical thinking, a facility for analyzing *business* problems that in later years will make *you* the man the directors pick for an important and high-salaried position.

LaSalle text-books, "lesson talks," lectures, quizzes and examinations have been prepared by leading members of the American bar—prominent practitioners, judges, law professors in the great universities. You graduate with the degree of LL.B.—possessed with all the advantages of a thoro legal training as a foundation for independent practice or for a responsible position with one of the big corporations.

Prepare Now to Double Your Income

During the past few years literally thousands of ambitious men have doubled and tripled their earnings as a result of specialized business and professional training under the LaSalle Method. We will send you, if you like, the names and

addresses of 1,089 LaSalle members reporting definite salary increases during a three months' period. Read these typical statements from their letters:

"Passed the bar examination with second highest honors in a class of 71."

"Three years ago I was earning \$22.00 a week. Today I am comptroller of a good-sized corporation with an initial salary of \$4,500."

"Promoted to General Manager."

"Now Service Manager, with 466% increase."

"Passed bar examination in 'Class A', in competition with five graduates of resident universities."

Sign the Coupon

Whether you aim to practice law as a profession or to use it as a stepping stone to the big rewards in business, opportunity is fairly thumping on your door. It stands revealed in the coupon at the foot of the page. This coupon, signed and mailed, will bring you full information regarding the training you are interested in, together with details of our convenient-payment plan; also your free copy of that inspiring book, "Ten Years' Promotion in One."

Mail the coupon NOW and make TODAY your starting point toward big success.

LaSalle Extension University

The Largest Business Training Institution in the World
Dept. 364-L R Chicago, Illinois

Gentlemen: Send without obligation to me information regarding course indicated below:

LAW, Degree of LL. B.

LaSalle is the largest business training institution in the world. It offers training for every important business need. If more interested in any of these courses, check here:

- | | |
|--|--|
| <input type="checkbox"/> Business Management | <input type="checkbox"/> Modern Business Correspondence and Practice |
| <input type="checkbox"/> Higher Accountancy | <input type="checkbox"/> Modern Foremanship and Production Methods |
| <input type="checkbox"/> Traffic Management—Foreign and Domestic | <input type="checkbox"/> Personnel and Employment Management |
| <input type="checkbox"/> Railway Accounting and Station Management | <input type="checkbox"/> Expert Bookkeeping |
| <input type="checkbox"/> Commercial Law | <input type="checkbox"/> Business English |
| <input type="checkbox"/> Industrial Management Efficiency | <input type="checkbox"/> Commercial Spanish |
| <input type="checkbox"/> Banking and Finance | <input type="checkbox"/> Effective Speaking |
| | <input type="checkbox"/> C. P. A. Coaching |

Name

Present Position

Address

SWEENEY

I'll Pay Your Railway Fare to Kansas City



My Big Announcement This Season—

I am bringing this great Sweeney Million Dollar School right to your door—No matter where you live. My big announcement means that you can come to Kansas City—to this great Trade School at no more expense than if it were located in your home town, for I am paying your railroad fare—I rebate to you the railroad fare from any point in the U. S. to the Sweeney School.

MECHANICAL TRAINING—it's the thing young men are thinking about today—it's what you are thinking about for it holds the big paying jobs. Thousands of young men have taken the first important step—wrote me for My Big Free Catalog—came to the Sweeney School—today, in all parts of the country they ARE MAKING GOOD.

These men **TOOK THE FIRST STEP**. They wrote for my catalog, and date their present success from that moment. They will tell you: "**Don't make any mistake. Take up the Auto Business. Learn it right. LEARN IT AT SWEENEY'S.**" But These Men Never Had the Opportunity You Have Right Now. The railroad fare to Kansas City is a big item. Lots had to pinch and scrape to make it.

But I Will Now PAY Your FARE!

I've got over 46,000 graduates all over the United States and a lot in foreign countries and I like to think they are all my friends. If you could read my mail you would believe they were. They ask me for Sweeney graduates, they are boosters for Sweeney training. That's **ONE REASON A SWEENEY man don't have to go about identifying his diploma. A SWEENEY diploma MEANS SOMETHING.** If a man goes to an unknown school and has a feeling of loyalty he says: "And that's a good school." But if he comes from Yale or Harvard he doesn't have to say it's a good school for the world knows it. And the world knows about the **SWEENEY SCHOOL** and the automobile man looks to this school like a soldier

looks to West Point. Now that's a mighty big reason for you to **WASTE NO TIME** but come right to the Sweeney School and be **RIGHT** from the start.

Start Right Now

I like to talk to go-getters. I want the man who is looking for the real things in life. I want the man who is looking for independence and success. **AND I WILL HELP HIM.** We have all got to make a living. I say make it doing the thing you like. I don't care if you have never had any mechanical experience. I don't care if you are not a book scholar. The Sweeney System uses tools instead of books. If you are in earnest and will work, there is a **REAL JOB LOOKING FOR YOU.** Write me today. Don't put it off. Get busy **NOW.** **BE A GO-GETTER.** Write for that big free catalog today and I'll guarantee to open your eyes to **DOLLARS** that you are overlooking and **HAPPINESS** and **INDEPENDENCE** that you are missing. Make a start **RIGHT NOW.** Write me at once! Yours very truly,

EMORY J. SWEENEY, Pres.



LEARN A TRADE
Sweeney
SCHOOL OF AUTO-TRACTOR-AVIATION
997 SWEENEY BLDG. KANSAS CITY, MO.

SCHOOL

LEARN A TRADE AND GET A GOOD JOB!

MEN WANTED! IN AUTO BUSINESS Mechanics Needed Everywhere

Young men mechanically inclined, get into the automobile business now and make real money. And remember you are never too old. Henry Ford was 40 when he started the Ford Co.

Get Jobs Like These

SWEENEY trained men are in demand everywhere at good wages, **\$50 a week and more**, from garages, tire shops, welding concerns, auto repair shops, etc. Thousands of men are hunting jobs, but the autos still keep running and no trained mechanic has to hunt a job. Top wages are paid, but **SWEENEY TRAINED MEN ARE WANTED**. The skilled man is in demand; the untrained man walks the street. Here's the proof:

The Million Dollar Sweeney School—Greatest **SUCCESS** Factory in America

Hundreds of Openings For Men!

Pick the Job You Like

Chauffeurs - -	\$90 to \$150
Truck Driver - - -	\$125
Tire Vulcanizers	\$100 to \$200
Welders - -	\$140 to \$200
Battery Man -	\$150 to \$200
Auto Mechanic	\$6 to \$10 a day
Auto Electrician - -	\$225
Tractor Engineers	\$10 a day
Garage Manager	\$150 to \$400
Demonstrator and Salesman -	\$150 to \$500

South Dakota wires: "Will pay most any price for a good man. Send him right away." Neck City, Mo., says: "Put us in touch with a first class repair man. Excellent opening." Indiana says: "Want one more Sweeney man for my new garage. Steady work at good prices." Kansas appeals: "Send me a man who understands Ford Car from A to Z. Will pay top wages." Mississippi telegraphs: "Want a post graduate mechanic. Will pay all he is worth. Wire at my expense." Florida calls: "Want head mechanic. Will pay \$50 a week. Let me hear by return mail." **Thousands of Sweeney graduates now owning their own business** in various parts of the country naturally favor the Sweeney trained men. Sweeney loyalty is wonderful. Our daily mail is conclusive proof that the trained man with a Sweeney diploma can secure jobs like these at **\$50.00 a week and more**.

GET MY FREE BOOK



EMORY J. SWEENEY, Pres.
Dept. 997, Sweeney Bldg.,
Kansas City, Mo.

Send free, without any obligation, your 72-page catalog. Tell me of the opportunities in the Auto and Tractor Business.

Name

P. O. State

Free

I will gladly send my 72-page illustrated catalog FREE. Also a free copy of the Sweeney School News, a most interesting monthly school paper published here. You will enjoy them. Read the worth-while stories of men like yourself who came to Sweeney's and found success. Read how Frank Powell and Harry Wilson built up a \$20,000 business in about two years after graduating. Read how Elbert A. Pence built up a \$25,000 yearly garage business at Clearmont, Mo. These stories and others are told by the Sweeney students. Also I want you to learn how my students enjoy themselves after work in the swimming pool, the club and reading rooms, etc.

EMORY J. SWEENEY, President

Send Coupon Right Now!

Do You Want a Better Job?

DO you want a better job than you have now? Do you want to be sure of this job no matter whether business is good or bad? Do you want a job with a larger salary—a future?

You can have such a job if you really want it. Yes, you can!

Right now, despite all the unemployment, there are thousands of good jobs open for trained men. It is only the untrained man who is at the mercy of business conditions.

If you want to make sure of your present job—if you want a better job—start now to become a trained man!

You can do this easily in your spare time at home, without denying yourself a single pleasure—without losing a day or a dollar from your present work.

Let the International Correspondence Schools show you how easy it is—how fascinating—how profitable.

This is all we ask:—Tear out and mail the coupon below. This does not obligate you in any way, but it will bring you the full story of what the I. C. S. can do for you.

Right now is the time to take your pencil from your pocket and do the thing you know is for your own good.

TEAR OUT HERE

INTERNATIONAL CORRESPONDENCE SCHOOLS
BOX 5610-C SCRANTON, PA.

Without cost or obligation please explain how I can qualify for the position, or in the subject before which I have marked an X in the list below:

- ELECTRICAL ENGINEER
- Electric Lighting & Railways
- Electric Wiring
- Telegraph Engineer
- Telephone Work
- MECHANICAL ENGINEER
- Mechanical Draftsman
- Machine Shop Practice
- Toolmaker
- Gas Engine Operating
- CIVIL ENGINEER
- Surveying and Mapping
- MINE FOREMAN or ENG'R
- STATIONARY ENGINEER
- Marine Engineer
- ARCHITECT
- Contractor and Builder
- Architectural Draftsman
- Concrete Builder
- Structural Engineer
- PLUMBING & HEATING
- Sheet Metal Worker
- Textile Overseer or Supt.
- CHEMIST
- Pharmacy

- BUSINESS MANAGEM'T
- SALESMANSHIP
- ADVERTISING
- Show Card & Sign Ptg.
- Railroad Positions
- ILLUSTRATING
- Cartooning
- Private Secretary
- Business Correspondent
- BOOKKEEPER
- Stenographer & Typist
- Certified Public Accountant
- TRAFFIC MANAGER
- Railway Accountant
- Commercial Law
- GOOD ENGLISH
- Common School Subjects
- CIVIL SERVICE
- Railway Mail Clerk
- AUTOMOBILES
- MATHEMATICS
- Navigation
- AGRICULTURE
- Poultry Raising
- BANKING
- Spanish Teacher

Name.....

Street and No.....

City..... State.....

Occupation.....

Please Mention Popular Mechanics

Learn ELECTRICITY by the new Keysheet System

Mastering electricity is no longer a problem. The keysheet system has been perfected at a cost of \$10,000. Your problems worked out in advance.

**Be an Electrical Expert—
Earn \$50 to \$100 per week.**

Most complete, accurate, up to date electrical training course ever conceived. Students taught as in practice.

Valuable free booklet. Send for it today.

WORLD TECHNICAL INSTITUTE
Dept. EE, Fuller Building JERSEY CITY, N. J.

Music Lessons

UNDER MASTER TEACHERS

At Home

A Complete Conservatory Course By Mail

Wonderful home study music lessons under great American and European teachers. Endorsed by Paderewski. Master teachers guide and coach you. Lessons a marvel of simplicity and completeness.

Any Instrument Write telling us course you are interested in—Piano, Harmony, Voice, Public School Music, Violin, Cornet, Mandolin, Guitar, Banjo or Reed Organ—and we will send our FREE CATALOG with details of course you want. Send NOW.

University Extension Conservatory, 524 Siegel-Myers Bldg., Chicago, Ill

Learn Autos and Tractors



Wonderful opportunities constantly offered trained men; we train you thoroughly to start your own business or make good money as motor expert, driver, shop foreman, etc.

7,000 Graduates making good. Catalog Free

Cleveland Automobile School, 1814 E. 24th St., Cleveland, O.

SELL US YOUR SPARE TIME

after enrolling for our course in Show Card Writing. We will train you to write show cards for us. No canvassing or soliciting; we supply you with work; distance no object; will pay you good money for work done.

Wilson Methods, Ltd., Dept. C, 64 E. Richmond, Toronto, Canada

BE AN ARTIST

We can teach you **DRAWING** in your own home during your spare time.

Our 18 years of successful teaching prove our ability. 10 Courses in Commercial and Illustrative Drawing.

Teachers Normal and Applied Art. Endorsed by high art authorities.

Students trained by members of our Faculty are filling high-salaried positions. Artist's Outfit FREE to Enrolled Students. Write today for Art Year Book.

OUR HANDSOME ART YEAR BOOK FREE 75¢ Book

SCHOOL OF APPLIED ART

APPLIED ART BLDG. NO. 2 BATTLE CREEK MICH.



I Guarantee To Train You

**Until You Are Placed
in a Position Paying**

**\$250 to \$300 Per
Month**

— Chief Draftsman Dobe



Write and I'll tell you how I make you a first-class, big-money-earning draftsman in a very few months! I do this by a method no other man nor institution can imitate. I give you personal training at home by mail. And I mean just what I say—I train you until you are actually placed in a position paying from \$250.00 to \$300.00 per month. Six thousand draftsmen are wanted every month. Hurry up and register so you can start earning.

**I Give YOU
FREE**

**This \$25⁰⁰ Outfit
of Drafting Tools**

High-grade plated instruments. Every one you need. Packed in a handsome plush lined case. Just the kind I use myself. Write to me. I'm giving it entirely and absolutely free.

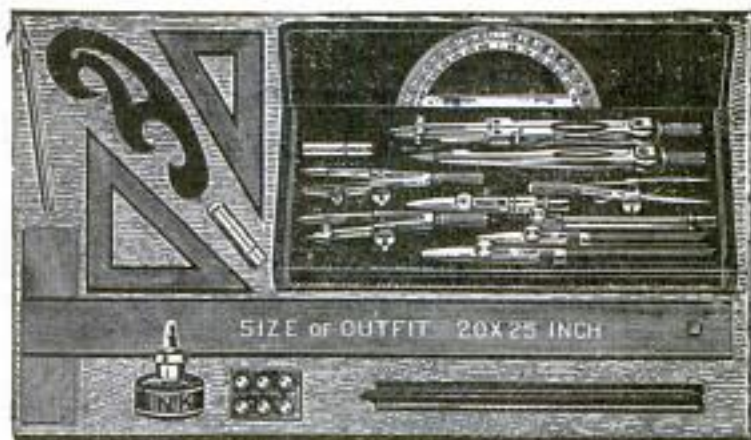

**Send This Free
Coupon To Me!**

It costs you nothing but a stamp to send the coupon for my free book, "Successful Draftsmanship" that tells you all. It tells you how my students get the good positions and how I can afford to train you until you get YOUR position. Remember, 6,000 men wanted every month. So hurry. Register early because I can take only a few students. Send coupon NOW!

Chief Draftsman Dobe

Dept. 1353 4001 Broadway, Chicago

Chief Draftsman Dobe

Dept. 1353, 4001 Broadway, Chicago, Ill.

Without any obligation whatsoever, please mail your book, "Successful Draftsmanship," and full particulars of your liberal "Personal Instruction" offer to a few students.

Name.....

Address.....



THE SCIENTIFICALLY BUILT WATCH

Every American Boy

Should know something about fine watchmaking. The Waltham Watch contains all the great principles of scientific engineering. And many profound laws of physics are exemplified in its "works." The lever, the screw, the fulcrum, the spring, and many more mechanical perfections, are there related to the different parts in a most wonderful manner. The "movement" of a Waltham Watch is one of the most perfect examples of motor mechanism ever evolved by man. It pulsates 420,000 times every twenty-four hours. And it keeps up this marvelous performance for a lifetime with very little care. Some of the parts are so tiny that you can barely see them with the naked eye, yet under the microscope they are amazingly perfect. A screw is used which exhibits 257 threads to the inch; 47,000 will barely fill a small thimble — and it takes one hundred and eleven of them to weigh one grain. But the most wonderful fact of all is the marvelous machine which makes automatically these little screws. The Waltham factory is filled with miracle-working machinery, all invented and perfected during the past seventy years by Waltham inventors, men whose names are famous wherever watches are made. The Waltham Watch made our country famous for watchmaking and has invariably defeated all foreign watches in competition for excellence in precision and reliability. Every American Boy should be proud of this achievement. All are invited to visit the great factory at Waltham, Mass. to see how these world-famous watches are made. Or, to write for a beautifully illustrated booklet which is a liberal watch education.

Makers of the famous Waltham air-friction quality Speedometers and Automobile Time-pieces used on world's leading cars

WALTHAM

THE WORLD'S WATCH OVER TIME

Where you see this sign they sell Waltham Watches

GIFTS THAT LAST

Popular Mechanics Magazine

REGISTERED IN U. S. PATENT OFFICE

WRITTEN SO YOU CAN UNDERSTAND IT

Vol. 37

MARCH, 1922

No. 3

Flame-Throwing Machine Melts Snow ^{Removal}

VERY heavy drifts of snow, packed and hard to handle by any method of removal, are now being cleared away much more easily and rapidly by demolishing, instead of moving them. The snow is melted by a stream of flame thrown at it in much the same manner that fire is quenched by a stream of water from a nozzle. The flame thrower also has a nozzle, which is connected to a pair of pipes, one leading to a boiler with steam at 50 to 70-lb. pressure, and the other to a tank of crude oil, which is kept at a temperature of about 90° F. by a coil of pipe connected to the boiler, the whole forming a unit mounted on a small motor

truck. Behind the nozzle the steam pipe is spouted into the oil pipe, acting upon the oil in a manner similar to the action of the steam on the water of a boiler injector, thus forcing the oil out of the nozzle in a spray under high pressure. A kerosene torch, or other means, located beside the nozzle, ignites this oil spray, which consequently forms a stream of fire about nine feet long. In clearing away a snowdrift on a street, the flame is aimed high enough to do no damage to the pavement. As it bores a tunnel into the drift, the water drips onto the snow beneath, and helps to thaw it. Complete penetration of the drift demolishes it.

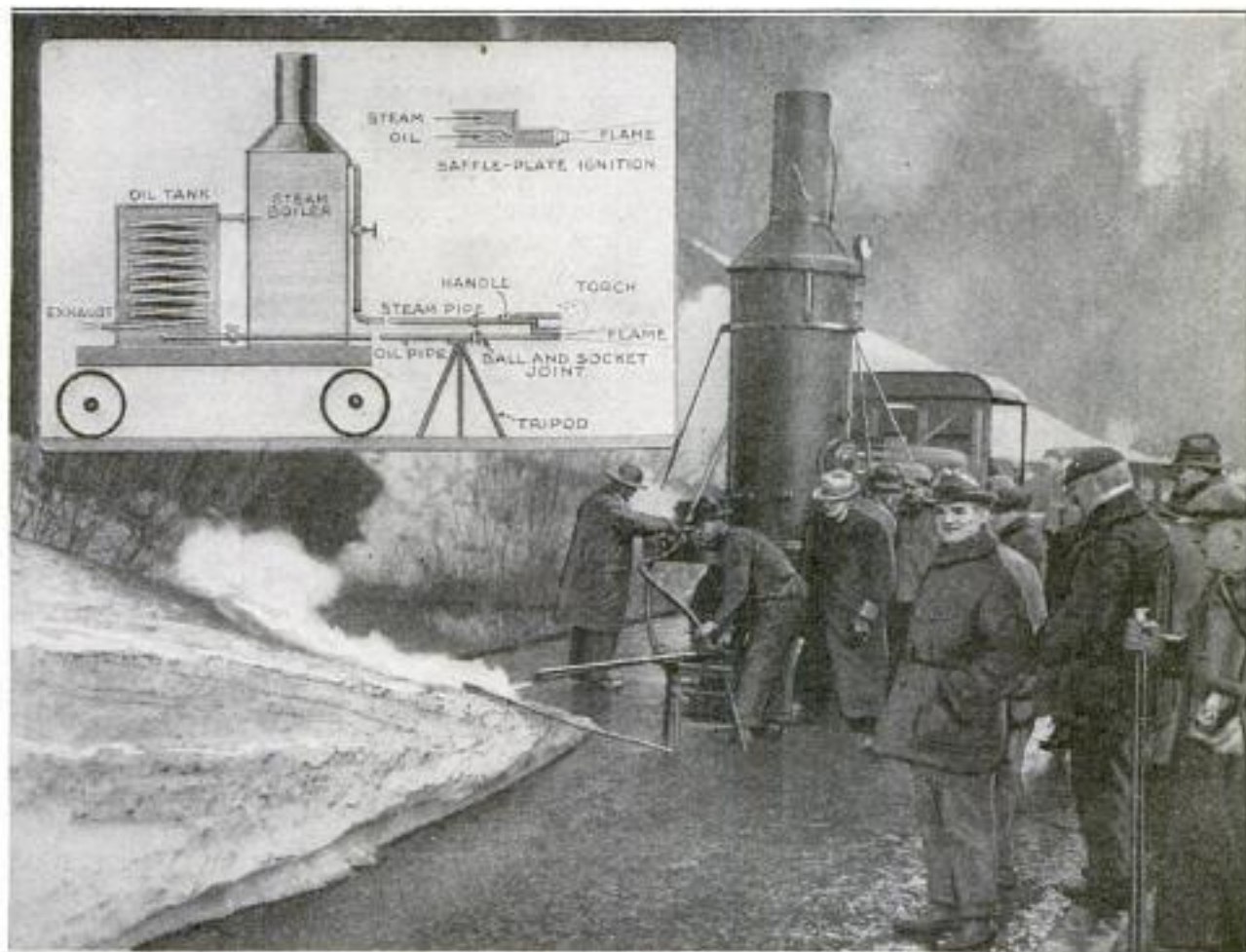

Flame-Throwing Machine Used for Melting Heavy Hard-Packed Drifts of Snow: This is Melted Much More Rapidly Than It could be Loaded into Wagons and Moved Away. The Inset Shows the Machine in Sectional Elevation, with a Detail of the Nozzle, All Fully Explained by the Notations

W. A. Eatchel, Roadmaster of Multnomah
courthouse, Portland, Oregon. 325

8056
326

Refer inquiries to:
Walbrunn, Kling & Co. Chicago.
327 S. Clark

CURVE-CUTTING KNIFE CUTS DIFFICULT SCROLLS EASILY

A curve-cutting knife, designed for the cutting of stencil board, also leather, oil-cloth, and other stiff material, has its

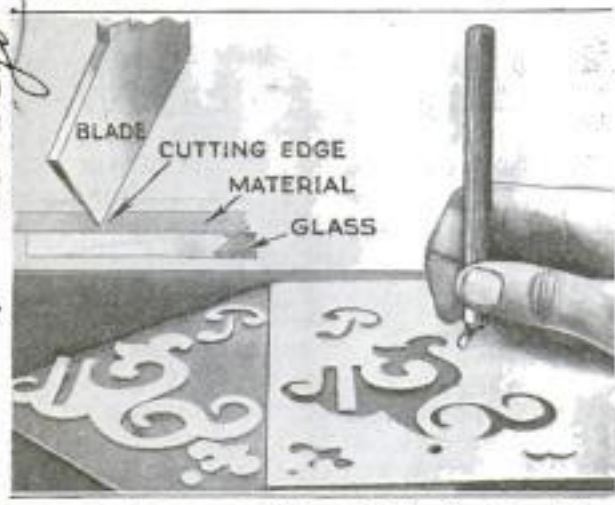

Small Knife Blade, Swiveled in Handle, Cuts These Intricate Scrolls with One Continuous Stroke without Twisting the Handle or Lifting the Blade

small pointed blade swiveled in the handle, like a caster, so that difficult scrolls can be cut rapidly with one continuous stroke, and without lifting the blade from the material. This is laid on top of a piece of smooth glass, and the cutting is all done by the blade edge. In time the point becomes dull, but this does not matter, as long as the edge is kept sharp.

Distributors - Kerye Cutter Co., Chicago, Ill.
19 E. Cedar St., Chicago, Ill.
Emb. Charles H. Dorr
241 Waverly Place, New York, N.Y.

from eight designs that were submitted in a contest. On one side is represented the Porte Chaussée, back of which are seen the ruins of Verdun. The other side portrays the heroic struggle between the armies, represented by the figures of two Titans in combat, and bears the inscription, "Ils ne Passeront pas," which means, "They shall Not Pass"—the famous watchword which inspired the French defenders during their year-long resistance against the German attacks.

SERVICE OF WEATHER BUREAU SAVES LIVES AND PROPERTY

The importance of the service of the U. S. Weather Bureau is made very clear in its recently issued annual report. This service, besides its direct economic benefits, has been the means of saving many lives, by forecasting great atmospheric disturbances, particularly since there has been such a great increase in aviation. Many shipwrecks have, in the past, been avoided by timely warnings, and now a similar service is furnished to all engaged in aeronautics. Another very important branch of this service is in connection with the protection of forests from fires, and in their control after having been started. Highway weather service, at present confined to great highways, has been very valuable, and is now deemed essential wherever the traffic is heavy. The report contained the interesting announcement that 106 separate earthquake shocks, strong enough to be felt, occurred during the last fiscal year.

HUGE CANADIAN POWER PLANT COMPLETED AT NIAGARA

Construction work, started in 1914, on a mammoth power project owned by Canadian interests at Niagara Falls, was brought to a termination recently, and water turned into the 12½-mile Chippewa-Queenston Canal. Completion of this channel raises the total water-power development at that place to more than 1,000,000 hp., the latest addition being 650,000 hp., all of which has been accomplished since 1895, at which time the first of the many hydroelectric stations located there began operation. Representatives of American and Canadian cities were present and assisted in the impressive opening ceremonies.

GOLD MEDAL COMMEMORATES DEFENDERS OF VERDUN

In commemoration of the valorous defenders of Verdun, the United States has presented a gold medal as a gift from the American people, to that city. The medal, which is 4 in. in diameter, was designed by a sculptor of this country, and chosen



This Gold Medal Which was Presented by the People of the United States to the City of Verdun, will be Placed in the Hotel de Ville in That Famous City

9213

Detroit Free Press
1/22/22

8086 Akers Airphoto Corp.
332 S. Michigan Ave
Chicago

AIR VIEWS OF MUSCLE SHOALS AND NITRATE PLANT



Airplane Photograph of Muscle Shoals, Located on the Tennessee River, near the Northwest Corner of Alabama: Across the Shoals is Seen the Wilson Dam, Now About One-Third Finished, Which will Be 4,426 Feet Long, and 160 Feet Wide at the Base—the Largest Example of Monolithic Concrete Construction in the World

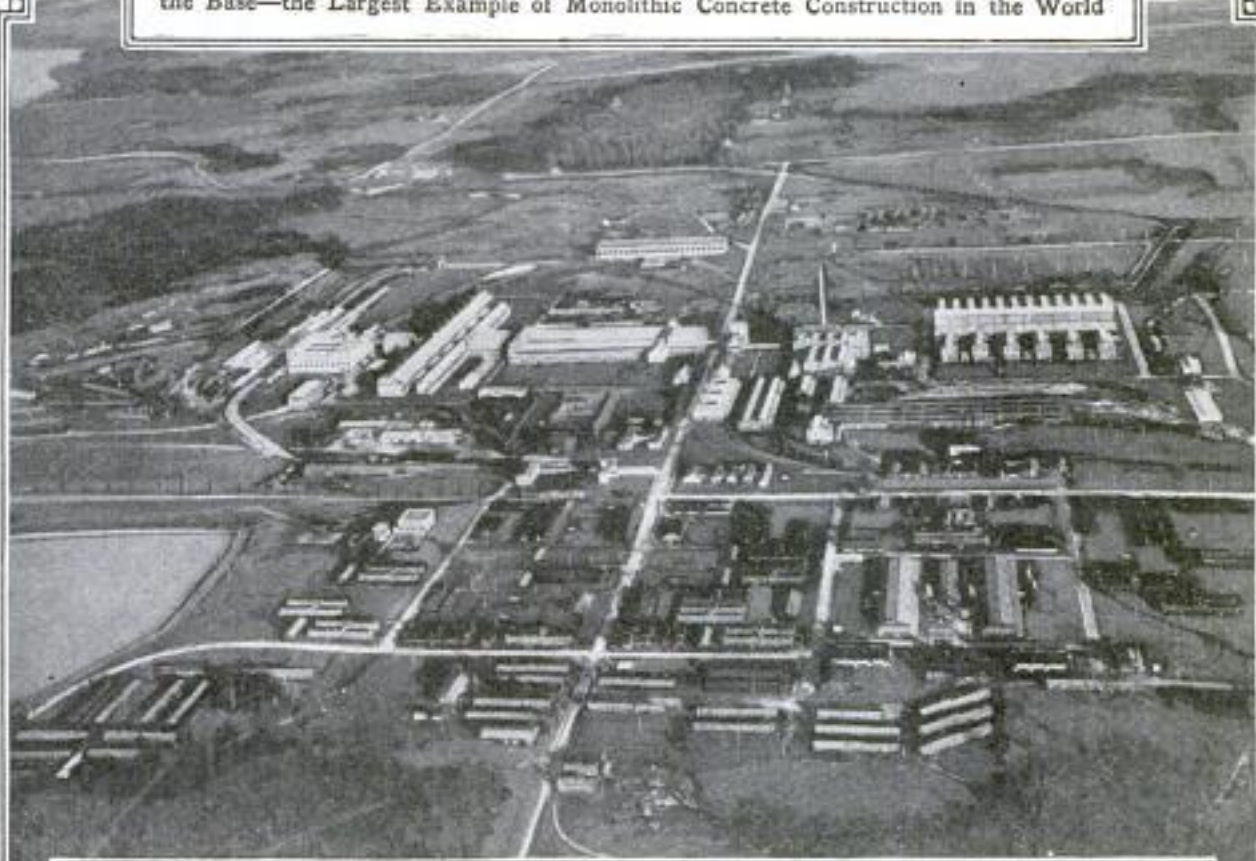

Looking East from Muscle Shoals, Air Photo of the Nitrate Plant, Which Is Now Idle, and Which Cost \$60,000,000 to Build and Equip: It Has a Yearly Capacity of 110,000 Tons of Ammonium Nitrate. One of the Largest Phosphate-Rock Deposits in the United States Lies Adjacent to Muscle Shoals, Which Has a Potential Horsepower Next to That of Niagara

AIRPLANE STABILITY DEMONSTRATOR

New and ingenious mechanical devices to aid in the study of the airplane in flight continue to be developed at the

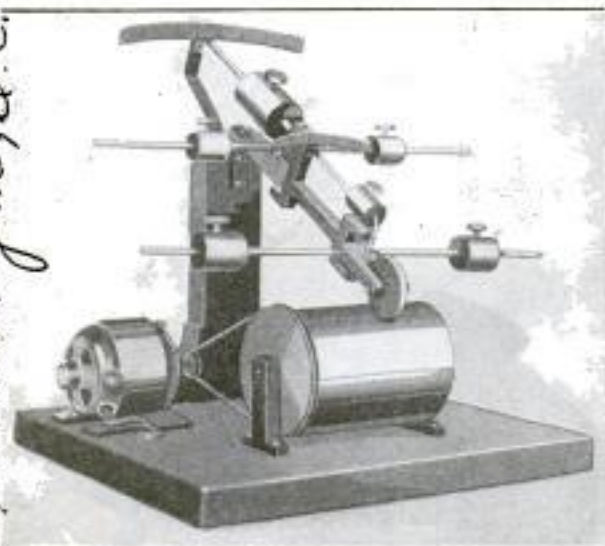

Through the Use of a Double Pendulum and a Recording Cylinder, the Stability of an Airplane in Flight is Shown Diagrammatically

Langley Memorial Laboratory of the National Advisory Committee for Aeronautics. The latest is a device for illustrating airplane stability. The principal part of the machine is a double pendulum. Attached to the lower end of the pendulum is a wheel which rests on a drum. When the drum is revolved by a small motor, the pendulum imitates the motions of an airplane in flight. This machine will greatly interest lecturers on aeronautics, and scientists and mathematicians who study the behavior of airplanes in laboratories. There is a possibility that it may greatly assist in solving the problem of automatic stability.

8/103 TONE PRODUCER FOR VIOLINS AND SIMILAR INSTRUMENTS

It is said that a modern violin, of any ordinary make, can be converted into the equivalent of a Stradivarius, or other violin of Italy's golden days of string-instrument making, by the attachment to it of a

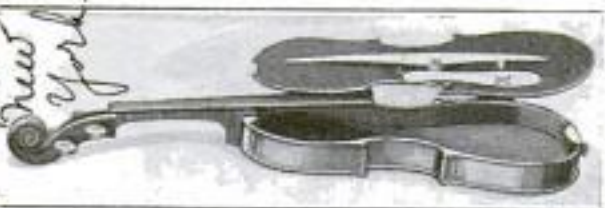

By the Use of This Tone Producer It is Claimed Tones Equal to a Stradivarius can be Produced on an Ordinary Violin

newly invented tone producer. The device, applicable to any kind of string instrument, is made of specially prepared wood, and is so constructed that it conforms to the shape of the instrument to which it is attached. It fits to the underside of the top of a violin, and similarly on other string instruments. On an enlarged scale, it may also be used on pianos and piano players.

7953 WRIST METER FOR MOTORISTS DETECTS ELECTRICAL FAULTS

Motorists will appreciate a new wrist meter, which was designed to aid in the detection of battery, starter, and ignition troubles on a car. The meter fastens on the wrist, thus allowing the freedom of both hands in testing for grounds, short circuits, broken wires, weak batteries, etc. Included in the instrument is a small ammeter which is automatically protected against burning out, and a tiny buzzer to give audible indications in making certain tests. A complete manual has been compiled for use in conjunction with the

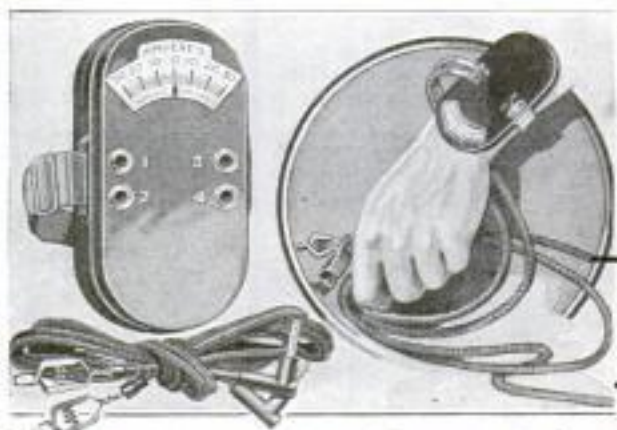

Electric "Trouble-Shooter" That Fastens on the Operator's Wrist, Leaving Both Hands Free When Testing for Short Circuits and Other Troubles

apparatus, giving in detail the faults to look for if the car does not run properly, so that one need not be an expert mechanic to locate trouble of an electrical nature quickly.

2203 PORTUGAL PRODUCES IMMENSE QUANTITY OF CORK

Few people realize that Portugal produces more cork than all other countries combined, the annual production being about 188,000,000 lb., harvested from more than one million acres of cork-oak trees. This is not its only industry, however, for Portugal produces more than 15,000,000 gal. of olive oil, besides employing more than 18,000 persons in the flour-milling industry.

Board of Trade Journal 10
London
A. S. Sleft. of Commerce

Emb. John W. Keane Navy Dept. Bureau of Navigation, Washington, D. C.

J + J Virzi Bros. 75 5th Ave New York

Auto Access
Jester
Hand W. Keane's
of the
Hastings
3-17
Electric
the
main
main

8034 *Aeronautics*

WIRELESS WAVES GUIDE AIR NAVIGATORS THROUGH NIGHT AND FOG

Underground Cables Send Electric Waves Miles into Air Which Pilot Airplanes from Starting Point to Landing Place

Frederick Lee's BY H. A. DANE *London Studios, Paris, 66 Rue St. Honoré,*
Acting upon this principle, a French inventor, W. A. Loth, has perfected an *Paris France*

WORLD interest has centered upon recent developments which have proved to be of inestimable value to the art of practical aeronautics in solving one of its most perplexing problems—that of making a safe and ready landing at night, in fogs, or under other adverse weather conditions. Navigation of the air is being developed until it will soon be as safely carried on as is that of the sea, which, through the invention of Earl C. Hanson, is made comparatively easy as far as pertains to narrow and dangerous waterways. In brief, the Hanson method consists in submerging a cable in the proper course for a ship to follow in entering a harbor, and then sending an electrical current through it. The waves radiating from the cable are picked up by receiving instruments on the ship, and the intensity of these serves as a guide to the pilot, who sets his course over the cable.



This Boat was Used in Making Experiments on the Seine River in Connection with the Magnetic-Cable Guide. The Receiving Frames are Seen at the Extreme Ends of the Apparatus on the Stern

arrangement for use with all types of flying craft. In the adoption of the electrical-cable idea, M. Loth differed to the extent that he buried it in the landing field. He had previously discovered, through personal investigations, that in the case of aviation at sea, the "listening zone" in the air directly over a submerged cable, was nearly two miles in height. Having established this fact, the Frenchman equipped a plane with specially designed antennæ, of the frame type, and conducted extensive experiments which resulted in the present practical application to aeronautics.

In making the tests, it was demonstrated beyond a doubt, that air craft could be guided just as effectually as seagoing vessels were controlled. When a current was sent through the buried cable, the electrical waves radiating therefrom impinged upon the receiving frames on the plane, and were then transmitted to receivers fastened to the ears of the pilot. Due to the character of the current and the instruments used, there was produced in the listener's ears a singing noise which has been likened to the



Listening to the Sounds Made by the Impinging of Electrical Waves upon the Receiving Frames of a Large Airplane: The Speaking Tube Shown Terminates at the Pilot's Station

sound of a miniature siren. The sound was heard in little volume when the machine was barely within range of the

would link all the aerodromes with electric cables for the guidance of air craft at night, and in foggy or stormy weather.

Then the pilot could follow his course with positive assurance, instead of having to grope his way through the night, or vainly endeavor to pierce an enveloping fog, as he strove to navigate his craft with its passengers and cargo safely to its haven.

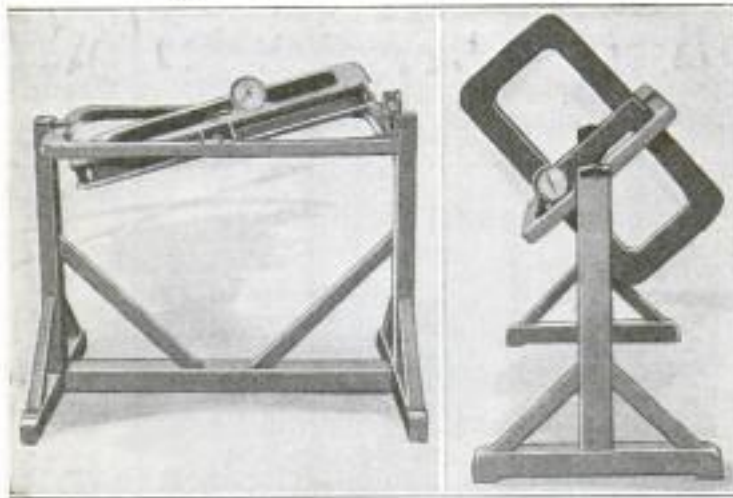

Left: Horizontal Oscillating Receiving Frame. Right: Combined Horizontal and Vertical Oscillating Receiving Frame for Use on Air Craft in Determining the Source of Electric Waves

FREAK LIGHTNING KILLS MAN AND HURTS WIFE

Lightning is always playing queer tricks, but one of the most unusual occurrences happened in Michigan recently. During a severe electrical storm a woman was standing at the kitchen door of her home. Her husband had just brought his team in from the field, and was standing at the door of the barn watching the storm. Suddenly there was a bright flash of lightning, and the woman saw her husband fall and knew that he had been struck. She immediately ran to him and seized his hands. As she did so she received a shock so severe that it rendered her unconscious.

BRICKS MAY BE BY-PRODUCT OF OIL-SHALE INDUSTRY

The experiment of making bricks from the spent shale of the oil-shale mines of Scotland is now being tried. The finely ground shale is mixed with a small percentage of lime, enough water being added to form a thick paste, which is then pressed into the shape of bricks and dried in steam tunnels. It is claimed that they are superior to clay bricks.

only. Often all the papers of the newspaper contain articles.

waves, but as the center of the aerodrome was approached, there followed a steady increase in tone, until, from a position exactly over the cable, the notes became sharp and piercing. After passing beyond the cable, the sound gradually decreased until the plane traveled out of range.

Consequently it is apparent that the adaptation of the original marine idea for aviation, is going to prove a boon to the rapid evolution of the lighter-than-air machines. Particularly in the instance of the passenger-carrying planes, which now operate upon regular schedules in European countries, will it cause a greater feeling of security to those who wish to journey in this manner. The transit companies will no longer be obliged to arrange the itinerary of their carriers so as to conform with the duration of daylight. Tentative plans now under advisement

London Times Ingr. Supplement 10/11

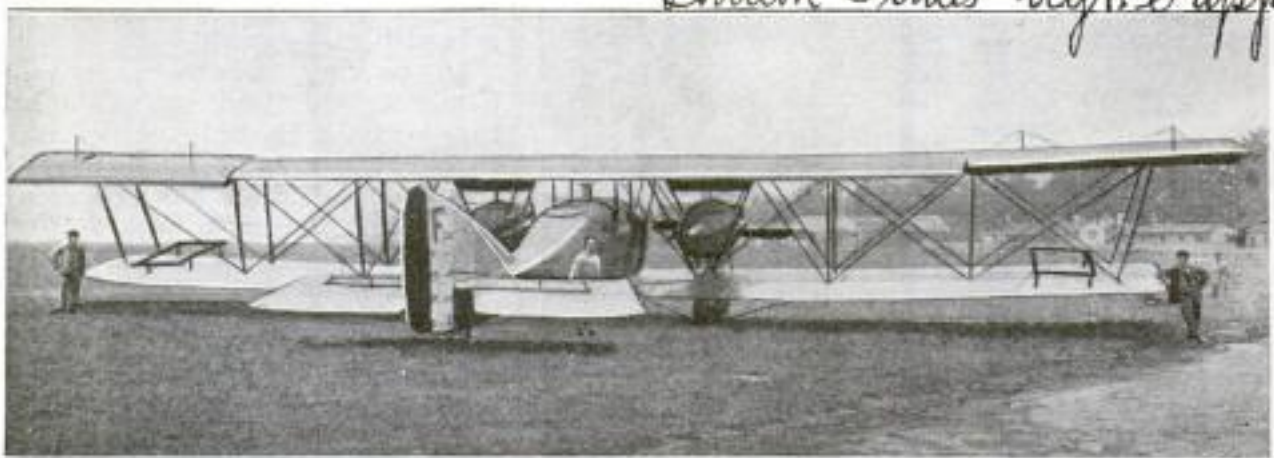

Large Biplane on Which are Installed Specially Designed Receiving Frames of the Horizontal Type Located at the Extreme Ends of the Lower Plane: The Latest Machines to be Fitted with Receiving Frames have These Placed within the Fuselage So That They are Completely Hidden

SEVEN LOCOMOTIVES PULL LONG TEST TRAIN TO RIDGE OF CONTINENTAL DIVIDE

BY GEORGE F. PAUL,

900 Ellsworth
Bldg., Chicago



Above is a view of part of the Continental Divide on the Denver and Salt Lake Railroad, showing a test train, composed of 34 cars, hauled by seven locomotives, climbing the divide. Lower right: sketch showing, with dotted line, the route of the proposed six-mile tunnel to obviate the necessity of climbing the divide. The full line shows the present route of the railroad with its numerous sharp curves. In the sketch above is a profile of the railroad with notations that show the relative elevations and grades between Denver and Craig.

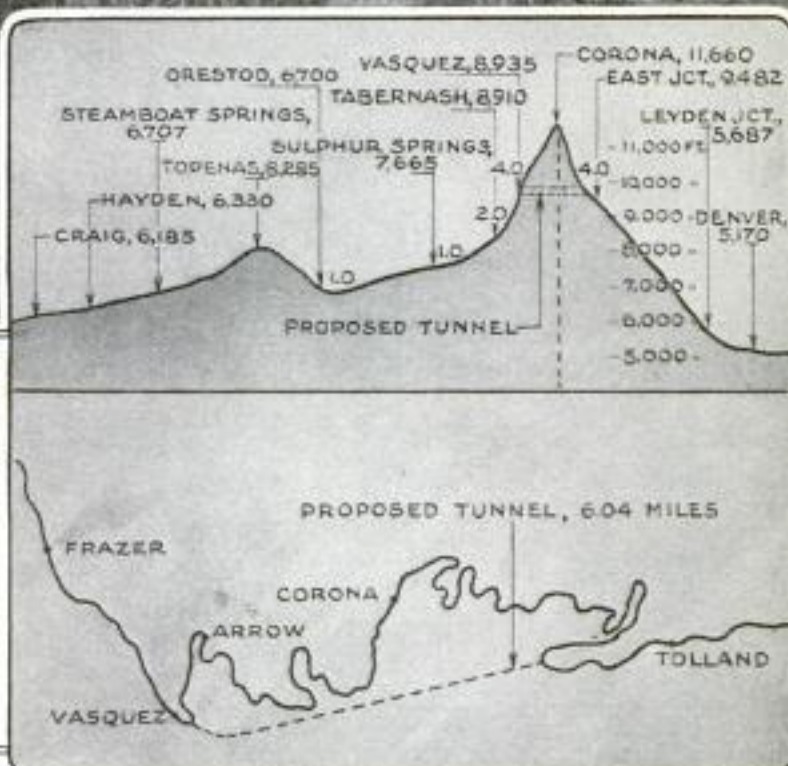

AIR-BRAKE tests recently made with heavily loaded trains on the steep grades between Corona and Denver on the Denver and Salt Lake Railroad, may prove important in the development of the Yampa coal fields in Routt County.

Up to the present it has been impossible to haul many loaded cars at a time because of the heavy grades and numerous curves. As a matter of fact, 50 per cent of the mileage consists of curves. These curves vary from radii of 11,459 ft. to 359.3 ft. In addition, there are 58 tunnels on the line, with an aggregate length of 24,763 ft. Of this number, about one-half are located on the eastern slope of the continental divide.

Denver has an altitude of 5,170 ft. above sea level. For 13 miles west from Denver the track climbs at the rate of 1.65

per cent. Then for 40 miles there is a rise of two per cent, and from there on comes the stiff climb of 12.41 miles to the summit, up a grade of four per cent. The summit has an elevation of 11,660 ft. This means that in the 65 miles there is a climb of 6,490 ft. On the western slope, conditions are practically the same, for the road drops over a four-per-cent grade for 15 miles, then over a two-per-cent grade for four miles, followed by easier grades for 66 miles to Orestod. Then comes the climb over the hill at Topenas, followed by an easy descent to Craig.

The difficulties of handling freight over this line have made it practically impossible to develop the great Yampa coal fields, and yet there is an urgent need for the coal that could be produced in this region. The coal itself is bituminous and declared

7782

to be remarkably free from impurities. Furthermore, the mining end of the operations can be readily cared for if the shipping problem can be solved.

The haul over the four-per-cent grade is the bad feature. In the wintertime snowfall is always heavy from December on, and intense cold is all too often the rule. The summit rises about 1,500 ft. above the timber line. This means that snow blockades can become very serious. When the wintry gales are sweeping over the mountain tops at 60 miles an hour, filling the air with powdered snow, it takes only a few minutes to fill the cuts so that a train cannot operate.

It has been proposed to do away entirely with these four-per-cent grades by the simple expedient of tunneling through the continental divide, but this in turn means a tunnel six miles in length, an undertaking not to be started on the spur of the moment.

To negotiate these grades calls for two Consolidation and two Mallet locomotives to handle a train of 1,250 tons. These four locomotives have a tractive effort of 244,000 lb. Because of the great risk of runaways on the descending grades, trains have been limited to this tonnage.

For demonstration purposes on these grades, a train of 34 cars and weighing 2,431 tons was used. The cars were equipped with a special automatic straight air brake. The test was made to determine whether a train equal in length to the number of empty cars that one engine could haul back could be taken

down the grade. The train pulled east out of Tabernash and up the foot of the four-per-cent ascending grade, being pulled by three Mallets and two Consolidations, the five engines having a total tractive effort of 322,000 lb. At the foot of the heavier grade, two more Mallets were hooked on. These seven engines had a total tractive effort of 478,000 lb. Before leaving Corona for the descent of the eastern slope and the run to Denver, all of the engines were removed but one, leaving the train to be handled by a single Consolidation locomotive. All of the triple valves were placed in graduated release position, the brake-pipe pressure raised to 100 lb., and the piston travel limited to 6 in. One of the chief troubles of operation on this slope arises from hot wheels due to brake application. The 12.5 miles of the four-per-cent grade were covered in 1 hour 40 minutes, or at the average running rate of 7.5 miles an hour. Stops were made at Dixie Lake and Antelope for inspection. It was found that the temperature was very uniform, there being only a few cars in the train with wheel temperature slightly higher than the average of the others, but any wheel in the train could be touched with the fingers without discomfort.

Officials who witnessed the demonstration declared that, with modernized equipment, the tonnage down the grade could be doubled with safety, and operating expenses per ton-mile trimmed to half. If this proves true, far greater activities in the Yampa coal fields are assured.

2956
TENNIS ON "POGO STICKS" LATEST FAD IN SPORTS

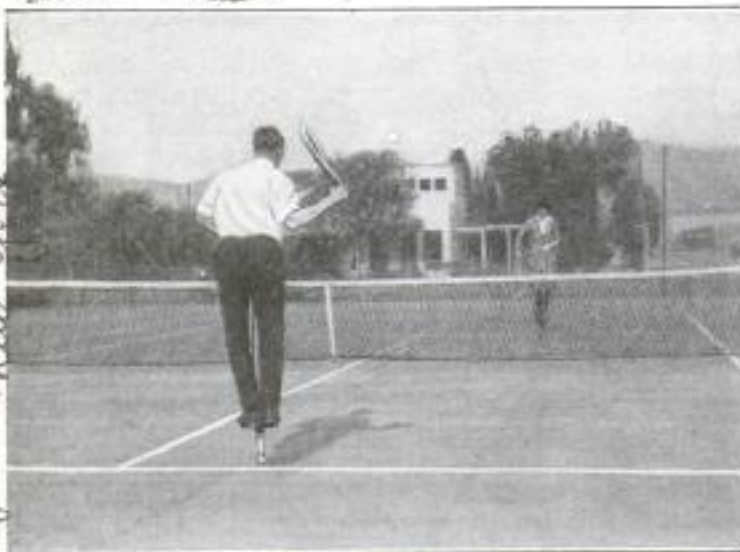

Playing Tennis on "Pogo Sticks": The Manipulation of a Racket in a Tennis Game, or the Handling of a Pogo Stick, Is Enough for Most People Separately; Their Combination Fascinates Experts

Tennis on "pogo sticks," which is rapidly becoming a fad on the Pacific coast, was first suggested by a Los Angeles sportsman. The "pogo stick" is a slender upright pole, with steps on opposite sides for the feet and a handle at the top. The base operates against a heavy spring contained in the stick. Balancing on the stick, one starts to hop, and the spring accelerates the bouncing so that each hop takes one two or three feet into the air. It requires considerable skill to handle the stick and, when the maneuvers of tennis are attempted, falls are almost unavoidable. Needless to say, the game furnishes plenty of amusement for those that are watching it.

The Pogo Co. 35 E. 19th St. New York

Emb. Frank B. Howe

412 Mason Opera House Bldg, Los Angeles

Agent. Abercrombie + Fitch Madison Ave. N.Y. 45 St. N.Y.



Mormon Temple Which is Built in the Form of a Maltese Cross and has been Designed on Strictly Straight Lines: Work has been under Way for Several Years on This Building, Which is Located on the Prairies of Alberta, Canada, Not Far from the United States Border

George H. Paul, 900 Ellsworth Bldg Chicago
MORMON TEMPLE IS DESIGNED ON STRAIGHT LINES

Mormonism in Canada will center around the town of Cardston, in Alberta, where a large temple is being constructed by people of this faith. Here has been the greatest gathering place of the immigrants from Utah, who have established themselves in a land that is wonderfully fertile and promising. The temple, which will cost \$1,000,000, is built in the form of a Maltese cross, and from a distance gives the impression of a huge pyramid, being 118 ft. square and more than 100 ft. in height. On closer inspection, however, the beauty of the structure becomes apparent, with its light-gray granite and concrete outer walls, 6 ft. in thickness, and its simple straight lines.

A decided contrast to the impressive severity of the exterior is found in the richness of the interior decorations and paintings, which are the product of some of the foremost mural artists of America. The woodwork and paneling are especially pleasing to the visitor, who, upon entering, finds himself first confronted by the baptistery. The principal feature of this is a mammoth marble font, which rests upon the backs of 12 life-sized oxen, representing the 12 tribes of Israel. Next are seen three special rooms, which have been designed for use in connection with

the elaborate marriage ceremonies of this cult.

In the first of these, known as the "creation room," are depicted upon the walls scenes representing the various phases of the creation of the world. A second, designated as the "garden room," contains illustrations of the Garden of Eden, while the third, termed the "world room," portrays conditions on the earth after the entry of discord. Above these three, is another room, luxuriously furnished, which is intended to suggest celestial glories, and which has three prayer compartments in it. The decorations of this "heavenly room" are in mahogany, onyx, and marble, the cost of which amounted to nearly \$100,000.

This temple has been under construction for several years, and sometime during the summer of 1922, will be held the dedication services. After these rites, entrance to the edifice will be denied to all nonbelievers, and even to those of the same religion who do not totally abstain from the use of tobacco, coffee, tea, and alcoholic stimulants, which abstinence is among the requirements of those desiring to be in good standing among the Mormons, according to their iron-clad rules.

Auto Bed Camp Co,
2201 Penn St., Kansas City, Mo.

33488

POPULAR MECHANICS

Camping Aulfer

LIGHTWEIGHT KITCHEN TENT FOR MOTOR TOURISTS

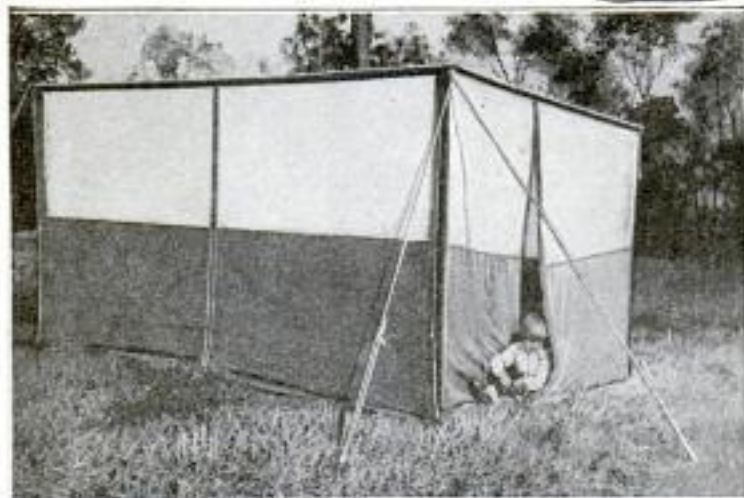

To meet the demand of motor tourists, a special lightweight kitchen tent is being made. It is not intended as a weatherproof shelter, but as a protection against sun and insects when cooking and eating in the open. The flat roof and the lower part of the walls are made of light olive-drab drill, and the upper half of the walls of fine-mesh bobbinet, reinforced with drill. It occupies an 8 by 10-ft. space and is 6 ft. high. The entire weight, without the poles, is only 15 lb. and it folds into small compass so that it can be conveniently carried.

Lightweight Kitchen Tent Specially Designed for Motorists as a Protection against Sun and Insects When Cooking in the Open

8064

Accessories

TRACTOR HAS LEVELING ATTACHMENT FOR HILLSIDE

Tractor owners have experienced considerable difficulty in operating their machines upon the hillsides, and to offset this disadvantage, an Oregon man has con-

and a front axle composed of three flexible bars which work on the parallelogram principle in assuming the same position as the rear wheels. A lever controls the

adjusting mechanism, which is driven by power from the motor, and which can be operated while the tractor is in motion, or when it is stationary. Due to this successful overcoming of the tractor's serious drawback, it is thought that the leveling attachment will be enthusiastically welcomed by all users of agricultural implements of this kind.

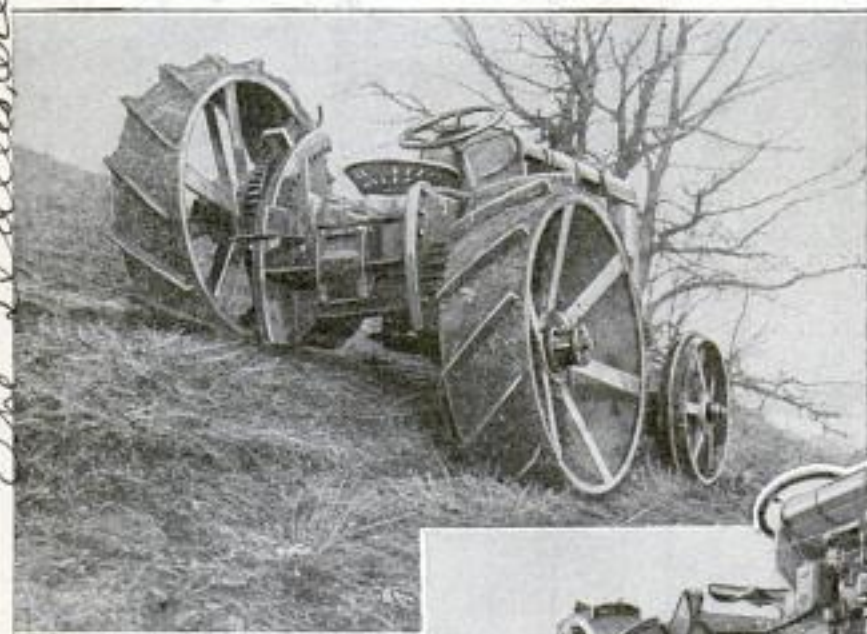

Hillside Tractor with Leveling Attachment as It Appears on an Incline, Showing Plainly the Sideplates, by Means of Which the Wheels are Raised or Lowered



Another View of the Hillside Tractor, Showing the Front Axle Which Works on the Parallelogram Principle in Maintaining the Level of the Machine Constant

*Adamo Sutehill Tractor Co
The Hillside*

structed a leveling attachment for use with ordinary implements of this type. The leveling is accomplished by using rising and lowering sideplates which have stub axles, for the rear wheels,

8126

deposits

RADIUM-BEARING MINERALS FOUND ON BRITISH COLUMBIA ISLANDS

BY FRANCIS DICKIE, *Herald Otago, B. C., Canada*

AFTER nine years of persistent searching in a great many parts of the world, from South Africa to Alaska, H. E. Neave, a mining engineer and prospector, recently discovered two radium-bearing ore deposits on the islands of Valdez and Vancouver, off the coast of British Columbia. The story of the long hunt for an area of radioactive rocks is in a way reminiscent of those of the searchers for the Holy Grail, the fountain of youth, or the philosopher's stone, and other mythical objects, for, like them, Neave was actuated by an altruistic purpose. Though not a man of independent means, he continued his search for nine years, supporting himself and family by at times working small gold claims, come upon while searching for radium, or acting in the capacity of mining engineer. But always foremost with him was the search for the most precious mineral in the world, the twentieth-century wonder-working radium, which has in it nearly all the powers that the ancients sought for in various ways.

With the need of more of the precious metal foremost in his mind, Mr. Neave, nine years ago, decided to devote his time to field work in search of radioactive areas, for while there were plenty of men experimenting with the medical and scientific possibilities of radium, there was no one, as far as he could learn, making a systematic search for the areas which undoubtedly must exist on the earth's surface where this precious substance was hidden. So he started out. He covered a good deal of South Africa. He came to North America and covered on foot the mountain regions of Idaho, Montana, and Washington, a great portion of the heart of British Columbia in the Rossland, Fort Steele, Vancouver, Sloacan, and adjoining regions, where the mineral might possibly be discovered. Following this, he prospected the west coast of Vancouver Island, one of the most difficult portions of the Pacific coast. He spent two years on Cook Peninsula, a desolate and uninhabited region, where

landings have to be made through several miles of surf from a coasting steamer. In this region, while conducting his prospecting, he found that for some unknown reason the flora was unusual, particularly the hemlock trees. Whole forests of these had their branches growing in an inverted way, that is, the branches were small at the trunk and grew larger outward, ending in natural twigs and foliage. This was also true of other trees and shrubbery. Here the wild-pea vine yielded peas as large as the cultivated variety, which were used satisfactorily for food.



H. E. Neave, the Discoverer of Radium on British Columbia Islands

Moving down the coast after two years of ineffectual search, he discovered, in the fall of 1920, after nearly nine years of searching, a stretch of radioactive rocks on Tahsish Inlet, Vancouver Island. These he tested in two ways, by using an electro-scope, and also by taking photos, or radiographs, two of the principal tests for radium-bearing strata. Radiographs are taken by utilizing the rays given off by the rocks to obtain photographs of coins, keys, etc., through

such opaque substances as lightproof paper on a sensitized photographic plate. At the time of making his discovery, Neave was not in possession of an electro-scope, a very sensitive instrument. But he was of an inventive turn of mind, and manufactured one which answered the purpose. This homemade electro-scope consisted of a small glass jar with a rubber cork through which passed a metal rod. On the rod (and inside the bottle) a piece of gold leaf was suspended by its center. The rod and gold leaf were charged with electricity generated by rubbing a piece of ebonite with a silk handkerchief, this causing the two ends of



A Scene on Vancouver Island: The House Is within a Few Yards of the Area Where the Radium-Bearing Ore Deposits were Found

gold leaf to fly apart; in a little time, the gold leaf slowly drops to its original position, but if a radioactive rock is brought near the instrument, the gold leaf drops suddenly.

Though the discoverer found radioactive rocks covering a considerable area, he was still anxious to locate another area, and guided by his knowledge of geology at once began exploring near-by islands, with the result that in August, 1921, he made another find on Valdez Island at a place called Open Bay, an uninhabited stretch of logged-off land, where copper mining had formerly been carried on. The tests applied this time, in addition to using the electroscope, and making photographs by rays from the rocks, also consisted in using the scintilloscope. This is a high-powered magnifying glass mounted at the proper focus above a sensitized screen or plate of glass which is coated with zinc sulphide. This latter chemical has the property of becoming luminous when struck by the Alpha ray or helium particles, which radioactive substances emit at the enormous velocity of 18,000 miles a second. A good sample under the instrument shows numberless twinkling pin points of light.

Satisfied with the area of these two fields, Neave forwarded samples of the rock to Sir Ernest Rutherford, the famous British radium expert. The mere analysis for simple rocks costs \$250, and for complex ones much more. Sir Ernest's reply, fully confirmed his own experiments as to the highly radioactive nature of the minerals found. At this writing, of course, no estimate as to the new field's productive possibilities can be ventured. Development work alone will reveal the amount of radium which may be anticipated. But with the

very few fields as yet in existence in the entire world, and the pitiful smallness of their output, the finding of any radium-bearing region is of great importance. It was in anticipation of exciting prospectors to hunt out this precious metal that the British Columbia Provincial Legislative Assembly passed an act respecting the discovery and conservation of radium. The act reads in part: "To the person proving to the satisfaction of the Lieutenant-Governor in Council that he has discovered radium within the Province, the Lieutenant-Governor in Council may pay a reward not exceeding

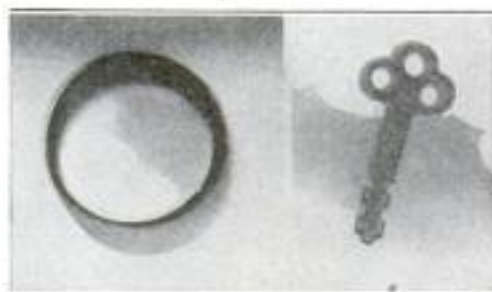

Photos of Key Ring and Key, Made by Exposing Them through Light-Proof Paper, against a Photographic Plate, to Rays from Radioactive Rocks

\$5,000; and also make provision of a retention for the crown of an interest, not exceeding fifty per cent, in all radium produced from such lands." Previous to this strike, the island of Madagascar was the last place where radium was discovered.

WATER-POWER EXPANSION IN OHIO RIVER BASIN

Nowhere more than in the Ohio River basin are there great opportunities for

future expansion of water power. Although its drainage area is only about one-third that of the upper Mississippi and Missouri, its average water flow is very much greater than their combined flow. The Ohio River, with about half the drainage area, has a water discharge which is much more than that of the St. Lawrence River at Ogdensburg, N. Y. These conditions result from a greater rainfall in the Ohio basin, and from the general character of

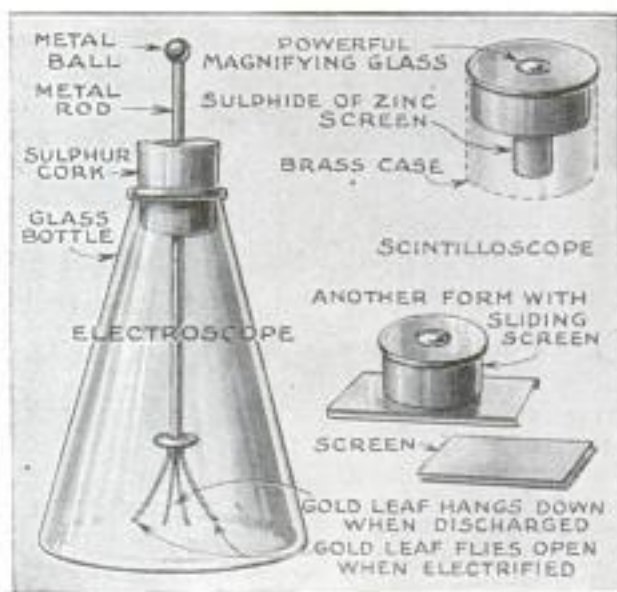

The Homemade Electroscope Which the Discoverer Used to Prove the Radioactivity of the Ore Deposits He had Located, and the Scintilloscope

the region. Added to this advantage in water flow is the great number of exceptionally favorable sites for storage, many of which have already been located. Some of these give opportunity for developments.

N.Y. Times 12/21/21 P-8
Copyrighted material

Jeffrey Mfg. Co., Columbus, Ohio
 Patents owned by E. C. Morgan,
 New York City.

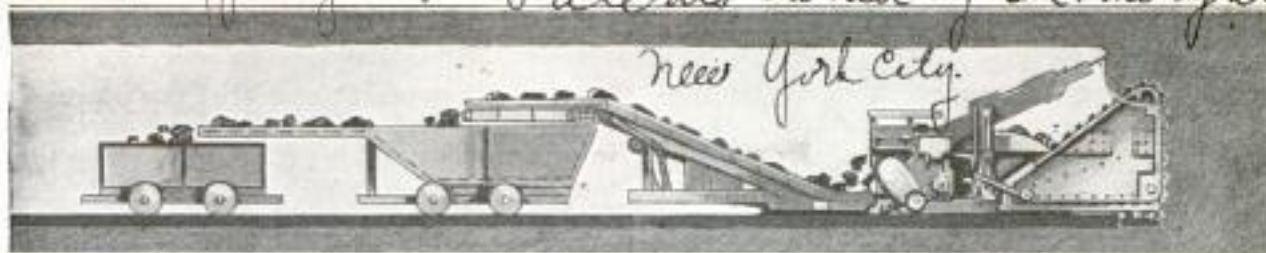

Here is Shown Diagrammatically the Coal-Mining Machine Advancing into the Coal: All of the Operations of Cutting, Breaking, and Loading are Carried on at the Same Time

COAL MINER NOW BECOMES OPERATING ENGINEER

BY EVERETT J. LOVETT

WITH the rapid development of labor-saving methods, the coal miner is being transformed into a keen-eyed operator of a powerful machine which not only mines and loads the coal, but does it in a safer and more economical manner; safer, because the coal is broken down without the use of explosives which tend to shatter the roof and make it dangerous, and more economical, because it produces more lump coal and fewer fines, and does it more rapidly.

One machine developed for this work

the handle raises or lowers the ram. It is customary to leave 6 in. or more from the top of the shears to the roof in order to prevent the shearing chains from interfering with the roof in handling the machine. The forward feed of the machine is 7 ft. Thus, from each cut in a 6-ft. vein, is taken out a volume of coal 5 ft. wide, 6 ft. high and 6 ft. deep, or 180 cu. ft., the equivalent of $7\frac{1}{2}$ tons. The time required for making the first cut in the face, ordinarily called the "sumping cut," is about 20 minutes.

The machine is mounted in a pan and fed forward by means of a steel rope. When the cut has been made, the machine is pulled back in the pan by means of a rope; then, this rope is hooked over a sheave on the forward side of the machine and the eye fastened to a jack at the face of the opposite rib. By this means the machine is pulled sideways the width of the cut. This

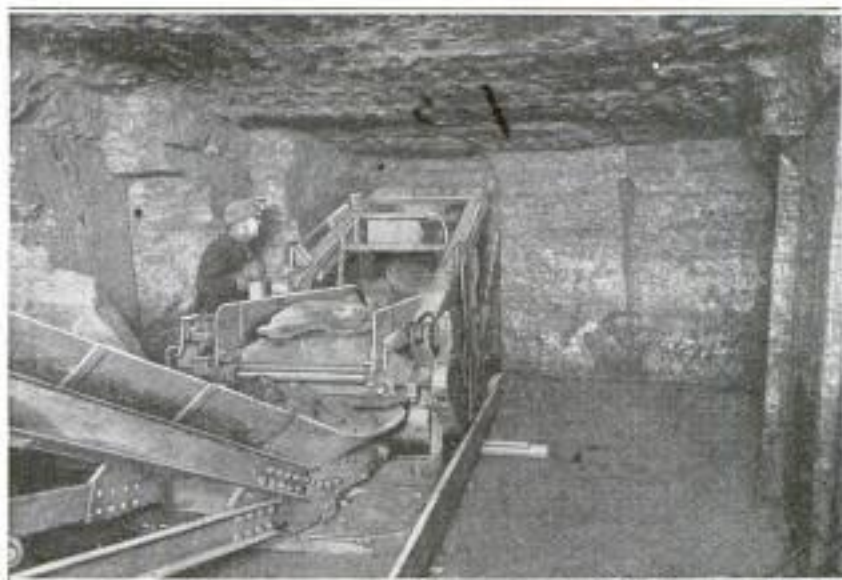

Coal-Mining Machine Making "Sumping Cut": Coal is Sheared on Both Sides and Undercut. A Powerful Ram Breaks Down the Coal onto a Conveyor

consists of an undercutting frame with cutter chain, and a shearing frame on each side of the machine. In the undercutting frame is a conveyor. There is provided a powerful ram which breaks down the coal onto the conveyor. This ram can be directed at any height of the coal face. A slight touch on



A Storage Hopper with a Conveyor Receives the Broken Coal from the Mining Machine and Loads It into the Mine Cars. By Using the Storage Hopper the Mining Machine may be Operated Continuously

requires about three minutes. The machine is then ready to take another cut.

Where the coal is tough and does not break down readily after being sheared on both sides and undercut, one or more hydraulic jacks are fitted in one of the shearing frames. When the machine has advanced into the coal a certain distance—20 or 30 in.—water is pumped into the jacks, which will exert an enormous pressure on the coal and crack it so that it makes easy work for the ram to bring it down.

The machine can be used in combination with a movable storage hopper provided with a loading conveyor. By this

system the machine operates continuously during the time the loaded mine car is being removed and replaced by an empty one.

One great advantage of the use of the machine is the rapid development of the mines. Under the present system it may take as long as three years to develop enough entries and start sufficient working chambers to obtain a good output. This means that there is no return on the investment, which sometimes amounts to a million dollars, for the first three years. With these machines the entries can be driven very rapidly, and the desired output can be obtained in a few months.

8099 CHICKENS ARE VACCINATED LIKE HUMAN BEINGS

Chickens are now being made immune from chicken pox in the same way as human beings are protected from small-pox—by vaccination. At a number of ranches in California thousands of chickens have been treated in this manner. The



One of Thousands of Chickens on a California Ranch That are Vaccinated for Protection against Chicken Pox

vaccination is done exactly as in the human operation. The chickens have the advantage of not suffering any disfigurement from the resulting scar, for this is concealed by their feathers.

Mr. Morris, Petaluma, Calif.

8215 ANCIENT LAKE IN NEVADA THAT HAS DISAPPEARED

Where there now remains only a comparatively small body of water, called Pyramid Lake, in northwestern Nevada, there existed in a comparatively recent geological age a huge lake that covered an area of 8,400 square miles, according to reports from the U. S. Geological

Survey. This great lake, now almost completely gone, was called by geologists Lake Lahontan, in honor of Baron La Hontan, one of the early explorers of that region. Part of the old lake bed is now covered with sand dunes, forming a vast field of sand that is slowly traveling eastward. This movement is irresistible and has caused much trouble to the roads and telegraph poles in the southern part of Little Humboldt Valley.

8155 CORNET-PLAYER ATTACHMENT ELIMINATES FINGERING

The principle upon which the mechanical piano player operates has been applied to the cornet, and a simple device has been developed which, attached to the instrument, will finger the keys to produce the proper tone. It is only necessary then for the performer to blow through the instrument as one would blow a trumpet. A knowledge of music is not required to operate the mechanical cornet player. It is an English invention.



The Strip of Perforated Paper is Fed Through Mechanically, Causing the Proper Keys to be Depressed

Dr. W. P. Private Journal, Cornet Player, Army of Occupations on the Chinese, August 1st, 1911, New York City

N.Y. Times 12/21/21 P.9.

Central News Photo Service 100 W. 40th St. New York City



Elaborate Set Built by a Motion-Picture Company for the Filming of a Beautiful Bubble Scene: In the Fore-ground can be Seen the Huge Iridescent Mass of Bubbles Which were Manufactured from Hundreds of Barrels of Soap, and in Which the Dancers are Performing

MOVIE BALLET PERFORMS AMONG SOAP BUBBLES

Beautiful scenes are common in the motion-picture studios, and many mechanical effects are produced which fairly dazzle the eye of the onlooker. As a climax to an unusually gorgeous "set" a director recently called for a dance in the midst of soap bubbles. Accordingly, since a space 20 by 40 ft. had been designated to be filled with the frothy substance, a metal sieve of this size was fitted in the floor. A soap solution, made with 200 bbl. of the product and mixed in the same manner as plasterers prepare lime, was piped to the porous floor, and steam forced

through it. The immediate transition into bubbles began, and these soon rose to a huge scintillating mass, in which the dancers performed, the whole presenting a scene of fairylike splendor.



Behind the Scenes, Showing the Soap Solution being Mixed in a Large Vat Preparatory to Piping It underneath the Sieve-like Stage Where It was Transformed into Bubbles

a European radio company which will also build a substation at Para, in the northern part of the same country.

Ⓒ Brazil will have an international radio central at Rio de Janeiro, according to the announcement of recently completed plans, which will be modeled after the gigantic station at Port Jefferson, L. I. The new venture will be constructed by

7969
340

marcott Auto Signal Co,
103 1/2 5th St., Olympia Wash
POPULAR MECHANICS

AUTO SIGNAL HAS DISTINCTIVE AND PENETRATING LIGHTS

Another automobile signal has appeared and is being marketed on the Pacific coast.

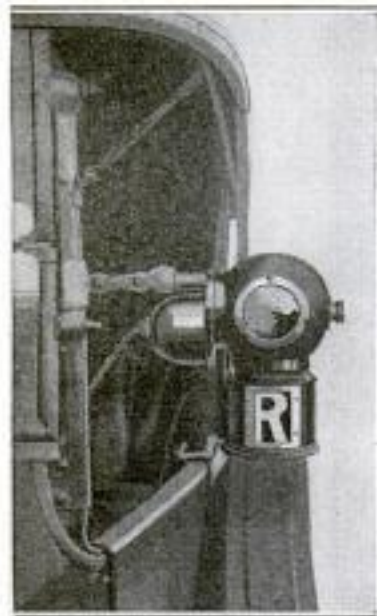

It is mounted on the left side of the windshield, and is electrically operated by current from the car batteries. An upper lens is provided with a stationary light and revolving colored lenses which produce a distinctive "attention" signal, visible for a mile or

more at night. Below is a direction signal, visible from front and rear, the letters "R," "L," and "S" indicating right, left, and stop, respectively. The light is said to be remarkably penetrating and visible for a great distance, even through a dense fog.

back for the A and E-strings, and a pine front and cherry back for the D and G-strings. The bridge used has a broader base than the ordinary type, so as to span the space which separates the two halves of the instrument.

8092 MILITARY RIFLE-RECOIL PAD PASSES SEVERE TESTS

In tests, recently held at Fort Snelling, Minn., a new rifle-recoil pad proved highly satisfactory for use with military rifles.



A recess in the stock of military rifles, to hold an oilcan and field cleaner, opens through the butt plate and would be inaccessible with ordinary pads. This pad is either hinged to the stock or attached with clips and studs so that the recess remains accessible. It is made of sponge rubber, covered

with leather. In the tests, two men fired, one using the pad. The second man was forced to quit after 250 rounds, because of a sore shoulder. The next day his shoulder was badly swollen, while the first man showed no bad effects.

8190 AMERICAN DRUG TRADE BOOMING IN BOMBAY

The unrest in India is apparently not hurting some lines of business, for an American drug company, with offices in Bombay, reports that the sale of medicines in the country districts around that city is increasing so rapidly that it is impossible to fill all orders. The business is conducted on aggressive American lines by extensive advertising and the missionary work of traveling agents, and possibly this more than counteracts any adverse conditions. The goods are shipped from Bombay cash on delivery.

8094 VIOLIN OF DIFFERENT WOODS FOR HIGH AND LOW TONES

Daniel H. Neely, Bradford, Pa.

Violin construction is controlled by the desire to produce the clearest of tones, and the materials of which these instruments are made are always selected with the greatest of care. A Bradford, Pa., man has introduced a violin, in which two kinds of woods are used, his theory being that hard-wood vibrates faster and favors the



higher tones, while softer wood has an opposite effect. His invention has two sections, with a hemlock front and maple

higher tones, while softer wood has an opposite effect. His invention has two sections, with a hemlock front and maple

Mr. J. D. Kennedy, 1/10 Arthur Williams, 319 Cedar St., Providence, R.I.

Chicago Bulletin
76 W. Monroe, Chicago.

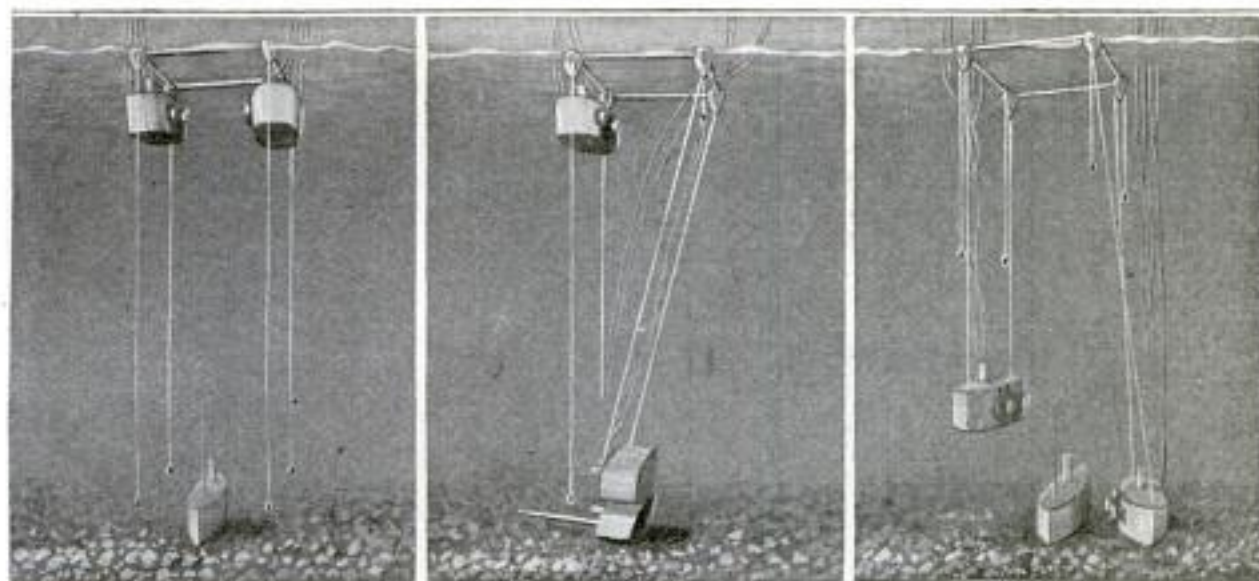

Diagrammatic Representation of the Operation of Pontoons in Salvaging a Wrecked Vessel, Showing, from Left to Right: Pontoons in Position above Wreck and Ready to be Lowered; Method of Dealing with Vessel Lying on Its Side; One Pontoon Lowered, and Other on Its Way Down to the Other Side of the Wrecked Vessel

WRECKED VESSELS SALVAGED WITHOUT DIVERS

Methods used, at present, for salvaging wrecked vessels, sunk in deep water, involve the employment of divers, whose powers of endurance are limited. A depth of about 200 ft. is considered the greatest in which divers can operate, but great hardship is experienced at much less depth. Thus, it has hitherto been considered that vessels sunk in the high seas are unsalvageable. A great deal of study has been given to this subject in England, and an electromagnetic system of salvage has been evolved which has demonstrated the possibility of salvaging vessels at any depth without the use of divers. The system is based upon the use of submersible pontoons, to one side of which are attached powerful electromagnets. These pontoons work in conjunction with tugs, from which all electrical and air controls are directed. Each pontoon is subdivided into a number of airtight compartments, one of which is made habitable by means of maintaining atmospheric air

pressure within it, independently of the depth of the water. Here the crew operates, and in connection with it is a conning tower. The pontoons are sunk by filling the other compartments with water, and the crew has control over these compartments, so that the pontoon can be tilted at any angle to make the best possible contact with the sunken hull. The current is then turned into the electromagnets, which cling to the wreck with sufficient force to move it. The wrecked hull is secured in this manner between two of these pontoons. By compressed air the water is blown out of the compartments in

the pontoons, which then have a buoyancy sufficient to rise to the surface. The pontoons are of various sizes, suitable to the size of the vessel to be raised.

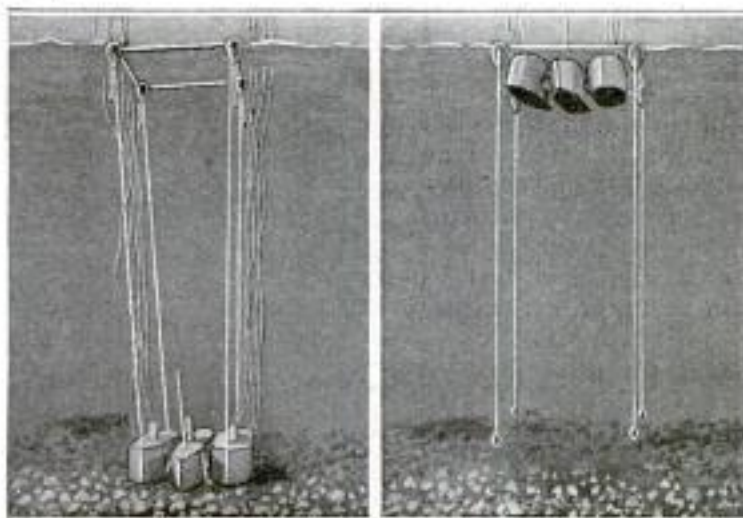

Left: Both Pontoons in Position for Raising the Wrecked Vessel, to Which They are Electromagnetically Attached. Right: Wrecked Vessel Raised, Ready to be Hauled Ashore

means of maintaining atmospheric air

duced from entirely unmixed coal from the Sarre basin.

By a new system, the discovery of a Paris chemist, a hard and resistant metallurgical coke has been pro-

8101
**POWER PRESS PRINTS FROM
COPPER OR STEEL PLATES**

Up-to-date plate printing has been done on hand-operated presses, but a machine has now been developed which performs

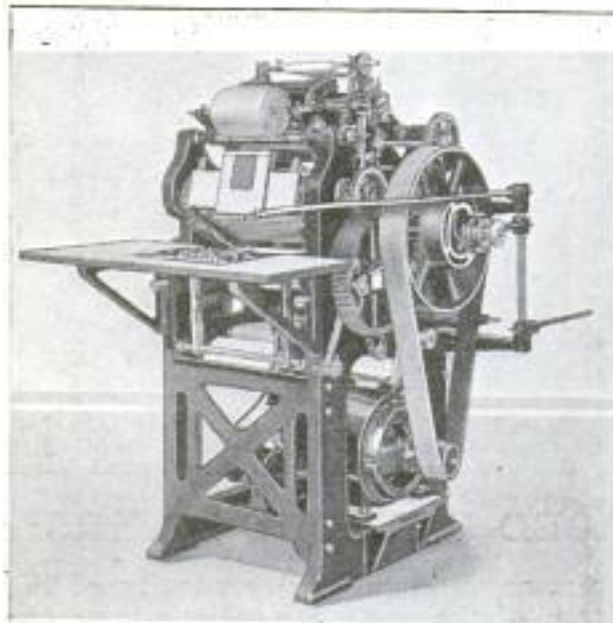

An Automatic Power Press Which Performs All Operations of Plate Printing Mechanically

all the operations of plate printing automatically. The plate being set up, it is only necessary for the operator to feed in the stock and remove the finished work. Results are said to equal the finest handwork.

8159
**MECHANICAL STOP SIGNAL
SIMPLE AND PRACTICAL**

Stop signals are many and of various makes, but one of an extremely simple type, which has lately appeared, deserves

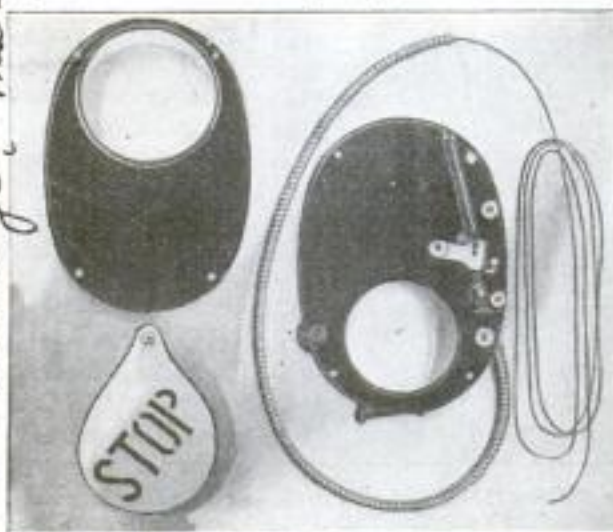

Upper Left: Plate Which Fits over Tail Light. Lower Left: Shutter That Swings across Opening in Plate. Right: Plate with Armored Tubing Containing Operating Wire

recognition. The accessory is fastened over the tail light, and has an opening in it large enough for the rays to shine through. An iron wire, to which tension is applied by pressure on the brake, causes a white-enameled shutter to swing across the aperture. Stamped out of this shutter, is the word "Stop," in two-inch letters, which are covered with red silk, thus allowing them to be strikingly illuminated at night, while in the daytime they are readily seen as a warning.

8150
**ATTRACTIVE PARKING LAMP
OF UNUSUAL DESIGN**

Every driver of an automobile knows the danger of leaving his car parked at night without showing lights, so a new parking light will be of interest, as it shows a light at front and rear, but uses very little current from the battery. Aside from the built-in appearance of the lamp, it has other attractive points. It uses only a 2-cp. 6 to 8-volt bulb, and in case it becomes necessary to replace a

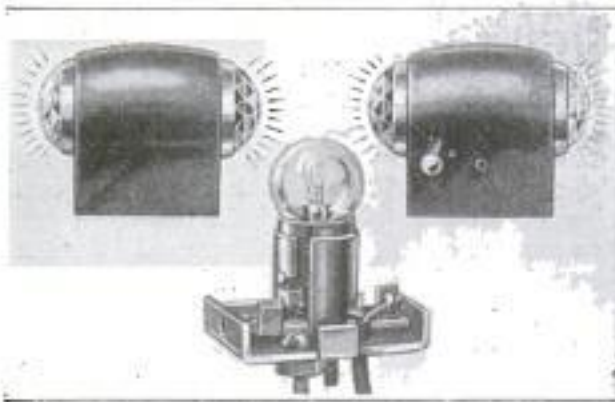

Parking Lamp with Two-Candlepower Bulb and Concealed Switch Which Shows a White Light Forward and a Red Light Rearward

bulb, the cover of the lamp is snapped off, leaving the socket fully exposed.

8263
**ELECTRIC POWER FOR SEATTLE
FROM SKAGIT RIVER PLANT**

A great hydroelectric project on the upper Skagit River is being undertaken for the purpose of furnishing electricity for the city of Seattle, Wash. At a point where the river makes a great bend a tunnel is being driven through the solid hill, which, when completed, will carry water from the river to the turbines that drive the electric generators. The tunnel will be more than two miles long and will take two years to complete. A dam is to be constructed at the upper end of the tunnel to form a storage reservoir. The transmission line to Seattle will be over 100 miles long.

Jiffy lamp mfg. Co., 90 S. Peering St. Milwaukee, Wis.

Emil E. C. Hughes 57 Austin St. Cambridge, Mass.

Poepffel Novelty Works The Christian Science Monitor
1800 Dearborn Ave. Chicago 9/17/22

8142

Designer. A. H. Linsenmeyer
 Cont. S. Q. Winters, 702 Electric National
 POPULAR MECHANICS Bank Bldg. 13
 Washington D. C.

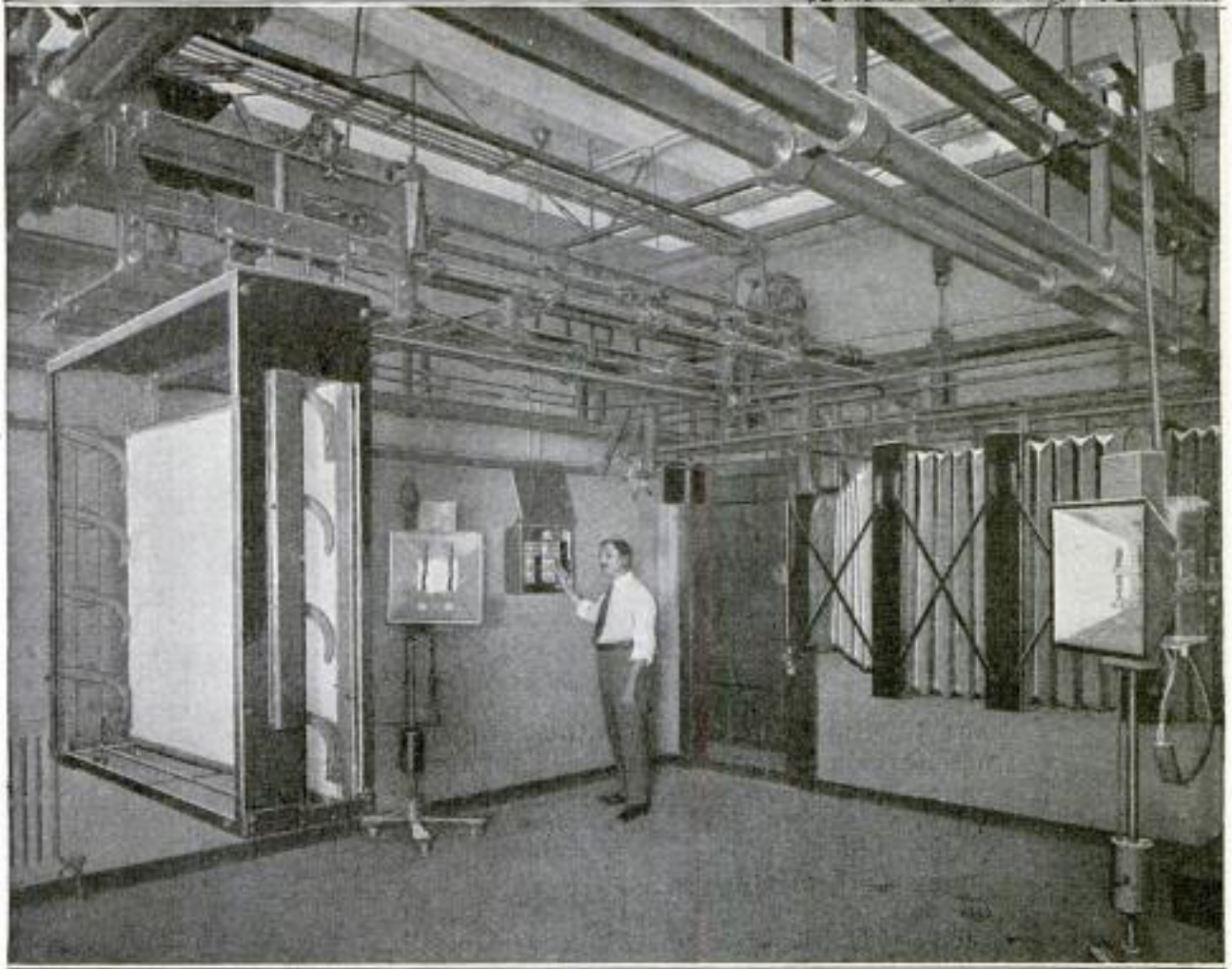

Electric Map-Making Camera: At the Left Is the Huge Copyholder and at the Right Are the Bellows, Both Operated by Cranes. Overhead Is the Rigid Tubular Framework Suspended by Springs to Avert Any Possible Vibration of the Various Units of the Camera

MAMMOTH ELECTRIC CAMERA USED IN MAKING MAPS

In the photographic laboratory of the Geological Survey, Department of the Interior, is located a camera of such huge dimensions that it has to be operated by means of small electric cranes. A rigid tubular-steel framework is suspended from the ceiling of a large room by springs, to avert any possible vibration of the various units of the camera which are hung from this frame. In one corner of the room is placed the plate holder, which is at all times stationary, and which extends through the wall into the adjacent dark room. The bellows, terminating in the lens and prism, are just in front of the plate holder, as in ordinary usage, and are fastened to a carriage or crane for focusing purposes. The copyholder, or frame, consists of two 4 by 6-ft. plate glasses held in a steel frame, and also affixed to an electric crane for centering the copy. Lenses of 31 and 42-in. focal length are attached to a heavy brass

plate and will produce any-size photograph accurately in this 7,000-lb. camera. The entire mechanism is electrically operated, and electrical contacts are arranged according to a scale, so that the operator can easily determine when he has the proper focus with the gigantic outfit, by the lighting of signal lamps. The camera was built by the government for the sole purpose of reproducing maps.

RADIO TO BE USED IN TRACING LOST SHIPMENTS OF GOODS

New uses for the radiotelegraph and telephone are being found every day, so it occasions no surprise to learn that an eastern company is planning to use this means of tracing shipments of goods lost in transit. In tracing strayed or stolen goods, the question of time is of vital importance, and this was one of the governing reasons in adopting this means of communication. The plan, as outlined, contemplates the establishment of 35 radio plants in all parts of the country.

Christian Science Monitor
 1/16/22

Edw. E. Isarotta, Esq.

Electrical World

3, Via Settembrini

344

POPULAR

MECHANICS

1/21/22

8169 MILANO ITALY
ITALIAN AIRPLANE ENGINE
OF DIESEL TYPE

THAW SLEET FROM WIRES
BY SHORT CIRCUIT

8269

A water-cooled Diesel engine of radial-cylinder type has recently been designed

Sleet storms periodically wreak havoc with electrical transmission lines, and as

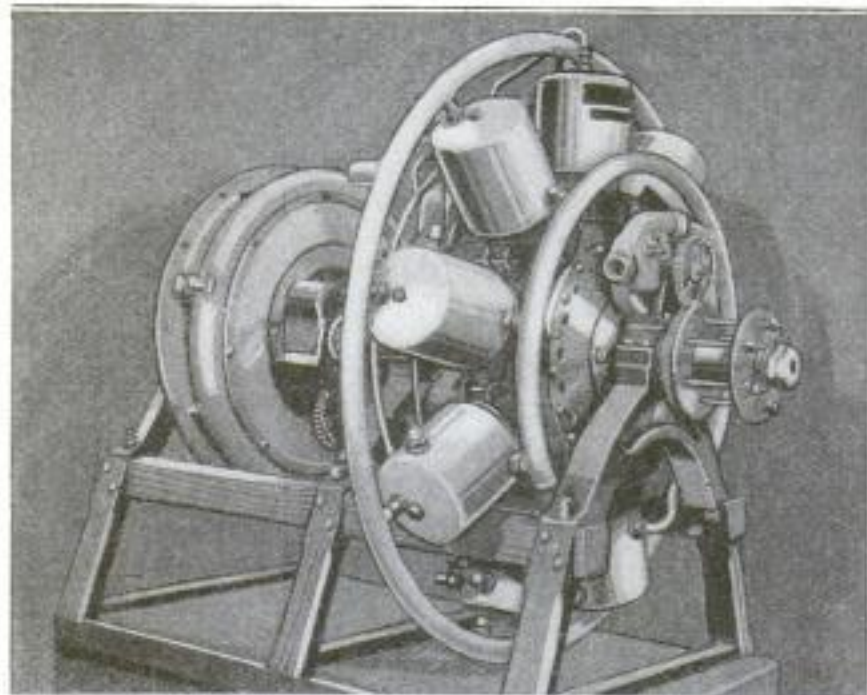

This Formidable Looking Airplane Engine is Designed to Operate on Heavy Fuel Oil. It Has Auxiliary Magneto and Carburetor for Starting with Gasoline

in Italy. It is claimed that the engine will operate on any of the heavy fuel oils, and will develop 1 hp. for less than 2 lb. of engine weight. It is equipped with magneto and carburetor for starting with gasoline, and also has a special device for reducing compression when starting.

ice to the customers was delivered as usual, during the 15 hours required entirely to free the wires from ice.

When Paris suburban trains arrive late, slips giving the time of arrival are presented to passengers upon request.

BIG DITCHER QUICKLY TURNS SWAMPS INTO FARMS

The immense scale on which reclamation of swamp lands in Freeborn and Mower counties, in southern Minnesota, is carried on, means that, within a short time, great tracts will be added to the productive lands of that state. Work is being concentrated on a tract of 15,000 acres, which has been subdivided into eight units of from 1,000 to 3,000 acres each. Each unit is in turn subdivided into farms, most of which contain either 80 or 120 acres.

The chief agent in this reclamation work is a wheel excavator of unusual design and capacity. This 76-ton ditching machine crawls steadily ahead like some great land monster, and as it advances it digs a ditch that is 12 ft. wide on top and 7 ft. deep. A huge revolving wheel scoops out the dirt and a conveyor belt is kept

busy carrying it out 20 ft. to the side, where it builds up a spoil bank. Working steadily with a crew of five men, the machine, which is 65 ft. long over all and has a 110-hp. engine, can drive a ditch ahead at the rate of about a quarter of a mile in a working day.

After the tile drains are laid, the sides of the ditches are thrown in to cover the tile. This work is done with a grading machine drawn by a tractor. Submains and laterals are added after the main drains have been laid. Then follows the building of bridges, roads, and groups of farm buildings. Work is done on a big scale, dozens of teams, workmen, and tractors being employed. Artesian wells are driven, fences built, and in a short time the marshlands have been changed into highly productive farms.

Edw. E. Isarotta, Esq.
3, Via Settembrini
Milano, Italy
7959

7959 Buckeye Traction Hitcher Co,
Windsor, Ohio



The View Above Shows the Rear of the Big Ditch Digger at Work Excavating Drain Trenches in Southern Minnesota Marshlands. It Makes a Ditch 12 Feet Wide at the Top and 7 Feet Deep, Depositing the Excavated Dirt, by Means of a Conveyor, along the Side of the Ditch



The Immense Excavator, Weighing 76 Tons and Equipped with a 110-Horsepower Engine, is Here Seen from the Front. It is 65 Feet Long over All, and 33 Feet Wide; the Front Wheels Are 8 Feet High by 7 Feet Wide, and the Track-Layer Wheels in the Rear, 20 Feet Long by 8 Feet Wide. The Crew Eats and Sleeps in the House on Top of the Machine

*Hulophane Glass Co.,
342 Madison Ave*

346

POPULAR MECHANICS

New York City

**NEW ILLUMINATION METER
PORTABLE AND ACCURATE**

Until recently illumination meters have all been large and heavy, never really

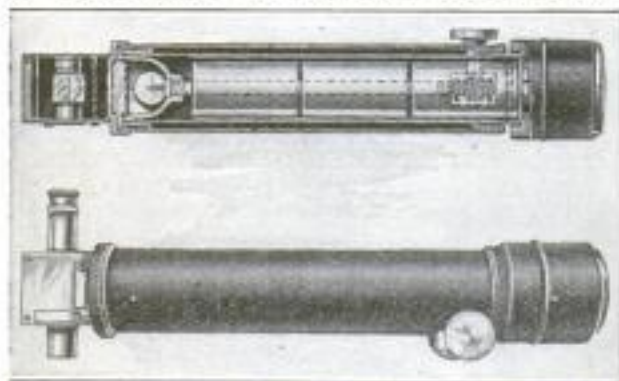

By Adjusting the Thumbscrew the Strength of Any Light may be Compared with the Strength of the Test Lamp

portable. Now a light meter has been placed on the market which measures only 11 in. in length, but is entirely accurate. It is designed for measuring foot-candles, Lamberts, candles per square inch, candlepower, coefficients of reflection, transmission factors, and for color matching. It is supplied in a compact carrying case.

☐ Nearly 4,500,000 acres of land have changed hands in Scotland since November, 1918, this vast amount being practically one-fourth of the entire country. About 800,000 acres were sold in 1920 alone, and in 1921 the total was more than 600,000. It is estimated that, altogether, land to the value of over \$260,000,000 has been sold since the signing of the armistice.

TESTING CHEMICAL ACTION UNDER GREAT PRESSURE

Nitrates, the basis of explosives and fertilizers, can be produced chemically, and one step in the process is the formation of ammonia by combining hydrogen and nitrogen in proper proportions in the

American University
catalyst developed by the Fixed Nitrogen Research Laboratory in Washington is said to be the most efficient yet discovered, and its behavior at various temperatures and pressures is now being studied. For this purpose it is placed in metal cylinders called "testing bombs," where the chemical action takes place at different temperatures and at various pressures up to as much as 1,500 lb. per square inch.

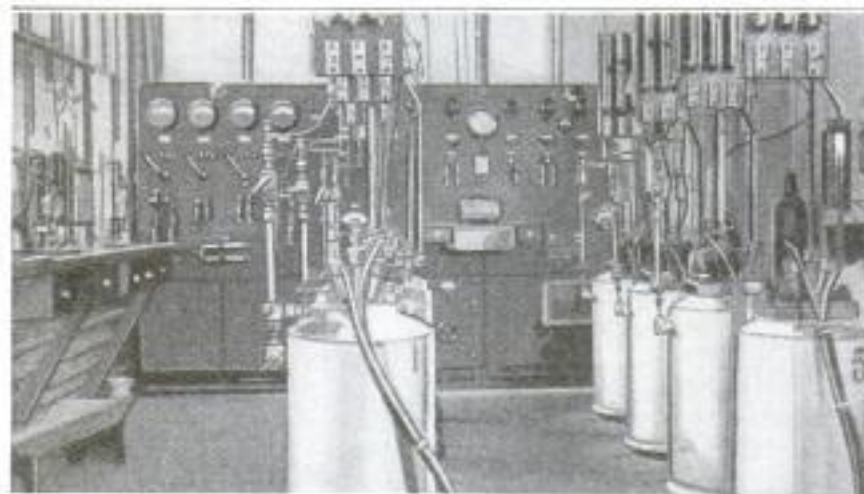

Above: In the Metal Cylinders, Called "Testing Bombs," the Action of the Catalyst is Studied at Various Temperatures and Pressures

Right: The Recording Instruments on Which the Reactions are Observed and the Records Carefully Compiled

presence of a catalyst. The quantity of ammonia that is produced depends, among other things, on the nature of the catalyst and upon the temperature and pressure at which the chemical action takes place. A

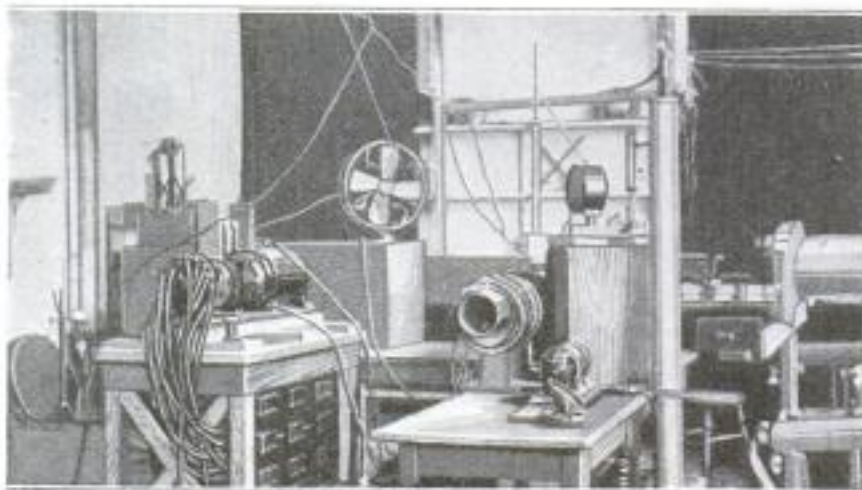

☐ Whenever you find that you wish to know more about any article in the magazine, write our Bureau of Information.

LIGHTING THE MISSISSIPPI

By Lewis R. Freeman
287 E. California St.
Pasadena, Calif.



Setting Up a Beacon on a Sand Bar on the Mississippi River: It Is One of 700 Similar "Aids" That have been Established along the 1,200-Mile Course of the River between St. Louis and New Orleans, to Direct Navigation of the Constantly Shifting Channel

MARK TWAIN, in his "Life on the Mississippi," devotes a number of pages to an almost interminable list of things that the river pilot of the old days had to remember in order to stand a chance of avoiding disaster in the 1,200-mile run between St. Louis and New Orleans. So slight were the shades of differentiation between the marks that spelt danger or safety, that one is surprised, not to learn that the lower Mississippi is paved with an average of a half dozen wrecks to the mile, but that it was ever possible to carry on navigation at all.

The almost prohibitive difficulties in the way of lighting and marking a channel that was here today and there tomorrow, made progress slow in the matter of safeguarding navigation on the lower Mississippi, and no comprehensive system was worked out and put into operation until a number of years after the crest of traffic was past. Then, over a long interval during which river trade dwindled year by year, the lights were maintained with the characteristic thoroughness of the U. S. Lighthouse Service. Channels

that scarcely were churned once a month by a dilapidated stern-wheeler were kept dredged, sounded, and marked, although the cost of the service must have been far and away in excess of the benefits accruing from it. But now, with the establishment of Federal barge lines and

rehabilitation of river traffic generally, the long chain of little beacons of what is called the Fifteenth Lighthouse District is finally beginning to justify its establishment.

I think I am well within the truth in stating that none of the great navigable rivers of the world offers so baffling a lighting problem as does the "Father of Waters" in its twisting, turning, caving-banked reaches from the mouth of the Missouri to the Gulf. I might mention parenthetically that all the old river pilots and skippers resent the use of the masculine gender in speaking of the great river. Anything that changes its mind as often as does the lower

Mississippi, they say, ought to be called she. And she they call it—when they aren't calling it something worse.

It is this capriciousness, this unstable-



Carrying a 12-Foot Aid Post up a 20-Foot Bank, on Top of Which It is to be Erected

ness of mind (which the lower Mississippi gets from the Missouri, and which the latter, in turn, has got from the Yellowstone) that makes the stretch of the river from St. Louis to New Orleans so hard to light effectively. A river that flows in front of a town one day and behind it the next, cannot, obviously, be lighted with fixed beacons. Indeed, if changes of this description—which have, in several instances, had the effect of transplanting a town from Missouri to Illinois, or from Mississippi to Arkansas—were at all common, it would be out of the question trying to light it at all. Since for the most part, however, changes of channel go on steadily but slowly, it has been possible to devise and maintain a lighting system that is of incalculable assistance to the navigator of the great river.

The lights on the lower Mississippi are officially referred to as "aids to navigation." The term light, or lighthouse, is reserved for a fixed beacon, the purpose of which is to warn a ship away from a shoal or dangerous point. An aid, on the contrary, is almost invariably intended to give a pilot an approximate bearing for a course that will keep his steamer in the always narrow and winding channel. As this channel is constantly changing as the river rises and falls, it follows that the position of the aids will have to be shifted in order that they may help rather than mislead. The task of sounding out the channel and moving the aids to conform to it, is only one of the multifarious services performed by the government lighthouse tender that is kept in constant operation between the mouth of the Missouri and New Orleans. Two smaller tenders are operated on the Ohio and upper Mississippi, respectively, but the work of light tending is far less onerous than on the lower waters.

The type of aid that is uniformly used on the Mississippi and Ohio (and on the lower Missouri in the event navigation is

ever opened up regularly there) consists of a heavy post, about 12 ft. in height, deeply set in the ground and furnished with props, crossarms, stairway, and a bracket to receive the lamp. All parts of the structure are painted white. The lamps hold enough oil to keep them burning continuously for 72 hours. A highly refined grade of kerosene is used, furnished under specifications which require that it shall burn the full three days without depositing any soot upon the glass. In order to simplify the work of tending, the lamps burn in the daytime as well as at night, so that the principal thing to do is to refill them every third day.

In my recent boat trip down the Mississippi, I found that the aid, or light, at the mouth of the Missouri bore the number 686, and that the Westwego aid, five miles above the foot of Canal Street, New Orleans, was numbered 1. As several of the intervening aids bore the same number, differentiated by the addition of a letter, I think it probable that there are something over 700 aids scattered at irregular intervals along that 1,200-mile stretch of river.

The manner in which the aids are placed to help the pilot keep to his channel, will be plain from the accompanying diagram, which shows a 10-mile section of the lower Mississippi. With the steamer channel following the course indicated by the line A, the aids would be placed approximately as shown by the points marked 1A, 2A, 3A, etc. But if soundings made by the lighthouse tender at the end of the spring high water were to show that the channel had shifted to the course indicated by the dotted line B, then the position of the lights would be altered at the first opportunity to conform roughly with the points marked 1B, 2B, 3B, etc. Immediately after making the fresh sounding and shifting the aids, the captain of the tender forwards a report descriptive of the new channel to the headquarters of the Fif-

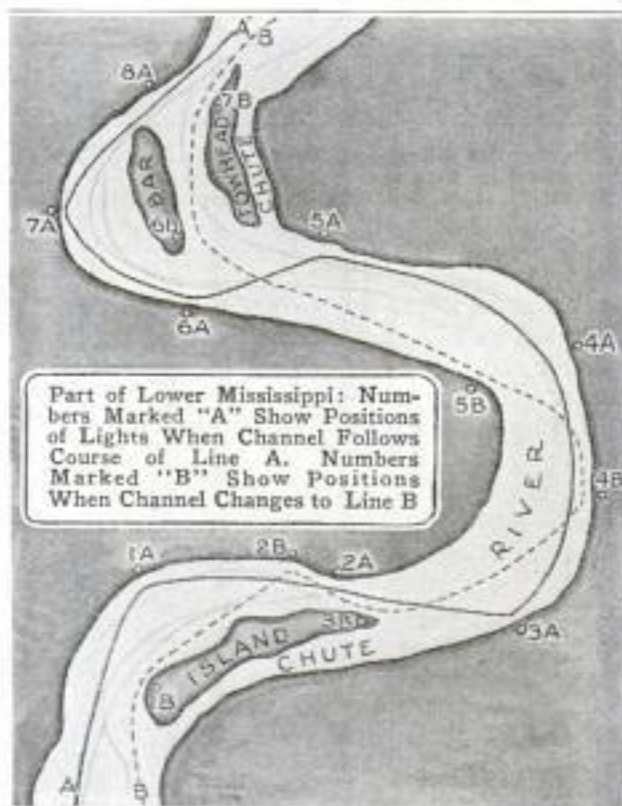

teenth Lighthouse District, in St. Louis. Here this is manifolded and copies dispatched to every master navigating a boat on the lower river. The latter immediately enters a summary of the fresh data at the proper point of his latest light list, where there are blank spaces left for remarks, changes, etc. The full report is kept ready to hand in the pilot house in the event difficulties develop in navigating the stretch covered by it.

The language of these reports is in the purest "riverese," a lingo of its own, and quite distinct from ordinary nautical jargon. A deep-sea sailor would be as much at a loss to get the sense of one at first reading as would the landlubber. With a little study, however, the meaning of the strange phrases will become plain to a person of average intelligence.

The word "towhead" is one that crops up often in Mississippi parlance. It might best be defined, perhaps, as a cross between a sand bar and an island—an island in the making. It is usually formed in the first slack water below a point where the river has cut heavily into its

banks. The first year or two after it begins to appear above water, it is covered with a thick growth of young wil-

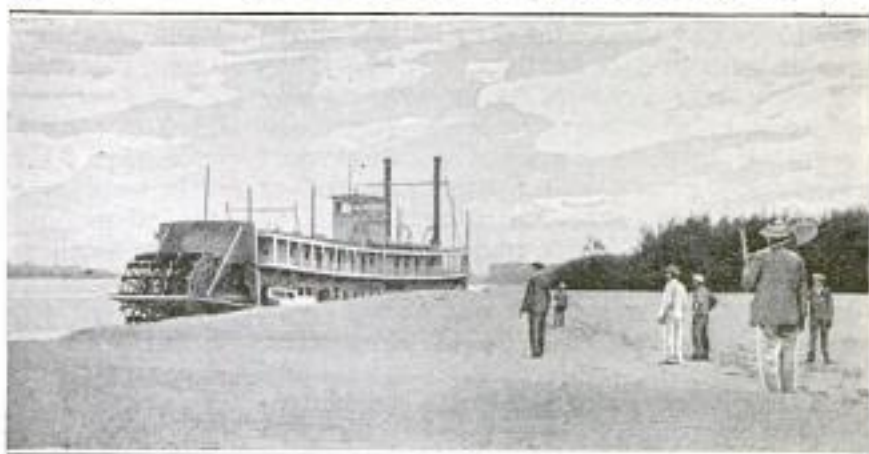

Men Returning to the "Oleander," the Lighthouse Tender for the Lower Mississippi, after having Shifted a Light on Account of a Change in the Course of the River Channel



Old Negro "Mammy" Who Tends the Aids at Pecan Point, Arkansas

lows. Later, cottonwood trees appear and choke out the willows. If a towhead augments, or holds its own long enough for the cottonwood to attain a growth of 20 or 30 ft., it attains the dignity of, and is thenceforward called, an island. A "chute" is a narrow back channel behind an island. If there is water enough, a steamer taking it may often save many miles of distance over the main channel. Directing a steamer down "the shape of the bar," or "the shape of the bank," means that it should

run fairly close to bar, or bank, and on a parallel course.

The lighthouse tender for the lower Mississippi is the "Oleander." It has been commanded from the day it was commissioned by Capt. Thomas Good, who has spent a long lifetime as pilot and master on the river. The duty of the "Oleander" is to cruise back and forth between St. Louis and New Orleans as fast as the exigencies of water, weather, and coaling permit, sounding out the channel, shifting, repairing, or replacing lights, and replenishing the supplies of the keepers. Under favorable conditions, it may average 100 miles a day on a downstream run, and perhaps 75 going up. A keeper may tend from one to ten lights, though I only recall one man with so many as the latter num-



Light on Lower End of a "Towhead," or Mississippi River Island in the Course of Formation

ber. If he has more than three or four lights, he will need a motorboat of some kind to get around to them. As all of the river fishermen have power boats, it is only to be expected that they should make up the bulk of the keepers. Those tending only one or two lights are usually squatters cultivating a small patch of corn or cotton outside the levee. To support a family without other work, a keeper should have at least five or six lights, as the pay per light is not high.

The duties of a keeper are: to keep the brush trimmed away in front of his light, so that it will always be in clear view from the channel; to replenish the oil and keep the wick trimmed and the light burning day and night; to set back the light in case the bank below it is caving, and in such a way as to maintain approximately its former bearing from the channel; to report to St. Louis his needs far enough in advance to allow the "Oleander" to be prepared to bring, or do, what is necessary on its next trip. If a light is carried away entirely, it is the duty of the keeper to set up a spare lantern on a post, or tree, and keep it burning until the "Oleander" comes along with the materials for a new installation. If, as

occasionally happens through the tender being delayed, a keeper runs out of kerosene, he is expected to buy enough to keep his lights going, at his own expense, trusting to the government to reimburse him later. As it is impossible to buy kerosene of anything approaching the high quality furnished him by the tender, a keeper confronted by an emergency of this kind is always in for a very trying period of smoky lights.

Although running the whole gamut of the social scale from the old black "mammy" to an effete scion of British nobility (I met both tending lights on the river), there is still to be found a remarkable *esprit de corps* among the keepers. Every effort is made by Captain Good to impress his keepers with the fact that the maintenance of their lights in all weathers, and in the face of every difficulty, is a matter of life and death importance. A number of men have lost their lives while endeavoring to save their lights in flood time, and of actual betrayals of trust there have been almost none. This is a wonderful showing, especially when one considers the strange odds and ends of humanity with whom it has been necessary to work.

John H. Mansel

267! "WALKING" TRACTOR FOR USE ON PLOWED SOIL

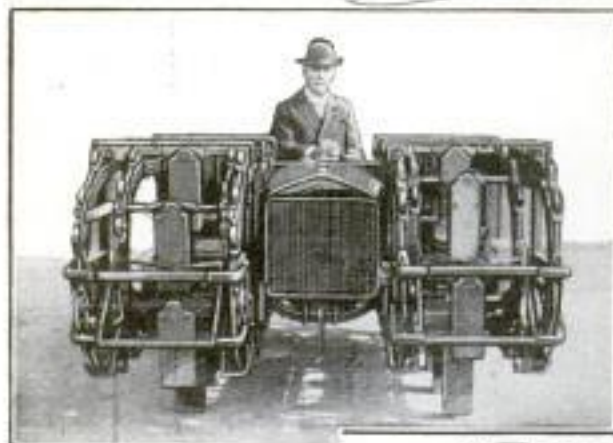

Front View of Tractor, Showing the Clearance between the Bottom of the Engine and the Ground

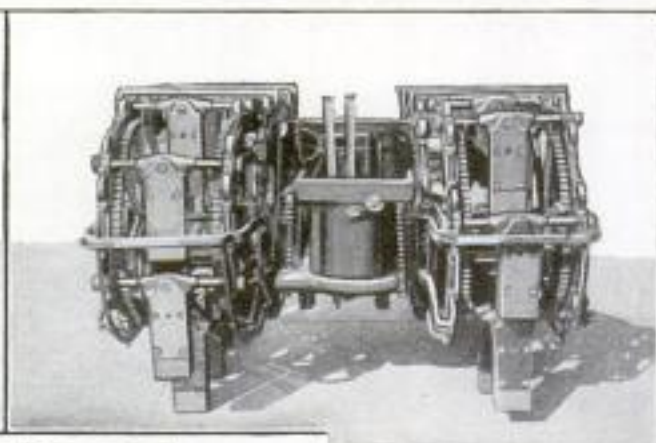

Rear View of Tractor, Showing the Driver's Seat and the Method of Lifting the Feet from the Ground



Side View of the Tractor, Which Illustrates How the Machine Has Four "Feet" on Each Side to Rest Upon

Loose, muddy, or sandy soil will not hinder the planting or cultivation of crops if a new "walking" tractor is used. The tractor travels on "feet" which extend 12 in. below the frame, and these are set in an endless chain, so arranged that they take, or leave the ground in a perpendicular

position. Thus only small holes, instead of continuous tracks, are left in the soft earth. The engine is mounted between the two rows of feet, and can be raised or lowered to accommodate the height of the crop being cultivated, so that there is little chance of its receiving any damage.

I. W. S. J. Corbith, 802 W. Broadway, Enid, Okla.

8219 *Com. Maurice E. Belgrims*
 35 *Place de la Scaire, Antwerp*
Belgium

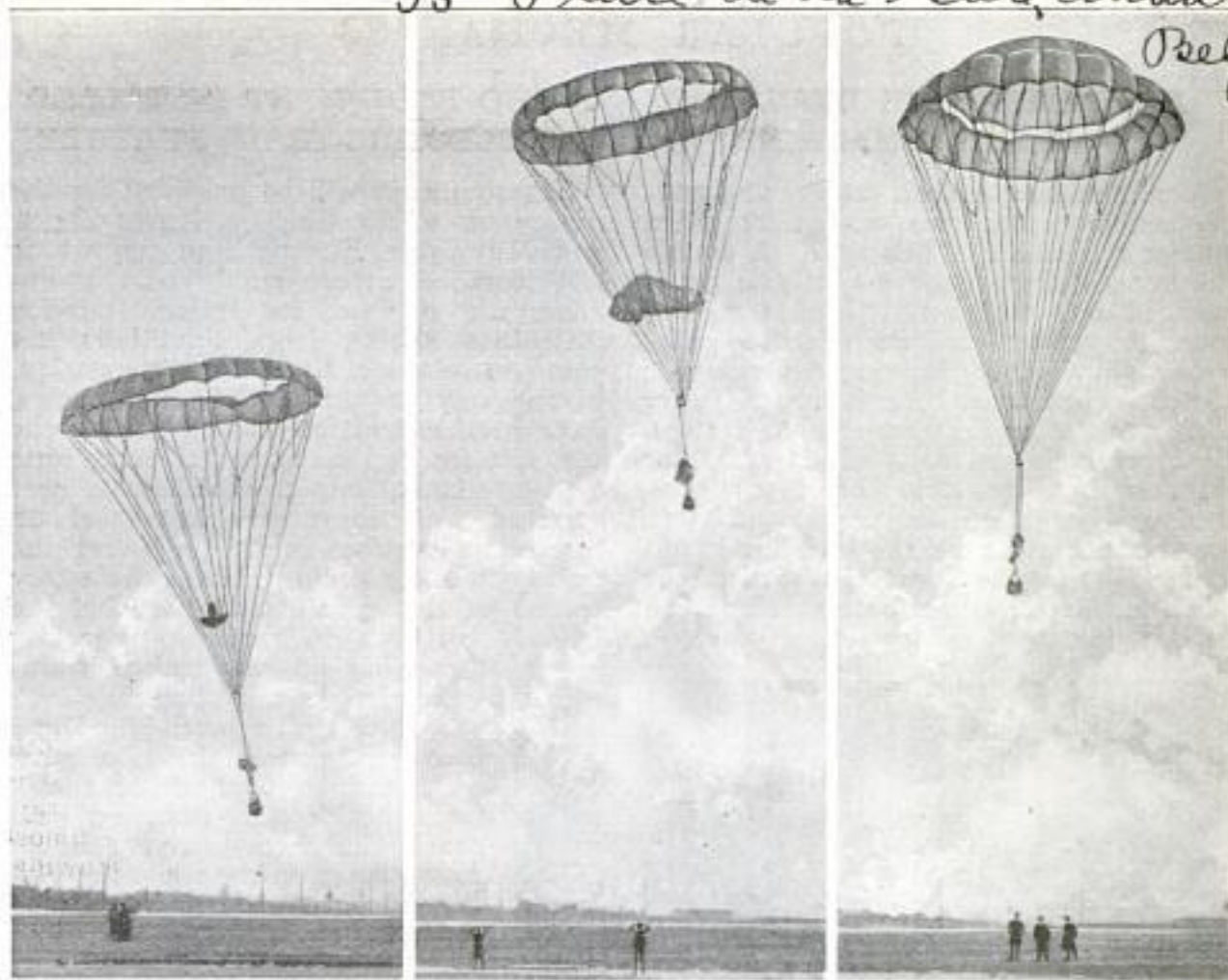

Successive Stages in the Opening of the Two-Part Parachute: First, the Outer Ring Opens, Checking the Fall; Second, the Inner Parachute Moves Up into Place; and Third, It Opens, Nearly Filling the Ring

Aeromobile
PARACHUTE IN TWO PARTS REDUCES SHOCKS

The parachute holds the same relation to the air craft that the life preserver holds to water craft, and even when air travel has become reasonably safe, the parachute will continue to play its part in case a forced landing is necessary. As the speed of air travel increases, the strain placed upon the parachute in leaving the air craft becomes greater, and the danger of rupture of the fabric is also increased. To reduce this hazard and to lessen the shock on the person using the parachute, the two-part parachute has been tested in Germany. In making a jump, the outer parachute, which is merely a ring of fab-

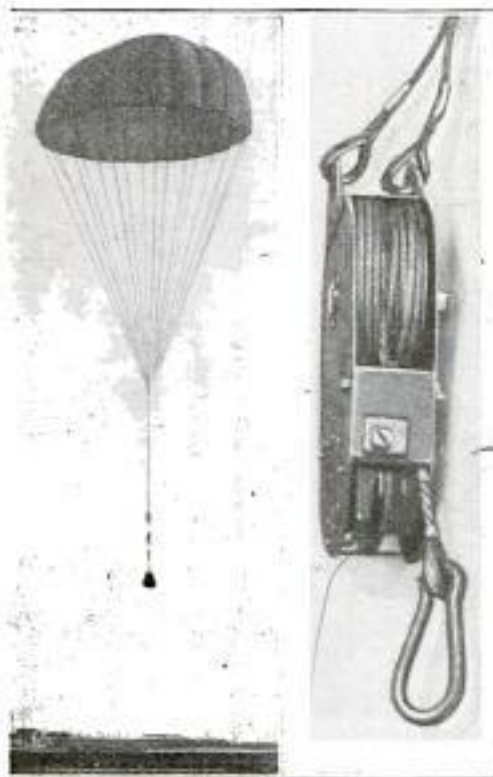

Ordinary Parachute, Fitted with the Special Brake, Shown at the Right

ric, opens first, checking the speed of fall, whereupon the inner parachute then opens and the falling speed is reduced to not over 15 ft. per second.

Another device destined to accomplish the same result, using the regular parachute, is in the form of a brake which is interposed between the parachute and the jumper. When the initial pull on the parachute is greater than the fabric will stand, the cables take up the shock by unwinding, somewhat on the order of the spring counterweight. The tension of the brake may be adjusted to compensate for the different weights of the jumpers.

COMBINED CASH DRAWER AND ADDING MACHINE

A new combined cash drawer and adding machine occupies a distinct place among equipment of this type. A double roll is used, with a narrow strip of paper overlaid on a wide strip. Each item and total is printed on both strips. The wide strip rewinds, forming a permanent record. The narrow strip is torn off, after each transaction, as a customer's receipt. Cash received and paid out is added or subtracted. The clerk or department, cash or charge, on account or paid out, are indicated. When the machine is unlocked, the rewind forms a record of the day's business. The adding machine can be instantly detached for ordinary use.

8328

RADIO EQUIPMENT INSTALLED AS ELECTRIC-TRAIN FEATURE

Entertainment will be provided for the passengers of the Chicago, North Shore, and Milwaukee Electric Railway, which has installed experimental radio equipment on one of its trains. Serious difficulties arising from conditions not common to the ordinary wireless station, in the way of the trolley and motors, have been successfully overcome by the engineer for this company. During tests made recently, music for dancing was received, and conversations carried on between a station in Chicago and the swiftly moving train. The satisfactory results of the experiments have led the officials of the railroad to consider equipping all the limited trains with wireless, and supplying each passenger with a receiver. These instruments will have a plug which can be inserted in a receptacle beside the seat, so that those who choose may, while en route, listen to the radio news or music now broadcast from many stations.

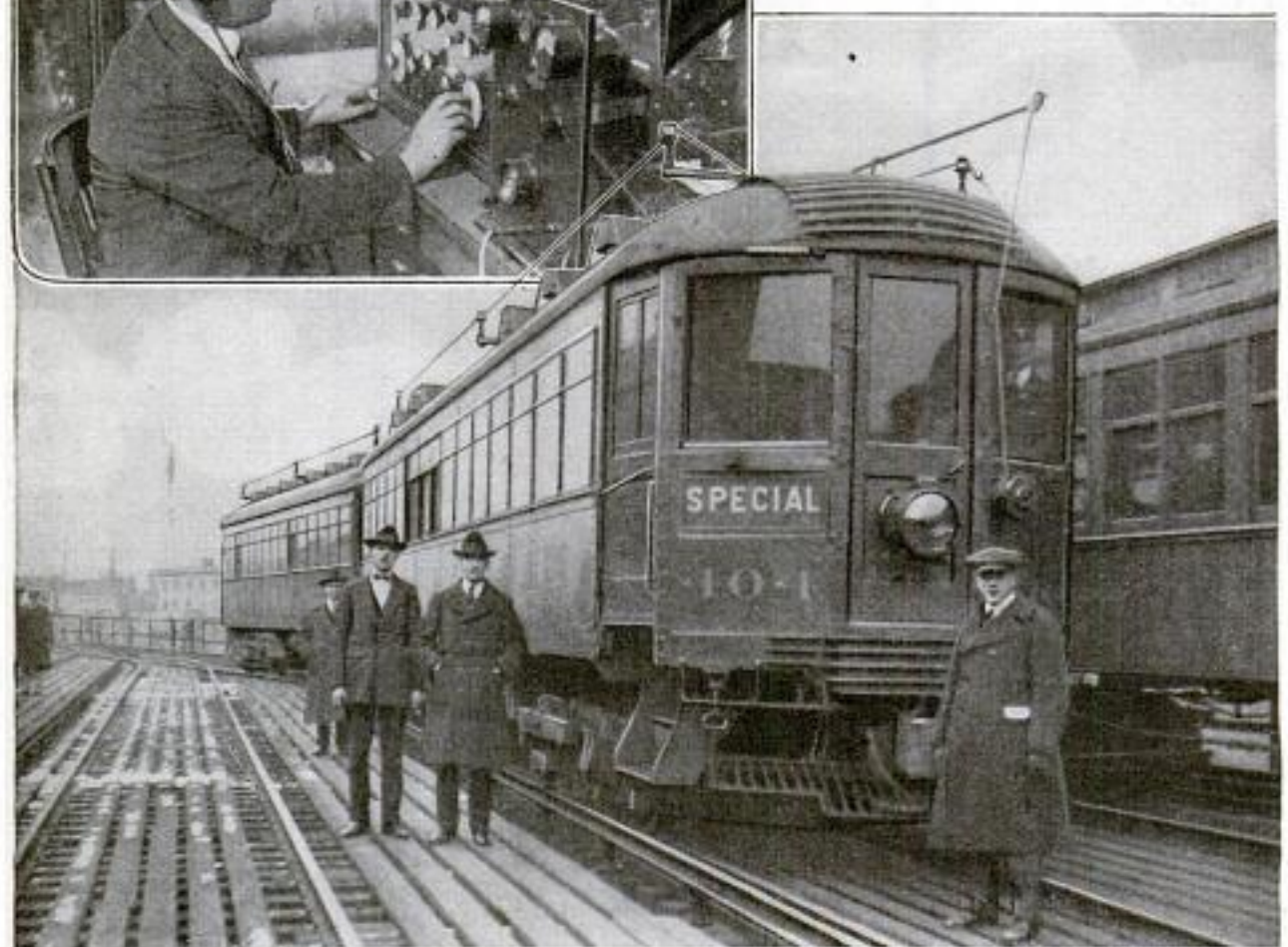

Electric Railway Train That was Equipped with a Wireless Outfit from Which Satisfactory Results were Obtained in All the Experiments Attempted. Above: Part of the Equipment Installed inside the Train

COPYRIGHT, UNDERWOOD & UNDERWOOD

8218 Cont. Hays + Ford, 416 Union
League Bldg.

Los Angeles Calif.

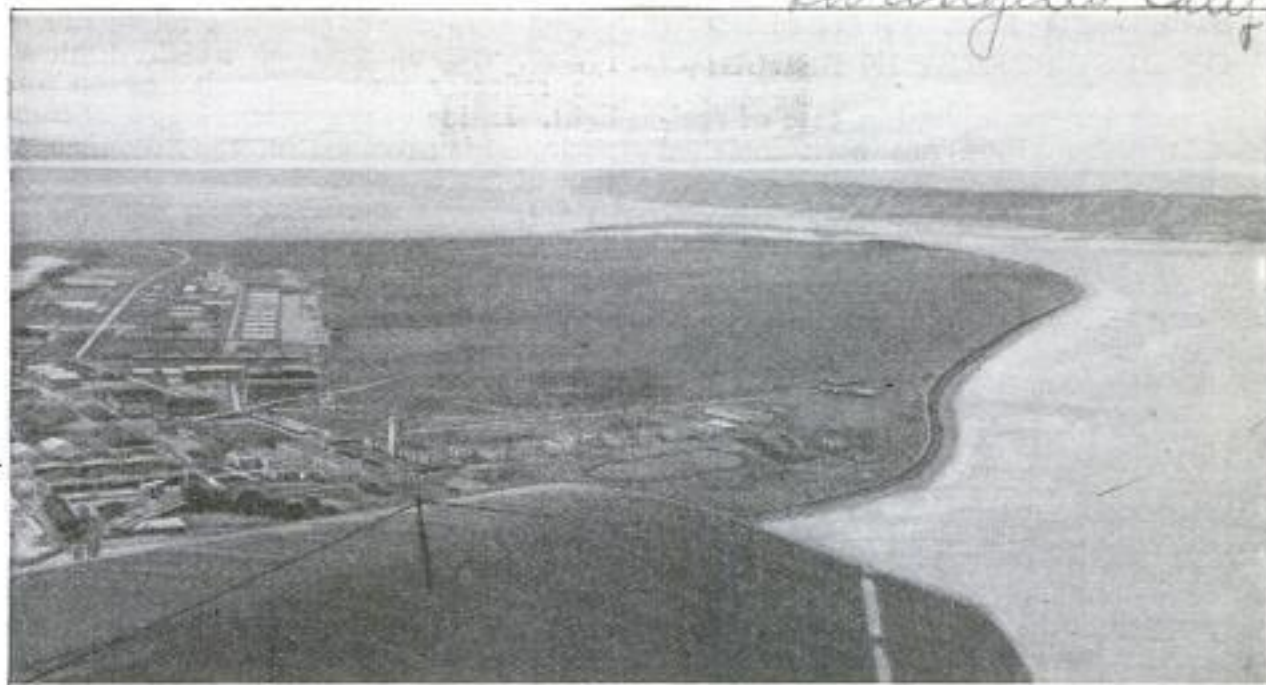

Airplane View of North Island, Showing Its Broad Expanse of Almost Level Ground: This is Said to Be the Most Nearly Ideal Air-Craft Base in the World. Sunshiny Days, Gentle Winds, and Even Temperature Make This a Wonderful Location for Aeronautical Experimentation

8218

CLIMATIC CONDITIONS PUT FABULOUS VALUE ON LAND

That the climatic conditions may justly be taken into account in fixing the value of a piece of land, was recently exemplified when the government purchased North Island, near San Diego, Calif. The island is to be used as a training station and air-craft base, its exceptional climate making it particularly suited for this purpose. Fifteen years ago North Island was merely a flat piece of land, worth probably \$5,000. Today it is an ideal aviation base worth \$5,000,000, this value being due primarily to the climatic conditions, which make it possible to carry on aeronautical experiments during the entire year, obtaining maximum results with minimum risks. With the rapid advances that are being made in science, who can say what will be the value of land which today is worth only a nominal amount?

TUBULAR-RIVET MACHINE HAS 8.52 INGENIOUS TELLTALE

Because of the small size of the drill used in making small tubular rivets, close attention to the drilling machine has been necessary to prevent the passing through of spoiled work, in case the drill should break. This has led to the development of a telltale that automatically inspects the rivets for proper drilling. The rivets being held in the V-slots, the drill and telltale are moved forward by a cam, and

if the rivet has not been properly drilled, the telltale pushes it into a compartment separate from the compartment for the properly drilled rivets. The telltale may be adjusted for different depths of drilling if necessary.

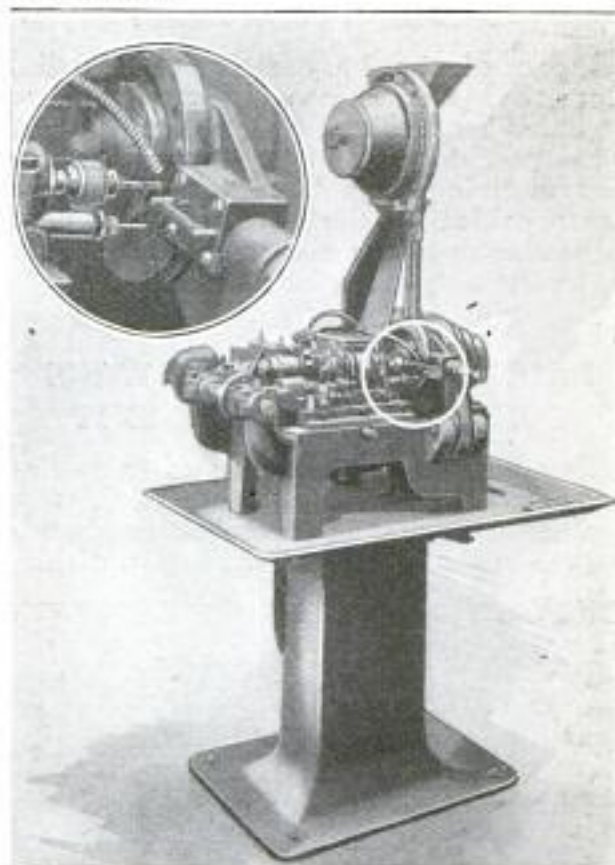

The Tubular-Rivet Machine: The Insert Shows the Drill with the Telltale below It. Improperly Drilled Rivets are Rejected by the Telltale

Reichel + ...

8.52 is copyrighted material
circled

8/82 **FIRST-AID BOX INSTALLED ON BUSY STREET IN BERLIN**

To care for the injured in case of accident, a first-aid box has been installed



Conveniently Placed near the Curb, This First-Aid Box Contains Essential Articles Which may be Needed in Case of Accident

on one of the busy streets of Berlin, Germany. One compartment of the box contains a stretcher, while others contain bandages, drugs, and necessary accessories for giving first aid. Advertising spaces are provided on the outside of the box. A road map to the nearest hospital seems to be the only thing lacking.

8/84 **LADIES' HANDBAG CONTAINS CONVENIENT FLASHLIGHT**

European manufacturers of novelties have added to their extensive lists a flashlight which is fitted into a ladies' handbag. On the outside of the bag, a nickel-

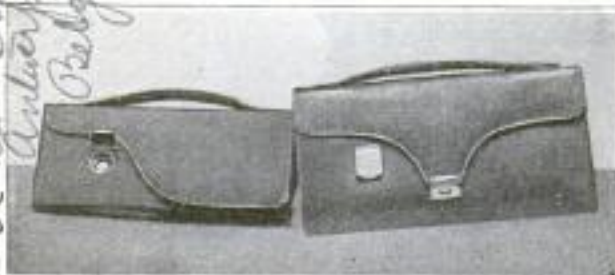

Left: Handbag with Snap Open Exposing Reflector of Flashlight. Right: Another Form of Handbag with Snap Cover Closed

*Emi. Maurice & Pignone
25 Place de la Bourse
Antwerp, Belgium*

*made in Germany
no record of mfr. made in*

plated snap cover, about 5/8 in. square, is placed, the opening of which discloses the reflector and also switches on the light. Inside of the article, a special compartment is provided for the accommodation of the battery.

8274 **TELESCOPE LONG IDLE NOW PUT TO USE**

Harvard College Observatory will soon put to use one of the largest telescopes in the world, which has been idle since its purchase 20 years ago, at which time it was declared unsuited for the work for which it was intended, because of certain features of construction. However, developments in the science of astrophysics, or astronomy, during the intervening decade, have served to find new fields for these instruments, so that now the 60-in. telescope can be utilized for special investigations of the stars and planets.

n-y. Post 10/22
COAL CHUTE INCLOSED

8168 **TO REDUCE DUST**

As a means of overcoming the dust and dirt nuisance attendant upon the unloading of slack coal, a Texas engineer has produced an inclosed chute. The chute, constructed of galvanized sheet steel and



Inclosed Chute Placed in Position over a Manhole for the Purpose of Unloading Slack Coal without Producing the Usual Dust

angle iron, has an opening at the top about 3 by 5 ft. square, tapers down to the size of an ordinary manhole at the bottom, and when in position, its height is the same as the common type of coal wagon.

According to recent estimates, 62,000,000 sq. yd. of concrete highway were laid during 1921, almost double the figure for the previous year:

*Emil. John R. Munn, Jr., 1619 Rowley St.
Dallas, Texas.*

Universal Leather Goods Co 442 W. Chicago

8181 Atlantic-Photo Co.
Berlin & W. H. Koeniggratzer
POPULAR MECHANICS
E. Haese 355 62

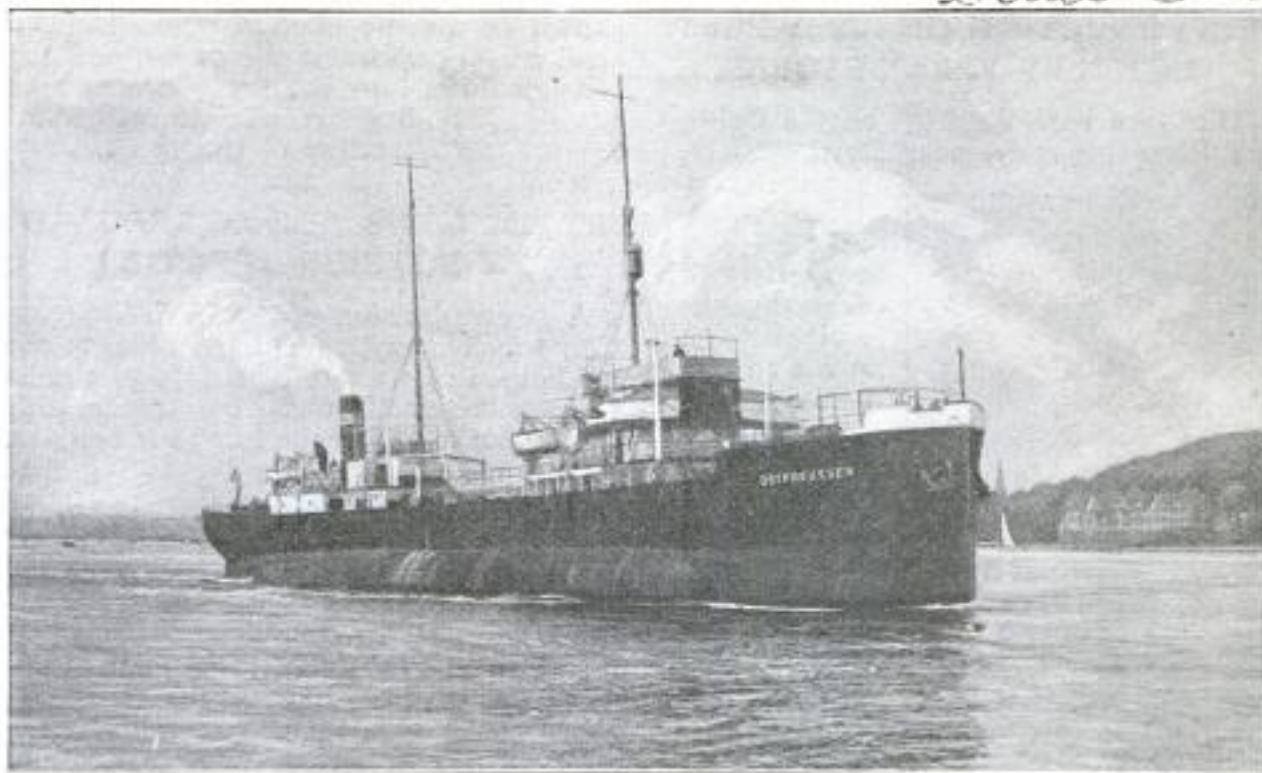

CONDEMNED U-BOAT HULLS CONVERTED INTO TANKSHIPS

A GOOD example of German thriftiness is their utilization of their condemned submarines. Out of the hulls of two of these U-boats they have built a twin-screw motor tankship, called the "Ostpreussen." A sister ship, the "Oberschlesien," which made its first trip with oil from Texas to Hamburg, encountered very bad weather, and proved its thorough seaworthiness. These ships were built at the Germania Yards at Kiel. They are the first attempts to convert U-boats into trading vessels.

8161 Parkinsons Ltd. Box 87 Revelstoke,
B. C., Canada.



FISH LADDERS ON RIVER OBSTRUCTIONS IN CANADA

FISH ladders are universal at dams and river obstructions in Canada, being compulsory by law. Therefore, they are comparatively more common there than in this country. A good example is one at Calgary, Alberta, at a dam on the Bow River. This ladder enables fish, in the spawning season, to surmount an otherwise impassable obstacle on their way upstream to the glacial waters in the Rocky Mountains.

Civil. Harold B. Day
Portland Telegram

Chicago Tribune
1/17/22

POPULAR MECHANICS

Portland Oregon

356
8229

REPRODUCTION OF LAMP-POST
IN ICE BY FREAK STORM

During a recent storm on the Columbia River highway, near Portland, Ore.,

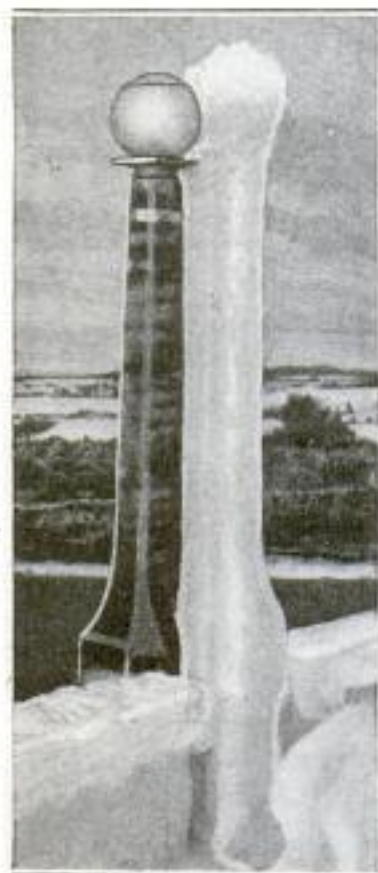

when rain froze as fast as it fell, some very freakish formations resulted. One particularly quaint, was at a substantial concrete lamp-post, high and very much exposed, where the wind blew so hard that it forced the rain away from the windward side of the post to the leeward, where it quickly froze. The accumulating frozen rain drops grew gradually larger and larger until finally an exaggerated reproduction of the post was formed in ice and snow.

aggregated reproduction of the post was formed in ice and snow.

CHECK PROTECTOR ON PEN
PREVENTS FORGERY

Protection against the activities of forgers is aided by the introduction of a new fountain pen, which has a check-protector attachment. The innovation consists of a small self-inking steel cutting wheel, which is built into the end of the pen, and exposed by unscrewing the cap. After the check is written, the cap is removed, and the red-inked cutter is



Top: Illustrating the Method of Using the Check Protector. Bottom: Cap of Pen Removed, Showing Steel Cutting Wheel of Protector

Kritikson Bros. Inc.
New York City

drawn across the filled-in amount. The steel wheel perforates the paper, and the red ink flows into the perforations; thus rapidly providing an efficient safeguard against any alteration of the check.

STATE LAWS ARE OVERRULED
BY FOREIGN TREATIES

A recent decision of the U. S. Supreme Court makes any state law relating to the holding of real estate by a foreigner subject to the conditions of a treaty with the nation to which the foreigner belongs. The decision establishes the ruling that the California law that prohibits an Italian from holding property in that state is invalid because it is in conflict with the treaty with Italy made in 1871.

ELECTRIC WATER HEATER HAS
HOT-WATER STORAGE TANK



For household use in the kitchen, bathroom, or laundry, a new electric water heater, in combination with a 10-gal. tank, heats the water in the tank in 30 minutes, and if necessary keeps the water hot for 24 hours or more. This is done by means of special insulation between the double shell of the tank on the same principle as in the fireless cooker. The heating elements are between these steel walls.

NEW NATIONAL FOREST
IN PENNSYLVANIA

According to an announcement of the U. S. Forest Service the Allegheny National Forest is to be created on the headwaters of the Allegheny River in northern Pennsylvania. The tract will consist of some 400,000 acres, of which, it is expected, at least 50,000 acres will be acquired during the coming year. The balance will be acquired as fast as appropriations are made by congress.

Engineering News Record 1/19/22
Copyrighted material
New York City

Studebaker Pen Co. 116 W. Illinois St. Chicago

Cook Electric Heating Co. 917 Blankfort Ave

8279

CHAMPIONSHIP EXHIBITIONS OF SKI JUMPING

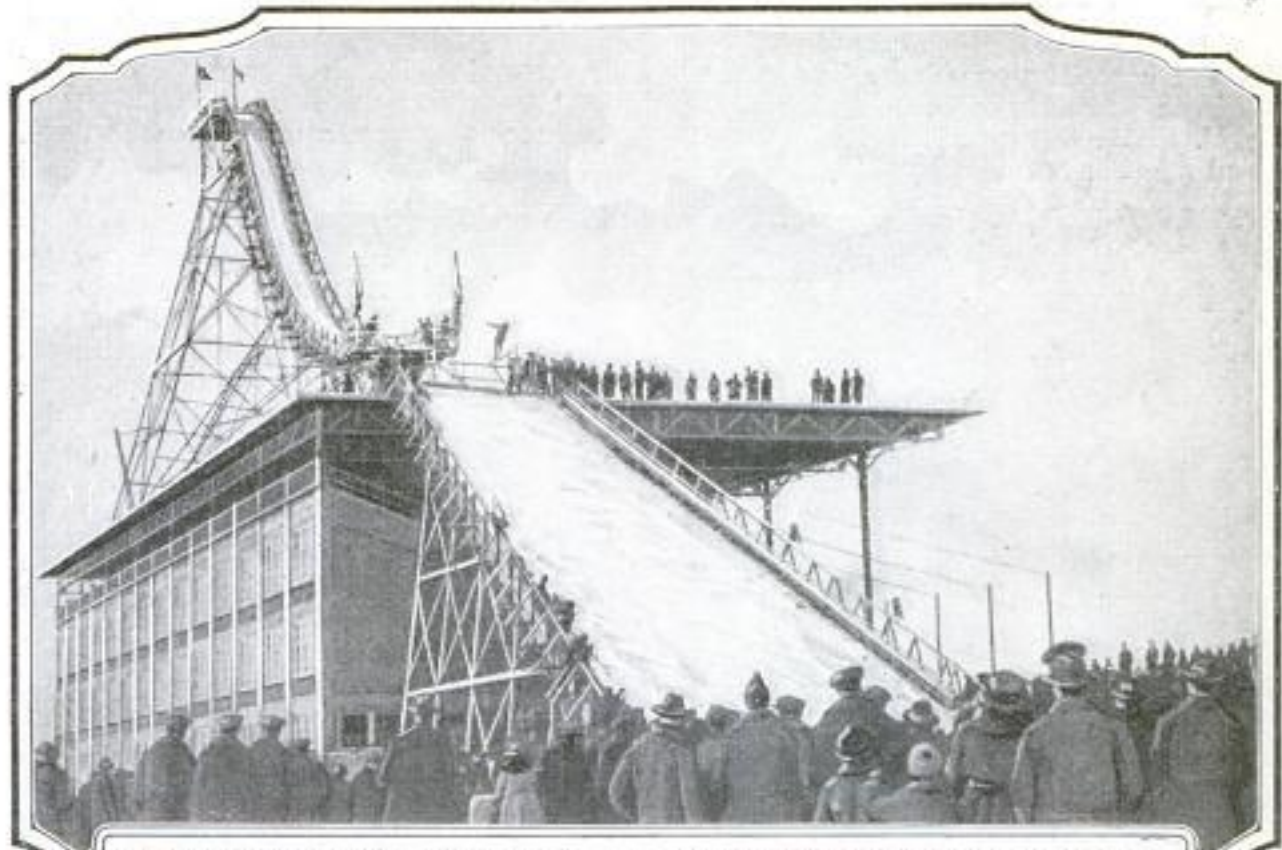

This is the Largest Ski-Jumping Slide in the World and is Located at Calgary, Alberta, in Canada. It is Constructed of Steel, upon the Roof of the Provincial Exhibition Building, and Rises 150 Feet in the Air. One of the Ski Jumpers can be Seen Just Leaving the Bottom of the Slide, Which Affords a Sheer Jump of 150 Feet

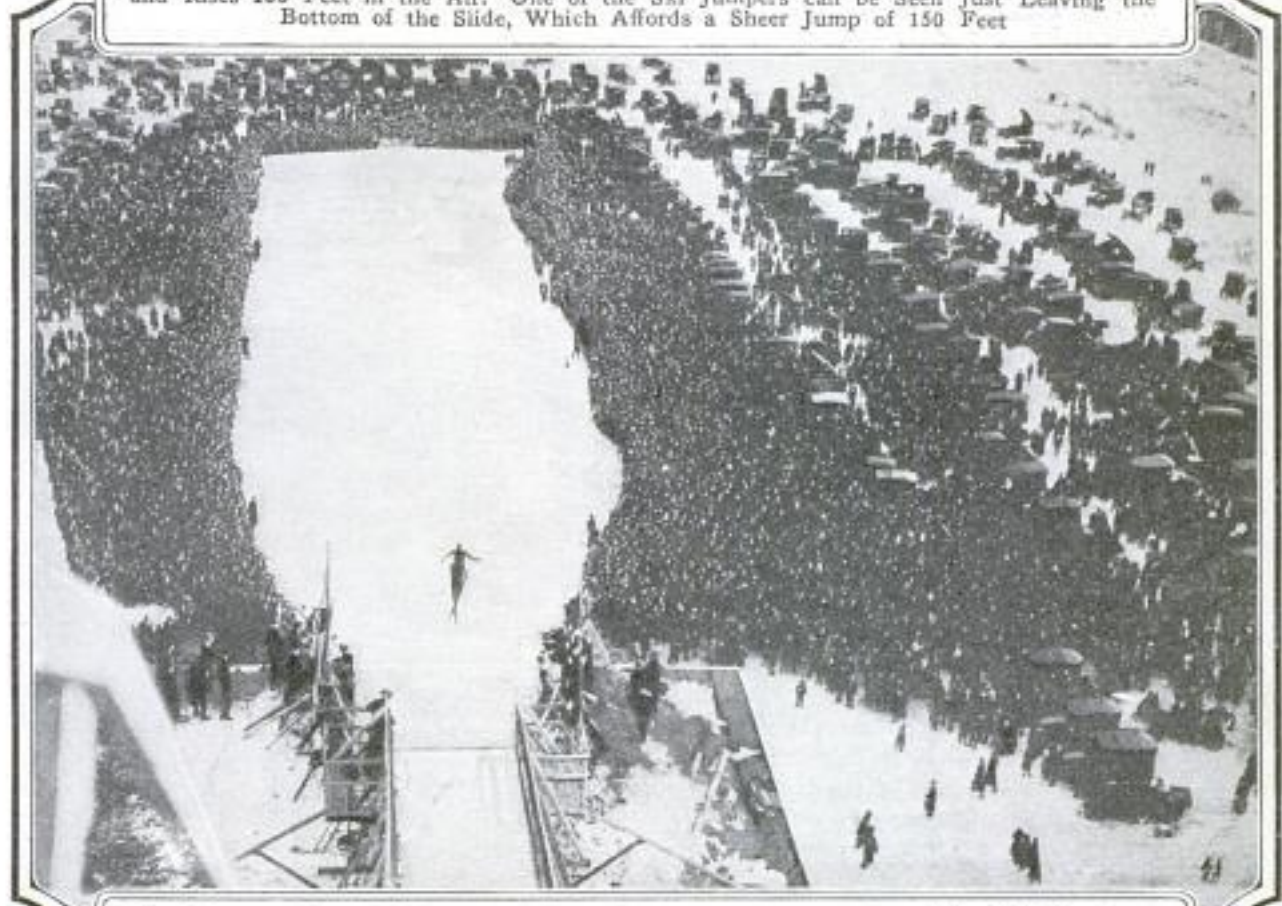

The Mammoth Steel Ski-Jumping Slide as It Appears from the Top of the Tall Structure: In the Foreground can be Seen a Jumper in Mid-Air. Around the Base of the Slide are Gathered Many Thousands of People Who Stand in the Snow and Bitter Cold to Watch the Championship Events, Which Always Arouse the Greatest Interest

MINING METHODS APPLIED TO DAM CONSTRUCTION

BY S. R. WINTERS

*402 District
National Bank Bldg Washington
D. C.*

IN the construction of the Tieton dam of the Yakima project in Washington, the U. S. Reclamation Service will have added another noteworthy achievement to

230 ft. and a length along the crest of 900 ft., with a top width of 25 feet.

A concrete corewall will extend through the full length of the dam and from its

crest into the bedrock. The nature of the bedrock encountered will determine the depth to which the corewall will be extended, but in all cases it will be carried to a point where a solid footing is assured. Below the ground level, the corewall will be 5 ft. thick without reinforcement. Above the ground level, it will taper from 5 ft. at the base to 1 ft. at the crest, and will be heavily reinforced. During the placing of this corewall the river is being carried in a diversion tunnel, 2,200 ft. long and approximately 21 ft. in diameter, which will later be used as part of the water-control system.

The excavation for and placing of the

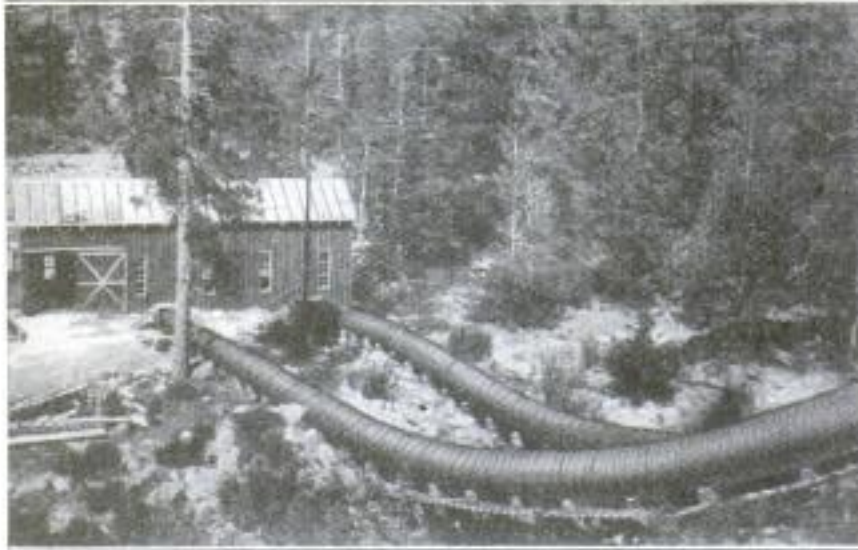

During the Construction of the Diversion Tunnel, a Temporary Power Plant was Installed Which, Taking Water through a Stave Pipe, Converted It into Electric Power to be Used for the Power Shovels and Rock Drills

its already long list. The dam itself will be one of the largest earth dams in the United States, having a visible height of



Site of the Tieton Dam, Which will Rise to a Height of 230 Feet, Being One of the Highest Earth Dams in the United States: A Corewall of Concrete will Extend through the Center of the Dam for the Full Width of the Cañon

7753

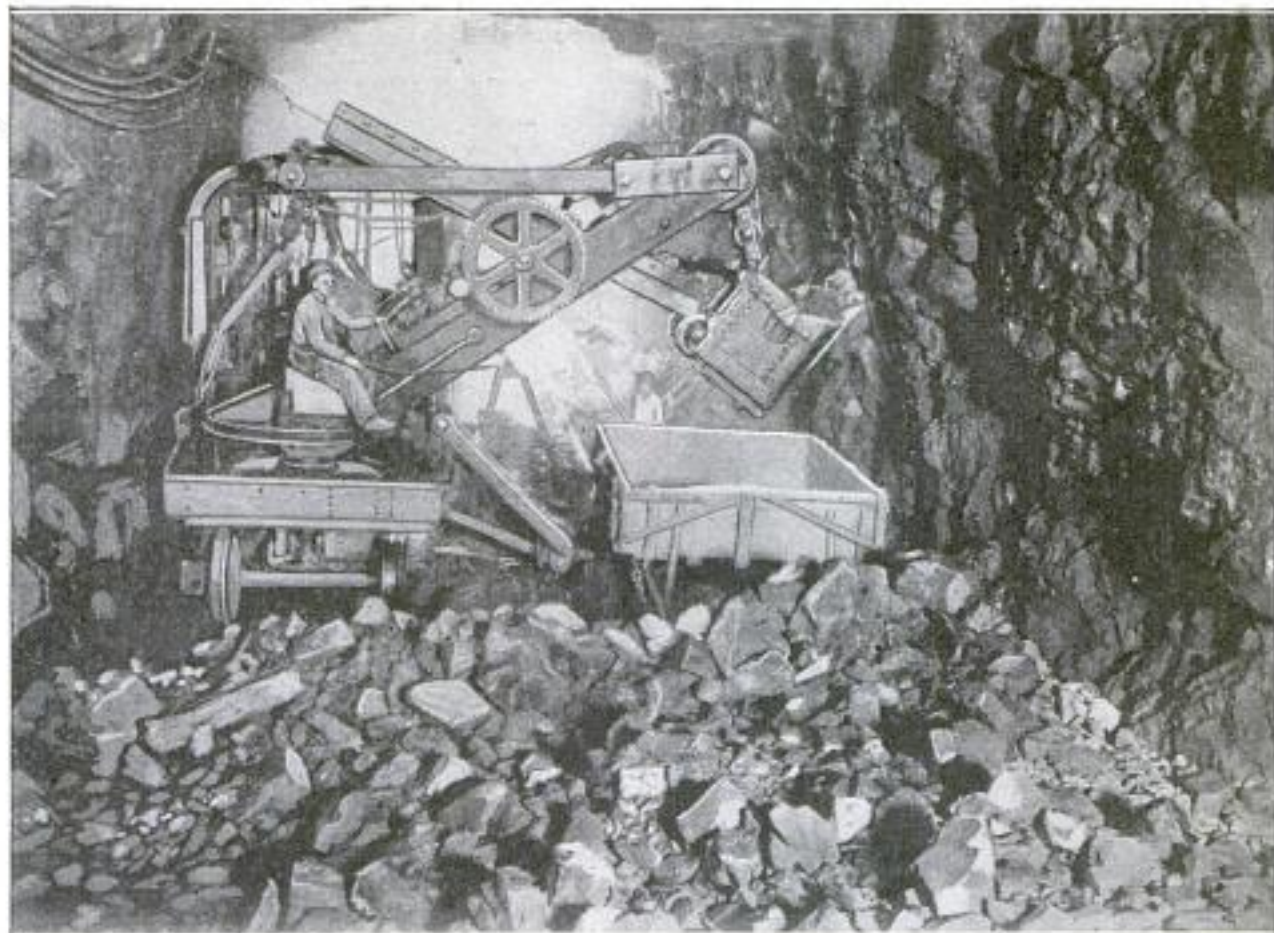

Remodeled Power Shovel with Short Boom, Used for Loading Cars during the Construction of the 2,200-Foot Diversion Tunnel: This Tunnel is Driven through the Solid Rock and Is Approximately 21 Feet in Diameter

corewall is one of the features of the work. In the river bed it will be necessary to excavate to a depth of approximately 110 ft. in order to secure a proper foundation. The following method is being used: Three shafts are sunk from the surface of the ground into the bedrock. At the bottom of each shaft a large sump is cut and a pump is installed. Drifts, 6 ft. high and 5 ft. wide, are then driven in both directions along the line of the corewall. The depth of these drifts in the bedrock depends on its nature and contour, but in no case is it less than 5 ft. After the lower drift is completed, a second drift is driven immediately above it. The material from this second drift is broken down into mine cars placed in the lower drift, and from there is taken to the shaft and hoisted to the surface. After the two drifts are completed, the lower drift is filled with concrete from cars running in the second drift. A third drift immediately above the second drift is then driven, and the process is repeated until the surface is reached. This method, known in mining as "stopping," while unusual in dam construction, has proved very satisfactory and has shown marked advantages over the open-trench method.

The embankment will be a hydraulic fill blanketed with rock, the upstream slope with a 3-to-1 grade, and the downstream slope 2 to 1. Material will be brought from borrow pits to a central pool, where a pump will be installed. The fine clayey material will be pumped against the upstream side of the corewall, while the fine sandy material will be placed against the downstream side. The completed dam will contain nearly 2,000,000 cu. yd. of material, and will create a reservoir having a capacity of 202,500 acre-feet.

823 / AIRPLANE HELD MOTIONLESS BY WIND OF HIGH VELOCITY

One of the airplanes of the Air Mail Service was recently caught over Mineola, L. I., in a gale of such violence that it was almost impossible to make any progress against the wind. By careful handling, the airman was able to make a landing, nosing down in an almost perpendicular line with his engine running at full speed.

Our Bureau of Information will answer all questions regarding articles appearing in this magazine.

Bell + Howell Co
1803 Marchmont Ave.
Chicago

La Nature 12/3/21
120 Boulevard de
Serravallo
Paris France

360

POPULAR MECHANICS
8196
**LIGHT-DENSITY CONTROL
FOR FILM PRINTER**

8022

**REINDEER ACCLIMATIZED
IN BAFFIN LAND**

In printing moving-picture positives it has been found that as many as 22 different degrees of light intensity may be nec-

So complete has been the success of the acclimatization of reindeer in Alaska, that the Canadian government has been tempted to do the same thing in Baffin Land, that great barren island situated between Hudson Bay and Davis Strait. For this purpose herds of reindeer have been bought in Norway, and Laplanders have been engaged for a period of three years to take care of the animals. Six Lap families and their herds embarked, late last fall, at a northern Norwegian port, on a ship specially equipped for their transport.

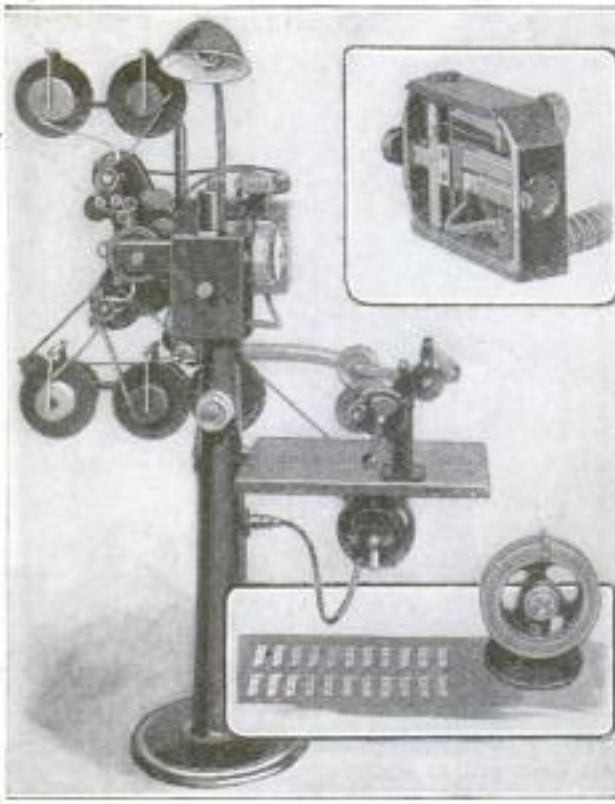

As Film is Printed, Control Keys in the Dial Change the Volume of Light as Necessary

essary in a single reel to compensate for the different densities of the negative. Up to date it has been necessary for an operator to change the amount of light as required by a manual control, but this is now done by a control device which is mounted upon the disk and in which a different key is inserted for each necessary change of light. As each key comes into position, the light density is automatically changed by electrical control of the shutter.

8209
**TIMESAVING DEVICE SPEEDS
SALES OF RAILWAY TICKETS**

On systems such as the elevated railways of large American cities, where a flat-rate fare exists for all destinations, passenger tickets are dispensed with, but in a system such as the underground railways of London, Eng., where the fares vary with the destination, tickets are essential. In these conditions, every second saved in issuing tickets is of importance, and a new device is now being tried out that automatically dates the tickets, clips them, and at the same time registers the

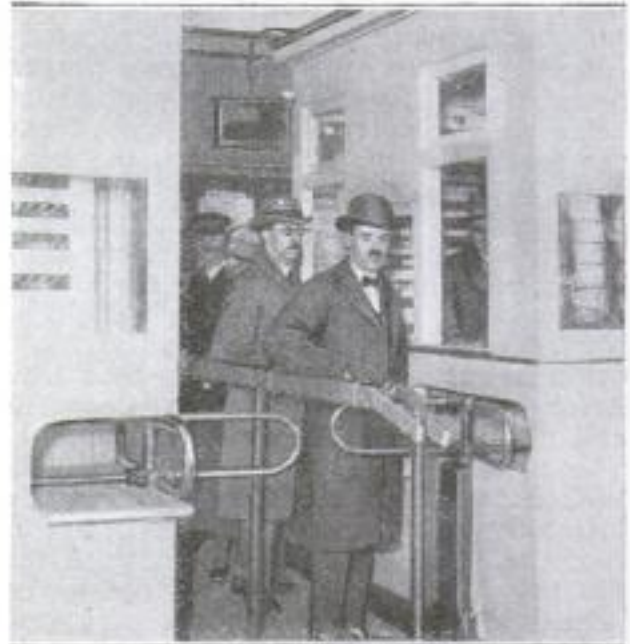

Timesaving Ticket-Selling Device being Tried Out on the Underground Railways of London, England: Tickets are Dated, Clipped, and Recorded Automatically, Before the Buyer Passes the Self-Registering Turnstile

8261
**METAL OXIDATION PREVENTED
BY ALUMINUM TREATMENT**

A process for preventing the surface oxidation of metals or alloys exposed to high temperatures has recently been patented. The metal to be treated is placed in a retort filled with fine-powdered aluminum and heated to redness. The aluminum penetrates the surface of the metal, and when exposed to high temperatures after this treatment, the surface becomes coated with a layer of aluminum oxide, which prevents further oxidation of the metal beneath.

operation on a cyclometer, before allowing the buyer to pass a self-recording turnstile.

General Electric Co. Inventors
Schenectady, N.Y.

The Engineer 12/30/21

Wide World Photos
229 W. 43rd St. New York

Users of process } E. S. Doljambé } 1122
 } J. C. Hall } Washington
 } } Calif. - La



Los Angeles
 Calif.

This Seven-Room Bungalow, with all Modern Conveniences, was Built by the New Cement-"Shooting" Process and Has Walls Five and Six Inches in Thickness. The Surrounding Garden Wall Is Only Two Inches Thick and Has Seats Constructed into It in Such a Manner That the Whole Is One Solid Mass

"SHOOTING" HOUSES FROM A "GUN"

BY CLEVELAND GAINES

Concrete Work

"SHOOTING" houses out of a "gun" is the startling latest wrinkle in concrete construction. This radical method of building dwellings in short order, not only has proved successful in the first two houses on which it was tried, but has shown itself to have a number of advantages not possessed by other methods of construction. The gun itself consists of a nozzlelike affair at the end of a 3-in. hose. Dry concrete is put into a container and water forced through it. The mixture is thus made at the last moment before it is applied.



Interior of the Bungalow, Showing the Method of Shooting the Concrete around the Door and Window Frames

In building the first of the houses in this fashion, a one-sided framework of tar paper and chicken wire was erected. Iron reinforcing rods were placed against this and the concrete shot against it with the use of the gun. A wall 2 in.

thick was "shot" in this way, allowed to dry, and the tar paper and chicken wire peeled off. The result was a solid concrete wall. Doors, windows, and plumbing were put in place and the wall shot around them.



Exterior of the Bungalow, Showing One of the Outer Walls before Shooting the Concrete Mixture against the Framework

In similar fashion, ceilings, floor, a fence around the yard, and other parts of the house and yard were shot. Seats were shot into the wall at one place, decorative designs in another, and so on. The resulting house and yard was a complete home in one piece—a monolith.

The second house built with the gun employed wallboard in place of tar paper and chicken wire, with even better results, for the former was much

main office - The Cement Iron Co., Allentown, Pa. Copyrighted material

*4 1/2 Mason Pella
 (C. and C. Home) Los Angeles
 Calif.
 Winter Concrete Bungalows Co., or
 Los Angeles
 Calif.*

more quickly put into place, ready for the gun work. It is probable that this will be the method of forming the framework against which to shoot the concrete, which the inventors will finally adopt.

With the gun method, the walls of a five-room bungalow can be completed in two days. The concrete is applied at a pressure of 30 lb. to the square inch, thus packing it as no other force could do. Concrete improperly mixed is automatically rejected—it does not stick—therefore there is no chance of imperfect materials going into the house. The concrete is practically mixed at the instant of application; thus there is no loss of strength in the concrete, due to partial drying before it is applied. These are a few of the outstanding advantages of the shooting method of house erection. There are many others which must be obvious. It is not necessary to mention the great saving of time effected through the fact that there is no need of building forms into which to pour the concrete, nor the saving effected by having no waste of lumber, such as is the case where forms must be built of wood.

There is no need of detailing the innumerable possibilities or advantages of the method, nor to draw upon the imagination to illustrate them. The few high lights mentioned do that sufficiently. There is no limit to the thickness of the structures shot by the gun—it is simply a case of shooting on more concrete until the desired thickness is attained. In the first house, one of the garden walls is 6 in. thick.

Concrete engineers are of the opinion that this method of applying concrete will eventually replace that of pouring it in forms, as is common at present. There seems no logical reason why it should not, and the many advantages it offers make it very desirable that it should do so. Within a few years, all concrete construction may be by the gun method.



Garden of the Bungalow, Illustrating Some of the Ornamental Effects Obtained by Using the Cement-Shooting Process

8262 — *Signal*
NEW SUBMARINE CABLES OF GREAT CAPACITY

Two new cables to be laid during the year, one between New York and Germany and one between San Francisco and Japan, will have a sending capacity at least six times greater than that of the present cables, if the claims of the engineers are fulfilled. One great difficulty in submarine cables has been the loss of current through leaks and faulty insulation. Recent research has developed an alloy of steel which, it is claimed, will prevent this seepage, and this new alloy is to be used as the insulating cover for the copper core in the new cables. With the seepage loss reduced, the strength of the sending current will be increased, and the speed of sending messages will consequently be much greater.



Another View of the Bungalow Garden, Showing a Corner of the Surrounding Wall into Which is Built an Artistic Seat. The Wall and Seat are Constructed in One Solid Mass

That the Panama Canal is being used to advantage was recently proved, when a new high record for commercial tonnage passing through was set. Eighteen merchant vessels carrying cargo of more than 76,000 tons and yielding revenue of nearly \$80,000 passed through in one day.

*N.Y. Times 1/11/12 8.1
Commercial Cable Co.
20 Broadway New York*

N.Y. Times 1/18/22 P. 15 *Mfr. Bell + Howell Co*
Chicago Tribune 1/23/22 P. 13 *1804 Larchmont*
Ar. Chicago

8271

SNOW REQUIRED FOR SKIING TRANSPORTED BY TRAIN

With one of the largest ski slides in the world, a structure 115 ft. high, built on top of the highest hill at Fox River Grove, near Cary, Ill., and with a chute 360 ft. long, everything was ready for the most sensational kind of skiing at the National Ski Tournament—everything except the snow. The absence of this quite indispensable element in the performance of skiing did not prove to be an insuperable obstacle to the success of the tournament. The Norge Ski Club, which was in control, followed the example of Mohammed, and as the snow would not come to them, they went to the snow, situated in ample quantities at Baraboo, Wis. Thence they brought it by train—10,000 loads of it—displaying their utter independence of the weather man. Although the slide was not in such perfect condition as it might have been, the tourney, which was held on January 22, and attended by 20,000 onlookers, proved to be one of the best ever staged in the history of ski sport. In order to make up for his remissness in the matter of the snow, the weather man provided perfect atmospheric conditions.

METAL END FOR GAS TUBING FITS ANY HOSE CONNECTION

A metal end for gas tubing that will fit any-size hose connection on any stove, hot plate, or gas fixture, without any other adjustment than screwing it tight.



is composed of a thin metal ferrule, partly threaded, and with four longitudinal slots that make it compressible. Over this ferrule is a hollow nut, threaded at one end and tapered at the other, so that when it is screwed on the ferrule, it compresses it and the hose end as tightly as desired on any gas connection, making it leak-proof.

Atlantic Tubing Co
Providence, R. I.

CAMERA ATTACHMENT TAKES "SLOW-MOTION" PICTURES

Formerly a specially built camera was required for taking "slow-motion" mov-

Right: Interior of Camera, Showing the Chute Effect for Carrying Film. Below: Left, Special Mechanism for Carrying the Film Past the Lens; Right, Arrangement to Which the Crank is Attached and Which Gears Up the Speed to a Ratio of Eight to One

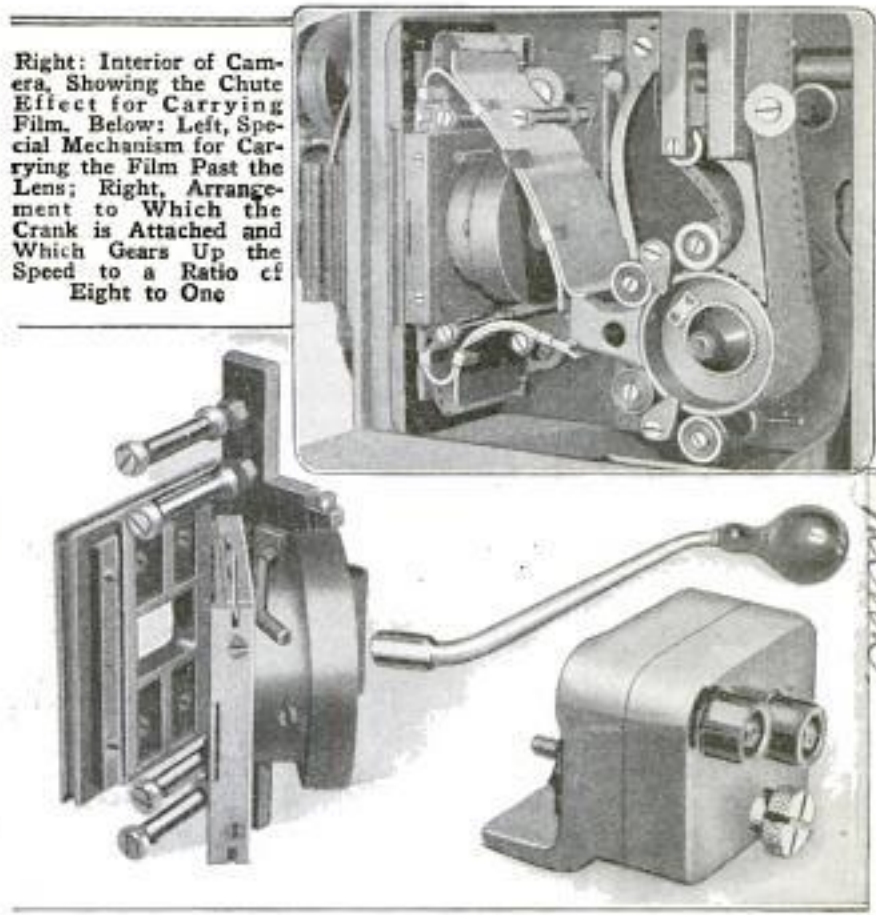

ing pictures, produced by running the film through the camera at high speed and projecting it at normal speed. Now an attachment is available by the use of which any motion-picture camera will produce films at the rate of 128 to 200 exposures per second, instead of 16 per second, the normal rate. A special shutter mechanism is used, and a gear which gives eight revolutions of the driveshaft to one of the crank. For carrying the film to and from the lens, an extra-heavy chute is used, to withstand the strain and eliminate vibration and static electricity due to friction. The device can be attached or removed in about one minute, and when removed, the camera may be used in the regular way without further change.

Popular Mechanics Magazine does not publish the name of maker or seller of any device described in its pages, but this information is kept on file and will be furnished free by addressing our Bureau of Information.

Carl. Arthur Halstead
317 Cedar Ave. Newmarket
Virginia

Cml E H Lemonon, 27, Rue d'Engliën,
Paris, France.

Armandus. Lucas

364

POPULAR MECHANICS

P133

AUXILIARY STARTING ENGINE FOR AIRPLANES

Anyone who has seen a large airplane engine started by turning the propeller

by hand knows what a strenuous and dangerous task this is. To make this dangerous practice unnecessary, the auxiliary starting engine has been developed. It consists of a single-cylinder air-cooled engine mounted on the same shaft with a pump. The pump draws a rich mixture from the auxiliary carburetor and forces it under pressure to the proper cylinder of the main engine, through a distributor which is geared to the main-engine shaft. This causes the engine to start revolving, and, ignition being furnished from the auxiliary magneto, after one or two revolutions the engine begins to fire, and thereafter will be supplied with gasoline and spark from its own carburetor and magneto.

This Auxiliary Engine Starts the Main Airplane Engine by Pumping the Gasoline Mixture under Pressure into Each Cylinder Successively and Firing Same

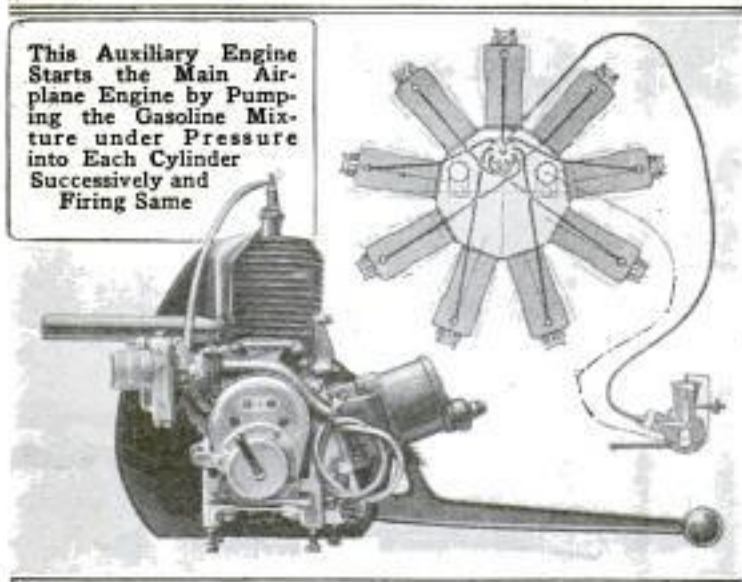

8276

"CONVERSATION" UNDERSTOOD BETWEEN BLIND AND DEAF

24 Times

1/22/22
P.14

Two blind and deaf girls who have attained world-wide fame, recently carried on a "conversation" by placing their hands on the face and chest of the other, to interpret the vocal sound vibrations. Miss Willetta Huggins, of Janesville, Wis., and Miss Helen Keller were the principals in the demonstration, and each was easily

able to understand the meaning of the other. Miss Huggins also possesses the peculiar ability of distinguishing colors by her highly developed sense of smell, as described in the January, 1922, issue of this magazine.

Subjecting glass in the soft state to a pressure of 3,000 lb. per square inch, to eliminate bubbles, is the basis of an application for a British patent.

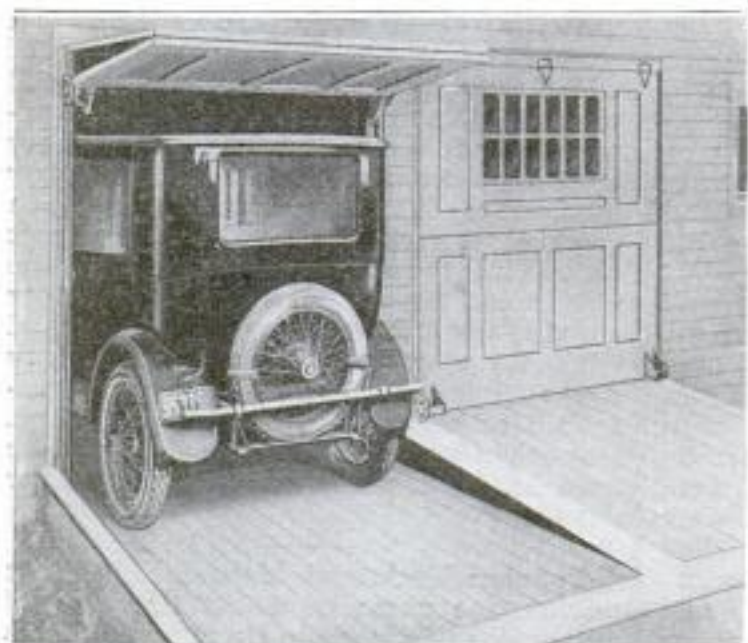

Garage Door That is Automatically Opened by Weight of Car on Hinged Platforms, of Which One is Placed on Either Side of the Doorsill, and Closed When the Weight of the Car is Removed from Both Platforms

7801

GARAGE DOOR OPENS AUTOMATICALLY BY WEIGHT OF CAR

Quite a simple form of automatic garage door that is opened and closed by the action of a car entering a garage or leaving it, is composed of a door, pivoted at the top, that folds horizontally at its center, and is raised above the top of the car by the depression of a hinged platform. There is a platform on each side of the doorsill for entry to, and exit from, the garage. The downward movement of the platform raises the door by means of pulleys and small guide wheels, and when the weight of the car is removed from both platforms, the raised door falls to a closed position by gravity, and automatically locks itself.

Edw. Arville C. Johnson, Acars, Ill.



Above: Left, One of the Halves of the House Which was Cut in Two Parts, as It Appeared When Finished and Ready for Occupancy; Right, the Other Half of the Dwelling after having been Given a Covering of Tar Paper While Waiting for the Carpenters to Begin Remodeling. Below: The House Immediately After It had been Severed in Twain, with One of the Halves being Moved to a New Location. The Unusual Undertaking was Made Possible by the Substantial Manner in Which the Old Mansion was Originally Constructed



7990 Alteration
TWO HOUSES MADE FROM ONE *Crankcase*
TO MEET HOUSE SHORTAGE *8/45* **OIL-TESTING INSTRUMENT** *rel. 40*
FOR AUTOMOBILE ENGINES

An ingenious method of meeting the housing shortage was displayed when an architect and a contractor in Pittsfield, Mass., made two houses out of one. Like most communities, Pittsfield has been seriously affected by the lack of house construction during the past few years, and like many towns, especially in New England, it contains a number of large houses, the old mansions of some of the early wealthy families, built in the days when good material and good workmanship were inexpensive. When the owner of one of these residences died, it was closed up and offered for sale. Its 20 rooms, with the attendant expense for care and heating, were too much for any of the present-day families, and it remained empty. Finally the plan of cutting it in two was hit upon. The halves were moved to new locations and finished as separate houses, of nine and ten rooms. Because of the fine construction, they were unusually desirable and easily sold, at a price which yielded the contractor a very profitable return on the investment.

An instrument, similar to a hydrometer that measures the density of water, has been specially designed for ascertaining the condition of the lubricating oil in the crankcase of an automobile engine. On its graduated stem it has a thin celluloid sleeve which can be raised or lowered. On this sleeve are four horizontal spaces denoted successively: good, fair, poor, and dangerous. Any convenient container, such as a pint measure, is first filled with new oil of the kind used in the crankcase. Into this the instrument is placed, and the sleeve is adjusted so that a line marked "new oil" is just at the surface. The instrument is then placed in the used oil to be tested, and the condition of the oil is indicated on the stem by the depth to which the instrument sinks. The "new-oil" line is on the sliding sleeve just below the space marked "good."



S. S. Jackson Co. material
29 N. La Salle, Chicago

4674

366

Mr. Clifford L. Burdick
Berrien Springs Mich
Auto. Mech.

The Engineer
10/14/21

POPULAR MECHANICS

8/93

PNEUMATIC TIRES FOUND WELL INFLATED AFTER SIX MONTHS

RAILWAY SYSTEM OF MOROCCO CHANGED TO NORMAL GAUGE

In one case, at least, automobile tires have remained well inflated for six

Transportation in the French zone of Morocco has heretofore been accomplished over narrow-gauge railways, which were originally constructed for military purposes. With the throwing open of these railroads for commerce, it was quickly discovered that the narrow-gauge type was incapable of handling the constantly increasing amount of traffic. Therefore it became necessary to build roads of normal gauge, and accordingly a program was started which will give the country approximately 720 miles of track, when completed. Coal-burning locomotives will be used in the beginning, although electrification of the system is under consideration, as is the use of oil-

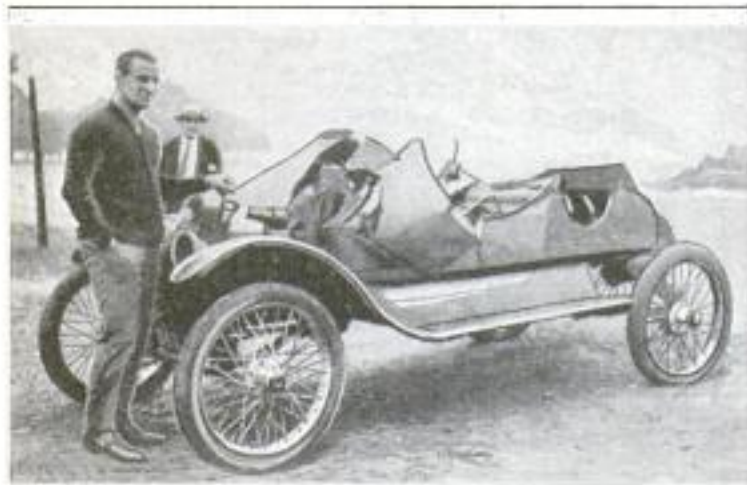

Racing Car Just after having been Dragged from a Lake Bottom Where It had Reposed for Six Months: Note Fully Inflated Tires

months. Two machines were racing on the ice on Lake Winnebago, at Oshkosh, Wis., when one car suddenly broke through. The driver escaped, but the machine went to the bottom. More than six months later, a reward of \$50 was offered to anyone who located and recovered the machine. By dragging the lake it was found in 18 ft. of water. A diver fastened a chain to the axle and a tug dragged it ashore. The tires were found to be fully inflated. After six months on the bottom of the lake the machine was taken to the garage on the old air.

burning engines, should recent indications of an oil field in Morocco prove to be of substantial worth.

8065
IMPROVED VENTILATOR COWLS PRESERVE SHIPS' CARGOES

An improved ventilator cowl has been tried out on several Pacific liners and found very satisfactory. The improvement consists of a simple appliance on the inside of the mouth of the cowl which prevents rain or spray, or even sea water shipped in heavy weather, from running down an open ventila-



tor. This allows uninterrupted ventilation in the holds, with the result that there is no damage to the cargo from sweat, as is common with ordinary ventilators that have to be closed in heavy weather.

The Popular Mechanic's Bureau of Information offers its free service to all readers of our magazine. Names and addresses of manufacturers and dealers in articles described, and any other details in our possession will be promptly furnished by addressing the Bureau.

Mr. J. M. Brown
1402 9th Ave. N.E.
Seattle, Wash.

821
SANITARY MILKING STOOL FOR MODERN DAIRYMAN

In the modern dairy, with its sanitary conditions and white-clad attendants, the old-fashioned milker's stool would be entirely out of place, but an aluminum stool which can be sterilized is now available. A hole through the seat makes it possible for the milker to carry the stool over his arm and still have both of his hands free.



Lafayette Blvd
Vermont St.

John W. Ladd Co., Shelburne, Vt.

La Nature 7/31/21

Western Envelope Corp. 65 Hope St.

8198

POPULAR MECHANICS

8080 Brooklyn, N.Y. 367

REPRODUCING ORGANIC CELLS FROM INORGANIC SUBSTANCES

EIGHT GAMES TO BE PLAYED ON THE PHONOGRAPH

Remarkably successful experiments have been made by a Mexican scientist in the artificial reproduction of organic cells from inorganic substances. The biological importance and general presence of fluoro-silicates in cells and tissues have been recognized for some time. In his work of reproduction, the Mexican scientist placed a drop of silicate under a thin plate to which pressure was applied by placing on it a weight of 50 lb. Under a contiguous plate a drop of chloride of calcium was subjected to pressure by a weight of 11 lb. These plates were covered by a glass vessel containing wet rags. The outside of the vessel was coated with plaster, as commonly done by chemists on retorts, to prevent the drying out of the solution. After 24 hours the product was washed, colored, and mounted on balsam, when microscopic inspection showed it to have a remarkable likeness to living cells.

Playing games on the phonograph is the latest form of amusement. A card-board disk is placed on the turntable.



Playing Games by the New Method of Placing a Card-board Disk on a Phonograph: Inset Shows Appearance of Disk and Indicator Used

8247 LIGHTWEIGHT CASH REGISTER IS ADDING-CHECKING MACHINE

A very compact little machine which combines the functions of a cash register, adding, and checking machine, has recently been invented. Used as a checking machine, it is light enough to be easily supported with one hand while the keys are operated with the other hand, yet it is of substantial construction. There are no levers to manipulate, and there are less than 100 working parts, all told. The cash drawer is operated by a push button on one corner of the machine.

This disk has eight circles of letters, numbers, colors, and so on, printed on it. A strip of cardboard, with a hole at one end, is placed over the center pin of the turntable and its other end bent down to support it clear of the disk. This strip has an indicator printed on it for each circle on the disk. The turntable and disk are revolved and stopped. The games progress according to directions and the signs pointed out by the indicator.

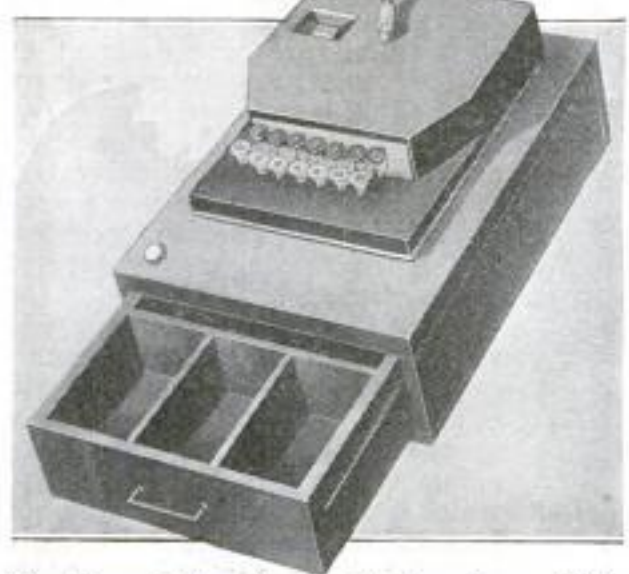

Two Rows of Keys Control the Operations of This Combined Cash Register, Adding, and Checking Machine, Which Weighs Less Than Five Pounds

8173 DUST-PROOF RUBBER CAPS FIT AUTOMOBILE-TIRE VALVES

Dust caps for the tire valves of automobiles are now being made of rubber. They are made so that they slip onto the valve stem tightly, without any screwing, and are as secure and dust-proof as a metal cap. Being made of rubber, they are, of course, rust-proof as well.



Letter sold to reader 4/13/26

Wagon Rubber Co. 1000 W. 1st St. Chicago

Illinois Paid Adding Machine Co. Copyrighted material R. 840, 1st National Bldg. Chicago

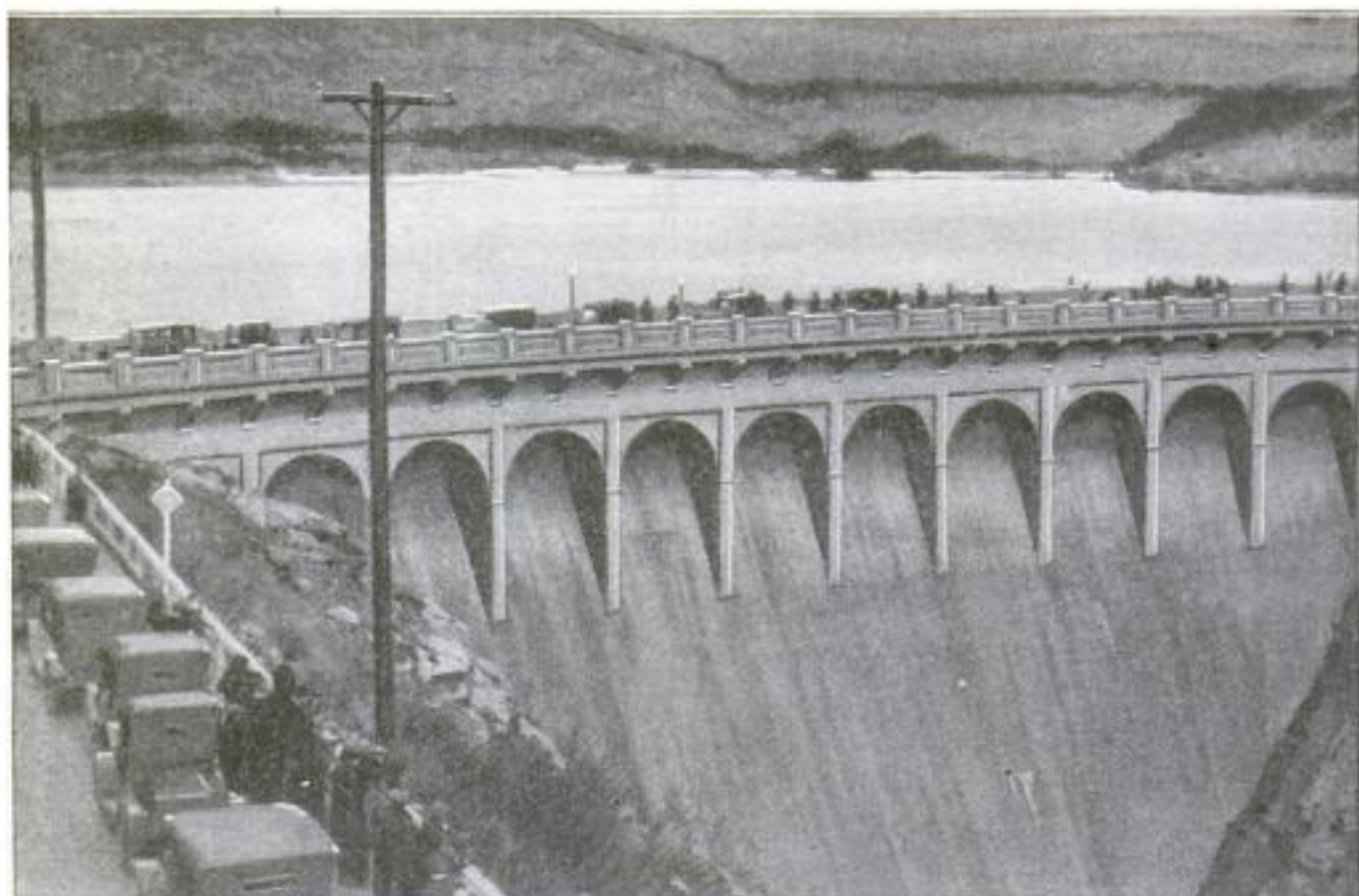

Panoramic View, Showing the Huge Dam with the Automobile Drive on Its Crest: The Lake Formed by the Impoundment of the Spillway at the 89-Foot Level, and Some Idea of the Size of the Steps may be Had by Comparison with the People

MUCH WATCHED DAM PROVES SUCCESS

By FRANK B. HOWE

IT will be remembered that some time ago there was chronicled the completion of the Devil's Gate dam in southern California, a piece of engineering involving several new and radical features, whose construction was examined with the greatest interest by engineering experts. With the completion of the dam, there remained nothing to be done except

to wait for a storm to see how the innovations would work out in practice.

The test was more than the contractors bargained for. It so happened that the greatest flood southern California has had in 32 years came along to do the work. In three days, a lake 2½ miles long and three-quarters of a mile wide had formed behind the dam. Heretofore storm waters had gone rushing down the Arroyo Seco, spreading destruction as they went, and causing great loss of life and property. Instead, this time the huge dam held the entire mass of water. As an ordinary dam, it was a success, but the greatest interest lay in the functioning of its several special features.

At 89 ft. a large concrete spillway had been constructed around one end of the dam, to carry off overflow water and prevent a great accumulation of water from going clear over the dam, on top of which is an automobile boulevard. It had been expected that this spillway would rarely be needed. The unexpected storm, however, showed the extreme wisdom of



The Outlet of the Flood-Control Tunnel is Located at Some Distance down the Cañon in Order That the Released Waters Rushing Out may Not Undermine the Foundations of the Dam

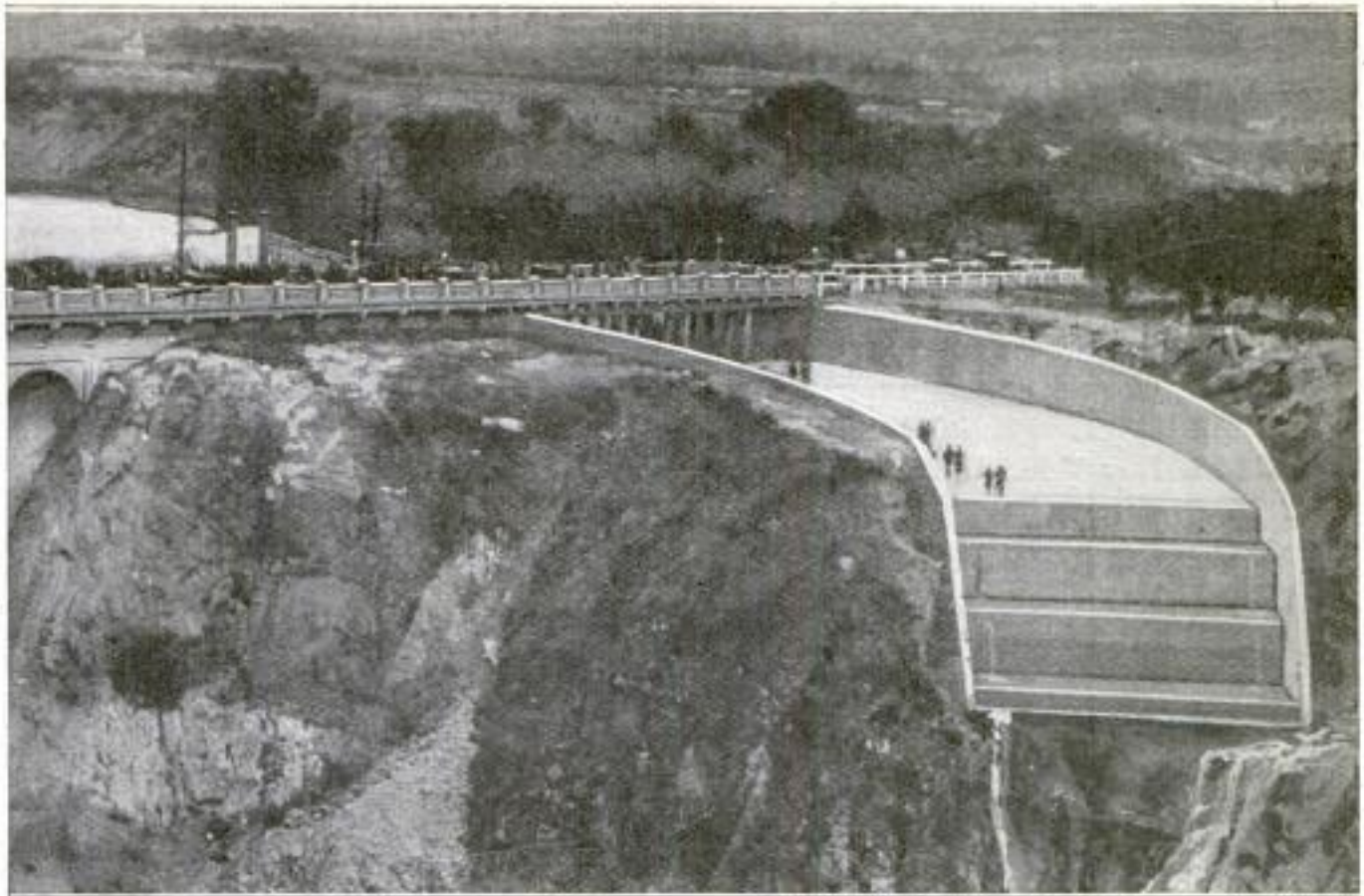

ed Waters Is Two and One-Half Miles Long and Three-Quarters of a Mile Wide. The Giant Stairway at the Right Is Who are Walking along It. The Spillway is Used Only as an Auxiliary Means of Controlling the Height of the Water

the structure. The water rose to the 89-ft. level on the third day and started to gush over the spillway in great quantities. Here is where the second feature of the dam came in.

An outlet tunnel had been built from the bottom of the dam, not to the other side, but sufficiently far down the cañon from the dam, to prevent its opening from causing a rush of water that might undermine the dam. As the water reached the top of the spillway, this outlet tunnel was opened and the water kept just under the spillway level by drain-



The Spillway Acts Only as an Emergency Overflow in Case of a Sudden Rise of Water in the Storage Reservoir



The Dam Presents a Curved Surface on the Upstream Side and Has the Appearance of a Concrete Wall along a Lake

ing it from below. This water, liberated from the outlet tunnel, was hurled dozens of yards with terrific force; yet, being a long distance down the cañon, it did no damage to the dam, and permitted control of the height of water behind the dam. At its height, a pressure of 12,000 lb. was exerted against each square foot of the dam.

Controlling the waters in this way has done away for the first

time with the peculiar problem with which California is confronted—that of rainfall coming in sudden and torrential quantities. Coming in this way, the resultant waters have swept everything in their path, doing millions of dollars in damage. Heretofore no one has been able to devise a means of handling this water.

The basic principle of the Devil's Gate

dam is to catch this water and stop it; then to let it out gradually and in small quantities, thus permitting its disposal (in the ocean) without causing any damage en route. The success of the dam in its greatest test—southern California's greatest flood—proves the unqualified success of the system, and is a tribute to modern engineering.

8121
**CITY HALL OF PHILADELPHIA
 BRILLIANTLY ILLUMINATED**

Reverence is felt by the inhabitants of Philadelphia toward City Hall, the most

the high tower, and the lighting effect first displayed on New Year's Eve. The tower, sharply silhouetted against the night, served as a beacon to guide the throngs of celebrators who always journey to City Hall Square, silently to watch the huge and lofty clock toll off the last few minutes of the old year, and to greet the new with loud acclaim, thus at the same time paying the old building added homage.

8203
**WATER-POWER DEVELOPMENT IN
 SOUTHWESTERN STATES**

Among the many projects now under consideration in the southwestern states for the development of water power, one of special interest is actually under way in Arizona. The building of a dam in the Grand Cañon, above the intersection of Diamond Cañon, is being promoted by a number of copper companies. The power developed, approximately 150,000 hp., will be distributed throughout the state, especially among the mines of the southwestern part, which are now dependent on fuel oil and coal, the cost of which is constantly increasing. Another project, under consideration in southern

California, is the construction of dams in Boulder and Black cañons that, besides power development, would impound so much water that millions of acres of now idle land could be made arable by irrigation.



City Hall of Philadelphia Illuminated for New Year's Celebration: Two Faces of the Huge Clock are Seen on the Tower. Insert: Plan View of Building, Illustrating the Lighting Arrangement. Each Extreme Corner Has 38, and the Intermediate Points 37 Lamps

famous of their buildings, and the culmination of this feeling was the brilliant illuminating of that structure. Eight batteries of floodlights, of 500-watt size, and totaling 300 lamps in all, were installed in the form of a square around

*She Mohave County Mince
 + Our Mineral Wealth*

Kingman, Ariz.

Cmd. E. V. Wenzell, 328 N. Redfield St. Philadelphia

Copyrighted material

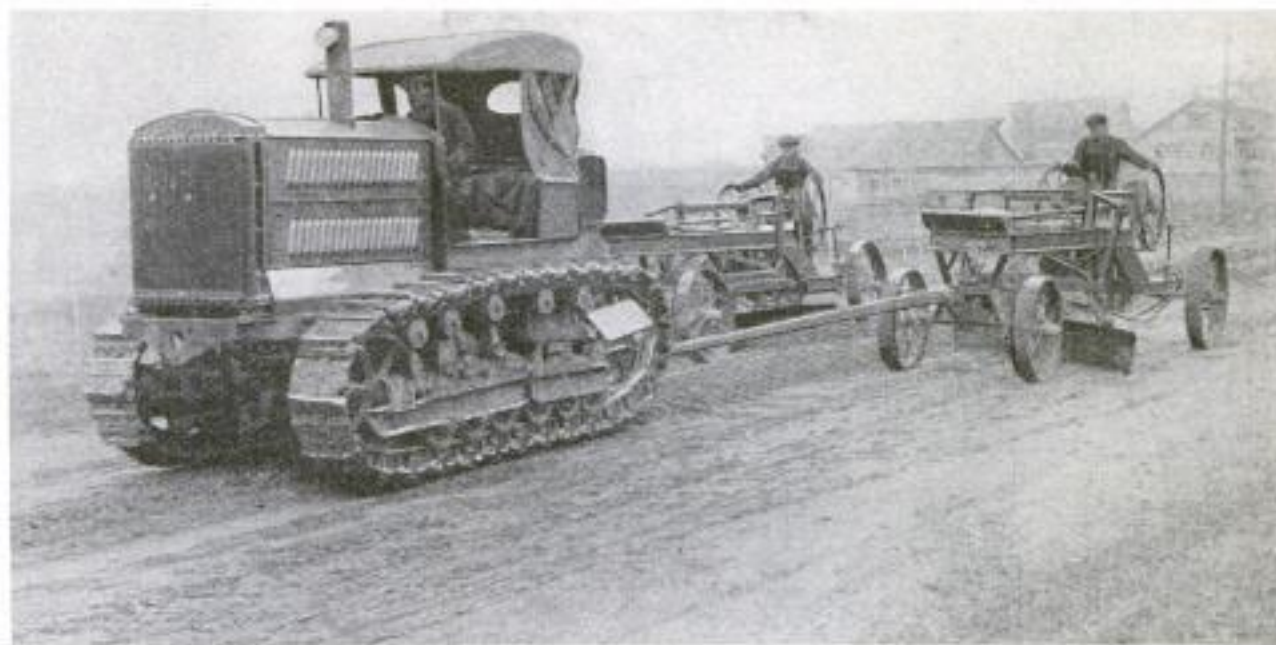

The 10-Ton Tractor Pulling Two Eight-Foot Graders Abreast: More Even Working of the Road is Assured, as the Graders are More Inclined to Keep in Proper Relation to the Crown of the Road

NOVEL ROAD-GRADING METHOD USES TWO GRADERS ABREAST

That such a commonplace operation as the grading of dirt roads is susceptible of improvement has been shown in Wisconsin. It was to be expected that the tractor would displace the four or six horses formerly used for pulling the grader, but

the idea of putting the two graders abreast behind the tractor is novel. A 10-ton tractor pulling two 8-ft. graders has been covering an average of 30 miles of road in a 10-hour day. The crown of the road may be leveled off by adding a small drag in the center, behind the graders, in this way smoothing off the ridge that is usually left.



Showing How the Tractor Keeps to the Center of the Road: The Space between the Graders may be Varied to Suit the Width of the Road. The Cable is Used as a Towline in Crossing Narrow Bridges

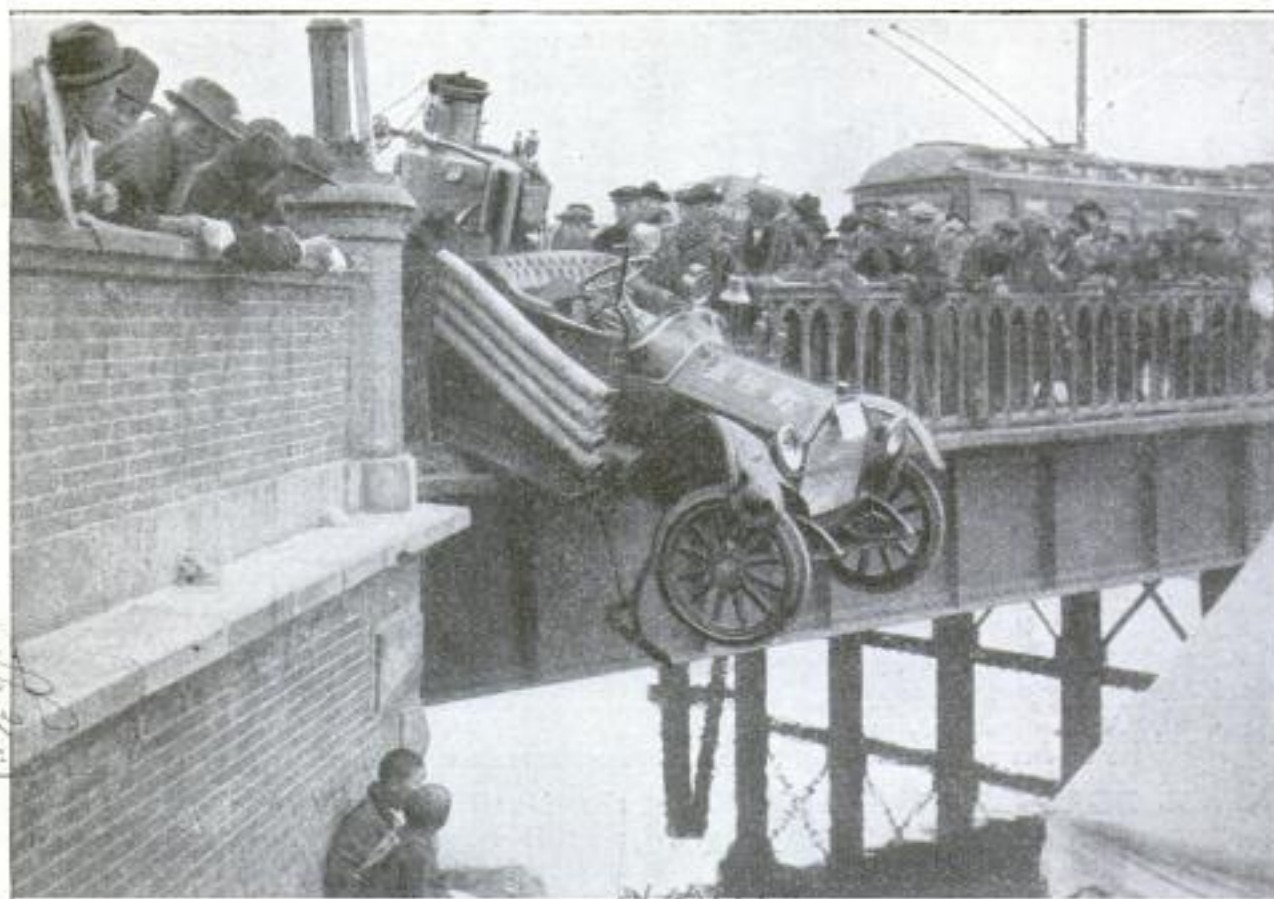

JAPANESE MOTOR FIRE ENGINE HAS NARROW ESCAPE

ONLY the guard rail and the weight of the boiler in the rear saved this motor fire engine from a disastrous plunge into the river from the Watanabe bridge in the city of Osaka, Japan. Evidently the Japanese fire departments also believe in speed.

8163
SCENE PERFECTLY PORTRAYED
IN NATURE'S MIRROR

It is seldom that a pool of water is so absolutely motionless that the reflection of a rural scene on its bank is so perfect that in a photograph it is difficult to tell which is the landscape and which the reflection. A recent photo of this kind shows a rustic building, surrounded by trees in full foliage, mirrored in this perfect way in a body of water beside them.

8197
AMSTERDAM STOCK EXCHANGE
SENDS WIRELESS REPORTS

Stock-exchange reports in Amsterdam, Holland, are sent at frequent intervals throughout the day, to nearly 200 banks in that country, by means of wireless telephony. Thus is illustrated another practical use to which this method of communication has been adapted, in the transmitting of the latest prices on the stock market and other commercial information. This, so far as known, is the first instance of such usage of wireless in Europe.



In This Example of Nature's Mirror, Reflections Are So Perfect That It Is Almost Necessary to Indicate on Photo Which Is Which

The Engineer

Copyrighted material 2/16/21

Emb. J. R. W. Lanagan, 5 Virginia St. Jersey City, N. J.

7850

Printed by: Broatch & Magendesh
Ice Co., Pepin, Wis.

RAILROADS USE CUTTING MACHINES TO HARVEST ICE

BY F. L. CLARK *McGregor, Iowa*

THE Mississippi is a splendid source of ice for refrigeration uses of the railroads in the northern Mississippi Valley, particularly for lines operating in Wisconsin, Minnesota, and Iowa. At McGregor, Ia., large amounts of ice are annually cut and shipped to various ice houses on the Chicago, Milwaukee, and St. Paul system. At Lake Pepin, ice-harvesting operations are carried on on a large scale every winter for the Burlington company.

The lake is an unusually good place to harvest natural ice because of its size, the fine quality of ice which forms over it, and also because it stays frozen so late in the winter that operations may be carried on for a longer time than elsewhere on the great river. In early steamboating days, when lines of steamers were run from St. Paul in connection with the railroads which terminated on the east bank of the Mississippi, at Prairie du Chien, Wis., and Dunleith, Ill., navigation of the Mississippi below Lake

Pepin was resumed each spring considerably earlier than navigation above it.



Elevating and Loading Machines for Conveying to Railroad Cars, on the Burlington, Ice Cut on Lake Pepin, in the Northern Mississippi Valley. Which on Account of Its Size, Is a Good Place for Harvesting Ice

The word the railroads, river men, and shippers waited for with utmost impatience along in April was, "Ice has gone out of Lake Pepin."



One of the Gas Ice-Cutting Machines, Which have Supplanted Horse-Drawn Machines in the Northern Mississippi Valley: They can be Used on Ice Too Thin to Bear the Weight of Heavy Teams

Gas cutting machines there, as at McGregor, have supplanted horse-drawn machines. They are more efficient and economical, and have this great advantage that in open winters, when ice does

not freeze to great thickness, they can be used with the ice not more than 8 or 10 in. thick, when it would be extremely dangerous, if not impossible, to use heavy teams.

With elaborate elevating gas-run machinery and long scaffolding supporting loading runways at the level of the top of freight cars, whole trains are loaded by the Burlington ice crews at once. The trains are sidetracked beside the runways with doors open, and as the cakes of ice are sent hurrying down the runways, a whole train is quickly filled.



Loading a Whole Train at a Time with Ice on the Burlington Railroad: The Train is Sidetracked alongside the Runway from Which the Ice is Quickly Pushed through the Open Car Doors

N. Sakata 10 Isachome,

Idamachi, Kojimachi-Ku,

374

POPULAR MECHANICS

4912

RETURN OF CROWN PRINCE
CELEBRATED BY JAPAN

7548

MARINE-ENGINE CONDENSER
OF NOVEL CONSTRUCTION

When the crown prince of Japan returned home after his recent six months' trip through Europe, he was received

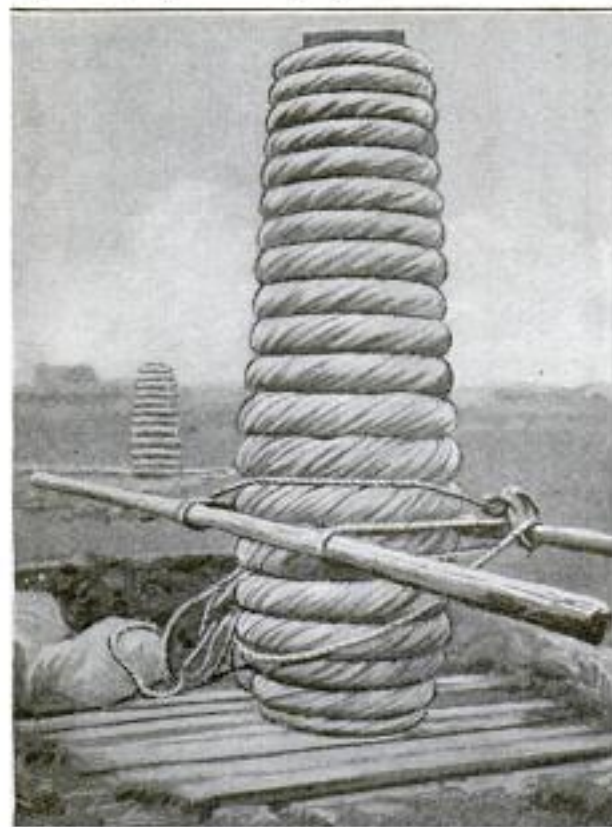

Pyrotechnical Cylinders, the Largest Ever Built in Japan, That Furnished a Brilliant Display of Fireworks to Celebrate the Return of the Crown Prince

with a celebration which was without precedent in the history of the country. One of the striking features was a magnificent display of fireworks. Some of the single pieces cost as much as 300 yen, about \$150, and the balls measured 2 ft. in diameter. The largest balls ever made before that time measured only 5 in. in diameter. When discharged, these great balls expanded to a diameter of 4,851 ft. in the air, and shed sufficient light to read a newspaper anywhere within a radius of four miles, it is said. Not only the prince, but also the emperor and empress, were cheered by the people, a demonstration which has occurred only twice before since the restoration of the present imperial family. Traditional etiquette demands great formality and silence in the presence of the imperial family of Japan, but they seemed to enjoy this exception.

When you want anything and do not know where to get it, write Bureau of Information, Popular Mechanics, Chicago.

Considerable attention has been attracted to a surface condenser for marine engines that has been invented in Belgium, and patented in several countries. The object of the invention is to eliminate automatically all causes for engine breakdown due to defective feed water, preventing the entrance of salt water into the boilers, and maintaining in the condenser a constant state of cleanliness. The condenser has a steam chamber at one end connected to the engine exhaust, and another at the other end connected to the air pump. Between these two chambers, in the main body of the condenser in which the water circulates, are series of pipes, divided into two or more separate groups, so that one group can be cut off by a shut-off valve from the others, and can be attended to without requiring the stoppage of the engine. In connection with each of these groups is a specially designed salinometer—an instrument for measuring the quantity of salt that there may be in solution in the water of the condenser—that is electrically connected with an instrument board in the engine room, containing warning lamps that by ignition indicate a dangerous condition of the water. At intervals each of the separate pipe groups can be shut off successively, and can have its water spaces cleaned out, so that no salt or grease will ever be there in sufficient quantities to do any harm. Thus the condenser can be kept running continuously, and at the same time be maintained in perfect condition.

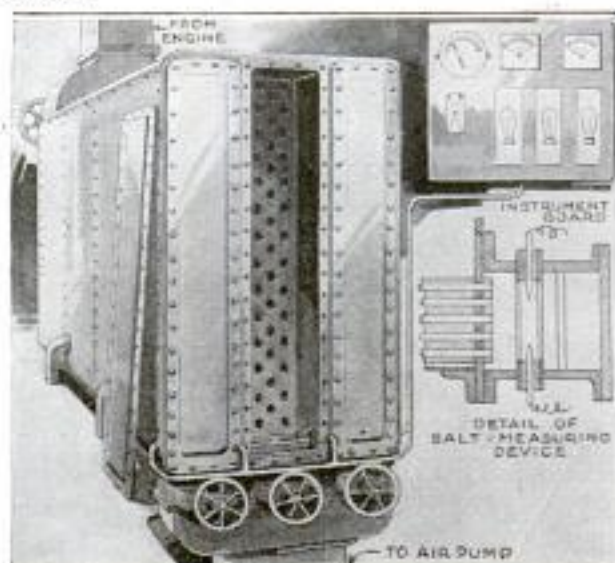

Marine-Engine Condenser, Showing Cover Removed from One Group of Pipes, Which can be Cleaned While the Other Two Groups Remain in Operation: Inserts Are Self-Explanatory

Cl. no. Q. 7548, 68 Patent No. 1111111 (1111111) Amoco

8200

deal Auto Bodies + Top Co.
1106 Pine, Seattle, Wash.

Alex Christie & Co. 1100 E. Pike, Seattle, Wash. 375

Build to order

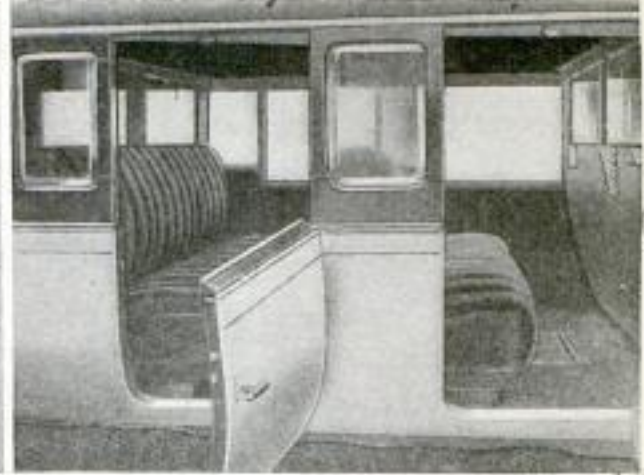

PACIFIC-COAST MOTOR BUS SEATS FORTY PASSENGERS

TRANSPORTATION on the Pacific coast has been greatly facilitated by the introduction of large motor busses which have a seating capacity of 40 passengers. Five compartments, holding eight persons each, are built in the bus and are separated by glass partitions, so that parties of this number may journey in comparative privacy. The machines, besides being elegantly upholstered, are especially designed to insure comfortable riding, and it is claimed that the average rate of fare is less than that charged for railroad travel.

8046

GERMAN PAPER-PULP MILL FIRST IN ARGENTINA

Initial ventures are not always a success, but the first step in the introduction of paper-pulp making in Argentina, seems to be progressing favorably. German interests are responsible for the undertaking, which is located in the Gran Chaco territory, near the Parana River, and 600 miles from Buenos Aires. A single mill has been erected, that produces five tons of paper pulp per day, for which a ready market is found in the above-named city, thus assuring the prosperity of the enterprise,

and illustrating the pioneering efforts of the Germans in South America.



German Paper-Pulp Mill Recently Built in the Gran Chaco Territory of Argentina, near the Parana River, and 600 Miles above Buenos Aires, Where the Entire Output is Sold

7919

SWIVEL JOINT FOR HOSE AT GASOLINE STATIONS

Bending, cracking, and wearing out of hose at the curb connections of automo-

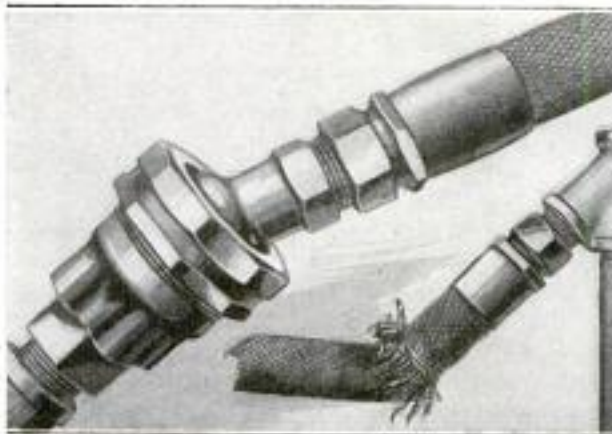

Swivel Joint for Use in Connection with Pumps at Gasoline Stations

bile gasoline stations can be avoided by the use of a new swivel joint for the hose that allows it to be turned or twirled in any direction without injury. It is a common ball-and-socket joint, with a specially designed seat that is kept pressed against the ball by four springs. These are adjustable, and sufficient pressure can be maintained to prevent any leakage at the joint, without interfering with its flexibility. The swivel joint is attached to the pump, and its socket slopes downward so as to act as a spout.

Electrical exports, which now aggregate an approximate monthly total of \$5,000,000.00, are largely composed of orders from the Orient, thus illustrating the steadily growing importance of that part of the world as a market for American-made electrical equipment.

Morrison Bros., Lubuque, Iowa.

Copyrighted material

immense
The
375
and
no
George
Charles
708
Business
Cures
American
Embassy
Cures
Disgritling

7297

Rec. up

BUILDING SAFETY-DEPOSIT VAULTS

BY T. BENJAMIN FAUCETT

*402 B'klyn. Ave
Brooklyn, N.Y.*

THE safe-keeping of Liberty bonds has made almost everybody familiar with the general plan of safety-deposit boxes

laid across them to reinforce the concrete. This makes a construction that is not only fireproof

but practically proof against burglary as well, because of the time necessary to drill through it.

But, even if the outer walls and the concrete floor were destroyed by design or accident, the valuables within the vaults would be found intact within the well-nigh heat-proof steel wall surrounding them on every side. The entrance to these vaults is guarded by a cylindrical steel door weighing several tons, though it is so accurately balanced that the push of a finger will swing it in either direction. Four



Sheet-Steel Forms for Pouring the Reinforced Concrete Floor on the Ground Level of an Addition to a New York City Bank Branch

and bank-storage vaults. A burglar and fireproof place is necessary for such a bank department, but few know the type of construction required to obtain these qualities. Neither do we realize the various additional precautions and safeguards thrown around even the smallest deposit boxes in order that they may be fully protected.

The building of an addition to a New York City bank branch in a near-residence district offered exceptional opportunity to observe the method of fireproofing the structure. No wood or other inflammable material was used, even the windows and doors being of thin metal, while the glass was of a special kind that will resist terrific heat. The making of the concrete section, serving as a ceiling for the basement vaults and as a floor for the ground-level safety-deposit department, was especially interesting. The metal molds, over which the concrete mixture is spread, are of thin sheet steel, strong enough to sustain the weight of the concrete until it has hardened, and are fitted together in 3-ft. sections, that enable running lengths of molds to be made for any size structure. Before the concrete mixture is poured over the molds, steel rods are

time clocks are on the outer side of it and control the many 3-in. steel bolts that project from its circumference into the proper openings of the heavy steel facing. At the close of business the big doors are shut, the clocks set for opening time the next morning, and when the designated hour is reached the bolts are withdrawn so that the vault can be entered. Four clocks are used, so that in the un-

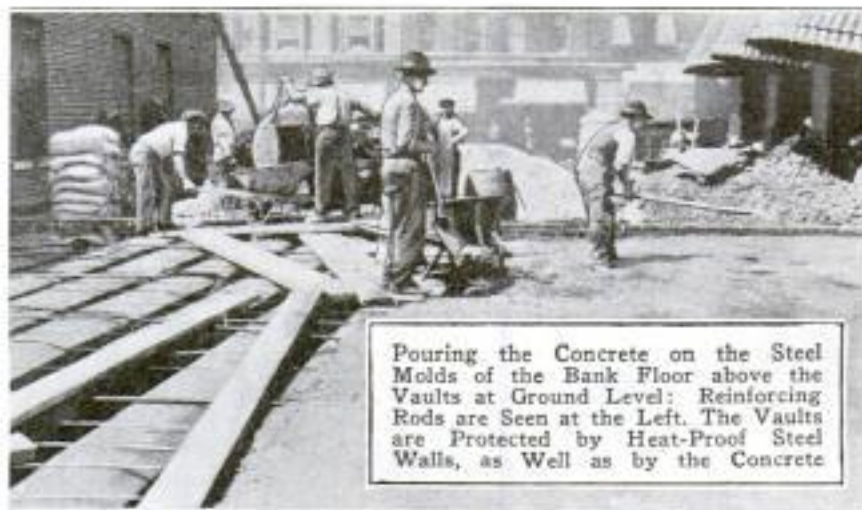

Pouring the Concrete on the Steel Molds of the Bank Floor above the Vaults at Ground Level: Reinforcing Rods are Seen at the Left. The Vaults are Protected by Heat-Proof Steel Walls, as Well as by the Concrete

likely event that three of them should stop, the fourth would yet withdraw the bolts at the proper time. Electric burglar alarms, directly connected with police headquarters, give quick notice of any tampering with doors or fixtures, while watchmen on the premises are also on constant guard. Bankers believe that prevention is better than cure.

8114

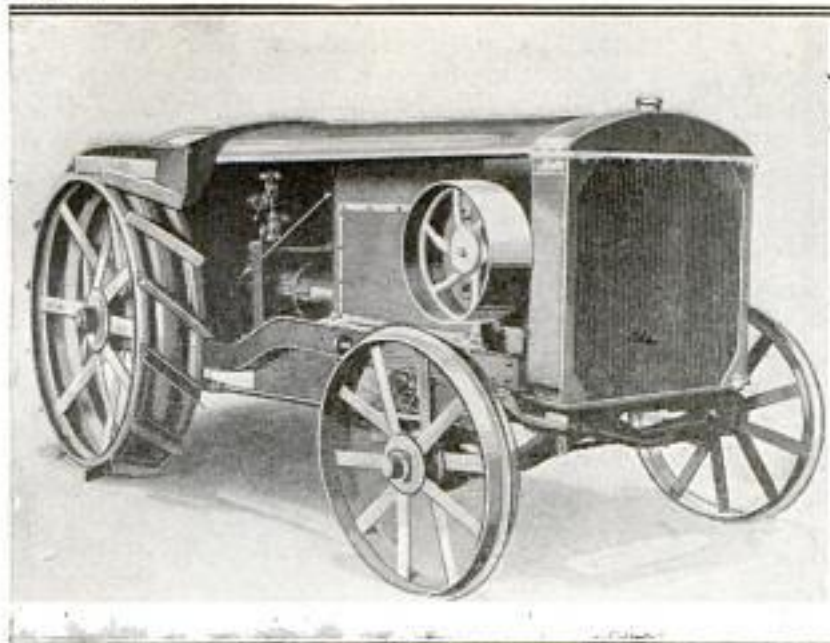

Left: Lightweight Steam Tractor Ready for Operation. The Cleats on the Wheels Are of Angle Iron, and the Removable Belt Pulley is Shown above the Front Wheel. Right: The Engine; All Its Shafts, Piston Rods, Main Rods, and Crossheads Are of Heat-Treated Chrome-Nickel Steel

8114

LIGHTWEIGHT TRACTOR OPERATES BY STEAM

Lightness and simplicity have been combined in a small steam tractor lately put on the market by a Cleveland, Ohio, concern. The machine weighs 5,500 lb., has a rating of 15 to 30 hp., and possesses a speed range of from five miles per hour down to creeping. The steam generator, of water tubing, is sectionally constructed so that any tube can be removed and replaced by a new one without disturbing the others. The firing system is of the vaporizing kind, having a positive automatic steam control which shuts off the fuel when 600-lb. pressure is obtained, and starts it again when the pressure falls below that point. A two-cylinder double-acting engine with piston valves is used, which has a 4-in. bore with a 5-in. stroke. Possessing no electrical parts, carburetor, clutch, or gear shift, this tractor should be popular for its apparent reliability and economy.

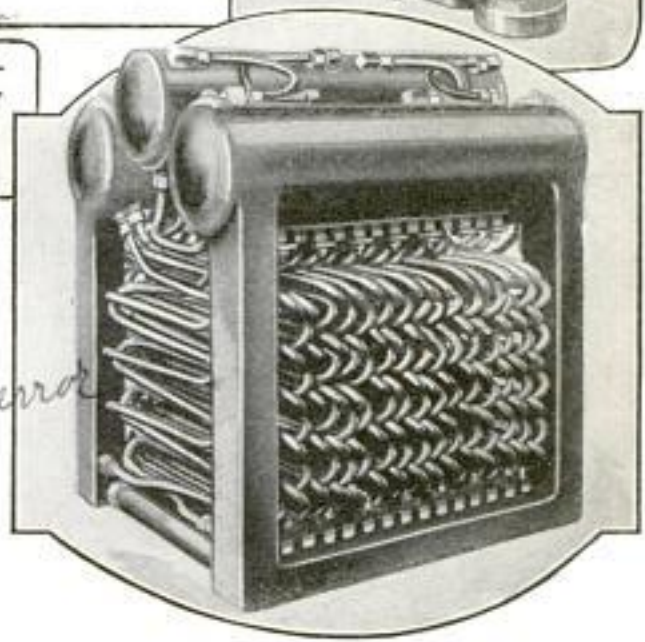

The Steam Generator to Which Water is Supplied by Plunger-Type Pumps, Driven from the Jackshaft: The Tanks Shown Have a Capacity of 60 Gallons, Enough to Operate the Machine for from Five to Ten Hours

8164

ITALY DEVELOPS SYNTHETIC INSULATING MATERIAL

As a result of the great activity in hydroelectric development in Italy, a new insulating material, made by chemical synthesis, has been developed. It is said to be ideal for insulating purposes.

BASCULE BRIDGE IN OPENING 191 ROLLS OVER BACKWARD

Recently, at Gray's Harbor, Wash., a bascule bridge of the rolling-lift type—which opens by rolling on a geared track, and to facilitate this is completely counterbalanced around each side of the center of rotation—when being opened experimentally by a newly installed gasoline engine, continued rolling until it fell over backward. In the usual design of these bridges there is a stop provided directly under the heavy concrete counterweight, but in this case this was absent, making the unprecedented accident possible. It was a single-leaf span of 110 ft., originally built for operation by hand.

Power 1/3/22
Sept. 4 Commerce Engineering News Record
12/16/21

Oxy. Acetylene Industries
Suite 1527, Carbide & Carbon Bldg.
New York City

80 378 47

POPULAR MECHANICS

METAL ROSE TREE PRODUCED WITH WELDING TORCH

Realistic in design and beautiful in appearance is a metal rose tree recently pro-



Ornamental Rose Tree Which Consists of Many Pieces of Metal Painstakingly Joined Together by an Oxyacetylene-Welding Mechanic

duced by a Philadelphia welding mechanic. The artisan, Steven Gavoorin, built the tree entirely of metal, except the "hearts" of the roses, which were represented by colored electric lights. Piece by piece the metallic sections were joined by the oxyacetylene torch, until when finished the whole presented a work that appeared almost genuine.

8/47

OLD JINRIKISHA MODERNIZED WITH PNEUMATIC TIRES

The most popular vehicle in the Far East is the jinrikisha. It is as popular there as the automobile is here, and it is apparently adopting some of the latter's refinements, for it is now being equipped with pneumatic tires. The ubiquitous Oriental "rikisha" is a two-wheeled ve-

hicle, built somewhat on the lines of the obsolete hansom cab, with a coolie between the shafts who combines the work of the cab's horse and its driver. The tires now used on the wheels are very like motorcycle tires, with similar inner tube and a flanged type of outer tire.

8202

REPORT SHOWS MINING TO BE HAZARDOUS OCCUPATION

The report of the Bureau of Mines shows that, during 1920, for every thousand persons employed in mines, quarries, and metallurgical plants, 3.19 were killed and 221.22 injured. These figures do not include those killed or injured in blast furnaces. With all our safety devices there seems to be still room for improvement.

New York Times 11/3/21 P. 4

COAL-DUST BRIQUETTES SOLVE FRENCH RAILWAY PROBLEM

8202

Since the destruction of the coal mines in northern France, the shortage of locomotive fuel has been a serious handicap to the railways. The imported coal contains much dust, making it unsatisfactory for use as locomotive fuel, but this dust is now utilized by making it into briquettes, weighing from 6 to 20 lb. and containing as much as 92 per cent coal.

U.S. Dept of Commerce by Magazine SALVAGE LOCOMOTIVE PINNED TO RIVER BED BY PILING

8/86

At the time of the Colorado floods in the spring of 1921, a bridge on the Burlington Railroad near Brush, Colo., was washed out, and a locomotive and baggage car went into the river. In order that traffic might be quickly resumed, a temporary wooden bridge was put in on the site of the washed-out structure. Later in the year it was decided to attempt to salvage the sunken locomotive. Pumps were installed, and the sand which had accumulated over the engine was pumped away. A diver then fastened a cable about the engine, and a 150-ton wrecking crane attempted to pull it out of the river, but without success. Investigation showed that two of the piles which had been driven to support the temporary bridge had passed through the engine and into the bed of the river, one pile passing through one of the driving wheels and one through the fire box. When these piles were disconnected from the bridge, the wrecking crane lifted the locomotive without further trouble.

New York Times 1/8/22 Sec. 8, P. 12

A. D. Lerskov
Brush, Colo.
Copyrighted material

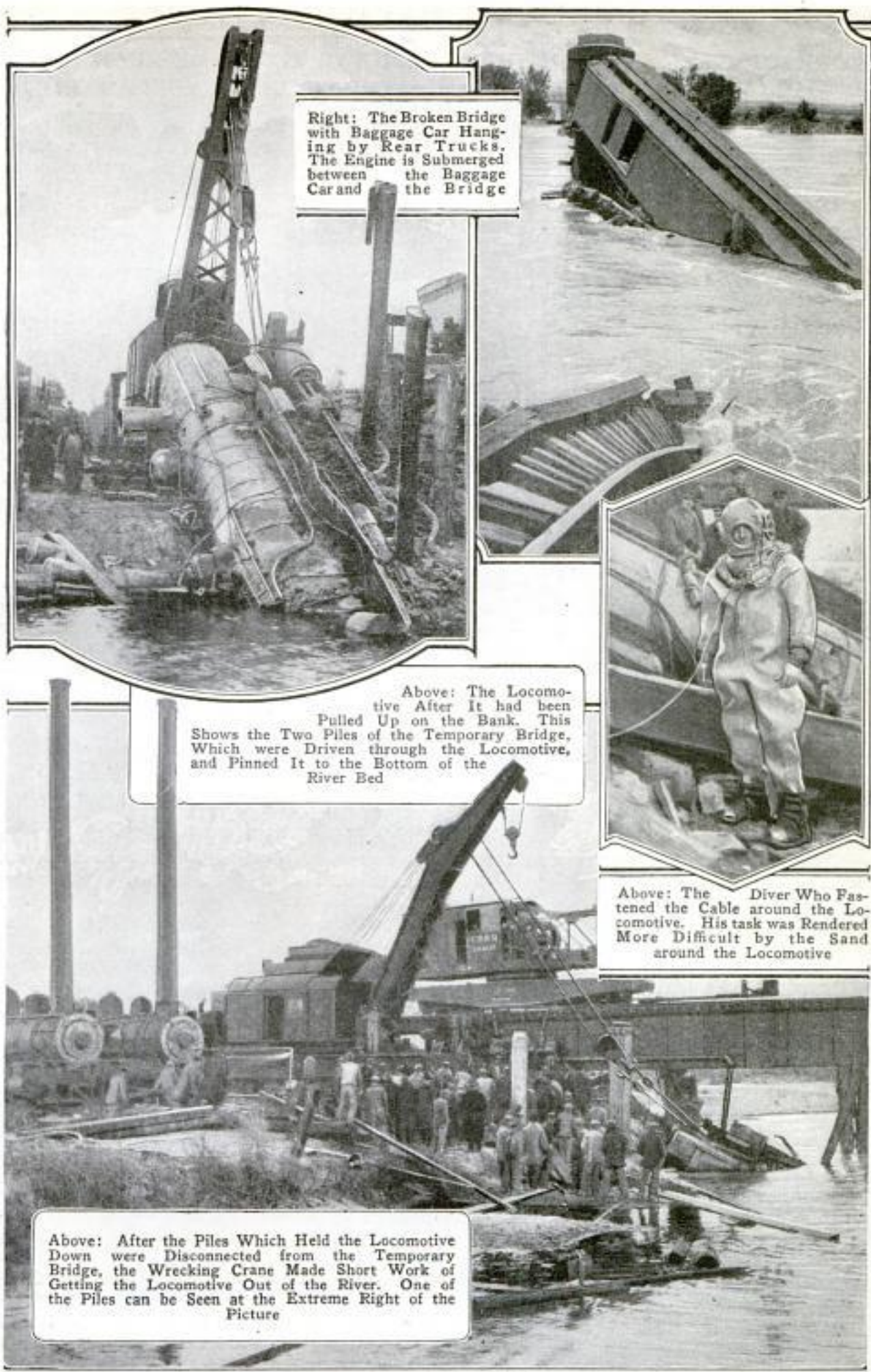

Right: The Broken Bridge with Baggage Car Hanging by Rear Trucks. The Engine is Submerged between the Baggage Car and the Bridge

Above: The Locomotive After It had been Pulled Up on the Bank. This Shows the Two Piles of the Temporary Bridge, Which were Driven through the Locomotive, and Pinned It to the Bottom of the River Bed

Above: The Diver Who Fastened the Cable around the Locomotive. His task was Rendered More Difficult by the Sand around the Locomotive

Above: After the Piles Which Held the Locomotive Down were Disconnected from the Temporary Bridge, the Wrecking Crane Made Short Work of Getting the Locomotive Out of the River. One of the Piles can be Seen at the Extreme Right of the Picture

7768

Isoldwyna Motion Picture Studios, Los Angeles, Calif.

380

POPULAR MECHANICS

8/46

WORK OF ELEMENTS ON HULK IMITATED WITH TORCH

When a motion-picture studio on the Pacific coast needed a weather-beaten old hulk of a wrecked ship for one of its pic-



Means Employed by a Motion-Picture Company to Counterfeit the Weather-Beaten Hulk of a Wrecked Ship: An Acetylene-Torch Outfit was Used to Burn Away and Char the New Lumber

tures, there was none of a suitable type to be found on the beach near by. So a resourceful carpenter conceived the idea of building a "wreck" out of new lumber and turning a man with an acetylene torch loose on it.

The torch worked perfectly, and in a short time as realistic a job was accomplished as wind and waves could have done in years.

AMERICA SETS WORLD RECORD FOR ENDURANCE FLIGHT

By remaining continuously in the air for 26 hr. 19 min. 35 sec., two American airmen have set a world's record for airplane flights. An all-metal monoplane of the JL-6 type was used. The flight took place Dec. 29-30, 1921, at Mineola, L. I., under very adverse weather conditions. The only difficulty encountered, which finally caused the airmen to descend while they still had sufficient fuel for more hours of flying, was the breaking of an oil pipe in the emergency oiling system.

The U. S. Forest Service and the California State Automobile Association have agreed to cooperate in preventing the mutilation of road signs. The signs of the automobile association will be protected by the forest rangers.

TONE OF NEW AMERICAN BELLS EQUALS OLD EUROPEAN ONES

Hitherto the cause of the superiority of the tone of European bells, as compared with American, has been attributed to their greater age. It has now been proved by an ingenious American bell maker that the only effect of their greater age was to wear away the inner surface of the lip of the bell, and the striking point of the clapper, until much greater areas come into contact when the bell is rung. Consequently, it has been a simple matter to cast the bell, and make the clapper, in forms which give this greater contact surface from the beginning, instead of waiting 100 years for time to produce the same condition. This American manufacturer has proved that bells made in this manner possess the desired tonal quality after only a month's ringing, instead of having to wait a century or two.

new York Times 1/8/22

THINNING OF CRANKCASE OIL SHOWN BY SIMPLE METER

A meter which shows when the oil in the crankcase of an automobile has lost its viscosity, in other words, become too thin, is expected to prove valuable to automobile owners. Much serious damage is done by driving when the oil is in this state. Because of variations in driving conditions, weather, and oils, mileage is an unsatisfactory gauge by which to change oil. The meter has a continuous stream of oil flowing across the dial, behind which is a temperature gauge. As the oil becomes thinner it flows faster and rises on the temperature gauge. When it passes a certain mark, the driver knows that the oil must be changed.



William Ahers, Jr. Co., 10th & N. Street, Philadelphia

Chicago Herald-Examiner 12/31/21

8043

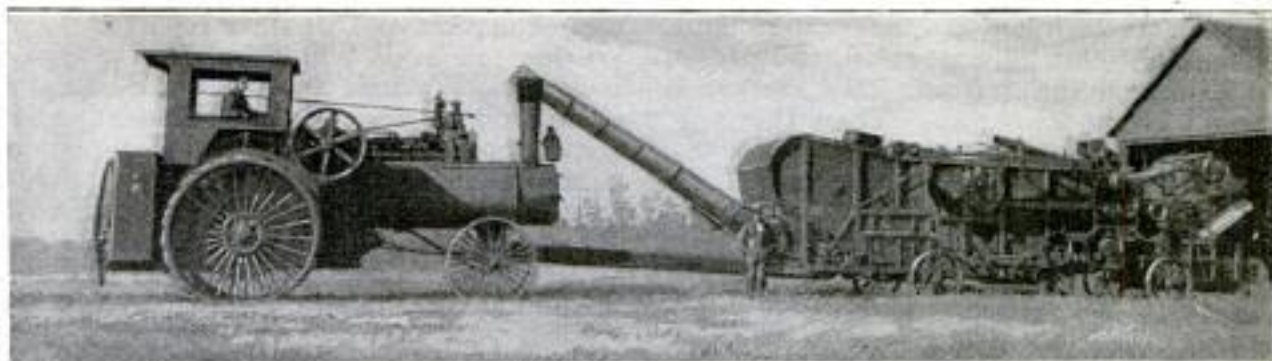

This Threshing Machine, Built from Parts of Seven Different Makes, Is Probably the Largest Ever Constructed. It is Used in the Wheat Fields in the Vicinity of Bottineau, North Dakota



The Outfit, from Header to Blower, Measures 36 Feet in Length, and the Straw Travels over 60 Feet before being Discharged from the Blower. It is Operated by a Crew of 27 Men

GIANT THRESHING MACHINE BUILT FROM SEVEN OTHERS

ELECTRICAL CONTROL FOR GAS WATER-TANK HEATERS

Probably the largest threshing machine ever built is one constructed by J. J. Krogen, of Bottineau, N. D., from parts and attachments of seven different makes of separators. It is so constructed that the grain is separated twice, and it will do 100-per-cent work even when crowded. The length of the outfit, from the folded header to the blower, is 36 ft., and the straw travels over 60 ft. before it comes out of the latter. Its capacity is 4,000 bu. of wheat a day, or 700 bu. of oats an hour. A 110-hp. steam engine, with an 11-in. belt, is used for operating the machine. It requires a crew of 27 men, 21 being needed for pitching.

For lighting the gas under an ordinary tank water heater, an electric switch can be placed in the bathroom, kitchen, and laundry. This switch has "on" and "off" buttons and a pilot light. When the "on" button is pressed, a circuit is closed. This operates a solenoid or magnet which turns on the gas under the heater. A small pilot light, burning all the time, ignites the gas. The lever that opens the gas burner closes a switch on a circuit with the first pilot light, and a second switch in this circuit is closed by a small

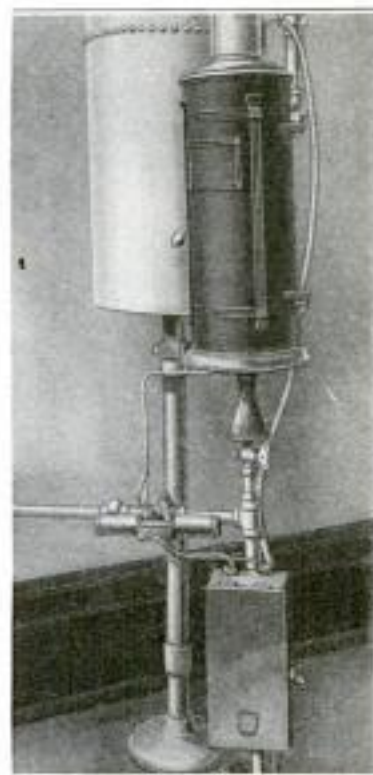

WOODEN PICTURE PAINTED WITH NATURAL COLORS

A novel picture has recently been completed by a skilled woodworker in which all the coloring and variations of light and shade have been produced by the natural color of the various kinds of wood used. Thirty-seven different kinds of wood were employed, the completed picture being 22 by 24 in. in size. The scene represents a boy starting on a fishing expedition, accompanied by his dog, the background showing a landscape.

Maker. John S. Perkins, Wilmington, Del. American Forestry Magazine.

N.Y. Times 1/4/22 p. 8.

Brenco Corp 406 6th St. Minneapolis, Minn.

thermostat operated by the heater flame. When the pilot light goes on, the person who pressed the switch knows the gas is turned on and lighted. When the "off" button is pressed, the action is reversed. The thermostat can be set to shut off the heater automatically.

8029 GOVERNMENT INFORMATION BY RADIOTELEPHONE

Recent advances in the art of wireless telephony make it appear highly probable that the government will adopt this means of broadcasting information relating to market and weather conditions. Since April 15, 1921, this information has been furnished the agricultural interests by means of radiotelegraphy, but the simplicity of the radiotelephone, and its universal appeal, give it marked advantages over the older method.

Congress is being urged to establish a Bureau of Communication in the Post Office Department, and if this is done, radiotelephony will be the means adopted for broadcasting information of varying nature. The Post Office Department will draw upon the different government bureaus for information that will not only serve the interests of the farmer, but will be of benefit to the miner, rancher, fruit grower, forester, and lumberman. The service will also be enlarged so that isolated points of the United States may be reached. There are at present eight radio stations, originally established in conjunction with the transportation of mail by airplane, employed as distributing agen-

cies of market and weather reports. They are located in Washington, D. C., Ohio, Nebraska, Wyoming, and Nevada. In the event of the service being extended, new radiotelephone stations will be established in Georgia, Texas, California, Montana, Illinois, and at one point in the New England states.

Already, one specially designed radiotelephone transmitting outfit has been installed, and regular schedules of transmission will be effective early this year. The apparatus itself deserves mention. In transmitting messages a current having a strength of 14 amperes is produced in the aerial, the normal sending-wave length being 1,160 meters. The voice modulation is said to be nearly perfect. Preliminary tests have succeeded in transmitting the

voice in distinct tones, as great a distance as 1,200 miles. The transmitter has three control switches so arranged that low-power input may be used for local sending, or high-power for long-distance sending. Also, it is possible to use either straight continuous-wave system or interrupted continuous-wave system for sending radiotelegraph messages, as well as the continuous-wave system for sending radiotelephone messages, with an adjustment making possible the use of four different wave lengths varying from



Copyright, Harris & Ering
Specially Designed Radiotelephone Transmitting Outfit for Broadcasting Weather and Market Reports, Occupies Small Space, and is Arranged for Either Local or Remote Control

800 meters to 2,000 meters. Four 250-watt "power" tubes are employed in conjunction with a 50-watt amplifier. The transmitter is equipped with an operator's switch so constructed as to render possible the control of the transmitting outfit either locally or at a distance, with an

Director - J.C.
11th St. &

Edgerton U.S.P.O.
Pennsylvania Ave, Washington
D.C.

Emd. S. C. Winters, 702 Ulysses National Bank Bldg
Washington, D.C.

added interphone connection to remote control points. The transmitter is compactly built and may be incased behind a panel, the space requirements being only 7 by 3 by 2 ft. The motor generator is of the three-unit design. A direct-current motor drives a plate-voltage generator at one end, while a combined exciter and filament generator is located at the other end. The plate generator supplies 2,000 volts through the use of two 1,000-volt armatures.

Up-to-date market and weather developments have been transmitted by continuous-wave radiotelegraphy through the use of an arc transmitter. With the installation of a radiotelephone outfit in central headquarters at Washington, eventually telephone transmitters will be installed at all of the broadcasting stations under the supervision of the Post Office Department.

7995 —
SIMPLE FAIR-LEADER MADE FOR GUIDING CABLES

Problems arise in the logging industry, in the effort to wind and unwind steel cables without their becoming entangled,



with consequent loss of much valuable time. As a remedy for this difficulty, an Oregon man has made a fair-leader of simple construction,

which consists of a pair of sheaves held in a disk that revolves in the direction of the strain placed upon it. The cable is inserted between the two pulleys, and they are always in line, regardless of what the angle of pull may be.

8095 —
"SHOVEHA'PENNY" BOARD MAKES GAME POPULAR

"Shoveha'penny" has, for many years, been intimately associated with taverns and similar places, in England, as "the poor man's billiards." Because it requires considerable skill, an attempt has been made recently to popularize the game. The method of scoring, with chalk, was very dirty, but a new board has been devised which eliminates this disadvantage. The game is played by shoving coins along a board, ruled off in sections, and the chalk was used to mark scores in the

proper sections. The new board has two rods along each side. Metal markers are attached to the inner rods, three to a sec-

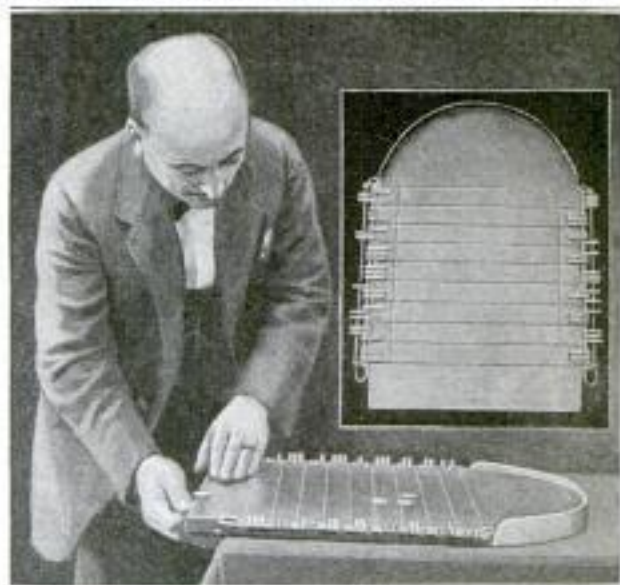

New "Shoveha'penny" Board in Use: In the Insert Is a Top View, Showing the Arrangement of the Rods and Markers

tion, on each side. When not in use these markers rest on the outer rods. To mark a score, a marker is swung over onto the board, in the proper section.

7914 —
MECHANICAL TIRE PUMP OF SIMPLE DESIGN

Patterned after the revolving-cylinder engine, a new tire pump has an eccentric shaft carried on a bracket hinged to the chassis. When the bracket is swung to bring the case into contact with the revolving flywheel, or other rotating part, air is drawn in through one end of the fixed eccentric shaft, and is distributed to the cylinders by air ports in the eccentric. The compressed air is delivered by other air ports to the opposite end of the shaft, to which the air hose may be attached. The pump is so constructed that the entire case may be packed with grease.

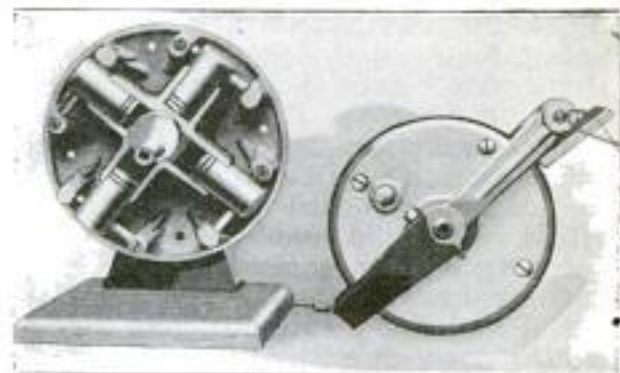

Revolving-Cylinder Tire Pump, Delivering Air through Fixed Eccentric Shaft to Which Air Hose may be Attached

*Chas. A. J. Johnson
 Oregon City, Ore.*

*Wm. A. Prichard
 4 Newbury Street
 Boston, Mass.*

*Edw. A. Smith
 c/o George Pringle
 1401 Bushfield Road*

Chelmsford, England

384
8134
Paris France
Builder M. Sanchez
Besa, 2 Avenue
de Bellevue
Sures, Seine
France

POPULAR MECHANICS
FRENCH-DESIGNED MULTIPLANE
HAS STRANGE APPEARANCE

At first glance a new multiplane of French design seems like a step backward, as some of the very early exper-

imental machines were of similar type, but the advantages of the multiplane and the narrow wing have long been recognized. The machine has 21 planes, or aerofoils, of only 6-in. chord, the span being only 14 ft. 9 in. These narrow aerofoils permit a construction which would be impossible in wings of ordinary size, and under test, have proved very rigid and free from vibration, besides being fire-proof. Certain of the outer elements are free to rotate on their central spar, and, by proper connection to the pilot's control, can be made to act as do the ailerons of the standard airplane. Equipped with a 40-hp. motor, this multiplane has a maximum speed of 74 miles and a landing speed of only 25 miles an hour.

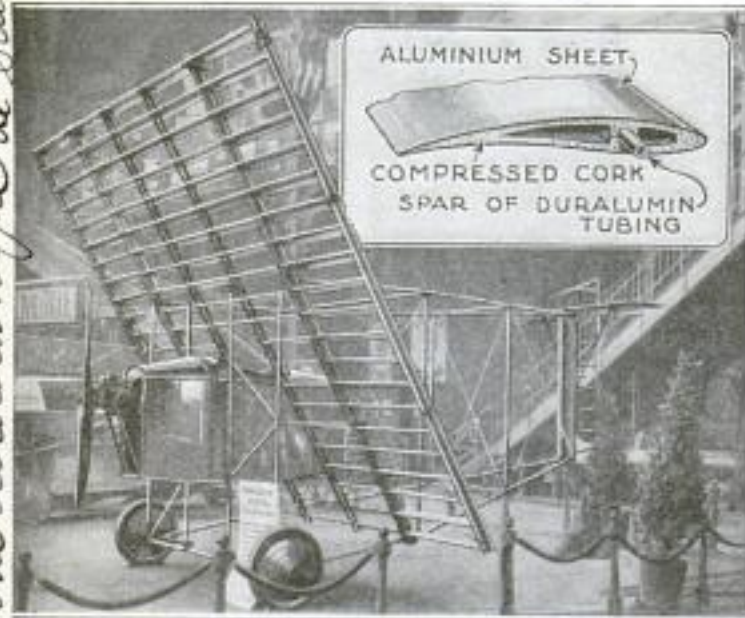

French-Designed Multiplane of Small Span, with 21 Narrow Wings, Which Has a Landing Speed of Only 25 Miles. The Insert Shows the Wing Construction in Detail

Popular Mechanics Magazine does not publish the name of maker or seller of any device described in its pages, but this information is kept on file and will be furnished free by addressing our Bureau of Information.

Director M. Toussaint
Laboratoire Aerotechnique de Saint
Cy

HARNESSING A TREACHEROUS MEXICAN RIVER

Difficulties of railroading along the western coast of Mexico are strikingly shown by the experience of bridge engineers of the Southern Pacific Railroad Company of Mexico in trying to harness the Fuerte River. This is a treacherous stream in the state of Sinaloa, between Hermosillo and Culiacan. When it is on its good behavior, it is a peaceful waterway, but during the flood periods it rises with startling rapidity, sweeping everything before it.

steel girders. Although some of these girders weighed as much as 70,000 lb., they were carried downstream for a long distance by the resistless flood.

When the railroad was first built, the river was spanned by a so-called temporary structure. In addition to 750 ft. of pile and timber trestle, 12 steel deck-plate girders, 70 ft. long, were installed. These were placed on the south side of the river, over the deepest part of the channel where the current was strongest. This structure rose to an average height of 40 ft. above normal low water.

Thereupon it was decided to replace the part of the bridge thus destroyed, in the meantime operating the trains on a temporary track and depressed trestle on a "shoofly" alinement.

This bridge did good service for several years. Then came a period of excessively heavy rains. When the flood was at its peak, the tremendous current, rushing down at a height of nearly 35 ft. above normal low water, carried away four piers at the lower end of the bridge and dropped into the river five sets of

On the very day that the main bridge was put into service again, the river went on a rampage. Before sunset the raging flood had carried away three of the new piers and dropped four sets of girders. The shoofly trestle was also a sufferer in this flood as it had been in previous flood times.

When to these adverse physical conditions is added the consideration that all common laborers, mechanics, clerks, foremen, and master mechanics were native Mexicans, it can readily be seen that the special engineer who was in charge of the bridge work had his hands full when it was decided to sink a pneumatic caisson. However, it was found the men were eager to master the principles and theory of what they were trying to do, and the experiment resulted in the work being completed in good shape.



Laborers were Kept Busy Trying to Prevent the Accumulation of Brush in Front of the Temporary Track

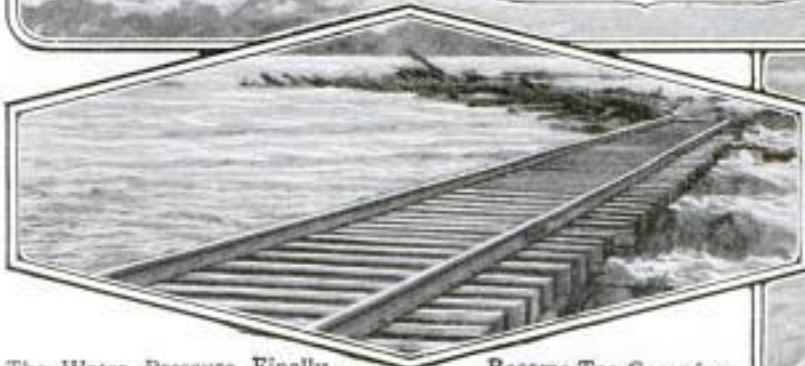

The Water Pressure Finally Became Too Great for the Temporary Structure to Resist, and It Gave Way in the Center, Timbers and Rails being Piled Up like Jackstraws

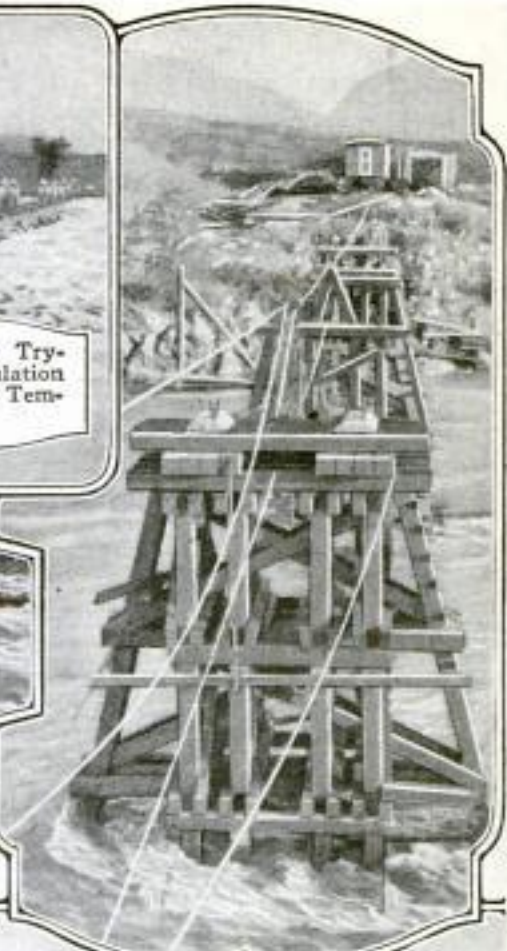

Above: High Water Delayed the Construction of the Main-Line Bridge. Strongly Anchored Foundations Were Necessary to Withstand the Rush of Water



The Engine is Crossing the River on the Temporary Track Which is Now under Water. The River at This Time was 1,200 Feet Wide and from 12 to 15 Feet Deep

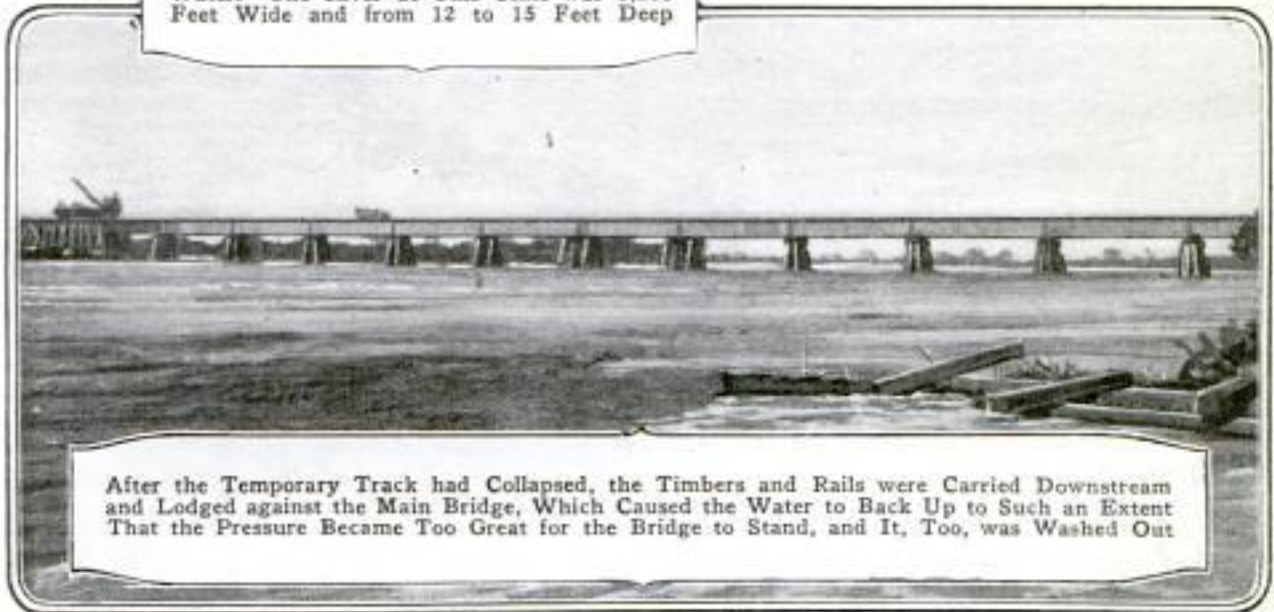

After the Temporary Track had Collapsed, the Timbers and Rails were Carried Downstream and Lodged against the Main Bridge, Which Caused the Water to Back Up to Such an Extent That the Pressure Became Too Great for the Bridge to Stand, and It, Too, was Washed Out

Adel + Becher
153 & 42nd St.
New York City

Com. John W. Keane
Nav. Dept. Bureau of
Navigation, Washington
D.C.

386

POPULAR MECHANICS

FIGS ARE RAPIDLY PICKED
USING WHEELED PLATFORM

SUPERCHARGING COMPRESSOR
FOR AIRPLANE ENGINES

To use a three-wheeled platform for the purpose of picking figs, was the timely idea of a grower of that fruit, in order to

At high altitudes, where the atmospheric pressure is considerably reduced, it is important to be able to maintain the air pressure at the carburetor intake so that it will be equivalent to the pressure at ground level, for which the engine of an airplane is designed. This is done by means of a supercharger in connection with an air compressor. As the pressures required are comparatively low, it has been found possible to do this compression with a modified form of the well-known Root blower. This Root type of positive-displacement blower, used as a compressor for supercharging airplane engines, has been subjected to a great deal of study by the National Advisory Committee for Aeronautics at the research laboratory at Langley Field. Tests made there



Three-Wheeled Platform, Designed for the Purpose of Picking Figs, and with Which Four Pickers can Strip a Tree of Its Fruit in Much Less Time Than would Be Possible by Using Ladders

harvest his crop quickly. Bicycle-type wheels were fastened to a wooden platform, which was large enough to hold four pickers, and which was easily pushed around a tree or from tree to tree in much less time than four ladders could have been handled.

showed that, at normal engine speed and a pressure ratio equivalent to an altitude of 16,000 ft., the supercharged unit gave within 11 per cent of its ground-level power output. In nonsupercharged engines there is a 50 or 55-per-cent power loss at that altitude.

ELECTRIC BRASS FURNACE
HAS REVOLVING
MOLD TABLE

The advantages of pouring molten metal directly from the furnace into molds has led to the development of an electric furnace with a revolving table on which the molds are carried. An operator controls electrically the rotation of the mold table, and pours the molten metal as each mold is brought successively into position below the tapping spout.

Names and addresses of manufacturers of articles described in this magazine will be furnished free by our Bureau of Information.

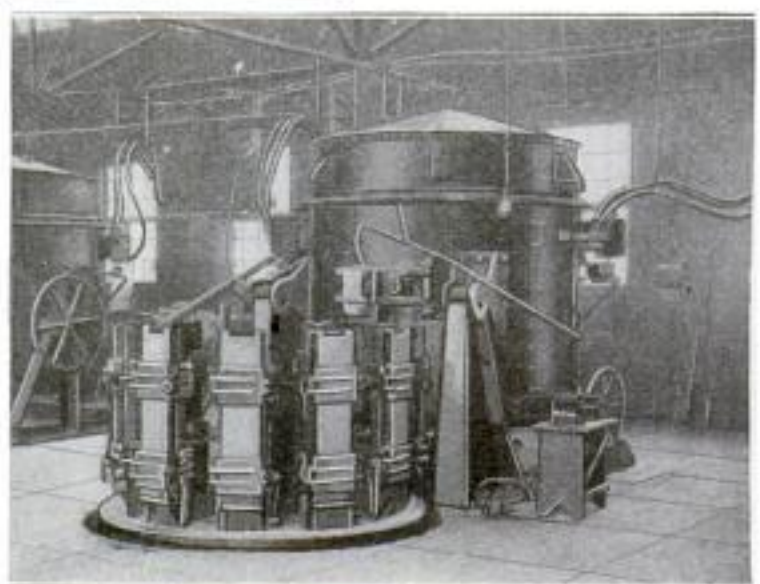

The Molds on the Revolving Table Are of Sufficient Capacity to Take the Output of the Furnace

Com. E. J. Case, Wash. D.C.

2060

8226

**CONCRETE IS AUTOMATICALLY
PROPORTIONED BY WEIGHT**

One of the latest developments in building equipment is a device that measures and proportions concrete aggregates with extreme accuracy, and with a saving in time and labor. This new proportioner measures the aggregates by weight instead of volume, and only one man is required to operate the mixer as well as the proportioner. Constructed so that it

can be framed into any standard bin is a steel panel having at its lower end three openings fitted with bin gates, the center one being for stone, and the two at the sides for sand and cement, respectively. The gates are operated by cams on a shaft above them that extends the full width of the panel. Bell cranks, keyed to each end of the shaft, have each a long vertical arm which is connected by a series of cables and pulleys to supports for three counterweights, one for each of the aggregates, proportioned suitably so that, when a weight of stone equal to its counterweight is discharged into an auxiliary hopper hung from the lower arm of the bell cranks, this counterweight rises, and through the movement of the horizontal shaft, automatically closes the gate on the stone bin, and opens the cement bin. The additional weight of the cement in the auxiliary hopper has a similar effect on the gate of the sand bin. The batch is then complete, and is dumped from the auxiliary hopper into the concrete mixer, returning every part to its original position, ready to proportion another batch.

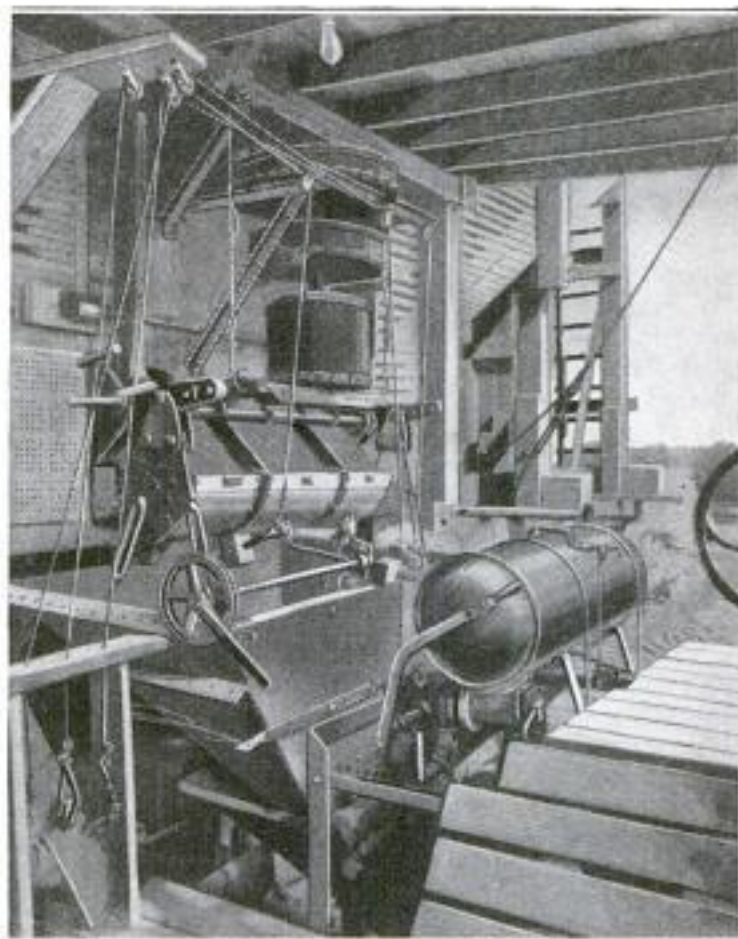

Concrete Proportioner That, by Means of Three Counterweights, Discharges from Three Bin Gates below Them, Measured Quantities of Stone, Sand, and Cement into a Hopper, from Which They Pass to the Mixer; after the Discharge, All the Parts are Automatically Returned to Original Position

**PIGEONS AS SUBSTITUTES
FOR WIRELESS MESSAGES**

Innumerable have been the uses of homing pigeons, in both warlike and peaceful services, but it has remained for an ingenious resident of San Pedro, Calif., to make use of them as a substitute for wireless messages in connection with the fishing industry. The home loft for the pigeons is situated on shore at a point central with relation to the area,

extending 70 miles radially, over which the fishing boats operate. Each boat takes out a pigeon, and at the end of the day, before starting for the cannery, there is attached to the bird's leg a regulation army container, in which a slip of paper reports the day's catch. It takes each boat six hours to return to the cannery, and each pigeon not more than one to reach the homing loft, which is so constructed that as the intelligent little winged messenger pushes its way through the entrance door, an electrical connection rings a

bell that announces its arrival. The note is then taken off, and the information is telephoned to the cannery. The value of this advance information is obvious.

8232

¶The practice of crowding around an airplane when it is about to take off is a very dangerous one and resulted fatally at Red Bank, N. J., recently. An airman landed on the frozen river, and such a crowd collected that there was danger of the ice giving way. In attempting to leave the river, the airplane struck the crowd, killing one woman and injuring several people.

Chas. H. Hayward, San Pedro, Calif.

**CEMENT TENNIS COURTS LAID
 WITH PERMANENT LINES**

Tennis has been growing rapidly in popularity as a sport, throughout the country, and to increase the playing season, asphalt and cement are being adopted for surfacing tennis courts. Though the Pacific coast led in the use of this type of court, New York City, which has lately taken up the idea, has introduced a

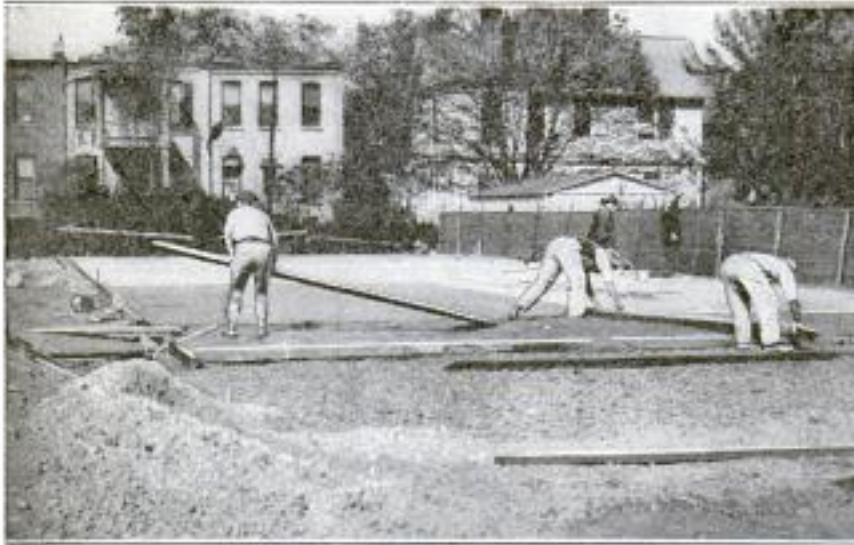

Laying a Cement-Surface Tennis Court: The Initial Cost of Such Courts Is High, but There Is Practically No Expense for Upkeep, and They Permit a Much Longer Playing Season Than Grass or Clay Courts

new method of lining the courts. The lines were formerly painted on the surface of the cement. Now, while the cement is still soft, the lines are grooved out and the material removed. After the court, which is laid with cement colored with lampblack to relieve the glare, has hardened, the grooves are filled with white cement. The expansion joint, necessary for such a large surface of cement,



The Cement is Colored with Lampblack to Relieve the Glare, and the Lines are Made by Laying White Cement in Grooves in the Surface

is placed under the net, where it does not interfere with the playing. These courts can be used several weeks earlier in the

spring and later in the fall than clay or grass courts. After a rain, it is not necessary to wait for them to dry, and they do not require rolling and sprinkling to keep them in condition.

**BAGGING LAUNDRY ELIMINATES
 UNSIGHTLY MARKING**

Marking "flat-work" laundry with indelible hieroglyphics as a means of identifying it is no longer necessary under a system installed by a Massachusetts laundry. Under this system the housewife may send her best tablecloths, centerpieces, doilies, etc., to the laundry without fear of having them returned with their appearance marred by marks.

The goods are sent to the laundry in the usual way—with the name on the package. At the plant the soiled articles are put into an individual cloth container, in which they remain while going through the various processes of cleansing.

Marks on the container instead of on the articles permit quick identification after the laundering. Of course, if there is enough in one batch of laundry to fill more than one container, two or three are used.

The first week the no-mark system was in use, there was a reduction of 70 per cent in the number of articles reported missing. Through this process the company expects to lower the number of lost articles to an extremely small figure.

The chances of soiled articles, especially if they are worn thin, being torn or damaged in the washing processes, are also greatly reduced, as the containers afford the articles additional protection.

**RAILROAD IN ALASKA OPENED
 FROM SEWARD TO FAIRBANKS**

Formal opening, accompanied with elaborate ceremonies, of the government railroad in Alaska, between Seward and Fairbanks, took place early in February. Representatives of the chambers of commerce of several Pacific-coast cities were present, and the event was celebrated by an excursion over the entire system.

*Write Alaska
 Engineering Department
 of Seward Alaska
 R. C. 39*

*New York Times
 12/2 2/21 1911*

7920



Above: A Truck on Which is Mounted One of the New Centrifugal Machine Guns. The Motor on the Rear Supplies the Power for Operating the Gun

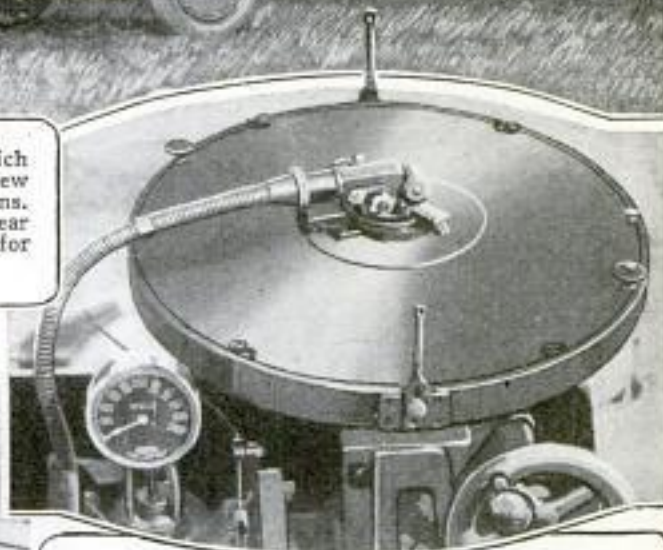

Above: The Drum Which Throws the Round Steel Bullets, and Which Incloses the Principal Mechanism of the Gun. Left: The Method of Mounting the New Gun, on the Dashboard of an Automobile, is Shown in This Picture, Taken during the Recent Tests at Sea Girt, New Jersey

PHOTOGRAPHED BY KEYSTONE VIEW CO.

TESTS MADE OF MACHINE GUN USING CENTRIFUGAL FORCE

Tests were made, not long ago, by the New York National Guard, at Sea Girt, N. J., of a new machine gun of the type in which centrifugal force instead of an explosive is employed to propel the bullets, which are of the ball-shot type and made of steel. They are thrown from a drumlike gun, mounted on the front of a motor truck, at the rate of 1,200 a minute. The power is furnished by a special gasoline motor mounted on the rear of the truck. It is possible to regulate the velocity of the bullets. At their greatest velocity they are capable of killing a man at 2,000 yd. This can be reduced so that, at extremely short ranges, they will merely wound without penetrating the body or causing a fatal injury. Because of this feature, it is hoped that this gun will prove useful in controlling riots without causing fatalities. It was with the idea of this use in mind that the tests were carried out, and the results proved most gratifying.

NEW CROSSING SIGNAL HELPS GUARD DEATH TRAPS

In a determined effort to cut down the tremendous loss of life, and the many injuries which are due to grade-crossing accidents, a large number of illuminated crossing signs of a new type are being installed. Between two bright-red lights is displayed the warning, "Stop." These signs are attached to the posts of the ordinary highway-crossing sign. The two oil lamps have large founts and long-time burners. Back of the letters is a trans-



Adams & Westlake
 319 W. Ontario, Chicago

cent glass, on which light is thrown from the two lamps by mirrors set at an angle. By this means the light can be seen clearly for nearly 300 ft. Each container will hold a gallon of oil. The lamps will burn continuously for about a month with a long-time burning oil.

8000
**NEW GIANT OFFICE STRUCTURE
 AROUND OLD DWARF BUILDING**

The greater will include the less—very much greater, and very much less—and include it very completely in a new Chi-

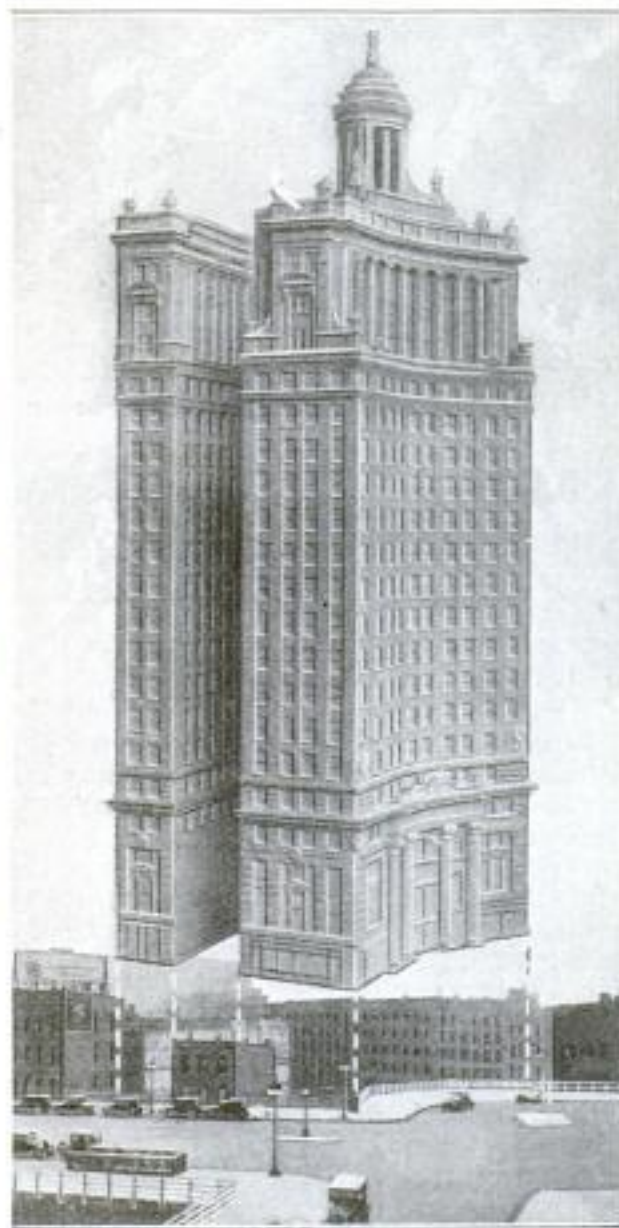

Model, on a Scale of One-Eighth Inch to the Foot, of a 21-Story Chicago Office Building to be Erected around the Old Two-Story Brick Building Which the Owner Refused to Vacate

Chicago office building about to be erected, at a total cost of \$4,000,000, on the site of old Fort Dearborn, facing the new Michigan Avenue bridge. The area of the site

is 13,600 sq. ft., and of this only 1,200 sq. ft., less than one-tenth, is occupied by an old two-story brick building, the owner of which refused to sell out. Consequently, the new building will be built around it, leaving an air shaft above it. The new building will be a superlative contrast to the old one, in both size and finish, for it is to be 260 ft. high, surmounted by a 60-ft. tower, and will have an all-stone finish outside, with marble floors and corridors inside. It will have lights all around, and in every respect will be the last word in modern office buildings.

8135
**SELLING GAS BY HEAT VALUE
 AS WELL AS BY VOLUME**

The difference of opinion, prevalent in every country, between the producer and the consumer regarding the quality of the gas furnished for heating and power purposes, was recently settled in the United Kingdom by measuring not only the volume of the gas consumed, but also the number of thermal units contained in the gas, which is paid for accordingly. Before reaching the ordinary volume meter, the gas passes through a heat-recording calorimeter at some point in the distributing mains of the gas company, and this instrument graphically records on paper tape the calorific value of the gas at all hours of the day. These records are periodically exposed in some public place for the inspection of the consumers.

800
**SNAP-ON RUBBER HEELS
 ATTACHED BY WEARER**

Applying the principle of the snap fastener, commonly used on gloves, to the attaching of rubber heels, is the idea of an eastern inventor. After first fitting the shoe with a metal plate containing 12 metal studs having enlarged heads, the rubber heels, which have corresponding cavities on the inner side, are pressed over the studs until they snap into place. Those who wear their heels down on one side can interchange them frequently, thus assuring a longer life and a neater appearance of the heel.



Chicago Tribune Architect-Architects
 E. W. L. Sarge & Chady
 Bridgeport, Conn.

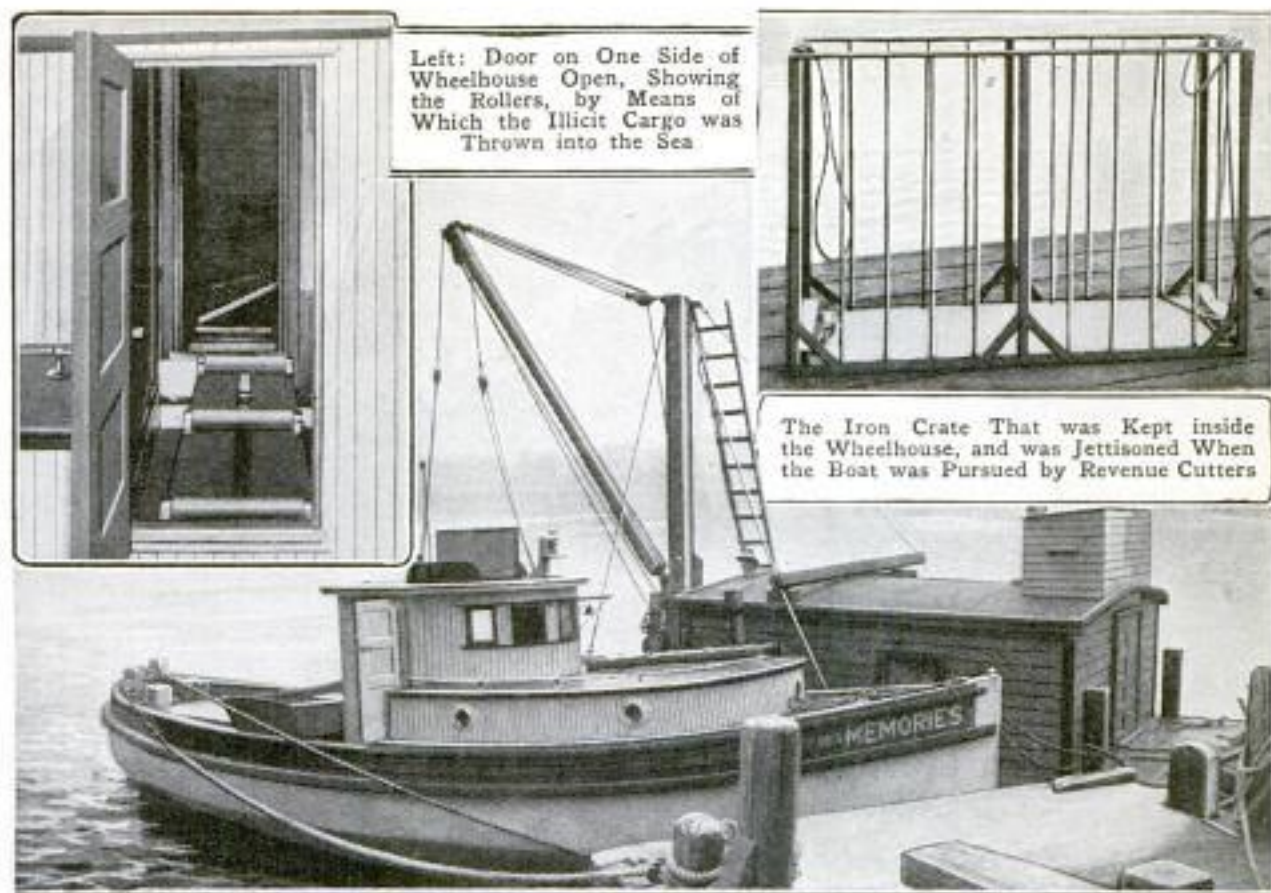

Left: Door on One Side of Wheelhouse Open, Showing the Rollers, by Means of Which the Illicit Cargo was Thrown into the Sea

The Iron Crate That was Kept inside the Wheelhouse, and was Jettisoned When the Boat was Pursued by Revenue Cutters

Boat Used for Smuggling Contraband from Canada to the United States, That was Finally Captured in the Lake Washington Ship Canal at Seattle: The Goods were Left inside the Wheelhouse in a Large Iron Crate Which could be Pushed through the Door and Thrown Overboard

SMUGGLERS USE CLEVER DUMPING DEVICE

BY LAWRENCE WILLIAM PEDROSE

WHAT is said to be one of the cleverest devices ever developed for smuggling was uncovered on Puget Sound recently by Federal officers when a speedy power boat, believed for several months to be a successful smuggler of illicit goods from Canada into the United States, was captured in the Lake Washington Ship Canal at Seattle.

A feature of the boat's equipment was a mechanical device by which the illicit cargo could be temporarily jettisoned should it be overtaken by revenue cutters. Inside the wheelhouse was a specially built runway with smoothly working rollers, on which rested a large crate formed of iron grating, capable of holding several thousand dollars' worth of contraband. This runway connected with rollers on either side of the deck opposite the wheelhouse. The crate with its illicit cargo rested inside the wheelhouse with the doors closed. Should the boat be pursued and in danger of capture, either door of the wheelhouse could be opened and the crate noiselessly run over the side of the vessel.

When the cargo had to be jettisoned in deep water, the position of the crate was marked by a small floating buoy, attached to the sunken contraband with a line. The boat was also equipped with a complete deep-sea diver's outfit and a set of grappling hooks.

It had been known for some time, Federal officers state, that a dumping device was in use on some of the smuggling boats, but a complete outfit of this type had never before been captured. Along with the seizure, more than \$2,000 worth of contraband was taken, which made it possible for the government to confiscate the boat.

UNIFORM FIRE CALL ADOPTED BY CANADIAN COMMUNITIES

All the cities, towns, and municipalities of Canada have agreed to adopt the number "100" for telephone fire calls. Henceforth when the operator gets this number, no matter whether there are exchanges in the city or not, she will know immediately that a fire call is wanted.

Capt. W. E. Seymour,
301 Lister Chambers
Hamilton, Ontario, Canada

8039
 392

71st Avenue Coach Co., New York City.

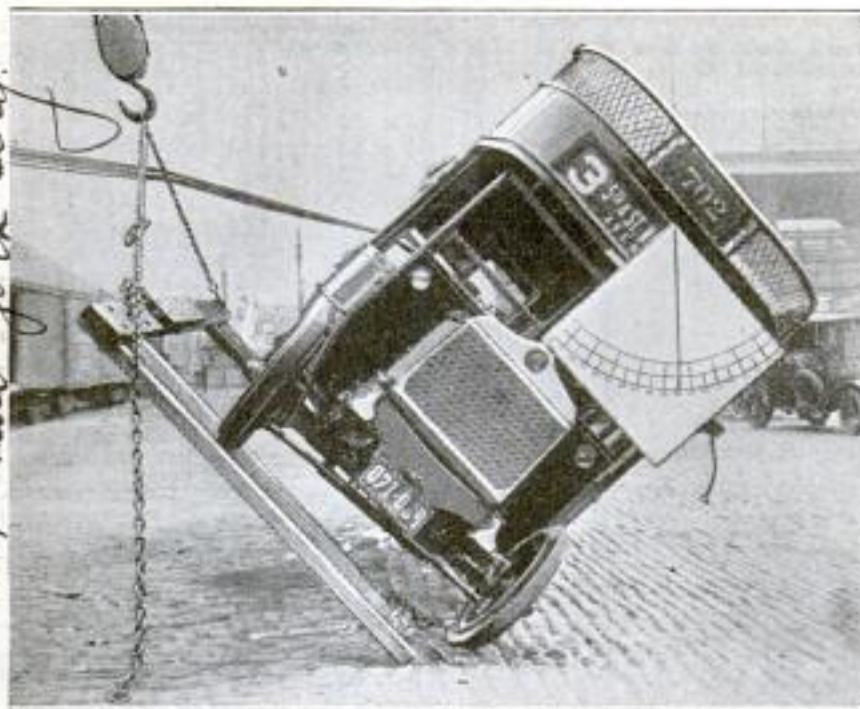

WIDE WORLD PHOTOS
 The Tilting Test Which Showed the Center of Gravity of These Big Busses to Be Only 52 Inches from the Ground, an Assurance of Safety Which is Supported by the Record of 14 Years' Use in New York City

TILTING TESTS PROVE SAFETY OF BIG MOTOR BUSES

Tilting tests of motor busses, used in New York City, showed that their center of gravity is extremely low, only 52 in. from the ground. Their safety is further proved by the fact that, in the 14 years they have been used, they have safely carried 270,000,000 passengers and have had only two overturns. Both were due to an extraordinary combination of circumstances. The same type of bus is used in Chicago, Detroit, Toronto, Can., and other large cities, and in all these places with an equal degree of safety.

ANIMATED STATISTICS TELL ACCIDENT STORY

Walking letters that told their story in a most effective manner were the striking

the significant message: "We Represent the Syracuse People Who Lost Their Lives Last Year by Accident." Thousands of spectators watched the parade, and naturally they were deeply impressed by the message so vividly presented. Of the 63 who were killed by accident in 1920, 17 were boys and girls who lost their lives in accidents that could have been prevented.

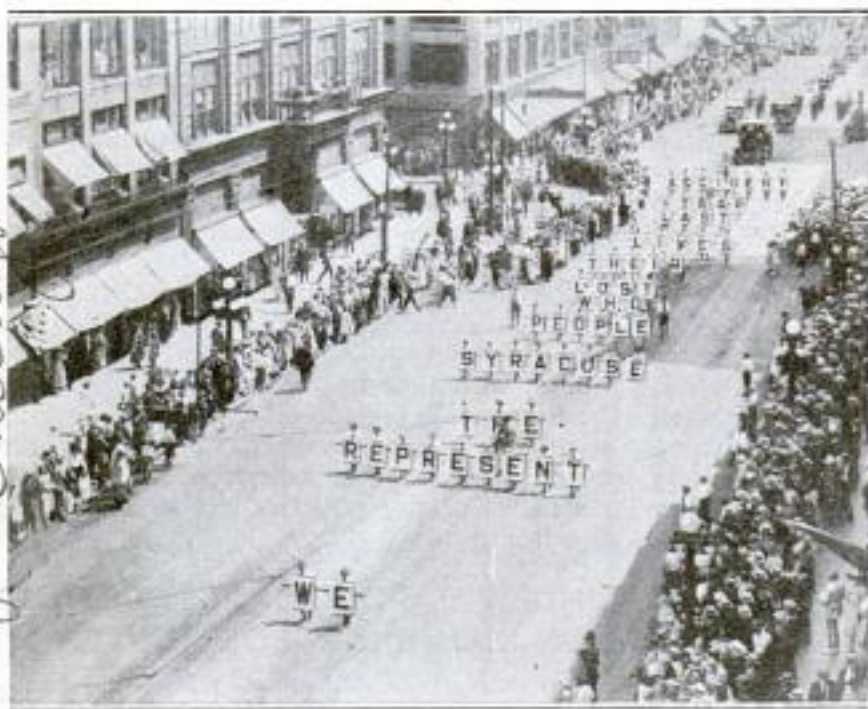

A Striking Feature of a Safety-First Parade in Syracuse, New York, Which Speaks for Itself by a Graphical Representation of the Results of Accidents Which might have been Avoided

The marchers were preceded in the parade by a large truck, carrying an immense sign which read, "First Think of Your Safety," and an ambulance containing a sadly wrecked man and a nurse. At the head of the column of children a boy carried a placard—"63, Count Us." Following the sentence represented by the children was a truck load of children waving flags and bobbing balloons up and down, carrying out the spirit of the sign that they displayed.

feature of a safety-first parade at Syracuse, N. Y. There were 63 children in the group, each child bearing one letter of

and which bore the words: "We Are Happy Because We Practice the A. B. C. of Safety—Always Be Careful."

George H. Paul, 900 Ellsworth Bldg Chicago

4992 American Road Machine Co.
 Kennett Square, Pa.

POPULAR MECHANICS 393
 Tractor Holt Mfg. Co., Peoria, Ill.

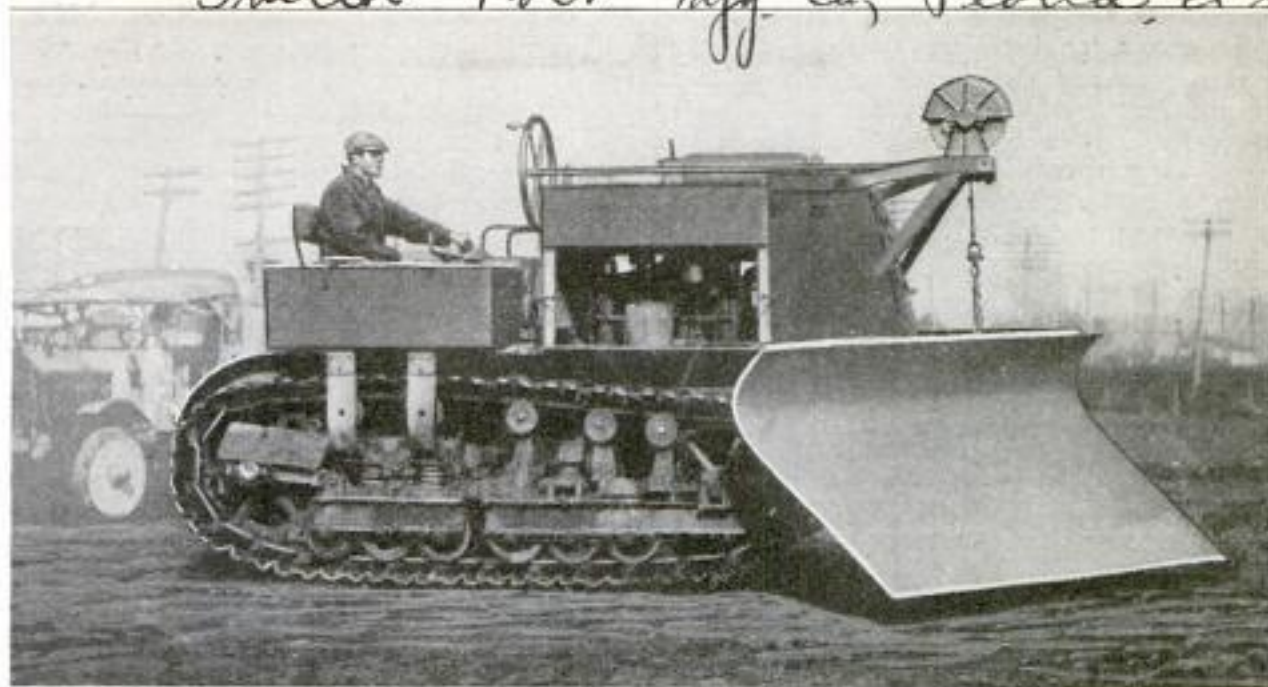

Endless-Tread Tractor, Showing the Method of Attaching a V-Shaped Plow for Scraping Snow from Roads: The Chain and Pulley Permit the Raising and Lowering of the Plow as may be Desired, the Lift being Operated from the Driver's Seat by a Hand Wheel.

7992
ENDLESS-TREAD TRACTOR MADE TO SERVE AS SNOWPLOW

Another adaptation of the endless-tread tractor, which gained wartime fame in the tank service, is seen in a snowplow being turned out by an eastern manufacturer of road machinery. This tractor is equipped with a large V-shaped plow. It is suspended, at the front, in such a way that it can be raised clear or lowered to scrape away snow which has drifted onto a roadway.

8707 Radio

WIRELESS MESSAGES IMMUNE FROM BEING "PICKED UP"

Privacy of wireless communications has been made possible, it is said, by a method which is the discovery of an electrical engineer in the employ of the Ukrainian Government. Utilizing his idea, messages may be sent to a definite receiving station, without danger of their being "picked up" by other operators. It is reported that the same man has also found a way to straighten out, and group, the "locked power lines" of the magnetic field into parallel rays, which can penetrate mountains, thus avoiding the necessity of high antennae.

When you want anything and do not know where to get it, write Bureau of Information, Popular Mechanics, Chicago.

7924
CLEVER IDEA MAKES CONCRETE DAM A FOAMING WATERFALL

In the Cook County Forest Preserve, near Palatine, Ill., an ingenious idea has been used to give a small concrete dam the appearance of a foaming waterfall. The dam retains a small pond during normal weather. When it rains, the pond



The Face of the Dam, Showing How the Rocks are Imbedded in the Concrete to Procure the Effect of a Foaming Waterfall

Encl. Mrs. U. S. Vestal
 550 Courtland Ave.
 Park Ridge, Ill.

New York Times 12/18/21 p. 1

Chicago Tribune
12/29/21

overflows and the water must be carried off into a ravine. A shallow channel, passing under the roadway which runs along the top of the dam, carries the water over it. For a few feet the face of the dam is perpendicular and then merges into a more gentle slope. Small rocks have been imbedded in the concrete of this slope. When the sheet of water strikes them, it breaks into a splashing mass.

789 **MODEL OF ONE MOLECULE ENORMOUSLY MAGNIFIED**

The structure of a molecule which, before the discovery of radium, was considered by physicists to be the minutest par-

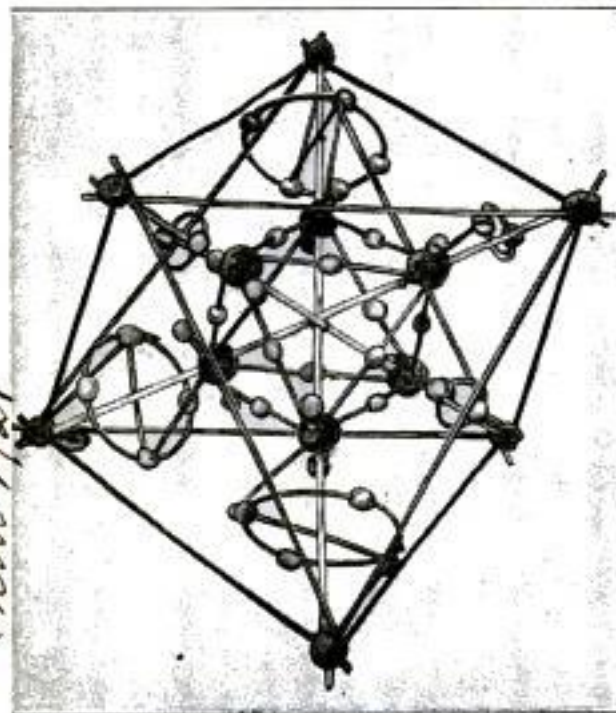

7933
COPYRIGHT, UNDERWOOD & UNDERWOOD
Model of a Molecule 250,000,000 Times Its Size, Being Nine Inches in Diameter: The Component Atoms are Shown by Putty Balls of Various Colors

ticle of matter capable of separate existence, has been reproduced in a model shown recently at the 111th meeting of the American Physics Society. The model is in three dimensions, superficially of crystalline form, and with a diameter of 9 in. This makes it 250,000,000 times as large as an actual molecule, and therefore there is plenty of room to display its component atoms, which are represented by putty balls of various bright colors. These are all constructed in proper proportion and location, and show that the arrangement is similar to the solar system, and all other planetary systems of the universe, leading to the deduction that these atoms, like the planets, are revolving in orbits within the molecule.

CHICAGO'S POWER STATIONS HAVE ENORMOUS CAPACITY

"Cutting in" two 45,000-hp. units of the Calumet station, now under construction, brought the total generating capacity of the Chicago Commonwealth Edison Company up to the huge amount of 880,000 hp. When the Calumet station is completed, at a cost of \$20,000,000, its output will be 250,000 hp., thus taking rank as one of the largest electric-generating plants in the world. For the first time in a decade, and made possible by this latest addition, the company will have a supply of power available that exceeds the demand, and it is estimated that this condition will continue for two years. With its vast production of power, Chicago has become the hub of a gigantic network of interconnected electric-transmission lines in the upper Mississippi Valley, reaching from Minnesota to Kentucky.

RECIPROCATING MOTOR USED IN ELECTRIC HAIR CLIPPER

Hair clipping by electricity is no new idea, but the introduction of an appliance for this purpose that possesses a reciprocating motor, is a distinct departure from ordinary usage. Unlike other electric hair-cutting machines, the driving motor for the blades of this clipper is installed in the handle. The usual connection is made to a lighting outlet of 110-volt alternating current, and at .26-ampere flow the apparatus consumes from 18 to 25 watts. Because of the extreme flexibility obtained in the use of the instrument, its appearance will no doubt be welcomed by barbers in general, and should prove a great aid to the tonsorial trade.

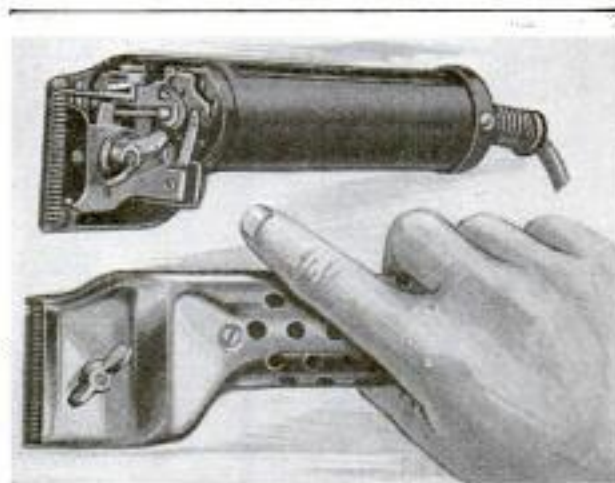

Top: Electric Hair Clipper with Outer Casing Removed, Showing Interior Mechanism. Bottom: Clipper as It Appears in Barber's Hands

7933
Mfr. Berry & Putts Co
201 Palace Bldg
Chicago, Ill.

Tribune 11/26/21
Journal of Franklin & Metcalf
Nov 1921

BORROWING A LAKE BOTTOM TO RAISE GRAIN

By Fred S. Walker, Tulare, Calif

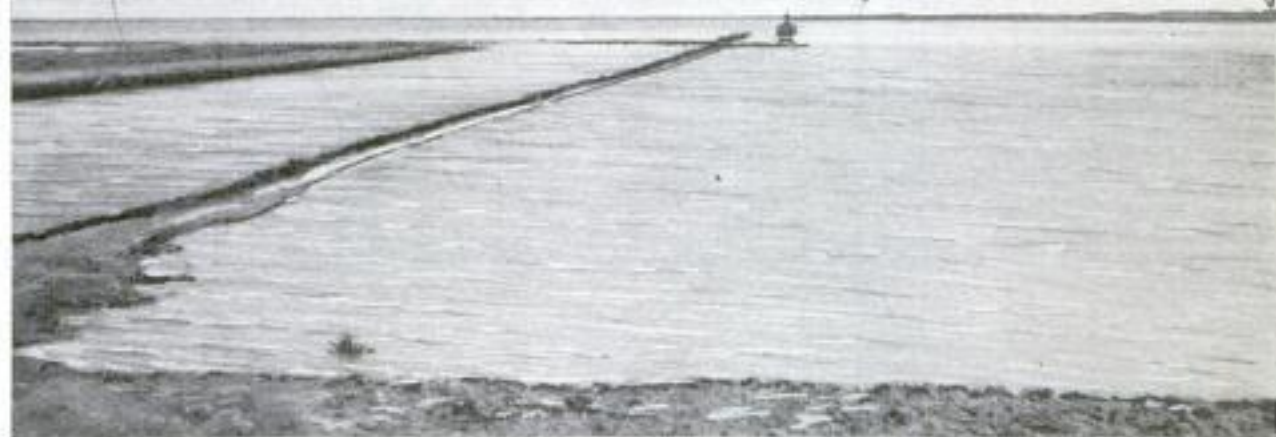

Dredger, Seen in the Distance, at Work Building a Levee, or Dike, across a Section of Tulare Lake, as the First Step in Reclamation of Lake Bottom for Farming Purposes: When the Levee is Completed the Water will be Pumped across It, Leaving One Portion of the Lake Bottom Dry

RAISING a grain crop, as a rule, requires a farmer rather than an engineer, yet during the past 30 years farming in the bottom of Tulare Lake in California has presented an engineering problem that has never been satisfactorily solved, even though, in 1920, a yield of wheat and barley aggregating in value more than \$5,000,000 was harvested and hauled to market from the last low reaches of what has been an inland fresh-water sea. Through it all the lake has only slowly yielded to the attempts to convert its ancient bed to the uses of agriculture. When it is realized that a watershed

more than 100 miles in length, from the highest mountains in the United States, has its natural flow into this lake;

that the laws of California recognize the lake bottom as the only outlet for a dozen streams on this watershed, and that the time of possible operations is limited, some conception of the difficulties of the development involved may be seen.

In 1892, the lake was described as "the largest body of fresh water west of the Mississippi River." Geologists claim that ages ago the drainage of this extreme upper section of the San Joaquin Valley was obstructed by the débris washed into

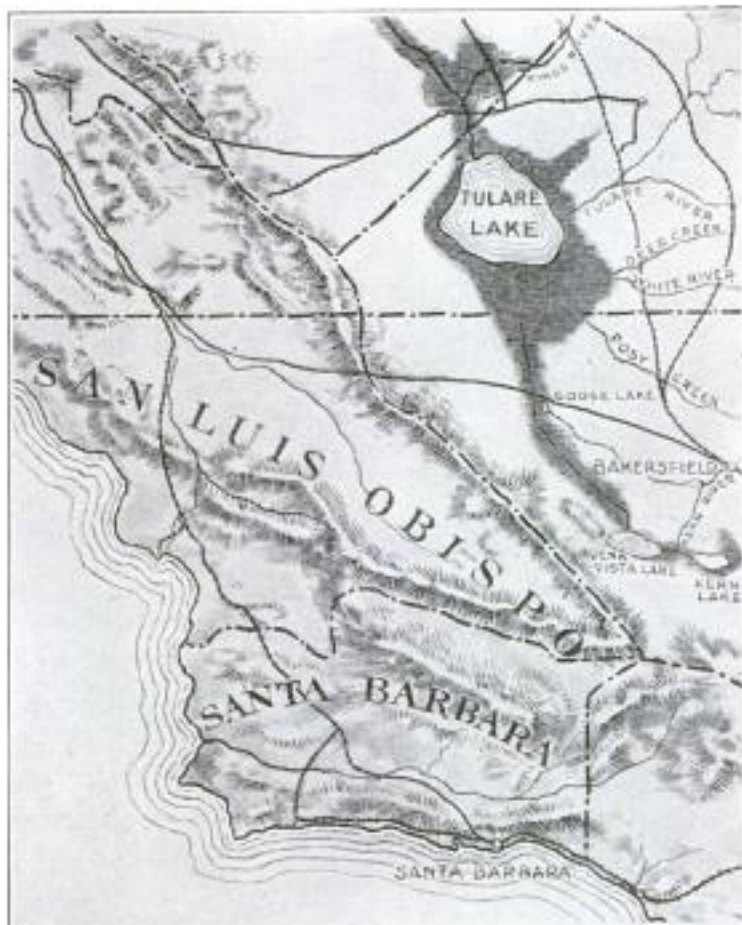

Map of the Watershed of Upper San Joaquin Valley and the Tulare Lake Basin, as It Was in 1890, Before the Reclamation Operations were Started



Hauling Five Four-Horse Scrapers by Means of One 45-Horsepower Tractor to Build a Levee to Protect Growing Grain from Threatened Floods: This Battery of Scrapers Makes It Possible to Build a Levee Three Feet High and One Mile Long in 12 Hours

the channel by Kings River, filling it to a depth of 40 ft., and thus forming a basin on the plain, catching the waters of all the streams south of the San Joaquin

River, the principal of which are Kings and Kern rivers, having their headwaters on the western slopes of Mt. Whitney—Kings River flowing north and Kern River south from that point and describing a great oval before again uniting in the waters of Tulare Lake.

In 1852, when Tulare Lake was first surveyed, it spread over 1,000 square miles of territory and broke over its northern rim into the San Joaquin River, but not in a suffi-



Above: Digging Machine Working on Levee to Protect the Enormous Wheat Field, Seen at Left, from Danger of Floods. Below: Looking from Lake toward a Section of the Levee That Bounds It. Two Rows of Willows on Lake Side are Planted to Protect the Soil from Waves



Part of a Battery of Tractors Hauling Rotary-Disk Plows over the Reclaimed Bed of Tulare Lake in the Fall, After the Season's Crop had been Harvested: Deep Plowing Is Not Necessary, and the Disks Turn Over the Top Crust, Providing a Satisfactory Seed Bed

ciently powerful stream to form a permanent channel. The lake abounded in fish of many kinds—mud cats, perch, and pike being the principal varieties—while receding waters left the shores white with the shells of fresh-water clams. In seasons of flood and heavy rainfall, when the lake was filled with water, it also became filled with rank wild grasses and tules, where the fish and clams multiplied. Then in seasons of drought the evaporation of the water was so great on the nearly flat surface as to leave millions of fish stranded on the mudflats of the plain. The shores of the lake became putrid with decaying fish and vegetable matter. This

process, repeated over and over through many decades, left the bottom lands incalculably rich in animal and vegetable deposits, and finally paved the way for gambling against the chance of flood seasons, and also to the more gradual work of permanent reclamation.

In the early efforts of reclamation a few furrows around large tracts by individual growers were often sufficient to hold the water from flooding the land; but as the



Above: One Tractor Pulling 125 Feet of Rollers over the Growing Grain to Pack the Soil about the Roots and Prevent Evaporation. Below: Hauling the Grain to Market with Teams of 10 Horses or Mules, Handled by a Single Driver, Who Usually Rides the Near Wheel Horse

area of the lake was decreased by this method, higher and stronger levees became necessary. A break in the levees of one grower often caused heavy loss to scores of others. Concerted effort became urgent, and led to the formation of recla-



Dense Growth of Grain on Part of a 5,000-Acre Field, Taken Just Before the Heads Filled and Weighted Them Down Till They Touched the Ground. The Yield Was 70 Bushels an Acre

mation districts and systematization of the construction of greater bulwarks against flood.

Unquestionably helping to reclaim the lake to agriculture are irrigation projects on the higher plain around the lake, where intensive farming is profitable. Alfalfa fields early took the place of the old stock ranges, while horticulture and viticulture have proved less insecure than dry farming of grain on the arid plain. These industries have required vast quantities of mountain water in addition to the local rains. Then, a score of years ago, the foothill section of the Sierras developed one of the most famous citrus belts in the annals of industrial enterprise, and in a decade the towns of Lindsay and Portersville have become commercial centers for the orange, the grapefruit, and the lemon. With the rise of the citrus culture, the water from the normal rainfall and the slowly melting snow of the high mountain region went into use for irrigation long before it reached the lake in dry and normal years. Each irrigation district, however, takes care of its own affairs, will take only such water as it needs from day to day, and turns back into the rivers any surplus of the snow waters of the high mountains which fill every stream during a few sudden warm days in May and June. These freshets, which come three months after grain must be seeded in the lake bottom, form the basis of the hazard under which the lake farmer must work.

This, then, is the situation today. The Tulare Lake now covers only 42 square

miles of territory, around which an immense levee, more than 20 ft. high and 100 ft. broad, cuts this final remnant of lake bottom from the other 958 square miles of fertile valley land which it once held.

In dry seasons, outside the levee, are farm lands under irrigation stretching for 50 miles across the plain to the foothills; inside the levee are 42 sections of bottomless mud, level as a floor, yet covered in a great part by a few inches of tepid water. It is miles away from rodent pests, is free from stones, roots, and weeds of any kind, and seemingly invites the farmer to drain and plant in its matchless fertility. Yet every grower who engages in the enterprise does so with the knowledge that this muddy pond is the legally allotted catch basin for more than 7,000 square miles of mountain watershed, and now 20 times smaller than it once was.

Tractor power has proved to be the key to success in farming the bottom of Tulare Lake. Without the facility to perform large operations under limited-time pressure, every attempt of the growers would have been doomed to failure.

With two feet of water in the lake bottom at the deepest point, spreading over an area of more than 14,000 acres, the first step toward the production of a grain crop is a battery of dredgers, which run levees, or dikes, through the lake from end to end. Then, with large motor-driven centrifugal pumps, the water is drawn out of one section into another, to



Timbering the Levee to Prevent It from being Washed Away by the Waves: The Water Here Stood 17 Feet Deep against the Levee

facilitate the drying of each tract to be farmed. Finally, it is pumped across the large levee, protecting the reclamation

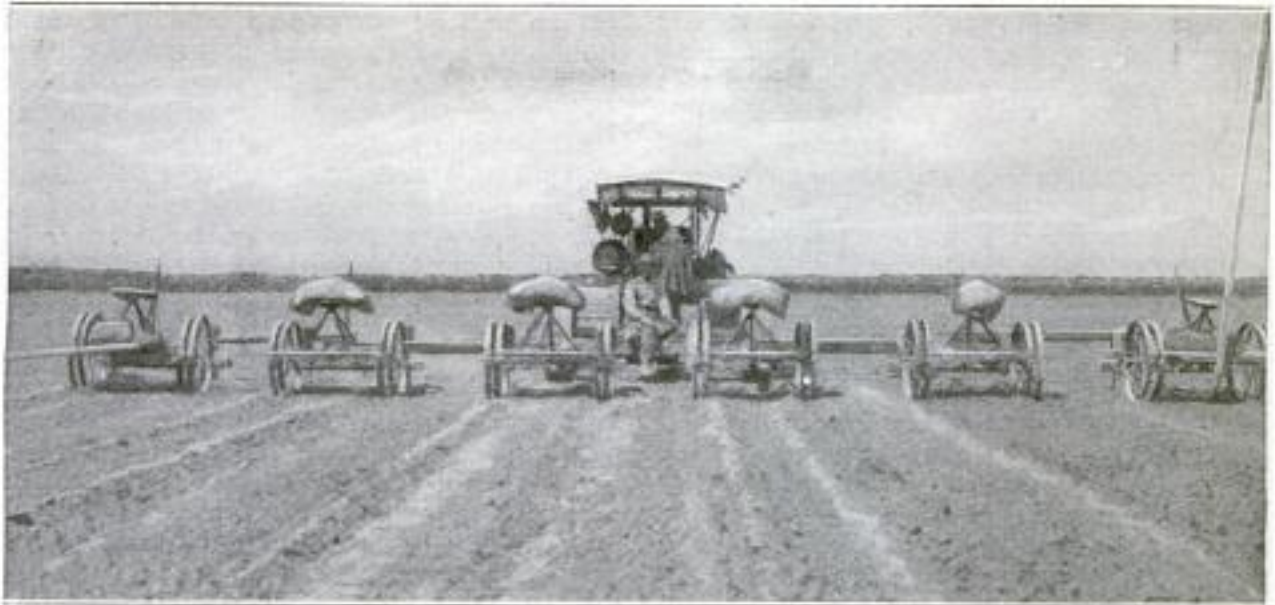

Battery of Six Corn Planters Operating on the Reclaimed Bed of Tulare Lake: They are All Hauled by One Tractor, Making It Possible to Plant 12 Rows Simultaneously with the Labor of Only Two Men, One on the Tractor, and the Other on the Planters

districts outside, and is used for the irrigation of the higher ground.

Removal of the water leaves a sea of bottomless mud, picturesquely described as "not bearing the weight of a mosquito." A sheep or an ox venturing into it is helpless and soon sinks from sight. Warm dry winds and spring sunshine, however, dry the surface within a short time so it will bear the weight of tractors of the track-layer type, though it shakes under a man's foot, and for months will not bear the pulling weight of horses. During the entire course of the work of plowing, seeding, and caring for the crop, no domestic animal is permitted to enter the district. Naturally, for 20 miles across this expanse, no permanent house, no tree or fence may be seen. For temporary use by tractor operators and helpers, mosquito-screened camps are set up for instant removal in case of heavy rains or mountain floods.

As soon as the drying soil permits, tractors, pulling rotary plows and working in batteries, turn under the top crust and provide a seed bed for the coming crop. This is followed by seeding and harrowing on a gigantic scale. After the grain is a few inches in height the soil must be treated to prevent too great evaporation. As the drying process goes on after the planting is complete, the soil cracks and crumbles into a myriad of tiny fissures. This is overcome, in part, by pulverizing the soil with rollers which packs the soil and keeps the moisture about the roots of the plants. Working day and night, a tractor, pulling 125 ft. of rollers, rolls and packs 280 acres of land in 24 hours.

The grain sown, sprouted, and rolled, there is left for the operator only the work of strengthening and repairing the levees. The weather of the high Sierras has much to do with successful crop conditions in the lake bottom. A mild spring brings about a gradual melting of the banked-up snow in the mountains, but with a backward spring, followed by warm rains and sunshine during May and early June, every stream out of the snows becomes a tumbling cataract of potential flood waters. Then every grower in the wheat pit of the lake bottom is transformed from a placid farmer into a dynamic force for concentration and coöperation. Barometer changes are reported hourly from forester stations and electric power plants in the mountains, and the rise of a fraction of an inch in every stream is reported 24 to 36 hours before it can reach the valley. Specialists employed by the lake farmers know the capacity of every irrigating stream out of the rivers, and the probable demand for every foot of water. What they do not know, and what they must gamble on, is the probable duration of a flood.

This happened on one occasion last year and it was only met by prompt and decisive action on the part of the growers. One grower in the irrigation district outside the big lake levee held 5,000 acres of grain that would average in the neighborhood of 25 bushels to the acre, as it stood on the ground late in May. Acting for the lake-bottom growers, a committee waited upon this grower and quickly closed a deal for his entire holdings in growing grain at a price of \$70,000. Then, as the flood waters swept down the sandy

bottom of the Kings River, a dam was thrown across the stream and the cutting of the river levee sent the flood into this new 5,000-acre reservoir. Again the operators gambled on the chance that this area would suffice to hold the waters until the hot spell ceased. Hundreds of men armed with shovels and empty sacks patrolled the levees ceaselessly, while steam dredges operated day and night, raising and strengthening the embankments. Still the hot wave in the hills filled the streams, and hour by hour the battle went on to keep the levee from breaking and flooding the country, which would have involved heavy damage suits for loss of crops. But the flood subsided and the levee held, and for the first time in history a full harvest was taken from the lake bottom.

Yet, though the flood condition had been met, the great problem of lake-bottom farming was but half solved. One inch of rain might again render it a slimy mass of mud, so slippery and sticky that nothing could be hauled away until it dried. An inch of early-fall rain, too, would wet the sacks of grain in the wake of the harvesters, and these, drying in the blistering sun, would rot like paper. If harvesting was done, it would be necessary to remove the grain before the fall rains, which sometimes fall in September.

The harvest began during the third week of June. The lake bed was a sea of standing grain, relieved only by tall stakes

set on section corners to mark individual holdings, and to guide the work of the harvester. Grain "buck" wagons followed close upon the harvester, and every effort was made to haul the grain from the field and place it near the roadways as rapidly as the filled sacks fell from the machine. With every facility for transportation in use, moving 700 tons of grain daily, it would require 100 days to get the crop out of the lake, even after it was harvested. To speed the work, one firm, having 5,000 acres of wheat, employed eight large tractors in the harvest field cutting and harvesting the grain, while smaller tractors, pulling trains of five low-wheeled farm wagons, followed the harvesters, gathering the filled sacks and hauling them to roadways previously rolled and packed, where heavy motor trucks and freight teams hauled them to warehouses and depots.

It is claimed that every straw in the immense crop was utilized, for following close upon the removal of the grain from the field, sheep were turned into the stubble in droves of 2,000 to 5,000 each. Small camps, embracing a sleeping tent for the herder and troughs for watering the animals, were established and moved from place to place as the need arose. Specially equipped supply wagons visited these camps daily. By November 1 the lake bed was again seemingly as bare as before the farming operations began.

Tire

ELECTRIC VULCANIZER HAS MANY MERITS

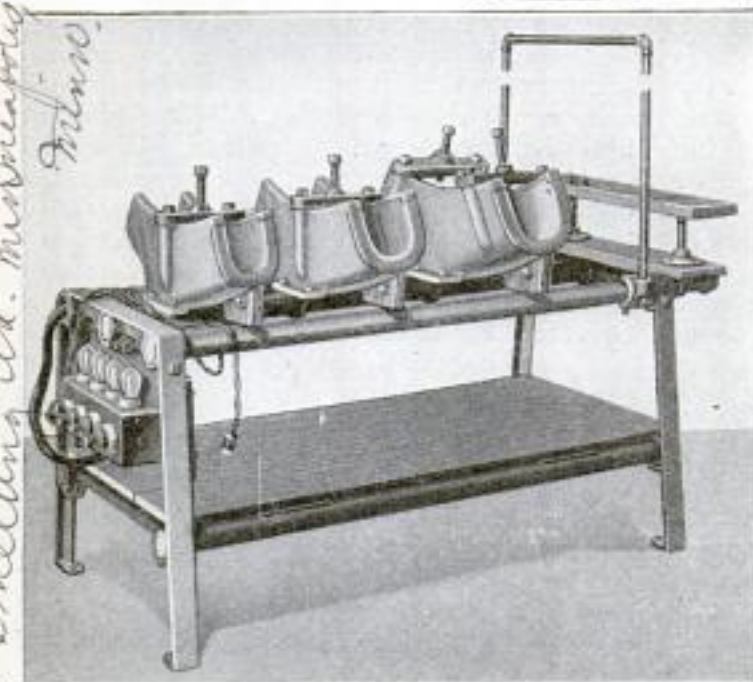

Electric Vulcanizer, Showing Molds, Tube Rack, and Hot Table on Top, with Switches and Pilot Lamps at End

Efficient electrical vulcanizing, excluding all steam apparatus and the consequent danger of explosion, is performed with an appliance developed by a Minneapolis firm. Three molds are provided for holding the tires, in sizes of 3 to 3½ in., 4 to 4½ in., and 5 to 5½ in., together with extra bead molds for accommodating both the clincher and ordinary-type casings. Each mold can be operated independently, has individual pilot lamps, and the whole receives power from a cord attachment to any light socket. In addition are supplied a hot table for vulcanizing inner tubes, and a bracket upon which these can be hung while the work is being done. As many of the units as desired may be joined, so that tire repairs in any size shop can be effectually executed.

5946
Progressive Shoe Machinery Co.
112 Snelling Ave. Minneapolis
Minn.

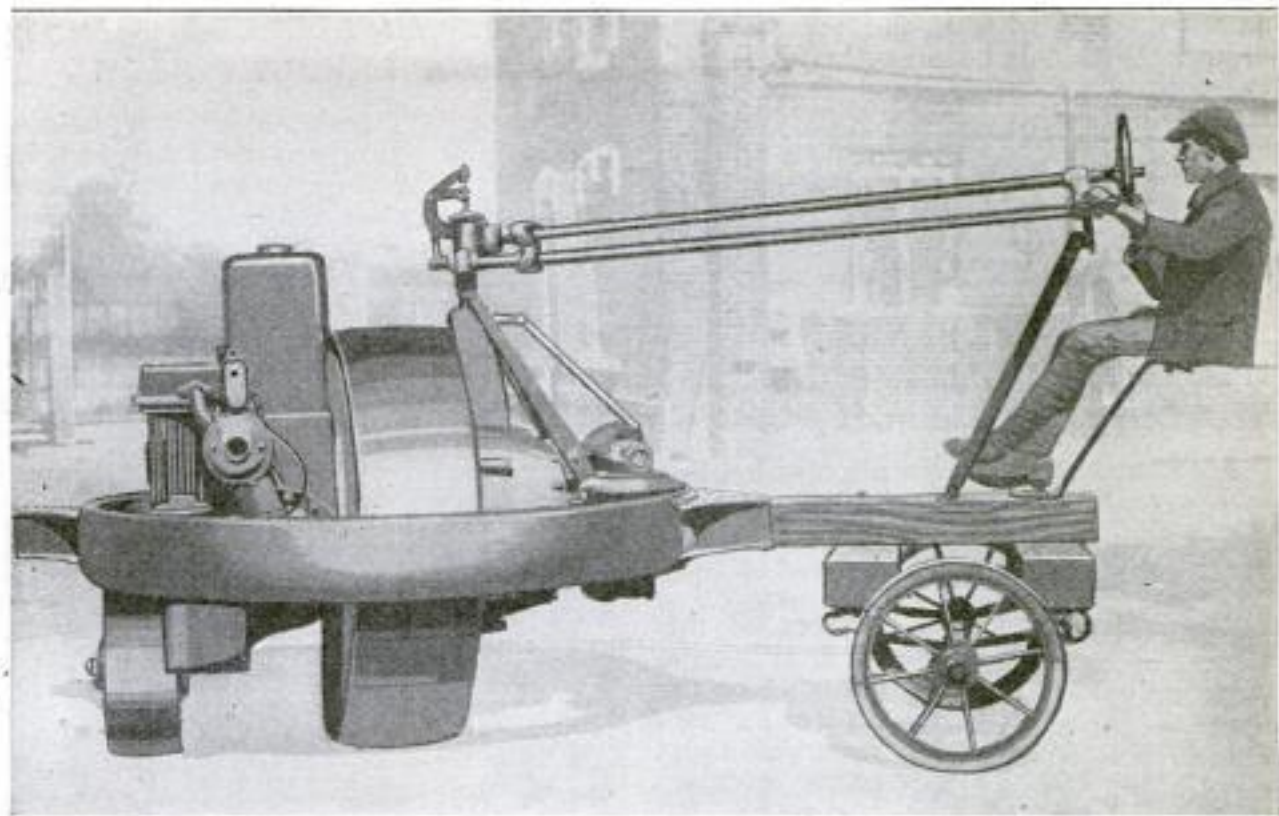

Novel Farm Tractor Making an Abrupt Turn: The Large Traction Wheel has been Turned at Right Angles to the Direction in Which the Tractor was Traveling, and will Thus Follow a Curve around a Stationary Center

FRENCH TRACTOR—SIMPLE AND ORIGINAL IN DESIGN

7460

To all intents and purposes the ordinary farm tractor is a more or less skillful adaptation of the principles of operation embodied in the automobile. More-

over, these tractors, as a rule, are adapted for hauling the same kind of farm implements as are used with horses. A novel type of tractor has been constructed in France that has little more in common with the ordinary motor car than the fact that it is driven by an internal-combustion engine. Even at that, its motor, which consists of two opposed cylinders, is valveless, depending for its

gas distribution upon one rotary device, and bears no resemblance whatever to any automobile motor. This new tractor consists of one large traction wheel some-

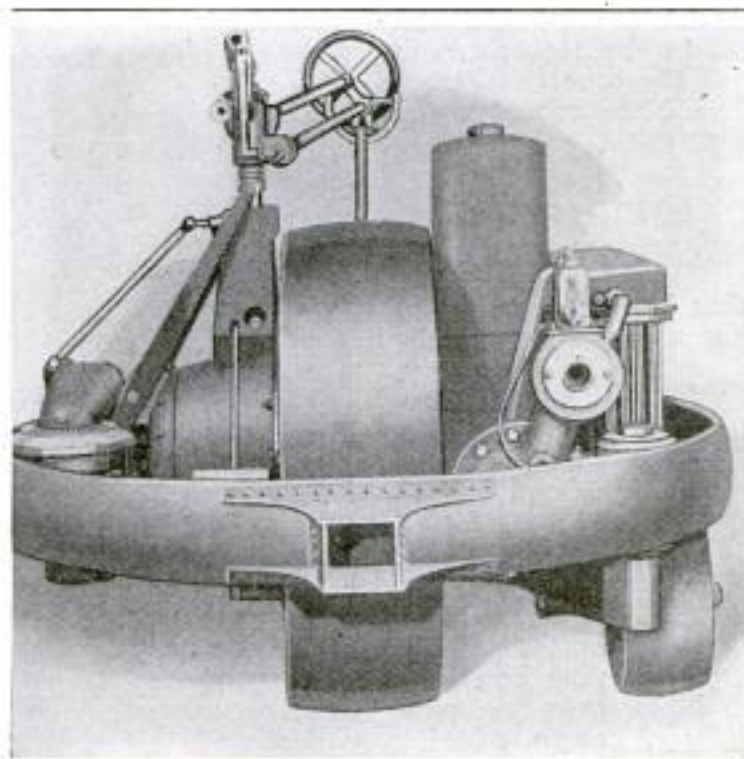

Front View of Tractor, Showing Large Traction Wheel in Center: To the Right of It Are the Motor and Radiator. To the Left Are Steering Devices That Turn These Parts as a Unit

what in the nature of a wide disk wheel, which contains in its interior a complete system of transmission and speed gears. The motor and its adjuncts, as well as the wheel and its supports and the water-cooling radiator, form a unit that is pivoted in a horizontal circular frame, to which can be attached any suitable means for hauling the implements, as well as a trailer which supports,

on two small wheels, the seat for the driver. With this construction, it is easy to make very abrupt changes of direction. Beside the driver's seat is a lever by which the speed is controlled and the tractor driven forward or reversed. The models that have been built up to the present have proved to be very efficient in doing the work for which they were designed.

DENATURED ALCOHOL ALWAYS 808 2A DANGEROUS POISON

Reports of denatured-alcohol poisoning, since the adoption of prohibition, indicate a failure fully to understand what denatured alcohol really is. Denatured alcohol is alcohol to which some poisonous substance has been added to make it unfit for internal use, and is always sold with a poison label on the container. Some of the mixtures are: carbolic acid 1 part, alcohol 99 parts; formaldehyde 1 part, alcohol 99 parts; corrosive sublimate 1 part, alcohol 2,000 parts; corrosive sublimate 1½ gr., hydrochloric acid 2 dr., alcohol 4 oz.; formaldehyde 2 parts, glycerine 2 parts, alcohol 96 parts; carbolic acid 1 dr., tannic acid 1 dr., alcohol 1 pt., water 1 pt.; alum ½ oz., formaldehyde 2 dr., camphor 1 oz., alcohol 1 pt., water 1 pt.; lysol 1 part, alcohol 99 parts. All these are violent poisons, astringents, or corrosives, strong enough to cause intense suffering and lingering physical decay. The proportions of denaturing substances are in some cases so small that they cannot readily be detected by smell, and in others entirely imperceptible.

7985

IMPROVED HOLDER SQUEEZES TOOTHPASTE FROM TUBE

A recently invented fixture, for holding and squeezing a tube of toothpaste, is said to have a definite advantage over other devices of this kind. When the pressure on the tube is released, no more paste escapes from it. It consists of a boxlike case containing a movable plate, which is pressed back by bearing down on a handle protruding from the front of the box. The tube is held upside down in the box by means of a slot in the top, through which the bottom of the tube is inserted and bent over. The plate squeezes the tube with a flattening effect.

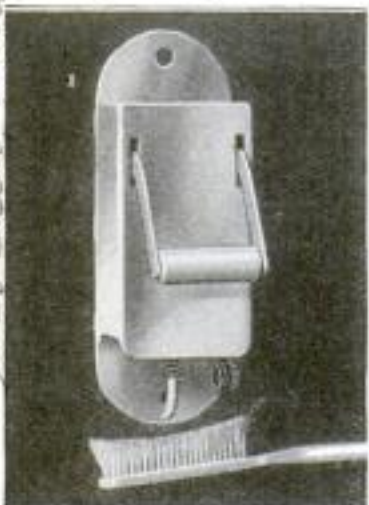

It consists of a boxlike case containing a movable plate, which is pressed back by bearing down on a handle protruding from the front of the box. The tube is held upside down in the box by means of a slot in the top, through which the bottom of the tube is inserted and bent over. The plate squeezes the tube with a flattening effect.

The tube is held upside down in the box by means of a slot in the top, through which the bottom of the tube is inserted and bent over. The plate squeezes the tube with a flattening effect.

STRAINER OF STEEL WOOL KEEPS PIPE STEM OPEN

Clogged stems, that bane of pipe users, can be averted by the use of a new smokers' accessory, which consists of a small, loosely wound ball of fine steel wool. This, pressed down against the bottom of the pipe bowl, allows free passage of the smoke, but prevents tiny particles of tobacco from entering the stem.



which consists of a small, loosely wound ball of fine steel wool. This, pressed down against the bottom of the pipe bowl, allows free passage of the smoke, but prevents tiny particles of tobacco from entering the stem.

OLD SWEDISH COIN TEN INCHES SQUARE IS LARGEST KNOWN

Probably the largest coin in the world is one belonging to Farron Zerbe, internationally famous expert on rare coins.



It is a piece of stamped copper plate 10 in. square, and weighs 6½ lb. It has a value of "4 Daler" (the daler was a coin of varying value) stamped on it, and the date 1730. Such coins were commonly

used in Sweden for some time during and after the wars of Charles XII. It is part of a collection of more than 30,000 specimens, representing mediums of exchange of all countries and periods from the earliest times to the present day. The total face, or original exchange, value of the collection is counted in millions, but no present value has ever been placed on it. Many of the coins are, of course, rare, and of much greater value than their face.

German makes unknown to C.W. Frankly Electric company

Com. Mortimer J. Tessier
24 Mills St. Nyack, N.Y.

Com. J. P. Lynch
3557 St. Charles

7812

SPECIAL RACING MOTOR-CYCLE DESIGNED BY ENGLISH RIDER

A 20-hp. motorcycle of novel design has been constructed by G. W. Baker, a well-known English motorcycle racer. The machine is especially designed for the cycling pacing track, for the purpose of breaking the present world's record of 63 miles in an hour, held by Paul Guinard, of Paris, France. It is the highest-powered machine of its kind in Great Britain, and is equipped with a two-cylinder V-type motor, with a belt drive. The unusual arrangement of the steering mechanism is particularly conspicuous. The speed attained will depend as much upon the driver's skill as upon the machine.



The New 20-Horsepower Motorcycle Built by an English Motorcycle Racer for the Purpose of Breaking the World-Cycle Pacing-Track Record

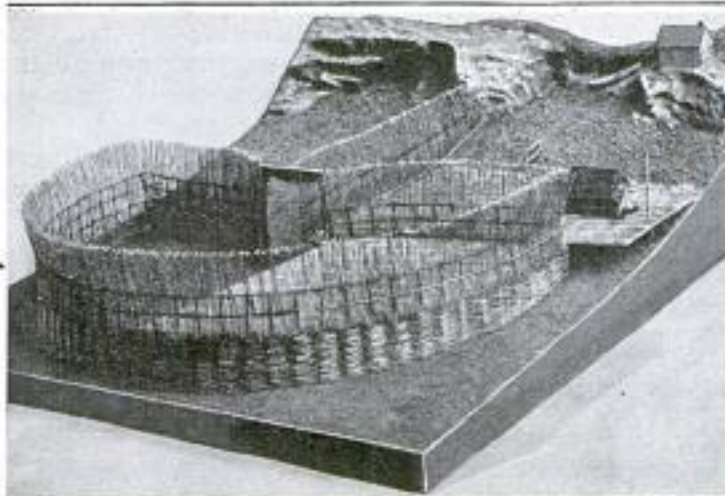

A Perfect Reproduction of a Typical Maine-Coast Herring Weir, the Product of Four Months of Patient Work on the Part of an Old New England Fisherman

MODEL HERRING WEIR BUILT BY MAINE FISHERMAN

Through four long winter months Capt. John A. Anderton worked patiently building a model herring weir. The result is a perfect reproduction, in miniature, of the type of weir commonly used along the Maine coast. It is 3 ft. long and 4 ft. wide, one-fiftieth the size of the original. The brush work was reproduced by the use of straws from a broom and small twigs. The beach and rocks were modeled in clay and sand. A fisherman's cottage is on the rocks.

HAND-DARNING MACHINE WORKS LIKE A LOOM

Darning is made into a pleasant occupation, it is claimed, when done with a device recently introduced in England. The little darning machine consists of a flat stretcher which is placed behind the hole in the stocking, and over which is slipped a saddle that holds the stocking in place. The thread is wound back and forth over the hole on hooks on this saddle. A third piece, hinged on the saddle, hooks under every other thread and raises or depresses them alternately while a threaded needle is passed back and forth between them, as in weaving.

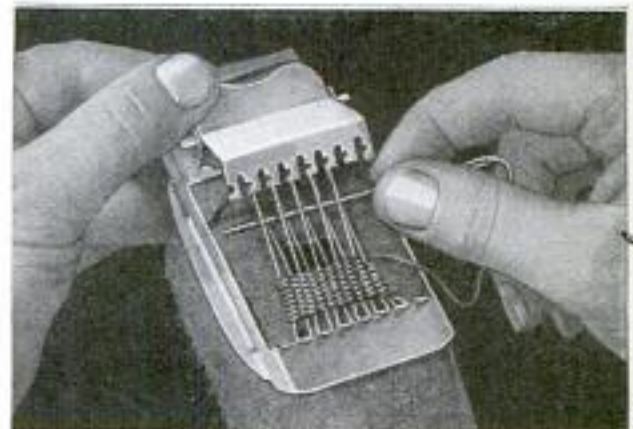

Darning Machine: With the Left-Hand Thumb the Saddle is Raised and Depressed, While with the Right Hand the Needle is Passed between the Threads

~~E. J. A. Co., 656 Holloway Road, N. 19, London, England.~~
Wm Penn.

Emb. Cecil Lereau, Maine
168 Water St. Eastport.

7837

7941

No representations in U.S.
\$6.00 per dozen

Wm. H. L. Healy
c/o Arthur Hallam,

404
 7954 317 Cedar St. **POPULAR MECHANICS**
Minneapolis, Minn.

**NEW ADJUSTABLE HANGER
 FOR WALL RADIATORS**

The growing popularity of hanging heating radiators against the wall calls attention to a new adjustable hanging

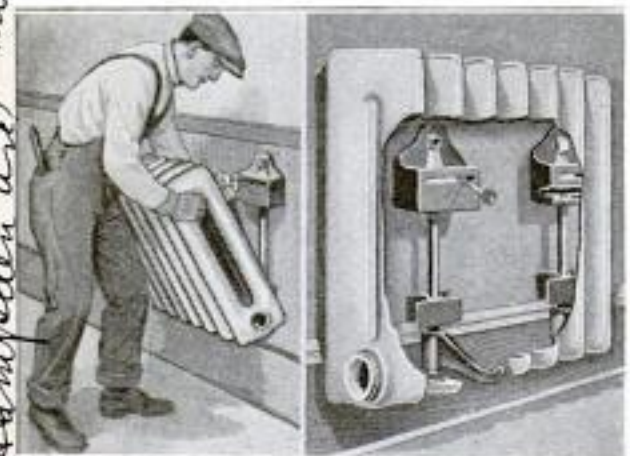

Left: Hanging a Radiator on the New Adjustable Support. Right: Radiator Cut Away to Show How the Support is Adjusted

device. It consists of a boxlike bracket, fastened to the wall by a single bolt. A bolt, through a slot in the front of the bracket, is passed between two sections of the radiator and screwed tight with the washer against the inner columns of the two sections. Two brackets are used for each radiator, and the slots make it pos-

sible to bolt them to the wall studs, yet permit the radiator bolts, by moving them laterally, to come between the sections of the radiator. A 1/2-in. pipe extends down from a slot in the bottom of the bracket. It can also be adjusted laterally. Near the lower end is a brace which holds the radiator 2 1/2 in. from the wall. At the end is a bracket on which the radiator rests.

**USE OF THE ROOF FOR SHOPS
 IS LATEST GARAGE ECONOMY**

One western garage owner believes in using all the space possible around his garage, for on the roof of his service station is located sheet-metal, blacksmith, and paint shops, and also an apparatus for cleaning engines with a distillate spray. This apparatus consists of an air compressor and a spraying rig. The distillate is blown from a reeled hose by the compressed air, and the reel for the hose is fitted with a spring which rewinds it when not in use. A large drain is conveniently located to dispose of the residue from cleaning the engines, and all the dirty or greasy work around the garage is assigned to the lofty workshops. The interior of the garage is thus kept entirely free from all smoke, gas, and grease, resulting from this work.

Below: Under This Shed on Top of Garage Roof are Installed, at Extreme Left, a Sheet-Metal Shop; to the Right of That, a Blacksmith Shop, and Farther to the Right, a Paint Shop



Above: Part of the Garage Roof. On the Parapet Wall at the Extreme Right Are the Pipe Coils That Cool the Air While Passing from the Compressor at Their Left to the Air Tank beneath Them

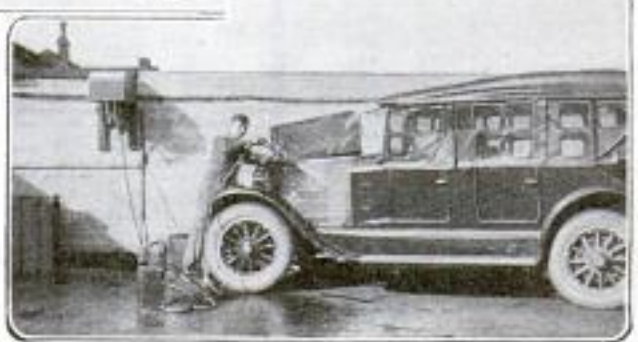
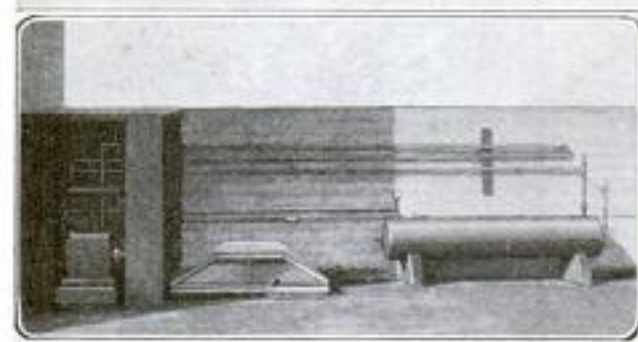

Left: Air Compressor, with Its Cooling Pipes on Wall Leading to Receiver Tank beneath Them, Which Furnishes Supply of Compressed Air to the Spraying Device Seen at Right, being Used for Cleaning the Engine of an Automobile. The Sprayer is Connected by a Hose to a Five-Gallon Can of Distillate

Carl Chas W. Iseliger, Press Club,
Powell & Sutter, San Francisco, Calif.

mfr - Healy - Ruff Co / St. Paul
795 Hampden Ave / Minn

Copyrighted material

7871
 mfr. *Thos W. Bland & Co.*
 2 King William St, Strand
 W.C. 2, London, England
A TWENTY-GAUGE SHOT PISTOL

BY CAPT. EDWARD C. CROSSMAN

3416 Helen Allyn Drive, Los Angeles Calif

SINCE the earliest days of their colonial empire, the British have almost continuously found themselves engaged in various arguments with primitive peoples, widely separated in location, but having the same failing of refusing to consider themselves dead when duly shot with the British-army firearms provided for the purpose.

It proved of no comfort to the relatives of an officer who had "gone west" from an assegai stab or the slash of a long knife, to know that the Zulu or Pathan had first been neatly shot by the officer, and had eventually passed on to a heathen paradise. The missiles from the British service rifles and pistols took too long to work, and in the meantime the heathen often proceeded to carve the soldier to suit his taste.

Wherefore appeared both the British dum dum, or mushrooming, bullet for the service .303, and the shotgun pistol which was intended to knock the festive native right out from under his hat. The pistol was evolved by British gunmakers for the use of officers of the army having to do with natives. It is literally a 20-gauge shotgun—about .67-caliber if measured in rifle terms—fitted with two short barrels and a pistol handle, especially shaped to permit control of the gun and its rather heavy recoil. It has the locks, the frame, the top lever, and even the ejector of the

is a practical and most powerful double-barreled hammerless pistol, which will deliver a frightful shock with either its



The 20-Gauge Double-Barreled Shot Pistol, the Missile of Which Is More Deadly Than Even a Dumdum Bullet, in Position for Firing: With a Smaller Bore, It Resembles in Effect the Sawed-Off Shotgun

buckshot loads, or ordinary loads of duckshot, such as "6'es" or larger. The pistol is made with single trigger for firing the two barrels, for the officer willing to sink the additional money in the gun.

My wife and I tried the British gun, for the first time, in fear and trembling. All we could buy for it in the sporting-goods store was a good stiff 20-bore load of $\frac{7}{8}$ -oz. duckshot, in front of $2\frac{1}{2}$ dr. of powder, which is the heaviest combination



Close-Up of the 20-Gauge Double-Barreled Shot Pistol

put up for the 20-gauge shotgun. Memory of the good stiff jolt of the 6-lb. 20-gauge shotgun when fired at the shoulder, made firing this gun, held in the grip of one lone hand, seem a sure way to depart this sad vale of tears. However, firing it with two hands didn't develop anything very fearful in the way of kick; the hands and arms, springing under the thrust, seemed to cushion the kick, and it was felt less than with a gun held against a comparatively unyielding shoulder.

Our courage restored, we tried a shot with one hand, pistol-fashion, arm extended, everything according to Hoyle. The pistol rose into the air a little, and came back into the crotch of the hand with a good firm jolt, but the hand remained intact, and there was no tendency, as we feared, to tear out of the grip.

The handle, or grip, is made with an overhang, coming just above the junction of thumb and hand, and this aided in the control of the up-



Photo Snapped at the Instant That the 20-Gauge Shot Pistol was Fired, Showing the Effect of Recoil: It Is Double-Barreled, Hammerless, and Resembles an Ordinary Shotgun on a Very Small Scale

ordinary shotgun, and the fine workmanship of the British arm of this class, yet

ward thrust of the gun with its load of $\frac{7}{8}$ oz. of shot, three or four wads, and $2\frac{1}{2}$ dr. of smokeless powder, a combination about twice as weighty as the most powerful of ordinary revolvers. We shot up the box of shells without untoward results to our right hands. The gun is not a desirable weapon for a woman for target practice, but the lady of the family shot this one single-handed several times to prove that a woman had no trouble controlling it.

At the receiving end of the fire, the gun patterned like any other cylinder-bored shotgun of this gauge, and with buckshot at 20 yd., was a far more formidable weapon than any revolver or automatic pistol. A buckshot of a quarter-inch or larger diameter, with its velocity of not far from 1,200 ft. per second, has a more vigorous wallop at short ranges than the bullet from the ordinary type of .32 pocket revolver or automatic pistol, and in a gun of this 20-bore persuasion one fires from each barrel from eight to fifteen of the round leaden pellets, depending on the size.

The two barrels can be fired, of course, as fast as the hand is recovered from the upward throw of the first shot, and the finger is shifted to the rear trigger. At a dozen feet, or so, the load from one barrel would inflict a knockdown shock, even if only duckshot were used.

For stopping a rush or discouraging one that is ready to start, the gun would be much superior to any pistol firing only one ball. And if the shooter fancies hitting his quarry with just one round and weighty pellet, the gun will fire 20-gauge round balls, of nearly .67-caliber, and weighing nearly an ounce—but the shooter will know that he's pulled trigger on something when he fires it.

For a half century the most effective weapon of American firearms for close-range fighting has been the sawed-off shotgun, but it remained for the British gunmakers to put out the shotgun idea in the form of a pistol, easily carried in a holster, and yet as sure death as the old express messenger's pet, which took up room and advertised its presence by its length.

7964
**PILES DRIVEN WITH SWINGING
 LEAD TO PREVENT BREAKING**

To do away with the breaking of piles under the weight of the hammer, which caused much trouble in the construction

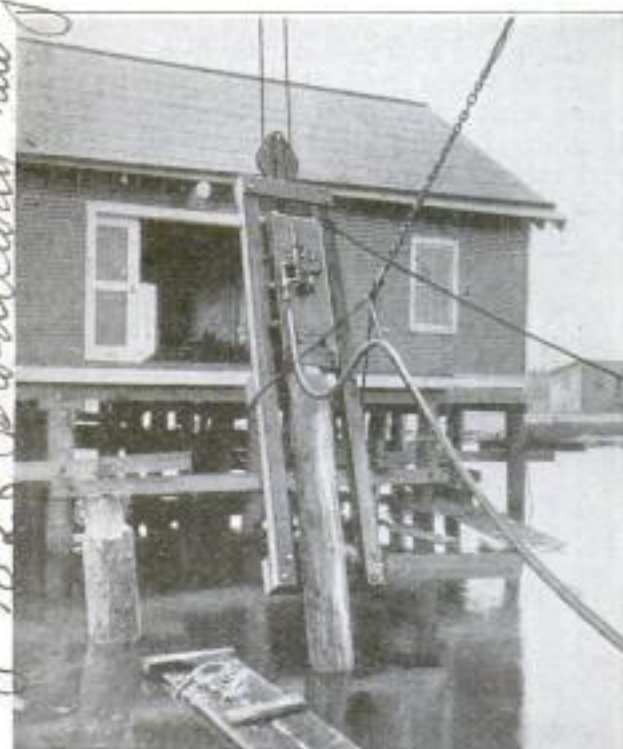

Swinging Lead Used in Place of the Ordinary Type for Driving Piles at an Angle: By This Means the Piles were Prevented from Bending and Breaking

of a sea wall at New York City, the contractors devised a swinging lead. A floating derrick was used, and the weight of the piles caused them to penetrate the mud several feet, when placed. By means of guys they were pulled to the right angle and held while being driven. The hammer operated between two 6 by 6-in. timber leads, extending 8 ft. below the butt of the pile, and handled by a hoisting tackle and derrick boom.

8053
**OLD MISSISSIPPI CRAFT USED
 AS POWER PLANT**

One of the survivors of the days made famous by Mark Twain's "Life on the Mississippi," the steamboat "Andrew Paddock," is now serving as a power plant at New Orleans, La. Perched high in the air on stilts, smoke still belches forth in black masses from its tall stacks, but the sternwheel that once churned the murky waters of the river is motionless. The captain and crew of the "Andy," as it was affectionately termed by the negro roustabouts, were transferred to other boats, and the crew now consists of two firemen, each of whom is addressed jocularly as "captain." The numerous passing craft invariably blow their sirens in salute, and old "Andy" always replies vigorously from its position just beyond the water's edge. The boat is owned by an oil com-

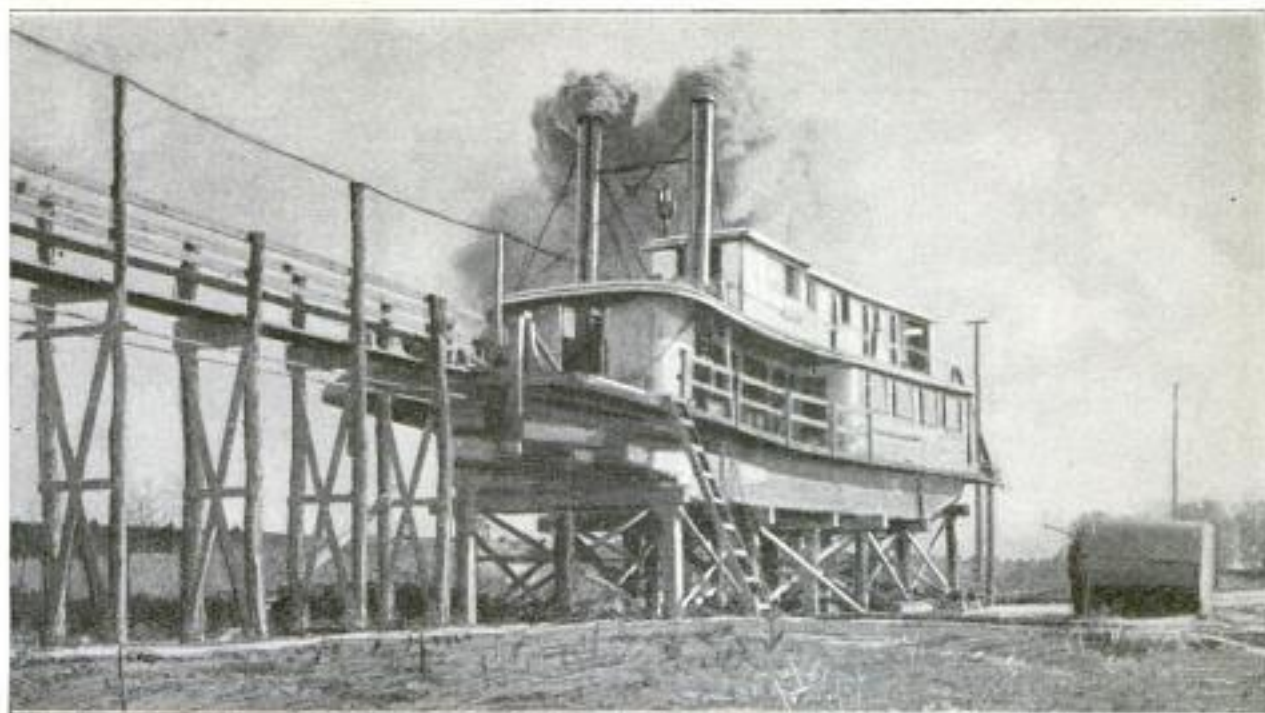

This Is How the Old Mississippi River Steamboat Now Appears as It Rests High upon Stilts at the Water's Edge and is Used as a Power Plant. The Elevated Sidewalk Leads from the Former Craft to the Bunkering Offices of the Company, for Which It Furnishes Light, Heat, and Power

pany, and furnishes power for its bunkering offices on the Mississippi River. The rooms in the rear of the offices are occupied by employes of the company, and are also heated by the steam from the boat. Very little ceremony attended the lifting of the "Andrew Paddock" from the water, and elevating it to the present position. After the stilts were driven in place, it was raised by jacks to its final resting place, thus ending an active river career which extended over a period of 25 years.

9909
BUFFALO FUR TO BE SHEARED AND USED LIKE SHEEP'S WOOL

There are 8,000 American bisons, commonly known as buffalo, in captivity, and it is calculated that, if sheared, the fur of these animals would furnish 160,000 lb. of raw material that could be used as a substitute for wool in the manufacture of blankets, sweaters, socks, or other products. That buffalo skin is a greater warmth retainer than any other hide was well known to northern pioneers, and it has now been demonstrated in a practical way, in Canada as well as in this country, that the hair or wool when sheared from the pelt has real commercial value. Unfortunately, buffalo cannot be sheared as sheep are, because of their great strength and pugnacity. It will therefore be necessary to handle them in some manner similar to the way unbroken horses are held when being

branded. Held without danger to themselves or the shearers, the loose wool could be pulled off, and what remains



Photo of Buffalo, Taken While in Captivity in Canada Where Arrangements are being Made for Utilizing the Fur of These Animals as a Substitute for Wool

could be sheared. Arrangements are now being made in Canada to shear 5,000 head of buffalo at Wainwright, Alberta.

For quick transportation, the company owning the diamond mines in the Province of Kasai, in the Congo State, Africa, sends diamonds to the town of Kinshassa, their nearest destination, by airplane.

W. inc. V. Fair Vancouver, B. C., Canada
 Col. Chas. Goodnight Goodnight, Texas

6,000 buffaloes at Wainwright, Alberta, Canada.

Bill Cochran, Buffalo Park, Wainwright, Alberta, Canada.

Copyrighted material

Louis B. Mayer Studios
 Los Angeles, Calif.

POPULAR MECHANICS

8064

IMITATION CONCRETE BLOCKS
 ARE MADE OF SANDPAPER

Counterfeit concrete blocks for motion-picture photography, when made of sandpaper, have been found to yield a more



This Imitation Stone Doorway of a Motion-Picture Set is Made by Tacking Sheets of Sandpaper on Wood to Represent Concrete Blocks

natural appearance than the genuine product. The stone borders on doorways have always proved to be a source of annoyance to moving-picture producers, because of the unnatural aspect they present in the finished photograph. By accident, the usefulness of sandpaper in this connection was discovered, and due to the minimum of expense involved, it is thought that the future "stone" of the movies will consist of a sandpaper imitation.

VALUABLE DIATOMITE MINE
 IS OPERATED IN OREGON

Diatomite, or infusorial earth, composed of the remains of myriad microscopic underwater organisms, or diatoms, of past ages, is now being mined near Redmond, Ore. A company has acquired nearly 1,000 acres of land, under which is a deposit of this product, 35 ft. in thickness and claimed to be 100-per-cent pure.

Western Diatomite Corp.
 Redmond, Ore.

This commodity is used for numerous purposes; for example, as an ingredient in tooth paste, nail polish, in vulcanized rubber, in sirup and sugar filters, as an insulation material, in dynamite, and in cement mixtures for the plastering of marble or other hard substances.

PECULIAR MACHINE BUILT
 FOR EMPTYING CANALS

On Belle Isle, the municipal playground of Detroit, Mich., there is a peculiar pumping machine which was improvised for the purpose of draining the water from the canals on the island. These canals are drained and cleared of refuse each year in preparation for the skating season. The machine is a box, 3 ft. wide and 20 ft. long, open at the ends and mounted on two wagon wheels at the center. At each end are two sprocket wheels. Endless chains pass over these sprockets and through the box. On the chains, at intervals of 14 in., paddles are attached. One end of the box is lowered into the canal and the paddles carry the water up through the box to a sluice, which drains into the river. The machine is operated by either a tractor or a steam engine, according to the amount of power which happens to be required.



The End of This Peculiar Pump is Lowered into Canals Which are to be Emptied of Water for Cleaning. The Outside Box is Here Removed

Emb. W. K. Croason, 414 29 Townsend Ave
 Detroit Mich.

Standard Oil
 Bulletin Sept 1911

ARTIFICIAL CRANBERRY BOGS IN THE NORTHWEST



Typical Artificial Cranberry Bog in the Pacific Northwest: The Bog has been Drained, Cleared, and then "Scalped" of Vegetation. Through Soil Made of White Sand the Cranberry Shoots are Thrust and Take Root in the Peat below It. This Work Costs \$1,000 an Acre

SHORTAGE in the cranberry crop in other parts of the United States last year has focused attention upon this new industry of the Pacific Northwest, which promises to furnish strong competition for the product of the eastern part of the American continent. After years of experimentation and selection and the development of artificial growing areas, the states of Washington and Oregon have come to the front as producers of cranberries in large commercial quantities.

Lewis and Clark, in the log of their trip across the continent in the early part of the 19th century, mention the fine flavor of the wild cranberries purchased from the Indians

along the Columbia River. Cultivation of the wild cranberry bogs was not attempted until about 35 years ago, and continued in a desultory manner until recently, when a successful means of preparing growing ground was developed.

Preparation of cranberry ground in the Pacific Northwest is an expensive under-

taking, the cost being around \$1,000 an acre. A wild marsh is selected, drained by ditches, cleared of trees and brush, then the turf is removed by what is called the "scalping" process, leaving bare the peat of the bog. Over the peat is spread a 4-in. layer of clean white sand. Planting is the next proceeding. Vine cuttings are used for this purpose, and are pressed through the sand into the peat with a dibble or planting tool. The vines are

planted 10 in. apart, which makes about 60,000 to the acre.

During the first year the plants send out runners, which in the second year form a vine growth, 6 to 10 in. in height. Every two or three years the

ground must be carefully weeded by hand. Flooding the ground in winter has proved effective in keeping down the weeds.

For the first year or two after the productive stage has been reached, the cranberries must be picked by hand, because the vines are tender. Thereafter a long-toothed wood comb is used, and is about



After the Bog has been Drained and Cleared Down to the Peat Bottom, Four Inches of Clean White Sand is Spread on Top of the Peat

8021

ten times faster than hand picking. The field is marked off in 4-ft. avenues with white twine, and a picker is delegated to each avenue. The ground is dry and clean, and the pickers work sitting or

carefully picked over by hand. Care in picking over the berries is necessary, as one decayed berry will spoil a whole crate. The floor of the warehouse is thoroughly ventilated, and the berries are stored in their crates until time to send them to market, whereupon they are again examined and packed in barrels for shipment.



The Cranberry Warehouse: The Berries Brought In from the Field are Mechanically Separated from the Chaff, Then Carefully Sorted by Hand, after Which They are Stored in the Warehouse until Marketing Time

kneeling, gathering the fruit into shallow dishes, which are emptied from time to time into crates at the end of the avenues.

The crates, which have slatted bottoms to provide ventilation for the berries, are transported to the warehouse as rapidly as they are filled. A machine separates the chaff from the berries, which are then

minute drop of oil so strongly flavored that in comparatively small numbers these organisms impart to the whole water supply a disagreeable taste. The affected reservoir, the Kensico basin at Valhalla, has been cut out from the water-supply system by a by-pass. Thus isolated, the water will be treated with a sulphate-of-copper solution that will kill the Synura.

8130
HARMLESS ORGANISM MAKES WATER DISTASTEFUL
Brown

N. J. James 7/6/22 Q. 1



Pickers at Work on an Artificial Cranberry Bog: The Plantation is Marked Off with White Twine into Avenues Four Feet Wide, to Each of Which a Picker is Assigned. They Work Sitting or Kneeling



CIRCULAR SAW MOUNTED ON AUTO CUTS COMMUNITY'S CORDWOOD

WHEN this young man, who lives up in northern Wisconsin, needed to cut cordwood for his furnace, he made his inventive mind save him from the back-breaking labor of the handsaw. Removing the body from his automobile, he mounted a circular saw on the chassis, with a belt from the rear wheels to drive it, and went into the business of cutting wood for the whole community. It proved so profitable that he was soon able to buy a new car.

8008 apparatus _____ *Accessories*

**RADIO CHANGE-OVER SWITCH
 OF SIMPLE CONSTRUCTION**

**8044 AUTO BABY BED USABLE
 ALSO IN THE HOUSE**

Simplicity of design and operation, in addition to the elimination of all "kick" in the phone receiver, are the chief features of a new radio change-over switch. When changing from sending to receiving, the turning of a knob causes three knife-blade contacts, first, to cut off the power, then ground the aerial for a moment to drain away any accumulated charges, and finally connect the aerial to the receiving circuit. Being small, compact, and possessing a high insulation factor, the switch should be welcomed by all who look for simplicity in radio apparatus.

A bed, designed to carry babies in automobiles, is equally suitable for use in the



A Baby Bed, Which can be Used Either in an Automobile or in the House, should Prove to Be a Great Convenience

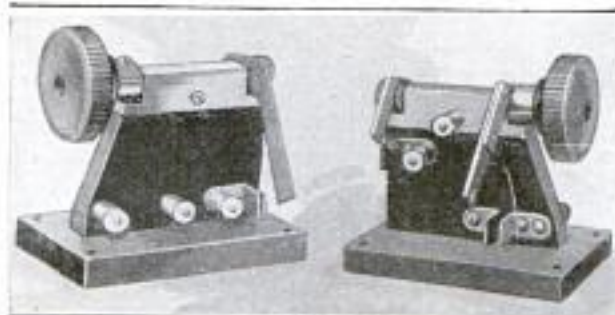

Left: Radio Change-Over Switch as It Appears from the Receiving Side. Right: Sending Side of Switch

*Signal Electric Co.
 Menominee Wis.*

home. It is made of heavy steel-gray covert cloth, strongly reinforced and mounted on a folding frame. The frame is of black-enameled steel and is supported by legs. The bed is intended to be placed back of the front seat of the machine. It is 18 in. high, 14½ in. wide, and 33 in. long.

*Perfection Mfg. Co.,
 2701 N. Central Ave.
 St. Louis, Mo.*

Cml. M. H. Allen,
283 1/2 Regent St.

412

POPULAR MECHANICS

8035

Berkeley, Calif.
JAPANESE WOOD CARVING
INCREDIBLY LIFELIKE

San Franciscans are paying homage to one of the most remarkable wooden statues ever conceived. It is the work of



Life-Size Statue of the Japanese Artist Hananuma Masakichi, Carved in Wood by Himself: Two Thousand Pieces were Separately Fashioned and Put Together with Pegs to Complete the Figure

Hananuma Masakichi, greatest Japanese artist in wood or ivory, who posed for

himself by the aid of adjustable mirrors, and carved his own life-size image from wood. More than 2,000 separate pieces of wood were used, each member of the anatomy having been carved separately before putting the whole together. The joints were perfectly made, dovetailed and glued together, only wooden pegs being used for fastening. With the woodwork completed, the artist applied lacquer to the statue, giving it the appearance of flesh and blood. Skin blemishes, blue veins, discolorations—everything is reproduced faithfully.

The hair on the figure is the artist's own. He used the clippings from his head and beard, boring tiny holes for the hairs and setting them in place one by one. The body hairs were all pulled from his own body and put in exactly the same position on the figure as they occupied on himself. The teeth are visible through slightly parted lips, and the eyes, made of glass by the artist, have the appearance of real eyes.

The figure is in every particular, even the most minute, an exact counterpart of the artist. The carving required three years, even to so adroit and masterly a workman as Masakichi.

7998

ROLLER AND ICE SKATING ON RESERVOIR COVER

On the large, specially designed concrete cover of a fire reservoir in Dubuque, Ia., can be seen crowds of youngsters enjoying the unusual roller-skating facilities offered there. A small store and many other conveniences are installed for the benefit of the youthful merrymakers who daily throng the smooth surface during the summer months. In cold weather, the cover is flooded with a foot of water, the freezing of which provides an excellent ice-skating rink.



Showing the Large, Specially Designed Concrete Cover of a Fire Reservoir as It Appears during the Summer Months When Children are Permitted to Use It as a Roller-Skating Rink

Cml. S. J. Jellison, 2506 Windsor Ave.
Dubuque, Ia.

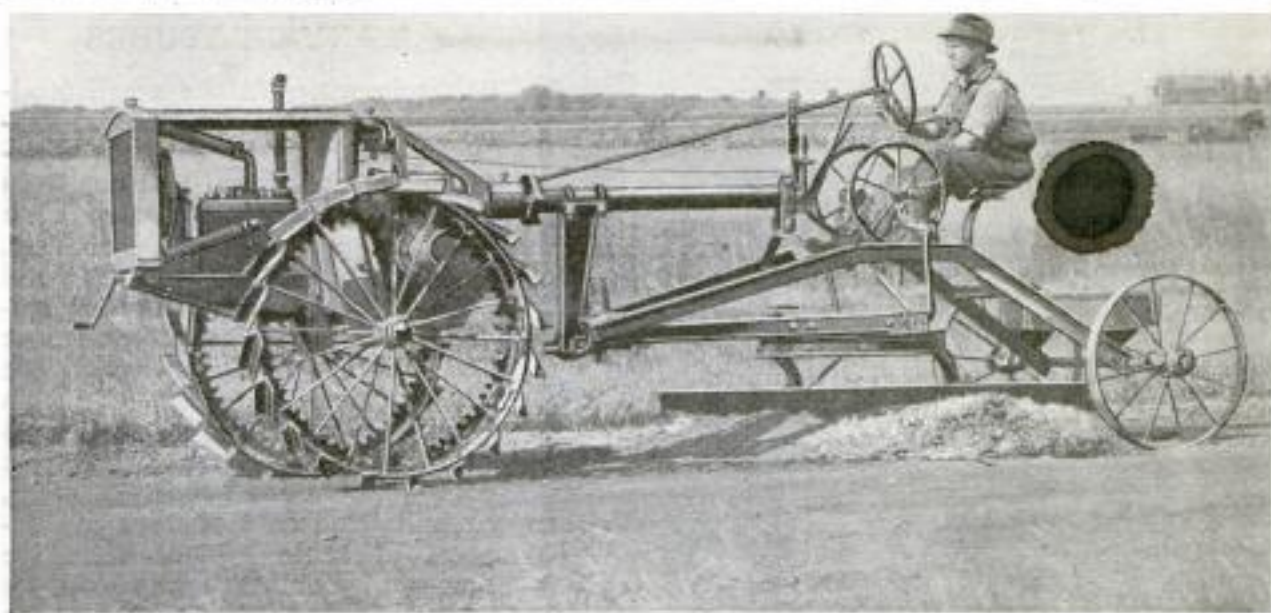

The New Road-Grading Tractor, Showing the Novel Design Which is Said to Permit Easy Operation by One Man, and Results in More Economical Work Than can be Done with Horse-Drawn Graders: The Entire Front Part is Pivoted for Steering

7973
**NEW TRACTOR ROAD GRADER
SIMPLE AND ECONOMICAL**

A company, which has been producing road-building machinery for some time, is now turning out a tractor grader of novel design, for which it claims great ease and economy of operation. Only one man is required to operate it, both the tractor and grader controls being easily handled from the driver's seat. The front, or tractor, part turns on a vertical pivot, and is steered by means of a segmental gear and pinion operated by the steering wheel, so that the whole machine can be turned in about the same space required by an automobile. The 6-12-hp. motor operates on gasoline, and low-grade fuel can be used effectively. It will grade from 1½ to 3 miles of road an hour, about the amount of work done by three teams, at about half the expense of horse grading.

7997
**BRITISH COLUMBIA ADOPTS
AMERICAN TRAFFIC SYSTEM**

On January 1, this year, the province of British Columbia abandoned the English custom of driving on the left side of the road and adopted the American "keep to the right" system. With this change, all of Canada, except Nova Scotia, New Brunswick, and one or two other small eastern territories, have come under the American plan. The change was made necessary because of the increasing traffic across the international border and the many accidents resulting from the conflicting systems. Though the change involves heavy expense in altering the entire traffic system of the provinces concerned, it is expected to prove profitable.

8179
**COINS COATED WITH POWDER
AID IN TRAPPING THIEF**

In solving a mystery of petty thievery, an English detective coated several coins with a chemical known to produce a stain on the hands, and placed them in the purse of the complainant. Later, upon being informed that some of the money had been stolen, he commanded certain suspects to expose their hands, thereby revealing the telltale stains and obtaining a complete confession and the conviction of the guilty person.



One of the Many Signs in British Columbia Affected by the Changed Traffic Regulations

London Times Weekly
12/23/21

Copyrighted Material
416
12/23/21

7921

Electric Kitchenette Co.,
Hort Wayne, Ind.

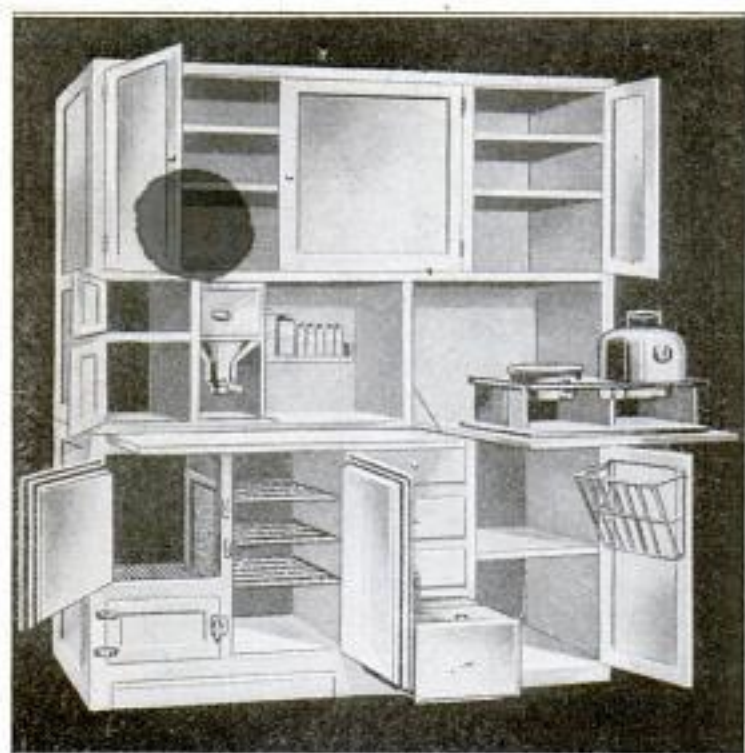

Kitchenette, Showing the Three Compartments at the Left Which Have Front and Rear Doors, and the Folding Electric Range at the Right

**KITCHENETTE CONTAINS
MANY FEATURES**

Kitchenettes in the small modern apartment must possess features that will save work, eliminate useless steps, and assist in the general saving of space. One of this type, now on the market, has incorporated in it many good points in this connection. In addition to the usual complement of shelves and drawers, the kitchenette in question includes a folding electric range with two burners, a built-in refrigerator, a compartment for groceries, meat, or milk, and also one for the deposit of table refuse. The ice box and compartments can be opened from the rear, so that ice and food can be put in, and garbage removed, without entering the kitchen, thus solving one of the housewife's vexatious problems—the safe deposition of the ice or food delivery.

8041

End. Stanley W. Todd, 327 Mc Donough St. Albany, N.Y. 8071

**PRESIDENT'S TURKEY SHIPPED
IN BATTLESHIP CRATE**

A Thanksgiving turkey, presented to President Harding by the Chamber of Commerce of Cuero, Tex., made the trip

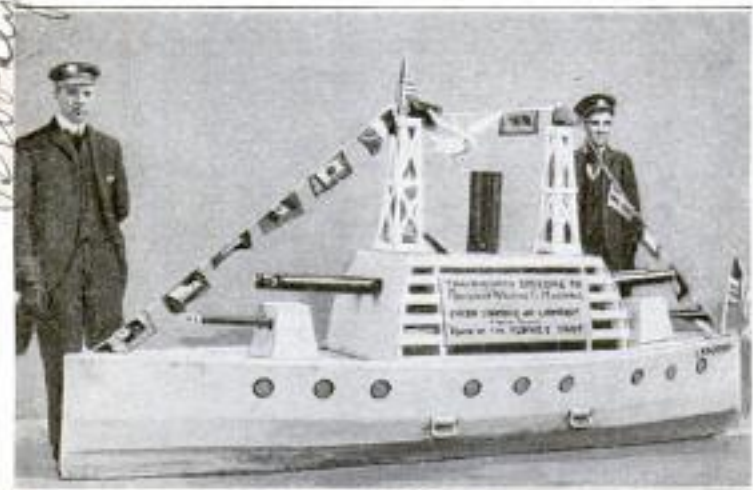

Novel Battleship Crate, in Which a Thanksgiving Turkey was Shipped to President Harding, from Cuero, Texas

to Washington in a novel sort of crate. It was built to represent a battleship, with turrets and guns, and decorated with flags and pennants. The idea was suggested by the fact that the Conference for the Limitation of Armaments was in session in Washington at the time, with the question of scrapping battleships occupying a conspicuous position.

**SUNSPOTS CONSIST OF GASES
COOLED BY EXPANSION**

The sun's spots are cooler than the surrounding portions of the surface of the sun, and the dark patches thus formed make them visible. Recently an American astronomer has made several interesting deductions concerning them. It is well known that gases are cooled by expansion, and in the sunspots there is an upward movement of gas, producing an expansion and corresponding drop in temperature. It is thought that the increase in volume of the gas is 30 times or more. By making allowance for the effect of heat being radiated into the sunspots and for an increase of temperature with depth, as would be established by the radiation of the sun's heat, it is estimated that the lower part of the vortex of the

sunspots must be in a region of extremely high temperature, probably over 20,000°C. (36,000°F.). The temperature of the sunspots is lower than the adjacent luminous-gas envelope by 2,000 to 2,500°C., so that on account of the tremendous drop in temperature produced, the sunspots may be regarded as the most powerful refrigerating engine known to science.

C.A. Briggs, 1524 Cal St Hall Washington, D.C.

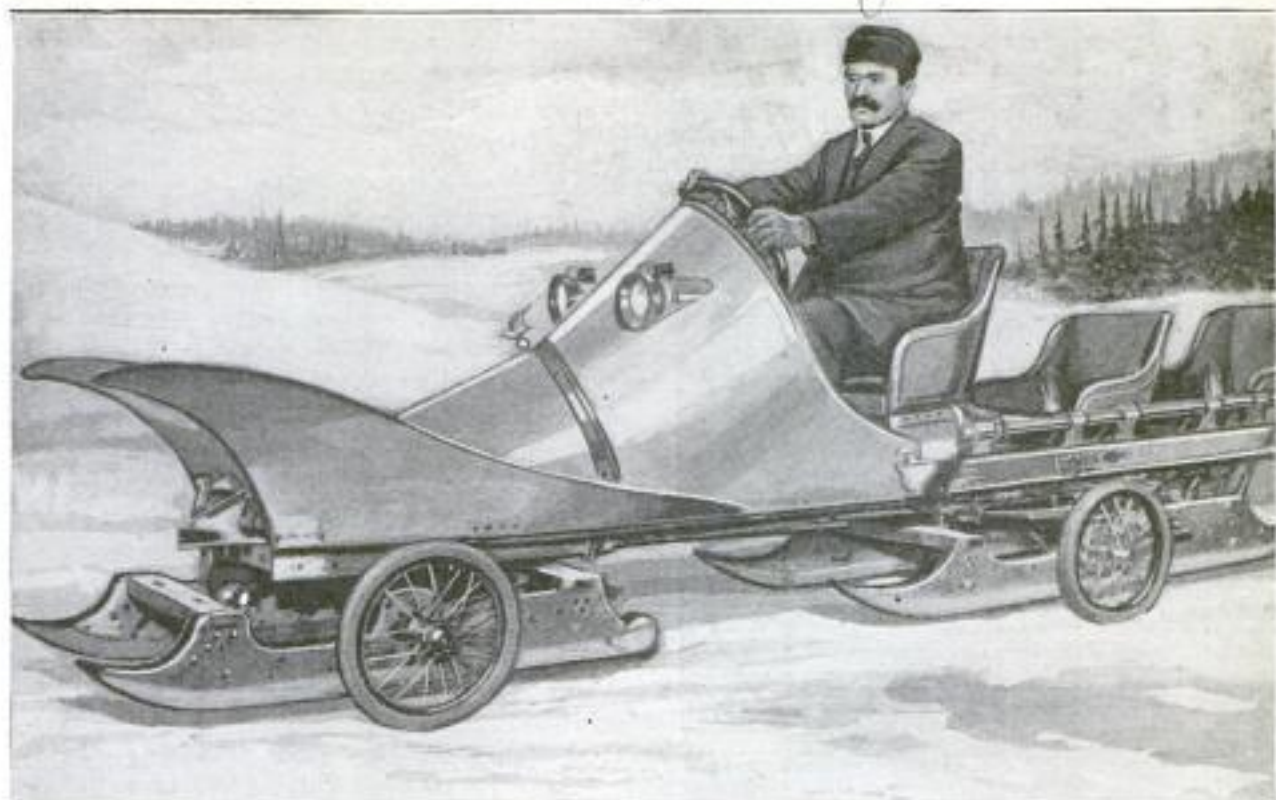

Motor Coasting Sled Which Climbs the Hills under Its Own Power: For Coasting, It Rests on the Runners; for Climbing, the Wheels are Lowered to Support It, and the Engine is Started

8073 MOTOR SLED SAVES CLIMBING —FOR COASTING PARTIES

Coasting would be much more enjoyable if it were not for the work of dragging the sled back uphill after the downhill slide. With a new motor sled the climb is no longer necessary. This sled is equipped with a gas engine and wheels. For coasting downhill, the wheels are raised, and the sled rests on the runners. At the bottom of the hill the wheels are lowered, the engine started, and the sled climbs back under its own power.

834 HOLDER FOR TRANSPLANTING SAPLING TREES SAFELY

The difficulty of transplanting young trees may be overcome by a recently invented transplanting receptacle. The chief reason for failure is that the nourishment stored in the soil about the roots is needed by the transplanted sapling to continue its growth. The receptacle is designed to transfer this soil with the tree. It consists of two curved pieces of sheet iron hinged together and fastened with straps to form a bucket-shaped container. Two pins and four slides pass through slots, near the lower edge, to form a bottom. A circle is cut about the tree, and the surrounding soil dug out, so that the receptacle can be fastened about

the column of earth and the pins and slides inserted. The tree is placed in a hole prepared to receive it, the slides and pins are removed, and earth is



Left: How the Soil about a Tree is Removed for Transplanting. Right: Method of Attaching the Receptacle

tamped in to the level of the first buckle, which is then unfastened. This is repeated until the hole is filled, when the receptacle is withdrawn from the ground and the soil packed firmly about the roots.

¶ The U. S. Bureau of Mines is experimenting in the Nevada gold mines in an attempt to prevent or minimize the danger of rock bursts in deep metal mines, by the use of the cement spray gun.

cl. w. Lionel Neil
Esoldsbors, N. C.

7913 no record of address - Inquire
Oakland Garages.



A Street in the "Bungalow" Village Which will Accommodate 500 Motorists When Completed: At the Extreme End of the Street, on the Right, can be Seen a Store Which was Erected Expressly for the Convenience of the Villagers. When Finished, This Street will be Paved with Crushed Stone

"BUNGALETTE" CAMP FOR MOTOR TOURISTS

By JOHN ANSON FORD

HERE is the latest idea in camps for motorists. An Oakland, Calif., concern is spending no less than \$80,000 in erecting "bungalettes" on an eight-acre tract, to be let to motoring tourists by the night or for any longer period "up to fifteen years" (as the management jokingly announces), which is the length of the lease on the land. These simple resi-

is commonly offered by an ordinary tent. These bungalettes are of two types, some with one room and some with two rooms. They are built entirely of wood, and are equipped with sinks, running water, electric lights, two-burner gas plates, etc. They rent for \$20 to \$35 per month, and at corresponding rates for shorter periods. A third type of structure is designated as a "shelter house," and consists of a shed, about 9 ft. square, open on two sides, furnished with a combination table and benches for four persons, and a two-burner gas plate. These shelter houses rent for 75 cents per day or \$4.50 per week.



The Building on the Left Is One of the Sanitary Toilet Houses of the Village, While the One on the Right Is a Laundry. Both Structures Possess Modern Plumbing

dences are designed to take the place of tents, and while their furnishings are meager compared with regular houses, they offer considerably more in the way of conveniences than



Another View of the Village Street, Showing Some of the Houses Which Contain Electric Lights, Running Water, and Two-Burner Gas Plates

2913

All rates quoted include gas for cooking, as well as the use of community laundries, which are equipped with sanitary tubs with running hot and cold water.

The bathhouse, which occupies a central location on the grounds, is equipped with enameled tubs and is piped for hot and cold water. Sanitary toilets are also conveniently located. Construction of the bungalows and shelters began in the late summer last year, and the demand for them proved so great that the owners decided to double the number of structures to be erected. As soon as they have erected enough shelters and houses to accommodate the steady stream of incoming tourists, they propose to erect a dance pavilion where entertainment will be provided evenings and on rainy afternoons.

It has been found that a surprising demand for accommodations of the kind provided here, exists among traveling salesmen, who evidently consider it more economical to motor to this camp with their wives than to put up at hotels. Here they can set up housekeeping at very little cost, and in the week or two consumed in "doing" the Bay District, the salesmen's wives enjoy sight-seeing, shopping, etc. Another class of patrons are members of theatrical troupes. Already a considerable number who are on the Pacific-coast circuit have found it more enjoyable and economical

to travel by automobile and stop in auto camps.

When all the structures in the Oakland



One of the "Shelter Houses" of the Village, Which Is Open on Two Sides: It Has a Combination Table and Benches Accommodating Four Persons, and Also a Two-Burner Gas Plate

camp have been completed, it is expected that between 400 and 500 cars will be parked there nightly. In view of the shortage of houses, many new arrivals in the vicinity of Oakland have turned to these structures as temporary homes, parking their automobiles close by their bungalows, and preparing to stay for several weeks or months. The camp is located close to a public school, and several "tenants" have already enrolled their children there.

1748
SMALL TRACTOR ATTACHMENT IS PLOW AND WEED KILLER

Originally designed as a weed killer, but also adapted to the work of plowing,

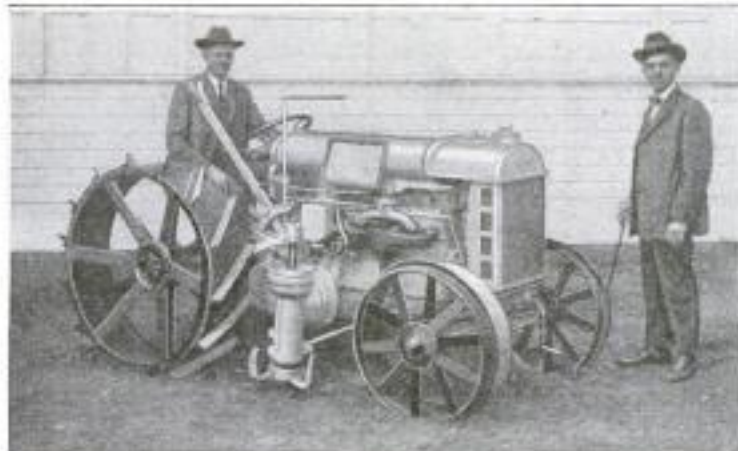

Attachment for Weed Killing and Plowing, Designed to Fit a Small, Widely Used Tractor

disking, cultivating, and dragging, there is now being manufactured an attachment for a standard small tractor, of which there are a large number now in use. The tractor has a belt pulley, which is removed, and on its shaft the attachment is mounted vertically, so that through gears, as in an ordinary drill press, its cutting knives at the bottom of its spindle can be rotated at 500 r.p.m., through a 2-to-1 gear reduction to the motor of the tractor. While the ordinary plow merely buries the weeds, without destroying them, the whirling knives of this attachment cut the weeds to pieces. It is specially effective on wild, rank grass, which on the northern prairies is so prevalent and harmful. It quickly improves any weedy soil.

A. M. L. L. Burr Pine & Land Machine

418
7932
**ELECTRIC SEALING MACHINE
IS SAFE AND ECONOMICAL**

A sealing machine, in which the wax is electrically melted, and which is intended to meet the requirements of bankers, brokers, jewelers, and large commercial institutions in the sealing of valuables, has made its appearance. The machine can be attached by a cord to any light socket, and operated at a cost of one-half cent an hour. In operating, a spring holds the seal to one side, and the wax is released by a

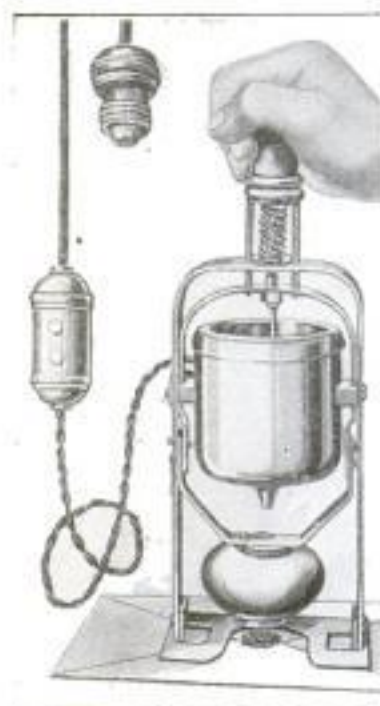

small lever, after which a downward pressure on the apparatus brings the seal into position for making the impression. The use of the appliance gives protection against the fire hazard, to say nothing of the avoidance of burnt fingers and "mussy" seals.

Because of the scarcity of timber for use as props, a South African coal-mining company, which produces nearly 40,000 tons a year, has planted 250 acres to trees, and another equal amount of land is now under preparation for the same purpose.

4862
**SLOUGH BECOMES SEWAGE
CHANNEL IN BIG SYSTEM**

By creating an inlet to a slough, and excavating a uniform channel throughout its length, the city of Portland, Ore., has furnished an outlet for sewage for a large residential district including 40,000 city lots. The successful completion of the new channel at a total cost of \$350,000 also makes unnecessary the construction of a trunk-sewer system that would have cost 3,500,000 dollars.

The slough that was thus utilized branches off from the Columbia River on the northern boundary of Portland. At low water it had no inlet, and consequently there was no current, so that it could not be used to carry off sewage. Both the Columbia and Willamette rivers are several miles distant, and it was first planned to build a trunk sewer to empty into one of them. Then engineers hit upon the idea of transforming the slough into a branch of the Columbia.

Six large dredging machines were employed, nearly 1,500,000 cu. yd. of earth were excavated, and 25,000 yd. of rip-rap placed. A uniform channel, 150 ft. wide at the bottom, was dug for a distance of 2 1/4 miles, and dikes were placed along it to protect the adjacent drainage districts.

When the project was first proposed there was much opposition to it on the ground that there would be too much current during high water and not sufficient current to carry off the sewage during low water. Tests of the velocity of the water, as the project was nearing completion, proved that these fears were groundless, and that the channel is a practical solution of the sewage problem in the district that it serves.

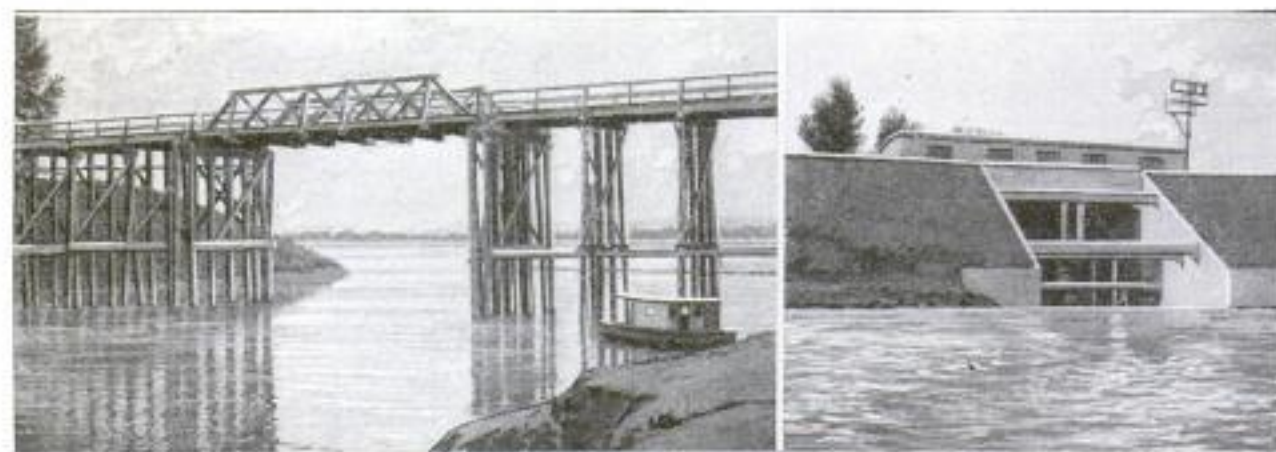

Left: The Mouth of the Drainage Canal in the Foreground Emptying into the Columbia River, Which is Seen in the Background. Right: A Section of a Dike with Water Gate, Built along the Drainage Canal to Protect the Adjacent Farm Lands during High-Water Periods

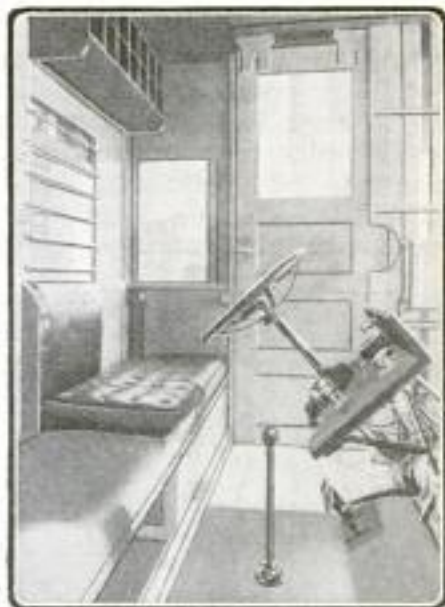
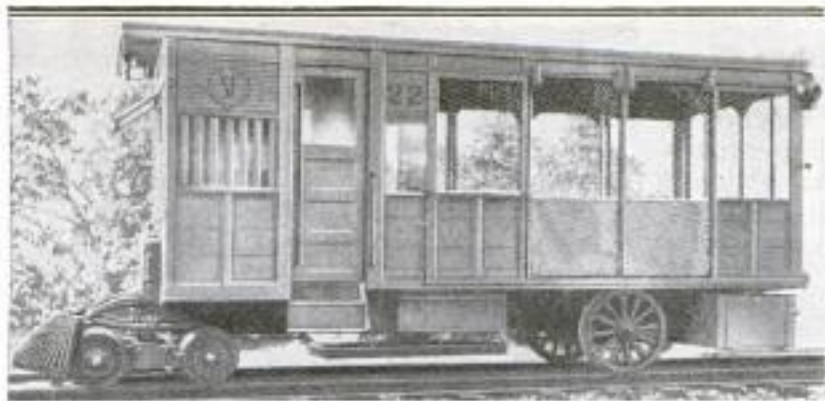

Above: One of the Truck Cars Used for Carrying Mail and Express in the Hetch Hetchy Valley. Left: Interior of the Combination Mail and Express Car. Right: The Dashboard is Raised to Accommodate a Brake Ratchet

operated in a portable electric drill, which is driven by a gasoline engine and 1/2-hp. generator. As the total weight of the ap-

**RAILROAD USES MOTOR TRUCKS
 ON HETCH HETCHY LINE**

The Hetch Hetchy Valley reservoir, in Yosemite National Park, which is to supply water to San Francisco, is reached by a short railroad, circling up through the mountains, over which automobile trucks of a novel type are operated. They are equipped with flanged wheels, to fit the rails, and special bodies. For handling mail and express, the bodies are inclosed partly with solid sides and partly with heavy wire net. Two sliding doors in the sides are used in loading, and another door gives access to the driver's compartment. There the dashboard is raised and placed at right angles, part way up the steering post, to support a brake ratchet. The steering wheel, being useless for its ordinary purpose, operates one of the three brakes made necessary by the many steep grades along the line. One truck is equipped as an ambulance, with a stretcher hung under the top. Others are arranged for handling tourist traffic.

**"TREE SURGEONS" AIDED
 BY PORTABLE OUTFIT**

"Surgical instruments" consisting of a cutter, or reamer, having 11 small circular saw blades, and ordinary steel bits, have been introduced as an aid in removing the dead and diseased wood from trees undergoing treatment. These tools are

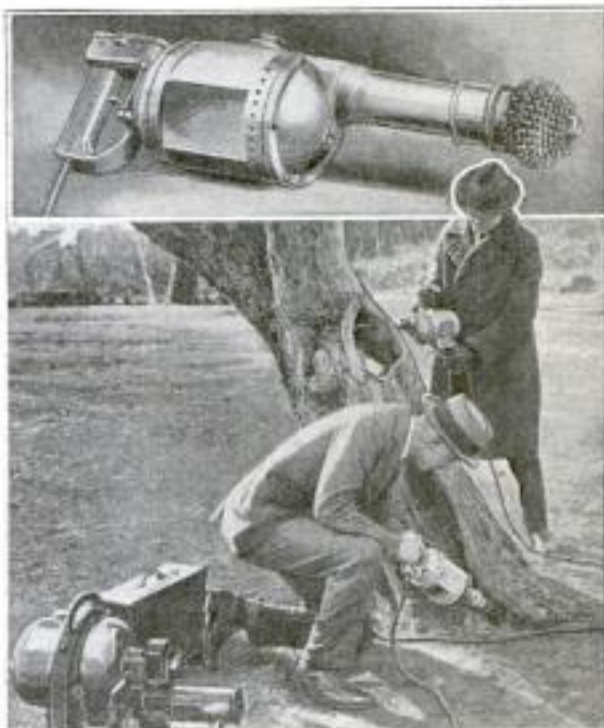

Above: Portable Electric Drill Showing Special Reamer. Below: Treating a Diseased Tree with the Portable Electric Outfit

paratus is only about 120 lb., it can readily be transported to any tree requiring attention.

¶ We want all our readers to write us freely and often whenever they wish additional information on articles published in this magazine. Address Bureau of Information, Popular Mechanics, Chicago.

*C. W. H. A. Bartlett
 Stamford, Conn.*

4996

Universal Motion Picture Corp., Los Angeles
Calif. 'Koolish Wives'

MOVING-PICTURE FILM PREPARED ON RUNNING TRAIN

By JACK A. BRISTOL, Cheyenne, Wyo.

CAUGHT short on time with a New York opening date booked, and facing a huge loss for each day's delay, a moving-picture producer made arrangements to edit, title, and cut the play en route between Los Angeles and the eastern metropolis recently. With a special

and utilizing high-pressure steam from the locomotive for its operation. A steady supply of current was available at all times, regardless of train speed or whether the train was in motion or not, thus enabling the projector to function without interruption, a feat impossible with the ordinary belt-driven equipment.

Twenty-eight heavy steel containers carried the original film, which remained in the "cans" all the time it was not actually in use. Editors and cutters worked continuously, stopping only for meals and for a few hours' sleep at night, and on these occasions every scrap of film was returned to its proper container. The work was entirely successful; and by the time the train arrived in

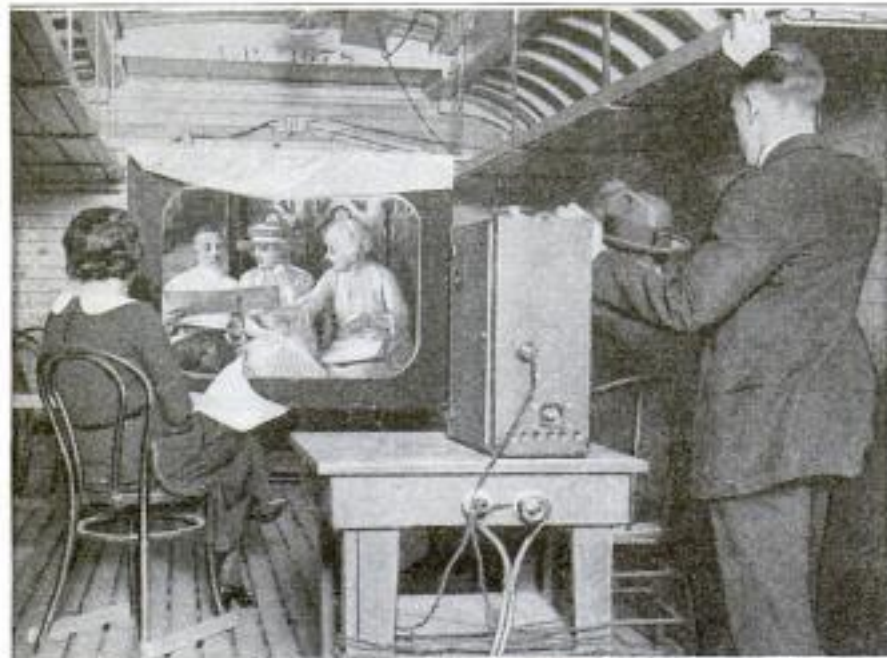

Projection of Movies aboard a Train in a Specially Equipped Car: The Projector on the Table, and the Silver Screen, were Rigidly Built In to Eliminate Flicker

car equipped as a laboratory and attached to a limited train, the work was found entirely practical even while speeding eastward at a mile a minute or more.

The equipment in the special car consisted of all the cutting apparatus ordinarily used in a laboratory, in one end, a silver screen rigged across the other, and a projecting machine about "amidships" of the car. Both screen and projector were rigidly fastened to the car, and thus, while there was the same motion and vibration attendant upon all moving trains, it was apparently so synchronized that the projected pictures were sharp and clear at all times. With this arrangement, more than 100,000 ft. of film were run off to enable the film editor and his assistants to select the 12,000 ft. needed.

Electricity for the heavy arc lights in the projector was furnished by a dynamo car running ahead of the laboratory car,



Cutting End of Car, Where Film Editor and His Assistants Trimmed 100,000 Feet of Film to 12,000 Feet While Traveling from Los Angeles to New York

New York the film was finished and ready for delivery.

Ⓒ Popular Mechanics Magazine does not publish the name of maker or seller of any device described in its pages, but this information is kept on file and will be furnished free by addressing our Bureau of Information.

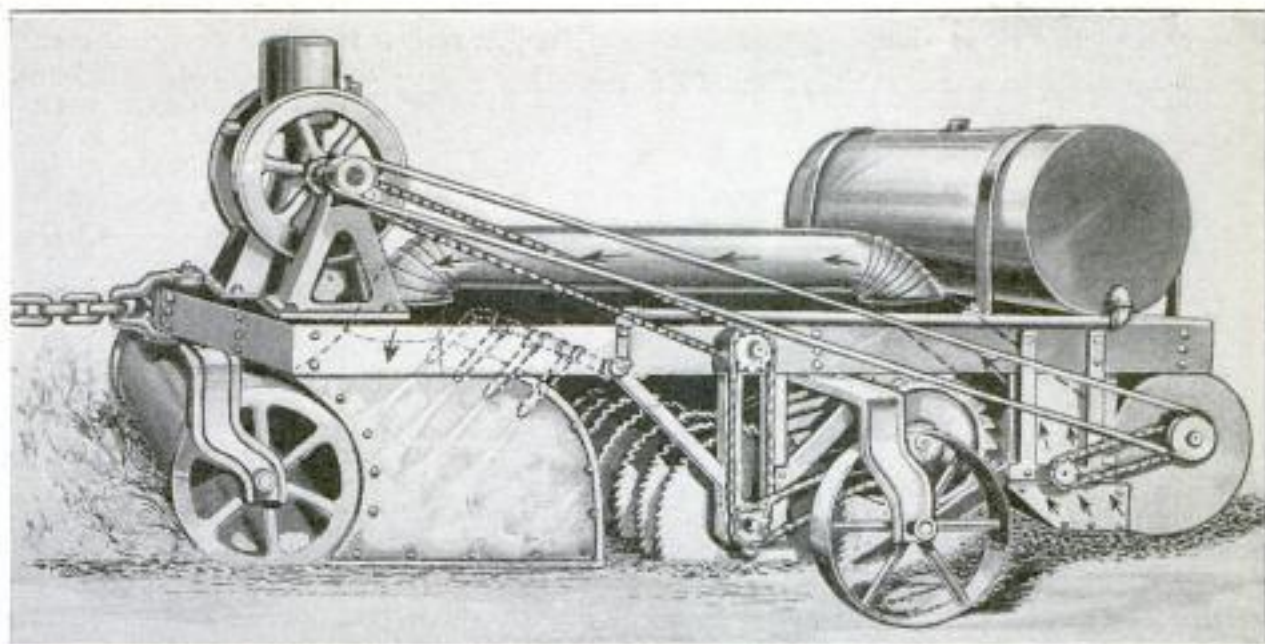

The New Weed and Insect-Exterminating Machine, Showing the Combination of Roller, Hood-Inclosed Burners, and Saws, behind Which are Placed the Cremating Furnace and Distributor: This Machine is Said to Be One of the Most Important Developments in Agricultural-Implement History

7942

NEW MACHINE EXTERMINATES WEEDS AND INSECT LIFE

If a recently developed farm machine fulfills expectations, a large part of the loss to farmers from weeds and insect pests can be eliminated. The processes used are not new, in themselves, but their practical combination has been described as one of the most important developments in the history of agriculture. The entire mechanism is operated by a small gasoline engine, mounted on the frame. A front roller crushes all vegetable matter and is followed by a hood, which controls the flames from a row of oil burners, so that the fire cannot spread. This cremates all vegetable and insect life, and prevents germination. Next, close-set saws cut the soil and roots, which are then carried up an incline to a spiral cutter, where the roots are further cut. They are then carried to a set of sieves which separate roots and soil by pressure from an air fan. Refuse is blown back into a furnace and consumed. The soil is distributed in the field absolutely free of vegetable and insect life. The machine works a strip 40 in. wide and easily covers eight acres a day.

758

COIN-OPERATED AIR-HOSE SUPPORT FOR GARAGES

A coin-operated air-hose support, for garages and filling stations, has recently been invented. It consists of a hollow pipe standard with a tilting arm at the top. The air hose extends through the arm and will not reach a machine unless

the arm is brought to a horizontal position. Normally, the arm is held nearly vertical by a counterweight and by a catch at the fulcrum point. A rod, attached to the catch extends

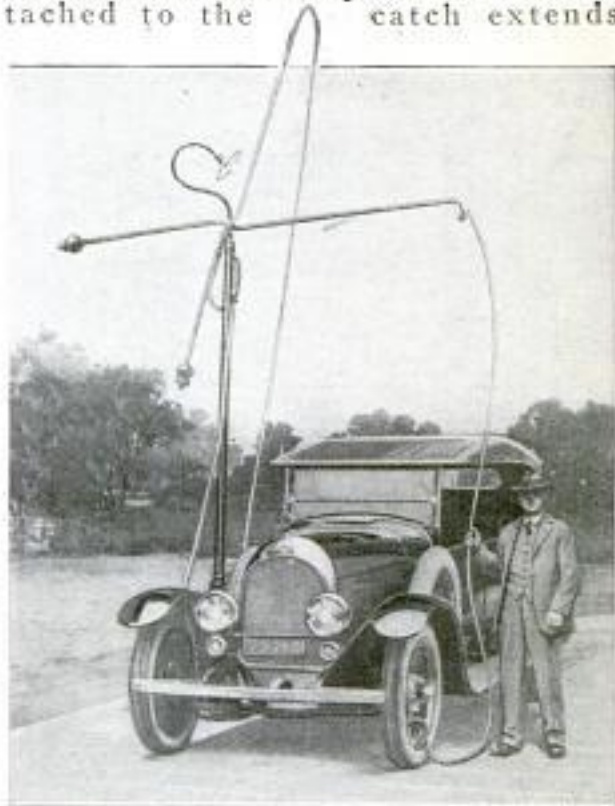

This Coin-Operated Support Keeps the Garage Air Hose Up off the Sidewalk When Not in Use. Its Construction Is Simple and Strong

down through the standard and ends in a coin receiver. When a coin is inserted in a slot in the standard, a lever can be pressed against it to release the catch.

d.w. & C. Arguth
811 N. Andrews Blvd.
Los Angeles, Calif.

1999 d.w. Michael Kenna,
 1/0 L. J. Jellison, 2506 Windsor Ave.,
 Dubuque, Iowa

NEW PRINTING OUTFIT USES TYPE STRUNG ON WIRES

SINCE the time of Benjamin Franklin and the laborious hand press, the considerable quantities of office stationery, might find it a profitable investment.

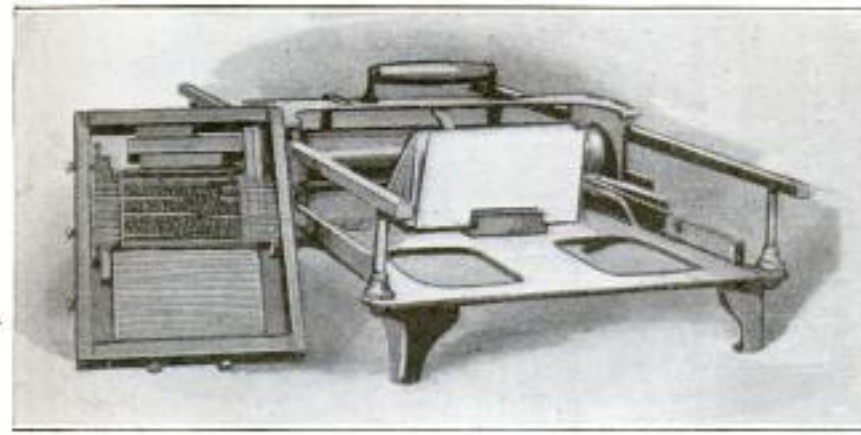

Ordinary Printers' Job Form Set Up in the New Manner: The Printing Press Has a Stack of Envelopes in It

printing industry has evolved but slowly. The present day has seen the development of the type-setting

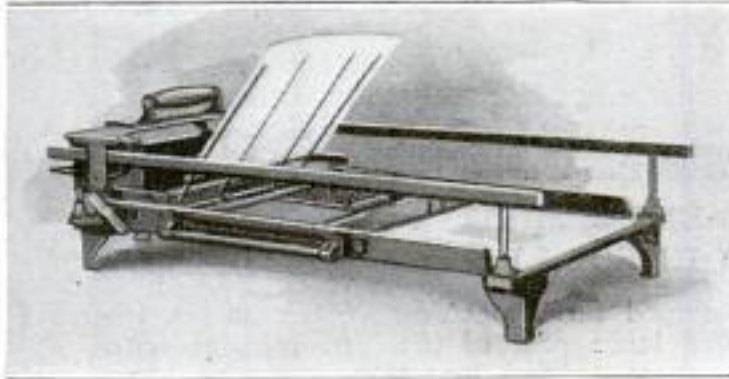

Form on the Press Which is Equipped, in This Case, with Automatic Paper Feed of Flat-Bed Type

The press and paper feed are an adaptation of the old flat-bed-press idea, and the work turned out cannot be distinguished from regular printing. The type-setter is the most interesting part of the invention. A touch of the operator's thumb releases a metal type slug and strings it on a wire. A little practice gives the right spacing. When a line is strung, it is removed from the setter and placed in the form. The distributor, also, is an interesting bit of mechanism, which allows rapid distribution of the type after using it.

Our Bureau of Information will answer all questions regarding articles appearing in this magazine.

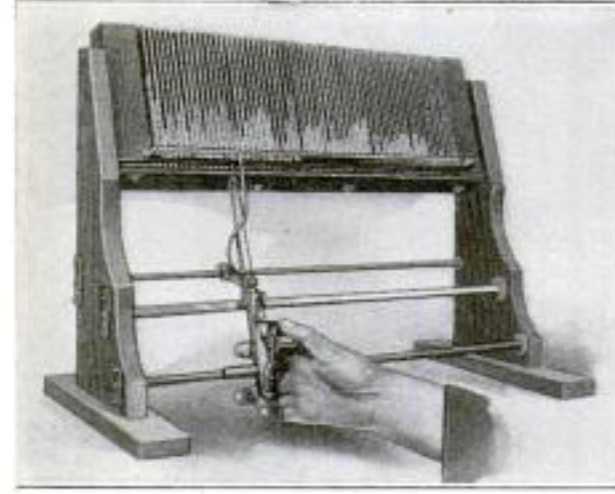

Above: The Type Rack, Showing the Method of Stringing Type from the Rack onto Form Wires by a Simple Pressure of the Thumb. Right: Type Distribution, with Type Pinion Ready to Receive and Distribute Type from Forms After It has been Used

machine which produces type in uniform slugs, but the individual type remains the same. Now a Dubuque, Ia., inventor has built a printing plant so simple in operation that any firm, using any

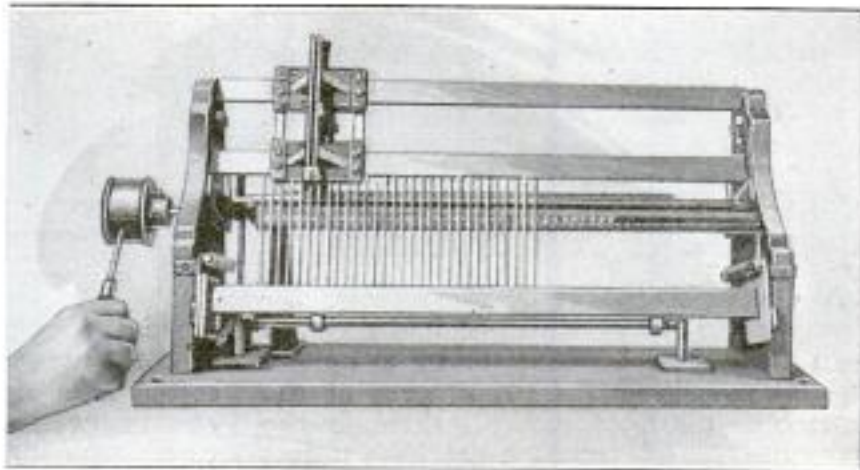

*Owner - Frank Griswold
 Willoughby Ohio*

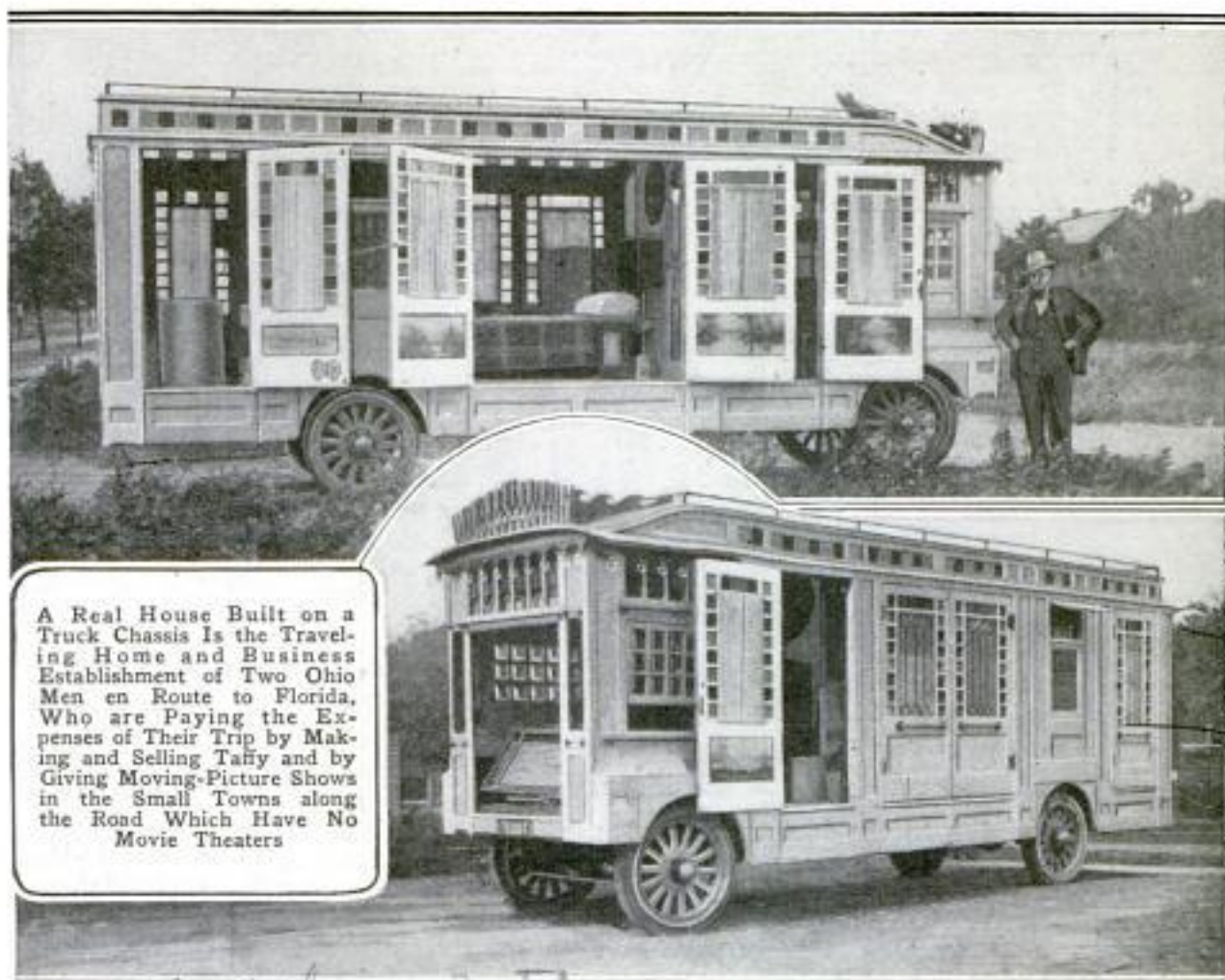

A Real House Built on a Truck Chassis Is the Traveling Home and Business Establishment of Two Ohio Men en Route to Florida, Who are Paying the Expenses of Their Trip by Making and Selling Taffy and by Giving Moving-Picture Shows in the Small Towns along the Road Which Have No Movie Theaters

Traveling
COMBINED HOME AND BUSINESS ESTABLISHMENT ON WHEELS

7991 Recent years have produced many motor vans for touring, but the one in which Frank Griswold, of Willoughby, Ohio, is traveling to Florida is distinctly novel. The body, built on a truck chassis, has the appearance of a real house and is elaborately decorated, with stained glass and painted scenic panels in the doors. The interior is well furnished for comfortable living, and in addition is equipped with a stove, for making candy, a moving-picture machine, and a small pipe organ. Accompanying the owner is D. Roberts, an expert taffy maker. The two men are paying the expenses of their trip by selling taffy and giving picture shows in towns which have no regular movie theaters.

the brush is an interlocking arrangement, achieved by having the faceplates constructed with corrugated surfaces. When two sections are properly placed together, these corrugations intermesh, thus precluding any possibility of slipping. The sections are made in half-inch widths, and with any diameter of shaft hole de-

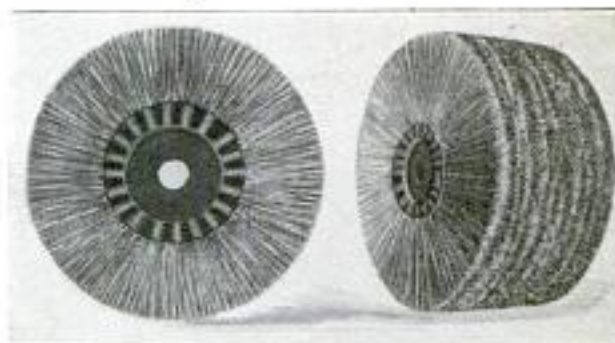

At the Left is Shown a Single Section of the Interlocking Wheel, While at the Right are Seen Numerous Similar Sections Joined to Make a Large Wheel

1928 6
SECTIONAL BUFFING BRUSHES HAVE INTERLOCKING PLATES

An eastern firm has placed on the market a sectional buffing-wheel brush, which is made in three materials—wire, horse-hair, or fiber. The outstanding feature of

sired, so that buffing wheels of various sizes can be built up to fit different classes of work. The wheel was specially designed for tire and rubber manufacturers, and is said to be efficient and economical for tire-repair work of all kinds.

*North Eastern Mfg. Co.
 New Haven, Conn.*

Capt. Alfred Powers,
1065 Alder St.
Eugene, Oregon

Capt. C. A. Briggs,
1521 Oak St. N.W.
Washington,
D.C.

426
893

POPULARITY OF MYRTLE WOOD REDUCES LIMITED SUPPLY

The growing popularity of myrtle, as a wood for the manufacture of novelties, special furniture pieces, and interior panel

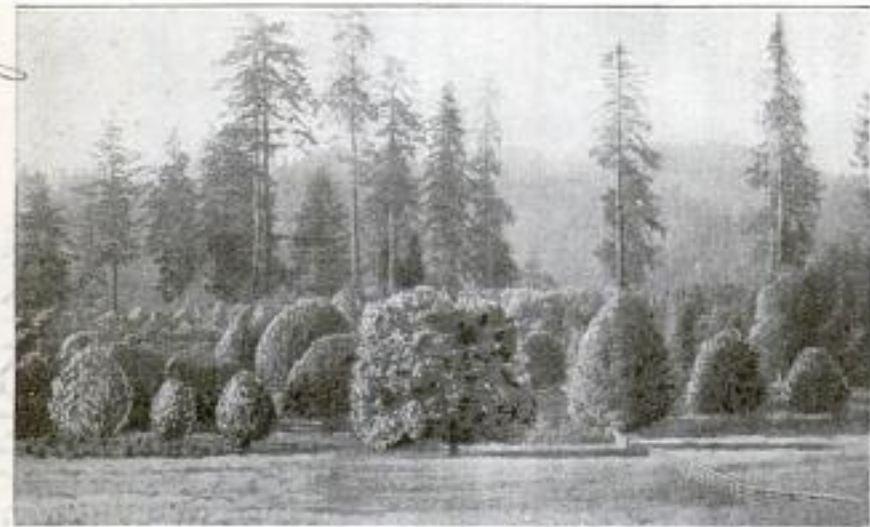

Grove of Myrtle Trees in Coos County, Oregon, the Only Place in the United States Where They are Found in Quantities Sufficient for Cutting on a Commercial Scale

work, calls attention to the fact that it is found, in commercial quantities, in only one place in this country. It is estimated that about 687,000 ft. are available in Coos County, in southwestern Oregon, and that the demand will soon require a cutting in excess of the production. Myrtle grows very slowly, a tree of the greatest size, about 12 ft. in diameter and 100 ft. high, requiring about 300 years to develop. Most of the trees in Oregon are from 18 to 48 in. in diameter. The wood is greatly prized because of its beautiful graining. No two pieces are ever exactly alike, and matching is impossible, which adds to the manufacturing cost. Its cost is also increased by the fact that it will not float in water. Because of this, trucks



Bowls Turned from Myrtle Wood: This Wood has Become Popular for Such Purposes Because of Its Beautiful Graining

or trains must be used to transport the logs to the mills. This is, of course, a much more expensive method of handling than floating them down the rivers, as is commonly done with other kinds of timber.

INTERESTING DEMONSTRATION OF RADIO-WAVE VELOCITY

The tremendous speed with which electricity travels was demonstrated in an interesting way at a recent gathering in Washington, D. C. The evening had been spent in listening to a radio concert coming over the Allegheny Mountains from the station of an electrical company in Pittsburgh. Just before 10 o'clock, the time signals sent out by Arlington, just across the Potomac from Washington, were picked up on the long wave by Pittsburgh and retransmitted on the short wave used for broadcasting music. Washington is almost in the shadow of the great steel towers of the Arlington station, and

the direct signals were so strong that they forced themselves on the receiving set tuned for Pittsburgh. Both the original and the retransmitted signals were therefore heard at the same time and identified by a slight manipulation of the tuning knob. At the receiving station at Washington, a telephone receiver was attached to a phonograph horn, permitting all present to listen at the same time. The signal returned from Pittsburgh seemed to come in just at the same time as the one received direct from near-by Arlington. It was then figured that, if there were no perceptible delay at Pittsburgh, the signal took only .002 of a second for the round trip. The direct signal was just coming out of the large end of the horn at the moment the signal relayed back from Pittsburgh was starting in at the small end. It was also computed that, if the telephone receiver at Pittsburgh were connected to the transmitter through a tube carrying the sound by air through a distance of seven inches, the signals reaching Washington from Pittsburgh would be such that the vibrations of the musical notes would be exactly out of step, and the two signals would tend to weaken each other.

☐ We want all our readers to write us freely and often whenever they wish additional information on articles published in this magazine. Address Bureau of Information, Popular Mechanics, Chicago.

UTAH MINE GIVES PROMISE OF U. S. JET INDUSTRY

By FREDERIC KINNEY

Tribune, Salt Lake City

Right: Outcrop of Vein of Jet in Wayne County, Utah, the First Deposit of This Mineral Discovered in the United States. It is Now being Mined as Shown Below. Where the Vein is Stripped and a Miner Is at Work in It



Below: Auto Truck Full of Jet Slabs from the Utah Mine, Accompanied by a Number of the Men Interested in Its Development



Above: Two of the Miners at the Jet Vein with Some of the Jet Slabs in Sacks Ready for Shipment

WHAT is believed to be the first jet deposit to be developed in the United States is now being successfully mined in Wayne County, Utah, where recently mineralogists discovered the largest commercial body of the mineral known to exist in the world. Singularly, discovery of the jet was accidentally made by a party of miners engaged in assessment work for a copper company. The work of mining the jet began late in the summer of last year, and with financial backing assured is expected to develop into great proportions.

For ages jet has been prized by barbaric and semicivilized peoples for use in ornamentation, and the taste has survived. The possibility of carving the mineral into ornaments of rare beauty and delicate workmanship and of giving the black mineral a beautiful velvety polish,

has made deposits of jet widely sought for. Proof of its age-long use is given by the discovery in barrows of the Bronze Age of beads, buttons, rings, and other personal ornaments made from the mineral. Its occurrence in Britain is mentioned by a Roman writer, and it is certain that it was used in pre-Roman times. The early supply was probably obtained from the Yorkshire coast, near Whitby, from mines which still supply the world's markets with the much-prized mineral. Spanish jet is said to be deficient in luster and hardness. Cannel coal from Scotland is occasionally used as a substitute for jet.

While the origin and nature of the jet deposits in Utah are, of course, a matter of conjecture, there is good reason to believe that during the geologic age, when the Henry Mountain Range was thrust

above the surrounding territory, a great forest was covered with hundreds and perhaps thousands of feet of overburden. The pressure of this overburden flattened out trees that were probably a foot or more in diameter to a thickness of from 4 to 6 in. Squeezing out of the sap, the closing of the pores of the wood, and the tremendous heat and pressure, fossilized the vegetable matter and converted it into the mineral known as jet. That the deposit was once a forest is apparently proved by the fact that, in the large slabs of the mineral exhibited in the office of the state mineralogist, is easily detected the fibrous character of the material.

The Utah deposit is overlaid by a tough

fireclay substance about 6 in. thick. The remainder of the overburden is soft and is readily slushed off the mineral by the use of water. Despite the tough and firm character of the jet, it is easily mined with pick and trowel-like blades, the mineral being cut out in slabs of varying length and thickness, averaging, however, 12 to 14 in. in length and 4 to 6 in. in width.

At the present time, the work of mining the mineral is more or less crudely done, but it is the intention of the owners of the decidedly valuable deposits soon to install modern machinery and develop the industry into the largest of its kind in the world.

FUR DURABILITY MEASURED BY NEW DEVICE

IN order that a standard test of fur durability may be had, and that various furs, or the same furs differently treated, may be rated or standardized on the basis of their wearing qualities, there has been recently devised at Cornell University the apparatus shown in Fig. 1. It consists of a hammer, and a slide, which can be operated upon a fur sample placed in the position indicated by B. The weight of the slide is known, as is also the force of the impact of the hammer. When the motor is set in motion, the fur sample at B is alternately rubbed and beaten. The force of the hammer stroke and the weight of the slide can be varied

at will. In this way the fur samples are subjected to the same tests, and their durability definitely recorded.

From time to time the block containing the sample, Fig. 2, is removed and the fur examined under the microscope, to note the first signs of breakdown of the individual hairs. When these indications of disintegration are noted, the sample is removed, recorded, and a second sample introduced. Or the sample may be left in the testing device until the individual fur hairs break off. Various tests can thus be applied.

By means of these tests it is also possible to distinguish between the wearing qualities of the same kind of fur which has been subjected to different treatments, such as plucking—that is, picking out the long coarse overhairs—dyeing, clipping, and so forth.

Tests in this so-called "attritiometer" have also been found useful for rating the wearing qualities of clothing fabrics. In such cases the material to be tested is stretched over the blocks which are used for fur samples, or the fabric may be fastened in a small crumpled mass to the block, or arranged in any way which the test may call for.

Whenever you find that you wish to know more about any article in the magazine, write our Bureau of Information.

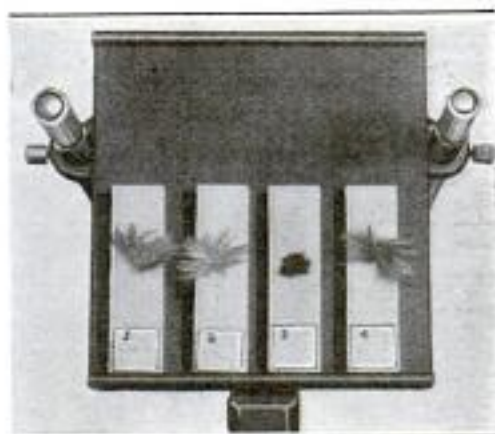

Fig. 2—Four Blocks of Fur Samples Which have been Removed from the Testing Machine for Microscopic Examination to Note Breakdown of Hairs

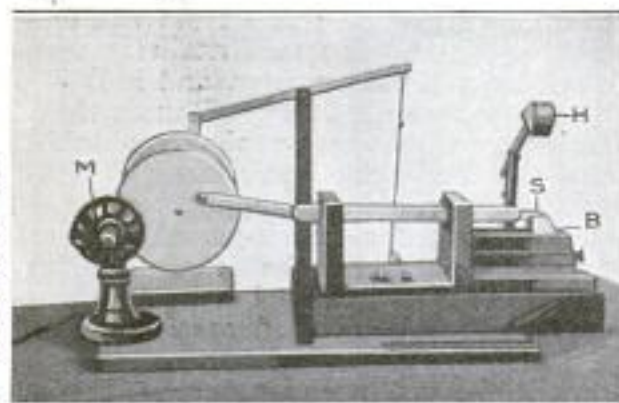

Fig. 1—The "Attritiometer" Which Tests the Durability of Furs for Standardization Purposes Consists of the Following Parts: M, Motor; H, Hammer; B, Block, upon Which the Fur Sample is Placed, and S, Slide That Rubs against the Sample

8120
 data and
 card missing
 501

POPULAR
 AERONAUTICAL CHAMBER OF
 COMMERCE ORGANIZED

The organization of the air-craft industry into a national body, recently effected, is a step which, it is believed, will greatly hasten the development of American aviation. The organization, composed of approximately 100 charter members, representing practically every element of the industry, such as designing, constructing, operating, etc., has for its objects the development of the market for airplanes and the increase of their use by individuals and corporations. It will act as a credit bureau for its members, and as a board of arbitration in case of disputes; assist in mapping of air lanes, and in all ways help to promote the industry.

7866

HANDY LUBRICATING DEVICE
 WORKS WITH AIR PRESSURE

A portable pressure-lubricating device has been designed specially for dispensing grease accurately by measure with the least possible effort, and with the elimination of waste from leakage. It is particularly adapted for use in garages, and greasing-service stations, where air pressure is available. It consists of a tank, with a capacity of 70 lb. of grease, which is placed under air pressure that forces the grease



through a hose to a double-acting weighing nozzle, which delivers 1/2 lb. to the stroke.

At Montgomery, Ill., the Burlington railroad has completed a sheep shelter, said to be the largest in the world, consisting of seven barns, each 450 ft. by 130 ft.; a 1,000-acre pasture; hay, grain, and feed barns, and a 100,000-bu. elevator. The plant accommodates 70,000 sheep.

Levee & Co. Chicago

Hamilin, Hygrostat
 corp., 438 W. 125th St
 MECHANICS
 7970
 new York City
 429
 DEVICE TO PREVENT DAMAGE
 OF OBJECTS BY MOISTURE

For the purpose of preventing the presence of moisture in sufficient quantities to do harm to works of art, musical instruments, or perishable foodstuffs, a simple little device has been placed upon the market. It is in the form of a perforated cylindrical container for a chemical that is harmless, odorless, and noninflammable, and which when placed in a piano, or a case containing any instrument, or in a wall case, protects these objects from excessive moisture. It acts in a similar manner on brass and silver articles, preserving them from tarnish and corrosion. The device is made in a number of sizes for the various purposes.



7688
 KEY ATTACHMENT SAFEGUARDS
 LOCKS FROM BEING PICKED

To make the picking of a lock impossible, an attachment that holds a key securely in a key-hole after the lock is turned, has been designed. A small clamp, adjustably secured to the stem of the key, in cooperation with a plate that is inserted in the keyhole, after moving the bolt so as to lock the door, makes it impossible to turn the key from the outside, or to force it out of the lock. Thus it is not only practically impossible to pick the lock, but no counterfeit key can be used to open it.



Edw. Edward Tiller
 Racine, Wis.

Copyrighted material

7579
430

Compression Loss Leage Co.
2926 Telegraph Ave.
Berkeley, Calif.

London Times Week
12/23/21

POPULAR MECHANICS

South Pole

GAUGE TESTS COMPRESSION LOSS IN MOTOR CYLINDERS

Any means of determining by test, not only the amount of the loss of compression in the cylinder of a gasoline engine, but also the cause of that loss, whether past the piston or the valves, will be of valuable assistance in directing the work of the repair man. A recently patented compression-loss test gauge makes this possible. It does more than that, for it shows what percentage of the theoretical compression is lost by leakage past the piston, and what percentage is lost by leakage past the valves. The dial of the gauge is graduated to give readings as close as a

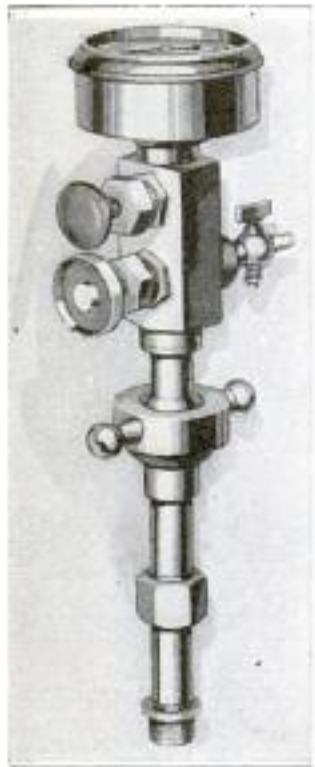

fraction of one per cent. The instrument is small, weighing only a few pounds, and the time required for testing a motor is approximately five minutes for each cylinder.

of that loss, whether past the piston or the valves, will be of valuable assistance in directing the work of the repair man. A recently patented compression-loss test gauge makes this possible. It does more than that, for it shows what percentage of the theoretical compression is lost by leakage past the piston, and what percentage is lost by leakage past the valves. The dial of the gauge is graduated to give readings as close as a

8148 POLAR SHIP "QUEST" SAILS FROM RIO DE JANEIRO

After a series of tests that proved that all the machinery and equipment were in perfect order, the "Quest," with the polar expedition in command of Sir Ernest Shackleton, sailed Dec. 17, 1921, from Rio de Janeiro, bidding farewell to about its last contact with civilization before it reaches the southern polar region. On the 19th, Sir Ernest telegraphed London, "Our engines are running perfectly. There is a fair wind. All well and looking forward." The added weight of stores taken aboard at Rio caused the ship to ride low in the water.

806.2 ROADS SPRINKLED IN WINTER TO MAKE AN ICE SURFACE

Street sprinklers are a familiar sight to the city dweller in summer, but up in the northern lumber camps the roads are sprinkled in winter. Logging roads are usually temporary affairs, slashed through the woods and swamps, with no attempt at surfacing or anything more than clearing the right of way. But, as the logging is done in winter, it is a simple matter to maintain a smooth surface of packed snow and ice. A large tank, mounted on a sled, is driven over the roads. From it streams of water fall into the tracks and quickly freeze. This makes a smooth ice surface, over which the big bobsleds, loaded with five tons or more of logs, are easily hauled by two horses.



One of the Bobsled Road Sprinklers Used in the Northern Lumber Regions during the Winter Months, to Keep the Surface of Logging Roads Ice-Coated, So That Huge Sled Loads of Logs may be More Easily Hauled

Cont. Area O. Mulliken, Eastport, Maine

Copyrighted material

7788 Byron Jackson Iron Works,
 410 Sharon Bldg.
POPULAR MECHANICS
 San Francisco, Calif. 431

PUMP LINED WITH RUBBER HAS GREAT DURABILITY

Soft resilient rubber has been successfully used to line pumps, because acid corrosion, or abrasion from rough substances passing through the pump, is practically eliminated by the rubber lining. The pump is designed for operation with either a belt drive or by direct connection to an electric motor. Both bearings are mounted outside the pump case and are of the ring-oiling reservoir type. It is said, that the mechanical and hydraulic efficiency of the rubber-lined pump is equal to that of the old-style metal-lined pump of corresponding size. Although a new pump, there are many of this type that have been in

operation for a sufficient length of time fully to demonstrate their wearing qualities.

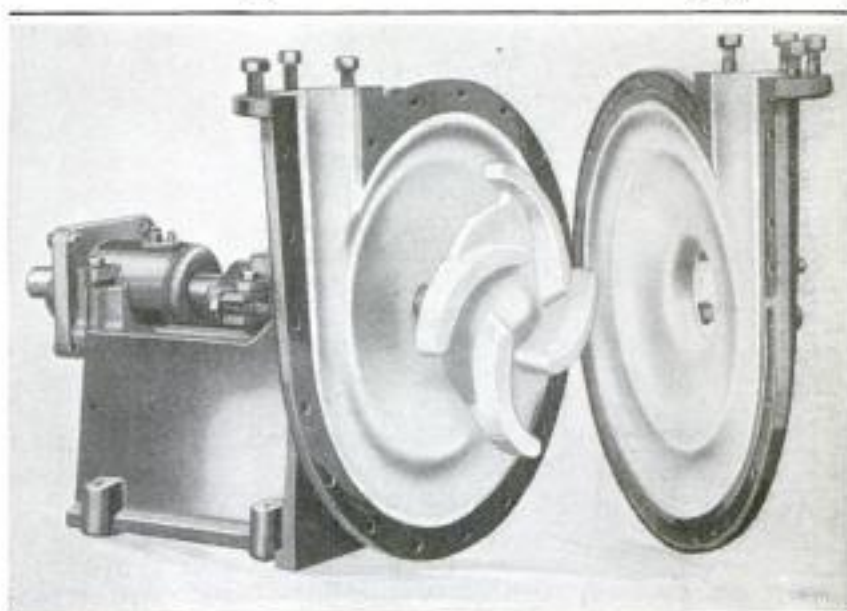

Rubber-Lined Pump Opened, Showing the Resilient Interior: In Pumps of Four-Inch Size, and Smaller, the Lining is Attached to the Pump Casing; in Larger Sizes the Lining is Removable

8/25
ALL NEW YORK CITY TRAFFIC GUIDED FROM ONE CENTER

In all large cities the problem of traffic control is becoming constantly more difficult of solution, but nowhere so much so as in New York City. Plans, such as the control towers on Fifth Avenue, described in Popular Mechanics for May, 1920, have been more or less successful, but as yet nothing has been attempted of such wide scope as the present plan to control all traffic from one central station in Times Square. It is planned to install red, green, and yellow search-lights conspicuously, that will control simultaneously all the traffic north and south, as well as the cross-town traffic, east and west, all operated by a single switch in Times Square. A traffic director, seated in the center of the city, by the pressure of a button will cause a number of red lights to flash that will stop all traffic moving in one direction, while green lights will govern the traffic in the other direction.

Control 8086
STEEL TANKS MORE DURABLE IF FEWER PLATES ARE USED

Building steel tanks with only four longitudinal plates has been found to increase the strength of the container, as well as reduce the liability of leakage. According to engineers, these tanks are 50 per cent stronger than the ordinary type with 10 to 14 plates, and cost much less, as there is a great decrease in the amount of riveting necessary and a corresponding increase in production.

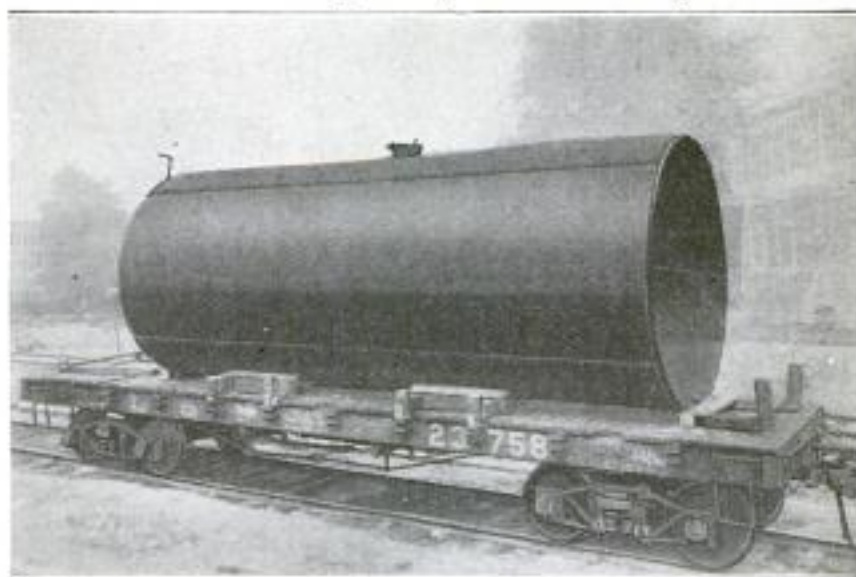

Steel Tank Having Only Four Longitudinal Plates Which has Proved More Efficient for the Storage of Oil Than Those of Ordinary Make

R. U. Grimes
 1/5/22

Standard Tank Car
 Sharon, Pa.

Alfred Lunhill 137 High St
 Nottingham Esate W. 18, London, England.
 432 POPULAR MECHANICS

8069 **AUTOMATIC PIPE SMOKER
 FOR TESTING TOBACCO-**

Testing the cool-smoking properties of tobacco blends, and "breaking in" new pipes, are now performed with the aid of a smoking machine lately developed in London, Eng.

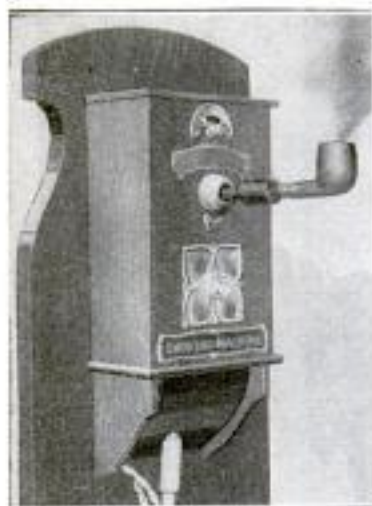

The apparatus is operated by electricity, and has adjustments with which it can be regulated to "puff fast" or to consume the contents of a pipe as

slowly as desired, thus providing any manner of smoking experiment.

steel supports and connections for a light latticed girder, supporting on its top a movable carrier to which is slung the block and tackle that does the lifting. The tripods are placed on either side of the load to be lifted, and are first spread so that the girder can be clamped in position by hand. The legs can then be arranged and braced with their chains, to suit any conditions of the work to be done. This apparatus complete, with a lifting capacity of 2,200 lb., weighs only 92 lb., and one with a capacity of 3,300 lb. weighs 115 pounds.

8129 **CULTIVATION MADE DIFFICULT
 BY HARDENING OF FARM SOIL**

The annual report of the Bureau of Plant Industry reveals the fact that some of the most fertile irrigated land in the West has become unproductive by reason of the hardening of the soil to such an extent as to make cultivation exceedingly difficult. It is believed that this hardening is due primarily to the sodium salts carried in the irrigation water, and experiments with corrective applications of calcium, iron, or other salts are now being undertaken.

U. S. Times 4/22-08
 Road construction, with Federal aid, throughout the country for the past four years, has averaged in cost per mile: graded and drained roads, \$8,115; sand clay, \$8,250; gravel, \$10,400; macadam (water-bound), \$17,320; macadam (bituminous), \$31,300; bituminous concrete, \$30,350; concrete, \$39,540, and brick, 49,570 dollars.

797 **LIGHTWEIGHT PORTABLE CRANE
 LIFTS 30 TIMES ITS WEIGHT**

For lifting weights of any kind, wherever they may happen to be deposited, a very light and easily transported hoist that acts as a crane is in use in France. It is composed of two similar tripods, with strong steel legs, which when opened out are braced in any desired position by chains

between them. On top of these tripods are

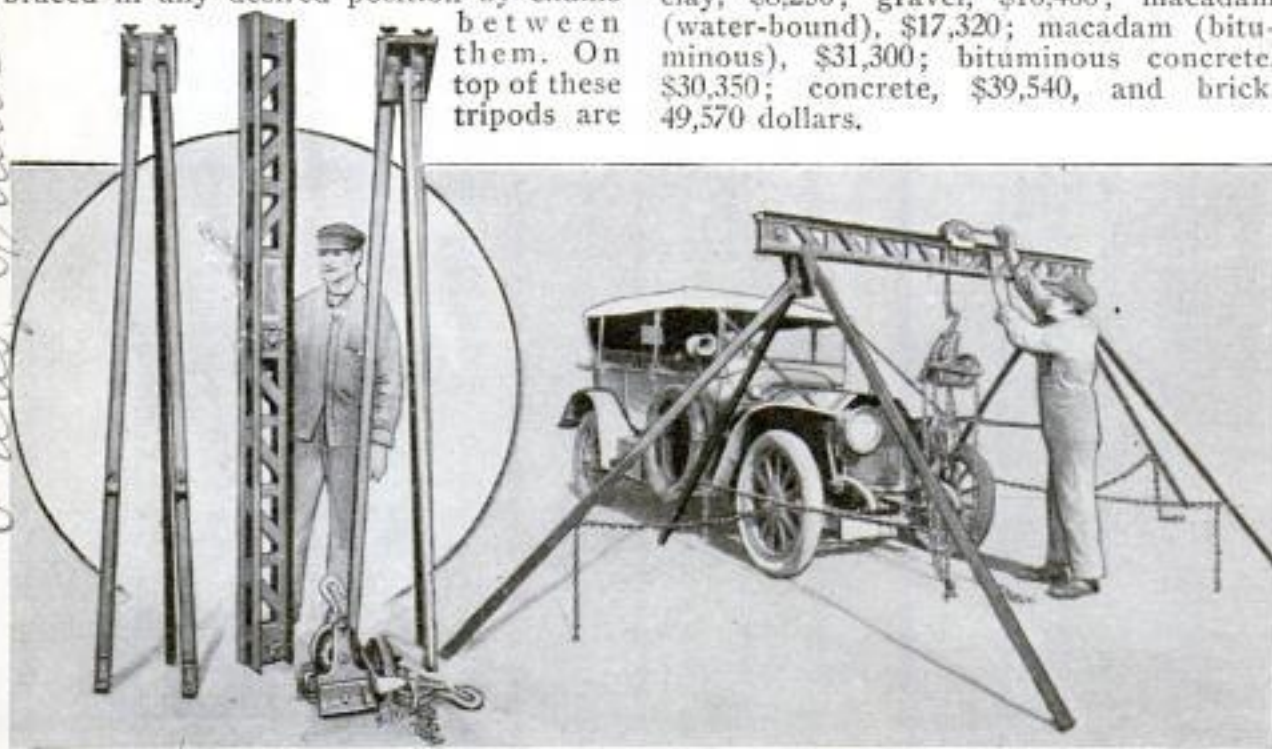

Light, Portable Lifting Crane, in Use in France: It Is All Steel; the Tripods are Braced by the Chains between Them, and Held in Any Position. The Girder Clamped to the Tops of the Tripods Supports the Block and Tackle for Lifting Loads About 30 Times the Weight of the Complete Crane

Em. E. Weiss 80 Boul. Jourdan
 Paris, France

PEPPERMINT ROOTS PLANTED BY AUTOMATIC MACHINE

Planting the roots of the fragrant peppermint crop has heretofore been accomplished by hand, but a lately designed machine is available, which takes the place of 16 men. The mint planter has an endless-belt arrangement driven by the front wheels of the machine, which feeds the roots to a hopper. From the hopper, the roots fall into a furrow, which is dug and then covered by the planter. The inventor manages a 10,000-acre mint farm in Michigan, from which state, together with Indiana,

comes three-quarters of the entire world's peppermint and spearmint-oil production.



Machine for Planting Peppermint, Showing the Endless Belt Leading into the Hoppers, below Which can be Seen the Tool That Makes the Furrow

7980 *Chicago*

AUTO-RADIATOR TRUSS AFFORDS QUICK AND CHEAP REPAIR

A simple, quick, and inexpensive repair for broken or leaky automobile radiators is now available. It consists of a long bolt which is attached in front of the radiator by means of hooks, at each end, which fasten over the front-fender brackets. Tightening the nuts pulls the ends of the frame toward the center and relieves all strain. The result is that cross members are kept from breaking, or if already broken, are pulled together and need not be replaced. It also prevents the breaking of ears, and leaking. The truss can

be attached to a machine in a few minutes, using only a pair of pliers or a wrench, and can easily be removed.



The Radiator-Repair Bolt, and, Above, the Method of Attaching It to a Broken or Leaky Radiator

7829 *Railroad*

"DEATH-CROSSING" HAZARD CONTAINS TRIPLE RISK

Dangerous crossings are numerous, but one of the worst is to be found near Ottawa, Ill. The crossing possesses an almost fiendish design, there being three risks for the driver, which are greatly magnified should he prove to be careless or incompetent. These three are a railroad crossing, a high and narrow canal bridge, and an interurban right of way. A steep hill, the descent of which is a task in itself, precedes the railroad hazard, and if the railway is

safely passed, the autoist finds a sharp incline directly ahead, leading to the bridge. Coming down from the other end of the bridge, there loom in his path the interurban tracks.

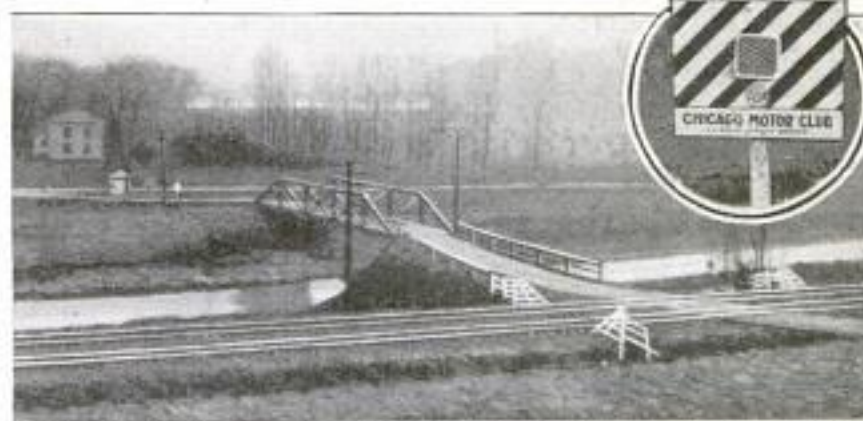

Triple-Hazard Crossing with Railroad Tracks in Foreground: Insert Shows Metal Sign with Red-Glass Center Erected to Warn Motorists

*Con. William L. Crover, 819 Canal St
 Ottawa, Illinois.*

*Steam Tractor Auto St.
 + mfg. Co. 219 W. 7th St.
 Chicago, Ill.*

Copyrighted material

AND ENJOYMENT OF VISITORS AND RESIDENTS

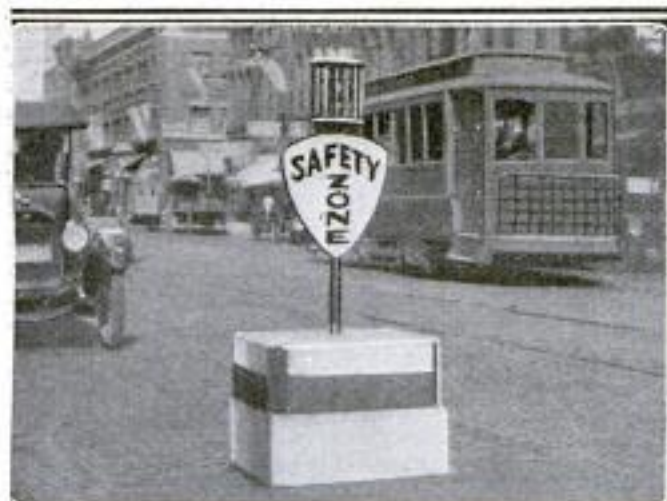

The Solid Concrete Base on Which This Sign is Mounted will be Avoided by Motorists Who Have Any Respect for Their Cars. It is Used in the Streets of Springfield, Illinois, to Preserve a Safety Zone for Passengers Boarding and Alighting from Street Cars. Above the Sign is a Red Lantern.



Rounded Block of Concrete, Built against an Unusually High Curb, That Makes It Easy for Pedestrians to Mount to the Sidewalk, and at the Same Time Forms No Obstacle to Wheeled Traffic: It Is of Such Shape That Automobiles can Pass over It without a Jolt.

Inside the Concrete Curb, Located Right on the Sands, at the Beach of Santa Barbara, California, Bathers can Stand under an Ordinary Overhead Shower Sprinkler, Supplied with Fresh Water, and Wash Off the Sand and Ocean Brine, without Having to Wait Till They Get Back to Their Dressing Rooms, as Is Usual at Most Beaches. This Is a Very Popular Convenience.

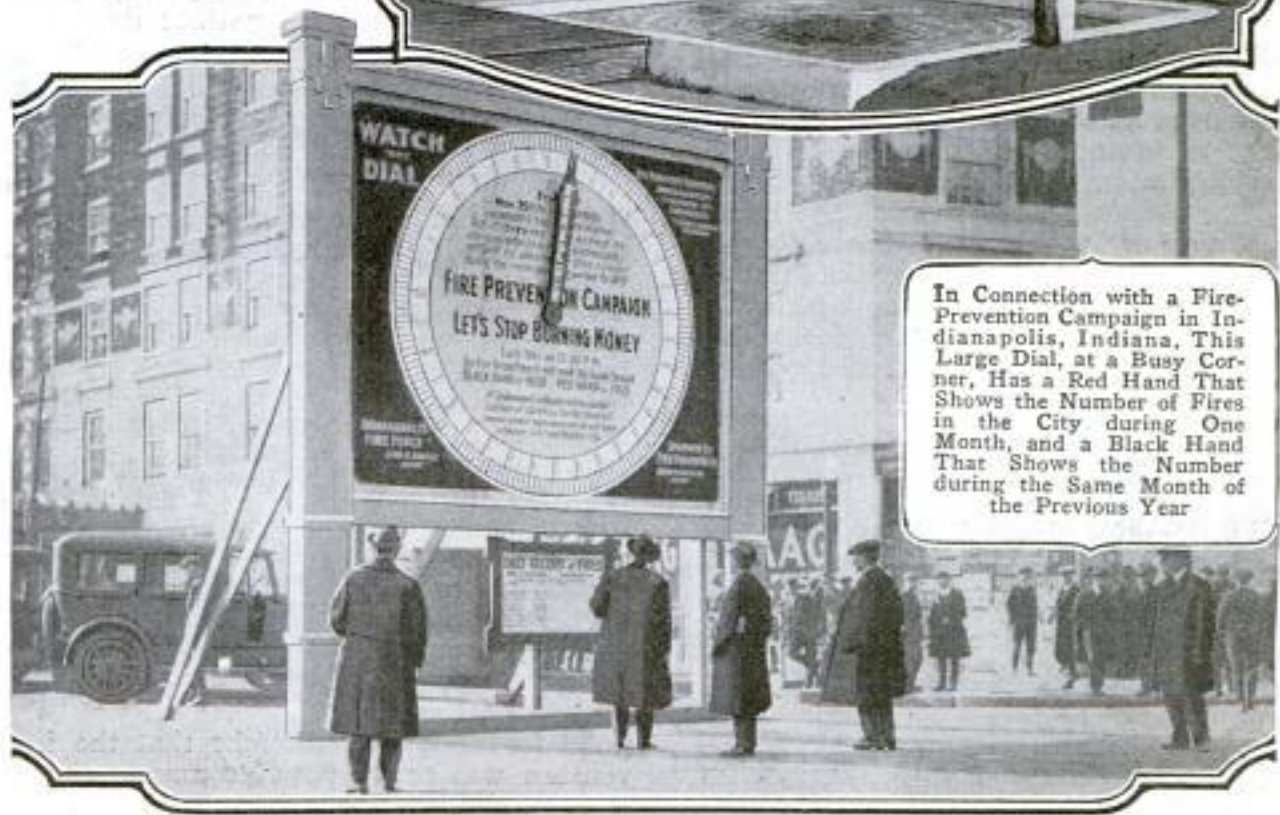
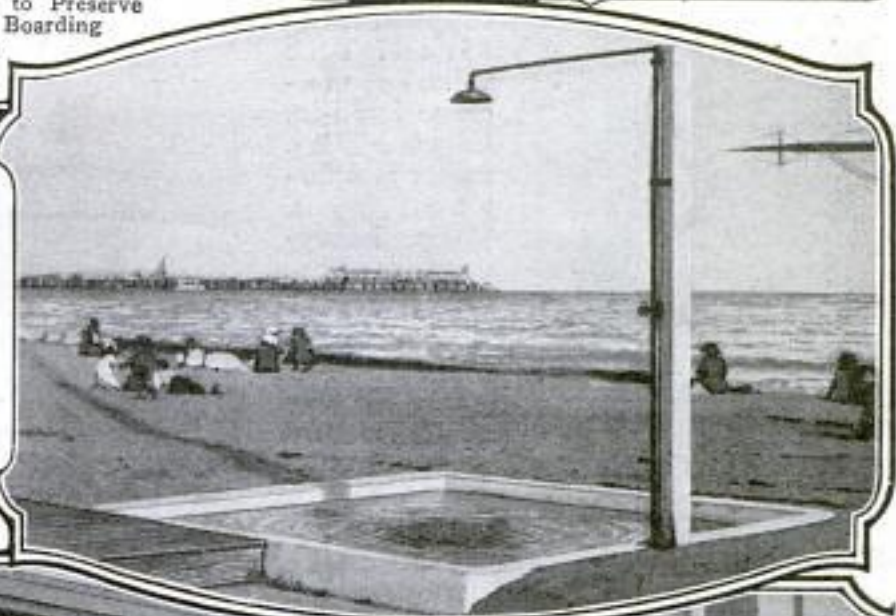

In Connection with a Fire-Prevention Campaign in Indianapolis, Indiana, This Large Dial, at a Busy Corner, Has a Red Hand That Shows the Number of Fires in the City during One Month, and a Black Hand That Shows the Number during the Same Month of the Previous Year.

8081 **ELECTRIC FOOD MIXER BUILT FOR MEDIUM-SIZED KITCHENS**

A new electric food mixer is designed especially for the kitchens of hotels, restaurants, clubs, bakeries, and ice-cream parlors. It has a 24-qt. mixing bowl, supported by a stand which occupies a 24 by 23-in. floor space. It is also furnished without the stand. A food chopper is supplied if desired. The whole machine is 55 in. high. The mixer is operated by a 1/4-hp. heavy-duty motor, mounted at the top of the

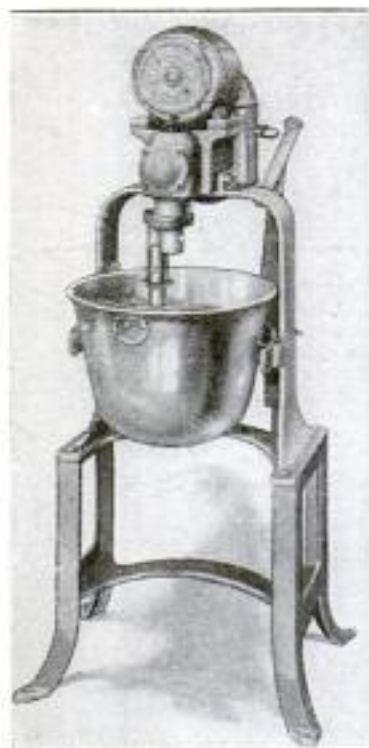

frame, and a gear shift provides two speeds. It is finished in light-gray enamel.

7981 **FUEL IN GASOLINE ENGINES COMPLETELY ATOMIZED**

Improvement of the carburation of the charge in the internal-combustion engine has been effected by the application of heat to promote vaporization, or of violent agitation to increase atomization. In a new device, that is now on the market, agitation of the mixture is caused by placing in the inlet manifold, at the inlet port of the cylinder, a short tube with a Venturi orifice, which has the property, as is well known, of greatly increasing the ve-

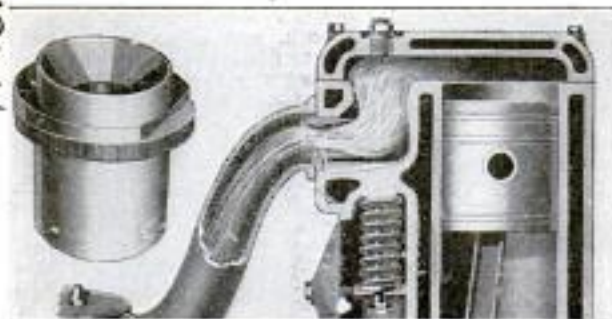

Atomization of Charge in Gasoline Engines Increased by Tube with Venturi Orifice in Inlet Port of Cylinder, and Jets for Atomizing Liquid Deposits below Tube

locity of the flow of a fluid from the outlet side of the Venturi throat, and of causing suction on the inlet side. Below the tube is a small sump, into which any unatomized units of the mixture drop by gravity, and the suction has the effect of lifting these units through a jet in the tube which atomizes them when they reach the main body of the inflowing charge. Thus no liquid fuel reaches the inside of the cylinder, with resulting advantages that every motorist will appreciate.

7923 **NEW CONVENIENCES FOR INVALID'S WHEEL CHAIR**

Wheel chairs are now being made with accessories, for the convenience of the invalids who must depend upon them. One of these is a luggage carrier which provides a place for books, magazines, and wraps. Cane and crutch carriers are attached to



the back of the chair, where they are out of the way but always within easy reach. Brakes, similar to those used on baby carriages, are also provided. These hold the chair steady when the patient does not wish to move about.

7994 **METAL UKULELE PEG FITS ALL TYPES**

Any size or shape of ukulele shaft can be fitted with a universal metal peg lately patented by a New York inventor. The peg, which has a celluloid button, will hold a string at a heavy tension without slipping, because of its construction, and may be manufactured to sell at a very low price, according to the inventor. Because of its many good features, it is thought that the invention will prove popular among those who play this instrument.

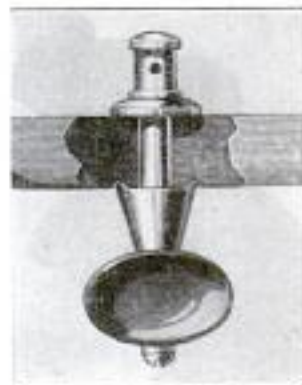

Chas. G. K. Trout
 Waverly Novelty Co. 200 Fifth St. New York

Turbulator Corp. 2635 S. Michigan Chicago

Walter Robertson 158 E 23rd St. New York

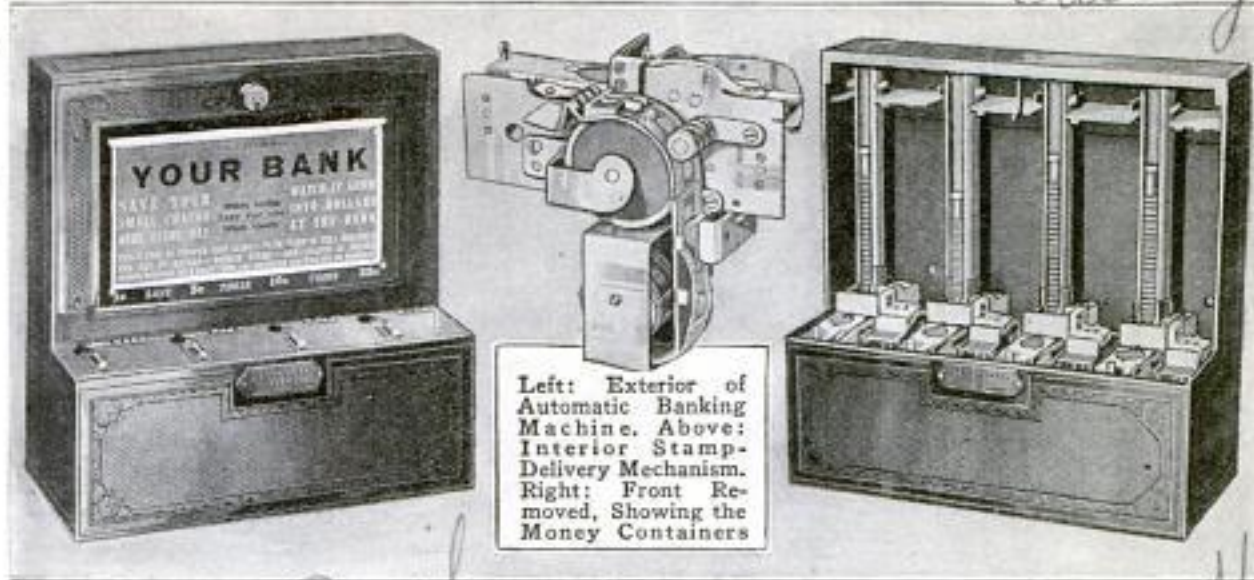

Left: Exterior of Automatic Banking Machine. Above: Interior Stamp-Delivery Mechanism. Right: Front Removed, Showing the Money Containers

Bank
 789.6 THRIFT EFFECTUALLY TAUGHT BY NEW SAVINGS SYSTEM 7982

Thrift is being effectually taught to school children by the installation of automatic banking machines, which are located in the school buildings. The machines are operated after the fashion of the familiar candy or gum-vending appliances, in so far as pertains to inserting money. The child may put in a cent, nickel, dime, or quarter, and receives in return a stamp marked with the respective amount of his insertion. These stamps are pasted in a previously distributed folder, and when the amount on the stamps totals one dollar, the child takes the folder to a savings bank, and opens an account. Although primarily designed for the efficient handling of school savings, this system has been installed in numerous factories, business houses, and public buildings.

7939
 PEN WITH AN INK RESERVOIR AVOIDS CONSTANT REDIPPING

Writing pens that will take up, when dipped in the ink, a much larger supply than the common pen point are the simplest form of fountain pen. One that is now on the market consists of a perforated piece of rubber tubing that is inserted into the hollow shank of the pen point, and that fills up with ink, holding, it is claimed, enough to write 1,000 words without redipping. The ink is fed gradually through holes in the rubber tube to the writing point of the pen, and does not blot the paper.

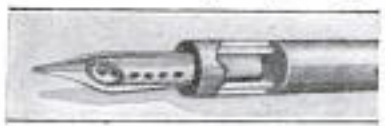

consists of a perforated piece of rubber tubing that is inserted into the hollow shank of the pen point, and that fills up with ink, holding, it is claimed, enough to write 1,000 words without redipping. The ink is fed gradually through holes in the rubber tube to the writing point of the pen, and does not blot the paper.

7982 SIMPLIFIED AIR PORT HAS NO TUMBLE BOLTS

Many of the troubles, well known to seafarers, of the ordinary air port are avoided in a patented port that is being manufactured in New York. Instead of the dogs for tumble bolts, as in the conventional port, the glass frame has four fixed curved lugs on its outer circumference. Snugly fitted to the inside of the fixed frame of the port is a ring with four

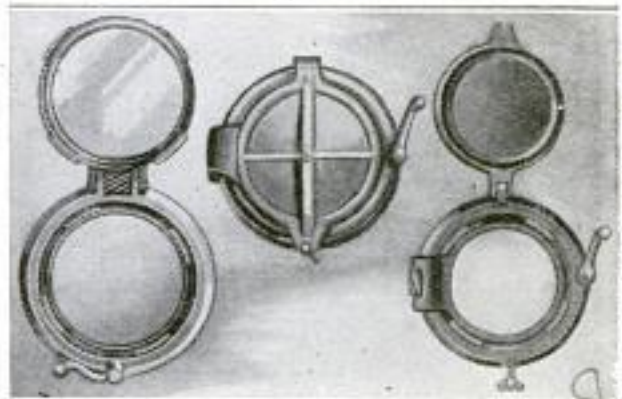

Left: Air Port, without Deadlight, Completely Open. Center: Air Port with Deadlight Closed. Right: Air Port Closed and Locked, with Deadlight Up

similar lugs on its outer circumference, which engage the lugs on the glass frame when the port is closed. In the fixed frame is a crank handle, which, when turned, revolves the ring until the lugs become disengaged, and then by means of spiral gearing on the hinge of the glass frame opens the light, the operation being so timed that as it opens, the light clears the crank handle. By reversing the handle, the light is closed and latched. A deadlight, similar to those in common use, may be attached to this port. This requires the conventional swivel closing bolt.

Ship Equip
 Steward
 Larvik + Equipment Corp
 19 Battery Place, New York

Ad no. Peter J. Pappas. Data missing

8017

SOME NOVEL AND LITTLE-KNOWN ACCESSORIES



Left: This Salt or Pepper Shaker Opens When the Top is Pressed. Below: By Merely Pressing the Sides, the Top is Again Closed



With This Shellfish Scraper, the Meat can be Removed from the Inside of Shells and Claws



A Counterbalanced Electric Lamp Which can be Hung Quickly over the Back of a Chair, Bed, or Dressing Table: The Fixture Has an Ordinary Cord Attachment

A Dustpan Which is Held in Position by the Foot, So That the Housewife can Use Both Hands in Taking Up Sweepings, without Stooping

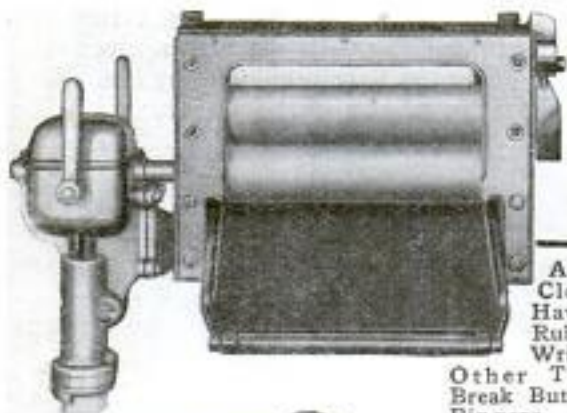
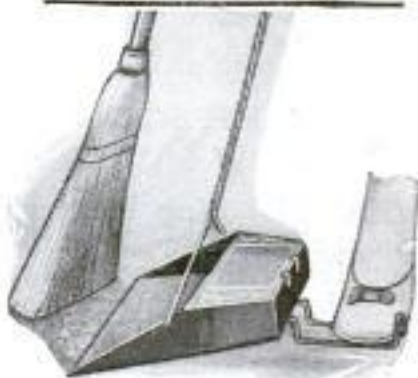

An Electric Clothes Wringer Having Large Soft-Rubber Rolls, Which Wring Drier Than Other Types, do Not Break Buttons, Nor Injure Fingers, and Are Self-Cleansing



This Fruit-Jar Sealer and Opener, Made of Unbreakable Malleable Iron and Steel Wire, Opens and Tightens Any Jar, and Smooths Out the Edges of the Covers



Top: The Combined Crib and Wardrobe Showing the Drawers Built under the Mattress. Right: One of the Drawers Pulled Out for Use as a Table. One Side of the Crib can Also be Lowered

INTENDED FOR THE HOME AND ITS MEMBERS



This Brush, Made for Cleaning the Drain Pipe of Refrigerators, Has a Long Flexible Wire Handle, and Its Use will Prevent the Pipe from Clogging and Overflowing



Tube Support Which Prolongs the Life of the Tubing by Preventing It from becoming Kinked and Consequently Broken, as Is Often the Case When a Tube is Hung from a Nail

Dripless Broiler Which Retains All the Juice of the Food and Thus Prevents the Stove from being Soiled and Causing Smoke



A Jelly Tumbler Which is Sealed by Simply Pressing the Sides of the Cover, and, Opened by Pressing the Center

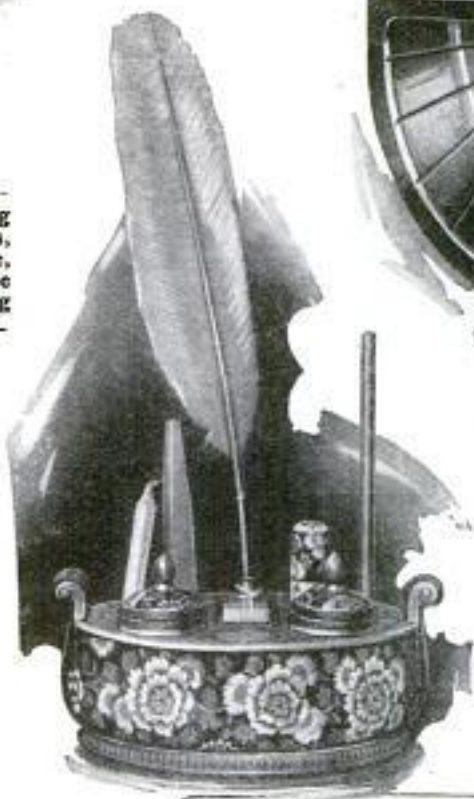

A Paper Weight, Which Also Serves as a Writing-Desk Set, Has Compartments in Which can be Placed Pens, Ink, Stamps, and Sealing Wax. There is Also a Space for the Owner's Monogram

A Combined Electric Toaster and Heater, Making Possible the Use of These Two Appliances at the Cost of Only One

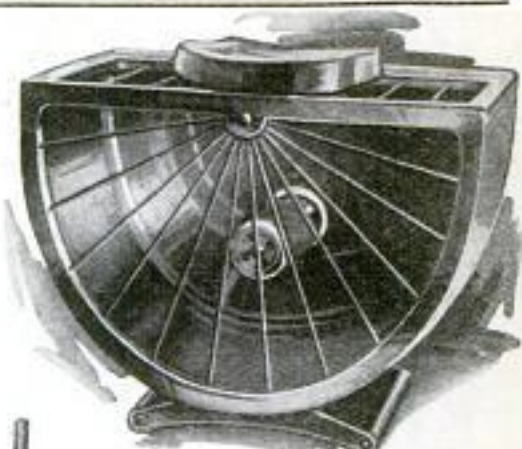

Left: Folding Table Ready to be Used as Breakfast Table. Right: The Table with the Sides Down and Ironing Leaf in Position for Use. Below: The Table Knocked Down and in Readiness for Moving

The Markham Co.
1410 Wrightwood Ave

440
7478

POPULAR MECHANICS
Chicago

**SIMPLE PRINTING TELEGRAPH
COVERS NEW FIELD OF USE**

A simplified printing telegraph suitable for inter-department communication in large plants, as well as main-line traf-



Combined Receiving and Sending Unit: The Receiving Tape Protrudes from the Left Side. A Full-Size Section of Tape is Shown Above

fic, is now on the market. The simplicity is obtained by printing on a tape in place of a sheet, so that much complicated mechanism is done away with. A transmitter, with a keyboard similar to that of a typewriter, is mounted with a printer to form a single unit. This unit is operated on either direct or alternating current, of 110 volts, by a 1/40-hp. motor. The keys control a camshaft, which revolves, opening and closing the line. The maximum speed is 45 words a minute, a safety device preventing too rapid operation.

**NEW TOOTHBRUSH STERILIZER
KEEPS BRUSH SANITARY**

Because of the opinion, generally held by doctors and dentists, that an unsterile toothbrush may be a greater hindrance than benefit to health, the claims made for a new toothbrush sterilizer are interesting and important. It is stated



Toothbrush Case Open, Showing the Pad Container and a Bottle of the Sterilizing Solution

795
Dental Hygiene Laboratory
La Crosse, Wis.

that by using this simple container the brush is kept perfectly sterile. It consists of a two-piece case, of aluminum, just large enough to hold a toothbrush. In one half a small metal box, containing a pad, is held on the inside by ridges in the case. At regular intervals the pad is moistened with a special sterilizing solution, and the brush is kept in the case at all times when not in use.

8048
**NEW CARDS MAKE BRIDGE GAME
OF SKILL ONLY, NOT LUCK**

Cards for playing bridge, in any of its forms, have been produced which remove all of the element of luck from the game, and make it purely a game of skill. The backs of the cards are marked with numbers and indicators and the cards are dealt according to the indicators, instead of in the usual way, by rotation. The result is that four absolutely equal combinations of cards are obtained by the four players. There are 12 sets of indicators on each pack of cards, making possible 12 entirely different hands or sets of combinations. After the cards have been dealt, the game is played in any of the ordinary ways.

Milton Bradley Co., Springfield Mass

778
**NEW APPLIANCES MADE
TO AID BATTERY MEN**

Two new tools for the use of the battery man have lately been produced and placed on the market. One is a small hoe-shaped tool for the disagreeable task of removing the compound from the bottom of old battery cases. The other is a knife-shaped blade with teeth on one



Top: Scraper for Removing Old-Battery Compound. Below: Knife for Separating Battery Elements

side, to be used in removing the separators between the elements of the batteries.

As a means of combating counterfeits of her creations hereafter, each garment of a celebrated French modiste will bear a special serial number, a notice of license, an autographic signature, and the thumb print of the designer.

American Bureau of Modistes
Chicago

THREE-DIMENSION WEATHER MAPS MADE FOR AIRMEN

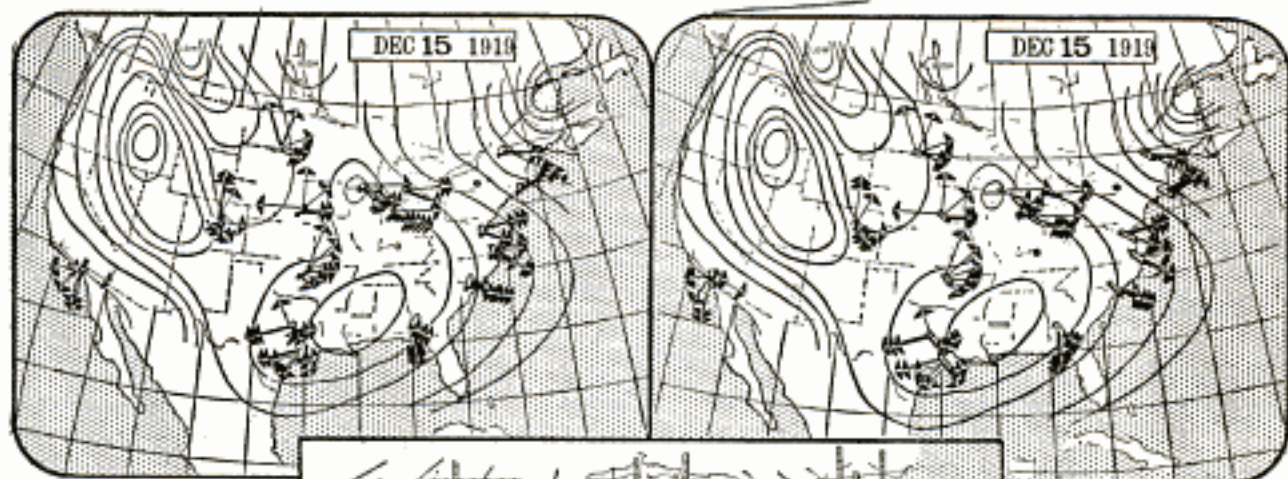

The Maps are Photographed from Two Different Angles, and the Two Photographs are Mounted Side by Side

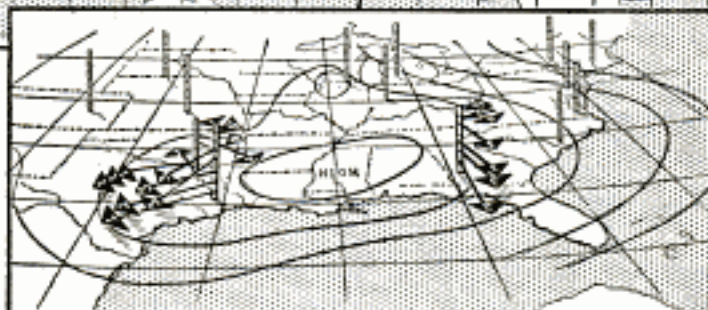

When the Two Maps, Shown Above, are Viewed through a Stereoscope, They Blend and Appear, as Seen Here, with the Posts and Arrows in Strong Relief

Upper-Air Stations are Marked by Posts and Arrows, Indicating the Wind Direction and Velocity at Different Levels

Three - dimension maps are being made by the United States Weather Bureau as a result of the development of flying. It was found necessary to chart wind directions at different levels for the airmen. At first, separate maps for each level were made, but these proved awkward. Now an ordinary weather map is drawn and at the location of each upper-air station a little metal

post, supporting a series of arrows, is set up. Each arrow is a little shorter than the one below. They are set to indicate the wind direction at the levels they represent. Numbers on the arrowheads show the wind velocity. The map is photographed from two angles, and when the two pictures are seen through a stereoscope, they blend, bringing the posts and arrows into strong relief.

7450

INGENIOUS SYSTEM SOLVES DOUBLE-CARFARE PROBLEM

Street-car passengers between St. Paul and Minneapolis must pay two full fares. Formerly the conductor collected in the car and repeated the collection after passing Snelling Avenue, going east, and Bedford Street, going west. Snelling Avenue is east of Bedford Street and the space between the two forms a neutral zone from which a person may ride in either

direction for one fare. This year the company adopted "pay-as-you-enter" cars with rear entrance and front and rear exit. A system of collection had to be worked out so that the conductor would not have to leave his money box to collect. When a passenger boards the car before passing the neutral zone, he pays at the rear on entering and can get off at either end before passing the neutral zone. After passing that zone all passengers must get off at the rear and pay

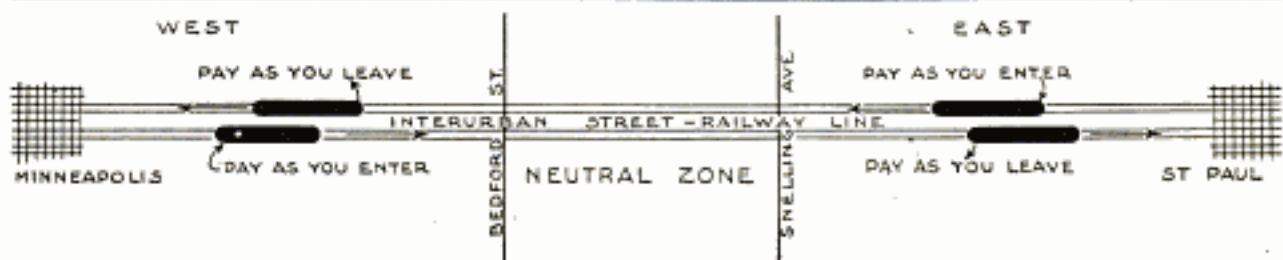

Diagram Showing How the Interurban Street Railway, between Minneapolis and St. Paul, Handles the Collection of Double Fares on Pay-as-You-Enter Cars, and the Neutral Zone in Which Only One Fare is Required

Capt. Arthur Hallaw,
 317 Cedar Av., Minneapolis, Minn

Western Electricity News, 195 Broadway New York

on leaving. Passengers boarding the car in the neutral zone are given blue identification slips which they give the conductor on getting off, in place of the second fare, which they are not required to pay.

CHINESE GREATLY MYSTIFIED BY WIRELESS TELEPHONE

Mystification of the usually placid Chinese was accomplished by a noted American professor, who has been lecturing on, and demonstrating, the latest developments of electricity throughout the Orient during the past six months. Placing a wireless-telephone station on a wheelbarrow, the professor had the outfit trundled through the streets, stopping every little while to converse with associates, who had set up similar stations in their living quarters. The carrying on of conversations from the interiors of thick stone walls, and receiving responses from several different directions at once, particularly impressed the Orientals, and added to their bewilderment.

4830 **ELECTRIC HAND DRIER BUILT INTO WALL TO SAVE SPACE**



Space, so valuable in modern city apartments and buildings, is now being economized by recessing the ordinary electric hand drier into the wall of the bathroom. The movable blower is set in a plate at the correct height, and below it, the operating pedal is set in a second plate,

just above the floor. This eliminates the awkward pedestal which was formerly used.

7570 **NEW SAFETY RELIEF VALVE OF IMPROVED DESIGN**

A plumbing specialty in the form of a safety relief valve of improved design, is now on the market. Integral with the valve body is the valve seat, which is made small in order to prevent it from damaging the valve disk when under pressure. On top of the body is a removable cap, upon the outside of which is bolted a C-shaped spring that never comes in contact with the water, an undesirable condition that is common in other relief valves.

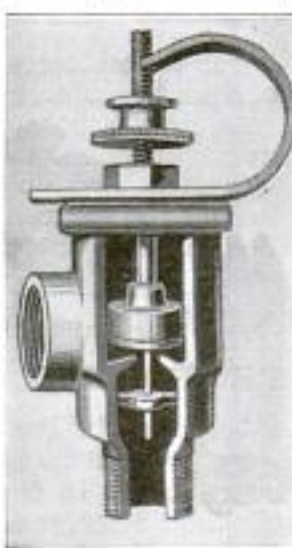

Above the bolted end of this spring, a small adjusting wheel is threaded on the plunger that is connected with the valve disk. When this is set for any desired pressure, it is retained in its position by means of a loose lead-tipped wire on the upper end of the spring. A side outlet on the body provides means for taking care of the drip by piping it to any open-plumbing fixture.

Those wishing further information on anything described in the editorial pages can obtain it by addressing Bureau of Information, Popular Mechanics Magazine, Chicago.

Widely incorporated Laboratory, Ill.

4806 **DISPENSING MACHINE DELIVERS WELL-MIXED PEANUT BUTTER**

Properly mixed peanut butter can be dispensed in small quantities from 60 or 80-lb. cans by means of a new dispensing machine. It is placed on top of an open can, clamped on with three rods, and the whole then inverted. Two paddles, revolved by the dispensing handle, extend into the butter. The handle is turned a few times before opening the dispensing valve, to mix the light and heavy oils and butter thoroughly.



Each time it is turned to dispense butter it again revolves the mixing paddles.

Wm. C. S. Emright 612 N. 6th Tacoma Wash.

Donnelly 10 High St. Boston? has

POPULAR MECHANICS

CHARACTERISTIC SOFT X-RAYS
FROM ARCS IN GAS VAPORS

The outstanding characteristic of the X-rays which were first discovered was that they would pass through solid bodies which were opaque to ordinary light. Experiments have recently been conducted in which soft X-rays from arcs in gas vapors have been produced inside vacuum tubes. All known substances, including ordinary air, are opaque to these soft X-rays, which can only be detected by their effect on objects inside the vacuum tube. These soft X-rays have wave lengths greater than those previously known. The shortest wave lengths of light, at the violet end of the visible spectrum, are much longer than the longest previously known X-rays, and measurements of the wave lengths of these soft X-rays have shown that they partially close the gap between the ultra-violet radiations and the ordinary X-rays.

7783

SLOT IN TABLE FACILITATES
WORK ON SEWING MACHINE

Sewing-machine tables are now being provided with an L-shaped slot, 3 in. wide, that enables an operator to feed material more conveniently to the needle. A piece of material requiring a continuous band

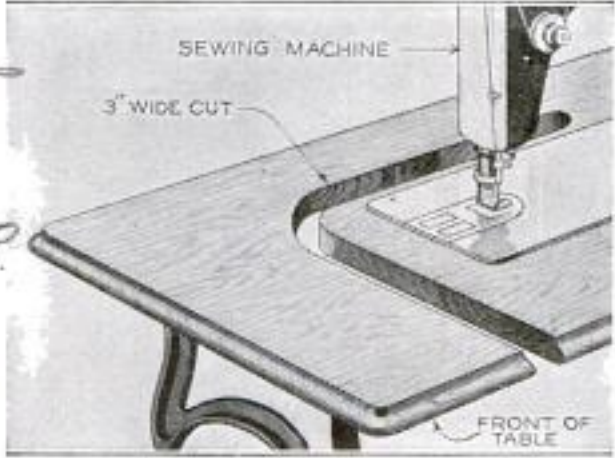

Slot in Sewing-Machine Table through Which Material Hangs So That It can be Fed without Difficulty under the Presser Foot at the Needle

can be sewn by letting it hang through the slot while it is fed under the presser foot at the needle.

¶An engine on the Canadian Pacific Railway recently demonstrated its hauling possibilities by pulling 112 cars, including the usual tender, and caboose. The train was nine-tenths of a mile long, and was loaded with 165,000 bu. of grain.

PERFECT LIGHT BUT NO DAZZLE
FROM ENGLISH AUTO LAMP

An automobile lamp, being marketed in England, is said to control the light rays in such a way that while an approaching

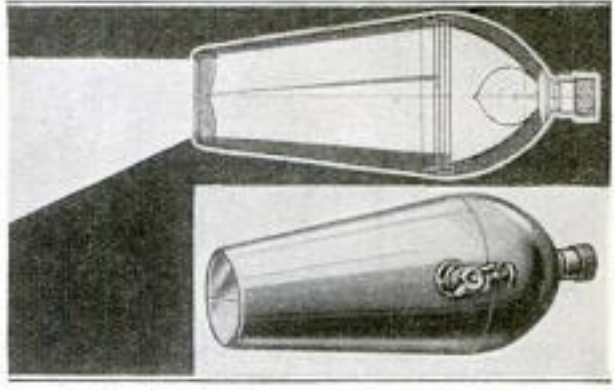

The Nondazzle Auto Lamp: The Diagram Above Shows Arrangement of Diaphragm and Lenses, and the Outline of the Stream of Projected Light

pedestrian suffers no blinding effect, at a distance less than 200 ft., yet it lights the road perfectly for that distance. The body of this lamp is a tapered tube, 10 in. long, with two D-shaped lenses in the front and a horizontal diaphragm dividing its whole length. The two streams of light mingle, giving a single horizontal and downward stream. The width of the stream, at any point, is about one-half the distance of the point from the lamp, but the construction can be varied to give a narrower and more intense or wider and less intense stream.

BURGLAR-PROOF WINDOW CATCH
LOCKS SASH AT ANY POINT

Windows are made completely burglar-proof by a new catch, which the makers claim cannot be jimmied, and will lock the window in any position. From the inside, the window may be opened to any desired height, but cannot be opened any farther from the outside. The catch is set flush in the frame, so that it does not catch and tear the curtains.



¶Write our Bureau of Information, if you wish to know who makes or sells any article described in this magazine. Send no postage; the service is free.

John H. Stewart
Poughkeepsie, N.Y.

C. M.

Ray - Lynch Co. Ohio
Toledo, Ohio

Cont. P. I. Connelly
20 Eagle St. Schenectady
N.Y.



A Group of Native Girls from India Arriving in London, England: These Girls were Given the Trip as Guests of the Salvation Army, as a Means of Furthering and Broadening Their Education by First-Hand Contact with the Western World. Dressed All Alike, in Their "Little Red Riding Hood" Cloaks, the Youthful Visitors from the Far East Attracted Much Attention Wherever They Appeared and, Needless to Say, They were Delighted with the Many Strange Sights, Experiences and Entertainments Encountered on Their Trip, Which had Taken Them So Far from Home and Familiar Surroundings

Small Visitors at the New York Zoölogical Gardens can Now See All the Sights without Becoming Tired. Their Mothers may Hire One of These "Prams," Furnished by the Zoo, and Also an Attendant to Push It, for a Small Price

COPYRIGHT, KEYSTONE VIEW CO.



"Jimmie" Uses the Phonograph as a Merry-Go-Round. He Presses the Starting Lever and Jumps on for a Ride. This Is One of Many Tricks of This Pet Squirrel, Belonging to Miss Manilla Martan, of New York City

COPYRIGHT, RADEL & HERBERT



Benjamin Eldredge Co., 8916
 207 S. Green St. Chicago
 OF MODERN ACTIVITIES AND INTERESTS



A White-Enameled Table and Chairs, for the Children, are Shown at the Left. The Table Top Is of White Porcelain and may be Washed Easily if Food is Spilled on It

The Shooting Gallery, at the Right, Has a Ball for a Target. Air Pressure, Obtained by Pressing the Lever, Supports the Ball, or a Model Operated by Current from an Electric-Light Socket may be Had

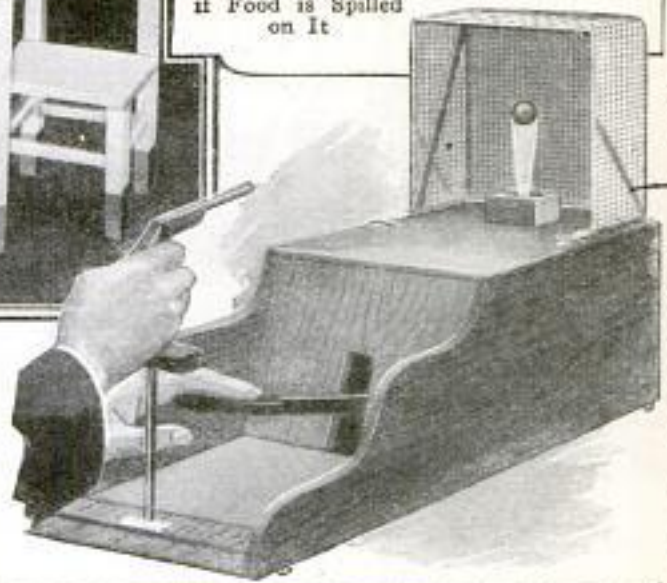

Circus Parade Carved from Soap, for a Window Display: The Material Resembles Old Ivory; the Coloring Is Ink, Applied with a Pen and Brush

The Original Horseless Carriage, Exhibited at the Chicago World's Fair in 1893, was Run by Steam. It is Now Owned by Colonel Wm. N. Selig, of Los Angeles. The Crew of the Machine, as Seen in the Picture, Are "Mary" and Mike," Two Chimpanzees of the Moving-Picture Colony, Which have Entertained Thousands of People by Their Almost Human Antics in the Movies

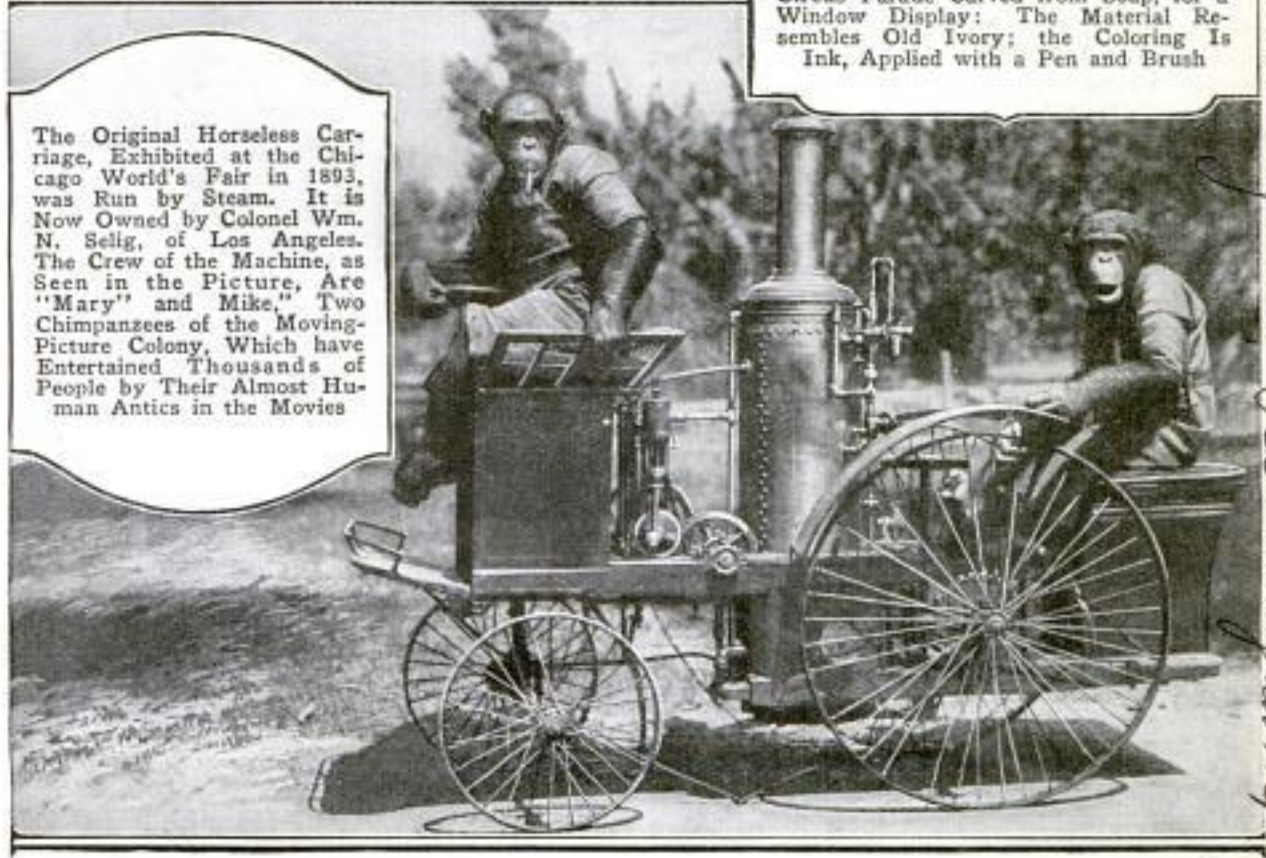

Glass Vacuum Cleaner Co. Ltd. Leverette Hotel Birmingham England

*Mrs. E. Jermoine
Chauvont. France.*

416
7962

POPULAR MECHANICS

CARBON-PROOF SPARK PLUG
MANUFACTURED IN FRANCE

A carbon-proof spark plug, similar to any ordinary plug, except that, in place of a side electrode at the sparking point, it

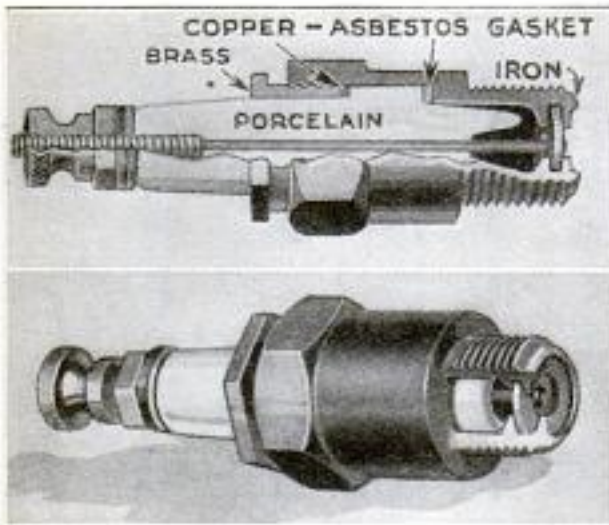

Below: Carbon-Proof Spark Plug with the End Milled Out to Show Disk in Its Circular Slot. Above: Sectional View Notated Fully to Explain the Construction

has a loose movable metal disk that is retained in a circular slot made by spinning over the end of the plug, has been patented, and is now being sold in France. In the center of the disk is a hole, which surrounds the end of the central electrode, and the space between this and the inner circumference of the hole forms the spark gap. With this construction it is impossible for carbon or oil to pass the metal disk and reach the porcelain inside the plug, one of the commonest causes of short-circuiting. As the disk is constantly vibrating and rotating in its slot, it is unlikely that oil or carbon will lodge in the spark gap.

SOD-CUTTING MACHINE AIDS
IN PRESERVATION OF LAWN

For the laying of pipe, or similar purposes, where the turf must be cut, a machine is available that removes a strip of sod quickly, and

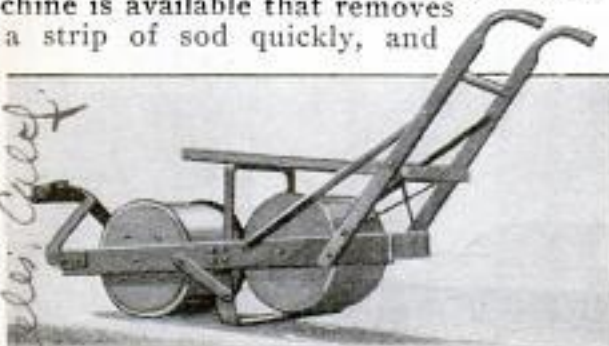

Sod Cutter with Sharp-Flanged Front Roller, Lifting Tool, and Rear Roller with Cutting Knives Affixed

without damage to it. The appliance has two handles like a plow, two heavy rollers, and a tool for lifting the cut turf. The front roller has sharp flanges on either side which cut through the sod, and the lifting tool is adjusted so as to raise the turf as the roller cuts it into strips. The rear roller has knifelike projections on it to cut the sod in regular lengths, after which it is piled up and relaid when the work is completed.

8070
SHELLS HUNG IN CHURCH TOWER
REPLACE CONFISCATED BELLS

Church bells throughout Germany were confiscated during the war to be melted up and used in the manufacture of munitions. One of the most novel and ingenious substitutes which has been reported was used in the town of Marhorst. Two large shells were suspended in the church tower and a pendulum swung between them. When the pendulum struck the shells it produced a pleasing tone with surprising carrying power.

Musik Industrie
SIMPLE MACHINE DISTRIBUTES
ARTICLES INTO COMPARTMENTS

7846
For distributing articles, such as fruit, into several compartments, a newly invented machine is quite simple. The end

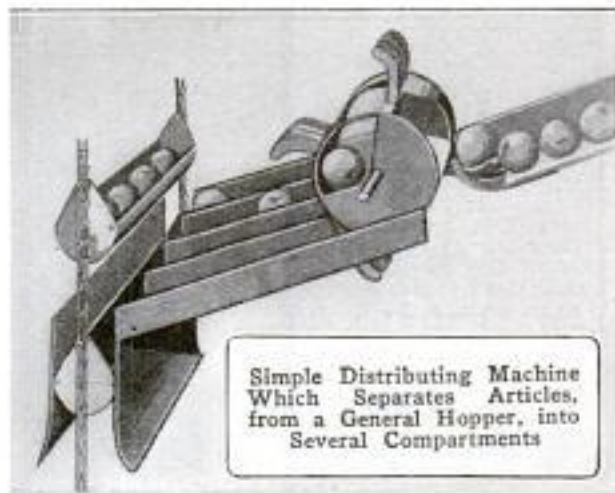

of a chute, down which the articles pass from a hopper, is provided with upward curving teeth. A revolving cylinder below has rows of teeth, which pass between those on the chute, and pick up the articles. From the teeth they fall into an opening in the cylinder and a small chute carries them to one of the compartments below.

Our Bureau of Information is for your benefit. Use it as often as you please.

*Chas. E. & J. Kohr,
North York, Pa.*

*Grand O. Home, 412 Mason Opera House Bldg
Soan Peoples, Calif.*

*G. Klein, 807 Broadway Place,
Chicago*

Copyrighted material

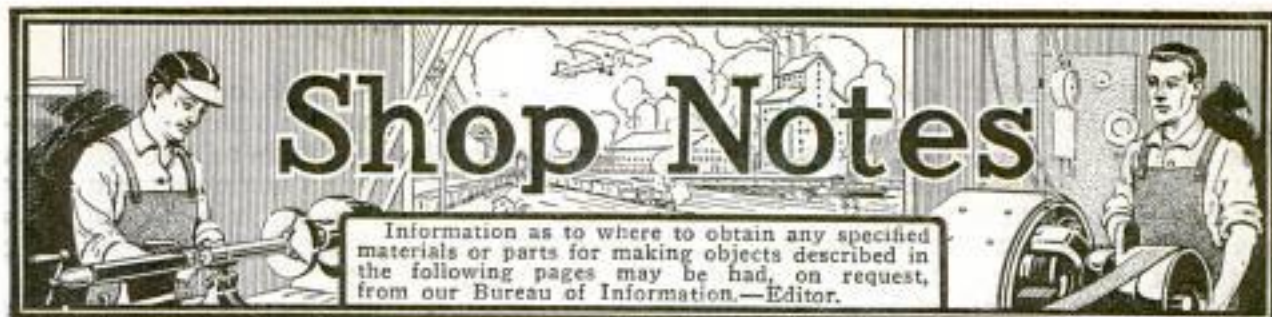

Information as to where to obtain any specified materials or parts for making objects described in the following pages may be had, on request, from our Bureau of Information.—Editor.

Corners for Log Cabins

BY A. NEUMAN

IN building log cabins, the parts that cause the most trouble are the corners, where the logs cross each other at right angles. To get the best and most attractive effect, and to retain the "pioneer" look, the logs should project beyond the corners, but, unless properly done, the effect will not be pleasing. The pictures show how accurately and neatly the logs can be joined at the corners. To make

although, if necessary, it can be done. The logs should be cut about 6 ft. longer than the inside dimensions of the building, and good straight ones should be selected; they should also hold their size well, that is, they should not taper very much.

The notches are marked with a compass with an indelible-lead point, if green timber is used, as an ordinary pencil or

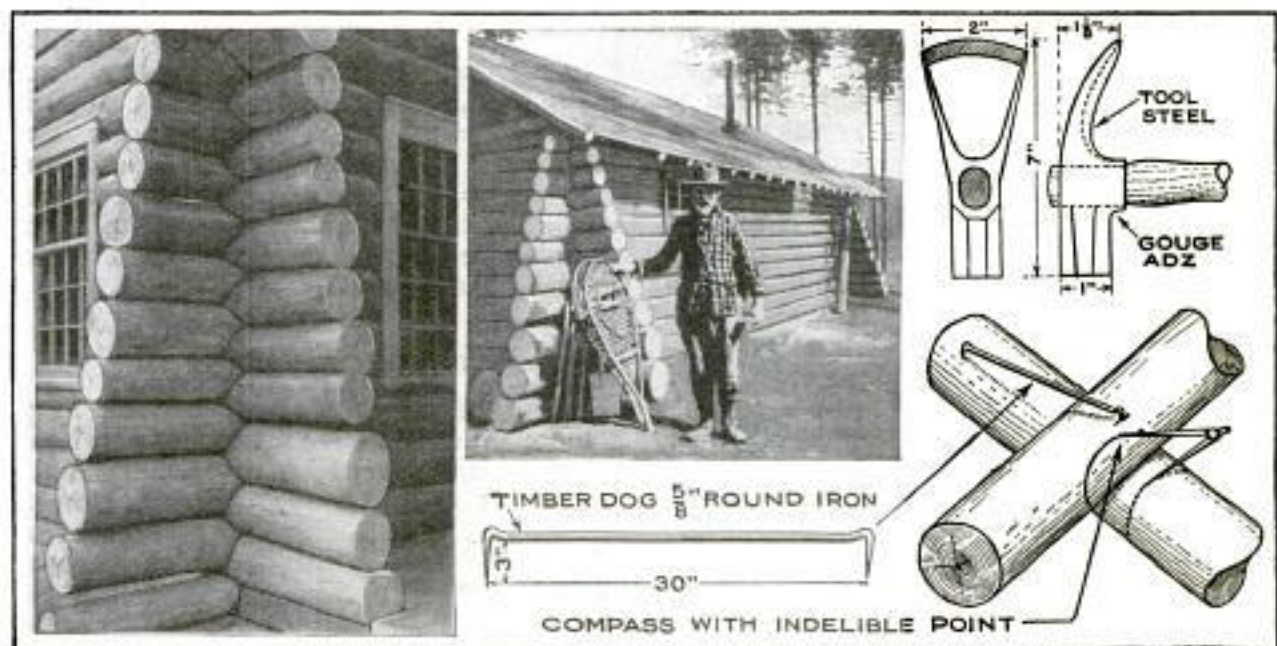

If a Neat and Finished Job is Desired in a Log Building, Particular Pains must be Taken to Fit the Logs Accurately at the Corners. By Marking the Notches According to the Method Described, a Very Neat Corner Is the Result. The Drawings Show the Tools Used and the Method of Marking Off the Logs

this type of corner it is necessary to have made at a blacksmith shop a gouge adz along the lines of the one shown. The cutting edge is ground with an inside bevel and sharpened with a slip stone. The hammer head is to give it the right "heft" and balance, and is useful to drive the timber dogs into the logs to hold the latter while they are being notched. Two of these timber dogs are needed, and they are made and used as shown in the drawing. Peeled logs are best to use, as it is quite difficult to get a distinct pencil mark on the bark of a rough log,

lead will not make a good mark on the surface of freshly peeled logs. Two logs are dogged together at right angles, as shown; the compass is set to a radius of a little less than half the diameter of the log to be cut, then, with the steel point against the lower log and the pencil point against the upper one, it is drawn over the surface of the logs as shown, marking, on the upper log, an accurate representation of the contour of the lower one.

A similar mark is made in the same manner on the opposite side of the upper log, which is then rolled over, dogged

again, and the notch cut. It should be noted that the notches are cut in only one side of each log—the underside.

As the logs taper somewhat, the diameter of the notch at the small end must be a trifle smaller than the diameter of the notch at the larger end. If the joints do not fit exactly when first cut, the compass should be set with its points $\frac{1}{4}$ to $\frac{1}{2}$ in. apart, new marks made, and the notches cut down to these marks. If the work has been carefully done, extra fitting is usually unnecessary; after the first few experiments with the method, neat and accurately fitting notches can be cut, and, where the work is exceptionally well done, it is hard to tell which log is cut.

About an inch of space is left between the logs, and this space is "stuccoed" ac-

ording to the methods commonly used. Straight logs should be selected for building purposes, but if there should be a slight bend or bow in some of them, they should be placed in the building with the bow up, so that, in time, they will sag and straighten out.

The logs settle a great deal more than is generally thought after being put in place, and it is advisable to allow the building to settle for two or three months before furring in the doors and windows, or trying to stucco the chinks between the logs. If the building is allowed to settle for a while, nails driven close up into the cracks, about 2 or 3 in. apart, and the chinks then filled, the stucco will stay tight for years, as the heads of the nails will be imbedded in it and hold it tightly.

Wrench for Cylinder-Head Bolts

It is difficult to place a straight open-end wrench on the cylinder-head bolts of certain makes of automobile engines, as the nuts are set below the surface in such a manner that a good grip cannot be taken. In such cases a wrench of the type shown in the drawing can be used to considerable advantage. It is only necessary to bend over the open end of the wrench, so that the jaws will fit into the counter-bore or depression in the casting.

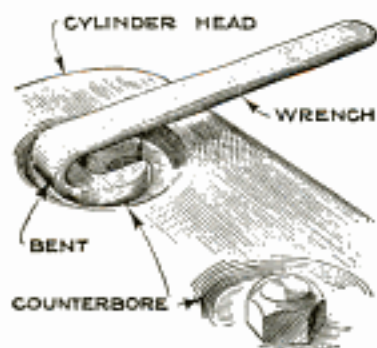

Cleaning Silver Cathodes

Silver cathodes for use in the electro-deposition of copper are cleaned by placing them in contact with pure tinfoil in a boiling 10-per-cent solution of sodium hydroxide until bright. They are then washed successively with dilute hydrochloric acid, dilute ammonia, and distilled water, rinsed with alcohol, burning off any adhering alcohol by igniting it. The electrolysis is carried out as usual, except that the electrode is not immersed in the solution until the current has been switched on. To remove the copper deposit, after the final weighing, the cathode is placed in a wide-mouthed stoppered bottle, filled with a 10-per-cent solution of trichloroacetic acid in aqueous ammo-

nia (.90 specific gravity), to which an equal volume of water has been added. The copper is removed in about ten minutes and the silver electrode is not attacked. Chloroform or carbon tetrachloride may be substituted for trichloroacetic acid, but in this case the ammonia solution should be made from one part ammonia (.90 specific gravity), and one part alcohol. The reaction is slower, and care must be taken that no sulphur compounds are present in the carbon tetrachloride that is used.

Driving Long, Slender Pins

A very efficient tool for driving long, slender pins that have a tendency to bend when being driven, because their length is so much out of proportion to

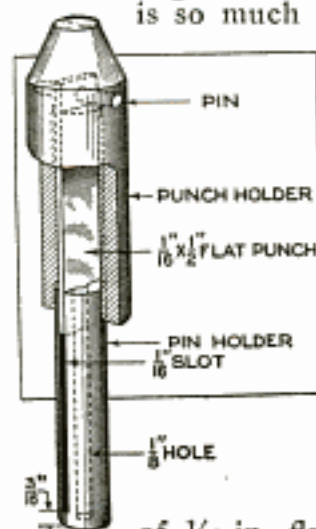

their diameter, and also because they are not always set squarely, is shown in the drawing. The part that holds the pin is made from $\frac{1}{2}$ -in. steel, drilled through to accommodate the pins, and a slot is cut through to within $\frac{3}{16}$ in. of the end. The punch, or driver, is a piece of $\frac{1}{16}$ -in. flat steel, $\frac{1}{2}$ in. wide, held by means of a pin in the sliding punch holder, which is drilled out, $\frac{1}{2}$ in. in diameter, to within a short distance of the top. Care should be taken in making this tool to see that the flat piece fits

the hole in the punch holder neatly, as this supports the driver lengthwise. When the two parts are assembled, the flat punch should slide nicely in the slot of the pin holder.

When driving the pins, they are first placed in the hole and the driver slipped over them; then, taps on the top of the punch holder will drive them home to within $\frac{3}{16}$ in., a final tap being sufficient to bring the pin flush with the face of the work. It will be seen that the pin is supported at all times by the holder, and that the punch holder pilots the punch down centrally, thus overcoming the two main difficulties mentioned. — Harry Moore, Montreal, Can.

Shop Uses for Old Razor Blades

Old safety-razor blades can be put to good use on the bench by soldering on

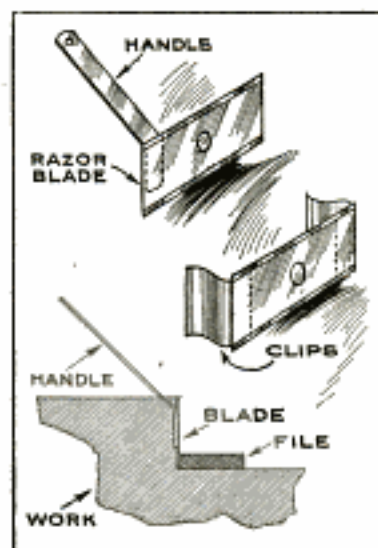

sheet-metal handles, and then using the blade as a guard in filing the corners of dies and castings. Even a safe-edge file will sometimes cut up a finished metal surface badly, and the blade will form a good protection when any file, even a three-cornered one,

is used. Instead of a single handle, especially on repetition work, a metal clip can be soldered to each side of a blade to hold it up against the work, so that both hands will be free to use the file.

Sticker Identifies Rush Orders

Small gummed-paper stickers, such as can be bought at any stationery store, are used on the order cards of a large concern to indicate rush orders. A red seal is stuck in the upper left-hand corner of the card, and everyone who gets the shop ticket knows instantly that the order is to be handled with speed. A variation of the same idea makes use of a blue seal, which enjoins everyone to take particular pains in filling the order, or in working to dimensions.

Heating Water with Steam

Heating cold water by steam is accomplished in various ways, the most common method being to insert the end of a steam pipe into a tank of water and turn on the steam. This method, besides being wasteful of steam, produces disagreeable noises. The drawing shows a simple fitting in which the steam is mixed with the cold water, so that this is heated and passes on to an outlet without any fuss. The water and steam-supply pipes are controlled by separate valves, making it possible to regulate the temperature of the heated water very closely. — Earl Stevens, Niagara Falls, N. Y.

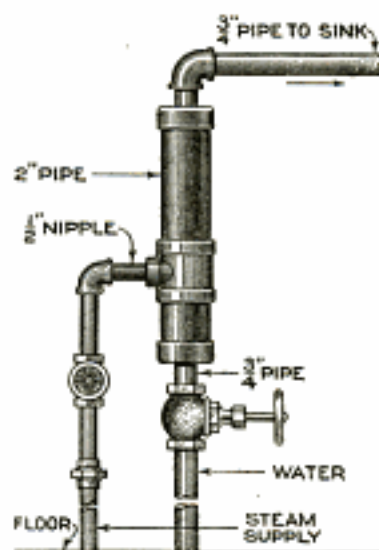

Safety Container for Gauge Glasses

In dismantling large ammonia compressors for shipment, most of the small parts are easily disposed of by packing them in a box fastened to the skids. There is one piece, however, that does not mix well with the rest, no matter how carefully it is wrapped in burlap or corrugated cardboard, as it invariably works its way under a heavier piece and is crushed. This is the gauge glass. The difficulty of transporting such glasses, and for that matter all kinds of glass tubing in short lengths, can be solved by using a block of wood in which a hole, 1 in. longer and about $\frac{1}{32}$ in. larger than the glass, is drilled. The tube is inserted in the hole, and a small block, fastened over the opening with four brads, makes it possible for the gauge glass to ride safely along with valves, oil cups, and other small parts.

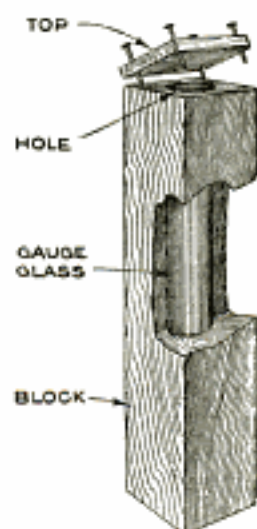

Automatic Stop for Tumbling Barrel

When tumbling some small castings, to remove the sand and burrs, trouble was experienced when the pieces were tumbled

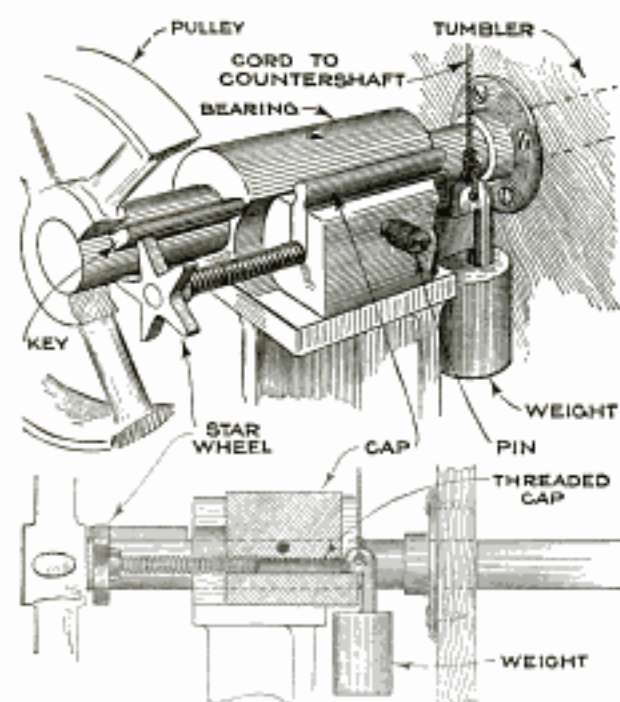

An Automatic Stop for a Tumbling Machine Prevents Injury to Castings by being Tumbled Too Long

too long, the result being that the corners were worn round. The trouble occurred mainly because the operator forgot to stop the tumbler when the work was done.

The result of this experience was that the automatic stop illustrated was devised; this required a new bearing at one end of the machine. The cast-iron bearing supports the tumbler shaft and the threaded stem of the star wheel, a hole being first drilled for the stem, then the hole slotted out on top, and a machine-steel cap fitted. The bearing for the star-wheel stem is tapped to fit the thread on the stem when the cap is in place, as shown. Afterward the thread in the bearing is removed so that the only part having a thread is the movable cap, which is held in place by a pin. A key is driven into the tumbler shaft to operate the star wheel. The end of the star-wheel bearing nearest the tumbler has a weight hooked over it to operate the countershaft, which is not shown.

When the tumbler is ready to start, the attendant takes out the pin, lifts the cap and slides the star wheel out to the position shown; then the cap is secured in place again, the countershaft cord pulled to start the machine, and the weight hooked over the bearing; the tumbler can

then be left to stop itself. As the threaded stem of the star wheel is 3 in. long and makes only one-fifth turn for each revolution of the tumbler, and the stem has a 20-pitch thread, it takes 300 revolutions of the tumbler before the star wheel is fed through enough to push the weight off its bearing, and stop the machine.—S. A. McDonald, Brooklyn, N. Y.

Stencils Made from Old Films

I find that the best material from which to make air-brush stencils is old photographic film, such as can be obtained from any professional negative finisher or photographer, many of whom have discontinued the use of glass plates. Such celluloid masks are much more durable than those of paper, and the alcohol in the colors cannot strike through and stain the work underneath. The designs may be drawn on the rough surface of the stencil directly, then cut out with an old razor blade.—R. E. Deering, Clements, Kan.

Marking Bolt Circles

When turning a cover, flange, gland, or other work that will afterward require a circle of bolt holes drilled in it, it is the usual practice to mark or "strike" the bolt circle, that is, cut a fine tool mark in the face of the work at the required diameter, while the work is held in the chuck or faceplate. This is generally accomplished with a V-shaped tool, held in the toolholder, and the proper radius is obtained by adjusting the

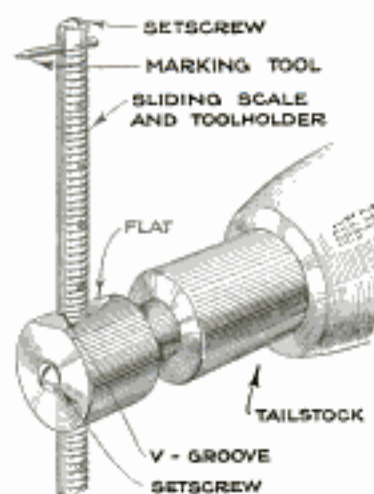

obtained by adjusting the tool to a scale held against the lathe center. The drawing shows a special tool for this work, which is simple to make and easily adjusted to the correct radius.

The body is turned on the shank to fit into the tailstock spindle, the front end having a $\frac{3}{8}$ -in. hole drilled through it at right angles to its center, and a small hole at the center, tapped for a setscrew. A piece of $\frac{3}{8}$ -in. cold-rolled steel, of suitable

length, is centered and placed in the lathe, where a 16-pitch thread is "scratched" on it. The thread is not actually cut, but a fine helical line is made on the rod, which is then grooved on one side to fit the point of the setscrew, and fitted at one end with the marking tool and setscrew. The diameter of the body of the tool should be large enough to permit a flat to be filed on one side, the flat being filed at an angle corresponding with the angle of the thread, and so that when the marking tool is snugly against the flat, the distance from the center of the tool to the center of the body is exactly one inch. When setting the tool, pull out the bar until the measurement of half the diameter of the required circle is obtained, and then tighten the screw. The tool is held in a vertical position so as to clear the toolholder of the lathe, and is fed in by means of the tailstock until a fine line is marked on the work.

Face Milling with Side Mills

A good deal of quick face milling can be done with the ordinary face and side-milling cutter when held in the simple holder illustrated. This is turned, on the shank, to fit the spindle, and on the front

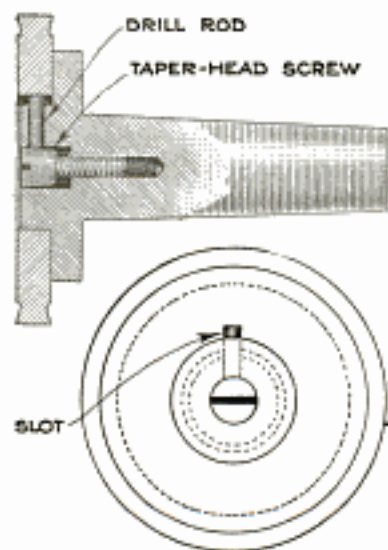

to a snug fit in the bore of the cutter. A shoulder, to take the end thrust of the cut, is left on the holder. The center of the holder is next drilled, tapped, and counterbored for the special screw indicated. This is an ordinary filister-head screw with the head turned to a slight taper. At right angles to this hole is another, drilled to a diameter the same as the width of the keyway in the cutter. A piece of drill rod is inserted in this hole, and the tool is ready for use. It will be seen that when the screw is tightened, the drill-rod pin will be forced out against the cutter and act as a driving key. With a cutter held as shown, and close to the spindle of the machine, face-milling operations can be successfully accomplished.

Rack for Storing Sheet Glass

So-called "country" hardware and paint stores, that carry an extensive assortment of sizes in sheet window glass, realize

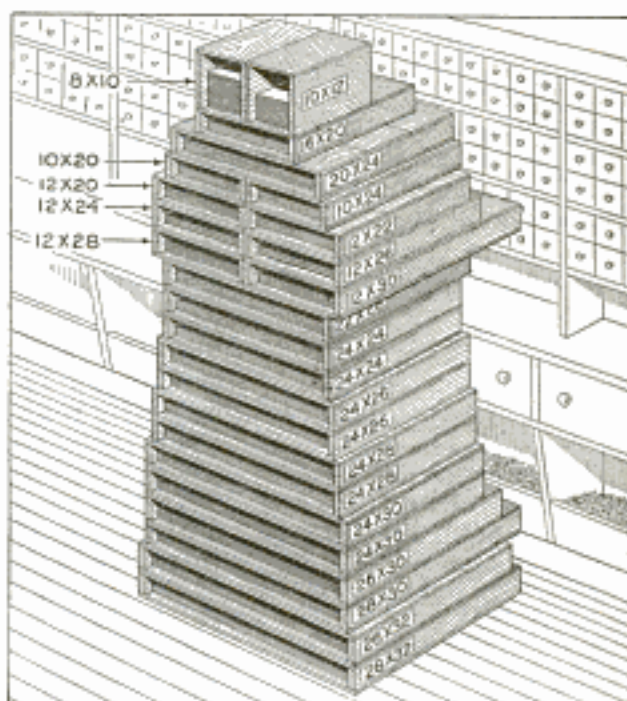

Correct Design of Movement for Intermittent Motion

Most machine designers and draftsmen have occasion to make use of cams and Geneva movements in their work, and these certainly form two of the principal elements in the study of machine design. Results are obtained by using them which would otherwise be impossible, and upon whether they are correctly or incorrectly used depends the success of the machine in a great many cases. High-speed production is a

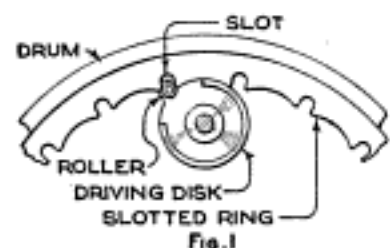

Fig. 1

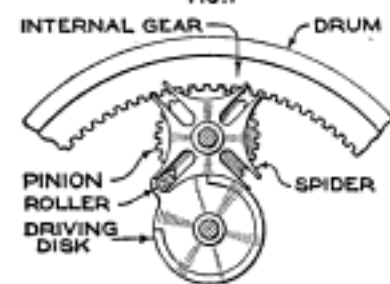

Fig. 2

used whenever possible. When a uniform or constant motion is required for the cam roller, the entire movement cannot, of course, be harmonic, but an effort should be made gradually to accelerate the roller at the start and gradually retard it at the end of its movement; in most cases this can be done, though often neglected.

In the present example a machine was to be redesigned. The highest possible speed was 15 cycles per minute; it would have broken down at a higher speed, and to make it a commercial success more speed was absolutely necessary. Its various moving elements consisted mainly of abrupt-movement cams and Geneva movements. A close examination revealed the fact that the design of these parts was not based upon the principle of gradual acceleration and retardation. The cams and Geneva parts were redesigned, and in so doing it was found that most of them could be given true harmonic forms, and, in consequence, the machine was operated up to a speed of 90 cycles per minute, without undue vibration, and without exceeding safe stresses.

One of the several sources of trouble in the original design was the Geneva action

illustrated in Fig. 1. The drum was driven with an intermittent motion and had a diameter of about 24 in. Attached to it was a slotted ring engaging the driving disk. The drum remained stationary while the disk revolved, excepting when the roller was in engagement with the slot, as shown, when the drum started to revolve at nearly the full speed of the disk. As the parts driving the disk had considerable weight, as had also the drum, their opposing inertia forces caused a shock each time the roller struck the side of the slot. This condition was entirely overcome in the redesigned movement, shown in Fig. 2, in which the slotted ring was replaced by an internal gear, engaging a pinion which was secured to a slotted spider. A driving disk was located so that its roller engaged in the radial slots of the spider, care being taken to have the roller begin to enter the slot in a direction parallel to the slot, or radial to the center of the spider. This arrangement insured the starting of the spider and drum at zero speed, accelerating to full speed, and retarding to zero again. The engaging curved surfaces of the spider and disk were slightly tapered on their faces so that, by axially adjusting the disk, lost motion was easily taken up.—

R. E. Bates, Dorchester, Mass.

Lock for Firm-Joint Calipers

Anyone who has used calipers of the firm-jointed type knows how easily the setting may be altered when this kind of

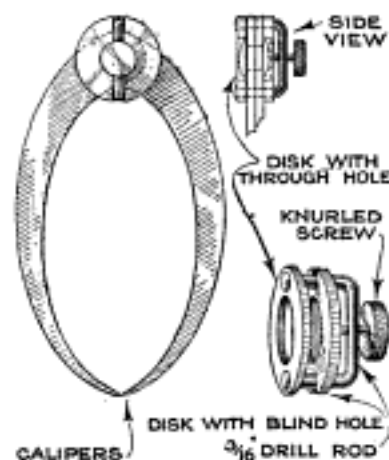

tool is being tried on the work. The knowledge of this causes the user to be continually testing the setting with a scale, which, of course, takes much time. The drawing shows a simple lock that will give the user of firm-jointed calipers confidence that the setting will not be disturbed by any ordinary usage. Two disks are bored out, one with a clear hole and the other with a blind one, the diameter of the holes being a snug fit over the joint washers. A piece of drill rod or cold-rolled stock is bent as shown, the two

ends entering holes in the through-drilled disk, while the disk with the blind hole has slots cut in the edge to fit the rod. A tapped hole in the center of the bent rod receives a small knurled-head screw for tightening after adjustment. When the attachment is made as described, it is placed on the caliper and the ends of the drill rod riveted over, thus making it a fixture, with no possibility of loss.

It will immediately be apparent that the lock is out of the way and will not interfere with the full capacity of the instrument. When the calipers are set to the required dimensions, a slight turn of the screw tightens the two legs firmly together. The depth of the blind hole should be such that its bottom will not touch the face of the washer, in order that the pressure may fall on the caliper legs only.

Combining Grinder Light and Switch

The usual practice of placing a separately controlled light over the tool grinder results in considerable wasted current, because the person using the machine generally forgets to turn off the light when finished with the grinder. A simpler method, and one which makes it impossible to start or stop the grinder without turning the light on and off, is shown in the drawing. The switch that controls the grinding-wheel motor also controls the lamp, as the light circuit is tapped into the one supplying current to the motor. When the user throws the switch to stop the grinding wheel, the light is extinguished.—G. A. Luers, Washington, D. C.

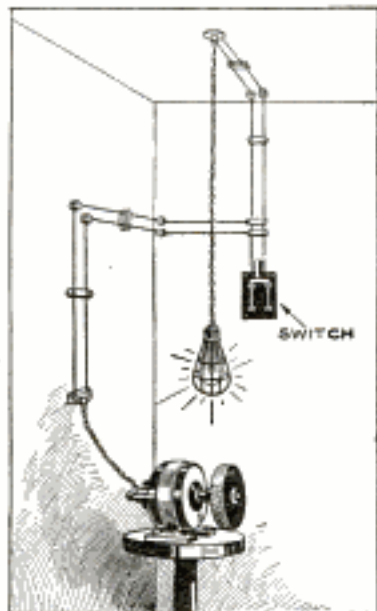

Ⓒ No plates or bars of steel or iron should be worked at a blue or black heat; the material will stand far more strain worked either red-hot or cold. At an intermediate point, great risk is run, as strains will probably be induced that will produce rupture later on.

Making Stereotype Matrices from Type Forms

Country newspapers equipped with plate-casting boxes can make their own stereotype matrices by a simple method that has been worked out with satisfactory results in the composing room of a Minnesota paper.

Lock up the type in any job or cylinder-press form. Cut a piece of medium-weight blotting paper to the exact size of the casting box.

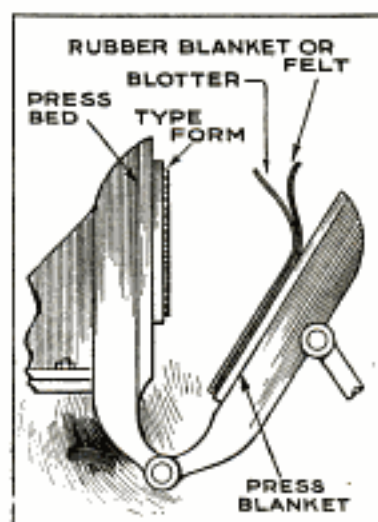

Place the blotting paper on a felt or rubber blanket, blotter on top. Take an impression and the type form will be pressed into the blotter in the form of a matrix.

Too much pressure will crack the blotter and spoil it, and too light an impression will leave the matrix too shallow for the casting of a good plate. Strips of strawboard, pasted behind the places on the matrix that correspond to white portions in print, will keep the open parts of the plate from being too shallow and smudging up on the impressions made from the plate.

Composing-room foremen will find it possible and profitable to set up in this way business cards, small advertisements, and similar matter that run for considerable periods without change.—J. Harold Curtis, Columbia, Mo.

Cutting Glass with a Soldering Bit

For cutting glass when there is no glass cutter at hand, a heated soldering bit or any other piece of heated brass or copper can be used. The edge of the glass to be cut is nicked, and the soldering copper, very hot, is passed above the section of the glass to be cut. Then, starting at the notch, the bit should be drawn slowly across, keeping just ahead of the crack that will follow the hot iron. With practice, fairly accurate cuts can be made, but it is advisable to practice the method on a worthless piece of glass before undertaking to cut an expensive sheet.

Two Simple Machine Guards

Anything that protects the operator of a machine from injury without interfering with production is well worth while, and

flying into the operator's face, but the hands are kept from contact with the revolving cutters. The other picture shows a small wire guard which is so placed around the die of a punch press that the

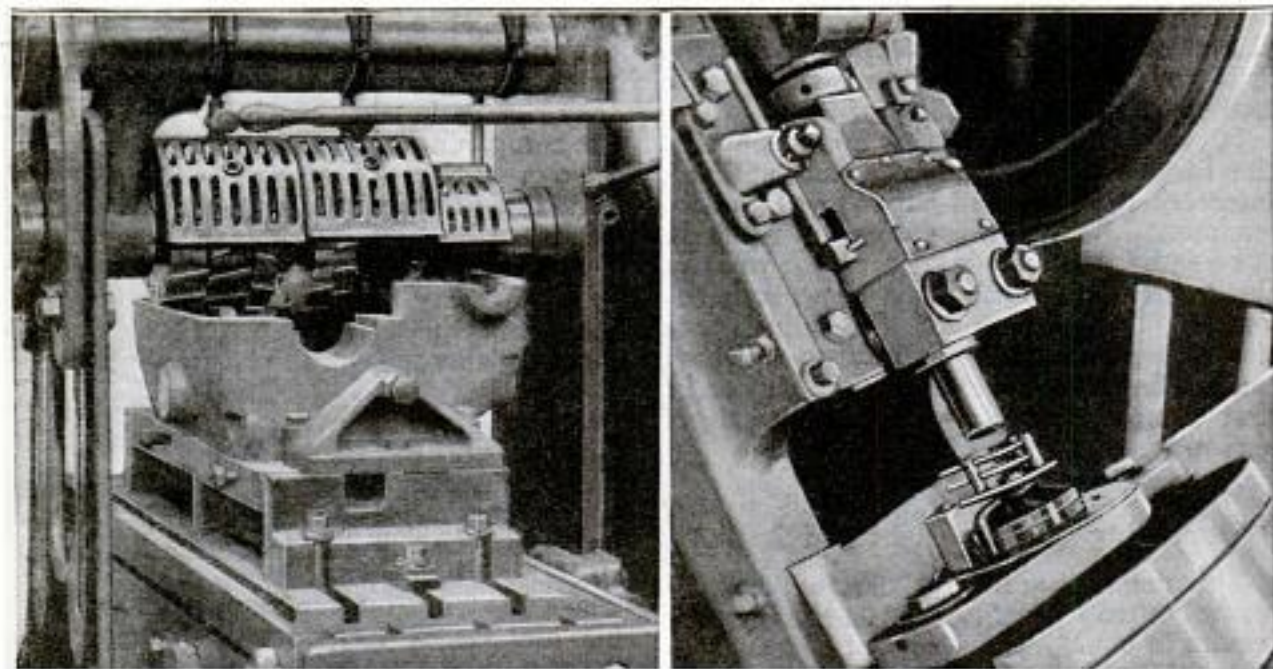

Left, Guard for a Milling Machine That Prevents Chips from being Projected into the Operator's Face and Keeps His Hands from Contact with the Cutters; Right, a Safety Guard for Punch Presses That Prevents the Operator from Getting His Fingers under the Descending Ram

the photographs illustrate two such safety devices that have been found quite efficient.

The first picture shows how the cutters on a milling machine have been covered so that not only are chips prevented from

operator cannot possibly get his hand underneath, and, of course, he would never want to put it over the top. This particular type of guard saved so many fingers that it was installed on all the punch presses of the firm using it.

Sponging Wood before Staining

There are a number of advantages to be claimed for sponging wood before it is stained. First, the action of the water, which should preferably be cold, raises the grain of the wood, so that after subsequent drying, this raised grain may be leveled off with sandpaper, thus doing away with its recurrence upon application of the stain. Hot water should not be used on veneer work, since it may strike through and loosen the glue on the cross-banding. With any work, it is best to play safe and use cold water. The second advantage in sponging lies in the fact that the water opens the pores of the wood, relieving them of the clogged condition resulting from previous sandings, and so enables the staining material to be drawn deeply into the wood, thereby producing a very even color, which is capable of withstanding light sanding

with fine sandpaper, if such should be necessary to produce that perfect smoothness of surface upon which the subsequent varnish coats depend for their beauty.

The last big advantage is also the result of opening the pores, and this has to do with the use of a filler previous to varnishing. If the wood is filled without sponging and sandpapering previous to staining, the old sandpaper dust and other material which clog the pores will absorb water from the stain and remain in a condition considerably more damp than that portion of the wood in direct contact with the air. When filling is now attempted upon such a foundation, this material in the pores dries out through the absorption of the water by the surrounding wood, with the result that shrinkage and settling develop, causing the varnish coat to be pulled down into the pores.

On the other hand, the same moist condition in the pores of the wood may result, in some cases, in the varnish being forced out in small spots, due to expansion of the moisture if the varnish work is done in an excessively warm room.

Why Pumps Become Air-Bound

Under atmospheric conditions water contains about two per cent of air. When subject to a lower pressure than that of the atmosphere, the air expands, and when given sufficient time, as while the water is flowing through a long suction pipe, the air will escape from the water in small bubbles. These bubbles will stick to the pipe or pump surfaces, or the air will gather in the pockets of the pump spaces. The trouble can largely be prevented by increasing the head of the suction supply and by operating the pump more slowly, so that the pressure of the suction water in the pump cylinder will be higher.

Driving Unit for Banding Motor Generators

Having experienced a great deal of difficulty in turning over large motor-generator armatures for banding, a western electric railway built the device shown in the photograph. The driving unit, a 600-volt variable-speed motor, is controlled by a portable rheostat. Connected to the motor is a three-speed

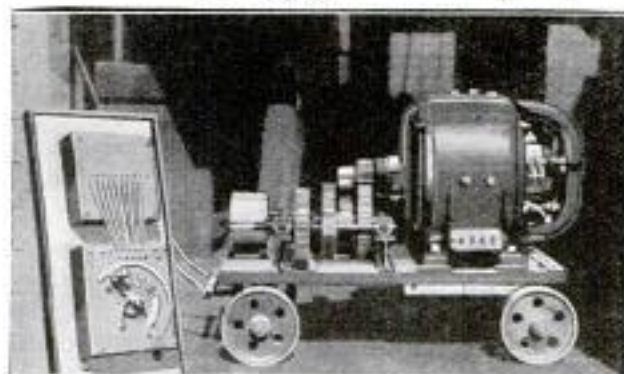

A Western Electric Railway Uses the Portable Arrangement Illustrated to Turn Motor-Generator Armatures for Banding. It Consists of a 600-Volt Motor Connected to a Three-Speed Transmission

transmission, the lowest ratio being slow enough to turn the heaviest armature over for banding. The entire arrangement is mounted on a wheeled truck so that it can easily be pulled to any part of the shop where its services may be needed.—Hyman M. Fink, Los Angeles, California.

Safety Attachment for Printing Press

A common accident in printing shops where platen job presses are used is the crushing of a feeder's fingers between



A Safety Device for Platen Printing Presses That Forces Out the Pressman's Hand Before It is Caught between the Platen and Type Form

the chase and platen, because he did not withdraw his hand fast enough. A Pennsylvania concern has equipped a press with a safety device that prevents accidents of this character.

A wooden bar is mounted outside the upper platen band, on adjustable metal strips. These strips are attached to rods at the side and are adjustable vertically. The side rods are provided with cam rollers, and attached to the sides of the press in such a manner that, just before the platen closes on the type form, the connecting rods between the platen and gears that operate it, strike the cams and elevate the wooden bar. The pressman's arm and hand, if not previously removed, will be forced out of the press before they can be caught between the form and platen.—Armstrong Perry, New York City.

Carburetor Leakage

That dirt and grease on the outside of some types of automobile carburetors may cause leakage and dripping is rarely suspected. However, this is possible, and occurs in numerous cases. At the top of the float chamber of the carburetor is a small vent that must be kept open in order to permit the escape of air, and so allow the incoming gasoline to raise the float. When this vent is closed, the air is trapped in the upper part of the chamber, and as the air pressure will not allow the float to rise and shut the needle valve, the gasoline will continue to flow. When the carburetor develops flooding, before replacing or overhauling, inspect this vent for dirt, as, in many cases, nothing more than this is wrong.



TESTING MOTORS, GENERATORS, and TRANSFORMERS

By KENNETH C. COGGESHALL

Part II—Generators and Transformers

TO determine what is known as the external characteristics of a generator, that is, the variation in terminal voltage with an increase or decrease in load, connections are made as in Fig. 8, which shows a shunt-wound dynamo under test. The generator must be driven at constant speed during the test, and this should be the speed shown on the nameplate. The field rheostat, once adjusted, should not be touched again during the test. A water rheostat, lamp bank, or other device capable of being adjusted, should be used to vary the load by steps, from 0 to 150-per-cent load. At each step, readings of the meters should be made, recorded, and plotted graphically, as shown in Fig. 9. The line drawn through the points representing the readings indicates the trend of the terminal voltage under varying loads. The characteristic curve of a series-wound or over-compounded dynamo will rise above that of a shunt-wound dynamo.

The power necessary to drive the generator is:

$$H_p = \frac{E \times I}{746 \times \text{Efficiency}}$$

If the efficiency is not known, but the power necessary to drive the dynamo is, then

$$\text{Efficiency} = \frac{E \times I}{746 \times H_p}$$

Figure 10 shows the connections for testing the output of a three-phase a-c. generator. Only one set of instruments need be used, if a switching system is used to connect the meters in the various phases in quick rotation. During the test the field current should be kept constant. An external characteristic curve should be plotted, as in Fig. 9, from the data recorded during the test. The load, if the test is conducted in the laboratory, may be a water rheostat or lamp bank; if the regular commercial load is used, the test may be of longer duration. The average current flowing in each phase is:

$$I = \frac{I_1 + I_2 + I_3}{3}$$

that is, the average value, I , is obtained by adding the readings of the three am-

meters and dividing by 3. Similarly, for the average value of E ,

$$E = \frac{E_1 + E_2 + E_3}{3}$$

The power output is:

$$P = E \times I \times 1.73 \times \text{Pf.}$$

The horsepower required to drive the generator, when the efficiency of the machine is known, is:

$$H_p = \frac{E \times I \times 1.73 \times \text{Pf.}}{746 \times \text{Efficiency}}$$

and, consequently,

$$\text{Pf.} = \frac{H_p \times \text{Efficiency} \times 746}{E \times I \times 1.73}, \text{ or, } \frac{P}{E \times I \times 1.73};$$

and

$$\text{Efficiency} = \frac{E \times I \times 1.73 \times \text{Pf.}}{746 \times H_p} = \frac{P}{746 \times H_p}$$

It is a good plan to measure the operating temperature of a motor or generator, to make sure that the insulation is not in danger of injury by heat. Place the bulb of a thermometer in the hottest available spot on the machine, and take temperature readings while the machine is running. Continue the test until the thermometer indicates no further increase in temperature. Compare the reading with the room temperature; the difference, or temperature rise, should not exceed 50° C. (90° F.). In no case, regardless of surrounding conditions, should the thermometer show a temperature of more than 90° C. (194° F.).

As intimated in the preceding paragraph, the capacity of a machine depends, to a large extent, upon the temperature at which it operates. This is especially true of transformers. Insulation breaks down very rapidly at high temperatures, and weakened insulation materially shortens the life of a transformer.

To test the capacity of a transformer, suspend a thermometer in the oil in the case, placing the bulb as near to the coils as possible. An ammeter connected in the low-tension side indicates the load current, while a voltmeter shows the line voltage, as shown in Fig. 11. If the load consists only of lamps, as is preferable, then the product of the volts and amperes approximates the output. Temperature readings of the surrounding air should

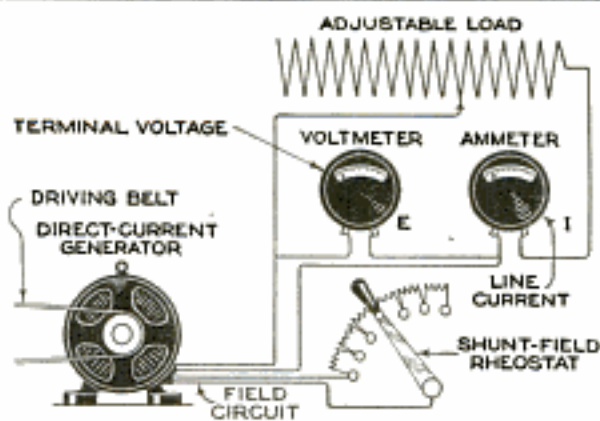

CONNECTIONS FOR OBTAINING TERMINAL VOLTAGE AND LINE CURRENT FOR VARIOUS OUTPUTS

Fig. 8

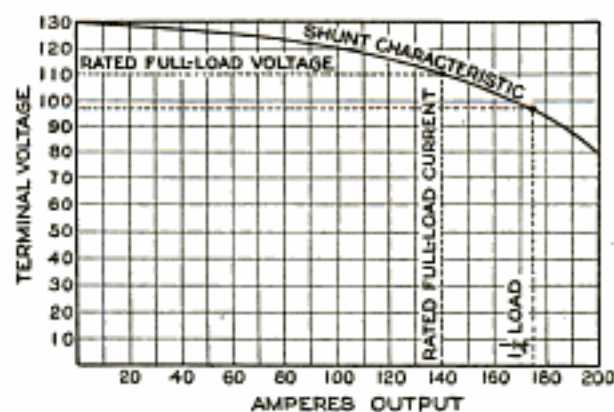
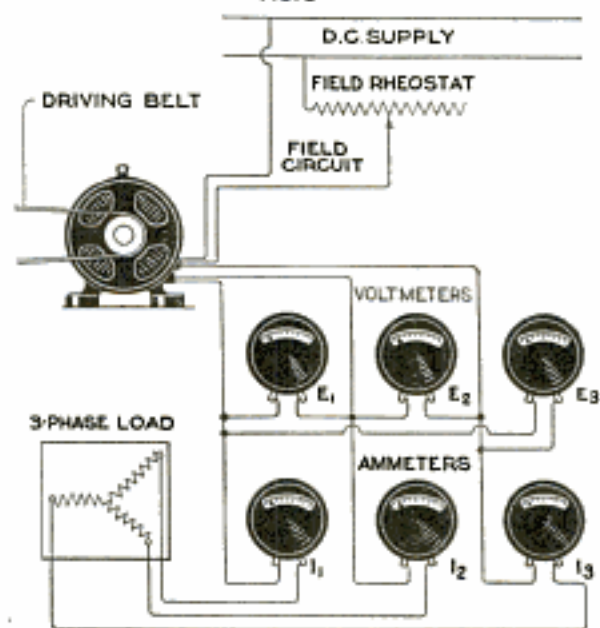

Fig. 9



CONNECTIONS FOR TESTING 3-PHASE GENERATOR

Fig. 10



TEST FOR TEMPERATURE RISE

Fig. 11

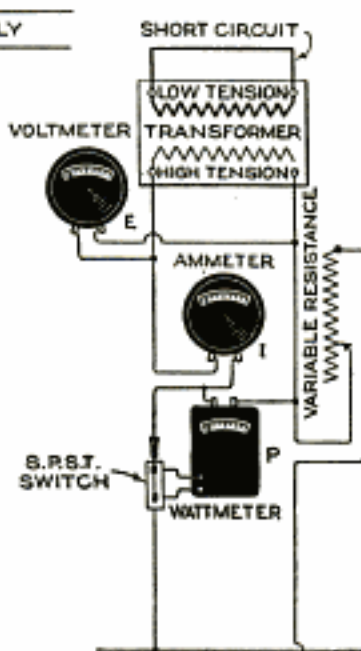

TEST FOR COPPER LOSS

Fig. 12

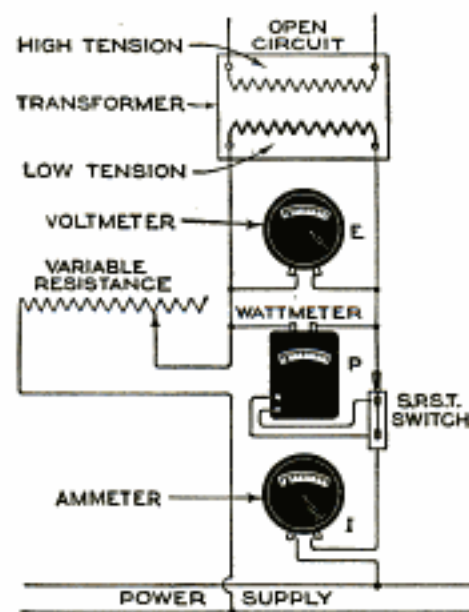

TEST FOR CORE-IRON LOSS

Fig. 13

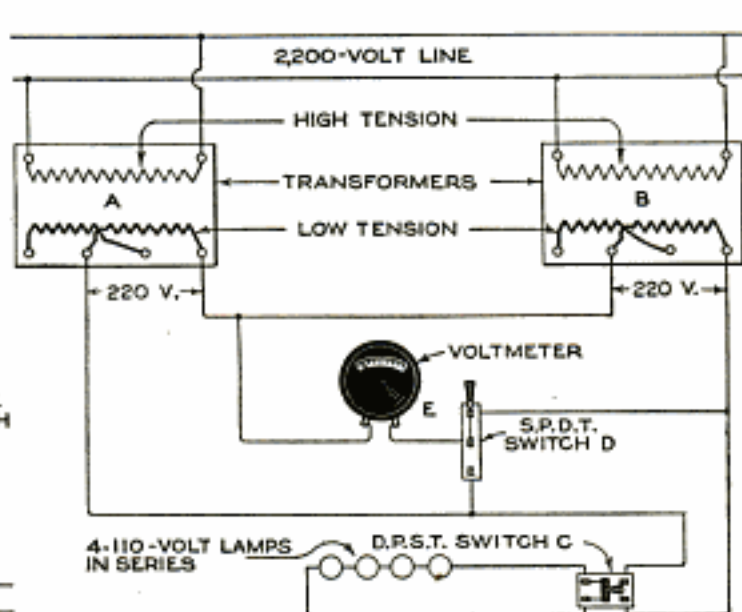

TEST FOR POLARITY AND WINDING RATIOS

Fig. 14

Connections for Making Most Usual Tests on Direct-Current and Alternating-Current Generators and Transformers: Figure 8 Shows Connections for Direct-Current Generators; Figure 9, External-Characteristic Graph for a Direct-Current Shunt-Wound Generator; Figure 10, Connections for Testing Alternating-Current Dynamos, and Figures 11 to 14, Connections for Various Tests on Transformers

also be taken so that the temperature rise may be determined. This difference should not exceed 50° C. (90° F.) nor should the temperature of the oil rise above 90° C. (194° F.).

It is both difficult and dangerous to obtain the current and voltage values of the high-tension circuit without special testing apparatus. The efficiency of a transformer is, therefore, determined by finding the copper and iron losses; the input is, then, the output plus the iron or core loss plus the copper loss.

To make the copper-loss test, short-circuit the low-voltage windings and place a voltmeter, an ammeter, and a wattmeter in the high-tension circuit, as in Fig. 12. Connections are made through a rheostat to a low-voltage power supply. Manipulate the rheostat until the full-load current, the value of which will be found on the nameplate, flows in the windings. The wattmeter will then indicate the copper loss of the transformer—since the transformer is doing no outside work and the power consumed is that due to the heat loss in the windings. Take other readings at various loads, and record the readings graphically.

The test for iron loss is somewhat similar to the copper-loss test, as indicated in Fig. 13. In this instance, the high-voltage winding is left open-circuited, and the instruments are connected in the low-tension side. Since no current flows in the high-voltage winding, the wattmeter shows the power consumed in exciting the iron. The wattmeter reading also includes the potential coil losses in both voltmeter and wattmeter, but unless very accurate tests are being made, these losses can be disregarded.

If possible, an auto transformer should be used instead of the rheostat for varying the testing voltage.

Using Drawing Pencils

Always sharpen a drawing pencil at both ends; the ordinary round point at one end and a knife-edge at the other. Use the knife-edge whenever a long line is to be drawn, as it will do much more work than the round point before re-sharpening is necessary.

In forming a knife-edge on a drawing pencil, always hold the pencil so that the edge will be made parallel with one of the six flats on the hexagon pencil—preferably the one on which the name and grade of the pencil are stamped. This makes it easy to form the second side of the edge,

Knowing, now, the copper and iron losses, the efficiency of the transformer under test is:

$$\text{Efficiency} = \frac{P}{P + \text{copper loss} + \text{iron loss}}$$

Should it be necessary to change the transformer leads, or should there be any question as to whether the connections are correct, a polarity test is advisable. Such a test requires a transformer of equal rating for comparison. Make the connections as indicated in Fig. 14, which shows a relative-polarity test on a 2,200 to 220-440-volt transformer. The high-tension windings of both A and B are connected to a 2,200-volt power-supply circuit. Four 110-volt lamps are connected in series through a double-pole single-throw switch, C, with leads from the low-tension side of both A and B. A voltmeter is connected through a single-pole double-throw switch, D, in such manner that the voltage of either transformer may be read as desired.

When all is ready for the test, throw switch C and note if the lamps light brightly. If they do, the leads are brought out correctly; if not, the leads are reversed. The latter case indicates that the transformers are opposing each other. Repeat this test on all leads until every connection is known to be correct.

The ratio between the windings of a transformer may be found by making the same connections as for the polarity test. Transformer B must, however, be of a known ratio. Leaving switch C open, quickly throw switch D from one contact to the other. If the transformers have similar windings, and similar ratios, the two readings should be identical.

In making transformer tests, high voltages are sometimes encountered and great care must therefore be exercised to insure personal safety.

for it is simply made parallel with the opposite flat of the "hex," and the edge thus comes out straight, instead of on a slant. Thus, when the pencil is gripped by the fingers, the edge will always have the proper angular relation to the hexagon, bringing it instantly parallel with the edge of the T-square.

Since sharpening a pencil in this way soon removes the maker's mark, it is necessary to mark the pencil near the middle; this is done by cutting the required number of notches near the center of the flat; that is, two notches for a 2H pencil, three for a 3H, and so forth.—Curtis Ralston, Chicago, Ill.

Lubricating Broaches

Square broaches should be pulled with a corner upward. The cutting lubricant then flows down around both sides, and does not spatter off, as would be the case were a flat surface used upward. Spline broaches should be so slotted that a channel between two of the splines will be on top; the channel then serves to conduct the lubricant into the hole.

Wick-Feed Oiler Made from Grease Cup

A satisfactory homemade wick-feed oiler can be applied to the bearings of a dynamo or similar mechanism, so that

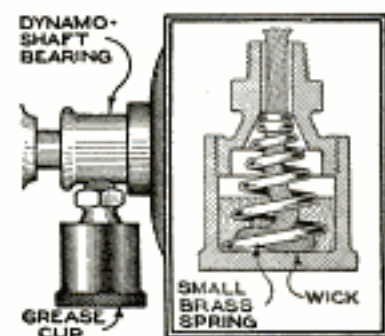

the necessity of constant hand oiling, with the attendant possibility of flooding, are eliminated. A large grease cup is screwed to the underside of the bearing, with a

piece of wicking extending through it and touching the revolving shaft. The cap of the grease cup serves as a reservoir for a liberal supply of oil. This is a simple method, for use where small quantities of oil are required, and where excess oiling is to be avoided.

Special Trowel for Concrete-Road Work

Concrete workers on road-paving contracts are familiar with those jobs in which a groove, or flangeway, must be molded on the inside of street-car or railway tracks, in order to provide clearance for the flanges on the car wheels. The drawing shows a type of trowel used on one such contract, for forming the flangeways. A single block of wood is used for the trowel, which can be cut out on a bandsaw or formed in a pattern shop on a shaper.

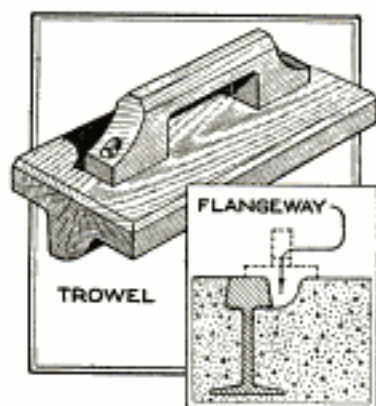

Lifting Check-Valve Balls

The drawing shows clearly how a small metal ball can be removed from its position in a ball-check valve, or other position where it is inaccessible to the fingers or ordinary tools. Nothing more than a piece of rubber tubing, such as can be bought at any drug store, is needed. The rubber tube can be used alone or it



can be fitted with a small piece of metal tubing in each end, as shown in the drawing, for handling balls smaller than the diameter of the rubber tube. In use, the operator places one end of the tube in his mouth, the other end being in firm contact against the surface of the ball, which is drawn up and held tightly against the tube by suction.—C. A. Clark, Miyazaki, Japan.

Drilling Tempered Springs

After attempting to drill a $\frac{3}{8}$ -in. hole through a number of tempered springs with no better success than a number of broken drills, an observant mechanic noticed that the lips of the drill would still cut, even when the center was dulled, and an idea being suggested by this, he proceeded to put it into execution, with satisfactory results. In order

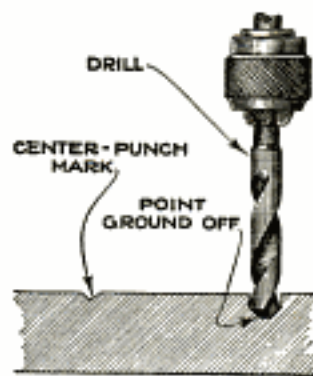

to bring the lips of the drill into contact with the metal, the point of the drill was ground off square so that when set into the punch mark the drill immediately began to cut. The drill was run at slow speed, and, when it stopped cutting, was raised from the work, a heavy center punch used to make another depression in the center of the hole, and the drill fed down again. By alternately punching and drilling in this manner, the steel was finally drilled through.—E. K. Wehry, Cedar Rapids, Ia.

An Improved Blueprint Washer

The washing of large blueprints is always an awkward job because of the splashing and mess, which is impossible

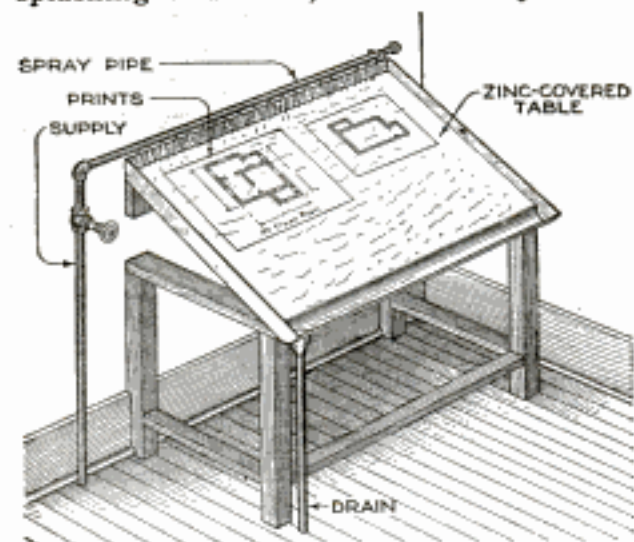

A Blueprint Washer That Uses Nothing but Clean Water to Develop the Exposed Prints, and Eliminates the Need of Using Trays and Sinks

to avoid when large trays are used. Also, owing to the size of some of the trays and the inconvenience of emptying them, they are not uncommonly left for a long time full of dirty greenish-yellow water.

The washing device illustrated does away with the tray or sink, as the washing is done entirely by a flow of clean water over the print. An inclined table, which is built in any convenient location, is provided with raised sides and a trough at the bottom for carrying off the excess water, the whole being covered with sheet zinc or lead. A water pipe, which is drilled with a series of small holes, is arranged parallel with the top of the table so that there will be a uniform flow of water over the surface of the prints.—B. Francis Dashiell, Dunkirk, Md.

Testing for Vibration in Buildings

In a western city, a reinforced-concrete building had but recently been completed when the plastering began to fall from the ceilings. The owner claimed that work was not according to specifications, and the contractor asserted that the trouble was the result of vibrations, which were caused by trolley cars crossing a frog in the street just in front of the building. As none of the vibrations were heavy enough to be seen or felt in the four-story building, an engineer solved the problem and traced down the trouble in a novel manner. A shallow bowl of me-

tallic mercury was placed on the floor of the top story, in such a manner that the mercury would be in direct sunlight. Those interested in the result of the test stationed themselves at a window and watched. A reflection from the sun was thrown onto the ceiling by the mercury and as the street cars passed, it was noticed that the reflection on the ceiling moved several inches, thus greatly magnifying the movement of the building and vindicating the contractor.—J. R. Linton, Sioux City, Ia.

Curing Slapping Exhaust Valves

Sometimes, when a Corliss engine is running under a light load, a slapping noise will be heard from the exhaust valves. Examination of the indicator diagrams will usually show that, under light load, the cut-off is very short, and expansion is carried to a pressure below that of the atmosphere. The exhaust valves are then forced from their seats, causing the slapping or chattering noise.

The steam should be throttled, or the boiler pressure lowered, and the cut-off made later in the stroke, so that the steam will not be expanded below atmospheric pressure.

An Adjustable Bench Stop

A bench stop, which can be adjusted to any height, or lowered so as to be flush with the top of the bench, is quite easily installed on any bench in the manner illustrated.

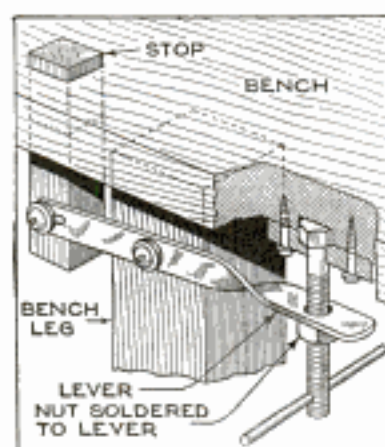

installed on any bench in the manner illustrated. A square hole is cut through the bench, in line with one of the legs; this hole is for the piece of oak that forms the stop proper. A flat-iron lever is next made;

twist one end of this to lie flat, drill a hole for a capscrew, and solder or braze a nut underneath. Drill two other holes in the lever—one to pivot it to the bench leg and the other to fasten it to the lower end of the stop. This latter hole should be slotted, so that the stop will be moved upward in a straight line. Fit a bolt into the nut on the lever, then bore a blind

hole in the underside of the bench, to receive the capscrew head, and screw a wooden block, with a hole for the screw shank, below it. Drill a small hole through the bottom end of the bolt for a turning lever, which may be a piece of stiff wire or a nail. To raise or lower the stop, it is only necessary to turn the screw either to the right or left.—L. B. Robbins, Harwich, Mass.

Polishing the Ends of Pins

The appearance of pins with round or spherical ends will be greatly improved if the ends are well polished. It is a difficult matter to get a good polish by holding the emery cloth with the fingers while the work is revolved, because it is impossible to hold the cloth perfectly steady, with the result that fine grains of the abrasive cross and recross the surface, producing a scratchy appearance. To

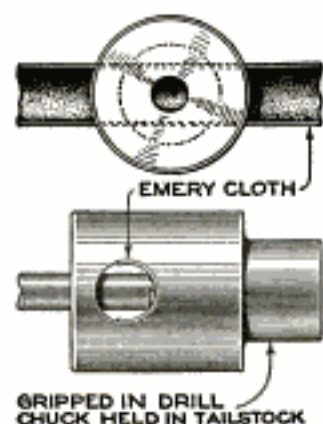

GRIPPED IN DRILL CHUCK HELD IN TAILSTOCK

obtain the best results when using emery cloth, it should be held, if at all possible, in some kind of rigid holder of the type illustrated. A holder of this kind is merely a piece of cold-rolled steel which is turned down to a handy diameter to fit into a drill chuck. A hole of the same diameter as the work is drilled in the center, and another hole, of a diameter that will conform to the radius of the end of the pin, is drilled at right angles to and intersecting the first hole, as shown. A strip of emery cloth is inserted into the side hole and moved along as it becomes worn. This method gives a very high polish quickly and easily, and is well worth the trouble when a quantity of work is to be finished.

Presses for Straightening Bent Fenders

The drawing shows two devices that can be used to advantage for the quick and easy removal of dents from fenders, or any other sheet-metal work to which they can be applied.

The upper tool is made entirely of $\frac{1}{4}$ -in. flat iron to the dimensions shown. The tight joint indicated should be very solid and should be riveted, although a nut

and bolt will hold it sufficiently tight. Downward pressure on the hand lever gives a powerful compression at the ends of the jaws. Any width of fender or any curve can be restored to its original shape

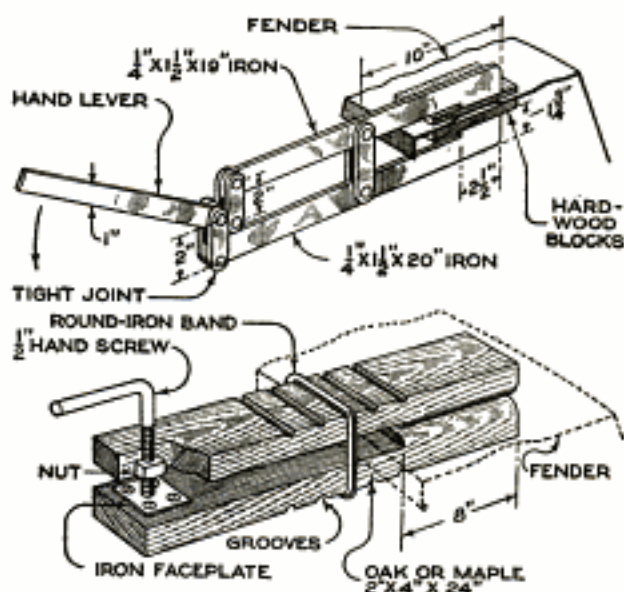

Two Convenient and Simple Tools for Pressing Out Bumps and Dents in the Fenders and Bodies of Automobiles and Similar Sheet-Metal Work

by inserting hardwood blocks of the proper size and shape between the jaws and the work.

The lower tool is made from hardwood, with a handscrew at one end which serves to press the outer ends of the members together with sufficient force to flatten out practically any dent. Notches are cut in both members, to permit changing the position of the round iron band holding them together, so that the tool can be adjusted to fenders of different widths. The thrust of the screw is taken by an iron plate, screwed to the lower member.

Size for Porous Walls

A good size for preparing walls for papering or calcimining may be made by dissolving 1 lb. of glue in 1 gal. of boiling water, as in making ordinary size; dissolve also 1 lb. resin soap (yellow laundry soap), cut in thin slices, in 1 gal. of boiling water; then 2 lb. of alum in 2 qt. water. Thoroughly stir together the glue and soap solutions, then add the dissolved alum. This makes about 3 gal., which will require 2 gal. of water to thin to the proper consistency for a porous wall, and still more water for a hard surface. One or more applications should be put on, as hot as possible. This size is more resistant to moisture than ordinary size.—A. MacCullough, Chicago, Ill.

Adjustable Planer Vises

Many jobs that are machined on the planer could be done better, and in less

upon the thickness and length of the work; they can be bolted anywhere on the table so as to hold odd-shaped work at any angle. The length of these vises

is left entirely to the requirements of the user; some will prefer them made to the width of the table, and others will not want them quite so long.

The body and stationary jaw are cast in one piece from a simple pattern, the resulting casting being machined on the top, bottom, and face of the jaw. On the top face of the jaw slide, a number of key slots, $\frac{1}{4}$ by $\frac{1}{4}$ in., are cut, $1\frac{1}{2}$ in. apart.

The sliding, or movable, jaw is built up in two parts, the front member being the real jaw, while the rear piece serves as a buttress, and as a nut for the clamping screws. The rear block is shaped so as to overhang and slide on the tongue of the front member, and serves to hold the latter down to the slide. The

countersunk screw seat is the only means used to hold this loose jaw centrally, which is free to float, to adjust itself to the face of the work. The rear part of the sliding jaw has a tongue that fits into the slot in the base, to which it is loosely clamped by a screw or bolt, as shown.

The key, which fits loosely, is used to form an absolute buttress and prevents the jaw from sliding backward while the clamping screw is tightened.—J. V. Romig, Allentown, Pa.

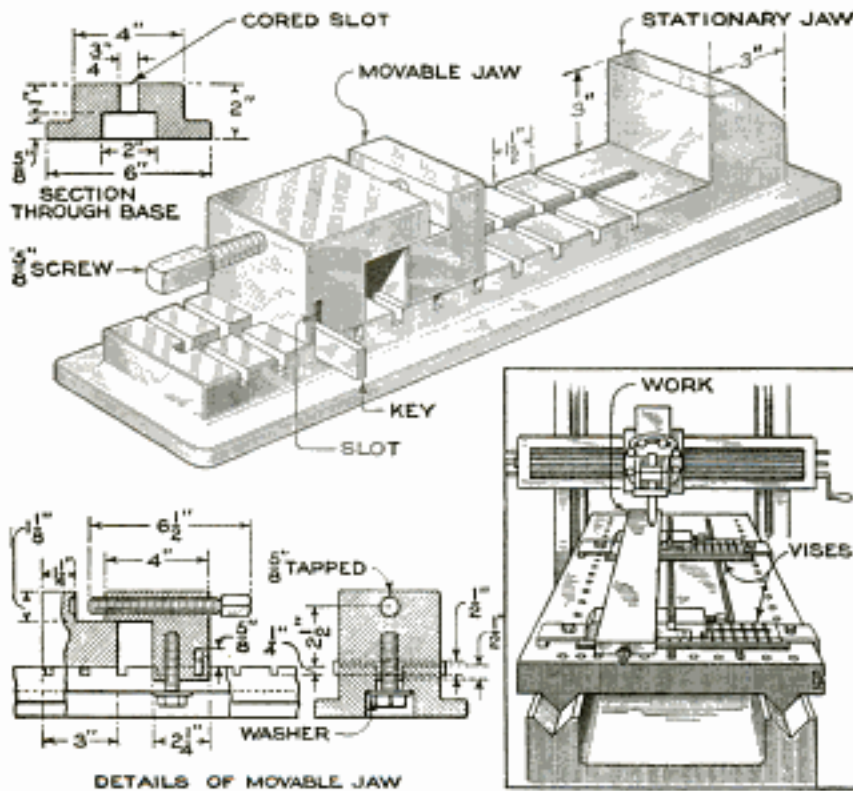

Adjustable Vises for the Planer. That Make It Possible to Set Up and Remove the Work Quickly with a Considerable Saving in Time, Particularly on Repetition Work

time, if the work were held in vises instead of being bolted to the planer table. The work is generally bolted to the table because suitable vises are lacking, the only ones available being generally of too limited capacity for wide work.

The drawing shows a type of planer vise that permits rapid set-up, which is an advantage when several pieces of the same kind are to be worked. For a planer having an 8-ft. stroke, three or more of these vises should be used, depending

Testing New Refrigerating System

When testing a new installation of coils in a refrigerating system, a small, portable, air-cooled, motor-driven air compressor is used to provide the necessary test pressure, which, depending upon the contract specifications, runs up to 200 lb. and over. A suitable connection is made between the coils and pump for the insertion of a high-pressure gauge, and also an ammonia-charging valve. Pressure is pumped into the coils, using fresh air, for the first test. If there are any serious leaks, they will be detected immediately

by the hissing of escaping air. Should there be no such leaks, watch the pressure gauge and see whether the pressure falls very much, remembering, however, that a slight fall in pressure will accompany the cooling of the highly compressed air. After this slight drop, which should take place within a half hour, the pressure should remain constant. If this test is satisfactory and the pressure stands up well, discharge the air, and connect a drum of ammonia to the ammonia valve between the air pump and the coils, and allow a small amount of the ammonia to escape into the closed-up system, enough

to raise the pressure to about 10 lb. This amount of ammonia will be sufficient to make the detection of any leaks, no matter how small, possible. Now, pump the system to 200-lb. pressure again and go over all the joints, smelling for the sharp ammonia odor, which will escape through any porous or leaky spots.

Leaks come from badly cut pipe threads, poorly cemented joints, bad seams in the piping, porous and honeycombed spots in the fittings, and from cracked fittings.

If the second test is successful, discharge the ammonia-laden air into the open, and pump a vacuum in the coils, before filling the system with the full ammonia charge.

Small leaks are sometimes closed by peening the metal with small punches and ball-peen hammers. Another way consists in pumping a strong vacuum and smearing the leaky spots with a thin mixture of glycerin and litharge, which has a tendency to be sucked into the holes and porous parts, closing them when the litharge sets. Soldering may also be resorted to, but never with the system under pressure.

A Novel Scale for Machinists

A new die, having 16 threads per inch, was being tested out on some $\frac{1}{4}$ -in. drill rod, the result being an exceptionally fine-cut thread. A few of these threaded rods were made into 6-in. scales by one of the

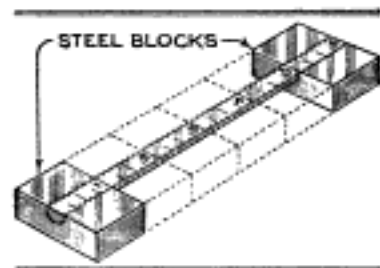

machinists in the shop in the following manner: Two steel blocks were drilled and tapped for a $\frac{1}{4}$ -16 screw and then cut down at the ends, as shown in the drawing, to about half the diameter of the rod. The threaded rod, resting on the steel half-blocks, was placed on the magnetic chuck of a surface grinder, and faced down flat. After grinding, the rod was removed from the grinder, graduated with a very sharp chisel, and marked with small figures. The half-blocks were moved along, as indicated by the dotted lines, to serve as anvils for the rod during the graduating. The threads, being 16 to the inch, take the place of $\frac{1}{16}$ -in. graduations, and the chisel marks are $\frac{1}{4}$ -in. apart.—M. E. Duggan, Kenosha, Wis.

Ball-Bearing Puller

A puller for inner races of ball bearings, that is different from the usual device, is built on about the same principle

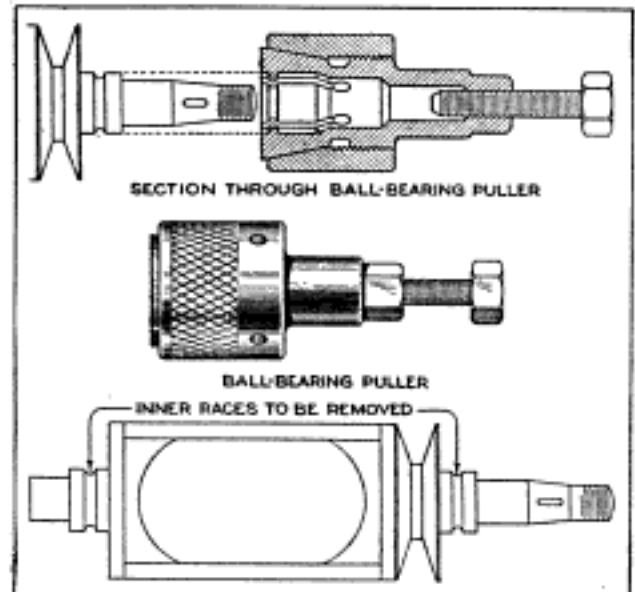

A Ball-Bearing Puller That Embodies the Principle of a Lathe Collet, Holding the Inner Race While the Screw is Turned, to Force the Shaft Out

as a lathe collet. As the puller can be made for use on bearings of different sizes, no dimensions are given in the drawing, which clearly shows the constructional details.

The inner part is machined, as shown, with split jaws. The largest diameter of this part is tapered so that the similarly tapered and threaded sleeve can be screwed down to tighten the jaws of the puller on the bearing race. A long screw at one end of the puller bears against the end of the shaft; when this is tightened the race is pulled off.—J. Magis-Frankart, Ouffet, Belgium.

Belt-Loop Hammer Holder

Carpenters, and others who must always have their hammers within easy reach, or those who work with two styles of hammers, will find the hanger shown in the drawing to be of great utility. All that is required to make such a holder is a piece of leather, about 3 by 4 in., which is pierced with a hole for the hammer handle and slitted to fit over the belt.—A. C. Cole, Chicago, Ill.

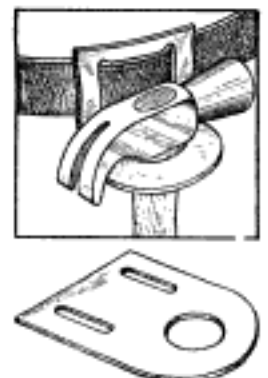

Planer-Tool Lifter

When a machinist is working at piece rates on duplicate production work, every little trick to preserve the cutting edge

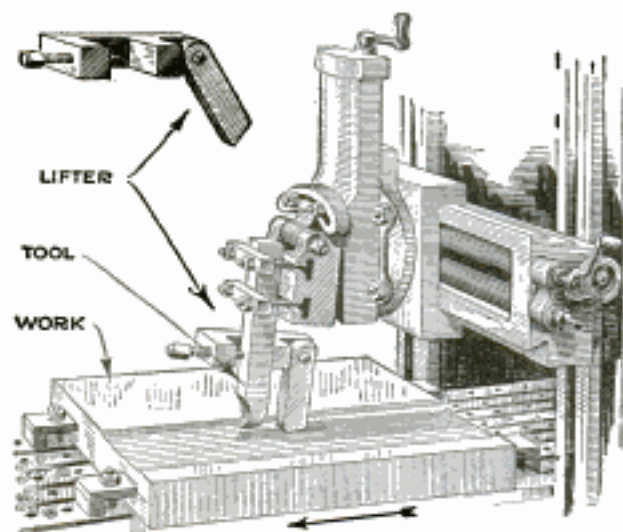

A Lifter for Planer Tools That Prevents the Tool from Rubbing on the Work on the Backstroke, Thus Preserving the Cutting Edge of the Tool

of his tools helps to put money in his pocket. As everyone knows who is familiar with planer tools, the rubbing of the cutting edge on the return stroke soon makes resharpening necessary, and many operators lift their tools on the backstroke by hand, just to eliminate this dulling action.

While there are many devices for the automatic elevation of the tool above the surface of the work, the one shown in the drawing is among the simplest and most effective, as it is easily made and quickly clamped to any cutting tool. The body is made from a piece of flat steel; it is fitted with a latch, which has a form somewhat similar to that of the cutting tool and is held to the body by a bolt or rivet. By rounding off the top corner, this latch will drag behind the tool on the forward or cutting stroke, but will fall in a vertical position on the return stroke. When the lifter has been adjusted to the proper height, it will cause the tool to rise on the return stroke, as shown.

Making Good Brazed Joints

A method which adds strength to a brazed joint, in either tubular or plate work, consists in drilling one of the parts with a series of holes, at the point where the braze is to be made. Ordinarily the practice is to apply the spelter and flux to the pieces and then heat until the spelter flows and runs into the joint. Lack of heat, or dirt in the joint, will cause an

imperfect union, that cannot be detected from the outside. Drilling the holes, as suggested, and applying the spelter to this portion of the joint, causes the melted brass to enter between the surfaces where it is desired. The size of the holes depends, of course, upon the size of the job, but ordinarily holes not larger than $\frac{1}{4}$ in. should be used; these can be filled with spelter and finished to present a smooth job. This method has been satisfactorily used in brazing automobile-axle housings.

Beveling Edges of Wallboard

In working with wallboard, it is sometimes desirable to bevel the edges to form a neat joint; this can be done without sawing, which generally leaves ragged edges, by means of a simple device that uses sandpaper for forming the bevel. A piece of wood, about 6 in. square, is cut diagonally to make two 45° triangles, and these are fastened together by two braces, as shown, a handle also being provided. A piece of wallboard is nailed to the hypotenuses of the triangles, and the sandpaper is fastened to this with thumbtacks. In use, the sanding device is moved back and forth across the edge of the panel, and, by raising or lowering the panel, the whole surface of the sandpaper can be used.—Karl L. Martin, Cleveland, Ohio.

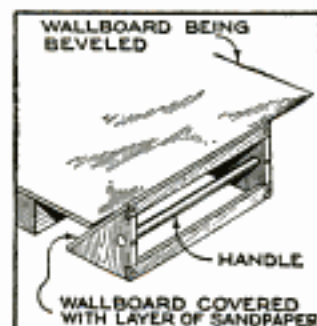

Spring Circular-Saw Guide

When the circular saw is used to split narrow stock, the simple spring holder shown in the drawing will enable the operator to do his work faster and without danger of having a finger cut off. Such a holder is made by bolting a piece of $\frac{1}{8}$ by $\frac{5}{8}$ -in. spring steel between blocks of hardwood. The length of the spring will vary with different saw tables, but 12 in. is about the average.

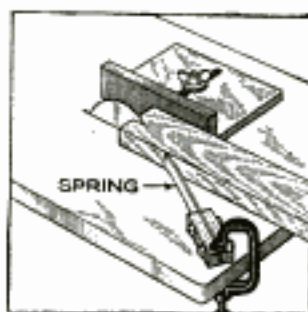

A piece of stock is set against the saw guide, and the spring holder is clamped in

place on the saw table with a C-clamp, in such a manner that the spring presses firmly against the stock. Make certain that the extreme point of the spring cannot come into contact with the saw itself. A similar spring can be used to press downward on the stock, in which case the holder would be clamped to the saw guide, and the steel spring would be adjusted to press on the wood between guide and saw. With two such guides in position, the stock can be sent through the saw from one end to the other without carrying the hands beyond a safe distance from the saw. Once started, the man "taking away" can pull the stock toward him and at the same time be certain that the wood is bearing hard against the saw guide.—E. L. Bragdon, New York City.

Rustproofing Iron

A new method of rustproofing, which has been applied especially to small automobile parts, consists in boiling the articles in a solution of hydrophosphate of iron. An attractive dark-gray finish is produced, and this is practically proof against all attacks of rust. The process is more rapid than others, and there is no effect upon the strength or temper of the metal.

The Engineer
Sept. 9, 1921

Artist's Magnifying-Glass Holder

An artist's ability to do fine work on a drawing, such as producing a fine stipple with pen or pencil, can be greatly increased by using a 3-in. reading glass.

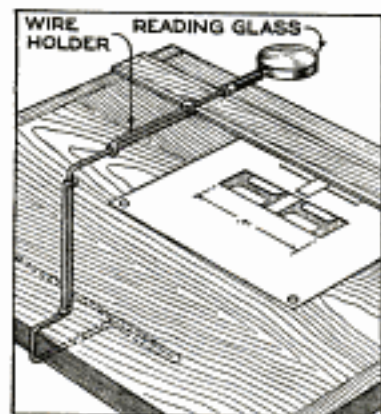

Besides, the eyes are relieved of a great deal of strain, and the pen can be more accurately guided. The drawing shows a wire support for the magnifying glass, which is slipped underneath the edge of the drawing board and can be instantly removed. The support can be made to any suitable measurements from stiff wire, and is adjustable horizontally and vertically. The magnifying glass has a hole drilled in its handle to make a tight fit over the wire, as shown in the drawing.

Discarded Vise Makes Arbor Press

Scrapped on account of a broken jaw, an old vise was made to serve in the capacity of an arbor press, the device

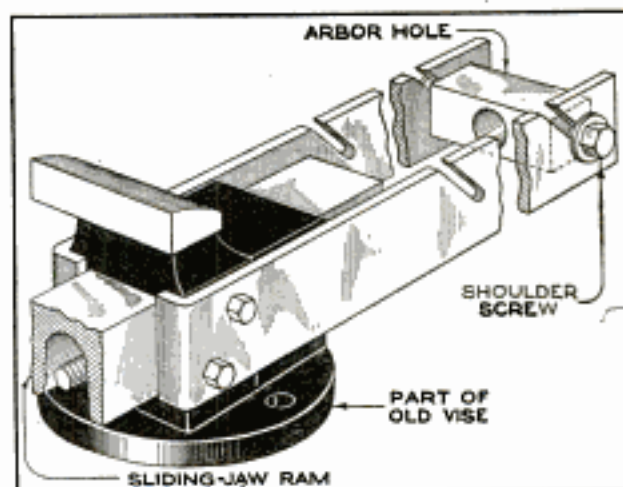

Discarded Because of a Broken Jaw, This Vise was Made into a Substantial and Quick-Acting Arbor Press for Work within Its Capacity

proving very quick and solid. Two pieces of $\frac{3}{4}$ by $2\frac{1}{2}$ -in. flat steel are used for the sidepieces, which are fastened to the fixed part of the vise by screws. One end of each piece is bent at right angles and fits around the vise, to give extra strength and rigidity. Next, a piece is made that serves as the arbor plate of the fixture; this is a 3 by 3-in. piece of machine steel, the length of which is such as to fit easily between the sidepieces. It is bored in the center for the arbors to slip through, and each end is drilled and tapped for $\frac{3}{4}$ -in. bolts. To make the press quick-acting, holes are drilled in the sidepieces at intervals of about 2 in., and slots are cut at an angle, as shown. From the drawing it will be seen that the part bored to take the arbors is free to revolve, and that, consequently, the arbor can be inserted in the hole while in an upright position, thus lessening the distance necessary between this part and the end of the vise ram. This feature, in conjunction with the freedom with which the piece can be dropped into any convenient slot that the length of the arbor may call for, makes this press quite rapid. For small arbors, a bushing is made to fit the hole. When the whole fixture is assembled, it should be bolted securely to a bench, preferably one mounted on wheels, so that it can be moved around the shop.

☛ Nails and screws dipped in grease, wax, or soap will drive more easily, particularly in hardwood.

Truss Stiffens a Long Ladder

The use of long ladders, such as fire ladders, is only made possible because of a system of trussing, which can be

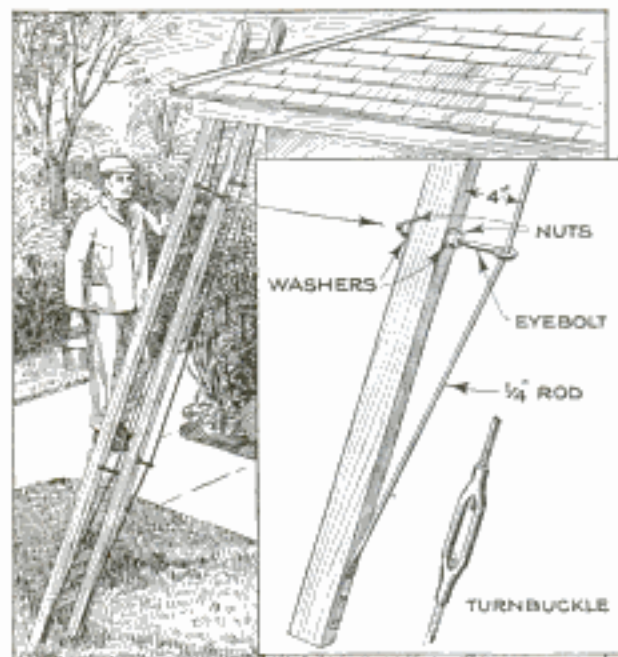

Trusses on the Underside of a Long Ladder Prevent It from Swaying and Swinging and Give a Sense of Safety to the Worker

adopted, in a modified form, for stiffening other long ladders and preventing them from swaying. Four eyebolts are made, large enough to permit a $\frac{1}{4}$ -in. rod to be inserted through the eye, which should be about 4 in. away from the underside of the ladder. Four pieces of $\frac{1}{4}$ -in. mild steel are used for the trusses, and each of these is about half the length of the ladder itself; one end of each is flattened and drilled for heavy screws, the other ends of two lengths are threaded with left-hand threads, the other two being threaded right-hand. Turnbuckles are fitted to each truss after the ends have been passed through the eyebolts. With each side of a long ladder braced as shown, practically all spring will be eliminated, and it will be sufficiently strong to be used in many places where otherwise it could not be considered.—Lowell R. Butcher, Ames, Ia.

A Cheap Board for Large Drawings

The high price of a large drawing board and the still higher price demanded for a large-size drawing table are items that must be seriously considered when the board is required only for some special piece of work. An idea that represents an economical and practical solution makes use of a variety of wallboard that can be

obtained in panels of almost any dimensions up to 4 by 12 ft. The type of wallboard best suited for the purpose is that which is built up of wooden strips, cemented together to make a continuous board, with a smooth surface of tough brown paper. The cost of this material is but a few cents per square foot. Wallboard of this kind is made $\frac{1}{4}$ in. thick, and the large panels are therefore flexible and should be well supported when used horizontally; when used vertically, this is unnecessary. A standard $\frac{1}{4}$ -in. metal channel, fitted to the edges of the board, makes a fine sliding edge for the T-square.—C. Nye, New York City.

Making Smooth Joints in Large Tile

Where firmly cemented joints are required in lines of large sewer tile, several difficulties are encountered unless an unnecessarily large quantity of cement mixture is used. If a dry, coarse mixture is used, it will

be hard to make an absolutely tight joint, and if a thin, rich mixture is used it will flow through the joints. The latter is, of course, the better mixture, as it will flow and fill in below the tile without

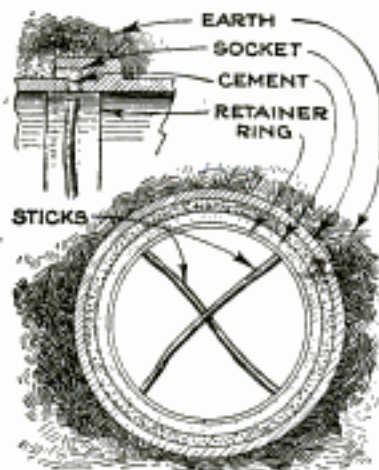

tamping or the use of a great amount of the cement mixture, and will make a good joint if some means of confining it is used. This is easily done. Having placed a new section of tile in position and centered it by means of small bits of stone or like objects, placed between the socket of one pipe and the end of the other, take a narrow strip of some thin springy material—wallboard is excellent—and shape it to the inner curve of the joint to be cemented. The ends of the strip should butt closely together; if this retainer ring is correctly made, it will hold itself in place, but light sticks, a trifle longer than the diameter of the pipe can be sprung into place to help retain it. With the aid of this device, a very thin cement mixture can be poured about the joint, into which it will flow, filling it completely and showing a smooth inner bore when set.—Louis Schneider, Clinton, Mo.



Amateur Mechanics

Information as to where to obtain any specified materials or parts for making objects described in the following pages may be had, on request, from our Bureau of Information.—Editor.

Concrete Boat Landings and Docks

By A. C. COLE

A BOAT landing at the summer home, or resort, is something that is frequently lacking, and in most cases where one exists, it is, as likely as not, a rickety structure supported on a few half-rotted posts. Such a landing is not only unsafe but unsightly, requires frequent repairs,

will be required to build the necessary wooden forms, but once constructed, the job is practically everlasting, and repairs are seldom if ever necessary.

The drawing shows four types of landings and docks; dimensions are given for three, and all are suitable for the accom-

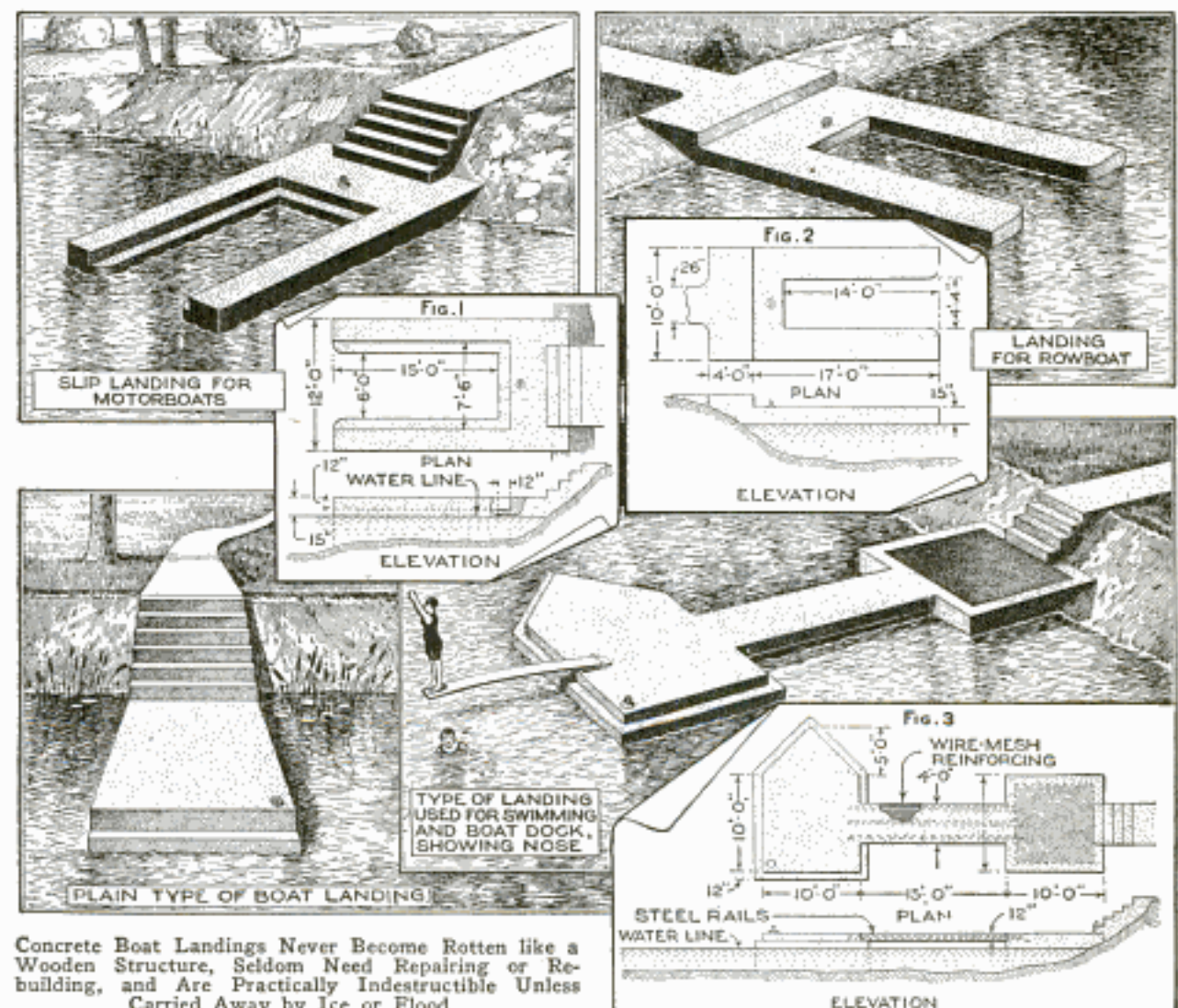

Concrete Boat Landings Never Become Rotten like a Wooden Structure, Seldom Need Repairing or Rebuilding, and Are Practically Indestructible Unless Carried Away by Ice or Flood

and, from time to time, rebuilding. The disadvantages of wooden structures cannot, however, apply to a boat landing made of concrete. A little more work

moderation of the average small boat. Neither the style nor dimensions given need be adhered to, of course, but can be altered in any way desired.

In the construction of a boat landing, as well as in the building of any other monolithic structure, a form is required to contain the concrete mixture until it sets. A form for the construction of work of this character is made by driving boards or sheet piling into the bed of the stream, to form a hollow, into which the concrete mixture is poured and tamped. In making the form, care should be taken to have it well braced, so that the weight of the concrete will not force it apart. Also, the boards forming the sides of the form should be close enough together to prevent a free flow of water through the form, as this would have a tendency to wash away the cement binder, leaving an imperfectly bonded mass consisting largely of broken stone. It does not make any particular difference whether or not there is water inside the form; if it can be pumped dry, all the better, but this is not necessary. The concrete will harden under water, although at a slower rate than when exposed to the air.

The mixture for work of this kind should consist of at least 1 part cement, $2\frac{1}{2}$ parts sand, and 5 parts of crushed stone or screened gravel. A little more cement than the above quantity will not hurt, however. All the ingredients should

be thoroughly mixed before adding water, and when the water is added, the mass must be mixed again until every stone and grain of sand has its coating of cement. In this manner the strongest possible mass will be obtained once the cement has set or hardened.

The estimated materials required for landings of the style and dimensions shown are: for Fig. 1, cement 38 bbl., sand $14\frac{3}{4}$ cu. yd., and stone 29 cu. yd.; and for Fig. 2, $33\frac{1}{2}$ bbl. cement, 12.8 cu. yd. sand, and $25\frac{1}{2}$ cu. yd. of broken stone. The plain type of landing shown in the lower left-hand corner is built to meet individual requirements, and no dimensions or estimate of materials are given. The rather elaborate style of Fig. 3 is built in two parts, which are connected by means of a reinforced runway above the water line. The nose of the outer pier is pointed upstream to break up floating blocks of ice, and the inner pier is cast hollow, being afterward filled in with well-packed earth. The materials required for this landing, built to the dimensions given, are cement $46\frac{1}{2}$ bbl., sand 18 cu. yd., crushed stone 35 cu. yd., woven-wire mesh, 3 sq. yd., and old steel rails, 60 ft. Eye-bolts and rings, for tying the boats to, are imbedded in the concrete as shown.

Automatic Stock Tie

Although the knotted rope is the oldest tie for stock at the manger, it is not always the most convenient, for, with mittened hands, it is difficult to tie the clumsy rope into a knot that will hold. Again, as the rope becomes worn at the knot, it breaks at that point before the

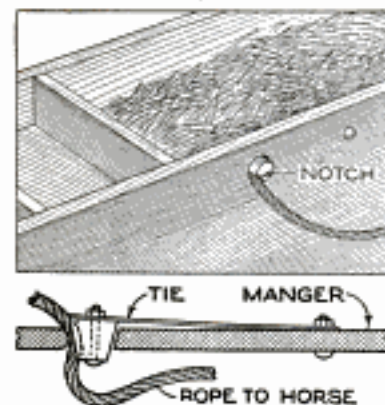

remainder of the rope shows appreciable wear. To save the rope and make the tying and untying practically automatic, the device shown in the drawing can be made and attached to the manger. A hole is drilled in the front of the manger and a plug is made, so tapered that its larger diameter will just fit into the hole. A notch is cut in one side of the plug to hold the rope, and a strip of ash, or some other springy wood, is used

to attach the plug to the manger by means of a bolt, as indicated. To make the rope fast, it is simply passed through the hole by pushing in on the outer end of the plug. The animal is released by pushing the plug the same way and pulling out the rope.—Geo. G. McVicker, North Bend, Neb.

Developing Holder for Cut Films

The drawing shows a film-holding device used when developing the individual

films of a film pack. The holder is made from a single strip of brass, aluminum, or galvanized wire, formed into a number of loops into which the

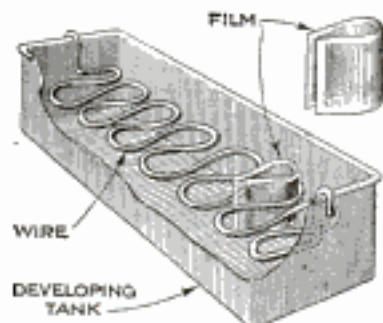

films are inserted in the manner indicated. The ends of the holder are bent upward, and a hook is formed in the extremity for suspending it from the edges of the tank containing the developing solution.

Removing Tight Screw Caps

When the screw cap of a fruit jar, or similar container, refuses to move, the following plan is frequently successful in getting it started: Get a strip of sandpaper, twice as wide as the screw top and long enough to reach entirely around it. The sandpaper is folded lengthwise of its center, with the abrasive side out, placed around the outside of the cap, and tied in place with a stout string. Pass the cord around several times, drawing it as tightly as possible, and end it in a loop. Into this loop a stick, or similar lever is inserted, the end of which, pressed against the top, provides sufficient leverage to loosen it.

Attachment for Glasses Aids Marksman

The elderly marksman, on account of changing eyesight, often finds himself handicapped by the limitations of focus.

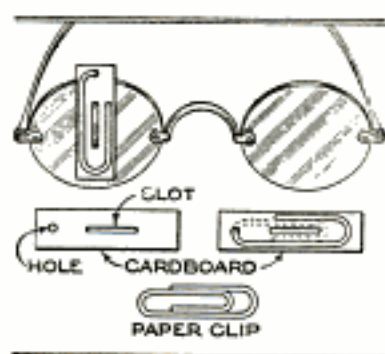

If he uses glasses to overcome a tendency to farsightedness, the target and front sight are clear, but the rear sight is more or less indistinct, and if "nearsighted" glasses are used, the target and front sight are blurred while the rear sight is clear and sharp. The little device shown in the drawing, which one sharpshooter has found eliminates these troubles, is made from a narrow piece of cardboard having a narrow slot cut in the center; it is held to the lens of the "sighting" eye by a wire paper clip.—J. G. Brown, Evanston, Illinois.

A Water Popgun

The only thing needed to make a safe and sane popgun is a cork large enough to fit tightly into the end of a length of garden hose after the nozzle has been removed. The hose is connected to the faucet and, aiming the cork as desired, the water is turned on; this compresses any air that may be inside the hose and causes the cork to be expelled violently, with a considerable "pop."—Everett Gordnier, Denver, Colo.

Grain Scoop Made from Washboiler

There are many times during the year when a scoop such as that illustrated will be found very useful around the farm. For filling grain sacks it is faster than the scoop shovel, there is less danger of spilling, and it is also used with good effect in handling grain in other ways. The dotted lines show the part of the boiler which is to be cut away; the cutting should be done carefully, and, if desired, the edges may be beaded over a piece of stiff wire, which will make the scoop stronger and eliminate sharp edges. Two pieces of flat iron are riveted to opposite sides of the boiler, just back of the cut, and a piece of pipe is fitted between them to form a handle, a long bolt being used to hold it in place. When partly filled, the scoop can be carried by the pipe handle like a pail.

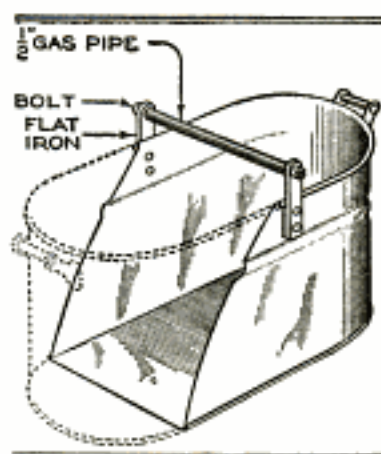

is to be cut away; the cutting should be done carefully, and, if desired, the edges may be beaded over a piece of stiff wire, which will make the scoop stronger and eliminate sharp edges. Two pieces of flat iron are riveted to opposite sides of the boiler, just back of the cut, and a piece of pipe is fitted between them to form a handle, a long bolt being used to hold it in place. When partly filled, the scoop can be carried by the pipe handle like a pail.

Brackets for Spare Tire

The form of tire bracket shown in the drawing is made from short lengths of iron or steel rods, bent into shape, and threaded at one end to take a suitable wingnut.

The clamps are covered with rubber tubing to prevent chafing. When attached to the back of the deck of a roadster, and the cover locked down, the tire is practically secure against theft. To remove the tire it is only necessary to loosen the nuts and turn the clamps to one side.

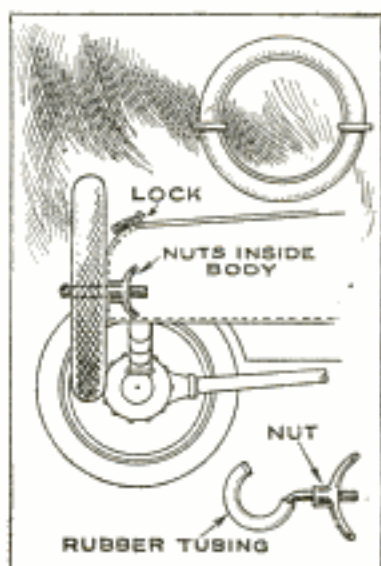

Making the Stairs Safe for Baby

To keep the baby from climbing the stairs until he can do it safely and without the usual danger of falling back, to

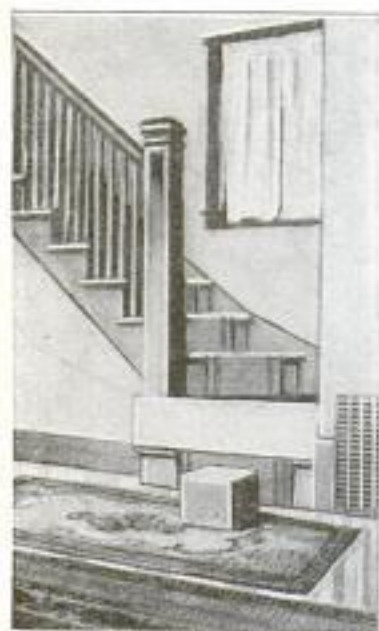

the consternation of the household and possible injury to himself, the false step shown in the photograph provides an effective barrier to the infant's progress.

The step is built to conform as closely as possible in appearance to the rest of the woodwork, and when placed on the

lowest step, leaves no foothold for the baby. When in position, the barrier is held in place by screen-door hooks, and when the child is large enough to climb over the obstruction, he can be safely trusted to go the rest of the way upstairs. The small box in the foreground of the picture is for the other members of the family, and is so small that the baby cannot get on top of it.—Uri V. Averitt, Gary, Ind.

Using Cheap Flashlight Batteries

Among the small types of pocket flashlights, the most popular is the 1½ by 3-in. two-cell flat case, in which both cells are side by side. Both cases and batteries of this size are sold in large numbers through novelty and five and ten-cent stores. By knowing how to fit the cheap batteries into the case properly, they may be used with results comparable with those obtained with the higher-priced ones. The cheap batteries are sold at a low price largely because they are not so accurately made. It will usually be found that, when inserted in the case, the cheap battery will rattle loosely, and this frequently results in short-circuiting the contact springs of the battery, either directly to the case, or through the lamp. When this happens, the battery rapidly discharges, and the owner may never know why his battery suddenly goes dead.

After some experiences of this char-

acter, the idea of wrapping the new battery with strips of gummed tape to make a fairly tight fit in the case occurred to me. Since that time my cheap batteries have had a long life. It is, of course, also necessary to bend the battery springs so as to get the right tension and contact with the switch, but this bending does not insure satisfaction unless the battery is "padded out" to fit the case properly. Where this fitting is properly done and the usual attention given to tensioning the springs, most of the ten-cent batteries will give satisfactory service.—Curtis Ralston, Chicago, Ill.

Preventing Theft of New Tires

The general custom of carrying new automobile tires in the tire rack of the car as "spares," instead of mounting them upon the wheels and getting mileage out of them, is responsible for many tire thefts. Even when they are protected by a chain and lock, an enterprising thief can find ways and means to open the lock or cut the chain; the best way to foil him is to put the new tires on the wheels and carry the old ones as "spares." A new tire is much more easily disposed of by the thief than an old one, and as the thief reasons that the old one is probably of little value, he passes on to find a car attractively baited with new tires.

Chemical Crusher Made from Spoon

Photographers who mix their own chemicals frequently find it necessary to crush some of the crystals in order to



make them dissolve rapidly, and the same is true of amateur chemical experimenters. The photograph shows how an ordinary ice-cream-soda spoon, one of the long-handled variety, can be made into a very effective

crusher, which, unlike glass crushers, is unbreakable. It is only necessary to bend the spoon bowl at right angles to the handle so that the bottom of the bowl is downward.

Bottle Caps Make Good "Metal Lath"

The proprietor of an amusement resort makes it a point to gather all the soda-water bottle caps which are left scattered around by picnickers. There are several reasons for this, the main one being that the caps, concealed in the grass, dull the edge of the scythes. The second reason for gathering the caps is that they may be nailed to the sides of small buildings, serrated edge out, with a shingle nail through the center, and form a good foundation for a coat of cement stucco. From 12 to 24 of the caps are needed to cover a square foot of surface.—John Mignone, Spring Valley, Ill.

Agitating Negatives during Development

Tray development of photographic negatives has one advantage over the method of developing the plates in a tank, as the



tray can be rocked and the developing solution agitated. However, time is often limited, and it is desirable to develop the negatives in a tank. The photograph shows a method of developing the plates in a hard-rubber or vulcanite tank in which the developing solution is agitated by a massage vibrator, which is clamped to the side of the tank with an ordinary C-clamp. Care should be used that the clamp is not screwed up so tightly as to break the tank.—Thomas Allen, Flushing, N. Y.

"Art" Glass as Showcards

Squares of so-called "art" glass, opal, ruby, or other color, can be used as showcards in stores and display windows. They are lettered in the usual manner with water colors or showcard colors; then, when a new card is needed, the paint can be washed off and the new lettering applied. Green or brown art glass, which is also called "cathedral" glass, "pot metal," and other names, held in a harmonizing frame, makes a very attractive sign which will save the continual expense of Bristol-board cards.

Heater Made from Auto Headlamp

The photograph shows an electric heater that was made from a discarded automobile headlamp. The heating element from a standard heater was bought from an electrical-supply store, inserted in the position occupied by the bulb, and the electric wires led out through a porcelain tube placed in the hole previously occupied by the lamp receptacle. A



circular piece of copper screen in place of the headlamp lens prevents anything from coming into contact with the red-hot heating coil. The base of the heater is made from an old automobile-hub flange to which flat-iron supports are fastened, the latter being attached to the heater so that it can be tilted at practically any angle.—A. F. Willey, Jr., Grand Rapids, Mich.

Forcing Obstruction from Drain Pipes

Bathtub and similar drain pipes will become clogged at times, and it is frequently found that the ordinary suction cup will not dislodge the obstruction. The photograph shows a device which has been successfully used for opening up drain pipes with water pressure, and that, unless the stoppage is caused by a hairpin or similar article, usually clears the pipe.

An ordinary rubber bathtub stopper has a hole cut through its center, into which a piece of $\frac{1}{2}$ -in. pipe is inserted and held by a nut on each side of the stopper.



A suitable length of garden hose is slipped over the end of the pipe and fastened securely with wire, or with a regular hose clamp. In use, the rubber stopper is placed in the drain pipe, the hose is then attached to a faucet and the water turned on, forcing the obstructing matter through the pipe.—W. S. Standiford, Youngstown, Ohio.

Milk Cart Made from Buggy Shafts

Having a few cans of milk to take from the barn to the highway each day, a Michigan farmer devised a means of wheeling



The Front Wheels and Shafts of an Old Buggy Made into a Truck for the Convenient Transportation of Milk from the Dairy to the Roadside

them without spending any money. He simply took the front wheels of an old buggy, turned the shafts upside down and rested the cans on the crossbar, as the picture shows. Three milk cans can be carried at one time, and by placing a loose board or two across the shafts, other articles can be carried as well.

Polishing Bore of Gun Barrel

When a shotgun or rifle has been neglected and allowed to go for some time without cleaning or oiling, the bore becomes rusted, due to the action of atmospheric moisture and chemicals in the powder. Although a good cleaning with kerosene will partly remove the worst of the incrustation, if the original high polish, which is conducive to good shooting, is desired, it may be obtained without much

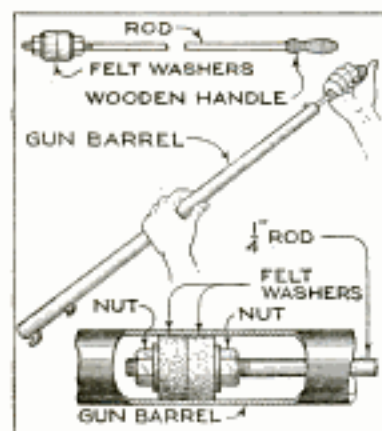

difficulty. Make an emery lap of the type shown in the drawing. A $\frac{1}{4}$ -in. steel rod is threaded at one end and fitted with two nuts, two hard-felt washers, and two smaller metal washers, while a handle is fitted to the opposite end. With the lap assembled as shown, use fine emery flour mixed with vaseline smeared on the felt washers, and clean out the spots with a

reciprocating movement of the rod. "Fine" valve-grinding compound will also answer. If the felt washers are too loose-fitting, expand them slightly by screwing down the nuts until they fit rather snugly into the bore. After polishing off the spots, clean out the barrel and grease well.

When the Light Fuse "Blows" Out

When the fuse plug of the house-lighting circuit "blows" out, there is usually an anxious wait until another is obtained.

Any of the following suggestions will permit the use of an old plug during the interval. While effective, none of the methods are recommended or advised for other than temporary use, as the regular fuse is designed to blow when the circuit becomes overloaded, while the makeshifts are not.

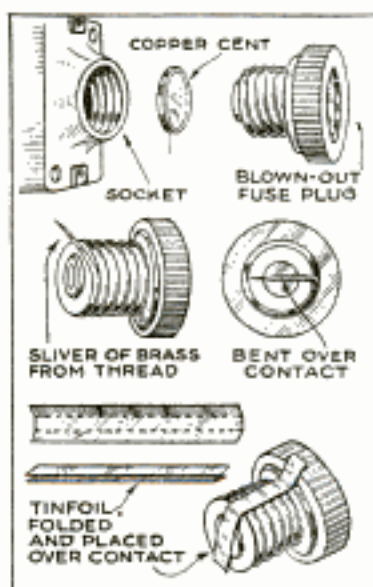

Should the wires become short-circuited the fuse will burn out, and unless the cause is found and removed, the new fuses will burn out as fast as they are put in.

The first method consists in placing an ordinary copper cent in the socket and screwing in the old plug on top of it. The cent will fit the socket of either a fuse or a lamp, and is ever handy to complete a circuit. The second method is to split a thin rim or edge from the threaded brass rim on the fuse, with the blade of a knife, and bend this rim over the center contact, as shown. This is a practice often resorted to by electricians. The third method consists in folding a piece of tinfoil, placing it over the fuse plug across the center contact, and screwing the plug into the socket.

Adjustable Front for Brood Coop

The proper housing of a hen and chicks is always a problem to the back-yard poultryman, who must avoid letting the youngsters out in the early morning before any of the family are astir, in order

that a stray cat or dog may not get them. By using two strips of an old inner tube and the usual vertical slats, the openings in the front of the coop can be regulated to allow the chicks to pass through or restrain them within. An old inner tube is cut lengthwise into strips about 1 in. wide. Two of these rubber strips are spaced to come at the top and bottom of the coop opening, and to them a row of slats or lath is tacked. The projecting ends of the rubber strips are permanently fastened to one side of the coop, and the ends on the opposite side are held by projecting nails. By stretching or releasing the rubber, the width of the openings between the slats can be regulated to confine or liberate the chicks as desired.—G. E. Hendrickson, Argyle, Wis.

Repair for Broken Battery Post

Owing to the vibration, a post was broken from an automobile storage battery; this resulted in starting troubles, burnt-out lights, and other evils, until a temporary repair was effected in the manner shown. The halves of the post were

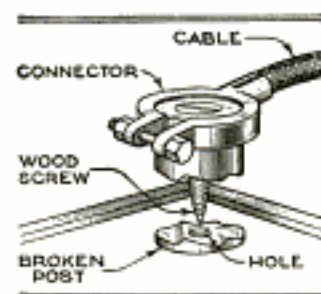

scraped bright, and a $\frac{1}{10}$ -in. hole was drilled into each; some lead filings were then placed between the rough faces, and a woodscrew was turned down through the sections until they were brought together solidly.

Soldering Holes in Tanks

When a hole in a tank, can, or sheet-iron pipe is to be plugged by soldering, it will frequently be found difficult to make the solder bridge the opening. In an instance like this, an ordinary brass paper fastener may be pressed into service with satisfactory results. The prongs are pushed through the opening, cut to a suitable length, if necessary, and pressed down on each side. The hole is then soldered over, the fastener providing at once a means of bridging the space and strengthening the repair.

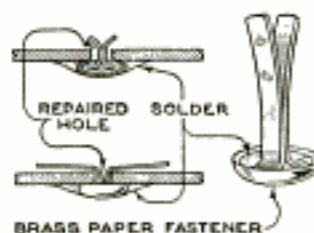

A Sailor Wind Vane

A wooden sailor, who waves his arms and indicates the quarter of the wind, is something a little different from the



conventional weather vane, or revolving wind wheel. The wooden figure is cut from $\frac{1}{2}$ -in. white pine, or other soft wood, the arms being made separately and attached to the body by means of light iron wire passing through

screweyes on the back of the body. The figure is supported on a pole by an iron rod driven into the latter. After a large-diameter iron washer has been dropped over the vertical iron rod, it is inserted into screweyes on the back and leg of the sailor, so that the figure can revolve freely with each change of the wind.—Duncan M. Halliday, Chesley, Can.

Mousetrap Prevents Theft of Auto

An ordinary spring mousetrap, of the type that can be bought for a few cents, can be converted into an effective burglar alarm for preventing the theft of an automobile.

Two wires, with spring clips attached to their outer ends, are attached to the trap in the manner illustrated, and the trap is set in the usual manner. One of the clips is attached to the live terminal of the horn and the other is grounded to the frame to complete the circuit. The front wheels of the car are turned at an angle and the mousetrap is set in the mud pan so that the steering arm will touch the trigger when the steering wheel is turned. When the trap is sprung the horn circuit is closed, and the horn sounds until the trap is removed.

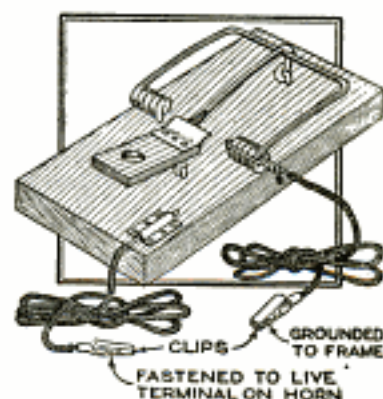

A Motorcycle Bobsled

Most motorcycle owners put their machines away when the snow begins to

sled that uses the motorcycle power plant to drive it along the frozen surface.

The front wheel and handlebars are removed from the machine, which is held upright in a wooden framework built as part of the sled body. The front fork is firmly fastened, and the rear wheel is placed between two guideboards, so arranged as to prevent the walls of the tire from rubbing against the sides. An old tire was used on the single wheel, and additional traction obtained by the use of a tire chain. The sled is steered by means of a steering wheel operating the front set of runners, which swivels on a pin at the center.—S. E. Gibbs, Colfax, Ia.

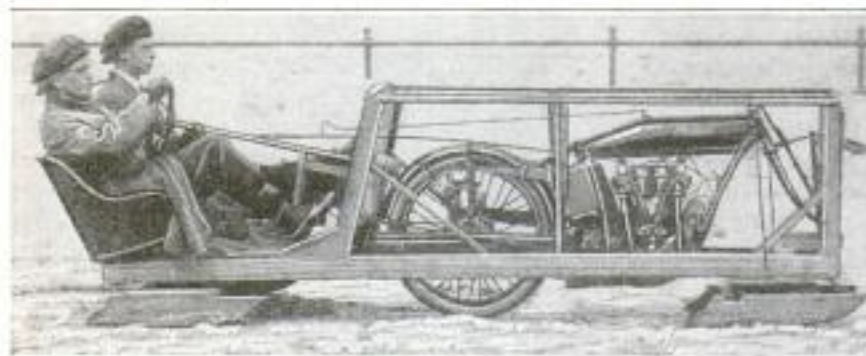

Instead of Storing the Motorcycle during the Cold Winter Months, It is Used, in This Case, to Drive a Bobsled: the Front Wheel and Handlebars are Removed, and the Machine is Held Upright in a Wooden Framework

fly, and forgo their use during the winter months. However, the photograph shows how one enthusiast constructed a bob-

Cork Extractor Made from Buttonhook

An ordinary buttonhook, such as can be obtained from any shoe dealer, is easily converted into an effective imple-

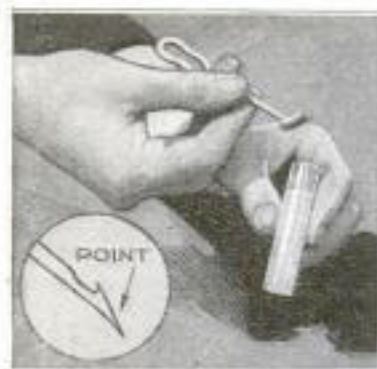

ment for removing thin corks and cardboard caps from bottles and tubes. In making the extractor, the hooked end of the buttonhook may be either cut off or straightened out. A

barbed point is then formed on the end, either by filing or grinding.—John H. Schalek, Pittsburgh, Pa.

Safety in the Use of Electric Lamps for Heating

It is a quite common practice to use electric lamps for heating purposes, but the misuse of them is also very common, and may lead to serious consequences. It should be remembered that if conditions are such that the heat cannot be dissipated, a fire may be started.

An ordinary 25-watt electric lamp, burning under normal conditions, is entirely too hot to be put, with safety, into a rubber boot to dry it. If such a lamp at the end of an extension cord is placed in a bed to keep a person's feet warm,

and bedding is piled over it, there will be little chance for the heat to escape, and it will almost certainly char the bedding within a few hours—possibly set it on fire.

When lamps are used for these or similar purposes, although such a misapplication is not recommended, the best and safest way is to employ bulbs of twice the voltage of the service current, for instance, a 220-volt lamp on a 110-volt circuit. These "oversize" lamps will generally give sufficient heat without becoming dangerously hot. Another way to accomplish the same result is to use two lamps in series, as by connecting two 110-volt lamps in series on a 110-volt circuit.

Safety Catch for Box Camera

Everyone who has carried a camera of the fixed-focus box type in a crowd, has been afraid that some one might accidentally rub against the trigger and expose the film so that the next picture taken on the same film would be worthless. By drilling a $\frac{1}{16}$ -in. hole in the position indicated by the dotted lines and inserting a wire pin or small nail back of the trigger, the trigger cannot be moved and the lens uncovered until the pin is withdrawn.—Chas. N. Shaw, Jr., Oxford, Ga.

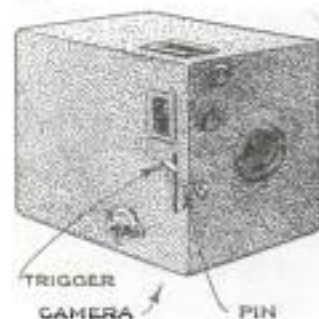



An Efficient Wireless Telephone

By FRANK L. BRITTIN

MANY amateur radio operators throughout the country are building radiophones, and more would doubtless do so, were it not for the fact that, while many articles have been written on the subject, in nearly all definite constructional detail is conspicuous by its absence, and, unless the amateur is thoroughly grounded in radio theory, he meets with little success. The telephone described in this article is simple and practical; the construction cost, which varies, of course, with locality, is about \$125, which is not much more than the cost of many good receiving sets. The range will vary with local conditions; with a good aerial and ground system, music and the voice have been transmitted from 100 to 200 miles, while under specially good conditions, an extreme range of 500 miles has been recorded with this instrument.

The greatest hindrance to the development of amateur radio-telephones has been that the builder was compelled to use a motor generator, an expensive unit, in order to get the necessary high-potential direct current. This objection

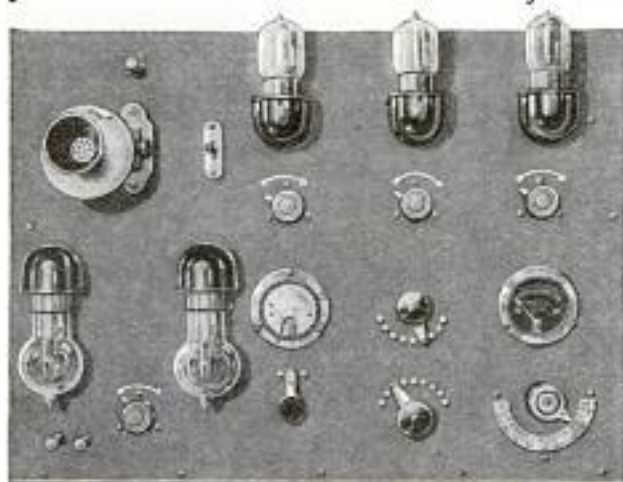

Front View of Instrument Panel: The Tubes at the Top Are the Transmitting Tubes, Those at the Lower Left-Hand Side the Rectifying Tubes

does not apply to the instrument herein described, however, as a new type of transformer is employed, being connected to a 110-volt alternating current source of supply as simply as screwing in a light-

ing bulb or plugging in an electric iron. The rectifier tubes, shown in the upper right-hand corner of the full-page illustration, may be any of the various types on the market, but the transmitting tubes should be UV-202 tubes, the correct filament voltage for which is $7\frac{1}{2}$ volts. The current for the transmitting-tube filaments is taken from the posts on the

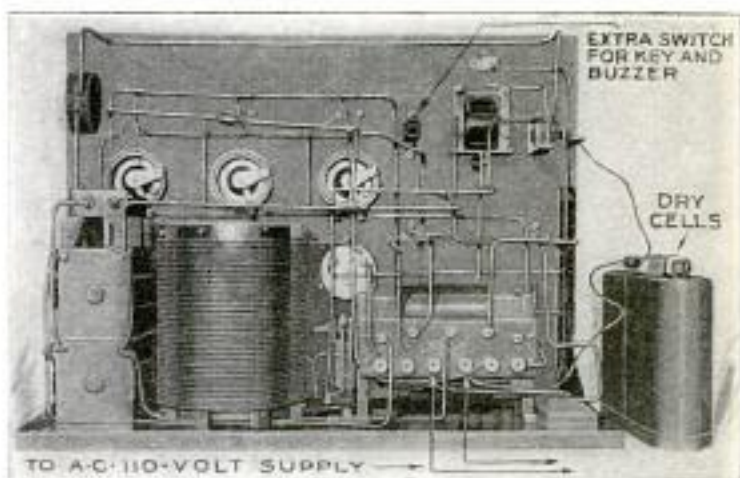

Back View of Panel: The Inductance and Choke Coils are Seen at the Left, the 200-Watt Continuous-Wave Transformer at the Right. The Dry Cells Are a Standard Four-Cell Unit

transformer, marked "O.F." (oscillation filaments), and the voltage is regulated by means of the heavy-duty rheostats, shown between the tubes. The rheostats are necessary because this winding of the transformer furnishes a potential of 12 volts instead of $7\frac{1}{2}$. An a-c. voltmeter can be used to advantage in this circuit, and adds to the ease of adjustment, although it is not absolutely necessary.

The rectifier-tube filaments are lighted from the posts marked "R.F." (rectifier filaments), and heavy-duty rheostats, as shown in the winding diagram, are recommended for this circuit also (only one rheostat is shown in photo, as the instrument was originally built with but one). The posts marked "PRI." are for the 110-volt a-c. supply, and in this line, a 50-ohm rheostat, such as a 10-hp.-motor field rheostat, which can often be picked up cheaply, is of great benefit in tuning the entire circuit to best advantage. It is a good idea to have every part of the circuit variable, as far as possible. The post above and between the posts R.F. is

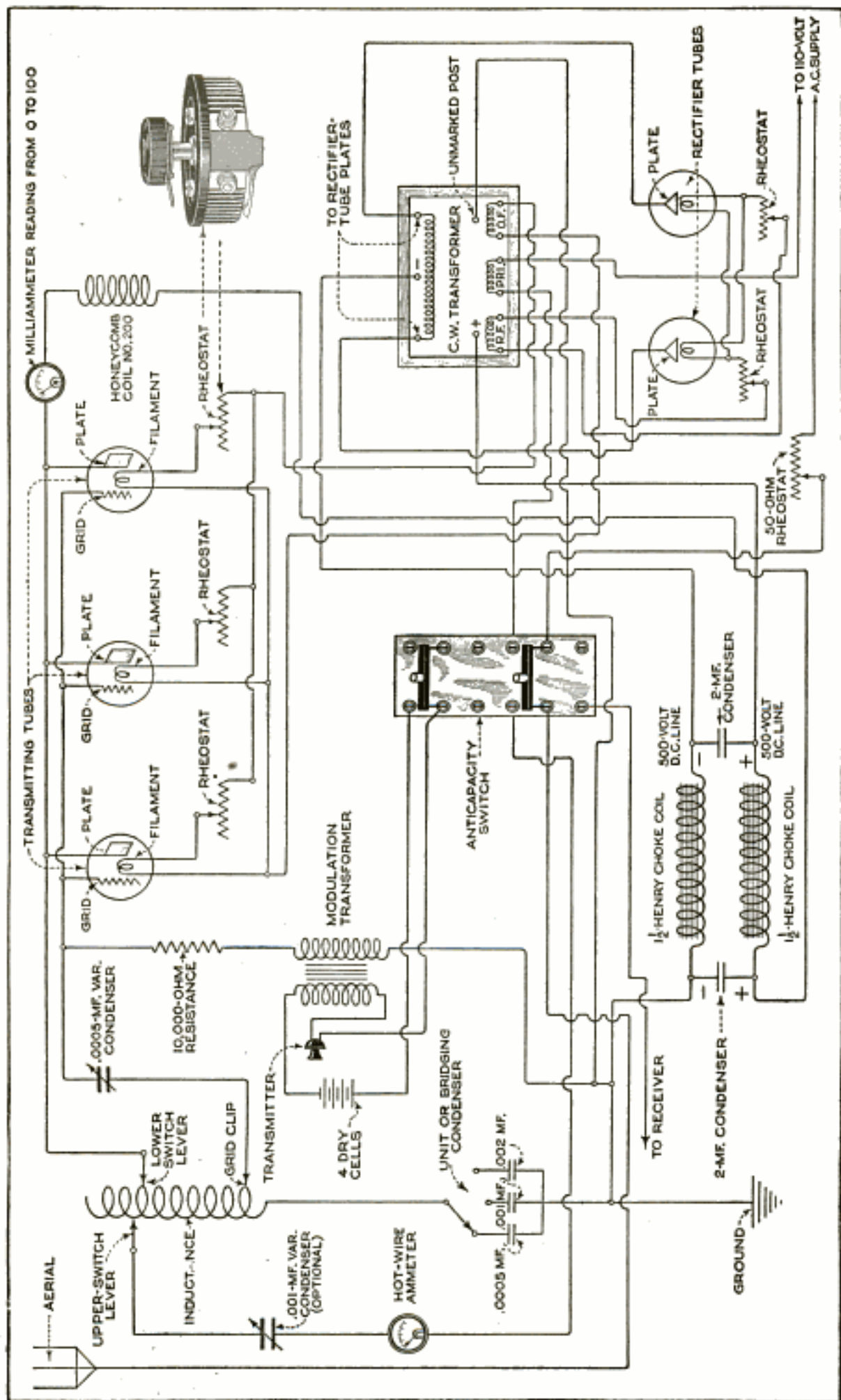

Complete Wiring Diagram for the Telephone: The Various Circuits should be Thoroughly Studied and Understood Before Connections are Made, and the Connections Checked against the Diagram Before Soldering. A Little Care in This Respect will Save Much Trouble Later. The Continuous-Wave Transformer Is of a Standard Make, as Are Most of the Other Instruments, with the Exception of the Unit Condenser and the 50-Ohm Rheostat; the Latter may Be One Taken from a 10-Horsepower Motor

marked +, this is for the positive lead of the d.-c. potential; the post for the negative lead, marked -, is found at the top, in the center of the transformer panel. This d.-c. current, which goes to the transmitting-tube plates, first passes through two $1\frac{1}{2}$ -henry choke coils as shown, which serve to "smooth out" the current; a 2-mf. condenser is bridged across the line on each side of the choke coils. Each choke coil may be made by winding, on a soft-iron core $\frac{5}{8}$ in. in diameter by $3\frac{1}{2}$ in. long, 1 lb. of No. 26 double cotton-covered magnet wire, or they may be purchased at a reasonable price. The 2-mf. condensers must be able to stand the high voltage; condensers specially built for this purpose are now generally available. The plates of the rectifying tubes are connected to the posts marked "P." (plates), and when the unmarked post is connected to the ground circuit, the transformer wiring is complete.

Following the 500-volt d.-c. line through the choke coils, the negative lead is connected to the ground; the positive lead goes to a No. 200 honeycomb coil, which prevents the high-frequency oscillations in the transmitting tubes from backing up into the transformer. From this coil the lead goes to a milliammeter, to the tube plates, then to the lower-switch lever on the inductance. The inductance consists of 40 turns of No. 12 hard-drawn copper wire, wound on a threaded bakelite tube, 6 in. in diameter and 8 in. long; this tube can be obtained threaded, ready to wind.

The connections of the inductance taps to the upper and lower switches are shown clearly in the detail drawing; helix clips, instead of the switches, can be used here to advantage. The upper switch is connected to the aerial circuit, and in this circuit a condenser of .001-mf. capacity is recommended; it should be able to stand a heavy voltage, and, while not absolutely necessary, is of great advantage in tuning. The hot-wire ammeter should read, by fractions, to one ampere, and be as sensitive as possible. The lead from the lower end of the inductance is taken to the lever of the three-point switch controlling the unit or bridging condenser. This may be homemade, and the units are of .0005, .001, and .002-mf. capacity, respectively. The dielectric in each unit is the best grade of India mica, 2-in. by $1\frac{3}{4}$ -in. pieces being used, and copper-foil sheets, $1\frac{3}{4}$ in. by $1\frac{1}{2}$ in., are used between the mica sheets; the tabs on alternate sheets of foil are brought out at top and bottom, on the same side, being soldered together and connected as shown

in the detail drawing, when the units are assembled. Bakelite panels, $\frac{3}{16}$ by $1\frac{3}{4}$ by $3\frac{1}{2}$ in., are used to separate the units, and the assembly is supported by a metal strip, as shown. The .0005-mf. unit has five sheets of foil, the .001-mf. unit seven sheets, and the .002-mf. unit 11 sheets. A bridging condenser, with a fan switch, can be used at this point if the builder does not wish to make his own.

The grids of the transmitting tubes are connected in parallel; the variable condenser in this circuit is of .0005-mf. capacity, and should also be able to stand a high voltage; the lead from this condenser goes to a helix clip on the inductance, to facilitate close tuning. The 10,000-ohm resistance, shown in the grid circuit, which is used to hold the grid negative, is connected to one secondary terminal of the modulation transformer, the other secondary terminal being connected to the ground. The modulation transformer and microphone transmitter are of standard make, and the primary is connected in series with a four-cell battery; this circuit, as well as the others, is operated through the anticapacity switch, which, when thrown up, cuts in the transmitter, and when down, puts the receiver into operation. A key and buzzer can be used in this circuit instead of the transmitter, for c.-w. telegraphy. This completes the circuit.

The instrument panel is of bakelite, $\frac{5}{8}$ by 18 by 24 in., mounted on a $\frac{3}{4}$ by 8 by 24-in. wood base by means of metal shelf brackets, the panel being drilled for the instruments before screwing to the base. A shelf can be placed at the rear of the panel to hold the choke coils and condensers, if desired. The entire "works" can be inclosed in a cabinet, but this makes it harder to get at if any adjustments are necessary. The wire used for the circuit may be No. 18 insulated fixture wire, wire smaller than this should not be used; a tinned-copper wire, now on the market, which can be covered, as the winding proceeds, by the so-called "spaghetti" tubing, is better still, as it makes a neater job and saves time. All connections should be soldered but the circuit should be carefully studied before the connections are made permanent, and carefully checked before turning on the power.

Put all the resistance in the circuit, then turn on the power. First regulate the rectifier-tube rheostats; the current flow from these tubes can be regulated much more easily if a d.-c. voltmeter, reading to 500 volts, is connected to the d.-c. out-

put. By means of this the rheostat scale on the panel can be graduated for the various voltages desired.

Calibrate the rheostat and graduate the

be adjusted to find the oscillation point, no exact directions can be given for this.

The unit-condenser switch is then adjusted, and the circuit tuned to the maxi-

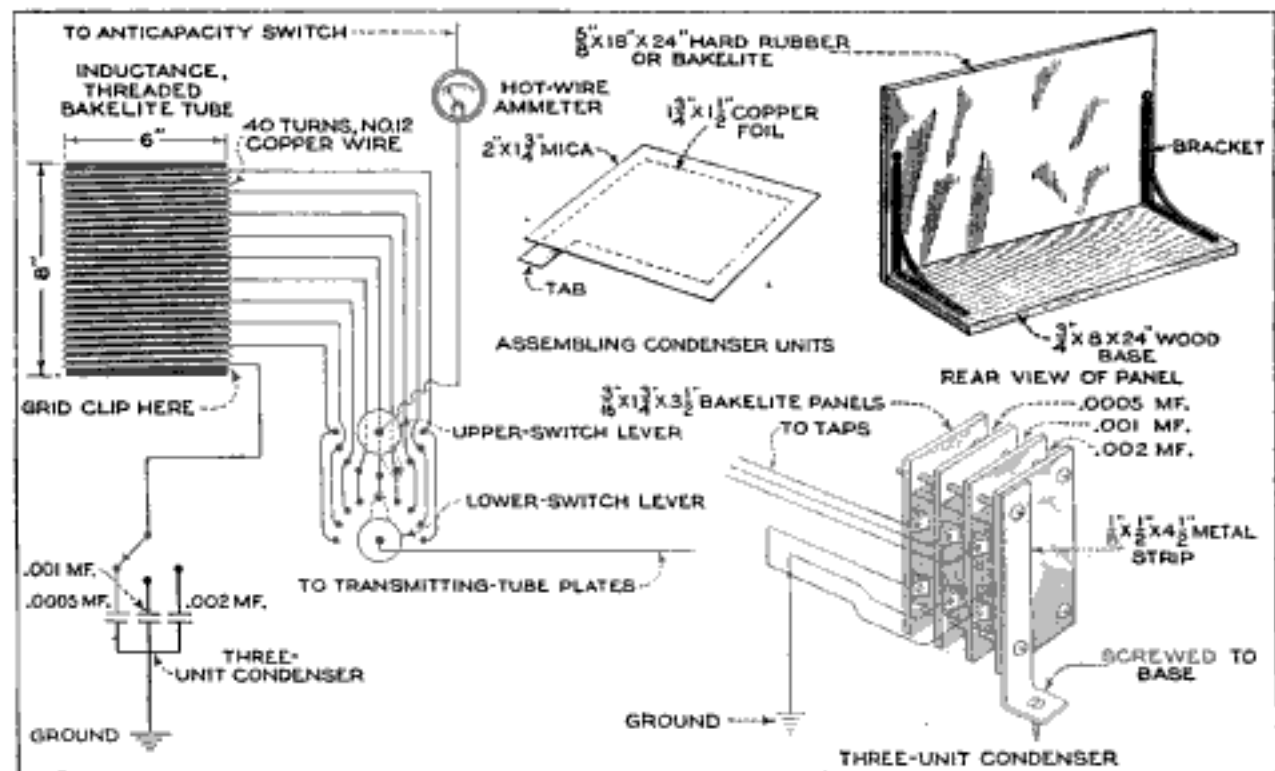

Details of Connections for Upper and Lower Switches of the Inductance; Method of Fastening Panel to Base, and Details of Construction of the Unit Condenser

scales to, say, 250, 300, 400, and 500 volts; then the voltmeter may be discarded. Now adjust the rheostats of the transmitting tubes to the proper positions for regulating the filament voltage ($7\frac{1}{2}$ volts), by means of an a.-c. voltmeter, graduating these scales also. In tuning, after these adjustments are made, it will be found easier to adjust the entire circuit by means of the 50-ohm rheostat in the 110-volt a.-c. line.

Next, place the upper and lower-switch levers of the inductance at about the position indicated by the dotted lines in the detail drawing, and place the grid clip in position. As these points must, of course,

be adjusted to find the oscillation point, no exact directions can be given for this. The reading on the milliammeter should be low.

The circuit is tuned by adjusting the variable grid condenser and the variable condenser in the aerial line, and also by changing the position of the switch lever on the unit condenser; by moving the switch on the 50-ohm rheostat carefully, the change of potential will often start the circuit oscillating. There is no specific method of reaching the point of oscillation, as every instrument requires individual treatment.

MATERIAL LIST

- | | |
|---|--|
| 1 bakelite panel, $\frac{5}{8}$ by 18 by 24 in. | 21 switch points. |
| 4 pieces bakelite, $\frac{3}{16}$ by $1\frac{3}{4}$ by $3\frac{1}{4}$ in. | 1 .001-mf. variable condenser (optional). |
| 23 sheets copper foil, $1\frac{3}{4}$ by $1\frac{1}{2}$ in. | 1 .0005-mf. variable condenser. |
| 26 sheets mica, $1\frac{3}{4}$ by 2 in. | 1 milliammeter, reading 0 to 100. |
| 1 hardwood base, $\frac{3}{4}$ by 8 by 24 in. | 1 hot-wire ammeter, reading by fractions to 1 or 2 amp. |
| 2 shelf brackets. | 1 threaded bakelite tube, 6 in. in diameter, 8 in. long. |
| 3 switch levers. | 2 2-mf. fixed condensers for 1,000 volts d. c. |
| 1 standard 10,000-ohm resistance. | 2 $1\frac{1}{2}$ -henry choke coils. |
| 5 heavy 7-ohm rheostats. | 1 No. 200 honeycomb coil. |
| 1 50-ohm rheostat. | 1 200-watt e.-w. transformer. |
| 5 gooseneck tube sockets. | 1 standard modulation transformer. |
| 3 UV-202 transmitting tubes. | 10 binding posts. |
| 2 standard rectifier tubes. | 4 nickelplated wood screws, $1\frac{1}{2}$ in. long. |
| 1 anticapacity switch. | 8 nickelplated wood screws, 1 in. long. |
| 1 radiotelephone hand or panel transmitter. | |
| 4 dry cells. | |

Emergency Oilstove Wicks

During the war, the owner of an odd make of oilstove was unable to obtain wicks, as the manufacturers had closed their factories. In the emergency, a stove dealer suggested that heavy outing flannel might be used to advantage for making wicks. The strips of flannel were cut to the exact size of the original wicks, and the edges were brought together and sewed by "overhanding," so that there would be no lap at the joint. Although these wicks did not last as long as the regular ones, it was at least possible to keep the stove in use.—Mrs. James Doremus, Passaic, N. J.

Releasing Hook from Fish's Mouth

It is often quite difficult to take the hook from a fish's mouth, because the teeth or scales of the fish make the undertaking disagreeable, if not one of possible injury. In such cases a simple tool like the one shown in the drawing will be of great assistance. Obtain a piece of corset steel, or clock spring, about 8 in. long, and grind the ends round. Soften the ends in a flame, and bend them back so as to form hooks, then reharden the steel by dipping it, still heated, in water. Bend the steel into the shape shown, so that the ends will be about 4 in. apart.



When a hook is caught in the fish's mouth, insert the ends of the tool in the mouth by pressing the ends together, then release them, and the tension of the steel spring will force the jaws apart so that the fisherman can get at the hook with both fingers.—L. B. Robbins, Harwich, Massachusetts.

Old Propeller Used as Anchor

Not having a regular anchor at hand, a motorboat owner picked up an old propeller, put a long bolt through the shaft hole, and tied it to the boat by a length of rope. By dropping this overboard, it is easy to anchor the boat, as the propeller blades catch in the bottom of the stream or lake as readily as the flukes of an anchor.—John Y. Beaty, Chicago, Ill.

Muting the Violin

Three original ideas for muting a violin in the absence of a mute of the ordinary type, are shown in the drawing.

Three ordinary wire paper clips, slipped over the upper edge of the bridge between the strings, are quite effective in softening the instrument's tone. They cost next to nothing and can be carried tucked away in the pocket. A pocketknife may be used as shown, one of the blades being opened and the knife then closed around the lower part of the bridge in such a manner that the weight of the knife is supported entirely by the bridge. The third example shows the application of an ordinary comb, which is slipped over the strings, and thus reduces the volume of sound.—Henry O'Connell, New Haven, Conn.

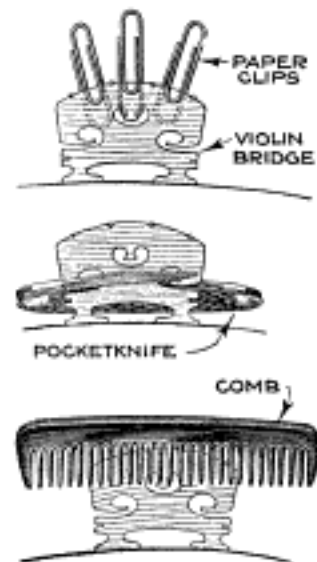

Stopping Noise in Demountable Rims

Demountable rims often squeak in an annoying manner, in spite of efforts to tighten them by various means or to remedy the trouble by the application of oil. This noise often arises from the fact that the bolt heads pull into the rim of the wheel so that the lug fails to grip the steel rim tightly. An effective method of ending the trouble

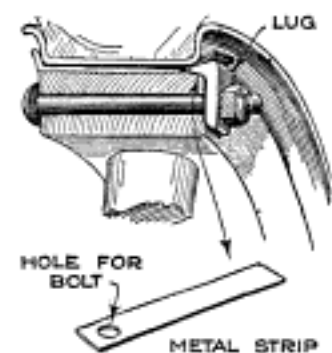

is to take some pieces of rather heavy sheet metal, about the same width as the lug, and bend them as shown in the drawing. A hole large enough to allow the strip to slip over the bolt is drilled or punched at one end. The strips are then placed over the offending lugs, which are screwed down in the usual manner with the metal strip projecting between the lug and rim. This will take up the play and usually eliminate the noise.—G. W. Greene, Madison, Wis.

Worm Gears for Toy Machinery

Every youngster who owns a small battery motor delights in rigging up hoists, mills, and all manner of "machinery" for

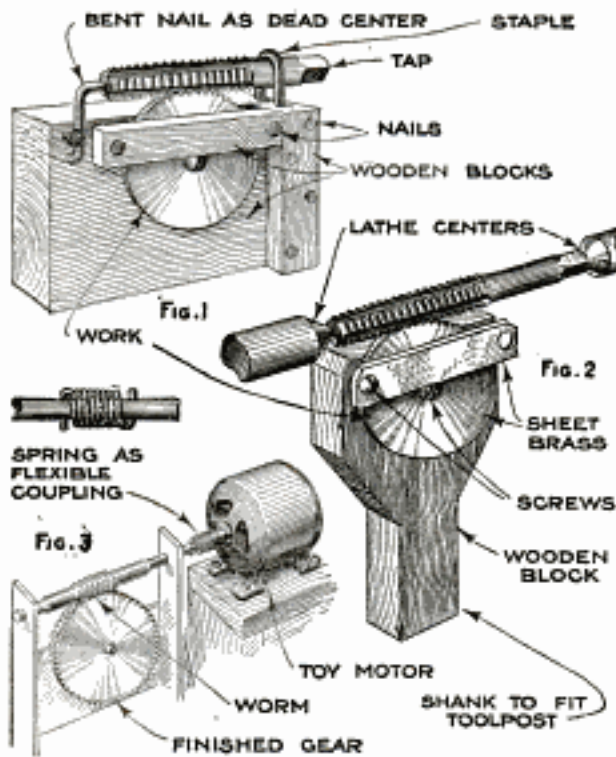

Two Fixtures are Shown for Cutting Small Worm Wheels; the First Is for Use by Hand and the Second with a Lathe. The Last Picture Shows How the Worm Drive is Connected

the motor to drive. As these motors necessarily run at high speed, and have only a very small torque, or turning force, it is always necessary to have some sort of speed-reduction gear, usually a system of large and small pulleys carrying strings as belts. A better arrangement is to use worm gearing, and the fine thing about this is the fact that a speed reduction of 100 to 1 is just as easy to obtain or perhaps easier than a 10-to-1 reduction. And as the speed is much reduced, the turning force is greatly increased, so that a very small motor will, when provided with a worm-gear drive, operate mechanism it could not even turn by means of the strings running over small V-pulleys.

In worm gearing the driving member or "worm" is nothing but a screw; a special kind of thread is used on large screws made for the purpose, but this is not at all necessary for small worms to drive toys—any bolt or machine screw that has a good, full thread will do for the driving worm, provided that the proper gear, or worm wheel, to serve as the driven member can be obtained. The worm wheel must have a number of teeth equal to the

desired speed ratio, one with 50 teeth giving a reduction of 50 to 1, when used with an ordinary single-thread screw.

The only special tool needed for cutting worm wheels is an ordinary machinists' tap. It should be of some common size, such as $\frac{1}{4}$ -20, and the worm or screw must, of course, be of the same pitch, in this case, 20 threads to the inch.

Two methods of cutting the worm wheel are illustrated. Fig. 1 shows a fixture that can be made of three wooden blocks nailed together. A screw for holding the gear blank, a wire nail, and a large wire staple are the only other materials needed. Fig. 2 shows how the work is done in a lathe; any lathe having a cross-feed can be used. It may be remarked that although the shank of the wooden block may be held quite rigidly in the toolpost, some kind of bracing block will have to be wedged under the forward end of the block to prevent chattering.

The blank for the worm wheel is merely a disk of sheet brass or soft iron, with a hole in the center. It can be turned out of the sheet, or filed, if no lathe is handy. The diameter need not be determined accurately, unless the speed reduction must be exactly as it is desired. The rule for determining the diameter of the worm wheel is to multiply the pitch (distance between teeth) by the number of teeth wanted, and take $\frac{7}{22}$ of the result. Thus, for a 100-tooth wheel to fit a $\frac{1}{4}$ -20 worm, the diameter would be $100 \times \frac{1}{20} \times \frac{7}{22}$, or $1\frac{13}{22}$ in. In practice, the diameter should be somewhere near $1\frac{5}{8}$ in., the main thing being to get the disk as nearly round as possible. In the hand fixture, shown in Fig. 1, the feed is obtained by striking light blows on the heavy staple. The staple should at first be driven in just so far that the teeth of the tap scratch the edge of the blank. The tap is then revolved with a bit brace or wrench; when it has made 100 revolutions the blank will be scratched clear around. As the turning is continued, notice whether the tap teeth have worked into the scratches previously made, or are cutting new ones. If the latter is the case, apply a little pressure with the hand, backward or forward, on the blank, as the turning is continued and the tap is fed in with an occasional blow on the staple, so that the teeth will revolve in the grooves previously cut, and not cut double-pitch.

Figure 3 gives an idea as to how the motor is connected to drive the slow-speed shaft by means of the worm and wheel. There must be plenty of play between the worm and gear, as the simple

teeth of this type will not work well if pressed tightly together. The worm in Fig. 3 is made by turning, or filing down, a screw or bolt having the proper thread, so that journals are formed on the ends; the thread is also filed off for the sake of appearance, except at the center, where it meshes with the gear.

To Prevent Funnel from Tipping

A simple method of preventing a funnel from tipping to one side and spilling the liquid being poured, consists in slipping an iron washer over the stem; if desired, the washer can be permanently attached by soldering. This arrangement will be found particularly useful when both hands are required for pouring, as, for example, when filling the fuel tank of an automobile.

A Screwjack Gear Puller

Wherever gears or wheels are to be removed from their shafts, considerable damage may be done if the work is not properly performed, and, as gear pullers are not always available, or have not a

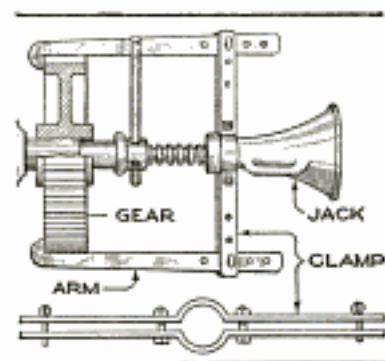

large enough range for the work to be done, the repairman is often tempted to resort to drastic methods to remove an obstinate gear. If a screwjack and a few pieces of flat iron are

at hand, they can be made into a powerful puller, thus removing the necessity of hammering the gear, with the attendant possibility of damage.

Two bars are shaped to fit around the top part of the jack standard, and drilled for clamping bolts; these bars should not be made from material lighter than $\frac{1}{2}$ by 2-in. steel. Holes are also drilled through each end of the crossarm thus formed, to take the pins which hold the pulling hooks. The hooks are cut from $\frac{1}{2}$ by $1\frac{1}{2}$ -in. stock, and are also drilled for the adjusting pins. With the hooks holding the wheel to be removed, and the head of the jack against the shaft, it is only necessary to turn the screw to exert pressure sufficient to pull off the wheel. Where possible, the hooks should pull against the gear hub.

Improvised Scraper for Hardwood Floors

A combination of a roller skate, plane blade, and a heavy block of iron makes a serviceable and efficient scraper for re-

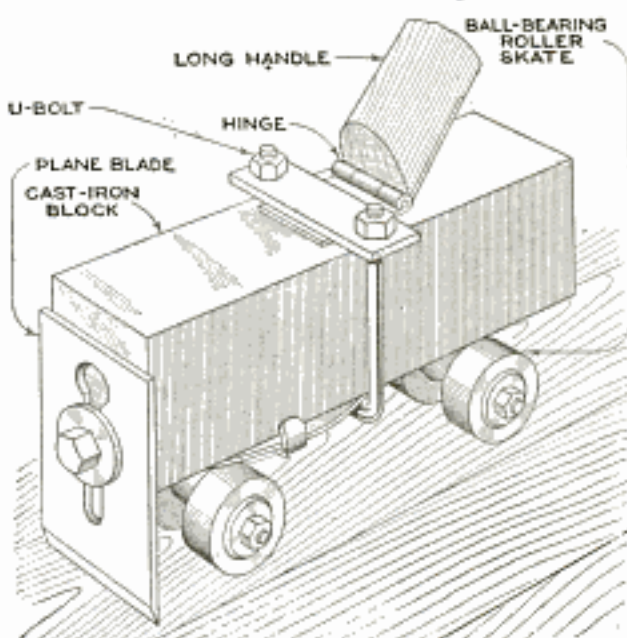

A Scraper for Refinishing Hardwood Floors can be Made from a Roller Skate, an Iron Block, and a Plane Blade

finishing hardwood floors. This improvised scraper was made by an amateur workman simply by clamping the cast-iron block to the top of the roller skate. The plane blade was fastened to the forward end of the block by a screw and washer, for which a hole was drilled and tapped in the block.

A hinged handle was attached to the device by bolting one leaf of the hinge under the U-shaped clamp, which also serves to hold the iron block to the roller skate.

With the scraper shown, all the floors of a six-room house were resurfaced, the work being done with much more rapidity and ease than would have been possible by the hand-scraping method. The edge of the scraper blade should be beveled at an angle of about 30° , and the iron block should weigh about 30 or 40 lb. to get the best results.

Cure for Slipping Fan Belts

An automobile fan belt that is inclined to slip on the pulley, either because it is too loose or because the pulley is worn too smooth, can quickly be made to run true and take hold by lining it with adhesive tape the width of the belt. The adhesive tape is that used for bandages, and can be bought at any drug store.

A Burglar Alarm That Shoots

A burglar alarm that will fire blank cartridges, when operated by the entrance of an intruder, can easily be made at a

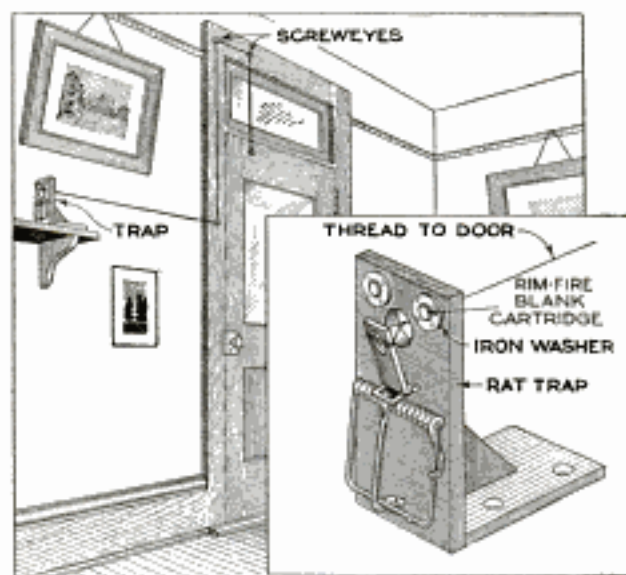

An Ordinary Spring Rat Trap, Converted into a Burglar Alarm, Shoots Blank Cartridges When the Door or Window to Which It is Connected is Opened

cost of but a few cents, from an ordinary spring rat trap. To convert the trap into a burglar alarm, it is only necessary to drill one or two holes in the base, into which .22-caliber blank cartridges are inserted, in such a manner that the spring of the trap will strike the rim of the cartridges and fire them. A hole is drilled underneath the trigger arm, and a thread or wire attached to the arm for releasing the trap. The burglar alarm is mounted on a base in the manner shown, the base being screwed down to the floor or shelf. The alarm is connected to the door or window by means of a stout thread or string, so that the door or window cannot be opened without giving an alarm.—Van Allen Lyman, Aromas, Calif.

Test for Water in Gasoline

The low specific gravity of most of the gasoline on the market makes it imperative that some caution be observed to prevent water from entering the supply tank. Chamois skin is frequently used, but this is too expensive to permit its common employment and is seldom at hand in emergencies. Cotton cloth will serve the same purpose if several layers are placed within the funnel to act as a strainer when the tank is being filled. Cotton is a powerful absorbent of moisture, and will remove all the water from the gasoline up to its point of saturation.

Care must be taken to see that nothing but cotton material is used.

A good test for determining the presence of water in gasoline is made by dipping a cotton cloth into a pan of the liquid. If the cotton remains damp after the gasoline has evaporated, there is water present in sufficient quantity to cause trouble in operating a gas engine or stove.

Preventing Wear on Copper Kettle

Having had considerable trouble in soldering a copper teakettle, that was worn through in several places around the bottom edge, means were sought to prevent this wear. This object was accomplished by soldering a ring of $\frac{1}{8}$ -in. copper wire around the bottom edge, thus preventing the bottom of the kettle from coming into actual contact with the stove, and preventing further wear.—Chas. G. England, Washington, Pa.

Mountain-Type Wagon Brake

A form of wagon brake which is more or less familiar in mountainous parts of the country produces a powerful pressure against the circumference of the wheels, and the speed of a wagon descending any grade which can be safely traveled is very nicely regulated.

A cylindrical brake bar is suspended, parallel with the axles, from the underside of the wagon gear by short chains, as in the drawing. The ends of the brake bar, which is made from part of the trunk of a small tree, should project 6 to 8 in. beyond the wheels on each side. A lever is inserted into the brake bar at one end so that the brake can be operated by the driver. When braking the vehicle, a forward pull on the lever brings the bar back against the wheels, and the amount of friction is controlled by the pressure exerted on the lever. When not in use, the brake hangs from the wagon gear out of contact with the wheels.—Louis Schneider, Clinton, Mo.

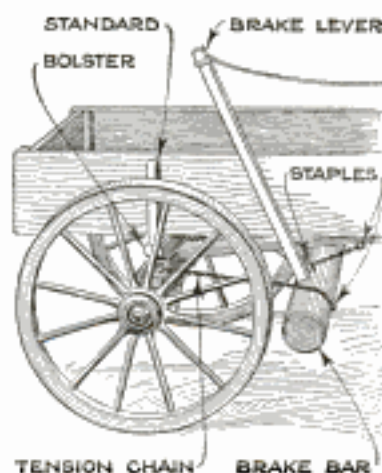

How to Make an Inlaid Checkerboard

By EDWIN M. LOVE

IN the checkerboard design illustrated, each square is a miniature checkerboard in itself, composed of 64 light and dark squares.

For the dark squares, 16 strips each of ebony and mahogany, $\frac{3}{16}$ by $\frac{1}{2}$ by 17 in., are needed, and as many strips of maple and oak of the same size will be needed for the white squares, a total of 64 strips. Using alternate strips of light and dark-colored wood, eight strips are glued together to make a laminated piece, $1\frac{1}{2}$ in. wide. From this piece, after it has been glued and both faces sanded, $\frac{3}{16}$ -in. sections are

seven strips of red oak, $\frac{1}{16}$ by $\frac{1}{2}$ by $12\frac{1}{2}$ in., and 56 similar strips, $1\frac{1}{2}$ in. long. Paint the face of the board with glue and place in the angle formed by the strips at the edge, which should be at the lower left corner, one of the dark squares, with an ebony square in the corner, and the grain running parallel with the left edge of the board.

Glue one of the short separator strips to the upper edge, and then place a light block in position, with the grain at right angles to that of the dark, and with the light maple square in the lower left corner.

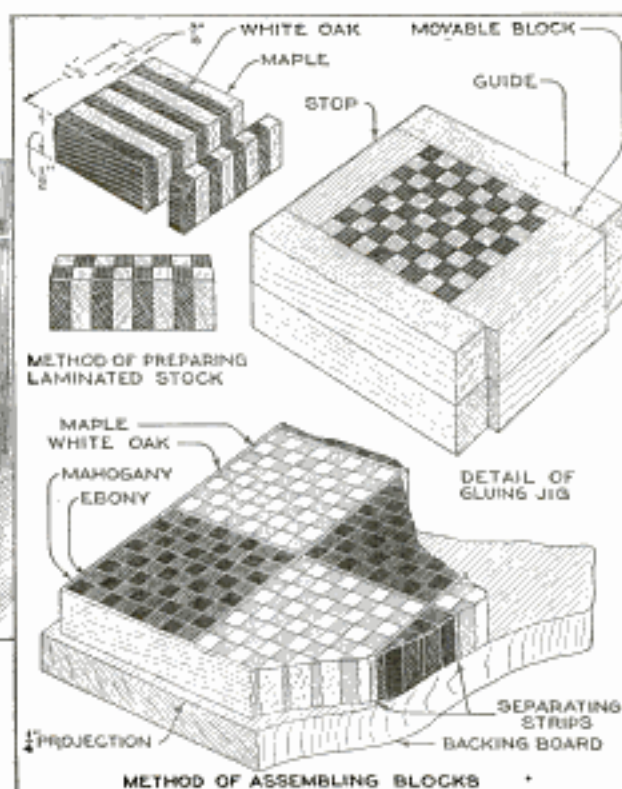

An Inlaid Checkerboard, the Squares of Which Are Miniature Checkerboards Themselves, being Built Up of Light and Dark-Colored Woods



cut transversely, and eight such sections glued together to form a square of the board, using the gluing jig illustrated for the purpose. The sections are cut $\frac{3}{16}$ in. wide in a miter box. The strips are glued together so that light squares will come next to dark ones, the mahogany and ebony being used for the "black" squares, and the oak and maple for the "white" ones.

All of the gluing operations should be done in a warm room and the stock should also be warmed. The wooden gluing jig should be made long enough to accommodate about eight squares at a time, each being separated from the other by a strip of paper. By rubbing the edges of the jig with paraffin, the glue will be prevented from sticking, and the blocks can easily be removed.

For a backing board use a $\frac{1}{2}$ -in. pine board, $14\frac{1}{2}$ in. square. Nail and glue two $\frac{1}{16}$ by $\frac{1}{2}$ -in. red-oak strips near two edges, to form a right angle, and also prepare

the row and start building up the next row. When all the blocks are assembled, inclose the two open sides with strips, and clamp them tightly until the glue sets. When the glue has dried thoroughly, trim the ends of the separator strips flush, and glue $\frac{1}{16}$ -in. strips around the remaining two sides. Cut off the edges of the backing board to leave a $\frac{1}{4}$ -in. projection, and scrape and sand the surface smooth; wax it, or, if a higher gloss is desired, fill with a light paste filler and give three coats of varnish.

When the row of eight squares has been placed against the pine strip at the left, glue one of the long separator strips to the inner edge of the row and start building up the next row. When all the blocks are assembled, inclose the two open sides with strips, and clamp them tightly until the glue sets.

Before using raveled-out wool for knitting, wind it in hanks, and place it in a steamer until thoroughly moistened. Then let it dry and wind into balls. The yarn will be straightened out and the color freshened.

Safety Spring-Hanger Bolts

One job that will try the patience of the automobile repairman consists of lining up the eye of a spring with the spring hanger in the chassis. The stiff springs are difficult to handle unless some means is provided for aligning the two eyes. A simple jack for flexing the spring and lifting the weight of the car can be improvised from a bolt and a short piece of pipe or tubing, as indicated in the drawing. These materials are usually easily obtainable, and with a few of these jacks, much time can be saved in working the eye of the spring into the proper position for the insertion of the shackle bolt.—G. A. Luers, Washington, D. C.

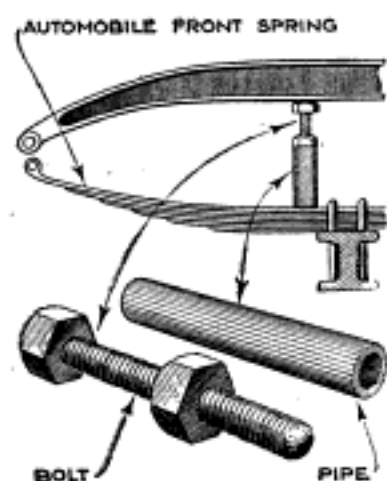

a bolt and a short piece of pipe or tubing, as indicated in the drawing. These materials are usually easily obtainable, and with a few of these jacks, much time can be saved in working the eye of the spring into the proper position for the insertion of the shackle bolt.—G. A. Luers, Washington, D. C.

A Simple Dimming Switch

The drawing shows a very sensitive and simple dimming switch for use with an electric incandescent lamp, in locations where a dim light must be kept burning constantly. A hard-fiber, or bakelite, rod is turned down, as shown, to form a plunger, leaving enough of the original diameter to form a head, which is then knurled. A portion of the length of this rod, at the upper end, is threaded to fit the tapped hole in the mercury container. The latter consists of another piece of rod which is bored and tapped, the diameter of the hole below the thread

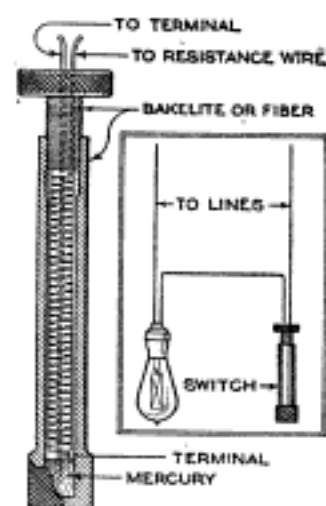

being slightly larger than the plunger. The plunger is drilled, along the vertical axis, with a $\frac{1}{16}$ -in. drill, a copper wire being run through the hole, and projecting through the bottom of the plunger.

Resistance wire is then wound around

the outside of the plunger, being firmly fastened at the bottom and led ir at the top through another $\frac{1}{16}$ -in. hole paralleling the center one. At the bottom of the container, a small quantity of mercury is placed; as the container is screwed upward, the mercury rises in the annular space between plunger and container, so that the current flows through less of the resistance wire, thus increasing the current strength until full light is obtained. Screwing the container downward, of course, reverses this process. This type of switch has been successfully used on small motors and baking ovens, in addition to lamps.—W. Burr Bennett, Honesdale, Pennsylvania.

Combined Spring Spreader and Tire Remover

A tool that serves equally well for spreading the leaves of automobile springs for the application of lubricant, or for removing a tire when the beads have rusted to the rim, is shown in the drawing. The tool can be forged on the anvil, from parts of old wagon tires, in less than an hour.

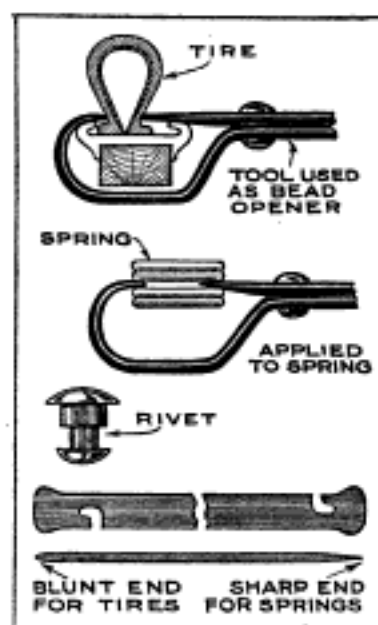

A shouldered rivet is permanently fastened to the curved part, as illustrated, and curved slots that fit around the shoulder of the rivet are provided in each end of the lever handle, but on opposite sides. The span of the tool is somewhat different for the two uses, and for that reason the blade ends are not quite duplicates, the difference being in the distance from the pivot hole to the end of the blade. The hook portion of the tool is simple enough to understand without explanation, while the only detail of the handle that need be further explained is that the end used for tires should be blunt, the opposite end being sharpened for easy insertion between the spring leaves. The blade can be removed from the device and used as an ordinary tire tool for pulling the bead over the rim.

Spring Prevents Breaking of Fishline

"The big one that got away" would, perhaps, have been landed, had the strain on the line been applied more easily when the fish struck the bait. However, as fish are not particularly considerate, the angler must provide a means for preventing his line from breaking, and one that will materially assist in landing his game. This may be done by merely interposing a short length of small-diameter spiral spring of the proper tension between line and hook. The spring will absorb a considerable portion of the strain on the line caused by the vicious lunging of certain varieties of game fish.—O. S. Billings, Ruskin, Fla.

A Jumping-Frog Toy

An entertaining little toy can be made from the wishbone of a fowl after it has been well cleaned and freed from flesh.

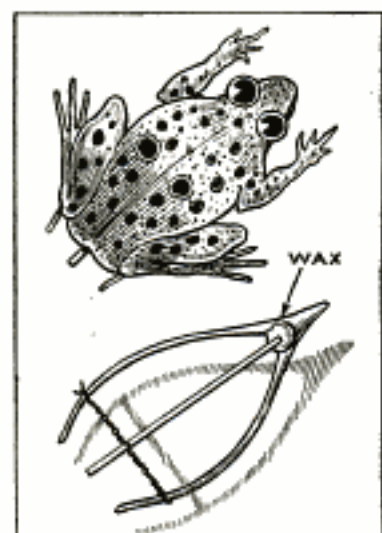

Take a piece of strong, thin string and double it, tying it securely to opposite sides of the wishbone about 1 in. from the ends, as in the drawing. Cut a strip of wood a little shorter than the bone, and make a circular notch about $\frac{1}{2}$ in. from one end.

Push the stick through the doubled string for about half its length, twist the string tightly by means of the stick, then pull the stick through until the notch is reached. From a piece of paper or thin cardboard cut out the outline of a frog, paint it to resemble the animal as nearly as possible, and paste this to one side of the wishbone. The only thing now required is a piece of shoemaker's wax, which is placed on the underside of the bone, just where the free end of the stick will rest. When it is desired to make the frog jump, push the stick down and press the end into the wax. Place the frog on the table, and after a short while the toy will, all of a sudden, make a very lifelike leap as the end of the stick pulls away from the wax.—S. Leonard Bastin, Bourne-mouth, Eng.

The "X-Ray" Pack of Cards

This trick is a "mind-reading" stunt which is worked on a new principle, and is very puzzling. A full pack of cards is

shown and half of them are handed out, the other half being kept by the performer. A spectator is asked to select any card from those he holds, and insert it in the pack held by the performer, while the latter's eyes are closed or his head is turned.

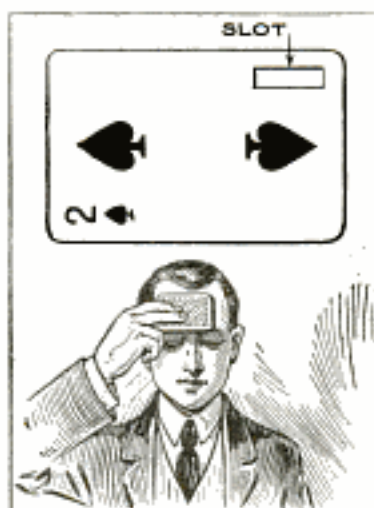

Without manipulating the pack in any way, the performer places it against his forehead and instantly names the card chosen by the spectator.

The cards held by the performer are prepared for the trick by cutting a slot $\frac{1}{8}$ in. wide and 1 in. long in one corner of 25 cards, with the sharp point of a penknife, in such a manner that all the slots coincide. In presenting the trick the performer keeps all the prepared cards, and also one card which has no slot, the latter being kept on top of the pack so that the slots cannot be seen by the spectators. The performer's thumb is held over the slots when the bottom of the pack is shown. A spectator is asked to insert a card face down into the cards the performer holds in his hand. When this is done the thumb is lifted from the slot as the cards are raised to the forehead, when the performer can look through the pack and see the index on the card the spectator has selected. After the forehead "stall," the performer announces the card selected. The trick is repeated by "fanning" out the cards and extracting the card named.

Corked Bottle Used as Float

A simple and effective substitute for a wooden float, which becomes waterlogged after continued use, for water tanks and similar purposes, can be made from old bottles. The bottle is stoppered with a tight-fitting cork, which is made leak-proof with sealing wax. The bottle can be fastened to the end of a float arm by means of metal clamps.

Artistic Lamps Made from Vases and Drain Tile

There are few household furnishings that create an atmosphere of hominess

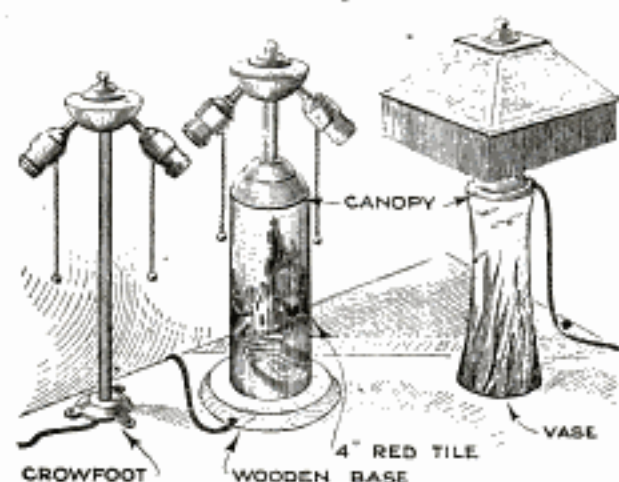

Attractive Table Lamps That can be Made from Such a Humble Article as the Ordinary Brick-Red Farm Drain Tile, or from Vases of Any Size and Form

and furnish cheerfulness to the whole family more completely than lamps which harmonize with their surroundings.

The common brick-red drain tile can be elevated to a position of beauty by using it as a part of a lamp of the type shown in the drawing. The tile itself can be decorated in any desired manner, as by painting some simple scene in oils against an enameled ground. The wooden base should have a diameter large enough to prevent the completed lamp from being easily upset. The electrical fittings, shown at the left, can be obtained from any dealer in such articles. The crow-foot should be screwed to the center of the wooden base in such a manner that the upright pipe will be in the exact center of the tile. When all parts have been assembled the space inside the tile is filled with cement. The vase lamp is practically the same in construction, but because the value of the vase is to be retained, no hole is drilled in its base, which makes it necessary to run the cord in over the edge, and down to the crowfoot. In order to make a lamp of this type stable, the vase is partly filled with dry sand.—Truman R. Hart, Ashtabula, Ohio.

Soil Crusher Made from Mower Wheels

A very useful implement for the farm, for breaking up hard lumps or clods on the surface, is a soil crusher made from old mowing-machine wheels, or wheels from a similar implement. If the maker of such a device does not possess a sufficient number of wheels, a few visits

among his neighbors, or to the nearest junk man, will provide plentiful material.

The construction of such a roller is quite simple and is done by merely mounting the wheels on a shaft of the proper length and diameter, with a thin washer between each pair of wheels. This shaft is mounted on a strong wooden framework of 4 by 4-in. lumber. A tongue is attached to the implement for hitching to the horses or tractor. The wheels revolve freely on their stationary axle and consequently the proper differential effect is obtained so that corners can be turned without skidding. The wheels should be kept well lubricated to prevent undue wear on the shaft.

Hook Pulls Straw from Stack

Looking somewhat like the harpoon of the old-time whalers, the wooden hook shown in the drawing is used for pulling hay or straw from a stack, without wasting a considerable amount of it.

The hook can be made from either wood or metal, so that it can be thrust easily into the stack. The barb is formed about 3 in. from the end; this



catches the straw, and, when the hook is pulled out, a quantity of straw comes along with it. By using this method it is unnecessary to disturb the top that has been arranged to shed the rain. In case a metal hook is used, it can be fastened to a wooden handle, but a straight sapling will answer just as well, especially if there is a conveniently formed crotch near one end that can be utilized in forming the barb.

Flexible Liquid Court-Plaster

A formula for making a flexible liquid court-plaster that can be painted over small bruises, cuts, and other unimportant wounds to keep them free of dirt, is made in the proportion of 10 oz. of flexible colloidion, which can be obtained at any drug store, 20 gr. of Canada balsam, and 10 drops of castor oil.

PRIZE OFFERS

8023
**EXAMINATIONS FOR INSTRUMENT MAKERS
 BY U. S. CIVIL SERVICE COMMISSION**

The U. S. Civil Service Commission announces an open competitive examination for instrument makers. From this examination vacancies will be filled under the following bureaus and departments, at the yearly salaries indicated: Coast and Geodetic Survey, \$1,400; office of the Secretary of Agriculture, \$1,200; Bureau of Standards and Department of Commerce, \$900 to \$1,800; Weather Bureau, \$1,300 and \$1,440; supervising instrument maker, \$1,620; and Naval Observatory, at \$6.88 a day. Appointees whose services are satisfactory may be allowed the bonus granted by Congress of \$20 a month. The examinations are open to all U. S. citizens who have reached their 20th, but not their 65th birthday. Applications will be received by the commission at Washington, D. C., until the business-closing hour on March 31, 1922. Competitors will not be required to report for examination at any place, but will be rated upon sworn statements of their education and experience. Applicants must show that they have completed the eighth grade of common school. Particulars of the experience required for each position can be obtained from Washington.

All desirous of competing should at once apply for form 1312, stating title of examination, to the Civil Service Commission, Washington, D. C., or to the Secretary of the U. S. Civil Service Board in the applicant's locality.

8026
**WORKMAN HONORED FOR WAR INVENTION
 BY THE AWARD OF A GOLD MEDAL**

"In recognition of an extraordinary engineering achievement with great public service," was the unanimous expression of 2,000 members of the American Society of Mechanical Engineers, when at their annual meeting, Dec. 8, 1921, they awarded the gold medal of the society to Hjalmar C. Carlson, a sheet-metal worker of Worcester, Mass. The engineering achievement that won the award was described by the society as "his invention making possible the production of 30,000,000 drawn-steel booster casings; used principally as a component of 75-millimeter high-explosive shells, and also extensively in gas shells and bombs, as an aid to victory in the World War." These shells, which were used by the American army, were of French origin, and they had a peculiar "booster casing" which gave trouble in American plants. Carlson's invention more than removed this trouble, for it made possible the manufacture of the shells at a speed, and with an economy, that surpassed anything done in France. For the benefit of the layman, it may be stated that a booster casing is a casing for the primary detonating charge in a shell. This is in direct connection with the fuse.

8027
**PRIZES FOR AMERICAN-HISTORY ESSAYS
 OFFERED BY KNIGHTS OF COLUMBUS**

Fuller particulars are now available regarding the prizes for American-history essays offered by the Knights of Columbus, as announced in our issue of November, 1921. The five prizes offered for the best studies, based on research in primary sources, are as follows: a prize of \$3,000 for professors or instructors in history, and other social sciences, in the colleges in the United States; a prize of \$2,000 for specialists, not college teachers, on the same subjects; a prize of \$1,000 for school superintendents and teachers in the United States, and another of the same amount for scholars and graduate students who have access to material in the universities, libraries, and archives of Mexico, Central and South America, and the Caribbean Republics, dealing with the international relations of the Americas; and a prize of \$500 for undergraduates in United States colleges. Manuscripts must be in triplicate typewritten form, fully annotated as regards the authority for statements made, and must include a complete bibliography. Studies submitted in competition for prizes must have been prepared especially for this purpose, and must be mailed on or before May 31, 1922. Other particulars, including a

synopsis of the topics, and the periods, suggested to be taken as themes for special investigation, may be obtained from the Knights of Columbus Historical Commission, K. of C. Bldg., 199 Massachusetts Ave., Boston.

7999 — Prize
**AUTOMOBILE CLUB OF MINNEAPOLIS
 AWARDS GOOD-ROADS TROPHY**

Each year the official pathfinder of the Automobile Club of Minneapolis makes a tour in his car to some distant point in the state of Minnesota. The counties through which he passes are then notified. Thirty days later a party of about 75 cars belonging to the club takes the same tour, led by the pathfinder, who keeps about an hour ahead of the party, and leaves behind him a trail of confetti to show the route. Then comes another car, the pacemaker, which sets the speed at which the party shall travel. With the party is a pilot car, whose duty it is to guide them on the trail. The object is to decide which of the counties traversed has made most improvements on its roads in the interval of 30 days between the notification of the pathfinder and the tour of the party. This is judged by the pathfinder, the pacemaker, and the pilot, and to the county they select is awarded a handsome trophy, consisting of a winged bronze figure, bearing in one hand a scepter, and beckoning with the other hand to the auto tourist. This figure stands upon a marble pedestal, making the trophy altogether 7 ft. high. Its cost was 1,200 dollars.



8028
**BLIND WORLD-WAR
 VETERAN WRITES
 PRIZE-WINNING
 BOOK**

The prize offered by a New York publisher for the book of highest literary value written, during 1921, by a student of Columbia University, was won by David P. Sentner, a blind veteran of the World War. The winner is studying journalism at the university, under the auspices of the U. S. Veterans' Bureau. The book, entitled "Cobblestones," is a collection of poems and essays. The blind veteran wrote all the manuscripts on a typewriter.

8029
**GOOD EXAMPLE OF THE KIND OF CONTEST
 THAT BENEFITS A WHOLE COMMUNITY**

A contest of the kind that benefits all members of a community, whether contestants or not, is one that was recently conducted by the Fort Wayne, Ind., Chamber of Commerce, called "Better Yards Contest." As its name implies, the object was to stimulate interest in beautifying the yards of the community's homes. Prizes were given for excellence in the care of lawns and sidewalks, in the growth of flowers, shrubs, trees, and in the general outside appearance of the house. The purpose of the contest was further promoted by the nature of the prizes, which were shrubs of a dis-

W. S. U. S. Civil Service Examination

Cont. Arthur Hallam 317 Cedar Ave. Minneapolis, Minn.

newark Ohio Advocate
 12/16/21
 Copyrighted material

tinctive variety. These added to the beauty of the yard and at the same time conferred distinction upon the winner, to whom probably the former benefit was as gratifying as the latter.

BIG REWARDS OFFERED IN AUSTRALIA FOR DISCOVERIES OF PETROLEUM

Up to the present very little oil has been discovered in Australia. In order to stimulate prospectors to greater activity in boring for oil, the government of the Commonwealth of Australia has offered a cash reward, equivalent to \$243,000, for the discovery of petroleum oil in commercial quantities anywhere in Australia. This is defined as production, to the extent of 50,000 gal., with the oil still flowing freely. A similar, separate reward of \$48,600 has been offered by the state of New South Wales to the person or company who first produces 100,000 gal. of petroleum within that state. It is now more than a year since these rewards were first offered.

ROOSEVELT JUNIOR MEMBERSHIPS OFFERED BY WOMAN'S MEMORIAL ASSOCIATION

Theodore Roosevelt's birthplace in New York City is being restored by the Woman's Roosevelt Memorial Association, who, when the work is completed, propose to conduct therefrom a national educational movement. In this connection they contemplate the foundation of a scholarship with annual prizes for the best essays on the life of Roosevelt. In the meantime, the association will present a copy of that famous book, "Theodore Roosevelt's Letters to His Children," to each junior who obtains 25 junior memberships for the association. For the sum of only 25 cents, a junior receives full membership, and as a token thereof, a bronze medallion of Theodore Roosevelt mounted to be worn as a pin. This work is being carried out by the formation in schools of Roosevelt clubs. For particulars address: Woman's Roosevelt Memorial Association, 1 East 57th St., New York City.

In answering prize offers please mention Popular Mechanics Magazine

CONTESTS PREVIOUSLY ANNOUNCED

Essays on Economics: Prizes, \$1,000 and \$500; announced June issue, 1921; closes Dec. 31; address, Dr. Wm. T. Foster, Newton 58, Mass.

Medals, Diplomas, and Money Awards: Announced August issue, 1921; awards offered by the Franklin Institute.

For Service to City of Philadelphia: Prize \$10,000; announced September issue, 1921; awarded in spring or summer of 1922 by Edward Bok, former editor of The Ladies Home Journal.

Research Thesis by a Woman: Prize \$1,000; announced October issue, 1921; closes Feb. 25, 1922; address, Dr. Lillian Welsh, Goucher College, Baltimore, Md.

Model in Clay by Students of Chicago Art Institute: Prizes, \$1,000, \$100, and \$50; announced November issue, 1921; closes April 15, 1922; address, Daily News Office, 15 N. Wells St., Chicago, Ill.

One Million Francs for Best Motor: Announced January issue, 1922; closes June 1, 1923; address, Aero Club of France.

Best Slogan Describing Razor: Prize \$500; announced January issue, 1922; closes June 30; address, Durham Duplex Razor Co., 190 Baldwin Ave., Jersey City, N. J.

Hunting Stories, True or Fiction: Prizes, \$1,000, \$600, \$400, \$300, \$250, \$200, \$150, and \$100; announced February issue, 1922; closes March 1; address: Contest Editor, Outers'-Recreation, 9 S. Clinton St., Chicago, Ill.

Essays on Life of Roosevelt: On page 159 of our January, 1922, issue, and for some time previously, we have announced scholarship prizes offered by the Woman's Roosevelt Memorial Association, with the addition that the contest closed Dec. 31. This statement was premature, as a new announcement in this month's Prize Offers makes clear.

LATEST DEVELOPMENTS IN SCIENTIFIC RESEARCH

By C. A. BRIGGS

SATURN'S RINGS WILL BE DISPERSED BY ITS SATELLITES

The rings of Saturn are unique in the sky and have always commanded the interest of the astronomer. The first question they raised was, "What are they?" The first mathematical investigation showed that they could not be solid but must consist of small particles. This was later verified by examining, through sensitive spectroscopes, the sunlight reflected from them, and determining that the inner edges moved faster than the outer, which could not be true if the rings were solid. The next question was, "How did they originate?" In attempting to get an idea of their source, astronomers and mathematicians have for years been trying to answer the preliminary question as to why the rings persist and why they are not broken up by the action of the moons of Saturn, and why they consist of a series. Furthermore, it has been determined recently that fine lines appear on some of the rings, suggesting subdivisions.

A complicated mathematical study just concluded has developed some very curious facts about the matter. It appears that if the particles in any ring were all of equal size they would, under certain circumstances, tend to leave that ring and mingle with those of the other rings, and the well-defined boundaries would tend to disappear. If there were a large number of particles of all sizes ranging from very small ones up to a certain maximum value in the rings, the divisions of the ring would tend to become more extended and therefore more readily visible.

It has also been discovered that the spacing of the rings is determined by the satellites, or moons, which revolve about the planet. Moreover, it is predicted that in the course of time one of the satellites will cause the disappearance of the crêpe, or innermost dusky, ring, and another moon will cause the other rings to be dispersed.

SOUNDS MEASURE FEEBLE ELECTRIC CURRENTS

As science makes progress, there are many reversals of practice, and what yesterday was used to obtain the best results is done differently today. For instance, the character and magnitude of sounds and musical notes have been determined by converting the sound waves into alternating currents and then measuring them by electrical instruments; but recently the tables have been turned, and very feeble alternating currents have been measured by converting them into corresponding sound waves which are measured on an acoustic device.

The instrument developed for this work is somewhat similar to previous ones, but this particular arrangement is one in which remarkable sensitiveness is achieved. It is a well-known fact that a flat object, as a disk, tends to set itself at right angles to a stream of air or water in which it is held, and in the new device this is used as the actuating principle by suspending from a slender filament of quartz a very light mirror, which forms a disk in the neck connecting two resonating chambers. The feeble alternating currents to be measured are passed through a telephone receiver in the base of one of the resonators. The resulting sound sets up a minute pulsating draft of air in the connecting throat which causes the mirror to rotate to a degree that is a measure of the sound intensity and the current which produces it, and which is read by a suitably arranged telescope and scale, or by the movement of a spot of light.

Such an instrument will probably have many uses in scientific investigations, as, for instance, in telephone research, where it will serve to some extent as an artificial ear, and in making psychological tests for measuring the sensitiveness of hearing of different persons under various circumstances.



Here's the ANSWER to
How to
PLAN, FINANCE AND BUILD
YOUR HOME

**"How to Plan,
Finance and
Build Your
Home"**

is 11x16 inches containing 156 pages. One hundred and two homes are shown with their floor plans and a detailed description of the completed house. It has been pronounced by building authorities to be the most complete home plan book ever compiled.

*The home pictured above
was built from this
plan service.*

BBETTER built small homes—3 to 6 rooms—at lower cost from plans designed to eliminate building waste without sacrificing good looks—this was the ideal of the group of practicing architects who compiled the remarkable new home plan book, "How to Plan, Finance and Build Your Home."

This book and plan service is part of the national small home building movement originating with the Architects' Small House Service Bureau of Minnesota, Inc., and now being extended by the Architects' Small House Service Bureau of the United States, Inc. The United States Service Bureau has the endorsement of the Department of Commerce of the United States Government and the American Institute of Architects. The Minnesota group of architects compiled this book for the Southern Pine Association, which, jointly with the Minnesota Bureau, now the Northwestern Division of the United States Service Bureau, is interested in its distribution.

In endorsing the work of the Architects' Small House Service Bureau of the United States, Inc., Mr. Herbert Hoover, Secretary of the Department of Commerce, says:

"I have looked into the work of the Architects' Small House Service Bureau of the United States with its divisions and branches and have examined its organization and incorporation papers. The complete plans, specifications, documents and bills of materials with the designs worked out for local conditions and to use stock materials and eliminate waste, materially simplify home building problems. The form of control by The American Institute of Architects should guarantee a high standard of service. It gives me pleasure to endorse this work and to assure you that the Department of Commerce will do all it can to cooperate with the Institute and the Bureau."

The book and plans may be obtained direct from either the Architects' Small House Service Bureau, Northwestern Division, Inc., or the Southern Pine Association. The book is sold for \$2.50 prepaid. The service includes complete working drawings, details, specifications, quantity surveys, forms of agreement, ready to use, at prices ranging from \$17.50 to \$32.50, depending upon the size of the house.

Please Use
This Coupon:

Southern Pine Association
New Orleans, La.

The Architects' Small House Service Bureau
Northwestern Division, Inc. Minneapolis, Minn.

Order either from The Southern Pine Association, New Orleans, La., or The Architects' Small House Service Bureau, N. W. Div., Inc., 1200 Second Ave., South, Minneapolis, Minn.

I enclose \$2.50 for which please send me a copy of the book, "How to Plan, Finance and Build Your Home"

Name.....

Address.....

(Please PRINT name and address)

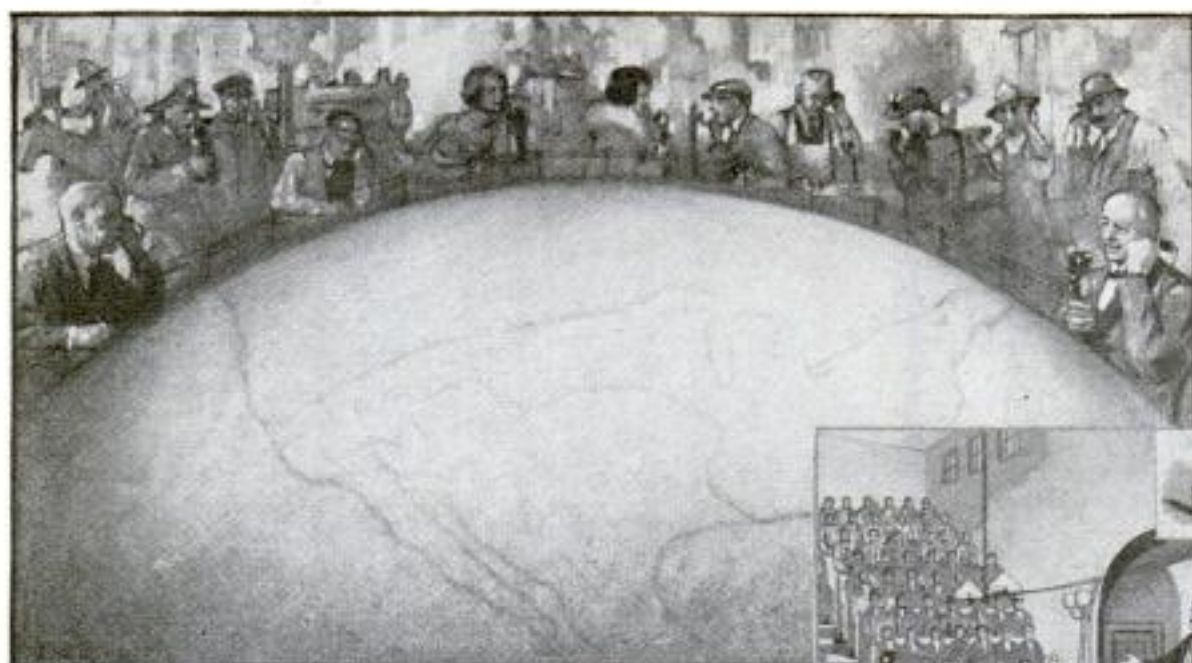

FORTY-THREE years ago Alexander Graham Bell, the inventor of the telephone, wrote this inspired forecast: "It is conceivable that cables of telephone wires could be laid underground or suspended overhead, communicating by branch wires with private dwellings, country houses, shops, manufacturers, etc., and a man in one part of the country may communicate by word of mouth with another in a distant place."

At the right, an old print of Bell lecturing on telephony, 1877.

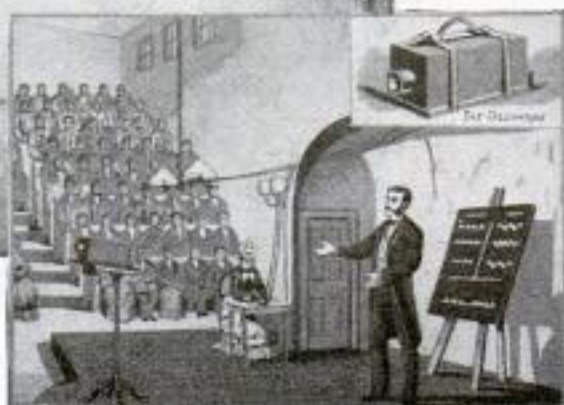

Foresight

More than forty years ago, when the telephone was still in its experimental stage, with but a few wires strung around Boston, the men back of the undertaking foresaw a universal system of communication that would have its influence upon all phases of our social and commercial life.

They had a plan of organization capable of expansion to meet the growth they foresaw; and their wisdom is borne out by the fact that that plan which they established when telephones were numbered by dozens is efficient now when telephones are numbered by millions.

This foresight has advanced the scientific development of the art of telephony to meet the multiplied public

requirements. It has provided for funds essential to the construction of plant; for the purchase of the best materials on the most advantageous terms; for the training of employees to insure skilled operators; for the extension of service in anticipation of growth, with the purpose that no need which can be foreseen and met will find the Bell System unprepared.

The foresight of the early pioneers has been developed into a science during the years which have elapsed, so that the planning of future operations has become a function of the Bell System. This is why the people of the United States have the most efficient and most economical telephone service in the world.

" BELL SYSTEM "

**AMERICAN TELEPHONE AND TELEGRAPH COMPANY
AND ASSOCIATED COMPANIES**

***One Policy, One System, Universal Service, and all directed
toward Better Service***



Just the tension to suit the job

Small drills, large drills, hard wood, soft wood—you can make pressure exactly right with the adjustable tension of the "Yankee" Automatic Push Drill No. 44. No other tool has it.

Using fine drills in brittle material, you turn cap in handle to left, easing tension. With bigger drills in tough wood, you turn cap to right, increasing tension.

"YANKEE" Automatic Push Drill No. 44

Saves drill points. Saves time. Saves labor. Seven different tensions. Eight drill points, 1-16 inch to 11-64 inch. Practically a special tool for each job.

Drill points are held conveniently in magazine handle. It opens UP. No need to turn tool upside down to change drills. All drills in sight at once.

Another "Yankee" Automatic Push Drill—No. 41—is made without adjustable tension, for workers not requiring adjustable feature.

Some other "YANKEE" Tools

*Ratchet Breast Drills
Ratchet Bench Drills
Ratchet Chain Drills
Ratchet Tap Wrenches
Bench Vises, Removable Base*



FREE

Write today for condensed catalogue with many illustrations, showing complete line of ingenious "Yankee" Tools for saving time and labor.

"YANKEE" Quick Return Spiral Ratchet Screw-driver No. 130

Illustrated at right. Spring in handle keeps blade in screw-slot and drives handle back for the next push. Less strain on your muscles. Quicker, better work.

Three adjustments—Right-hand Ratchet, Left-hand Ratchet, and rigid. Draws screws as easily as it drives them. Three sizes of bits included.



Dealers everywhere sell "Yankee" Tools

NORTH BROS. MFG. Co., Philadelphia

"YANKEE" TOOLS

Make Better mechanics

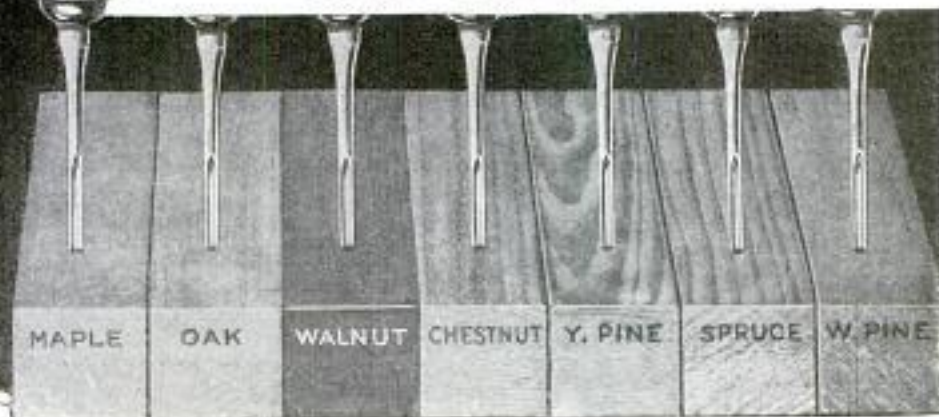



Ask Us Now

This test will delight you

Again we offer, and urge you to accept, this new teeth-cleaning method.

Millions now employ it. Leading dentists, nearly all the world over, are urging its adoption. The results are visible in whiter teeth wherever you look today.

Bring them to your people.

The war on film

Dental science has declared a war on film. That is the cause of most tooth troubles. And brushing methods of the past did not effectively combat it.

Film is that viscous coat you feel. It clings to teeth, enters crevices and stays. Then night and day it may do serious damage.

Film absorbs stains, making the teeth look dingy. It is the basis of tartar. It holds food substance which ferments and forms acid. It holds the acid in contact with the teeth to cause decay.

Millions of germs breed in it. They, with tartar, are the chief cause of pyorrhea. Very few people have escaped the troubles caused by film.

Two film combatants

Now two combatants have been found. Many careful tests have proved their efficiency.

A new-day tooth paste has been created, and these two film combatants are embodied in it. The paste is called Pepsodent.

Now every time you brush your teeth you can fight those film-coats in these effective ways.

Another tooth enemy is starch. It also clings to teeth, and in fermenting it forms acids.

To fight it Nature puts a starch digestant in saliva. She also puts alkalies there to neutralize the acids.

Pepsodent multiplies the salivary flow. It multiplies the starch digestant in the saliva. It multiplies the alkalies. Thus these teeth protecting forces, twice a day, are much increased.

See what the new way does.

Make this pleasant ten-day test and watch your teeth improve.

A few days will tell

Send the coupon for a 10-Day Tube. Note how clean the teeth feel after using. Mark the absence of the viscous film. See how teeth whiten as the film-coats disappear.

Do this now. The effects will delight you and lead to constant delights. To all in your home they may bring new beauty, new protection for the teeth.

10-Day Tube Free 777

THE PEPSODENT COMPANY,

Dept. 690, 1104 S. Wabash Ave., Chicago, Ill.

Mail 10-Day Tube of Pepsodent to

Only one tube to a family

PAT. OFF.
Pepsodent
REG. U.S.

The New-Day Dentifrice

The scientific film combatant, which brings five desired effects. Approved by modern authorities and now advised by leading dentists everywhere. All druggists supply the large tubes.



"I never travel without my Corona
—and many a time Corona has paid
the expenses of the trip!"



"How Corona has added to my income"

By day he is a successful business man; but in the evening his Corona gives him another income.

HE IS just a hard-working business man, who claims no special writing ability. Yet year by year he sells enough material to the magazines and trade papers to give him quite a surprising income.

And this is the secret of his *double* income told in his own words:

"I have owned a Corona—the same one—for seven or eight years; I have carried it with me into nearly every State.

"In one month, when I was away more than usual, I finished up \$200 worth of material for certain papers, which means that Corona paid for itself four times in that month.

"It is surprising," he says, "how much money Corona can make for even an average man or woman, entirely on the side.

"And, of course, Corona pays for itself over and over again right in my regular job. At home, in an hour's time, I can clean up work that would take half the morning in my office. Confidential letters which I dislike to dictate are easy with my tireless little travelling secretary—Corona!"

And the best part of it is that Corona—including the case—costs only \$50! Easy payments if you desire.

CORONA

The Personal Writing Machine
TRADE MARK

Built by CORONA TYPEWRITER CO. Inc., 108 Main Street, Groton, N.Y.



"I've coronatyped letters and manuscripts in hotels, on trains and even on shipboard."

Send for the booklet that tells how to add to your income

IN OUR NEW booklet "Increasing Your Output and Income," you may read personal experiences of men and women who have found this little typewriter a friend worth having. Send for this booklet today if you, too, would like to make more of your opportunities.

Increasing your output and income

Corona
Typewriter
Company, Inc.
Groton, N. Y.

Send me a copy of your booklet No. 8, "Increasing Your Output and Income."

Name

Address

Enjoy a smooth-
running Engine,
for less vibration
means a long
Lived Car.

Genuine



Champion

Dependable Spark Plugs

Produce Best
Possible Results

1922 Prices

*Represent a value you
must consider when buying*
Champion X(Ford).....60¢
Champion Regular.....75¢
Champion "Heavy"....\$1.00

Your Dealer has a CHAMPION for your car

CHAMPION SPARK PLUG COMPANY TOLEDO, OHIO

Nation-wide Life Insurance

Out of a population of 100,000,000 less than 20,000,000 carry life insurance. That is largely because many people live in remote districts not visited by life-insurance agents, and these people were never reached until the method of doing business direct-by-mail was begun by the

Postal Life Insurance Company

The Postal now makes the taking of a policy almost as practicable and easy for a man living in the Yukon district as in a suburb of New York, and this is so because Uncle Sam's splendid postal service carries the insurance proposal to the man, carries his answer back, and arranges all details quickly, directly and at trifling cost. And so it comes that

Policies are issued everywhere and policy-claims paid promptly by the Postal's Direct Method

25,000 Policyholders In the POSTAL LIFE

It might not be difficult for organizations of life-insurance agents throughout the country to induce, let us say, 15,000 people to apply for policies in a certain company. That's because the agents not only do most of the *talking*, but also, for the most part, the *thinking*.

There is one Company, however, that, when requested, supplies by mail, *official information, printed or written*, thus aiding the public directly and in a most responsible manner, to think the matter out for themselves, answering in writing any questions that may be asked. Thousands of men and women have thus taken out policies and repeatedly declared their great satisfaction in having cast their lot with the

POSTAL LIFE INSURANCE COMPANY

Resources \$10,000,000 Annual Income \$2,000,000 Insurance in force \$42,000,000

These thoughtful people discover that by cutting out middlemen, the Company makes important savings, enabling it to guarantee an annual dividend of 9½% which may be deducted from the first premium and from each annual premium thereafter during the life of the Policy, so that policyholders thus

Effect a Substantial Economy

What POSTAL policyholders in our own and other countries have done, other thoughtful men and women everywhere *can do and are doing*. It will pay you, therefore, to

Find Out What You Can Save

To secure full particulars simply write and say:

"Mail me official insurance information as mentioned in Popular Mechanics for March."

In your first letter be sure to give

1. Your full name
2. Your occupation
3. The exact date of your birth

No agent will be sent to visit you. The Postal, as stated, has no agents and the resultant commission-savings go to you, because you deal *direct*. Our new descriptive booklet, "*Buying Direct*," will be mailed on request.

POSTAL LIFE INSURANCE COMPANY

Wm. R. Malone, *President*

511 Fifth Avenue Cor. 43rd St. New York, N. Y.

POSTAL LIFE
BUILDING



P. M. 3-22

POSTAL LIFE INSURANCE CO.
511 Fifth Ave., New York

Without obligating me, please mail full insurance particulars for my age.

Name.....

Address.....

Occupation.....

Exact date of birth.....



GODELL-PRATT

1500 GOOD TOOLS



High-Speed
Bench Grinder
No. 485
Price \$10.80



“What can be worse than a dull tool?” asks Mr. Punch

“You show *your* good sense and keen judgment when you get this Goodell-Pratt High-Speed Grinder. It will sharpen anything 'cept a dull wit,” adds Mr. Punch.

And say! Maybe this grinder isn't fast! Makes 22 revolutions to one turn of the crank. Easily attached and detached most anywhere you want to put it. Gears are enclosed; they're packed in grease. Notice the adjustable work rest.

A 5" x 1" high-grade Abrasive Wheel of the proper grit and grade for sharpening small tools comes with each machine.

No more dull tools in your shop or dull knives in your kitchen! Sharpen up the hatchet—help out the Missus by fixing up the scissors. There's dozens of uses you'll put this grinder to that will make it pay for itself.

Whether you use tools for “fun” or for your bread and butter—or just “putter 'roun'” on rainy Sundays, if your judgment tells you that it's only a GOOD tool that's worth owning and working with, you'll be mighty glad to get acquainted with the Goodell-Pratt Line.

They're tools with a name on them that *means* something.

Write for illustrated booklet, showing many of the tools that every normal man with two good hands would like to own. It's Free.

GODELL-PRATT COMPANY, *Toolsmiths*, Greenfield, Mass.

Your Home Is Within Your Reach When You Buy From Us

NOW is the time to build your Harris Home!

And here is a mighty organization of thirty great departments ready to serve you. Managed by expert material buyers, designers and practical builders. We have vast stocks bought at huge quantity price savings which are now at your command. Our sole aim and purpose is

To help you get a home that will prove entirely satisfactory at a price that will mean a substantial saving in actual dollars of your money.

The combined efforts of these great departments in experimenting and testing materials and methods of construction have produced for you a **GUARANTEED** home, expert machine cut, bundled and marked—the last word in building economy.

Not One Penny in Advance

So sure are we of the super-excellence of our material and our **GUARANTEED** Ready-Cut System that we will ship you any **HARRIS HOME** without the payment of one cent down. Our Plan Book explains our liberal terms fully.

FREE Plan Book

The latest edition is waiting for you, contains our **FREE PLAN OFFER** and photographic reproductions, with floor plans and specifications of 100 beautiful homes. Mail coupon today.

Building Material of All Kinds

For over a quarter of a century, thrifty wise buyers have realized that here is the "open door" to real economy, whether it be a brand new home or material for improvements or repairs. Our big stocks of brand new building material, all purchased in tremendous quantities at savings that are passed along to you are ready for quick and complete shipments.

"PRESTO-UP" Patented Bolt-together Buildings!

The wonder buildings of the age. Guaranteed buildings, for quick industrial housing. Individual Homes, etc., extra strong, practical and suitable for all year 'round habitation in any climate. 50 different plans. They come to you in easily handled sections—painted and stained, ready to bolt together and move in.

Plumbing and Heating!

Hot water and heating systems, warm air heating plants, pipeless furnaces and plumbing material of every kind—the product of America's leading makers. Our mammoth plumbing stock offers unlimited possibilities for you to save money. Our heating plants are guaranteed to heat your home in any weather with big fuel economy. Mail the coupon for our Plumbing and Heating Book and get the benefit of our Expert Engineering Service.

Department NM-7

HARRIS BROTHERS CO.
1349-1525 W. 35th St., CHICAGO

HARRIS BROTHERS CO.
Dept. NM-7, Chicago

These books are **FREE** and sent post paid. Mark an "X" in the squares to indicate which ones you wish.

- Harris Home Book of Plans Book of "Presto-up" Houses and Garages
 Building Material Catalog Plumbing and Heating Book

Name.....

Address.....

**FREE BOOK
of Plans**



Why Pay Full Prices NOW

Diamonds Here at 60% of Market Price



\$63

1/2—3/32 Ct.

Blue white diamond in this ring. Try to match at 60 per cent more. Guar. loan \$50. Same style, various sizes, see Bargain List.



\$200

1—3/16 Ct.

Blue white diamond mounted as shown. Try to match at \$400. Guar. loan \$150.

Same ring, \$50 to \$500 in other weights. See the Bargain List.



Why pay full prices? Buy HERE where loan values the price basis, not market values. This famous 75 year old firm, the largest and oldest diamond banking institution of its kind in all the world, rated more than \$1,000,000.00 capital, having made loans on diamonds in excess of \$20,000,000.00, now has thousands of unpaid loans and other special advantage bargains that we must sell to get back our cash.

Why Pay Full Prices Costs Nothing to See

We send you any diamond for absolutely free examination at our risk. No obligation. Have valued any way you wish. Don't buy unless satisfied you could not match the gem at 60 percent more. If you decide not to buy, you are not out one penny.

Diamonds Here as Low as \$60 per Carat

Yes, some even lower priced, but also diamonds of finest qualities at higher per carat charges. Get a diamond now around half its market price. We must turn these diamonds into cash NOW.

Send for Latest List of Diamond Loans

Not like ordinary catalog. Diamond Bargains described in detail with exact weight, color, quality, etc. Tells of guaranteed loan value, unlimited exchange privilege at full price paid, details of free examination. Why pay full prices? Send for latest list. It's FREE. No obligation. Just send name.

Jos De Roy & Sons, 1984 De Roy Bldg.

Only Opposite Post Office, Pittsburgh, Pa.

References by permission—Bank of Pittsburgh—N. A.
Marine National Bank—Union Trust Company,
Pittsburgh, Pa. Your bank can look us
up in mercantile agencies.



\$388

1 1/4 less 1/16 Ct.

Blue white diamond. White gold ring with sapphires. Try to match at 60 per cent more. Guaranteed loan \$350. Page 29 in Bargain List.



\$350

Blue white, perfectly cut diamond in genuine platinum diamond studded ring. Other diamonds in platinum mountings, \$150 to \$1000. Also magnificent mountings in 18 kt. Swiss white Gold, the exact replica of platinum. See latest Bargain List.



\$75

1 1/2 Ct. Size

Diamond Cluster Ring. Platinum Disk. Try to match at \$140.

Other clusters from \$25 to \$350. Pages 10, 11 and 33 in latest Bargain List.

\$57

3/8—1/16 Ct.

Blue white, perfectly cut diamond. Fancy green gold ring. Try to match at \$120. Guar. loan \$45.

Various size diamonds in this mounting. See Bargain List.



\$48

1 Ct. Show.

Steel white diamonds. Try to match at \$100.

Plain styles, \$25 to \$150, shown in Bargain List.

Jos. De Roy & Sons
1984 De Roy Building
Only Opposite Post Office
Pittsburgh, Pa.

Gentlemen: Please send me free and prepaid, your latest bargain list of diamonds, watches and other jewelry. It is understood I assume no obligation of any kind.

Name

Address

**FREE
Diamond
Expert**

New service FREE to you. World recognized diamond authority will value any diamond for you. Has backed his judgment of diamond values by actual cash advances in loans and other deals in excess of \$20,000,000.00. Write for details.

Guaranteed Cash Loan

Diamonds bought here are like insurance policies. You know what you can borrow before you decide to buy—see
Our Cash Back Guarantee



Actual photo
of one of
our rebuilt
Underwood
Typewriters.

\$3
DOWN

And It's Yours

Standard Underwood

Rebuilt like new. Every typewriter in factory rebuilt by typewriter experts. New enamel—now nickeling—new lettering—new platen—new key rings—new parts wherever needed—making it impossible for you to tell it from a brand new Underwood. An up-to-date machine with two-color ribbon, back spacer, stencil device, automatic ribbon reverse, tabulator, etc. In addition, we furnish FREE, waterproof cover and a special Touch Typewriter Instruction Book. You can learn to operate the Underwood in one day.

From factory to you

Yes, only \$3 brings you this genuine Rebuilt Standard Visible Writing Underwood direct from our factory, and then only small monthly payments while you are using it makes it yours; or, if convenient pay cash. Either way, there is a big, very much worth-while saving, too. Genuine new Underwood parts wherever the wear comes

—genuine standard four row, single shift keyboard—thoroughly tested—guaranteed for 5 years.

\$3 Puts It in Your Home

You don't even have to scrimp and save to pay cash. Instead, you pay only a little each month in amounts so conveniently small that you will hardly notice them, while all the time you are paying,

you will be enjoying the use of and the profits from the machine.

10 Days' Free Trial

Remember, you don't even have to buy the machine until you get it and have used it on 10 days' free trial so that you can see for yourself how new it is and how well it writes. You must be satisfied or else the entire transaction will not cost you a single penny.

**Typewriter Emporium
Shipman-Ward Mfg. Co.**
2123 Shipman Bldg., Montrose and
Ravenswood Aves., Chicago, Ill.



All shipments made direct to you from our big modern factory (shown above)—the largest typewriter rebuilding plant in the world

Use Coupon

Now is the time when every dollar saved counts. Let us save you many dollars. Don't delay. Get this wonderful easy payment bargain offer now, so you can send for and be sure of getting your Underwood at a big saving—and our easy terms or for cash.

**Act Now—
Send Coupon Today!**

FREE TRIAL COUPON

**Typewriter Emporium
Shipman-Ward Mfg. Co.**
2123 Shipman Bldg., Montrose and
Ravenswood Avenues, Chicago, Illinois

Send by return mail Bargain Offer No. 3123 of a Standard Visible Writing Underwood. This is not an order and does not obligate me to buy.

Name.....

Street or
R. F. D. No.

Post
Office.....State.....

No Money Down!

Our determination to double our sales of the world famous **Santa Fe Special Watch** prompts this matchless Offer.

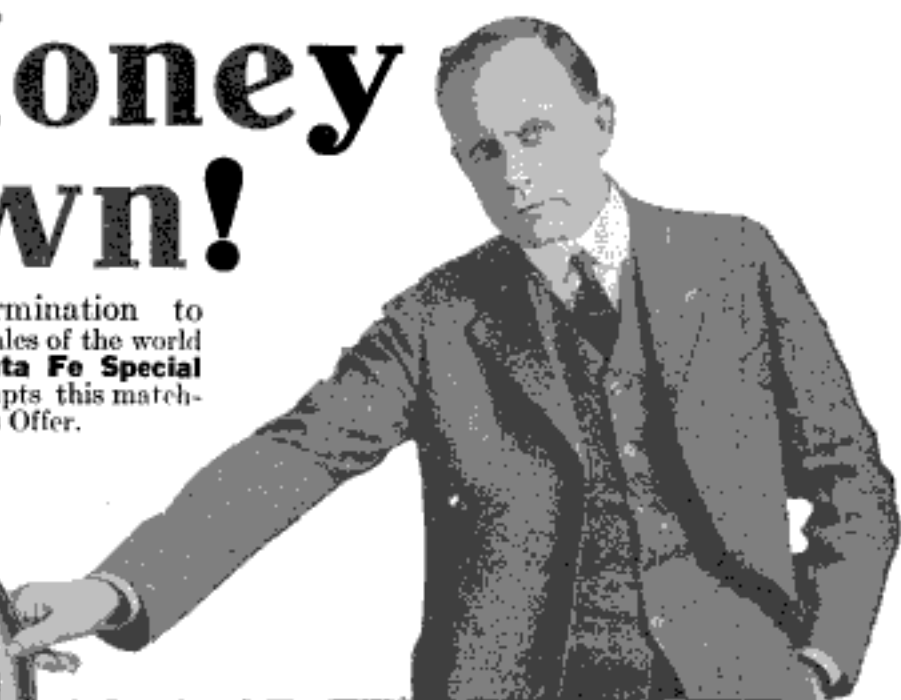

21 Jewels Santa Fe Special Watch

**Newest Designs
Engraved Free
Montgomery Dial**

**21 Jewels
Adjusted to
Temperature**

**Isochronism
and
to Positions**

Without one penny of advance payment let us place in your hands to see, to examine, to inspect, to admire, to approve, a real masterpiece in watch creation.

A watch which passes the most rigid inspection and measures up to the exacting requirements of the great Santa Fe Railway System, and other great American trunk lines.

Ask for our Watch Book free—then select the Watch you would like to see and let us explain our easy payment plan and send the watch express prepaid for you to examine.

Page twelve of our Watch Book is of Special interest to You
Let us send the watch, express prepaid, no money down

Remember—No money down—easy monthly payments buys a master timepiece—a 21 Jewel guaranteed for a lifetime at about half the price you pay for a similar watch of other makes. No money down—a wonderful offer.

SANTA FE WATCH CO.
36 Thomas Bldg., Topeka, Kans.

SANTA FE WATCH CO.
36 Thomas Bldg., Topeka, Kans.

Please send prepaid and without obligation your Watch Book free, explaining your "No Money Down" Offer on the Santa Fe Special Watch.

Name.....

Address.....

City.....
State.....

THE AJAX EYELET FASTENER

Binds Papers Quickly and Permanently

It Saves Time by Punching the Hole, Feeding the Eyelet and Clinching it in One Operation.

Drop the eyelets into the magazine and go right ahead. Order from your stationer or direct.

Write for our catalogue of office tools



MACHINE APPLIANCE CORPORATION
351-353 Jay Street * Brooklyn, N. Y.

ASBESTOS

We are miners and shippers of Crude Asbestos in any quantity. We produce all grades at our world-famous BELL ASBESTOS MINES, in Canada. We also card fibres, spin yarns, weave cloths, and make all sorts of Asbestos products.

For anything you want in Asbestos, turn to

KEASBEY & MATTISON COMPANY
Dept. S-3, AMBLER, PENNA., U.S.A.
Owners of the world's largest Asbestos Mines

Moore Push-Pins
Glass Heads—Steel Points
Moore Push-less Hangers
To hang up things
Ask your dealer to show them
Sold Everywhere **10¢** per packet
Moore Push-Pin Co.
Wayne Junction Philadelphia

SELF-FILLING INK PENCIL "INDEPENDENT"

Meets all requirements. Self-filling, non-leakable, safety cap. Attached clip. Smooth writing gold stylo point.

Guaranteed Improved Fountain Pen. Eliminates fatigue. Promotes efficiency. Writes uniform. A business necessity.

Your Name in Gold—35 Cents Extra

AGENTS WANTED
J. C. ULLRICH & CO., 161 Washington St., New York

MOVIES BOYS! GIRLS! GROWN-UPS!

Write to-day for free Catalogue of our MOVIE MACHINES

REAL MOVIES FOR THE HOME
Wonderful Models \$6.00 to \$25.00, with film
PARAMOUNT MFG. CO., Dept. M
Box 1371 Boston, Mass.

Buchstein's Fibre Limb

is soothing to your stump—strong, cool, neat, light. Easy payments. Braces for all deformities.
D. BUCHSTEIN CO.
113 6th St. S., MINNEAPOLIS, MINN.

Send for a Complete Catalogue of

MASONIC BOOKS

Jewelry and Goods

REDDING & CO.

Publishers and Manufacturers

Dept. D, 200 Fifth Avenue, New York



Note the renewable cutting blades. There's the reason why Neverslips will outcut and outlast any plier made

Here's a Husky Plier That You Can't Wear Out

Just pick up a pair of Neverslip Pliers—heft them—now look at the blades. Here's a pair of pliers you can't wear out.

The secret of Neverslips' long life is just this: When other pliers are made, their cutting edges are made at the same time, from the same piece of metal. That's why they cannot have high carbon crucible steel edges like Neverslips. Moreover, as the Neverslip cutting edges are made separately it means they are renewable. You can cut nails, heavy wire, soft metal or insulation cleanly and quickly with Neverslip Pliers.

For Neverslips will outlast and outcut any plier made. And when it comes down to a matter of price, Neverslip Pliers cost no more than the short-lived pliers you've been buying only to throw away as soon as they become worn.

If your dealer hasn't them in stock, send us his name and we will see that you are supplied.

THE NEVERSLIP WORKS

NEW BRUNSWICK

NEW JERSEY

NEVERSLIP

side cutting pliers

Neverslip Pliers are furnished in 6-7 and 8 inch sizes.



WHITING-ADAMS BRUSHES

Vulcan Rubber Cemented Shaving Brushes make shaving a pleasure. They wear for many years.

Invincible Hair Brushes. Strong, stiff bristles. Beautiful wood, richly finished. Very popular with lovers of good brushes.

Send for Illustrated Literature

JOHN L. WHITING-J. J. ADAMS CO.
Boston, U. S. A.

Brush Manufacturers for Over 112 Years and the Largest in the World

Made **\$164** in one Week



R. A. Meyer

"For just one week my net profits were \$164," writes R. A. Meyer. He is only one of hundreds making big money acting as our representative for this wonderful new light.

Burns Kerosene or Gasoline

Gives 300 candle power soft, brilliant light, restful to eyes. Costs 1c an evening. Absolutely safe. Lights with match. Most wonderful light of age—Table Lamps, Hanging Lamps, Lanterns. Big season now on. You can earn as Meyer has. Work all or spare time. Commissions paid same day you take orders. No experience necessary. Write today for catalog and agents FREE outfit offer.

THE AKRON LAMP CO.

103 Lamp Bldg., Akron, Ohio



THE DIAMOND LIGHT

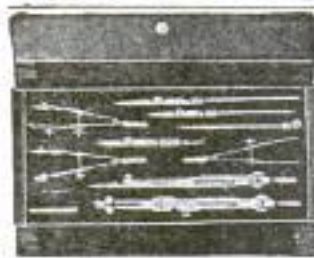

\$29.00 Value Set Mechanical Drawing Instruments

Special Wholesale Price \$6.75 Postpaid

Pocket case 4x8 1/2 inches—velvet lined—Instruments constructed of solid nickel silver and steel—guaranteed. Order now—supply limited. Free illustrated particulars.

NATIONAL INSTRUMENT CO.

4704 N. Hamilton Avenue, Chicago, Ill.

GREEN AUTOMATIC MACHINE



ADD TO YOUR INCOME WITH LITTLE EFFORT \$5 to \$10 A DAY MADE EASY WITH

New Improved Green Automatic Machine

Sharpens, Honed and Straps all kinds of safety razor blades, in one operation, from four to six blades per minute. For both Quality and Quantity, this machine is in a class by itself. There is nothing like it on the market. Let us send you our descriptive literature explaining everything, including the "AMERICAN" Key Cutter—cuts square, angular or round slots.

AMERICAN SHARPENING MACHINE CO. (Inc.), Dept. 3, 114 W. Washington St., CHICAGO



"AMERICAN" Key Cutter

SEND NO MONEY

Try this Portable Typewriter 10 Days FREE



Now you can buy famous 9-pound National Typewriter direct from the factory, after 10 days' trial—absolutely free. You be the judge. Then we give you

10 MONTHS TO PAY

Same machine as used by thousands of doctors, lawyers, bankers, salesmen, students, writers and business men in 31 countries. Every feature of best, standard size machines. 28 keys.

10 Months to Pay

84 characters. Brand new—not a rebuilt typewriter. Neat, compact carrying case free with every machine. Send today for our 10 Days' Free Trial offer and 10 Months' Easy Payment Plan.

NATIONAL TYPEWRITER CO.

Dept. 7C.

Fond du Lac, Wis.

MAKE MONEY Building Phonographs

We furnish everything—blue print plans—case material, tone arms, motors, full instructions. You can easily make \$100 to \$200 a month in spare time. Even boys of 14 make them. They play any record. Wonderful tone—equal to any you ever heard. Sell to friends and neighbors. Write now for free blue print offer.

Choraleon Phonograph Co.
322-1st Street ELKHART, IND.



It's easy with our plans.



New Book Free

Write today for the book that tells about the opportunities in the profession of Signal Engineering. Men are needed. Learn, too, how you can get the training that you need to fill the big job.

\$125 to \$300 a Month

The free book will give you just the information you want. Write for it now—immediately. Here is a golden opportunity.

Dept. 1353, 1924 Sunnyside Ave. Ravenswood St., Chicago, Ill.

\$600 to \$5,000 PROFIT FROM WASTE STORE SPACE



Business men! Send for amazing story of Butter-Kist Peppers and Peanut Machine profits. Pays big in drug, department, candy, other stores, theatres, etc. Write

HOLCOMB & HOKE MFG. CO.
946 Van Buren St. Indianapolis, Ind.

HAWAIIAN IM. DIAMONDS



No. 8010 Special price \$2.98

The Greatest Discovery the World Has Ever Known

Just to advertise these famous Im. diamonds we will send you one of these 14K gold rings, postage paid. When it arrives pay postman \$2.50 C.O.D. change to cover cost, etc. Only 10,000 rings given away. Money refunded if you can tell it from a genuine diamond. Send size of finger.

KRAUTH & REED

Dept. C Masonic Temple Chicago



No. 8011 Special price \$2.98



AGENTS 500% PROFIT

Gold and Silver Sign Letters

For store fronts, office windows and glass signs of all kinds. No experience necessary. Anyone can put them on and make money right from the start.

\$75.00 to \$200 a Week!

You can sell to nearby trade or travel all over the country. There is a big demand for window lettering in every town. Send for free samples and particulars. **Liberal Offer to General Agents.**

METALLIC LETTER CO.

43B North Clark Street

CHICAGO, ILL.

AGENTS: \$6 PER DAY AND UP

Selling concentrated non-alcoholic food flavors. Always fresh. Put up in collapsible tubes. Ten times the strength of bottled flavors. Guaranteed under U. S. pure food laws. All flavors. Sells in every home. Used every day. Not sold in stores. Big demand. Big repeater. 100% profit.

Men or Women

can make big money. Hunt sold over \$300 in one month. You will find this a big, easy seller and a sure repeater. Must satisfy customers or money back. Write for territory and sample outfit. Get a big line of customers. Get repeat orders every month and have a steady income. Write quick.

American Products Co.

5521 American Bldg., Cincinnati, O.



Act
Quick
Write
Today

Do Your PRINTING

Cards, circulars, labels, tags, book, menus, paper, Press, \$12. Larger \$35. Job Press \$150 up. Save money. Print for others. **BIG PROFITS.** All easy, rules sent. Write factory TODAY for press catalog, TYPE, cards, paper. **THE PRESS CO. D-37, MERIDEN, CONN.**

DISTRIBUTORS

DISTRICT SALEMEN MANAGERS AGENTS

Do you know that we make the best Waterproof Aprons and Sanitary Specialties on the market? Sell for less, and your profits are largest.

Write now and construe yourself.

B & G RUBBER MFG. CO.

618 Penn Ave., Dept. 126, Pittsburgh, Pa.



A GENUINE \$2 KNIFE
FOR
\$1.38 POSTPAID

Direct at Factory Prices

This \$2 KNIFE \$1.38 Postpaid
Hand Forged Razor Steel Blades

Handy shaped blade makes this knife best for mechanics, sportsmen and farmers; light but strong; re-sharpened easily. Stag handle. German silver finish; blades file tested, hand forged from razor steel and warranted.

Sample \$1.38. 3 for \$3.60 postpaid.

Send for our 100 page List and "HOW TO USE A RAZOR" **FREE**

MAHER & GROSH CO., 106 A. St., Toledo, Ohio

Going to Build Remodel or Repair?

DON'T think of planning a new home or repairing an old one without copies of our two free books.

Our Building Material Catalog shows latest ideas and most advanced styles for everything in building. We ship everywhere everything in the way of high grade lumber roofing, doors, windows, porchwork, screens, builder's hardware, paints, wallboard, interior woodwork, plumbing, heating and water supply outfits — all at money saving prices direct to you. Plan Book shows skillfully planned homes of all kinds, bungalows, city houses, suburban residences, country homes, barns. Tells you how to get building plans FREE. Write today. No obligation.

Let us develop plan from your rough sketches. Send your material bills for free estimate price.

Material Complete for Houses from \$500.00 Up

Catalog of 6000 Price Barparais

Beautifully Illustrated PLAN BOOK

CHICAGO MILLWORK SUPPLY CO., 1144 W. 37th St., Chicago, Ill.
PLEASE SEND ME YOUR FREE BOOKS.

Name _____
Town _____
State _____
Occupation _____

Books Are Free

GREAT INTERCHANGEABLE-TYPE TYPEWRITER

Hammond

MULTIPLY

A NEW **FOLDING MODEL**
Full Capacity

Write for Free Booklet, Hammond Typewriter Co., 561A East 69th St., New York

10 Cents a Day Pays



For smaller Symphonola, Style pictured and others 17c to 25c a day. Tens of thousands giving satisfaction.

SYMPHONOLAS

No expensive attachments needed to play all Records. Tone natural, life like. Well built. Highest quality equipment.

NO MONEY DOWN

Shipped anywhere in U. S. 30 Days FREE Trial before you make first payment. If pleased take up to 2 years time.

RECORDS 70c EACH

Play on all phonographic (basic steel) needles. Latest vocal and instrumental hits. Also Sacred and Operatic. Full size 10 inch. Postpaid. Ask Today for Symphonola Booklet and Record List.

Larkin Co. Inc.

Desk SPM-322

Buffalo, N. Y.

A MOTO-MOWER For Only \$175.00

We announce a new model 24-inch mower—exactly the same simple, durable construction as our larger, more expensive machines, for the remarkably low price of \$175.00.

Only eleven moving parts—weighs only 100 pounds. Built by an old, well-established concern.

Used in New York City parks and by hundreds of other cities, estate owners and institutions throughout the country.

Send us the dimensions of your grass areas, and we will give you an estimate of what your cutting cost and time should be, and the savings you could expect, together with an interesting book about the Moto-Mower.

Large Model, 27-inch
Moto-Mower
Price Complete, \$210

THE MOTO-MOWER COMPANY
3250 E. Woodbridge St., Detroit, Mich.



KEITH'S \$2.50 OFFER



3 Plan Books, showing 100 designs of artistic bungalows, cottages, or two-story houses—in frame, stucco and brick—with floor plans and descriptions, and 8 months' subscription to Keith's Magazine, all for \$2.50.

Keith's Magazine for over 20 years an authority on planning, building and decorating homes—25¢ a copy on newsstands. With its help and Keith's Plans you can get the most distinctive, comfortable and satisfactory home with greatest economy.
Set of 3 plan books (260 plans) and Keith's for 12 months—\$4.50
Keith Corporation, 529 Abbey Bldg., Minneapolis, Minn.

A LATHER THAT SOOTHES

Palmolive Shaving Cream gives a full, creamy lather that makes the beard wiggle. The razor moves smoothly. Palmolive is also a lotion. Contains both Palm and Olive oils. Write for free trial tube. Large size tube at drugstore 35¢.
THE PALMOLIVE COMPANY, Milwaukee, U. S. A.
PALMOLIVE SHAVING CREAM.

Small Payment Down

Balance Oct. 1st



Stove prices hit bottom. Manufacturers slashed prices—greatest money-saving event of years. Order now—small first payment—pay balance October 1st. No interest. Wonderfully beautiful styles—porcelain blue enamel—finest ranges ever made. Write today. Also get offer on other home needs. Ask for Catalog No. 473.

Kalamazoo Stove Co., Mfrs.
Kalamazoo, Mich.

A Kalamazoo
Trade Mark
Registered
Direct to You

High Grade WATCH



This renowned high-grade standard man's or boy's watch at a special introductory offer, only \$3.45. We sell direct by mail at importer's prices, eliminating all middlemen's profits—(saving you \$8.00 to \$12.00). This perfect time-keeping watch has beautiful fancy engraved dial of latest and most popular designs, including gold, silver and radium fronts. Guaranteed movement. Carefully adjusted to position and accuracy in latest thin model, highly polished, solid silveroid case. Unequaled for beauty.

FREE KNIFE & CHAIN

A handsome, up-to-date, gold finished waltz-dance chain and knife absolutely free with every watch at this special introductory offer. Our supply is limited, so send for yours today.

Send No Money

Just send your name and address. The watch, with free knife and chain will be shipped C. O. D. postage prepaid. You take no risk. Our written guarantee with every watch is your protection. Send today while this offer holds good.

FIRST NATIONAL WATCH CO.
1526 S. Wabash Ave., Dept. 206, Chicago, Ill.

PLAN YOUR FUTURE HOME NOW



Send for Stillwell Building Books with Economy Plans of new California Styles suitable for any climate. Famous for comfort and beauty

- "Representative Cal. Homes"
50 Houses—7 to 10 Rooms, \$1
- "The New Colonials"
60 Houses—6 to 10 Rooms, \$1
- "West Coast Bungalows"
50 Houses—6 & 7 Rooms, \$1
- "Little Bungalows"
75 Houses—3-4-5 Rooms, \$1

SPECIAL OFFER: Send \$2.50 for any three of these FREE books and get Garage Folder

Money back if not satisfied.

E. W. STILLWELL & CO., Architects, 783 Calif. Bldg., LOS ANGELES

Beautiful HOUSES \$900 and BUNGALOWS

CAN BE BUILT FOR AND UP

This and many others in my new book, Building Plans for Modern Homes, will save you hundreds of dollars. One of the most complete and comprehensive books of plans ever published by any architect. New edition just off the press. Nearly 500 floor plans and photographs of bungalows, Colonial houses, etc., costing from \$200 up; gives sizes and cost to build.

Sent postpaid for \$2.95

FREDERICK H. GOWING
ARCHITECT

18 Tremont St., BOSTON, MASS.

"Lighting Fixtures"

READY TO HANG

(Direct from Manufacturers)

Completely wired, including glassware. New designs. Send for catalogue No 20.

ERIE FIXTURE SUPPLY CO.
STA. A. ERIE, PA.



The BEST LIGHT



Positively the cheapest and strongest light on earth. Used in every country on the globe. Makes and burns its own gas. Casts no shadows. Clean and odorless. Absolutely safe. Over 200 styles. 100 to 2000 Candle Power. Fully Guaranteed. Write for catalog. AGENTS WANTED EVERYWHERE.
THE BEST LIGHT CO., 324 E. 5th St., CANTON, O.

EASY NOW TO KILL EVERY RAT AND MOUSE

Startling New Discovery Gets Rid of Every One—Not a Poison

Absolute freedom from rats and mice is now assured everyone. No more trapping and poisoning just a few. Clean out the whole bunch, old, young, big and little. Rats do millions of dollars worth of damage, carry cholera, plague, kill chickens, destroy grain, damage buildings, merchandise, and carry disease into every home.



Chemists, after working for years in the laboratory of Chas. M. Hick, a Chicago chemist, discovered this wonderful new scientific rat killing virus called HICK'S RAT KILLER. It kills every rat or mouse on your place. Most wonderful of all, it does not harm anything but rats, mice, gophers, and other rodents. It is harmless to children, pets, poultry, and all kinds of stock. It can be spread anywhere and will kill only rats and mice. One rat or mouse infects the others and soon the whole colony is wiped out. There is no smell or odor for they run outside for water and die away from the building.

A Trial Costs You Nothing

So confident is Mr. Hick that Hick's Rat Killer will kill every rat or mouse on your place that he is making a special guaranteed offer of three regular full sized double strength \$1.00 bottles for the price of one. Use one yourself according to the simple directions on the bottle, and sell the other two to your neighbors at one dollar each, thus getting your own free and making one dollar profit. Mr. Hick will also tell you how you can make more money by telling your friends about it. You should clip this article out now for this offer may not appear again.

Send no money; just your name and address and deposit with the postman \$1.00 and postage when the three bottles arrive. It costs you nothing if it does not do the work as Mr. Hick positively guarantees to refund your money any time after thirty days if you are not satisfied. Write to

CHAS. M. HICK & CO.

Dept. 300, 1018 S. Wabash Ave., Chicago, Ill.

GILBERT BOY ENGINEERING

The greatest boys' book in years, 128 pages of articles on athletic Training, Football Strategy, Flying, etc., by noted authorities. Chapters on many wonderful sciences. Contains complete catalog of Gilbert Toys. Sent at cost, 25c. Also write for free folder on Gilbert Toys.

A. C. GILBERT CO., 477 Blatchley Ave., New Haven, Conn.

5 Master Keys

Only keys of their kind in existence—(patented). Open and test thousands of different locks. Tell you instantly if your door or padlocks are burglar proof. Serve in emergencies, too. Thousands of sets in daily use among detectives, policemen, contractors, locksmiths, firemen, mechanics, travellers, home and hotel owners, etc. Give feeling of security and protection worth many times their cost. Novel key chain FREE with each set. Send only \$1 today. **MASTER KEY CO., 67 MANHATTAN BLK., MILWAUKEE, WIS.**

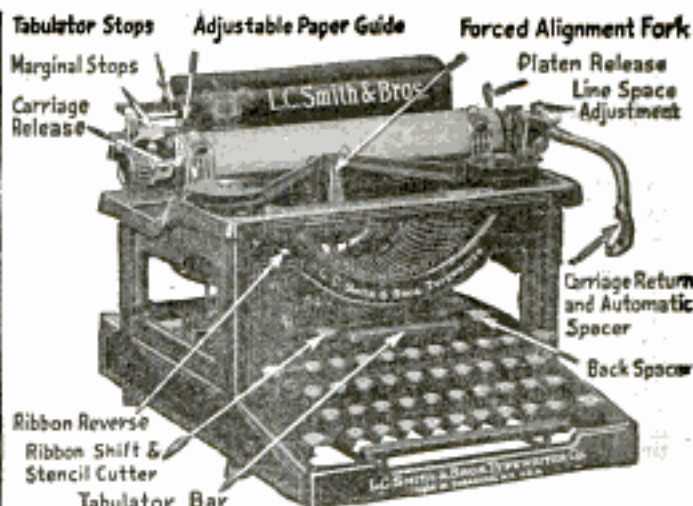

TYPEWRITER SENSATION!

Free Trial—Use as You Pay

Send us only \$5.00 a month until the low total price of \$64.85 is paid, and the machine is yours.

This is absolutely the most generous typewriter offer ever made. Do not rent a machine when you can pay \$5.00 a month and own one. Think of it—Buying a \$100.00 Machine for \$64.85. Cash price, \$59.85, just a little more than half its original price.

L. C. SMITH Model No. 5

Perfect machines. Standard size. Keyboard of Standard Universal arrangement, 42 Keys, writing 84 characters—universally used in teaching the touch system. The entire line of writing completely visible at all times, has the tabulator, the two color ribbon, with automatic reverse, the back spacer, ball bearing type bars, ball bearing carriage action, ball bearing shift action, in fact every late style feature and modern operating convenience. Comes to you with everything complete; tools, cover, operating book and instructions—nothing extra to buy. You cannot imagine the perfection of this beautiful reconstructed typewriter until you have seen it. We have sold thousands of these perfect late style machines at this bargain price and every one of these thousands of satisfied customers had this beautiful, strictly up-to-date machine on five days' free trial before deciding to buy it. We will send it to you F. O. B. Chicago for five days' free trial. It will sell itself, but if you are not satisfied that this is the greatest typewriter you ever saw, you can return it at our expense. You won't want to return it after you try it, for you cannot equal this wonderful value anywhere.

SEND NO MONEY Put In Your Order Now

**\$4.85
AFTER
TRIAL**

When the typewriter arrives deposit with the express agent \$4.85 and take the machine for five days' trial. If you are convinced that it is the best typewriter you ever saw keep it and send us \$5.00 a month until our bargain price of \$64.85 is paid. If you don't want it, return it to the express agent, receive your \$4.85 and return the machine. We will pay the return express charges. This machine is guaranteed just as if you paid \$100.00 for it. It is standard. Over half a million people own and use these typewriters and think them the best ever manufactured. The supply at this price is limited, the price will probably be raised when next advertisement appears, so don't delay. Fill in the coupon to-day—the typewriter will be shipped promptly. There is no red tape. We employ no collectors—no collectors—no chattel mortgage. It is simply understood that we retain title to the machine until full \$64.85 is paid. You cannot lose. It is the greatest typewriter opportunity you will ever have. Do not send us one cent. Get the coupon in the mails to-day—sure.

SMITH TYPEWRITER SALES CO., 222, 218 N. Wells St., Chicago, Ill.

SMITH TYPEWRITER SALES CO., 222, 218 N. Wells St., Chicago, Ill. Ship me the L. C. Smith Model No. 5, F. O. B. Chicago, as described in this advertisement. I will pay you \$5.00 monthly as rent until the \$60.00 balance of the Special \$64.85 sale price is paid. The title to remain in you until fully paid for. It is understood that I have five days in which to examine and try the typewriter. If I choose not to keep it I will carefully repack it and return it to the express agent. It is understood that you give the standard guarantee.

Name.....
Street Address.....
City..... State.....
Occupation or Business.....

1/2 SAVED
BUY DIRECT
GET BIG BOOK



DO YOUR OWN PLUMBING & HEATING AT LOW COST



Pipeless Furnace

Send for our big instructive 256-page well-bound **HANDY MAN** Book-Catalog. Every homeowner, contractor, farmer, mechanic, institution, etc., needs it. Shows over 10,000 fixtures and supplies in plumbing and heating at wholesale; how to save skilled labor, hard work and unnecessary material by our new

Cut-To-Fit Method

This wonderful encyclopaedia on plumbing and heating helps you select and install the proper plumbing, water system, hot air, water or steam plant. Besides being our wholesale catalog, it has many practical plans, diagrams, sketches, elevations, handy kinks, etc., showing how to do the work this newer easy way. Any handy man with a few tools can do his own installing with the aid of this

Big Handy Man Book

We have spared no effort, and have gone to a **GREAT EXPENSE** to compile this valuable book, and to keep from sending it to uninterested persons, we request 25c, which will be refunded on your first order, or send for our free bulletin.

Write today and save.

HARDIN-LAVIN CO.

50 Years at 4547-4557 Cottage Grove Avenue, CHICAGO

\$500,000 Plants Behind Our Guarantee



Hot Water boiler

WHITE FLAME

BURNERS make your old kerosene lamps and lanterns give a brilliant white light better than electricity or gas. Doubles your light. Saves oil. **NO MANTLE TO BREAK.** Guaranteed Safe and Reliable. Delights every user. Send now for complete details postpaid 25 cents, stamps or coin. 3 for \$1.25. Money Back if Not Satisfactory. Live Representatives Wanted. Exclusive Territory. WHITE FLAME LIGHT CO., 68 Clark Bldg., Grand Rapids, Mich.



Lice-Proof Nests

WRITE QUICK for Catalog and our **SPECIAL OFFER**
Nests won't cost you 1/2 your hens will pay for them in more Eggs

Get from 20 to 50% more Eggs, have healthier hens, make more money with the Ever-lasting and Sanitary **KNUDSON** Galvanized Steel Lice Proof Nests. 50,000 in use. Costs less than wood. Unlimited guarantee. Send name today for Special Offer and interesting literature. Also prices on Poultry Fountains, Brood Coops and other poultry appliances.

WRITE TODAY! Box 516
SEAMAN SCHUSKE METAL WORKS CO., St. Joseph, Missouri

New Gum Vending Machine Makes You \$10 to \$20 a Day

Pays Rent for Store Owner

Install one in your store or any public place and get this easy profit. Requires no attention. Always works. Machine's profits pay the rent. Write us about rebuilt penny and nickel machines. Finished like new. In excellent running order. Pay their cost in 10 days.

Write or wire today for full particulars. \$25 down payment. Balance C. O. D. Mints \$30 per case - 2,000 5 cent packages. Single boxes, 100 5 cent packages, \$2.50.

SILVER KING NOVELTY CO.
400 Williams Bldg. Indianapolis, Ind.



Detroit Incubator \$12⁴⁵

140-Egg Size—Guaranteed—has double walls, copper tank, full-size nursery, automatic regulation thermometer held so that chicks cannot break it when hatching. Detroit Brooders, too. Double walled, hot water heated. Write for special low price on both machines.

Detroit Incubator Company

Dept. 32 Merritt Street, Detroit, Michigan



RAISE BELGIAN HARES

New Zealand Reds - Flemish Giants - American Blues. **BIG PROFITS, WE PAY \$1.50 TO \$8 EACH.** Also Cavies, Mink, Skunk, Fox, Muskrat, Etc. Easily raised anywhere. **FREE!** Illustrated book and Contract "COMMON SENSE RABBIT RAISING," quarterly journal, and copy of America's leading small stock magazine, all for 10 cents. Address Outdoor Enterprise Co., 1005 S. E. Bldg., KANSAS CITY, MO.

MONEY IN MUSHROOMS
NOW TIME TO START
BIG DEMAND. HIGH PRICES BEING PAID
An uncrowded occupation. Exceptional opportunities for live men and women. Raised at home. Only small space needed. Small expenditure will start you in a practical money-making enterprise. Big profits. Booklets selling all free. Write Nat'l Spawn Co., Dept. 17, Waban, Mass.

POULTRY MILLER'S GUIDE

—tells all about raising chickens, care, feeding, etc. Quotes special low prices on eggs for hatching, poultry, baby chicks, incubators, brooders, and poultry supplies, fully illustrated, sent **FREE**
J. W. MILLER Co., Box 12, Rockford, Ill.



SQUAB BOOK FREE

Squabs are selling at the highest prices ever known. Breed them and make money. Write at once for free book, prices, etc.
Plymouth Rock Squab Co., 634 Howard St., Melrose Highlands, Mass



GREIDER'S FINE CATALOG

of fine bred poultry for 1922; all choicest breeds illustrated and described; information on poultry, how to make hens lay, grow chicks—all facts. Low price on breeding stock and hatching eggs. 30 years in business. This book only 10c.
B. H. GREIDER, Box 19, RHEIMS, PA.

PLANS FOR POULTRY HOUSES!

All styles. 150 illustrations; secret of getting winter eggs; and copy of "The Full Egg Basket." Send 25 cents.
INLAND POULTRY JOURNAL, Dept. 74, Indianapolis, Ind.

IVER JOHNSON

The SAFE Revolver



TYPEWRITERS

All Makes. Save \$25 to \$50 on rebuilt at the factory by the well-known "Famous Young Process." Sold for low cash—installment or rented. Rental applies on purchase price. Write for full details and guarantee. Free trial.
YOUNG TYPEWRITER CO., Dept. 155, Chicago

Different from all others—the NEW BENJAMIN



AIR RIFLE

Made on a different principle from all other Air-Rifles. The Benjamin is really a strong air-pump used to compress the air in the air chamber to any degree of power desired. From one to six strokes of the pump give all the force necessary. Each additional stroke gives increased power. The Benjamin works on the same principle as all air-drills and air-hammers—with this difference:

You control the shooting force as you desire. Look at this block of hardwood. It shows how Benjamin power is regulated as you wish.

You can't have accidents with a Benjamin. It's safe, always, because you control the power. The Benjamin never loses shooting force, and has no springs to get out of order or shake your aim. Write us for an interesting folder about this wonderful air-gun.

For sale by all dealers. Price \$5.00.

BENJAMIN AIR-RIFLE & MFG. CO.
615 N. Broadway, St. Louis, Mo.

Ask your dealer for demonstration.

Pacific Coast Representatives
McDonald & Liorth,
Call Bldg.,
San Francisco



Cut Price!

Save money. Try this wonderful range at OUR RISK. We pay the freight. Over 150,000 in use. All sold on THIRTY DAYS' FREE TRIAL.

Great Fuel Saver. Wonderful Baker!

Housewives delighted with results. Amazing demand. Many exclusive features. **Odor**—carries all odors up chimney. **Ash Sifter**—sifts ashes right in range. No dust. **Stone Oven Bottom** absorbs and holds heat. Makes baking sure and successful. **GUARANTEED**. Will last for years. You can buy this wonderful range **DIRECT FROM FACTORY** at **WHOLESALE PRICE**—our only selling plan. New 1922 design has white enamel front. Hurdled other styles from which to choose. **Easy Credit Terms** if desired. Write today for big FREE catalog.

THE IMPERIAL STEEL RANGE COMPANY
769 Detroit Avenue Cleveland, Ohio



\$2.63 \$3.25

SEND NO MONEY

If You Can Tell it from a GENUINE DIAMOND Send it back

To prove our blue-white MEXICAN DIAMOND cannot be told from a GENUINE DIAMOND and has same DAZZLING RAINBOW FIRE, we will send a selected 1 carat gem in ladies Solitaire Ring. (Cat. price \$5.20) for Half Price to introduce, \$2.63, or in Gentle Heavy Tooth Belcher Ring (Cat. Price \$6.50) for \$3.25. Our finest 12k Gold Filled mountings. **GUARANTEED 20 YEARS. SEND NO MONEY.** Just mail postcard or this ad, State Size. We will mail at once. When ring arrives deposit \$1.63 for Ladies ring or \$3.25 for Gentle with postman. If not pleased return in 7 days for money back less handling charges. Write for Free catalog. Agents Wanted.

MEXICAN DIAMOND IMPORTING CO., Dept. ET-Las Cruces, N. Mex.
(Exclusive controllers Mexican Diamonds)

New Invention Revolutionizes The Art of Cooking

I am now able to offer to the world the cheapest, easiest and most perfect method of preparing the family meals ever known. Here is a cooking appliance that saves 50% to 75% of fuel cost—saves hours of time—saves countless steps—and insures better prepared, more tasty and healthful meals, from cereals to dessert.

Automatic Rapid Electric Cook Stove

A new, simple, practical invention that gives you every cooking, baking, roasting, frying, boiling and toasting facility of the expensive electric range, plus every advantage of the fireless cooker, at less than you would pay for even a good gasoline or oil cookstove, and at less fuel expense than any other known method of cooking. No other cooking stove or appliance needed.

Simply snap on the switch and electricity heats the food. When the cooking starts, it shuts off automatically and the "fireless cooker" principle does the rest, without any additional heat or attention from you.

Attaches to any electric light socket, requires no special wiring. Ready for use when you receive it. Aluminum lined throughout. Equipped with "Wear-Ever" cooking utensils. Guaranteed.

Try It Thirty Days At My Risk

I want you to try this great invention 30 days in your own kitchen—at my risk. I want to prove what it will do for you.

Send for my FREE Home Science Cookbook Today
A Postcard will do. Write today!

THE WM. CAMPBELL CO.
Dept. 64 Detroit, Mich.

Wm. Campbell,
President
The
Original
Fireless
Cooker
Man



Saves
50% to 75%
of Fuel Cost
for Cooking

Send No Money

21 Jewel Illinois

The greatest watch value ever offered. Unequalled for beauty, accuracy and reliability. 21 ruby and sapphire jewels—adjusted to positions, temperature and isochronism, 20-year gold-filled case. SPECIAL: Silver Damascened Dial.

10 Days' Free Trial

Wear it for 10 Days at our risk. Note its absolute exactness. If at the end of ten days you are not satisfied, just send it back at our expense.

Knife and Chain Free

We are offering for a limited time this handsome gold-filled knife and chain ABSOLUTELY FREE.

ONLY 11c A DAY

Just send your name and address. The watch, chain and knife come to you, prepaid. Give the expressman \$8.50 as a deposit. If after 10 days, you do not wish to keep them, return at our expense; your deposit will be refunded instantly. Trial is absolutely free. If you keep the watch pay \$3.40 a month until full price of \$42.50 is paid. This splendid watch will cost you less than 11c a day. Act at once. De Luxe catalog of Diamonds, Jewelry, etc., sent free. Address Dept. 62-H

CAPITAL \$1,000,000

"The House of Quality"

L. W. SWEET, INC.
1650-1660 Broadway New York



MOTORCYCLES

RELIABLE STANDARD MAKES that you can **DEPEND** on.

Enjoy the glorious experience of going wherever you like—whenever you like. The price is within your means—35% to 50% less than others. These machines are slightly used, thoroughly overhauled or rebuilt. Best for economy.

MYEROW BROS.,
258 Columbus Ave., Boston, Mass.

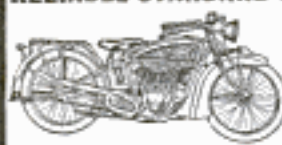

\$SAVE MONEY\$

MOTORCYCLE & BICYCLE PARTS, ACCESSORIES, TENNIS GOODS, CAMPING EQUIPMENT, CHILDREN'S VEHICLES, FISHING TACKLE.

Send us your name for our 1922 72-page illus. Catalog No. 6. It saves you the middleman's profits of 10 to 25%.

GOTHAM SPORTING GOODS CO.
128 Chambers St., New York City.



Used Motorcycles
\$40° and up
Bulletin
FREE
ALL MAKES
ASH MOTOR CORPORATION ROCHESTER, N.Y.

STEADY WORK



in a fast growing business. With Vanderpool latest improved Vulcanizer made in America you can **MAKE MORE MONEY**

\$100 to \$150 worth of work can be turned out in a day with the five cavity plant—profit about one-half.
VANDERPOOL VULCANIZER CO., Dept. P3, Springfield, Ohio
F. H. Dibb, Agent for the British Isles, 26 Fairfield Rd., Winchester, England

AUTO DRIVERS

Can make big money in spare time or devote entire time to introducing and taking orders for our

IMPROVED CORD TIRES

Highest quality. Sensational prices. Big profits. Permanent business.

Write today for catalog and agent's special offer.

LANGAN & PHILLIPS
Dept. 104 CHICAGO



25 MILES PER HOUR!



is record of our stock car, using our special 1922 motor. Anybody can assemble this car. Send 30 cents for plans, instructions and price list of parts.

SYEPHER MFG. CO.
146 Sypher Bldg. TOLEDO, OHIO

Get this Combination



Handle Bar and Carrier

Can't joggle or unbalance load. Handles located on side of basket. Only sensible way to carry packages, papers, tools, etc. Write now for facts on this and Recker's new size tube Clincher Tires. Ask **FREE** for illustrated book.

THE BECKLEY-RALSTON COMPANY
1819 Michigan Ave. CHICAGO, ILL.



Catch Fish, Eels, Turtles, Mink, Muskrats and other fur-bearing animals in large numbers, with our new Folding, Galvanized Steel Wire Trap. It catches them like a fly-trap catches flies. Made in all sizes. Strong and durable. Write for Descriptive Price List, and our Free Booklet on best bait known for attracting all kinds of fish.
J. F. GREGORY, Dept. 24 LEBANON, MO.



HB Battery Charging Pays \$150 to \$300 Monthly

Only \$20 brings an HB Charger and starts you making big steady profits. Balance on easy monthly terms, quickly paid by your earnings. Big demand **RIGHT NOW** for reliable battery service. Don't wait, write **TODAY**. Let us suggest outfit to make you biggest profits. Sizes for 6, 10, 16 or 32 batteries. Ask about HB tire buffers, lighting generators, ball bearing motors, air compressors, and other money-making shop equipment.

HOBART BROTHERS COMPANY, Box M3, TROY, OHIO
\$20 Brings an HB Battery Charger



GET FACTORY PRICES ON GALVANIZED ROOFING



EDWARDS "REO" Metal Shingles

Absolutely rust-proof — edges as well as sides. Not the space of a pin point exposed to weather. Also fire and lightning proof. Reduces insurance. Outlast buildings. Need no repairs — and all roofing expense. Easy to lay — one man can do the work — hammer and nails only tools needed. Lay over old shingles if desired. Patent Interlocking Device makes water tight seams — all nail heads covered — no rust or leaks possible.

Exclusive "Tightcote" Process

Put all Edwards Galvanized Roofing in a class by itself. Bend, twist, strike it with a hammer as much as you like — you can't loosen or scale off the galvanizing — due to our "TIGHTCOTE" process which practically makes zinc covering a part of the metal sheet. No other galvanized roofing can withstand this test.

FREE Roofing Book Don't buy roofing until you get our big free book, describing Edwards famous "Tightcote"



THE EDWARDS MFG. CO.
331-350 Pike St. CINCINNATI, O.



Corrugated



Patent Side Lock
No nail heads in sight or exposed to the weather



Brick Siding

Roofings, Sidings, and Ceilings, and our lowest factory prices. We sell you direct and save you in-between-dealers' profits. Write for Roofing Book No. 100.

Low-Priced Garages

Lowest prices on Ready-Made Fire-Proof Steel Garages. Get up any place. Send postal for Garage Book showing styles.



The Musical Notes, bit of Broadway musical shows, all use Conn instruments.

Easy to Play for Pleasure and Profit

Whether you are interested in music purely for the joy of playing, or as a means of additional income, the Conn Saxophone is the instrument for you. Its exclusive features make it so easy to master that you can learn a tune in one hour; play all popular music after brief, fascinating practice. Saxophone soloists, trios, quartets and sextets, like that pictured above, are in demand for all sorts of entertainment. Make big money "on the side", or whole time, as you choose.

Free Trial, Easy Payments on any Conn instrument. All exclusive Conn features at no greater cost. Send coupon for details and your copy of New Saxophone book, FREE.



331 Conn Bldg., Elkhart, Indiana
New York Conn Co., 233-7 W. 47th St.
Agencies in All Large Cities

FREE

Handsome new book explains superior features of Conn saxophones; tells how to use saxophones singly or in quartets, sextets, etc., illustrates and describes complete line; scores of popular stars tell why they prefer the Conn.

Send coupon now for your copy



C. C. Conn, Ltd., 331 Conn Bldg., Elkhart, Ind.
Please send Saxophone Book and details of your free trial plan. Mention instrument.

Name
St. or Rural Route.....
City..... State.....
County..... Instrument.....

\$100 TO \$200 MONTHLY PROFIT RECHARGING FORD MAGNETS

The "GOLDEN" Magneto Recharger for Ford cars, clears all "SHORTS" in the magneto coil and Recharges Magneto to full strength in less than 5 minutes without removing a single bolt or nut. No storage batteries needed. It operates from any alternating current light socket; will also operate from Farm Lighting Plants, Direct Current Circuit, Storage Batteries, and Dry Cells. Nothing to wear out. No up-keep cost. Weighs 12 lbs. Used and recommended by Authorized Ford Dealers. **ORDER ONE TODAY.** Price \$37.50 Complete. Agents, get your share while low. A 30-day trial, money-back if not satisfactory — protects you. Catalog FREE. Write today.

MAGNETIZER MANUFACTURING CO.
146 W. Florence Ave., Dept. M200, Los Angeles, Cal.

2 Tires for \$11.25

FREE Tube with Each Tire

Most sensational used tire offer of the year! Two tires for less than the usual cost of one — and a free tube with each tire! This is a special lot — all standard makes — selected for record-breaking sale. No double trends or saved tires. Our big volume means best tire values! Thousands of steady customers everywhere are getting full mileage out of these tires and you, too, can get

8000 Miles

Size	1 Tire	2 Tires	Size	1 Tire	2 Tires
30x3	\$ 7.00	\$11.25	32x4 1/2	\$13.50	\$22.90
30x3 1/2	7.95	13.65	32x4 3/4	13.95	23.45
32x3 1/2	9.00	15.45	34x4 1/2	14.45	23.90
31x4	10.00	16.30	35x4 1/2	14.95	24.45
32x4	11.50	19.75	36x4 1/2	15.45	25.45
33x4	12.25	20.90	35x5	15.90	26.15
34x4	13.25	22.45	37x5	16.45	26.55

SEND NO MONEY! Shipment C.O.D. Express or Parcel Post. Examine tires on arrival and if not fully satisfied return within 30 days and your money will be promptly refunded, including shipping charges. State whether Straight Side or Clincher. **DON'T DELAY! ORDER NOW!**

ALBANY TIRE & RUBBER COMPANY
2721 Roosevelt Road Dept. 164 C Chicago, Illinois

You Can Save \$50.00

By Recovering Your Old Auto Top Frame Yourself

We make these recovers to fit all makes and models of cars. Any person that can drive a car can put it on. We furnish instructions. Roof and quarters sewed together with rear curtain, fasteners, welts and tacks. All complete. Give us the name, year and model number of your car, and we will send you our catalog with samples and quote you exact price.



\$540 and up
Parcels
Post Paid

LIBERTY TOP & TIRE CO., Dept. E7, CINCINNATI, OHIO



IN wide-open water, against a head-wind an "Old Town Canoe" responds instantly to every paddle stroke. In placid streams, the lightest dip of the blade shoots you forward. In the shallowest water, an "Old Town" floats loaded.

"Old Towns" are the lightest, steadiest and strongest canoes made. Their construction combines the old-time Indian skill with "Old Town" craftsmanship. All "Old Town" models are built on Indian speed-lines. An "Old Town Canoe" will last for years with no upkeep. \$54 up from dealer or factory — "Old Towns" are the lowest priced canoes.

Make your choice from the new "Old Town" catalog. Free. All popular models illustrated in color. Write today.

OLD TOWN CANOE CO.

1263 Middle Street Old Town, Maine, U. S. A.

"Old Town Canoes"

Auto Owners WANTED!



To introduce the best automobile tires in the world. Made under our new and exclusive Internal Hydraulic Expansion Process that eliminates Blow-Out—Stone-Bruise—Rim-Cut and enables us to sell our tires under a

10,000 MILE GUARANTEE

We want an agent in every community to use and introduce these wonderful tires at our astonishingly

low prices to all motor car owners.

Write for booklet fully describing this new process and explaining our amazing introductory offer to owner agents.

Hydro-United Tire Co.

Dept. 100 Chicago, San Francisco, Pottstown, Pa.

TIRES BEST VALUES EVER OFFERED

32x4-\$9. 33x4-\$9.50. 34x4-\$10.50
Used tires. Other sizes just as low. Cords and fabrics. Send no money. Return tires if not satisfactory when received. State if you want u.s. or cl. Supply limited at this price. Order quick. ROYAL TIRE & SUPPLY CO., 1245 S. MICHIGAN AVE., DEPT. P, CHICAGO, ILL

An Easy Way to Make Money

Don't be content to plod along on a small salary. Be independent. Go in the tire repairing business and make \$60 or more a week. One man made \$45 the first day he received his outfit. Others are making \$25 a day and hundreds of wide-awake men are making \$200 to \$500 a month.

No experience needed. We teach you how. Very little capital required. But slight risk, as every car owner in your town is a possible customer. Jobs are plentiful because tires blow out and puncture every day. Business is good the year round.

SHALER Tire Repair Outfit, \$75

Will do as much and as perfect work as the big \$250 to \$500 vulcanizing outfits. A boy can vulcanize perfectly with this simple machine. It's the only vulcanizer that has Automatic Heat Control. It must vulcanize just right. It can't undercure or overcure a tire. Requires no watching or regulating. You can learn to do expert tire vulcanizing in half an hour with the Shaler.

WRITE FOR FREE BOOK "HOW TO OPEN A TIRE REPAIR SHOP" and complete Catalog, which gives full information.

WRITE QUICK BEFORE SOME HUSTLER GETS AHEAD OF YOU.

C. A. SHALER CO., 2002 Fourth Street, WAUPUN, WISCONSIN

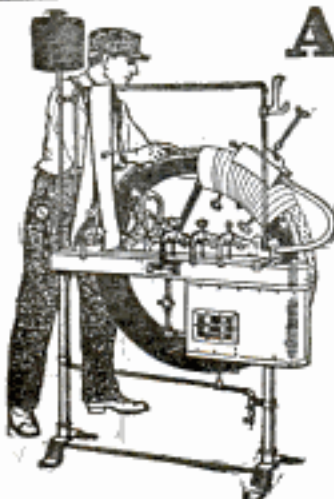

DIAMONDS

For a Few Cents a Day



Send No Money

We will send you—upon your simple request—your choice of diamond bargains—the greatest in America! Do not send a penny in advance. When the ring comes, examine it. You are the judge. If it is not, without exception, the greatest value you have ever seen, send it back—at our expense! If you decide to keep it, it is yours—for a few cents a day. You may order direct from this advertisement if you wish. Don't send a cent. You do not risk a penny.

Charge-Account Plan

By our new charge-account plan, you may pay for your choice of hundreds of pieces of exquisite jewelry in sums so small that you would never think of saving them. You are also guaranteed 8% yearly dividends—and a 5% bonus may be earned.

Send for Bargain Book

Send your name and address today for our new 128-page book, showing hundreds of unmatched diamond bargains. Sent absolutely free. It explains the dividend offer and bonus plan.

Write today to Dept. 1773

J. M. LYON & CO.
1 Maiden Lane, New York N.Y.

STOP RADIATOR LEAKS

in 10 Minutes

SAVE BIG REPAIR BILLS

When radiator leaks, don't waste time and money putting car up for repairs. Pour into radiator contents of one can of

RADIATOR NEVERLEAK

Stops leaks quickly and permanently. Guaranteed not to harm or clog radiator. Money back if not satisfied. Carry a 75c can in your tool kit.

You are protected by our

MILLION DOLLAR GUARANTEE

If dealer can't supply, send 75c



Buffalo Specialty Co.
Buffalo, N. Y.



LAKWOOD FAN BELT FASTENERS



MAKE or repair your own flat belts for Autos, Trucks, Tractors, Electric Washers and small Shop Machinery with Lakewood Quick attachable Fasteners. Two sizes— $\frac{3}{8}$ in. and 1 in.; used alone and in combinations handle eight widths flat belting. Simply square up ends, rivet half of fastener to each end, slot together and go. Belt can be removed from pulleys instantly, but can't open in driving. Complete Fastener with rivets, 15c per set; 2 for 25c; 6 for 60c; or 12 sets in neat slide box for \$1.00. Specify size wanted. Sent postpaid same day order received. Fine proposition for Garage, Repairmen, and Dealers.

LAKWOOD FABRIC BELTING & MFG. CO.
1518 W. 117th St., Lakewood, Ohio

START IN BUSINESS

Make Real Money
on Small Capital

All over the U. S. and Canada we are establishing Vulcanizing Service Stations. Start one in your town. Make \$10 to \$30 per day on a \$350 investment. We instruct you and furnish the Most Modern Methods and Equipment—

THE ANDERSON

Known the World Over

We have 34 Schools in U. S. and 4 in Canada. One is near you. School pays you \$5 per day while learning to operate your station. Write for full particulars—TODAY.

THE ANDERSON STEAM VULCANIZER CO.

Manufacturers of Modern Tire Repair Equipment,
103 Williams Bldg., Indianapolis, U. S. A.



A.I.D. FOR FORDS

The A.I.D. Airs pumps a Ford tire in less than 5 minutes.

AeroFan keeps motor cooler—any one can attach.

A Real Tire Pump—no gears, extra chains or noise.

Agents Wanted. Send for Circular
A. I. D. Inc.

1352 Beacon St., Boston 47, Mass.

RECTOR

SINGLE TUBE CLINCHER

TIRES

Great new idea—no cement—no pulled valve stems, no tire trouble. Tires wear extra long—guaranteed. Put on in a moment on any standard rim. Valve stem snug on side. Beads clip over rim (see section above). Can't come off in riding.

This Book FREE

Send for book—tells all about tires. How to get longest wear, etc.—also about benefits and savings of the Rector Tires and Rector's New Combination Handle Bar and Carrier. Write quick. Give favorite dealer's name.

THE BECKLEY-RALSTON CO.
1817 Michigan Ave., CHICAGO



PRICE
\$185

To and From Work—
Gain Pleasure—Save Money

Riding the Cleveland Motorcycle beats the cars for time and money saved and throws in better health and enjoyment for good measure.

The Cleveland is the lightest, lowest-priced real motorcycle made in America. As safe and easy to ride as a bicycle. 75 miles to the gallon of gas—15,000 miles on tires!

The Cleveland is the Molybdenum motorcycle, and is the very best value you can get. Write now for Catalog "M."



Can you recommend a "live" man for a Cleveland dealer in your town?

CLEVELAND MOTORCYCLE MFG. CO. 7th
CLEVELAND, U.S.A. YEAR

MOTOR CYCLE
Cleveland

CIGARETTE EJECTOR

"JUST press the button, that's all." The latest in "smoke" cases. Keeps cigarettes in perfect condition and prevents crushing. Works perfectly every time. Every smoker wants one.

AGENTS—Write for exclusive territory. It's an easy seller—from \$1.00 to \$16.00. Agents are making big money. Send \$1.50 for sample of this popular case. Act now—today—before your territory is sold.

THE LYONS MFG. CO., Dept. M. P.
342 YORK STREET, NEW HAVEN, CONN.



\$2 Puts this
ELGIN WATCH
In Your Hands

No Red Tape, No Waiting

Simply send \$2.00 and receive watch. Full seven Jeweled Elgin in stylish Octagon Case. Thin model, guaranteed 20 years.

30 DAYS FREE TRIAL

Send only \$2.00 and watch comes charges paid. Carry for 30 days and if not satisfactory your deposit is returned. Pay balance \$2 a month for 10 months. Price only \$22.00. Send for FREE CATALOG, addressing Dept. 487.

ROYAL DIAMOND & WATCH CO.
35 Maiden Lane, New York



New 300 Candle Power Lamp



AGENTS Send
FREE Outfit Offer

Make \$60 to \$100 a Week
Introducing this wonderful new lamp. Gives soft, brilliant, glowing light; restful to eyes; ideal illumination.

Burns Kerosene or Gasoline
Clean, odorless, economical. Burns 94% air, 4% fuel. Absolutely safe. Lights with match, 100 times brighter than wick lamps. Patented. Greatest improvement of the age. Table lamps, hanging lamps, lanterns.

No Capital Required
Work all or spare time. You simply take orders. We deliver by Parcel Post and do collecting. Commissions paid same day you take orders. No experience necessary. We give free selling instructions. Get started at once. Big season now on. Write today for catalog and special agents offer.

THE AKRON LAMP CO.
103 Lamp Bldg., Akron, O.

NEW MONITOR SELF-HEATING IRON

AGENTS SEND FOR
FREE OUTFIT OFFER

\$60 to \$80 a week actually being made now by men and women. The original—the best—the lowest priced. Nickel plated—looks good—makes good—sells fast—guaranteed. No experience needed. Women as well as men. Exclusive territory. Work all or spare time. Mrs. Stockman, Kans., sold 10 in half a day. Pearman, Ky., made \$150 first week. Liberal terms. Prompt service. Write today.



THE MONITOR SADDLE IRON CO.
433 Fay St., BIG PRAIRIE, OHIO

MAKE \$15 A DAY: EVERY HOME NEEDS IT
Wonderful Easy Knife, Scissors and Tools sharpener. Sells 50cts. 200% profit to agents.

Write for particulars
PREMIER CO.
806 E. Grand Blvd.
Detroit, Mich.
Sample sent for 25c coin or stamps.

BIG CHANCE FOR YOU



GET THIS

A PERFECT POLISH WITH CLEAN HANDS



KAXO SHOE BRUSH

POLISH, DAUBER and BRUSH combined in one convenient article. Polish is in a tube enclosed in metal case on top of brush, and when tube is used up, new ones may be obtained at leading stores everywhere, 25 cents. Buy of your dealer or order direct, stating whether black tan, mahogany or white is desired. Fine opportunity for agents.

Postpaid anywhere \$1.25
Address Sales Dept.
The Kaxo Co., Cambridge, Mass.

10 Buys
100



From Engel Mfg. Co.

Engel
"Art Corners"

NO PASTE NEEDED

Use them to mount all kodak pictures, post cards, clippings in albums

Made in Square, Round, Oval, Fancy and Heart of black, gray, sepia, and red gummed paper. Stick them on corners of pictures, then wet and stick. QUICK-EASY-ARTISTIC. No fuss, no fuss. At photo supply, drug and stat'y stores. Accept no substitutes; there is nothing so good. 10c brings full pkg. and samples

Dept. S-C 4711 N. Clark St. CHICAGO

VICTOR Portable STEREOPTICON



WRITE FOR INFORMATION
VICTOR ANIMATOGRAPH CO. INC.
229 VICTOR BLDG. DAVENPORT IOWA

The PERFECT PROJECTOR for every need

SHIPPED ON TRIAL
SPECIAL EASY TERMS

Hundreds of illustrated lectures for rent.

FOR SMALL POWER USERS

1 H.P.

Light-
Weight
Compact
Reliable



½ H.P.

Over
200,000
now in
operation

Maytag Multi-Motor

If you build any machine or device that is operated by a small power unit—especially for places where electricity is not available—get the facts about this remarkable gas engine. Made in ½ h.p. and 1 h.p. sizes. Air cooled. Operates on gas or gasoline. Equipped for battery or magneto ignition.

Our Engineering Department can help you with the details of your power problem. Special prices to manufacturers using large quantities. Write for information.

MADE BY

THE MAYTAG CO., Dept. X, Newton, Iowa

137

Little Giant Drill Press
Just the thing for small shop and experimental work. Mechanically right and well made. Size 0 to ¼ in. drill. Weight 22 pounds. Price \$15.00.
Send for circular.
SYEPHER MANUFACTURING CO.
Dept. "D" Toledo, Ohio



LATHES

9 to 18-inch Swing

List price \$165 and up according to size. When ready to buy send for Lathe Catalog and prices.

W. F. & John Barnes Co.
100 Ruby Street, ROCKFORD, ILL.

NEW MOTORS

FOR ALL PURPOSES
STANDARD MANUFACTURERS
PROMPT DELIVERY

ALL SIZES UP TO 5 H.P.

We Specialize In Small Motors & Generators

ALL PHASES AND FREQUENCIES IN STOCK AT ALL TIMES
Largest exclusive Mail Order Small Motor dealers in the world.

CHAS. H. JOHNSTON, Box 113, West End, Pittsburgh, Pa.

WIRELESS, TELEPHONE GENERATORS
500 VOLT - 100 WATT - 3400 R. P. M.
FOR MOUNTING MOTOR GENERATOR SETS.

\$28⁵⁰
EACH

WRITE FOR
CATALOG



"Red Devil" Pliers made in 100 styles—one for every need. Known and used the world over. Style 1024—6½ inch shown here. From dealers or from us, \$1.00.

Red Devil Pliers

Reg. U. S. Pat. Off.

Cut and Stay Sharp



YOU'LL like to work with their keen cutting edges—hand honed and tested to cut wire with the finest silk insulation.

You get a firm grip on the handles, without pinching the hand. Handles designed with powerful leverage to increase cutting power—fit the hand like a glove.

"Red Devil" Pliers multiply the strength of your hand and wrist;

they grip as your fingers can't possibly grip—no slipping—no bruised knuckles, no exasperation from trying to do good work with poor tools. They give you greater value for the money.

"Red Devil" Diagonal Plier No. 942

for all around cutting purposes, forged of steel—guaranteed to give absolute satisfaction. Made in 4, 5 and 6 inch sizes.

At reliable hardware dealers everywhere, or if not, send \$1.50 for a 6 inch "Red Devil" Diagonal Plier No. 942.

Mechanic's tool booklet free

SMITH & HEMENWAY CO., Inc.
260 Broadway, New York, N. Y.

"Red Devil" Glass Cutters—the glaziers' standard tools of the world. "It's all in the wheel."
Made in 40 styles. No. 024 shown here, 20c.



Great Motor Bargain

Think of it! A big-capacity $\frac{1}{4}$ hp., A.C. motor, tested at the factory for 50% overload, and fully guaranteed for one year for You'd pay nearly **double** from any other source.

Motor is for 110 volt—60 cycle service, 1740 rpm, split phase, fan-cooled, induction type; with cord and plug as shown; or, reversible style with binding post terminal. Weight 24 lbs. bare or 33 lbs. boxed.

Quantity Discounts: On three motors ordered in one shipment, price is \$13.00 each; six motors, \$12.50 each; 12 motors, \$12.25 each; 25 motors, \$12.00 each.

SEND CASH WITH ORDER or we will ship by express C. O. D., if you prefer.

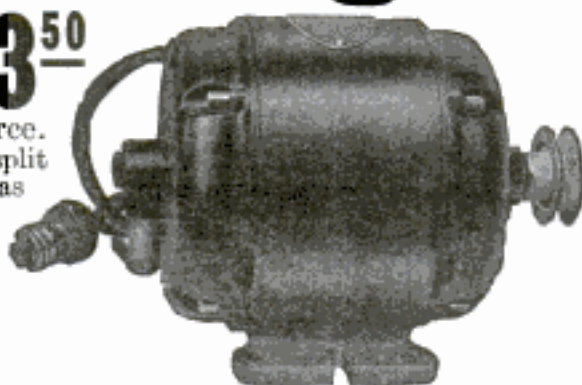

NORTHWESTERN ELECTRIC COMPANY

408 So. Hoyne Avenue

CHICAGO, ILLINOIS

Mend Your Own Utensils With

SOLDERALL

Patented Oct. 3, 1911

A Paste That Turns Into Metal When Heated

Our New Improved Torch \$1.50



25c per tube

A match will do it, but best results can be obtained by using our new improved torch. Requires no acid or soldering iron. Joins or repairs wires, metal or metalware. Sold by Hardware and Electrical Stores, or sent by us postpaid.

COMBINATION SET \$1.75
Tube and Torch Complete

SOLDERALL CO., Dept. P
129 Sussex Avenue NEWARK, N. J.
Dealers Send for Quantity Prices
Beware of Imitations with Similar Names



STARK PRECISION BENCH LATHES

For laboratory, experimental or manufacturing purposes wherever precision and long life are essential. Six sizes, with attachments for Screw Cutting, Drilling, Milling, Gear Cutting, Grinding, etc. Price No. 3 $\frac{1}{2}$ Lathe complete with Draw-in Spindle, $\frac{1}{2}$ " Collet, 6 Turning



Tools, Compound Slide Rest, Tool-post, Hand Rest, Face Plate, Centers and Two Speed Countershaft - - \$198.00

STARK TOOL CO., Waltham, Mass.
Established 1862

Save Money On Your Tools!

Save your tools—prevent damage—discourage "borrowing"—have your tools in order and increase your efficiency.

A style, size and price to suit your trade and purse. Catalog free.



H. Gerstner & Sons

707 Columbia Street DAYTON, OHIO

"BOW LEGS and KNOCK-KNEES" UNSIGHTLY

SEND FOR BOOKLET SHOWING PHOTOS OF MEN WITH AND WITHOUT THE PERFECT LEG FORMS

PERFECT SALES CO.
140 N. Mayfield Ave., Dept. S, Chicago, Ill.

Every boy loves boats and trains

Send 10 cents to The Ives Manufacturing Corporation, Bridgeport, Conn., for complete catalog of Boats and Trains. **IVES TOYS MAKE HAPPY BOYS**

DISSTON SAWS

"The Saws Most Carpenters Use"
HENRY DISSTON & SONS, INC.
Philadelphia, Pa. Canadian Works, Toronto, Can.

Prosthesis A 100-Page Book With Many Illustrations

Written for and by Users of Artificial Limbs (NOT a catalogue)
Gives interesting, valuable and up-to-date information about Artificial Limbs—Surgical and Mechanical discoveries, etc. Contains many ads by foremost limb makers. Price 50c (inc. postage). You need not pay until you have seen the book.
IF UNSATISFACTORY RETURN IT AND NO CHARGES

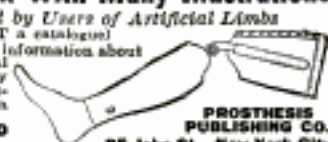

PROSTHESIS PUBLISHING CO.
85 John St., New York City

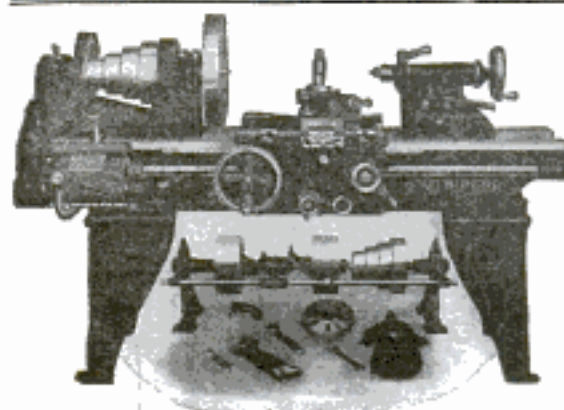

REDUCED PRICES

Back to Normalcy -- 20% Further Reduction
SOUTH BEND LATHES

	Standard Change Gear	Quick Change Gear		Standard Change Gear	Quick Change Gear
9'x3' Lathe	\$176.00	\$216.00	16'x 8' Lathe	\$452.00	\$512.00
11'x4' Lathe	228.00	273.00	18'x10' Lathe	656.00	721.00
13'x5' Lathe	304.00	354.00	21'x12' Lathe	848.00	923.00
15'x6' Lathe	376.00	431.00	24'x14' Lathe	1140.00	1230.00

64-page Catalog No. 73 for 1922 sent free to any address

ESTABLISHED 1906

SOUTH BEND LATHE WORKS,
625 E. Madison St. SOUTH BEND, IND.

How to Run a Lathe An 80-page book, postpaid to any address for ten cents, silver or stamps accepted.



SO many everyday uses for Bernards! On the farm; in the home; in the garage, office, machine shop. Pliers that grip like a vise and easily cut metal ordinary pliers won't dent. Hardware dealers

MADE IN SEVEN SIZES

Send for illustrated Plier Booklet M



**BERNARD
PLIERS**

Wm. SCHOLLHORN CO.
NEW HAVEN, CONN.



PARALLEL JAWS

OUTSIDE CUTTER



The Midget "FIVE-IN-ONE" Slide Rule is a combination Mannheim, Log-Log, Add and Subtract, Polyphase and Binary Slide Rule. It will instantly add, subtract, multiply and divide any combination involving whole numbers, fractions, decimals and mixed numbers. Gives every possible root and power of every quantity. The graduations are printed on metal, coated with white celluloid and are grease and waterproof. While it is the most versatile calculator ever invented, its operation is simple and easily understood. Diameter 4 inches. Price with 16-page instruction book, \$1.50. Leatherette carrying case 50c extra. Catalog free. Your money back if you are not satisfied.
GILSON SLIDE RULE CO., Niles, Mich.

MECHANIC'S POCKET SECRETARY

Constructed of finest steel. Just push the button and out comes the article you require. Worth \$1.00. Postpaid

25c

See One To-day



25c

10 in 1

Adjustable Pencil, pen, paper knife, ink eraser, pencil sharpener, nail file and cleaner, mechanic's marking point, fine compass with screw attachment, foot rule.

Universal Co., Box 300, Stamford, Conn.

USE LIGHT WAVES

Measure gages, plugs, balls, wires, etc., in millionths of an inch.

Anyone can use this most practical and wonderful new measuring facility, the most accurate known.

To use light waves means advancement for the mechanic.

Write today for Circular M.21, giving valuable information.

THE VAN KEUREN CO.
361 Cambridge Street, Allston, Boston, Mass.

MYERS WONDERFUL SEWING AWL

Tools in Handle



A complete repair shop in itself. Sews anything heavy or light, leather, shoes, harness, buggy tops, canvas, belts, etc. \$1.00 Postpaid.
C. A. MYERS COMPANY, 6329 Woodlawn Ave., Chicago, Ill.

ATKINS

AAA NON-BREAKABLE
HACK SAW BLADES

Compare it with
any other blade

Take it in your hands—give it a quick twist or turn that would snap an ordinary blade—you'll find out what Atkins has done in making a "non-breakable" hack saw blade.



Why This
Hack Saw
Blade Does
Not Break!

A special, perfected process of gas and oil tempering, combined with selected steels make Atkins Hack Saw Blades practically non-breakable. Men who use them tell us they are the best cutting blades ever made. They save time and work but cost no more. Send 10c for sample 8 or 10 inch blade. Money back if not satisfied.

ATKINS "KWIK-KUT"

Metal-Cutting Machines
Give 25% More

Other metal-cutting machines use about 50% of the blade in cutting metal. These machines use 76% of the cutting edge. Ask for book giving full details regarding their remarkable savings.

A Better Saw For Every Use

No matter what kind of saws or saw machinery you need—for metal or wood cutting—it will pay you to know the savings in time and labor—the increased efficiency—the longer life and greater value of Atkins Products.

Send For These FREE Booklets

"Atkins Metal Saws," "Kwik-Kut Metal Cutting Machines," "Hack Saw Blades and Frames," "Metal Band Saw Blades and Machines." Just fill in your name and address and the use you make of the saw—below and mail it—NOW!

E. C. Atkins & Co., Inc.
Dept. P., Indianapolis, Ind.

I am interested in saws for.....

Please send booklets to.....

Finest Instruments Are Easiest to Play

You cannot learn to play correctly on a cheap, imperfect instrument and expect to achieve success in music. The best teachers will always recommend the finest instruments for their pupils.

King Instruments Now Easy to Own

A quarter century ago the first King Brass Instrument was made to the specifications of a famous artist, and for years thereafter Kings were made and sold only for cash to great musicians. But now, our new easy payment plan makes it possible for anybody to own a King. You can now buy direct from the factory, save middleman's profit, and get a brand new, acoustically perfect, laboratory-tested King Instrument. And, with every new King goes our famous free factory-service and guarantee.

Big Stock of Used Instruments
Thousands of musicians have turned in good instruments as part payment on new and better Kings. These used instruments we sell for cash at very low prices. They are refinished and look like new. Send for our latest complete catalog and list of these bargains before they are gone. Ask for details of easy payment plan on new instruments.

THE H. N. WHITE CO.
5237 Superior Avenue,
Cleveland, Ohio



KING

UNION TOOL CHESTS

TOOLS SCATTERED AROUND!

Tools left scattered around carelessly are apt to be lost, stolen or damaged. If you have a Union Tool Chest it keeps your tools safe and orderly. Saves its cost in a month. Compact, strong, durable.

UNION TOOL CHEST CO.
22 Mill Street Rochester, N. Y.



THE HANDIEST TOOL in the WORLD THE OLSON MAGAZINE SCREW DRIVER

Large enough to hang a door. Small enough to fix a bell. Used by—Carpenters, Machinists, Farmers and Automobile men.

Three blades and one awl guaranteed. Dealers and agents write for special proposition.

Only 53¢ long.

\$1.25
Prepaid

Olson Mfg. Co., 52 Commercial St., Worcester, Mass.

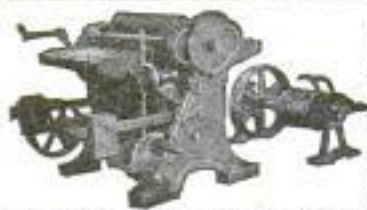

THE CRESCENT MACHINE CO., 93 Columbia Street, Leontia, Ohio

It is the well known quality of CRESCENT machines that justifies you in selecting one of them each time you have need for wood working machinery. The CRESCENT line is better than ever and will always give you satisfaction in every particular. Ask today for catalog of hand saws, saw tables, jointers, shapers, planers, borers, planes and matchers, swing saws, disk grinders, cut off tables, hollow chisel mortiser, variety wood worker, Universal wood workers.

VITALIC Bicycle Tires

TRADE MARK REGISTERED
Tougher Than Elephant Hide

MONARCH JUNIOR LATHES

"The Biggest Little Lathe Built"

A real engine lathe—small, sturdy, compact, low-cost—guaranteed to do all small work with 1/1000 of inch accuracy. Built with the same care and precision that made MONARCH ENGINE LATHES the world's standard of quality and efficiency.

THE MONARCH JUNIOR is ideal for beginners. Occupies small space in your own home or shop. Easy and economical to operate. Simple and trouble-proof, automatic safety features. Fully equipped.

The Greatest Achievement in Lathe Building History

Monarch Junior 9 in. Engine Lathe **\$225** With Bench Legs

Full particulars and a Monarch Junior Catalog will be sent you on request.

THE MONARCH MACHINE TOOL CO.
200 Oak Street Sidney, Ohio

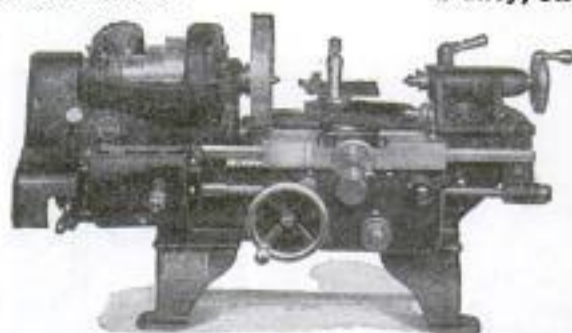

BURN YOUR NAME ON TOOLS WITH

ARKOGRAF

Protect your tools from theft. Write any name, engrave any design on metal with electricity as easily as writing on paper with pen or pencil. Complete outfit \$3.50, prepaid anywhere. Interesting descriptive circular free. Write today. Agents Wanted. Arkograf Engraving Company, 899 Capitol Ave., Portland Oregon



MUSIC LESSONS FREE

IN YOUR OWN HOME
You can read Music like this quickly

Piano, Organ, Violin, Mandolin, Guitar, Banjo, etc. Beginners or advanced players. One lesson weekly. Illustrations make everything plain. Only expense about 2¢ per day to cover cost of postage and music used. Write for FREE booklet which explains everything in full.

AMERICAN SCHOOL OF MUSIC, 50 Lakeside Building, CHICAGO



CAMERAS

Over a Hundred Styles and Sizes
Send for new illustrated catalog showing latest reduced prices. It's Free.

10 days' trial given

SENECA CAMERA MFG. COMPANY
300 Central Avenue Rochester, N. Y.

TIRRO

the ideal mending tape of a thousand uses—sticks to anything and stays stuck. For sale at all druggists. A Bauer & Black product.

DIAMONDS, WATCHES ON CREDIT

YOU SHOULD HAVE THE JAMES BERGMAN JEWELRY BOOK IN YOUR HOME. It is full of many bargains. Diamonds, Watches, Jewelry, Toilet Articles, etc. Select any article desired, have it sent to you at charge postponed. If satisfactory, send one-fifth of purchase price and keep it, balance in TEN monthly payments. No interest charged. No security required. Write Today for Big Free Catalogue No. 8. It tells JAMES BERGMAN 27-39 MAIDEN LANE, Est. 1895, NEW YORK CITY about Our Low Prices and binding guarantee.



Jewel 22 in. Band Saw \$70

Here's the machine for your shop at a moderate price. Strongly constructed to last a lifetime. Angle-steel frame, electric welded. Build on your own bench-top to suit your special needs. Roomy table with tilting adjustment for sawing bevels. Band saw has 22 in. swing cutting to center of 44 in. circle. Hand-wheel tension regulator. Will take material up to 7 in. thick.

Price with $\frac{3}{8}$ in. band saw, \$70.



Send for complete catalog of Parks machines

THE PARKS BALL BEARING MACHINE CO.
1500-1540 Kewilton Street CINCINNATI, OHIO
Canadian Factory, 200 Notre Dame East, Montreal

48

PARKS

WOODWORKING MACHINES

Be A Floor Surfacing Contractor

Make \$5,000 to \$15,000 or More—Yearly

New, uncrowded field. Architects and general contractors know the American Universal and prefer its work. They prefer to subcontract the floor surfacing contract, as it is a big business in itself. Business comes easy the American Universal Way. We furnish office forms, advertising, etc.—in fact we practically set a man up in a business of his own. We will prepare you for the spring building boom. The housing problem is more serious now than ever before. Get an American Universal Machine and get started.

RE-SURFACING OLD FLOORS

Every building, large or small, is a prospect. Hundreds of floors right in your own vicinity need resurfacing. The owners will be glad to have you do it when you show them how easily and quickly the work can be done the American Universal Way. Old floors made like new—new floors made perfect.

Don't ever get caught out of work again—get into a big paying business of your own. Floor Surfacing Contractors pay for machines first month and make big profit besides. WRITE TODAY for full information. Act NOW.

The American Floor Surfacing Machine Co.
Originators of Floor Surfacing Machines
823 South St. Clair St. Toledo, Ohio, U. S. A.



DIAMONDS

WATCHES

ON CREDIT

Genuine Diamonds GUARANTEED

Our Diamonds are distinctive in fiery brilliancy, blue white, perfect cut. Sent prepaid for your Free Examination, on

CHARGE ACCOUNT

Send for FREE

Catalog

A wonderful book. Everything fully explained. There are over 2000 illustrations of Diamond-set Solid Gold and Platinum Jewelry, Watches, Wrist Watches, Silverware, etc., at

REDUCED PRICES!

We invite comparisons
We defy competition

The beautiful Diamond Ring illustrated is only one of a multitude shown in our large Catalog, from which you can make selections. Exquisite Diamonds, latest style mountings, from \$25 up to as much as you wish to pay. LIBERTY BONDS ACCEPTED at PAR.

WRIST WATCH



\$1.00 A WEEK

Solid 18-k, engraved; White Gold, 15-Jewel Imported movement, guaranteed. Silk Ribbon Bracelet, Special at \$35. Rectangular and other shapes, 17 Jewels, \$40 and \$45. All 18-k white gold. Other Solid Gold Wrist Watches, \$26 up. Gold filled, \$15 up. Men's Watches, \$15 up.

for this handsome Lady Louise DIAMOND RING. Exquisite, brilliant, blue white, perfect cut Diamond, set in 18-k Solid White Gold prongs. The Ring is Solid Green Gold, hand carved. Specially priced at \$50 Others at \$75, \$100, \$125 up. Terms \$1.50, \$2.00, \$2.50 a week.

USE YOUR CREDIT

\$1.00
A WEEK

SEND FOR FREE BARGAIN CATALOG

LOFTIS
BROS & CO. 1853

OLD RELIABLE CREDIT JEWELERS
Dept. L-234
108 N. State St., Chicago, Ill.
Stores in Leading Cities

Try This Typewriter

5 Days FREE



\$4.00 and you keep it

The balance in easy monthly payments. Save fully \$25 to \$60 on any standard make.

Every rebuilt machine guaranteed to be in perfect condition. Try 5 days at our expense. Write for specs (press). A postcard will do. Read NOW.

WYNN TYPEWRITER EXCHANGE, 9 Reliance Bldg., Kansas City, Mo.

Only
\$15
Down

Play Well in
4 Weeks

—Seven Months to Pay

Latest C Melody Saxophone Outfit complete, only \$85—lowest price ever quoted. Sent on 8 days' trial. If satisfied, pay only \$10 a month for 7 months. No interest to pay—no extras. Outfit includes finest nickel trimmed and richly lined Case, Instruction Book, Album of Popular Saxophone Solos, Music Lays, Carrying Strap, Mouthpiece and three fine Reeds.

"Masterbilt" Saxophones

Highest quality, built in perfect tune, assembled and tested by experts. Has all latest key improvements, light, quick action and beautiful finish. Order direct from this advertisement or write for Free Catalog Folder today.

The Saxophone Shop, 427 S. Wabash Ave., Chicago
Largest Exclusive Dealers in Saxophone Supplies in the World

WANT MONEY?

FULL or SPARE TIME

Selling Goodyear Guaranteed All-Weather Coats Direct-to-Wearer is Profitable, Dignified, Pleasant work. We tell you what to say and do. A real business proposition for the man or woman who wants more money and will work. Farris made \$48 his first week working spare time. Don't give up your job—Cost you no money—

Complete Sales Outfit Free

With free Course in Scientific Salesmanship sent by return mail. WRITE TODAY.

General Sales Manager

GOODYEAR MFG. COMPANY
1523-D Goodyear Bldg. Kansas City, Mo.

Motor Troubles Ended

New Invention Creates Wonderful Spark—Doubles Power, Makes Winter Starting Easy, Stops Oil Pumping, Eliminates Carbon, Saves Gas—Free Trial Offer.

Any car owner who is bothered with a motor which pumps oil, foul spark plugs, wastes gas or carbonizes badly, can stop these troubles by using a remarkable device called Warren Transformers, perfected by W. H. Warren, a Kansas City motor expert.

In two minutes a boy can attach Warren Transformers. Then you will be amazed to see your car go whizzing up hills on high where you formerly had to shift gears. You will also notice a big increase in your mileage and instant starting in coldest weather. Spark plugs that formerly fouled and cylinders that pumped oil will be clean and dry and fire with full power.

If you want to save 25% to 50% on fuel and repair bills, be rid of missing cylinders, dirty plugs and carbon, have a quick start in coldest weather and pep on hills, write the Warren Mfg. Co., 270 Gray Bldg., Kansas City, Mo., and a set of Warren Transformers will be sent immediately, with the understanding that they do not cost you a cent if not entirely satisfactory.

So confident is the Warren Mfg. Co. that Warren Transformers will more than delight you that they offer to send a \$4 set for only \$2. This is a special introductory offer, good for only a few days, and readers should take advantage of it immediately.

Send No Money with your order—just your name and address, name of car and number of cylinders. Warren Transformers will be sent immediately. When they arrive merely pay the postman \$2 and postage. Use them 10 days. If not satisfactory return and your money will be refunded. Write today. End your motor troubles. This offer fully guaranteed.



START NOW—SAVE 2/3 COST



Build Your Own Boat
LOWEST PRICED and BEST BOATS in the World Built by BROOKS SYSTEM
 Brooks K. D. Outfits make Boat Building a pleasure. You can easily and quickly assemble your own boat by using our simple method. Let us furnish you at trifling cost our instructions, Full Sized Patterns, a K. D. Outfit with parts already shaped and fitted, or build your a Completed Boat. Brooks Models are speedy, staunch and seaworthy. Thousands of satisfied patrons. Get our prices before building, they are lower than ever before.
 Brooks, Oldest Established Boat Builders

BROOKS MANUFACTURING COMPANY

Address Cat. Dept. Saginaw, Mich.

MOTORCYCLE BARGAINS

Save 25% to 65%

on Slightly used and Rebuilt Motorcycles, Side Cars, Johnson Motor Wheels, Evans Power Cycles, Bicycles. Send for Free Bargain Bulletin and Money Saving Message, listing hundreds of Bargains in used, rebuilt and new machines, supplies, accessories, etc.

AMERICAN MOTOR CYCLE CO., CHICAGO
 Dept. 314 3047 W. Chicago Avenue.



\$20 BRINGS YOU AN HB BATTERY CHARGER

Pay balance on long easy monthly terms. You can make \$150 to \$300 clear profit every month with an HB Charger. No repairs, no renewals—steady, continuous service. Get your HB outfit NOW when demand for reliable battery charging is greatest. Sizes for 6, 10, 16 or 32 batteries. Let us recommend size to make you most money. Write today. Get prices also on HB motor grinders, air compressors, electric motors, tire buffers, etc.—all big money-makers for your shop.

HOBART BROTHERS COMPANY, Box M3, TROY, OHIO



KENNEBEC CANOES



A glance at our new illustrated catalogue will convince you that we are giving wonderful values this year—because prices are much lower than in 1921 and the Quality remains the best. The book is yours for the asking.

KENNEBEC BOAT & CANOE CO. 28 E. E. Square Waterville, Me.

\$2,500 Monthly for Miller With Willey Universal Vulcanizer



Walter J. Miller invested \$175 in 1919, came to our plant for instructions for three weeks. Since that time he has bought his own home. He is now doing \$2,500 worth of business per month, employing two men and making big money.

Sold on Installments

Tire repair business all cash. Only small investment necessary. We give you practical training in our plant and shop or by mail FREE. The machine burns coal, wood, kerosene or gas. Economical to operate. Set up in a few minutes. FULLY guaranteed.

WILLEY RUBBER BOOT AND HALF SOLE MACHINE

Can be connected to regular vulcanizer or set up separate. Repairs auto tubes, water bottles, boots, rubbers—in fact anything made of rubber.

Write for complete catalog and Free Training Offer—all free.

WILLEY UNIVERSAL VULCANIZER CO., BATTLE CREEK, MICH.
 23 WILLEY BLDG.

MAKE YOUR FORD INTO THIS SPORT CAR \$ ONLY 6.40

Other types down to \$1.50. Favorite sure fit. Red-Red life-size patterns and simple instructions show all details. You can easily convert your Ford into this fast, sexy Sport Car as hundreds have done with a few dollars worth of material from the hardware store. No need to buy up the car. The "PAL" with conical disc wheel patterns. Pressed Metal Streamline Rear only \$6.40 delivered. Built low, rides wonderfully easy. Order NOW while we can make good delivery. Send for coin for illustrated prospectus of "Sport Bodies," "Jugs," "Tops and 'Gowns'" Windshields. Kuespel Co., 84 Kuespel Bldg., Gattsburg, Iowa



Kuespel Co., 84 Kuespel Bldg., Gattsburg, Iowa

Kuespel Co., 84 Kuespel Bldg., Gattsburg, Iowa

Kuespel Co., 84 Kuespel Bldg., Gattsburg, Iowa

Kuespel Co., 84 Kuespel Bldg., Gattsburg, Iowa

Kuespel Co., 84 Kuespel Bldg., Gattsburg, Iowa

Kuespel Co., 84 Kuespel Bldg., Gattsburg, Iowa

Kuespel Co., 84 Kuespel Bldg., Gattsburg, Iowa

Kuespel Co., 84 Kuespel Bldg., Gattsburg, Iowa

Kuespel Co., 84 Kuespel Bldg., Gattsburg, Iowa

Kuespel Co., 84 Kuespel Bldg., Gattsburg, Iowa

Kuespel Co., 84 Kuespel Bldg., Gattsburg, Iowa

Kuespel Co., 84 Kuespel Bldg., Gattsburg, Iowa

Kuespel Co., 84 Kuespel Bldg., Gattsburg, Iowa

Kuespel Co., 84 Kuespel Bldg., Gattsburg, Iowa

Kuespel Co., 84 Kuespel Bldg., Gattsburg, Iowa

Kuespel Co., 84 Kuespel Bldg., Gattsburg, Iowa

Kuespel Co., 84 Kuespel Bldg., Gattsburg, Iowa

Kuespel Co., 84 Kuespel Bldg., Gattsburg, Iowa

Kuespel Co., 84 Kuespel Bldg., Gattsburg, Iowa

Kuespel Co., 84 Kuespel Bldg., Gattsburg, Iowa

Kuespel Co., 84 Kuespel Bldg., Gattsburg, Iowa

Kuespel Co., 84 Kuespel Bldg., Gattsburg, Iowa

Kuespel Co., 84 Kuespel Bldg., Gattsburg, Iowa

Kuespel Co., 84 Kuespel Bldg., Gattsburg, Iowa

Kuespel Co., 84 Kuespel Bldg., Gattsburg, Iowa

Kuespel Co., 84 Kuespel Bldg., Gattsburg, Iowa

Kuespel Co., 84 Kuespel Bldg., Gattsburg, Iowa



The Stromberg Gasoline Filter

Avoid Trouble!

Remove the sediment, dirt and water from the gas—the Stromberg Gasoline Filter does it. It filters the fuel just before it enters the carburetor—removes all dirt and water.

Easily attached to vacuum tank, carburetor or gas line. Needle valve shuts off gas when sediment chamber is removed for cleaning. Prevents theft—it locks the car. State name and model of your car.

STROMBERG MOTOR DEVICES CO.

Manufacturers of the Stromberg Carburetor
64 East 25th Street
Dept. 314
Chicago, Ill.

\$3.00

Taxidermy Book FREE

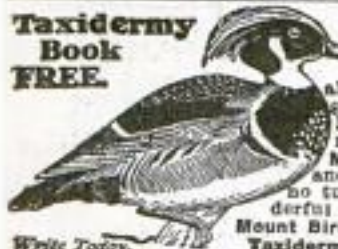

Write Today

Stuff Beautiful Birds.

Learn by mail to stuff and mount all kinds of birds, animals, fish and game heads; make rugs, tax skins. Mount your own specimens and make money preserving for others. Men, women and boys learn easily and quickly. Success guaranteed or no tuition. Write today for our wonderful FREE book "How to Learn to Mount Birds and Animals. N.W. School of Taxidermy, 9773 Elwood Bldg., Omaha, Neb.

BIG MONEY SAVED

REBUILT MOTORCYCLES

Harleys, Indians, Excelsiors, and Hendersons Sidecars, Motorwheels, Bicycles and Accessories. Lowest Prices; Terms Cash; Subject to Inspection. Write For Latest Free Bulletin No. 368

EDWARDS & CRIST CO.

1253-63 Michigan Avenue Dept. E Chicago, Ill.
Largest Motorcycle Dealers in the World

10c CHARGES STORAGE BATTERY

FROM A LAMP SOCKET

AT HOME OR BUSINESS With An F-F BATTERY BOOSTER, which is a Full Wave Magnetic Rectifier for 105-125 volt 60 cycle A. C. Leave battery just as it is in your car. Snap Clips on battery terminals. Turn Switch, lock Garage, knowing battery will be charged in morning. **AMMETER** eliminates guess work. A completely compact self-contained portable Automatic Charging Unit. No skill required. A Fully Charged Battery starts Cars & Trucks quick in the coldest winter weather & thus saves expensive Re-placement Storage Batteries must be bought, when kept Fully Charged; so it actually Costs Less to Buy Booster than to buy one. Don't think your battery is dead and worn out simply because it will not start your car. Buy a Booster. Fill it with Lila and hear Engine spin. **BY BUYING A BOOSTER YOU SAVE MONEY.** These Types Last A Lifetime. **PRE-WAR PRICES:**

- Bantam Type 6 charges 6 volt Battery at 6 amps \$15
- Bantam Type 12 charges 12 volt Battery 3 amps \$15
- Type 156 charges 6 volt Battery at 12 amperes \$24
- Type 1612 charges 12 volt Battery at 17 amperes \$24
- Type 1626 Combination Type charges both 6 & 12 volt Batteries at 12 & 7 amperes.....\$35

CHARGING SERVICE

The Larger Types are recommended for heavy batteries, or where time is limited. Shipping Weights Complete with **AMMETER & BATTERY CLIPS**, 12 to 15 Pounds. Mail Check for Prompt Express Shipment. Or 3 for Parcel Post Shipment add Postage & Insurance charges. Or Order us to forward the Type you desire 45. 0. 0. Order Now or Write Immediately for **FREE Descriptive BOOSTER BULLETIN 24**. For **GROUP CHARGING** write for **Free ROTARY RECTIFIER BULLETIN 24-A**. Real Economy in First Cost & in Service. It charges up to 26 Cells. Automatically. **THE FRANCE MFG. CO., CLEVELAND, OHIO, U. S. A.** Canadian Representative: Battery Service & Sales Co., Hamilton, Ontario, Canada.

TIRE AGENTS WANTED \$4000 A YEAR

I'll Show You How to Make More Money Taking Orders For Mellinger Tires

I want exclusive Agents, all or part time, to handle Mellinger Extra Ply and Cord Tires under the **MELLINGER PLAN**. No experience necessary. My Plan literally guarantees your success without risk or investment. Thousands of car owners say Mellinger Tires are the finest and most serviceable made.

Guarantee Bond Up to 10,000 Miles

behind my Extra Ply and Cord Tires. Everywhere Mellinger Tires are making big money for agents and giving Auto Owners **BETTER TIRES FOR LESS MONEY**. My new low prices amaze everyone.



I Guarantee Your Profits

So confident am I that you can earn big money under the **MELLINGER PLAN**, that I literally guarantee your profits. The **MELLINGER PLAN** offers you a permanent business. No matter what you are doing—what you are making—let me put this remarkable plan in your hands. I don't ask you to carry a big stock—to risk **ONE CENT** of an investment. Sample Sections Furnished. My **BIG FREE BOOK** tells you all about it—about tires—their construction—how sold—explains manufacturers', jobbers', retailers' prices—tells you **WHAT REAL WHOLESALE PRICES ARE**. A post card brings you this remarkable book by return mail.

Prove It for Yourself

Don't buy anyone's tires until you see these amazing values—see these tires on your own car. **THINK OF IT**. Oversize Cord Tires for less than Fabrics used to cost. Read amazing reports of my agents' successes under the **MELLINGER PLAN**. Read what Car Owners say about these Super-quality Tires. Read how you can get a brand new set of Mellinger Tires for a little of your time and good will. I'll take all the risk to have you try Mellinger Tires on your car. **Tires shipped prepaid on approval.**

My Amazing Offer

I say this is the big thing for you—your opportunity for a big future—wealth—independence—big business with hosts of friends and customers. I appoint only one exclusive agent in each locality. Let me explain the **MELLINGER PLAN**—Let me show you. Tweedie, of Maine sells \$1436 in few short weeks. A. M. Amigo of Santurce, Porto Rico, sold \$4024 in seven months. Keithley of Idaho, says: "I have sold \$900 worth of tires since I took the agency and all have given good satisfaction." These are ordinary results—you can do it—you can make \$4000 a year—you can make more. **BETTER TIRES FOR LESS MONEY** are business getters. **DON'T SEND A CENT**—all in the coupon this minute before you turn another page—tear it off—mail it now—My Big Free Book will be in your hands in a few days.

MELLINGER TIRE & RUBBER COMPANY

1032 Oak St. Kansas City, Mo.

Mr. B. L. Mellinger, Pres., Mellinger Tire & Rubber Co., 1032 Oak St., Kansas City, Mo. Without obligation, send me details of the Mellinger Plan, Free Book and Wholesale Prices and how, without investing any money, I can become your authorized agent.

Name
Address

WANTED IDEAS



Inquiries from Manufacturers and Others Who Are Looking
for Good Ideas

PROTECTED BY PATENTS

are constantly being received. Manufacturers are always interested in any new device for which there is a market, which fills a long felt need, which makes production possible at a lower cost, or which will do the work BETTER. Extracts from some of the more recent letters received are printed herewith. There is undoubtedly a great demand today for really worth while inventions.

Your First Step

If you have an idea, send immediately for my blank form "TO RECORD YOUR INVENTION." You should serve your own best interests by filling out and signing this form before you disclose your invention TO ANY ONE. This document will help you determine and establish evidence of invention before filing an application in the U. S. Patent Office. A copy, with full instructions, will be gladly sent free on request.

NEW BOOK "SUCCESSFUL PATENTS" SENT FREE

Every man who has an invention, or ever hopes to have one, should send for a copy of my book "SUCCESSFUL PATENTS." It tells what everyone should know about patents, trade-marks, copyrights, etc. It describes my methods, fees and terms, gives information relative to assignment or sale of rights, and instructions in detail. Mail coupon today for a free copy of this book or a post card request will do.

To the Man with an Idea

I offer a comprehensive, experienced, efficient service for his prompt, legal protection, and will endeavor to aid him in the commercial development of his proposition—my service is distinguished by over 12 years' successful practice, and by thousands of satisfied clients and by reasonable fees.

Send sketch, or model, and description, for advice as to cost, opinion as to its patentable nature, etc. Preliminary advice gladly furnished without charge.

-----COUPON-----

RICHARD B. OWEN, Patent Lawyer

Main Office, 9-303 Owen Bldg., Washington, D. C.
Branch Office, 2276-E Woolworth Bldg., New York City.

Please send me, without charge, or other obligation, a copy of your book, "SUCCESSFUL PATENTS," your form "TO RECORD YOUR INVENTION," and information concerning patents, etc.

Name.....Address {

Can You Help?

Here are abstracts from a few recent requests I have received from those who wish to buy, finance or manufacture good inventions. Have you an idea that will fill the bill?

Following is an extract from letter dated July 20, 1921, from a middle western manufacturer whose volume of business last year was approximately \$1,000,000. "If you are in touch with any meritorious proposition seeking manufacturing facilities, in the automotive or some other good field, we shall be glad to have you place us in touch with it. We are willing to consider outright purchase of patents or manufacture upon a royalty basis."

Another request from a large corporation, dated June 27, 1921, follows: "Should you have clients whose inventions are worthy of commercial manufacture and exploitation, we shall be glad to consider the financing of such projects, if they are interesting. In that event, we indicate also that we are identified with two large machinery manufacturing plants located, respectively, in Bridgeport, Ct., and Providence, R. I. These plants, besides having their own foundries, are thoroughly equipped to manufacture anything from a small lathe to a complete automobile. Whether your clients have mechanical inventions or otherwise, we shall be pleased to hear of any proposition requiring financing."

Another letter dated April 28, 1921, from a large corporation whose officers include some of the best known men of the country, says in part: "We are in the market for an invention of merit possessing undoubted economic and commercial value combined with ADEQUATE PATENT PROTECTION."

PATENTS TRADE-MARKS AND COPYRIGHTS

SPECIAL OFFER — Free Opinion as to Patentable Nature

Before disclosing an invention, the inventor should write for our blank form "Evidence of Conception." This should be signed and witnessed and if returned to us together with model or sketch and description of the invention, we will give our opinion as to its patentable nature.

Our Three Books Mailed FREE to Inventors

OUR ILLUSTRATED GUIDE BOOK

HOW TO OBTAIN A PATENT

Contains full instructions regarding Patents, Trade-Marks, Foreign Patents. Our Methods, Terms, and 100 Mechanical Movements illustrated and described; Articles on Patent Practice and Procedure, and Law Points for inventors.

OUR TRADE MARK BOOK

Shows the value and necessity of trade-mark protection and gives information regarding unfair competition.

OUR FOREIGN PATENT BOOK

We have direct agencies in all the principal foreign countries and secure foreign patents in the shortest possible time and at the lowest cost. Write for our illustrated Guide Book on Foreign Patents, sent free to any address.

Specialization—Our Staff

The field of invention is so vast that it is impossible for any one man to become an expert in all the different classes of invention. Only those practically skilled in the class to which the invention relates are capable of rendering efficient service. For this reason Victor J. Evans & Co. employ a number of patent lawyers and mechanical experts who have been selected for their special knowledge and ability in certain lines of invention. Each case is placed in charge of experts in the classes to which the invention relates.

THE VALUE OF YOUR PATENT

will depend much upon the skill and care with which your case is prepared and prosecuted in the United States Patent Office. This work will receive the benefit of skill and experience acquired by a long and successful practice. We spare neither time nor pains to secure the broadest possible patents that the inventions will warrant. That every case entrusted to us receives our best efforts, and that our work is done consistently, skillfully, and thoroughly is evidenced by the many unsolicited letters of commendation that we receive constantly from our clients. We will furnish upon request lists of clients from any State in the Union for whom we have secured patents.

Our New York, Philadelphia, Pittsburgh, Chicago and San Francisco Offices

Owing to the growth of our business we have established for the benefit of our clients Branch Offices in New York City, Philadelphia, Pa., Pittsburgh, Pa., Chicago, Ill., and San Francisco, Cal. These branch offices being located in these large commercial cities together with our Main Office located near the U. S. Patent Office, in Washington, enables us to more promptly handle the business of our clients, particularly as the branch offices are in constant touch with the Main Office and fully equipped to handle patent business in all its branches.

Highest References — Prompt Attention — Reasonable Terms

---FREE COUPON---

VICTOR J. EVANS & CO., Patent Attorneys

NEW YORK OFFICES
1007 Woolworth Building

CHICAGO OFFICES
1114 Tacoma Building

PHILADELPHIA OFFICES
135 South Broad Street

PITTSBURGH OFFICES
514 Empire Building

SAN FRANCISCO OFFICES
Hobart Building

MAIN OFFICES: 765 9TH STREET, N.W., WASHINGTON, D. C.

Gentlemen: Please send me FREE OF CHARGE your books as described above.

Name Address



PATENTS

IF YOU HAVE AN INvention which you wish to patent you can write fully and freely to Munn & Co., for advice in regard to the best way of obtaining protection. Please send sketches or a model of your invention and a description of the device, explaining its operation.

All communications are strictly confidential. Our vast practice, extending over a period of seventy years, enables us in many cases to advise in regard to patentability without any expense to the client. Our Handbook on Patents is sent free on request. This explains our methods, terms, etc., in regard to **Patents, Trade Marks, Foreign Patents, etc.**

If you are a reader of the **SCIENTIFIC AMERICAN**

you are probably aware of the fact that it has a special appeal to the inventor. Each issue contains a description of a large number of recently patented inventions. Pending patent legislation as well as the most recent rulings of the Patent Office and the courts are considered in its columns.

MUNN & CO.

SOLICITORS OF PATENTS

672 Woolworth Bldg., NEW YORK

Scientific American Bldg., WASHINGTON, D. C.

801 A Tower Bldg., CHICAGO, ILL.

582 Market St., SAN FRANCISCO, CALIF.

Please Mention Popular Mechanics



**PROTECT
YOUR
RIGHTS**

WRITE TODAY FOR FREE BOOK ABOUT PATENTS and "RECORD OF INVENTION" for establishing evidence of conception. The book tells how to proceed, the usual cost of obtaining a patent, and contains good sound practical advice every inventor should know. "RECORD OF INVENTION" should be filled out, signed and witnessed before you disclose invention to anyone. Send rough sketch or model and description for free report upon patentable nature and cost to Patent, etc. **Prompt, personal service.** Reasonable fees. Partial payment plan. Preliminary advice without charge.

J. REANEY KELLY
PATENT LAWYER

612-COLUMBIAN BLDG. WASHINGTON, D.C.

PATENTS
Send us sketch or model for patentability opinion and exact cost of patent. Our book "How to Obtain a Patent." Sent Free on request. It tells how to apply for Patents, Trade Marks, Foreign Patents, Copyrights, etc.; gives information on Patent Procedure; tells what every inventor should know. Thousands of Inventors, who are our clients, are our references. **Chandlee & Chandlee, 25 Years Experience.**
422 7th St. Washington, D. C.

PATENTS Inventors should write for our "Evidence of Disclosure" form. It's Free. Avoid Dangerous Delays. Send sketch or model of your invention for examination and advice. Ask for Free Book "How to Obtain a Patent." Highest references. Write to-day.
Merton-Roberts & Co., 184 Mather Bldg., Washington, D.C.

PATENTS
TRADE-MARKS COPYRIGHTS
Send for our free book of patent information.
Beale & Park 802 F St., Washington, D. C.
16 S. Broad St., Philadelphia, Pa.

PATENTS **C. L. PARKER**
Formerly Member Examining Corps, U. S. Patent Office
PATENT LAWYER
MCGILL BLDG.
WASHINGTON, D. C.
Patents, Trade Marks, Copyrights, Patent Litigation
Handbook for Inventors, "Protecting, Exploiting and Selling Inventions," sent free upon request.

PATENTS

Booklet Free

Highest References

Promptness Assured

Best Results

Send drawing or model for preliminary examination

ALL BUSINESS GIVEN PROMPT AND PROPER ATTENTION

WATSON E. COLEMAN, Patent Lawyer, 624 F St., Washington, D. C.

Can You

think of a simple, practical idea that will fill one of the many requests we have on file for new inventions? It may mean a fortune for you. Thousands of things are needed right now. Your brains can help. Send today for our great new book—

"Inventions and Trade-Marks, Their Protection and Exploitation"

and learn more about making money from ideas than you ever knew before. It tells many things that are wanted, too.

**A postal will do—
It is free**

We Help Our Clients

without charge, to get the dollars out of their ideas—having facilities none others possess. Advice free. Don't delay—get the book at once.

American Industries, Inc.
200 Patent Dept.
WASHINGTON, D. C.

Patents Advertised For Sale Free

in Invention and Manufacturing Supplement

Published for the man with an idea. Send for free sample copy. One year's subscription, 50c.

U.S. PATENTS



DON'T LOSE YOUR RIGHTS TO PATENT PROTECTION

Before disclosing your invention to anyone send for blank form "EVIDENCE OF CONCEPTION" to be signed and witnessed. A sample form together with printed instructions will show you just how to work up your evidence and establish the same before filing application for patent. As registered patent attorneys we represent hundreds of inventors all over the United States and Canada in the advancement of inventions. Our schedule of fees will be found reasonable. The form "Evidence of Conception," sample, instructions relating to obtaining of patents and schedule of fees sent upon request. Ask for them—a post card will do.

PATENTS AND TRADE MARKS

LANCASTER & ALLWINE

204 Ouray Bldg. Washington, D. C.
Originators of forms "Evidence of Conception."

PATENTS If You Have an Invention and Desire to Learn How to Secure a Patent

Send for our Guide Book, **HOW TO GET A PATENT**, sent Free on request. Tells our terms, methods, etc. Send model or sketch and description of your invention and we will give our opinion as to its patentable nature.

RANDOLPH & CO.
600 F St., N.W., Washington, D. C.

NAME.....

STREET.....

CITY..... STATE.....

PATENTS PROMPTLY PROCURED TRADEMARKS REGISTERED

Send disclosure of invention, design, or trademark for actual search of U. S. Patents and novelty report. Validity and infringement investigations. Patent and trademark suits prosecuted and defended anywhere in the United States. Discriminating clients appreciate my efficient service. No literature will be sent you as this is a professional service, *individual* and *Personal*. Specific information and advice given regarding each individual case. Specialize in prosecution of pending cases that have been previously rejected by the Patent Office. Specialize also in unfair competition litigation before the Federal Trade Commission.

George P. Kimmel, Master of Patent Law
53-F Loan & Trust Bldg., Washington, D. C.

Inventors

in all cities and many towns in the United States and Canada have secured patents through us. We secure patents in **delayed, neglected, and**

Rejected

cases. Write giving data.

Abraham Lincoln in an Address to Law Students said:

"As a rule, never take your fee in advance, nor any more than a small retainer. When fully paid beforehand, you are more than a common mortal if you can feel the same interest in the case as if something was still in prospect for you, as well as your client; and when you lack interest in the case, the job will very likely lack skill and diligence in the performance."

Engaged in Patent Soliciting exclusively since 1875, we have procured more than 40,000

Patents

Send us a model, drawing or photo with description of invention, remit \$5.00 for search in U. S. Patent Office to find if patentable.

Our booklet on patent protection at home and abroad sent free. Write or come to

C. A. SNOW & CO.

Patent Attorneys Since 1875

710 8th Street, Opp. North Front of U. S. Patent Office
WASHINGTON, D. C.



GEARS ALL KINDS SMALL

The most accurate made and prices reasonable. We carry a complete line of gears in stock for immediate shipment. Can also quote on special gears of all kinds. Send us your inquiries. WRITE FOR CATALOGUE.

CHICAGO STOCK GEAR WORKS
105-109 S. Jefferson St., CHICAGO

PATENTS and TRADE-MARKS

As one of the oldest patent firms in America, and representing a clientage extending to all parts of the country, we afford Inventors and Manufacturers, at lowest consistent charges, a service noted for efficiency and results, evidenced by many well-known Patents and Trade-Marks of extraordinary value

Lacey & Lacey, K639 F St. Washington, D.C.

ESTABLISHED 1869

PATENTS Secured

Prompt service. Avoid dangerous delays. Send for our "Record of Invention" form and Free Book telling How to Obtain a Patent. Send sketch or model for examination. Preliminary advice without charge. Highest references. Write TO-DAY. J. L. Jackson & Co., 327 Ouray Bldg., Washington, D. C.



SEND FOR CATALOGUES

Gear and Experimental Parts, 15c
Materials of all kinds 10c
Model Engine Circulars 5c
COLBURN GEAR & MFG. CO. Successors
5 Woodworth St., Boston 22, Mass.

Deafness



Perfect hearing is now being restored in every condition of deafness or defective hearing from causes such as

Relaxed or Sunken Drums, Roaring or Hissing Sounds, Perforated, Partially Destroyed Drums, etc.

Wilson Common-Sense Ear Drums

"Little Wireless Phones for the Ears"—require no medicine but effectively replace what is lacking or defective in the natural drums. They are simple devices, which the wearer easily fits into the ears where they are invisible. Soft, safe and comfortable to wear at all times.

Write today for our 168 page FREE book on DEAFNESS, giving you full particulars and plenty of testimonials.

WILSON EAR DRUM CO., Incorporated
495 Inter-Southern Building LOUISVILLE, KY.

STOP USING A TRUSS

Do Away With Steel And Rubber Bands

FREE TRIAL



Inner surface is made adhesive to secure the PLAPAO-PAD firmly to the body, keeping the PLAPAO continually applied and the pad from slipping. No straps, buckles or springs attached. Soft as velvet—easy to apply.

PAT'D
APRIL 6
1909

FREE to 5,000 Truss Sufferers

To the extent of 5,000 sufferers who may apply I will send, ABSOLUTELY FREE, a sufficient quantity of the Plapao to positively convince them that this is the only logical, commonsense way of treating ruptures. Plapao is a highly astringent medication placed within the Plapao-Pad and being absorbed through the skin, creates a wonderful feeling of relief and at the same time tends to strengthen the weakened muscles and thus permanently close the rupture opening. The process of recovery is natural, so you'll have no use for a truss—you can throw it away forever! Old and young have testified under oath that the Plapao-Pads cured their ruptures—many of them long-standing, aggravated cases—without delay from work. Patent allowed in U. S. and foreign countries. Awarded Gold Medal at Rome and Grand Prix at Paris.

Send No Money—for a sufficient quantity of the Plapao is sent without charge to enable you to give it a thorough test; you pay nothing for this trial now or ever. Write for it and full information today. Address: Plapao Laboratories, Block 1497 St. Louis, Mo.

DEAFNESS IS MISERY

I know because I was Deaf and had Head Noises for over 30 years. My invisible Antiseptic Ear Drums restored my hearing and stopped Head Noises, and will do it for you. They are Tiny Megaphones. Cannot be seen when worn. Effective when Deafness is caused by Catarrh or by Perforated, Partially or Wholly Destroyed Natural Drums. Easy to put in, easy to take out. Are "Unseen comforts." Inexpensive. Write for Booklet and my sworn statement of how I recovered my hearing.

A. O. LEONARD, Suite 226, 70 5th Avenue, New York City

The WONDERFUL ERICKSON PATENT LEG

Will not chafe, overheat, nor draw end of stump.



ERICKSON ARTIFICIAL LIMB CO., 38 Wash. Av. N., Minneapolis, Minn.

NO MORE BALD HEADS



WHEN our VACUUM CAP is used a few minutes daily. We accept no pay until you have tried the Cap 60 days and are satisfied. The Vacuum Cap is an appliance that draws the blood to the Hair Roots and starts a new healthy crop of hair. It stops Dandruff, stops the hair from falling out.

Bought by Doctors and men who know that it is the only reasonable HAIR GROWER known to science. No Drugs Used. Write for application blank, testimonials and booklet on "HAIR," sent sealed in plain envelope. FREE.

THE MODERN VACUUM CAP CO.

V 559 BARCLAY, DENVER, COLO.

Develop Your Inventive Ability

Invention is a Science

Let Great Inventors Now Teach You How to Invent

Every man, woman, and child is born with creative imagination. Some develop this faculty to a greater degree than others, and those who develop it to the greatest extent are successful inventors. Invention is an orderly process of the mind, which combines two or more known facts to produce a new fact. Anyone who develops the right mental process can become



Raymond Francis Yates

Author of the New Course in Inventive Science, in collaboration with 15 other inventors. Mr. Yates is known throughout the country as Editor of scientific magazines, writer of hundreds of articles and inventor of many practical devices and machines.

an inventor. Every successful inventor has this type of mind, developed by constant experience over a period of perhaps many years. Heretofore those who succeeded in the field of invention had to discover all the principles themselves. But, now, just as any student of medicine, law, or engineering can take full advantage of all the recorded experience in these fields of study, so can YOU take the same kind of short cut to the habits of thought, and the methods of work required of successful inventors.

Little Inventions Win Fortunes

Fortunes have been made by men who have thought of a "little" idea in a flash. The man who invented the bottle top, the man who invented the crimped hairpin, the man who invented the thin lead automatic pencil, the man who invented the snap fastener—all these

men, perhaps, got their ideas in a flash, and founded their fortunes as a result of a single idea. But in every case their minds operated in accordance with the scientific laws of successful invention. Edison says: "Invention should be taught as a profession." Every inventor realizes the hopelessness of groping in the dark for the habits of thought and methods of work required for successful invention. Trying to invent without knowing the fundamental requirements of invention is like trying to build a bridge without knowing engineering.

Don't Waste Ideas! Every man at some time or other has an idea for something he would like to invent, but his mind doesn't know how to work. He doesn't know what to do about it—doesn't know how to think along inventive lines—and soon someone whose mind is trained along inventive lines invents just the thing you may have thought of.

WRITE FREE BOOK FOR

A wonderful book explaining this wonderful new course in detail has been written and will be sent free to those genuinely interested. This book explains the course in detail, and proves that anyone can become an inventor who trains his mind—it may be the beginning of a fortune for you. If you have ever had an idea for an invention, or if you would like to become a spare-time or professional inventor, and if you would like to know what to invent, send in your name at once on the coupon NOW! Only a limited number of these books are available for free distribution.

BUREAU OF INVENTIVE SCIENCE
Dept. 43, Wisner Bldg.
Rochester, N. Y.

Please send me your free book, "The Science of Invention."

Name
Address
City
State

Bureau of Inventive Science, 43 Wisner Bldg., Rochester, N. Y.

Agents Wanted

to sell the finest
ALL-WOOL
tailored-to-measure
Suits and Overcoats
at the sensationally
Low Price of

\$26.50

Nothing like it in America!

\$26.50 Values positively sensational **\$26.50**
Competition swept aside

You get your profits in advance

Understand that \$26.50 is the price for which you sell to your customers. Understand that at this price you give Guaranteed ALL-WOOL Fabrics, hand-tailored, Serge and Alpaca lined. Understand that this price includes a very handsome profit for yourself and above all understand that you get these profits in advance — cash in hand — every time you take an order.

Now is the time to sign up

The Selling Outfit we supply is the greatest thing of its kind ever gotten out. It's put up in a handsome carrying case containing everything necessary to do business and besides the Tailoring Samples and Fashions contains a complete display of Men's Furnishings. Good Agents make \$75.00 a week easy. Lines are going fast. If you want yours—write us—right away. Address Dept. E-473

GOODWEAR (Inc.) Chicago

843 W. Adams St.

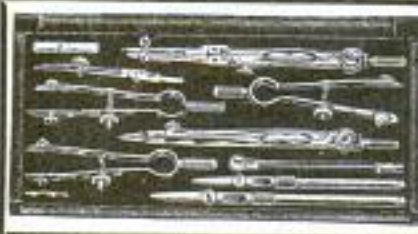

Mechanical Drawing
Instruments
List Price \$15.00
NOW \$4.75
Write for catalog
G. G. CO., 4331 N. Oakley
Avenue, CHICAGO, ILL.

Bead Making Outfit **FREE**



Yes, we give you free a complete bead making outfit and materials. We teach you by mail to make beautifully colored beads—jade beads, turquoise, jet and amber beads. Fascinating and profitable. More than \$15 daily can be made. We teach you every detail at very small cost. Write us now for descriptive circulars free. Write now.

HOME INSTITUTE OF TRADES, Dept. 2213
445-446 Houseman Bldg. Grand Rapids, Mich.

Aladdin Homes Save \$200 to \$800

Aladdin Homes will save a substantial amount for you through eliminating dealers' profits, saving over 18% waste in lumber and lowering labor costs in building. Aladdin Homes come to you direct, thereby reducing freight charges, and are cut to fit, saving waste of lumber and hundreds of hours of carpenter labor. Send stamps for the Aladdin catalog at once.

Bungalows, Dwellings, Summer Cottages

Aladdin prices include all the timbered frame work, millwork, the siding, outside finish, porch, shingles, windows, doors, interior woodwork, lath, glass, nails, hardware, lock sets, paints, stains and varnish.

Send Stamps Today for Catalog No. 1269

THE ALADDIN CO., BAY CITY, MICHIGAN

Branches; Offices and Mills: Portland, Oregon; Wilmington, North Carolina; Hattiesburg, Miss.

Canadian Offices and Mills: Toronto, Vancouver, Winnipeg, St. John



GENUINE GERMAN MAUSER

Latest Model 9 Shot Automatic

25 CAL.

\$12.95

Less than half
pre-war price.

32 Cal. 13.95. 8 shoots COLTS and all standard cartridges. Convenient to carry—lies flat in the pocket—perfect safety device. All our guns brand new direct from factory, absolutely perfect.

8.45 25 Cal. BLUE STEEL ARMY AUTOMATIC — 32 Cal. \$10.45. OUR OTHER BIG SPECIALS:

Vest Pocket Pistol \$4.95
World's Famous Larger 30 cal. \$19.95. — Hand Ejector Revolver swing out cylinder 32 cal. blue steel or nickel \$16.95. Pearl Handle \$19.95.

SEND NO MONEY

Pay Postman on Delivery.

UNIVERSAL SALES CO.

141 Broadway Dept. 138 New York, N.Y.

AGENTS: \$54 A WEEK

2 in 1 Reversible Raincoat



One side dress coat, other side storm coat. Tailored seams, sewed and strapped. Two coats for the price of one. Brand new. First season. Not sold in stores. We control the entire output. Take orders from men and women who object to paying present high prices.

Guaranteed Waterproof

or money back. Our men and women representatives having wonderful success. Right now is the big season. No experience or capital needed. You take the orders. We ship by parcel post and do all collecting. Commission paid same day you take orders. We are paying thousands of dollars to our agents taking orders for this new Reversible Coat. We have all of the latest and best styles of raincoats, for men, women and children. Our new, big swatch book, 48 pages, shows all new and distinct patterns. Write today for agency and sample coat and make some ready money this season.

Parker Mfg. Co., 578 Storm St., Dayton, O.

Dollars in Hares

We pay \$7.00 to \$18.50 and up a pair and express charges. Big Profits. We supply guaranteed high grade stock at lowest prices and buy all perfect pairs you raise. Use back yard, barn, cellar, attic. Contract and Illustrated Catalog FREE.

STANDARD FOOD & FUR ASS'N
407 B Broadway NEW YORK





Get this valuable Book on Better Lawn Care



The Ideal Junior

Every one interested in the care of large, beautiful lawns should have a copy of this book which tells all about Ideal Power Lawn Mowers. It shows many photos of well-known homes, parks, golf clubs, cemeteries, colleges, etc., where the lawns are cared for the "Ideal Way." It tells about the Ideal Junior, a moderate-priced power mower for medium-sized lawns, the 30-inch Ideal Power Lawn Mower for large lawns, and the Ideal Triplex Power Mower for large parks, golf clubs, etc. Write for this book today—learn how to keep your lawn in better condition at less cost.

IDEAL POWER LAWN MOWER CO.

R. E. OLDS, Chairman

418 Kalamazoo St. Lansing, Mich.

World's Largest Builders of Power Lawn Mowers.

Dealers in all principal cities.

IDEAL Power Lawn Mowers



The Wideweb Boston

is The Garter for neatness and efficiency. Made of wide mercerized shirred web, has slide adjustment, and cast-off so to fit any size leg. NO METAL PARTS on face of Pad.

GEORGE FROST CO., BOSTON, Makers of Velvet Grip Hose Supporters for All the Family

Build and Fly Model Aeroplanes



Build your own Model Aeroplane; make trial flights and learn the principles of Aeronautics. With IDEAL Sessle Drawings and Building and Flying Instructions you can easily build exact 1/2-ft. duplicates of Real Planes. Read how for the Plans for the one you want to build.

Curtiss JN4D-2 Training Plane; Duffavilland Battle Plane; NC-4 Naval Seaplane;

Curtiss Military Tractor; Bleriot, Nieuport or Taube Monoplanes; also Cecil Paul Racing 25c each, postpaid.

Catalogue IDEAL Model Aeroplanes and Supplies, 5c postpaid

IDEAL AEROPLANE & SUPPLY CO.

159 Wooster St., cor. W. Houston St.

New York City

PLANS AND INSTRUCTIONS 25¢

DIAMONDS

ONE CARAT \$195⁰⁰

Former retail cash price \$325.

New low prices 40% discount. 3/4 carat \$146.25;

1/2 carat \$97.50; 1/4 carat \$48.75. If satisfied, pay 20% down; balance in 10 monthly payments.

10 MONTHS TO PAY

Genuine sparkling blue-white diamonds now sold direct to you by DIAMOND IMPORTERS on credit at 40% discount. 14 Kt. solid gold ring included free. We guarantee to satisfy you or return your money. 30 DAYS FREE TRIAL!

Order direct from advt. or write for 128-page bargain catalog, sent free.

\$1,000,000 and 42 years' experience are back of our guarantee

B. GUTTER & SONS 172 NASSAU STREET Div. 365, NEW YORK

Buy Direct from Headquarters

By buying direct from us you save from 25% to 40% on new Columbia motors, and as high as 50% on Fuerst-Friedman rebuilt motors. You save retailer's profit—you save retailer's high sales cost and you get motors fully guaranteed for one year.

No matter what your motor requirements are, from tiny buffing motors to heavy-duty factory motors, we have a new or rebuilt motor to suit your exact needs. And the cost is from 25% to 50% less than you would pay elsewhere. Send for our big free motor book—see for yourself the savings you get by buying from us. It tells all about our twenty years of successful motor service—all about many vast engineering projects we have handled. Ask for Book No. 10—the price regulator on new and rebuilt motors.

Electrical Machinery of all kinds promptly repaired or taken in exchange

THE FUERST-FRIEDMAN CO.

CLEVELAND, OHIO

"Reliability Built In"

COLUMBIA MOTORS



"Some Present" from "Dad"

Give your boy a quick start in Music with this wonderful Easy-to-Play, Easy-to-Pay Instrument—the

BUESCHER

TRUE-TONE SAXOPHONE

Of all musical instruments, this is a man's or a boy's instrument. It is the easiest of all wind instruments to play, and one of the most beautiful. You can learn the scale in an hour's practice and in a few weeks be playing popular airs. Nothing can take the place of a Saxophone for home entertainment, church, lodge or school. In big demand for orchestra dance music.

FREE TRIAL Easy Payments

We make it easy for you to get a Buescher True-Tone Saxophone or other musical instrument. You may order any Buescher instrument without paying in advance, and try it six days in your own home, without obligation. If perfectly satisfied, pay for it on easy payments to suit your convenience.

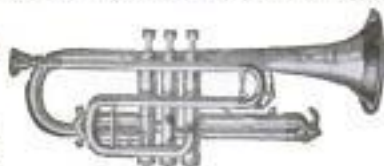

Buescher-Grand Cornet

The Buescher-Grand Cornet is exceptionally easy to blow, yet possesses a tone of wonderful volume. If you expect to learn to play a Cornet, you should by all means have a good instrument. With a Buescher-Grand, you own an instrument similar to that with which the greatest cornetists of America have made their reputations. If interested in a Cornet or other instrument, ask for our complete Catalog—sent free.

Free Saxophone Book

"The Origin of the Saxophone" tells just what each Saxophone is best adapted for; when to use singly, in quartettes, sextettes, octettes, or in regular band or full saxophone band, and how to transpose for tello parts in orchestra. A copy is yours free. Just send your name.

BUESCHER BAND INSTRUMENT CO., 2537 Buescher Block, Elkhart, Indiana
Makers of Everything in Band and Orchestra Instruments

Agents
Make Big
Money
EVERY-
BODY
BUYS



New Improved Door Handles FORD

Every Ford Owner Needs These Neat, NICKEL PLATED LORAIN KNOBS.

Fits perfectly on door handles—saves clothes and fingers. Fit on gas and spark levers—makes driving easier. Easily attached. The original and most perfect knob. Send \$1 Bill today for complete set of 4 postpaid. AGENTS

WRITE QUICK FOR QUANTITY PRICES.

Loraine S. & R. Co., Dept. E 25 N. Dearborn
Chicago, Ill.

Light Fibre Legs and Arms

636
Dean Bldg.
RAY TRAUTMAN Minneapolis, Minn.

Only \$45.00 For This Job Complete

Save exorbitant freight rates and one-half original cost by buying Ford Speedster Bodies knocked-down. Simple, complete. Instructions furnished, all parts cut to exact fit. Any one can assemble this job. Complete with hood, radiator shell, instrument board, wheel-oring, metal parts, wood parts, bolts, screws, etc. Flat radiator shell furnished made up with lack of wind resistance. Price set up \$90, further particulars on request.



Not Paper Patterns
All Parts Complete

The Central Auto Supply Co. Eng. Dep. 120, Louisville, Ky.

Agents: We Pay \$7 a Day

Taking Orders for New Reversible Raincoat

Two coats in one. One side black raincoat—other side fine dress coat. Guaranteed Waterproof. Latest style. Brand new. Easy to take orders on account of two coats for the price of one. Every man in your community a prospect.

\$45 A WEEK GUARANTEED

FOR 3 AVERAGE ORDERS A DAY

All you do is take orders. Your commission paid same day. Just send your name; we will tell you how to start on this big money making proposition, even if you can devote only a few hours a day to it. You don't have to invest any money. You need no experience. Some of our successful representatives are making from \$40 to \$80 a week. Write at once and get our plan. We will arrange to pay you the same day you book the orders. Act quickly. The Big Season is now on.

THOMAS MFG. CO., R-1448, DAYTON, OHIO



\$375.75 One Day!

Ira Shook, of Flint, Did That Amount of Business in 1 Day

—making and selling **Popcorn Crispettes** with this machine. He says in letter dated March 1, 1921: "I started out with nothing, now have \$12,000.00 all made from **Crispettes**." Others have amazing records: Gibbs says: "Sold \$50.00 first night!" Erwin's little boy makes \$35.00 to \$50.00 every Saturday afternoon. Melxner reports \$600.00 business in one day. Kellogg writes: "\$700.00 ahead first two weeks." Master's letter says: "—sold \$40.00 in four hours." During March, 1921, Turner was offered \$700.00 clear profit above cost of his investment to sell. **There is money—lots of money—in Crispettes.**



Times make no difference for most of these records were made in 1921—were made while people are crying hard times and are looking for jobs! Location makes no difference. It's common for Crispette machines to make \$10.00 to \$25.00 profit daily in small towns!

I Start You In Business

Write me—get my help. Begin now. Others are making money selling **Crispettes**. You can, too! You don't need much capital. Experience not necessary. I furnish everything—secret formulas, equipment for shop or store, full directions, raw materials, wrappers, etc. Splendid chances galore everywhere! Crowded streets, amusement parks, concessions, wholesaling and stores!

\$1,000.00 Monthly Easily Possible

Crispettes are a delicious, delightful confection. People never get enough. Always come for more. Raw materials are plentiful and cheap. You make enormous profits. Trade grows by leaps and bounds. It's an easy, pleasant and fascinating business. Send post card for illustrated book of facts. Contains enthusiastic letters from men and women who have quickly succeeded. Tells how to start. Explains most successful methods. Gives all information needed. It's FREE! Write Now! Address

LONG EAKINS COMPANY

328 High Street Springfield, Ohio

Harley-Davidson

World's Champion Motorcycle

PRICES REDUCED ONE HALF Rebuilt and Guaranteed

1915, three speed twin electric \$125; 1916, \$135; 1917, \$150; 1918, \$165; 1919, \$180; 1920, \$200. Shipped on approval. Catalog A free, describing Harley-Davidson's, Excelsiors, Indians, Smith Motors at \$40 and upwards. Liberty Bonds taken at full face value. Letters of recommendation from hundreds of satisfied customers. Heds.: Buick and Harley-Davidson Motor Co. Rapid service on 1902 to 1922 Harley-Davidson parts. 100 page PARTS catalog B, 25 cents. Stamp or coin.

WISCONSIN CYCLE SALES COMPANY

726 NATIONAL AVENUE MILWAUKEE, WIS.
Oldest and Largest Dealers in the North-West. Milwaukee—World's Largest Motorcycle Center



Please Mention Popular Mechanics

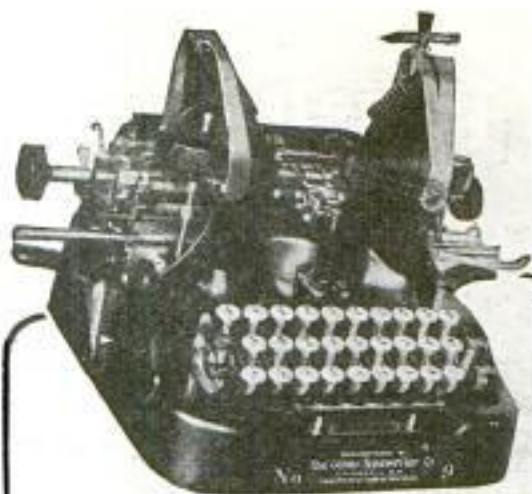

Famous No. 9 OLIVER \$38.90

Was \$100 Value

Only 10 Cents a Day for This Wonderful Typewriter. Only 40 Left

Slashing cut to clean out at once the last 40 of our big stock of the famous No. 9 Oliver two-color and back spacer latest model that originally sold at the regular manufacturer's price. A selected lot of machines that sold at higher prices, every one reconstructed for grade A showing.

See it at our expense—any child can operate it
Complete book of instructions FREE

You don't have to take anybody's word for the value of these machines. Prove it to yourself. Our special price is only \$38.90, F. O. B. Chicago. If you think that it is not a bargain at \$50, or if you are not satisfied with it in every way, return it to us within 5 days and you'll be nothing out. We want you to see this machine at your own home or office. Work on it for five days and then if satisfactory it is yours on our easy payment plan for ONLY 10 CENTS PER DAY.

5 DAYS FREE TRIAL—GUARANTEED 5 YEARS

Send only \$3 with order. Every machine guaranteed for 5 years. Fill in coupon today. Begin the enjoyment of this wonderful bargain at once. Remember, we will take it back and refund your \$3 if you don't like it. We stand behind our guarantee—we've been in business 16 years—money back if not satisfied. Cash Price, only \$35.00, F. O. B. Chicago.

All Orders Returned After This Lot is Sold

SEND COUPON NOW

INTERNATIONAL TYPEWRITER EXCHANGE,
177 N. State Street, Dept. D-51, Chicago, Illinois

Ship above typewriter. I enclose \$3.00 deposit and agree to remit \$3.00 per month for 12 months. Title to remain in you until fully paid for. If I am not satisfied after 5 days I will return same and receive refund of deposit.

Name.....

St. No.....Rfd. No.....

City or Town.....State.....

TWO-YEAR GUARANTEED BATTERIES SAVE 50%



Famous "Royal" Batteries—highest quality made—now selling direct from factory to car owner. You save half. We give written 2-year guarantee—longest on any battery. Big responsible organization backs guarantee. Batteries for any car, tractor or gas engine.

Save time. Order from this ad. Battery fully charged, shipped immediately—by express C.O.D. You run no risk. Our location same for eight years. References: Nat'l Bank of the Republic, Dan or Broadstreet.

Free Booklet If you want description, write first, send this superior battery. Get this booklet before you buy any battery. Write today! Give year and model of your car.

K - E BATTERY CO., Dept. 87
14 E. Jackson Blvd., Chicago

© 1921
SPECIMEN PRICES
Ford-Dort-Chev. \$18.80
Overland-Buick 21.85
Maxwell-Dodge 25.60
Save 50% saving on all cars

Largest Exclusive Mail Order Battery House in America
Members of Chicago Association of Commerce



Puzzle Peg

The Great Puzzle Game

Played by One
Makes fun for All

Watch a few moves of Puzzle Peg and you will get a set of your own. It is simply irresistible—the most baffling, mysterious puzzle game ever invented. You are sure you can solve it easily. It looks so simple you expect to solve it in 5 minutes. When the 5 minutes are up you ask for 15. When the 15 are up you declare you can solve it in half an hour. But the cleverest puzzle workers often spend hours before they find one solution, and remember already there are

30 Solutions Known Can YOU Find One?

Are you good at puzzles? How long will it take you to do it? Can you find more than one solution? Can you find a solution that has not been found before? Give yourself and your friends the hours of pleasure that Puzzle Peg brings. Enjoy the fun of watching the other fellow fail—when he is sure he can solve it. Remember it is the greatest game-for-one ever invented. If you travel, if you are shut-in, if you are lonely, if you have spare time, if you like fun, if you want to make an appreciated gift to a friend, go to any dealer in good games and ask him for a set of

Puzzle Peg



If your dealer does not have it send only 50 cents and we will mail you a complete set by return mail postpaid, together with booklet showing thirty problems—every one a fun maker for all the family.

Lubbers & Bell, 725 Second Avenue
CLINTON, IOWA

Please Mention Popular Mechanics

AGENTS \$1.75

YOU CAN
Sell This For



and Give **FREE**
These Shears

VALUE
\$1.25



6 inch—with spring tension device

MY! HOW THEY SELL!

ONLY 20 Boxes A Day Means \$18.00 Daily Profit

You get the interest with the free Shears. Walter Harris sold 800 boxes in 6 Weeks. Profit over \$100.00 a week. A total retail value of \$4.00. A real bargain at \$1.75. The array of fine toilet goods (that always appeals to milady's heart) will dazzle her eye, and when at the end of your talk you state the low price of \$1.75 for these 11 articles, with the shears FREE, the money is yours, even if she has to borrow, or beg it.

ACT NOW! Sells like hot cakes year 'round. A baby could sell Lucky 11. Don't delay a minute. Save time. Send \$1.75 for complete outfit including display case. At least write for circulars explaining our unique plans, including 50 other packages. **ACT NOW.**
E. M. DAVIS CO., Dept. 2353 CHICAGO, ILL.

SEND for the INTERNATIONAL CATALOG

Factory to Consumer direct—

PAY ONLY ONE PROFIT



Our net price list of auto bodies and body supplies at Wholesale Prices. Save big money by buying Direct from Factory

For Ford and Chevrolet—prices from \$27.85 up
International Body Works 314 W. Ohio Street, Chicago, Ill. Dept. 7

WINDOW SIGN LETTERS

LARGE PROFITS

184

EDWARD GOLDSMITH
DELICATESSEN
AND
GROCERY

CIGARS & TOBACCO
GOODS DELIVERED

AGENTS WANTED

AGENTS WANTED

SAMPLES FREE

AGENTS

\$75.00 to \$150.00 a week. Lowest price gold and silver sign letters for stores, offices, automobiles, etc. Large demand everywhere. Anybody can do it. Exclusive territory or travel all over while you earn. Write for free samples and catalog.
ACME LETTER CO., 2800 X Congress St., Chicago

No Heavier Than a Good String of Fish

For you outdoor men and women, whose playgrounds are the lakes and streams of many states brought within easy reach by motor car, train or trolley—for you has been designed and perfected this lighter, more portable rowboat motor—the Evinrude "Lightweight."

Weighing not quite 50 pounds, *complete*—21 pounds less than the Standard Evinrude—this new sport model is the lightest practical outboard motor made. Weight has been saved and strength maintained by replacing many bronze and malleable parts with aluminum alloys.

See these Evinrude motors at your sporting goods or hardware dealers.
Or write for catalog and new prices (recently cut to pre-war level).

631 Evinrude Building **EVINRUDE MOTOR CO.** Milwaukee, Wis.

DISTRIBUTORS:

69 Cortlandt St., New York, N. Y. 440 Market St., San Francisco, Calif.
780 Commonwealth Ave., Boston, Mass. 211 Morrison St., Portland, Ore.

Practically the counterpart of the Standard 2 H.P. model in design, and its equal in power and speed, the "Lightweight," though not intended for such rugged service, is a motor entirely worthy of the Evinrude name.

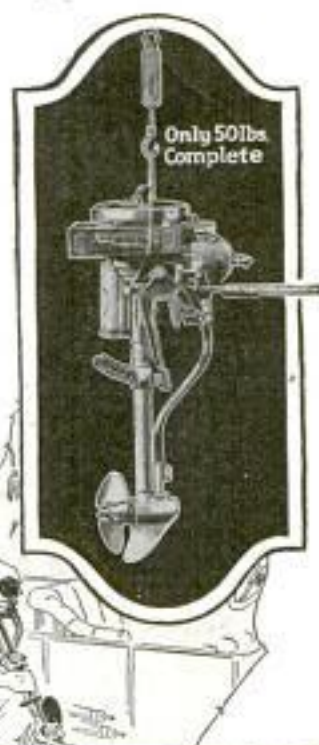

EVINRUDE "LIGHT-WEIGHT"
DETACHABLE MOTOR FOR WATERCRAFT

Free Trial

YOU may have any instrument with complete outfit, for a week's free trial at home. No obligation to buy. Return it at our expense after trial if you wish. No charge for trial. Outfit includes velvet lined case, self instructor, music and all accessories at factory cost. A tremendous saving.

Convenient Monthly Payments

A few cents a day will pay for instrument and outfit. This offer gives you genuine Wurlitzer instruments, known all over world for artistic quality. Have one now for Free Trial.

Send Coupon for Beautiful New Catalog

Every instrument known illustrated with price, easy terms and free trial blank. Catalog absolutely free. Write today.

The Rudolph Wurlitzer Co., Dept. 1773
117 East 4th Street, Cincinnati — 700 Jackson Blvd., Chicago
120 W. 42nd St., New York — 215 Stockton St., San Francisco

Send me your new catalog illustrated in color with full details of Wurlitzer Complete Outfits and free trial and easy payment offer.

Name.....
Address.....
.....
(State instrument you are especially interested in)

WURLITZER
200 YEARS OF MUSICAL INSTRUMENT MAKING
Cincinnati Chicago
New York San Francisco
Copyright 1920, Rudolph Wurlitzer Co.



Queen
Anne
Vanity

Dresser 20c a Day

Figured Walnut, full length mirror. Complete suite and 1228 other beautiful Furnishings on easy payments in our FREE 128 Page Larkin Book of Better Homes.

- Furnishings
- Symphonic Pianos
- Symphonic Player Pianos
- Symphonolas

(Check offer interested in)

Symphonic Pianos, Symphonic Player Pianos and Symphonolas (the phonograph with natural tone, which plays all Records) sold to tens of thousands of music lovers past nine years. Get our book describing these famous musical instruments by checking above.

NO Money Down—30 Days FREE Trial—1 to 4 Years TIME

Check offer now. Cut out this ad. Give your full name and address. Mail TODAY.

Desk FPM-322 *Larkin Co Inc.* Buffalo, N. Y.

"I Would Not Part with it for \$10,000"

So writes an enthusiastic, grateful customer. In like manner testify over 100,000 people who have worn it. Conserve your body and life first.

The Natural Body Brace

Overcomes WEAKNESS and ORGANIC AILMENTS of WOMEN AND MEN. Develops erect, graceful figure. Brings restful relief, comfort, ability to do things, health and strength.

Wear It 30 Days Free at Our Expense

Does away with the strain and pain of standing and walking; replaces and supports misplaced internal organs; reduces enlarged abdomen; straightens and strengthens the back; corrects stooping shoulders; develops lungs, chest and bust; relieves backache, curvatures, nervousness, ruptures, constipation, after effects of Flu. Comfortable and easy to wear.

Keep Yourself Fit

Write today for illustrated booklet, measurement blank, etc., and read our very liberal proposition.

HOWARD C. RASH, Pres. Natural Body Brace Co.
223 Rash Building SALINA, KANSAS



For
Children
Also

DEAF?

Here's
Free Proof
That You
Can Hear!



The wonderful, improved Acousticon has now enabled nearly 500,000 deaf people to hear. We are sure it will do the same for you; are so absolutely certain of it that we are eager to send you the

1922 ACOUSTICON
For 10 Days' FREE TRIAL
No Deposit No Expense

There is nothing you will have to do but ask for your free trial. No money to pay, no red tape, no reservation to this offer. Our confidence in the present Acousticon is so complete that we will gladly take all the risk in proving, beyond any doubt, that the

Joy of Hearing Can Be Yours Again!

The new Acousticon has improvements and patented features which cannot be duplicated, so no matter what you have ever tried, just ask for a free trial of the New Acousticon. You'll get it promptly, and if it doesn't make you hear, return it and you will owe us nothing—not one cent.

DICTOGRAPH PRODUCTS CORP.
1307 Candler Bldg. 220 W. 42 St., N. Y. City

Don't Wear a Truss

Brooks' Appliance, the modern scientific invention, the wonderful new discovery that relieves rupture, will be sent on trial. No obnoxious springs or pads.



MR. C. E. BROOKS

Brooks' Rupture Appliance

Has automatic Air Cushions. Binds and draws the broken parts together as you would a broken limb. No salves. No lies. Durable, cheap. Sent on trial to prove it. Protected by U. S. patents. Catalog and measure blanks mailed free. Send name and address today.

BROOKS APPLIANCE CO., 1266 State St., Marshall, Mich.

Clear-Tone
FOR

PIMPLES

Your skin can be quickly cleared of Pimples, Blackheads, Acne Eruptions on the face or body, Enlarged Pores, Oily or Shiny Skin. \$1,000.00 Cold Cash says I can clear your skin of the above blemishes. WRITE TODAY for my FREE Booklet—"A Clear-Tone Skin"—telling how I cured myself after being afflicted for fifteen years.

FREE

E.S. GIVENS, 129 Chemical Bldg., Kansas City, Mo.

Make Your Bike a Motorcycle

With a **SHAW** MOTOR ATTACHMENT



MOTOR SPECIFICATIONS

Power Plant—2½ H. P. SHAW Super Motor, 4-cycle type. Bore 2¼ inches. Stroke 3 inches.

Transmission—Two roller chains with countershaft clutch on crank hanger shaft, giving free engine.

Ignition—American magneto; water and oil proof.

Control—Grip control.

Tank—Flat for double bar or round for single bar frame.

90 to 125 Miles per Gallon!

That's what the SHAW gives! 1,200 to 1,800 miles per gallon of lubricating oil; speed 4 to 40 miles an hour. Easily controlled; always dependable.

Easy to Attach

Fits double or single bar frame. Just use a common screw driver and a monkey wrench. No expert required. No drilling; no tapping; no welding. You can attach it in about 30 minutes' time.

The Complete SHAW Motorbicycle

The SHAW Motorbicycle is a light-weight, powerful motorbicycle, complete in every detail. All latest improvements. 2½ H. P. 4-cycle motor of highest efficiency. A Special Low Price on this machine now.



Spring and Summer will soon be here. Get ready! Turn your old bike into a powerful, speedy motorbicycle—quickly, easily and at very little cost! Clamp on a SHAW Motor Attachment. Go anywhere you want to, any time, for about one-fourth cent a mile. No more hard pedaling—the SHAW Attachment furnishes the power—and plenty of it!

New Lower Prices Now!

Striking reductions now on SHAW Attachments—prices right down to bedrock. At our Special Low Prices any man or boy can now afford one. Thousands in use everywhere. Known everywhere for their high quality. Sold on a **Guarantee**.

WRITE your name and address on the Attached Coupon. Then send it at once for Complete Descriptive Literature and New Reduced prices on SHAW Attachments and the complete SHAW Motorbicycle. Clip it. Send the Coupon NOW!

SHAW MANUFACTURING CO.
Dept. 37. Galesburg, Kansas



**SHAW
MFG. CO.**
Dept. 37,
Galesburg, Kans.

**Mail This
Coupon
Now!**

Send in Complete Descriptive Literature and Special Reduced Prices on SHAW Attachments and Motorbicycles.

Name.....

Address.....

I Made \$1412.63 on the Side

During the Grass Season with your IDEAL Lawnmower Grinder, writes W. F. Kendt.

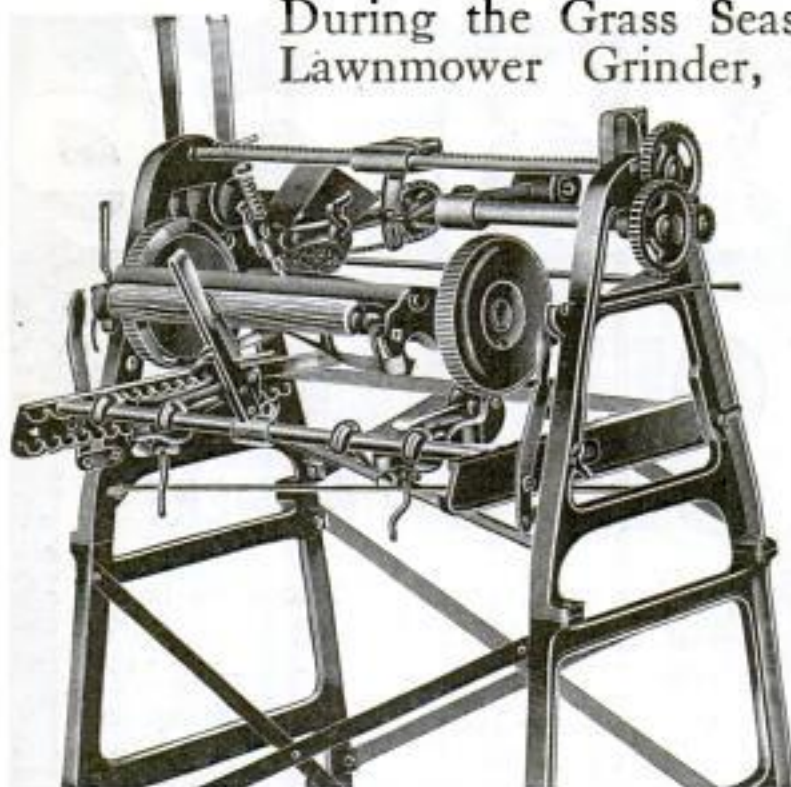

Mr. Kendt lives in Buffalo, and sharpened 790 lawnmowers. Says best investment ever made.

Read What Zeno Says:

Zeno Brandon lives at Middletown, Ohio, and writes:

"I have worked 55 days and made \$820.70. Have made as high as \$38.70 in one day."

WRITE FOR CATALOG

And little booklet, "LET GEORGE SAY IT." It tells the stories of profit as the boys tell it. Mr. Brown bought early, made \$1400 by fall, and built a new shop with the money. Write today.

The Fate-Root-Heath Co.
PLYMOUTH, OHIO

Automobile Batteries



Guaranteed 28 Months Unconditional at a saving of 65 per cent

6 VOLT 11 PLATE
for Overland, Elgin, Ford, Scripps-Booth, Grant, Dort, Saxon, Hupmobile, etc. Usual Cost \$32.00. **Our Price... \$13.00**

6 VOLT 13 PLATE
for Oakland, Velle, Nash, Studebaker, Maxwell, Cole, Chevrolet, Mitchell, Buick, Reo, Hudson, Paige, etc. Usual Cost \$40.00. **Our Price... \$15.00**

12 VOLT 7 PLATE
for Dodge, Maxwell, Crow-Elkhart, Regal, Franklin, Hriscoe, etc. Usual Price \$32.00. **Our Price... \$20.00**

The Best Battery Offer Ever Made

GLOBE BATTERY COMPANY

Dept. P, 1217 S. Wabash Ave. Chicago, Illinois

Any Boy Can Build This 30 Inch Boat



With Our Construction Set

Also other sailboats, power boats, engines, boilers.

Complete
Partly finished
Rough.

CATALOG FREE

The H. E. Boucher Mfg. Co.

154 Lafayette St. New York



Race Electric Grinder \$16⁵⁰

Complete With 3" Emery Wheel, Grooved Pulley and Electric Cord

F. O. B. CHICAGO

For sharpening tools, polishing or grinding, the Race Motor Grinder will prove a great convenience in the Carpenter Shop, Machine Shop, Garage, at Home, or on the Farm; it is a practical machine that will prove its value to every mechanic. It is portable, plugs into any electric light socket, push button start and stop, operates on either A. C. or D. C. current of 110 to 130 volts, or 25 to 60 cycles. Weighs only 7 lbs.

These small Grinders are dependable in every respect and satisfactory service is guaranteed to the extent that if you are not entirely pleased after ten days' use, the Grinder may be returned to us and your money will be cheerfully refunded.

A neat adjustable tool rest can be supplied for \$1.50 extra if desired.

RACINE UNIVERSAL MOTOR CO., 4642 Ravenswood Ave., Chicago, Ill.

ATTRACTIVE DEALER PROPOSITION

BOYER PRESSURE COOKER

The cooking utensil of 100 uses. Saves fuel and cooks food more rapidly. Ideal for home, hotel or restaurant. Write TODAY for our free illustrated booklet showing our complete line of copper ware. It is sent by first class mail.

Cap's'y. Price
3 gal. \$7.00
5 gal. 9.00
7 gal. 11.00
10 gal. 15.00
20 gal. 22.00
30 gal. 28.00
40 gal. 35.00



Boyer & Co., 1212 Jones St., Omaha, Neb.
DEALERS—Write for dealer prices

BIG BUSH AUTOMOBILE OFFER

Write at once for our Big Offer. Get a Bush Car and the Agency for them in your territory. Big Values, Low Prices Now



6 and 4 Cyl. Cars

BUSH MOTOR CO.
Bush Temple, Chicago, Ill.

The Dying Pig



The most laughable novelty yet produced. Made of rubber, and you blow only to blow it up and it is a dead pig on his feet, when he begins to squeal as he slowly collapses and finally lies down and dies in the most natural manner. You can blow him up as often as desired, and each time he will go through the same performance to the great amusement and delight of your friends.

Price 15 cents; 3 for 40 cents; one dozen \$1.35, insured postpaid.

Popular Watch Charms



Very pretty little curiosities and decidedly novel. Fitted with Magnifying Lenses that enlarge the picture to a very surprising degree; in fact, it seems almost incredible that a clear picture could be possible in such a small compass, and how sharp and distinct they show up when you look through. Come in assorted views—Actress, view of Panama Canal, Lord's Prayer in type, etc.

Price 15c; 3 for 40c; \$1.35 doz.

Johnson Smith & Co., 3224 N. Halsted Street, Dept. 773, Chicago

MADE-TO-MEASURE 197



Guaranteed for 2 years solid wear or your money cheerfully refunded. These pants are a "Wonder-Value" worth \$6.50 sent to you for \$1.97 as a sample of fine tailoring.

AGENTS WANTED

EARN \$50.00 a week in your spare time. No experience necessary. Write today for our

BIG FREE OUTFIT

with dozens of the newest styles and attractive woolen samples to choose from. Everything sent FREE. WASHINGTON TAILORING CO., Dept. C-345 Chicago, Ill. Note

Express or Postage Prepaid

The Famous YORK Saxophone

The Easiest Instrument to Play

Sent to You ON FREE TRIAL

Yes, you can have the World famous York Saxophone shipped to you on 10 days' Free Trial. Play it at home for ten full days. Convince yourself of its superb quality and richness of tone.

And then, if our instrument does not completely sell itself to you simply ship it back to us, and it won't cost you a penny.

Take Your Choice

You can get any one of these fine band instruments made by the House of York on 10 days' Free Trial. Send the coupon below for beautifully illustrated literature and take your pick of the following:

- Saxophones
- Clarinets
- Cornets
- Drums
- Trombones
- Baritones

Easy Payments

You can pay while learning to play. Make a small payment down and the balance in monthly remittances. We send you everything you need—carrying case and all necessary attachments.

Send Coupon Today

Fill out the Coupon now with your name and address and simply mention the instrument you are interested in and we will send illustrated literature and full details of our Trial Offer and Easy Payment Plan. This literature also tells you how to practice and how to learn to play. Send Coupon today.

J. W. YORK & SONS
Dept. 2213,
Grand Rapids, Mich.

Mail This Coupon Today

J. W. YORK & SONS,
Dept. 2213, Grand Rapids, Mich.

Gentlemen:- Kindly mail, without cost to me, your beautifully illustrated literature and details of your Free Trial and Easy Payment Offer.

NAME.....
ADDRESS.....
INSTRUMENT.....
(Mention above the instrument most interested in)

2-Year Guaranteed Automobile BATTERIES at Lowest Prices



Look at This
\$14.95

For Ford, Studebaker, Chevrolet, Dort

\$17.70

For Buick, Overland, Essex, Reo, Hudson, Nash

\$21.95

For Maxwell, Dodge

BATTERIES
For All Other Cars
at Similar Prices

Highest Standard batteries made by one of the oldest Standard Battery companies in America, now come direct from the maker to you without a single profit in between.

Two Year written guarantee. Highest bank references. Prices in many cases 60% lower than batteries bought through dealers, and much lower than ordinary commercial mail order batteries jobbed through mail order houses.

Send no money. Order direct from these prices, being sure to state name, model and year of car, and battery will be sent immediately by express C. O. D.

All batteries shipped fully charged, ready to install. Prices like these as you must know are lower by far than any other battery prices ever made. Order direct from these prices or send for full price list on every car together with free descriptive literature.

Write right now and we will ship right back. Address

DEFIANCE BATTERY CO.

Direct Sales Department 11

725 Hearst Building, Chicago

RADIO DETECTOR

This is the smallest and lowest priced detector on the market. It does a variety of things as well and better than many \$5.00 detectors. Has composition base; all metal parts nickel plated; furnished complete with galena crystal. Study illustration and notice new features. Note particularly patent nickel detector cup and binding post. Size 1 1/2 x 1 1/4 x 1 inch. Sent prepaid anywhere. Price complete **50c**

If you build your own radio set you must have the RASCO catalog containing 185 illustrations and 50 vacuum tube connection diagrams—the greatest collection published in any catalog. Catalog contains the greatest assortment of parts and raw materials in U. S. Send 15c in stamps or coin for this catalog. "Radio Rex Jr."

RADIO SPECIALTY COMPANY, 98E Park Place, N. Y. City

THIS IS THE MACHINE THAT MAKES YOUR WASH TUB INTO a Washing Machine

Don't get a lame back and wrinkles. Wash your clothes clean quickly and easily without wear this way. Surely your better health and less wear on clothes is worth 8 cents a week for three years. This simple machine is guaranteed that long. Delivered prepaid on 20 days' free trial anywhere in U. S. A. Even easy monthly payments if desired. Send for circular how to save work.

VACCUP Semi Automatic

BURLINGAME MFG. CO.
322 Sunset Avenue Syracuse, N. Y.

Stop Your Hydrants and Faucets from Leaking and Wasting Water — with an AJAX BIBB RESEATER



It cuts new seats on household hydrants, faucets, bibbs, etc., and saves buying new faucets and does away with annoyance and waste of dripping water.

Fits all faucets—4 steel cutters with each tool. At Hardware Dealers and Supply Houses, or send us \$2.00 for one postpaid.

Ajax Mfg. Co., 848 Jackson Street, Pittsburgh, Pa.
Dealers write for proposition.

Build This Phonograph Yourself — TREMENDOUS SAVING IN COST

Easy, fascinating work with our SIMPLIFIED PLANS. We furnish blue prints, diagrams, motor, cabinet pieces, ready-built horn, etc. You don't need to be a cabinet maker. A few hours assembling and you will have a fine instrument at one-quarter the regular retail price. **AGENTS MAKE MONEY** making and selling these instruments. Write today for full details of our FREE OFFER. Address:—

Modern Phonograph Supply Co.
638 Springer Bldg., 313 S. Clinton St., Chicago, Ill.

DIAMONDS

Lowest Prices in America on Genuine Diamonds. Free trial; lowest monthly terms. 300,000 satisfied customers. Write now for new Bargain Book, Harold Lachman Co., Dept. 1773 204 S. Peoria St., Chicago

1000 SHOT ALL STEEL MAGAZINE AIR RIFLE GIVEN **WE GIVE TO BOYS** **HAMILTON 22 CAL. HUNTING RIFLE WITHOUT COST**

Choice of Six Guns (on four easy plans) for selling our Magic Healing Wav-o-lens at 25c Box. **WE TRUST YOU!** Order Seven Boxes Today On Postal Card—we send promptly, Prepaid. Easy to sell—used in every home. Return money as instructed, choosing your Gun according to one of the plans shown in our Big Premium List. Also 200 other Gifts or Big Cash Commission if you prefer. If you are prompt—a special Free Gift.

WAVERLY CO. 225 Tower Bldg., Monaca, Pa.
350 SHOT REPEATER
SEND ORDER TODAY, FREE!

\$47.25 PROFIT in Four Hours

Doughnut Making business has wonderful possibilities. Doughnuts have taken the country by storm. Enormous demand. \$25 to \$75 a day. Capacity 800 doz. a day. Doughnuts sell fast at 30c to 40c doz., 100% profit. No experience needed. Flour ready prepared—add water—put dough in hopper—turn crank—out drop sweet, savory, golden doughnuts. **Money-Making Possibilities Unlimited.** Put this Automatic Doughnut Machine in display window. Attract crowds. Enticing odor whets appetite. You take in money fast. Jos. F. Donmoyer, Pa., says: "Made \$47.25 profit four hours." Others report earnings equal or better. Big money wholesaling. Be First Man in Your Town to Start. Get in on the ground floor—act quickly before others start. These machines pay big anywhere—no town too small. Get full details of this new, profitable business—costs nothing to investigate. Sign and send coupon today.

BUTLER MFG. CO.
5650 W. Lake Street Chicago, Ill.
BUTLER MFG. CO. 5650 W. Lake St., Chicago, Ill.

Send details of Automatic Doughnut Machine and business.

Name

Address

Buddies of the Road

FOLLOWING the trail to "Anywhere"—you and your pal and a Harley-Davidson! Away from congested traffic and dusty main-roads—off by yourselves, with hundreds of miles of the great outdoors for your playground.

That's the sport! The feeling of eager, limitless power under easy control as you ride comfortably and swiftly over paths impassable to an automobile—and the famed economy of it (50 miles for a dollar—gas, oil, tires and all)—why, man, you should have had a Harley-Davidson years ago!

Ask your local dealer for free demonstration of the 1922 Harley-Davidson. The reduced prices will surprise you. Or write us for free, illustrated literature.

Attractive dealer proposition for unassigned territories. Address Desk A-2

HARLEY-DAVIDSON MOTOR CO.
Milwaukee, Wis.



Harley-Davidson

World's Champion Motorcycle

Length 17 in.	You Cannot Afford To Throw Away Wrinkled Neckties	Width 4 1/2 in.
	This package contains: Six All-Metal Adjustable Necktie Pressers that Make old neckties smooth like new! Without Ironing Them. Sent postpaid for \$1; and one Six-Way Necktie Hanger—Given FREE. Home Agents Wanted—Manufacturing Outfits Furnished. Full information and directions given to Agents with each order. NECKTIE NOVELTY CO., 199 Pilgrim, Highland Park, Michigan	

BABE RUTH delights in the sport of Motoring

FORD
SPORT
BODIES



So do you

16 Valve Heads
Speed Differential Gears
Full line Speed & Power Specialties for the Ford. If you own a Ford rebuild it new. Prices see now at Rock Bottom, sure to go up in Spring. Ford chassis can be bought cheaply at this time of the year. Dealers equip Ford speed cars now at low cost and you will be sure to harvest Big Profits in the Spring. Reductions of 20 to 50 per cent on Ford speed Products. Write for our catalog and special prices.

S. R. FORD SPEED & POWER EQUIPMENT MANUFACTURERS
250 West 54th St., New York. Cable Address "Fordspeed"

BLANK CARTRIDGE PISTOL



PRICES
50c.
\$1.00

Well made and effective, modelled on latest type of Revolver; appearance alone is enough to scare a burglar. When loaded it may be as effective as a real revolver without danger to life. It takes standard .22 Cal. Blank Cartridges obtainable every where. A Great Protection Against Burglars, Tramps and Dogs. You can have it lying about without the danger attached to other revolvers. PRICE 50c Postpaid. Better make and superior quality for \$1.00. Blank Cartridges .22 cal., shipped express 50c per 100. **JOHNSON SMITH & CO., Dept. 778, 3224 N. Halsted St., CHICAGO**

FORC-FUL \$6.00

LUBRICATOR FOR COMPLETE OUTFIT

FOR FORDS
Here at last, Ford lubrication made easy. No muss or fuss. Simplest and most efficient lubricator for Fords. Hinged cap connections are dust and water proof. Easy to grease every part of Ford car.



The Only Gun That Will Lubricate Front Wheels

The FORC-FUL grease gun and seven connections illustrated here comprise the outfit. Ask your dealer. If he cannot supply you, order direct. Use coupon below. Send only \$6.00 with order.



Satisfaction guaranteed or money back



STANDARD MOTOR PARTS CO.
1420 Michigan Blvd., Chicago

Name _____
Address _____
Dealer's Name _____

PROTECTION

FOR
COLT .25 CAL.
Cartridges

Retail Value \$22.50
A beautiful little pocket gun. Shoots 7 times, .25 cal. steel jacketed bullets. Checkered grips and safety lever. Small and compact, doesn't bulge in pocket. .32 calibre \$11.50.

\$875

471

.38 Special

A real "he-man" gun. S.&W. Pattern. Used by police and secret service. Blue steel 6 shooter and one of the very finest guns made. (Cut shows cylinder partly open.)
Regular Price, \$35.00

\$1750

4711

Send for GUN AND NOVELTY CATALOG

When You Need A Gun, You Need It Bad
Don't put it off. Protect your person, your home and HER. Order NOW while these bargain prices last. Write name and address plainly and order by number.

SEND NO MONEY

Unless you wish. We will ship by return mail and you can pay the above low price, plus postage, to the postman, on arrival of your revolver.

AMERICAN NOVELTY COMPANY
2455-57 Archer Avenue Chicago, Ill.

FEDERAL BODIES



FOR FORD and CHEVROLET CHASSIS

"THE FOURSUM" illustrated above is a cozy, convertible four passenger complete with special long and narrow radiator with a massive hand hammered German silver shell. Makes driving a pleasure. Other roadster, touring and speedster designs. Big cut in prices. Bodies as low as \$29.50. Territory open for live wire dealers and agents. Make real profits. Write for our catalogue.

Buy Direct from Factory

FEDERAL MOTOR SUPPLY CO., Inc.
2626 So. Michigan Blvd. Chicago

CANADIAN DISTRIBUTORS
Federal Auto Body Co., Toronto, Ont.; Campbellton, N. B.

A MOTOR FOR YOUR BICYCLE



Attach powerful Belt Drive ROLLAWAY to your bicycle. Forget pedals. Ride in comfort. ROLLAWAY gives positive, dependable power. Light weight. Runs 100 to 150 miles on gallon gasoline. Fits any bicycle. Economical—costs less than one-fifth cent per mile to operate. Shipped complete. Anyone can attach in few minutes. Outfit includes motor, reinforced fork, wheel and guaranteed tire. Hundreds in use. A wonder for economy and performance. Price, F.O.B. factory \$55.00. Write for circulars. Adds joy, speed and comfort to cycling.

Be Our Salesman!

Buy a demonstrator. Sell. Good commission paid. Write today for our proposition. Address

The Rollaway Motor Co.

321 Shepard Street
Toledo, Ohio

Rollaway

TRADE MARK

One Man Saw Rig

Cuts Faster—Pays for Itself

Saw your own wood for winter. Make big money cutting wood for market. New OTTAWA One-Man Saw Rig saves time and labor. Easily moved. Magneto equipped. No extras to buy.

4-H.P. OTTAWA Friction Clutch

A complete, powerful, 4-H.P. engine for belt work. 30 Days Free Trial. Buy for Cash or on Easy Terms. Write for FREE BOOK and new low factory price. Ottawa Mfg. Co. Dept 171 Ottawa, Ont.

Special Safety Guard over saw.

TWO NOVELTIES FOR THE PRICE OF ONE



The DYING PIG: Inflates him, and will look like a real pig; stand him up on his wooden legs, and wash him die, then collapse. Can be inflated as often as desired. The BARKING DOG: Made of metal head, and rubber bulb. Press the bulb, and he will bark like a real dog. Will send both novelties, postpaid for 25c, or six Dogs and six Pigs for \$1.00, together with our big novelty Catalogue.

M. K. BRODY, 1118-20 S. Halsted St., Chicago, Ill.

LUMINOUS PAINT



Make Your Watches, Clocks, Etc., Visible by Night

The very latest discovery in the scientific world. Halsted, practically unobtainable except at an exorbitant price, we have at last succeeded in producing this remarkable LUMINOUS PAINT, which applied to the surface of any article, emits rays of white light, rendering it perfectly visible in the dark. THE DARKER THE NIGHT, THE MORE BRILLIANT IT SHINES. Quite simple to use. Anyone—you can do it. A little applied to the dial of your watch or clock will enable you to tell the time by night. You can coat the push buttons or switch plates of your electric lights, match boxes, and innumerable other articles; make your own Luminous Crockery, Luminous Houses, etc. Small bottle, price 25c. Larger sizes, 50c and \$1 postpaid. Johnson Smith & Co., 3224 N. Halsted St., Dept 771, Chicago

POWERFUL AIR RIFLE

Length 32 inches. Working parts of the best grades of steel. The stock is finely polished walnut. Shoots small game. Powerful, accurate, durable. You can have this air rifle for distributing only 8 of our fast selling art pictures at 25 cents on our special offer. Everybody will take one. IT COSTS YOU NOTHING to try, as we take back those you can't dispose of.

Send no money, C. M. THOMAS, 337 W. MADISON ST. 3-D-93 CHICAGO.



GIVEN

1/6 H.P. Motor Less than cost to make \$10



to buy high grade motor made and backed by substantial manufacturer at less than his actual cost. Get one to run your washing machine, ironer, dish washer, compressor, bench lathe, blower, fan, drill press, scroll saw or any small machine around house, shop, garage.

Delivers full 1-6 H. P. with liberal overload capacity. Made for 110 volts, 60 cycle current. (Also for 25, 30, 40, 50 cycle or 220 volts, if desired, at \$1.00 extra.)

Less Than Half Usual Retail Price Satisfaction Guaranteed or Money Back

New motor or free repairs if anything goes wrong within one year. Parts always obtainable. Net weight 20 pounds, shipping weight 26 pounds. Easy means of reversing direction of rotation. 10 ft. cord with 2-piece attachment plug, 65c. Pulleys, 1 1/4 inch or 2 inch, 50c. Don't lose out. Send cash or order C. O. D. by express. **Get your money back quick if you aren't more than satisfied.**

REYNOLDS ELECTRIC CO.

2610 W. Congress

Chicago, Ill.



Pilliod General Service Case

Heavy copper-plated over zinc. Brass-plated hardware. Handsome, durable, great for machinists, repair men, motormen, autoists, etc. Will last a lifetime.

FREE—Illustrated folder including tool cases for every purpose.
THE PILLIOD LUMBER CO.
Dept. 1 SWANTON, OHIO



POCKET KNIFE PISTOL

Shoots 22 shorts. Pay when delivered, \$5.25. Money refunded if you are not satisfied. Orders outside U. S., C. O. D., mail service must be accompanied by the price.

L. E. POLHEMUS CO. Miami, Ariz. Dept. 116

30 DAYS FREE TRIAL \$10 Worth of Records FREE



Simply wonderful! The limit of value giving! Just think! A GENUINE DAVIS PHONOGRAPH on 30 Days' Free Trial, and on terms as low as

\$2 A MONTH

in case you decide to buy. Magnificent instruments in quartered oak or mahogany piano finished cases, equipped with the finest worm gear motors, rich toned machines—at less than half the standard price—and \$10 worth of records FREE.

Send No Money
Just a postal with your name and address. Only a limited number of machines shipped on this extra-liberal offer. Better act quickly. This is a life-time opportunity.
DAVIS, Dept. C41
6101 MAY ST., CHICAGO

21 Jewel Burlington



Adjusted to the Second 21 Ruby and Sapphire Jewels
Adjusted to Temperature 25 Year Gold Strata Case
Adjusted to Isochronism Your Choice of Dials
Adjusted to Positions (Including Montgomery R. R. Dial)
New Ideas in Thin Cases

Only \$1.00 Down

Only One Dollar Down will buy this masterpiece of watch manufacture. The balance you are allowed to pay in small, easy, monthly payments. The Burlington—a 21-Jewel Watch—is sold to you at a price much lower than that of other high-grade watches. Besides, you have the selection of the finest thin model designs and latest styles in watch cases. Don't delay! Write for the FREE Watch Book and our SPECIAL OFFER today.

Write While This Special Offer Lasts

Get the Burlington Watch Book by sending this coupon. Find out about this great special offer which is being made for only a limited time. You will know a great deal more about watch buying when you read this book. You will be able to "steer clear" of the over-priced watches which are no better. Remember, the Burlington is sent to you for only One Dollar down, balance in small monthly payments. Send the coupon for watch book and our special offer TODAY! Do not delay one minute!

Burlington Watch Company

Dept. 1353, 19th St. & Marshall Blvd., Chicago
Canadian Address: 62 Albert St., Winnipeg, Manitoba

Please send me (without obligations and prepaid) your free book on watches with full explanation of your \$1.00 down offer on the Burlington Watch.

Name _____

Address _____

OTTAWA

Engine Prices Hit Bottom

Read this new low schedule of prices; and then act! And Remember—you are getting these bargain prices on the famous Ottawa—the most dependable engine on the market. Easier to start; Pulls more than its rated H.P.

Big Book Free

Write Today for our **Big Free Engine Book** and a complete list of the New Low Prices.

OTTAWA MFG. CO.
5370 KING ST. OTTAWA, KANSAS

1½ H.P.	\$ 35.00
2 H.P.	- 38.50
3½ H.P.	- 54.50
7 H.P.	- 117.50
10, 12, 16 and 22 H.P. at proportionally Low Prices.	

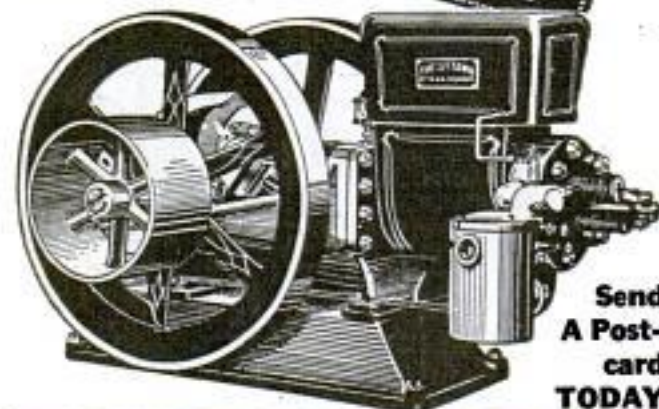

Send
A Post-
card
TODAY

BINOCULARS

SPECIAL VALUE in high grade, genuine, imported **FRENCH PRISM Conde Binoculars**. Give remarkably clear and brilliant image. Come in an elegant plush lined, genuine calf skin carrying case with straps.

\$45.80

including War Tax

8 POWER, 32 mm. 23 OZ.

BRAND NEW—not war stock! Sent C. O. D. express prepaid, subject to examination and 10 day approval. If not satisfactory we refund your money and pay return charges.

Order Now!
Over 1000 pairs sold. Wonderful value. Order now or write for descriptive folder.

BARLER & CO.
645 N. Michigan Ave.
CHICAGO



QUICK START ON COLDEST DAY

Just what you need. No fussing, fuming, cranking or delay. Step on starter. Turn motor once. Away she goes with a rush! Zero days have no terror for the

QUICK START VAPOR-MAKER

Hot coil does the trick. Just touch button. **Gasoline boils and bubbles.** Fills cylinders with vapor. Slightest spark ignites. It's a wonder. Simple. Durable. Dependable. **Saves time—trouble—battery.** No raw gas to flood—to cut oil, burn bearings or score walls. Any one can install. Job done in fifteen minutes. No drilling, boring or reaming. **Absolutely guaranteed.** You need one. Gives summer starting in winter.

Send No Money Put name, address, model and make of car on postal. Within three days postman hands you Vapor-Maker complete ready to attach. Pay him \$4.50. Try for ten days. If not all we claim, send it back. **Money returned without quibble.** You run no risk. Get our agent's proposition. **\$10 to \$20 day easy.** Send that postal today. Address

VAPOR-MAKER COMPANY
411 Smith & Baker Bldg. TOLEDO, OHIO

Own a Factory Like This



YOU CAN! Make canvas gloves. Nation-wide demand. Big market everywhere. Retail in dozen lots. Wholesale in thousand lots. Splendid profits. You can go into this wonderful business. Factory shown above grew in three years from two sewing machines. Same rapid development possible for you.

FREE EQUIPMENT

We Furnish Equipment Free

We start you in business. No experience needed. Very little capital required. We teach you how to make quality gloves—how to market them. We do all this for you—start you out right—with understanding that you buy materials from us so long as you cannot do better elsewhere.

Big Market in Your Locality

Many wear canvas gloves. Farmers, laborers, linemen, mill men, drivers, gardeners, and so on. Millions of pairs required annually to supply vast demand. You can under-rell big manufacturers. Can operate on closer margin. Can build wonderful, paying business in just few months.

Write for Full Particulars

Don't pass this opportunity without investigation. We tell all about this business in interesting booklet. Costs nothing to learn about it. Your copy is ready to mail minute we get your name and address. Send it tonight. Delay may be costly, as we are furnishing only a limited number of **FREE** equipments. Write NOW!

McCreery Mfg. Co., 316 Factories Bldg., Toledo, O.

Evans **\$135**

150
Miles to
Gallon of
Gasoline



LOW FUEL COST
DEPENDABLE
SPEEDY

America's Lightest Weight and Lowest Priced Complete Motorcycle

Join the thousands of motorcycle riders who have chosen the Evans because it costs less to operate, is easier to handle and readily understood even by a boy.

The Evans catalogue, fully describing this wonderful machine, sent upon request

Attractive offer to rider agents in territory not controlled by an Evans dealer

Manufactured by

CYCLEMOTOR CORPORATION

Box 1031 - Rochester, N. Y.



Don't
Miss
This
Fun!



Bam-Bee-No
THE NATIONAL GAME

PLAY REAL BASEBALL AT HOME OR CLUB

Bam-Bee-No will give you all the thrills and excitement of a big league game. Exactly the same as baseball. All the tight pinches, strikes, balls, hits, triples, home runs and double plays. You'll be crazy about it from the start. Two or more can play—youthsters or grown-ups (not for tots). You can keep a full box score. No need to wager to make it exciting. Game complete with size men, three dice, three counters, score cards, 10" x 14" playing field, and original copyrighted 16-page book containing practically every play known to baseball. \$2 prepaid. Money back if not satisfied. Descriptive folder free.

THE BAMBEENO SALES CO.

Dept. 632, 406 Madison Ave. Toledo, Ohio

MEN WANTED

to call on garages, stores, factories, schools, hotels, homes, auto owners and demonstrate and take orders for new

Super Fyr-Fyter

Approved by Underwriters, makes spectacular demonstration. Sells easily. Blank made \$50.00 first week. DePries has averaged \$7000 per year for last 3 years. We can train you, without cost, so you can do as well or better. No experience necessary. Write at once for free details showing how you can earn \$2000 to \$10,000 a year.

THE FYR-FYTER COMPANY
43 Fyr-Fyter Bldg. Dayton, Ohio

BANG! You Can't Beat
OUR PRICES
on these **PISTOLS**
\$ 8.75

This \$22.00
GUN FOR **\$8.75**

25-Calibre Regulation 7-shot, Blue Steel, Handsome Automatic; accurate and reliable; highest grade material and workmanship; double safety attachment makes accidental discharge utterly impossible; perfect grip; small, compact; you need this gun for your protection. Regular value \$22; get one now.

No. 109, while they last... **\$8.75**



Shoots
COLT'S
Cartridges

\$10.75

\$25 Military Model Automatic for \$10.75

Just like they used "Over There." A MAN'S gun, built for hard service. .32-calibre, with EXTRA magazine FREE. Shoots **COLT'S** Cartridges. A 10-shot gun, regularly sold for \$25.00. Our special price **NOW**, for .32-Calibre

No. 209, while they last... **\$10.75**



\$14.00

Genuine MAUSER

Latest model; 9-shot Automatic. The World-Famous Most Powerful Weapon known; shoots **COLT'S** cartridges; is perfectly balanced with substantial and comfortable grip; accurate and efficient; two safety attachments; it is flat-shaped; has no sharp edges or projections and does not bulge the pocket; it is solidly and simply constructed from blue steel; can be dismantled and reassembled in a few seconds.

Regular Value \$35 25-Cal., No. 895..... **\$14.00**
32-Cal., No. 899-A..... **15.00**

\$17.00

Regular Value \$35

Swing Cylinder

Hand Ejector

This \$35 SWING CYLINDER is one of the finest revolvers ever made; double action, solid frame. Nickel or Blue finish. Shoots S. & W. long cartridges. Order one NOW. 32 Cal. No. 409... **\$17.00**
38 Cal. No. 409-A..... **18.50**
Or with Pearl Grip, \$3.00 extra.



\$24.50

GENUINE LUGER

30-Cal., 9 Shot Automatic; with automatic magazine ejector—the latest, best and most reliable pistol made. Safety attachment Shoots Standard American ammunition. Regular Value \$90.

Our Special Price No. 909..... **\$24.50**

ALL OUR MERCHANDISE IS BRAND NEW

Order one of these Specials NOW

Mail orders promptly filled upon receipt of cash or money orders, or if you prefer

SEND NO MONEY

We ship by mail. You pay Postman on arrival. Full satisfaction guaranteed or money back. Bank reference.

We also carry a complete line of Field Glasses, Binoculars, Pistols and Shotguns at prices that cannot be equalled

IMPORT TRADING COMPANY

258 Broadway

Dept. 9

New York

A Home and Income For You in Sunny Florida



Be Independent—Own a Grapefruit and Orange Grove—A Truck or Poultry Farm. Increase Your Income

You Can Start a Grove Today Under Our New Plan

Develop a profit-earning fruit farm without leaving your present position—provide for your future. A small payment now and a few dollars invested each month.

A profit-producing fruit grove is a permanent investment and provides protection against old age.

**THE RIGHT LAND
IN THE RIGHT LOCATION AT
THE RIGHT PRICE**

We Have It—Any Size Farm

These splendid lands are suburban to Tampa, the metropolis of South Florida. Here you find the most healthful, the most delightful climate in North America. For Ten years we have been right here helping develop Hillsboro—the banner agricultural County of Florida, and we are still here to serve you and to help you obtain the farm you want, on very easy payments extending over 2 or 3 years' time to suit.

Groves Developed for Non-Residents

If you want to remain in your present position for a few years we can develop a grapefruit and orange grove for you. When you are ready we will clear your land, furnish fruit trees, plant and care for your grove until you are ready to look after it.

We Raise Our Own Guaranteed Citrus Trees in Our Own Nurseries

This insures every purchaser the best fruit trees that can be grown. This also insures a successful grove. We can save you money on planting and caring for your grove.

\$300.00 to \$500.00 Per Acre Profit

This is not an unusual return for truck farmers in the Famous Tampa district. All kinds of vegetables can be grown. Big prices are paid for early potatoes, winter cabbage, Bermuda onions, tomatoes, celery and dozens of other vegetables during the winter and early spring, when the north is covered with ice and snow. Strawberries, Melons, and other small fruits also yield large profits.

Write for Facts About Sunny Florida

IT COSTS YOU NOTHING TO LET US PROVE TO YOU that we have the land you want—in the location you want—at a price you can afford to pay and on the easiest terms you can imagine. Let us show you.

Fill out and mail us the coupon today and receive our large descriptive book FREE!

NORTH TAMPA LAND CO.
Suite 526 Monon Bldg. CHICAGO

Coupon for FREE Book on Florida

NORTH TAMPA LAND CO.
Suite 526 Monon Bldg., CHICAGO

Please send me your large illustrated book "The Call of the Southland" on choice Citrus Fruit and Truck Farms suburban to Tampa, Florida, and information on how I can have a grove developed on the monthly payment plan. P.M. 3-22

Name.....

St. No.....

City.....

State.....

WIRELESS TELEPHONE

BBROADCASTING stations are now in operation at important centers all over the country. You can easily receive these interesting daily programs with an ABC wireless receiving UNIT. ABC UNITS come to you ready-to-operate and complete in every detail. They are built on the sectional system, so that you can increase the range of your station at any time.

Ask your radio or electrical dealer about this and other exclusive features of ABC UNITS. If he cannot supply you, send us his name and address and enclose ten cents, for your copy of our booklet, "How I Put Up a Complete Radio Station in Two Hours." Request Booklet P3.

Jewett Mfg. Corp.
21 E. 40th St., N. Y. C.

ABC UNITS
Standardized Radio Sectional Receiving

NEW AUTOMATIC ADDER, \$3.50
Makes adding easy. It's accurate, quick, durable and easily operated. Capacity 8 Columns. Saves time, brain work and errors. 65,000 pleased owners. Fully Guaranteed. Price \$3.50. Delivered. With METAL OPERATING BANDS, \$5. Delivered. Agents wanted. Immediate shipment made. Send your order now.

J. H. Bassett & Co., Dept. 204, 1455 Hollywood Ave., Chicago, Ill.

50¢ FOR

An Unusual Introductory Offer
Save you money
Write today for particulars
CALIFORNIA LEATHER PRODUCTS CO.
610 Luckenbach Bldg., Los Angeles, Cal.

YOUR OLD BELT

BURN Home Made GAS
In Your Old Wood or
COAL STOVES

Change your coal or wood stove into a gas stove in 3 minutes. A Child can do it. Burn kerosene Vapor Gas—hotter than coal or wood and costs less. Safe and simple.

FREE TRIAL

Just turn a valve and get even heat instantly. No ashes, no dirt, no smoke, no wood to chop or carry. No fires to build and feed. No fuel wasted. Cooks and bakes better. No damage to stoves. Makes its own gas from common coal oil, cheapest, cleanest fuel. Guaranteed five years. Money back if not satisfied after 30 days trial.

Write for FREE folder with proof and SPECIAL OFFER
SIMPLEX UTILITIES MFG. CO.
310 Simplex Bldg. 2537 S. State St., Chicago

A New Thrill, A New Pleasure

The Ace Four-Cylinder Motorcycle brings to you an entirely new idea of motorcycle transportation

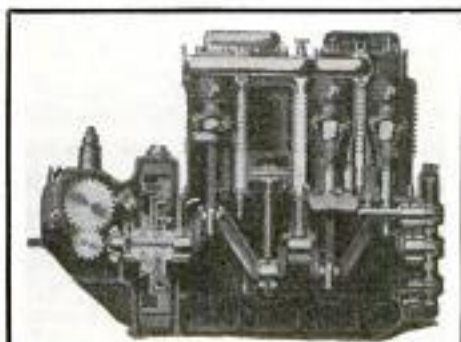

This cross-section drawing shows the remarkable, refined design of the Ace four-cylinder motor. An exclusive pre-heating device prepares the fuel for perfect combustion; large valves insure ample gas and air supply and provide for quick and complete expulsion of exhaust gases from the cylinders; compact combustion chambers with spark plugs firing in center of fresh gas give snappy ignition; precision-ground cylinders and pistons insure maximum compression; large sized, case-hardened, three-bearing crank shaft ground to glass smooth surface minimizes friction; long connecting rods, by reducing the angularity of thrust, add wonderfully to the driving power that reaches the wheel.

SMOOTHNESS that you have never imagined, silence that you have never dreamt of and comfort that has never before been possible in a motorcycle belong to the owners of the Ace four-cylinder motorcycles.

A steady flow of great power and silent vibrationless action come from Ace perfected four-cylinder construction. The real thrill of flying, sweeping motion is yours the moment you mount this new Master of the Highway. Instant pick-up at a twist of the wrist—comfort, safety and speed that give you a new control over time and distance.

Learn these things for yourself—go to the nearest Ace dealer—have a demonstration of the machine whose beauty, strength, power and flexibility are giving its riders a transportation service never before available.

If you do not know the Ace dealer, send for illustrated descriptive catalog and we will refer you to him.

ACE

Ace Motor Corporation

Erie Avenue, at Sepviva Street
Philadelphia, Pa., U. S. A.

DEALERS

Limited territory is still open to a few responsible dealers. Send for complete agency particulars.



Wear it 15 Days FREE
Truly a wonder GEM

ART-GEM The Stone that defies Diamond Experts—

We want you to be the sole judge of the Blue-White-Perfect Art-Gem, the most wonderful scientific Diamond known. We say it is Blue-White, Perfect-Cut, and full of fiery sparkle, radiance and brilliancy; that it has diamond hardness and acid resisting qualities and only an Expert can distinguish it from a Genuine Diamond. You too will say the same or we don't want you to keep it.

SEND NO MONEY Just rush your name, address, style and finger size (a strip of paper just long enough to meet over the second joint of your finger will do) for your Art-Gem. It weighs one and one-quarter Carat and is mounted in 14K (Guaranteed U. S. Assay) Solid Yellow or Green Gold for gentlemen and 14K Solid Yellow, Green or White Gold for ladies.

Wear It 15 Days FREE. Give it every test used to determine genuine diamonds—then if it proves to your complete satisfaction, pay \$3.00 monthly for three months. If dissatisfied return to us and get your money back without a question or quibble by return mail, immediately. You run no risk, merely deposit \$4.20 with the postman when your ring comes.

ART GEM COMPANY Dept. 154 138 5th Ave., New York, N. Y.



Reduced Prices

and THREE YEARS TO PAY for this beautiful

MEISTER PIANO

Eight exquisite styles to choose from and the one you select will besent you on

30 DAYS FREE TRIAL—ALL FREIGHT PREPAID

A guaranteed saving of \$100 to \$150.

If you like the piano we will sell it to you on small monthly payments to suit your convenience as low as \$6.00 per month. No cash deposit asked. No interest on payments. No extras of any kind. Stool free with piano. Write today for our catalog, illustrated in the natural colors of the wood. It's free. If you are interested in player-pianos send for free catalog. We have a fine selection. **Rothschild & Co., Dept. 19H Chicago**

EARN \$150.00 A WEEK BY YOURSELF

WITH A Duncan Vulcanizing Plant

Includes every tool and vulcanizer for a high-grade repair business. Will handle the work of six men.

We teach you approved factory methods of tire repair in your own home or in one of our many schools **FREE**.

When you equip with the Duncan Plant, we pay you \$5.00 to \$6.00 per day for the last eight to ten days of your time. You can earn it for us and more than double this amount for yourself in your own shop—we teach you how.

We will start you in business for as low as \$125.00 and balance easy monthly payments.

F. M. DUNCAN COMPANY

OFFICES AND FACTORY:
341 East Ohio St., Dept. 5, Chicago, U. S. A.



The Duncan will cure two or three times as many tires a day as any other mould. It is the only mould made that will operate with sand bags equally as well as with air bags.

\$50 a Week EASY AGENTS

Free Sample Offer



You can start a big paying business at once. Don't wait. Get big money. We tell you how—selling the famous E-Z Self-Heating Solder Iron. No experience necessary. Easy to sell. Possibilities great. Every home a prospect. Satisfaction guaranteed. Absolutely safe. Thousands in use.

Write today for proposition.

Enterprise Tool & Metal Works, Dept. 33, 129 So. Clinton St., Chicago

SPRINGFIELD CARBINE

\$3.50

45 Caliber



Made by U. S. Gov't
Breech Loading

First Class Condition. 41 inches long, weight 7 lbs., \$3.50. Then for \$3 more, you may have a smooth bore barrel to shoot shot. This makes a wonderful combination. The smooth barrel can be interchanged by anyone in 5 minutes. Millions of Bird or Ball Shot cartidges, 3 cents each. Send for Catalogue.

W. STOKES KIRK, 1627 N. 10th STREET
Dept. P. M., Philadelphia, Pa.

WHEEL-O-TIME Auto, Motorcycle or Bicycle WATCH HOLDER



for any watch. No more fumbling in your pocket. Watch instantly released. Handsomely made, heavily nickel-plated. \$1.00. With genuine Ingraham watch \$2.25. Radium

50c extra prepaid. Money order or C. O. D.

Money-back Guarantee

WHEEL-O-TIME CO. 186 East Avenue
Rochester, N. Y.



SOMETHING NEW, CATALOG No. 22



New goods, new ideas, small boilers, engines, steam and gasoline, 1-8 H. P. up, pumps, castings, blue prints, gears, pulleys, electrical goods, model makers' supplies, accessories, 2-4 H. P. Motor engines, 2 1/2 inch ga. model locomotive, etc. Catalog postpaid 20 cents stamps (2 dimes preferred). Refunded first order.

Modern Engine and Supply Co.
53 W. Jackson Blvd. CHICAGO



Send for Your Free Copy of the
NEMCO AUTOMOBILE CATALOG
3000 BIG BARGAINS
in Automobile Accessories
NEMCO BARGAIN SUPPLY HOUSE
1017 Jackson Boulevard, Chicago, U. S. A.

Make \$200. to \$1000. Profit Monthly

With Balba Perfume Sales Machines

There were \$700,000,000.00 worth of perfumes and toilet preparations sold in one year in the U. S. Approximately one-third of this, or \$250,000,000.00 was spent for perfume. Humanity has always wanted to radiate fragrance and today the demand for perfume is greater than ever. Men, women and children love to use it. They spend a dime for it, when they can't spend more. Dimes fairly flow into the Balba Sales Machines. The average machine will make about 80% profit per month on the first investment and repeat the earnings monthly. Just think what this means—one machine containing 100 bottles in an average location will empty every 30 days and the profit is \$4.00. That means only 3 1-3 people use the machine daily. Assuming a man owns 100 machines, he will average \$400 profit a month. It's the greatest opportunity ever offered to people with a little money. It is a clean, legitimate, safe, permanent, big profit business. It earns day and night. Can easily be handled in spare time. You own machine and business. Machines Fully Guaranteed.

Balba Bouquet Perfume Exquisite in Fragrance and Quality

Balba is a lasting perfume of rare and wonderful quality—it radiates a fragrance of elegance and refinement about the wearer. Where Balba machines are in use, hundreds are regular customers and buy from 5 to 12 bottles at one time, because of the convenience in size—they are easily carried in vanity case, hand-bag, coat or vest pocket.

25c to 35c Value—Price 10c a Bottle

Balba is a high quality, exquisite perfume. We manufacture it in large quantities and sell it only through Balba Sales Machines in plain, inexpensive bottles, thus reducing the cost and leaving out all middle men's profits for we sell direct.

Sold Only Through Balba Sales Machines

Balba Sales Machines are always ready to wait on customers—never high-priced nor wasteful—have no overhead expense—are attractively nickel-plated—give out a fragrance that attracts the customer—practically thief-proof—easy to fill—simple to operate—nothing to break or get out of order—weather proof, can be placed out of doors in any climate—occupy small space on wall or counter—get and hold customers because it's the lowest priced way to sell perfume and give the highest quality and largest quantity.

We Want Balba Sales Machines in Every City, Town and Recreation Resort

We have thoroughly proven that Balba Bouquet Perfume is a good seller—it repeats—it makes new users. Balba machines in good locations show an increasing business, which proves we have hit the safe, sane, logical way to sell Quality perfume. Think of this small investment as compared with the 5c and 10c stores and yet they make millions yearly. We are now going to offer a tested, proven, big profit, permanent business to a live person, (man or woman) in each territory. We do not sell territory rights—we sell an allotment of Balba machines in proportion to population, large cities may be subdivided, and then give the purchaser exclusive rights to sell Balba perfume in that territory. There is no other perfume sold like this, and as quickly as we get general sales distribution, we are going to advertise Balba nationally.

FREE Newspaper Advertising in Your Territory

When our representatives have bought and placed a full allotment of Balba Sales Machines we will then run advertising in his local newspaper, giving the locations of all the Balba Sales Machines. This makes every one start buying Balba, and the Balba quality makes them buy again. We tell you how to place machines and handle them. In a short time, when we have general distribution of Balba, we will advertise in the National weeklies and Women's magazines and make Balba popular every place.

Guaranteed 100% Earnings or Money Refunded

We guarantee that Balba Sales Machines will earn at least 100% on their original investment the first year, provided the machines are all placed in use and kept filled, or we will refund the original price of the machines and perfume then on hand and take them back.

Write NOW for complete information, literature and sample of Balba. Territory given to first to qualify. A telegram holds territory until you get our proposition. Act quickly if you want choice locations. Remember Fortunes are made in Dimes.

References: Northern National Bank, Toledo, Ohio, or R. G. Dun & Co.

THE BALBA CORPORATION of AMERICA
Dept. 43 1306-1308 Jackson St. Toledo, Ohio, U. S. A.



WHERE BALBA MACHINES CAN BE PLACED		
Theaters	Moving Picture Houses	Waiting Rooms
Pool Halls	Billiard Parlors	Drug Stores
Depots	Apartment Houses	Cigar Stores
Clubs	Public Buildings	Hotel Routes
Restaurants	Bowling Alleys	Hotel Lobbies
Cafeterias	Ticket Offices	Dance Halls
Elevators	Street Car Shelters	Lodge Rooms
Trains	Ice Cream Parlors	Fruit Stands
Parks	Office Building Lobbies	Candy Shops
Bath Houses	Passenger Boats	Lunch Counters
Factories	Recreation Buildings	Skating Rinks
Rest Rooms	Interurban Cars	Street Cars
Boats	Shoe Shine Parlors	Barber Shops

Send 10c Coin or Stamps
—with name and address for full size bottle of Balba Bouquet Perfume. This offer is open to any one.

WE GUARANTEE OUR AGENTS \$60 A WEEK FOR ONLY FOUR \$5 ORDERS A DAY

No Delivering—Commissions Same Day You Take Orders

READ WHAT NEW AGENTS SAY:

S. B. KURTZ, of Hartsville, Ohio, writes: "I sold eight FUGOS in my first three evening's work."

HENRY TUP, of Green Bay, Wis., writes: "The FUGO is a superior extinguisher and by far the best seller."

WALTER S. NYE, of Oneonta, N. Y., writes: "Ship twenty-four FUGOS immediately. Check enclosed. Have fifty additional orders for later delivery."

FUGO AUTOMATIC Fire Extinguisher A Simple Practical Dependable Fire Extinguisher For Only \$5



Millions of people want a handy, reliable, fire extinguisher for their homes, offices, factories and garages, but they've held off paying \$15.00 or \$20.00. The FUGO Automatic costs but \$5.00 and is just as efficient and dependable as the highest priced.

Everyone can afford to have FUGOS in the home, office, and garage. Agents take orders on every call. There is nothing equal to it for the price—A FIVE MINUTE DEMONSTRATION SELLS IT—no talking, no price arguments. An inexperienced agent can take four orders a day—others take ten orders, easily. No competition, the field is unlimited. Customers are so pleased they tell others. Sales multiply fast.

NO EXPERIENCE NEEDED

Our proved instructions guide you—you cannot go wrong—a five minute demonstration and it's sold. Your neighborhood fire department will recommend it. Boost it—push it.

Exclusive Territory

Become our licensed agent, control your own exclusive territory and employ sub-agents. You take no risk—you don't invest a penny. We deliver—you receive commission same day you take orders. Trained agents are accepting this opportunity without hesitation.

Write now for full particulars, showing the real possibilities that you have with the FUGO.

Sample FUGO Automatic free to every active agent.

THE OHIO INSTRUMENT COMPANY,

9412 St. Catherine Avenue,

CLEVELAND, OHIO.

NEW IDEA TURNS OLD CLOSET INTO GENTLEMAN'S WARDROBE



THE OLD WAY—
Wrinkled, tummy and shapeless
clothes



THE RITE-WAY—Snappy, well-pressed suits

Clothes make the man. When hung on hooks and nails, they tear, wrinkle and lose their shape. You make a bad appearance.

Only \$1⁵⁰ EACH

Big Money for Agents

LAWSON
RITE-WAY
Hangers sell on sight to everyone. Our agents earn \$20.00 to \$30.00 a day. Easy work—large profits. Write NOW for discounts and start at once to make big money.

Keep your clothes as neat, snappy and well pressed as a millionaire's by making your old closet into a gentleman's wardrobe with the LAWSON RITE-WAY Sliding Hanger.

Put up in a minute with a screw-driver. Doubles your closet room. Just pull and the whole rod slides out—every well-kept suit and coat is easy to see and remove.

Send \$1.50 for one RITE-WAY. Save their cost first month in pressing and repair bills. You look RIGHT all the time.

Send today to

LAWSON MFG. CO.

Dept. 23

230 W. Superior St. CHICAGO

Marvelous New Improved Oil-Gas Burner Makes Red Hot Fire in Two Minutes



Make your wood or coal stove a gas stove instantly with a Marvel Burner. Marvelous new device makes gas from Kerosene,

cheapest fuel known! Twice the heat at half the cost. Great for cooking, baking, heating. No fuss! No dirt! No kitchen drudgery! Saves time, labor, money! ABSOLUTELY SAFE!

No Coal—No Ashes—No Smoke Save Half Your Fuel Bill

Most modern, improved burner made, yet is lowest in price. You can install it easily in a few minutes. Full directions. Marvel Burner gives strong, hot flame instantly! Fits any stove. Lasts a lifetime!

30 Days' Free Trial Write Quick!

For details of our amazing 30-day trial and Special Introductory Price Offer. Don't delay; this offer might be withdrawn any day. Write right now.

AGENTS! This wonder burner sells like wildfire. Ask quick for our "Special Proposition."

MARVEL HEAT & LIGHT CO.
Dept. 123, 609 Fulton St., Chicago



Save Time and Money

Prices \$20 to \$400 Less

Eventually you will want some kind of power you can depend on. Perhaps you could use a 16, 22 or 30 H-P.—or you might want a 2, 3, 4, 6, 8 or 12. Whatever your needs—Kerosene or Gasoline—why not

Get a

WITTE

FIRST

You can have a Stationary Engine up to 30 Horse; a Portable Engine, 2 to 16 Horse; a Portable Sawing Outfit to operate on kerosene or gasoline, 4 to 12 Horse; a Combined Log and Tree Saw; a Stationary Buzz Saw Outfit, 2, 3 or 4 H-P.; or the new WITTE Portable One-Man Stump Borer used in preparing stumps for burning and blasting. Anything you want at a money-saving price—

Cash or Easy Payments

Built in Sizes 2 to 30 H-P.

Stationary or Portable

Sizes—
2 to 30
H-P.

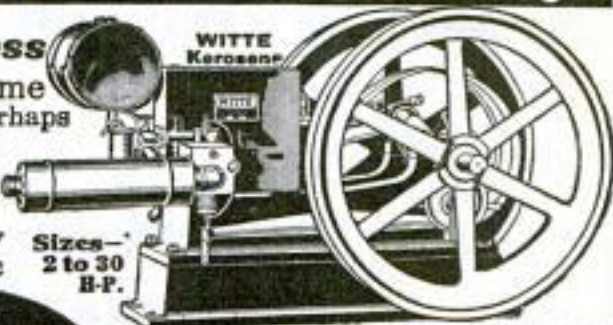

**Made
By the Man
Who Sells
'em**

Direct From Factory

When you buy a WITTE, you come direct to the man who makes your engine or other power outfit. You get your rig all complete ready to install and start using. You pay only the factory price from Kansas City, plus my one small profit—carload freight added from Pittsburgh. Whatever you select, I give you a straight

Lifetime Guarantee

This guarantee covers any and all defects of material or workmanship on any WITTE Engine or outfit you get for the entire life of the rig. 90-Day Test proves Quality and Service. My prices are now \$20 to \$400 less than a year ago, according to size, and style. Tell me what kind of power outfit you need, and I'll send you catalog and lowest price for Immediate Shipment.—ED. H. WITTE, President,

WITTE ENGINE WORKS,

1741 Oakland Avenue, KANSAS CITY, MISSOURI.
1741 Empire Building, PITTSBURGH, PENNSYLVANIA.



WITTE
Gasoline

WITTE

Arm Swing

Cuts $\frac{1}{3}$
Faster Than
Former Rigs



Make
Money—
Save Hard Work

Just The Log-Saw Outfit You Have Been Looking For—Latest Log Saw Improvements. Surplus power engine, with two fly-wheels for belt work. Friction Clutch, Lever Controlled, for starting, stopping or slowing down saw. Reversible wheels. Rugged construction. Natural feed when sawing logs makes saw cut fast. Adjustable force feed when sawing trees.

Special Points of Merit Saw finishes cut parallel with ground. No sawing dirt or rocks, no jacking up logs. Only interchangeable Log and Tree Outfit of the kind sold direct. Tree Saw parts make Log Saw a complete Tree Saw. Rig anchors to stump below saw—cuts tree clear down. Saws uphill or downhill, anywhere. Log Saw Outfit sold on our regular

90-Day Test—Lifetime Guarantee

Buy for cash, or, on easy payments, as you wish. Separate Branch Saw Outfit, only \$19.90. Write for the Log and Tree Catalog. It tells all about sawing. We also build stationary engines, all sizes, up to 30 H-P. If interested, ask for Stationary Engine Catalog, and state size. Sent Free on request.

WITTE ENGINE WORKS,

1747 Oakland Avenue, - Kansas City, Mo.
1747 Empire Building, - Pittsburgh, Pa.

LOG SAW

Now \$75⁰⁰
only ^{F.O.B.}_{K.C.}

From Pittsburgh \$80

Tree Saw Equipment at Small Cost Additional, Giving You Two Rigs in One, Operated by Same Engine

**Quick
Change
From Log
To Tree
Saw**

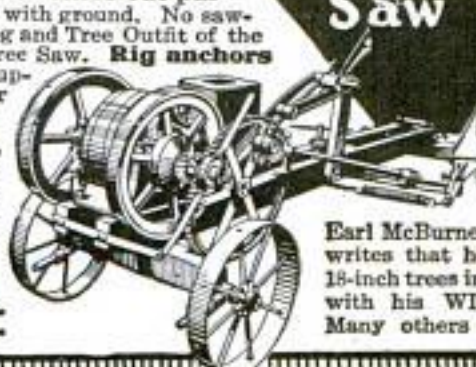

Earl McBurney, of Iowa, writes that he cut fifty 18-inch trees in five hours with his WITTE Rig. Many others delighted.

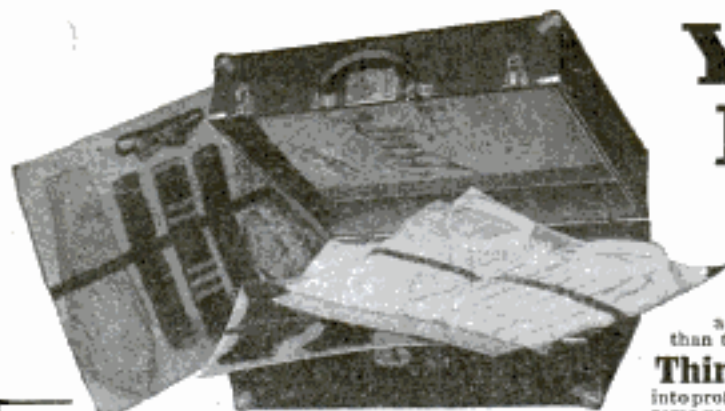

You do not invest one penny. We furnish you with complete when you make the sale. We insure your success by giving you now making \$5,000.00 to \$7,000 a year. **WRITE FOR FULL PARTICULARS AND OUR FREE COURSE IN SALESMANSHIP.**
WRIGHT & COMPANY, Dept. 1353 Congress, Throop and Harrison Streets, Chicago, Illinois

You Can Make More Money

Make Your Spare Time Pay You a Profit!

The Wright Line is the most complete line of its kind in the world. Everything that men wear—made-to-measure suits—shirts—hats—shoes—underwear—work clothing—and a full showing of boys' suits. A complete retail clothing store in a sample case. Prices that are 25 per cent to 30 per cent less than the same quality can be bought for elsewhere.

Think What This Means to You! Turn your spare time into profit—add \$25 a week to your income. Every man you know needs some goods in our line. Easy to sell. Profits large. No capital is required. outfit—we carry the stock—we deliver and collect. You get your profit complete Training Course FREE. You follow the methods of men.

Interlox

Always Ready to make instantly accurate

inside or outside measurements. Slides in and out. No slow folding;



Strong brass-trimmed boxwood. Any length, 2 to 8 ft. If not at your dealer's, sent postpaid.
MASTER RULE MFG. CO., INC.
 841-43 East 136th Street, New York City
 Dealers and agents: Request attractive proposition.

LOOK 50¢ LOOK



Wonderful instrument. Greatest thing yet. Nine separate articles in one. Everybody delighted with it. Odd, curious and interesting. Lots of pleasure as well as very useful. It is a double Microscope for examining the wonders of nature. It is also an Opera Glass, a Stereoscope, a Burning Lens, a Reading Glass, a Telescope, a Compass, a Pocket Mirror, and a Laryngoscope—for examining eye, ear, nose and throat. It is worth all the cost to locate even one painful cinder in the eye. Folds flat and fits the pocket. Something great—you need one. Don't miss it. Sent by mail, with 300 page Novelty Catalog, ONLY 50¢ or 3 for \$1.25

JOHNSEN SMITH & CO., Dept. 770 3214 N. Halsted St., CHICAGO

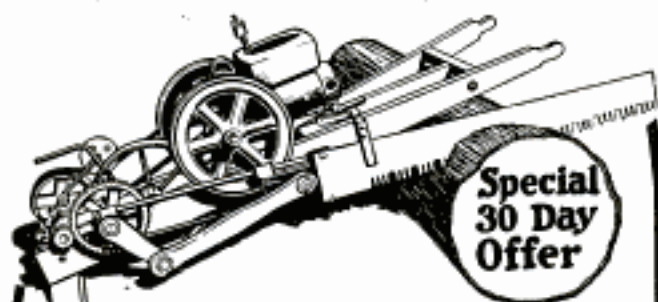

Special 30 Day Offer

A New \$69⁰⁰ OTTAWA

Lower factory costs, and closer buying enables us to build this new improved Log Saw and sell it for a lower price. Ottawa's Newest Log Saw saws 8" logs as easily as 5 ft. logs; lighter in weight; easier to move; new non-skidding base; many other wonderful improvements; has genuine Ottawa quality. Write today for Big Free Book and complete information about this new saw.

FREE BOOK

Send Today—a postal will do, and get the Big new book on wood cutting. Valuable and interesting. Get it Now!

OTTAWA MFG. CO.
 1745E Wood St.
 Ottawa, Kansas

FREE
 Greatest Wood-Sawing BOOK

Protect Yourself!

The bravest man UN ARMED GUN-MAN. Crime is increasing everywhere. Marbe you, your home are next. Be Prepared.



38 CALIBER DOUBLE ACTION AMERICAN MADE



REAL PROTECTION for Life, Home, Money and Your Dear Ones

Heavy Nickel Plated

This genuine H. and R. revolver has safety trigger and every other feature of famous American made guns. Hexagonal barrel. Central fire, double action, 38 caliber, uses S & W Cartridges obtainable everywhere. Five shots, removable cylinder, accurate, fine and ABSOLUTELY SAFE! In fact at only \$5.85 you get everything you need in a revolver, so why pay more!

SEND NO MONEY!

Nowhere else can you get this bargain today! Simply send name and address. Pay postman \$5.85 and a few pennies postage when package is delivered. Wrapped in plain paper. Hurry while this low price remains in effect! Money back if you want it.
LINCOLN NOVELTY CO. Ravenswood Sta. Dept. 50 Chicago



A Five-Thousand Dollar Job Goes Hunting!

An army of men out of work, an army of men feverishly scanning the want-ads in search of a chance to make perhaps twenty or thirty dollars a week—

—While a prominent Chicago business house finds it necessary to invest over \$100 in a single advertisement in a daily newspaper, just to find *one man*—an expert accountant—who will best fill the \$5,000 job which it has to offer!

A serious indictment, this, of the average office man in America, for failing to be *ready!*

Also, a wonderful *tip*—for YOU—if you are willing to devote a few spare hours of your time each week to the mastery of Higher Accountancy!

Make no mistake about the *need* for trained accountants—it has never been so great as today.

Make no mistake about the *opportunities* in this profitable profession—thousands of LaSalle-trained men are today earning from \$3,000 to \$10,000 a year by reason of their expert knowledge in this field. A smaller but very considerable group of LaSalle-trained accountants report even higher incomes.

A. J. Hatton, for example, was promoted from Junior Accountant to Senior Accountant within eight months from the time he commenced the LaSalle course of Higher Accountancy. He writes: "I am at present holding a position as manager of the Fiscal Department of a large financial corporation, with a salary of \$15,000 a year."

Rodney B. Horton, of Savannah, Ga., writes: "At the time I took up the study of Higher Accountancy, I accepted a position at \$75 a month which required only a few hours a day keeping a set of books. Because of making this sacrifice in salary in order to have time for study, I am today a full partner in the above firm (Clayton, Eaton, Horton & Saussy) with offices located at Atlanta and Savannah, and with a net income of \$20,000 per annum. My previous training was very limited, as I was raised in West Texas, where our school terms are from 6 to 9 months, and include only the studies that our present grammarschools give."

Make the Bigger Job Hunt You

Why let next year find you still at the same old desk, performing the same petty tasks and drawing the same inadequate pay, when so simple a thing as marking, signing and mailing the coupon will set you squarely on your path to a bigger job?

Stop losing, start winning—begin this very week to schedule some of your evening hours for advancement!

Under the LaSalle Problem Method, your progress will be *rapid*, for by this remarkable plan you do not merely *read* how to do a thing, you pit your strength against *actual problems*, under the direction of some of the ablest business minds in America.

As a result, you step into that better job *assured* of success—first, because you have already met and mastered the problems of your new position, and second, because you know that LaSalle stands absolutely back of you, ready at a moment's notice to give you authoritative counsel regarding any problem whatsoever that may arise in your daily work. LaSalle not only helps you *land* the better position, it helps you *make good*, every step of the way.

Mail the Coupon

The coupon below will bring complete information regarding the business training that you need for real achievement, together with a wealth of evidence from men still in their twenties and early thirties who have won high-salaried positions by the Problem Method. With this information we will send you details of our *convenient-payment plan*, also your free copy of that inspiring book, "Ten Years' Promotion in One." Get away with a "flying start"—by mailing the coupon NOW.

LaSalle Extension University

The Largest Business Training Institution in the World

Dept. 384-H R

Chicago, Illinois

Please send me catalog and full information regarding the course and service I have marked with an X below. Also a copy of your book, "Ten Years' Promotion in One," all without obligation to me.

Higher Accountancy

Training for positions as Auditor, Comptroller, Certified Public Accountant, Cost Accountant, etc.

Other LaSalle Training Courses

LaSalle is the largest business training institution in the world. It offers training for every important business need. If more interested in any of these courses, check here:

- | | |
|---|---|
| <input type="checkbox"/> Business Management | <input type="checkbox"/> Banking and Finance |
| <input type="checkbox"/> Traffic Management—
Foreign and Domestic | <input type="checkbox"/> Modern Foremanship
and Production Methods |
| <input type="checkbox"/> Railway Accounting and
Station Management | <input type="checkbox"/> Personnel and Employ-
ment Management |
| <input type="checkbox"/> Law—Degree of LL. B. | <input type="checkbox"/> Expert Bookkeeping |
| <input type="checkbox"/> Commercial Law | <input type="checkbox"/> Business English* |
| <input type="checkbox"/> Industrial Management | <input type="checkbox"/> Commercial Spanish |
| <input type="checkbox"/> Efficiency | <input type="checkbox"/> Effective Speaking |
| <input type="checkbox"/> Modern Business Corre-
spondence and Practice | <input type="checkbox"/> C. P. A. Coaching |

Name.....

Present Position

Address

Club Feet

Ruby Booth was born with Club Feet. At ten months she was brought to McLain Sanitarium. Photos show result of treatment. Parents' letter tells everything.

When Ruby was 8 months old, a doctor put her feet in plaster paris casts. After 3 months they were no better than when he started. We had given up all hope of a cure, when we heard of McLain Sanitarium and took her there. Her feet are now perfectly straight. I shall never cease to be thankful. Refer anyone to me. MR. and MRS. GEORGE BOOTH, Carbon, Iowa.

FOR CRIPPLED CHILDREN

The McLain Sanitarium is a thoroughly equipped private institution devoted exclusively to the treatment of Club Feet, Infantile Paralysis, Spinal Disease and Deformities, Wry Neck, Hip Disease, Diseases of the Joints, especially as found in children and young adults. Our book, "Deformities and Paralysis," also, "Book of References" sent free.

L. C. McLain
Orthopedic Sanitarium

902 Aubert Ave.,
St. Louis, Mo.
E349



has enabled John G. Anderson, Aurora, Ill., to keep on the payroll since his right arm was amputated some years ago. The reproduction (from an actual photograph) shows Mr. Anderson at work on an intricate machine using his Carnes Artificial Arm.

INCONSPICUOUS - SERVICEABLE

The Best Substitute for the Natural Arm.

To see him on the street you would not realize that his right arm was artificial. Wearers of this wonderful arm find that it practically takes the place of the natural arm. With it you can dress yourself, use knife and fork, carry grips, write, pick up large and small objects—in fact, do practically everything that was possible before. Even though the amputation be at the shoulder, the CARNES ARTIFICIAL ARM bends at the elbow and wrist, and the fingers open and close as desired.

WONDERFUL BOOK SENT FREE Every armless man or woman should write today for the wonderful illustrated 110 page book showing with actual photographs what can be done with this invention. Write today to
CARNES ARTIFICIAL LIMB CO.
205 CARNES BUILDING KANSAS CITY, MO.

How to Get Rid of Moles



A simple, safe home treatment—
15 years' success in my practice.
Moles (Also BIG Growths) Dry Up.

Ask for Free Booklet of Full Particulars

WM. DAVIS, M. D.

124-5 Grove Ave., Woodbridge, N. J.

For Nerve-Wracking
Rheumatic Aches



Use **Sloan's**

Have a bottle of Sloan's Liniment handy in case of sudden attacks of rheumatism, neuralgia, sciatica or lumbago. Also good for lame back, sprains and strains, over-worked and sore muscles.

Penetrates without rubbing. Sold by dealers you know and can trust, 35c., 70c., \$1.40.

Keep it handy

Sloan's
Liniment (Pain's enemy)

MOTORCYCLES

ONE YEAR TO PAY

Know the joy of owning—for business or pleasure—a HARLEY-DAVIDSON, EXCELSIOR, HENDERSON, INDIAN, CLEVELAND, or any other standard make; thoroughly rebuilt in our own factory.

Write for Free Bargain Bulletin and Easy Payment Plan.

HAVERFORD CYCLE COMPANY
America's Largest Cycle House
Established 26 years
503 Market St., Phila., Pa., Dept. P. M.

CONQUER Your Weaknesses



Resist the elements of weakness and ill-health that are dragging you down and sapping your very life forces. Get rid of the nagging complaints that make your life a wretched failure. Shake off Catarrh, Constipation, Indigestion, Dyspepsia, Biliousness, Headache, Nervousness, Rheumatism, Asthma, Weak Lungs, Weak Heart, Rupture, and the numerous other results of neglect and abuse. Don't put it off until you are down and out. Get busy NOW.

STRONGFORTISM—The Modern Science of Health Promotion will show you how to Banish Your Ailments, Conquer Your Weaknesses and fit yourself for the Joys of Life. I guarantee it.

Mention the ailments on which you want special confidential information and send with 10c for postage, etc., on my book—"Promotion and Conservation of Health, Strength and Mental Energy." It will point your way to health and happiness. Send for my free book Right Now—TODAY.

LIONEL STRONGFORT

Physical and Health Specialist
Dept. 738 Newark, New Jersey

FREE! A BOOK ON PERFECT HEALTH via **VI-REX VIOLET RAYS**



Do You Glow With Health?

Build Up Personality, Magnetism, Vitality with

VI-REX VIOLET RAYS

Some people are dull, drab, uninteresting and sickly! Others are vital, compelling and magnetic! WHICH ARE YOU? It is all a matter of vitality and health. The greatest discovery in years is that of VIOLET RAYS, electricity in a curative, medical form. Violet Rays put new life into over-taxed and sluggish tissues; penetrate and invigorate all the muscles and nerves of the body; give new tone and vitality to the entire body.

Learn the Secret of Physical Perfection

Learn how you can multiply your energy and vim! Learn how to banish those pains, aches, and ailments that run down your system, drain your personality and ruin your looks. WHAT IS PHYSICAL MAGNETISM? It is PERFECT HEALTH—plus the keen mentality based on perfectly balanced nerve centers. We will be glad to send you on request the most interesting book ever published on this subject.

Treat Yourself at Home for Asthma, Constipation, Headache, Rheumatism, Neuritis, Neuralgia, Catarrh, Pimples, Blackheads, Dandruff, Goitre, Pains, Skin Diseases.

Write Now for Startling Book and Free Trial Offer



Just write postal or mail coupon for wonderful free 52-page book explaining in detail. Read how Violet Rays massage every cell in the body. Read letters from users. See what physicians, sanitoriums, home-users say.

Why suffer? Why be satisfied with less than your full share of health and beauty? See what wonderful Violet Rays will do for you.

Mail coupon or write postal for free book and 10 days Trial Offer. Do not miss this offer. Address NOW

VI-REX ELECTRIC CO.

Dept. 23, 326 W. Madison Street, Chicago, Ill.
For New York City ONLY: 47 W. 34th St., New York

VI-REX ELECTRIC CO.

Dept. 23

326 W. Madison St., Chicago, Ill.

Please send me your free book and particulars of your Trial Offer of the Vi-Rex Violet Ray Machine.

Name

Address

City State

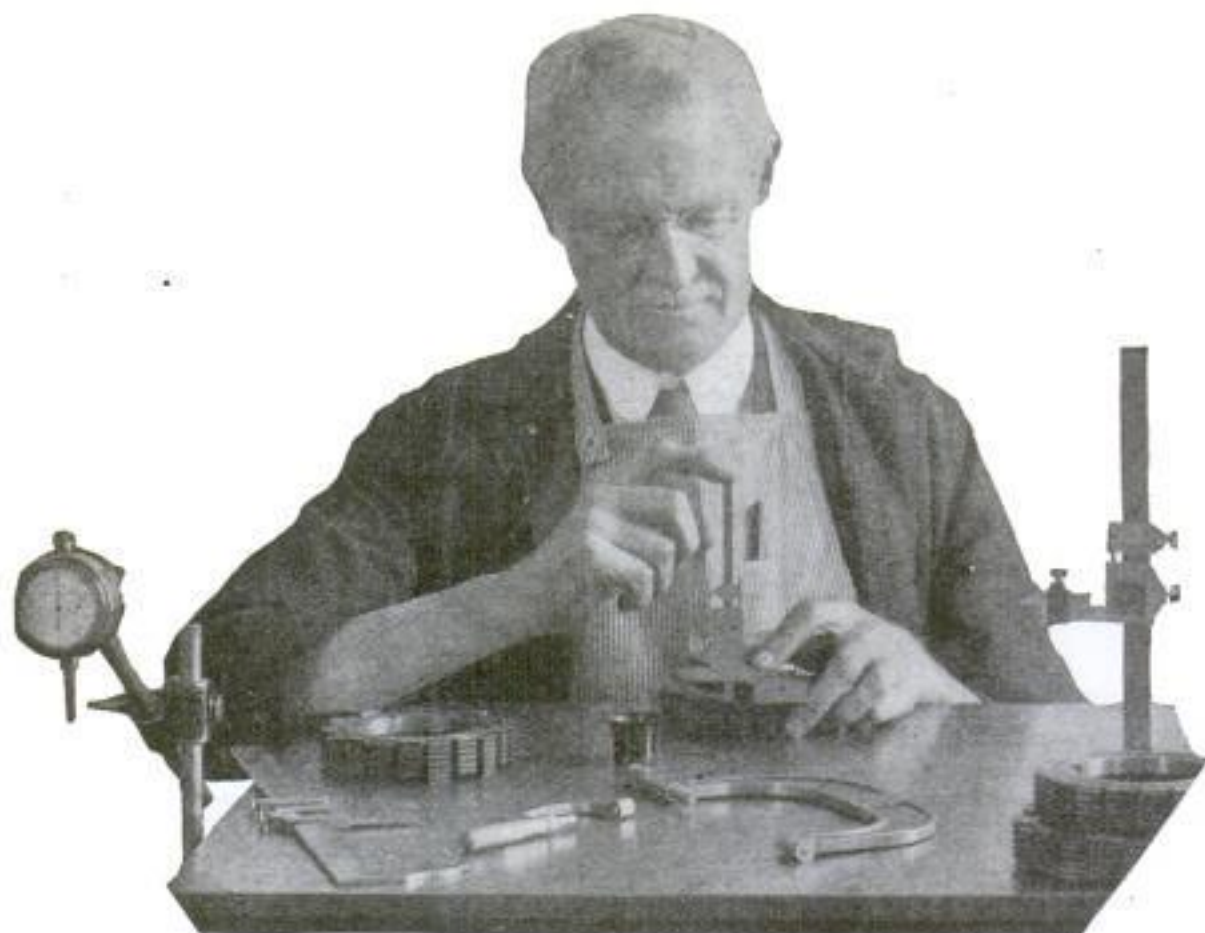

THE experienced mechanic knows the points of superiority in Brown & Sharpe Machinists' Tools that make a difference to his work.

The correct and carefully fitted parts, the clear and clean cut graduations, the distinguishing finish, the world-known accuracy, and long life are reasons why Brown & Sharpe Machinists' Tools are the skilled craftsmen's choice.

Their use brings a constant and increasing appreciation. These superior tools are shown—over 2000 of them—in our Catalog No. 28. Send for it.

BROWN & SHARPE MFG. CO.

PROVIDENCE, R. I., U. S. A.

SIZES OF HOLES - PUNCH NO. 1

SAMSON No. 1 HAND PUNCH
Handles interchangeable. Punches and Dies as Illustrated

Maximum punching capacity $\frac{1}{4}$ " thru 20 gauge untempered metal. Will also Perforate Paper, Cardboard, Leather, etc., up to $\frac{1}{4}$ " thickness. A Powerful Punch of general utility, made of Drop Forge Steel. Throat $1\frac{1}{8}$ " deep.

PRICE,
Postpaid, with
3 extra Punches
and Dies, any
sizes specified,
\$3.50

THE MACHINE APPLIANCE CORPORATION
351 Jay Street,
BROOKLYN, N. Y.

DRIVE 100 TACKS AND SAVE \$25.00

Easy to put on. We furnish instructions. We tailor top recoverings for all cars, and guarantee them to fit. Ford Roadster, \$6.25. Touring, \$6.50; other cars, \$14.00 to \$19.00, delivered at your door. Hide contains that open with doors \$10, \$14, others \$6.50 and up. Seat covers \$2.15 up.

\$520 up
Delivered

Write for Catalog and Samples

AUTO EQUIPMENT CO., 32 Canal Street East, Cincinnati, Ohio

MURDER WILL OUT

Police departments, factories, banks and industries everywhere are adopting the finger print method of identification to locate criminals.

BE A FINGER PRINT EXPERT

You can train yourself at home in spare time. Write for **FREE** reports telling of the uses of finger prints and how you can learn this profitable profession. **Positions Guaranteed.**

U. S. SCHOOL OF FINGER PRINTS
ROOM 933, 7003 N. CLARK ST. CHICAGO, ILL.

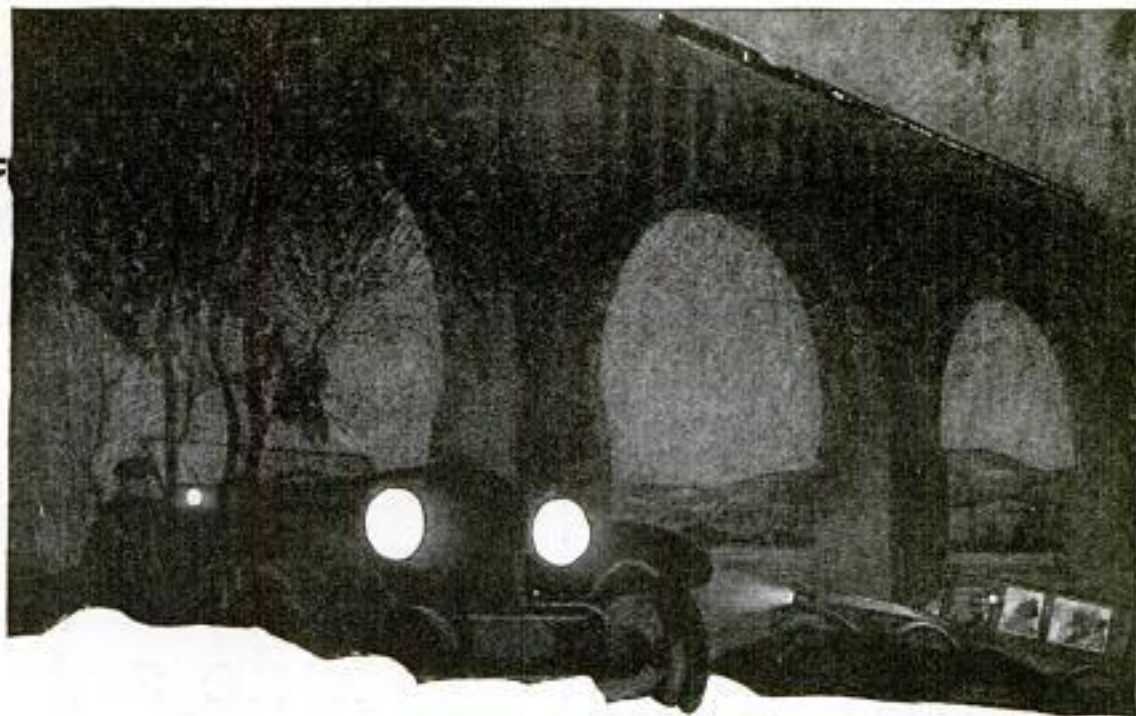

The margin of safety

YOU always carry more than enough gasoline, oil and tires for your probable needs. Why? For emergencies! And for your peace of mind!

What about your battery—most vital of all considerations in motor-car operating? A dead battery, and you are even more helpless than you would be without gasoline. For battery "juice" is something you can't borrow.

Why, then, ignore the margin of

safety in the current you need for ignition, lights and starter? Why not give yourself an "oversize" battery—a Westinghouse? It has greater plate area than ordinary types. This greater area means longer battery life—and in the common sizes up to 25% greater capacity.

Withal, you get a battery built by Westinghouse! To uphold the fame of a great name Westinghouse Batteries must make good.

Seventeen hundred Westinghouse Service Stations are ready to give any make of battery Westinghouse Attention.

WESTINGHOUSE UNION BATTERY CO., SWISSVALE, PA.

WESTINGHOUSE BATTERIES

One quality—the BEST Westinghouse can make

MAKE MORE MONEY TORIT ACETYLENE TORCH NO. 13

For soldering, heating, melting, tempering, auto radiator repairing, battery repair work, and for all kinds of small jobs requiring a hot flame instantly.

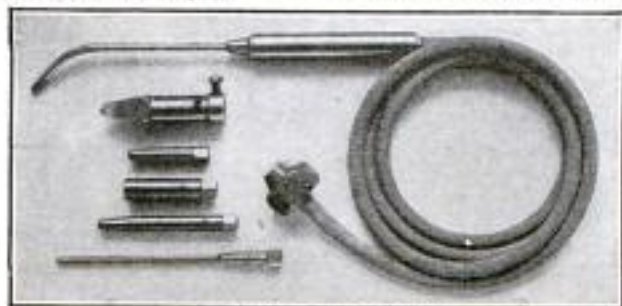

USES ACETYLENE GAS ONLY

Torch with 4 tips for different kinds of work, soldering copper, 5 ft. tubing and connection for auto-acetylene tank, \$7.50
Order from your jobber. If he cannot supply you send your order to us.
St. Paul Welding & Mfg. Co., 177 W. 3rd St., St. Paul, Minn.

Six Machines in One

Combines bench grinder, polisher, buffer, disc sander, drill and saw for working in wood and soft metals.

A Precision Machine

A high production precision machine especially adapted to the rapid and accurate production of small duplicate parts.

Handles 4" and 5" grinding wheels, 6" saws, 6" and 8" sand discs and 3/4" chuck. Saws 1 1/2" wood. Mountable on separate base with motor. Height 10". Weight 31 lbs. Top 10" x 12" easily removed. All metal construction. Easily driven by 1/4 HP. motor. Especially suited for Private Shops, Laboratories, Manual Training Schools, Shipping Depots, Printers, Builders, Cabinet and Pattern Makers, Furniture Repairmen, etc. Machine sold with a Money-Back Guarantee.

We also handle bench joiners, bench band saws, 1/2 and 3/4 HP. Ball-Bearing motors, circular saws, disc Sanders, and large motor driven bench saws.

Write for circular

W. & J. Boice

114 23d St.

Toledo, Ohio



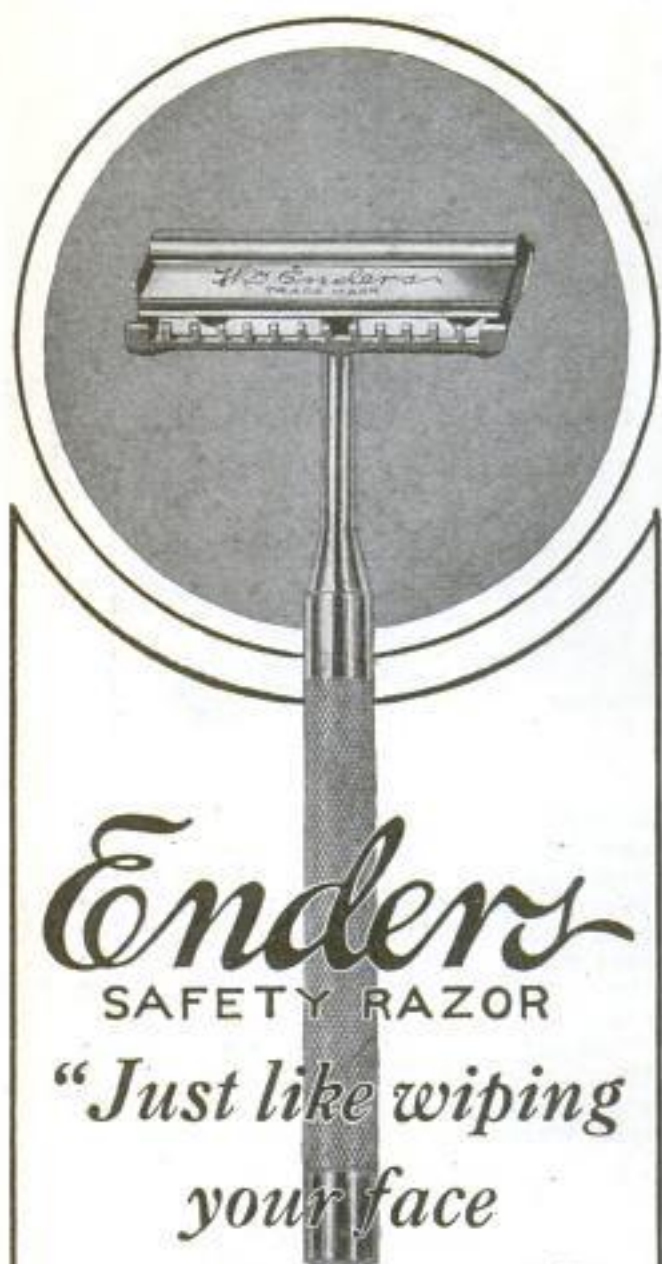

Enders
SAFETY RAZOR

*"Just like wiping
your face
with a towel"*

ENDERS SALES COMPANY
105-111 West 40th St. New York

ENDERS SELLS FOR \$1.00 with six blades of the best quality Swedish-base steel. Packed in black Keratol box, velvet lined. Extra blades, package of 5—35 cents. In Canada—Razor, \$1.50; Blades, 50c.

FOR SALE by *All UP-TO-DATE*
DEALERS EVERYWHERE

Blades—Hand-stropped, Hand-tested

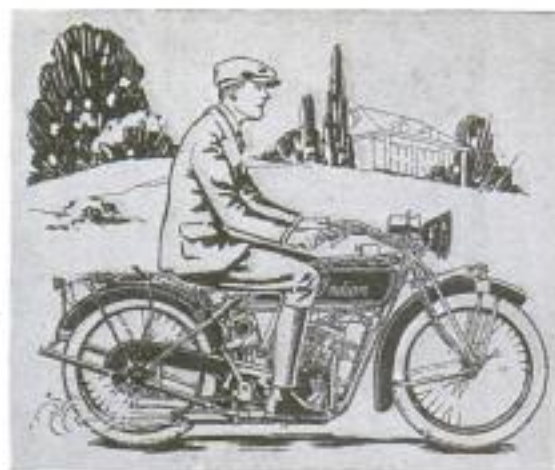
You'll like to
ride an
Indian
Scout

because it's the motorcycle that is different. It's lighter, lower, more easily handled.

Clean—most quiet. Economical and yet powerful.

With an INDIAN Scout you can GO. Go anywhere. Go any time. Go cheaply. Go quickly.

New, low prices. Write for literature.

Address Dept. 39

Hendee
Manufacturing
Company

*Largest Motorcycle Manufacturer
in the World*

Springfield

Mass.

W. L. DOUGLAS

FOR MEN AND WOMEN

YOU CAN ALWAYS
SAVE MONEY BY WEARING
W. L. DOUGLAS SHOES
SOLD DIRECT FROM FACTORY
TO YOU AT ONE PROFIT

\$7.00 & \$8.00 SHOES

SPECIAL SHOES \$10.00 HAND WORKMANSHIP STYLISH AND DURABLE SHOES \$5.00

W. L. DOUGLAS PRODUCT IS GUARANTEED
BY MORE THAN FORTY YEARS
EXPERIENCE IN MAKING FINE SHOES

W. L. Douglas shoes are made of the best and finest selected leathers the market affords. We employ the highest paid, skilled shoemakers, all working with an honest determination to make the best shoes for the price that money can buy.

When you need shoes look for a W. L. Douglas store. We own 107 stores located in the principal cities. You will find in our stores many kinds and styles of high class, fine shoes that we believe are better shoe values for the money than you can buy elsewhere.

Our \$7.00 and \$8.00 shoes are exceptionally good values. There is one point we wish to impress upon you that is worth dollars for you to remember. W. L. Douglas shoes are put into all of our stores at factory cost. We do not make one cent of profit until the shoes are sold to you. When you buy shoes at any one of our stores you pay only one small retail profit.

No matter where you live, shoe dealers can supply you with W. L. Douglas shoes. They cost no more in San Francisco than they do in New York. Insist upon having W. L. Douglas shoes with the name and retail price stamped on the sole. Do not take a substitute and pay one or two extra profits. Order direct from the factory and save money.



BOYS' SHOES

\$4.50 & \$5.00

W. L. Douglas name and portrait is the best known shoe Trade Mark in the world. It stands for the highest standard of quality at the lowest possible cost.

The intrinsic value of a Trade Mark lies in giving to the consumer the equivalent of the price paid for the goods.

Catalog Free.

W. L. Douglas
President
W. L. Douglas Shoe Co.,
128 Spark St., Brockton, Mass.



STAMPING THE RETAIL PRICE AT THE FACTORY

W. L. DOUGLAS
\$7.00
SHOE

THE STAMPED PRICE
IS YOUR PROTECTION
AGAINST
UNREASONABLE PROFITS



AT SEVEN YEARS OF AGE

Hear the Wireless Concerts at Home

from far and near. The Latest News, Market and Weather Reports now broadcasted by radio by our Government.

Stations all about you.

Ever since the year 1909 Duck's Radio Catalog has blazed the way with everything worthwhile and dependable in radio.

This catalog eclipses all previous editions. It is all other catalogs in one. No other is even half as large. Over 50 pages of diagrams and data on radio.

Complete sets sell for as little as \$20.00—some even less.

Duck's 275-Page No. 16 Radio Catalog—Just Out. Send 12 cents in stamps or coin for your copy of this wonderful catalog. Not sent otherwise.

You could spend \$3.00 for text books and other catalogs and then not have the contents of this catalog.



THE WILLIAM B. DUCK CO., 223-227 Superior St., Toledo, O.

Send No Money

for this 25 Cal. regulation blue steel

Automatic Revolver



Pay the
Postman
only

9.75
\$

and postage when the revolver is delivered. We guarantee full satisfaction or money back after examination.

Keep one of these brand new safety revolvers in your home and be fully protected against burglars, thieves and hold-up men. It's a terrible fright to wake up in the night—hear noises down stairs or in the next room—and realize your neglect has left you wholly UNPROTECTED. One of these revolvers will fully protect you.

Shoots Quick—7 Shots in 3 Seconds



Just pull the trigger. Each shot automatically ejects the cartridge and loads ready for the next shot.

This revolver HAS DOUBLE SAFETY and is practically "fool-proof" against accidents. Perfect grip, accurate aim. Handsome blue steel gun metal finish. Rifled barrel, checkered grips, safety lever. Holds 7 cartridges. Small, compact, fits in vest pocket, lies flat and will not bulge out pocket. Shoots all makes of Standard Auto Cartridges. Fine for target practice.

SEND NO MONEY

Order today. Just send your name and address and say which revolver you want.

No. 156 is 25 cal., 7 shot. Big bargain. Our price..... **\$9.75**

No. 3656. Same style as above, only 32 cal., 7 shots. Extra Value. Our price only..... **\$11**

No. 4656. 25 cal. genuine Mauser. The only 25 calibre automatic that shoots ten shots. Blue steel finish. Extra Value. Our price only..... **\$14.50**

No. 5156. 32 cal. genuine Mauser automatic. Shoots 9 shots. Blue steel finish. Exceptional bargain. Our price only..... **\$15.50**

Don't wait. Order these bargains today. You take no risk. Write clearly your name, address and the Number of the Revolver you want. Send No Cash. We ship by return mail. Pay Postman on arrival our price, plus postage. Send for free catalogue.

No. 556. 32 cal. automatic military model, 10 shot, extra mag. FREE, 19 shots in all. Special price **\$12**

Genuine LUGER

No. 4156. 30 cal. genuine Luger. Don't be misled by a gun that looks like a Luger. We are selling this wonderful world famed automatic at such ridiculously low prices because of our ability to purchase in quantities. Shoots 9 shots. Has automatic magazine ejector. Latest model with safety attachment. Great reduction. Our special price while they last, only... **\$28.50**

Security and PROTECTION

Has popular swing-out cylinder, made by expert mechanics, of extra fine steel. Nickel or blue finish. Pearl handles, \$3.00 extra.

SEND NO MONEY Order to-day. Send name, address and number of revolver you want. No. 1073, 32 cal., \$17.50. No. 1573, 38 cal., \$19.00. Pay postman our price, plus postage.



32 CAL. 6 Shot
Slide Hand Ejector
Swing-out Cylinder

HOLSTER for any of above revolvers. Genuine leather, \$1.50

GUARANTEE We guarantee absolute satisfaction after examination or your money back. Rush your order today.

PARAMOUNT TRADING CO.
34 West 28th St., New York, N. Y.

STANDARD
C Melody

SAXOPHONE

NOW
\$64.85



Was \$105

By direct-from-factory selling and eliminating all waste we have cut the price to \$64.85, actually less than wholesale! Don't wait—order from this ad. C. O. D. with privilege of inspection.

STANDARD "Professional" Saxophone on 6 Days FREE TRIAL

Express agent will return amount deposited within 6 days if you are not delighted.

Easy to Learn!

You can actually learn to play tunes in an hour! Quickest and easiest of all-instruments to learn, and therefore most popular today!

MAKE EXTRA MONEY!

Saxophone players are in demand all the time and get big money! Here's the easiest way to add to your income.

"A World of Pleasure"

All doors are open to the fellow or girl who can play the Saxophone. You don't know what a good time is until you can play. And the C Melody will be your choice because it's the Saxophone for solos and every other kind of playing.

Illustrated Catalog FREE. Hurry!

Standard Music Co. Dept. 22 P.O. Box 503 **Chicago**

You'll Smile Too

when you know the Comfort and Easy Stretch



of *Nu-Way* or **EXCELLO** RUBBERLESS SUSPENDERS

Guaranteed One Year—Price 75¢

Always insist on NU-WAY or EXCELLO Guaranteed Suspenders, Garters and Hose Supporters.



Ask Your Dealer If he hasn't them, send direct, giving dealer's name. Accept no substitutes—look for name on buckles Nu-Way Stretch Suspender Co., Mfrs., Adrian, Mich.

Tycos

Thermometers for inside and outside temperatures

Taylor Instrument Companies
ROCHESTER, N. Y.

There's a Tycos Thermometer for every purpose.

"Sugar-Coated" Electricity

Absolutely shockless and painless, overcomes nervousness, banishes aches and pains, renews the vigor of youth and builds healthy, well-developed bodies

THOUSANDS of volts of stimulating, up-building, high frequency electricity—as painless and pleasant as a ray of sunshine—can be sprayed into any weak, diseased or under-developed part of your body. Instantly you will feel its healing, strengthening, tonic effect. You will feel the warm, fresh blood surge to the treated part, bringing with it the tissue-building and disease-fighting forces that Nature provides. Poisons and diseased tissues will be washed away, pains and inflammations relieved and the part treated will be nourished and strengthened. It literally helps Nature **build new bodies.**

Renulife Violet Ray High Frequency

makes it possible for you to secure the benefits of this wonderful treatment at home. The simple, durable and efficient Renulife Generator takes current from your light socket and transforms it into the life-giving, health-building Violet Ray, that penetrates and saturates the entire body. It increases the oxygen content of the blood, increases the number of germ-fighting white corpuscles and sends the blood coursing throughout the body with renewed vigor. It aids the digestive process and the assimilation of food. It helps Nature throw off waste products and poisons. It stimulates every organ to healthy, normal activity.

Send for Free "HEALTH" Book

It tells of treatment and results obtained in more than a hundred diseases, weaknesses and painful disorders. If you are interested in developing a healthy, strong body and steady nerves, send for your copy now. It will come to you by return mail.

RENULIFE ELECTRIC CO. 1103 Newberry Bldg., Detroit, Mich.

In Canada, Netting Bldg., Windsor, Ont.

Renulife Line
includes 7 Models
—Priced within
reach of all

Sales Agents--
Investigate our
exclusive sales
contract. Very
attractive propo-
sition

—MAIL THIS COUPON—

Renulife Electric Co.
1103 Newberry Bldg.,
Detroit, Mich.

Please send me your
Free "HEALTH" Book
giving full information
concerning Renulife
Violet Ray Treatment.



Name.....

Address.....

City..... State.....



Courtesy Miss Grace Almond

Pleasant, Convenient and Effective Home Treatment for 100 Disorders

Be sure it is a Renulife Generator

Renulife Treatment is a household remedy in 50,000 homes. We have thousands of testimonials telling of benefits derived in cases where all other treatments have failed.

To get equal satisfaction, be sure that the generator you buy is a genuine RENULIFE. There are many imitators but the genuine RENULIFE Generator is supreme in its field. It is made by a fully responsible company under guarantee of satisfaction or money back. Get the genuine and be sure of maximum benefits.



Starrett Thickness Gage No. 71

Made especially for the Automobile Mechanic

Contains six leaves particularly adapted for adjusting motor tappets. Also useful for gaging slots. The six leaves have, respectively, thicknesses of .0015, .002, .003, .004, .006, and .015. Auto drivers and mechanics have been looking for this tool.

The combination affords scope for gaging dimensions ranging from .0015 to .031. A neat metal case protects the leaves from kinks, and any leaf may be easily replaced by removing the screw stud on which it is pivoted. An eyelet in the case permits the gage to be carried on a ring or hung from a hook. Extra leaves supplied on order.



Full details of this new Starrett No. 71 Thickness Gage and other new Starrett Tools are given in Supplement to Starrett Catalog No. 22 "AP" completely illustrated. Write for copy.

THE L. S. STARRETT COMPANY

*The World's Greatest Toolmakers
Manufacturers of Hack Saws Uneexcelled
ATHOL, MASS.*

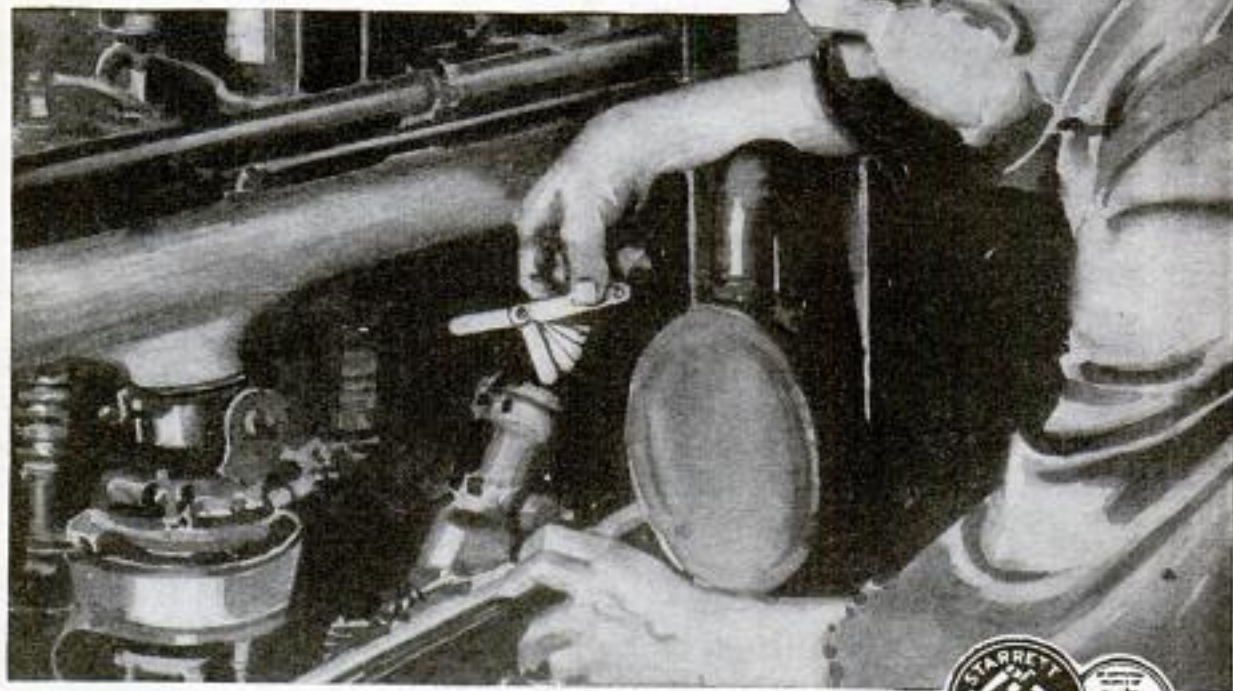

43-271



Starrett Tools

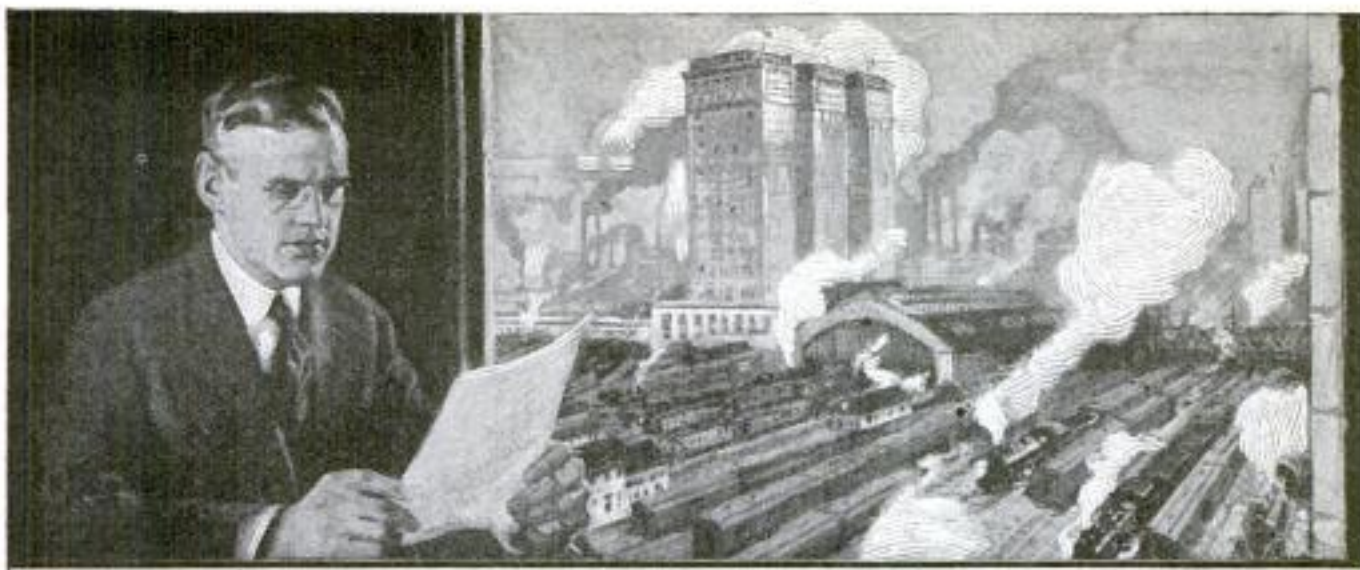

A Real Chance to Command Big Pay!

Competent Traffic Managers Earning \$100 to \$200 a Week

Five hundred thousand business firms in the United States are paying freight charges annually totaling billions of dollars. Fifty thousand concerns pay a freight bill of \$5,000 and over every month.

Once—when business was riding the crest of the wave—these firms could entrust their transportation problems to "second-raters"—shipping clerks who had learned all they knew about traffic at the warehouse.

TODAY—in this era of intense competition upon which Business is entering—

WANTED—as never before in the history of American commerce—*trained traffic managers*. To men who are really competent in this field, business firms are gladly paying from \$50.00 to \$200.00 a week.

The Straight Route to Promotion

Here's the way promotions are won in this field of Traffic Management:

A trained traffic man recently pointed the way for a large concern making woodworking machinery to save \$6,000 a month on freight charges simply by making a few changes in construction to permit its bandsaws to be shipped in box cars instead of on flat cars. Result—a salary of \$6,000 a year.

Another LaSalle man—at that time only a rate clerk for one of the big packing companies—discovered by investigation and study that his firm was paying a rate of \$1.60 a hundredweight on certain shipments, as against a rate of \$1.53 to which it was entitled. He recommended the filing of claims with the Interstate Commerce Commission and recovered for his company \$200,000 in cash—\$80,000 of which was refunded by a single railroad company. He is now Traffic Manager for the largest cement company in the world.

Nothing extraordinary about these men. They are simply cashing in on *scientific knowledge*—instead of *haphazard experience*. Big promotions are the logical result.

Swift Advancement by the Problem Method

Here, then, is a field in which the *demand* for competent men vastly exceeds the *supply*—a field that affords every opportunity to *show results*—a field in which you are offered every opportunity to qualify—swiftly, surely—right in your own home—under the direction of a Traffic Advisory Council of 150 nationally-known traffic men, who will train you in the practical traffic methods utilized by the most efficient organizations in America.

Under the LaSalle Problem Method you will work to all purposes side by side with men who are authorities in their field, handle the very problems met daily by the traffic managers of the railroads and by the big shippers. They will answer every question you ask, make every point clear, direct your training every step of the way. You will cover under their instruction the entire field of traffic, including the

organization and administration of a traffic department, freight classification, rates, claims, law of carriers, procedure before the Interstate Commerce Commission, express service and rates, ocean traffic and trade, even to the point of working with the actual forms, agreements and contracts in daily use.

Make Your Start TODAY!

"Big men," says J. Ogden Armour, "are simply small men who have had a chance to grow." Give yourself that chance!

The coupon below will bring you complete information regarding the training you are interested in, together with details of our *convenient-payment plan*. With this information we will send you your free copy of "Ten Years' Promotion in One," a book that has inspired thousands of ambitious men to greater achievement.

Make TODAY your starting point toward big success—by mailing the coupon NOW.

LaSalle Extension University

The Largest Business Training Institution in the World

INQUIRY COUPON

LaSalle Extension University
Dept. 364-TR Chicago, Ill.

Please send me catalog and full information regarding the course and service I have marked with an X below. Also a copy of your book, "Ten Years' Promotion in One," all without obligation to me.

Traffic Management—
Foreign and Domestic:

Training for positions as Railroad and Industrial Traffic Managers, etc. **Other LaSalle Training Courses**

LaSalle is the largest business training institution in the world. It offers training for every important business need. If more interested in any of these courses, check here:

- | | |
|--|--|
| <input type="checkbox"/> Business Management | <input type="checkbox"/> Banking and Finance |
| <input type="checkbox"/> Higher Accountancy | <input type="checkbox"/> Modern Foremanship |
| <input type="checkbox"/> Railway Accounting and Station Management | <input type="checkbox"/> and Production Methods |
| <input type="checkbox"/> Law—Degree of LL. B. | <input type="checkbox"/> Personnel and Employment Management |
| <input type="checkbox"/> Commercial Law | <input type="checkbox"/> Expert Bookkeeping |
| <input type="checkbox"/> Industrial Management Efficiency | <input type="checkbox"/> Business English |
| <input type="checkbox"/> Modern Business Correspondence and Practice | <input type="checkbox"/> Commercial Spanish |
| | <input type="checkbox"/> Effective Speaking |
| | <input type="checkbox"/> C. P. A. Coaching |

Name

Present Position

Address



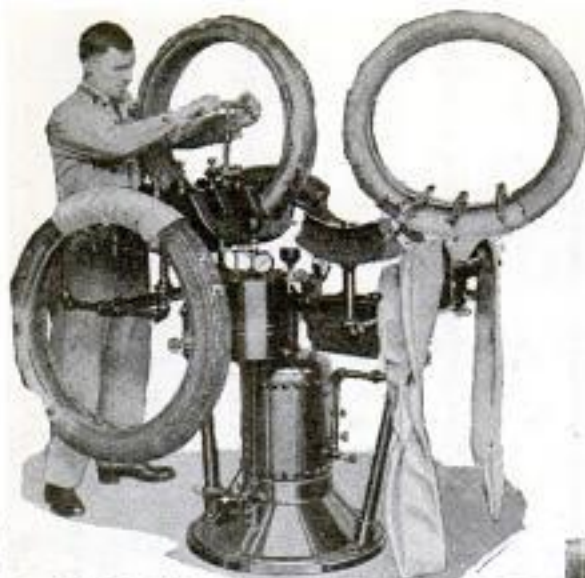

\$6000.00 YEAR WITH THIS MACHINE

WHAT others have done, YOU CAN DO! \$6,000.00 year is low estimate. Many make more. This new machine and Haywood's Tire Surgery method marvelous. Starts you in paying business quickly. No experience needed. Taught at my school or by mail within two weeks. Very little capital required. It's a bonanza for ambitious men.

Many Men Making Money

Are you one of the crowd drifting back to 1914 wage scales? Protect yourself! Join the ranks of those who have forsaken jobs, time clocks and bosses! Be among these money makers! Hargan, of Ill., did \$20,000.00 last year. Fetzner Bros., Pa., made clear net profit of \$3,500.00 during first year. Spring City Tire Co., Wis., did about \$26,000.00 to date, and expect year's total to reach \$50,000.00. Ramsay, S. D., working alone, cleared \$441.56 in one month. Wendt, Ind., approximates \$500.00 month. Tucker, Ill., runs high as \$127.00 weekly single handed. Mitchell, Ill., says, "Record day was \$360.00—last month did \$2,600.00." And so on!

Great Opportunity Now

Above successes were made within past eighteen months. These men took advantage of splendid conditions. Right now car owners are economizing. Not buying new tires. Making old ones do. This work Booming Tire Surgery stations with cash business.

Get My Big Proposition

Start like others have done. Get the facts. There's nothing to stop you. I'll help you to the limit. My proposition is highly interesting. My machine is marvelous. Its compact design and size make small, handy shop possible. Its big capacity earns money fast. Send this coupon or postal to me, personally. Write me tonight.

M. Haywood, Pres.

Haywood Tire & Equipment Co.
973 Capitol Ave. Indianapolis, Ind.

Mr. M. Haywood, Pres.,
Haywood Tire & Equipment Co.,
973 Capitol Ave., Indianapolis, Ind.

Dear Sir:—I am interested in Tire Surgery. Please tell me all about this profitable business and your modern equipment.

Name.....
Address.....

Do it with the

ONE-HAND-Y



Weight
3 lbs.

Capacity
 $\frac{1}{4}$ in.

The ONE-HAND-Y Electric Drill Rapid, Economical, Indispensable

Application

The ease with which holes may be drilled in metal or wood with the ONE-HAND-Y makes it one of the most desirable tools in existence.

Ease of Operation

Its light weight—3 pounds—insures rapid, economical and accurate work, as it can be moved about easily, and can be used constantly without tiring the operator.

Cost

The ONE-HAND-Y is the lowest priced, most economical electric drill on the market.

Motor

Westinghouse, Universal Type, 110, 220, and 32 volt AC and DC. Air cooled. Ample power controlled by switch always under thumb.

Guarantee

The ONE-HAND-Y—the lightest electric drill on the market—is guaranteed against defective workmanship and material.

Write nearest office for details

Knight Engineering & Sales Co.

30 West Walton Place,
Chicago, Ill.

210 W. Seventh Street,
Los Angeles, Calif.



Brings
HARTMAN'S
Richly Upholstered
7-Piece Suite

Quarter-Sawed and Solid Oak
Send only \$1 for this complete suite of library, parlor, or living room furniture. Use it 30 days on Free Trial.

If you don't say that it is even more than you expected, ship it back and we return your \$1 and pay transportation charges both ways.

A Full Year to Pay

Only by seeing this splendid quarter-sawed and solid oak suite can you realize how it will add to the appearance of your home. Only by examining it can you appreciate what a record-breaking bargain it is at our smashed price. Furniture like this can be bought nowhere else at near our price. **Handsome Fumed Finish!** TABLE, solid oak with top 24x36 in. ARM ROCKER, solid oak with quarter-sawed top panel and rounded arm rests; seat 18x19 in. SIDE ROCKER, solid oak with quarter-sawed oak top rail, seat 18x14 in. ARM CHAIR, 37 in. high and SIDE CHAIR, 36 in. high, with seat 16x14 in. Table and chairs stand on noiseless glides. Ornamented backs and seats upholstered in durable, imitation Spanish brown leather. Comfortable spring seats. TABOURETTE, 16 1/2 in. high with 10 in. top, is solid oak. BOOK BLOCKS, heavy enough to support a liberal number of volumes. Shipped (fully boxed, "knocked down" to lessen freight charges) from factory in Central Indiana, Western N. Y. State or Chicago warehouse.

Order No. 112DMA7. Reduced Bargain Price \$37.95. Send \$1.00 now. Pay balance \$3.00 per month.

FREE Bargain Catalog

368 pages of the world's greatest price smashing bargains. Everything you need in Furniture, rugs, linoleum, stoves, watches, silverware, dishes, washing machines, sewing machines, aluminum ware, phonographs, gas engines, cream separators, etc.—all sold on our easy monthly payment plan and on 30 days' FREE Trial.

Post card or letter brings this big bargain book Free.

"Let Hartman Feather YOUR Nest"

HARTMAN

Furniture & Carpet Co.

Dept. 4290 Chicago, Ill.
Copyright, 1922, by Hartman's, Chicago

368-Page Book FREE



Upholstered Backs and Seats Comfortable Spring Seats



HARTMAN Furniture & Carpet Co.
Dept. 4290 Chicago, Illinois
Enclosed find \$1.00. Send the 7-piece Living Room Suite No. 112DMA7 as described. I am to have 30 days' free trial. If not satisfied, will ship it back and you will refund my \$1.00 and pay transportation charges both ways. If I keep it, I will pay \$3.00 per month until the full price, \$37.95, is paid. Title remains with you until final payment is made.

Name.....
Street Address.....
R. F. D.....Box No.....
Town.....State.....
State Your Occupation.....Color.....

Let Me Pay You \$12 for 15 Minutes of Your Time

\$215 in One Day

"Ye gods—some seller! I made \$215 today!"

F. W. Bentley,
of Philadelphia.

Buys Car With Profits

"Have earned enough in one month to buy me a new auto."

S. W. Knappen, Cal.

\$7 Profit per Hour

"I started out and made \$21.50 in about 3 hours. The Oliver does the work. It certainly is the real thing."

L. Zucker, Ohio.

"Sells Like Beer in a Dry Town."

"Am sending today for 7 Oliver's. This is one day's orders (\$85 profit). Selling like beer in a dry town."

W. H. Drew, Mich.

Mr. T's 28th Order in Six Months.

"Ship 52 Oliver's: 10 No. 30; 6 No. 1; 12 No. 2; 24 No. 4." (Mr T's profit on this order alone is \$711).

G. T., Ottawa, Ont.

Russel Earned \$3,300 in Five Months

"Have averaged \$660 profit a month for last six months."

A. M. Russel, Conn.

Carnegie—\$1000 a Month.

"Am making \$1000 per month. I have made big money before, but did not expect so much. Your Burner is just the thing."

J. Carnegie, S. D.

Berger—\$258.50 per Week.

"Send following weekly hereafter: 10 No. 1; 8 No. 2; 4 No. 5."

R. Berger, Ont.

\$11.75 in Ten Minutes.

"I took order for a neighbor. \$11.75 profit in ten minutes."

Mrs. N. B., Hattiesburg, Miss.

\$43 in One Evening.

"I made \$43 last night selling Oliver Burners."

N. B. Chelan, Wash.



B. M. OLIVER

The man who built the **Oliver and Largest Manufacturing Concern for Oil-Gas Burners in the World.** Now he wants to show you how to make \$12 for 15 minutes of your time! Read what he has done for others right on this page.

New Invention Is Sweeping Salesmen Into Big Profits

AGENTS find it no work at all to sell this amazing invention—the Oliver new improved Oil-Gas Burner. They just show it—taking only one minute to connect it—then light it. And the sale is made! This new invention is its own salesman. It sells itself! About 15 minutes does it. The Oliver Oil-Gas Burner is the most timely thing that could be put out. It dispenses entirely with coal and wood when both are now high-priced. It burns the cheapest fuel—oil. It saves a woman work now in times when she is looking for just such things. Just as much or as little heat as wanted, off and on instantly by simply turning a valve. It makes an immediate hit with her. Because in the winter it gives her 3 times the heat of any other method. And in the summer she has heat for her cook stove or range whenever she wants it—but does not have to have a hot, roasting kitchen.

The Secret of Big Money—Any Season of the Year

Of course, now that you know the facts you yourself can understand why this new invention is going over like wildfire! And you can understand why F. W. Bentley made \$215 in one day. Why J. Carnegie made \$1,000 in one month and why hundreds of other agents are cleaning up big too.

These men know the secret of big money. They know a good thing when they see it and they know that the time is ripe for this new Oliver Improved Oil-Gas Burner. They know that this age of high-priced coal and wood makes it necessary for some substitute. They see ships and locomotives being run by oil and big buildings being heated by

YES, \$12 for 15 minutes of your time. This wonderful invention practically sells itself. Just this little short-time demonstration puts the sale over for you. And you pocket the big profit. Read how easily others are drawing down enormous earnings.

No wonder this amazing new invention is bringing fortunes to agents. All over the whole country this new device is doing away with old-fashioned methods of heating with coal stoves, ranges and furnaces. Already over \$1,000,000 worth have been sold. You can readily understand why this new invention—the Oliver Perfected Oil-Gas Burner—is sweeping over the country like wildfire. It does away with all the expense of coal—making every stove a modern oil-gas burner. Saves money, time and drudgery. Three times the best of any other method—right on tap when the housewife wants it. No hot kitchen for housewives in the summer when they don't want it. No wonder agents are riding in on the tide of big Oliver profits.

it. And they know that an invention that makes use of this cheap fuel for every home—and yet does it so as to give more heat than coal or wood—is the thing they want to tie up to.

Big Profits Quickly Made

You too can use this secret of big money. You do not need to be a high-powered salesman. The Oliver's amazing features sell it for you. When people see it they know at once that it is the thing they want. You will realize that this is a proposition that will pay you as big money as it does others. We have a definite number of open territories which we are ready to dispose of to those who act quickly. Every territory allotted is filled with big-money opportunities. And this big money comes easily. Because not only does this invention practically sell itself on sight but when you have sold one this one will sell several others as soon as your customer's friends and neighbors see it. And thru our special plan you get credit and commissions for every sale in your territory.

You can also make big money just by using your spare time. Note how N. B. Chelan made \$43 in one evening.

Coupon Brings Full Offer

If you want to make at least \$5,000 a year easily, mail this coupon now for our offer. We are not making any extravagant claims about this. We do not have to. We believe that your common sense will indicate a good proposition to you when you know about it. We want to give you the facts. Won't you write us? And by doing so quickly you will be allotted an exclusive territory with private selling rights. The coupon will bring you the facts and will save you writing a letter. But mail the coupon at once.

OLIVER OIL-GAS BURNER AND MACHINE CO.

2014-O Pine Street, St. Louis, Mo.

Oliver Oil-Gas Burner and Machine Co.

2014-O Pine Street, St. Louis, Mo.

Please send me full facts about how I can make at least \$5,000 a year representing you in my territory. Also your plan if I just wish to make big money in my spare time.

Name.....

Address.....

Win \$5000

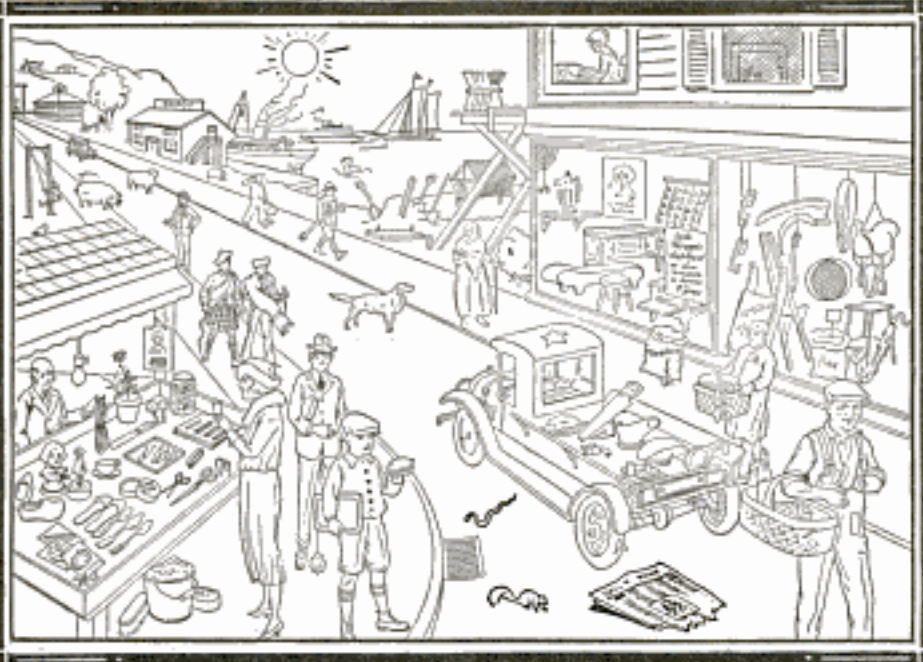

Bank Guarantee

State Bank of Philadelphia PHILADELPHIA PA

E. J. REEFER

This will acknowledge your deposit of \$50,000 with this bank which we will hold as a guarantee that the prizes awarded by the judges to the winners of your puzzle contest will be paid.

It is understood that the Cashier of this bank will serve as one of the judges of this puzzle contest as a guarantee that E. J. Reefeer will award these prizes.

Yours very truly,

E. C. KRAUSOFF
PRESIDENT

*How many objects
in this picture
Begin with "S"?*

A Great Big Puzzle Picture Free

Join in this fascinating puzzle game. Work from this picture or send for large size puzzle picture.

Costs Nothing to Try List all the objects you find in picture beginning with "S." You need not buy any Reefeer's Yeast Tablets to win a prize. Open to everybody. Largest and nearest correct list wins first prize of \$50 even if you buy nothing. But look to right! See how you can win \$5000, \$2500, or one of the other 103 biggest cash prizes. \$50 or \$5000, which do you want? Start now. Contest is for the purpose of introducing the latest scientific aid to —

BEAUTY—Health—Vim—Vigor

The world has waked up to Nature's own beauty and health secret. Vitamins!

Reefeer's Yeast Tablets

—embody all 3 necessary vitamins. Help to build up vitality, strength, endurance, induce youthful natural complexion. A food. Has all the elements your body needs to derive the proper nourishment from the food you eat. Send for some today.



E. J. Reefeer, Dept. A-1773. 9th and Spruce Sts., Philadelphia, Pa.

Win the \$5000 Prize

A one package order for Reefeer's Yeast Tablets qualifies your list for first prize of \$750. A two package order qualifies you for \$1500. But if you have ordered five \$1.00 packages and your list is largest and nearest correct, you win \$5000. Study the Prize List.

105 Prizes

Winning answers will receive prizes as follows:

	If no Reefeer's Yeast Tablets are ordered	If one \$1 pkg. Reefeer's Yeast Tablets are ordered	If two, \$1 pkgs. Reefeer's Yeast Tablets are ordered	If five \$1 pkgs. Reefeer's Yeast Tablets are ordered
1st prize	\$50	\$750	\$1500	\$5000
2nd prize	35	375	750	2500
3rd prize	25	200	400	1250
4th prize	25	125	250	600
5th prize	25	75	150	400
6th to 55th prizes, each	2	4	8	25
56th to 105th prizes, each	1	2	4	10

Observe These Rules:

1. The contest is open to every man, woman, girl or boy living in America, except employees or relatives of employees of E. J. Reefeer, 9th and Spruce Sts. There is no entrance fee of any kind.
2. You must use only one side of paper. You must number your list of objects in regular order—1, 2, 3, etc. Your full name and address must be written on each page in the upper right hand corner. Use a separate sheet for anything you may wish to write outside of your list of names and your name and address.
3. English words only will be accepted as they appear in the English dictionary. Obscure words will not be counted. Both the singular and the plural of a word will not count; either one of them may be used.
4. Compounds or words which are made up of two or more complete English words cannot be used.
5. The same spelling of a word will be counted only once even though it is used for different articles or objects, or parts of them. Each article or object can be given only under one name.
6. Two or more people may co-operate in answering the puzzle. However only one prize will be given to anyone household. No prizes will be awarded to more than one of any combination outside of the family where a number—two or more—have worked together.
7. If a contestant sends more than one list under the same name, an assumed name, or a pre-married name, then all lists of such contestant will be

- disqualified. If more than one list is sent by any group or by any members of the same group who have co-operated in the preparation of such lists, then all lists of such contestants will be disqualified.
8. All answers must be received through the mail by E. J. Reefeer, 9th and Spruce Streets, Philadelphia, Pa., and must be post-marked by Post Office closing time, April 10th, 1922.
9. The first prize will be awarded for the answer containing the largest and most nearly correct list of the names of visible objects and articles beginning with "S" shown in the picture. No other consideration, such as neatness, style or handwriting will have any bearing in making the decision.
10. The full amount of any of the prizes will be awarded to each contestant in the event of a tie.
11. The decision will be made by three judges entirely independent of and having no connection with E. J. Reefeer. They will judge the answers submitted and award the prizes at the end of the contest. Participation in the contest carries with it the acceptance of the decision of the judges as final and conclusive.
12. All answers will receive full consideration whether or not "Reefeer's Yeast Tablets" is purchased. At the close of the contest, when all lists have been graded, the names of the prize winners will be announced and the list of words will be sent upon request to any participant who sends us a stamped, addressed envelope.

Copyright 1922, by E. J. Reefeer

JOHNSON'S WOOD DYE



How to Finish Woodwork

The finishing of woodwork—old or new, is just a matter of using the proper materials. The Johnson Line of Artistic Wood Finishes is complete—it includes Johnson's Wood Dye, Perfectone Enamel and Undercoat, Varnishes, Prepared Wax, Paste Wood Filler, Crack Filler and everything necessary for woodwork, floors and furniture.

Johnson's Wood Dye is the proper material to use for staining wood—old or new—soft or hard. For the popular enamel finish on either new or old work use Johnson's Perfectone Undercoat and Enamel. Made in White, Ivory and French Gray.

For refinishing old woodwork, floors and furniture in color where you do not care to go to the trouble or expense of removing the old finish, apply one coat of Johnson's Sani-Spar Varnish Stain. Made in four beautiful shades.

This Book on
Home Beautifying

Free!

This book gives complete instructions for finishing all wood—hard or soft, old or new. Tells how inexpensive soft woods may be finished so they are as beautiful and artistic as hardwood. Explains just what materials to use and how to apply them. Includes color card—gives covering capacities, etc. Use coupon.

S. C. Johnson & Son, Dept. PA 3, Racine, Wis.

Please send me, free and postpaid, your Instruction Book on Wood Finishing and Home Beautifying.

NAME.....

ADDRESS.....

CITY & STATE.....

Dealer's Name.....

Are You Building?

If so, you will find our book particularly interesting and useful. It will tell you how to do the work yourself or enable you to talk intelligently on the subject to your architect and contractor. Our Individual Advice Department will give a prompt and expert answer to all questions on interior wood finishing—without cost or obligation.

S. C. JOHNSON & SON, Dept. PA 3, Racine, Wis.
"The Wood Finishing Authorities"
Canadian Factory—Brantford

FREE TRIAL

No Money Down

13c a day soon buys an Oliver Typewriter—latest model

Before you realize it you have this splendid Oliver paid for. And you get to use it right away — while you pay.

To begin with, you save \$50.50 on the price, for we now sell the standard \$100 Oliver for \$49.50 cash, or you can save \$45 if you pay the installment price of \$55. It is our latest and best model, the No. 9, brand new.

We are able to make these great savings for you through the economies we learned during the war. We found that it was unnecessary to have great numbers of traveling salesmen and numerous, expensive branch houses through the country.

We were also able to discontinue many other superfluous sales methods.

You may buy direct from us, via coupon. We even send the Oliver for five days free trial, so that you may act as your own salesman. You may use it as if it were your own. You can be the sole judge, with no one to influence you.

Used by U. S. Steel Corporation, New York Central Lines, National City Bank of New York, Encyclopedia Britannica, New York Edison Co., Otis Elevator Co., Boston Elevated Railways, and other big concerns.

Now \$49.50



\$100 Value

Let us send you the Oliver for Free Trial. The coupon brings it.

If you agree that it is the finest typewriter, regardless of price, pay \$49.50 cash for it, or \$55 in installments—\$3 after trial, then \$4 per month.

If, after trying it, you wish to return it, we even refund the out-going transportation charges. So the trial does not cost you a cent. Nor does it place you under obligations to buy.

Our new plan has been a tremendous success. We are selling more Olivers this way than ever before. Over 500,000 Olivers have been sold! Oliver popularity is increasing daily.

This, the Oliver 9, has all the latest improvements. It is noted for its sturdiness, speed and fine workmanship. It is handsomely finished in olive enamel and polished nickel. If any typewriter is worth \$100, it is this Oliver, for which we now ask only \$49.50, after its being priced for years at \$100.

Mail the coupon for EITHER a free trial Oliver or further information. Be your own salesman and save half. This is your great opportunity.

Canadian Price, \$79

The **OLIVER** Typewriter Company
1093 Oliver Typewriter Bldg., Chicago, Ill.

This coupon brings you a Free Trial Oliver without your paying in advance. Decide yourself. Save half. Or this coupon brings further information. Check which you wish.

THE OLIVER TYPEWRITER COMPANY,
1093 Oliver Typewriter Bldg., Chicago, Ill.

Ship me a new Oliver No. 9 Typewriter for five days' free inspection. If I keep it I will pay \$55 as follows: \$3 at the end of trial period and then at the rate of \$4 per month. The title to remain in you until fully paid for. If I make cash settlement at end of trial period I am to deduct ten per cent and remit to you \$49.50.

If I decide not to keep it, I will ship it back at your expense at the end of five days.

My shipping point is
 Do not send a machine until I order it. Mail me your book—"The High Cost of Typewriters—The Reason and the Remedy," your de luxe catalog and further information.

Name

Street Address

City State

Occupation or Business

1922 Ranger = 100% Equipped

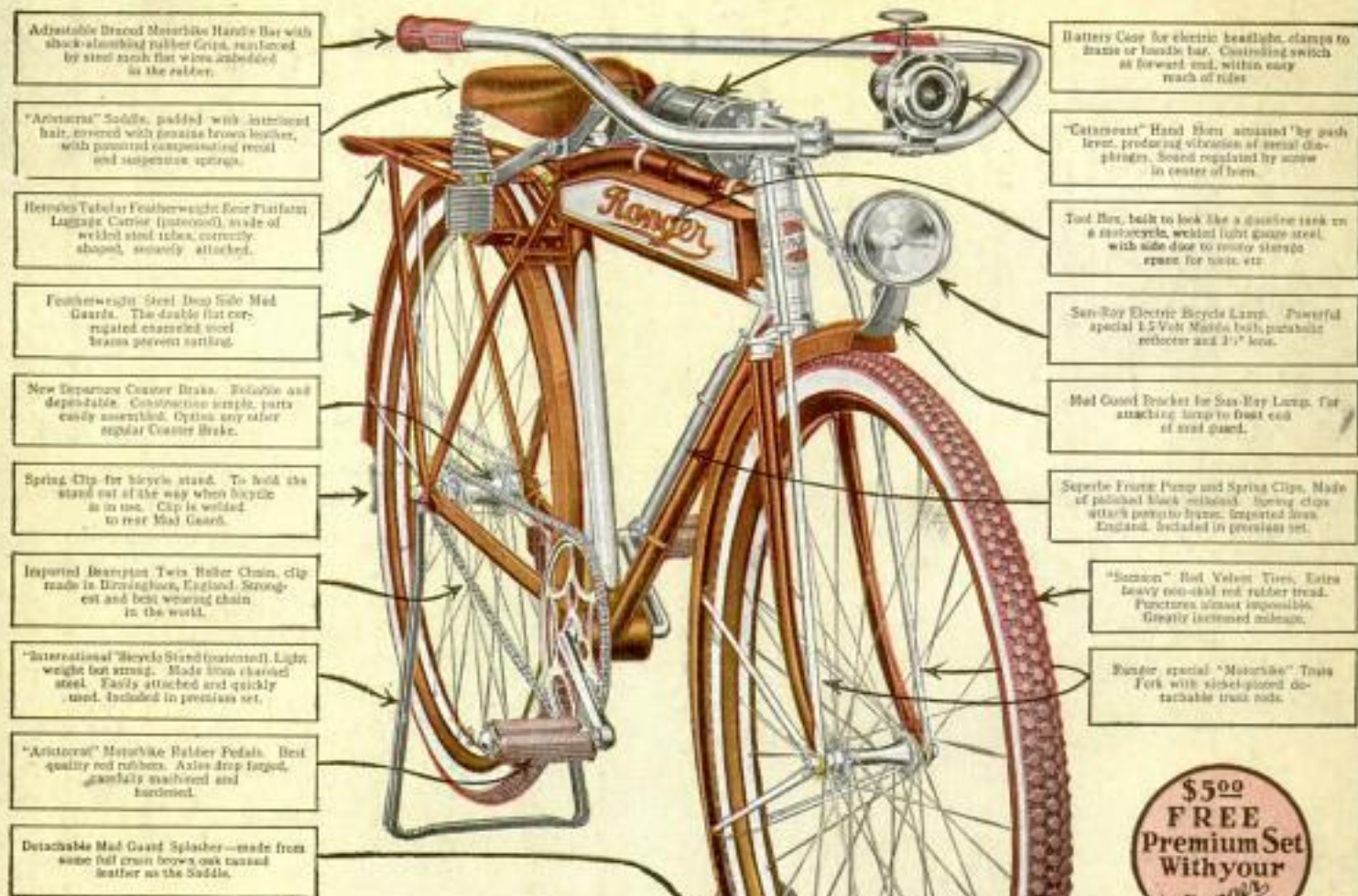

Adjustable Braided Motorbike Handle Bar with shock-absorbing rubber Grip, reinforced by steel mesh flat wire imbedded in the rubber.

"Artists' Saddle, padded with imported hair, covered with genuine brown leather, with patented compressing recoil and suspension springs.

Removes Tubular Featherweight Rear Platform Luggage Carrier (patented), made of welded steel tubes, correctly shaped, securely attached.

Featherweight Steel Drop Side Mud Guards. The double flat corrugated channelled steel beams prevent rattling.

New Departure Center Brakes. Reliable and dependable. Construction simple, parts easily assembled. Option any other regular Center Brake.

Spring Clip for bicycle stand. To hold the stand out of the way when bicycle is in use. Clip is welded to rear Mud Guard.

Imported Besanton Twin Roller Chain. Clip made in Birmingham, England. Strongest and best wearing chain in the world.

"International" Bicycle Stand (patented). Light weight but strong. Made from channelled steel. Easily attached and quickly used. Included in previous set.

"Artists'" Motorbike Rubber Pedals. Best quality red rubbers. Axles drop forged, carefully machined and hardened.

Detachable Mud Guard Splasher—made from same full grain brown oak tanned leather as the Saddle.

Battery Case for electric headlight, clamps to frame or handle bar. Controlling switch at forward end, within easy reach of rider.

"Caterpillar" Hand Horn activated by push lever, producing vibration of metal diaphragms. Sound regulated by screw in center of horn.

Toot flux, built to look like a genuine tank on a motorcycle, welded light gauge steel, with side door to easily storage space for tools, etc.

Sea-Ray Electric Bicycle Lamp. Powerful special 1.5 Volt Mazda bulb, parabolic reflector and 1 1/2" lens.

Mud Guard Bracket for Sea-Ray Lamp. For attaching lamp to front end of mud guard.

Superbe Front Pump and Spring Clips. Made of polished black metal. Spring clips attach to pump to frame. Imported from England. Included in previous set.

"Samson" Red Velvet Tires. Extra heavy non-slip red rubber tread. Punctures almost impossible. Greatly increased mileage.

Ranger special "Motorbike" Tread Fork with side-mounted detachable tread rods.

\$5.00 FREE Premium Set With your Ranger

There are 44 styles, colors and sizes in the famous line of **RANGER Bicycles** a model to suit every taste and any pocket book.

30 Days Free Trial We want you to see for yourself what wonderful values are found in Ranger bicycles with their complete equipment of accessories and extras. Therefore, send today for the Ranger catalogue and select the model you prefer from 44 styles, colors and sizes. Ride it for thirty days, test its speed, sturdy qualities, deluxe equipment and many exclusive features. If at the end of thirty days you want to return it for any reason, send it back and you will not be out one cent. In addition to all the accessories usually found on bicycles, we give you with the Ranger Motorbike model, (as illustrated), over \$25.00 worth of extra equipment and a \$5.00 (extra) Premium Outfit. Where else can you get such value for your money?

Direct From Factory When you buy a Ranger you do business direct with the makers, at factory prices. For more than a generation Mead Ranger bicycles have been recognized everywhere as giving the most for the money in complete equipment, style, long life, finish and freedom from repairs. Every Ranger is backed by a factory guarantee for five years.



12 Months to Pay

To make it easy for you to own a Ranger of your choice, we will arrange with you to accept twelve small monthly payments, enabling you to take advantage of our rock bottom factory-to-rider cash prices—only a slight amount is added to the factory-to-rider price to cover cost of extra book-keeping. Pay while you ride and your Ranger will pay for itself with money that you save and earn.

WRITE TODAY Send no money. Just the coupon or a postcard. Get our big FREE catalogue. Select your Ranger and we will send it to you for thirty days free trial, express charges prepaid.

MEAD CYCLE COMPANY
 Dept. P-108, Chicago, U. S. A.

Send me the new Ranger Catalogue, factory-to-rider wholesale prices, 30-day Free Trial Offer and Easy Payment Terms.

Name.....
 R. F. D. or
 Street No.

Town..... State.....

FACTORY DISTRIBUTORS IN 264 CITIES

The nearest city (with a population of 25,000 or more) which I can conveniently visit to select a Mead Ranger is.....

If you have a Special Factory Distributor there, send me letter of introduction to him so I can inspect the Rangers and take delivery from there at Factory prices or on Easy Payment Plan if I prefer.

MEAD CYCLE COMPANY
 DEPT. P-108 CHICAGO U.S.A.