

POPULAR MECHANICS MAGAZINE

WRITTEN SO YOU CAN UNDERSTAND IT

REG. U.S. PAT. OFF.

REGD. TRADE MARK GREAT BRITAIN No. 410426



Go SEE PAGE 177

War Mechanics Offer No Prizes: Don't Join in Clubbing Offers and Employ No Substitutes

Now 3 Big Rahe Schools



Chicago, Illinois
~ MICHIGAN AVE ~ ONTARIO ST. ~



Kansas City, Missouri
~ 22ND & OAK ST. ~



Cincinnati, Ohio.
~ 9TH & WALNUT ST. ~



I have brought the **Rahe Way** OF AUTO & TRACTOR TRAINING to YOU OPPORTUNITY is now hundreds of miles closer

**MONEY
MONEY
more
MONEY**

Thousands of men come
or write to me—

"How can I make more
money? I want a better job—
more pay—a bigger future."

I answer them—"Know how
to do some one thing well.
Be a trained man. Learn by
actually doing, under com-
petent instructors, the work
you would like most to do.
Become an expert in the best
paying business today—the
Auto Service Business."

Come to a RAHE School.
Learn Auto Mechanics thor-
oughly. Qualify for BIG
MONEY Jobs. Don't delay.
Write for my 68-page cata-
log. Write TODAY.

This Big 68-page Book describes the Rahe-Way
—tells how thousands have learned Automotive
Training. Shows how Big Money is made. It is
FREE to you. Write today. Clip the Coupon and
send for it now.

You can Make \$150 to \$400 a Month. RAHE Graduates every-
where are making Big Money. This is YOUR opportunity to BREAK AWAY
from LOW PAY. Clip the Coupon and send today. It will be one of the most
fortunate things you've ever done.

NOW you have the choice of THREE BIG RAHE SCHOOLS.
I have established the famous RAHE-WAY of Automotive Training
in Chicago and Cincinnati, as well as at Kansas City. To thousands of
young men, OPPORTUNITY now is hundreds of miles closer—as near as
Chicago or Cincinnati.

Hundreds Train at Cincinnati

For 14 years I have been teaching Auto and Tractor training at Kansas
City. The great success of my school meant I must expand—add more
floor space or establish new schools. Why not, I thought, take Automotive
Training to the thousands of men who could not come to Kansas City? My idea proved sound.
The Cincinnati School has been a big success from the day its doors were opened. From the
Eastern, Southern and Central States, hundreds of students have poured into Cincinnati.

Chicago School is Popular

Now the Chicago School is going full-blast. It is a full-fledged, independ-
ent institution, teaching the famous RAHE-WAY, equipped just the
same as the other RAHE Schools. Already hundreds of students are
in training. Hundreds and thousands more are coming. Why?

This Is an Automotive Year. More money is being spent this year than last for auto
and tractor upkeep and repair. THREE BILLION DOLLARS this year to keep autos running. You can
have a big part of this \$3,000,000,000 if you train yourself the RAHE-WAY—the Practical Job Method
of teaching Automotive Mechanics.

**HENRY J. RAHE, Dept. CHICAGO, ILL., Ontario and Michigan Blvd.
2898 KANSAS CITY, MO., 22nd and Oak Streets
CINCINNATI, OHIO, 9th and Walnut Streets**
(Send to Nearest Address)

Please send me your 68-page Catalog showing graduates' success and oppor-
tunities now open.

Name.....Occupation.....

Address.....Age.....

The Victor Record Catalog is the world's greatest catalog of music



From its 486 pages come to you the most famous artists of this generation. Here are listed their offerings—here you will find cataloged the greatest music the world has produced. In this book are also portraits and biographies and interesting information which help to a better appreciation of all music.

Do you know, for instance, the story of *La Boheme*, and which two composers wrote operas of that name?

Did you know that James Whitcomb Riley himself recited some of his poems for Victor Records?

Can you name the great composer who though born in Germany is buried in Westminster Abbey?

Did you know Mozart wrote a concerto when but six years of age?

Can you recall the principal numbers in the *Mikado* and *Pinafore*?

Get a copy of this new Victor Record Catalog. It is a book that interests every one, and you can have a copy free at any Victor dealer's. Or write to us for it.



"HIS MASTER'S VOICE"
REG. U.S. PAT. OFF.

This trademark and the trademarked word "Victrola" identify all our products. Look under the lid! Look on the label!
VICTOR TALKING MACHINE CO.
Camden, N. J.



Victrola

REG. U.S. PAT. OFF.

Victor Talking Machine Company, Camden, N. J.

This One



WSEF-823-8HFJ

aterial

NEW - Vol. 42 in the Famous Cypress Pocket Library!

The Cypress Bird-House Book

20 Working Plans
on double supplement

2 rare portraits of AUDUBON
on special supplement. Suitable for framing

Well, we suppose you'd better
GET THAT BOY TO WRITE
right away for this very special

Vol. 42 of the internationally famous
Cypress Pocket Library. Just out.
"Good Bungalows for Good Birds"

It is a wonderful compilation of bird lore and bird information. **BIG DOUBLE SUPPLEMENT WITH 20 BEAUTIFUL and CORRECT DESIGNS**—all specially made by artists who know birds. (Not one is like the other good designs in bird house catalogs.) Also in this volume you'll find **20 FULL WORKING PLANS** with complete specifications. And **ALSO EXTRA ART SUPPLEMENT, 12 x 29 inches, in FIVE COLORS** with a total of **3 PORTRAITS OF AUDUBON SUITABLE FOR FRAMING**, one a reproduction in colors of a rare old steel engraving, also photograph of his home. **ALSO 5 BIRDS in NATURAL COLORS** and **180** correct pen portraits of other birds.

"Your Cypress Volume 42 is one of the most complete and authentic books on this subject I have ever seen." Thus recently wrote a bird-lover who has read much.

You will be astonished and delighted with the variety of the contents of Vol. 42. And it is **FREE**. *Send your name. Today is best.*

SOUTHERN CYPRESS MFRS' ASSN.

1219 Poydras Bldg., New Orleans, La., or
1219 Graham Bldg., Jacksonville, Fla.



Dashboard Instrument, P. 198.

Popular Mechanics Magazine

6 N. Michigan Avenue, Chicago, U. S. A.

H. H. WINDSOR, Editor

London: Hachette & Cie.
16-17, King William Street, Charing Cross, W. C. 2

Paris: Hachette & Cie.
111 Rue Reaumur

Melbourne, Australia.
The Australasian News Co.

ISSUED MONTHLY

SUBSCRIPTION:

SINGLE COPY, 25 CENTS

In United States, and its possessions, Cuba, Mexico, and Canada, per year, postpaid - \$3.00

To all other countries in the Postal Union 3.50

All subscriptions are discontinued at expiration. Please examine the date printed on your wrapper.

Entered as Second Class Matter Sept. 15, 1903, at the Post Office at Chicago, Illinois, under Act of March 3rd, 1879.
Entered as Second Class Matter at the Post Office Department, Canada.

Published monthly by POPULAR MECHANICS CO.

Copyright, 1922, by H. H. Windsor

Copyright in Australia.

Vol. 37

Contents for February, 1922

No. 2

Air Craft, Naval and Marine, Extensive Flights by.. 218
 Airplane and Automobile Tie in Tug of War..... 238
 Airplane, Motorless, Progress Made in Flight by... 212
 Arch, Granite, State Line on Meridian Trail Marked
 by..... 247
 Arm, Artificial, Cripple's Handicap Overcome by... 241
 Athlete, Movie Star, Horse Defeated in Foot Race by 232
 Auctions, "Going-Going-Gone" Phrase Obsolete at.. 224
 Automobile Body, Drawerlike Seat Slides into Side of 202
 Automobile, French, Has Locker in Rear of Body.. 192
 Automobile Pedal, Air Cylinder Aids Stepping on the
 Gas..... 274
 Automobile Spotlight and Control for Closed or Open
 Cars..... 279
 Automobile Traffic Signal, New, Six Signals Given
 by..... 215
 Aviation Field, Crissy, Recently Completed..... 250
 Bacteria, New Strategies Used in War on..... 190
 Balloon Control Taught Observers, by Frank B.
 Howe..... 225
 Bandits, Safety Door to Outwit..... 221
 Banjo with Sound Throwing Horn..... 162
 Baseball Scene Whittled from Wood with Knife..... 254
 Bath Cabinet, Electric, Folding..... 233
 Battery Voltage Reverses at Low Temperature..... 242
 Battleship, Japanese, Mighty "Mutsu" Is Latest..... 203
 Barge Stations, Pollution of Harbors to Be Prevented
 by..... 166
 Biplane, Folding Wing, Is "Flying Automobile"..... 164
 Blowtorch, Automatic, Pressure Generated by..... 218
 Boat, Sailing, Paper Model Made of..... 279
 Boosters' Meetings, Horn Calls to Order..... 242
 Bridge, Clever Engineering Seen in Opening of..... 191
 Bronze for Weatherproofing Bridge Construction... 194
 Bureau, Special, Established in Minneapolis Post
 Office..... 276
 Busses, Motor, Latest Mode of Travel..... 176
 Cafeteria, Yosemite Park, Popular with Tourists... 261
 Cakes, Sixty Pound Fruit, Famous Persons Presented
 with..... 236
 Candle, Electric, Fire Risk Minimized by..... 218
 Casings, Porous Concrete, Used as Well Strainers.. 226
 Casting, Huge, Three Cranes Carry..... 247
 Chair, New Device Adjusts Height of..... 251
 Chair-Bed Has Bookshelf and Medicine Cabinet.... 201
 Chart, Simple, Pay Rolls Figured Quickly by..... 246
 Children's Pages..... 280
 Chip, Steel, 160 Feet Turned Out on Lathe..... 232
 Civic Features..... 268
 Clay Digger Resembles Pneumatic Hammer..... 257
 Coal Handling Plant, New, at New Orleans..... 215
 Coal Screenings, Old Clay Pit Used to Store..... 241
 Coal, Waste, Develop Effective Process for Reclaim-
 ing..... 174
 Coconut Oil Butter, How Manufactured, by C. W.
 Geiger..... 262
 Collision—Locomotive Thrown Up Side of Hill.... 172
 Comment and Review, by H. H. Windsor..... 187
 Compass Mounted in Top of Automobile..... 164
 Contest, Employees, Safety Inspectors Boosted by... 274
 Conveyor Unloads and Piles Stone for Storage..... 198
 Corn, Monster Ear, Thirty Feet High..... 223
 Cotton, Egyptian, American Ships Carry Imports of 196
 Crane Anchored in Wall of Building..... 226
 Crawfish, Canal Bank Leakage Stopped by Extermi-
 nation of..... 253

Desk Tray, New, Windproof and Convenient..... 242
 Dial Micrometers, Piston Grooves Measured by.... 276
 Dial Recorder, Shape Irregularities Shown by..... 240
 Dock, Barge, New Type of..... 232
 Documents, Historic, Placed in Library of Congress 164
 Dogs, Hunting, Cage on Auto Running Board for.. 171
 Doors, Double Swing, Locked in Any Position..... 278
 Drill Press Mounted on Auto for Salesman..... 246
 Drydock, Smallest Floating Steel, Launching of... 223
 Egg Opener, New Sanitary Device..... 266
 Elevator, Fish Lifted over Dam with..... 277
 Engine Direction, Automatic Telltale Shows..... 222
 Expedition, Harvard-Boston, Ethiopian Records Found
 by..... 172
 Explosion, Oil Refinery, Peculiar Nature of..... 252
 Falls, Minnehaha, Beauty of to Be Restored..... 232
 Ferns, Florida Grows for Northern Market..... 188
 Fish Farming, Occupation of South Sea Islanders.. 278
 Flashlight, Hand, Adapted as Movie Film Projector. 173
 Flower Show, Attractive Entrance to..... 238
 Fly, House, "Fingerprints" of..... 253
 Fog Signals, Wireless Controls..... 236
 Football Game, Ingenious Emblems Seen at..... 206
 Forest Ranger's Fire Engine Carried on Back..... 170
 Furniture, Efficiency, Table and Bed Combined in.. 185
 Galvanized Coatings, Testing Device Weighs..... 235
 Garage Zoning Regulations Tested by Application... 178
 Garbage Can, Two Shell, Refuse Disinfected by.... 277
 Gasoline, Asphalt Removed from Concrete with... 184
 Germs in Milk, Economical Process for Counting... 240
 Glove, Motor, Flashlight in Back for Signaling.... 253
 Golf Bag Holder Clamps on Auto Running Board... 175
 Gopher Trap, New Type, Record Catch Made by... 206
 Grapes, Seedless, Eastern and Northern States De-
 velop..... 166
 Grinders, Small Turbine Type, High Speed of..... 249
 Headlight on Rear of Car, Latest Auto Feature... 218
 Heater, Electric Manifold, Cold Engines Warmed by 266
 Helium Inflated Navy Dirigible, First Flight with.. 230
 Helmet, Diving, Good Results from..... 222
 Highway, Columbia River, Icebound, by H. E.
 Thomas..... 216
 Hotel Company, New York, Novel Extension Built
 by..... 218
 House Moving, Unexpected Ending of..... 257
 House, One Room, Rooms in Walls of, by Frank B.
 Howe..... 209
 Household Devices..... 272
 Hydroglider, Speed and Comfort of, by Henry S.
 White..... 243
 Ice, Cable Ferry System Floats Across River..... 192
 Ice, Sea Water, Fish Packed in..... 274
 Iceboat, Exciting Moment with..... 207
 Indians, Argentine, Crowded Out of Old Haunts... 227
 Indians, Chiapas, Pose for Photographs..... 214
 Ladder for Fighting Chimney Fires, Fireman Device 274
 Lakes, Sardinia Artificial, Rank Among Largest... 231
 Land Registry, Calgary, Canada, Land Seekers' Ex-
 periences in..... 198
 Leg, Artificial, Has Natural Knee Motion..... 184
 Levees, Flexible Concrete Mattress Protects, by Ivan
 E. Houk..... 220
 Lifeboat Releasing Gear as Safety Device..... 271
 Linoleum, Wearing Qualities Demonstrated..... 266
 Lock, First, being Built for Illinois Waterway.... 255
 Locomotive, Turbine Driven, Operates Successfully.. 183

[Continued on Page 4]

[Contents—Continued]

Locomotives, Automatic Fire Door for.....	193	Trailer, Heavy Load, Has Four Wheels on One Axle	226
Locomotives, Smokiest, Made Smokeless.....	191	Trailer, New, Wide Range of Adaptability of.....	256
Lumber Handled with Electric Machinery.....	228	Treaty, Four Power, Eighteen Delegates Sign.....	189
Luncheon, Social, Served in Sixty Foot Boiler.....	246	Trout Landing Net Carried in Pocket.....	182
Magnet and Crane Mounted on Electric Locomotive	175	Truck, Motor, Train Transported by.....	242
Maps, Wall Size, Growth of City Shown by.....	265	Truck, Repair, Men and Materials Transported by..	249
Merchant Marine, German, Enormous Growth of...	206	Trucks Loaded Too High to Pass Door, Bell Warns	270
Mercury for Thermometers, Cheaper Liquids to Re-		Truing Device, Machinists and Inspectors Aided by..	224
place.....	232	Turnstiles, Nickel First, for Subway Entrances.....	213
Mines, Two, One Tipple Serves.....	266	Typewriting Students, Touch, Keyboard Shield Aids	235
Model, Water Power Problems Studied by, by Sam		Typists, Blind, Machine Makes Raised Letter Copy	
E. Conner.....	275	for.....	173
Money Exchange Rates, Foreign, New Methods of..	246	Vault Floors, Motors Raise and Lower.....	186
Mortar, Machine for Cutting from Joints of Brick-		Ventilation Problems, Test Tunnel Solves.....	199
work.....	196	Violins, Group Control Method of Playing.....	230
Mosquitoes, Rabbits a Protection from.....	162	Warnings, Automobile, Instrument on Dashboard	
Motorboat, Auto, Resembles Boat on Wheels.....	183	Gives.....	193
Motorcycle, New, Peculiar Construction of.....	252	Watch, Remarkable, Complicated Dials on.....	238
Motorcycles, Steam Driven, Economical to Operate..	204	Water Walking Machine, San Francisco Bay	
Motorist, Daily Recording Accessory a Help to....	260	Crossed by.....	222
Motorship, Largest Twin Screw, All American Made	173	Welding Torch Has Portable Equipment.....	192
Mountain, Pacific Ocean, Is Huge Mass of Sulphur	184	Whale Hunting on Top of World, by Lawrence	
Odors, Bad, "Gassing," by Harry A. Mount.....	219	William Pedrose.....	167
Oil Burning Plant, Heavy Oils Used in.....	251	Wheelbarrow, Auto, Latest Type of Dumping Truck	261
Oil Field, Shallow Well, by Albert Marple.....	248	Windmill, Electricity for Eleven Days' Use Stored	
Paper Making, Rubber Used in.....	227	by.....	254
Pen, Scorching, Forgery Prevented by.....	231	Windscreens, Streamline, for Motorcycle Sidecars...	276
"Photograph Sculpture," Relief from Pictures Carved		Window Lock, Sash Held in Any Position by.....	249
by.....	204	Wireless Station, Ireland's, Is Norway's Weather	
Piano with Double Keyboard.....	205	Outpost.....	185
Pistol, Fire Extinguishing, Burglars Repelled by...	237	Wreath Incased in Ice Sent from Antipodes to Eng-	
Powder Resources, War Department Keeps Record		land.....	231
of.....	198	X-Ray Apparatus, Lead Diaphragm Used with.....	166
Precision Leveling and Its Practical Value, by C. A.		X-Ray Tubes Operated Experimentally at 300,000	
Briggs.....	207	Volts.....	198
Prize Offers.....	323		
Propeller Made Adjustable for Wind or Motor Drive	202		
Propellers, Drilling and Stud Settling Machines for.	234		
Pump, Mammoth, 40,000,000 Gallons Capacity of...	270		
Radiator Cap and Thermometer, Locking Device for	193		
Radiator Fins, Bent, Tool to Straighten.....	252		
Radio Messages, Amateur, Atlantic Ocean Crossed by	184		
Radio Service Broadcast over Entire Country.....	231		
Rails, One Hundred Tons, Souvenirs Made of.....	175		
Rattlesnakes, War Poison Gas Kills.....	204		
Register, Furnace, Combination Wall and Floor...	253		
Rescue of Workman from Smokestack.....	162		
Reservoir, 22,000,000 Gallon, New York to Have	224		
Residences, City and Country, Camouflage Conven-			
iences Characterize.....	238		
Revolver, Sixteen Shot, Made in Belgium.....	261		
Rubber Contest Draws 10,000 Ideas.....	234		
Rubber Tubing, Dust and Moths Excluded from			
Clothing with.....	248		
Russian Government, Reading Matter Distributed by	237		
Saw, Power Driven Circular, Ice Harvested with...	214		
Scientific Research, Latest Developments of, by C.			
A. Briggs.....	324		
Seals, Migrating, Travel in Military Formation.....	237		
Settlement, Abandoned, Reclaimed by Wells, by			
Horace E. Thomas.....	197		
Shearing Pin, Soft, Used in Quick Change Chuck..	274		
Silver Recovered from Fixing Bath by New Process	230		
Skull, Prehistoric, New Type Discovered.....	190		
Smokestack, Two Section, Erected with Crane....	182		
Smokestack Wrecked by New Method.....	277		
Sorghum Sirup, Improved Methods for Manufac-			
ture of.....	192		
Steel, Barges Carry from Pittsburgh to Cincinnati..	208		
Steel, Hollow, "Sand Blast" Process Used in Making	238		
Steel, Rustless Plastic, England Now Makes.....	266		
Steel, Shafting, Tested for Stress Limit.....	213		
Steeplejack Climbs Chimney with Aid of Box Kite..	214		
Street Repair Work, Winter, Old Asphalt Used for.	232		
Street Widened to Relieve Congestion.....	205		
Streets, City, Location System for.....	271		
Stump Cutter, Power Driven, Work Done Rapidly by	203		
Stump Puller, Sunken Engine Raised by.....	239		
Submarine Service, Peace Time Perils of.....	194		
Substation, Automatic, in American Coal Mine....	264		
Sugar, Production, Possible Source of Discovered...	202		
Tank, Fuel Measuring, Oil Consumption Tests Aided			
by.....	270		
Tennis Courts, Roofed in Water Reservoir Provides	233		
Tire Pump for Low Priced Cars.....	169		
Tower, Memorial to Men of Ulster of 36th Division	186		
Toys and Dolls Made from Old Inner Tubes.....	164		
Track Torpedo That Appeals to Sight, Smell and			
Hearing.....	171		
Traffic Director, Accidents Cannot Damage.....	279		

SHOP NOTES

Ammonia, Hot Bearings Cooled with.....	286
Arbors, Improved Centers for.....	294
Automobile Ignition, Tester for.....	288
Automobile Seat, Auxiliary.....	299
Band Saws, Window Box Aids in Filing.....	302
Battery Terminals, Scraping.....	287
Blocks, Parallel, Adjustable.....	299
Bolts, Frozen, Removing.....	297
Brass and Copper, Galvanizing.....	301
Bridge Models, Shipping Problems Shown by.....	293
Bushings, Tap Removes.....	293
Car, Delivery, Rack Makes of Touring Car.....	297
Clamp for Drawing Board.....	295
Clothespins, Auto Cylinder Head Protected by.....	292
Commutators, Small, Truing in Vise.....	295
Corners, Insuring Sweeping of.....	293
Dogs, Wood Sawing Aided by.....	297
Door, Wedge Holds for Planing.....	292
Drill Press Drift, Handy.....	288
Eye Splice, Superior.....	288
Fan Belt, Emergency.....	286
File, Mill, Sharpening Tools with.....	293
Gravel in Concrete Mixtures.....	299
Gun Greases, Making.....	285
Keyhole, Locating in the Dark.....	284
Lanterns, Cement Bases for.....	297
Lathe Dog, Adjustable.....	299
Leather Lagging, Stretching on Pulleys.....	293
Motors, Generators, Transformers, Testing.....	289
Pattern Construction, Unusual Type of.....	300
Piles, Concrete, without Forms.....	286
Pinch Dogs, Emergency.....	293
Pit, Drain, for Filling Stations.....	302
Radiator Testing, Plugs for.....	298
Radius Tool, Simple.....	301
Reflector, Light, for Drafting.....	301
Rivets, Brake Band, Cutting.....	294
Screwdriver, Geared Offset.....	286
Scribing Tool, Precision.....	298
Shafts, Marking OH Centers on.....	300
Springs, Auto Transmission, Tool Clamps.....	287
Sprinkler Heads, Protecting.....	282
Square, Useful Attachment for.....	294
Stencils, Decorator's, Roller for.....	286
Stone Boat, Improved.....	285
Tap and Reamer Milling Fixture.....	296
Toolholder, Novel.....	299
Tracings, Preventing Loss of.....	302
Tractor Started with Carbide.....	288
Trees, Decayed, How to Save.....	283
Umbrella Ribs for Welding Rods.....	284
Valve, Check, Removing Ball from.....	295

DRAKE'S PRACTICAL MECHANICAL BOOKS

THEY WILL RAISE YOUR PAY—

ORDER ON 5-DAY TRIAL

The books listed below will perfect you in your chosen trade — pave the way to the big positions. Written in non-technical language—easy to read and understand. *Every book covers its subject completely. An entire course of instruction condensed into one volume.* Your choice sent postpaid — you benefit 5 days — money refunded in full if not entirely satisfactory. Order direct from this page.



1921
Edition
\$2.00

Automobile Books

- Automobile Ignition, by ManlyLeatherette \$2.00
- Automobile Starting and Lighting, by Manly.....Leatherette \$2.00
- Brookes' Automobile Handbook.....Leatherette \$2.00
- Ford Motor Car, Truck and Tractor, by Manly.....Cloth \$1.50
- Starting and Lighting Troubles, Remedies and Repairs, by ManlyLeatherette \$3.00
- Automobile Battery, Care and Repair, by Manly.....Leatherette \$2.00
- Automobile Catechism and Repair Manual.....Leatherette \$1.50
- Tires and Vulcanizing, by TuffordCloth \$2.00
- Gas and Oil Engine Handbook.....Cloth \$1.50
- Automobile Upkeep and Care, by Manly.....Cloth \$1.50
- Motorcycle Handbook, by Manly.....Cloth \$1.50

Shop Practice Books

- Sheet Metal Workers' Manual.....Leatherette \$2.00
- Oxy-Acetylene Welding and Cutting.....Leatherette \$1.75
- Sound Welds.....Cloth \$2.00
- Slide Rule and Logarithmic Tables.....Leatherette \$2.00

- Handbook for Millwrights.....Cloth \$2.00
- Modern Blacksmithing.....Cloth \$1.25
- Machine Shop Practice.....Cloth \$2.00
- Mechanical Drawing and Machine Design.....Cloth \$2.00
- Pattern Making.....Cloth \$1.50

Carpentry Books

- Cloth Binding
- Modern Carpentry, 2 vols.....\$3.00
- The Steel Square, 2 vols.....\$3.00
- Wooden Boat and Shipbuilding.....\$1.50
- Modern Estimator.....\$1.50
- Timber Framing.....\$2.00
- Builder's Architectural Drawing.....\$2.00
- Concrete.....\$1.50
- Practical Bungalows.....\$1.00
- Low Cost Homes.....\$1.00
- Roof Framing.....\$1.50
- Stair Building and Hand Railing.....\$1.50

Electrical Books

- Practical Applied Electricity.....\$2.00
- Alternating Current.....\$1.50
- Electric Motor Control Systems.....\$1.50
- Wiring Diagrams and Descriptions.....\$1.50
- Electrical Tables and Data.....\$1.50
- Armature and Magnet Winding.....\$1.50
- Modern Electrical Construction.....\$1.50
- Modern Electric Illumination.....\$1.50
- Electricians' Operating and Testing.....\$1.50
- Motion Picture Operation.....\$1.50
- Drake's Electrical Dictionary.....\$1.50
- Electric Motors, D. & A.....\$1.50
- Electrical Measurements and Meter Testing.....\$1.50
- Drake's Telephone Handbook.....\$1.50
- Modern American Telephony.....\$2.00
- Easy Electrical Experiments.....Cloth \$1.25
- Wireless Telegraph and Telephone Handbook.....Cloth \$1.25
- Telegraphy Self-Taught.....Cloth \$1.25

Steam Engineering

- Swingle's Handbook for Steam Engineers and Electricians.....Leatherette \$4.00
- Examination Questions and Answers for Marine and Stationary Engineers.....Leatherette \$2.00

- Steam Boilers.....Leatherette \$2.00
- Swingle's Catechism of Steam, Gas and Electrical Engineering.....Leatherette \$1.50

Painting Books

- Scene Painting and Bulletin Art.....Cloth \$4.00
- A Show at Sho' Cards.....Cloth \$4.00
- Sign Painting.....Cloth \$4.00
- Strong's Book of Designs.....Leatherette \$4.00
- Strong's Art of Show Card Writing.....Cloth \$4.00
- Signist's Alphabets.....Cloth \$1.50
- Modern Painter's Cyclopaedia.....Cloth \$2.00
- Automobile Painting.....Cloth \$1.50
- Estimates, Costs and Profits, Painting and Decorating.....Cloth \$1.50
- New Hardwood Finishing.....Cloth \$1.50
- The Amateur Artist.....Cloth \$1.50
- New Stencils.....Cloth \$1.25

Farm Books

- Farm Mechanics.....Cloth \$1.25
- Farm Buildings.....Cloth \$1.25
- Farm Engines.....Cloth \$1.25
- Traction Farming.....Cloth \$1.50

Business and Reference Books

- Better Business Letters.....Leatherette \$1.50
- Better Business English.....Leatherette \$1.50
- Better Advertising.....Leatherette \$1.50
- Finger Prints Simplified.....Cloth \$2.00
- Practical Bricklaying.....Cloth \$1.25
- Practical Instruction for Detectives.....Cloth \$1.00
- Practical Plumbing.....Cloth \$1.50
- Hot Water Heating.....Cloth \$1.50
- Elementary Chemistry.....Cloth \$1.50
- Courses in Civil Service.....Cloth \$1.50
- Cyclopedia of Recipes.....Cloth \$1.50
- American Star Speaker.....Cloth \$1.50

Modern Languages

- By Prof. F. S. Allen, U. of Chicago
- French without a Teacher.....Cloth \$1.25
- Spanish without a Teacher.....Cloth \$1.25
- German without a Teacher.....Cloth \$1.25
- Everyday French.....\$1.25
- Everyday Spanish.....\$1.25

ORDER DIRECT FROM THIS PAGE—ON OUR MONEY-BACK PLAN

The books listed above are only a few of the many in our catalogue, which you will receive promptly after filling out and mailing us the attached coupon. For quick action order direct from this page—cross name of each book wanted and send in with price quoted. We prepay postage and send the books on our money-back plan.

FREDERICK J. DRAKE & CO.

PUBLISHERS

1008 Michigan Ave., Chicago

Drake Books Are For Sale at All Book Stores

FREDERICK J. DRAKE & CO.
1008 Michigan Avenue
Chicago, Ill.

GENTLEMEN:—Please send me free, postage paid, your illustrated catalogue which lists and describes over 100 Practical Mechanical Books for Home Study.

My name is

and my address

Mail Coupon For Free Catalogue
Your Guide to Home Study

NEW KIND OF HEAT!



Try It in Your Stove
30 Days Free
The OLIVER Oil-Gas Burner

Keeps home warmer. Three times the heat.
Does away with coal and wood—cheaper.
Makes your stove or range an oil-gas stove.

No fires to make. No ashes, dirt, smoke, odor, chopping, shoveling, carrying dirty coal or wood. Saves hours of work. Makes your stove heat or bake better, cleaner, quicker. Doesn't change your stove, simply sets in firebox, easily slipped in or out, absolutely safe. Lasts lifetime. Makes its own gas from coal-oil (kerosene) at small cost. Oil is cheap and getting cheaper. Gives even heat instantly, much or little, by simply turning valve. Fits any stove. Saves money, time, labor, health. BURNS 95% AIR—5% OIL.



FREE Attractive Book telling all about the "New Kind of Heat," sent you free, postpaid. Also amazingly low introductory-price offer, including 30-Day Trial, if you act quickly. Write today.

OLIVER Oil-Gas Burner & Machine Co.
2014-B Pine Street St. Louis
Oldest, Largest Mfrs. Oil-Gas Burners in World.

AGENTS Oliver Agents earn as high as \$500 a month—\$25 a day spare time is easy. Exclusive territory—real co-operation.

Write for full money-making details. Big season on.

WEALTH, HONOR, RICHES

Do not depend upon opportunity or intellectual brilliancy of any kind, because it is well known that uneducated people often acquire great wealth, while cultured and talented people remain in poverty.

Again, they do not depend upon capital, because many men with capital lose what they have, while others with no capital acquire phenomenal wealth.

Whatever finds a place in human experience is the result of the operation of natural laws, and the determining factors are therefore within your own control.

This may seem "too good to be true," but if you will consider that by the touch of a button or the turn of a lever science has placed almost infinite resources at the disposal of man, it becomes evident that there may be still other laws not generally known which contain even greater possibilities.

We have published a Remarkable little book, giving the conclusions of science concerning these laws, which we will send upon request. If you want to underwrite success on a magnificent scale, send for it.

MASTER-KEY INSTITUTE

210 Howard Bldg., St. Louis, Mo.

[Contents—Continued from Page 4]

Valve Seats, Ball Check, Grinding.....	301
Wrench for Cylinder Base Nuts.....	297

AMATEUR MECHANICS

Automobile Painting, Hint for.....	314
Automobile, Rear Signal for.....	306
Automobile Wheels, Wire, Removing.....	314
Banio, Muting.....	318
Bearings for Model Machinery, Making.....	320
Bicycle Grinding Outfit, Original Features of.....	303
Bookbinding, Clamp for.....	319
Bookmarkers, Practical.....	308
Bowling Balls, Retarder for.....	317
Broom Holder Made from Shoehorn.....	317
Ceilings, Cleaning.....	315
Clock, Alarm, Electric Lights Turned on by.....	312
Collars, Soft, Stiff Ones Made into.....	313
Condenser, Adjustable Bridging, How to Build.....	319
Cotter Pin, Tube Repairs Aided by.....	305
Countershaft, Small Lathe.....	316
Cupboard, Shallow, Enlarging.....	322
Electric Light Pull Chains, Extension for.....	318
Electrolyte, Testing Height of.....	321
Exercising Machine, Homemade.....	306
Footrail for Radiator.....	308
Furnaces, Cleaning.....	304
Furnaces, Hot Air, Pipe Coils in.....	321
Gambrel, Simple Skinning.....	322
Gasoline, Test for Water in.....	315
Heater Made from Old Tank.....	321
Hoist, Simple, for Farm.....	312
Iron, Electric, Used as Vulcanizer.....	306
Irons, Electric, Indicating Switch for.....	305
Lamp Made from Artillery Shell.....	322
Lamp, Trouble, Shade for.....	317
Light, Bed, Convenient.....	321
Motorists, Feminine, Aid for.....	316
Phonograph, Increasing Tone of.....	313
Phonograph, Softening Tone of.....	315
Pictures, Printed, Transferring.....	308
Pill Box, Magic.....	315
Plates, Dinner, Scraper for.....	313
Plowshares, Cleaning.....	312
Radiator Cap, Locking.....	317
Ridgepole Seat, Comfortable.....	307
Sandpaper Used for Bushings.....	322
Scraper, Boot, Made of Wire.....	304
Sewing Stand Easily Made.....	314
Siphon, Laundry, Made from Grease Gun.....	315
Sled, Aero, Powerful.....	303
Sled Runners for Baby Carriage.....	313
Snow Building Blocks, Making.....	307
Snowflakes, Photographing.....	309
Soldering Bit, Gas Iron Used as Heater for.....	322
Scot Removers, Cheap.....	313
Spool, Eccentric.....	308
Stovepipe Cap, Simple.....	318
Tires, Identification Marks on.....	318
Water, Alkaline, Making Drinkable.....	307
Water Heater Control, Step Saving.....	314

Every boy loves boats and trains

Send 10 cents to The Ives Manufacturing Corporation, Bridgeport, Conn., for complete catalog of Boats and Trains.
IVES TOYS MAKE HAPPY BOYS

Earn \$35-\$125 a Wk



Your Opportunity in MECHANICAL DENTISTRY

Ambitious men of all ages can rise above small salaried positions into this profession of unlimited possibilities.

Taught by actual practice—day or evening. Three months' course. Modern laboratories. No previous knowledge or experience required. No charge for tools or equipment. The men we train are in demand. Established 30 years. Catalog free.

Address your inquiry to Dept. 2

BODEE'S SCHOOLS OF MECHANICAL DENTISTRY

NEW YORK
136 W. 52 St.

PHILADELPHIA
15 1/2 Ave Walnut Sts.

BROOKLYN
15 Flatbush Ave.

Let These Guides

Solve Your Problems

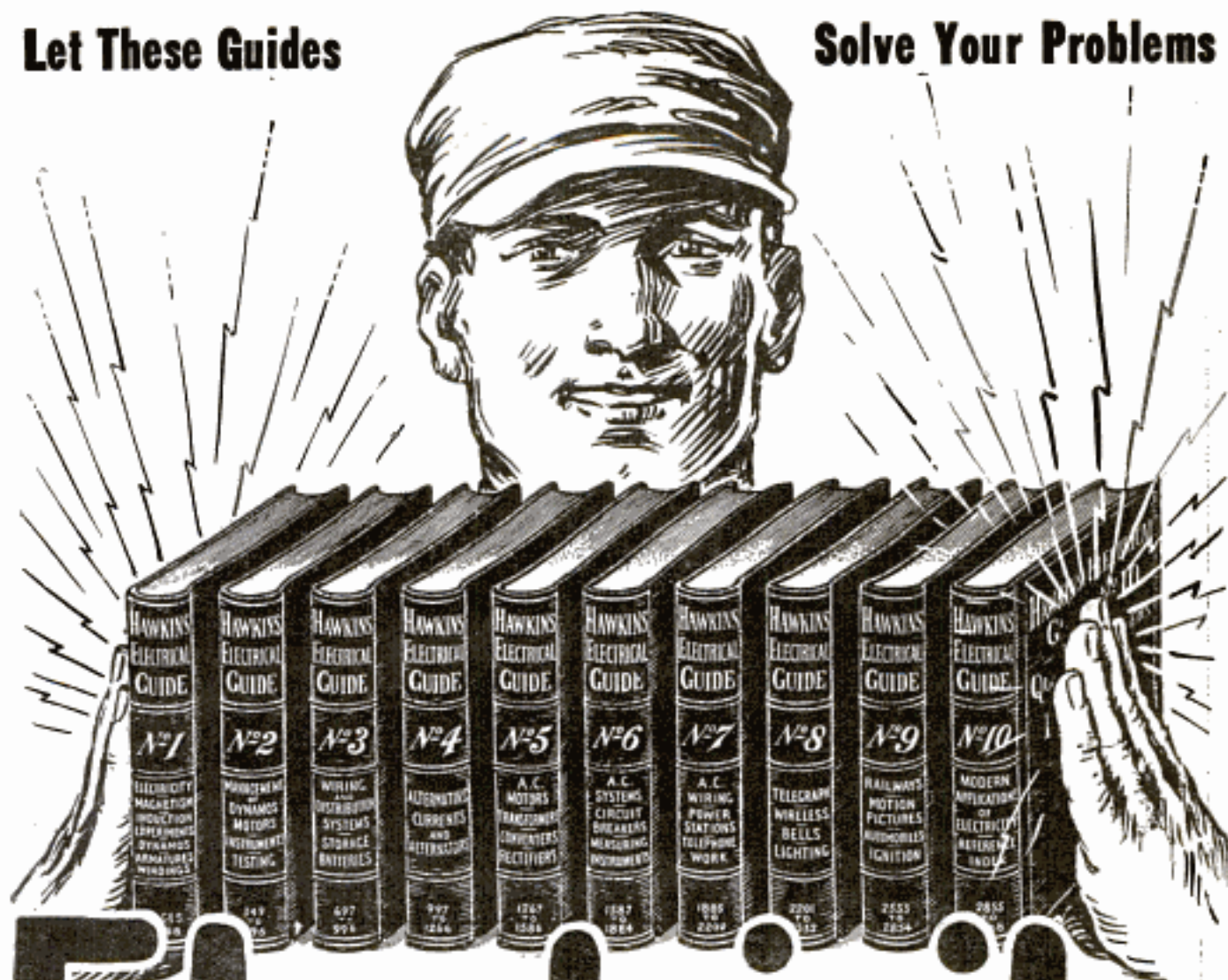

Electricity at your finger ends

HAWKINS ELECTRICAL GUIDES IN TEN VOLUMES

3500 PAGES

4700 PICTURES

\$1 A VOLUME

\$1 A MONTH

Send No Money--Send Only This Coupon

Know the facts in Electricity. They mean more money and better position for you. Hawkins Guides tell you all you need to know about Electricity. Every important electrical subject covered so you can understand it. Easy to study and apply. A complete, practical working course, in 10 volumes. Books are pocket size; flexible covers. Order a set today to look over.

LEARN ALL ABOUT

Magnetism—Induction—Experiments—Dynamios—Electric Machinery—Motors—Armatures—Armature Windings—Installing of Dynamios—Electrical Instrument Testing—Practical Management of Dynamios and Motors—Distribution Systems—Wiring—Wiring Diagrams—Sign Flashers—Storage Batteries—Principles of Alternating Currents and Alternators—Alternating Current Motors—Transformers—Converters—Rectifiers—Alternating Current Systems—Circuit Breakers—Measuring Instruments—Switchboards—Wiring—Power Stations—Installing—Telephone—Telegraph—Wireless—Bells—Lighting—Railways. Also many Modern Practical Applications of Electricity and Ready Reference Index of the ten numbers.

SHIPPED FREE

Not a cent to pay until you see the books. No obligation to buy unless you are satisfied. Send Coupon now—today—and get this great help library and see if it is not worth \$100 to you—you pay \$1.00 a month for ten months or return it.

THEO. AUDEL & CO.,
72 Fifth Ave., New York City

Please submit me for free examination, HAWKINS ELECTRICAL GUIDE, (Price \$1 a number). Ship at once prepaid, the 10 numbers. If satisfactory, I agree to send you \$1 within seven days and to further mail you \$1 each month until paid.

Name.....

Occupation.....

Employed by.....

Home Address.....

Reference.....

PM FEB 23

I Guarantee To Train You

**Until You Are Placed
in a Position Paying**

**\$250 to \$300 Per
Month**

— Chief Draftsman Dobe



Write and I'll tell you how I make you a first-class, big-money-earning draftsman in a very few months! I do this by a method no other man nor institution can imitate. I give you personal training at home by mail. And I mean just what I say—I train you until you are actually placed in a position paying from \$250.00 to \$300.00 per month. Six thousand draftsmen are wanted every month. Hurry up and register so you can start earning.

**I Give YOU
FREE**

**This \$25⁰⁰ Outfit
of Drafting Tools**

High-grade plated instruments. Every one you need. Packed in a handsome plush lined case. Just the kind I use myself. Write to me I'm giving it entirely and absolutely free.

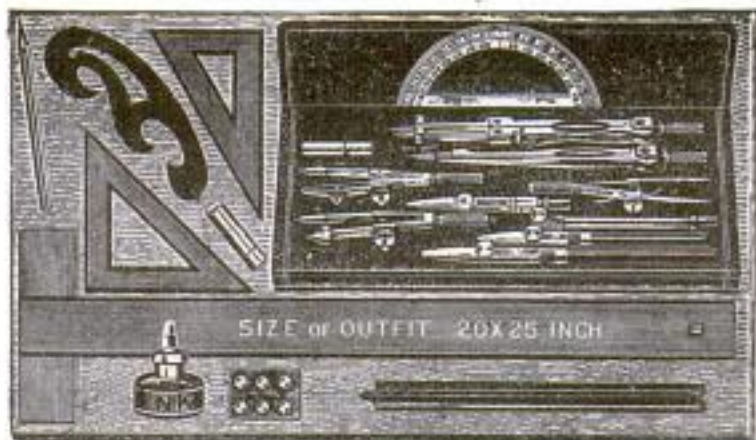

Chief Draftsman Dobe

Dept. 1352, 4001 Broadway, Chicago, Ill.

Without any obligation whatsoever, please mail your book, "Successful Draftsmanship," and full particulars of your liberal "Personal Instruction" offer to a few students.

Name.....

Address.....

**Send This Free
Coupon To Me!**

It costs you nothing but a stamp to send the coupon for my free book, "Successful Draftsmanship" that tells you all. It tells you how my students get the good positions and how I can afford to train you until you get YOUR position. Remember, 6,000 men wanted every month. So hurry. Register early because I can take only a few students. Send coupon NOW!

Chief Draftsman Dobe

Dept. 1352

4001 Broadway, Chicago

I Teach Piano a Funny Way

So people told me when I first started in 1891. But now after over twenty-five years of steady growth, I have far more students than were ever before taught by one man. I am able to make them players of the piano or organ in half the usual time and at quarter the usual cost.

To persons who have not previously heard of my method this may seem a pretty bold statement. But I will gladly convince you of its accuracy by referring you to any number of my graduates in any part of the world. There isn't a State in the Union that doesn't contain many players of the piano or organ who obtained their training from me **by mail**. Investigate by writing for my 64-page free booklet, "How to Learn Piano or Organ."

My way of teaching piano or organ is **entirely different** from all others. Out of every four hours of study, one hour is spent **entirely away from the keyboard**, learning something about Harmony and The Laws of Music. This is an awful shock to most teachers of the "old school," who still think that learning piano is solely a problem of "finger gymnastics." When you **do** go to the keyboard, you can accomplish **twice as much** because you **understand what you are doing**. Within four lessons I enable you to play an interesting piece not only in the original key, but in other keys as well.

I make use of every possible scientific help—many of which are **entirely unknown** to the average teacher. My patented invention, the **COLOROTONE**, sweeps away playing difficulties that have troubled students for generations. By its use, Transposition—usually a "nightmare" to students—becomes easy and fascinating. With my fifth lesson I introduce another important and exclusive invention, **QUINN-DEX**. Quinn-Dex is a simple, hand-operated moving-picture device, which enables you to see, right before your eyes, every movement of my hands at the keyboard. You actually see the fingers move. Instead of having to reproduce your teacher's finger movements from **MEMORY**—which cannot be always accurate—you have the correct models before you during every minute of practice. The **COLOROTONE** and **QUINN-DEX** save you months of wasted effort. They can be obtained **only from me**, and there is nothing else, anywhere, even remotely like them.

Men and women who have failed by other methods have quickly and easily attained success when studying with me. In all **essential** ways you are in closer touch with me than if you were studying by the oral method—yet my lessons cost you only 43 cents each—and they include all the many recent developments in scientific teaching. For the student of moderate means, this method of studying is **far superior** to all others; and even for the wealthiest student there is nothing **better** at any price.

You may be certain that your progress is at all times in accord with the best musical thought of the present day, and **this makes all the difference in the world**.

My course is endorsed by distinguished musicians, who would not recommend any course that did not maintain the highest musical standards. It is for beginners or experienced players, old or young. You advance as rapidly or as slowly as you wish. All necessary music is supplied without extra charge. A diploma is granted. Write today, without cost or obligation, for 64-page free booklet, "How to Learn Piano or Organ."

**MARCUS LUCIUS QUINN
CONSERVATORY OF MUSIC**

Studio PM-42, 598 Columbia Road
BOSTON, 25, MASS.



DR. QUINN AT HIS PIANO

From the Famous Sketch by Schneider, Exhibited at the St. Louis Exposition.



-----**FREE BOOK COUPON**-----

QUINN CONSERVATORY, Studio PM-42,
598 Columbia Road, Boston, 25, Mass.

Please send me, without cost or obligation, your free booklet, "How to Learn Piano or Organ," and full particulars of your Course and special reduced Tuition Offer.

Name.....

Address.....



I'LL SHOW YOU HOW TO GET A JOB YOU CAN'T LOSE!

Every newspaper in the country is full of stories about men being thrown out of work. We are facing a period of depression which many say will lead to "soup kitchens and bread lines." Already in New York State tens of thousands of people are idle. "At the present rate," says the Daily News Record, "there will soon be two workers for each job." In Philadelphia in one line of business alone 40,000 employees were dropped. In New England mills and factories have closed or are running on part time. In the South, with cotton selling at low prices, wages are being cut and factories are closing in every section. In Detroit it is reported that the automobile plants laid off 100,000. In Akron the tire companies are running only part of their capacity. In every city in the country, from Coast to Coast, people are working part time, or looking for work or accepting radical reductions in wages.

How Soon Will You Be Out of Work?

Are you going to wait until YOU are out of work before insuring yourself against loss of income—or are you going to get a job NOW that you cannot lose? That kind of a job is—working for Uncle Sam in any of the numerous branches of the Civil Service. According to Federal Law you cannot be fired or laid off for any religious, personal or political reason. Hard times do not affect the government employe. There are no strikes or lockouts. Your pay comes regularly all year round. You can COUNT exactly on what you will get. Increases are rapid in position and salary.

Let Me Train You for a Job With Uncle Sam

Uncle Sam is careful about his employes. You must pass a Civil Service Examination before you are accepted. There are certain things you MUST know. It is my business to PREPARE you for the examination so you can pass successfully. For eight years I was a Civil Service Secretary-Examiner, so I am perhaps the best qualified man in the country to coach you. I guarantee to coach you until you succeed in GETTING A POSITION.

\$1600 to \$2300 a Year

NO STRIKES--NO LAYOFFS--NO LOCKOUTS

Figure your earnings for the past year and if you are an average man you didn't get as much as the average government employe! That is due to strikes, lockouts, slack work, layoffs—none of which can happen to Civil Service employes. They get \$1600 to \$2300 a year to start and they get it. Other positions in the government service pay as high as \$3000 to \$10,000 a year! Hours are easy—eight or less a day. Vacation every year with full pay, work at home or travel, or work in Washington or at Panama Canal.

Get My Free Book

Patterson Civil Service School,

Arthur R. Patterson,
Principal

82 Wisner Bldg., Rochester, N. Y.

Please send me your free book about Government positions.

Name

Address

City.....State.....

If you are an American citizen 18 years old or more you are eligible to a Government Civil Service Position, and if you have a common ordinary 4th grade education as a foundation I want you to have a copy of my splendid fully illustrated book telling how I can help you to secure a position with the U. S. Government, in the Railway Mail Post Office, Rural Carrier, Departmental, Internal Revenue, Immigration, Customs House or Postmaster Services (send in the coupon today or just a postal card).

Arthur R. Patterson,
Principal, Patterson
Civil Service School
Dept. 82 Wisner
Building,
ROCHESTER, N. Y.

LEARN The BUSINESS of Advertising



QUICKLY BY MAIL

We guarantee to teach you. It's easy to learn—and easy to get into! Make them start *this week*. This free book tells how.

\$75 to \$100 a Week

—frequently paid beginners. There is *no limit* to opportunities which men and women trained in advertising meet on every hand.

FREE This interesting book on advertising is sent free. Tells just the things you want to know about getting into this fascinating field. Full of facts.

PAGE-DAVIS SCHOOL, Dept. A14, Page Bldg., Chicago



NAVIGATION TAUGHT BY MAIL

Hundreds of Ship Officers needed in Merchant Marine and Navy. Salaries up to \$412 monthly and living expenses. You can qualify through Captain Warren Sheppard's Home Study Course on Navigation. Chance of a lifetime to see the world as a ship's officer at a big salary. Write for free Book, "Your Future is on the Seven Seas."

World Technical Institute, Dept. 100A, Fuller Building, Jersey City, N. J.



Be a
Taxidermy
Artist

Marvelous Book Sent FREE

You can now learn Taxidermy, the wonderful art of mounting birds, animals, tanning skins, etc. Learn at home, by mail. The free book tells how. Mount your own trophies. Decorate home and den. Hunters, trappers, nature lovers, you need taxidermy. Interesting, fascinating, big profits. Join our school. 55,000 students. Success guaranteed. Get our free book without delay. Send right now—today.

N. W. School of Taxidermy, 1772 Elwood Bldg., Omaha, Neb.

PALATIAL FLORIDA HOME

THE finest estate in that part of Florida, situated amid five acres of orange, grape fruit, sweet bay, palmetto and a large variety of semi-tropical trees and foliage. A water front of 400 feet, with entrance from a Boulevard, in a community of 30,000, affording every modern convenience. House recently completed and never occupied. Has every modern improvement, large sun parlors, sleeping porches and eight bath rooms. Inexhaustible supply of absolutely soft water; steam heat, high, light basement under entire house. This is one of the best built houses in the entire state of Florida. Surf bathing all winter within 5 minutes walk.

For full details, photographs and price, address

E. H. PECK

S. OSGOOD PELL & COMPANY
17 West 44th Street New York City

What the Old Timer said to Charley

by
C.L. Hardy



“ONLY a few years ago, Charley, the man whose name you see on that door was just where you are today.

“I remember the day he came to work for us. He didn't know much about the business. But he was always asking questions—always anxious to learn.

“And by and by we got to noticing that Billy Stevens was getting ahead of some of us old fellows who had been around here for years.

“I can remember as clearly as though it were yesterday, the day Billy showed old Tom Harvey how to figure out the pitch of some new bevel gears we were making on an important contract.

“Tom told me afterward how respectful Billy was—nothing fresh, or ‘I know it all’ about him. He just made a suggestion and showed Tom a quicker way to start the problem and a shorter, surer way to finish it.

“One day I said to him—‘Where'd you get hep to all that fancy figuring, Bill?’ We were eating lunch and he was reading some little book he always carried. He looked up at me and said innocently: ‘Oh, I just picked it up!’ I knew different than that, so I quizzed him until he told me the whole story.

“‘Did you ever notice the old men around the shop,’ he asked—‘the men with families who drudge along day in and day out—never getting anywhere?’ I admitted that I had noticed quite a lot of them.

“‘Well,’ he said ‘I made up my mind I wasn't going to spend my whole life in a humdrum job at small wages. So I took a home-study course with the International Correspondence Schools that would give me special training for this business.

“‘I tell you frankly that I never dreamed it would be so fascinating and so helpful in my work. I'm making mighty good money—twice as much as formerly—and I'm going to have even a bigger job around here some day.’

“Well, Charley, that boy went straight on up. The members of the firm heard about his studying in his spare time and encouraged him to keep on. You see where he is today.

“And I—I'm still plugging along at the same old job—struggling to make both ends meet. I had just as good a chance as Billy Stevens, but I let it slip by. Yes, I let it slip by.

“Now, Charley, you've got to want your training bad enough to go get it. That's as far as I can help you; you've got to do the rest yourself.

“I've seen a lot of young men come into this business. Those who went ahead were always those who trained themselves for the job ahead. You can do the same thing.

“Start now! It will take only a moment to sign and mail that coupon. It doesn't obligate you in any way. But it's the most important thing you can do today. Some day I know that you will come to me and thank me for what I'm telling you.”

TEAR OUT HERE

INTERNATIONAL CORRESPONDENCE SCHOOLS
BOX 5598-C SCRANTON, PA.

Without cost or obligation please explain how I can qualify for the position, or in the subject before which I have marked an X in the list below:

- | | |
|---|---|
| <input type="checkbox"/> ELECTRICAL ENGINEER | <input type="checkbox"/> BUSINESS MANAGEM'T |
| <input type="checkbox"/> Electric Lighting & Railways | <input type="checkbox"/> SALESMANSHIP |
| <input type="checkbox"/> Electric Wiring | <input type="checkbox"/> ADVERTISING |
| <input type="checkbox"/> Telegraph Engineer | <input type="checkbox"/> Show Card & Sign Ptg. |
| <input type="checkbox"/> Telephone Work | <input type="checkbox"/> Railroad Positions |
| <input type="checkbox"/> MECHANICAL ENGINEER | <input type="checkbox"/> ILLUSTRATING |
| <input type="checkbox"/> Mechanical Draftsman | <input type="checkbox"/> Cartooning |
| <input type="checkbox"/> Machine Shop Practice | <input type="checkbox"/> Private Secretary |
| <input type="checkbox"/> Toolmaker | <input type="checkbox"/> Business Correspondent |
| <input type="checkbox"/> Gas Engine Operating | <input type="checkbox"/> BOOKKEEPER |
| <input type="checkbox"/> CIVIL ENGINEER | <input type="checkbox"/> Stenographer & Typist |
| <input type="checkbox"/> Surveying and Mapping | <input type="checkbox"/> Certified Public Accountant |
| <input type="checkbox"/> MINE FOREMAN or ENG'R | <input type="checkbox"/> TRAFFIC MANAGER |
| <input type="checkbox"/> STATIONARY ENGINEER | <input type="checkbox"/> Railway Accountant |
| <input type="checkbox"/> Marine Engineer | <input type="checkbox"/> Commercial Law |
| <input type="checkbox"/> ARCHITECT | <input type="checkbox"/> GOOD ENGLISH |
| <input type="checkbox"/> Contractor and Builder | <input type="checkbox"/> Common School Subjects |
| <input type="checkbox"/> Architectural Draftsman | <input type="checkbox"/> CIVIL SERVICE |
| <input type="checkbox"/> Concrete Builder | <input type="checkbox"/> Railway Mail Clerk |
| <input type="checkbox"/> Structural Engineer | <input type="checkbox"/> AUTOMOBILES |
| <input type="checkbox"/> PLUMBING & HEATING | <input type="checkbox"/> Mathematics |
| <input type="checkbox"/> Sheet Metal Worker | <input type="checkbox"/> Navigation |
| <input type="checkbox"/> Textile Overseer or Supt. | <input type="checkbox"/> AGRICULTURE |
| <input type="checkbox"/> CHEMIST | <input type="checkbox"/> Poultry Raising <input type="checkbox"/> Spanish |
| <input type="checkbox"/> Pharmacy | <input type="checkbox"/> BANKING <input type="checkbox"/> Teacher |

Name.....

Street and No.....

City..... State.....

Occupation.....

7-1-21

From FARMHAND to EXPERT DRAFTSMAN

in less than a Year

How this Man hit the trail to Success



Edw. C. Berger

"It is certainly more enjoyable to be doing interesting work in a comfortable Drafting Room at a good salary than to be working at hard labor on a ranch under all kinds of difficulty. I was an ordinary ranch laborer with all the prospects of remaining the same. I had nothing to back me except my bare hands and physical strength. I had not even attended any of the public schools, but had picked up what I knew a little at a time. Then one evening in March, 1919, I saw an advertisement of the COLUMBIA SCHOOL OF DRAFTING in Popular Mechanics and after investigation I believed that school could help me to find the success which I wanted. So I enrolled. The result I hardly need to tell about. After completing my course in Drafting eight months later, I secured an excellent position as Professional Draftsman. Later I secured a still better position with a large firm where I am still employed. I have not met a problem I could not handle, although I have been assigned to regular work found in any Drafting Room. I did not even have to be 'broken in' as is the case with other Draftsmen. A noticeable thing that speaks well for the preparation which

Get Our Interesting Booklet

- If you are ambitious to succeed, fill out and mail us the accompanying coupon NOW. You will receive an interesting booklet "Your Future in Drafting" which tells you
- How YOU can become a professional Draftsman at home through COLUMBIA training in 5 to 10 months, without losing any time from your present occupation and without any special ability or talent.
- How you are furnished with the complete, highest-grade Draftsman's equipment for use in your training and after you get your position in a Drafting Room.
- How COLUMBIA serves YOU—personally—and actually helps you get into a real Drafting position at an expert's pay when qualified.
- How you can "earn while you learn" and how many have earned the price of COLUMBIA training many times over before completing it.
- What Drafting really is and how it leads to even bigger paying positions.
- Why manufacturing concerns and employers of Draftsmen in general recognize COLUMBIA trained men as the kind they want and must have.

How you will have the personal attention, service, and instruction of Roy C. Claflin,

an experienced Draftsman, the Founder, President

and Owner of the COLUMBIA SCHOOL OF DRAFTING. How and why YOU, like Berger, will be happy that you selected COLUMBIA as your stepping stone to the success which YOU want.

MAIL COUPON TODAY

Fill out carefully the accompanying coupon or send your name and address to the

COLUMBIA SCHOOL OF DRAFTING
 ROY C. CLAFLIN, President
 Dept. 1629, Cor. 14th & T Sts. WASHINGTON, D. C.

Dept. 1629 COLUMBIA SCHOOL OF DRAFTING,
 Roy C. Claflin, President.

Dear Sirs: Please send me, absolutely without charge, or obligation to me, your booklet "Your Future in Drafting," together with your rates and full particulars on COLUMBIA TRAINING.

Name

Street Address

City and State

your training has given me is that nearly every one in our company has suffered wage cuts from 15% to 25%—while my pay has remained unchanged!



That, I regard as a 'raise.'

"I have a number of friends who have been watching my progress as a Draftsman. First they thought it 'wouldn't last long'—NOW they say I'm of an 'unusual type' and would succeed anyway! But I KNOW it is the training of the COLUMBIA SCHOOL OF DRAFTING that caused my change in life and lifted me to success.

"COLUMBIA has helped me to greater things than I at first thought, and I will 'boost' it every chance I get."

Thus writes Edward C. Berger, who, located on the Pacific Coast, took the practical training of the COLUMBIA SCHOOL OF DRAFTING entirely by correspondence in eight months with absolutely no previous knowledge of the subject.

You, Too, Can Succeed

Are YOU less equipped to start than Berger? Haven't YOU the same ambition to get away from the routine grind of life and enter a work that is interesting, uplifting and more profitable? Do YOU not want to be successful and more independent? COLUMBIA gives to YOU also this same opportunity. It has helped thousands just like you!

The Time to Act Is Now

Don't put it off another day. It means too much to you. Get into the class of successful men like the other COLUMBIA graduates. The quicker you start the sooner will you realize the benefits of an increased earning power. ACT NOW.

Your First Step

Your first step is to "investigate" the COLUMBIA SCHOOL OF DRAFTING, like Berger did, by writing in for full information.

ENGINEERS JUST OUT A \$10,000 MASTER SET ON LATEST ENGINEERING



AUDEL'S ENGINEERS & MECHANICS GUIDES \$12^{COMPLETE}

\$1 4750 PAGES—8754 ILLUSTRATIONS—POCKET SIZE—FLEXIBLE

Every Engineer, Mechanic and Electrical Worker will welcome this "New Eight Master Set." It will prove to be a sure source of advancement and higher pay. Contain complete, up-to-date information that is thoroughly and easily explained on every branch of Modern Engineering and Electrical Practice. These new Engineers' and Mechanics' Guides answer your problems. They will help you with your daily work.

THESE BOOKS TELL YOU ALL ABOUT—

ALL Steam, UNIFLOW and POPPET VALVE ENGINES, LOCOMOBILES, Locomotive and Marine Engines; Turbines, Rotary Engines—The Indicator—Lubrication—PRACTICAL MANAGEMENT, GAS, GAS ENGINES—Aeroplanes and Aviation—Rules and Formulae. Steam Boilers; Heat-Combustion; Fuel and Flue Gas Analysis—CO₂ Recorders—Boiler Construction, Mechanical Stokers—Oil Burners—Setting—Chimneys—Mechanical Draught—BOILER DESIGN, Pipes, Fittings, Heating and Ventilation—Refrigeration—Cooling Towers—Condensers—Distilling Apparatus—Elevators—Cranes—Ropes and Cables—Splicing—Practical Electrical Engineering, covering entire field of Modern Electricity.

SHIPPED TO YOU FREE Not a cent to pay until you see the books. No obligation to pay unless you are satisfied. Send coupon now—today—and get this new Master Set for Engineers and Mechanics and see if it is not worth \$100 to you. Pay only \$1 a month.

SEND NO MONEY—SEND ONLY THIS COUPON
 THEO. AUDEL & CO., 72 Fifth Ave., New York City, New York
 Please submit me for Free Examination. Audel's New Eight Master Set for Engineers and Mechanics. If satisfactory I agree to send you \$1 monthly in seven days, and to further mail you \$1 each month until \$12 is paid.

Name.....
 Occupation.....
 Employed by.....
 Home Address.....
 Reference.....
 P. M.
 Feb. 24

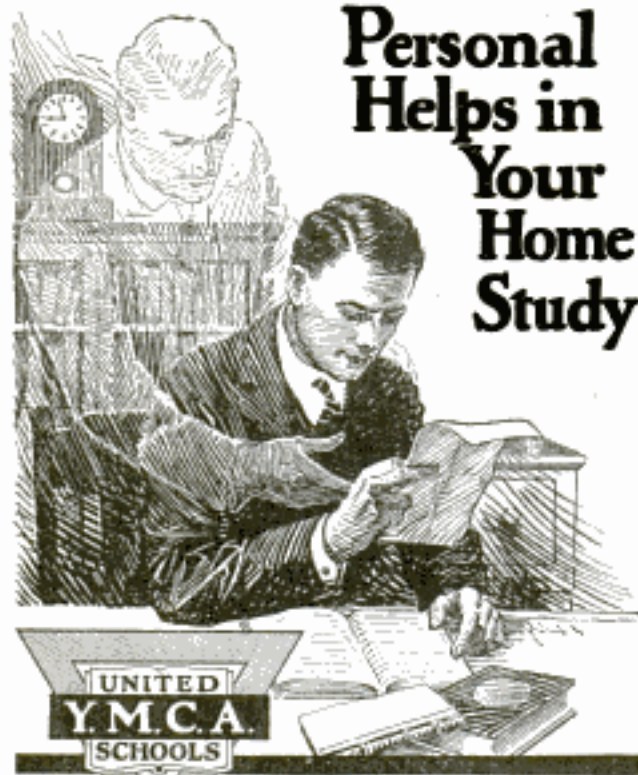

Personal Helps in Your Home Study

UNITED
Y.M.C.A.
SCHOOLS

A student in a Middle Western State writes:

"I am enthusiastic about your Accounting Course. It is the best arranged and most practical I have seen. The service you give in correcting papers and the personal attention and individual interest shown are as fine as any organization can offer."

This is only one of hundreds of letters of appreciation of the unique instruction methods of the United Y. M. C. A. Schools, which are the development of 25 years of successful experience in training men by the individual method.

Nothing is more important in correspondence instruction than the help of a friendly, competent instructor who deals with you as a real person, writing to you frequently in aiding you to solve your problems.

This kind of service is available to you, no matter where you live, or how special your needs may be, and at a surprisingly moderate cost.

There are five other good reasons why you should enroll in the United Y. M. C. A. Schools for your home-study course and learn how to get "the most service for the least money."

Mark and mail the coupon for these reasons and other interesting details. Our counsel is free.

UNITED Y. M. C. A. SCHOOLS Dept. 2-F, 375 Lexington Ave., New York City

I am interested in the position or home-study course I have marked. Please give full information.

- | | |
|------------------------|------------------------|
| —Accountant | —Farm Management |
| —Advertising Man | —Farm Motor Mechanics |
| —Agricultural Courses | —Foreign Languages |
| —Applied Psychology | —Foremanship |
| —Architect | —Freehand Drawing |
| —Auto Mechanic | —Highway Engineering |
| —Banking | —Illustrator |
| —Better Letters | —Locomotive Operation |
| —Bookkeeper | —Machine-Shop Practice |
| —Building Construction | —Mathematical Courses |
| —Business English | —Mechanical Engineer |
| —Business Law | —Plumber |
| —Business Organization | —Poultry Husbandry |
| —Chemistry | —Radio Operator |
| —Civil Engineer | —Railroad Engineering |
| —Civil Service | —Salesman |
| —Commercial Spanish | —Secretarial |
| —Concrete Engineer | —Steam Engineer |
| —Dairy Farming | —Stenographer |
| —Draftsman | —Structural Drafting |
| —Electrician | —Surveyor |
| —Electrical Engineer | —Tool Designing |
| —English Courses | —Traffic Management |
| —Factory Management | —Use of the Slide Rule |

Name and Occupation _____
Please Write Plainly

Complete Address _____

COMMERCE ^{calls for} SPEED
FLYING IS ^{the} ANSWER

LEARN TO FLY

in Chicago with
**RALPH C. DIGGINS SCHOOL
of AERONAUTICS**

Scores of graduates from our flying school are filling big-paying positions. Splendid opportunities for competent pilots are opening everywhere. Your chance is now! Get into this newest, fascinating, best paid profession.

Prepare NOW!

You can prepare now for spring and summer flying classes. Take our home study Special Extension Course, the most modern and practical course ever given, prepared by our experts right on our flying field. This course gives you thorough training in air navigation, flying, aeroplanes, motors, instruments, theory of flight, etc. Contains only what you must know to be a successful pilot. Gives you big start over the others in learning to fly a machine when you reach our field.

Easy terms. Write NOW for full information.

**THE RALPH C. DIGGINS SCHOOL
of AERONAUTICS**
Dept. 301, 140 N. Dearborn St., Chicago, Ill.



Does Your Wife Dress to Suit You?

Do her clothes and hats look worth the money paid for them?

Every woman, or girl 15 or over, can easily, in 10 weeks' time, learn to Design and Make her own Dresses and Hats

DRESS DESIGNERS FREQUENTLY Get \$2,000 to \$10,000 a Year

Students often start parlors in their homes and make big money.

Surprise your wife, daughter or sweetheart. Sign her name and address to the coupon and send to us for free SAMPLE LESSONS from the course selected.

A Dance Dress, made of metal lace with scarlet velvet bodice.
Shop Price \$75.00
ACTUAL COST TO MAKE
4½ yds. lace at \$4.00 \$18.00
1½ yds. velvet at \$4.00 4.50
Ornament 1.50
Findings 1.25
Cost to make \$25.25

On this gown our course will save your wife

\$49.75

Franklin Institute
Dept. W-641
Rochester, N. Y.
Kindly send to the address below, absolutely free, book containing sample lessons in Dress and Costume Designing, Dress Making and Cost Making, or Millinery Designing. * Taught in 10 weeks spare time.

Dress Designing Millinery Designing

Name _____

Address _____

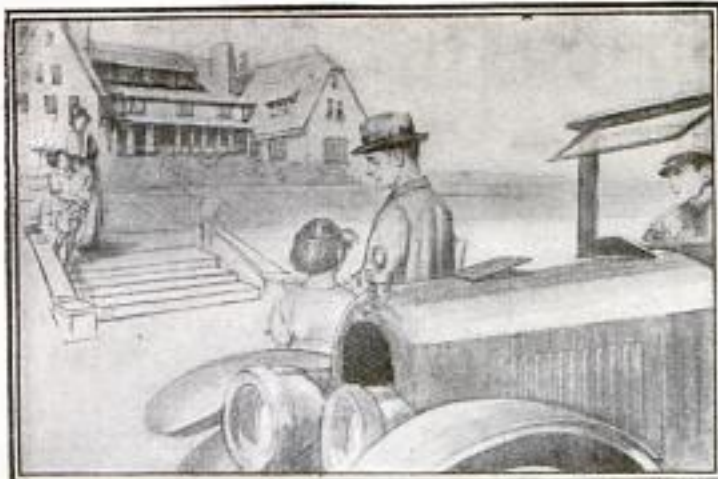

At thirty-three he was the head of a promising little business of his own

At thirty-five he was back again at a job; a cog in a big machine



Will you be one of the 38.2%?

FIVE years ago a man of thirty took his savings, and the savings of some of his friends, and embarked in business for himself. He was honest, industrious and attractive; there seemed to be every reason why he should succeed.

To-day, at thirty-five, he is filling a departmental position in a big concern—a position no better than the one he left five years ago.

What happened to his business that promised so much? Fraud? No. Lack of capital? Not primarily. Neglect? Not at all.

The trouble was with the training of the man. He was an expert salesman but he knew absolutely nothing of the other phases of business.

The failures the Institute could prevent

HE could sell goods, but he was wholly ignorant of factory and office organization and control. Costs and accounting were a foreign language to him; transportation, advertising, corporation finance—he made mistakes in every one of them, and each mistake cost him money.

He belonged to the 38.2% of business failures whom Bradstreet groups under the tragic head: "Incompetence."

It is these failures—and those due from "inexperience" and lack of capital (which is merely another word for bad judgment) that the Alexander Hamilton Institute can prevent.

For its Modern Business Course and Service is designed to round out a man; not to make him a better specialist in the single department he already knows, but to give him a working knowledge of all other departments.

That is why so large a proportion of the thousands of Institute men have stepped from mere positions into busi-

Here are the Reasons Why Men Fail

as reported by Bradstreet

Cause	Percentage
*Incompetence	38.2%
*Inexperience	5.6
*Lack of capital	39.3
*Unwise credits	1.3
*Fraud	7.0
Failures of others	1.7
Extravagance	1.1
Neglect	1.7
Competition	1.1
Specific conditions	11.3
Speculation	.7
Total	100.0%

*These are the needless failures that a well-rounded business training would prevent.

Lack of training in the fundamentals which underlie all business makes men incompetent; leaves them ignorant of the experience of others; rates them as poor risks for capital; blinds them to the ordinary safeguards of credit extension; and exposes them to all the frauds which prey on business ignorance.

nesses of their own, and have achieved unusual success.

Will you work all your life in a routine job?

YOU may never have thought of it in this way but you are paying for the training of the Alexander Hamilton Institute whether you accept it or not.

If you do accept it, the cost is a little investment in money and time. But who can figure what the cost of indecision and delay may be?

Suppose tomorrow an opportunity comes in your present organization for a trained and self-confident man to step up

into the class of executives? Or suppose some day you, with your savings and experience, start a business of your own.

Most men look forward to such a day—the day they will be made executives or go into business for themselves. It is the beginning of real independence. Will you be equipped when that day comes?

"Forging Ahead in Business"

THE Institute has helped thousands of men to shorten their path to independence. It makes no special argument; it asks only for an opportunity to lay the full facts before thoughtful men for their consideration and decision. The facts are gathered into a book of 120 pages entitled "Forging Ahead in Business."

It explains the Modern Business Course and Service in full, and tells just what it has done for other men in positions similar to yours. Any thoughtful man may have a copy on request, and without obligation. For your convenience we attach a coupon, and suggest that you fill it in now.

Alexander Hamilton Institute
374 Aster Place, New York City



Send me "Forging Ahead in Business" which I may keep without obligation.

Name.....

Print here

Business Address.....

Business Position.....

Canadian Address, C. P. R. Building, Toronto; Australian Address, 42 Hunter St., Sydney

An Easy, Fascinating Way to Learn CHEMISTRY AT HOME



BECAUSE of conditions which grew out of the war, there never was a time in the history of America when chemists were in such demand as now.

Good salaries await the right men. No work is more interesting—no other profession offers greater opportunities.

For 30 years the International Correspondence Schools have been training men in just your circumstance for success in Chemistry and over 300 other subjects. They will help you prepare right at home for a position in the line of chemical work you like best—or in any other work that appeals to you. Thousands of men have stepped into fine jobs through I. C. S. training.

Let the I. C. S. help you, too. Choose the work you like best in the coupon below, then mark and mail it today. This doesn't obligate you in the least, and it will bring you the full story of what the I. C. S. can do for you.

TEAR OUT HERE

INTERNATIONAL CORRESPONDENCE SCHOOLS
Box 5600-C, Scranton, Pa.

Without cost or obligation, please send me complete information about the subject before which I have placed an X in the list below:

- | | |
|---|--|
| <input type="checkbox"/> CHEMISTRY | <input type="checkbox"/> ADVERTISING |
| <input type="checkbox"/> DRAFTING | <input type="checkbox"/> Salesmanship |
| <input type="checkbox"/> Mechanical Engineering | <input type="checkbox"/> BOOKKEEPING |
| <input type="checkbox"/> Civil Engineering | <input type="checkbox"/> Civil Service |
| <input type="checkbox"/> ARCHITECTURE | <input type="checkbox"/> Railway Mail Service |
| <input type="checkbox"/> Electrical Engineering | <input type="checkbox"/> Pharmacist |
| <input type="checkbox"/> Stationary Engineering | <input type="checkbox"/> Traffic Manager |
| <input type="checkbox"/> SURVEYING | <input type="checkbox"/> Business Management |
| <input type="checkbox"/> Automobiles | <input type="checkbox"/> Certified Public Accountant |
| <input type="checkbox"/> STENOGRAPHY | <input type="checkbox"/> Airplane Engines |

Name.....

Address.....

Occupation.....

Please Mention Popular Mechanics

MONEY IN POULTRY



Do you know how to MAKE MONEY from poultry? How to get most fall and winter eggs? How to hatch and brood strong, healthy chicks *successfully*? We can show YOU—Positively. Our officers are nationally known poultry authorities and our course the **ONLY** poultry correspondence course indorsed by the leading agricultural colleges. Send TODAY for new FREE book, "How to Raise Poultry for Profit."



THE NATIONAL POULTRY INSTITUTE
Dept. 312 Washington, D. C.

Let Me train You in AVIATION



Capt. G. F. Campbell
formerly Third Ace of the
Royal Flying Corps.

want you to take up this work. Positions are going begging because there are not enough trained men to fill them. Let me train you for these big positions. I know the game for I have been flying for years. I urge you to begin now to take a **HOME COURSE IN AVIATION** in your spare time. **GET OUT OF THE RUT.** Send today for our FREE BOOK, and I will write you a personal letter when it goes to you. I will give you some "inside" expert advice about how to get into this great industry. You'll join me!

Capt. G. F. Campbell, Chief Instructor
NATIONAL AERO INSTITUTE
Dept. 1192 916 S. Michigan Ave. Chicago



HOW TO BECOME A PROFESSIONAL PHOTOGRAPHER

Earning \$35 to \$125 a Week

An interesting illustrated booklet (free) on choosing a vocation, the exceptional opportunities Photography offers you and how to avail yourself of these advantages.

Motion Picture—Commercial—Portraiture

Three to six months' course. Practical instruction. Modern equipment. Day or evening classes. Easy terms. Call or write for Catalog No. 49.

N. Y. INSTITUTE OF PHOTOGRAPHY
141 W. 36th St., N. Y. or 505 State St., Brooklyn

Our Scientific Method will stop that STAMMER!

Send for free 200 page book. It tells how to permanently stop stammering or stuttering in a few weeks' time. A natural guaranteed method.

The Lewis School for Stammerers
32 Lewis Bldg., 71-77 Adelaide St., Detroit, Mich.



200 Kinds Iron, Wood and Wire PUZZLES

One of our leaders and illustrated folder, postpaid 10 cents. Ask for one difficult if desired.
WESTERN PUZZLE WORKS, St. Paul, Minn.



LEARN JIU-JITSU

Know how to protect yourself and your loved ones against a bully or a villain. Muscle and weight are helpless before this marvelous science. Anyone can master it easily. Complete instructions in book outlined

JUDO (Improved)

by Sakurao Yokoyama, Professor of Jiu-Jitsu in the Kodokwan leading athletic university in Japan. 200 pages. Illustrated with 80 actual photos. **Special Reduced Price Only \$2.00, Postpaid.** (Same edition originally sold for \$5). Money cheerfully refunded within 3 days if not entirely satisfactory.

RICHARD PRICE MILLER
Dept. A, 120 1/2 So. Broadway Los Angeles, Cal.

Will ship C. O. D. anywhere in U. S. A. if desired.



An Amazingly Easy Way to Earn \$10,000 a Year

Let Me Show You How FREE

TO the average man the \$10,000 a year job is only a dream. Yet today there are a surprising number of men earning five figure salaries who were merely dreaming of them a short while ago. The secret of their success should prove a startling revelation to every ambitious man who has ever aspired to get into the \$10,000-a-year class.

There is nothing "different" about the man whose salary runs into five figures. He is made of the same stuff as you and I. For example, take J. P. Overstreet, of Dallas, Texas. A few short years ago he was a police officer earning less than \$1,000 a year. Today his earnings are in excess of \$1,000 a month—more than \$12,000 a year. C. W. Campbell, Greensburg, Pa., was formerly a railroad employe on a small salary—last month his earnings were \$1,562.

Why Don't YOU Get into the Selling Field?

Read These Amazing Stories of Success

Earned \$524 in Two Weeks

I had never earned more than \$50 a month. Last week I cleared \$506 and this week \$215. You have done wonders for me. Geo. W. Kearns, 107 W. Park Place, Oklahoma City, Okla.

Now Earn as High as \$100 a Day

I took your course two years ago. Was earning \$15 a week clerking. Am now selling many of the largest firms in the U. S. I have earned more than \$100 in a day. You secured me my position. Our Sales Manager is a graduate of yours.—J. L. DeBolis, 4615 Warwick Avenue, Chicago, Ill.

Earns \$1,562 in Thirty Days

My earnings for the past thirty days are \$1,562.00 and I won Second Prize in March although I only worked two weeks during that month.—C. W. Campbell, Greensburg, Pa.

Earned \$1,800 in Six Weeks

My earnings for March were over \$1,000 and over \$1,800 for the last six weeks, while last week my earnings were \$350.00. I travel eleven months out of the year, working 5 days each week. The N. S. T. A. dug me out of a rut where I was earning less than \$1,000 a year and showed me how to make a success.—J. P. Overstreet, Dallas, Texas.

Mr. Overstreet, Mr. Campbell, and the others whose letters you see on this page, are all successful salesmen. They have stepped into the \$10,000-a-year class—and they never sold goods before! It is hard to believe that such big success could come so quickly and easily. Yet it was all amazingly simple! Ask them the secret of their sudden success. They will tell you they owe it to the National Salesmen's Training Association. This is an organization of top-notch salesmen and sales managers formed expressly for the purpose of training men to sell and helping them to good selling positions. It has taken hundreds of men from all walks of life and made them Master Salesmen—it has lifted them out of the rut and shown them the way to magnificent earnings, to fascinating careers and big selling positions.

We Train You and Help You Land a Job

What these men have done, you can do! In your spare time at home you can easily master the secrets of selling that make Star Salesmen. Whatever your experience has been—whatever you may be doing now—whether or not you think you can sell—just answer this question: Are you ambitious to earn \$10,000 a year? Then send me your name quick! I will prove to you without cost or obligation that you can easily become a Star Salesman. I will show you how the Salesmanship Training and Free Employment Service of the N. S. T. A. will help you to wonderful success in Selling.

Free Book on Salesmanship

Just mail the coupon or write for our great illustrated book, "A Knight of the Grip," which we will send you free. Let us prove to you that regardless of what you are doing now you can quickly become a Star Salesman. Let us show you how you, too, can step into the ranks of the big money makers of business. See how easily you can learn this fascinating, big pay profession at home in your spare time. Learn what we have done for others and what we stand ready to do for you. Don't put it off until tomorrow—write us today. Mail the coupon at once.

National Salesmen's Training Association
Dept. 12-B, Monadnock Bldg. Chicago, Ill.

National Salesmen's Training Association
Dept. 12-B, Monadnock Bldg. Chicago, Ill.

Please send me, without any obligation on my part, your free book, "A Knight of the Grip," and full information about the N. S. T. A. system of Salesmanship Training and Employment Service. Also a list showing lines of business with openings for salesmen.

Name

Street

City State

SWEENEY

I PAY YOUR RAILROAD

This Is
"E. J."



Learn a Trade and Get A Good Job

I know that there is a great future for every man who will take my advice as thousands of others have. The only question is, **Are You Mechanically Inclined?** If you are, then **TODAY IS YOUR OPPORTUNITY.** No matter what you are doing—what you have been doing—I am sure that the Automotive Business offers you bigger—better—more prosperous future. I want to see you grasp your big opportunity right now—and remember its the trained man that gets the big paying jobs.

I Will Pay Railway Fare to Kansas City

My Big Announcement this Season. You can come to this great Trade School at no more expense than if it were located in your home town, for I am rebating fares from any point in the United States to the Sweeney School. No advance in tuition. No extras. Just a fair, square rebate. No matter where you live this brings the Sweeney Million-Dollar Trade School to your door.

Thousands upon thousands of young men thought as you have been thinking about **MECHANICAL TRAINING** and they answered my advertisement, got my big Free Catalog, came here, learned the business and today, in all parts of the country **ARE MAKING GOOD.** I can give you hundreds of letters from these men that relate circumstances and hopes so like your own that you will be amazed.

Begin Right That's what I want to impress upon every man who sees the great future in the Automotive business. **COME TO SWEENEY'S**—the School of practical Experience. Sweeney Graduates are in every part of the U. S. and in foreign countries—over 46,000 of them—and they are loyal Sweeney boosters. They are proud of **THEIR SCHOOL**—their success in business is creating demand for thousands of Trained Mechanics and they look to the **OLD SCHOOL** for these men. Hundreds of letters come to my desk—these boys of mine write me personally—They want **SWEENEY GRADUATES**—every day—every week brings more openings. Again I say **START RIGHT**—come direct to the **SWEENEY SCHOOL**—and in 8 short weeks you will have a Sweeney Diploma—it commands recognition for you. Don't delay—send for my **BIG FREE BOOK** today—I want to tell you of my **Big New Special Offer**—this is in addition to my Free Railway Fare offer—it's the greatest offer that I have ever made.

EMORY J. SWEENEY, President.



LEARN A TRADE
Sweeney
SCHOOL OF AUTO-TRACTOR-AVIATION
984 SWEENEY BLDG. KANSAS CITY, MO.

SEE SWEENEY DOUBLE-PAGE AD ON THE TWO PAGES PRECEDING TEXT

SCHOOL

FARE TO KANSAS CITY

Pick the Job You Like

Chauffeurs	\$90 to \$150
Truck Driver	\$125
Tire Vulcanizer	\$100 to \$200
Welders	\$140 to \$200
Battery Man	\$150 to \$200
Auto Mechanics	\$6.00 to \$10 a day
Auto Electricians	\$225
Tractor Engineers	\$10 a day
Garage Manager	\$150 to \$400
Demonstrator and Salesman	\$150 to \$500

Hundreds of Openings for Men

SWEENEY trained men are in demand everywhere at good wages, **\$50 a week and more**, from garages, tire shops, welding concerns, auto repair shops, etc. **HERE'S THE PROOF:**

South Dakota wires: "Will pay most any price for a good man. Send him right away." Neck City, Mo., says: "Put us in touch with a first-class repair man. Excellent opening." Indiana says: "Want one more Sweeney man for my new garage. Steady work at good prices." Kansas appeals: "Send me man who understands Ford Car from A to Z. Will pay top wages." Mississippi telegraphs: "Want a post graduate mechanic. Will pay all he is worth. Wire at my expense." Florida calls: "Want head mechanic. Will pay \$50 a week. Let me hear by return mail." **Thousands of Sweeney graduates now owning their own business** in various parts of the country **naturally favor Sweeney trained men.** Sweeney loyalty is wonderful. Our daily mail is conclusive proof that the trained man with the SWEENEY diploma can secure jobs like these at **\$50 a week and more.**

The Sweeney System

THE SWEENEY SYSTEM, famous the world over, can be had only in the Sweeney School. It trains men to be mechanics by practical work. You learn by doing—no books—you do the actual work. The course takes only 8 weeks. No place in the world can you get so much real instruction—so much actual value, for so little money. If you are in earnest, there is a real job looking for you. Write me today—don't put it off—I've got some information that will open your eyes—but you must take the first step—Write for my Big Free Book.

My Big Special Offer I am offering to pay your railway fare from any point in the U. S. I have another offer—a bigger offer to make you—an offer greater than I ever made before—Mail the coupon today.

Send for My Big Free Catalog Now

GET INTO THE FASTEST GROWING BUSINESS IN AMERICA AND MAKE BIG MONEY. Thousands of good jobs go begging. There is over a quarter million dollars more invested in the Automotive business than the entire capitalization of all our National Banks. This is a business you are interested in—now is the time to make a start—reconstruction in the Automobile business is well under way—factories are getting back on full time—we're just on the eve of greater opportunities in the Automotive business than ever. Trained men—expert mechanics will be in demand as never before—they are in demand today—the SWEENEY SCHOOL stands as a great monument to thousands of successes—thousands of men who came to the Sweeney School and today are known as successful men in the business world. You can do what these men have done. The big paying jobs are open to you and This Million Dollar Trade School is now placed right at your door—no matter where you live in the U. S., for I am paying your railway fare.

Free

I will gladly send my 72-page illustrated catalog **FREE.** Also a free copy of Sweeney School News, a most interesting monthly school paper, published here. You will enjoy them. Read the worth-while stories of men like yourself who came to Sweeney's and found success. Read how Frank Powell and Harry Wilson built up a \$20,000 business in about two years after graduating. Read how Elbert A. Pence built up a \$25,000 yearly garage business at Clearmont, Mo. These stories and many more are told by the Sweeney students. Also I want you to learn how my students enjoy themselves after work in the swimming pool, the club and reading rooms, etc.

Send today for this free catalog. Get my big, new, special offer. See page after page of mechanical pictures. Read what students say. Note the latest ideas in auto work. Hundreds of illustrations. Learn about the jobs open—the actual present opportunities in the business for Sweeney men. **DO IT NOW**

Yours very truly,

EMORY J. SWEENEY,
President.

Mail the Coupon Today

DO
IT
NOW



For Big Free Catalog Mail This Coupon.

EMORY J. SWEENEY, President
Dept. 984, Sweeney Bldg., Kansas City, Mo.

Please send me free without any obligation on my part, your 72-page catalog and your Sweeney School News. Tell me of the opportunities in the Auto and Tractor Business.

Name.....

P. O.....State.....

SEE SWEENEY DOUBLE-PAGE AD ON THE TWO PAGES PRECEDING TEXT

This Complete Drawing Outfit **FREE**

You can have this complete Drawing Outfit absolutely free. It has everything needed:—A drawing board, "T" square rule, French curve, protractor, triangles, triangular boxwood scale, erasing shield, drawing ink, pencils, erasers, paper, etc. The coupon will bring you information as to how you can get this splendid outfit free.

Earn \$50.00 to \$100.00 a Week

There are few professions that offer greater possibilities than that of the expert draftsman. If you want to get into a line of work that is uncrowded—where the job will seek you—where you will earn \$50.00 a week or more, then here is your chance. Become a trained draftsman.

Thousands of Jobs Are Open

for the trained draftsman. Right now, while a great number of men of other lines of work are out of work you won't find the trained draftsman hunting for a job. The demand for men in this line far exceeds the supply. Take advantage of that fact, and without quitting your present job, in your spare time, get the preparation that will fit you for this profitable profession. **YOU NEED NO PREVIOUS TRAINING.** An hour or two after supper is all the time you need and in a few months you will have mastered this interesting job.

Our Free Employment Service

will assist you in placing yourself to the best advantage in this well-paying profession. Our improved system of practical instruction has reduced the method of becoming efficient in this work to a very simple process. It will help you to cash in quickly on your natural ability.

Don't Turn This Page Until You Have Made Up Your Mind to find out all about our free offer to you. The coupon will bring full information and our free book. Send for it today—*right now.*

AMERICAN SCHOOL

Drexel Avenue & 58th Street Dept. D-274 Chicago, U. S. A.

TEAR HERE

AMERICAN SCHOOL, Dept. D-274 Drexel Ave., & 58th St., Chicago, U. S. A.

Please send me particulars on how I can get the Drawing Outfit Free and explain how I can get the job checked. This request is to put me under no obligation.

- | | | |
|---|---|---|
| <input type="checkbox"/> Machine Drawing and Design | <input type="checkbox"/> Surveying and Topographical Drafting | <input type="checkbox"/> Structural Drafting |
| <input type="checkbox"/> Architectural Design | <input type="checkbox"/> Sheet Metal Pattern Drafting | <input type="checkbox"/> Sanitary Drafting and Estimating |

Name.....Address.....



Learn

In the Great Shops of COYNE

Electricity Will Pay You \$150 to \$400 a Month

Only the trained man gets the big pay. Make up your mind to be one. And get your training in the best paying of all the professions—Electricity. You can learn Electricity in the Great shops of Coyne in 3½ months. Then you can go out and command from \$150 to \$400. These are not exceptional figures. Thousands of our men earn even more in businesses of their own—as Electrical Contractors, as Auto-electricians in Garages and Service Stations, as Armature Winders, Electrical Supply Dealers and as Battery Experts.

When you graduate from Coyne in 98 days you can enter any of more than a dozen lines of work—power house operating, telephony, railway signal work, house wiring, electric sign work, motor maintenance, automobile and battery work, street railway service, etc., and earn big money and quick advancement.

EARN WHILE YOU LEARN

You don't need to wait until you have saved up all the money you need to get this Electrical education. Our Welfare Department will help you get a part-time job at which you can earn money to help pay your way.

Auto Truck and Tractor Course Included

If you enroll within a limited time you can get the full course in Automobile, Truck and Tractor Electricity without paying a cent above the cost of the Practical Electrical Engineering course. This is the finest course in America. The equipment is complete in every detail, and you get your instruction under experts in this branch of electricity. This training opens the way to get into a big paying business of your own—you learn wiring, ignition, lighting and starting systems of all cars, trucks and tractors. You learn how to make and repair batteries. You can open a battery service station and look after the repair and maintenance of auto electrical systems.

The field is Nation-wide and there is wonderful opportunity for big earnings. Write for full particulars. You will want to reserve the right to get this course free.

GET YOUR
LETTER OFF
TONIGHT

Bennett W. Cooke,
President,
Coyne Trade and
Engineering Schools
Dept. 12, 39-51 E. Illinois
St., Chicago, Illinois

Gentlemen: Send me your big free catalog with full particulars concerning your Electrical course and how I may secure your course of Automobile, Truck and Tractor Electricity and the course in Business Management, free. This places me under no obligation whatsoever.

Name.....
Address.....

We
Teach You
How to Manage
a Business of Your
Own—

We want every one of our graduates to succeed. If you enroll within a limited time, we will give you, free, a full course in Business Management. You take this course at the same time you take the others. You learn how to manage a business and to make money out of it.

Get Started Now— Learn Electricity. Make big money. Be somebody. Make good and get real pleasure and satisfaction out of life. Own your own car and home and be independent. You can do it. It's easy, if you get the right start. Filling in the coupon tonight starts you right. If you never do anything you'll never get anywhere. Will you?

BENNETT WELLINGTON COOKE, President

Coyne Trade and Engineering Schools
Dept. 12 39-51 East Illinois Street Chicago, Ill.

Electricity

Send Coupon Now!

Do You Like to Draw?

Here Is a Simple, Easy Way
to Draw a Comic Face

TRY IT



Make a square with pencil, then add to it with pencil as shown in the small squares above. Erase all pencil guide lines after the drawing is completed.

We will not give you any "grand prize," if you draw this picture. Nor will we claim to make you "rich in a week." But if you are anxious to develop your talent with a **successful cartoonist**, so you can **make money**, send a copy of this picture with six cents in stamps for portfolio of cartoons and sample lesson plate, and let us explain more in detail. Some of the **most successful cartoonists** are former students of this school. It is not hard to learn to draw **originals** when you are shown how in a **practical way**.



THE W. L. EVANS SCHOOL OF CARTOONING
"The School That Has the Reputation"
821 Leader Bldg. CLEVELAND, OHIO

The Technical or Scientific Book You Need

Turn to our 96-page catalog and find just the book you need on any scientific or practical subject—the latest book by the best author. This is the most complete catalog of its kind issued. You'll refer to it constantly in your work. Only 380 copies remain.

With the catalog will be sent the supplements for 1919 and 1920 and new 32-page book list for 1921. Prices are not yet entirely stabilized, but those in the supplements will be 80% correct. If there is any change in price you will be notified before your order is filled.

Send for catalog to-day. It's free. There will be no obligation for you to buy, and we want you to know our extensive book department.

Scientific American Publishing Company
Munn & Company
237 Broadway, New York City

Factory to Rider

Saves \$15 to \$25 on the model you select from 44 Styles, colors and sizes of **Ranger** bicycles. Delivered free on approval, *express prepaid*, direct from the makers for **30 Days' Free Trial**. We pay return charges if not satisfactory.

12 Months to Pay Possession at once on our liberal year-to-pay plan. Any boy or girl can save the small monthly payments.

Tires wheels, chains, parts and equipment at half usual prices. **Big Ranger Catalog** FREE with marvelous new prices, 30 day trial offer and terms.

MEAD CYCLE COMPANY
Dept. A-108, Chicago, Ill.



What 15c Will bring You From the

Nation's Capital

The little matter of **15 cts.** (coin or stamps) will bring you the **Pathfinder 13 weeks on trial**. The **Pathfinder** is a cheerful illustrated weekly, published at the Nation's center for people everywhere; an independent home paper that tells the story of the world's news in an interesting, understandable way. Now in its 28th year. This splendid National weekly supplies a long-felt want; it costs but \$1 a year. If you want to know what is going on in the world, this is your best means. If you want a paper in your home which is reliable and wholesome; if you would appreciate a paper which puts everything clearly, strongly, entertainingly, briefly—here it is. Splendid serial and short stories and miscellany. The Question Box answers YOUR questions and is a mine of information. Send **15 cts.** to show that you might like such a paper and we will send the **Pathfinder** on probation **13 weeks**. The 15 cents does not repay us, but we are glad to invest in new friends. Address: **The Pathfinder, 599 Langdon Sta., Washington, D. C.**

HOW TO PAINT SIGNS AND SHO' CARDS

Our book gives a complete course of instructions, enabling any one to learn to paint good signs. **WHY NOT MAKE YOUR OWN** either for your business or for others?

CONTENTS: Alphabets, Composition, Color Combinations, How to Mix Paints, Show Cards, Window Signs, Banners, Board and Wall Signs, Ready Made Letters, Gilding, Commercial Art and Tricks of the Trade—Contains 100 alphabets and designs. Cloth bound, size 7 x 5 inches, price **\$1.00 postpaid**.

J. S. Ogilvie Pub. Co., 577 Rose St., New York

STAMMER

If you stammer attend no stammering school till you get my large FREE book entitled "STAMMERING, Its Origin and the Advanced Natural Method of Cure," bound in cloth and stamped in pure gold. Ask for special illustration and a FREE copy of "The Natural Speech Magazine." Largest, best equipped and most successful school in the world for the cure of stammering, stuttering, etc. No sing-song or time beat. Write today. The North-Western School, 2317 Grand Ave., Milwaukee, Wis.

Copyrighted material



WANTED MEN—AT ONCE

To Become Automotive Electrical Experts

The Greatest Opportunity to Make Big Money and
Get Into Business That Men of All Ages Ever Faced

WHILE many are unable to find work of the sort anyone can do, the automotive industries are short of help in the trained electrical field. The pity of it is, the needed knowledge could be learned in a season!

For driving a tractor \$25 is a fair week's pay. For knowing how that tractor is ignited, fired and wired, a man is often paid \$25 a day!

What truck driver, or even mechanic, draws \$500 a month? Yet men who lay-out and inspect ignition and lighting systems make that and more.

Now Is the Time

In auto factories; branches, service shops; where tractors are made; in airplane work; with motorcycle and speed boat makers; around lighting-plant shops; you can practically pick your job, or own your own repair shop. And there is an easy way to get experience you need.



Why, the headlight laws alone—different in every state—means big pay for those who learn the *mechanical* requirements and how to con-



form auto lights to the regulations. Start now.

How Anyone Can Qualify

You can master this profitable line in three months! Not by digging it out of books; not by a long distance correspondence course, but *where the work is being done*. In your overalls. Doing it *yourself*. At the shops where 800 trained experts were turned out last year.

You will then know what a "troubleshooter," inspector, foreman must know. The mysteries of the "electric line" will be an open book.

While the demand is so strong, a famous resident school of electricity will make a special low tuition rate, and start new classes every few days; put you to work on the same things that ninety days later you'll be working at for money.



Act Immediately!

Send *now* for free book of facts and photographs. Explains all. Whether you are only 18, or past fifty, investigate this opportunity

If you are a *self-starter*, do not wait, but *come to Milwaukee*; we'll find you a room and have you in the thick of the work the day you arrive.

SCHOOL OF AUTOMOTIVE ELECTRICITY,
Division of School of Engineering,
415 Marshall Street, Milwaukee, Wis. (318)
Please send your FREE 48-page book telling
all about your 90-day course in Automotive
Electricity, without obligating me in any way.

Name.....
Address.....
City.....State.....



High School Course in Two Years!

You Want to Earn Big Money!

And you will not be satisfied unless you earn steady promotion. But are you prepared for the job ahead of you? Do you measure up to the standard that insures success? For a more responsible position a fairly good education is necessary. To write a sensible business letter, to prepare estimates, to figure cost and to compute interest, you must have a certain amount of preparation. All this you must be able to do before you will earn promotion.

Many business houses hire no men whose general knowledge is not equal to a high school course. Why? Because big business refuses to burden itself with men who are barred from promotion by the lack of elementary education.

Can You Qualify for a Better Position?

We have a plan whereby you can. We can give you a complete but simplified high school course in two years, giving you all the essentials that form the foundation of practical business. It will prepare you to hold your own where competition is keen and exacting. Do not doubt your ability, but make up your mind to it and you will soon have the requirements that will bring you success and big money. YOU CAN DO IT.

Let us show you how to get on the road to success. It will not cost you a single working hour. We are so sure of being able to help you that we will cheerfully return to you, at the end of ten lessons, every cent you sent us if you are not absolutely satisfied. What fairer offer can we make you? Write today. It costs you nothing but a stamp.

AMERICAN SCHOOL

Dept. H-274, Drexel Ave. and 58th St., Chicago

AMERICAN SCHOOL

AMERICAN SCHOOL

Dept. H-274 Drexel Ave. and 58th St., Chicago

Explain how I can qualify for position checked:

... Architect	\$5,000 to \$15,000	... Lawyer	\$5,000 to \$15,000
... Building Contractor	\$5,000 to \$10,000	... Mechanical Engineer	\$4,000 to \$10,000
... Automobile Engineer	\$4,000 to \$10,000	... Shop Superintendent	\$3,000 to \$7,000
... Automobile Repairman	\$2,500 to \$4,000	... Employment Manager	\$4,000 to \$10,000
... Civil Engineer	\$5,000 to \$15,000	... Steam Engineer	\$2,000 to \$4,000
... Structural Engineer	\$4,000 to \$10,000	... Foreman's Course	\$2,000 to \$4,000
... Business Manager	\$5,000 to \$15,000	... Sanitary Engineer	\$2,000 to \$5,000
... Certified Public Accountant	\$1,000 to \$15,000	... Telephone Engineer	\$2,500 to \$5,000
... Accountant and Auditor	\$2,000 to \$7,000	... Telegraph Engineer	\$2,500 to \$5,000
... Draftsman and Designer	\$2,500 to \$4,000	... High School Graduate	In two years
... Electrical Engineer	\$4,000 to \$10,000	... Fire Insurance Expert	\$5,000 to \$10,000
... General Education	In one year.		

Name..... Address.....

SPANISH LEARNED EASILY AND QUICKLY!

Also FRENCH and ITALIAN

Another language will enable you to make more money—whether you are an employer or employee, professional man or woman, boy or girl. A Few Spare Minutes Can Increase Your Income Learning a new language by the Rosenthal Language Phone Method, is as easy as learning a new tune. Study when you are in the mood—in the comfort of your own home—on your own phonograph. Soon, you can talk, read and write Spanish, French or Italian.

ROSENTHAL LANGUAGE PHONE METHOD

makes rapid progress possible

Any number of people can learn at the same time—the whole family or groups of friends.

FREE 64-Page Book. It shows how easy, interesting, and profitable it is to learn a foreign language; and explains Dr. Rosenthal's world-famous method of quick study. Also details of FREE Trial offer. Send a postal—*to-day*.

FUNK & WAGNALLS COMPANY
549 Hess Building, 354 Fourth Ave., N. Y.



Music Lessons

UNDER MASTER TEACHERS

At Home

A Complete Conservatory Course By Mail

Wonderful home study music lessons under great American and European teachers. Endorsed by Paderewski. Master teachers guide and coach you. Lessons a marvel of simplicity and completeness.

Any Instrument Write telling us course you are interested in—Piano, Harmony, Voice, Public School Music, Violin, Cornet, Mandolin, Guitar, Banjo or Reed Organ—and we will send our FREE CATALOG with details of course you want. Send NOW.

University Extension Conservatory, 494 Siegel-Myers Bldg., Chicago, Ill.

ELECTRICAL ENGINEERING men with training are in demand. For more than a quarter of a century this school has been training men of ambition and limited time, for the electrical industries. Condensed course in Electrical ENGINEERING enables graduates to secure good positions

and promotions. Theoretical and practical Electricity, Mathematics, Steam and Gas Engines, Mechanical Drawing. Students construct dynamos, install wiring and test electrical machinery. Course with diploma, complete



Thoroughly equipped fireproof dormitories, dining hall, laboratories, shops. Over 3000 men trained. Write for catalog. 30th year opens Sept. 27, 1922.

BLISS ELECTRICAL SCHOOL

104 YAKOMA AVENUE, WASHINGTON, D. C.

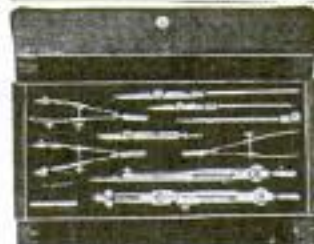

\$26.90 Value Set **Mechanical Drawing Instruments**

Special Wholesale

Price \$6.65 Postpaid

Pocket case 4x8 1/2 inches—velvet lined— instruments constructed of solid nickel silver and steel—guaranteed. Order now—supply limited. Free illustrated particulars.

NATIONAL INSTRUMENT CO.

4704 N. Hamilton Avenue, Chicago, Ill.

TELEGRAPHY

(Morse and Wireless) and RAILWAY ACCOUNTING taught thoroughly. Big salaries; great opportunities. Oldest, largest school. Endorsed by Telegraph, Railway, Radio, and Government officials. Expenses low—opportunities to earn large portion. Catalog free.

DODGE'S INSTITUTE, Dyke Street, Valparaiso, Ind.

LEARN WATCH REPAIRING

Be a watchmaker—you can learn this profitable trade by correspondence in a few weeks in your own home by the DeSelms Chart System. After you complete the course you will know a watch from A to Z. You will know just what the matter is and how to repair one. When you graduate you will be a practical watchmaker and repairer and competent to fill any position. Positions for our graduates.

Ask for our Free Book. It explains our system and terms.

THE DeSELMS WATCH SCHOOL
23 Perry Street ATTICA, INDIANA



The Other Day I Was Watching Two Fellows Exercising in a Gymnasium—

One was straining desperately to do the same feats of strength his companions were accomplishing, but his efforts were in vain. He did not have the physique and his methods were entirely wrong. Close by was a fine robust man whose every muscle smoothly rippled as he went through his exercising as though it were child's play. Being a great admirer of strong men and proper training methods, I introduced myself to this second man and asked where he had learned the knack of muscular contraction. He grabbed my hand and exclaimed: "Why, Mr. Liederman, I'm mighty glad to meet you. I'm one of your pupils." He turned out to be Arthur Lawrence, one of New York's well known strong men.

Only One of Many Hardly a week passes that I do not hear of such cases. It would take many volumes to contain the thousands of letters which stream into my office commending my system. Self praise means nothing so I leave it to my pupils to publish my achievements. They are my best arguments that the Liederman progressive system is the sure road to perfect "Muscular Development."

The Answer Is Simple Why did these two men work side by side with such opposite results? One apparently worked harder than the other but he burned up his vitality and destroyed his body, while the other had learned the science of muscular contraction, which not only brings a rapid increase in the development of muscle, but makes it possible to accomplish double the results with the same amount of development. This is the secret of my own success. After years of scientific study and application, I discovered the true basis of muscular development and applied it to my own body. The result was astounding. Just imagine a system that would do twice the work of any other in less than half the time. It is this very system that I am now imparting to others. My pupils are now among the leaders in both the athletic and business world. One recently was given a single prize of \$1,000 in a contest for the most perfect man, while many are living a life of ease through the money they receive by teaching others.

Don't Delay "He who hesitates is lost"—Save yourself from a life of misery and despair. Let this day be the start of a new life and a bigger one. Success is knocking at your door. Do not turn her away for she has big things in store for you: Strength, health and happiness. The man who succeeds is the one who obeys that impulse.

The 8th Edition of My Latest Book! "MUSCULAR DEVELOPMENT"

is just off the press. It tells the secret, and is handsomely illustrated with 26 full page photographs of myself and some of the world's best athletes whom I have trained, also full particulars of my splendid offer to you. The valuable book and special offer will be sent to you upon receipt of only 10 cents, to cover cost of wrapping and mailing.

Sit right down now and fill in the coupon. The sooner you get started on the road to health and strength the easier it will be to reach perfect manhood. Don't drag along one day longer—MAIL THE COUPON TODAY.

EARLE E. LIEDERMAN
Dept. 2002, 305 Broadway, New York City



EARLE E. LIEDERMAN

EARLE E. LIEDERMAN,
Dept. 2002, 305 Broadway, New York City

Dear Sir:—I enclose herewith 10 cents, for which you are to send me, without any obligation on my part whatever, a copy of your latest book, "Muscular Development." (Please write or print plainly.)

Name.....

Address.....

City..... State.....

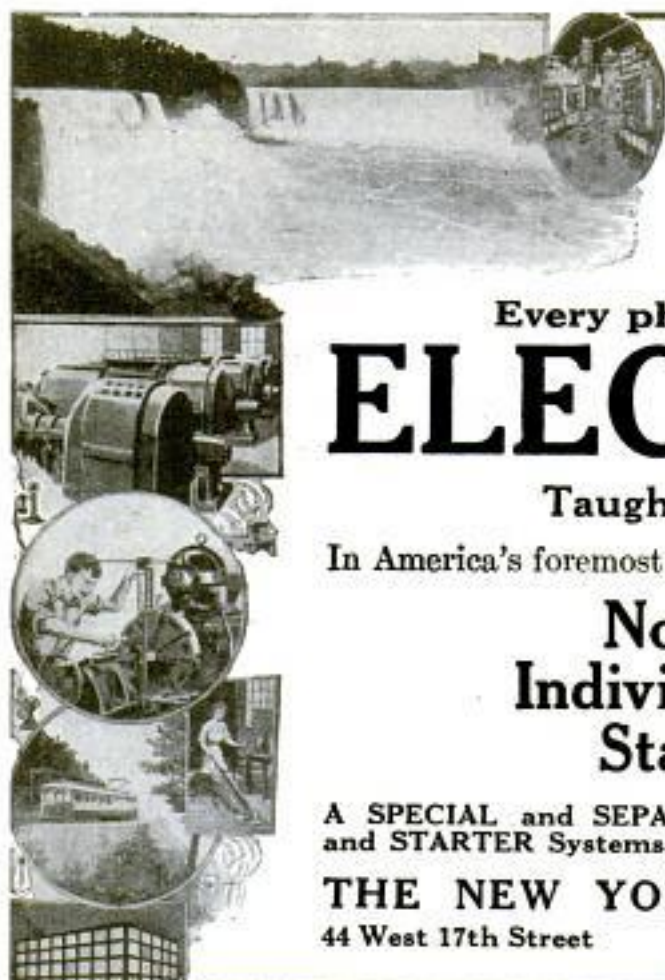

LEARN BY DOING

Every phase of all branches of ELECTRICITY

Taught by Actual Practice

In America's foremost and oldest institution for trade training.

No Books Used
Individual Instruction
Start Any Day

A SPECIAL and SEPARATE Course in Ignition, Auto Lighting and STARTER Systems. Write for FREE 64-page catalog.

THE NEW YORK ELECTRICAL SCHOOL
44 West 17th Street
NEW YORK CITY

WRITE NOW FOR Dyke's FREE Booklet

ANew OF TEACHING tells how you can learn at home—spare time—and **Become an Auto Expert** on repairing and electrical systems. **WITH DYKE'S WORKING MODELS** CHARTS, MANIKINS, ETC.

DYKE'S SCHOOL OF MOTORING, Box 300 Granite Bldg., St. Louis, Mo.
A department of the Firm: A. L. Dyke, Publisher. Original and only system of its kind. Endorsed by leading motor authorities of the world.

PIANO JAZZ

By note or ear. With or without music. Short Course. Adult beginners taught by mail. No teacher required. Self-Instruction Course for Advanced Pianists. Learn 67 styles of Bass, 180 Syncopated Effects, Blue Harmony, Oriental, Chime, Movie and Cafe Jazz, Trick Endings Clever Breaks, Space Fillers, Sax Slurs, Triple Bass, Wicked Harmony, Blue Obligato, and 247 other Subjects, including Ear Playing. 110 pages of REAL JAZZ, 25,000 words. A Postal brings our FREE Special Offer. Waterman Piano School, 259 Superba Theatre Bldg., Los Angeles, Calif.

"THERE'S MONEY IN IT"

AT HOME LEARN TELEGRAPHY AT HOME

MORSE AND WIRELESS

TEACH YOURSELF in half usual time, at trifling cost, with the wonderful Automatic Transmitter **THE OMNIGRAPH**. Sends unlimited Morse or Continental messages, at any speed, just as an expert operator would. Adopted by U. S. Government, and leading Universities, Colleges and Telegraph Schools. 3 styles. Catalog free.

OMNIGRAPH MFG. CO.
26 D Cortlandt Street, NEW YORK

**\$95 to \$135
a Month**

Men—boys—over 17—should write at once
Rapid advancement. "No Lay-offs." **THE POSITION IS YOURS FOR LIFE.**

Common-sense education sufficient. Political influence NOT REQUIRED.

Write immediately for schedule showing the places and dates of ALL COMING Government Examinations. Don't delay.

FRANKLIN INSTITUTE, Dept. W177 Rochester, N. Y.

WANTED!



Franklin Institute, (The Pathway to Plenty), Dept. W177, Rochester, N. Y.

This coupon, filled out as directed, entitles the reader to free specimen questions, a free copy of our book, "Government Positions and How to Get Them," a list of Government positions now open, and to consideration for Free Coaching for the examination, here checked.

COUPON

.... Railway Mail Clerk (\$1600-\$2300) Postoffice Carrier (\$1400-\$1800)
.... Bookkeeper (\$1400-\$1800) Rural Mail Carrier (\$720-\$2600)
.... Postoffice Clerk (\$1400-\$1800) Customs Positions (\$1100-\$2000)

Name

Address

Use this before you lose it. Write plainly.



New Easy Way to Become An Artist

THIS wonderful new method makes it possible for *anyone* to learn Illustrating, Cartooning, or Commercial Art. Hundreds of our students are now making splendid incomes. And most of them never *touched* a drawing pencil before they studied with us.

The simplicity of this method will astound you. You will be amazed at your own rapid progress. You learn by mail—yet you receive **personal** instruction from one of America's foremost Commercial Artists. Get into this fascinating game **NOW**. You can easily qualify. A few minutes' study each day is all that is needed.

Crying Demand for Trained Artists

Newspapers, advertising agencies, magazines, business concerns—all are looking for men and women to handle their art work. There are hundreds of vacancies right this minute! A trained commercial artist can command almost any salary he wants. Cartoonists and designers are at a premium. Dozens of our students started work at a high salary. Many earn more than the cost of the course while they are learning! **YOU**—with a little spare-time study in your own home—can easily and quickly get one of these big-paying artists' jobs.

No Talent Needed

This amazing method has exploded the old idea that talent is an absolute necessity in art. Just as you have learned to write, this new method teaches you to draw. We start you with straight lines, then curves. Then you

learn how to put them together. Now you begin making pictures. Shading, action, perspective, and all the rest follow in their right order, until you are making pictures that bring you from \$50 to \$500 or more! Many artists get as high as \$1000 for a single drawing!

Write for Interesting Free Book

Mail coupon now for this interesting free book, "How to Become an Artist." Explains about this amazing method in detail. Tells of our students—and their wonderful progress—and how we can qualify you for a high-salaried artist's position. Also tells of our free artist's outfit to new students and special low offer to a limited number of new students. Mail coupon **NOW!**

Washington School of Art, Inc.

Room 1767, Marden Bldg., Washington, D. C.

FREE COUPON

WASHINGTON SCHOOL OF ART, Inc.

Room 1767, Marden Bldg., Washington, D. C.

Please send me, without cost or obligation on my part, your free book, "How to Become an Artist."

Name

State whether Mr., Mrs., or Miss.

Address

Learn to Write

GOOD hand-writing has been truly called the "Bread and butter of a business education." It should be the determination of every body to learn to write at least a good business hand. **Good writing is the very foundation of business success.**

Easy to Learn By my system you can become a good penman at home, in your own room during spare time. Don't be content with the notion that good penmen "are born" such. Because one's ancestors may have been noted for poor penmanship, is no excuse for him to remain an illegible scribbler. My system is original, unique, and highly successful—the result of 25 years' experience.

Your Spare Time Just your spare moments—that's all I ask. If you follow my instructions you will soon be able to write a beautiful hand that will be a source of pride to yourself and envy to your friends. Notice the improvement shown in Mr. Campbell's writing below.

Leland M. Campbell

"I am astonished at the improvement I've made by means of The Tamblin System in so short time."

LELAND M. CAMPBELL,
Campbelltown, Ohio.

Leland M. Campbell

Mr. Campbell wrote his upper signature July 20, and the lower one November 10—a little less than 4 months apart. Hundreds and hundreds of others in all parts of the world are doing as well with my system.

I have had unbounded success in making poor writers good ones and good writers better penmen than they thought possible.

32
PAGES
HIGHLY
ILLUSTRATED



FREE
BOOK
WRITE
FOR IT
TODAY

Penmanship is particularly adapted to correspondence instruction, and I absolutely guarantee satisfactory improvement. Distance no barrier. Ladies taught just as successfully as men.

Don't wait, don't delay, begin now to prepare for that position where good penmanship will be required. Send today for my **Free Book**, "How to Become a Good Penman," which contains copies and beautiful specimens and tells how others have become good penmen by means of the Tamblin System. Your name will be beautifully written on a card with white ink if you enclose stamp.

F. W. TAMBLYN,
418 Ridge Building,
Kansas City, Mo., U.S.A.

FREE BOOK COUPON

F. W. TAMBLYN, 418 Ridge Bldg., Kansas City, Mo., U.S.A.

I am interested in improving my penmanship. Please send me free your Book "How to Become a Good Penman."

Name

Address

Sign and mail this today, before you forget it.

Motor Car Mechanics for Beginners

105 Pages.
Cloth Bound.

Size 4½ x 6½ in.
Illustrated.

By **GORDON W. HAYTER** and
CLYDE H. PRATT, B. Sc., M. E.

The first and essential principles of motor car construction told in plain language, for the instruction of the amateur who would master this interesting and valuable subject. Written by experts and thoroughly reliable. Shipping weight 10 oz.

Price, postpaid \$1.00

The Art of Driving an Automobile

113 Pages.
Cloth Bound.

Size 4½ x 7 in.
Illustrated.

By **CLYDE H. PRATT, B. Sc., M. E.**

To insure the greatest pleasure and safety in driving a car, every person should read and consult this book, the work of a master authority who has personally taught the art to students from every state in the Union and from many foreign countries.

Price, postpaid \$1.00

Shrewsbury Publishing Co.

5525 West Lake Street,
Chicago, Ill.

Free to Writers!



A **WONDERFUL BOOK**—read about it! Tells how easily Stories and Plays are conceived, written, perfected, sold. How many who don't DREAM they can write, suddenly find it out. How the Scenario Kings and the Story Queens live and work. How bright men and women, without any special experience, learn to their own amazement that their simplest ideas may furnish brilliant plots for Plays and Stories. How one's own imagination may provide an endless gold-mine of ideas that bring Happy Success and Handsome Cash Royalties. How new writers get their names into print. How to tell if you ARE a writer. How to develop your "story fancy," weave clever word-pictures and unique, thrilling, realistic plots. How your friends may be your worst judges. How to avoid discouragement and the pitfalls of Failure. How to win! This surprising book is absolutely free. No charge. No obligation. Your copy is waiting for you. Write for it now. Just address **AUTHORS' PRESS, Dept. 65, AUBURN, NEW YORK**

HIGHER EDUCATION

**HOME
STUDY**

Courses in English, Spanish, Mathematics, Chemistry, Drawing, Education, Business and in 35 other subjects are given by correspondence. Begin any time.

The University of Chicago

30th Year

Division 4, Chicago, Ill.

LEARN WATCHMAKING AND ENGRAVING



Earn while learning. Most practical watch school. Individual instructions. Graduates in great demand. Book free. Chicago School of Watchmaking, Dept. 20, State-Lake Bldg., Chicago

LEARN PIANO TUNING

MAKING TRIALS
OF TRUE TONE

By
**TUNE-A-
PHONE**



We furnish our accurate teaching device with tools, Action Model lessons, and analysis of business advertising which makes you a master of the tuner's art. Diploma given graduates. 18 years' experience in teaching the most independent and lucrative profession by correspondence. **SIMPLER and BETTER than oral instruction.** Write today for FREE booklet and guarantee plan.

NILES BRYANT SCHOOL OF PIANO TUNING
22 Bryant Bldg. Augusta, Mich.



Knowing how
wins on
Pay Day

KNOWING HOW is the thing that puts the big pay in the pay-envelope. It's the thing that lifts men out of a poor-paying job into a man's size job with a man's size pay. *The man with the "know how" under his hat always wins out.* No matter what kind of work you are doing, or what you expect to do—you can learn more about that work and get more money for doing it. You don't have to go to school. Neither do you take any special training. One of these home study courses in book form gives you all the "know how" you need.

Some of the world's greatest experts prepared these books just to help ambitious men get ahead. They are written in plain, good old U. S. language that anyone can understand. No puzzling technical terms. Everything is explained. Thousands of pictures, plans, blueprints, diagrams, etc., in each set. Over 100,000 sets have been sold. Pick out a set in line with your ambition and send the FREE TRIAL coupon that brings the books without your sending any money in advance.

Pay-Raising BOOKS

SELECT FROM THIS LIST FOR FREE USE IN YOUR OWN HOME

Accountancy and Business Management, 7 vols., 2700 pages, 1900 pictures. Was \$52.50.....	Now \$29.80
Carpentry and Contracting, 5 volumes, 2135 pages, 1000 pictures. Was \$57.50.....	Now 24.80
Civil Engineering, 9 volumes, 3900 pages, 3000 pictures. Was \$67.50. Now	39.80
Electrical Engineering, 8 volumes, 4100 pages, 3300 pictures. Was \$60. Now	34.80
Employment Management and Safety Engineering, 7 volumes, 1800 pages, 540 illustrations, charts and diagrams. Prepares for Employment Manager. Price \$52.50.....	Special price 29.80
Automobile Engineering, 6 volumes, 2700 pages, 2000 pictures. Was \$45.00.....	Now 24.50
Machine Shop Practice, 6 vols., 2300 pages, 2500 pictures. Was \$45. Now	24.80
Steam and Gas Engineering, 7 vols., 3300 pages, 2500 pictures. Was \$52.50. Now	29.80
Law and Practice (with reading course), 12 volumes, 6000 pages, illustrated. Was \$97.50.....	Now 49.50
Fire Prevention and Insurance, 4 vols., 1500 pages, 600 pictures. Was \$30.00.....	Now 19.80
Telephony and Telegraphy, 4 vols., 1728 pages, 2000 pictures. Was \$30. Now	19.90
Sanitation, Heating and Ventilating, 4 vols., 1454 pages, 1400 pictures. Was \$30.00.....	Now 18.80
Drawing, 4 volumes, 1578 pages, 1000 pictures, blueprints, etc. Was \$30.00.....	Now 19.80

SPECIAL With each set of these books goes a one-year membership in our society. This entitles you to consult our engineers and experts on any subject connected with your work FREE. This membership usually sells for \$12.00.



This picture shows the Automobile Engineering Books, five volumes closed and one open. The bindings will last a lifetime.

AMERICAN TECHNICAL SOCIETY, Dept. X-192, Chicago

FREE Examination!

Don't send one penny. Just fill out the coupon and mail it. This will bring any set you select (the whole set, not a sample) by express collect. The books will be yours to use as you please for an entire week. You be the judge and decide whether or not they will do for you what they have done for thousands of other men. If you don't think they will help you, send them back at our expense and you won't owe a cent.

75 Cents a Week

Pay only \$2.80 within 1 week if you keep the books and send us \$1 each, month until the special reduced price is paid. This amounts to about 10 cents a day. Mail Coupon NOW. You'll be mighty glad you did when pay day comes round.

AMERICAN TECHNICAL SOCIETY, Dept. X-192, Chicago, U. S. A.

Please send me set of.....
for **7 DAYS'** examination, shipping charges collect. I will examine the books thoroughly and, if satisfied, will send \$2.80 within 7 days and \$3.00 each month until I have paid the special price of \$..... If I decide not to keep the books I will return them within a week at your expense.

Name.....

Address.....

Reference.....

Please fill out all lines.

Guaranteed!



Money Back Guarantee

WE guarantee that a course of training in this school, the Michigan State Auto School, will qualify you for a position as repair man, demonstrator, auto electrician, garage man, automobile dealer, tractor mechanic and operator, chauffeur or farm lighting expert; or refund your money. A similar guarantee is made with all courses. Each course includes Life Membership with privilege of our service without charge at any time.

A. G. ZELLER,
President and General Manager
MICHIGAN STATE
AUTO SCHOOL

Learn autos where they make them—under factory endorsed methods. Guaranteed head and hand training that fits you to make big money. That's the kind of training you want. That's the kind you will get at the M. S. A. S. (the Detroit Auto School). The first step is to mail the coupon—write, or send post card today.

Make \$200 to \$500 a Month

Pick Any Job You Want No previous experience necessary if you are mechanically inclined. Make a start—that's the thing! In a few short weeks, under guaranteed quality training, you can become a first-class, all-around, practical auto and tractor mechanic, capable of filling any garage job at bigger pay. Or, you can quickly become an Auto Electrician, and double your earnings. You can go into business for yourself—start a garage—electric service station—tire repair shop—battery station or welding shop. You can sell cars, trucks, tractors, farm-lighting systems or engines. It's a great business—a certain money-making future.

Learn in Detroit—the Auto Center

Who Knows Better How to Teach Autos than the Men Who Build Them?

Come to Detroit—choose the school in the heart of the industry. Here's where they are made. Isn't it logical that this is the best place to learn? Here a nickel car fare will take you to the great FORD plants, or the PACKARD, the CADILLAC, the HUDSON, ESSEX, HUPMOBILE, CHALMERS, PAIGE, STUDEBAKER, MAXWELL, LINCOLN, DODGE, or to more than two hundred and fifty accessory factories. No other place can give you the same opportunity for first-hand knowledge.

The courses of the M. S. A. S. (Detroit's Auto School) are outlined and planned with the assistance of the leaders of the Auto industry and endorsed by them. Manufacturers here, and everywhere, supply M. S. A. S. with equipment, latest model cars, latest trucks, engines, transmissions, axles, electric equipment, etc.—everything complete to give thorough training. Everything is right up to date—the very last word in automotive training.

You Can Succeed

Success is certain if you are willing to work for it. You can have independence—be your own boss—get into work you like. Earn big money, be prosperous, happy and independent. You can do it just as well, or better, perhaps, than Benn Koehler, Pulaski, Wis., who says:—"The M.S.A.S. receives all credit for my success, and made it possible for me to go into business from which we made \$10,000 in six months." Or C. F. Swanson, Sioux City, Iowa, who, after graduating from the M. S. A. S., went back and soon averaged \$500 a month repairing and selling autos.



Get Better Jobs

Detroit trained men get the best jobs—the highest pay wherever autos are used. The Michigan State Auto School is known the world over. Auto, truck, and tractor factories employ M. S. A. S. graduates. Leading factories, dealers, service stations, garages, shops, and farms want men who have trained their heads as well as their hands—the M. S. A. S. Detroit-kind. Decide now to give yourself the training that will pay you big, and establish you in a successful life work.

MICHIGAN STATE AUTO SCHOOL

"The Detroit Auto School"

The Factory Endorsed School

Auto & Tractor Training

Unlimited Opportunities for Trained Men

There is hardly any limit in wages for the experienced, trained men. The business is getting greater every year—more men wanted. 10 million autos, trucks, tractors now in use. All need repairing, overhauling—millions to be rebuilt. Motorists must economize—make their cars last twice as long. 50 million tires to be retreaded, put into longer use. Millions of batteries must be replaced. Right now this spells the greatest money-making opportunity in the world for ambitious, red-blooded, "go-getting" men.

Open a Shop of Your Own

Learn in a Few Weeks A thorough training is the thing that fills the pay envelope. You can take a full Automotive Course, or specialize in any one of its money-making branches. You can be an Auto Electrician; a Tire Expert; a Battery Service man; a Chauffeur; a Repair Man; a Welder; a Machinist; or specialize in motorized farming, with special truck, tractor, or farm electric-lighting and farm engine training.

Life Scholarship Your enrollment entitles you to life-membership, with privilege of our service any time you want it. Many students come back to brush up on latest automotive ideas and new equipment. It doesn't cost a penny extra. The position of the M. S. A. S. (the Detroit Auto School) in the heart of this industry, insures most thorough, most practical, systematic training, at a cost so low any man, anywhere, can afford it.

This 188-Page Catalog

Decide NOW that you can make more money. Decide NOW that you will forever discard the old, plodding, low-pay life and make a success! You can do it! It may mean hard work, but hard work is a pleasure when you like it and are making a success. Learn all the interesting facts about this unlimited opportunity. We will send you FREE, without obligation, this 188-page book that tells all about it, and what the M. S. A. S. can do for you. Book is positive proof. Don't fail to get it. Send coupon or post card today.

A. G. ZELLER, Pres. and Gen. Mgr.
302 Auto Bldg., 3729 Woodward Avenue
DETROIT, MICHIGAN



QUALITY FIRST

The M. S. A. S. is the ONLY factory outlined and factory endorsed course in the world.
Why? Because ours is the highest grade course where QUALITY comes first.

Read What Factories Say:

CADILLAC MOTOR CAR COMPANY DETROIT BRANCH

CADILLAC BUILDING CASS AVENUE AT YORK STREET

"We believe you have the best and most complete school of its kind in the country."



BUICK MOTOR COMPANY

"We believe the MICHIGAN STATE AUTO SCHOOL, Detroit, would best meet your requirements, as its course of technical training is most thorough and complete in every detail."

THE STUDERBAKER CORPORATION OF AMERICA

"We do not know of a better automobile school than the MICHIGAN STATE."



HUDSON MOTOR CAR COMPANY

DETROIT, MICH., U.S.A.

"This school is thought very highly of by the automobile men of Detroit, and is considered one of the best equipped and most efficient schools in the country. You will make no mistake in attending the M. S. A. S."

FREE

CATALOG
MICHIGAN STATE
AUTO SCHOOL

Mail Coupon To Day

MICHIGAN STATE AUTO SCHOOL
302 Auto Bldg., Detroit, Mich.

Gentlemen:—Send FREE and without obligation, your 188-page catalog, and Auto School News, giving complete information and showing the opportunities and advantages of a Detroit-Training to make the most money.

Name

Street or R. F. D.

City State

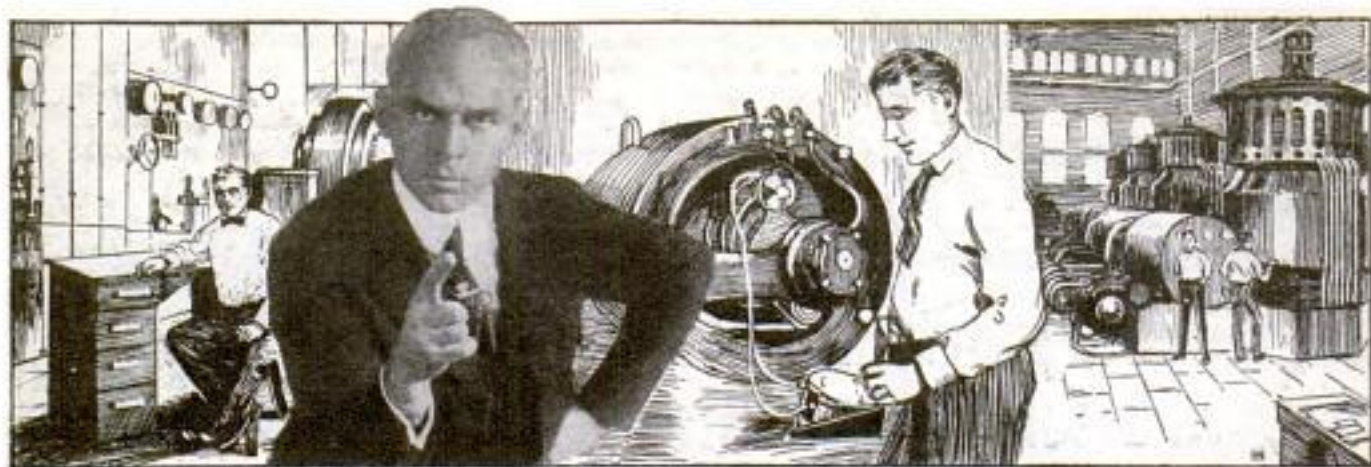

Electricity Needs You

I WILL TRAIN YOU AT HOME

Stop right here. This is YOUR opportunity! Electricity is calling you, and the Electrical Business is in for a tremendous increase. But it needs more trained men—at big pay. By my **Home Study Course in Practical Electricity** I can train you for these positions.

Earn \$70 to \$200 a Week

You've always had a liking for Electricity and a hankering to do electrical jobs. Now is the time to develop that talent; there's big money in it. Even if you don't know anything at all about Electricity you can quickly grasp it by my up-to-date, practical method of teaching. You will find it intensely interesting and highly profitable. I've trained and started hundreds of men in the Electrical Business, men who have made big successes. YOU CAN ALSO

Be a Big Paid ELECTRICAL EXPERT

What are you doing to prepare yourself for a real success? At the rate you are going where will you be in ten years from now? Have you the specialized training that will put you on the road to success? Have you ambition enough to **prepare** for success, and get it?

You have the ambition and I will give you the training, so **get busy**. I am offering you **success** and all that goes with it. Will you take it? I'll make you an **ELECTRICAL EXPERT**. I will train you as you should be trained. I will give you the benefit of my advice and 20 years of engineering experience and help you in every way to the biggest, possible success.

**CHIEF ENGINEER
COOKE**
Chicago Engineering
Works
Dept. 12, 2154 Lawrence Av.
CHICAGO, ILL.

Dear Sir: You may send me entirely free and fully prepaid, a copy of your book, "How to Become an Electrical Expert," and particulars about your **Home Study Course in Electricity**.

Name

Address

City State

Valuable Book Free

My book, "How to Become an Electrical Expert," has started many a man on the way to fortune. I will send a copy, free and prepaid, to every person answering this advertisement.

Act Now! Good intentions never get you anywhere.

It is action, alone, that counts. **NOW IS THE TIME TO ACT.**

L. L. COOKE, Chief Engineer

**CHICAGO
ENGINEERING
WORKS**

2154 LAWRENCE AVENUE
Dept. 12 Chicago, U. S. A.

FREE!

BIG ELECTRICAL OUTFIT

A fine outfit of Electrical Tools, Instruments, Materials, etc., absolutely FREE to every student. I will also send you FREE and fully prepaid—Proof Lessons to show you how easily you can learn Electricity and enter this splendid profession by my new, revised and original system of Training by Mail.

Free Use of Laboratory

I have a large splendidly equipped Electrical Laboratory where you can come at any time for special instruction without charge. Several competent assistants—practical Engineers—are in charge.

Earn Money While Learning

I give you something you can use **now**. Early in my **Home Study Course** I show you how to begin making money in Electricity, and help you get started. No need to wait until the whole course is completed. Hundreds of students have made several times the cost of their course in spare time work while learning.

CLASSIFIED ADVERTISEMENTS

WORLD'S BEST WANT AD MEDIUM

Advertisements in this section, 25 cents per word, each insertion, minimum 10 words, payable in advance. To be inserted under proper classification in March issue, copy should be in our office January 25th.

AUTOMOBILE SUPPLIES

AUTO Parts for any car. We save you 10 to 90% and ship same day order is received. Have gears, shafts, bearings, springs, pistons, pins and rings, bushings, cylinder-head gaskets, top slip roofs, clutch leathers, radiators, coils, magnetos, Atwater-Kent, Connecticut, Delco, Remy Ignition systems and parts. Radiators for Ford \$14.00, Chevrolet \$22.00. Chevrolet crankshaft \$13.00. Top roof recoverings Ford touring \$6.50. Ford roadster \$5.20. Send forty cents in stamps for one can quick tube repair outfit. Rex All Season Sedan-type tops seven-passenger Nash \$95.00. When you want auto parts write us, giving make model, and parts wanted. We have it, will get it, or it is not made. We guarantee to please you or will refund your money. Auto Tire & Parts Co., 501 Broadway, Cape Girardeau, Mo.

AUTOMOBILE and Motorcycle Tires and Tubes—Firestone! Goodyear! Fisk! Goodrich! All sizes, 50% off the list prices. Job lot of reclaimed army leather jerkins, shirts, breeches, gloves, at bargain prices. Agents wanted. Write for samples. Stern Brothers, 1519 2nd Ave., New York, N. Y.

WE pay \$8 a day taking orders for In-syde Tires. Guaranteed to prevent punctures and blowouts. Double tire mileage. Any tire. Tremendous demand. Low priced. Write quick for agency. American Accessories Co., B-278, Cincinnati, Ohio.

CHAMPION Automatic Carbon Scraper—\$1.85. Applied through spark-plug holes. Guaranteed. Send no money. Shipped on approval. Give make of car. Accessories Manufacturers, 2118 Northeast Grand, Minneapolis, Minn.

SAFE driving in rain or snow if windshield is wiped off with Kema Windshield Cloth. Send \$1.00. Address—Munyan & Myers, Dept. B, Fairton, N. J.

NEW Stop Signal lights, list price \$7.00, our price \$1.50. We also carry a complete stock of parts for all cars both new and used, at a great saving. Mail orders filled the same day as received. Standard Auto Parts Co., 1221 Wabash Ave., Chicago, Ill.

FILTER your oil. Double the life of your engine and save on your oil bill. Dirty oil is expensive. A Brownie Oil Filter removes the dirt. \$3.50 postpaid; \$4.00 west of Rockies. A. J. Brown, 376 31st St., Milwaukee, Wis.

PROTECT your rights. Write for Record of Invention which contains form to establish evidence of conception of your invention. Prompt personal service. Preliminary advice without charge. J. Reaney Kelly, 612 G. Columbian Bldg., Washington, D. C.

STORAGE Batteries: be a battery man. We have all material and can give instructions for making them. Sample plate, 40c; foreign countries, 50c. Windsor Specialty Co., 5419 Windsor Ave., Chicago, Ill.

PARTS! Repairing your own car? Large quantity in stock. New or used. Write description of parts wanted. Paige Rifner Motor Company, Salina, Kans.

SAVE 1/2 on auto oil. 50-gal. bbl., \$19.00; 30-gal. bbl., \$13.50. Satisfaction guaranteed or money back. Address, Gill Co., Wisconsin Rapids, Wis.

DEALERS, Repairmen: Buy your automobile bulbs at 50% discount. Write or send your order today. Akeley-Steel Co., Aurora, Ill.

AN aircraft distance thermometer for your car, tells the proper temperature of water. An instrument that cost the Government about \$25.00, we can now offer at \$5.50. Far superior to a monometer. Heath Airplane Co., Chicago, Ill.

BE your own Boss. Operate Automobile Refinishing Business. We teach you how. Big money-making opportunities everywhere. No experience necessary. Automobile Finishing Co., Sheboygan, Wis.

BIG money for you in old auto engines. Write for circulars. Candee-Smith Governor Co., Springville, N. Y., or 1041 So. Main St., Los Angeles, Cal.

MOTOR-TONE positively eliminates carbon. Easy to use. Sample 25c. Brandaw Company, 975 Atlas Bldg., San Francisco, Calif.

AMERICAN Garage & Auto Dealer publishes each month interesting and helpful suggestions and information on sales, merchandising, advertising, business management, accounting, welding, cutting, brazing, practical and progressive hints for office and shop for "small-town" automotive dealers, garagemen, repairmen, mechanics. Subscription price \$1.00 per year. Sample copy on request. American Garage & Auto Dealer, 1004 Lake View Bldg., Chicago.

AUTO Motors Supplies: Buick—Michigan—Stoddard-Dayton—E. M. F.—Cadillac—Overland—Continental and Buda Motors. All types, \$50.00 each and up. New Dixie Magnetos \$20.00, Splittorf High Tension Magnetos \$10.00. Kellogg Pumps \$3.50. Auto-Lite generators, new, \$10.00. Air Gauges 65c. Remy Ignition Coils, new, \$3.40. Electric and gas headlamps, coils, distributor heads, air compressors, etc. Write for catalog. Motor Sales Dept. 15, West End, Pittsburgh, Pa.

AUTOMOBILE Owners, Garagemen, Mechanics, Repairmen, send for free copy of our current issue. It contains helpful, instructive information on overhauling, ignition troubles, wiring, carburetors, storage batteries, etc. Over 120 pages, illustrated. Send for free copy today. Automobile Digest, 506 Butler Bldg., Cincinnati.

COMPRESSORS, Air, Automatic, electrically operated. \$25 cash, balance terms. Hobarts, Troy, Ohio.

AUTO Top Roof Recoverings, easy to put on. You drive 100 racks and save \$15 to \$40. Ford Roadster \$5.50. Touring \$6.95. Other cars \$14 and \$16, with plate glass curtain lights. Delivered at your door. Seat covers \$3.10 up. Write for catalog, samples free. Equipment Co., 30 Canal, Cincinnati, Ohio.

VULCANIZING and Repairing is a paying business. Forty million tires need repairing every day. Make big profits in tire repair. Easy to learn. Instructions free. No hard times. Always busy. Get into this moneymaking business quick! Plants \$200 up. Write for free catalog. Equipment Co., 1 Canal, Cincinnati, Ohio.

AUTO Owner Tire Agent wanted each locality to use and take orders for hand-made Mellinger extra ply and cord tires; guaranteed by bond for 8,000 and 10,000 miles (no seconds); shipped prepaid on approval; get your tires free; no capital or experience required; make \$100 to \$300 weekly. Write for wholesale prices and sample section. Mellinger Tire Co., 929-K Oak, Kansas City, Mo.

AIRPLANE motors for racing Automobiles; see my ad under Automobiles.

SAVE 50%. Order one of our recoverers for your Auto Top. Write for samples. Atlantic Auto Top Co., 3310 Atlantic Ave., Atlantic City, N. J.

AIR Compressor with Tank and Hose, \$46. Motor for same \$22.50. Equipment Co., 21 Canal, Cincinnati, Ohio.

STORAGE Battery charging earns unusual profits, using HB Chargers. \$20 starts; balance payments. Hobartsons, Troy, Ohio.

AUTOMOBILES

AUTOMOBILES: Chevrolet Touring, \$195; Maxwell, \$200; Studebaker, \$250; Mitchell, \$350; Buick, \$300; Ford, \$150. Time payments, all guaranteed. Automobile Broker, 708 East 161st, New York City, N. Y.

AUTO Owners Wanted to use and introduce our new 6,000 and 10,000 Mile Guaranteed Cord and Fabric Tires. Make big money, part or full time. Free Tires for your car. Write quick for special agent's offer and low wholesale prices. It will pay you to answer this little ad, now. Reliable Tire & Rubber Co., 35th St. and Michigan Ave., Dept. 90, Chicago, Ill.

BUILD your own light car or cycle cars. Use motorcycle engine. We furnish front axle, bucket seats, and other parts. Details free. Associated Supply Company, Dept. A. P., Cincinnati, Ohio.

AUTOMOBILE Repairshop Short Cuts. Over 1,500 time and labor saving hints from more than 1,000 of the best repairshops in the U. S. 256 pp., 1,500 figs. Price \$3.50 postpaid. Popular Mechanics Book Dept., 6 N. Michigan Ave., Chicago.

DYKE'S "Automobile and Gasoline Engine Encyclopedia" will teach everything you ought to know or want to know about automobiles. New, enlarged edition, has supplements on Ford, Packard, Airplanes, Airplane Engines, Trucks, Tractors and Motorcycles. Most practical and comprehensive book on the subject ever compiled. Over 500 pages, 3,000 illustrations. Price, \$6.00 postpaid. Popular Mechanics Book Dept., 6 N. Michigan Ave., Chicago.

BUILD yourself a racing Automobile with Airplane Engine. Complete blue prints, instructions, etc., \$5.00. Get my list of used and new Airplane motors, 5 red stamps. Address Heber H. Hunt, P. O. Box 1643, Washington, D. C.

AUTOMOBILE Owners, Garagemen, Mechanics, Repairmen, send for free copy of our current issue. It contains helpful, instructive information on overhauling, ignition troubles, wiring, carburetors, storage batteries, etc. Over 120 pages, illustrated. Send for free copy today. Automobile Digest, 506 Butler Bldg., Cincinnati.

PATENTS—Write for our free illustrated Guide Book and Evidence of Conception Blank. Send model or sketch and description of your invention and we will give our opinion of its patentable nature. Highest references. Prompt service. Reasonable terms. Victor J. Evans & Co., 185 Ninth, Washington, D. C.

TO FORD OWNERS

FORD Car Repair Book sent free. This complete, well illustrated, valuable book explains in a simple way the Causes and Cures of Over-heating; Repairing Ford Timer; Curling Piston Ring Troubles; Carburetor Adjustments and Repairs; Connecting Rods; Transmission Troubles; Care and Repair of Rear Axle; Stopping Axle Grease Leaks; also covers practically every other phase of Ford Car Repairing. Send 25c coin for three months' trial subscription and get the valuable repair book free. Ford Owners' Magazine, 514 Montgomery Bldg., Milwaukee, Wis.

CYCLE "Modified Vapor" System for Fords. Saves cost in first \$25 of gas. Plenty of power under all conditions. Agents' quick seller. Cycle Manifold Co., South High St., Akron, Ohio.

FORD cylinders rebored and accurately fitted with new oversize pistons, rings, bushings and wrist pins for only \$12. Write Central Auto Supply Co., Louisville, Ky.

DIXIE Magnetos, \$20; Ford Motor, rebuilt, \$74; One-man Ford Tops, \$28. Newhouse, Kingston, O.

FORD magnetos recharged in five minutes. Nothing to take apart, secret exposed. Makes easy starting; bright head lights; more power; saves gasoline; satisfaction guaranteed. Complete simple instructions and diagrams \$1.00 prepaid. Send money order or currency today. Magnetizer Manufacturing Co., 146 W. Florence Ave., Dept. 219, Los Angeles, Cal.

FORD Repairing—New valuable book explains use of all up-to-date tools and shop equipment; describes methods of performing work on all different mechanical parts of car. 250 pp., fully illus., leatherette binding. Price \$2.50 postpaid. Popular Mechanics Book Dept., 6 N. Michigan Ave., Chicago, Ill.

PROTECT your Ford Radiator from freezing while driven with a Thomas Metal Radiator Protector, \$1.00 postpaid. Give year of car when ordering. Geo. N. Thomas, Mankato, Minn.

FORD Magnets Recharged in car; nothing to take apart. Simple and complete instructions. 75c. Alfred Bentz, Wauwatosa, Wis., Box B.

SPEEDSTER Fans. See "Red-I-Kut" ad., page 135.

FARM with Your Ford. Do 2 days' work in 1. The Adapto-Tractor makes your Ford a tractor and power plant. Guaranteed to be as represented and not to injure your Ford or your money back. Agents wanted. Write for free circular. Geneva Tractor Co., Dept. P, Geneva, O.

SIMPLEX (Ford) Starter \$20.00. One agency sold 610. Easily sold. American-Simplex Co., Anderson, Ind.

ADJUSTABLE Intake and exhaust valves for Fords increase power. For circular address: Dept. F, Steel Products Mfg. Co., Racine, Wis.

A PATTON Body on your Ford chassis will give you the best looking car in town. Bodies \$50 and up. Illustrated folder sent on request. E. J. Patton Co., 786 Garfield Ave., Aurora, Ill.

\$39 PER day selling circulating water pumps for Ford cars. Exclusive territory. Polar Bear Pump Co., Los Angeles, Cal.

FORD Top Roof Recovering. Easy to put on. Drive 100 Tacks and save \$15. Ford Roadster \$5.50. Touring \$6.95. Parcel Post Prepaid. Equipment Co., 19 Canal, Cincinnati, Ohio.

MOTORCYCLES, BICYCLES & SUPPLIES

BIG Bargains Used Motorcycles, Bicycles, Accessories. Motorcycles \$40 up. Bicycles \$10. Bargain bulletin free. Bicycle electric lights \$1.98 complete. Guaranteed bicycle tires, chain tread, \$2.10 C. O. D. Shipped same day order received. Satisfaction or money back. Ash Motor Corporation, 163 Clinton, Rochester, N. Y.

SIDE cars, motorcycles, magnetos, carburetors, transmissions, engines, air propellers, at bargains (enclose stamp). Expert factory repair service; reasonable; genuine guaranteed parts used. Send work now. Erickson, 8039 Parnell, Chicago.

INDIAN, 1921 Scout; nearly new, \$198. Full lighting equipment, horn, excellent finish. Ask for Bargain Bulletin No. 6. Burnett Motor Sales, Providence, R. I.

FOR sale cheap, used rebuilt Motorcycles and parts for Excelsior, Indian and Pope. F. S. Senseman, New Kingston, Cumb. Co., Pa.

\$1.00 A WEEK buys New Autoped Motorcycle! Cheaper than carfare. Agents wanted. Stern Brothers, 1519 2nd Ave., New York, N. Y.

HARLEY twin with kick starter, \$50. Geo. Latch, Altamont, Ill.

CLOSING Out: Our large stock of New and Used Parts, all makes. Special prices on Cylinders, Crank Cases, Frames, Wheels, Tanks, Forks, Bars, Guards, Indian Sidecars, Magnetos, Lamps, and all other used parts. H. W. King, Des Moines, Iowa.

SEND for big list of slightly used motorcycles and bicycles on our easy payment plan. Howard Cycle Co., 152 N. Broad St., Trenton, N. J.

USED and new parts, Indian, Excelsior, Harley, Reading, Thor, Henderson, Yale. Get our price lists. Kingshighway Cycle Co., 1166 North Kingshighway, St. Louis, Mo.

HENDERSONS—Two 1919 3-speed Hendersons Demonstrators. Both new machines, \$260.00 each. Good guns acceptable. A Clarive, Walker, Minn.

WHY buy a used motorcycle? A new Cleveland costs only \$185. See page 132.

REBUILT Bicycles \$15. Sunderland Cycle Co., Canon City, Colo.

DON'T buy a Bicycle Motor Attachment until you get our catalogue and prices. Shaw Mfg. Co., Dept. 27, Galesburg, Kan.

NEW motorcycles have been reduced 10%. Our prices have been reduced 35%. Send for big bargain list of rebuilt motorcycles. Western Supplies Co., 359 Hayutin Bldg., Denver, Colo.

USED motorcycles, new and used parts; write us. Mahowald Cycle Co., Mankato, Minn.

INDIAN motorcycles—second-hand at extremely low prices. Howard A. French & Co., Baltimore, Md., and Washington, D. C.

BOYS, build your own cycle car! Send 25c for building plans and list of parts. We can supply motor with clutch and all parts at low prices. Shaw Mfg. Co., Car Dept., Galesburg, Kan.

MOTORCYCLE Cylinders reground, fitted with new piston rings, \$8.00. Guaranteed. Muncie Piston Co., Muncie, Ind.

AVIATION

PROPELLERS for Aeroplane propulsion, small propellers for motorcycle-driven snow and ice sleds, road speedsters, and hydroplanes, 4½ feet diameter \$10.00, 6 feet diameter for Fords \$15.00; others in proportion. Overhead countershafting, hub sprocket bearings and thrust, all complete, just right for installing, Ford type \$18.00, motorcycle type \$16.00. Our new ball-bearing countershafting complete for Fords \$18.00; motorcycles \$14.00. Full scale blueprints for building motorcycle snow and ice sleighs 75c. Ford plans \$1.00. Prices of blueprints refunded on purchase of propeller. Crawford Motor and Aeroplane Mfg., 142 South Rampart Street, New Orleans.

BUILD the Marinette Motorcycled Monoplane. Blue print plan 25c (contn). M. Meyler, R. 10, Kalamazoo, Mich.

SMALL Gasoline Engine repair parts. Spark coils, Plugs, Experimental work. Address, Weiss Mfg. Co., Brooklyn, N. Y.

FLYING School Instruction. Airplane Motors. Complete or knockdown sport planes. Money-saving prices. Aviation Engineering Co., Lawrence, Kans.

AIR-PROPELLED Ice Boat Assembly, \$75, or will take canoe part payment. W. A. Robinson, Iowa City, Iowa.

FOR February we offer the greatest bargains in the history of aviation. Dope \$1.65; turnbuckles, all sizes, 25c; zero cloth 39c yd.; tachometers \$7.00; altimeters \$12.00; air-speed indicators \$12.00; shock absorber 5c ft.; Curtiss or Gnome motors \$200; new propellers \$18.00; clevis pins 2c; wheel covers \$1.25; steel tubing 5c ft. Other wonderful bargains; get free sale sheet. Heath Airplane Co., Chicago, Ill.

VERY small rotary gasoline engine blueprints complete one dollar. Spark plugs, eighth-inch pipe size, castings, circular. Address, Bitter Mfg. Company, 325 Washington Street, Brooklyn, N. Y.

AEROPLANES: 1 seater \$225; 2 seater 60 HP, \$350; 3 seater 150 HP, \$600; 3 seater 300 HP, \$750; Aero Exchange, 38 Park Row, New York.

BUILD your plane now. Prepare for spring flying. Blueprints, materials, parts. KD planes lowest prices. Circular, price list, 2c stamp. Huntington Monoplanes, Hempstead, N. Y.

LEARN to fly, with America's oldest aircraft company. Six hours' flying worked in with three months shop training at \$190.00, makes our course the most complete ever offered, and an opportunity long waited for. Enroll at once. Heath Airplane Co., Chicago, Ill.

AERONAUTICAL Course and New Aeroplanes without motor, \$375. Aeroplane Curtiss parts, wheels, propellers, motors, astounding prices. G. A. Moore, 606 Clinton St., Buffalo, N. Y.

CURTISS Pusher Wings—Set \$25, Motorcycle Wings \$50.00. Fuselages \$100.00. Aircraft Supplies. Bulletin 4c. Ostergaard Aircraft, 4269 North Narragansett, Chicago.

GET into the Game early and wisely. Now! Write Leslie Coombs, Chief Engineer, Central Airplane Works, 843 Windsor Ave., Chicago.

INVENTORS desiring patents should write for our Free Illustrated Guide Book and Evidence of Conception Blank. Send model or sketch for our opinion of its patentable nature. Highest references. Prompt service. Reasonable terms. Victor J. Evans & Co., 187 Ninth, Washington, D. C.

THE American School of Aviation announces a new correspondence course in Mechanics of Aviation. A thorough training in Practical Aeronautics. American School of Aviation, Dept. 1861, 3601 Michigan Ave., Chicago, Ill.

MODEL builders. Latest Types, lowest prices. Our Special, flying model Pophker P111 Cantilever monoplane complete knock-down \$5 postpaid. Blueprint 50c. Price list 2c. Eagle Aircraft, Hempstead, N. Y.

10 H. P. twin cylinder air cooled motor, \$60.00. S. B. 473, Harlan, Ia.

AIRPLANE motors for racing Automobiles; see my ad under Automobiles.

HEATH propellers represent the most efficient method of aerial drive. Each propeller individually designed for the particular work to be done, as laid out by America's oldest Aeronautical Engineers. Propeller catalog 4c. Heath Airplane Co., Chicago, Ill.

MODEL Aeroplanes that fly. Buy your complete outfit, scale drawings, fittings, compressed air motors and all best model aeroplane supplies from The Wading River Manufacturing Co. Established 1908. Our new 52-page catalog illustrated, 24 latest models and designs. Send 10c for your copy. Wading River Manufacturing Co., 672 A Broadway, Brooklyn, N. Y.

BIGGEST, best catalogue Model Aeroplanes, Parts and Supplies; 5c postpaid. Ideal Aeroplane Co., 67½ West Houston, New York.

SEND for our large aeronautical supply catalog containing late ideas, 15c. Our Ford and Motorcycle Airplane Pamphlets describe the most complete little machines on the market, 4c each. Heath Airplane Co., Chicago, Ill.

WELDING

WELDING Encyclopedia, just published, is a complete instruction book on all Welding Processes, Oxy-Acetylene, Electric Arc, Electric Resistance and Thermit. Welding of all weldable metals fully discussed. 324 pages, 375 illustrations, clothbound. The accumulated experience of the welding brains of America is yours for \$5. Money back if not satisfied. Popular Mechanics Book Dept., 6 N. Michigan Ave., Chicago.

ELECTRIC Grinder and tire buffer, \$25 cash, balance terms. Also Money-Making Battery Chargers. Write us. Hobart's, Troy, Ohio.

BOOKS AND PERIODICALS

AMBITIOUS writers of Photoplays, Short Stories, songs, poems, newspaper articles, send today for free helpful booklet, "Successful Writing." Writer's Digest, 8-603, Butler Bldg., Cincinnati, O.

CORRESPONDENCE Courses and Educational books, Bargain prices. Bulletin 1968 free. Used Courses bought, Instruction Correspondence Exchange, 1966 Broadway, New York.

TOY maker book, 64 pages, illustrated. Postpaid 15c. Western Puzzle Works, St. Paul, Minn.

"500 THINGS To Sell By Mail," a compilation of new money-making plans. Prepaid \$1.00. Walkmore Company, Dept. PM, Lafayette Bldg., Philadelphia, Pa.

AMERICAN Fox and Fur Farmer. Devoted exclusively to Silver Fox and fur farming. Copy 35c. F. Semmelroth, Grand Rapids, Minn.

"MIND-READING" (Any distance). Wonderful. "Hypnotism." 25 easy lessons \$1.00. Science Institute, PM-1014 Belmont, Chicago.

ORIGINAL Master Key, 35 Full Course Lessons \$5.00. Transcendental Magic \$4.00. Address, Sovereign Company, 160 Sycamore, Buffalo, N. Y.

AGENTS' Law Book contains decisions showing that license not required, etc. \$1.00. A. Centerwall, 1817 Penn, Dallas, Texas.

TRADE, Mechanical magazines. List free! Toepf Magazine Agency, Middletown, N. Y.

LARGE Advertiser wants copies of Mail Order Magazines. Address, H. S. Harp, Green Island, N. Y.

PRACTICAL Books—Mechanical, Electrical, Engineering, many other subjects. Catalogue free. Colonial Book Co., 509 Fifth Ave., Suite 196, New York.

READ Family Record, devoted to genealogy, biography, history, dime. Research of family lineage red stamp. Box 871, Alliance, Ohio.

FREE Electrical Book. Tells how to earn \$12 to \$30 a day. You can learn at home and earn as you learn. Write today. Chief Engineer, 2144 Lawrence Ave., Dept. D13, Chicago.

OVER 1,000,000 Industrial Facts, Calculations, Receipts, Processes and Trade Secrets for every business are contained in the 1616 page book "Moore's Universal Assistant and Complete Mechanic." 500 Engravings. Cloth binding. Price \$2.00 postpaid. Popular Mechanics Book Dept., 6 N. Michigan Ave., Chicago.

BACK issues of magazines supplied by Boston Magazine Exchange, 109 Mountford St., Boston.

LATEST Magic—Professor Hoffman, world-famed authority. New stunts, card tricks, sleight of hand. Handsomely bound. Illustrated, \$2.15 postpaid. Spon & Chamberlain, 120 P. M. Liberty Street, New York.

INDUSTRIAL Alcohol, Wright's book everybody wants. Full directions for making with drawings of necessary apparatus. \$2.50 postpaid. Spon & Chamberlain, 120 P. M. Liberty Street, New York, N. Y.

100,000 USED and new books for sale: 55c up; all kinds; some cost \$25 new; catalogue 10c. (Moved from Chicago.) McCarthy Book House, Kellogg, Minnesota.

BIG Mail Order magazine 10 cents. Riley Publisher, 1333 S. 50th Court, Cicero, Ill.

BRINGING UP Father—Books 1 and 2. Everybody knows the funny cartoons by Geo. McManus. They may be had in book form. One volume for 35 cents or both for 60 cents postpaid. Cartoons Magazine Book Dept., 6 N. Michigan Ave., Chicago.

LIGHTNING Cartoonist's Book, Secrets, Tricks, \$1.00. Christman, 2925 Euclid, Kansas City, Mo.

BOOKS, Books, Books. No matter what you want in the realistic book line, I can fill your order. If you cannot find the books you want, send for my list today. Levi Bryant, 4808 Champlain Ave., Chicago, Ill.

6 DIFFERENT Business Publications covering Accounting, Advertising, Administration, Merchandising, Salesmanship and Taxation. All prepaid 25c. Value, \$1.50. Education in themselves. Walhamore Company, LaFayette Bldg., Philadelphia, Pa.

BOOKS. All Kinds. Lists. Address. Higene's, A-2441 Post St., San Francisco.

WHAT the World should know about Hun atrocities and their attacks on women and girls in Belgium, 50c. Belgian Specialty House, 6340 South Racine, Chicago.

INSTRUCTION Book (for shop use) on vulcanizing auto tire, boots and shoes, \$1 bill. Equipment Co., 3 Canal, Cincinnati, O.

PICTURES, POSTCARDS, NOVELTIES

"SEE America First." Sight-seeing tours start continuously. Schedules and rates free. Thirty interesting "colorviews" 25c. Mutual Supply Co., Bradford, Pa.

WORLD War Photos, actual battle scenes. Air, land, sea. 275 different \$5.00. Sample 10c. Lieut. Welsh, 50 Fort Greene Place, Brooklyn, N. Y.

QUAKER post card members everywhere. Yearly membership and list, twenty-five cents. 2445 So. Woodstock Street, Philadelphia.

TRUE-BLUERS everywhere. Exchange postals. Organized 1908. Membership: Year, \$1; half, 50c; quarter, 25c. Hundreds listings, 10c. Ed. Ericson, 222, Elroy, Wis.

WASHINGTON. Our Nation's beautiful Capitol, ten views 30 cents. Address, George Mitchell, Oriental Bldg., Washington, D. C.

JOIN Live Postcard club; Sample paper, list, catalog, 10c. Harvey Teeple, Decatur, Indiana.

25 MAILORDER Magazines and Papers 25c. Hansen Company, Brookings, S. Dak.

TWO Dimes bring six San Diego Views and four Beach Scenes; you return for mailing. "Indoor Sport." Write today. Christie Studio, 1322 5th, San Diego, Calif.

BEAUTIFULLY written name cards, 25c dozen. Prince, Station H, New York.

GAMES AND ENTERTAINMENT

PLAYS, musical comedies, revues, minstrel choruses, blackface skits, vaudeville acts, monologues, dialogues, recitations, entertainments, musical readings, stage handbooks, make-up goods. Big catalog free. T. S. Denison & Co., 623 So. Wabash, Dept. 11, Chicago.

VENTRILOQUISM taught almost anyone at home. Small cost. Send 2c stamp today for particulars and proof. George W. Smith, Room M283, 125 N. Jefferson Ave., Peoria, Ill.

HEY! Look! Hey! Card trick, great handkerchief trick, novelty picture, best plan for securing latest tricks. All for 10c, coin. None free. Show 'em something good. Doubly Company, 8-14, Ann Arbor, Mich.

"MARGO," a mystifying novelty that will make them all sit up and take notice. Fools the wise ones. Descriptive circular free. James T. Herr, Desk C, 2919 W. North Ave., Baltimore, Md.

SNEEZE powder, greatest fun maker on earth. Package 10c. Write C. Fenner, 2401 Jefferson, Louisville, Ky.

\$7,000.00 STOCK magical goods. Catalogues 15c. Address, Gilmagic, Morgan Park, Ill.

MYSTERIOUS Wonder Shavings when dropped into water turn into fish, flowers, animals. One dozen in pretty package 15c, three 35c. Excellent for dinner party favors; they create talk. Dozen packages \$1.00. George E. Heinemann, 1424 Rosemont, Chicago.

AMAZE and mystify your friends. Big book of 250 Magic Tricks—simple—easy to perform, only 10c. Catalog of Tricks, Magic Apparatus, Novelties and Books—stamp. Send today. Henry Moody, 6674 Stoney Island Ave., Chicago.

200 KINDS iron, wood and wire puzzles. Leader and illustrated list 10c. Western Puzzle Works, St. Paul, Minn.

MAGIC—Tricks, Books and Supplies. For Amateurs as well as the great professionals. Anyone can learn through our instructions. Feature Acts in Mind Reading, Spiritualism, Rope Ties, etc. Large illustrated Professional Catalog, 10c. Chicago Magic Co., Dept. B, 140 S. Dearborn St., Chicago, Ill.

TRICKS, Puzzles, jokes, magical apparatus, plays, stage supplies, mind-reading acts, and sensational escapes. Send 10c for 100-page illustrated professional catalogue. Oaks Magical Co., Dept. 548, Oshkosh, Wis.

FREE! "10 select pocket tricks" and illustrated catalog magic tricks, jokes, puzzles and imported novelties at reduced prices. Send today! Lyle Douglas, Station A, Dallas, Texas.

STAMP COLLECTING

LIKE Triangular Stamps? To introduce our Sudden Service Approvals we'll send triangular Fiume, set China ships, large \$1.00 United States revenue, also packet 50 foreign, millimetre scale, perforation gauge, ruler and bargain lists for only 9c! Fennell Stamp Company, Dept. P, Fullerton Bldg., St. Louis, Mo.

START a Stamp Collection—65 different stamps from 65 different foreign countries, including Africa, Asia, Australia, Europe, West Indies, etc. Our pamphlet which tells "How to make a collection properly," and price list of albums, packets and sets, all for only 16 cents. Queen City Stamp Co., Room 36, 604 Race St., Cincinnati, O.

1,000 AMERICAN Hinges and 100 Different Stamps, 25c. 12 Mexico, 10c. 25 Japan, 10c. Lists Free. Fine Approvals, Weber, 812 South Avenue, Plainfield, N. J.

SEND for my sixteen-page Price List bargain stamp sets, packets, etc. A. E. Hardman, 7 Iowa Circle N. W., Washington, D. C.

25 WURTEMBERG, catalogue 66 cents, 10 cents to applicants for 50% discount approvals. J. G. McIlhenny, 21 Oak Ridge Ave., Summit, N. J.

FREE, packet of desirable stamps, exceptional quality, to approval applicants sending satisfactory references. H. Argonbright, Box 352, Staunton, Va.

BEST one-cent approvals, in America. F. P. Hand, 1117 So. 60th St., Philadelphia, Pa.

100 ALL, different, from Serbia, Italy, etc., for ten cents. Nielsen, 1923 Melrose, Chicago.

STAMPS on approvals, ¼-cent up. Free premium. Herbert Keigwin, 31 Wallkill, Middletown, N. Y.

ALL different, 200 20c, 100 U. S. 25c, 25 Japan 10c. Michael, 5603 Prairie, Chicago.

ROYAL approvals—the world's best. Address, Belmont Stamp Co., Box 178, Ocean Grove, N. J.

100 FOREIGN Stamps sent free. Cornish Company, Schenectady, N. Y.

100 DIFFERENT foreign, fifty United States, forty Japanese, thirty Switzerland, or ten Newfoundland, free with Mekeel's Stamp Weekly, Beverly, Massachusetts; thirteen weeks 25c. Choose one.

ARGENTINA stamps, 30 different, 20c, 20 French Colonials free to applicants for approvals sending satisfactory reference. Nickles, 122 Florida Avenue, Washington, D. C.

HUNGARIAN Soviet Set, featuring European Bolsheviki Leaders; also 100 others, all different, 30c. Jacob Fischer, 1552 North Lawler, Chicago.

200 DIFFERENT Stamps, 25 cents. Perforation Gauge Free. I. Sonnee, 675 Ivy St., St. Paul, Minn.

100 VARIETIES 10c, approvals for reference. Maxfield, Box 315, Amsterdam, N. Y.

STAMPS Free—Ask for money-saving approvals. John P. Borresen, Cedar Falls, Ia.

FREE! 8 Latvia to approval applicants. Reference, William Rometsch, Bridgeport, Conn.

BIG Packet and collectors' supplies 10c. Merrill, Atkinson, Athens, Ohio.

HIGH-GRADE Approvals for Collectors beyond the beginners' class. All countries 1845 to date. Better than usual discounts. Satisfaction certain. References essential. Fred. R. Boterberg, 3753 Wilton Ave., Chicago, Ill.

JOIN International Stamp Club, 25 cents. Members in every Country. 4002 Brooklyn Ave., Seattle, Wash., U. S. A.

150 MIXED Foreign, Stam, French Colonies, etc. 15c. Bargain List 5c. Shinn, Box 702, Reading, Penna.

NYASSA, Abyssinia, Thrace Stamps, Menagerie Packet, 250 Hinges, only 10c. Liberty, 3974 Arsenal, St. Louis, Mo.

APPOMATTOX Railroad Ticket, 1854, 25c. A. W. Dunning, Brookline, Mass.

51 DIFFERENT, including scarce Stam, 8c. Co-operative Stamp Company, 710 Pelham, St. Paul, Minn.

THREE Abyssinian Pictorials 10c, sold to approval applicants only. Wilmar Edgar, Cherokee, Ia.

INDIVIDUAL Service! Triangle Fiume free to approval applicants. Progressive Stamp Co., Gloversville, N. Y.

50c WORTH of Stamps for Only 2c. Hull, 12 West 101st, New York.

FREE—5 Nyassas to approval applicants. Bob Yorkston, Box 54, Roselle, N. J.

100 DIFFERENT War Stamps 25c; 200, 60c. Buckley, 712 Bowen, Dayton, Ohio.

FINE! War Packet 10c. Chicago, Service, 2841 W. 25 St., Chicago, Ill.

25 EGYPT, Travancore, Newfoundland, etc., 2c. Harland Burgett, Lima, Ohio.

100 DIFFERENT Wars 15c. F. Buffham, Lake Ave., Racine, Wis.

100 STAMPS from 20 different countries, 5c. Luffberry, Yalesville, Conn.

FREE—New Europe, 20 diff., to applicants for my ¼, ½, 1, and 2c approvals; also the higher-priced stamps at 50% disc. Send reference and receive extra premium. Chas. T. Egner, 1335 Pike St., Philadelphia, Pa.

24 VARIETIES Cuban stamps, 10 cents. List of 6,000 low-priced stamps free. Address Chambers Stamp Co., 111P, Nassau St., New York City, N. Y.

500 U. S. and Foreign stamps and price list 10c. R. H. Carlton, 366 W. So. Temple, Salt Lake City, Utah.

FREE! Sectional Loose Leaf Postage Stamp Album at the rate of 8 pages each month given with subscription to our monthly Journal. Send two-cent stamp for prospectus. United Stamp Co., 140 S. Dearborn St., Chicago, Ill.

BIG Variety Packet Foreign Stamps free for 2c postage. Gray Stamp Co., Station E., Toronto, Canada.

25 U. S. FREE with approvals. Send 3 cents. St. Elmo Stamp Co., 4501 N. Ashland Ave., Chicago.

UNIVERSAL Packet, 100 varieties, all over the world, 10 cents. Covert Stamp, 39 State, Rochester, N. Y.

STAMPS sent on approval at 70% discount. Reference required. Emory Remoll, Hanover, Pa.

ALL different, 200, 25c; 300, 50c. Fred Onken, 630 79th St., Brooklyn, N. Y.

STAMPS—50 different Jamaica, Venezuela, etc., only 10c; 100 all diff., 13c; 1,000 all diff., \$4.53; 100 diff., U. S., 25c; 1,000 Hinges 10c; 50 percent approvals with every order. List free. I buy Stamps. Write L. B. Dover, Longmont, Colo.

57 DIFFERENT new and used stamps from Guatemala, Finland, Peru, India, Russia, France, Czechoslovakia, Philippines, etc., perforation gauge, millimetre scale, ruler, price lists to approval applicants. Don't wait. Send now 10c. Leader Stamp Co., Dept. P., St. Louis, Mo.

STAMPS, 50 Varieties, Africa, Brazil, Peru, Cuba, Mexico, etc., and Album, 10c. 50 Different U. S., 25c, 1000 mixed 40c, 1000 hinges, 10c. List free. I buy stamps. C. Stegman, 5948 Cote Brillante, St. Louis, Mo.

105 CHINA, etc., stamp dictionary, list, 2c. Album (500 illustrations), 3c. Ballard, Sta. A, Boston.

55 ALL Different Stamps, including China, Japan, French Colonies, etc., given to applicants for our high-grade approval selections. Send references and 2c stamp to the Edgewood Stamp Co., Dept. H, Milford, Conn.

20 UNUSED stamps free. All different. Postage, 2c. Fisk Stamps, Toledo, Ohio.

PACKET of 23 stamps, no two countries alike. Packet hinges. Set of \$1 and \$2 U. S. Rev., all for 5c. Mention paper. Miami Stamp Co., Toledo, Ohio.

158 GENUINE Foreign Stamps—Mexico War Issues, Venezuela, Salvador and India Service, Guatemala, China, etc., only 10c. Finest approval sheets, 50 to 60%. Agents Wanted. Big 12-p. Lists Free. We Buy Stamps. Estab. 25 yrs. Hussman Stamp Co., Dept. 54, St. Louis, Mo.

STAMPS, 20 unused, all different, free. Postage 2c. Mention paper. Quaker Stamp Co., Toledo, O.

FREE 10 different Scandinavian, millimetre scale, gauge, book, lists, etc., to all sending 10c for 57 different Stam. Ceylon, Guatemala, etc. 200 different, 25c; 300 different, 60c; 100 different U. S., 25c. Hawk-eye Stamp Co., Cedar Rapids, 39, Ia.

RARE COINS

OLD coins, large Spring selling catalogue of coins for sale, free. Catalogue quoting prices paid for coins, ten cents. William Hessler, 101B Tremont St., Boston, Mass.

OLD U. S. silver coins cheap. Old bust type dimes dated before 1838, 25c. Old half dollars with lettered edge, dated before 1836, 75c. Columbia half dollars with bust of Columbus (Sold at \$1 in 1893) price 75c. Five foreign coins, 1 over 100 years old and my large 50 page Illustrated Coin Catalog for only 20c. Or catalog free with any order for above coins. All kinds of Coins and Bills for Sale. B. Max Mehl, Numismatist, Mehl Bldg., Dept. P, Fort Worth, Texas. Largest Rare Coin Establishment in the United States.

WILL Pay Fifty Dollars Cash for nickel of 1913 with Liberty Head. Watch your change. We pay cash premiums for all rare coins. Send 4c for Coin Circular. Numismatic Bank, Dept. H, Fort Worth, Texas.

40 OLD coins, all different, \$1.00. 20 Large U. S. Cents, all different dates, \$1.00. Address, Claud Denney, Denison, Texas.

COINS, medals, paper money, guns, swords, pistols, stamp collections, curios, Lists free. Nagy, 33 South 18th, Philadelphia, Pa.

FLYING Eagle Cent and new list, 10c. Holco, Annawan, Ill.

CALIFORNIA gold, Quarter size 27c; 1/2 size, 53c. 3c Piece and catalog, 10c. Norman Shultz, Box 146, Colorado Springs, Colo.

\$2 TO \$500 Each paid for hundreds of old coins. Keep all old money. Send 10 cents for Illustrated Coin Value Book, 4x8. Guaranteed Prices. It may mean your Fortune. Address Clarke Coin Company, Ave. 2, Le Roy, N. Y.

CALIFORNIA Gold, Quarter size and Colombia nickel coin only 30c. Italy 20 cents and catalog 10c. Homer Shultz, King City, Mo.

FOR BOYS

PLAY mouth-organ. It's easy. Complete instructor, 25c. Gearina instructor, 25c. G. Elsea, Bowling Green, Ohio.

BUILD Aerocar, Single Passenger Speedster, "Flies" 35 Miles per Hour. Construction Plans 50c. Circular 2c. Aerocar Co., Racine, Wis.

BOYS! Build Things. Get our latest "The Boy Mechanic, Book 3." It tells how to make 800 different things, such as Boys' Motor Car—Houseboat—Model Monoplane—Water Toboggan and Slide—Aerial Cableway—Ski Sled—Sailing Canoe—Searchlight—Electric Locomotive, etc. 480 pages, 802 illus. Cloth binding, \$2.50 postpaid. Later on you will want the other two big books in the series, Books 1 and 2, same size, same price. Popular Mechanics Book Dept., 6 N. Michigan Ave., Chicago.

OUTDOOR Winter Sports—New 64 page illustrated book, just out, tells how to make motor-driven snow and ice sleds, ice yachts, coasting boards, bobbeds and toboggans, skis, ski gliders and ski sleds, ice gliders, portable fishing shacks, etc. 25 cents, postpaid. Popular Mechanics Book Dept., 6 N. Michigan Ave., Chicago.

FREE Electrical Book. Tells how to earn \$12 to \$30 a day. You can learn at home and earn as you learn. Write today. Chief Engineer, 2144 Lawrence Ave., Dept. B13, Chicago.

BOYS! A real airplane, guaranteed to fly, \$1.25 postpaid. Pulver's Sporting Goods Store, Hudson, N. Y.

CAMERAS AND PHOTO SUPPLIES

DEVELOP your plates and films in daylight without tank. Greatest discovery in photography! Chemical makes emulsion light-proof so plates can be developed in white light without risk of fogging. For ordinary plates, Fanchromatic, Autochroms! Cheap! Send 25 cents for tube sufficient for hundreds of plates, with instructions. Address, Gen-gora & Co., Box 234, St. Louis, Mo.

AMATEUR photographers, send your name on a post card for our free offer. Tompkins Photo Co., Dept. 1, Monroe City, Mo.

JUST published—Our new complete 128-page catalog and bargain book of new and used cameras and supplies. Our goods are guaranteed finest quality obtainable. We have thousands of satisfied customers. Write at once for this bargain bulletin, just hot from the press. Address Central Camera Co., 124 S. Wabash Ave., Dept. E54, Chicago.

BUY the RWK Photo-Printer for results and economy. It makes photography a pleasure. Size 6 1/2 x 3 1/2, delivered in U. S. A. for \$8.50, complete with bulbs. Prices of 8x10 and 11x14 printless upon request. R. W. Kittredge Co., 324 W. Superior St., Chicago, Ill. Write for information.

KODAK Finishing. Not the cheap way, but the most reliable. Our Quality Work insures best prints from every negative. Get particulars and List of Prizes. Or send Trial Order. Moon Photo Service, 21A, LaCrosse, Wis.

EARN \$1,200 to \$10,000 yearly. Travel anywhere. Sell photographs to Newspapers—Magazines—Advertisers. Guaranteed complete course in Kodaking—Five Dollars. Address today. Photographic Institute, Dept. M, Wedgway Building, Schenectady, New York.

ENLARGEMENTS De Luxe—7x11, 45c. Photo for \$1. Two alike, 50c. Ashton Photo Works, Ashton, Ill.

8x10 KODAK enlargement beautifully colored \$1.00. Kodafin, 387 Bellevue Place, Milwaukee, Wis.

CAMERA Bargains: Get your copy of the Bass Bargain List 20 right now. More actual camera bargains listed therein than in any two lists heretofore. Save money on every purchase. Bass Camera Company, Dept. 113, 109 No. Dearborn St., Chicago, Ill.

CAMERA Repairing by expert. Prompt service. Work guaranteed, reasonable price. Send by P. P.; will write you cost. Turner, 1679 Ave. A, N. Y. City.

SAMPLE Enlargement, dime, and negative (returned). Roll developed and six prints, 25c silver. Brown Studio, Lake Elmo, Minn.

MAIL us 20c with any size film for development and six velvet prints. Or send six negatives any size and 20c for six prints. Or send 40c for one 8x10 mounted enlargement. Prompt, perfect service. Roanoke Photo Finishing Co., 209 Bell Ave., Roanoke, Va.

HAVE You a Camera? Write for Free sample of our big magazine, showing how to make better pictures and earn money. American Photography, 790 Camera House, Boston, 17, Mass.

MOTION PICTURES

FILMS for Homes, 100 feet \$1.00, postpaid, 2,000 reels \$3.90 to \$10.00. Projectors \$45.00. Motor-driven suit case Projector \$100.00. Cameras \$50.00. Tripods \$5.00. Film cement 35c. Film rewinders \$5.00. Reflex Camera P. 4.5 lens, \$40.00. Ray, 326 Fifth Ave., New York.

PORTABLE Professional Moving Picture Machine, for Home, Church or School. Takes Standard Film. Can be operated with Globe from ordinary lamp socket; only \$35.00 cash. Monarch Theatre Supply Co., 225 Union Avenue, Memphis, Tenn.

MAKE money writing photoplays; details free to beginners. No correspondence course. Producers League, 230 Wainwright, St. Louis.

MOVIE Camera, 400-Foot Capacity. Stereopticons. Supplies. Catalogue. Heitz, 302 E. 23d, New York.

MOTION Picture Operation, Stage Electrics and Illusions—The only practical hand-book and guide published for motion picture operators, theatre electricians and managers. A thoroughly practical and useful book, covering the subject comprehensively. Pocket size, cloth, 393 pages, fully illustrated. Price \$1.50 postpaid. Popular Mechanics Book Dept., 6 N. Michigan Ave., Chicago.

STUDY Cinematography, the science of Motion Pictures. New, Fascinating, Remunerative. Positions pay \$3,000 to \$5,000. Write today for prospectus. American Institute of Cinematography, Dept. 2, Steinway Hall Bldg., Chicago, Ill.

MOVIE Film \$1.00 per hundred feet postpaid anywhere in the U. S. A. Gamble Bros., Mt. Airy, Philadelphia, Pa.

BIG Clearance sale of films. Westerns, comedies, and features \$3.00 per reel and up. Write for list. Also machines and supplies of all kinds. Monarch Theatre Supply Co., 225 Union Ave., Memphis, Tenn.

MOTION Picture cameras of all kinds at money-saving prices. Write Bass your needs at once. Bass Motion Camera Company, 169 No. Dearborn St., Chicago, Ill.

MOVIE Films 1c foot; 150 ft. \$1. Reels \$3 up. Send stamp for list. Address X. Sales Company, West Haven, Conn.

MOVIE Arc Generator. Eliminates Current bills. Superior projection light. Easy terms. Your engine operates. Hubrosco, Troy, Ohio.

THE Big Sacrifice. Our entire stock of 2000 reels, large assortment of the very best productions, comedies, westerns, dramas and special features, at prices far below anything offered on the market. We are almost giving them away. Our up-to-date bargain film list just off the press. Write for one immediately. Monarch Theatre Supply Co., 724 South Wabash Avenue, Chicago, Ill.

SCENARIOS Wanted, any form. Screen production assured, exceptional stories. Scenario Service Corp., 527 Mason Opera House, Los Angeles.

FREE to Writers—A wonderful little book of money-making hints, suggestions, ideas; the A B C of successful story and play writing. Absolutely Free. Just address Authors Press, Dept. 12, Auburn, New York.

MAKE money writing Photo-plays; details free to beginners. No correspondence charge. Producers League, 230 Wainwright, St. Louis.

MOVIE Projectors, \$2.50 up; \$25.00 machine shows 8x10 picture; accommodates 1000-foot reel. Films cheap. Second-hand Viascope; bargain. Werner Brothers, High Ridge, Mo.

EDUCATIONAL AND INSTRUCTION

WE teach you all there is to know about candy making here at the Institute or by Correspondence Course. Good income can be made on a moderate investment. The Candy Institute, 876A Flatbush Ave., Brooklyn, N. Y.

CORRESPONDENCE Courses. Less than half original prices. Any school; any subject for men or women. Bulletin 1069 free. Courses bought. Instruction Correspondence Exchange, 1966 Broadway, New York.

PATENT Drafting. Complete instruction book teaching this artistic, high salaried business for 50 cts. Patent Drafting Syndicate, Box 858, Schenectady, N. Y.

DRAUGHTSMANSHIP. English practice; complete course, 2 dollars monthly. School of Draughtsmanship, 19 Cannon St., Manchester, Eng.

SUCCEED: Home Shorthand, \$2.50. Send money order. We are responsible. Byrne Publishing Company, Tyler, Texas.

ARE you in the right work? Let our Vocational Dept. analyze your personal qualifications and give valuable advice, free. Send today for our free Chart. Sheldon School, Dept. 239, 24 So. State St., Chicago, Ill.

BE a Sign Painter—Earn Big Money. We teach by correspondence. Price reasonable. Send for free catalogue. New York School of Lettering, Medina, N. Y.

LEARN Photographic Journalism. Earn \$300 monthly. Complete 22 Lesson Course \$5.00. Particulars free. Walhamore Institute, Dept. P.J., Lafayette Bldg., Philadelphia, Pa.

ESTABLISH yourself—at home—as an Expert Photographer and train with R. Dupont, president International Studios. TC-4451 N. Robey, Chicago.

OPENING Safes and Vaults pays good money. Pleasant and interesting work. Write to Safe Expert, 913, 21st St., Rock Island, Ill.

PRINTING—Learn by correspondence. We furnish material to work with. Northwestern Printing School, 4104 Hirsch St., Chicago, Ill.

"ROPP'S Calculator and Short-Cut Arithmetic"—Shows the answer as quickly as a watch shows the time to all problems likely to occur in office, store, shop, bank, farm or factory. Over two million sold. Price, pocket size, cloth, 50 cents; pocket size, leatherette, \$1.00. Popular Mechanics Book Dept., 6 N. Michigan Ave., Chicago.

EARN more money this year; begin today by learning sign painting, auto painting, decorating, graining, marbling, commercial art, window trimming; no books, real work. Catalogue free. Chicago Painting School, 148 W. Austin Ave., Chicago.

FINGER Print Lesson based on Henry System included with Detective Course. Particulars free. Write George Wagner, 1968 Broadway, New York.

CIVIL Engineer, Mathematics Specialist, teaches arithmetic, algebra, geometry, Trigonometry, mathematical problems solved; private correspondence. Mondell, 280 Madison Ave., New York.

MATHEMATICS taught by mail. Spare time home study courses in Arithmetic, Geometry, Algebra and Trigonometry. J. A. Harding, 76 Brighton Ave., Highland Park, Mich.

WRITE articles, stories, news, in spare time for newspapers and magazines. Big pay. Copyright book free. Press Syndicate, 552, St. Louis, Mo.

LINCOLN-JEFFERSON University. Home study in Academy College, Theological, Law, Music, Pharmacy, Business and Graduate Schools, leading to degrees. Lock Box 239-W, Chicago.

ARTIFICIAL Marble, sanitary flooring instructions, ornamental casting, concrete plaster, papier-mache decorations, garden furniture, statuary, Rubber-moulds, Electrometallurgy, particulars and 200 illustrations free. Chris Mahler, Box 122, Huntington, N. Y.

DOUBLE Entry Bookkeeping mastered in 60 hours with 8 keys; guaranteed; Diplomas. International Bookkeeping Institute, Dept. 8, Springfield, Mo.

INVENTORS—Write for our illustrated guide book and Evidence of Conception Blank. Send model or sketch and description for free opinion of its patentable nature. Highest references. Prompt attention. Reasonable terms. Victor J. Evans & Co., 167 Ninth, Washington, D. C.

HAVE a business of your own; the most fascinating, best paying business-profession in the World, a foot correctionist; easy terms for training you at home in a few weeks, a new protected system that has enabled men and women to rise in one step to greater earnings than they ever thought possible; no capital required or goods to buy, no agency or soliciting. Address, Stephenson Laboratory, 1 Back Bay, Boston, Mass.

TELEGRAPHY

TELEGRAPHY (both Morse and Wireless) and Railway Accounting taught quickly. Big salaries. Great opportunities. Oldest and largest school; established 46 years. All expenses low—can earn large part. Catalogue free. Dodge's Institute, H St., Valparaiso, Ind.

WIRELESS

WIRELESS Apparatus: Build your own regenerative receiver, V-T Detector, 2 step amplifier, etc. Free plans, "hook ups," etc. Associated Supply Company, Dept. A. P. 2, Cincinnati, Ohio.

WIRELESS Apparatus: Complete crystal receiver outfit \$9.00. V-T sockets, cabinets, rheostats, condensers, switches, etc. Details free. Crosley Manufacturing Co., Dept. P, Cincinnati, Ohio.

TRADE SCHOOLS

MECHANICAL Dentistry. Why men are needed now; why you can earn \$35-\$125 weekly or establish a profitable business of your own; how to enter this field of opportunity. Details free. Bodee Schools of Mechanical Dentistry, Department 2A, 136 West 52nd Street, New York (also Brooklyn and Philadelphia).

EARN more money this year; begin today by learning sign painting, scenic painting, auto painting, decorating, graining, marbling, commercial art, window trimming; no books, real work. Catalogue free. Chicago Painting School, 148 W. Austin Ave., Chicago.

BUSINESS OPPORTUNITIES

START a lucrative business of your own. We teach you how to establish and operate a successful collection business, and refer items to you. Capital unnecessary. Practically no competition. Walter Sanford, Nashville, reports \$62,021.94 gross commissions last year. Joseph Cullen, Washington, sends sworn statement showing gross earnings \$8,032.07 for one month. Orrin Overholser, Dayton, says, "I averaged nearly \$400.00 net commissions monthly last year. Such earnings bought my home and farm." Start now in spare time. You can succeed like 4,700 others. Write today for New Plan. American Collection Service, 802 Cass Building, Detroit, Mich.

PATENTS—Trademarks. Before disclosing an invention, the inventor should write for my blank form "Evidence of Conception." This should be signed, witnessed and returned to me with sketch or model, upon receipt of which I will promptly render opinion as to patentable nature and send booklet on Patents. Highest references. Prompt attention. Reasonable terms. Clarence B. O'Brien, Registered Patent Lawyer, Woodward Building, Washington, D. C.

START a little business of your own. Large profits in an every day necessity. Importers Branch Co., established 50 years, formerly 141 Chambers St. Offer—Teas, Coffees, Spices, Baking Powder, Cocoa, Extracts and Corn Starch in one-pound packages all ready for delivery, at wholesale prices, in any quantity. Write to Dept. A., Importers Branch Company, 105 Water St., New York City, N. Y.

PARTNERS wanted to manufacture New Concrete Street and Railroad Ties. This tie will be made and put in place to my idea; it can be made at a price so that any company can use the new tie. This new tie will run with the rail; good chance for a fast growing business. For more detail, write to Pete Jarnowski, 3391 W. Walnut St., Chicago, Ill.

\$100,000 CORPORATION wants capable man; open office; manage sales for High Class New Device. Every Home a Prospect. Big money-making possibilities for the right man. Opening in every city. Cost \$2, retails \$5. \$500 to \$2000 necessary to finance exclusive agency. Scott Corporation, 82 W. Washington, Desk G, Chicago.

CHART Your Future. Two interesting hours filling out Bolger Vocational Chart will show you job you can do best. Earn more money. Send for Free Booklet M. Address, Bolger Vocational Service, 296 Broadway, New York.

IF you have about \$1,000 and capable of organizing sales force, to sell article needed by every merchant, wholesaler and retailer, which should net you \$10,000 profits first year, write Sales Director, 826 Reaper Block, Chicago.

LEARN nickel plating—the business with a big future. We will send necessary drawings and instructions for \$1.00. No checks nor stamps. Washington Street Auto Supply Company, Brookline, Mass.

\$5,000 TO \$10,000 Yearly. Investigate Silver Fox Ranching. Foxes are easy to raise. Pelts bring \$200 to \$1,000 each. Capital unnecessary. 20c stamps. Address, E. Semmelroth, Grand Rapids, Minn.

YOU can earn big money painting Smoke Stacks, Flag Poles, etc. Book of instructions sent postpaid for \$2.00. S. J. Lee, Publisher, 39 N. LaSalle St., Chicago.

WONDERFUL earnings in manufacture of peanut products—peanut butter, salted peanuts, etc. Send 10c for copy. Peanut Journal, Box 166, Suffolk, Va.

MAKE big money manufacturing marble, granite, tile, agate. Cost ten cents per square foot, sell at 75c. Fancy marble face brick, cost \$15, sell \$75 per 1,000. If you want to make several thousand dollars in the next few months, write for full information. Spencer Instruction, Dept. 703, N. Spring Street, Los Angeles, Calif., Master Cement Worker of the World.

PROTECT your rights. Write for "Record of Invention" which contains form to establish evidence of conception of your invention. Prompt personal service. Preliminary advice without charge. J. Beane Kelly, 612 G. Columbian Bldg., Washington, D. C.

PATENTS Procured—Trade Marks Registered. A comprehensive, experienced, prompt service for the protection and development of your ideas. Preliminary advice gladly furnished without charge. Booklet of information and form for disclosing idea free on request. Richard B. Owen, 30 Owen Bldg., Washington, D. C., or 2276-R, Woolworth Bldg., New York.

FINANCIERS of patentable ideas, write Walter S. Moore, Allen, Okla.

YOU Can Succeed With Our Master Formulas, Trade Secrets, Commercial Information. Write The Thaxly Co., Dept. 15, Washington, D. C.

ADVERTISE. 28 words 375 country town newspapers \$8.00. Pennell Company, Covington, Kentucky.

FOR Sale—Established, profitable garage at Daytona Beach, Florida, with established repair business and large line of accessories. Location in heart of city. Building is two-story fireproof construction, 48x108 ft., with large storage space on second floor, in addition to large and convenient living rooms. Daytona Beach has a summer resort patronage from all parts of the state, making the summer business as good or even better than the winter trade. The business also enjoys a large share of the local patronage in a city which has doubled in population in past 3 years and is growing faster all the time. Address F. J. Jones, Box 168, Daytona, Fla.

FREE Electrical Book. Tells how to earn \$12 to \$30 a day. You can learn at home and earn as you learn. Write today. Chief Engineer, 2144 Lawrence Ave., Dept. C13, Chicago.

YOUR Chance in life to own dignified profitable business. We teach you practical real estate, insurance and business brokerage. Earn \$5,000 year, no capital required. Office at home. Representatives wanted everywhere. Stamp for booklet. Hayes Realty Association, Cincinnati, O.

MEN handy with tools, Carpenters, Painters, Weatherstrip men, etc. I can show you how to make \$235 per month up in your own vicinity. E. C. Underwood (A), 109 Federation Bldg., Chicago.

NEW Business Openings—Make and sell your own goods. Expert will furnish manufacturing processes, trade secrets. Free information. Willard Chemical Co., Dept. 4, 2631 Milwaukee Ave., Chicago.

MAKE money with your kodak. Sell your photos in the best market. Free details. Write today. Lancaster, 409B Wright-Caldwell Bldg., Los Angeles, Calif.

VALUABLE territories open to salesman to take orders for "oilproof" spark plugs; big pay. Dinger Spark Plug Co., Melvina, Wis.

"HOW and What to Invent for Profit," free. Patent News-C., Washington, D. C.

MAKE good paints and varnishes, 50c gallon. Corkstone Company, 539 N. Wolfe, Baltimore, Md.

SHINE-OFF. Magical shine and grease spot remover from clothing, shine disappears permanently, guaranteed, easily applied, package 25 cents coin. Agents wanted. Royal Dye Works, Meriden, Conn.

LEARN to read blue prints. "Tradesman's Plan Reading Reference," key to building plans, 56 pages blue print hand book, \$3.50 leather bound, \$2.50 plain. Address Roy Hope, Consulting Engineer, 619 Walnut St., Milwaukee, Wis.

THIS May Be Your Opportunity. A large, modern Middle Western manufacturing institution will consider proposals from inventors and small manufacturers, with a view of manufacturing on royalty basis or of buying outright. Small brass products preferred, but any high-grade proposition will be considered. Address P. O. Box 426 Kokomo, Ind.

WE Start You in Business, furnishing everything; men and women, \$30.00 to \$100.00 weekly operating our "New System Specialty Candy Factories" anywhere. Opportunity lifetime; booklet free. W. Hillyer Ragsdale, Drawer 4, East Orange, N. J.

BIG Money Painting Signs, Cards, Banners. Our patterns do the work. Complete outfit \$4, or 2 sample sets \$1. Satisfaction guaranteed. Outdoor Adv. Service, Box 438, Lockport, N. Y.

OWN profitable business handling Corkstone Products. Corkstone Company, 539 N. Wolfe, Baltimore, Md.

"SCHEMER Magazine," Alliance Ohio, prints big profit schemes; one subscriber making \$25,000 from three; another \$10,000 from one. Try your luck. Year, only \$1.00; three months, 25c.

PATENTS—Book Free. Send sketch for free opinion of patentable nature. Address Talbert & Talbert, 434 Talbert Bldg., Washington, D. C.

\$275 MONTHLY from HB Battery Charging. Fastest growing business today. Anyone operates. \$20 starts you. Profits pay balance. Hobarth, Troy, Ohio.

START in business for yourself for \$250.00. Full time or evenings. At least \$6.00 per hour. Ex-Cell-O Tool & Mfg. Co., 1214 Beaubien St., Detroit, Mich.

START a Paying Business of Your Own. Be a business man. Any location. 8,000 new Tire Vulcanizing and Repair Stations needed. Business always good. Are you ambitious? \$200 will start you. Write at once. Wonderful opportunity. Equipment Co., 11 Canal, Cincinnati, Ohio.

INDEPENDENCE and prosperity await you in the furniture cleaning business. Course \$1.00. Circular free. Send today. Address E. M. Ellis, 110 Riverside Ave., Newark, N. J.

MACHINISTS—Make extra money—Spare time work. Write for particulars. Engineering Service Bureau, Dept. 511, 56 E. Randolph St., Chicago.

HOME manufacturing—Mechanics, and household necessities. Machinery experience, or engraving unnecessary. Enormous profits. Home Manufacturers' Association, 239 Court, Los Angeles, Calif.

GET in business yourself; \$4.00 buys marvelous Keystone Economizer. Easily attached to any make car and saves 25% to 50% present fuel consumption. Satisfaction guaranteed or money refunded. Agents make big money. Address Keystone Economizer Company, 323 Stock Exchange Bldg., Los Angeles, Calif.

I MADE \$30 a week home. French bread-making, 15 years' experience; free booklet tells. Ashbrook, 67, Marengo, O.

BE Independent. We teach by mail how to manufacture unexcelled Toilet Preparations. Earn while you learn. Results guaranteed. Particulars Free. School of Cosmetics, Box K, Omaha, Nebr.

DOLLARS yearly in your backyard. No Mushroom dope. Particulars free. Metz, 313 East 89th, New York, N. Y.

\$40 WEEKLY, making rubber stamps; full instructions to build paying business 25c. Peerless Specialty, Box 101, Waterville, Maine.

MANUFACTURE Extracts, and other necessities. 200% profit; we tell you how. Write White Manufacturing Drug Co., Box 322, Cincinnati, O.

EXCEPTIONAL Opportunity for Sales Manager capable of handling state distribution. Marvelous new Adding Machine. Returns \$15. Work equals \$350 machine. Tremendous possibilities. Unlimited profits. Write quick for details. Lightning Calculator Co., Dept. B, Grand Rapids, Mich.

GET into the specialty manufacturing business. Amazing profits. We will send you free book explaining our system. Write immediately. A wonderful opportunity awaits you. National Scientific Laboratories, 624 Main, Richmond, Va.

MARBLE mixing instructions, covering wood or cement flooring 1/2 inch thick, fireproof, waterproof, low cost, sanitary, all colors. Particulars, 200 illustrations free. Chris Mahler, Box 122, Huntington, N. Y.

LET Me Show you how to make real money. Absolutely new proposition and new products. Materials cost \$2.00, sell for \$15.00. One man sold a thousand dollars' worth in a week. Exclusive manufacturing and sales rights to one man in each territory. Write today for booklet 5, Crouch, Chemist, 309 Broadway, New York.

GOOD money easily earned at home, spare time silvering mirrors; no capital. Free instructive book tells how. Patterson & Co., Brookville, Ky.

LEARN the collection business. Good income, quick results. Interesting booklet. "Skillful Collecting," free. National Collectors Assn., Long St., Newark, O.

SILVERING Mirrors! My exclusive French Tartaric method opens enormously profitable business. Booklet free. H. Barstow, 514 23d Street, Oakland, Calif.

\$3,000 TO \$8,000 Yearly. Want it? Others are making it. Send check or money order today for our invaluable books "How to Sell Real Estate," \$3.00—and "How to Conduct Real Estate and Insurance Business," \$1.50. Absolute satisfaction guaranteed. Free catalogs. Realty Book Co., Dept. 52, Cleveland, O.

CHEMICAL Expert will furnish Formulas and Trade Secrets. All Bnes. Lists Free. W. L. Cummings, Ph.D., 228 Gordon Ave., Syracuse, N. Y.

MAIL Order Business is your opportunity. Brenner's Famous Handbooks teach how to start small, grow big. Sell merchandise, service, ideas; enormous profits. Spare time to begin. Get complete set, 11 books, \$2.50, and be posted. Brenner, 335 Walnut, Philadelphia. Descriptive Catalog and big batch interesting mail order information, 25c. None free.

ENTER a new business. Earn \$3,000 to \$6,000 yearly in professional fees making and fitting a foot specialty, openings everywhere, with all the trade you can attend to; easily learned by anyone at home in a few weeks, at small expense; no further capital required, no goods to buy, job hunting, soliciting or agency. Address Stephenson Laboratory, 11 Back Bay, Boston, Mass.

BUSINESS Brokerage pays well. Easy to understand; particulars free. Write, Eydman System, Box 647, St. Louis, Mo.

LEARN Plating, Etc. Profitable—Big Demand. Free Plans, Norman Rorick, 427 Carroll St., Akron, Ohio.

FREE—Formula Catalog, S. & H. Laboratories, Boylston Building, Chicago.

FORMULAS AND TRADE SECRETS

500 FORMULAS, 20c. Luminous paint—Resilvering Mirrors—Renewing dry batteries—Mechanics' Soap—Gas Tonic—Carbon remover. Puncture Plugger, 20c each. Entire collection, 50c. Ideal Book Shop, 5501FA, North Robey, Chicago.

1,000,000 FORMULAS. Trade Secrets, Processes for Every Business, \$2.25. Ideal Book Shop, 5501MA, North Robey, Chicago.

FORMULAS—Catalogue free. "Clover," 5510CA, North Robey, Chicago.

FORMULAS of the better sort. Write for our free catalog. National Scientific Laboratories, 624 Main, Richmond, Va.

MAKE furniture, auto-brass polish, leather dressing; 5 formulas \$1. Mogensen, 414 N. 14th, Omaha, Neb.

MANUFACTURE Chewing Gum. Easy as making candy. Formula and complete instructions \$1.00. Lloyd Steele, Aurora, Ill.

3,000 FORMULAS—400 pages, \$1.00. Catalogue free. Englewood Book Shop, 7021A So. Winchester, Chicago.

BOOK of 1,000 formulas—one dollar. Charles Schroeder, Neillsville, Wisconsin.

20 MONEY-MAKING plans, 20 mail-order schemes, both for \$1.00. A Centerwall, 1817 Penn, Dallas, Texas.

10,000 SELECTED scientific chemical, technological and practical recipes and processes, including hundreds of so-called trade secrets for every business, alphabetically arranged in one large volume of 800 pages. Price \$4.00 prepaid. Popular Mechanics Book Dept., 6 N. Michigan Ave., Chicago.

ABSOLUTELY any formula, \$1.00. Satisfaction guaranteed. Robert Tyler, Park St., Newton, Mass.

FOR reliable formulas, write Douglas Chemists, 8 St. Louis Ave., Chicago.

100 SELECTED Manufacturing Formulas, 10c. Chemists, 2845 S. Kedvale, Chicago.

BE Independent, learn to make Perfumes and Toilet Articles. Big profit. Commercial Laboratory, 70 So. Second, Memphis, Tenn.

NEWSHINE Auto and Furniture Polish. Best on Earth; cleans and polishes, leaves dry surface; costs 50c gallon; formula \$1, no stamps. Snyder, Box 512, Marshall, Texas.

FREE—Formula Catalog, S. & H. Laboratories, Boylston Building, Chicago.

CHEMISTRY

I SOLVE your chemical or electrical problem for Five Dollars. Write me. W. Stedman Richards, Consulting Chemist, 220 Washington St., Boston, Mass.

CHEMICAL analysis honestly and correctly done by L. E. Tenney, Colton, N. Y.

AGENTS WANTED

WHIRLWIND money-maker for agents—sample free. Sell powdered Hanslick, an absolutely new, non-competitive, and unbeatable hand cleanser. Removes grease, grime, ink, paint, etc., without slightest injury to skin. Its use spreads like wildfire. Cheaper than all others. Sells in cans (or bulk with dispensers) to garages, autoists, mechanics, factory and office folks, to housewives, hardware stores and to auto supply houses. Huge quantities used weekly by mercantile houses. (Names on request.) Big repeat business assured. Exclusive agencies, crews working for you, fast sales, splendid profits and a permanent business for hustlers. Live ones can clean up \$500 a month. Send 2c stamp for postage on Free sample. Complete sales plan goes with it. Write quick to Solar Products Company, 124 W. Lake St., Chicago, Ill.

FREE—Complete "Sanitary Cooking Ware" outfit; cost agents one dollar. Refunded on first order. National Pottery, Roseville, Ohio.

BIG Profits: Quick, Easy Seller. Klean-Rite, New Washing Compound. Washes clothes without rubbing. Women wild over it. Write quick for Free package and Special Offer. Bestever Products Co., 1941-K2 Irving Park, Chicago.

300% PROFIT—Earthquake—Shatters Dirt—The Original Wash Day Wonder. Nature's Mighty Marvel. Nothing else like it. Washes clothes snowy white in a few minutes without Rubbing or Boiling. Removes ink, fruit and blood stains like magic. Saves one-half the soap, time, worry and hard work. Contains no lye, lime, wax or acids—will not injure the finest fabrics. The greatest seller and repeater offered agents in twenty years. Men and women are making \$7.00 to \$14.00 daily. General agents and crew managers up to \$6,000 yearly. Profits guaranteed. Experience unnecessary—new plan makes sales quick and easy. \$6.50 quickly makes you \$68.00. Write quick for free package, proof and coupon worth \$2.00. Foster Laboratories, Box 295P, Eau Claire, Wis.

DOES \$120 weekly interest you? Putnam made this selling Mystic, the amazing vest-pocket windshield cleaner; for autoists, motormen, engineers; works like magic; one rub keeps glass clear 24 hours; cleans entire shield; sheds water like a duck's back; not a cloth or glove but chemical felt, the new discovery; enameled steel mountings; very snappy; fits pocket; guaranteed year; sells \$1. Smoote sold 2,000 in 4 days; big profits; exclusive territory amazing details free. Security Mfg. Co., Dept. 585, Toledo, Ohio.

AGENTS and Salesmen to handle Europe's Famous Wonder Glass. A newly imported form power prism Binoculetta. A field and opera glass combined; weighs only 2½ ounces. Has a large range of vision of from five feet to several miles. Can be carried in vest pocket or ladies' purse. Write for confidential prices to agents. Samples on request. George Mayerle Optical Co., Established 27 Years, Sole Distributors for U. S. and Mexico, 960 Market St., San Francisco.

ONE man wanted in each county to sell direct to user complete line of paint and paint specialties, also Kling-Tite Asbestos Roof Cement, most successful product for waterproofing any type of roof. Big demand in town and country; anyone can sell. Permanent business that will make you \$3,000 or more per year. No capital required. We ship and collect. Commissions advanced. Kling-Tite Products Co., 557 Tacoma Bldg., Chicago.

AGENTS, \$3 a day taking orders for Insipid Tyres. Positively prevent punctures and blowouts. Guaranteed double tire mileage. Old worn-out casings will give 3 to 5 thousand miles more service. No tools needed. Just slip inside casing before replacing tube. Will not heat or pinch. Katz made over \$500 first month. Biggest thing on the market. Low priced. Write for territory. American Accessories Co., B-1078, Cincinnati, Ohio.

AGENTS Wanted to sell the finest All Wool tailored-to-measure Suits at the sensationally low price of \$26.50, which includes a good profit for you. Nothing like it in America! Values positively sensational! Competition swept aside! You Get Your Profits in Advance. Our Selling Outfit is the greatest thing of its kind ever gotten out. Large swatch tailoring samples and fashions, and a complete line of men's furnishings. Everything complete in a handsome carrying case. Good Agents make \$75.00 a week easy. Lines going fast. Write quick—enclose \$3.00 deposit as evidence of good faith. We refund your \$3.00 as soon as you sell \$100.00 worth, or at once if you are not satisfied. Outfit costs us \$15.00. This is the chance of a lifetime for good men. Write today. Goodwear (Inc.), Chicago, Dept. G-52.

ONLY one sale a day means \$200 per month! Five sales, \$1,000 per month! Marvelous new adding machine. Retail, \$15.00. Work equals \$350 machine. Adds, subtracts, multiplies, divides automatically. Speedy, accurate, durable, handsome. Five-year guarantee. Offices, stores, factories, garages, buy one to dozen. A fortune for live agents. Write quick for protected territory and free trial offer. Lightning Calculator Co., Grand Rapids, Mich.

NEW Kitchen Specialty, most suitable for either high or low pitch. Works well in stores, fairs or on street, either opener or closer. A Winner; costs \$11.00 per hundred. Newly patented, already demonstrated, itself strong seller. Hundred shipped C. O. D. Money refunded if not O. K. Send couple dollars deposit. Circular free. E. Z. Pan Lifter Company, Dept. M, East Chicago, Ind.

AGENTS: Make \$50.00 a week and up in tailoring business. Get our big swatch sample outfit—119 powerful fast-selling fabrics to retail at \$23.00—\$27.50—\$31.50—\$37.50 per suit. \$15.00 to \$20.00 cheaper than store prices. You keep \$5.00 deposit on each sale—we deliver and collect balance. Write D. A. Kennedy, 202A S. Green St., Chicago, Ill.

TAILORING Agents: \$50 Suits, \$29.50. One-price line, retail \$29.50 per suit; \$10 to \$20 cheaper than retail prices; you collect profit at once; we ship C. O. D. to customer for balance. Exclusive territory; hustlers wanted; none others considered. Write fully, state experience. Sales Manager, 831 West Adams St., Chicago, Ill.

MAIL Order Business is your opportunity. Breniser's Famous Handbooks teach how to start small, grow big. Sell merchandise, service, ideas; enormous profits. Spare time to begin. Get complete set, 10 books, \$2, and be posted. Breniser, 335A Walnut, Philadelphia. Descriptive Catalogue and big batch interesting mail order information, 25c. None free.

START in a permanent business of your own selling guaranteed Hosiery and Underwear direct from mills. No capital or experience is needed; many representatives make \$3,000 to \$5,000 per year. Become our district manager—get others working for you. Write for details to Malloch Knitting Mills, 522 Grant St., Grand Rapids, Mich.

SELL the popular Universal Ray-Deflector for auto headlights. Notable invention far superior to lenses. Meets legal requirements for glare prevention plus giving full light intensity. Retail \$1.75 per set, ready apply any car. Attractive agents' discount. Big steady business. Write now for territory. Approved Appliances Corporation, Ann Arbor, Mich.

FREE Sample. "Rain Shield Wiper." Every autoist buys quickly. Retail \$1.00—Costs You 25c—(300% Profit). No Mechanical Attachment—No Cloth. One Rub Keeps Windshield Clear 24 Hours against Rain, Snow Storm. Wonderful Side Line—Carried in Pocket. Only 1 Free Sample given away in Your Town. Hurry. Write for Yours. NuLife Auto(D)Aid Corporation, Hartford, Conn.

CABBAGE Cutter, 5 knives, slices 20 vegetables finer than aluminum; never dulls; 18,000 users Cincinnati alone; endorsed by Good Housekeeping Institute. Agent's sample 48c. Meyer Co., Orland Ave., Cincinnati, Ohio.

AGENTS—We want more live demonstrator-agents to demonstrate and take orders for our Ideal Fiber Cutter. We furnish advance advertising matter, folders, etc., and guarantee exclusive territory to producers. High-grade article and big profits. Write immediately for details. M. H. Tyler Mfg. Co., Dept. 83, Muncie, Ind.

\$5,000 IS yours in 1922. Greatest Ford Accessory ever invented. Brand new—just out—no competition—sells on sight. Exclusive territory going fast. Reserve your county today and own a big, pleasant, profitable business tomorrow. Leslie F. Muter Company, 32 W. 69th Street, Chicago, Ill.

\$1,000 MADE by Wingo in six weeks selling Never Fail Razor Sharpeners. Purdy made \$40.50 first day. Other inexperienced men cleaning up big money. Applewhite, La., six orders in thirty minutes. Hurry—investigate—exclusive territory. Write today. Never Fail Co., 126 Allen Bldg., Toledo, O.

AMBITIOUS men, write today for attractive proposition, selling subscriptions to America's most popular automobile magazine. Every car owner, mechanic, garage-man interested. Quick and easy to sell. 100% profit. Pleasant work. Devote all or spare time. Automobile Digest, A595 Butler Bldg., Cincinnati.

AGENTS: Ever-Clean Windshield Wiper. Chemically treated cloth, rubbed over windshield causes rain, sleet or snow to run off as if by magic. Easy to sell. Nearly every auto owner buys. Big profits. Sample 50c. Auto Products Co., Marion, Ind.

AGENTS, Canvasers: Hard times cause many crimes. Hence the unprecedented demand for the inexpensive safety window catch we manufacture. Without an equal. Attached instantly without tools. Sells to housewives at sight. Burg-La-Proof Window Catch Mfg. Co., Everett, Mass.

UNDERSELL retailers. Complete line, factory to consumer, shirts. Sure, fast sellers. Price sells them; quality gets repeat orders. \$15 daily easy. Free samples to workers. Chicago Shirt Co., 209 So. Wells St., Room 954, Chicago.

AGENTS, Sell Mengo Sticette Patches for tires and tubes. Every Auto Owner and Dealer buys. Exclusive territory. Write for free sample and sales plan. Mengo Products Co., 505 Rosedale, Pittsburgh, Pa.

AGENTS—\$60-\$200 a week. Free Samples. Gold Sign letters anyone can put on store windows. Liberal offer to general agents. Metallic Letter Co., 431-C N. Clark St., Chicago.

WRITE for proposition on my three \$1.00 sellers: Ladies' Art Needle, Universal Soap Slicer, Easy-way Rug Machine. Eugene Marquis, 5209 North Keystone, Indianapolis, Ind.

AGENTS—Big profits in our E-Z-Put curtain rod, for homes, schools, factories. Sells at sight. Field unlimited. Big repeat orders. Write at once. Western Tube & Wire Co., 719 Lucas Ave., St. Louis, Mo.

NEEDLE Books are the best agents' proposition. We have the best, flashiest, cheapest Needle Books on the market. English make. Also self-threading needles. Send for samples and prices. Atlas Needle Works, 141 E. 23d St., New York.

FREE sample to agents. Magic Cloth. One rub on windshield and no rain, snow or fog can blur. Glass keeps clear. Be first in field; big profits. Perfect Laboratories, 312-C Lee St., Wichita Falls, Tex.

SELFOLITE—Agents, Streetmen—Selfolite lights any fire while user sleeps, or any time. Performs surprising stunts. Newly patented. Sample 25c, postpaid; money back. Particulars. Kaytwo Mfg. Co., C195 Station A, Boston, Mass.

\$10.00 A DAY Easily Earned; Seven Bar Boxes, Assorted Soaps, Perfumes, Combination Boxes; Selling like Hot Cakes. Men, Women, 100% profit. Catalog mailed free. Dept. 188, Crofts & Reed Co., Chicago.

AGENTS—Tilting locking larger wheel for Fords; retail \$7.50; easily installed; big commissions; easily sold; make \$50-\$100 weekly; exclusive territory. Harkleroad, 2204 Michigan, Chicago.

"ELEKTRO" Strop sharpens knives instantly. New. Unique. Sells 50c. Big, sure profits. \$10-\$20 per day. Dox \$2.00. Sample 25c. Agents, act quick. Carroll Co., 108 S. LaSalle St., Chicago.

AGENTS, make sixty dollars per week selling new Sallie May "Dressup" Aprons. Write and learn how to obtain samples without cost. Moss Apron Co., 58 Searle Bldg., Rochester, N. Y.

EARN Big Money Fast applying Lithogram Initials to automobile doors. Every owner buys. \$1.35 Profit on each sale. Full particulars mailed. Address, Lithogram Company, 17-8 East Orange, N. J.

WINTER months are money-makers. \$10 to \$50 a day selling Kema Windshield Kiths. Liberal proposition. Address, Munyan & Myers, Dept. K, Fairton, N. J.

MAKE Money at home making toys—we show you how. Send 50c (no stamps) for complete working drawings and instructions. Dekalb Designing Co., Decatur, Ga.

AGENTS Wanted. Big Profits. Vetex Transformers needed on every automobile. Saves gas—makes starting easier. Costs 60c. Sells \$2. Vetex Co., 521 Jackson, Chicago.

FREE—500 Ford cars to be given away; also cash for your spare time. Write for particulars. Universal Mfg. Co., 1110 Michigan Ave., Chicago.

AGENTS, Make \$1.50 on every shirt order from manufacturer direct to wearer. Address, Menxin Shirt Co., 3863 Third Ave., New York City, N. Y.

STRUCK "pay dirt" yet? Panaco Products are paying "claims." Samples and copy Agents' Illustrated Magazine 25c. Panaco, Box 5, Cambridge, 40, Mass.

AGENTS—Shoes: Big money easily made. All-leather shoes, \$5.45. Write R. B. Shoe Co., 115 So. Dearborn St., Chicago, Ill.

EARN \$60-\$100 weekly selling new auto necessity—to avoid glaring headlights. Nothing like it; all autoists buy on sight. American Reflector Co., Dept. 30, Hammond, Ind.

NEW absolute necessity, all business houses must have; costs 15c, sells for \$1.50. Tremendous profits for the early birds. Outfit 15c. Texply Co., Somerville, N. J.

\$40.00 WEEKLY (whole or part time) selling guaranteed Hose, Waterproof Aprons, Shampoo Capes, Toilet and Sanitary necessities. Credit given. Jas. C. Bailey Co., Dept. M5, Chicago.

\$15 DAILY selling Matchless Gas Lighters, 300% profit. Samples 10c. Rapid Mfg. Co., 10 E. 14th St., New York.

SELL Self-threading Sewing Needles. 25c seller costs 4c. Sample paper 10c. Hutter Specialties, Box 222, Milton, N. Y.

MOLES—Warts—False Growths removed without knife, blood or pain. 1922 Wonder. Gregor Kalisnik, Duluth, Minn.

MY "Sureshot" Selling Method Free to Agents. K. Home, 1957 Warren, Chicago.

PATENTS—Trademarks. Before disclosing an invention, the inventor should write for my blank form Evidence of Conception. This should be signed, witnessed and returned to me with sketch or model, upon receipt of which I will promptly render opinion as to patentable nature and send booklet on Patents. Highest references. Prompt attention. Reasonable terms s. Clarence B. O'Brien, Registered Patent Lawyer, Woodward Bldg., Washington, D. C.

DOUBLE your money. Sell to druggists and homes: Electronic medicinal Herbs, blood purifier, stomach tonic, colds, grip, etc. Polish, Bohemian, Russian, Slovak, etc., agents establish a steady income. Great demand. 50 cents in stamps for sample worth \$1.00, returned if agency accepted. Exclusive territory for crew managers. Electronic Remedy Co., 2008 N. Robey St., Chicago, Ill.

\$15 A DAY Easy—Red Hot Seller. "Simple Ironing Board Covers." Something new—just out. Women buy this article on sight. Your profit \$9 dozen. Easily sell one to two dozen daily. New agent sold eight in 40 minutes. Write quick. W. J. Lynch, Box 621, Springfield, Ill.

COUNTY distributors wanted throughout the entire country on automobile accessories manufactured by an old and established firm. All live items, big profits, nets 100%. Easy seller, as every car owner a prospect. Write for details. Dept. A, Moto Manufacturing Co., Incorporated, 616 W. Monroe St., Chicago.

AGENTS—Make big money selling Cats' Claw Brush Cleaners—Newly patented—Nothing like it—No competition—Sells on sight. Send 15c for sample and particulars. The Den-Wal Sales Co., Dept. C, 180 Market St., Newark, N. J.

SELL like hot cakes; big profits; ironing wax pad and asbestos rest, perfumes clothes; working outfit, 10c. Yankee Mfrs., 330 Atlantic Ave., Brooklyn, N. Y.

AGENTS—Wanted—Men or women. Mother Goose Wringer Mop is a whirlwind seller. New—Patented—Perfect. Demonstration means sale. Retail \$1.50. More than 100% profit. Sample mailed \$1.00. The Alline Company, 6523 Euclid Avenue, Cleveland, Ohio.

PROTECT your rights. Write for "Record of Invention" which contains form to establish evidence of conception of your invention. Prompt personal service. Preliminary advice without charge. J. Reaney Kelly, 612 G, Columbian Bldg., Washington, D. C.

FASTEST Selling Ford specialty on market; 500,000 will be sold next six months. Splendid proposition; write quick; \$5.00 brings sample and full details. Write O. B. Herth Mfg. Co., Inc., Hartford, Conn.

QUICK Seller, New Improved Midget Collapsible Hangers. Strong—attractive—penknife size in leather case. Everybody wants them. 100% profit. Sample 35c. Write for details. Kalina Co., 384-B, Alabama Ave., Brooklyn, N. Y.

WHY work for others? Make and sell your own goods. We show you how. Enormous profits. Write quick for free book explaining everything. National Scientific Laboratories, 624 Main, Richmond, Va.

AGENTS, we have the finest needle case. You can clear \$50.00 to \$200.00 weekly. Send 10c for sample, sells 25c. Empire Specialties Co., 1549 N. Wells, Dept. 301, Chicago, Ill.

MAKE big money selling leather bill folds and receipt cases, with name and lodge emblem Gold-stamped thereon. Postal will bring a good proposition. Fraternal Leather Goods Co., Coshocton, Ohio.

AGENTS—Distributors make 100% profit; Wonderful Mikaloth. Sells on sight; polishes silverware and other metals without powders or pastes; great opportunity for hustlers. Miller Brothers, Allendale, N. J.

AGENTS, Concessors: Enormous profits selling face powder, soaps, other toilet necessities. Permanent repeat business. Highest quality. Lowest prices. National Products, A16 E. 13th St., New York, N. Y.

AGENTS, we have 150 names of Mail Order Houses that buy mailing lists. This list sent upon receipt of \$2.00. Address, Taliaferro Farmer's Directories, Fort Worth, Texas.

AGENTS—Sell Our Marvel Can Opener. Make \$4 on every \$2 invested. Our tip—your opportunity. Write us now. Staples Mfg. Co., Mt. Vernon, Ind.

AGENTS: \$10 Daily, Selling our Vest-pocket Safety Razor. Uses Gillette Blades. Sample \$1.00. L. D. Thompson & Co., 4011 S. State St., Chicago.

AGENTS: Big Profits. Genuine Gold Leaf Window Letters anyone can put up. Scripts and 57 varieties. Chicago Agency Co., 842 Altgeld St., Chicago.

AGENTS, Big Profits. Gold Sign Letters, easily applied. Best and cheapest manufactured. Samples free. Interstate Sign, Dept. C, 2629 N. Halsted St., Chicago.

MONEY easily earned quick selling self-threading needles for failing eyesight, 25c. Hundred packages \$11.25, prepaid. American Mantle Co., Anderson, Ind.

AGENTS wanted to handle good automobile accessory line. Fine commissions. J. D. Ignition Construction Co., 6724 Low Ave., Chicago, Ill.

AGENTS—Big profits selling "Wunrub Polish" for Furniture, Woodwork, Autos, Etc. Cleans and Polishes. Fritch's Laboratories, 6431 Magnolia, Chicago.

\$25 DAILY, Soliciting Blades or Selling Finest Improved \$1.00 Double-Edge Razor. Standard Safety Razor Corp., Pittsburgh, Pa.

BIG money made silvering mirrors and plating tableware. Outfits furnished. E. Decie Laboratories, 286 Fifth Avenue, New York.

SALES representatives everywhere. Household necessity. Whirlwind seller. Sample 25c. Address, Box 591, New Haven, Conn.

WANTED Distributors for patented Improved Mud Chain. For information write Maurice Frank, Anthon, Iowa.

WONDERFUL article for direct selling. Address, Sanitary Mfg. Supply, Dept. 5, Akron, Ohio.

SELL my newest, useful necktie device. Box 237, Elgin, Ill.

MEN—300—wanted at once; the Music Chest, something new; amusement and entertainment made universal; easily carried with you anywhere. We paid Ted Gnan \$4,455 for four months' work; Gratz made \$394 one week; Jest made \$7,285 in six months; eight men placed over 15,000 music chests; send for terms, free sample. Thomas Mfg. Co., Class 2462, Dayton, Ohio.

\$5.00 to \$10.00 A DAY easily earned taking orders for High Grade Toilet and Laundry Soaps, Toilet Articles, Flavoring Extracts, Spices, Puddings, 7 bars Assorted Soap in Fancy Boxes, Big sellers. Our goods well known, nationally advertised. 100% profit. Write for catalog. Men and women everywhere make good money. Crofts & Reed Co., Dept. 223, Chicago.

SALES Agents, men or women: \$6 a day taking orders for new heat indicator for city and country homes. New invention. Tells exact heat in any oven. No guesswork when baking or cooking. Low priced. Big demand. Every housewife wants one. Write for terms and sample. Jennings Mfg. Co., Dept. 1368, Dayton, Ohio.

AGENTS: Make \$10 to \$20 daily taking orders for pure silk and silk and wool hosiery for men and women. We deliver for you direct from mill to home. Wonderful proposition. Be the first to take orders for us in your town. Write Pure Silk Hosiery Mills, Dept. PM, Masonic Temple, Chicago, Ill.

"HOW to Sell Patents" free. Patent News-H. Washington, D. C.

AGENTS—Brand new Wireless Umbrella. Two handles. Can be used by lady or gent. Only umbrella ever made without wires to hold stays in place. Handles collapse to fit suitcase. Not sold in stores. Popular prices. Write for sample. Parker Mfg. Co., 478 Dike St., Dayton, Ohio.

AGENTS—Quick sales, big profits. Outfit free. Cash or credit. Sales in every home for our high-class line of Pure Food Products. Soaps, Perfumes, Toilet Articles, etc. Write today for money-making plan. American Products Co., 5722 American Bldg., Cincinnati, Ohio.

AGENTS—\$50 a week taking orders for guaranteed hosiery for men, women and children. Must wear 12 months or replaced free. All styles and finest line of silk hose. Write for sample outfit. Thomas Mfg. Co., Class 262, Dayton, Ohio.

AIR-FILLED puncture sealing inner tubes. Fully guaranteed. Nothing like it. Autoists buy on sight. Enormous profits. Exclusive protected territory for producers. Wenstone Rubber Products Co., 3023 Indiana Ave., Dept. A, Chicago.

AGENTS See our display advertisement on page 129 in this magazine, then write us immediately. Wide awake agents need no other line. Address, Sales Dept., The Kazo Company, Cambridge, 39, Mass.

RAYLITE diamonds, marvelous gem discovery, true diamond color—beautiful guaranteed rings, jewelry, specialties, stretching knif buttons at factory prices. Big profits. Exclusive territory. Master Jewelers (pm), Sheboygan, Wis.

BEST and absolutely new articles for real live men to sell to trade and individuals. Big money. Fine repeaters. Fast sellers. Smith, 1316 N. American Bldg., Chicago.

WANTED—Agents everywhere to sell Visiting Cards and Social Stationery on generous commission plan. Write today to Forman Printery, Box 75X, Plantsville, Conn.

START your Ford in coldest weather, new invention, saves gasoline. Agents, Dealers, Ford Owners, write Jir Specialties Co., Cincinnati, O.

AGENTS' Money Maker—Presto Puncher. Sample 35c postpaid. The Idea Factory, 627 Texas St., Shreveport, La.

GET Posted for Spring. Good prices paid for butterflies, insects. See Sinclair's Display Advertisement, page 68.

NEEDED in every home. Sells at sight. Best profits. Central Mfg. Co., Fairfield, Iowa.

HOW and What to Invent for profit, free. Patent News-A, Washington, D. C.

HIGHEST prices paid for names. Easterbalm Co., 1827 Welton, Denver, Colo.

800% PROFIT, Agents' Sample Free. M. Barnard, 3019 Van Buren, Chicago.

MAKE \$50 Daily. Something New! 400% profit. All business, professional men need it. Sells \$5. Costs \$1. Brooks, Texas, sold 20 first day, profit \$80. Big weekly repeater. Sells quickly. Experience unnecessary. Write today for territory wanted. Sample outfit free. Federal Association, 71-K Asylum St., Hartford, Conn.

POCKET Electric Flashlight generates own electricity. Never needs battery. New imported novelty. Sells at sight. Louis Frank, 2 W. 134th St., New York.

WANTED agents to sell Pipeless Furnaces direct to the property owner or to the dealer. Our profit on each sale is \$50.00. Chas. P. Kulp Co., 1607-11 S. State St., Chicago.

AGENTS wanted; Automobile and Household specialties. Send for catalogue. M. W. Pettibone, 1425 Broadway, Detroit, Mich.

WOULD good durable paints and varnish 40c gallon interest you? Then write today. Dept. 2, Emmelmann Bros. Mfg. Co., Indianapolis, Ind.

SALES Folks: You want a timely product; repeat orders sure; profits plenty; advancement certain; and a plan that's failure-proof? Then write us! Address, The Robb-Tynan Co., Dept. 5, Bellefontaine, O.

"CALIFORNIA Buckskin Garment Mender" repairs clothing without thread. Housewives delighted. Enthusiastic agents coin-ing money. Splendid sideline. Attractive proposition and sample package free. Address, Norman Ovi, East San Diego, Calif.

MAKE thousands of dollars selling our exclusive Oriental Pearl Necklaces at importers prices. Enormous demand. Special sales plan mailing circulars. Write quick. McCallister Co., 1499 Union Street, San Francisco, Calif.

YOU can make \$12,000 a year selling well-known, standard, advertised make of hand-drawn chemical fire engines, motor fire apparatus, extinguishers, hose, and complete line of fire-fighting sundries. We have several openings in good territories. Other men are making \$1,000 a month in territories not so good as we now offer. Address Ajax Fire Engine Works, Bush Terminal Bldg., 10, Brooklyn, N. Y.

GENERAL Agents, Something New. Whirlwind seller. "Repeat" washing powder. Washes clothes without rubbing. Women throw away washboards. Big profits. Exclusive territory. Write today, free package. Kittredge Co., 8 Putnam St., Tunksanock, Pa.

GUARANTEED Brushes: 113 different kinds—household—commercial—auto. Tremendous sellers, everyone a prospect. Permanent business—Steady income. Write or wire Desk 6. Universal Brush Company, 181 Quincy Street, Chicago.

AGENTS! A sale in every home for our beautiful dress goods, silks and general yard goods. Quick sales! Big profits! Large book of 1000 handsome fabric samples. Write today. National Importing & Mfg. Co., Dept. 6X, 573 Broadway, New York, N. Y.

TAILORING Agents wanted in every town. We can use merchants, salesmen, foremen, barbers and cleaners who can sell ten or more suits a season. We ship free our large spring sample outfit showing over 250 all wool samples at \$15.00 and up for all wool guaranteed suit. This is an agency proposition. Write today for book or traveling. Dept. P., Jay Rose & Co., 411 S. Wells St., Chicago, Ill.

AGENTS—Big money, \$8 to \$16 a day. Aluminum handle cutlery set. Brand new. You display and take orders. We deliver and collect. Pay you daily. Sample free. Try it out. Jennings Mfg. Co., Dept. 1668, Dayton, Ohio.

PORTRAIT Agents—\$50,000 is what "Picture Man Friedman" made canvassing. Free circular "Profits in Portraits" tells how. 24-hour service prints, finished portraits, frames. Samples free. "Picture Man Friedman," Dept. 8, 127 N. Dearborn St., Chicago.

BUILD Permanent Business following our Sure Success Plan introducing Guaranteed Hosiery and Underwear from factory to family. Attractive outfit assures quick sales. Large profits. Investigate for yourself. Address C & D Company, 41-B, Grand Rapids, Mich.

MEN and women make \$100 upwards weekly selling greatest labor and money saving household necessity. Big repeater. Good crew managers' proposition. Free sample and particulars. Holly Co., A-1, Hastings, Neb.

\$1,000 PER man per county. Get yours. Inexperienced men pulling down star salesmen's profits. Write for proof: How farmers, ministers, clerks—men in all walks of life—made big money in whole or spare time. You can do it. Amazing proposition—wanted everywhere. Exclusive territory—no sales limit. A hot or cold running water bath equipment for any home at only \$7.50. Self-heating. No plumbing nor water works required. Investigate. Terms. Send no money. Write letter or postal today. Allen Mfg. Co., 654 Allen Bldg., Toledo, Ohio.

PORTRAIT Agents—A new portrait, something entirely different. Write for particulars, also catalogue and price list. Fidelity Portrait Company, Dept. 100, 3047 Harrison St., Chicago, Ill.

BIG Line—Big Profits—Cold Creams, face powders, perfumes, remedies, spices, extracts, pie fillers, baking powder. Catalog free. Western Laboratories, 1964 Van Buren, Chicago.

BIGGEST, fastest sellers. Every woman buys Hawkins' High Grade Toilet and Household Necessities on sight. 100% profit. Colonial Chemical Co., 631A Penn Ave., Pittsburgh, Pa.

A BUSINESS of Your Own—Make sparkling glass name plates, numbers, checkerboards, medallion signs. Big illustrated book free. E. Palmer, 30 Wooster, O.

WE pay \$200 monthly salary, furnish rig and expenses to all who qualify introducing guaranteed poultry and stock powders. Bigler Company, X368, Springfield, Illinois.

AUTOMOBILE Accidents prevented by new invention; costs distributor \$2.50, delivered; retails at \$7; wonderful self-selling plan. Carl Brown, Manager, Dept. 32, Columbus, Ohio.

GOOD income, spare time, refinishing chandeliers, brass beds, automobiles, etc., by new method; producing amazing results; every household possible customer; experience unnecessary; simple plan of manufacturing at home starts you in big money-making business. Write for free samples, showing finishes, etc. Gunmetal Finish Co., Ave. H, Decatur, Ill.

AGENTS—New patented article. Enormous profits. Everyone a prospect. Sample 10c. Gits, 3561 Fifth Ave., Chicago.

GALLAGHER made \$336.00 in one week selling guaranteed Collection Systems, used by all business men. Savers Cabinet Mfg. Co., 2815 Sheffield Ave., Chicago, Ill.

COPPER Pots, all sizes; also anything in copper goods desired. Write today for free catalog. Boyer & Co., 609 Reserve Bank Bldg., Omaha, Neb.

O-HELL-O, why didn't I see this before. \$1 an hour selling new product. Removes iron rust, mildew, fruit, ink, medicine and grass stain. Write for free sample and terms today. C. H. Stuart & Co., 24 Broadway, Newark, New York.

AGENTS Wanted, to sell an improved tool that often pays for itself first time used. Address today. J. 1940 Georgia St., Los Angeles, Calif.

AGENTS, male and female, new line necessities for home, office, Auto. P. O. Box 82, East Boston, Mass.

AGENTS: Self-threading needles. Every home buys. 175% profit. Sample free. Maher Co., Dover, N. J.

PORTRAIT Agents—Earn Big Money selling our Photo Medallions. Everybody buys. You charge \$3.00; make \$2.40 each sale. \$10 daily easy. Big variety designs. Quick service. Write Pudlin & Perry, Incorporated, Section 16, 340 Bowery, New York.

GOLD Leaf Sign Letters; make and sell; profits exceed 1,600%; immense demand; particulars free. Johnston Co., Quincy, Ill.

AGENTS—Tense Remedies 200%. Address Int'l. Remedy Co., 1831 Franklin, St. Louis, Mo.

BIG Profits Selling New \$3.50 Automatic Adding Machine. Absolutely accurate. Fully guaranteed. Quick sales. Ten daily easy. No competition. Pocket size. Business people everywhere positive customers. Thousands being sold. Tremendous demand. Here's high-grade money-maker. Bassett Co., 1458W Hollywood Ave., Chicago.

FOR the Holidays. Our Ex-Col Luminous Crucifix which "shines in the dark" is the most appropriate gift of all. An instant to demonstrate and the sale is made. Big profits. W. G. Hannan Co., Dept. B, 57 East 18th St., Chicago.

AGENTS! 1921's greatest sensation. 11-piece toilet article set selling like blazes at \$1.75 with \$1.00 dressmaker's shears free to each customer. Get lined up for Christmas rush. E. M. Davis Co., Dept. 504, Chicago.

FASTEST Selling Sanitary Brush Line in America. Huge profit-making opportunity for live workers, with advancement. Other specialties. Get complete details. Act quick. Best season at hand. A. A. Silver-Chamberlain Co., Clayton, N. J.

AGENTS, Salesmen, Canvassers, \$10 per day selling our Guaranteed Waterproof Aprons. \$4 per dozen; sample apron 50c. Meeker Sales, 192 Market Street, Newark, N. J.

AGENTS, Men or Women, full or spare time, earn \$25.00 to \$100.00 a week and be your own boss representing the Ho-Ro-Co Mfg. Co., manufacturers of the wonderful Ho-Ro-Co Tonic, the great blood purifier and system builder; some profit-maker. Ho-Ro-Co Medicated Skin and Scalp Soap for the baby, toilet, bath, skin and scalp; a repeater. Over 100 other fast-selling specialties, toilet preparations, perfumes, flavoring extracts, spices, medicinal preparations and household specialties. Every item a fast seller and a big profit-maker. Don't fail to ask for our free sample case offer. We furnish advertising matter and samples free of charge. Ho-Ro-Co representatives are successful. Write today. Ho-Ro-Co Mfg. Co., 154 Locust St., St. Louis, Mo.

AGENTS—Send for sample "Fretnot"—the washday wonder. Be convinced you can do a whirlwind business. You can clear at least \$20 to \$100 weekly, according to spare or whole time. You don't have to talk; if she doesn't buy at sight, leave sample; she will be looking for you long before you are able to make the rounds again. Samples furnished free. Premiums for your customers. Exclusive territory guaranteed to agents who can produce. Credits given. Don't call. P. M. Mosier & Sons, 20 E. Jackson Blvd., Chicago.

WONDERFUL Winter Auto Necessity invention. \$1.00 sale means 75 cents profit for you. Experience unnecessary. Absolutely New Specialty. Riley made \$108 three days. Stocum first hour made \$10. Every Automobillist buys after each quick demonstration. Carried in Pocket. Prevents Accidents. Better Service. Reduces Operating and Repair Expenses. Write Quick for Exclusive Territory and Free Sample. Secretary, Box 494, Hartford, Conn.

AGENTS—New Invention. Harper's Ten-Use Brush Set and Fibre Broom. It sweeps, washes and dries upstairs windows, scrubs and mops floors and does five other things. Big profits; easy seller. Free trial offer. Harper Brush Works, Dept. X, Fairfield, Iowa.

EASY, pleasant work for Mechanics, Shop Men, Clerks, during spare hours; will add many dollars to their salaries. Also want persons who can give full time. Big wages assured. Novelty Cutlery Co., 67 Bar St., Canton, O.

IF you need good live agents—fellows who can get the business—ask me how others are doing it. I'll gladly render the necessary assistance. J. Roy McClellan, Mgr. Classified Advertising. Popular Mechanics Magazine, Chicago.

BE Successful Agent—Free sample outfit worth \$2.25. "Quality" beauty preparations. Make big money. Extensive line. Established 50 years. Lynas Co., 216, Logansport, Ind.

ANY man handy with paint brush can start new mechanical business on nearly nothing; needed everywhere; nearly all profit; experience not required. John Braceland, 1457 So. Ninth, Philadelphia, Pa.

AGENTS Wanted—Something New—Fire Fighter sells easily. Makes a spectacular demonstration—car owners, homes, factories, stores practically buy on sight. Our men make \$10 to \$50 a day—exclusive territory. If you wish to establish a business of your own with unlimited possibilities for making big money, write us today. Fyr-Fyter Co., 103 Fyr-Fyter Bldg., Dayton, Ohio.

AGENTS make 140% profit. Iradium (luminous) crucifix shines in the dark. Sells for \$2.00. Costs 84c. Complete line religious articles, crucifixes, bulbs, switch plates, house numbers and match boxes. Novel! Ornamental! Useful! Every home a prospect. Big sales. Get free demonstrating outfit. The Pioneer Corporation, 1259 W. 63d St., Chicago, Ill.

"PEERLESS" Plate Glass Wind Deflectors give every car that "million-dollar" look. Most popular necessity ever invented. Handsome. Durable. Quickly demonstrated and attached. A fortune for live agents. Write Quick for liberal trial offer and illustrated booklet. Rapid Sales Corporation, 10-A, Grand Rapids, Mich.

AGENTS—Clever Invention! Inkspoon makes every pen a fountain pen. Fast office seller; big profit, demand increasing everywhere. Exclusive territory offered. Sample free. H. Marui Company, Tribune Bldg., New York, N. Y.

SELL washing tablets that are different. They work quicker, sell easier and at a greater profit. Get our proposition. Write Newton & Co., 1 Main St., Newark, N. Y.

WRITE for particulars; best article ever offered men; costs 5c, sells quick for dollar; \$15 daily; sworn statement. Beach, 22 Express Bldg., San Diego, Cal.

FREE—Formula Catalog. S. & H. Laboratories, Boylston Building, Chicago.

SELL Necessities. Everybody needs and buys the "Business Guide." Bryant cleared \$800.00 in July. Send for sample. It's free. Nichols Co., Box 4-B, Naperville, Ill.

SIGN letters for windows at honest prices. Genuine gold leaf. \$50 week easily made. Chicago Sign System F, 150 W. Austin Ave., Chicago.

AGENTS make 500% profit handling Auto Monograms, New Pictures, Window Letters, Transfer Flags, Novelty Signs. Catalog Free. Write Hinton Co., Star City, Ind.

AGENTS: Men and women, in spare of full time, make big money selling household necessity. Every home a prospect. Quick sales, big profit. Territory open. Write for particulars. Judd & Leland Manufacturing Company, Box 21, Clifton Springs, N. Y.

AGENTS—Steady Income. Large manufacturer of Handkerchiefs and Dress Goods, etc., wishes representative in each locality. Factory to consumer. Big profits, honest goods. Whole or spare time. Credit given. Send for particulars. Freeport Mfg. Co., 59 Main St., Brooklyn, N. Y.

STOP Making Money for Others. Manufacture These Goods Yourself From Miller's Guaranteed Manufacturer's Formulas—Profits Enormous, Investment Small. Business Quickly Established—Stamp Brings Valuable Literature Regarding Magic Windshield Cloth; Amazon Rubber Repair Laundry; Stovoff, Bluing Paddies, Mexican Yucca Soap, Food, Automobile, Household Specialties in all lines. Get this Valuable Literature. Miller Chemist (Old Reliable, Established 1897), Tampa, Florida.

LARGE shirt manufacturer wants Agents to sell complete line of shirts direct to wearer. Exclusive patterns. Big values. Free samples. Madison Mills, 503 Broadway, New York.

MAKE 600% Profit. Free Samples. Lowest priced Gold window letters for stores, offices. Anybody can do it. Large demand. Exclusive territory. Big future. Sideline. Acme Letter Co., 2806-D, Congress, Chicago.

AMERICO Booster auxiliary water carburetor makes autos burn water. Eliminates carbon. Low cost; liberal profits; details free. Americo Co., Dept. 178, Cincinnati, Ohio.

WORLD'S Fastest Selling Auto Accessory! County Distributors wanted; write today. G. L. W. Spring Oiler Co., San Diego, Calif.

PORTRAIT Agents, who want good work and prompt service and who desire to purchase their frames at factory prices, should write us at once for catalog and price list. W. G. Hannan Co., Dept. A-5, 57 E. 18th St., Chicago, Ill.

AGENTS—New patented curtain rod, necessity in every home; big profit; 4 to 10 sales at every house. Write for free sample. Home Curtain Rod Co., Providence, R. I.

CALIFORNIA Rosebuds selling like hot cakes. Agents coinng money; new stuff. Big profits. Catalog free. Mission Bead Co., PM-2819, West Pico, Los Angeles.

AGENTS: Big Money Monogramming By Transfer Method. Catalogue Showing Over 50 Styles and Particulars Free. Motorists' Accessories Co., Mansfield, Ohio.

SELL Padding Powders—Delicious dessert. Fast sellers; quick repeaters; big profit. Send for terms and sample. C. H. Stuart Co., 65 Union, Newark, New York.

AGENTS make one dollar per hour selling "De Luxe Art Panels." Newest thing in art. Men with automobile make forty dollars per day. Tremendous demand. Write for samples and expense money. Consolidated Portrait Co., 225 North Green St., Chicago.

\$200 WEEKLY. Free samples. Sell gold sign letters to stores, offices. No experience. Big future guaranteed. Can travel. Exclusive territory. Become our general agent. Acme Letter Co., 2806D Congress, Chicago.

MAKE \$25 to \$50 Week representing Clow's Famous Philadelphia Hosiery, direct from mill—for men, women, children. Every pair guaranteed. Prices that win. Free book "How to Start" tells the story. George Clow Company, Desk 31, Philadelphia, Pa.

YOU can letter Automobiles, Doors, Trunks etc., without any previous experience by Transfer Process. Make \$27.50 on \$2.50 outfit. Auto Monogram Supply Co., 16 Green St., Newark, N. J.

BEST Proposition on Earth. Kitchen Specialty Every Woman Wants. Nothing like it in existence. 200% profit. Best Novelty Mfg. Co., Dept. C, 160 N. Wells, Chicago.

AGENTS and portrait men. Crew managers. We give you more for your money. Better and quicker service. Lowest prices on frames and glass. Rejects credited. Catalog free. The Pioneer Corporation, 1259-A West 63rd St., Chicago.

FAST-SELLING Sanitary Brushes, Mops, Dusters. Positively best house-to-house line in America. Write and be convinced. Sanford Brush Co., 544 W. Lake St., Chicago.

AGENTS Make \$10 a day selling Presur-own Trousers presser and creaser. Connolly, 176 Greenwich St., N. Y.

WE Start You Without a Dollar. Soaps, Extracts, Perfumes, Toilet Goods. Experience unnecessary. Carnation Co., 201 Olive, St. Louis.

AGENTS: Big profits. Best and cheapest window letters made. Easily applied. Dime brings 50c samples. Particulars free. Stairlifts Co., 1115 Second Ave., New York.

PORTRAIT Agents: Our goods will make you big profits. Delivery guaranteed. Rejects credited. Prompt shipments. Send for latest catalog and prices. Adam J. Kroll & Co., 692 Blue Island Ave., Chicago, Ill.

MAKE \$2 an Hour. Article that removes iron rust, grass, medicine, fruit, mildew stains. Cleans Panama and Straw Hats. Bleaches clothes. Sells Every home. Write for free demonstrating outfit and start taking orders at once. Christy, 81A Union, Newark, N. Y.

AGENTS: Big Returns, fast office sellers; particulars and samples free. One Dip Pen Co., 2 Daily Record, Baltimore, Md.

AGENTS make a dollar an hour. Sell Mendets, a patent patch for instantly mending leaks in all utensils. Sample package free. Collette Mfg. Co., Dept. 401-B, Amsterdam, N. Y.

WANTED—Tailoring Sales Agent—Make big money from very start—\$60.00 to \$75.00 weekly. Largest made-to-measure tailoring house, furnishing an equipment of five hundred woolsens, wants you to take orders. Satisfaction guaranteed. Biggest merchants in many towns have started with our line. If you want to establish yourself permanently in business and make big money write for full particulars, giving your experience as salesman or tailor's sales agent. H. F. Foster, Sales Manager, Lock Box 483, Chicago.

AGENTS—Best seller: Jem Rubber Repair for tires and tubes; supersedes vulcanization at saving of over 800%; put it on cold, vulcanizes itself in two minutes, and is guaranteed to last the life of the tire or tube. Sells to every auto owner and accessory dealer. For particulars how to make big money and free sample, address Amazon Rubber Co., Amazon Bldg., Philadelphia, Pa., Dept. 505.

AGENTS—If you are making less than \$300 a month our proposition on Sentinel Burglar Alarms, for windows and doors will interest you. Many agents earn \$20 daily. Brand new inventions. No wires, batteries or nails. Instantly attached to any door or window. Handsomely nickel plated. Sell on sight. No competition. Provides cheap burglar insurance. Big money makers. Write today for extremely liberal terms to agents. Sentinel Alarm Co., 140 S. Dearborn St., Chicago, Ill.

AGENTS—Stamping names on Pocket Key Protectors; sample check with your name and address, 25c. Stamping Outfits, Emblem Checks, Check Fobs, Name Plates. Hart Mfg. Co., Desk 2, 303 Degraw St., Brooklyn, N. Y.

MOST Wonderful Seller. 96c profit every dollar. No stock to carry. License unnecessary. Sample free. Mission Bead Co., 1617 Iroha, Los Angeles, Calif.

AGENTS—Advertising Pencils, ready sellers, excellent sidelines. Write for proposition. North American Pencil Works, 501 Plymouth Court, Chicago.

YOU can be your own boss with our Key Check outfit. Good for \$5 a day stamping names on pocket key checks, fobs, etc. Sample check with your name and address, 29 cents. Pease Die Works, Dept. M, Winchester, N. H.

PATENTS—Write for our free illustrated guide book and Evidence of Conception Blank. Send sketch or model for our opinion of its patentable nature free. Highest references. Prompt attention. Reasonable terms. Victor J. Evans & Co., 163 Ninth, Washington, D. C.

BIG money and Fast Sales. Every owner buys Gold Initials for his auto. You charge \$1.50; make \$1.35. Ten orders a day easy. Write for particulars and free samples. American Monogram Co., Dept. 40, East Orange, N. J.

EXCLUSIVE rights to live agents on universal fabric cement. Mends socks and clothing, rubber and leather without needle and thread. Sells to housewives and merchants. Big profits. Inter sales Company, Old Whitney Bldg., Detroit, Mich.

POLMET Polishing Cloth cleans all metals. Retail 25 cents. Sample free. Gale & Co., Inc., 15 Edinboro St., Boston.

FREE—Complete "Sanitary Cooking Ware" outfit; cost agents one dollar. Refunded on first order. National Pottery, Roseville, Ohio.

HIGH-GRADE SALESMEN WANTED

FOR 1922 we will increase our sales force. Some valuable territory open. If you are a real salesman and want to build a permanent business, aided by our co-operation and national advertising, with success assured from the start, write today. Goods sell to hardware, drug and general stores. Splendid commissions with liberal weekly advances to producers. Continental Company (Established 1909), 1922 Euclid Ave., Dept. 200, Cleveland, O.

SALESMEN and agents, write for money-making offer selling Toys, 33 1/2% profit. Easy sales. Eastern Toy Co., 30 Lenox St., Worcester, Mass.

LEARN the secrets of Star Salesmanship and qualify for \$3,000 to \$10,000 a year as City or Traveling Salesman. Free Employment Service. Send now for free book about our amazing system, also list of lines, National Salesmen's Training Association, Dept. 128B, Chicago, Ill.

AMBITIOUS men, write today for attractive proposition, selling subscriptions to America's most popular automobile magazine. Every car owner, mechanic, garage man interested. Quick and easy to sell. 100% profit. Pleasant work. Devote all or spare time. Automobile Digest, A505 Butler Bldg., Cincinnati.

SALESMEN can make \$5.00 a day selling our Calendars, Fans, Pencils, Signs, Advertising Novelties, Yard Sticks, Whistles, etc. Liberal terms. Sells entire year. Fine side lines. Local and traveling agencies. Model Calendar Company, Dept. 226, South Bend, Ind.

SALESMEN: Make extra money easily. Sell our Accident and Sickness policies in your spare time. \$5,000 death, \$25 weekly benefit for \$10 yearly. Address North American Accident Ins. Co., Dept. K-26, Newark, N. J.

SALESMEN: \$250.00 to \$500.00 a month easily earned by the right man. Splendid new proposition for high grade salesmen as Fraternal Organizers. Unquestionable references insisted upon. Fraternal Order Beavers, Liberty Building, Philadelphia.

\$300 PER month and bonus guaranteed salesmen successfully demonstrating wonderful new adding machine. Retail \$15.00. Work equals \$350 machine. Genuine opportunity. Full time or side-line. Lightning Calculator Co., Dept. G, Grand Rapids, Mich.

AGENTS—\$60-\$200 a week. Free samples. Gold sign letters anyone can put on store windows. Liberal offer to general agents. Metallic Letter Co., 431-E N. Clark St., Chicago.

BIG Profits Easy. Duplex Transformers needed on every auto. Save gas. Easily sold. Exclusive Distributors wanted. Jubilee Mfg. Co., 32 Sta. C, Omaha, Nebr.

OIL Gauge for Fords. Remarkable new invention. Sells on sight. Big profits easy. Exclusive distributors wanted. Address Sales Mgr., 92 Sta. C, Omaha, Nebr.

HAVE exclusive territories to allot on quick selling advertising specialty. Address, Carry-ette Bag Company, 521 Cedar St., St. Paul, Minn.

SALESMEN with knowledge of auto engine. Fine opportunity. Marquette Mfg., 319 W. Ohio St., Chicago.

BENDING Machines. Cold bending all metals, tremendous savings, latest invention. Profitable commission. Gordon Mfg. Co., Los Angeles, Calif.

\$200 TO \$400 Weekly. Free Samples. Lowest priced Gold Sign Letters for Stores, Offices. No experience necessary. Large demand. Appoint subagents. Excellent sideline. Acme Letter Co., 2800H Congress, Chicago.

WANTED—Capable salesman to market fast selling automobile accessory. Unlimited sales during winter — exclusive territory — large profits for energetic men. Address Monroe Manufacturing Co., Box 1144, Mobile, Ala.

SOMETHING New, a necessity. All business and professional men need it. Sells \$7.50, costs you \$2.50. Big repeater. Sample free. Exclusive territory. Merchants Assn., Minneapolis, Minn.

SIDE Suspenders, \$1.00. "Outosite"; featherweight, indestructible aluminum; shirt down, pants up; no pressure on vital organs; enormous seller (agent's sample set 50c). Woods, 501 North Seventh, St. Louis.

SELLS on Sight—The Perco-Pot—a patented aluminum cooking utensil that cannot burn or boil over. Needs no watching. Food needs no stirring. Cooks thoroughly by percolation. Nationally advertised, already sold direct to thousands of housewives. Most phenomenal seller of the season. Here is a fortune for good salesmen and crew managers. Exclusive territory and liberal assistance. Write Perco Ware Company, Desk 10, Milwaukee, Wis.

\$20.00 A day easily made introducing Rite-Way Auto-Life—The newly perfected paste auto polish; demonstrates in two minutes. Makes old cars look new. Retail for \$1. Every car owner buys. Send \$1 for 2 full size Cans, instructions, territory reservation and Free sample-case offer. Sheldon Booth & Co., 922 East 41st St., Chicago.

ROOFFIX, Floorix, Firaxamel, Shinglefix, Rustfix, Glazefix, Cementfix, Silverfix; Great Profit Making Sellers; Retail and Trade. New Reduced Prices. Salesmen Wanted Every Town. Bruce made \$660 One Day, One Order. Others making spare time \$100 weekly; whole time \$850 to \$1500 monthly. Big Chance—Connect Quick, Empire Products, 1535 Chestnut, Philadelphia.

MANUFACTURER offers unusual opportunity to experienced sales manager capable of organizing crew to cover drug and grocery trade in your home territory. This is an opportunity of a lifetime for the right party. Product is fastest seller ever offered trade and the repeat business is simply phenomenal. Tremendous demand already existing with absolutely no competition. Profits should run from \$15,000 to \$35,000 per year. All replies considered confidential. State experience and qualifications fully. Boardley Specialty Co., Rock Island, Ill., Desk P.

LIVE Wire Distributors and Dealers everywhere make money selling Seal-Fast inner-tube repair kits because of the unequalled efficiency and our aggressive and helpful sales promotion and advertising co-operation. Write Sales Manager for particulars, Robert M. Bowes Co., Indianapolis, Ind.

WANTED—Salesmen—soaps, greases, oils; old manufacturer. Baum's Castorine Co., Rome, N. Y.

VENDING Machines—Peanut, Match and Gum Vendors. Excellent Line—Big Commission. Standard Adv. & Printing Company, Ft. Scott, Kans.

EVERYBODY Eats Every Day. You can handle Sugar, Flour, Canned Goods, Dried Fruit, Coffee, and entire line of groceries, as well as Paints, Roofing, Aluminum Ware and Automobile Oils, with no rent to pay; no money invested; take large orders from samples. Goods are guaranteed and proven quality. Selling experience not necessary. Steady, profitable work for "workers." Address Hitchcock-Hill Co., Dept. 200, Chicago, Ill. Reference: Any Bank or Express Co.

57 MILES per gallon made with new patented gasoline Vaporizer. Write for particulars. Vaporizer Co., Pukwana, S. Dak.

SALESMEN for Patented Cigar Lighters and Cigar Case Moisteners. Sell to Cigar Stands everywhere. Thousands in use. Exclusive or side line. Start Now. Drake Mfg. Co., Dept. M, Milwaukee, Wis.

MAKE \$50 Daily. Something New! 400% Profit. All Business, Professional Men Need It. Sells \$5. Costs \$1. Brokks, Texas, sold 20 first day, profit \$80. Big weekly repeater. Sells quickly. Experience unnecessary. Write today for territory wanted. Sample outfit free. Federal Association, 71-D Asylum St., Hartford, Conn.

HELP WANTED

AMBITIOUS men, write today for attractive proposition, selling subscriptions to America's most popular automobile magazine. Every car owner, mechanic, garage man interested. Quick and easy to sell. 100% profit. Pleasant work. Devote all or spare time. Automobile Digest, A-505 Butler Bldg., Cincinnati.

SUCCEED—Be an Automotive Electrical Specialist. Learn starting, lighting, ignition; generator, armature, magneto work; battery building, repairing. We pay fare 1,000 miles Denver. Greatest School. Free booklet. Johnson's Automotive Electrical School, 729 Broadway, Dept. L, Denver, Colo.

CLERKS for Postal Mail and Government Field Service. \$125 month. Experience unnecessary. For free particulars of examinations, write J. Leonard (former Civil Service examiner), 45 Equitable Bldg., Washington, D. C.

STORIES, poems, plays, etc., are wanted for publication. Good ideas bring big money. Submit manuscripts or write Literary Bureau, 522 Hannibal, Mo.

BOYS—Men. Become automobile experts. \$45 week. Learn while earning. Write Franklin Institute, Dept. W-401, Rochester, N. Y.

EARN \$25.00 daily taking orders for All-weather Raincoats. Permanent proposition, repeat orders. Experience unnecessary. No capital required. Write quickly for folder 9. Field Manufacturing Co., Mount Vernon, N. Y.

FIREMEN, Brakemen, Baggage-men, Pullman and train porters (colored). 810 Railway Bureau, East St. Louis, Ill.

WORK for your government. Men, Women, over 17. Steady. No "layoffs." Pleasant work. Short hours. Paid vacation. Commence \$90-\$135 month. Quick raise. Become Railway Mail Clerks—City Mail Carriers—Postoffice Clerks, Customs Clerks. Common education sufficient. Write immediately—today—for free list positions. Franklin Institute, Dept. A-3, Rochester, N. Y.

\$135 MONTH commence. U. S. Government Railway Mail Clerks. Men, Boys over 17. Steady. Vacations. List positions free. Write today sure. Franklin Institute, Dept. A-21, Rochester, N. Y.

WANTED—Men who want to earn good money while learning and establishing permanent business for themselves. Pickin & Co., 363 Commercial Bldg., Newark, N. Y.

MEN—Women, over 17. Get Government jobs. Steady. \$90-\$135 month. List free. Write immediately. Franklin Institute, Dept. A-21, Rochester, N. Y.

BECOME Government Railway Mail Clerks. \$135-195 month. List positions free. Write immediately. Franklin Institute, Dept. A-21, Rochester, N. Y.

BIG money made silvering mirrors and plating tableware. Outfits furnished. E. Deets Laboratories, 280 Fifth Avenue, New York.

GOVERNMENT wants Railway Mail Clerks. \$135 month. List positions free. Franklin Institute, Dept. A-21, Rochester, N. Y.

BE a Finger Print Expert. Particulars free. National System, 136 E. 79th, New York.

WOMEN — Girls. Become Dress-Gown Designers. \$135 month. Sample lessons free. Write Franklin Institute, Dept. W-587, Rochester, N. Y.

GOV'T. Positions Open. Railway Mail, Postoffice, Field Service, Auditors Income Tax. Short hours; Vacations; Sick-leave on Pay. Prepare for coming Examinations. Send for full particulars and free Booklet "M-1." Federal Service League, Box 1237-A, Washington, D. C.

NEW and used books; Practical, Mechanical, Automobile, Business, etc.; sold and rented. Bargains. Catalogue free. Lee Mountain, Box 101, Pisgah, Ala.

WANTED men. Become Automobile Experts. \$35 week. Sample lessons free. Write Franklin Institute, Dept. A401, Rochester, N. Y.

GET Posted for Spring. Good prices paid for butterflies, insects. See Sinclair's Display Advertisement, page 68.

GOVERNMENT needs Railway Mail Clerks, \$133 to \$192 month. Write for free specimen questions. Columbus Institute, Columbus, Ohio.

MANUFACTURERS of the most wonderful and efficient tire pumps made want representatives in every locality. Some capital required. Big profits. Exclusive territorial rights. Send Five Dollars for single and triple cylinder types, and get our liberal offer. Roberts Brass Co., Milwaukee, Wis.

SHOES—High grade, for men, direct from manufacturer. Send for proposition to salesmen. No deliveries or collections. Commission daily. Quick Shoe Co., Brockton, Mass.

UNITED States Government Wants Men. Excellent positions at attractive salaries. Railway Mail Clerk Examination soon. Let our expert (former United States Civil Service Examiner) prepare you for this and other fine positions. Write today for free catalog PM. Patterson Civil Service School, Rochester, N. Y.

DISTRICT Manager: 150,000 sales of a household appliance in New England have paid District Managers upwards of \$3,000 yearly. We are ready to expand. Office work entire or side line. The Reeves Co., 64 Broad Street, Milford, Conn.

BE a Railway Traffic Inspector! \$110 to \$250 monthly; expenses paid after 3 months' spare-time study. Splendid opportunities. Position guaranteed or money refunded. Write for free booklet CM-46. Stand. Business Training Inst., Buffalo, N. Y.

GOVERNMENT Wants Railway Mail, Postoffice Clerks. Other positions. Salary \$135 month. Experience unnecessary. Write for information concerning positions and instruction. Columbia School of Civil Service, 411 Pope Bldg., Washington, D. C.

LOCOMOTIVE Firemen, beginners \$150, later \$250 monthly, for railroads nearest their homes, everywhere in United States and Canada. Address Railway Association, Desk M-1, Brooklyn, N. Y.

START a Paying Business of Your Own. Be a business man. Any location. 8,000 new Tire Vulcanizing and Repair Stations needed. Business always good. Are you ambitious? \$100 will start you. Write at once. Wonderful opportunity. Equipment Co., 175 Canal, Cincinnati, Ohio.

SILVERING mirrors, French plate taught. Easy to learn, immense profits. Plans free. Wear Mirror Works, Excelsior Springs, Mo.

WRITE Articles, stories, news, in spare time for newspapers and magazines. Big pay. Copyright book free. Press Syndicate, 553, St. Louis, Mo.

GOVERNMENT Clerks Needed soon, (men-women). \$1600-\$2300. Permanent. Few to travel. Write Mr. Orment, Former U. S. Government Examiner, 101 St. Louis.

SIGN Letter Agents and Painters; 500% Profit Gold and Silver Sign Letters for Stores and Office Windows. Anyone can put on. Big demand. Free samples. Metallic Letter Co., 431D N. Clark St., Chicago.

CALIFORNIA Rosebuds selling like hot cakes. Agents coming money. Absolutely new. Big profits. Catalog free. Mission Bead Co., SP2819 West Pico, Los Angeles.

SALESMEN—Become Independent. Own your business; experience unnecessary; selling our \$7,500 Accidental Death, \$50 Accident, \$25 Sick Weekly Benefits; \$12.50 yearly; other amounts proportionate. Guaranteed steady income from renewals. \$250,000 deposited Insurance Department, Registration Dept. A, Newark, N. J.

INVENTORS desiring to secure patents should write for our book, "How to Get Your Patent," tells our terms and methods. Send sketch for our opinion of its patentable nature. Randolph & Co., Patent Attorneys, 620 F, Washington, D. C.

OUR genuine gold window sign letters are an excellent money-making proposition for handy men. Sign Sign System, St. Antoine St., Detroit, Mich.

MAKE money writing Photo-plays; details free to beginners. No correspondence course. Producers' League, 230 Wainwright, St. Louis.

WANTED: Railway Mail Clerks—\$1,600 to \$2,300. Exams everywhere. Write today for full information. Patterson, Civil Service Expert, Box 4025, Rochester N. Y.

FOR ADVERTISERS

SPECIAL!! Inch Display Advertisement 150 Magazines Thrice \$15. Page \$200. Wood's Popular Service, Atlantic City.

ADVERTISE. Country town newspapers. Lists free. Pennell Company, Covington, Ky.

INTERNATIONAL-Opportunity contains Inspiring, Pep-Instilling, Success-Compelling articles, poems, ideas, etc. (Copy 10c, Trial 3x Months 25c). Worldwide Circulation! Buy! Sell! Trade!—Everything!—Everywhere! 1c Word, 50c Inch. 2279 First Ave., New York.

YOUR 25-word ad. in 75 magazines \$1.00. Riley, Publisher, 1933 S. 50th Court, Cicero, Ill.

"COMMERCIAL Engraving and Printing," a remarkable new book by C. W. Hackleman, will answer any and every question which may arise concerning these subjects. A vast amount of time and thousands of dollars were expended to make this the most practical and complete book on engraving and printing and allied subjects ever published. Over 800 pages and 1500 illustrations presenting over 3500 distinct ideas on 35 separate subjects. Cloth binding. Price \$15 prepaid. We highly recommend this book. Popular Mechanics Book Dept., 6 N. Michigan Ave., Chicago.

ADVERTISE in 1,000 Corn Belt Weeklies, \$10.00 line. 25 words. 24 big Dailies, \$15.00. Booklet free. Address Union Advertising, Baltimore Bldg., Chicago.

INFORMATION

DEPENDABLE Information of practically any kind obtained and furnished for \$1.00, or money refunded. We also act as special representative in behalf of inquirers, if desired. Bank references. Address Eureka Service, 307 Jenkins Bldg., Kansas City, Mo.

LETTER SPECIALISTS

DO you want to sell it? Let my letters do it. Letters \$4.00. Leon Hatfield, Her- ington, Kan.

BIGGEST Pullers on Earth—Jacobus Letters, \$3.50. Jacobus Advertising Service, Irvington, N. J.

SUCCESSFUL sales letters, \$10. Results or fee returned. Free suggestions. Morse, 133 W. 103rd, New York.

ATTENTION—Gripping, desire-creating sales letters. So strenuous they have to bring business. Ewald, 200 East 87th, New York.

SECURE the position you want. I can give you genuine assistance. Particulars free. Floyd V. Studer, Canadian, Texas.

BUSINESS SERVICE

INCORPORATE. Our lawyers do the work, saving you time, annoyance and money in incorporating under the most liberal laws of Arizona. Laws and forms free. Southwestern Securities & Investment Co., Box D488, Phoenix, Ariz.

LITERARY SERVICE

WE Prepare Lectures, Speeches and original special articles, Expert Service, Manuscripts revised, placed. Herald Publicity Service, 415 Bristol Building, New York.

MAILING LISTS

MAILING Lists, live opportunity seekers, 1,000 names, \$1.00; 500, \$2.50. Knapp, 753 Fifteenth St., Milwaukee, Wis.

REACH best paid workers in Grand Rapids, Saginaw, Battle Creek, and Muskegon through our advertising columns. Two cents a word. Address, Michigan Associated Labor Press, Houseman Bldg., Grand Rapids, Mich.

4,000 NAMES of Dallas County farmers, showing acreage and amount assessed to each, sent upon receipt of \$2.50. Address Tallaferra Farmer's Directories, Fort Worth, Texas.

TYPEWRITERS AND SUPPLIES

UNDERWOOD Typewriters at far less than manufacturer's price; rebuilt, all worn parts replaced, guaranteed good as new. Cash, installment payments. Write for Catalogue 1512. Typewriter Emporium, estab. 1892. Montrose and Ravenswood Ave., Chicago, Ill.

TYPEWRITERS, all makes, \$15.00 up; fully guaranteed. Shipped one month's free trial. Send today for catalogue and agents' proposition. Address Peckskill Typewriter Exchange, Peckskill, N. Y.

TYPEWRITERS, \$20.00 up. All makes. Easy payments. Free trial. Payne Company, Rosedale, Kans.

REBUILT Typewriters, All Makes, \$10.00 Up. We sell for cash at prices 20 to 30 per cent lower than installment houses. Every machine fully guaranteed. Send for free descriptive circular. The M. & M. Typewriter Co., 42 N. Wells St., Chicago.

FIVE-DAY Free Trial—Underwoods—Remington—Smith—Royal—Oliver, etc., \$3 deposit, balance small monthly payments. Five-year guarantee; liberal discount for cash. Write for catalogue before buying. International Typewriter Exchange, 177 N. State St., Dept. A-5, Chicago.

DUPLICATORS AND DEVICES

"MODERN" Duplicators, Business Getters. \$2.25 up. 50 copies from pen, pencil, typewriter. No glue or gelatine. 40,000 in use. Free trial. Need one? Booklet Free. J. E. Durkin-Reeves Co., Pittsburgh, Pa.

"QUICK Process Duplicators," Makes 100 copies in 10 minutes. Remarkable time savers. Thousands in use. Circular Free. Hoyer Duplicator Co., 160-PM, N. Wells St., Chicago.

ADDING MACHINES

FREE Trial, Marvelous new Adding Machine. Adds, Subtracts, Multiplies, Divides, automatically. Work equals \$350.00 machine. Price only \$15.00. Speedy, durable, handsome. Five-year guarantee. Used by large corporations. Write today for catalogue and free trial offer. Lightning Calculator Co., Dept. E, Grand Rapids, Mich.

NEW \$3.50 Automatic Adding Machine, Adds, Subtracts, Multiplies. Absolutely accurate. Capacity \$999,999.99. Fully guaranteed. 75,000 pleased users. Makes adding easy, positive, quick. Eliminates Mistakes, Saves Time. Postpaid, \$3.50. Bassett Co., 1458-X Hollywood Ave., Chicago.

PRINTING, ENGRAVING AND MULTI-GRAPHING

100 IMITATION typewritten circular letters, 95c, prepaid. Franklin Mercantile Co., Huntington, Pa.

200 HAMMERMILL Noteheads \$1.00, samples 2c. G. C. Press, Box 224, Nashua, N. H.

MIMEOGRAPHED letters our specialty. 100, \$1.25. Samples, prices free. Name cards neatly printed, 100, 85c. T. R. Smith, Rolfe, Iowa.

SHIPPING Tag Users—our prices will interest you; write for them, Quality Print, Hudson, Wis.

250 LETTERHEADS or Envelopes, \$1.50; other printing. Samples, stamp. H. Roney, Paris, Mo.

GUMMED labels, Advertising stickers. Catalogue free. Pennell-Standard, Covington, Ky.

PRINTING AND ENGRAVING

REPRODUCTIONS quickly and clearly printed in black for inventors or Manufacturers of Newspaper articles, typewritten matter, testimonial sketches, and copies of patent drawings. Size 8x10. One hundred copies \$5. Three hundred \$10. Send money order with copy or stamps for sample of reproductions. Reliable Novelty Company, 600 F Street N. W., Washington, D. C.

100 BOOK-FORM Calling Cards \$1.25. Business size \$1.50. Process engraving and quantity prices on request. Salesman's sample case 30c. Book-Form Card Shop, 3461 Clark St., Chicago.

100 BOOK-FORM Cards with case, 85 cents; business size, 300 for \$1.75, postpaid. Arcraft Printshop, 19 Highland Ave., Elizabeth, N. J.

100 BOND Letterheads, 100 Envelopes, \$1.25. Others reasonable. Economic Press, Leona, N. J.

QUANTITY Users save 30%. Wolf Roll Labels, Sta. E, Philadelphia.

PRE-USED Printing Presses, Type and supplies. List for stamp. Popular Bargains, Richland, Pa.

EMBOSSING business, personal stationery. Samples, stamp. Daniels Co., Pittston, Pa.

1,000 LETTERHEADS or Envelopes, \$3.00, sent prepaid. Samples Free. Monitor Press, Morrillville, Pa.

REDUCED prices for better printing. 1,000 Bond letter-heads, \$5.00; 1,000 good envelopes, \$4.25; 1,000 four-page folders, 3 1/2 x 6 1/2 inches, \$12.00. Catalogues, circulars, booklets our specialty. All printing at reduced prices. Samples free. Fantus, 525 S. Dearborn St., Chicago.

TWO-COLOR Quality Printing for price of one. Samples, Arrow Print, 333P Walnut, Waterbury, Conn.

1000 FULL-SIZE Hammermill Bond Letterheads \$3.65. Postpaid. Other stationery in proportion. Business building Multigraph letters cheap. Samples free. Charles B. Hatfield, Box 353, Owego, N. Y.

250 LETTERHEADS, 250 White Envelopes, printed and mailed, \$3.00. Samples printing free. Write Sun, Mohawk, N. Y.

2,000 LETTERHEADS or Envelopes \$7.50 prepaid 3rd zone. Samples Free. Quality Printery, Marietta, Ohio.

PRINTING Outfits—Presses, type supplies, type novelties. Send stamp for catalogue. Model Press, York, Penna.

FOR MEN

SHAVE with comfort. Flexible Mirror helps wonderfully. Descriptive Circular free. Brandaw Company, 970 Atlas Bldg., San Francisco, Calif.

FOUR ounce "Handy" creases trousers in three minutes. \$1 postpaid. Acquaduck Mfg. Co., Portsmouth, R. I.

I WANT to send Free to every chronic pipe smoker in the country a good, big, generous sample package of my pure, succored, nature-flavored Old Green River Pipe Tobacco. No money to pay. If you are a tobacco crank, all the better. Try the pure stuff. No syrup, flavoring or dope. After you try it free, I'll show you how to cut your smoke bill one-half and get more pipe joy. Just send name and address, and say whether you want mild, medium or strong. Pete Moberly, Box 820, Owensboro, Ky.

RAZORS AND BLADES SHARPENED

TO every reader of Popular Mechanics Magazine we will send one of our patent one-piece safety razors, with three blades, for advertising purposes. Send 25c for shipping expenses. Midgett Razor Co., Room 3, 616 N. Michigan Ave., Chicago, Ill.

BLADES Resharpended 3c, any make. Straight Razors, 50c. Guaranteed Service. Standard Safety Razor Corporation, Pittsburgh, Pa.

BLADES re-sharpended. One edge 2c, double 3c each. Straight razors ground 75c. New York Edge Co., Glen Cove, N. Y.

GUNS, SPORTING GOODS, ETC.

WANTED—Good shotgun and pistol. Durso, 25 Mulberry, N. Y. City.

LUGER and Mauser Pistols; Mauser Sporting Rifles. Circular ten cents. Pacific Sales, Ltd., Moscow, Idaho.

BOATS AND LAUNCHES

16' ROWBOAT—Construction blueprint, 30c. Wee-Sho-U Co., West Market, Detroit, Mich.

"HOW to make your boat leakproof." Send for booklets. L. W. Ferdinand & Co., 152 Kneeland St., Boston, Mass.

TURN your boat into a high speed launch with one of these twelve-cylinder Motors. Displacement 530 cu. in., 32" long, 39" wide, 39" high; 66 h. p. and up. \$985. Can replace standard parts the world over. Triple Block Motor Works, Box 233, Garfield, Wash.

OPTICAL GOODS

ULTRALENS microscope. Patents pending. Magnifies 25,000 times, 75c. Adjustable power model magnifying up to 100,000 times, \$1.50. Others up to 250,000 times. Something new. Circular P-3 free. Specialty Mfg. Co., Milton, Penna.

DIAMONDS, WATCHES AND JEWELRY

MONTANA White Sapphires, very brilliantly cut. 1 carat size, \$3.50; sent C.O.D. Price on other gems on request. Address F. A. Pribyl, Box 111, Lewistown, Mont.

"BLACK" Opals. Beautiful colors. Australia's National Gem. Lists free. World-wide connection. Seward, Optician, Melbourne, Australia.

WATCH REPAIRING

I REPAIR American and Swiss finest wrist watches and best grade railroad watches. I positively guarantee first-class workmanship and prompt service. References furnished to anyone interested. Jos. A. Plotkin, 134 W. 32nd St., New York.

ANTIQUES AND RELICS

FOR Dens: Guns, pistols, helmets, medals, etc., collected Europe's battlefields. Catalogue and war photos 10c. Lieut. Welsh, 50 Ft. Greene Place, Brooklyn, N. Y.

INDIAN Beadwork and Curios. War-Clubs, Moccasins, Flute Saddle; numerous other articles for collections and dens. F. Hackert, Rushville, Neb.

INDIAN Relics—24-page Clearing List Free. Grutzmacher, Mukwonago, Wis.

PHONOGRAPHS AND RECORDS

BUILD a genuine Choraloon phonograph and save over half. Big profit building and selling. We furnish motors, tone-arms, full instructions and all necessary parts. Send for catalog and free blueprint offer. Choraloon Phonograph Co., 221 11th St., Elkhart, Ind.

BUILD Best Phonographs. Write for parts catalog and free blueprint offer. American Phonograph Co., 3515 North Crawford, Chicago.

BUILD Your Phonograph. "Perfection" high quality spring and electric motors, tone arms, reproducers, wonderful results. Big saving. New catalog and building instructions mailed for ten cents. Hoosier Manufacturing & Supply Co., Phonograph Supply Dept., 313 Baldwin Block, Indianapolis, Ind.

WONDERFUL Bargains in Phonograph Cabinets. Hunter Factory, McHenry, Ill.

MUSIC AND MUSICAL INSTRUMENTS

RAG Jazz Piano Playing Taught in 20 lessons the "Christensen" way. Christensen schools in most cities (refer to your telephone directory), or write for booklet about mail course. Teachers wanted in unoccupied cities. Christensen School, 423, 20 East Jackson, Chicago.

JOIN our Sheet Music Club and receive latest popular music of all publishers. \$1.00 year plan. Write for details. Sheet Music Club, Suite 703, 1545 Broadway, New York, N. Y.

SONG writers—Have you song poems or melodies? I have very best proposition to offer you. Ray Hibbeier, D110, 4040 Dickens Ave., Chicago.

EVERYBODY'S Singing. "I Ain't Got Nothin' To Give Away." "When You Just Can't Be Glad." Each 30c postpaid. Derrick Music Publisher, 4431 St. Lawrence Ave., Chicago.

POSSIBLY Antonio Stradivari's Seventeen-Twelve Genuine Violin. Write Henry Griffin, Goree, Texas.

GET the Bohemian imported violin; best grade, pure sweet tone. Peter Bozyk, Box 63, Portland, Ore.

SONG Poems wanted. Clarence Krause, composer and arranger of music. Box 1452, Dallas, Texas.

CORNETISTS—Trombonists—Saxophonists—Clarinetists. Send for "Free Pointers." Name instrument. Virtuoso School, Buffalo, New York.

I WANT Song Poems. Casper Nathan, Woods Theatre Bldg., Chicago.

WRITE Songs. Big money and reputation. Write for information. J. Gordon Pub. Co., 291 N. Hoyne Ave., Chicago.

"MUSIC Composed" to words. Bauer Bros. (formerly of Sousa's Band), Oshkosh, Wis.

PATENT ATTORNEYS

PATENTS Secured. Prompt service. Avoid dangerous delays. Send for our "Record of Invention" form and Free Book telling How to Obtain a Patent. Send sketch or model for examination. Preliminary advice without charge. Highest References. Write today. J. L. Jackson & Co., 244 Ouray Bldg., Washington, D. C.

PATENTS—Trademarks. Before disclosing an invention, the inventor should write for my blank form "Evidence of Conception." This should be signed, witnessed and returned to me with sketch or model, upon receipt of which I will promptly render opinion as to patentable nature and send booklet on Patents. Highest references. Prompt attention. Reasonable terms. Clarence B. O'Brien, Registered Patent Lawyer, Woodward Building, Washington, D. C.

PATENTS Procured—Trade Marks Registered. A comprehensive, experienced, prompt service for the protection and development of your ideas. Preliminary advice gladly furnished without charge. Booklet of information and form for disclosing idea free on request. Richard B. Owen, 20 Owen Bldg., Washington, D. C., or 2276 R. Woolworth Bldg., New York.

PATENTS—Trade Marks. Thirty-five years' experience. Send model or sketch for opinion as to patentability. Free "Inventors Guide." Highest references and personal attention assure best results. Franklin H. Hough, 523 Washington Loan & Trust Bldg., Washington, D. C.

PROTECT your rights. Write for "Record of Invention" which contains form to establish evidence of conception of your invention. Prompt personal service. Preliminary advice without charge. J. Reaney Kelly, 612 G, Columbian Bldg., Washington, D. C.

PATENTS—Prompt, personal, efficient service by an attorney-at-law, skilled in all branches of Patent Practice. Over 12 years' actual experience; full information upon request. B. P. Fishburne, 331 McGill Bldg., Washington, D. C.

PATENTS, Trade Marks, Designs and Copyrights. Registered firm of attorneys-at-law. Careful, prompt personal service assured. Moderate fees. Full information free upon request. Gross & Collings, 606 Ouray Building, Washington, D. C.

PATENT applications filed on partial payment plan. Trade-marks, copyrights, etc. Milo B. Stevens & Co., 685 F St., Washington; 352 Monadnock Bldg., Chicago. Estab. 1864.

INVENTORS—Send for form "Evidence of Conception" to be signed and witnessed. Form, fee schedule, information free. Lancaster and Allwine, 221 Ouray Building, Washington, D. C.

PATENTS. Prompt, personal, efficient service. Over 15 years' actual experience. Send sketch, model or photos and description. Lynwood B. James, 391 McGill Bldg., Washington, D. C.

KEEP up with progress. Promote your patents. Send 50c for year's subscription to best inventor's magazine, "Invention and Manufacturing." American Industries, Inc., Washington, D. C.

MONROE MILLER, Ouray Building, Washington, D. C., patent attorney, mechanical and electrical expert. Best quality of work and results. Moderate charges.

PATENTS Promptly procured. Personal, careful and efficient service. Highest references. Moderate fees. Send sketch or model for actual search and advice. George P. Kimmel, Master of Patent Law. 54E Loan and Trust Bldg., Washington, D. C.

TOTAL Patent cost divided into six payments. Ask Sterling P. Buck, 629 F, Washington, D. C.

PATENT, Trade-mark and Copyright specialist. Prompt, personal and efficient service. Advice on request. M. E. Jones, Lawyer, 569B 7th St., Washington, D. C.

INVENTORS should write for our book, "How to Obtain a Patent," which contains valuable information which every inventor should have. If you will send us a sketch, model or photograph of your invention we will promptly make search of the Patent Office records and advise you whether or not your invention is in our opinion patentable; our charge for the service being \$5.00. With an experience of over twenty years we feel that we are fitted to render you prompt, efficient service which will merit your confidence. Moderate charges. Write today, Talbert & Talbert, 422 Talbert Bldg., Washington, D. C.

INVENTORS! Send sketch or model of your invention for opinion concerning patentable nature and exact cost of applying for patent. Book, "How to Obtain a Patent," sent free. Gives information on patent procedure and tells what every inventor should know. Established twenty-eight years. Chandlee & Chandlee, 426 Seventh St., Washington, D. C.

PATENTS—Herbert Jenner, patent attorney and mechanical expert, 622 F St., Washington, D. C. I report if a patent can be had and its exact cost. Send for circular.

PATENTS and Trade-marks obtained. Prompt service. Write for our new book on patents. Established in 1889. D. Swift & Co., 369-7th St., Washington, D. C.

PATENTS. Booklet free. Highest references. Best results. Promptness assured. Send model or drawing for preliminary examination. Watson E. Coleman, Patent Lawyer, 624 F Street, Washington, D. C.

ROBB, Robb & Hill offer a strictly professional service to manufacturers and inventors in patenting inventions and registering trade-marks, a service which is the result of 20 years' experience. Write for free booklet and names of prominent manufacturers and inventors represented by us. Send sketch for preliminary advice, 811 McLachlen Bldg., Washington, D. C.; 1345 Hanna Bldg., Cleveland, Ohio.

PATENTS—Trade-marks—Write for our free illustrated guide book and Evidence of Conception Blank. Send model or sketch and description and we will give our opinion of its patentable nature free. Highest references. Prompt attention. Reasonable terms. Victor J. Evans & Co., 105 Ninth, Washington, D. C.

INVENTORS, write for free copy about designing, drawing and blue-printing. Emil T. Dahlene, Manson, Iowa.

PATENT ATTORNEYS

PATENT obtained; complete application, \$15. Try "Patent News Plan." Save Money. Patent News-C, Washington, D. C.

FOR INVENTORS

PATENTS. If you have an invention which you wish to patent you can write fully and freely to Munn & Co. for advice in regard to the best way of obtaining protection. Please send sketches or a model of your invention and a description of the device, explaining its operation. All communications are strictly confidential. Our vast practice, extending over a period of seventy years, enables us in many cases to advise in regard to patentability without expense to the client. Our Hand-Book on Patents is sent free on request. This explains our methods, terms, etc., in regard to Patents, Trade Marks, Foreign Patents, etc. "Scientific American" contains Patent Office Notes. Decisions of interest to inventors, and particulars of recently patented inventions. Munn & Co., Solicitors of Patents, 623 Woolworth Bldg., New York; Scientific American Bldg., Washington, D. C.; 801 A Tower Bldg., Chicago, Ill.; Hobart Bldg., 582 Market St., San Francisco, Calif.

OBTAIN your own patent under guidance of an expert and save money. Write for particulars. Send sketch or model for examination regarding patentability of your invention. Harry E. Coleman, Oriental Bldg., Washington, D. C.

DON'T patent your idea until you know that your invention is mechanically right, practical, and in demand; also that the patent is not controlled by other patents and has value. Consult an expert first. I advise on all matters pertaining to inventions and improve inventions. Write for free Disclosure of Conception forms before disclosing your idea to me or anyone. Strictly confidential, nominal fee. E. J. Gibson, Developing Engineer, Box 94, Olean, N. Y.

INVENTORS: The first step toward a patent is a proper search of the pertinent United States records. Send sketch. Horace L. Woodward, Attorney, 700 9th St., Washington. Highest references; reasonable charges.

PATENTS—Trade-marks. Before disclosing an invention, the inventor should write for my blank form "Evidence of Conception." This should be signed, witnessed and returned to me with sketch or model, upon receipt of which I will promptly render opinion as to patentable nature and send booklet on Patents. Highest references. Prompt attention. Reasonable terms. Clarence R. O'Brien, Registered Patent Lawyer, Woodward Bldg., Washington, D. C.

PATENTS—Procured—Trade Marks Registered—A comprehensive, experienced, prompt service for the protection and development of your ideas. Preliminary advice gladly furnished without charge. Booklet of information and form for disclosing idea free on request. Richard B. Owen, 30 Owen Building, Washington, D. C., or 2276-R, Woolworth Bldg., New York.

PATENTS Secured. Prompt service. Avoid dangerous delays. Send for our "Record of Invention" form and Free Book telling How to Obtain a Patent. Send sketch or model for examination. Preliminary advice without charge. Highest References. Write today. J. L. Jackson & Co., 242 Ouray Bldg., Washington, D. C.

PROTECT your rights. Write for Record of Invention which contains form to establish evidence of conception of your invention. Prompt personal service. Preliminary advice without charge. J. Beane Kelly, 612 G, Columbian Bldg., Washington, D. C.

INVENTORS. Send sketch or model of invention for advice. Write for Evidence of Disclosure form and Book on Patents, Free. Prompt Service. Merton-Roberts & Company, 182 Mather Building, Washington, D. C.

INVENTORS: If you have an invention and don't want to spend unnecessary money in securing a patent, write to Inventors & Engineers Consulting Co., P. O. Box 343, Washington, D. C.

INVENTORS: Have your invention perfected by expert draughtsmen—Patent working drawings, free hand illustrating. Send model or sketch for estimate. Address W. H. Rockwell, Oriental Bldg., Washington, D. C.

INVENTORS. Learn what has been patented nearest your idea. Write to A. Hartwell Balcom, 691 Jenifer Bldg., Washington, D. C.

INVENTORS, sell your own invention. We can furnish you quickly with 100 illustrations of copy of your patent drawing, same size, for \$5. Three hundred for \$10. Also with reproduction of typewritten description of its use and advantages on reverse side, \$3.50 extra for first hundred; \$4.00 extra for three hundred. Send money order with drawing. Anything printed or drawn reproduced. Reliable Novelty Company, 600 F Street N. W., Washington, D. C.

INVENTIONS—How to Protect, Sell and Buy Them. A practical and up-to-date guide for inventors and patentees. By F. B. Wright. Price 35 cents, postpaid. Popular Mechanics Book Dept., 6 N. Michigan Ave., Chicago.

MODEL making and experimental work; modern shop, expert workmen. Manufacturing. Lamson Model and Experimental Works, 625 W. Jackson, Chicago.

INVENTORS: Practicability report on your invention free. Learn obtaining, valuing, selling patents. Drawings made. John A. Buchanan, Engineer, Columbus, Ga.

I SELL Patents. Established 1900. Address, Charles A. Scott, 773PM Garson Avenue, Rochester, N. Y.

"**HOW** and What to Invent for Profit" free. Patent News-N, Washington, D. C.

WE are interested in promoting the sales of Patented Automobile Accessories. What have you to offer? Address H. P. C., care Popular Mechanics Magazine, Chicago.

900 MECHANICAL Movements and 50 Perpetual Motions Illustrated and explained in my book. Inventor's Universal Educator, 5th Edition—Tells how to procure and sell patents. Government and other costs. Covers the matter from A to Z—160 pages—Elegantly bound. Contains noted decisions of U. S. Supreme and State Courts on Patent cases. Mechanical Movements greatly assist inventors—suggest new ideas that might prove of great aid in perfecting inventions. Tells how to select an Attorney. Has valuable information regarding Patent Shark. Selling Agents and promoters. Price, \$2. Postage free everywhere. Fred G. Dieterich, 621 Ouray Bldg., Washington, D. C.

INVENTORS should write us for our book, "How to Obtain a Patent," which clearly sets forth what may be patented and the necessary steps to protect an invention. It describes the procedure in Patent Office and tells about assignments, licenses and trademarks, and gives many useful facts about patents which every inventor should know. Many persons well versed in patent matters have pronounced the book the best of its kind they have ever read. It is written so you can understand it. Copy sent free upon request. Talbert & Talbert, Patent Lawyers, 433 Talbert Bldg., Washington, D. C.

PRACTICAL Instructions to inventors and patentees written by the manufacturer and inventor, Charles Hunsicut, covering every problem relating to inventions. Experience has shown the best means of patenting, manufacturing and marketing inventions. Written in the plain style of an honest man. No patent lawyer connections. For sale by Thos. Coonan, Exclusive Agent, 1231 North Capital St., Washington, D. C. \$1 prepaid. Satisfaction or money refunded.

PATENTS. Write for free illustrated guide book. Send model or sketch and description for free opinion of its patentable nature. Highest references. Prompt attention. Reasonable terms. Victor J. Evans & Co., 157 Ninth, Washington, D. C.

HAVE You an Invention? If so, write for our free book, "How to Get Your Patent," tells our terms and methods. Send model or sketch for our opinion of its patentable nature. Randolph & Co., Dept. 144, Washington, D. C.

"**INVENTOR'S** Guide," free on request; it gives very valuable information and advice. Write Frank Ledermann, 21 Park Row, New York, N. Y.

PATENTS FOR SALE

PATENTS—Send for free book. Contains valuable information for inventors. Send sketch of your invention for Free Opinion of its patentable nature. Prompt service. (Twenty years' experience). Address Talbert & Talbert, 401 Talbert Bldg., Washington, D. C.

OUTRIGHT or royalty—Minto Fuel Saver; patent applied for February 24th, 1921. Guaranteed to save 25% coal bills. Attached to heaters and a good seller. Minto Sheet Metals, Ltd., Edmonton, Alta.

INVENTORS: The first step toward a patent is a proper search of the pertinent United States records. Send sketch. Horace L. Woodward, Attorney, 700 9th St., Washington. Highest references, reasonable charges.

FOR sale or royalty, the best wire hair pin ever invented. Sample sent to interested parties. W. F. Focha, 1100 Fourth Street, Berkeley, Calif.

OUTRIGHT or royalty. Electric Time Switch. For information and copy of patent, write to Tom South, 128 Maplewood, DeKalb, Ill.

AMERICAN and Canadian rights. Automatic plug for electric irons. Apply Hugh G. Ross, 315 Hingston Ave., Montreal, Canada.

PATENT for sale "Angle-Rite" safety razor with wonderful trade name for blades. C. L. Merz, 206 Broadway, N. Y. City.

PATENTED Inkwell. New idea. Good for common school use. Patent for sale. Mary L. Kayser, Tyler, Texas.

SELL Folding Sidecar Patent. Illustrated Dec. Popular Mechanics. Circulars. Buckland, 1757 Noe St., San Francisco.

PATENT for sale or Royalty. Improved Combination Tool, useful to all Mechanics. Big seller. Address Alex Miller, 132 N. Weber St., Colorado Springs, Colo.

PATENTS for Sale: To sell, buy or obtain patents, address Patent News-P, Washington, D. C.

BRAND new game board; cash or royalty. Canadian. Write for information. Olson, 429 Illinois Ave., Stevens Point, Wis.

FLAGMAN'S Lantern, five-in-one. Address, C. L. Laken, 709 N. Grand Ave., Enid, Okla.

FOR Sale, or manufactured and sold on royalty, Patented Kiddie Hand Car, Horace Leach, Mt. Carmel, Ill.

PATENT on double speed wrench. P. Firpo, 845 South Monroe St., Stockton, Calif.

PERMUTATION Padlock, Patent No. 1,343,582. Sale or royalty. Address, Fryer, 1024 Steuben, Utica, N. Y.

FORD transmission lock, Descriptive circular. Box 668, Charlotte, N. C.

AUTO accessories, simple, inexpensive. Indicator attaches without tools to steering wheel any automobile; indicates position front wheels, whether straight ahead, right or left. Compression Tester gives accurately pounds compression in engine cylinders. Investigate today! Frank J. Hess, Box 259, Enid, Okla.

PATENT covering two styles door silencers—automobile and building—household necessity. Nothing like them on the market. Metal stamping products. Retail 10c and 50c. Dies furnished. Send 25c for samples. Address, "Stopit," 580 McAllister Street, San Francisco, Cal.

INVENTORS. Send sketch or model of invention for advice. Write for Evidence of Disclosure form and Book on Patents, Free. Prompt Service. Merton-Roberts & Company, 183 Mather Building, Washington, D. C.

EXCEPTIONAL opportunity; self-blowing torch; Canadian patent. U. S. patent successfully on the market; big money maker; best offer takes it; investigate. Folgman, 31 Third Street, Brooklyn, N. Y.

DON'T Miss This: Big Profits—I want your proposition. Will send samples of my recent Patents upon request. J. Kuhhorn, 13 Chestnut St., Bradford, Pa.

"SAFETY First" Pat—Novelty Game—Proven seller—Cost 3c. No factory required. 50 games possible. Best offer. A. O. Couillard, Milford, Mass.

PATENT for Sale—Coat and Hat Hanger. U. S.—Canada patents. Inexpensively constructed; neat appearance. Cash. Okamoto, Box 858, Yakima, Wash.

PATENT 1,392,569; new trolley for electric railways, etc. Exclusive features. For full information, write The Solis Brass Works, New Orleans, La.

FOR Sale: Basic patent, four claims, packingless valve adapted to high pressure containers—oxygen tanks, carbon dioxide tanks, etc. Also adaptable to radiator valves, water spigots and other type valves for confining or controlling gases or liquids under pressure. Floyd T. Romberger, 521 Lafayette Life Bldg., Lafayette, Ind.

MANUFACTURERS—Inventors: Splendid opportunity to secure valuable patents on Wonderful Manicuring Instrument; Secretary or Portable Writing Desk; Beautiful Novel Token; New Sanitary Absorbent Pad. Meritorious. Especially useful articles. Large profits. Investigate immediately. M. V. Bauer, 2443 Eighteenth Street N. W., Washington, D. C.

No. 1,369,540, **MOTORCYCLE—Tractor,** for plowing, cultivating, farm machines, wagons, trailers. Cash, royalty or exchange for southern farm or land. Rev. Ino Pribula, 514 Chestnut St., Johnstown, Pa.

NOVELTY Mfrs. will sell Patent on Combination Checkerboard and Writing Case; can be utilized as a Candy Box, etc. Address, A. M. Deig, 522 Jefferson St., Seattle, Wash.

FOR Sale Outright, Patent on postal scale. Easily manufactured, yet excellent selling points. Albert E. Weise, Hillman, Mich.

PATENT Obtained; complete application \$15. Try "Patent News Plan." Save money. Patent News-E, Washington, D. C.

FOR Sale—My invention of a Rotary Steam Motor, no limit to speed and no dead center. Patented in U. S. and Canada. Can be seen and demonstrated at the Dyer Flour Mills, Dyer, Ind.

HAVE you a Patent to sell? Would you like to know what a small classified ad in this column could do for you? Ask me to send you proof of how other inventors sold their patents. J. Roy McClellan, Manager Classified Advertising, Popular Mechanics Magazine, Chicago, Ill.

AMERICAN and Canadian automatic wrench. Samuel Zwick, 333 Center, South Manchester, Conn.

SIX U. S. and Canadian Patents for sale. Stock punch, cow-tail holder, anti-kicking device; large demand; price reasonable. Alvah Blackburn, Alum Bank, Pa.

PATENTED, Inexpensive, effective check protector, ideal advertising specialty. Bargain. R. Home, 1957 Warren, Chicago.

MODELS AND MODEL SUPPLIES

STEAM power plants for racing model boats. Engines, boilers, blowlamps. Send stamps for circular "E" to Model Machine Shop Co., 415-17 East 71st St., New York City, N. Y.

MODELS, Tools, Dies, Machinery designed and built. Ideas developed. Engelmann, 3029 Portman Ave., Cleveland, Ohio.

MODEL Making and experimental work; Modern Shop expert workmen. Manufacturing. Lamson Model and Experimental Works, 625 W. Jackson, Chicago.

MODELS and patterns made. Light manufacturing. Hathorn, Mason City, Ia.

JUST Published—New, up-to-the-minute book on model making that will fill a long felt want. Covers workshop practice, design and construction of models. 400 pages, 303 illustrations. Cloth. Price, \$3.00 postpaid. Popular Mechanics Book Dept., 6 N. Michigan Ave., Chicago, Ill.

I IMPROVE and develop your idea. Make working blue print plans of your proposed patent. Prices right. Mathew Moratta, Princeton, Indiana.

WORKING Models Designed and Built. Inventions Developed. Dies, Tools, Metal Stamping, Manufacturing. Wisconsin Experimental & Model Works, Madison, Wis.

We make working models for inventors and do experimental work and carry a complete stock of brass gears and model supplies. Send for catalogue. The Pierce Model Works, Tinley Park, Ill.

INVENTORS—Write for our free illustrated guide book and Evidence of Conception Blank. Highest references. Prompt attention. Reasonable Terms. Victor J. Evans & Co., 165 Ninth, Washington, D. C.

TO MANUFACTURERS

WANTED, concern to take over manufacturing and sale of Fordson tractor accessories. Steps ignition troubles. Simple. Address, Jos. H. Jacobs, Paxton, Mont.

WHAT have you to sell in agents' specialties? Let us be your distributor. Miller Brothers, Allendale, N. J.

MODEL Making and experimental work; Modern Shop, expert workmen. Manufacturing. Lamson Model and Experimental Works, 625 W. Jackson, Chicago.

WANTED—A manufacturer to make Ball-Type Universal Joint. J. E. Fulton, Springfield, Ill.

WANTED—Metal Stamping and Model work taken on contract basis. We are ideally located and equipped to develop patents. Meyers Company, Box 263, Bedford, Ind.

MANUFACTURING

WANTED—Contract manufacturing by small metal and wood-working shop. Ingersoll, Buffalo, Minn.

WANTED metal stamping, press work, patterns and dies. We manufacture articles in wood and metal. Nero Manufacturing Co., Peoria, Ill.

YOU furnish the idea, we do the rest. Developing, designing and manufacturing. Precision machinery does your work; trained engineers develop your idea into a practical working model, and design the tools or dies for quantity manufacturing. Victor Engineering Co., 2524 W. Chicago Ave., Chicago.

MODEL Making and experimental work; Modern Shop, expert workmen. Manufacturing. Lamson Model and Experimental Works, 625 W. Jackson, Chicago.

WELL equipped machine shop, pattern shop and foundry is prepared to manufacture any automobile or garage tools or accessories, portions of which are castings, on royalty or other basis. Send us your prints and specifications for estimate. Patented articles preferred. Connersville Foundry Corporation, Connersville, Ind.

SPECIAL Devices and Machinery developed and built at reasonable rates. Jigs and fixtures designed and built for interchangeable and economical manufacturing. Punches and dies made for all kinds of metal stamping. Machine work to order. Simplex Tool Company, Woonsocket, R. I.

LET us be your factory! Write today. Logan Machine Company, 222 South Clinton Street, Chicago, Illinois.

PATENTED Articles, Models, Brass Work, Machine Construction; Dies Made. Baum's Metal Specialties, Kansas City, Mo.

METAL Stamping, Dies, Tools. Special Machinery and Machine Parts Remodeled, Designed and Built. Efficiency Increased. Cylinder Grinding. Wisconsin Experimental & Model Works, Madison, Wis.

WIRE Goods, all kinds made to order. Cooley Mfg. Co., 524-530 N. Western Ave., Chicago.

MACHINERY, TOOLS AND SUPPLIES

BENCH Lathes, Johnston "Monitor Nine" Hi-Duty Screw-Cutting Engine Lathe, actual swing 9½ in.; center distance 18 in.; hole thru spindle ¾ in. Stamp for Catalog. The Johnston Manufacturing Company, Arlington, N. J.

MUST sacrifice slightly used and guaranteed, Western Rubber Mold Company, Akron Williams, Zwebel Brns. and Miller Retread Molds, Sectional Molds, Tube Plates, Generators, etc. Prices sent on request. Columbia Industrial Machinery Company, 4020 W. Lake Street, Chicago, Ill.

17"x8' GRAY screw-cutting lathe, pl. rest, \$225.00 cash. Norton Machinery Co., Cincinnati, O.

OTHERS have successfully sold their machinery through our columns—so can you. Ask me for proof. J. Roy McClellan, Manager, Classified Advertising, Popular Mechanics Magazine, Chicago.

CONCRETE Building Block Machines and Molds. Catalogue free. Concrete Machine Co., 112 S. Second St., St. Louis, Mo.

MOTORS, Air compressors, \$25 cash, balance terms. Hobartx, Troy, Ohio.

BIG money for you in old Auto Engines. Write for circulars. Candee-Smith Governor Co., Springfield, N. Y., or 1041 So. Main St., Los Angeles, Cal.

OPPORTUNITY: Get a \$300.00 ten-thousandth set of 33 Combination Gages for \$63.00. Write Van Keuren Co., Boston 34, Mass.

ENGINES, MOTOR AND DYNAMOS

REBUILT Gasoline Engines 1 to 5 h. p. in first-class condition. F. J. Shotwell, Martelle, Iowa.

BALL-BEARING Motors. Highest quality. Brand new, 1/4 horse, \$21.50. 1/3 horse, \$24.50. Circulars. William Boice, 23rd St., Toledo, Ohio.

BLUE Prints, 3/4 H. P. Marine Engine, \$1.50 per set. 2 1/2" ga. Pacific Type Locomotive, \$2.00 per set. Other blue prints for steam and gas engines, lathes and drill presses. Rough castings, complete engines, dynamo motors, lathes, gears, pulleys, brass and iron materials, model-makers' supplies, electrical goods, etc. Send 20c (2 dimes preferred) for new catalog No. 22 (soon ready). Refunded first order. Modern Engine & Supply Co., 53 W. Jackson Blvd., Chicago.

MOTORS for sale, approximately 1/10 h. p., 10 to 30 volts, direct current, series wound, used but in good condition. Can be used with farm lighting plants and for experimental purposes. Price \$5.50 f. o. b. General Railway Signal Company, Rochester, N. Y.

ALTERNATING and direct current motor bargains. New and rebuilt. All guaranteed for one year. Special prices. Get our price list before buying. Motors exchanged and repaired. Hyre Electric Co., 633-34 South Dearborn St., Chicago.

AUTOMOBILE Owners, Garagemen, Mechanics, Repairmen, send for free copy of our current issue. It contains helpful, instructive information on overhauling, ignition troubles, wiring, carburetors, storage batteries, etc. Over 120 pages, illustrated. Send for free copy today. Automobile Digest, 507 Butler Bldg., Cincinnati.

SPECIAL Garage Motors: Manufactured by the General Electric Co. 1 H. P., \$78.50; 2 H. P., \$110.00; 3 H. P., \$128.50; 5 H. P., \$168.50. All sizes, both single and Poly-phase Motors, for immediate delivery. Special charging generators, all voltages. Write for catalog. Motor Sales Dept., 15, West End, Pittsburgh, Pa.

BALL-BEARING guaranteed Motors, only \$20 cash, balance monthly payments. Write us. Hobart, Troy, Ohio.

ELECTRICAL

SPECIAL for Farm Lighting Plants: 32 Volt Mazda lamps, sizes from 10 to 50 candle power, in original cartons at 25c each; terms cash. General Distributing Company, 22 West 1st St., Duluth, Minn.

BATTERY Men: Save Your broken Jars. Our Cement makes good as new. Send One Dollar. Address, Cement Works, Peace River, Alberta.

STORAGE Battery Plates, Separators, Rubber Jars, "Best Make." Gillette Process. Gillette Battery Corp., 2218 Wabash Ave., Chicago.

FREE Electrical Book. Tells how to earn \$12 to \$30 a day. You can learn at home and earn as you learn. Write today. Chief Engineer, 2144 Lawrence Ave., Dept. A13, Chicago.

STORAGE Batteries Simplified—A complete new treatise on action—maintenance—repair—use. Describes fully the Exide, Edison, Gould, Willard, U. S. L. and other forms. 208 pages, fully illustrated \$2.00 postpaid. Popular Mechanics Book Dept., 6 N. Michigan Ave., Chicago.

AIR Compressor with Tank and Hose, \$46. Motor for same, \$22.50. Equipment Co., 169 Canal, Cincinnati, Ohio.

ELECTRIC motors and supplies, including sockets, wire conduit, clevis, loom, rosettes, switches. New revised wholesale prices. Illustrated Catalog free. Hyre Electric Co., 633-GH, South Dearborn St., Chicago.

FOR MECHANICS

INVENTORS. Send sketch or model of invention for advice. Write for Evidence of Disclosure form and Book on Patents, Free. Prompt Service, Merton-Roberts & Company, 181 Mather Building, Washington, D. C.

START in business for yourself for \$250.00. Full time or evenings. At least \$6.00 per hour. Ex-Cell-O Tool & Mfg. Co., 1214 Beaubien St., Detroit, Mich.

WANTED—Men to prepare for positions as Mechanical Draftsmen. Address, R. Breece, South Gardner, Mass.

PATENTS—Write for our free illustrated guide book and Evidence of Conception Blank. Send model for sketch and description of the invention for our opinion of its patentable nature free. Highest references. Prompt attention. Reasonable terms. Victor J. Evans & Co., 184 Ninth, Washington, D. C.

FOR THE SHOP

SHOP Notes, Vol. 17, contains 702 practical articles, such as a Half Ton Traveling Crane—Boring Machine—Toggle Press—Gas-Fired Forge—Oil-Gas Generator—Movable Table for Drill Press, etc., 224 pages, 496 illustrations, 50 cents postpaid. Popular Mechanics Book Dept., 6 N. Michigan Ave., Chicago, Ill.

JUST Out—Shop Notes for 1922. Bench Lathes, Electric Soldering Outfit, Jib Crane, Pump Troubles, Road Roller, Bench Grinder and Miller are among the 435 articles in this new volume. 224 pages, 50 cents postpaid. Popular Mechanics Book Dept., 6 N. Michigan Ave., Chicago.

BLACKSMITHS

BLACKSMITHS, Listen: Any Handy man can make more money doing hard jobs easy. Forging and welding solid, with Toy's Modern Methods of Blacksmithing. Hardening and tempering to a standard with colored tempering charts. All for one dollar. Samples free. W. M. Toy, Sidney, O.

FOR SALE—MISCELLANEOUS

CHEAP—4-inch Sand Dredge—Engine and Barge. Concrete Block and Brick machines. Chatham Fanning Mill. Stereopticon, 150 slides. Twelve-gauge Remington Automatic gun. Thousands of choicest Gladiolus bulbs. Ingersoll, Buffalo, Minn.

FOR Sale—manufacturing rights or patent on royalty basis—folding carrier adapted to industrial, household and amusement uses. Excellent opportunity for companies having allied lines. The National Business Bourse, Inc., Chicago.

GENUINE Fur Cap \$3.95; Black coney; any size. Particulars sent. M. Criterion, 157 West 21st Street, New York.

FOR Sale—pending trouser hanger and dresser. S. Keel, Dallas, Ark.

ARMY-NAVY surplus. Tents, Blankets, Clothing, Camping Equipment, Boots, Shoes, Tarpaulins, Slickers, Everything for the farm, house and shop. Astounding bargains. Specify line in which interested. Nathan Frank & Sons, 317 L St., S. W., Washington, D. C.

LUMINOUS Paint—Bottle 20c. Laboratories H. Box 316, Portland, Ore.

AUTO Tire Vulcanizing Molds, Air Compressors, Motors, Battery Charging Outfits. Reduced Prices. Write for catalog. Equipment Co., 167 Canal, Cincinnati, Ohio.

ADDRESSGRAPHS, Letter Folders, Multigraphs, Envelope Sealers, Duplicators, less than half price. Guaranteed. Pruitt Co., 112-B N. La Salle, Chicago.

FEATHER Flowers. Fine seller Florists, Poultry Shows, Fairs, etc. Unexcelled for home, office, store. Samples one dollar. Address De Witt Sisters, Battle Creek, Mich.

KARSTADT'S Mammoth Pecans. Cultivated papershell varieties; delicious flavor; kernel easily removed; 10 1/2 ounces \$1.25; 10 pounds \$15.00. Muscle rubber stamps. Rubber type catalogue 25c. W. Karstaedt, Dayton, Ohio.

FACE Powders; face creams; razor strop paste. Burson Chemical Laboratory, 227 West Fourth Street, Ottumwa, Iowa.

HONEY AND FOOD PRODUCTS

HONEY—Nature's own sweet. White Clover, Amber, Buckwheat. Sample 15c. Price list free. John D. Dietrich, Box H, Middleville, Mich.

LANDSCAPE ARCHITECTURE

SOMETHING worth while. Never in history has an opportunity been so scientifically offered in Landscape which will be in reach of everybody. For \$15.00 we will make a colored sketch and furnish planting list showing you how to plant and arrange trees, shrubs, evergreens, hardy and annual flowers. Draw outlines of your lot and house; mark width and length of both, location of walks; mention condition of soil, we will do the rest. Don't wait until spring, do it now. Send \$5.00 deposit. Balance on delivery of sketch and specification. If too large a proposition, we will send an expert at very reasonable cost. David Hansen, Landscape Artist, 1243 Thorndale Ave., Chicago, Ill.

REAL ESTATE AND FARM LANDS

FREE Book of Florida Facts. Own your own orange grove in beautiful Fruitland Park. A few cents a day you now waste will buy it for you. A few dollars a month may provide you with a life income. Schnitzler sold his twenty acre grove here for \$40,000—two thousand an acre. He saw the same opportunity that's offered you and planted a grove. Result—he reaped a small fortune. You have the same chance but you must act now. Write today for Free Book of Actual Photographs, Florida Facts and the interesting story of a Fruitland Park Farm. Learn of crops that help you buy it. Address today, Lake County Land Owners' Association, 93 Sunset Way, Fruitland Park, Florida.

LANDSEEKERS! Opportunity awaits you in Michigan. 20, 40, 80-acre tracts, \$15 to \$35 per acre. Very easy terms. Write today for Free booklet. Swigart Land Co., P-1259 First Natl. Bank Bldg., Chicago.

99-ACRE Farm; 27 cattle, 3 horses, poultry, crops, implements, ample buildings, \$3,500; only \$1,500 cash. Details page 24 Illus. Catalog. Address, Strout Farm Agency, 150P Nassau St., New York City.

\$5.00 DOWN, \$5.00 monthly; 20 acres unimproved fruit, poultry, stock, woodland; Ozarks; \$100. Fishing, hunting, trapping. Address, Alfred Zimmerman, 1800 N. Fifth, Kansas City, Kan.

ANY question pertaining to opportunities, land, crops or conditions of West Texas Plains answered \$1.00 or refund. A. R. Keys, P. O. Box 64, Station, Texas.

ATTENTION!! Let's get acquainted. Cash for your property. Farm, Hotel, factory, or retail store. Write us particulars; confidential service. Hayes Business Agency, Cincinnati, Ohio.

REAL Estate. New plans; learn Real Estate and Building Business. Wonderful money-making system. Write Casto Realty System, Columbus, Ohio.

LANDLODY, free, special number just out, containing many facts of cloverland in Marinette County, Wisconsin. If for a home or an investment you are thinking of buying good farm lands, where farmers grow rich, send at once for this special number of Landlody. It is free on request. Address Skidmore-Rhie Land Co., 506 Skidmore-Rhie Bldg., Marinette, Wis.

UNUSUAL bargain in good Minnesota wild land. Address, P. Fosco, New Richmond, Wis.

SELL your property quickly for cash, no matter where located. Don't pay big commissions. Particulars free. Real Estate Salesmen Co., Desk B, Lincoln, Neb.

WANTED—MISCELLANEOUS

CASH Paid. Mail us your discarded jewelry, gold crowns and bridges, watches, diamonds, silver, platinum. War Savings Stamps and old false teeth. Highest prices paid. Money sent by return mail. Packages held 4 to 12 days and returned at our expense if our offer is refused. United States Smelting Works (The Old Reliable), Dept. 71, Chicago, Ill.

DOGS, BIRDS, POULTRY, PETS

FOR Sale: Fox hounds, Coon, Skunk and Opossum hounds. Rabbit hounds. Guaranteed. J. R. Thomas, Bonville, Miss.

BABY Chicks—Five Varieties. Catalogue Free. Goshen Poultry Farms, R. 29, Goshen, Ind.

BREED Squabs. Book free. E. Rice, Melrose Highlands, 77, Massachusetts.

GREAT Dane Pups—For Danes that have size and intelligence write Collins Kennels, Box 109, Reedsburg, Wis.

BELGIAN HARES, GUINEA PIGS, ETC.

\$5,000 TO \$10,000 yearly. Investigate Silver Fox Ranching. Pelts bring \$100 to \$1,000 each. Beginners taught in our ranch, if desired. Capital unnecessary. Particulars 20c stamps. G. Semmelroth, Grand Rapids, Minn.

Learn Draftsmanship

At Home



Train for More Money

Get into a paying profession. Be a man recognized as an expert in a specialized field. Make yourself independent by having the kind of knowledge for which high salaries are paid.

Big Demand for Draftsmen

Here lies your opportunity. Learn Draftsmanship and you can always find a ready market for your services. Great manufacturing organizations, architects, engineering concerns, contractors are always on the lookout for experts. Knowing Draftsmanship is having practical assurance of a steady income in the practice of an interesting occupation. Proficient men earn from \$60 to \$150 a week and have chances for advancement to executive positions.

Train Under Experts

Chicago "Tech" Experts Will Teach You Their Practical Methods

(At the College or by Mail)

You can get the most thorough practical training in Draftsmanship in your spare time under the direction of the practical engineers at Chicago Technical College. Learn the methods used by these experts in their own professional work. Let them instruct you how to handle actual drafting problems, explaining every detail, until you also have an expert knowledge with which you can secure a paying position in the great industrial field. No need for you to be satisfied with any small pay job when this great profession is calling you and when Chicago "Tech" experts are ready to give you their personal instruction.

SEND THE COUPON

You can get this Chicago "Tech" training by mail, if you cannot come to the College—and this for only a small fee and on easy monthly terms. Pay as you go along.

Find out about all this now. Simply your request brings our catalog, information about the course you want to take, and the free lesson. You incur no obligation in asking for this. Whether you decide to enroll or not we will gladly tell you about Chicago "Tech" instruction—show you how to easily get this professional training. Put an X in the to show which course interests you and mail the coupon.

CHICAGO TECHNICAL COLLEGE
230 Chicago "Tech" Bldg., 2721 S. Michigan Ave.
CHICAGO, ILL.

FREE Trial Lesson



While other schools ask you to enroll and send money first, we send this free lesson first. Read it, practice the exercises and then decide about enrolling.

FREE OUTFIT

—Instruments, drawing board, T square, etc.—is included with our Home Study course or credit given if you already have an outfit.

CHICAGO TECHNICAL COLLEGE

230 Chicago "Tech" Bldg., Chicago, Ill.

Send Free information on subject marked X:

- | | |
|---|--|
| <input type="checkbox"/> Machine Drafting | <input type="checkbox"/> Auto. Engineering |
| <input type="checkbox"/> Electrical Drafting | <input type="checkbox"/> Aero. Engineering |
| <input type="checkbox"/> Architectural Drafting | <input type="checkbox"/> Plan Reading—Buildings |
| <input type="checkbox"/> Structural Drafting | <input type="checkbox"/> Estimating—Buildings |
| <input type="checkbox"/> Sheet Metal Drafting | <input type="checkbox"/> Plan Reading—Machinery |
| <input type="checkbox"/> Topographic Drafting | <input type="checkbox"/> Plumbing, Heating, etc. |
| <input type="checkbox"/> Surveying | <input type="checkbox"/> Steam Engineering |

Name.....

Address.....

Post Office.....State.....

College or Home Study. State Which.....

Free Trial Lesson Included When Inquiry Is for Drafting or Plan Reading

Continued from Page 48

SILVERBLACK Breeding Foxes. \$300.00 Skunks, Coons. Booklet, dime. Arthur Schumacher, Lockland, O.

RAISE guinea pigs. Pay better than poultry or rabbits; easy to raise; little space required. We guarantee market. Particulars and booklet how to raise free. Caries Distributing Co., 3162 Grand Ave., Kansas City, Mo.

TOBACCO

TOBACCO: Send no money, pay when received for tobacco and postage. 10 lbs. chewing, \$1.80. Smoking, \$1.60. Weak smoking, \$1.40. Bert Adkins, Art., Patesville, Ky.

TOBACCO: Fine chewing and smoking. Aged in bulk. Long silky leaf, rich and sweet. Hand picked. 10 lbs., \$2.50. Adams Brothers, Bardwell, Ky.

HOMESPUN tobacco, collect on delivery 5 pounds, \$1.25; 15 pounds \$3.00. United Tobacco Growers, Mayfield, Ky.

TOBACCO, Natural Leaf, for mild smoking; 10 lbs. \$1.50; 20 lbs. \$2.75; will furnish free receipt for preparing. Leaf Tobacco Exchange, Mayfield, Ky., Star Route.

PERSONAL

COMPLETE Life reading 35c. Give birth date. Jay Wambaugh, Goshen, Ind.

SUCCESS or Failure? Which is your destiny? Scientific information. "Success" pointers and Personality sketch for 10c and birthdate. Thomson-Heywood, Dept. 985, Chronicle Bldg., San Francisco, Calif.

PLEASANT Root inexpensively overcomes any tobacco habit. Send address. Franklin Stokes, Mohawk, Fla.

FULL Horoscope Readings, three questions answered, birthdate, 50c. Crystal gazing balls; instruction books, \$1.00. Delnora, 664 N. 12th, Philadelphia.

ST-STU-T-T-TERING and stammering cured at home. Instructive booklet free. Walter McDonnell, 46 Potomac Bank Bldg., Washington, D. C.

TOBACCO, Liquor and Morphine Habits can be overcome by using Hill's Three Chloride of Gold Remedies. Why not banish these Health-Destroying Habits before it is too late? Satisfactory results or money refunded. Booklet sent Free. Address The Ohio Chemical Works, Dept. 9, Charleston, S. C.

FREE—Stop using tobacco. We will give free information how to conquer habit easily and permanently. Results guaranteed. Anti-Tobacco League, Box K, Omaha, Nebr.

TOBACCO or Snuff Habit cured or no pay. \$1.00 if cured. Remedy sent on trial. Superba Co., TP., Baltimore, Md.

MISCELLANEOUS

RUBBER Stamps—Print letterheads, envelopes, cards, etc. Mark linen, books, personal articles. Name and address, two lines and ink pad, prepaid 50c, additional lines 10c each. Flint Rubber Stamp Works, Flint, Mich.

BEST knife in the world for 25c coin. Pocket knife with changeable blade. Uses discarded razor blades. Fred Rutten, 3148 Lowry Ave., Chicago.

MANUAL Training Outfits for Boys and Girls to make toys. Woodcraft Shop, 31 South Third Ave., Mount Vernon, N. Y.

GET Posted for Spring. Good prices paid for butterflies, insects. See Sinclair's Display Advertisement, page 68.

TOBACCO Quitting made easy. Pleasant, harmless, sure. Trial my expense. Ni-Ko, Wichita, Kan.

CUTS anybody can make. Simple, cheap process. \$1. Specimens, particulars. 2c stamp. M. Day, Windfall, Ind.

FREE—Very useful and practical article for those mechanically or mathematically inclined. Send name, address, occupation. Engineering Service Bureau, Dept. A511, 56 East Randolph St., Chicago.

LOCKSMITHS—Complete instructions for opening safes and vaults of all kinds; \$2.00. Kimball, 1140 Van Buren St., Chicago, Ill.

ARTIFICIAL Eyes, \$3. Booklet free. Denver Optic, 559 Barclay, Denver, Colo.

LOCKSMITHS: Send \$1, get valuable chart for cutting tumbler padlock keys. Address Globe System, 139 Sixth Ave., New York.

LOCKSMITHING from A to Z—508 tricks of the locksmith trade, \$1.50—money back if dissatisfied. H. Rouston, 3406 Andover St., Oakland, Cal.

SAVE incorporating expenses and excess profit taxes and avoid personal liability by organizing your company on the Common Law Plan under a Declaration of Trust. Anyone, anywhere, can fill in Demaree Standard Forms, issue shares and begin doing business same day. Pamphlet B-53 free. C. S. Demaree, Legal Blank Printer, 613 Walnut, Kansas City, Mo.

SURVEYING INSTRUMENTS

NEW and used surveying instruments direct from factory. Satisfaction guaranteed or money refunded. Wissler, 619 Broadway, St. Louis.

FREE BOOK on SIGNAL ENGINEERING

SIGNAL ENGINEERING

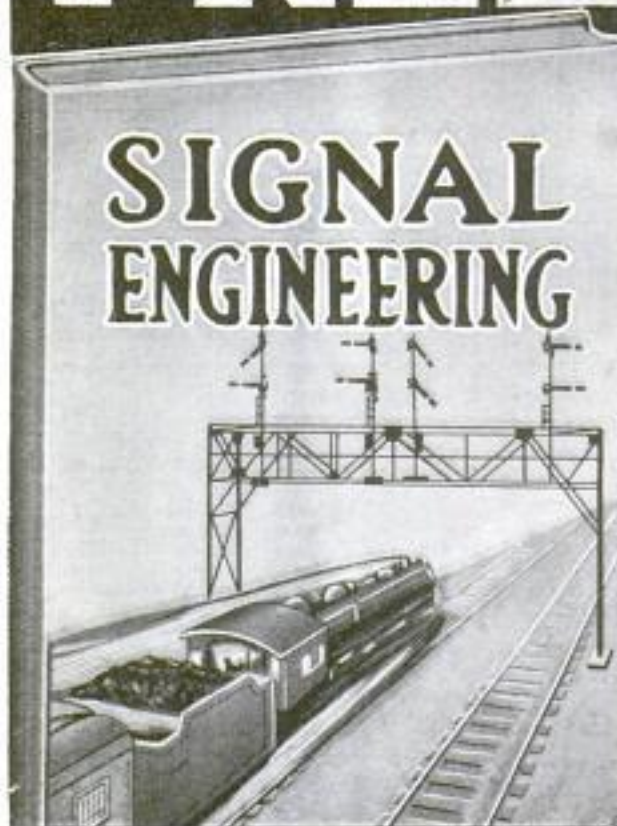

THERE are thousands of miles of railroad that must be equipped with block signal systems. To superintend these installations men are necessary. **Golden opportunities are offered.** Every ambitious man should write for the Free Book on Signal Engineering.

Men Are Needed to Accept High Salaried Positions

Less than one-fourth of the passenger lines in this country are equipped with automatic block signal systems. The day is fast coming when the law will compel railroads to install them. Remarkable opportunities are offered to ambitious men in the profession of Signal Engineering. High salaries are paid. \$250.00 a month is an ordinary salary for a Signal Engineer.

Send the Coupon

Now and get the free book about Signal Engineering. Too, we will tell you how you can get the training that you need in order to become a Signal Engineer. You will be under no obligation by writing for this free book. Do it **Now**.

DEPARTMENT OF SIGNALING
Dept. 1352, 1924 Sunnyside Avenue
CHICAGO

Gentlemen:—Please send me absolutely free and prepaid your big new book on Signal Engineering. Also full particulars about your great special free outfit offer. It is distinctly understood that I assume no obligations of any kind.

Department of Signaling

Dept. 1352
1924 Sunnyside
Ave., Chicago

Name.....
Address.....
Age.....Occupation.....

Get into the Big Pay Class



Learn **AUTOMOBILE TRUCK AND TRACTOR ELECTRICITY**

Trained men earn up to \$125 a week and more in the field of Automobile, Truck and Tractor Electricity. Such men are in demand—in every locality—all year 'round. There are plenty of mechanics, but the real demand is for trained electrical experts; this is because eighty percent of the auto troubles are electric troubles—and few automobile mechanics are electrical experts. Learn this profitable profession

IN THE BIG SHOPS OF **COYNE**

We train you for bigger pay in less than two months through our Learn-By-Doing Method. No big text books, no wasted time—simply personal instruction, problems, directions and practice. You learn in a real electrical School—on real equipment, new chassis. You learn through actual practice to become an expert in lighting, starting, ignition, testing, maintenance, and service. No previous experience needed.

Millions of automobiles, trucks, tractors and farm lighting plants call for real electrically trained men, and we train you for the big jobs.

Own Your Own Business

You can start a business of your own—make up to \$10,000 a year and be independent. Battery Stations, Service, Repair and other fields are open to you, anywhere. Get started in this profitable profession—be prosperous, successful—study Automobile, Truck and Tractor Electricity at the great shops of Coyne. Don't pass up this money-making opportunity. Decide NOW—Write us.

Free Business Course Earn While You Learn

Enroll now and secure a full course in Business Management, FREE. You learn how to manage a business and make more money out of it—no extra cost. Act on this offer, NOW! Send the Coupon. Get full details by return mail.



B. W. COOKE

PRESIDENT

COYNE

TRADE AND ENGINEERING SCHOOL

Dept. 12A, 39-51 E. Illinois Street, Chicago, Ill.

Coyne Trade & Engineering Schools,
Dept. 12A, 39-51 E. Illinois St., Chicago, Ill.

Send me FREE Information about your course in Auto Truck and Tractor Electricity that will help me get into the big pay class, and other information about your school, employment department and free Business Course.

Name.....

Address.....

Town..... State.....

MECHANICAL DRAWING

Practicing Engineer, Experienced Draftsman and Teacher Will Train You for High Class Position.

High salaries paid Mechanical Draftsmen. Learn by doing practical work at home under personal instruction of expert. Thoro. up-to-date courses by mail. **PREPARE NOW FOR BIGGER INCOME.** Complete draftsman's outfit included with course.

UNIVERSAL CORRESPONDENCE SCHOOLS
519 New York Life Bldg., Minneapolis, Minn.

Send me without obligation free book on draftsmanship and information concerning course marked below.

- | | |
|---|--|
| <input type="checkbox"/> Mechanical Drawing | <input type="checkbox"/> Architectural Drafting |
| <input type="checkbox"/> Machine Drafting | <input type="checkbox"/> Blueprint Reading and Cost |
| <input type="checkbox"/> Structural Drafting | <input type="checkbox"/> Estimating for Builders and Tradesmen |
| <input type="checkbox"/> Topographical Drafting | <input type="checkbox"/> Shop Mathematics |
| <input type="checkbox"/> Reinforced Concrete Drafting | |

Name.....

Address.....



STUDY OIL

Be a Certified Petroleum Expert

The tremendous growth of the Oil Industry has created as never before a demand for trained men. Every month 4000 new wells drilled; every year 100 new refineries and 1000 miles of new pipeline built. Geologists, drillers, refiners, salesmen, superintendents, are at a premium. Take advantage of this great world-wide need for trained men. New fields in this and foreign countries are constantly discovered.

\$100 a Week to \$100 a Day

This is the opportunity for the ambitious. Get into an industry where many are making millions and where all trained men are liberally rewarded. No matter what your present business or occupation, there is some practical phase of the Oil Industry that you can master and earn big money right from the start. Our practical and easy course will teach you the geology of the oil fields, drilling methods, oil refining and oil salesmanship. Get our free book telling all about this fascinating industry of opportunity. The book costs absolutely nothing. Yours for the asking. Write us today.

PETROLEUM EXTENSION UNIVERSITY,
Department 66, 165E Ontario Street, CHICAGO, ILL.

Genuine \$20.00 Imported **VIOLIN** Will Be Given To You **FREE**

Help me introduce this beautiful Violin in your district. Be first to show how easy it is to play with help of three new inventions and my scientific instructions. You can play it in one week.

10,000 Students Found Violin Playing Easy to Learn

You can learn as easily as others. Surprise your friends. My three new inventions make it very easy. Have been teaching 40 years. Write your name and address on bottom of page and send for free violin offer and three new violin inventions.

PROF. A. HINCHCLIFFE, 233 Broadway
Woolworth Bldg. Dept. 58 NEW YORK

Why Toil in an Uncertain Job?



\$133
a month

When you may be selected for a splendid Government life-time position! Railway Mail Clerk appointments, every state. Hotel expenses paid; vacations and sick-leave on pay; No strikes or shut-downs. Age 18-35, common education sufficient. Apply now for details and free specimen examination questions—

COLUMBUS INSTITUTE, K-62, Columbus, Ohio

Learn Photography at HOME

Make \$75.00 a Week on the Side

Establish yourself as a Photographic Expert quickly—during your spare time—under a leading photographer. I'll show you how to start your own business—your command a large salary. Send for my unusual offer—its only temporary. Act at once. A postal will do. N. Dupont, Pres.

INTERNATIONAL STUDIOS
Dept. 7, 4451 N. Robey St., Chicago, Ill.



The Chronicle of All the Ages Standard History of the World

10 MASSIVE ROYAL OCTAVO VOLUMES—From Dawn of History to World War—6,000 PAGES—1,000 ILLUSTRATIONS

EGYPT	GREECE	ROME	EUROPE	MODERN WORLD	AMERICA	19th CENTURY
THE FLIGHT OF THE ISRAELITES	WOODEN HORSE OF ULYSSES WINS A CITY	JULIUS CAESAR QUELLS MUTINY	DEEDS OF RICHARD THE LION HEARTED	PEOPLE AGAINST THE MONARCHS	WASHINGTON LEADS COLONISTS TO FREEDOM	AGE OF PROGRESS AND INVENTION
Age of Moses and Building of the Pyramids	Entrancing Story of Intrigue and Warfare	Nero Fiddles While Rome Is in Flames	The Crusaders Embark for Palestine	Masses Raise the Standard of Liberty	America Takes Its Place Among Nations	Wonders of Electricity—Growth of Science
How the Ancient Peoples Lived, Loved and Died	The Days of Alexander and the Field of Marathon	Persecution of the Christians in Pagan Rome	Dark Centuries of Feudalism and Birth of Science	The Meteoric Rise and Fall of Napoleon	The New World's March to Supremacy Begins	The Dawn of the Twentieth Century

Free

We will mail free a beautiful 32-page booklet of sample pages from the Standard History of the World, containing pictures of great characters in history, to every reader who mails to us the **COUPON**.



Six Thousand Years of History

JUST to show how alluring History would appear if presented like ordinary news we have set a few headings from the Standard History of the World, set up in ordinary newspaper style. The skill of the modern editor makes even the commonplace events such interesting reading that we would not willingly be deprived of our newspaper. How much more fascinating must be the stories of grandeur, daring, heroism and martyrdom, that make up the history of all the nations of the world?

With this set of books at hand you can lay aside your daily paper and spend an evening with your family in company with the immortals.

You can go back to the days of Julius Caesar and go with him through his campaigns in Gaul. Those were wonderful battles—wonderful fighters.

You can then come back with him to Imperial Rome. You will find the city in a turmoil. Great chariots thunder through the streets in triumph. The captives, the spoils, the banners, make a grand procession. The crowds cheer wildly.

Or if you prefer you can spend an evening with Napoleon.

You can go with him to Egypt where he fought the Battle of the Pyramids, and told the soldiers twenty centuries were looking down on them to observe their actions.

You can be with him when he tried to cross the Red Sea at the point where Moses led the Israelites and where he came near being overwhelmed as were the Pharaohs of Egypt.

You can be with him when he escaped his banishment from Elba.

Up through the Southern provinces he came, gathering a few troops here and there, winning over by his eloquence the regiments sent to capture him.

He arrives in Paris. With supreme confidence he organizes a make-shift army and sets out for the field of Waterloo. The description of that battle you will never forget.

Imagine the joy of surrendering yourself to the companionship of the great men of the past.

Rather than be contented with the commonplace you can enjoy and become familiar with Socrates and Caesar and Cleopatra and Napoleon and Cromwell and Washington and Columbus and Lincoln.

You can learn to face the world with a new confidence, a new poise, a new self-respect, a stronger mentality and wider vision, and be able to make a place for yourself among the representative men and women of your community.

Get the Standard History of the World and begin reading it.

Read it for the joy it will give you; read it for the good it will do you; read it for the inspiration that will lead you toward better things.

"Show me a family of readers," said Napoleon, "and I will show you the people who rule the world."

We are selling the introductory edition of this great History of the World at a very low price and on exceptionally easy terms.

We will name our low price and easy terms of payment to all readers interested who mail us the coupon below.

You incur no obligation whatever. The beautiful sample pages will give you some idea of the splendid illustrations and the wonderfully interesting style in which the history is written.

Tear out the following free coupon, write name and address plainly and mail to us now, before you forget it.

FREE COUPON

WESTERN NEWSPAPER ASSOCIATION (2-22)
140 So. Dearborn St., Chicago, Ill.

Please mail your 32-page free sample booklet of The Standard History of the World, containing photographs of great characters in history, and write me full particulars of your special offer to Popular Mechanics readers.

NAME

ADDRESS

Play
Without
Notes

Be a Master of JAZZ and RAGTIME

Anyone who can remember a tune can easily and quickly learn to play Jazz, Ragtime and Popular Songs by ear, at a very small cost. New Niagara Method makes piano playing wonderfully simple.

NO matter how little you know about music—even though you “have never touched a piano”—if you can just remember a tune, you can learn to **PLAY BY EAR**. I have perfected an entirely new system. It is so simple, so easy, and shows you so many little tricks of playing that it just comes natural to pick out on the piano any piece that is running through your mind. Even those who could not learn by the old-fashioned method grasp the NIAGARA idea readily, and follow through the entire course of twenty lessons quickly.

Play By Ear in 90 Days

No need to devote years to study, in order to learn piano nowadays. Neither is special talent necessary. Every lesson is so easy, so interesting and fascinating that you “can’t keep your hands off the piano.” Just devote a part of your spare time to it for ninety days and you will be playing and entertaining your friends almost before you realize how this wonderful new accomplishment has been acquired. No tiresome scales, no arpeggios to learn—no do-re-mi, no tiresome practice and meaningless exercises. You learn a bass accompaniment that applies to ANY SONG you play by ear. Once learned you have it for all time and become master of the piano. Experienced and talented musicians are amazed at the rapid progress of Niagara School students and say they cannot understand why this method was not thought of years ago. Yet it has never been used before and is not used by any other teacher or school today.

Be the Popular One in Your Crowd

One who can sit down any time without notes or music, reel off the latest jazz and ragtime song hits that entertain folks—always being the popular one in the crowd, the center of attraction, the life of the party, sought and invited everywhere.

As easily as hundreds of others have learned, so you, too, can learn and profit by it—not only through the pleasure it provides, but also by playing at dances, movies and other entertainments.

Decide to begin now. Just spend a little part of your time with my easy, fascinating lessons, and see how quickly you “catch on” and learn to play. You will be amazed, whether you are a beginner or an advanced student.

Write for my book, “The Niagara Method,” describing this wonderful new method of playing by ear. It is sent to you FREE.

RONALD G. WRIGHT, Director,

Niagara School of Music, Dept. 414,
Niagara Falls, N. Y.

Clip This Coupon Now

NIAGARA SCHOOL OF MUSIC, Dept. 414, Niagara Falls, N. Y.

Please send me your Free Booklet
describing “The Niagara Method.”

Name.....

Street..... City.....

Age..... Ever taken piano lessons?..... For how long a time?.....

THIS BOOK
FREE



Become an ARTIST!

If you like to draw, get into this fascinating profession of commercial art, where you can put your natural ability to its best use. Thousands of business firms pay millions of dollars annually for good advertising drawings and designs. Develop your talent—learn the methods and secrets that make your drawings worth real money.

\$100 a Week for Drawing

How would you like to earn \$100 a week as a commercial artist? The services of well-trained artists are always at a premium. They readily earn \$75, \$100, \$150 a week, and even more. You will not have to wait for years to get a good income, for beginners with practical ability soon command \$50 a week.

Learn Quickly at Home in Your Spare Time. Without previous training or experience, the Federal "Master" Course carries you rapidly forward to the producing point. It clearly explains each step, and gives you individual personal criticisms on all your lessons, by men who have themselves made good as commercial artists.

The Federal Course Brings You the Experience of Leading Successful Artists

Leading illustrating companies, designers, artists, and hundreds of successful Federal Students have enthusiastically endorsed Federal Training. You get the advice and experience of men who have produced and sold hundreds of thousands of dollars' worth of commercial art—through exclusive lessons contained only in the Federal Course.

Think of having the help of such men as **Franklin Booth**, the wonderful pen-and-ink artist called the "Painter with the Pen"; **Charles E. Chambers**, a leading magazine and story illustrator; **D. J. Lavin**, formerly head of the Chicago Tribune Art Dept.; **C. Matlack Price**, a poster authority; **Neysa McMein**, magazine covers; **Charles Livingston Bull**, the animal painter; **Harold Gross**, **Edw. V. Brewer**, **F. E. Schoonover**, **L. V. Carroll**, **Gayle Porter Hoskins**, and **N. C. Wyeth**, all illustrators and designers who have made reputations for themselves.

Get this Free Book "YOUR FUTURE"

Now is the time to investigate! The almost unlimited opportunities in this field will surprise you. By all means send for this book, beautifully illustrated in colors, telling every detail you need to know about the Federal Course. It shows work of Federal Students, many of whom earn more than the Course costs while they are studying. The Federal Course is aimed at practical results—and gets them. This book is free, but if you are ambitious to succeed in commercial art, it will be worth dollars to you. Send for it today, stating your age and occupation. Use the coupon below.



Federal School of Commercial Designing,
673 Federal Schools Bldg.,
Minneapolis, Minn.

Please send me "Your Future," without charge or obligation.

My age is Occupation

Name

.....

.....

THE FOREMOST SCHOOL OF ITS KIND IN THE WORLD

offers the way to attractive positions and

MONEY-MAKING OPPORTUNITIES

for ambitious men who are really earnest in their desire to achieve greater success in

ELECTRICITY

If you are interested in ANY BRANCH of electricity then you will find that

BURGESS Practical Electrical HOME TRAINING

will help you advance to the position and salary you desire. Hundreds of "Burgess-Trained" men throughout the world are now holding highly paid positions with electrical concerns or making money in their own business.

A constant stream of letters tell us of better jobs and bigger pay due entirely to Burgess Home Training in Practical Electricity. Positive proof of the unusual value of Burgess Training is the fact that it is

Endorsed by Important Plants

in the electrical industry who urge their men to use it. All electrical concerns want better men—the kind of fellows who know more than just one job. That's why "Burgess-Trained" men get the preference. They earn more because they are worth more. In some plants as many as 60 men are Burgess Students. No other course like it.

BEGINNERS

quickly fitted for electrical jobs by the Burgess Simplified Course—known as the easiest and quickest method.

Advanced Training for EXPERIENCED MEN

that gets right down to the practical technical knowledge that brings quick, sure advancement to higher positions at better pay. An exclusive copyrighted method.

This course has the enthusiastic approval of electrical engineers and executives of biggest concerns in the world.

Complete Electrical Outfit

including apparatus, tools, material, slide rule supplied with courses without extra charge. Beginners are soon able to earn good money with this outfit. The course alone is worth many times its very reasonable price to anyone electrically inclined. Easy to understand by anyone.

Special Advantages to men and boys who enroll now—fully explained in illustrated training catalog, sent on request. Complete satisfaction guaranteed.

BURGESS ELECTRICAL SCHOOL
744 E. 42nd Street, Dept. P. 2, Chicago, Ill.

Use coupon—check whether beginner or experienced

Burgess Electrical School,
744 E. 42nd St., Dept. P. 2, Chicago, Ill.

Send me your free catalog and special information.

Beginner Experienced.....Years.

Name

Address

PLAY MUSIC ON A SAW

You can produce most wonderful, soft, sweet music from any common carpenter's saw with a violin bow or soft hammer, if you know how. No musical ability required—you need not know one note from another.



EASY TO LEARN IN 3 WEEKS
I ABSOLUTELY GUARANTEE to teach you to play popular music within 3 weeks. I will give you all the secrets and tricks I have learned in my 10 years' success as a saw musician—secrets never before revealed and unknown to other musical entertainers. Very little practice required—it's all in knowing how.

MAKE BIG MONEY

Amuse your friends with this remarkable, new form of entertainment. You'll be the most popular person in your crowd. Your services will be in demand at Clubs, Lodges, Church Affairs and Dances all over your state. Your act will always be the big hit and you will be paid as much money for a few minutes entertaining as most men make in a day.

Send today for complete free information, "How to Play a Saw."

C. J. MUSSEHL, 235 Mack Building, Fort Atkinson, Wis.

TRAFFIC

Men Needed Everywhere

Big salaries. "Bankers" hours. Dignified position. Your own boss. Work easily learned in a few weeks at home. Course guaranteed. Satisfaction assured. Graduate coached free for two years after in position. You can't fail. Practical experience in actual traffic office offered graduates. Student R. W. Fish appointed General Traffic Manager after six months' study. His salary to start \$3,000.00. Complete training inexpensive. Make up your mind NOW to get started. Easy terms. Write today and save \$3.00. Act at once.

Interstate Traffic School
22 Traffic Building Fort Wayne, Ind.

Light Fibre Legs and Arms

636
Dean Bldg.
RAY TRAUTMAN Minneapolis, Minn.



Hotels Need Trained Executives

YOU can have one of these well paid, pleasant, executive positions—40,000 of them in the big hotels of the United States—now America's Fourth Largest Industry. Statistics show that ONE IN EVERY TEN HOTELS WILL HAVE AN OPENING FOR A MANAGER THIS YEAR. Thousands of other positions are also open to those who qualify through training.

The Lewis School guarantees to give you the valuable knowledge that it has taken some of the most successful hotel men years to obtain—men who are now making \$5,000 to \$50,000 a year. All of your training will be under the personal direction of Clifford Lewis—a hotel expert of national reputation. A few spare-time hours a week given to the simple, clear lessons of the course will give you the training for a good position, a fine living and a handsome salary. The training will in no way interfere with your present work or recreation.

LEWIS HOTEL TRAINING SCHOOL
Room 417
Washington, D. C.

Send me without obligation the FREE BOOK "Your Big Opportunity."

Send today for FREE BOOK, "Your Big Opportunity." Don't wait a minute—you may lose the opportunity of a lifetime. Mail the coupon NOW. Your whole future may depend on it.

LEWIS HOTEL TRAINING SCHOOL
Clifford Lewis, Pres.
Room 417
Washington, D. C.

Name

Street

City

State

Your Only Chance Today is in being a Skilled Man



F. D. Hennessy, President

THIS spring thousands of skilled auto mechanics will be needed in all parts of the country, your neighboring towns included. Everywhere car overhauling has been put off. In spring this work just has to be done. This means that a big opportunity is waiting for you—a chance to get right into this profitable business—if you get ready now.

Let the Iowa State School give you, in seven weeks, the kind of training that equips you for jobs paying \$150—\$400 a month, or for making even more money in a business of your own.

Read this interesting letter from Lewis A. Boulin. He tells the kind of training you get at this great institution for auto mechanics and electricians and the results of his experience here. I have received hundreds of such letters from our graduates.

Learn by Big Shop Standards—in 7 Weeks

Here we give you a thorough training in modern, practical, big shop standard methods. Our test and trouble work alone is worth the price of the entire course. You learn by doing, everything about the care, repair and operation of auto, truck, tractor, stationary gas engine and airplane mechanics. Go where you work with complete modern equipment and motors, including the Liberty Motor.

We give you a complete course at one price—everything you must know to be successful. No experience necessary. **Special Business Course** included. **Y. M. C. A. membership to students.** Life scholarships.

Now in Business for Himself

My Dear Mr. Hennessy:

Waterville, Maine.

In the first place I want to tell you how I happened to come to your school. Well, I had a number of catalogs from different schools and yours was the only one that appealed to me on account of the Standard Practical methods which you teach. Again I could have gone to a school much nearer home and saved the extra \$120.00 railroad fare, but I want to tell you that I got more than that amount in just one department alone and the entire course was worth three times the amount I paid.

I certainly appreciated your kindness in securing me a position when I had finished school, and after working there I decided to go in business for myself, for if I can make money for the other fellow, I can do the same for myself. I have a nice Battery and Vulcanizing place here all my own and have all the work I can do. You made this possible for me, Mr. Hennessy, and I want to thank you for the interest you have given me from start to finish. Your friend and student,

Lewis A. Boulin.

“The Quality School”



Big Free Book

Fully illustrated; shows our students at work. Gives full particulars on what we offer you. Tells all about the big present opportunities in the automobile business. Don't wait a single day. Write for this book at once. Send me a postal or use the coupon.

F. D.
Hennessy,
President

Iowa State Auto,
Tractor & Electrical
School,
739 Nebraska St.,
Sioux City, Iowa

Send me your big free 72-page book.



Name

Address

State



"I Knew You'd Make Good"

"I ALWAYS felt you had it in you to get ahead. But for a time I was afraid your natural ability would be wasted because you had never trained yourself to do any one thing well. Yes, I was afraid you would always be 'a jack of all trades and master of none.'

"But the minute you decided to study in your spare time I knew you'd make good. You seemed more ambitious—more cheerful—more confident of the future. And I knew that your employers couldn't help but notice the difference in your work.

"Think what this last promotion means! More money—more comforts—more of everything worth while. Tom, those hours you spent on that I. C. S. course were the best investment you ever made."

HOW about you? Are you always going to work for a small salary? Are you going to waste your natural ability all your life? Or are you going to get ahead in a big way? It all depends on what you do with your spare time.

Opportunity knocks—this time in the form of that familiar I. C. S. coupon. It may seem like a little thing, but it has been the means of bringing better jobs and bigger salaries to thousands of men.

Mark and mail it today and without obligation or a penny of cost, learn what the I. C. S. can do for you.

TEAR OUT HERE

INTERNATIONAL CORRESPONDENCE SCHOOLS BOX 5603-C SCRANTON, PA.

Without cost or obligation please explain how I can qualify for the position, or in the subject before which I have marked an X in the list below:

- ELECTRICAL ENGINEER
Electric Lighting & Railways
Electric Wiring
Telegraph Engineer
Telephone Work
- MECHANICAL ENGINEER
Mechanical Draftsman
Machine Shop Practice
Toolmaker
Gas Engine Operating
- CIVIL ENGINEER
Surveying and Mapping
MINE FOREMAN or ENG'R
STATIONARY ENGINEER
Marine Engineer
- ARCHITECT
Contractor and Builder
Architectural Draftsman
Concrete Builder
Structural Engineer
- PLUMBING & HEATING
Sheet Metal Worker
Textile Overseer or Supt.
- CHEMIST
Pharmacy

- BUSINESS MANAGEMENT
- SALESMANSHIP
- ADVERTISING
Show Card & Sign Ptg.
Railroad Positions
- ILLUSTRATING
Cartooning
Private Secretary
Business Correspondent
- BOOKKEEPER
Stenographer & Typist
Certified Public Accountant
- TRAFFIC MANAGER
Railway Accountant
Commercial Law
- GOOD ENGLISH
Common School Subjects
- CIVIL SERVICE
Railway Mail Clerk
- AUTOMOBILES
Mathematics
Navigation
- AGRICULTURE
Poultry Raising Spanish
- BANKING Teacher

Name.....

Street and No.....

City..... State.....

Occupation.....

Please Mention Popular Mechanics

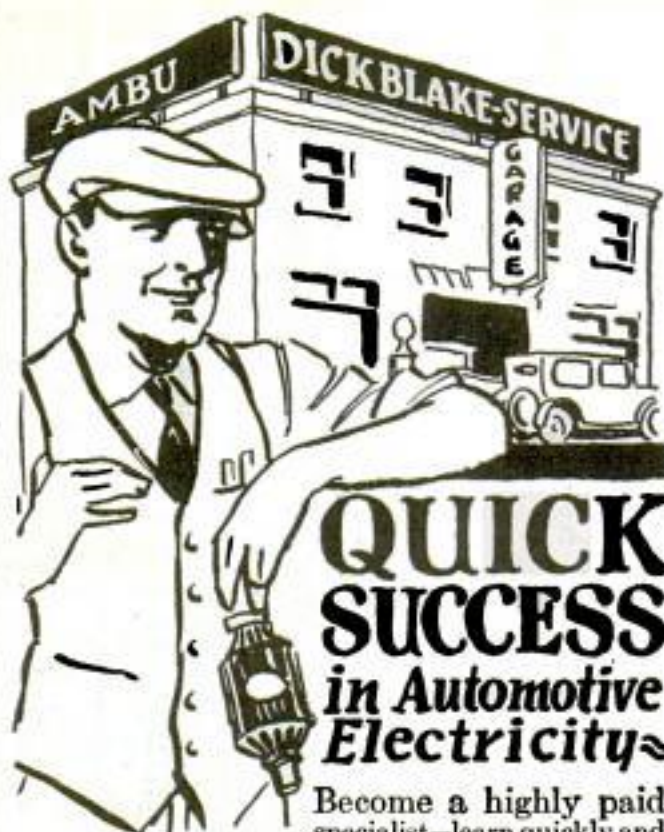

QUICK SUCCESS in Automotive Electricity

Become a highly paid specialist—learn quickly and easily about Automotive Electricity. Men trained in this branch are scarce and, therefore, well-paid. Thousands of big paying positions awaiting AMBU trained men.

Own a Fine Business

Great chance to start your own business—little money needed—we train you in spare time at home. Thousands of similarly trained men are drawing big salaries or running their own successful business. You can complete our course successfully even if you now know nothing of automobiles or electricity.

Salaries Up to \$6,000 Earnings Up to \$25,000

Big Corporations pay men who have the equivalent of AMBU training, up to \$6,000 per year. Millions of autos are operated, their owners are ready to patronize AMBU trained men to get expert service in Starting, Lighting, Ignition and Battery. AMBU trained men can earn up to \$25,000 yearly operating such service stations. You can do as well.

Young Dick Blake Earns \$2,600 in Own Business in Six Months

Without previous training or special experience, young Blake earned \$2,600 first six months through AMBU training. We can help you to quick success also—you don't risk a penny. Write for our "Money Back Guarantee Bond" and "Success Book"—free.

MAIL THIS NOW—

get into the Big-money Class—Success Book tells you how.

AMBU ENGINEERING INSTITUTE
C. J. BUCKWALTER, President
172-2632 Prairie Ave. CHICAGO, ILL.

AMBU ENGINEERING INSTITUTE,
172-2632 Prairie Ave., Chicago

Send FREE your Success Book and complete information. I want to learn how to train for Bigger Money in spare time.

Write Name and Address in Space Below. Tear Off on Dotted Line

Name.....

Address.....

City..... State.....

Are you now in auto business Yes No

He thought he could throw me—

Dear Tom: You know how Ted Brown has always been saying he could throw me with one hand tied behind him, if he wanted to. Well, yesterday, he grabbed hold of me and we had it out. Gee, I wish you'd been there. You know how much bigger Ted is than I. He thought he had me licked dead easy—

but



I wriggled around and got a hold on him that I'd learned from the Farmer Burns School of Wrestling. The next second—KERFLOP, and I had Mister Ted Brown on the ground, yelling for me to quit. It's a cinch to handle a fellow half as big again as you are if you know the secret holds. If I were you I'd write to Burns School for their free book about wrestling. So long—FRED.

Learn Wrestling Secrets from Worlds Champions Farmer Burns and Frank Gotch

Learn the marvelous holds, breaks, blocks and tricks that will enable you to handle big, strong men with ease. The renowned FARMER BURNS—"father of scientific wrestling"—and FRANK GOTCH the world's champion, have prepared a series of lessons in which they reveal the inside secrets of training that will make YOU, too, an expert wrestler. All the great secrets of self-defense and jui-jitsu illustrated by printed word and picture. The lessons teach you how to become a great athlete, and secret knowledge enabling you to throw boys and men larger and stronger than yourself.

Send for FREE Book

Our FREE ILLUSTRATED BOOK tells you all about the advantages in health, vigor and respect that being able to wrestle brings one. It tells you how to learn to become a skilled wrestler in your spare time. Brim full of interesting information about wrestling. Also lots of pictures. INVESTIGATE. Write today for this free book. No obligations. Tear out and mail coupon NOW!

Farmer Burns School 1772 Railway Exchange Bldg.
Omaha, Neb.

Farmer Burns School
1772 Railway Exchange Bldg., Omaha, Neb.

Please send me at once without obligation your FREE illustrated booklet on Scientific Wrestling, Physical Culture, Self-Defense, and How to Win.

Name

Address

Age

Improve Your Memory

IN ONE EVENING

Thousands have done it through the Roth Memory Course in seven easy lessons. Be able to remember names, faces, numbers, dates, appointments, speeches, etc., on the instant. Examine the course free for five days, then decide. Price \$3 if you keep it. Otherwise no obligation. Write today to Independent Corporation, Dept. R452, 319 Sixth Ave., New York City

TIME IS MONEY ROPP'S CALCULATOR



Saves Both. Shows prices, quantities, weights, etc., of familiar commodities in any business.

Desk Size, - - \$1.50
Pocket size, leatherette, - 1.00
Pocket size, cloth, .50
" paper, .35

Postage free anywhere

WELLS & EDWARDS
852 George St. Chicago, Ill.
Send for free book catalog



FREE PROFESSIONAL TONE MUSICAL INSTRUMENTS

and lessons sent on free trial. Violin, Tenor Banjo, Hawaiian Guitar, Ukulele, Mandolin, Cornet, Banjo-Mandolin, Banjo-Ukulele, Guitar, Banjo-Guitar, or Banjo. Wonderful new copyrighted system of teaching note music by mail. Four lessons will teach you several pieces. Over 100,000 successful players. Do not miss this free trial offer. Write for booklet. No obligations.

SLINGERLAND SCHOOL OF MUSIC, INC., 1815 ORCHARD ST., DEPT. 104, CHICAGO, ILL.

MORE MEN WANTED

**Big
Pay**

Succeed!

To make money, get into a field where money is made—and men are wanted. Today there is such a field—a big, profitable field that has been barely scratched. Men are succeeding in it and making money and uncounted opportunities for great success are still open. The Finger Print profession is the field that offers you this opportunity. Finger Printing is beyond the experimental. It is recognized as the one positive means of identification.

Be a Finger Print Expert

Finger Print Experts earn big money and occupy the respected position of the professional man because their work is conspicuous and essential. There are no lay-offs nor shut-downs in the Finger Print profession. Everything you do counts for yourself. Daily, just a handful of men are trying to answer the demands of the thousands and thousands of instances where the Finger Print Expert is vitally needed. Trained Finger Print Experts share in big incomes, fame and importance. For years my time has been devoted to the Finger Print profession. I will teach you how to become a Finger Print Expert. My course of study is simple, easily understood and I guarantee to assist you in securing a position. Read the letter from the Phillip State Bank. You can study during your spare time. No special education is needed. My simplified course makes everything clear.

Secret Service Course

In addition to my complete course in Finger Prints, I will also supply you free and without extra charge, a complete course in Secret Service. Study of this will equip you for all-round work. It gives you knowledge essential to the successful Finger Print Expert. Remember this course is free with my course in Finger Prints. It, alone, is worth the cost of my complete course in Finger Prints. But this offer, as is my Position offer and Free Professional Outfit offer, is limited. Men are needed at once. Unless you act at once, you may lose this remarkable free offer.

Actual Secret Service Reports

FREE To all who write for complete information at once, I will send, Free, copies of actual Secret Service reports. These reports give inside facts of amazing cases of interest to you. Send for them and my complete explanation at once. I will tell you fully what you can expect as a Finger Print Expert and I will help you succeed. Today—write for this information and my guaranteed-position offer.

U. S. SCHOOL OF FINGER PRINTS
Dept. 432, 7003 N. Clark St.
CHICAGO, ILL.

U. S. SCHOOL OF FINGER PRINTS
Dept. 432, 7003 N. Clark St., Chicago, Ill.

Please send me Free information about your Finger Print Course, Free Course in Secret Service together with Guaranteed-Position Offer, Free Outfit, Secret Service Reports and Special Low Prices.

Name.....

Address.....

City.....State.....Age.....

**Send
Coupon**

PHILLIP STATE BANK OF CHICAGO
CIVIL DEPARTMENT
JULY 22, 1921
CHICAGO, ILL.

TO WHOM IT MAY CONCERN

This is to certify that Mr. E. A. Shoek has deposited in this bank \$1000.00. Out of this special fund this bank is authorized and does hereby guarantee to return to any of Mr. Shoek's students at any time within 30 days after the completion of the course, all moneys the student has paid if Mr. Shoek has not fulfilled his obligation as agreed.

Very truly yours,
PHILLIP STATE BANK,
Geo. F. Phillips,
Vice-President.

Do you know that Clear-Tone—the wonder-working lotion—used like toilet water—

Clears Your Skin

of Pimples, Blackheads, Acne Eruptions, Enlarged Pores, Oily or Shiny Skin? *Elegant after Shaving.* Indispensable for sensitive, refined women.

GUARANTEED to banish unsightly blemishes easily and quickly, and leave the skin clear and smooth.



"A Clear-Tone Skin"

This Free Booklet tells how you can easily and quickly at home obtain a clear skin, free from all blemishes, like Nature intended you to have. Thousands of copies of this interesting book distributed monthly.

Clear-Tone is not a cure-all or a mail-order treatment, but a scientific, reliable SKIN LOTION, perfected after 15 years personal experience by Mr. E. S. Givens, who knows every embarrassment one has to suffer with a bad complexion. Endorsed and prescribed by physicians, druggists, and thousands of enthusiastic users, and sold on a direct and positive guarantee of absolute satisfaction or money back! The marvel of Clear-Tone is that it clears the complexion so quickly, no matter the cause.

Clear-Tone has had an unprecedented success as evidenced by the thousands of voluntary letters written by men and women who had very bad blemishes and tried various soaps, ointments and doctors without relief.

READ THESE LETTERS!

From U. S. Hospital--"Find myself improving wonderfully. Anyone I see that has skin trouble your wonderful Clear-Tone will be recommended. C. A. Rein, U. S. Hos. 41, Sta. Island, N. Y."

From a Barber--"Have been a barber for 30 years and never saw anything as good as Clear-Tone. All barbers should know about it." Otto Van Burin, Kansas City, Mo.

From a Musician--"I am obliged to be in public a great deal and my complexion was a great embarrassment. Clear-Tone improved me so greatly that I strongly recommend it." C. H. Lindeman, Steubenville, Ohio.

From a Lady--"I cannot thank you enough for all the good it has done me. One bottle has cleared my face wonderfully."

--Miss Mary Yonks, Haverstraw, N. Y.

From a Soldier--"It is certainly wonderful." Louis Langer, Troop F, 3d Cavalry, Ft. Ethan Allen, Vt.

From a Flyer--"Cleared my face of Acne." H. J. Howald, N. H. Station, Pensacola, Fla.

People Amazed--"Has cleared my skin completely of pimples and blackheads. Everybody who sees me is amazed." R. R. Wilson, Pearson, Ga.

Thousands of Others--men and women--praise Clear-Tone. We'll gladly send copies of most interesting testimonials.

FREE! Simply send name today for FREE booklet, "A Clear-Tone Skin," telling how I cured myself after being afflicted for 15 years, and my \$1,000 guarantee to clear your skin of the above blemishes.

E. S. GIVENS, 128 Chemical Bldg., Kansas City, Mo.

YOUR Opportunity

to land a Man's size job at \$35 to \$100 a Week

Ask yourself three simple questions:

Am I Satisfied With My Present Salary?

Am I Satisfied With My Present Occupation?

Am I Satisfied With My Future Prospects?

The Chance of a Lifetime

Be square with yourself now—it's **your** welfare we're talking about. If you're not satisfied this is the chance of your lifetime to do what thousands of other men, like you, have done and to quickly get into this big field of attractive salaries, congenial occupation and unlimited opportunity for further advancement.

One of our students rose in 8 months from a struggling farm laborer to a man's sized job as Draftsman with an Engineer in California. He has since stepped up to a bigger Drafting job with large Western iron works.

Other Men Like You Getting \$35 to \$100 a Week

David Jacques was promoted from Draftsman to Assistant Plant Manager at a handsome increase in salary.

W. N. Busey was a clerk in a store. Today he's a Draftsman in one of the country's largest organ works.

Verne Hornback was an apprentice machinist. When half through the Columbia course he was promoted to a Draftsman at \$45 a week.

Alan Ward rose from tape machine operator to Assistant Chief Draftsman before he finished the Columbia course.

J. P. Finkbone received two salary increases in nine months after completing the Columbia course.

No Previous Training Necessary

These aren't exceptional cases. Hundreds of Columbia men have done as well or better. The booklet I will send you tells about many of them. **You** can do just what they have done. All you must do now is to take advantage of this opportunity—the same opportunity they grasped. No matter who you are, where you live, what you are now doing or have done—even though you don't know a drawing board from an ironing board—though you are just an ordinary man, like Berger and Busey and the rest, we'll train you in your spare time at home by mail, so that in six to ten months you will be a practical, professional Draftsman, ready to take a man's sized job at an expert's pay. You'll learn Drafting work by making Mechanical Drawings—not by merely reading how it should be done.

Everything Furnished

You will be given **FREE**, a complete Mechanical Drawing outfit and a professional set of highest grade Drafting instruments to use throughout the course and after you become a Professional Draftsman.



Help in Getting a Position

You will be given the services of our Student's Employment Bureau in helping you to secure a position as Draftsman at good pay. We've helped hundreds of our graduates to excellent positions with many of the country's largest concerns and we're continually receiving requests for Columbia graduates.

Advancement to \$15,000 a Year or More

You'll find Mechanical Drafting the greatest game you ever tackled. It's one job you can put your heart into because each day's work is more and more fascinating and your opportunities for advancement never cease. You start in at more than the average man earns at ordinary work. From that it is just a few short steps to Assistant Chief Draftsman, then Chief Draftsman, Engineer, Production Manager, Plant Manager, and so on—positions that pay \$6,000 to \$15,000 a year and more. Don't let figures scare you. You can do it, man, as others have done, if you make Mechanical Drafting the stepping stone. Don't think you can't but **know** you can because others have done it.

Send Coupon for Free Booklet

Fill in the attached coupon and send it to me. I will send you an interesting booklet, "Your Future in Drafting" and a copy of "The Compass"—telling how easy it is for you to take advantage of this opportunity. Do this **right** now.

ROY C. CLAFLIN, President
Columbia School of Drafting
Department 1630 Washington, D. C.

Roy C. Claffin, Pres.,
Columbia School of Drafting,
Dept. 1630, Washington, D. C.,

Tell me how Columbia training will help me and send me your booklet, "Your Future in Drafting" and a sample copy of "The Compass."

Name.....

Address.....

City.....State.....Age.....



Tobacco Is Hurting You

Look at the facts square in the face, Mr. Tobacco User. You may think tobacco is not hurting you.

That is because you haven't as yet, perhaps, felt the effects of the nicotine poison in YOUR system. For you know that nicotine, as absorbed into the system through smoking and chewing tobacco, is a slow working poison. Slow, yes—but sure.

Tobacco is lowering your efficiency. It slows a man down. Makes it harder for you to concentrate your mind on your work. You haven't near the amount of "pep" and energy you would have if you stopped using it. There's many a man twice as old as you in years who's twice as young in energy, simply because he lets tobacco alone.

Some day you will realize to what an alarming extent tobacco has undermined your system.

When your hands begin to tremble—
and your appetite begins to fail—
and your heart seems to "skip a beat" now and then—
and slight exertion makes you short of breath—
then you have a right to suspect that
TOBACCO is getting the upper hand.

Any well-informed doctor will tell you that these are only a few of many symptoms of tobacco poisoning.

And YOU know that the use of tobacco in any form is an expensive, utterly useless habit. You know you ought to quit.

Tobacco Habit Banished Let Us Help You

It doesn't make a particle of difference whether you've been a user of tobacco for a single month or 50 years, or how much you use, or in what form you use it—whether you smoke cigars, cigarettes, pipe, chew plug or fine cut or use snuff—Tobacco Redeemer will positively remove all craving for tobacco in any form in a very few days. Not the slightest shock to the nervous system. Your tobacco craving will usually begin to decrease after the very first dose—there's no long waiting for results.

Tobacco Redeemer contains no habit-forming drugs of any kind and is marvelously quick, scientific and thoroughly reliable.

It is in no sense a substitute for tobacco. After finishing the treatment you have absolutely no desire to use tobacco again or to continue the use of the remedy. It helps to quiet the nerves and make you feel better in every way.

Results Guaranteed

A single trial will convince you. Our legal-binding, money-back guarantee goes with each full treatment. We will refund every cent you pay for the treatment if after taking it according to the easy-to-follow directions, it should fail to banish the tobacco habit completely.

SEND Free Proof

Let us send you our free booklet on the deadly effects of tobacco, together with testimonial letters from men all over the country telling how they have been absolutely freed from the tobacco habit by this simple home treatment. You could not ask for stronger proof that Tobacco Redeemer will free you from the habit than the evidence we will gladly send on request. Just mail the coupon—or a postal will do.

NEWELL PHARMACAL CO.

Dept. 300

St. Louis, Mo.



Free Book Coupon

NEWELL PHARMACAL CO.

Dept. 300

St. Louis, Mo.

Please send, without obligating me in any way, your free booklet regarding the tobacco habit and proof that Tobacco Redeemer will positively free me from the tobacco habit or my money will be refunded.

Name

Street and No.

Town..... State.....

Draftsman's Complete Outfit

FREE



Everything used by expert draftsmen given you absolutely free. Outfit includes "professional" complete set of fine drawing instruments with double set of compasses and dividers all in velvet lined case. Drawing board, T square, two triangles, protractor, universal curve, triangular, standard scale, water-proof ink, pens, pencils and all accessories—furnished you free in this expert's complete outfit.

Easy to Learn at Home from Great School Known All Over the World

The Coyne Home Study course guarantees to train you. Remember, the Coyne Trade and Engineering Schools are recognized by Educators all over the world. Students come from all over the world to get Coyne training. Why? Because of the Coyne school's long established, tremendous reputation for successful teaching by its great staff of experts. Coyne is not a "one man" school, but a great educational institution, 22 years old, an acknowledged leader and originator. Coyne originated the "Learn by Doing" method now endorsed by educators everywhere. Coyne has graduated thousands of successful, prosperous men all over the world. You can't make a mistake if you write for the Coyne free book. Coyne students say every minute of the course was enjoyable. Some students took good positions three months before their course was finished.



B. W. Cooke

President

COYNE
HOME STUDY DEPT.
TRADE & ENGINEERING SCHOOLS

Recognized Producer of Successful Men

39-51 East Illinois St., Dept. 1772, Chicago, Ill.

Draftsmen Make \$225.00 to \$500.00 a Month

There is a tremendous demand for trained draftsmen. Now is the time to start. Draftsmen get good pay from the start and can work up to \$500 a month *and more*. Draftsmen are needed everywhere. Once you are trained you can choose your own business and work in any part of the country you please. Coyne training makes everything easy for you.

Coyne student L. T. Dubendorf, writes: "Immediately after completing Coyne course I went to work for Armour & Co. Work was easy for me. Five months later I accepted a position in New York at a large increase in salary."

3 Months Course at School You can qualify as an expert draftsman by 3 months' intensive training at the school in Chicago. Living cheap. Possibilities of earning way while studying. If you prefer to come to school instead of the "Home Study" course, check coupon and send it for complete information

Send for FREE Book

Mail this coupon for our interesting book, "Drafting the Foundation of Industry," sent you free. It explains all about the Coyne home study method and shows you how to become a draftsman in the quickest and easiest way. You want to know all about this great institution. Don't put it off. Send for this book now. It's absolutely free, no obligation. It contains the most valuable information you will ever get in your life. Send the coupon now.

Check coupon below and mail now!

Coyne Trade and Engineering Schools,
Department 1772 39-51 E. Illinois St., Chicago, Ill.

Dear Sirs:—Please send me, absolutely free, without obligation, your book, "Drafting the Foundation of Industry," also full information about the Course in Drafting. (Check which course you prefer)

Home Study Course School Course

Name _____

Address _____

State _____



Do You Want to Be A Surveyor?

ARE you fond of outdoor work? Would you like to become a Civil Engineer? Then take up Surveying. It is a profession that not only pays big salaries itself, but it is the stepping stone to something even better. Probably 99 out of every 100 Civil Engineers were surveyors first.

Fill out the coupon below and let us tell you how you can prepare for success in Surveying, Engineering, Drafting, Chemistry, etc., through spare-time study at home with the I. C. S.

----- TEAR OUT HERE -----

INTERNATIONAL CORRESPONDENCE SCHOOLS
Box 5607-C, Scranton, Pa.

Without cost or obligation, please send me complete information about the subjects before which I have placed an X in the list below:

- | | |
|---|--|
| <input type="checkbox"/> SURVEYING | <input type="checkbox"/> ADVERTISING |
| <input type="checkbox"/> DRAFTING | <input type="checkbox"/> Salesmanship |
| <input type="checkbox"/> Mechanical Engineering | <input type="checkbox"/> BOOKKEEPING |
| <input type="checkbox"/> Civil Engineering | <input type="checkbox"/> Civil Service |
| <input type="checkbox"/> ARCHITECTURE | <input type="checkbox"/> Railway Mail Service |
| <input type="checkbox"/> Electrical Engineering | <input type="checkbox"/> Pharmacist |
| <input type="checkbox"/> Stationary Engineering | <input type="checkbox"/> Traffic Manager |
| <input type="checkbox"/> CHEMISTRY | <input type="checkbox"/> Business Management |
| <input type="checkbox"/> Automobiles | <input type="checkbox"/> Certified Public Accountant |
| <input type="checkbox"/> STENOGRAPHY | <input type="checkbox"/> Airplane Engines |

Name.....

Address.....

Occupation.....

Please Mention Popular Mechanics

Be an Expert Repairman on Motors and Generators



Repair men are in big demand—particularly men expert in armature winding. Get into this well paid line.

Learn in 3 Months

—to master this work and insure yourself a permanent income and bigger opportunities—here at this Great Electrical School. In this short time you learn the theory and actually wind all types of D. C. and A. C. armatures under expert instructors.

Write for FREE Booklet

—giving full particulars of this 3-months' Armature Winding Course. Write today—you will not be obligated. Address—

SCHOOL OF PRACTICAL ELECTRICITY

Dept. PM2, 415 Marshall St.

Milwaukee, Wis.

BRUSHES and SUPPLIES
FOR SIGN and SHOW CARD WRITERS

Chas. J. Brown
Founder

Largest sign shops and studios use **BLUE HANDLE BRAND** brushes and supplies. The FPO-NEER line, Established 1896.

Recognized Quality — Tremendous purchasing power, and long years of practical experience, permit us to offer the highest quality supplies at the lowest prices. — The Cusack Co., of Indianapolis, writes: "We offer you the highest recommendation for your goods."

Write for our new 1922 catalogue. It's FREE.

DETROIT SCHOOL OF LETTERING, 622 D. S. of L. Bldg.
SUPPLY DEPT., Detroit, Mich., U. S. A.

A LATHER THAT SOOTHES

Palmolive Shaving Cream gives a full, creamy lather that makes the beard wax-like. The razor moves smoothly. Palmolive is also a lotion. Contains both Palm and Olive oils. Write for free trial tube. Large size takes 45¢.

THE PALMOLIVE COMPANY, Milwaukee, U. S. A.
PALMOLIVE SHAVING CREAM

LEARN JIJITSU SECRETS IN 1 HOUR

Capt. Smith's famous army Jijitsu course—now open to civilians—enables you quickly and easily to master Jijitsu IN YOUR OWN HOME.

World's Most Effective Defence

The most formidable holds in existence can now be easily learned. With Capt. Smith's Japanese secrets, you can master an assailant twice your size INSTANTLY. Around these Jijitsu Tricks, Capt. Smith has developed a system of exercising, which as a body-builder and conditioner, has not been equaled in the army or out of it.



CAPT. ALLAN SMITH
Formerly Chief Jijitsu Instructor U. S. Army

The Master Secret of Jijitsu

So efficient is Capt. Smith's course that children can learn and practice his tricks without personal instruction. This is made possible by Capt. Smith's wonderful discovery of the Master Secret of Jijitsu—The Stahara. Ten years as wrestler and instructor of Jijitsu in Tokyo, Japan, Capt. Smith not only mastered the science, but unearthed the source of the mysterious power of Jijitsu. This secret you can learn and apply IN ONE HOUR. Once mastered, you can become expert in Jijitsu in an amazingly short time.

STAHARA PUBLISHING COMPANY,

Dept. 62, Exchange Bldg., Columbus, Ga.

Please send me Capt. Smith's complete course of seven books, secrets of Jijitsu. Within 5 days after receipt I will either remail them or send you \$5.00 in full payment.

Name.....

Address.....

Send No Money

Merely send coupon. The complete course will be sent you. Test its power on your strongest friend. If in any way it disappoints you, send it back. If satisfactory in every way, send only \$5 in full payment.

FREE BOOK Discloses Secret Which Makes Music Intensely Interesting and Easy

Explains how to become an accomplished player on any instrument, quickly, in your own home. No teacher needed.



Easy to Entertain



Easy to Teach



Easy to Play

WHAT U. S. SHORTCUT METHOD WILL DO

1. Enable you to master your favorite instrument easily, quickly, thoroughly.
2. Teach you to read and play popular, sacred, or classical music.
3. Disclose the principles, theory and practice of Music.
4. Make Music intensely interesting and easy to understand.
5. Prevent and correct mistakes in your musical education.
6. Fit you for a Teacher's Certificate.
7. Enable you to make money from Music.
8. Increase your power of enjoyment and happiness.
9. Gain you higher social recognition.
10. Help you to make friends who count.
11. Grant you the great pleasure of creating music yourself.
12. Increase your appreciation of Music.
13. Provide a conservatory training at a fraction of the usual cost.
14. Teach you in the privacy and convenience of your own home.
15. Permit all members of your family to study from your lessons without added charge.
16. Secure positive results and open to you all of the countless advantages enjoyed by the trained player.

This Wonderful FREE Book

Describes the joys and beauties of Music. Tells how hundreds who thought they had no talent suddenly discovered otherwise and became supreme masters of their favorite instruments. Discloses U. S. short-cut method which easily, quickly and surely shows you how to read and play Popular, Sacred, or Classical Music. Music is a natural taste. Everyone has it to more or less degree and it can be very readily cultivated.

A Remarkable Method

Through this remarkable method, without musical education or special training you can learn to play any kind of music by note. No long drawn out study. No complicated "number" or "ear" systems. No trick music or other make-shifts. No waste of time or energy. It is a positive, rapid, efficient, scientific method, for beginners or advanced pupils.

Test Your Own Ability

This book further explains how to test your ability. How to learn both theory and practice. How Music will help you win advancement. The advantages of Music as a profession or for recreation. How to choose an instrument. How automatic finger control can be gained. How to avoid making mistakes. How to get a Teacher's Certificate. And many other equally interesting facts.

Act Before Edition Is Exhausted

When learning to play is so easy, why continue to deny yourself the pleasure of Music? Why deny yourself all the splendid advantages that this method can give you? Why not send to-day for this Splendid Book which is **absolutely free**, without cost or obligation, before the edition is exhausted? Write us a Post Card, Letter, or use the FREE BOOK COUPON. Be sure to state instrument that you are most interested in playing.

U. S. SCHOOL OF MUSIC
72 Brunswick Bldg., New York City

FREE BOOK COUPON

U. S. SCHOOL OF MUSIC, 72 Brunswick Bldg., New York City

Yes, send me a copy of your wonderful booklet, and particulars of the U. S. courses which teach how to learn to read and play music easily and quickly on any instrument. I am especially interested in playing the instrument checked below.

.... Piano Guitar Harp Saxophone
.... Organ Hawaiian Guitar Cornet Cello
.... Violin Ukulele Piccolo Harmony and Composition
.... Banjo Sight Singing Trombone Drums and Traps
.... Tenor Banjo Vocal Culture Clarinet Automatic Finger Control
.... Mandolin Public Speaking Flute Language of Music

Name.....

Address.....

GET INTO COMMERCIAL WIRELESS

The Most Rapidly Growing Field Today

\$1,500 to \$10,000 a Year

No field is growing faster than wireless. No field has more to offer to the trained man. What's more important, a man can prepare himself for a good-paying position, with short hours and clean, pleasant work, in from **four to six months**. Think of it, you can be a trained wireless operator ready to take a position in one of the big land stations by next summer. Or, if you want to travel and see the world, you can take charge of a ship station on the sea. It would take you three or four years to learn most any of the modern professions, and then, after you finish, you would have to work hard for your salary. But not so with wireless! It is an uncrowded, growing field, where the work is interesting, the pay good, and the hours short. Everybody respects a "wireless man," too. No knowledge of electricity required. If you can read and write, you can get into wireless.

LEARN AT HOME DURING SPARE TIME

The National Radio Institute has revolutionized home instruction. We have trained 8000 men since 1914, and the field is calling for thousands more. Our course is one of the few that has been recognized by the United States Government. Wireless is a fascinating study, too. Think of messages flying through the air at a speed of 186,000 miles a second! You can learn to pick them up quickly and easily. With four to six months' instruction with the National Radio Institute you can get a training that will bring you more salary to start with than you would receive after a four-year college course.

"LISTEN IN" AT HOME WE SUPPLY ENTIRE OUTFIT

National Radio Institute training is practical training. We supply you with three wonderful wireless inventions. You learn the Wireless code with the "Learners' Transmitter." You learn to receive with the Multiplex Automatic Sender. Listen and learn, that is what it amounts to. Then as your training progresses, we send you a wireless receiving outfit with which you can pick wireless telegraph and telephone messages right out of the air. Right in your own home you can hear the operators of the big commercial stations sending, and furthermore, you will be able to read them. You can "listen in" on the wireless telephone concerts and speeches, too.

BOOK FREE

We cannot begin to tell you the interesting things about wireless that you should know. Send for our big book, "Wireless, The Opportunity of Today." It's Free. No obligation.



NATIONAL RADIO INSTITUTE, Desk 1001
Radio Headquarters
1345 Pennsylvania Avenue N.W., Washington, D. C.

National Radio Institute, Desk 1001
1345 Pennsylvania Avenue, N. W.,
Washington, D. C.,

Gentlemen: Send me your free book "Wireless, The Opportunity of Today." Tell me about your Home Study Course and your offer.

Name

Address

City State

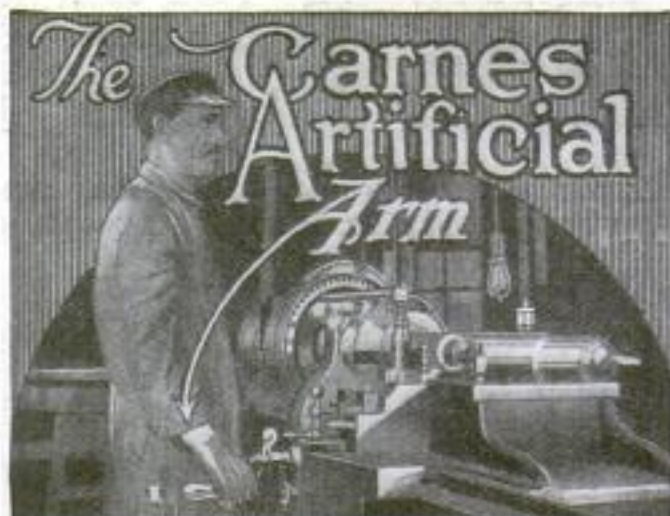

has enabled John G. Anderson, Aurora, Ill., to keep on the payroll since his right arm was amputated some years ago. The reproduction (from an actual photograph) shows Mr. Anderson at work on an intricate machine using his Carnes Artificial Arm.

INCONSPICUOUS - SERVICEABLE

The Best Substitute for the Natural Arm.

To see him on the street you would not realize that his right arm was artificial. Wearers of this wonderful arm find that it practically takes the place of the natural arm. With it you can dress yourself, use knife and fork, carry grips, write, pick up large and small objects—in fact, do practically everything that was possible before. Even though the amputation be at the shoulder, the CARNES ARTIFICIAL ARM bends at the elbow and wrist, and the fingers open and close as desired.

WONDERFUL BOOK SENT FREE Every armless man or woman should write today for the wonderful illustrated 190 page book showing with actual photographs what can be done with this invention. Write today to

CARNES ARTIFICIAL LIMB CO.
208 CARNES BUILDING KANSAS CITY, MO.

ELECTRICITY

Two-year course in six months, in your home

Practical Electrical Engineering, a Study Course Without Higher Mathematics, now ready.

G. E. Motor Free

Upon receipt of coupon below we will send you a valuable booklet free of all charge. Also our free motor offer. We will tell you just how easy it will be for you to become a master electrical worker or engineer.

Earn \$72 to \$100 per week

A complete electrical education, and the higher positions, now within the reach of every man, young or old. The lowest priced standard electrical course, and the easiest to understand, ever constructed.

YOUR FUTURE LIES IN THIS FREE COUPON

World Technical Institute
Fuller Building, Jersey City, N. J.

Gentlemen:—

Send to me free of charge your valuable booklet, also your free motor offer, and full particulars in regard to your Course on Practical Electrical Engineering.

Name

Address

PM2-22

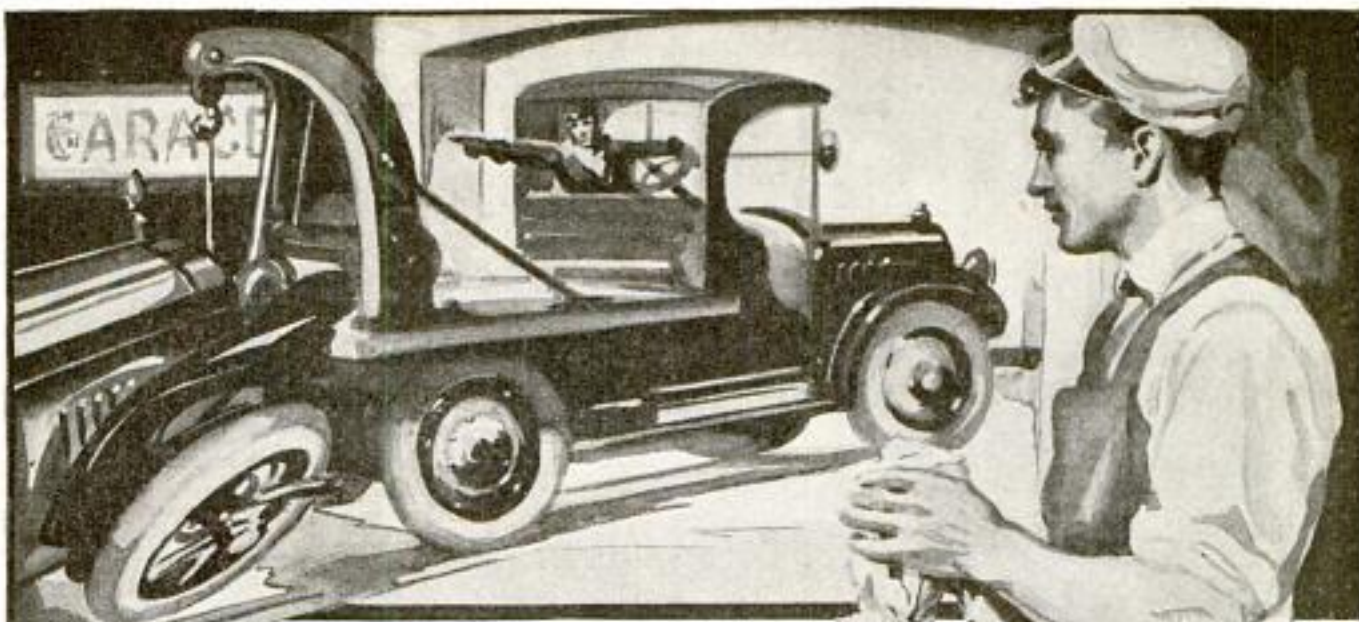

“YOU CAN FIX HER UP” and make \$35 to \$100 a Week

Every young man worth his salt wants to live decently, to fight and to win. That means **you**. You want more money—enough to afford the things you set your heart on. You want love and esteem. You want to see the world, to own a home. There are many more things that you do want and that you will have **if** you succeed in life. But you must stop dreaming! Be practical! Begin to build your future right now—this minute.

Be fair to yourself! Your future depends on the knowledge you acquire now. Knowledge is Power—the power to make money. Mechanical knowledge **always** brings money.

You know that the automobile industry is the most important, the best paying in the United States. Read the clipping. There are 10,000,000 cars in use in this country—one car for every ten persons!—and this figure does not include tractors, airplanes, motor boats!

The services of trained auto-mechanics are needed day after day on each of these 10,000,000 cars. Yet there are not enough trained men to fill the need.

You can make from \$35 to \$100 a week as an automobile mechanic, or your own boss, if you have the training.

We can train you along special lines in from six to eight weeks. Our experts make it easy for you to learn. Every teacher is a practical shop man. We offer intensive **practical** training which teaches you **why** as well as **how** you do things—the best, the most honest that can be secured—and we can prove it.

You can become a General Auto Repairman, Battery Expert, Welder, Vulcanizer, Tire Expert, Auto Electrician, Tractor Engineer, Airplane Mechanic, Auto Salesman or Chauffeur, depending on the Course you choose. These jobs **pay**. There are

plenty of openings. We help our students find positions.

Come to Washington—the Nation's Capital

See our new \$250,000 School Building. Watch our students work. Choose the course you want.

YOU NEED NOT PAY A CENT until you, yourself, have conducted a thorough investigation of our methods—until you are satisfied that we can furnish you **the standard** automobile training of America.

Because we want to be of real service to you, because we have room for a thousand new students—because we want these students to talk about us and recommend our School, **WE ARE STILL OFFERING—BUT NOT FOR LONG—A REBATE OF \$50—ENOUGH TO PAY YOUR FARE TO WASHINGTON AND LEAVE PLENTY OVER TO HELP DEFRAY YOUR EXPENSES. IF YOU ACT AT ONCE, YOU CAN SAVE \$50.**

Before you take your trip to Washington, you may wish to learn about the low cost of our courses and there is much more we would like to tell you. We want you to know all about us, so clip the coupon and mail it today.

AMERICAN MOTOR SCHOOLS, Inc.

Dept. 220, Washington, D. C.



**American Motor Schools, Inc.,
Dept. 220, 1612-22 U St., N. W.,
Washington, D. C.**

Without cost or obligation, please send catalogue of information on your Automobile Mechanics Course.

Name

Address

City

State Age



"I Wouldn't Sell It For \$10,000!"

—and all it cost me was a little spare time!"

So says D. H. Duncan, formerly Controller of Maintenance for the Diamond Chain Company, and now President of the D. H. Duncan Supply Co., of Indianapolis.

Does he mean his fine home? His automobile? No, sir! He means the training he got from his International Correspondence Schools course.

"I am an I. C. S. student," says Mr. Duncan, "and proud of it. If I could not gain access to what I have learned from my course, I would not sell it for ten thousand dollars. As a matter of fact I could not fill my present position without the knowledge gained from my studies.

"The first thing I ask a young man applying to me for work is if he is doing anything to improve himself. If he says no, I tell him about the I. C. S. A lot of your students are working here now. They are our best men."

HOW much longer are you going to wait before taking the step that is bound to bring you advancement and more money?

Once again you are face to face with that familiar coupon. Don't pass it by this time without at least finding out what the I. C. S. can do for you. Mail and mark it today!

----- TEAR OUT HERE -----

INTERNATIONAL CORRESPONDENCE SCHOOLS

Box 5605-C, SCRANTON, PA.

Without cost or obligation, please explain how I can qualify for the position or in the subject before which I have marked an X in the list below:

- | | |
|--|---|
| <input type="checkbox"/> ADVERTISING | <input type="checkbox"/> ELECTRICAL ENGR |
| <input type="checkbox"/> Salesmanship | <input type="checkbox"/> Tool Maker |
| <input type="checkbox"/> Commercial Law | <input type="checkbox"/> Gas Engine Operating |
| <input type="checkbox"/> Business Management | <input type="checkbox"/> Telegraph Engineer |
| <input type="checkbox"/> Cert. Public Accountant | <input type="checkbox"/> Telephone Work |
| <input type="checkbox"/> Bookkeeper | <input type="checkbox"/> Railroad Positions |
| <input type="checkbox"/> Stenographer | <input type="checkbox"/> ARCHITECT |
| <input type="checkbox"/> C & W TOONGING | <input type="checkbox"/> Contractor and Builder |
| <input type="checkbox"/> Good English | <input type="checkbox"/> CIVIL ENGINEER |
| <input type="checkbox"/> Civil Service | <input type="checkbox"/> Surveying and Mapping |
| <input type="checkbox"/> Mathematics | <input type="checkbox"/> Traffic Manager |
| <input type="checkbox"/> Common School Subjects | <input type="checkbox"/> MINING ENGINEER |
| <input type="checkbox"/> MECHANICAL ENGR | <input type="checkbox"/> AGRICULTURE |
| <input type="checkbox"/> Mechanical Draftsman | <input type="checkbox"/> Pharmacy |
| <input type="checkbox"/> CHEMIST | <input type="checkbox"/> AUTOMOBILES |

Name _____

Street and No. _____

City _____ State _____

Please Mention Popular Mechanics

WARNING

The public is warned not to pay any money intended for subscriptions to Popular Mechanics Magazine to agents of either the "Magazine Service Co., Masonic Temple, Chicago," or the "National Magazine Distributors, Woolworth Bldg., New York City," as there are no such companies at these addresses. Canvassers claiming to be agents of these fake companies are soliciting subscriptions to this magazine, and usually others also, offering a year's subscription at a cut rate of \$2.50 and an Atlas free.

As should be known by this time, Popular Mechanics Magazine employs no solicitors, offers no premiums and never cuts its rates. Any canvasser making the above offers of Popular Mechanics is a fraud, and should be arrested immediately.

Police Departments are requested to telegraph us (collect) of any such arrest, so we can bring legal action at once, and Chiefs of Police are hereby assured of our prosecuting such cases to the limit. The suit we won last year in the United States Court was that no one may legally represent himself as our agent without our consent, and that to solicit subscriptions is the act of an agent. We have no such agents.

Popular Mechanics Co.,

By H. H. Windsor,

President.

Chicago, Dec. 16, 1921.

TOBACCO Or SNUFF HABIT Overcome or NO PAY!

No matter whether used in pipe, cigarettes, cigars, chewed, or used in the form of snuff. Superba Tobacco Remedy contains nothing injurious, no dope, poisons, or habit-forming drugs. Guaranteed. Sent on trial. If successful, costs you one dollar. If it fails, or if you are not perfectly satisfied, costs you nothing.

Write for full remedy today.

SUPERBA COMPANY, M-19, BALTIMORE, MD.

OH BOYS-GIRLS GREAT SPORT



THROW YOUR VOICE



Into a Barrel, under the Table, Back of a Door, into a TRUNK, DESK, in SCHOOL, Any Old Place, Great FUN fooling the TEACHER, friends, EVERYBODY with Our **CLAXOPHONE**

Which Sets on your Tongue Unseen, it NEVER FAILS ANYBODY Int, Birds, etc. The CLAXOPHONE, with Full Instructions, a Set of SECRET-WRITING TRICK, (bests ever, ink) a MAGIC-DIAL Trick, (a Great Money maker), ALSO, This Marvellous Novelty—

NEW SCIENTIFIC WONDER

"X-RAY" CURIO

3 FOR 25c. BIG FUN

With it you Apparently See thru Coats, see the bones in your Fingers, Lead in Pencils, etc. No end of fun. WE SEND ALL ABOVE Novelties by prepaid Mail for 1 for 25 cts. A nice Souvenir Free with each 25c order.

CLAXO TRICK CO., Dept. X-P, NEW HAVEN, CONN. WE GIVE the BEST and MOST for the MONEY.

BIGGER AND BETTER THAN EVER!

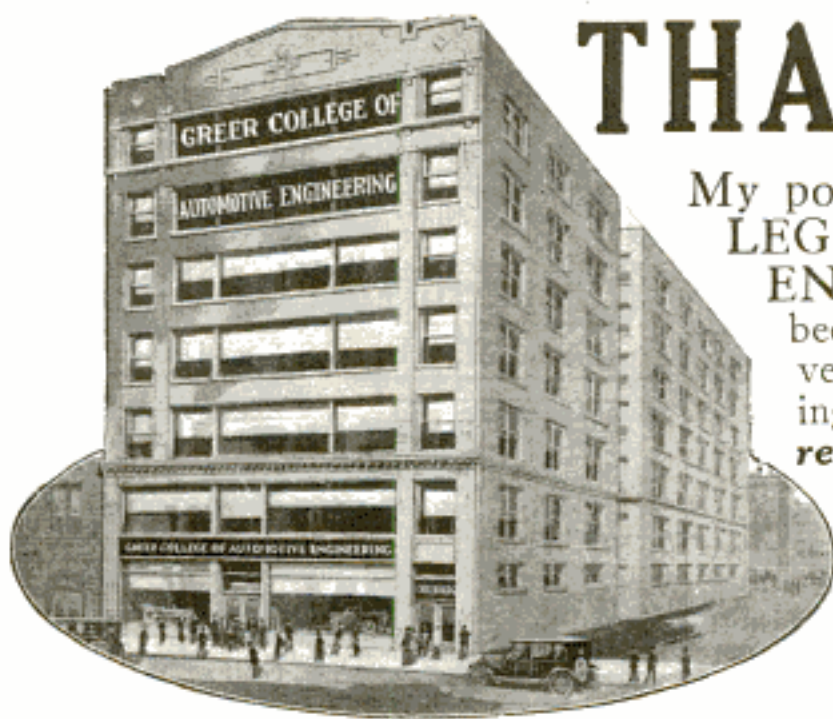

My policy for GREER COLLEGE OF AUTOMOTIVE ENGINEERING has always been to give our students the very best instruction and training possible. We aim to turn out *real* automobile men—**Certified Automotive Engineers.**

And now, in order to give our Students still greater advantages, we have moved into our new building, all of which is used by Greer College for

automotive educational training. In these seven big floors we have much more room, better equipment, better light—finer in every way. Here students study and work on the actual parts of all kinds of cars, under the direction of competent instructors.

BE A "C.A.E." (*Certified Automotive Engineer*)

The prestige enjoyed by Greer graduates is your cue. A *Greer Diploma means something.* Graduate from *Greer College of Automotive Engineering* and be recognized as "*The Man Who Knows.*" Greer students who complete the course and earn their diplomas become *Certified Automotive Engineers.*

REAL INSTRUCTION

It is not enough to merely go to some automobile school for a few weeks. You want to go to the College that makes Master Mechanics, real Certified Automotive Engineers. That means, Greer College of Automotive Engineering. Here we always aim to give such instruction and training that Greer graduates will continue to be recognized as the best. Here we prepare you for success. Write for *free* catalog today.

VALUABLE BOOK FREE

has just been published. Full of useful and practical information. Worth \$1.00 per copy—yet sent free to anyone interested. Write today.

A new up-to-date edition of my book, "*How to Succeed,*"

Orwin Greer

GREER COLLEGE
OF AUTOMOTIVE
ENGINEERING

2024 Wabash Avenue,
Dept. 12, Chicago, Ill.

Please send me free your big book as advertised in the February Popular Mechanics. Am interested in subjects before which I mark X.

Automobiles Vulcanizing
 Tractors Electric Starters
 Batteries Welding

Name.....

Present Occupation.....

Street or R. F. D.....

City..... State.....

GREER COLLEGE
of Automotive Engineering
2024 So. Wabash Ave., Dept. 12, Chicago,



"Look At Him Today!"

"Six years ago he started in here just as you are doing. Now he's General Manager and makes more in a day than he used to make in a week. The first week he was here he began to train for the job ahead by studying in spare time with the International Correspondence Schools. Inside of six months he got his first promotion. You've got the same chance he had, young man. Follow his example. Take up some I. C. S. course right away. What *you* are six years from now is entirely up to you."

This is the story of thousands of successful men. They did their work well, and in spare time, with I. C. S. help, trained themselves for advancement. That's the thing for *you* to do. Whatever your chosen work may be, there is an I. C. S. Course that will prepare you right at home for a better position with bigger pay.

More than 130,000 men are getting ready for promotion right now in the I. C. S. way. Let us tell you what we are doing for them and what we can do for you. The way to find out is easy. Just mark and mail this coupon.

TEAR OUT HERE

INTERNATIONAL CORRESPONDENCE SCHOOLS BOX 5604-C SCRANTON, PA.

Without cost or obligation please explain how I can qualify for the position, or in the subject before which I have marked an X in the list below:

- ELECTRICAL ENGINEER
- Electric Lighting & Railways
- Electric Wiring
- Telegraph Engineer
- Telephone Work
- MECHANICAL ENGINEER
- Mechanical Draftsman
- Machine Shop Practice
- Toolmaker
- Gas Engine Operating
- CIVIL ENGINEER
- Surveying and Mapping
- MINE FOREMAN or ENGR
- STATIONARY ENGINEER
- Marine Engineer
- ARCHITECT
- Contractor and Builder
- Architectural Draftsman
- Concrete Builder
- Structural Engineer
- PLUMBING & HEATING
- Sheet Metal Worker
- Textile Overseer or Supt.
- CHEMIST
- Pharmacy

- BUSINESS MANAGEMENT
- SALESMANSHIP
- ADVERTISING
- Show Card & Sign Ptg.
- Railroad Positions
- ILLUSTRATING
- Cartooning
- Private Secretary
- Business Correspondent
- BOOKKEEPER
- Stenographer & Typist
- Certified Public Accountant
- TRAFFIC MANAGER
- Railway Accountant
- Commercial Law
- GOOD ENGLISH
- Common School Subjects
- CIVIL SERVICE
- Railway Mail Clerk
- AUTOMOBILES
- Mathematics
- Navigation
- AGRICULTURE
- Poultry Raising Spanish
- BANKING Teacher

Name.....

Street and No.....

City..... State.....

Occupation.....

FREE a Ten Lesson Course in PUBLIC SPEAKING



A postal will bring you my wonderful book, "How to Speak in Public," 1921 de Luxe edition, 300 pages, colored illustrations. Introduction by **ELBERT HUBBARD**. Tells secrets of oratory, how to prepare speeches, overcome bashfulness, address lodge meetings, clubs, etc. Contains ready made speeches for all occasions. Chapter by **ORISON SWETT MARDEN**, "Self Improvement Thru Public Speaking."

NO MONEY IN ADVANCE

Pay your postman \$2 when book arrives, this pays in full for the book. Examine it for ten days, if not satisfied return it to me and I will at once refund your \$2.00. If you keep the book, then I will send you my Ten Lesson Public Speaking Course, with full scholarship privileges **ABSOLUTELY FREE.**

Prof. **HENRY DICKSON**
Dept. 705-P, 1041 Chicago Ave. EVANSTON, ILL.



MAKE MONEY Make Show Cards and Signs

EARN \$10.00 to \$25.00 DAILY—salary or have own shop and independence. Easy to learn by our new complete course with **individual correspondence instruction.** Course includes hand lettered show cards, and large assortment **MILKLINE COLORS and BRUSHES FREE.** Graduates established in paying sign shop, or good paying "Jobs" await them. This is your chance to get rid of "Bossism." **BE YOUR OWN BOSS.** Write for illustrated matter, price, terms.

Empire T Art Institute, Inc. 2050 Amsterdam Ave. New York City

BLUE-PRINT READING Taught by mail without drawing. Exclusive, new and easy system. Terms easy, prices low, booklet free.

Dept. F. 234, **INDUSTRIAL CORRESPONDENCE UNIVERSITY, Inc.**
1504 LOCUST ST., PHILADELPHIA, PA.



NEW AUTOMATIC ADDER, \$3.50

Makes adding easy. It's accurate, quick, durable and easily operated. Capacity 8 Columns. Saves time, brain work and errors. 65,000 pleased owners. Fully Guaranteed. Price \$3.50. Delivered. With **METAL OPERATING BANDS, \$5.** Delivered. Agents wanted. Immediate shipment made. Send your order now.

J. H. Bassett & Co., Dept. 199, 1458 Hollywood Ave., Chicago, Ill.

ALOIS P. SWOBODA

1301 Berkeley Building 21 West 44th Street, New York City



U. S. RAILWAY MAIL CLERKS

\$1600 to \$2300 Yearly Work 15 days monthly—paid full time. Travel Free. Hotel expense allowance. No experience required. All men and women over 17, should mail coupon below, NOW.

C. J. Ozment, Dept. 111 St. Louis, Mo.

You may send me Free, prepaid, personally prepared instructions how I may quickly secure Railway Mail Clerk and other Government Positions.

NAME.....

ADDRESS.....

You Can Play the Hawaiian Guitar Just Like the Hawaiians!

OUR STUDENTS SAY

Jacksonville, Ill., Dec. 5, 21.
First Hawaiian Conservatory of Music,
New York City.

Gentlemen—
I received my Certificate of Excellence to-day. I want to say I have enjoyed every minute of the time I have spent on my guitar and studying the lessons. I think you have a wonderful method of teaching it. I have enjoyed the lessons from the first to the last.

Yours truly,
Charles E. Williamson.

Joplin, Mo.,
November 27, 21

Dear Sir—
I thought I would write a few lines to you for fun. I am getting along fine with my outfit. I think, and I am sure glad that I sent to you for it.

I have some friends that are interested in the Hawaiian guitar and think they want one. What shall I do—send in their address?

Well I haven't much time to write as much as I would like so I will have to close.

Yours truly,
M. J. Biggs.

Electra, Texas.

First Hawaiian Conservatory of Music,
I have gotten much pleasure from my course on the Hawaiian guitar. Have my certificate framed. Many thanks for same and your patient assistance.

I shall always speak a good word for the company.

Your pupil,
Mrs. L. D. Pruner, Box 424.

Vinton, Iowa, 10-17-21

Dear Sir—
Received picks and first lesson September 29th. Sure was surprised how much I learned first lesson.

Wishing you the best of success with your course, I am
Respectfully yours,
Van Wright, Mar. Western Union,
Vinton, Ia.

Because Our Native Hawaiian Instructors Will Help You

Our method of teaching is so simple, plain and easy that you begin on a piece with your first lesson. In half an hour you can play it.

ONLY 4 MOTIONS We have reduced the necessary motions you learn to only four and you acquire these in a few minutes. Then it is only a matter of little practice to acquire the weird, fascinating, tremolos, staccatos, slurs and other effects that make this instrument so delightful. The Hawaiian Guitar plays any kind of music, both the melody and the accompaniment.

FREE Just think of it. 52 lessons on this wonderful guitar. You get a beautiful large sized genuine Hawaiian Guitar absolutely free as soon as you enroll for the lessons. All the necessary picks, the steel playing bar and 52 pieces of music are included without cost to you.



Special Arrangements for Lessons if You Have Your Own Guitar

Think of the great pleasure you will get from playing fascinating Hawaiian Melodies for your friends. How popular you will be. Surprise your friends. Entertain them. Send the coupon and we'll tell you how to get this wonderful Hawaiian Guitar absolutely free.

[TEAR OUT COUPON]

Tear Off and Mail Today

First Hawaiian Conservatory of Music, Inc.
233 Broadway (Woolworth Bldg.), New York City

I am interested in the HAWAIIAN GUITAR. Please send complete information, special price offer, etc., etc.

NAME.....

ADDRESS.....

TOWN.....STATE.....

Print name and address clearly. P.M.2

Electrical Course

In
Book
Form

Here is the quickest, easiest, cheapest way to learn electricity. Think of it! A complete electrical course in book form. No tiresome lessons with a lot of mathematics. Just plain everyday electrical facts—the very things and the only things you need know to hold down a good paying job. Written and simplified by 27 of the biggest men in the electrical field. 8 big books—4000 pages and 3000 pictures.

Electricity Means Success

—Good Pay and a Good Job. You can succeed in electricity. It's one of the best paying fields open to young men who know. Here's your chance to learn. Study at home aided by Free Consulting Membership. Free Employment Service Included. The Society helps you learn and helps you get a good job.

FREE TRIAL!

Just mail the coupon—don't send a cent. We send books for a week's free use and explain all about membership privileges. Mail coupon today—now.

American Technical Society, Dept. E-192, Chicago

Send me your 8-volume set of Electrical Books for a week's free use. I will either return the books in 7 days or remit \$2.00 and pay you \$3.00 each month until a total of \$24.00 is paid. If I buy the books I get a membership in your Society free.

Name.....

Address.....

Reference.....

Copy this coupon on larger sheet if more convenient



Hotel Clerks in Big Demand

Hundreds of openings every week in the 20,000 hotels in the United States; salaries up to \$300 per month with the finest of meals, and often your own private room.

Front clerks, room clerks, night clerks, mail clerks, key clerks, are always in demand. No unemployment, no "lay-offs" in hotel work. Bright, capable men behind the front office desk are right in line for promotion to Assistant Manager and Manager this year.

You can qualify for one of these pleasant, well-paid positions as hotel clerk, with a few spare-time hours a week given to the simple, easy, clear, lessons of the Lewis School. Special classes now forming for front office training, under the personal direction of Clifford Lewis—a hotel expert of national reputation. The training will in no way interfere with your present activities.

LEWIS
HOTEL
TRAINING
SCHOOL

Room 317
Washington, D. C.

Send me without obligation the FREE BOOK, "Your Big Opportunity."

Send today for FREE BOOK, "Your Big Opportunity." Don't wait a minute—you may lose an opportunity right in your own vicinity. Mail the coupon now. Your whole future may depend on it.

Name.....

Street.....

City.....State.....

Founded 1916
Lewis Hotel Training
School, Room 317,
Washington, D. C.

Have you the courage to read these figures?

Insurance statistics show that only 11 out of every 100 men who are twenty-five today will be able to support themselves at 65.

36 will be dead.

6 will be self-supporting.

Only 5 will be well-off.

53 will be dependent on others for support.

"What will you be doing at 65?"

Will you still be able to earn your own living? Or will you be dependent on relatives for support?

It all depends on what you do in your spare time. Train yourself to do some one thing well—put your services in demand—and old age will have no terrors. Your training and experience will make your services more valuable every year.

Neglect your opportunity—waste the precious years of youth—keep putting it off until the Tomorrow that never comes—and at 50 or 65 you will be only the shadow of the man you might have been.

Read over those figures again. And then, for the protection of the future years, send in the coupon that has meant the difference between failure and success to so many men just like yourself.

----- TEAR OUT HERE -----

INTERNATIONAL CORRESPONDENCE SCHOOLS
BOX 5602-C, SCRANTON, PA.

Without cost or obligation, please explain how I can qualify for the position or in the subject before which I have marked an X in the list below:

- ADVERTISING
- Salesmanship
- Commercial Law
- Business Management
- Cert. Public Accountant
- Bookkeeper
- Stenographer
- CARTOONING
- Good English
- Civil Service
- Mathematics
- Common School Subjects
- MECHANICAL ENG'R
- Mechanical Draftsman
- CHEMIST

- ELECTRICAL ENG'R
- Tool Maker
- Gas Engine Operating
- Telegraph Engineer
- Telephone Work
- Railroad Positions
- ARCHITECT
- Contractor and Builder
- CIVIL ENGINEER
- Surveying and Mapping
- Traffic Manager
- MINING ENGINEER
- AGRICULTURE
- Pharmacy
- AUTOMOBILES

Name _____

Street and No. _____

City _____ State _____

Occupation _____

Please Mention Popular Mechanics

Deafness



Perfect hearing is now being restored in every condition of deafness or defective hearing from causes such as

Relaxed or Sunken Drums, Roaring or Hissing Sounds, Perforated, Partially Destroyed Drums, etc.

Wilson Common-Sense Ear Drums

"Little Wireless Phones for the Ears"—require no medicine but effectively replace what is lacking or defective in the natural drums. They are simple devices, which the wearer easily fits into the ears where they are invisible. Soft, safe and comfortable to wear at all times.

Write today for our 168 page FREE book on DEAFNESS, giving you full particulars and plenty of testimonials.

WILSON EAR DRUM CO., Incorporated
405 Inter-Southern Building LOUISVILLE, KY.

FLEXO WEATHER STRIPPING

Superior to wooden and metal weather stripping. Can be applied by anyone who can use a hammer and tacks.

Saves Fuel and Doctor bills. Increases Comfort.

Keeps the heat in—Keeps the cold out.

Flexible—Durable—Waterproof.

Makes your house a home.

Send for FREE SAMPLE, descriptive literature and prices.

STUART PLASTER-PAD CO., 103 Stuart Bldg., St. Louis, Mo.



Easy to Save Chicks—

Success with poultry depends upon successfully raising chicks. Chicks that get a poor start seldom grow into good layers or breeders. Prof. Quisenberry has worked out practical methods and secrets which stop and prevent chick loss from bowel trouble and White Diarrhoea. Fully explained in a free 96 page book, "Dollars and Sense in the Poultry Business." Send at once! Address T. E. Quisenberry, Pres., American Poultry School, Dept. 185, Kansas City, Mo.

SELL US YOUR SPARE TIME

after enrolling for our course in Show Card Writing. We will train you to write show cards for us. No canvassing or soliciting; we supply you with work; distance no object; will pay you good money for work done.

Wilson Methods, Ltd., Dept. M, 64 E. Richmond, Toronto, Canada



PREMO, Jr. CAMERA FREE

Popular size, made by Eastman Kodak Co., has view finders, loads in daylight, makes 2 1-4 x 3 1-4 pictures, given for selling only 20 packages of Bluine at 15c. a package.

BLUINE MFG. CO.
690 Mill St., Concord Jct., Mass.



FREE LESSONS EXPERT AUTO and MOTOR WORK

Men—Boys, 15 or over, can easily learn Expert Motor and Auto operation and construction during spare moments

IN 10 WEEKS

Auto and Motor Experts frequently earn

\$40 to \$90 a week

Send Coupon Immediately

MAIL AT ONCE TO

Franklin Institute

Dept. A432, Rochester, N. Y.

Kindly send me absolutely free, sample lessons in MOTOR AND AUTO OPERATION AND CONSTRUCTION. Tell me also how I can take up this work at my own home and earn while learning.

Name _____ Address _____

Copyrighted material

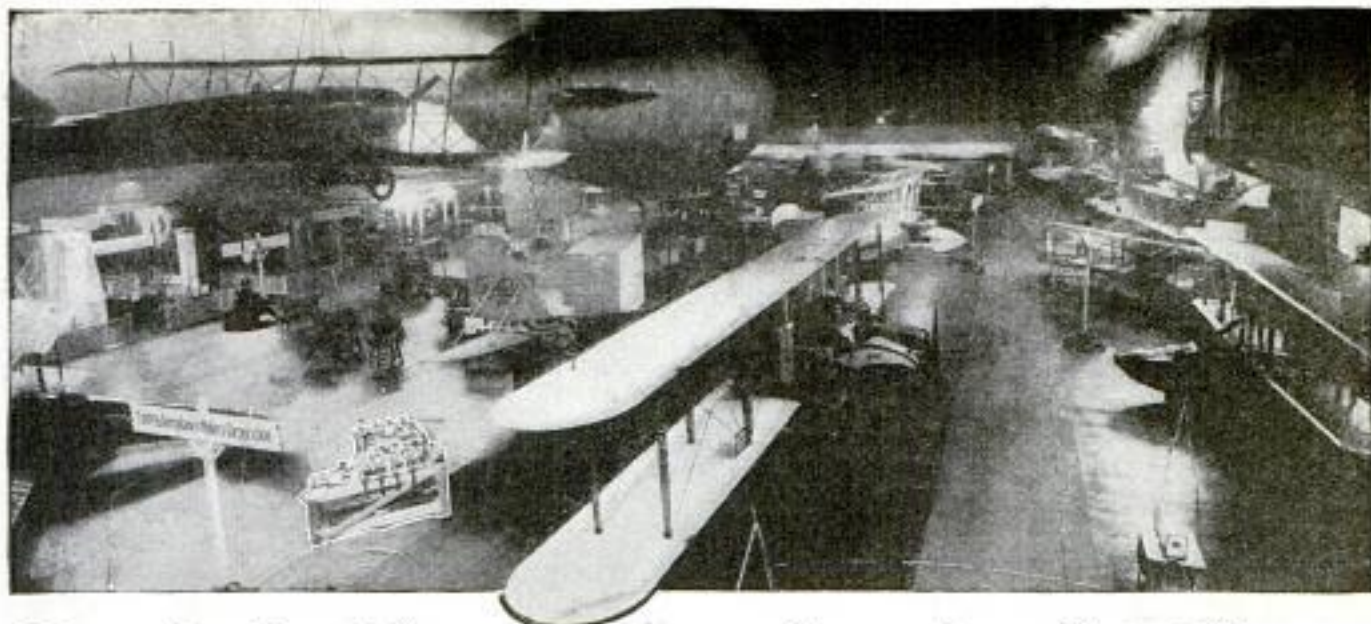

Quick Success in Aviation Fascinating—Daring—Big Paying

To young men of daring, no other field of work offers such a fascination, such high pay, nor such opportunities for quick success as the field of Aviation. As yet, aviation is practically in its infancy. NOW is the time to get in.

Amazing Opportunities in Airplane Industries

In the automobile industry and in the moving picture business hundreds of men got rich by getting in at the start. They made their success before others woke up. Today, these lines offer no greater opportunities than a hundred and one others. BUT AVIATION IS NEW. Get in while the opportunity and pay are big. All over the country there is a clamor for trained men. It is not a question of pay but of getting capable men.

Here Are Real Positions, \$50 to \$150 Per Week

Aeronautical Instructor, Aeronautical Engineer, Aeronautical Contractor, Airplane Repairman, Airplane Mechanician, Airplane Inspector, Airplane Salesman, Airplane Assembler, Airplane Builder.



View in an Airplane Factory

A Sure and Easy Way to Learn Aviation—at Home



A New Job—The Aerial Postman

The study of aviation is almost as fascinating as the actual work. Every lesson is full of interest. That is why it is easy to learn aviation. You do not have to make yourself study—it is like reading an in-

teresting book that tells you things you have always wanted to know. Only one hour each evening will give you the basic training in a surprisingly short time. You need only a common school education.

One of my students, James Powers, Pa., says, "I am indeed surprised that such a valuable Course can be had from such practical men for so little cost."



A New Seven-Passenger Airplane

Personal Instruction by Experienced Men

Men who have had actual experience give you personal attention. They select the lessons, lectures, blueprints and bulletins. They tell you things that are essential in everyday practice. Each lesson is easy to read and understand.

BIG BOOK FREE of Opportunities

Send coupon below for New Book, just out, "Opportunities in the Airplane Industry." It is interesting and instructive. It will show you many things you never knew before about aviation. Due to shortage of paper we could get only a limited supply of these books—send the coupon before they are all gone.

AMERICAN SCHOOL OF AVIATION
3601 Michigan Ave., Dept. 1192, Chicago, Ill.

AMERICAN SCHOOL OF AVIATION
3601 Michigan Ave., Dept. 1192, Chicago, Ill.

Without any obligation, send me your Free Book, "Opportunities in the Airplane Industry," also information about your Course in Practical Aeronautics.

Name.....

Street.....

City..... State.....

5,000,000 Men Are After the Routine Jobs—

*Break Away From
This Competition—*

Command Big Pay!

When business slackens, can your employer "let you go"—and tomorrow hire almost any routine man from this army of 5,000,000 men and find him competent to take your place?

Observe that when a business trims its crew, it is almost never the big-pay men who walk the plank.

Not only are the specialists retained—the Accountants, Production Managers, Traffic Managers, and, in fact, the managers of any of the important departments of a business—but they are frequently promoted. Other concerns are in need of their ability, and come bidding for their services.

Many of these men who today are going rapidly ahead were no better off than you, several years ago. Today, while others walk the streets, these men walk into the better jobs.

There is no mystery about their swift advancement. There is a way that's interesting and practical whereby any man of average intelligence can get the training that will put him in the big-pay class. Literally thousands of ambitious men have found this way in the LaSalle Problem Method. They have chosen the line of work that most appealed to them—then, right in the quiet of their own homes, without losing an hour from work or a dollar of pay, they have solved the problems they today are meeting in the better jobs.

Situations which they face today are identical with those they faced in spare-time study. They have been shown exactly how to meet them—guided every step of the way by some of the ablest business men, in their respective fields, in America.

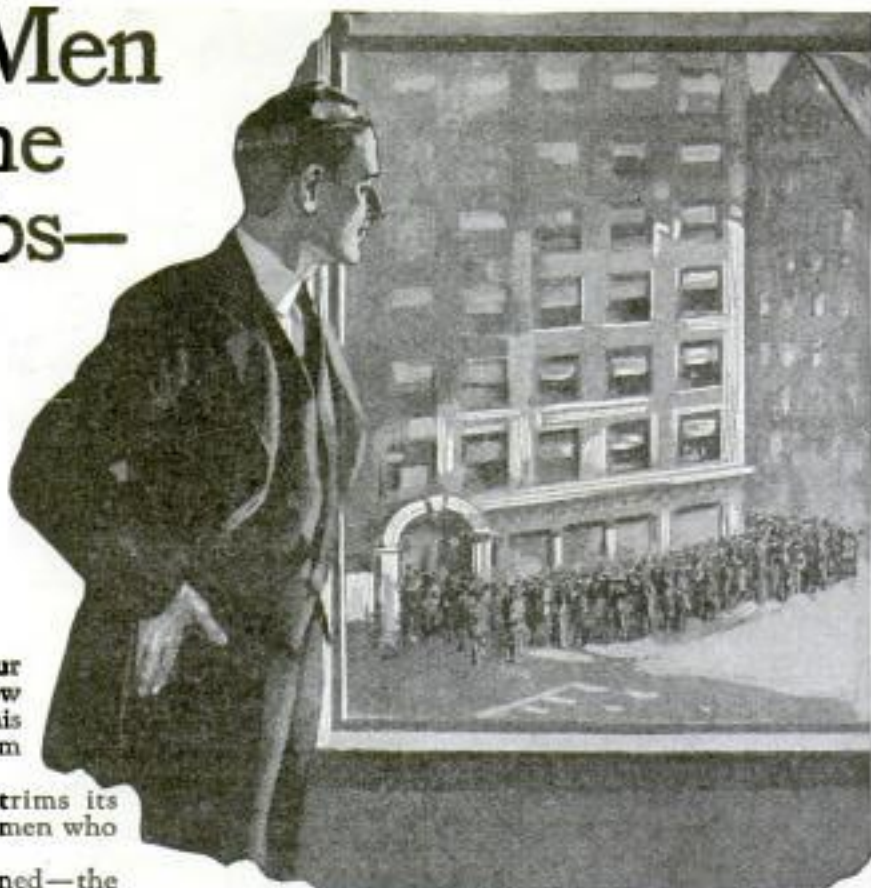

Read these statements, typical of over 1,000 which we will send you in booklet form and which represent but a small part of the many thousands of similar letters in our files:

"The most efficient and most rapidly promoted men in our whole organization are LaSalle-trained."

"Promoted to General Manager."

"Now a director in two banks."

"From bookkeeper advanced to chief accountant—salary increased 500%."

"Passed bar examination with highest grade, in competition with many resident school graduates."

"The Problem Method increased my income \$2,500 a year."

"Passed C. P. A. examination. You will be interested to know that 50% of the successful candidates were LaSalle-trained men."

An analysis of the letters from 1,089 LaSalle members reporting definite salary increases during 3 months' time shows an average increase per man of 36%.

While the axe hangs over every business office, it's the time of all times to free yourself forever from the treadmill jobs.

Mark on the coupon the training that attracts you, sign and mail it to the University. It will bring you full information, together with particulars of our convenient-payment plan; also your free copy of the inspiring book—"Ten Years' Promotion in One."

Break away from the crowd of routine pluggers. Find out today what YOU must do to put yourself among the men who command big money. Mail the coupon NOW.

INQUIRY COUPON

LASALLE EXTENSION UNIVERSITY. Dept. 264-R CHICAGO, ILLINOIS

Please send me catalog and full information regarding the course and service I have marked with an X below. Also a copy of your booklet, "Ten Years' Promotion in One," all without obligation to me.

- | | | | |
|--|--|--|---|
| <input type="checkbox"/> Business Management | <input type="checkbox"/> Law—Degree of LL. B. | <input type="checkbox"/> Banking and Finance | <input type="checkbox"/> Expert Bookkeeping |
| <input type="checkbox"/> Higher Accountancy | <input type="checkbox"/> Commercial Law | <input type="checkbox"/> Personnel and Employment Management | <input type="checkbox"/> Business English |
| <input type="checkbox"/> Traffic Management—Foreign and Domestic | <input type="checkbox"/> Industrial Management Efficiency | <input type="checkbox"/> Modern Foremanship & Production Methods | <input type="checkbox"/> Commercial Spanish |
| <input type="checkbox"/> Railway Accounting and Station Management | <input type="checkbox"/> Modern Business Correspondence and Practice | | <input type="checkbox"/> Effective Speaking |
| | | | <input type="checkbox"/> C. P. A. Coaching |

Name..... Present Position.....

Address.....

1922 ATLAS WITH MAPS OF NEW EUROPE FREE

To the Readers of the *Popular Mechanics* who take advantage of this offer now made in connection with

Webster's New International

The Only Grand Prize

(Highest Award) given to dictionaries at the Panama-Pacific International Exposition was granted to Webster's New International and the Merriam Series for superiority of educational merit.

Words of Recent Interest

Anzac, ace, barrage, Bertha, blighty, Boche, Bolshevik, camouflage, Lewis gun, Liberty bond, Sammy, soviet, tank, war bride. These are but a few of the thousands of late words—all clearly defined in this great work.

"The Supreme Authority"

THE MERRIAM WEBSTER

A Complete Reference Library in Dictionary Form—with nearly 3000 pages and type matter equivalent to a 15-volume Encyclopedia, all in a single volume, on India Paper, bound in rich, Full Red Leather or Library Buckram, and on Regular Paper, in strong Fabrikoid—can now be secured on the following remarkably easy terms:

THE ENTIRE WORK (WITH COMPLETE 1922 ATLAS)

DELIVERED for \$1.00

and easy monthly payments thereafter (in the U. S. and Canada)

ON SUPERIOR INDIA-PAPER

Reduced About One-Half in Thickness and Weight

India-Paper Edition

Printed on thin, opaque, strong, superior India-paper. This edition is only about one-half the thickness and weight of the regular edition. Size 12 $\frac{3}{4}$ in. x 9 $\frac{3}{4}$ in. x 2 $\frac{3}{4}$ in. Weight 8 $\frac{1}{4}$ lbs.

Regular Paper Edition

Printed on strong book paper of the highest quality. Size 12 $\frac{3}{4}$ in. x 9 $\frac{3}{4}$ in. x 5 $\frac{1}{2}$ in. Weight 16 $\frac{1}{4}$ lbs. Both editions are printed from the same plates and indexed. Over 400,000 Vocabulary Terms, and in addition 12,000 Biographical Names, nearly 30,000 Geographical Subjects, besides thousands of other references. Nearly 3,000 Pages. Over 6,000 Illustrations.

The only dictionary with the New Divided Page, characterized as "A Stroke of Genius."



"To have this work in the home is like sending the whole family to college"

To Those Who Mail This Coupon At Once!

G. & C. MERRIAM CO. Home Office DEPT. 5. SPRINGFIELD, MASS.

(Publishers of Genuine Webster Dictionaries for over 75 years)

Please send me, free of all obligation or expense, a copy of "Dictionary Wrinkles" containing an amusing "Test in Pronunciation" (with key) entitled "The Americanization of Carver"; also "125 interesting questions" with reference to their answers, and striking "Facsimile Color-Plate" of the new bindings. Please include specimen pages of India and Regular paper with terms of your free Atlas offer on Webster's New International Dictionary. P.M.

Name.....

Address.....

The ATLAS

is the 1922 "New Reference Atlas of the World" containing 148 pages, with 96 pages of maps beautifully printed in colors, including changes brought about by the Great War, New Census Figures, Parcel-Post Guide, etc., all handsomely bound in red cloth, size 9 $\frac{3}{4}$ x 12 $\frac{3}{4}$.

WANTED—RAILWAY MAIL CLERKS

\$135 to \$185 a Month for Life

Every second week off with full pay—no "lay offs" because of strikes, poor business, etc.—sure pay—rapid advancement to higher positions. City and country residents stand same chance. Common sense education sufficient—no political influence. Examinations likely in every city very shortly.

CANDIDATES PREPARED FREE

Write for free schedule of Winter and Spring examination places. Every day's delay means so much less coaching—so write at once.

FRANKLIN INSTITUTE, Dept. W178, Rochester, N. Y.

Mail This Coupon

Write Plainly

Use It Before You Lose It

COUPON

FRANKLIN INSTITUTE, Dept. W178, Rochester, N. Y.
Kindly send me, without any obligation whatever on my part and entirely free of charge, (1) a full description of the position checked below; (2) Sample examination questions; (3) Free copy of copyrighted book "Government Positions and How to Get Them"; (4) A list of U. S. Government Jobs now open; (5) Directories telling me how to get free counseling for the position checked; (6) Schedule showing dates and places of all coming examinations.

.. Railway Mail Clerk (\$1600 to \$2300)	.. Customs Positions (\$1100 to \$2000)
.. Postoffice Clerk (\$1400 to \$1800)	.. Internal Revenue (\$1100 to \$2000)
.. Postoffice Carrier (\$1400 to \$1800)	.. Stenographer (\$1440 to \$2200)
.. Rural Mail Carrier (\$ 770 to \$2600)	.. Clerk in the Departments
.. Bookkeeper (\$1400 to \$1800)	.. at Washington (\$1340 to \$1800)

Name.....

Address.....

BOYS



Learn Drafting

Drafting offers exceptional opportunities to boys and young men because drafting itself not only commands good pay, but it is the first step towards success in Mechanical or Structural Engineering or Architecture. And drafting is just the kind of work a boy likes to do. There is an easy, delightful way in which you can learn right at home in spare time. For 30 years the International Correspondence Schools have been giving boys just the training they need for success in Drafting and more than 300 other subjects.

Let the I. C. S. help you. Choose the work you like best in the coupon, then mark and mail it. This doesn't obligate you in the least but it will bring you information that will start you on a successful career. This is your chance. Don't let it slip by. Mark and mail this coupon now.

-----TEAR OUT HERE-----

International Correspondence Schools
Box 5599-C, Scranton, Penna.

Without cost or obligation, please send me complete information about the subject which I have checked below:

- DRAFTING
 CARTOONING
 AUTOMOBILES
 CHEMISTRY
 ADVERTISING
 SALESMANSHIP
 ELECTRICITY
 ACCOUNTING
 SURVEYING

Name

Address

\$75 a Week as a Cartoonist

New Way Makes It Easy To Learn At Home

At last, a method has been devised by which anyone can enter the high-paid, fascinating profession of cartooning. The old "inborn talent" theory is exploded. From years of practical experience, one of America's foremost cartoonists has developed a wonderful new way of training, by which in a few hours a week delightful spare time home study, you can qualify for one of the big jobs open in this uncrowded field.

The Most Fascinating Work in the World

The demand for cartoonists is growing greater every day. Your own boss, high pay, easy hours—those are the things cartooning holds for you. And \$75.00 a week is not at all an unusual salary for a beginner! Many of our students start selling pictures even before they finish training, and through this amazing new method, you can do as well or even better!

Send for Free Book

"How to Become a Cartoonist" tells you all about this wonderful easy method, what our students have done and all about the wonderful opportunities awaiting you in this field. Get your start in this big paying profession NOW.

Write for the Booklet TODAY

WASHINGTON SCHOOL OF CARTOONING
Room 1002, Marden Bldg., Washington, D. C.



"STAMMERING Its Cause and Cure"

You can be quickly cured if you stammer. Send 10 cents, coin or stamps, for 288 page cloth bound book on Stammering and Stuttering. It tells how I cured myself after Stammering and Stuttering for 20 years. BENJAMIN N. BOGUE
737 Bogue Building, 1147 N. Ill. St. Indianapolis



Wonderful, new device, guides your hand; corrects your writing in few days. Big improvement in three hours. No failures. Complete outline FREE. Write C. J. Oxment, D-34, St. Louis, Mo.

WHY not spend Spring, Summer and Fall gathering butterflies, insects? I buy hundreds of kinds for collections. Some worth \$1 to \$7 each. Simple outdoor work with my instructions, pictures, price list. Get posted now. Send 25c (NOT STAMPS) for my Illustrated Prospectus. Mr. Sinclair, Dealer in Insects, Dept. 8, Green Park, Calif.



MINSTRELS Musical Comedies and Revues with Complete Instructions for Staging. You can put on your own show with our books. Opening Choruses and Finales, Skits and Afterpieces, Monologues, Songs, Vandeville Acts, How to Stage a Minstrel Show, Wigs, Make-up. Big Catalogue free. T. S. DENISON & CO., 623 So. Wabash, Dept. 19 CHICAGO



SHORTHAND IN ONE MONTH

Boyd—the Wonderful, New, Easy System. Writers hold World's record. 100 to 150 words a minute in 30 days guaranteed. New Principles—dictation first week. Best for Court Reporting and Secretaries. Also Typewriting, Bookkeeping and Commercial Law. Send today for Catalog and Money-Back Guarantee. CHICAGO HOME STUDY SCHOOLS, 802 Reaper Block, Chicago, Ill.

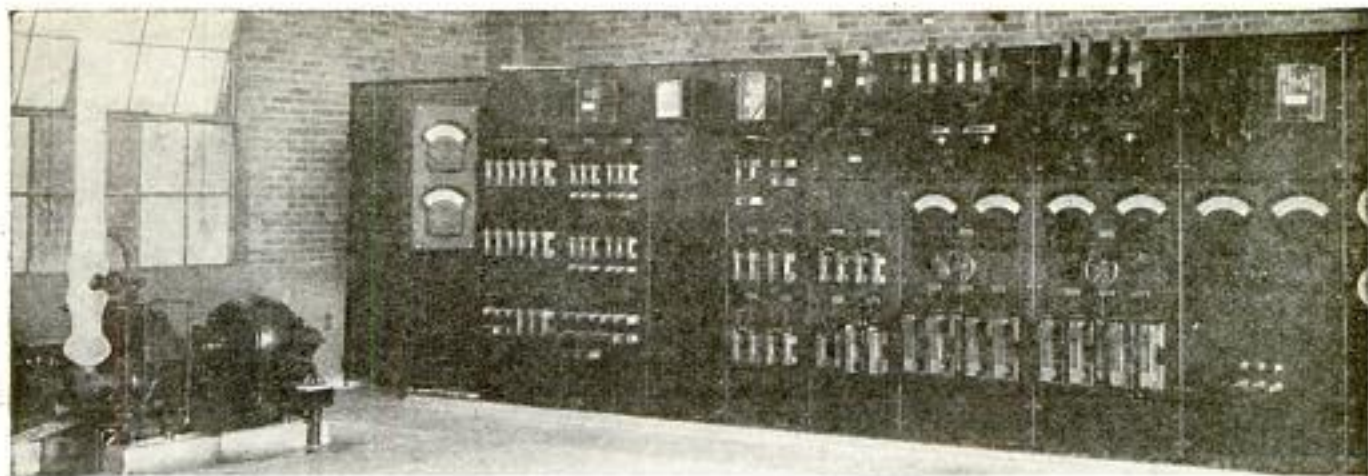

Low-Tension Switch-Board of Modern Type made by Electric Appliance Co., Chicago
S. & H. Shop Type Training is up-to-the-minute

What is the S. & H. Shop-type Method of

ELECTRICAL TRAINING?

It is the latest, quickest and most easily mastered method of training ever developed. We will train you in the Electrical Profession through the use of your hands as well as your eyes. By our Shop-type Method of Training as given in our Green Street plant you use your hands to fix firmly in your mind the Electrical facts taught you by Mr. Hart, our Works Manager and Chief Instructor.

Be a Money Maker

The Shop Trained Man is in greatest demand; for it is the **ACTUAL MONEY PRODUCING KIND OF SKILL** possessed by the man fitted to do expert electrical work in this practical, up-to-date manner that employers want and **SEEK** today. You can get this valuable skill in a shop course like ours and from a practical expert like Mr. Hart who will give you in a short time in our shops the benefit of his 21 years of active, **PRACTICAL** experience with the largest Electrical concern of its kind in the world.

Be an S. & H. Shop Trained Man and Learn to Earn \$70 a Week and Up

as an expert in **MOTOR MAINTAINING, BATTERY CHARGING, ELECTRO-AUTOMOTIVE ENGINEERING, HOUSE-WIRING, ILLUMINATING ENGINEERING, CENTRAL AND SUBSTATION INSTALLATION AND OPERATION, ARMATURE AND COIL WINDING, ELECTRIC TRACTION, LINE CONSTRUCTION, WIRELESS, FARM LIGHTING, etc., etc.,** which we cover in our course.

Home Study Course FREE OUTFIT

Home study students are given a similar training by means of a splendid practical and experimental outfit of high grade standard electrical instruments, apparatus and material given each student free of charge. Look up Feb. number Science and Invention for further particulars regarding S. & H. Home Study Training. Mail Coupon or **WRITE**—for Catalog—**NOW**—while Special terms are in force to 100 men.

S. V. SMITH, President,

S. & H. ELECTRICAL WORKS, Inc., Dept. B1
310 S. Green St. CHICAGO, ILL.



Harry Hart, E. T.,
Works Manager and
Chief Instructor S. &
H. Electrical Works. 21 years
with Commonwealth Edison Co.

S. & H. ELECTRICAL WORKS, Dept. B1

310 S. Green St., Chicago

S. V. Smith, Pres.

Dear Sir: Without cost or obligation on my part send me, fully prepaid and free, full particulars of your shop-type system of training in Electricity.

.....
.....
.....

LEARN CARTOONING



If you like to draw, develop your ability and quickly raise your income

Hundreds of others who had the same ambition have become successful cartoonists through the Landon Picture Chart Method of teaching cartooning. They are now earning from \$75 to \$400 and more per week.

The Landon Course of Cartooning with the famous Landon Picture Charts teaches you how to make original drawings. As your eye follows sketch after sketch on these charts, you learn just how and where to start a drawing and place each line in completing it.

You can learn during your spare time, at home—and a personal criticism service on each lesson corrects mistakes which you may make.

Celebrated cartoonists and educators everywhere pronounce **Landon Picture Charts** as the greatest achievement in the teaching of drawing. No other plan gives you such a thorough understanding of the fundamentals of drawing—none develops originality so rapidly.

The opportunities in cartoon work were never so great as at present.

Write today for sample Landon Picture Chart, long list of successful Landon students and full information showing the possibilities for you. Please state your age.

The Landon School

1438 National Bldg.

Cleveland, Ohio



Learn Photography

Good-paying positions in the best studios of the country await men and women who prepare themselves now. For 28 years we have successfully taught

Photography, Photo-Engraving and Three-Color Work

Our graduates earn \$35 to \$100 a week. We assist them to secure these positions. Now is the time to fit yourself for an advanced position at better pay. Terms easy; living inexpensive. Largest and best school of its kind. Write for catalog today.

ILLINOIS COLLEGE OF PHOTOGRAPHY
Box P, 999 Wabash Ave. Effingham, Illinois

30 Days' Free Trial

Select from 44 Styles, colors and sizes, famous **Ranger** bicycles. Delivered free on approval, from maker-direct-to-rider, at **Factory Prices**. Save \$10 to \$25 on your bicycle.

12 Months to Pay Immediate possession on our liberal Easy Payment plan. Parents often advance first deposit. Energetic boys earn the small monthly payments thereafter.

TIRES Horns, wheels, lamps, parts and equipment at half usual prices. **SEND NO MONEY**—Ask for big free Ranger Catalog, marvelous prices and terms.

MEAD CYCLE COMPANY
Dept. A-181, Chicago, Ill.



Special offer to Rider Agents

Learn to Dance

I CAN TEACH YOU Fox-Trot, One-Step, Two-Step, Waltz and newest "up-to-the-minute" society dances in a few hours—at home—in private by the wonderful **Peak System of Mail Instruction** **REMARKABLE NEW METHOD**. Easy—fascinating. **RESULTS GUARANTEED**. No music—no partner needed. Thousands taught successfully. Write me today for my interesting free book! Special low offer if you answer at once.

WILLIAM CHANDLER PEAK, M. B.
Studio 26 4737 Broadway Chicago, Ill.



Learn Autos and Tractors



Wonderful opportunities constantly offered trained men; we train you thoroughly to start your own business or make good money as motor expert, driver, shop foreman, etc.

7,000 Graduates making good. Catalog Free

Cleveland Automobile School, 1814 E. 24th St., Cleveland, O.

BE AN EXPERT
Penman

FREE Particulars: "How To Become An Expert Penman," and Your Name in Fine Penmanship on two Cards, Different Colors, Embellished, Attractive Designs. ALL FREE. Write Today
T. M. TEVIS, Box 25-K, Chillicothe, Mo.

STAMMER NO MORE

Kill the fear of stammering. Re-education the key. The widely famed Hatfield Method fully outlined in an accurate, dependable, worth-while book—"HOW TO STOP STAMMERING." It has inspired thousands. Free copy today.

THE HATFIELD INSTITUTE, 109 N. Dearborn, Chicago, Ill.

MUSIC LESSONS FREE

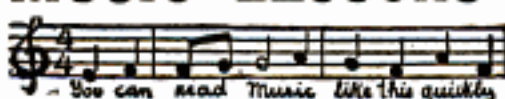

IN YOUR OWN HOME

You can read music like this quickly
Piano, Organ, Violin, Mandolin, Guitar, Banjo, etc. Beginners or advanced players. One lesson weekly. Illustrations make everything plain. Only expense about 2c per day to cover cost of postage and music used. Write for FREE booklet which explains everything in full.
AMERICAN SCHOOL OF MUSIC, 51 Lakeside Building, CHICAGO

New Way to Find and Correct Your Mistakes in English

Does your English reveal your lack of education or does it prove that you are a man or woman of culture and refinement? Are you handicapped in your speech and writing or does your command of English rise to meet every occasion and every situation? English is the one weapon you must use every day. Here is how you can improve it almost at once.

AS a result of thousands of tests, Sherwin Cody found that the average person is only 61% efficient in the vital points of English. In a five-minute conversation, or in an average one-page letter, from five to fifty errors will appear. It is surprising to see how many experienced stenographers fall down in spelling such common words as "business," "abbreviate," etc. It is astonishing how many business men say "between you and I" instead of "between you and me," and use "who" for "whom," and mispronounce the simplest words. Few people know whether to use one or two "c's" or "m's" or "r's," whether to spell words with "ie" or "ei," and when to use commas in order to make their meaning absolutely clear.

A Remarkable Discovery

Mr. Cody has specialized in English for the past twenty years. But instead of going along in the old way he has applied scientific principles to teaching the correct use of our language. He made tens of thousands of tests of his various devices before inventing his present method. In all his tests he found that the trouble with old methods is that points learned do not stick in the mind. In school you were asked to remember rules, and if you forgot the rules you never could tell what was right and what was wrong. For the past five years, Mr. Cody has worked almost day and night to find a way to replace bad habits in writing and speech with good ones. And as a result of his experience he evolved his wonderful new

Self-Correcting Method

Mr. Cody was granted a patent on his unique device, and now he places it at your disposal. This invention is simple, fascinating, time-saving, and incomparably efficient. You do the lesson given on any page, then you see exactly how Mr. Cody himself would correct it. You mark your errors and check them in the first blank column. Next week you try that page again, on the second unmarked sheet, correct your errors, and check them in the second column. You see at a glance what you have learned and what you have failed to remember, until you have reached the 100% point in spelling, punctuation, grammar, and expression.

Only 15 Minutes a Day

A remarkable advantage of Mr. Cody's course is the speed with which these habit-forming practice

drills can be carried out. You can write the answers to fifty questions in 15 minutes, and correct your work in five minutes more. You waste no time in going over the things you already know. Your efforts are automatically concentrated on the mistakes you are in the habit of making, and through constantly being shown the right way, you soon acquire the correct habit in place of the incorrect habit. There are no rules to remember. There is no tedious copying. There is no heart-breaking drudgery.



Sherwin Cody

New Book Free

Every time you talk, every time you write, you show what you are. Your English reveals you as nothing else can. When you use the wrong word, when you mispronounce a word, when you misspell a word, when you punctuate incorrectly, when you use flat, ordinary words, you handicap yourself. If you feel your lack of language power, if you are ever embarrassed by mistakes, if you cannot command the exact words to express your ideas, our new booklet "How to Speak and Write Masterly English" will prove a revelation to you. Merely mail the coupon, and it will be sent by return mail. Learn how Sherwin Cody's new invention makes command of language easy to gain in 15 minutes a day.

Mail this coupon or a postal AT ONCE

Sherwin Cody School of English

52 Searle Building

Rochester, N. Y.

SHERWIN CODY SCHOOL OF ENGLISH,
52 Searle Building, Rochester, N. Y.

Please send me at once your Free Book, "How to Speak and Write Masterly English."

Mr.....

Address.....

City.....State.....

Mechanical Engineering



Learn at Home!

EMPLOYERS everywhere are looking for men with mechanical ability. Splendid salaries and rapid advancement are offered those with special training.

There is an easy, delightful way in which you can learn right at home in spare time. For 30 years the International Correspondence Schools have been giving men and women just the training they need for success in mechanical engineering and more than 200 other subjects. Hundreds of thousands have stepped into good positions through I. C. S. help, but never were opportunities so great as now.

Let the I. C. S. help you. Choose the work you like best in the coupon below, then mark and mail it today. This doesn't obligate you in the least and it will bring you information that will start you on a successful career. This is your chance. Don't let it slip by. The most important thing you have to do is to mark and mail this coupon now.

TEAR OUT HERE

INTERNATIONAL CORRESPONDENCE SCHOOLS
BOX 5601-C SCRANTON, PA.

Without cost or obligation please explain how I can qualify for the position, or in the subject before which I have marked an X in the list below:

- ELECTRICAL ENGINEER
 - Electric Lighting & Railways
 - Electric Wiring
 - Telegraph Engineer
 - Telephone Work
- MECHANICAL ENGINEER
 - Mechanical Draftsman
 - Machine Shop Practice
 - Toolmaker
 - Gas Engine Operating
- CIVIL ENGINEER
 - Surveying and Mapping
- MINE FOREMAN or ENGR
- STATIONARY ENGINEER
 - Marine Engineer
- ARCHITECT
 - Contractor and Builder
 - Architectural Draftsman
 - Concrete Builder
 - Structural Engineer
- PLUMBING & HEATING
 - Sheet Metal Worker
 - Textile Overseer or Supt.
- CHEMIST
 - Pharmacy

- BUSINESS MANAGEMENT
- SALESMANSHIP
- ADVERTISING
 - Show Card & Sign Ptg.
 - Railroad Positions
- ILLUSTRATING
 - Cartooning
 - Private Secretary
 - Business Correspondent
- BOOKKEEPER
- STENOGRAPHER & Typist
- CERTIFIED Public Accountant
- TRAFFIC MANAGER
 - Railway Accountant
 - Commercial Law
- GOOD ENGLISH
 - Common School Subjects
- CIVIL SERVICE
 - Railway Mail Clerk
- AUTOMOBILES
 - Mathematics
 - Navigation
- AGRICULTURE
 - Poultry Raising
- BANKING Spanish Teacher

Name..... 7-1-21

Street and No.....

City..... State.....

Occupation.....

Please Mention Popular Mechanics

The Automobile Instructor

By Clyde H. Pratt, President of the Cleveland Automobile School
16 Easy Lessons

that teach you everything about automobiles. The book that tells it ALL.

The Automobile Instructor

By Clyde H. Pratt, B. Sc., M. E., Member Nat'l Society of Auto Engineers. 256 pages, 210 illustrations, cloth bound. Shipping wt., 25 oz. New edition just out. The standard work for home-study, class-room and reference, for amateur and expert. A complete course for all who desire to master this profitable profession.

LEARN AT HOME HOW TO DRIVE AND REPAIR ALL CARS

Invaluable pointers for every car owner, driver, garage man and repair man. Adopted by Cleveland and other Auto Schools and by Boards of Education as their standard text-book. The author will answer your auto inquiries FREE. This book is guaranteed to be just what you want or your money back.

Price, postpaid, - - - \$2.00

Shrewsbury Publishing Co. 5525 West Chicago, U. S. A.

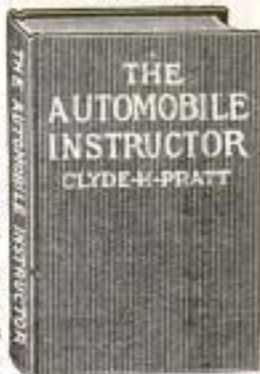

LEARN WATCH REPAIRING



You can learn by our modern and original system of instruction every part of the Watch Repairing Trade at home as good or better than at a shop. You can earn money while learning and secure a well paying position or start in business after completing our course of instruction. Good watch repairs are always in demand and earn from \$30 to \$70 per week. For particulars apply to the WISCONSIN SCHOOL OF WATCH REPAIRING 166 Mason St., MILWAUKEE, WIS.

STUDY HUMAN NATURE

Get along better, make more money, develop a winning personality; learn to know people as they are. Send 10 cents (stamp) for "PERSONAL POWER," a little book that points the way. Address PROGRESS LEAGUE, 31-Q UNION SQUARE, NEW YORK

STAMMERERS

For 55 years we have successfully corrected stammering by our simple and natural course of individual lessons. Attend no school until you have read our free booklet. SAMUEL A. ROBBINS, Director, Boston Stammerers' Inst. 246 Huntington Ave., Boston 17, Mass.

LEARN WATCHMAKING

and become independent. Good-paying positions secured. Easy to learn. Send for FREE CATALOG. ST. LOUIS WATCHMAKING SCHOOL, Dept. 5, ST. LOUIS, MO

\$5,000 SALARIES

are often paid to traffic managers. Numberless traffic positions pay \$2,500 to \$5,000 per year. Millions of dollars are wasted annually because of ignorance of cheaper ways to ship. You can be a traffic expert—stop losses—make big money for yourself. Thousands of men now needed.

Learn at Home—Book Free New home study Actual Practice Method will quickly make you a Certified Traffic Manager. You can very soon qualify for a splendid traffic position. Write quick for big new illustrated book describing this wonderful training in detail. Write today. Address American Commerce Association Dept. 102, 4043 Drexel Bldg. CHICAGO, ILL.

BOYS! BOYS! BOYS!



Into a trunk, under the bed or anywhere. Lots of Fun fooling the Teacher, Policeman or Friends.

THE VENTRILO,

a little instrument, fits in the mouth out of sight, used with above for Bird Calls, etc. Anyone can use it. NEVER FAILS. Also a 82 PAGE BOOK which gives full instructions on Ventriloquism. Formula for Secret Writing [Invisible Ink], 19 Money Making Secrets and a

NOVELTY X-RAY WONDER

With it you can apparently see the bones in your fingers, lead in pencil, etc. Lots of fun with this outfit. All the above sent by mail for only 15c.



VENTRILO COMPANY
Dept. 353 South Norwalk, Conn.
LARGEST and OLDEST Mail Order House in Connecticut.



\$2500 REWARD

For the Capture of An Unknown Man

Twice he had entered the St. Clair Mansion. What was he after? Who? What was in danger?

Berteau, the famous detective had warned St. Clair that the mysterious marauder would come again. And now—a noise in the passage! The creak of an opening door. A shot in the dark! A capture!

Is this wounded stranger the mysterious intruder? Who could tell? Yet Berteau identified the man without hesitation and won the \$2500 reward.

How did he do it? Easy enough for the Finger Print Expert. He is the specialist, the leader, the cream of detectives. Every day's paper tells their wonderful exploits in solving mysterious crimes and convicting dangerous criminals.

More Trained Men Needed

The demand for trained men by governments, states, cities, detective agencies, corporations, and private bureaus is becoming greater every day. Here is a real opportunity for YOU. Can you imagine a more fascinating line of work than this? Often life and death depend upon finger print evidence—and big rewards go to the expert. Many experts earn regularly from \$3,000 to \$10,000 per year.

Learn at Home in Spare Time

And now you can learn the secrets of this science at home in your spare time. Any man with common school education and average ability can become a

Finger Print Detective in surprisingly short time.

Free Course in Secret Service

For a limited time we are making a special offer of a *Professional Finger Print Outfit, absolutely Free, and Free Course in Secret Service Intelligence.* Mastery of these two kindred professions will open a brilliant career for you.

Write quickly for fully illustrated free book on Finger Prints which explains this wonderful training in detail. Don't wait until this offer has expired—mail the coupon now. You may never see this announcement again! You assume no obligation—you have everything to gain and nothing to lose. Write at once—address

University of Applied Science

Dept. 1352 1920 Sunnyside Ave. Chicago, Illinois

UNIVERSITY OF APPLIED SCIENCE

Dept. 1352, 1920 Sunnyside Avenue, Chicago, Illinois

Gentlemen:—Without any obligation whatever, send me your new, fully illustrated, FREE book on Finger Prints and your offer of a FREE course in Secret Service Intelligence and the Free Professional Finger Print Outfit.

Name.....

Address.....

Present Occupation..... Age.....

You Never Read the Like of This

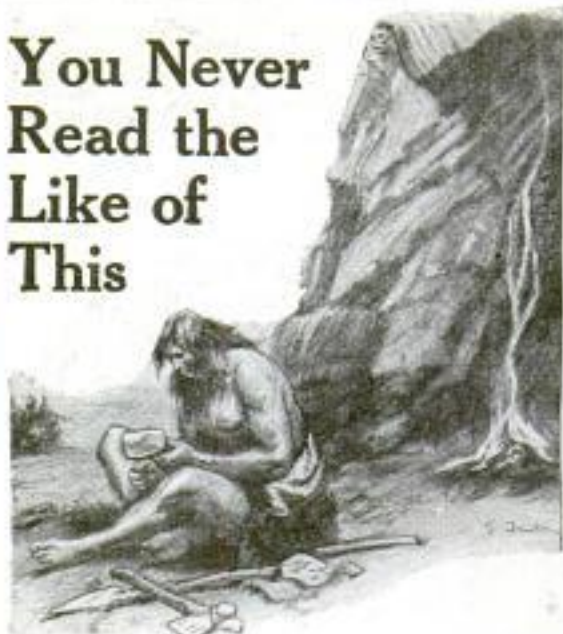

Only once in a long while does a magazine discover a story totally different from the usual. **THE AMERICAN BOY** has discovered a most remarkable one. "The Mammoth Man," by George Langford, beginning in the February **AMERICAN BOY**, is a weird, fascinating story of the strange men and giant creatures that lived, hunted and fought for existence on this earth more than 200,000 years ago.

S'posin' you were at one moment a young officer handling a battery on a fighting ship and the next you looked down and there was no ship, no guns and you found you had a long gray beard, your hands were wrinkled and old. That is the way it happened to the Admiral in "When the Admiral Waked," by Garrard Harris. It's the story of a man whose mind suddenly went to sleep not to awaken until years afterward.

When you've finished these stories, and the many others, you'll say the February issue of **THE AMERICAN BOY** is one of the best numbers you ever read. More good news is that March, April, May and all the rest of the year are going to be fully equal to February. You'd better get your subscription in now so you won't miss any of the good times coming.

A year's subscription to **THE AMERICAN BOY** now costs only \$2.00. Single copies are 20 cents at news-stands. Subscribe for a year or leave a standing order with your news-dealer.

American Boy

The Biggest, Brightest & Best Magazine for Boys in All the World

THE SPRAGUE PUBLISHING CO.
No. 371 American Bldg., Detroit, Mich.

Herewith find \$2.00. Please send **THE AMERICAN BOY** for one year, beginning with the current issue, to

Name.....

Address.....

Free Course in Draftsmanship

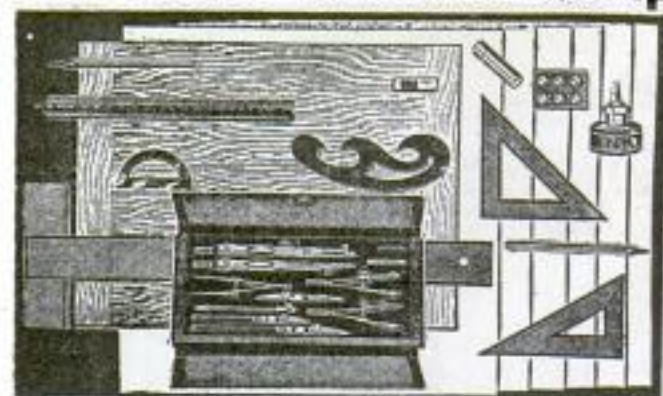

QUICK SUCCESS and MORE MONEY
Salaries up to \$100 per week. Here is your only OPPORTUNITY to get this wonderful, high-priced, Complete Drawing Outfit, including a FREE—PRACTICAL COURSE IN MECHANICAL DRAWING—now OFFERED to YOU as follows:

SEND YOUR NAME AND \$1 ONLY

Pay Balance \$9.98 on Delivery

This is a remarkable offer, with which you can build your Success in DRAFTSMANSHIP. You can put yourself in a class of Trained Men whose services are always in DEMAND.

EASY TO LEARN AT HOME IN YOUR SPARE TIME
And is your one chance to earn the biggest money of your life, and will be one of the most profitable investments you have ever made.

OUTFIT CONSISTS OF—Set large size Professional Draftsman's drawing instruments of Fine Nickel Silver, set into a handsome Velveteen Lined pocket book folding case, size 4 by 8 1/2 inches closed—also One Drawing Board 20 by 24 1/2 inches—One 24-inch T Square—One 12-inch Standard scale rule—One Protractor—Supply of drawing paper—Two Triangles—One French Curve—Pencil—Eraser—One bottle waterproof drawing ink—Thumb Tacks—and one enlarged Edition FREE—A PRACTICAL COURSE IN MECHANICAL DRAWING. You cannot make a mistake by taking up drawing, so ACT NOW.

OFFER IS LIMITED—Particulars FREE

NATIONAL INSTRUMENT COMPANY

4704 North Hamilton Ave.

Chicago, Ill.

LAW In Your Spare Time At Home for BUSINESS or PROFESSION

Degree of LL.B., Conferred

Only Institution which gives same Course by Correspondence through Lecture System as was given for years at resident classes of this college. We coach you free to pass the Bar Examination. Complete 1921, 18-volume library. Easy terms. Organized 1910. Low enrollment fee. Write for free illustrated book. Hamilton College of Law, 431 S. Dearborn St., Dept. 62 Chicago

FREE BOOK ON BANKING

Tells of the great opportunities in this attractive profession, and how you can learn by mail in spare time. Send for copy at once. No obligations. EDGAR G. ALCOHN, Pres.

AMERICAN SCHOOL OF FINANCE, 90 McLene Bldg., Columbus, O.

Learn Watchwork, Jewelrywork and Engraving.

A fine trade commanding a good salary, and your services are always in demand. Address HOROLOGICAL, Dept. P, Bradley Institute, Peoria, Ill., for our latest catalog.

BE AN ARTIST

We can teach you **DRAWING** in your own home during your spare time.

Our 18 years of successful teaching prove our ability. 30 Courses in Commercial and Illustrative Drawing. Teachers Normal and Applied Art. Endorsed by high art authorities. Students trained by members of our Faculty are filling high-salaried positions. Artist's Outfit FREE to Enrolled Students. Write today for Art Year Book.

OUR HANDSOME ART YEAR BOOK FREE YOU!

SCHOOL OF APPLIED ART
APPLIED ART BLDG. NO. 2 BATTLE CREEK MICH.

He Earns \$50 a Week Repairing Autos

THOUSANDS of men everywhere are doing the same. Many are getting more than this. Some are opening garages of their own. Why don't you get into the auto game too? Men in other lines with a little mechanical ability have doubled their earnings after getting into the fascinating field of auto construction and repairing. Ten times the number of men now engaged in the business are needed. Fine, big paying jobs are waiting for men who "know" to fill them. Read below and find out how you can fit yourself to hold one of these big, man's size jobs in your spare time, without going away from home at a cost of only 10¢ a day.

Learn at Home

No need to pay for an expensive course that will take you away from home. You can learn the auto game at a cost of one-tenth the expense of going away to school. You don't have to serve an apprenticeship either. Use spare time only and keep right on with your present work. This Library of Automobile Engineering and Tractor Information will make an expert out of you and fit you for the biggest kind of job. It is in six thick volumes, with 2600 pages and 2300 pictures, plans, diagrams and blueprints, etc. Every part of every well known car is explained. They teach you everything the best auto schools teach.

Fifteen great auto engineers prepared these money-making books for men like you. You don't have to know a thing about cars to understand them. Every page is written in plain, everyday language and they begin right at the beginning. With every set we give FREE a consulting membership in our society. You can write our engineers any time and get their help on any proposition on which you get stuck.

FREE Examination!

Mail the coupon for free examination. Don't send any money. We will ship the books (all six volumes) by express collect and you can have a whole week to use them as if they were your own. Give them away just as you think of. Take them to your shop. Show them to your friends and ship them back at our expense if you don't want to keep them. If you do keep the books to help you earn more, send us only \$2.50. You can send the balance of the \$24.00 price the same way—\$2.00 each month. Only 10 cents a day. This is your chance to double your earnings—men two dollars in the same time it takes to get one now. The coupon is your start. MAIL IT TODAY.



Everything About Autos

Automobile Motors; Welding; Motor Construction and Repair; Carburetors and Settings; Valves; Cooling; Lubrication; Flywheels; Clutch; Transmission; Final Drive; Steering; Frames; Tires; Valves; Ignition; Starting and Lighting Systems; Shop Kicks; Commercial Garage Design and Equipment; Electrical Storage Batteries; Care and Repair of Motorcycles; Commercial Trucks; Gasoline Tractors.

128 Blueprints of Electric Wiring Diagrams

**Don't
Send
Money—**

**Just
Mail
This
Coupon**

American Technical
Society :: Chicago

AMERICAN TECHNICAL SOCIETY
Dept A-192 CHICAGO, U. S. A.

Please send me the 6-volume set of Automobile Engineering for 7 days' examination, shipping charges collect. If I decide to buy I will send \$2.50 within 7 days and balance at the rate of \$2 a month until \$24.00 has been paid. Then you will send me a receipt showing that the set of books and the Consulting Membership are mine and fully paid for. If I want to get along without the books, I will notify you after 7 days to send for them at your expense.

NAME.....

ADDRESS.....

CITY.....STATE.....

REFERENCE.....

Please Fill Out All Lines



BE A RAILWAY TRAFFIC INSPECTOR



**POSITION
GUARANTEED**

**Earn Up to \$250⁰⁰ per Month
EXPENSES PAID**

Many fine opportunities for trained Railway Traffic Inspectors. Steady, pleasant outdoor work; travel or remain near home.

Easy to Qualify

Prepare in three months' spare-time study at home. Position then guaranteed at not less than \$110 per month and expenses, with many chances for advancement thru contact with big railway officials.

"MY SALARY WAS RAISED"

Read what Mr. James M. Hurt, Jr. says about the work

"After finishing your course in Traffic Inspection about three months ago, I was placed in a permanent position at \$110.00 per month. Several days ago my salary was raised to \$135.00 per month, and I have every reason to believe it will go higher soon if my work is satisfactory. Have come to the conclusion that there are very few classes of work in which the opportunities are as unlimited and at the same time, the work as pleasant as Traffic Inspection."

You Take No Risk

If position is not obtained for you, entire enrollment fee is refunded without question. You have nothing to lose.

Send coupon for details and booklet No. D-581.

**STANDARD BUSINESS TRAINING INST.
BUFFALO, N. Y.**

COUPON

Date.....

Standard Business Training Inst.,
Buffalo, N. Y.

Gentlemen:—

Send me by return mail, entirely free, full details about profession of Railway Traffic Inspection and booklet No. D-581.

Name.....

Street.....

Town and State.....

Stop Forgetting

Make Your Mind a File—Not a Pile

Let me show you how to make your mind as forget-proof as a card index file. When you wish to recall a name, place or date, must you grope in vain in a pile of miscellaneous knowledge? Summoned to give facts and figures does your mind become a blank? Be master of your mind's infinite resources—instead of a victim of its disordered details.

KNOWLEDGE IS POWER

and Memory Is the Basis of All Knowledge

I HAVE HELPED THOUSANDS

The Dickson Method of Memory and Mental Training, perfected by 20 years experience, is recognized as the most thorough, efficient of its kind. Highly endorsed—easy to master. Give me 10 minutes a day and I will train your memory so you can classify ideas, names, faces, etc., and recall them instantly. Develop self-control, concentration; overcome bashfulness.

Perfect Your Memory and Command What Salary You Will

Send name and address and I will send you free, my interesting booklet, "How to Remember," and unique, copyrighted Memory Test; also tell you how to secure free of charge my \$8.00 book, "How to Speak in Public."

Prof. Henry Dickson, Principal
DICKSON MEMORY SCHOOL
Dept. 705, 1041 Chicago Ave.
Evanston, Ill.



Stop Forgetting

The Key to Success



"I
WANT
YOU"

-Uncle Sam

PAY \$100 to \$195 MONTH

U. S. GOVERNMENT WANTS!

Railway Mail Clerks—City Mail Carriers—
Postoffice Clerks

Thousands men, boys, over
17, wanted.

Common education sufficient. Send coupon immediately.

SEND
COUPON
BELOW

FRANKLIN INSTITUTE
Dept. W 179, Rochester, N. Y.

This coupon, filled out as directed, entitles the sender to (1) free sample examination questions; (2) a free copy of our book, "Government Positions and How to Get Them;" (3) free list of positions now open; and (4) to consideration for Free Coaching for the examination here checked.

COUPON

.. Railway Mail Clerk (\$1600 to \$2300) .. Postoffice Carrier (\$1400 to \$1800)
.. Bookkeeper (\$1400 to \$1800) .. Rural Mail Carrier (\$ 720 to \$2600)
.. Postoffice Clerk (\$ 1400 to \$1800) .. Customs Positions (\$1100 to \$2000)

Name

Address

Use it before you lose it. Write plainly.

\$300 a Month Salary \$450 on the Side at Home



Chief Draftsman DOBE

That's the kind of money my drafting students make. Read what this one says:

"As a beginner I am doing fine. Am earning a salary of \$300 per month, besides I made over \$450 at home the last two months, drawing plans for private parties. The practical drafting training you gave me by mail put me where I am in less than six month's study. Thank you for all your personal interest and help you gave me so far."

(Signed) J. B.

(Name and Address upon request.)

I Train You Until You Get a Job

A very high-grade \$25 drafting outfit free. \$3,600 a year salary. Trained by me personally *until* you get a job. That's the big 3-featured offer I am making to you. "J. B." was trained by me. I train you personally in the same way. I make you qualified to draw \$3,600 per year like scores of my other graduates are doing. I give you practical drafting room work. Everything just exactly as you would get it in a real job. I give you my personal man-to-man attention.

And I train you *until* (now get the full meaning of this) *until* you are qualified and experienced as a first class draftsman and *until* placed in a first class permanent position drawing a first class draftsman's salary.

Free \$25 Outfit!

And *more*—I give you a whole set of drafting tools the minute you become my student. You get every tool you need. A magnificent \$25 set of instruments with which to build your success in draftsmanship.

Take this offer now—while it is open. Remember—the draftsman goes up and up to the fabulous incomes of engineers and architects. And I start you on this road—start you personally and stick by your side until success is yours.

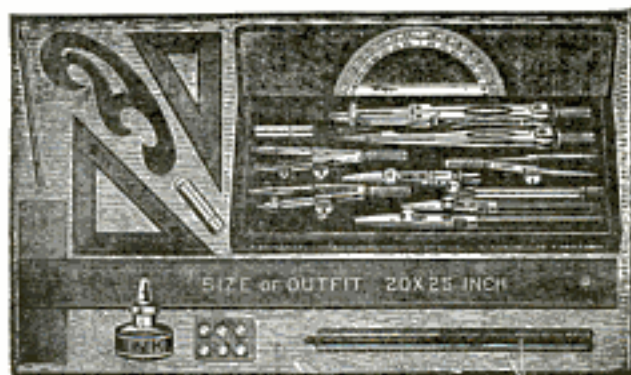

Free Book!

Send Coupon TODAY

No matter what plans you have for the future. Get this great book—"Successful Draftsmanship." Find out about the simply marvelous opportunities ahead now. How the world needs draftsmen, engineers, architects and builders. What great salaries and possibilities there are! Send coupon for free book today.

Chief Draftsman Dobe

Dept. 9352, 4001 Broadway Chicago, Ill.

Chief Draftsman Dobe

Dept. 9352, 4001 Broadway, Chicago, Illinois

Without any obligation whatsoever, please mail your book, "Successful Draftsmanship," and full particulars of your liberal "Personal Instruction" offer to few students.

Name

Address

Post Office State

Why Carson Gets \$100 A Week

"REMEMBER when Carson first came with us," said the vice-president. "He was just a raw kid, with only a grammar school education.

"Took a job in the shop at a machine. We paid him thirty cents an hour, I think. About six months after he came we decided to give old Ben Gray, the foreman, an assistant. I asked him who he wanted.

"Young Carson," he said.

"What, that youngster?" I exclaimed. "Why he hasn't been here a year!"

"I don't care," said Ben. "Carson's the man for the place. Why, Mr. Jenkins, do you know what he's doing? He's studying this business! Right after he came here, he took up a course with the I. C. S. He has helped me out of a dozen tight places already."

"So we gave Carson the job, and he handled it in such bang-up style that when old Ben was put on the pension list Carson was made foreman and later superintendent.

"And last year when we needed a new General Manager, Carson won the place hands down. We pay him \$100 a week and he's worth every cent of it. He's the youngest General Manager we have ever had—and the best."

EMLOYERS everywhere are looking for men like Carson—men who want to get ahead—who are willing to devote a part of their spare time to training for advancement.

No matter where you live, the I. C. S. will come to you. No matter what your handicaps or how small your means, we have a plan to meet your circumstances. No matter how limited your previous education, the simply-written, wonderfully-illustrated I. C. S. lessons make it easy to learn.

This is all we ask: Without cost or obligation, put it up to us to prove how we can help you. Just mark and mail this coupon.

TEAR OUT HERE

INTERNATIONAL CORRESPONDENCE SCHOOLS
BOX 5606-C SCRANTON, PA.

Without cost or obligation please explain how I can qualify for the position, or in the subject before which I have marked an X in the list below:

- ELECTRICAL ENGINEER
 - Electric Lighting & Railways
 - Electric Wiring
 - Telegraph Engineer
 - Telephone Work
- MECHANICAL ENGINEER
 - Mechanical Draftsman
 - Machine Shop Practice
 - Toolmaker
 - Gas Engine Operating
- CIVIL ENGINEER
 - Surveying and Mapping
- MINE FOREMAN or ENG'R
- STATIONARY ENGINEER
 - Marine Engineer
- ARCHITECT
 - Contractor and Builder
 - Architectural Draftsman
 - Concrete Builder
 - Structural Engineer
- PLUMBING & HEATING
 - Sheet Metal Worker
 - Textile Overseer or Supt.
- CHEMIST
 - Pharmacy

- BUSINESS MANAGEMENT
- SALESMANSHIP
- ADVERTISING
 - Show Card & Sign Ptg.
 - Railroad Positions
- ILLUSTRATING
 - Cartooning
 - Private Secretary
 - Business Correspondent
- BOOKKEEPER
 - Stenographer & Typist
 - Certified Public Accountant
- TRAFFIC MANAGER
 - Railway Accountant
 - Commercial Law
- GOOD ENGLISH
 - Common School Subjects
- CIVIL SERVICE
 - Railway Mail Clerk
- AUTOMOBILES
 - Mathematics
 - Navigation
- AGRICULTURE
 - Poultry Raising
- BANKING
 - Spanish
 - Teacher

Name..... 7-1-21

Street and No.....

City..... State.....

Occupation.....

Please Mention Popular Mechanics

WE TEACH COMMERCIAL

ART

Properly Trained Artists Earn \$100 a week and up. Meyer Both College—a Department of the Meyer Both Company—offers you a different and practical training. If you like to draw, develop your talent. Study this practical course—taught by the largest and most widely known Commercial Art Organization in the field with 20 years' success—which each year produces and sells to advertisers in the United States and Canada over ten thousand commercial drawings. Who else could

give you so wide an experience? Commercial Art is a business necessity—the demand for commercial artists is greater every year. It's a highly paid, intensely interesting profession, equally open to both men and women. Home study instruction. Get facts before you enroll in any school. Get our special booklet, "Your Opportunity"—for half the cost of mailing—4c in stamps.

MEYER BOTH COLLEGE
of COMMERCIAL ART
Michigan Ave. at 20th St.
Dept. 16 CHICAGO, ILL.



SAVE MAKE MONEY

Do your own Electrical Work and Work for Others in Your Spare Time.

ELECTRICAL KINKS tells how to do wiring and repairing of door bells, burglar alarms, garages, electric irons, vacuum cleaners, washing machines, table lamps, etc.; in fact everything electrical used in the HOME. This book is different from other books for the reason that it tells where to locate the trouble.

SEND NO MONEY—Just send your name and address now. When book is delivered simply pay postman \$1.00. You can save this amount on one small job.

HOME BOOK CO., 3318 West 94th St., Cleveland, Ohio.



The New Dances

Learned in One Evening
by Arthur Murray's New
Easy Picture Method.

Let the Vanderbilts' instructor teach you to be a good dancer. Learn the latest steps by Arthur Murray's remarkable new picture method; surprisingly easy and fascinating—you need no music or partner. "60,000 taught dancing by mail." You, too, can learn at home, privately, in a few hours.

FREE DANCING LESSON

One lesson (in plain wrapper) absolutely free to prove I can make you an accomplished dancer quickly! **HALF PRICE OFFER ON NOW!** For mailing, send 10c today!

Arthur Murray, Studio 93, 290 B'way, N.Y.

Be an Artist

Comics, Cartoons, Commercial, Newspaper and Magazine Illustrating, Postal Crayon Portraits and Fashioning. Earn money; become famous. Our simple method quickly develops your talent in spare time. By Mail or Local Classes. Write for terms and list of successful students.

ASSOCIATED ART STUDIOS
87-B Flatiron Building NEW YORK

Learn to Write Ads

I teach you advertisement writing by mail; 21 easy lessons. Fine for home work. Sell your "Copy" by mail.

Start a Little
Mail Order Business

I also teach you to start little Mail Order Business from your home anywhere, country or city, and furnish supplies.

Lesson & Samples FREE

Please enclose 2-cent stamp for Sample Lesson and free Mail Order SAMPLES. ADDRESS WILLIAMS, Dept. D, 72 Cortland St., New York





Read Law

To Daniel Boone, the great pioneer, is attributed this saying: "The light of the world comes principally from two sources—the sun and the student's lamp."

Thousands of LaSalle-trained men bear witness to this truth. "Passed bar examination with second highest honors in a class of seventy-one," writes one LaSalle member. Writes another: "Passed bar examinations in 'Class A' in competition with five graduates of resident universities." LaSalle graduates, to the number of many thousands, report incomes of from \$3,000 to \$10,000 a year, as a result of specialized training under the Problem Method

Build for Leadership—Be Independent

WOULD you be independent, command a substantial income and an opportunity for public service that will make you an influential figure in your own community?

The one profession above all others that brings to those who make good not merely wealth but prominence and public leadership is—LAW. Successful law-trained men, both in business and in active practice, earn from \$10,000 to \$50,000 a year. For the *ablest* minds in this great profession there is practically no income-limit.

Train at Home by the Problem Method

Mark out for yourself a *real career*—either as a lawyer or a law-trained business man!

Right in your own home, under the Problem Method, you can study the same cases you would read at the resident universities, master the fundamental principles set forth by some of the most eminent authorities in the profession, develop under their direction a power for keen and logical thinking that will yield you a steadily increasing income as long as you live.

LaSalle training is practical and thoro. LaSalle text-books, "lesson talks," lectures, quizzes and examinations have been prepared by leading members of the American bar—prominent practitioners, judges, law professors in the great universities. You are directed constantly by able instructors, who make every point clear and make certain that you *understand* it. You graduate with the degree of LL.B.—possessed with all the advantages of a thoro legal training as a foundation for independent practice or for a responsible position with one of the big corporations.

Send today for definite information regarding the unusual opportunities in law, together with letters showing just how scores of LaSalle-trained men are cashing in on home-study training. With this data, we will send you particulars of our *convenient-payment plan*; also your free copy of "Ten Years' Promotion in One."

Make TODAY your starting point toward real success by mailing the inquiry-coupon NOW.

LaSalle Extension University

The Largest Business Training Institution in the World

— — — — INQUIRY COUPON — — — —

LASALLE EXTENSION UNIVERSITY

Dept. 264-LR Chicago, Illinois

Please send me catalog and full information regarding the course and service I have marked with an X below. Also a copy of your book, "Ten Years' Promotion in One," all without obligation to me.

LAW { Training for bar;
LL. B. Degree

COMMERCIAL { Reading, Reference and
LAW Consultation Service for
Business Men.



LaSalle is the largest business training institution in the world. It offers training for every important business need. If more interested in any of these courses, check here:

- | | |
|--|--|
| <input type="checkbox"/> Business Management | <input type="checkbox"/> Modern Business Correspondence and Practice |
| <input type="checkbox"/> Higher Accountancy | <input type="checkbox"/> Modern Foremanship and Production Methods |
| <input type="checkbox"/> Traffic Management—Foreign and Domestic | <input type="checkbox"/> Personnel and Employment Management |
| <input type="checkbox"/> Railway Accounting and Station Management | <input type="checkbox"/> Expert Bookkeeping |
| <input type="checkbox"/> Industrial Management Efficiency | <input type="checkbox"/> Business English |
| <input type="checkbox"/> Banking and Finance | <input type="checkbox"/> Commercial Spanish |
| <input type="checkbox"/> C. P. A. Coaching | <input type="checkbox"/> Effective Speaking |

Name

Present Position

Address

SWEENEY

I PAY YOUR RAILROAD



E. J. SWEENEY
PRESIDENT

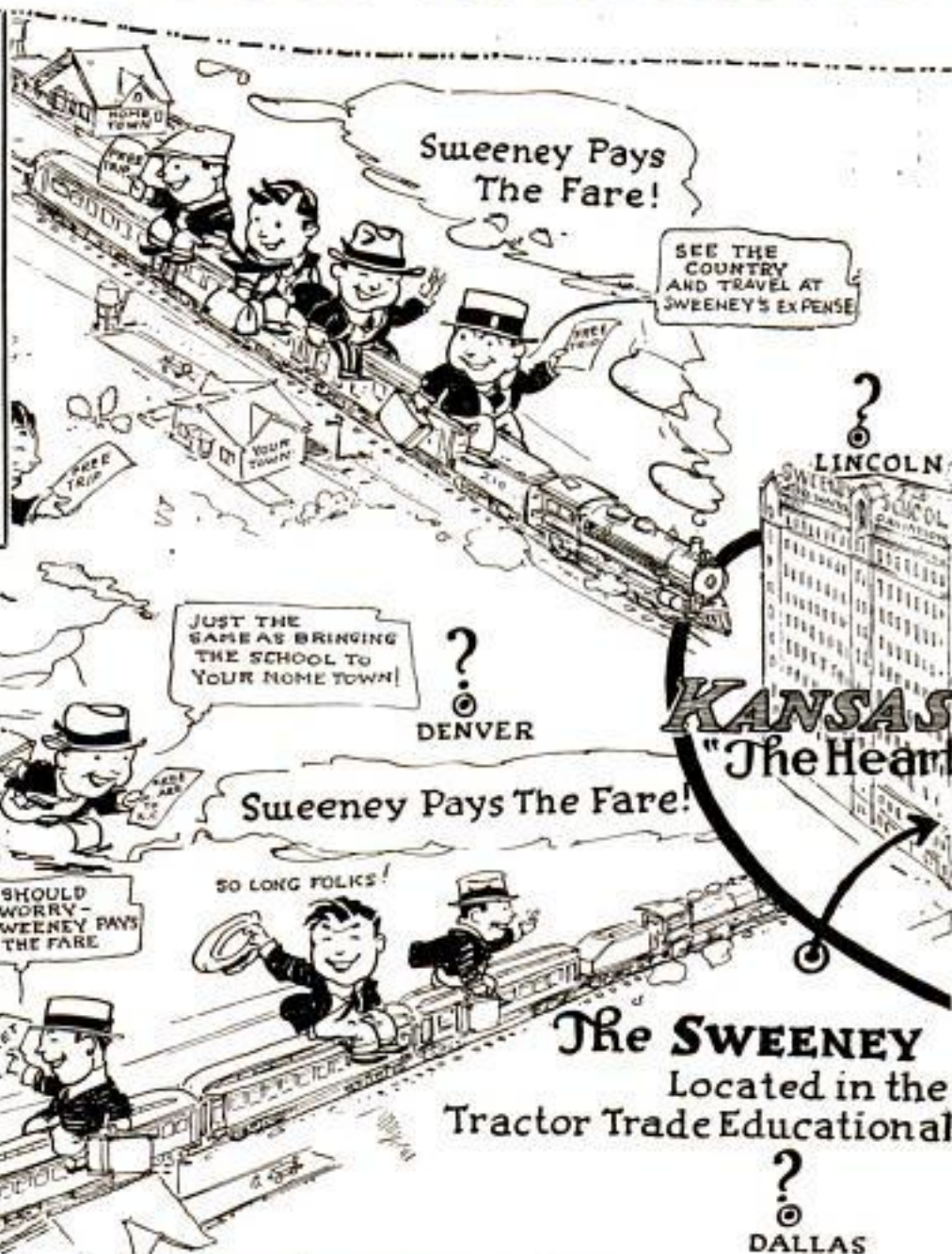

Now is the time for you to learn the world's best trade—repairing autos and tractors.

Who are the millions of men out of employment? They are untrained men, or men in other industries. Auto mechanics, tire men, battery men are WANTED EVERYWHERE.

Come to the Sweeney School now and GET READY FOR A GOOD JOB. No previous experience is needed. I teach with tools not books. And let me tell you that YOU ARE NEVER TOO OLD. Henry Ford was forty years old when he STARTED THE FORD COMPANY.

Thousands upon thousands of men who read Popular Mechanics as you are reading it now, and thought as you have been thinking about mechanical training, got my big free catalog and today in all parts of the country HAVE MADE GOOD. I have the proof, hundreds and hundreds of letters from successful men asking for our graduates. These men took the first step. They GOT THE CATALOG. They tell you: "Don't make any mistake. Learn it right. Learn it at Sweeney's."

But These Men Never Had the Opportunity You Have Today

The railroad fare to Kansas City is a big item. Lots of these men had to pinch and scrape to make it. BUT I WILL NOW PAY YOUR FARE. You can come to this great school at no more cost than if it were located in your home town. No extras. No advance in tuition. Just a fair and square rebate of your railway fare. No matter where you live in the United States this offer is good. Tell your friends "SWEENEY PAYS THE FARE." Tell them that SWEENEY has another big Special Offer besides Free Railway Fare. Travel, see the world at my expense.

SEE SWEENEY DOUBLE-PAGE SPREAD ON PAGES 18 AND 19

SCHOOL

FARE TO KANSAS CITY

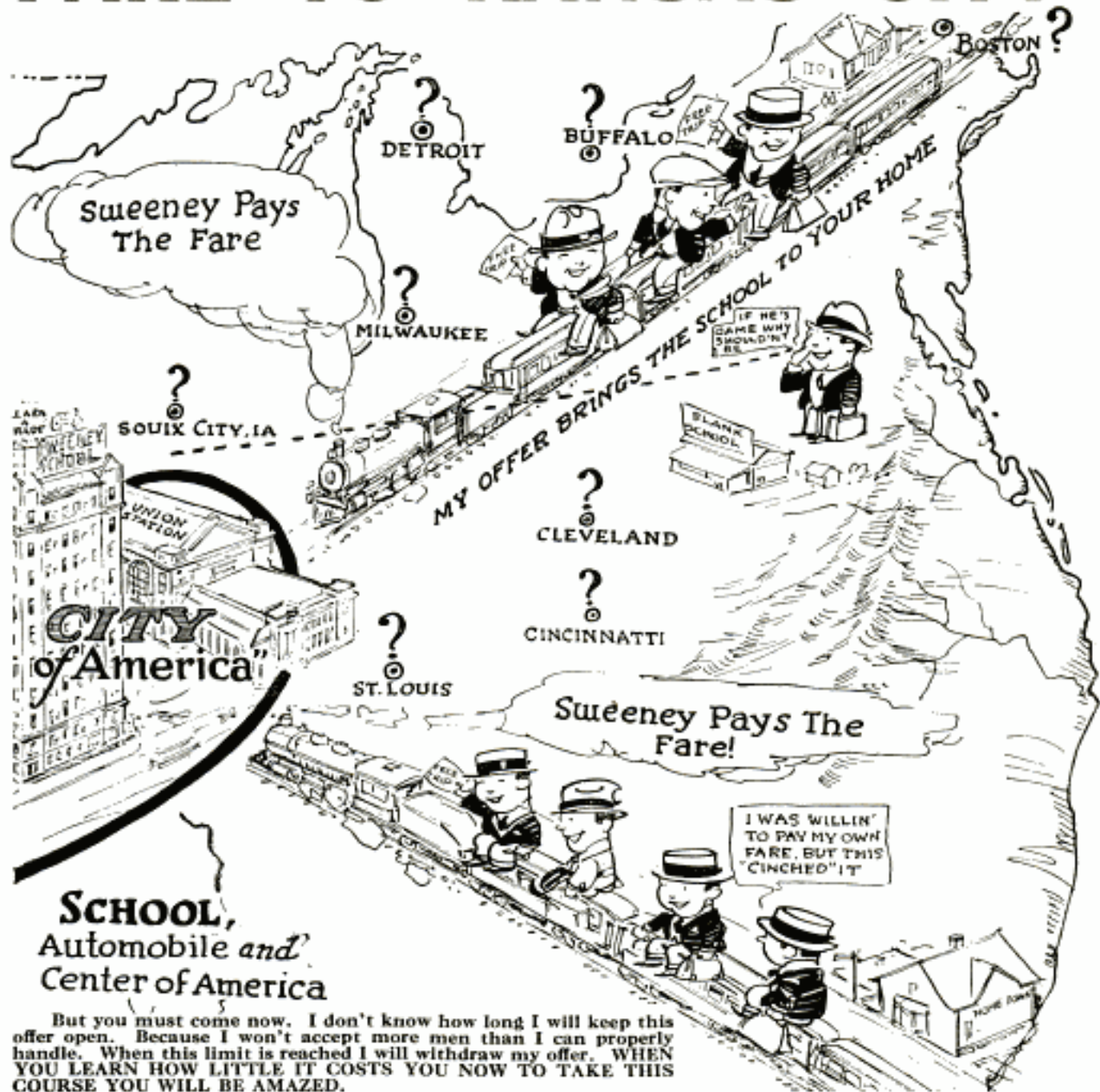

**SCHOOL,
Automobile and
Center of America**

But you must come now. I don't know how long I will keep this offer open. Because I won't accept more men than I can properly handle. When this limit is reached I will withdraw my offer. WHEN YOU LEARN HOW LITTLE IT COSTS YOU NOW TO TAKE THIS COURSE YOU WILL BE AMAZED.

Write me today. Use the coupon, or post card, or a letter. Any way will do. Or get on a train and come straight in. You simply can't lose by getting the greatest offer I have ever made. And the first step is to send for my catalog RIGHT NOW.

E. J. SWEENEY, President.

LEARN A TRADE
Sweeney
SCHOOL OF AUTO-TRACTOR-AVIATION
 985 SWEENEY BLDG. KANSAS CITY, MO.

Mail This Coupon

EMORY J. SWEENEY, President
 985 Sweeney Bldg., Kansas City, Mo.

Please send me free without any obligation on my part, your 72-page catalog and your Sweeney School News. Tell me of the opportunities in the Auto and Tractor Business.

Name

P. O. State

SEE SWEENEY DOUBLE-PAGE SPREAD ON PAGES 18 AND 19

THE SCIENTIFICALLY BUILT WATCH

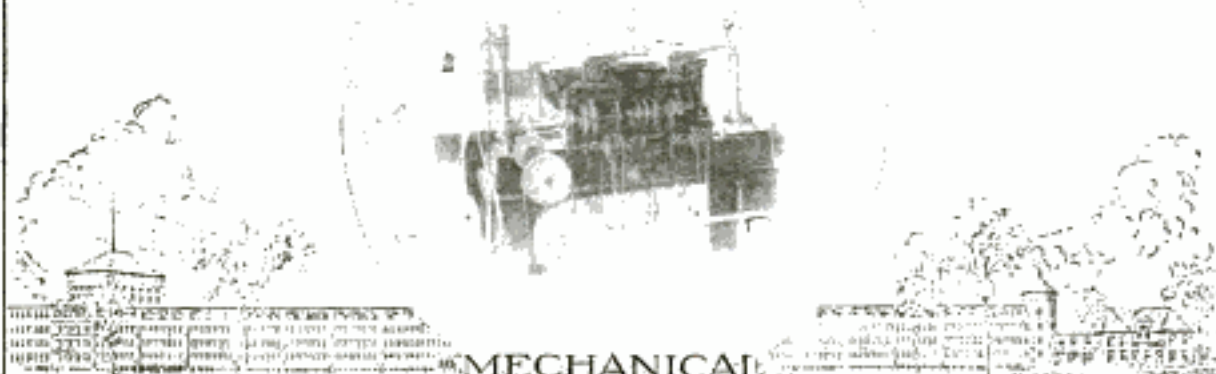

MECHANICAL PERFECTION

MAN'S achievements are intensified by machinery. We travel by machinery on land and sea and in the sky. A machine makes possible your morning newspaper. Would you know the correct time, a marvelous machine informs you, instantly.



The Lower Plate

For nearly three quarters of a century Waltham has been inventing and perfecting machines for watch-building. Machines

that have no counterparts elsewhere in all the world. Machines that perform true miracles of accuracy—turning and drilling and fashioning beyond the scope of any man's hand.

The machine illustrated builds the lower plate of a Waltham watch. Upon that plate it locates the foundation for the movement. One hundred and forty-one automatic operations are made by it with care beyond human brain and hand. Visitors never tire of watching its wonder working. And no other lower plate in any other watch is made like this Waltham plate.

When you buy a Waltham watch this machine is related to the famous Waltham accuracy. Its exclusive invention helps to make a Waltham watch exclusive. Its mechanical perfection is included in the purchase price. One more reason why the Waltham movement leads everywhere in true watch value.

Write for a valuable booklet that is a liberal "Watch" education. Sent free upon request. The Waltham Watch Company, Waltham, Mass.

Makers of the famous Waltham air-friction quality Speedometers and Automobile Time-pieces used on the world's leading cars



Waltham Colonial A

Extremely thin at no sacrifice of accuracy
Maximum movement 21 jewels, Reversible movement 19 jewels
\$200 to \$350 or more depending upon the case

WALTHAM

THE WORLD'S WATCH OVER TIME

Where you see this sign they sell Waltham Watches

Popular Mechanics Magazine

REGISTERED IN U. S. PATENT OFFICE

WRITTEN SO YOU CAN UNDERSTAND IT

Vol. 37

FEBRUARY, 1922

No. 2

7801 Smokiest Locomotives Made Smokeless

A PICTURE taken before and another taken after the application of a remedy are common in connection with advertised nostrums, but quite unusual in the matter of mechanical improvements. Probably for the first time in the history of railroading two pictures of this kind—and moving pictures at that—were taken

of 50 locomotives lined up in the Baltimore and Ohio Railroad yards, at Cincinnati, the first one showing the locomotives belching from their funnels dense clouds of smoke, and the second one, after the application by the engineers of smoke consumers, showing an almost total absence of smoke of any

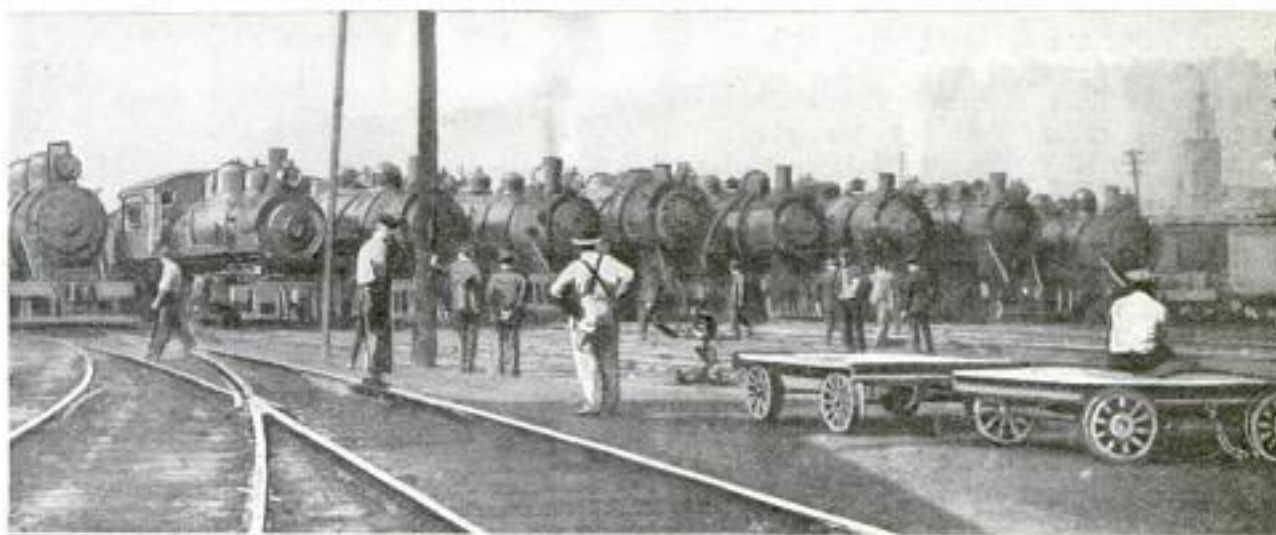

The Upper Picture Taken before, and the Lower One after, the Application of Smoke Consumers by the Engineers on 50 Locomotives That were Lined Up in the Yards of the Baltimore and Ohio Railroad, at Cincinnati, for the Purpose of having the Great Difference Shown Photographically

Baltimore + Ohio Railroad Yards
200 of Evans St Cincinnati, Ohio

J. R. Trichman Jan 16, Station 3 Cincinnati, Ohio

Copyrighted material

kind. It was a contrast equivalent to the difference between day and night. Smoke consumers on the locomotives are compulsory on all trains entering Cincinnati. It has been demonstrated there that they

result not only in smoke prevention, but also in fuel economy. The moving pictures of this demonstration will be shown all over the country as propaganda in the interests of smoke prevention.

7898
**BANJO FOR DANCE ORCHESTRAS
 THROWS SOUND FORWARD**

A new banjo is specially designed to meet the requirements of dance orchestras, stage performances, and playing in large halls. The sound from an ordinary

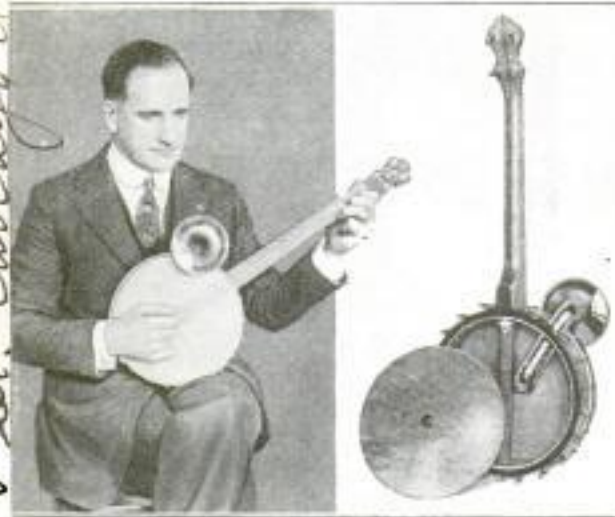

Left: Banjo with Sound-Throwing Horn. Right: Outer Sounding Board Removed from Instrument to Show Construction

banjo is thrown back from the head against the body of the player and much of it is deadened in this way. The new banjo has a wooden sounding board set just back of the head. A horn, opening from the space between the head and sounding board, passes through the frame of the instrument and throws the entire volume of sound forward into the hall. A second board covers the back of the instrument. This not only increases the volume of sound but, by variations in construction, the quality of tone can be controlled to suit special purposes.

3967
**RABBITS AS A PROTECTION
 FROM MOSQUITOES**

Careful observations have been made, in France, of the extent to which mosquitoes are attracted to domestic animals in preference to human beings. It was proved experimentally that mosquitoes have a strong predilection for the blood of rabbits, stronger than for that of any other domestic animal. This discovery has been practically applied in many parts

of France as a protection from mosquitoes, and particularly from those that carry germs of malaria, and similar diseases. In many parts of France now the inhabitants raise rabbits in conjunction with poultry, and thus protect themselves profitably against the dangers of disease-bearing mosquitoes.

7955
**CLEVER RESCUE OF WORKMAN
 MAROONED 150 FEET IN AIR**

While repairing, single-handed, the top of a smokestack, 125 ft. above the roof of a 30-ft.-high building in the plant of the American Bridge Company, Chicago, the workman let drop the line which was his only means of returning to the roof, and thence to the ground. There was no possibility of conveying a line to that height with any appliance in the plant, and so appeal was made for help from the fire department, which has a line-throwing gun, in appearance exactly like a military rifle, for use in such an emergency. Several futile attempts were made to fire the line within reach of the marooned workman, and finally this method of rescue had to be abandoned. Fortunately, as the stack had not been in use, it was cold, and finally a fellow workman climbed from the level of the roof up the first 30 ft. of the inside of the stack, to which height it was lined with asbestos. On a 3-in. steel ring, on top of the asbestos, the rescuer stood, with his legs astride the stack. In the meantime some long, light wooden scantlings, that had been cut and drilled for templates, as used in all structural work, were obtained and passed up to him. He pushed upward, first one of these scantlings, to the top of which a line was made fast, and to the bottom of that scantling he attached, with the aid of the holes, another, and so on, scantling after scantling, until the top one came within reach of the stranded workman. This did not happen until the poor fellow had spent four hours in his perilous position, 150 ft. above ground, in the frosty December atmosphere. Once he grasped the end of the line, it was a matter of only a few minutes before he had hitched it to the top of the stack, and slid down to safety.

La Nature 12/3/21

7955

International, Chicago
Chicago Herald + Examiner

Dec. 5, 1921



Roy Sutton, Who was Marooned for Four Hours on Top of the Smokestack

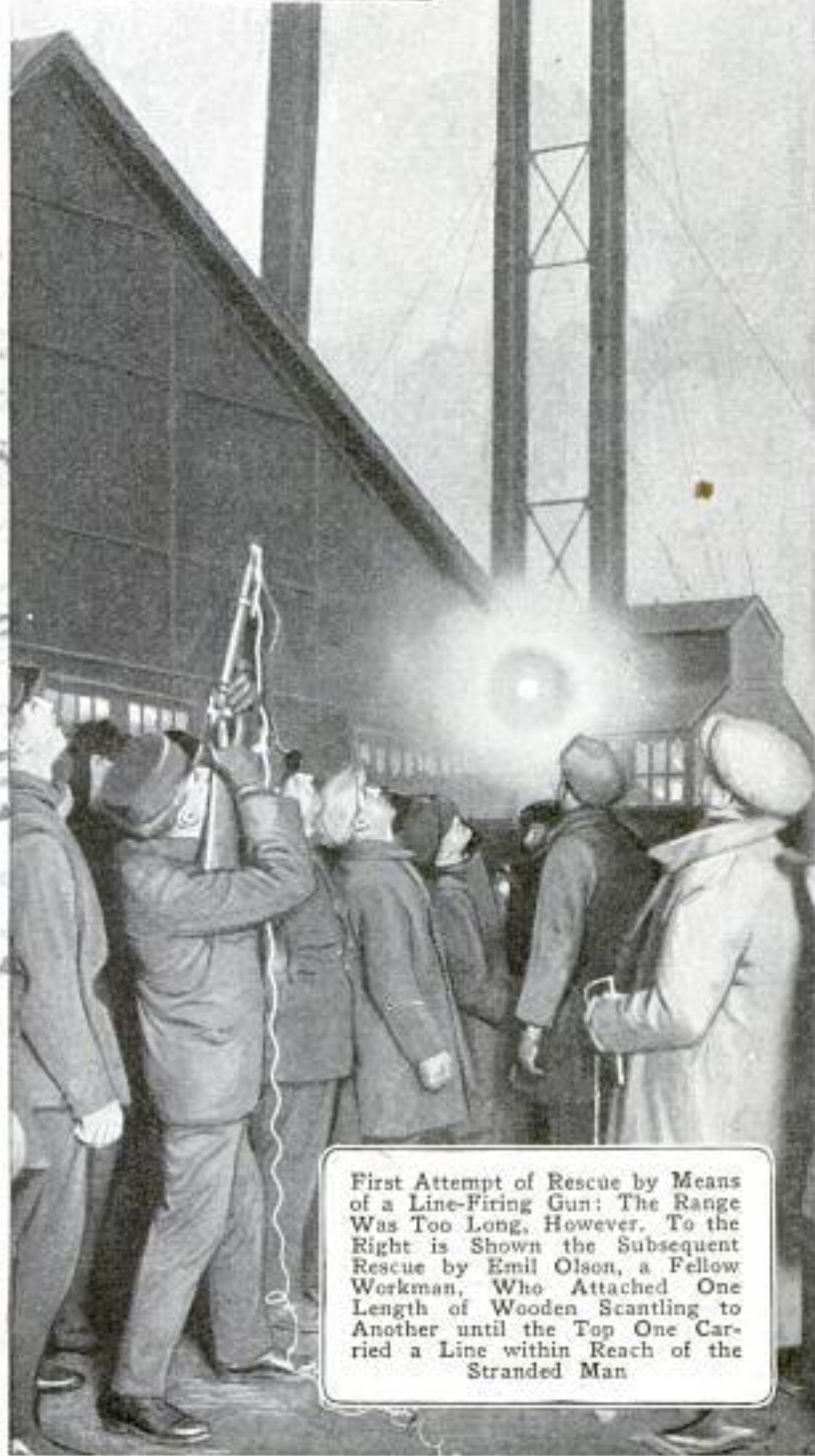

First Attempt of Rescue by Means of a Line-Firing Gun: The Range Was Too Long. However, To the Right is Shown the Subsequent Rescue by Emil Olson, a Fellow Workman, Who Attached One Length of Wooden Scantling to Another until the Top One Carried a Line within Reach of the Stranded Man

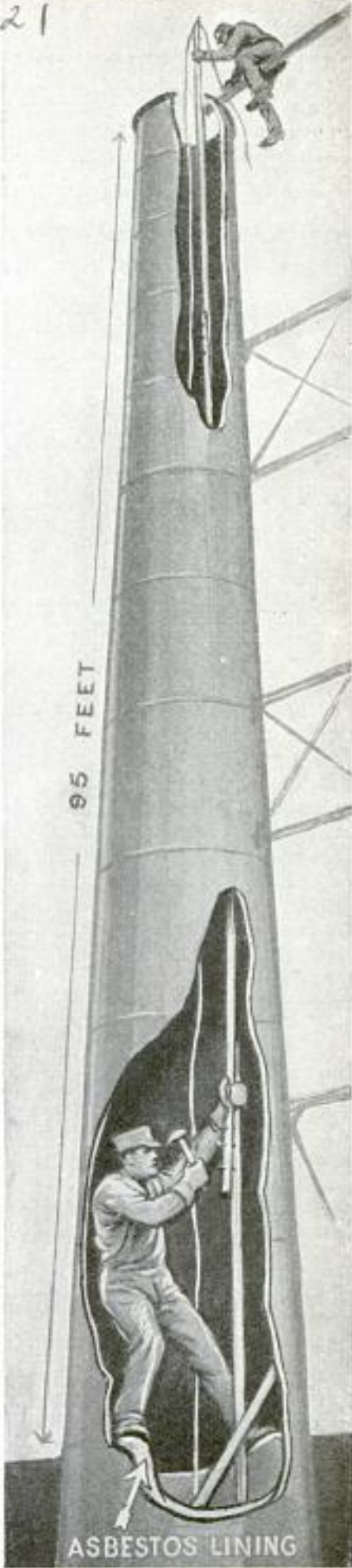

95 FEET

ASBESTOS LINING

one. noisom juis compass
D.P. Noisom, South Bend, Ind.

164 *info.*

POPULAR MECHANICS

Christian Science Monitor 9/30/2

COMPASS MOUNTED IN TOP OF AUTOMOBILE

7793 Though marine compasses have been successfully used on automobiles, difficulty has always been experienced in installing

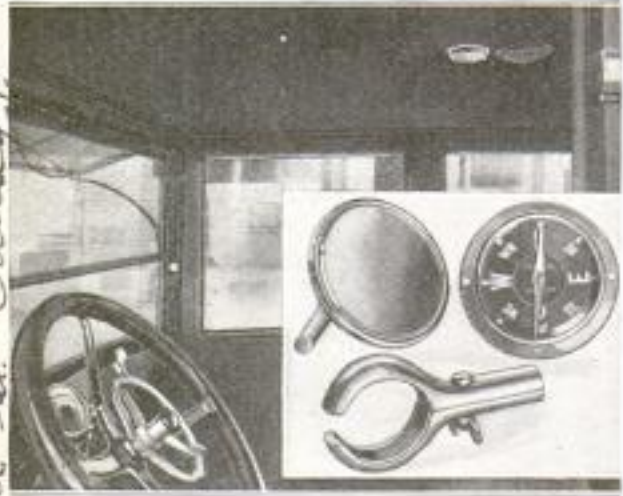

The Compass is Mounted in the Top of the Car and the Mirror on the Steering Column. The Separate Parts are Shown in the Insert

a compass in such a way that it would not be affected by the engine or other steel parts. A special automobile compass has now been developed which overcomes this difficulty. It is attached to the top of the car, about 24 in. back of the windshield and over the driver's head. A small mirror is mounted on the steering column in such a position that the driver can see in it the compass dial and read it without moving his head.

HISTORIC DOCUMENTS PLACED IN LIBRARY OF CONGRESS

The original manuscripts of the Declaration of Independence and the Constitution of the United States were recently removed from the State Department building and placed in the Library of Congress. The fireproof building and special facilities of the library make it

7853 DOLLS AND ANIMAL TOYS MADE FROM OLD INNER TUBES

One day a New Orleans business man was looking at a pile of worn-out inner tubes, but he was thinking of his baby and an idea occurred to him. With a pair of scissors, a bottle of rubber cement, and a pen and ink, he soon converted the old tubes into dolls and animals. The baby thought they were the finest toys he had even seen, and all the neighbors' babies agreed with him. Before long a small factory had to be built to supply the demand for the rubber toys, and the designs were copyrighted.

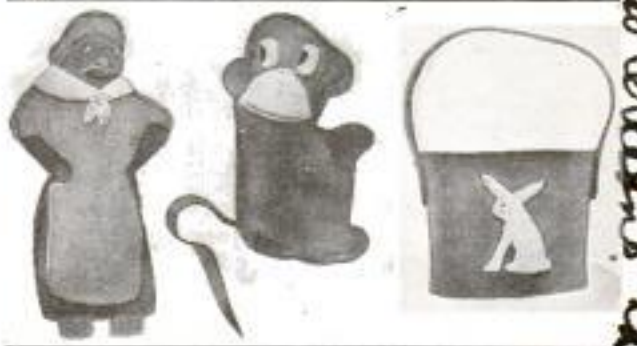

Some of the Toys, Made from Old Inner Tubes, Which are Becoming Popular for Babies

7752 "FLYING AUTOMOBILE" IS FOLDING-WING BIPLANE

At the annual Aero Show, in Paris, France, a new airplane was exhibited which has been popularly termed the "flying automobile." It is a biplane with folding wings and an auxiliary motor. The wings are hinged to the fuselage and fold back, along each side of it, in much the same way as the wings of some of the American folding planes. With the wings folded, the machine is about the size of a

large motor truck, and requires a hangar no larger than a garage. It can be run in the streets under its own power, using the 10-hp. auxiliary motor. For flying, a 300-hp. motor furnishes the power. A demonstration of its practicability was given at Buc, France, and it proved to be entirely successful in both the flying and land tests. It attracted much attention when run through the Paris boulevards.

Cook, R. H. Hamilton 1007 E 65th St. Chicago

Prof. Thomas E. Deakney of the former New Orleans La.

Rev. J. A. Peddicord, New Orleans, La.

Cont. No. 4, Rue Richer
Paris (X^e) France

7752

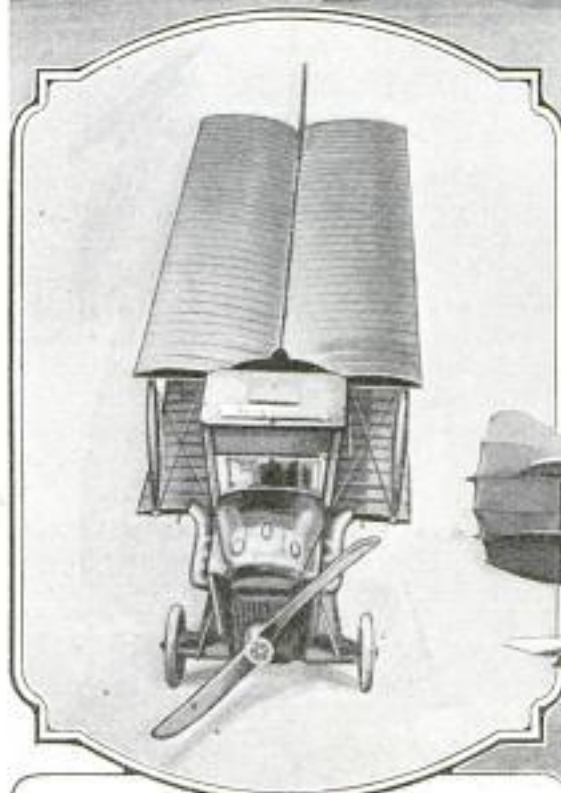
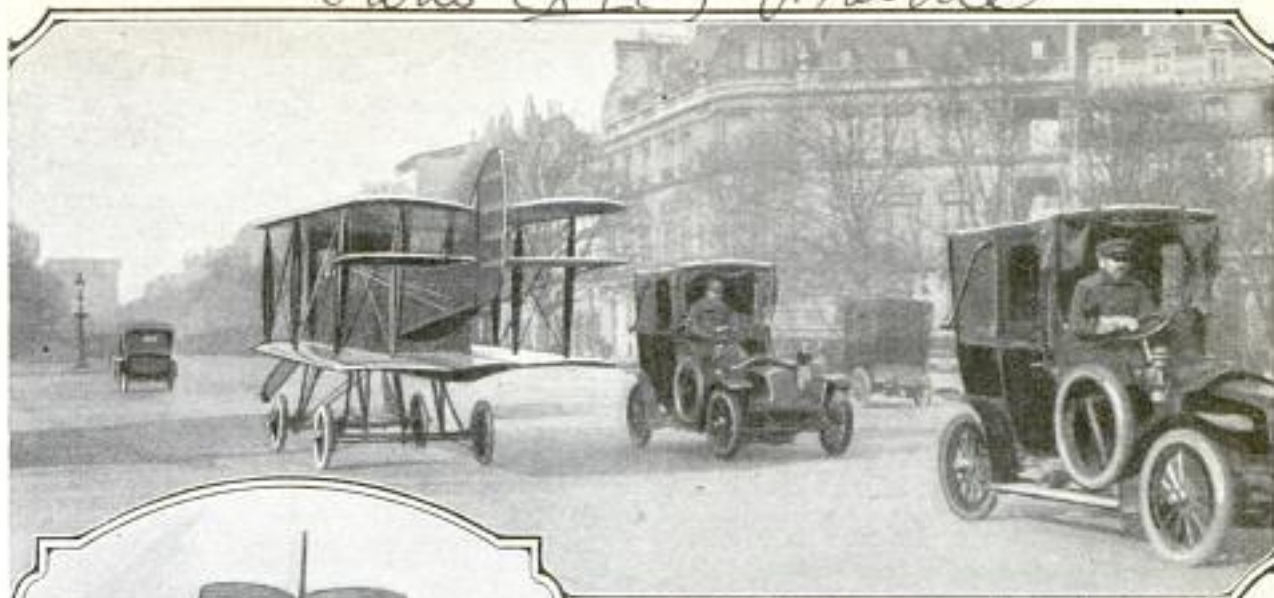

The New Campier Biplane, the French "Flying Automobile," on the Avenue des Champs-Élysées, in Paris: This Photograph Shows How the Machine, with the Wings Folded, Compares in Size with Ordinary Automobiles. Below: A Side View, Showing How the Wings Fold Back along the Fuselage



PHOTO, UNDERWOOD & UNDERWOOD

From Above, the Airplane, with Its Wings Folded, Looks Very Much like a Big Motor Truck or Bus, and It Requires About the Same Storage Space. When It is Run on the Ground, the Power is Furnished by a Small Auxiliary Motor



With the Extra Wheels Removed and the Wings in Normal Position, the Machine Is an Ordinary Biplane, with Nothing to Distinguish It from Other Planes of the Same Type

*I no. Potter Bucky,
New York Diagnostic Clinic
New York City*
166
7849
POPULAR MECHANICS'

LEAD DIAPHRAGM IS USED WITH X-RAY APPARATUS

Although it is not generally known, the accurate photographing of stout persons with X-ray apparatus has heretofore been



This Concave Lead Diaphragm Eliminates the Secondary Rays When a Stout Person is Photographed by X-Rays

a somewhat difficult task. The reason for this difficulty is the presence of secondary rays which make the plate "cloudy" and which are caused by the thickness of the patient's body. A new diaphragm composed of lead grids is now available, the use of which entirely eliminates these annoying rays. Thus the picture of the fleshy individual can be made as clear and well defined as that of the most frail subject.

SEEDLESS GRAPES IN EASTERN AND NORTHERN STATES

Considerable work has been done by the director of the New York Botanical Garden, in coöperation with the State Experiment Station at Geneva, in connection with the development of seedless grapes for the northern and eastern states. Plantations have been made in the Botanical Garden, and some have already borne fruit. Cuttings of others have been sup-

*N. Y. Times 12/13/21
P. 33*

plied by the State Experiment Station, and from the Experiment Station of California, cuttings of all the most important of the Vinifera grapes have been obtained and are now growing in a nursery. Later these are to be planted in a vineyard, containing specimens of wild grapes, the principal cultivated varieties hardy to that section, and several varieties of the Vinifera, which can be grown there successfully by providing protection in winter. Critical studies will then be made of these plantings.

7935 BILGE STATIONS TO PREVENT POLLUTION OF HARBORS

It has been proposed, in Baltimore, to establish two bilge stations in Chesapeake Bay, one to be utilized by incoming, and the other by outgoing ships, with the object of preventing the pollution of the bay from oil in bilge water. It is claimed that bilge water is now killing fish, oysters, and wild fowl by the thousands. Similar stations are operated successfully in New York. It is estimated that each station would cost about 50,000 dollars.

Christian Science Monitor
7823 TIRE PUMP AS AN ACCESSORY FOR LOW-PRICED CARS

As a standard equipment of an automobile a power-driven tire pump has long been in use on many makes of higher-priced cars. There has now been developed a power-driven tire pump that is available as an accessory for low-priced cars. It is a combination of tire pump and radiator fan, replacing the standard fan and bracket assembly. A simple clutch throws the tire pump into or out of operation. The pump is of the piston type, and it is driven by a disk crank connected with its fan pulley.



■ A New York City cigar store has a series of humidor compartments built into one wall. When a customer buys a box of cigars, he is given the only key to one of these compartments, and may keep his cigars in it as long as they last.

A. D. W. of no. 135 2nd Ave. Boston, Mass



The Alaskan Whalers Sailing for Home with the Captured Mammal in Tow: This Remarkable Picture was Taken at Night in the Light of the Midnight Sun

WHALE HUNTING ON THE TOP OF THE WORLD

BY LAWRENCE WILLIAM BEDROSE

*Henry Beldy
Seattle, Wash.*

ON the shore of the Arctic Ocean at the extreme northern point of Alaska lives a tribe of Eskimos who are declared to be the greatest whale hunters in the world. These hardy natives brave the dangers of the Arctic seas in open boats, skirting treacherous ice floes, facing deadly blizzards in search of game, which they often pursue scores of miles from land.

Whales are hunted in the Arctic in May and June, when the ice fields have broken up and swept southward into Bering Sea, and again in September, before

winter seals the ocean with its impenetrable cap of ice. The mammals enter the extreme northern waters when the ice goes out in the spring, and stay until the ice returns. But the Eskimo pursues the whale when it appears early in the season, then turns his attention to seal and duck hunting, returning to the hunt for the mammals in the fall to fill his larder for the long winter.

The Eskimos of the Arctic have strange customs. It has proved difficult to convert them to the ways of the white man. Of the practical arts of the latter, the



The Whale Hunters Making a Temporary Camp upon the Ice: These Camps Are Necessary, as the Hunters must Be near the Open Water

A Typical Shelter Used by the Whale Hunters on the Ice Floes: Spear Shafts, Boats, or Sleds Form the Frame, over Which is Stretched a Sail, While Fur Robes are Used for the Floor Covering



Anga-Took-Sanga, a Famous Arctic Hunter: This Native Has Steel Spikes in His Crutches. He is Said to Be a Very Swift Runner



Blanket Tossing, Which is a Popular Sport with the Eskimos and is Practiced during the Na-lu-ka-tak, or Celebration Following a Successful Whale Hunt: Young Women are the Best Jumpers, Often Going 30. to 35 Feet into the Air





Dragging the Great Slabs of Whale Meat Ashore: All the Men and Some of the Women and Children of the Tribe are Required to Lend a Hand. Salvaging of the Meat is Followed by a Great Feast, Dance, and Distribution of the Prize



Tak-Pak, Champion Whale Hunter of the Arctic: Last Fall Tak-Pak Killed Seven Huge Whales between the Alaskan and Siberian Coasts

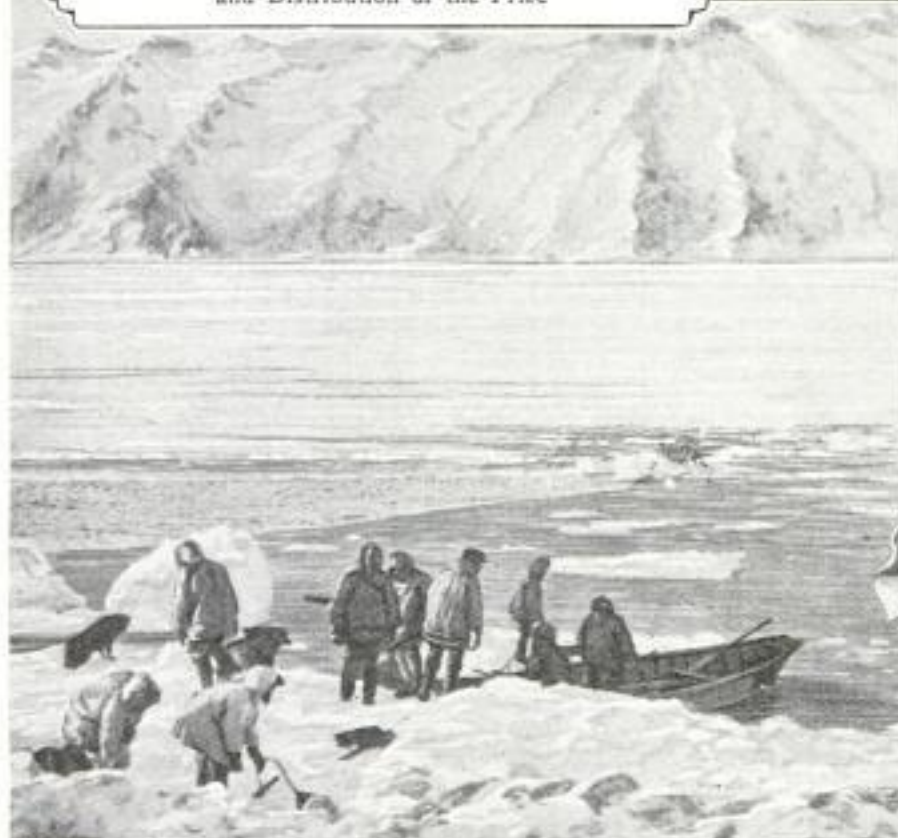

The Start upon the Whale Hunt in the Early Morning: In the Distance is Seen Bleak Diomedede Island. This Picture Tells Graphically the Conditions under Which the Eskimos Hunt Whale



A Whale is Struck and the Lucky Boat Hoists Its Flag as a Signal to the Other Boats to Hurry to Its Assistance. Generally the Mammal has been Killed by the Time the Other Whalers Come Up

natives have adopted whale boats and firearms. The methods of hunting are their own.

When the whaling season begins, the Eskimos make temporary camps on the ice fields off shore, so as to be as near as possible to the open water. These temporary camps consist of improvised shelters made from upturned boats or frames of sleds, over which skins or paulins are stretched. Fur robes form the floors of the shelters.

Whale hunting to the Eskimo is the most fascinating sport. It is much in the nature of a regatta, with honors going to the boat which kills the first whale of the season. Despite its romance and glamour for the native, however, the hunt has a serious purpose; a successful season assures a winter's supply of food for the entire village.

With sails hoisted to the wind, the boats to the number of 10 or 12, each carrying three or four hunters armed with rifles, depart out upon the Arctic Ocean. They spread out over a vast area fully 50 miles square. Each boat carries a flag, and when a whale is struck, the signal is hoisted, whereupon all the other boats hasten to the assistance of the fortunate hunters. Usually the whale has been killed by the time the other boats come up.

A few of the Eskimo hunters have whaling guns, which shoot an explosive harpoon that instantly kills. Others have only their rifles or spears, with markers and buoys consisting of seal skins inflated with air.

Weather conditions increase the hazards of hunting upon the ice-strewn Arctic sea. A storm may arise suddenly

and blow the hunters far from home. When these storms occur in the Arctic, they usually last for days. The hunters, carrying only bare necessities, suffer greatly. Blizzards are to them as deadly as fogs in temperate waters are to fishermen there. The Eskimo has an unerring sense of direction, but this avails him little when the wind, lashing the grinding ice floes, cuts off retreat toward home. He must fight it out on the open sea and wait for the storm to subside.

When a whale is captured, the boats of the hunters assemble at the scene as quickly as they can. The boats are lined out, with sails up, each towing the other, the dead whale bringing up the rear, and the slow voyage homeward is begun. When shore is reached, the whale must be cut up in the water, since there are not enough men to drag the great carcass up on shore.

When the whaling season is over, each successful hunter gives a *na-lu-ka-tak* (celebration), with the rest of the villagers as his guests. There is feasting, blanket tossing, and a dance at the end of the program, which often lasts for days. All the old men and women, and the sick Eskimos, are guests of the prince of the whale hunt. Those not able to walk are carried by the men or hauled on sleds to that part of the village selected for the feast.

A feature of the *na-lu-ka-tak* is blanket tossing. Girls and young women are the best blanket jumpers. Thirty to thirty-five feet is a common jump. Some of the men are also good at this popular sport, but because of their suppleness, women always carry away the honors.

7822 *Equipment*
**FOREST RANGERS'
FIRE ENGINE CAN
BE CARRIED
ON BACK**

Fire engines, light enough for one man to carry on his back, are being manufactured for the use of forest rangers. The complete outfit, including the tank filled with gasoline, weighs only 74 lb. and will deliver 20 gal. of water a minute through a 1,500-ft. hose. The single-cylinder gasoline engine is said to be the smallest and lightest

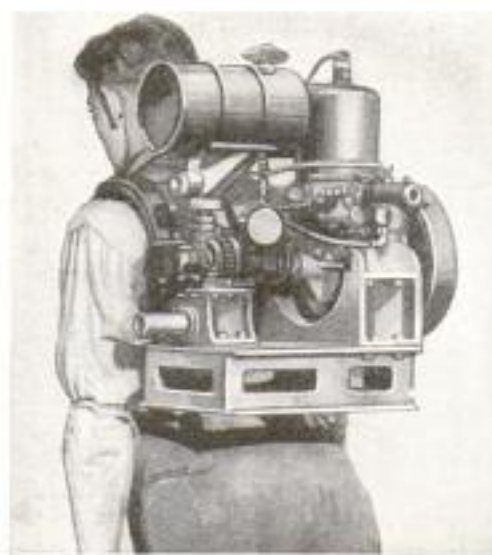

New Light-Weight Fire Engine for Forest Rangers, Showing How It is Carried

fire engine built. It will throw a stream ranging from 7 gal. a minute, with 160-lb. pressure, to 21 gal. a minute, with 90-lb. pressure. A two-cylinder outfit is also being made, which weighs 125 lb. Its stream ranges from 20 gal. at 115-lb. pressure to 40 gal. at 85-lb. pressure.

Write our Bureau of Information if you wish to know who makes or sells any article described in this magazine. Send no postage; the service is free.

*Northern Fire Apparatus Co.
Minneapolis, Minn.*

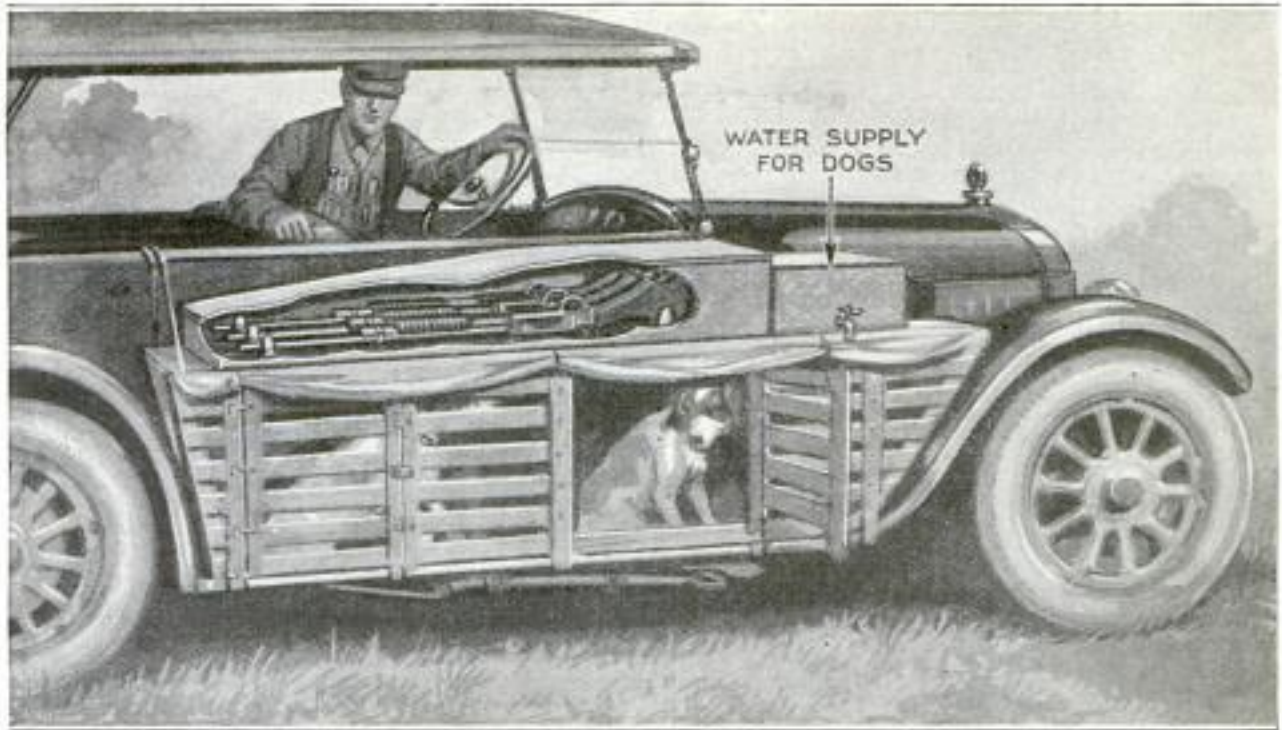

A Hunter's Automobile Fitted for a Long Trip: On the Running Board Is a Cage Large Enough to Hold Two Dogs in Separate Kennels. Above the Cage Are a Gun Case, Holding Three Guns, and a Water Tank

769.5
HUNTING DOGS RIDE IN CAGE ON AUTO RUNNING BOARD

To save the strength of hunting dogs for work in the field, they are carried, where the distances are long, in comfortable cages placed on the running boards of the automobiles which carry the sportsmen. The cage is 69 in. long at the bottom, 25 in. high, and 12 in. wide inside. A partition in the center divides the carrier into two kennels. The cage is made of light lumber and lath, and has a canvas curtain on the weather side which can be let down to protect the dogs from wind and rain. Two metal bars, bent to fit the running board, are clamped beneath to hold the cage. A rack or box carrying three guns is placed above the kennel. And, of interest to those shooting in Dakota, for instance, where water supplies are sometimes far apart, there is provided a metal water box, which also rests on the kennel. This box is fitted with a stopcock at the lower part, making it easy to draw off water without opening the box.

7817
TRACK TORPEDO THAT APPEALS TO SIGHT, SMELL, AND HEARING

A new track torpedo, or fog signal, has been adopted by the Canadian Pacific Railway, that instead of appealing only to the sense of hearing, like the conventional signal, appeals to three senses—

hearing, seeing, and smelling. When used by trainmen to protect trains from the rear, the torpedo is attached to the rail head, in the usual way, with a spring clip.

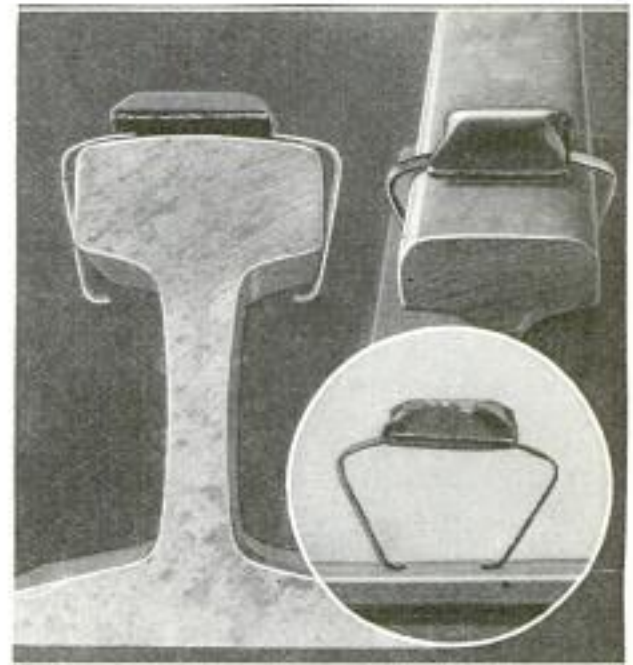

Track Torpedo, or Fog Signal, That, When Detonated, besides Making a Loud Report, Like Other Torpedoes, Gives Out a Brilliant Flash, and Emits a Pungent Odor

When fired, it not only makes a loud report, but also gives out a brilliant flash, and emits a pungent odor. It is made waterproof, and resists any atmospheric conditions of heat, cold, or moisture. This is essential in the Canadian climate with its great variations in temperature.

Canadian Pacific Railway
 342 Madison, New York City

172 Chicago POPULAR MECHANICS
478 ^{Wreck} LOCOMOTIVE THROWN UP SIDE OF HILL BY COLLISION

When two trains met in a head-on collision, near Bryn Athyn, Pa., not long ago, one of the locomotives was thrown

of the Ethiopian Empire. The expedition has returned from 10 years of exploration in Egypt. The principal discoveries, relating to this formerly unknown portion of history, were made at Napata, the ancient capital of Ethiopia, now called Gebel Barkal, at the foot of the Fourth Cataract of the Nile River. At this point a group of pyramids were examined, and it was learned that the royal family of Ethiopia sprang from a tribe of Libyan nomads, who entered and became a part of Egypt, revolted, and later conquered the older country. Pieces of sculpture, paintings, and art objects, which were obtained, represent a remarkable civilization and the highest development



After the Crash: One Locomotive was Thrown Up on the Side of the Hill by the Force of the Impact

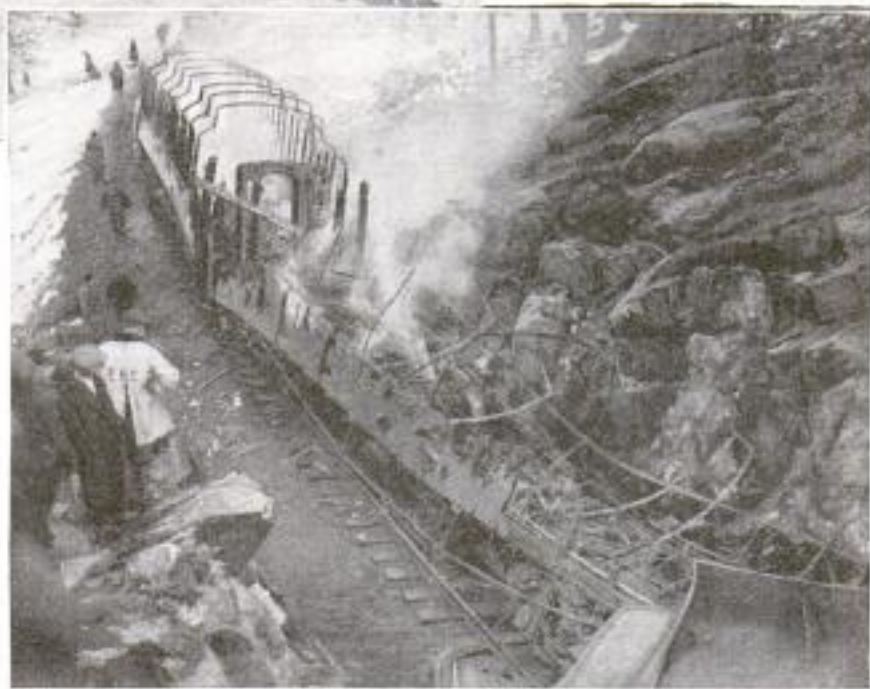

Most of the Injuries to Passengers and Damage to Property were Caused by Fire, Which Enveloped the Train Almost Immediately after the Collision

high up on the side of a hill bordering the track by the force of the impact. The accident occurred on a single-track line between Philadelphia and Newtown, over which two local trains were running in opposite directions. Through some error they met on a curve. Though both engines were smashed and the trains badly wrecked, the crash was not directly responsible for all the deaths and injuries. Almost immediately after the crash the coaches caught fire, and many of the 25 deaths and 20 injuries were the result of the fire.

of Egyptian art. The expedition was probably the most thorough, scientifically, that has ever been conducted.

47934 HARVARD-BOSTON EXPEDITION FINDS ETHIOPIAN RECORDS

Discoveries made by the Harvard-Boston Archaeological Expedition headed by Prof. George A. Reisner, of Harvard University, have made it possible to write the history of the establishment and rise

Miniature pieces of furniture and many other everyday objects are used by Miss Mary LaVergne to teach simple French to beginning students, in the Minneapolis, Minn., South High School. Pupils use no textbook during the first term but, after this preparation go through the book as easily in the following two terms as other students do in three.

Christian Science Monitor

12/2/21

GARAGE ZONING REGULATIONS TESTED BY APPLICATION

On the whole, the zoning regulations for garages, adopted by New York City in July, 1916, have proved highly satisfactory. Some defects have appeared, however, in the practical application of these regulations which should prove of interest to other communities now considering similar legislation. The principal defect is in the provision permitting the building of private garages, for not more than five motor vehicles, as accessories to residence buildings on the same lot, in residence districts. Such an accessory garage cannot be rented in whole, or in part, or used for business vehicles. It is felt that such rental and storage should be permitted as an incidental use, but that it would be abused if allowed. The proper solution is said to be the reduction of the number of cars permitted to three, and the allowing of one space for rental or storage of light business vehicles; which would require an amendment of the law.

7728
MACHINE MAKES RAISED-LETTER COPY FOR BLIND TYPEWRITERS

Teaching many of the soldiers blinded during the late war to use typewriters as a means of earning their living, is a laudable effort of the German government. To prepare copy for the use of those so afflicted, a machine has been designed which stamps raised letters upon a tape. These letters are "read" by the blind typists, who use the highly trained sense of

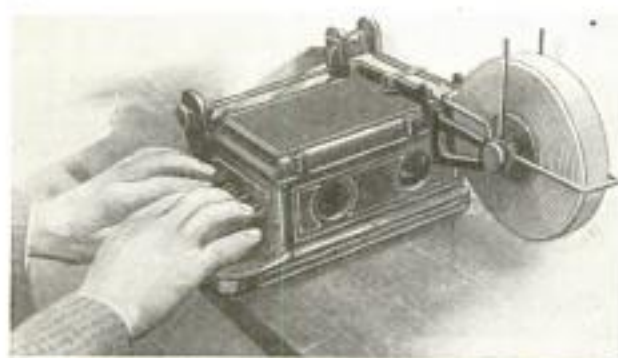

This Machine is Used to Prepare Copy for Blind Typists by Stamping Raised Letters on a Tape

touch in their fingertips, and afterward write them on a regular typewriter.

International Photo Service, 326 W. Madison, Chicago

HAND FLASHLIGHT ADAPTED AS MOVIE-FILM PROJECTOR

Single views, clipped from moving-picture films, can be projected on any

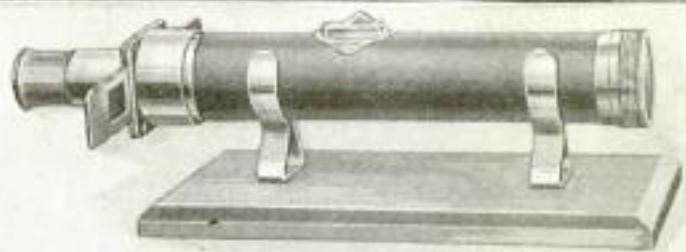

Above: The Projector, Placed on a Table, Throws Pictures on an Ordinary Wall. Below: Enlarged View, Showing Construction

white surface by means of an ordinary hand flashlight with a special lens and slide. The flashlight rests in nickelplated clips on a wooden base. A special reflector-and-lamp unit produces about 15 times the light of an ordinary flashlight and enlarges the 1-in. film view to a 9-ft. picture, with perfect detail. In the front end, which is telescoping, is mounted a metal slide carrier with three film apertures.

7902
LARGEST ALL-AMERICAN-MADE TWIN-SCREW MOTORSHIP

The "Californian," the largest twin-screw motorship built and fully equipped exclusively in the United States, was recently launched at Chester, Pa., and it will be followed at an early date by a sister ship, the "Missourian." They are considered the most efficient type of motorship for long-distance voyages. Their dimensions are, 461-ft. over-all length, 59-ft. 8-in. beam, with a draft of 28 ft. at a deadweight tonnage of 11,000. The power equipment consists of two six-cylinder single-acting Diesel engines, each rated at 2,250 indicated horsepower at 115 r.p.m. The contract speed is 13 1/4 miles, and the normal fuel capacity is 1,400 tons, with a reserve capacity of 760 tons, giving a normal cruising range of 25,000 miles.

Marine Journal Dec 5, 1921

Cordell Projector, Price \$17 & 94 Hk. \$1. New York.

7220
174

DEVELOP EFFECTIVE PROCESS FOR RECLAIMING WASTE COAL

Laboratory studies by the United States Bureau of Mines indicate the pos-

is then washed into a container and allowed to settle, after which it is transferred to a churn, with a paddle revolving at 1,000 r.p.m., where it is mixed with water. Oil is then added and the churning is continued. This action results in small egg-shaped granules, known as amalgam, which are the ultimate aim of the process, and are composed of purified coal, oil, and 10 to 30 per cent water. The entire mixture is next poured onto a 100-mesh screen and drenched with a fresh supply of water. It is then placed in the churn and washed until the amalgam is free of all mineral matter.

It is claimed that this process is practically effective. Combustible matter is recovered to an extent exceeding 95 per cent. Mineral matter is eliminated to a satisfactory degree with

Cont. Walter E. Trent, Bureau of Mines, Washington, D.C.

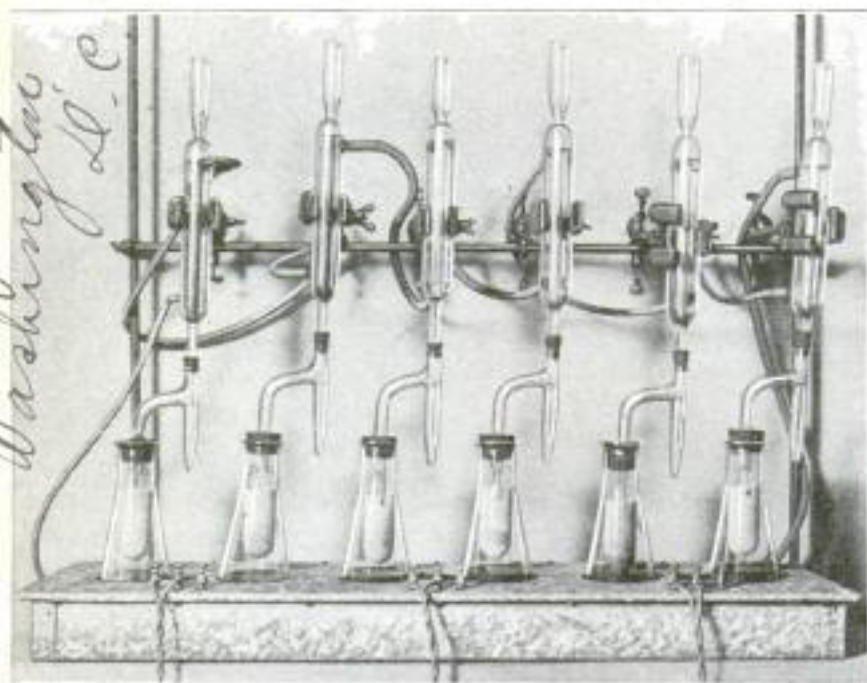

Laboratory Apparatus Used by the United States Bureau of Mines in Experiments to Develop a Practical Method of Reclaiming Waste Coal

sibility of reclaiming millions of tons of inferior coal, now going to waste at the mines, by a new method of refinement. The coal is pulverized sufficiently for free passage through a 200-mesh screen, finer pulverization not yielding a great enough reduction of ash to warrant the increased expense of finer grinding. It



Amalgam Granules, Varying in Size Down to About One-Eighth Inch in Diameter, the Final Product Obtained in Reclaiming Coal



At the Left: The Apparatus Used for Drying the Amalgam After It has been Washed. At the Right: The Churn Used, in the Laboratory Experiments, for Mixing the Powdered Coal with Oil

either bituminous or anthracite coals, and the sulphur reduction is favorable with anthracite, though not with bituminous coals. Any oil having a high viscosity may be used, and oil wastage is negligible. For coal containing 25 per cent waste material, 450 lb. of light fuel oil to the ton of coal are required. Reaction takes place most readily with coal which easily absorbs oil but is not readily wetted by water, and with oil which does not easily form emulsions with water. Bituminous coals and graphite are more responsive to this treatment than lignites.

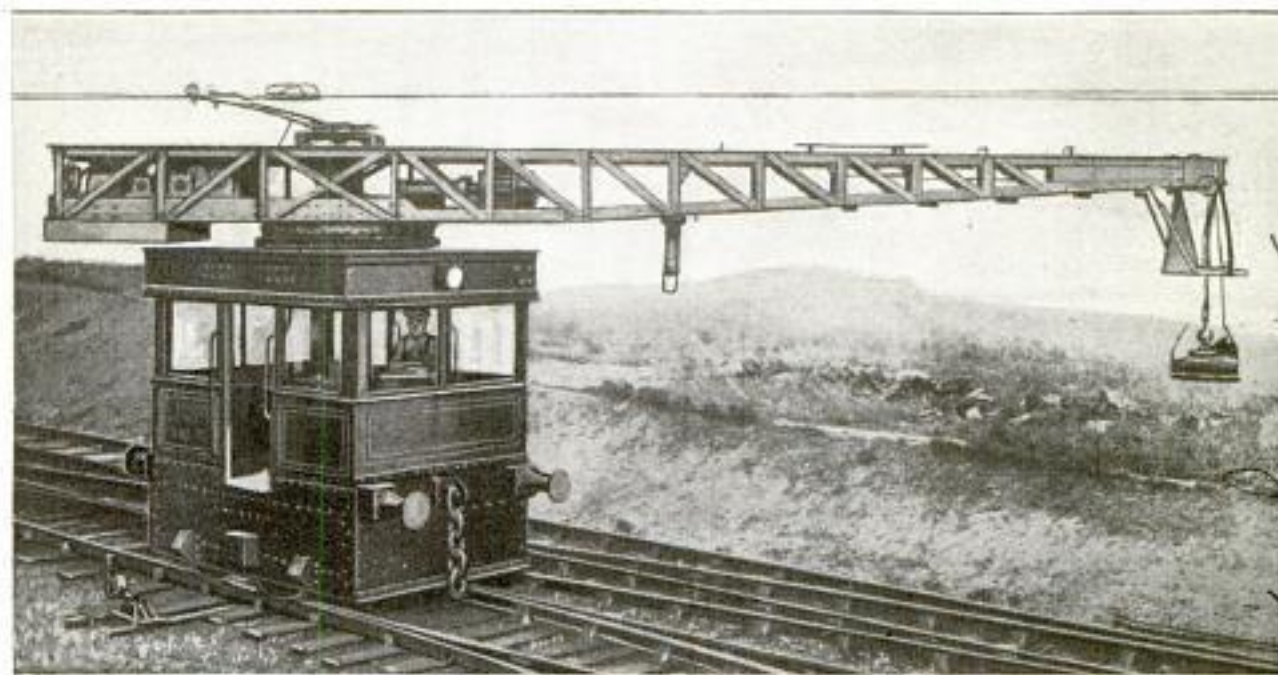

Combination Electric Locomotive and Magnet Crane Which is Operated by One Man: At the Top is Seen the Trolley, and at the Right the Lifting Magnet is Shown at the Extreme End of the Crane

9851
MAGNET AND CRANE MOUNTED ON ELECTRIC LOCOMOTIVE

The combining of an electric locomotive with a magnet crane has produced beneficial results in England, as it can be handled by one man in the loading or unloading of iron. The crane has a 28-ft. radius, traveling in a complete circle in 30 seconds, while the lifting magnet is strong enough to sustain 10,000 lb. with its 2-in. steel plate. The locomotive possesses a speed of seven miles per hour, and has a framework of steel. The equipment is fitted with the usual standard motors, controllers, and trolley system.

8011 Railroad Construction
ONE HUNDRED TONS OF RAILS MADE INTO SOUVENIRS

The fiftieth anniversary of the inauguration of railroad service in Japan was celebrated recently at Tokyo. About 3,000 persons took part in the ceremonies, which were held in a pavilion in front of the central station. More than 100 tons of steel rails were cut into 170,000 thin slices, bound with brass, and presented, as souvenir paper weights, to those attending the celebration. These rails were the first steel rails laid in the country, in 1871, on an 18-mile line between Tokyo and Yokohama. There are now 8,500 miles of railroad in Japan proper. The first locomotive, imperial coaches, and other pieces of early equipment were exhibited.

Railway Age 012/19/21

4667
GOLF-BAG HOLDER CLAMPS ON AUTO RUNNING BOARD

To the golf enthusiast who drives his own car, a new golf-bag holder for the machine should prove a great convenience. It is made of strong flat-steel stock, neatly finished in black enamel. Firmly clamped onto the running board of an automobile, it provides a safe and convenient place to carry golf bags.



This Golf-Bag Holder, Clamped to the Running Board, does Not Detract from the Appearance of the Car

Standley Shid Chain Co. Borne, Java

Wm. Chaplin & Co. Ltd., Engineers

7491 English-Blair Co. Ltd
Coventry, England

E. H. Lemonon 27, Rue d'Enghien, Paris, France
Faged-Motors Co., Oakland, Calif.

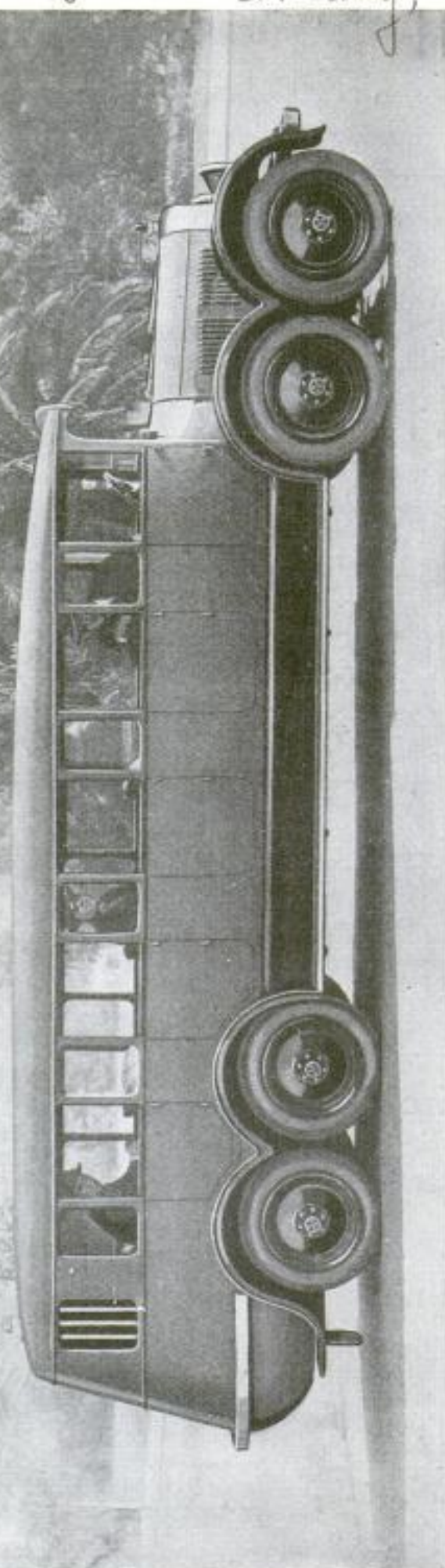

An American Motor Bus of the Latest Type Which Seats 20 Persons, Weighs 8,000 Pounds, Has a Speed of 50 Miles an Hour, and Possesses Two Trucks of Four Wheels Each: The Eight Wheels Are a Distinctive Feature of This Car, and Due to Them Are Advantages Such as Double Axles at Either End, Elimination of Skidding, Easier Riding, and Added Traction

MOTOR-BUS

Astonishing Develop Prefer Busses to Rail

NOTEWORTHY departures from the usual manner of travel by tourists, have been evidenced by the constantly increasing demand for reservations on motor busses operating in various parts of the world. And equally remarkable have been the developments in the construction of these busses, until at the present time there have been incorporated into them sumptuous appointments which rival the best accommodations available on railroad trains or steamship lines. If present indications may be taken as a prophecy, the bulk of tourist migration in the future will be handled by this method of transportation.

Ancient and medieval ruins, together with historic and romantic localities, will always be the Mecca of tourists, and pilgrimages to these places are being made more pleasurable each year by the facilities offered by the motor bus. While pleasure seekers annually migrate to all sections of this country, in advance of inclement weather, California is undoubtedly the greatest magnet for this class of people, and it is fitting that the latest development of the motor bus should emanate from there. The innovation consists of an eight-wheeled car, with a seating capacity of 20 persons, and a spacious compartment for the baggage of the passengers. For safeguarding the traveling public, the eight-wheel bus possesses many advantages over the four-wheel type. The new machine steers on all front wheels, which are fastened together by a special spring suspension, and constitute a truck, as likewise do the rear

American-White, International 7491

TRAVEL ATTAINS WORLD SCOPE

ments in This Mode of Transportation—Tourists of the Future may roads—Motor-Car Touring will be Brought within the Reach of All

BY H. A. LANE

wheels. The car is driven by, and the brakes are applied to, the four rear wheels, so that its superiority is obvious. If, when running at top speed, one front or rear axle should break, the other axle would maintain the weight of the car. Likewise, if under the same conditions a front tire blows out, the machine can be steered on the three remaining tires, thus avoiding an accident. Although the bus weighs 8,000 lb., the pavement strain is considerably less than would be the case with a four-wheel car of the same weight, because of the eight bearing points, and because an air pressure of only 70 lb. is used in the tires, in comparison with the 90 lb. of the four-wheel type. Extensive tests made with this machine have satisfactorily proved that it will not skid, that it rides more smoothly and more comfortably than any four-wheel motor car, and that an average of 10 miles can be made on one gallon of gasoline. The eight-wheel bus has five cross seats for passengers, with a door for each seat, while the driver's seat has a door on each side. Although the interior of this new departure in motor-bus building is comfortably upholstered, there can be no comparison be-

tween it and some of the luxuriously arranged busses in Europe.

European motor-bus travel has reached



Rear End of the Eight-Wheeled Motor Bus, Showing the Compartment for Accommodating the Baggage of the Passengers and the Spare-Tire Compartment Just Below

such enormous proportions as to warrant the construction of veritable "palaces on wheels." The most elaborate of these coaches are to be found on the French line operating between Calais and the Riviera. Nothing has been spared which might add

to the comfort of the six-day trip between these points. The huge inclosed busses, with their highly polished maroon bodies, and fitted with large plate-glass windows, present a most imposing appearance. The seating capacity of this type of car is 20 persons, and provision is made for the travelers' baggage by the construction of lockers beneath the chassis, and by a guard rail on the top. Seats which hold two persons each, are placed, three on a side, at the forward end of the bus, and face forward also, leaving an aisle down the center to the seats in the rear. A U-shaped seating arrangement, extending around the bus in the rear, gives space for eight persons. The seats are beautifully upholstered in a serviceable French gray rep, with the back and seat cushions deep



Front Truck of the Eight-Wheeled Motor Bus, with One Wheel Resting upon a Curb, Graphically Illustrating the Remarkable Flexibility of the Axle Arrangement

S. C. & M. C. A. 9 Rue Tronchet, Paris, France

French. Mess. D'Automobiles, 162, Rue Champeignelles, Paris, France

7491

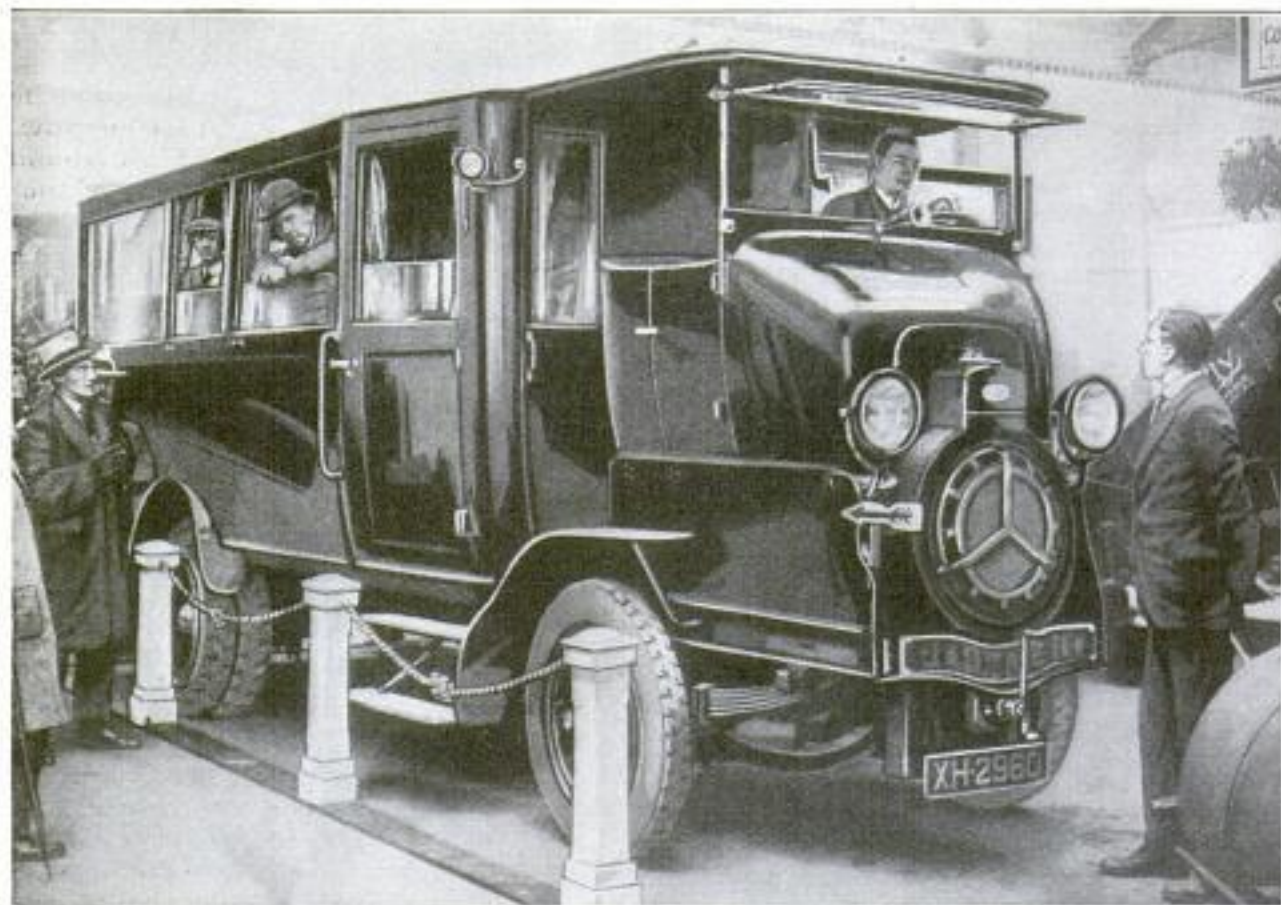

One of the Lavishly Equipped French Motor Busses Now Operating between Calais and the Riviera, Which Have a Seating Capacity of 20 People: They are Fitted with Tire-Safety Apparatus and Arrow-Signaling Appliances; One of the Latter can be Seen under the Right Headlight

and well sprung. Nickelplated fittings are used throughout, including the grip handles on the transverse seats at the front end. Electric cigar lighters are installed, ash trays are fastened to the seats, and neat electric-light fixtures are mounted in

the ceiling, which is finished with the same cloth as the seats.

There are four windows which can be raised or lowered at will, on each side of the bus, and one large square observation window, which is immovable, is placed in the rear of the body. A bevel-edged full-length mirror is located just behind the driver's compartment, and at the end of the center aisle. The vehicle is fitted with day and night safety signals and tire-safety valves. The safety signals consist of two arrow indicators, one at the front and one at the rear, and are operated from a control box near the driver. At night, the arrows are illuminated, the front one showing green, and the rear one being red. An electric horn sounds automatically with the operation of the signals, so that other motorists have their attention drawn to the intended change of direc-

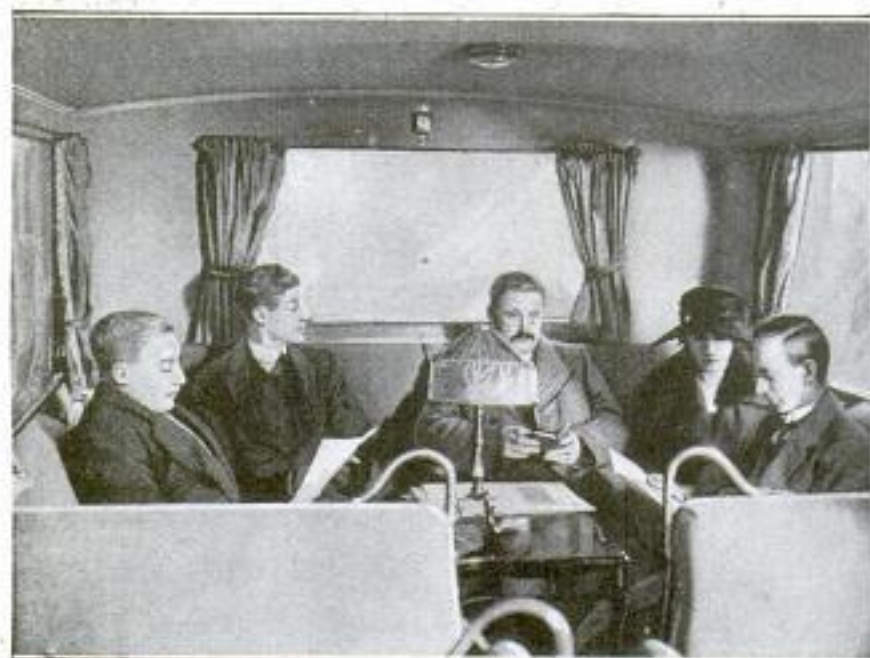

Interior of the Calais-Riviera Motor Bus, Showing the Seating Arrangement: On the Table and the Ceiling can be Seen the Electric Fixtures. The Windows Shown Are All of the Finest Plate Glass

tion. The tire-safety valves project from the rim of each wheel, and when the pressure of air in the tire falls below a certain amount, a spring attachment is released, which explodes a cartridge, thus informing the driver of the condition.

Somewhat similar to the French busses are those to be seen in England, which are designed to accommodate 26 passengers. The English vehicle is divided into

two distinct compartments, one immediately behind the driver's seat and one at the rear. In the front compartment are two transverse seats extending the width of the body, and having a capacity of 10 persons. The rear compartment has seats running around the sides of the car which comfortably accommodate 16 persons. Each section of the bus has a separate entrance. The interiors are elaborately fitted, and have polished-walnut finish, except the ceilings, which are of white-enameled linoleum. Electric lighting is provided throughout, as in the

French machines, and the upholstery is of real antique leather.

Plate-glass windows,

which can be raised or lowered, surround the rear compartment except at the back, where a large oval observation window is placed. A locker extends along the entire left side of the bus for the carrying of baggage. Another type of English motor bus has a capacity of 18 passengers, and

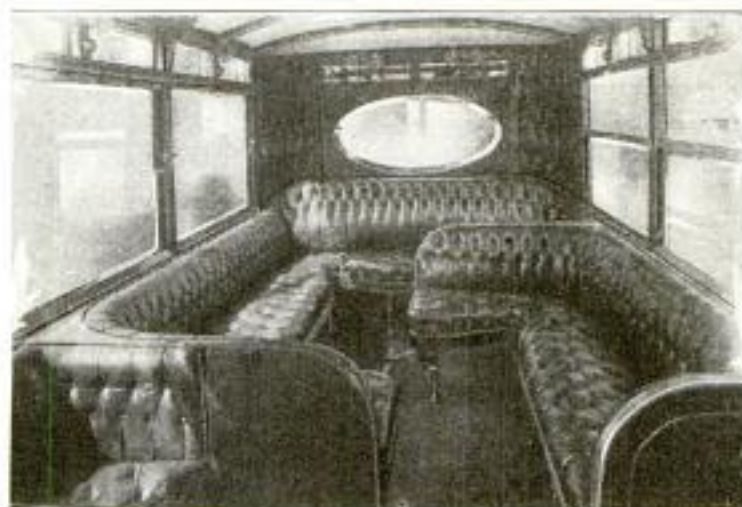

Interior of an English Motor Bus Which Has Two Separate Compartments with a Seating Capacity of 26 Persons: The Rear Compartment Only is Shown Here

all the seats are of the revolving-armchair kind, except four that are built into the back of the body. The swivel seats are arranged in three rows facing forward. If the bus should be engaged by a small party, the four seats in the center row can be removed, and a long table brought into use. The table folds neatly against the underside of the top when not in use, and is held there by spring brackets, entirely out of the way of the passengers. It is a simple matter to lower the table into position, and as the seats revolve, it is possible to turn them toward the table,

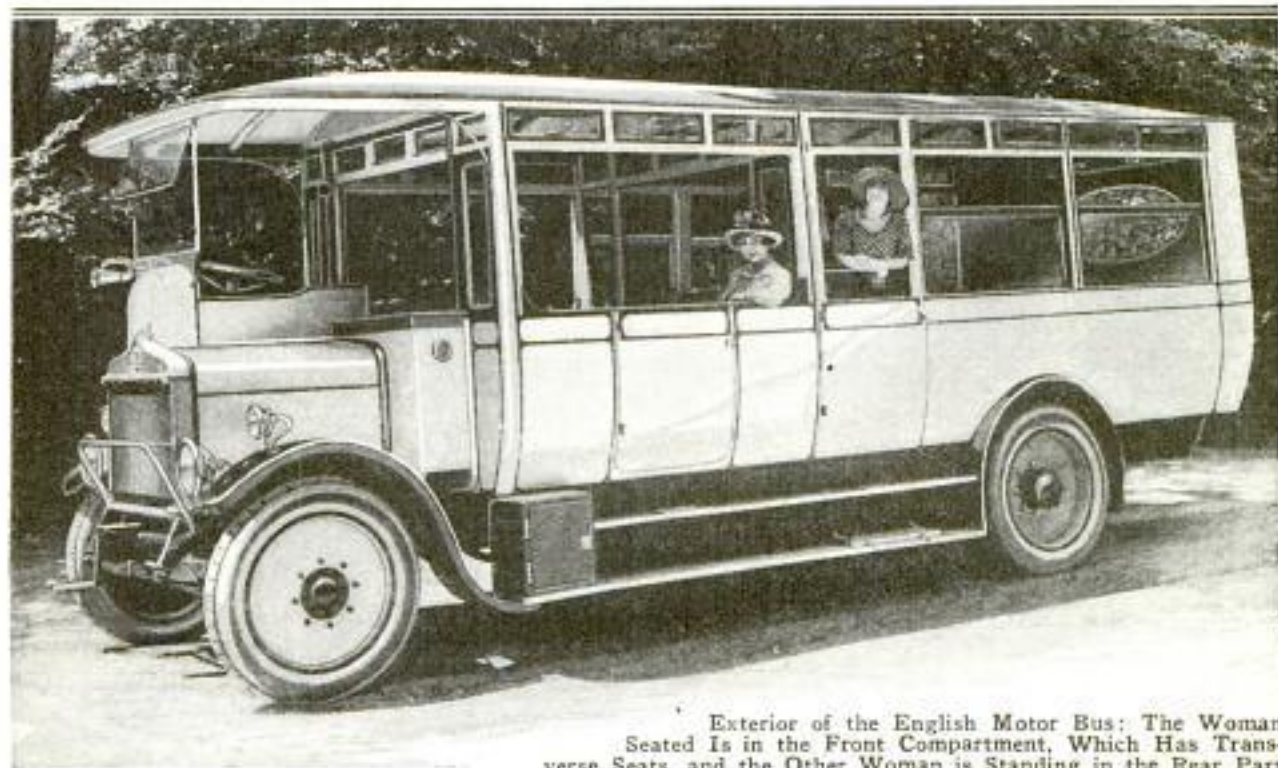

Exterior of the English Motor Bus: The Woman Seated Is in the Front Compartment, Which Has Transverse Seats, and the Other Woman is Standing in the Rear Part

so that the tourists can enjoy one another's company in the participation of refreshments, or in various kinds of games. As in the French motor busses, nothing has been overlooked in the way of conveniences for the passenger, as far as it was in the power of the bus builders to install them. The same holds true of the many busses now operating in Scotland, Norway, Switzerland, the French Alps, the Pyrenees, and other points at which tourists gather in Europe. When a traveler makes a reservation on one of these modern motor busses, he is assured of all the comforts of a private limousine, while enjoying a wonderful sight-seeing trip.

While pleasure seekers undoubtedly dominate motor-bus travel in Europe, this mode of transportation is being applied in practical usage in the United States. Numerous sections of this country have found these cars to be an essential means of overland travel. Especially is this true in Minnesota, where between 70 and 80 bus lines are operated to connect the peculiar fan-shaped system of railroad lines, which run out of St. Paul and Minneapolis to all corners of the state. Thus, a traveler desiring to go from a point on one line to a point on another, can take a cross-country trip by motor bus, instead of riding back to the Twin Cities and then out on another line. Even along the railroad right of way, the busses can successfully compete with the steam roads, because of the possibility of stopping at every farmhouse on the route,

if necessary. Each of these farmhouses is designated as a "station" on the bus-line schedule, consequently the farmer is assured of transportation to his very doorstep. The Minnesota busses have regular passenger terminals, time tables, tickets, and advertising literature similar to that used by the railroads, and this is prominently displayed in hotels and other public places along the route. These motor busses are not as lavishly equipped as the European bus, as they are not considered pleasure conveyances, but this country may see the entry of the elaborately furnished motor bus into the coast-to-coast touring field, if certain rumors of an intended bus line to extend from New York to California, prove to be founded on fact. Regardless of the rumored Atlantic-to-the-Pacific line, the initial trip of Lakes-to-the-Gulf expeditions has recently been completed. This premier of bus-touring parties to southern climes was organized in Chicago and departed from there not long ago.

The owner of a fleet of the familiar sight-seeing cars endeavored to find a profitable use for his property during the winter months. He advertised a proposed trip to New Orleans, with side excursions to the Mammoth Cave, Civil War battlefields, and other places of interest. The idea was eagerly accepted by prospective tourists, and in a few days all available seating space was reserved on his six machines. The cars were then fitted with inclosed tops similar to those used on the

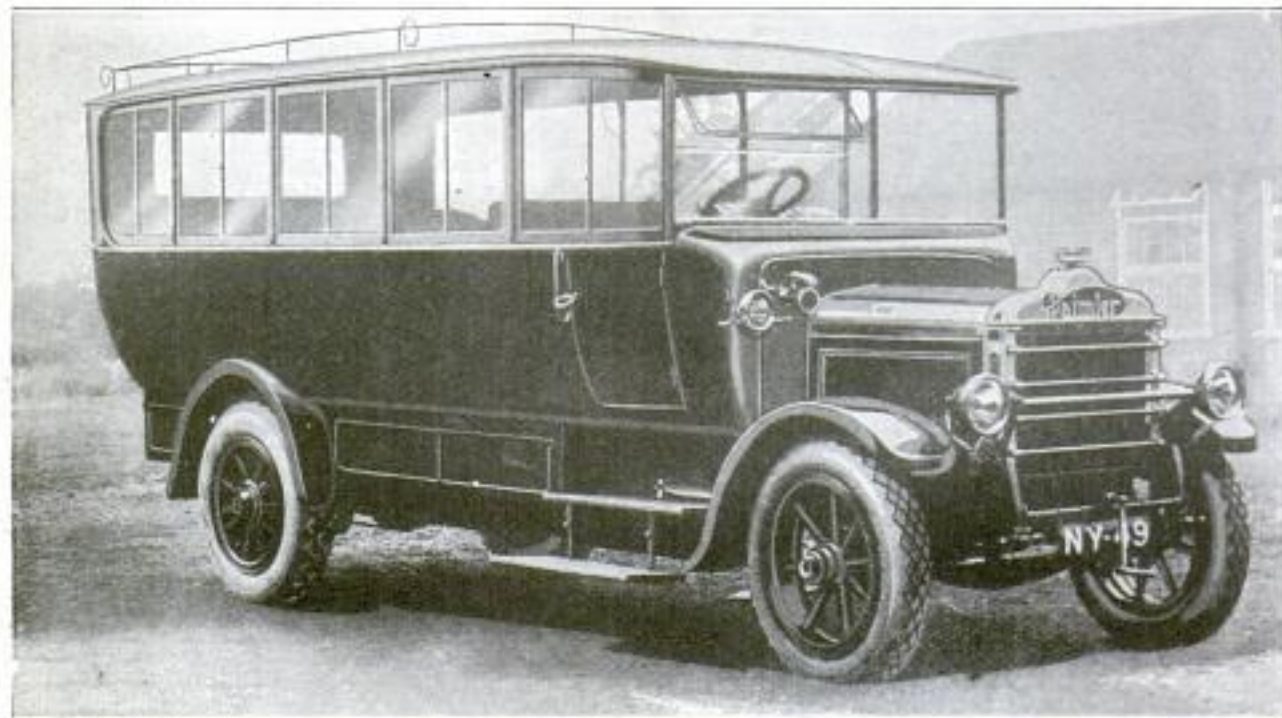

Another Type of English Motor Bus, Having One Compartment Only, with a Seating Capacity of 18 Passengers: On the Running Boards, in Front of and behind the Rear Fender, Are Lockers for Baggage

7491

busses in the national parks, and the first Lakes-to-the-Gulf motor-bus party started on its pioneering trip. The picturesque Dixie Highway was chosen as the route of travel, and a wonderful 1,600-mile sight-seeing trip was enjoyed on the way to New Orleans. While in the South, the busses can be returned to their usual use as sight-seeing cars, and in

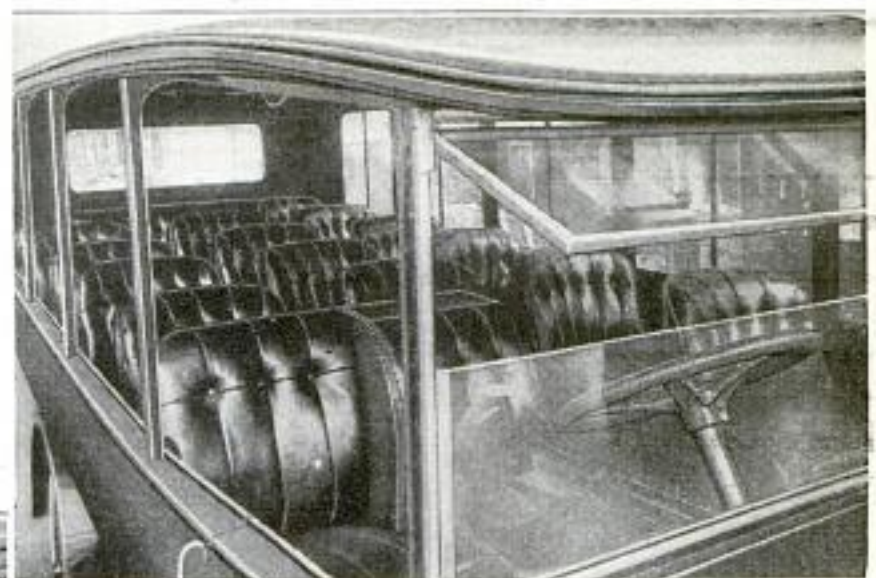

Interior of an English Motor Bus, Showing the Seats Arranged in Three Rows: With Small Parties the Middle Row is Removed to Make Room for a Table

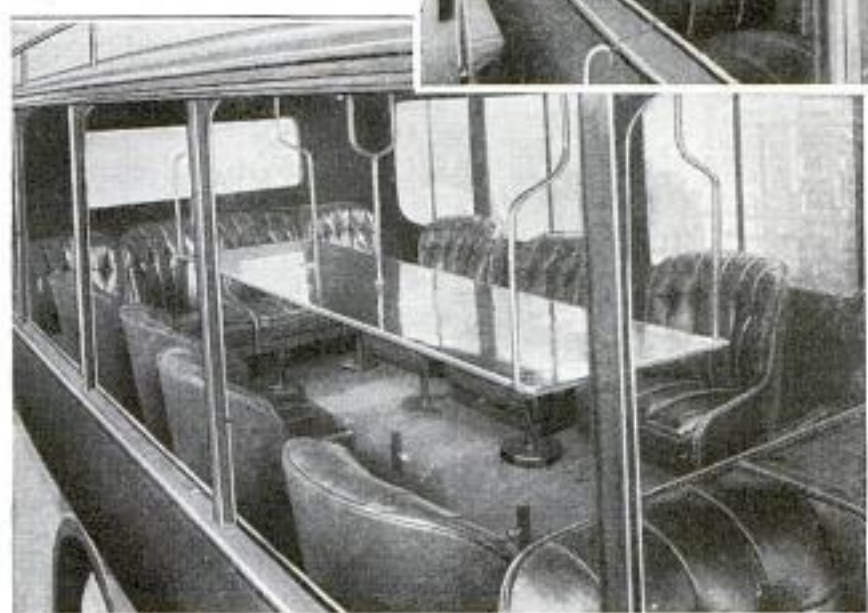

Same as Above, Except with Middle Row of Seats Removed and a Table Installed: When Not in Use, the Table Folds and is Fastened against the Ceiling of the Car

the spring, the owner will doubtless find many tourists eager to make the trip back north.

Thus it is apparent that motor-bus touring, the world over, is going to increase in popularity each year, and to the people will be offered ample opportunities of forming an intimate acquaintance with the many wonders and beauties of the earth.

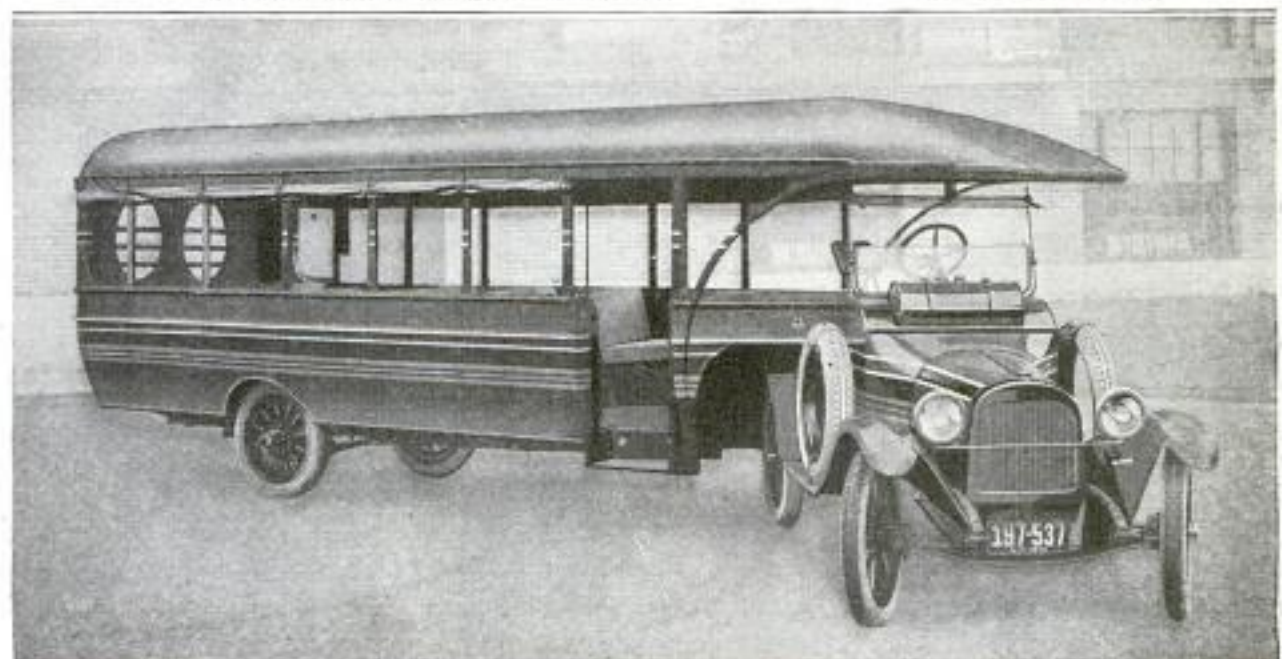

An American Motor Bus of the Trailer Type: The Trailer will Accommodate 26 Passengers and is Attached to the Chassis of a Small Car. Although the Bus Appears Unwieldy, It can be Turned Around in a 50-Foot Space without Backing, and in an Ordinary Street by Backing Only Once

Adams Trailer Corp., Garden City, N. Y.

Chas. S. Van Horn,
 702 S. Spring St.
 Los Angeles, Calif.

Dubuque Boat
 & Boiler Works
 Dubuque
 Iowa.

182
 7890

POPULAR MECHANICS
NEW TROUT-LANDING NET
CARRIED IN POCKET

SMOKESTACK IN TWO SECTIONS
ERECTED WITH A CRANE

2/17 No more need the fisherman lose his temper, and perhaps the fish, because his landing net becomes entangled at the



Left: Trout-Landing Net Sprung Open by Simple Pressure of Handle. Center: Net Closed by Releasing Spring Mechanism. Right: Folded Net Carried in Pocket

psychological moment. A lover of the sport has made a folding net with a spring-steel rim, which can be carried in the pocket until the fish has been hooked and played clear up to the angler. Then the net is grasped, and a simple pressure on the handle, causes it to spring open in circular shape, ready for landing purposes. Should the lively trout thrash around too energetically after being landed, the release of the spring mechanism closes the net, making it impossible for the fish to get free.

7790

An 80-ft. smokestack was to be erected on top of a building only 25 ft. high, in Dubuque, Ia., and therefore, with the exercise of a little ingenuity, it was found possible to do this with a crane standing beside the building. The stack was 54 in. in diameter, and weighed seven tons. To facilitate its erection in this manner, it was made in two pieces, the lower one 52 ft. long, and the upper one 28 ft., with a hinge provided for connecting them. A 15-ton crane, with a 70-ft. boom, was used, first to lift from its position an old stack which was to be replaced by the new one. The first section of the new stack was then raised by the crane, and when in position, the second section was raised, and held so that a man on top of the boom could make the hinge connection. This left the upper section hanging parallel with the lower one. To the side of the upper section, opposite the hinge, an I-beam was lashed, with one end projecting so as to form a lever, which, when pulled downward with a line connected to a winch at the base of the stack, swung the upper section vertically. The two sections were then bolted securely together. The simplicity of the operation made it possible to finish the whole job in one day.

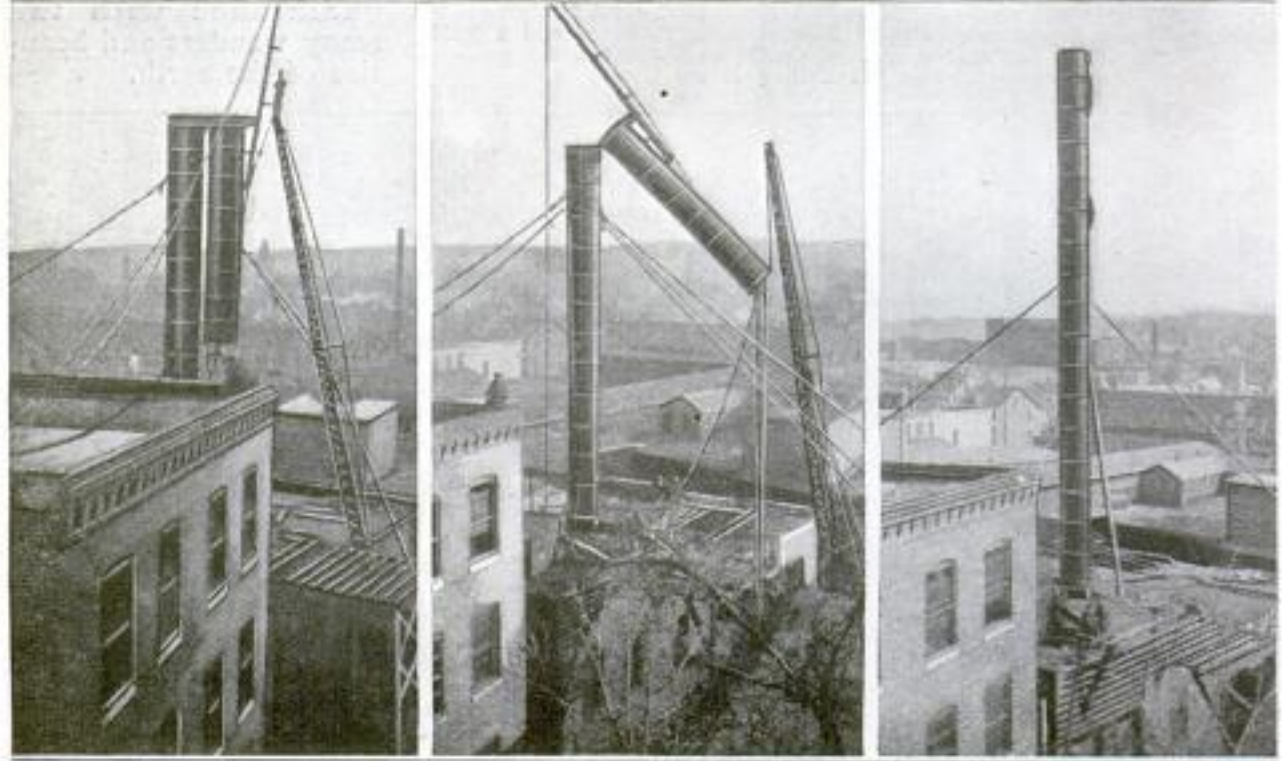

Erecting a Smokestack with a Crane: Left, the Man on Top of the Crane Boom has Connected the Two Sections at the Hinge between Them; Center, the Top Section is being Swung Upward by Means of a Rope from the Boom, Lashed to the Upper Half of the Stack, to a Winch at the Base, and Right, It has Reached the Vertical Position, and the Two Sections are Locked Together

7697

Williams Service
32 Union Square, E.
POPULAR MECHANICS
New York City

183

W. Gally, Escher
Locomotive
Works, Winterthur
Switzerland

W data on maker



PHOTO BY WILLIAMS SERVICE

In the Water, at the Left, This Machine Looks No Different from Any Motorboat, but When It Reaches the Shore, as at the Right, One Sees That It is Mounted on Wheels

7697
NEW MOTORBOAT-AUTO LOOKS LIKE A BOAT ON WHEELS

Another combination automobile and motorboat has been built, by a New Jersey inventor. In general appearance, it is like a boat, mounted on springs, on four pneumatic-tired wheels. It was thoroughly tested at Bayonne, N. J., recently, and is said to have performed in a most satisfactory manner. It worked equally well on the land and in the water. By the state authorities, it is classified as a motor vehicle, and it carries a regular state automobile license.

7813
TURBINE LOCOMOTIVE FOR SWISS RAILWAYS

Up to the present there has been comparatively little effort made to apply the steam turbine to locomotives, and less here than in Europe. Among other attempts that have been made in Europe, a notable one is that of a turbine-driven locomotive now being tried on the Swiss federal railways. The turbine, by means of a reduction and reversing system of gears, drives a shaft

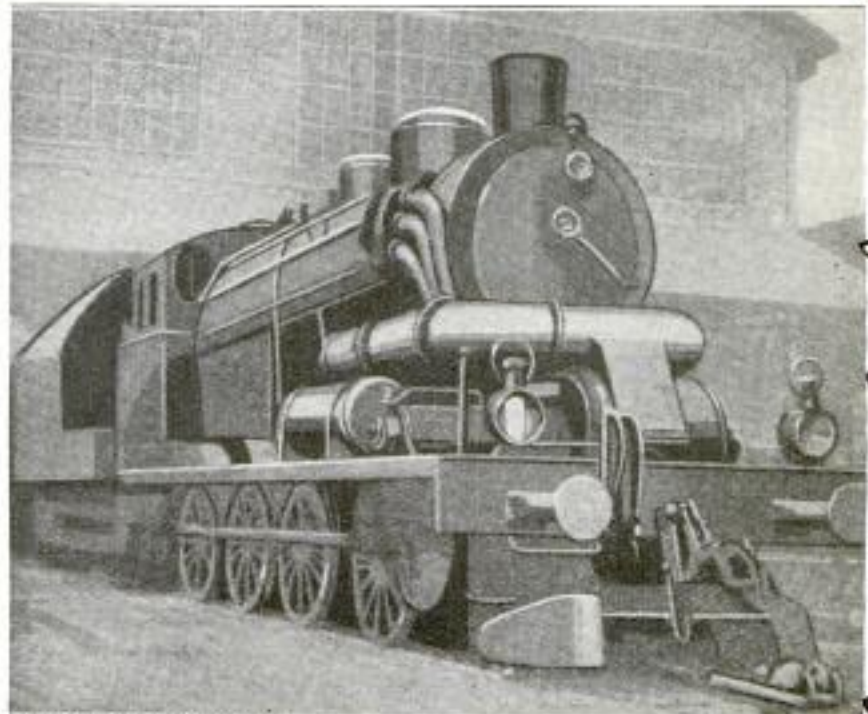

PHOTO BY COURTESY OF MECHANICAL ENGINEERING
Standard Locomotive Changed from Reciprocating to Rotary Drive by Means of the Turbine Seen in Front of the Smokebox: This, through Reduction Gears, Drives a Transverse Shaft above the Forward Truck, Which Has Link Connections to the Coupled Wheels

perior efficiency on the locomotive as it does on stationary and marine engines.

Mechanical Engineering, March, 1921
La Nature 10/1/21 Chicago Daily News 9/20/21

NEW ARTIFICIAL LEG PERMITS NATURAL KNEE MOTION

An inventor of artificial limbs has long sought an appliance which would force a flexion, or bending of the knee, at every

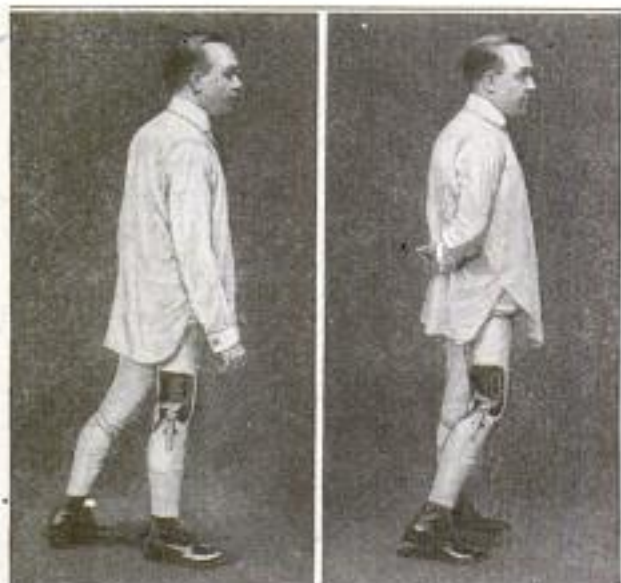

Left: Weight of Body on Artificial Limb. Right: Weight on Other Limb Allows Elastic Band to Flex the Leg for the Next Step

step, thus producing a natural motion for the manufactured leg. In solving this problem, the maker of the new leg strove to imitate, as near as possible, the muscles of the human limb. By means of elastic bands and a suspender-cord arrangement, he has succeeded to an amazing degree. When the weight of the body is shifted from the artificial member, as in walking, the suspender cords raise the leg and cause it to bend at the knee. The next action of these cords, together with an elastic band, straightens the leg again, so that it is ready to support the body on the next step.

MOUNTAIN IN PACIFIC OCEAN IS HUGE MASS OF SULPHUR

The recent rediscovery of the great sulphur mountain of Vanua Lava, an island situated some 900 miles due east from Australia, which consists almost entirely of sulphur, brings into prominence the possibilities of exploiting the natural fertilizer beds of the islands of Nauru and Ocean, in the southern Pacific Ocean. These islands are famous for their extensive and rich deposits of phosphate of lime, and this, together with sulphur, forms the necessary combination for producing a soluble, or powdered, superphosphate, which is sold to farmers for a fer-

tilizer. Thus it appears that, as sulphur is the special agent needed to change phosphate rock to a soluble state, and since the islands containing the essential ingredients are comparatively close neighbors, as distances in the Pacific go, the economical production of fertilizer will be an assured possibility.

AMATEUR RADIO MESSAGES CROSS ATLANTIC OCEAN

In a recent ten-day experiment, by the American Radio Relay League, 26 amateur wireless stations in the United States succeeded in sending test messages across the Atlantic Ocean. These messages were officially received by Paul Godley, the representative of the league in Glasgow, Scotland. A message was received at the league headquarters, from P. R. Coursey, editor of an English radio magazine, stating that some of the test messages had been picked up by a number of British amateur receiving stations.

GASOLINE REMOVES ASPHALT FROM CONCRETE BY BURNING

Many a workman might have been saved much labor removing asphalt from joints between concrete slabs, or from concrete surfaces, with tools, if he had known it could be burned off by pouring gasoline on it and setting fire to it. Though this method requires caution, it is much quicker and cheaper than the old method, and does not damage the concrete if properly applied. A continuous fire, which might overheat and damage the concrete, should be avoided. It is better to make short, repeated applications of the gasoline. Great care must be taken, in inclosed reservoirs, to provide plenty of ventilation and to avoid setting fire to wooden roofs.



Photo from Waterproof Paint Co., Lancaster, Calif.

78 74
 521 W. Monroe
 Commerce Reports 12/19/21

8003

P. 1

7698

**ISLAND WIRELESS STATION
NORWAY'S WEATHER OUTPOST**

On the little arctic island known as Jan Mayen Land, about 71° north latitude, there is a wireless station which serves as a weather outpost for the coast of Norway, 500 to 600 miles to the east and southeast. The island is only 34 miles long and 9 miles wide, its mean temperature is about 4° below freezing, and its weather is exceedingly stormy. Only once, until recently, and then only for a year, has anyone ever remained on it. Because it lies in the direct path of violent storms, which often strike the coast of Norway suddenly and with great

**TABLE AND BED ARE COMBINED
IN "EFFICIENCY" FURNITURE**

Every inch counts in the modern "efficiency apartments," and an aid in the saving of valuable space has appeared in the production of



Right: Combined Table and Bed Shown as Ordinary Library Table. Left: Elevating the Table Top Preparatory to Making Up the Bed

Below: Combined Table and Bed with Mattress Unfolded and Bed Made Up. The Articles on Top of the Table are Seen Undisturbed

damage to shipping, the idea occurred to Norwegian meteorologists to establish a radio station there. An appropriation of \$10,000 was secured and the difficult task of establishing the station accomplished last summer. Since then regular reports, and warnings of storms, have been sent from the Jan Mayen. Once a violent storm blew down the masts and the reports were interrupted, but in a few weeks they had been replaced and the reports were resumed.

a new combined table and bed. In appearance, the table resembles the ordinary four-legged library type, but inside of the legs are a second set of legs which can be raised by means of a crank, thus elevating the top of the table. A peculiar advantage of this innovation lies in the fact that the table need not be cleared off before the top is elevated, as the mechanism simply causes the whole to rise. With the top raised out of the way, the exposed mattress is then unfolded.

11/25/21

186
7883

TOWER WILL COMMEMORATE FAMOUS IRISH DIVISION

Dedicated to the memory of the men of Ulster, who, as members of the famous 36th division, recruited in that province



Tower Dedicated to the 36th (Ulster) Division, on Thierval Ridge, Where Some 5,000 of the Ulstermen were Killed or Wounded in One Day

of Ireland, fell in the first Somme offensive, a stately tower, one of the most imposing monuments on the western front, was unveiled November 19, last year, by Field Marshal Sir Henry Wilson, Ulster's most illustrious soldier. The memorial tower is erected on Thierval Ridge, where, as the division rushed to the capture of the successive objectives, some 5,000 of its men were left dead, dying, or wounded on the field that memorable day of the first battle of the Somme. It was announced that this site on the Thierval slope will be preserved forever intact, with the German trenches, the barbed wire, and all the wreckage of battle.

VAULT FLOORS ARE LOWERED AND RAISED BY MOTORS

In several great steel vaults, where safety-deposit boxes are kept, the use of electricity is employed in the preparations for opening the vault door. The vaults are so built with respect to the

floors, that it is impossible to open the huge circular time-clock doors without the shifting of a floor section directly in front. A section in the shape of a half circle, and large enough to accommodate the arc of the swinging door, is lowered by means of electric motors. After the massive door is swung open, the motors are again operated to bring the floor back into place, and the same operation is repeated when the door is closed.

GROWING FERNS IN FLORIDA FOR NORTHERN MARKETS

Just outside of Leesburg, Fla., are two large ferneries where many of the ferns sold in northern cities are grown. Since frosts are unknown here, ferns can be raised outdoors throughout the year. It is necessary, however, to protect them against the sun, and for this purpose overhead latticework is built, often covering three or four acres. Its cost is one of the chief expenses. When ferns are to be shipped they are packed in Spanish moss and sent by express to insure fresh delivery. The business is a profitable one, and brings thousands of dollars into the town every year.



A Florida Fernery, in Which the Plants are Protected against the Sun by These Shelters, Built of Latticework and Covering Several Acres

Electrical World
12/10/21

Copyrighted material
Cm. Loyal F. Esarris
Leesburg, Fla.

COMMENT AND REVIEW

[These pages were printed December 27, 1921]

SSOME 150 years ago a few shiploads of daring pioneers left the Island of Minorca and settled on the east coast of Florida in and around what is now New Smyrna. They cleared the jungle, dug many miles of huge drainage ditches, and planted the land to sugar cane. Several of their sugar mills for crushing the cane, made in Spain of an iron of wonderful endurance, still remain in a fair state of preservation and are today objects of wonder to winter tourists. The Minorcan colony, struggling against the forces of nature and hostile neighbors, worked with tools of very primitive character. In fact they had absolutely nothing corresponding to what we know as labor-saving devices. Soon hundreds of acres of most luxuriant growth

of sugar cane swayed to the fanning of the trade winds. Just as a rich reward was almost in their hands, a series of terrible misfortunes came to pass through cruel enemies, and very few escaped to tell the tale. Nature, as though jealous at the intrusion, quickly restored the state of dense jungle, until there remained little trace of the once prosperous colony except the sugar mills and the great drainage ditches, which latter are today in a remarkable state of preservation and still doing useful service. During the past decade attempts, in a small way only, have been made to raise sugar cane in another part of the state.

*The
Old
Way*



TODAY, in startling contrast to the comparatively childish efforts of the Minorcans, vast sugar plantations, planned eventually to occupy hundreds of thousands of acres, are being laid out in the fertile stretches of the Florida Everglades, whose soil, harvesting for untold centuries a rich tropical growth, possesses a fertility which rivals the valleys of the Euphrates and Nile when at their best. Instead of ax and shovel, mammoth tractors, drawing every kind of modern labor-saving machinery, move in solid phalanxes, 150 of them, and at each setting of the sun 60 acres more have been cleared, plowed, harrowed, and made ready for the army of planters who follow. In one year or a little more, the hard roads and tramways will bring

*The
Modern
Way*

in long trains of wagons and cars loaded with sugar cane to the crushing mills, from which the sweet juice will flow night and day through a system of pipe lines to the refinery, work on which has already begun. Inasmuch as the sugar cane of the Everglades is said to rank, both in percentage of yield and quality, with the best Cuban cane, the industry may before many years produce a very large share of our sugar requirements, and at a minimum cost, as freedom from frost makes replanting necessary only once in five or six years.

What a contrast between the heroic yet puny efforts of the Minorcans and the irresistible, highly organized, powerful mechanical forces of today, which know neither the pangs of hunger nor the fatigue of tired muscles; and what better illustrates the mechanical progress of recent years, and what the inventor has accomplished to lighten heavy human loads?

While speaking of Florida it is interesting to note that indications of oil in at least one portion of the state are sufficient to warrant drilling, which has already commenced. Whether or not oil is found, Florida will one day be among the most prosperous of our states, with its ability to produce a great variety of grains, fruits, and winter vegetables; its rapidly increasing live-stock interests of pork and beef; its oysters and fish; its abundance of artesian water, and a climate, skies, and sea waters which fairly rival the Mediterranean.



IT cannot be other than a tremendous satisfaction to Marconi to have lived to witness the universal use of his discovery of how to hurl a message through air across oceans to ships and over continents to cities, thousands of miles apart. What hardly 20 years ago was almost a miracle, to be performed only by experts and scientists, has now become so easily done and understood, that some 60,000 amateurs, chiefly boys in their "teens," with antennæ raised from barn or ridgepole, daily and nightly pick up messages from points thousands of miles distant, or listen to lectures, concerts, and grand opera delivered far from their homes. While it yet seems a long way off, is it unlikely

*Progress
in
Wireless*

that before another 20 years shall have passed we may be provided with instruments which anyone can conveniently carry in his pocket, and so converse with home or office while walking from one to the other?

The electrical department of the city of Chicago has announced completion of plans for the installation of wireless telephones which will enable headquarters to communicate with police rifle squads, police and fire boxes, and police and fire-engine stations within a radius of 30 miles.

In telephoning over metallic circuits the important departure just now is the beginning of the end of the career of that efficient and much abused personage—the telephone girl. The start is already made, and as soon as the enormous task can be accomplished, telephone exchanges, even the largest, will require but a few attendants, and these mechanics.



THERE can be little argument over the fact that it takes longer to build up than to tear down, and that in the case of human agencies it is a very much more difficult job. Even in the most remote hamlet few have failed to realize to what

Improved Mail Service

depths of inefficiency our once so greatly admired national postal system had sunk: letters which once had seldom failed to pass from one part of a city to another part in three hours, at last took three working days, or more, to get through. When the previous postmaster-general finally relegated practically all second-class matter to the realm of coal and corn, and sent it like them by freight train, it seemed as if the last prop had been removed, and the morale of the whole army of postal employes went down at

the same time. It has been no easy task to rebuild the once fine spirit of the men, especially after large numbers of the best had been forced to take up other occupations, and it is therefore a great source of satisfaction that already we can all see good results and a vastly improved service.

Among the many needed reforms, perhaps none is more directly felt and appreciated by the millions than the restoration of newspapers and magazines to carriage in mail cars on mail trains instead of box cars on freight trains. No longer the wait of two and three days until enough accumulated to make a carload. Now it goes out promptly, and keeps going, instead of being sidetracked and forgotten, sometimes for weeks. Where a year ago one copy in each 150 of this magazine sent to mail subscribers was reported to us as not received, last month only one in each 1,500 failed to reach destination, which includes copies carelessly wrapped or whose wrappers were unavoidably torn in transit.* And what is really exasperating is, after having suffered several years with a most abominable service, that the present postmaster-general is actually able to rush the papers and magazines without increasing his force and still save \$268,000 a year of what the freight system cost. The letter service has shown a corresponding improvement, possibly even more so, and grateful readers and publishers alike say, "Thank you, Will Hays, P. M. G."



THAT there is a steady, even though somewhat slow, reaction toward the sales-tax idea cannot be denied. Secretary of the Treasury Mellon has now expressed himself as favoring a general sales tax with a continuation of the personal income

The Sales Tax

tax for the "rich." As no one, rich or poor, who has given the subject even moderate consideration, has asked or expected anything different, it ought to be worth the while of anyone whose income is over \$6,000 a year to inform himself about the sales tax. If his income is less than \$6,000 per year, it affects him only to the extent that where he is now "soaked" 23 per cent through indirect tax on what he buys, under a sales tax he would pay about 2½ per cent in the same indirect tax.

In some mysterious way the farmer and laboring man have been made to believe a sales tax would all come out of them, which, like Mark Twain's reported death as related by that beloved author, is "important if true."

A farmer puts the case like this: "A farmer sells a bushel of wheat and gets paid for a peck. The consumer pays for a bushel of wheat and gets a peck." Quite so, and the worst of it is, this condition is bound to continue with very little

abatement as long as the present system of taxation continues. Can anyone be surprised at sluggish sales and reluctant buyers when every retail purchase, from potatoes to penknives, imposes an average tax of 23 cents on the dollar? "When one week of unemployment costs the worker as much as he would pay for a 1-per-cent sales tax for a whole year, it is not difficult to say which he would prefer." And our present system of taxation is largely responsible for the blocking of the wheels of industry.



DO strikes really pay the strikers? How much would be your guess on what strikes cost in 1920? Our government, after carefully compiling the figures of wages lost in this country that year to men on strike, finds it to be \$13,000,000 for every working day, after allowing six national holidays and 52 Sundays. The total for the year is the stupendous sum of \$4,000,000,000, almost enough to run the government itself even in these times of expensive government.

*Cost
of
Strikes*

Four billion dollars lost in idleness, which might have been earned, spent on families and homes, and put in circulation!

The striker seems to take an inexplicable sense of independence in going on strike, but if those who have been indulging in the occupation of striking, or are thinking of doing so, would take a pencil and sit down to figure out the net result with their wives, they would then be in a better position to answer to themselves the somewhat essential question—"Does it pay?"

Strange how seldom a strike occurs where there is one employer and one employe!

H. H. WINDSOR

2957
NINETEEN SIGNATURES TO "FOUR-POWER TREATY"

Eighteen delegates signed the "Four-Power Treaty" which was adopted by the Conference for the Limitation of Armaments, but there are, in fact, 19 signatures to the act. The four delegates representing the United States, headed by Secretary Hughes, signed first. They were followed by the seven British delegates, headed by Arthur James Balfour, who signed twice, once for the United Kingdom of Great Britain and Ireland, and once for the Union of South Africa, the only division of the British Empire not having a special delegate; the three French delegates, led by René Viviani, and the four Japanese delegates, led by Baron Kato. Seals were first affixed to the document and each delegate touched his seal, when he signed, to indicate that it was official. The single original copy, written on parchment and bearing the official seals and signatures of the several delegates, will be preserved in the archives of the State Department of the United States, but a certified copy will go, for

ratification to each of the contracting governments. The entire subject matter of the treaty is printed in English and French.

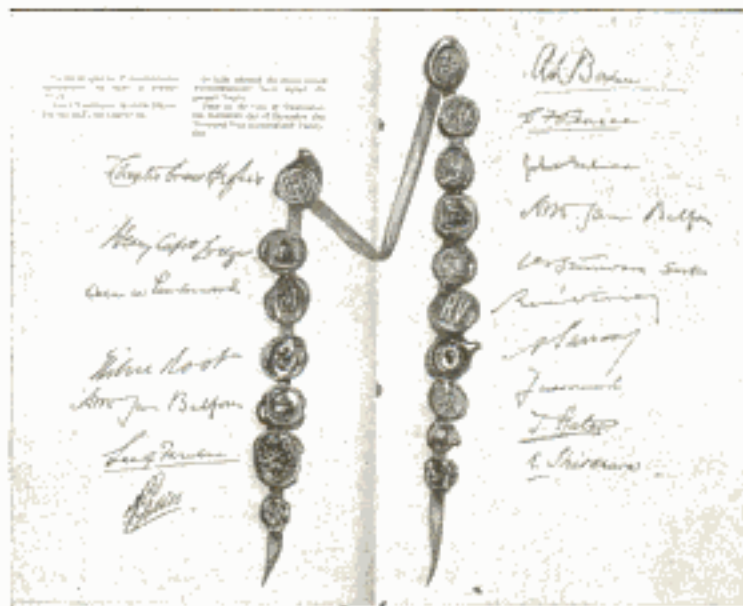

COPYRIGHT, UNDERWOOD & UNDERWOOD
Facsimile of a Page of the Treaty, Showing Signatures of the Delegates: Two Japanese Signed on the Next Page

According to earlier usage the document would have been printed in French and in each of the languages of the signatory powers.

190
7904

POPULAR MECHANICS

Illustrated London News Nov. 19/1921

PREHISTORIC HUMAN SKULL OF
NEW TYPE DISCOVERED

Another link in the development of the human race was recently discovered in the south-central portion of Africa. The open quarry excavation of the Broken Hill Mine, in northern Rhodesia, contains what is known as "Bone Cave." In this cave many tons of bones have been discovered. These included bones of many different kinds of animals, but none

represents a more advanced stage of development. The scientists of the British Museum hope, with more thorough study, to determine its exact place in the development of the race.

7975
NEW STRATEGIES EMPLOYED
IN WAR ON BACTERIA

In years past, great stress has been placed on the bacteria which are responsible for disease, and attempts to reduce human ills were largely made by trying to destroy the organism which produced them. Recently the tendency has been to combat disease germs not so much by efforts to eliminate them entirely by direct means, which is a matter of extraordinary difficulty, but by making conditions unfavorable for their growth, as illustrated in part by the vaccines and antitoxins which are coming more and more into use.



The Broken Hill Mine in Northern Rhodesia: The Small Circle Marks the Spot Where the Prehistoric Skull was Found, When the Open Quarry Work Uncovered the End of "Bone Cave." In the Large Circle the Skull is Shown in the Position in Which It was Discovered

of extinct species or of human beings. Recently, at the extreme end of the cave, one human skull was found. Some portions of the skeleton were also recovered, but most of the bones were broken to pieces by the native laborers, who were ignorant of their scientific importance. The skull, which has been presented to the British Museum by the mine owners, is different from any prehistoric skull previously found. Though it resembles a southern European type, it undoubtedly

It has been found that stone masons, under certain conditions, appear somewhat susceptible to consumption on account of silica dust inhaled reaching the lungs. Recently it has been determined that this dust does not operate directly as an irritant on the tissues, as was first assumed, but appears to act as a sort of fertilizer for the bacteria, making it easy for them to flourish, once they gain access.

Attention now is being directed toward finding repellent materials of satisfactory character. It is well known that immunity from diseases, or capacity to resist or render them mild in form, apparently comes from the ability of the body, in course of time and acting through several generations, to elaborate or produce these counteracting or, one might say, defertilizing substances. In the future, further understanding of the problem may permit the laboratory to aid man more directly by producing these substances as they are needed to reduce old diseases or to combat new ones.

and E. A. Beringer, 1521 Oak St. N. W. Washington, D. C.

CLEVER ENGINEERING SEEN IN OPENING NEW BRIDGE



COPYRIGHT, INTERNATIONAL

Above: The New Double-Deck Bascule Bridge in Use after being Lowered into the Opening Cut in the Old Center-Pier Bridge. Traffic was Closed for Only 48 Hours, While the Cut was being Made. Left: The South Section of the New Bridge being Lowered into Place. At Each Side the Edges of the Old Bridge, Which Also Was a Double-Deck Structure, can be Seen, Showing How It was Cut Away to Make Room for the New Structure, After It had First been Swung Open

PHOTO, UNDERWOOD & UNDERWOOD

The opening of the new Wells Street bridge, by which one of the elevated railroads of Chicago crosses the main branch of the Chicago River, marks the completion of what is considered a particularly clever piece of engineering. This new double-deck bascule bridge replaces an old structure of the center-pier type. The two sections of the new bridge were built standing upright, over and around the ends of the old structure, without interrupting traffic until they were fully completed. The old bridge, which was also double-decked, was swung open, and a section cut from its center with oxyacetylene torches. The new bridge was then

lowered into the opening, and traffic was resumed after a delay of only 48 hours. The wrecking and hauling away, in barges, of the old bridge then proceeded without interfering with traffic. The new structure, of the most modern type, weighs 5,000 tons and was built at a cost of approximately 1,000,000 dollars.

❑ Snow, in engine terminals of Canadian railroads, is being satisfactorily disposed of by the use of steam coils in the turntable pits. This not only keeps the turntables clear, but makes the pits available as snow melters. Snow is thrown into the pits, melted, and carried off by the drains.

192
 7815

**WELDING-TORCH EQUIPMENT
 CONVENIENTLY PORTABLE**

Specially adapted for use in garages and small machine shops, a new welding torch and carrying-case outfit has been placed on the market. It is a complete



Complete Oxyacetylene-Welding Equipment Packed in Convenient Portable Fiber Case with Handle and Metal Hinges and Fasteners

oxyacetylene-welding equipment that can be packed in a fiber case, with a handle that makes it conveniently portable. The equipment consists of one torch, three extension tubes, five welding tips, one decarbonizing tube, one oxygen and one acetylene regulator, with 12 ft. of hose for each, one spark lighter, one pair of colored glasses, one torch, and one regulator wrench.

4993
**SORGHUM SIRUP MANUFACTURED
 BY IMPROVED METHOD**

Raising of pedigreed cane, improvement of chemical operations, and a general cheapening of the processes of manufacture, are three features that have been introduced into the production of sorghum sirup. A cleaning machine has been developed, that does away entirely with handwork in the harvesting and cleaning of cane, and is said to have cut the labor cost nearly in half. The waste from the cane is now constantly fed into the fire boxes in these plants, and constitutes 85 per cent of the fuel used.

New York Times 12/15/21

*Dr. J. W. Williams
 University of Minnesota
 Dr. Paul
 Minn.*

6590

CABLE-FERRY SYSTEM FLOATS ICE ACROSS RIVER

During open winters, men harvesting ice on the rivers and lakes of the northern states are driven to many expedients to obtain the ice. In many places only the quiet waters of rivers freeze, leaving the

cable is stretched from the shore across the open channel to the ice field, about half a mile away and slightly upstream. Ice is cut in cakes about 40 ft. square. A piece of plank, having a length of rope tied to it, is dropped through a hole in the cake, and the other end of the rope is attached to a pulley mounted horizontally on a wooden block, which is thus anchored to the ice floe. The ferry cable runs over this



An Ice Cake being Carried along the Ferry Cable, Using the Current to Transport the Ice across the Open Channel

main channel open, and it is difficult to get the ice across the channel to the shore. At an Iowa town, where ice is cut extensively for the railroads and inland communities, a cable-ferry system is used. The



The Block and Pulley, over Which the Cable Runs, are Anchored to the Ice by a Rope and Plank, Dropped through a Hole in the Cake

*Arch. Florence J. Clark
 Mc Carlgar, Iowa*

Franklin Railway
Supply Co, Chicago
333 Michigan

pulley, and the pressure of the current against the ice cake forces it along the cable to the shore, where it is pulled in by hand.

and even specially prepared booths. The booths were light boxes with a covering of heavy canvas, much resembling a portable steam-bath outfit. Inside of the

7558

AUTOMATIC FIRE DOOR FOR LOCOMOTIVES

Locomotive fire doors, whether automatic or not, interfere, when they are opened, to some extent with some of the appliances behind the boiler head. An improved fire door that occupies exactly the same space whether opened or closed, consists of two semirotating door plates, an operating cylinder with pedal for power operation, and a grip for manual operation. In operating it by power, pressure on the pedal admits air to the cylinder, moving its piston upward, which by a link connection rotates the upper door on its pivots and opens it. By means of a bell crank and link, the movement of the upper door is communicated to the lower one reversely, rotating it to



These Men, Bundled in Robes, Blankets, and with a Lighted Lantern beneath Their Chairs, are Waiting for the Opening of the Land-Office Registry

booth was a chair, with a lighted lantern underneath, the heat from which kept the men from freezing while they slept in their seats.

7848

LOCKING DEVICE FOR RADIATOR CAP AND THERMOMETER

By using a new locking device, the danger of losing the auto radiator cap and thermometer, or of forgetting the key which locks them, may be avoided. A collar is riveted about the inlet of the radiator. A slotted arm curves up from the collar, and a pin, terminating in a knob, passes through the slot. The other end of the pin is formed into a ring, within which the radiator cap revolves. The cap

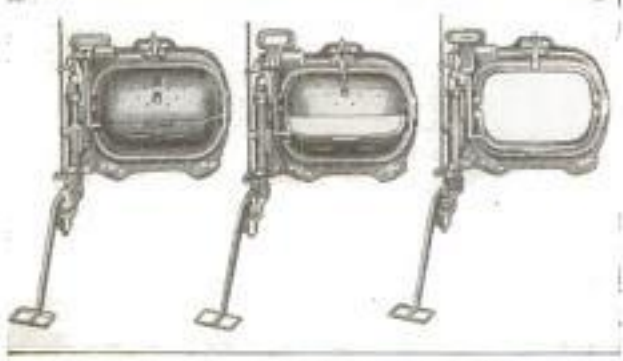

Locomotive Fire Door That Opens by Pressure on Pedal, Which Admits Air to the Operating Cylinder, Moving the Piston Upward: Link Connections Open Upper and Lower Door Plates

the open position also. When the pressure is removed from the pedal, the doors close automatically, and are cushioned by the air so that they do not slam.

9987

SIT THREE WEEKS IN COLD TO REGISTER FOR LAND

Three weeks of patiently sitting in the bitter cold of Calgary, Can., was the trying experience of two land seekers who were determined to be the first to register for the valuable oil lands recently thrown open by the government. The usual custom of the land office is "first come—first served," hence the desire to head the long line, which always forms on an occasion of this kind, in order to get the choice of the land. The two men who sat exposed to the elements for nearly a month, were adequately provided with blankets, robes,

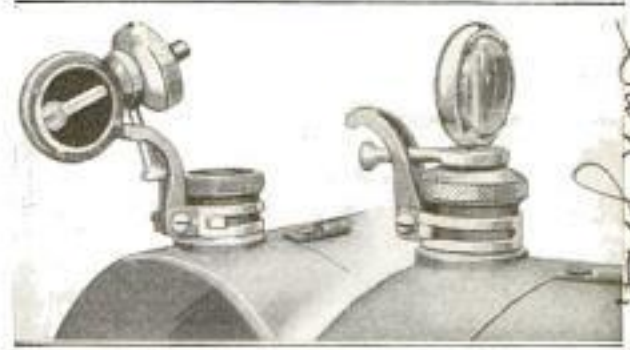

Left: Radiator Cap Unscrewed and Tilted Up, but Still Attached to Machine. Right: Cap in Place

is simply unscrewed, and the whole tilted up when the radiator is to be filled.

See Aug. 1924 244
A new paper-backed photographic film has been introduced in Germany. It is cheaper than celluloid film, but as good, and is particularly suited for X-ray work.

E. W. Allen, 14 Empress's Bldg. San Jose, Calif.

Carl C. J. Henderson, Earlhart Business College, Calgary, Alberta, Canada

7791
NEW FRENCH CAR HAS LOCKER
IN THE REAR OF BODY

80/0
BRONZE FOR WEATHERPROOF-
ING IN BRIDGE CONSTRUCTION

One of the latest-model French auto-
mobiles is provided with doors in the

Bronze as a substitute for paint for
preserving structural steel, particularly
where it is exposed to the weather
as in a bridge, has the advantage
of being a permanent weather-
proofing material, and, therefore,
of avoiding the cost of repeated
renewals. For this reason bronze
will be used as a protective cover-
ing for nearly all the steel in
the Hudson River suspension
bridge, the \$100,000,000 proposed
structure that is to connect Man-
hattan Island with the New Jer-
sey shore. It will be the first
time that this method of weather-
proofing has been applied in a
structure of anything like the
immensity of this suspension
bridge, with a central span of
3,240 ft. and approaches of 1,650
ft. each. It is estimated that it
will result in an annual saving of
\$400,000 in the upkeep of the
structure. Each of the four
trussed cable systems from which
the bridge is to be suspended
will be completely inclosed in a

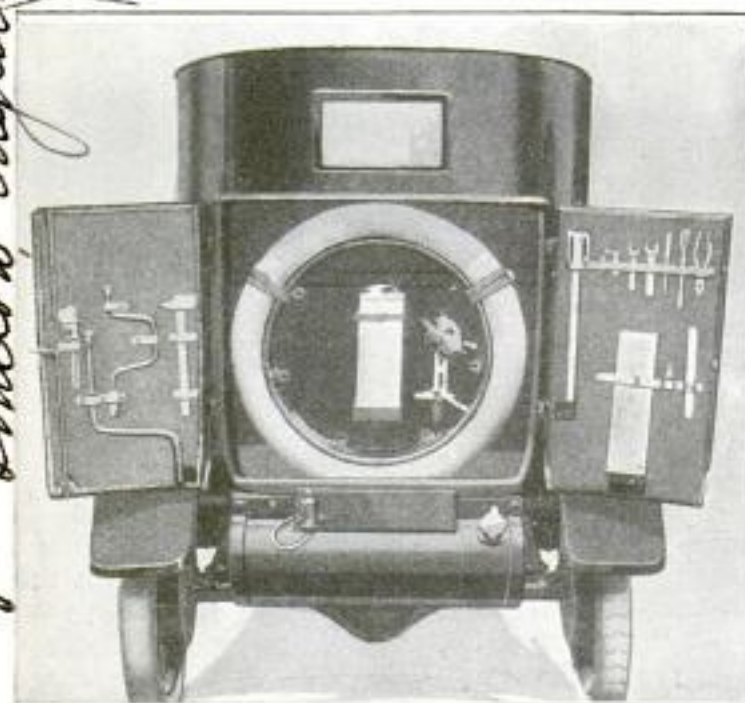

Rear Locker, for Tools and Extra Parts, in New French Machine:
The Doors Close, Forming a Neatly Finished Back

back of the body which, when swung
open, give access to a locker. Inside
the locker is space for carrying a spare
rim and tire, cans of oil, an emergency
supply of gasoline, tools, and extra
parts. When closed, it presents a neat
appearance with all the equipment
out of sight, but readily accessible
if needed for emergency repairs
when on the road.

continuous bronze gallery, provided
with enough doors to permit occa-
sional inspection. Similar methods
will be adopted in other parts of
the bridge where the steel is ex-
posed to the weather.

Improved accuracy of American-made
weights is shown by recent tests,
only seven per cent failing to meet
requirements.

7769
PEACE-TIME PERILS OF SUBMARINE SERVICE

To the submarine sailor, as to the air-
man, there are perils of peace when
there is no war. From their nature,
the least mishap in either endan-
gers the lives of the human occu-
pants. In the case of the subma-
rine this has been strikingly exem-
plified by two recent accidents. On
September 26, the "R-6" suddenly
filled with water and sank in less
than two minutes, while moored
alongside the tender "Camden,"
off Los Angeles. Fortunately, most
of the crew were at supper aboard
the tender, and only two lives were
lost. There then arose the problem
of raising the submarine. As the
depth was only 35 ft., it was easy
for divers to work on the sunken
hull, and this was done from a
40-ft. tug that was anchored at
the spot. After the hull had been
made air and water-tight,

pumps on the tug succeeded in
replacing the water in the hull
with air. Fifteen days after the
sinking this was accomplished,
and the giant submersible then
slowly rose to the surface, where
it finally rested on an even keel.

The other mishap was to the
"S-48," off Bridgeport, Conn.,
when this submarine was submer-
ged for 12 hours before the 41
members of the crew, after blowing
the water out of some of the ballast
tanks, succeeded in raising the
vessel's bow above the surface so
that they were able to escape
through a torpedo tube. Then,
perched upon the exposed bow,
they waited for 10 hours, until
finally they attracted the atten-
tion of a passing steamer, and
were picked up and taken ashore.
Only three of them required
medical attention.

Elect. Agency, 158 A. Lee St., E. C.
London, England.

Emb. Frank B. Howe
412 Mason Opera House,
So
any
chil

accidents

17769

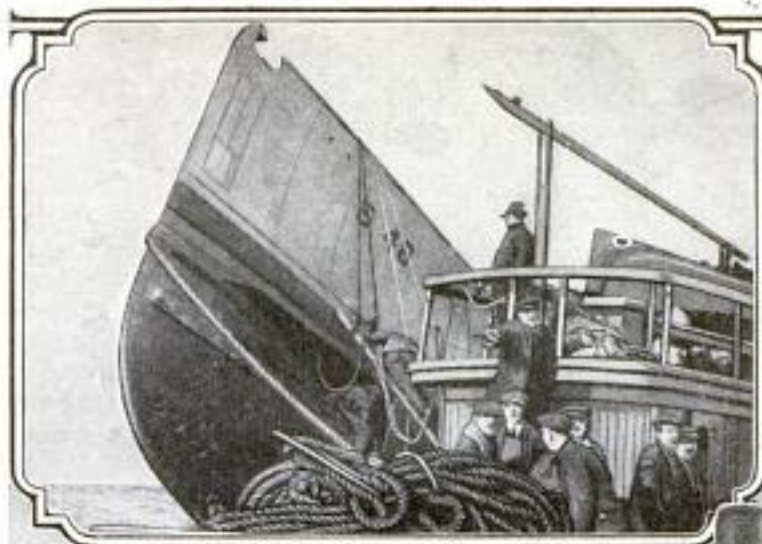

Below: U. S. Submarine "S-48," Sunk near Bridgeport, Connecticut. The Photo Shows the Exposed Bow of the Submarine from Which the 41 Members of the Crew Escaped through a Torpedo Tube, and were Later Rescued by the Tug Shown Alongside. Left: Wrecking Tug That Rescued the Crew of the Submarine Shown Lashed to the Exposed Bow. At the Time the Photo was Taken a Member of the Crew was Entering the Torpedo Tube through Which the Trapped Crew of the Submarine Escaped

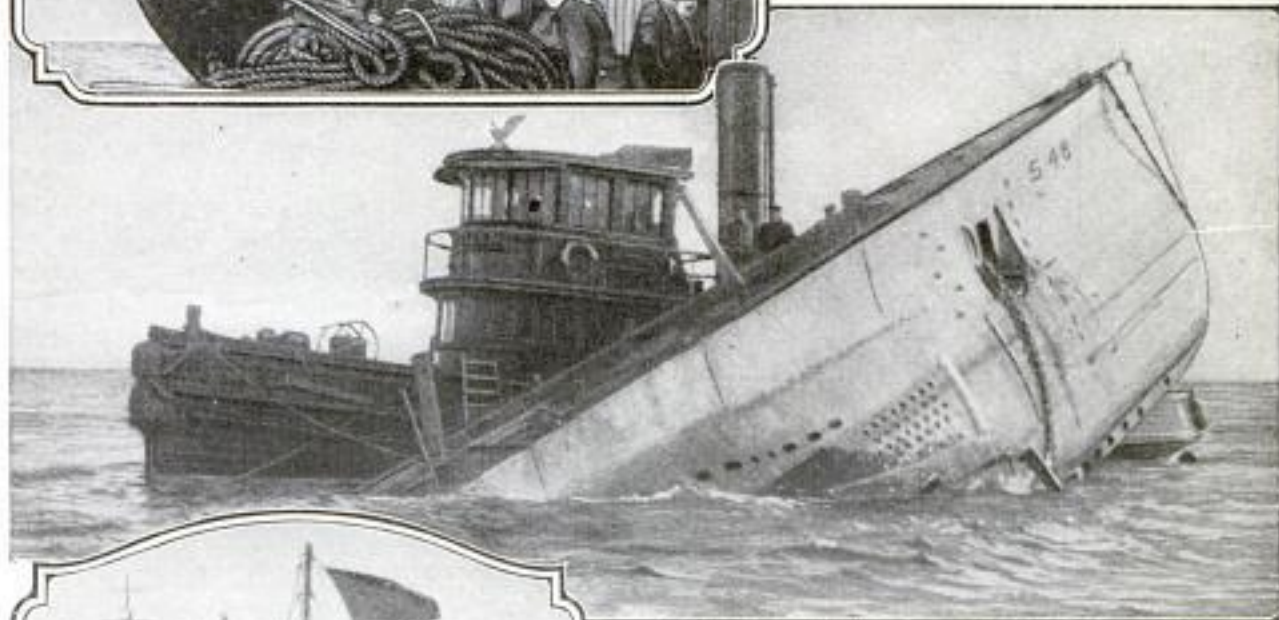

Left: In the Foreground Is the Small Tug Engaged in Pumping the Water Out of the U. S. Submarine "R-6" Which Sank Suddenly While Moored alongside the Submarine Tender "Camden." Seen in the Background, Behind the "Camden" Are Other R-Type Submarines. It Took Fifteen Days to Raise the "R-6." Only Two of the Crew Were on Board When It Sank

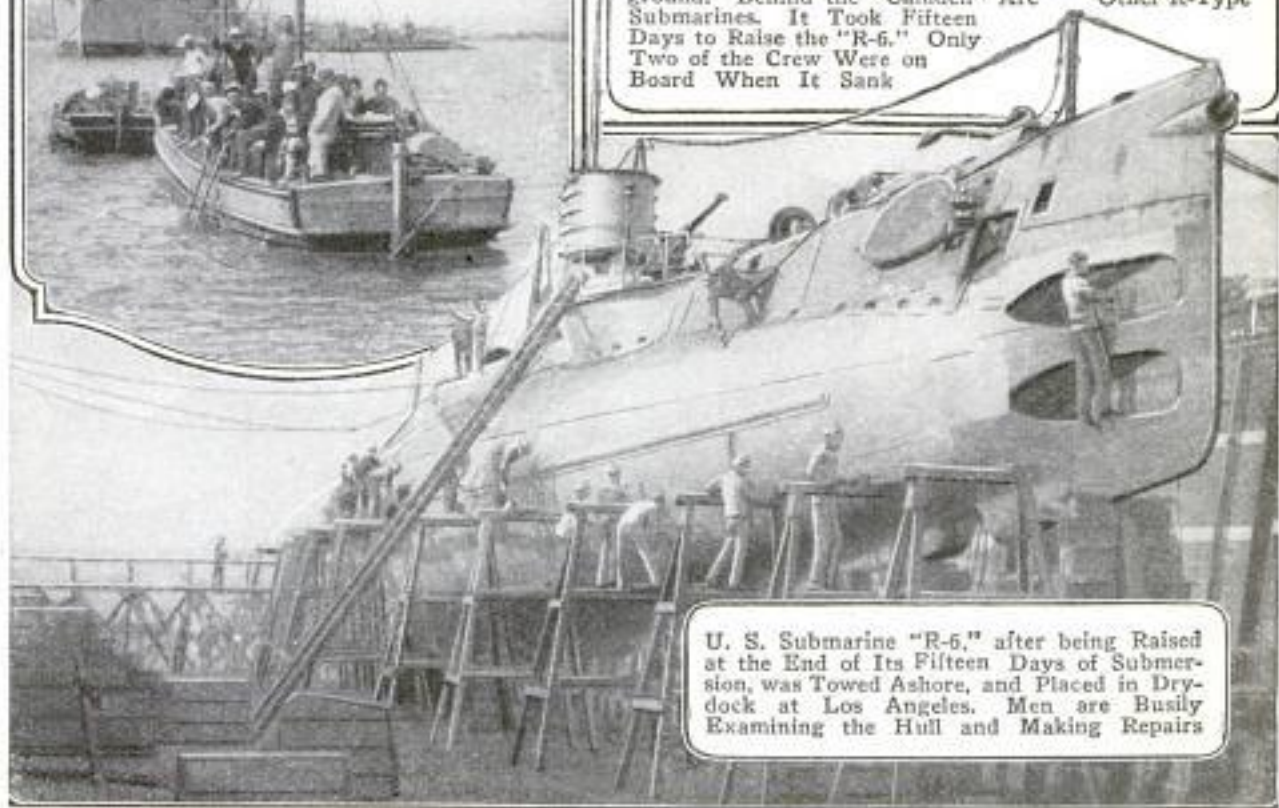

U. S. Submarine "R-6," after being Raised at the End of Its Fifteen Days of Submersion, was Towed Ashore, and Placed in Dry-dock at Los Angeles. Men are Busily Examining the Hull and Making Repairs

W. B. Hasbun Co
 7927 27 & Desplaines
 CHICAGO
 POPULAR MECHANICS
 8024

*Dept. of
 Commerce
 Washington
 D.C.*

MACHINE FOR CUTTING MORTAR FROM JOINTS OF BRICKWORK

IMPORTS OF EGYPTIAN COTTON CARRIED IN AMERICAN SHIPS

A special machine was recently placed on the market which is intended for cutting out the mortar between bricks. It

Exports of Egyptian long-staple cotton to the United States have always been very considerable, exceeded only by those to the United Kingdom. Egypt is still suffering from the effects of the cotton crisis, during which, in the year 1920, there was a decline of price, at normal exchange rates, from \$1.60 to 20 cents per pound. A partial cause of this was a corresponding decrease in the amount of cotton exported, but in spite of that there were shipped to the United States during the first nine months of 1921, over 42,000,000 lb. of cotton. Up to the present, the carrying of these heavy shipments has been a monopoly enjoyed by British liners, and it is therefore gratifying to learn that, on Nov. 16, 1921, a contract was signed between various British steamship companies and the Emergency Fleet Corporation, by the terms of which 50 per cent of all cotton shipments from Alexandria to the United States, whether consigned directly or via British ports, may be carried in American bottoms.



A Workman Removing Mortar between the Bricks of a Wall with the New Machine: Goggles Protect His Eyes from Flying Bits of Mortar

consists of a small wheel which is operated at 3,500 r.p.m. by a flexible shaft from a 1/4-hp. electric motor. A case, partly covering the wheel, extends down to form a handle, and a safety guard is provided to protect the operator's hands from flying bits of mortar. Wheels of various thicknesses are supplied so that they may be changed to fit layers of mortar of different width.

7725
CONVEYOR UNLOADS AND PILES STONE FOR STORAGE

An original means of storing stone for future use in concrete work, in connection with highway construction, has been devised by an eastern contractor. A conveyor that carries the stone from the loaded car to the storage pile is supported on cribbing made of railroad ties. This cribbing is added to as the pile of stone increases in height. It is claimed that it is possible to pile about 50 tons of stone an hour in this manner.



Conveyor for Unloading and Storing Stone for Future Use in Highway-Construction Work: The Conveyor is Supported on Cribbing Made of Railroad Ties Which are Added To as the Height of the Stone Pile Increases. It is Claimed That 50 Tons of Stone an Hour can be Piled in This Manner

Used by Winston & Co. Hughesville, Pa.

7469

Capt. H. E. Thomas

911 Munchley Ave.

Portland Ore



One Hundred People, the Entire Population of Fort Rock Valley, Oregon, Which Covers 100 Square Miles, Turned Out to the Opening of the Well Which Proved the Desert Valley can be Made a Garden Spot

ABANDONED SETTLEMENT RECLAIMED BY WELLS

By HORACE E. THOMAS

DEVELOPMENT of a great arid waste that was being abandoned to the sagebrush and the jackrabbit is foreshadowed by an experiment that has been conducted by the state of Oregon. Irrigation from wells is expected to redeem vast stretches of desolate and barren plains. The first well has been completed with money appropriated by the state legislature, and geologists employed to make a survey declare that the whole Fort Rock basin of central Oregon, in which the experiment was made, is underlaid by an abundant supply of water.

When a railroad was built into central Oregon in 1910 there was a great rush of homesteaders attracted by the opportunity. Cabins sprang up over the prairie, and the settlers began to till the soil. But in the Fort Rock Valley, a few seasons completely chilled the enthusiasm with which they had entered upon their pioneering. So parched was the land, so small the rainfall, that even approved methods of dry farming failed to wrest a living from the reluctant earth. No feasible method of irrigation was available, and the discouraged settlers moved away, most of them having lost live stock and other possessions they brought with them. Soon the valley became a district of abandoned ranches, with only a handful of people left—those who were too poor to move away, and a few who still believed in its agricultural possibilities.

So distressing was the situation, that an appeal for help to the state legislature gained an appropriation of \$10,000 to determine whether the land might be irrigated from wells. It was hoped to find an artesian supply, but this was not realized. There was tapped, however, a great reservoir of water at a depth of about 100 ft. below the surface. It lies in a basin formed by layers of hard basaltic lava, and is practically inexhaustible.

When the first well was completed, the people in that part of Oregon were invited to witness a demonstration. There was present the entire population of the Fort Rock Valley, 100 persons, living in a district of 100 square miles, and others from near-by valleys. A turbine pump driven by a tractor raised water at the rate of 600 to 800 gal. a minute. In the first few minutes the surface of the water in the well fell slightly. Then it remained stationary during the six hours that the pumping continued. Although the well was drilled to a depth of 220 ft., the water level was only 25 ft. below the ground. At the average flow of 700 gal. a minute, the well will supply sufficient water to irrigate 200 acres of land and transform it from a barren desert into a garden.

The state authorities who conducted the experiment pronounce it a success in every particular. Sufficient money remains of the appropriation to bore two additional wells, which will be located in

Located in Lake County.

other parts of the valley to prove that the supply is uniform. Then the situation will be left to the resources of the ranchers.

It is expected that many more wells will be sunk and that the desert will be made to bloom, just as it has elsewhere where

gravity irrigating systems have been installed. A day is looked forward to when the deserted farms will be rehabilitated and the owners, freed of the discouragement that drove them away, will return with new hope and confidence in the land that once failed them.

9746
X-RAY TUBES EXPERIMENTALLY OPERATED AT 300,000 VOLTS

Development of X-ray apparatus has reached a more advanced stage in this country than most people imagine. Re-

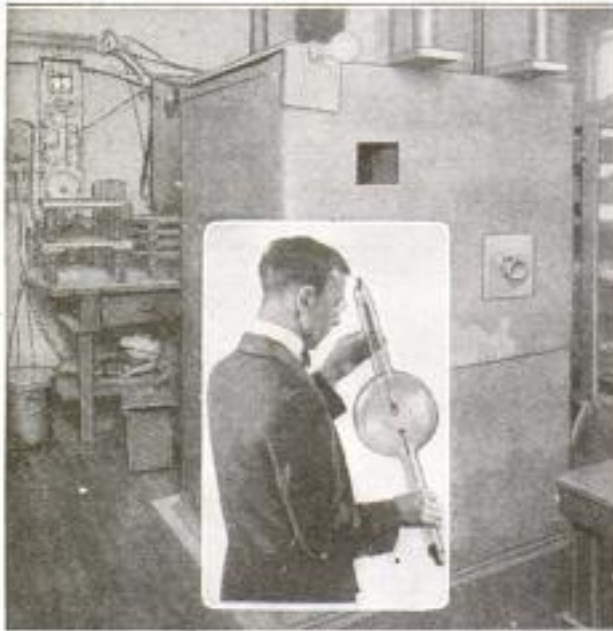

Laboratory Containing Lead-Lined Cabinet for Testing High-Power X-Ray Tubes: The Insert Shows One of the Recently Built 300,000-Volt Tubes

cently X-ray tubes have been built which operate experimentally at 300,000 volts. These are among the highest-power tubes ever constructed. The test of these instruments is a delicate and dangerous task. In conducting the test, the operator stands within a lead-inclosed cabinet from which he can observe the behavior of the tube.

8013
RECORD OF POWER RESOURCES KEPT BY WAR DEPARTMENT

As a war-preparedness measure, the engineering division of the War Department has decided to compile and maintain an inventory of all available electric-power resources of the whole United States. This will be done by the cooperation of all the power-producing concerns in the country, who will furnish the engineers of the War Department with information of the maximum output which

can be maintained by each of their plants, and of the power uses, and the needs of the large power consumers, in each district. It will also be ascertained to what extent each district is surveyed for development of increased power resources, so that the government will know the best means of developing these resources, and of administering the distribution of power in case of war.

7592
INSTRUMENT UPON DASHBOARD GIVES WARNINGS TO DRIVER

Located on the dash of an automobile, a recently developed instrument, by flashing red lights in three small windows, shows the driver when the oil in the crankcase gets too low for safety, when the water in the radiator is approaching the boiling point or the freezing point, and also when the level of gas in the reservoir reaches any minimum for which it is adjusted. Thus the auto driver is provided with a positive warning against burnt-out bearings, from lack of oil, against delay because of gas shortage, against overheating of the engine, and against damaging the radiator by frost.



Three Small Windows on Auto Dash, in Each of Which a Red Light Flashes, Warning the Driver of Lack of Oil, Gas Shortage, or Overheating of the Radiator

Electrical World
12/17/21

Selometer Mfg. Co.
Copyrighted material
Binghamton, N.Y.

General Electric & Schenectady N.Y.

Auto Care
N.Y.
Selometer Mfg. Co.
Binghamton, N.Y.

VENTILATION PROBLEMS SOLVED IN TEST TUNNEL

By S. R. WINTERS

*702 Electric
National Bank Bldg.*

IMMUNITY from ill effects of carbon monoxide—a poisonous constituent present in gases discharged by exhaust systems of automobiles and motor trucks—when operating vehicles through a tunnel, is assured if persons are not exposed to more than 4 parts of carbon monoxide to 10,000 parts of air. This is the outstanding conclusion of a series of tests completed on November 1, last year, in a test tunnel constructed by the Bureau of Mines in connection with its experimental mine at Bruceton, Pa. Coöperating with the New York and New Jersey State Bridge commissions, the bureau built an experimental tunnel to study ventilation problems when au-

tomobiles operate underground. The results of the investigation are particularly applicable to the regulation of air ade-



Air-Sampling and Temperature-Measuring Station at Entrance to Experimental Tunnel: Forty-Eight Samples from Different Parts of the Tunnel are Taken to This Station for Testing. Temperatures in All Parts of the Tunnel are Measured

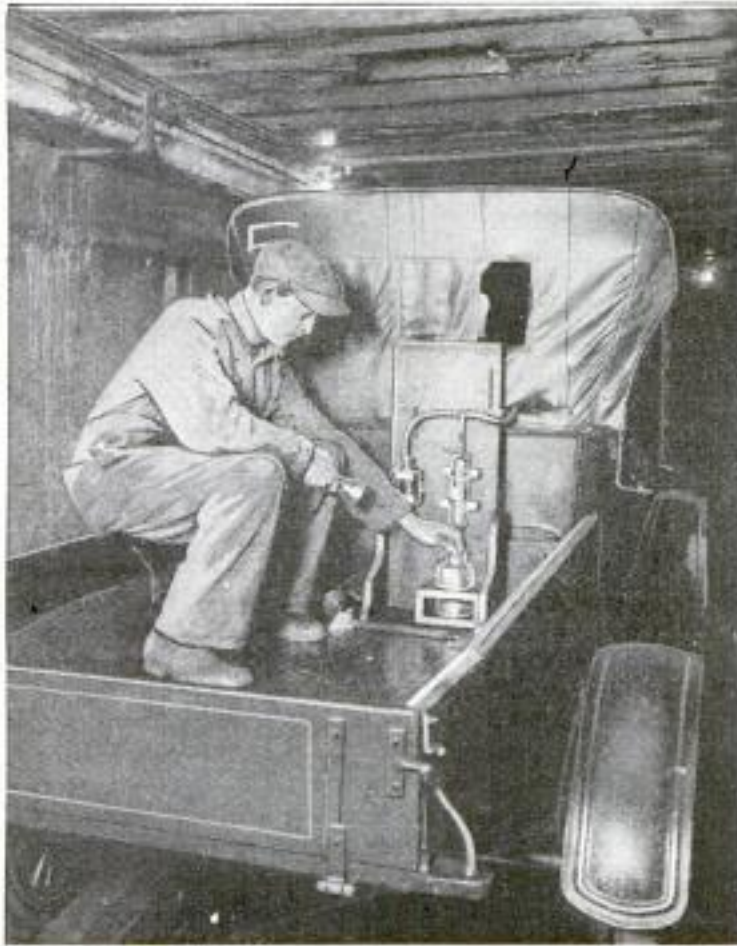

Taking a Sample of the Gas from the Exhaust Pipe of One of the Motor Trucks Used for Making Observations in the Experimental Tunnel: There Were Several of These Trucks in the Tunnel, Each Carrying the Driver and at Least One Observer

quate to the use of the 9,000-ft. tubes to be used as traffic passageways between New York City and New Jersey under the Hudson River.

The underground roadway is located on the outskirts of Pittsburgh. It consists of an oval track, tunneled under the surface of the ground. It penetrates 130 ft. below the ground and is situated 1,050 ft. from the pit mouth of the mine. The axial length of the track is 400 ft., with a cross section 9 ft. wide and 8 ft. high. Above the ceiling of the tunnel is an air duct, 3 ft. high, and below the floor is a like unit, 2½ ft. high. Both of these ducts either introduce fresh air or discharge foul or poisonous atmosphere.

Elaborate and sensitive apparatus is found in the experimental tunnel, including units for determining the temperature, humidity, volume, rate of flow, and pressure of the air in all sections.

Forty-eight air-sampling tubes, placed along the tunnel, form a complete equipment for obtaining samples of air for chemical analysis, and for determining the spreading and concentration of the exhaust gases in various por-

Washington D.C.

2965

tions of the tunnel, under different methods of ventilation. A car collecting samples of atmosphere is continuously in operation through the tunnel while observations are in progress. Fresh air is introduced through horizontal slots in expansion boxes near the floor of the underground track. Impure air is discharged through a center opening in the ceiling. Physicians periodically take blood samples from the arms of the drivers of automobiles to ascertain the percentage of carbon monoxide absorbed by the blood.

Eight lightweight automobiles, spaced at 50-ft. intervals and operating at a speed of 10 miles an hour, were used in the observation tests. From 21,000 to 28,000 cu. ft. of air a minute, or a volume sufficient to maintain a ratio of 4 parts monoxide to 10,000 parts of air, was forced through the underground oval

track. Each driver and observer participating in the tests was subjected to examination before and at the conclusion of the performance by physicians and physiologists. The quantity of carbon monoxide absorbed by each participant in the experiments was revealed by examination of drops of blood extracted immediately after the tests. Sensitive apparatus for making these blood analyses was developed by the Bureau of Mines. The influence of smoke and temperature on the drivers of the automobiles was determined also. The improvised tunnel has a constant temperature, free from fluctuations and leakages common to models built above the surface of the earth, and the

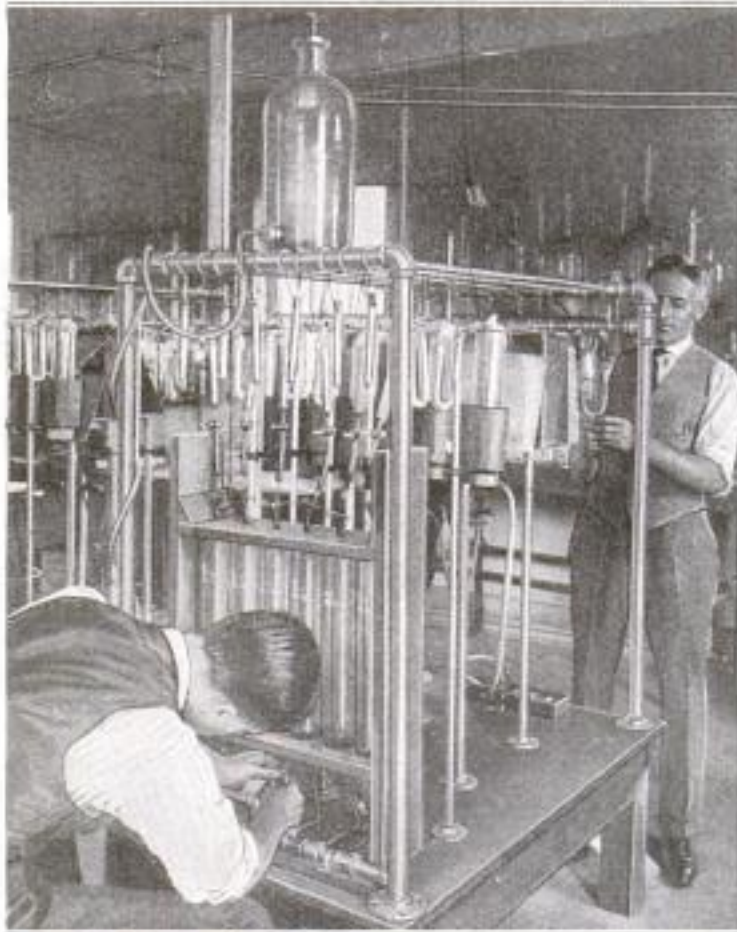

Apparatus for Making a Chemical Analysis of the Experimental-Tunnel Atmosphere in Order to Determine the Percentage of Carbon Monoxide

ground temperature surrounding it approximates that underneath the Hudson River. The air was heated and humidified as representative of an extreme condition during the final observations.

Each automobile transported a driver and from one to three observers. From two to ten other observers remained stationary or walked alongside the passageway in an effort to check the accuracy of the preliminary tests. Thus sometimes as many as 42 persons submitted themselves to the influence of the gas given off by the automobiles for a period ranging from one to two hours. Air was introduced from varying angles—at the bottom and top of the ventilation system—to find out the method yielding the most efficient ventilation at a minimum air circulation. Purposely, the engines of the cars were so adjusted as to yield a substantial volume of smoke. The result was without variation, that the smoky exhaust ascended behind the automobile

Each automobile transported a driver and from one to three observers. From two to ten other observers remained stationary or walked alongside the passageway in an effort to check the accuracy of the preliminary tests. Thus sometimes as many as 42 persons submitted themselves to the influence of the gas given off by the automobiles for a period ranging from one to two hours. Air was introduced from varying angles—at the bottom and top of the ventilation system—to find out the method yielding the most efficient ventilation at a minimum air circulation. Purposely, the engines of the cars were so adjusted as to yield a substantial volume of smoke. The result was without variation, that the smoky exhaust ascended behind the automobile



Surgeon Taking Sample of Blood from Arm of Driver of One of the Test Cars After He had Driven the Car One Hour in Experimental Tunnel

7965

toward the ceiling. Upward or downward ventilation produced this effect invariably. Presence of considerable smoke in the tunnel was a condition readily met by stopping the automobiles.

From the results of these observations, the investigators are unanimous in the conclusion that no ill effects will be sustained by persons exposed to carbon monoxide in the dilution stated above. Earlier experiments with both animals and men at the physiological laboratory of Yale University, under the direction of Dr. Yandell Henderson, consulting physiologist of the Bureau of Mines, had established this ratio of carbon monoxide to air as being safe. This conclusion is applicable to mines and blast furnaces as well as to vehicular tunnels. An increase in humidity and temperature to 88° F., as measured by the wet-bulb thermometer, did not influence the results as far as causing bad effects is concerned, although subjects were exposed for one hour 10 minutes. This figure represents the maximum heat and humidity that could possibly occur in the Hudson River tunnel.

The results of the study of the Bureau of Mines may be accepted as final. The tests were planned as checks on the conclusions arrived at in the investigations

at Yale University just referred to and that of the University of Illinois relating to the volume of fresh air necessary to the functioning of the Hudson River tun-

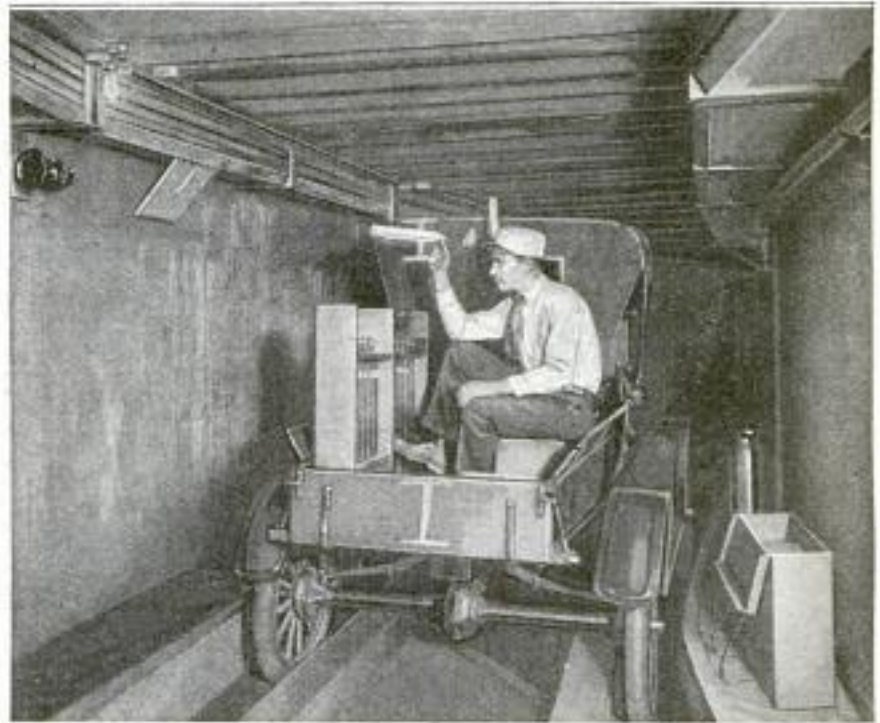

Reading Temperature and Humidity in Atmosphere of Tunnel: Fresh Air is Admitted from Openings Near Floor, and Vitiated Air is Removed through Opening in Ceiling, or Vice Versa

nel. Road tests on 101 automobiles and motor trucks at the Pittsburgh Experiment Station likewise revealed the percentages of carbon monoxide discharged by individual vehicles. The range is from .5 to 14 per cent. Passenger cars and speed motor trucks operating on level grades at 15 and 20 miles an hour averaged 7 per cent; motor trucks ranging from 1½ to 5-ton capacity, traveling at a rate of 10 miles an hour, 7.3 per cent.

7709

CHAIR-BED HAS BOOKSHELF AND MEDICINE CABINET

Invalids, book lovers, and smokers should be interested in a new reclining chair, which

combines a number of features. A small compartment in the side can be used as a medicine cabinet, or to contain the smoker's needs. Between the front legs is a shelf for holding books, and to the right arm can be fitted a detachable writing table.



Left: Chair-Bed Showing Bookshelf. Right: Chair-Bed Showing Cushion Unfolded, Medicine Chest and Writing Table

Besides these advantageous points, the chair has the additional feature of being convertible into a bed, so that it is a useful piece of furniture not only in the daytime but also during the night.

Ans. Scl. Spector 503 Ashford St. Brooklyn, N.Y.

7774

DRAWERLIKE SEAT SLIDES INTO SIDE OF AUTO BODY

An extra seat, which pulls out of the side of the car body like a drawer, is a feature of one of the latest-model run-

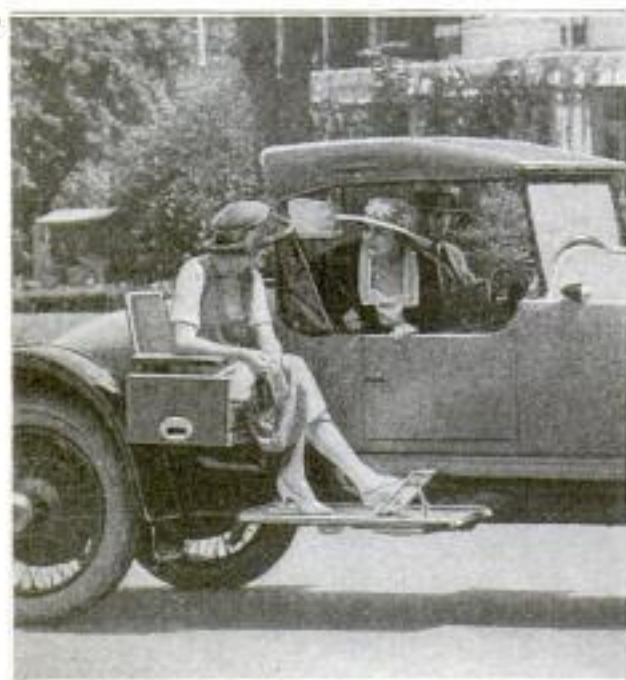

When Pulled Out, This Drawer Forms a Comfortable Extra Seat. At Other Times It Fits Neatly into the Side of the Body of the Car

bouts. The back and armrests fold into the drawer, which is entirely out of the way when not in use. For the comfort of the occupant, a short running board is provided, a section of which is hinged so that it can be raised to form a footrest and brace.

PROPELLER MADE ADJUSTABLE FOR WIND OR MOTOR DRIVE

Ordinarily a propeller on a sailing vessel possessing an auxiliary engine, would prove to be a hindrance when the engine is not in use, but an adjustable-bladed

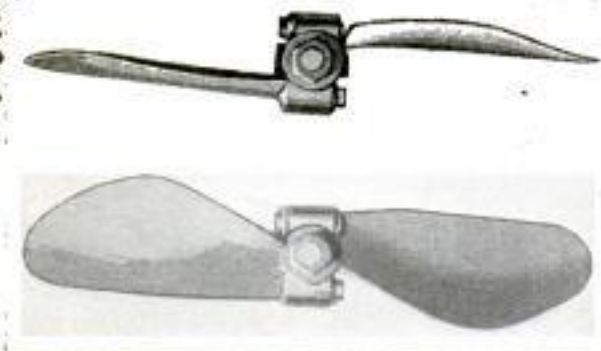

Above: Adjustable Propeller Alined with Course of Ship When Sails are Used. Below: Position of Propeller When Engine is Used

type has been introduced, which automatically adjusts itself so as not to be a "drag" on the boat when idle. The blades of this propeller turn loosely in a bearing on the shaft, and when sails are used, the blades revolve in the bearings until their edges are alined with the ship's course, in much the same manner as a weathervane adjusts itself to the wind. When it is found desirable to employ the engine, the revolving of the engine shaft brings the blades back to their original position again, for the purpose of propelling the boat.

POSSIBLE SOURCE OF SUGAR PRODUCTION DISCOVERED

Sugar may be obtained from a new source as a result of a recent discovery made by the United States Department of Agriculture. It has been found that a substance, known as inulin, which has a 60-per-cent greater sweetening quality than the sirup made from sugar cane, can be extracted from the tubers of the



Left: Flowers, Leaves, and Tubers of the Jerusalem Artichoke. Right: The Tubers, Showing How They Grow on the Roots of the Plant

Jerusalem artichoke, a plant related to the common sunflower. The discovery is so new, that so far it has been impossible to make complete tests of the commercial possibilities of this plant as a source of sugar. The plant is most prolific, however, needing only to be planted once, after which it reproduces itself each year. In fact, it is considered a pest in some parts of the country. In the past these tubers have been used for making pickles by saturating them with vinegar. The Jerusalem artichoke is a native North American plant and was used as a food, by the Indians, before the coming of white men.

Mr. D. A. Winters, Department of Industry, Washington, D.C.

D. A. Winters, 402 District National Bank Bldg. Washington D.C.

Carl E. Weiss, 80 Boulevard Jordan, Paris, France

Copyright material

7988

MIGHTY "MUTSU" IS LATEST JAPANESE BATTLESHIP

THE mighty "Mutsu," named after a Japanese province, is the latest addition to the battle fleet of Japan, and one which that nation succeeded in having excluded from the "scrapping" program of the recent Limitation of Armaments Conference. Japan claimed that her protests arose from sentimental reasons due to the fact that the huge ship is wholly the product of Japanese designers and engineers. The warship is capable of a speed of 26.5 miles an hour, has a tonnage of 33,800, and carries a main armament of eight 16-in. guns.

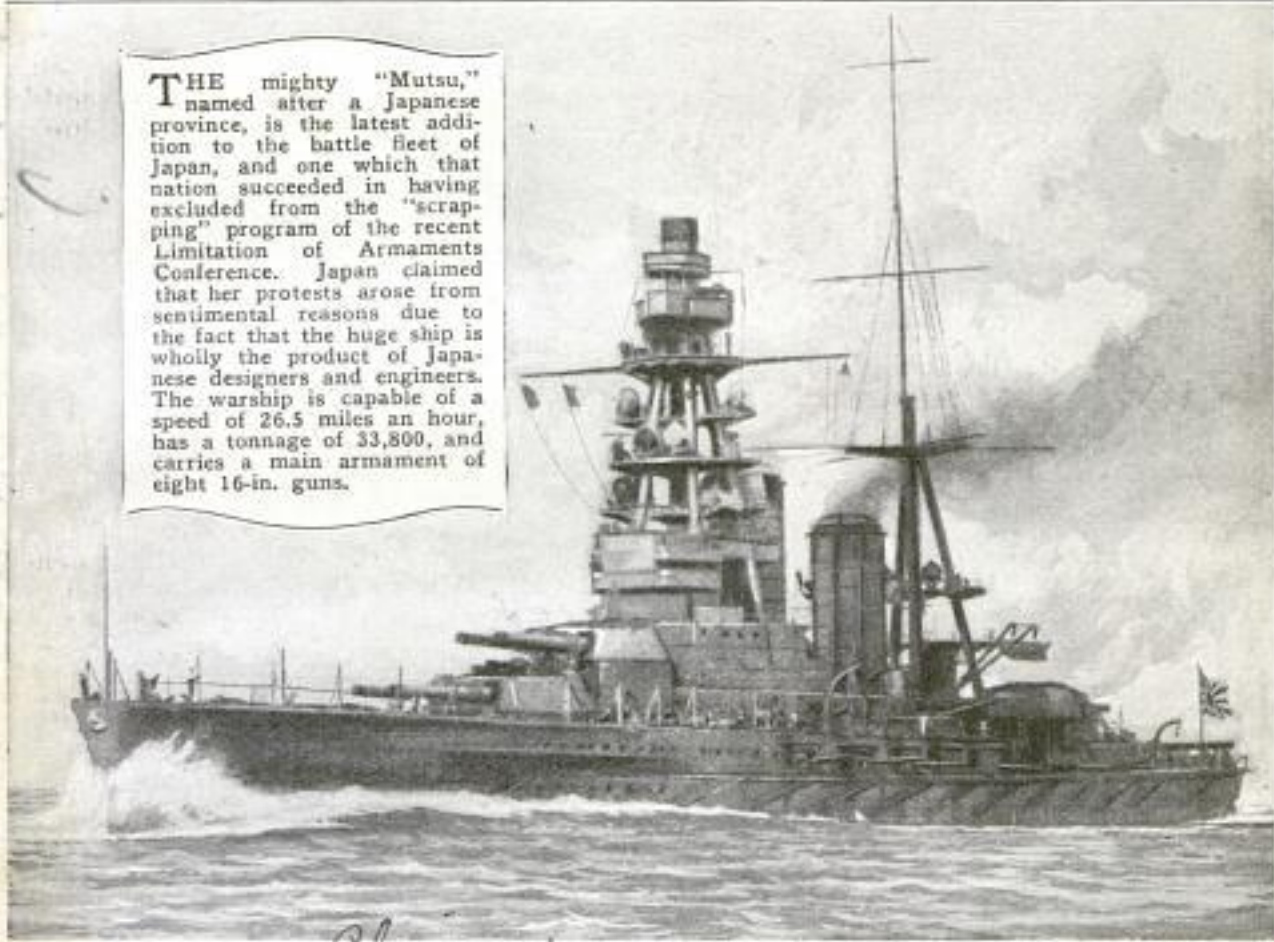

COPYRIGHT, UNDERWOOD & UNDERWOOD

Chicago

7338

POWER-DRIVEN STUMP CUTTER DOES ITS WORK RAPIDLY

Tree stumps can be cut off at ground level, or as much as 30 in. below, very rapidly by a machine that does the cutting with a sort of combined band and circular saw, for though it is flat, like a band saw, it is $\frac{5}{8}$ in. thick, and maintains its circular shape. The saw is rotated rapidly by a small gasoline engine, and when cutting below ground, it is sloped and fed downward so that it descends into the ground and strikes the stump at the desired depth. After cutting through the stump the slope of the saw is reversed, and it proceeds to cut upward, ending by having cut out a

saucer-shaped section of the ground containing the tree stump. The saw is made of the same material as stone-cutting saws. The machine is mounted on wheels, making it easily portable. It is made in

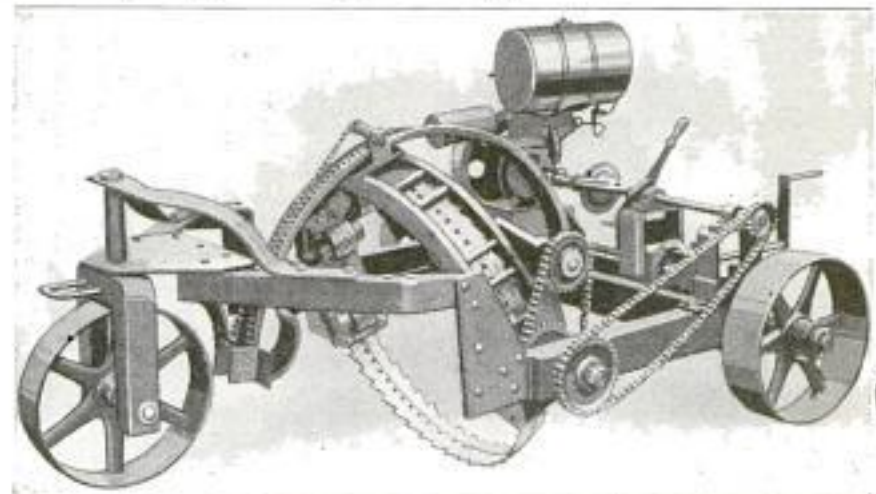

Machine for Cutting Tree Stumps at Ground Level, or 30 Inches below It: The Circular Band Saw Cuts through the Stumps While It is being Rotated Rapidly by the Small Gasoline Engine at the Rear.

two sizes, with saws of 8 and 12 ft. diameter, respectively.

Spiral Machinery Co.
1421 Arcade Bldg.

St. Louis, Mo.
 Copyrighted Material

18th + Brady, East St. Louis, Ill.

7869 Langford Steam Motor Association, 3816 W. 26th Ave
 Denver, Colo.

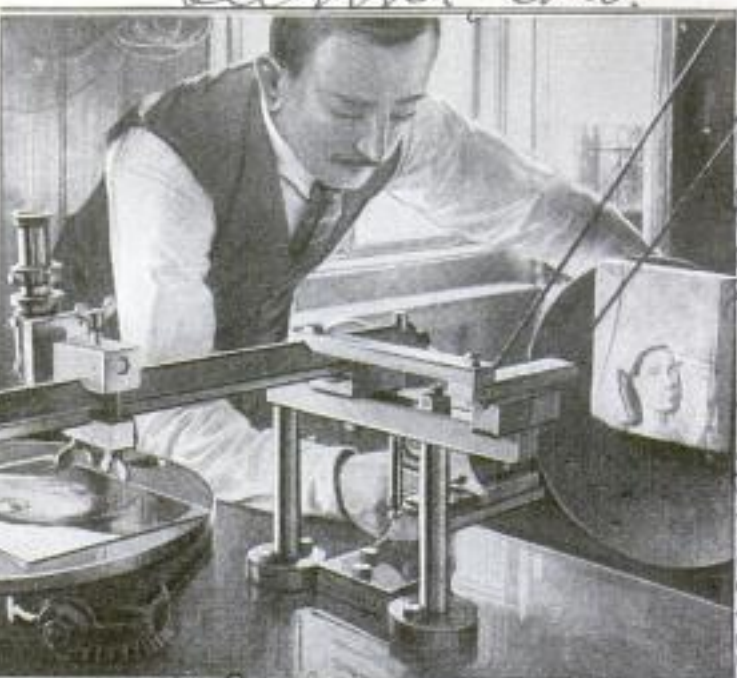
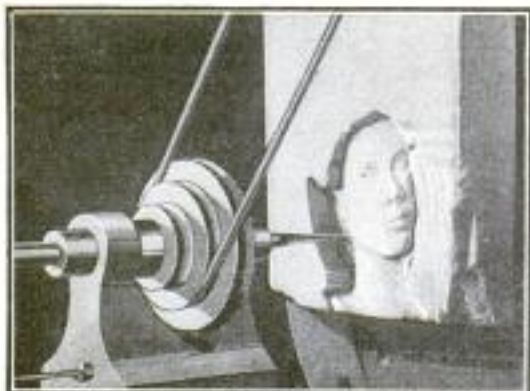

Operating the Machine for Carving Reliefs from Photographs: The Drill, an Enlarged View of Which is Shown Above, is Guided by the Aid of a Microscope along a Spiral Line on a Special Photographic "Print," Similar to the Groove in a Phonograph Record

Steel Agency's 152 Steel
 11/16/21 Scientific American Dec 1921

7869

STEAM-DRIVEN MOTORCYCLE ECONOMICAL TO OPERATE

An economical steam-driven motorcycle has been built by a Denver, Colo., man, and as there are no gears, chains, belts, or clutches, it is practically noiseless. The inventor claims that the machine develops a speed of 60 miles per hour from a standing start, within a distance of 174 ft., and that 1 gal. of kerosene furnishes sufficient steam to travel 35 miles. The driving power is applied directly to the axle of the rear wheel, by a two-cylinder single-expansion double-acting engine. It is estimated that the steam machine can be operated at one-fifth the cost of a gaso-

7908 used see Aug. 1923-230

"PHOTO SCULPTURE" CARVES RELIEFS FROM PICTURES

dr. Mr. LaMonda

At the Royal Photographic Society exhibition, in London, Eng., a demonstration was recently made of a process of "photo-sculpture." The subject to be photographed is illuminated by a projector which throws a spiral of light, similar to the groove in a phonograph record, upon it. This spiral is distorted, on the negative, by the irregularities of the subject. A positive is made, on glass, to be used in the carving machine. This has a disk, to hold the material to be carved, a carrier for the photographic record, and a microscope and high-speed drill, mounted together. The operator moves the microscope so that the cross hairs follow the spiral lines of the photograph. This moves the drill so that it cuts the material at varying depths according to the form of the subject. In this way excellent reliefs have been obtained in wood, ivory, and alabaster.

Bl. E. C. London, England 5 miles 9/25/21

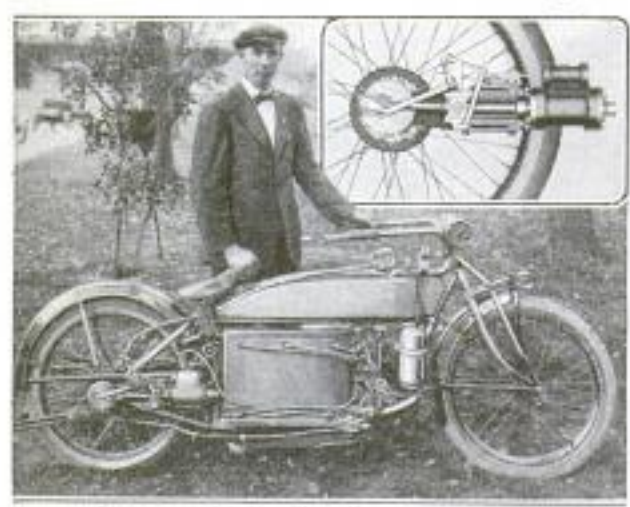

Steam Motorcycle Showing the Kerosene and Water Tanks and Various Piping. Insert: Engine and Eccentric on Rear Axle

line motorcycle, not including the saving in tires due to the smooth, even application of power.

RATTLESNAKES ARE KILLED WITH WAR POISON GAS

Mustard gas has been employed by the Department of Agriculture to aid in the extermination of rattlesnakes in the state of Washington. The experiment consisted of forcing the gas into a bed of lava rock, which had hitherto proved to be an invulnerable retreat for the reptiles. Soon there appeared snakes of all sizes, dazed and blinded, in which condition they were quickly clubbed to death.

Chicago Feb 12 1921

7632 Walter Brinkman
of James Star, Cincinnati, Ohio

STREET WIDENED TO RELIEVE CONGESTION IN CINCINNATI

Widening the intersection of Freeman and Western avenues with Liberty Street, in Cincinnati, Ohio, will relieve one of the most seriously congested spots in the city. Liberty Street is so narrow that it has been impossible for cars to turn north into Western Avenue while a car was turning south into Freeman Avenue. There was barely clearance for one car to turn at a time, and automobiles were compelled to wait until all cars had passed the corner. This corner is only three blocks from Redland Field, the home of the Cincinnati National League baseball team, and during the ball season especially the traffic is heavy. The city has purchased and torn down several buildings on the

corner of Liberty Street and Freeman Avenue, which will be one of the broadest in the city when the work is completed. The change will greatly simplify traffic problems.



This Intersection Was So Narrow That One Street Car Turning the Corner Blocked All Other Traffic. Buildings have been Torn Down, and the Corner is being Widened. It will Be One of the Widest in the City

4835

DOUBLE KEYBOARD IN PIANO SIMPLIFIES THE FINGERING

By a rearrangement of the conventional piano keyboard several attempts have been made to make the fingering easier. One of the most recent is a double keyboard, the production of a Belgian inventor, which has attracted a great deal of attention among musicians, and which is said to be a decided improvement of the existing single keyboard. It simplifies the study of the piano, and at the same time makes possible a wider range of scale combinations and harmonics. The upper key is a half tone above the lower one. On the new keyboard the same fingering is used to play the major and minor scales. Modern piano compositions are easier to play, and the new keyboard permits the creation of

many new effects and combinations that would be impossible on the conventional keyboard. The construction of the double keyboard is extremely simple, and it can be adapted to any type of piano, old



DOUBLE KEYBOARD, THE PRODUCTION OF A BELGIAN INVENTOR, WHICH FACILITATES THE STUDY OF THE PIANO, AND MAKES POSSIBLE THE PLAYING OF EFFECTS AND COMBINATIONS IMPOSSIBLE TO PLAY ON THE ORDINARY SINGLE KEYBOARD

or new, without necessitating interior changes of any kind.

Agent: *Cmt Maurice & Belgrims*
Antwerp Belgium 35 Place de la Gare

Copyrighted material

7779 Inventor
 C. Pewther, Winfield, Kans
 POPULAR MECHANICS

206

**NEW TYPE OF GOPHER TRAP
 MAKES RECORD CATCH**

In farming districts where the eradication of gophers is necessary to profitable



A Single Night's Catch of 102 Gophers, from a Set of 114 Traps: The New Gopher Trap, Which was Used, is Shown in the Insert

production of crops, a gopher trap which will catch 102 gophers in a single setting of 114 traps, should prove of great value. That is the record of a new type of trap, which seems to succeed where many previous inventions have failed. When a gopher finds light entering its run, it im-

mediately plugs the hole by pushing dirt into it. This trap is set in such holes. The dirt passes over the trap, but, when the animal's nose touches the trigger, the jaws instantly close on its body.

8026

**GERMAN MERCHANT MARINE
 SHOWS ENORMOUS GROWTH**

During the last half of 1921, the German merchant marine has shown a phenomenal growth. The present total is from 850,000 to 1,000,000 tons, an increase of about 250,000 tons since July. At present the German shipyards are intensely busy turning out additional vessels. This activity has been stimulated by the action of the government to withhold indemnities payable to shipping interests for vessels delivered to other countries, under the terms of the treaty of Versailles, unless new vessels are built to replace those lost. In spite of the increase in available tonnage, 80 per cent of Germany's foreign shipping is being carried in foreign bottoms. About three per cent is handled by American ships.

Dept. of Commerce 12/17/21

7741

**INGENIOUS EMBLEMS SEEN
 AT FOOTBALL GAME**

As usual, the rivalry between the universities of Indiana and Purdue called forth great enthusiasm at the annual football game, played at Bloomington, last fall. One of the features of the celebration was a prize contest for emblems displaying the spirit of the Indiana team and its coach, "Jumbo" Stiehm. Many novel ideas were represented, the favorite being a play on the name of the popular Indiana coach, in the form of an Indiana "Stiehm" roller. The preliminary enthusiasm was turned into a real celebration by a 3-to-0 victory for the Indiana team.



Some of the Clever Emblems at the Indiana-Purdue Football Game, the Past Season, Took the Form of an Indiana "Stiehm" Roller

Cont. Will Peterson, 116 N. Grant St
 Bloomington, Illinois.

Mr. The Sleeth-Klitch Trap Co 423 N. Water, Wichita, Kans.

Copyrighted material

AN EXCITING MOMENT IN AN ICEBOAT

SUCH dangerous tips are common experiences in ice boating, where every shifting puff of wind offers the possibility of new sensations to the pilot of the light craft, which skims over the surface of the ice at a speed greater than that of the fastest trains. This photograph was taken on one of the frozen inlets near Stockholm, Sweden, where ice boating is a favorite sport throughout the long winter season.

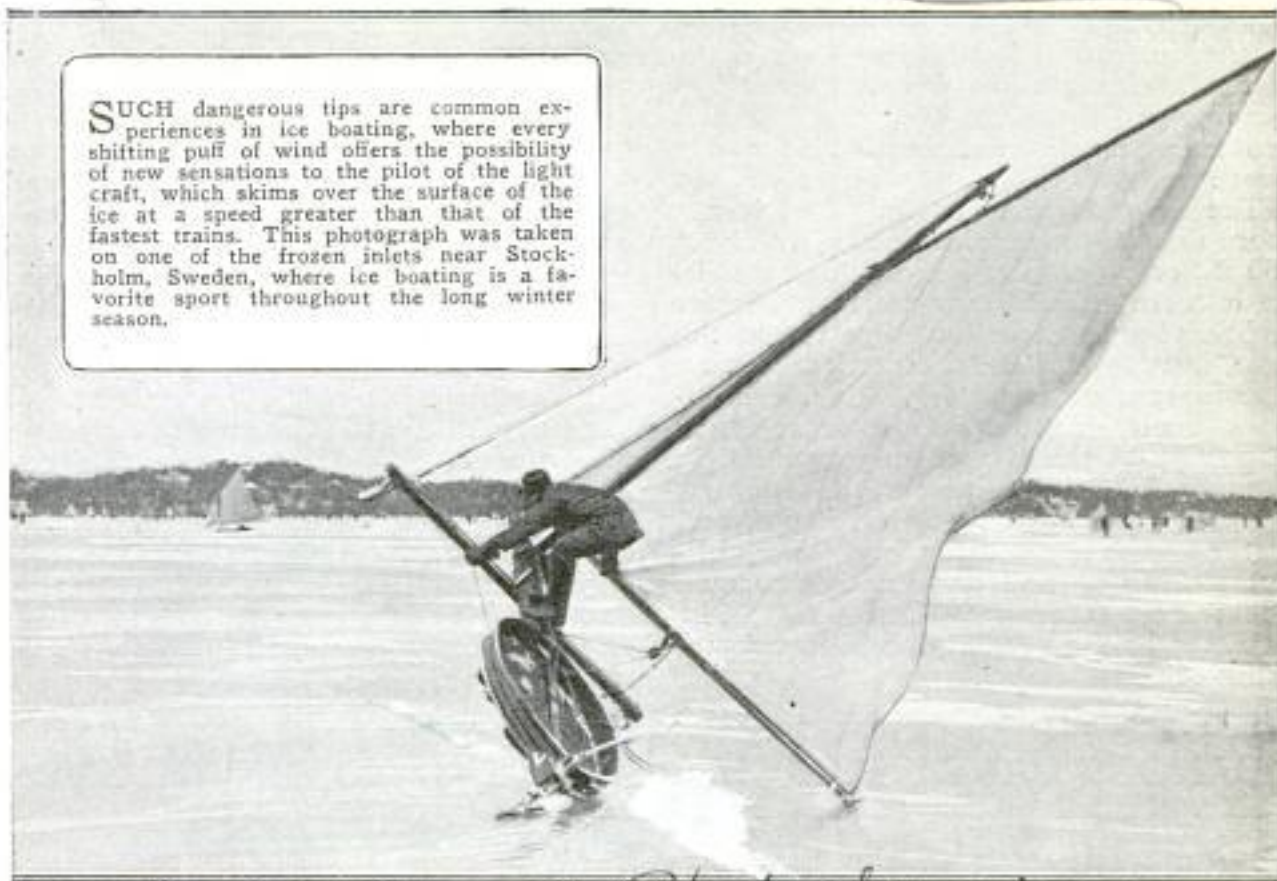

International Photo Service
 PRECISION LEVELING AND ITS PRACTICAL VALUE

BY C. A. BRIGGS

IF a person stands where he can get a clear view of a point a mile away and tries to estimate the position of an object having the same elevation as himself, he will find, first, that it is hard to reach any conclusion at all, and secondly, that he cannot think of an error of a foot in a mile as meaning very much. However, it is of great practical importance to establish level lines to a very much greater degree of accuracy than this; and the most precise work is done by the United States Coast and Geodetic Survey, which prepares the most accurate maps obtainable, showing elevations, for all sections of the country.

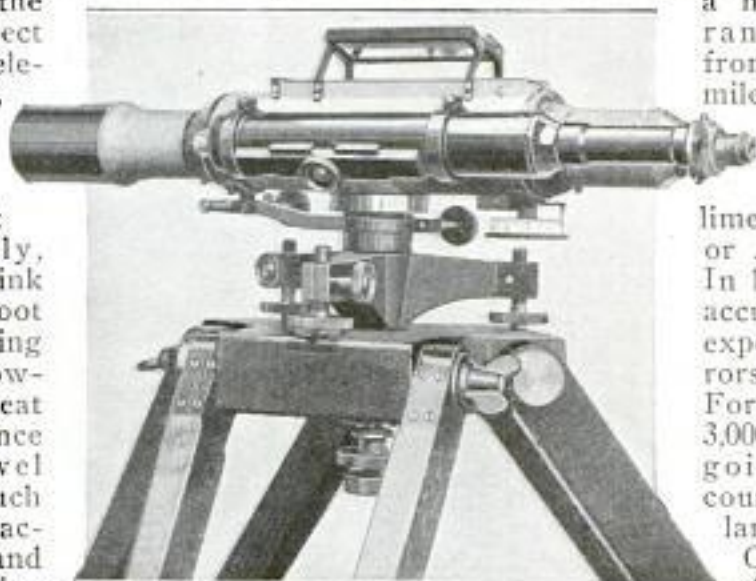

Precision Level Used by the United States Coast and Geodetic Survey Which Is Remarkably Accurate

The precision-level lines established by this institution form a network of over a hundred circuits ranging in length from 100 to 4,700 miles. The average closing error of these circuits is less than .2 millimeter per kilometer or .013 in. per mile. In long lines greater accuracy than this is expected, as the errors tend to cancel. For a distance of 3,000 miles, as in going across the country from the Atlantic to the Pacific Ocean, the error should be less than two feet, a proportionate error which would be negligible in any elevation survey made for practical application. A person on the Pacific coast who

built a sea-level landing at a height established by running a line across the country and over the mountains from the Atlantic Ocean, instead of having his shoes at the water level might possibly find himself in water up to his waist or knees, but it is probable that his nose would be safely above water.

The longest sight that is taken is not more than 150 meters, which is just about 500 ft., or practically one-tenth of a mile. If it were unnecessary to take shorter sights, so that there were but ten to the mile, five forward and five back sights, an uncompensated error of .001 in. consistently made one way, on each sight, in observing at the 500-ft. range, would, in running 3,000 miles across the country, grow to be 30 in. Instruments and methods which will carry level lines without picking up and perpetuating a small uncorrected error of .001 in 500 ft. will be admitted by the ordinary person as something of a refinement.

Accurate level lines are of vital importance when it comes to the drainage of swamps, where a fraction of a foot may determine whether or not a large area can be caused to drain by certain methods. It may determine whether the swamp can be drained into a river, or whether the river will drain into the swamp—rather important information to persons concerned in projects of the kind. Accurate level lines also determine the elevation of permanent marks which are of great value in mining, and for scientific and technical purposes. In the course of time they will tell what portions of the country are rising or sinking, and will give evidence of what the geological history of the future may be, as well as shed light on the past.

The precision network of level lines thrown over the United States by the Coast and Geodetic Survey, will eventually be filled in by secondary surveys that will establish the level of all points in the country.

7758

BARGES CARRY PITTSBURGH STEEL TO CINCINNATI

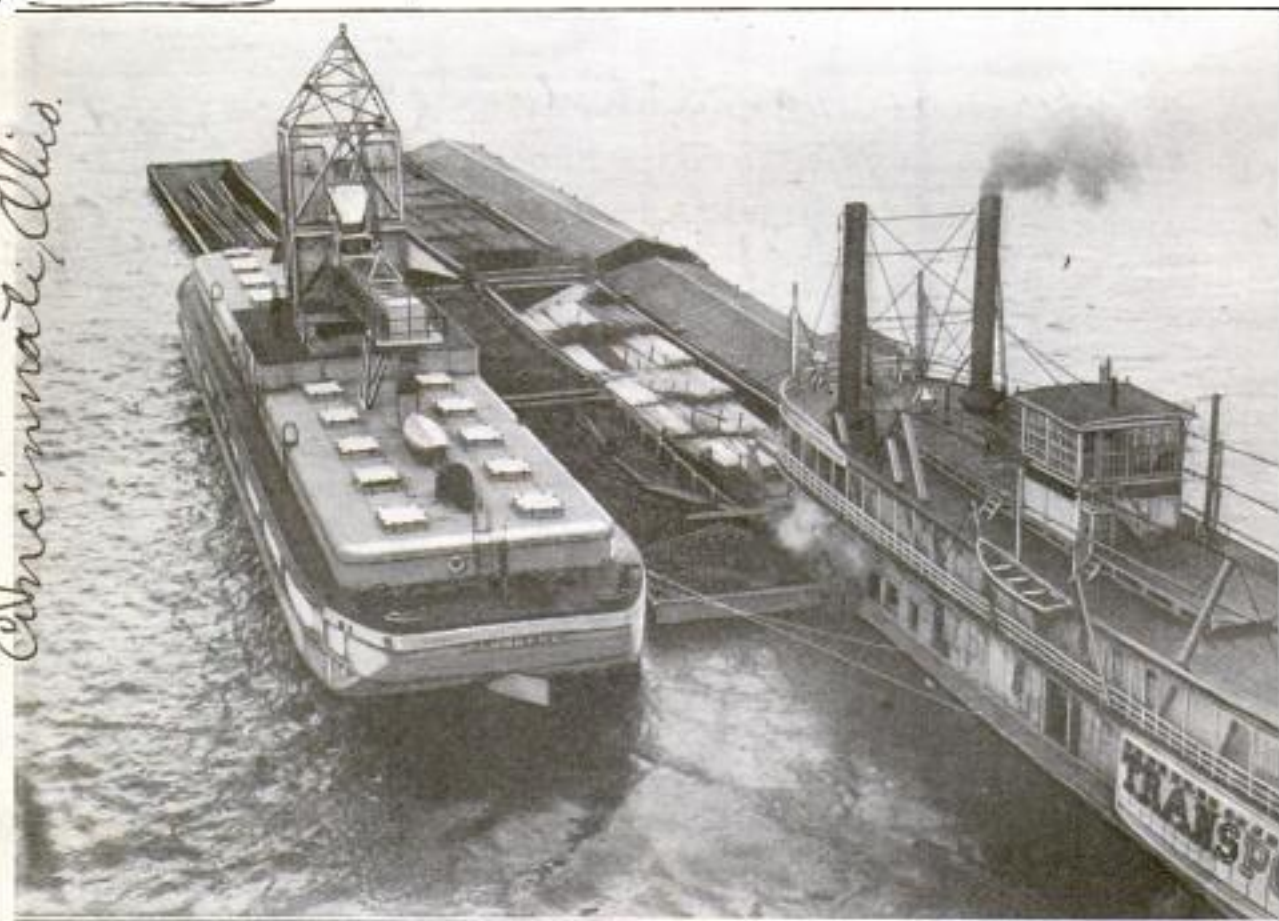

FOR the first time in many years a shipment of steel was recently made from Pittsburgh, via the Ohio River, to Cincinnati harbor. The steel was loaded on six barges which were towed by the steamboat "Transporter." From Cincinnati a large ocean-going craft, with a derrick towering 75 ft. above its deck, carries freight by river to the Gulf of Mexico, and across the Gulf to South America. This shipment will be followed by others, and it is expected that this will become a common method of transportation of products of the iron and steel district around Pittsburgh to points beyond Cincinnati, and also to St. Paul.

*used by Jones & Laughlin
Iron Brothers, Cincinnati, Ohio*

Joseph S. Bradford, Cincinnati, Ohio

7271

Inventor Earle Livingston
 2213 Rancherie St, Santa Barbara
 Calif



One-Room Bungalow, in Which the Owner Employed His Practical Experience as a Boat Builder to Utilize Every Inch of Space to the Best Advantage, without Sacrificing Attractiveness of Appearance

ONE-ROOM HOUSE HAS ROOMS IN WALLS

BY FRANK B. HOWE

412 Mason Opera Bldg Los Angeles, Calif
PATENTS have recently been granted on a most unusual miniature house, at Santa Barbara, Calif., which although it is in reality a one-room bungalow, has all the other rooms of an ordinary dwelling concealed in various places about it.

The basic plan of the queer structure is a central room, surrounded by double walls placed from 3 to 7 ft. apart. In these hollow walls are concealed a kitchen, a bathroom, dressing rooms, and other of the orthodox accompaniments of the usual modern home.

The entrances leading from the main central room into the various wall rooms have been concealed so that there is no indication of their existence. When he desires to go into one of them, the owner walks to an apparently blind wall, and, presto, it opens.

Starting at one end of the central room, the first side opens into a complete kitchen. The next side contains a bathroom, a bed, and several little accessories, such as a wood box, telephone closet, and desk. The third side contains two dressing closets, while the remaining wall accommodates another bed, and also the front entrance.

Special mention must be made of the built-in beds, which can be transformed into window seats. Realizing that a comfortable bed is too springy to be practicable as a seat, and that a comfortable seat is far too hard for a bed, the inventor has devised a plan to make the seat-bed hard by day and soft by night. A board is mounted on hinges below the springs, in

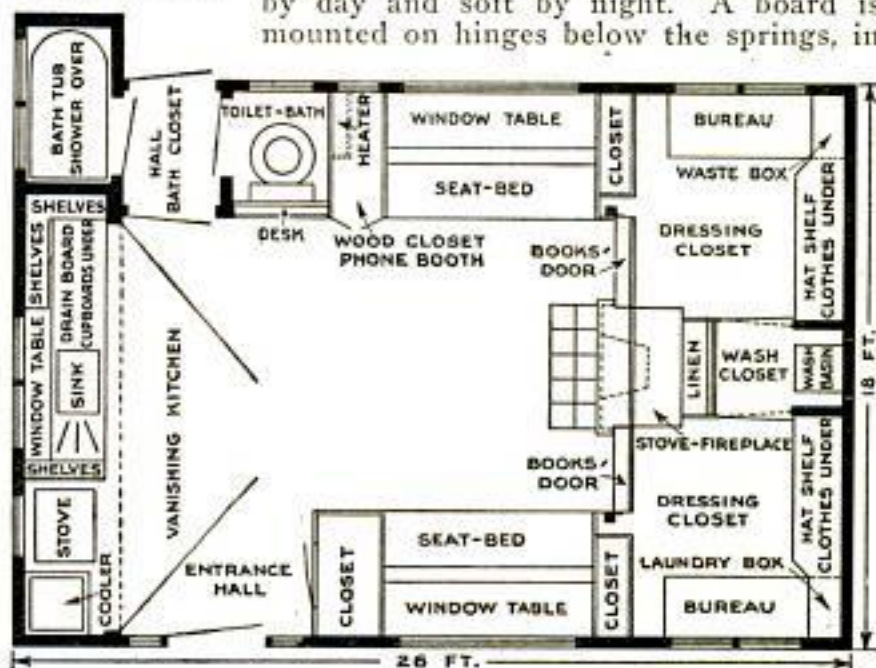

Floor Plan of This Unusual Bungalow, Showing the Ingenious Way in Which a Complete Home was Secured in a Space 18 Feet by 26 Feet, No Larger Than a Single Big Living Room in Many Houses

such a way that it rises, describing an arc, at the pull of a rope. When the seat-bed is to be used as a seat, this board pulls up against the springs, preventing them from acting, and converting the bed into



Rear View of the Bungalow: The Foundations were Kept Entirely below Ground to Avoid Giving the Appearance of a Box Sticking Up in the Air. The Effect of This Toylike House Is Artistic Throughout

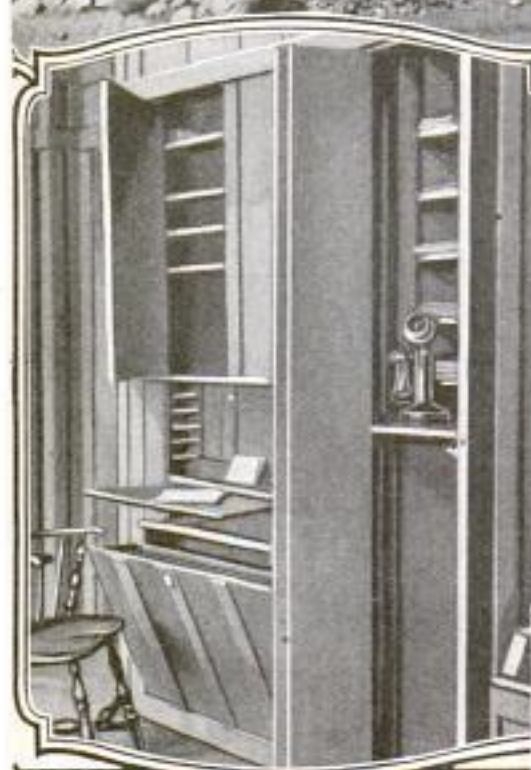

The Paneled Wall at the Right Looks No Different from Any Other Part of the Wall, but It Opens to Give Access to the Furnishings Seen at the Left. Here Are a Telephone Closet and a Desk, with Shelves above It and a Waste Basket Below. There Are Only Three Pieces of Detached Furniture in the House, a Table, Which Serves as a Living-Room and Dining-Room Table in One, and Two Chairs



Under Each of the Two Large Windows Is a Comfortable Built-In Seat. At Night, These Seats can be Converted into Equally Comfortable Beds. An Entirely Original Device is Used So That the Springs can be Made More Rigid When Required as Seats, or Given That Additional Resiliency Needed for a Bed



This Diagram Shows the Hinged Support Used under the Seat-Bed Springs, to Control Their Rigidity



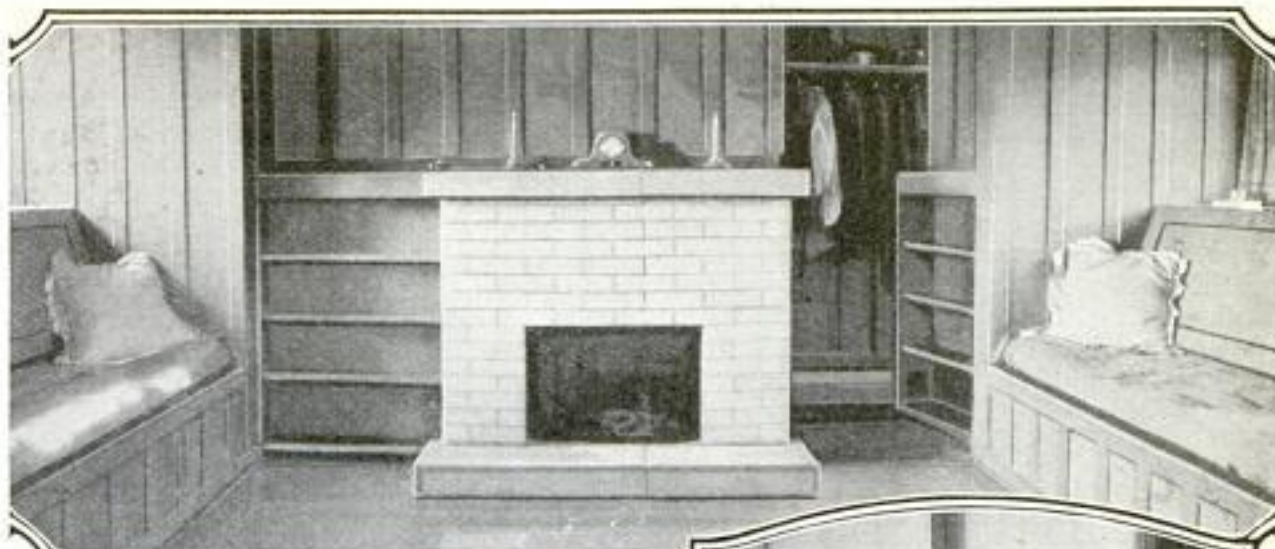

One End of the Room, Showing the Open Fireplace, the Window Seat-Beds, and the Bookcases, at Each Side of the Fireplace, Which Swing Open to Admit One to the Two Dressing Rooms: The Entrance to the Dressing Room at the Right Is Open

Interior of One of the Dressing Rooms: Each Contains a Hat Shelf, with Hooks Below for Hanging Clothes, a Closet, a Laundry Box, and a Complete Bureau, Built into the Wall. They are Well Lighted by Two Windows Directly over the Bureau



Another Wall, Above, Which Is Apparently Nothing More Than Plain Paneling, Is Really Two Doors, Which, When Swung Open, Disclose a Well-Equipped Kitchen, Shown at the Right. The Backs of the Doors are Supplied with Hooks and Racks for Holding Various Utensils. The Kitchen Itself Is Only Three Feet Deep, but Contains a Sink and Drainboard, a Full-Sized Stove, a Cooler, and Ample Shelf and Cup-board Space



a comfortable seat. When the device is to be used as a bed, this board is dropped down, the springs function as usual, and a soft bed is obtained.

With the exception of a table and two chairs, all furniture is built in, most of it being concealed here and there in the blind walls, and coming forth when desired. Everything is built clear down to the floor, to do away with sweeping under the furniture.

The net result of the strange home is

7265 *Reynolds*
**ASTONISHING PROGRESS MADE
 IN MOTORLESS FLIGHT**

Restrictions in regard to airplane motors, placed upon Germany by the

that 10 minutes suffice to do the housework each day; yet the residents are fully as comfortable and have all the conveniences of persons living in much larger houses.

At first glance one might criticize the house as being poorly ventilated. Such, however, is not the case. Ventilation has been carefully planned and is ample, through a system of air currents. In fact everything considered necessary in a modern dwelling has been provided for.

men who remained there for further experiments. These flights have aroused great interest, and in France have stimulated similar activity. Flights by Klemperer, Martens, and Harth, of 13, 15, and

21 minutes' duration, respectively, are particularly noteworthy. Though Harth made the longest flight, 15 miles, Klemperer's six-mile flight offered a better opportunity to analyze soaring flight. Such an analysis seems to support the theory that soaring is accomplished by utilizing ascending air currents to attain or maintain altitude, and by gliding between points where such air currents exist. Klemperer flew between two points $2\frac{3}{4}$ miles apart, but, by turning and circling maneuvers, including a complete figure "8," covered about six miles. He attained an altitude fully 400 ft. higher than his starting point.

The method of launching the machines is of interest. It is done in the same manner as a boy throws a missile with a sling shot. The glider is placed on sloping ground, a rope is passed around its undercarriage, and to its ends are attached stout rubber cords, anchored on either side and in front of the machine. Three men pull the machine and the rope backward until the rubber parts are under high tension, when they let go of it, and the glider flies away as if thrown from a catapult. After the launching, the machine continues its flight, at first by the impetus

received and then by manipulation of the movable wing. Experiments have shown that motors of only 3 to 5 hp. would suffice to overcome wind resistance, and thus enable suitably designed gliders to make very long flights. Further developments along this line are expected.



One of the Motorless Airplanes Flying in the Rhön District: This Human Bird Caused Great Astonishment to the Peasants Engaged in Haymaking

peace treaty, have resulted in extensive experiments in soaring flight with motorless planes. Weather conditions during the second annual soaring competition, held last summer in the Rhön district, were unfavorable, but some astonishing and important flights were made by air-

Chicago Trib. 9/3/21

7777

Cont. Hugh Learny,
of The Sun,
POPULAR MECHANICS

New York City 213



Left: Prospective Passenger Obtaining Change to Drop in the Automatic Turnstile. Right: Passenger Dropping Nickel in Slot to Operate Turnstile

7 "NICKEL-FIRST" TURNSTILES FOR SUBWAY ENTRANCES

Turnstile admittance gates, with attendants watching them, are a common sight, but the spectacle of a gate of this kind operating automatically is a new feature. When a person wishes to pass through the gate, a nickel must first be dropped into a slot on the turnstile, and this coin allows one prospective passenger to enter. Passengers arriving at their destinations can use the gate as an exit, as it turns freely in the reverse direction. One of the subway systems of New York City is conducting experiments with this automatic gate, and if it is found practical, the entire system will be equipped with this type of entrance.

7968 SHAFTING STEEL TESTED TO FIND STRESS LIMIT

Tests have been conducted to determine the fatigue of metals, in which the general problem was to find out what relation exists between the static elastic strength of steel, and its ability to withstand millions of reversals of stress. In making these tests, a large number of

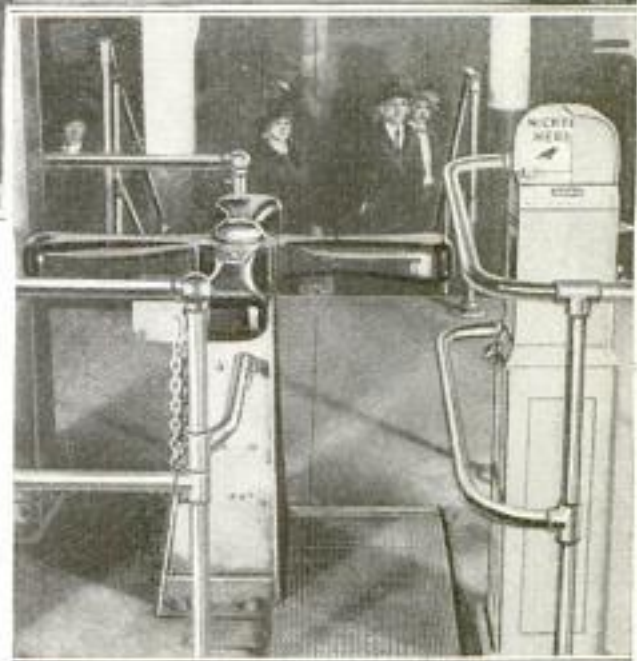

This Automatic Turnstile is Locked, but will Operate Readily if a Nickel is Dropped in the Slot. This Allows One Passenger to Enter

identical pieces of steel were used. A piece was selected, loaded heavily to insure its breaking in a short time, and then rotated until it gave way. With successive pieces, the load was gradually reduced until one piece withstood 100,000,000 revolutions without breaking. The experiments showed that the number of revolutions required for a breakdown increases uniformly as the load is decreased, until a certain load is reached. A slight reduction from this particular load makes it impossible to break the piece, even when run up to 100,000,000 revolutions. These tests have been made under the supervision of the University of Illinois.

Power 12/18/21 P-922

7807
214

Cont. James Mc d ntyre,
apartado 370,
POPULAR MECHANICS
Mexico, U. S.

CHIAPAS INDIANS POSE RELUCTANTLY TO CAMERA



In Chiapas, the most southern and probably the least developed state of Mexico, there are 14 distinct tribes of Indians. Each of these tribes has a language of its own, but they all have one characteristic in common. They do not mingle with the white people who live in that part of the country, and it is difficult to learn much about their life and habits. Cameras are mysterious and terrible to them, and it is seldom possible to persuade a native to have his picture taken. There is an unverified but persistent report, among the white inhabitants of Chiapas, that these Indians have some means of communicating across distances of many miles.

Chiapas Indians and the White Men Who Persuaded Them, with Great Difficulty, to Pose for Their Photographs

7748
Cont. David H. Colcord
217 N. Butler St Lansing, Mich.

POWER-DRIVEN CIRCULAR SAW FOR HARVESTING ICE

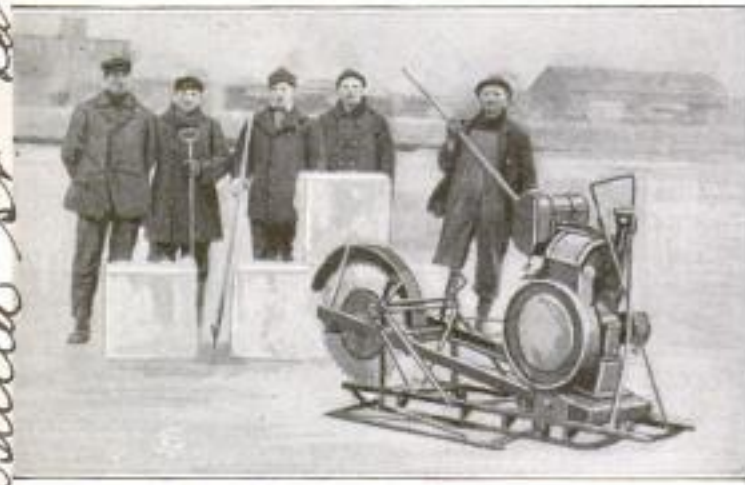

Power-Driven Circular Saw Mounted on a Bobsleigh for Harvesting Ice: The Man with the Pole beside the Sleigh Moves It Forward as the Saw Cuts Its Way through the Ice

On a lake in northern Michigan the ice is being cut with a power-driven circular saw mounted on a small bobsleigh. The saw overhangs the rear of the sleigh, and in front of it is a 5-hp. air-cooled gasoline engine with a chain-drive connection. After the saw is started, and has cut its way through the ice, the sleigh is impelled forward and guided by one man. As the saw cuts its own way, this requires only enough force to keep it up against the ice, and in this manner one man can with little exertion do as much work as several with the old crosscut handsaw.

34 Tremont St
Boston or top man

STEEPLEJACK CLIMBS CHIMNEY WITH AID OF BOX KITE

With the aid of an ordinary box kite, Thomas Fitzpatrick, better known in New England as "Steeple Tom," recently placed a harness on a 165-ft. brick chimney in Peace Dale, R. I., and raised himself to the top. It was the second chimney he had scaled in this way, and the highest he had ever climbed. By skillful maneuvering, he made the kite graze the top of the chimney and drop to the ground on the opposite side. Then, by the successive raising of cords and ropes of increasing strength, a hook line was

run up, followed by a 1-in. rope and a block and tackle, strong enough to raise him to the top in a chair.



Flying a Box Kite over a 165-Foot Chimney Enabled "Steeple Tom" to Put Up His Climbing Tackle

Putnam House.

7727 Cont. P. J. Spitzfaden, Pres
 309, New Orleans, La.
 POPULAR MECHANICS
 Board of New Orleans



Steamship "Emergency Aid" being Loaded with 550 Tons of Coke at the New Coal-Handling Plant at New Orleans, Louisiana, Operated by the Board of Commissioners of That Port

7727
NEW COAL-HANDLING PLANT AT NEW ORLEANS

There was recently put into service a new coal-handling plant at the port of New Orleans, La. The plant is for the purpose of unloading coal or coke from railroad cars, or barges, on the Mississippi River, and transferring it to steamships. The coal pile in the yard has a capacity of 25,000 tons, and to or from this a conveyor carries the coal to the boat and barge docks, where there are three loading towers, with a maximum capacity of 1,000 tons an hour, that can load three ships simultaneously, and one unloading tower for taking the coal from barges. Two of the loading towers travel along a track so that they can discharge directly into the ships' hatches, and the unloading tower at the barge dock is also of the traveling type.

7584
NEW SIGNAL GIVES WARNING OF ALL AUTO MOVEMENTS

Six distinct signals are provided by a new auto-traffic signal device. It consists of a front and a rear signal mounted on the fenders and equally visible by day or night. The front signal indicates to the traffic officer or pedestrian, by means of arrows, the intention to turn right,

turn left, slow down or stop, and go forward or park. In the same way the rear signal warns the driver of any machine following. Stop and slow-down signals are operated automatically when the brake is applied. The other signals are operated by a toggle switch on the steering column. Attention is attracted to the signals by an automatically operated rear horn which can be cut out by means of a switch.



This All-Purpose Signal Shows the Officer That the Driver Intends to Turn to the Left

Automatic Safety Traffic Signal Co.
 940 Syndicate Trust Bldg. St. Louis, Mo.

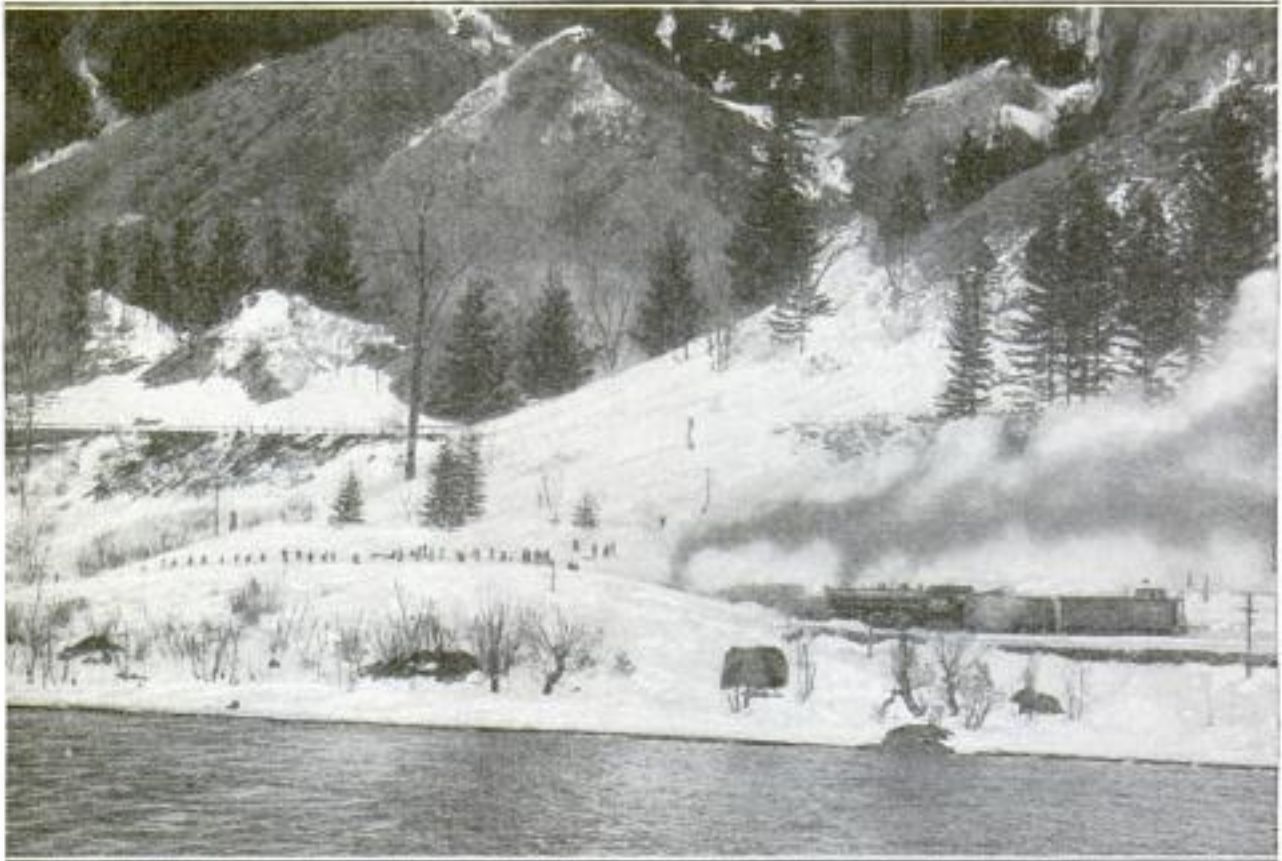

The Railroad, along the South Bank of the Columbia River, was Less Affected by the Snow Slides Than the Columbia River Highway, Which Runs Closer to the Mountainside, but in Places the Drifts Were 25 Feet Deep, and It Took a Week to Dig Out Seven Trains Which were Snowed In

COLUMBIA RIVER HIGHWAY ICEBOUND

BY H. E. THOMAS

911 Blunckley Ave.
Portland Oregon

SNOW and ice recently buried the lower Columbia River district in the worst storm that western Oregon and Washington have known in many years. It came on so suddenly that travelers were caught unawares. Automobiles and trains were snowbound, and the famous Columbia River highway was buried by a combination of drifts and slides.

On the edge of Portland, and east of that city for 20 miles, there was an "ice storm," known locally as a "silver thaw." Western Oregon has such storms about once in five years. The heavy rain froze as it fell until poles and wires were carried down in tangled masses, and trees broken and overturned. More than 11,000 telephones were put out of commission in Portland, and communication with other cities was cut off. Entire orchards in the storm zone were ruined.

In the Columbia River gorge there was a snowstorm of great severity. Tourists and pleasure drivers along the highway were forced to leave their cars to the elements and flee for safety. Some of them sought shelter in homes and hotels along the highway, while others caught the last train that was able to get through to Portland before the tie-up.

Parts of the highway are buried under slides as much as 30 ft. deep. Bridges were carried out and great masses of snow and ice came down the mountainside. At first, trucks and snowplows tried to clear the roadway, but found it an impossible task. The western end of the highway was cleared for some distance, but along the river the drifts and slides were so deep that it was concluded the job was not feasible, and that it would probably be necessary to wait until the spring thaw before parts of the highway could be opened.

More than 100 automobiles were stranded along the boulevard. Some of them were later rescued and taken away on trains and boats. Others, however, are completely buried under snow and ice, and are probably marooned for the winter.

Seven passenger trains were stalled on the railroads on the north and south banks of the Columbia. The passengers, after several days, were rescued on river boats sent out from Portland, and were none the worse for their experience. It was a week before the tracks could be cleared and the trains taken out. The railroad was not so seriously blocked as

Republic of China
1921
108 Park Road, New York City



Near Portland There Was No Snow, but an "Ice Storm" Left the Country as Shown Above, with Telephone Poles Down, Trees Broken, and Orchards Ruined. Where the Snow Fell, Drifts Almost Covered Telephone Poles, as Seen Below. This View Also Shows a Path from a Train, to Take the Passengers to a River Boat

the highway, because it is farther from the mountainside and was therefore less affected by the slides.

Merchants of Foochow, China, have formed a \$300,000 irrigation company and purchased American machinery for the project. About 500 acres of land will be irrigated at an annual cost of \$36 an acre.

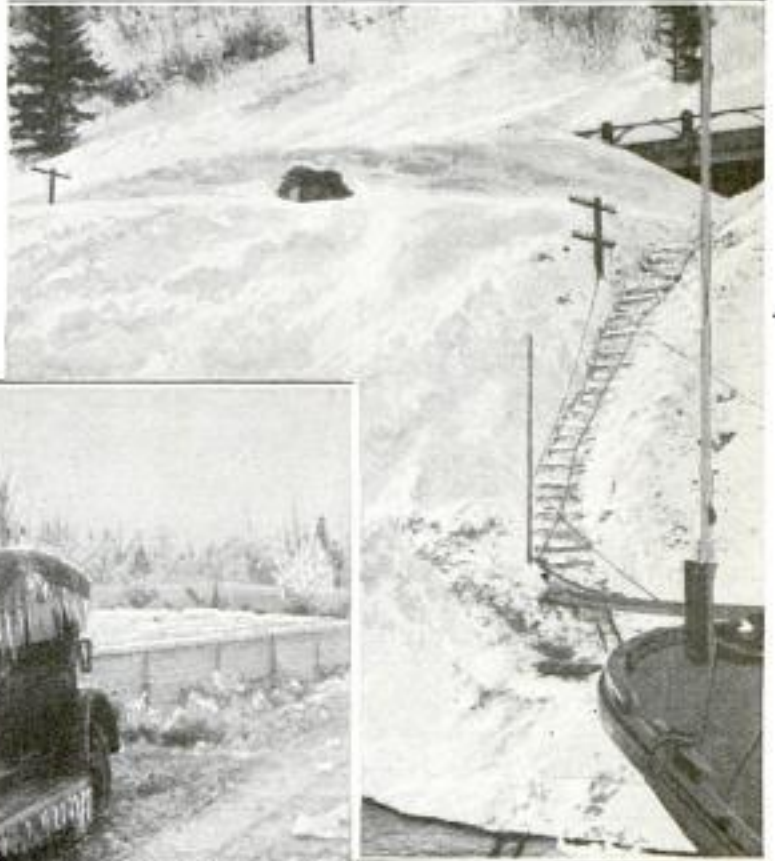

The Machine at the Left was Incrusted with Ice by Only a Few Hours' Exposure to the "Silver Thaw," One of the Ice Storms Which Occur Here About Every Five Years

**HEADLIGHT ON REAR OF CAR
 LATEST AUTO FEATURE**

A headlight, beside the taillight and mounted with it, is a feature which is being supplied on one of the new-model automobiles.



It serves the double purpose of warning persons and cars behind when the machine is backing up, and of lighting the road behind so that

the driver can see where he is going when backing. It is automatically switched on when the gears are thrown into reverse, and turned off when the reverse is disengaged.

**AUTOMATIC BLOWTORCH NEEDS
 NO AUXILIARY PRESSURE**

A blowtorch that does not blow, in the sense that it does not depend upon air pressure pumped up in the usual way, but instead generates its own pressure, is being placed upon the market. On top



of the torch can is the burner in the shape of a coil containing an asbestos wick from the burner orifice to the interior of the can. When this coil is heated it

vaporizes the gasoline, or other volatile fuel, in the can, which ignites at the orifice. It is said that the heat of the burner generates the vapor more rapidly than it can issue from the orifice, and therefore pressure is established inside the can, and the power of the flame is increased.

**NEW YORK HOTEL COMPANY
 ADDS NOVEL EXTENSION**

A novel extension of the Hotel Van Rensselaer, in New York City, is just being completed. The hotel stands on Eleventh Street near Fifth Avenue. On the corner of Fifth Avenue is an eleven-story apartment building and between the

two there has been an old garage, covering a 25 by 100-ft. lot. In order to protect the hotel's light, the company decided to take over and improve this property by building a two-story seven-room house. This house, of distinctive Moorish architecture, is set back 50 ft. from the sidewalk with a picturesque formal garden, laid out with a flagstone walk and low brick walls in front of it. Tucked away between its tall neighbors, it is almost lost to the view of the casual passer-by.

**ELECTRIC CANDLE AND WREATH
 MINIMIZE FIRE RISK**

The custom of using candles with the holly wreaths placed in windows at Christ-



mas time has been growing more popular, especially since the war. A dry-holly wreath and a lighted candle present a very real danger of fire, but the custom has been made safe by electricity, just as the Christmas-tree

custom was made safe by it. Wreaths are being made of cloth, sewed onto a metal ring. At the bottom of the ring is a round ball containing a standard candelabra socket, in which a flame-type bulb is used. An 8-ft. silk cord, connected at the bottom of the socket, supplies the current from one of the regular light fixtures.

**NAVAL AND MARINE AIR CRAFT
 MAKE EXTENSIVE FLIGHTS**

The annual report of the Naval Board of Aeronautics for the last fiscal period states that a total distance of 2,511,000 miles has been covered by naval and marine air craft, in flights during the past year. It states that satisfactory long flights have been made by the squadrons attached to the fleets, and that a special type of "spotting" plane is being manufactured, after a contract competition between American manufacturers. Only passing reference is made to the bombing tests made upon warships, which were conducted last summer.

Columbus, Ohio
7819
Dr. H. Howell
Dr. D. M. ...

ent. ...
Dr. M. J. ...
... Minneapolis, Minn.

New York Evening Post 11/19/21
New York Times 12/14/21

7276

Mfr. Wallace + Tierman Co
Newark, N. J.**"GASSING" BAD ODORS**

BY HARRY A. MOUNT

Cresskill, N. J.

THE problem of getting rid of odors from garbage and sewage-disposal, fertilizer, and similar plants, which generally are a public nuisance unless located at isolated spots, has been somewhat simplified by the practical demonstration of the fact that minute quantities of chlorine gas will effectively kill the noxious odors, and by the construction of a compact apparatus for its application.

As tanks of chlorine gas, compressed to a liquid state, have largely replaced chloride of lime as a means of purifying water supplies, so these same tanks are utilized in "gassing" bad odors. The complete deodorizing plant consists of one or more tanks of liquid chlorine and apparatus for controlling automatically the flow of gas. This automatic control comprises a pressure compensator, which keeps the flow of liquid chlorine from the tanks constant in spite of varying pressure in the tank and temperature changes; pressure gauges to show tank pressure and back pressure in the gas line, and a meter to indicate the rate of flow.

The chlorine is allowed to vaporize into a gas in the control apparatus, and is then piped directly to a mixing chamber, where, by means of fans or otherwise, it is mixed with the odorous air. When the proportion of chlorine is cor-

rectly adjusted, the odor disappears at once and entirely.

Two severe tests have brought convic-

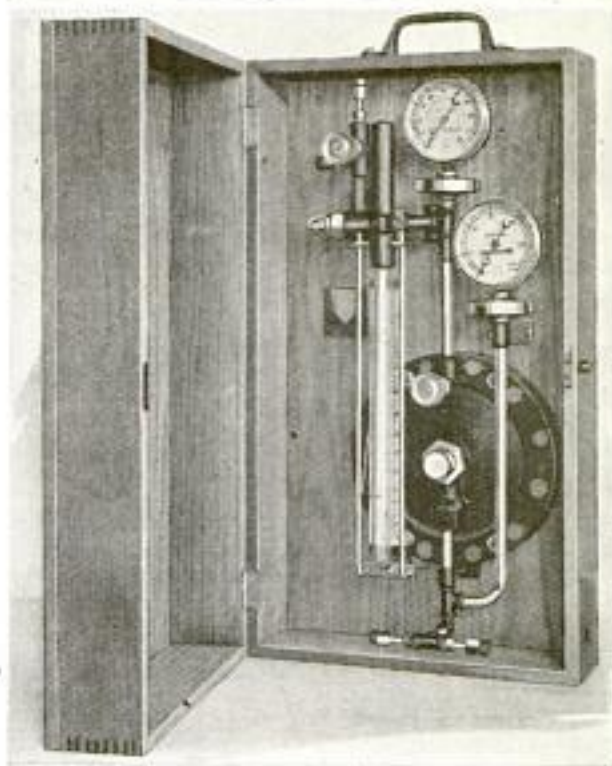

Portable Chlorinator, Showing Pressure Compensator, Pressure Gauges, and Meter for Measuring Chlorine Gas



A Chlorinator of the Type Commonly Used for Water Purification, but Modified for the Purpose of "Gassing" Bad Odors

tion that the process is practical. One of these took place at the Barren Island plant, where dead animals from New York City are cremated. The odors are carried off by means of a large stack. After it had been demonstrated that the odors from this stack, which are particularly offensive, could be completely overcome, a permanent installation of the sort described was made.

The second test was made in getting rid of sewer gas in Cleveland. The city is planning a large sewage-disposal plant on the lake front, near the heart of the city, and was faced with the problem of getting rid of the sewer gas in an inoffensive manner. It was finally decided to build an enormous stack, 200 ft. high, to carry the gas to a height where it would not be a nuisance.

The efficiency of the chlorine process was tested in this case by introducing the gas into the sewer about 175 ft. from the point of discharge. It was found that only a white haze was left at the mouth of the sewer and this was entirely without odor. As a result of this test, the plans for the new plant have been modified, and a stack only 50 ft. high will be provided.

7832P



Laying Concrete-Block Paving along the Miami River at Dayton: The Ends of the Half-Inch Cables, Which Hold the Blocks in Place, can be Seen Projecting from the Last Row. Though the Cables Keep the Blocks from Sliding into the River, They Allow the Entire Mattress to Settle and Adjust Itself

FLEXIBLE CONCRETE MATTRESS PROTECTS LEVEES

BY IVAN E. HOUK

*City Engineer's Office
Dayton, Ohio*

RECENT floods in the Great Miami River at Dayton, Ohio, have demonstrated beyond question the practicability of protecting levee slopes from erosion during periods of high water by flexible concrete-block paving. Owing to the comparatively crooked course of the river through the city, which throws the center

of the current from side to side, the velocity of the water is unusually high along the banks on the outer edges of the bends during even moderate freshets. To protect the earth and gravel slopes from erosion at such times, the engineers of the Miami Conservancy District constructed the flexible concrete paving



The Blocks are Anchored to Concrete Slabs Laid on the Bank just above them. The Tops of Piles, Driven at the Lower Ends of These Slabs, are Imbedded in Them When They are Poured, as are Also the Upper Ends of the Cables Which Run through the Blocks

shown in the accompanying views. The concrete blocks which form the flexible paving are 5 in. thick, 12 in. wide, and 24 in. long. They were laid flat on the river bed and bank, breaking joints like brick in a wall, and were tied together by $\frac{1}{2}$ -in. galvanized-steel cables, run at right angles to the levee through holes in the blocks, thus weaving them into a continuous flexible mattress. There are no connections whatever between the blocks except the steel cables. Consequently the entire mattress, or any part of it, can sink down whenever it is undermined by the current.

The mattress is anchored in place by tying the steel cables into reinforced-concrete slabs laid higher up on the bank. The slabs are 6 in. thick, 8 ft. wide, and of variable length, depending on the length of the slope to be protected. They have footings at their lower ends, extending 18 in. into the ground. The slabs are held in place by timber piles, driven deep into the bed of the river beneath the footings before the slabs are cast. The upper

ends of the slabs are left projecting above the ground, and the concrete to form the footings is poured around, so that the slabs are fastened rigidly to the piles.

During flood times the concrete slabs and blocks protect the river bed and



When Floods Scour Out the River Bed under the Edge of the Block Mattress, It Settles into the Depression. After One or Two Floods, the Mattress becomes Adjusted So That No Further Erosion and Settling Occur

banks beneath them. At the river edge of the mattress, however, the swift current cuts away the earth and gravel, gradually undermining the concrete blocks. When this happens, the mattress simply settles down so as to cover the shore side of the hole, thus stopping the erosion.

7548
**BANDITS OUTWITTED
BY SAFETY DOOR**

Bandits have been outwitted by the use of a patented revolving door which op-

erates similarly to the ordinary revolving door seen in large buildings, except that its turning can be controlled with a pedal. If placed in front of a paying teller's, or cashier's window, it insures privacy to any

person receiving money, so that in the case of large withdrawals for pay-roll or other purposes, the amount cannot be seen by possible holdup men. By means of a properly placed mirror, the person entering the door can be seen by the cashier, before the window is reached. Thus if a suspicious-looking character enters the door with the apparent intent of holding up or shooting the custodian of the money, the simple release of the pedal would imprison the would-be thief until the arrival of the police.

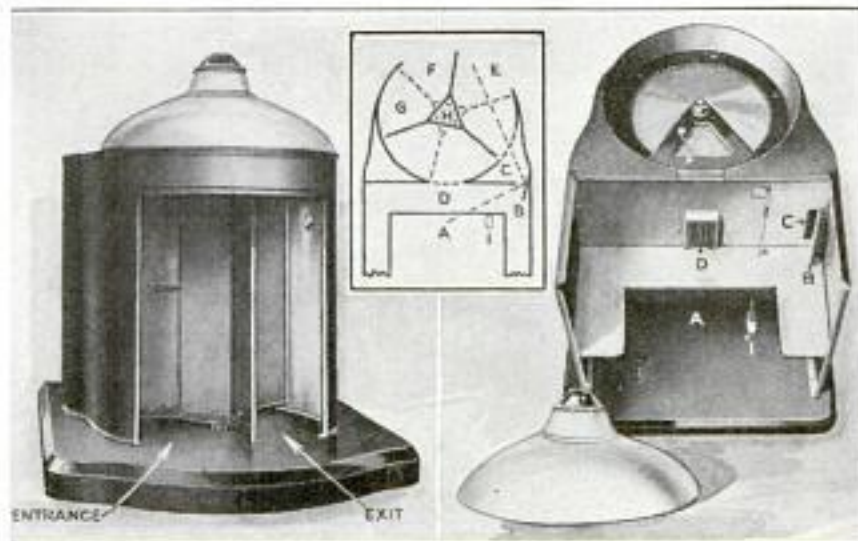

Views and Diagram of Door: A Indicates Cashier's Place; B, Mirror; C, Window; D, Cashier's Window; E, Entrance; F, Exit; G, Space Where Bandit may be Locked In; H, Locking Device, and I, Control Pedal

el no. H. H. Brown, Duluth, Minn.
Cont. A. B. Thompson, 20 W. 2nd St. Duluth

cl no Mr. A. C. Christopher,
 Millard, Ohio.
 POPULAR MECHANICS

222
 78/4

**SIMPLE DIVING HELMET
 GIVES GOOD RESULTS**

A diving helmet, which is not water-tight but gives good results in water not



The Complete Diving Helmet and Air-Supply Pump Which Gives Satisfactory Results in Water of Any Depth Up to 20 Feet

more than 20 ft. deep, has been invented. It is made of cloth, fitting loosely over the head and shoulders and tied about the

neck. It requires only a moment to adjust it, and it is kept inflated by means of a hand pump. The air compression excludes water in the same way that the air in a glass, thrust into water, open end down, excludes the water. A glass window permits clear vision under water. The diver sinks by means of weights carried in his hands, which he can drop, in case of a failure of the air supply, and rise to the surface without assistance.

7451
**SAN FRANCISCO BAY CROSSED
 ON WATER-WALKING MACHINE**

Walking on water has been reduced from the miraculous to the practical before now—once, for instance, with a pair of pontoon shoes—but never quite in the manner done recently by a California rancher, who with his device has actually walked across the bay from San Francisco to Oakland. The water-walking machine is in the form of two light metal pontoons, each about 9 ft. long, and 12 in. wide at the center, tapering to points at either end. These are suspended from a flat wooden frame, so constructed that when the operator stands, with his feet connected to the center of the pontoons, rollers between the frame and the pontoons permit him to move them back and forth by the act of walking. Hinged to the sides of the pontoons, and operated beneath them, are three self-feathering paddles, which give propulsion. There is also a rudder for steering.

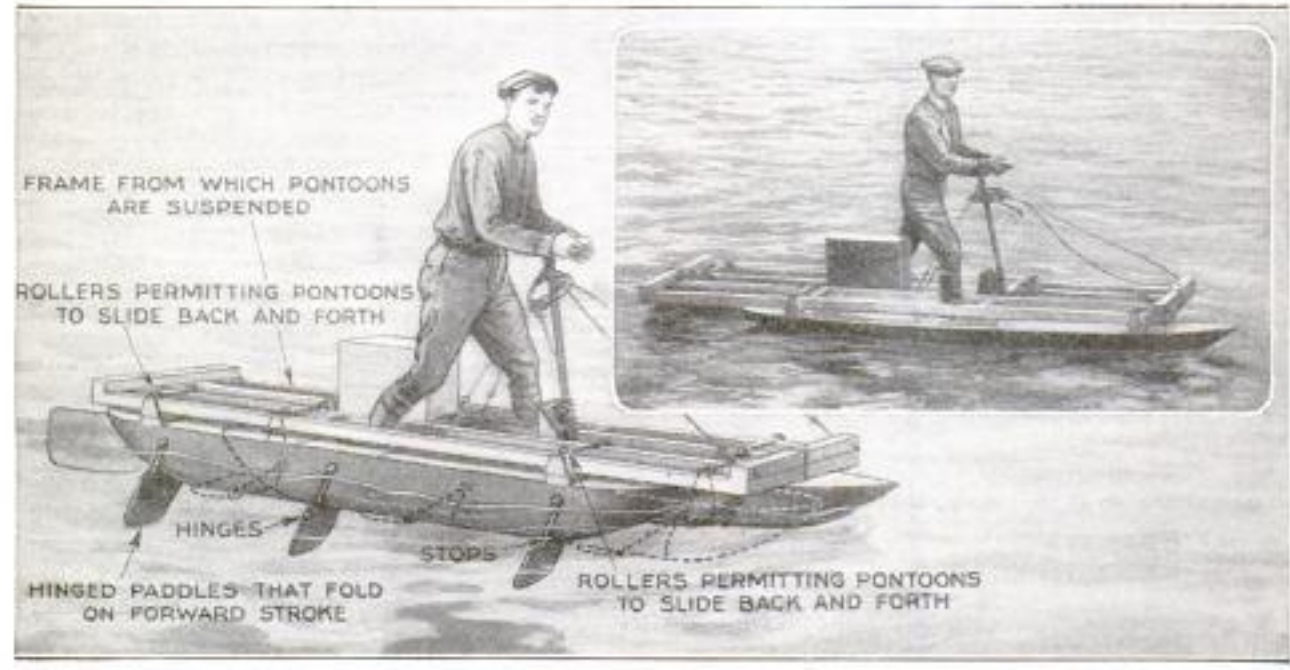

Machine for Walking on the Water Shown in Operation in the Inset, and in More Detail in the Enlarged View with Notations: The Propelling Paddles, Shown below the Hull, Are Self-Feathering. The Rudder at the Stern is Controlled by a Tiller in the Operator's Hands Which Also Affords Him Support, Enabling Him to Move His Legs Freely

cl no. A. N. Sheldon, Ventura, Calif.

7687

Bertelsen + Peterson

POPULAR MECHANICS

223

East Boston, Mass

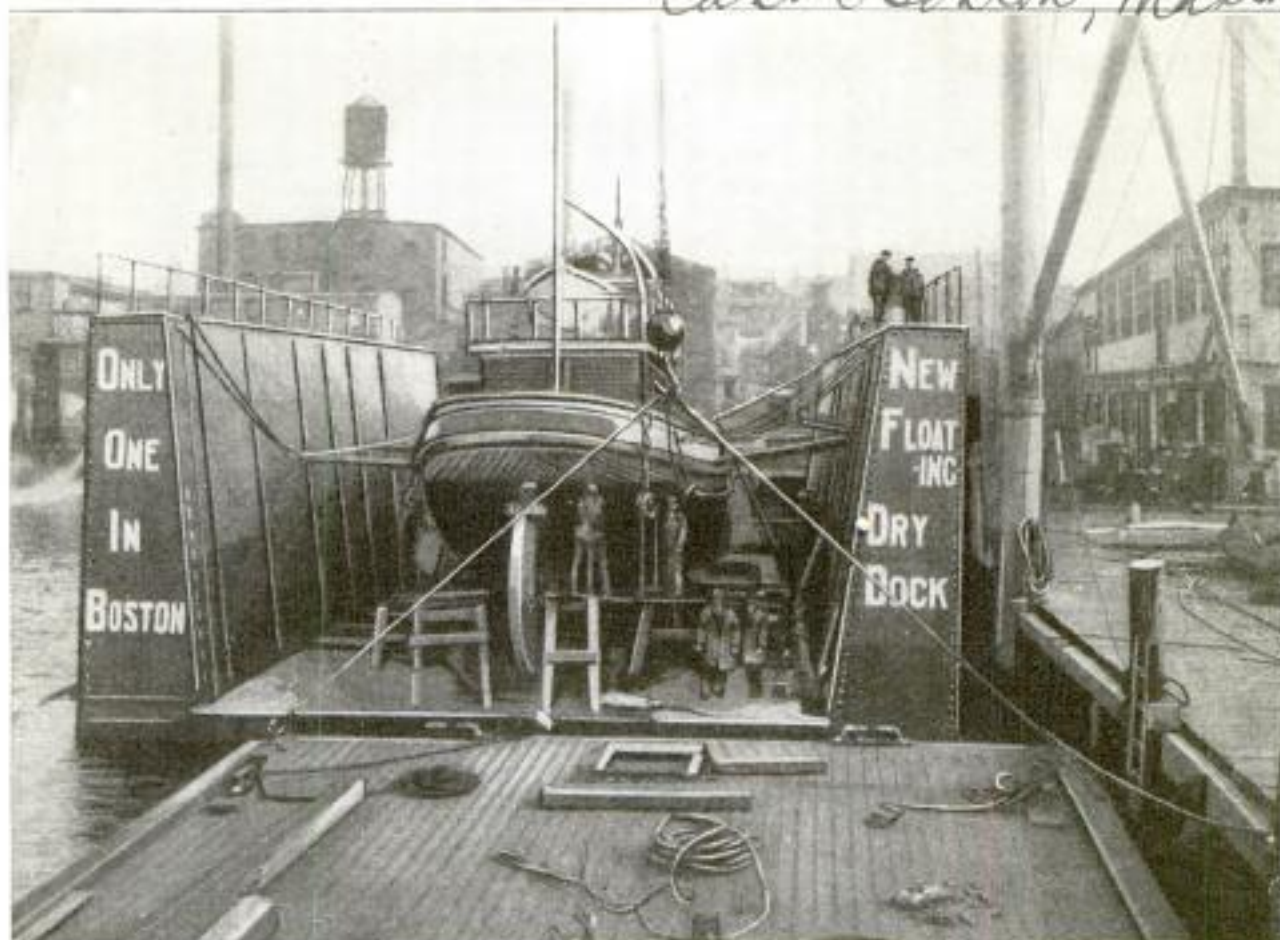

Floating a Tug on the New Steel Drydock Recently Built and Put into Operation at Boston, Massachusetts: This Dock is the Only One of Its Kind in Boston and Probably the Smallest Floating Dock in the United States

SMALLEST FLOATING DRYDOCK OF STEEL IS LAUNCHED

A floating steel drydock, said to be the smallest in the United States, was recently completed and put into operation at Boston, Mass. There are no other drydocks of the same type in that city and only a few in the entire country. It is 100 ft. long, 45 ft. wide, and its pontoons are 6 ft. deep. The nine water-tight compartments can be emptied in 20 minutes by three centrifugal pumps. It has a lifting capacity of 500 tons and was especially built, by the company operating it, for handling small tugs and trawlers.

MONSTER EAR OF CORN THIRTY FEET HIGH

Among the exhibits at the International Grain and Hay Show, in Chicago, was a monster ear of corn, 30 ft. long. It was man-made, of course, but was such a close imitation that, at a little distance, there was nothing to distinguish it from a natural ear. Sixty bushels of corn were used to build it. The ears were split in half and attached to a central "cob." The

corn used to build this exhibit would have been sufficient to fatten five hogs from 100 lb. to 220 lb. each.

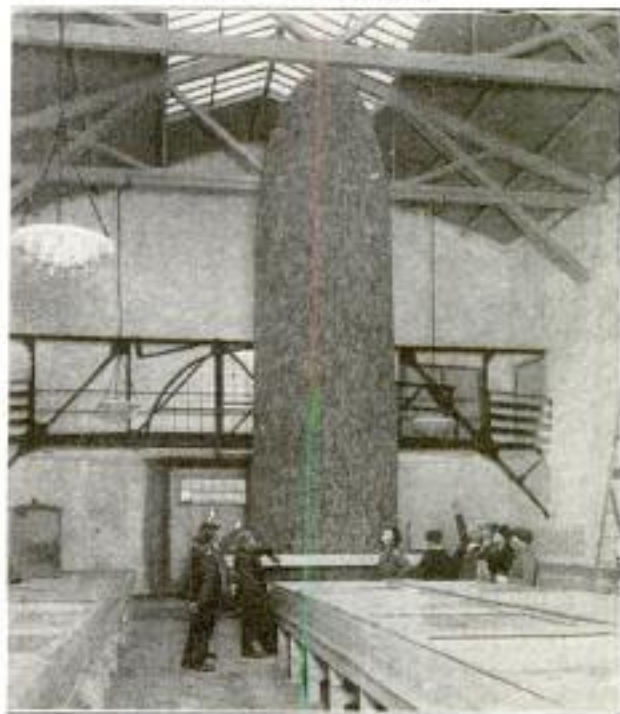

Monster Ear of Corn, 30 Feet High, Exhibited at the International Grain and Hay Show, Which was Recently Held in Chicago

Cust. C. to Moulton
Room 2 Board of Trade, Chicago

**"GOING-GOING-GONE" PHRASE
IS OBSOLETE AT AUCTIONS**

Auctioneering by electricity, which entirely eliminates the familiar loud-voiced methods formerly used, is carried on with

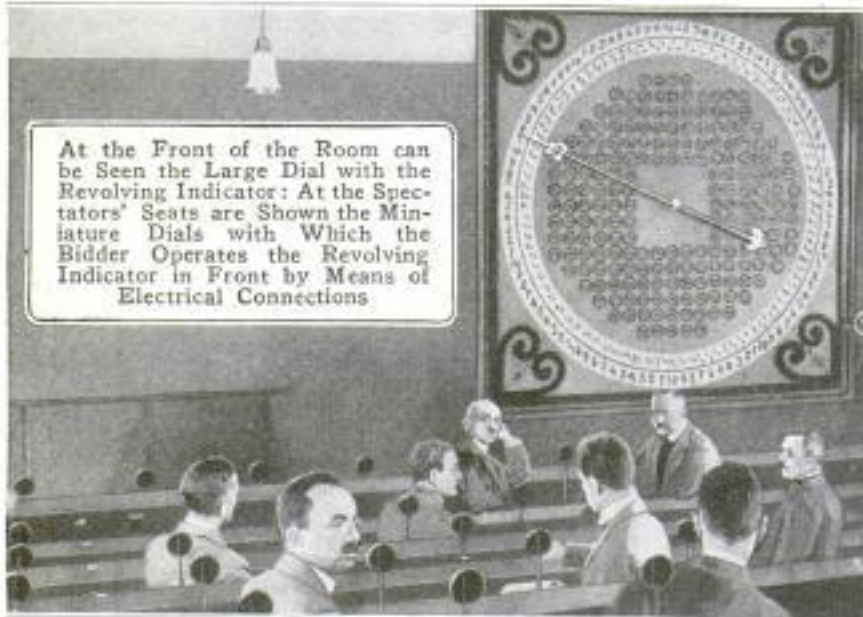

the aid of lately developed apparatus. A large dial, with a revolving indicator, is divided into numerals representing money, and has the designations of all the seats in the auction room appearing on it. This large dial is elevated in full view of those present, and at the bidders' seats are placed miniature duplicates of the large dial. When a bidder wishes to make an offer, he turns the indicator of the small instrument before him to the amount offered. By means of electrical connections, the indicator of the large dial swings to the same number, and the designation of the bidder's seat is illuminated on its face. Thus the auctioneer, and others present, can tell without confusion, how much has been bid and the location of the bidder.

**NEW 22,000,000,000-GALLON WATER
RESERVOIR FOR NEW YORK**

The water supply of New York City will be supplemented by the new Gilboa reservoir, being built on the headwaters of the Schoharie River, in the Catskill Mountains. It will cover 1,170 acres, be 5.8 miles long, from .3 to 7 miles wide, 57 ft. deep, and have a capacity of 22,000,000,000 gal. The water to maintain this great reservoir supply will come from a 314-square-mile watershed on which the average annual rainfall since 1907 has been 40 inches.

Machinists and inspectors can now true, or check up on, their work, very rapidly and efficiently by using an electrical locator recently brought out by a Lynn, Mass., concern. The instrument receives the current necessary for its operation from any light socket. It has a ball pointer, which can be placed in an ordinary chuck, and also a small steel lamp base holding an electric-light bulb. For operation, a plug and cord are attached to a light socket, one of the cord wires being connected to the ball pointer, while the other is connected to the lamp in the steel base. This base is placed on the bed of the machine, and the current

flows from the base to the work. When anything with a round surface is tested, the object is rotated in a lathe, and then the ball pointer is set so as to make contact with the turning piece of work. If the surface of the work is true, there will be a constant flow of current from the ball pointer to the revolving surface, thus causing the lamp on the instrument to burn steadily. If the work is not accurate, the low or uneven places will not come in contact with the pointer, and the electrical circuit from the socket to the lamp will be broken. The lamp will then flicker on and off as the contact is broken.

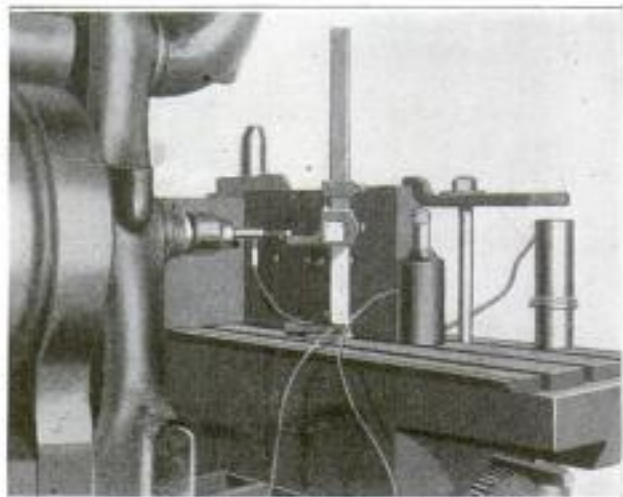

In the Chuck at the Left is Shown the Ball Pointer Which Rests on the Work being Tested. The Indicating Lamp is Seen in the Center

TEACHING BAL- LOON CONTROL TO OBSERVERS

By FRANK B. HOWE

*472 Mason Opera House,
Los Angeles.*

GREAT progress and many interesting developments are being made at the Naval Air Station, San Diego, Calif., in the training of balloon observers.

In the first place, a mechanism has been devised, somewhat on the order of the army trucks, which is equipped with balloon-handling apparatus. This enables the novices to practice balloon control without the usual attendant danger.

An old automobile engine was mounted on a stationary platform in the middle of the field and made to operate the drum carrying the cable that holds the kite balloon used in this work. Here the sailors who are learning to manage balloons can practice to their heart's content

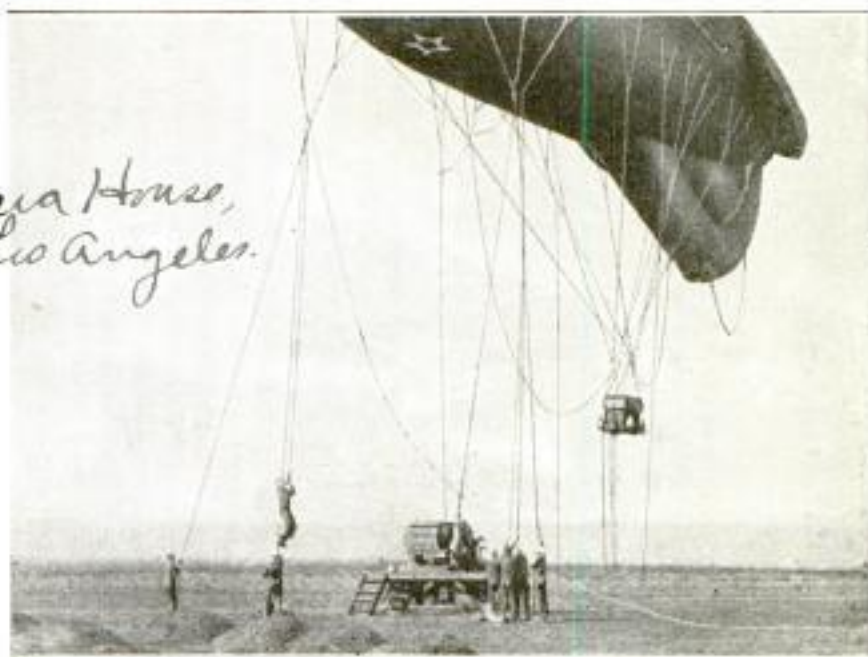

The Balloon Pulled Down within 30 Feet of the Ground, While the Students Practice the Difficult Task of Climbing up and down the Rope Ladder

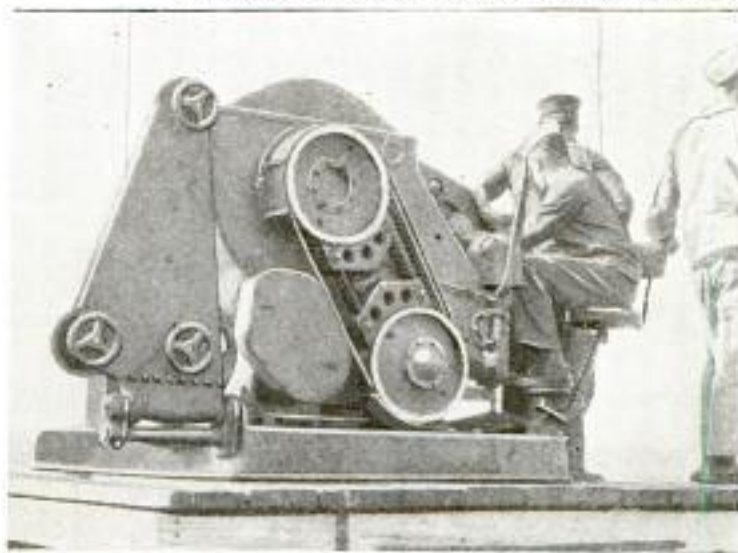

The Old Automobile Engine, Mounted upon a Platform for the Purpose of Operating the Winding Drum for the Cable That Holds the Balloon in Leash

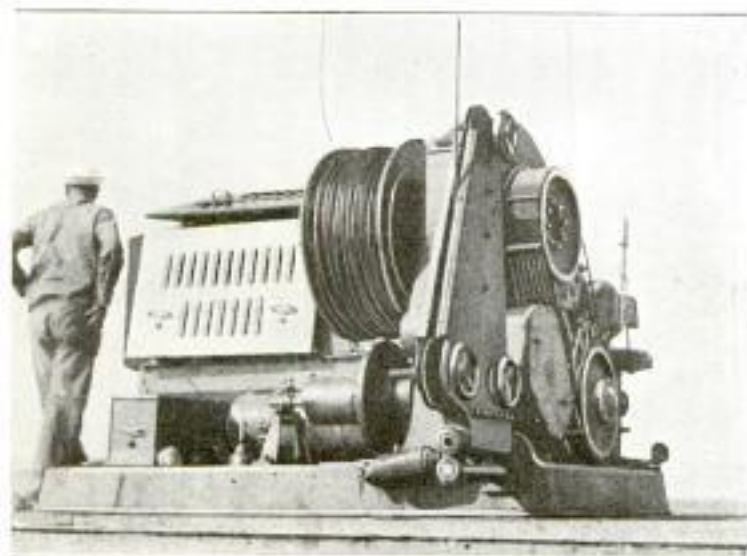

This Is Another View of the Automobile Engine and Cable-Drum Apparatus Which is Used in Controlling the Raising and Lowering of the Practice Balloon

without taking any chance of damaging the expensive balloon. The engine, which is kept running, is thrown in and out of gear with the drum at will, and two dials indicate the length of cable that has been let out. With this mechanism, they let the balloon out and haul it in until they are thoroughly

familiar with its handling.

To avoid having to pull the balloon clear to the ground each time some one wants to get in or out of the basket, a rope ladder, about 20 ft. long, is suspended below it. Hauling the balloon down with the auto engine until the rope ladder just comes within reach, the sailors practice running up and down the ladder until they become proficient enough to be able to do it under actual flying conditions.

Observation can also be studied under actual conditions by this method of rapid handling of the balloon. It is a simple matter to take up a number of the students, leave the big balloon at any given height, and let them

practice in making observations and determining distances, ranges, and weather conditions, all of which are of vital importance in warfare.

By the use of the stationary balloon-controlling apparatus, it is possible to give the students practical experience, instead of theory alone. As a result, they will be thoroughly familiar with the work, should they be called upon for duty in a future war.

7205 **CRANE ANCHORED IN WALL OF BUILDING**

When a company in Dayton, Ohio, decided to erect a 13-story addition to their

J. E. Herbit, 322 Middle St. Dayton, Ohio.



The Crane, Extending above the Tall Building, is Anchored to Its Wall. The Anchor can be Seen About Three Stories below the Roof

present building, they discovered that there was no ground on which to set their hoisting crane. All the surrounding property was occupied, and, the site being

in the center of the city, use of the street was out of the question. However, the addition is going right up. The crane for hoisting the heavy steel girders and other material was anchored in the wall of the building to which the new structure is to be an addition.

7244 **POROUS-CONCRETE CASINGS USED AS WELL STRAINERS**

Casings of porous concrete for well strainers are being used with satisfactory results in place of the usual brass strainer and steel casing. The porosity of the concrete is obtained by using a mix of one part cement to four of gravel, without sand, and with the gravel suitably screened. A casing of 36-in. internal diameter is made in 48-in. lengths, which are reinforced with 1/4-in. steel rings and 1 1/4-in. vertical pipes. These are sunk by means of a steel casing with a cutting edge, which is removed when the concrete casing is in place. The concrete shell permits a flow of about 10 gal. of water a minute, and does not become choked with sand as readily as the ordinary brass strainer.

7691 **TRAILER FOR HEAVY LOADS HAS FOUR WHEELS ON ONE AXLE**

A trailer with four wheels on one axle, for the transportation of extremely heavy loads, has been built for a large steel concern. Between each pair of wheels a separate set of springs is provided. In this way a bump on one side only is absorbed without bouncing the load to an extent which would injure either the load or the trailer. This trailer is attached to the truck on its own turning pivot, and a set of heavy coil springs takes up any shock from sudden starts or stops.

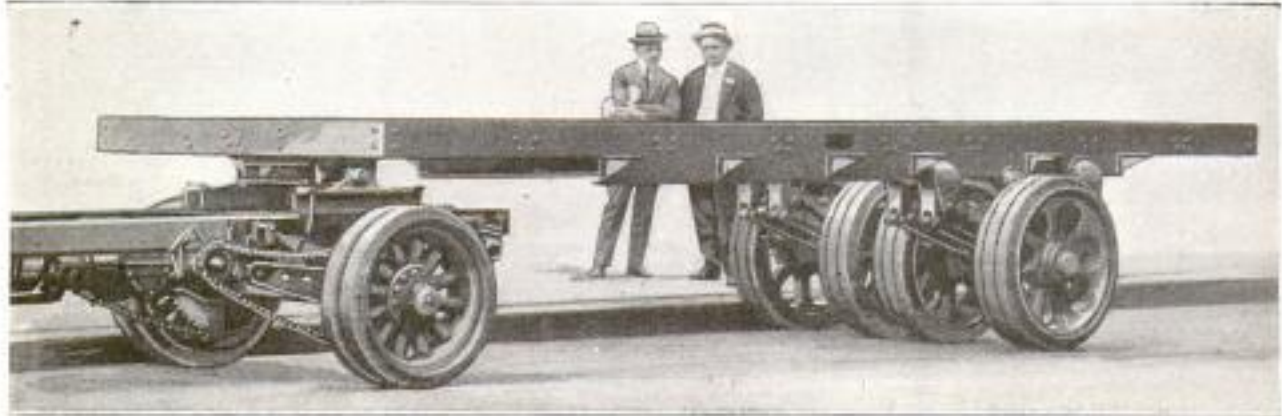

Exceptional Strains Caused by the Extremely Heavy Loads Carried on This Trailer are Met by the Novel Arrangement of the Wheels and Heavy Springs. The Rear Springs can be Seen Placed between the Two Sets of Wheels. Those Taking Up Starting and Stopping Strains are in the Turntable

Eng Charles C. Reid 221 Salem Ave Dayton, Ohio.

7391 Emb. Ins. Ls. & Brady
 American Embassy, Chaicas 708
 POPULAR MECHANICS
 Buenos Aires, Argentina S.A.
 ARGENTINE INDIANS CROWDED OUT OF OLD HAUNTS



Mataco Indians, Members of a Warlike but Intelligent Tribe of the Argentine Chaco Family: Upper Left, Men, Who Have Two Languages; Below, Women, Who are Allowed to Learn Only One; Right, One of the Mataco Chiefs Who Act as "Labor Leaders" on the Plantations. One Chief Led His Indians Off to the Forest When Refused a Wage Increase

7391
 As the great quebracho forests of northern Argentina are being cut away to satisfy the ever-increasing demands of the United States and Europe for quebracho tanning extract, the fierce tribes of natives that held out against Spanish rule for three centuries are losing their old hunting grounds, and are sullenly taking their places in the sugar and cotton fields of the white settler.

During the three centuries after the conquest of Peru, the Spanish missionaries penetrated all parts of South America, but were never able to gain headway among the wild tribes of what is known as the Gran Chaco of northern Argentina and western Paraguay. This vast country is flat and densely covered with forest, and many tribes still roam over it in primitive state. These tribes, belonging to what is known as the Chaco-Guaycuru family of Indians, were described by the early Spaniards as ferocious and irrecconcilable, with an intense hatred of the white man. They were restless nomads who lived by hunting and fishing. Only within the last 20 years have they allowed the white man to advance his settlements, and then only because of fear of the Argentine army. They are now almost resigned to their fate, and they come to

the settlements in large numbers to work in the cotton fields or in the sugar mills.

One sugar plantation and mill employs over 2,000 of these Indians at present. They still keep to themselves and persist in their own customs. They live apart in "toldos," or reed huts, dye and tattoo their skins, and adhere to their ancient ceremonies. They have formed a great liking for the American moving pictures, however. At the plantation, owned by an English company, a moving-picture show is provided at the Indian village every Saturday night, and although they understand neither English nor Spanish, the Indians squat on the ground and follow the actors with many grunts in their guttural language. The American cowboy actors are their favorites.

7840
NEW PROCESS TO USE RUBBER AS PAPER-MAKING MATERIAL

Rubber will be used in paper making by a recently patented process, which is the result of many years' experiments. Rubber latex, or milk, as it comes from the tree, is mixed with the paper pulp. Many kinds of paper are benefited in this way. The proportion of rubber varies, up to 20 per cent, for different papers.

*Inv. Fred Kaye, Eng.
 New Rubber Age. 1/21*

7717 Cmt. Arthur Hallam
317 Cedar Ave. Minneapolis, Minn.
YARD HANDLES LUMBER WITH ELECTRIC MACHINERY

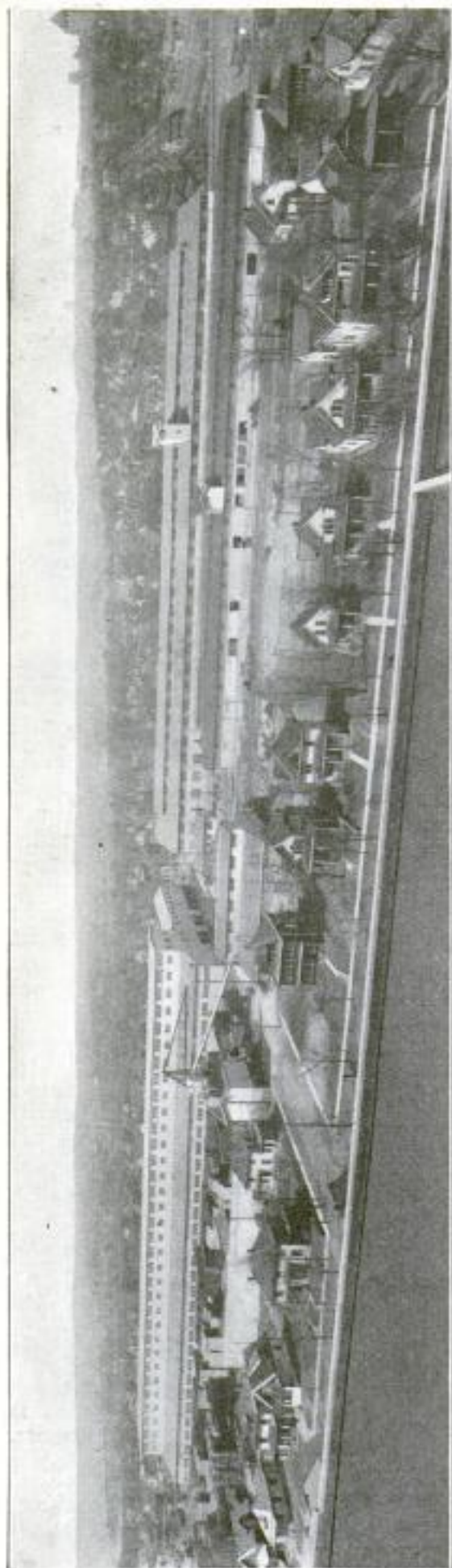

General View of the Minneapolis Lumber Yard Where Electrically Operated Machinery has Almost Entirely Done Away with Manual Handling of Lumber Previously Used: The Method in Operation Here was Worked Out as the Only Practical Means of Reducing Costs in the Lumber Business

IN a large lumber yard at Minneapolis, Minn., practically all the handling of lumber is done in large units by electrically operated machinery. Realizing that the cost of lumber production is thoroughly standardized, this company decided that the only point at which a saving could be effected was in the handling of the lumber in the retail yard. The method, based on large-scale machine handling and systematic routing, is the result of that decision, and it has proved highly successful in every detail of practical operation.

Incoming cars of lumber are made into trains each morning at the railroad yard, hauled to the company's plant and placed on sidetracks, alongside the building used to store the particular type of material which they contain. An electric overhead crane lifts the lumber from the cars in large "bites," and piles it in the storage sheds. In this way a car can be unloaded in 30 minutes, while formerly it took two men an entire day to unload a car by hand. This is typical of the efficiency with which every operation in the yard is now performed, in contrast with the old method.

When an order comes to the yard, it is turned over to the yard foreman. Under his direction it is picked up from the piles in large units by the electric cranes, which deposit it on trucks or trailers waiting at the ends of the storage sheds. The piles are so arranged in the sheds as to facilitate the rapid filling of orders, and only a few minutes are required for the loading of each truck. When it is necessary to deliver a load to another part of the yard, the crane places it upon a small trailer, or "lumber buggy." This is pulled by a small electric tractor to the point where it is needed. The whole process of transfer requires only a few minutes for completion.

Heavy timbers, which are piled outdoors, are handled in the same way as other lumber. A special crane, on a track running the full length of the yard, is used for handling this type of material, and the timbers are piled in jagged piles so that they may be picked up easily, in units, by the crane.

The yard is planned in such a way that it is almost completely self-contained, and no outside help is required in any of its operations. A sawmill is so located that the cranes can carry lumber from the piles of stock to the saws. For orders needing special preparation, a planing mill is also provided which is supplied in the same way, by the cranes. In addition

Thompson Yards, Inc.
 Sawing + Harnischfeger Milwaukee



Main Lumber-Storage Shed, Showing the Crane Which Picks Lumber from the Cars and Piles Inside the Shed: The Crane Is About to Deposit One of Its "Bites"

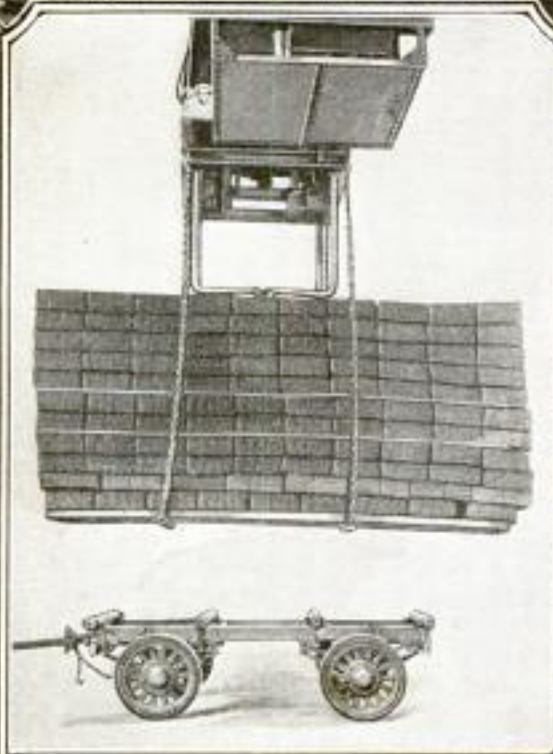

Placing a Load of Shingles on a Truck Trailer for Delivery: A Whole Load is Picked Up from Stock and Loaded in This Way

Mercury Mfg. Co., Chicago

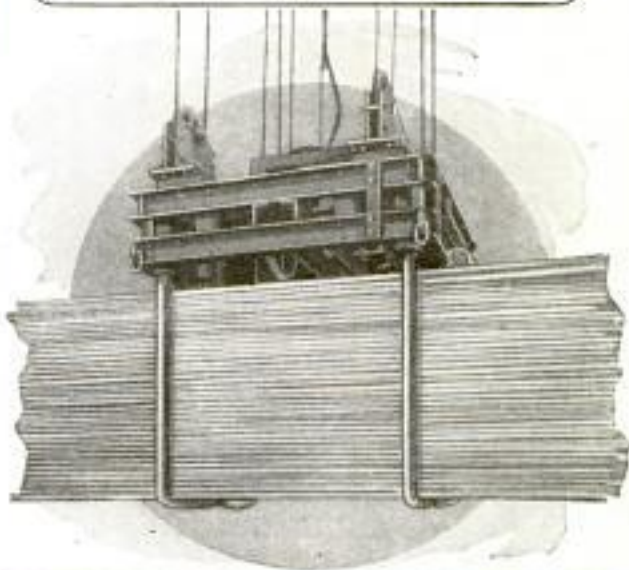

One of the "Bites" of Lumber Picked from the Flat Cars by the Electric Overhead Crane Which is Used for Unloading: This Method Effects a Great Saving in Labor and Time

Colby Steel & Eng. Co.



Seattle, Wash.

A Truck and Trailer Loaded by the Electric Crane and Ready for Delivery within a Few Minutes After the Order had been Turned Over to the Yard Foreman: Here Again the Saving in Time Greatly Reduces the Total Cost of Handling Lumber in This Yard

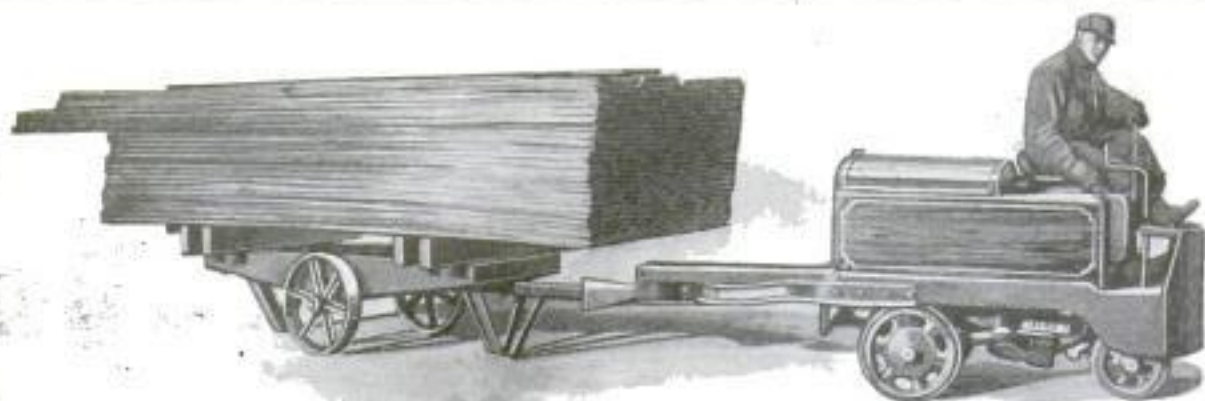

One of the Small Trailers or "Lumber Buggies," Which are Used When It Is Necessary to Transfer Lumber from One Part of the Yard to Another: The Tractors Which Pull These Trailers are Electrically Operated

to these, the yard contains a horse barn and a garage where 24 trucks are housed. The garage includes a shop for repairing

gas, was necessary in maneuvering. The United States has the only known sources of helium in the world of sufficient magnitude to permit its use for balloon inflation; which would give this country a tremendous advantage in the air, in case of any future war. Helium is obtained from natural-gas wells.

2839
NEW PROCESS RECOVERS SILVER FROM FIXING BATHS

Fixing baths used in photography contain more or less of the silver emulsion with which the plate or film is treated to make it light-sensitive. While the amount of silver is too small for the amateur to recover profitably, those doing this class of work on a large scale, find it worth while to regain this necessity. A scientist has recommended a compound called sodium hydrosulphite, which precipitates metallic silver from the solution in the fixing bath. After the bath has been treated with sufficient of this compound, it is thereby revived, and can be used again. This compound has industrial application along several lines, considerable amounts being used in reducing indigo in the ordinary methods of dyeing with this color.

For the first time wireless-telephone messages have been sent from a balloon, at McCook Field, Dayton, Ohio. Though messages have been received by balloons, sending was considered impossible because of the danger of sparks igniting the gas. Lieut. Philip Schneebarger successfully kept in touch with the ground for 25 miles.



The Outside Crane, Used in Moving Heavier Lumber Which can be Stored Outdoors: The Crane Is Just About to Place Its Load upon the Delivery Truck

trucks and tools, for blacksmithing, building truck bodies, painting, and for charging the electric tractors which are used within the yard.

7876
FIRST FLIGHT WITH HELIUM-INFLATED NAVY DIRIGIBLE

The United States naval dirigible "C-7," the first balloon ever inflated with helium gas, made its trial flight, from Hampton Roads, Va., to Washington, D. C., and return, early in December. This test of the noninflammable gas proved satisfactory in every particular. The most notable features of the test were that there was no dispersion of gas through the balloon fabric, perfect inflation being maintained during the entire trip, and that no "valving," or release of

Ref. Times 12/5/21
 P. 13

Colby Steel & Engineering Wash
 D.C.

Journal of November 1921

7886

Westinghouse Electric Co. *Wide World Photos*
E. Pittsburgh Pa. *231 New York*
POPULAR MECHANICS
RADIO SERVICE BROADCAST
OVER ENTIRE COUNTRY
7715
WREATH INCASED IN ICE SENT
FROM ANTIPODES TO ENGLAND

Great success and widespread interest has been the outcome of pioneering in radio-telephone broadcasting, and a plan is contemplated whereby the entire United States will be covered with a service to the home, that will allow anyone to enjoy the many benefits of wireless. The service started with the transmission of the presidential election returns in November, 1920, and now includes the sending of musical recitals, grand opera, church services, speeches of prominent men, results of sporting events, government and stock-market reports, and national or international news of all kinds. Even "bedtime stories" have been sent out for children. It is predicted that this undertaking will prove to be of such expanding value to mankind, that the radio-telephone will soon be as popular in the home as the phonograph is today.

7653
**FORGERY CAN BE PREVENTED
BY USE OF SCORCHING PEN**

Those who fear forgery, or the "raising" of their personal checks, may find relief from these fears by using a scorching



When the Cord of This Pen is Attached to an Electric-Light Socket the Point Becomes Hot Enough in 30 Seconds to Scorch Paper

pen when filling out checks. The pen is an electrical instrument, operating on the same principle as the familiar electric curling irons, and similar appliances, with cord attachment for sockets. A heating element inside the barrel of the pen, makes the point hot enough to scorch paper, leather, wood, cloth, and like materials. Thus, besides safeguarding checks by making letters and figures which cannot be removed, the pen can also be used for pyrographic work on wood or leather.

The anniversary of the battle of Trafalgar, known in England as Trafalgar Day, is always celebrated by the decora-

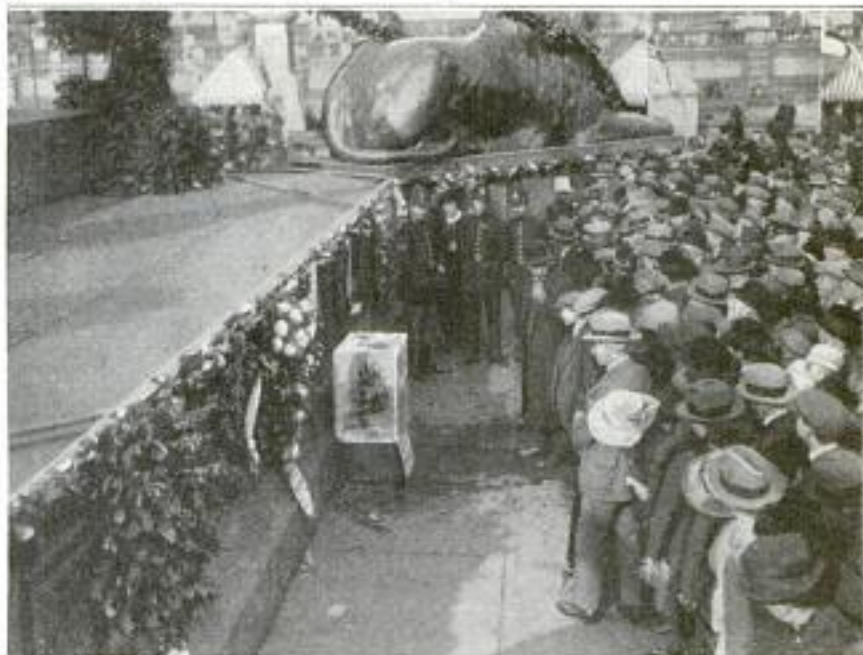

Among the Decorations Placed upon Nelson's Monument, in London, England, Last Year, in Celebration of the Anniversary of the Battle of Trafalgar, Was a Wreath Preserved in a Block of Ice Sent from New Zealand

tion with flowers and wreaths of the great monument in Trafalgar Square, London, which was erected in honor of Admiral Nelson, who commanded the British fleet at the notable victory. Last year a wreath was sent all the way from New Zealand preserved in the center of a block of ice weighing 600 lb. It reached the monument in good condition, and in time to take its place among the other decorations.

7861
**SARDINIA ARTIFICIAL LAKES
AMONG LARGEST IN WORLD**

Sardinia, one of the island possessions of Italy, will soon have artificial lakes ranking among the largest in the world. These lakes are being constructed for irrigation and hydroelectric-power purposes. At the present time, the mining industry of this island forms more than a quarter of the entire Italian output. Zinc alone is produced in the amount of 200,000 tons yearly, but has to be transported to other countries for manufacture. With the hydroelectric power soon to be available, it is expected that, instead of the zinc being exported and then imported in the finished state, this and various other mining products can be manufactured at home.

Electrical Review 11/4/21

Post Electric Co. }
30 E 42nd St. } New York.

7656 Cont. W. K. Crosson
4429 Townsend Ave.

Engineering
New Rochelle

232

POPULAR MECHANICS

Detroit Mich. 7841

11/24/21

NEW TYPE OF DOCK BUILT FOR LOADING BARGES

WINTER STREET-REPAIR WORK DONE WITH OLD ASPHALT

A new idea in dock construction has been employed by the city of Detroit,

Old asphalt is employed for street repairs during the winter months by a

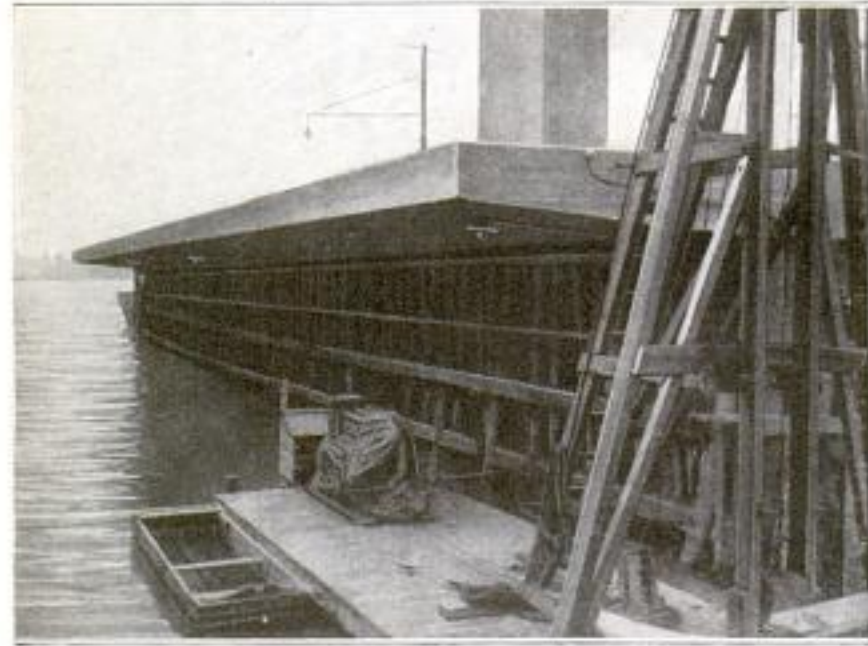

Detroit's New Barge Dock, with a 20-Foot Projection over the Water, Is a Great Aid to the Rapid Loading of Barges

Mich., to facilitate the loading of barges. Dirt, used in the reclamation project by which 200 acres are being added to Belle Isle, is dumped into the barges at this dock. It is built on heavily reinforced piling and the edge projects 20 ft. over the water. Because of this projection half the barge is under the dock, and motor trucks can dump their loads of dirt directly into the center of the barge. The city charges 30 cents a cubic yard for the dumping privilege, collecting revenue at the rate of \$100,000 a year, while securing dirt for its own work free.

method developed at Cincinnati, Ohio. It is broken to about 2½-in. size and heated, with 4 or 5 gal. of water, in 100-gal. tanks, about half full. After steaming for half an hour, the asphalt is turned over and allowed to steam again. This is repeated for three hours, when the water has evaporated, and the asphalt is ready for use at 325 to 375° F. It is hauled to the street in another kettle, over a hot fire, and is laid exactly like new asphalt except that it is tamped instead of rolled. No additional bitumen or dust filler is used, and the cost for repairing is

slightly less than it would be if the repairs were made with new material.

7730 Oct 21

MOVIE-STAR ATHLETE DEFEATS HORSE IN FOOT RACE

George Walsh, the well-known athlete and moving-picture star, has achieved new distinction by outrunning a race horse.



The Finish of a Novel Race: George Walsh is Shown Here Beating a Race Horse at the Aqueduct Race Track, Long Island, New York

CHEAPER LIQUIDS TO REPLACE MERCURY FOR THERMOMETERS

A discovery by Dr. Guido Moeller, a German scientist, may replace expensive mercury thermometers with a cheaper substitute, in places where accuracy within 1 or 2° is sufficient. Previous experiments in this field have failed because suitable liquids were colorless, and dyes did not darken them sufficiently, or would partly decompose at temperatures approaching 400° F. Doctor Moeller has found that three commercial chemicals—cumol, methylbenzoate, and amylbenzoate—can be relied upon for temperatures up to 300°, 400°, and 500° F., respectively. They can be dyed a dark brown with about one per cent of Syrian asphalt.

Engineering 11/18/21

International Photo Service 326 W. Madison Chicago

*New York Edison Co
 W. 42nd St
 New York 23rd
 7660*

POPULAR MECHANICS

**ELECTRIC-BATH CABINET
 MADE IN FOLDING FORM**

The race was the result of a wager made between Walsh and two jockeys, named Sande and Fator. It was held at the famous Aqueduct Race Track on Long Island, N. Y. Walsh's speed enabled him to beat the horse by a good lead.

7684

ROOFED-IN WATER RESERVOIR PROVIDES TENNIS COURTS

What was formerly an unsightly dumping ground at Arkansas City, Kan., has now been made to serve a double purpose—first, as a 2,000,000-gal. reinforced-concrete water reservoir, and second, as courts for playing tennis and volley ball. The new reservoir adjoins a small city park that is thus enlarged, offering more opportunities for play. The roof slab, 5 in. thick, was divided into 24-ft. squares, with expansion joints, which were also cast free from the supporting beams by the use of tar-paper joints. The man-hole openings and ventilators were so placed that ample space was provided for two tennis courts. Pipe couplings were installed in the roof slabs for the net posts, and sockets provided around the wall for posts so that the entire area could be fenced in. The reservoir is 156 ft. in inside diameter and 14 ft. deep below the overflow weir. The water in the reservoir will have the effect of keeping the concrete tennis courts cooler in hot weather than courts on solid ground.

Electric-light baths have proved to be of great value in the treatment of various diseases, and a folding cabinet that can

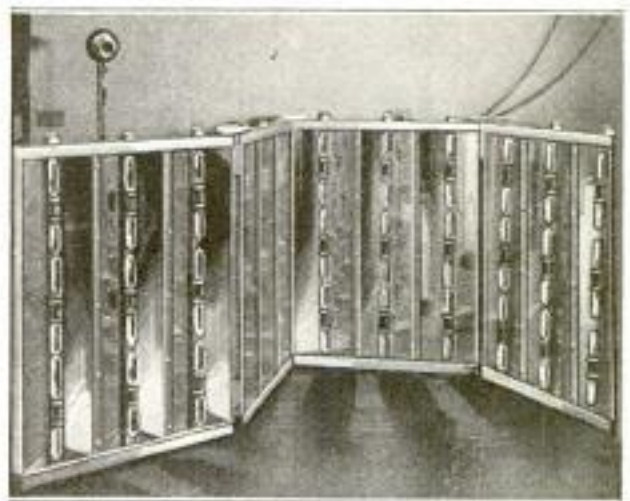

The Four Sections of the Folding Electric-Bath Cabinet: There Are 12 Rows of Lamps, with Reflectors in the Cabinet, and a Connection for Each Row is Mounted on the Top

be used at home, should be welcomed by those needing such attention. The new cabinet has four sections, so that it can be folded small enough to be placed out of the way behind a door or in a closet when not in use.

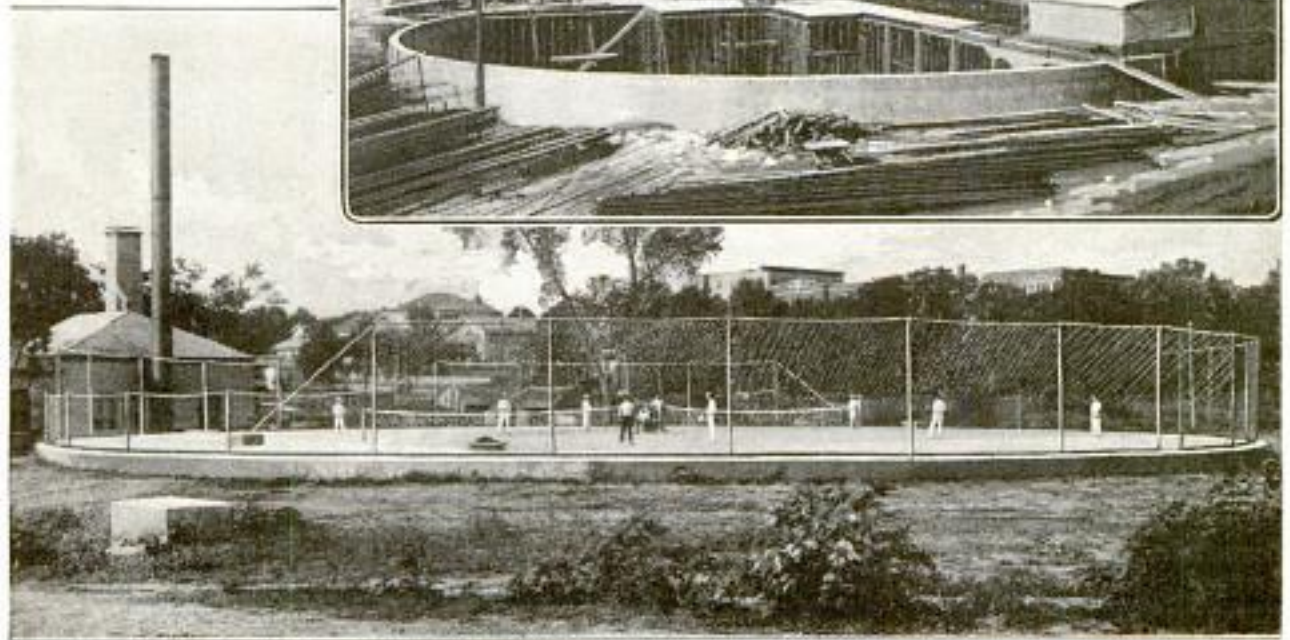

Above: Two-Million-Gallon Water Reservoir Before It was Roofed In, as Seen Below. The Roof, Made of Concrete Slabs, Accommodates Two Full-Size Tennis Courts, Which are Screened In to Prevent the Balls from Straying. Pipe Sockets are Provided in the Concrete for the Screen and Tennis-Net Posts

*Com. George A. Paul }
 900 Ellsworth Bldg } Chicago*

Wm. J. J. Hendricks
H. R. L. Motor Co.,

Engineer

11/11/21

234

POPULAR MECHANICS

7531 Seattle, Wash. 98142

**DRILLING AND STUD-SETTING
MACHINES FOR PROPELLERS**

**CONTEST DRAWS 10,000 IDEAS TO
INCREASE USE OF RUBBER**

With the use of two new machines, the time consumed in drilling and assembling a propeller is said to be reduced from 50 man-hours to as little as three. These machines are respectively a propeller-blade drill and a stud setter for the hub. The propeller blade is set, with its flange downward, on top of the drilling machine, where it is centered and held by three clamps. A handwheel, in connection with a horizontal spindle and a bevel gear, rotates the blade-carrying part of the machine, so that the flange is moved as required for drilling each hole correctly. Within the rectangular body of the machine, below this, is the drill, which is controlled by a crank handle on the outside vertical face. The drill is positioned with a handwheel beside this crank. Adjustments for drilling the blade flanges can be made with extreme accuracy. The other machine is motor-driven, and sets the studs in the propeller hub after the holes are drilled.

Those wishing further information on anything described in the editorial pages can obtain it by addressing Bureau of Information, Popular Mechanics Magazine.

Results of a prize contest for ideas of new uses, or of extending present uses, of rubber, have just been announced. About 10,000 suggestions were received, from more than 2,000 persons, by the Rubber Growers' Association, Inc., of Great Britain, which offered the prizes, totaling £5,000, or about \$25,000 at normal exchange. Though the results were extremely disappointing to the judges, who state that hardly a suggestion was made which had not been anticipated by Goodyear in his book published in 1855, it is thought that the contest will give a great impetus to all the lines suggested. Prizes were awarded for suggestions for using rubber in sponge form for upholstery and mattresses; in liquid form with paint, for preserving wood and metal against the action of sea water, and to prevent the fouling of ships' bottoms; in paint for general decorative and preservative purposes; for automobile mudguards and curtains; with cement, for building purposes; for heat-retaining covers for hot-water cisterns; for the construction of sea buoys; for lining egg boxes and bottle-packing cases; in the con-

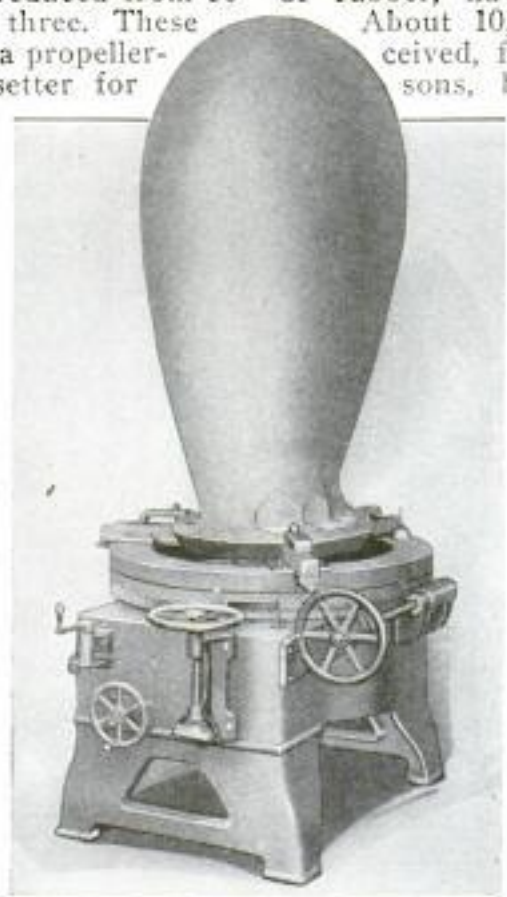

Propeller Blade with Its Flange Clamped to Top of Drilling Machine: Handwheel at Right Rotates Blade into Position for Drilling with Drill inside Machine

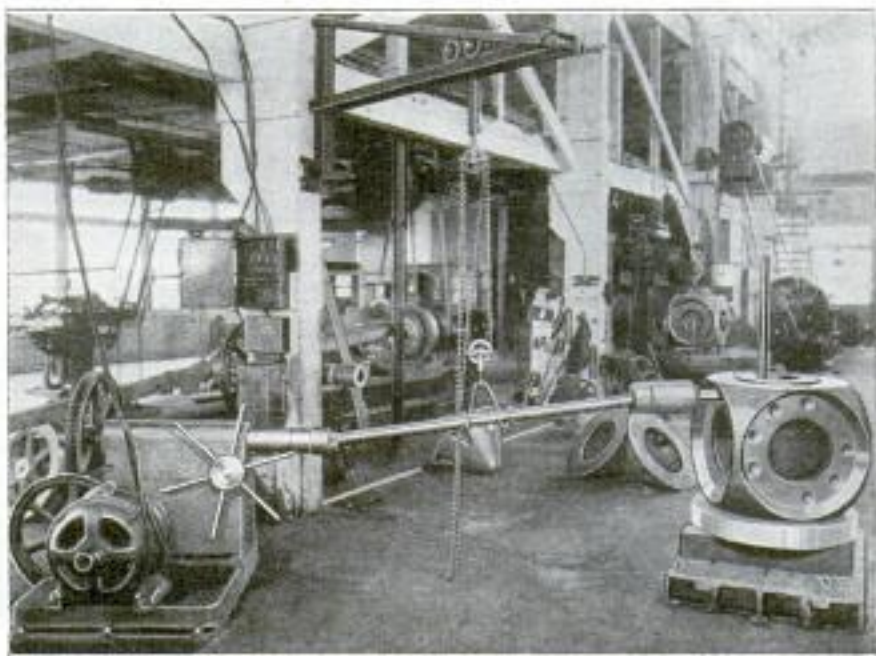

Motor-Driven Machine Setting a Stud in a Propeller Hub: The Holes for the Other Studs can be Seen Already Drilled and Tapped. The Driving Shaft Is Flexible, and can Set Studs in Any Position

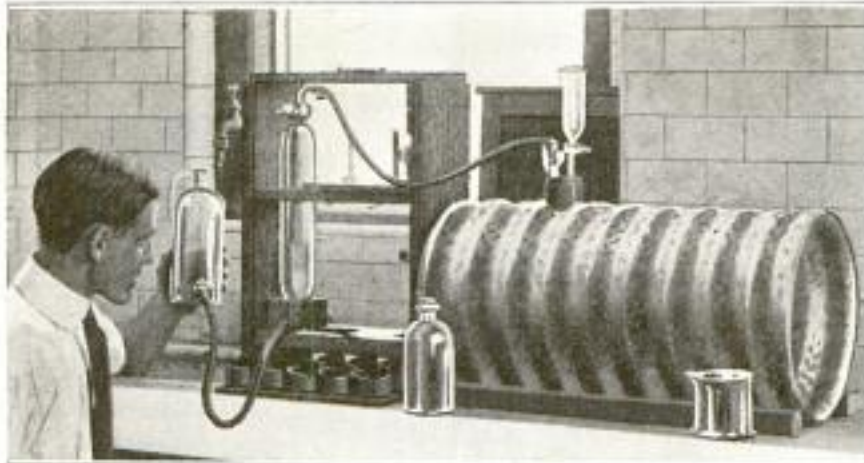

Determining the Weight of Galvanized Coating: The Acid-Resisting Ring Is in Place with the Tubing Connecting It to the Burette in the Cabinet. The Leveling Bottle is being Held at Measuring Level. At the Right, the Apparatus is Shown in Its Cabinet



struction of ship and wharf fenders; for washstand tops; under carpets in place of paper or felt; for fixing window glass in the place of putty; for cistern-chain handles; for clothes pegs or hooks; as fillets for patternmakers; in caps, for the ends of ladders to prevent slipping; for bouncers attached to footwear; in equipment for the arctic regions; as linings to preserve bleaching vats; in bellows, particularly for foundry purposes; as slip-on jar and bottle covers; in crêpe form for rough-surfacing cement; as covers for door handles; for phonograph-table tops; for kneecaps for coal-mine workers; in the composition of certain lubricants, and for water deflectors to be used on the handles of mops and brooms.

TESTING DEVICE WEIGHS GALVANIZED COATINGS

The galvanized coating on sheet metal or wire is usually specified to be of a required weight per square foot. There has been developed an instrument for determining the weight of galvanized coating on a known area by test, either in the laboratory or in the field. The operation of the instrument is based upon the action of hydrochloric acid on the galvanized coating, the hydrogen gas produced being collected and measured. A flat acid-resisting ring of known area, sealed with acid-resisting wax to the object to be tested, has inserted into it a filling tube provided with a glass stopcock, and beside this two exit tubes, which are connected by a rubber tube to a graduated glass tube, or burette, filled with water. Another rubber tube from the bottom of the burette connects it to a leveling bottle. By treating the ring successively with

small amounts of hydrochloric acid and antimony-chloride solution, when the leveling bottle is held so that the water in it and in the burette are brought to the same level, the volume of hydrogen in the burette can be measured, and by this means, in proportion to the known area of the ring, the weight of the coating per square foot can be calculated with sufficient accuracy.

TOUCH-TYPEWRITING STUDENTS AIDED BY KEYBOARD SHIELD

To aid students in learning touch typewriting, a combined keyboard shield and divider can be attached to the regular typewriter. The shield covers the keyboard in such a way that it does not interfere with operation, but prevents the student from watching the keys and drifting into the sight habit. It also serves as a convenient support for a notebook. The divider separates the keys operated with the left hand from those operated with



Keyboard Shield and Divider, Attached to a Typewriter, at the Left: The Shield may be Used to Support a Notebook, as Shown at the Right

the right, and keeps the hands from wandering over onto the wrong part of the keyboard.

*The Kauffman-Lattimer Co.
263 N. 7th St. Columbus, Ohio.*

*Chas. Allen P. Child
Box 73, Station E, Kansas City, Mo.*

Copyrighted material

*7772 — Attachment
J. W. King & Co.
3837-D*

7673

PRESENT SIXTY-POUND FRUIT CAKES TO FAMOUS PERSONS

Several hundred 60-lb. fruit cakes were placed on display in Seattle, Wash., not long ago. These cakes were made and



This 60-Pound Fruit Cake, Specially Made for Pope Benedict XIV, Was One of Several Hundred Presented to Famous Men and Women

sold by a local cake bakery, to be presented to famous men and women in all parts of the world. Some of the persons for whom cakes were made were President and Mrs. Harding, the president of

France, the king and queen of England, the king and queen of Belgium, the president of China, the king of Italy, the king of Sweden, Mary Garden, Pope Benedict XIV, Thomas A. Edison, Henry Ford, and Chief Justice Taft. Each cake was decorated with appropriate designs and flags.

7860 *Radio Application*
FOG SIGNALS CONTROLLED BY USE OF WIRELESS

Controlling fog signals by the aid of wireless is a development that will be appreciated by seafarers, as they have been urging protection of this kind for some time. A wireless transmitter, suitably located on shore, sends out a series of "dots," which are received upon a small aerial on the fog-signaling apparatus. These dot impulses in turn operate a relay, which controls the valve of the gas, or compressed-air tank, and thus sounds the fog signal. It is said that the system has proved entirely satisfactory wherever tried, and also that it has continued in operation even under the most adverse weather conditions. Apparatus of this description is now being used to protect the shipping along the Clyde, in Scotland.

7742

AIRPLANE AND AUTOMOBILE TIE IN TUG OF WAR



given signal both drivers started their motors. The two machines seesawed back and forth across the field, amusing the spectators, but neither gaining a permanent advantage. After this had gone on for some time, the judges were finally forced to declare the contest a tie.

A Novel Tug of War, between an Airplane and an Automobile, Which Resulted in a Tie

At a recent California air meet, one of the feature events, a tug of war between an automobile and an airplane, attracted much attention. The ends of a strong rope were attached to the rear of the car and the fuselage of the plane. At a



These Two Machines, Pulling Each Other Back and Forth across the Field, Furnished Much Entertainment for the Spectators at a California Air Meet

Have think it was a Curtis J H-6, funny?

A rank B. Howe, 413 Mason Opera House Bldg. Los Angeles, Calif.

Copyrighted material

Upper Right: The Exterior of the Soviet Government's Propaganda Train Which Travels over the Country Distributing Radical Literature. Below: The Interior of the Train, Showing How It is Fitted Up as a Library

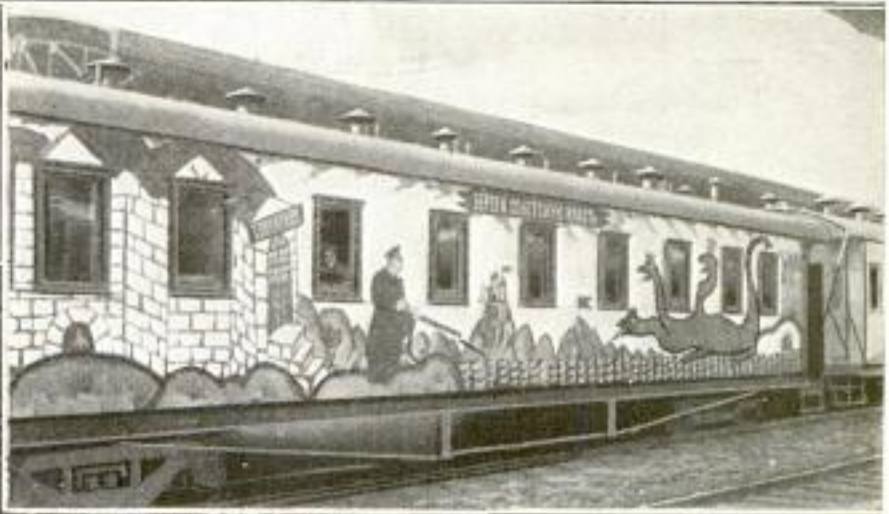

The exterior of the cars are highly decorated with suggestive cartoons in which older forms of society are represented as monsters, which the Soviets successfully conquer. The interiors are fitted up as libraries, where Soviet propaganda literature, consisting of books, pamphlets, and newspapers, is given free

to all those who apply. It is said that the peasants look forward with eagerness to the arrival of these trains.

MIGRATING SEALS TRAVEL IN MILITARY FORMATION

Little is known of the habits of Alaska fur seals after they have left their breeding grounds on the Pribilof Islands, but a report from John Kunder, former keeper of the Farallon Light Station, on an island west of San Francisco, adds some interesting information. In March, 1920, Kunder saw a herd of about 10,000 seals approach the island from the south. They advanced in a line about two or three miles long, stopped for a moment and then swung around in perfect military formation and advanced rapidly in a west-northwest direction. Three years before, Kunder saw a similar performance by a herd of about 15,000 seals. These are, as far as known, the only times that seals have been seen in large herds in the open sea, where they usually appear either singly or in scattered groups.

Science 12/2/21

READING MATTER DISTRIBUTED BY RUSSIAN GOVERNMENT

As a means of distributing its radical literature, the Russian Soviet government uses railway trains which travel through the country continuously, and from which are given radical lectures,

FIRE-EXTINGUISHING PISTOL ALSO REPELS BURGLARS

Poison gas in some form or other is apparently being applied in Germany to domestic uses, judging from an advertisement in a Berlin paper. A picture of a pistol, that looks very much like an automatic with an enlarged barrel, is described as being for protection against fire and burglars. The means of protection is not mentioned, but presumably it is something on the order of the ordinary chemical extinguisher, and is operated by pulling a trigger instead of turning it up-



German Pistol That Offers Protection against Fire and Burglars, by Discharging a Gas

side down. The gas that is then discharged is apparently equally effective against attack by fire or burglars.

*B. Falckenfleck
Berlin W.30, Haberlandstr.*

8th
ag-
ecol
N-6.
ath th
am r
T
o ver
nyone
nd
o
ei.
rsi
e

7881

L.F.S

4724

Isas

7474

Approved material

7706 Cont. E. J. Cone,
8 Ash St. I.ushing, N.Y.

manufacture
"SAND-BLAST" PROCESS USED
IN MAKING HOLLOW STEEL

A patented process for making hollow steel, such as used in mining drills, is applied by an American company. This

steel must be very hard in order to enable the drills to cut through stone. In the new process a thin steel tube is thoroughly cleaned, then filled with sand, and inserted in an ingot mold, where hot metal is poured around it.

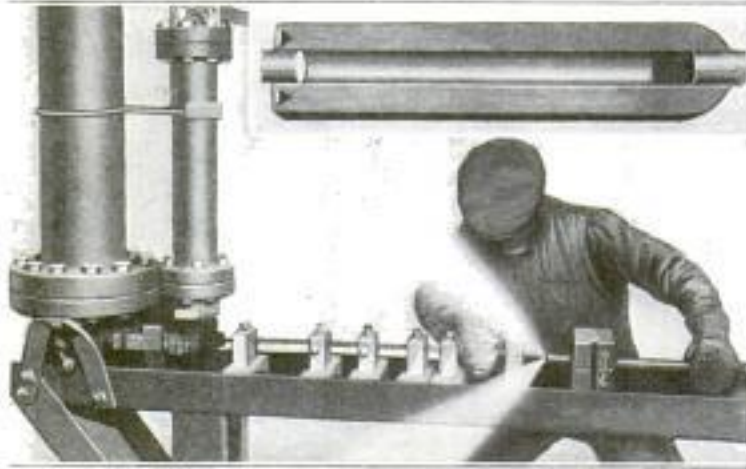

Air and Sand Tanks, at the Left, and Small Tube Carrying the Sand-Blast Mixture: The Workman is Cleaning Out a Piece of Hollow Drill Steel. Insert: Cross Section of Drill-Steel Ingot

After the ingot is cast, the sand remains in the tube to maintain its shape while the ingot is rolled. Following the rolling process, the sand filler is removed by a sand blast. This apparatus has a compressed-air tank, a sand reservoir, and a small tube connected to both. When the air is released from the tank, it passes a hole at the bottom of the sand reservoir, and sucks a certain amount of sand therefrom. This jet of mixed air and sand possesses great cutting power, and it is stated that a round hollow steel bar, 20 ft. long and 1 1/4 in. in diameter, can be cleaned in one minute.

7803
ATTRACTIVE ENTRANCE GREETES
FLOWER-SHOW VISITORS

Perhaps the most attractive feature of the California Flower Show, held at Los Angeles, was the entrance. A huge basket was built directly in its center, and a small room in the lower part served as a ticket office. The upper part was completely filled with shrubbery, palms, and

7887
REMARKABLE WATCH CARRIES
MANY COMPLICATED DIALS

One of the most complicated watches ever made has been produced by a company in London, Eng., for an American customer. The intricate mechanism is inclosed in a case 3 in. in diameter and about 1 1/2 in. thick. Dials in the front carry the usual hour and minute hands; a hand showing the difference between mean and true sun time; a fly-back second hand moving in fifths of seconds, the indications of which are added on a dial at the side of the face, up to 12 hours; a record of the phases of the moon; the day of the week and month. A dial on the back is graduated to 24 hours, two sets of 12 hours each, for forenoon and afternoon time. Its hour and minute hands show sidereal or astronomical time. The watch strikes the hours, quarters, and minutes, repeating them at any desired time.



Novelty and Beauty are Strikingly Combined in This Entrance to the California Flower Show

giant artificial poppies, the state flower of California. In the center of each poppy was mounted an electric bulb, and, at night, the effect was most pleasing.

As a result of traffic policemen giving the right of way to private automobiles, mistaking them for fire trucks, the Chicago city council has passed an ordinance, effective January 1, prohibiting the use of the same shade of red for private automobiles as that used by the fire department.

Keystone View Co. 91 - 7th Ave. New York

Annual

London Times Weekly 11/18/21

HAND-POWER STUMP PULLER RAISES SUNKEN ENGINE

AN impromptu demonstration, as sensational as it was successful, was made recently in the Pacific Northwest of a newly invented one-man stump puller of original design.

A donkey engine, weighing nearly 10 tons, was being taken across a swamp under its own power, when, just as what appeared to be a patch of solid ground in the middle of the bog was reached, one of the sled runners broke through, and before skids could be brought into use, the donkey capsized. In a few minutes the engine had settled until only the steam pipes and cylinder on one side could be seen above the surface.

The inventor of the new stump puller happened to be in the vicinity showing his device at work on logged-off land. He rushed to the scene and fastened his tackle to the fast-disappearing donkey engine. The puller weighs, with



The 10-Ton Donkey Engine Capsized in a Swamp: Except for a Cylinder and the Steam Pipes, the Engine was Entirely Submerged in Muck

complete equipment, only 135 lb., as compared with the 20,000-lb. weight of the donkey engine. But in one hour 15

minutes it had pulled the donkey upright. The boiler was then guyed to a near-by tree with a line, but before steam could be gotten up, the engine had settled again so that the firebox was submerged. Thereupon the pulling device was placed ahead of the



This Is the Hand-Power Stump Puller with Which the Donkey Engine was Hauled Out of the Swamp. The Lever Shown on the Mechanism Is 12 Feet Long

donkey, the tackle reset, and before nightfall the engine was extricated from the bog.

The new stump puller consists of eight simple parts, only three of them moving. Without hook and cable, it weighs less than 100 lb. It is operated under normal conditions by one man with a 12-ft. sweep, which gives a straight-line pull of more than 20,000 lb. Equipped with one block, it pulls 20 tons, and with a luff, more than 150 tons, it is claimed. A drum protects the heavy steel



The Raising of the Donkey Engine by Means of the Stump Puller and a Rope Fastened around the Top of the Sunken Machinery: In This Manner the Engine was Dragged to Dry Land

cable used on the machine from cutting and grinding, and an internal safety dog holds the load at any time. There is a ratchet on the sweep, so the operator need not endanger himself by stepping over the cables.

SHAPE IRREGULARITIES SHOWN BY DIAL RECORDER

Emery wheels on grinding machines, compound rests on lathes, and similar attachments often become loose, and the

result is that pieces in the process of working get slightly out of round. An indicator built of three pieces—a base, a vertical arm, and a cylindrical impulse recorder—constitutes



a device for discovering such trouble. The recorder is held up to the piece of

spinning stock by the vertical arm which can be set at any angle desired by loosening the joint bolts, adjusting the recorder to the position necessary and tightening the bolts again. The contact with the spinning stock to the cylindrical recorder is established by a little ball on the recorder's end. This ball rubs on the stock and, as it is moved up and down by the undulations of the piece being worked, transmits the varying impulses to a gauge which records in thousandths of an inch how far the piece is out of shape.

GERMS IN MILK ARE COUNTED BY ECONOMICAL PROCESS

Germ in milk can be counted quickly by means of a new testing cabinet designed at the University of Wisconsin, and which is being used with success by dairymen of the middle West. Instead of costly laboratory equipment, the tester consists of a field outfit in a small metal case, weighing but 20 lb. when fully equipped, and with which 96 samples can be analyzed on a single trip. The case is heat-insulated so that the contents may be kept at the proper temperature at all times. In making a test, a measured drop of milk, and a drop of germ food, called agar, are spread together on a glass slide, or plate, over an area of about .16 sq. in., with a sterilized needle. The plate is then

placed on one of the many shelves in the cabinet, or incubator as it is termed, and allowed to "grow" for a period of eight hours. At the end of this time, the plate is removed and the germs dried upon the glass, after which they are colored with a stain, so that they can be easily counted by the aid of a microscope. Thus the number of germs in any given quantity of milk can be determined. The method is said to be so simple of operation that a man can be taught to do this work in one week. This new field outfit reduces the amount of glassware ordinarily used, to an amazing minimum.



Above: Placing a Drop of Milk, Together with Germ Food, on a Glass Plate. The Small Case with Numerous Shelves for Holding the Plates is Seen in the Background. Below: Amount of Glassware Required by Old Method at Right, and at the Left, the Few Pieces Needed with the New Cabinet

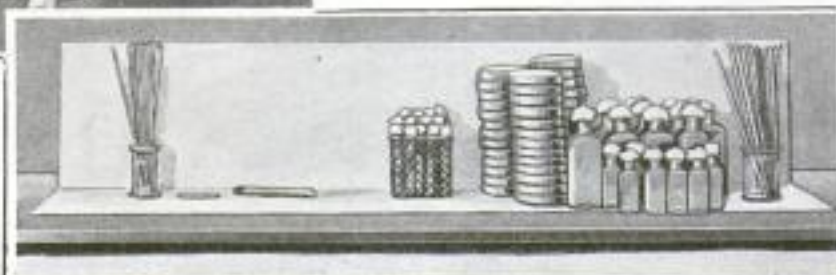

Atchison Tool & Die Co. 609 My Fourth St. Columbus, Ohio
3208
6888
Dr. Russell E. A. root, 1010 Israel St. Madison, Wis.

7490 Cmt. George J. Paul
 900 Ellsworth Bldg
 POPULAR MECHANICS
 Chicago



Illustrating the Manner of Unloading a Carload of Coal Screenings with the Aid of Water Which is Pumped from the Pond and Directed into the Cars at Either End: The Screenings are Washed down the Chute into the Pond, Where They Are Safe from the Danger of Spontaneous Combustion

7490

OLD CLAY PIT USED TO STORE COAL SCREENINGS

Good use is being made of an old clay pit at Springfield, Ill. Coal screenings are stored here throughout the dull seasons. The pond, which covers two acres and in parts is over 50 ft. deep, will hold about 75,000 tons. It was formerly used for the storage of zinc screenings, and consequently the pipes were already in place for the handling of coal. An electric pump has been installed. With this, water is pumped from the pond through two pipes that reach either end of the car, thus washing the coal into the pond. The company estimates that coal can be unloaded in this manner at a cost of three cents a ton, and that by reversing the operation the coal can be reclaimed at a cost of 10 cents a ton. This storage method prevents spontaneous combustion, which is ordinarily an almost constant menace. It also gives the company washed screenings to market when there is the right demand.

☐ The Popular Mechanics Bureau of Information offers its free service to all readers of this magazine. Names and addresses of manufacturers and dealers in articles described, and any other details in our possession, will be promptly furnished by addressing the Bureau.

7729 **ARTIFICIAL ARM OVERCOMES CRIPPLE'S HANDICAP**

During the medical exhibition in Central Hall, Westminster, London, Eng., a demonstration was given which showed the great possibilities of a new artificial arm. This appliance makes it possible for a person who has lost one arm to do almost anything which he was able to do before his loss. The principal feature of the demonstration was the playing of a violin. A one-armed man was able not only to play, but to play quite well.



COPYRIGHT, GRAPHIC PHOTO UNION
 A Demonstration of a New Artificial Arm at Recent Medical Exhibition at Central Hall, London: The Man Was Able to Play Quite Well

Salles St. London, E.C.4, England

NEW DESK TRAY BOTH WIND-
PROOF AND CONVENIENT

7714

A new desk tray holds papers in a vertical filing position and prevents their being blown away by drafts from electric

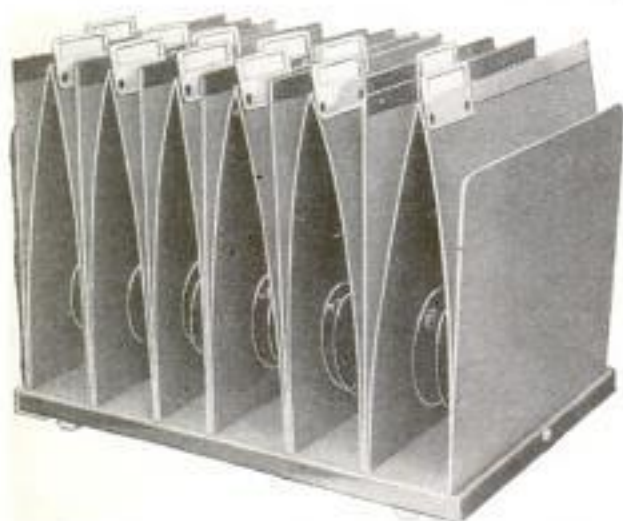

When Compressed, the Springs, Extending the Guides, Lie Flat, Taking Up No More Room Than the Ordinary Compressor Blocks

fans or open windows. It consists of a base with endpieces and fixed guides at regular intervals. Between the fixed guides are compression guides made of two pieces of cardboard hinged at the upper edge. Spiral springs between the two parts keep them spread and hold the papers in place.

General Use

7771 MOTOR TRUCK TRANSPORTS
TRAIN IN NOVEL MANNER

It became necessary to transport a train of "batch boxes," used in the construction of a cement road forming a part of the Pennsylvania highways, and this was done in a novel manner by the use of a large motor truck. A section of railroad track was inclined to the level of the deck

of the motor truck, on which rails were mounted. The train was then backed up this incline until three of the batch-box trucks were on top of the motor truck. These were then taken to their destination, where they were unloaded down a similar incline. The operation was repeated until the whole train, as well as the locomotive, were transported.

7858

BATTERY VOLTAGE REVERSES
AT LOW TEMPERATURES

Recent tests to determine the reliability of batteries at low temperatures, resulted in the startling discovery, that a reversal of their polarity occurred at 170° F. below zero. The experiments were conducted by the Bureau of Standards, and, so far as known, the phenomenon has never been observed before. It was stated, however, that the reverse currents were so small that there was no probability of their being used to recharge the battery.

Electrical World 12/3/21

BOOSTERS' MEETINGS CALLED
7806 TO ORDER BY HORN

The gavel, or hammer, the symbol of the knocker, has disappeared at the meetings of the "100 per Cent Club" of San Francisco, and has been replaced by the horn, the symbol of the booster. Since the club is an organization of boosters,



D. R. Pinney, the president, decided that it would be most appropriate to call the meetings to order with a horn.

Vertical text on the right margin, possibly a signature or note.



Train of "Batch Boxes," Used in Building This Cement Road, being Loaded, Three at a Time, on the Large Motor Truck at the End of the Inclined Track: These Batch Boxes are Then Transported, and Unloaded in a Similar Manner, Whereupon the Motor Truck Returns and Repeats the Operation

Charles A. Reid, 221 Salem Ave.
Copyrighted material
Clayton, C.

*Shed Agency. Kadel + Herbert. The Rod
maurice Belgrims 35 Place de la Esare
Antwerp Belgium.*

Speed and Comfort on the Hydroglider

By Henry S. White

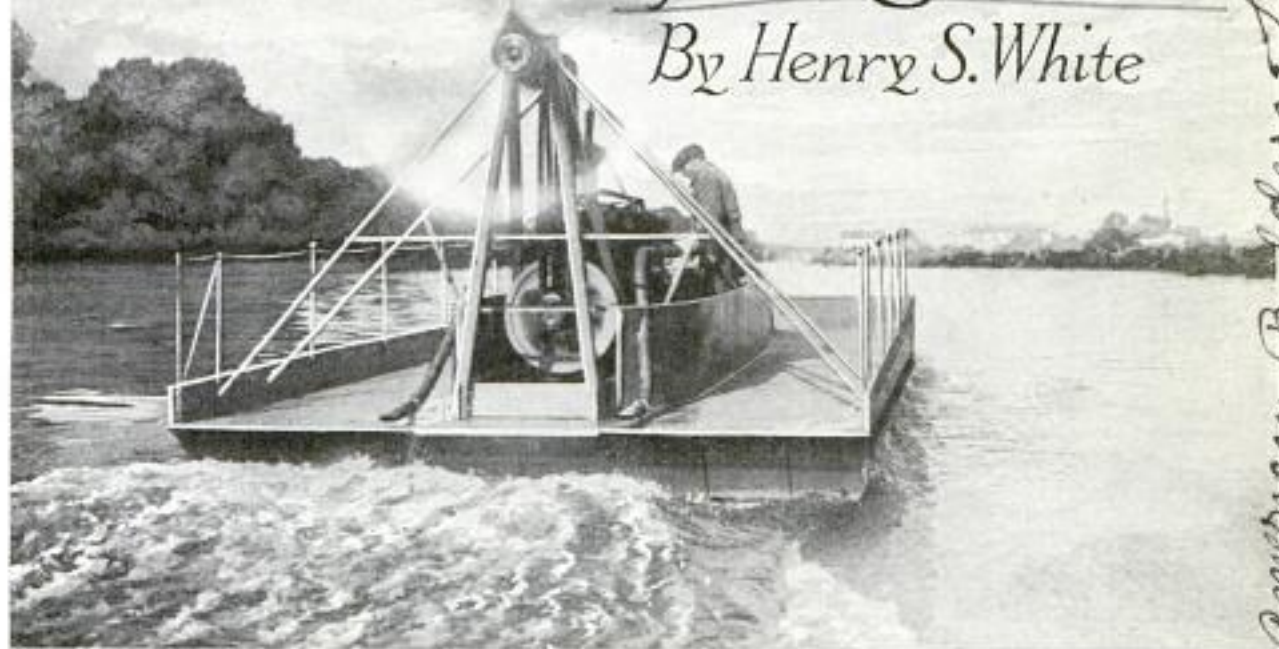

COPYRIGHT, M. ROL

An Example of the Modern Hydroglider, without Cabin Accommodation, Built for Any Form of Rough River Work: The View Shows the Stern with the Aerial Propeller Revolving at High Speed

IN land transportation, within the last 20 years, there has occurred a transformation from the horse and buggy to the high-speed automobile. In the navigation of rivers and lakes a similar development is now taking place. The ancient paddle wheeler is being supplanted by the modern hydroglider. The development has been gradual. It began, as in

the case of the land vehicles, with the introduction of the internal-combustion engine. This led to the first design of the hydroplane, or craft that skims on the surface rather than plows through the depth of the water. In this connection there have been many modifications of hull design. Until recently they were driven by immersed or semi-immersed propellers, which, besides lacking in efficiency, were likely to hit any obstruction, or to get fouled by reeds or other weeds, which are common in shallow waters. Finally came the type now under

development, which skims on the surface of the water, and is driven by an aerial propeller. These are known as water or hydrogliders. The pioneering work in this type was done by a French aerial engineer, who during the war developed a glider that proved to be of great service in the Mesopotamian river campaign. The most recent developments are exemplified

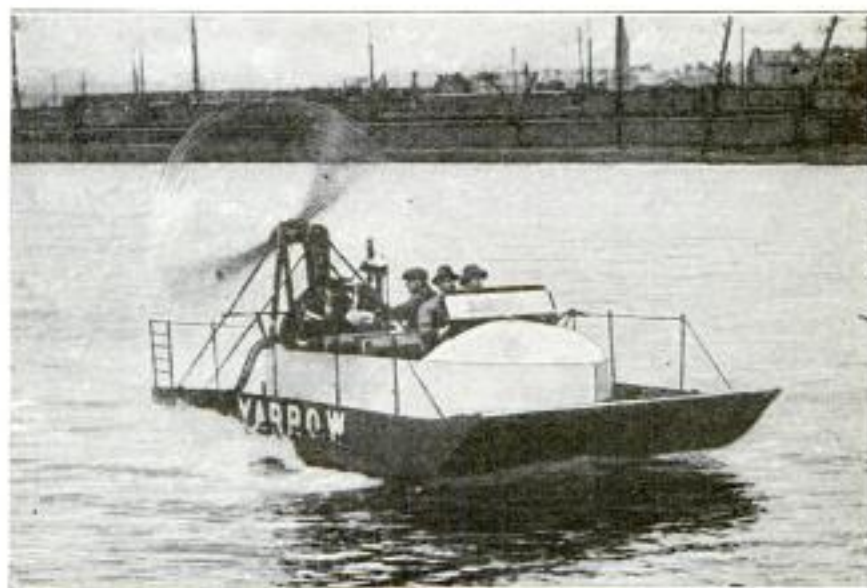

The "Yarrow," a Hydroglider Built on the Clyde, in Scotland, Which Attained a Speed of 50 Miles an Hour When Operating as a Passenger Boat, Not as a Racer, as Its Speed might Well Suggest

Europe - Harman & Co., 167, Rue de Sully, Paris, France. Pullancourt, Seine

*American Builders The Sea
Shed Co., West Nyack, Conn.*

*American agent Wallace Kellett
November 1922, Philadelphia, Pa.*

*December 1922 - 837
January 1923 - 907
1921 - 585*

7421

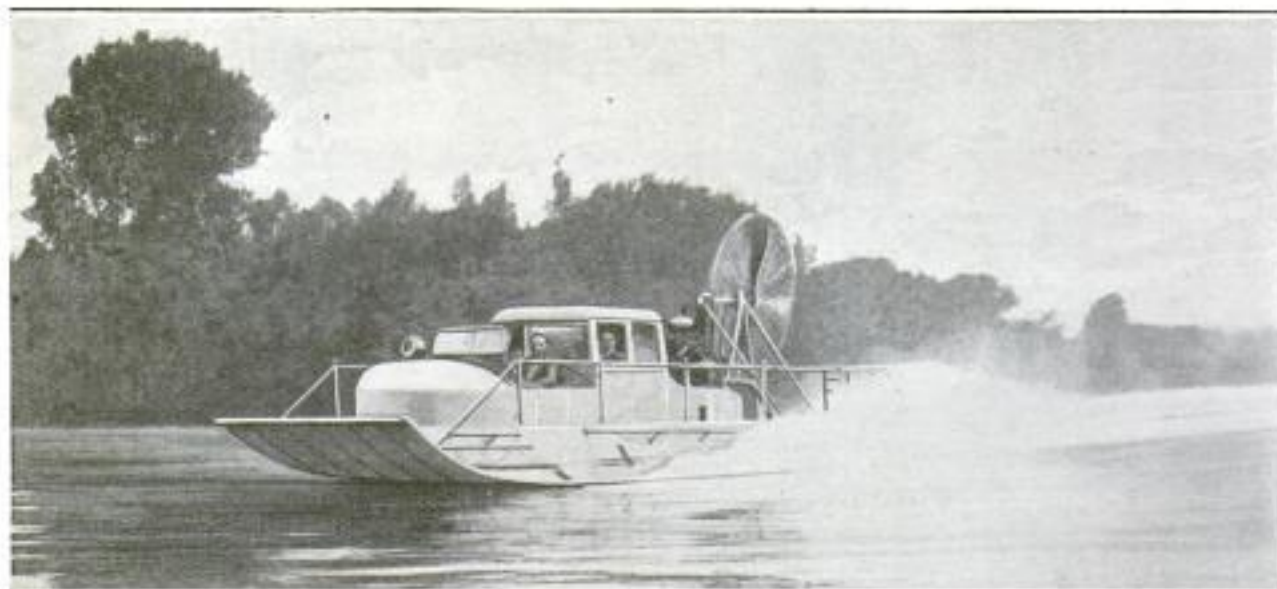

French Hydroglider with Turned-Up Prow to Facilitate Gliding: Its Cabin Accommodation Closely Follows Automobile Lines, and Its General Appearance might Reasonably Suggest That It Is a Water Taxi

in a glider built on the Clyde, in Scotland, called the "Yarrow," which has attained a speed of 50 miles an hour. In this type all models are characterized by a rectangular hull built up of five or more separate caissons, and between the caissons a narrow space of varying form according to its position in the hull, and to the size

and horsepower of the boat. This construction gives great elasticity, and is in every way superior to the older type, known as the "stepped" hull, especially for high speeds. These newer hulls are uncapsizable, and are easily made unsinkable. The propeller is of the aviation type, and is driven with silent chains by a water-cooled internal-combustion engine. When at rest, or moving slowly, these gliders draw 8 or 9 in. of water, but as the speed increases they climb out of the water until, at 50 miles an hour, the hull merely skims the surface, suffering comparatively little resistance—that of the air instead of the water. The gliders

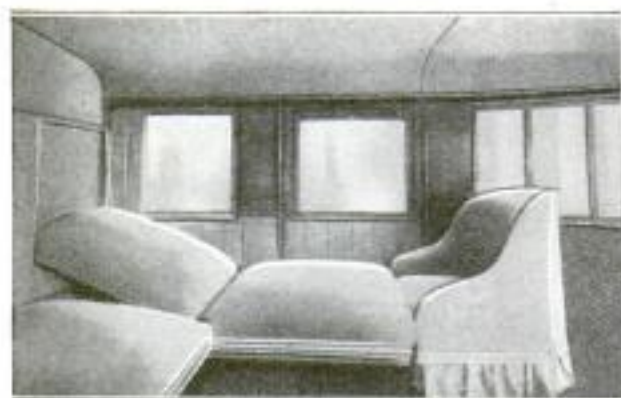

Latest Development of the Hydroglider by the French Engineer Who Was the Pioneer of This Type of Craft: This Model Follows Automobile Lines, and Has a Limousinelike Body. The Inset Shows Its Pullmanlike Seating and Sleeping Accommodations

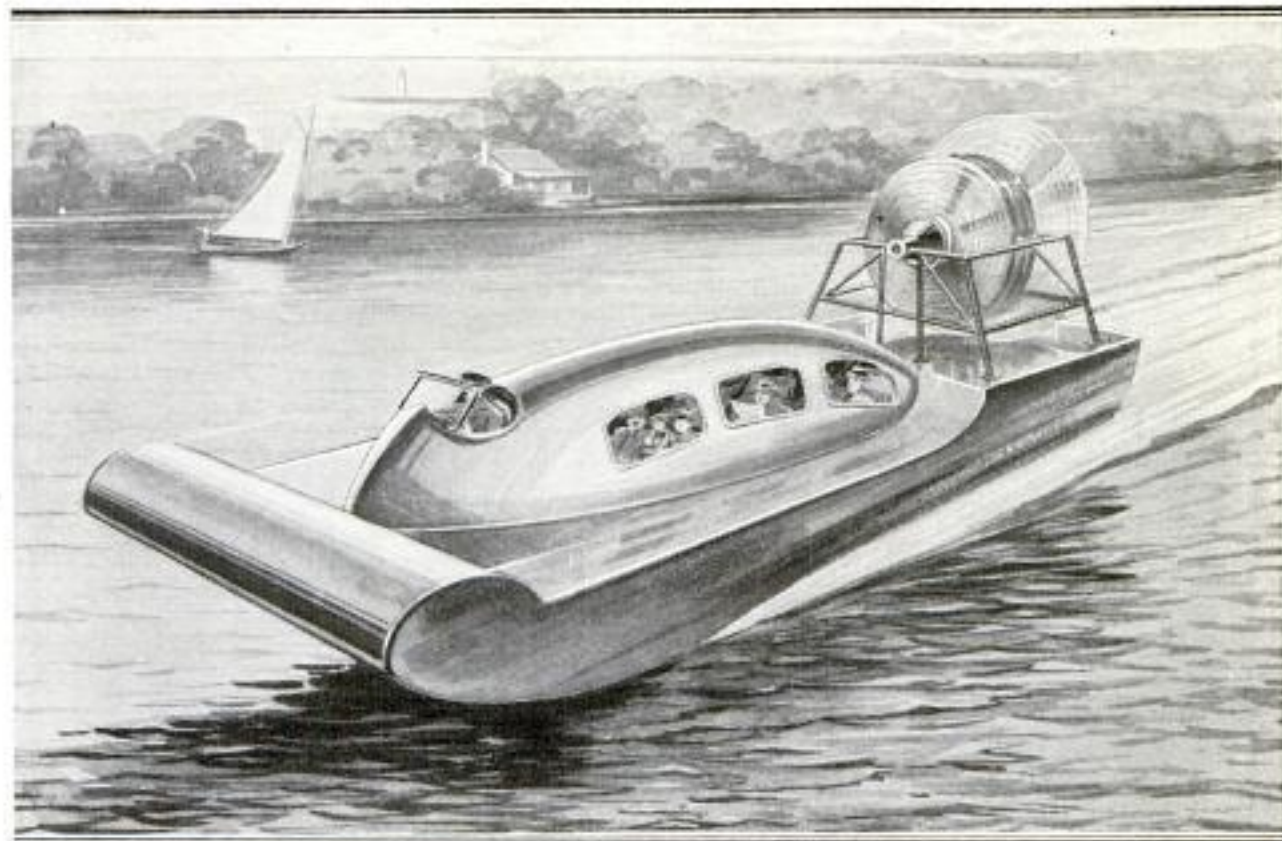

Modification of the Hydroglider as Designed by a Belgian Lady: Its Special Novelty Is in the Curved Shape of Its Hull Bottom. It Has Exceptionally Luxurious Cabin Accommodations. The Motor at the Stern Is of the Rotating Air-Cooled Type, Formerly Used on Airplanes

are controlled and steered by an ordinary automobile wheel.

Fundamentally, all of these hydrogliders are similar. They vary in size and power, and also quite considerably in cabin design and accommodations. One, called the "Farnum," that is used on the river Seine, in France, as a sight-seeing boat, is said to have attained a speed of 56 miles an hour. Another, the special design of the French aerial engineer referred to above, has a cabin much on the lines of an enlarged limousine, with Pullmanlike seats that can be converted into sleeping berths. Another of this type has a wide curled-up prow that facilitates gliding. One, still more recent, is the invention of a Belgian

lady, and has the bottom of the hull shaped like a figure "3" laid on its back. This hydroglider, still under construction, has exceptionally luxurious cabin accommodations, and is distinguished by the fact that its aerial propeller is driven by a rotating air-cooled engine, such as were used on airplanes, particularly in France, before the war.

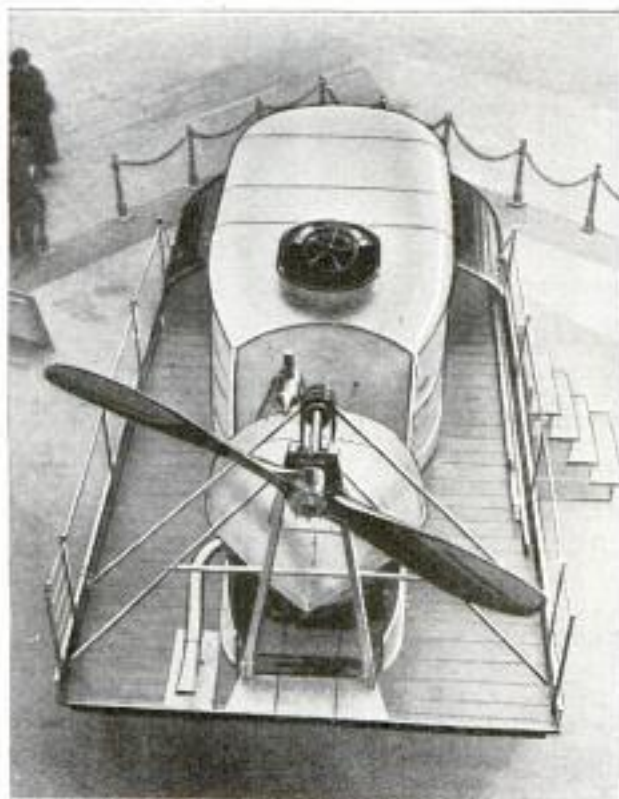

All-Metal Hydroglider on Exhibition at Paris Aero Show: It was Specially Designed as a Racer

Twenty years ago the first sardine-fishing boat with a gasoline engine to appear at Eastport, Me., which is the center of the sardine industry of that state, chugged up the harbor. Today the entire fleet of such boats, estimated at 1,800, is equipped with gasoline, kerosene, or crude-oil engines.

Van Horn Electric Tool Co.

New York Times

Cleveland, Ohio
POPULAR MECHANICS

11/3/21

P. 10

246

76 72

**DRILL PRESS MOUNTED ON AUTO
FOR ENTERPRISING SALESMAN**

"Seeing is believing," may be an old saying, but it has been proved a true one by a tool salesman of Cleveland, Ohio.



This Drill Stand Holding a Portable Electric Drill was Placed on a Salesman's Car for Demonstrating Purposes

Discovering that his prospective customers were inclined to be skeptical of mere catalog photos and descriptions, he decided to use practical methods. Accordingly, a drill-press stand was attached to the running board of his automobile, and a portable electric drill was placed in the stand. Thus he was enabled to give convincing demonstrations, which resulted in increased orders.

**SOCIAL LUNCHEON SERVED
IN SIXTY-FOOT BOILER**

Members of a social colony in New York City were the guests, not long ago, at a luncheon, given by the officials of a power company, which was served in the firebox of a 60-ft. boiler. Certain of the guests, residents of the neighborhood, had complained of the smoke and cinder nuisance prevailing because of the proximity of the company's power plant. The gathering in the boiler was for the purpose of demonstrating that every known appliance for the prevention of these inconveniences had been installed. The demonstration and luncheon proved a success, and apparently all points of friction were amicably smoothed over.

**NEW METHOD OF RATE CHANGES
FOR FOREIGN MONEY ORDERS**

Because of the rapid fluctuations in foreign exchange rates, a new conversion table and system of changing foreign money-order rates has been adopted by the Post Office Department, which will save purchasers considerable loss. The tables have been sent to all international money-order offices. Rate changes are reported to central offices, in different zones, by wire. These offices notify all others in their zone by mail. The complete notification, which formerly required two weeks, is now accomplished in two days.

**SIMPLE CHART FOR FIGURING
PAY ROLLS QUICKLY**

Offices may save time in figuring pay rolls by the use of a new calculating chart. It is mounted on a cast-iron base with a felted bottom. A case, of enameled sheet steel, revolves on this base and the charts, of extra-heavy cardboard, slide in and out of it with a slight pull on the index tabs. On the edge of the case are celluloid strips, listing hours from 1 to 99. On the cards are columns showing wages at rates from 12½ cents to \$1.50 per hour, for hours from 1 to 99. The card is pulled out till the proper rate column is opposite the hour column. The proper num-



The Calculating Chart Takes Up Little Space and is Easily Moved Wherever Needed

ber of hours is located and the total read opposite. Similar charts are provided for other kinds of calculations.

Whenever you find that you wish to know more about any article in this magazine, write our Bureau of Information.

*Mr. J. M. Gray
12/12/21
Van Horn Electric Tool Co.*

Mr. J. M. Gray

5884

*New York Times
12/12/21 P. 1
22*

*Universal
Visible
Calculator
Co.
Pittsburgh Pa*

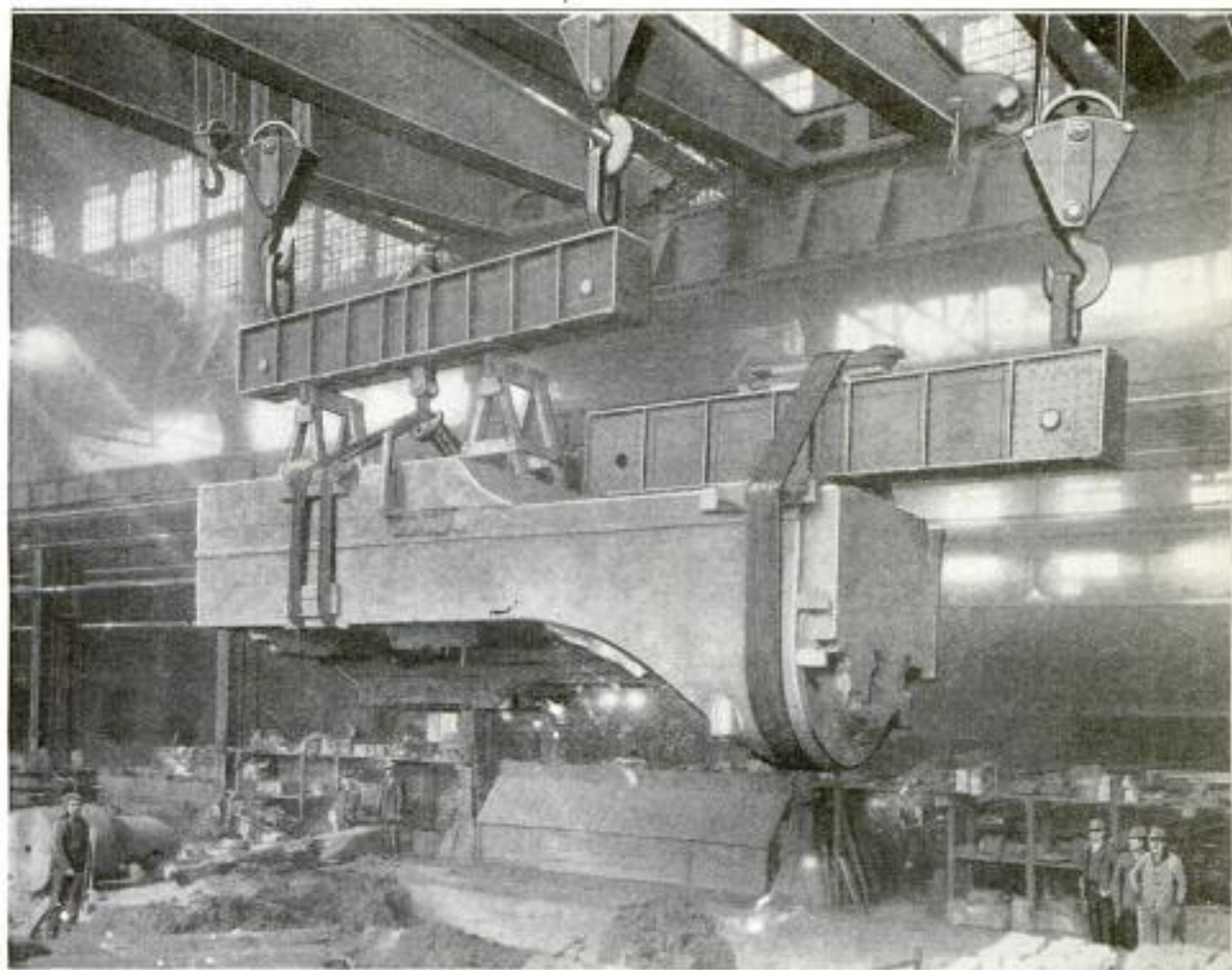

HUGE CASTING CARRIED COÖPERATIVELY BY THREE CRANES

IN a large foundry recently, the difficulty of lifting and moving a huge casting, weighing 225 tons, was overcome by doing the work cooperatively with three overhead traveling cranes, two rated at 60 tons each, and one at 40, thus overloading them about 40 per cent. From two of the cranes was suspended a plate girder that carried the heavier end of the casting, and a similar plate girder was lashed to the other end, and was carried by the third crane. The casting was for a large engine bed.

7722 *Atlas. Chalmers Foundry, Milwaukee Wis.*

GRANITE ARCH TO MARK STATE LINE ON MERIDIAN TRAIL

Marking the point where ^{highway} the Meridian Trail crosses the line between Illinois and Wisconsin, a granite arch will be erected as a gateway to the two states. This highway, which will probably prove to be the first hard road linking Canada with the Gulf of Mexico, after passing through Wisconsin and Illinois, will continue along the Mississippi River to New Orleans. Twenty miles of it, between Rockford, Ill., and the state line, have been surfaced with concrete and opened with a dedication ceremony on Nov.

11, 1921. A large part of it has been completed through Wisconsin, and much of the Illinois section is to be finished next summer. The design for the arch, which is to cost about \$8,000, has been approved.



Architect's Drawing of the Meridian-Trail Gateway between Illinois and Wisconsin; Inscriptions on Each Side of the Arch will Inform the Tourist He Is About to Enter Another State

Conl. P. E. Pierson, Bloomington, Ill.

A SHALLOW-WELL OIL FIELD

BY ALBERT MARPLE

*716 S. Louise St.
Estevada, Calif.*

7546

ONE of the most unusual oil fields to be found in this country is located in the hills between Conejo grade and Camarillo, Calif. The depth of the wells in this field ranges from 40 to 50 ft., and

3-in. pipe, all of the pipes emptying into a large tank.

The quantity of oil produced by these wells makes them a remarkably good investment. Many come in with 50 bbl.

a day, and the average output is about 25 bbl. There are wells in this field that were drilled 20 years ago and are still producing a fair quantity of oil. This field is now paying so well that some wells which were abandoned 10 years ago are now being reopened and operated at a good profit. Six or eight wells can be placed on a single acre of ground here, while five acres are needed for the average deep-well.

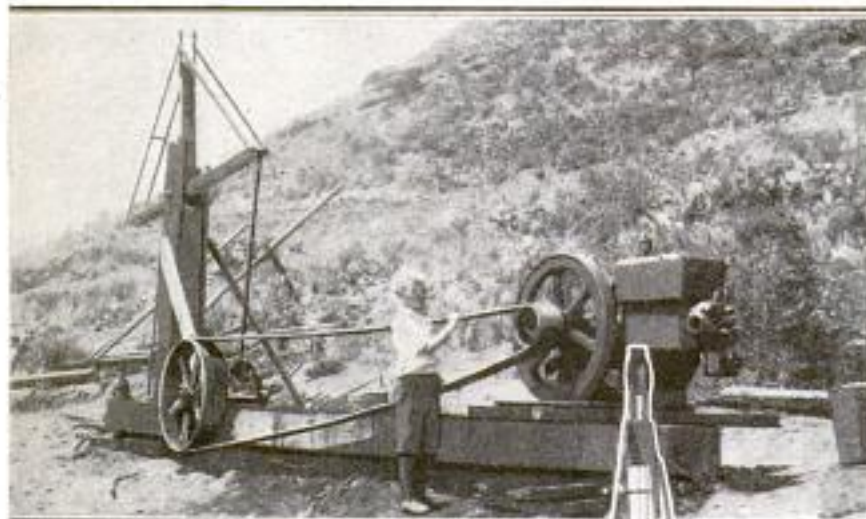

A Small Gasoline Engine Furnishes Power to the Pumps of an Entire Row of Wells through a Single Cable, Which is Fastened to the Pump at Each Well

oil is struck, usually, at about 30 ft. The oil is so close to the surface that, with the pump removed, a person can see it by looking down the 6-in. casing used in connection with all these wells.

In drilling such wells, a regular water-well drilling outfit is used. Two men are required for each rig, and it takes about a week to complete the drilling of one well. The average cost is about \$150. In some of the more level stretches of the field the wells are "set out" like an orchard, in rows about 50 ft. apart and with the wells in each row a like distance apart. For operating these wells a cable is run along an entire row. It is fastened to the pump at each well, so that all the wells in the string, a dozen perhaps, are pumped with one operation. From each well the oil is carried off by means of a



7905
RUBBER TUBING EXCLUDES DUST AND MOTHS FROM CLOTHING

Clothing is perfectly protected from both dust and moths by a new wardrobe in which rubber tubing is employed as a means of sealing. The tubing is used as a cushion around the door of the wardrobe, with the

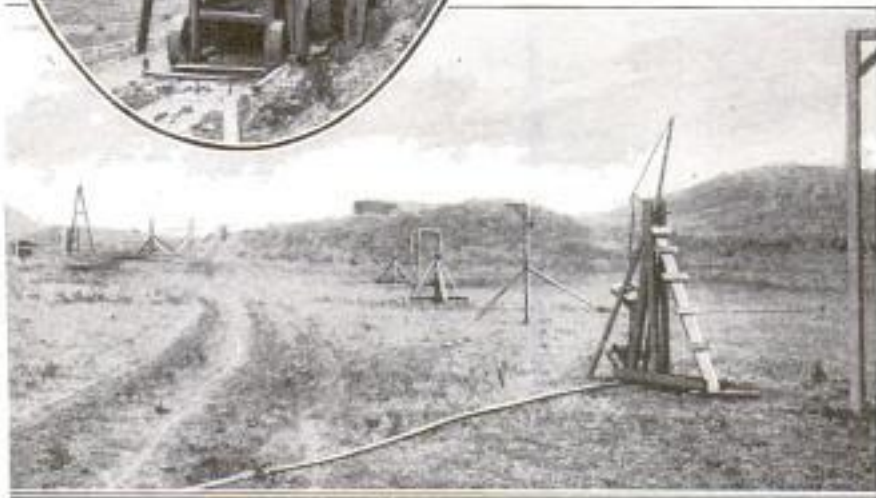

Above: An Ordinary Water-Well Drilling Outfit, Used for Drilling in This Shallow Oil Field. Below: The Wells are Set in Rows like the Trees in an Orchard

result that an absolutely tight joint is formed when the door is closed. These wardrobes are made as separate pieces of furniture or can be built into a house.

India Rubber World

12/10/21 printed material

Cml. Charles d. Reid
 221 Salem Ave. Dayton, Ohio
 POPULAR MECHANICS
 Paving Division, Detroit

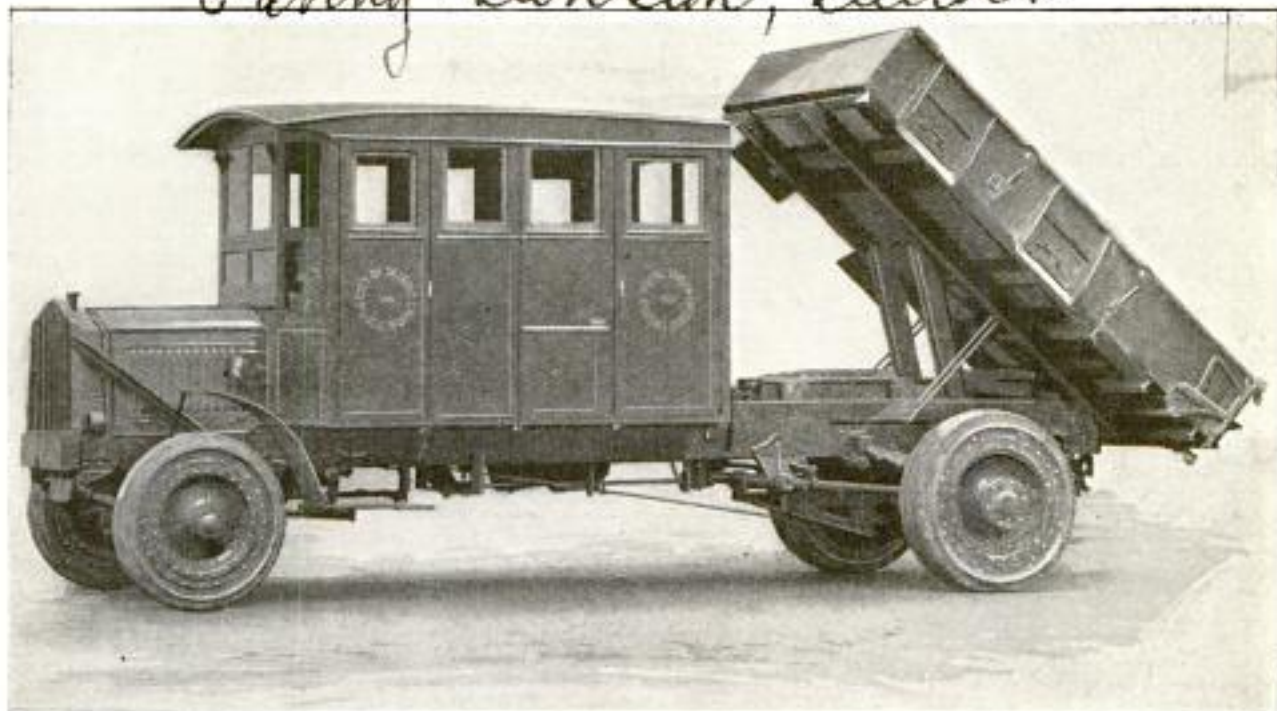

This Five-Ton Truck was Specially Built for Emergency Street-Repair Calls. The Inclosed Body Carries the Workmen Needed and Gets Them All to the Job at the Same Time and as Soon as the Materials Which are Hauled in the Dump Body

Street
REPAIR TRUCK TRANSPORTS BOTH MEN AND MATERIALS

Emergency-repair calls, of the paving division of the city of Detroit, Mich., are answered by an unusual type of repair-truck unit. It is a five-ton truck with an ordinary dumping body operated by a hydraulic hoist. In front of this is an inclosed body which accommodates 15 workmen. In this way it is possible to reach a job with both the materials and men needed in a single run, and the men have a very comfortable means of transportation.

5972

SASH HELD IN ANY POSITION BY AUTOMATIC WINDOW LOCK

An attachment to the top of the lower sash that automatically locks a window at all times, whether opened or closed, and that prevents it from rattling, is now on the market. The upper sash may be lowered, or the lower one raised, and in any position the attachment keeps both locked. To release the lock, when it is required

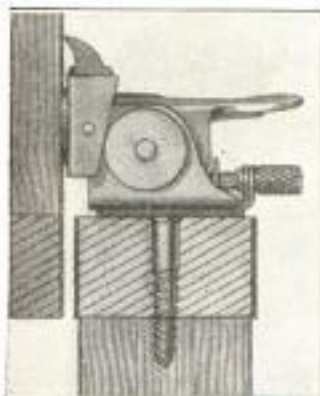

to raise or lower the window, all that is necessary is to press a small lever.

Pneumatic
SMALL TURBINE-TYPE GRINDER HAS SPEED OF 30,000 R.P.M.

4789
 Extremely high speed, without vibration, and consequently very high power in proportion to weight, are the distin-

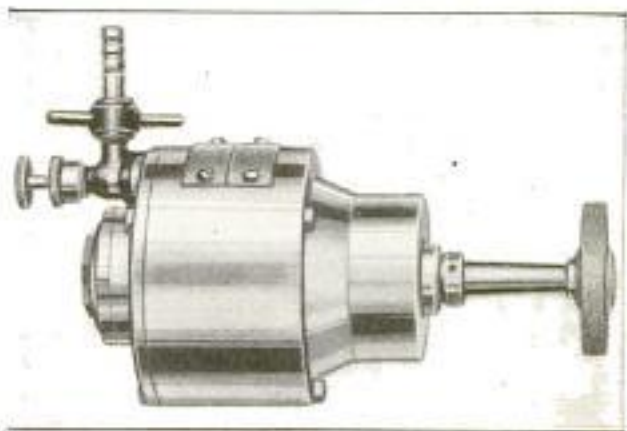

Pneumatic Turbine-Type Grinder That Has a Speed of 30,000 Revolutions per Minute

guishing features of a new pneumatic turbine-type grinder. The turbine unit has an outside diameter of about 4 1/4 in., and weighs only 5 1/2 lb. At its extreme speed of 30,000 r.p.m., it transmits 1/4 hp. It can be used as a hand tool, and by mounting it on machine tools by various fixtures, work can be done in the original setting. In connection with a special mounting, it can be used as a bench grinder. It is provided with interchangeable arbors, allowing a quick change of grinding wheels. Besides grinding, the unit can be used for buffing and drilling.

*Patented March 20, 1924
 3908 Palmetto St.
 Chicago, Ill.*

*Alson Mfg. Co. 39 State St.
 Rochester, N.Y.*



A Panoramic View of the New Crissy Aviation Field, at San Francisco, on the Former Site of the Panama-Pacific
 Consist of the Following: A, Boathouse Which will Accommodate the Speed Boats and
 H, the Landing Field; J, Living Quarters; K, Modernly

7256

Aeronautics

\$2,000,000 AVIATION FIELD RECENTLY COMPLETED

CRISSY FIELD, located on the old Panama-Pacific exposition grounds, has just been completed at a cost of \$2,000,000. The buildings, which are of fire-proof construction, include two hangars 160 ft. long and 100 ft. wide. They are equipped with rolling steel doors, each in 12 sections. One of the hangars is intended for seaplanes, having a concrete runway down to the bay. Special dollies

were made, to fit under the pontoons of the planes, which are towed by small tractors. Gasoline is supplied to the front of each hangar by two 10,000-gal. tanks, but for emergency use, two hand pumps are provided. A large garage has been built to take care of the trucks and trailers used. One of these trailers carries a complete photographic dark-room equipment, and is hauled by a truck carrying a 3-kw. gen-

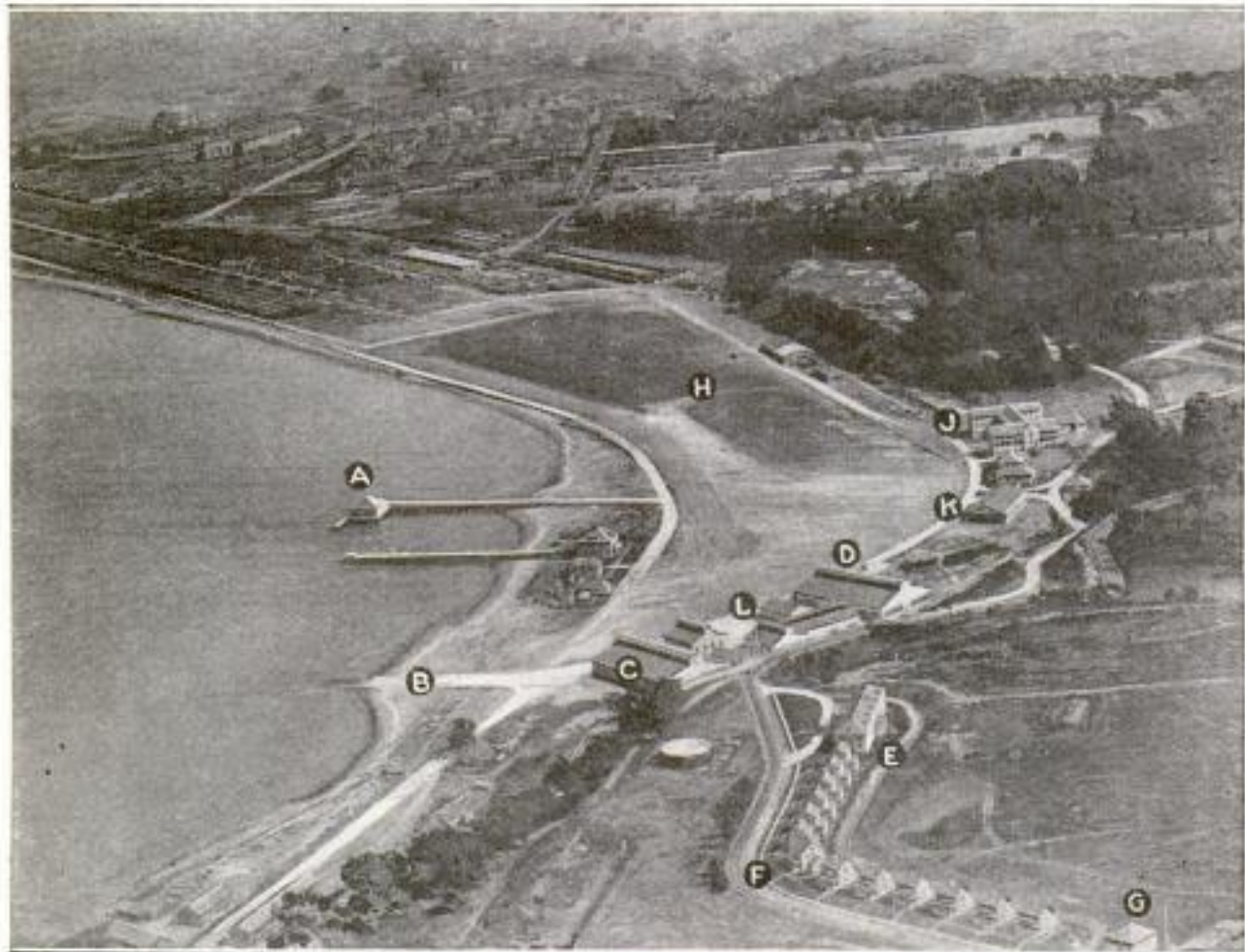

An Airplane View of the New Crissy Aviation Field, Showing the Same Buildings Indicated by the Same Letters as Those Seen at the Top of the Page: In Addition, This View Shows, at B, Concrete Runway for Seaplanes; E and F, Living Quarters; G, the Wireless Station. The Beauty of the Site Is Apparent in This View



Exposition: The Buildings are Constructed of Reinforced Concrete and Steel and Are Fireproof Throughout. They Three of the Hydroplane Tenders; C, Hangar for Seaplanes; D, Hangar for Land Planes; Equipped Garage; L, the Machine Shop and Testing House

erator. Another truck, with two trailers, is especially designed for bringing in wrecked planes. The trailers have steel stands with padded bumpers to protect the wings.

7719 —
**NEW DEVICE EASILY ADJUSTS
 HEIGHT OF CHAIR**

A new adjusting device for swivel chairs and stools is conspicuous for its simplicity of operation.

The seat is supported on a notched upright and held by a catch. To adjust its height, it is only necessary to trip the catch by means of a spring lever and raise or lower the seat as desired.



The device is made of steel throughout. Its easy operation assures adjustment to the most comfortable height for type-writing and various kinds of work.

7576 —
**NEW SYSTEM BURNS HEAVY OIL
 IN SMALL HEATING PLANTS**

An oil burner has been placed on the market which, it is claimed, makes possible the use of heavy fuel oil for heating residences or firing any small boiler, in place of the lighter and more expensive oils, such as kerosene. An improved feed and atomizer eliminates the obstacle of clogging, by impurities, which has in the past limited the use of heavy oils to large installations and left only the light oils available for the small plants. Fuel is

drawn through a strainer into a compressor, and forced through a revolving needle valve into the feed pipe. The per-

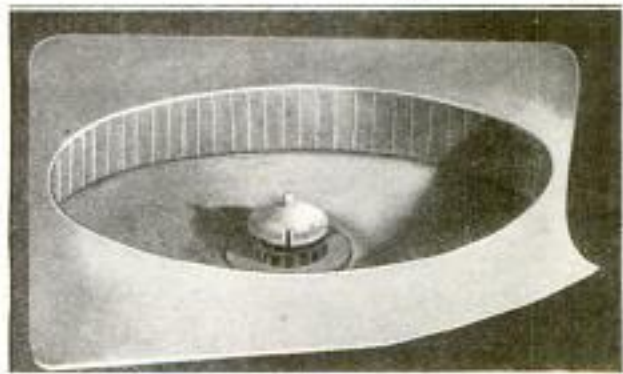

Interior View of a Firebox Equipped with the New Oil-Burning System: The Revolving Cap of the Atomizer can be Seen in the Center of the Box

fection of this valve was the first step in making the burner possible. The atomizer system consists of a cup, about the outlet of the feed pipe, and a cap above, both of which revolve. Oil flowing into the cup is mixed with air, thrown up against the cap and out into the combustion chamber. Centrifugal force carries the dirt to the sides of the cup.

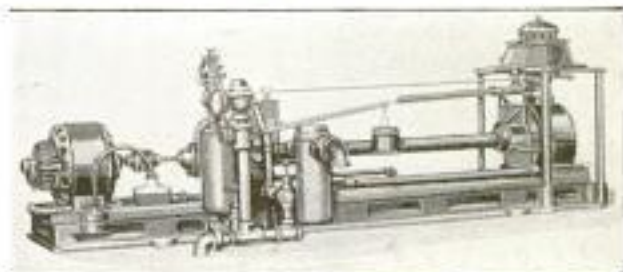

The Complete Oil-Burning Plant as It Appears Set Up, Ready for Installing under Any Boiler

Clogging here is prevented by an agitator. This is a small metal strip, attached immovably to the feed pipe, and bent upward near the sides of the cup.

When you want anything and do not know where to get it, write Bureau of Information, Popular Mechanics, Chicago.

*Harding Brothers
 Bertalan + Lawrence Ave,
 Chicago*

Bonney Forge & Tool Works
 Allentown, Pa.
 POPULAR MECHANICS

252
 7770 Auto Access

SIMPLE TOOL TO STRAIGHTEN BENT RADIATOR FINS

Bent radiator fins, on any automobile having a flat-fin radiator, may be straight-

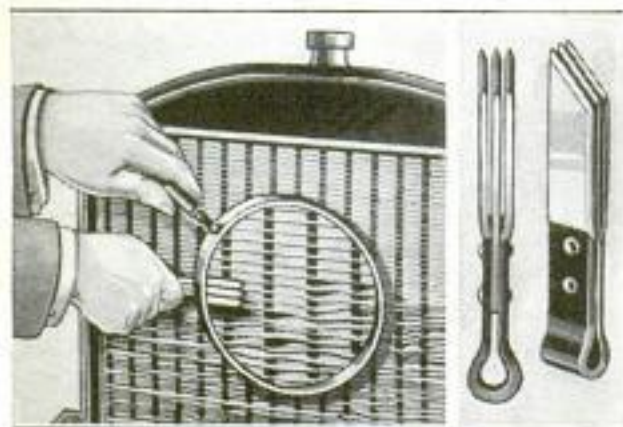

Straightening Bent Radiator Fins: At the Right Two Views Showing How This New Tool is Made

ened quite easily with a small tool which was recently placed on the market. It consists of a flat piece of metal, bent

7622

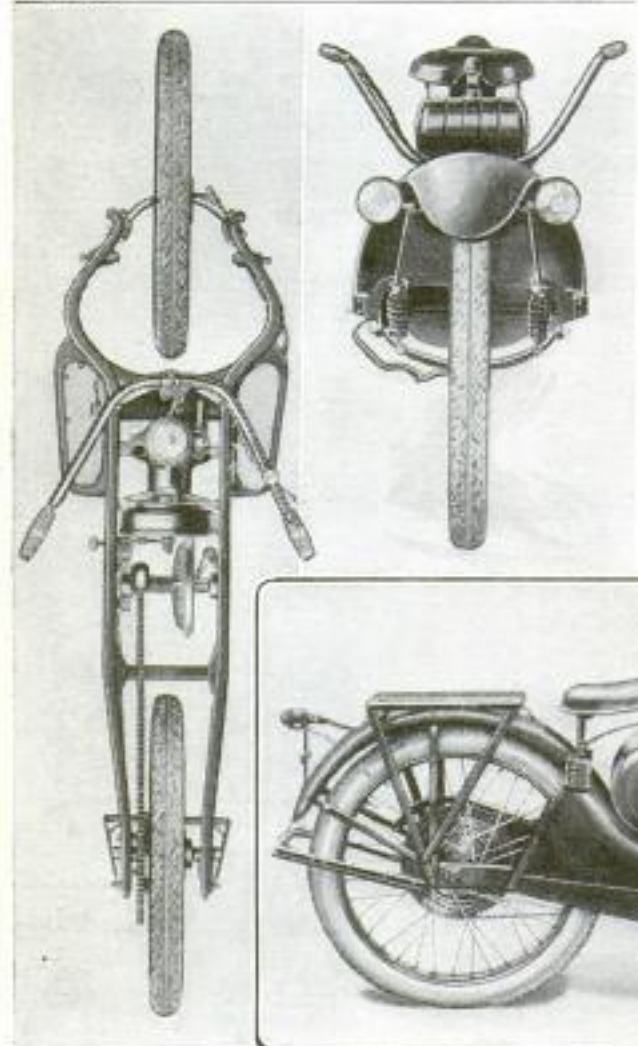

double to form a handle and two prongs, or teeth. Another piece, inserted between the teeth, and held by rivets, forms a third tooth. In use the teeth are inserted between the bent fins and twisted from side to side.

7903

OIL-REFINERY EXPLOSION OF PECULIAR NATURE

Oil refineries usually protect the distillation tanks against the entrance of water, but a laxity of this safeguard recently resulted in an explosion of one of these stills. Water in the tank produced a rise in pressure, due to the formation of steam. The safety valve operated, but the opening in this was not of sufficient size to allow the steam to escape fast enough, and the still exploded.

7622 *Handmade*
MACHINE FILLS GAP BETWEEN MOTORCYCLE AND LIGHT AUTO

Halfway between the heavy motorcycle and the light automobile is a new machine embodying a number of novel features. The frame, of the automobile type, is supported on two wheels. A barrel-type spiral-spring suspension eliminates the wheel fork. An extra-wide stationary front mudguard extends back, forming a hood for the engine, gears, and clutch. Power is transmitted from a one-cylinder 2 1/2-hp. motor through a friction drive and clutch. This machine is designed for cheap, clean, and comfortable transportation, not speed. It will give 85 to 100 miles from a gallon of gasoline and make 35 miles an hour. The low center of gravity reduces the danger of skidding.



Three Views Showing the Peculiar Features of Construction of a New Motorcycle Designed Primarily for Comfort, Convenience, Safety, and Economy of Operation: It Is Not a Speedster

Mer. A. Car Corp. 296 S. Madison St.
 Syracuse, N.Y.

Engineer 11/15/21

Price, \$225.00

Copyrighted material

EXTERMINATION OF CRAWFISH STOPS CANAL-BANK LEAKAGE

Trouble is sometimes caused by the presence of crawfish holes, under water in canal banks, which cause leakage, and to eliminate these an experiment has been made that successfully exterminated the crawfish in a canal embankment 75 years old. After unsuccessfully attempting to stop the leakage with sheet piling and concrete, it was finally decided to try impregnating the soil with enough chloride of lime to kill the crawfish. It was necessary to get the lime down 16 ft. under water, and this was done by boring with post-hole augers. With these a barrage of holes filled with lime, and scattered through the earth with dynamite, was laid across the paths of the crawfish. This stopped the leakage.

COMBINATION WALL REGISTER DOES NOT CUT INTO WALL

In the warm-air furnace-heating systems in common use, the registers are either in the floor or in the wall. Now there is a dual register that is partly in the floor and partly set against the wall. The part against the wall is the outlet for the warm air, and



the part set in the floor is for the inlet of the return air.

THE "FINGERPRINTS" OF THE MURDEROUS HOUSE FLY

A casual glance at the picture herewith would lead one to believe it was a bird's-eye view of a shell-devastated portion of France, but such is not the case. It is a record of the footprints, or "fingerprints" if you please, of the common house fly—murderer, food despoiler, and baby killer.

The fly was caught last fall and made to walk over a prepared medium of agar. Wherever its feet touched the medium a colony of bacteria grew. The performer of this experiment isolated 13 kinds of harmful bacteria from the footprints.

The picture also tells another story: While the fly left its footprints, it also

left a memento of its approaching doom. The two large spots are mold colonies of the *Empusa musca* variety. Each fall



Footprints of House Fly on Bacteria-Breeding Gelatine: Every One of the Little Dots Represents a Colony of Bacteria Carried by the Fly's Feet; the Large Spots Are Growths of a Mold That Causes the Death of the Flies

this mold starts to propagate, and the spores float through the air. They attach themselves to the fly under the wings, and start growing inside its body. In a short time the fly becomes so weakened that it can scarcely crawl. Finally, it stops, but the white shroud of fungus keeps on growing. If some scientist could so cultivate the mold that it would start its work in the summer, the pestilential fly would soon disappear.

MOTOR GLOVE HAS FLASHLIGHT IN BACK FOR SIGNALING

Quite novel among the automobile signals which have been developed lately, is a glove with a small flashlight set in the back. It is provided with a red bulb and operated by pressing a push button, placed under the thumb. It is used to warn cars approaching from the rear that the driver intends to stop or turn. The battery is said to be sufficient for 2000 flashes.

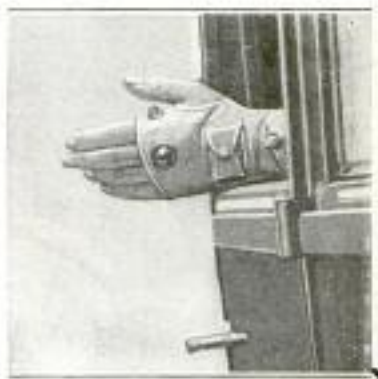

Cont. Lias B. Chase
 819 Lawrence St.
 St. Louis, Mo.

Block of stand registers
 2435 - 2 1/2th Ave.

Copyrighted material

1005 Medical
 Banner Sales
 1672 Howard St.
 St. Louis, Mo.

**WINDMILL STORES ELECTRICITY
 FOR ELEVEN DAYS' USE**

Although there have been many attempts made to harness the wind to generate electric power, yet work along this

use it as required about the farm. On the main casting at the top of the tower is mounted a 1-kw. generator. It is geared directly to the shaft of a 14-ft. steel windmill. The spur gears are carried on roller bearings, the entire reduction gearing running in an oil bath. The generator gives a constant voltage over a speed variation ranging from 750 to 2,500 r.p.m. The storage battery has a capacity of 280 ampere-hours and will store enough electricity to operate the lights on an average farm for 11 successive days without wind. This is a condition of weather seldom, if ever, encountered. The collector ring is so designed that it allows the wheel to turn and face any wind.

Main wires lead down from the collector ring to the switchboard and battery. The switchboard is very simple and is provided with cut-out switch, ammeter, voltmeter, and a specially designed relay which permits the apparatus to charge at 16 volts in moderate winds and automatically change over to a 32-volt charge in winds of 18 miles an hour or more. This makes it possible, according to the inventor's claim, to take advantage of all wind conditions, and get maximum charging efficiency from winds ranging from 7 to 30 miles an hour.

producing a baseball game in wood, with a jackknife as his only tool. The scene represents a double steal with the runner out at home. The field is 8 ft. square and is painted grass-green, except the base lines which are of sand color, and the bases and pitcher's slab which are gray. Each figure is 6 in. high. The players having the field have light cream-colored suits, and blue socks, belts, and caps. Those at bat have light gray suits, and green socks, belts, caps, and sweaters. The umpire is dressed in dark blue.

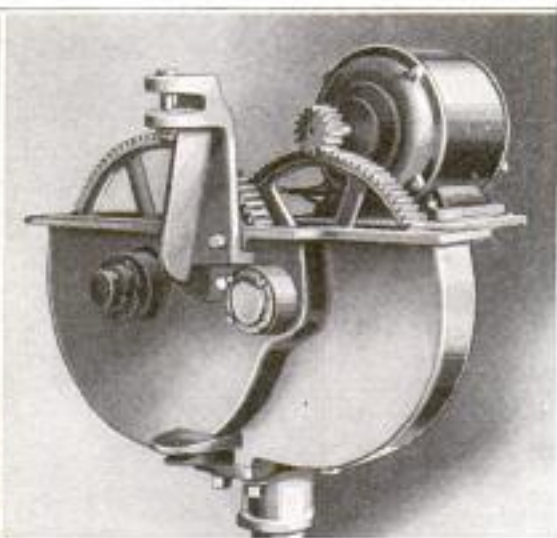

Left: The Steel Windmill. Right: The One-Kilowatt Generator and the Reduction Gears Which are Directly Connected to the Windmill Shaft. The Lower Parts of the Gears are Immersed in Oil

line is still in the experimental stage so far as actual farm installations are concerned. Thus considerable interest is attached to the announcement made by a windmill manufacturer that he has at last succeeded in constructing a model that, he believes, will meet all the requirements in this special line.

The combined windmill, generator, and storage-battery outfit is designed to transform the wind power into electric energy, store it in storage batteries, and

**BASEBALL SCENE WHITTLED
 FROM WOOD WITH KNIFE**

For 12 years August Bruyere, of Green Bay, Wis., devoted his spare time to re-

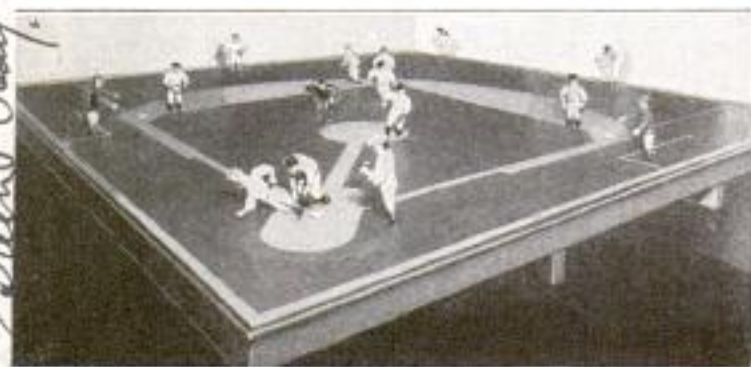

A Baseball Game Carved in Wood, Which Is the Product of Many Hours of Patient and Skillful Work, with a Jackknife as the Only Tool

Names and addresses of manufacturers of articles described in this magazine will be furnished free by our Bureau of Information.

7459 Cml. E. E. Pierson
 Bloomington Ill.

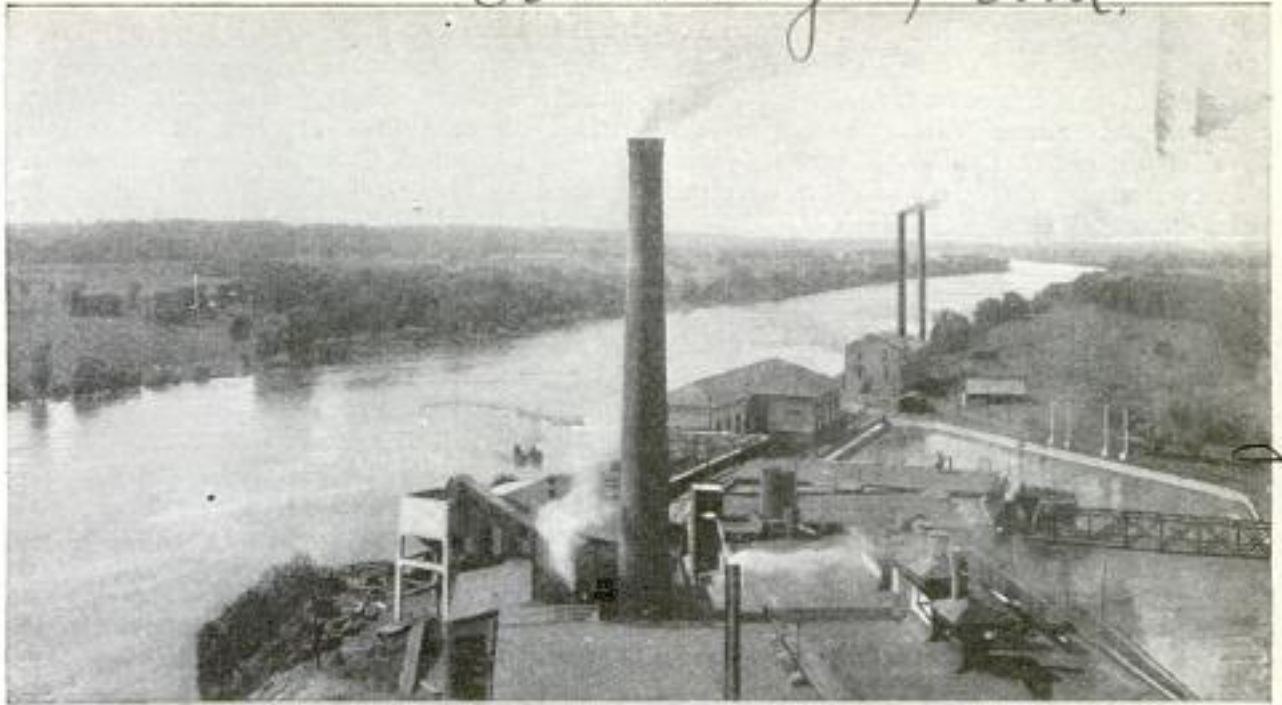

The Illinois Waterway as Seen from a Point in Marseilles, La Salle County, Where the First of the Five Locks Connected with the Enterprise is Now being Built near the Bend in the River Seen in the Background: The Lock will Be One of the Largest in the World

FIRST LOCK BEING BUILT FOR ILLINOIS WATERWAY

IN connection with the Illinois Waterway—the \$20,000,000 improvement of river navigation authorized in 1919—the excavations for the first lock are now in

progress at Marseilles, La Salle County. The lock will be 600 ft. long from gate to gate, with an over-all length of 938 ft., and a width of 110 ft., making it nearly



Excavations in Connection with Initial Work on the First Lock, near Marseilles, La Salle County, for the Illinois Waterway Improvement That will Make It Navigable for Large Steamers from Chicago to the Gulf of Mexico: The Lock will Be Parallel with the Illinois River, Which Is in the Background near the High Tower

Engineers - Green & Co., 332 & Michigan Ave
 Chicago, Ill.

the size of the Panama Canal locks. It is situated at some distance from, and parallel with, the Illinois River, to which it is connected above and below by channels, 40 or 50 ft. wide, which will have a difference in level of 21 ft. At the low level there will be 14 ft. of water over the lock sills, and the walls will be 50 ft. high. The lock will be filled and emptied by means of conduits, 12 ft. in diameter, built into its concrete walls. The lock is on the south side of the river, and as the railroads are all on the north side, a spur was built to the bank, and a temporary bridge was thrown across the river, as well as a 1,400-ft. span cableway. The bridge is in sections, which can be removed at flood time. The concrete mixing plant is on the north side of the river. Its two 1-yd. mixers are installed so that $\frac{3}{4}$ -cu. yd. trucks can run under them and

receive their loads. Concrete construction on this lock started in September. It is expected that the lock will be finished by Oct. 1, 1922. The whole project is scheduled to be completed some time in 1926, when deep-water navigation will be open from Chicago to the Gulf.

The course of the Illinois Waterway extends from the power plant of the Sanitary District of Chicago, near Lockport, to a point on the Illinois River near Utica. At the junction of the canal with the Desplaines River, it passes through the city of Joliet, and thence along the course of the Illinois River until Utica is reached. The channel of the waterway will have a minimum width of 150 ft., but through Joliet this width is to be increased to 270 ft., in order to provide room for dockage at wharves on either side, without interfering with the passage of vessels.

NEW TRAILER HAS WIDE RANGE OF ADAPTABILITY

A trailer, specially designed for heavy duty with tractors in trains of from four to eight, embodies a number of features

The rear drawbar and wheels are locked in a central position by means of a locking pin, and slots in the drawbar and drawbar rest. Those which happen to be in front are left free to swing. Two heavy coil springs at each end take up all torsional strains. A hinged link connection, between each two trailers, folds back within the drawheads, so that, in backing, they come in contact and form a connection of ample rigidity to meet any demand placed upon it.

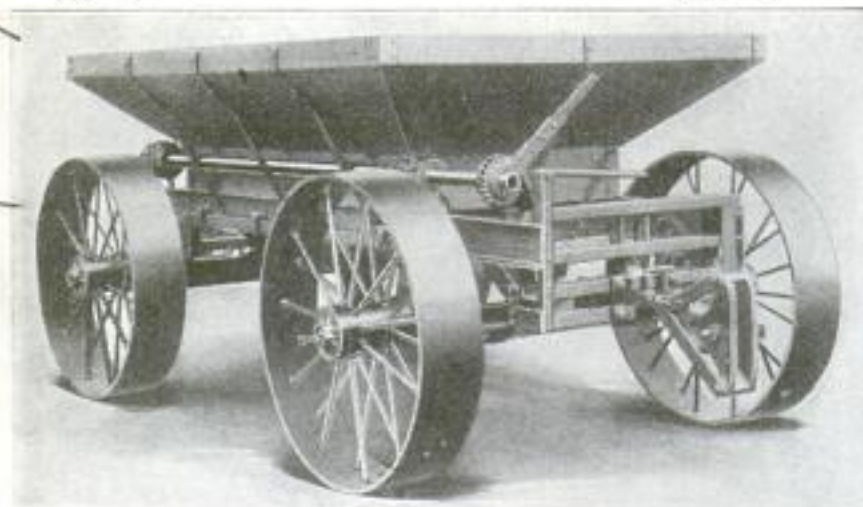

The Heavy-Duty Trailer Equipped with a Hopper Dump Body Which can be Quickly Removed from the Frame

which give it a wide range of adaptability. This trailer is provided with a hopper dump body. By removing a few bolts, the hopper body and dumping mechanism may be removed, leaving an all-steel frame, upon which any sort of body can be mounted. A drawbar at each end makes the unit reversible.

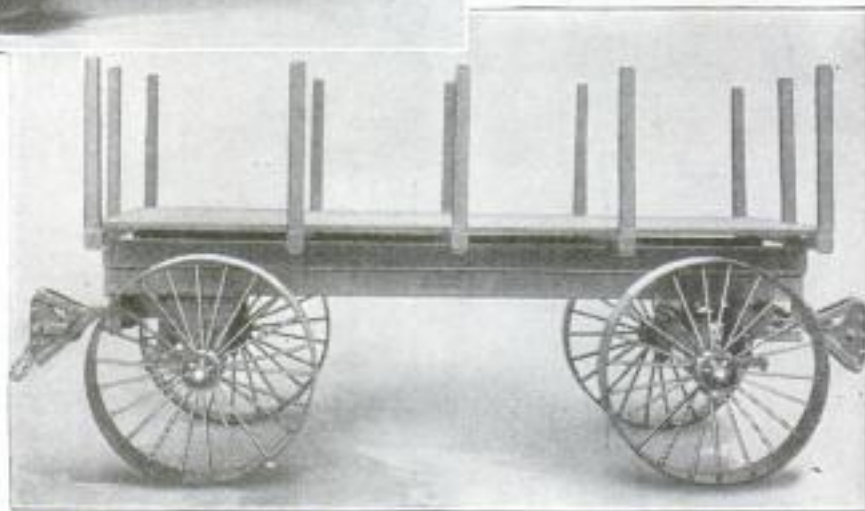

The Hopper is Replaced by Any Other Type of Body. A Drawbar is Provided at Each End for Making Up Trains. Both Pairs of Wheels Are Movable, but Either can be Locked, Making the Unit Reversible

7214 Cml. Harry Seaman

798 1/2 Henderson St.
POPULAR MECHANICS

Newark, N.J.



House being Moved along a Street in Newark, New Jersey: The Building Was So Wide That It Played Havoc with the Trees on Either Side



Showing How the House, While being Moved along the Street, Totally Destroyed Some Trees



Above: Residents of the Neighboring Houses Beginning the Wreckage of the House. Right: All That was Left of the House



7214

HOUSE-MOVING ENTERPRISE WITH UNEXPECTED ENDING

House moving along streets in a city is generally accompanied by a certain amount of excitement, but not often to the degree that was caused recently by the attempt to move a house along a Newark, N. J., street, where the building itself was so wide that it damaged the trees that lined the road on either side of it. After traveling about 50 ft. from its original location, the damage done aroused the neighboring residents to such a degree that they first caused the city authorities to order the work stopped, then gave the owners of the house a certain time to do something about it. When this time expired and nothing had been done, they did something themselves—so effectively that, at the end of the doing, there was not a vestige of the house left at a higher level than three feet.

CLAY DIGGER RESEMBLES PNEUMATIC HAMMER

A clay-digging tool that is said to do work equivalent to that of seven men digging by hand, is now on the market. It is similar in principle and appearance to the ordinary pneumatic riveting hammer. In place of the hammer is a spade. It has a long stroke, and its speed is 800



Clay-Digging Tool That Is an Adaptation of a Pneumatic Riveting Hammer, with a Spade in Place of the Hammer: It Strikes 800 Blows a Minute

blows a minute. Like the pneumatic hammer it can be operated in a space too limited to swing a pick.

Chicago Pneumatic Tool Co 6 E. 44th St. New York

5294

Cont. Jane Frederickson
 1822 Curson Ave. Los Angeles, Calif.
 CAMOUFLAGE CONVENIENCES CHARACTERIZE

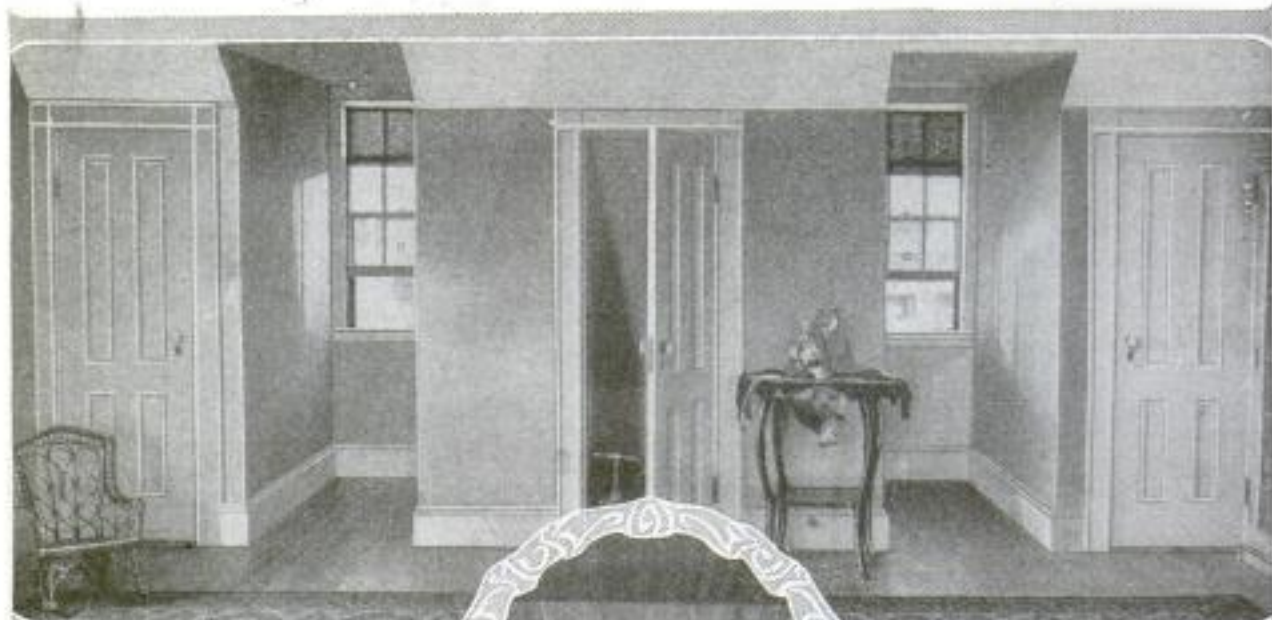

Above, Left and Right: A Model Nursery and Playroom. Though the Toys may be Strewed from One End to the Other One Moment, the Next Sees the Room Spick, Span, and Tidy, Everything being Whisked into the Three Closets, One of Which may Be for New Playthings, the Second for Those Not Quite So Fresh, and the Third for Such as Are in Need of Repairs



Left: What in Most Dwellings Is an Unlovely Spot, Buried Away under the Eaves, in One Home has Become an Attractive Attic Nook, Fitted with Shelves for the Storage of Seldom Used Odds and Ends, and a Long Rod, Well Supplied with Hangers, Where Out-of-Season Garments are Disposed, Out of the Way, Protected by Moth and Dust-Proof Bags

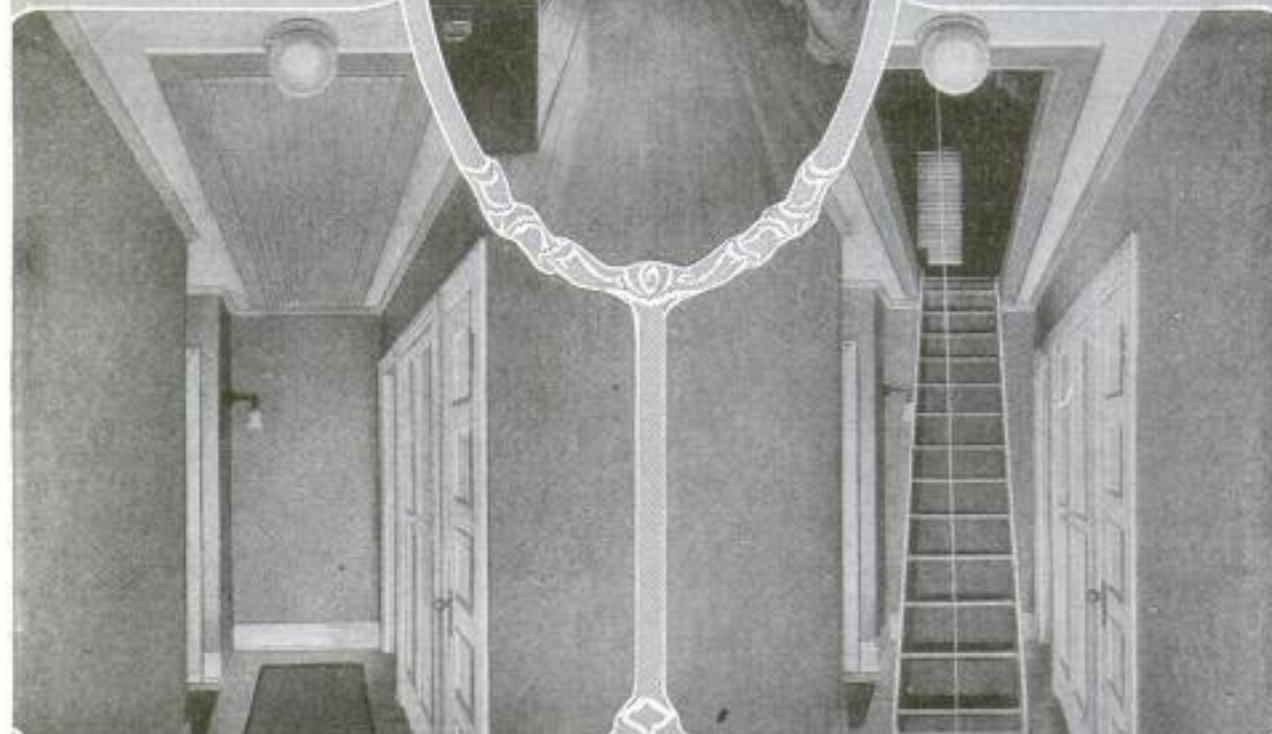

A Concealed Stairway Affords Access to Attic Storeroom. Finished on Its Underside with a Full-Length Panel, Matching the Rest of the Woodwork, It Gives No Hint of Its Existence When It is Folded Up. Right: The Cord, Which Passes over a Pulley in the Attic, Has a Counterweight Attached to It. A Slight Lift on the Stairway Sends It Up into Its Niche, Where the Counterweight Holds It Securely

MODERN CITY AND COUNTRY RESIDENCES

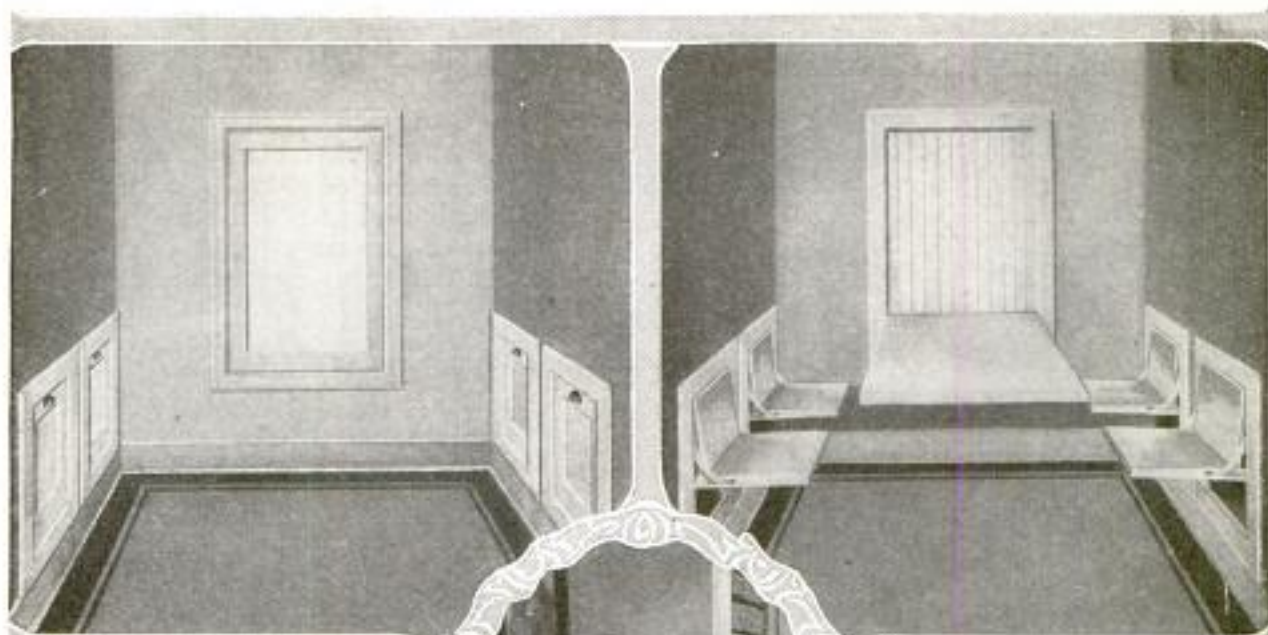

Above, Left and Right: A Masterpiece of Interior Camouflage. One Not Familiar with the Design would Never Suspect That He Was in the "Fade Away" Breakfast Room of a Cleverly Thought-Out Dwelling. With the Family and Guests Assembled, the Signal is Given, and, Presto, the Wall Panels Drop Outward, and the Room Becomes a Dining Hall

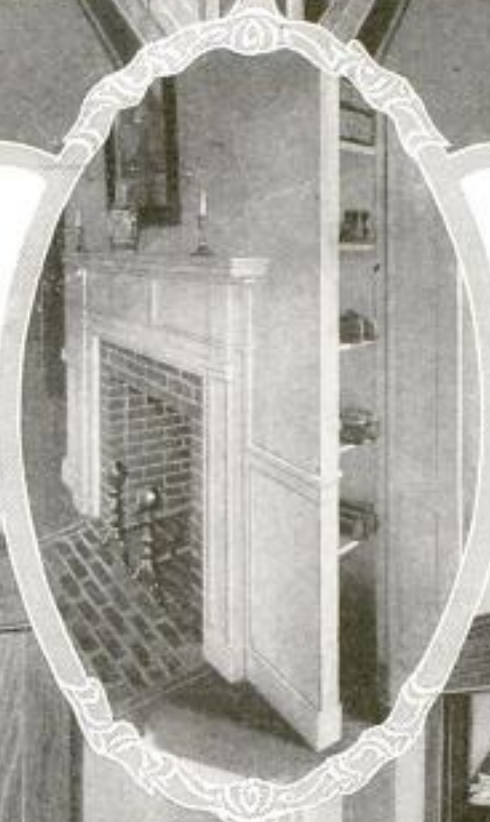

Left: The Fireplace Is a Concession to Sentiment and Custom, and Serves No Useful Purpose Other Than to Mask a Tiny Closet Built behind It. Here are Kept in Orderly Array, Always Findable When Wanted, but Never Underfoot Causing Vexation and Unnecessary Work in Moving Them About, Those Hundreds of Little Things Which So Often Clutter Up the House



A Camouflaged Sewing Room: At First Glance One might be Led to Believe That This Is a China Cupboard or Buffet. However, the Lady of the House Knows Better, and could, If She Chose, Disclose the Interior of a Well Arranged, Though Somewhat Large, Sewing Cabinet, by Pulling the Panels Down and Outward, from the Top, into the Lowered Position Shown at the Right

Mills Novelty Co
 Jackson Blvd. + Esplanade St

260

7582

POPULAR MECHANICS

Chicago

GROUP-CONTROL METHOD OF PLAYING VIOLINS

Essentially different from anything in the nature of an automatic musical instrument is a new group-control violin

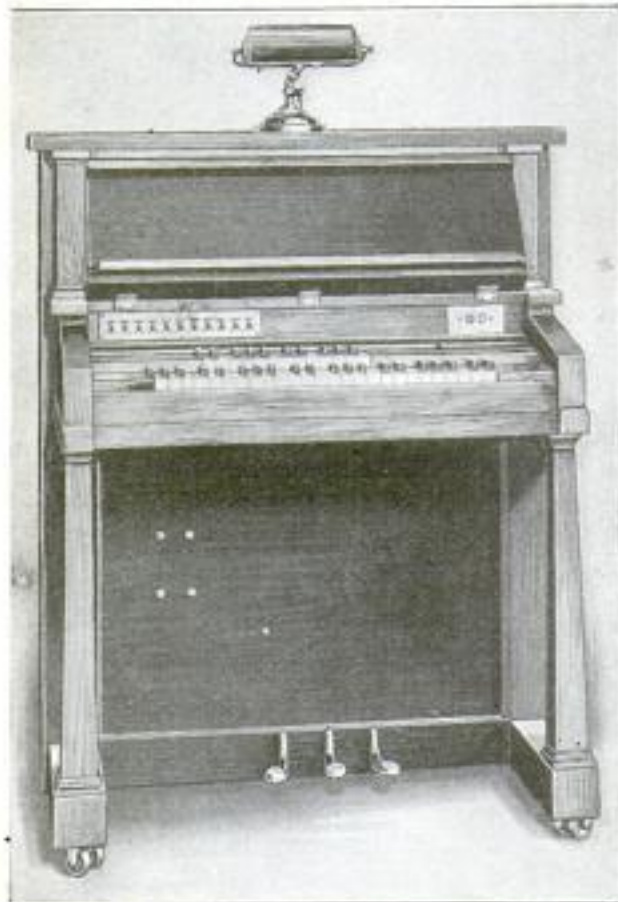

Console by Means of Which One Musician Plays Any Number of Violins: Electrical Control Is by the Switches above the Keyboard and by the Three Pedals

player that was recently demonstrated in Chicago, as the first-violin basis of an orchestra of 30 pieces. The new instrument, singly or in groups, is played from the keyboard of a console by means of which the musician's fingers do exactly the same things—and more of them—that are done by a violinist with the instrument in his hand. Moreover, from one keyboard one performer can play any

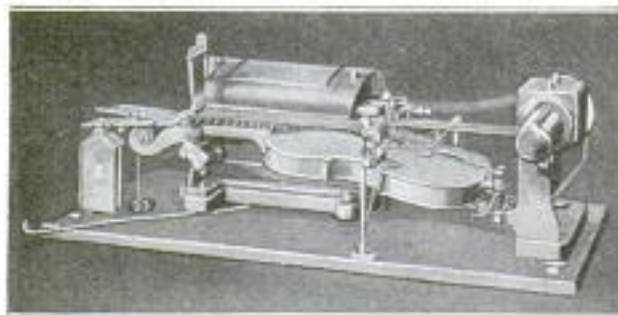

Violin That is Played Electrically from a Console at Any Distance: At the Right Is the Motor That Rotates the Bow Disks. At the Left Are the Mechanical Fingers

number of violins. Each violin is a complete unit, and is mounted on a stand that is connected with the console by an electric cable controlled by a switch. A small motor on the violin stand rotates four celluloid disks—one to each string—that take the place of the ordinary bow, but do what that can never do, because they can play all four strings at once. Under the strings, instead of over them, are the fingers that are electrically controlled by the keyboard and by switches on the console, enabling the performer to get all the usual bowing effects. Further control is by means of three pedals, one piano, one forte, and the other for playing progressively, or simultaneously, on any number of violins desired, when there are more than one connected to the console.

7689

ACCESSORY HELPS MOTORIST TO KEEP DAILY RECORD

Motorists who wish to keep a handy record of the daily expense and mileage of their cars, can do so with the use of an accessory recently placed on the market. The accessory has a paper disk divided into 31 parts, representing the days of the month. The miles traveled, and any purchases of gasoline or oil, are recorded upon the disk, which is revolved to the proper date by turning a thumb-screw on the top. At the end of the

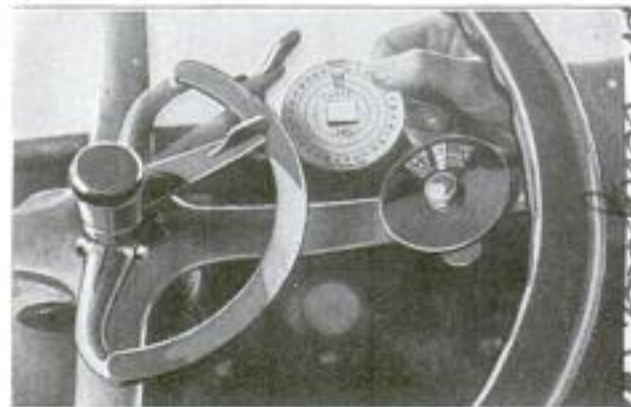

Removing the Disk from the Daily Recording Accessory to Ascertain the Month's Expenditures for Gasoline and Oil, and Miles Traveled

month, a complete record is found on the card of the total expenditures, and the mileage.

At Port Etienne, in the French West African colonies, the center of a growing fishing industry, a former French cruiser has been anchored in the bay and turned into a fish-drying factory. Sixty tons of fish can be dried on its decks at one time.

Order for C. 1932 J. Sprague Ave.

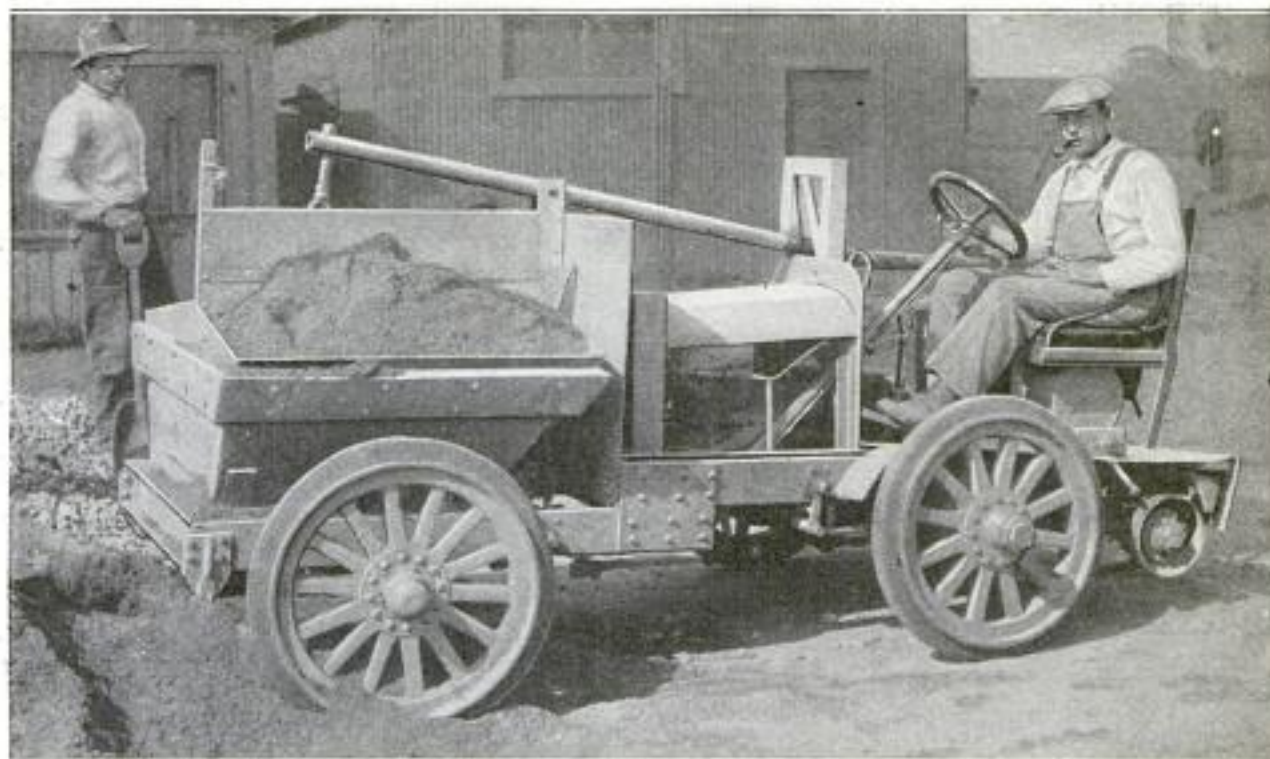

One of the Auto-Wheelbarrows Designed for Paving Work in Long Beach, California, Which have Proved Economical of Both Time and Labor: They are Built on Standard Light Motor-Truck Chassis and are Equipped with a Hopper and Dumping Mechanism

7317
AUTO-WHEELBARROW IS LATEST TYPE OF DUMPING TRUCK

Auto-wheelbarrows, designed by a contracting firm, are really miniature dumping trucks with a new arrangement of their parts. The machine is built on a light-truck chassis, with the driver's seat at the rear, back of the wheels. The engine is placed between the front and rear wheels, and the hopper is in front of the engine, directly over the front wheels. The dumping mechanism is operated by means of a lever. These machines have a much greater capacity than the ordinary wheelbarrow and have proved economical of both time and labor. They are used for carrying materials to concrete mixers, and the load can be dumped directly into the mixer skip.

7810
CAFETERIA IN YOSEMITE PARK POPULAR WITH TOURISTS

The first cafeteria ever established in a national park was operated last season in Yosemite Park. It proved so successful that others will probably be established in national parks throughout the country. Its purpose was to supply meals to park employes, about half the patrons, and to tourists and campers, at the lowest possible cost. In five months 250,000 meals were served at an average cost of about 48 cents each.

Columbus Dispatch
 10/23/21

7701
A SIXTEEN-SHOT REVOLVER MADE IN BELGIUM

A Belgian concern is manufacturing a revolver which enables the user to fire 16 bullets without reloading. The arm has two barrels, one above the other, registering with two series of eight holes each in the cartridge chamber. It is fitted with a double firing pin, and the bullets are fired alternately from the inner and outer circles. When all the cartridges have been discharged, the empty shells are thrown out all together by pressure

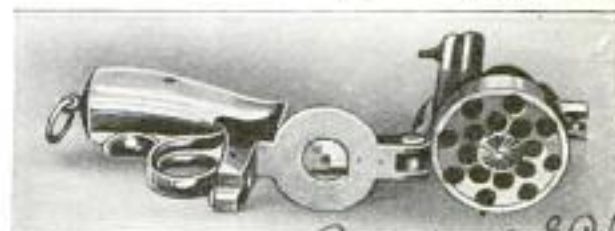

COPYRIGHT, PHOTO REPORTAGE BELGE
 The 16-Shot Revolver Broken, to Show the Arrangement of the Two Circles of Cartridge Chambers

on an ejector rod. The caliber of the gun is .32. A similar type of arm fires 20 bullets without reloading, but is of somewhat smaller caliber.

□ We want all our readers to write us freely and often whenever they wish additional information on articles published in this magazine. Address Bureau of Information, Popular Mechanics, Chicago

Agents Maurice & Belgrin
 1000 Broadway
 New York City

141

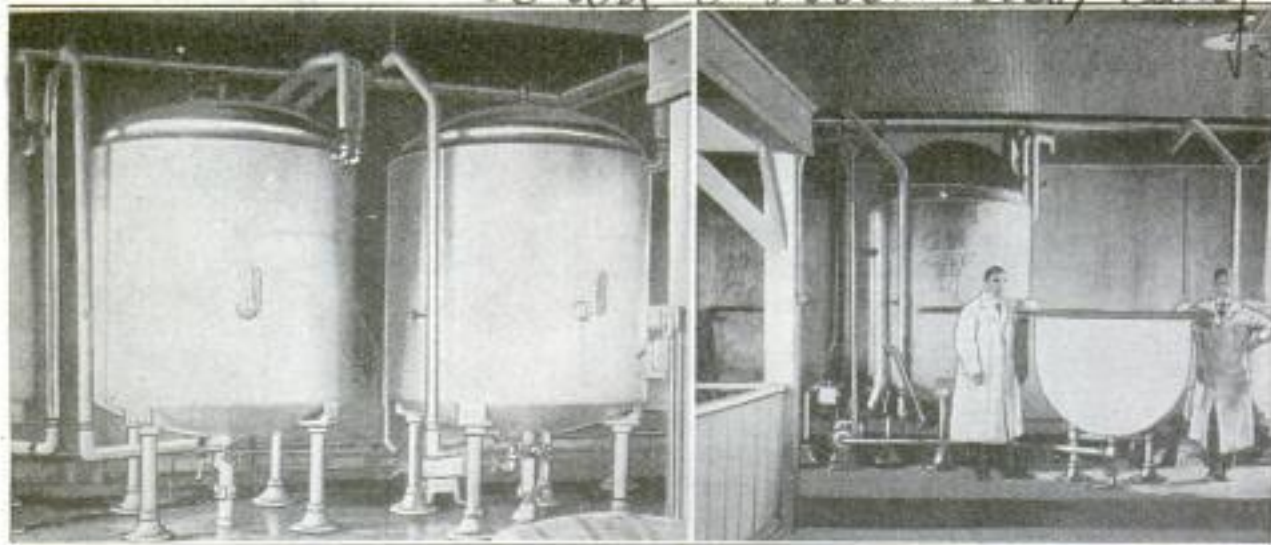

Glass-Lined Preparation Tanks, in Which Coconut Oil is Alternately Heated and Cooled, the First Step in Making Coconut-Oil "Butter," are Shown at the Left. The Pump and Pipe, at the Right, Used in Filling the Tanks, are Taken Apart and Cleaned Immediately after being Used

HOW COCONUT-OIL BUTTER IS MANUFACTURED

By C. W. GEIGER,

815 Mason St.
San Francisco, Calif

THOSE not interested in the manufacture of butter from coconut oil have probably forgotten that the price of the natural product has advanced con-

soap; so they worked out secret formulas by which they have manufactured the butter by the thousands of tons. In the United States the process is of more recent introduction, but is now conducted quite profitably on the western coast, where the "copra," or dried coconut meat, is received directly from the islands of the South Pacific.

San Francisco is thus the home of the factory illustrated on these pages, and considered to be one of the most efficient in the United States. This

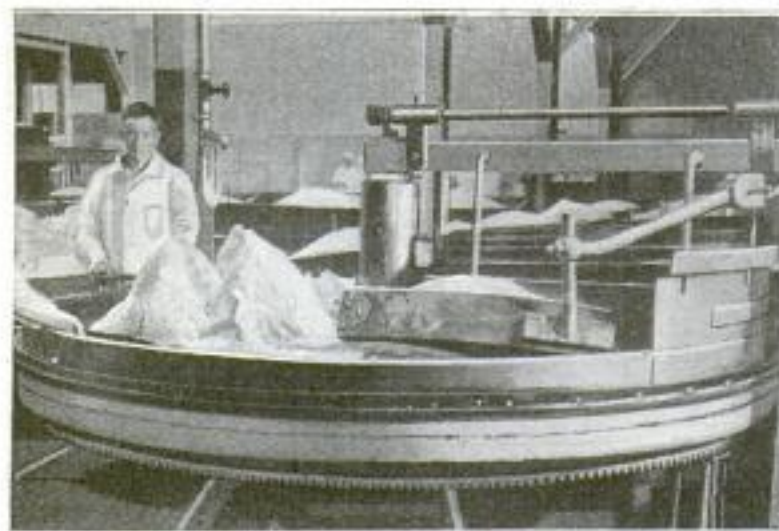

On This Revolving Kneading Table, Excess Water is Forced Out of the Mass of Crystallized Oil, and Salt is Worked into It

siderably in the last few years. In view of present conditions, the growing use of this substitute is worth the attention of every sufferer from the expensive habit of eating food. As a matter of fact, producers in Germany and France learned several years ago that coconut oil made edible butter as well as good candles and



After being Cut into One-Pound Bricks, the Finished "Butter" is Placed on an Endless Belt Which Moves down the Center of a Wrapping Table. Girls, Sitting along the Table, Pick the Bricks from the Belt and Wrap Them

From the Preparation Tanks the Oil is Pumped into Churns and Mixed with Milk. The Man is Standing beside the Churns. The Mixture is Pumped into the Centrifugally Operated Glass-Lined Crystallizer, in the Fore-ground, Where It Forms Crystals

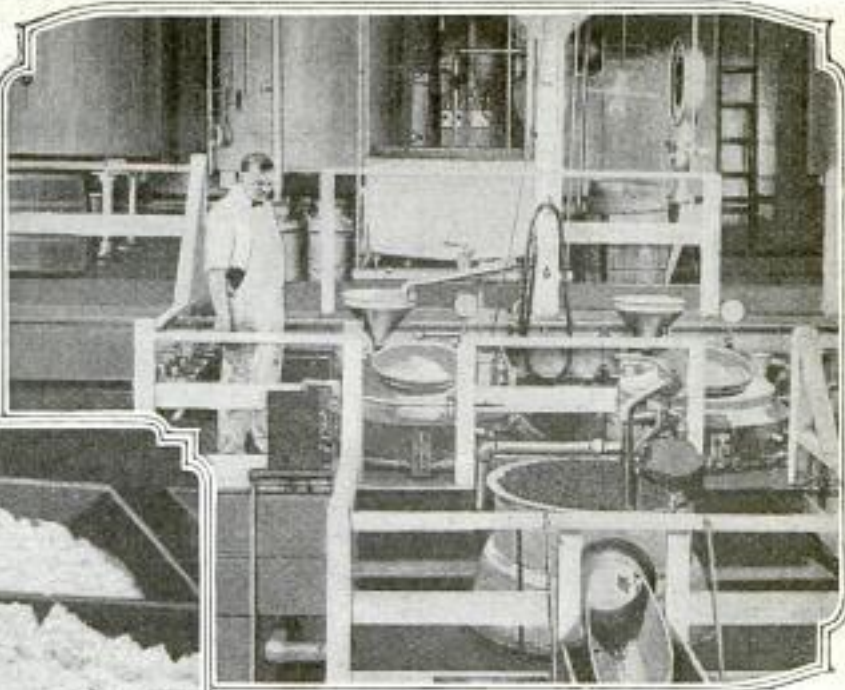

The Crystallized Mixture, Shown Here, is Scooped into Trays and Taken to a Vat of Cold Water, Where It is Thoroughly Washed. The Water is Cooled by Brine Coils

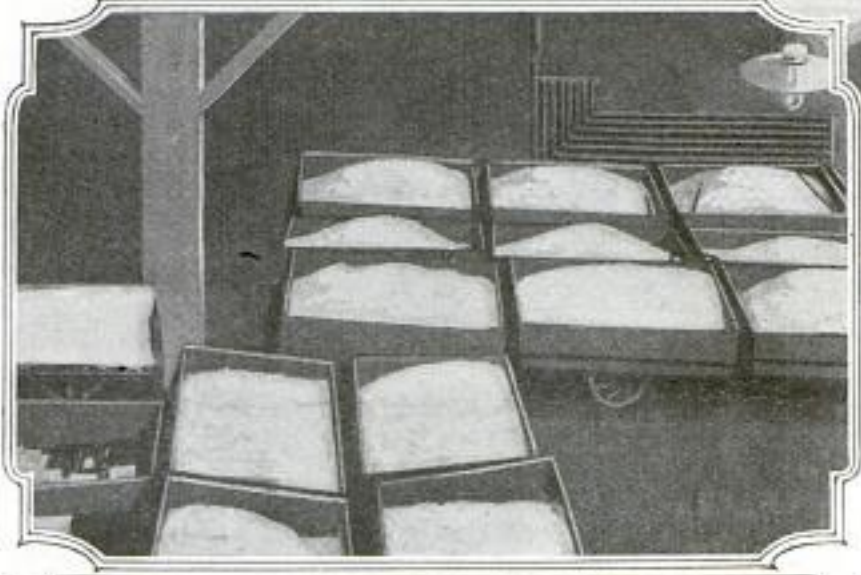
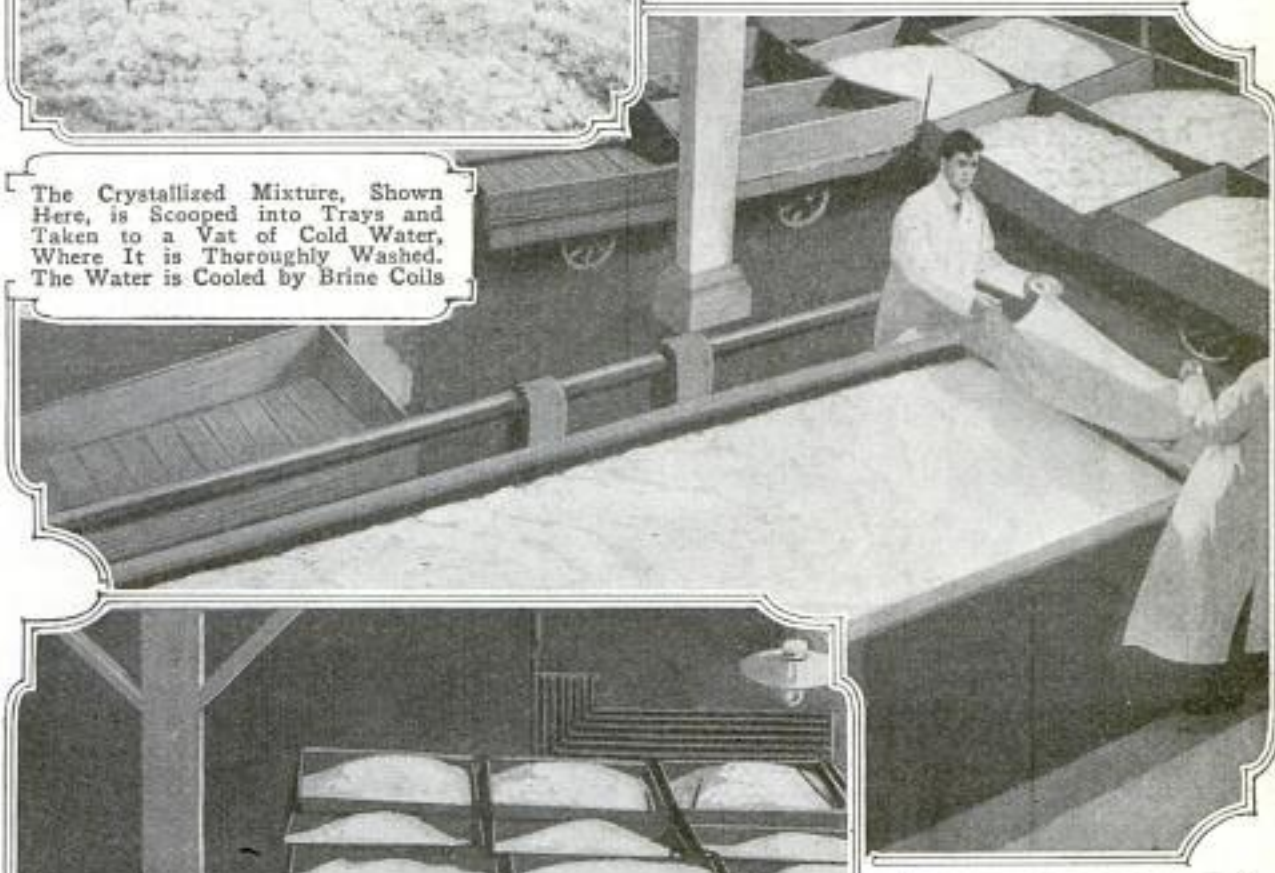

After the Crystals have been Washed in the 20-Foot Vat, Which is Shown Above, Two Men Again Scoop Them into Trays, Mounted on Wheels, and They are Taken to a Room, Where They are Allowed to Stand from 20 to 26 Hours

While Standing in the Trays, the Crystals become "Tempered" and Take On the Aroma of Butter. They are Then Taken to the Kneading Table for Final Preparation



concern is unusual, too, in pressing out the oil at its own mill, from which the heavy, ill-smelling liquid is hauled in special tank wagons to the factory. Here it is stored in great glass-lined tanks until needed, when the oil is pumped into preparation vats, also glass-lined, in which it is alternately heated and cooled by steam and brine pipes. Then comes treatment in churns where 30 per cent of milk is added, this mixture passing into a "crystallizer" where contact with cold water converts it into solid "crystals."

Scooped into trays, these crystals are then set out for 20 to 26 hours, permitting the butter aroma to penetrate thoroughly. At the end of this period the crystals are placed on a broad table where rollers and knives knead them into appetizing butter, pressing out excess water and working in the salt. To permit handling, the butter is then hardened in a freezing room; later cut into the one-pound portions of commerce, and finally placed on a wide, moving belt, from which it is seized and wrapped by quick-fingered girls.

Power. Electric

AUTOMATIC SUBSTATION IN AMERICAN COAL MINE

Far back under the coal-veined hills at Nanty Glo, Pa., a powerful substation

central-station lines, the substation will automatically shut down. In like manner whenever the power comes on, the substation will automatically resume operation instantly and pick up the mine load. Thus power conditions at the load centers are greatly bettered, consumption of power is trimmed down, and the service of attendants is made unnecessary. The first day's operation of the station showed an increased production of 200 tons.

This motor-generator set operates in parallel with engine-driven generators in the power plant near the drift mouth. The compounding of the motor-generator set is so designed as to throw the maximum load on the power plant. Thus the motor-generator

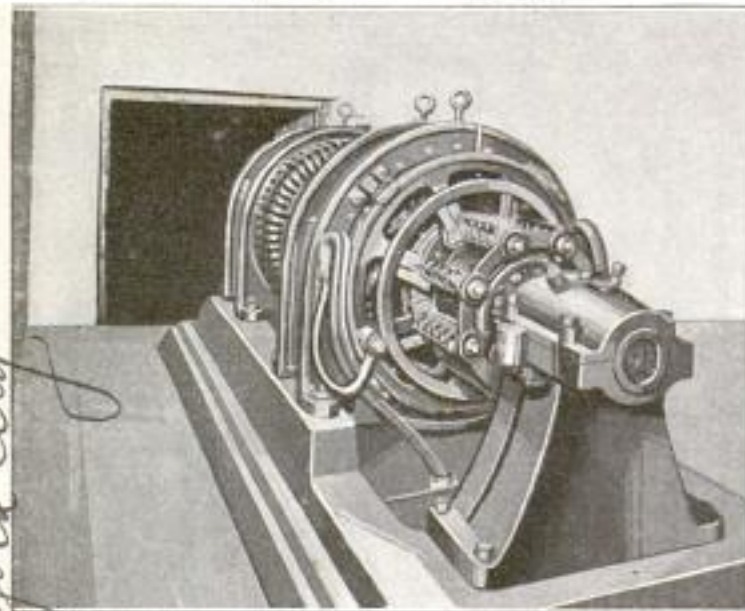

Motor-Generator Set at Automatic Substation in a Coal Mine at Nanty Glo, Pennsylvania: Without the Presence of an Engineer It is Perfectly Protected against Overload, Hot Bearings, or Overspeed

keeps steadily at work without the presence of any attendant. It is located two miles from the drift mouth and occupies a most substantial apartment. The walls are of heavy masonry with steel beams for ceiling. A 2,200-volt cable comes from the surface through a bore hole.

The substation is in many respects superhuman, for the motor-generator set is protected against overload, short circuit, hot bearings, reverse current, and overspeed to a degree that even the most efficient attendant could not approach.

If power is interrupted on the

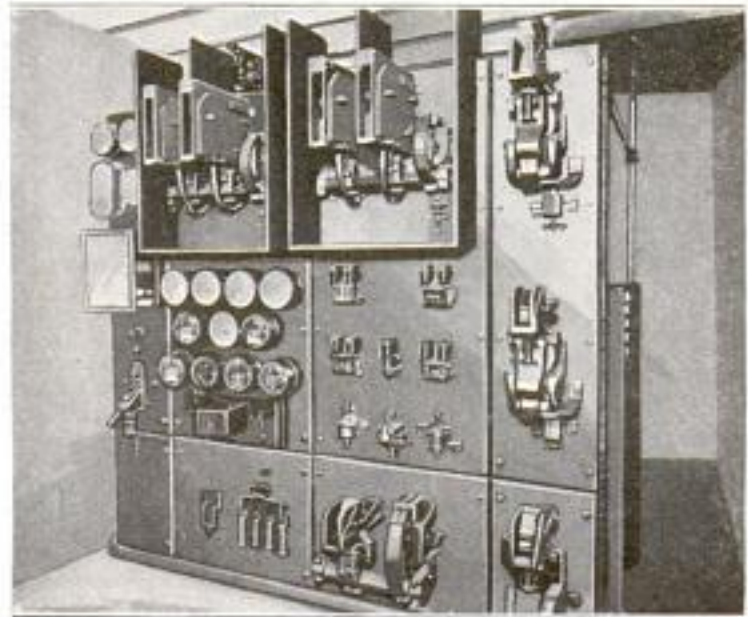

Switchboard in Power Plant near Drift Mouth That Controls the Motor-Generator Set at Automatic Substation Located Two Miles Away

Stuart, James & Cook, New York City

6378

set acts as a booster. It takes off the peak loads and reduces the purchased-power consumption to a minimum.

In general it may be said that with automatic substations installed, it is entirely practicable and feasible to start and stop any number of generator sets with the aid of remote control either from the mine office or from any other convenient point. In the case of the station here in question, the starting and stopping of the set is simply effected by means of a push button located in the engine room of the power plant.

Indian settlement with a fort, established by Anthony Wayne, at the juncture of the St. Mary and St. Joseph rivers, down

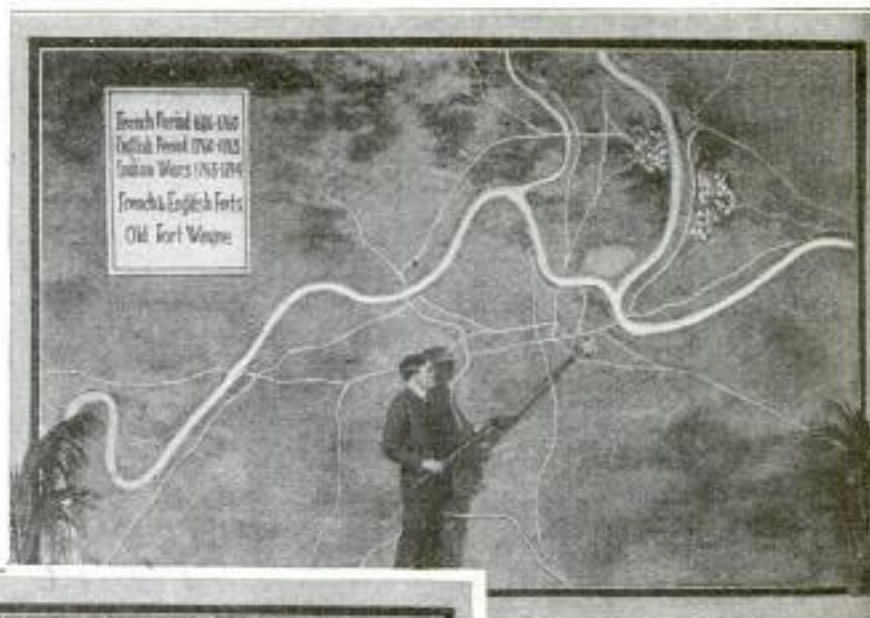

This Map Shows Fort Wayne as an Indian Village and Frontier Fort



to the present time. Mr. Griswold recently delivered lectures, which were well attended, to the Chamber of Commerce, to joint assemblies, the city's business clubs, and gatherings of school children. The maps depict in detail the various steps in the city's growth.

Another Step in Its Development to a Thriving Industrial Community: In 1854 It Occupied a Considerable Territory South of the River

650
WALL-SIZE MAPS SHOW GROWTH OF CITY

An interesting and unusual method of visualizing the growth of a city has been worked out by B. J. Griswold, of Fort Wayne, Ind. A series of wall-high maps graphically demonstrate the growth of the city by contrasting various stages in its development from the days when it was a little



In 1921: Lectures, Graphically Illustrated in This Way, Proved Equally Interesting to the Chamber of Commerce, Civic Organizations, and School Children

*Cml. Frank H. Williams
1920 Spy Run Ave. Fort Wayne, Ind.*

Emil Harry Es. Schultzy
Park Ave. J

Mess. Samuel
Osborn & Co. Ltd

266

7658

POPULAR MECHANICS

Clyde Steel Works
Sheffield, England

NOVEL METHOD DEMONSTRATES
QUALITY OF LINOLEUM

Advertising of a most convincing sort was recently adopted by a dealer in house furnishings who wished to demonstrate



Linoleum, Covering the Sidewalk in Front of a Store, was Given a Severe Test of Its Wearing Quality, Where All might See and be Convinced

the wearing qualities of his floor linoleum. On the sidewalk in front of his store, he laid a strip of the linoleum with the price per yard, and a request to the public to "watch it wear" printed on it. The way in which the sample stood the unusually hard wear and the constant exposure to the weather was an effective demonstration of quality.

7683

EGG OPENER NEW SANITARY
DEVICE FOR KITCHENS

Sanitary handling of eggs, in restaurants, hotels, and soda fountains, is made possible by a new egg-opening device. It consists of an enameled frame, in which a glass is placed. Over the glass is a cradle to hold the egg. By lowering a handle, a saddle strap is pressed down on the egg, forcing two fine points through

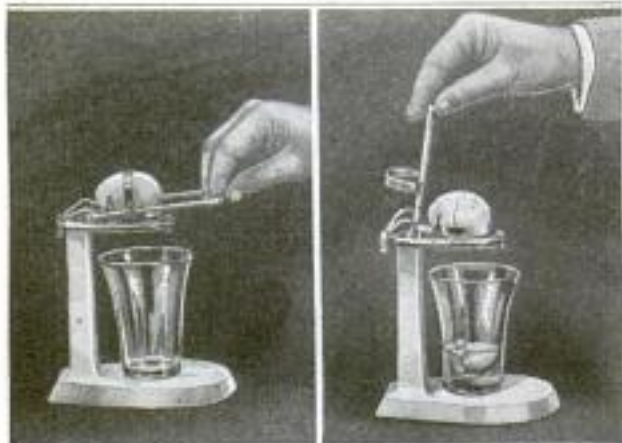

The Egg, Resting in the Cradle, is Pressed Down, as Shown at the Left. When the Handle is Raised, as at the Right, the Shell is Drawn Open

Chas. R. P. Clarkson, 14 E 44th St, New York City

the shell. Lifting the handle draws the points apart, separating the shell into two pieces and allowing the contents to drop into the glass. All metal parts are made of an alloy which is not affected by the sulphur in the eggs.

7838

RUSTLESS PLASTIC STEEL
NOW MADE IN ENGLAND

Steel that is both rustless and plastic has been produced at Sheffield, Eng. It has perfect rust-resisting properties, and can be stamped, punched, pressed, or engraved cold. When bent cold to a radius equal to its thickness, it shows no sign of fracture. It will retain a silver-bright polish in any atmosphere. Articles have been made of this steel that have the same strength as if made of brass or nickel, and only about half the weight.

7776

ELECTRIC MANIFOLD HEATER
WARMS "COLD" ENGINES

An easily attached electric intake-manifold heater of recent development will be appreciated by those who have to crank a "cold" engine. The heater is connected to the storage battery by means of a socket mounted on the dashboard of the

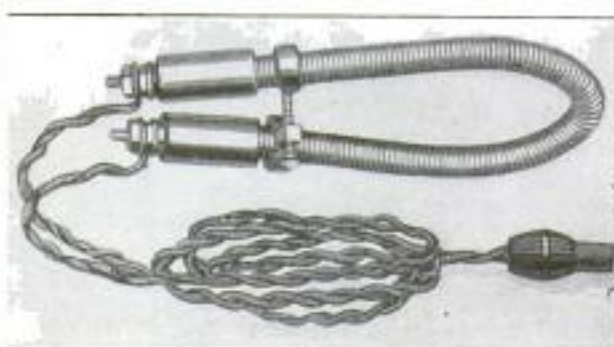

The Manifold Heater, with the Cord and Plug Attachment for Connecting to the Storage-Battery Socket on the Dashboard

car, and is simply wrapped around the intake manifold, where it is operated for two to five minutes before the engine is started.

7551

ONE TIPPLE SERVES TWO MINES
THROUGH LONG CONVEYOR

In Fayette County, West Virginia, where two coal mines, opening on opposite hills, are served by a single tippie in the valley below, a conveyor is used which is probably the longest of its kind in the world. One side is 1,070 ft. long and drops 458 ft., while the other is



Long Conveyors Carry the Coal, from Mines on Opposite Hill-tops, to a Common Tipple, on a Railroad in the Valley Lying between the Hills

1,125 ft. long and drops 470 ft. The cable-and-button-type conveyor consists of a $1\frac{1}{4}$ -in. cable with 12-in. transversal iron disks bolted to it at 4-ft. intervals. The cable runs through a wooden trough, with a $\frac{1}{4}$ -in. steel bottom plate, the disks serving to carry the coal along. Steel prongs distribute the coal over the cables in such a way that the lumps rest on the slack. The friction of the slack keeps



The Conveyor Trestles Consist of Towers and Trusses Built of Timbers Which were Shipped Ready-Cut and Numbered

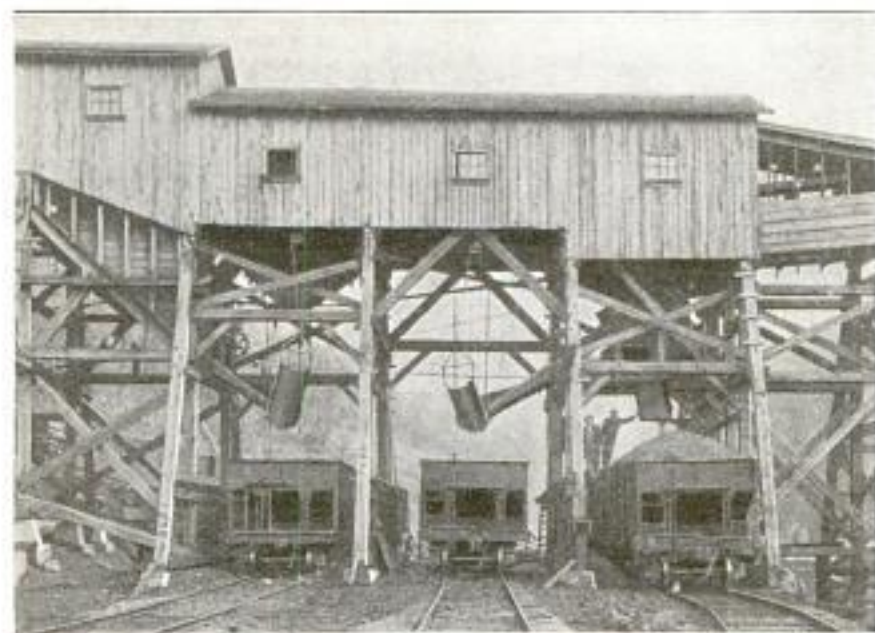

The Tipple Where Coal from the Two Mines is Dumped into the Waiting Cars: Though One Tipple Serves Both Mines, Their Coal does Not Mingle

the conveyor from running away, and the lumps cannot grind the trough. A device connected with the driving gears acts as an automatic brake. The pull of the conveyor applies the brake if the belt breaks or the power fails, and prevents the danger of the conveyor, with its 50-ton load of coal, getting beyond control. Impurities, such as slate, are picked from the coal as it passes down the troughs, and are thrown into chutes emptying onto the hillsides.

CIVIC FEATURES THAT PROMOTE THE COMFORT

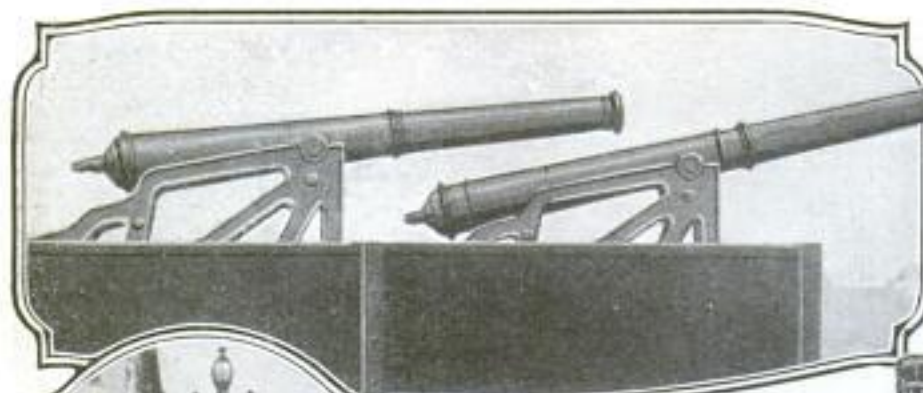

Two Sixteenth-Century Cannon, Similar to Those Mounted on the First Fort at Plymouth, Massachusetts, were Presented to the Town of Plymouth by the British Government, in Connection with the Tercentenary Celebration of the Landing of the Pilgrims, and were Placed at Plymouth Rock



Parking-Restriction Signs, Erected by the California State Automobile Association in the Downtown District of San Francisco, Have a Right-Angle Bend to Protect Them When High-Bodied Trucks Pass Close to the Curb

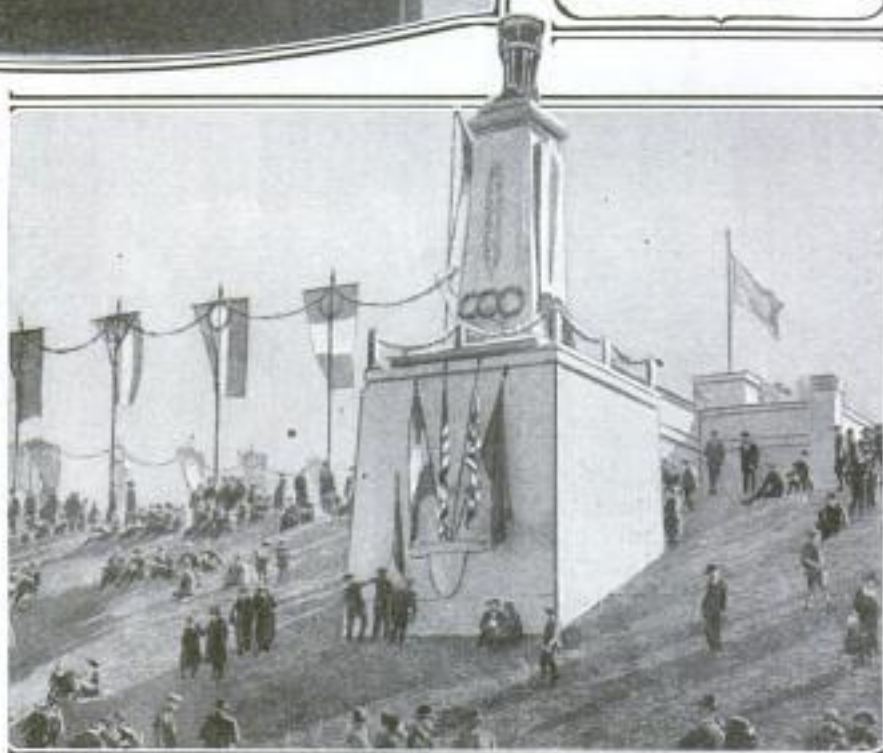

Dedication of the Kansas City, Missouri, War Memorial, during the 1921 American Legion Convention: In the Torch, at the Top, the "Flame of Inspiration" was Lighted, and Representatives of England, France, Belgium, Italy, and the United States Decorated It with Wreaths



This Picturesque Old Church, Built in 1769, Stands near Wellsville, Pennsylvania. In a Century and a Half, There have been Held in It Only about as Many Regular Services as Other Churches Have in a Year. Because It Is Not Easily Accessible, Services are Held Only on the Fourth Sunday of Each September



Trees Planted by the "Tree Club" of Ottawa, Illinois, Said to Be the First Organization Formed to Plant Soldiers' Memorial Trees, are Protected by Signs. A Bronze Tablet will be Placed on Each Tree, Bearing the Record of the Dead Soldier in Whose Honor It was Planted

AND ENJOYMENT OF VISITORS AND RESIDENTS

The trees around this boulevard were planted by the Civic Clubs of Salt Lake for its beautification. The Kiwanis Club will pay a \$25 reward for the arrest and conviction of anyone damaging them.

One of a Number of Signboards Placed along the Boulevards of Salt Lake City, Utah, by Civic Clubs, to Protect Trees, Which They have Planted along These Boulevards, against Vandals



Built in 1826, This "Old Log Courthouse," in Independence, Missouri, a Suburb of Kansas City, is Still Used. It has been Repaired Somewhat, but Still Shows the Bullet Scars of Indian Days



"King Fisher," a Hunting and Fishing Camp on the Cedar River in the Mountains near Seattle, Washington: It was Built, 26 Years Ago, by Harry Watson, a Seattle Sportsman, as a Place Where All Sportsmen would Be Welcome to Camp and Only be Expected to Leave the Place as They Found It

Street-Car Terminal at the Presidio, San Francisco: Beside the Platform and Shelter, There Is a Building Containing a News Stand, Restaurant, Telephone Booths, and Shoe-Shining Stand



Cml. Maurice E. Pelgruis
 35 Place de la Esare
 270 POPULAR MECHANICS
 7123 Antwerp, Belgium

**FUEL-MEASURING TANK AIDS
 OIL-CONSUMPTION TESTS**

Tests of the fuel consumption of oil and gasoline engines may be made quickly,

and at any time, by the use of an automatic fuel-measuring tank being manufactured in England. This tank is fixed in the fuel-supply line, well above the level of the carburetor or fuel-injection pump, preferably near the main fuel tank and below it. A float-operated valve, at the top, allows the escape and entrance of air when the tank is filling or the engine is running, and also controls, automatically and accurately, the amount of fuel admitted. Fuel enters the tank from the supply pipe through a cock and passes out to the engine through another cock. Both cocks are always open except when making a test. To make a test, the cock at the supply pipe is closed, and at the end of a fixed time the cock to the engine is also closed. The consumption can then be read on the scale opposite the oil level in the glass gauge. This scale is calibrated in pints.

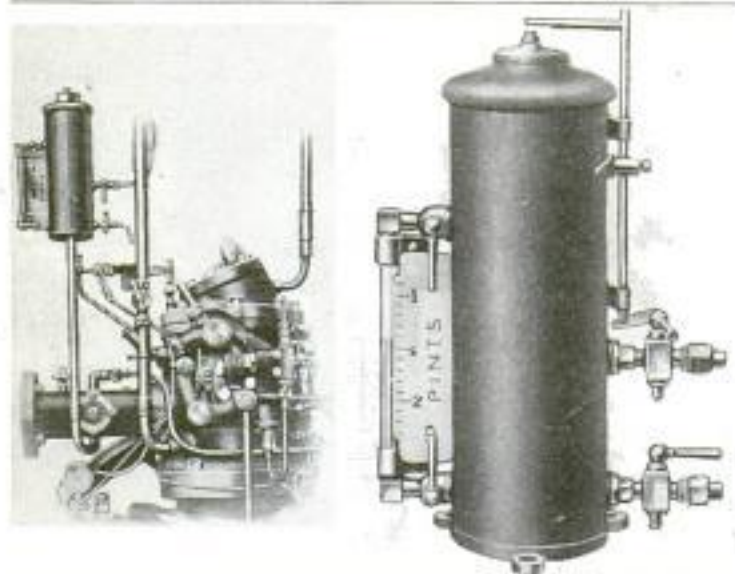

Left: The Fuel-Measuring Tank, as It Appears Mounted in the Engine-Supply Line, Above the Level of the Carburetor.
 Right: The Tank Enlarged to Show Its Construction

7527 *Industrial*
**BELL WARNS TRUCKS LOADED
 TOO HIGH TO PASS DOOR**

To warn drivers when their trucks are loaded too high to pass through the doorways of express terminals, boards are being hung from the ceiling, at the height of the entrance. A load that is too high, strikes the board and rings a small warning bell. This device is also used in front of eleva-

tor shafts, and is said to prevent many accidents to persons and much damage to shipments.

7786 *Water supply*
**MAMMOTH PUMP HAS CAPACITY
 OF 40,000,000 GALLONS**

An addition was recently installed at the Louisville, Ky., waterworks, consisting of a mammoth pumping engine, the capacity of which is 40,000,000 gal. every 24 hours. This vast amount of water is rather beyond comprehension, but may be found easier of conception by remembering that the average daily consumption of water per person in Louisville, is estimated at 107 gal. Not all the water pumped is delivered through the mains for consumption, as approximately 20 per cent is used for washing the various filters. Thus out of the total amount pumped, only about 32,000,000 gal. would be delivered, which, however, is enough to supply a population of 299,065 at that rate.

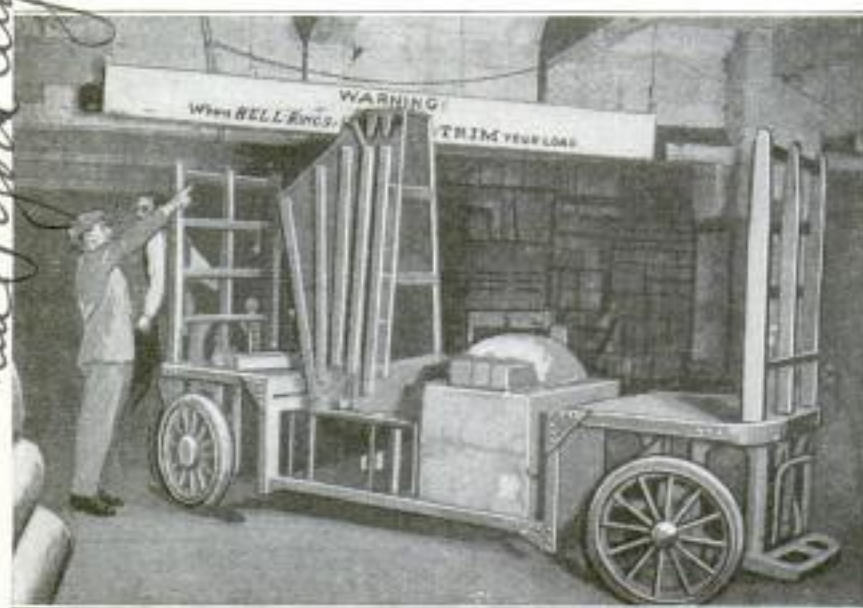

This Load Is Too High to Pass through the Doorway, but a Warning is Given by a Bell When the Load Strikes the Board in Front of the Door, So That the Truck may be Stopped and the Load Properly Adjusted to Avoid Any Possible Damage to It

*Louisville Water Co.,
 Louisville, Ohio*

*American Railway Express Co.
 New York City*



LIFEBOAT-RELEASING GEAR ACTS AS SAFETY DEVICE

Safety devices for the release of lifeboats when lowered from a ship's davits have taken many forms. One that looks simpler than most has been recently invented. A pipe supported along the bottom of the boat just above the keel has at each end a small crank that operates a vertically disposed rod on the end of which is a roller that locks the hook at each end of the boat by engaging its shank. The hook is pivoted on a support connected to the boat in such a manner that when the shank is left free, the hook is automatically overturned, releasing the boat from the davit falls. The unlocking is done by giving the pipe a half turn with a lever that is connected to it at any convenient point at the bottom of the boat. 7027

SIMPLE LOCATION SYSTEM FOR CITY STREETS

Application has been made for a patent upon a system of locating streets, residences, and other points in cities, which is similar to the method of locating points by latitude and longitude. The city is quartered by two main division streets. All enumerations begin at these division streets, 100 numbers being allowed to each block, and even numbers are used on the right side of the street, odd numbers on the left. To locate any building, its street number is given first, followed by a letter indicating its direction from the division street. This is followed by a number and letter indicating the distance

and direction, from the division street, of the street on which the building is situated. Supposing that a person inquires for the location of some building, and is told that it is at 1225 E. 400 S., he knows immediately that it is in the southeast quarter of the city, $12\frac{1}{4}$ blocks east of the division street running north and south, and on the left side of a street four blocks south of the division street running east and west.

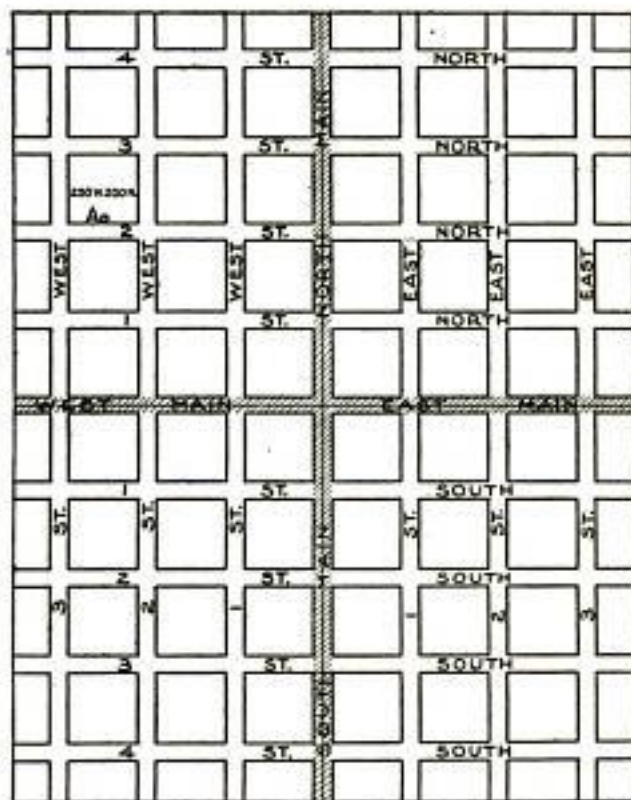

A in the Plat is Indicated by 250 W. 200 N. in Other Words, It Is Two and One-Half Blocks West of North Main Street and Two Blocks North of West Main Street

cl no. J. W. Carlson.
 1375 S. 1900 E.
 Salt Lake City, Utah

4739

SOME NOVEL AND LITTLE-KNOWN ACCESSORIES



This Needle Case Holds Five Different Sizes. The Top is Turned to the Desired Size and the Needle Drops Out of a Small Hole



This Sewing Pin is Used by Fastening the Long End at the Sewer's Knee and Allowing the Projecting Short End to Hold the Material being Hemmed

A Baby's Collapsible Bathtub over Which is Adjusted a Dressing Table Having a Safety Belt Attached to Prevent the Child from Rolling Off



A Garment for Car Owners Which can be Put On or Taken Off in Four Seconds without being Pulled over Dirty Shoes: It is Held in Place by Flexible Steel Bands



A Medical Thermometer Which does Not Require the Usual Vigorous Shaking: Slight Pressure on the Top Brings the Mercury Down in One Second



This Electrically Heated Pad for Earache is Shaped to Fit over or behind the Ear and is Kept in Place by Bands Fastened around the Head



A Combined Vanity and Watch Case with Silver Mesh Chain Has Coin and Powder Holders, Card Clip, and Writing Pad



An Electric Hot Plate Which can be Used As a Toaster, or As a Heating Element for the Various Professions

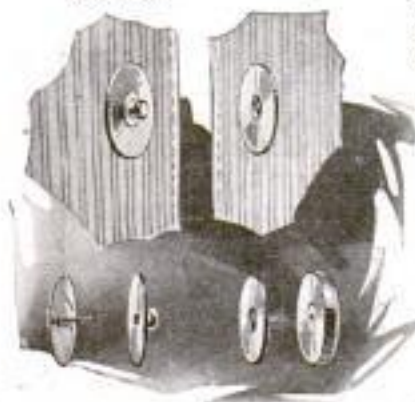

This Snap Fastener can be Attached to Any Material without Sewing. The Screw Point Pierces the Goods and the Other Half Fastens on It. The Combined Parts Then Snap Together

INTENDED FOR THE HOME AND ITS MEMBERS

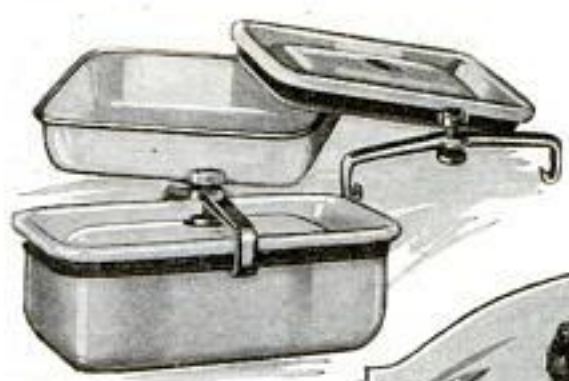

This Container Is Valuable for Storing Food or Liquids of All Kinds, Because It Is Water and Air-Tight, and Is Especially Useful in Hospitals for Holding Sterilized Instruments or Gauze



For Marcelling the Hair, the Lower Instrument is Electrically Heated and Thrust into the Hair. The Upper Instrument is Then Tightly Squeezed over the Hair Surrounding the Heated Part



A Telephone-Slug Holder, with Which the Subscriber Always Has the Necessary Means Handy to Operate the Telephone in Case of Emergency Instead of Frantically Searching for a Nickel



A Rubber Boot without a Heel, So That It can be Worn by School Children over Their Shoes in Snow or Slushy Weather: The Boot Folds into a Small Container When Not in Use



With the Use of This Necktie Press the Wrinkles can be Taken Out of the Necktie Overnight



This Is a Highly Ornamental Table with a White-Porcelain Top Which can be Folded Out of the Way When Not in Use, Thus Saving Space in Modern Kitchens



Flexible Cuff Links will be Appreciated by Those Having Occasion to Do Dirty Work While Wearing Clean Cuffs. Instead of Soiling Clean Linen in Removing the Ordinary Link to Push Up the Sleeve, the Flexible Link Yields without being Unfastened

274
768 1

LADDER FOR FIGHTING CHIMNEY FIRES DEvised BY FIREMEN

A light, easily handled ladder for fighting roof and chimney fires has been devised by members of the Brunswick, Me.,

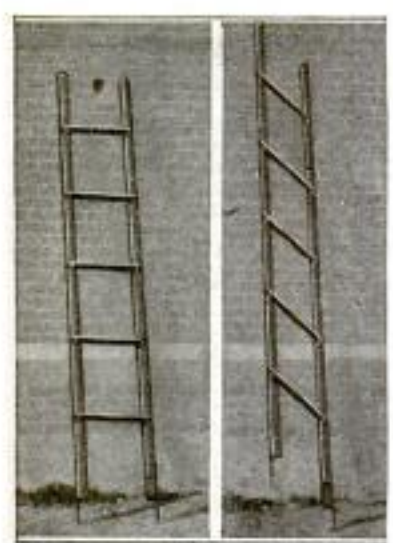

fire department and is attracting much attention among firemen in New England. It consists of two wooden, 2 by 3-in. side-pieces, with rungs of heavy strap iron and strong spikes at the lower ends. The rungs are fastened with a single bolt at

each end so that the ladder may be collapsed when not in use. It can be carried anywhere by one man, and the spikes, biting into the roof, hold it firmly in place.

SOFT SHEARING PIN IS USED IN QUICK-CHANGE CHUCK

Combining a soft shearing pin with a quick-change chuck is an innovation that will be noted with great interest by those who have occasion to use a drill press of any kind. The chuck is made to hold ordinary drills with tapered shanks, and has a safety arrangement which prevents the breaking, or "burning," of drills, taps, reamers, counterbores, etc. The safety

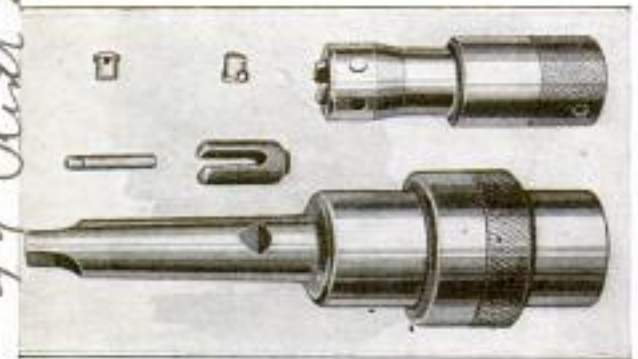

Top: Two Views of Ejector and Collet. Center: The Soft Shearing Pin and Jaws. Bottom: The Assembled Quick-Change Chuck

method lies in the insertion of a soft-steel pin into the jaws of the chuck, where it is held in place by a setscrew. In the event of the drill, or other tool, being overstrained, which would break, or burn

it, the soft pin is sheared off, thus saving the tool from injury. By loosening the setscrew, the sheared pin can be removed, and a new one inserted.

7733

SEA-WATER ICE IS USED FOR PACKING FISH

An innovation in the fish industry of France is the making of ice from sea water, by a process which eliminates the concentration of salt, that usually occurs when brine or salt water freezes. This "salt ice" performs the double service of keeping the fish cold, and also of "salting down" the fish as a means of preserving them. In recent experiments conducted with this ice, it has proved far superior to the ordinary fresh-water ice, both in cooling and in preserving qualities.

7702

"STEPPING ON THE GAS" AIDED BY USE OF AIR CYLINDER

An air cylinder attached to a pedal placed over the accelerator is a new automobile accessory now being manufactured in the East. It is claimed that the appliance eliminates any "fluttering" of the throttle caused by driving over rough roads or shifting of



gears. In this manner the even running of the motor is assured.

EMPLOYEES CONTEST TO BOOST PLANT-SAFETY INSPECTORS

Employees of a large manufacturing concern, with several plants, have reduced accidents to a remarkably low figure in their effort to raise their own plant-safety inspectors above others on the company's monthly chart. This chart shows a comparison of hours lost, due to accidents, with total hours worked in each plant, by columns of varying height. The smaller the percentage of loss, the higher is the column. In each column are printed the name of the plant, percentage of loss, number of hours lost, and number of accidents for the year and month.

B. C. Christy
Svine Mill Works
Clearing.

making separate numbers 1921

Wade-American Tool Co. Waltham, Mass. 7641

MODEL BUILT TO STUDY WATER-POWER PROBLEMS

By SAM E. CONNER

*34 Orange St.
Leicester, Maine*

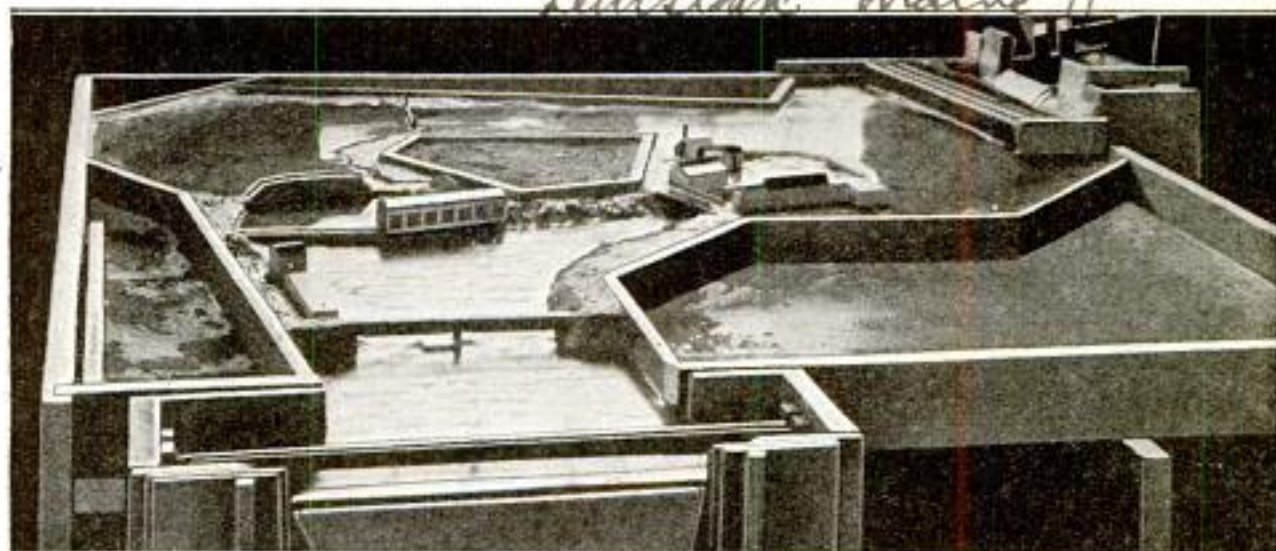

Model of a River and Contemplated Power Plant Made to Exact Measurements from Careful Surveys So That It Was an Identical Miniature Duplicate of the Originals: Tests were Conducted by Allowing Water to Flow through the River of the Model under Conditions Found in the Real River

ENGINEERS called upon to install a hydroelectric power plant on the Kennebec River, Me., in the town of Skowhegan, found themselves confronted with a serious problem. The place where the plant and dams must be located, was in the center of the town, with valuable property all around it. It was necessary, in order that the power desired be obtained, to change the existing water head from a range of 12 to 18 ft. to a constant head of 32 ft., and at the same time the dams must be so constructed that, besides caring for a normal flow of 3,600 cu. ft. per second with the 32-ft. head, they would handle, with equal facility, a flood-time flow of 150,000 cu. ft. per second to protect the surrounding property from damage by freshets on the river.

To add to the difficulties of the engineers, the falls, at the point where the power plant was to be built, were divided by a large island in such a way that the falls of the river's south channel were nearly 1,000 ft. farther down the river than those of the north channel, which were of horseshoe shape.

In order that they might be certain of their plans, the engineers made a model of the river bottom, banks, dams, power station, and other buildings in close proximity to the place. This was made to exact measurements from careful surveys, so that it was an absolute duplicate of the river and power plant in miniature. It was then tested by permitting water to flow through the river of the model under conditions as nearly like those which were to be met at various times on the real waterway, as could be pro-

vided. These results were such that the engineers felt they were right, but determined upon a further test which they thought would be a final stamp of approval.

Old rivermen, who had driven logs on the Kennebec and over these falls countless times, were called in. Miniature logs—also made to scale—were floated through the model. Each time before the logs were started on the river, the rivermen were asked to designate the starting point and to tell what, on the main river, in actual work, the logs ought to do. They were also asked into what eddies they should float, and how they should strike the sluices. Acting upon the rivermen's information, it was found that the miniature logs traveled exactly where predicted in every instance, thus demonstrating the accuracy with which the model was built, and also the correctness of the plan for the installation.

The power plant will have a present installation of three 3,000-hp. units, with provision made for a fourth, and will be located upon the south fall. As the bulk of flood water must be handled at the north dam it was necessary to provide exceptional facilities for letting through the freshet pitch. This has been accomplished by flashboards, hinged to the top of the middle section of the dam, each one being $7\frac{1}{2}$ ft. high. These are operated by men sent out in a basket on a cable over the dam. When the boards are lifted, a toggle joint on the downstream side falls into place, securely fastening the boards. To release them the men reach down upon the upstream

side with a hook, catch the trigger which releases the joint, and the board falls. The north section of this dam is equipped with flashboards, 11 ft. high, of the raising and lowering type, while at the south end

have been installed two radial 32 by 17-ft. gates, having a capacity to discharge 7,500 cu. ft. of water per second. This north dam is 475 ft. in length and built of solid concrete reinforced with steel.

DIAL MICROMETERS ARE USED TO MEASURE PISTON GROOVES

The depth of piston-ring grooves can be rapidly measured with a new dial micrometer. Instead of the old way of using an ordinary micrometer, which is a difficult and delicate operation, the mechanic can use this dial instrument and tell the cor-

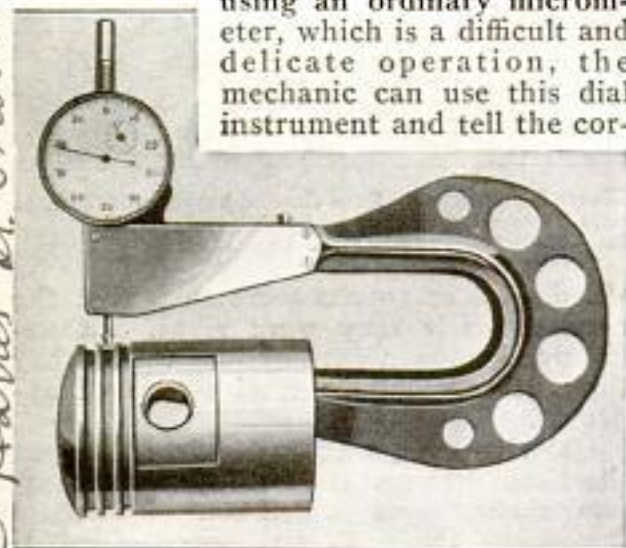

With the Handle, Seen Above the Dial, the Point is Raised or Lowered and the Depth of the Piston-Ring Groove is Indicated by the Dial

rect thickness at first glance. The dial has two hands on it, one large and one small. The small hand is used solely to record the number of revolutions made by the large hand, so that the total is quickly seen.

STREAMLINE WINDSCREEN MADE FOR MOTORCYCLE SIDECARS

A windscreen for motorcycle sidecars, which has been used with great satisfaction in England for some time, has just made its appearance in this country.

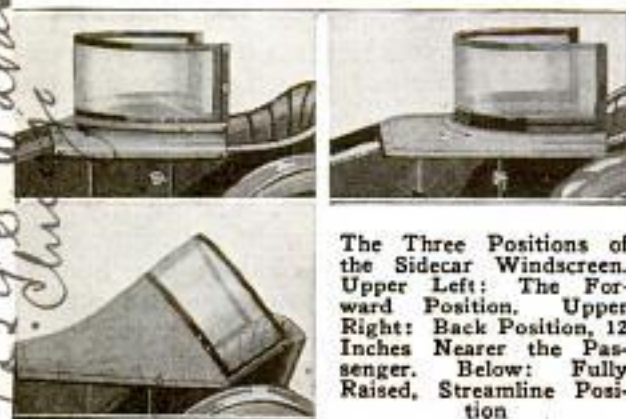

The Three Positions of the Sidecar Windscreen. Upper Left: The Forward Position. Upper Right: Back Position, 12 Inches Nearer the Passenger. Below: Fully Raised, Streamline Position

A flexible, transparent panel is mounted in a steel frame. To the bottom of the frame is attached a waterproof twill apron. This screen is adjustable by means of wingnuts. When fully raised, it deflects all air, rain, or snow over the head of the passenger, giving absolute protection, and decreases the air resistance of the car.

SPECIAL BUREAU ESTABLISHED IN MINNEAPOLIS POST OFFICE

In the post office at Minneapolis, Minn., there is a special bureau which is the novel and highly successful attempt of Postmaster Purdy to assist foreigners. Many foreigners, who could not speak English, and were accustomed to going to government offices for everything in their native countries, applied for help in reading or writing addresses, making customs declarations, and filling out all sorts of papers, and also made use of the money-order and postal-savings services. An "Information Bureau" was established, "information" being one of the first English words a foreigner learns to recognize. A survey was made of the 1,155 employes in the post office to learn what foreign languages each could speak or read. Whenever a foreigner applies for service, an interpreter is called from the staff. Every dialect of Europe is represented in the post office, and the only languages employes have failed to interpret are Chinese and Japanese. Besides assisting foreigners, the Information Bureau is called upon to answer all kinds of questions, especially by automobile tourists. It keeps on hand road maps, time tables, lists of resorts, and many other kinds of information. Because of his success with this bureau and other innovations, Postmaster Purdy was summoned to Washington by Postmaster-General Hays, to tell him and other postmasters how to do it.

Popular Mechanics Magazine does not publish the name of the maker or seller of any device described in its pages, but this information is kept on file and will be furnished, free, by addressing our Bureau of Information.

Federal Products Co. 333 Harris St. Providence, R.I. 7630
Shillan Buck & Co. 1229 W. Wabash St. Chicago 7640

*Enl. Arthur H. Hearn
317 Cedar Ave. Minneapolis, Minn.*

7098
C. W. L. Atwood, Boston, Mass

**NOVEL FORM OF ELEVATOR
LIFTS FISH OVER A DAM**

A dam in a river is often an obstacle that prevents fish from going up the river to spawn. Where it is desirable that the fish should spawn in the part of the river above the dam, a means has been devised by a fisherman of Massachusetts for lifting the fish over this obstacle. The contrivance is in the nature of an elevator in the form of a counterbalanced beam that is pivoted on trunnions rotating in supports at the top of the dam, and extends downward from this pivot far enough to reach the water below the dam, the end of the beam above the pivot extending to a convenient length for the attachment of a counterweight. To the end at the lower water level is connected a metal scoop, large enough to hold several fish. From this scoop, along the whole length of the upper surface of the beam, there is an outlet pipe, so that when the scoop is raised a little above the horizontal by swinging the beam on its pivot, the water and the fish in the scoop

run down the pipe and are discharged into the river above the dam. The elevator is operated by a system of gears driven by an electric motor. The fish are attracted to the vicinity of the scoop by a disturbance of the water caused by the discharge from

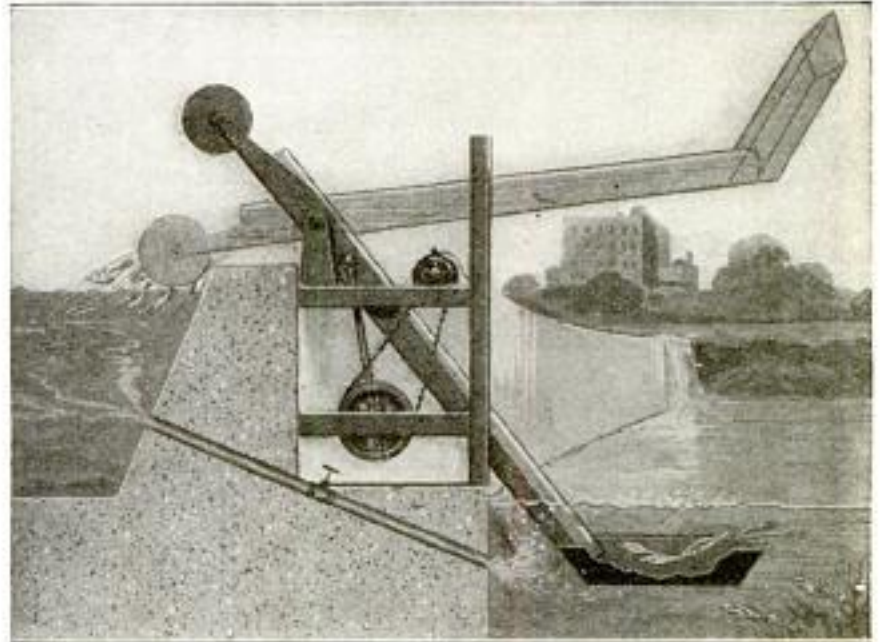

Elevator for Lifting Fish over a Dam When Going Upstream to Spawn: Elevator is Shown, Dark, Catching the Fish in Its Scoop, and, Light, in Its Raised Position Discharging the Fish into the River above the Dam

a water pipe that penetrates the dam. It is expected that this means of helping fish over a dam during the spawning season will be found superior to the customary fishway or ladder. It has the added advantage of wasting no water.

7447
**TWO-SHELL GARBAGE CAN
DISINFECTS REFUSE**



Anything leaking from an ordinary garbage can spreads on the ground, and becomes a breeding place for flies and a culture bed for bacteria. This defect is remedied by a two-shell container that is now being made in Kentucky. The inner shell is the garbage can, and the outer one catches any leakage there may be, and contains a germicide.

5808
**SMOKESTACK WRECKED BY NEW
METHOD IN 55 MINUTES**

Five workmen recently brought a 148-ft. smokestack to the ground in 55 minutes, by a new method. This stack, on Staten Island, N. Y., measured 47 ft. in diameter at the base and weighed 350 tons. Three openings were made at the base, and wooden blocks, 4 ft. high and 4 in. in diameter, were inserted as shorings. A gap, 4 ft. high, was then made in more than half of the circumference by removing the bricks. Two of the shoring blocks were removed and the center block, soaked with kerosene, was burned out. The stack crashed with such force that some of the bricks were buried 2 ft. in the ground, but most of them remained intact and can be used again.

Our Bureau of Information will answer all questions regarding articles appearing in this magazine.

Hagan Lead Engine & Mfg. Co. Winchester, Ky.

cmd. Germania St. Truettley
43 South St. Everett, Mass

new York Times 11/24/21 P. 8

Lindberg Double Swing Door Control Co
 939 S. Olive St. Los Angeles
 POPULAR MECHANICS
 Calif.

278
 6268

DOUBLE SWING DOORS LOCKED IN ANY OPEN POSITION

While entering or leaving a garage, one of the swing doors is likely to be blown to a partly closed position, often damaging a car while passing it. To make this impossible, a control has been devised that securely locks the doors in any open position. It consists of a pair of rods in connection with two brackets, each of which is fastened to the top of one of the doors. At one end of the rods is a toggle arrangement with two arms, one of which has a segmental end perforated with holes by means of which the toggle can be adjusted to hold the doors locked at any desired angle of opening. A pull on a chain releases the toggle so that the door can be closed and locked again.

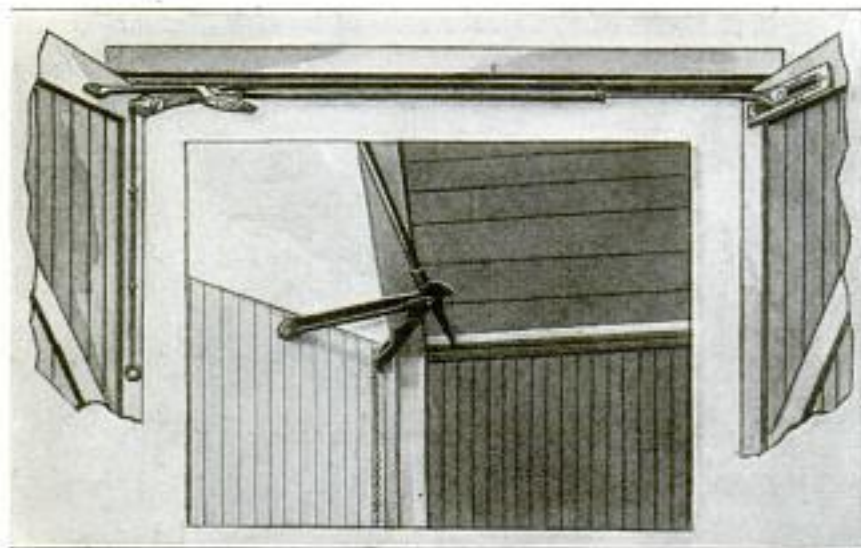

Above: Outside View of Garage Doors Open and in Locked Position; by Pulling the Chain on the Left-Hand Door the Lock is Released and the Doors can be Closed. Inset: View from Inside of Garage Looking Up at the Locking Toggle

7470



PHOTO BY GILL AND SERVICE

FARMING FISH IS ODD OCCUPATION OF SOUTH SEA ISLANDERS

ALTHOUGH the word farming is usually associated with the cultivating of land and the sowing of grain, the South Sea islanders have a method which is quite different. Instead of planting grain and harvesting crops, they catch fish and place them in inclosed bodies of water, to be harvested at the owner's pleasure. The fish are obtained from shallow lagoons, caused by the formation of coral walls, which surround these islands, and are left in the "farms" until an opportunity offers to sell or barter them for other necessities.

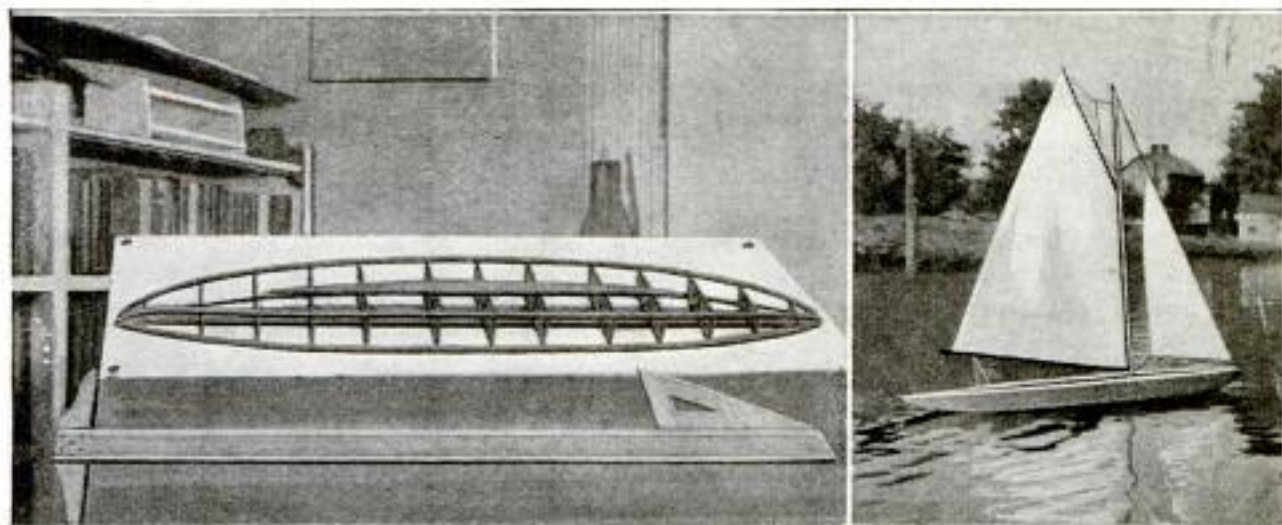

Left: Framework of Boat Made Entirely of Strips of Heavy Paper and Shellac Held Together with Glue, Shown on an Ordinary Drawing Board. It is the Same Length as the 42-Inch T-Square beneath It.
 Right: The Paper Boat Finished and Rigged, Seen in Full Sail on the Water

**HULL OF SAILING-BOAT MODEL
 MADE ENTIRELY OF PAPER**

More different kinds of material can be used in connection with boat building than in almost any other form of structure. Boats have been built of every kind of wood, of every kind of metal, of stone and of concrete, and even of paper. A model of such a boat has a hull 42 in. long, 6 in. wide, and with a draft of 7 in., made entirely of paper and shellac, finished with several coats of oil paint and spar varnish. Frame, sheathing, deck, and keel are all made up from paper held together with glue, and the only metal used was 1½ lb. of lead required for ballast. It is a sailing boat, with the spars of pine. Its total weight is 2 lb. 13¼ oz. The boat is now nearly three years old, and though it has been sailed a great deal, it is just as good as new.

7560 *advertis*
**AUTO SPOTLIGHT AND CONTROL
 FOR CLOSED OR OPEN CARS**

Though specially designed for use on closed cars a new spotlight and control is

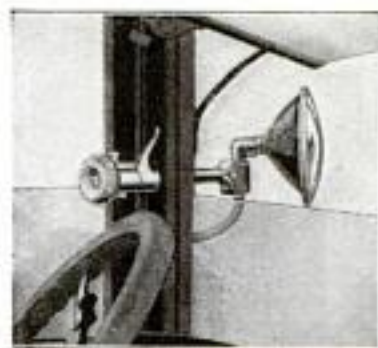

equally suitable for any style of automobile. On open cars it is attached to the windshield by means of a bracket. To install it on a closed car, a ¾-in. hole is bored through

the corner post of the car, and the control housing is passed through this hole. A

knob on the control handle, inside the car, is turned to move the lamp to the right or left horizontally. When a release key is pressed, turning the knob moves the lamp with a circular motion, throwing the light in any direction desired. The lamp may be locked in any position.

7306 *control*
**TRAFFIC DIRECTOR CANNOT
 BE DAMAGED BY ACCIDENTS**

A new traffic director is made of a one-piece metal casting and is practically indestructible, besides having other characteristics that recommend it. It is 22 in. high, 18 in. wide, and weighs 250 lb. When placed in the street, it leaves a clearance of 12 in. to the street-car tracks on each side. It is so made that it is self-righting when tipped over, will not spin if struck a glancing blow, and cannot be moved far if hit directly. It is not affected by weather.



Plans have been made for extensions of many of the existing subways in London, Eng., for the linking up of others, and for enlarging the oldest one sufficiently to accommodate the present subway rolling stock. This enterprise involves new capital to the amount of 30 to 40 million dollars.

Little Patent Co., Manufacturers, Birmingham

*Thompson Mfg. Co.
 4th + St. Clair Sts. Dayton, Ohio*

CHILDREN'S PICTURE-STORY DEPARTMENT



When Doctor George J. Fisher, Deputy Chief Scout Executive, Visited the Boy Scouts of San Diego, California, He Found This Novel Headquarters, an Indian Village Which was Saved from the Panama-California Exposition and Presented to the Scouts by the City. This Push-Ball Game Was Part of the Program Given for Doctor Fisher

near baby Co. Cleveland, Ohio



A Kiddie Car with a Sidecar: There Is Always Something New to Please the Children, and the Most Popular Toys Are Those That Are "Just Like Big Folks Have." With This Outfit the Youngster can Take His Favorite Doll, Woolly Dog, or Other Pet, for Company When He Goes Riding



PHOTO COPYRIGHT SAUEL & HERBERT

When Andrew J. Abell, Jr., Left San Francisco on Horseback He Had Four Companions, but He Was the Only One to Reach Washington, District of Columbia, after a 5,926-Mile Ride. His Dog, "Trix," Rode Back of the Saddle, and Was Probably the First Dog to Make Such a Trip and to Meet the Governors of 29 States. Young Abell, Who Is 18 Years Old, Obtained the Autographs of All the Governors along His Route

Convertible Bike Wagon - The Cole Co

OF MODERN ACTIVITIES AND INTERESTS

7765
Clyria
Ohio

Only Two Minutes are Required to Change from a Velocipede to a Wagon. Two Pins are Removed, the Rear Wheels Shifted to the Wagon, and the Wagon Attached to the Frame. It is Simply and Substantially Built of Tubular Steel.



A Padded Iron Ring Surrounds and Supports the Child, and the Front Props Keep the Vehicle from Tipping Over. The Straddle Seat is Just High Enough to Allow Baby's Feet to Touch the Floor, and He Learns to Walk in a Natural Way. The Rear Wheels Are Specially Designed Rubber-Tired Disks



Here is a New Sort of "Pep" Testing Machine, Invented by a Physical-Culture Expert of Boston, Massachusetts. The Person to be Tested Stands under the Suspended Platform and Jumps Straight Up into the Air, Pushing the Platform Up. At It Moves, It Registers the Height of the Jump



This Six by Eight-Foot Library, Built Almost Entirely of Old-Fashioned Green Shutters, is the Business Undertaking of Two Schoolboys, in the Suburbs of Kalamazoo, Michigan. They Started a Year Ago with 50 Books and Now Have About a Thousand, Which They Lend for One Cent Each

Dr. Dudley Sargent

Crowley Mfg. Co., Cincinnati, Ohio

7629

ENGINE DIRECTION IS SHOWN BY AUTOMATIC TELLTALE

Telltales for giving the direction of engines, are necessary aids on a ship, and the installation of these appliances usually

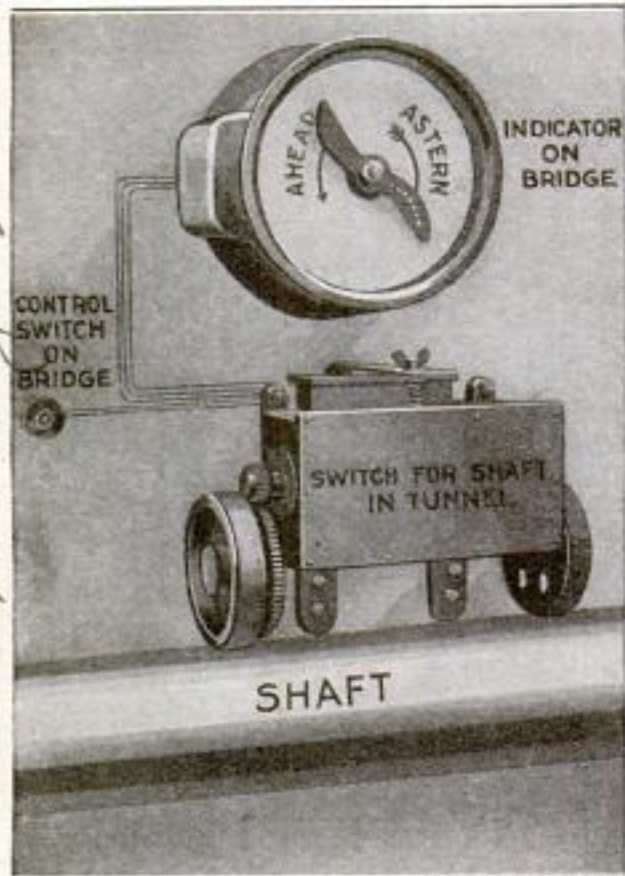

The Ahead and Astern Indicator Electrically Connected to the Inclosed Switches, Which are Controlled by the Wheels Resting on the Shaft

proves to be quite expensive, especially if the ship is driven by high-speed turbines. With turbines, costly reduction gears have to be placed on the driveshaft, and these gears require close attention if they are to function properly.

As a relief from this combined problem of expense and maintenance, an automatic electric telltale has been brought out by a firm in Glasgow, Scotland. The new instrument has two selector switches placed at the driveshaft, which are controlled by two small wheels, turned by the shaft. The wheels are arranged so that one will close a switch when the shaft revolves in the "ahead" direction, and the other will close a switch when the shaft revolves in the "reverse" direction. The switches, in turn, control a distant electric motor and two electromagnets. The magnets represent the two respective wheels on the driveshaft, and are operated when the selector switches are closed. An indicator, having driving gears for "ahead" and

"reverse," is thrown into gear by either magnet, as the case may be, and the motor revolves the indicator in the same direction as the ship's propeller. Any number of these telltale stations may be located about the ship, all dependent on the one set of selector switches, and the electric current required can be obtained from the lighting circuit, or from batteries.

7821

BEAUTY WILL BE RESTORED TO MINNEHAHA FALLS

Restoration of the beauty of Minnehaha Falls, famed in Indian lore and in Longfellow's poems, is a project recently undertaken. The water feeding the falls has diminished during the past 10 years, until this beauty spot possesses only remnants of its former grandeur. A reservoir is planned at Rice Lake, which would empty into Minnehaha Creek and thence over the falls.

7887

STEEL CHIP 166 FEET LONG TURNED OUT ON LATHE

What was probably the longest steel chip on record, measuring 166 ft., was turned out not long ago on a 30-in. lathe, operating on a machine-steel forging for turbine-shaft sleeves. The unusual length of this chip was credited to the clever workmanship of the operator in handling the lathe, to good tools, and the high quality of the material.



Steel Chips, Curling off Lathe Work, Are a Common Sight, but Few Approach the Length of This One, Which Probably Holds the Record

Emil. John Beauty, 1010 W. Michigan, Chicago

Mechanics Bldg., Scotland Iron Works, Glasgow, Scotland



How to Save Decayed Trees

By A. H. SCOTT, 44

*Livingstone Ave
Pittsfield, Mass*

DURING recent years, the art of tree surgery has made great strides, owing, in part, to the attention drawn to the problem of preserving our fast-disappearing supply of lumber.

The secret of successful tree surgery lies in the prevention of any possible contact of water with the woody fiber of the tree, and it is just in this one point that the uninstructed man fails. By following the directions given here, an aged and

sound wood. This usually means enlarging the cavity to several times the original size, but it is absolutely necessary that none of the rotten brown particles be left to form a new nucleus of decay. Care must be taken that the bark is not loosened when cutting around the edges of the cavity; this is best done by striking the first blow with the gouge slanted inward, then drawing it away from the edge. Having thoroughly cleaned the



At the Left, the Cavity Cleaned, Braced, and Ready for Filling; at the Right, the Cavity Filled, Showing How the Cement is Laid in Sections and Smoothed Off So That the Growing Bark can Push Easily across the New Surface

decayed tree may be given a further period of life and its beauty preserved as part of the landscape.

The tools needed are: a 2 or 3-lb. mallet, a heavy 2-in. gouge, and a 1-in. and a 1½-in. chisel; the necessary materials: cement, sand, disinfecting solution, coal tar, burlap, and bolts, together with some miscellaneous material that will be mentioned later.

Using the gouge, the rotten matter should be cleaned out, right down to the

cavity, the margin should be smoothed off to a continuous line as indicated in the various views.

The top of the cavity is undercut, and the bottom slanted upward, as shown in Fig. 2. The sides should be leveled off with a flat chisel before cutting the water-course; this is designed to drain off any water that might enter the sides of the cavity, and should be from ¾ to 1 in. wide and extend the full length of the cavity. It is cut to a depth of from ⅜ to ½ in.

It is essential that the watercourse is clean-cut and level, so that it will drain even the smallest quantity of water finding its way between cement and wood; the chisel and a sharp-pointed knife will accomplish this if carefully used. The bark at the edges of the cavity should be leveled off at an angle of 45° , and a $\frac{1}{16}$ -in. strip of bark cut off all around the cavity, exposing the bare wood, as shown in Fig. 2. This strip, the beveled edge of the bark, and the watercourse are quickly painted over with any heavy paint at hand, to prevent drying of the bark.

The sides of the cavity are then braced by $\frac{3}{4}$ -in. bolts, spaced 12 to 14 in. apart, as shown in Fig. 1; $\frac{3}{4}$ -in. iron rods, threaded at both ends and fitted with four nuts, are best for this purpose, the holes being bored with an extension bit. The outer nuts should be countersunk into the tree, and each countersink treated exactly as though it were a miniature cavity. The entire cavity should now be thoroughly disinfected with a solution made by dissolving bichloride-of-mercury tablets

(poison) in denatured alcohol, one tablet to each quart. When the cavity is dry, it is given a coat of hot coal tar, which is best applied with a long brush, nailed to a stick. The tar must be kept out of the watercourse.

The cement, in the proportion of three shovelfuls of sand to one of cement, is now prepared, using only enough water to bring the mixture to such a consistency that a ball of it, when squeezed in the hand, will retain its shape. Mark a point halfway between the bottom of the cavity and the first bolt, nail on a piece of burlap, completely inclosing this portion, and fill in the cement, tamping it in thoroughly. Smooth off the top of the cement, slanting it upward toward the back, and over it place two layers of roofing

paper, cut to the contour of the cavity. Hold this paper in place with nails stuck through it into the cement.

Nail another piece of burlap up to a point midway between the next two bolts, fill in the cement, and repeat the operation until the cavity is filled. If the cavity is a shallow one, nails or spikes should be driven into the sides to assist in holding the cement. Pull off the lower burlap and smooth off the cement, continuing upward as the cement sets. A small mason's trowel and molder's slick make the best tools for this purpose. The cement surface should meet the $\frac{1}{16}$ -in. strip accurately, to enable the bark to grow over the cement easily. The countersinks are then filled in and smoothed off; the roofing paper can be trimmed close when the cement is hard.

If the cavity extends up into the crotch of the tree, the main branches should be tied with a strong rope, to prevent the tree from splitting until the bolts are in place. In this case, these branches should be permanently chained together slightly more than half-

way to the top of the tree, and bolts put through just above the crotch, if the tree is large.

The growth of new wood over the cement may be doubled in speed if the edge of the past year's growth is slightly skinned with a knife each spring, and once during the early part of the summer. This causes the bark to reach out instead of curling under, especially if the surface of the filling is rough.

Locating a Keyhole in the Dark

The insertion of keys into keyholes and the location of doorknobs, in the darkness, are simplified if the surface about the keyhole and knob is coated with luminous paint.

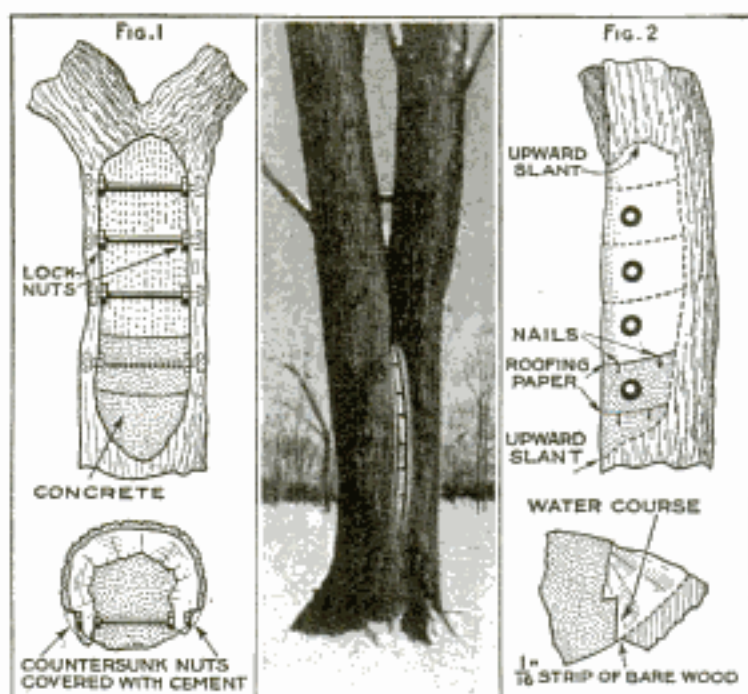

Left, Method of Bracing and Filling in Concrete; Right, How the Cavity is Cut and the Sections Divided; Center, Cavity Extending into Crotch. Note the Bolt between the Two Main Branches

An Improved Stone Boat

For building garden walls, stone fences, laying foundations, or similar masonry work that requires the transportation of heavy stones or other weighty masses, the old stone boat can well be resorted to. The farmer perhaps appreciates the utility of this "vehicle" better than anyone, and he knows that it is easier to move heavy objects horizontally than vertically. However, the stone boat that is now helping the settlers of cut-over lands to avoid the dangers of hernia and strained backs in the clearing of their land, is built along different lines from the old type.

Large weights that are to be moved by a stone boat are usually dragged by a team of horses, yet one man can pull a surprisingly heavy object with it, and two men can make quite a showing; if handled carefully, a light car can also furnish the pulling power without undue strain.

The making of a stone boat of the type illustrated requires only two pieces of plank, about 8 ft. long, a wooden cross-piece, two straight bolts, and two ring bolts, together with the necessary length of chain. The planks are pointed at one end, and the two squared ends are bolted to the cross-piece, which should be of about 2 by 8-in. stuff and less than 2 ft. long. A space of several inches is left between the planks at the cross-piece, to

permit the rear ends to move together when pull is applied to the forward ends. On fastening the ring bolts to the front end, about 1 ft. from the point, the stone

boat is complete. A chain attached to the ring bolts enables the draw-

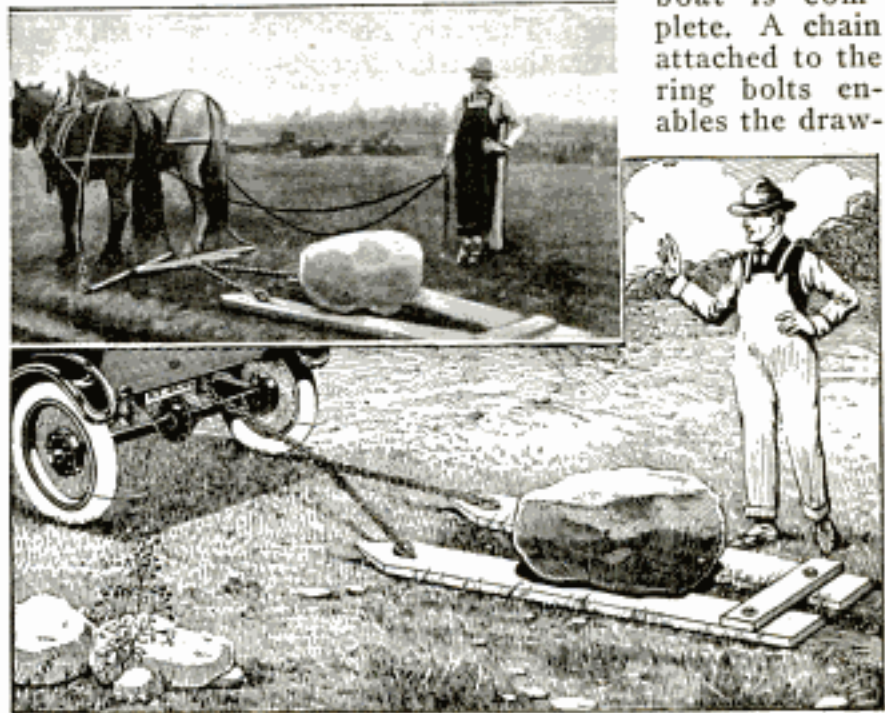

A Stone Boat for Moving Heavy Boulders or Tree Stumps: This Type of Boat Itself Lifts the Load, Thus Relieving the Operator of Much Heavy Work and Clearing the Land More Rapidly

bar pull to be applied at a convenient distance from the pointed ends of the planks.

This particular type of stone boat works like a pair of scissors. Placed behind a stump or boulder, it opens up as the pulling power forces its two pointed planks apart. As the pull is steadily applied the load is lifted or rolled onto the stone boat and then hauled away. Where a team, or other pulling power, is available the operator has no work except to adjust the pointed planks and the chain—this stone boat loads itself.—Mark G. Troxell, Madison, Wis.

Making Gun Greases

During the war, the deterioration of arms and equipment of different kinds from rusting was a serious matter, and the government spent much time and money in extensive experiments upon "slushing oils" for the prevention of rust. As a result of this work, the following formulas were developed and gave excellent results:

Resin (preferably H-grade) 1 part, vaseline 10 parts, and kerosene 1 part. The resin is melted and mixed with the previously heated vaseline. The mixture is

stirred well while cooling, and then the kerosene is added. If a more solid grease is desired, a little candelilla wax may be substituted for a part of the vaseline. The more wax used, the more solid will be the resulting grease. In government tests, this mixture almost perfectly preserved bright-steel plates that were exposed to outside winter weather for eight months.

Two other formulas are given for semi-solid greases, as follows: Formula A; candelilla wax 3 parts, resin (preferably, but not necessarily, H-grade) 6 parts, and vaseline 50 parts; Formula B; 2 parts

carnauba wax, 5 parts resin, and 50 parts vaseline. The materials in the above formulas should be heated together to about 250° F., until all the ingredients are melted, and the mixture thoroughly stirred while cooling. They are best applied so as to cover the surfaces completely. When it is desired to remove the grease, slightly warm the article protected by it, and wipe off with a clean cotton cloth.—Chas. E. Mullin, Philadelphia, Pa.

An Emergency Fan Belt

In an emergency, when a fan belt breaks or is lost, a serviceable substitute, that will hold until the proper kind of belt can be obtained, can be made from tire tape.

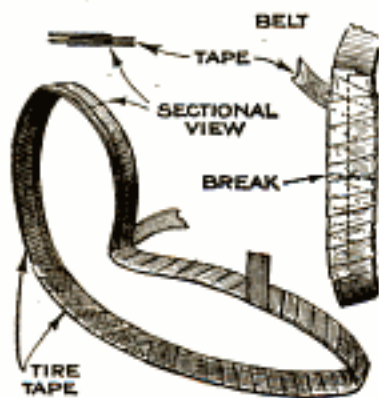

Such a belt is made by looping about four layers of tape to make an endless ring of the proper diameter. Each layer is slightly staggered as in the sectional view. A diagonal wrapping in each direction is then applied for further strength. Under some conditions, when the belt is not lost, it can be repaired with tape strips.

Roller for Decorators' Stencils

Nearly all stencil brushes will tear the ties and fine lines of complicated decorators' stencils and patterns. To overcome this, I make use of a tool that works faster and gives better results than the brush, and saves the stencil. A wooden roller, about 3 in. in diameter, has a slot, 1/2 in. deep, cut parallel with its center. The roller is covered with a piece of plush or felt, preferably the former, about an inch longer than the circumference of the roller, the excess material being forced into the slot and tacked to hold it in place. Pins are driven into the ends of the roller, and a handle is made from stiff wire and bent over the pins. The paint, or calcimine, is spread on a board, or slab, and the roller is run over this until the plush or felt covering is sufficiently charged with color; the roller is then run over the stencil.—C. F. Herbert, Chicago, Ill.

Concrete Piles without Forms

Although concrete piling is no novelty, a method of using bored holes as forms for foundation piles for a summer cottage may be of value in many instances. To secure solid footings for the sills in the case in question, an 8-in. post-hole auger was used, and the holes were bored about 5 ft. deep and 6 ft. apart. Sill levels were established and the holes filled with the concrete mixture to the ground level. Short sleeves or forms of 8-in. stovepipe were then forced into the soft concrete in each hole until the tops were on the established sill level. These extension-sleeve forms were then filled with concrete, with suitable anchor bolts imbedded in it.—T. W. Ingersoll, Buffalo, Minnesota.

Geared Offset Screwdriver

A screwdriver, for use where the space above the screw head does not permit the application of the usual straight-handle type, is made,

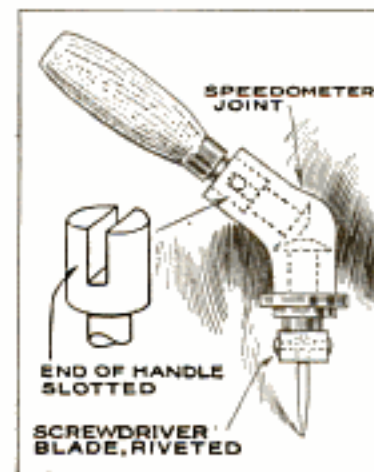

as shown in the drawing, from a speedometer joint, in which two bevel gears rotate shafts held at an angle to each other. There are usually two such joints on each speedometer, at the points where the flexible shaft is connected. The joint is modified by riveting a screwdriver blade to one end and fitting a handle to the second shaft, as indicated. In use, the casing about the gears forms a convenient hold for the palm of the left hand, while the right hand is used to turn the handle.

Ammonia for Cooling Hot Bearings

When a 100-hp. motor, running at 1,800 r.p.m. and driving a blower used to furnish the induced draft to a battery of six boilers, developed a hot bearing on the pulley side, it created a problem that was satisfactorily solved by cooling the overheated bearing with chemically pure ammonia.

The heating was caused by excessive

Es. G. Luero, 3104 Mt. Pleasant Washington, D.C.

tightness of the belt, but although the tension was decreased immediately this was noticed, the bearing failed to cool, and as it was impossible to shut down the motor until the bearing cooled off, and flooding the bearing with oil produced no result, the ammonia treatment was used as a last resort. A small amount of chemically pure liquid ammonia was mixed into an emulsion with the oil, and the mixture was carefully and slowly fed into the bearing drop by drop; it sputtered at first, but after about 15 minutes' steady application, the bearing had cooled nearly to normal. The oil was then changed, and no further trouble was experienced. If the liquid ammonia is not chemically pure and nearly free from water, the water in the mixture will decrease the lubricating property of the oil sufficiently to render it useless for high-speed bearings. This system of cooling bearings by utilizing the rapid-evaporating qualities of ammonia has since been used many times with perfect success.—C. E. Diehl, Mammoth, Utah.

Tool Clamps Auto-Transmission Springs

When replacing the cover of the light-automobile planetary transmission after

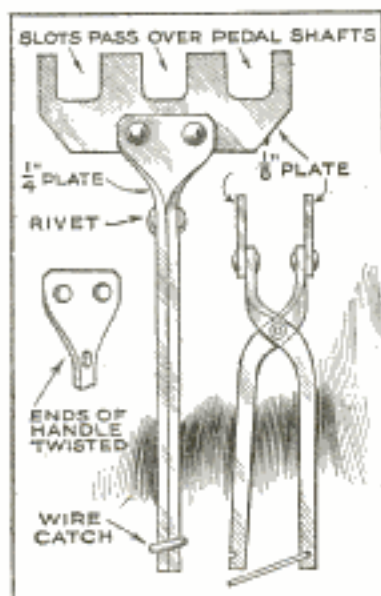

repairs have been made, much difficulty is experienced in compressing the springs enough to get them between the ears of the transmission bands. The tool shown in the drawing is specially adapted for this purpose; it will compress the springs and hold them so that they can be inserted easily. The tool consists of a simple pair of tongs or pliers provided, on each jaw, with a slotted plate that fits over the springs. A link or catch in one of the handles slips over the opposite handle and retains the adjustment. The use of such a tool will immediately reduce the time of placing the transmission cover, especially when new lining has been placed on the brake bands.

Rack Makes Delivery Car of Touring Car

A baker made use of his passenger car to deliver the products of his shop to customers, by adding a rack that fitted

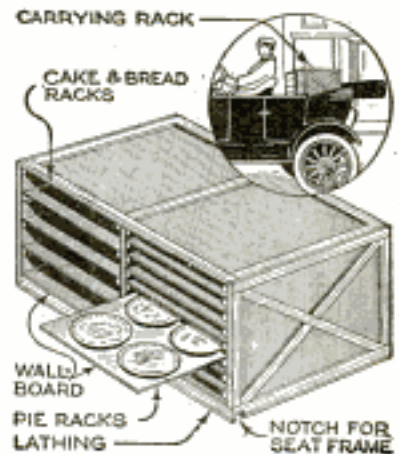

neatly and securely into the back-seat frame after the cushion had been removed. A light but substantial wooden frame was made, covered with wallboard, and a notch cut in the underside of the frame bottom, to fit over the edge of the frame that retains the cushion. The whole rack was suitably reinforced with lattice strips, and shelves were made from wallboard, sliding on light strips. A central partition divides the rack into two compartments. This arrangement is easily removed from the passenger car and saves its user the cost of a commercial truck. The original rack has eight shelves with a capacity of 64 pies, but the shelving can be adjusted as desired.—O. H. Hampsch, Nashville, Tenn.

Scraping Battery Terminals

Scraping the scale from the terminals of storage-battery plates is a tedious and time-consuming job, requiring a strong

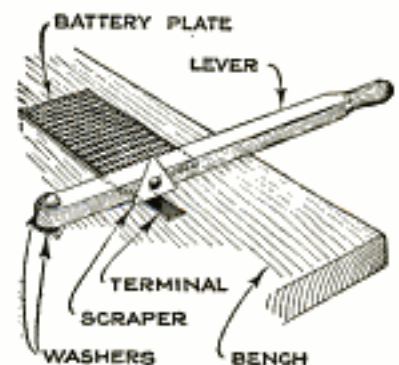

arm for continued work when done in the ordinary manner. By making and using a scraper of the type shown, in which the blade from an ordinary hand scraper is attached to a lever, the obstinate scale, on the positive plate in particular, can be removed with but a single operation for each surface, and the leverage makes greater speed possible. The lever is permanently attached to the bench top and has just enough vertical play to permit the insertion of the plate terminal underneath the scraper blade.—H. Sibley, Pasadena, Calif.

A Superior Eye-Splice

Unless the workmanship has been very good, an eye-splice of the ordinary kind will become loosened, and eventually pull

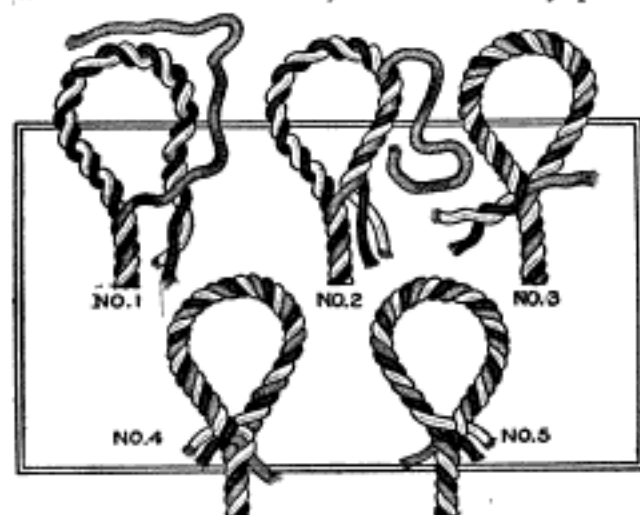

The Various Operations Required to Make an Eye-Splice Superior to the Usual One: The Steps Require but Little More Time than the Old Way

out when the rope is subjected to intermittent but excessive strain. In order to prevent this, the splice, shown in the drawing in the successive operations of making it, has been devised, and as can be readily seen, the rope must break before the splice will pull out. The splice is built on the principle of the one-strand grommet. A bight is made in the rope, one strand is unlaidd, and then relaid around the eye in reverse order. The three ends are then worked under and over after the usual manner of making a short splice, or finishing an eye-splice. The work can be done in very little more time than is usually required for the other type, while the strength is greatly increased.—G. Dallas Hanna, San Francisco, Calif.

A Handy Drill-Press Drift

A handy drift for knocking out sockets or taper-shank tools, made as shown in the drawing, does away with the necessity of using a hammer, and leaves one of the operator's hands free to catch the socket or tool as it is released.

Made of $\frac{1}{4}$ -in. flat stock, it is turned down at one end to form a guide for the sliding weight which takes the place of the usual hammer; the screw in the end prevents the hammer from sliding off. The side of the hammer is made concave

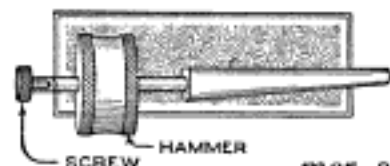

to provide a better grip for the fingers. The drift is used in the same manner as ordinary ones, the blow of the hammer against the end of the tapered drift releasing the socket or tool.

Tractor Started with Carbide

For starting my tractor in cold weather, I have a small tin can with a few $\frac{1}{16}$ -in. holes punched in it. A handful of waste is dipped in water and the surplus squeezed out. Four or five pieces of calcium carbide, the size of a pea, are placed in the middle of the wad, which is placed in the can. The can is shoved into the intake, and the flywheel turned over until the engine fires, which is usually on the first or second turn. As soon as the engine is operating properly, the acetylene-generating can is removed and placed in the toolbox.—Russell Adams, Seward, Oklahoma.

Tester for Auto Ignition

An efficient tester for the ignition circuit of an automobile can be made from a circular block of wood, a screwhook, and some nails, as shown in the drawing. The nails are driven through the wooden

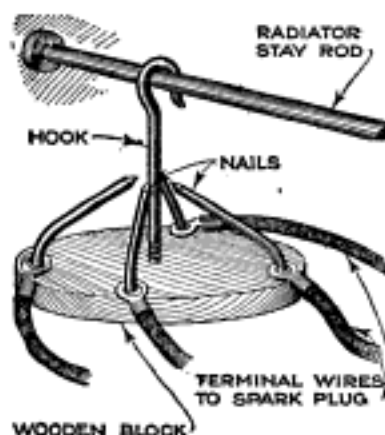

disk, around the edge, and are bent over so that the points are at the proper distance from the central screwhook, by which the tester is suspended from the radiator stay rod. The spark-plug terminal wires are slipped over the nails and the motor turned over. Perfect sparking at the tester indicates that the ignition units are operating up to the spark plugs. For six and eight-cylinder engines a larger number of nails will be required, as one is needed for each spark-plug wire.

¶ In some drafting rooms the practice is followed of making long dashes for invisible lines, not only because they require less time, but also to preclude the possibility of a short dash near a dimension being mistaken for the figure 1, and read as part of the dimension.



TESTING MOTORS, GENERATORS, and TRANSFORMERS

By KENNETH C. COGGESHALL

Part I—Motors

TESTS on motors, generators, and transformers are usually made to ascertain if the apparatus can carry additional load without injury; to make certain that the rating guarantees have been fulfilled; to see if the temperature rise is within safe limits; to determine the efficiency of the apparatus under varying loads, or to find the most economical conditions of operation.

It is often necessary to find the resistance of the windings, and this is done by connecting a voltmeter and ammeter in the circuit, as shown in Fig. 1, using a direct-current supply. The basis of this method, known as the fall-of-potential method, is Ohm's law, which states that the resistance of any circuit, in ohms, is equal to the electromotive force, in volts, divided by the current strength in amperes. Expressed as a formula, this is:

$$R = \frac{E}{I}$$

where R is the resistance in ohms, E the voltage, and I the current strength in amperes. The values of E and I are read from the meters simultaneously. It should be understood that the resistance of a winding increases with a rise in temperature, consequently, for purposes of comparison, it is best to note and record the temperature of the winding when the test is made.

The power input to a direct-current motor is measured as shown in Fig. 2, the connections being very similar to those of Fig. 1. While the motor is running under various loads, several readings of the ammeter and voltmeter are recorded, and the average value of E and I obtained. The product of the average values of E and I is expressed in watts, and represents the power input to the motor. The formula is:

$$P = E \times I$$

where P represents the power, expressed in watts; E and I are, of course, the voltage and current strength as in measuring resistance. If the power is to be expressed in horsepower units, the product of E and I is divided by 746, as 746 watts are equivalent to one horsepower

(Hp.); the formula then becomes:

$$\text{Hp.} = \frac{E \times I}{746}$$

By comparing the ammeter reading with the full-load current value, as shown on the motor nameplate, a fair estimate of the load on the motor may be made, where no more accurate method of determining the load is available.

The efficiency of a machine is the ratio of the output to the input, or the power given out divided by the power supplied. Motor efficiency may be determined either by the measurement of its losses, or by actually measuring the output by mechanical or other means. The mechanical method, while not so accurate, is the simpler, and is the only one that will be described here. As shown in Fig. 3, a Prony brake is used to measure the horsepower produced. This consists of a pair of brake blocks, clamped on the pulley of the motor; a long lever fastened to one of the blocks, and a spring balance. If L represents the distance, in feet, from the center of the pulley to the center of the spring balance; W the pull or weight shown on the scale, and N the number of revolutions per minute of the motor, then

$$\text{Hp.} = \frac{2 \times 3.142 \times L \times N \times W}{33,000}$$

by making the length L equal to 5 ft. 3 in., the formula may be simplified to

$$\text{Hp.} = \frac{N \times W}{1,000}$$

that is, simply multiply the number of revolutions per minute by the weight shown on the scale, and divide by 1,000. If this result is multiplied by 746, the number of watts delivered is obtained, and if this figure is divided by the input, as calculated from the meter readings, the efficiency of the motor is obtained. The formula is:

$$\text{Efficiency} = \frac{746 \times \left(\frac{N \times W}{1,000} \right)}{E \times I}$$

Another formula,

$$\text{Efficiency} = \frac{8.52 \times L \times N \times W}{E \times I}$$

may be used; in this formula, N is the

number of revolutions per *second*. The result of either of these formulas, multiplied by 100, will give the percentage of efficiency.

It is often desirable to know at what load a motor operates most efficiently; some motors, for example, show their peak efficiency at a slight overload, others, again, at slightly under full load. To test, take readings at various loads, up to 50-per-cent overload, as compared with the nameplate rating. Using these values, calculate the output for each reading, and for each output value compute the per cent efficiency. This information can then be put into graphical form, as shown in Fig. 4. The curve will show the point of highest efficiency, as that point will be the peak of the curve.

Tests on alternating-current machinery cannot be carried out in the same manner as on direct-current apparatus. Another instrument, the wattmeter, must be employed to measure the actual power input or output. This is necessary because the voltage and current alternate in value from positive to negative, completing each second as many cycles as the frequency of the generator; the current strength also either leads the voltage or lags behind it, usually the latter, therefore the product of the volts and amperes is not the actual, but only the apparent power. The true or actual power is shown by the wattmeter, which is designed to compensate for what is known as the power factor.

The apparent power, in watts, is indicated by the formula:

$$P = E \times I,$$

but the actual power is

$$P = E \times I \times \text{P.f.},$$

and the power factor (P.f.) is equal to the actual watts divided by the apparent watts, that is,

$$\text{P.f.} = \frac{\text{Actual watts}}{\text{Apparent watts}}.$$

The connections for testing a single-phase a.-c. motor are shown in Fig. 3. Taking the values of E, I, and P, where P is the wattmeter reading, then

$$\text{P.f.} = \frac{P}{E \times I}.$$

The kilowatt (Kw.) input is

$$\text{Kw.} = \frac{E \times I \times \text{P.f.}}{1,000} = \frac{P}{1,000}.$$

If a Prony-brake test is made, then

$$\text{Efficiency} = \frac{746 \times \left(\frac{N \times W}{1,000} \right)}{P},$$

that is, multiply the number of revolutions per minute by the weight, divide by

1,000, multiply by 746, and divide the last result by the wattmeter reading.

The formula

$$\text{Efficiency} = \frac{8.52 \times L \times N \times W}{P}$$

can also be used, N again being the number of revolutions per *second*.

To test a three-phase a.-c. motor, six instruments are necessary, as shown in Fig. 6, except where a switching system is provided, as in Fig. 7, when the tests may be made with but three instruments. The total input, in this case, is the sum of the wattmeter readings. If the load is very light, it is possible that one of the wattmeters will show a negative value. To obtain a reading, reverse the current leads. In this instance, the actual watts input is the reading of the positive wattmeter minus the reading of the one the connections of which were reversed.

It should be realized that the values found for each phase are not one third of the total, and that, considered individually, they mean nothing. In reality, the apparent power is equivalent to the product of E and I multiplied by the square root of 3, that is,

$$\text{Apparent power} = E \times I \times 1.73,$$

in which

$$E = \frac{E_1 + E_2}{2}, \text{ and } I = \frac{I_1 + I_2}{2}.$$

The total power is

$$P_1 + P_2;$$

and the power factor

$$\text{P.f.} = \frac{P_1 + P_2}{E \times I \times 1.73}.$$

In these formulas, it must be remembered that E and I are the average readings. E₁ is the reading of the upper voltmeter (Fig. 6); E₂, the reading of the lower one; and similarly for I₁, I₂, P₁, and P₂. The average values of E are obtained, as stated in the formula, by adding the readings of E₁ and E₂ and dividing by 2. The average values of I are obtained in the same way.

By using a Prony brake to determine the horsepower output, the efficiency at any load can be computed, and the data recorded graphically.

$$\text{Efficiency} = \frac{8.52 \times L \times N \times W}{P_1 + P_2},$$

N being the number of revolutions per *second*. If the full-load efficiency is known, the output in horsepower may be calculated thus:

$$\text{Hp.} = \frac{(P_1 + P_2) \times \text{Efficiency}}{746}.$$

In order that the operator may be able at any time to estimate quickly the output of the motor when the input is

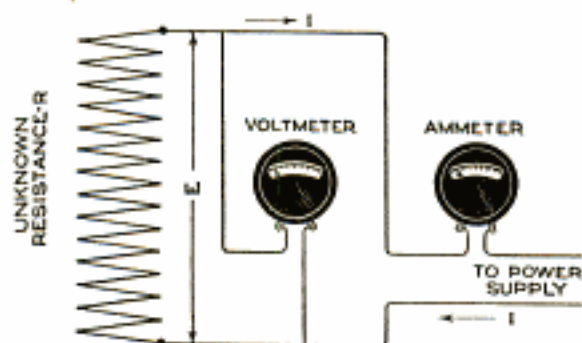

Fig. 1 MEASURING RESISTANCE WITH AMMETER & VOLTMETER

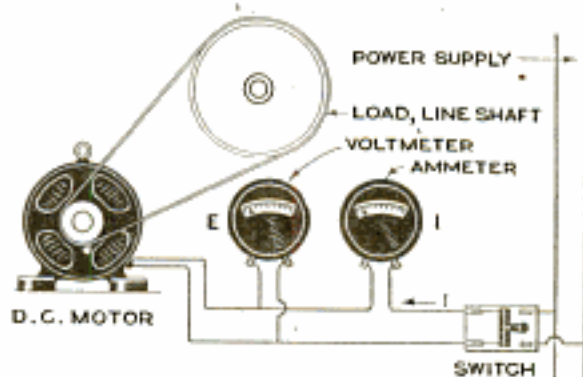
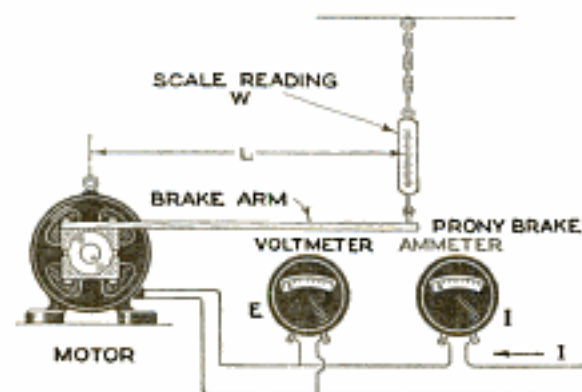

Fig. 2 MEASURING POWER INPUT



MEASURING MECHANICALLY POWER OUTPUT WHILE INPUT IS DETERMINED BY METER READINGS
Fig. 3

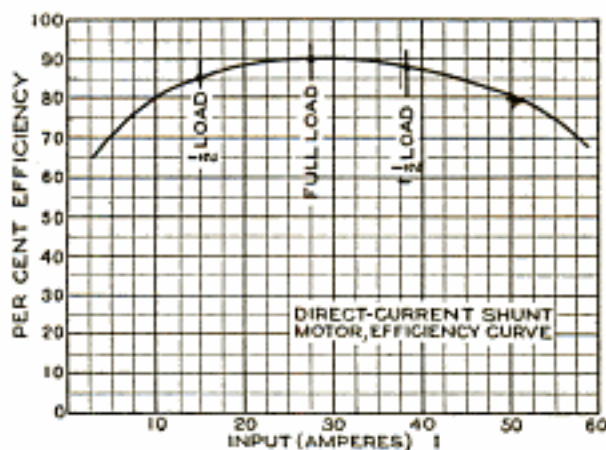
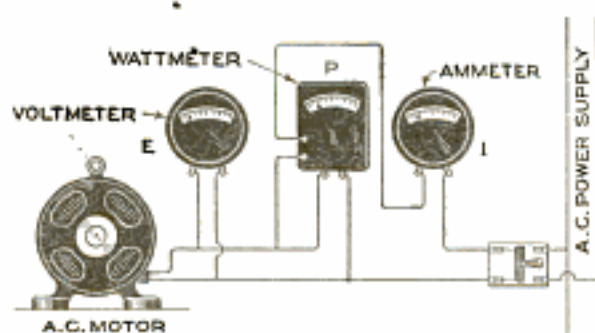
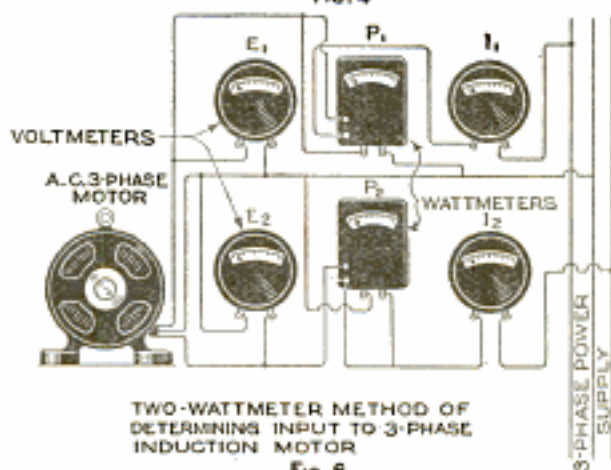

Fig. 4



INSTRUMENT CONNECTIONS FOR TESTING SINGLE-PHASE A.C. MOTOR
Fig. 5



TWO-WATTMETER METHOD OF DETERMINING INPUT TO 3-PHASE INDUCTION MOTOR
Fig. 6

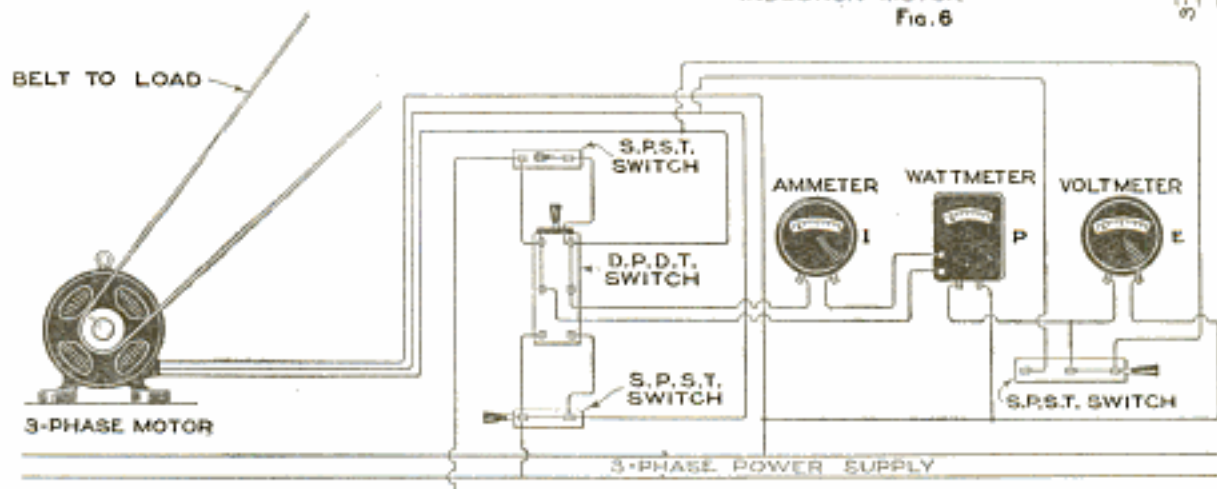

ONE-WATTMETER METHOD OF DETERMINING INPUT TO 3-PHASE INDUCTION MOTOR
Fig. 7

Fig. 1 Shows the Method of Measuring Resistance; Figs. 2 and 3, Connections for Power Tests on Direct-Current Motors, and Figs. 5 and 6, Connections for Testing Single and Three-Phase Alternating-Current Motors.

Fig. 7 Shows How a Three-Phase Motor may be Tested with Only Three Instruments

known, an efficiency curve, as shown in Fig. 4, should be plotted.

A very rough check of the power input can be made with only a voltmeter and ammeter connected in one phase. Compare the readings with the nameplate data. If the voltmeter reading is as specified, then the ammeter reading, as

compared with the nameplate value, will indicate whether the motor is over or underloaded.

In calculating either input or output, the values of E, I, P, L, N, and W must be read as nearly simultaneously as possible, dividing the work between several persons if necessary.

Wedge Holds Door for Planing

Carpenters, when planing doors, hold their work in a vertical position by inserting the end in a notched board horizontally between the door jambs. However, the work is not held rigidly, and it must be supported by the workman. A

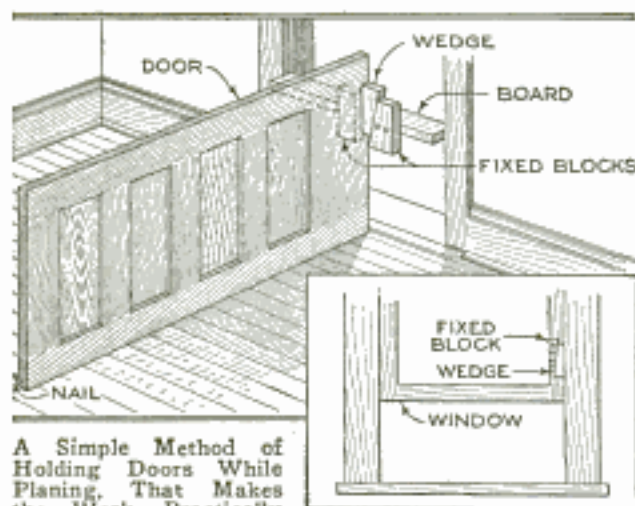

A Simple Method of Holding Doors While Planing. That Makes the Work Practically Immovable. The Smaller Drawing Shows How Heavy Windows can be Held in Any Position by Wedges

much more effective method makes use of tapered blocks affixed to the edge of the board, then, by inserting a wedge and tacking the door down to the floor at the opposite end, the work is practically immovable. Windows that overbalance their sash weights to such an extent that they cannot be kept up, can be wedged into position in much the same manner, as shown in the lower illustration.—Wm. E. King, Monessen, Pa.

Protecting Sprinkler Heads

To be sure that an automatic-sprinkler system is in good order the sprinkler heads should be carefully watched. Sprinkler heads having four different melting points are made; the lowest is 160° and the highest 360°. The latter are used in boiler rooms, drying rooms, and other places where there is a high temperature at all times. Extreme care should be used in replacing the sprinklers, so that only those of the proper melting point are used. To get the greatest pro-

tection from the system, however, the heads should have the lowest melting point that can be safely used. Where chemical fumes or moisture come into contact with and corrode the heads, the protection is decreased, because the thin skin of oxide on the surface increases the temperature required to melt the fusible metal. This trouble can be overcome by covering the heads with a waxlike substance that melts at a temperature somewhat lower than that required to melt the head. In a case where the likelihood of corrosion is great the heads should be changed frequently. Under some conditions, as in woodworking shops, paper mills, and the like, the heads become coated with flying particles of sawdust or paper pulp, which hardens and thus reduces their effectiveness. Paint or calcimine, that is accidentally smeared over the heads when painting, also lowers their efficiency. When painting or calcimining, the sprinkler heads should be protected by tying small paper bags over them, removing the bags when the work is finished.

Clothespins Aid in Replacing Auto Cylinder Head

The last two bolts on the light-automobile cylinder head, are located directly underneath the dash, and must be in

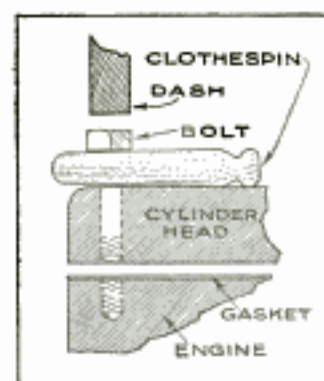

place while the head is inserted on the engine block. To push the head into place with these bolts protruding results in the gasket being bent or torn. The usual practice is to have a helper who holds the bolts while the cylinder head is being put on or taken off. A simple solution to this problem consists in the application of two clothespins, one underneath the head of each bolt, as shown in the drawing.

Sharpening Tools with Mill File

That a fine flat mill file may be used for sharpening and dressing tools is a fact that many mechanics have overlooked completely. Possibly it is not generally realized that the edges of scissors, tin-snips, screwdrivers, and numerous other tools, are softer than the file and can be dressed down to a sharp cutting edge. It is advisable to keep an old file with a broad surface for this purpose, and use it by clamping the tool to be sharpened in the vise. Occasionally a tool too hard to file will be met with, and for this reason the use of an old file is advised. In sharpening scissors, especially when used for cutting cloth, the file-sharpened edges are better than oilstoned ones. The file marks should run downward and inward on both cutting edges; the wire edge left by the file is removed by simply closing the scissors as in cutting.

Emergency Pinch Dogs

We had occasion to use a large number of small pinch dogs on a pattern job, and after we had used all we could find, we still needed several dozen more, and the shop boy came to the rescue with a box of belt fasteners. These were cut up so as to leave about three points on each side, and we discovered that the makeshift article was better than the regular manufactured pinch dog, as it not only drew the pattern segments together but prevented any lateral movement. Furthermore, any length suitable is easily made, they are cheap, and will not break at the corners like the factory-made article.—C. M. Graham, Waterloo, Ia.

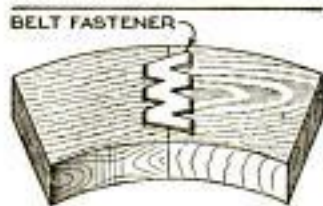

Insuring the Sweeping of Corners

One concern, which found that the janitors, when sweeping, consistently slighted the corners, has now painted all the corners in the factory white. The paint extends about a foot up the walls, and an arc of about 1-ft. radius is painted on the floor.

Where corners are dark, this brightens them up, and dirt is easily seen. The corners are not slighted now.—A. MacCullough, Chicago, Ill.

Bridge Models Show Problems Clearly

A little time spent in the drafting room in the making of models similar to those

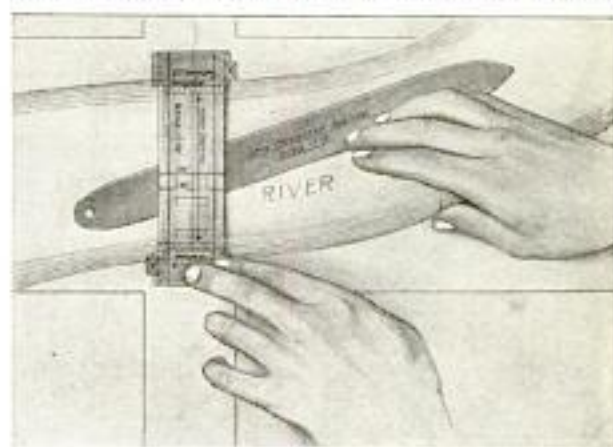

Paper Models for Showing the Relation of a Proposed Bridge to the Shipping That Must Pass Through, Makes It Possible to Present the Situation Clearly to Those Unfamiliar with the Problems Involved

illustrated will save a great deal of useless argument in consultation with engineers, business men, and commissions in large cities. It will be immediately apparent to even those most unfamiliar with the problems involved, just what size boat can pass up the river and through the proposed bridge. The outline model of the bridge is adjustable so that the distance between the abutments can be increased or shortened. It is only necessary to place the models, which are cut from ordinary Manila drawing paper, on a map of the proper scale to make the situation self-explanatory.

Bushings Removed with a Tap

A simple and convenient method of removing a small bushing consists in cutting into it with a tap slightly larger than the internal diameter of the bushing. With the tap in place, a punch or drift is used to drive the bushing out from the opposite side, in cases where this is possible.

Old taps are useful for this purpose and, as the tap is likely to be injured in the operation, a good tap should not be used unless absolutely necessary, and then only with great care. Coarse-threaded taps are better than finer ones for this purpose.

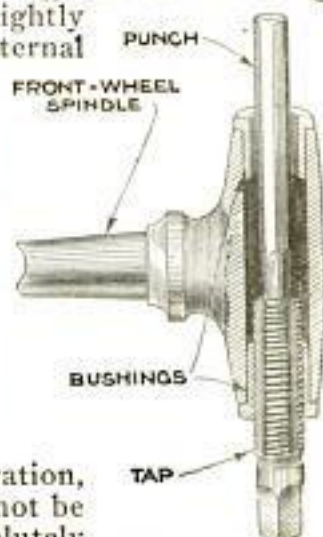

Useful Attachment for Square

By fitting up his combination square as shown in the drawing, so that a cold-rolled steel rod can be inserted and tightened in position

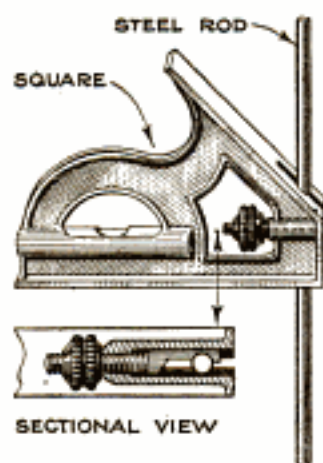

instead of the usual straightedge blade, a pattern-maker doubles the usefulness of this indispensable tool. A hole that will make a sliding fit for the rod is drilled through the head, as shown in the detail, and a semicircular groove is filed in the clamping bolt,

just back of the jaw, to allow the rod to pass through it.

This arrangement enables the tool to be used as a depth gauge in small holes or slots where the rule will not enter; by inserting a small steel point near one end of the rod, a good marking gauge is formed.

Improved Centers for Arbors

An improvement on lathe and milling-machine arbors, that overcomes the all too familiar burring of the centers, has

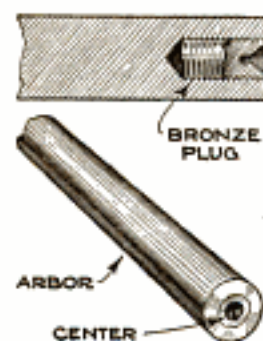

been used by the owner of a general machine shop with satisfactory results. The idea is simplicity itself, and consists in boring out the working end of the arbor to a depth of about 1 in. with a $\frac{1}{16}$ -in. drill; this hole is tapped to accommodate a $\frac{3}{8}$ -in. threaded bronze plug.

The plug is screwed in flush and centered in the usual way. The bronze center produces a bearing that is tough, yet not hard enough to burr the lathe centers.—John M. Pipp, Muncie, Ind.

Umbrella Ribs for Welding Rods

I have been using the ribs from old umbrellas in place of welding rods for such work as lengthening twist drills, augers, and for sheet-metal work, with perfectly satisfactory results. On account of the thinness of the ribs a smaller flame

is required to melt them, and no hard spots are apparent in the weld when machining or filing. When the neutral flame strikes the rib, numerous sparks will appear which may cause the operator to believe his torch is not adjusted properly, or that the steel is burning. This is merely the action of the oxygen on the rust and enamel on the rib, and does not interfere with the free flow of metal into the weld.—Fred Brand, Middletown, N. Y.

Cutting Brake-Band Rivets

To cut off the old rivets cleanly, when relining brake, clutch, or transmission bands of an automobile, without bending them over, the cold chisel used should have a specially ground edge.



The ordinary cold chisel is beveled on both sides, but, to get the most satisfactory results with the type of rivets generally used for the purpose mentioned, the chisel

should be ground with a bevel on but one side and used with the flat side against the band.—J. H. Rouse, San Francisco, California.

Stretching Leather Laggings on Pulleys

When it is desired to stretch a piece of leather over the face of a pulley to increase its diameter, or to reduce slip, and to rivet it in place, the mechanic finds that he does not possess enough

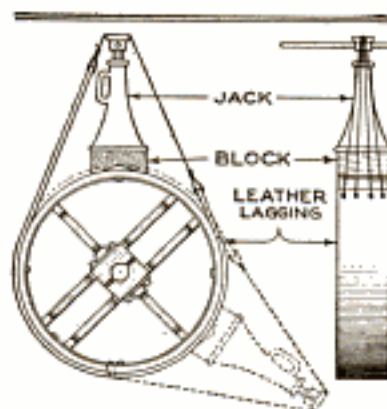

hands and fingers to manipulate the lever that is commonly used, and to insert and head over the rivets while the leather is taut.

The drawing shows how an ordinary screw-jack is used by one old-time mechanic to draw the leather laggings up tight, and hold it thus while the rivets are inserted and headed. Holes are punched through the end of the leather, which should be

about 3 in. longer than necessary to reach around the pulley. The ends of the belt are connected by a number of strong wires, twisted together into a single strand and placed over the head of the jack. With a V-block underneath the jack, the screw is turned until the leather, which has been previously soaked in warm water for about 10 minutes, is sufficiently stretched. Rivets are placed in holes drilled through the leather and pulley, except in two near the rim of the pulley on the side opposite the jack. The jack is loosened, the wire removed from one end and this end cut off squarely. The jack is then reset in the position indicated by the dotted lines, the free end of the wire being inserted into the holes in which no rivets were inserted. The leather is again stretched and the rest of the rivets inserted. The jack is then removed, the ends of the lagging scarfed off, and the final rivets inserted where the wires were attached. When the leather becomes dry, as nearly a perfect fit as it is possible to obtain will be the result.—Geo. G. McVicker, North Bend, Neb.

Clamp for Drawing Board

The clamp shown in the drawing eliminates the need of thumbtacks to hold standard-size drawings to the board, and

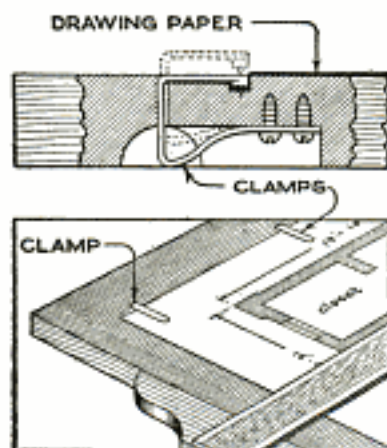

it will not spoil the board for use in making larger drawings, as the clamp is let in flush with the surfaces of the board. Only two clamps are used, and they are located at the top of the board in such a position that they will accommodate the majority of the drawings. The clamps are made from spring wire and fit into mortises of the proper size, cut in the surface of the board. A recess is made for the fingers on the underside of the board, so that the springs can easily be pressed upward.—Geo. Simonson, Cambridge, Mass.

☛ The boiler should be set 30 to 42 in. above the fire grate to give room for air and gases to mix.

Truing Small Commutators in a Vise

In truing up the commutator of a small motor generator, such as found in

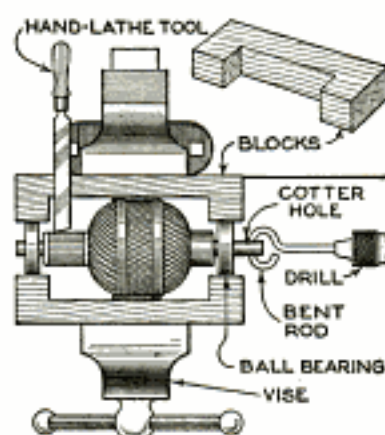

automobile electric systems, when no lathe is available, the vise set-up illustrated can be used. Two wooden blocks, relieved at their centers to clear the winding, are clamped in

the vise, the armature being held by its ball bearings, so that it can rotate freely.

At one end of the shaft is a hole for a cotter or taper pin, and this is connected to a drill chuck in the manner shown. Then, while the work is being rotated, a hand lathe tool is brought to bear against the copper and the proper amount of metal removed. Sandpaper is used to smooth the turned work and give a polished finish.

Removing Ball from Check Valve

An ordinary horseshoe magnet, kept around the automobile repair shop, will

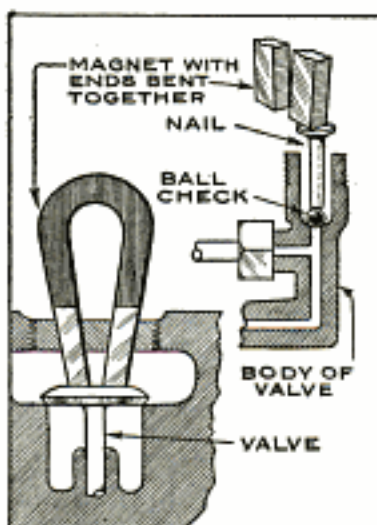

make it possible to remove easily the balls from oil check valves, inaccessible valves, and other parts that it is difficult to get a grip upon with fingers or tools. A magnet from an old magneto, with its ends bent close together, but not in contact with each other, can be found around almost any shop and will give excellent results. In removing the check-valve ball, a nail or similar short piece is inserted into the valve, and nail and ball drawn out together. Brass parts are unaffected by magnetism and therefore cannot be removed in this manner.

A Tap and Reamer-Milling Fixture

By J. V. ROMIG

INEXPENSIVE, yet a useful and time-saving addition to the shop equipment, the tap and reamer-milling fixture described in this article fully justifies the slight cost of its construction. With it, taps and reamers can be milled as quickly and as accurately as when using a large and bulky index head. Furthermore, this fixture permits the work to be done on

machined from cast iron to the form and dimensions shown; it is machined all over and the T-slot is cut throughout its length.

The index head and foot center are cast in soft gray iron from simple patterns, and machined to the dimensions given. The index-head spindle is taper-turned, and should be a snug fit in its bearing.

It has a center turned on its front end and is also threaded for the index plate.

The index plates, of which there should be several, say, one of 16 holes and another of 18 holes, give nearly all the spacings needed in the fluting of taps or reamers. The indexing is done by pulling the pin out, rotating the plate by hand, and then inserting the pin to hold the head in position. The foot-center head slides along the front face of the head slide, and can be clamped in any position to suit the length of the work held between the centers. The foot-center spindle should be of hardened tool steel and be fitted with a screw and hand-wheel for advancing the center into the work, as in a lathe tailstock.

By using a fixture of this type, more speed can be made on small

work, as it allows the work to be done on a high-speed machine of small size.

Lock and Chain Prevent Accidents

Deaths and accidents are often the direct result of a machine being set in motion by some one who does not know that there is a man working on it. Practically all such accidents can be prevented by providing the men who do work of this kind with a piece of chain and a padlock, and making the use of them compulsory, to lock the starting lever, switch, or whatever it is that makes the machine operative. In the same way, whenever it is necessary for a man to enter a boiler, gasometer, or similar ves-

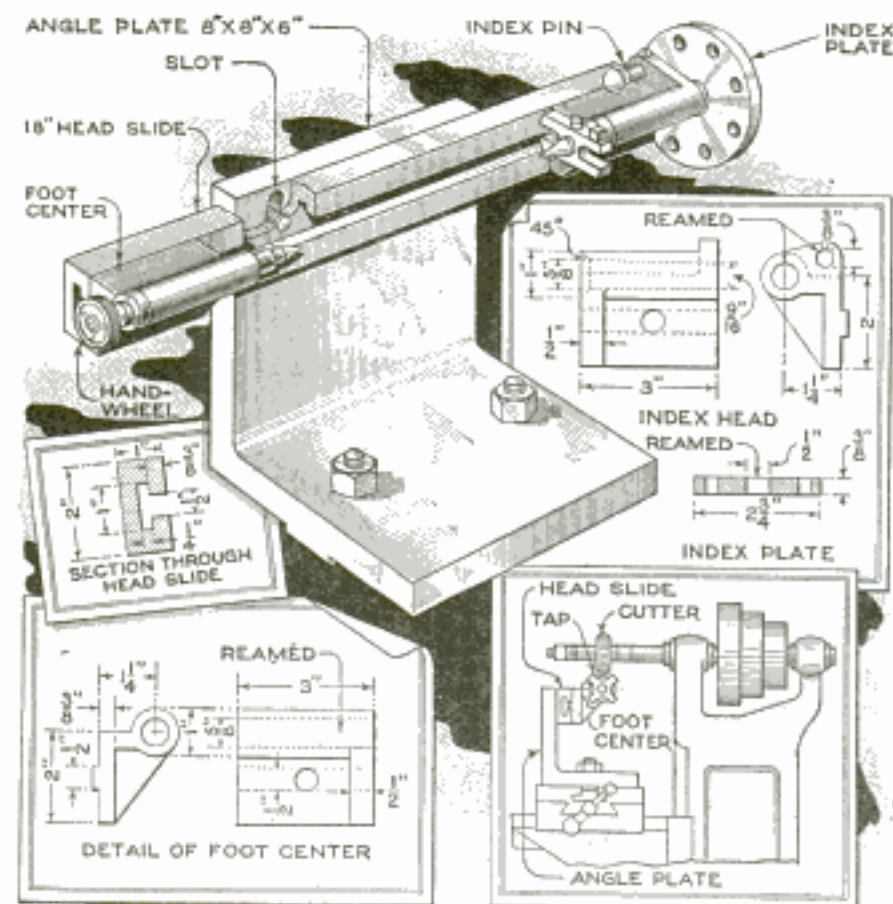

A Tap and Reamer-Milling Fixture That Has Its Index Head Self-Contained: It Accommodates Itself to Tapered Work, and can be Mounted on Small High-Speed Millers

a small miller, thereby saving the larger miller and its index head for larger and possibly more important jobs. Being self-contained in a single unit, much time is saved on the set-up of each job, as the fixture only requires to be clamped to the milling-machine table with two bolts.

The base of the fixture is an angle plate, machined square on its bottom and inside faces and having a tongue on the bottom machined to fit the table slots; to this the head slide is bolted with two capscrews. The capscrew on the index-center end is a turning fit in a hole drilled in the angle plate, while the other, at the foot-center end, slides in a curved slot, so that the slide can be tilted to take care of taper work. The head slide is

sel, he should lock all inlet-control valves, and take the key along with him to prevent the steam or gas from being turned on. Sprinkler-system valves, and other valves that are connected to the fire-protection system, which should be kept open, can also be kept from being closed by the application of a lock and chain.

Cement Bases for Lanterns

Lanterns that are used by contractors and municipalities to warn traffic against obstructions or dangers in the roadway are easily upset and extinguished by the wind, when set on the ground. If suspended from a barricade or stake there is frequently considerable swaying that may dislodge the lantern and extinguish the light. However, by molding a cement base around the oil reservoir of the lantern it can be set on the ground with every assurance that it will not be blown over or accidentally upset.



Removing "Frozen" Bolts

Owing to rust, or the end of the bolt being riveted over the nut, bolts in the chassis of automobiles frequently resist all efforts to start

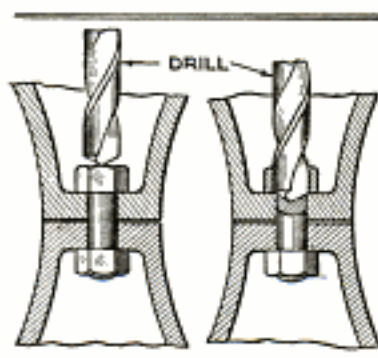

them with wrenches, and sometimes they are so located as to prevent the use of a chisel or drift on the nut. A simple method for removing such bolts is to drill through the bolt head down into the body of the bolt. Make a punch mark in the center of the head, and using a drill slightly larger than the diameter of the bolt body, drill as shown: if an air or electric drill is used, the bolt will be out in a comparatively short time. In any case the drilling method is better than cutting the head off the bolt, as there is no possibility of a flying bolt head striking and injuring anyone, breaking a window, or doing any other damage.

Wrench for Cylinder-Base Nuts

Cylinder-base nuts are, in many cases, so located that they can only be turned with a chisel. The reason for this is simple; the corners of the hexagon nut being 60° apart, the nut requires to be turned 60° before the wrench can be replaced on it and the turning movement continued; on the other hand, conditions usually permit turning the wrench no more than 30° , obviously making it impossible for the common wrench to resume its hold on the nut.

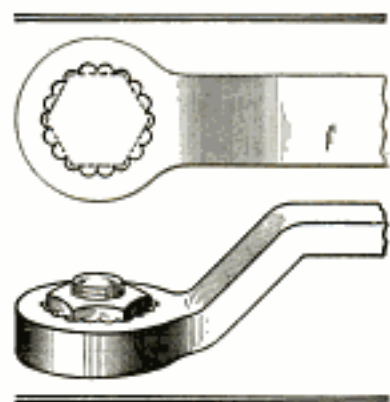

The drawing illustrates the construction of a simple wrench that will grip the hexagon heads of capscrews or nuts in any position so that the wrench can turn the nut as far as possible. A circle of holes is drilled in the wrench, as indicated, and the center piece knocked out; with this arrangement, no matter in what way the wrench is applied, the corners of the nut or bolt head will fit into some of the holes in the manner shown. The wrench head should, of course, be case-hardened.—C. Nyc, New York, N. Y.

Dogs Aid in Sawing Wood

Two simple grippers, or dogs, fastened to opposite sides of a sawbuck, as shown in the drawing, will greatly facilitate the work of sawing wood into stove lengths, by holding it so that it cannot move as it is being sawed. The dogs are made of iron and bolted to the buck in the manner shown. In use, the sharp points are pressed into the wood, relieving the sawyer of all the effort that is generally required to keep the wood from turning a little with each stroke of the saw.—P. T. Williams, Hairoa, N. Z.

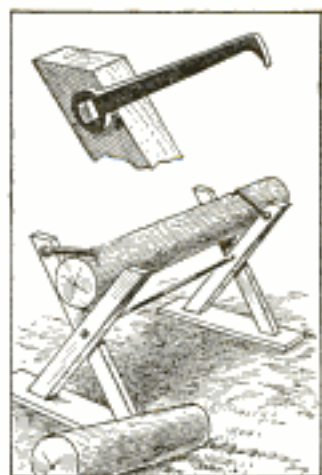

Plugs for Radiator Testing

Old automobile valves are utilized for the essential parts of the automobile-radiator testing

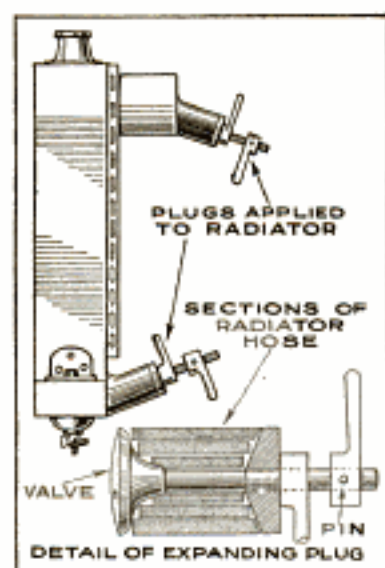

the valve stem, the conical washer applied, and then the two handles, one of which is pinned rigidly to the valve stem, as shown. In use, the plugs are inserted into the openings of the radiator headers and the handle screwed down; this forces the sections of rubber tubing against the valve head and conical washer, causing the rubber to expand and completely fill the opening, so that the radiator can be tested for leaks.

A Novel Toolholder

The toolholder shown will be found handy when used on work that requires a frequent changing of tools, as it is self-contained, requires no separate wrench to operate it, and is very quick in action.

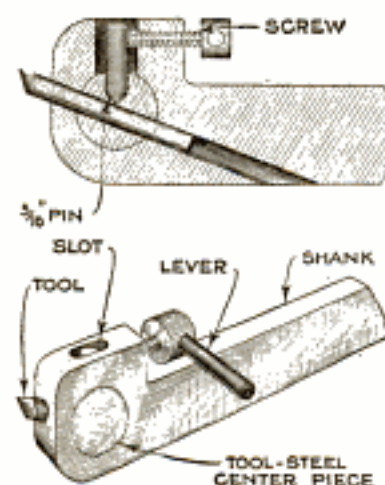

the top. A short piece of drill rod is driven tightly into a disk of 1-in. tool

plugs shown in the drawing. The end of the stem is threaded and two threaded handles and a conical washer are provided. In assembling the plugs, a number of sections of heavy rubber tubing of different diameters are slipped over

steel, which is made a snug fit in the reamed hole. The holder is drilled and tapped for a tightening screw, the head of which is drilled for a 3-in. length of drill rod that serves as a lever. When the piece has been thus assembled, a hole is drilled, at the proper angle, clear through the holder and the tool-steel disk or centerpiece. This hole is afterward broached square to take the tool bit. While the broaching is being done, a piece of packing is placed in the slot, and the screw is tightened on this to hold the centerpiece firm. The lever in the tightening screw should be set in a vertical position when the tool is released, one-quarter turn tightening the tool and bringing the lever down to a horizontal position. It will be immediately apparent that the screw, bearing on the pin driver in the centerpiece, forces the latter around and binds the tool on the bottom of the square hole.

Precision Scribing Tool

It is an exceedingly delicate operation to scribe a perfectly true line along the edge of a scale with an ordinary scriber

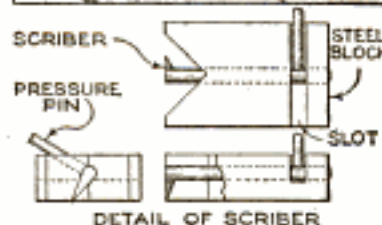
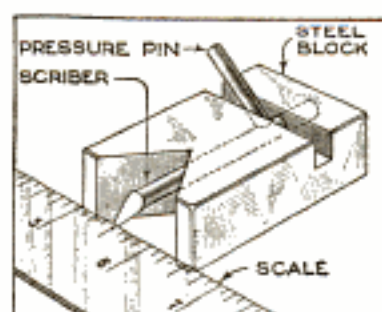

or scratchawl. Since the scriber is round and tapering to a point, and it is almost impossible to keep the hand in exactly the same position the whole time the line is being drawn, an uneven line usually results, which may cut through a fine center on one end of the work and probably be off at the other. If the line is not exactly true, other attempts will be necessary, and this will make other fine lines that will be confusing.

The tool shown in the drawing will draw a dead-straight line exactly between two points, providing, of course, that the scale is accurately placed on the points. The body is a steel block, ground on the base, with a V-cut in the front end. The piece is drilled from the back end clear through to the center of the "V," to take the bent scriber, which is made as shown. A slot, cut across the top of the block, enables a pin to be threaded into the

scriber in a position at right angles to the scriber point. When the piece is thus assembled, a light finishing cut, preferably on the grinder, is taken across the front of the block and end of the scriber, insuring that these will form a dead-flat face.

In use, the block is placed close against the edge of the scale, and, with one finger pressing on the pin, the block is drawn along the scale, scribing a light or heavy line according to the pressure exerted.

Auxiliary Automobile Seat

The auxiliary automobile seat illustrated is designed for the use of a child, and is simply constructed of iron rod and a board of suitable size to form the seat. The iron rod is bent to form a hook that fits over the back of the car seat, and the board is attached to the lower ends. Arms for the seat are made from the same material and fastened to the underside of the seat, which can be upholstered as desired, or, by the exercise of a little more ingenuity, the back and arms may be formed of one length of rod. Completed, the seat is intended to elevate the young passenger so that he can see over the side of the car.—F. C. Davis, St. Joseph, Mo.



An Adjustable Lathe Dog

The drawing shows a lathe dog that is capable of holding various sizes of work. Merely by releasing the regular binding screw at the top and dropping the lower portion of the dog a notch, larger work can be accommodated. The design is very simple, the parts easily made to suit individual requirements, and considerable time can be saved because a large variety of sizes is not necessary. This dog is driven from a face-plate in the usual manner, the tail being made to fit into the slot in the plate.

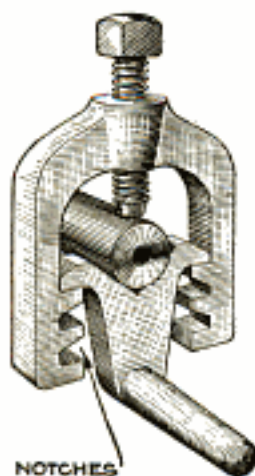

Adjustable Parallel Blocks

A very handy and useful parallel block that will save much time, and facilitate setting of work, is made according to the form and dimensions given in the drawing. The vertical adjustment is made by two screws that support the upper member. Such blocks can be used individually, in pairs, or three, as the job in hand may require, and, by using a micrometer as in the drawing, the blocks are easily set to the same height. The screws should be threaded with a fine S.A.E. thread, which will permit close adjustment. The base of the block is shaped, drilled, and tapped as shown, and notice should be taken of the retaining rib that keeps the two parts of the block from coming apart. The base is wide enough to furnish a good support, and it, as well as the top, is ground to a flat surface. The upper member slips over the tongue of the base and is countersunk for the points of the adjusting screws. A small pin through each end of the upper member catches against the rib and holds the top and base together.

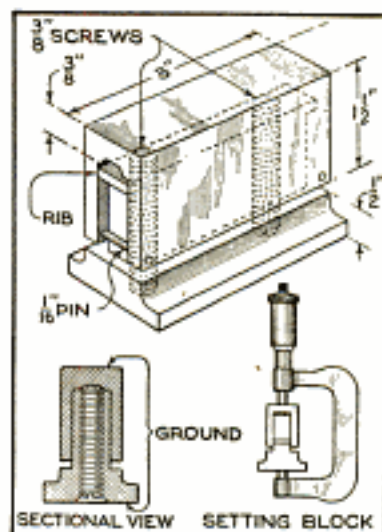

Blocks of different heights, each set overlapping the other in its limits of adjustability, should be made; one set with a 1-in. adjustment, starting with a height of 2 in. and opening out to 3 in., with the next size opening from 3 to 4 in., and so on.

Gravel in Concrete Mixtures

Most bank-run gravels contain a great deal more sand than is desirable in a concrete mixture. Sometimes this sand is twice as great in quantity as would be best. If about 75 per cent of bank-run gravel were fine material, the proper proportion of cement would vary widely from that required in case only 30 per cent of the gravel were fine material. Only by separating the fine sand from the pebbles can definitely specified concrete mixtures be secured.

Unusual Type of Pattern Construction

It is common practice among pattern-makers to build a cylindrical pattern in segmental courses, in which case it is of

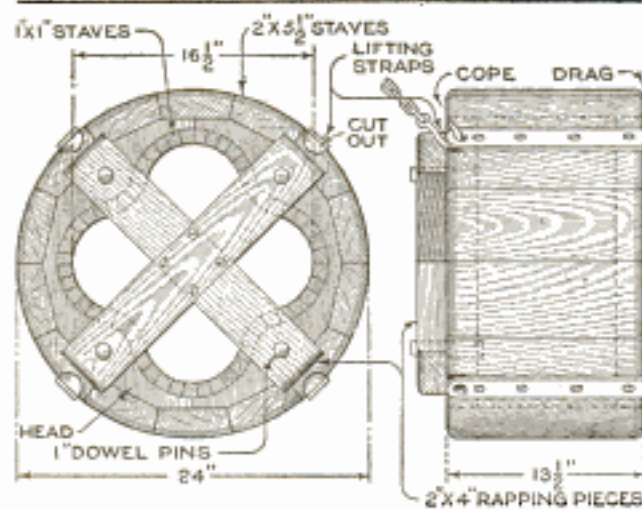

A Method of Building Cylindrical Patterns That Uses Staves Parallel to the Center of the Pattern Instead of Segmental Sections, Makes the Work of the Molder Easier and Prolongs the Life of the Pattern

the utmost importance that the lumber is thoroughly dried and seasoned; that the segments are securely glued and fastened together, and that at least three coats of good varnish are applied to the surfaces of the finished work. If these things are not done carefully, the damp molding sand will loosen the glued joints, causing the segments to warp, twist, and contract or expand, so that the pattern will not be truly cylindrical. This expansion or contraction will cause pockets in the sides of the cylinder, in which one or more segments may overlap slightly. When this occurs, the molder has a troublesome job in extricating the pattern from the sand mold, and the sand that forms the face of the mold is, in many cases, "sheared" away when the pattern is lifted from the mold. A pattern in this condition receives rough treatment at the hands of the molder, as considerable rapping is required to loosen it enough to enable him to extract it from the mold.

The objections above outlined, and others that could also be cited, do not apply to cylindrical patterns of the type shown in the drawing; if they did, very few castings could be produced from it, as it has a rather weak cross section. The pattern is made stave-fashion, with the staves running parallel to the center instead of being built up in segments. The pattern consists of the heads and the outer and inner staves. Contrary to the usual practice of making the heads in

a complete circle and building the staves around them, the heads are made in two pieces that are temporarily held together on a flat board. The body staves are next fitted and fastened to these half heads. The half pattern is now removed from the board, and reinforcing pieces are fastened inside the heads with an overlap at the joints, to which the opposite half of the pattern is fastened. The opposite half heads are put in place and fastened securely with glue and screws. The inside staves are fitted and fastened with glue and finishing nails, and finished with a round-bottom plane to the required shape and dimensions. This is done very simply, if the pattern is laid out and built up correctly. The pattern is now turned and finished in the lathe, sanded, and given three coats of good black varnish. The $\frac{3}{16}$ by $1\frac{1}{4}$ -in. lifting straps are then fastened to the side of the pattern. The straps are made the same length as the pattern and do not project beyond it, and cup-shaped depressions are cut into the wood to permit the insertion of hooks into the holes in the straps.

A novel feature of this mold is the rapping piece, made from two pieces of 2 by 4-in. lumber, fastened at right angles to each other. This piece has a 1-in. dowel pin at each end which fits into holes in the cope head. Instead of the heavy iron bar that is usually driven into the pattern for rapping purposes, the rapping is done on the rapping piece, which is put on after the cope flask has been lifted, and removed after the rapping has been finished.—M. E. Duggan, Kenosha, Wis.

Marking Off Centers on Shafts

When large numbers of short lengths of round stock require to be marked off at the ends, preparatory to center drilling, much time can be saved by the simple set-up shown in the drawing, together with a special marking-off gauge.

Arrange the shafts, after cutting to the proper length, in layers six wide and six deep, between two angle plates bolted down to a drill-press table, or other plane surface. The gauge can be made from any flat stock, but its width must be the exact diameter of the shafts. A pin is driven into each end

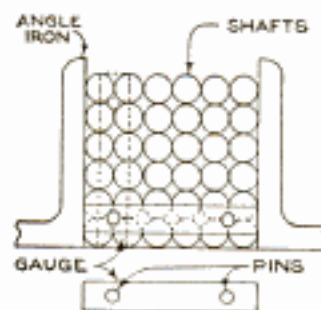

of the gauge, their diameter being such as to make them a snug fit into the spaces formed by the junction of four shafts. The distance apart of these pins is the same distance as the first and last spaces in the rows of stock.

When marking off, place the gauge in a horizontal position, with the pins in the spaces, as indicated in the drawing, and scribe a line along the shafts; this will give the center in one direction. After the lot has been scribed horizontally the gauge is placed in a vertical position and lines are scribed perpendicularly, the intersections of the horizontal and perpendicular lines being the centers of the shafts.

Light Reflector for Drafting

Often the light on a drafting board is poor and the shadows of the triangle and T-square are dense enough to cause eye-strain in detecting

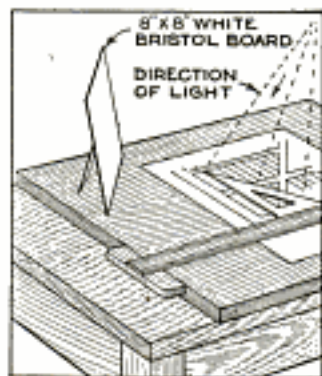

the exactness of the lines to be drawn or traced. Under such conditions it is advisable to use a reflector of the type shown in the drawing. Nothing more than a square of white Bristol board is required, with a

strip of the same material glued to the back to form an easel. By moving the reflector about so that the shadows are illuminated by the reflected light, the strain on the draftsman's eyes will be considerably lessened.—Truman R. Hart, Ashtabula, Ohio.

Galvanizing Brass and Copper

Copper and brass may be coated with metallic zinc in the following manner: Place finely divided zinc in a nonmetallic vessel, and cover it with a concentrated solution of sal ammoniac. This is heated to the boiling point, and the copper or brass articles are introduced. A few minutes in the boiling bath will suffice to produce a firm and brilliant covering over the surface of the work. The zinc can be reduced to the requisite fineness by pouring the melted metal into an iron mortar and pounding it with an iron pestle until the solid mass has been granulated to the desired fineness.

A Simple Radius Tool

The illustration shows a simple and almost automatic arrangement for cutting radii in a lathe. It only requires that the

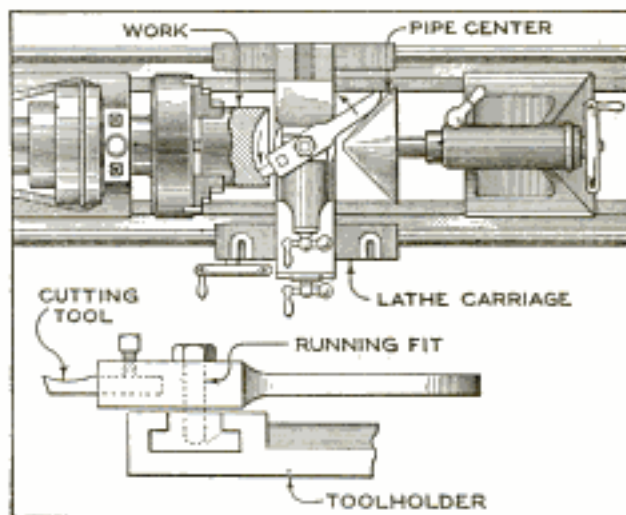

A Simple Radius-Cutting Tool That Is Almost Automatic in Its Operation: The Toolholder Is Pivoted, and a Projecting Tail Bears against the Conical Center

tailstock center be fed forward. The tool bit is held in a holder that is pivoted at its center to the cross slide, in the manner shown. The projecting tail of the holder bears against the pipe center held in the tailstock. Consequently, as the conical center is fed forward, the tool is forced to travel in an arc.—Jos. F. Convery, Worcester, Mass.

Grinding Ball-Check Valve Seats

After a considerable period of use, ball-check valve seats will pit and rust, the valve will leak, and it will be found that the trouble cannot be entirely corrected by the insertion of a new ball into the worn seat. It is a simple matter to regrind such a check-valve seat by the method illustrated. The end of a piece of copper tubing is flared by driving it over one of the hardened steel or brass balls used. After the end is flared, it is hammered in to hold the ball securely. With this tool, held in the breast drill, and a small amount of valve-grinding compound, the seat of the valve may be quickly reground.

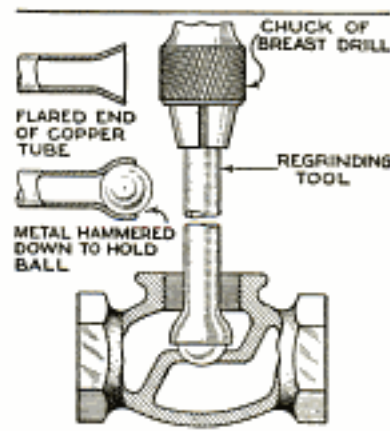

The end of a piece of copper tubing is flared by driving it over one of the hardened steel or brass balls used. After the end is flared, it is hammered in to hold the ball securely. With this tool, held in the breast drill, and a small amount of valve-grinding compound, the seat of the valve may be quickly reground.

Drain Pit for Filling Stations

A small pit used for draining crankcases, and placed convenient to the filling station, has proved to be a good investment to a

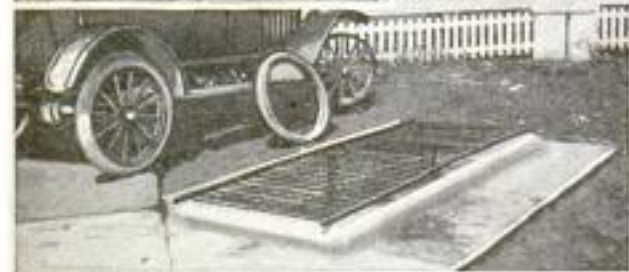

A Concrete Pit for Automobile-Service Stations Facilitates Drainage of Crankcase Oil. A Five-Inch Molded Rim Prevents Cars from Running over the Edge, and the Pit is Covered with an Iron Grating.

number of automobile-filling stations. Once the pit has been installed, there is no operating expense, and the sale of crankcase oil is greatly increased, since

the draining is not charged for. The stations can afford to do the work of draining the crankcases of their customers' cars free, since it results in the sale of several quarts of oil in each instance. The pits are of concrete, made with a 5-in. molded rim, to prevent cars from running over the edge. An iron grating is always kept handy, and is put over the opening when the pit is not in use, to prevent accidents. By providing filtering facilities, the oil that is drained from the crankcases can be restored to salable condition, and can be sold for the lubrication of farm machinery and similar purposes.

Preventing Loss of Tracings

The chief draftsman in a large shop uses a very effective method of keeping track of tracings taken from the file by draftsmen for reference, alteration, or other purposes. A draftsman taking any tracing is required to leave with the file clerk a receipt in the form of a card 2 in. wide and 3 in. high, which is then filed by number in a tray. When the tracing is returned, the file clerk destroys the card before filing the tracing. This much

of the procedure is very common. The shop referred to had experienced a great deal of trouble because the draftsmen failed to return valuable tracings, and the receipt cards remained forgotten in the file. To prevent this, all the blank cards are now beveled off at the top; one month, cards are used beveled off toward the right side of the card, and the next month's supply of cards are beveled off toward the left. Toward the end of the month the file clerk goes through the card tray and takes out any cards which show by their bevel that they are remaining from the previous month. He then inquires of the writer of each of these receipts why he has not returned the tracing. If there is a good reason for keeping the tracing so long, the old receipt is destroyed, and a new one written on a card beveled to conform to those for the current month. In this way, the receipt file is brought up to date at the first of each month, and cases of "buried" and forgotten tracings are avoided.

of the procedure is very common. The shop referred to had experienced a great deal of trouble because the draftsmen failed to return valuable tracings, and the receipt cards remained forgotten in the file. To prevent this, all the blank cards are now beveled off at the top; one month, cards are used beveled off toward the right side of the card, and the next month's supply of cards are beveled off toward the left. Toward the end of the month the file clerk goes through the card tray and takes out any cards which show by their bevel that they are remaining from the previous month. He then inquires of the writer of each of these receipts why he has not returned the tracing. If there is a good reason for keeping the tracing so long, the old receipt is destroyed, and a new one written on a card beveled to conform to those for the current month. In this way, the receipt file is brought up to date at the first of each month, and cases of "buried" and forgotten tracings are avoided.

Window Box Aids in Filing Band Saws

In pattern shops and other places where band-saw blades are filed frequently, the arrangement shown will facilitate the work of setting and filing the teeth, and keep the saws from getting snarled up on the bench or floor so that there would be—as there generally is in such cases—

danger of breakage. A wooden box is permanently fastened to the outside of a window frame, so that it will clear the sash and not interfere with its operation. The folded saw is inserted in the box, where it is kept coiled throughout the operation. In this manner the saw filer requires but a minimum of room for his work, and he can get his vise as close as possible to the source of light.



In addition to the time-honored expedient of ruling lines for tables on the reverse side of a tracing, this side can be used for inking in temporary details. These can be removed later without affecting the main drawing.

These can be removed later without affecting the main drawing.



Bicycle Grinding Outfit with Many Original Features

BY JOHN ANSON FORD

BY constructing a particularly ingenious grinding outfit, which is mounted on a bicycle, a westerner has emancipated himself from indoor shop work, and provided himself with a practical means of earning a livelihood in a congenial manner. The equipment is such as any person used to handling tools can make with little or no difficulty.

tact with the rear wheel, when the rear of the bicycle is raised from the ground on the special stand provided for making the outfit stable. The friction wheel is operated by a spring-held lever which holds it firmly against the rubber tire of the rear wheel, and so provides a very satisfactory means of driving the grinding wheel. The stand, or frame, for elevating the rear of the bicycle from the ground and supporting both the outfit and its operator, consists of two rods, about 5 ft. long, which are hinged to a block fastened just underneath the saddle; these are spread out, and their ends thrust into the ground, when the grinding outfit is to be used.



A Tool and Knife-Grinding Outfit Mounted on a Bicycle, the Rear Wheel of Which is Raised by Long Rods: The Upper Photograph Shows the Rods Extended; the Lower Picture Illustrates How the Rods Fold Out of the Way

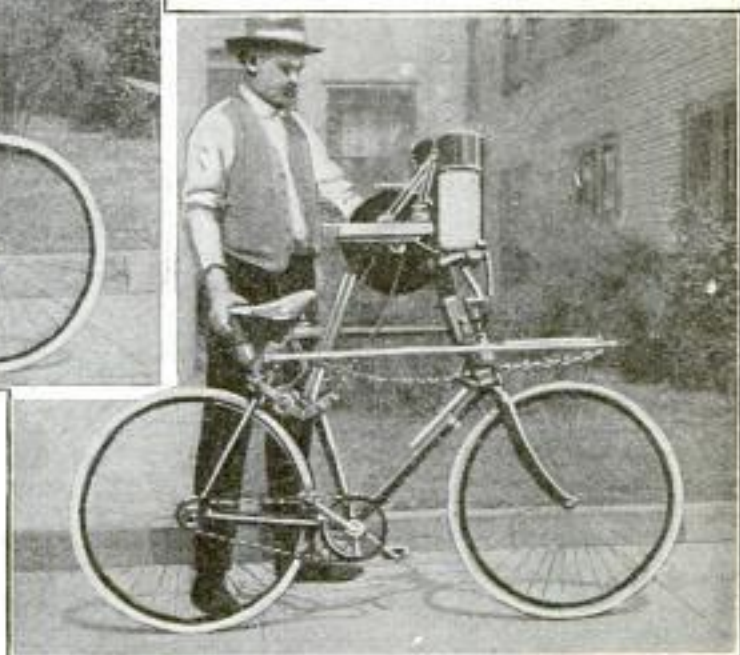

The equipment, as illustrated in the several photographs, is original with the builder, who worked up his own design. It consists of an oak frame that forms a table on which a fine-grained emery wheel, for knife and tool grinding, is mounted. The ordinary arbor of the grinding wheel was removed, and a bicycle hub substituted, to insure even, easy running. A small sprocket on the side of this hub carries a chain, which runs over another sprocket, also mounted on a bicycle hub; this is fitted with a friction wheel, which is brought into con-

To each side of the machine two chains are fastened, one to the rear of the frame, at the hub, and the other at the upper end of the front fork. When the supporting rods have been put into position, the chains are stretched taut to the lower ends and fastened there by hooks, thus forming a rigid support.

The manner in which this important feature of the device folds up parallel to

the frame, without interfering with the operator when he is traveling, is shown in the second photograph.

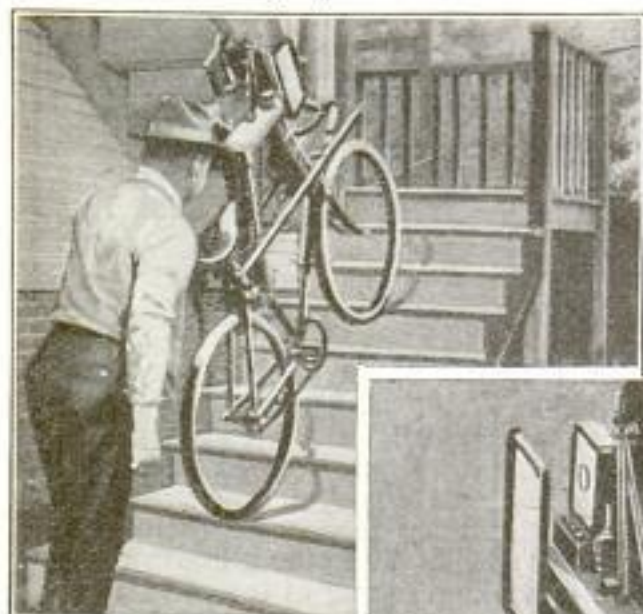

A Counterweight and Pulley, Fastened to the Porch, Makes It Easy to Move the Outfit Up and Down Steps. The Lower Picture Shows the Complete Equipment as Mounted on the Wheel.

Much ingenuity has been displayed in designing the various accessories, which include a buffer and scratch brush, mounted on a third bicycle hub, upon which, at its center, a friction wheel is mounted. By means of an adjustable frame, which is clearly shown in the lower photograph on this page, these wheels can be brought down to

make contact with the grinding wheel, so that polishing and cleaning can be done without the operator changing his position. A level is mounted on the table to enable the owner to set up his machine accurately, while a small vise, pivoted to one corner of the stand, is used to hold a fine-grained oilstone. When not in use, the vise is swung around out of the way. Convenient holders are provided on the table for two socket wrenches and an oil-can, other tools being carried in a case attached just underneath the water can, which is provided with a petcock to drip

water onto the grinding wheel.

The whole outfit cost its maker about \$45, and two months of his spare time to complete. The total weight of the wheel and its attachment is about 80 lb., and while this is a rather heavy wheel, it has not been found hard to manage, except when carrying the outfit up and down stairs to the room in which it is kept. To overcome this difficulty a counterweight and pulley

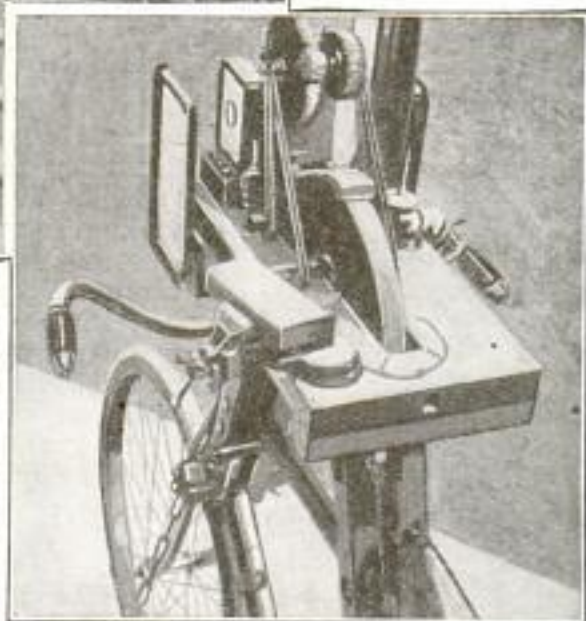

have been rigged up in the corner of the porch. When the rope fastened to the counterweight is hooked at the front of the bicycle, it is a very easy matter to move the outfit up or down the steps.

A Wire Boot Scraper

A most efficient boot scraper can be made from two boards and a few feet of strong wire. A T-shaped support is made

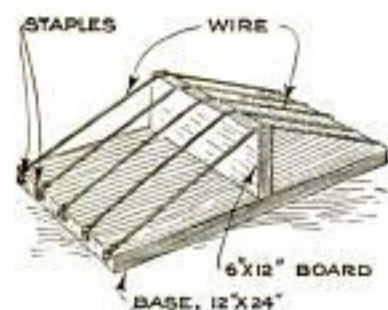

by nailing the two boards at right angles to each other. The upper edge of the perpendicular board is notched to keep the several wires from shifting their positions. One end of each wire is fastened to one end of the horizontal board with staples, the wires being then

drawn up tightly across the vertical support and made fast with staples to the opposite end of the base. When the foot is drawn across the taut wires, the mud is scraped off and falls onto the base.

Cleaning Furnaces

In cleaning out furnaces of the pipeless or hot-air types, an automobile-speedometer shaft, about 6 ft. long, can be used to reach parts of the furnace, such as the radiator, that are inaccessible to the usual cleaning tools. A brush is attached to one end and a round can fastened a short distance behind it. In use, the arrangement, brush first, is pushed around the smoke flues, the brush dislodging the soot and dust and the can collecting and removing it.

A Powerful Aero Sled

Something a little different from the usual type of air-propelled sled—one that uses two propellers instead of one—is shown in the photograph. This particular vehicle uses both "pusher" and tractor propellers and is designed for use on hard-packed snow or ice. Two motors, one for each propeller, of the ordinary twin-cylinder motorcycle type are used, the motors being bolted to the frame of the sled. Brackets support the countershaft bearings and give the proper clearance to the blades. One end of each countershaft is bolted to the propeller, and sprocket wheels are keyed to the opposite ends, as the propellers are both driven from the motors by sprockets and chains. The speed of both motors can be controlled by a single lever within easy reach of the driver, and separate fuel tanks are provided for each engine. The frame of this aero sled is made from two spruce sticks, about 12 ft. long, with ash crosspieces. The runners are made like skis, and have steel shoes underneath to prevent skidding.

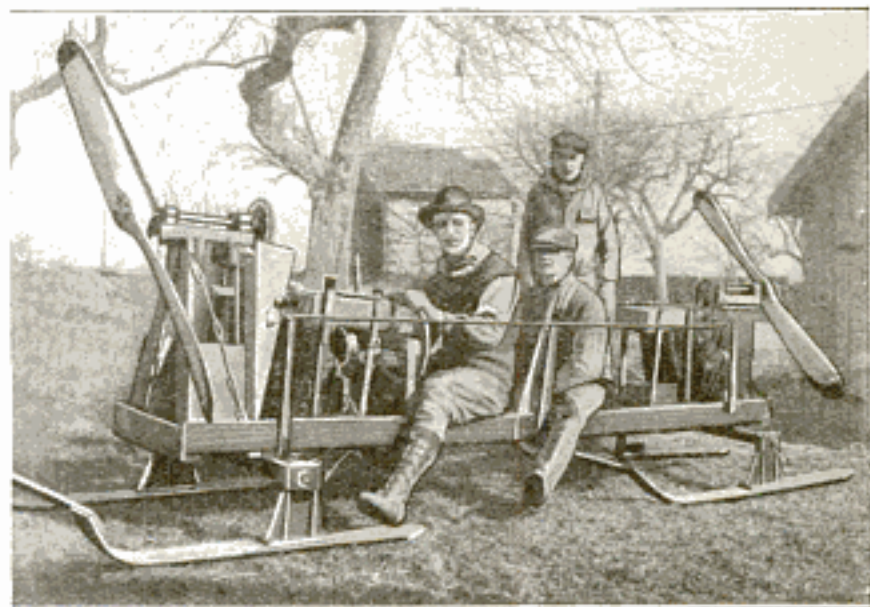

A Powerful Aero Sled That Uses Fore and Aft Propellers, Driven by Separate Engines of the Twin-Cylinder Motorcycle Type

The front propeller is 5½ ft. in diameter, and the rear one is 4 ft. 10 in. The forward propeller is geared to run at about 1,100 r.p.m., while the one aft turns at

from 1,300 to 1,400 r.p.m., so that even though it is in the air stream of the forward propeller it will take a good grip on the air.

This sled is very strongly built and has great speed, with a passenger capacity of three. Wire guys, fitted with turnbuckles, are used throughout the entire structure to keep the frame and mechanism rigid.—C. S. Greene, New York, N. Y.

Indicating Switch for Electric Irons

In order to prevent wear on the electric-iron plugs, and at the same time have some convenient means of controlling the

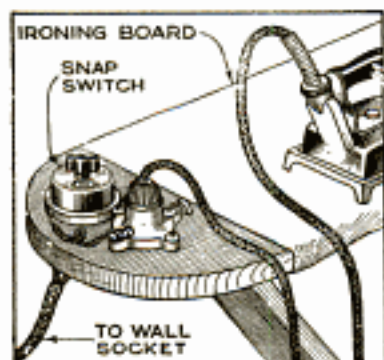

current as well as knowing when the "juice" is turned on or off, an indicating snap switch and keyless porcelain socket may be permanently fastened to the ironing board. Connection is made to the source of current by means of a suitable length of cord with a plug, which is attached to the snap switch on the ironing board. This arrangement makes it unnecessary to pull the plug from the

iron, and besides, the cord hangs down from the board instead of being in the way, as it is when connected to an overhead lamp.—K. L. Martin, Cleveland, Ohio.

Cotter Pin Aids in Tube Repairs

When a tire is punctured and the inner tube deflated, it is necessary to pump up the tube to locate the hole. When the hole is located, the air is let out through the valve so that the tube can be cemented and patched. A simpler way than removing the inside of the valve or depressing it, is to insert a cotter pin into the puncture. The ends of the cotter pin are spread apart to distend the sides of the hole, and it is then an easy matter to force the air through the enlarged opening. Also, the application of a little patching cement to the inside edges of the hole makes a better job, and with the cotter pin holding the hole open, this is easy to do.

A Simple Rear Signal

The "stop" signal illustrated is designed to be attached to the left rear fender of the car. It is connected to the service-

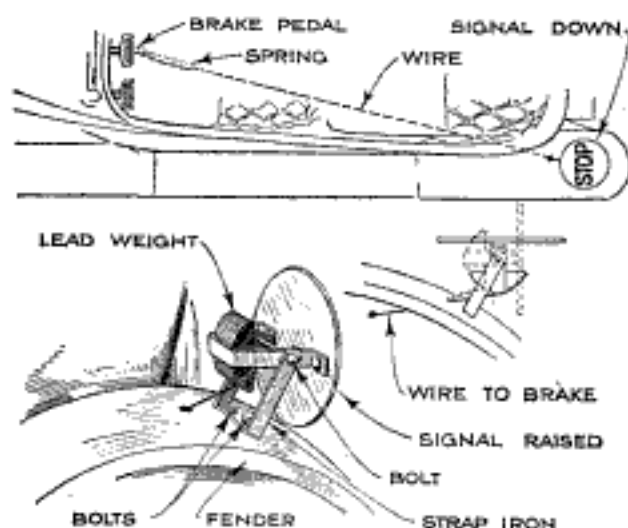

An Automatically Operated Warning to the Car Behind That the Driver Intends to Stop or Slow Down is Operated by Pressure on the Service-Brake Pedal. Normally the Warning "Stop" is Not Displayed

brake pedal so that the slightest forward movement of the pedal will swing the circular target to a perpendicular position and display its warning. The sheet-metal disk is provided with a weight, which is attached to it by a bracket, as indicated in the drawing. Another bracket is bolted to the fender to support the weighted disk. Normally, the weight will keep the disk in a horizontal position, and operation of the brake pedal is required to make the device show its warning; this is accomplished by means of a wire, running from the weight to the brake pedal. To compensate for wear of the brake bands, which allows the pedal to move forward a greater distance, a coil spring is attached, as indicated. A signal of this character is of special value to truck drivers, where the rear view is obstructed by the body.

Electric Iron Used as Vulcanizer

Tube vulcanizing is expensive, and often a new tube is discarded because of a single blowout that is too large to be covered with a cold patch. To be sure, there are various types of vulcanizers that are to be had for a small sum, but as a rule they are mussy and inefficient, often ruining the tube beyond repair, and with small gasoline vulcanizers, there is the added danger of fire.

A safe and reliable vulcanizer that covers a large area can be made by removing the handle from an electric flatiron and

using it as the heating unit. Inner tubes can then be vulcanized anywhere that current is available. A repair can be made very close to the valve without removing it, and any size of hole can be mended by making one or more settings of the iron. It is advisable to try out the vulcanizer on an old tube first. In making a repair, always powder the patch with soapstone, or French talc, and lay a piece of paper over it before applying the vulcanizer. This will prevent the hot iron from sticking to the tube.

A short piece of iron, with holes bored in one end, screwed on in place of the handle, will make the removal of the hot iron an easy matter. In use, the electric-iron vulcanizer is clamped to the tube with one or more ordinary C-clamps.—Glen F. Stilwell, Collinsville, Ill.

A Homemade Exercising Machine

Old inner tubes, and some stiff wire or iron rod, together with three large spools, are the materials used for making a home

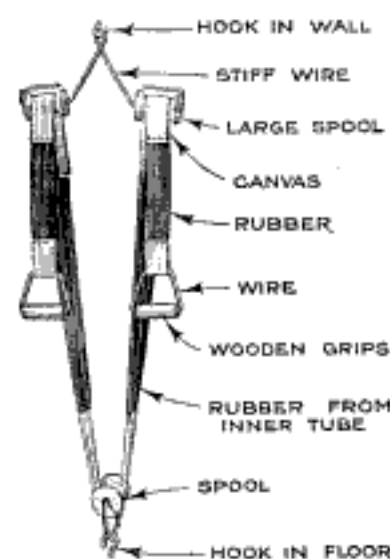

exerciser at insignificant expense.

The rubber is cut into strips, 2 in. wide and of the length desired, two or more of the strips being cemented to each other, as may be desirable. Where the bands pass over the spools, canvas is used instead of rubber, on account of the wear. The pieces of canvas are sewed along the edges and turned inside out to make a flat tube the same width as the rubber bands. The ends of the rubber strips are covered with rubber cement on both sides, inserted into the canvas, and weighted down until thoroughly dry. The arrangement of strips, spools, and hooks is clearly shown in the drawing.

Any discoloring matter in water will stain a water gauge glass and make it difficult to see the water level. When it becomes necessary to clean the glass use hydrochloric or muriatic acid.

Making Snow Building Blocks

Forts, Eskimo igloos, and other buildings can be made quite elaborate architectural accomplishments if constructed of snow building blocks. The snow is compressed in a simple rectangular wooden mold, which produces a block about the same size as the standard concrete block, or 8 by 8 by 16 in., although any other size or shape may be produced by altering the mold. The mold is placed on a flat surface, filled with snow that is tamped down hard, and the snow struck off level with the mold top. After the snow has been sufficiently compacted, the mold is removed, and the block is set aside until a sufficient number have been made to complete a fort or other structure. In building, the blocks are held to-

gether by a "mortar" of wet snow or slush, which, when frozen, unites the building into one solid mass. The trowel used for spreading the mortar can be

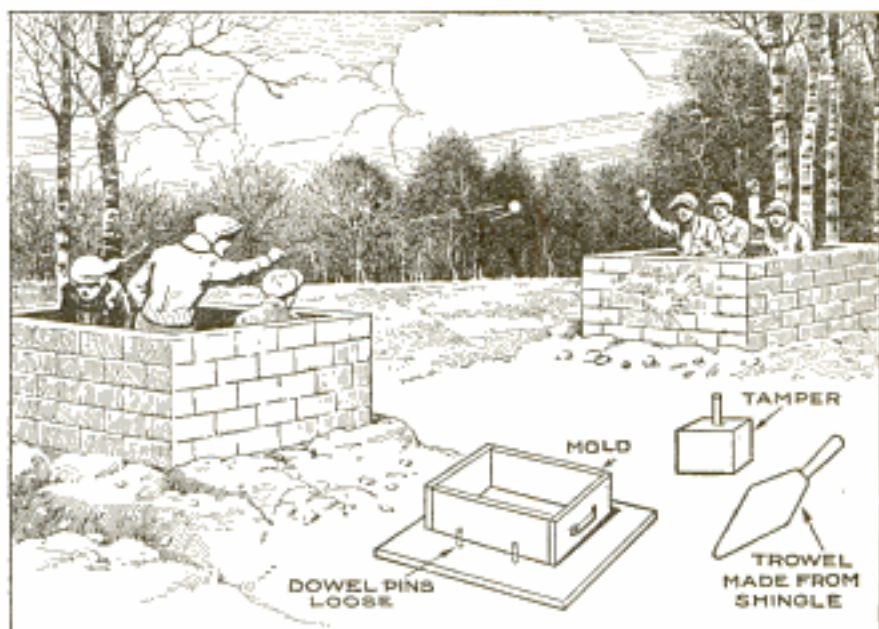

Forts Erected with Building Blocks Made of Snow: The Blocks are Molded in a Wooden Form and Then Laid in a Mortar of Wet Snow, Which, When Frozen, Unites the Building into One Solid Mass

made from a shingle or piece of board.—John L. Dougheny, Toledo, Ohio.

Comfortable Ridgepole Seat

The drawing illustrates a device that can be used to equal advantage by carpenters and others doing work on the ridge of a roof. The seat is made from a board 2 ft. long, which is supported in a horizontal position by braces at each side. Naturally, the length of the perpendicular supports will vary more or less to correspond to the pitch of the roof. A seat of this type can be moved forward or backward while the worker is sitting on it, and the fatigue caused by assuming uncomfortable positions is thus obviated. Such a seat is also a safety device for the worker, that will materially reduce the possibility of accident either to himself, or to those below from falling tools.—Augustus C. Hausman, New Haven, Conn.

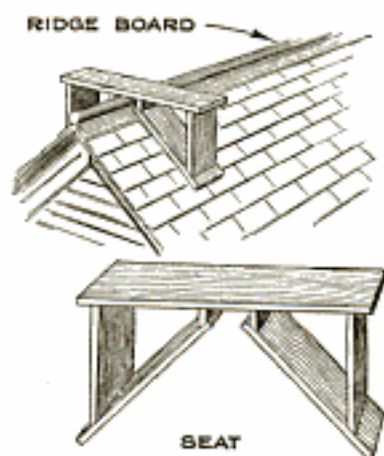

Making Alkaline Water Drinkable

Settlers in parts where the water is alkaline find it difficult to get water that is fit to drink, as it must be distilled or otherwise purified. The illustration shows an easily made condenser that is often used for this purpose, consisting of nothing more complicated than a length of iron pipe provided with a tee in the center, and passing through the roof of the house. The spout of a teakettle is connected to the tee by a short length of hose. When the water in the kettle boils the steam will issue into the iron pipe where it will condense into drops on the inside, the distilled water dripping into a pan.

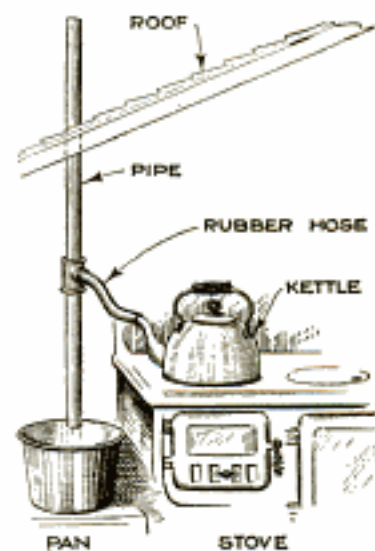

A Footrail for the Radiator

A quickly detachable footrail that can be used on any type of radiator, can be made from a piece of $\frac{1}{2}$ -in. pipe or iron

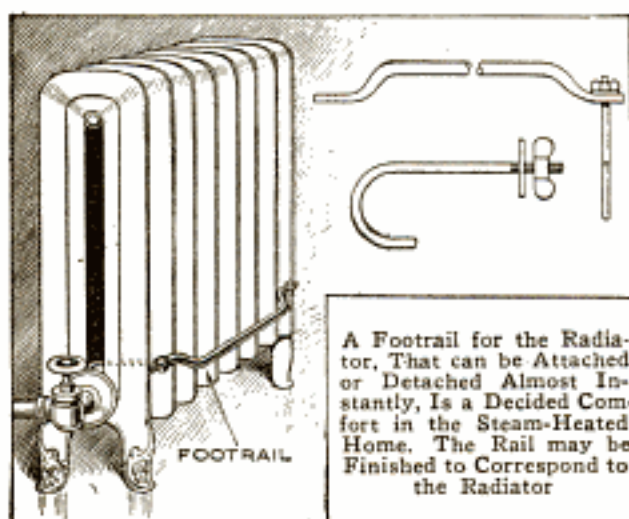

A Footrail for the Radiator, That can be Attached or Detached Almost Instantly, Is a Decided Comfort in the Steam-Heated Home. The Rail may be Finished to Correspond to the Radiator

rod, although the former will probably be found to be stiffer. A piece of pipe of suitable length is bent to the form shown, and the ends are flattened and drilled to take the threaded ends of hooks made of iron rod. These hooks, or clamps, are hooked over the inner part of the radiator between the sections. The threaded ends are inserted in the holes provided in the ends of the rail, which is held rigid by the application of washers and wingnuts.—B. Francis Dashiell, Dunkirk, Md.

Practical Bookmarkers

A bookmarker that is free from the many objections of most types and that slips over a corner of the page is very simply made. Cut a square of rather thin

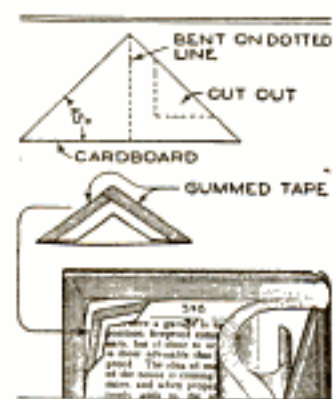

cardboard, about 2 in. on a side; cut along one diagonal, and place the resulting two triangles together. Now cut two 2-in. pieces of gummed tape and use them to fasten the short edges of the paper triangles together. Finally, cut a small notch in the middle of the long edge of one of the triangles and fit the completed bookmarker over the corner of a stiff card, to clear out any paste or gum that might remain between the two triangles.

To use this bookmark attach it over the corner of the left-hand page of the book on the upper side of the leaf. Do not try to catch more than one leaf in the bookmark, for it will then be sure to come loose when the book is opened. It is a good idea to see that the notched side of the marker always indicates the side where the "place" in the book is.—Curtis Ralston, Springfield, Ohio.

Transferring Printed Pictures

This method may be used for transferring the pictures printed in papers and magazines to paper and fabric for various purposes.

Dissolve a bar of common soap in 1 gal. of hot water and add $\frac{1}{2}$ pt. of turpentine. Allow the mixture to stand overnight, stir well, and bottle, after which it is ready for use.

The solution is applied to the face of the picture it is desired to transfer, with a brush or tuft of cotton. A piece of clean cloth or paper is laid over the picture and firmly rubbed with the bowl of a teaspoon, or a similar smooth article.

The Eccentric Spool

A very simple toy will interest the young folks because of its eccentric

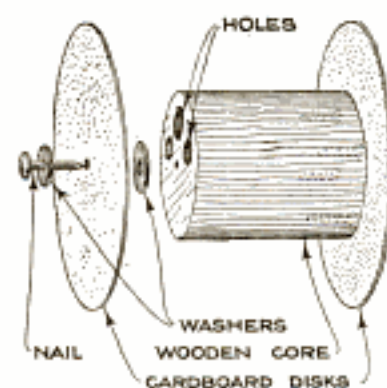

conduct and movements when rolled, and because of the unusual principle involved. All that is required is two heavy cardboard disks, and a section of curtain pole about $1\frac{3}{8}$ in. in diameter. One disk is permanently tacked to the end of the wooden core, while the other is attached so as to revolve freely. Three holes, one $\frac{1}{2}$ in. in diameter and two $\frac{1}{4}$ in. in diameter, are drilled all the way through the wood parallel to the center. A washer is provided on each side of the revolving disk to prevent it from binding; this and the holes drilled through the crosspiece are responsible for the unexpected spins and turns that the spool automatically performs when rolled. A very slight push makes it do this; a hard one will send it rolling in a straight line.



EVERY snowflake has an infinity of beauty which is enhanced by the knowledge that the investigator will, in all probability, never find another exactly like it. Consequently, photographing these transient forms of Nature gives to the worker something of the spirit of a discoverer. Besides combining her greatest skill and artistry in the production of snowflakes, Nature generously fashions the most beautiful specimens on a very thin plane so that they are specially adapted for photomicrographical study.

The photographing of snowflakes, although quite delicate work, can hardly be called difficult, although some hardships attend it, because the work must all be done in a temperature below freezing, and under conditions of much physical exposure. The temperature at which photography is possible depends somewhat upon the thickness of the crystals; this varies greatly from time to time, and depends upon whether the temperature is rising from an intense degree of cold or falling from a point above freezing. If rising after a cold snap, photographing can often be continued until actual thawing commences.

Of course, location is everything in this work, and no one except those living in arctic climates or in regions having long and severe winters, can accomplish very much. Generally speaking, the western quadrants of widespread storms or blizzards furnish the most beautiful and perfect forms. At such times the wind is usually westerly or northerly, with the

barometer standing at 29.6 to 29.9 in. and slowly rising. The percentage of perfect crystals is likely to be larger when the snowfall is not too thick and heavy, with the crystals medium to small in size rather than large. The character of the snowfall often undergoes quite abrupt changes as a storm progresses.

The apparatus required for snowflake photography consists of a compound microscope, fitted with a joint that permits the instrument to be turned down horizontally, at right angles to its base,

so that it can be coupled to a camera bellows by means of a light-tight connection. The microscope objectives are used alone, without the eyepiece. It is best to have several different objectives; $\frac{1}{2}$, $\frac{3}{4}$, and 3-in. combinations, which give magnifications of from 8 to 60 diameters (64 to 3,600 times), will serve well.

Ordinary daylight, coming through a window, is used for illuminating the crystal after it has been placed on a microscope slide, a tiny beam of light entering through the small aperture in the substage of the instrument. The apparatus is placed indoors, near by and facing a window. The room, the apparatus, and its accessories should always be away from any source of artificial heat, and at a temperature approximately that of the outside air. The necessary accessories are an observation microscope, a pair of thick mittens, microscope slides, a sharp-pointed wooden splint, a feather, and a turkey wing or similar duster; also, an extra focusing back for the camera, con-



A Variety of Strange Forms of Snow Crystals: The Specimens near the Center Are of the Most Interest on Account of Their Rarity

taining clear glass instead of the usual ground glass, with a magnifying lens attached; this is used for final focusing. A blackboard, about 1 ft. square, with stiff wire or metal handles at the ends, so that the hands will not touch and warm it, is used to collect the specimens. As it is necessary to cover the end of the microscope objective with a strip of black card, that takes the place of the usual

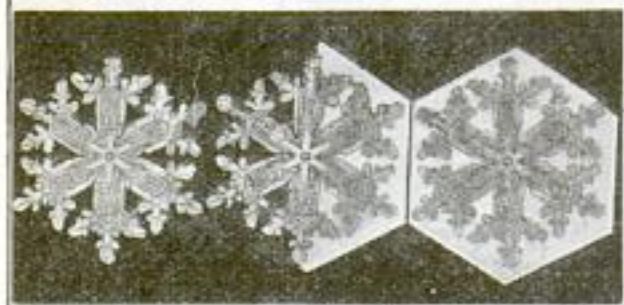

Blocking Out the Snow-Crystal Images on the Photographic Negative: Right, Original Negative; Center, Negative Partly Blocked Out; Left, Completely Blocked-Out Negative

camera shutter which controls the duration of exposure, it is necessary to fit two vertical rods at each side of the microscope tube to hold the card.

The snowflakes are caught on the blackboard as they fall, and examined by the naked eye or with the assistance of a hand magnifying glass. The feather duster is used to brush the board clean every few seconds, until two or more promising specimens alight upon it, when it is immediately removed indoors. From this point onward the photographer must work fast. The promising specimens are placed for a moment's observation under the observation microscope. The removal of the snowflake from the board to the microscope slide is accomplished with the sharp-pointed splint, which is pressed gently against the face of the crystal until

the latter adheres to it, so that it can be picked up and placed on the glass slide. Usually several crystals are placed together on a single slide, a momentary glance being given to each, and care taken while doing this not to breathe on the crystals. The utmost haste must be used, for a snow crystal is often exceedingly tiny, and frequently not thicker than heavy paper. Furthermore, once these bits of pure beauty are isolated, evaporation (not melting) soon wears them away, so that, even in zero weather, they last but a very few minutes. When a desirable specimen is obtained, it is pressed flat against the glass with the edge of the feather and the slide inserted in the stage of the microscope on the camera stand, centered, roughly focused with the camera ground glass, then sharply focused with the clear-glass screen and magnifier, focusing on some tiny air tube near the center of the crystal. The plate holder is then inserted into the camera, the objective covered with the black card and the slide removed from the plate holder. The objective is then uncovered, and when the exposure, which may vary from 8 seconds to 100 or more, is deemed sufficient, the operation is reversed. Naturally enough, no rule for the length of exposure can be given, except that the greater the magnification, the longer the exposure should be.

The frail, feathery flakes are the most difficult to photograph, and it is always best to place five or six other crystals around the specimen, as this greatly retards the evaporation of the central one.

When working from the rear of the camera, and the bellows extension is such as to make it impossible to reach the focusing screw on the microscope, an arrangement similar to that shown in the page illustration can be used. This consists of a cord that runs over a wheel on each side of the camera and around the focusing screw. No lens is required in the camera, the microscope furnishing the optical equipment for projecting the images onto the sensitized plates.

Having recorded the fleeting substance of the snowflakes on the photographic negative and brought out the image by development, the photographer discovers that the body of the snow crystal is so transparent, that it does not contrast enough with its background to make a print in which the form will stand out in relief. There is no purely photographic method for producing the white images against a dark background, and yet it is necessary to do so if the images are to be

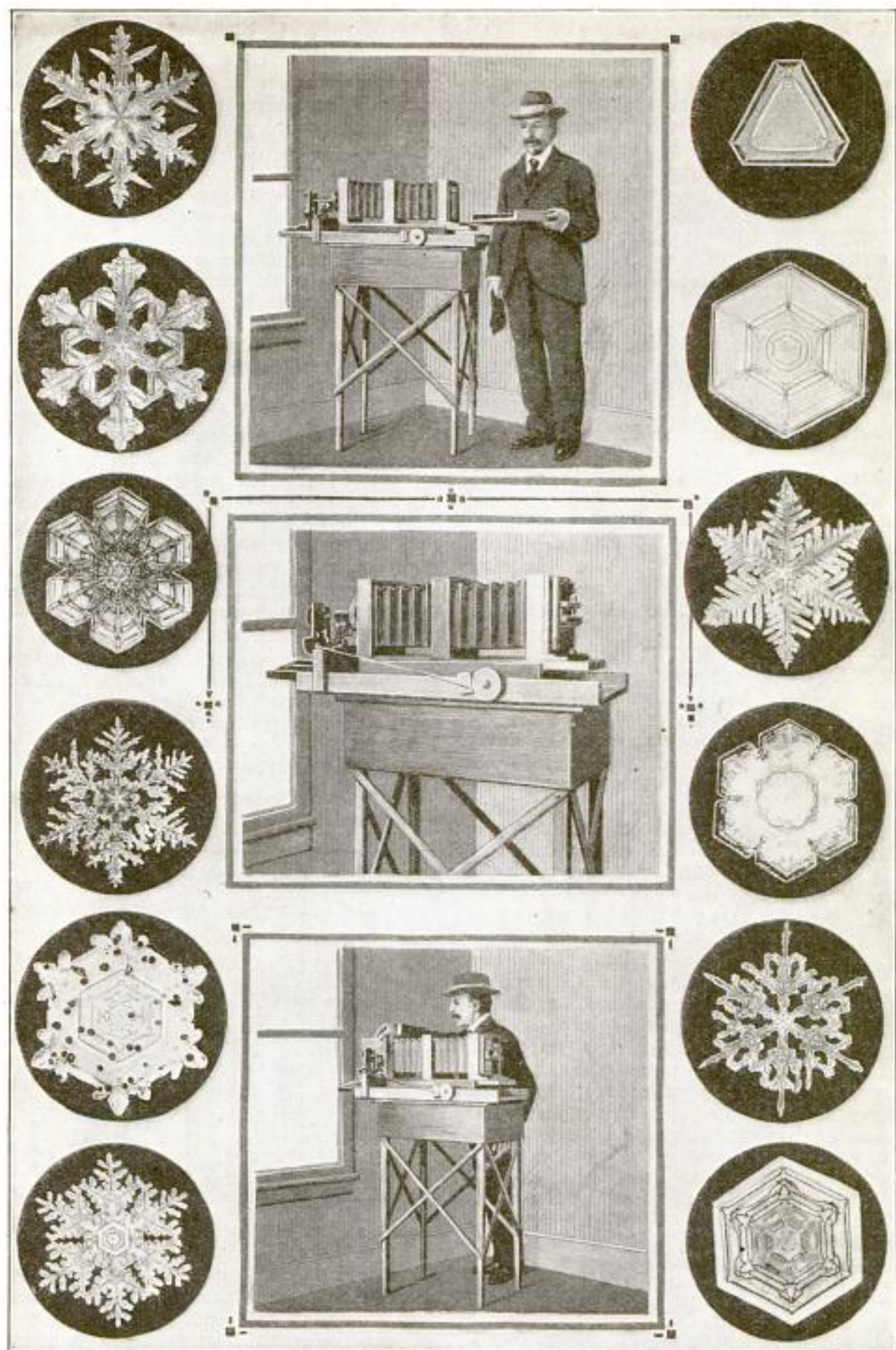

The Apparatus Used for Photographing Snowflakes and Some of the Specimens Selected. Above: The Author Holding the Tray on Which the Snowflakes are Collected. Center: A Cord That Passes over the Microscope Focusing Screw and Wheels at Each Side of the Camera Makes Sharp Focusing Possible. Below: Inserting the Transparent-Glass Microscope Slide, on the Surface of Which Is One or More Snowflakes, into the Microscope Stage, Preparatory to Photographing

appreciated by most people, whose ideal of snow is that of immaculate whiteness. The only effective method of accomplishing this result is what is known among photographers as "blocking out."

The negative is supported on an ordinary retoucher's desk, which may be merely a piece of glass, arranged to hold the negative so that the image is illuminated by transmitted light. Then, with an etching knife or other fine, sharp-pointed tool, the operator proceeds to scrape away the emulsion around the outline of the crystal to leave it standing

alone against a background of clear glass. This requires considerable patience, and often considerable time as well. In order to avoid irreparably spoiling the original negative, it is best not to alter it in any way, but to make a copy negative on which the actual blocking out is done. After the negative has been thus prepared, prints or lantern slides are made in the usual manner. Blocking out the negatives is done indoors, instead of outdoors as shown by the photograph, which was thus taken to get sufficient light to allow the exposure to be made.

Alarm Clock Turns on Electric Lights

The use of artificial light in poultry houses has become quite popular, as, by increasing the number of hours of light,



the hens have more time for feeding, and lay more eggs.

Where electric lights are used in the morning, say from 4:00 a. m. until daylight, the alarm-clock time switch illustrated will be found very useful.

A piece of light, flexible chain, passing over a small pulley, has one end fastened to the handle of the light-controlling knife switch, while a weight is attached to the opposite end. A nail is run through a link of the chain, about

level with the alarm-wind key of the clock. One end of this nail is supported on a small block immediately behind the clock and the other rests on the alarm key of the clock, after it has been wound. This arrangement holds the chain and weight, and provides for enough slack chain to leave the switch open. When the alarm goes off at the time set, the alarm key turns and allows the nail to slide off; the weight drops down and closes the switch.

Cleaning Plowshares

To keep plowshares and moldboards, as well as cultivator shovels, from rusting during the time they are laid up, it is best to give them a liberal coating of some thick grease. If the grease hardens on

the surface so that its removal is difficult when the implement is to be used, a small amount of gasoline or kerosene may be poured over the share, and ignited just before the plow is to be used. The heat, together with the solvent action of the gasoline, will soften the grease, and if the plow is started in the ground while the grease is still warm, the coating will peel off easily and completely. A handful of dry hay or grass ignited under the plowshare will answer in the absence of gasoline. Either of these methods is better than scraping the grease off.

A Simple Farm Hoist

A simple hoist that will find many uses about the farm, for raising bags of grain and other bulky weights to the upper floor of a barn or other building, is shown in the drawing.

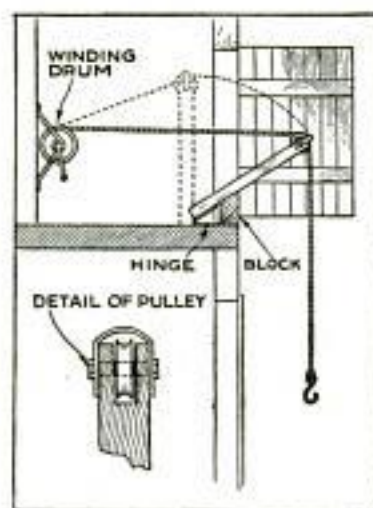

A wooden beam, of suitable thickness and length, is hinged to the floor at a convenient point inside the door or other opening. The upper end of the

beam is provided with a single-sheave pulley, over which the rope passes to the winding drum; this can be easily improvised. A wooden block can be made and inserted underneath the projecting beam so that the arm is held in an inclined position, as shown. The packages are raised clear of the building and, when they reach the pulley, swing inward as the arm rises to a vertical position.

Increasing Tone of Phonograph

"Extra-loud" phonograph needles are furnished that have a comparatively blunt point so that none of the amplitude of the vibrations is lost as in the long and tapering "soft-tone" needles. When it is desired to obtain a still greater volume of sound, these extra-loud needles can be shortened by breaking off about one-third of the needle at the blunt end. This is done by holding the needle in two pairs of pliers and bending it. The needles are hardened and will break easily. The shortened needle is secured in the reproducer and permitted to protrude just enough to allow the other parts of the reproducer to clear the record. The greatest possible volume of sound is then obtained from the records for playing dance music or piano records.—Chas. I Reid, Millersburg, Pa.

Cheap Soot Removers

To clean out stovepipes and furnace flues of an accumulation of soot without trouble or muss, is entirely possible by the use of common materials. Metallic zinc is one of these soot-removing agents, and it can be used in any form, such as old tops from fruit jars, old washboard coverings, dry-cell cases, and the like. In the case of the last-named, a particularly pleasing effect is obtained when an old dry cell is dropped into the flames of an open fire, which produces a delightful play of colored light. A handful or two of salt thrown into the furnace is also good for removing accumulations of soot.—Cora Hamilton, Binghamton, N. Y.

Scraper for Dinner Plates

A little convenience for the kitchen that will save a considerable amount of labor

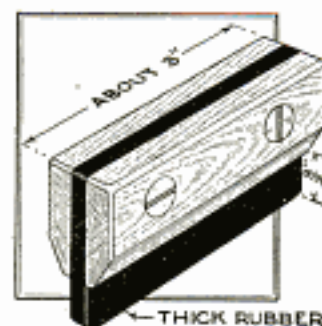

is the easily made scraper shown in the drawing. A sheet of thick rubber is clamped between two hardwood blocks of the proper dimensions with ordinary screws. One or two passes of such a scraper over a dish cleans off practically all grease and other remains much more quickly and effectively than is possible by the use of a knife or similar implement.

Sled Runners for the Baby Carriage

Four pipe tees, and suitable lengths of pipe, bent upward at the ends, are the only materials required for a set of de-

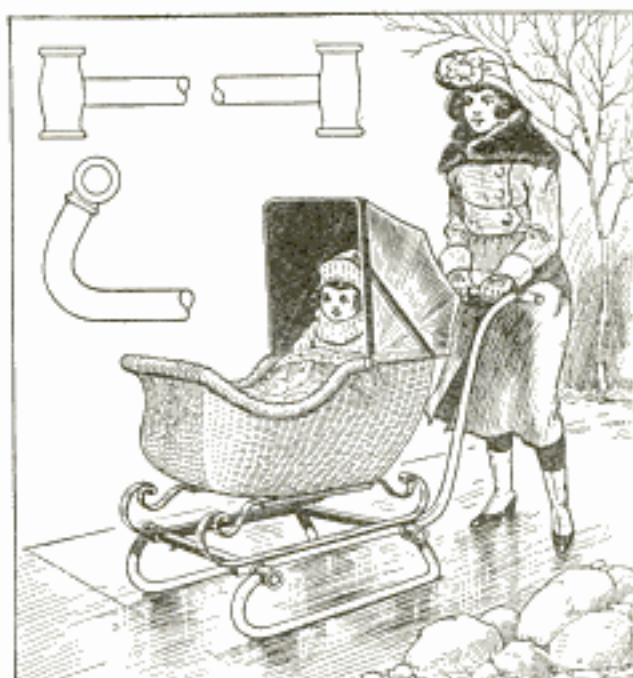

A Pair of Gas-Pipe Runners for the Baby Carriage Makes It Almost Instantly Convertible into a Sleigh for Snowy Weather. It Is Only Necessary to Remove the Wheels and Slip the Runners over the Axles

tachable runners by means of which the baby carriage can be converted into a sleigh in a few minutes.

To attach or detach the runners, it is only necessary to remove the nuts and washers that hold the wheels, slip on the runners and replace the nuts, although in some cases it is possible that larger washers will be needed on each side of the tee, to hold the runners rigid when the nut is turned down. If some form of catch is employed instead of nuts to hold the wheels, it may be necessary to cut a groove in the inner ends of the tees to take the catch. This is easily done, however, and will not worry the amateur mechanic. The size of the tees used, and, therefore, the pipe size, will be determined by the diameter of the axles.—Clare B. Smith, Chicago, Ill.

Stiff Collars Made into Soft Ones

Most stiff linen collars are discarded at the slightest sign of wear, although in this condition they can be made to give weeks of extra use by converting them into soft collars. This is done by boiling out all the starch, making neat repairs where needed, with silk thread, and laundering in the usual manner for unstarched work.—S. S. Sutherland, Detroit, Mich.

Step-Saving Water-Heater Control

The water-heater regulator illustrated is one that has resulted in saving many steps between the first floor and basement

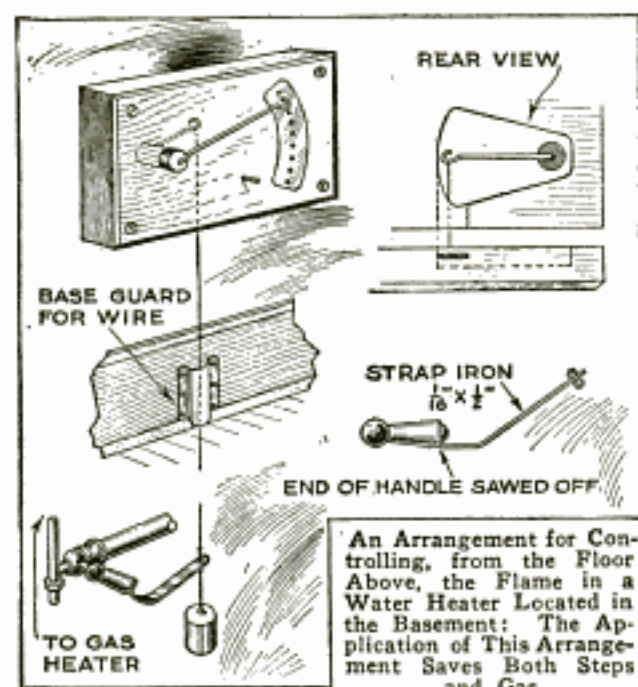

of a residence, and that has also effected a saving in the amount of gas consumed. The construction of the regulator is simple, and involves nothing that cannot be made by the home mechanic. An extension is attached to the gas-cock handle, as indicated, and this is connected by a wire to the controlling arrangement on the upper floor. The controller consists of a U-shaped wire lever mounted on a wooden block attached to the wall. One end of the lever is bent at right angles, and its position is adjusted and maintained by inserting this projection into holes drilled in a metal plate and into the block. A weight is attached to the underside of the valve-handle extension, so that should the wire break, or the lever become loose, the gas will be turned off automatically.—Donald W. Clark, Buffalo, N. Y.

A Hint for the Auto Painting Job

When the automobile is given a coat of paint at home, the most important thing is to keep dust from settling on the paint before it has dried. The old finish should be sandpapered and carefully wiped off, to make the surface as smooth as possible and remove all dust and dirt. Before applying the paint, tack paper over all cracks and crevices in the garage that might let in dust from the outside;

then, if an especially dust-free job is desired, make a frame of light lath, big enough to stand on the floor and cover the car and at the same time leave room to work. Cover this frame with thin paper—light will come through the paper but dust will not. Save a new brush and an unopened can of varnish for the finishing coat on the body and fenders, and when the painting job is completed, do the finishing work under the covered frame.—J. Paul Suter, Youngstown, Ohio.

Removing Wire Wheels

Owing to a puncture, it was found necessary to remove one of the wire wheels on a new automobile that had been driven only a few hundred miles. The nuts on the wheels had been set up very tight, and it was found impossible to unscrew them by simply pulling on the spanner wrench, with the wheel jacked up. The nut was finally unscrewed by the following method:

The jack was removed and the spanner set on the nut so that its handle was horizontal; then the jack was set under the end of the handle. By "pumping" on the jack, the end of the handle was raised slowly, while the wheel revolved, slipping over the road surface. By proceeding in this manner, the nut was loosened sufficiently to enable it to be entirely unscrewed without difficulty by turning the spanner by hand.

An Easily Made Sewing Stand

The sewing stand shown in the drawing is the outcome of a woman's inability to obtain an article suitable to

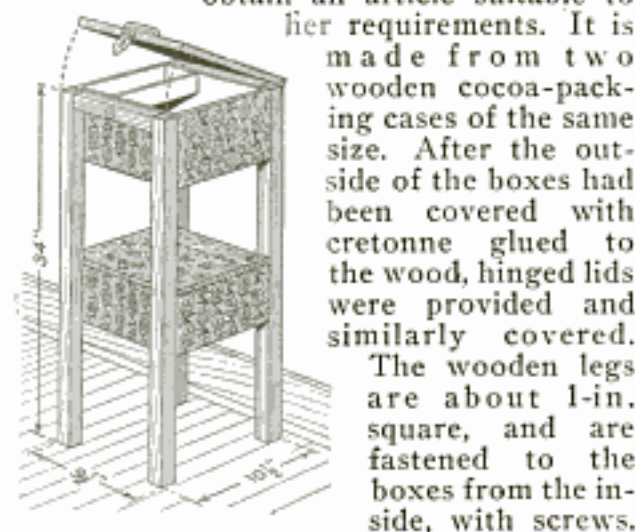

her requirements. It is made from two wooden cocoa-packing cases of the same size. After the outside of the boxes had been covered with cretonne glued to the wood, hinged lids were provided and similarly covered. The wooden legs are about 1-in. square, and are fastened to the boxes from the inside, with screws. The top section is provided with a neat brass hasp so that it can be locked.—T. H. Lynn, Hyattsville, Maryland.

Cleaning Ceilings

To clean smoke, dirt, grease, fly specks, etc., from a painted ceiling or wall, make a mixture of vinegar, baking soda, and a little table salt, and rub the grimed surface with it. Follow by washing off with warm water and soap, and wipe dry, using a soft rag. This method is also good for enameled baths, glass, and white porcelain.

Test for Water in Gasoline

Water will "lick" molasses off a stick, gasoline will not; and water, being heavier than gasoline, sinks to the bottom of a tank. On these principles a simple test for water in gasoline has been evolved by a state inspector. A stick is coated with molasses and plunged into a gasoline tank. If there is water present it will show up as a bare section on the gauge when withdrawn, the length of the bare wood indicating the depth of water. —Hjalmer Lindquist, Minneapolis, Minn.

Softening Tone of Phonograph

The attachment shown in the drawing is cut from a piece of thick sheet rubber,

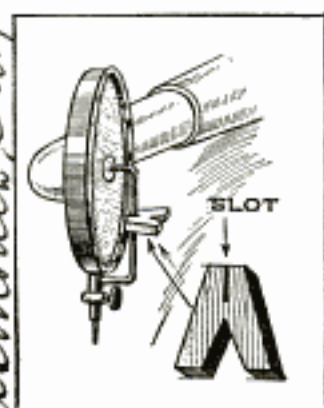

leather, or similar flexible material, in the form shown, and fitted over the needle bar of the phonograph reproducer to subdue the tone of the instrument. In applying or removing the "mute," for such it properly can be called, the ends are pressed together

by the fingers; this expands the slot in the opposite side and makes its application or removal very simple.

Laundry Siphon Made from Grease Gun

A washing machine or boiler can be filled or emptied easily and without dipping the water by means of the novel siphon shown in the drawing. An ordinary grease gun was obtained and elbow and hose connections were brazed to the side of the cylinder. The siphon is screwed to the laundry-tub faucet, and, with the piston in the position shown in Fig. 1, the water flows through the nozzle at the bottom and may be con-

ducted into any receptacle, or used, with the hose removed, for filling the stationary tub. With the piston in the position indicated in Fig. 2, the water flows

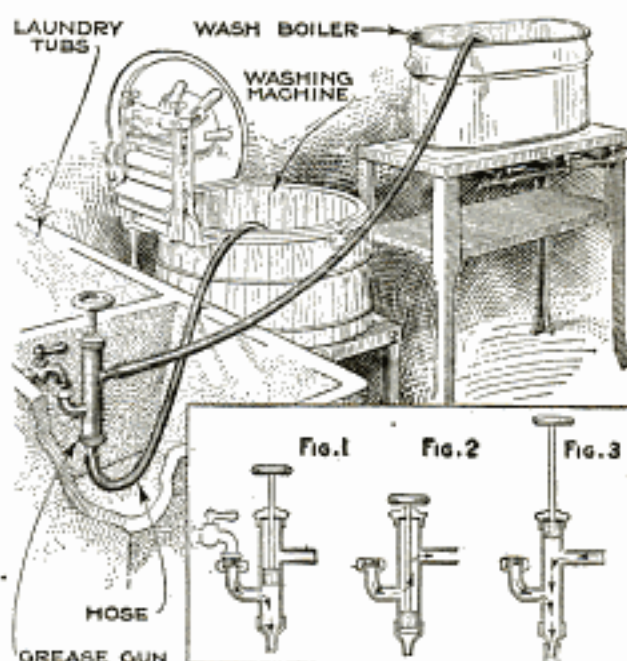

By Brazing a Hose Connection and Nipple to the Cylinder of an Ordinary Grease Gun, a Laundry Accessory is Produced That will Drain or Fill the Washing Machine, Boiler, or Other Vessels

through the upper tube. To drain the washing machine or boiler, it is only necessary to raise the piston to the position shown in Fig. 3 and turn on the water, which will suck the dirty water out into the stationary tub. —J. G. Brown, Evanston, Ill.

The Magic Pill Box

The magic pill box makes coins disappear and return at will; the trick is very simple, and any pill box can be fixed for performing it in a few minutes.

Get a regulation round pill box, and cut a cardboard disk just large enough to fit into the bottom. Drop a coin in the box and put the lid on; then, turn it upside down and shake it, calling attention to the fact



that the coin is still there, by the rattling inside. Now, pull the box apart, holding the lid in the left hand, so that the cardboard disk covers the coin, which has vanished. Then, still holding the lid upside down, put them together again and reverse the operation, holding the bottom in the right hand; upon opening the box the coin will reappear.

Ent. Jap. & Noble, Canada
Portsmouth, N.H.

A Small-Lathe Countershaft

By J. V. ROMIG

INSTALLING a small bench lathe in the shop of the experimenter or model maker, has caused many an amateur me-

Both ends of the tee are dammed to prevent the melted metal from flowing out; this may be done by fitting a cardboard disk over the shaft, against the end of the tee, and holding it in place with putty, or with a metal collar screwed against the tee. The opposite end is similarly dammed. A lip-shaped opening must be provided at the highest point of the dam for pouring the metal. If properly made, such bearings will require but very little after-treatment to obtain a true-running bearing. The countershaft and its pipe standards are assembled, as shown in the drawing, with collars against the bearings to prevent end play.

For small lathes up to 6-in. swing, a 1/4-hp. electric motor is perhaps the

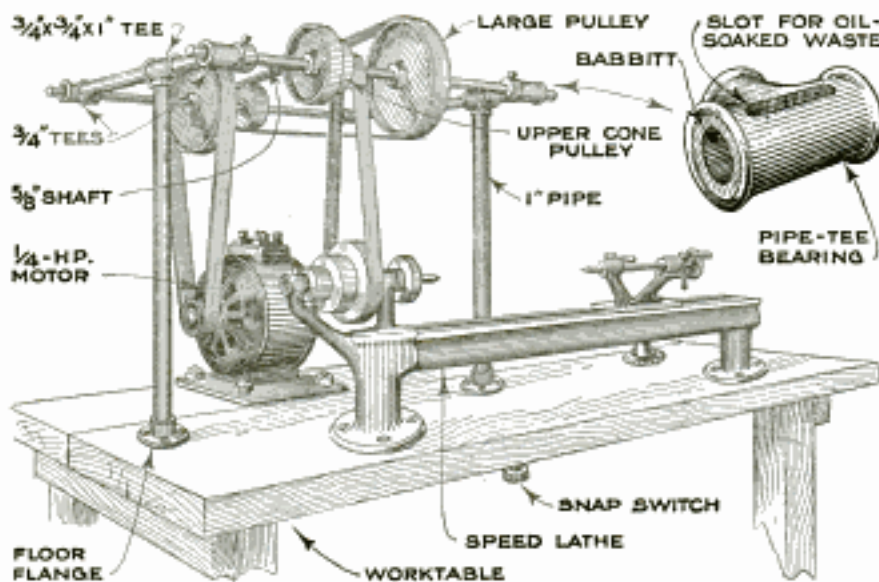

Setting Up a Small Bench Lathe in the Experimenter's Shop is Accomplished without the Use of an Overhead Countershaft. The Countershaft is Supported on an Easily Made Standard and Bearings Made of Iron Pipe and Fittings

chanic to lie awake nights figuring how to avoid overhead countershafts, with their attendant long belts, particularly when the lathe is to be operated by a small electric motor. A system that has been satisfactorily used for several such installations eliminates entirely the countershaft fastened to the ceiling, and substitutes for it an easily constructed and economical arrangement made of iron pipe, and secured to the bench as shown in the drawing.

Two lengths of 1-in. pipe of the proper length form standards for supporting the countershaft; one end of each is fitted with a floor flange, the other with a 3/4 by 3/4 by 1-in. tee. Pipe nipples of the proper length are screwed into the tees, and a 3/4-in. tee is screwed onto each end of the T-shaped assembly of pipe and fittings; these latter tees are lined with babbitt for shaft bearings.

Slots are cut in each of the bearing tees and plugged with pieces of wood, which must reach to the shaft before the babbitt metal is poured; the blocks are later removed, and the resulting slot is packed with oil-soaked waste.

In pouring the babbitt bearings, the shaft is inserted into the tees and blocked up so that it will be central. The shaft is wrapped with a single thickness of paper to prevent sticking after the metal cools.

most satisfactory source of power, and this is bolted to the bench, back of the headstock. A snap switch of suitable capacity can be mounted at a convenient location underneath the bench, for controlling the operation of the motor.

If it should be undesirable, for any reason, to have the countershaft mounted on the top of the bench, several modifications of this arrangement are possible, and will suggest themselves to the builder. The same idea can be carried out by inverting the arrangement and bolting it to the underside of the bench, or to the floor under the bench, cutting slots on each side of the headstock and bringing up the belts from underneath.

Aid for Feminine Motorists

When motoring in a brisk breeze, many women are bothered by the problem of preventing the skirts of light and thin dresses from blowing up. With both hands occupied it is impossible for the feminine driver to keep tucking her skirts under her.

A clever girl conceived the idea of taking an ordinary paper clip and fastening the front and back hems of her skirt together after she had seated herself in the car. Thus, her limbs are left free to manipulate the foot pedals and her hands

can be kept where they belong—on the steering wheel. The slight weight of the clip, added to the fact that the front of the skirt is fastened to the back part, which does not sag down so far in the car, helps to hold the skirt easily, and there is no sense of weight or restriction of movement.—Ethel Van Cise, San Diego, Calif.

Retarder for Bowling Balls

To prevent bowling balls from coming together too hard when they reach the end of the return ways, thereby shortening their life and making an unnecessary amount of noise, the proprietor of a set of alleys rigged up the retarder shown in the drawing.

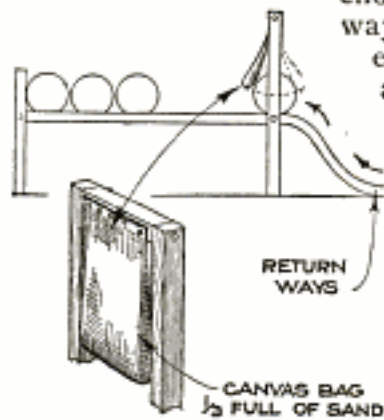

Two upright pieces, connected by a crosspiece, were fastened to the sides of the ways, and from the crosspiece a canvas bag, about a third filled with sand, was suspended in such a manner that the bottom was in line with the center of the ball. The velocity of the ball is reduced when passing underneath the bag to such an extent that it rolls into place easily and almost noiselessly.—Geo. A. Volz, Monroe, Mich.

Shade for a Trouble Lamp

To shade a trouble lamp that is protected from damage by a wire guard, a suitable piece of an old inner tube that has a hole cut in one side and pulled over the guard, as shown in the drawing, will serve very well. The hole can be cut to permit the passage of as

much light as desired without having it shining into the workman's eyes. Besides serving as a shade, the rubber is also an additional protection for the bulb.

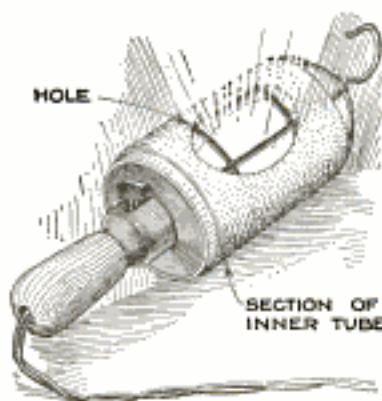

Broom Holder Made from Shoehorn

An iron ring, such as is commonly known as a harness ring, and an ordinary shoehorn can be converted into a very satisfactory holder for brooms, mops, and similar round-handled articles. As shown in the drawing, this particular form of holder is simplicity itself; the ring is slipped over the small end of the shoehorn, both ends of which are then fastened to the wall with screws. Roughening the inside of the ring will improve its grip on the handle of the broom.—M. H. Bolsinger, Johnstown, Pa.

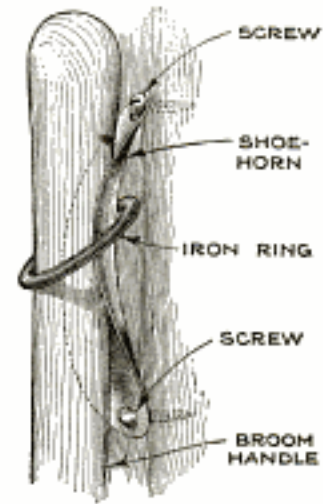

Locking the Radiator Cap

Radiator caps of automobiles that are fitted with thermometers for registering the temperature of the cooling system, and for giving warning of overheating, are expensive enough to attract the attention of the "doormat" type of thief. A simple protective measure consists in attaching a short length of light brass chain to the instrument and the radiator-filler tube, in such a way that the cap can be unscrewed for filling the radiator, but cannot be dropped or carried away. A brass clip is cut to the form shown and screwed underneath the nut that holds the thermometer to the radiator cap. One end of the chain is fastened to this clip, and the other is riveted to the neck of the radiator. While it is possible to cut the chain with a pair of wire-cutting pliers, the thief, finding the cap secured, will more than likely seek easier booty.

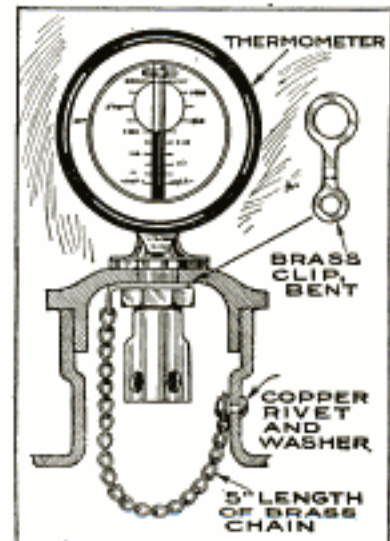

A Simple Stovepipe Cap

The chimneys of most summer kitchens are mere stovepipe extensions beyond the roof or walls of the building,

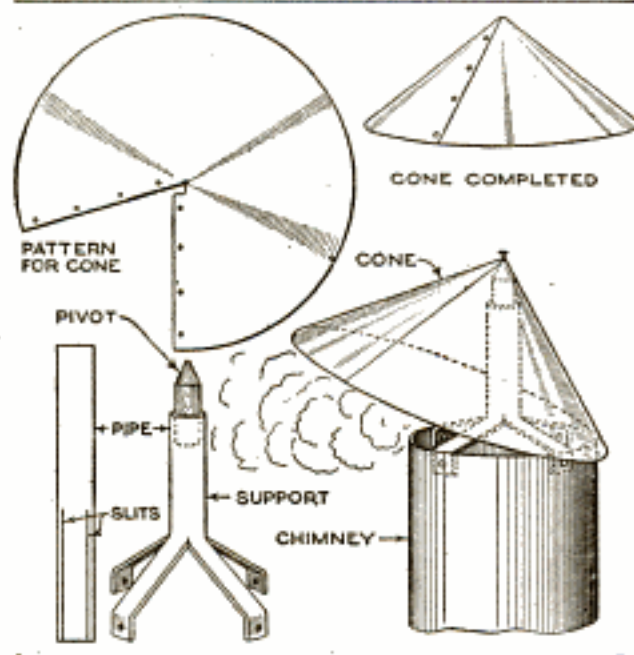

A Simple Cap for a Stovepipe Chimney That Not Only Increases the Draft and Prevents Water from Entering but Keeps the Stove from Smoking

and should be provided with rain caps, to prevent water from entering and causing them to rust rapidly. Stationary caps, while suitable for the purpose, cause the stove to smoke more or less in windy weather. Of course the location of the building in relation to surrounding structures has much to do with smoking chimneys and imperfect draft. However, the simple wind and rain deflector illustrated will insure against such annoyances.

A piece of 1-in. pipe, about 8 in. long, and a 12 by 12-in. sheet of heavy tin or galvanized iron, with a few stove bolts, or rivets, are the only materials required. The pipe is slit with a hacksaw to a depth of 4 in., as shown, and the four quarter sections thus made are bent at an angle to the remaining section, the bent part being heated to make the work easier and prevent breaking. The ends of the projections are turned down 1 in. from the end and drilled to take suitable bolts or rivets, as indicated. A wooden plug is driven tightly into the upper end of the pipe and tapered off as indicated. The standard thus made is bolted or riveted to the stovepipe.

The conical cap is cut from the piece of sheet metal provided, the edges being drawn together and riveted or soldered,

and the completed cone is placed on the pivot and held in place by a nail driven into the wooden plug.

The slightest wind will operate the cap, causing it to tilt against the windward side of the pipe, so that the draft is increased and back drafts prevented.

Identification Mark on Tires

An aluminum slip on which the name of the owner is stamped can be placed in the mold when a section is being vulcanized into a tire, and provides a means for permanently marking the tire with the name of the owner pressed into the rubber. Nameplates of the type in question are produced by slot machines more or less generally located in public places and amusement resorts, and cost only a few cents. If desired, the name of the repairman can be used.

When the tire is ready for vulcanizing, the nameplate is placed in the mold, face out, and then the tire. The nameplate can be used indefinitely, and the same idea can be applied to a number of different methods of marking and identifying tires.

Extension for Pull Chains

An inconveniently placed electric light can be quickly changed to be the most convenient in the whole house by using the idea illustrated, or some variation of it.

Two bell cranks, having 2½-in. arms, are fastened to the baseboard, and connected to each other and the pull chain of the lamp socket by means of a cord. Another cord is run up through a screweye on the door frame, and a washer tied to the end of the string to keep it from falling through. A small washer behind each of the bell cranks prevents them from binding against the wall.

Before this extension pull chain was installed, it was necessary to walk around the bed in order to operate the light, but with the extension, the light can be turned on from the doorway.

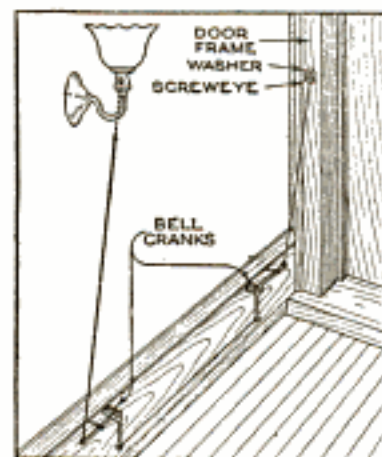

Muting a Banjo

In the rendition of some selections, or under circumstances where the loud tone of a banjo is more or less objectionable, the instrument can easily be muted to give a more subdued tone. All that is necessary is two five-cent pieces; these are interposed between the ends of the bridge and head of the instrument.

How to Build an Adjustable Bridging Condenser

An adjustable bridging condenser for wireless work, that will serve as well as the high-priced manufactured articles on the market, can be built easily and economically. It will work in the ground lead in C. W. transmission sets, but when used for this purpose, the mica should be of the best quality, and all units, when clamped together, should be tested out with 500 volts of direct current before installation. This condenser works nicely in receiving sets, and can be made in various capacities, which are cut into and out of the circuit by the fan switch.

The eight condenser units are made up of 2-in. squares of tinfoil, clamped between $2\frac{1}{2}$ -in. square mica sheets. Make one unit with five sheets of foil and the remaining seven with three sheets of foil each. The foil sheets are cut out with a tab at one edge which projects beyond the mica plates.

In assembling the first unit, a mica sheet is laid on the table, a tinfoil sheet placed on it with the tab projecting to the right, another mica sheet placed on top, and the next tinfoil sheet placed with the tab pointing to the left, and so on until the five sheets of foil and six sheets of mica are assembled. The remaining units are assembled in the same manner, the tabs of the alternate sheets being brought out at opposite sides.

After assembling each unit, bind it with electrician's tape, or bolt the whole number of units together between metal plates and impregnate with paraffin. The foil tabs are all brought together at the ends and a lead wire soldered to each, the whole being bridged at the back, as shown, and the leads brought out to contacts in the bakelite top of the cabinet; 16 points are used, eight of these are idle or dead taps, and merely serve to carry the switch blade smoothly. The switch blade is formed from sheet aluminum and screwed to the underside of the switch knob. If sheet aluminum is not to be had, use one of the fixed plates of an ordi-

nary variable condenser, and saw out the radial teeth, as shown. The five-sheet unit is connected to the first point, shown at the left in the wiring diagram.

The cabinet is made from $\frac{1}{4}$ -in. stock to the dimensions given, and the lead

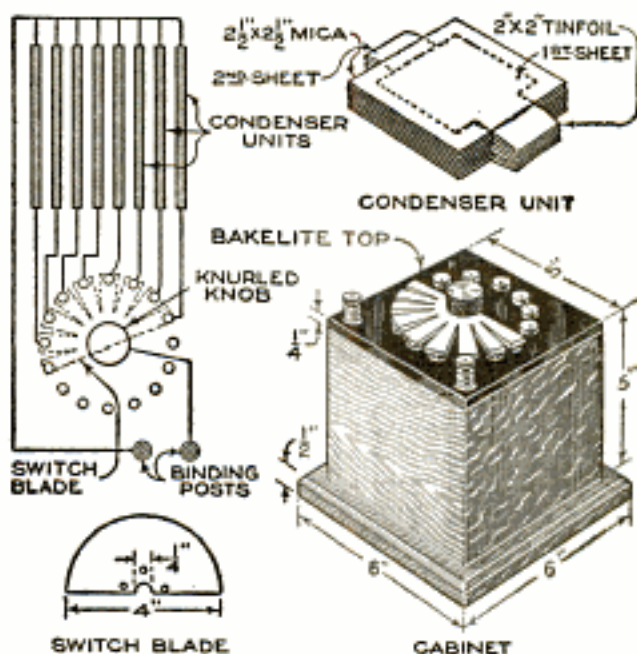

An Efficient Bridging Condenser That can Easily be Built at Low Cost and That will Work Well in the Ground Lead of Continuous-Wave Sets: It Works Nicely in Receiving Sets and can be Made in Various Capacities

wires are brought to binding posts in the top. The cabinet should be finished to correspond to the finish of the other instruments. This condenser can also be back-mounted on the panel, instead of making it into a separate unit, if so desired.—F. L. Brittin, Chicago, Ill.

Clamp for Bookbinding

In casting about for a clamp to hold a number of loose pamphlets that were to be bound together in the form of a book, a pair of lineman's wire connectors was found to be just the thing. The connectors

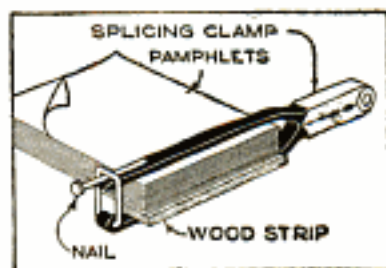

were a little wide between the handles for the thickness of the number of pamphlets, so a wooden strip was placed against one handle. The pamphlets were evenly placed and the other handle brought down and the clamp link sprung over the end. As the link did not hold the pamphlets together tightly, a nail was inserted, as shown, and the binding cloth applied.

Making Bearings for Model Machinery

By HOWARD GREENE

THE weak point of much model machinery is in the bearings, which are frequently made of pieces of sheet metal with holes drilled for the shafts. Brass channel-bar stock is much better for this work and is susceptible of a variety of treatment; it is much easier to work with than solid bar stock, as well as lighter and cheaper.

To make a plain bearing, as shown in Fig. 1, cut a piece of the channel to the length of the box, plus twice the height, or a little more, to allow for finishing up. Cut away the flanges at both ends for a distance equal to the height of the box, and bend the remaining strip at each end

If extra rigidity is needed, the bearing may have three feet, instead of two, by bending out the web instead of cutting it off. If desired, the hole for the shaft may be drilled through the babbitt filling, omitting the tube entirely. Another method of making a high bearing is to proceed as in Fig. 1, but the projecting parts of the web are made longer and run down the sides of a neat block of wood, or fiber, as shown in Fig. 3.

Quite an elaborate type of bearing is made as shown in Fig. 4. Two pieces of channel are cut and feet are formed as indicated; a single foot can be made from the web, if extreme rigidity is not an es-

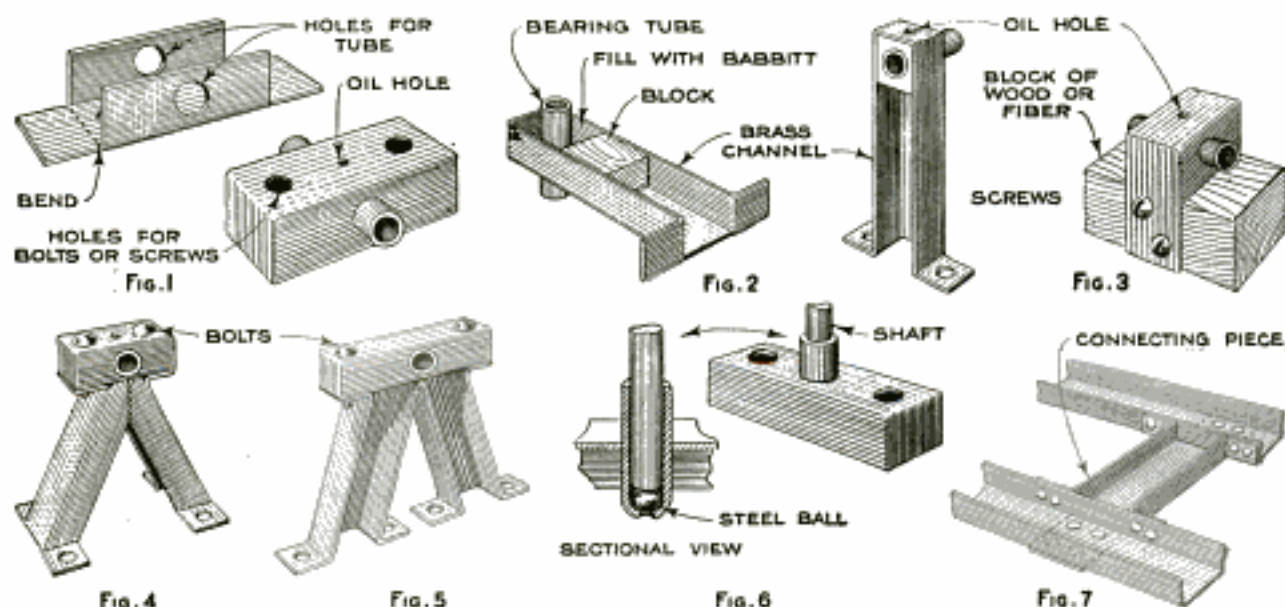

The Bearings in Model Machinery Are Frequently the Weak Points. Brass Channel Bar Is Extremely Useful for Making Bearings That Are a Distinct Addition to the Appearance, Rigidity, and Durability of the Model. Figure 7 Shows How Pieces of the Channel Bar are Riveted Together

over until the ends are closed. For the actual bearing, a piece of brass tube of the right size is forced into the holes through the flanges, as shown. Leave the tube somewhat longer than the width of the box to improve the appearance.

Figure 2 shows a high bearing. Cut away the central part of a piece of the channel, called the web, and bend the flanges outward to form feet, then drill them for the holding-down screws. At the desired height drill for a bearing tube and force the tube in. The top of the channel is to be closed by cutting away the flanges for the necessary distance and bending over the web; then insert a wooden block in the channel, a little below the tube, and fill the space between the top and block with melted lead, babbitt, or type metal. File off the end of the tube flush with the webs on either side.

essential. The bearing itself may be of the type shown in Fig. 1. A variation of this construction is shown in Fig. 5, and this, in many ways, makes a better job, as far as rigidity is concerned.

A thrust, or bottom, bearing for a vertical shaft is made as shown in Fig. 6. A piece of channel is prepared as for the bearing in Fig. 1, but is drilled for the tube through the web instead of through the flanges. Before inserting the tube, one end of it is partly closed by turning over the edge, to hold a steel ball as large as the tube will accommodate. Put the tube in the channel, with the ball end flush with the edges of the flanges, and fill in the channel with babbitt, or solder the tube in place. The end of the shaft should be made perfectly square. If a lathe is available, chuck the shaft, perfectly true, and form a rounded end to

bear against the ball, to secure the minimum of friction.

While channel stock is under discussion, it may be well to indicate a good way of attaching two pieces together. The connecting piece is split on the corners and the flanges are bent outward at

right angles, the web being left straight. The flanges and webs are riveted to the parts to be connected with small brass rivets as in Fig. 7. Incidentally, the small brass nails known to the hardware trade as "escutcheon pins" make excellent rivets for such light work.

Testing Height of Electrolyte

The electrolyte in storage batteries must be kept at a uniform height above the plates at all times for the most efficient operation; if the electrolyte is below a certain level, distilled water must be added to bring it up again. To determine when the cell is filled to the usual height of $\frac{1}{2}$ in. above the plates while the battery is in position, and where the light is poor, a piece of glass tubing, about 8 in. long, can be used. The tube is inserted into the cell until it presses against the plates and the first finger is placed over the upper end. Holding the finger over the end of the tube, the latter is withdrawn, and the level of the solution held in it will indicate the depth to which the electrolyte covers the plates.

A Convenient Bed Light

For the comfort of invalids, or those addicted to reading or writing in bed, the bed light shown in the drawing was devised. The actual installation is quite simple and consists in leading the electric-light wire through the tubular bedpost in the manner shown. A

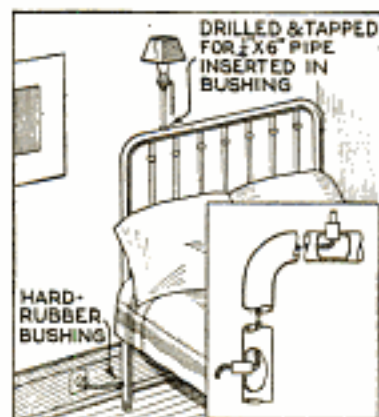

hole is drilled and tapped near the foot of one of the posts and fitted with an insulating bushing for the wire, which is passed through the post and out of a similar hole in the top of the bedstead. The latter hole is drilled and tapped for a bushing, into which a suitable length of $\frac{1}{4}$ -in. pipe is screwed to form a support for the lamp. The outer end of the pipe is threaded and an ordinary chain-pull light socket is attached and wired. A plug on the end of the wires to the lamp is screwed into a flush-plug receptacle.—Truman R. Hart, Ashtabula, Ohio.

Heater Made from Old Tank

The illustration shows how a discarded steel tank was put into service for heating a room on the second floor of a dwelling.

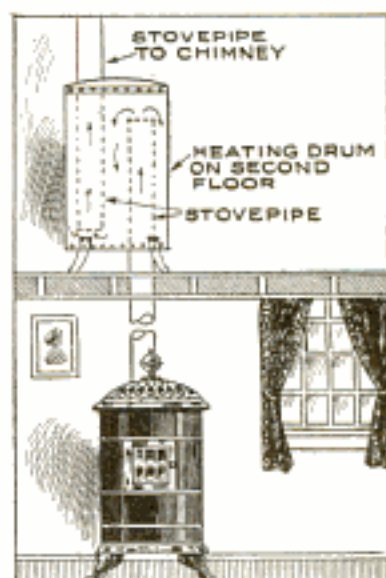

Four legs were riveted to the tank and a hole was cut into each end just large enough to admit a stovepipe. The bottom stovepipe conducted the heat and smoke into the tank from the stove below,

the pipe being inserted to within a few inches of the top. The smoke escaped through the second stovepipe which was inserted through the hole in the top of the tank, as indicated.

Pipe Coils in Hot-Air Furnaces

The installation of a few coils of pipe in heating furnaces, to provide hot water, is quite common, but many are finding that the running in of the pipe into the firepot at the side of the dome, or heated surface, and out again to the water heater is more or less dangerous unless a tee connection is made on the lower pipe as it leaves the furnace, and a faucet screwed into the outer end of the tee.

The use of the faucet will eliminate all the common troubles of this method of heating water. The coil is bound to clog up more or less during the summer months, and when heated continually it is only a short time before serious damage will be done to the whole furnace. The faucet will permit frequent draining, and as these heating coils are usually of small-diameter pipe, cleaning is often an absolute necessity if the system is to work at all.—L. H. Georger, Buffalo, N. Y.

Enlarging a Shallow Cupboard

A shallow cupboard, built into the partition separating two rooms, was enlarged to more than double its former capacity by the simple method illustrated, the finished work forming a distinct addition to the furniture of the room. In carrying out the work, none of the original cupboard framing was removed with the exception of the door,



which was made to do service in the remodeled job without alteration. The new woodwork was fastened directly to the edges of the original woodwork, as shown in the plan view, thus increasing the width and height as well as the depth of the cupboard.—Philip Myers, Baltimore, Maryland.

Lamp Made from Artillery Shell

A soldier of the World War cherishes an 18-lb. artillery shell as a souvenir of his experiences, and this he has converted into the good-looking table lamp shown by the photograph. A hole was drilled through the nose and this was tapped to receive the supporting standard and lamp cluster. The base upon which the shell rests was turned from a piece of black walnut and appropriately finished.—Edgar Downie, College Point, N. Y.



Sandpaper Used for Bushings

The following method of repairing a push-bit pipe, the joint of which had become worn and loose, proved very satisfactory. A small strip of sandpaper was cut to the proper size, and placed in the stem end of the pipe bowl, with the rough or sand surface out. The stem

or bit was then fitted in, and as the thickness of the sandpaper made the bushing too thick, the stem was filed to fit. The rough surface of the sandpaper will prevent the bushing from coming out when the bit is removed for cleaning. Sandpaper bushings can be used for many purposes, such as repairing loose chair legs and the like.—R. B. Clifton, Denver, Colo.

Gas Iron as Heater for Soldering Bit

The drawing shows the manner in which I use an ordinary gas iron to heat a soldering bit. The fact that the iron is so used does not interfere with its service in the laundry. Therefore, either an old or a new iron may be used.

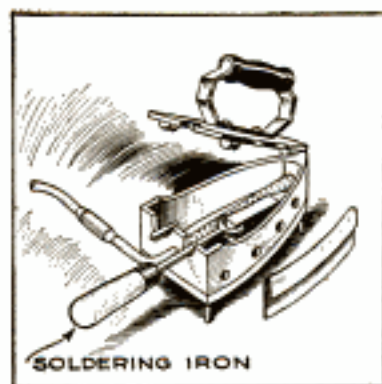

By turning the pipe to which the gas hose is connected to one side, the flame is forced directly onto the soldering iron. To help keep the heat in the

gas iron, it is best to make two side-pieces similar to those shown; these are slipped over the sides and cover the air holes. If the openings in the back of the iron are too small to admit the tang of the soldering bit, it may be necessary to enlarge the hole a trifle by filing.—H. A. Gustafson, Chicago, Ill.

A Simple Skinning Gambrel

For suspending the carcasses of small animals while removing the pelts, some form of gambrel is necessary. The drawing illustrates an original form of skinning gambrel which will not allow the carcass to slip during the skinning, with possible damage to the skin from unlooked-for contact with the sharp edge of the skinning knife. About 3 ft. of steel or brass wire is required to make such an article, which is easily formed by twisting around a stick or piece of tubing, bending the ends, and pointing.

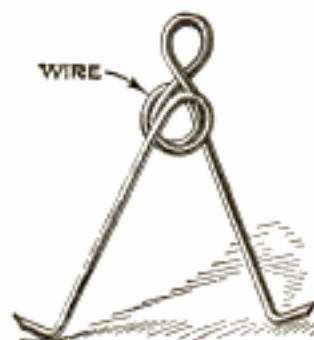

End. S. R. Winters 792 District Washington
National Bank Bldg.

PRIZE OFFERS

Aeronautics Prizes
7800

TROPHY FOR AIRPLANE EFFICIENCY

The last day of the aviation meeting held in connection with the International Aero Congress, at Omaha, November 4, and 5, last year, witnessed the contest for the aerial-efficiency trophy, donated by John M. Larsen. The conditions governing the contest might be specified broadly as the demonstration of the air-going machine that is capable of carrying the heaviest load, at the highest average speed, with the lowest fuel consumption. There were 18 entrants in the contest, and the winner was officially declared to be Earle F. White, who was accorded 4,671 points, as compared with 4,640 points, the score of Max Goodenough, who was second with a Larsen airplane. The course of the contest was of an approximate length of 250 miles, and White did this with a total useful load of 1,160 lb., at an average speed of 97.21 miles an hour, and with a fuel consumption of 23 3/4 gal. The second winner carried 1,640 lb., at an average speed of 97.21 miles an hour, with a fuel consumption of 36 gal. The points were calculated on the basis of the ratio of fuel consumption to load and speed, and on account of alleged miscalculations in this connection, the donor of the trophy has taken out an injunction to prevent the Aero Club of Omaha from paying the official winner the \$3,000 cash prize which



Larsen Trophy for Airplane Efficiency, Won by Earle F. White, at the International Aero Congress, at Omaha

goes with the trophy. The Larsen efficiency trophy, with an over-all height of 4 ft. 6 in., is a product of the sculptor's art, strikingly symbolical of what it rewards. Standing on a diminutive globe, made of silver, are two figures, also of silver, one representing a mechanic and the other an army airman. They are holding above their heads a small airplane, made of gold. A propeller mounted at an equatorial axis of the globe symbolizes the ability of air craft to move the earth.

NEW ORGANIC-CHEMICAL ASSOCIATION

With the designation "Synthetic Organic Chemical Manufacturers' Association of the United States," a new society has been organized to represent the several closely related lines of manufacture included in this branch of chemical industry. The association is subdivided into four sections: dyestuffs, pharmaceuticals, intermediates, and fine organic chemicals. The main purpose of the association is to promote the manufacture in the United States of all kinds of organic chemicals, and to cooperate with the government in its effort to develop a complete organic-chemical industry. The association will take such collective action as will best aid the establishment of the organic-chemical independence of the United States.

Science 11/18/21

OUTERS'-RECREATION OFFERS PRIZES FOR TRUE STORIES OR FICTION

For outdoor true stories, or fiction, on the subjects of hunting, fishing, camping, including auto camping, \$3,000 in cash prizes is offered by Outers'-Recreation, as follows: First, \$1,000; second, \$600; third, \$400; fourth, \$300; fifth, \$250; sixth, \$200; seventh, \$150, and eighth, \$100. Manuscripts must be typewritten, double-spaced, on one side of the sheet only. The title of the story must appear at the head of each sheet, but the author's name must not appear on the manuscript. On a separate sheet, attached to the manuscript, must appear: the title of the story; name and address of the author, and number of words in the story. Manuscripts must be mailed flat between sheets of cardboard. If return of manuscripts is desired, postage for the purpose must be inclosed. The story must not be less than 4,000 words nor more than 6,000. No manuscript will be entered which is postmarked later than March 1. No more than one prize will be awarded any author. Address: Contest Editor, Outers'-Recreation, 9 S. Clinton St., Chicago, Ill.

SCENARIO-STORY CONTEST FOR SCHOOLS OFFERED BY THE CHICAGO DAILY NEWS

A second scenario-story contest, similar to the first, announced in our November, 1921, issue, but open to school pupils only, is offered by the Chicago Daily News. The contest is open to all grammar-school pupils of the sixth, seventh, and eighth grades, and to all high-school students in Cook County, and the counties that lie wholly or partly within 100 miles of the city of Chicago. In each case the prizes will be as follows: First, \$500; second, \$250; third, \$100, with

Nov. 28, 1921

additional prizes for the best scenario story in each grammar school in Chicago of over 250 pupils, one of \$15 for the whole school, and one of \$5 for each of the sixth, seventh, and eighth grades. There will be similar additional prizes for each high school in Chicago of more than 250 pupils, the \$5 prizes being for each of the first, second, third, and fourth-year grades. In each grammar or high school outside of Chicago, there will be awarded 25 prizes of \$15 each. Any scenario story submitted must be accompanied by a scenario-story certificate clipped from the Daily News, which must be signed by the teacher or principal of the school in which the student is regularly enrolled. The stories are not to exceed 2,000 words. All stories must be legibly written, or typewritten, on one side of the paper only. The contest closes for all schools on February 5, at midnight.

AN INTERCOLLEGIATE EDITORIAL CONTEST IN INTEREST OF CULTURAL EDUCATION

In order to stimulate the interest in liberal arts of every male undergraduate in every college and university of both the United States and Canada, and also in order to refute the claim, sometimes advanced, that the four-year cultural course is time misspent, Pi Delta Epsilon, Honorary Collegiate Journalism Fraternity, has announced that for its 1921-22 intercollegiate editorial contest the subject will be "The Practical Value of a Cultural Education." President Harding, a member of Pi Delta Epsilon, former editor and present owner of the Star, of Marion, Ohio, will represent the fraternity in the presentation of awards. Three prominent metropolitan-newspaper editors will act as final judges. A local contest will be conducted at each college and university, and the first prize winner in this

American Forestry Association
1214-16th St
Washington
7907
22 20

contest will receive the "Certificate of Merit" of the fraternity, and will be eligible to submit his editorial in the national contest. Three prize winners in the national contest will be awarded the Pi Delta Epsilon gold, silver, and bronze medals. The contest is now open, and will close February 15, at midnight. Editorials submitted must not exceed 500 words, written in regular manuscript form, with an assumed name on the upper left corner of each sheet, and also on an accompanying envelope, in which should be sealed a paper bearing contestant's name, age, home city, class, and local address and telephone number. This is to be submitted to the local committee, who will forward it to the fraternity's contest committee, in care of P. C. Pack, 6415 Greenwood Ave., Chicago, Ill.

REDMEN GAVE MASSASOIT MEMORIAL TO PLYMOUTH, MASSACHUSETTS

A statue of Massasoit, Wampanoag Indian chief, was presented last Labor Day to Plymouth, Mass., by the National Order of Redmen. Popular Mechanics, in describing this incident in the December magazine, page 840, mistakenly credited the presentation to the Society of Mayflower Descendants, having been misinformed by a contributor who had proved reliable theretofore. Minnie E. Burke, librarian, and a native of Plymouth, calls our attention to the mistake and gives us a very interesting account of the unveiling. "The memorial," she states, "was paid for by contributions from Redmen all over the United States. It was unveiled on Labor Day by an Indian woman, the last lineal descendant of the great chief. The Redmen held their national convention in Plymouth on that day, and she unveiled the statue at their invitation. The statue is a memorial to Massasoit himself, in recognition of his kindness to the Pilgrims, and not a commemoration of the first settlement."

CIVIC INTERESTS PROMOTED BY NOVEL KIND OF CONTEST

With the object of promoting good municipal management, an original form of prize contest was instituted, last year, by a luncheon club of New Orleans, La. At the weekly gatherings, members were invited to submit suggestions in writing of work to be done in 1922 by the Association of Commerce. Prizes were awarded for the best suggestions. This provided the board of directors with much valuable material, when they met at the end of the year to arrange the 1922 program of the organization.

In answering prize offers please mention Popular Mechanics Magazine

LATEST DEVELOPMENTS IN SCIENTIFIC RESEARCH

By C. A. BRIGGS

TIDES RESPONSIBLE FOR PRESENT LIFE FORMS

The insignificant portion of the earth represented by the narrow strip along the ocean shore which is covered and uncovered by the tides, appears to have had a profound influence on the development of life on the earth, according to the studies of a zoologist. He states that if life did not originate there, it at least in its earlier youth served an apprenticeship in the tides; and in its present forms it is continuing to show the effects of its early environment.

A curious influence of habit was noted in this connection in the case of a small flat worm which lives in large numbers on sandy beaches in some parts of the world. These small animals come to the surface when the tide goes out, and burrow down in the sand when the water rises and reaches them. When they are removed from the beach to the laboratory and placed in test tubes containing sand, it is found that they move up and down at regular intervals of time, just as though the tide were present. Perhaps in their wormish way they think they cause the tides.

AS SEMICENTENNIAL OF FIRST ARBOR DAY MAKE 1922 BANNER TREE-PLANTING YEAR

To celebrate the semicentennial of the first arbor day in the United States, held in Nebraska in 1872, the American Forestry Association calls upon women's clubs, civic organizations, and schools to make plans now for the spring tree planting this year. Its object is to make 1922 the banner year in tree planting.

CONTESTS PREVIOUSLY ANNOUNCED

Essays on Economics: Prizes, \$1,000 and \$500; announced June issue, 1921; closes Dec. 31; address, Dr. Wm. T. Foster, Newton 58, Mass.

Medals, Diplomas, and Money Awards: Announced August issue, 1921; awards offered by the Franklin Institute.

For Service to City of Philadelphia: Prize \$10,000; announced September issue, 1921; awarded in spring or summer of 1922 by Edward Bok, former editor of The Ladies Home Journal.

Research Thesis by a Woman: Prize \$1,000; announced October issue, 1921; closes Feb. 25, 1922; address, Dr. Lilian Welsh, Goucher College, Baltimore, Md.

Model in Clay by Students of Chicago Art Institute: Prizes, \$1,000, \$100, and \$50; announced November issue, 1921; closes April 15, 1922; address, Daily News Office, 15 N. Wells St., Chicago, Ill.

Cash Prizes for Needlework: Prizes, \$200, and others varying from \$100 to \$1; announced January issue, 1922; closes, Jan. 31; address, Star Needlework Journal, 260 West Broadway, New York City.

One Million Francs for Best Motor: Announced January issue, 1922; closes June 1, 1923; address, Aero Club of France.

Best Slogan Describing Razor: Prize \$500; announced January issue, 1922; closes June 30; address Durham Duplex Razor Co., 190 Baldwin Ave., Jersey City, N. J.

Essays on George Washington: Prizes, \$2,500, and others from \$500 to \$25; announced, January issue, 1922; closes Feb. 22; address "Essays," Chicago Tribune, 7 S. Dearborn St., Chicago, Ill.

The small suspension bridge described on page 589 of the October Popular Mechanics Magazine is located at New Carlisle, Ohio, instead of Winchester, Ky. It is an attractive feature of Silver Lake Park, owned by H. S. Credlebaugh.

7826

QUARTZ CRYSTALS FURNISH STANDARD FOR HIGH TEMPERATURES

It has recently been discovered that quartz crystals can be used to establish very accurately a standard high temperature for use in calibrating pyrometers, the instruments used for measuring high furnace temperatures, and the like. When a crystal of this material is heated to 573.3° C., or 1,063° F., a sharply defined critical point is reached at which there is a rearrangement of the molecules, and heat is absorbed, causing a kink to occur in the rate at which the temperature of the quartz rises, as shown by a thermocouple making contact with it. Specimens of quartz from all parts of the world have been examined, and this critical temperature has been found to be very nearly the same in all of them, the differences being less than .3° C. The variation given by any one piece of quartz on repeated trials gives results within the same limit.

This property of quartz crystals just discovered has an interest and value which extend far beyond the laboratory and into the practical field.

IN accordance with the editorial policy of this magazine never to accept compensation in any form for what appears in our reading pages, and also to avoid all appearance of doing so, we are obliged to omit the name of the maker or the seller of any article described. This information, however, is kept on file and will be furnished free, by addressing Bureau of Information, Popular Mechanics Magazine, Chicago. [Editor.]

For You and Yours

WIFE: *Well, Jim, expenses are coming down a bit now and we can put a bit more money in the bank.*

HUSBAND: *That's good, of course, but I'm going to put "a bit more" into another Postal Life policy, so that if anything happens you and the "kiddie" (or kiddies, maybe) will have enough to live on.*

WIFE: *That's fine, Jim. That's just like you.*



THERE is no better purpose for which money can be used than to secure sound insurance protection for yourself and for the benefit of those depending upon you. The advisability, or rather, the obligation to do this is simply undoubted.

The only questions are: How much insurance ought you to carry; what kind of policy contract is best and what company should you select?

There are of course many good ones, but when it comes to the three essentials: *safety, saving and service*, you can not do better than to choose the

POSTAL LIFE INSURANCE COMPANY

Resources, \$10,000,000
Annual Income, 2,000,000
Insurance in force, 42,000,000

The Postal is *safe* because it has ample resources to meet every obligation to policyholders, who are further protected by the fact that the Company operates under the strict supervision of the State Insurance Department, and, as it transacts its business principally by mail, it is subject to the United States Postal Authorities.

It *saves* for you because it pays no commissions to agents or middlemen, and you and other policyholders get the benefit; for example, a 9½% annual dividend guaranteed in your policy and which may be deducted from your first and from each subsequent annual premium as paid. The usual commission-dividends will also be paid as earned.

The Company *serves* you in every practical way, especially along the line of health-preservation and disease-prevention through its Policyholders' Health Bureau and periodical Health Bulletins.

Because of the foregoing features and others, the Postal is truly designated as the Company of

Safety, Saving and Service

These features have, during the past sixteen years, built up the Company from small beginnings until it has become a National institution with policyholders throughout the United States, Canada and in foreign lands.

Find Out What You Can Save

Simply call at the Company's office, or use the mail-bag coupon, or write and say:

"Mail me insurance information as mentioned in *Popular Mechanics* for February." And in your first letter be sure to give:

1. Your full name.
2. Your occupation.
3. Exact date of your birth.

When your inquiry reaches the Company no agent will be sent to visit you. It desires to co-operate with you directly, and help you think out your problems from printed documentary matter submitted. Because it employs no agents the resultant commission savings, as stated, go to you. Our new descriptive booklet, "**Buying Direct**," will be mailed on request.

Twenty-five thousand thrifty people are now enjoying POSTAL Life economy and service.

POSTAL LIFE INSURANCE COMPANY

WM. R. MALONE, President

511 Fifth Avenue, cor. 43d St., New York, N. Y.



P. M. 2-02

POSTAL LIFE INSURANCE CO.
511 Fifth Ave., New York

Without obligating me, please send full insurance particulars for my age.

Name

Address

Occupation

Exact date of birth



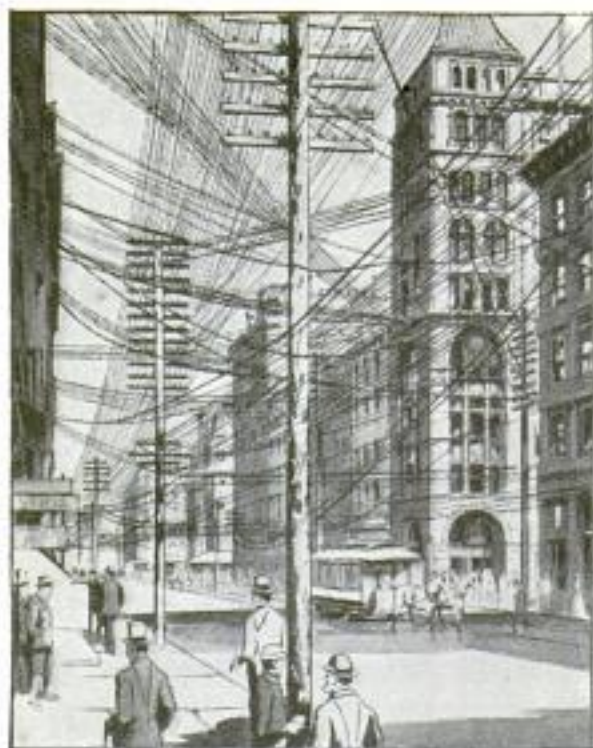

A scene on Broadway, New York, in 1890, showing the density of overhead wires



The same scene after the overhead wires were replaced by underground cables

Improvements

The history of the telephone is a record of constant improvement. Only by numerous inventions and ceaseless research for new and better ways has the present standard been reached.

Two-score years ago the telephone could hardly carry the human voice across a city. Now it carries it distinctly across this great continent. The once familiar network of overhead wires in large cities has been replaced by systems of underground cables, each cable containing thousands of slender, sensitive wires.

Switchboards, once primitive devices, called upon to handle only a few connections and limited in their workings, have now become great and precise

mechanisms through which the volume and complexity of telephone traffic is handled with mechanical perfection.

With the continued growth in the number of telephone users, there is a continued increase in the problems of speed, accuracy and speech transmission.

These are the problems forever before the scientists and engineers of the Bell System; and the solution of these problems, in advance of necessity, is the objective of this great body of specially trained experts.

The Bell System will continue the improvements necessary to maintain its standard of service, which is the best and cheapest telephone service in the world.

" BELL SYSTEM "

AMERICAN TELEPHONE AND TELEGRAPH COMPANY
AND ASSOCIATED COMPANIES

One Policy, One System, Universal Service, and all directed toward Better Service





YOUR HOME Is Within Your Reach When You Buy From Us

NOW is the time to build your Harris Home!

And here is a mighty organization of thirty great departments ready to serve you. Managed by expert material buyers, designers and practical builders. We have vast stocks bought at huge quantity price savings which are now at your command. Our sole aim and purpose is

To help you get a home that will prove entirely satisfactory at a price that will mean a substantial saving in actual dollars of your money.

The combined efforts of these great departments in experimenting and testing materials and methods of construction have produced for you a **GUARANTEED** home, expert machine cut, bundled and marked—the last word in building economy.

Not One Penny in Advance

So sure are we of the super-excellence of our material and our **GUARANTEED** Ready-Cut System that we will ship you any **HARRIS HOME** without the payment of one cent down. Our Plan Book explains our liberal terms fully.

FREE Plan Book

The latest edition is waiting for you, contains our **FREE PLAN OFFER** and photographic reproductions, with floor plans and specifications of 100 beautiful homes. Mail coupon today.

Building Material of All Kinds

For over a quarter of a century, thrifty wise buyers have realized that here is the "open door" to real economy, whether it be a brand new home or material for improvements or repairs. Our big stocks of brand new building material, all purchased in tremendous quantities at savings that are passed along to you are ready for quick and complete shipments.

"PRESTO-UP" Patented Bolt-together Buildings!

The wonder buildings of the age. Guaranteed buildings, for quick industrial housing, Individual Homes, etc., extra strong, practical and suitable for all year 'round habitation in any climate, 50 different plans. They come to you in easily handled sections—painted and stained, ready to bolt together and move in.

Plumbing and Heating!

Hot water and heating systems, warm air heating plants, pipeless furnaces and plumbing material of every kind—the product of America's leading makers. Our mammoth plumbing stock offers unlimited possibilities for you to save money. Our heating plants are guaranteed to heat your home in any weather with big fuel economy. Mail the coupon for our Plumbing and Heating Book and get the benefit of our Expert Engineering Service.

Department NM-7

HARRIS BROTHERS CO.
1349-1525 W. 35th St., CHICAGO

HARRIS BROTHERS CO.
Dept. NM-7, Chicago

These books are **FREE** and sent post paid. Mark an "X" in the squares to indicate which ones you wish.

- | | |
|--|---|
| <input type="checkbox"/> Harris Home Book of Plans | <input type="checkbox"/> Book of "Presto-up" Houses and Garages |
| <input type="checkbox"/> Building Material Catalog | <input type="checkbox"/> Plumbing and Heating Book |

Name.....

Address.....

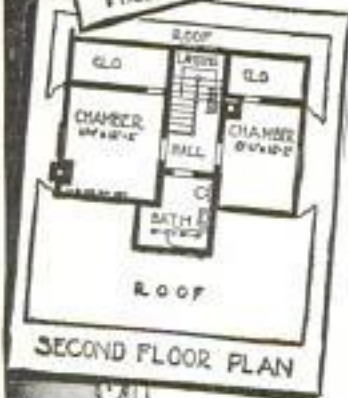
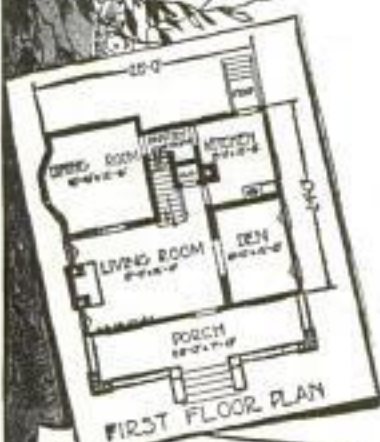

**FREE BOOK
of Plans**

GODELL-PRATT

1500 GOOD TOOLS

Mr. Punch says:

*"Meet my big brother,
Automatic Screw Driver"*

"I don't care whether you're a full fledged carpenter, an apprentice, or a 'home putterer,' if you want to do first-class work, you've got to have first-class tools."

It's a fact, men—and here's one of the handiest first-class tools you ever put your two hands on.

You push—that's all; in goes the screw—tight as beeswax. Same idea when pulling out a screw—simply *push* the handle—out comes old screw quick as a wink! Can be used as a stationary screw driver by setting the shifter knob at the star marked on ferrule.

Member of a good family

This Automatic Screw Driver is one of the Goodell-Pratt 1500 Good Tools. And, like every other member of this Good Tool Family, it's the kind that makes a good workman proud of his tools and happy about the work they do.

An old-fashioned stationary screw driver is about as efficient compared with this automatic as a "one-lung" motor is compared to a twin six.

You need this Automatic Screw Driver in *your* home. Your hardware dealer has it or can get it for you. Ask him about the Goodell-Pratt 1500 Good Tools.

Write for FREE interesting illustrated booklet, "The House that Jack Fixed." It gives you a lot of good ideas about keeping things ship-shape around the home.

GODELL-PRATT COMPANY, Greenfield, Mass., U.S.A.

Toolsmiths

Automatic
Screw-Driver
No. 111
Price, \$3.20



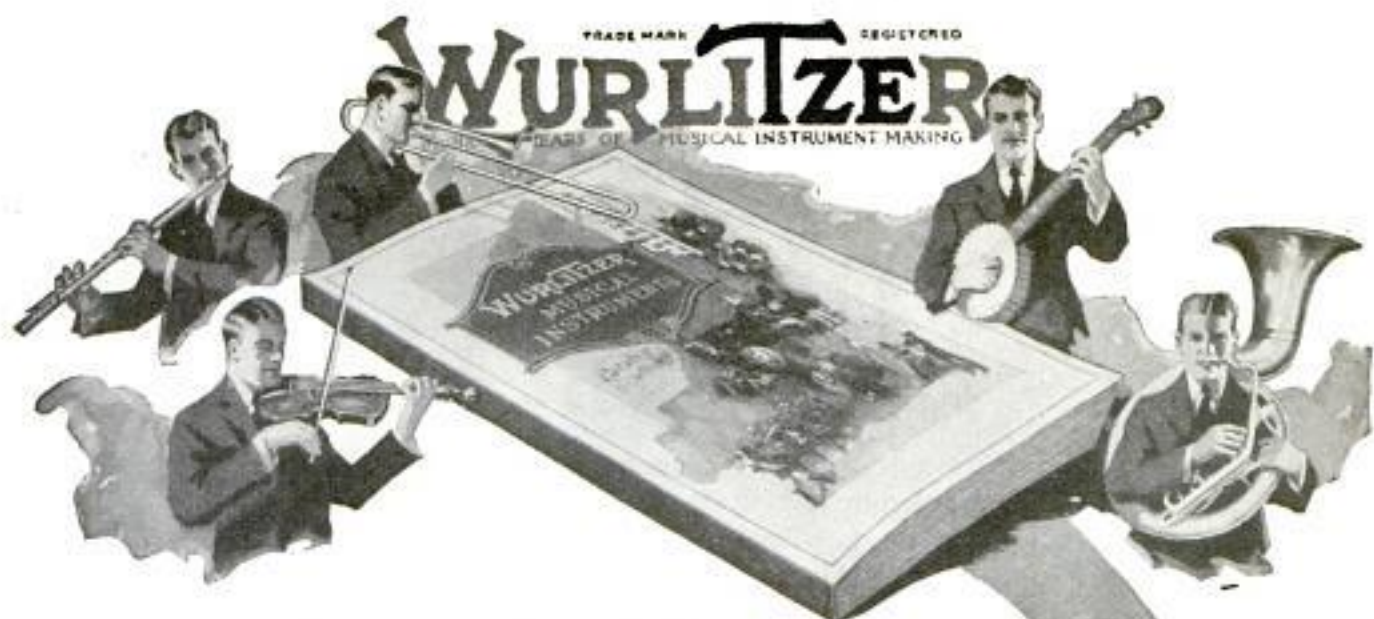

The Greatest Musical Catalog Ever Published

Over 3,000 Musical Articles—Every Known Musical Instrument Fully Described

For Professionals — Beginners — Amateurs

WURLITZER will send you any musical instrument known for a week's free trial in your own home. There is no obligation to buy. Not a penny cost to you unless you decide to keep it. You are the sole judge. Send the coupon for this catalog now. Read the details of this wonderful opportunity. This is your chance to buy any musical instrument you wish on *Free Trial*.

Any Known Instrument On Free Trial

Wurlitzer instruments have been used for three generations by famous artists, great bands and orchestras. Wurlitzer sends you any instrument on free trial. Many instruments come in velvet and plush lined carrying cases with all accessories, self-instructor, music, etc., all at factory prices, if you decide to buy. You get the entire outfit practically for the cost of the instrument alone.

Monthly Payments A few cents a day will pay for instrument and outfit if you decide after trial that you wish to keep it.

Send
for this
Catalog
Now!



The Rudolph Wurlitzer Co., Dept. 1772
117 E. 4th St. 700 W. Jackson Blvd. 120 W. 42nd St.
Cincinnati, O. Chicago, Ill. New York, N. Y.
Please send me your FREE 150-page catalog which features over 3000 articles of musical merchandise.

Name

Address

Instrument

(State instrument in which you are especially interested)

The Rudolph Wurlitzer Co.

Cincinnati

Chicago

New York



Alouys Thomas
Pres. Santa Fe Watch Co.

The Santa Fe Special Watch

A masterpiece of mechanical perfection, unapproached in its matchless time-keeping qualities, is NOW being sold at greatly reduced prices. The exorbitant war time prices have passed. I want you to see the big saving in price—the easy payment plan, but most of all I want to send you a watch designed to your order—let you see it with your own eyes before you pay a cent.

The **ILLINOIS** Famous \$
Santa Fe Special **3⁵⁰**
21 JEWEL RAILROAD WATCH **A MONTH**

The Standard Railroad Watch

that is GUARANTEED FOR A LIFE-TIME OF SATISFACTORY SERVICE. These watches are now in service on practically every railroad in the United States and in every branch of the Army and Naval Service. Thousands of them are distributed around the world. Your name or monogram and any emblem you may desire will be engraved in the case to suit your own ideas.

Save One-Third to One-Half the price you pay for a similar watch made by other manufacturers. Most Liberal Offer Ever Made. Our "Direct-to-You" low Wholesale terms and Extra Special Distribution Plan is fully explained in the new Santa Fe Special booklet just off the press. The "Santa Fe Special" Plan means a big saving of money to you and you get the best watch value on the market today.

Send Your Name Today

Clip the coupon, fill out and receive the beautiful FREE 52-page, 4-color art watch book. All the newest watch case designs are shown. Read our easy payment offer. READ the so-called secrets of watchmaking and the jewelers' trade—tells how we can sell Railroad watches at practically half the price charged by retail jewelers. READ our great "Direct-to-You" offer. DON'T BUY A WATCH UNTIL YOU HAVE SEEN THE "SANTA FE SPECIAL."

Watch sent for you to see without one penny down.

SANTA FE WATCH CO., 26 Thomas Bldg., Topeka, Kans.

A letter, post card or this coupon will bring my
Beautiful Watch Book FREE

SANTA FE WATCH COMPANY
26 Thomas Bldg., Topeka, Kans.

Please send me your New Watch Book with the understanding that this request does not obligate me in any way.

Name

Address

State

Mail
Coupon
Today

believe is the best value for the money I have ever seen. I have heard many favorable comments in regard to the watch among my friends in this city.

ARTHUR CAPPER
United States Senator.

LOOK

21 Perfect Jewels
Adjusted to
Positions
Adjusted to
Temperature
Adjusted to
Isochronism
Adjusted to
the Second
Montgomery
Dial

Thin Model. All Sizes

ALL FOR

3⁵⁰
A Month



Senator Capper
O. K.'s Santa Fe
Special

I am glad to say that your "Santa Fe Special" Watch has given entire satisfaction. I have watched it closely for three weeks and found a variation of less than ten seconds. It is certainly one of the best time-keepers on the market, and I



Actual photo
of one of
our rebuilt
Underwood
Typewriters.



\$3
DOWN

And It's Yours

Standard Underwood

Rebuilt like new. Every typewriter in factory rebuilt by typewriter experts. New enamel—new nickeling—new lettering—new plates—new key rings—new parts wherever needed—making it impossible for you to tell it from a brand new Underwood. An up-to-date machine with two-color ribbon, back spacer, stencil device, automatic ribbon reverse, tabulator, etc. In addition, we furnish FREE, waterproof cover and a special *Yatch* Typewriter Instruction Book. You can learn to operate the Underwoodness day.

From factory to you

Yes, only \$3 brings you this genuine Rebuilt Standard Visible Writing Underwood direct from our factory, and then only small monthly payments while you are using it makes it yours; or, if convenient pay cash. Either way, there is a big, very much worth-while saving, too. Genuine new Underwood parts wherever the wear comes

—genuine standard four row, single shift keyboard—thoroughly tested—guaranteed for 5 years.

\$3 Puts It in Your Home

You don't even have to scrimp and save to pay cash. Instead, you pay only a little each month in amounts so conveniently small that you will hardly notice them, while all the time you are paying,

you will be enjoying the use of and the profits from the machine.

10 Days' Free Trial

Remember, you don't even have to buy the machine until you get it and have used it on 10 days' free trial so that you can see for yourself how new it is and how well it writes. You must be satisfied or else the entire transaction will not cost you a single penny.

Typewriter Emporium Shipman-Ward Mfg. Co.

2122 Shipman Bldg., Montrose and
Ravenswood Aves., Chicago, Ill.



All shipments made direct to you from our big modern factory (shown above)—the largest typewriter rebuilding plant in the world

Use Coupon

Now is the time when every dollar saved counts. Let us save you many dollars. Don't delay. Get this wonderful easy payment bargain offer now, so you can send for and be sure of getting your Underwood at a big saving—and our easy terms or for cash.

Act Now—
Send Coupon Today!

FREE TRIAL COUPON

**Typewriter Emporium
Shipman-Ward Mfg. Co.**
2122 Shipman Bldg., Montrose and
Ravenswood Avenues, Chicago, Illinois

Send by return mail Bargain Offer No. 2122 of a Standard Visible Writing Underwood. This is not an order and does not obligate me to buy.

Name.....

Street or
R. F. D. No.

Post
Office.....State.....



THROUGHOUT the years Brown & Sharpe Tools have led the way in accuracy, quality and workmanship. These *superior* tools repay you through their long wear, and with the help they give you in doing your work better.

We shall be glad to send a copy of our No. 28 Small Tool Catalog.

BROWN & SHARPE MFG. CO.

Providence, R. I.
U. S. A.

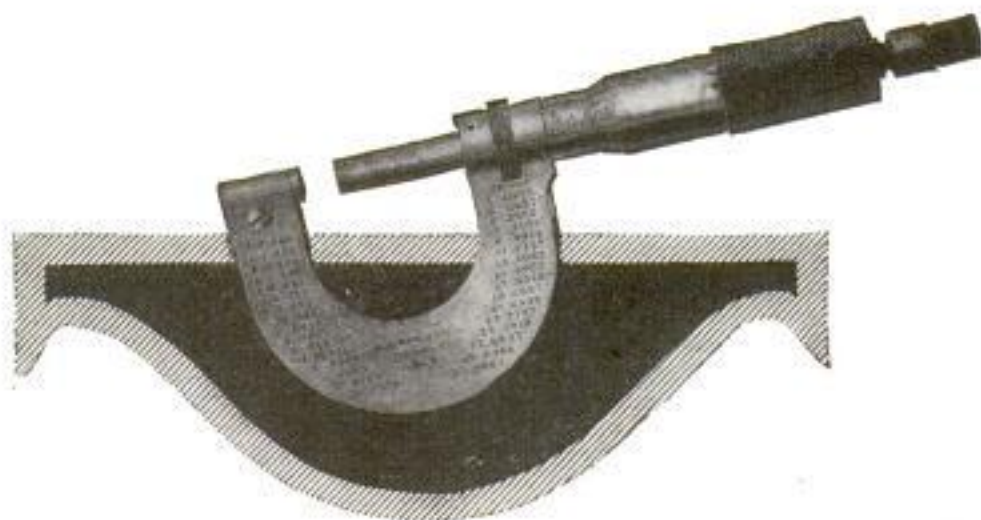

THE AJAX EYELET FASTENER

Binds Papers Quickly and Permanently

It Saves Time by Punching the Hole, Feeding the Eyelet and Clinching it in One Operation.

Drop the eyelets into the magazine and go right ahead. Order from your stationer or direct.

Write for our catalogue of office tools

MACHINE APPLIANCE CORPORATION
351-353 Jay Street ★ Brooklyn, N. Y.



UNION TOOL CHESTS

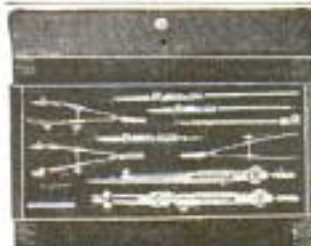

PROTECT TOOLS — SAVE MONEY

Ask your dealer to show you Union Tool Chests for Machinists, Tool Makers, Carpenters, Plumbers, Steamfitters, Auto Mechanics and General Use—the guaranteed tool chests.

Write us for free description booklet that explains about the 50 different styles of Union Tool Chests.

UNION TOOL CHEST CO.
22 MILL STREET, ROCHESTER, N. Y.

\$29.00 Value Set Mechanical Drawing Instruments

Special Wholesale Price \$6.65 Postpaid

Pocket case 4x8½ inches—velvet lined—Instruments constructed of solid nickel silver and steel—guaranteed. Order now—supply limited. Free illustrated particulars.

NATIONAL INSTRUMENT CO.
4704 N. Hamilton Avenue, Chicago, Ill.

21 Jewel Burlington



Adjusted to the Second
Adjusted to Temperature
Adjusted to Isochronism
Adjusted to Positions

21 Ruby and Sapphire Jewels
25 Year Gold Strata Case
Montgomery Railroad Dial
New Ideas in Thin Cases

Only \$**100**
Down

Only One Dollar Down will buy this masterpiece of watch manufacture. The balance you are allowed to pay in small, easy, monthly payments. The Burlington — a 21-Jewel Watch — is sold to you at a price much lower than

that of other high-grade watches. Besides, you have the selection of the finest thin model designs and latest styles in watch cases. Don't delay! Write for the FREE Watch Book and our SPECIAL OFFER today.

Write *While This Special Offer Lasts*

Get the Burlington Watch Book by sending this coupon. Find out about this great special offer which is being made for only a limited time. You will know a great deal more about watch buying when you read this book. You will be able to "steer clear" of the over-priced watches which are no better. Remember, the Burlington is sent to you for only One Dollar down, balance in small monthly payments. Send the coupon for watch book and our special offer TODAY!

Burlington Watch Company
Dept. 1352, 19th Street and Marshall Blvd., Chicago
Canadian Address: 62 Albert Street, Winnipeg, Manitoba

Burlington Watch Company

Dept. 1352, 19th St. and Marshall Blvd., Chicago
Canadian Address: 62 Albert St., Winnipeg, Manitoba

Please send me (without obligations and prepaid) your free book on watches with full explanation of your \$1.00 down offer on the Burlington Watch.

Name

Address

You Need a Farm in Canada

If you are to secure that independence, success and prosperity which has been the reward of thousands of American farmers who have preceded you.



Thousands of American farmers have made prosperous homes in Canada. There will be more this year. Can you afford not to follow them?

☞ These farmers knew of the rich tracts of Canadian Pacific agricultural land for sale in Western Canada at low prices—open prairie, partially wooded, or park lands—all virgin, fertile and productive. They knew they could not obtain such lands elsewhere at such prices—at an average of \$18 per acre.

☞ They knew that Western Canada has carried away, year by year, first international honors for wheat, oats, barley and livestock.

☞ They knew of the success that had been won by farmers from their own state who had preceded them. They knew that Canadian farm values are steadily increasing and that each year they delayed they would have to pay more to purchase desirable farms.

☞ They wanted larger holdings for their growing families. They knew they could secure sufficient land upon terms unobtainable elsewhere—20 YEARS TO PAY.

☞ As a result, 16,000 American farmers took advantage of their knowledge and moved to Western Canada last year.

☞ In Canada the government and the railroads help the farmer in every possible way. It is to their interest to do so. Taxes are moderate; laws are just; transportation facilities and markets are excellent. Language, social customs, religion, money and other conditions are the same as in the United States.

Investigate these facts for yourself and let us fill your need. Write today for information to

M. E. THORNTON, Superintendent of Colonization
CANADIAN PACIFIC RAILWAY

966 First Street, E.

CALGARY, ALBERTA

MOVIES Every Boy in the land interested in Movies

BOYS

Write to-day for cost-free information

PARAMOUNT MFG. COMPANY
27 School St. Dept. M, Box 1371 BOSTON, MASS.



Build This Phonograph Yourself
TREMENDOUS SAVING IN COST
Easy, fascinating work with our SIMPLIFIED PLANS. We furnish blue prints, diagrams, motor, cabinet pieces, ready-built horn, etc. You don't need to be a cabinet maker. A few hours assembling and you will have a fine instrument at one-quarter the regular retail price. **AGENTS MAKE MONEY** making and selling these instruments. Write today for full details of our FREE OFFER. Address:—**Modern Phonograph Supply Co.**
636 Springer Bldg., 313 S. Clinton St., Chicago, Ill.

4 Direct From Factory
Week's Trial

NOT ONE CENT IN ADVANCE
Wing Pianos and Player Pianos shipped on 4 weeks' trial freight prepaid. Save 25 to 50 per cent. 40 year guarantee. Thousands in use every where. Write at once for workbook showing 50 strings. Also latest factory prices and easy terms.
WING & SON (Est. 1868), Dept. 62 9th Ave. & 12th St., New York

5 Master Keys

Only keys of their kind in existence—(patented). Open and test thousands of different locks. Tell you instantly if your door or padlocks are burglar proof. Serve in emergencies, too. Thousands of sets in daily use among detectives, policemen, contractors, locksmiths, firemen, mechanics, travellers, home and hotel owners, etc. Give feeling of security and protection worth many times their cost. Novel key chain FREE with each set. Send only \$1 today.
MASTER KEY CO., 43 MANHATTAN BLK., MILWAUKEE, WIS.



A Bigger Job Yours—If You Master Traffic Management

"We must have efficient traffic men" say manufacturers, jobbers, railroads, ship owners. Hundreds are needed where one is available. This is the chance for ambitious men to rise to higher positions—to get into an uncrowded calling—to have the specialized knowledge which commands big salaries.

If your job isn't big enough—if you haven't a prosperous future in sight where you are, become a Traffic Expert. Make your spare time count now for quick advancement and higher pay.

Train Under the LaSalle Experts

Learn from men who have held or who are among those holding the highest positions in the field—men who will train you by the famous LaSalle Problem Method—by which you actually handle the same problems that the Traffic Managers of railroads and great shippers have to meet and solve daily. Become familiar with every phase of Interstate Commerce and Traffic Management in the most practical way ever devised.

Every point concerning Freight Rates, Classifications, Tariffs, Bills of Lading, Routing, Claims, Demurrage, Express Rates, Ocean Traffic, R. R. Organization, Regulation and Management, Laws of Carriers, Interstate Commerce Rulings, etc., will be clearly explained. You will cover the entire subject and be put in line for an executive job.

How LaSalle Men Win

B. S. McMullen was a freight checker on the docks at Seattle. Two years after beginning the LaSalle Course in Interstate Commerce and Traffic Management he was appointed General Freight and Passenger Agent.

He said that it probably would have taken him 8 or 10 years to make this advance if he had depended merely upon routine work.

LaSalle experts helped him to reach the top in the space of months.

T. J. Wright, an Illinois member, reports three promotions since taking the course.

S. H. Watson, of Michigan, figures his increased earning capacity at 400 per cent.

Fred Hoffman, an Ohio member, reports 500 per cent profit on his investment in one year.

Among the many LaSalle trained men who are now Traffic Managers or Experts on Interstate Commerce are:

Wm. Ritchie, Vice-President and Traffic Manager, Philadelphia Lawn Mower Co.

F. E. Combs, Traffic Commissioner, Michigan State Farm Bureau, Lansing, Mich.

F. E. Hamilton, Traffic Manager, Retail Merchants' Association of Canada.

Mr. Hamilton says: "I cannot speak too highly of this institution. The course is up-to-date, authentic and easily understood. My only regret is that I did not take it up five years ago."

The success these men have made can be paralleled by any other ambitious man who will do as they did—train!

Send the Coupon

Your request will bring complete information about the opportunities open to traffic experts and about the LaSalle course of training. We will also send you our book, "Ten Years' Promotion in One," which has shown thousands of men the short road to promotion. Mail the coupon today.

LaSalle Extension University

The Largest Business Training Institution in the World

Dept. 264-TR Chicago, Ill.

Please send me catalog and full information regarding the course and service I have marked with an X below. Also a copy of your book, "Ten Years' Promotion in One," all without obligation to me.

Traffic Management—Foreign and Domestic } Training for positions as Railroad and Industrial Traffic Managers, etc.

Other LaSalle Training Courses

LaSalle is the largest business training institution in the world. It offers training for every important business need. If more interested in any of these courses, check here.

- | | |
|--|--|
| <input type="checkbox"/> Business Management | <input type="checkbox"/> Banking and Finance |
| <input type="checkbox"/> Higher Accountancy | <input type="checkbox"/> Modern Foremanship and Production Methods |
| <input type="checkbox"/> Railway Accounting and Station Management | <input type="checkbox"/> Personnel and Employment Management |
| <input type="checkbox"/> Law—Degree of LL.B. | <input type="checkbox"/> Business English |
| <input type="checkbox"/> Commercial Law | <input type="checkbox"/> Expert Bookkeeping |
| <input type="checkbox"/> Industrial Management Efficiency | <input type="checkbox"/> Commercial Spanish |
| <input type="checkbox"/> Modern Business Correspondence and Practice | <input type="checkbox"/> Effective Speaking |
| | <input type="checkbox"/> C. P. A. Coaching |

Name

Present Position

Address

Agents Wanted

to sell the finest
ALL-WOOL
tailored-to-measure
Suits and Overcoats
at the sensationally
Low Price of **—**

\$26.50

Nothing like it in America!

\$26.50 Values positively sensational **\$26.50**
Competition swept aside

You get your profits in advance

Understand that \$26.50 is the price for which you sell to your customers. Understand that at this price you give Guaranteed ALL-WOOL Fabrics, hand-tailored, Serge and Alpaca lined. Understand that this price includes a very handsome profit for yourself and above all understand that you get these profits in advance—cash in hand—every time you take an order.

Now is the time to sign up

The Selling Outfit we supply is the greatest thing of its kind ever gotten out. It's put up in a handsome carrying case containing everything necessary to do business and besides the Tailoring Samples and Fashions contains a complete display of Men's Furnishings. Good Agents make \$75.00 a week easy. Lines are going fast. If you want yours—write us—right away. Address Dept. E-312

GOODWEAR (Inc.) Chicago

ASBESTOS

We are miners and shippers of Crude Asbestos in any quantity. We produce all grades at our world-famous BELL ASBESTOS MINES, in Canada. We also card fibres, spin yarns, weave cloths, and make all sorts of Asbestos products.

For anything you want in Asbestos, turn to

KEASBEY & MATTISON COMPANY
Dept. S-3, AMBLER, PENNA., U.S.A.

Owners of the world's largest Asbestos Mines

1000 SHOT ALL STEEL MAGAZINE AIRRIFLE GIVEN **WE GIVE TO BOYS** **HAMILTON 22 CAL. HUNTING RIFLE**

Choice of Six Guns (on four easy plans) for selling our Magic Healing Way-o-lens at 25c Box. **WE TRUST YOU!** Order Seven Boxes Today On Postal Card—we send promptly, Prepaid. Easy to sell—used in every home. Return money as instructed, choosing your Gun according to one of the plans shown in our Big Premium List. Also 200 other Gifts or Big Cash Commission if you prefer. If you are prompt—a special Free Gift.

WAVERLY CO., 235 Turner St., Monaca, Pa.

350 SHOT REPEATER
SEND ORDER TODAY. FREE!

Hand Forged
Razor Steel
Blades, No. 57



Direct at Factory Prices

This \$2 KNIFE \$1.38 Postpaid

Hand Forged Razor Steel Blades

Handy shaped blade makes this knife best for mechanics, sportsmen and farmers; light but strong; re-sharpened easily. Stag handle. German silver finish; blades file tested, hand forged from razor steel and warranted.

Sample \$1.38, 3 for \$3.60 postpaid.

Send for our 100 page List and "HOW TO USE A RAZOR" **FREE**

MAHER & GROSH CO., 106 A. St., Toledo, Ohio

MAKE MONEY Building Phonographs

Make Big Money Building Phonographs

Ask for Our Sure-Fire Plan and Free Blue Print Offer

You can make hundreds of dollars easily. Ask us. We tell you how and help you. We have started many others. We can start you. Pleasant, easy work. N. J. Adams, Michigan, says: "Just sold my phonograph which I built from your plans and parts at nearly \$100 profit. Only took about a week working evenings to build it. Those who have heard it say that it is better than phonographs they have seen and heard at \$200."

We furnish everything—blue print plans—case material, tone arms, motors, full instructions. You can easily make \$100 to \$200 a month in spare time. Even boys of 14 make them. They play any record. Wonderful tone—equal to any you ever heard. Sell to friends and neighbors. Write now for free blue print offer.

Become a Home Dealer—Wonderful Plan

Our dealers' proposition on our ready-built Phonographs will appeal to you. It's the best thing yet. No canvassing—no work—no capital needed. It works every time. We give you full particulars and show you how to make sure, easy money. Remember, we are the old reliable house-originators of the home building and home dealers ideas. Write today. Get our proposition. Have a fine phonograph at half price and make money besides.

Choraleon Phonograph Co.

221 1st Street ELKHART, IND.



BLANK CARTRIDGE PISTOL

PRICES
50c.
\$1.00



Well made and effective; modeled on latest type of Revolver; appearance alone is enough to scare a burglar. When loaded it may be as effective as a real revolver without danger to life. It takes standard .22 Cal. Blank Cartridges obtainable everywhere. A Great Protection Against Burglars, Tramps and Dogs. You can have it lying about without the danger attached to other revolvers. PRICE \$6c Postpaid. Better make and superior quality for \$1.00. Blank Cartridges .22 cal., shipped express 50c per 100

JOHNSON SMITH & CO., Dept. 770, 3224 N. Halsted St., CHICAGO



SAXOPHONE MUSIC Catalog

Just out—complete catalog **FREE** of latest jazz hits, also standard saxophone solos, duets, trios, quartettes—2000 selections. Largest general dealers of saxophone music and supplies in the world. *Expert repairing.* Send for free catalog today.

SAXOPHONE SHOP, 427 S. Wabash Ave., Chicago

A Full Year's Wear In Every Pair of
Nu-Way & EXCELLO
 Rubberized **SUSPENDERS**

The Nu-Way Line

Nu-Way and Excello Suspenders—75¢
 Men's Garters—50¢
 Ladies' Hosiery—Children's Hose Supporters 25¢
 Ladies' Corset "Sleeve" Hose Supporters 25¢

Guarantee Label Attached to Every Pair
 "The Stretch is in the Spring"

Ask Your Dealer
 If he hasn't them—Send direct.
 Accept no Substitute
 Look for Name on Buckles

Nu-Way Stretch Suspender Co.
 MANUFACTURERS
 Adrian, Mich.



The Business End of a Pair of Neverslips

YOU know how sore you get when you buy a new pair of pliers, only to have their cutting edges look like saw teeth before they've been on the job very long.

Here's a pair of pliers that you can't wear out. Neverslips are built to stand hard work. They'll outcut and outlast any plier made because their business end is *right*.

Most pliers are made from one piece of steel—pliers and cutting edges all made at the same time. But not Neverslips. We make their cutting blades *separate*, from high carbon crucible steel. Which means that you can *renew* them instead of buying new pliers.

And the cost of new cutting blades is nothing alongside of the money you waste sending short-lived pliers to the scrap heap.

Ask your hardware dealer to show you a pair of Neverslips. If he doesn't stock them send us his name and we'll see that you are supplied.

THE NEVERSLIP WORKS
 New Brunswick New Jersey

NEVERSLIP side cutting pliers



Neverslip Pliers are furnished in six, seven and eight inch sizes.

If you use pliers you ought to read this interesting booklet. It's mailed free upon request.

Please Mention Popular Mechanics

Copyrighted material

SAVE 25% to 60%
 on slightly used
GRAFLEX-KODAKS

Cameras and Lenses of every description. Equal to new. Save money. Write now for **FREE BARGAIN BOOK AND CATALOGUE** listing hundreds of money-saving bargains in slightly used and new cameras and supplies. All goods sold on 10 days' Free Trial. Money back if not satisfied. You take no chances dealing with us. We have been in the photographic business over 15 years. Write now.

CENTRAL CAMERA CO., Dept. 12, 124 S. Wabash Ave., CHICAGO

Send for a Complete Catalogue of
MASONIC BOOKS
Jewelry and Goods

REDDING & CO.
 Publishers and Manufacturers
 Dept. D 200 Fifth Avenue, New York

Moore Push-Pins
 Glass Heads—Steel Points
Moore Push-less Hangers
 To hang up things

Ask your dealer to show them

Sold Everywhere **10¢** per packet

Moore Push-Pin Co.
 Wayne Junction Philadelphia

TIRRO

the ideal mending tape of a thousand uses—sticks to anything and stays stuck. For sale at all druggists. A Bauer & Black product.

SEND NO MONEY

If You Can Tell it from a GENUINE DIAMOND Send it back

To prove our blue-white MEXICAN DIAMOND cannot be told from a GENUINE DIAMOND and has same DAZZLING RAINBOW FIRE, we will send a selected 1 carat gem in Ladies Solitaire Ring, (Cat. price \$6.95) for Half Price to introduce, \$2.63, or in Gents Heavy Tooth Helber Ring (Cat. Price \$9.00) for \$3.25. Our finest 12k Gold Filled settings. GUARANTEED 25 YEARS. SEND NO MONEY. Just mail postcard or this ad. State Size. We will mail at once. When ring arrives deposit \$2.63 for Ladies ring or \$3.25 for Gents with postman. If not pleased return in 3 days for money back less handling charges. Write for Free catalog. Agents Wanted.

MEXICAN DIAMOND IMPORTING CO., Dept. ET, Las Cruces, N. Mex.
 (Exclusive controllers Mexican Diamonds)

DIAMONDS WATCHES ON CREDIT

GENUINE DIAMONDS GUARANTEED
Prices Greatly Reduced CASH OR CREDIT
Send for Catalog
 Write for Free wonderful BARGAIN Catalog today. Credit terms fully explained. Amazing money-saving prices on Diamonds, Watches and Jewelry. \$75 Diamonds reduced to \$50. \$100 values now \$66.75. Proportionate reductions on all Diamonds—you save. LIBERTY BONDS ACCEPTED



Special Bargain
WRIST WATCH, \$35 Cash or Credit
 Solid 18-k White Gold, engraved; looks like genuine Platinum. Full jeweled imported movement, guaranteed. Silk Ribbon Bracelet. Special at \$35. Other Solid Gold Wrist Watches, \$26 up. Gold filled, \$15 up. Men's Watches, \$17.50 up.

USE YOUR CREDIT
PRINCESS DIAMOND RING. Solid 18-k White Gold, pierced; octagon top. Fine Diamond, \$160 value reduced to \$100
 Cash or Credit
 Proportionate reductions on all other Rings at \$75 \$125, \$190, \$200 up.

LOFTIS BROS & CO. 1875
THE NATIONAL CREDIT JEWELERS
 Dept. K-334
 108 N. State Street, Chicago, Ill.
 Stores in Leading Cities

KEEP WARM

by wearing Russell's Outing Clothing. Here are a few genuine bargains:

Sheep-lined Coats, 34 inches long.....	\$ 8.75
Sheep-lined Moccasins.....	1.00
All wool Army Underwear, suit.....	2.50
Heavy wool Army socks.....	.45
Wool flannel Army shirts.....	3.55
Coat style, wool, Army Sweaters.....	5.00
Army wool blankets.....	3.50
Aviator's leather helmet.....	3.50
U. S. Navy Pea Jackets.....	16.00

We have a complete assortment of Army and Navy Uniforms, insignia and equipment. Also all winter sporting goods.
 Write for FREE CATALOG 112 containing over 2000 Army, Navy, and Sporting Goods specials.
RUSSELL'S (Incorporated)
 245 West 42nd Street New York
 Formerly Army & Navy Store Co., Inc.

VICTOR Portable STEREOPTICON

The PERFECT PROJECTOR for every need
 SHIPPED ON TRIAL SPECIAL EASY TERMS
 Hundreds of illustrated lectures for rent.



WRITE FOR INFORMATION
 VICTOR ANIMATOGRAPH CO. INC.
 239 VICTOR BLDG. NEW YORK, N.Y.

SELF-FILLING INK PENCIL "INDEPENDENT"

Guaranteed Improved Fountain Pen. Eliminates fatigue. Promotes efficiency. Writes uniform. A business necessity.



Meets all requirements. Self-filling, non-leakable, safety cap. Attached clip. Smooth writing gold 5-lyo point.
 Your Name in Gold—25 Cents Extra
 AGENTS WANTED
 J. C. ULLRICH & CO., 161 Washington St., New York

New CONN Saxophone Book FREE

Explains improvements and simplified key system which makes Conn saxophones easiest of all to play. You can make a good "side income" and increase your pleasure playing saxophone. In demand nightly for solos and in orchestras. Book tells uses of various types and proper instrumentation for trios, quartets, etc. Today's popular stars choose the Conn; you'll make faster progress with this world-famous instrument.
Free Trial—Easy payments on any Conn instrument. All exclusive Conn features at no greater cost. Send coupon for free book and details.

C. G. Conn, Ltd.
 231 Conn Bldg., Elkhart, Ind.
 Highest Honors at World Expositions



C. G. Conn, Ltd., 231 Conn Bldg., Elkhart, Ind.—Please send Book and details of free trial plan.
 Name.....
 St. or Rural Route.....
 City, State.....
 County.....
 Instrument.....

10 Buys Engel "Art Corners"

Millions Billions in use today
 No PASTE NEEDED
 Use them to mount all kodak pictures, post cards, clippings in albums
 Made in Square, Round, Oval, Penny and Heart of black, grey, sepia, and red gummed paper. Slip them on corners of pictures, they wet and stick. QUICK-EASY-ARTISTIC. No fuss, no fuss. At photo supply, drug and stat'y stores. Accept no substitutes; there is nothing as good. 10c brings full pkg. and samples

from Engel Mfg. Co. Dept. S-9 4711 N. Clark St. CHICAGO

MAKE \$15 A DAY: EVERY HOME NEEDS IT
Wonderful Easy Knife, Scissors and Tools sharpener. Sells 50c. 200% profit to agents.

Write for particulars
PREMIER CO.
 806 E. Grand Blvd.
 Detroit, Mich.
 Sample sent for 25c coin or stamps.
BIG CHANCE FOR YOU



GET THIS

IVER JOHNSON

The SAFE Revolver

TYPEWRITERS

All Makes. Save \$25 to \$50
 on rebuilt at the factory by the well-known "Famous Young Process." Sold for low cash—installment or rented. Rental applies on purchase price. Write for full details and guarantee. Free trial.
YOUNG TYPEWRITER CO., Dept. 151, Chicago



Different from all others—the NEW BENJAMIN



AIR RIFLE

Made on a different principle from all other Air-Rifles.

The Benjamin is really a strong air-pump used to compress the air in the air chamber to any degree of power desired. From one to six strokes of the pump give all the force necessary. Each additional stroke gives increased power. The Benjamin works on the same principle as all air-drills and air-hammers—with this difference:

You control the shooting force as you desire. Look at this block of hardwood. It shows how Benjamin power is regulated as you wish.

You can't have accidents with a Benjamin. It's safe, always, because you control the power. The Benjamin never loses shooting force, and has no springs to get out of order or shake your aim. Write us for an interesting folder about this wonderful air-gun.

For sale by all dealers.
Price \$5.00.

BENJAMIN
AIR-RIFLE & MFG. CO.
615 N. Broadway, St. Louis, Mo.

Ask your dealer for demonstration.

Pacific-Coast Representatives:
McDonald & Lisle, Inc.,
Call Bldg.,
San Francisco



MUSIC LESSONS FREE

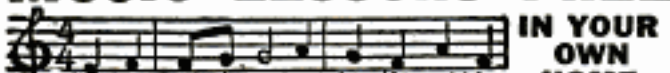

You can read music like this quickly

IN YOUR OWN HOME

Piano, Organ, Violin, Mandolin, Guitar, Banjo, etc. Beginners or advanced players. One lesson weekly. Illustrations make everything plain. Only expense about 2c per day to cover cost of postage and music used. Write for FREE booklet which explains everything in full.

AMERICAN SCHOOL OF MUSIC, 50 Lakeside Building, CHICAGO

A PERFECT POLISH WITH CLEAN HANDS



KAXO SHOE BRUSH

POLISH, DAUBER and BRUSH combined in one convenient article. Polish is in a tube enclosed in metal case on top of brush, and when tube is used up, new ones may be obtained at leading stores everywhere, 25 cents. Buy of your dealer or order direct, stating whether black tan, mahogany or white is desired. Fine opportunity for agents.

Postpaid anywhere \$1.25
Address Sales Dept.
The Kaxo Co., Cambridge, 39/Mass.



Catch Fish, Eels, Turtles, Mink, Muskrats and other fur-bearing animals in large numbers, with our new Folding, Galvanized Steel Wire Trap. It catches them like a fly-trap catches flies. Made in all sizes. Strong and durable. Write for Descriptive Price List, and our Free Booklet on best bait known for attracting all kinds of fish.

J. F. GREGORY, Dept. 24 LEBANON, MO.



CAMERAS

Over a Hundred Styles and Sizes
Send for new illustrated catalog showing latest reduced prices. It's Free.

10 days' trial given

SENECA CAMERA MFG. COMPANY
300 Central Avenue Rochester, N. Y.

Protect Your Checks

Free Trial Use as
You Pay

Send Me Only
\$3.00
A Month

until my low total price of \$29.30 is paid and this Guaranteed F & E Check Protector is yours.

This is absolutely the most generous offer ever made—Think of it—buying this reliable F & E Check Protector for \$29.30. F & E machines from the manufacturer sell at \$60.00 today. Cash price \$27.70. Never before has anything like this been attempted.



F. & E. Check Protector Protects Your Bank Account

More than 95% of all business is transacted by checks and drafts—less than 5% by cash. Unprotected checks are the most inviting form of easy money. If your checks are raised you are the loser—not the bank. Your signature is good for every cent you have on deposit. Modern check artists know how to obtain your checks—how to raise them—how to cash them. Why furnish these professional crooks this opportunity to easily obtain your hard earned money? Clever check crooks defraud farmers, doctors, lawyers, ladies and business men of all kinds everywhere every day. One insurance company claims knowledge of over

\$30,000,000 Lost Yearly From Check Frauds

Check raising is increasing constantly. The up-to-date Jesse James and modern Bill Sykes don't counterfeit money—check raising is easier, quicker and more dependable. Counterfeiting means trouble with Federal Authorities—check raising is a minor offense in comparison. Over 10% of the male inmates in leading penitentiaries are doing time for check frauds.

Don't wait for one of the many check raising gangs to teach you a bitter lesson. If you value your peace of mind and your bank account, stop before you sign another check and protect it. It is your duty to your business—yourself—your family. It is not luck or clever salesmanship that has put over 1,500,000 check protectors in use today. Protected checks are an evidence of business efficiency. Losses from properly protected checks are unheard of. Your banker will tell you a check protector is a necessity.

Stop Taking Chances Send Your Order Now

I am offering a limited number of F & E Check Protectors at less than half manufacturer's present price. These are used machines, guaranteed to be thoroughly overhauled and in absolutely first-class mechanical condition and appearance. Will give you years of honest, loyal service and protection.

The F & E is Visible Writing—it writes and protects the exact amount in figures in the body of the check—all at one speedy operation. Each figure is shredded through the paper and indelible ink forced through the shreds. You have real, honest, complete protection—there is no mistaking the amount of your businesslike checks. More than 200,000 have been sold and never a less heard of where the F & E protected the check.

Order Today. When protector arrives pay Postman \$8.50 and Parcel Postage (box weighs 11 pounds) and take it for five days' trial. If convinced it is worth my low price in protection to your checks, keep it and send me \$3.00 per month until \$29.30 is paid. If you don't want it, return it. I will immediately refund your money. Nothing could be more fair. It is simply understood I retain title to protector until full \$29.30 is paid. I will ship you F & E protector promptly on receipt of coupon. The supply is limited. Don't delay—send me the coupon today.

HARRY A. SMITH, 1022 Bower Street, Elkhart, Ind.

Harry A. Smith, 1022 Bower St., Elkhart, Ind.
Ship me F & E Check Protector on terms described in this adv.

Name.....

Address.....

Get This Wonderful Ring. If You Can Tell It From a Genuine Diamond Send It Back

These amazing, beautiful CORODITE diamonds positively match genuine diamonds in every way—same glitter, flash and dazzling play of living rainbow fire. They, alone, stand the diamond tests, including the terrific acid test. Even lifetime diamond experts need all their experience to see any difference. Prove this yourself.

Wear a Corodite Diamond 10 DAYS FREE

Make this test. You risk nothing. Wear a genuine Corodite and a diamond side by side on the same finger for 10 days. If you or your friends can tell the difference, return the Corodite. You won't be out a single penny. If you decide to keep the ring, the price printed here is all you pay. No instalments. Remember, only Corodites have exactly the same cutting as genuine stones.

No. 1—Ladies' Tiffany Style 14K Gold B. Ring	\$3.94
No. 2—Gents' Heavy Bulber 14K Gold B. Ring	\$3.48
No. 3—Gents' Massive Hexagon Platinum Finished	\$4.27
No. 4—Ladies' Carved Platinum Finish	\$3.96

All stones 1 carat size and the mountings are beauties of the very latest design. Gold or the popular white platinum finish. Unqualified 20-year guarantee. Handsome art-leather velvet-lined case free with each ring.

SEND NO MONEY Keep your money right at home. Just send your name, address and number of ring wanted and size as shown by strip of paper fitting end to end around finger joint. Your ring will come by return mail. When ring arrives deposit amount shown with postman. If you decide not to keep ring after 10 days' wear, send it back and your money will be immediately returned. Send today.

E. RICHWINE CO.
333 South Dearborn Street, Dept. 71, Chicago, Ill.
We are sole importers of Corodite Gems for the United States

Cut Price!

Save money. Try this wonderful range at OUR RISK. We pay the freight. Over 150,000 in use. All sold on THIRTY DAYS' FREE TRIAL.

Great Fuel Saver. Wonderful Baker!

Housewives delighted with results. Amazing demand. Many exclusive features. **Odor Hood**—carries all odors up chimney. **Ash Sifter**—sifts ashes right in range. No dust. **Stone Oven Bottom** absorbs and holds heat. Makes baking sure and successful. **GUARANTEED**. Will last for years. You can buy this wonderful range **DIRECT FROM FACTORY AT WHOLESALE PRICE**—our only selling plan. New 1922 design has white enamel front. Hundred other styles from which to choose. **Easy Credit Terms** if desired. **Write today for big FREE catalog.**

THE IMPERIAL STEEL RANGE COMPANY
669 Detroit Avenue Cleveland, Ohio

Gets Big Play
New Gum Vending Machine

This machine is making \$10 to \$20 day profits for many store owners.

Install one in your store or any public place and get this easy profit. Requires no attention. Always works. Machine's profits pay the rent.

Write us about rebuilt penny and nickel machines. Finished like new. In excellent running order. Pay their cost in 10 days.

Write or wire today for full particulars.

\$25 down payment. Balance C. O. D.

Mints \$30 per case—2,000 5 cent packages. Single boxes, 100 5 cent packages, \$2.50.

SILVER KING NOVELTY CO.
490 Williams Bldg. Indianapolis, Ind.

"Sloan's for every muscle in the Human Body"

Relief for all external pains and aches: rheumatism, neuralgia, sciatica, lumbago, sprains and strains, overworked and sore muscles. Sloan's is good for all of them! Don't rub—it penetrates.

Sold by dealers you know and can trust, 35c, 70c, \$1.40.

Keep it handy
Sloan's
Liniment (Pain's enemy)

KEITH'S \$2.50 OFFER



3 Plan Books, showing 100 designs of artistic bungalows, cottages, or two-story houses—in frame, stucco and brick—with floor plans and descriptions, and 8 months' subscription to Keith's Magazine, all for \$2.50.

Keith's Magazine for over 20 years an authority on planning, building and decorating homes—25¢ a copy on newsstands. With its help and Keith's Plans you can get the most distinctive, comfortable and satisfactory home with greatest economy.

Set of 3 plan books (260 plans) and Keith's for 12 months—\$4.50
Keith Corporation, 528 Abbey Bldg., Minneapolis, Minn.

Beautiful HOUSES \$900 and BUNGALOWS

CAN BE BUILT FOR AND UP

This and many others in my new book, Building Plans for Modern Homes, will save you hundreds of dollars. One of the most complete and comprehensive books of plans ever published by any architect. New edition just off the press. Nearly 500 floor plans and photographs of bungalows, Colonial houses, etc., costing from \$200 up; gives sizes and cost to build.

Sent postpaid for \$2.00



FREDERICK H. GOWING
ARCHITECT
18 Tremont St., BOSTON, MASS.

PLAN YOUR HOME NOW



Send for Stillwell Building Books with Economy Plans of new California Styles suitable for any climate. Famous for comfort and beauty

"Representative Cal. Homes"
50 Houses—7 to 10 Rooms, \$1

"The New Colonials"
60 Houses—6 to 10 Rooms, \$1

"West Coast Bungalows"
50 Houses—6 & 7 Rooms, \$1

"Little Bungalows"
75 Houses—3-4-5 Rooms, \$1

SPECIAL OFFER: Send \$2.50 for any three of these **FREE** books and get Garage Folder

Money back if not satisfied.

E. W. STILLWELL & CO., Architects, 782 Calif. Bldg., LOS ANGELES

LUMINOUS PAINT



Make Your Watches, Clocks, Etc., Visible by Night

The very latest discovery in the scientific world. Hitherto, practically unobtainable except at an exorbitant price, we have at last succeeded in producing this remarkable LUMINOUS PAINT, which applied to the surface of any article, emits rays of white light, rendering it perfectly visible in the dark. THE DARKER THE NIGHT, THE MORE BRILLIANT IT SHINES. Quite simple to use. Anyone—yet can do it. A little applied to the dial of your watch or clock will enable you to tell the time by night. You can coat the push buttons or switch plates of your electric lights, push boxes, and innumerable other articles; make your own Luminous Crosses, Luminous Hourglasses, etc. Small bottle, price 25c. Larger sizes, 50c and \$1 postpaid.

Johnson Smith & Co., 3224 N. Halsted St., Dept. 776, Chicago



AGENTS 500% PROFIT

Gold and Silver Sign Letters

For store fronts, office windows and glass signs of all kinds. No experience necessary. Anyone can put them on and make money right from the start.

\$75.00 to \$200 a Week!

You can sell to nearby trade or travel all over the country. There is a big demand for window lettering in every town. Send for free samples and particulars. **Liberal Offer to General Agents.**

METALLIC LETTER CO.

433B North Clark Street

CHICAGO, ILL.

AGENTS: \$42 a Week

New hosiery proposition for men, women and children. All styles, colors and fancy stripes, including the finest line of silk hose.



Guaranteed One Year
Must wear 12 months or replaced Free!
A prospect in every home. Often sell dozen pair to one family. Repeat orders will make you a steady income. You can sell for less than store prices. Mrs. McClure made over \$200 first month. Mrs. Perry made \$27 a week in afternoons. Work spare time or full time. Anybody can sell this guaranteed line.

Silk Hose Free—Try our hosiery before selling it. We want you to become familiar with our hosiery line. Write for particulars if you mean business, and state size of hose worn.

Thomas Mfg. Co. E 4048 Dayton, Ohio.

AGENTS - AUTO GIVEN

We need special agents to travel by Automobile introducing our great line of Nationally-advertised Pure Food Products, Soaps and Household Necessities. Here is an opportunity to earn \$6 to \$12 a day, all or spare time and earn an Automobile besides. Write at once for full particulars. Address

AMERICAN PRODUCTS CO.
5520 American Bldg. Cincinnati, O.



GREAT INTERCHANGEABLE-TYPE TYPEWRITER
Hammond
MULTIPLY **A NEW FOLDING MODEL**
Full Capacity

Write for Free Booklet. Hammond Typewriter Co., 569A East 69th St., New York

SALES MEN

Dandy proposition selling Chewing Gum to dealers. Clean, profitable, spare-time work. Write at once.

HELMET GUM MFG. CO., Cincinnati, O.

SELL GUM

"Best" Hand Lantern



A powerful portable lamp, giving a 300 candle power pure white light. Just what the farmer, dairyman, stockman, etc., needs. Safe—Reliable—Economical—Absolutely Rain, Storm and Bug proof. Burns either gasoline or kerosene. Light in weight. Agents wanted. Big Profits. Write for Catalog.

ADOPTED BY THE U. S. GOVERNMENT

The Best Light Co., 324 E. 5th St., Canton, O.



High School Course in Two Years!

Lack of High School Training has kept thousands of men and women from attaining business and social position. Without this training you are absolutely barred from a successful business career, from the leading professions, from well-paid civil service jobs, from teaching and college entrance. In fact, all preferred positions are closed to you without this vital training. You can't stand this heavy handicap nor do you have to. The American School can give you the valuable training you missed.

Put Your Idle Hours to Work

You can complete our simplified High School Course within two years by spare-time study. Then you will be mentally equipped to handle a worthwhile position. This Course, prepared by some of America's leading professors, will broaden your mind, give you a wider outlook and make you keen, alert and capable.

Remove Your Handicap

Whether you need High School Training or specialized instruction in your chosen line—NOW is the time to remove your handicap. You must know the short cuts and efficiency methods. You must know the HOW and WHY. Over 50,000 students owe their success to training received from the practical, money-making Courses in the coupon below. Let us tell you about this training—about the Course you are interested in. Check and mail the coupon

Try Ten Lessons FREE At our expense—not yours—try ten lessons in any Course before deciding. If you are not completely satisfied you are not out one cent. **We guarantee satisfaction.**

AMERICAN SCHOOL

Dept. H-274-X, Drexel Ave. and 58th St., Chicago

AMERICAN SCHOOL

Dept. H-274-X, Drexel Ave. and 58th St., Chicago
Send me full information on how the PROMOTION PLAN will help me win promotion in the job checked.

- | | |
|------------------------------|----------------------------|
|Architect |Lawyer |
|Building Contractor |Machine Shop Practice |
|Automobile Engineer |Photoplay Writer |
|Automobile Repairman |Mechanical Engineer |
|Civil Engineer |Shop Superintendent |
|Structural Engineer |Employment Manager |
|Business Manager |Steam Engineer |
|Cert. Public Accountant |Foremanship |
|Accountant and Auditor |Sanitary Engineer |
|Bookkeeper |Surveyor (& Mapping) |
|Draftsman and Designer |Telephone Engineer |
|Electrical Engineer |Telegraph Engineer |
|Electric Light & Power |High School Graduate |
|General Education |Fire Insurance Expert |

Name

Address

1/2 SAVED
BUY DIRECT
GET BIG BOOK

DO YOUR OWN PLUMBING & HEATING AT LOW COST

Send for our big instructive 256-page well-bound **HANDY MAN Book-Catalog**. Every homeowner, contractor, farmer, mechanic, institution, etc., needs it. Shows over 10,000 fixtures and supplies in plumbing and heating at wholesale; how to save skilled labor, hard work and unnecessary material by our new

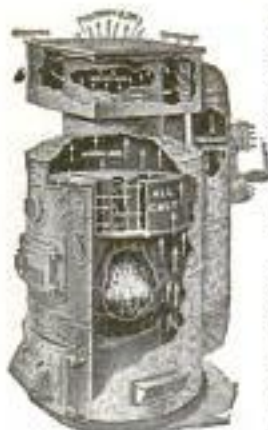

Pipeless Furnace

Cut-To-Fit Method

This wonderful encyclopaedia on plumbing and heating helps you select and install the proper plumbing, water system, hot air, water or steam plant. Besides being our wholesale catalog, it has many practical plans, diagrams, sketches, elevations, handy kinks, etc., showing how to do the work this newer easy way. Any handy man with a few tools can do his own installing with the aid of this

Big Handy Man Book

We have spared no effort, and have gone to a **GREAT EXPENSE** to compile this valuable book, and to keep from sending it to uninterested persons, we request 25c, which will be refunded on your first order, or send for our free bulletin.

Write today and save.

HARDIN-LAVIN CO.

50 Years at 4547-4557 Cottage Grove Avenue, CHICAGO

\$500,000 Plants Behind Our Guarantee



Hot Water Boiler

We Pay \$7 a Day



taking orders for **Can't Clog Coal Oil Burner**

Most perfect burner ever invented. Intense blue flame. Can't clog up. Turns any coal or wood stove into a gas stove. Heats oven to baking point in 10 minutes. Cheapest fuel known. Low priced. Sells everywhere. Nothing else like it. Not sold in stores. Write quick for sample. **PARKER MFG. CO., 878 Coal Street, DAYTON, OHIO**

"BOW LEGS and KNOCK-KNEES" UNSIGHTLY

SEND FOR BOOKLET SHOWING PHOTOS OF MEN WITH AND WITHOUT THE PERFECT LEG FORMS

PERFECT SALES CO.

140 N. Mayfield Ave., Dept. S, Chicago, Ill.

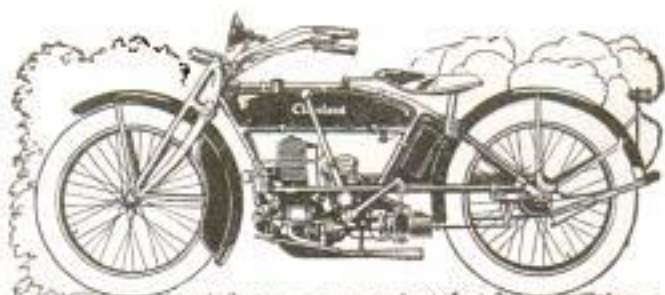

PRICE \$185

One-Half the Average Motorcycle Price

Six other of the "big" motorcycles average \$370 in selling price. Yet the Cleveland—with leadership quality unquestioned—sells at \$185.00. Consistently, through the seven years of its manufacture, Cleveland has linked lower price with unchallenged value.

We are selling economical transportation. 75 miles to the gallon of gas—15,000 miles on tires!

The Cleveland is light of weight and has a low saddle position. As safe as riding a bicycle.

Lowest priced real motorcycle you can buy. Write now for Catalog "M."



Can you recommend a "live" man for Cleveland dealer in your town?

CLEVELAND MOTORCYCLE MFG. CO. 7th YEAR CLEVELAND, U.S.A.

MOTOR CYCLE Cleveland

Delivered to You Free

for 30 days' trial on approval. Your choice of 44 Styles, colors and sizes of famous **Ranger Bicycles**. **Factory-to-Rider** lets you buy at wholesale prices, express prepaid, direct from maker.

12 Months to Pay lets you enjoy at once. Many boys and girls easily save the small monthly payments. The **Ranger** is a better bicycle than you can buy anywhere at any price.

TIRES lamps, horns, wheels, parts and equipment at half usual prices.

Send No Money Simply write for our big, illustrated

MEAD CYCLE COMPANY Free Ranger catalog with lowest prices and terms. Also special Rider Agent Offer.



CASH PROFITS!!

HB BATTERY CHARGING PAYS \$150 TO \$300 EVERY MONTH

Start your own business NOW. No electrical knowledge needed. Small cash payment brings you any HB Charger, balance on loan, easy terms. Money back guarantee. Thousands making big money—you can too. Write TODAY for information and liberal payment plan.

Hebart Brothers Company, Box M12, Troy, Ohio.

Small Cash Payment Brings You any HB Charger—Balance Easy Terms



"BOW LEGS and KNOCK-KNEES" UNSIGHTLY
 SEND FOR BOOKLET SHOWING PHOTOS OF MEN WITH AND WITHOUT THE PERFECT LEG FORMS
PERFECT SALES CO.
 140 N. Mayfield Ave., Dept. S, Chicago, Ill.

ENINGER WILL SAVE BIG MONEY SAVINGS FOR YOU
 Used and rebuilt motorcycles, single and twins, \$25 to \$100. Used bicycles, \$5.00; tandems, \$10. All machines guaranteed in good working order. New bicycles and motorcycles at Factory prices. You save dealers' profits. Motorcycle and automobile tires too, \$3.00. Complete line of parts and supplies.
 \$40
 Send for catalog
Eninger Cycle Co., Rochester, N.Y.
YOU 25 TO 50 DOLLARS

DIAMONDS, WATCHES ON CREDIT
 YOU SHOULD HAVE THE **JAMES BERGMAN JEWELRY BOOK** IN YOUR HOME. It is full of money bargains. Diamonds, Watches, Jewelry, Toilet Articles, etc. Select any article desired, have it sent to you, all charges prepaid. If satisfactory, send one-fifth of purchase price and keep it, balance in TEN monthly payments. No interest charged. No security required. Write Today for Big Free Catalogue No. 5. It tells about our Low Prices and binding guarantee.
JAMES BERGMAN 37-39 MAIDEN LANE, N.Y. City, N.Y. Est. 1896, NEW YORK CITY

Automatic Rapid Electric Cook Stove

EASIEST method known to prepare family meals. Saves 50% to 75% fuel cost—saves time, labor. Insures better prepared, more tasty food. Gives every facility of electric range plus every advantage of fireless cooker at less cost than a good oil stove.

New Invention

Revolutionizes Cooking—Bakes, roasts, boils, steams, fries, broils, toasts. Needs no watching. Shuts itself off. Attaches to any electric socket. No special wiring. Write for 30-day FREE trial offer. Complete facts and special introductory, direct factory prices.

SEND NAME AND ADDRESS

Wm. Campbell Co., Dept. 64, Detroit, Mich.



NEW LAMP BURNS 94% AIR Beats Electric or Gas

A new oil lamp that gives an amazingly brilliant, soft, white light, even better than gas or electricity, has been tested by the U. S. Government and 35 leading universities and found to be superior to 10 ordinary oil lamps. It burns without odor, smoke or noise—no pumping up, is simple, clean, safe. Burns 94% air and 6% common kerosene (coal oil).

The inventor, L. D. Johnson, 609 W. Lake St., Chicago, is offering to send a lamp on 10 days' FREE trial, or even to give one FREE to the first user in each locality who will help him introduce it. Write him today for full particulars. Also ask him to explain how you can get the agency, and without experience or money make \$250 to \$500 per month.

Made \$164 in one Week



"For just one week my net profits were \$164," writes R. A. Moyer. He is one of hundreds making big money acting as our representative for this wonderful new light.

Burns Kerosene or Gasoline

Gives 300 candle power soft, brilliant light, restful to eyes. Costs less an evening. Absolutely safe. Lights with match. Most wonderful light of age—Table Lamps, Hanging Lamps, Lanterns. Big season now on. You can earn as Moyer has. Work all or spare time. Commissions paid same day you take orders. No experience necessary. Write today for catalog and agents FREE outfit offer.

THE AKRON LAMP CO.

102 Lamp Bldg., Akron, Ohio



WHITE FLAME

BURNERS make your old kerosene lamps and lantern give a brilliant white light better than electricity or gas. Doubles your light. Saves oil. **NO MANTLE TO BREAK.** Guaranteed Safe and Reliable. Delights every user. Send now for complete sample postpaid 20 cents stamps or coin. 3 for \$1.25. Money Back if Not Satisfactory. Live Representatives Wanted. Exclusive Territory. **WHITE FLAME LIGHT CO., 68 Clark Bldg., Grand Rapids, Mich.**



"Lighting Fixtures"

READY TO HANG

(Direct from Manufacturers)

Completely wired, including glassware. New designs. Send for catalogue No 20.

ERIE FIXTURE SUPPLY CO.
STA. A. ERIE, PA.



Send No Money for this 25 Cal. regulation blue steel Automatic Revolver



Pay the Postman only

9.75 and postage when the revolver is delivered. We guarantee full satisfaction or money back after examination.

Keep one of these brand new safety revolvers in your home and be fully protected against burglars, thieves and hold-up men. It's a terrible fright to wake up in the night—hear noises down stairs or in the next room—and realize your neglect has left you wholly UNPROTECTED. One of these revolvers will fully protect you.

Shoots Quick—7 Shots in 3 Seconds



Just pull the trigger. Each shot automatically ejects the cartridge and loads ready for the next shot.

This revolver HAS DOUBLE SAFETY and is practically "fool-proof" against accidents. Perfect grip, accurate aim. Handsome blue steel gun metal finish. Rifled barrel, checkered grips, safety lever. Holds 7 cartridges. Small, compact, fits in vest pocket, lies flat and will not bulge out pocket. Shoots famous Colt Auto Cartridges. Fine for target practice.

SEND NO MONEY

Order today. Just send your name and address and say which revolver you want.

- | | |
|--|---|
| No. 433. 25 cal., 7 shot. Regular price \$22.50. Our price... \$9.75 | No. 833. 32 cal. automatic military model, 10 shot, extra mag. FREE, 19 shots in all. Special price \$12 |
| No. 3547. Same style as above only 32 cal., 7 shots. Regular price \$25. Our price only... \$11 | Genuine LUGER |
| No. 4528. 25 cal. genuine Mauser. The only 25 calibre automatic that shoots ten shots. Blue steel finish. Value \$35. Our price only... \$14.50 | No. 4043. 30 cal. genuine Luger. Don't be misled by a gun that looks like a Luger. We are selling this wonderful world famous automatic at such ridiculously low prices because of our ability to purchase in quantities. Shoots 9 shots. Has automatic magazine ejector. Latest model with safety attachment. Regular value up to \$60. Our special \$28.50 only. |
| No. 5028. 32 cal. genuine Mauser automatic. Shoots 9 shots. Blue steel finish. Value \$40. Our price only... \$15.50 | |

Don't wait. Order these bargains today. You take no risk. Write clearly your name, address and the number of the revolver you want. Send No Cash. We ship by return mail. Pay Postman on arrival our price, plus postage. Send for free catalogue.



Has popular swing-out cylinder, made by expert mechanics, of extra fine steel. Nickel or blue finish. Pearl handles, \$3.00 extra.

SEND NO MONEY Order to-day. Send name, address and number of revolver you want. No. 1064, 32 cal., \$17.50. No. 1564, 38 cal., \$19.00. Pay postman our price, plus postage.

HOLSTER for any of above revolvers. Genuine leather, \$1.50

GUARANTEE We guarantee absolute satisfaction after examination or your money back. Rush your order today.

PARAMOUNT TRADING CO.
34 West 28th St., New York, N. Y.

DIAMONDS For a Few Cents a Day



Send No Money

We will send you—upon your simple request—your choice of diamond bargains—the greatest in America! Do not send a penny in advance. When the ring comes, examine it. You are the judge, if it is not, without exception, the greatest value you have ever seen, send it back—at our expense! If you decide to keep it, it is yours—for a few cents a day. You may order direct from this advertisement if you wish. Don't send a cent. You do not risk a penny.

Charge-Account Plan

By our new charge-account plan, you may pay for your choice of hundreds of pieces of exquisite jewelry in sums so small that you would never think of saving them. You are also guaranteed **8% yearly dividends**—and a **5% bonus** may be earned.

Send for Bargain Book

Send your name and address today for our new 128-page book, showing hundreds of unmatchable diamond bargains. Sent **absolutely free**. It explains the dividend offer and bonus plan.

Write today to Dept. 1772

J. M. LYON & CO.
1 Maiden Lane, New York N.Y.

Roofing Book FREE

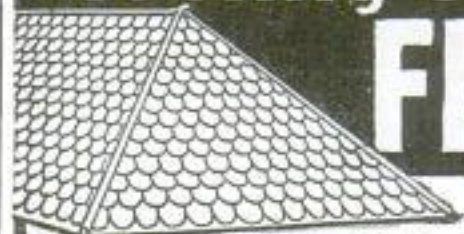

World's

Best Roofing at Factory Price

Don't buy Roofing of any kind until you get our big Free Roofing Book, describing full line of Edwards Famous "Tightcote" Galvanized Roofings, Sidings and Ceilings, and our lowest factory prices. Then see for yourself how much we save you by selling direct and saving you all in-between dealers' profits.

EDWARDS Metal Shingles

Absolutely rust proof. By our patented "Tightcote" process, edges as well as sides of metal sheets are heavily coated with zinc—not a space the size of a pin point exposed to weather. Fire and lightning proof. Outlasts three ordinary roofs. Forever wind and weather proof. Need no repairs—end all roofing expense. Patent INTERLOCKING DEVICE makes water tight seams—all nail heads covered—no chance for rust or leaks.

EDWARDS Galvanizing Test

Edwards "Tightcote" Galvanized Roofing can be bent, twisted or struck by lightning, and the galvanizing will not crack or flake. Bend it or hammer it—you can't loosen or scale the galvanizing. No other galvanized roofing can withstand this test.

Low Priced Garages

Wide variety of styles, all sizes of Portable Fireproof Metal Garages. Lowest prices ever made. Postal brings Big Garage Catalog free.

Write Today for free samples and proof that we can save you a lot of money on any kind of roofing, siding or ceiling you may need. Ask for Roofing Book No. 150.

THE EDWARDS MFG. CO.,
200-250 Pike St., Cincinnati, O.

FREE
Samples &
Roofing Book

MAKE \$10.00 A DAY

Two sales a day will do it. Any hustler can make them selling Stephens Calason Cord Tires.

GUARANTEED 10,000 MILES

Our agents get exclusive proposition. No experience or investment required. Simply send us your name and will show you how. Stephens Calason Cords are 40% cheaper than any other cord tire. We furnish sample sections and literature.

BE FIRST

WRITE QUICK

STEPHENS TIRE STORES COMPANY, INC.
104 Stephens Bldg. Kansas City, Mo.



START IN BUSINESS



Make Real Money on Small Capital

All over the U. S. and Canada we are establishing Vulcanizing Service Stations. Start one in your town. Make \$10 to \$30 per day on a \$350 investment. We instruct you and furnish the **Most Modern Methods and Equipment**—

THE ANDERSON

Known the World Over

We have 34 Schools in U. S. and 4 in Canada. One is near you. School pays you \$5 per day while learning to operate your station. Write for full particulars—TODAY.

THE ANDERSON STEAM VULCANIZER CO.

Manufacturers of Modern Tire Repair Equipment,
103 Williams Bldg., Indianapolis, U. S. A.

A. I. D. FOR FORDS

The A. I. D. Airmat pumps a Ford tire in less than 5 minutes.

Aero Fan keeps motor cooler—any one can attach.

A Real Tire Pump—no gears, cams, chains or noise.

Agents Wanted. Send for Circular
A. I. D., Inc.

1352 Beacon St., Boston 47, Mass.

MOTORCYCLES

RELIABLE STANDARD MAKES that you can **DEPEND ON**.

Enjoy the glorious experience of going wherever you like—whenever you like. The price is within your means—35% to 50% less than others. These machines are slightly used, thoroughly overhauled or rebuilt. Send for catalogue.

MYEROW BROS.,
258 Columbus Ave., Boston, Mass.

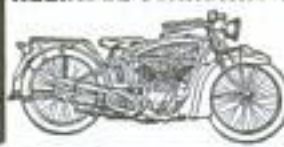

The
Prophy-lactic

Tooth Brush

Used every day—note how
your smile improves

WHEN you see a big car gliding easily up one of those endless hills, it's almost certain that a New Stromberg Carburetor is under the hood.

The Stromberg is vital equipment of the motor car today. It gets more mileage out of a gallon of gas—increases power—cuts down gas bills, which means economy.

If your car is not equipped with a Stromberg, write us for literature. Give name, model and year of your machine.

Stromberg Motor Devices Co.,
64 E. 25th Street
Dept. 214 Chicago, Ill.



New STROMBERG Does it!
CARBURETOR

MAKE YOUR FORD INTO THIS SPORT CAR \$ ONLY 6.40

Other types down to \$1.50. Famous wire fit, *Pat-Kit* life-size patterns and simple instructions show all details. You can easily convert your Ford into this fast, snappy Sport Car as hundreds have done with a few dollars worth of material from the hardware store. No need to lay up the car. The "P.A.L." with control disc wheel pattern. Pressed Metal Streamline Rear only \$6.40 delivered. Built low, rides wonderfully easy. Order NOW while we can make good delivery. Send \$6 coin for illustrated prospectus of Sport Bodies, "Pat-Kit" Type and "Pat-Kit" Wheelsets. Koempel Co., 57 Koempel Bldg., Guttenberg, Iowa



Keen, Classy Up-to-the-Minute

SAVE MONEY

MOTORCYCLE & BICYCLE PARTS, ACCESSORIES, TENNIS GOODS, CAMPING EQUIPMENT CHILDREN'S VEHICLES, FISHING TACKLE.

Send us your name for our 1922 72-page illus. Catalog No. 6. It saves you the middleman's profits of 10 to 25%.

GOTHAM SPORTING GOODS CO.
128 Chambers St., New York City.



MAKE BIG PROFITS from HB Battery Charging

MAKE BIGGEST PROFITS THIS WINTER
With winter here and batteries needing special care, HB battery charging can pay you \$150 to \$250 extra profit every month. Someone gets the business of charging those batteries—why not you? Start now—get a sturdy, dependable HB Charger with ample capacity to handle this profitable business.

THIS HB 16-BATTERY CHARGER
Recharges 1 to 16 6-volt batteries or equivalent at once. Uses 2 or 3 phase city current—cheapest and best. Current costs 4c to 12c each—owner pays 75c to \$2.00. Quick, clean, permanent profits easily made.

Small Payment Puts This Money-Maker in Your Garage or Shop
Balance on easy monthly terms. Absolute Money Back Guarantee. Write TODAY for information. Ask about HB air compressors, motor grinders, ball bearing motors, etc.

HOBART BROTHERS COMPANY
Box M-2 TROY, OHIO
Successful Manufacturers since 1893

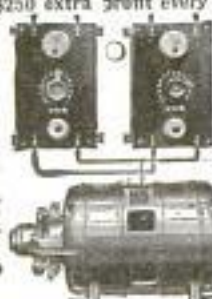

— OLD KENTUCKY — HOMESPUN TOBACCO

Direct From Our Farms to You

The Cream of the finest crops Kentucky's bountiful soil can produce—ripe, rich leaves—smooth and mellow—with that rare old-fashioned flavor and fragrance that only the proper "aging" can produce. We bank on it you have never tasted a finer flavored, more satisfying tobacco in all your life.



Ripe, Rich, Old-Fashion Leaf

Our Famous Old Kentucky Homespun is no more like manufactured tobacco than day is like night—guaranteed free from chemicals and all other adulterations that conceal imperfections, debase the sense of taste and undermine the health. Grown and matured in Kentucky's finest soil, cut at the proper time, carefully selected, aged, mellowed, cured and "seasoned" by the same method our grandfathers used in preparing tobacco for their own use—every trace of harshness leaves it—nothing to "bite" your tongue or parch your mouth—nothing to tire your taste. Mellow as the moonlight—fragrant as the rose. Like old wine from the cellar its rich fragrance permeates the air. Thousands of tobacco lovers the world over swear by its luscious smoking and chewing qualities.

"For sixteen years I have used almost every brand on the market but yours is the best I ever tasted."—W. B. Swiney, St. Marys, Penn.

Tobacco satisfactory in every way. I now realize how foolish I have been—paying exorbitant prices of the middlemen instead of buying direct from the growers' association."—C. J. Feltz, Monticello, Wash.

"Buy men, your tobacco is the best I have had since 1866 when Abraham Lincoln and I smoked together in the Sunny South. Tell all the old soldiers about it."—John F. Strad, Libby, Mont.

REDUCE YOUR TOBACCO BILL 75% We are growers of tobacco and sell none but our own crop—our co-operative marketing plan eliminates all revenue tax—all middlemen—you deal direct with the growers' association thereby saving 75% or more. No fancy packages, no decorations—just Quality and lots of it.

MONEY SAVING PRICES

5 lbs. \$2.98—10 lbs. \$5.85

(We Pay All Shipping Charges)

5 pounds will make 65 big sacks of smoking, or 65 chewing or smoking twists. With each order we send complete illustrated instructions showing how to make guaranteed smoking, old-fashioned chewing and smoking twists, cigars, etc.

WE PAY ALL SHIPPING CHARGES



Send No Money

Pay only when tobacco arrives. Try it for ten days—if it fails to please you—if it doesn't suit your taste—if for any reason you are dissatisfied, send it back and your money will be returned promptly without question. You risk nothing. Sign and mail the coupon today and enjoy the tobacco treat of your life.

Use the Coupon

TOBACCO GROWERS ASSOCIATION OF KY. MAYFIELD, KENTUCKY

TOBACCO GROWERS ASS'N OF KENTUCKY, Warehouse 524, Mayfield, Kentucky

Send me pounds of Old Kentucky Homespun Tobacco by parcel post prepaid. I will pay the price of on arrival. If not satisfied after a 20-DAY TRIAL, I will return the tobacco and you will refund my money.

Name.....
Address.....

Enter below pounds each grade wanted:
SMOKING: —mild —medium —strong
CHEWING: —mild —medium —strong

Please Mention Popular Mechanics

You Can Save \$50.00

By Recovering Your Old Auto Top Frame Yourself

We make these recoveries to fit all makes and models of cars. Any person that can drive a car can put it on. We furnish instructions. Roof and quarters sewed together with rear curtain, fasteners, welts and tacks. All complete. Give us the name, year and model number of your car, and we will send you our catalog with samples and quote you exact price.



LIBERTY TOP & TIRE CO., Dept. E7, CINCINNATI, OHIO

Auto Owners WANTED!



To introduce the best automobile tires in the world. Made under our new and exclusive Internal Hydraulic Expansion Process that eliminates Blow-Out—Stone-Bruise—Rim-Cut and enables us to sell our tires under a

10,000 MILE GUARANTEE

We want an agent in every community to use and introduce these wonderful tires at our astonishingly

low prices to all motor car owners.

Write for booklet fully describing this new process and explaining our amazing introductory offer to owner agents.

Hydro-United Tire Co.
Dept. 100 Chicago, San Francisco, Pottstown, Pa.

AUTO DRIVERS



Can make big money in spare time or devote entire time to introducing and taking orders for our

IMPROVED CORD TIRES

Highest quality. Sensational prices. Big profits. Permanent business.

Write today for catalog and agent's special offer.

LANGAN & PHILLIPS
Dept. 104 CHICAGO

Oh Boy! BUILD THIS CAR

This nifty little car driven by gasoline motor, can be built by any boy. New plans, bigger, better than ever, now ready. Send 20c for building plans and price list of parts showing how to build this lad's car.

SYPPER MFG. CO.
146 Sypher Bldg. TOLEDO, OHIO

MAKE BIG PROFITS CHARGING BATTERIES \$20*Brings You an HB*Charger

Balance on long easy terms, more than paid for by your big monthly profits. No expense for bulbs, burn-outs or expensive renewals. Sizes for 6, 10, 16 or 22 batteries. Write us for recommendation on outfit to make you biggest profits. HB users clear \$150 to \$300 monthly—you can, too! Write today.

Hobart Brothers Company
Box M 222 Troy, Ohio



SHOMONT WHITE COLLIES

Thoroughbreds—the Aces of All Dog-dom. The most beautiful dogs in the world. Intelligent, fearless, faithful. They guard your home, watch your herds, play with your kiddies. Are guaranteed right. Write for special lists. SHOMONT KENNELS, BOX 101, MONTICELLO, IOWA.

An Easy Way to Make Money

Don't be content to plod along on a small salary. Be independent. Go in the tire repairing business and make \$60 or more a week. One man made \$45 the first day he received his outfit. Others are making \$25 a day and hundreds of wide-awake men are making \$200 to \$500 a month.

No experience needed. We teach you how. Very little capital required. But slight risk, as every car owner in your town is a possible customer. Jobs are plentiful because tires blow out and puncture every day. Business is good the year round.

SHALER Tire Repair Outfit, \$75

Will do as much and as perfect work as the big \$250 to \$500 vulcanizing outfits. A boy can vulcanize perfectly with this simple machine. It's the only vulcanizer that has Automatic Heat Control. It must vulcanize just right. It can't undercure or overcure a tire. Requires no watching or regulating. You can learn to do expert tire vulcanizing in half an hour with the Shaler.

WRITE FOR FREE BOOK "HOW TO OPEN A TIRE REPAIR SHOP" and complete Catalog, which gives full information. WRITE QUICK BEFORE SOME HUSTLER GETS AHEAD OF YOU.

C. A. SHALER CO., 2001 Fourth Street, WAUPUN, WISCONSIN

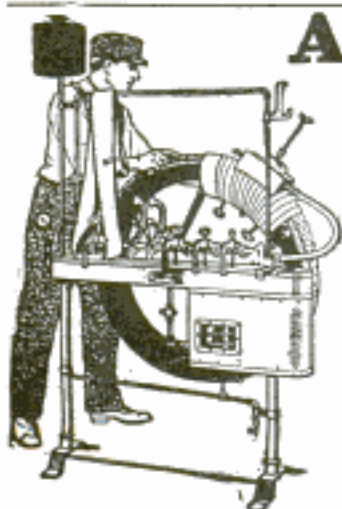

NOW ONLY \$295
PRICES SMASHED

Was \$625.00 **Direct from Factory**

1922 Model H. U. 1250 Watt
Lalley Light and Power Plant
 Electricity for Farms and Rural Places

World's greatest lighting plant value. My famous model HU 1250 watt capacity Lalley Plant sold until recently for \$625. You can get it, if you act promptly, for only \$295, complete with battery, direct from factory to you. Anyone can install it. Ample capacity for your future needs. Proved by 12 years' service. Guaranteed. Approved by National Fire Underwriters—30 days' trial—terms. Don't confuse this big 1250 watt capacity Lalley with smaller plants. Don't miss this opportunity.

FREE! Write today for free literature and information. ACT NOW—as I may have to increase this price almost any day.

W. H. LALLEY, President
 Lalley Light Corp.
 Dept. 73
 Detroit, Mich.
Save \$330



Electric light and power for Farms, Country Residences, Summer and Winter Cottages, Lumber Camps, Yachts, Motor Boats, Charging Batteries, etc.

WAS \$625.00 NOW \$295.00

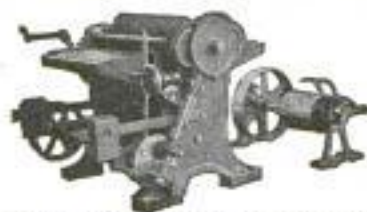

It is the well known quality of CRESCENT machines that justifies you in selecting one of them each time you have need for wood working machinery. The CRESCENT line is better than ever and will always give you satisfaction in every particular. Ask today for catalog of hand saws, saw tables, jointers, shapers, planers, borers, splacers and matchers, swing saws, disk grinder, cut off table, hollow chisel mortiser, variety wood worker, Universal wood workers.

THE CRESCENT MACHINE CO., 93 Columbia Street, Leetonia, Ohio

Swing 4 in., 11 in. between centers, 17 in. total length. Shipping weight 13 lbs. Bed of lathe is machined. Workmanship first-class. Equipped with wood turning chuck. Can be fitted with 3 in. face plate and drill chuck as special equipment. Order one today.



Price \$6.00 cash with order
 Made also in larger sizes.
 SYPHER MFG. CO.
 Dept. D, TOLEDO, OHIO

NEW MOTORS FOR ALL PURPOSES
 STANDARD MANUFACTURERS
 PROMPT DELIVERY

ALL SIZES UP TO 5 H.P.

We Specialize In Small Motors & Generators
 ALL PHASES AND FREQUENCIES IN STOCK AT ALL TIMES
 Largest exclusive Mail Order Small Motordealers in the world.
 CHAS. H. JOHNSTON, Box 15, West End, Pittsburgh, Pa.

WIRELESS, TELEPHONE GENERATORS
 500 VOLT - 100 WATT - 3400 R. P. M.
 FOR MOUNTING MOTOR GENERATOR SETS.

\$28.50 EACH

WRITE FOR CATALOG



Enders

SAFETY RAZOR

*“Just like
 wiping your
 face with
 a towel”*



Perfectly
 Simple
 Simply
 Perfect

ENDERS SELLS FOR \$1.00 with six blades of the best quality Swedish-base steel. Packed in black Keratol box, velvet lined. Extra blades, package of 5—35 cents. IN CANADA—Razor, \$1.50; blades, 50 cents.

For Sale by all Up-to-Date Dealers Everywhere

ENDERS SALES COMPANY
 105-111 West 40th Street, New York

H. E. Enders
 TRADE MARK
 PAT. MAY 2, 1906

This 1/4 hp A.C. Motor \$13⁵⁰ Guaranteed for One Year

MOTOR is for 110 volt 60 cycle service; 1740 rpm, split phase, fan cooled induction type, suitable for washing machines, churns, cream separators, fans, blowers, lathes, drills, etc. With cord and plug as shown, or reversible type with binding post terminal.

Send cash with order or we will ship by express C. O. D. if you prefer.

NORTHWESTERN ELECTRIC COMPANY, 408 So. Hoyne Ave., CHICAGO



WOODWORKERS! Make Big Money

Put this PARKS in your workshop!



"Four-in-One"—a husky machine for fast, clean work and long service. Steel frame construction. Thousands in use. Four machines in one. Circular rip and cross-cut saw, band saw, jointer, and borer. Guaranteed 10 years. 10 days' free trial.

Many Other
Combination
Woodworkers
LOW PRICES

Send for Catalog

THE PARKS BALL BEARING MACHINE CO.
1500-1540 Knowlton Street, Cincinnati, O.

Canadian Factory: 200 Notre Dame East, Montreal, Canada

PARKS

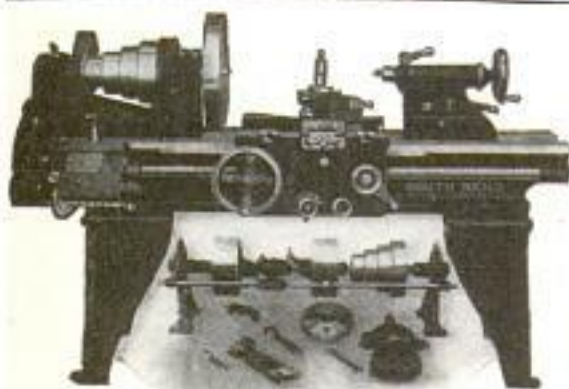

How to Run a Lathe An 80-page book, postpaid to any address for ten cents, silver or stamps accepted.

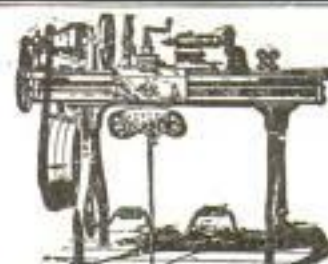

LATHES

9 to 18-inch Swing

List price \$165 and up according to size. When ready to buy send for Lathe Catalog and prices.

W. F. & John Barnes Co.

100 Ruby Street, ROCKFORD, ILL.

STARK PRECISION BENCH LATHES and BENCH MILLERS



The original Spring Chuck Bench Lathe. Six sizes, with attachments for Turning, Screw Cutting, Milling, Drilling, Grinding, etc. The best for laboratory, experimental and manufacturing purposes. Prices, No. 4, with Milling Attachment like cut, \$365.00. Plain Lathe \$155.00. Catalog free.

STARK TOOL CO., Waltham, Mass.
Established 1868



Pilliod General Service Case

Heavy copper-plated over zinc. Brass-plated hardware. Handsome, durable, great for machinists, repair men, motormen, autoists, etc. Will last a lifetime.

FREE—Illustrated folder including tool cases for every purpose.
THE PILLIOD LUMBER CO.
Dept. 1 SWANTON, OHIO

MECHANIC'S POCKET SECRETARY

Constructed of finest steel. Just push the button and out comes the article you require. Worth \$1.00. Postpaid

25c

Get One Today



25c

10 in 1 —

Adjustable Pencil, pen, paper knife, ink eraser, pencil sharpener, nail file and cleaner, mechanic's marking point, fine compass with screw attachment, foot rule.

Universal Co. Box 300, Stamford, Conn.

REDUCED PRICES Back to Normalcy -- 20% Further Reduction "SOUTH BEND" LATHES

	Standard Change Gear	Quick Change Gear		Standard Change Gear	Quick Change Gear
9'x3' Lathe	\$176.00	\$216.00	16'x 8' Lathe	\$452.00	\$512.00
11'x4' Lathe	228.00	273.00	18'x10' Lathe	656.00	721.00
13'x5' Lathe	304.00	354.00	21'x12' Lathe	848.00	923.00
15'x6' Lathe	376.00	431.00	24'x14' Lathe	1140.00	1230.00

64-page Catalog No. 75 for 1922 sent free to any address.

ESTABLISHED 1906

SOUTH BEND LATHE WORKS,
625 E. Madison St. SOUTH BEND, IND.

Mend Your Own Utensils With **SOLDERALL**

Patented Oct. 3, 1911

A Paste That Turns Into Metal When Heated



25c per tube

A match will do it, but best results can be obtained by using our new improved torch. Requires no acid or soldering iron. Joins or repairs wires, metal or metalware. Sold by Hardware and Electrical Stores, or sent by us postpaid.

COMBINATION SET \$1.75
Tube and Torch Complete
SOLDERALL CO., Dept. P
129 Sussex Avenue NEWARK, N. J.
Dealers Send for Quantity Prices
Beware of Imitations with Similar Names



The only stitcher that works with or without bobbin. A valuable feature. Saves refilling.

STEWART-SKINNER CO.

26 Green St.
Worcester,
Mass.



MENDING WITH THE **SPEEDY STITCHER**
IS EASY

PRICE 1.00

AGENTS WANTED

Interlox

Always Ready to make instantly accurate

inside or outside measurements. Slides in and out. No slow folding:

Strong brass-trimmed boxwood. Any length, 2 to 8 ft. If not at your dealer's, send postpaid.

MASTER RULE MFG. CO., INC.
841-43 East 136th Street, New York City
Dealers and agents: Request attractive proposition.

THE HANDIEST TOOL in the WORLD

THE OLSON MAGAZINE SCREW DRIVER

Large enough to hang a door. Small enough to fix a bell. Used by—Carpenters, Machinists, Farmers and Automobile men.



Three blades and oneawl guaranteed. Dealers and agents write for special proposition.

Only 5/8" long.

\$1.25

Olson Mfg. Co., 52 Commercial St., Worcester, Mass.

BURN YOUR NAME ON TOOLS WITH ARKOGRAF

Protect your tools from theft. Write any name, engrave any design on metal with electricity as easily as writing on paper with pen or pencil. Complete outfit \$3.50, prepaid anywhere. Interesting descriptive circular free. Write today. Agents Wanted. Arkograf Pen Company 895 Capitol Ave. Portland, Oregon

DISSTON SAWS

"The Saws Most Carpenters Use"

HENRY DISSTON & SONS, INC.
Philadelphia, Pa. Canadian Works, Toronto, Can.

THE WORLD FAMOUS

Alvan Clark Telescope

We are now able to supply these wonderful instruments for terrestrial and astronomical observations. Cut shows new type 3" portable terrestrial. Light weight—compact—easily carried anywhere—highest quality throughout. Circular and prices on request.

THE ALVAN CLARK & SONS CORP.
Makers of the famous "Yerkes" and "Lick" Telescopes
55 Henry St. Cambridge, Mass.



"Red Devil" Pliers made in 100 styles—one for every need. Known and used the world over. Style 1024—6½ inch, from dealers or from us, \$1.25.

Do that difficult drilling job right and in less time with a

Red Devil

Reg. U. S. Pat. Off.

Chain Drill



JUST the tool for that difficult drilling job! It makes it easy for you to drill engine cylinders, angle irons, pipes, pipe flanges, tanks, boilers, wagon tires, etc.

The "Red Devil" Automatic Chain Drill drills with less work on your part

than driving an auger bit through wood. No adjustments necessary—saves drills—saves time—no pressure required—the automatic feed does it all.

The "Red Devil" Chain Drill is portable. Weighs only 2¼ lbs. You take the tool to the work, instead of the work to the shop.

Uses ordinary twist drills, either round or square shank, from 1/8" to 1/2".

At all reliable dealers everywhere or from us \$4.80. Mention style 2018.

Write for mechanic's tool booklet

SMITH & HEMENWAY CO., Inc.
Manufacturers of "Red Devil" Tools
260 Broadway, New York, N. Y.

"Red Devil" Glass Cutters—the glaziers' standard tools of the world. "It's all in the wheel." Made in 40 styles. No. 024 shown here, 20c.



MONARCH JUNIOR LATHES

"The Biggest Little Lathe Built"

A real engine lathe—small, sturdy, compact, low-cost—guaranteed to do all small work with 1/1000 of inch accuracy. Built with the same care and precision that made **MONARCH ENGINE LATHES** the world's standard of quality and efficiency.

THE MONARCH JUNIOR is ideal for beginners. Occupies small space in your own home or shop. Easy and economical to operate. Simple and trouble-proof, automatic safety features. Fully equipped.

The Greatest Achievement in Lathe Building History

Monarch Junior 9 in. \$225 With Bench Engine Lathe Legs

Full particulars and a Monarch Junior Catalog will be sent you on request.

THE MONARCH MACHINE TOOL CO.
200 Oak Street Sidney, Ohio



MYERS WONDERFUL SEWING AWL

Tools in Handle



A complete repair shop in itself. Sews anything heavy or light, leather, shoes, harness, buggy seats, covers, belts, etc. \$1.00 Postpaid.
C. A. MYERS COMPANY, 6339 Woodlawn Ave., Chicago, Ill.



The Midget "FIVE-IN-ONE" Slide Rule is a combination Mannheim, Log-Log, Add and Subtract, Polyphase and Binary Slide Rule. It will instantly add, subtract, multiply and divide any combination involving whole numbers, fractions, decimals and mixed numbers. Gives every possible root and power of every quantity. The graduations are printed on metal, coated with white celluloid and are grease and waterproof. While it is the most versatile calculator ever invented, its operation is simple and easily understood. Diameter 4 inches. Price with 16-page instruction book, \$1.50. Leatherette carrying case 50c extra. Catalog free. Your money back if you are not satisfied.
GILSON SLIDE RULE CO., Niles, Mich.



Save Money On Your Tools!

Save your tools—prevent damage—discourage "borrowing"—have your tools in order and increase your efficiency.

A style, size and price to suit your trade and purse. Catalog free.

Gerstner & Sons

707 Columbia Street DAYTON, OHIO



MAJOR'S CEMENT

UNEXCELLED for repairing china, glassware, earthenware; furniture, meerschautin, vases, books; for tipping billiard cues, etc. Saves money. The reliable cement, famous since 1876. Major's Rubber and Leather Cements are good.

All three kinds—20c per bottle. At dealers or write us.
MAJOR MANUFACTURING COMPANY NEW YORK

OSTER

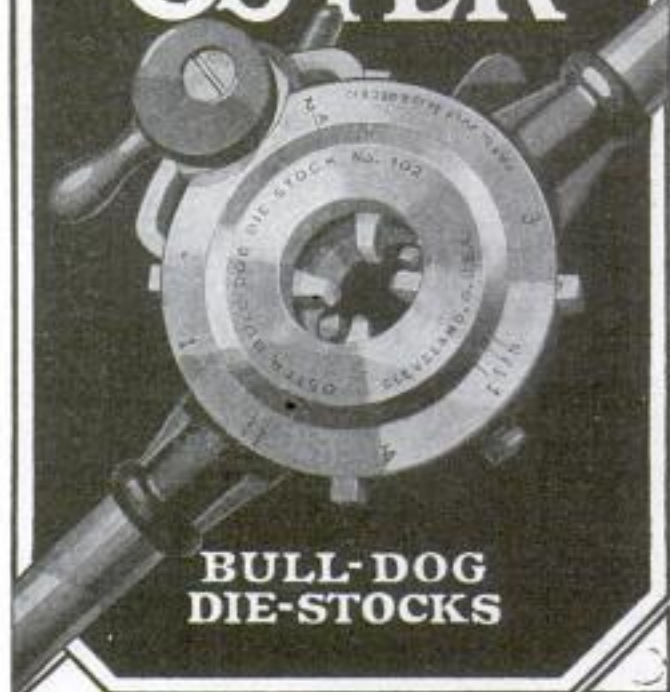

BULL-DOG DIE-STOCKS

Send for illustrated folder describing the tools with the 5 Big Features—Oster Bull-Dog Die-Stocks.

THE OSTER MANUFACTURING COMPANY
2100 E. 61st Place Cleveland



DISTRIBUTORS

DISTRICT MANAGERS SALEMEN AGENTS

Do you know that we make the best Waterproof Aprons and Sanitary Specialties on the market? Sell for less, and your profits are largest.

Write now and convince yourself.

B & G RUBBER MFG. CO.
618 Penn Ave., Dept. 118, Pittsburgh, Pa.

HAWAIIAN IM. DIAMONDS



No. 2010 Special price \$2.98

The Greatest Discovery the World Has Ever Known

Just to advertise these famous Im. diamonds we will send you one of these 14kt gold rings, postage paid. When it arrives pay postman \$2.98 C.O.D. charges to cover cost, etc. Only 10,000 rings given away. Money refunded if you can tell it from a genuine diamond. Send size of finger.

KRAUTH & REED

Dept. C Masonic Temple Chicago



No. 2011 Special Price \$2.98

The WONDERFUL ERICKSON PATENT LEG

Will not chafe, overheat, nor draw end of stump.



ERICKSON ARTIFICIAL LIMB CO., 35 Wash. Av. N., Minneapolis, Minn.



The "BEST" LIGHT

Positively the cheapest and strongest light on earth. Used in every country on the globe. Makes and burns its own gas. Casts no shadows. Clean and odorless. Absolutely safe. Over 200 styles, 100 to 2000 Candle Power. Fully Guaranteed. Write for catalog. **AGENTS WANTED EVERYWHERE.**

THE BEST LIGHT CO., 324 E. 5th St., CANTON, O.



BALE 'EM UP with Bernard's! Pliers with the open throat that will swallow a wire a mile long. A vise-like grip and a sure, clean cut. Many styles and sizes at hardware dealers.

MADE IN SEVEN SIZES

Send for illustrated Plier Booklet M



BERNARD PLIERS

Wm. SCHOLLHORN CO.
NEW HAVEN, CONN.



OUTSIDE CUTTER

FURS

Coats, Scarfs, Muffs, Chokers, etc., made from your raw or tanned furs. Enormous savings. Write for FREE CATALOG today. Tells everything.
ARTHUR FELBER FUR CO.
Dept. PM, 29 N. Dearborn St., Chicago, Ill.



Save 1/2 Shoe Cost

Can't Come Off

Can't Slip

FLEXIBLE STEEL SOLE AND HEEL PLATES

Make sole and heel out-last uppers. Bond to fit shoe. Non-skid; corrugations prevent slipping. Weight 2 oz. Tacks with plates; put on yourself; money back if not satisfied.

By mail postpaid. Set (sole and heel plates) Men, Women or Boys' size, **50c**

Agents, dealers, cobblers wanted.
SHOE SHIELD CO., Dept. 92, AUGUSTA, KY.

No More Shapeless Twisted Neckwear



Salesmen wanted everywhere. MEN AND WOMEN take orders for high grade TAILORED neckwear, cheaper than ordinary kind. Lasts and looks five times better.

SIX MONTHS' GUARANTEE

Patented. Not sold in stores. No competition. No delivering. No collecting. BEAUTIFUL SILK SAMPLES. Customers hunt you up to place their orders.

ASK FOR EVERY DAY MONEY PLAN

BETTER-MADE CRAVAT CO.

614 Clinton Bldg.

Columbus, Ohio



Boston Garters never grow tired of their job—holding socks in place. They stay "Peppy" no matter how much leg work a chap has to do.

GEORGE FROST CO., BOSTON, Makers of Velvet Grip Hose Supporters for All the Family

'47.25 PROFIT IN FOUR HOURS MAKING DOUGHNUTS

Take in \$25 to \$100 a day with this Machine.

Doughnut Making business has wonderful possibilities. Doughnuts have taken country by storm. Enormous demand must be supplied. \$25 to \$100 a day earned with this Automatic Doughnut Machine. Capacity 800 doz. a day. Doughnuts sell fast at 40c to 50c a doz., netting over 100% profit. No experience needed. Flour ready prepared—add water—put dough in hopper—turn crank—out drop sweet, savory, golden doughnuts.

Money-Making Possibilities are Unlimited
Put this Automatic Doughnut Machine in display window and attract crowds; entice odor whets appetite; you take in money fast. Jos. F. Donnemeyer, Pa., says: "Made \$47.25 profit four hours after set up machine." Others report earnings equal or better. Big money wholesaling to hotels, stores, restaurants, etc.

Be First Man in Your Town To Start This Big Paying Business. Get in on the ground floor—act quickly before others start. These machines pay big anywhere—no town too small. Get full details of this new, profitable business—it costs nothing to investigate. High and good coupon today.

BUTLER MFG. CO.
5650 W. Lake Street
Chicago, Ill.

BUTLER MFG. CO.
5650 W. Lake St., Chicago, Ill.

Send details of Automatic Doughnut Machine and business.

Name.....
Address.....

Learn Salesmanship FREE

Learn it in the easiest, quickest, most practical way—in the school of actual experience. The way to learn anything is by doing. The way to learn Salesmanship is by selling. Let us show you the way. Let us start you out in this most fascinating and profitable of all professions, teach you the rules of the game and show you how to play it, in such a clear, concise and simple way that you can go right out and sell from the very start.

Make Money While Learning

We supply everything, including the finest Selling Outfit in America. Young men and old veterans at the game pronounce ours the most effective Salesmanship training in the world—and the most profitable. Bear in mind that by our plan you start learning and earning from the very first moment you take up the work.

Get the Facts—Now Investigate our proposition. It may prove a turning point in your career. Send no money. Just a line to let us know that you're really interested. The full facts about us and our plan will come back to you by return mail. Address Dept. A-212

GOODWEAR (Inc.) Chicago

10 Cents a Day Pays



For smaller Symphonola. Style pictured and others 17c to 25c a day. Tens of thousands giving satisfaction.

SYMPHONOLAS

No expensive attachments needed to play all Records. Tone natural, life like. Well built. Highest quality equipment.

NO MONEY DOWN

Shipped anywhere in U. S. 30 Days FREE Trial before you make first payment. If pleased take up to 2 years time.

RECORDS 70c EACH

Play on all phonographs using steel needles. Latest vocal and instrumental hits. Also Sacred and Operatic. Full size 10 inch. Postpaid. Ask Today for Symphonola Booklet and Record List.

Larkin Co., Inc.

Desk SPH-222

Buffalo, N. Y.

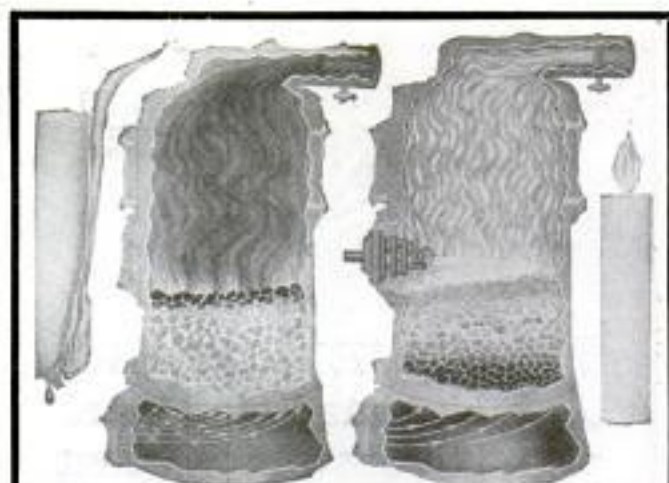

Rich Gases Unburned, Wasted Up the Chimney—WRONG WAY.

Pre-Heated Air Injected Turns Gases into Intense Heat—RIGHT WAY.

Make Big Profits Selling Crown Fuel Savers

RIGHT now is a mighty good time to get into business for yourself as a Crown Fuel Saver Distributor. High fuel prices create big demand for this wonderful device, which saves 20% of fuel in furnaces and boilers with less labor, smoke, soot, clinkers and ashes.

Crown Fuel Savers have a six-year success record and sell everywhere on their merit **the year 'round**. Distributors are making \$250 to \$500 a month clear.

Exclusive territory—high-power selling helps—constant service and backing of strongest company on field. Write now for full details of our extra liberal contract which puts you into a money-making business on the right footing.

CFSCO, 15 N. 10th St., RICHMOND, IND.

\$2 Puts this **ELGIN WATCH** In Your Hands

No Red Tape, No Waiting

Simply send \$2.00 and receive watch. Full seven Jeweled Elgin in stylish Octagon Case. Thin model, guaranteed 20 years.

30 DAYS FREE TRIAL

Send only \$2.00 and watch comes charges paid. Carry for 30 days and if not satisfactory your deposit is returned. Pay balance \$2 a month for 10 months. Price only \$22.00. Send for FREE CATALOG, addressing Dept. 481.

ROYAL DIAMOND & WATCH CO.
35 Maiden Lane, New York



Profit and Protection \$7.75

Carry this revolver and be always fully protected. This handsome firearm is the style of weapon adopted by the police and secret service of many cities. The most accurate and dependable of firearms. Has popular break cylinder. Made of extra fine nicked steel by expert mechanics. Shoots five times before reloading.

Send No Money

Order to-day. Just send your name and address and state which style revolver you want. Pay Postman our price and postage on arrival. Money back if not completely satisfied after examination.

No. 2020 is 32 cal., 3 1/4-in. barrel. Pay Postman \$7.75 and postage on arrival.
No. 2520 is 38 cal., 3 1/4-in. barrel. Pay Postman \$9.00 and postage on arrival.

Paramount Trading Co., 34 West 28th St., New York City

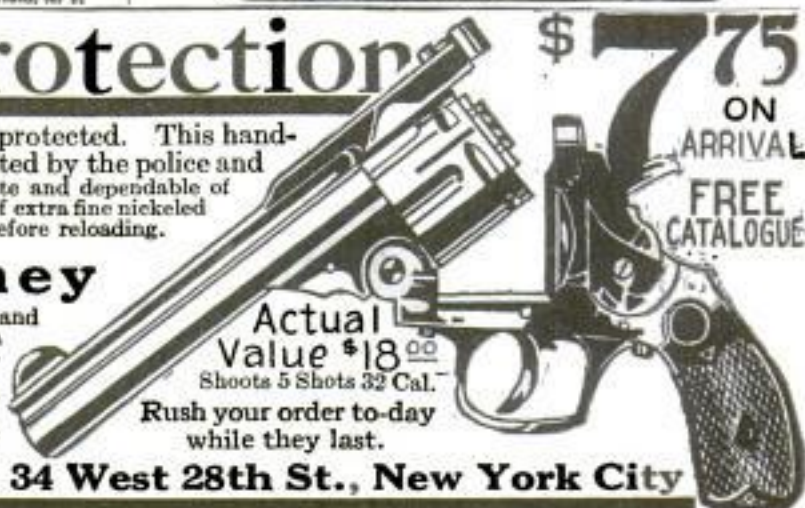

Actual Value \$18.00
Shoots 5 Shots 32 Cal.

Rush your order to-day while they last.

ON ARRIVAL
FREE CATALOGUE

ONE-HAND-Y ELECTRIC DRILL

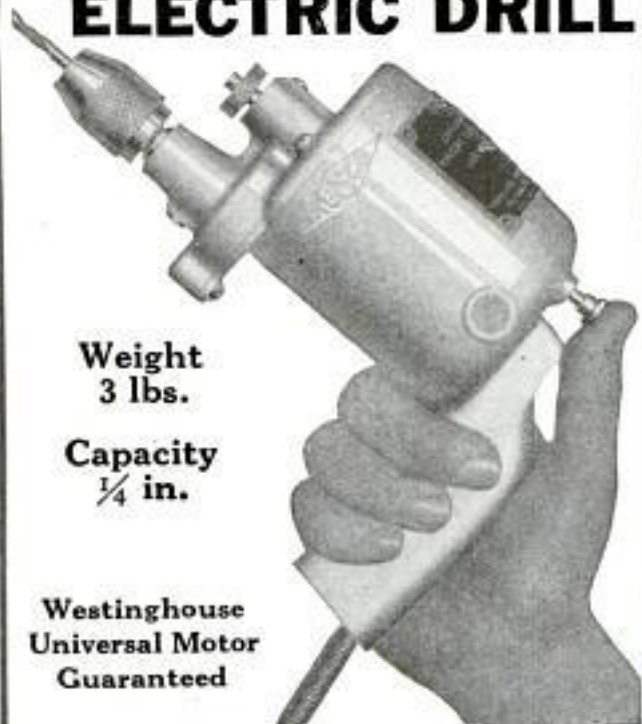

Weight
3 lbs.

Capacity
1/4 in.

Westinghouse
Universal Motor
Guaranteed

Knight Engineering & Sales Co.

30 West Walton Place,
Chicago, Ill.

210 W. Seventh Street,
Los Angeles, Calif.

Peppodent

PAT. OFF.
REG. U.S.

The New-Day Dentifrice

\$600 to \$5,000 PROFIT FROM WASTE STORE SPACE



Business men! Send for amazing story of Butter-Nut Popcorn and Peanut Machine profits. Pays big in drug, department, candy other stores, theatres, etc. Write
HOLCOMB & HOKE MFG. CO.
946 Van Buren St. Indianapolis, Ind.

THIS IS THE MACHINE THAT MAKES YOUR WASH TUB INTO A Washing Machine

Don't get a lame back and wrinkles
Remedy the SPENDING QUICKEST & EASIEST

Wash your clothes clean quickly and easily without wear this way. Surely your better health and less wear on clothes is worth 5 cents a week for three years. This simple machine is guaranteed that long. Delivered prepaid on 30 days' free trial anywhere in U. S. A. Even easy monthly payments if desired. Send for circular how to save work.

VACCUP
Semi Automatic

BURLINGAME MFG. CO.
222 Sunset Avenue Syracuse, N. Y.

The Dying Pig



The most laughable novelty yet produced. Made of rubber, and you blow it up and stand the pig on his feet, when he begins to squeal as he slowly collapses and finally lies down and dies in the most natural manner. You can blow him up as often as desired, and each time he will go through the same performance to the great amusement and delight of your friends.

Price 15 cents; 3 for 40 cents; one dozen \$1.35, mailed postpaid.

Johnson Smith & Co., 3224 N. Halsted Street, Dept. 776, Chicago

Popular Watch Charms



Very pretty little curiosities and decidedly novel. Fitted with Magnifying Lenses that enlarge the pictures to a very surprising degree; in fact, it seems almost incredible that a clear picture could be possible in such a small compass, and how sharp and distinct they show up when you look through. Come in assorted views—Artresses, views of Panama Canal, Lord's Prayer in type, etc.

Price 15c 3 for 40c; \$1.35 doz.



TYPEWRITER SENSATION!

Free Trial—Use as You Pay

Send us only \$5.00 a month until the low total price of \$64.85 is paid, and the machine is yours.

This is absolutely the most generous typewriter offer ever made. Do not rent a machine when you can pay \$5.00 a month and own one. Think of it—Buying a \$100.00 Machine for \$64.85. Cash price, \$59.85, just a little more than half its original price.

L. C. SMITH Model No. 5

Perfect machines, Standard size, Keyboard of Standard Universal arrangement, 42 Keys, writing 84 characters—universally used in teaching the touch system. The entire line of writing completely visible at all times, has the tabulator, the two color ribbon, with automatic reverse, the back spacer, ball bearing type bars, ball bearing carriage action, ball bearing shift action, in fact every late style feature and modern operating convenience. Comes to you with everything complete; tools, cover, operating book and instructions—nothing extra to buy. You cannot imagine the perfection of this beautiful reconstructed typewriter until you have seen it. We have sold thousands of these perfect late style machines at this bargain price and every one of these thousands of satisfied customers had this beautiful, strictly up-to-date machine on five days' free trial before deciding to buy it. We will send it to you F. O. B. Chicago for five days' free trial. It will sell itself, but if you are not satisfied that this is the greatest typewriter you ever saw, you can return it at our expense. You won't want to return it after you try it, for you cannot equal this wonderful value anywhere.

SEND NO MONEY Put In Your Order Now

\$4.85 AFTER TRIAL

When the typewriter arrives deposit with the express agent \$4.85 and take the machine for five days' trial. If you are convinced that it is the best typewriter you ever saw keep it and send us \$5.00 a month until our bargain price of \$64.85 is paid. If you don't want it, return it to the express agent, receive your \$4.85 and return the machine. We will pay the return express charges. This machine is guaranteed just as if you paid \$100.00 for it. It is standard. Over half a million people own and use these typewriters and think them the best ever manufactured. The supply at this price is limited, the price will probably be raised when next advertisement appears, so don't delay. Fill in the coupon to-day—the typewriter will be shipped promptly. There is no red tape. We employ no solicitors—no collectors—no chattel mortgage. It is simply understood that we retain title to the machine until full \$64.85 is paid. You cannot lose. It is the greatest typewriter opportunity you will ever have. Do not send us one cent. Get the coupon in the mails to-day—sure.

SMITH TYPEWRITER SALES CO., 222, 218 N. Wells St., Chicago, Ill.

SMITH TYPEWRITER SALES CO., 222, 218 N. Wells St., Chicago, Ill. Ship me the L. C. Smith Model No. 5, F. O. B. Chicago, as described in this advertisement. I will pay you \$5.00 monthly as rent until the \$60.00 balance of the Special \$64.85 sale price is paid. The title to remain in you until fully paid for. It is understood that I have five days in which to examine and try the typewriter. If I choose not to keep it I will carefully repack it and return it to the express agent. It is understood that you give the standard guarantee.

Name.....
Street Address.....
City..... State.....
Occupation or Business.....

Please Mention Popular Mechanics

PATENTS TRADE-MARKS AND COPYRIGHTS

SPECIAL OFFER — Free Opinion as to Patentable Nature

Before disclosing an invention, the inventor should write for our blank form "Evidence of Conception." This should be signed and witnessed and if returned to us together with model or sketch and description of the invention, we will give our opinion as to its patentable nature.

Our Three Books Mailed FREE to Inventors

OUR ILLUSTRATED GUIDE BOOK

HOW TO OBTAIN A PATENT

Contains full instructions regarding Patents, Trade-Marks, Foreign Patents, Our Methods, Terms, and 100 Mechanical Movements illustrated and described; Articles on Patent Practice and Procedure, and Law Points for inventors.

OUR TRADE MARK BOOK

Shows the value and necessity of trade-mark protection and gives information regarding unfair competition.

OUR FOREIGN PATENT BOOK

We have direct agencies in all the principal foreign countries and secure foreign patents in the shortest possible time and at the lowest cost. Write for our illustrated Guide Book on Foreign Patents, sent free to any address.

Specialization—Our Staff

The field of invention is so vast that it is impossible for any one man to become an expert in all the different classes of invention. Only those practically skilled in the class to which the invention relates are capable of rendering efficient service. For this reason Victor J. Evans & Co. employ a number of patent lawyers and mechanical experts who have been selected for their special knowledge and ability in certain lines of invention. Each case is placed in charge of experts in the classes to which the invention relates.

THE VALUE OF YOUR PATENT

will depend much upon the skill and care with which your case is prepared and prosecuted in the United States Patent Office. This work will receive the benefit of skill and experience acquired by a long and successful practice. We spare neither time nor pains to secure the broadest possible patents that the inventions will warrant. That every case intrusted to us receives our best efforts, and that our work is done consistently, skillfully, and thoroughly is evidenced by the many unsolicited letters of commendation that we receive constantly from our clients. We will furnish upon request lists of clients from any State in the Union for whom we have secured patents.

Our New York, Philadelphia, Pittsburgh, Chicago and San Francisco Offices

Owing to the growth of our business we have established for the benefit of our clients Branch Offices in New York City, Philadelphia, Pa., Pittsburgh, Pa., Chicago, Ill., and San Francisco, Cal. These branch offices being located in these large commercial cities together with our Main Office located near the U. S. Patent Office, in Washington, enables us to more promptly handle the business of our clients, particularly as the branch offices are in constant touch with the Main Office and fully equipped to handle patent business in all its branches.

Highest References — Prompt Attention — Reasonable Terms

---FREE COUPON---

VICTOR J. EVANS & CO., Patent Attorneys

NEW YORK OFFICES
1007 Woolworth Building

CHICAGO OFFICES
1114 Tacoma Building

PHILADELPHIA OFFICES
135 South Broad Street

PITTSBURGH OFFICES
514 Empire Building

SAN FRANCISCO OFFICES
Hobart Building

MAIN OFFICES: 765 9TH STREET, N.W., WASHINGTON, D. C.

Gentlemen: Please send me FREE OF CHARGE your books as described above.

Name Address

WANTED IDEAS



Inquiries from Manufacturers and Others Who Are Looking
for Good Ideas

PROTECTED BY PATENTS

are constantly being received. Manufacturers are always interested in any new device for which there is a market, which fills a long felt need, which makes production possible at a lower cost, or which will do the work BETTER. Extracts from some of the more recent letters received are printed herewith. There is undoubtedly a great demand today for really worth while inventions.

Your First Step

If you have an idea, send immediately for my blank form "TO RECORD YOUR INVENTION." You should serve your own best interests by filling out and signing this form before you disclose your invention TO ANY ONE. This document will help you determine and establish evidence of invention before filing an application in the U. S. Patent Office. A copy, with full instructions, will be gladly sent free on request.

NEW BOOK "SUCCESSFUL PATENTS" SENT FREE

Every man who has an invention, or ever hopes to have one, should send for a copy of my book "SUCCESSFUL PATENTS." It tells what everyone should know about patents, trade-marks, copyrights, etc. It describes my methods, fees and terms, gives information relative to assignment or sale of rights, and instructions in detail. Mail coupon today for a free copy of this book or a post card request will do.

To the Man with an Idea

I offer a comprehensive, experienced, efficient service for his prompt, legal protection, and will endeavor to aid him in the commercial development of his proposition—my service is distinguished by over 12 years' successful practice, and by thousands of satisfied clients and by reasonable fees.

Send sketch, or model, and description, for advice as to cost, opinion as to its patentable nature, etc. Preliminary advice gladly furnished without charge.

-----COUPON-----

RICHARD B. OWEN, Patent Lawyer

Main Office, 9-303 Owen Bldg., Washington, D. C.
Branch Office, 2276-E Woolworth Bldg., New York City.

Please send me, without charge, or other obligation, a copy of your book, "SUCCESSFUL PATENTS," your form "TO RECORD YOUR INVENTION," and information concerning patents, etc.

Name.....Address {

Can You Help?

Here are abstracts from a few recent requests I have received from those who wish to buy, finance or manufacture good inventions. Have you an idea that will fill the bill?

Following is an extract from letter dated July 20, 1921, from a middle western manufacturer whose volume of business last year was approximately \$1,000,000. "If you are in touch with any meritorious proposition seeking manufacturing facilities, in the automotive or some other good field, we shall be glad to have you place us in touch with it. We are willing to consider outright purchase of patents or manufacture upon a royalty basis."

Another request from a large corporation, dated June 27, 1921, follows: "Should you have clients whose inventions are worthy of commercial manufacture and exploitation, we shall be glad to consider the financing of such projects, if they are interesting. In that event, we indicate also that we are identified with two large machinery manufacturing plants located, respectively, in Bridgeport, Ct., and Providence, R. I. These plants, besides having their own foundries, are thoroughly equipped to manufacture anything from a small lathe to a complete automobile. Whether your clients have mechanical inventions or otherwise, we shall be pleased to hear of any proposition requiring financing."

Another letter dated April 28, 1921, from a large corporation whose officers include some of the best known men of the country, says in part: "We are in the market for an invention of merit possessing undoubted economic and commercial value combined with ADEQUATE PATENT PROTECTION."

PATENTS PROMPTLY PROCURED TRADEMARKS REGISTERED

Send disclosure of invention, design, or trademark for actual search of U. S. Patents and novelty report. Validity and infringement investigations. Patent and trademark suits prosecuted and defended anywhere in the United States. Discriminating clients appreciate my efficient service. No literature will be sent you as this is a professional service, *individual* and *Personal*. Specific information and advice given regarding each individual case. Specialize in prosecution of pending cases that have been previously rejected by the Patent Office. Specialize also in unfair competition litigation before the Federal Trade Commission.

George P. Kimmel, Master of Patent Law
53-E Loan & Trust Bldg., Washington, D. C.

U.S. PATENTS



SEND FOR
THIS FORM

DON'T LOSE YOUR RIGHTS TO PATENT PROTECTION

Before disclosing your invention to anyone send for blank form "EVIDENCE OF CONCEPTION" to be signed and witnessed. A sample form together with printed instructions will show you just how to work up your evidence and establish the same before filing application for patent. As registered patent attorneys we represent hundreds of inventors all over the United States and Canada in the advancement of inventions. Our schedule of fees will be found reasonable. The form "Evidence of Conception," sample, instructions relating to obtaining of patents and schedule of fees sent upon request. Ask for them—a post card will do.

PATENTS AND TRADE MARKS

LANCASTER & ALLWINE

204 Ouray Bldg. Washington, D. C.
Originators of forms "Evidence of Conception."

Patents

C. A. SNOW & CO. Patent Business
Exclusively Since 1875

Send model, sketch or photo for free advice, cost of Patent, etc. Book on Patents, Trademarks and Copyrights free. Write or come to C. A. SNOW & CO., 710 8th St., opposite United States Patent Office, Washington, D. C.

Please Mention Popular Mechanics

INVENTORS

who derive largest profits know and heed certain simple but vital facts before applying for

PATENTS

Our book Patent-Sense, for Inventors and Manufacturers, gives those facts: free. Write Lacey & Lacey, 639K, F St., Washington, D. C.

ESTABLISHED 1869

PATENTS

TRADE-MARKS COPYRIGHTS

Send for our free book of patent information.

Beale & Park 802 F St., Washington, D. C.
16 S. Broad St., Philadelphia, Pa.



PATENTS

Send us sketch or model for patentability opinion and exact cost of patent. Our book "How to Obtain a Patent," Sent Free on request. It tells how to apply for Patents, Trade Marks, Foreign Patents, Copyrights, etc.; gives information on Patent Procedure; tells what every inventor should know. Thousands of Inventors, who are our clients, are our references. **Chandlee & Chandler, 25 Years Experience.** 422 7th St. Washington, D. C.

PATENTS: Conservative service of a dependable character. Reasonable charges. Send sketch for advice. **HORACE L. WOODWARD, Attorney since 1906.** 700 9th St., Washington.

PATENTS **C. L. PARKER**
Formerly Member Examining Corps, U. S. Patent Office
PATENT LAWYER

MCGILL BLDG.
WASHINGTON, D. C.

Patents, Trade Marks, Copyrights, Patent Litigation

Handbook for Inventors, "Protecting, Exploiting and Selling Inventions," sent free upon request.

PATENTS

Booklet Free Highest References Promptness Assured Best Results

Send drawing or model for preliminary examination

ALL BUSINESS GIVEN PROMPT AND PROPER ATTENTION

WATSON E. COLEMAN, Patent Lawyer, 624 F St., Washington, D. C.

Can You

think of a simple, practical idea that will fill one of the many requests we have on file for new inventions? It may mean a fortune for you. Thousands of things are needed right now. Your brains can help. Send today for our great new book—

"Inventions and Trade-Marks, Their Protection and Exploitation"

and learn more about making money from ideas than you ever knew before. It tells many things that are wanted, too.

**A postal will do—
It is free**

We Help Our Clients

without charge, to get the dollars out of their ideas—having facilities none others possess. Advice free. Don't delay—get the book at once.

American Industries, Inc.
200 Patent Dept.
WASHINGTON, D. C.

Patents Advertised For Sale Free

in Invention and Manufacturing Supplement

Published for the man with an idea. Send for free sample copy. One year's subscription, 50c.



**PROTECT
YOUR
RIGHTS**

WRITE TODAY FOR FREE BOOK ABOUT PATENTS and "RECORD OF INVENTION" for establishing evidence of conception. The book tells how to proceed, the usual cost of obtaining a patent, and contains good sound practical advice every inventor should know. "RECORD OF INVENTION" should be filled out, signed and witnessed before you disclose invention to anyone. Send rough sketch or model and description for free report upon patentable nature and cost to Patent, etc. **Prompt, personal service.** Reasonable fees. Partial payment plan. Preliminary advice without charge.

**J. REANEY KELLY
PATENT LAWYER**

612-COLUMBIAN BLDG. WASHINGTON, D.C.

PATENTS If You Have an Invention and Desire to Learn How to Secure a Patent

Send for our Guide Book, **HOW TO GET A PATENT**, sent Free on request. Tells our terms, methods, etc. Send model or sketch and description of your invention and we will give our opinion as to its patentable nature.

RANDOLPH & CO.
600 F St., N.W., Washington, D. C.

NAME.....

STREET.....

CITY.....STATE.....

PATENTS

IF YOU HAVE AN INvention which you wish to patent you can write fully and freely to Munn & Co., for advice in regard to the best way of obtaining protection. Please send sketches or a model of your invention and a description of the device, explaining its operation.

All communications are strictly confidential. Our vast practice, extending over a period of seventy years, enables us in many cases to advise in regard to patentability without any expense to the client. Our Hand-Book on Patents is sent free on request. This explains our methods, terms, etc., in regard to **Patents, Trade Marks, Foreign Patents, etc.**

If you are a reader of the SCIENTIFIC AMERICAN

you are probably aware of the fact that it has a special appeal to the inventor. Each issue contains a description of a large number of recently patented inventions. Pending patent legislation as well as the most recent rulings of the Patent Office and the courts are considered in its columns.

MUNN & CO.

SOLICITORS OF PATENTS

672 Woolworth Bldg., NEW YORK

Scientific American Bldg., WASHINGTON, D. C.

801 A Tower Bldg., CHICAGO, ILL.

582 Market St., SAN FRANCISCO, CALIF.

STOP USING A TRUSS

Do Away With Steel And Rubber Bands

FREE TRIAL



Inner surface is made adhesive to secure the PLAPAO-PAD firmly to the body, keeping the PLAPAO continually applied and the pad from slipping. No straps, buckles or springs attached. Soft as velvet—easy to apply.

It's the Non-Slip- ping, yet Non-Rigid Pad and What is Within It That Counts

FREE to 5,000 Truss Sufferers

To the extent of 5,000 sufferers who may apply I will send, ABSOLUTELY FREE, a sufficient quantity of the Plapao to positively convince them that this is the only logical, common-sense way of treating rupture. Plapao is a highly astringent medication placed within the Plapao-Pad and being absorbed through the skin, creates a wonderful feeling of relief and at the same time tends to strengthen the weakened muscles and thus permanently close the rupture opening. The process of recovery is natural, so you'll have no use for a truss—you can throw it away forever! Old and young have testified under oath that the Plapao-Pads cured their rupture—many of them long-standing, aggravated cases—without delay from work. Patent allowed in U. S. and foreign countries. Awarded Gold Medal at Rome and Grand Prix at Paris.

Send No Money—for a sufficient quantity of the Plapao is sent without charge to enable you to give it a thorough test; you pay nothing for this trial now or ever. Write for it and full information today. Address Plapao Laboratories, Block 1427 St. Louis, Mo.



GEARS ALL KINDS SMALL

The most accurate made and prices reasonable. We carry a complete line of gears in stock for immediate shipment. Can also quote on special gears of all kinds. Send us your inquiries.

WRITE FOR CATALOGUE

CHICAGO STOCK GEAR WORKS
105-109 S. Jefferson St., CHICAGO

PATENTS Secured

Prompt service. Avoid dangerous delays. Send for our "Record of Invention" form and Free Book telling How to Obtain a Patent. Send sketch or model for examination. Preliminary advice without charge. Highest references. Write TO-DAY. J. L. Jackson & Co., 243 Ouray Bldg., Washington, D. C.



Buchstein's Fibre-Limb

is soothing to your stump—strong, cool, neat, light. Easy payments. Braces for all deformities.
D. BUCHSTEIN CO.
113 6th St. S., MINNEAPOLIS, MINN.

Mystic Skeleton

A jointed figure of a skeleton 14 in. in height. will dance to music and perform various gyrations and movements while the operator may be some distance from it.

Serpent's Eggs

Box contains 12 eggs. When lit with a match, each one gradually hatches itself into a snake several feet long, which curls and twists about in a most life-like manner. Price per box, 10c per doz.



Good Luck Ring

Quaint and Novel Design

A VERY striking and uncommon ring. Silver finish, skull and crossbone design, with two brilliant, flashing gems sparkling out of the eyes. Said by many to bring Good Luck to the wearer, hence its name, Good Luck Ring. Very unique ring that you will take a pride in wearing. ONLY 25 CENTS.

JOHNSON SMITH & CO., Dept. 778, 3224 North Halsted Street, CHICAGO

DEAF?

**"I Now Hear Clearly"
You, Too, Can Hear!**

500,000 satisfied users have testified to the wonderful results obtained from the "Acousticon." We therefore feel perfectly safe in urging every deaf person, without a penny of expense and entirely at our risk, to accept the



1922 ACOUSTICON

For 10 Days' FREE TRIAL
No Deposit—No Expense

Just write saying that you are hard of hearing and will try the "Acousticon." The trial will not cost you one cent, for we even pay delivery charges.

WARNING! There is no good reason why every one should not make as liberal a trial offer as we do, so do not send money for any instrument for the deaf until you have tried it.

The "Acousticon" has improvements and patented features which cannot be duplicated, so no matter what you have tried in the past send for your free trial of the "Acousticon" today and convince yourself—you alone to decide.

DICTOGRAPH PRODUCTS CORP.
1307 Candler Building, 220 W. 42nd St., N. Y. City

GILBERT BOY ENGINEERING The greatest boys' book in years. 128 pages of articles on athletic Training, Football Strategy, Flying, etc., by noted authorities. Chapters on many wonderful sciences. Contains complete catalog of Gilbert Toys. Sent at cost, 25c. Also write for free folder on Gilbert Toys.

A. C. GILBERT CO., 477 Blatchley Ave., New Haven, Conn.

12 Months to Pay

Enjoy your 1922 "Ranger" at once. Earn money for the small monthly payments on our Easy Payment Plan. Parents often advance first small payment to help their boys along. **FACTORY TO RIDER** wholesale prices. Three big model factories. 44 Styles, colors and sizes in our famous Ranger line.

DELIVERED FREE ON 30 DAYS' TRIAL. We ship by prepaid express. Select bicycle and terms that suit—cash or easy payments—you take no risk.

TIRES lamps, horns, wheels, parts and equipment at half retail prices. **SEND NO MONEY**—Simply write today for big FREE Ranger catalog and marvelous prices and terms.

MEAD CYCLE COMPANY
Dept. A-108, CHICAGO, ILL.



GENUINE DIAMONDS

We have always sold for cash only, but to unload our surplus stock, we will open charge accounts with reliable buyers, if desired. There is no extra charge for credit. Just send 1-5 of price as deposit with order.

EASY TO PAY—TAKE 10 MONTHS

SPECIAL LOW PRICES—30 DAYS TRIAL

Genuine blue-white diamonds, full of brilliance, and very radiant, sold direct to you by DIAMOND IMPORTERS at wholesale prices. Each diamond is set in a 14 karat solid gold ring included free of charge. Choose your ring and give finger size and send your order.

One carat \$195.00. Former retail cash price \$325.00;
3-4 carat \$146.25; 1-2 carat \$97.50; 1-4 carat \$48.75.

If satisfied pay 1-5 of price and balance in 10 monthly payments. We guarantee to satisfy you or refund your money. \$1,000,000 and 42 years' experience are back of this offer.

Order direct from advertisement or write for 126-page catalog.

B. GUTTER & SONS WHOLESALE JEWELERS
112 NASSAU ST., Div. 364, N. Y.

Great Inventors Now Teach You How to Invent

How to develop, patent and market your ideas; amazing new course teaches science of invention by mail.

Every man, woman, and child is born with creative imagination. Some develop this faculty to a greater degree than others, and those who develop it to the greatest extent are successful inventors. Invention is an orderly process of the mind, which combines two or more known facts to produce a new fact. Anyone who develops the right mental process can become



Raymond Francis Yates

author of the New Course in Inventive Science, in collaboration with 15 other inventors. Mr. Yates is known throughout the country as Editor of scientific magazines, writer of hundreds of articles and inventor of many practical devices and machines.

an inventor. Every successful inventor has this type of mind, developed by constant experience over a period of perhaps many years. Heretofore those who succeeded in the field of invention had to discover all the principles themselves. But, now, just as any student of medicine, law, or engineering can take full advantage of all the recorded experience in these fields of study, so can YOU take the same kind of short cut to the habits of thought, and the methods of work required of successful inventors.

Little Inventions Win Fortunes

Fortunes have been made by men who have thought of a "little" idea in a flash. The man who invented the bottle top, the man who invented the crimped hairpin, the man who invented the thin lead automatic pencil, the man who invented the snap fastener—all these

men, perhaps, got their ideas in a flash, and founded their fortunes as a result of a single idea. But in every case their minds operated in accordance with the scientific laws of successful invention. Edison says: "Invention should be taught as a profession." Every inventor realizes the hopelessness of groping in the dark for the habits of thought and methods of work required for successful invention. Trying to invent without knowing the fundamental requirements of invention is like trying to build a bridge without knowing engineering.

Don't Waste Ideas! Every man at some time or other has an idea for something he would like to invent, but his mind doesn't know how to work. He doesn't know what to do about it—doesn't know how to think along inventive lines—and soon someone whose mind is trained along inventive lines invents just the thing you may have thought of.

WRITE FREE BOOK FOR

A wonderful book explaining this wonderful new course in detail has been written and will be sent free to those genuinely interested. This book explains the course in detail, and proves that anyone can become an inventor who trains his mind—it may be the beginning of a fortune for you. If you have ever had an idea for an invention, or if you would like to become a spare-time or professional inventor, and if you would like to know what to invent, send in your name at once on the coupon NOW! Only a limited number of these books are available for free distribution.

**BUREAU OF
INVENTIVE SCIENCE**
Dept. 42, Wisner Bldg.
Rochester, N. Y.

Please send me your free book,
"The Science of Invention."

Name

Address

City

State

Bureau of Inventive Science, 42 Wisner Bldg., Rochester, N. Y.

Hear the Wireless Concerts at Home

from far and near. The Latest News, Market and Weather Reports now broadcasted by radio by our Government.

Ever since the year 1909 Duck's Radio Catalog has blazed the way with everything worthwhile and dependable in radio.

This catalog eclipses all previous editions. It is all other catalogs in one. No other is even half as large. Over 50 pages of diagrams and data on radio.

Complete sets sell for as little as \$20.00—some even less.

Stations all about you.

Duck's 275-Page No. 16 Radio Catalog—Just Out. Send 12 cents in stamps or coin for your copy of this wonderful catalog. Not sent otherwise.

You could spend \$3.00 for text books and other catalogs and then not have the contents of this catalog.



THE WILLIAM B. DUCK CO., 223-227 Superior St., Toledo, O.

BUY TODAY

10 MONTHS TO PAY

SPECIAL VALUE

Sweet's Cluster
7 Fine Diamonds set in Platinum. Looks like 1 1/2 carat solitaire.

Only \$3.80 a month

SPECIAL TERMS—Ten months' credit on any article selected from the SWEET catalogue. **NO MONEY IN ADVANCE.** Shipment made for your examination. First payment to be made only after you have convinced yourself that SWEET values cannot be equalled. If not what you wish return at our expense.

No Red Tape—No Delay

Every transaction **CONFIDENTIAL.** You don't do justice to yourself and your dollars unless you inspect our unusual values in Diamonds, Watches, Jewelry, Silverware, Leather Goods, etc. Send **TODAY** for SWEET De Luxe Catalogue. Write **NOW** to Dept. 532-G.

Capital \$1,000,000

"THE HOUSE OF QUALITY"

L.W. SWEET INC.

1650-1660 BROADWAY, NEW YORK

30 DAYS FREE TRIAL \$10 Worth of Records FREE

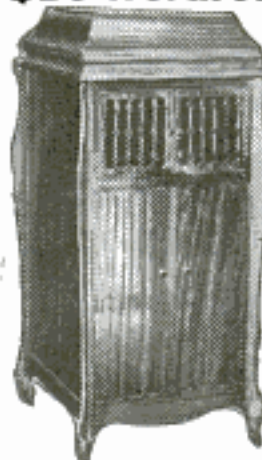

Simply wonderful! The limit of value giving! Just think! A GENUINE DAVIS PHONOGRAPH on 30 Days' Free Trial, and on terms as low as

\$2 A MONTH in case you decide to buy. Magnificent instruments in quartered oak or mahogany piano finished cases, equipped with the finest worm gear motors, rich toned machines— at less than half the standard prices—and \$10 worth of records FREE.

Send No Money Just a postal with your name and address. Only a limited number of machines shipped on this extra-liberal offer. Better act quickly. This is a life-time opportunity.

DAVIS, Dept. B41
6101 MAY ST., CHICAGO



Do Your PRINTING

Cards, circulars, labels, tags, book, menus, paper, Press, \$12. Larger \$35. Job Press \$50 up. Save money. Print for others. **BIG PROFITS.** All easy, rules sent. Write factory **TODAY** for press catalog, TYPE, cards, paper. **THE PRESS CO., 9-37, MERIDEN, CONN.**



RAISE BELGIAN HARES

New Zealand Reds — Flemish Giants — American Blues. **BIG PROFITS, WE PAY \$1.50 TO \$8 EACH.** Also Cayes, Mink, Skunk, Fox, Muskrat, Etc. Easily raised anywhere. **FREE!** page Catalog and Contract. Illustrated book "COMMON SENSE RABBIT RAISING," quarterly journal, and copy of America's leading small stock magazine, all for 10 cents. Address **Outdoor Enterprise Co., 1005 O. E. BLDG., KANSAS CITY, MO.**

WE GUARANTEE OUR AGENTS \$60 A WEEK

FOR ONLY FOUR \$5 ORDERS A DAY
No Delivering—Commissions Same Day You Take Orders

AT LAST

A Simple
Practical
Dependable Fire
Extinguisher
for only



FUGO
Automatic
Fire Extinguisher

\$5

MILLIONS OF PEOPLE want a handy, reliable fire extinguisher but they've held off paying \$15 or \$20. The **FUGO AUTOMATIC**—just patented—costs only \$5 and is just as efficient, just as dependable as the highest priced. Everyone can afford one—agents take orders on every call. Nothing like it at the price—a **5 minute demonstration sells it**—no talking—no arguments. An inexperienced agent can take 4 orders a day—others book 10 orders—easily. No competition—the field is unlimited. Customers so pleased they tell others—sales multiply fast.

NO EXPERIENCE NEEDED Our proved instructions guide you—you can't go wrong—a 5 minute demonstration and it's sold. Your neighborhood fire department will recommend it—boost it—push it.

EXCLUSIVE TERRITORY Become our licensed agent—employ sub-agents—each one brings you a good profit. You take no risk—you don't invest a penny. We deliver—you receive commission same day you take orders.

THE OHIO INSTRUMENT MFG. CO.
9412 St. Catherine Ave. Cleveland, Ohio

Get Our Plan—TODAY

You don't hear of an invention like this every day—don't delay. Trained agents will jump at this opportunity. **Write now for full particulars** showing big possibilities for YOU. Sample Fugo Automatic FREE.

SEEDS GROWN BY A WOMAN

Everybody is delighted with my New Early June Asters—Largest, earliest and best. Continuous bloomers.

For 10c I will send 5 liberal packages, white, pink, lavender, crimson and purple. No better seeds grown.

Guaranteed to Please

Order today, send 10c to help pay postage and packing and receive the 5 new varieties of asters and my bargain seed book.

Charlotte M. Haines

Dept. 63 Rockford, Illinois



Get My Reduced Prices on OLD TRUSTY

Find out how much I can save you on Old Trusty Incubators and Brooders. Nearly a million owners.

Quick shipment from factory at Clay Center, Neb., or warehouse at St. Joseph, Mo. Mail a postal or letter today.

H. H. JOHNSON, "Incubator Man" Clay Center, Neb.



Detroit Incubator \$12⁴⁵

140-Egg Size—Guaranteed—has double walls, copper tank, full-size nursery, automatic regulation thermometer held so that chicks cannot break it when hatching. Detroit Brooders, too. Double walled, hot water heated. **Write for special low price on both machines.**



Detroit Incubator Company

Dept. 32 Merritt Street, Detroit, Michigan

KEEP YOUR HENS A LAYING

Trust your hatching to time-ried and tested

"SUCCESSFUL"

Incubators and Brooders

Used by the big money-makers who stay in business year after year. Poultry Lessons Free. Booklet, "How to Raise 48 Out of 50 Chicks," 10 cents.

Catalog Free. Write Today. **DES MOINES INCUBATOR CO.** 689 Second Street Des Moines, Iowa



29 Years Making Good



World's Best Poultry Journal

You be the Judge!

4 Months' Trial 20c

SEND U. S. STAMPS

Tells how to keep poultry with greatest profit; 190 to 168 pages monthly; 27th year. Best articles; expert advice; profusely illustrated. 1 yr., \$1.00; 3 yrs., \$2.00. Reliable Poultry Journals Pub. Co., Dept. 118, Quincy, Ill.



GREIDER'S FINE CATALOG

of fine bred poultry for 1922; all choicest breeds illustrated and described; information on poultry, how to make hens lay, grow chicks—all facts. Low price on breeding stock and hatching eggs. 30 years in business. This book only 10c.

B. H. GREIDER, Box 19. RHEEMS, PA.

PLANS FOR POULTRY HOUSES!

All styles, 150 illustrations; secret of getting winter eggs, and copy of "The Full Egg Basket." Send 25 cents. INLAND POULTRY JOURNAL, Dept. 74, Indianapolis, Ind.



64 BREEDS Most Profitable pure-bred Northern raised chickens, ducks, geese, turkeys. Fowls, eggs, incubators at reduced prices. 29th year. Largest plant. Large valuable poultry book and catalog free. **R. F. NEUBERT Co., Box 103 Mankato, Minn.**



NOW TIME TO START

BIG DEMAND. HIGH PRICES BEING PAID

An uncrowded occupation. Exceptional opportunities for live men and women. Raised at home. Only small space needed. Small expenditure will start you in a practical money-making enterprise. Big profits. Booklet telling all free. Write

Nat'l Spawn Co., Dept. 12, Waban, Mass.

3,000⁰⁰ yearly for YOU in the Chicken Business

Yes, that's exactly what we mean. You can positively make \$3,000 a year for yourself in the chicken business. We have put hundreds of others on the road to success and made them independent in this fascinating and money making business. We can do exactly the same for you. **No Experience Necessary**

You need no previous experience, and very little money. **Just a small plot of ground will be enough.** You can give the business your whole or your spare time. We tell you exactly the right thing to do according to the ground and time you have.

Remember, we are the largest Poultry breeders of Blue Ribbon Winning and Egg Record Stock in the world. We supply you with **guaranteed high quality, egg-producing chickens.**

3 Months Instruction FREE

Our organization of 14 poultry specialists will teach you how to care for chickens at all ages; proper mating, proper feeding, avoiding disease, getting the largest profits, etc. The result of 22 years of study and experimentation. You get all we know **FREE** because we want you to be a future customer for special prize winning and egg record stock. Furthermore, you can make **big money developing prize winners** from the high grade stock we furnish you.

\$193 Net Profit

In one month E. C. Van Valem cleared this sum from 307 hens on very little ground space. Harry Cottrell writes: "My little backyard flock of only 4 hens produced \$36.48 worth of eggs". What these people have done you can do, and on **very little money.** Every year for 55 years the poultry business has paid good profits.

Send Coupon Now

Don't put this matter off! Get our Special Offer to beginners. Simply mail Coupon with your name and address and we will send you full particulars and Free Catalog. Write or send Coupon today.

GEORGE B. FERRIS, Dept. 2212 Grand Rapids, Mich.

GEORGE B. FERRIS,
Dept. 2212 Grand Rapids, Mich.

Gentlemen: Kindly send me at once, without cost to me, your illustrated Catalog on the chicken business, and full details of your Special Free Instruction Offer.

Name _____

Street or R.F.D. _____

City or Town _____ State _____

FREE!

The
Book
You've
Been
Waiting
For



Auto Supplies Wholesale!!

Fidelity Bodies



Most Beautiful Bodies
Made As Low As
\$29⁸⁵

For Fords & Chevrolet's

3000 BARGAINS
like these are listed in our big "NEMCO" Auto Supply Book. This big new book with all the latest price reductions is now ready

The Greatest Automobile Supply Book in America

Auto Supplies



For Fords and All Cars

FREE! TO YOU
Just send your name and address. You are not obligated to buy. Know the very latest reductions in automobile accessories

Whether You Buy From Us or Not—You Need this Book

Nemco Bargain Supply House 1015 JACKSON BLVD. CHICAGO-U.S.A.

TWO-YEAR GUARANTEED BATTERIES SAVE 50%



Famous "Royal" Batteries—highest quality made—now selling direct from factory to car owner. You save half. We give **written 2-year guarantee**—longest on any battery. Big responsible organization backs guarantee. **Batteries for any car, tractor or gas engine.**

Save time. Order from this ad. Battery, fully charged, shipped immediately—by express C. O. D. You run no risk. Our location same for eight years. **Reference:** Nat'l Bank of the Republic, Dun or Bradstreet.

Free Booklet If you want descriptive matter sent, send for free booklet. Gives full details of this superior battery. **Get this booklet before you buy any battery. Write today!** Give year and model of your car.

K - E BATTERY CO., Dept. 76
14 E. Jackson Blvd., Chicago

Largest Exclusive Mail Order Battery House in America
Members of Chicago Association of Commerce

FORDS RUN 34 MILES on Gallon of Gasoline

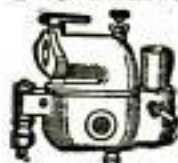

Wonderful new carburetor. Guaranteed to reduce gasoline bills from one-half to one-third and increase power of motors from 30 to 50%. Start easy in coldest weather.

Sent on 30 DAYS' TRIAL

Fits any car. Attach yourself. Fords make as high as 34 miles to gallon. Other cars show proportionate saving. Send make of car and take advantage of our special 30-day trial offer. **Agents Wanted.**

AIR FRICTION CARBURETOR CO.
3380 Madison Street Dayton, Ohio

FORD and CHEVROLET SPEED BODIES

Dealers:
Write for Accessory Catalogs

MAKE DRIVING A PLEASURE



Copyright 1921—F. M. S. Co.
Equip your old Ford or Chevrolet Chassis with one of our new distinctively modern bodies. Up-to-date Roadster, Touring and Speedster designs. Ford bodies as low as \$29.50 and up. Territorial open for live wire dealers and agents. Make real profits. *Buy Direct from Factory.*

FEDERAL MOTOR SUPPLY CO., Inc.
2626 So. Michigan Blvd. Chicago
CANADIAN DISTRIBUTORS
Federal Auto Body Co., Toronto, Ont.; Campbellton, N. B.



Every Home should have a
Tycos
Fever Thermometer
Your doctor will tell you why

Ask your dealer

He will also tell you how it will guard your health and help him keep you well. Booklet on request.

Taylor Instrument Companies
Rochester, N.Y. U.S.A. A 123

There's a Tycos and Taylor temperature instrument for every purpose

CHAMPION Dependable Spark Plugs

Champion Spark Plug Company, Toledo, Ohio
Champion Spark Plug Company, of Canada, Limited, Windsor, Ontario

VITALIC Bicycle Tires

TRADE MARK REGISTERED

Tougher Than Elephant Hide

Get this Combination



Handle Bar and Carrier

Can't jiggle or unbalance load. Handles located on side of basket. Only sensible way to carry packages, papers, tools, etc. Write now for facts on this and Rector's new single tube Clincher Tires. Ask for illustrated book. **FREE**

THE BECKLEY-RALSTON COMPANY
1819 Michigan Ave. CHICAGO, ILL.

Taxidermy Book FREE.



Stuff Beautiful Birds. Learn by mail to stuff and mount

all kinds of birds, animals, fish and game heads; make rugs, tax skins. Mount your own specimens and make money preserving for others. Men, women and boys learn easily and quickly. Success guaranteed or no tuition. Write today for our wonderful **FREE** book "How to Learn to Mount Birds and Animals. N.W. School of Taxidermy, 9772 Elwood Bldg., Omaha, Neb.

Write Today.



Stop Radiator Leaks and Save Big Repair Bills

Thousands of motorists have used Radiator Neverleak for sealing up leaks in radiator (or anywhere in cooling system). Many carry a can in the tool kit.

RADIATOR NEVERLEAK

has made good wherever used. It is no experiment. Four contents of 75c can into radiator, let mix thoroughly and leaks are stopped permanently in less than 10 minutes. Cannot clog or impair cooling.

Million Dollar Guarantee

protects you. Satisfaction guaranteed or money back.

At all dealers or send 75c direct

BUFFALO SPECIALTY COMPANY
Buffalo, N. Y.

Going to Build Remodel or Repair?

DON'T think of planning a new home or repairing an old one without copies of our two free books.

Our Building Material Catalog shows latest ideas and most advanced styles for everything in building. We ship everywhere everything in the way of high grade lumber roofing, doors, windows, porchwork, screens, builder's hardware, paints, wallboard, interior woodwork, plumbing, heating and water supply outfits — all at money saving prices direct to you. Plan Book shows skillfully planned homes of all kinds, bungalows, city houses, suburban residences, country homes, barns. Tells you how to get building plans FREE. Write today. No obligation.

Let us develop plan from your rough sketches. Send your material list or job estimate price.

Material Complete for Houses from \$500.00 up

Catalog of 6000 Products Bargains

Beautifully Illustrated PLAN BOOK

CHICAGO MILLWORK SUPPLY CO., 1414 W. 37th St., Chicago, Ill.

PLEASE SEND ME YOUR FREE BOOKS.

Name _____ St. No. _____
 Town _____
 State _____
 Occupation _____

Books Are Free

LOOK

50¢

Look

Wonderful Instrument. Greatest thing yet. Nine separate articles in one. Everybody delighted with it. Odd, curious and interesting. Lots of pleasure as well as very useful. It is a double Microscope for examining the wonders of nature. It is also an Opera Glass, a Stereoscope, a Burning Lens, a Reading Glass, a Telescope, a Compass, a Pocket Mirror, and a Laryngoscope—for examining eye, ear, nose and throat. It is worth all the cost to locate even one painful cinder in the eye. Folds flat and fits the pocket. Something great—you need one. Don't miss it. Sent by mail, with 309 page Novelty Catalog, ONLY 50c or 3 for \$1.25

JOHNSON SMITH & CO., Dept. 770 3224 N. Halsted St., CHICAGO

Be A Floor Surfacing Contractor

Make \$5,000 to \$15,000 or More—Yearly

Now, uncrowded field. Architects and general contractors know the American Universal and prefer its work. They prefer to subcontract the floor surfacing contract, as it is a big business in itself. Business comes easily the American Universal Way. We furnish office forms, advertising, etc.—in fact we practically set a man up in a business of his own.

RE-SURFACING OLD FLOORS

Every building, large or small, is a prospect. Hundreds of floors right in your own vicinity need resurfacing. The owners will be glad to have you do it when you show them how easily and quickly the work can be done the American Universal Way. Old floors made like new—new floors made perfect.

Don't ever get caught out of work again—get into a big paying business of your own. Floor Surfacing Contractors pay for machines first month and make big profits besides. WRITE TODAY for full information. Act NOW

American Floor Surfacing Machine Co.
Originators of Floor Surfacing Machines
523 South St. Clair St., TOLEDO, OHIO, U. S. A.

SQUAB BOOK FREE

Squabs are selling at the highest prices ever known. Breed them and make money. Write at once for free book, prices, etc.

Plymouth Rock Squab Co., 634 Howard St., Melrose Highlands, Mass

WANTED

Railway Mail Clerks

\$1600 to \$2300

A YEAR

Men—Boys—Over 17—should write at once

Rapid advancement. "No lay-offs." THE POSITION IS YOURS FOR LIFE.
 Common-sense education sufficient. Political influence NOT REQUIRED.
 Write immediately for schedule showing the places and dates of ALL coming Government examinations. Do it to-day.

FRANKLIN INSTITUTE, Dept. W176, Rochester, N. Y.

Hundreds of Railway Mail Clerks Appointed Yearly

FRANKLIN INSTITUTE (The Pathway to Plenty) Dept. W176, Rochester, N. Y.

This coupon, filled out as directed, entitles the reader to free specimen questions; a free copy of our book, "Government Positions and How to Get Them"; a list of Government positions now open, and to consideration for Free Coaching for the examinations here checked.

COUPON

.. Railway Mail Clerk (\$1600 to \$2300) .. Postal Carrier (\$1400 to \$1800)
 .. Bookkeeper (\$1400 to \$1800) .. Rural Mail Carrier (\$ 720 to \$2600)
 .. Postoffice Clerk (\$1400 to \$1800) .. Customs Positions (\$1100 to \$2000)

Name _____ Address _____
Use this before you lose it. Write plainly.

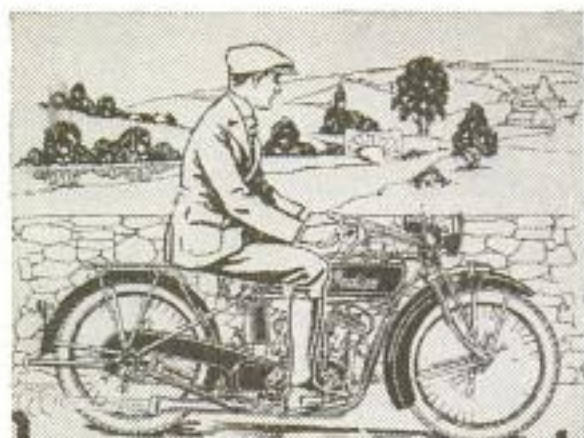

You're invited

to join in the celebration of a custom we instituted a score of years ago, by visiting your nearest INDIAN MOTORCYCLE dealer on

Indian Day
FEBRUARY 22

Enjoy the special entertainment, get a souvenir, meet the boys. See the complete line of 1922 *Indians*. Two brand new models. Numerous improvements. Substantial price reductions. Buy a motorcycle—cheapest means of motor transportation, lowest operating cost.

Indian
Motocycle

HENDEE MANUFACTURING CO.

Largest Motorcycle Manufacturer in the World

Dept. 37 Springfield, Massachusetts

\$2,500 Monthly for Miller With Willey Universal Vulcanizer

Walter J. Miller invested \$175 in 1919, came to our plant for instructions for three weeks. Since that time he has bought his own home. He is now doing \$2,500 worth of business per month, employing two men and making big money.



Sold on Installments

Tire repair business is all cash. Only small investment necessary. We give you practical training in our plant and shop or by mail FREE. The machine burns coal, wood, kerosene or gas. Economical to operate. Set up in a few minutes. FULLY guaranteed.



WILLEY RUBBER BOOT AND HALF SOLE MACHINE

Can be connected to regular vulcanizer or set up separate. Repairs auto tubes, water bottles, boots, rubbers—in fact anything made of rubber.

Write for complete catalog and Free Training Offer—all free.
WILLEY UNIVERSAL VULCANIZER CO.
22 WILLEY BLDG. BATTLE CREEK, MICH.

FINE OLD VIOLINS

On Easy Payments 30 Days Free Trial



allowed, no matter where you live. If not more than pleased with our values return violin AT OUR EXPENSE—and no harm done. Ability to play the violin brings social and financial success. Get a violin with a rich, mellow tone and it will create in you a desire to master it.

Free! Magnificent Album-Catalog

containing portraits of the world's greatest violinists since Paganini's time, a half-tone of "Stradivarius in His Workshop," and the romantic story of The King of Musical Instruments. A postal brings all to you FREE—no obligations.

CREMONA VIOLIN SHOP
Dept. B41 Chicago

TIRES BEST VALUES EVER OFFERED
32x4-\$9. 33x4-\$9.50. 34x4-\$10.50

Used tires. Other sizes just as low. Cords and fabrics. Send no money. Return tires if not satisfactory when received. State if you want s.s. or cl. Supply limited at this price. Order quick.
ROYAL TIRE & SUPPLY CO., 1245 S. MICHIGAN AVE., DEPT. P, CHICAGO, ILL.

2 Tires for \$11.25
FREE Tube with Each Tire

Most sensational used tire offer of the year! Two tires for less than the usual cost of one—and a free tube with each tire! This is a special lot—all standard makes—selected for record-breaking sale. No double treads or sewed tires. Our big volume means best tire values! Thousands of steady customers everywhere are getting full mileage out of these tires and you, too, can get

Size	1 Tire	2 Tires	Size	1 Tire	2 Tires
30x3	\$ 7.00	\$11.25	32x4 1/2	\$13.00	\$22.90
30x3 1/2	7.95	13.65	33x4 1/2	13.95	23.45
32x3 1/2	9.00	15.45	34x4 1/2	14.45	23.90
31x4	10.00	16.90	35x4 1/2	14.95	24.45
32x4	11.50	19.75	36x4 1/2	15.45	25.45
33x4	12.25	20.90	35x5	15.90	26.15
34x4	13.25	22.45	37x5	16.45	26.55

SEND NO MONEY! Shipments C.O.D., Express or Parcel Post. Examine tires on arrival and if not fully satisfied return same at our expense and your money will be promptly refunded, including shipping charges. State whether Straight Side or Clincher. **DON'T DELAY! ORDER NOW!**

ALBANY TIRE & RUBBER COMPANY
2721 Roosevelt Road Dept. 164 B Chicago, Illinois

King of Winter Sports



WINTER MOTORCYCLING! Another thrill for you "red bloods" who love vigorous sports in the open—hunting, ice fishing, skiing, tobogganing, ice boating.

While others shiver (walking home or waiting for a trolley) your Harley-Davidson whisks you and your pal comfortably and economically to and from your sport—if necessary, over roads and paths impassable to an automobile.

Anyone can afford a Harley-Davidson. Its upkeep averages only a dollar for 50 miles—gasoline, oil and tires.

Ask your Harley-Davidson dealer for free demonstration of the new models—also, for the new reduced prices (25% lower). Or write to us for illustrated literature.

HARLEY-DAVIDSON MOTOR CO.
Milwaukee, Wisconsin

Harley-Davidson World's Champion Motorcycle



Big Money

Made by agents selling our wonderful Facial Soap, Perfumes, Toilet Articles, Spices, Extracts, etc. Free cake of soap and agents' terms mailed to any address.

LACASSIAN CO. Dept. 455 ST. LOUIS, MO.

How to Get Rid of Moles



A simple, safe home treatment—15 years' success in my practice. Moles (Also BIG Growths) Dry Up. Ask for Free Booklet of Full Particulars

WM. DAVIS, M. D.
124-5 Grove Ave., Woodbridge, N. J.

LAKWOOD FAN BELT FASTENERS



MAKE or repair your own flat belts for Autos, Trucks, Tractors, Electric Washers and small Shop Machinery with Lakewood Quick attachable Fasteners. Two sizes— $\frac{3}{8}$ in. and 1 in.; used alone and in combinations handle eight widths flat belting. Simply square up ends, rivet half of fastener to each end, slot together and go. Belt can be removed from pulleys instantly, but can't open in driving. Complete Fastener with rivets, 15c per set; 2 for 25c; 6 for 60c; or 12 sets in neat slide box for \$1.00. Specify size wanted. Sent postpaid same day order received. Fine proposition for Garage, Repairmen, and Dealers.

LAKWOOD FABRIC BELTING & MFG. CO.
1518 W. 117th St., Lakewood, Ohio

DEAFNESS IS MISERY



I know because I was Deaf and had **Head Noises** for over 30 years. My invisible Antiseptic Ear Drums restored my hearing and stopped Head Noises, and will do it for you. They are Tiny Megaphones. Cannot be seen when worn. Effective when Deafness is caused by Catarrh or by Perforated, Partially or Wholly Destroyed Natural Drums. Easy to put in, easy to take out. Are "Unseen comforts." Inexpensive. Write for Booklet and my sworn statement of how I recovered my hearing.

A. O. LEONARD, Suite 226, 70 5th Avenue, New York City

RECTOR

SINGLE TUBE CLINCHER

TIRES

Great new idea—no cement—no pulled valve stems, no tire trouble. Tires wear extra long—guaranteed. Put on in a moment on any standard rim. Valve stem snug on side. Heads clinch over rim (see section above). Can't come off in riding.

This Book FREE
Send for book—tells all about tires. How to get longest wear, etc.—also about benefits and savings of the Rector Tires and Rector's New Combination Handle Bar and Carrier. Write quick. Give favorite dealer's name.

THE BECKLEY-RALSTON CO.
1817 Michigan Ave., CHICAGO



Watch the Finish!

It's funnier than a circus—especially when YOU know how and the other fellow doesn't. Puzzle Peg is the name of this real man's game you hear everybody talking about. Men are spending hours of their spare time in trying to solve this, the most baffling, mysterious puzzle ever invented.

Can it Be Done?

That's what they all ask after they have tried for hours in one fruitless attempt after another—of course it can. Already *twelve* ways of doing it have been found. Surely you can find ONE. And you will have more honest-to-goodness entertainment out of it and more fun watching your friends try it than you ever had out of any other game you ever played.

Puzzle-Peg



is the greatest solitaire game wherever men gather. Played by one it makes fun for all. Splendid for home entertainment, also for travelers and for those who are shut in. Get your Puzzle Peg set today. Sold at druggists, newsdealers, department stores, in fact wherever good games are sold.

If you have trouble in getting your set send only 50c and we will mail you one postpaid.

LUBBERS & BELL 725 Second Ave., CLINTON, IOWA

Send No Money

21 Jewel Illinois

The greatest watch value ever offered. Unequaled for beauty, accuracy and reliability. 21 ruby and sapphire jewels—adjusted to positions, temperature and isochronism, 20-year gold-filled case. SPECIAL: Silver Damasked Dial.

10 Days' Free Trial

Wear it for 10 Days at our risk. Note its absolute exactness. If at the end of ten days you are not satisfied, just send it back at our expense.

Knife and Chain Free

We are offering for a limited time this handsome gold-filled knife and chain ABSOLUTELY FREE.

ONLY 11c A DAY

Just send your name and address. The watch, chain and knife come to you, prepaid. Give the expressman \$8.50 as a deposit. If after 10 days, you do not wish to keep them, return at our expense; your deposit will be refunded instantly. Trial is absolutely free. If you keep the watch pay \$3.40 a month until full price of \$42.50 is paid. This splendid watch will cost you less than 11c a day. Act at once. De Luxe catalog of Diamonds, Jewelry, etc., sent free. Address Dept. 62-G

CAPITAL \$1,000,000

"The House of Quality"

L. W. SWEET, INC.
1650-1660 Broadway New York



SEND NO MONEY

Try this Portable Typewriter 10 Days FREE



Now you can buy famous 9-pound National Typewriter direct from the factory, after 10 days' trial—absolutely free. You be the judge. Then we give you

10 MONTHS TO PAY

Same machine as used by thousands of doctors, lawyers, bankers, salesmen, students, writers and business men in 31 countries. Every feature of best, standard size machines. 28 keys.

84 characters. Brand new—not a rebuilt typewriter. Neat, compact carrying case free with every machine. Send today for our 10 Days' Free Trial; offer and 10 Months' Easy Payment Plan.

NATIONAL TYPEWRITER CO.

Dept. 7B.

Fond du Lac, Wis.

Fibre-Lite Limbs

Easy Payments—Do Nature's Work. AGENTS WANTED who use Artificial Leg. GOOD PAY. FREE Fibre Sample. DESCRIBE STUMP TO **WORMAN CO.** 252-P HENNEPIN AVE. MINNEAPOLIS, MINN.



GREEN AUTOMATIC MACHINE



ADD TO YOUR INCOME

WITH LITTLE EFFORT
\$5 to \$10 A DAY MADE EASY WITH

New Improved Green Automatic Machine

Sharpens, Hones and Strops all kinds of safety razor blades, in one operation, from four to six blades per minute. For both Quality and Quantity, this machine is in a class by itself. There is nothing like it on the market. Let us send you our descriptive literature explaining everything, including the "AMERICAN" Key Cutter—cuts square, angular or round slots.

AMERICAN SHARPENING MACHINE CO. (Inc.), Dept. 2, 184 W. Washington St., CHICAGO





This book tells what you want to know about the

WIRELESS TELEPHONE

BROADCASTING STATIONS operating on a regular schedule now reach practically every section of the country.

This book explains how you can enjoy the modern romance of wireless. Its title is "How I Put Up a Complete Radio Receiving Station in Two Hours"—a true story by a young man with no previous experience whatever. It also describes in detail ABC sectional receiving UNITS. (Complete receiving station, ready to operate, including phones, aerial wire and all accessories, only \$32.) Send ten cents for your copy today. Request Booklet P2.

Wireless Equipment Co., Inc.
Newark, New Jersey

ABC UNITS

PATENTS

Inventors should write for our "Evidence of Disclosure" form. It's Free. Avoid Dangerous Delays. Send sketch or model of your invention for examination and advice. Ask for Free Book "How to Obtain a Patent." Highest references. Write to-day.

Merton-Roberts & Co., 184 Mather Bldg., Washington, D.C.

MOTORCYCLE BARGAINS

Save 25% to 65%

on Slightly used and Rebuilt Motorcycles, Side Cars, Johnson Motor Wheels, Evans Power Cycles, Bicycles. Send for Free Bargain Bulletin and Money Saving Message, listing hundreds of Bargains in used, rebuilt and new machines, supplies, accessories, etc.

AMERICAN MOTOR CYCLE CO.
Dept. 201 2047 W. Chicago Avenue. CHICAGO



BURN Home Made GAS

In Your Old Wood or COAL STOVES

Change your coal or wood stove into a gas stove in 3 minutes. A Child can do it. Burn kerosene Vapor Gas—hotter than coal or wood and costs less. Safe and simple.

FREE TRIAL

Just turn a valve and get even heat instantly. No ashes, no dirt, no smoke, no wood to chop or carry. No fires to build and feed. No fuel wasted. Cooks and bakes better. No damage to stoves. Makes its own gas from common coal oil, cheapest, cleanest fuel. Guaranteed five years. Money back if not satisfied after 30 days trial.

Write for FREE folder with proof and SPECIAL OFFER

SIMPLEX UTILITIES MFG. CO.
Room 10, Simplex Bldg. 2537 S. State St., Chicago



BANG! You Can't Beat OUR PRICES on these PISTOLS \$ 8.75

This \$22.00 GUN FOR \$8.75



25-Calibre Regulation 7-shot, Blue Steel, Handsome Automatic; accurate and reliable; highest grade material and workmanship; double safety attachment makes accidental discharge utterly impossible; perfect grip; small, compact; you need this gun for your protection. Regular value \$22; get one now. No. 109, while they last... \$8.75

Shoots COLT'S Cartridges

\$10.75

\$25 Military Model Automatic for \$10.75

Just like they used "Over There." A MAN'S gun, built for hard service. .32-calibre, with EXTRA magazine FREE. Shoots COLT'S Cartridges. A 10-shot gun, regularly sold for \$25.00. Our price NOW, for .32-Calibre No. 209, while they last... \$10.75



\$14.00

Genuine German MAUSER

Latest model; 9-shot Automatic. The World-Famous Most Powerful Weapon known; shoots COLT'S cartridges; is perfectly balanced with substantial and comfortable grip; accurate and efficient; two safety attachments; it is flat-shaped; has no sharp edges or projections and does not bulge the pocket; it is solidly and simply constructed from blue steel; can be dismantled and reassembled in a few seconds.

Regular Value \$35

25-Cal., No. 809... \$14.00
32-Cal., No. 809-A... 15.00



\$17.00

Swing Cylinder

Regular Value \$35

Hand Ejector

This \$35 SWING CYLINDER is one of the finest revolvers ever made; double action, solid frame. Nickel or Blue finish. Shoots S. & W. long cartridges. Order one NOW. 32 Cal. No. 400... \$17.00
38 Cal. No. 409-A... 18.50
Or with Pearl Grip, \$3.00 extra.



\$24.50

GENUINE GERMAN LUGER

30-Cal., 9 Shot Automatic; with automatic magazine ejector—the latest, best and most reliable pistol made. Safety attachment. Shoots American ammunition. Regular Value \$90.

Our Price No. 909... \$24.50

ALL OUR MERCHANDISE IS BRAND NEW

Order one of these Specials NOW

Mail orders promptly filled upon receipt of cash or money orders, or if you prefer



SEND NO MONEY

We ship by return mail. You pay Postman on arrival. Full satisfaction guaranteed or money back. Bank reference.

We also carry a complete line of Field Glasses, Binoculars, Pistols and Shotguns at prices that cannot be equalled

IMPORT TRADING COMPANY

258 Broadway Dept. 9 New York

Saved from the Junk Pile by Weldene



This \$200.00 aluminum crank case was repaired with WELDENE Aluminum. Cost, \$10.00; saving, \$190.00.

No Preheating and in Most Cases No Dismantling Applied with an Ordinary Soldering Iron

Preferable to welding in a thousand uses—minimum expense

The largest Automobile Factories, Ship Yards, Packing Plants, Machine Shops, Welders and Garages in the U. S. are now using WELDENE to make all kinds of metal repairs—instead of welding or throwing away what cannot be welded—and have given it their unqualified recommendation. WELDENE has given universal satisfaction during **four years' general use.**

Repairs made with WELDENE are permanent and are guaranteed to last.

Specify WELDENE and save both time and money—the quickest and best method. If your repair man or garage does not use WELDENE refer him to this ad or write us and we will put you in touch with the nearest WELDENE SERVICE SHOP.

SPECIAL TRIAL OFFER!

One trial is ample proof of the merits of WELDENE—**Sold on a money-back guarantee of satisfaction.** There is nothing else like it. Write for details of our offer and our FREE CIRCULAR on WELDENE.



WELDENE Hard repairs scored cylinders without reboring. It will not crack nor loosen.



MECHANICS! START YOUR OWN BUSINESS!

WELDENE SERVICE SHOPS, making WELDENE repairs exclusively, are being established everywhere and are yielding exceptional profits. Our new plan sets you up in this fast-growing business with complete equipment at small expense and protects you in what amounts practically to a monopoly. We assist in bringing work to you from the very day you open your shop. No special experience is needed. Write for our

"EXCLUSIVE SERVICE SHOP PROPOSITION"

THE WELDENE COMPANY
7 WEST MADISON STREET CHICAGO

MEN WANTED

who are anxious to get out of a rut and into something new where their opportunity is unlimited. We need more men to sell the New Model

Super Fyr-Fyter

approved by Underwriters, and acknowledged to be the latest and best fire-fighting device in the world. We train our men so thoroughly that they are soon earning \$2,000 to \$10,000 a year. No experience necessary. Write today for complete details.

THE FYR-FYTER COMPANY,
23 FYR-FYTER BLDG. DAYTON, O.

Small Payment Down Balance Oct. 1st



Stove prices hit bottom. Manufacturers slashed prices—greatest money-saving event of years. Order now—small first payment—pay balance October 1st. No interest. Wonderfully beautiful styles—porcelain blue enamel—finest ranges ever made. Write today. Also get offer on other home needs. Ask for Catalog No. 473. Kalamazoo Stove Co., Mfrs. Kalamazoo, Mich.

"A Kalamazoo Direct to You"



3 in 1

Just Out

Showing Etching Pencil in Use

ELECTRIC ETCHING PENCIL, DEMAGNETIZER, and ANNEALING INSTRUMENT

of interest to proprietors and shop superintendents

Keep your tools in good shape by demagnetizing them on the "Luma." Avoid inaccuracy in machining. The Luma prevents "sticky" tools—avoids bother of particles of steel clinging to them. To demagnetize the tools simply pass them across the surface plate. Indispensable to up-to-date shops using magnetic chucks. **A real shop economy.** Combines in one compact portable instrument three important tools.

Etching Pencil included in outfit makes the "Luma" ready for instant use in etching tools with sizes, descriptions, numbers, etc. **Annealing point** also furnished makes the "Luma" ready for light annealing or soldering in any part of the shop.

Attaches to Any Alternating Current Light Socket

The "Luma" is the very latest instrument of its kind. Has capacity of three separate single-purpose instruments yet costs complete not more than any one of them.

Fully Guaranteed—Price complete with Etching Pencil, Annealing Point, light cord and connecting plug, \$125, f. o. b. Toledo. Illustrated descriptive folder free.

LUMA ELECTRIC EQUIPMENT CO., 405 Spitzer Bldg., Toledo, Ohio

One Man and This Machine Can Earn \$500 a Month



FIVE hundred dollars month is low estimate. Many make more. Gibbard, Mich., had amazing record of \$60,000.00 last year! Others had wonderful successes. My new Tire Surgery machine did the trick!

**HAYWOOD'S
TIRE SURGERY**

is the new and better tire repair method. You can learn in two weeks. I'll teach you. I'll furnish you with one of these new, compact Tire Surgery outfits. Will place you on direct road to fortune and financial independence. Your determination to succeed and this wonderful machine is all you need.

Experience Not Necessary

To start is the thing! Haywood's easy Tire Surgery method and Haywood's "One Man" machine will do the rest. Will make money for you—lots of it—from very beginning. Charlie Evans of Indiana, carpenter, past middle age, knew nothing of tires less than year ago. He bought a Haywood machine. Learned Tire Surgery. Now is earning more than \$100 week!

Opportunity Never Better

Seven million car owners in country. Most of them must economize. Can't buy new tires. Must make old tires do. They can tinker with their auto, but can't mend tires. This work will swamp present Tire Surgery stations. Many more needed in every section of United States.

I Can Place 500 Men in Good Locations Right Now!

It's a proposition you can handle. Cash in on this great economic wave that is sweeping old tires into repair shops instead of junk piles. Etzrod of Pennsylvania averages \$30,000 in this business. Blair of Ohio does more than \$100 daily with small Tire Surgery shop. Oldham of Illinois reports recent earnings of \$2200 in four months. And so on. These men acted. They had no experience. Possessed very little capital. Enjoyed no advantages you haven't got.

M. HAYWOOD, Pres.

HAYWOOD TIRE & EQUIPMENT CO.
970 Capitol Avenue Indianapolis, Ind.

\$6000.00 Year Easy

Haywood's Tire Surgery is so successful—so profitable—because it is thoroughly efficient. Look at the machine. See how compact and complete it is. Whole plant can be placed in space eight feet square. Observe its convenience—how one man can easily watch every detail from steam plant to vulcanizing without turning head. Look at its capacity—think of the dollars it will pour into your pockets in one single day. Its operation is so simple any man can do perfect work without long experience or apprenticeship.

Fill Out Coupon Now!

I have ready to mail you, the day I get your request, a fascinating book which tells all about tires. How to repair them by the Haywood method of Tire Surgery. How to start in business. How to build up trade. What to charge. You needn't write a letter. Just tear out the coupon right now. Fill it in and mail. Within 48 to 72 hours you can have the whole proposition before you. It's a case of walking right into \$3000 to \$5000 a year. Use the coupon below.

Send for Free Book

M. Haywood, Pres.
HAYWOOD TIRE & EQUIPMENT CO.
970 Capitol Ave., Indianapolis, Ind.

Dear Sir: Please send me by return mail your free book on the new Haywood Tire Surgery method and the details of this profitable business.

Name.....

Address

Easy to Own a Dependable Ottawa

Prices Lower Than Ever!

**90
Days' Trial.**



**10-Year
Guarantee.**

Prices on famous OTTAWA Engines have hit rock-bottom! Cheaper, now, to own a dependable OTTAWA for farm or shop than to be without one. Shipping direct from factory saves you more money on a better engine. Get prices on all sizes before you decide on any engine.

OTTAWA

GASOLINE ENGINES KEROSENE

1½ H.-P. to 22 H.-P. Magneto equipment or batteries. Easy to start; Easy to operate. Dependable power at all times, for all uses. Better built throughout for hard work. Thousands in use. Every owner a booster.

OTTAWA MFG. CO. OTTAWA, KANSAS.

**1½ H.P.
\$35.50**

**2 H.P.
\$38.50**

Write for Special Offer NEW FLYING and "HOW TO JUDGE ENGINES."

FREE BOOK:



SAVE MONEY ON GUARANTEED MOTORS

Fuerst-Friedman MOTORS

Buy Direct from Headquarters

By buying direct from us you save from 25% to 40% on new Columbia motors, and as high as 50% on Fuerst-Friedman rebuilt motors. You save retailer's profit—you save retailer's high sales cost and you get motors fully guaranteed for one year.

No matter what your motor requirements are, from tiny buffing motors to heavy-duty factory motors, we have a new or rebuilt motor to suit your exact needs. And the cost is from 25% to 50% less than you would pay elsewhere. Send for our big free motor book—see for yourself the savings you get by buying from us. It tells all about our twenty years of successful motor service—all about many vast engineering projects we have handled. Ask for Book No. 10—the price regulator on new and rebuilt motors.

Electrical Machinery of all kinds promptly repaired or taken in exchange

THE FUERST-FRIEDMAN CO.,
CLEVELAND, OHIO
"Reliability Built In"

Build and Fly Model Aeroplanes



Build your own Model Aeroplane; make trial flights and learn the principles of Aeronautics. With IDEAL Scale Drawings and Building and Flying Instructions you can easily build exact 1/2 ft. duplicates of Real Planes. Send now for the Plans for the one you want to build.

Curtiss JN4D-2 Training Plane; DeHavilland Battle Plane; NC-4 Naval Seaplane; Curtiss Military Tractor; Blériot, Newport or Tzabe Monoplane; also Cecil Peell Racers; 25c each, postpaid.

Catalogue IDEAL Model Aeroplanes and Supplies, 5c postpaid

IDEAL AEROPLANE & SUPPLY CO.
150 Wooster St., cor. W. Houston St., New York City

PLANS AND INSTRUCTIONS 25¢

MOVING PICTURE MACHINE FREE



This genuine New Model American made Moving Picture machine with film—ALL GIVEN for selling 20 packages. Prints at 15c a pkg. Write for them. We send them postpaid. When sold return \$3.00 and we send machine, film and extra premium free of set of admission tickets, postage prepaid.

BLUINE MFG. CO.,
554 Mill St.
Concord Junction, Mass.

SOMETHING NEW, CATALOG No. 22



New goods, new prices, small boilers, engines, stoves and gasoline, 1-3 H. P. up, pumps, castings, blue prints, gears, pulleys, electrical goods, model tractors, supplies, motors, 3-4 H. P. Marine engine, 2 1-2 inch ga. model locomotive, etc. Catalog postpaid 20c stamp (2 dimes preferred). Refunded first order.

Modern Engine and Supply Co.
53 W. Jackson Blvd. CHICAGO

WHEEL-O-TIME

Auto, Motor Cycle or Bicycle WATCH HOLDER



For any watch. Puts the time where safest to have it. No more fumbling in your pocket. Watch can be instantly released. Handsomely made and heavily nicked. Sent prepaid for \$1.00 bill or C. O. D.

Money-back Guarantee

WHEEL-O-TIME CO. 186 East Avenue
Rochester, N. Y.

COLUMBIA MOTORS

MOTORCYCLES

ONE YEAR TO PAY



Know the joy of owning—for business or pleasure—a HARLEY-DAVIDSON, EXCELSIOR, HENDERSON, INDIAN, CLEVELAND, or any other standard make; thoroughly rebuilt in our own factory.

Write for Free Bargain Bulletin and Easy Payment Plan.

HAVERFORD CYCLE COMPANY
America's Largest Cycle House
Established 26 years
503 Market St., Phila., Pa., Dept. P. M.

Your Old "Bike" and The SHAW Motor

Makes A Complete Motorbicycle

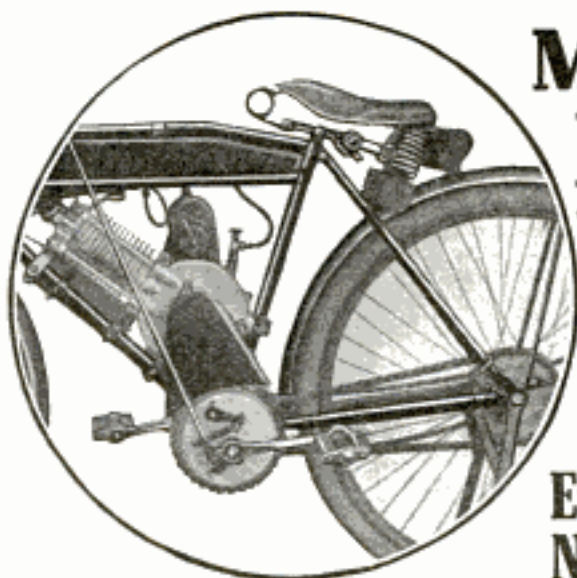

Gives speed of 4 to 40 Miles an Hour!
90 to 125 Miles per Gallon of Gasoline!
1,200 to 1,800 Miles per Gallon of Lubricating Oil!

Easy to Ride—Easy to Control—Dependable.

**Easy to Attach—No Special Tools!
No Mechanical Skill Required!**

Shaw Specifications

Power Plant—2½ H-P SHAW Super Motor, 4-cycle type; Bore 2½ inches; Stroke 3 inches.
Transmission—Two roller chains with countershaft clutch on crank hanger shaft, giving free engine.
Ignition—American magneto; water and oil proof.
Carburetor—Celebrated Kingston Boat feed type.
Lubrication—Sight feed; automatic.
Control—Grip control.
Fuel Tank—Two compartments; one for oil and one for gasoline; round tank for single bar frame, or flat tank for double bar frame, is furnished without extra cost.

Shaw Motors!

SHAW Motors are in daily use by thousands in all parts of the country and are known everywhere for their high quality and dependability. Every SHAW Motor leaves our factory with an IRON-CLAD GUARANTEE. The name "SHAW" is assurance of full satisfaction.

The Complete Shaw Motorbicycle

The SHAW Motorbicycle is a lightweight, powerful motorbicycle, complete in every detail. All latest improvements. 2½ H-P 4-cycle motor of highest efficiency. Special Low Price now.



You don't have to do any filing, fitting or boring to make your old "foot-power" bike a dependable motorbicycle with the SHAW Attachment. A monkey wrench and a screw driver are the only tools you need. You can clamp the SHAW Attachment to your bike in 30 minutes time. Just follow the simple directions that come with it.

Fits Any Make Bicycle

The SHAW fits any standard bicycle frame. No cutting or making over. Nothing at all complicated.

SHAW MFG. CO.,

Prices Reduced Now

We have made tremendous price reductions—effective **at once!** You can now get the SHAW Motor Attachment at a lower price than ever before. Take advantage—ACT!

Write Today—

For Complete Descriptive Literature and New Low Prices on SHAW Motor Attachments and Motorbicycle. Use the Coupon below. Fill out and mail it NOW!

**Department 37,
GALESBURG, KAN.**

Send This Coupon for New Low Prices

SHAW MFG. CO.,
Dept. 37 Galesburg, Kansas.

Please send me New Low Prices and Full Particulars on the SHAW Motor Attachment and Complete Motorbicycle, all without obligating me.

Name

Address

R. F. D. State

AGENTS--SALESMEN--SALES MANAGERS

EXCLUSIVE TERRITORY ON NEW INVENTION

Will you listen when opportunity knocks? Fortunes have been made in new automobile inventions. Grab this one quick. Your minutes are like dollars—don't waste them now. Read—investigate—then act. The Speederator for Ford cars is a new invention that makes any Ford run like a Packard. Stops stalling—bucking and motor racing. Gives a smoothness to Ford driving that is wonderful. And just think—Speederator is put on without boring holes or special tools of any kind. Any Ford driver can put one on complete in twenty minutes. Never wears out—never needs attention—operates automatically. Sells like lightning. Old Ford drivers say best and only necessary Ford part. Get full information.

LISTEN This is not a ready made fortune but it is the opportunity to secure the exclusive sales agency for this new invention. Don't take our word—get the proofs. Just be honest with yourself and investigate. Let the money you make talk from now on. Smashing records of success will show the way; Helton, Utah, sold six hundred in five weeks—profit \$1,800.00. Crist, N. Y., sold 23 first day—said would have sold more if he had had them—now averages more than 400 a month—profit \$1,200.00. McAllister, Ills., say, sold four first afternoon: He is now using 100 a week. These straight-from-the-shoulder-facts point the way. Hoover down in Ohio sold 29 in one day, profit \$87.00. Benke, Mo., averages 200 a month. Campbell, Tenn., 1,000 a month. Crandall, Iowa, put on thirty sub-agents in one week. Dryden, Calif., sold 150 in ten days. Grace, Hawaii Island, 200 in two weeks. Teeters, Mich., first three dozen in ten days. We say you can make

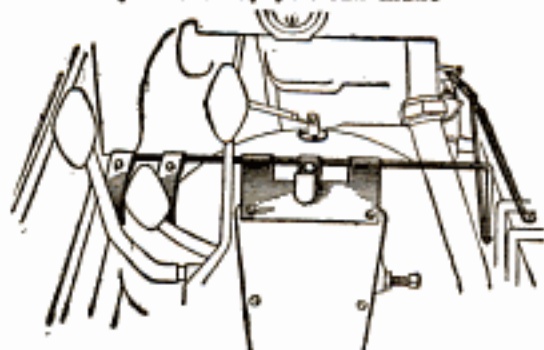

THE GREATEST FORD INVENTION

THE PERRIN METAL PARTS CO.

\$55.00 TO \$300.00 WEEKLY

selling the Speederator. Best article to advertise itself you ever saw. Once on a car the driver will never let you take it off. Sales are made fast and furious. Boyer, Penna., made \$72 first day. Cook, N. Dak., 150 sold first two weeks. Cahon, Ariz., 72 in two weeks—\$216.00 clear. Join the ranks of successful men in this work.

NO EXPERIENCE NECESSARY

Just show us that you mean business and are ready for business and we will show you how. But first, make us prove these facts. We have nothing to apologize for. The Speederator is a grand success—you can make money fast if you have the territory—so get busy now. Write to-day for the necessary information and see for yourself. Don't delay—plenty of good territory left—if you are a hustler you can have money in the bank in a few weeks. Just write—now—to

1125 Wolverine Bldg.

Toledo, Ohio

You Cannot Afford To Throw Away Wrinkled Neckties

This package contains: Six All-Metal Adjustable Necktie Pressers that Make old neckties smooth (like new) Without Ironing Them. Sent postpaid for \$1; and one Six-Way Necktie Banner—Given FREE. Home Agents Wanted—Manufacturing Outfits Furnished. Full information and directions given to Agents with each order.

NECKTIE NOVELTY CO., 110 Pilgrim, Highland Park, Michigan

Today, write for catalog explaining the 19 big new features of Ole Evinrude's new outboard motor, the Elto. Full 3 H. P., only 48 lbs.

ELTO OUTBOARD MOTOR CO.

Ole Evinrude, Pres.

Mfrs. Home Bldg.

Milwaukee, Wis.



THROW YOUR VOICE

Under the table, down in the cellar, into a trunk or any old place. With our **VENTRILO** which fits into the mouth you can have lots of fun fooling your friends. Also full instructions in the art of Ventriloquism, and big book of jokes. Sent by mail for 10 cts. Stamps or coin.



AERIAL AIRSHIP

UP IT GOES!

Climbs in the air by its own power. The propeller spinning automatically at a lively rate. Floats around a

room or outdoors. Lots of fun. By mail 10c.



Invisible Ink



Letters written with this ink look like blank paper. Can be brought out plainly by heating over lamp or stove. Bottle in wooden box, 10 cents.

SKULL RING



The eyes in this ring are either Emeralds or Rubies and would scare the timid. Either Roman Gold or Oxidized Silver. 25c by mail.

WONDERFUL WIRELESS TELEGRAPH

Two instruments and 2 Codes in a box. Can Telegraph from room to room or house. Full instructions. By mail 12 cents.

All the Above by Mail for 50c.

STAMPS OR COIN

UNIVERSAL NOVELTY CO.

DEPARTMENT 204 STAMFORD, CONN.

POWERFUL AIR RIFLE

Length 32 inches. Working parts of the best grade of steel. The stock is finely polished walnut. Shoots small game. Powerful, accurate, durable. You can have this air rifle for distributing only 5 of our fast selling art pictures at 25 cents on our special offer. Everybody will take one.

IT COSTS YOU NOTHING to try, as we take back those you can't dispose of.

Send no money.

C. M. THOMAS, 337 W. MADISON ST.

2-D-93 CHICAGO.



GIVEN



You Are Welcome Everywhere With a Buescher Saxophone

Nothing can take the place of a sweet-toned Buescher Saxophone for home entertainment, church, lodge or school. In big demand for orchestra dance music.

You will be astonished at the ease with which you can master a Saxophone. It is the easiest of all wind instruments to play and one of the most beautiful. **Three first lessons sent free.** You can learn the scale in an hour's practice and play popular music in a few weeks. Practice is a pleasure because you learn so quickly. You can take your place in a band within 90 days, if you so desire.

Free Trial—Easy Payments

You may order any Buescher Saxophone, Cornet, Trumpet or Trombone or other band or Orchestral Instrument without paying in advance, and try it six days in your own home without obligation. If perfectly satisfied, pay for it on easy payments to suit your convenience. Mention the instrument interested in and a complete catalog will be mailed free.



The Buescher-Grand Cornet is exceptionally easy to blow, yet possesses a tone of wonderful volume. With a Buescher-Grand, you can own an instrument similar to that with which the greatest cornetists of America have made their reputations.

Free Saxophone Book

Tells what each Saxophone is best adapted for; when to use singly, in quartettes, sextettes, octettes, or in regular band or full Saxophone Band and how to play from cello parts in orchestra. Send for free copy.

Buescher Band Instrument Co.

Makers of Everything in Band and Orchestra Instruments

2550 Buescher Block Elkhart, Ind.



**Clip
and Mail**

**Buescher Band
Instrument Co.
2550 Buescher Block,
Elkhart, Ind.**

Kindly mail to me Saxophone Book.
Shall we also send you Free Complete Catalog of all Buescher True-Tone Brass Band Instruments?

Name.....

P. O. Address.....

Instrument I play is.....

BUESCHER

True-Tone Band Instruments

TIRE AGENTS WANTED

\$4000 A YEAR

I'll Show You How to Make More Money
Taking Orders For Mellinger Tires

I want exclusive Agents, all or part time, to handle Mellinger Extra Ply and Cord Tires under the **MELLINGER PLAN**. No experience necessary. My Plan literally guarantees your success without risk or investment. Thousands of car owners say Mellinger Tires are the finest and most serviceable made.

Guarantee Bond Up to 10,000 Miles

behind my Extra Ply and Cord Tires. Everywhere Mellinger Tires are making big money for agents and giving Auto Owners **BETTER TIRES FOR LESS MONEY**. My new low prices amaze everyone.



I Guarantee Your Profits

So confident am I that you can earn big money under the **MELLINGER PLAN**, that I literally guarantee your profits. The **MELLINGER PLAN** offers you a permanent business. No matter what you are doing—what you are making—let me put this remarkable plan in your hands. I don't ask you to carry a big stock—to risk **ONE CENT** of an investment. Sample Sections Furnished. My **BIG FREE BOOK** tells you all about it—about tires—their construction—how sold—explains manufacturers', jobbers', retailers' prices—tells you **WHAT REAL WHOLESALE PRICES ARE**. A post card brings you this remarkable book by return mail.

Prove It for Yourself

Don't buy anyone's tires until you see these amazing values—see these tires on your own car. **THINK OF IT**. Oversize Cord Tires for less than Fabrics used to cost. Read amazing reports of my agents' successes under the **MELLINGER PLAN**. Read what Car Owners say about these Super-quality Tires. Read how you can get a brand new set of Mellinger Tires for a little of your time and good will. I'll take all the risk to have you try Mellinger Tires on your car. **Tires shipped prepaid on approval.**

My Amazing Offer

I say this is the big thing for you—your opportunity for a big future—wealth—independence—big business with hosts of friends and customers. I appoint only one exclusive agent in each locality. Let me explain the **MELLINGER PLAN**—Let me show you. Tweedie, of Maine sells \$1436 in few short weeks. A. M. Amigo of Santurce, Porto Rico sold \$4024 in seven months. Keithley of Idaho, says: "I have sold \$900 worth of tires since I took the agency and all have given good satisfaction." These are ordinary results—you can do it—you can make \$4000 a year—you can make more. **BETTER TIRES FOR LESS MONEY** are business getters. **DON'T SEND A CENT**—fill in the coupon this minute before you turn another page—tear it off—mail it now—My Big Free Book will be in your hands in a few days.

MELLINGER TIRE & RUBBER COMPANY
1069 Oak St. Kansas City, Mo.

Mr. E. L. Mellinger, Pres.,
Mellinger Tire & Rubber Co.,
1069 Oak St., Kansas City, Mo.

Without obligation, send me details of the Mellinger Plan, Free Book and Wholesale Prices and how, without investing any money, I can become your authorized agent.

Name

Address



MAKE MORE MONEY

TORIT ACETYLENE TORCH No. 13

For soldering, heating, melting, tempering, auto radiator repairing, and for all kinds of small jobs requiring a hot flame instantly.

An improved method—saves time and affords greater convenience over old methods of using gasolene, kerosene or charcoal.

For garages, electricians, dentists, jewelers and every kind of repair shop.

USES ACETYLENE GAS ONLY

A splendid use for discarded auto tanks, and a profitable investment.

Torch with 4 tips for different kinds of work, soldering copper, & ft. tubing and connection for auto acetylene tank..... **750**

ST. PAUL WELDING & MFG. CO., 177 W. 3rd St., ST. PAUL, MINN.

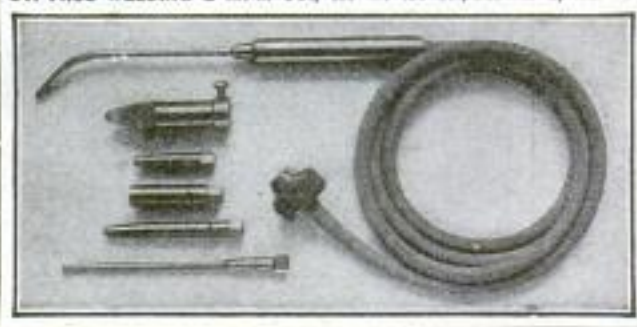

SPRINGFIELD CARBINE

\$3.50



Cal. 45 Breech Loading

Men or women can handle it with perfect safety. This style and calibre used by the Army for over 30 years and is simple in construction. Used and in first class condition. Inside barrel like new. Length over all, 41 inches. Weight 7 lbs. Can be loaded and fired 10 times a minute. **\$3.50.**

Then for \$3 more you may have a smooth bore barrel to shoot shot, for small game, scare sparrows, kill a chicken and what not. This is a wonderful combination. The smooth barrel can be interchanged by anyone in 5 minutes. Millions of Bird or Ball shot cartridges, 3 cents each.

W. STOKES KIRK, Dept. P. M.
1627 N. 10th St., Philadelphia, Pa.

Clear-Tone
FOR

PIMPLES

Your skin can be quickly cleared of Pimples, Blackheads, Acne Eruptions on the face or body, Enlarged Pores, Oily or Shiny Skin. **\$1,000.00** Cold Cash says I can clear your skin of the above blemishes. **WRITE TODAY** for my **FREE** Booklet—"A Clear-Tone Skin"—telling how I cured myself after being afflicted for fifteen years.

FREE

E.S.GIVENS, 129 Chemical Bldg., Kansas City, Mo.

Make

A

New

Farm

in

Ten

Days

**Save \$25 to \$75
An Acre
Clearing
Land**

**BORE
and BURN
YOUR STUMPS**

Simply bore hole in stump as shown to create draft—Then set it afire

A Light Powerful One-Man Outfit

Boring and Burning is the easy and quick way to rid your land of old dry stumps. No danger—no hard work—no big holes to fill—no hauling. First and only practical power stump borer ever offered at a price within reach. Now in use by large owners of cutover lands.



Bores 3-Foot Stump in 30 Seconds

The WITTE Stump Borer

Earn \$10 to \$15 a Day

BIG CHANCE for men who are first in their locality to get busy boring and burning stumps for others.

TELL US

How many acres of stumps you have and we will send you some interesting information how to get rid of them quick.

Converts your valuable stump land into a big, productive farm. Lightest, most powerful and easiest to handle. Bores a 2 inch hole through the average stump in less than a minute. Lever Control. Start or stop auger without stopping engine. Specially built engine develops over 8 H-P. Use either kerosene or gasoline. BOSCH Magneto built in. Engine simple and easy to operate. Outfit complete as shown.

Costs Less Than 5 Cents a Stump

Counting 40 stumps to acre, you can cover 2 or 3 acres a day—bore a hole through every stump. Start your fires with blow torch and auger shavings. Thousands of acres of valuable cut-over lands throughout the U. S. are waiting for the practical use of this wonderful outfit in either burning or blowing. Order now while we can make prompt shipment. Directions for operating the WITTE Stump Borer, and best method of burning stumps with each machine.

Use Engine For Other Work Special clutch pulley enables you to use engine for all classes of belt work. Every outfit sold on LIFE-TIME GUARANTEE same as all WITTE Engines. Cash or Easy Terms. Write for complete description.

WITTE ENGINE WORKS,

1174 Oakland Avenue, KANSAS CITY, MO.
1174 Empire Building, PITTSBURGH, PA.

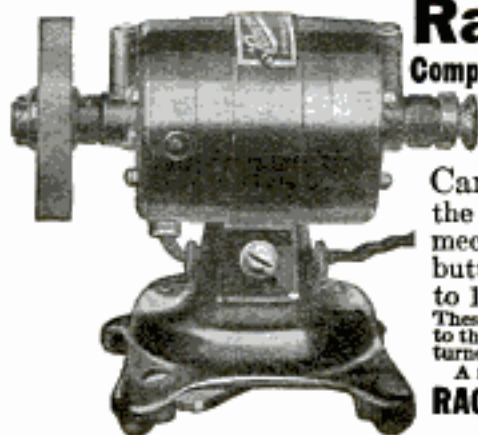

Race Electric Grinder \$16⁵⁰
Complete With 3" Emery Wheel, Grooved Pulley and Electric Cord

F. O. R.
CHICAGO

For sharpening tools, polishing or grinding, the Race Motor Grinder will prove a great convenience in the Carpenter Shop, Machine Shop, Garage, at Home, or on the Farm; it is a practical machine that will prove its value to every mechanic. It is portable, plugs into any electric light socket, push button start and stop, operates on either A. C. or D. C. current of 110 to 130 volts, or 25 to 60 cycles. Weighs only 7 lbs.

These small Grinders are dependable in every respect and satisfactory service is guaranteed to the extent that if you are not entirely pleased after ten days' use, the Grinder may be returned to us and your money will be cheerfully refunded.

A neat adjustable tool rest can be supplied for \$1.50 extra if desired.

RACINE UNIVERSAL MOTOR CO., 4642 Ravenswood Ave., Chicago, Ill.
ATTRACTIVE DEALER PROPOSITION

2-Year Guaranteed Batteries at Lowest Prices



HIGHEST standard battery made by one of the oldest standard battery companies in America now comes direct from the maker to you without a single profit in between.

Most remarkable battery opportunity ever offered to car owners.

Two year written guarantee. Highest bank references. Prices in many

cases 60% lower than batteries bought through dealers and much lower than ordinary mail order batteries jobbed through mail order houses.

Sample Prices

Ford, Studebaker, Chevrolet, Dort... \$14.95
 Buick, Overland, Essex, Reo... \$17.70
 Hudson, Nash, Maxwell, Dodge... \$21.95

Prices like these, as you must know, are lower by far than any other battery prices ever made. And the reason is, there is not a single extra profit—not even a jobber's profit—in between.

Send no money—order direct from these prices, being sure to state name, model and year of car, and battery will be sent immediately by express C. O. D.

Order to-day. Remember, highest standard batteries by one of the oldest standard battery companies in America at lowest prices ever offered.

Defiance Battery Company

Direct Sales Department 11
 725 Hearst Building, Chicago, Ill.

Finest Instruments Are Easiest to Play



You cannot learn to play correctly on a cheap, imperfect instrument and expect to achieve success in music. The best teachers will always recommend the finest instruments for their pupils.

King Instruments Now Easy to Own

A quarter century ago the first King Brass Instrument was made to the specifications of a famous artist, and for years thereafter Kings were made and sold only for cash to great musicians. But now, our new easy payment plan makes it possible for anybody to own a King. You can now buy direct from the factory, save middleman's profit, and get a brand new, acoustically perfect, laboratory-tested King Instrument. And, with every new King goes our famous free factory-service and guarantee.

Big Stock of Used Instruments

Thousands of musicians have turned in good instruments as part payment on new and better Kings. These used instruments we sell for cash at very low prices. They are refinished and look like new. Send for our latest complete catalog and list of these bargains before they are gone. Ask for details of easy payment plan on new instruments.

KING

THE H. N. WHITE CO.
 5237 Superior Avenue,
 Cleveland, Ohio

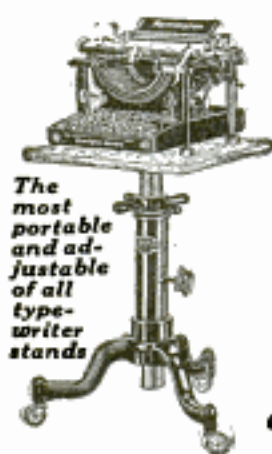

The most portable and adjustable of all typewriter stands

FOR A LIMITED TIME

ONLY \$100 DOWN

Brings You The World Popular "SATELLITE" TYPEWRITER STAND

That's all—just a single dollar bill and we will send you the famous portable and adjustable, indestructible "Satellite" Typewriter Stand—brand new—1922 Model—direct from the factory. You need not send a penny now. Simply send us your name and address for full details of our amazing Free Trial Easy Payment Offer.

10 DAYS' FREE TRIAL

Positively we will ship you the Satellite Typewriter Stand on 10 Days' Free Trial in your own home or office. Convince yourself of its serviceable features, its durability and its appearance. See how much better and faster work you can do when the keyboard is adjusted to the exact height you want. This is the same stand used by Morgan & Co., Standard Oil, Larkin & Co., Pennsylvania Railroad, Remington Typewriter, Dayton Laboratories and thousands of others.

EASY PAYMENTS

If you decide to keep it after 10 days' free trial all you have to do is pay the balance in small monthly installments. If for any reason you do not want it, ship it back to us and we will refund your dollar and all shipping charges.

Remember our supply of stands for this offer is limited.

Send today, without delay, for full free particulars of this great offer.

Adjustable Table Company
 Dept. 2212 GRAND RAPIDS, MICH.

AGENTS \$1.75

YOU CAN Sell This For



and Give These Shears **FREE**



8 inch—with spring tension device

MY! HOW THEY SELL!
 ONLY 20 Boxes A Day Means \$18.00 Daily Profit
 You get the interest with the free Shears. Walter Harris sold 800 boxes in 6 Weeks, Profit over \$100.00 a week. A total retail value of \$4.50. A real bargain at \$1.75. The array of fine toilet goods (that always appeals to milady's heart) will dazzle her eye, and when at the end of your talk you state the low price of \$1.75 for these 11 articles, with the shears FREE, the money is yours, even if she has to borrow, or beg it.
ACT NOW! Sells like hot cakes year 'round. A baby could sell for complete outfit including display case. At least write for circulars explaining our unique plans, including 30 other packages. **ACT NOW.**
 E. M. DAVIS CO., Dept. 2352 CHICAGO, ILL.

Make \$200. to \$1000. Profit Monthly

With Balba Perfume Sales Machines

There were \$760,000,000.00 worth of perfumes and toilet preparations sold in one year in the U. S. Approximately one-third of this, or \$250,000,000.00 was spent for perfume. Humanity has always wanted to radiate fragrance and today the demand for perfume is greater than ever. Men, women and children love to use it. They spend a dime for it, when they can't spend more. Dimes fairly flow into the Balba Sales Machines. The average machine will make about 80% profit per month on the first investment and repeat the earnings monthly. Just think what this means—one machine containing 100 bottles in an average location will empty every 30 days and the profit is \$4.00. That means only 3 1-3 people use the machine daily. Assuming a man owns 100 machines, he will average \$400 profit a month. It's the greatest opportunity ever offered to people with a little money. It is a clean, legitimate, safe, permanent, big profit business. It earns day and night. Can easily be handled in spare time. You own machine and business. Machines Fully Guaranteed.

Balba Bouquet Perfume Exquisite in Fragrance and Quality

Balba is a lasting perfume of rare and wonderful quality—it radiates a fragrance of elegance and refinement about the wearer. Where Balba machines are in use, hundreds are regular customers and buy from 5 to 12 bottles at one time, because of the convenience in size—they are easily carried in vanity case, hand-bag, coat or vest pocket.

25c to 35c Value—Price 10c a Bottle

Balba is a high, quality, exquisite perfume. We manufacture it in large quantities and sell it only through Balba Sales Machines in plain, inexpensive bottles, thus reducing the cost and leaving out all middle men's profits for we sell direct.

Sold Only Through Balba Sales Machines

Balba Sales Machines are always ready to wait on customers—never high-priced nor wasteful—have no overhead expense—are attractively nickel-plated—give out a fragrance that attracts the customer—practically theft-proof—easy to fill—simple to operate—nothing to break or get out of order—weather proof, can be placed out of doors in any climate—occupy small space on wall or counter—get and hold customers because it's the lowest priced way to sell perfume and give the highest quality and largest quantity.



We Want Balba Sales Machines in Every City, Town and Recreation Resort

We have thoroughly proven that Balba Bouquet Perfume is a good seller—it repeats—it makes new users. Balba machines in good locations show an increasing business, which proves we have hit the safe, sane, logical way to sell quality perfume. Think of this small investment as compared with the 5c and 10c stores and yet they make millions yearly. We are now going to offer a tested, proven, big profit, permanent business to a live person, (man or woman) in each territory. We do not sell territory rights—we sell an allotment of Balba machines in proportion to population, large cities may be subdivided, and then give the purchaser exclusive rights to sell Balba perfume in that territory. There is no other perfume sold like this, and as quickly as we get general sales distribution, we are going to advertise Balba nationally.

FREE Newspaper Advertising in Your Territory

When our representatives have bought and placed a full allotment of Balba Sales Machines we will then run advertising in his local newspaper, giving the locations of all the Balba Sales Machines. This makes every one start buying Balba, and the Balba quality makes them buy again. We tell you how to place machines and handle them. In a short time, when we have general distribution of Balba, we will advertise in the National weeklies and Women's magazines and make Balba popular every place.

Guaranteed 100% Earnings or Money Refunded

We guarantee that Balba Sales Machines will earn at least 100% on their original investment the first year, provided the machines are all placed in use and kept filled, or we will refund the original price of the machines and perfume then on hand and take them back.

Write NOW for complete information, literature and sample of Balba. Territory given to first to qualify. A telegram holds territory until you get our proposition. Act quickly if you want choice locations. Remember Fortunes are made in Dimes.

References: Northern National Bank, Toledo, Ohio, or R. C. Dun & Co.



WHERE BALBA MACHINES CAN BE PLACED		
Theaters	Moving Picture Houses	Waiting Rooms
Pool Halls	Billiard Parlors	Drug Stores
Depots	Apartment Houses	Cigar Stores
Clubs	Public Buildings	Hotel Rooms
Restaurants	Bowling Alleys	Hotel Lobbies
Cafeterias	Ticket Offices	Dance Halls
Elevators	Street Car Stoppers	Lodge Rooms
Trains	Ice Cream Parlors	Fruit Stands
Parks	Office Building Lobbies	Candy Shops
Bath Houses	Passenger Buses	Lunch Counters
Factories	Recreation Buildings	Skating Rinks
Rest Rooms	Interurban Cars	Street Cars
Boats	Shoe Shine Parlors	Barber Shops

Send 10c Coin or Stamps

—with name and address for full size bottle of Balba Bouquet Perfume. This offer is open to any one.

THE BALBA CORPORATION of AMERICA

Dept. 42

1306-1308 Jackson St.

Toledo, Ohio, U. S. A.



ART-GEM

The Stone that defies Diamond Experts—

Wear it 15 Days FREE

Truly a wonder GEM

No. 84

We want you to be the sole judge of the Blue-White-Perfect Art-Gem, the most wonderful scientific Diamond known. We say it is Blue-White, Perfect-Cut, and full of fiery sparkle, radiance and brilliancy; that it has diamond hardness and acid resisting qualities and only an Expert can distinguish it from a Genuine Diamond. You too will say the same or we don't want you to keep it.

SEND NO MONEY Just rush your name, address, style and finger size (a strip of paper just long enough to meet over the second joint of your finger will do) for your Art-Gem. It weighs one and one-quarter Carat and is mounted in 14K (Guaranteed U. S. Assay) Solid Yellow or Green Gold for gentlemen and 14K Solid Yellow, Green or White Gold for ladies.

Wear It 15 Days FREE. Give it every test used to determine genuine diamonds—then if it proves to your complete satisfaction, pay \$3.00 monthly for three months. If dissatisfied return to us and get your money back without a question or quibble, by return mail, immediately. You run no risk, merely deposit \$4.50 with the postman when your ring comes.

ART GEM COMPANY Dept. 77 138 5th Ave., New York, N. Y.

Ladies Ring No. 91
14 K

BINOCULARS

SPECIAL VALUE in high grade, genuine, imported FRENCH PRISM Condé Binoculars. Give remarkably clear and brilliant image. Come in an elegant plush lined, genuine calf skin carrying case with straps.

\$45.80

Including War Tax

8 POWER, 32 mm. 23 OZ.

BRAND NEW—not war stock! Sent C. O. D. express prepaid, subject to examination and 10 day approval. If not satisfactory we refund your money and pay return charges.

Order Now! Over 1000 pairs sold. Wonderful value. Order now or write for descriptive folder.

BARLER & CO.
645 N. Michigan Ave.
CHICAGO



A NEW WAY TO GET YOUR CLOTHES ABSOLUTELY FREE

and Make Big Money during your spare time—something different, better, bigger, more liberal than any offer ever made. Lower prices—better clothes—bigger cash profits—express or postage paid on everything.

DOUBLE PAY

Free Clothes and Cash Profits Besides. You can easily earn \$30.00 cash, extra, every week during your spare time, taking orders for our made-to-measure clothes. We don't ask you to use your cash profits for your own clothes. That's not our way of doing business. Ours is a new and better plan.

Fifty-six stylish, real cloth samples—FREE colored fashion plates inside wholesale prices—everything FREE. Just drop us a line today and we will send complete outfit FREE.

SPENCER MEAD CO., Dept. B-245, Chicago



Try This Typewriter 5 Days FREE



\$4.00 and You Keep it

The balance in easy monthly payments. Save fully \$25 to \$60 on any standard make. Every rebuilt machine guaranteed to be in perfect condition. Try 5 days at our expense. Write for special prices. A postcard will do. Send NOW.

WYNN TYPEWRITER EXCHANGE, 1 Reliance Bldg., Kansas City, Mo.

POULTRY MILLER'S GUIDE

—tells all about raising chickens, care, feeding, etc. Quotes special low prices on eggs for hatching, poultry, baby chicks, incubators, brood-free, and poultry supplies, fully illustrated, sent FREE.



J. W. MILLER Co., Box 12, Rockford, Ill.



\$100 TO \$200 MONTHLY PROFIT RECHARGING FORD MAGNETOS

The "COLPEN" Magnet Recharger for Ford cars, clears all "SHORTS" in the magnets coil and Recharges Magnet to full strength in less than 5 minutes without removing a single bolt or nut. "No storage batteries needed." It operates from any alternating current light socket; will also operate from Farm Lighting Plants, Direct Current Circuit, Storage Batteries, and Dry Cells. Nothing to wear out. No up-keep cost. Weighs 12 lbs. Used and recommended by Authorized Ford Dealers. **ORDER ONE TODAY.** Price \$37.50 Complete. Agents get your state rights now. A 90-day trial, money-back if not satisfactory—protects you. Catalog FREE. Write today.

MAGNETIZER MANUFACTURING CO.
146 W. Florence Ave., Dept. M200, Los Angeles, Cal.

Aladdin Homes \$200 to \$800

Aladdin Homes will save a substantial amount for you through eliminating dealers' profits, saving over 18% waste in lumber and lowering labor costs in building. Aladdin Homes come to you direct, thereby reducing freight charges, and are cut to fit, saving waste of lumber and hundreds of hours of carpenter labor. Send stamps for the Aladdin catalog at once.

Bungalows, Dwellings, Summer Cottages

Aladdin prices include all the timbered frame work, millwork, the siding, outside finish, porch, shingles, windows, doors, interior woodwork, lath, glass, nails, hardware, lock sets, paints, stains and varnish. Send stamps today for catalog No. 1568.

THE ALADDIN CO.
BAY CITY, MICH.

Branches; Offices and Mills: Portland, Oregon; Wilmington, North Carolina; Hattiesburg, Miss.
Canadian Offices and Mills: Vancouver, Winnipeg, St. John



Free Loan

Guarantee

We

BUYING
POWER

Now comes a concern big enough to loan *furniture* free while you leisurely decide on it



Our new Home Lovers' Bargain Book is absolutely Free to you. In it we show many thousands home needs all loaned free. Entirely as an extra advantage we bring the most agreeable longest credit—free to all. No matter how clearly and simply we state these facts—it's all so different, so entirely new—that some folks will go right on thinking it cannot be so. For fear the least shadow of a doubt can remain in anyone's mind we go way beyond mere promises. We guarantee every statement we make here. This free loan guarantee comes with our free book. It is legally binding.

Your own postmaster, or station agent; any bank in Chicago, New York or other large city; or any bank in any town in the United States, no matter how small, will vouch for the fact that Spiegel, Mau, Stern Company will keep its every promise.

Read This Out Loud

We realize that before you decide on any purchase, even though the article seems to be

exactly what you desire, there are several questions to be finally answered. Above everything else comes price, then quality, service and appearance. Nobody can tell how a rug, for instance, is actually going to look and fit when you get it on the floor in your home.

So, again we say, before you actually get right down to buying anything, let us first loan it to you free to be compared anywhere and used freely. This is the only test that means anything.

Forget About Buying Ask for Our Free Book Anyway

We invite you to have a free copy of our Home Lovers' Bargain Book. It comes to you for the asking without the slightest promise to buy.

When your particular need arises we like to have you look everywhere else first. All we ask is to look in our book, too, and compare our display.

Then let us take all the burden of proving that, in one way or another, we can please you better. Our way of proving it is to loan the article free of all cost or risk to you. We loan it to you long enough so that you have plenty of time to leisurely make up your mind.

SOME DEPARTMENTS

FURNITURE RANGES	DISHES
CARPETS	SEWING MACHINES
RUGS	SILVERWARE
LINENS	ALUMINUM and ENAMEL WARE
BEDDING	WASHING MACHINES
PHONO-GRAPHS	TRUNKS—BAGS
STOVES	CRIBS
	DIAMONDS
	WATCHES
	JEWELRY

Credit Free to All! Without Asking—Pay Little by Little!

With our free book comes a credit certificate that opens your account in advance. This credit is offered freely to everybody. No matter where you live, what your position may be, or what your earnings are, it makes no difference.

There is never any annoyance; no bother before you order or afterwards. We have no collectors; we hate red tape. After all, our credit feature is simply an added advantage. We loan things to everybody alike, whether they pay cash or use their credit.

That is what makes our plan so different. That is why our offer is so new. That is why credit here cannot ever mean extra costs, or annoyances.

After you decide to keep an article, begin to pay little by little.

If not satisfied we bear every expense — all freight and hauling charges.

You see we have done away with all formality;

all old-fashioned rules and embarrassing practices. It's just a friendly arrangement. We never write to your neighbor or employers or try to pry into your affairs.

If you are the least likely to need the slightest thing for your home now or in the next six months or year, have our free Home Lovers' Bargain Book on hand for comparison purposes, if nothing else.

Just mail a post card.

Spiegel, Mau, Stern & Co.

1522 West 35th Street, Chicago, Ill.



The Easiest Instrument to Play Sent to You ON

FREE TRIAL

Yes, you can have the World famous York Saxophone shipped to you on 10 days' Free Trial. Play it at home for ten full days. Convince yourself of its superb quality and richness of tone. And then, if our instrument does not completely sell itself to you simply ship it back to us, and it won't cost you a penny.

Take Your Choice

You can get any one of these fine hand instruments made by the House of York on 10 days' Free Trial. Send the coupon below for beautifully illustrated literature and take your pick of the following:

Saxophones
Clarinets
Cornets

Drums
Trombones
Baritones

Easy Payments

You can pay while learning to play. Make a small payment down and the balance in monthly remittances. We send you everything you need—carrying case and all necessary attachments.

Send Coupon Today

Fill out the Coupon now with your name and address and simply mention the instrument you are interested in and we will send illustrated literature and full details of our Trial Offer and Easy Payment Plan. This literature also tells you how to practice and how to learn to play. Send Coupon today.

J. W. YORK & SONS
Dept. 2212
Grand Rapids, Mich.

Mail This Coupon Today

J. W. YORK & SONS,
Dept. 2212, Grand Rapids, Mich.
Gentlemen:-

Kindly mail, without cost to me, your beautifully illustrated literature and details of your Free Trial and Easy Payment Offer.

NAME.....

ADDRESS.....

INSTRUMENT.....

(Mention above the instrument most interested in)

1/6 H.P. Motor Less than cost to make



\$10

F. O. B. Chicago

Here's the chance of your life to get a motor to run your washing machine, ironer, dish washer, compressor, bench lathe, blower, fan, drill press,

scroll saw or any small machine around house, shop, garage.

Delivers full 1-6 H. P. with liberal overload capacity. Made for 110 volts, 60 cycle current. (Also for 25, 30, 40, 50 cycle or 220 volts, if desired, at \$1.00 extra.)

Motor strictly high grade. Backed by a substantial manufacturer. Cancellation of a big order reason for this opportunity. Our loss is your gain.

LESS THAN HALF USUAL RETAIL PRICE Satisfaction Guaranteed or Money Back

New motor or free repairs if anything goes wrong within one year. Parts always obtainable. Net weight 20 pounds, shipping weight 26 pounds. Easy means of reversing direction of rotation. 10 ft. cord with 2-piece attachment plug, 65c. Pulleys, 1½ inch or 2 inch, 50c. Order quick, don't lose out. Send cash or order C. O. D. by express.

REYNOLDS ELECTRIC CO.

2610 W. Congress

Chicago, Ill.

Own a Factory Like This~



YOU CAN! Make canvas gloves. Nation-wide demand. Big market everywhere. Retail in dozen lots. Wholesale in thousand lots. Splendid profits. You can go into this wonderful business. Factory shown above grew in three years from two sewing machines. Same rapid development possible for you.

FREE EQUIPMENT

We Furnish Equipment Free

We start you in business. No experience needed. Very little capital required. We teach you how to make quality gloves—how to market them. We do all this for you—start you out right—with understanding that you buy materials from us so long as you cannot do better elsewhere.

Big Market in Your Locality

Many wear canvas gloves. Farmers, laborers, linemen, mill men, drivers, gardeners, and so on. Millions of pairs required annually to supply vast demand. You can undersell big manufacturers. Can operate on closer margin. Can build wonderful, paying business in just few months.

Write for Full Particulars

Don't pass this opportunity without investigation. We tell all about this business in interesting booklet. Costs nothing to learn about it. Your copy is ready to mail minute we get your name and address. Send it tonight. Delay may be costly, as we are furnishing only a limited number of FREE equipments. Write NOW!

McCreery Mfg. Co., 301 Factories Bldg., Toledo, O.

Big Special Offer

on One-Man Log Saw

Every man with wood to cut will be interested in my latest offer on the world famous OTTAWA Log Saw. It's the greatest offer I have ever made! It enables any honest man to own this fastest cutting money-maker and work-saver. If you want a log saw now or in the future, NOW is the time to Act! Use the coupon below and send today. Let me tell you about my great money-saving offer.

4 H-P—Fastest Cutting!

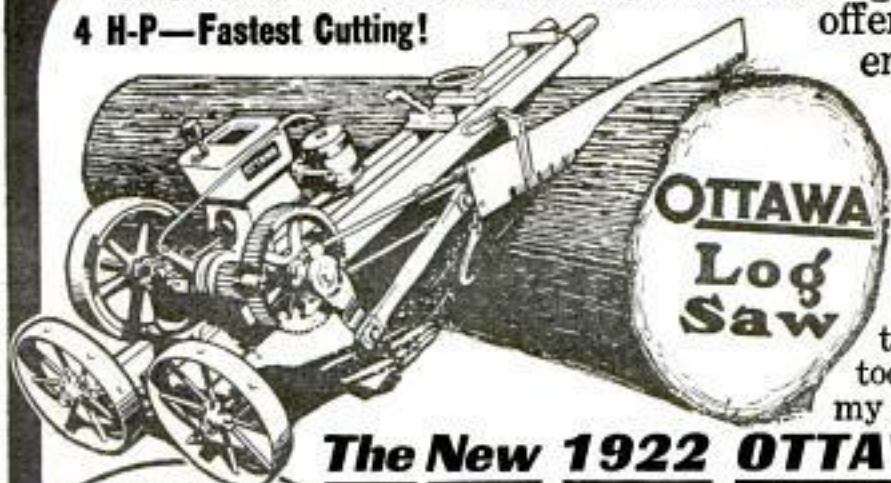

The New 1922 OTTAWA Cuts Faster!

Makes 350 cuts a minute—almost 6 a second! Saws right through the toughest log. And it cuts the human way—the easy, sure, safe way, because of the **POWER FORCE FEED**—an exclusive OTTAWA feature. It is the Standard Log Saw of the World! It does more work—quicker.

Magneto Equipped. No batteries. The New 1922 OTTAWA comes all ready for use. 4 H-P Motor. Nickel Chrome valves—just like high priced automobile motor. Has all power needed for sawing and belt work. Wide, hard bearings.

Prompt Delivery: To save you from 1/2 to 1/2 on freight and to get your OTTAWA to you more quickly, we have sent this new 1922 model to 9 conveniently located warehouses: Albany, Pittsburgh, Indianapolis, Atlanta, San Francisco, Dallas, Portland, Pueblo, St. Paul, Ottawa, Kansas. **Ottawa Ships 'em Quick.**

30 Days Trial: Cash or Easy Terms



Prices Way Down!

Get This Book

A real saving on this greatest of all Log-Saws if you act quick and take advantage of my Special Offer! Greatly reduced prices and the easiest kind of terms on this **Guaranteed** outfit. Get full particulars. See

Wood
Sawing
Encyclopedia
FREE

what you save. Don't wait; don't delay. Act NOW!

Get Free Book; Clip Coupon Now

Just write your name and address on the coupon opposite—or a post card, if you prefer. Then send it today! Get my New Book, beautifully illustrated in colors. Describes the new 1922 OTTAWA and tells how hundreds are making big money selling fire wood. Also get my Special Offer—it will surprise you! Send NOW.

H. C. OVERMAN, Gen. Mgr.

OTTAWA MFG. CO.

1748-Q Wood St.

OTTAWA, KAN.

H. C. Overman, Gen. Mgr.,
OTTAWA MFG. CO.,
1748-Q Wood St., Ottawa, Kansas

Send me your New Book and Special Money-Saving Offer on New 1922 Model OTTAWA Log Saw at once, without any obligation on my part.

NAME

ADDRESS



\$ 215⁰⁰ In One Day

New Invention Sweeping Country Like Wildfire!

NO wonder this amazing new invention is bringing fortunes to agents. All over the whole country this new device is doing away with old-fashioned methods of heating with coal stoves, ranges and furnaces. Already over \$1,000,000 worth have been sold.

You can readily understand why this new invention—the Oliver Oil-Gas Burner—is sweeping over the country like wildfire. It does away with all the expense of coal—making every stove a modern oil-gas burner. Saves money, time and drudgery. Three times the heat of any other method. No wonder agents are riding in on the tide of big Oliver profits!

AGENTS Are Making Fortunes

These men know the secret of big money. They know a good thing when they see it and they know that the time is ripe for this new Oliver improved Oil-Gas Burner. They know that this age of high-priced coal and wood makes it necessary for some substitute. They see ships and locomotives being run by oil and big buildings being heated by it. And they know that

an invention that makes use of this cheap fuel for every home—and yet does it so as to give more heat than coal or wood—is the thing they want to tie up to.

Big Profits Quickly Made

You too can use this secret of big money. You do not need to be a high-powered salesman. The Oliver's amazing features sell it for you. When people see it they know at once that it is the thing they want. You will realize that this is a proposition that will pay you as big money as it does others. We have a definite number of open territories which we are ready to dispose of to those who act quickly. Every territory allotted is filled with big-money opportunities. And this big money comes easily. Because not only does this invention practically sell itself on sight but when you have sold **one** this one will sell several others as soon as your customer's friends and neighbors see it. And thru our special plan you get credit and commissions for every sale in your territory.

You can also make big money just by using your spare time. Note how Norton Brown made \$43 in one evening.

Coupon Brings Full Offer

If you want to make at least \$5,000 a year easily, mail this coupon now for our offer. We are not making any extravagant claims about this. We do not have to. We believe that your common sense will indicate a good proposition to you when you know about it. We want to give you the facts. Won't you write us? And by doing so quickly you will be allotted an exclusive territory with private selling rights.

The coupon will bring you the facts and will save you writing a letter. But mail the coupon at once.

OLIVER OIL-GAS BURNER AND MACHINE CO.
2014-N Pine Street, St. Louis, Mo.

SAYS F. W. Bentley of Philadelphia

"Ye Gods—some sell! I made \$215 today!"

Buy's Car with Profits

"Have earned enough in one month to buy me a new auto."
S. W. Knappen, Cal.

\$7 Profit per Hour

"I started out and made \$21.50 in about 3 hours. The Oliver does the work. It certainly is the real thing."
L. Zocher, Ohio.

"Sells Like Beer in a Dry Town."

"Am sending today for 7 Oliver's. This is one day's orders (\$45 profit). Selling like beer in a dry town."
W. H. Drew, Mich.

Mr. T's 28th Order in Six Months

"Ship 52 Oliver's 10 No. 30; 6 No. 1; 12 No. 2; 24 No. 4." (Mr. T's profits on this order alone is \$711).
G. T., Ottawa, Ont.

Russel Earned \$3300 in Five Months

"Have averaged \$600 profit a month for last six months."
A. M. Russel, Conn.

Carnegie— \$1000 a Month

"Am making \$1000 per month. I have made big money before but did not expect so much. Your Burner is just the thing."
J. Carnegie, S. D.

Berger— \$258.50 per Week

"Send following weekly here, after: 10 No. 1; 8 No. 2; 4 No. 5."
H. Berger, Ont.

\$11.75 in Ten Minutes

"I took order for a neighbor, \$11.75 profit in ten minutes."
Mrs. N. B., Hattiesburg, Miss.

\$43 in One Evening

"I made \$43 last night selling Oliver Burners."
N. B., Cheika, Wash.

It Sells Itself

Agents find it no work at all to sell this amazing invention—the Oliver new improved Oil-Gas Burner. They just show it—taking only one minute to connect it—then light it. And the sale is made! This new invention is its own salesman. It sells itself! The Oliver Oil-Gas Burner is the most timely thing that could be put out. It dispenses entirely with coal and wood when both are now high-priced. It burns the cheapest fuel—oil. It saves a woman work now in times when she is looking for just such things. Just as much or as little heat as wanted, off and on instantly by simply turning a valve.

The Secret of Big Money

Of course, now that you know the facts you yourself can understand why this

new invention is going over like wildfire! And you can understand why F. W. Bentley made \$215 in one day. Why J. Carnegie made \$1,000 in one month and why hundreds of other agents are cleaning up big too.

Oliver Oil-Gas Burner and Machine Co.

2014-N Pine Street, St. Louis, Mo.

Please send me full facts about how I can make at least \$5,000 a year representing you in my territory. Also your plan if I just wish to make big money in my spare time.

Name.....

Address.....

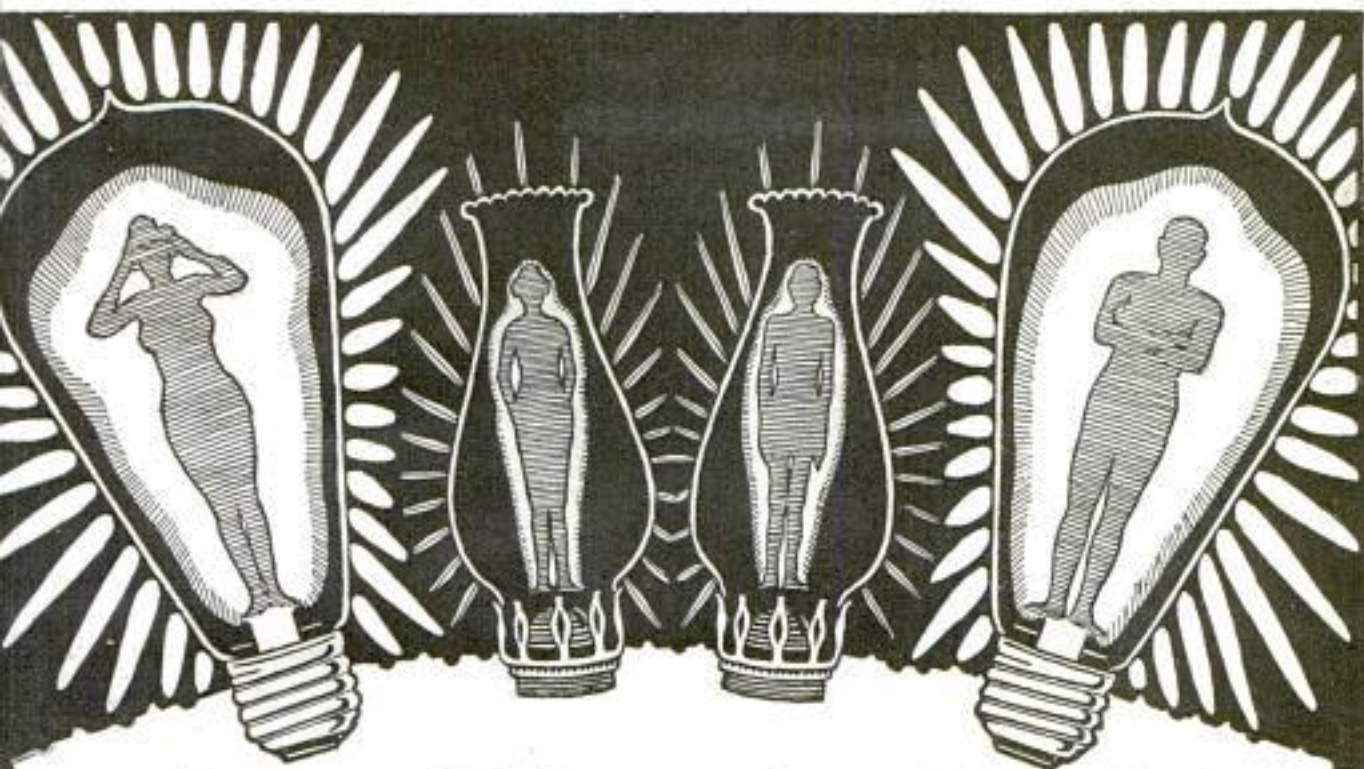

Do You Glow With Health?

Build Up Personality, Magnetism, Vitality with

VI-REX VIOLET RAYS

Some people are dull, drab, uninteresting and sickly! Others are vital, compelling and magnetic! WHICH ARE YOU? It is all a matter of vitality and health. The greatest discovery in years is that of VIOLET RAYS, electricity in a curative, medical form. Violet Rays put new life into over-taxed and sluggish tissues; penetrate and invigorate all the muscles and nerves of the body; give new tone and vitality to the entire body.

Learn the Secret of Physical Perfection

Learn how you can multiply your energy and vim! Learn how to banish those pains, aches, and ailments that run down your system, drain your personality and ruin your looks. WHAT IS PHYSICAL MAGNETISM? It is PERFECT HEALTH—plus the keen mentality based on perfectly balanced nerve centers. We will be glad to send you on request the most interesting book ever published on this subject.

Treat Yourself at Home for Asthma, Constipation, Headache, Rheumatism, Neuritis, Neuralgia, Catarrh, Pimples, Blackheads, Dandruff, Goitre, Pains, Skin Diseases.

Write Now for Startling Book and Free Trial Offer

Just write postal or mail coupon for wonderful free 52-page book explaining in detail. Read how Violet Rays massage every cell in the body. Read letters from users. See what physicians, sanatoriums, home-users say.

Why suffer? Why be satisfied with less than your full share of health and beauty? See what wonderful Violet Rays will do for you.

Mail coupon or write postal for free book and 10 days Trial Offer. Do not miss this offer. Address NOW

VI-REX ELECTRIC CO.

Dept. 22, 326 W. Madison Street, Chicago, Ill.
For New York City ONLY: 47 W. 34th St., New York

VI-REX ELECTRIC CO.

Dept. 22

326 W. Madison St., Chicago, Ill.

Please send me your free book and particulars of your Trial Offer of the Vi-Rex Violet Ray Machine.

Name

Address

City State

GENUINE

ELGINS

**\$2.00
A
MONTH**

WORLD'S LOWEST PRICES

Again—Elgins Lead the World!

This Fine New Thin Model 12 or 16 Size Genuine Elgin, Complete in 20 Year Gold-Filled Case, plain or engraved—A regular \$20 value. Special this month only.....

**AT LAST! A Real Watch
At A New Low Price.**

You know the Elgin reputation—it is the watch nine out of every ten men want! Now, you can own one at our astoundingly low price and on such easy terms you'll never miss the money.

**AT LAST! A Real Watch
At A New Low Price.**

**Sent on 30 Days
Free Trial** You take no risk — we'll trust you—you have 30 days in which to inspect and compare this handsome watch. Your decision is final—if you do not wish to keep it, send it back at our expense.

Send No Money! Just name and address will bring full particulars of this remarkable offer and our Free Catalog. No interest, no red tape. A great watch bargain for you if you act now.

HARRIS-GOAR CO., Dept. 361, Kansas City, Mo.

DURING THIS SALE customers living in the several Cities where we have Branch stores will be given This Special Price.

14.95



SAVE YOUR BODY

Conserve Your Health and Efficiency First

"I Would Not Part with it for \$10,000"

So writes an enthusiastic, grateful customer. "Worth more than a farm," says another. In like manner testify over 100,000 people who have worn it.

The Natural Body Brace

Overcomes **WEAKNESS** and **ORGANIC AILMENTS** of **WOMEN AND MEN**. Develops **erect, graceful figure**.

Brings restful relief, comfort, ability to do things, health and strength.

Wear It 30 Days Free at Our Expense

Does away with the strain and pain of standing and walking; replaces and supports misplaced internal organs; reduces enlarged abdomen; straightens and strengthens the back; corrects stooping shoulders; develops lungs, chest and bust; relieves backache, curvatures, nervousness, ruptures, constipation, after effects of flu. Comfortable and easy to wear.

Keep Yourself Fit Write today for illustrated booklet, measurement blank, etc., and read our very liberal proposition.

HOWARD C. RASH, Pres. Natural Body Brace Co.
223 Rash Building SALINA, KANSAS



**For
Boys
and
Girls
Also**

Be your own Boss

Make \$25 to \$100 a week

Let me put you in a pleasant, profitable, independent business of your own.

If you are making less than \$25 a week, I can show you the way to a bigger income at once. By my plan you can build up in a few weeks a profitable business, paying a growing income, in which you'll be your own boss. You can use spare time or all your time, just as you like.

I have put hundreds of men and women on the road to financial success and independence. In all parts of the country you will find my representatives utilizing their spare time to add to their earnings, or, in full time, making more money than they ever did before.

I can do the same thing for you—you don't need any experience. If you've got grit and confidence in yourself, you can make \$25 to \$100 a week in as pleasant an occupation as anybody could wish.

Read below what a few of my representatives are doing:

C. A. Shelton, Missouri, made sales of \$280 last month working two hours a day.

D. F. Shugrue, Mass., sells \$300 worth of goods a month in part time.

Rosenburger, Ill., averages \$370 a month sales in a community of 500 families.

Frank Schoak, New Jersey, writes he sold \$250 worth of Ho-Ro-Co goods in two weeks.

Mrs. Rouse, Georgia, quit school-teaching to sell our products. In two months her sales were over \$600.

Pawling, Massachusetts, writes. "I make \$50 a week and am my own boss."

I will show letters from these representatives to anybody desiring to see them.

With the backing I give you, and the wonderful quality of Ho-Ro-Co Products, all you need is grit and confidence. Repeat orders come easy because our goods satisfy users, every time. H. B. Tenneman of Illinois, says "People call me up—stop me on the street—even write me to bring more goods."

The Quick Selling Ho-Ro-Co Line

includes household specialties, toilet articles, soaps, remedies, and other necessities required by every family. Our agents make thousands of dollars on our two leaders alone. Ho-Ro-Co Tonic and Ho-Ro-Co Skin and Scalp Soap. You can do the same. Why not start now?



Mail this coupon at once—make your start to success,

M. G. ROTH, Pres.

Ho-Ro-Co Mfg. Co.

Established in 1908

155 Locust St.,

St. Louis, Mo.

Hundreds of men and women make from \$25 to \$100 a week without previous experience in selling.

Experience is not necessary. Very few of my most successful representatives had previous experience. Ho-Ro-Co products are so good, so well-known, that it's no task to sell them. Furthermore, I give you the benefit of my years of experience—I show you how to go about this easy, pleasant work with full confidence in your ability to make money.

Get Free Sample Case

Let me tell you how to get a big, well-filled sample case absolutely free—how to show Ho-Ro-Co products to your friends and acquaintances. Then you'll realize how easily you can double or triple your present income.

If you'll send me the coupon below, I'll give you full particulars.



M. G. Roth
President,
Ho-Ro-Co Mfg. Co.

Write your name and address clearly in ink on the coupon.

Mail coupon at once!

M. G. Roth, President,

Ho-Ro-Co Mfg. Co. 155 Locust St. St. Louis Mo.

Send me without obligation, full particulars of your Ho-Ro-Co representative's plan whereby I can increase my income.

Name

St. & No.
or R. F. D.

City

State

A Home and Income For You in Sunny Florida



Be Independent—Own a Grapefruit and Orange Grove—A Truck or Poultry Farm. Increase Your Income

You Can Start a Grove Today Under Our New Plan

Develop a profit-earning fruit farm without leaving your present position—provide for your future. A small payment now and a few dollars invested each month.

A profit-producing fruit grove is a permanent investment and provides protection against old age.

**THE RIGHT LAND
IN THE RIGHT LOCATION AT
THE RIGHT PRICE**

We Have It—Any Size Farm

These splendid lands are suburban to Tampa, the metropolis of South Florida. Here you find the most healthful, the most delightful climate in North America. For Ten years we have been right here helping develop Hillsboro—the banner agricultural County of Florida, and we are still here to serve you and to help you obtain the farm you want, on very easy payments extending over 2 or 3 years' time to suit.

Groves Developed for Non-Residents

If you want to remain in your present position for a few years we can develop a grapefruit and orange grove for you. When you are ready we will clear your land, furnish fruit trees, plant and care for your grove until you are ready to look after it.

We Raise Our Own Guaranteed Citrus Trees in Our Own Nurseries

This insures every purchaser the best fruit trees that can be grown. This also insures a successful grove. We can save you money on planting and caring for your grove.

\$300.00 to \$500.00 Per Acre Profit

This is not an unusual return for truck farmers in the Famous Tampa district. All kinds of vegetables can be grown. Big prices are paid for early potatoes, Winter cabbage, Bermuda onions, tomatoes, celery and dozens of other vegetables during the Winter and early Spring, when the north is covered with ice and snow. Strawberries, Melons, and other small fruits also yield large profits.

Write for Facts About Sunny Florida

IT COSTS YOU NOTHING TO LET US PROVE TO YOU that we have the land you want—in the location you want—at a price you can afford to pay and on the easiest terms you can imagine. Let us show you.

Fill out and mail us the coupon today and receive our large descriptive book FREE!

NORTH TAMPA LAND CO.

Suite 524 Monon Bldg. CHICAGO

Coupon for FREE Book on Florida

NORTH TAMPA LAND CO.
Suite 524 Monon Bldg., CHICAGO

Please send me your large Illustrated Book "The Call of the Southland" on choice Citrus Fruit and Truck Farms suburban to Tampa, Florida, and information on how I can have a grove developed on the monthly payment plan. P.M. 2-22

Name

St. No.

City

State



Made in Our Own
Great Factories

Yours for 20c a Day

That's just our offer on this cozy, roomy, handsome, inviting, overstuffed, tapestry-covered Rocker, Chair and Sofa to match if you wish. Also 1227 other desirable Furnishings. All on easy, monthly payments. Just check first square below for our big FREE 128 Page Book, showing Furnishings in colors for every room.

- Furnishings
 Symphonic Pianos
 Symphonic Player Pianos
 Symphonolas

(Check offer interested in)

Symphonic Pianos, Symphonic Player Pianos and Symphonolas (the phonograph with natural tone which plays all Records) sold to tens of thousands of music lovers the past nine years. Get Book describing these musical instruments by checking above.

**No Money Down—30 Days FREE Trial
1 to 4 Years TIME**

Check offer now. Cut out this ad. Give full name and address. Mail today.

Larkin Co. Inc.

Desk FPM-222

Buffalo, N. Y.



TWO GREAT FUN MAKERS

The dog head is made of metal, with rubber bulb. When you squeeze bulb the dog barks and it's a wise dog that can tell the difference from the real thing. The cat is worked the same way, only the sound is produced by a bellows within sack. This cat's meow will fool any cat or your friends. Both are small enough to be concealed in the pocket. Thousands of these have been sold in Chicago.

The Two Sent Postpaid For Only 25 Cents
The Flasmus Co., Dept. 30, 3802 Ellis Av., Chicago, Ill.

**Only \$10 DOWN
A YEAR TO PAY**

30 DAYS' TRIAL

3 YEAR GUARANTEE

Get your Kirstin now!

Act Now! Get This Special Offer

One Man Pulls Big Stumps Alone

Take a whole year to pay in small monthly payments. Earn as you pay by being our Demonstrator. Clear your land! Increase your income! Make your tax-eating stump fields pay big profits.

Kirstin One Man STUMP PULLER

Weights less—costs less. Greater power, speed, strength. A few pounds pull on the lever means tons on the stump. You can pull big stumps alone—quick, easy, cheap—without extra help. 30-page illustrated book—Land Clearers' Guide—free. Tells best clearing methods under all conditions. Low prices to demonstrators on one-man and horse-power pullers. Write today.

A. J. Kirstin Co., 3204 1st St., Escanaba, Mich.

AUTOMOBILE ENGINEERS - REPAIRMEN CHAUFFEURS - GARAGE OWNERS - TRACTOR EXPERTS **NEEDED NOW AS NEVER BEFORE**

*Reduced
in Price
for
YOUR
BENEFIT*



*They
Lead the
Way to a
BIG PAY
JOB*

Use these pay raising books a week FREE

Everything You Need to Know About Autos!

Automobile motors; welding; motor construction and repair; carburetors and settings; valves, cooling; lubrication; fly wheels; clutch; transmission; final drive; steering frames; tires; vulcanizing; ignition; starting and lighting systems; shop kinks; commercial garage; design and equipment; electric; storage batteries; care and repair; motorcycles; commercial trucks and tractors.

Get ready for a big pay job. Investigate this great bargain offer on our popular six-volume set of Automobile Engineering! We have already sold over 75,000 sets of these books to help young men forge ahead into the big pay class—a fact that allows us, because of lowered cost of production, to sell these great books at only \$24.80—regular price \$45.00!

Learn at Home—In Your Spare Time

You can learn at home—in your spare time—all you need to know to make you an expert auto authority. Don't let an opportunity like this go by—mail the coupon today and the books will be sent by express collect—for your careful examination—right in your own home.

DON'T SEND A PENNY NOW

Just the coupon. You get the books for FREE examination. Then at the end of the week, either send the books back to us without a penny's cost to you, or send \$2.80 to show that you want to advance to a big job with big pay.

ONLY A DIME A DAY

is all you have to pay—\$3.00 a month until our special reduced price of \$24.80 is paid. Don't delay a day. If you will fill in and mail the coupon NOW, we will include with the set of books, membership in the Society.

Free Consulting Service

This membership entitles you to consult our staff of experts on any problem or question that may confront you—their advice is free to you! (Regular price, \$12.00.) Mail the coupon now before the limited membership is filled.

American Technical Society
Dept. A-A-192, Chicago, U. S. A.

AMERICAN TECHNICAL SOCIETY Dept. A-A-192, Chicago, U. S. A.

Send me a set of Automobile Engineering for 7 days' FREE examination by express collect. Within one week after the books arrive I will either return them at your expense or send you \$2.80 as first payment and \$3.00 each month until the special reduced price of \$24.80 is paid. With the books I am to receive Free a consulting membership in your society.

Name

Address

Reference

Please fill out all lines

Build a New Body



Treat Yourself at Home For—

- Nervousness
- Neuralgia
- Rheumatism
- Sciatica
- Headaches
- Anaemia
- Insomnia
- Brain-fag
- Neuritis
- Paralysis
- Lumbago
- Inflammations

Any nervous disorder or painful Chronic Disease.

Rid Yourself of Weakness, Pain and Disease

Just as sunshine purifies the air and strengthens every living thing, Violet Ray treatment will purify your blood, strengthen and stimulate your body, drive out aches and pains and give you the steady nerves and vitality necessary for success. One treatment in your own home will prove this without risk to you. Our free "Health Book" tells how this wonderful treatment increases the number of red corpuscles and the oxygen content of the blood, and how it saturates the body with life-laden health-building energy.

Renulife Violet Ray High Frequency

—possesses the wonderful power of bringing a vigorous surge of rich, fresh blood to any weak, diseased or painful part of the body. Congestion is relieved, poisons are washed away, the part is warmed and soothed and the new blood carries away the diseased cells and replaces them with healthy, new nerve and muscle tissue. It literally builds new bodies. If your body is thin and undeveloped, if you lack nerve force and vitality, if you suffer from insomnia and brain-fag and if you want immediate relief, you should

Send For Free "HEALTH" BOOK NOW

It has pointed the way to health and success for thousands. It has shown them how to acquire "driving power" for their daily work, and calm nerves that permit sound sleep at night. It has enabled them to cure painful chronic diseases such as rheumatism, headaches, neuritis, etc. More than 100 disorders and weaknesses are successfully treated. It is not a "cure-all," but no matter what your trouble is, our Free Book will tell you whether or not you can be benefited.



Stimulates, invigorates and develops weak bodies

Renulife Electric Co.
1102 Newberry Bldg. Detroit, Mich.

In Canada: Netting Bldg., Windsor, Ont.

— — — MAIL THIS COUPON — — —

Renulife Electric Co., 1102 Newberry Bldg., Detroit, Mich.

Please send me your Free "Health" book, telling of the benefits derived from Renulife Violet Ray Treatment in a hundred disorders and weaknesses.

Name

Address

City

State

Sales Agents: Investigate our attractive contract.

Crippled 33 Years



Although deformed 33 years from Infantile Paralysis, F. L. Kelsey, age 35, now "walks straight and flat" after only 5 months' treatment at McLain Sanitarium. See his photos. Read his letter. Write him.

After being crippled for thirty-three years, by Infantile Paralysis, and walking on my toes for all that time, I am now walking straight and flat on both feet, after taking only five months' treatment at your Sanitarium. I will be only too glad to recommend it to any one who is crippled, for I know you can do the work.

F. L. KELSEY,
Box 1307, Tonopah, Nevada



For Crippled Children

The McLain Sanitarium is a thoroughly equipped private institution devoted exclusively to the treatment of Club Feet, Infantile Paralysis, Spinal Disease and Deformities. Wry Neck, Hip Disease, Diseases of the Joints, especially as found in children and young adults. Our book, "Deformities and Paralysis," also "Book of References" sent free.

L. C. McLAIN ORTHOPEDIC SANITARIUM
902 Aubert Ave., St. Louis, Mo. E-348b

PANDICULATE FOR HEALTH



BE WELL YOUNG STRONG

Booklet Free

Fifteen glorious minutes on Pandicator better than two hours in gymnasium. Refreshes, rejuvenates; frees impinged, irritated nerves; corrects contracted muscles, spine ligaments; relieves congestion, improves circulation and body drainage. Doctors recommend it. No electricity, no discomfort; delightfully restful. Write now

PANDICULATOR COMPANY

Dept. E, 2807 Prospect Ave.,

Cleveland, Ohio

Nobody Wants A Miserable Misfit



At first they pity him—then they have contempt for him—next they avoid him—and finally they throw him overboard and leave him to his doom. **How about you?** Are you a weakling without sufficient pep and courage to be a real man and do a man's work in this world? Are you a complaining misfit loaded with ailments such as Catarrh, Constipation, Nervousness, Indigestion, Dyspepsia, Weak Heart, Lung Trouble, etc., and crippled with Rupture, Rheumatism, Round Shoulders, Flat Chest and Flat Feet, Vital Depletion and the other defects that come from neglect of the body and disregard of the natural laws of health. Come—wake up—make yourself a 100% Man! I want to help you—I can help you.

STRONGFORTISM—The Modern Science of Health Promotion will banish your ailments, revive your vital powers and fit you for the joys of life. I guarantee it.

Mention the ailments on which you want special confidential information and send with 10c to help pay postage, etc., on my free book "Promotion and Conservation of Health, Strength and Mental Energy. Send for it RIGHT NOW—TODAY."

LIONEL STRONGFORT

Physical and Health Specialist
Dept. 655 Newark, New Jersey

Big Salaries for Executive Accountants

Business needs more Business Architects!

Not carpenters of business, mind you, bookkeepers who merely do the detail work, but trained accountants, who can go behind the figures of the bookkeeper, determine costs to the fraction of a penny, lay finger on unprofitable departments, point the way to greater profits.

Never have the services of the executive accountant been so vital to the success of business enterprises—or so well rewarded. Salaries of \$10,000 and better are not uncommon. Many heads of successful accounting firms make from \$25,000 to \$50,000 a year.

**Set Your Mark At
\$5,000 to \$10,000 a Year**

Why not find out what you must do to qualify in this attractive and profitable profession?

During the next few years hundreds of men will be advanced to private offices of their own, and on the glass will appear titles such as these: General Auditor—Specialist in Income Tax—Cost Accountant—Comptroller—Treasurer—Certified Public Accountant.

The majority of these men, at the present time, have their desks with the bookkeepers and clerks. Today they have no better start than you, but they have fixed their aim on a definite goal—they have resolved to command an income of from \$5,000 to \$10,000 a year. And they will get there! They will make their spare time count during coming months—and by home-study training they will win their way to high-salaried positions.

Train by the "Problem Method"

Begin today to reckon yourself among the men who will swing these big-pay jobs. Train at home, by the LaSalle Problem Method; equip yourself, in the most practical way known to educational science, for swift advancement.

Under the LaSalle plan of training you will get the benefit of the combined experience of hundreds of authorities; you will solve the very problems which the professional accountant solves for our greatest business organizations; you will handle every practical situation in every phase of accounting work, and will have the personal direction by mail of prominent members of the Accounting profession, who will see that every question is answered, every point made clear on business analysis, organization, general accounting, cost accounting, auditing, commercial law, and income tax.

The result of such training is that when you step into that bigger job you will find yourself at home in it from the very beginning—because you will have mastered, under the direction of practical business men, the problems of your new position.

All this counts toward the swiftness of a man's promotion; it explains, in part, how L. S. Railsback, for example, won a salary raise of 288 per cent, how H. E. Brown won an increase of 200 per cent, and how John J. Decker was enabled to make ten times the cost of his course within six months of his enrollment.



It also helps to explain why as many as 1,089 LaSalle members, in a period of only three months, reported salary-increases resulting from training under the LaSalle Problem Method totaling \$889,713, an average increase per man of 56 per cent.

Mail the Coupon

Find out today about this training—learn how you can get it in the quiet of your own home, without losing an hour from work or a dollar of pay—see if it is not just what you need to increase your earning power. The coupon, mailed today, will bring you all the facts, together with particulars of our convenient-payment plan; also your free copy of the inspiring book, "Ten Years' Promotion in One." It places no obligation on you and it brings you—opportunity. Mail the coupon NOW.

LASALLE EXTENSION UNIVERSITY

The Largest Business Training Institution in the World
Dept. 264-HR Chicago, Illinois

Please send me catalog and full information regarding the course and service I have marked with an X below. Also a copy of your book, "Ten Years' Promotion in One."

Higher Accountancy

Training for positions as Auditors, Comptrollers, Certified Public Accountants, Cost Accountants, etc.

Other LaSalle Training Courses

LaSalle is the largest business training institution in the world. It offers training for every important business need. If more interested in any of these courses, check here:

- | | |
|--|--|
| <input type="checkbox"/> Business Management | <input type="checkbox"/> Banking and Finance |
| <input type="checkbox"/> Traffic Management—Foreign and Domestic | <input type="checkbox"/> Modern Foremanship and Production Methods |
| <input type="checkbox"/> Railway Accounting and Station Management | <input type="checkbox"/> Personnel and Employment Management |
| <input type="checkbox"/> Law—Degree of LL. B. | <input type="checkbox"/> Expert Bookkeeping |
| <input type="checkbox"/> Commercial Law | <input type="checkbox"/> Business English |
| <input type="checkbox"/> Industrial Management Efficiency | <input type="checkbox"/> Commercial Spanish |
| <input type="checkbox"/> Modern Business Correspondence and Practice | <input type="checkbox"/> Effective Speaking |
| | <input type="checkbox"/> C. P. A. Coaching |

Name.....

Present Position.....

Address.....

New Tools You Should Know

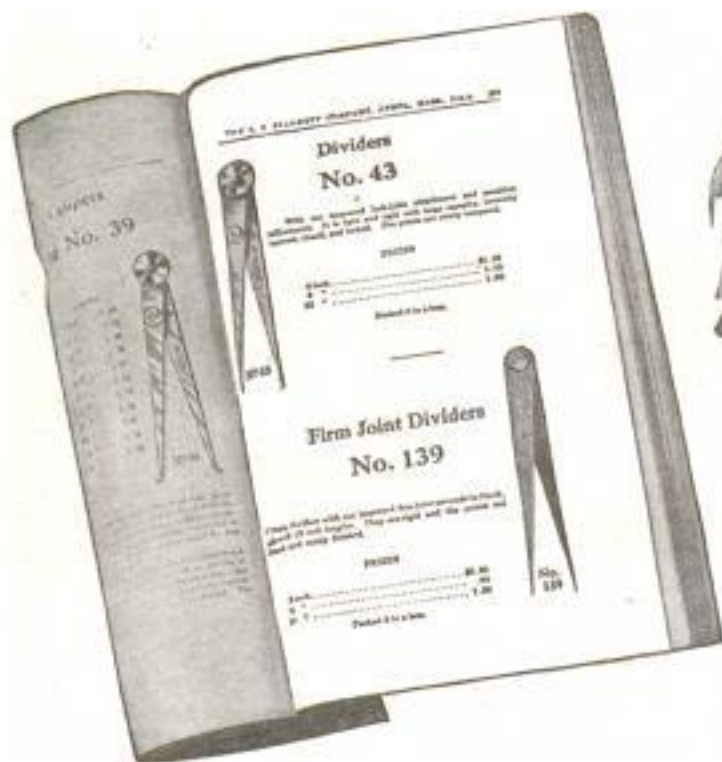

FIRM JOINT DIVIDERS No. 139

A new line of high grade Starrett dividers selling at a moderate price. These dividers are fitted with an improved firm joint and will be found very rigid. The points are hardened and the dividers are well finished throughout. Described and illustrated on page 277 of the new Starrett Catalog No. 22 "AP." Copy of this catalog sent free on request, also Special Supplement showing new Starrett Tools.

THE L. S. STARRETT COMPANY

The World's Greatest Toolmakers
Manufacturers of Hack Saws Unexcelled
ATHOL, MASS.

42-245



Use Starrett Tools

ENGINE PRICES

All Sizes—2, 3, 4, 6, 8, 12, 16, 22 and 30 H-P.
All Styles—Kerosene, Gasoline or Gas.
Stationary, Portable or Saw-Rigs.

SMASHED

NOW is the time to get your WITTE

Engine—while prices are lower than they have been for years. You need engine power to reduce labor costs, do more and earn more. Tell me what you want, Engine, Power Saw, BuzzSaw, Log Saw or Tree Saw, and I will send you special information, catalog, and lowest direct-from-factory price. To give an idea how low prices are, this

WITTE

2 H-P Engine

\$39⁹⁵ F.O.B. K.C.

From Pittsburgh, \$5 More.

Here is a chance to get your power plant, any size, up to 30 H-P., at a big saving. I can make Immediate Shipment, guarantee safe delivery. Engine shown is shipped on skids, ready to operate. Easy to set and use. Easy to buy now.

Liberty Bonds Same as Cash

If you are short of cash, I will take your Liberty Bonds—any issue—full face value, or I will sell you on easy terms at the regular payment price, if you wish terms.

90-DAY TEST—Lifetime

Guarantee All WITTE Engines, Saw Outfits, Log and Tree Saws sold on 90-Day Test and Life Guarantee against defects.

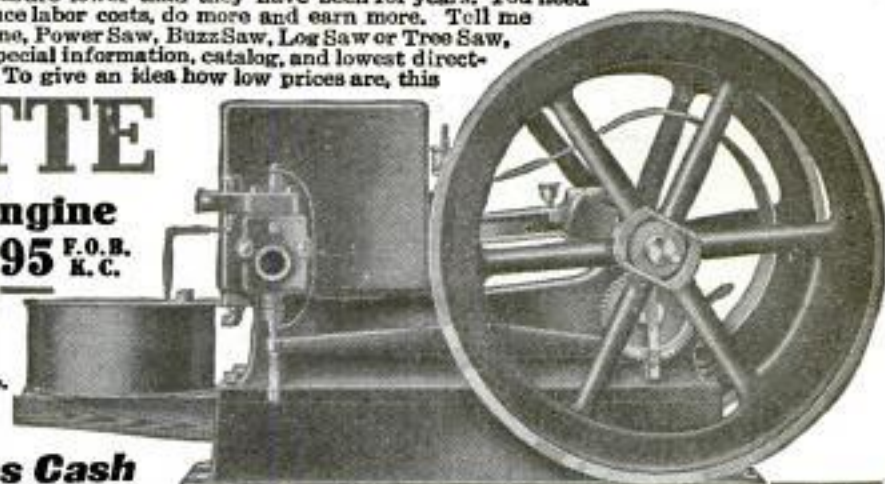

Write For Engine Catalog No. 49—FREE

It tells about Stationary and Portable Engines, or if you want to know about Saw Outfits, write for Saw Catalog No. 17.

WITTE ENGINE WORKS,

1745 Oakland Avenue,
1745 Empire Building,

Kansas City, Mo.
Pittsburgh, Pa.

WITTE

Arm Swing

LOG SAW

Cuts $\frac{1}{3}$
Faster Than
Former Rigs



Make
Money—
Save Hard Work

Now only \$99⁵⁰ F.O.B. K.C.
Saves \$50

\$35 TREE SAW
FREE

From Pittsburgh
\$105.50

Just The Log-Saw Outfit You Have Been Looking For—Latest Log Saw Improvements. Surplus power engine, with two fly-wheels for belt work. Friction Clutch, Lever Controlled, for starting, stopping or slowing down saw. Reversible wheels. Rugged construction. Natural feed when sawing logs makes saw cut fast. Adjustable force feed when sawing trees.

Special Points of Merit Saw finishes cut parallel with ground. No sawing dirt or rocks, no jacking up logs. Only interchangeable Log and Tree Outfit of the kind sold direct. Tree Saw parts make Log Saw a complete Tree Saw. Rig anchors to stump below saw—cuts tree clear down. Saws up-hill or downhill, anywhere. Log Saw Outfit sold on our regular

90-Day Test—Lifetime Guarantee

Buy for cash, or, on easy payments, as you wish. Separate Branch Saw Outfit, only \$19.90. Write for the Log and Tree Catalog. It tells all about sawing. We also build stationary engines, all sizes, up to 30 H-P. If interested, ask for Stationary Engine Catalog, and state size. Sent Free on request.

WITTE ENGINE WORKS,

1740 Oakland Avenue, Kansas City, Mo.
1740 Empire Building, Pittsburgh, Pa.

Quick
Change
From Log
To Tree
Saw

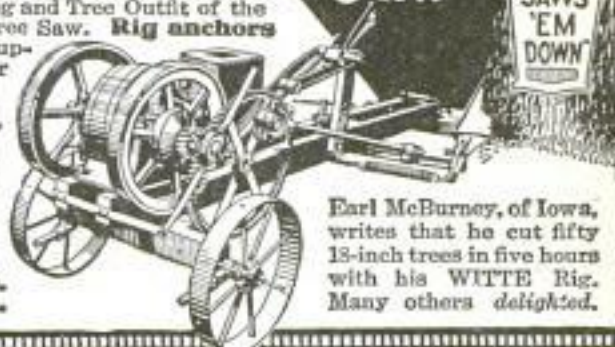

Earl McBurney, of Iowa, writes that he cut fifty 18-inch trees in five hours with his WITTE Rig. Many others delighted.

Why Pay Full Prices NOW

Diamonds Here at 60% of Market Price



\$63

1/2—3/32 Ct.

Blue white diamond in this ring. Try to match at 90 per cent more. Guar. loan \$50. Same style, various sizes, see Bargain List.



\$200

1—3/16 Ct.

Blue white diamond mounted as shown. Try to match at \$450. Guar. loan \$160. Same ring, \$50 to \$500 in other weights. See the Bargain List.



\$75

1 1/3 Ct. Size

Diamond Cluster Ring. Platinum Disk. Try to match at \$190.

Other clusters from \$30 to \$300. Pages 10, 11 and 23 in latest Bargain List.



\$48

1 Ct. Show.

Steel white diamonds. Try to match at \$100.

Plain styles, \$20 to \$150, shown in Bargain List.



\$388

1 1/4 less 1/16 Ct.

Blue white diamond. White gold ring with sapphires. Try to match at 60 per cent more. Guaranteed loan \$200. Page 29 in Bargain List.



\$350

Blue white, perfectly cut diamond in genuine platinum diamond mounted ring. Other diamonds in platinum mountings, \$150 to \$1500. Also magnificent mountings in 18 kt. Swiss white gold. The exact replica of platinum. See latest Bargain List.



\$57

3/8—1/16 Ct.

Blue white, perfectly cut diamond. Fancy green gold ring. Try to match at \$120. Guar. loan \$45.

Various size diamonds in this mounting. See Bargain List.

Why pay full prices? Buy **HERE** where loan values the price basis, not market values. This famous 75 year old firm, the largest and oldest *diamond banking institution of its kind in all the world*, rated more than \$1,000,000.00 capital, having made loans on diamonds in excess of \$20,000,000.00, now has thousands of unpaid loans and other special advantage bargains that we must sell to get back our cash.

Why Pay Full Prices Costs Nothing to See

We send you any diamond for absolutely free examination at our risk. No obligation. Have valued any way you wish. Don't buy unless satisfied you could not match the gem at 60 percent more. If you decide not to buy, you are not out one penny.

Diamonds Here as Low as \$60 per Carat

Yes, some even lower priced, but also diamonds of finest qualities at higher per carat charges. Get a diamond now around half its market price. We must turn these diamonds into cash NOW.

Send for Latest List of Diamond Loans

Not like ordinary catalog. Diamond Bargains described in detail with exact weight, color, quality, etc. Tells of *guaranteed loan value*, unlimited exchange privilege at full price paid, details of free examination. *Why pay full prices?* Send for latest list. It's FREE. No obligation. Just send name.

Jos De Roy & Sons, 1983 De Roy Bldg.

Only Opposite Post Office, Pittsburgh, Pa.

References by permission—Bank of Pittsburgh—N. A., Marine National Bank—Union Trust Company, Pittsburgh, Pa. Your bank can look us up in mercantile agencies.

Jos. De Roy & Sons
1983 De Roy Building
Only Opposite Post Office
Pittsburgh, Pa.

Gentlemen: Please send me free and prepaid, your latest bargain list of diamonds, watches and other jewelry. It is understood I assume no obligation of any kind

Name

Address

**FREE
Diamond
Expert**

New service FREE to you. World recognized diamond authority will value your diamond for you. Has backed his judgment of diamond values by actual cash outlays in loans and other deals in excess of \$50,000,000.00. Write for details.

Guaranteed Cash Loan

Diamonds bought here are like insurance policies. You know what you can borrow before you decide to buy—see **Our Cash Back Guarantee**

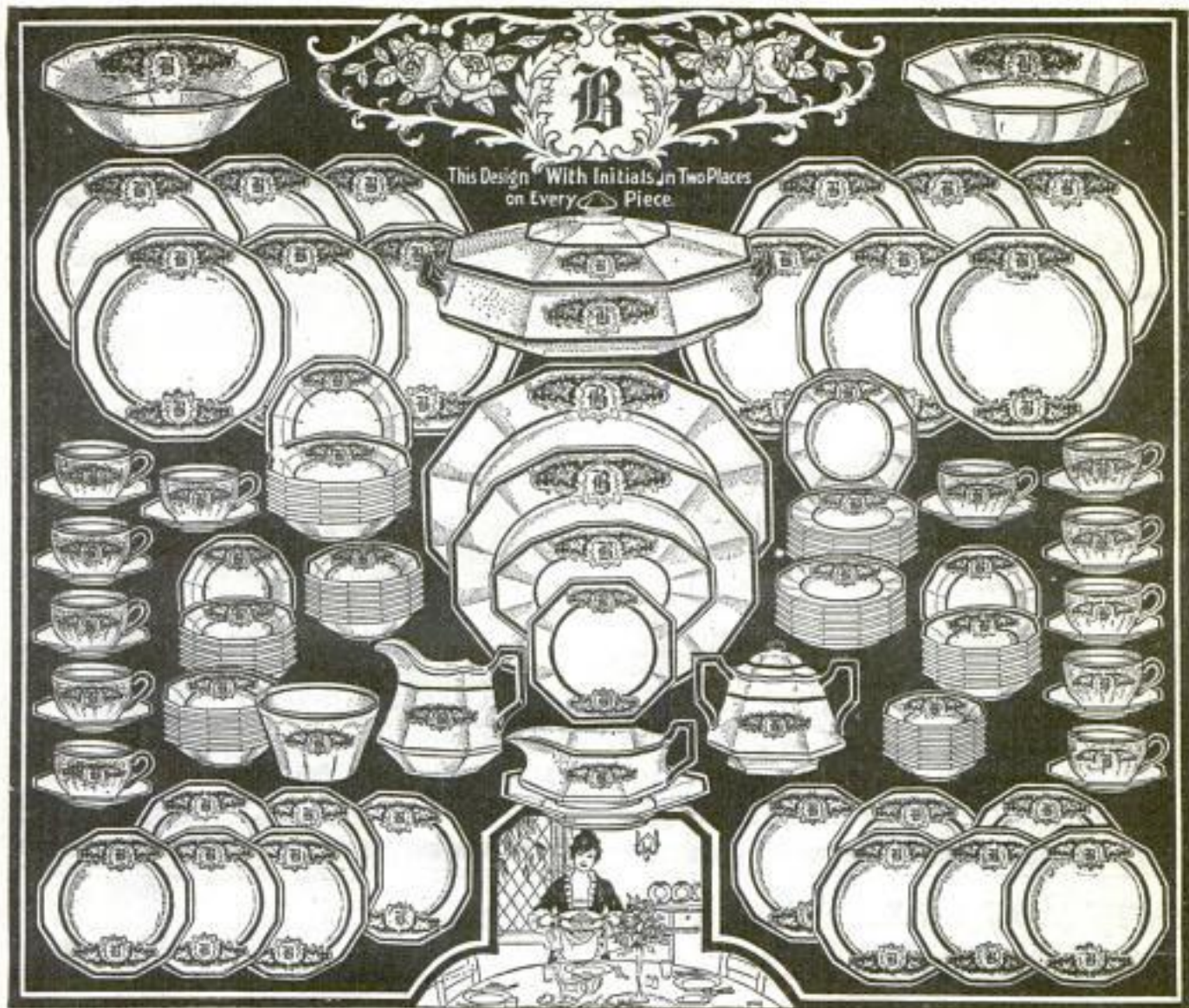

This Design With Initials in Two Places on Every Piece.

This Superb 110-piece Set, with initial in 2 places in wreath with 5-color decorations on every piece and gold covered handles, consists of:
 12 Dinner Plates, 9 inches
 12 Breakfast Plates, 7 inches
 12 Cups
 12 Saucers

12 Soup Plates, 7 1/4 inches
 12 Cereal Dishes, 8 inches
 12 Fruit Dishes, 6 1/4 inches
 12 Individual Bread and Butter Plates, 6 1/4 inches
 1 Platter, 13 1/4 inches

1 Platter, 11 1/4 inches
 1 Celery Dish, 8 1/4 inches
 1 Sauce Boat Tray, 7 1/4 inches
 1 Butter Plate, 6 inches
 1 Vegetable Dish, 10 1/2 inches, with lid (2 pieces)

1 Deep Bowl, 8 1/4 inches
 1 Oval Baker, 9 inches
 1 Small Deep Bowl, 5 inches
 1 Gravy Boat, 7 1/4 inches
 1 Creamer
 1 Sugar Bowl with cover (2 pieces)

368-Page Book Free

Brings 110-Piece Gold Decorated Martha Washington Dinner Set

Send only \$1 and we ship the full set—110 pieces. Use it 30 days. Then if not satisfied, return them and we refund your \$1 and pay transportation charges both ways. If you keep them, take nearly a year to pay on easy terms.

Your Initial in 2 Places on Every Piece—5-Color Floral Decorations and Gold

Wonderful artistic effect is given by the wreath and rich design surrounding the initial. Your initial appears in 2 places on every piece.

All Handles Covered with Gold
 Every handle is covered with polished gold. Shipping weight about 90 lbs.



Important!

Hartman guarantees that every piece in this set is absolutely first quality—no seconds. This is a standard or "open" pattern. Replacement pieces may be had of us for three years. Each piece wrapped in tissue paper. Excellent packing to prevent breakage. Shipped without delay.

Order No. 324DMA13. Bargain price, \$32.85. Pay \$1 now, \$3 monthly.

HARTMAN Furniture & Carpet Co.

Dept. 4289 Copyright, 1922, by Hartman's, Chicago Chicago, Ill.



FREE Bargain Catalog

368 pages of bargains in furniture, rugs, stoves, silverware, washing machines, kitchen ware, gas engines and cream separators, etc.—all on our easy terms—30 days FREE trial. Post card or letter brings it FREE.

HARTMAN FURNITURE & CARPET CO. CHICAGO, ILL.
 DEPT. 4289

I enclose \$1.00. Send 110-piece Golden Martha Washington Dinner Set No. 324DMA13. I am to have 30 days' free trial. If not satisfied, will ship it back and you will refund my \$1.00 and pay transportation charges both ways. If I keep it I will pay \$3.00 per month until full price, \$32.85, is paid. Title remains with you until final payment is made.

Name.....
 Street Address.....
 R. F. D..... Box No.....
 Town..... State.....
 State your Occupation..... Color.....
 Give Initial Wanted (Any One Letter).....

ABCDEFGHIJKLMNOPQRSTUVWXYZ

**JUST
OUT**

"666"
Bam-Bee-No"



Bam-Bee-No

THE NATIONAL GAME—PLAY REAL BASEBALL AT HOME!

Real baseball played on any table, anywhere. Everybody going wild about it. All the interest of an actual ball game without delays, discomfort or inconvenience. Excitement! Wow! Oh, Man! Nothing else like it. Just the thing for these times. You'll have a thousand dollars' worth of enjoyment every evening.

Don't Buy If You Don't Like Baseball

You'll be crazy about it right from the start. Two or more can play—the more on the sides the greater the fun. **Exactly the same as baseball.** All the tight pinches, strikes, balls, hits, doubles, triples, home-runs, wild pitches, passed balls, sacrifices—every combination known to baseball. "Three men on—two outs—and sing"—"666! Home Run! Bam-Bee-No!" Oh, Man!

Don't Miss This Fun

Be first in your neighborhood. Give a "Bam-Bee-No" party and see what a hit you make. (This is not a game for little children.)

"Bam-Bee-No," The National Game, complete with playing field, nine men, three counters, three "combination cubes" and original copyrighted book containing easy-to-learn rules and **every play known to baseball**—all in handsome box with full directions for use. \$1.50 postpaid (Canada \$2.00.) Money back if not satisfied. **Descriptive folder free.**



\$1.50
Post-paid
(Canada \$2.00)

THE NATIONAL GAME CO.

622 Tenth St., Toledo, Ohio

**Recommended, Endorsed and Praised
by Leading Ball Players**

Babe Ruth says: "I have seen the baseball game which you have doped out and certainly think you have hit on a popular idea." Sport writers all say it's a "Wiz." Joe Villa, Sport Editor of the New York Sun, says: "I've played your baseball game and found it one of the most interesting novelties I've ever seen."

Special Trial Offer

Buy a Bam-Bee-No outfit today. Have a game with the family or choose up sides with your friends. Play every day for three days. If you're not satisfied at the end of the third day, return the outfit and we'll refund your \$1.50. Descriptive folder free.

Any Boy Can Build This 30 Inch Boat



With Our Construction Set

Also other sailboats, power boats, engines, boilers.

Complete
Partly finished
Rough.

CATALOG FREE

**The H. E. Boucher
Mfg. Co.**

154 Lafayette St. New York

Our BUREAU OF INFORMATION will answer all questions regarding articles appearing in this magazine. Address Bureau of Information, Popular Mechanics Magazine, Chicago.

BABE RUTH delights in the sport of Motoring

FORD
SPORT
BODIES

So do you



16 Valve Heads
Speed Differential Gears
Full line Speed & Power Specialties for the Ford. If you own a Ford rebuild it now. Prices are now at Rock Bottom, sure to go up in Spring. Ford chassis can be bought cheaply at this time of the year. Dealers equip Fordspeed cars now at low cost and you will be sure to harvest Big Profits in the Spring. Reductions of 20 to 50 per cent on Fordspeed Products. Write for our catalog and special prices.
R. P. FORD SPEED & POWER EQUIPMENT MANUFACTURERS
250 West 54th St., New York. Cable Address "Fordspeed"

Don't Wear a Truss



MR. C. E. BROOKS

Brooks' Appliance, the modern scientific invention, the wonderful new discovery that relieves rupture, will be sent on trial. No obnoxious springs or pads.

Brooks' Rupture Appliance

Has automatic Air Cushions. Binds and draws the broken parts together as you would a broken limb. No salves. No lies. Durable, cheap. Sent on trial to prove it. Protected by U. S. patents. Catalog and measure blanks mailed free. Send name and address today.

BROOKS APPLIANCE CO., 126G State St., Marshall, Mich.

NO MORE BALD HEADS



WHEN our VACUUM CAP is used a few minutes daily. We accept no pay until you have tried the Cap 60 days and are satisfied. The Vacuum Cap is an appliance that draws the blood to the Hair Roots and starts a new healthy crop of hair. It stops Dandruff, stops the hair from falling out.

Bought by Doctors and men who know that it is the only reasonable HAIR GROWER known to science. No Drugs Used. Write for application blank, testimonials, and booklet on "HAIR," sent sealed in plain envelope, FREE.

THE MODERN VACUUM CAP CO.
U 559 BARCLAY, DENVER, COLO.

Please Mention Popular Mechanics



Learn Electricity

LEARN IN THE GREAT SHOPS OF EARN
IN 3½ MONTHS COYNE! \$150 to \$400 A MONTH

Your future lies in the Electrical field. You love the work—decide to enter now. The opportunities are limitless. This industry is growing faster than any other and attracting BILLIONS of capital. Get your share. The demand for trained men was never so urgent and the pay was never so large. Act—**ACT NOW.** Make a start in this wonderful calling.

Hundreds of our graduates are making big money as Power Plant Operators, Electrical Engineers, Telephone Men, Superintendents, Electro Auto Engineers, etc. Hundreds of others are in the electrical contracting business for themselves and making from \$3,000 to \$20,000 a year. I want you to drop your present line and come to Coyne now and let us prepare you for big opportunities. *Spend the next three and one-half months in Chicago, the electrical center of the world.*

Coyne Training Is Complete

I offer you EXCLUSIVE advantages here. \$100,000.00 worth of massive electrical apparatus is reserved for your special use. You learn quickly because you work—in a class of ONE—with a special instructor to help you—on our immense and modern equipment of dynamos, switchboards, generators, locomotives, etc. This REAL work with REAL tools on REAL machinery trains you five times as fast as studying from books, and enables us to put you through in about one-fifth the time—3½ months instead of 1 to 4 years. And when you graduate you KNOW your business, for everything is learned by DOING.

Auto Truck and Tractor Course Included

To those enrolling in our complete electrical course now we offer you this entire Auto Truck and Tractor Electricity course. You become an expert in starting, lighting, ignition, testing, maintenance, service. You learn in a real electrical school, on real equipment, and can enter a field of highly paid specialists. This training would cost you elsewhere more than we charge for our entire course—Act on this offer NOW.

Business Management

A thorough training in business management is now given to you, without an extra cent of cost. You are now technically trained, and gain a thorough knowledge of business which enables you to apply your technical knowledge to much greater advantage. You



B. W. COOKE

PRESIDENT

COYNE
TRADE AND ENGINEERING SCHOOL

Dept. 52

39-51 East Illinois St., Chicago, Ill.

can command \$500 to \$800 a month and more in a business of your own.

Learn in Chicago—the Electrical Center

There are many advantages in coming to Chicago now. You can visit the world's greatest electrical plants; during the evenings and Sundays you can visit Chicago's libraries, museums, art galleries and countless other places of interest. Resolve to come to Chicago now and learn the electrical trade.

Earn While You Learn

Don't wait to save a lot of money. Our employment department places students in spare time jobs to earn their living expenses or if they must earn all expenses we place them where they work days, generally at electrical work, and go to school evenings for a while, then later change to day school.

Hundreds of our students have worked their way through, you can do the same. Make up your mind right now—send the coupon this very minute for our big free catalog and full information.

Mail Coupon for Big FREE Book

Get this book of Opportunity! From cover to cover it tingles with interest. Tells about our great shops! Covers many jobs open for Coyne trained men! Tells of great successes of Coyne graduates. Get this book by all means! It's FREE. Merely fill in the coupon, and mail it **now**—at once!

Bennett W. Cooke,
 President

**Coyne Trade and
 Engineering Schools,**
 Dept. 52, 39-51 E. Illinois
 St., Chicago, Illinois

Gentlemen: Send me your big free catalog with full particulars concerning your Electrical course and how I may secure your course of Auto Truck and Tractor Electricity and the course in Business Management, free. This places me under no obligation whatsoever.

Name

Address

You Can Learn to Boss This Job

What's YOUR Future?

Trained "Electrical Experts" are in great demand at the highest salaries, and the opportunities for advancement and a big success in this line are the greatest ever known.

"Electrical Experts" earn \$70 to \$200 a week. Fit yourself for one of these big paying positions.

Don't plug along year after year—get the Big Money now—I will make you an Electrical Expert.



Experience Not Necessary

You don't have to be a College Man; you don't have to be a High School graduate. My course in Electricity is the most simple, thorough, and successful in existence, and offers every man, regardless of age, education, or previous experience, the chance to become, in a very short time, an "Electrical Expert," able to make from \$70 to \$200 a week.

Electrical Experts Earn \$3,500 to \$10,000 a Year

Read Thompson's Letter

TODAY even the ordinary electrician—the "screw driver" kind—is making money—big money. But it's the trained man—the man who knows the whys and wherefores of Electricity—the "Electrical Expert"—who is picked out to "boss" ordinary electricians—to boss Big Jobs—the jobs that pay.

I Give You a Real Training

As Chief Engineer of the Chicago Engineering Works I know exactly the kind of training a man needs to get the best positions at the highest salaries. Hundreds of my students are now earning \$3,500 to \$10,000. Many are now successful ELECTRICAL CONTRACTORS. Read the letter at left, sent me by A. T. Thompson. I have several thousand of such letters on file.

FREE Electrical Outfit I give each of my students a splendid outfit of fine electrical tools, materials, instruments, etc., absolutely FREE. You do practical work at home, right from the start. These tools will help you pay for your course in picking up spare-time money. Many of my students do this.

Start NOW! I want to send you my Electrical Book, "Vital Facts," and Proof Lessons, both FREE. These cost you nothing and you'll enjoy them. Make the start today for a bright future in electricity. Send in coupon—NOW.

L. L. COOKE, Chief Engineer
CHICAGO ENGINEERING WORKS
Dept. 512 2150 Lawrence Ave., Chicago, Ill.

Satisfaction Guaranteed

So sure am I that you can learn Electricity—so sure am I that after studying with me, you, too, can get into the "big money" class in electrical work, that I will guarantee under Bond to return every single penny paid me in tuition if, when you have finished my course you are not satisfied it was the best investment you ever made.

Dear Sir: Send at once Sample Lessons, your Big Book, "Vital Facts," and full particulars of your Free Outfit and Home Study Course—all fully prepaid, without obligation on my part.

L. L. COOKE,
Chief Engineer,
Chicago Engineering Works, Dept. 512,
2150 Lawrence Ave.,
Chicago, Ill.

Name.....

Address.....



Started With 67¢ —Now an Electrical Contractor

Sussexville, Calif.
Dear Mr. Cooke:
I have not been sending in any letters lately on account of being very busy in my business. Am now working 7 Electricians, paying each of them \$1.00 a day above the Union scale. I have on hand now, unfinished, over \$12,000 worth of contracts for electrical work, and am now making arrangements to have a nice stucco building, 50x100 ft., put up for my shop and store.
Not so bad for a student who is practically a new beginner one who had to borrow \$5 for his first payment on your Course and who started in business with just 67¢ to his name. In addition to building up a nice little business I have built a little home, in which I owe less than one thousand dollars.
Things are moving early now, and I expect soon to get back to my Lessons and complete your wonderful Course.
Sincerely yours,
A. T. THOMPSON.

The Cooke trained man is the 'Big Pay' man

Motor Secrets That Quickly Put Me On Easy Street

By O. H. Justus

Not so very long ago it looked like I might plod along in the wage rut all my life.

Today I'm living on "Easy Street," and when friends look over my property they say: "Justus, you've been lucky!"

They see a big, busy auto repair shop, new stocks of tires, cars and trucks and scores of cars and customers coming and going. And they wonder how a wage earner could have got hold of such a business.

Well, I didn't do it by "luck," brilliance or somebody else's money. I did it by simply using the common sense every man has. And any man who wants to can do as well or better.

First, I made up my mind to TRY. Then I saw that the greatest demand for men, best pay and surest future were in keeping our millions of cars, trucks and tractors in repair. But I soon found out that becoming a mechanic by the old "experience" system meant several more years of the grind. I also saw that the men who had learned that way were not getting anywhere, while the good jobs and big money were going to men with special training—men who knew the mechanical secrets of motors. "I don't want to be a grease hound or a second-rate wrench twister," I said to myself. "I'm going to learn those secrets, too."

Henry J. Rahe made it possible. Remember his name, because he can do the same for YOU. I read an advertisement about his quick, easy practical course in auto and tractor work in his big shop-schools—learning with tools, not books, and from master instructors under Mr. Rahe's personal supervision. Largely out of curiosity, I mailed "the coupon in the corner." And it turned out to be my ticket to "Easy Street."

A few days later I was on my way to one of the Rahe Schools



O. H. Justus and his big agency and repair shops at Parkersburg, W. Va.

which I consider the ONLY schools. A few weeks later I was back home, a Rahe graduate—master of all the motor secrets that separate the \$2-a-day laborer from the \$40 to \$100 a week of the real mechanic. Easy Rahe training had made me a free man for less money than a good Rahe-trained mechanic earns in three weeks.

Since then I've never wanted to work an hour. My big pay as a mechanic soon enabled me to open my own shop, which ALWAYS has had from a week's to a month's work ahead of it. No job ever has "stuck" me; none of my work has "fallen down." I have employed mechanics who had just "picked up" the trade—almost invariably to my sorrow. But I've never hired a Rahe-trained man who didn't make good. The only trouble was, I couldn't keep them—they all went into business for themselves. And, so far as I know, every one of them is now on "Easy Street."

If you want to get somewhere, be your own boss and make some real money, find one of those "coupons in the corner" and send it to Henry Rahe today. Then, if you use your wits, it will prove to be your ticket to "Easy Street," too. I'm giving it to you straight. I KNOW.

I Want Men! I'll Pay Your Fare to Chicago, Cincinnati or Kansas City

I want to help 500 ambitious men follow Justus to "Easy Street" in the next few months. YOU—regardless of your age or education—can get there easier than he did. Today the field is bigger, the demand for Rahe-trained men greater and the pay better. And you can get to my school nearest your home FREE OF CHARGE! I'll pay your railroad fare in full to my nearest school, no matter where you live. It's going to be a BIG year for Rahe-trained men. Get started early! Just jump on a train for the nearest Rahe school. Every cent of your fare will be refunded the minute you enroll. (Read my 7-day guarantee.)

Master Instructors Wonderful Shops

Every instructor in my three schools is a MASTER of his business—trained by me and always under my direction. I keep constantly in touch with each school and see that things are done RIGHT. The Rahe shops are really wonderful. They contain everything needed to make YOU, too, a MASTER of this big-money business.

You don't need "book learning" to succeed in this business—just a few weeks' pleasant training on actual motors and cars. If you don't want to go into business for yourself, you can make REAL MONEY working for others. Bill Peace, one of my graduates, writes me that he's making \$250 a month and expenses operating a tractor in the



I've put 40,000 men on "Easy Street." I can and WILL do it for you if you'll simply tell me you want to go. Say it right now.

HENRY J. RAHE.

oil fields. THOUSANDS of Rahe-trained men make reports like this.

Special Money-Saving Price

I've always given as good a course and at as low a price as that made by any reliable school, bar none. Now, with schools in three locations—getting nearer to my prospective students and increasing my capacity—I can reduce my price still further—and pay your railroad fare besides! Get my low tuition figures. You'll be pleasantly surprised.

7-Day Guarantee

Try a Rahe School a week. Then, if you don't like it—if you don't believe my methods will make you a competent auto and tractor mechanic—you can withdraw and the 7 days' training will cost you NOTHING. No other school offers this guarantee. It's your INSURANCE of satisfaction. Don't forget—this will be a BIG year for Rahe-trained motor-maintenance engineers—thousands will be needed. Get started QUICK! Send the coupon or a post card and find out about the EASY Rahe way to "Easy Street."

Do it today.

Yours for quick success,

Henry J. Rahe

It Costs You Nothing to Get the PROOF

The coupon will bring my big free book, with proof that Rahe training will start you to "Easy Street." No cost—no obligation. Write me NOW.

Address the nearest School—Dept. 2895

Rahe Auto & Tractor Schools

CHICAGO Michigan Boul. and Ontario Street
CINCINNATI Ninth and Walnut Streets
KANSAS CITY 22nd and Oak Streets

Send This Coupon NOW

HENRY J. RAHE, Dept. 2895

Please send me your big illustrated FREE BOOK and proof that you can put me on "Easy Street."

Name.....

Street, R. R. or P. O. Box.....

Town..... State.....

Age..... Occupation.....

Address me at my school nearest your home.—H. J. R.

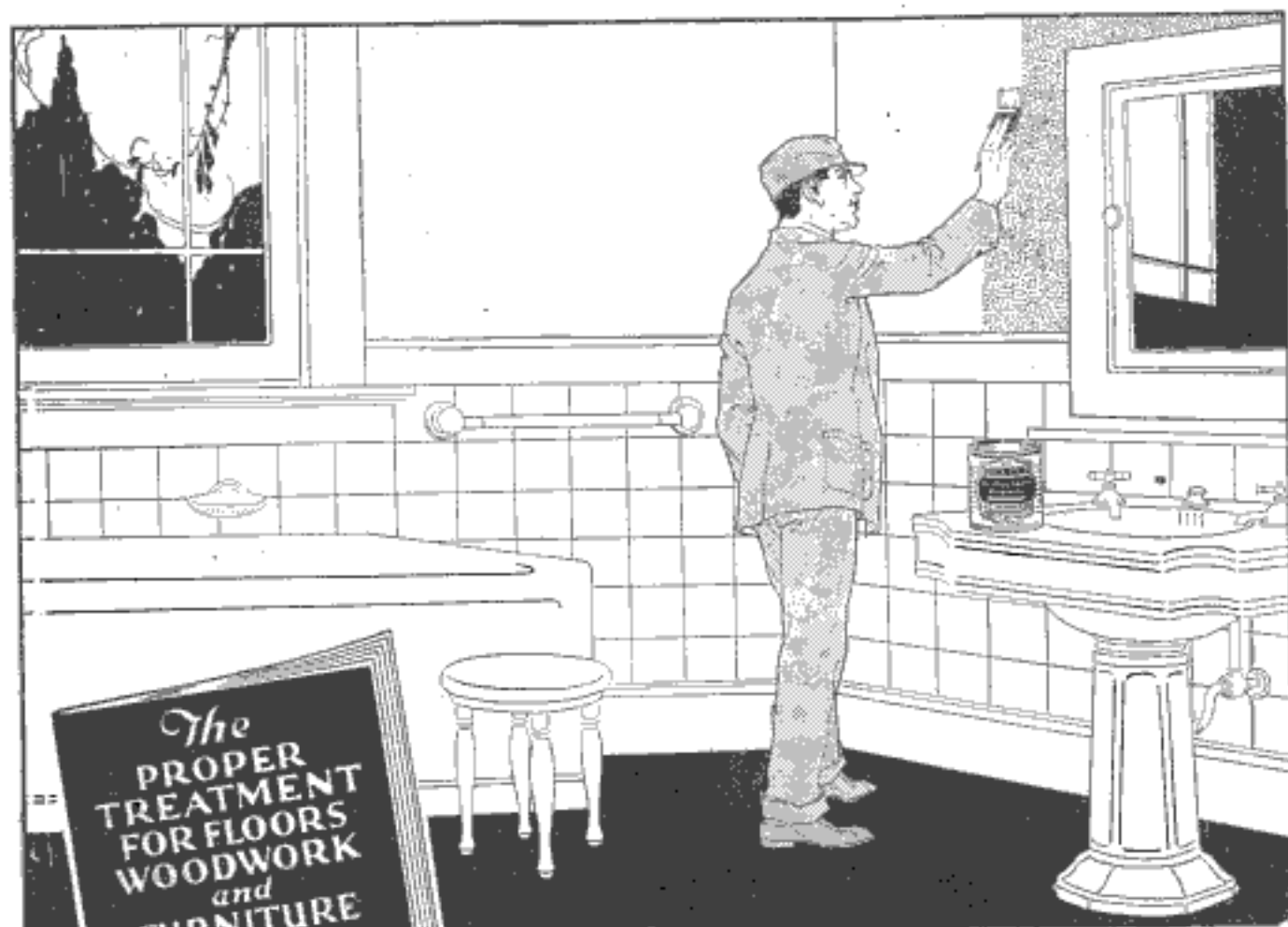

This Beautiful Book on Wood Finishing FREE

GIVES complete instructions for finishing all wood—hard or soft, old or new. Explains just what materials to use and how to apply them. Tells how inexpensive soft woods may be finished so they are as beautiful and artistic as hard wood. This book is the work of experts—illustrated in color. Gives covering capacities, includes color charts, etc.

JOHNSON'S ENAMEL

Johnson's Perfectone Undercoat and Enamel is the ideal finish for wood, plaster and metal. It will not chip, check, crack, peel or change its color. Gives a beautiful, germ-proof, porcelain-like finish which is impervious to hot soapy water, iodine, ammonia, etc.

S. C. JOHNSON & SON, Dept. PA2, Racine, Wis.

Please send me, free and postpaid, your Instruction Book on Wood Finishing. The best dealer in paints

here is.....

My Name.....

My Address.....

City and State.....

Fill out and mail coupon for a free copy of "The Proper Treatment for Floors, Woodwork and Furniture."

S. C. JOHNSON & SON

"The Wood Finishing Authorities"

Dept. PA2, Racine, Wis.

Canadian Factory—Brantford

Amazing Low Price For Brand New Oliver Typewriters

Here is the most wonderful opportunity for buying a typewriter. It saves you from paying the usual price. Never has such a liberal offer been made before by any other typewriter maker. Get the facts. You'll be astonished.

This advertisement brings you an unusual opportunity to own a fine new Oliver, shipped direct from the factory at a remarkably low price—the greatest saving today.

In addition to the rock-bottom price, it is offered to you on easy payments—over a year to pay.

Furthermore, it is sent to you for Five Days' Free Trial, without your paying a single penny in advance.

These are only several of the remarkable details of this great offer. You should mail the coupon at once for complete information. We know you will agree that this is the greatest bargain you've heard of in many a day.

FREE TRIAL

Just think of it—this offer includes a free trial of the famous Oliver No. 9 in your own office or home. We ship it direct from the factory, and you can keep it or return it. We leave the decision to you. If you want to keep it, you can pay on unusually low terms, just like renting. If you want to return it, remember you've not obligated yourself in the slightest.

The Oliver you get on this offer is in every way a \$100 machine. It is our latest and finest model, the identical one used by some of the foremost businesses in the country, such as The New York Central Lines, Hart, Schaffner & Marx, U. S. Steel Corporation, N. Y. Edison Company, National Cloak & Suit Company, Morris & Co., and a host of others.

Regardless of price, you cannot buy a finer

typewriter, nor one more durable, nor one with so many superiorities. This offer is your greatest opportunity to own the finest typewriter conceivable at the lowest possible price.

Over a Year to Pay

Our plan of payment is as liberal as the price. You get the use of the Oliver and hardly know you're paying for it.

Remember, what we offer is a brand new Oliver, our latest Model No. 9. Do not confuse it with second-hand or used machines. We offer a brand new Oliver for less than the usual price for second-hand or used typewriters.

It takes only a minute to clip the coupon and fill it out. Then mail it. Our offer, including beautifully illustrated catalog and a startling expose, entitled "The High Cost of Typewriters—The Reason and the Remedy," will be sent at once by return mail.

Remember, this is the most astounding typewriter offer ever made and you cannot afford to be without the facts. So mail the coupon at once.

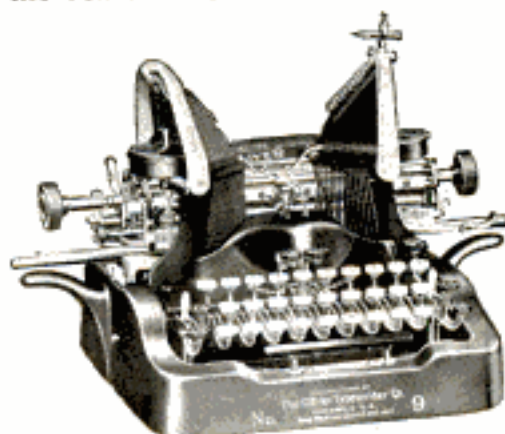

Over 900,000
Olivers Sold

The OLIVER Typewriter Company
1092 Oliver Typewriter Bldg., Chicago, Ill.

Mail today and Learn all about this Special Offer

The Oliver Typewriter Company

1092 Oliver Typewriter Bldg., Chicago, Ill.

Please send me without the slightest obligation on my part your special offer, illustrated art catalog and the booklet, "The High Cost of Typewriters—The Reason and the Remedy."

Name

Street

City..... State.....

Occupation or Business

SEND NO MONEY JUST THIS COUPON

Old King Cole loved
 the Mint with a Hole,
 "I enjoy Life Savers,"
 said he;
 "One after my pipe,
 two after my bowl,
 They're always Lifesavers
 to me."

Pep-O-mint

Wint-O-green

Lic-O-riee

Cl-O-ve

Cinn-O-mon